

## Pupal Distribution of *Dacus dorsalis* Hendel in Relation to Host Plants and its Pupation Depth

YUSOF IBRAHIM and ROSLI MOHAMAD

Department of Plant Protection, Faculty of Agriculture, Universiti Pertanian Malaysia

Key words: Fruit fly *Dacus dorsalis* Hendel; Pupal Distribution; Pupation depth.

### RINGKASAN

Penyelidikan mengenai pertaburan kepompong *Dacus dorsalis* Hendel berkaitan dengan pokok-pokok perumah dan ujian paras dalam kepompong ditanah telah dijalankan. Sampel-sampel daripada pokok betik menunjukkan kelebihan bilangan kepompong ( $P < 0.05$ ) berbanding dengan bilangan yang didapati dari pokok-pokok jambu, belimbing segi, dan nangka. Tidak terdapat perbezaan diantara ketiga-tiga pokok perumah yang kemudiannya. Kepompong juga telah didapati bertaburan lebih kurang samarata dibawah pokok-pokok perumah. Keputusan yang didapati juga menunjukkan serangga ini lebih gemar berkepompong pada paras 2 cm dan 3 cm dalam tanah.

### SUMMARY

Studies on pupal distribution of *Dacus dorsalis* Hendel in relation to host plants and its depth of pupation were conducted. Samples from papaya trees gave significantly ( $P < 0.05$ ) higher pupal count compared to those from guava, starfruit, and jackfruit. No significant differences were obtained among samples from the latter three host plants. The pupae were also found to be almost evenly distributed under the trees. The results obtained also showed that this insect prefers to pupate at 2 cm and 3 cm soil depth.

### INTRODUCTION

The oriental fruit fly, *Dacus dorsalis* Hendel, is an important pest of fruit trees in Malaysia. Starfruit (*Averrhoa carambola*) is one of the important hosts of this pest. Other fruits include papaya (*Carica papaya*), guava (*Psidium guajava*) and the jackfruit (*Artocarpus heterophyllus*).

Work on this pest had been reported as early as 1913 in the Philippines (Jones), 1914 in Indonesia (Dammerman), and 1940 in Malaysia (Miller). The females oviposit the eggs immediately beneath the skin of the fruit. The fruit soon becomes damaged as the newly hatched larvae burrow and consume the succulent flesh of the fruit. The affected fruits drop prematurely resulting in poor yield. The life-cycle is completed in the soil where the larva pupates and emerges in ca. 10 days later.

Current control practices involve bagging and/or insecticide spraying of the fruits. These procedures, however, are laborious and time consuming. Furthermore, the success of the control depends on the precise timing of the spraying operation. There is also the danger of insecticidal residues being consumed.

In view of the above problems a study was conducted to determine the distribution of the insect in the soil, and its behavioural activity with regard to pupation depth.

### MATERIALS AND METHODS

Two related studies were undertaken: a field study on the pupal distribution in relation to host plants; and a laboratory observation on the pupation depth of the pest.

#### *Pupal Distribution:*

Four fruit areas, papaya, starfruit, guava, and jackfruit in the University Farm were selected. Five fruiting trees were selected randomly from each area. Four soil samples per tree spaced 30.5 cm, 61 cm., 91.5 cm., and 122 cm., away from the stem were randomly taken under the canopy where heavy fruit sets were located.

Each soil sample, 15.25 × 15.15 × 7.625 cm. deep (6" × 6" × 3"), was placed in a saturated solution of NaCl to separate the pupae and the debris from the soil. This was then passed

through a 25 mesh sieve (Endecoff Ltd., London) and allowed to dry for about 2 hr. before the actual pupal count was made.

*Pupation depth :*

In this study paper containers as in Fig. 1 were used to determine the pupation depth of *D. dorsalis*. Petri dishes of 95 cm. diameter were used as the bases. Six layers of Manila cards, each 1 cm. taller than the successive inner layer, were wrapped around each petri dish and secured with cellophane tape. The containers were then filled to the brim with loose, friable, moist soil (Serdang Series: Sandy loam top soil).

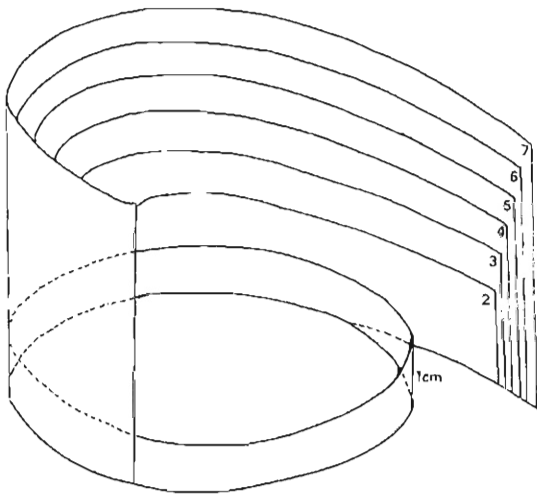

Figure 1: Manila card container used in the pupation depth study.

Thirty 3rd. instar fruit fly larvae were released into the container which was then immediately covered with another petri dish to prevent larvae from escaping. The cover was removed after all the larvae had successfully burrowed into the soil. Pupation depth, as determined by pupal count made five days later, was recorded by successive removal of the outer wall of the container. The test was replicated eight times at room temperature of ca. 28°C.

**RESULTS AND DISCUSSIONS**

*Pupal Distribution :*

Pupae recovered from samples in papaya areas were greater in number ( $P < 0.05$ ) than those from guava, starfruit, or jackfruit (Table 1). This is perhaps due to the heavy fruiting nature of the papaya trees compared to the other trees sampled. The result also showed no significant

TABLE 1

Pupal count of *Dacus dorsalis* Hendel to random samples of fruit trees.

No. of Observations	No. of pupae recovered			
	Papaya	Guava	Starfruit	Jackfruit
1	13	8	7	4
2	6	3	4	2
3	11	6	4	3
4	12	6	5	5
5	9	2	3	3
Total	51	25	23	17
Mean	10.2A	5.0B	4.6B	3.4B

Means followed by the same letter are significantly different ( $P < 0.05$ ) as determined by DMRT.

difference in pupal number recovered among guava, starfruit and jackfruit.

There were no significant differences among all the treatments (Table 2). This indicates that the pupae were randomly distributed under the canopy of all the fruit trees sampled.

*Pupation Depth :*

The 2cm and 3cm depth of soil seem to be the preferred regions of pupation. As shown in Table 3, highly significant ( $P < 0.01$ ) readings were recorded at these depths in comparison to those at the other levels. AliNiaze (1974), however, reported from a field study that cherry fruit fly pupae preferred to diapause within the top 4 in (approx. 10 cm) of soil depth. He attributed this preference to the physical and environmental factors of the soil. Shah *et al.* (1948) found that there was variation in the depth of pupation in ploughed and unploughed soils. Cavalloro and Delria (1975) believed that chemical factors did not have any influence on the depth of pupation. Their study revealed that the fruit fly *Ceratitidis capitata* pupated deeper in cracked and dry soil than they did in wet soil. In this investigation it would appear that at the regions of 2cm and 3cm soil depths, the soil environment would be most favourable in that it would not affect pupal development and eventual adult emergence.

**CONCLUSION**

Significantly more pupae of *Dacus dorsalis* Hendel were recovered from the papaya trees than from the other fruit trees sampled. The results also indicate no significant differences

PUPAL DISTRIBUTION OF *DACUS DORSALIS* HENDEL

TABLE 2

Number of pupae recovered at various sampling distances from the host plants.

Sampling dist. (cm) fr. stem	No. of pupae recovered per observation					Total	Mean
	1	2	3	4	5		
<i>Papaya</i>							
30.5	3	2	5	5	6	21	4.2
61.0	6	0	2	2	1	11	2.2
91.5	4	1	1	1	0	7	1.4
122.0	0	3	3	4	2	12	2.4
<i>Guava</i>							
30.5	2	0	0	3	1	6	1.2
61.0	3	1	5	2	0	11	2.2
91.5	1	2	1	0	0	4	0.8
122.0	2	0	0	1	1	4	0.8
<i>Starfruit</i>							
30.5	1	1	0	2	2	6	1.2
61.0	3	1	1	2	0	7	1.4
91.5	2	2	1	1	1	7	1.4
122.0	1	0	2	0	0	3	0.6
<i>Jackfruit</i>							
30.5	1	1	2	3	1	8	1.6
61.0	2	0	0	1	0	3	0.6
91.5	1	1	0	1	2	5	1.0
122.0	0	0	1	0	0	1	0.2

No significant difference ( $P > 0.05$ ) among all treatment means as determined by DMRT.

TABLE 3

Pupation depth of *Dacus dorsalis* Hendel.

Sampling depth (cm)	No. of pupae recovered in each replicate								Mean
	1	2	3	4	5	6	7	8	
1	0	1	9	1	0	1	2	1	1.88b
2	15	13	7	9	7	9	13	16	11.13a
3	10	4	6	4	10	13	11	8	8.25a
4	3	4	6	5	8	4	1	2	4.13b
5	1	2	1	2	2	2	1	2	1.63b
6	0	4	1	1	1	0	1	1	1.13b

Means followed by the same letter are highly significantly different ( $P < 0.01$ ) as determined by DMRT.

among samples from guava, starfruit, and jackfruit trees. The distribution of the pupae under these trees was also about even. Laboratory tests on pupation depths showed that in loose, friable, and moist soil the larvae of the insect preferred to pupate at 2 cm and 3 cm depth of soil.

ACKNOWLEDGEMENT

We wish to express our sincere thanks to En. Abd. Ghani Ibrahim, Plant Protection Department, Universiti Pertanian Malaysia, for reviewing this manuscript and to all those who helped in this study.

YUSOF IBRAHIM AND ROSLI MOHAMAD

REFERENCES

- ALINIAZEE, M.T. (1974): The Western cherry fruit fly, *Rhagoletis indifferens* (Diptera: Tephritidae). Distribution of the diapausing pupae in the soil. *Can. Ent.* **106**: 909-912.
- CAVALLORO, R. and DELRIA, G. (1975): Soil factors influencing the pupation of *Ceratitis capitata* Wiedmann. *Bull. Lab. Ent. agr. 'Filippo Silvestri' Portici.* **32**: 190-195. (Abstract)
- DAMMERMAN, K.W. (1914): The fruit fly question in Java. *Meded. v.d. Afdeel. v. Plantenziekten,* Dept. van Landboun, Nijverheid en Handel, Buttenzorg, No. 8, pp. 12. (Abstract).
- JONES, C.R. (1913): The Mango fruit fly and other pests in the Philippines. *Philipp. agric. Rev.* Part 1, **3**: 141-142 (Abstract).
- MILLER, N.C.E. (1940): Fruit flies. *Malay. Agric. J.* **28**: 112-121.
- SHAH, M.I., BATRA, H.N., and RENJHEN, P.C. (1948): Notes on the biology of *Dacus (Strumeta) ferruginus* Fabr. and other fruit flies in North-east Frontier Province. *Ind. J. Ent.* **10**: 249-266.

(Received 7 September 1978)

