

STUDENTS' EMPLOYABILITY OPPORTUNITIES THROUGH SIMULATION IN LOGISTICS AND TRANSPORTATION

ADAM MOHD SAIFUDIN
NIZAMUDDIN ZAINUDDIN
AHMAD YUSNI BAHAUDIN
MOHD HANIZAN ZALAZILAH
ROSLAN JAMALUDIN

*School of Technology Management & Logistics,
Universiti Utara Malaysia*

ABSTRACT

Student's employability is crucial factor that brings development to all economy. The present study looked into simulation content development which is all about developing, enriching and the applications of internet protocols in order to enrich the work-related competencies experience among graduate in the field of logistics and transportations. The study was carried out within multi-national and local manufacturing companies, third party companies and government agency which are selected from Peninsular Malaysia. The sampling of the study focuses on undergraduate studying technology management and logistics and transportation in the public universities. A framework was proposed in the study that will cover the education through simulation in logistics and transportation. A qualitative approach was mainly conducted to gather data in the study. The findings assert that the resources involved in the outbound and inbound processes are computerized documentation. The study contributes to the body of knowledge on the enrichment of the student's employability. It also provided a practical recommendation for the organizations, employees and fresh graduate from the universities.

Keywords: Employability, Simulation, Enriching, Outbound and Inbound

INTRODUCTION

As educational technology has improved, the effective use of simulations has greatly increased to the point where simulations should be considered a valuable, mainstream pedagogical tool. Lecturers often express the challenges involved in educating students from the millennium generation. It can be said that the teaching needs of this generation are more experientially focused. Simulations, in concert with other experiential teaching tools, allow lecturers to facilitate learning more effectively. Additionally, in this era of ongoing (some say never-ending) assessment, simulations offer a rich resource for objective measurement and comparisons. Simulation is not just another in the long line of passing fads (or short-term opportunities) in educational technology. It is, rather, a real key to helping our students understand the world. It is a way for students to acquire experience about how things and systems in the world behave and react, without actually touching them. In short it is about interactive pretending (Prensky, 2007). Simulation is all about representing the real world which includes grasping the complex issues and solving intricate problems.

Malaysian companies would continually increase their capabilities in the logistics services in the near future through the implementation of activities such as warehousing management, inventory replenishment and order fulfilment (Sohail and Sohal, 2003). In today's competitive business environment which many companies are strategizing to gain and share the global markets, companies are actively taking advantage of higher production and sourcing efficiency. Keys to that success are determined by the role of the logistics function in ensuring the smooth flow of materials, products and information throughout a company's supply chains (Sum *et al.*, 2001). Due to the ever increasing importance of the logistics and transportation industry, it has resulted to the expansion of the international trade as well as an active endorsement of the company's and business's globalization strategy (Rosena *et al.*, 2008), as cited by Saifudin (2012).

Students' employability especially among local graduates had been in the limelight for the last five years and it will still be on years to come if no proper revolutionary initiatives introduced to transform the tertiary education delivery system in the public universities in Malaysia. Students' employability is beyond focussing on career options, or on transferable skills, but it requires a far deeper understanding and interrogation of knowledge. According to Baker (2011), students are not just disturbed about costs of study but also interested in the return on their investment. Furthermore, students' and their sponsors' are having interest more on the employability with the industry needs. As what had been reported by UNESCO (2011), as cited by Kalaimagal and Yasin (2011), reasons for being unemployed as being mentioned by employers were attributed to a lack of generic skills and serious inadequacy in terms of work-related competencies.

Simulation content development is about developing, enhancing and applying IP's in order to enrich the work-related competencies experience among graduate in the specific fields. Furthermore the usage of IPs' (internet protocols) will directly enhance the application of ICT (Information and Communication Technology) as the main medium to expands the learning horizon among garduates at the least possible costs. Developing simulation content or IPs' is about depicting the reality of the industry on how they run the day to day business at the operation and planning levels. The IPs' that was developed among others related to copyright of literary works that documented in terms of work flow of several industry players and change it and make use on a specialize platform using ICT for the students to get their hands on or realise the purpose of learning by doing (Kalaimagal and Yasin, 2011),

The main objective of this approach is to expose the students to the experience of working in the related fields. This is done during the period of student studying in the university. Besides reducing the time and cost of sending the students to work for a limited period of time (internship) in the industry, it adds more experience to what the students has learnt in the university.

OBJECTIVES

This study embarks on the objectives to explore and investigate the work flow practised by industry players, document the work flow, establish a generic work flow and to enhance students' employability experience through the learning simulation.

LITERATURE REVIEW

Logistics and transportation is a significant and strategic industry to developing countries like Malaysia. As the volume of trade increases, the needs for efficient, integrated and optimal logistics and transportation system is essential for the movement of goods and people.

Overall issues on logistics management are not extensively studied, not until after the globalization of business process took place (Rosena, Harlina & Sabariah, 2008; Jusoh & Kamis, 2009; Ismail, Hashim, Ghani, Zulkifli, Kamilah & Rahman, 2009) as cited by Saifudin (2012). Tomkins and Smith (1998), described that logistics and transportation effectiveness has now become essentially strategic that many companies realized to increase their positions.

Logistics is part of Supply Chain Management (SCM) which plans, implements and controls the proper flow of goods throughout the supply chain. Logistics stands as the transportation of goods with the use of different modes of transportation. Logistics also involves the flow of materials from different part of suppliers into an organization, its movement within the organization over diverse operations, and delivery to customers which is purpose of logistics (Waters, 2003).

According to Royal Malaysians Customs and Excise Department (2013), in spite of the integration of Sabah and Sarawak in the Federation of Malaysia Sabah and Sarawak are moving under regulations and Customs Duties separately. This affects the free flow of goods between regions because it cannot be easily implemented due to these differences. Consequently the controllers for the three provinces met in mid-1967 and the outcome of the meeting have expressed a No.62 Customs Act, 1967 which gives the whole Malaysia a Customs law alone. As a

result of the indirect Tax Committee of the Treasury has been actively preparing for a tariff within these three regions.

Transportation relates with the movement of goods (raw materials) or products from its point of origin to the organization and finally deliver to the consumer using the most economical transportation mode i.e. land, sea and air. High market share of the organization can be achieved through customer satisfaction, standard price and growth, and an efficient transport management. Therefore, organization should adopt certain criteria in selecting the modes of transportation because it can easily leads to either gain or loss if the mode of transportation for a particular product is wrongly selected. Alternatively, organization may consider changing the dimensions of their products to aids easy transportation to different destinations (Bozarth, *et al.*, 2007). Since there are various mode of transporting goods, the selection of the transportation can be one of the most challenging tasks in logistics.

Information Technology (IT) performs three important roles in any type of organization i.e. in supporting managerial decision making, strategic competitive advantage and business operation. Business operation, up and downstream partnership in the supply chains and customer relationship are changing. Marri *et al.*, (2006), stated that new information technologies, like product identification, mobile technologies and applications that utilize satellite location technologies e.g. Global Positioning System (GPS) are the enabler for new logistical systems. Hence, passing information to all parties in the supply chains through IT will improve organization performance (Saatçioglu *et al.*, 2004).

Employability becomes paramount nowadays as it enables moving from one job to another, within and between the organizations (Fugate, Kinicki, and Ashforth, 2004). Employability has primarily helped employees with high developed demanded skills (Clarke and Patrickson, 2008). Groot and Maasen (2000), differentiate between workers' internal and external employability. External employability refers to the willingness and ability to change to a similar or another job from another firm. Therefore the value of workers' human capital is in the external labor market. Internal employability refers to a worker's willingness and ability to persist employed with the current employer. Therefore, it is the value of a worker's human capital from the internal labor market.

THEORETICAL FRAMEWORK

Based on Figure 1 below, shows the education model that learning logistics and transportation is best achieved through simulation as hands-on experiential learning process. Students will focus seriously by going through the cycle of learning process in simulation on logistics and transportation studies. This contributes to the university achievement in producing quality graduates who practice what they studied during their undergraduates programs and in compliance to the industrial needs.

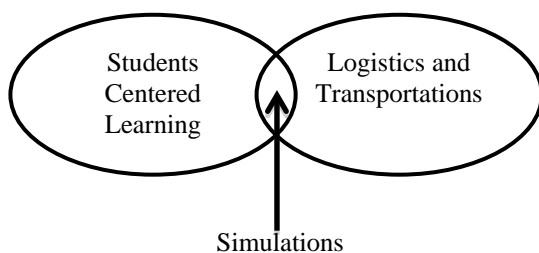

Figure 1 Simulation Content Development Model

METHODOLOGY

This research methodology is to capture generic processes in running a logistics and transportation business in Malaysia. The duration of the research covers visits, interviews, identifying the application system commonly used and collecting documents from the participants.

The processes of interviewing and site visits were conducted over a durations of six months from November 2013 until April 2014. From these interviews, site visits and documentations were collected, including a generic process and information identified. These processes and documentations identified can be used as generic processes and documentations (Baron and Kenny, 1986) required in running a Logistics and Transportation business simulation as in the objectives of this research.

The questions from the interviews focused on the issues of 5W's and 1H consisting of What, Why, Who, When, Where and How related to the objectives of the research. While the selected practicing manufacturing companies visited in Northern Malaysia are four Multi-National Companies (MNC), ten local companies, three Third Party Logistics (3PL) companies and a government enforcement agency is the Royal Custom and Excise Department in Penang.

The generic processes and documentation identified and compiled from the visits, some will be selected based on suitability, practicality and agreed to be used in a classroom simulation environment. These selected processes and documentations are very much suitable for students or related participants for learning the basic process in logistics and transportation companies in Malaysia. The generic processes and documentation selected based on the Malaysia Practice Enterprise Corporation (MyPEC) as follows:

- A stable process and documentation (which does not change much over the years).
- Frequently used processes and documentations in most logistics and transportation business in Malaysia.
- Relevant for learning the basic process of logistics and transportation business in Malaysia.

FINDINGS

This research explored the work flow of industry players, which explained the management staff and workers involved in the outbound and inbound processes. The categories are well trained, experienced and fresh staff. The Person-in-Charge (PIC) is a senior staff of the warehouse operations and inventory management department of the company. The job is usually given to receiving section managers or executives, who have experiences in dealing with the delivery and shipping of materials, transportation (containerization, lorries and hauliers), knowledgeable about Royal Customs and Excise Department documentation process and Customs Act 1967.

During the interviews, it was observed that most companies would not engage any fresh graduates without experience unless they have undergone extensive internship training. Mainly companies employ or engage well experience staff for the job functions to avoid mistakes during the delivery and shipment out.

The operations take place at receiving area (inbound) and shipping area (outbound). Both places are at warehouse receiving and warehouse shipping. It is a daily operation except during weekends and public holidays unless under certain circumstances the operations have to continue during those days.

The research have established the documents to be assessed in the documents work flow specified by the industry players. The processes and documents will be updated according to its relevance and categories of the processes. The documents are PO, DO, Invoices, Customs forms and Manifest (sea and air) that need to be updated with current data. It is later process by the relevant departments such as Purchasing (confirmation that the materials or goods are delivered) and Finance (confirmation to process the payment).

For the big local companies or MNCs, the documentation process commences from the computer data entry upon approval by the receiving area. The data entry information is later transmitted directly to Purchasing and Finance Department for acknowledgement so that they can proceed for payment. But for local and small companies, most of the operations are still semi computerized. Those documents may need to be sent directly to

Purchasing Department for clearance of goods or materials delivered and Finance Department for payment process to the suppliers. The detail findings of generic work flow with challenging inputs (opportunities and threats) are referred to Appendix A and Appendix B.

The efficiency and effectiveness of the process plan, implementation, monitoring and control are observed from this research findings, which depict that most of the companies have already up-graded their documentation processes through computerization. Some are using the EDI to check on the Suppliers Own Inventories (SOI) as part of their up-dating solutions. This is to ensure the inventories by the suppliers are at the required limit. Such practices increase the space savings in the companies' premises.

One of the major important factors is the Human Capital Management (HCM) development plan for staff to be savvy and equipped with computer skills. The training is provided and the staff to at least have the minimal skills in operating the computer and software. This is to enhance their capability in managing the process documentation networking implementation. By doing so, their monitoring over the inbound and outbound processes is effectively controlled.

The research concluded that in order to enhance students' employability experience through the learning simulation, the detailed of the generic documentation process as shown in Appendix A and Appendix B are the justifications for their learning enhancement.

CONCLUSIONS

Based on the research findings, it can be concluded that the information gathered are fundamentally adequate as the focus of the research is education through simulation in logistics and transportation. This suggests that there are concrete evidence of the enrichment of student's employability experience through simulation in the logistics and transportation industry. The evidence from the generic documented process flow from the participants' suggested that simulation in the content development as learning process is effective in this area of study. This is proven based from the companies HCM development to train their respective staff to be skillful in operating the documentation process efficiently.

REFERENCES

- Baker, R. J. (2011). *CMOS: circuit design, layout, and simulation* (Vol. 18): John Wiley & Sons.
- Baron, R.M., & Kenny, D.A. (1986). The moderator-mediator variables distinction in social psychological research: Conceptual, strategic, and statistical consideration. *Journal of Personality and Social Psychology*, 51(6), 1173-1182.
- Bozarth, C., Blackhurst, J., & Handfield, R. B. (2007). Following the thread: Industry cluster theory, the New England cotton textiles industry, and implications for future supply chain research. *Production and Operations Management*, 16(1), 154-157..
- Clarke, M., & Patrickson, M. (2008). The new covenant of employability. *Employee Relations*, 30(2), 121-141.
- Fugate, M., Kinicki, A. J., & Ashforth, B. E. (2004). Employability: A psycho-social construct, its dimensions, and applications. *Journal of Vocational behavior*, 65(1), 14-38.
- Groot, W., & De Brink, H. M. V. (2000). Education, training and employability. *Applied economics*, 32(5), 573-581.
- Kalaimagal, R., & Yasin, N. M. (2011). Knowledge Management: Building a bridge between higher learning institution and employer. *INTED2011 Proceedings*, 2679-2688.
- Marri, H., Irani, Z., & Gunasekaran, A. (2006). *E-commerce and its impact in logistic management: A state of art*.
- Prensky, M. (2007). Simulation nation: The promise of virtual learning activities. Retrieved February, 4, 2008. .
- Royal Malaysians Customs Department, (2013). Custom Act 1967. <http://www.customs.gov.my/>. Accessed September 18, 2014.

- Saatçioğlu, Ö. Y., Deveci, D. A., & Cerit, A. G. (2009). Logistics and transportation information systems in Turkey: e-government perspectives. *Transforming Government: People, Process and Policy*, 3(2), 144-162.
- Saifudin, A.M. (2012). Mediating Effect of Management Information system on the relationship of Warehouse attributes and its Efficiency in Malaysia's small and medium enterprises. Unpublished DBA Dissertation. Universiti Utara Malaysia (UUM).
- Sohail, M. S., & Sohal, A. S. (2003). The use of third party logistics services: a Malaysian perspective. *Technovation*, 23(5), 401-408..
- Sum, C.-C., Teo, C.-B., & Ng, K.-K. (2001). Strategic logistics management in Singapore. *International Journal of Operations & Production Management*, 21(9), 1239-1260.
- Tompkins, J. A., & Smith, J. D. (1998). *The warehouse management handbook*: Tompkins press.
- Waters, C. D. J., & Waters, C. (2003). *Logistics: an introduction to supply chain management*: Palgrave Macmillan New York City.

APPENDIX A

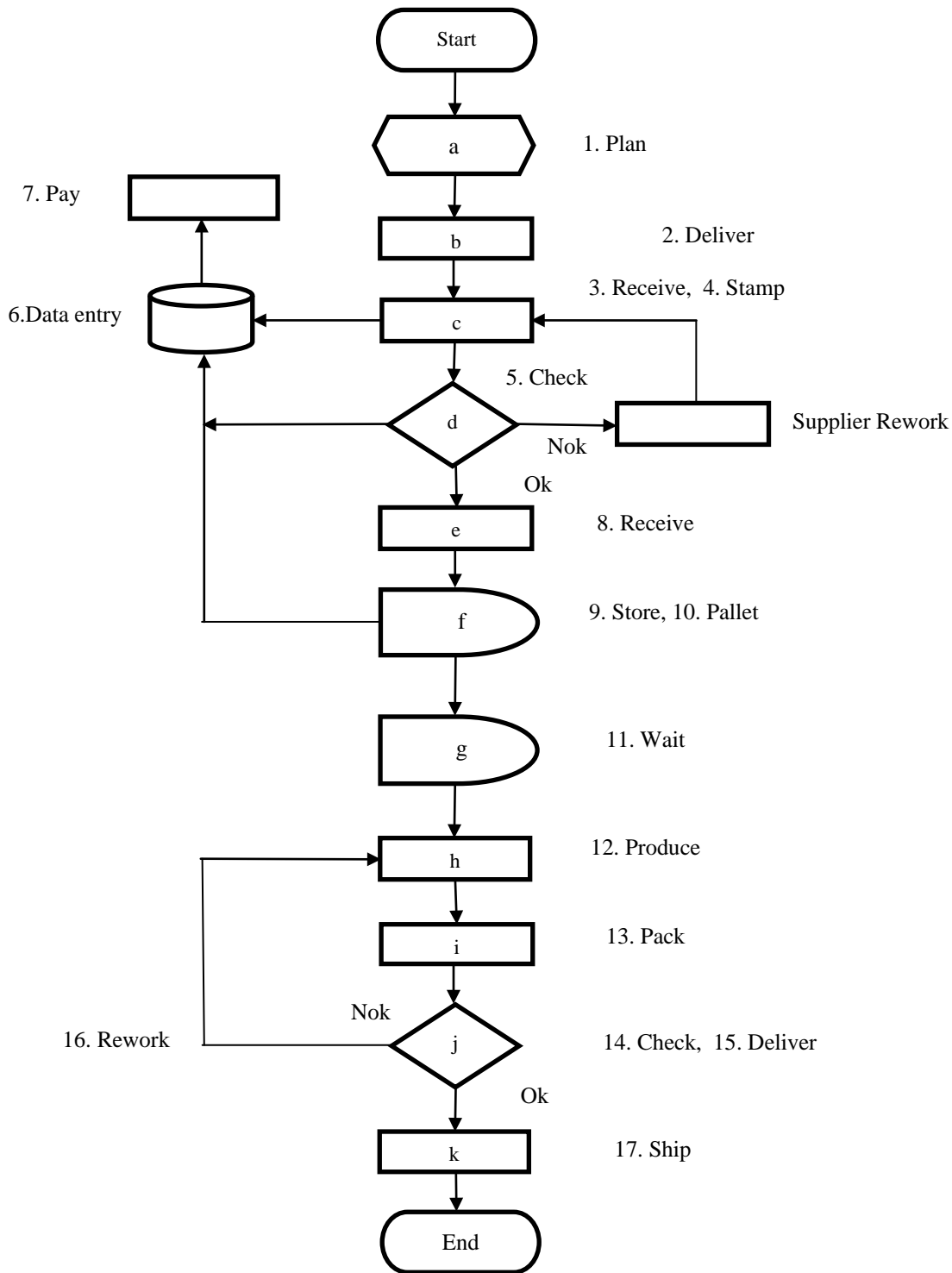

Actual practice of inbound and outbound process flow in manufacturing or logistics company

APPENDIX B**Description to the actual process flow from Appendix A**

| ACTUAL PRACTICE OF INBOUND AND OUTBOUND PROCESS FLOW IN A MANUFACTURING OR LOGISTICS COMPANY | | |
|---|---------------------------------|--|
| a. | Business Planning | (1) The company plan for the models of the products to be manufactured in quantities based on the customers demand. |
| b. | Procurement | (2) Procurement will plan to purchase the raw materials based on business plan and to bring the raw materials to the company. |
| c. | Warehouse Receiving (Inbound) | (3) To receive the physical raw materials with the documents (PO, DO, Invoice and Bill of Laden (by sea) or manifest (by air). Customs form to be attached if the company or plant is situated at Free Trade Zone area, as whether it is taxable or tax exemption.(4) The documents are stamp received once the physical counts are made and confirm tally with the documents. (7) It is then data entry into the computer by Receiving clerk to be transmitted to Purchasing Department to liaise with supplier and Finance Department for payment process. |
| d. | Product Quality Assurance (PQA) | (5) Physically the raw materials will be checked for Quality checking by PQA. Once OK, it is then data entry and transmitted into Receiving system as confirmation of quality checking is done and OK. (6) But if Not OK, then Purchasing Department is alerted about it to refer to the respective supplier. The supplier then will ensure the problem by rework or replace the new supply to the company. |
| e. | Warehouse Putaway Area | (8) The materials are then sent to Putaway area before being pulled into Storage area. |
| f. | Warehouse Storage Area | (9) The materials are then pulled into the storing area by store material handlers to be stored on the racks. (10) The materials are then picked and put into pallets based on the material requisition list by Production Department. It will then data entry into the computer system as Materials-Out from the store. |
| g. | Production Staging Area | (11) It will then pull into the Staging area waiting to be pushed into Production Floor. |
| h. | Production Floor and Area | (12) The materials are pulled into the Production Floor for production process to produce a model product. |
| i. | Production Packaging Area | (13) Once the model is completed as product, it is stationed at the end of the Production Floor to be packed and group into pallets. |
| j. | Quality Control (QC) | (14) Quality Control checking is done on random or between 1 to 5 percent of the amount of the products, depending on the production quantities. (15) If is OK, then proceed to Shipping Area for Shipment or Export. (16) If not OK, then a rework needs to be done to the whole quantity of the production. |
| k. | Warehouse Shipping (Outbound) | (17) All the products on pallets will then push into Shipping Area (Outbound). Documentations such PO, DO, Invoice, Customs Form, Bill of Lading (sea) and Manifest (air) are prepared and data entry into the system before it is transferred physically into the lorry or containers to ports or airports destination for export purposes. |