

# Bluetooth-Based Alarm System

Mohd. Helmy Abd. Wahab , Nor Ezna Juniza Md. Janah, Ayob Johari, Danial Md. Nor, Rahmat Sanudin

Faculty of Electrical and Electronic Engineering  
Universiti Tun Hussein Onn Malaysia, 86400 Parit Raja, Batu Pahat, Johor  
E-mail : {helmy, ayob, danial, rahmats}@uthm.edu.my

## ABSTRACT

*This paper proposes the implementation and the advantage of Bluetooth technology on wireless alarm system. The system is realized using a microcontroller PIC16F877A and MPLab IDE software as the control block to link between input and output signals. This paper is using both Bluetooth adapter and Bluetooth module to manipulate the command given to the system. In fact, the traditional 32-bit alarm security system seems dwarfed by this wireless alarm system due to its high security, more user-friendly and lower-cost. Moreover, this wireless technology could operate within a distance of up to 10m independent of line of sight even with obstacles in between. The result shows the wireless system could control intended output with no trouble within specified distance. Hence, it is concluded that the system works effectively with more improvement over the conventional system.*

## Keywords

Bluetooth, wireless alarm system, microcontroller

## 1.0 INTRODUCTION

For the last ten years, wireless application has been rapidly evolved in personal computing and communications devices which is to enhance the usage portability. This trend has open a new means of transferring data other than wired communication. One of them is known as Bluetooth, a new standard developed by a consortium, Special Interest Group (SIG) for an open specification for short range wireless connectivity. The standard offers low-power and low-cost radios that can be interfaced with existing devices. Hence, it is a promising wireless technology for cable replacement. Another advantage of Bluetooth technology is that it can be used for communication range of up to 10 meters apart; which is a perfect solution for home alarm system. Using the Bluetooth technology, this system can be activated or deactivated without the presence of line of sight. The objective of this project is to establish a low-cost, user-friendly alarm system that can work seamlessly for the user.

## 2.0 RELATED WORK

The wireless alarm system developed that used air as the transmission medium with wireless sensor depends on the energy consumption, wave propagation and interferences (Philip, 2002). The wireless sensor composed of sensor elements that are in contact with environment in order to detect the events, a processor unit for control and a wireless device to transmit and receive the messages and a power supply unit. This system used the frequency hopping spread spectrum (FHSS) techniques to combat the interference from other systems i.e. wireless LANs, microwave ovens and so forth that share the same frequency band (Peerson and Mannivanan, 2003). Another work done by Seng (2001) developed the Bluetooth-based motion detector which uses the Ericsson ROK 101007. The application runs on microprocessor (ATMEL) and the motion detector gets the data from serial port and then changes the settings on the motion detector. This technology also has been used in Remote Control Programming by Mohd Kamal Nordin (2005) which used to control the robot remotely. The technology is embedded on Personal Digital Assistant (PDA) via a graphic user interface (GUI) (Hang-Wang, 2005).

## 3.0 METHODOLOGY

MPLAB IDE v7.0 is chosen as software development tool in developing the control software of the project and HI-TECH PICC Lite Compiler a third party development tool also had been used in the software development for writing the program in C language. Hardware development had been divided into three main parts. Figure 2.1 explains briefly the entire project in block diagram.

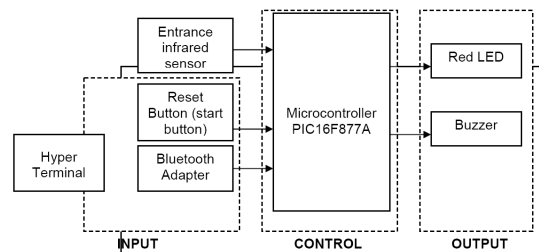

Figure 1: Block diagram of the system

Input command to PIC microcontroller is entered via Hyper Terminal. It is sent to Bluetooth USB adaptor, and then to Bluetooth module. The user can activate or deactivate the alarm circuit or activate the buzzer alone. Infrared (IR) sensor is installed in front of the entrance. Infrared is a typical light source used as sensor to sense opaque object. The basic principles of infrared sensor are based on an IR emitter and IR receiver. The generated voltage is in the range from 0V to 5V depends on the intensity of infrared it received. The infrared sensor is shown as the Figure 2.

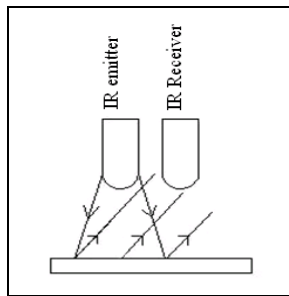

Figure2: Infra red sensor

The most important portion in this project is the employment of Bluetooth technology in term of transmitting and receiving commands to the circuit. The technology is implemented by using two Bluetooth devices i.e. Bluetooth USB adapter and remotely located Bluetooth module. The USB adapter, shown in Figure 3, is attached to personal computer while the module, depicted in Figure 4, is attached to the circuit. The circuit is activated or deactivated by entering a command through Hyper Terminal. The command in shape of packet of data is sent to Bluetooth USB adapter and delivered wirelessly to the module via the USB adapter before sending to the microcontroller.



Figure 3: Bluetooth USB adapter

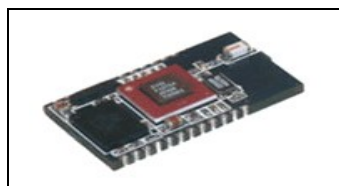

Figure 4: Bluetooth module

At the circuit, as illustrated in Figure 5, Bluetooth module is connected to microcontroller via:

- i. Pin number 8 – RXD (*receive data*) pin – to pin RC6/TX/CK at the microcontroller.
- ii. Pin number 6 – TXD (*transmit data*) pin – to pin RC7/RX/DT at the microcontroller

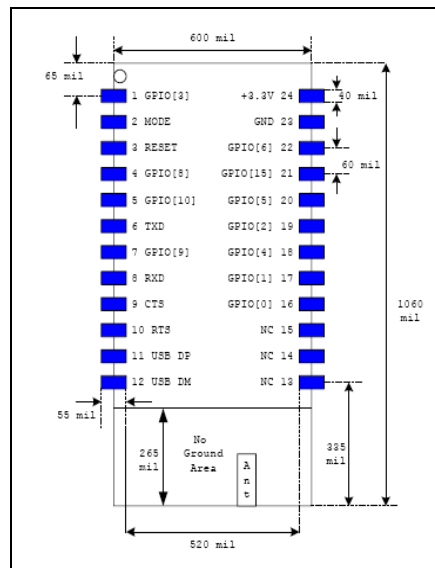

Figure 5: Pin configuration of Bluetooth module

A buzzer circuit is triggered as when the IR sensor senses some one in front of the entrance and sounds the buzzer. The buzzer is directly connected to pin RD1 at the microcontroller as shown in Fig.6.

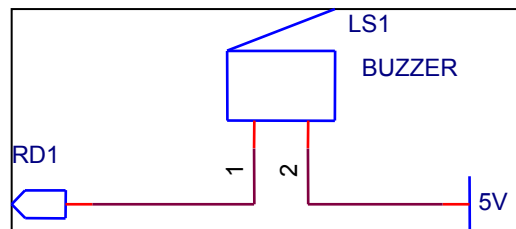

Figure 6: Buzzer circuit

#### 4.0 RESULT AND DISCUSSION

The project was tested on its efficiency and the pin voltage. On its efficiency, the test was conducted to see the interaction between the master (Bluetooth USB adapter) and the slave (Bluetooth module) when both were located a few meters away from each other. The result was negative as the master could not discover the presence of slave. This is due to the slave that was unable to communicate with the

microcontroller. The test result on sensor efficiency is shown as in Table 1.

Table 1: *The efficiency of IR sensor.*

Action taken	Distance	Result	
Object passing the sensor	3cm	LED red is flashing	Buzzer is producing sound
Object passing the sensor	Greater than 3cm	LED red is not flashing	Buzzer is silence

The green LED at the circuit flashed and the buzzer sounded when the passing object was about less than 3 cm from IR receiver. The distance range of IR sensor depends on the brightness of the surroundings. The darker the surrounding the farther it will be as no external light source will interrupt the IR beam. Meanwhile, when the object is about more than 3 cm from IR sensor, the sensor can not detect the presence of the object.

Tests on the voltage consumption on each individual component were carried out as shown in Table 2. All the components selected on the basis that are of low in power consumption and designed for battery operated.

Table 2: *Voltage level of the main components*

Component	Voltage (Volt)
Bluetooth module	3.2
IR sensor	3
Buzzer	2
Microcontroller	5

All the readings show that the voltage level is still within their voltage range. For this reason, a battery with 9V is adequate in this project to ensure the circuit running properly. The circuit was working as required when the reset button is pressed, but when activating the circuit using Hyper Terminal via Bluetooth devices from PC; the circuit sometimes did not work properly. Sometimes it can be directly activated by PC and it showed at Hyper Terminal but sometimes the circuit did not show the expected result. This happened because a few steps in setting up the Hyper Terminal were not correct when every time a user want to employ the PC using Bluetooth devices to activate the circuit

## 5.0 CONCLUSION

Based on the result and analysis, it can be concluded that this project almost achieved its aims and objectives in which the main objective was to build the prototype of alarm system that can be activated by Bluetooth technology. The circuit has the capability to interface with the PC using Bluetooth

communication protocol and therefore the circuit can be activated wirelessly. The PC serves its function as a master control panel giving commands to the circuit. The product fulfils the wireless communication requirement within the operating range. Every component in the input and output parts had showed the expected result. These parts include Bluetooth devices, IR sensor, a buzzer, a microcontroller, and a LED.

The product can be further improved to make it more feasible for practical application. The recommendations are i) Replace the PC with actual remote control ii) Add other sensor such as temperature sensor, PIR detector, heat sensor, motion detector and siren to make the project a complete home/office security system iii) Add LCD at the output part so that the user knows that the alarm had been activated and iv) Add short messaging services (SMS) or phone service to the project, so that when someone is trying to break in the home, the user will be acknowledged by SMS that send to him or her or get the call from the phone service.

## REFERENCES

- Cynx, J., Williams, H., & Nottebohm, F. (1992). Hemispheric differences in avian song discrimination. *Proceedings of the National Academy of Sciences, USA*, 89, 1372-1375.
- Han-Wang Huang . (2005). "PIC Microcontroller: An Introduction to Software and Hardware Interfacing". 1st. ed. Clifton Park, N.Y.: Thomson Delmar Learning
- Jiantao Pan (1999). *Software Testing*. Retrieved January 5, 2006, from [http://www.ece.cmu.edu/~koopman/des\\_s99/sw\\_testing/](http://www.ece.cmu.edu/~koopman/des_s99/sw_testing/)
- Mohamad Kamal bin Nordin (2005). "PDA: Pengaturcaraan Kawalan Jauh." Kolej Universiti Teknologi Tun Hussein On. Tesis Ijazah.
- Persson, K. E. dan D. Manivannan (2003). "Secure Connections in Bluetooth Scatternets." *Proceeding Of 36th Hawaii International Conference on System Sciences*. 3. 1-10
- Philips, B. (2002). "The Complete Book of Electronic Security." 1<sup>st</sup> ed. Two Pen Plaza, N.Y.: McGraw-Hill. 35-56.
- Seng, C. H. (2001). "Home Security System with Bluetooth Technology." University of Queensland. Tesis Ijazah.