

DIFS Modifications to Support QoS in IEEE 802.11g DCF Ad-hoc Networks

Mohd Najwan Md Khambari^a, Shahrin Sahib^b, Mohd Fairuz Iskandar Othman^c

Fakulti Teknologi Maklumat dan Komunikasi
Universiti Teknikal Malaysia Melaka, 75450 Ayer Keroh, Melaka
Tel : 06-2332510, Fax : 06-2332508

E-mail : ^anajwan_ra@utem.edu.my, ^bshahrinsahib@utem.edu.my, ^cmohdfairuz@utem.edu.my

ABSTRACT

This paper describes and investigates the QoS provisioning technique used in IEEE 802.11g ad-hoc structure. This research then propose better scheme to support QoS by modifying the DCF Interframe Space (DIFS) to use new values to bias towards the high priority traffic flow and distinguish it from the low priority traffic. Simulations are done using NS-2 and the findings presented. Results showed that better throughput can be achieved to provide better traffic flows on high priority traffic.

Keywords

IEEE 802.11, wireless, QoS, DIFS, SIFS, ad-hoc, NS-2

1.0 INTRODUCTION

Wireless LAN (WLAN) is a technology connecting multiple devices as in LANs, with data transmission done over the air. It is a LAN, to which mobile stations (MS) can connect and communicate by means of high-frequency radio waves rather than wires. Technically, WLAN standard is described by IEEE 802.11.

As the network world becomes more popular, the network load has become a critical issue. The wired LAN, which was originally designed to carry data traffic (such as file transfer, e-mail and Internet browsing) is now being used to carry real-time and multimedia traffic such as video and voice. Highly congested network are demanding for better enhancement to support Quality of Service (QoS) that requires fast yet reliable transmission.

One of the main reasons of the popularity of wireless network is that users can access the network without being physically attached where they can reach the Internet wherever they are, whether they are in the office or at home whenever and wherever they want. With the wireless network technology becomes more matured, a lot of improvements had been made to enhance it. This includes reduced errors in health care facility (where the “anytime anywhere” aspect of wireless communications allows increased access to accurate information when needed most), time saving, improved

profitability in terms of cost saving for cabling and labour and flexibility (Molta, 2004). With the encouraging growth of wireless network usage which saw increased productivity as much as 22% from a research of end users and IT network administrators of more than 300 U.S.-based organizations (Cisco, 2001), it is seen that pervasive high-speed wireless data services are both compelling and inevitable

The strong and growing demand for WLANs in both consumer markets such as residential networks (Vanucci and Truong, 2003) and industrial markets such as retail, education, health care and wireless hot-spots in hotels, airports, and restaurants (Molta, 2004) has been documented repeatedly in business, industry and education (Pattara-Atikom, 2005).

In this research, the proposed technique involves modifying the DIFS. This is done by fine tuning the SIFS because DIFS and SIFS are related with each other, which will be discussed later in the next sections. **Using different values of SIFS will lead to different values of DIFS.** The experiments are done exhaustively where the possibility of each scenario is put into test. The total numbers of scenarios involved in modifying the DIFS are 238. However, only the key scenarios are highlighted in this paper.

The remainder of this paper is organized as follows. Firstly, this paper will discuss on the IEEE 802.11 channel coordination function before focusing on the Distributed Coordination Function (DCF). Then, other proposed techniques from previous research on **DIFS** are presented before outlining the author’s proposed techniques. Finally, a brief description of simulation scenarios using NS-2 and findings are given.

2.0 IEEE 802.11 CHANNEL COORDINATION FUNCTION

In wireless networks communications, radio frequency are used as the medium of data transfer. Since its half-duplex behavior, radio frequency can be used only by one device at a time; therefore there will be a method for the devices to take turns to use the radio frequency channel to avoid collision, which is called the **coordination function**.

There are two types of coordination functions which are the **Point Coordination Function (PCF)** and **Distributed Coordination Function (DCF)**. Since this paper focuses on **DCF**, the following section will discuss more on the **DCF** access method.

2.1 Distributed Coordination Function (DCF)

In **DCF**, the technique to use the RF channel is distributed to each of the MS. The MS themselves determine whether they have the opportunity to transmit data. It is a contention-based method where MS have to compete with each other to use the RF. In the contention basis, any MS can attempt to transmit data at any time it wanted to, if the channel is sensed to be idle.

However, problem occurs when two or more MS start to transmit data at the same time, where a collision will happen. In order to avoid collision, DCF implements a mechanism called **Carrier Sense Multiple Access with Collision Avoidance (CSMA/CA)** which is primarily adopted by wired LAN's **Carrier Sense Multiple Access with Collision Detection (CSMA/CD)** to avoid collision. Figure 1 below illustrates on how DCF mechanism avoids collision.

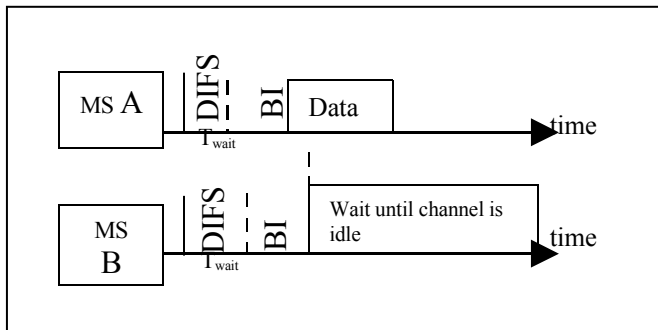

Figure 1: The operation of DCF mechanism

Instead of having the two MS, MS A and MS B responsible for the collision to wait a random amount of time (as in CSMA/CD), **CSMA/CA** has all the clients to wait for a random amount of time, T_{wait} , which consists of **DCF Interframe Space (DIFS)** and **backoff interval (BI)** before attempting to do transmission, as shown in (1). **BI** is a uniform random value, sampled exponentially from $[0, CW]$ where CW is the Contention Window with a maximum value of 1023 time slots.

$$T_{wait} = \text{DIFS} + \text{BI} \quad (1)$$

Note that the value of **DIFS** is the same for each station. **BI** value is taken randomly to avoid collision. Meanwhile, **DIFS** is derived from an equation as in (2) below:

$$\text{DIFS} = 2 (\text{SlotTime}) + \text{SIFS} \quad (2)$$

It is essential to know where the **DIFS** is derived from, as this involves on providing QoS which will be discussed later in this paper.

In this paper, the modification of **DIFS** value involves using different values for **SIFS** whereby **using different values of SIFS will result to the change of the DIFS** value. Therefore we will discuss more on **DIFS** in the next sections.

3.0 RELATED WORKS IN DIFS AND SIFS MODIFICATIONS

Deng and Chang (1999) rejects reservation scheme which was used in Intserv (RFC 1633, 1994) of wired LAN, as it leads to a major drawback. When the source is reserved but unused, it is simply wasted. The author proposed a method to support two priorities. Higher priority stations will wait for duration of PIFS, while lower priority stations will wait for duration of DIFS before attempting data transmission. Several assumptions are made where there is no hidden MS an issue, no stations operates on power-saving mode and no interference from nearby BSSs. Simscript simulation of video, voice and data traffic with priorities of 3, 2 and 0 with the ratio of 1:1:2 is performed. Results (IFS based, combined with CW separation) showed that there are performance improvements for high priority traffic in heavy load conditions where video traffic uses most of the bandwidth (55%) and lower priorities use the remaining bandwidth. In low load condition, lower priority traffic has the required bandwidth. Although it is illustrated that video and voice traffic has lower access delay and lower packet loss probability than in DCF, data traffic suffers access delay and higher packet loss than in DCF.

Aad et al. (2001) uses almost the same scheme as Deng. Higher priority, $j+1$ and low priority j have different IFS values, DIFS_{j+1} and DIFS_j , where DIFS_{j+1} is lower than DIFS_j . The maximum random range random range RR_{j+1} of priority $j+1$ is defined as the maximum Backoff Interval (BI) of that priority. If the strict condition $\text{RR}_{j+1} < \text{DIFS}_j - \text{DIFS}_{j+1}$ is satisfied, then all packets of priority $j+1$ have been transmitted before any packet of priority j is transmitted. In less stringent condition, $\text{RR}_{j+1} > \text{DIFS}_j - \text{DIFS}_{j+1}$, a packet which could not access the medium the first time may have its priority decreased in the subsequent attempts. Simulations were carried out and the results show that the method does not change the system efficiency, with data sums remains the same (Pham, Sekercioglu and Egan, 2004). The method works well for both Transmission Control Protocol (TCP) and User Datagram Protocol (UDP) flows with more significant effect on UDP flows compared to TCP flows. It also works in noisy environment and keeps the same stability of the system.

Meanwhile Benveniste (2002) recommends Urgency Arbitration Time (UAT) to differentiate services, which is the time a station has to wait before a transmission attempt following a period when the medium is busy. Benveniste also introduces AIFS and Backoff Counter Update Time (BCUT) but both are actually DIFS and SlotTime. Higher priority traffic is assigned shorter AIFS and BCUT values compared to the low priorities. The AIFS value for high priority is the same as PCF Interframe Space (PIFS) and a minimum backoff time of 1 in order to prevent conflict with medium access by centralized protocol PCF. A simulation was carried out where AIFS (high_prio) = PIFS, AIFS (low_prio) = DIFS, CW (high_prio) = [1, 32] and CW (low_prio) = [0, 31]. Results showed that the delay and jitter of high-priority traffic are decreased and under moderate load condition, the performance of low priority traffic is also improved compared to DCF

4.0 PROPOSED SCHEME

As discussed before, **DIFS** is the duration for a mobile MS that wants to transmit data has to wait after sensing the channel is idle. The technique proposed to support QoS in this experiment is that the high priorities MS are assigned shorter **DIFS**. This means high priority MS have a shorter waiting time, which allows the higher priority MS to transmit ahead of the lower priority MS. While high priority MS will always have a shorter waiting time, it means high priority MS are most likely to have the opportunity to always being first to transmit data after the channel is sensed idle compared to the low priority MS. This scheme can further be depicted in below.

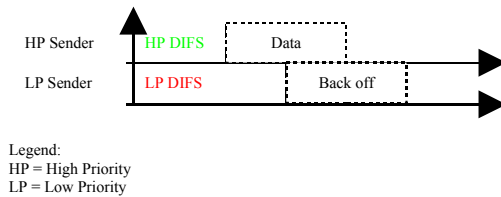

Figure 2: High priority MS and Low Priority MS transmission on proposed scheme

In order to test the outcomes of the proposed scheme, a simulation using NS-2 was carried out which will be described in the next section.

5.0 SIMULATION SETUP AND SCENARIO

Since the simulation is done using NS-2 version 2.31 (2007), simulation setup is done using Tool Command Language (TCL). The selected environment is configured to radio channel on which the channel type is set to wireless channel.

In order to simulate a realistic environment as in a real wireless network, radio propagation models are used to predict the received signal power of each packet. Since IEEE 802.11 considers both the direct path and a ground reflection, the propagation model used in this simulation is the Two-Ray Ground Reflection Model.

Some assumptions were made during this experiment where the simulation is done as a per-based mobile communication. This means that each MS only transmit one type of data, whether a high priority data, or a low priority data. 16 MS are used where eight MS acts as the data source and the other eight of the MS as the destination where in the end there will be eight pairs of traffic flow, namely **fid 1** to **fid 8**.

For the sake of simplicity and clarity, only one flow will be configured as high priority, which is the **fid 1**. On **fid 1**, the MS is configured to **use different values of SIFS in order to change its DIFS value**.

In order to see the difference in terms of improvement or degradation of the proposed scheme, the simulations findings are compared with the default IEEE 802.11g findings. Therefore, the default IEEE 802.11g network was also simulated as the controlled experiment. Table 1 below shows the different values of **SIFS** tested on the simulations.

Table 1: The different values of **DIFS** used in the simulations

Experiment	DIFS (μ s)
Default 802.11g	28
DIFS 1	26
DIFS 2	24
DIFS 3	22

Each of the experiment is then put into test by simulating the scenarios to conform to the default (as the benchmark) and proposed parameters.

6.0 RESULTS AND FINDINGS

Recapping back the objective of the proposed scheme in previous sections, it is expected that the new scheme will provide better results in terms of network throughput. In this section, the effects of different values of **DIFS** towards network throughput will be discussed.

Since NS-2 only provides a raw log file (called tracefile) that dumps the entire network scenario timeline, several scripts has been developed to facilitate the process of extracting the important data from the tracefile. This includes AWK scripts to manipulate and extract the tracefile and Shell script (particularly Bash script) to automate the TCL and AWK

scripts to execute independently and automatically with a single command through the terminal console.

After extracting the data, analysis of the result is computed using SPSS. The mean value of the throughput is examined to determine the performance of the throughput. This is because the mean value of the throughput will reflect the overall throughput performance of the selected network flow. Table 2 below shows the results of the simulations of using different values of **DIFS**.

Table 2: Mean throughput results of simulations

Results of fid 1			
Experiment	No. of successful Transmission	DIFS (μ s)	Mean Throughput (kbps)
IEEE 802.11	583	28	2493.0149654
DIFS 1	580	26	2816.7237122
DIFS 2	4	24	17.3602780
DIFS 3	4	22	16.1535090

From the table above, an increase of mean throughput can be seen on Experiment *DIFS 1* where the **DIFS** value is 26 μ s compared to *Experiment IEEE 802.11* where the **DIFS** value is 28 μ s. It is an increase from 2493.0149654 kbps to 2816.7237122 kbps, an improvement of 12.985%. The result is as expected, because using shorter **SIFS** allows the high priority MS to transmit earlier and more frequent compared to low priority MS.

Surprisingly, using **DIFS** shorter than 26 μ s will result to the mean throughput to drop dramatically. Results also revealed that using **DIFS** shorter than 26 μ s stunted the number of successful transmissions. This phenomenon can be described in the next paragraph

In this paper, the different values of **DIFS** are derived by using different values of **SIFS**. However in the IEEE 802.11, **SIFS** are not only used in **DIFS**. **SIFS** is also being used during the transmissions of TCP packets where ACK packets are involved. This can be shown as in Figure 3 below.

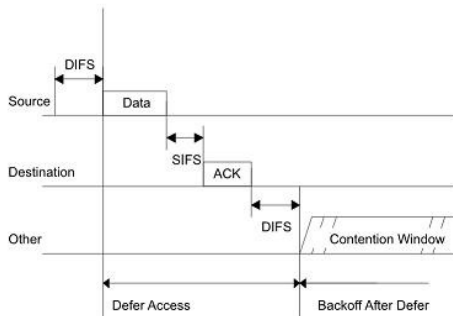

Figure 3: The usage of **SIFS** in TCP packet transmission

From the figure above, the source MS has transmitted data to the destination MS. In TCP transmission, each packet sent by the sender will be replied by the receiver to notify the sender that the packet has already arrived. The notification is called the ACK packet. In IEEE 802.11, the receiver has to wait an **SIFS** period of time before transmitting the ACK to avoid collision. With regard to the experiment done in this research, changing the value of the **SIFS** has not only affected the **DIFS** but also the waiting time of the receiver to send the ACK to the sender which explains the very low number of successful transmissions.

The **SIFS** behavior of being the waiting time for ACK packets leads to low successful transmission. Initially, the sender sends the packet to the receiver. After the sender sends the packet, it then waits for **SIFS** and listen for any ACK. However since the **SIFS** is too short, the sender only listens for the ACK for a very short time where the ACK could not arrive before the **SIFS** times out. The sender then suspects packet collision or packet drop. When the channel is idle, the sender retransmits the packet and the cycle continues where the ACK cannot arrive before **SIFS** times out. The looping process can be depicted as in Figure 4 below.

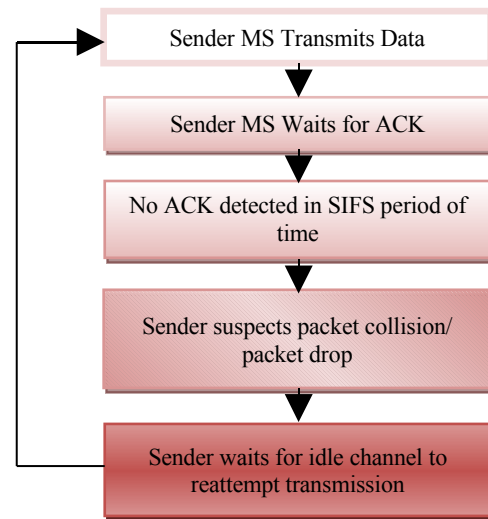

Figure 4: Scenario on low number of successful transmission in shorter value of **SIFS**

Therefore with regard to this research, the best **DIFS** value to support QoS done in the NS-2 simulation is 26 μ s on which the **SIFS** value is 8 μ s.

7.0 CONCLUSION

The primary contribution of this paper focuses on detailed investigation on many of the **DIFS** and **SIFS** modifications to support QoS by past researchers. New scheme of different

shorter **SIFS** values are then tested to unearth the best **DIFS** value to support QoS for better throughput.

The simulation model proposed in this paper is done by modifying the **DIFS** through **SIFS** to differentiate services between high priority and low priority traffic. From the findings and result of the experiments, it is proved that the new provision technique proposed for the IEEE 802.11g ad-hoc network in this paper has the ability to enhance the throughput of the high priority network flow thus improving the IEEE 802.11 to support Quality of Service

Vannuccini, G. and Truong, H.L. (2003). *The IEEE 802.11e MAC for Quality of Service in Wireless LANs*. IBM Research, Zurich Research Laboratory, Switzerland.

REFERENCES

Aad I. and Castelluccia C. (2001). Differentiation Mechanisms for IEEE 802.11. *Proceedings of the Twentieth Annual Joint Conference of the IEEE Computer and Communications Societies (INFOCOM '01)*, USA, 1, 209-208.

Benveniste, M. (2002). Tiered Contention Multiple Access (TCMA), A QoS-Based Distributed MAC Protocol. *The 13th IEEE International Symposium on Personal, Indoor and Mobile Radio Communications*, Portugal, 2, 598 – 604.

Cisco Systems Inc (2001). *Cisco Announces New Independent Study Demonstrating Productivity Gains Achieved Through Wireless LAN Use*. Retrieved January 14, 2007, from http://newsroom.cisco.com/dlls/corp_111201b.html

Deng J. and Chang R. S. (1999). A Priority Scheme for IEEE 802.11 DCF Access Method. *IECE Transactions on Communications*. Vol. E82-B (1), 96-102

Molta, D. (2004). *Wi-Fi Tales*. Network Computing, 44-62.

NS-2 ver. 2.31 (2007). Retrieved January 23, 2008, from <http://www.isi.edu/nsnam/ns/>.

Pattara-Atikom, W. (2005). *Quality of Service Support in IEEE 802.11 Wireless Lan*. Ph.D Thesis, University of Pittsburgh.

Pham D., Sekercioglu A. and Egan G. (2004). *A Survey of IEEE 802.11 MAC Mechanisms for Quality of Service (QoS) in Wireless Local Area Networks (WLANs)*. Technical Report MECSE-5-2004, Monash University.

RFC1633 (1994). *Integrated Services in the Internet Architecture: an Overview*. Retrieved August 5, 2007, from <http://www.ietf.org/rfc/rfc1633.txt>