

Design a MATLAB-based System Architecture for Locating Fiber Fault in Optical Access Network

Ng Boon Chuan, Siti Asma Che Aziz, Mohammad Syuhaimi Ab-Rahman, Kasmiran Jumari

*Spectrum Technology Division, Computer and Network Security Research Group Department of Electrical, Electronics and Systems Engineering
Faculty of Engineering and Built Environment, Universiti Kebangsaan Malaysia,
43600 UKM Bangi, Selangor, Malaysia
Tel : 03-89216837, Fax : 603-89216146
E-mail : ngbc@vlsi.eng.ukm.my, saca@vlsi.eng.ukm.my, syuhaimi@vlsi.eng.ukm.my, kbj@vlsi.eng.ukm.my*

ABSTRACT

This paper experimentally demonstrated a MATLAB-based graphical user interface (GUI) named Smart Access Network Testing, Analyzing and Database (SANTAD) that able to measure the optical signal level, attenuation, losses, as well as detect any occurrence of fault and address the failure location in optical access network with point-to-multipoint (P2MP) configuration. This paper also presented a restoration mechanism scheme, where the protection mechanism for tree based optical switch will have capability to divert the signal onto protection line according to the types of failure condition and location of failures in access network. This will ensure the data flow continuously due to breakdown occur in the network and instantly repair the operation. The restoration scheme was simulated using OptiSystem, Inc. software in order to prove the solution feasibility.

Keywords

SANTAD, GUI, Fault, P2MP Configuration, Restoration

1.0 INTRODUCTION

The optical single mode fiber (SMF) is a very attractive communication medium since it offers a large scale useful bandwidth (25 THz) and low attenuation (0.2 dB/km), therefore it can facilitate demanding services such as high quality video transmission (Menif & Fathallah, 2007). Due to the large bandwidth and the associated high bit rates, the optical fibers can deliver greater capacity as compares to copper-based technologies. Today, optical access network has been recognized as the ultimate solution for providing various communications and multimedia services, including carrier-class telephony, high-speed Internet access, digital cable television (CATV), and interactive two-way video-based services to the end users (Lee, 2006).

When any fault occurs in an optical access network with P2MP configuration, the network system will without any function behind the break point. Any service outage due to a

fiber break can be translated into tremendous financial loss in business for the network service providers (Chan, 1999). According to the cases reported to the Federal Communication Commission (FCC) in US, more than one-third of service disruptions are due to fiber cable problems. These kinds of problems usually take longer time to resolve compared to the transmission equipment failure (Bakar et al., 2007). Therefore, fiber fault within optical access network becomes more significant due to the increasing demand for reliable service delivery (Prat, 2007).

2.0 SANTAD

To overcome these problems to achieve desired network survivability, we developed SANTAD by using Graphical User Interface Development Environment (GUIDE) Layout Editor in MATLAB version 7.0 programming that able to measure the optical signal level, attenuation, losses, as well as detect any occurrence of fault and address the failure location in a P2MP network system. The working principles of SANTAD are structured into three main parts to support its operations: (i) Measuring optical fiber line with OTDR, (ii) Interfacing OTDR test module with remote personnel computer (PC)/laptop, and (iii) Advanced data analyzing to support its operations.

SANTAD will identify and present the parameters of each optical fiber in the network system such as the fiber's status either in working (good/ideal) or non-working (breakdown/failure) condition, magnitude of decreasing as well as the location, failure location, and other details as shown in the OTDR's screen with the GUI processing capability of MATLAB programming. The whole operation process can be simplified in a flow chart as depicts in Figure 1.

2.1 Implementation of SANTAD in Optical Access Network

In this section, we briefly illustrated the application of SANTAD in an optical access network testbed composed by

30 km fiber to proof the feasibility of the proposed system as shown in Figure 2. A few data samples were gained from this experiment for further analyzing the OTDR measurements in order to identify the faulty fiber and address the failure location in the network system using SANTAD. During the experiment, one of the optical fiber lines is not connected to any device at another end (unplugging) to represent the break point in a testing line. It visualized the actual break point of an optical fiber line at that distance in a real condition.

A commercially available OTDR with 1550 nm laser source is used to measure the characteristics of optical fiber lines (The OTDR used in this study is FTB-400 Universal Test System manufactured by EXFO Electro-Optical Engineering Inc). The measurement for each line is saved in the OTDR and then transferred into PC using EXFO ToolBox Office PC Emulation software such as ToolBox 6. However, transferring data between FTB-400 and remote PC has never been easier. In this case, we transferred the data through RS-232 connection (connect the FTB-400 and PC with a serial port extension cable). The data synchronization will begin automatically and we have to activate the data transfer application in the FTB-400 and ToolBox 6 software (see Figure 3) (EXFO, 2006).

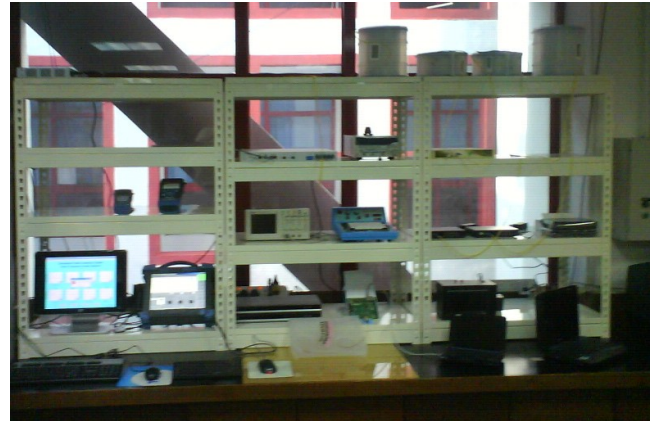

Figure 2: Photographic view of optical access network testbed at Networking System Laboratory in Faculty of Engineering and Built Environment, Universiti Kebangsaan Malaysia (UKM).

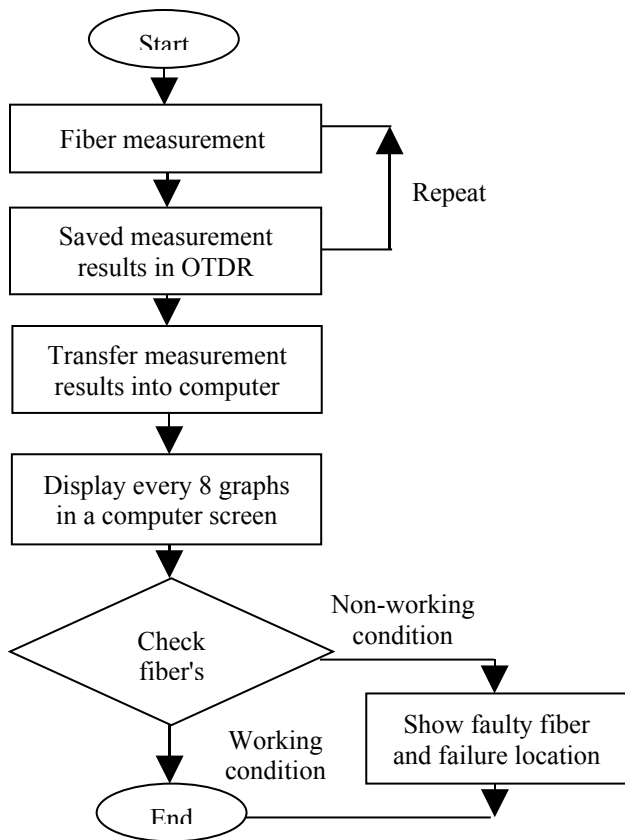

Figure 1: Flow chart for mechanism of fiber fault localization in optical access network.

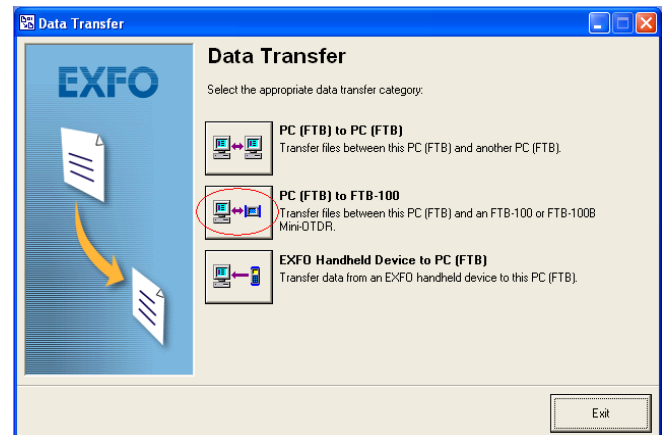

Figure 3: Activate the data transfer application in ToolBox 6 software.

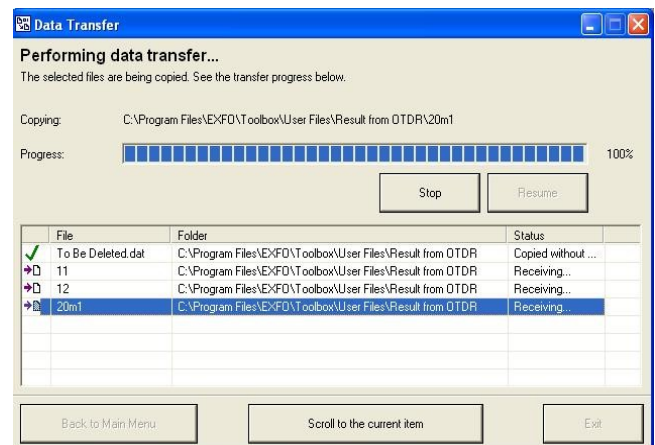

Figure 4: Transferring files from FTB-400 into remote PC.

After completing the data transfer process (Figure 4), we can analyze the results and make any changes as illustrated in Figure 5 and 6. All the results will be saved in database and then loaded into the developed program from database. SANTAD will accumulate every measurement result to be displayed on a single computer screen for further analyzing. SANTAD used event identification method to differentiate the mechanism of the optical signal at working and non-working condition. The loss in reflective fault event is representing the condition of an optical line. In working condition, a “Good condition” or “Decreasing y dB at z km” message will be displayed at the line's status panel in *Line's Detail* window, else a failure message “Line x FAILURE at z km from CO!” will be displayed in non-working condition.

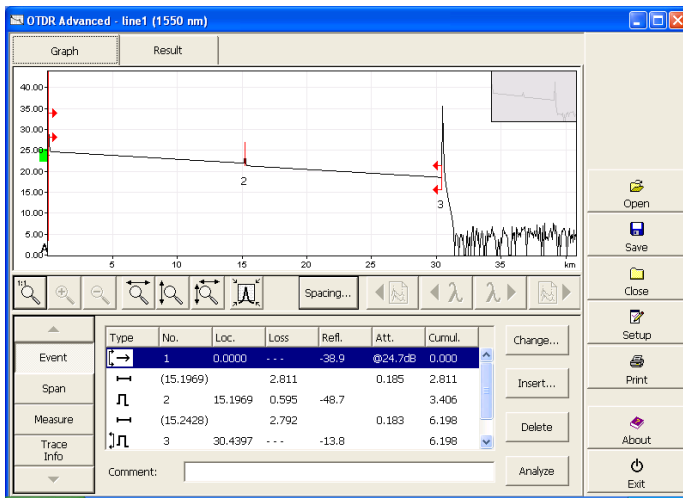

Figure 5: Execution display for line 1 in working condition (in ToolBox 6 software).

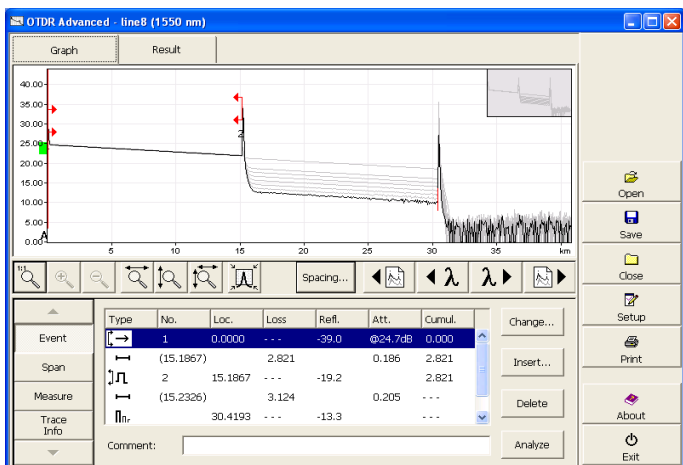

Figure 6: Execution display for line 8 in non-working condition (in ToolBox 6 software).

2.2 Experimental Results and Discussions

SANTAD is combining by the *Line's Status* and *Line's Detail* windows to provide the fiber testing and failure analyzing features. When the *Open* button in *Line's Status* window is pressed, all the measurement results are loaded from database into MATLAB Current Directory. SANTAD accumulated every 8 results to be displayed in *Line's Status* window for centralized monitoring as depicted in Figure 7. SANTAD checked the status for each fiber when pressing the *Status* button. A failure message “Line 8 FAILURE at 15.1918 km!” displays to inform the user regarding the faulty fiber and the exact failure location. Further detail will be displayed in the *Line's Detail* window (as shown in Figure 8) when click at the individual line in the combo box. All the information is mentioned in specified units such as distance in km, losses and attenuations in dB, wavelength in nm, pulse width in km, and time in min.

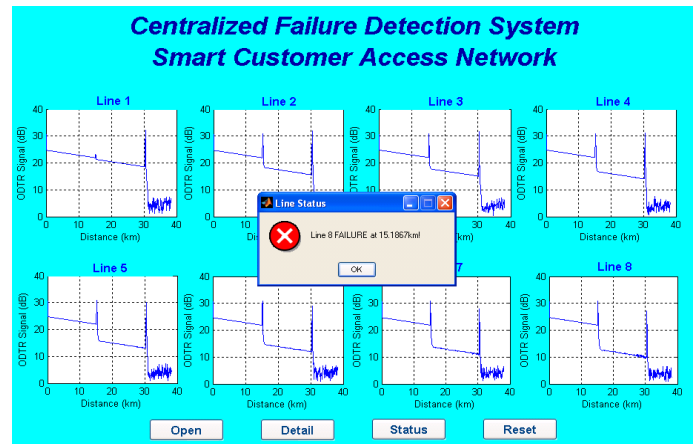

Figure 7: Every 8 graphs displayed in *Line's Status* window for centralized monitoring (in SANTAD).

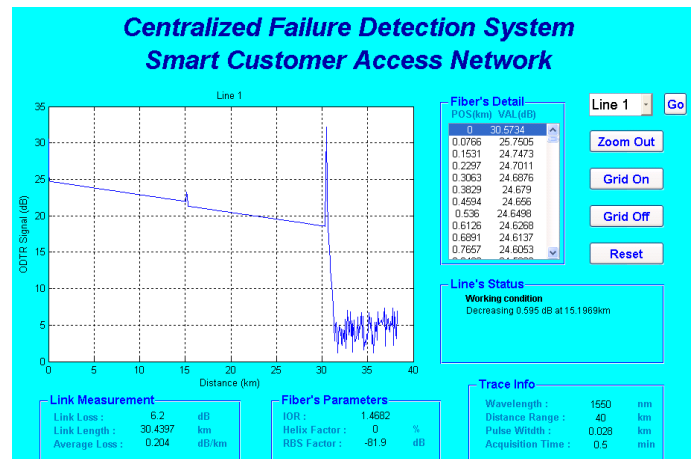

Figure 8: Optical power in line 1 decreasing 0.595 dB at 15.1969 km (in *Line's Detail* window).

During the experiment period, we were able to observe the behavior of the optical fiber. Theoretically, a signal is transmitted through a medium without any loss in a good condition and we will get a straight line in a power-distance graph. However the OTDR don't show this characteristic in the real case due to there is a device loss. There are two main fiber performance parameters determine how effective the light pulses transmit down the fiber. Attenuation is the reduction of light power over distance. Even with the highly pure materials used to manufacture the fiber core/cladding, light power is lost over distance by scattering and absorption within the fiber (NIC, 2007).

In this case, the fiber is attenuated with 0.19 dB/km for wavelength 1550 nm. For guided media such as optical fiber, the signal strength normally decays exponentially. Normally the logarithmic power ratio measures the changes in the strength of a signal at two different points in unit of decibels (dB) (Keiser, 2000). Fiber attenuation limits the distance light pulses can travel while still being detectable. Attenuation is expressed in decibels per kilometer (dB/km) at a given wavelength or range of wavelengths (NIC, 2007).

Apart from the propagation loss in a fiber, bending of fiber, connector, splice, coupler and optical device may also contribute significantly to the losses in an optical fiber communication link. Another key parameter is dispersion is inversely related to bandwidth, which is the information carrying capacity of a fiber. This can be broadly described as the amount of distortion or spreading of a pulse during transmission. If pulses spread out too far, the detection unit at the other end of the fiber is not able to distinguish one pulse from another, causing loss of information. Chromatic dispersion occurs in all fibers and is caused by the various light colors (components of a light pulse) traveling at slightly differing speeds along the fiber (NIC, 2007).

3.0 FIBER FAULT RESTORATION SCHEME

In restoration mechanism scheme, we employ the dedicated protection and shared protection. If traffic prioritization is implemented, high priority traffic is transmitted on the primary path whereas the best effort traffic is diffused on the backup path. In case the primary path breaks, the high priority traffic is transferred to the backup path. The failure protection and recovery of services needs the following actions: When the breakdown occurs, then it must be detected, and the information about the failure has to be propagated to the nodes triggering protection switching actions.

For switching the service from a failed working path to a backup path, then the backup path has to be set up. Thus, a suitable route with sufficient resources has to be found for the backup path means that a pre-established backup path has to be disjointed from the working path. Resources need to be

allocated to the backup path. Finally, the service has to be switched over to the backup path. The described actions may take place at different points in time. Survivability in network system will provide the protection and restoration architectures and it continued services in the presence of failures. Protection switching or restoration is the mechanisms used to ensure survivability. The survivability will add redundant capacity, detect faults and automatically re-route traffic around the failure. So the mechanism of restoration for the system was designed to meet the network specification.

Figure 9 represented the restoration scheme proposed to prevent the fiber fault and simultaneously provide the alternative path if breakdown occurs in distribution fiber line. Green arrow shows the normal condition when there is no breakdown occurs for both working line and protection line. Purple arrow shows the mechanism of dedicated protection in optical access network with P2MP configuration when there is breakdown occurs at working line. Orange arrow shows the mechanism of shared protection in optical network when there is breakdown occurs at both working line and protection line. This mechanism of protection will find the near neighbor protection line. Blue arrow shows the another mechanism of shared protection in optical network when there is breakdown occurs at both working line and protection line and also breakdown at working line neighbor. This mechanisms of protection will find the neighbor protection line with good condition.

The optical network for restoration scheme design was modeled and simulated using the Optisystem CAD program by Optiwave System, Inc. Moreover, the power budget of the architecture as follows. In normal condition (no breakdown fiber occurs), 1480 nm and 1550nm signals will traverse one circulator bidirectional (1 dB), bidirectional optical splitter (3 dB), and about 20 km single mode fiber (SMF) (5 dB), one multiplexer (0.5 dB), one demultiplexer (0.5 dB), and two numbers of optical switch (2.4dB). Therefore, the total loss budget is about 12.4 dB. The sensitivity of optical receiver, which is used in our test system, is nearly to -34 dBm. The bit error rate (BER) performances are measured by a 1.25 Gb/s non-return-to-zero (NRZ) pseudo random binary sequence (PRBS) with a pattern length of $2^{31}-1$ for the downstream traffic between the OLT and 8 ONUs. Each ONU numbers is shown in Figure 9.

4.0 EYE DIAGRAM OF SIMULATION

Eye diagram from the simulation results for restoration scheme in distribution fiber was observed at ONU 1, ONU 2, ONU 5 and ONU 8. Eye diagrams show parametric information about the signal which is the effects deriving from physics such as system bandwidth health. It will not show protocol or logical problems. If a logic 1 is healthy on

the eye, this does not reveal the fact that the system meant to send a zero. However, if the physics of the system mean that a logic one becomes so distorted while passing through the system that the receiver at the far end mistakes it for a zero, this should be shown in a good eye diagram. Figure 10 (a), (b), (c), and (d) showed the eye diagram for downstream

wavelength. Clear opening eye diagram was observed from the eye diagram at ONU 8 if compared to the eye diagram at ONU 1. The dynamic range for failure line at ONU 1 gives the highest value since the protection route mechanism uses ten numbers of optical switches to perform the restoration scheme in fiber distribution line.

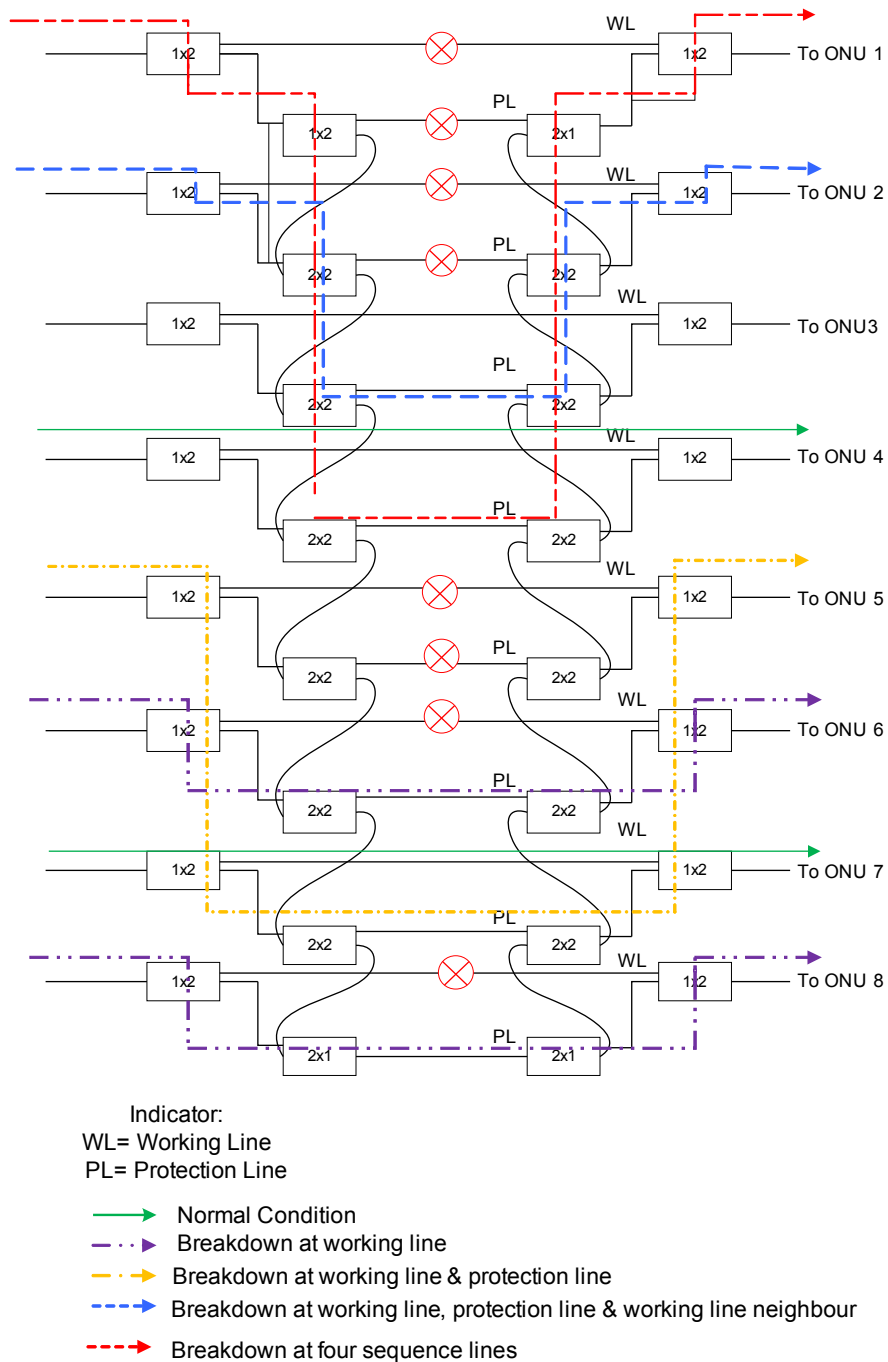

Figure 9: Restoration scheme mechanisms for various failures.

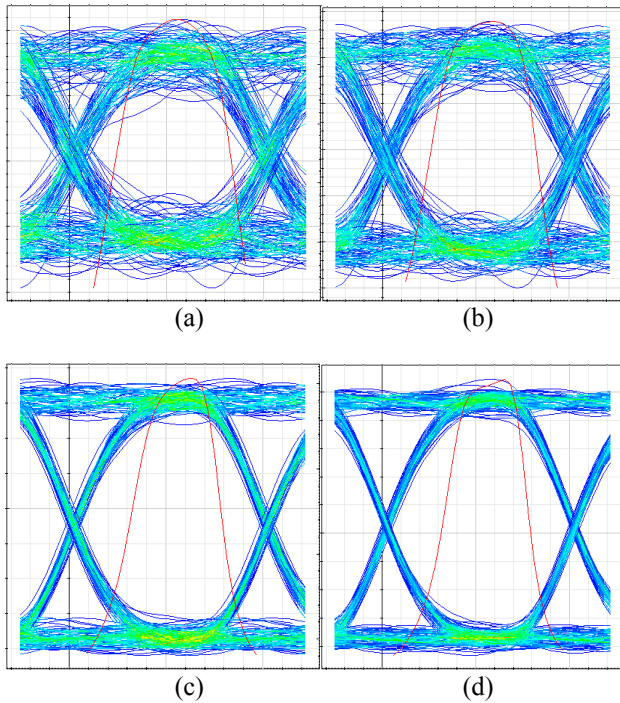

Figure 10: Observed eye diagrams for (a) 1550nm downstream at ONU 1 (b) 1550nm downstream at ONU 5 (c) 1550nm wavelength at ONU 2 (d) 1550nm wavelength at ONU 8.

5.0 CONCLUSION

SANTAD accumulated all the OTDR measurement into a PC screen and then accurately determined the faulty fiber as well as the failure location in the P2MP network system using event identification method. SANTAD is potentially to improve the survivability and increase the monitoring capabilities optical access network with P2MP configuration as compared to the conventional fiber fault localization technique by using OTDR. Overall, it can reduce the time needed to restore the fiber fault to maintain and operate the network system more efficiently. The restoration scheme proposed used to switch the signal to the protection line when failure occurs in the working line. The two optical switches are allocated in the transmission line in which both ONU and splitter are located. Single failure in the line connected will activate the dedicated protection while shared protection is activated when both fiber (working and standby fiber) are breakdown. The BER characteristics were measured at 1.25 Gbps for both upstream and downstream direction.

ACKNOWLEDGMENT

This work was support by the Ministry of Science, Technology and Innovation (MOSTI), Government of Malaysia, under National Science Fund (NSF) 01-01-02-SF0493.

REFERENCES

- Bakar, A.A.A., Jamaludin, M.Z., Abdullah, F., Yaacob, M.H., Mahdi, M.A., and Abdullah, M.K. (2007). A new technique of real-time monitoring of fiber optic cable networks transmission. *Optics and Lasers in Engineering*, 45, 126-130.
- Chan, C.K., Tong, F., Chen, L.K., Ho, K.P. & Lim, D. (1999). Fiber-fault identification for branched access networks using a wavelength-sweeping monitoring source. *IEEE Photonic Technology Letter*, 11(5), 614-616.
- EXFO. (2006). FTB-400 universal test system user guide. Canada: EXFO Electro-Optical Engineering Inc.
- Keiser, G. (2000). *Optical fiber communication*. 3rd Ed. New York: McGraw Hill.
- Lee, L., Kang, S.B., Lim, D.S., Lee, H.K. & Sorin, W.V. (2006). Fiber link loss monitoring scheme in bidirectional WDM transmission using ASE-injected FP-LD. *IEEE Photonic Technology Letter*, 18(3), 523-525.
- Menif, M. & Fathallah, H. (2007). An encoder/decoder device including a single reflective element for optical code division multiple access system. *Journal of Optical Communications*, 28(3), 172-174.
- Network Infrastructure Committee. (2007). FTTH infrastructure components and deployment methods. Retrieved Dec 12, 2008, from <http://www.europeftthcouncil.com/>.
- Prat, J. (2007). Optical networks: towards bandwidth manageability and cost efficiency. Retrieved Jan 1, 2008, from http://www.e-photon-one.org/ephotonplus/servlet/Utils.MostrerFitxerPublic?fitxer=D_VD-A_3.pdf&pathRelati u=EPhoton+One+%2B%2FPublic%2FPublic+Deliverables%2F/.