

THE ULTRASTRUCTURE AND  
BIOCHEMISTRY OF THE DEVELOPING  
BARLEY GRAIN

Jennifer Margaret Williams

Submitted for the degree of Doctor of Philosophy at the  
University of Edinburgh. 1975.



The work contained in this thesis is  
my own original work and has not been  
submitted for a degree at any other  
University.

J. M. Williams

## ABSTRACT

The morphological changes accompanying endosperm development in barley have been described using electron microscopy. Starch synthesis within the young amyloplast was initiated at a number of sites which later coalesced into a single granule. By 14 days after anthesis two populations of amyloplast, large and small, were seen. These were present throughout endosperm maturation.

A method was devised whereby the two populations could be separated at all stages of development. It was then possible to follow any biochemical changes accompanying maturation within each amyloplast population. The proportions of amylopectin and amylose in the starch of the amyloplast were shown to vary throughout maturation. The small amyloplasts have more amylopectin than the large at early stages but by 60 days after anthesis the large amyloplasts have the greater proportion of amylopectin.

Variation in activity during maturation of some of the enzymes of the endosperm concerned in starch synthesis was also investigated. Starch synthetase activity was associated with both types of amyloplast. The nucleotide specificity of the starch synthetase associated with each population varied independently as development proceeded.

A method was devised for the assay of branching enzyme (E.C. 2.4.1.18) in the presence of amylases and a time course of enzyme activity throughout endosperm development was determined. A peak of activity of the purified enzyme was found to be at 25 days after anthesis.

The development of amyloplasts was investigated using UDP- $[U^{14}C]$  glucose with the UDPG introduced to the endosperm via the flag

leaf. It is suggested that small amyloplasts do not arise from the large amyloplasts but that they constitute a separate population.



TABLE OF CONTENTS

	Page
Chapter 1. Introduction	1
1.1 History and Use of Barley	1
1.2 Fertilization and Development of Cereal Grain	1
1.3 Structure of Starch	3
1.4 The Amyloplast	8
1.4.1 Amyloplasts and chloroplasts	9
1.4.2 The shape and size of starch granules	9
1.4.3 Internal structure of the starch granule	10
1.4.4 Large and small amyloplasts	14
1.5 Enzymes of Starch Metabolism	16
1.5.1 Phosphorylase	16
1.5.2 Glucosyl transferases	16
1.5.3 Inter-relationship of phosphorylase and glucosyl transferases	18
1.5.4 Branching enzyme	19
1.5.5 $\alpha$ -amylase	20
1.5.6 $\beta$ -amylase	21
1.5.7 $\alpha$ -glucosidase	21
1.5.8 De-branching enzyme	21
1.6 Enzymes Associated with the Amyloplast	21
1.7 Aim of this Work	22
 Chapter 2. Materials and Methods	 23
2.1 Development of the Barley Grain	23
2.1.1 Plant material	23
2.1.2 Fresh weight, dry weight and water content determinations	23

2.1.3	Chemical analyses of whole grains and endosperms	25
2.1.4	Bacterial counts in the homogenates	26
2.1.5	Electron microscopy	26
2.2	Enzymes in the Soluble Fraction	28
2.2.1	Branching enzyme	28
2.2.1.a	Control	28
2.2.1.b	Assay of branching enzyme	29
2.2.1.c	Assay using partially purified enzyme preparations	29
2.2.2	Other enzymes	33
2.2.2.a	De-branching enzyme	33
2.2.2.b	Assay of $\alpha$ -glucosidase	34
2.2.2.c	Phosphorylase	35
2.2.2.d	Disc gel electrophoresis	35
2.2.2.e	Release of amyloplast bound starch synthetase	37
2.3	The Amyloplast	38
2.3.1	Separation of large and small amyloplasts	38
2.3.2	Acid treatment of amyloplasts	41
2.3.3	Determination of amylopectin and amylose content	41
2.3.4	Starch content of amyloplasts	42
2.3.5	Lipid content of amyloplasts	42
2.3.6	Degradation of amyloplasts by $\alpha$ -amylase	43
2.3.7	Amyloplast degradation at germination	44
2.3.8	The starch synthetase associated with large and small amyloplasts	45
2.3.9	Uptake of carbon-14 by large and small amyloplasts	47

Chapter 3. Results	49
3.1 Development of the Barley Grain	49
3.1.1 Fresh weight, dry weight and water content determinations	49
3.1.2 Chemical analyses	49
3.1.3 Bacterial contamination in the homogenates	53
3.1.4 Electron microscopy	53
3.2 Enzymes in the Soluble Fraction	55
3.2.1 Branching enzyme	55
3.2.2 De-branching enzyme	59
3.2.3 $\alpha$ -glucosidase	63
3.2.4 Phosphorylase	63
3.2.5 Gel electrophoresis and starch synthetase	63
3.3 The Amyloplast	69
3.3.1 Separation of large and small amyloplasts	69
3.3.2 Acid treatment	71
3.3.3 Determination of amylose and amylopectin content	72
3.3.4 Starch content of amyloplasts	75
3.3.5 Lipid composition of amyloplasts	75
3.3.6 Degradation of amyloplasts by $\alpha$ -amylase	75
3.3.7 Amyloplast degradation at germination	83
3.3.8 The effect of added potassium chloride in the starch synthetase assay	83
3.3.9 Starch synthetase associated with large and small amyloplasts	83
3.3.10 Uptake of carbon-14 by large and small amyloplasts	87
3.4 Accuracy of Experimental Results	90

## Chapter 4. Discussion

4.1	Introductory Remarks	91
4.2	Development of the Barley Grain	92
4.3	Enzymes in the Soluble Fraction	98
4.3.1	Branching enzyme	98
4.3.2	De-branching enzyme	100
4.3.3	$\alpha$ -glucosidase	101
4.3.4	Phosphorylase	101
4.3.5	Starch synthetase and branching enzyme	102
4.4	The Amyloplast	104
4.4.1	Separation of large and small amyloplasts	104
4.4.2	Structure of the amyloplast	105
4.4.3	Enzymic degradation of amyloplasts	107
4.4.4	Enzymes associated with the amyloplast	109
4.4.5	Amyloplast development	110
4.5	Conclusions	113
	Acknowledgements	115
	References	116
	Plates 1 - 28	123

## ABBREVIATIONS

G	glucose
G1P	glucose-1-phosphate
G6P	glucose-6-phosphate
P <sub>i</sub>	inorganic phosphate
UDPG	uridine diphosphoglucose
UDP	uridine diphosphate
ADPG	adenosine diphosphoglucose
ADP	adenosine diphosphate
ATP	adenosine triphosphate
NADP <sup>+</sup>	nicotinamide adenine dinucleotide phosphate
NADPH	reduced nicotinamide adenine dinucleotide phosphate
EDTA	ethylene diamine tetra-acetic acid
UDP [ <sup>14</sup> C] - glucose, UDPG*	UDPG uniformly labelled in the glucose moiety

### Electron microscopy resins:

DDSA	dodecenyl succinic anhydride hardener 964
MNA	methyl nadic anhydride
DMP 30	2,4,6 - tri(dimethylaminomethyl)phenol

INTRODUCTION

1.1 History and Use of Barley

Barley is thought to be the first cereal crop cultivated by man and originated probably as early as 18,000 B.C.<sup>(1)</sup>. Certainly pots made in Britain in Neolithic times have been found with impressions of barley grains in the clay<sup>(2)</sup>. Barley is now one of the major cereal crops grown in temperate regions, and its success is due mainly to the wide variety of climatic and geographic conditions in which it will grow. In Scotland barley accounted for seventy percent of the cereal acreage in 1974<sup>(3)</sup>.

Barley grain is a valuable feed for livestock, particularly beef animals. Very little is used directly for human consumption but about sixteen percent of the British crop is sold for malting<sup>(4)</sup>. Malt is used in the production of beer and whisky and also as a flavouring in the food industry.

The earliest species of barley cultivated was probably Hordeum spontaneum Koch, a wild barley closely resembling modern two-row varieties<sup>(1)</sup>. Cultivated barley is a diploid ( $2n = 14$ ) and may be either two-rowed, in which only one-third of the spikelets have a fertile floret, or four- or six-rowed with all the florets fertile.

1.2 Fertilization and Development of the Cereal Grain

Barley is a member of the family Gramineae. In most Gramineae anthesis, or flowering, occurs just before pollination. The lodicules swell, causing the lemmas and paleae to separate so that the stigmas can spread out and the anthers elongate. However, in barley, pollination and fertilization frequently occur before,

or without, the opening of the paleae, in which case self-fertilization takes place.

The fusion of one male gamete with the female gamete (the true fertilization) results in a diploid oöspore which develops into the embryo of the seed. The endosperm is produced from the triploid nucleus formed by the fusion of a second male gamete with the two secondary female nuclei. This endosperm nucleus rapidly divides without division of the enclosing cell walls, thus the embryo sac is at first polynucleate. At this stage in wheat endosperm Golgi bodies are distinguishable. There are also spherical and oval bodies in which an internal structure cannot be determined<sup>(5)</sup>. Cell walls are later laid down between the free nuclei. They can first be seen in electron micrographs taken about two days after anthesis. After this, new cells are produced by cell division. Harlan<sup>(6)</sup> reports that the barley grain grows rapidly following fertilization, since in the period between two and four days after anthesis half the growth in length of the grain occurs. This growth may be by cell division or enlargement.

In the barley variety 'Prior' under conditions in which anthesis to maturity took 30 days many organelles could be seen in the endosperm by five days after anthesis<sup>(7)</sup>. Among these organelles nuclei, mitochondria, proplastids, endoplasmic reticulum (ER) and Golgi bodies were recognisable. There is evidence in wheat that the ER develops from the nuclear membrane<sup>(7)</sup>. Starch deposition can be seen around five to six days after anthesis<sup>(7, 8)</sup>.

During further development to maturity endosperm cells fill almost entirely with starch and protein deposits. The protein bodies are seen about one week after fertilization. They are spherical and oval granules 0.1  $\mu\text{m}$  to 8  $\mu\text{m}$  in diameter enclosed by a membrane

and probably surrounded by small vesicles<sup>(7)</sup>. According to Buttrose<sup>(7)</sup> the young wheat endosperm contains no lipid deposits. Since his identification of protein bodies is based not on chemical analysis, but rather on their electron scattering power and correlation of their volume with the known percentage of protein in wheat endosperm, it is possible that some of the bodies identified as protein may in fact contain lipid. Some development of cristae in the endosperm mitochondria is seen during the early stages of wheat grain development.

Food reserves which will be used by the embryo at germination are stored in the cells of the endosperm. At maturity the barley grain consists of approximately 65% starch and sugars, 12% protein and other nitrogenous compounds and 10% cell wall material - the remainder being lipid and small quantities of other materials. These proportions vary slightly depending on which barley variety is being considered<sup>(9)</sup>.

### 1.3 Structure of Starch

Starch is a polymer of  $\alpha$ -D-glucopyranose molecules and consists of two polysaccharide fractions - amylose and amylopectin. The amyloses are long, generally unbranched chains in which the glucose monomers are linked by  $\alpha$ -(1,4) glucosidic bonds. Amylopectins are branched, the branches being caused by the presence of  $\alpha$ -(1,6) glucosidic links. Starch therefore differs from cellulose, where the glucose monomers are linked by  $\beta$ -(1,4) bonds. The bonding in amylose and amylopectin is shown in fig. 1.1.

The average chain length (CL) of amylose (that is, the number of glucose residues) is thought to be several thousand, although earlier methods gave CL 250-500, probably due to contaminating amylopectin<sup>(10)</sup>.

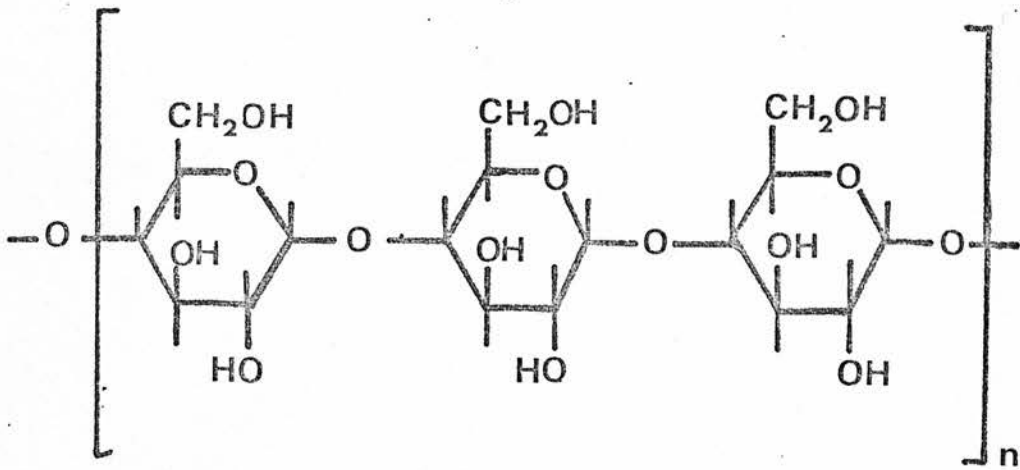

Fig.1.1 Bonding in amylose and amylopectin

(a) amylose

(b) the  $\alpha$  - (1,6) bond in amylopectin

Fig. 1.1



(a)

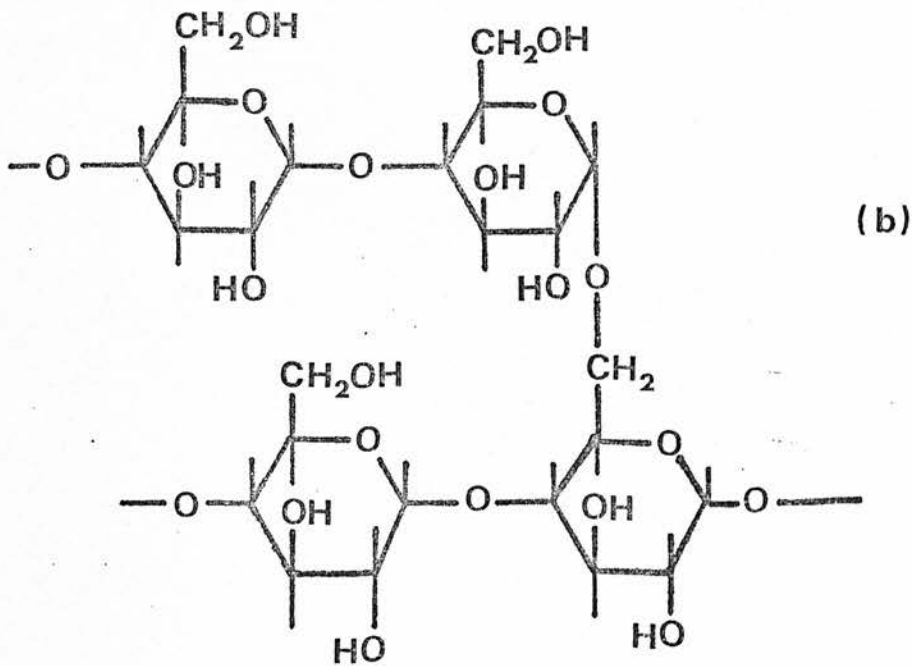

(b)

Amylose retrogrades in aqueous solution due to the alignment of the linear molecules by hydrogen bonding. It is thought to be the component which gives starch its crystallinity.

In solution amylose may occur as a random coil or as a helix. It is thought to exist in the helical conformation when complexed with reagents such as iodine. Amylose may contain a small number (perhaps around 0.1%) of  $\alpha$ -(1,6) glucosidic interchain linkages similar to those present in amylopectin<sup>(11)</sup>.

Chemical analysis of amylopectin has shown it to have an average chain length of 24-30 glucose residues<sup>(12)</sup> and molecular weight determinations by Meyer and Bernfeld<sup>(13)</sup> on the acetate derivatives gave the molecular weight as over 200,000. Aqueous solutions of amylopectin are stable at room temperature. Parrish and Whelan<sup>(14)</sup> have shown the presence of about 0.06% covalently bound phosphorus in potato amylopectin, but the exact location of this within the molecule is not known. Amylopectin has about half as many branches as glycogen<sup>(15)</sup>.

Evidence for the branching in amylopectin was found by Haworth, Hirst and Isherwood, using methylation and degradation methods<sup>(12)</sup>. They found that as well as the expected monomethylated glucose residues some dimethyl glucose was also produced. It was therefore suggested that some glucose molecules in the amylopectin are joined to another chain at a position other than carbon 1 or 4. The diagram (fig. 1.2a) shows the structure for amylopectin which was therefore proposed. A further structure, put forward by Staudinger<sup>(16)</sup> is also shown (fig. 1.2b).

More recent work on the structure of starch has exploited the specificity of enzyme action. Investigations by Meyer and Bernfeld<sup>(13)</sup> have shown that amylopectin  $\beta$  limit dextrin is degraded by

Fig.1.2 Proposed structures of amylopectin

- (a) Structure proposed by Haworth, Hirst and Isherwood
- (b) Structure proposed by Staudinger
- (c) Structure proposed by Meyer
- (d) Revised Meyer structure proposed by Gunja-Smith  
et al.

A ..... 'A' chain

B ..... 'B' chain

C ..... 'C' chain

—○ reducing end

Fig1.2

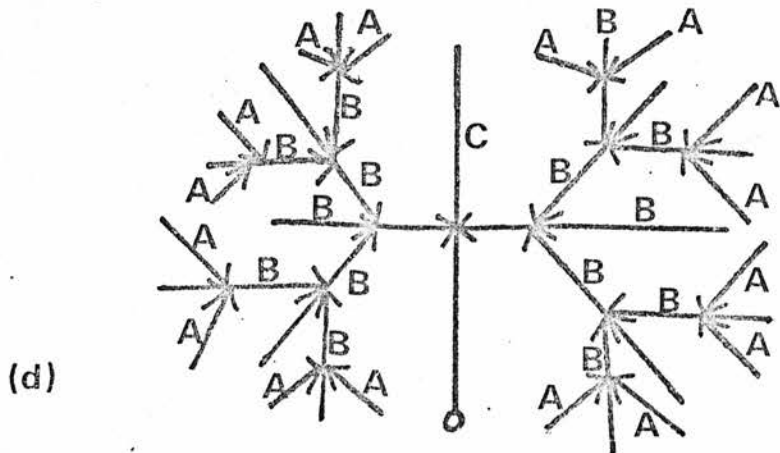
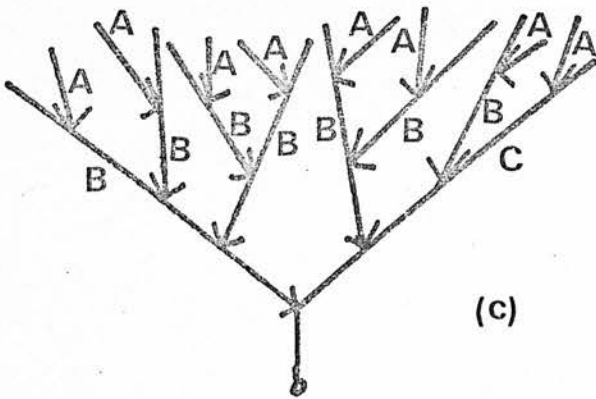
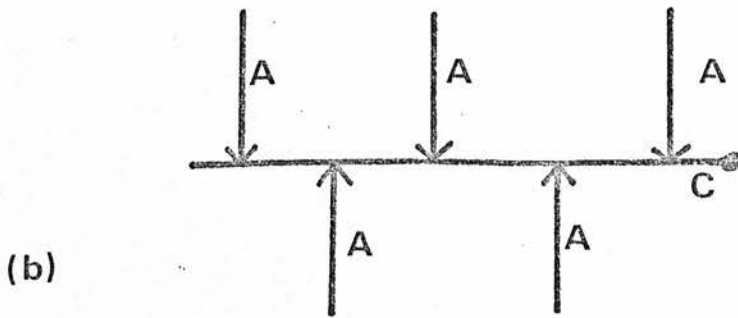
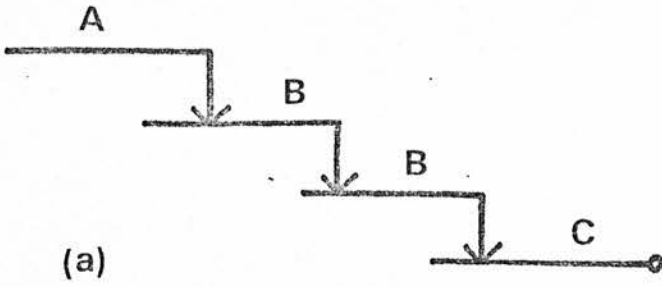

$\alpha$ -glucosidase (E.C. 3.2.1.20) but not by  $\beta$ -glucosidase (E.C.3.2.1.21) indicating that the glucosidic bonds are of the  $\alpha$  configuration. Confirmatory evidence for the  $\alpha$ -(1,6) linkage was produced by Thompson and Wolfson<sup>(17)</sup> by the degradation of waxy maize amylopectin to panose. The model proposed by Meyer and Bernfeld is shown in fig. 1.2c. This differs from the Staudinger structure in that not all of the side chain branches are joined to the chain terminating in the reducing group.

To distinguish between these models the terms "A"-chain, "B"-chain and "C"-chain were introduced. An "A"-chain is defined as one of the chains of glucose residues in the amylopectin molecule which is linked to another by its potential reducing end. A "B"-chain is linked to another chain in the same way but has one or more "A"-chains attached to it. The "C"-chain is the chain which terminates in the sole reducing group in the molecule. Each of the proposed models for amylopectin structure would have different proportions of "A"-, "B"- and "C"-chains.

Whelan<sup>(15)</sup> attempted to distinguish between the three amylopectin structures (fig. 1.2a, b and c) by degrading amylopectin  $\beta$  limit dextrins with the debranching enzyme R-enzyme (E.C. 3.2.1.9) and separating the products on charcoal. The amounts of maltose produced (12.8%) corresponded most closely to what would be expected from the Meyer structure. However experiments using pullulanase (E.C. 3.2.1.41) to determine the chain length gave conflicting results and a modified Meyer structure was therefore proposed by Gunja-Smith et al<sup>(18)</sup>. This is shown in the diagram (fig. 1.2d).

#### 1.4 The Amyloplast

The starch of higher plants is stored as granules within organelles called amyloplasts. There is conflicting evidence whether or not the amyloplast membrane persists around the granules throughout their development.

Seckinger and Wolf, using flour from a hard red spring wheat, did not find electron microscopic evidence of a continuous layer of protein around the starch granule, although their granules did have some adhering protein<sup>(19)</sup>. This does not, however, constitute evidence that there is no amyloplast membrane in vivo. Swift and Buttrose<sup>(20)</sup> were unable to establish whether or not mature pea amyloplasts were surrounded by an intact membrane envelope. On the other hand Simmonds<sup>(21)</sup> examined the protein matrix from wheat endosperm by electron microscopy and found that the edge of the matrix is outlined where it had abutted onto a starch granule, suggesting the presence of a membrane residue at this interface. Badenhuizen<sup>(22)</sup> suggested in 1958 that the plastid membrane did not remain around the growing starch granule, but more recently<sup>(23)</sup> has suggested from electron micrographic evidence that the amyloplast appears to be a vesicle surrounded by a double membrane. Electron micrographs of barley proplastids, assumed to be the young amyloplasts, and of amyloplasts at 14 days after anthesis, showed a double membrane at both these stages<sup>(7)</sup>. Buttrose, however, produces no evidence at later stages in barley development because of the difficulty in preparing the tissue for the electron microscope. In barley endosperm there is generally only one starch granule in each mature amyloplast, although in oats and rice there may be several granules contained within one membrane. Mahlberg<sup>(24)</sup> describes a wrinkled area in the midregion surface of starch granules

of Euphorbia terracina and E. tirucalli seen under the scanning electron microscope. This may represent the plastid membrane.

No real evidence for, or against, the presence of an amyloplast membrane which persists throughout the development of the barley endosperm has therefore been produced.

#### 1.4.1 Amyloplasts and chloroplasts

In general chloroplasts and amyloplasts are thought of as distinct organelles since the starch granules found in chloroplasts are generally of a transitory nature and little, if any, lamellar structure has been reported in amyloplasts. Some cases of dual function have, however, been reported; for example, in Pellionia daveauana chloroplasts have been found which store starch<sup>(25)</sup>. In potato (Solanum tuberosum) the amyloplasts become green after exposure to light<sup>(26)</sup>.

#### 1.4.2 The shape and size of the starch granules

The shape of the starch granule varies from species to species. For instance, Mahlberg<sup>(24)</sup> has shown that the starch granules in Euphorbia terracina are elongated and greater in diameter at the midregion than at the tip, while in E. tirucalli they are bone-shaped. Starch granules in barley are of two sizes (see page 71 ) and either spherical or ellipsoid. The starch granules in potato are also of two sizes, the large ones being elliptical with dimensions about 80  $\mu\text{m}$  by about 50  $\mu\text{m}$  and the small being generally circular with a diameter around 20  $\mu\text{m}$ <sup>(27)</sup>. In this case the amyloplast membrane is thought to be close to the starch granule so these dimensions are those of the amyloplast too. Pea starch granules exhibit a wide range of forms<sup>(28)</sup>.



### 1.4.3 Internal structure of the starch granule

It has been shown that the starch in the granules is in the form of layers which are seen as rings under the electron or light microscope. The relationship between these layers and the chemical composition of the starch granule is not clear. Buttrose, using the electron microscope, has demonstrated concentric rings in barley starch except in the centre of the granule, after staining with  $\text{KMnO}_4$ <sup>(7)</sup>. There were up to 12 rings in each section. The rings were composed of dark bands 0.1  $\mu\text{m}$  in width alternating with lighter bands 0.2  $\mu\text{m}$  wide. These rings could also be seen in the separate granula of the compound oat granule. Digestion with acid also produced a series of rings visible under the electron microscope. He concluded that one ring or shell was produced in the large starch granules every day until 16 days after anthesis when ring production became less regular. Since the rings can more easily be seen after acid treatment Buttrose suggested that they may indicate areas in the granule with different degrees of organisation and crystallinity. The rings do not depend on the proportions of amylose and amylopectin present in different areas since they are seen in waxy maize which has a very high proportion of amylopectin.

In barley the centre of the granule is resistant to hydrolysis by acid whereas in waxy maize the centre is rapidly broken down by acid. The centre of waxy maize granules also stains blue with iodine (29,30) and therefore probably contains a greater proportion of amylose than the remainder of the granule.

Sterling and Spit<sup>(31)</sup> described rodlets and microfibrils in the granule structure of wheat and maize. They used carbon replicas of fractured granules, viewed under the electron microscope.

They could not detect any correspondence between these microfibrils and the concentric rings seen by other workers. They considered that the microfibrils were in an amorphous matrix. Buttrose<sup>(7)</sup> also detected needle-like structures about 25 nm wide and 0.5  $\mu$ m long; these were arranged radially in the granule rings. He states that these might correspond to the microfibrils of Sterling and Spit, but might equally be artefacts of the staining and dehydration procedures.

A granular surface to the starch has been noted by Whistler and Turner<sup>(32)</sup> in electron micrographs of chromium shadowed sections of cornstarch. However, no details are given of the isolation procedure of the starch granules so it is a possibility that the granulation was due to damage caused during their preparation. Finkelstein and Sarko<sup>(33)</sup> have demonstrated layering in potato starch granules by laser optic techniques. They also showed that the centre of the granules is isotropic and therefore probably amorphous.

Nikuni and Whistler<sup>(34)</sup> have shown a shell structure produced by enzymatic degradation of maize starch granules. This indicates that some areas of the granule are more resistant to enzyme attack than others, and therefore is further evidence that the starch granule is not chemically the same throughout its structure. However these experiments have given little indication about what the actual differences in chemical structure within the granule might be.

In all these experiments it is possible that the rings seen under the light microscope and those seen under the electron microscope are due to different causes.

According to Sandstedt<sup>(29)</sup> Fritzsche concluded that starch granules were produced as the outer layers of starch were laid down upon the inner. This theory of "apposition" was contradicted by the "intussusception" theory of Walpers - that is, the theory that new material is laid down inside the old. Evidence for the apposition theory has been produced by Badenhuisen and Dutton<sup>(35)</sup>. After photosynthesis in  $^{14}\text{CO}_2$  the outer layers of potato amyloplasts were found to be radioactive suggesting that new material had been added to the outside. These radioactive layers were detected by autoradiography. From this it was concluded that the layers or rings seen under the microscope were produced as the granule enlarged. Since Buttrose<sup>(7)</sup> had produced preliminary evidence to support the theory that one ring was produced per day it was suggested that the dark and light rings seen under the electron microscope were due to different arrangements of starch molecules brought about because the starch was laid down at different rates in daytime and during the night. It was further stated<sup>(36)</sup> that granules in barley plants grown under a constant environment showed no evidence of rings and this appeared to confirm this theory. In wheat rings can be produced in granules by varying the light and dark environment. However, in potato starch rings developed even under constant conditions. These results with potato were confirmed by Roberts and Proctor<sup>(37)</sup> and Mes and Menge<sup>(38)</sup>. These contradictory results might be due to differences in the starch metabolism of cereals and potato which are naturally found under very different environmental conditions.

The crystalline parts of the starch granule structure give rise to X-ray diffraction patterns, although the correlation between these physical measurements and the chemical structure is not clear. An "A"-type pattern is seen when little water is present. In this case there is hydrogen bonding between the molecules. When more water is present an intermediate "C"-type pattern is seen. A "B" pattern occurs when there is sufficient water to mask the hydroxyl groups of the starch so that hydrogen bonding occurs between starch and water and not between the starch molecules<sup>(30)</sup>.

Native starch granules from tubers, for example potato show a "B" pattern and those from cereal starches an "A" pattern. Complexes of amylose with iodine or solvents such as n-butanol give a different, "V" pattern. This pattern may be due to the helical conformation of amylose under these conditions (page 5 ).

Hizukuri et al.<sup>(39)</sup> showed that the X-ray diffraction pattern for the starch granules for any one species depended on the metabolic state of the starch granule or amyloplast. Soybeans (Glycine soya) were germinated at fixed temperatures. As the temperature increased the X-ray diffraction pattern of the starch produced during germination changed gradually from "B" to "Ca" (i.e. an intermediate between "C" and "A"). The pattern obtained by moving plants back and forth between two temperatures was that which would have been obtained if the plants had been kept at a constant intermediate temperature. This indicated that the "C" type pattern may be due to a mixture of the configurations of starch giving "A" and "B" diagrams.

When examined under the polarising microscope starch granules show birefringence. This is another indication that there is some crystallization in the starch structure in the granule.

#### 1.4.4 Large and small amyloplasts

Buttrose<sup>(5)</sup> in his study of developing wheat amyloplasts from immature endosperm stated that in each plastid there occurs the initiation of one starch granule, which grows rapidly in size. This is followed later (at about two weeks after fertilization) by the initiation of small amyloplasts in the stroma space. Amyloplasts in barley can be divided into two populations - large and small. The initial, transparent, bean-shaped granules which can be seen in the amyloplasts of barley endosperm at four days after anthesis grow rapidly and may be up to 35  $\mu\text{m}$  in diameter at maturity. At about 14 days after anthesis, as in wheat, small, spherical amyloplasts appear. These do not grow larger than 10  $\mu\text{m}$  in diameter. According to Bathgate and Palmer<sup>(40)</sup> there is more difference between the two populations in barley than there is in wheat.

May and Buttrose<sup>(41)</sup> have called the large granules type 'A' and the small ones type 'B'. Type 'A' granules were said to be initiated up to two weeks after anthesis but not later while type 'B' granules are produced only after 14 days. They did not give any evidence to support this.

Investigations by Sandstedt<sup>(29)</sup> suggested that the two amyloplast populations differed in their birefringence properties. This has been disputed by work using more modern microscopes where the small starch granules were demonstrated to show birefringence in the same way as the large<sup>(42)</sup>.

The relative numbers of large and small amyloplasts in different barley varieties has also been investigated<sup>(42)</sup>. It was found that the ratio by numbers of small amyloplasts to large in mature barley varied from 5.5:1 to 37:1. The number of small starch granules was less in short-awned varieties of the barleys Compana and Glacier than in the corresponding long-awned varieties.

Evers, Greenwood and Muir<sup>(43)</sup> stated that the high amylose line of Glacier has more small amyloplasts (by weight) than normal Glacier. However other work<sup>(42)</sup> (also using weights) did not find this to be the case and if comparisons were done by number and not by weight the high amylose Glacier had fewer small amyloplasts than the normal variety. In neither case was evidence given that the relative numbers of small and large amyloplasts were the same before and after the separation procedures.

There is also controversy concerning the amylose and amylopectin content of the large and small starch granules. Bathgate and Palmer<sup>(40)</sup> have reported the large and small amyloplasts of wheat to have similar proportions of amylose. In barley on the other hand the amylose content of the small amyloplasts was said to be higher than that of the large. They suggested that this high amylose content might be a property of all barley small starch granules. However other workers have not found any difference in the amylose content of the small and large amyloplasts of normal barley and wheat although in high amylose varieties the small granules had a greater amylose content than the large<sup>(43)</sup>. Yet again, other studies have shown that in some cases the amylose content of the small granules is less than that of the large<sup>(44)</sup>.

Preparations of small starch granules are said to be associated with more protein than similar large granule preparations<sup>(40,44)</sup>. Since some of the discrepancies observed may be due to the techniques of separation a method is required which ensures satisfactory separation of amyloplasts before any definite conclusions can be drawn.

## 1.5 Enzymes of Starch Metabolism

### 1.5.1 Phosphorylase

The first enzyme which was thought to be involved in starch synthesis was phosphorylase ( $\alpha$ -1,4 glucan; orthophosphate glucosyl transferase E.C. 2.4.1.1). This enzyme catalyses the reaction:-

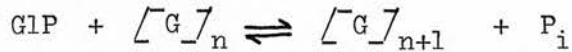

This is a readily reversible reaction; thus phosphorylase might be involved either in starch synthesis or degradation. The involvement of phosphorylase in glycogen metabolism and the identity of the glucose donor, glucose-1-phosphate, was first described by Cori et al.<sup>(45)</sup>. It was later discovered that phosphorylase, together with branching enzyme (q.v.) could produce glycogen from GLP in the absence of added primer<sup>(46)</sup>.

Phosphorylase was first detected in plants by Hanes<sup>(47)</sup> using pea and potato. Several plant iso-enzymes of phosphorylase have been discovered. In barley the two phosphorylase iso-enzymes are seen up to 15-16 days after anthesis. After this age one is degraded so that by 22 days after anthesis only one, primer-requiring, enzyme persists<sup>(48)</sup>. Frydman and Slabnik<sup>(49)</sup> conclude that in potato the primed and unprimed phosphorylase reaction is carried out by the same protein and that some conformational change prevents it carrying out the unprimed reaction. The enzyme may be a glycoprotein, with the glucan portion acting as the primer.

### 1.5.2 Glucosyl transferases

It was then discovered that there was an alternative route for glycogen synthesis, apart from phosphorylase. This involved the nucleotide sugar uridine diphosphoglucose (UDPG)<sup>(50,51)</sup>. The synthesis was catalysed by the enzyme UDPG glycogen glucosyl



transferase, or glycogen synthetase (E.C. 2.4.1.11) the reaction being:-

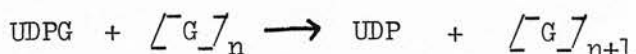

A similar enzyme has been found in plants by Recondo and Leloir<sup>(52)</sup>. The activity of this enzyme was ten times greater with ADPG than it was with UDPG.

As with phosphorylase it has been shown that starch and glycogen synthetases can, in some cases, be active in the absence of added primer. Gahan and Conrad<sup>(53)</sup> describe an ADPG glycogen synthetase which did not require an added primer in Aerobacter aerogenes. Several isozymes of spinach starch synthetase have been identified, one of which appears to be active in the absence of added primer<sup>(54,55)</sup>. With all such work the possibility exists that endogenous primers might be present unless enzyme preparations are carefully purified. It is possible that some, at least, of the transferases are glycoproteins, the glucan portion being removed from the enzyme by branching enzyme. Fox et al.<sup>(56)</sup> suggested that this was the case for the ADPG glycogen transferase of Escherichia coli B. In the potato, too, the glucose acceptor is thought to be a glycoprotein<sup>(57)</sup>.

Since glycogen synthetase is strongly adsorbed onto glycogen de Fekete, Leloir and Cardini<sup>(58)</sup> investigated starch granules for the presence of a starch synthesising enzyme. A granule-bound starch synthetase was isolated from Phaseolus vulgaris. This could not be separated from the granule by buffers, digitonin or detergents<sup>(59)</sup>.

Frydman and Cardini<sup>(60)</sup> investigated the properties of the granule-bound enzyme in potato. Grinding of the starch granules increased the activity of the enzyme but changed its specificity towards nucleotide sugars so that it was now, like the soluble, potato, enzyme active with ADPG rather than UDPG.



The soluble and granule-bound enzymes are found together in most plants.

In barley endosperm the enzyme associated with the plastids is more active with UDPG than ADPG at early stages of development, although the ADPG-linked activity predominates in older grain<sup>(61)</sup>. This contrasts with the soluble enzyme which is more active with UDPG<sup>(62)</sup>.

As with phosphorylase, starch synthetase synthesises only  $\alpha$ -(1,4) bonds so branching enzyme must be present for the production of amylopectin. Glutinous rice, which has a high proportion of amylopectin in its starch, was found to have only soluble starch synthetase activity. This led to speculation that it is the soluble enzyme which acts in co-operation with branching enzyme in the pathway leading to branched molecules<sup>(63)</sup>. Schiefer, Lee and Whelan<sup>(64)</sup> have proposed a soluble starch synthetase-branching enzyme complex in maize, although there are other isoenzymes of the soluble enzyme which do not participate in such a complex.

### 1.5.3 Inter-relationship of phosphorylase and glucosyl transferases

Since the increase in starch production during development of rice and pea parallels the increase in phosphorylase activity<sup>(65,66)</sup>. Mangat and Badenhuizen<sup>(67)</sup> conclude, without further evidence, that phosphorylase is the predominant starch synthesising enzyme. Furthermore, in the alga Polytoma uvella, while high temperatures led to a loss of starch synthetase activity some phosphorylase activity remained. Starch synthesis continued at these temperatures. It may be concluded that phosphorylase is important in starch synthesis at high temperatures, although Mangat and Badenhuizen extrapolate this to the in vivo system too. Badenhuizen<sup>(68)</sup> also stated that since the pH of the

'stroma' was about 6.0 this would be more favourable to phosphorylase than to starch synthetase which has a pH optimum of about 8.3. Whether these measurements have any relevance to the pH in the immediate environment of the starch synthesising process is unknown.

The maize mutant shrunken-4 has 90% less phosphorylase - and also less starch - than the wild type<sup>(69)</sup>. But the conclusion that phosphorylase is therefore involved in starch synthesis is scarcely tenable, since ADPG pyrophosphorylase activity, amongst others, is also decreased. Thus glucosyl transferase activity may not be expressed due to lack of substrate.

In the bark of the black locust tree there are periods of starch synthesis and starch degradation. When the  $P_i$ :G1P ratios were studied during the starch synthesising periods<sup>(70)</sup> it was found that conditions were unfavourable for the production of starch by phosphorylase. This is also true for a number of other plant tissues<sup>(59)</sup>. However it was likely that phosphorylase was the enzyme involved in starch degradation.

It has also been shown<sup>(55,71)</sup> that ADPG pyrophosphorylase and soluble starch synthetase activities are sufficient to account for the starch synthesis in spinach leaves and at all stages of endosperm development in maize. In these calculations no allowance was made for starch turnover.

#### 1.5.4 Branching enzyme

The enzyme which brings about the production of the  $\alpha$ -(1,6) glucosidic linkages in amylopectin or glycogen is known as branching enzyme (E.C. 2.4.1.18.  $\alpha$ -1,4-glucan:  $\alpha$ -1,4-glucan 6-glycosyl transferase, or "Q"-enzyme). The branch is formed by the splitting of an  $\alpha$ -1,4 linkage in an amylose chain, with the segment removed being transferred to another part of the same, or an adjacent amylose chain and joined to it by an  $\alpha$ -1,6 linkage. Branching enzymes have also been found which use amylopectin as the

substrate<sup>(72,73)</sup>.

Branching enzyme was first found in muscle by Cori and Cori<sup>(74)</sup> and later isolated from potato by Haworth et al.<sup>(75)</sup>. It has since been extracted in crystalline form<sup>(76)</sup>. It has been shown to facilitate polysaccharide synthesis by producing new non-reducing ends which act as glucosyl acceptors<sup>(77)</sup>.

It is known that branching enzyme and phosphorylase can together, in vitro, produce a branched-chain molecule<sup>(78)</sup>. It is not known, however, how the in vivo system is regulated, since straight chain molecules can be produced even in the presence of branching enzyme. Studies involving the use of <sup>14</sup>C compounds in intact wheat plants<sup>(79)</sup> have shown that amylose and amylopectin are not produced by different routes but that amylopectin is produced from amylose. Pulse-chase experiments<sup>(80)</sup> have confirmed this in Phaseolus vulgaris chloroplasts, except at early stages in development when the synthesis of the two compounds may be independent.

#### 1.5.5 $\alpha$ -amylase

There are a number of starch hydrolysing enzymes present in living tissue other than phosphorylase. These include the amylases.

$\alpha$ -amylase (E.C. 3.2.1.1  $\alpha$ -1,4-glucan-4-glucanohydrolase) hydrolyses  $\alpha$ -1,4 links where there are three or more  $\alpha$ -1,4 linked D-glucose units. Starch, glycogen and related polysaccharides and oligosaccharides are attacked in a random manner to give dextrans and later maltotriose, maltose and glucose.

$\alpha$ -amylase is concerned in the hydrolysis of starch during germination and is also found during the development of barley grain<sup>(81)</sup>. It has been crystallized from germinating barley endosperm by Schwimmer and Balls<sup>(82)</sup>. It has been shown that  $\alpha$ -amylase is

capable of attacking native starch granules<sup>(29)</sup> and it is thought to be the enzyme concerned in the degradation of starch grains in vivo<sup>(83)</sup>.

#### 1.5.6 $\beta$ -amylase

$\beta$ -amylase (E.C. 3.2.1.2  $\alpha$ -1,4-glucan maltohydrolase) removes maltose units from the non-reducing ends of the D-glucose chain.  $\beta$ -amylase cannot, however, hydrolyse the  $\alpha$ -1,6 links in glycogen and amylopectin and thus hydrolysis stops at the branch points, giving  $\beta$  limit dextrins.

#### 1.5.7 $\alpha$ -Glucosidase

$\alpha$ -glucosidase (E.C. 3.2.1.20,  $\alpha$ -D-glucoside glucohydrolase) is found in extracts from a wide variety of plants<sup>(84)</sup>. It is responsible for the hydrolysis of maltose and other  $\alpha$ -linked disaccharides of glucose, such as isomaltose, to D-glucose.

#### 1.5.8 De-branching enzyme

The  $\alpha$ -1,6 bonds are degraded by the enzyme de-branching enzyme (amylopectin 1,6 glucosidase [E.C. 3.2.1.9] or "R"-enzyme in plants, iso-amylase in yeasts). It used to be thought that there were two de-branching enzymes in plants; limit dextrinases and "R" enzyme, which had different specificities for the various branched substrates<sup>(85,86)</sup>. However, results from the earlier experiments were probably misleading due to poor isolation procedures and there is now considered to be just one de-branching enzyme<sup>(87)</sup>.

#### 1.6 Enzymes Associated with the Amyloplast

In addition to the starch synthetases a number of other enzymes may be associated with the amyloplast. Lavintman and Cardini<sup>(88)</sup> isolated a glycolipid from sweet-corn starch granules which they suggested was produced by an enzyme incorporated in the granule.

Buttrose<sup>(7)</sup>, in his electron-micrographs of cereal endosperm did not find any pores in the amyloplast membrane. He therefore postulated that the large starch molecules do not pass through the membrane but that all the starch synthesising enzymes are inside the amyloplast. Badenhuizen agrees with this and although there is no evidence given states that after deposition of the starch in solid form there is no turnover, although some starch synthesising activity continues inside the granule<sup>(30)</sup>.

#### 1.7 Aim of this Work

Although much work has been done on starch metabolising enzymes very little is known of the mechanisms concerned in starch deposition within the amyloplast. There still appears to be controversy surrounding the structure of the amyloplast. The work described here is designed to determine some of the ultrastructural and biochemical properties of the amyloplast in relation to starch synthesis throughout amyloplast development in maturing barley endosperm.

MATERIALS AND METHODS

2.1 Development of the Barley Grain

2.1.1 Plant Material

Barley (Hordeum distichum (L.) Lam. var. Julia)

was used throughout. This was grown either on the School of Agriculture farms, Bush Estate, Penicuik, Midlothian or in the greenhouse. Soil analysis of the field (Low Fulford) for the 1974 season gave a pH of 6.4, phosphorus content of 14 mg/kg and potassium content of 86 mg/kg, based on three random samples taken over the whole field. Fertilizer (N: P<sub>2</sub>O<sub>5</sub>: K<sub>2</sub>O 23 : 11½ : 11½) was applied at a rate of 251 kg/ha at sowing time. In the greenhouse germinated seedlings were planted four to a pot in a mixture of John Innes No. 2 compost (pH 6.0) and washed river sand. During the winter months artificial lighting, in the form of fluorescent light, was supplied between 10.00 h and 16.00 h. The temperature was not controlled. Water was supplied to the bed on which the pots were placed. When necessary nicotine shreds were burnt in the greenhouse to control aphids.

Ears were either used immediately or were stored at -19°C for up to three months. The age of the barley (in days after anthesis) was determined subjectively with reference to the table of Baxter<sup>(89)</sup> which is reproduced in Table 2.1.

2.1.2 Fresh weight, dry weight and water content determinations

Dry weights were obtained by drying grains at 80°C to constant weight. Fifteen grains were used for barley less than 16 days after anthesis. After this age 10 grains were used for each determination.

TABLE 2.1

Changes in Main Morphological Features of Developing  
Barley Grain

Age in days after anthesis	Size of Amyloplasts (nm)	Morphological description of grain	Colour of grain
2		Free nuclear stage	Pale Green
3	1	Propolastids and Promitochondria	
5	1	Formation of cell walls	
7	2	Turgid 'pearl like' endosperm amyloplasts stain with iodine	
10-12	3-4	Watery endosperm	Bright green due to chlorophyll layer of testa-pericarp
14	3-4	Thin sliver of endosperm 3-4mm	
15	5	Endosperm thickening	
18	6	Milky stage of endosperm embryo can be separated	
21	8	Aleurone can be scraped off endosperm	
25	10		
30	12	Chlorophyll layer begins to be reabsorbed	Turns yellow, beginning with awns
33-35	15-17		
40	16	Endosperm begins to dry out. Testa-pericarp adhering to endosperm	
45-50	15		
50-60	15-16	Grain shrinks due to water loss	

From E.D. Baxter Ph.D. thesis (1972) University of Edinburgh



Water content was calculated by subtracting dry weight from fresh weight.

### 2.1.3 Chemical analyses of whole grains and endosperms

Total carbohydrate, reducing sugar, glucose and soluble protein were measured in a homogenate of whole grains or endosperms in 0.15 M phosphate buffer pH 7.3. A Potter-type all glass hand-held homogeniser was used for all homogenisations in these and other experiments. In general a minimum of ten whole grains or endosperms were homogenised. Two ml buffer was used for younger grains and 5 ml for older grains. The homogenate was then diluted as necessary. Total carbohydrate was determined by the anthrone reagent method of Morris<sup>(90)</sup>. This method is specific for carbohydrate and involves the reaction of anthrone with the carbohydrate, brought about by the heat produced when the concentrated acid in the reagent is mixed with water. The reducing sugar content of the homogenate was measured by the method of Somogyi<sup>(91)</sup> as modified by Nelson<sup>(92)</sup>, in which the cupric oxide in the Somogyi reagent is reduced by the sugar to cuprous oxide. This is then determined by reaction with the chromogen arsenomolybdate, the optical density of the resulting colour being determined at 540m $\mu$ .

Glucose was determined enzymatically using glucose oxidase. This method was a modification of that described by Raabo and Terkildsen<sup>(93)</sup>. Glucose oxidase, in the presence of oxygen and water converts the glucose present to gluconic acid and hydrogen peroxide. The dye o-dianisidine dihydrochloride is then oxidised by the hydrogen peroxide in a reaction catalysed by peroxidase. The intensity of the brown colour of this oxidised compound is a measure of the original glucose concentration. Glucose oxidase is



highly specific for glucose, although 2-deoxy-D-glucose, D-mannose and D-fructose are also substrates to a much lesser extent.

Soluble protein was measured by the method of Lowry<sup>(94)</sup>.

This is again a colour reaction, based on the co-ordination of cupric ion with the nitrogen in a peptide bond and on a reaction of the folin reagent with tyrosine and tryptophan. The standard used was bovine plasma albumin.

In all these analyses concentration was determined by reference to a standard curve.

#### 2.1.4 Bacterial counts in the homogenates

0.01 ml from homogenates of endosperms aged 14, 22 and 25 days after anthesis were streaked on to nutrient agar. The barley used had been stored at  $-19^{\circ}\text{C}$  for not more than three months. The plates were then kept at room temperature for 48 h after which the number of colonies present were counted.

#### 2.1.5 Electron microscopy

##### Preparation of tissue

Endosperms were dissected out of the grain at various ages and cut into approximately 1 mm cubes. Testa pericarps and whole grain 3 days or less after anthesis were thin enough to be fixed without cutting. Starch granules and amyloplasts from the sucrose gradient, before or after acid treatment, were fixed in potassium permanganate without prior preparation.

##### Fixation, staining and embedding

###### i) Glutaraldehyde/osmium tetroxide fixation:

The prepared tissue was fixed in 4% glutaraldehyde in 0.1 M phosphate buffer, pH 7.4, for 2 h. It was then washed three times in the same buffer and further fixed and stained in 2% osmium tetroxide in buffer for 2 h. Remaining osmium tetroxide was

removed by three more washes in buffer. The tissue was then dehydrated by placing in a series of aqueous ethanol concentrations, 30%, 50%, 70%, 90% and 100% (v/v) for one hour in each. The 70% alcohol contained 1% uranyl acetate to increase staining. This was followed by a further period of one hour in 100% ethanol.

Preliminary embedding was carried out by putting the tissue through a series of 100% ethanol and resin mixtures. The resin used was TAAB embedding resin (TAAB Laboratories) made up as follows:-

TAAB embedding resin	50 parts
DDSA	30 parts
MNA	20 parts
DMP 30	2 parts

The tissue was left for successive periods of 1 h in each of 20%, 50%, 70% and 90% resin in ethanol. It was then left in 100% embedding resin in a cool place for four weeks after which individual pieces of tissue were removed and placed at the bottom of a plastic mould tube. The mould tube was filled with fresh resin, and the resin polymerised at 60°C for 30 h.

ii) Potassium permanganate fixation:

The tissue was placed in an unbuffered 5% (w/v) potassium permanganate for 2 min<sup>(95)</sup>. This solution acts both as a stain and a fixative. The tissue was then washed with three changes of 25% (v/v) aqueous ethanol for a total of 20 min. Dehydration and embedding was then carried out as for glutaraldehyde/osmium tetroxide fixation except that the uranyl acetate was omitted.

## Sectioning

The embedded tissue was removed by cutting the mould tube with a scalpel. Sections were cut on an LKB Ultramicrotome III using a glass knife. 500 Å thick sections were cut from tissue which did not contain starch. Sections 600 Å - 700 Å in thickness were cut when the tissue contained starch because in thinner sections the starch was often removed from the tissue by the knife. The sections were collected on copper grids coated with necloidine and post-stained in Reynolds' lead citrate<sup>(96)</sup> for 20 min. After washing and drying, the sections were lightly shadowed with carbon. The microscope used was a GEC/AEI EM802 electron microscope.

### 2.2 Enzymes in the Soluble Fraction

#### 2.2.1 Branching enzyme

Since barley endosperm contains some  $\alpha$ -amylase activity<sup>(81)</sup> the method of Krisman for the assay of branching enzyme in its presence<sup>(97)</sup> was initially attempted. This assay exploits the difference in substrate specificity between the two enzymes, that is, since  $\alpha$ -amylase degrades both glycogen and amylopectin whereas branching enzyme acts only on amylopectin it is possible, by subtraction, to estimate branching enzyme only. The method assumes that  $\alpha$ -amylase acts at the same rate on amylopectin and glycogen.

##### 2.2.1.a Control

A control experiment was first set up to determine the rate of hydrolysis of the two substrates amylopectin and glycogen with barley  $\alpha$ -amylase. The reaction mixture contained:-

1% glycogen or 1% amylopectin	1.5 ml
5 mg/ml Malt $\alpha$ -amylase (Sigma Chemical Co.)	1.0 ml.

This was incubated at 25°C. 0.2 ml was removed at 0, 3, 6 and 9 min after adding the enzyme to the polysaccharide and blown into 10 ml iodine solution (0.254 g iodine and 4 g. potassium iodide per litre). The optical density was read at 460 m $\mu$  for the glycogen experiment and at 605 m $\mu$  for the amylopectin experiment. Controls were run in which the enzyme was replaced by distilled water.

#### 2.2.1.b Assay of branching enzyme (ref.97)

The reaction mixture contained:-

0.05 M sodium citrate - phosphate buffer pH 6.4	0.03 ml
1% amylopectin or glycogen	0.02 ml
solution to be tested	0.05 ml

After incubation at 37°C for 30 min, 2.9ml iodine reagent was added and the optical density recorded continuously at wavelengths of 850-450m $\mu$  in a Unicam SP800B spectrophotometer. A control was run in which the test solution was added after incubation.

Branching enzyme activity was measured as the decrease in absorbency at 520 m $\mu$  with amylopectin as substrate minus the decrease in absorbency at 460 m $\mu$  with glycogen as substrate.

#### 2.2.1.c Assay using partially purified enzyme preparations

Since immature barley endosperm contains a number of starch hydrolysing enzymes<sup>(81)</sup>, in addition to  $\alpha$ -amylase, which might interfere with the assay of branching enzyme using decrease in colour of the starch-iodine complex, a method was devised for the partial purification of branching enzyme which would enable a simpler assay procedure to be used.

## Separation of branching enzyme from starch degrading enzymes

All procedures were carried out at room temperature.

One hundred endosperms were homogenised in 10 ml; 30 mM sodium citrate buffer pH 7.0 containing 1 mM dithiothreitol. The homogenate was centrifuged in the bench centrifuge (MSE Minor centrifuge swing out head, top speed = 3250 rpm) for 10 min. The precipitate was discarded. To the supernatant was added 4 ml 0.02 N sodium hydroxide, 3 ml distilled water and 3 ml lead acetate prepared as in Barker, Bourne and Peat<sup>(98)</sup>. The lead-protein precipitate was collected by centrifugation (bench centrifuge) and re-dissolved by stirring with 10 ml 0.2 N sodium bicarbonate for 5 min. Carbon dioxide gas was then passed through the solution for 2.5 min, after which any remaining precipitate was removed by centrifugation as above.

Ammonium sulphate solution (50 g/100 ml) was added to the supernatant to give a 9% solution, the precipitate removed by centrifugation (bench centrifuge, 10 min) and re-dissolved in 3 ml buffer. More ammonium sulphate solution was added to the supernatant to give a 20% solution and the precipitate collected. This was repeated to give precipitates from 27.5% and 38.5% ammonium sulphate.

The precipitates were then tested for branching enzyme activity and reducing sugar production. Branching enzyme was assayed by the method of Krisman (above) except that 1% amylose was used instead of amylopectin or glycogen. A duplicate set of tubes was incubated as for the branching enzyme assay but following incubation they were diluted to 1.0 ml with buffer and the reducing sugar produced determined by the method of Somogyi and Nelson (section 2.1.3).

In subsequent experiments the solution was brought to 20% ammonium sulphate and the precipitate from this discarded. The supernatant was then brought to 38.5% and the precipitate from this collected and re-dissolved in 3 ml buffer for use.

This precipitate was then tested for the presence of starch hydrolases:-

#### $\alpha$ -amylase

$\alpha$ -amylase was determined by the method of Briggs<sup>(99)</sup>. This involves the decrease in starch-iodine colour at 605 m $\mu$  as  $\beta$  limit dextrin is broken down by the amylase. Activity is expressed as arbitrary units as described by Duffus<sup>(100)</sup>.

#### Phosphorylase

Phosphorylase was determined by the method of Slabnik and Frydman<sup>(101)</sup>. The phosphate released from the GLP substrate is detected by the method of Lowry and Lopez<sup>(102)</sup>. This is based on the principle that the phosphate forms a blue complex with ammonium molybdate under the assay conditions and the intensity of the colour can be measured from the absorption of light at 700 m $\mu$ .

#### De-branching enzyme

De-branching enzyme was assayed by the method described in section 2.2.2.a (*σ.v.*).

#### Separation of branching enzyme from $\alpha$ -amylase

##### 1) Method of Loyter and Schramm

This method<sup>(103)</sup> involves the complexing of  $\alpha$ -amylase with glycogen and removing the activity in the insoluble precipitate produced.

##### ii) Effect of heating on $\alpha$ -amylase

$\alpha$ -amylase is not destroyed by heating at 70°C whereas many other enzymes are<sup>(82)</sup>. This was tested using commercial malt  $\alpha$ -amylase. 1 ml  $\alpha$ -amylase (2 mg./25 ml) was assayed for activity by

the method above. A further portion was heated at 70°C in a water bath for 20 min. 1 ml of this was then also assayed for  $\alpha$ -amylase activity.

#### Branching Enzyme Activity in Barley Endosperm throughout Development

Branching enzyme was prepared as described above from endosperms of different ages. The assay used was as follows:-

1% amylose	0.02 ml
0.05 M sodium citrate-phosphate buffer pH 6.4	0.03 ml
prepared branching enzyme	0.05 ml

A similar test was set up in which the branching enzyme preparation had been previously heated at 70°C for 20 min and then cooled. The tubes were incubated at 37°C for 30 min. Controls were run in which the branching enzyme preparation or heated branching enzyme preparation were added at the end of incubation. 2.9 ml iodine reagent were then added and the optical density recorded continuously at wavelengths 850-450 m $\mu$ . The activity of branching enzyme was calculated from the decrease in optical density at 680 m $\mu$  in the unheated preparation (due to branching enzyme plus  $\alpha$ -amylase) minus that decrease produced by the heated preparation (due to  $\alpha$ -amylase alone). Activity is expressed as arbitrary units where one unit is defined as the amount of enzyme required to give a decrease in optical density at 680 m $\mu$  of 0.1 absorbance units.

#### Absorption spectra of the starch-iodine complex as the starch becomes more branched

Tubes were set up containing 0.08 ml sodium citrate-phosphate buffer pH 6.4 and 0.02 ml of a mixture of amylose and amylopectin - 0%, 37.5% and 75% amylopectin were used. 2.9 ml iodine was added and the absorption again recorded continuously at wavelengths 850-450 m $\mu$ .



## 2.2.2 Other Enzymes

### 2.2.2.a De-Branching enzyme

The method was adapted from that described by Manners and Yellowlees<sup>(104)</sup> for the assay of limit dextrinase. The substrate used was pullulan, a linear polymer of  $\alpha(1-6)$  linked  $\alpha$ -maltotriose units.

The reaction mixture contained:-

10 mg/ml pullulan solution	1.0 ml
0.2 M sodium phosphate-citrate buffer, pH 5.0	0.3 ml
endosperm homogenate	1.0 ml
distilled water	1.7 ml

The pullulan was prepared by heating a 1% solution in a boiling water bath for 2 h followed by dialysis against distilled water for at least 2 h. The endosperm homogenate consisted of 15 endosperms in 3 ml buffer (as above). The supernatant from centrifugation in the bench centrifuge for 10 min. was used as the source of enzyme.

The reducing sugar content was measured by the method of Somogyi and Nelson (section 2.1.3) at 0 and 150 min after adding the endosperm homogenate to the other reagents. Incubation was carried out at 37°C. Enzyme activity is expressed in mg. glucose produced/endosperm/150 min.

### Paper chromatography of pullulan

Paper chromatography was carried out on the pullulan to determine the extent of contamination of the pullulan by maltotriose and higher maltosaccharides. The method was a modification of that described by Waygood et al.<sup>(105)</sup>. 25  $\mu$ l aliquots of pullulan, maltotriose, maltose and sucrose (all 1% (w/v) solutions) were spotted on to Whatman No. 1 paper and separated by descending paper chromatography in one dimension. The solvent was 840 g phenol, 10 ml glacial acetic acid, 0.372 g ethylene diamine tetra acetic acid



and 161 ml distilled water. After 19 h the paper was removed, dried and sprayed with p-anisidine reagent for carbohydrates<sup>(106)</sup>. After drying at 105°C for 5 min the position of the carbohydrate was indicated by a brown stain.

#### 2.2.2.b Assay of $\alpha$ -glucosidase

For ages older than 14 days after anthesis, ten endosperms were homogenised in 2 ml 0.15 M phosphate buffer pH 7.3, for 6 day and 14 day barley, 15 endosperms were homogenised in 2 ml buffer. Homogenisation was carried out at 4°C and the homogenates used directly without filtration or centrifugation.

$\alpha$ -glucosidase was assayed by the method of Bergmeyer<sup>(107)</sup>.

The assay is based on the following reactions:-

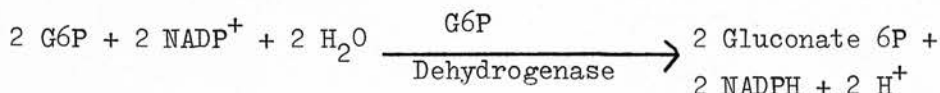
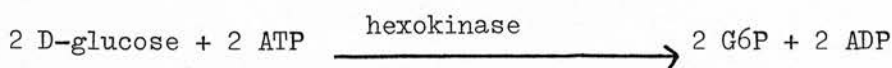
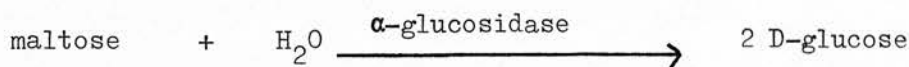

The incubation mixture contained:

0.1 MMES buffer pH 6.0	1.49 ml
200 mg/ml maltose	0.50 ml
enzyme to be tested	0.01 ml

This was incubated at 25°C for 5 min.

A blank was set up in which the test solution was added after the incubation. The reaction was stopped by placing the tubes in a boiling water bath for 3 min. This was followed by centrifugation (5 min, 3250 rpm) and the supernatant assayed for glucose as follows:-



the supernatant was layered on the gel. 50  $\mu$ l sample was loaded per gel. The gels were 7% acrylamide, with bisacrylamide in a ratio 1:37.5 bisacrylamide:acrylamide<sup>(64)</sup>. The buffer used in the gels was 7% sucrose in Tris-HCl pH 7.9. In some experiments 0.4 mg/ml starch, amylose or amylopectin were also polymerised in the gel. The samples were loaded directly on the gel without the use of spacers. The running buffer used was 0.1 M Tris-glycine pH 8.3. A Shandon disc electrophoresis apparatus was used, fitted to a Vokam power pack. The electrophoresis was carried out at a current of 5 mA per gel, using bromophenol blue as the tracking dye. After electrophoresis the gels were removed from the glass tubes by syringing with water and incubated overnight in 6 ml of a solution containing:-

0.025 mM UDPG or ADPG

2 mM EDTA

25 mM sodium citrate

25 mM glycine

adjusted to pH 8.6. If no primer polysaccharide was incorporated in the gel it was added to give a 0.2 - 0.4% solution in the above incubation. Following incubation the gels were washed in distilled water and stained in 0.2%  $I_2$  in 2% KI.

To ensure that the activity stained areas coincided with a position at which protein was present on the gel, duplicate gels were run for each sample. After electrophoresis these were stained overnight in 0.5% (w/v) naphthalene black in N acetic acid. De-staining was carried out on cotton wool soaked in N acetic acid, with a potential difference of 100-150 V applied perpendicular to the gels. Areas of protein are shown up by dark blue bands remaining on the gel.

The Rf for each stained band was calculated as:

$$\frac{\text{distance moved by band}}{\text{distance moved by tracking dye}}$$

A control was set up to show that the bands seen were due to starch synthetase and not phosphorylases. The homogenates were layered on the gels as before. After electrophoresis the gels were incubated in solutions in which the nucleotide sugar in the incubation mixture was replaced by one of the following A, B, C or

D:-

A - 20 mM phosphate + 0.025 mM UDPG

B - 0.025 mM UDPG

C - 20 mM phosphate + 1 mM G1P

D - 1 mM G1P

The gels were then stained in iodine as before.

ii) Gel electrophoresis of starch synthetase and branching enzyme

Endosperm homogenates were layered as before on three gels containing 0.05 mg/ml amylose. One gel was stained for protein and one for starch synthetase as described. The third was incubated overnight in 0.05 M citrate-phosphate buffer pH 6.4 and then stained in the iodine solution. Rf values were calculated as before.

2.2.2.e Release of amyloplast bound starch synthetase

Three methods were tried for releasing the amyloplast bound starch synthetase.

i)  $\alpha$ -amylase

Five 18 day endosperms were homogenised in 2 ml buffer and centrifuged at 10,000 x g for 10 min. The supernatant was layered on a gel as in section 2.2.2.d. The pellet was resuspended

in 2 ml buffer and 2 mg bacterial  $\alpha$ -amylase added. After incubation at 37°C for 3 h this was centrifuged again at 10,000 x g for 10 min and 50  $\mu$ l of the supernatant loaded onto a gel. The gels were then run, incubated and stained as before.

ii) Sonication

Amyloplasts were separated on the sucrose density gradient described in section 2.3.1. iv.(q.v.). The pellets were resuspended in 2 ml buffer and subjected to four 15 sec bursts of sonication at maximum speed. After centrifugation at 10,000 x g for 10 min, 50  $\mu$ l of the supernatant was loaded onto a gel. The gels were run as before. Samples of the supernatants in this experiment were also removed to be tested for soluble protein by the method of Lowry (section 2.1.3.)

iii) Grinding with sand

After preparation of the amyloplast pellet as before and removal of the supernatant for layering on a gel, the pellet was ground with sand in a pestle and mortar. The sand had previously been washed once in concentrated sulphuric acid and then several times in distilled water. The pellet was resuspended in 1 ml buffer and centrifuged at 10,000 x g. A sample of the supernatant from this centrifugation was again loaded onto a gel. Starch synthetase activity was also assayed in these supernatants using the colorimetric method described in section 2.3.8.i.(q.v.).

2.3 The Amyloplast

2.3.1. Separation of Large and Small Amyloplasts

Endosperms 14 or 25 days after anthesis were homogenised in 0.15 M phosphate buffer, pH 7.3, before being layered on a column or gradient as described below.

i) Sephadex column

A column 22 mm diameter and 200 mm long was filled with Sephadex G200. After equilibration with the phosphate buffer 2.0 ml sample was layered on top.

ii) Ludox gradient

A Ludox gradient consisting of 1.3 ml each of 90%, 88% and 84% Ludox was set up and 0.6 ml sample layered on top<sup>(27)</sup>. This was centrifuged at 1,000 x g for 10 min and the layers removed for examination under the light microscope. Ludox TM (a colloidal suspension of silica) was supplied by E. J. du Pont de Nemours and Co., Inc., Industrials and Biochemicals Dept., Wilmington, Del., U.S.A.

iii) Urografin gradient

A Urografin gradient consisting of 1.3 ml 70%, 65% and 60% Urografin with 0.6 ml sample was centrifuged at 4,000 x g for 10 min. In another experiment centrifugation was at 10,000 x g for 10 min, 76% Urografin (2 g. sodium and 13.2 g methyl glucamine salts of 3,5 diacetyl amino - 2, 4, 6 triiodo benzoic acid) in sterile 20 ml ampoules was supplied by Schering A. G. Berlin.

iv) Discontinuous sucrose gradient

Five endosperms were homogenised in 1 ml 0.15 M phosphate buffer, pH 7.3 at 4°C. The homogenate was filtered through two layers of muslin and 0.5 ml filtrate layered on top of a discontinuous sucrose gradient consisting of 1 ml each of 80%, 60%, 40% and 20% (w/v) sucrose, in a 5 ml cellulose nitrate tube. This was then centrifuged at 500 x g, 4°C for 10 min in a swing-out head. In other experiments centrifugation was carried out at 600 x g for 5 min or 10 min. After centrifugation the original layers, which were still visible,

were separately removed with a Pasteur pipette and the pellet at the bottom was scraped off and resuspended in buffer. The amyloplasts could be recovered from the sucrose solutions by centrifugation.

When larger quantities were required 50 endosperms were homogenised in 10 ml buffer. After filtration as before the filtrate was layered on a gradient of 20 ml each of 80%, 60%, 40% and 20% sucrose, in a 100 ml centrifuge tube. This was centrifuged and the layers removed as for the smaller gradient.

The 60% layer was used as a source of small amyloplasts and the pellet at the bottom as a source of large amyloplasts.

Photographs of the fractions under the light microscope were taken using a Leitz Orthoplan microscope at a magnification of 250 diameters.

#### Counting amyloplasts

The method for counting amyloplasts was adapted from May and Buttrose<sup>(41)</sup>. A known volume of amyloplasts was diluted with a suitable known volume of iodine solution (0.2% I<sub>2</sub> in 2% KI). This was mixed vigorously. A portion was taken up into a wide bore pipette which was held horizontally to prevent differential sedimentation. A drop was then placed on the haemocytometer slide and covered immediately with a cover slip. All operations were carried out as quickly as possible. The haemocytometer slide was  $\frac{1}{400}$  mm<sup>2</sup> with a depth of 0.02 mm. The number of amyloplasts within the grid was determined under the light microscope, magnification x 10 at least six times and the mean used in the calculations of amyloplast numbers.



### 2.3.2 Acid Treatment of Amyloplasts

Large and small amyloplasts taken from the sucrose gradient were left in 7% (v/v) hydrochloric acid for three weeks. They were then washed in 0.15 M phosphate buffer pH 7.3 and prepared for electron microscopy using potassium permanganate fixative as before (Section 2.1.5).

### 2.3.3. Determination of Amylopectin and Amylose Content

The ratio of amylopectin to amylose was determined in the starch of whole endosperms and separated amyloplasts. Endosperms were homogenised in 2 ml 0.15 M phosphate buffer pH 7.3, filtered through double muslin and the filtrate centrifuged at 10,000 x g for 10 min. The pellet was dried at 40°C before being used for the amylopectin determination. Ten endosperms were used for all ages apart from 14 days after anthesis when 20 endosperms were used and 18 days when 15 endosperms were used.

Large and small amyloplasts were prepared on the sucrose gradient as described and washed twice with distilled water. They were then dried at 40°C for at least 48 h.

Amylopectin and amylose contents were determined using the blue value method of Gilbert and Spragg<sup>(110)</sup> except that 1 mg amyloplasts was used and reagent quantities were adjusted accordingly. The method is based on the principle that pure amylose gives a brilliant blue complex with iodine whereas amylopectin gives a less intense purple colour. The intensity of colour obtained measured at 680 m $\mu$  when a mixture of amylose and amylopectin is added to iodine solution is proportional to the percentage of amylopectin and amylose in that mixture.



Total amylopectin and amylose was calculated from the percentage amylopectin and amylose and the total carbohydrate minus the reducing sugar for each age.

#### 2.3.4 Starch Content of Amyloplasts

Preparations of large and small amyloplasts were obtained as described above by centrifugation on a sucrose density gradient. Pellets were washed three times in distilled water and then left to dry at 40°C. The amyloplasts from several gradients had to be combined in some cases to give sufficient for the analysis. 2 mg were hydrolysed in 10 ml of 1.0 N hydrochloric acid in a boiling water-bath for 6 h as described by Jennings and Morton<sup>(111)</sup>. After this time 0.2 ml was removed and the glucose content determined as described in section 2.1.3. Controls were run to determine the glucose content before hydrolysis and starch standards were also included. Results were expressed as mg starch calculated from mg glucose x 0.91.

#### 2.3.5 Lipid Content of Amyloplasts

The lipid content of the amyloplasts was investigated by thin layer chromatography of a chloroform:methanol extract. About 0.03 gm dried, washed large amyloplasts from barley 25 days after anthesis were homogenised in 4 ml chloroform:methanol (2:1 v/v). Clean gloves were worn throughout the experiment and forceps used to hold the apparatus so that no lipid was transferred from the skin onto the glass. All apparatus was also first washed in chloroform to remove contaminants. The homogenate was allowed to stand at room temperature for 10 min before being filtered through glass fibre filter paper. The filtrate was then evaporated to dryness and re-dissolved in 0.1 ml chloroform. 25 µl was spotted on de-activated silica gel G plates. Standards used were β-sitosterol

(2 mg/ml), phosphatidyl ethanolamine (2 mg/ml) and a mixture of lecithin and sphingomyelin (1 mg/ml of each). In each case 25  $\mu$ l was spotted on the plate. The plates were run with 90:10 chloroform:methanol solvent. Lipids were detected as pink spots by spraying the plates with 50% sulphuric acid followed by heating at 80°C for about 20 min.

### 2.3.6 Degradation of Amyloplasts by $\alpha$ -Amylase

5 mg washed, dried amyloplasts were suspended in 1.9 ml HEPES buffer pH 6.9, except for one experiment with amyloplasts from 25 day barley when 2 mg were used. To this was added 0.1 ml  $\alpha$ -amylase from hog pancreas (Sigma Chemical Co.) containing 0.01 units. The reagents were incubated at 25°C. A control was run at the same time in which 0.1 ml buffer was added instead of enzyme. 0.1 ml samples were removed at zero time immediately after addition of the enzyme and at known time intervals thereafter. These samples were estimated for reducing sugar by the method of Somogyi and Nelson as described in section 2.1.3. The  $\alpha$ -amylase used was tested by the method described in section 2.2.1.c before and after 4 h incubation to show that the activity did not decrease during this time.

The following experiment was carried out to show that the  $\alpha$ -amylase was not being inhibited by the products of starch granule degradation. After incubation as above for 1 h the amyloplasts were removed and washed with buffer. A further 0.1 ml  $\alpha$ -amylase was then added to the amyloplasts and the incubation continued.

In some experiments 0.1 ml pullulanase (Boehringer Mannheim GmbH) 7.5 units, was added instead of the  $\alpha$ -amylase, or together with the  $\alpha$ -amylase, replacing 0.1 ml buffer.

An experiment was also carried out to ensure that the pullulanase was active with amylopectin as substrate. In this case the amyloplasts were replaced by 5 mg amylopectin and pullulanase was used instead of  $\alpha$ -amylase.

To investigate the activity of extracts from germinated barley grain on the isolated amyloplasts barley grains were germinated overnight at 18°C on damp filter paper. The radicles were removed from 30 of these and the grains homogenised in 5 ml M sodium chloride. The homogenate was allowed to stand for 1 h and then centrifuged (10 min, bench centrifuge). 1 ml of the supernatant was then used instead of the commercial  $\alpha$ -amylase in the above system on amylopectin from barley 38 days after anthesis. In another experiment 30 2 mm endosperm slices were incubated at 18°C for 18 h with 4 ml  $10^{-5}$  M gibberellic acid. These were then homogenised in 3 ml M sodium chloride and used as above.

### 2.3.7 Amyloplast Degradation at Germination

Endosperms were dissected out from barley at two ages of developing grain (25 days and 60 days after anthesis) and at four stages of germination (radicle just showing, 0.7 cm shoot growth, 5 cm shoot growth and 15 cm shoot growth). These were homogenised in 1 ml iodine solution (0.2%  $I_2$  in 2% KI) and the numbers of large and small amyloplasts determined by the method of May and Buttrose as described in section 2.3.1.

2.3.8 The Starch Synthetase Associated with Large and Small Amyloplasts

i) The effect of potassium chloride concentration on the activity of starch synthetase

An experiment was carried out to determine the optimum potassium chloride concentration for starch synthetase activity. A series of starch synthetase assays was carried out as described using the colorimetric assay (section 2.3.8.ii) with 0, 0.25, 0.5, 0.75, 1.0, 1.2, 1.4, 1.5, 1.8 or 2.25 M moles potassium chloride in the reaction mixture. The source of enzyme was ten 16 day endosperms homogenised in 2 ml phosphate buffer pH 7.3. Maximum activity was obtained using 1 m mole potassium chloride and this concentration was therefore used in all subsequent experiments.

ii) Nucleotide dependence

Large and small amyloplasts were separated on the sucrose gradient and washed in 0.15 M phosphate buffer pH 7.3. This was carried out at 4°C. Starch synthetase was estimated in each fraction by a colorimetric assay with either adenosine diphosphoglucose or uridine diphosphoglucose as the nucleotide sugar substrate. The amyloplasts were suspended in 1.0 ml glycine buffer, and 0.2 ml used for the assay. The reaction mixture contained:-

0.1 M glycine buffer pH 8.6	0.5 ml
0.025 M ethylene diamine tetra-acetic acid	0.1 ml
2 M potassium chloride	0.5 ml
0.02 M adenosine diphosphoglucose or uridine diphosphoglucose	0.15 ml
enzyme sample (amyloplasts)	0.2 ml

After incubation at 25°C for 2 h the ADP or UDP produced was estimated by the method of Leloir<sup>(112)</sup>. Controls were run in which enzyme was

added at the end of the incubation period.

The number of amyloplasts in 0.2 ml was determined by the method described in section 2.3.1.

iii) pH dependence

Large and small amyloplasts from endosperms 25 days after anthesis were prepared as above. The starch synthetase activity was then determined at different pH values, produced by varying the pH of the glycine buffer. The ionic strength was not kept constant. The enzyme was assayed using the incorporation of  $^{14}\text{C}$ -glucose into starch from UDP [ $\text{U} - ^{14}\text{C}$ ] - glucose. The method of Leloir et al<sup>(59)</sup> was used.

The reaction mixture contained:-

0.1 M glycine buffer, pH 8.6	0.15 ml
0.025 M ethylene diamine tetra-acetic acid	0.1 ml
2 M potassium chloride	0.1 ml
0.025 $\mu\text{Ci}$ UDP [ $\text{U} - ^{14}\text{C}$ ] - glucose	0.1 ml
.005 M UDPG carrier	0.05 ml
enzyme	0.5 ml

This was again incubated at  $25^{\circ}\text{C}$  for 2 h. The reaction was then terminated by adding 0.5 ml 50% ethanol. A small amount of carrier starch was added and the tubes centrifuged at  $10,000 \times g$  for 10 min. Unreacted UDP  $^{14}\text{C}$ -G was removed by washing three times with distilled water. The final pellet was resuspended in 0.15 ml distilled water by boiling, and this was then poured into the scintillation vial and 5 ml scintillation liquid added (NE 220, Nuclear Enterprises Ltd., Edinburgh). The counting system used was a Beckmann Liquid Scintillation Counter, the counting efficiency under these conditions being 73%. Controls were again tubes with the enzyme added after the incubation period. UDPG was used as the nucleotide since at 25 days after

anthesis both large and small amyloplasts are active with this nucleotide.

### 2.3.9 Uptake of carbon-14 by large and small amyloplasts

Carbon-14, in the form of UDP [ $U - ^{14}C$ -glucose], was supplied to growing barley plants from a vial attached to the flag leaf. A slit was cut parallel to the veins in the flag leaf to allow the leaf to take up the solution more easily (fig. 2.1). The vial contained 0.25  $\mu$ Ci UDPG \* in 2 ml distilled water. A control plant was set up in which the vial contained unlabelled UDPG.

The vial was left in place for 24 h after which it was removed and the plant allowed to develop until 25 days after anthesis (where the vial was attached before this age) or 50 days after anthesis when older plants had been used.

Five endosperms were then removed from the treated ear and homogenised in 1.0 ml 0.15 M phosphate buffer pH 7.3. This was then layered onto a sucrose gradient and the large and small amyloplasts separated as described in section 2.3.1. The amyloplasts were washed three times in distilled water and then suspended in 1.0 ml distilled water by boiling for 5 min. 0.5 ml of this suspension was placed in a scintillation vial and 5 ml scintillant added. This was counted in the Beckman counter as described in section 2.3.8.iii.

Total uptake of  $^{14}C$  to the endosperm was determined by counting 0.5 ml of the original endosperm homogenate.

Fig.2.1 Diagram of apparatus for uptake of carbon-14  
by barley flag leaf

Fig.2.1

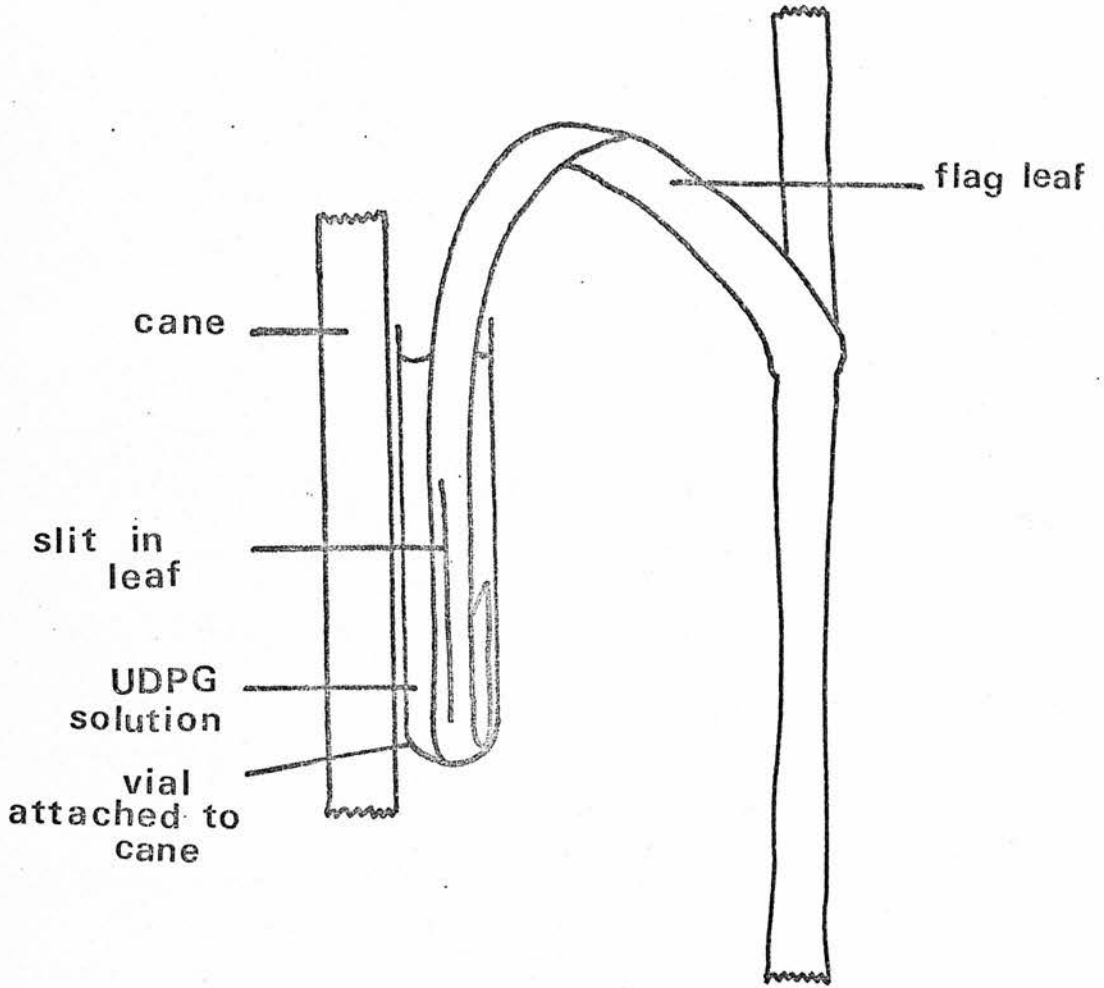



RESULTS

3.1 Development of the Barley Grain

3.1.1 Fresh weight, dry weight and water content determinations

The fresh weight of the developing grain of the barley variety studied increased up to 35 days after anthesis, after which it fell again to just over half the maximum value by 53 days after anthesis (fig. 3.1). That this is due to loss of water is indicated by the water content results which show an increase until 25 days after anthesis followed by a decrease. This decrease was slow at first but more rapid in the period 45 to 53 days after anthesis. The dry weight also increased until 35 days after anthesis, after which there was only a very slight drop in dry weight over the remainder of the developmental period.

3.1.2 Chemical analyses

The total carbohydrate content of both the whole barley grain and the endosperm increased until 50 days after anthesis, followed by a slight fall before maturity. The rate of increase was faster between 28 and 50 days after anthesis than it was in the earlier stages of development (fig. 3.2). After an increase up to 25 days after anthesis reducing sugar levels in the whole grain showed a sudden sharp rise at 35 days after anthesis and a maximum at 40 days after anthesis. In the endosperm there was a fairly steady increase in value until 40 days after anthesis although a slight fall in reducing sugar level occurred at 25 days after anthesis (fig. 3.3). At early stages virtually all the carbohydrate could be accounted for by reducing sugar but as the barley matured the non-reducing carbohydrate portion increased rapidly. At 50 days, for example,

Fig.3.1 Fresh weight, dry weight and water content of Julia grain throughout development

- × Fresh weight
- △ Dry weight
- Water content

Fig. 3.1

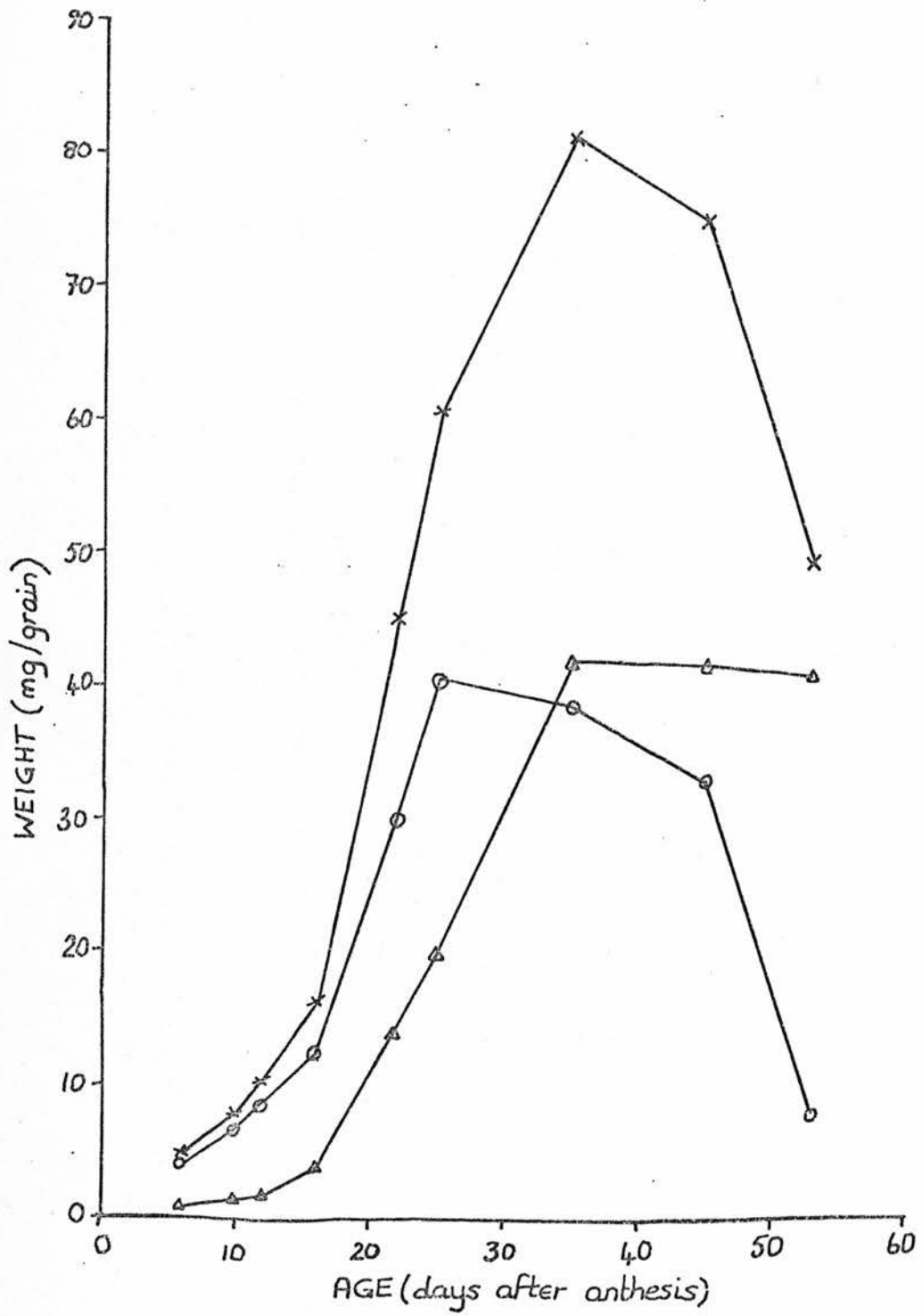

Fig.3.2 Total carbohydrate content of whole grain and endosperm throughout development

Δ whole grain  
× endosperm

Fig.3.3 Reducing sugar content of whole grain and endosperm throughout development

Δ whole grain  
× endosperm



Fig.3.2

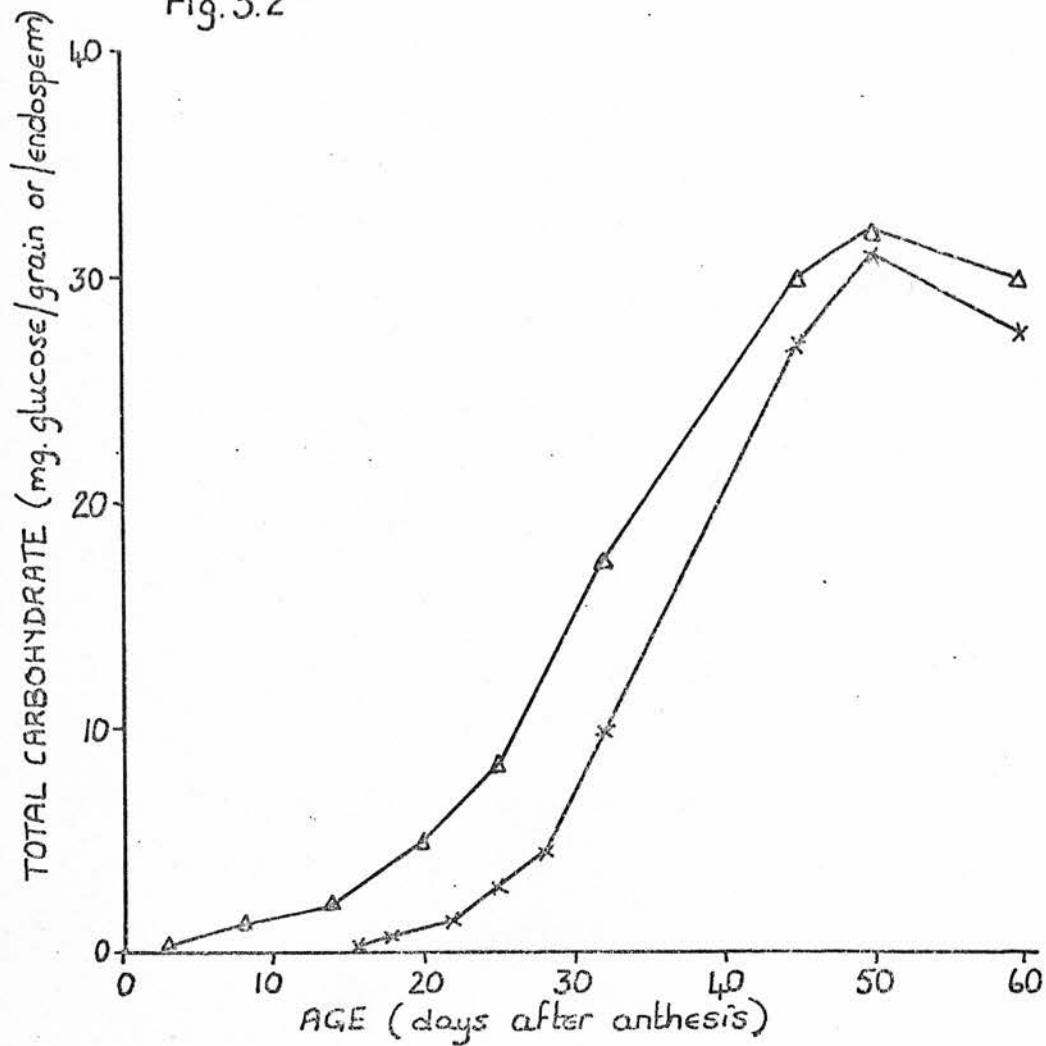

Fig.3.3

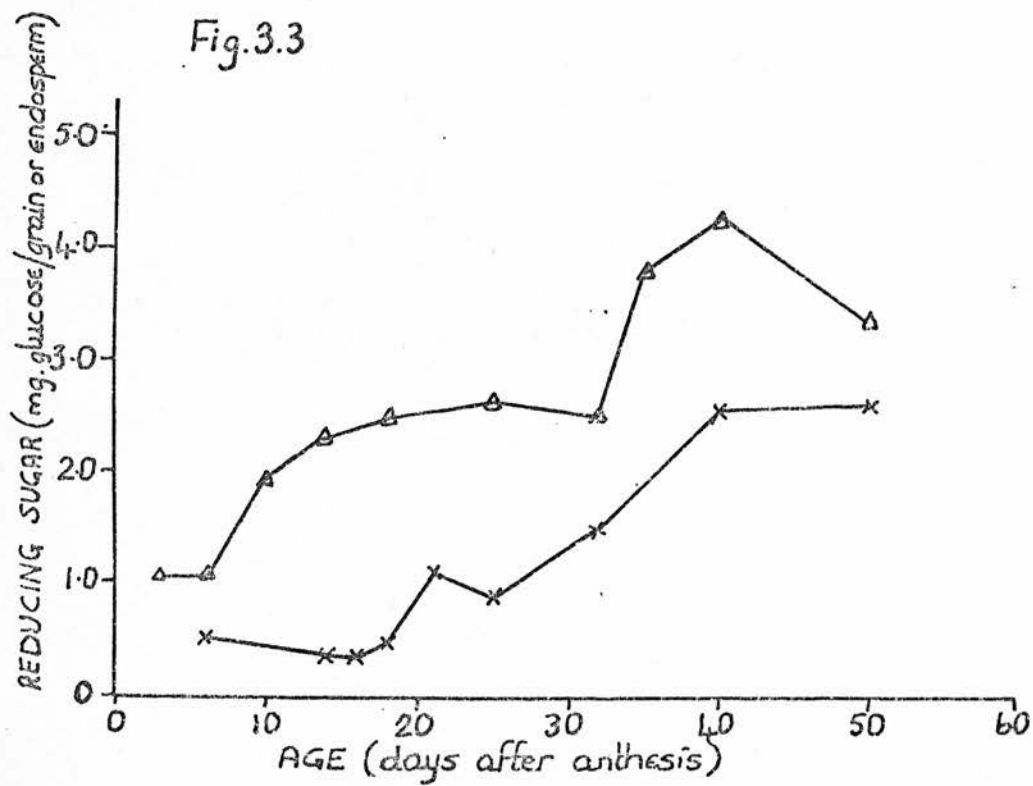

Fig.3.4 Glucose content of whole grain and endosperm  
throughout development

Δ whole grain  
× endosperm

Fig.3.5 Soluble protein content of whole grain and  
endosperm throughout development

Δ whole grain  
× endosperm

Fig. 3.4

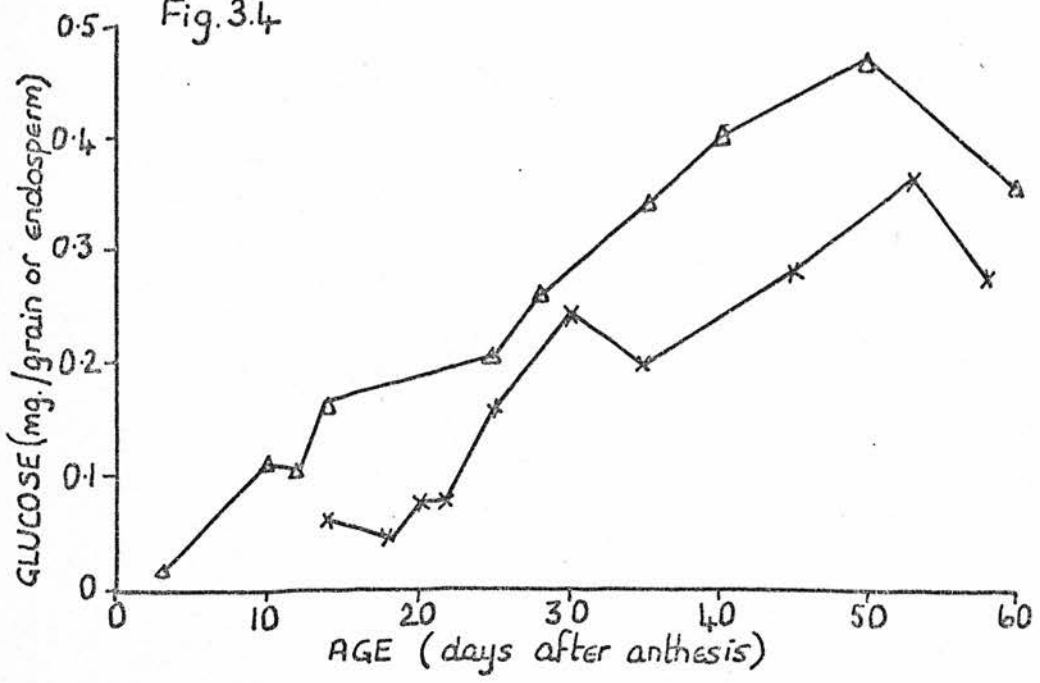
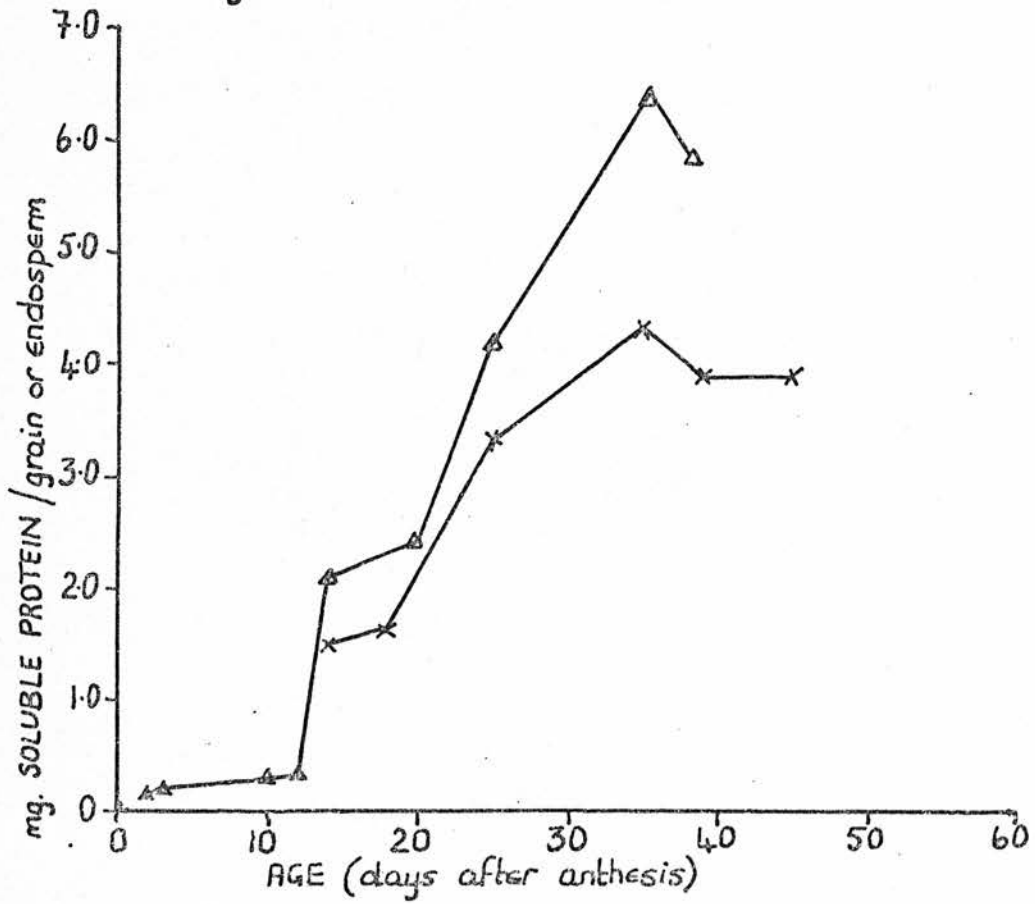

Fig. 3.5



reducing sugar constituted 10% of the total carbohydrate in the whole grain and 12% in the endosperm.

Glucose content (fig. 3.4) increased in both whole grain and endosperm to a maximum at 50 to 53 days after anthesis, when there was a slight drop in glucose level in the period just before maturity. The glucose content values are about one-tenth of the reducing sugar values throughout the developmental period.

There was a maximum soluble protein content in the developing barley grain and endosperm at 35 days after anthesis (fig. 3.5).

### 3.1.3 Bacterial contamination in the homogenates

The maximum number of bacterial colonies counted was seven. Since 0.1 ml endosperm homogenate had been plated out the original homogenate contained a maximum of 700 bacteria/ml.

### 3.1.4 Electron microscopy

The results shown here (Plates 1-28) are typical of the results obtained on many occasions, with the exception of Plate 20 (see Discussion).

It was found that potassium permanganate fixed membranes much better than osmium tetroxide/glutaraldehyde; thus mitochondria for example, were more clearly defined by this method. However, the cytoplasm in potassium permanganate fixed sections has a very granular appearance. Older endosperm tissue often gave poor sections because of the difficulty in cutting tissue containing large quantities of starch.

Plates 1 and 2 show endosperm from barley 2 days after anthesis. Amyloplasts could be seen, each containing many small starch granules. Plate 3, also from endosperm 2 days after anthesis, shows some larger starch granules (0.2  $\mu\text{m}$  x 0.15  $\mu\text{m}$ ) which are surrounded



by a membrane . Cell walls were also clearly visible at this stage, as were various osmiophilic droplets and concentric rings of endoplasmic reticulum. These rings are seen more clearly in Plate 4. Mitochondria were less distinct, but have been seen in many of the sections taken at this age. By three days after anthesis some of the starch granules seen were 0.5  $\mu\text{m}$  to 1.0  $\mu\text{m}$  (Plate 5).

Plates 6, 7 and 8 show the endosperm at 6 days after anthesis. A cell containing no starch can be seen in Plate 6. Cell walls were again clearly visible. As in many cases with the endosperm prepared by these methods the chromatin was diffuse and there was no visible nuclear membrane. Starch granules of different sizes were seen, ranging from 0.25  $\mu\text{m}$  to 1.5  $\mu\text{m}$  along the longest axis. In some cases the membrane appeared to be close to the starch (Plate 7) whereas in others there was a gap between the starch and its surrounding membrane (Plate 8). In Plate 9 two starch granules can be seen lying close together surrounded by many dark globules. It is possible there these are the remaining parts of a membrane surrounding both these granules. This can also be seen in Plate 20.

By 14 days after anthesis many of the cells were almost completely filled with starch granules (Plate 10). At this stage too, large and small starch granules could be seen, the large ones being about 11  $\mu\text{m}$  across and the small ones 3  $\mu\text{m}$  or 4  $\mu\text{m}$  across. The amyloplast membrane can be seen in Plate 11 away from the starch granule with two mitochondria lying close to it. Mitochondria have also been seen lying next to the amyloplast membrane in other sections and ages, for example Plates 17 and 18. An example of plasmodesmata from the cell wall in an endosperm 14 days after anthesis is shown in Plate 12.

Plates 13 and 14 show amyloplasts from barley 18 days after anthesis. In Plate 13, which was fixed with potassium permanganate, the amyloplast membrane can be seen lying very close to the starch granule. These granules are  $4.25 \times 2.7 \mu\text{m}$  and  $2.0 \times 1.5 \mu\text{m}$ . Dark shaded areas were seen in the starch. Osmiophilic droplets can also be seen (Plates 14, 15). These are  $3 \mu\text{m}$  in diameter and are probably stores of lipid or protein. At other parts of the cell at this age polyribosomes in the form of long strands and concentric rings could be seen (Plate 16).

The mitochondria can be seen very clearly in the section from endosperm 38 days after anthesis. Again some are lying very close to the amyloplast membrane (Plates 17 and 18). Some parallel membrane structure is present inside the amyloplast membrane (Plate 17). Plate 19 shows a well-preserved Golgi body. In Plate 20 two starch granules are again lying within one membrane. On one side there are also two layers of the usual double membrane.

The structure of the testa-pericarp is shown in Plates 21, 22 and 23. At 3 days after anthesis (Plate 21) the chloroplasts have one or two thylakoid stacks. By 25 days after anthesis far more internal membrane structure can be seen in the chloroplasts. Some of these chloroplasts contain starch granules (Plate 23). The chloroplasts in Plate 22 have no starch granules.

### 3.2 Enzymes in the Soluble Fraction

#### 3.2.1 Branching enzyme

The results of an experiment designed to determine the rate of activity of  $\alpha$ -amylase with glycogen and amylopectin substrates are shown in Table 3.1.

Table 3.1 $\alpha$ -Amylase Activity with Glycogen  
and Amylopectin Substrates

<u>Substrate</u>	<u><math>\alpha</math>-Amylase Activity (units)</u>
Glycogen	0.37
Amylopectin	0.66
Controls	0.01

It can be seen that the commercial  $\alpha$ -amylase had a far greater activity with amylopectin as substrate than it did with glycogen as substrate. This confirms results obtained by Duffus (personal communication). Krisman's assay for branching enzyme in the presence of  $\alpha$ -amylase<sup>(97)</sup> was therefore unsuitable for the barley enzyme.

3.2.1.1 Separation of branching enzyme from starch - degrading enzymes

3.2.1.1(a) Branching enzyme activity and reducing sugar production in the ammonium sulphate precipitates during branching enzyme preparation

The results of this experiment are shown in Table 3.2. Branching enzyme activity shown here will include the decrease in colour of the starch-iodine complex brought about by hydrolases as well as by branching enzyme. This activity was present in all the precipitates. However there was concomitant reducing sugar production only in the precipitates from 9% and 20% ammonium sulphate, indicating that the majority of hydrolases were present in these samples. When the protein precipitated from 38.5% ammonium sulphate, after removal of all protein precipitated by 20% ammonium sulphate was used, neither de-branching enzyme nor phosphorylase activity were detectable.  $\alpha$ -amylase activity was, however, found to be present, the activity being 0.088 units.

3.2.1.1(b) Separation of branching enzyme from  $\alpha$ -amylase

(i) Method of Loyter and Schramm

The method of Loyter and Schramm for removing  $\alpha$ -amylase from the branching enzyme preparation was attempted but proved unsatisfactory because branching enzyme activity could not be detected following this procedure.

Table 3.2. Enzyme Activity in Ammonium Sulphate Precipitates during Branching Enzyme Preparation

<u>Ammonium Sulphate Concentration</u>	<u>Branching Enzyme Activity (units)</u>	<u>Reducing Sugar Produced (mg glucose)</u>
9%	0.66	0.046
20%	0.78	0.03
27.5%	0.90	0
38.5%	0.76	0

(ii) Effect of heating on  $\alpha$ -amylase

Table 3.3. shows that the activity of a commercial preparation of  $\alpha$ -amylase is not destroyed by heating to 70°C for 20 min.

3.2.1.2 Branching enzyme activity throughout development of the barley grain

Absorption spectra of the starch-iodine complex as the starch becomes more branched

As the percentage of branched component in the amylopectin amylose mixture increased, the wavelength at which maximum absorption was seen ( $\lambda_{\max}$ ) became lower (Table 3.4). This could be used as confirmation that branching enzyme activity was present, since in the presence of branching enzyme the absorption peak would move to lower wavelengths during the course of the assay.

No branching enzyme was detectable in the amyloplast fraction by the assay described. The activity of branching enzyme in the soluble endosperm fraction throughout development is shown in fig. 3.6. No activity was detected before 18 days after anthesis, but after this age activity rose rapidly to a maximum at 25 days after anthesis. This was followed by a fall in activity before maturity, although by 60 days after anthesis there was still some activity remaining.

3.2.2 De-branching enzyme

De-branching enzyme activity during development is shown in fig. 3.7. Up to 25 days after anthesis  $\alpha$ -glucosidase is also present in the endosperm (fig. 3.8). This would have the effect of breaking down the maltotriose produced by the de-branching enzyme from pullulan, thereby increasing the reducing sugar content in the assay. The values for de-branching enzyme activity shown before

Table 3.3      Effect of heating on  $\alpha$ -amylase  
(Malt  $\alpha$ -amylase, Sigma Chemical Co.)

	<u><math>\alpha</math>-amylase activity (units)</u>
Unheated enzyme	0.076
Enzyme heated to 70°C for 20 min in a water-bath	0.075

Table 3.4      Maximum absorption of the iodine complex  
of mixtures of amylopectin and amylose

<u>Amylopectin Content</u> (%)	<u><math>\lambda_{\max}</math> (nm)</u>
0	608
37.5	600
75	560

Fig.3.6 Branching enzyme activity in the soluble  
fraction of the endosperm throughout  
development



Fig.3.b

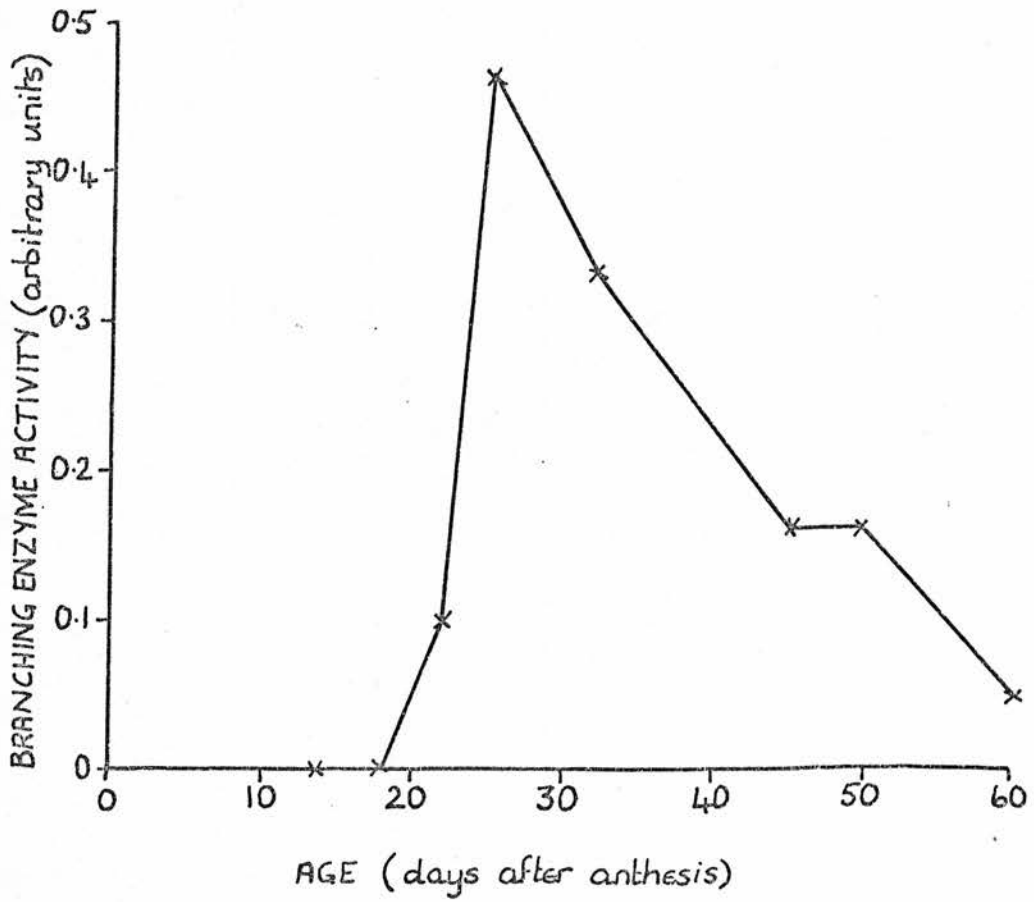

Fig.3.7 De-branching enzyme activity in the soluble  
fraction of the endosperm throughout development  
Mean s.d. =  $\pm 0.007$

Fig.3.8  $\alpha$ -glucosidase activity in the soluble fraction  
of the endosperm throughout development

Fig. 3.7

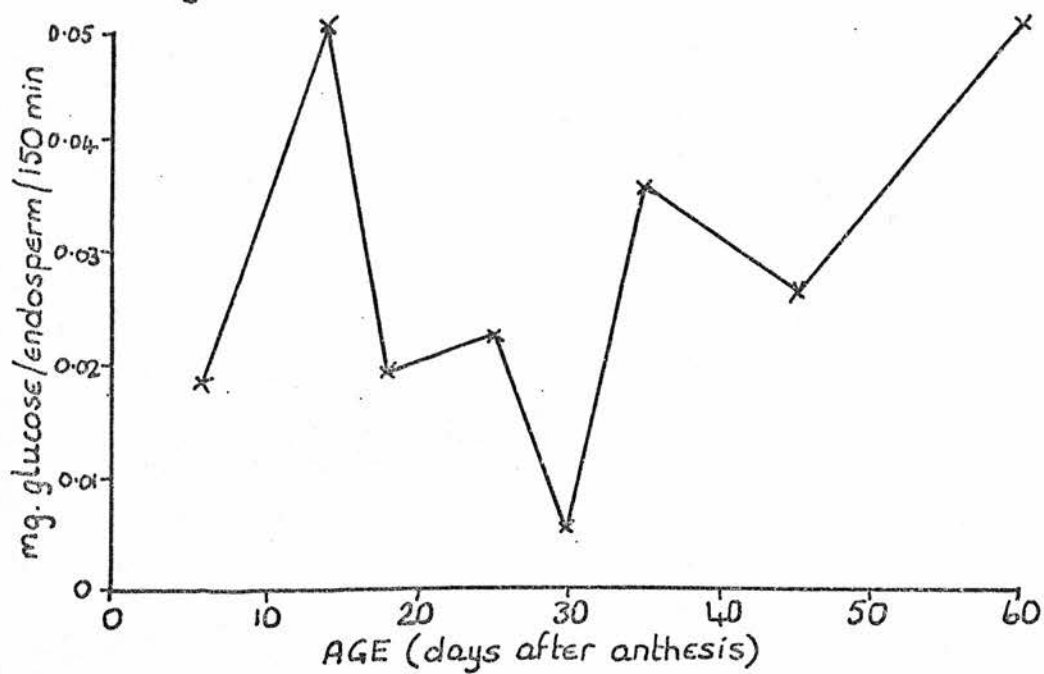
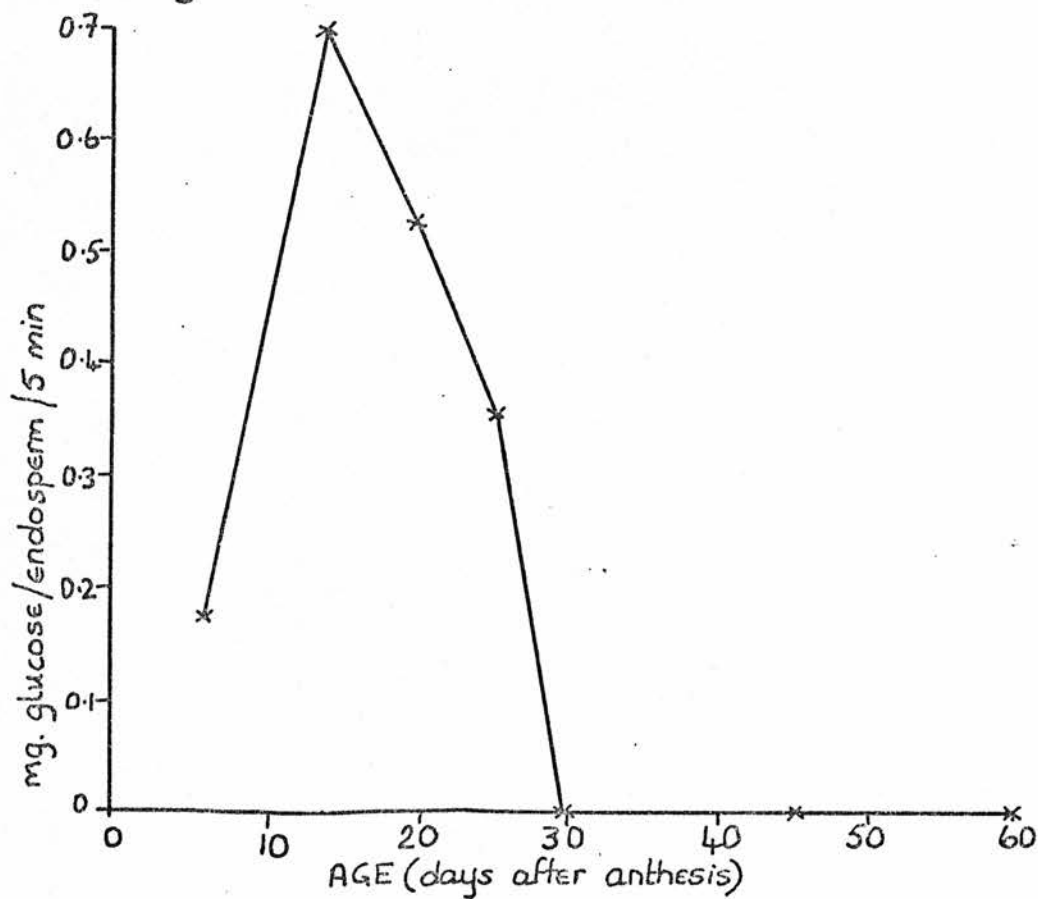

Fig. 3.8



25 days after anthesis may therefore be higher than the true values. At 30 days after anthesis the de-branching activity is low but after this it rises to a high level at maturity.

Paper chromatography did not show any glucans contaminating the pullulan apart from glucose itself (fig. 3.9). If present, these might have been degraded to reducing sugars by amylases or  $\alpha$ -glucosidase and again the de-branching enzyme results would have been higher than the true values.

### 3.2.3 $\alpha$ -glucosidase

$\alpha$ -glucosidase activity was only detectable up to 25 days after anthesis. Activity was measurable as early as 6 days after anthesis, after which it rose to a maximum at 14 days after anthesis (fig. 3.8.)

### 3.2.4 Phosphorylase

The change in phosphorylase activity throughout development is shown in fig. 3.10. Activity was first detectable from 14 days after anthesis. Low levels of activity were recorded until a rapid rise occurred between 25 and 30 days after anthesis. After this the activity fell slightly less sharply until by 60 days after anthesis there was no measurable activity.

### 3.2.5 Gel electrophoresis and starch synthetase

The polysaccharides synthesised by starch synthetase were shown up as dark brown bands. The rest of the gel stained a pale yellow colour. In some cases clear areas were seen. This was where the polysaccharide in the gel had been removed by amylases. The positions of the bands were independent of the nucleotide (UDPG or ADPG) used. Examples of the results obtained with gels in which amylopectin was incorporated are shown in fig. 3.11. At 14 days

Fig.3.9 Paper chromatography of pullulan

Fig.3.9

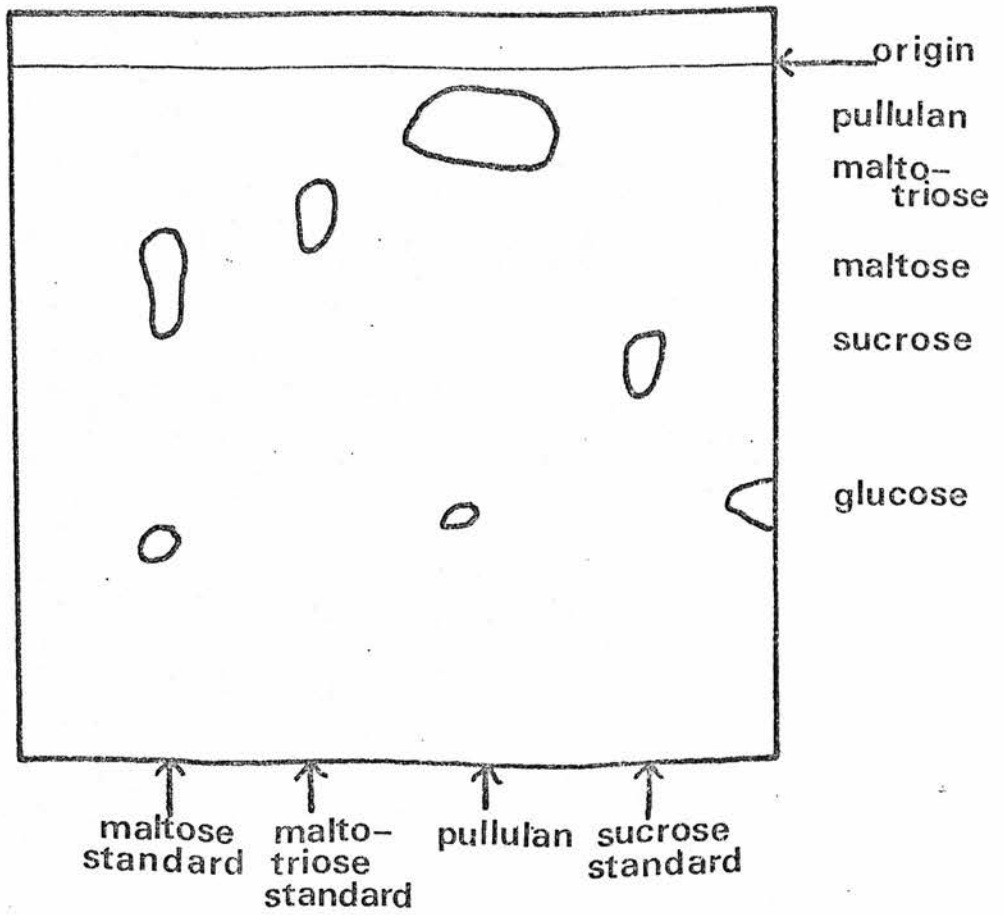

Fig.3.10 Phosphorylase activity in the soluble fraction  
of the endosperm throughout development

Fig.3.10

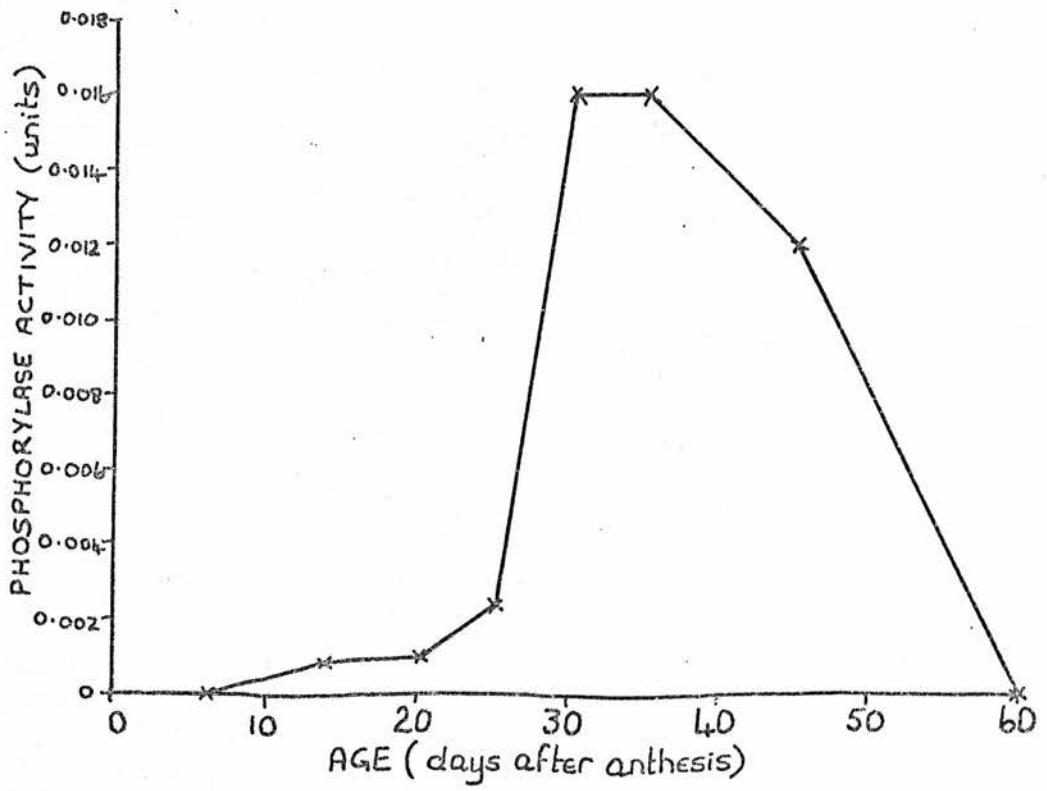



Fig.3.11 Polyacrylamide gel electrophoresis of  
starch synthetase

Fig.3.12 Polyacrylamide gel electrophoresis of  
phosphorylase

Fig.3.11

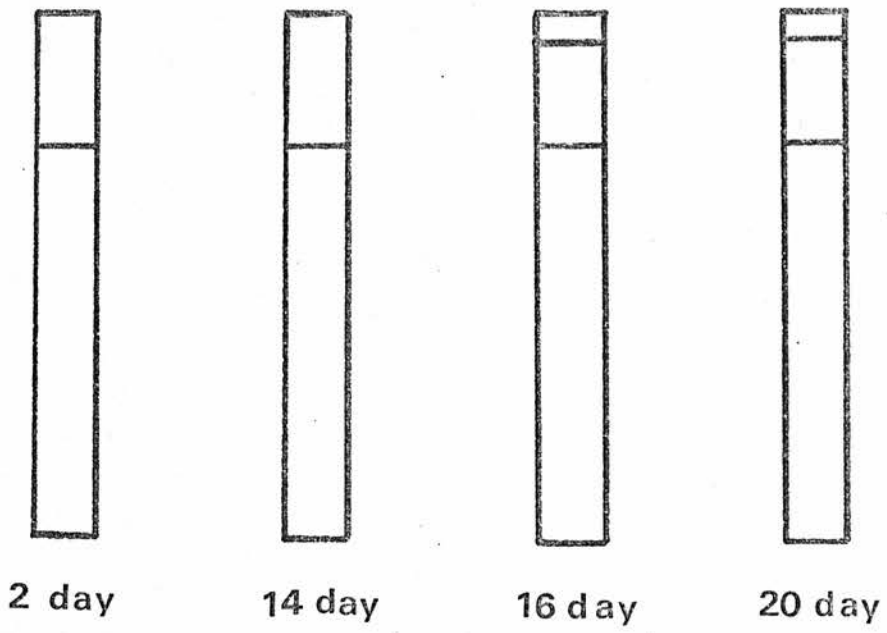
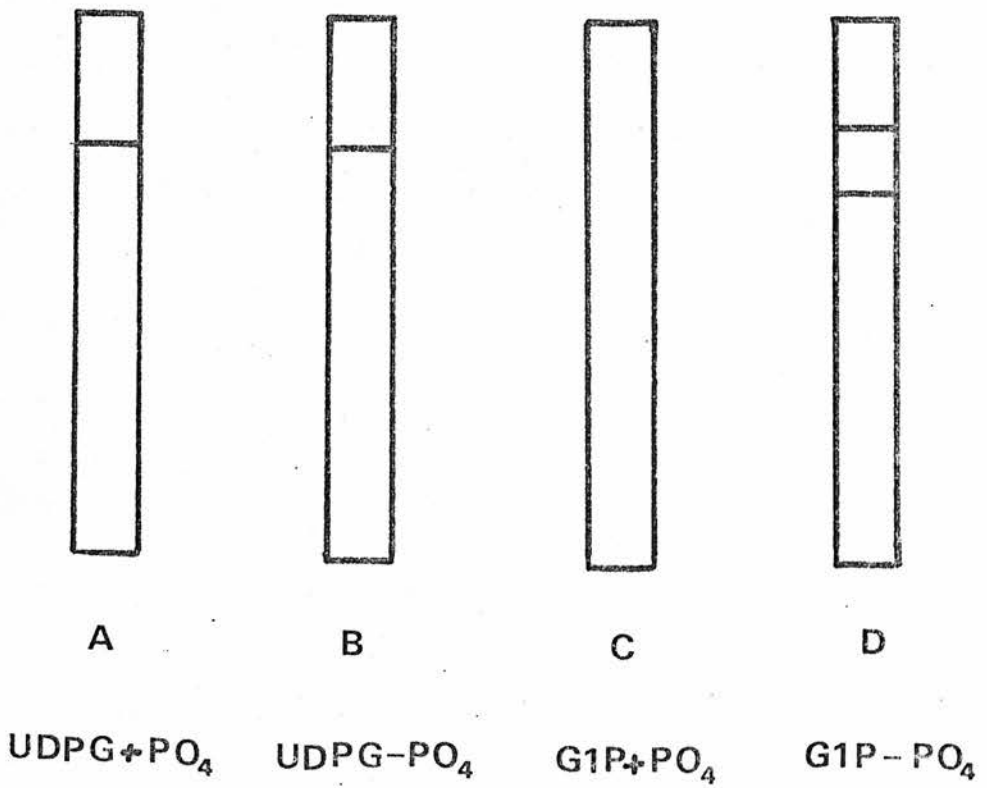

Fig.3.12



after anthesis and before only one band was seen on each gel. This had an Rf value of around 0.35. The Rf values of the starch synthetase bands varied slightly from one series of gels to the next. However, after 14 days another much more slow-moving band appeared as well, which had an Rf of about 0.06. When duplicate gels were stained for protein bands were obtained which corresponded with the starch synthetase activity stain bands of the control experiment.

When the amylopectin was in the incubation medium and not incorporated in the gels the Rf values obtained were lower, around 0.23.

The results of the control to show that the bands seen were not due to phosphorylases are shown in fig. 3.12. Gels A and B, which were incubated with UDPG but with and without phosphate had bands in the same position (Rf 0.35) indicating that the activity was not phosphate dependent. However, when the UDPG was replaced by GlP bands with different Rf values (0.28, 0.43) were seen (Gel D). These were not seen when phosphate was also included in the incubation mixture (Gel C), which would push the phosphorylase reaction in the direction of degradation. This indicates that phosphorylases are present and can be detected when the correct conditions are used.

#### 3.2.5.1 Gel electrophoresis of starch synthetase and branching enzyme

Typical results from this experiment are shown in fig. 3.13. The Rf values in this case where amylose was incorporated in the gel were different from those obtained on gels where amylopectin was incorporated. In each age the starch synthetase band and the branching enzyme band had almost exactly the same Rf values.

Fig.3.13 Polyacrylamide gel electrophoresis of  
starch synthetase and branching  
enzyme



### 3.2.5.2 Release of amyloplast bound starch synthetase

No starch synthetase activity could be detected on polyacrylamide gels when the supernatant from the  $\alpha$ -amylase treated amyloplasts was layered on the gel. When the amyloplasts were subjected to sonication some protein was released but this also did not have starch synthetase activity detectable on the gel. Protein was released from the small amyloplasts but not from the large amyloplasts.

However, starch synthetase activity was released from the amyloplast pellet when it was ground with sand. The supernatant from the original homogenate gave a band on the polyacrylamide gel with an Rf value of 0.29 and the supernatant from the ground amyloplast pellet gave a band with Rf 0.26. When the starch synthetase activities were measured there was found to be more activity in the supernatant from the ground amyloplast pellet and this pellet than there was originally in the pellet, indicating again that some had been released by grinding (Table 3.5).

### 3.3 The Amyloplast

#### 3.3.1 Separation of Large and Small Amyloplasts

When the endosperm homogenate was layered on the Sephadex column a fraction was obtained from the column which contained predominantly small amyloplasts. The layer on the top of the column contained predominantly large amyloplasts. However a complete separation could not be obtained using this technique.

The 90% Ludox layer, after centrifugation of the Ludox gradient, was found to contain small amyloplasts but the large amyloplasts could not be completely separated from small amyloplasts and cell debris by this method. The Urografin gradient did not give any separation of amyloplasts at all at the centrifugation speeds used.

Table 3.5

Starch Synthetase Activity in Amyloplasts  
before and after Grinding with Sand

<u>Fraction</u>	<u>Starch synthetase activity</u> ( $\mu$ moles ADP produced/endosperm)
original } supernatant	0.043 $\pm$ 0.004 s.d.
homogenate } amyloplasts	0.014 $\pm$ 0.004
amyloplasts } supernatant	0.039 $\pm$ 0.011
ground with } amyloplasts	0.015 $\pm$ 0.005
sand }	

When the discontinuous sucrose gradient was used for the separation of large and small amyloplasts the 60% sucrose layer was found to contain an almost homogeneous population of small amyloplasts and the pellet at the bottom of the gradient was found to contain a similarly homogeneous population of large amyloplasts. Light micrographs of the original homogenate and large and small amyloplast fractions are shown in Plates 24, 25 and 26. The 80% sucrose layer contained a mixture of large and small amyloplasts. The 20% and 40% sucrose layers contained small amyloplasts, mixed with other small particles and larger portions of intact cells. Most of these larger pieces from the original homogenate were, however, removed by the initial filtration through double muslin. 67% of the amyloplasts from the homogenate were recovered from the gradient. The ratio of small to large that were recovered from barley 25 days after anthesis (3.7:1) was almost exactly the same as the ratio found in vivo at that age (3.9:1). Electron micrographs did not show that any damage had been caused to the amyloplasts by the techniques used in the gradient. Plate 27 shows an electron micrograph of the edge of a large amyloplast from barley 25 days after anthesis. This appears to be intact, with no visible cracks or pits.

The large amyloplasts are ellipsoid and, at 25 days after anthesis measure 16-20  $\mu\text{m}$  x 12-16  $\mu\text{m}$ . The small are spherical, 4-6  $\mu\text{m}$  in diameter at 25 days after anthesis.

### 3.3.2 Acid treatment

Reaction of amyloplasts with 19% hydrochloric acid was found to have a different effect on large and small amyloplasts. Under the electron microscope some, but not all, of the large amyloplasts had developed a ring structure (plate 28). However this could not be seen in any of the small amyloplasts.



### 3.3.3 Determination of Amylose and Amylopectin Content

There was no detectable starch in the supernatant fraction of the endosperm. The percentage amylopectin in the amyloplast fraction of the endosperm is shown in fig. 3.14. At 14 days after anthesis amylopectin constitutes 81% of the endosperm starch. This remains high until 25 days after anthesis when it drops to 66%. After remaining at around this level until 45 days after anthesis the amylopectin content then drops again, reaching 61% by 60 days after anthesis.

The total amylopectin content in the endosperm rose slowly at first and then more rapidly until at 50 days after anthesis there was 16.8 mg amylopectin/endosperm (fig. 3.15). Amylose content showed a similar pattern, but the maximum value was only 9.1 mg amylose/endosperm. The rate of amylopectin production was greater than the rate of amylose production at all stages during development.

The amylopectin and amylose content of the separated large and small amyloplasts is shown in fig. 3.16. At 25 days after anthesis the large amyloplasts contain 75% amylopectin. This falls to 55% amylopectin at 40 days after anthesis and then rises again to 71% by 60 days after anthesis. At 25 days after anthesis the amylopectin content of the small amyloplasts is 95%. This drops to 69% at 35 days after anthesis and remains around this level until 50 days after anthesis. After this it drops again until by 60 days after anthesis the amylopectin content is only 60%. This means that the amylopectin content of the small amyloplasts is higher than that of the large amyloplasts throughout development until 60 days after anthesis when it falls below that of the large amyloplasts.

Fig.3.14 Percentage amylopectin content of the amyloplast fraction of the endosperm throughout development. Mean s.d.=  $\pm 3.7$

Fig.3.15 Total amylopectin and amylose production throughout development

x amylopectin  
 $\Delta$  amylose

Fig. 3.14

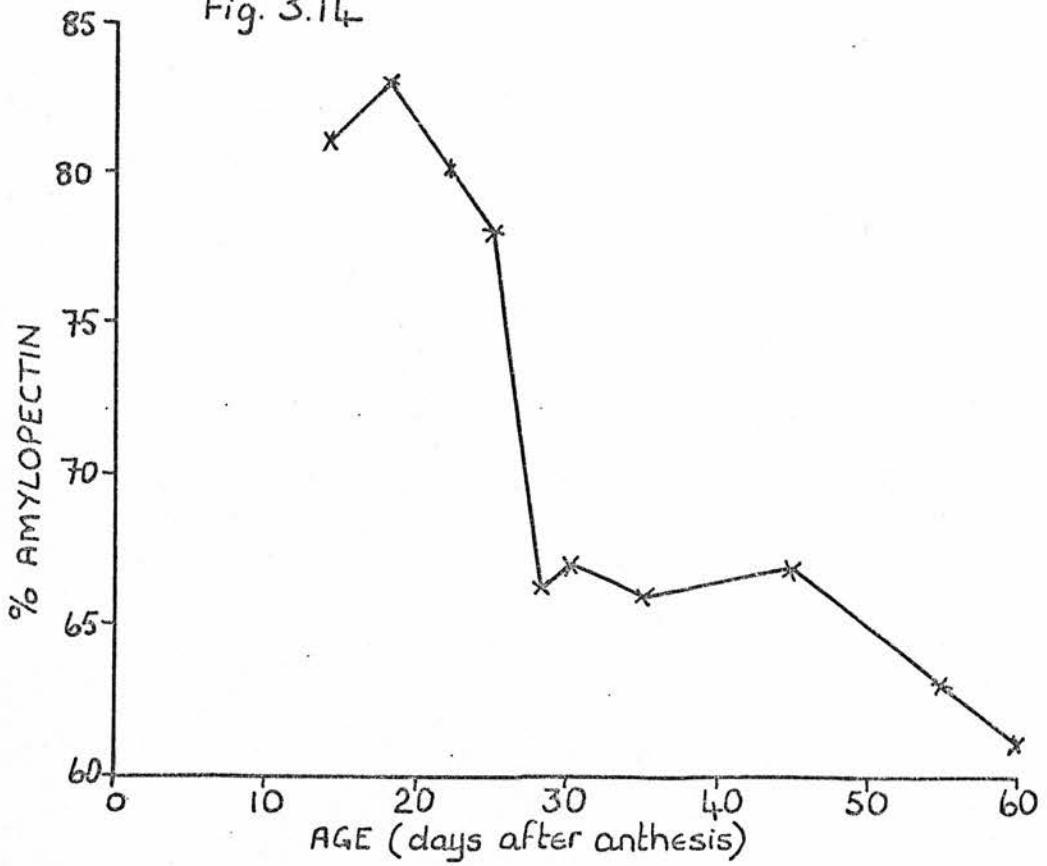

Fig. 3.15

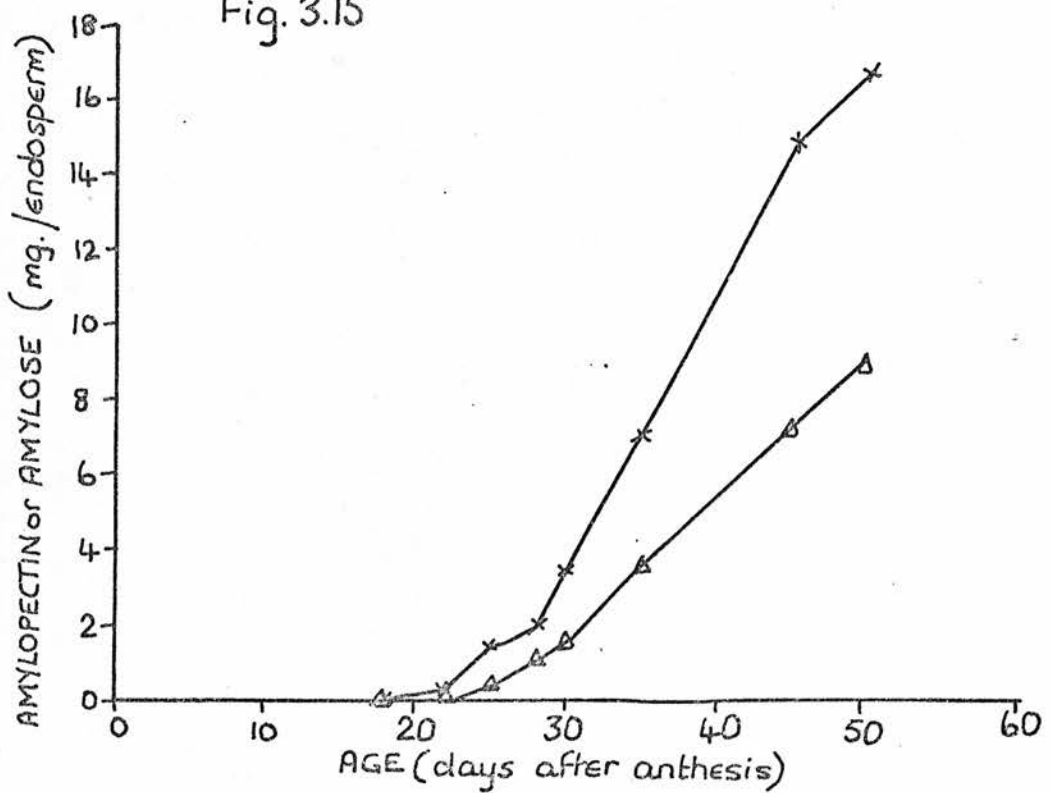
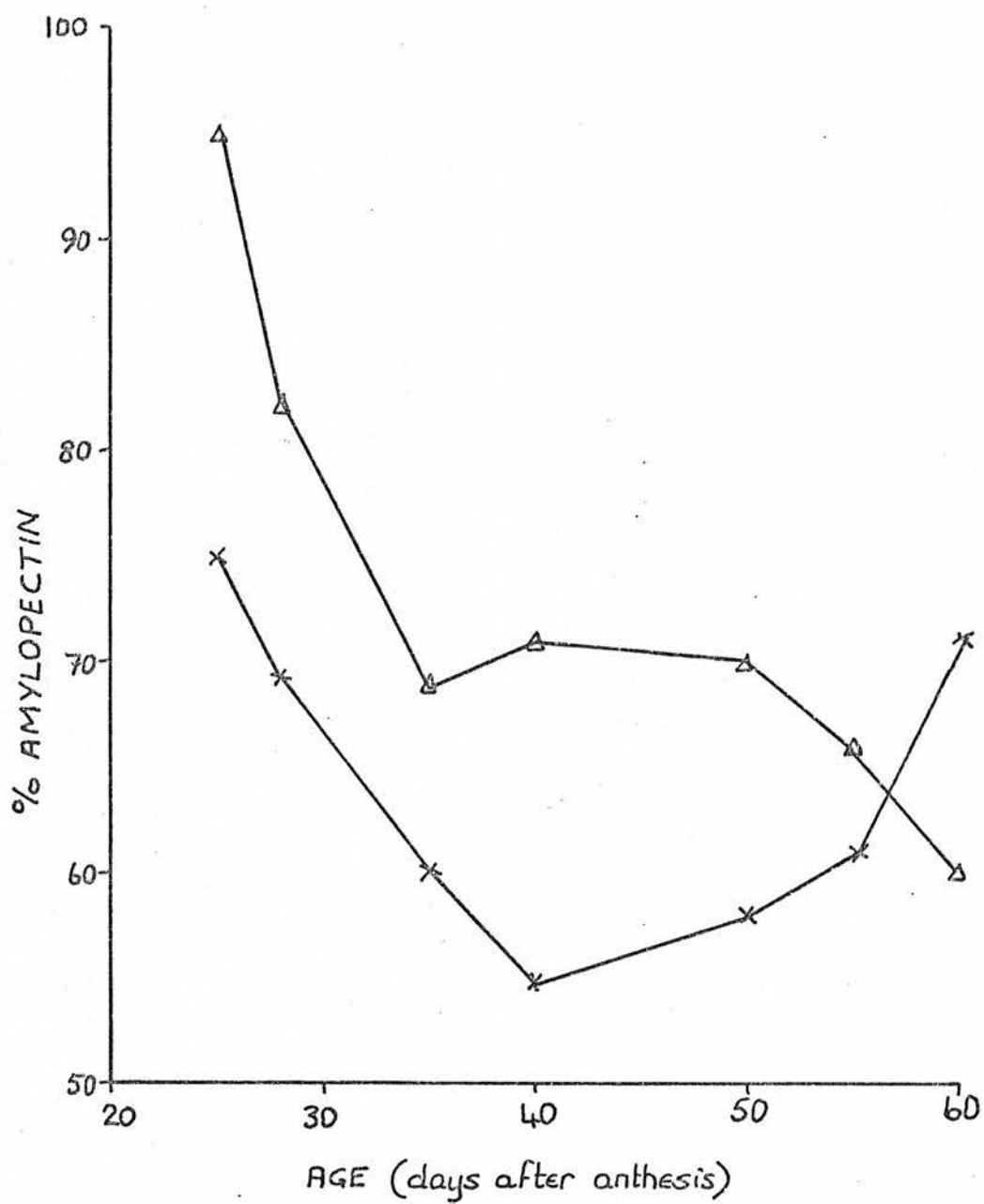

Fig.3.16 Percentage amylopectin content of large  
and small amyloplasts throughout  
development. Mean s.d. =  $\pm 4.5$

- x large amyloplasts
- Δ small amyloplasts

Fig. 3.16



#### 3.3.4 Starch content of amyloplasts

When starch content of the amyloplasts was determined by acid hydrolysis the total dry weight of large amyloplasts could be accounted for by starch. This indicates that the method is not sufficiently accurate to allow for the small amounts of protein and lipid that are present and can be detected by other methods (for example, see section 3.3.5). This was also true of the small amyloplasts, except at 38 days after anthesis when a value of 97.8% starch was obtained.

#### 3.3.5 Lipid Composition of Amyloplasts

Thin layer chromatography of the chloroform:methanol extract of 25 day large amyloplasts showed that lipid was present in this extract. Two different spots were detected on the plate, these had R<sub>f</sub> values 0.96 and 0.175 (fig. 3.17). There was also staining at the origin. Although the tests did not run exactly with any of the standards used it is possible that the fast-moving component is a sterol, since  $\beta$ -sitosterol was fast-moving under these conditions, the R<sub>f</sub> being 0.91.

#### 3.3.6 Degradation of Amyloplasts by $\alpha$ -amylase

In all the ages tested (25, 38 and 60 days after anthesis and germinated grain) the small amyloplasts at each age were more susceptible to  $\alpha$ -amylolysis than the corresponding large amyloplasts with the exception of those from barley 25 days after anthesis where the large amyloplasts were more susceptible (figs. 3.18, 3.19).

In all the experiments the rate of reducing sugar production was faster at the beginning than at the end of the incubation period. This slowing down was most marked after one hour's incubation.

Fig.3.17 Thin layer chromatography of chloroform:  
methanol extract from 25 day large  
amyloplasts

PE phosphatidylethanolamine

L/S lecithin/sphingomyelin

Fig. 3.17

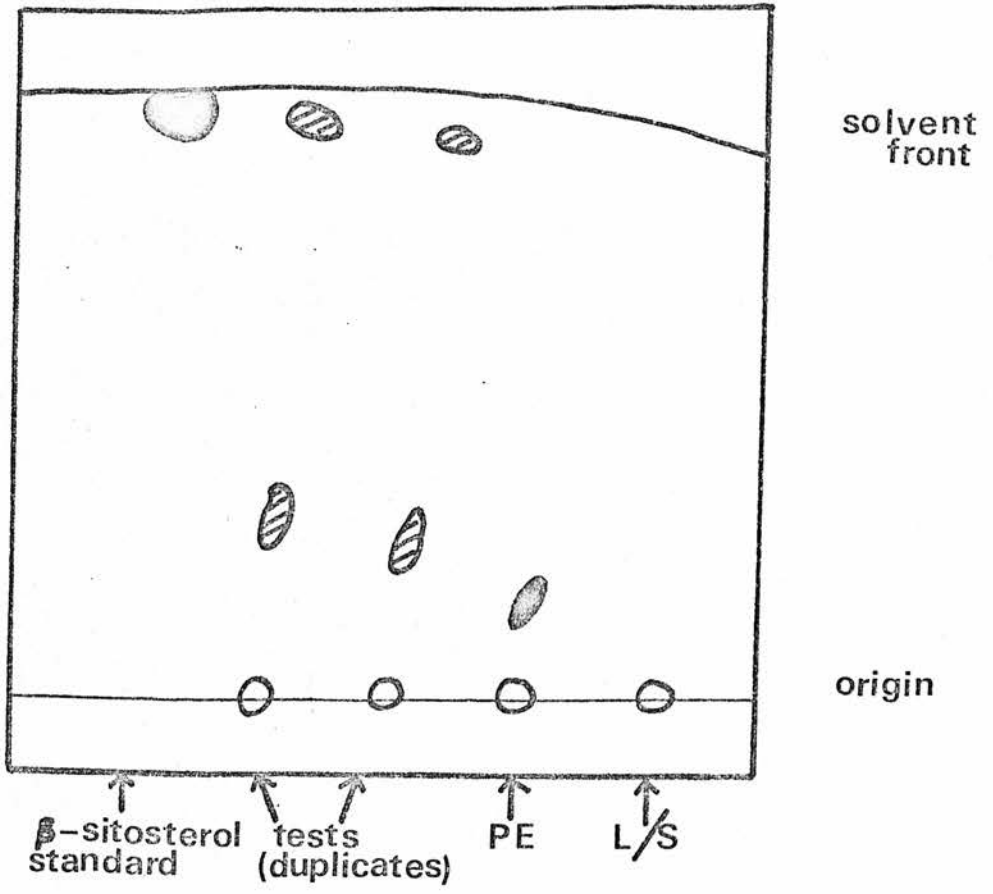



Fig.3.18  $\alpha$ -amylase degradation of large and small amyloplasts

- X small amyloplasts, germinated grain
- ▲ small amyloplasts, 60 days after anthesis
- small amyloplasts, 38 days after anthesis
- large amyloplasts, germinated grain
- △ large amyloplasts, 60 days after anthesis
- large amyloplasts, 38 days after anthesis

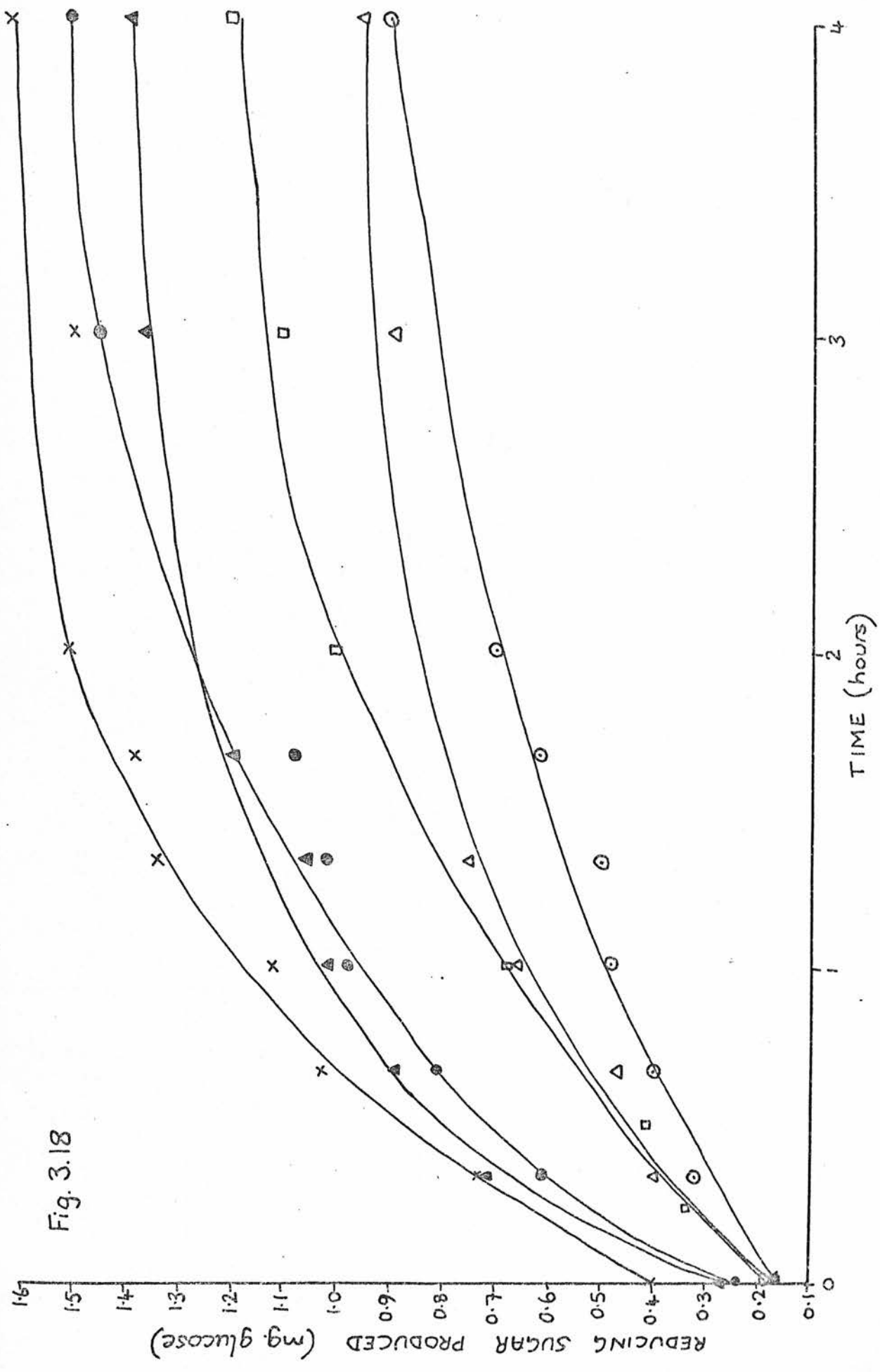

Fig. 3.18

Fig.3.19  $\alpha$ -amylase degradation of 2 mg. large and small amyloplasts from endosperms 25 days after anthesis

× large amyloplasts

⊙ small amyloplasts

Fig. 3.19

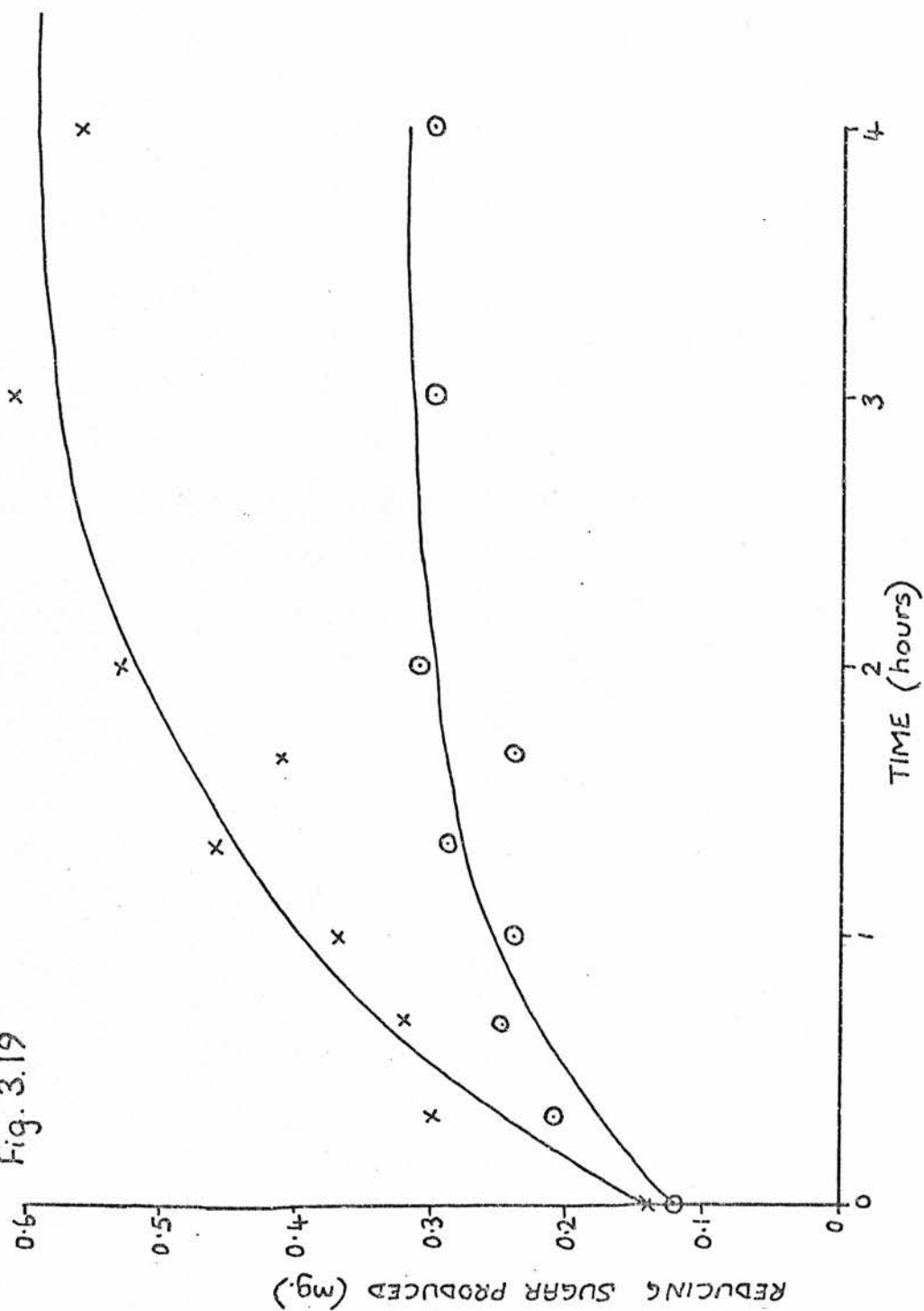

The rate of reducing sugar production from amyloplasts did not appear to depend upon the starch composition (i.e. the percentage amylopectin content of the starch) of the amyloplasts.

The activity of the  $\alpha$ -amylase preparation used did not decrease over the four-hour incubation period, so the changes in rate of degradation observed were not due to denaturation of the enzyme. Also addition of extra  $\alpha$ -amylase after one hour's incubation did not lead to any increase in rate of  $\alpha$ -amylolysis of the amyloplasts (fig. 3.20). There was no spontaneous breakdown of the amyloplasts over the four-hour period, since there was no reducing sugar production in the control, where enzyme was replaced by buffer.

When the amyloplasts were washed after incubation for one hour and more  $\alpha$ -amylase added the rate of  $\alpha$ -amylolysis did not increase, in fact a slight decrease occurred, indicating that the products of degradation, which would have been removed by washing, were not inhibiting the  $\alpha$ -amylase under the conditions of this assay (fig. 3.21). Although the enzyme pullulanase was active with amylopectin it did not attack native amyloplasts. Nor did the addition of pullulanase have any effect on the rate of  $\alpha$ -amylolysis of the amyloplasts (fig. 3.22).

It was found that when observed under the light microscope the small amyloplasts were clumped together after  $\alpha$ -amylase attack whereas the large ones remained separated.

When extracts from germinated barley or endosperms and gibberellic acid were used in this experiment there was no measurable reducing sugar production during the four hour incubation, although these extracts were shown to contain  $\alpha$ -amylase.

Fig.3.20 Effect of adding extra  $\alpha$ -amylase after one  
hour's incubation on  $\alpha$ -amylase degradation  
of 25 day large amyloplasts

x control

o experiment with added enzyme

Fig. 3.20

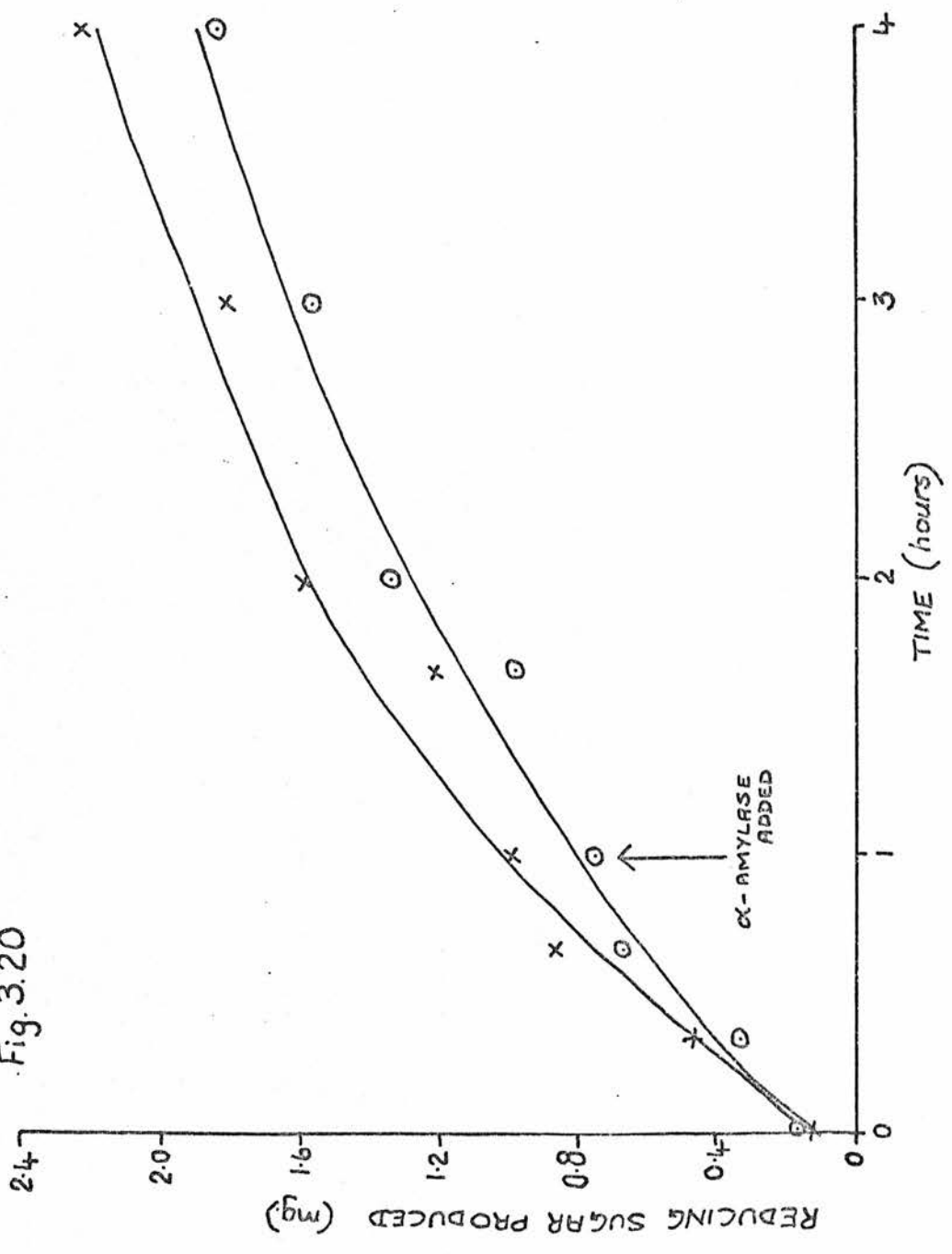

Fig.3.21 Effect of washing 25 day amyloplasts after  
one hour's incubation with  $\alpha$ -amylase

x control

o washed amyloplasts



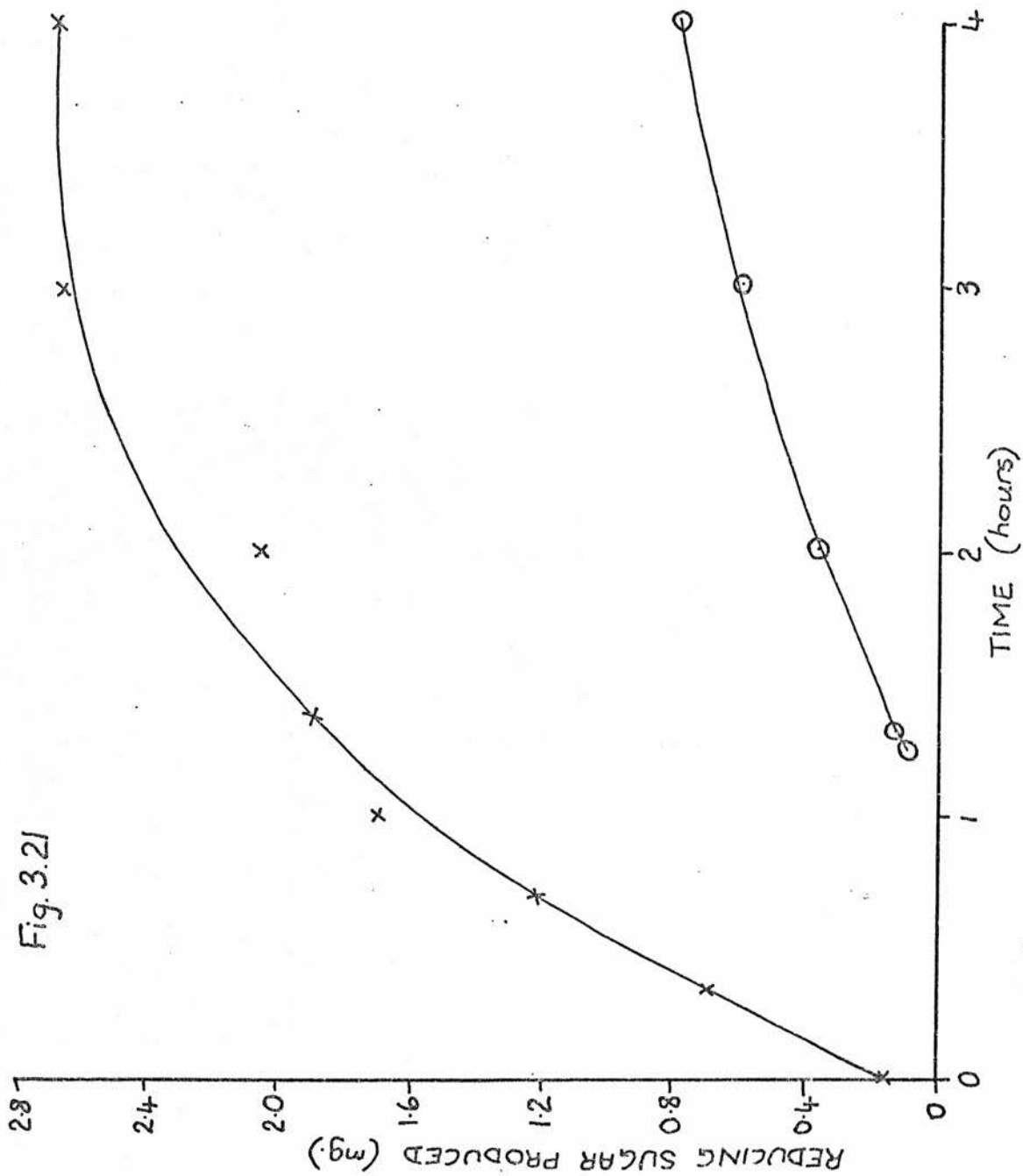
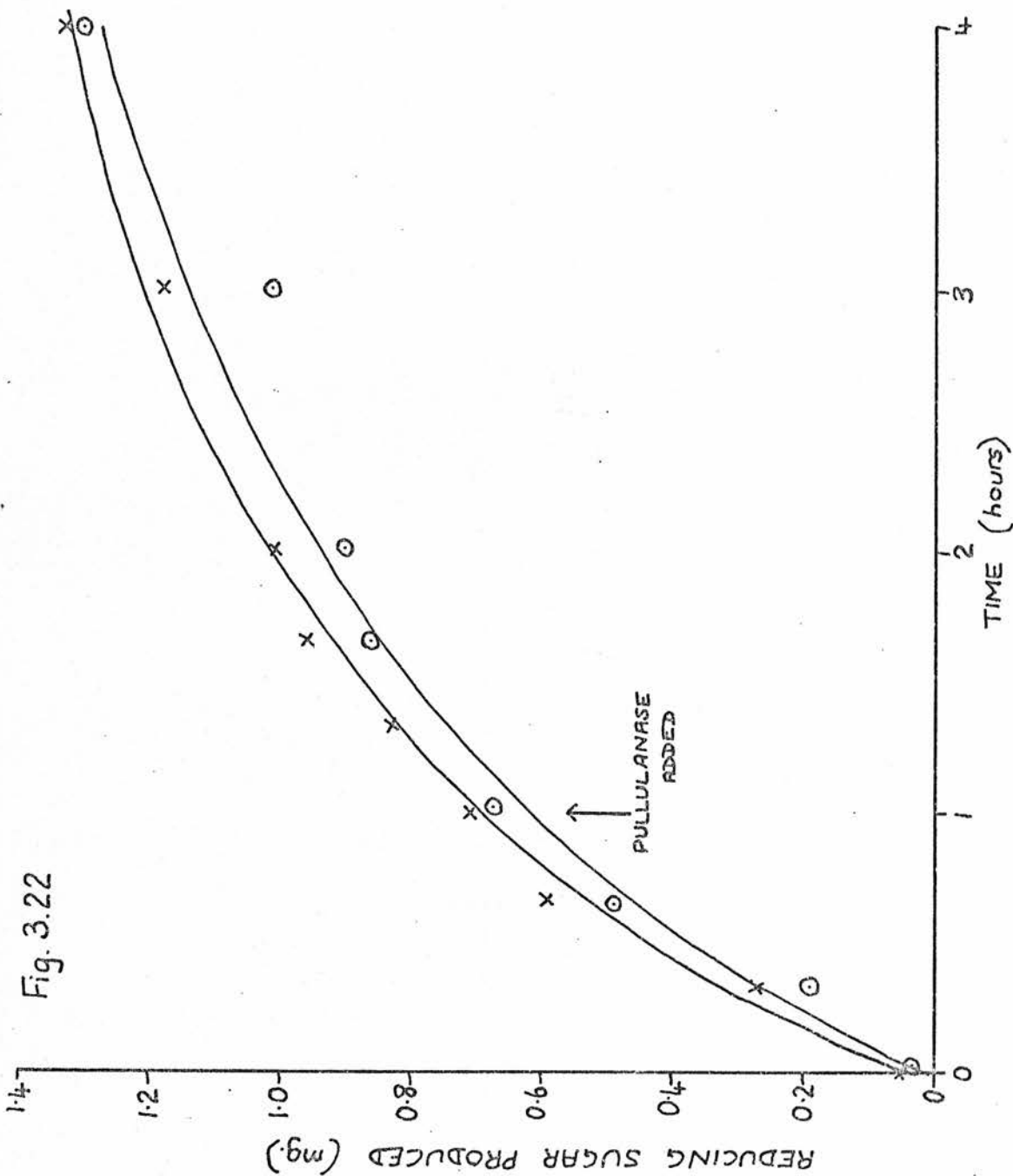

Fig. 3.21

Fig.3.22 Effect of added pullulanase on  $\alpha$ -amylase  
degradation of 25 day amyloplasts

- x control
- o added pullulanase

Fig. 3.22



### 3.3.7 Amyloplast degradation at germination

The ratios of small:large amyloplasts at different stages in development and germination are shown in Table 3.6.

The number of small amyloplasts compared to the number of large increases during development. At germination there is a slight but insignificant drop in the ratio, but the ratio increases again as the shoot develops, with a very rapid increase between the 5 cm. and 15 cm. shoot stage. After the stage at which the shoot is 15 cm. long the endosperm is degraded completely and the amyloplasts can no longer be counted.

### 3.3.8 The effect of added potassium chloride in the starch synthetase assay

The maximum starch synthetase activity of a preparation of 16 day endosperms was measured when 1.0 m mole potassium chloride was incorporated in the assay mixture (fig. 3.23). This concentration was therefore used for all subsequent starch synthetase assays.

### 3.3.9 Starch synthetase associated with large and small amyloplasts

#### i) Nucleotide dependence

The starch synthetase associated with large amyloplasts was found to be active with UDPG only between 20 and 25 days after anthesis (fig. 3.24). Activity with ADPG was present by 22 days after anthesis and continued throughout development. The maximum activity with ADPG occurred at 40 days after anthesis. With the small amyloplasts the opposite effect was seen. Until 22 days after anthesis the starch synthetase associated with small amyloplasts was active with ADPG. However after this age it was active with UDPG.

Table 3.6      Ratio of small:large amyloplasts at  
different stages in development and  
germination

<u>Stage in development or</u> <u>germination</u>	<u>Ratio small:large (average of</u> <u>at least 3 determinations)</u>
	Mean   s.d. = $\pm 3.3$
25 days after anthesis	3.9 : 1
60 days after anthesis	9.2 : 1
Germinated—radicle just showing	8.2 : 1
0.7 cm shoot	16.5 : 1
5 cm shoot	25.1 : 1
15 cm shoot	133.0 : 1

Fig.3.23 Effect of potassium chloride on the  
starch synthetase assay

Fig. 3.23

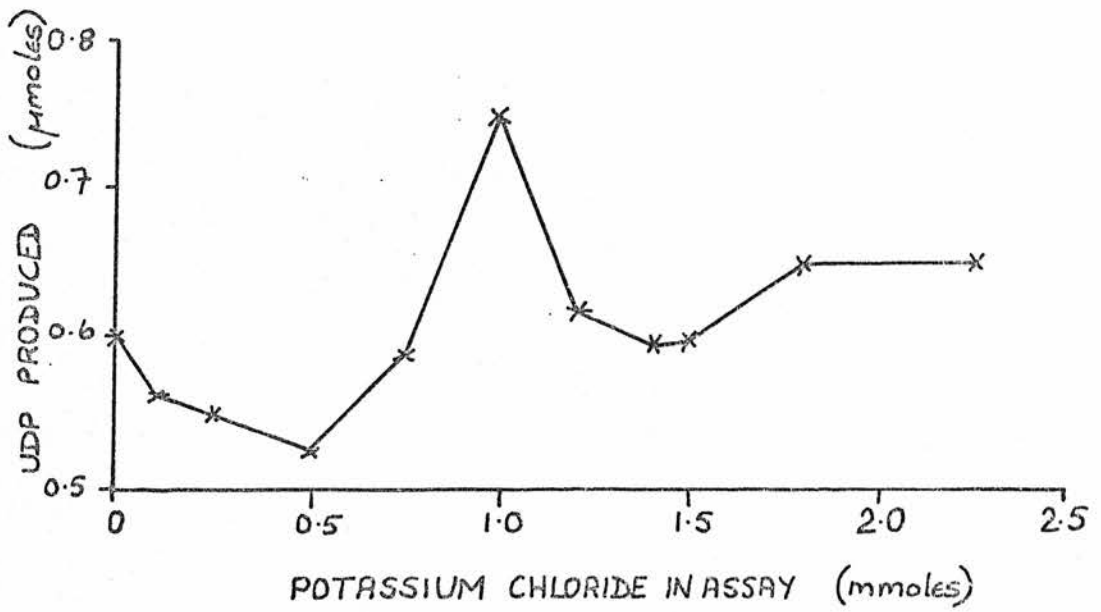

Fig.3.24 Starch synthetase activity in large and small amyloplasts throughout development. Mean s.d.  $\pm$  2.2

(a) large amyloplasts

(b) small amyloplasts

x activity with UDPG

$\Delta$  activity with ADPG



Fig. 3.24  
(a)

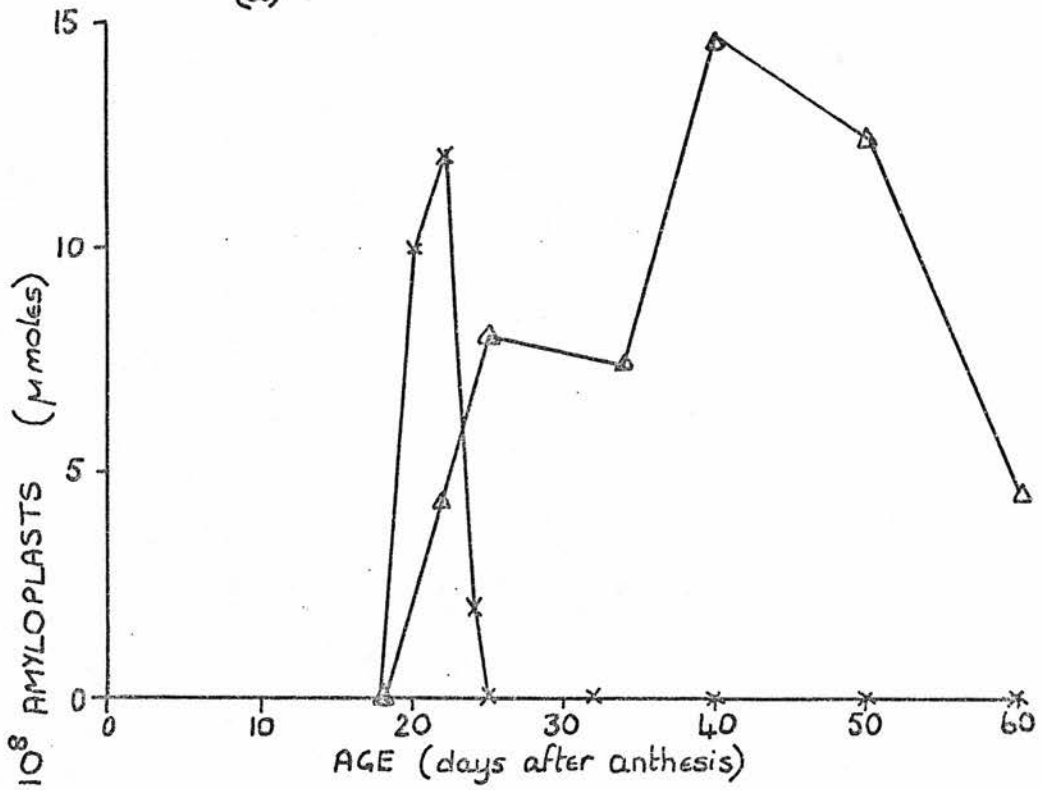

(b)

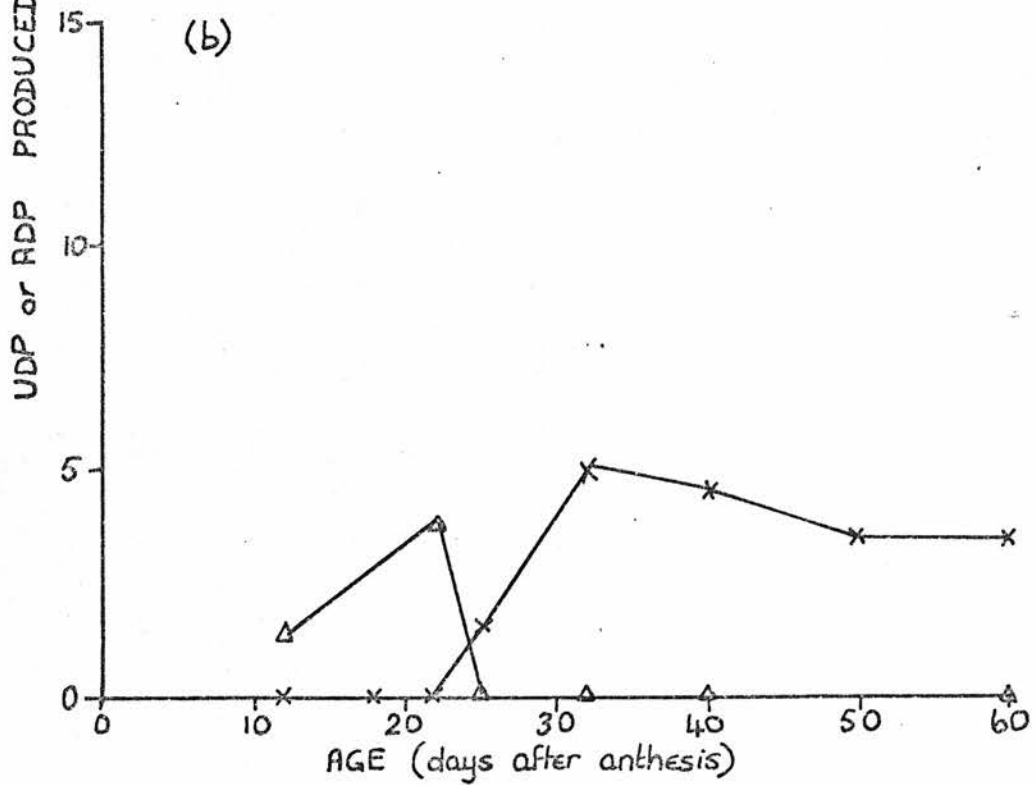

ii) pH dependence

The pH curves between pH 7.5 and 9.5 for the starch synthetase activities associated with large and small amyloplasts are shown in fig. 3.25. The pH optimum of the large amyloplast activity was found to be 8.6 and that of the small amyloplasts to be 9.0.

3.3.10 Uptake of carbon-14 by large and small amyloplasts

Attempts to inject the UDPG solution directly into the endosperm of the barley grain using a small syringe were unsuccessful.

Attaching the vial to the plants and cutting the flag leaf did not affect the normal development of the plant. This was determined by direct comparison with other plants in the same pot and of the same age. The UDPG could be taken up through the slit in the flag leaf.

When the original endosperm homogenate was counted before separation of the amyloplasts on a gradient it was found that between 0.2% and 0.9% of the counts were taken up from the vial to the endosperm. The exact amount of UDPG taken up in this way varied slightly between experiments.

Table 3.7 shows the results obtained from the labelling experiments. The large amyloplasts were found to be labelled at 25 days after anthesis when the labelling had been done at all the ages tried. When labelling was done at 35 days after anthesis the large amyloplasts were labelled by the time the gradient was done at 50 days after anthesis. The small amyloplasts were not found to be labelled at 25 days when labelling was done at earing or at 10 days after anthesis. When labelling was done at 14 and 24 days after anthesis there was a small, but significant, labelling of small amyloplasts by the time of separation at 25 days after anthesis.

Table 3.7Labelling of amyloplasts after uptake  
of  $^{14}\text{C}$  by the plant

<u>Age at which labelling was carried out</u>	<u>Amyloplast fraction</u>	<u>c.p.m./1 ml amyloplast suspension</u> (average of at least 2 determinations)
earling	large	244
	small	0
10 days after anthesis	large	198
	small	4
14 days after anthesis	large	586
	small	30
24 days after anthesis	large	206
	small	33
35 days after anthesis	large	73.5
	small	0

Fig.3.25 pH optimum of starch synthetase activity  
of large and small amyloplasts. Typical  
results from 3 experiments

- △ large amyloplasts
- × small amyloplasts

Fig. 3.25

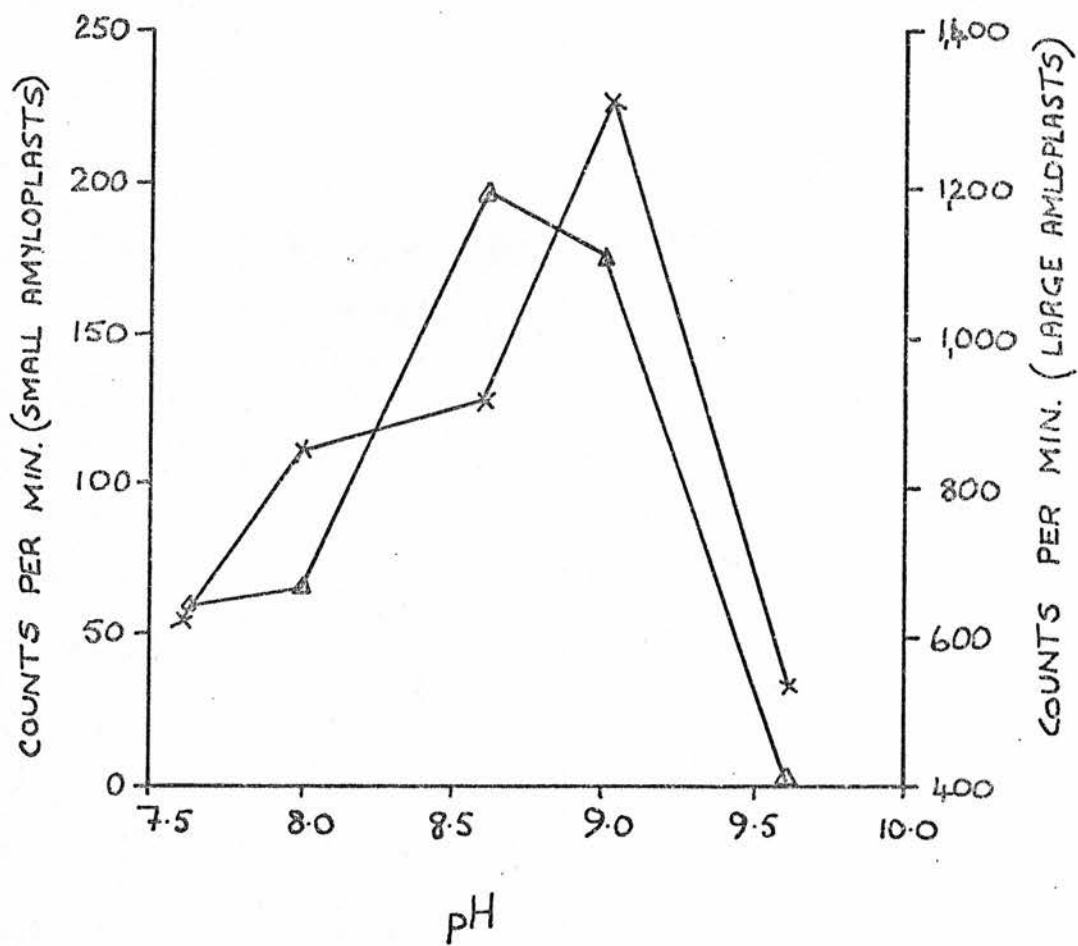

There was no labelling in the small amyloplasts when labelling was carried out at 35 days after anthesis. At earing no amyloplasts could be seen under the light microscope. At 10 days all the amyloplasts seen were small amyloplasts. The two populations of amyloplasts were not seen under the light microscope until 14 days after anthesis.

#### 3.4 Accuracy of Experimental Results

Chemical reagents used were generally 'Analar' quality. Biochemicals were obtained from Sigma Chemical Co. except where otherwise stated.

Endosperms were generally not removed from barley 10 days after anthesis since at this age the endosperm is very watery. This makes removal of the complete endosperm extremely difficult and would lead to misleading, usually low, results.

In most cases it was found that there was no difference in the results obtained whether fresh or deep frozen material was used although electron microscopy showed that there are possibly fewer mitochondria in the endosperms from barley which has been stored in the deep freeze. However, fresh material was used whenever it was available, especially for experiments involving enzyme assays.

In all cases curves were fitted by hand. In many of the results standard deviations from the mean have been calculated. However the fact that ageing was to a certain extent subjective means that estimations may not have been carried out on grains exactly the same age. The means and standard deviations calculated are therefore only an indication of the accuracy of each result.

DISCUSSION

4.1 Introductory Remarks

Variations are often noted when the results of one worker are compared with those of others. These can sometimes be accounted for by differences in the length of time taken for the barley to develop under various climatic conditions. For example, La Berge, MacGregor and Meredith found times of 35-50 days for grain to develop from anthesis to maturity in Winnipeg<sup>(113)</sup> and Buttrose found that from anthesis to endosperm maturity took 30 days in the variety Prior in Zurich<sup>(7)</sup>. Therefore, when comparing results with those of other workers, barley at the same morphological stage in development must be considered. The method of cultivation and the variety is also important, since results can vary between one variety and another.

In all the experiments where the variation of chemical constituents or enzyme activities are considered throughout development the proportion of the total amount present which is extracted is important. For example, the results of the soluble protein assay indicate an increase in soluble protein in the grain as development proceeds. It may be, therefore, that more protein is solubilized as development progresses. This also applies to the enzyme assays, where apparent changes in activity with time may in fact be due to differences in the proportion of the enzyme extracted.

The results reported here therefore refer to total extractable activity. However in results quoted by Duffus<sup>(114)</sup> the percentage of total nitrogen which was extracted as soluble protein varied little throughout development, indicating that the extraction procedures

were satisfactory. It is also known that insoluble forms of enzymes are frequently in an inactive or latent state, for example,  $\beta$ -amylase in the developing cereal grain<sup>(115)</sup>.

#### 4.2 Development of the Barley Grain

The pattern of change of fresh weight, dry weight and water content during the maturation of grain from the barley variety Julia is very similar to that obtained by other workers using different barley varieties, for example Betzes<sup>(113)</sup> and Maris Baldric<sup>(89)</sup>. The results are also in agreement with those obtained for wheat<sup>(116)</sup> and maize<sup>(117)</sup>. The decrease in fresh weight of the grain after 35 days after anthesis has been accounted for by water loss during development. This is borne out by studies of the associated morphological changes taking place where the grain visibly shrinks and dries out.

The increase in total carbohydrate throughout development in Julia resembles the pattern obtained for wheat and the barley cultivars Iris<sup>(116)</sup> and Conquest<sup>(118)</sup>. The anthrone reagent method used is specific for carbohydrates, the colour being due to the complex formed between the monosaccharides (formed after hydrolysis if the carbohydrate is an oligosaccharide or polysaccharide) and the anthrone reagent. However, different monosaccharides give a slightly different intensity of colour, for example galactose gives much less colour than glucose. It is therefore possible that some of the changes which are seen during the development of Julia are due to differences in the type of carbohydrate present and not in the actual carbohydrate content. Barley (cultivar Iris) has been shown to have a high concentration of pentosans (2.5 mg/grain at maturity)<sup>(116)</sup>. However, this was measured in the whole grain



including the outer layers of lemma and glumes which would be expected to contain a large proportion of pentosans. In the results determined here for Julia it can be seen that by 30 days after anthesis over half the carbohydrate is contained in the endosperm and probably consists primarily of starch. By maturity total carbohydrate constitutes three quarters of the dry weight of the grain. Visible increases in the size of the amyloplasts occur during development, which agrees with the increase seen in total carbohydrate.

Glucose content was said to be negligibly small in the barley Iris by Cerning and Guilbot<sup>(116)</sup>. However Julia was found to have a glucose content which increased during development to 0.35 mg per whole grain at maturity. This is just under 1% of total dry weight at this stage. Measurable quantities of glucose were found throughout development in both the whole grain and endosperm. Glucose has also been detected in the varieties Carlsberg and Spratt Archer<sup>(119)</sup> and Betzes<sup>(113)</sup> although the pattern of change throughout development is different from that obtained here for Julia.

Commercial glucose oxidase was found to be contaminated with  $\alpha$ -glucosidase and thus some of the glucose measured here is possibly derived from maltose. La Berge et al<sup>(113)</sup> separated the sugars by chromatography and found very little maltose present in Betzes. If this is also true of Julia this  $\alpha$ -glucosidase would not affect the results to any great extent. Because of this contamination of glucose oxidase an alternative test for glucose was used when determining  $\alpha$ -glucosidase. The values for glucose content observed could also be due to hydrolysis of polysaccharides during preparation of the samples, although the speed of extraction

makes this unlikely. Due to the factors discussed the results given for glucose might be higher than the true values.

The results show that glucose constitutes slightly less than one-tenth of the reducing sugar content at early stages in the developmental period and about one-tenth at later stages. There are, therefore, other reducing sugars apart from glucose present in the developing barley grain. These probably include fructose and cell wall monomers such as galactose and mannose. The possible presence of maltose has already been discussed.

The increase in soluble protein per grain indicates that protein synthesis probably continues throughout development. This is also indicated by the fact that RNA increases during the development of the endosperm (Duffus, Personal Communication). It is stated that protein synthesis probably occurs in the barley embryo, but in that tissue the rate of increase in soluble protein was rapid, especially at later stages in development<sup>(120)</sup>. Pomeranz et al<sup>(121)</sup> state that protein biosynthesis in the varieties Larker, Dickson and Conquest is completed by the time the final kernel weight is obtained.

Maximum bacterial contamination of homogenates was around 700 per ml. Since a minimum of 10,000 per ml is usually required to give detectable enzyme activity these levels are unlikely to affect any of the experimental results obtained. These low counts were obtained in spite of the fact that no particular precautions were taken to keep the barley sterile during handling and dissecting out of endosperms. The lemma and glumes were removed in all cases. One function of these layers is possibly to act in the growing barley plant as a barrier to bacterial attack on the grain. Ears which were infected with aphids were not used.

The electron micrographs (Plates 1-23) show the presence of an amyloplast membrane both at early and late stages in development. This will be discussed in more detail in section 4.4.2.

In amyloplasts at two and three days after anthesis many small starch granules are seen. It is possible, therefore, that the starch granule in the amyloplast is initiated at several sites and that these then join together. At later stages (for example, Plate 9, 12 days; Plate 20, 38 days) it appears that two starch granules are lying inside one membrane. This might occur if the initial granules had not joined together properly. It is, however, possible that the section has been cut through one starch granule which had a deep fissure so that the 'two' granules seen are actually part of the same one. Buttrose<sup>(7)</sup> states that "sometimes two or more starch granules are found in a proplastid, but sooner or later such plastids are found to divide to give daughter plastids containing only one granule".

Plate 20 could be such a plastid dividing, probably unusual, since this was the only occasion on which this phenomenon was observed.

It is interesting that no indication of development from multiple initiation sites is seen in the small amyloplasts. However, at the stage at which small amyloplasts appear the starch granules in the large amyloplasts are thought to be increasing in size by addition of layers to the existing structure and therefore the small granules probably grow in the same way.

In some of the amyloplasts at later stages in development (Plate 17, 38 days) a rudimentary lamellar structure can be seen. It may be that the amyloplast has the potential to become a chloroplast under certain conditions, such as exposure to light,

although no evidence has been produced for this phenomenon in barley. It may also be that amyloplasts and chloroplasts develop from one common organelle - the proplastid.

In most of the amyloplasts observed under the electron microscope dark shaded areas are seen in the starch granule. These are attributed by Buttrose<sup>(7)</sup> to compression and folding of the starch during sectioning. In some cases a structureless area is seen between the starch granule and the amyloplast membrane. This is possibly caused by unfixed starch shrinking within the amyloplast<sup>(19)</sup>.

It was confirmed that two sizes of amyloplast were seen at and after 14 days after anthesis.

The electron micrographs show the presence of many intact mitochondria with well-developed cristae throughout development, for example Plates 7, 11, 14, 17. This is in contrast to reports that mitochondria were not seen at the late stages in wheat grain<sup>(21)</sup>. At many stages these are lying close to the amyloplast membrane. This indicates that active respiration is probably taking place to provide the energy required for the various synthetic processes in the endosperm, for example, the synthesis of carbohydrate which can be seen to occur (fig. 3.2). That energy is required for starch biosynthesis from sucrose can be calculated from the free energy production or loss in the reactions involved. The reactions concerned in the most direct pathway for the biosynthesis of starch are as follows:-

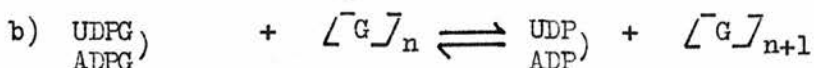
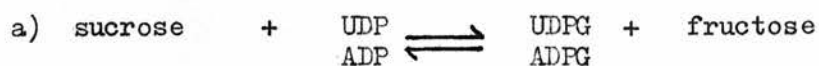

The free energy produced in reaction a) is + 4.8 kJ/mol. sucrose at 37°C. The free energy required by reaction b) is -12.55 kJ/mol. UDPG at 37°C. The total free energy required to add one glucose moiety to the starch primer with an  $\alpha$ -(1,4) bond using this system is therefore 8.37 kJ. Cell walls were seen from the earliest stages at which electron micrographs were taken. This indicates that cell wall production in the endosperm probably takes place during the first few hours after anthesis.

No evidence of cell division was seen in the electron micrographs, suggesting that growth in the endosperm is by cell expansion rather than division. This is borne out by the fact that although RNA content increases during endosperm development DNA remains relatively constant after 20 days after anthesis (Duffus, Personal Communication).

The function of the concentric rings of endoplasmic reticulum (Plates 4, 16) is not known. Simmonds<sup>(21)</sup> noted structures in wheat in which there were concentric channels of endoplasmic reticulum leading to a central area of storage protein. However there were not any visible protein deposits in this work.

The chloroplasts from the testa-pericarp at three days after anthesis already show lamellar structure. Thorne<sup>(122)</sup> has demonstrated apparent photosynthesis in the ears of wheat and barley at around ten days after anthesis and it is likely that photosynthesis is taking place before this age. The testa-pericarp is already green at three days after anthesis.

Evans and Rawson<sup>(123)</sup> have shown that in wheat photosynthesis by the grain itself can account for as much as 34% of gross photosynthesis in the intact ear. Intact chloroplasts can

be seen in electron micrographs of testa-pericarp at 25 days after anthesis. Some of these contain granules of starch. These resemble electron micrographs of bundle sheath cells of C4 plants, although the grana are more pronounced. The other section (Plate 22) shows chloroplasts which do not contain starch and which resemble C3 plant chloroplasts or the mesophyll cells of C4 plants. There is some evidence <sup>(124)</sup> that C4 metabolism might occur in barley testa-pericarp. The starch granules in Plate 23 do not completely fill the space in which they are lying in the chloroplast. They are 0.82  $\mu\text{m}$  and 0.44  $\mu\text{m}$  along the longest axis, much smaller than the endosperm starch granules at this age. It is probable that these starch granules store the starch for short periods only, the majority of starch being stored in the adjacent endosperm tissue. Bailey and MacRae<sup>(125)</sup> have shown that leaf starch grains are hydrolysed more quickly than those from storage organs, indicating differences in structure between the two types.

#### 4.3 Enzymes in the Soluble Fraction

##### 4.3.1 Branching enzyme

The most commonly used assay for the determination of branching enzyme activity in the presence of  $\alpha$ -amylase is that described by Krisman<sup>(97)</sup> in which  $\alpha$ -amylase is assumed to act equally on glycogen and amylopectin. It was found that commercial malt  $\alpha$ -amylase had far faster activity with amylopectin as substrate than it did with glycogen as substrate. The malt enzyme therefore differs from the mammalian enzyme and it is likely that the barley enzyme produced during development will also differ. Krisman's assay is therefore unsuitable in this case. Thus a new method was required either for the assay of branching enzyme in the

presence of  $\alpha$ -amylase and other hydrolysing enzymes, or for its separation from them and assay in their absence. An attempt was made to separate the branching enzyme from the other enzymes which would produce a decrease in the colour of a starch-iodine complex and thus interfere with the assay of branching enzyme by this method. These other enzymes would include  $\alpha$ -amylase,  $\beta$ -amylase, phosphorylase and debranching enzyme. Of these, only  $\alpha$ -amylase was detectable after precipitation with 38.5% ammonium sulphate as described. The results show that the method of Loyter and Schramm<sup>(103)</sup> of complexing the  $\alpha$ -amylase with glycogen was not suitable since branching enzyme activity was not detectable after this procedure. The branching enzyme may have been removed together with the  $\alpha$ -amylase, or it may have been inactivated by the reagents involved. The  $\alpha$ -amylase activity was therefore determined after the removal of branching enzyme activity by heating and the value obtained subtracted from the total branching enzyme plus  $\alpha$ -amylase activity. A control was carried out which showed that  $\alpha$ -amylase activity was unaltered by heating to 70°C.

Branching enzyme activity is not detectable before 18 days after anthesis. It is noteworthy, therefore, that amylopectin is present from the earliest age assayed (14 days after anthesis) and moreover forms a large proportion of endosperm starch at this age. The absence of branching enzyme might be accounted for by one of two reasons: either the amount of branching enzyme present at this stage is so small that it is lost during the purification procedures; or the branching enzyme might be modified in some way at early stages in development and therefore not removed by the same purification procedures as at later ages.



The relationship between branching enzyme and soluble starch synthetase is discussed in section 4.3.5.

Branching enzyme activity is at a maximum 25 days after anthesis and then declines. The amylopectin content of the endosperm also drops at 25 days after anthesis. It is therefore possible that the fall in amylopectin content is due to the decrease in branching enzyme activity. Branching enzyme activity remains up to maturity indicating that some starch synthesis is probably still taking place at this time. This is also indicated by the fact that starch synthetase activity is also present at maturity.

#### 4.3.2 De-branching enzyme

Since the substrate used for the debranching enzyme assay was pullulan, the debranching activity measured can be more accurately described as a pullulanase. However, R-enzyme or debranching enzyme from a number of plants is now known to be active with pullulan as well as with the natural substrate, amylopectin<sup>(87)</sup>.

As well as the  $\alpha$ -glucosidase described (see section 3.2.3.)  $\alpha$ -amylase might also be responsible for the breakdown of the maltotriose produced in the de-branching enzyme assay. However,  $\alpha$ -amylase activity in the variety Maris Baldric falls at the end of development<sup>(81)</sup> when debranching enzyme activity is rising so this factor is probably unimportant. Furthermore, maltotriose is only slowly hydrolysed by large concentrations of  $\alpha$ -amylase<sup>(84)</sup>.

Pullulan itself is not attacked by  $\alpha$ - and  $\beta$ - amylases<sup>(87)</sup>.

De-branching enzyme activity rises in the later stages of development (fig. 3.7) when the proportion of amylopectin in the endosperm is falling. The branching enzyme activity results have indicated that this fall in amylopectin may be due to the rate of amylose synthesis exceeding that of amylopectin. These results,



however, indicate that a second factor involved may be the increased rate of breakdown by de-branching enzyme of the amylopectin which is produced.

It is surprising that de-branching enzyme is present at all during development, which is a period of starch synthesis rather than degradation. Other starch hydrolysing enzymes, such as phosphorylase,  $\alpha$ -amylase and  $\beta$ -amylase are also known to be present at certain stages of development<sup>(81)</sup>. This suggests that starch synthesis exists as a dynamic process in which synthesis and degradation take place simultaneously but to different extents. De-branching enzyme may thus be involved in the regulation of starch synthesis.

#### 4.3.3 $\alpha$ -glucosidase

$\alpha$ -glucosidase activity was found to be high between six and 25 days after anthesis. It then falls and no activity can be detected from 30 days onwards. This correlates well with the results of Manners and Yellowlees<sup>(104)</sup> who found low levels of  $\alpha$ -glucosidase in germinated barley grain. As with de-branching enzyme the high levels of  $\alpha$ -glucosidase at the start of development are surprising. This enzyme may be involved in regulation of starch metabolism, or in provision of glucose substrate for respiration.

#### 4.3.4 Phosphorylase

Another enzyme which was found in the soluble fraction was phosphorylase. This was assayed in this case in the degradative direction, but in vivo the activity might be either degradative or synthetic. Activity was not detectable in the first 14 days after anthesis. Maximum activity was seen at 30-35 days. However, in the barley Maris Baldric phosphorylase activity assayed in the synthetic direction was at a maximum at 22 days after anthesis, declining to low values during the 30 to 40 day period<sup>(89)</sup>.

It is therefore possible that phosphorylase acts as a synthetic enzyme at the beginning of development, but later becomes more important in degradation. This conclusion was also reached by Baxter<sup>(89)</sup> after measurement of inorganic and labile phosphate levels present in the endosperm.

#### 4.3.5 Starch Synthetase and Branching Enzyme

The results of the investigations into barley starch synthetase using polyacrylamide gel electrophoresis show that bands were obtained at the same place on the gels whichever of the two nucleotides (UDPG or ADPG) were used. It is possible, therefore, that the same enzyme is responsible for the activity with both nucleotides. There is evidence, however, that the relative activity with UDPG and ADPG changes during development<sup>(61)</sup>.

Figure 3.11 shows that up to about 14 days after anthesis only one starch synthetase isoenzyme can be seen, whilst after this time two isoenzymes are detected. These two bands were not always present (fig. 3.13 20 day and 30 day). Isoenzymes seen on electrophoresis may be artefacts caused by modification of the protein during extraction. However isoenzymes of starch synthetase have been detected in many plant species using various methods, for example maize<sup>(64, 126)</sup> spinach leaves<sup>(54)</sup> and rice<sup>(126)</sup>. Schiefer et al<sup>(64)</sup> suggest that in maize some of these isoenzymes are responsible for amylose production, whereas others are present in a complex with branching enzyme to produce amylopectin. Hawker et al<sup>(127)</sup> have also suggested that the branching enzyme in spinach leaf may be attached to the starch synthetase. A close relationship between these two enzymes can also be seen in barley since the results here (fig. 3.13) show that branching enzyme and starch synthetase always run at the same place on the gels. Branching enzyme activity was not

found in the amyloplast fraction (section 3.2.1.2) indicating that there is not an active starch-granule bound form as is the case for starch synthetase.

The relation between the soluble and amyloplast-bound starch synthetase was investigated. The starch synthetase activity associated with the amyloplasts could not be released by  $\alpha$ -amylase or by sonication. Some protein, which did not have starch synthetase activity was released by sonication. This was probably membrane protein. Perdon et al<sup>(128)</sup> were able to release the granule-bound activity of rice after the granules had been made amorphous by sonication. This difference between rice and barley is probably because of a difference in structure between the granules of these two species. Chandorkar and Badenhuizen<sup>(129)</sup> were also unable to release the granule-bound activity using  $\alpha$ -amylase. They measured the starch synthetase activity during germination in sweet-corn, two varieties of pea and barley (cv. York) assuming that the natural  $\alpha$ -amylase corrosion of the granules might release bound starch synthetase but in fact the starch synthetase activity decreased during germination.

However, as with potato and waxy maize<sup>(60)</sup> the granule-bound starch synthetase of barley could be released by grinding the granules with sand. The enzyme could be detected by polyacrylamide gel electrophoresis and by direct measurement of activity. After electrophoresis the Rf values of the soluble and released enzymes were very similar (section 3.2.5.2) indicating that the two enzymes might be the same.

The difficulty involved in removing the enzyme associated with the amyloplast indicates that it may lie within the structure of the starch granule and is not simply adsorbed onto the surface. Tanaka and Akazawa<sup>(126)</sup> have suggested that the bound enzyme is not

biologically important but gets trapped within the granule during starch granule production. Again, if this is the case, there would be no reason for the differences seen between the enzymes associated with the large and small granules.

#### 4.4 The Amyloplast

##### 4.4.1 Separation of large and small amyloplasts

Large and small amyloplasts were separated using the discontinuous sucrose gradient, since the other methods attempted did not give a satisfactory separation. The methods using Ludox and Urografin gradients have previously been found to be successful in the separation of large and small potato amyloplasts<sup>(27)</sup>. However barley amyloplasts are much smaller than potato amyloplasts and this probably accounts for the lack of success with these gradients for barley.

The 60% sucrose layer was used as the small amyloplast fraction and the pellet at the bottom of the tube as the large amyloplast fraction. This method of separation had the advantages that

- i) the structure of the amyloplasts was preserved (as seen from the electron micrographs)
- ii) at least some of the associated enzymic activity was retained
- iii) the same ratio of small to large amyloplasts was observed before and after separation, in spite of the fact that many amyloplasts could be seen to be lost during the procedure.

This latter result means that comparisons between the two fractions probably give similar results to those which would be obtained if comparisons could be made in the original homogenate.

#### 4.4.2 Structure of the amyloplast

The electron micrographs (Plates 1-23) show that an amyloplast membrane is present at all stages of development. At early ages there is a visible area of cytoplasm between the starch granule or granules and the membrane, but later in development the membrane is seen lying close to the starch granule. In some cases (for example, Plates 3 and 9) the membrane is not complete. This may be because it has been damaged during storage of the barley in the cold as is thought to happen in potato<sup>(130)</sup>. The presence of an amyloplast membrane is also indicated by the fact that there is protein and lipid associated with the isolated, washed amyloplasts. Lipid, which was probably a sterol, was detected in an extract from well-washed 25 day large amyloplasts. The protein released from the small granules by sonication did not have starch synthetase activity and is therefore thought to be membrane protein.

The results show that the percentage of amylopectin compared to amylose in the starch of the endosperm decreases as development proceeds. This has also been found to be the case in the barley varieties Maris Baldric<sup>(89)</sup>, Carlsberg and Spratt Archer<sup>(119)</sup> and two genotypes of the variety Glacier<sup>(28)</sup>. Since no starch was detectable in the supernatant fraction from the endosperm this decrease in amylopectin content is not due to changes in the solubility of either the amylose or amylopectin during development. As stated by Banks et al<sup>(28)</sup> this alteration in amylopectin content could be caused either by a change in structure of the amyloplasts as they mature, or because different types of granule are being laid down during the growth period. The decrease could also be accounted for by the presence of less branching enzyme and more de-branching enzyme towards the end of development. It has been suggested, too, that the formation

of a complex between amylose and starch synthetase reduces the access of branching enzyme and thus less amylopectin can be formed<sup>(63)</sup>.

When amyloplasts were separated on the sucrose gradient, differences in amylose and amylopectin contents between large and small were found throughout development. Although the differences between large and small are not always significant statistically, each time an experiment was performed on a particular age the same sort of difference was seen. At maturity (that is, about 60 days after anthesis) the large amyloplasts have a higher proportion of amylopectin than the small amyloplasts. This agrees with the work of Bathgate and Palmer<sup>(40)</sup> using the varieties Maris Otter, where the large amyloplasts had 75% amylopectin and the small had 59% amylopectin and also with the work of Evers et al<sup>(43)</sup> on high-amylose Glacier where the large had 56% and the small 47% amylopectin. In this same work, however, Evers et al did not find any difference in the amylopectin contents of the large and small in normal Glacier. The situation is reversed in Julia in the stages of development leading up to maturity when the small amyloplasts have a higher percentage amylopectin content than the large. One explanation for these results could be that there are in fact two types of small amyloplasts. The first type (type A) would be produced at the start of development and would be high in amylopectin, producing the high amylopectin content of the total endosperm early in development. These would grow to become large amyloplasts. They are really, therefore, no different from the large amyloplasts and are more accurately described as young large amyloplasts. The other type (type B) of small amyloplasts would be produced later in development - possibly at around 14 days after anthesis when the two populations of amyloplasts are first seen.

These would have a higher amylose content than the first type.

Because they would stay small throughout development they would account for the majority of small amyloplasts at maturity and hence the higher amylose content of small amyloplasts at that time.

When the amyloplasts were treated with 19% hydrochloric acid, ring structure was seen in some of the large, but not the small amyloplasts. Buttrose<sup>(7)</sup> has stated that the presence or absence of rings is not affected by the amylose/amylopectin content of the starch granule. The difference observed here between the large and small must therefore be due to some other cause. It may be that the actual physical arrangement of the starch components within the granule varies between the large and small.

#### 4.4.3 Enzymic degradation of amyloplasts

Dunn<sup>(83)</sup> has shown that bacterial or malt  $\alpha$ -amylase will break down maize starch granules in vitro.  $\beta$ -amylase did not attack the native starch granules<sup>(83, 131)</sup>. The effect of  $\alpha$ -amylase and the de-branching enzyme pullulanase on amyloplasts isolated at various stages of barley development was therefore investigated here, in an effort to determine the structure of large and small amyloplasts.

It was thought that pullulanase might increase the rate of hydrolysis of the starch granule by  $\alpha$ -amylase since it would attack the  $\alpha$ -(1,6) bonds either in the dextrans released by  $\alpha$ -amylase or in the structure of the granule itself. However pullulanase did not give any increase in rate of reducing sugar release from native starch granules.

In most instances the small amyloplasts were more susceptible to  $\alpha$ -amylolysis than the large of the same age. This correlates with the work of Palmer<sup>(132)</sup> who found, using the scanning electron microscope, that the small granules were degraded first on malting,



although Bathgate and Palmer<sup>(133)</sup> using malt  $\alpha$ -amylase on barley starch found that the small amyloplasts were more resistant to  $\alpha$ -amylolysis than the large. This later work was, however, done at the temperature of 65°C required in brewing and not at 25°C which more closely approximates the in vivo system. The higher temperature would affect the gelatinisation state of the starch and change the susceptibility to  $\alpha$ -amylolysis.

One reason why the small amyloplasts might be degraded more readily than the large is because of the greater surface area for their volume for adsorption of the enzyme. However, Walker and Hope<sup>(131)</sup> showed that in starch granules from several species increased adsorption of  $\alpha$ -amylase led to decreased hydrolysis. Adsorption was calculated from the loss of activity in the supernatant from the reaction mixture. It might also be the case that the small amyloplast membrane is for some reason more permeable to  $\alpha$ -amylase than the large. In the case of amyloplasts from barley 25 days after anthesis the small were less susceptible to  $\alpha$ -amylolysis than the large. This indicates that the amyloplasts are changing as they mature.

The extract from germinated barley did not appear to break down starch in isolated amyloplasts. However, the amyloplasts used were immature (38 days after anthesis) and therefore possibly resistant to attack by an extract from mature grain. This might be due to the membrane structure of the amyloplast being less permeable to barley extract than to the large quantities of the hog pancreas  $\alpha$ -amylase used in the other experiments. This is very likely, since the immature amyloplasts must be resistant to the hydrolases found in the developing grain. The results may also be due to the fact that no attempt was made to purify the  $\alpha$ -amylase from the barley extract. Since



germinated extracts doubtless contain some glycolytic enzymes, it is possible that the absence of reducing sugars is due to their removal by glycolysis.

During germination the ratio of small to large amyloplasts increased rapidly, indicating that the large amyloplasts were degraded first. This contrasts with the results of the in vitro experiments with hog pancreas  $\alpha$ -amylase and isolated amyloplasts. However, the in vivo system will be more complex with a number of hydrolytic enzymes in addition to  $\alpha$ -amylase, and possibly other regulating systems, taking part. When  $\alpha$ -amylase degradation alone is being considered the other factors regulating amyloplast breakdown have been removed. The results reported here are confirmed by those of Dronzek et al<sup>(134)</sup> who showed by scanning electron microscopy that in wheat at sprouting most of the enzyme attack was on the large granules.

#### 4.4.4 Enzymes associated with the amyloplast

The starch synthetases associated with the large and small amyloplasts have different pH optima and nucleotide specificities. The amyloplast bound enzyme of mature barley has been shown to be active with both UDPG and ADPG as nucleotide, although the activity is greater with ADPG<sup>(61)</sup>. This can probably be accounted for by the relative activities of the enzyme associated with the large and small amyloplasts. If the majority of the small amyloplasts seen at early ages are going to develop into large amyloplasts it is not surprising that small amyloplasts at this stage are active with ADPG. The activity with UDPG might therefore be due to the second type of small amyloplasts. The early activity of the large amyloplasts with UDPG is more difficult to explain. It is possible, however, that the starch synthetase of the large amyloplasts is capable of utilizing both nucleotides until about 22 days. After this time the enzyme

may be modified and loses its ability to utilize UDPG. The activity with UDPG is then seen in the small amyloplasts.

#### 4.4.5 Amyloplast development

It is possible to devise at least three theories of amyloplast development. One is that the 'A-type' amyloplasts are produced throughout the growth of the barley grain and grow until the barley reaches maturity. The small ones are therefore those which are produced later in development.

A second theory is that both 'A' and 'B' types of amyloplasts are produced at all stages of development of the barley. The 'B' type would stay small, whereas the 'A' type would grow larger throughout development. These two theories, however, do not easily account for the fact that two types of amyloplast are first seen at around 14 days after anthesis.

A third theory is that one type (the 'A' type) are produced throughout growth but that the 'B' type of small amyloplasts are produced at around 14 days after anthesis and thereafter stay small. This is the theory put forward in section 4.4.2 to explain the results of amylose and amylopectin content values. May and Buttrose<sup>(41)</sup> have suggested that this second small type may be produced simply because of lack of space in the endosperm at this age for larger amyloplasts to be produced.

Different results can be predicted using each of these three theories if the amyloplasts are labelled with carbon-14 at various stages during development. Labelling was carried out at earing and 10, 14, 24 and 35 days after anthesis.

According to the first theory the large amyloplasts should be labelled at all these stages and the small amyloplasts labelled only when labelling was done at 24 and 35 days after anthesis.

According to the second theory both large and small amyloplasts would be labelled, regardless of the age at which labelling was carried out. By the third theory the large amyloplasts should again be labelled at all ages but the small amyloplasts labelled at 14 and 25 and possibly 35 days (see fig. 4.1). The results indicate that of these three theories the third is most likely. Those amyloplasts which were labelled at the earing stage grew to become large amyloplasts. The small were produced later. The fact that the small amyloplasts were not labelled when labelling was done at 35 days after anthesis indicates that all the small amyloplasts of both types have been produced by this age.

The method used (that of attaching a vial of solution to the flag leaf) was found to be the most suitable for this experiment. Injecting the grain was unsuccessful, since it was impossible to inject an exact amount of liquid into the grain at successive attempts. Sodek and Wilson<sup>(135)</sup> rejected results obtained when  $^{14}\text{C}$ -labelled amino acids were injected into corn endosperm suggesting that the conflicting results which they obtained might be partly accounted for by the different physical states of the endosperm at various stages in development. It would also be difficult to inject label into exactly the same part of the endosperm each time. Enzyme activity will vary from area to area within the endosperm.

The results of this experiment would be less reliable if there was a considerable turnover of starch in the granule. Although the results given earlier suggest that during the production of starch molecules degradation and synthesis occur simultaneously it is likely that once the starch has been laid down in the structure of the granule it is not further metabolised until germination<sup>(79)</sup>.

Fig. 4.1 Theories of Amyloplast  
Development

- ⊗ labelled amyloplast
- unlabelled amyloplast

# THEORIES OF DEVELOPMENT

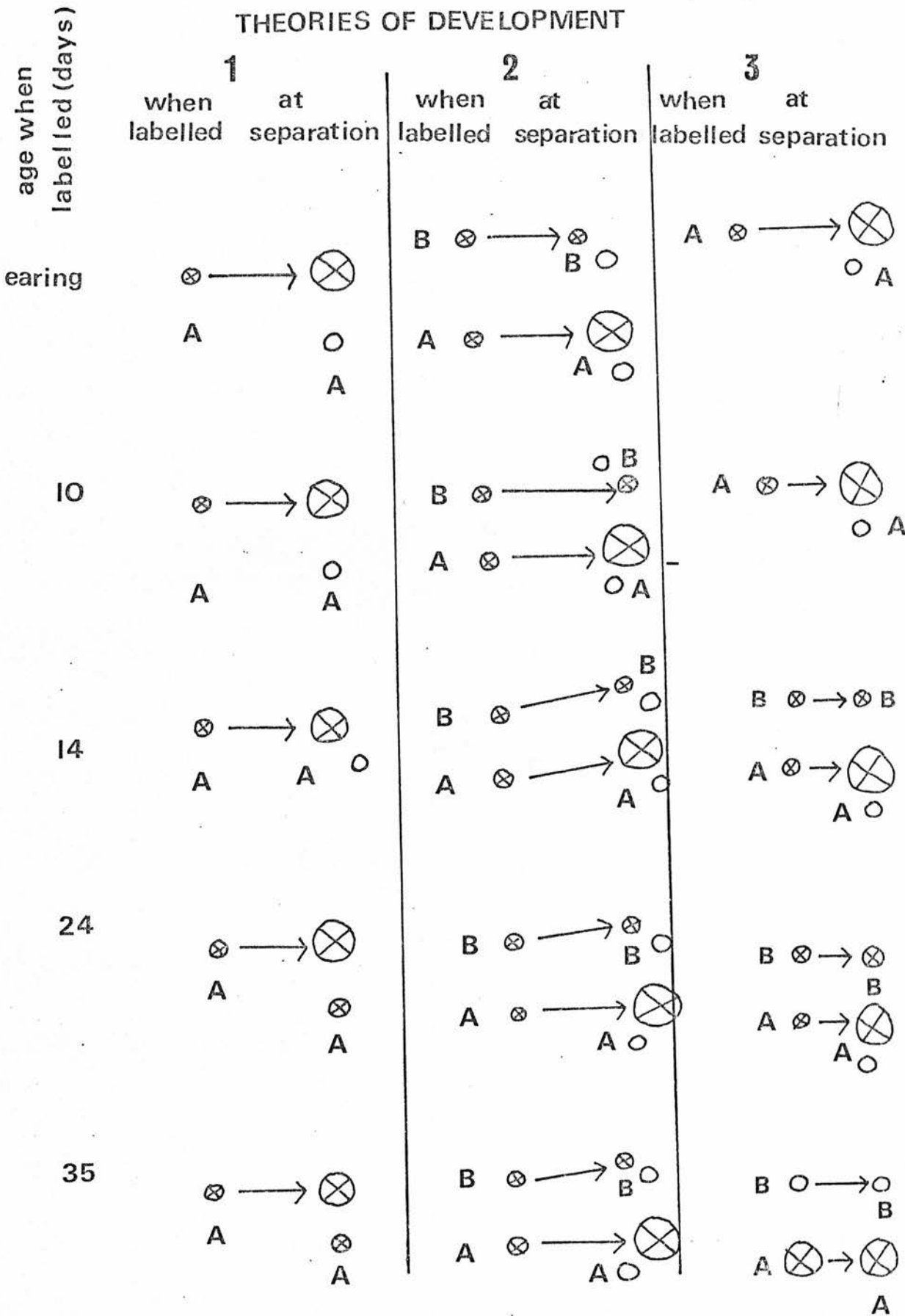

Fig.4.1

Buttrose<sup>(7)</sup> has suggested that the small amyloplasts arise from the large amyloplasts. This theory was based on electron microscopic evidence in the barley variety 'Prior' in which evaginations of the amyloplast double membrane surrounding a large starch granule were seen. The small granules were claimed to develop in this evagination and to separate from the large granule by constriction of the intervening cytoplasm. No electron microscopic evidence was seen for this in the present work. That this theory is scarcely tenable is also indicated by the fact that the small and large amyloplasts have been shown to be different in chemical composition and in the enzymes associated with each.

#### 4.5 Conclusions

While much has been discovered about the development of the grain of the barley variety Julia, the enzymes present in the endosperm and the development of large and small amyloplasts, much more work remains to be done before the structure of the amyloplast, its development and its relationship to the enzymes of the barley endosperm are fully understood. For instance, it has been suggested here that amyloplasts are initiated at multiple sites. There appears to be no biochemical evidence so far for this phenomenon. This might possibly be obtained using  $^{14}\text{C}$  labelled starch precursors.

The relationship between starch synthetase and branching enzyme also requires further consideration. The results given here suggest that these two enzymes are very closely related and this could be confirmed by other attempts to separate the two, with, for example, chromatography or different electrophoretic methods.

In the experiments with  $\alpha$ -amylase on amyloplasts the germinated barley extracts did not appear to degrade the amyloplasts and it was suggested that this was due to the interference of glycolysis.

This could be avoided in future experiments if a glycolytic inhibitor such as fluoride was included in the reaction mixture.

It must also be taken into account that the results given here apply to the variety Julia and further work must be done on different varieties before the results can be applied to barley and cereals in general.

## ACKNOWLEDGEMENTS

I would like to thank my supervisor, Dr. C. M. Duffus, for her assistance and encouragement throughout this investigation and for her helpful suggestions in the preparation of this thesis. I am also grateful to Dr. P. McDonald and Professor N. Robertson for their continued interest in my work.

I am indebted to Dr. C. Johnston, Mr. J. Buchanan and other members of the staff of the Electron Microscope Unit at the Heriot-Watt University for permission to use their electron microscope and ancillary equipment and for guidance in its use.

My thanks also go to the Scottish Plant Breeding Station for the use of greenhouse facilities and for supplying the plant material.

The pullulan used was the generous gift of Dr. B. Catley, Heriot-Watt University.



## REFERENCES

1. Beaven, E.S., 'Barley' (Duckworth, 1947)
2. Hunter, H., 'The Barley Crop' (Crosby, Lockwood and Son, 1952)
3. 'Scottish Agriculture and the EEC' (Scottish Agricultural Development Council, 1974)
4. Bland, B.F. 'Crop Production: Cereals and Legumes' (London 1971)
5. Buttrose, M.S., Aust. J. Biol. Sci. 16, 305 (1963)
6. Harlan, H.V., J. Agr. Research 19, 393 (1920)
7. Buttrose, M.S., J. Ultrastructure Res. 4, 231 (1960)
8. Wardlaw, I.F., Aust. J. Biol. Sci. 23, 765 (1970)
9. Russell, E.J. and Bishop, L.R., J. Inst. Brewing 287 (1933)
10. Whelan, W.J., Enc. Plant Physiol. 6, 154 (ed. Ruhland, W., Springer-Verlag (Berlin) 1958)
11. Kjolberg, O. and Manners, D.J., Biochem. J. 84, 50P (1962)
12. Haworth, W.N., Hirst, E.L. and Isherwood, F.A. J.Chem. Soc. p.577 (1937)
13. Meyer, K.H. and Bernfeld, P., Helv. Chim. Acta 23 875 (1940)
14. Parrish, F.W. and Whelan, W.J., Die Stärke 6 231 (1961)
15. Whelan, W.J., Nature 190, 954 (1961)
16. Staudinger, H. and Husemann, E., Annalen der Chemie 527, 195 (1937)
17. Thompson, A. and Wolfrom, M.L., J. Amer. Chem. Soc. 73, p.5849 (1951)
18. Gunja-Smith, Z., Marshall, J.J., Mercier, C., Smith, E.E. and Whelan, W.J., F.E.B.S. Letters 12, 101 (1970)
19. Seckinger, H.L. and Wolf, M.J., Cereal Chem. 44, 669 (1967)
20. Swift, J.G. and Buttrose, M.S., Planta 109, 61 (1973)

21. Simmonds, D.H., *Cereal Chem.* 49, 212 (1972)
22. Badenhuizen, N.P., *Eric. Plant Physiol.* 6, 137  
(ed. Ruhland, W., Springer-Verlag (Berlin) 1958)
23. Badenhuizen, N.P., *Nature* 197, 464 (1963)
24. Mahlberg, P., *Planta* 110, 77 (1973)
25. Salema, R. and Badenhuizen, N.P., *J. Ultrastructure Res.* 20,  
383, (1967)
26. Anstis, P.J.P. and Northcote, D.H., *New Phytol.* 72 449 (1973)
27. Duffus, C.M. and Rosie, R., *Anal. Biochemistry* 65, 11 (1975)
28. Banks, W., Greenwood, C.T. and Muir, D.D., *Die Stärke* 25, 153 (1973)
29. Sandstedt, R.M., *Cereal Chem.* 23, 337 (1946)
30. Badenhuizen, N.P., 'Biogenesis of Starch Granules in Higher Plants'  
(Appleton-Century-Crofts, New York, 1969)
31. Sterling, C. and Spit, B.J., *J. Exp. Botany* 9, 75 (1958)
32. Whistler, R.L. and Turner, E.S., *J. Polymer Sci.* 18, 153 (1955)
33. Finkelstein, R.S. and Sarko, A., *Carbohydrate Res.* 23, 31 (1972)
34. Nikuni, Z. and Whistler, R.L., *J. Biochem.* 44, 227 (1957)
35. Badenhuizen, N.P. and Dutton, R.W., *Protoplasma* 47, 156 (1956)
36. Buttrose, M.S., *J. Cell Biol.* 14, 159 (1962)
37. Roberts, E.A. and Proctor, B.E., *Science* 119, 509 (1954)
38. Mes, M.G. and Menge, I., *Physiol. Plantarum* 7, 637 (1954)
39. Hizukuri, S., Fujii, M. and Nikuni, Z., *Nature* 192, 239 (1961)
40. Bathgate, G.N. and Palmer, G.H., *Die Starke* 24, 336 (1972)
41. May, L.H. and Buttrose, M.S., *Aust. J. Biol. Sci.* 12, 146 (1959)
42. Goering, K.J., Fritts, D.H. and Eslick, R.F., *Die Starke*, 25, 297  
(1973)
43. Evers, A.D., Greenwood, C.T., Muir, D.D. and Venables, C.,  
*Die Starke*, 26, 42 (1974)
44. Goering, K.J. and DeHaas, B., *Cereal Chem.* 51, 573 (1974)

45. Cori, C.F., Colowick, S.P. and Cori, G.T., J. Biol. Chem. 121  
465 (1937)
46. Illingworth, B., Brown, D.H. and Cori, C.F., Proc. Nat. Acad.  
Sci. 47, 469 (1961)
47. Hanes, C.S. Proc. Roy. Soc. (London) Series B, 128, 421 (1940)
48. Baxter, E.D. and Duffus, C.M., Phytochemistry 12, 2321 (1973)
49. Frydman, R.B. and Slabnik, E., Annals N.Y. Acad. Sci. 210, 153  
(1973)
50. Leloir, L.F. and Cardini, C.E., J. Amer. Chem. Soc. 79, 6340  
(1957)
51. Leloir, L.F., Biochem. J. 91, 1 (1964)
52. Recondo, E. and Leloir, L.F., Biochem. Biophys. Res. Comm.  
6, 85 (1961)
53. Gahan, L.C. and Conrad, H.E., Biochemistry 7, 3979, (1968)
54. Ozbun, J.L., Hawker, J.S. and Preiss, J., Biochem. Biophys.  
Res. Comm. 43 631 (1971)
55. Ozbun, J.L., Hawker, J.S. and Preiss, J., Biochem. J. 126,  
953 (1972)
56. Fox, J., Kennedy, L.D., Hawker, J.S., Ozbun, J.L., Greenberg, E.,  
Lammel, C. and Priess, J., Annals N.Y. Acad. Sci. 210, 90 (1973)
57. Lavintman, N. and Cardini, C.E., F.E.B.S. letters 29, 43 (1973)
58. De Fekete, M.A.R., Leloir, L. and Cardini, C.E. Nature 187  
918 (1960)
59. Leloir, L.F., De Fekete, M.A.R. and Cardini, C.E.  
J. Biol. Chem. 236, 636 (1961)
60. Frydman, R.B. and Cardini, C.E., J. Biol. Chem. 242, 312 (1967)
61. Baxter, E.D. and Duffus, C.M., Phytochemistry 10, 2641 (1971)
62. Baxter, E.D. and Duffus, C.M., Planta 114 195 (1973)

63. Murata, T., Sugiyama, T. and Akazawa, T.  
Biochem. Biophys. Res. Comm. 18, 371 (1965)
64. Schiefer, S., Lee, E.Y.C. and Whelan, W.J., F.E.B.S. letters  
30, 129 (1973)
65. Turner, D.H. and Turner, J.F., Aust. J. Biol. Sci 10, 302 (1957)
66. Hamada, I., Chem. Abs. 61 4714 (1964)
67. Mangat, B.S. and Badenhuizen, N.P., Can. J. Botany, 49 1787  
(1971)
68. Badenhuizen, N.P., Annals N.Y. Acad. Sci. 210 11 (1973)
69. Burr, B. and Nelson, O.E., Annals N.Y. Acad. Sci. 210 129 (1973)
70. Ewart, M.H., Siminovitch, D. and Briggs, D.R., Plant. Physiol.  
29 407 (1954)
71. Ozbun, J.L., Hawker, J.S., Greenberg, E., Lammel, C., Preiss, J.  
and Lee, E.Y.C., Plant Physiol. 51, 1 (1973)
72. Manners, D.J. and Rowe, J.J.M., Chem. Industry (London) 1834 (1964)
73. Manners, D.J., Rowe, J.J.M. and Rowe, K.L. Carbohydrate Res. 8  
72 (1968)
74. Cori, G.T. and Cori, C.G. J. Biol. Chem. 151, 57 (1943)
75. Haworth, W.N., Bourne, E.J. and Peat, S., Nature 154, 236 (1944)
76. Gilbert, G.A. and Patrick, A.D., Biochem. J. 51, 181 (1952)
77. Lares, C., Frixon, C., Creuzet-Sigal, N. and Thomas, P.  
J. General Microbiol. 82, 279 (1974)
78. Barker, S.A., Bourne, E.J., Peat, S. and Wilkinson, J.A.  
J. Chem. Soc. 3022 (1950)
79. McConnell, W.B., Mitra, A.K., and Perlin, A.S. Can. J. Biochem.  
Physiol. 36, 985 (1958)
80. Kovacs, M.I.P. and Hill, R.D., Phytochemistry 13, 1335 (1974)
81. Duffus, C.M. and Rosie, R., Planta 109, 153 (1973)

82. Schwimmer, S. and Balls, A.K., J. Biol. Chem. 176 465 (1949)
83. Dunn, G., Phytochemistry 13, 1341 (1974)
84. Manners, D.J. in 'Essays in Biochemistry' 10, 37 (Academic Press 1974)
85. MacWilliam, I.C., Nature 181 1143 (1958)
86. Manners, D.J., Advances in Carbohyd. Chemistry 17, 371 (1962)
87. Lee, E.Y.C. and Whelan, W.J. in 'The Enzymes' 5 191  
(ed. P.D. Boyer, Academic Press, 1971)
88. Lavintman, N. and Cardini, C.E., Biochem. Biophys. Acta 201  
508 (1970)
89. Baxter, E.D. Ph.D. thesis, University of Edinburgh, (1972)
90. Morris, D.L., Science 107, 254 (1948)
91. Somogyi, M., J. Biol. Chem. 160, 69 (1945)
92. Nelson, O.E., J. Biol. Chem. 153, 375 (1944)
93. Raabo, E. and Terkildsen, T.C., Scand. J. Clin. and Lab.  
Invest., 12, 402 (1960)
94. Lowry, D.H., Rosebrough, N.J., Farr, A.L. and Randall, R.J.,  
J. Biol. Chem. 193 265 (1951)
95. Mollenhauer, H. and Zebrun, W., J. Biophys. Biochem. Cytol. 8,  
761 (1960)
96. Reynolds, E.S., J. Cell. Biol. 17, 208 (1963)
97. Krisman, C.R., Biochem. Biophys. Acta 65, 307 (1962)
98. Barker, S.A., Bourne, E.J. and Peat, S., J. Chem. Soc. 1705 (1949)
99. Briggs, D.E., J. Inst. Brewing 73, 361 (1967)
100. Duffus, J.H., J. Inst. Brewing 75, 252 (1969)
101. Slabnik, E. and Frydman, R.B., Biochem. Biophys. Res. Comm.  
38, 709 (1970)
102. Lowry, D.H. and Lopez, J.A., J. Biol. Chem. 162, 421 (1946)
103. Loyter, A. and Schramm, M., Biochem. Biophys. Acta 65, 200 (1962)

104. Manners, D.J. and Yellowlees, D., *J. Inst. Brewing* 79, 377 (1973)
105. Waygood, E.R., Arya, S.K. and Mache, R., in 'Photosynthesis and Photorespiration' 246 (ed. M.D. Hatch, C.B. Osmond and R.O. Slatyer, Wiley-Interscience 1971).
106. Bialeski, R.L. and Young, R.E., *Anal. Biochemistry* 6, 54 (1963)
107. Bergmeyer, H.U., Bernt, E., Schmidt, F. and Stork, H. in 'Methoden der Enzymatischen Analyse' 2nd ed. p.1163 (H.U. Bergmeyer, Verlag Chemie, Weinheim, 1970)
108. Cori, C.F., Colowick, S.P. and Cori, G.T., *J. Biol. Chem.* 123 375 (1938)
109. Fiske, C.H. and SubbaRow, Y., *J. Biol. Chem.* 66, 375 (1925)
110. Gilbert, G.A. and Spragg, in 'Methods in Carbohydrate Chemistry' 4 168 (ed. Whistler, Academic Press, 1964).
111. Jennings, A.C. and Morton, R.K., *Aust. J. Biol. Sci.* 16 318 (1963)
112. Leloir, L.F. and Goldemberg, S.H. in 'Methods in Enzymology' 5, 145 (ed. Colowick, S.P. and Kaplan, N.O., Academic Press, 1962)
113. LaBerge, D.E., MacGregor, A.W. and Meredith, W.O.S., *J. Inst. Brewing* 79, 471 (1973)
114. Duffus, C.M. and Rosie, R., *J. Agricultural Sci* (1976) IN PRESS
115. Paleg, L.G., *Plant Physiol.* 35, 902 (1960)
116. Cerming, J. and Guilbot, A., *Cereal Chem.* 50, 220 (1973)
117. Ingle, J., Beitz, D. and Hageman, R.H., *Plant Physiol.* 40, 835 (1965)
118. MacGregor, A.W., LaBerge, D.E. and Meredith, W.O.S. *Cereal Chem.* 48, 255 (1971)

119. Harris, G. and MacWilliam, I.C., *J. Inst. Brewing* 63, 210 (1957)
120. Duffus, C.M. and Rosie, R., *Phytochemistry* 14, 319 (1975)
121. Pomeranz, Y., Standridge, N.N. and Shands, H.L., *Crop Science*, 11, 85 (1971)
122. Thorne, G.N., *Annals Botany (N.S.)* 29, 317 (1965)
123. Evans, L.T. and Rawson, H.M., *Aust. J. Biol. Sci.* 23, 245 (1970)
124. Duffus, C.M. and Rosie, R., *Planta* 114, 219 (1973)
125. Bailey, R.W. and MacRae, J.C., *F.E.B.S. letters* 31 203 (1963)
126. Tanaka, Y. and Akazawa, T., *Plant and Cell Physiol.* 12 493 (1971)
127. Hawker, J.S., Ozbun, J.L., Ozaki, H., Greenberg, E. and Preiss, J. *Arch. Biochem. Biophys.* 160, 530 (1974)
128. Perdon, A.A., Del Rosario, E.J. and Juliano, B.O., *Phytochemistry* 14, 949 (1975)
129. Chandorkar, K.R. and Badenhuizen, N.P., *Cereal Chem.* 44, 27 (1967)
130. Ohad, I., Friedberg, I., Ne'eman, Z. and Schramm, M. *Plant Physiol.* 47, 465 (1971)
131. Walker, G.J. and Hope, P.M., *Biochem. J.* 86, 452 (1963)
132. Palmer, G.H., *J. Inst. Brewing* 78, 326 (1972)
133. Bathgate, G.N. and Palmer, G.H., *J. Inst. Brewing* 79, 402 (1973)
134. Dronzek, B.L., Hwang, P. and Bushuk, W., *Cereal Chem.* 49, 232 (1972)
135. Sodek, K. and Wilson, C.M., *Plant Cell Physiol.* 12, 889 (1971)

PLATES 1-28



CAPTIONS TO PLATES 1-28

Plate 1 and Plate 2 Grain 2 days after anthesis. Glutaraldehyde/  
osmium tetroxide fixation. x20,000

Plate 3 Grain 2 days after anthesis.  $\text{KMnO}_4$  fixation. x125,000

Plate 4 Grain 2 days after anthesis. Glutaraldehyde/ $\text{OsO}_4$   
fixation. x35,000

Plate 5 Endosperm 3 days after anthesis.  $\text{KMnO}_4$  fixation. x35,000

Plate 6 Endosperm 6 days after anthesis. Glutaraldehyde/ $\text{OsO}_4$   
fixation. x5,000

Plate 7 Endosperm 6 days after anthesis.  $\text{KMnO}_4$  fixation. x31,000

Plate 8 Endosperm 6 days after anthesis. Glutaraldehyde/ $\text{OsO}_4$   
fixation. x80,000

Plate 9 Endosperm 12 days after anthesis. Glutaraldehyde/ $\text{OsO}_4$   
fixation. x50,000

Plate 10 Endosperm 14 days after anthesis. Glutaraldehyde/ $\text{OsO}_4$   
fixation. x1,250

Plate 11 Endosperm 14 days after anthesis.  $\text{KMnO}_4$  fixation. x35,000

Plate 12 Endosperm 14 days after anthesis. Glutaraldehyde/ $\text{OsO}_4$   
fixation. x31,000

Plate 13 Endosperm 18 days after anthesis.  $\text{KMnO}_4$  fixation. x31,000

Plate 14 Endosperm 18 days after anthesis. Glutaraldehyde/ $\text{OsO}_4$   
fixation. x20,000

Plate 15 Endosperm 18 days after anthesis. Glutaraldehyde/ $\text{OsO}_4$   
fixation. x12,500

Plate 16 Endosperm 18 days after anthesis. Glutaraldehyde/ $\text{OsO}_4$   
fixation. x20,000

Plate 17 Endosperm 38 days after anthesis.  $\text{KMnO}_4$  fixation. x 35,000

Plate 18, Plate 19 and Plate 20 Endosperm 38 days after anthesis.  
 $\text{KMnO}_4$  fixation. x50,000

Plate 21 Testa - pericarp 3 days after anthesis. Glutaraldehyde/ $\text{OsO}_4$   
fixation. x50,000

Plate 22 Testa - pericarp 25 days after anthesis. Glutaraldehyde/ $\text{OsO}_4$   
fixation. x 31,000

Plate 23 Testa - pericarp 25 days after anthesis. Glutaraldehyde/ $\text{OsO}_4$   
fixation. x50,000

Plate 24 Whole endosperm homogenate before separation on the sucrose  
gradient. x500

Plate 25 Large amyloplasts after separation on the gradient. x 500

Plate 26 Small amyloplasts after separation on the gradient. x 500

Plate 27 Amyloplast from the sucrose gradient.  $\text{KMnO}_4$  fixation. x50,000

Plate 28 Amyloplast after treatment with HCl.  $\text{KMnO}_4$  fixation. x80,000



1.

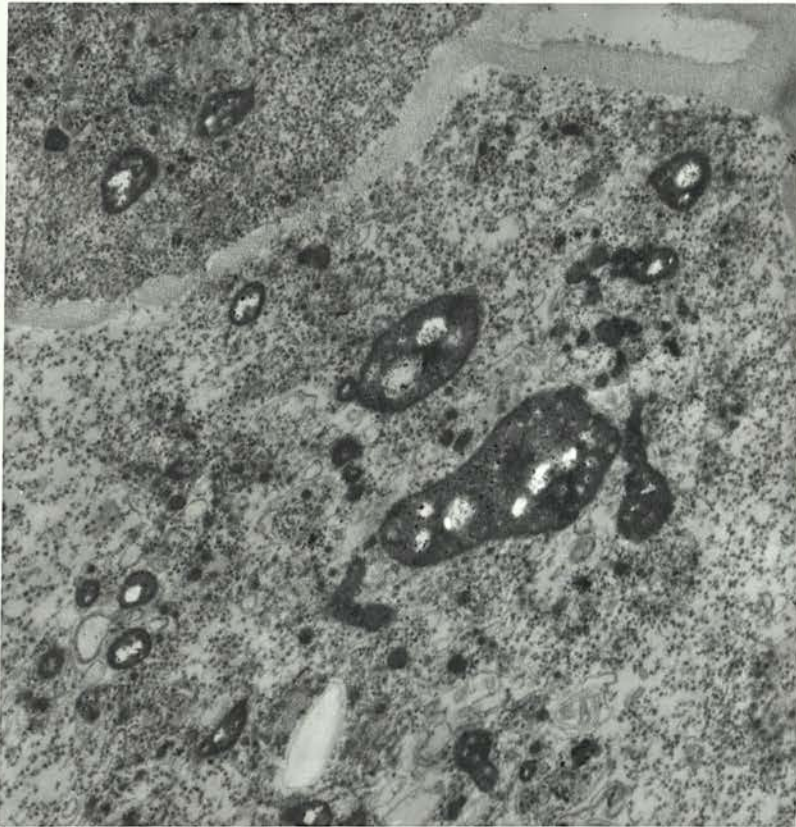

2.

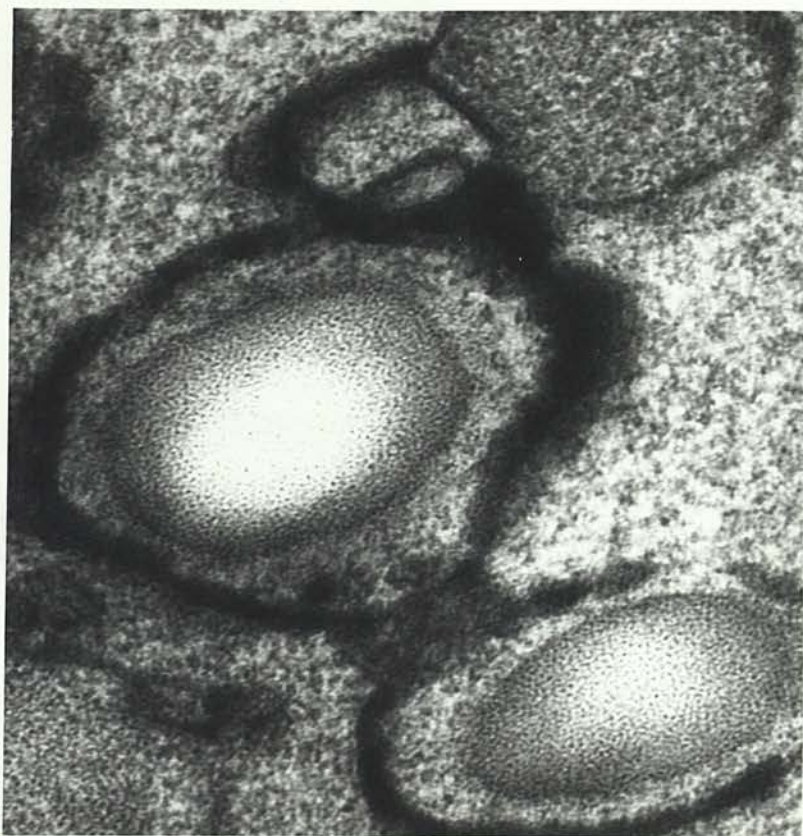

3.

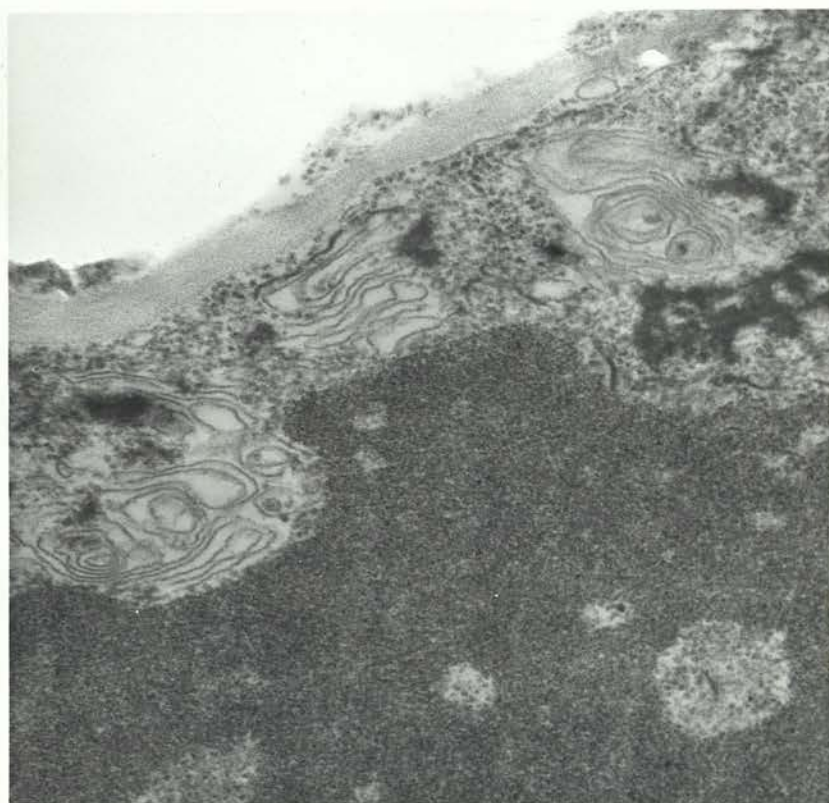

4.



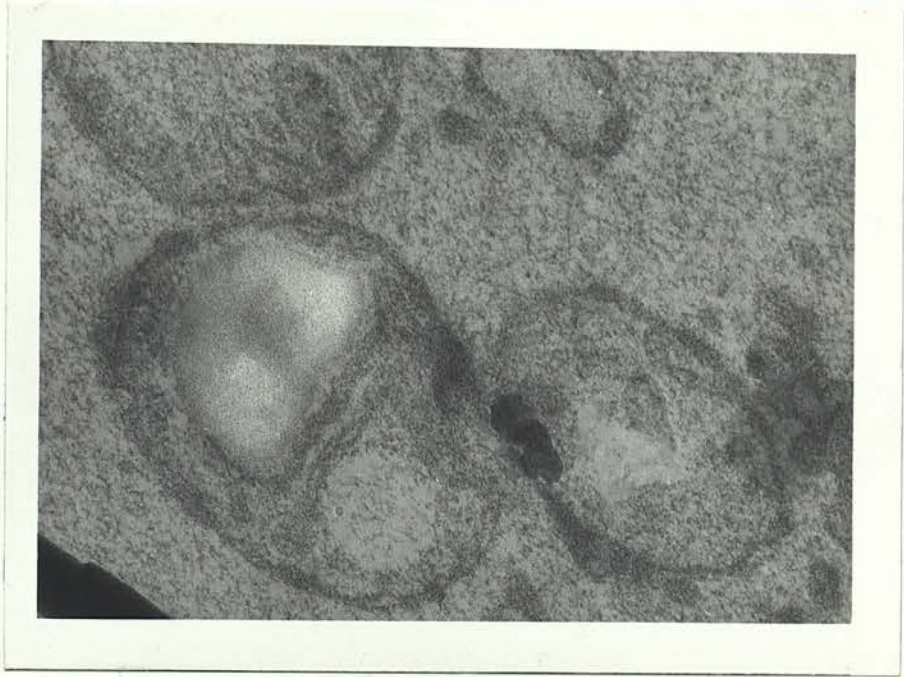

5.



6.



7.

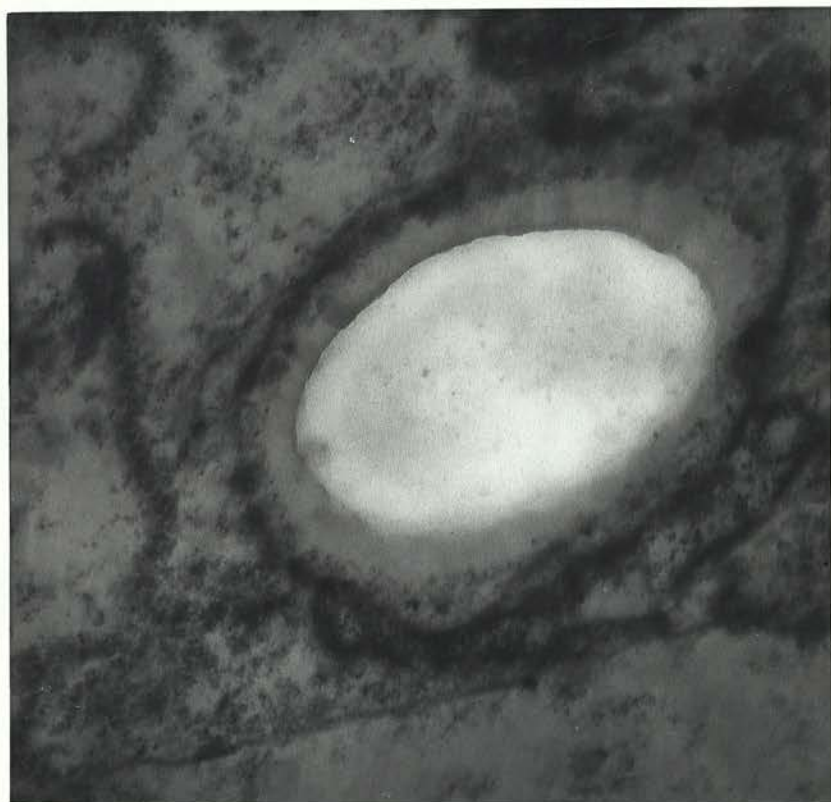

8.

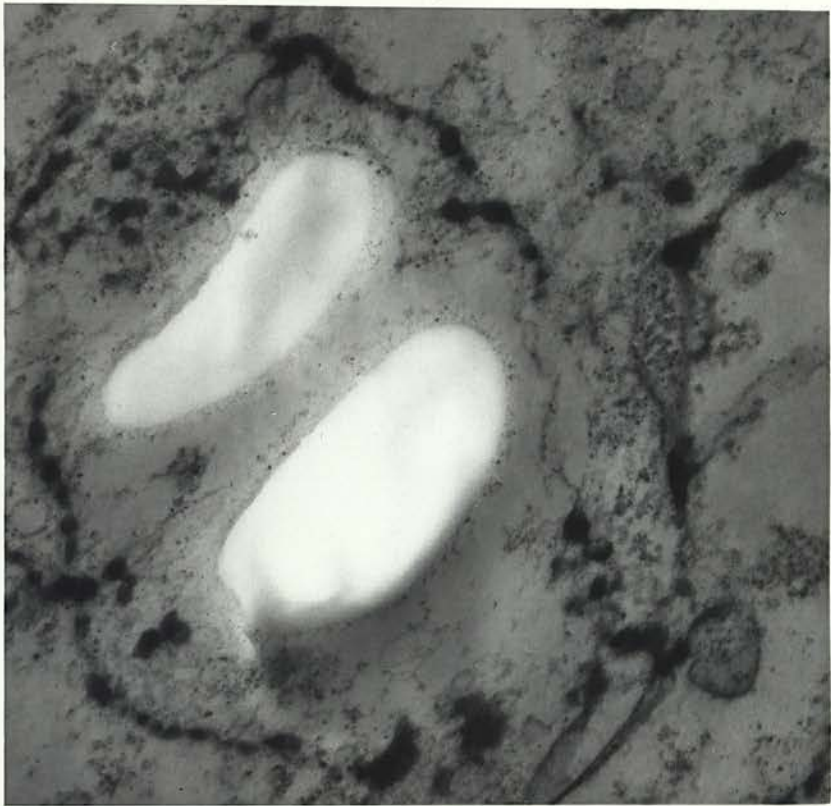

9.

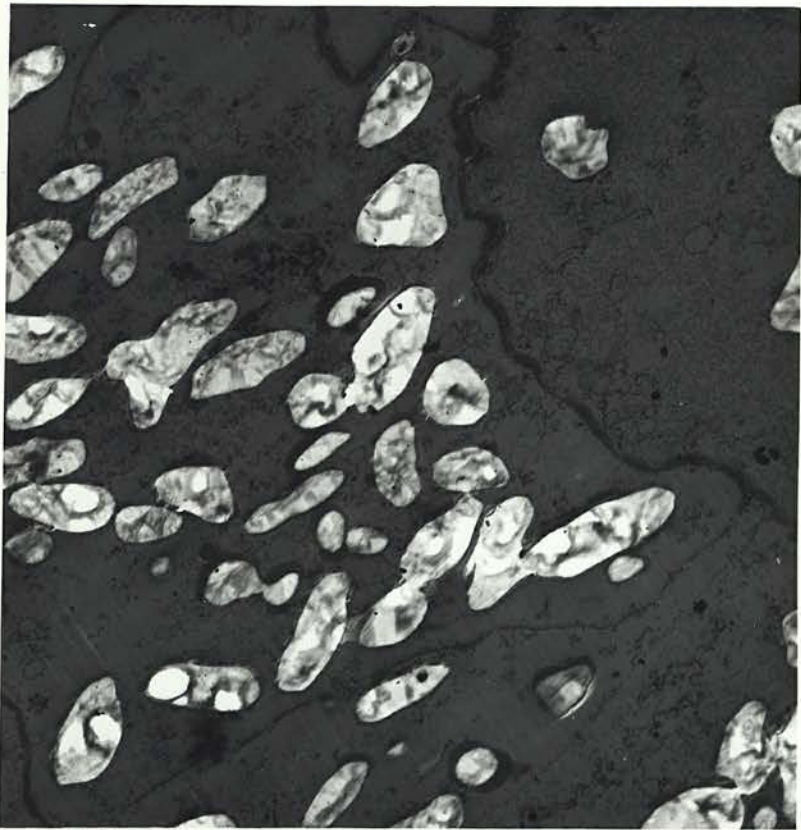

10.



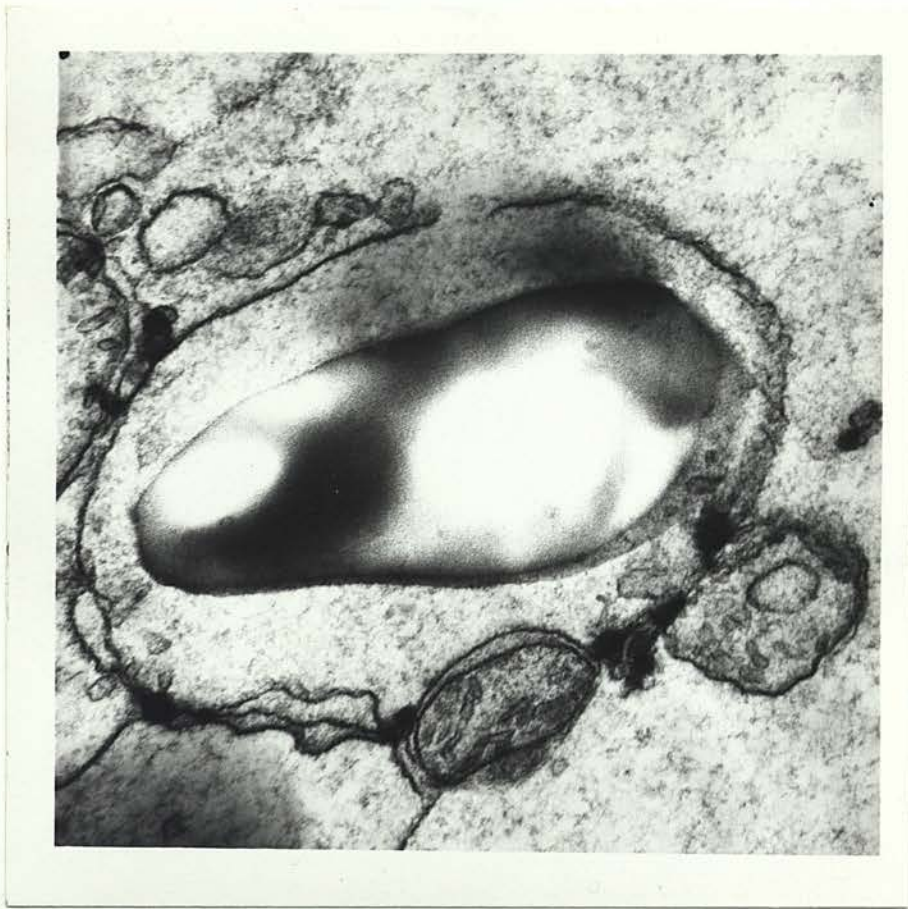

11.



12.



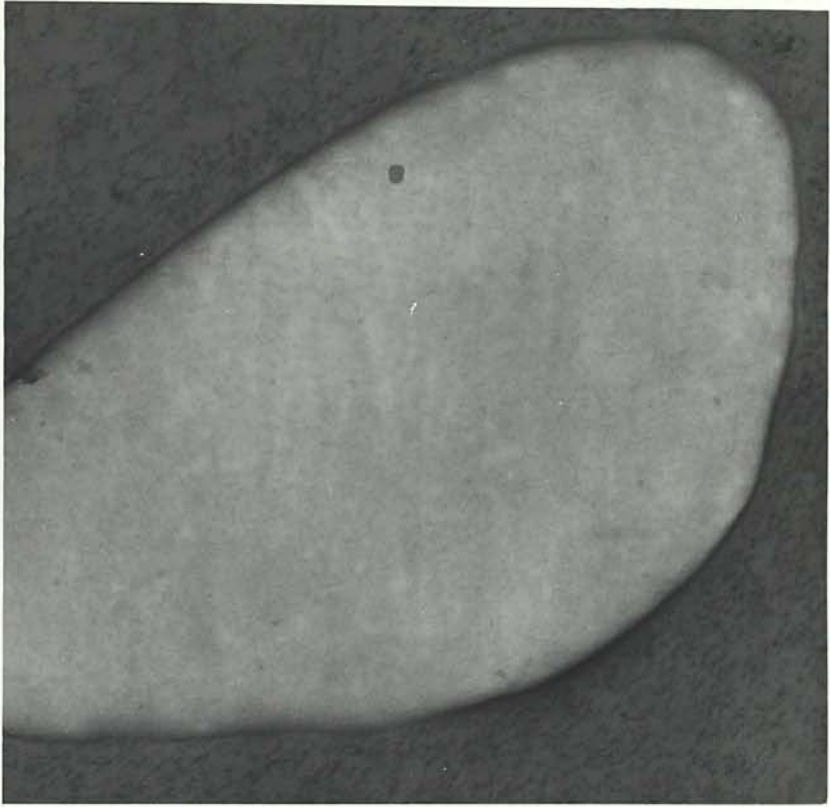

13.

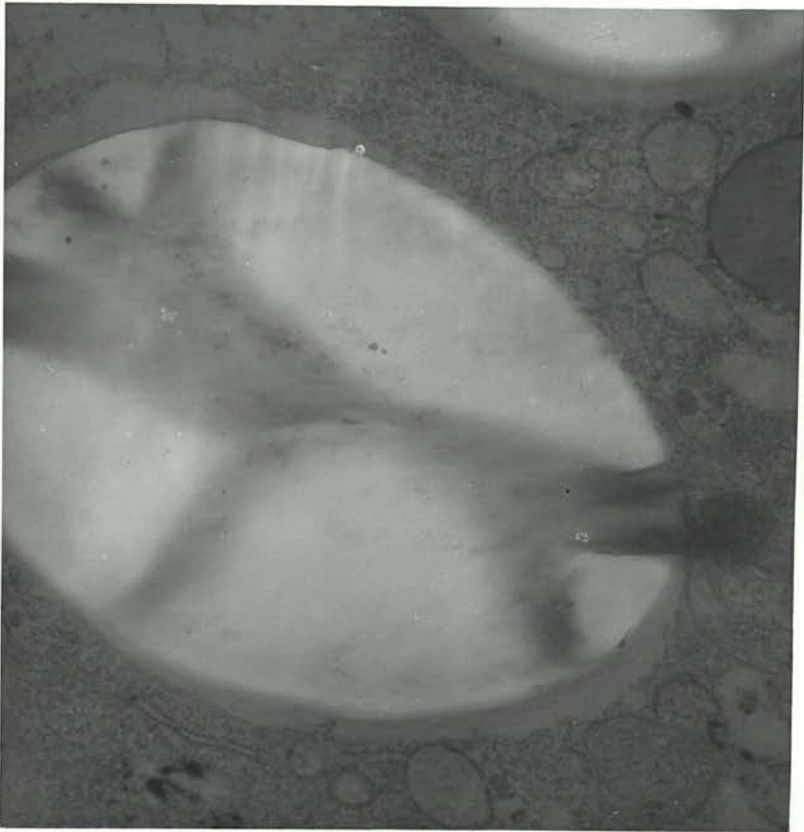

14.

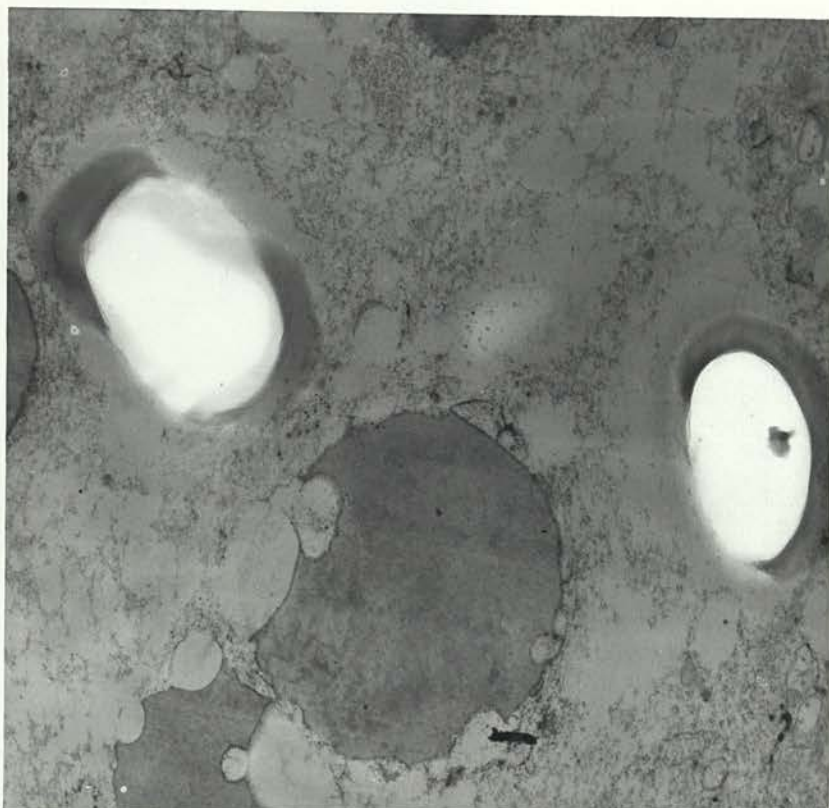

15.

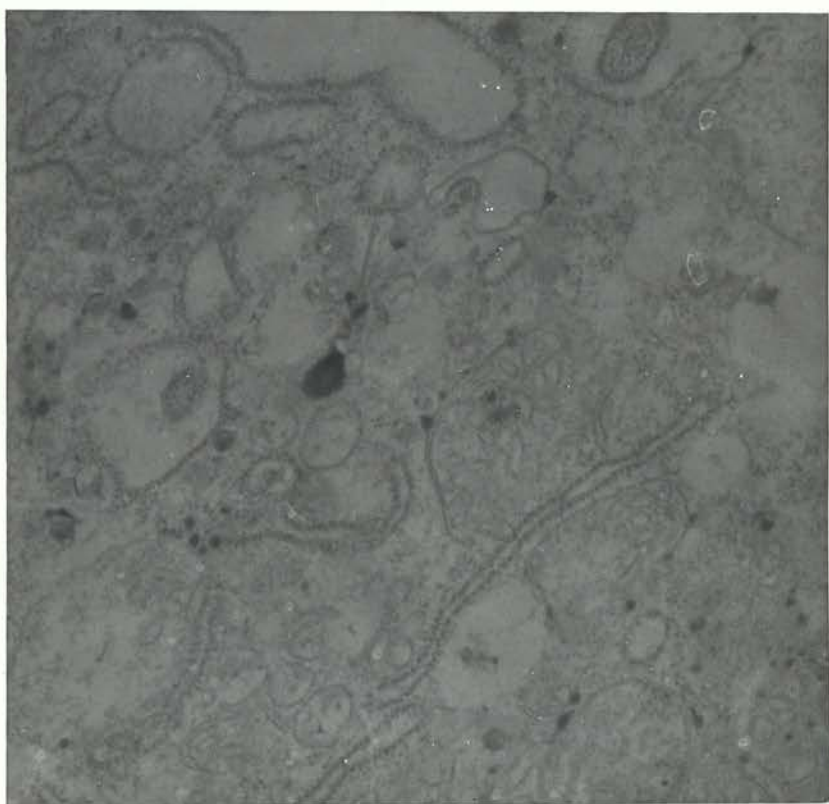

16.

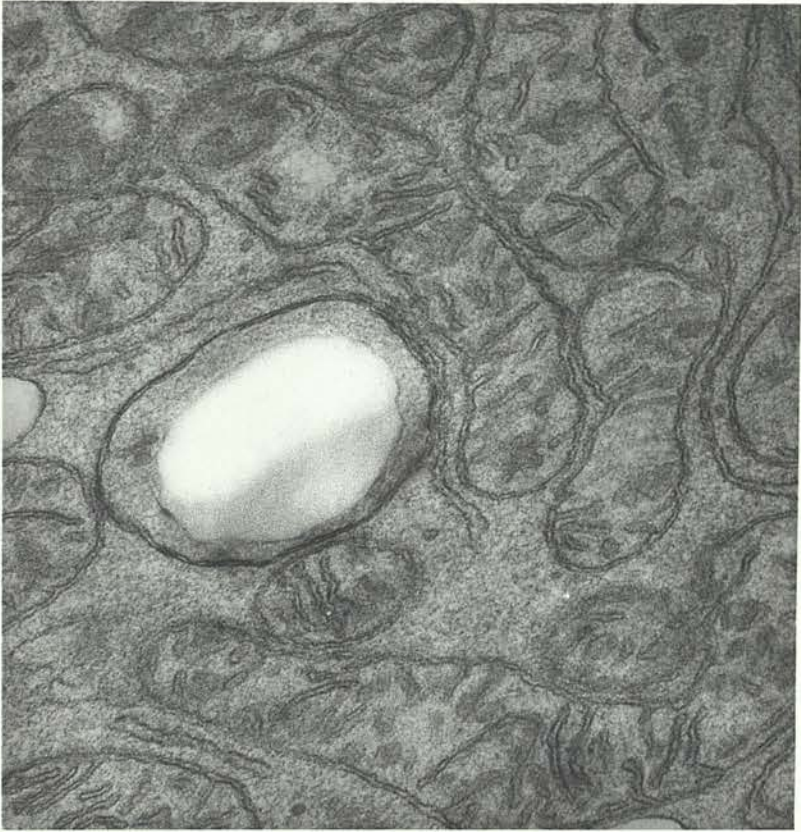

17.



18.





19.

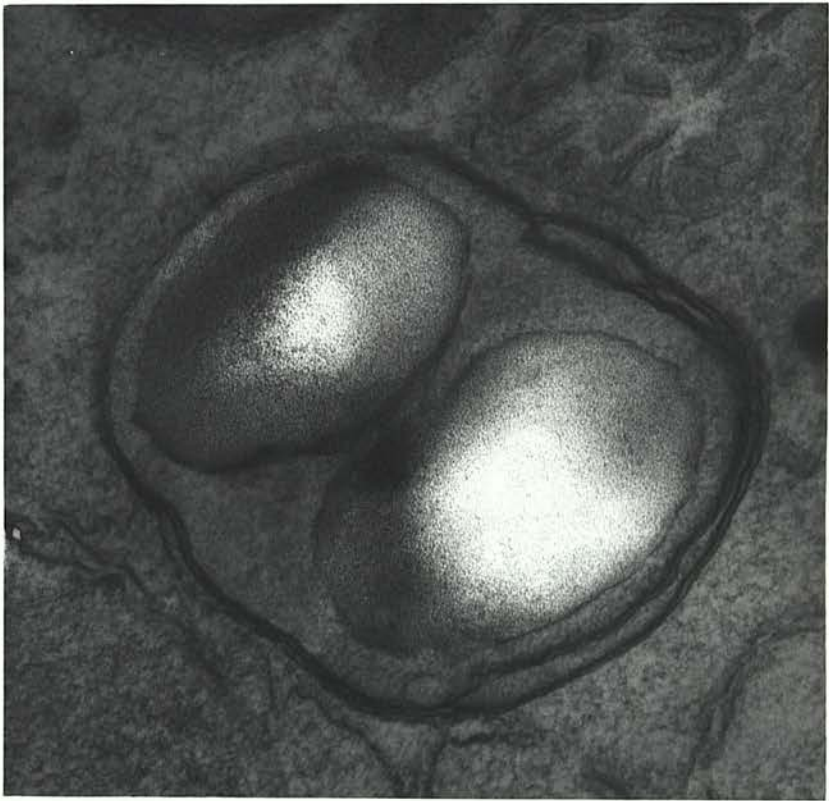

20.

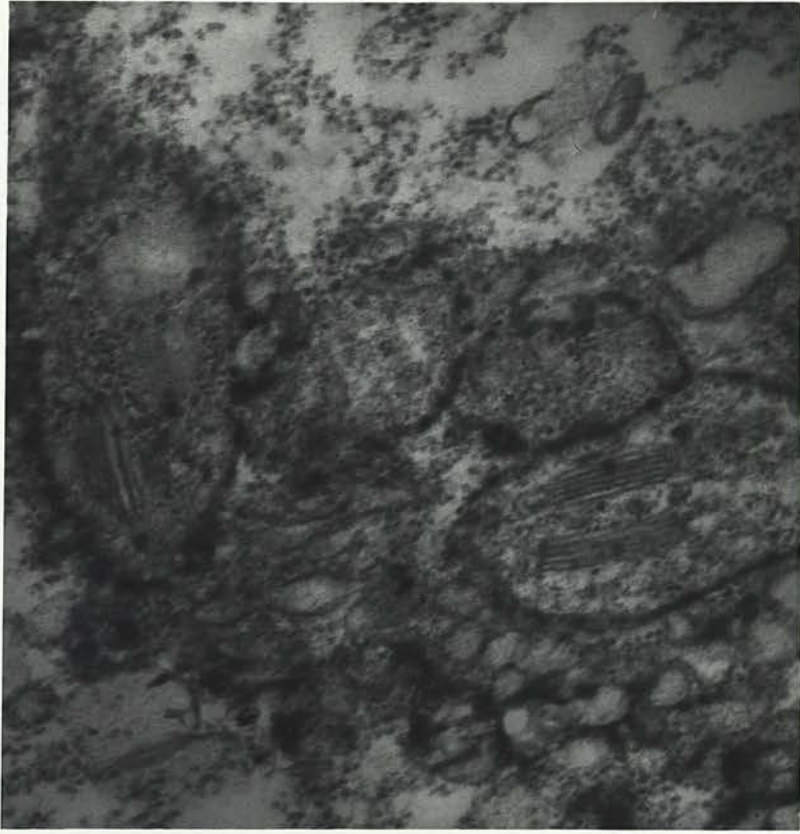

21.



22.





23.

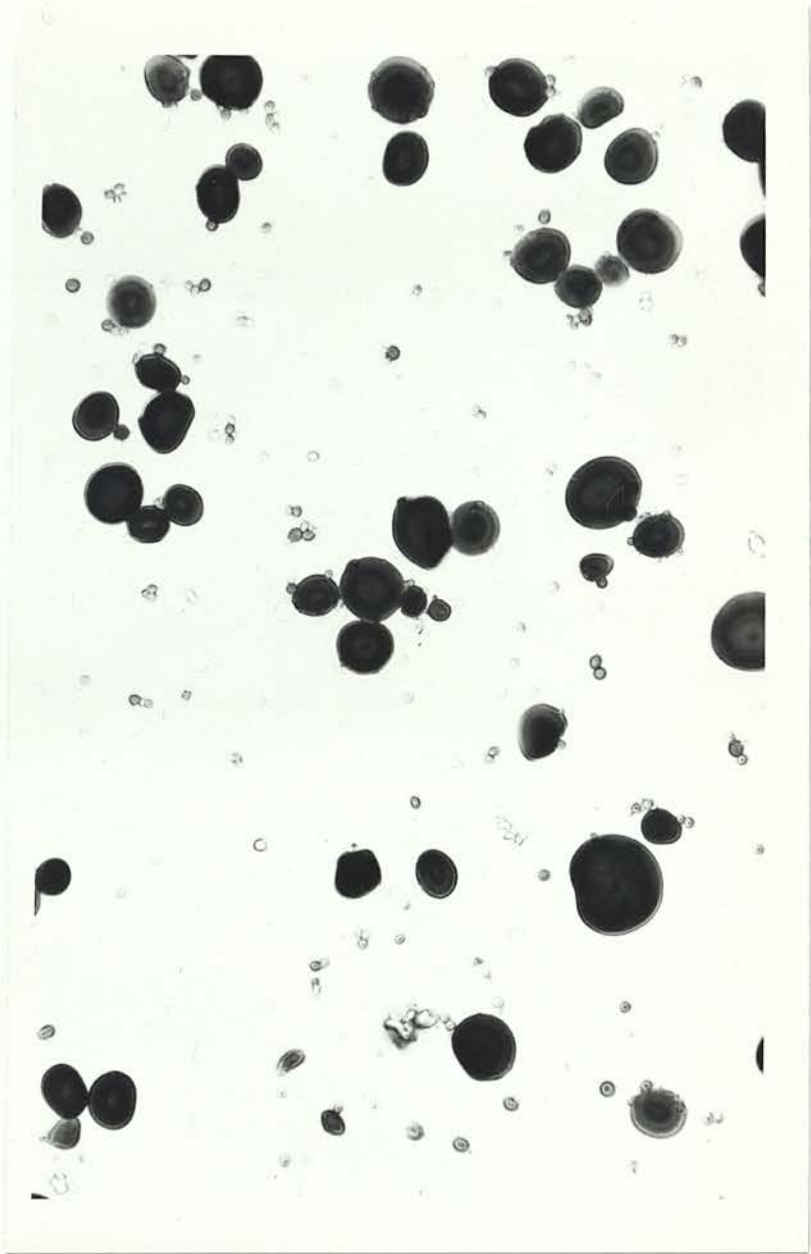

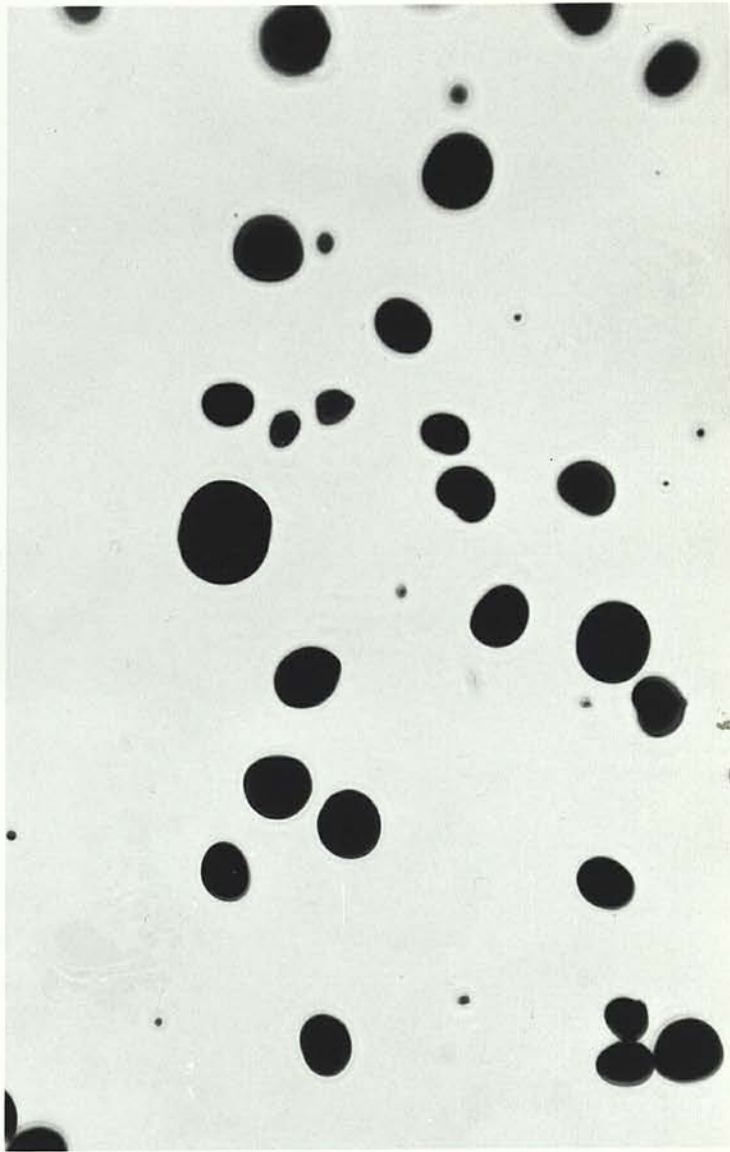

25.



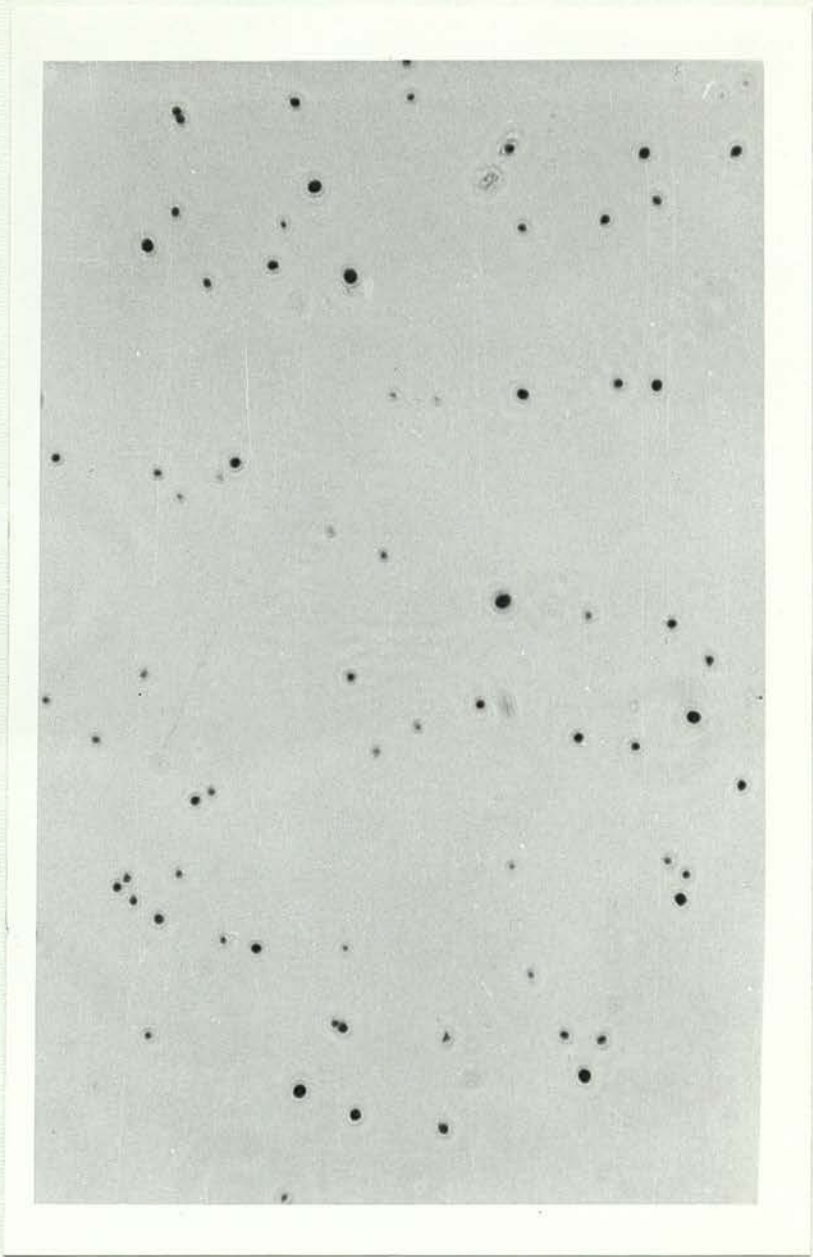

26.

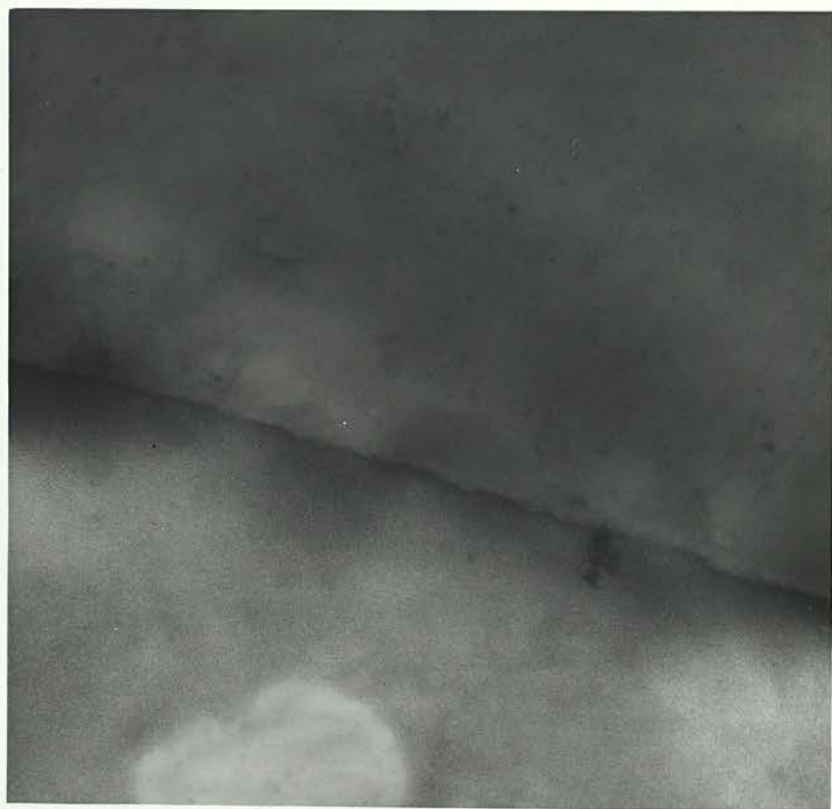

27.



28.