

SELECTIVITY IN CATALYTIC REACTIONS OF ACETYLENE

A THESIS PRESENTED FOR THE DEGREE OF DOCTOR OF PHILOSOPHY
IN THE FACULTY OF SCIENCE OF THE UNIVERSITY OF EDINBURGH

William Taylor McGown, B.Sc.

Department of Chemistry, University of Edinburgh, West Mains Road,
Edinburgh EH9 3JJ

CHEMISTRY LIBRARY



ABSTRACT — Studies have been made of the kinetics of the hydrogenation of mixtures containing 2% of acetylene in ethylene on an alumina supported palladium catalyst in a static system. Information has been obtained about the nature of the selectivity of the reaction of acetylene. Detailed analyses of the kinetics have been made as the ratio of the pressures of acetylene to ethylene decreases and subsequently as the remaining hydrogen is used up. The poisoning action of carbon monoxide, which selectively inhibits the hydrogenation of ethylene, has also been studied. Tracer studies using carbon-13 labelled acetylene, light ethylene and hydrogen with analysis by combined gas chromatography - mass spectrometry, have shown unambiguously that ethane produced from the hydrogenation of a mixture of acetylene in ethylene comes predominantly from the ethylene. The reaction between acetylene, ethylene and deuterium gives a greater understanding of the surface processes involved and produces ethane which is mainly ethane-d₂. It is postulated that two types of site exist on the surface, type X which hydrogenates both acetylene and ethylene and on which acetylene is adsorbed ~ 2200 times more strongly than ethylene at 293 K and type Y which is easily poisoned by carbon monoxide and can hydrogenate ethylene even in the presence of acetylene.

The hydrogenation of acetylene has also been investigated in a spinning-basket reactor. The rate of disappearance of acetylene was found to be controlled by pore diffusion at low acetylene concentrations and was independent of acetylene at high acetylene pressures. In the non-diffusion-controlled region the reaction of acetylene was first order in hydrogen and the rate of ethane formation was independent of both the acetylene and ethylene pressures. This latter observation is consistent with the presence of two types of site. The nature of the C_n products has been shown to be dependent on the packing of adsorbed acetylene molecules and on the availability of surface hydrogen. The analysis of a heavy involatile product is also reported.

FOREWARD

The studies described in this thesis were undertaken by myself in the Chemistry Department of the University of Edinburgh between October 1973 and October 1976. Part of this work has been published in the Journal of the Chemical Society and Journal of Catalysis (see inside back cover).

Of the many people who have helped to make this thesis possible, I am particularly grateful to my academic supervisors Professor C. Kemball F.R.S. and Dr. D.A. Whan for their guidance and encouragement. I am also indebted to Dr. M.S. Scurrrell and Dr. P.J. Robertson for their help and patience in computing matters, to the other members of the catalytic research group, to the technical staff of the Chemistry Department, in particular Mr. A. Anderson, for their various skills, to the Science Research Council for a C.A.S.E. scholarship, to Agricultural Division, Imperial Chemical Industries Ltd., for provision of equipment and research facilities, to my industrial liaisons Mr. B.M. Collins and Mr. D. Lobley for many helpful discussions and hospitality.

Finally I would like to thank my wife, Gillian, and my parents for their patience and encouragement.

In the course of this work I attended the following seminars and lecture courses:-

1. Catalytic Group Seminars (1973-76)
2. Chemistry Department Seminars (1973-76)
3. Introduction to Fortran Computing (1973)
4. Adsorption and Catalysis. Honours Chemistry Course (1973)
5. Research in the Oil Industry (1975)
6. High-Speed Liquid Chromatography (1975)
7. Chemistry of the Atmosphere (1975)

8. N.M.R. Spectroscopy

(1975)

9. Vibrational Spectroscopy

(1975)

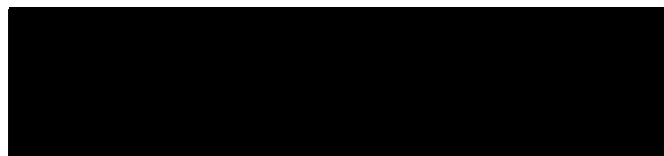

William T. McGown
March 1978

TO GILLIAN

CONTENTS	PAGE
CHAPTER 1 — Introduction	1
1.1 Industrial Importance	1
1.2 Introduction to Acetylene Hydrogenation	2
1.3 Adsorbed State of Ethylene on Metal Surfaces	2
1.4 Adsorbed State of Acetylene on Metal Surfaces	4
1.5 The Hydrogenation of Ethylene	6
1.6 The Hydrogenation of Acetylene	8
1.7 The Exchange of Acetylene with Deuterium	9
1.8 Selectivity in Acetylene Hydrogenation	10
1.9 The Catalysed Polymerisation of Acetylene	13
1.10 Studies Undertaken in the Present Investigation	15
CHAPTER 2 — Experimental Procedure	17
2.1 The Preparation of the Catalyst used in this Investigation	17
2.2 Apparatus	17
2.3 Procedure	21
2.4 Analytical Techniques	25
CHAPTER 3 — Treatment of Results	29
3.1 Reactions in Static System	29
3.2 Flow System Data	32
CHAPTER 4 — The Kinetics of Acetylene Hydrogenation in Excess Ethylene in a Static System	36
4.1 Introduction	36
4.2 Experimental Procedure	36
4.3 Results	37
4.4 Discussion	47

CHAPTER 5 — Tracer Studies of Acetylene Hydrogenation
in Excess Ethylene in a Static System

60

5.1 Introduction

60

5.2 Experimental Procedure

61

5.3 Results

61

5.4 Discussion

67

CHAPTER 6 — The Kinetics of Acetylene Hydrogenation
in Excess Ethylene in a Flow System

75

6.1 Introduction

75

6.2 Experimental Procedure

75

6.3 Results

76

6.4 Discussion

83

References

92

CHAPTER 1

Introduction

1.1 Industrial Importance

Olefins produced from naphtha crackers are invariably contaminated with appreciable amounts of acetylenes and diolefins. Whenever ethylene is to be used in chemical processing these impurities must be removed since acetylene may be a potential hazard in low-temperature process equipment and is also a poison for ethylene polymerisation catalysts. The most elegant method of acetylene removal is catalytic hydrogenation where the acetylene impurity is not only removed but the yield of ethylene is increased. The permissible level of acetylene has become progressively lower in recent years from ~ 100 ppm in the 1950's until the present time where many ethylene producers allow no more than 5 ppm of acetylene in the ethylene product.

Early industrial plants employed catalysts based on iron, nickel or cobalt which rarely operated under conditions of net ethylene gain needing continuous injections of mercaptans to reduce ethylene loss¹. These catalysts also required frequent regeneration to remove polymers produced as a side effect of the acetylene hydrogenation reaction and were thus not operating to maximum efficiency.

In 1960 alumina-supported palladium catalysts were introduced which operated with net ethylene gain and with greatly reduced polymer formation and for the first time continuous operation was achieved with longer periods between regeneration of the catalysts. Since the production of polyethylene is such a widespread and important chemical process any small increase in the ethylene yield has, almost of necessity, to originate in an improvement in the catalyst efficiency which can only be derived from fundamental research into the nature of the acetylene hydrogenation process in ethylene streams.

1.2 Introduction to Acetylene Hydrogenation

Catalytic hydrogenation embraces all reactions where unsaturated molecules combine with hydrogen to give less unsaturated products. The homogeneous hydrogenation of unsaturated hydrocarbons proceeds at an immeasurably slow rate at normal pressures at temperatures up to 473 K but in the presence of transition metals, especially those of Group VIII the hydrogen addition reaction is effectively catalysed. A hydrogenation catalyst increases the rate at which the reacting system approaches equilibrium without itself becoming permanently involved in the reaction.

In the past sixty years much attention has been paid to the hydrogenation of acetylene over heterogeneous catalysts. Most early workers studied only the products of the reaction²⁻⁹ and only in 1944 were the reaction kinetics first studied¹⁰⁻¹⁴. When acetylene and hydrogen react on a hydrogenation catalyst three types of reaction occur simultaneously.

These are:-

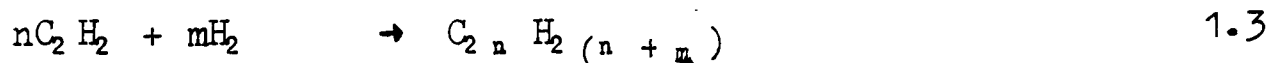
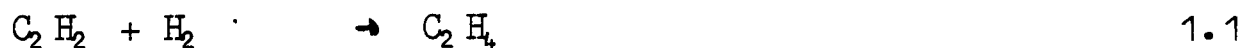

Thus an acetylene molecule will generally hydrogenate to give both an ethylene or an ethane molecule along with dimers and higher products. The extent to which an olefin is produced as opposed to a paraffin is termed the "selectivity" of the acetylene hydrogenation and is a function of the catalytic surface. To understand fully the acetylene hydrogenation reaction some attention must be focussed on the adsorbed states of ethylene and acetylene on metal surfaces.

1.3 Adsorbed State of Ethylene on Metal Surfaces

Information regarding the adsorbed states of hydrocarbons has been obtained from three main sources: (i) studies of surface reactions such as hydrogen - deuterium exchange¹⁵, self-hydrogenation and self-poisoning; (ii) changes in

the properties of the metal such as magnetic susceptibility and work function;
 (iii) direct observation by infra-red spectroscopy.

When ethylene was admitted to a freshly prepared metal surface self-hydrogenation occurred resulting in the production of ethane¹⁶⁻¹⁹. This ethane could have arisen from the reaction of adsorbed ethylene with hydrogen atoms released by dissociation of associatively adsorbed ethylene:

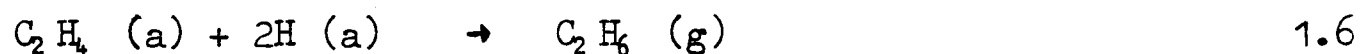
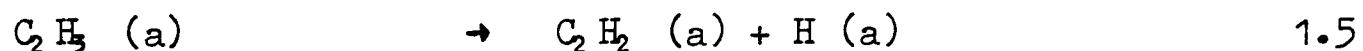
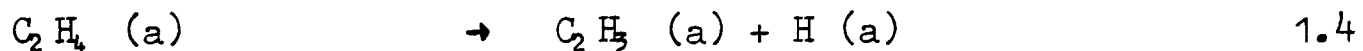

or by the disproportionation of two associatively adsorbed ethylene molecules:

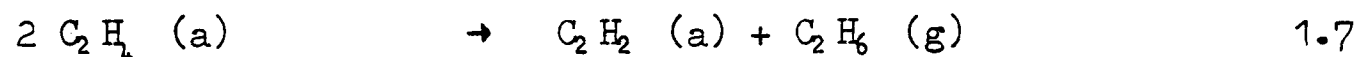

Magnetic studies on nickel-silica catalysts at 273 K suggested that ethylene was adsorbed associatively²⁰ i.e.

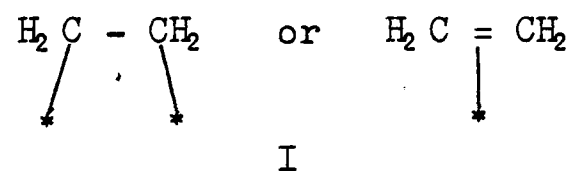

and that on increasing the temperature a greater degree of dissociation occurred producing self-hydrogenation. Above 403 K carbon-carbon bond fission and the formation of surface carbide occurred. Similar findings have been observed over palladium²¹.

The existence of at least two modes of ethylene adsorption has also been demonstrated using [¹⁴C] ethylene adsorption²². When [¹⁴C] ethylene was adsorbed on to alumina-supported nickel, ruthenium, rhodium, palladium, iridium or platinum only a fraction of the initially adsorbed ethylene could be removed by hydrogenation, by exchange with non-radioactive ethylene, or by evacuation and each of these processes removed the same fraction of the ethylene. The remainder of the adsorbed ethylene was retained on the catalyst surface and has been identified with a dissociatively adsorbed species.

Although the radiotracer method obtained information about the fate of adsorbed species it yielded no information about their structures. This information can be derived from infra-red (i.r.) spectroscopic studies mainly using silica-supported catalysts since silica exhibits a large i.r. window²³. The adsorption of ethylene on a 'bare' platinum-silica catalyst²⁴⁻²⁶ at room temperature led to spectra in which the associatively bonded structure (I) predominated but bonds ascribable to dissociatively adsorbed ethylene (II) were also observed.

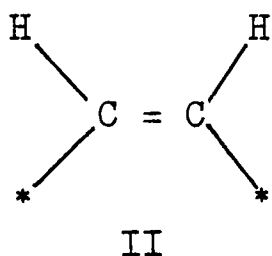

The i.r. spectra of ethylene adsorbed on nickel-silica were similar to those observed on platinum-silica but with less dissociation on nickel. On palladium-silica surfaces only weak i.r. bands were observed²³ and these indicated species with double bond character together with methyl and methylene groups. On admission of hydrogen the olefin bands disappeared and intense bands corresponding to surface ethyl groups were observed.

1.4 Adsorbed State of Acetylene on Metal Surfaces

The adsorption of acetylene²⁴⁻²⁷ on palladium-alumina and on silica and alumina-supported platinum exhibited the same general characteristics as those observed with ethylene but with some important differences in that the extent of acetylene retention was larger than that of ethylene retention and the amounts of acetylene retained by 'clean' and ethylene-precovered surfaces were identical. Since acetylene can prevent adsorption of the reactive form of ethylene under selective hydrogenation conditions^{28,29} then it would appear that the adsorbed states of ethylene and acetylene involved in retention and hydrogenation are different and that the heterogeneity of a

surface depends on the adsorbate molecule. The greater degree of acetylene retention may be due to the formation of surface polymers³⁰.

Infra-red studies on acetylene adsorption follow a similar pattern to those observed with ethylene. On silica-supported nickel, palladium or platinum³¹ adsorption of acetylene on the 'bare' metal gave rise to bands ascribable to olefinic species (structure II) and to surface alkyl groups. As with ethylene, the degree of dissociation of the adsorbed acetylene was greater with platinum than with nickel. Palladium was very similar to platinum except that the proportion of olefinic groups was somewhat higher on palladium. More recent studies of acetylene adsorption over palladium-alumina³² and platinum-alumina³³ have shown that the spectra are very similar to those obtained with silica-supported metals.

Therefore when unsaturated molecules are adsorbed on a metal surface both dissociatively and associatively adsorbed species are formed and the proportions of each species vary from metal to metal and also depend on the history of each individual metal sample. This last point has been demonstrated by Inoue and Yasumori³⁴ who studied the adsorption and hydrogenation of acetylene on a cold-worked palladium foil. [¹⁴C] Acetylene adsorption studies revealed four types of adsorbed acetylene: A, which desorbed on evacuation; B, which was removed from the surface during hydrogenation; C, not removed by hydrogenation but by the addition of hydrogen at 423 K; and D, which remained on the surface after reduction at 423 K. The relative amounts of each type of adsorbed acetylene varied with the annealing temperature of the palladium foil.

The effect of the addition of hydrogen to a hydrocarbon-precovered surface indicated that the active species in hydrogenation was an associatively bonded species as has been assumed in the formulation of a reaction mechanism for the hydrogenation reaction^{9, 28, 29}. There is still some doubt however

as to the precise nature of the associatively adsorbed species. From i.r. studies it has been concluded that a di- σ -bonded complex III is formed with olefins but Rooney et al^{35, 36} have proposed that a π -complex IV is present during hydrogenation.

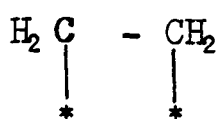

III

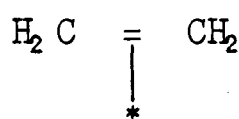

IV

With acetylene the corresponding di- σ -bonded and π -complex structures are represented by V and VI respectively.

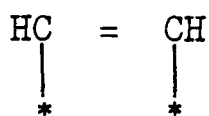

V

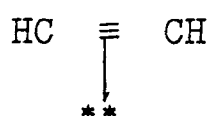

VI

Surface potential measurements on nickel films have suggested the existence of structures VI and IV for acetylene and ethylene respectively³⁷.

1.5 The Hydrogenation of Ethylene

Many studies have been made of the hydrogenation of ethylene to ethane over transition metals especially those of Group VIII and Group IB. Much early work was carried out over nickel catalysts the most notable being that on films by Beeck¹⁹ and Jenkins and Rideal¹⁶. Schuit and van Reijen³⁸ studied nickel, iron, cobalt, copper, platinum, rhodium, ruthenium and palladium catalysts supported on silica for the hydrogenation of ethylene and published valuable kinetic data.

The rate of ethylene hydrogenation may be expressed as

$$r = k P_{\text{H}_2}^x P_{\text{E}}^y \quad 1.8$$

where r is the rate of ethylene hydrogenation, k is a rate constant, P_{H_2} is the partial pressure of hydrogen, P_{E} is the partial pressure of ethylene and x and y are the reaction orders in hydrogen and ethylene respectively.

All metals studied, irrespective of their physical nature, gave values of

$0.5 < x < 1.2$ and $-0.8 < y < 0.5$ indicating that ethylene was strongly adsorbed on the surface and that very little hydrogen covered the surface during hydrogenation³⁹. The activation energy was also independent of the metal and its nature at $35 \pm 10 \text{ kJ mol}^{-1}$.

Overall a general order of reactivity of pure metals towards ethylene hydrogenation may be given as^{38,39}:



The generally accepted mechanism for ethylene hydrogenation to ethane is one in which the intermediate is an adsorbed alkyl radical frequently referred to as a 'half-hydrogenated state' first suggested by Polanyi and Hortiuti⁴⁰ and shown in equation 1.9.

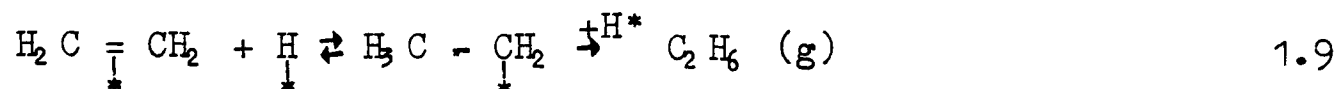

Once the ethane is produced it is assumed to be unreactive and does not undergo readsorption.

Evidence for the addition of hydrogen atoms as opposed to molecules has been obtained using equilibrated and non-equilibrated hydrogen-deuterium mixtures where the same products were formed on reaction with ethylene irrespective if hydrogen and deuterium molecules or hydrogen deuteride (HD) molecules were used⁴¹. This has also been supported by work involving propylene⁴².

However, some evidence does exist to the contrary where ethylene hydrogenation may occur via the addition of a hydrogen molecule in one step over platinum supported on silica or silica-alumina⁴³.

More recently some interesting results have been obtained by Bond et al⁴⁴ on the reaction between ethylene and deuterium over palladium-alumina. No hydrogen exchange was observed and about 80% of the ethane produced came from a disproportionation reaction as in equation 1.10.

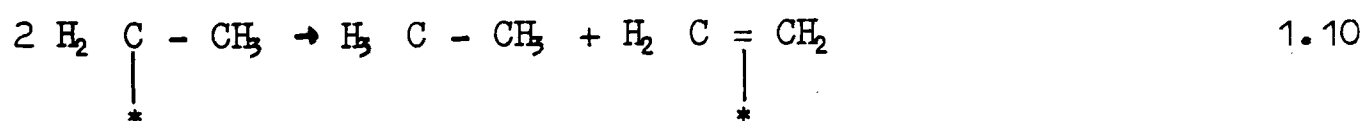

The predominant ethane was either ethane $-d_0$ or $-d_1$ with very little ethane $-d_2$ being produced. The activation energy for ethylene hydrogenation was $47.7 \pm 4.2 \text{ kJ mol}^{-1}$.

1.6 The Hydrogenation of Acetylene

The acetylene hydrogenation reaction has received relatively little attention in comparison with the volume of work published on ethylene hydrogenation. The acetylene system is complicated by the fact that the major product, ethylene, can also hydrogenate on the catalyst surface and gives rise to complex kinetic behaviour.

All the metals of Group VIII catalyse the hydrogenation of acetylene and kinetic information has been available for some time^{9-13, 28, 29, 45-50}. As in the case of ethylene hydrogenation an equation similar to equation 1.8 may be written for acetylene hydrogenation as shown in equation 1.11.

$$r = k P_{\text{H}_2}^x P_{\text{A}}^y \quad 1.11$$

where P_{A} is the partial pressure of acetylene in the mixture³⁹. Again the orders of reaction in hydrogen and acetylene were independent of the metal used with $1.0 < x < 1.5$ and $-0.5 < y < 0$ indicating that acetylene was strongly adsorbed on the surface with very little hydrogen coverage.

Bond³⁹ reported the activation energies for acetylene hydrogenation over various metals with that over palladium at $48 \pm 2 \text{ kJ mol}^{-1}$, the extremes were cobalt at 17 kJ mol^{-1} and copper at 88 kJ mol^{-1} . Over all the Group VIII metals the reaction kinetics depended on the reactant ratio of hydrogen to acetylene. This was well illustrated by the reaction on palladium-alumina²⁹. When the hydrogen: acetylene ratio was 2.0 the removal of acetylene was zero order in acetylene followed by a mild acceleration and after complete

acetylene removal ethylene rapidly hydrogenated to ethane. However, on increasing the reactant ratio to 3.5:1 or greater, ethylene hydrogenation occurred in the presence of acetylene. The implications of these results will be discussed in the section on selectivity.

As with ethylene hydrogenation acetylene hydrogenation is presumed to occur via a half-hydrogenated state as shown in equation 1.12⁹.

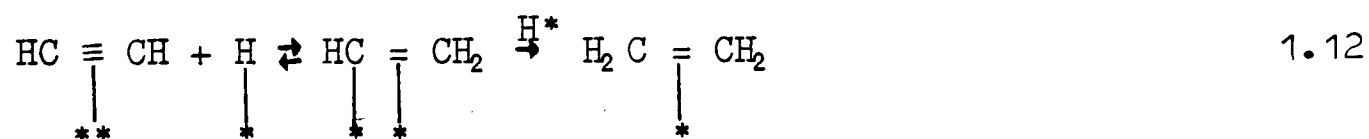

Douglas and Rabinovitch⁵¹ reported that, as with ethylene hydrogenation, hydrogen atoms and not hydrogen molecules were active in acetylene hydrogenation over nickel-kieselguhr and palladium-kieselguhr using equilibrated and non-equilibrated hydrogen and deuterium mixtures.

1.7 The Exchange of Acetylene with Deuterium

Farkas and Farkas⁸ reported that reaction took place between acetylene and deuterium over platinum foil at 293 K and that the rates of formation of deuterated acetylene and hydrogen deuteride were negligible. Douglas and Rabinovitch⁵¹ used nickel and palladium catalysts in an attempt to prepare cis-ethylene-d₂ but the product was a mixture of all possible deuterioethylenes. More recently Bond and Wells⁵² reacted acetylene with deuterium over α-alumina supported rhodium, palladium, iridium and platinum and found no evidence of acetylene exchange. The authors stated that deuterated acetylenes were probably formed but did not desorb and hence were not detected in the gas phase. Hydrogen exchange was found to occur over rhodium and iridium but was slow over platinum and negligible over palladium. Ethylene-d₂ was found to be the most abundant deuterioethylene with the cis isomer being the major component. A subsequent paper⁵³ reported fast acetylene exchange with deuterium over ruthenium and osmium supported on

γ -alumina.

1.8 Selectivity in Acetylene Hydrogenation

All the Group VIII metals catalyse the hydrogenation of acetylene and, above about 348 K, ethylene is invariably the major product (Ru, Rh, Os, Ir, Pt) and sometimes the only initial product (Fe, Co, Ni, Pd)⁵⁴.

Even in the presence of a stoichiometric excess of hydrogen the selectivity for ethylene formation is often retained until almost all the acetylene has disappeared. The selective removal of acetylene from a gas mixture where the acetylene:ethylene ratio is very low can only be achieved if either (i) the acetylene is very much more strongly adsorbed than the ethylene or (ii) the catalyst is unable to hydrogenate ethylene. The ratio of the surface coverages of acetylene and ethylene is given by equation 1.13⁸.

$$\theta_A/\theta_E = P_A/P_E \exp(-\delta\Delta G_a/RT) \quad 1.13$$

where θ is the surface coverage, P is the gas phase partial pressure and $\delta\Delta G_a$ is the difference in the free energies of adsorption of the two gases. The subscript A refers to acetylene, E to ethylene. Equation 1.13 represents what is termed the thermodynamic factor in selectivity. If $\delta\Delta G_a$ is sufficiently large then the ethylene may be excluded from the surface until very small acetylene concentrations are reached. For chemisorption at Group VIII metal surfaces $\delta\Delta G_a$ takes values such that the surface coverage of hydrogen atoms attainable by competitive adsorption is very low and so selective hydrogenation always proceeds under conditions of hydrogen starvation⁵⁵.

Another factor in selectivity is termed the kinetic or mechanistic factor⁸ and is a measure of the ratio of the rate of desorption as ethylene to the rate of hydrogenation to ethane of the species produced by the hydrogenation of acetylene. The presence of acetylene may influence the

desorption of ethylene in a manner similar to that occurring in thermodynamic selectivity so the mechanistic and thermodynamic factors are interrelated.

Measurements of selectivity in acetylene hydrogenation have been extensively studied by Bond et al and patterns of selectivity emerge for the Group VIII metals^{28, 29, 52, 53, 56}. The results may be summarised as a selectivity pattern where S indicates the selectivity of the reaction and may be represented by the rate of ethylene formation/rate of ethane formation.

$$\begin{array}{ccccc}
 S_{Fe} & \approx & S_{Co} & \approx & S_{Ni} & \approx & S_{Cu} \\
 \downarrow & & \downarrow & & \wedge & & \\
 S_{Ru} & \leq & S_{Rh} & < & S_{Pd} & & \\
 \downarrow & & \downarrow & & \downarrow & & \\
 S_{Os} & \approx & S_{Ir} & < & S_{Pt} & &
 \end{array}$$

From the selectivity pattern it may be observed that the selectivity increases on ascending each vertical triad of Group VIII and increases on passing from left to right across the group. It is of value to compare the selectivity pattern with the order of reactivity of the metals for ethylene hydrogenation given in section 1.5. The high selectivity of the first row metals can be related to their low activity for ethylene hydrogenation and similarly the low selectivities of ruthenium and rhodium can be attributed to their high activities for ethylene hydrogenation. The mechanistic factor is therefore predominant for these metals. The problem remains of the third row metals since iridium and platinum have reasonably low activities for ethylene hydrogenation and also have low selectivities. This is thought to be due to a weak thermodynamic factor operating in the case of osmium, iridium and platinum⁵⁴. The only metal to break the selectivity pattern is palladium which has a higher selectivity and also a higher activity for ethylene hydrogenation than has nickel and is indicative of a more powerful thermodynamic factor operating over palladium. There is also the ability of palladium to

occlude hydrogen and this may have the effect of reducing the surface coverage of hydrogen atoms to an unusually low level as has been observed during ethylene hydrogenation over palladium⁴⁴. The selectivity pattern has also been found to hold for the hydrogenation of other unsaturated hydrocarbons e.g. propadiene^{57, 58}, propyne^{5, 9}, but-1-yne⁶⁰, but-2-yne⁶¹, and buta-1.3-diene^{62, 63}. Over all Group VIII metals the selectivity for ethylene formation has been reported to decrease with increasing hydrogen pressure probably due to an increase in the surface coverage of hydrogen atoms so optimum selectivities are obtained by using minimal hydrogen pressures.

Bond and Wells²⁹ reported what they termed as the 'premature breakdown in selectivity' in the acetylene hydrogenation reaction over palladium where non-selective hydrogenation occurred the higher the temperature, ethylene pressure or hydrogen pressure. The authors suggested that this phenomenon was due to the interaction of ethylene from the van der Waals layer with adsorbed hydrogen atoms and that the extent of ethylene hydrogenation depended on the surface hydrogen atom concentration which would be greater at higher temperatures and higher hydrogen pressures. The selectivity increase with an increase in temperature was also perhaps due to the adsorbed ethylene becoming less stable at higher temperatures⁵⁴.

If the molecular weight of the alkyne is increased, e.g. to methyl acetylene, the selectivity for olefin production tends to increase. This has been suggested to be due to a steric factor which prevents the addition of hydrogen to the adsorbed olefin¹⁵.

The normal product distribution in acetylene hydrogenation reactions can be influenced by: (i) poisoning of the catalytic surface^{64, 65}; (ii) concentration gradients in the beds of flow reactors; (iii) diffusion in the pores of the catalytic surface^{66, 67}.

Selective poisoning refers to a situation where the presence of a poison causes a catalyst to operate more selectively than it would have without the poison. The poison may affect both the thermodynamic and mechanistic factors e.g. the selectivity for acetylene hydrogenation to ethylene may be increased by the addition of a substance which is more strongly adsorbed than ethylene, does not interfere appreciably with the adsorption of acetylene and does not undergo catalysis itself. This may be brought about by the addition of mercury vapour⁶⁴, carbon monoxide or sulphur containing molecules^{68 69}. With carbon monoxide and sulphur containing molecules such as hydrogen sulphide or carbon disulphide the poisoning effect was reversible with high activity returning when the poison was removed from the feed gas but with mercury vapour poisoning was irreversible.

The effect of diffusion effects in the catalyst pores has been interpreted by Mars and Gorgels⁶⁷ who suggested that selective hydrogenation of acetylene takes place near pore entrances but deeper inside the pores the acetylene concentration is reduced to zero allowing ethylene hydrogenation to occur.

1.9 The Catalysed Polymerisation of Acetylene

During the hydrogenation of acetylene hydrocarbons containing more than two carbon atoms frequently appear in the reaction products. The earliest investigation of this process was by Sheridan over nickel-pumice¹⁰ and platinum-pumice^{11 12}. Molecules containing even numbers of carbon atoms predominated and C₄ compounds formed the main fraction.

The percentage composition of the C₄ products produced during acetylene hydrogenation over alumina-supported Group VIII metals with an initial hydrogen: acetylene ratio of 1:1 is shown in table 1.1³.

Table 1.1: The Percentage Compositions of the C₄ Products Produced During Acetylene Hydrogenation

Metal	Temp/K	Buta-1,3-diene	But-1-ene	Cis But-2-ene	Trans But-2-ene	n Butane
Pd	291	Trace	59.3	13.5	23.3	3.9
Rh ^a	403	0.0	42.5	34.3	7.3	7.2
Pt	408	8.3	46.5	20.3	22.1	2.8
Ir	403	0.0	35.4	17.9	1.5	45.2

^a The rhodium catalyst also produced isobutene which was not detected with any of the others.

The butenes produced had a very different composition from the thermodynamic equilibrium composition of butanes at 298 K which is but-1-ene 2.4%, trans but-2-ene 74.4% and Cis but-2-ene 23.2% as calculated from their free energies of formation⁷⁰.

Over most pumice-supported metals the yields of polymers from acetylene^{11, 12, 46} were only slightly dependent on temperature and reactant partial pressure with the exception of nickel where the yield of polymeric products increased with temperature.

Typical yields of monomeric hydrocarbons from acetylene hydrogenation over pumice-supported Group VIII metal catalysts, with an initial hydrogen: acetylene ratio of 1:1, are shown in Table 1.2^{11, 12, 46}.

Table 1.2: Yields of Monomeric Hydrocarbons Produced During Acetylene Hydrogenation

Metal	Fe	Co	Ni	Cu	Rh	Pd	Ir	Pt
Temp/K	408	473	356	473	358	297	448	436
C ₂ yield/%	71	50	41	40	75	75	85	70

The extent of polymerisation was greatest in the first row metals and it has been suggested that a geometric factor in adsorption may be important here³⁹.

A mechanism for acetylene polymerisation has been put forward by Sheridan^{11 12} who suggested that the origin of polymerisation lay in the possibility of the half-hydrogenated state existing in a free radical form which attacks one end of an adjacent chemisorbed acetylene molecule as in equation 1.14.

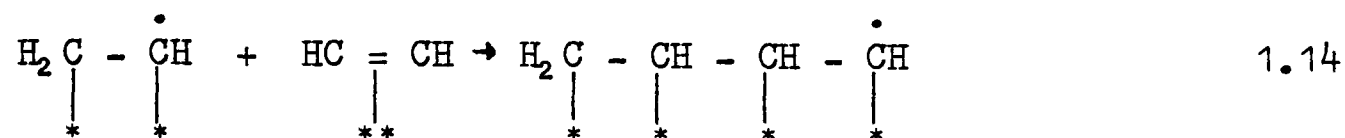

Continuation of this process would lead to polymeric chains containing even numbers of carbon atoms. Branched chains could also be produced by rearrangement of the electronic structure of the radical so that the radical centre did not lie at the end of the carbon chain. Addition of a hydrogen atom to the product in equation 1.14 would yield an adsorbed buta-1,3-diene molecule which could undergo further hydrogenation to produce butenes and even butanes. Evidence for the existence of buta-1,3-diene as an intermediate in the production of butenes has been reported by Bond et al⁶³ who found that the butene distribution obtained from the hydrogenation of buta-1,3-diene over various metals was the same as that found during acetylene hydrogenation^{28, 29}.

When long chain polymers are produced in industrial plants they form what is termed as 'green-oil' which reduces selectivity and makes catalyst regeneration necessary⁶⁹.

1.10 Studies Undertaken in the Present Investigation

From this review of the catalytic hydrogenation reactions of acetylene and ethylene it is apparent that the great majority of work has been carried out with acetylene as the sole initial hydrocarbon and is thus somewhat removed

from the industrial situation. The nature of the selectivity for acetylene hydrogenation in the presence of a large excess of ethylene is not clearly understood and the aim of this work was to examine, using detailed kinetic studies and isotopic labelling, the reason for the selectivity and the factors influencing it.

The catalyst studied was a palladium-alumina catalyst chosen because of its use in industrial plants as the most selective catalyst for ethylene formation available. The action of carbon monoxide which is known to increase the selectivity but whose manner of action is not known with certainty was also examined as was the formation of C_4 hydrocarbons during acetylene hydrogenation:

The work presented in this thesis falls into three main parts: kinetic studies in a static system; isotopic tracer studies in a static system; and kinetic studies in a flow system.

CHAPTER 2

Experimental Procedure

2.1 The Preparation of the Catalyst used in this Investigation

The catalyst used was type 38-3, manufactured by Imperial Chemical Industries Ltd., Agricultural Division, and consisted of 0.04% palladium on pellets (5.4 mm x 5 mm) of a transitional alumina which had been prepared by calcination of aluminium trihydrate at 923K. The total surface area of the catalyst determined by B.E.T. adsorption of nitrogen was $90\text{m}^2\text{ g}^{-1}$ and the metal surface area, as determined by carbon monoxide adsorption, was $160\text{m}^2\text{ g}^{-1}$ of palladium. Impregnation of the support with the solution containing palladium was carried out in such a manner that the bulk of the palladium was deposited near the outside of the pellets.

2.2 Apparatus

The present work was carried out on gas handling systems designated gas-lines I to III. Gas chromatography was used to analyse reactions on gas-lines I and III and combined gas chromatography - mass spectrometry (G.C.M.S.) was used on gas-line II.

2.2.1 Gas-line I - Static System with Gas Chromatographic Analysis

Gas-line I has been previously described in detail by Dowie⁷¹. A diagram of the gas handling vacuum line is shown in fig. 2.1. The line was constructed of 'Pyrex' glass, all the ground glass joints and stopcocks being lubricated with low vapour pressure Apiezon L high vacuum grease. The gas handling apparatus provided facilities for purification and storage of hydrogen, deuterium and hydrocarbons in the glass bulbs 'GB' permanently attached to the line and any additional gases required could be stored in detachable bulbs via the ground glass joints at 'DJ'. Pressures were measured using a diaphragm pressure gauge 'DG' calibrated in Torr ($= 133.3\text{ Nm}^{-2}$) and connected to the mixing volume 'M'

Fig. 2.1 Gas-line I — static system with gas chromatographic analysis.

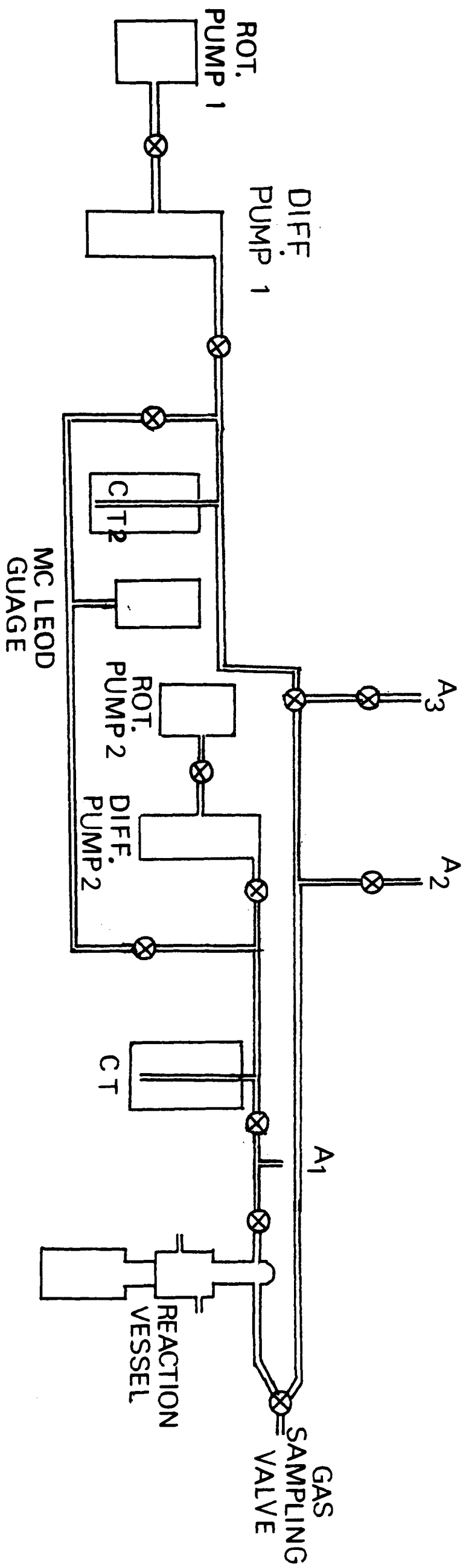
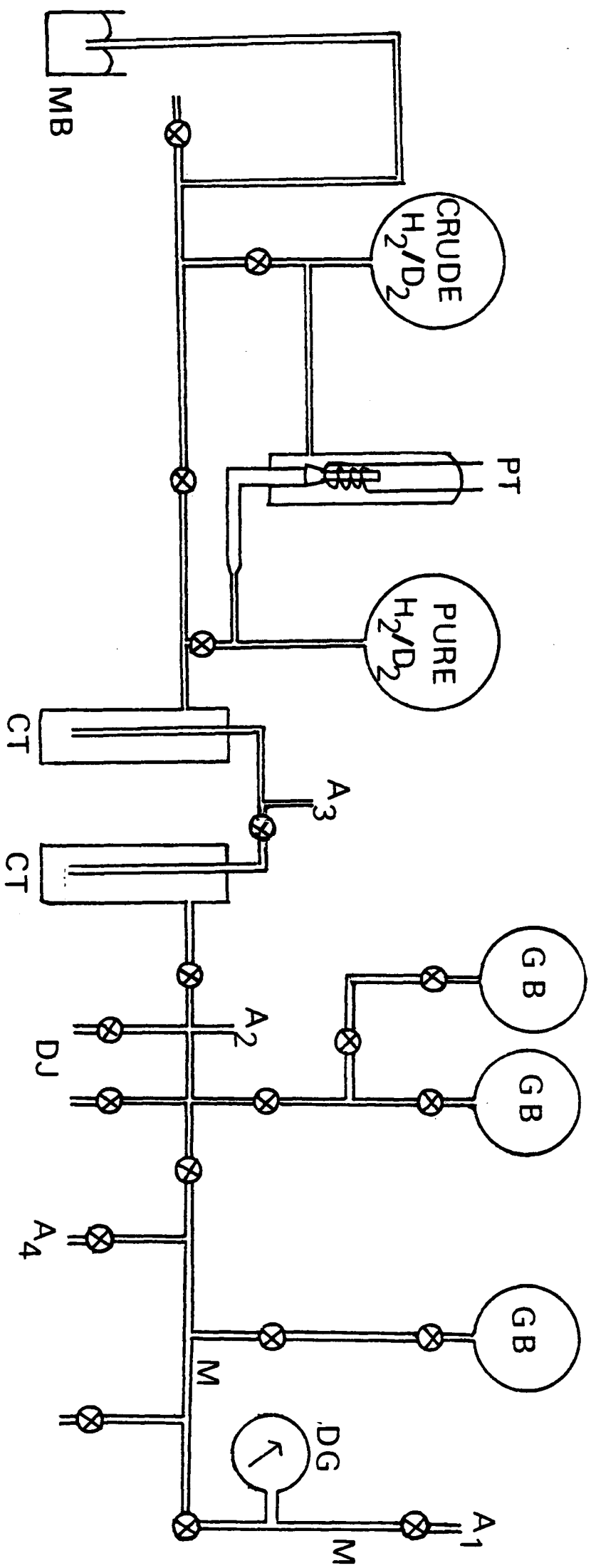

which was $1.26 \times 10^{-4} \text{ m}^3$. Reaction mixtures of the required composition were made up in 'M' and expanded into 'R', the reaction volume, which had a volume of $2.00 \times 10^{-4} \text{ m}^3$. The reaction vessel 'R' was a 'Pyrex' glass reactor consisting of a removable cylindrical vessel, approximately 35 mm in diameter and 0.16 m in length and was attached to the apparatus by means of a greased ground glass joint which fitted into a water cooled jacket. The reactor could be outgassed to a pressure of $1.33 \times 10^{-4} \text{ Nm}^{-2}$ with a mercury diffusion pump and rotary pump combination with mercury being excluded from the vessel by the liquid nitrogen trap 'CT2'. The pressure in the reaction vessel was measured using the McLeod gauge 'MG'. Heating was carried out using a close-fitting electric furnace controlled to within 0.5K by a Eurotherm proportional controller. Temperature control of experiments at ambient temperatures was achieved by a vacuum flask containing water at the required temperature.

Sampling of the gas from the reactor was by a three-way stopcock and a Perkin-Elmer gas sampling valve connected to one of two interchangeable loops, one of volume $1 \times 10^{-6} \text{ m}^3$ for experiments involving gas chromatography only and one of $5 \times 10^{-6} \text{ m}^3$ for G.C.M.S. experiments.

2.2.2 Gas-line II - Static System with Combined Gas Chromatographic - Mass Spectrometric Analysis

The gas handling line was the same as gas-line I but the isotopic distribution of each component of the reaction mixture was analysed by a fast-scanning mass spectrometer after chromatographic separation.^{72, 73} The apparatus is shown diagrammatically in fig. 2.2.

In reactions involving a single hydrocarbon continuous sampling from the reaction vessel could be carried out via a capillary leak into a mass spectrometer but where two or more constituents are present it is necessary to separate the various hydrocarbons before admission to the spectrometer if their cracking patterns overlap.

Fig. 2.2 Gas-line II — static system with combined gas chromatographic — mass spectrometric analysis.

ADC	Analogue -to- Digital Convertor.
C	Gas Chromatograph Column.
GRO	Cathode Ray Oscilloscope.
EM	Electron Multiplier.
GA	Galvanometer Drive Amplifier.
GL	Gas Handling Line.
GS	Gas Sampling Valve.
MS	Mass Spectrometer.
PDPII	Mini Computer.
R	Reaction Vessel.
S	Molecular Separator.
TIM	Total Ion Monitor.
UV	Ultra-Violet Recorder.
V	Pumping System.

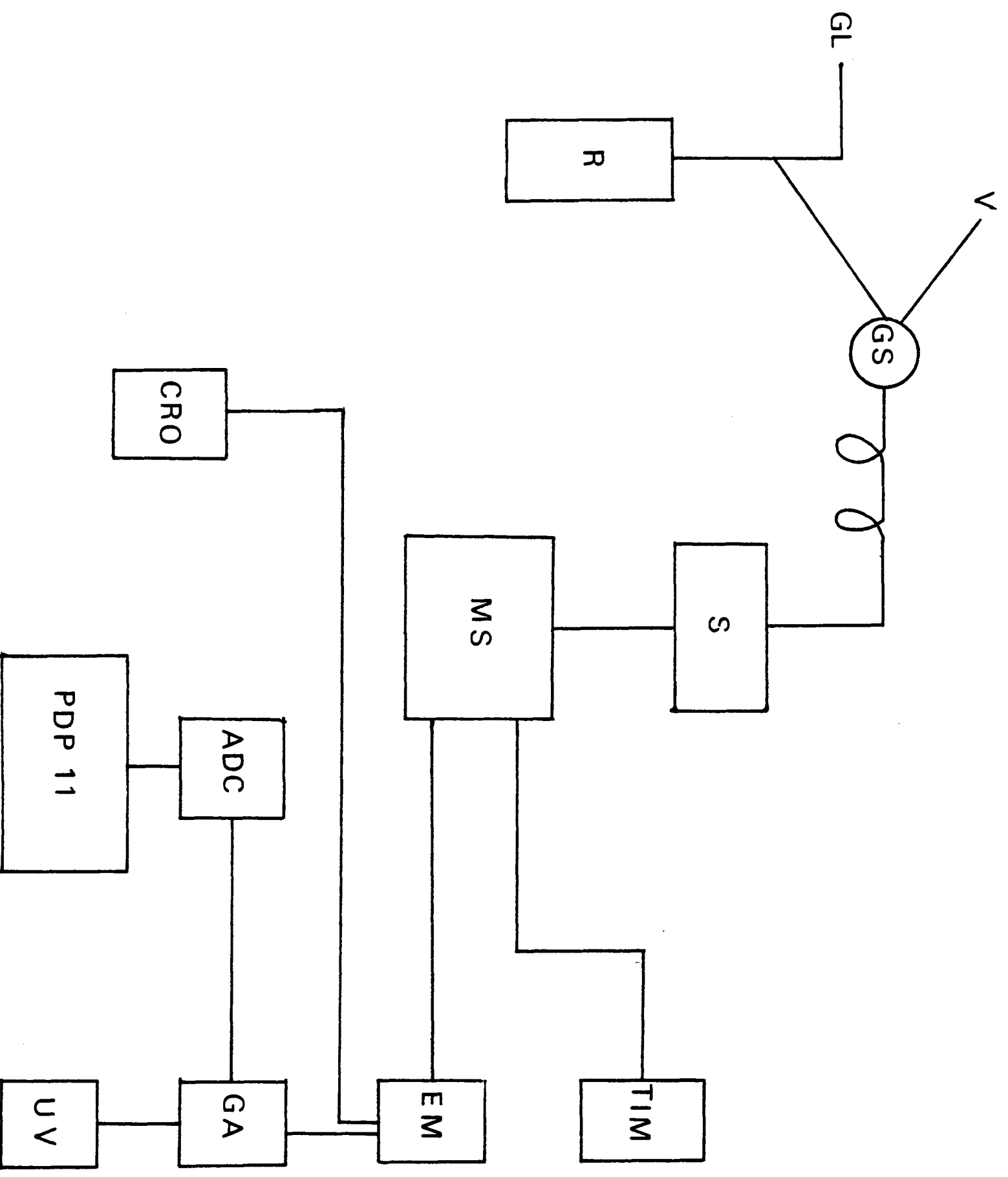

The separation of components was achieved by a Perkin-Elmer F11 gas chromatograph operated with helium as the carrier gas. After separation the components of the reaction mixture entered a Biemann-Watson⁷⁴ molecular separator which removed most of the helium carrier gas away leaving an enriched hydrocarbon mixture to enter the mass spectrometer - an A.E.I. MS 20 "Rapide" which was a single focussing, π radian deflection instrument with rapid magnetic scanning.⁷⁵ A complete description of the mass spectrometer and data handling technique has been reported by Robertson.⁷⁶

Experimental data could be recorded in three ways, the total ion intensity meter gave a trace which was equivalent to that obtained from the flame ionisation detector of the gas chromatograph and, as each peak appeared, spectra were recorded by switching the electromagnet to the repetitive scanning mode between present high and low mass numbers, 100-0 in this case. The spectra were fed to the analogue-to-digital convertor (ADC) of an on-line computer (PDP 11 Digital Equipment Corp., Maynard, Mass., U.S.A.) and could also be displayed on ultra-violet sensitive chart paper. All the spectra were fed to the PDP 11 and stored for subsequent processing. The chart paper was usually used to monitor the reaction but could be used to record all the data in the event of a computer failure.

2.2.3 Gas-line III - Flow System with Gas Chromatographic Analysis

In order to investigate the acetylene hydrogenation reaction under conditions similar to the industrial situation reactions were investigated on a flow system at atmospheric pressure. The apparatus is illustrated in fig. 2.3.

Cylinder gases were fed via two-stage pressure regulators through Brooks flow controllers types 8743 and 8744 into G.E.C. - Elliott rotameters for the measurement of large flow rates or liquid-in-glass flowmeters for small flow rates such as acetylene or carbon monoxide/hydrogen. The flow controllers maintained a constant flow of gas irrespective of any variations in the

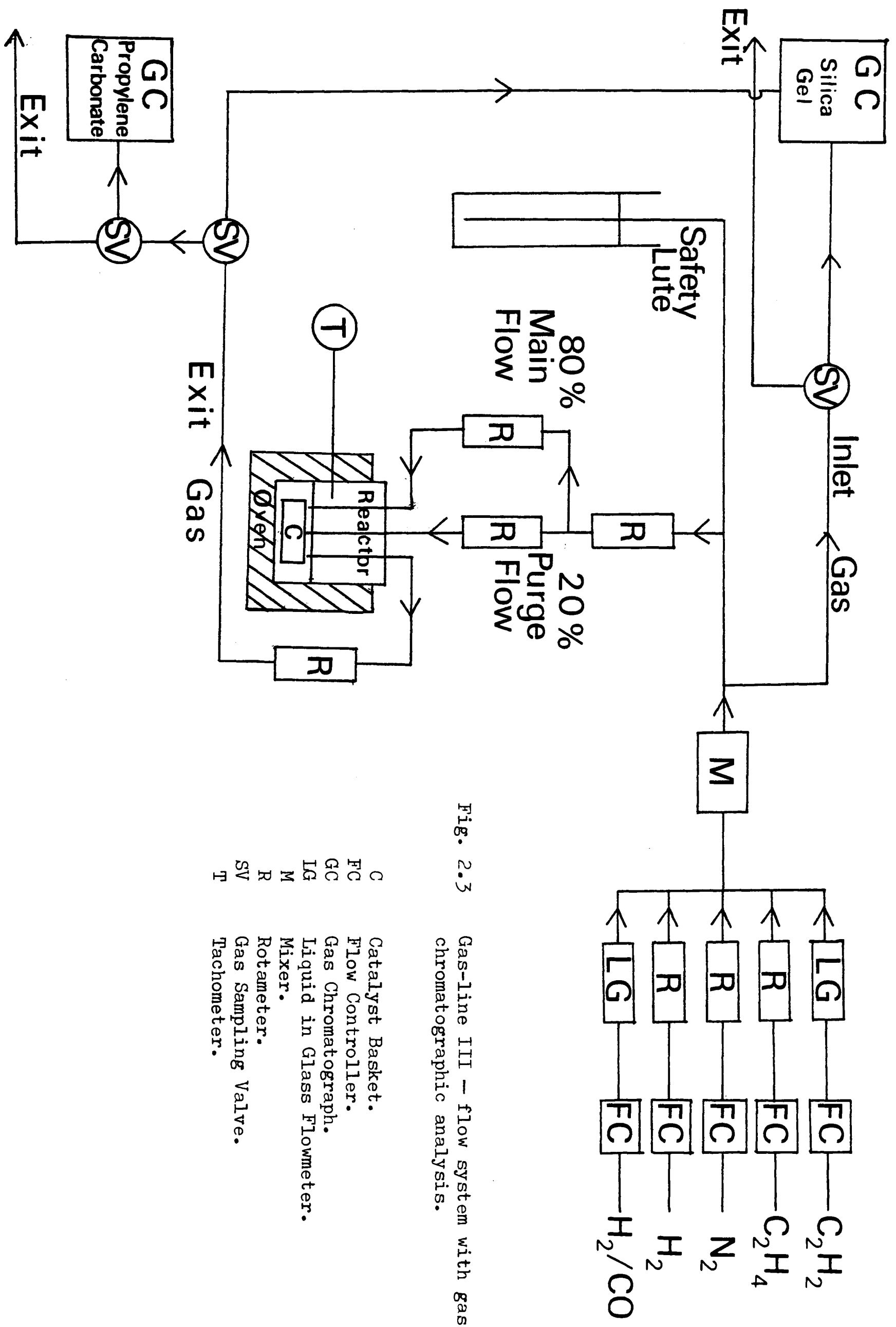

Fig. 2.3 Gas-line III — flow system with gas chromatographic analysis.

- C Catalyst Basket.
- FC Flow Controller.
- GC Gas Chromatograph.
- LG Liquid in Glass Flowmeter.
- M Mixer.
- R Rotameter.
- SV Gas Sampling Valve.
- T Tachometer.

down-stream gas pressure provided that the up-stream gas pressure at the cylinder head was constant. Stainless steel was employed in the flow controller and couplings in the acetylene gas line until the gases were mixed in order to prevent reaction of the copper present in brass with acetylene to produce the explosive copper acetylide.

The gas streams were combined and passed through a Dreschel bottle full of glass chips to thoroughly mix the gases. The composition of this inlet gas was analysed by gas chromatograph 1 via a Carle Instruments Inc. gas sampling valve. In the event of a blockage or a sudden increase in pressure in the system a safety lute was installed after the mixer to act as a blow-off. During normal operation the pressure in the system was 102.7 kN m^{-2} . The gas flow rate, normally $5.556 \times 10^{-6} \text{ m}^3 \text{ s}^{-1}$ was then measured by a rotameter and was then split into two for entry into the reactor, 20% of the gas flow was passed down the reactor shaft to prevent catalyst dust from entering the reactor bearings, the remaining 80% entered by the main inlet. The exit gas flow rate was measured by a rotameter and analysis of the exit gas was carried out by gas chromatography via two Carle gas sampling valves, one of which injected into gas chromatograph 1 for C_2 analysis and one of which injected into gas chromatograph 2 for C_4 analysis. The sampling valve loops were all of volume $5 \times 10^{-7} \text{ m}^3$.

2.2.4 The Stirred Gas - Solid Reactor⁷⁷

The reactor was a stirred gas-solid reactor manufactured by I.C.I. Ltd., similar to that developed by Carberry.⁷⁸ The reactor consisted of a catalyst basket which doubled as a stirrer paddle rotating in a small reaction vessel. Rotation at high speed caused the gas phase to be perfectly mixed and the concentration of the gas was assumed to be identical not only in every part of the free gas space but also over the surface of every catalyst particle. Under steady state conditions the inlet gas was mixed almost instantaneously

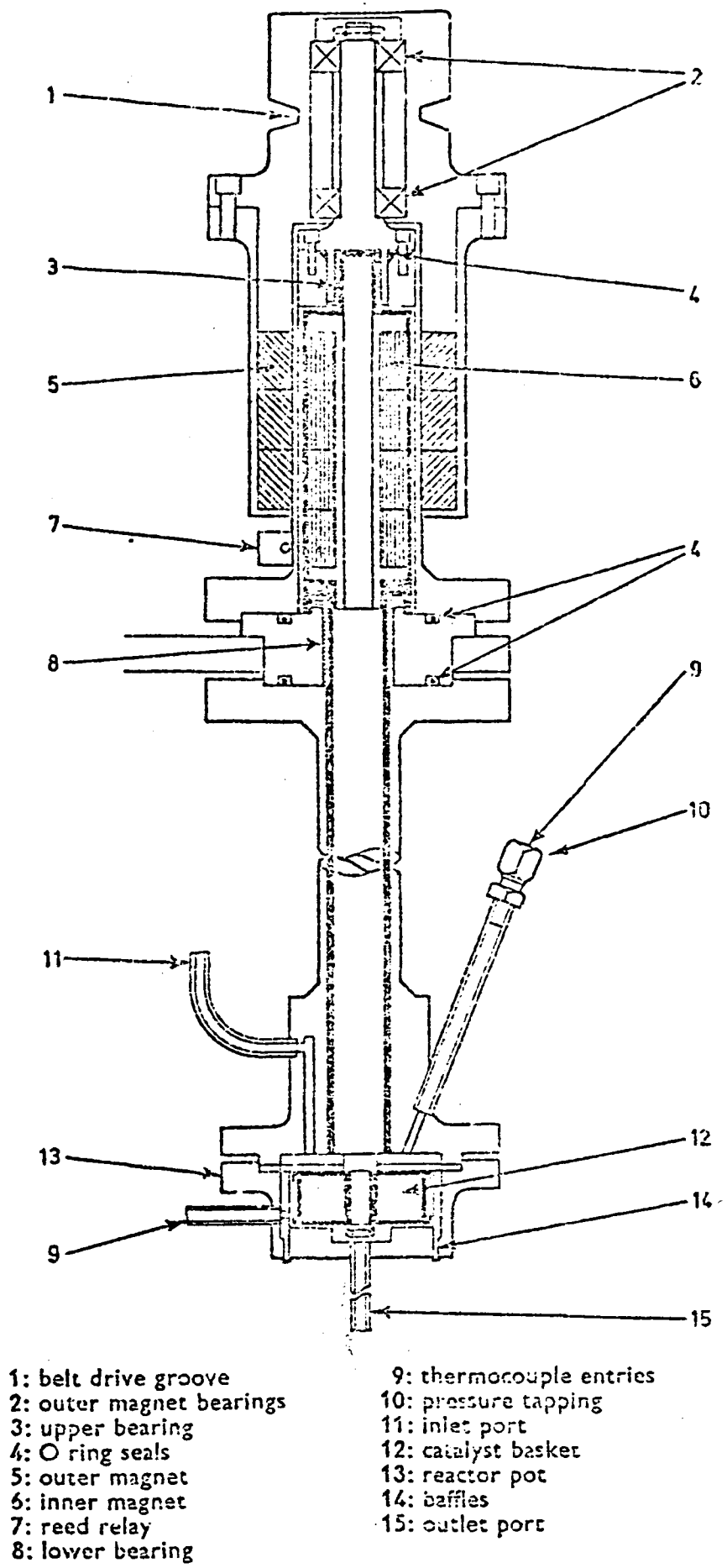

Fig. 2.4 Reactor including stirrer drive unit.

with the recirculating gases in the reactor and the exit gas was identical with the bulk gas of the reactor. The reaction rate was therefore dependent on the bulk reacting gas concentrations and not on the inlet gas.

The other benefits from this system were high rates of heat and mass transfer due to the fast rate of gas recirculation and good gas to wall heat transfer which enabled the reactor to be operated isothermally.

A diagram of the reactor is shown in fig. 2.4. The drive unit was a completely sealed, magnetically coupled drive which enabled the catalyst basket to rotate at speeds up to 6000 r.p.m. with no gas leakage or contamination of the gas or catalyst by bearing lubricants. Rotation speeds were measured using an analogue tachometer triggered by a reed switch. The catalyst basket was made of stainless steel and was circular in shape with a volume of $22.3 \times 10^{-6} \text{ m}^3$. The reactor was heated using a Perkin - Elmer gas chromatograph oven stable to $\pm 0.5\text{K}$ for experiments at temperatures above 327K. Below this temperature the reactor was immersed in a bucket containing water or ice and water for experiments at 273K. Readings of temperature were obtained using a Comark digital thermometer type 3000, the thermocouple of which entered the reactor as shown in fig. 2.4.

2.3 Procedure

2.3.1 Source and Purification of Reactants

In static system experiments Matheson C.P. grade hydrocarbon gases were used and, where appropriate, distilled under reduced pressure the middle third being retained. Carbon-13 labelled acetylene, which was used in tracer experiments on gas-line II was obtained from British Oxygen Corporation Ltd., and had a composition 84.3% $\text{H}^{13}\text{C} \equiv {}^{13}\text{CH}$, 15.0% $\text{H}^{13}\text{C} \equiv {}^{12}\text{CH}$. This was purified by a freeze-pump-thaw-cycle at 77K. Hydrogen (B.O.C. Ltd) and deuterium (Matheson) were purified by diffusion through an electrically heated palladium - silver alloy thimble (see fig. 2.1) from a storage bulb, through a trap at 77K and

into a smaller storage bulb. Carbon monoxide for use in poisoning experiments was obtained from I.C.I. Ltd., as a 3% mixture in hydrogen and was purified by passage through a liquid nitrogen trap. In poisoning experiments at higher concentrations of carbon monoxide Matheson C.P. grade carbon monoxide was used after similar purification.

In flow system experiments acetylene, nitrogen 'white-spot' purity, ethylene and hydrogen were supplied by B.O.C. Ltd., and used without any further purification although checks were run on the hydrocarbons by gas chromatography and ~170 ppm of ethane was found to be present in the ethylene. Propylene was obtained from I.C.I. Ltd., and was used without further purification. Carbon monoxide was obtained from I.C.I. Ltd., as a 3% mixture in hydrogen and was used without further purification.

2.3.2 Static Systems

The experimental procedure in static systems I and II was almost identical. Samples of catalyst, typically two pellets, of ~0.35g were placed in the reaction vessel and outgassed at 473K followed by two successive reductions in 13.3 kNm⁻² of hydrogen at 473K for a total of 17 hours. The catalyst was then evacuated at 473K for 30 minutes and until the reaction vessel was at the reaction temperature. Using the diaphragm pressure gauge reactants were admitted to the mixing volume 'M' and frozen into a cold finger one by one. A normal reaction mixture consisted of 19.6 kNm⁻² of ethylene, 0.4 kN m⁻² of acetylene and 0.8 kN m⁻² of hydrogen. This gave a mixture of 2% acetylene in ethylene having a hydrogen to acetylene ratio of 2:1. The mixture was expanded from the mixing volume to the reaction vessel giving a total pressure of 7.3 kN m⁻² in the reaction vessel. The composition of the contents of the reaction vessel was determined immediately on admission of the reactants and at appropriate intervals thereafter. Variations in the reaction mixture composition were carried out, mainly involving different acetylene to hydrogen ratios. Experiments were also performed where the time of reduction in hydrogen

was varied.

In the G.C.M.S. experiments on gas-line II it was necessary to increase the proportion of acetylene present to 10-20% in order to produce sufficient ethane to reduce background error in the ethane peaks of the mass spectrometer.

All catalyst samples underwent two reductions in 13.3 kN m^{-2} of hydrogen or deuterium at 473K for a total of 17-18 hours, followed by evacuation at 473k for 30 minutes and until the catalyst was at the reaction temperature. Three types of experiment involving tracers were carried out.

(I) Mixtures containing 20% of carbon-13 labelled acetylene in ethylene, with a hydrogen to acetylene ratio of 2:1, were reacted over 0.54g of catalyst at 293K. The reaction mixtures consisted of 16.00 kN m^{-2} of ethylene, 4.00 kN m^{-2} of acetylene and 8.00 kN m^{-2} of hydrogen. This was expanded from the mixing volume into the reaction vessel giving a pressure of 9.76 kN m^{-2} in the reaction vessel.

(II) Mixtures of 12% acetylene in ethylene, with a deuterium to acetylene ratio of 2:1, were reacted over 0.58g of catalyst at 313K. The reaction mixtures consisted of 17.60 kN m^{-2} of ethylene, 2.40 kN m^{-2} of acetylene and 4.80 kN m^{-2} of deuterium giving a pressure of 8.64 kN m^{-2} in the reaction vessel.

(III) Experiments were carried out involving the reaction of 2:1 deuterium to acetylene mixtures over 0.54g of alumina support, indentical to that which was present in 38-3, at 293K and 313K. The reaction mixtures consisted of 4.00 kN m^{-2} of acetylene and 8.00 kN m^{-2} of deuterium giving a pressure in the reaction vessel of 4.48 kN m^{-2} . No ethylene was present in these experiments. After carrying out a reaction at 293K the reaction vessel was evacuated for 15 minutes at 473K and the reaction was repeated at 313K.

2.3.3 Flow System

The three gas sampling valves in the flow system enabled the inlet gas to be analysed for C_2 compounds in gas chromatograph 1 (see fig. 2.3) and the exit gas to be analysed for C_2 compounds in gas chromatograph 1 or C_4 compounds in

gas chromatograph 2.

The catalyst basket was filled with 14.04g of I.C.I. 38-3 catalyst with care being taken to evenly distribute the catalyst pellets in order to avoid unnecessary vibration of the reactor upon rotation of the basket. The same sample of catalyst was used throughout all the experiments described. Reduction of the catalyst was achieved by heating the reactor to 473K and passing a 30% mixture of hydrogen in nitrogen for 2 hours at a flow rate of $5.556 \times 10^{-6} \text{ m}^3 \text{ s}^{-1}$ and a basket rotation speed of 1500 rpm. Overnight and between experiments the reactor was left under a small purge of hydrogen and nitrogen in order to prevent reoxidation of the catalyst. A control experiment on the reduced but empty catalyst basket showed no evidence for acetylene hydrogenation or ethylene hydrogenation at 343K.

The reactant gases were set at their prescribed levels on the rotameters by adjustment of the flow controllers and the reactor was left for 45 minutes in order that a steady state could be reached. The exit gas was then analysed with samples being injected into gas chromatograph 1 and gas chromatograph 2 simultaneously. The inlet gas was then analysed in gas chromatograph 1. This process was repeated until consistent results were obtained before the composition of the inlet gas was varied and left for a further 45 minutes.

In a typical experiment the inlet concentrations of ethylene, hydrogen, nitrogen and carbon monoxide were kept constant while that of the acetylene was varied. The procedure was to gradually increase the inlet acetylene concentration to a maximum and then to decrease it to ensure that no hysteresis effect was operating. The maximum concentration of acetylene which could be admitted to the inlet gas stream was 2.7%.

In a new experiment where either the ethylene, hydrogen or carbon monoxide concentration was varied the total gas flow was adjusted to the standard level of $5.556 \times 10^{-6} \text{ m}^3 \text{ s}^{-1}$ by variation of the nitrogen diluent.

Because the rotameters were calibrated in terms of the flow rate of air the conversion factors had to be calculated for the reactant gases. This was achieved using the relationship given in equation 2.1.

$$\text{Flow rate} \propto \left(\frac{1}{\text{Molecular Wt.}} \right)^{\frac{1}{2}} \quad 2.1$$

The conversion factor, x, which the rotameter scales were required to be divided by are shown in table 2.1.

Table 2.1 : Conversion Factors for Rotameter Scales

Gas	Mol. Wt.	X
Air	28.8	1.00
C ₂ H ₄	28	1.01
N ₂	28	1.01
H ₂	2	3.79
C ₃ H ₆	42	0.83

2.4 Analytical Techniques

2.4.1 Gas Chromatography

Gas chromatographic analyses were carried out on gas-line I using a Perkin-Elmer F.11 chromatograph equipped with a flame ionisation detector. Amplified signals from the detector were recorded on a Servoscribe potentiometric recorder and the peak areas were integrated using a Hewlett Packard 3373B integrator.

The chromatographic columns used in the analysis of the hydrocarbon mixtures in the static system I were either a 2m column of 3% squalane on alumina held at 273K followed by a 0.75m column of silica gel held at 333K or a 2m column of silica gel held at 333K. The carrier gas was nitrogen at a pressure of 207 kN m⁻².

The mode of operation of the first system was that the squalane on alumina column separated acetylene from ethane/ethylene and the silica gel column

separated the ethane and ethylene. The silica gel column was switched out of series with the squalane on alumina column after the appearance of ethylene since a large retention time for acetylene was found if it was admitted to the silica gel column. Subsequent experiments achieved good separation of the three hydrocarbons using only a 2m silica gel column held at 333K.

Sensitivity factors were obtained for all three hydrocarbons by repeated measurement of the integrated peak areas of known pressures of each gas. The values for the sensitivity factors, normalised to that of ethylene are given in table 2.2 along with the retention time for each hydrocarbon. The 2m silica gel column was also used for chromatographic separation in the G.C.M.S. of static system II where the carrier gas was helium at a pressure of 207 kN m⁻² and the column was held at 363K.

Table 2.2 : Gas Chromatographic Analysis in Static System I

Column	Gas	Retention Time/s	Sensitivity Factor
2m 3% squalane on alumina + 0.75m silica gel	Ethane	79	0.931
	Ethylene	145	1.000
	Acetylene	315	1.173
2m silica gel	Ethane	120	0.943
	Ethylene	220	1.000
	Acetylene	550	0.972

On gas-line III gas chromatographic analyses were carried out using two Perkin-Elmer F.33 chromatographs equipped with flame ionisation detectors, the peak traces were recorded on Servoscribe potentiometric recorders and the peak areas were integrated using Hewlett Packard 3373B integrators. The chromatographic column used in gas chromatograph 1 was the same 2m silica gel

column held at 333K so used in static system I. The carrier gas was nitrogen at a pressure of 207 kN m⁻². This column separated the C₂ compounds from both the inlet and exit gas streams. Gas chromatograph 2 contained a 10m column containing 20% w/w propylene carbonate on Chromosorb P held in a water and ice bath at 273K. The carrier gas was nitrogen at a pressure of 173 kN m⁻². This column separated the C_n compounds from the exit gas stream. Sensitivity factors were obtained for the C₂ compounds in gas chromatograph 1 and for C₂ and C_n compounds in gas chromatograph 2. Gas chromatograph 2 could not separate ethane from ethylene but, because of the large excess of ethylene employed and the near equivalence of sensitivity factors of ethane and ethylene in gas chromatograph 1, no correction was made for the ethane under the ethylene peak. The sensitivity factors were obtained by passing pure samples of each gas through the sample loop and injecting into the corresponding gas chromatograph. The sensitivity factors and retention times in the analysis of the flow system experiments are shown in table 2.3. Again the sensitivity factors were normalised to ethylene.

Table 2.3: Gas Chromatographic Analysis in Flow System III

Gas Chromat.	Gas	Retention Time/	Sensitivity Factor
1	Ethane	120	0.989
	Ethylene	190	1.000
	Propane	291	1.432
	Acetylene	480	1.138
	Propylene	686	1.252
2	Ethane/Ethylene	324	1.000
	Propane/Propylene	370	1.493
	Acetylene	379	1.066
	n-Butane	499	1.859
	But-1-ene	564	1.865
	Trans But-2-ene	638	1.824
	Cis But-2-ene	703	1.853
Buta-1,3-diene	773	1.786	

2.4.2 Mass Spectrometry

The ionising energy for the electron beam was always 20eV so chosen to prevent the formation of ions from residual helium which has an ionising potential of 24eV and also to prevent loss of intensity which would take place if the ionising energy was too low. When 20eV electrons were used extensive production of fragment ions occurred and this had to be allowed for when analysing the mass spectra. It was also necessary to measure the sensitivity of the gas chromatograph-mass spectrometer to each component of the reaction mixture. This was achieved immediately after each experiment by making up a known mixture of light hydrocarbons and passing a sample of that mixture through the system. The fragmentation pattern for each component was also obtained at this stage.

CHAPTER 3

Treatment of Results

3.1 Reactions in Static System

3.1.1 Gas Chromatographic Data

Since only hydrocarbons could be analysed using a flame ionisation detector the total peak areas were corrected for variations in sensitivity and the composition of the reaction mixture was expressed in percentages of the total hydrocarbon present. Calculation of the amounts of hydrogen present during the reaction was carried out using the percentages of ethylene and ethane formed from acetylene and ethylene so that for every molecule of ethylene that was formed one molecule of hydrogen was consumed and for every molecule of ethane produced two molecules of hydrogen were consumed. Therefore, knowing how much hydrogen was initially present the instantaneous concentration of hydrogen could be obtained by subtraction of the amount of hydrogen consumed. The amount of hydrogen present was expressed in terms of a percentage of total hydrocarbon and thus had the same units as the hydrocarbon compositions. The experimental data were plotted as percentage composition versus time to give a general picture of the course of the reaction and of the product ratios. The rates of reaction could be obtained from such plots as the gradient of each curve at a particular instant during the reaction.

3.1.2 Gas Chromatography - Mass Spectrometry Data

This section deals with the methods used to convert the raw spectra obtained in experiments into chemically significant results. The calculations were carried out using a computer for which programs had already been written⁷⁹, the calculations were performed on either an IBM 370/158 machine or an ICL 4/75 machine. A large quantity of mass spectral data was produced in each G.C.M.S. experiment and before the isotopic content of each species could be

determined the data had to be subjected to several stages of processing. Once a peak was identified the computer assigned a centroid value which defined the position of the peak with reference to the start of the spectrum and an integrated intensity value for the peak. The next stage in processing was to assign mass numbers to the intensities in the spectra. This could be achieved by using the background spectra which were recorded before the appearance of hydrocarbon species. The most prominent peaks in the background were those of water, nitrogen and oxygen which could be assigned to mass numbers 18, 28 and 32. From the centroid positions of these background peaks the centroid positions of the hydrocarbon peaks could be assigned a mass number. However, no single scan was representative of the overall composition since a chromatographic column has the ability to partially separate the different isotopic species of the same hydrocarbon. This has been illustrated by Dowie et al⁷² on an equimolar mixture of propane -d₀ and -d₃. An average over the series of scans over each hydrocarbon peak was therefore required. This was accomplished using Simpson's Rule⁸⁰. It was also necessary to correct for background peaks arising from residual gases in the mass spectrometer and from "bleed" from the chromatographic column. Therefore five background peaks were recorded before each G.C.M.S. hydrocarbon sample and the average of these peaks was subtracted from the integrated intensity values in the hydrocarbon spectra to which they contributed.

Isotope corrections were carried out to allow for the contribution from carbon - 13 and deuterium present naturally in the hydrocarbons since the presence of either of these isotopes would have resulted in peaks at mass numbers greater than that of the parent molecule. The isotopic abundances of carbon - 13 and deuterium are 1.108% and 0.016% respectively and so for the molecule C_nH_m of mass M the peak heights at masses M + 1, M + 2 etc. can be

calculated relative to the peak height P_M , at mass M . Therefore the following relationships may be derived from statistics.

$$100 \frac{P_{M+1}}{P_M} = n(1.108) + m(0.016) \quad 3.1$$

The binomial expression

$$(0.98931 + 0.01069x)^n (0.99984 + 0.00016x)^m \quad 3.2$$

can be used to yield the intensity ratios for peaks containing natural isotopes relative to that of the parent hydrocarbon.

For a range of deuterated products the values of these ratios will

depend on the isotopic content of the molecule since when hydrogen is replaced by deuterium in the molecule the probability of naturally occurring deuterium being present in the molecule decreases. If the species is designated $C_nH_m - xD_x$ the correct ratios of P_{m+1}/P_m and P_{m+2}/P_m may be found by substitution of $(m-x)$ for m in equations 3.1 and 3.2. Isotopic corrections could then be made starting with the lowest mass number and working upward to higher masses using the corrected intensity at each mass to calculate the contribution to the next mass. In experiments where carbon - 13 labelled acetylene was a reactant no natural isotope corrections were made since non-natural acetylene was reacting.

Finally a correction had to be applied because of fragmentation in the mass spectrometer source. Some hydrocarbon molecules may lose one or more hydrogen or deuterium atoms on collision with the electron beam to produce peaks at mass numbers lower than that of the parent molecule. The fragmentation factors f_i were calculated from the fragmentation patterns of the light hydrocarbons where

$$f_i = \frac{\text{height of } C_nH_{m-i} \text{ peak}}{\text{height of } C_nH_m \text{ peak}} \quad 3.3$$

The fragmentation patterns were calculated from statistics after the

method employed by Dowie et al⁸¹ where it was assumed that the ratio of heavy and light fragmentation factors was $f'/f \approx 0.65$ where f is the fragmentation factor when a hydrogen atom is lost and f' is the fragmentation factor when a deuterium atom is lost. Fragmentation corrections were made systematically starting with the highest mass peak and correcting to low masses making corrections using each newly corrected intensity and taking into account all possible fragmentation processes. The fragment ion contributions from each peak were calculated by multiplying the peak intensity by the appropriate fragmentation factors and subtracting the value so obtained from the appropriate peak intensities at lower mass numbers. The corrected peak intensities were then summed and each isotopic species was expressed as a percentage of the total.

In the G.C.M.S. system background peaks were sometimes rather large especially at peaks of mass numbers 18, 28 and 32 corresponding to water, nitrogen and oxygen respectively. This presented problems in the interpretation of the spectra of ethane which has a parent ion mass of 30 and peaks of its deuterated species and fragments at mass numbers 32 and 28. Ethylene, however, was in such large excess in the experiments performed so as to make the background peaks negligible as far as data processing was concerned.

The results were usually plotted as percentage composition against time, usually as a percentage of the total hydrocarbon present after a correction using the sensitivity factor of each hydrocarbon in the G.C.M.S. but occasionally isotopic compositions were plotted as a function of the percentage of the individual hydrocarbon in the interests of clarity.

3.2 Flow System Data

Raw data was acquired in the form of inlet and exit hydrocarbon compositions

expressed in terms of percentages of the total hydrocarbon present. To convert the inlet and exit concentrations into the rate of reaction an examination of the mass balance of each reactant or product is required. As was stated in Section 2.2.4 the exit gas composition is identical to that found inside the reactor so each catalyst particle is in contact with an identical sample of gas.

The method of calculation of reaction rates is explained with the help of Fig. 3.1.

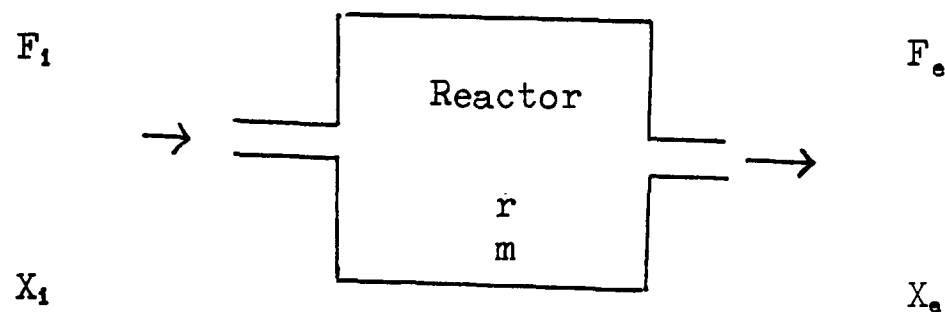

Fig. 3.1 Diagram of Reactor Flow

F represents the gas flow rate, X the mole fraction of the reactant or product, m is the mass of catalyst and r is the reaction rate per unit mass of catalyst. Subscripts $_1$ and $_e$ denote inlet and exit gas streams respectively.

For any particular gas the mass balance equation is:

(a) for reaction of a reactant;

$$\text{moles in} = \text{moles out} + \text{moles reacted} \quad 3.4$$

(b) for production of a product;

$$\text{moles out} = \text{moles in} + \text{moles produced} \quad 3.5$$

Equation 3.4 is represented in symbol form by

$$F_1 X_1 = F_e X_e + rm \quad 3.6$$

and equation 3.5 by

$$F_e X_e = F_i X_i + r m \quad 3.7$$

Combining equations 3.6 and 3.7 into a general equation gives

$$r = \pm \frac{(F_i X_i - F_e X_e)}{m} \quad 3.8$$

where the positive prescript operates for the removal of a reactant and the negative prescript of the production of a product. In the system used only small amounts of acetylene were present and so the total conversion of the reactant gas was small with small amounts of hydrogen being consumed. For this reason the inlet and exit flow rates were assumed to be equal.

Equation 3.8 can then be simplified to give

$$r = \pm \frac{F_i (X_i - X_e)}{m} \quad 3.9$$

As the flow rates were measured in units of ml hr^{-1} ($\equiv 2.778 \times 10^{-10} \text{ m}^3 \text{ s}^{-1}$) and the catalyst mass expressed in g the reaction rates were recorded in units of $\text{ml hr}^{-1} \text{ g}^{-1}$.

Again hydrogen was not detected by the flame ionisation detectors of the gas chromatographs so the consumption of hydrogen had to be calculated from the rates of consumption or production of the hydrocarbon species including the C_4 products. The concentrations of carbon monoxide present were assumed to be those calculated to be present in the inlet gas streams since carbon monoxide adsorption would have reached a steady state in the 45 min. that the system was left to achieve steady state conditions.

Since only hydrocarbons were analysed by the gas chromatograph and their compositions were expressed as percentages of the total hydrocarbon present these values had to be corrected using the nitrogen and hydrogen

flow rates to give the percentages in terms of total gas present. In experiments in the absence of ethylene the hydrocarbon flow rate was read from the liquid-in-glass flowmeter used to measure the acetylene flow rate.

The experimental data were usually plotted as reaction rate for acetylene or hydrogen removal, ethane or C_4 production against the exit acetylene concentration.

CHAPTER 4

The Kinetics of Acetylene Hydrogenation in Excess Ethylene in a Static System

4.1 Introduction

When a reaction occurs at the surface of a solid the reactants and reaction intermediates are confined to a thin layer over the surface and the kinetics of surface reactions are determined by the concentrations of the reactants in the reactive layer. These concentrations are only indirectly related to the gas pressures through adsorption isotherms.

From the work described in Chapter 1 it may be gathered that the main factor governing the selectivity for ethylene formation during the hydrogenation of acetylene is the comparatively weak adsorption of ethylene compared to that of acetylene. An attempt, therefore, has been made in the present work to correlate the relative proportions of ethylene and ethane produced during the hydrogenation of small amounts of acetylene in excess ethylene with the surface concentrations of acetylene, ethylene and hydrogen. The influence of carbon monoxide on the surface balance of acetylene and ethylene has also been studied. Previous work has supplied information about the competitive effects of acetylene with hydrogen or ethylene with hydrogen but no reports have been published dealing with the adsorption of acetylene in the presence of large ethylene: acetylene gas phase pressure ratios which are important in industrial service.

4.2 Experimental Procedure

The experiments described in this chapter were performed on gas-line I as described in Chapter 2. Most experiments involved the hydrogenation of a 2% mixture of acetylene in ethylene with a hydrogen : acetylene ratio of 2:1 but the effect of different hydrogen : acetylene ratios was also studied. Experiments were also carried out to examine the role of carbon monoxide and the reactivity of the catalyst support.

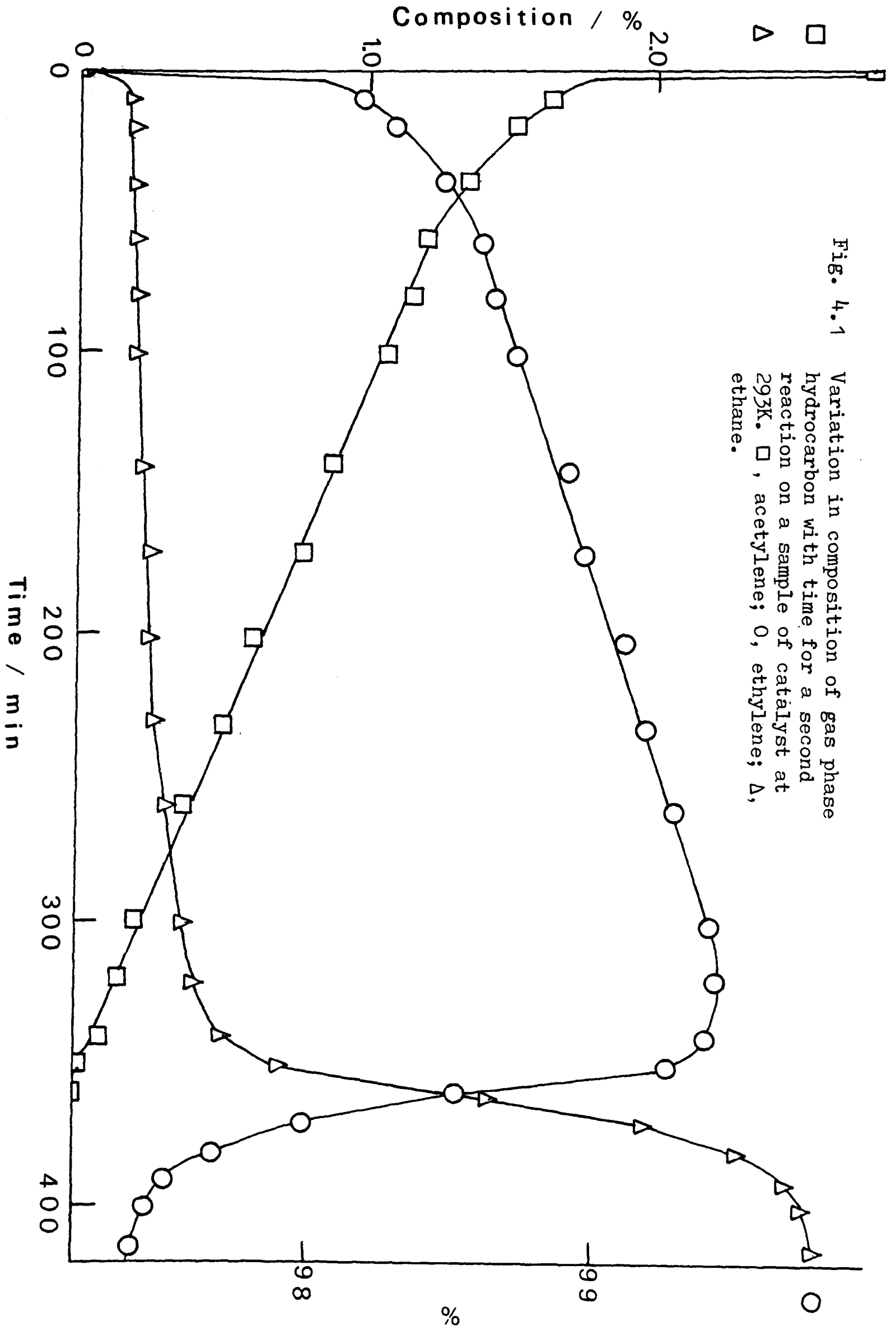

Fig. 4.1 Variation in composition of gas phase hydrocarbon with time for a second reaction on a sample of catalyst at 293K. □, acetylene; ○, ethylene; Δ, ethane.

4.3 Results

The general characteristics of a typical reaction are illustrated in fig. 4.1 where amounts of acetylene, ethylene and ethane are plotted as percentages of the total gas phase hydrocarbon as a function of time at 293K. The total reaction can be divided into four regions of behaviour.

4.3.1. Region A

Region A consisted of an initial rapid process lasting from the time of admission of the reactants until approximately 10 min. in fig.4.1. Here the concentration of acetylene fell rapidly and the concentrations of ethylene and ethane increased. Up to 40% of the initially added acetylene was removed from the gas phase and this value did not vary much with a change in the initial hydrogen : acetylene ratio as shown in table 4.1.

Table 4.1. The Effect of the Initial Hydrogen : Acetylene Ratio on the Initial Stages of Acetylene Removal and Ethane Formation for Freshly Reduced Catalyst Samples

Initial H_2/C_2H_2	Decrease in C_2H_2 / % in 10 min.	Increase in C_2H_6 / % in 10 min.	Temp/ K
1	0.850	0.066	292
2	0.860	0.011	293
2	0.950	0.114	323
8	1.035	0.145	293

Table 4.1 shows that the initial ethane production has more dependence on the hydrogen : acetylene ratio or temperature than has acetylene removal but only to a small extent. The ethane produced during the first 10 min. of reaction only amounted to up to 0.2% of the gas phase hydrocarbon. Catalysts which had undergone a previous reaction and had not undergone a second reduction in hydrogen also showed a rapid initial reaction but generally to a lesser extent than that observed on freshly reduced catalysts.

Fig 4.2

Effect of presorbed reactants on the initial stage of reaction at 293K.

□, acetylene; O, ethylene; Δ, ethane.

- (a) 1.2 kN m^{-2} of ethylene presorbed,
- (b) 0.13 kN m^{-2} of acetylene presorbed,
- (c) 0.27 kN m^{-2} of hydrogen presorbed,
- (d) all gases admitted simultaneously.

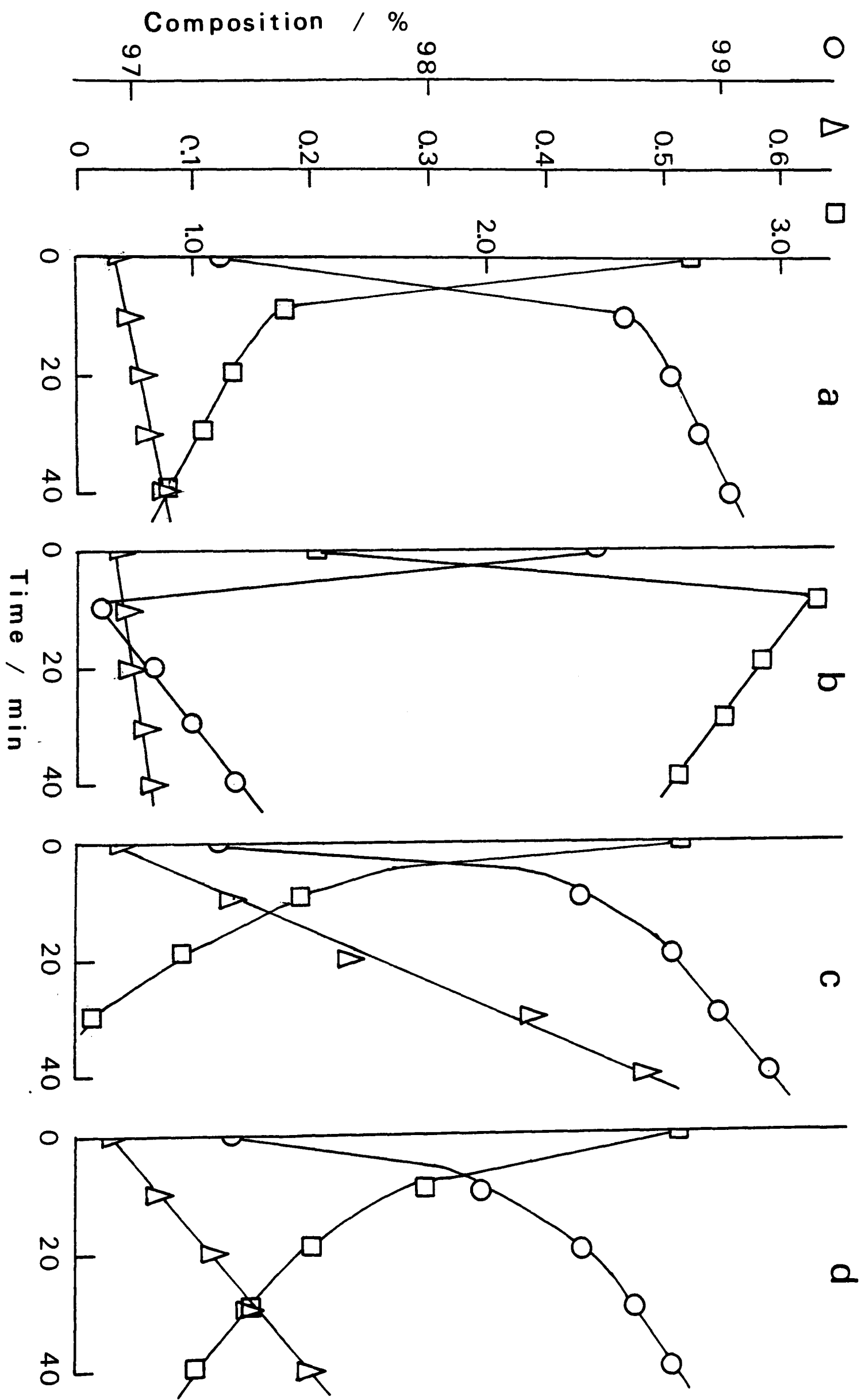

A control experiment was carried out in which no catalyst was present in the reaction vessel and no removal of acetylene or production of ethane was observed.

In order to investigate if the initial fast stage was influenced by the order of admission of the reactant gases a series of experiments was carried out in which the catalyst was predosed with one of the reactants or products prior to the admission of the remaining constituents of a normal reaction mixture. The same catalyst sample was used being evacuated at 473K for 30 min. between each run. The results are illustrated in fig. 4.2, all experiments were carried out at 293K. The catalyst was reduced initially and a reaction allowed to proceed before beginning the predosing experiments to eliminate the effect of hydrogen left on the surface after reduction. Predosing with ethylene, fig. 4.2 a, had little effect on the reaction characteristics compared to when all gases were allowed to enter the reaction vessel simultaneously as in fig. 4.2 d except for a slight decrease in the rate of ethane formation. The prior admission of hydrogen, fig. 4.2 c, resulted in a much greater production of ethane than that observed in fig. 4.2 d. When the surface was predosed with acetylene as in fig. 4.2 b the percentage of acetylene in the gas phase increased on admission of the remaining reactants and the rate of production of ethane was less than in fig. 4.2 d.

4.3.2. Region B

In this region, from ~ 30 to ~ 250 min. in fig. 4.1, the rates of acetylene hydrogenation and ethylene and ethane production remained constant.

The selectivity of the hydrogenation of acetylene may be expressed as the ratio of the rate of formation of ethylene, R_2 , to the rate of formation of ethane, R_1 .

$$S = R_2/R_1 \qquad 4.1$$

Experiments were carried out on a single catalyst sample to investigate the effect of different initial hydrogen : acetylene ratios on the rates of ethylene

and ethane formation. Between each run the catalyst was evacuated for 30 min. at 473 K. Results are expressed in table 4.2 for experiments with hydrocarbon compositions of 2% acetylene in ethylene.

Table 4.2. Variation of Rates^a of Production of Ethylene and Ethane with Initial Hydrogen : Acetylene Ratio at 293 K

P_2/P_3^b	Ethylene Formation $R_2/10^3 \text{ \% min}^{-1}$	Ethane Formation $R_1/10^3 \text{ \% min}^{-1}$	S
2	9.0	3.8	2.37
8	33.7	14.7	2.29
4	14.9	7.7	1.94
2	9.5	3.3	2.88

^a Rates expressed in terms of percentage of total hydrocarbon

^b Subscript 3 denotes acetylene.

The order is found to be 0.94 for ethylene formation and 1.05 for ethane formation from these results. The selectivity S was found to decrease with repeated use of a sample of catalyst typically from 16 for a fresh catalyst to 2 or 3 on a catalyst being used for the fourth time at 293 K. This fall in selectivity with catalyst use was independent of whether the catalyst was reduced in hydrogen or simply evacuated between runs. The experiment illustrated in fig. 4.1 was the second experiment on a sample of catalyst and had an S value of 7.3 in region B compared to a value of 16.8 for the first experiment. The low S values shown in table 4.2 are part of this phenomenon.

The decrease in the selectivity for ethylene formation with catalyst use was due to an increase in the relative rate of ethane formation as opposed to a reduction in the relative rate of ethylene formation. The absolute values of the reaction rates of ethylene and ethane production both depended on whether the catalyst had been evacuated or reduced between runs, higher reaction rates

being found when reduction had taken place.

The dependence of S and the rates of ethylene and ethane formation for freshly reduced catalyst samples on the initial hydrogen : acetylene ratio is shown in table 4.3.

Table 4.3. Dependence of Selectivity and Rates of Ethylene and Ethane Formation on the Initial Hydrogen : Acetylene Ratio for Freshly Reduced Catalyst Samples

P_{H_2}/P_3	Rate Ethylene Formation /10 ³ % min ⁻¹	Rate Ethane Formation /10 ⁴ % min ⁻¹	S	Temp/ K
2	3.50	2.23	15.7	293
2	15.63	8.21	19.0	323
8	11.01	10.57	10.4	293
1	1.18	0.61	19.3	292

The selectivity for ethane formation decreased with an increase in the hydrogen : acetylene ratio and also decreased as the reaction temperature was lowered as shown in table 4.3.

An investigation was also carried out into the effectiveness of the reduction procedure on the reaction selectivity. The results for experiments in which the time of reduction of new catalyst samples was varied are shown in table 4.4, all reaction mixtures were 2% acetylene in ethylene with a hydrogen : acetylene ratio of 2:1. All experiments were conducted at 293 K.

Table 4.4. Variation in Selectivity with Time of Reduction in Hydrogen at 473 K

Time of Reduction/hours	S
1	5.7
3	11.0
5	15.4
17	15.8
70	15.8

From table 4.4 the reaction selectivity was constant for experiments with reduction times of 5 hours or more indicating that the catalyst surface could be fully reduced by treatment with 13.3 kN m^{-2} of hydrogen at 473 K for at least 5 hours.

The activation energy for acetylene hydrogenation was determined by studying a reaction at various temperatures and applying the Arrhenius equation:

$$R_3 = A \exp(-E_a/RT) \quad 4.2$$

where $R_3/\text{molecules s}^{-1} \text{ m}^{-3}$ and T/K are the rate and temperature of the reaction, $R/\text{JK}^{-1} \text{ mol}^{-1}$ is the gas constant, $A/\text{molecules s}^{-1} \text{ m}^{-2}$ the frequency factor and $E_a/\text{J mol}^{-1}$ the activation energy. Measurement of the rate of disappearance of acetylene, R_3 , at temperatures between 273 and 323 K showed that the reaction rate could be expressed as

$$R_3 = 1.27 \times 10^{21} \exp(-46.8 \times 10^3/RT)$$

In experiments in the static system no evidence was found for the formation of butenes or higher molecular weight compounds as is found in industrial plants. This was probably due to the low pressure of acetylene used and the probability that any polymeric compounds formed would be adsorbed irreversibly on the catalyst.

4.3.3. Region C

Region C, from ~ 250 to ~ 355 min. in fig. 4.1, occurred where the rate of production of ethylene decreased as the acetylene pressure approached zero.

This was also accompanied by a gradual increase in the rate of ethane production. It was also observed that occasionally the rate of acetylene hydrogenation increased as the last traces of acetylene, (< 0.1% of the total gas phase hydrocarbon), disappeared.

4.3.4. Region D

After the disappearance of all the acetylene, > 360 min. in fig. 4.1, the rate of production of ethane gradually decreased until all the available hydrogen was consumed. This region corresponded to the hydrogenation of ethylene and the rates of ethane formation were initially very rapid. The rate constants and the reaction orders in hydrogen for the hydrogenation of ethylene in region D are shown in table 4.4. Unless otherwise stated reactions were on typical reaction mixtures of 2% acetylene in ethylene and acetylene : hydrogen ratios of 2:1. A detailed derivation of the rate equation will be given in section 4.4.3.

Table 4.5. Rate Constants and Reaction Orders in Hydrogen for Ethylene Hydrogenation

Rate Constant, k / x 10 ² min ⁻¹	Reaction Order in Hydrogen, n	Temp/K
9.1	0.8	293
7.1	0.9	293
12.0	1.0	323
^a 16.6	1.1	293
^b 13.5	0.8	273

^a Initial hydrogen : acetylene ratio of 8:1

^b No acetylene present initially, reaction mixture

a 2% mixture of hydrogen in ethylene.

From table 4.4 it can be observed that the reaction rate did not vary appreciably with temperature in the range 273-323 K and that little difference exists between the rates of reaction on catalysts which have experienced acetylene

hydrogenation prior to ethylene hydrogenation and those which only have experienced ethylene hydrogenation.

4.3.5. The Effect of Added Carbon Monoxide

When carbon monoxide was present the reaction rates were depressed so higher temperatures were used to obtain measurable rates. This necessitated raising the standard reaction temperature from 293 K to 323 K or 343 K.

The effect of carbon monoxide on region A, the fast initial stage, is shown in table 4.6. All reactions were on freshly reduced catalyst samples with standard reaction mixture compositions.

Table 4.6. Effect of Added Carbon Monoxide on the Initial Stages of Acetylene Removal and Ethane Formation at 323 K^a

Concentration of CO/p.p.m.	Decrease in Acetylene/% in 10 min.	Increase in Ethane/% in 10 min.	Temp/K
0	0.95	0.114	323
578	0.74	0.002	323
1155	0.66	0.032	323
5000	0.55	0.006	343

^a Concentrations expressed in terms of percentages of total hydrocarbon.

The effect of carbon monoxide was to reduce the initial rate of ethane production much more than the initial rate of acetylene removal.

The steady rates of ethylene and ethane formation in region B were also reduced by the presence of carbon monoxide as shown in table 4.7 for reactions on freshly reduced catalyst samples with typical reaction mixture compositions.

Table 4.7. Effect of Added Carbon Monoxide on the Steady Rates of Formation of Ethylene and Ethane

Concentration of CO/p.p.m.	Ethylene Formation R_2 / $10^2\% \text{min}^{-1} \text{g}^{-1}$	Ethane Formation R_1 / $10^4\% \text{min}^{-1} \text{g}^{-1}$	S	Temp/ K
0	4.42	23.2	19.1	323
578	3.63	10.6	34.2	323
1155	1.34	2.77	48.5	323
5000	1.06	< 0.15	>707	343

From table 4.7 as the concentration of carbon monoxide was increased the rate of ethylene formation was reduced but to a very much lesser extent than the rate of ethane formation which was almost completely poisoned in the presence of 5000 p.p.m. of carbon monoxide. These two effects manifest themselves as an increase in the selectivity for ethylene formation as the carbon monoxide concentration was increased as shown in table 4.7.

In region B it was found that the rate of acetylene disappearance in the presence of 1155 p.p.m. of carbon monoxide could be expressed as

$$R_3 = 4.66 \times 10^{20} \exp(-45.4 \times 10^3 / RT)$$

where R_3 is in molecules $\text{s}^{-1} \text{m}^{-2}$ and R is in $\text{J K}^{-1} \text{mol}^{-1}$.

In region D, after the complete removal of all acetylene, amounts of carbon monoxide ≤ 578 p.p.m. had little effect on the rate of ethylene hydrogenation but when 1155 p.p.m. or greater concentrations of carbon monoxide were present a very slow rate of ethylene hydrogenation ($< 1.2 \times 10^{-3} \% \text{min}^{-1}$) resulted at 323 K. This rate was very much lower than the extremely rapid rate of ethylene hydrogenation observed in fig. 4.1 on disappearance of the acetylene.

To investigate the effect of carbon monoxide on ethylene hydrogenation experiments were performed on systems where acetylene was absent. Mixtures of 2% hydrogen in ethylene with varying concentrations of carbon monoxide were reacted over the same sample of catalyst at 413 K which was evacuated for

30 min. at 473 K between runs to remove any adsorbed carbon monoxide. The results are expressed in table 4.8.

Table 4.8. Effect of Carbon Monoxide on Ethylene Hydrogenation in the Absence of Acetylene at 413 K

Concentration of CO / p.p.m.	$R_1^a /$ 10^3 \% min^{-1}	Order in sequence of runs
1000	10.5	4
2000	9.2	1
2000	8.8	5
5000	5.6	3
10000	2.8	6
20000	2.6	2
0	11800 ^b	-
0	100 ^c	-

^a Rate of production of ethane expressed in terms of total hydrocarbon at a hydrogen concentration equivalent to 1% total hydrocarbon.

^b Extrapolated from 293 K with an activation energy³⁹ of 40 kJ mol⁻¹.

^c Diffusion controlled rate at 293 K.

From table 4.8, carbon monoxide had a very marked effect in reducing the rate of ethylene hydrogenation. As little as 1000 p.p.m. of carbon monoxide caused the rate of ethylene hydrogenation at 413 K to be $\frac{1}{10}$ th. of the rate expected in the absence of carbon monoxide at 293 K, and only $\frac{1}{100}$ th. of the rate expected in the absence of carbon monoxide from Arrhenius considerations. Thereafter, on increasing the carbon monoxide concentration the rate of ethylene hydrogenation was reduced but the initial 1000 p.p.m. of carbon monoxide had a predominantly large effect.

Experiments were also carried out to test the effectiveness of evacuation at 473 K between runs in removing adsorbed carbon monoxide. It was found that evacuation at 373 K for 30 min. of a catalyst which had been exposed to a

Fig. 4.3 Reaction at various temperatures on alumina support. \square , acetylene; \circ , ethylene; Δ , ethane.

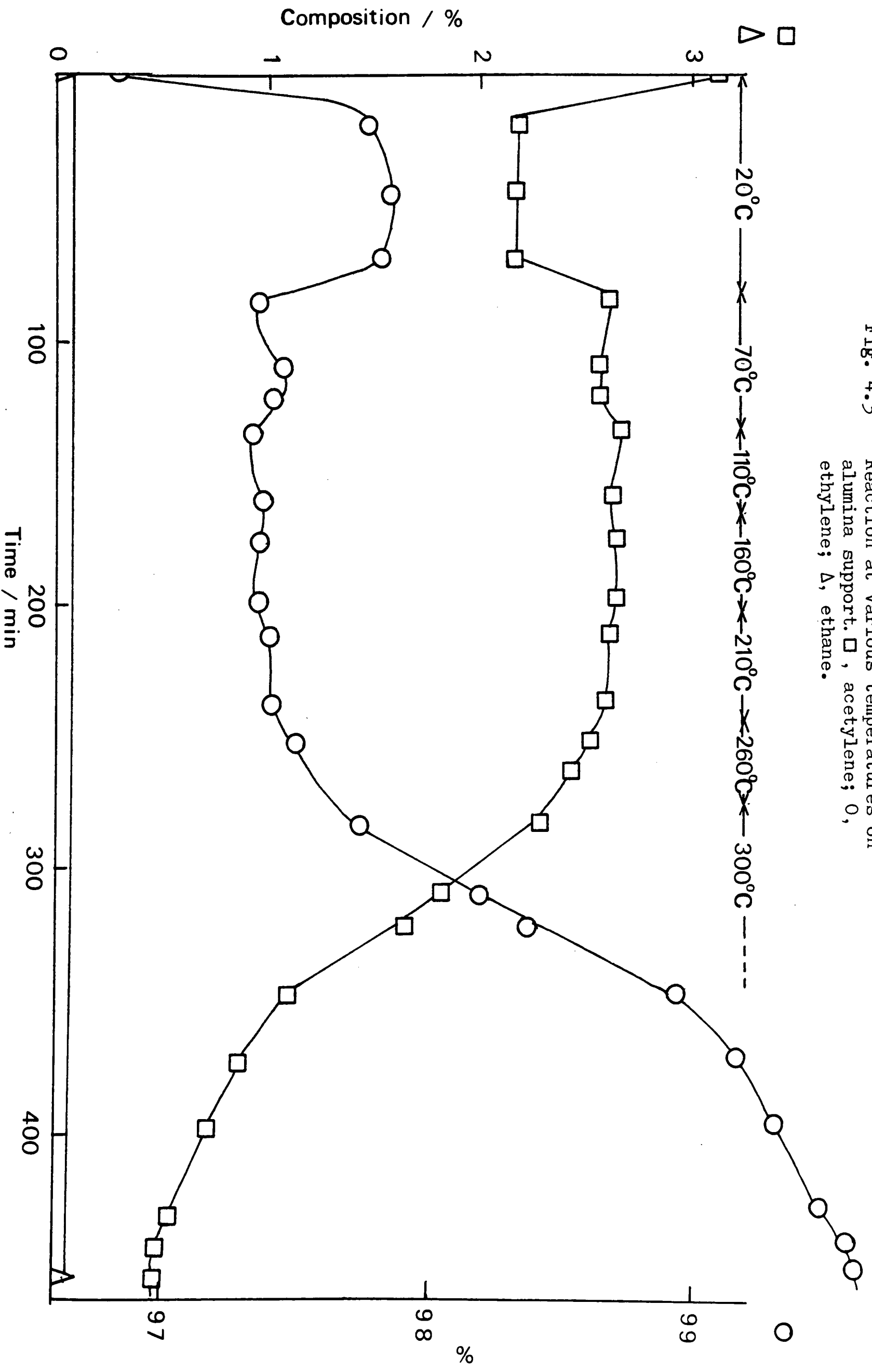

reaction mixture containing 578 p.p.m. of carbon monoxide gave rise to a surface which had similar activity as a catalyst which had not been exposed to carbon monoxide. Evacuation at 343 K did not restore the activity after exposure to 578 p.p.m. of carbon monoxide. Also, from table 4.8, the two experiments containing 2000 p.p.m. of carbon monoxide both had comparable reaction rates although up to 2% of carbon monoxide had been in contact with the catalyst between these experiments. Therefore evacuation at 473 K for 30 min. would appear to have returned the catalyst to its original condition.

4.3.6. Reactions on the Alumina Support

To investigate the role of the support experiments were performed on samples of alumina support type 12-2, manufactured by I.C.I. Ltd., which was the base for the palladium - alumina catalyst 38-3. The alumina was pretreated with hydrogen at 473 K and a typical reaction mixture was admitted. The results are shown in fig. 4.3 in which the reaction was started at 293 K and progressively heated to 573 K. At 293 K there was an initial fast stage of acetylene removal after which the removal of acetylene removal ceased. Heating to 343 K caused an increase in the percentage of gas phase acetylene present but no evidence of acetylene removal was observed until 533 K. Further heating to 573 K produced a reaction rate of $1.4 \times 10^{-2} \% \text{ min}^{-1}$ for acetylene removal, a figure comparable to the rates of acetylene removal observed on palladium - alumina at 293 K. From fig. 4.3 it may be seen that the rate of acetylene removal did not remain constant but decreased when the acetylene concentration fell below $\sim 1.0\%$. There was no evidence for ethane production even at 573 K but on heating further a very small rate of ethane production, $7.2 \times 10^{-4} \% \text{ min}^{-1}$, was observed after complete disappearance of the acetylene at 719 K.

Further experiments were attempted using the same sample of alumina as that used in the experiment shown in fig. 4.3 to investigate whether the

disappearance of acetylene was due to adsorption or whether hydrogenation to produce ethylene was occurring. This involved the reaction of 5.15 kN m^{-2} of acetylene and 10.30 kN m^{-2} of hydrogen in the absence of ethylene at 662 K. It was found that when 99.8% of the acetylene had disappeared 0.17% of the removed acetylene had been converted to ethane, 2.30% to ethylene, 0.35% to methane and 97.18% had not formed any gaseous product and had probably been adsorbed on the catalyst surface. After this experiment the catalyst surface was grey in colour, contrasting with the brilliant white of an unused sample.

Experiments were also carried out to investigate the role of the support in the initial fast acetylene removal in region A. From fig. 4.3 it can be observed that in the first 10 min. of reaction 0.92% of acetylene (expressed as a percentage of the total hydrocarbon present) disappeared at 293 K. The specific surface area of the alumina support was $90 \text{ m}^2 \text{ g}^{-1}$ and the surface area of the catalyst used was 32.6 m^2 . When an identical experiment was carried out on an alumina sample with a specific surface area of $25 \text{ m}^2 \text{ g}^{-1}$ and surface area of 8.5 m^2 the decrease in the acetylene level in the first 10 min. of reaction was 0.53%. There was therefore a relationship between the extent of acetylene removal in region A and the surface area of the support but this was non-linear.

4.4 Discussion

4.4.1. Region A

The initial fast stage can be affected by the order of admission of the reactant gases as shown in fig. 4.2. Prior adsorption of hydrogen results in an enhanced rate of ethane formation over that observed when all gases are allowed to enter simultaneously. It seems reasonable to explain the rapid initial rate of ethane production by the presence of hydrogen on the surface before the arrival of the hydrocarbons. It is possible that on admission of a standard reaction mixture, hydrogen, because of its small size, can diffuse to the active centres of the

catalyst faster than the hydrocarbons. When acetylene and ethylene reach the active centres the catalyst surface is hydrogen covered and equivalent to that found on a hydrogen pretreated surface. The initial fast production of ethane and, to some extent, the disappearance of acetylene may be attributed to the removal of this excess hydrogen and equilibration of surface species.

Prior admission of acetylene to the surface causes a substantial proportion to be adsorbed on the catalyst surface. On admission of the remainder of the gas mixture some of the preadsorbed acetylene is displaced producing an increase in the proportion of acetylene in the gas phase as observed in fig. 4.2 b. The amount of acetylene displaced was 1.7% of the total gas phase hydrocarbon and equivalent to 6×10^{18} molecules of acetylene. In 0.35g of catalyst the palladium surface area is $2.24 \times 10^{-2} \text{ m}^2$ and if the cross sectional area of an adsorbed acetylene molecule is assumed to be 0.2 nm^2 then there is room on the metal for $\sim 10^{17}$ acetylene molecules. Therefore only $\frac{1}{60}$ of the desorbed acetylene molecules could have been adsorbed on the palladium the remainder must have been adsorbed on the alumina support which had a surface capable of adsorbing 1.3×10^{20} acetylene molecules. Admission of the remainder of the gas mixtures causes desorption of the acetylene probably by ethylene. Ethylene would be unlikely to desorb any acetylene chemisorbed on the palladium because of the much larger adsorption strength of acetylene as opposed to ethylene. On the alumina it may be the case that ethylene and acetylene are adsorbed with not widely different strengths and desorption of the preadsorbed acetylene by ethylene can occur.

The possibility does exist of hydrocarbon upon hydrocarbon adsorption⁸² on the palladium but this can probably be excluded as this would involve up to 60 layers of coverage to account for the extent of acetylene adsorption.

When the surface is predosed with ethylene a similar result as that found when all gases are admitted together is observed but with a decrease in the

initial production of ethane. This reduction in the rate of initial ethane formation is also found when acetylene is preadsorbed and can be attributed to preadsorbed hydrocarbon preventing hydrogen from adsorbing. Adsorption of the acetylene on the support, although probably weak and reversible, would produce an effect similar to a reaction since only the hydrocarbons were analysed. Preferential adsorption of acetylene would manifest itself as an increase in the percentages of ethylene and, to a very small extent, ethane present. From gas chromatographic studies alone it was impossible to separate the contributions to acetylene removal by adsorption or reaction in the initial fast stage. Conclusive evidence for the existence of reaction as well as adsorption in the initial stage is the production of ethane.

Another explanation for the initial fast stage of reaction could be the presence of a number of highly active sites which rapidly poison. However, the initial fast stage can be reproduced simply by evacuation at 293 k without any further reduction so region A is unlikely to be attributable to poisoning which would only be expected to be reversible under more drastic conditions of surface cleaning. The experiments with alumina of different surface areas show that acetylene adsorption does occur on the alumina to an extent governed by the available surface area.

4.4.2. Region B

In this region the rate of acetylene hydrogenation remains constant and zero order kinetics are observed in acetylene and it can be assumed that the surface is completely covered with acetylene. Hydrogen atoms will adsorb on sites between the packed acetylene molecules which are too small to permit the adsorption of acetylene. If one assumes that all the available sites are eligible for both acetylene and hydrogen adsorption it seems likely that acetylene, because of its mode of adsorption parallel to the surface as described in section 1.4, will not be able to adsorb on all the available sites because of

steric effects and gaps will be left which can accommodate hydrogen atoms. The extent of the surface coverage in hydrogen in these spaces depends on the hydrogen pressure leading to first order kinetics in hydrogen. The selectivity in region B has been described⁸ as kinetic selectivity and has been attributed to the chance of an adsorbed ethylene molecule, formed by the hydrogenation of acetylene, desorbing to produce gaseous ethylene being appreciably greater than the chance of it hydrogenating further to yield ethane.

The results presented in this chapter can be interpreted in terms of kinetic selectivity but tracer studies as described in Chapter 5 show this to be incorrect. Therefore a detailed discussion of region B is better postponed until Chapter 5.

The decrease in the selectivity for ethylene formation with catalyst use can be attributed to the formation of surface residues such as carbides which may affect the activity of the sites involved in ethane formation in region B. This decrease in selectivity is not due to poisoning of the sites involved in acetylene hydrogenation but to increasing activity of the sites producing ethane.

4.4.3. Regions C and D

In region C the rate of production of ethane increases and the rate of production of ethylene decreases as the acetylene pressure falls. This can be assumed to be due to an increasing fraction of the surface being covered by ethylene at the expense of acetylene. The onset of region C corresponds to the point referred to by Bond et al²⁹ as the onset of the premature breakdown of selectivity where non-selective acetylene hydrogenation occurred over palladium the higher the temperature, ethylene or hydrogen pressure.

The total rate of production of ethane in region C is the sum of the steady rate of ethane production as observed in region B plus the rate of ethane production caused by the increase in the surface coverage of ethylene in region C. If an estimation can be made of the contribution to the rate of ethane production made by ethylene which is being adsorbed in competition with acetylene in

region C, then it should be possible to interpret the increase in the rate of ethane production on the basis of simple Langmuir competition⁸³⁻⁸⁶ between ethylene and acetylene.

Thus

$$R_1 = R_{1s} + R_{1c}^{\dagger} \quad 4.3$$

The steady rate of ethane production, R_{1s} , can be measured directly from region B and subtracted from the rate of ethane formation in region C to give R_{1c}^{\dagger} , the rate of ethane production on sites where competition between ethylene and acetylene is possible. If it is assumed that R_{1c}^{\dagger} is proportional to the fraction of the surface covered with ethylene, θ_2 , and that two hydrogen atoms⁴¹ are required to convert ethylene into ethane then

$$R_{1c}^{\dagger} = k \theta_2 (\theta_H)^2 \quad 4.4$$

where k is a rate constant and θ_H is the fraction of the surface covered with hydrogen.

From Langmuir equations

$$\theta_H = a_H P_{H_2}^{1/2} / X \quad 4.5$$

where $X = 1 + a_H P_{H_2}^{1/2} + a_2 P_2 + a_3 P_3$ and a_H , a_2 and a_3 are constants relating to the strengths of adsorption of hydrogen, ethylene and acetylene respectively and the P terms are the corresponding pressures. The square root term in hydrogen pressure takes into account the dissociation of a hydrogen molecule into two hydrogen atoms each adsorbed on separate sites. The equation assumes that competition occurs between all three gases for the same surface sites.

A simple Langmuir equation may be written for the fraction of the surface covered by ethylene

$$\theta_2 = a_2 P_2 / X \quad 4.6$$

Substitution into 4.4 from 4.5 and 4.6 yields

$$R_{1c}^{\dagger} = k a_H^2 P_{H_2} a_2 P_2 / X^3 \quad 4.7$$

As acetylene and ethylene are more strongly adsorbed on metals than hydrogen⁸⁷

it may be assumed that $a_H P_{H_2}^{1/2} \ll 1 \ll a_2 P_2$ and $a_2 P_3$

Therefore

$$R_{1c}^+ = k a_H^2 P_{H_2} / (a_2 P_2)^2 [1 + (a_3 P_3 / a_2 P_2)]^3 \quad 4.8$$

In region D, where all the acetylene has been consumed and only ethylene hydrogenation is occurring, equation 4.8 simplifies to

$$R_1^+ = k a_H^2 P_{H_2} / (a_2 P_2)^2 \quad 4.9$$

If ethylene is assumed to be strongly adsorbed compared to hydrogen⁸⁷ then equation 4.9 reduces to

$$R_1^+ = k^1 P_{H_2} \quad 4.10$$

where $k^1 = k a_H^2 / (a_2 P_2)^2$ and corresponds to the rate constant in region D. The term $a_2 P_2$ is effectively constant since ethylene is in great excess over the hydrogen present. The rate of ethane formation in region D was found to be proportional to the hydrogen pressure, as shown in table 4.5, and supports the assumptions made in deriving the equation.

In the derivation of equation 4.8 it has been assumed that three sites are required for the reaction to take place — one for ethylene and two for the hydrogen atoms. Other descriptions of the mechanism involving (a) two sites — one for ethylene and one for an adsorbed hydrogen molecule, or (b) only one site for ethylene and where hydrogen reacts directly from the gas phase or a physically adsorbed layer can be considered.

Equations equivalent to 4.4 may be written for these two alternatives

(a) two sites

$$R_{1c}^+ = k \theta_2 \theta_{H_2} \quad 4.11$$

(b) one site

$$R_{1c}^+ = k \theta_2 P_{H_2} \quad 4.12$$

A general equation may be derived to account for these three different descriptions of the mechanism which takes the form

$$[\text{PH}_2/\text{R}_1\text{c}^+]^{1/n} = [1/k^1]^{1/n} + a_3/a_2 [1/k^1]^{1/n} P_3/P_2 \quad 4.13$$

where n corresponds to the number of sites required for the reaction. Equation 4.8 corresponds to the special case where $n = 3$. The values of R_1c^+ correspond to the gradient of a graph of percentage ethane present versus time minus the steady rate of ethane formation from region B.

The appropriate graphs to test equation 4.13 for values of $n = 1, 2$ or 3 are shown in fig. 4.4. A straight line is only obtained when competition is assumed between acetylene molecules, ethylene molecules and hydrogen atoms, i.e. for $n = 3$. This agrees with the results of Douglas and Rabinovitch⁵¹ who reported that hydrogen atoms and not hydrogen molecules were active in acetylene hydrogenation over nickel - kieselguhr. The intercepts in fig. 4.4 are found experimentally from region D where P_3/P_2 is zero since no acetylene is present. Values of the gradient and intercept in fig. 4.4 indicate that the value of a_3/a_2 , representing the ratio of adsorption strengths of acetylene to ethylene, is 2200 at 293K. The experimental results plotted in fig. 4.4 correspond to the experiment illustrated in fig. 4.1. A similar experiment, again at 293K, obtained a value of a_3/a_2 of 2075.

This kinetic treatment can only be applied for reactions having reasonably low rates of reaction as in fig. 4.1 since more rapid reaction rates prevent the collection of enough data in region C. It must also be emphasised that the above kinetic analysis is only valid when the rates used are those after subtraction of the steady rate of ethane production measured from region B. In region B the production of ethane is independent of the acetylene: ethylene ratio and thus cannot be incorporated into a mathematical model employing Langmuir-type competition.

There is also the possibility that the rate of ethane formation in region C may depend upon the possibility of a site neighbouring the adsorbed ethylene containing a hydrogen atom. Therefore Θ_4 itself may not be a completely adequate

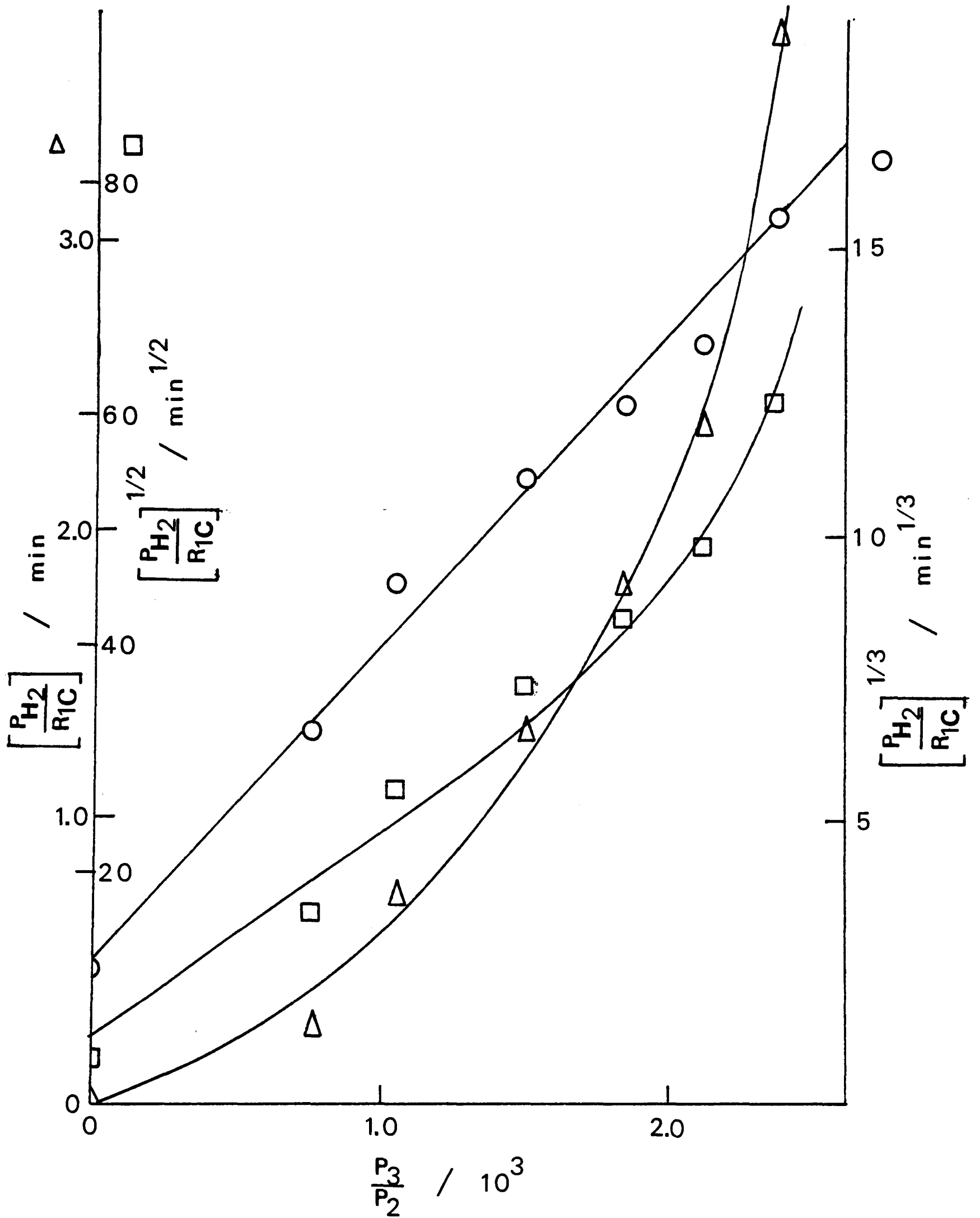

Fig. 4.4 Plots of $(P_{H_2}/R_{1C})^{1/2}$ against P_3/P_2 for reaction at 293K. Δ , $n = 1$; \square , $n = 2$; \circ , $n = 3$. Values of intercepts obtained from region D.

description of hydrogen availability.

The selectivity in region C can be regarded as essentially thermodynamic in origin⁸ and depends on the relative strengths of adsorption of acetylene and ethylene. As the acetylene is progressively used up more of the surface is occupied by ethylene until eventually only ethylene is undergoing hydrogenation. The ratio of the strengths of adsorption of acetylene and ethylene may be expressed as

$$a_3/a_2 = \exp (\Delta G_2 - \Delta G_3) / RT \quad 4.14$$

Bond et al⁸ applied equation 4.14 to the competition between acetylene and ethylene on a metal surface and concluded that if the selectivity arose because of the stronger adsorption of acetylene then this would imply a most improbable value for $(\Delta G_2 - \Delta G_3)$, the difference in the free energies of adsorption of acetylene and ethylene. This conclusion probably holds for region B but when the experimental value of 2200 for a_3/a_2 at 293K is substituted into equation 4.14 then a value of 18.7 kJ mol⁻¹ is obtained for $(\Delta G_2 - \Delta G_3)$. This value is not unreasonable.

As the final traces of acetylene are removed there is some evidence for an acceleration in the rate of its disappearance which may be accounted for by an increase in the hydrogen coverage as the coverage in strongly adsorbed acetylene falls.

On complete removal of all the acetylene the hydrogenation of ethylene continues in region D until the hydrogen supply is exhausted. A change in temperature from 293 to 323K makes negligible difference to the very fast rate of this reaction as observed in table 4.5. The rate of ethylene hydrogenation in region D may well be determined by the rate of diffusion of hydrogen through the gas phase to the surface of the catalyst.

The diffusion constant, D, of hydrogen in ethylene⁸⁸ is 0.486 (X atm) cm² s⁻¹. At a pressure of 6.67 kN m⁻² in a 1% mixture of hydrogen in ethylene D has a

value of $7.5 \text{ cm}^2 \text{ s}^{-1}$. The Einstein and Smoluchowski diffusion law states that

$$d^2 = 6 D t \quad 4.15$$

where d is the distance travelled by a molecule and t is the time taken to move that distance. The cylindrical reaction vessel used in the present investigation had a length of 0.16 m and thus the average distance to be travelled by a molecule to reach the surface of the catalyst was 8 cm. The time taken to travel this distance under reaction conditions is $2.40 \times 10^{-2} \text{ min}^{-1}$ from equation 4.15. The available geometric area of the catalyst pellets is $\sim 0.5 \text{ cm}^2$ and therefore the fraction of molecules travelling from the centre point of the reaction vessel, within the appropriate solid angle that they impinge upon the catalyst, is $0.5/4\pi 8^2$, $4\pi 8^2$ being the area of a sphere of radius 8 cm. In the reaction vessel in region D there are $\sim 4 \times 10^{18}$ hydrogen molecules and therefore the number reaching the surface in $2.4 \times 10^{-2} \text{ min}$ is $4 \times 10^{18} \times 0.5/4\pi \times 64$ which is 2.3×10^{15} molecules. The rate of molecules impinging on the catalyst is therefore $\sim 10^{17} \text{ min}^{-1}$. The measured rate constant is 10^{-1} min^{-1} and corresponds to a rate of 4×10^{17} molecules min^{-1} under the appropriate conditions. The calculated rate, assuming that diffusion through the bulk gas is limiting, is, within an order of magnitude, in agreement with the experimentally measured rate. There is a fair chance therefore that the rate of ethylene hydrogenation in region D is dependent on the rate of diffusion of hydrogen through the bulk gas to the catalyst surface.

4.4.4 The Effect of Added Carbon Monoxide

From table 4.7 it is clear that carbon monoxide has a very marked retarding effect on the hydrogenation of ethylene in the absence of acetylene at 413K.

The information in table 4.8 may be correlated by the equation

$$R_1^{\tau} = k P_{\text{CO}}^n \quad 4.16$$

where k is a constant and n is the reaction order in carbon monoxide. A graph of $\log R_1^{\tau}$ versus $\log P_{\text{CO}}$ yields a straight line with gradient n as shown in

Fig. 4.5 Plot of \log (Rate ethane formation) against $\log P_{CO}$ in the absence of acetylene at 413K.

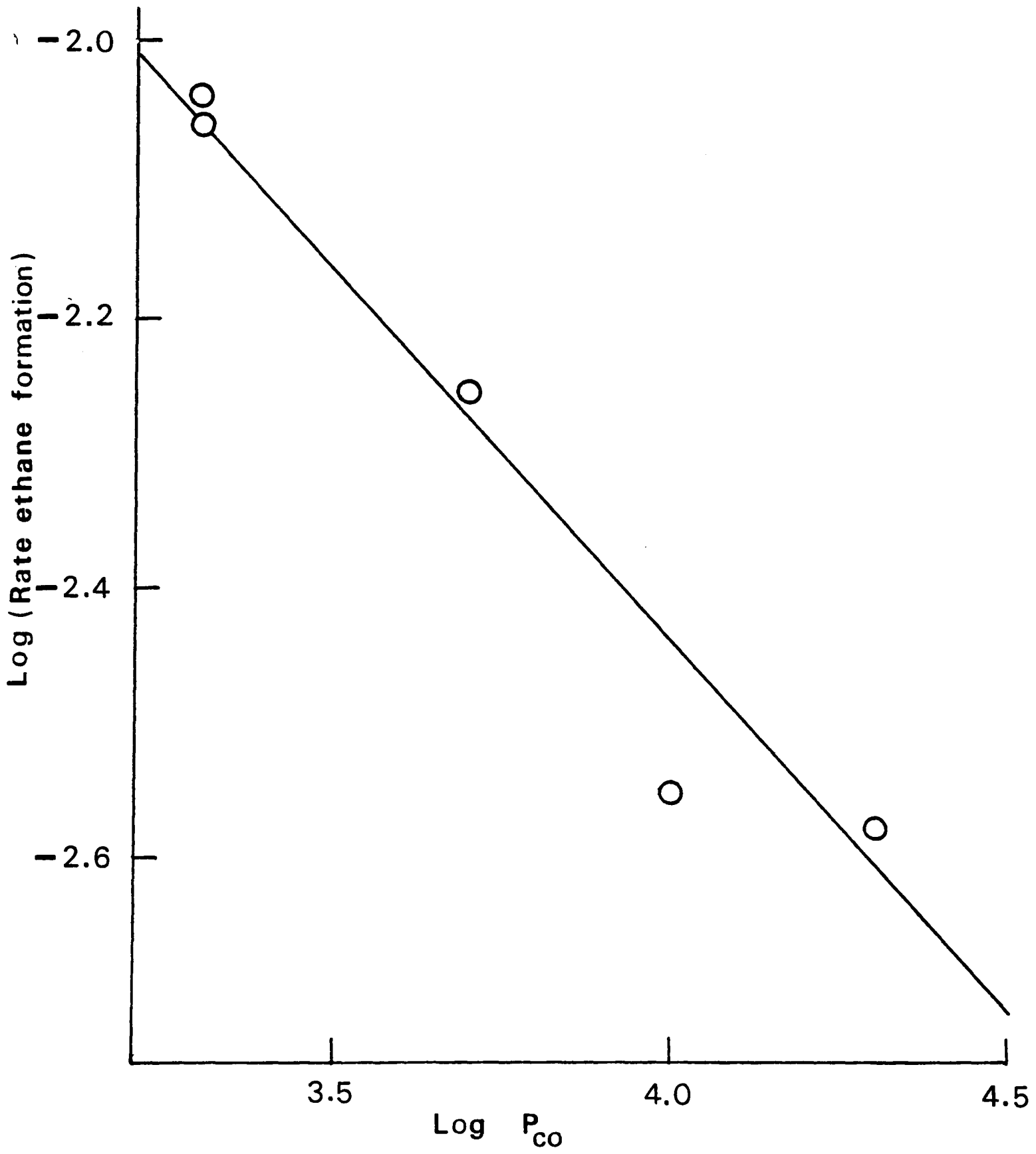

fig. 4.5. If the value for zero carbon monoxide is excluded the value of n which satisfies the results is $n = -0.54$. Because the experimental point for zero carbon monoxide does not coincide with the value predicted by equation 4.16 it must be assumed that some sites are more susceptible to poisoning by carbon monoxide than others and that certain very active sites can be poisoned by a relatively small concentration of carbon monoxide. An experiment in which 578 p.p.m. of carbon monoxide was added to a standard mixture of acetylene, ethylene and hydrogen at 323K yielded a value of $9 \times 10^{-2} \text{ min}^{-1}$ for the rate constant for the hydrogenation of ethylene in region D. This value is very similar to those observed in the absence of carbon monoxide as shown in table 4.5. It is reasonable to assume therefore that the rate of ethylene hydrogenation in the presence of small amounts of carbon monoxide is, as in the case of no carbon monoxide, diffusion controlled. If 1155 p.p.m. of carbon monoxide is present then a marked decrease in the rate of ethylene hydrogenation is observed indicating that the rate of diffusion of hydrogen is no longer rate determining and that now the reaction itself controls the rate at higher levels (>578 p.p.m.) of carbon monoxide.

The Arrhenius equation for the rate of acetylene hydrogenation in region B in the presence of 1155 p.p.m. carbon monoxide has a similar activation energy (45.4 kJ mol^{-1}) to that observed in the absence of carbon monoxide (46.8 kJ mol^{-1}). This indicates that the mechanism of acetylene hydrogenation is not altered by the presence of carbon monoxide. The pre-exponential factor is decreased to correspond to the lower rate observed from 1.27×10^{21} in the absence of carbon monoxide to 4.66×10^{20} in the presence of 1155 p.p.m. of carbon monoxide suggesting that carbon monoxide reduces the number of sites which are available.

The effect of added carbon monoxide on region B is to increase the selectivity for ethylene formation as shown in table 4.7. This is achieved by the rate of ethylene hydrogenation being depressed to a greater extent than that of acetylene

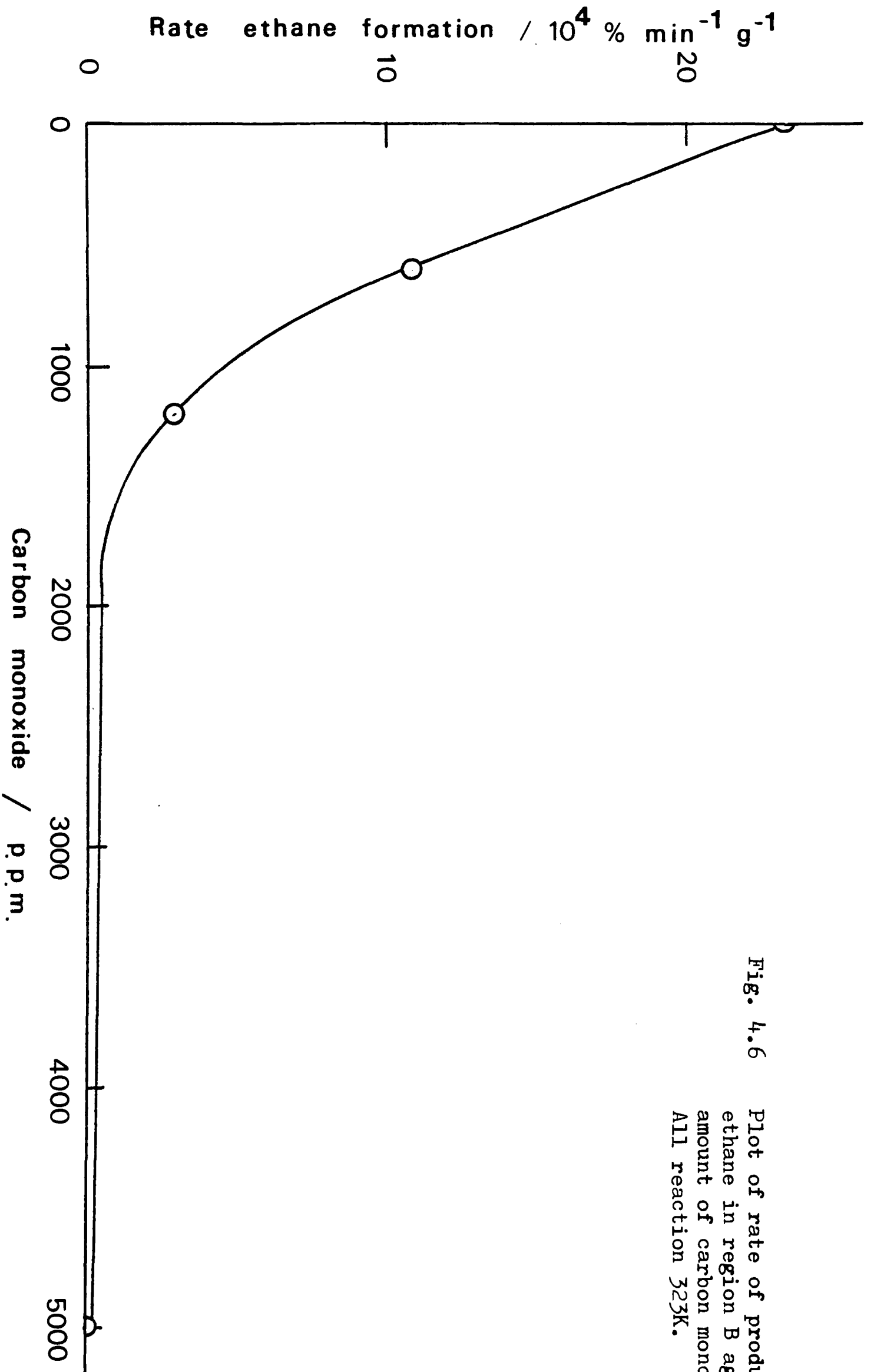

Fig. 4.6 Plot of rate of production of ethane in region B against the amount of carbon monoxide added. All reaction 323K.

hydrogenation. The increase in S with carbon monoxide level is the reason why carbon monoxide is added⁶⁹ to ethylene streams in commercial practice. The reasons for the increase in selectivity with the addition of carbon monoxide may be that reported by Takeuchi et al^{89, 90} who postulated that a nickel atom with one or more sulphur ligands is a very different and more selective catalyst than a nickel atom without such ligands. This mechanism such that catalytic activity can be controlled by the degree of co-ordinative unsaturation of the active sites may also be applicable to the palladium - carbon monoxide system where a palladium atom attached to carbon monoxide ligands is a much more selective catalyst for ethylene formation than a palladium atom in the absence of carbon monoxide.

An alternative mechanism for the role of carbon monoxide in enhancing the selectivity may be that carbon monoxide is adsorbed with a strength of adsorption intermediate^{87, 89, 90} between the strengths of adsorption of acetylene and ethylene. This would mean that carbon monoxide could effectively block ethylene adsorption while having relatively little effect on the adsorption of acetylene. This may be the case in region C where both acetylene and ethylene are competing for the surface but in region B the rate of production of ethane is not dependent on the acetylene : ethylene ratio so this mechanism of intermediate adsorption strength is unlikely to apply.

If the rates of ethane production from table 4.7 are plotted versus the concentration of carbon monoxide present then fig. 4.6 is obtained. This shows that the addition of a small amount of carbon monoxide has a disproportionately large influence on the rate of ethane production in region B. Fig. 4.6 suggests that ~ 1000 p.p.m. of carbon monoxide can effectively poison the steady rate of ethane formation and may be attributed to the presence of a type of active site which is active in ethane production even in the presence of appreciable quantities of acetylene. It is not possible to use the turning point of fig.4.6

to quantify the number of these ethane production sites since the apparatus used did not permit the determination of the amount of gas phase carbon monoxide present and it would be invalid to assume that all the added carbon monoxide was adsorbed. A more detailed description of the ethane production site will follow in Chapter 5.

Added carbon monoxide also has an effect on the initial fast stage, region A. From table 4.6 it seems that the presence of carbon monoxide has the effect of reducing the amount of acetylene which disappears in the first ten minutes of reaction. Since the disappearance of acetylene can be mainly attributed to adsorption on the support the effect of carbon monoxide may be to adsorb on sites which are normally occupied by acetylene molecules. The reduction in the initial production of ethane is much more significant than that observed for the disappearance of acetylene and may arise from competition by the carbon monoxide for sites on which hydrogen required for ethane production would normally be adsorbed.

4.4.5 Reactions on the Alumina Support

From the reaction of a 2:1 hydrogen to acetylene mixture in the absence of ethylene at 662K it seems that most of the acetylene, 97.2%, is adsorbed on the catalyst without forming gaseous products. The remainder of the acetylene is converted to ethylene, methane and ethane in the ratio 14 : 2 : 1. This result is very similar to that reported by Halliday⁹¹ who reacted a similar reaction mixture over rutile (Ti_2O_3) at 578K. She observed that 98% of the initial dose of acetylene was adsorbed on to the surface while small amounts of ethylene, methane and ethane were formed in the ratio 4 : 1 : 1. The grey colour of the catalyst is probably due to surface carbon deposited on dehydrogenation of the adsorbed acetylene. In the presence of ethylene a similar phenomenon may be assumed to be occurring. As shown in fig. 4.3 reversible adsorption of acetylene occurred at low temperatures since heating from 293 to 343K produced an increase

in the amount of gas phase acetylene present. Only at 533K did acetylene adsorption of an irreversible nature occur where a further increase in temperature increased the extent of adsorption. This is due to the dehydrogenation of acetylene to surface carbon which is likely to be irreversible unlike the reversible low temperature process where acetylene is adsorbed as acetylene molecules as in region A of a standard experiment.

CHAPTER 5

Tracer Studies of Acetylene Hydrogenation in Excess Ethylene in a Static System.

5.1 Introduction

In the results discussed so far no attempt has been made to formulate a mechanism for the production of ethylene and ethane during acetylene hydrogenation in excess ethylene. The origin of the ethane which is produced has been usually assumed to be from the stepwise addition of two molecules of hydrogen to an acetylene molecule and that any ethylene which is present in the gas phase behaves as an inert diluent⁹². This theory is also present in the concept of kinetic selectivity⁴⁸ where the selectivity for ethylene formation is a measure of the ratio of the rate of desorption of an ethylene molecule produced from acetylene hydrogenation to the rate of further hydrogenation to ethane. This chapter deals with tracer experiments using carbon-13 labelled acetylene in the presence of an excess amount of normal 'light' ethylene which were carried out to determine the origin of the ethane produced in region B.

The mechanism of hydrogen consumption was also studied using 'light' hydrocarbons and deuterium. The use of deuterium in place of hydrogen was also useful in providing information concerning the extent to which the adsorption of each reactant was reversible and the interconvertibility of adsorbed species. As described in section 1.7 some work has previously been performed on the reaction of acetylene with deuterium over Group VIII metals^{8,51-53} but in the absence of added ethylene. Experiments were also carried out to investigate the effects of carbon monoxide and the alumina support on the reaction mechanism.

5.2 Experimental Procedure

The experiments described in this chapter were performed on the G.C.M.S. apparatus of gas-line II as described in Chapter 2.

5.3 Results

The results of the tracer studies on the acetylene, ethylene, hydrogen system can be separated into three sections as described in section 2.3.2.

(I) Reactions involving carbon-13 labelled acetylene, 'light' ethylene and hydrogen over samples of 38-3 catalyst :- palladium on alumina.

(II) Reactions involving 'light' acetylene and ethylene and deuterium over samples of 38-3 catalyst.

(III) Reactions involving 'light' acetylene and deuterium in the absence of ethylene over the alumina support of 38-3 catalyst.

5.3.1 Tracer Studies Using Carbon-13 Labelled Acetylene

Typical fragmentation and sensitivity factors obtained during a reaction of type I are shown in Table 5.1.

Table 5.1: Typical Fragmentation and sensitivity Factors Used In Carbon-13 Labelled Acetylene Tracer Studies.

Gas	f_1	f_2	f_3	f_4	Parent Ion Sensitivity
Ethane	0.5411	2.3315	0.1793	0.1620	0.367
Ethylene	0.1763	0.2575	0.0235	0.0026	1.000
Acetylene	0.0481	0.0256	-	-	0.957

f_1 etc. are fragmentation factors.

The analyses of the gas mixture throughout a typical experiment are presented in table 5.2. This table shows the incorporation of ^{13}C - ^{13}C skeletons from acetylene into the ethane and ethylene as the reaction proceeded. From table 5.2

Table 5.2: Composition ^a of the Reaction Mixture in the Reaction of 20% ¹³C₂H₂ in C₂H₄, H₂ :

C₂H₂ = 2:1 at 293K

Time/ Min.	Percentage Ethane			Percentage Ethylene			Percentage Acetylene					
	Total	12-12	13-12	13-13	Total	12-12	13-12	13-13	Total	12-12	13-12	13-13
	0	0	0	0	0	80.21	75.70	4.46	0.05	19.79	0.14	2.96
18	0.32	0.23	0	0.09	86.74	79.26	4.91	2.57	12.94	0.19	1.79	10.96
37	0.80	0.63	0	0.17	89.09	79.63	4.94	4.52	10.11	0.23	1.49	8.39
56	1.45	1.18	0.03	0.24	91.28	80.12	5.00	6.16	7.27	0.21	1.11	5.95
75	2.01	1.67	0.03	0.31	93.16	80.41	5.05	7.70	4.83	0.22	0.74	3.87
93	2.97	2.48	0.03	0.46	94.22	79.33	5.47	9.42	2.81	0.17	0.47	2.17
111	3.76	3.11	0.08	0.57	95.25	79.89	5.21	10.15	0.99	0.10	0.14	0.75
128	10.60	9.47	0.23	0.90	89.40	74.55	4.86	9.99	0	0	0	0
144	12.20	10.79	0.20	1.21	87.80	73.12	4.73	9.95	0	0	0	0
∞	13.61	12.05	0.27	1.29	86.39	71.46	4.94	9.99	0	0	0	0

^a Expressed as a percentage of total gas phase hydrocarbons

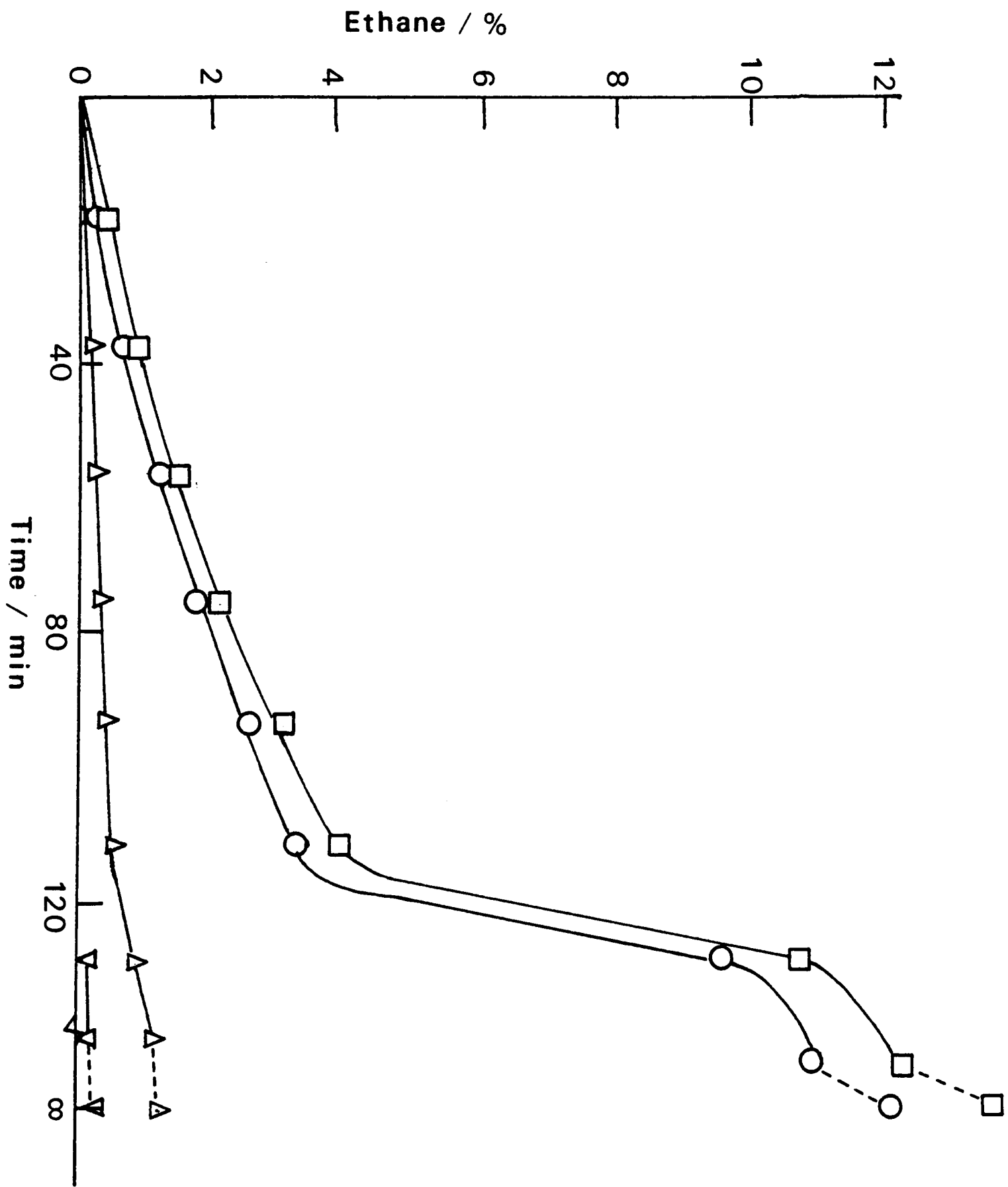

Fig. 5. 1 Variation in composition of ethane in experiment I with time at 293K. □ , total ethane; ○, $H_3^{12}C$; △, $H_3^{13}C$ — $^{13}CH_3$; ▽, $H_3^{13}C$ — $^{12}CH_3$.

it can be seen that the reaction proceeded in a similar manner to the reactions described during kinetic experiments in Chapter 4. There was an initial rapid disappearance of acetylene whereupon the acetylene removal rate remained constant until all the acetylene had disappeared. The production of ethane remained constant until most of the acetylene had disappeared and only at very low acetylene concentrations did the rate of ethane production increase. The incorporation of ^{13}C - ^{13}C skeletons into ethylene proceeded steadily as the acetylene hydrogenated to ethylene. The ethane composition as a function of time is shown in fig. 5.1 where it can be observed that the rate of formation of $\text{H}_3^{12}\text{C}-^{12}\text{CH}_3$ was six times that of the rate of formation of $\text{H}_3^{13}\text{C}-^{13}\text{CH}_3$ in the steady region of ethane production i.e. before the disappearance of acetylene at ~ 120 min. After disappearance of the acetylene, ethylene was hydrogenated. Since the ethylene contained $\sim 10\%$ of ^{13}C - ^{13}C skeletons produced from acetylene hydrogenation the ethane produced after removal of the acetylene contained a similar proportion of ^{13}C - ^{13}C skeletons.

Labelling of the acetylene molecules also enabled measurements to be made of the amount of acetylene lost to the catalyst surface rather than being hydrogenated to ethylene during the reaction. Table 5.3 shows the percentage of total gas phase hydrocarbon which contained ^{13}C - ^{13}C skeletons at various stages of the reaction.

During the initial 18 min. of reaction there was a loss of 3.1% of ^{13}C - ^{13}C skeletons (expressed as a percentage of the total gas phase hydrocarbon) from the gas phase. As the reaction proceeded a further 2.3% of ^{13}C - ^{13}C skeletons were removed from the gas phase without forming gaseous products.

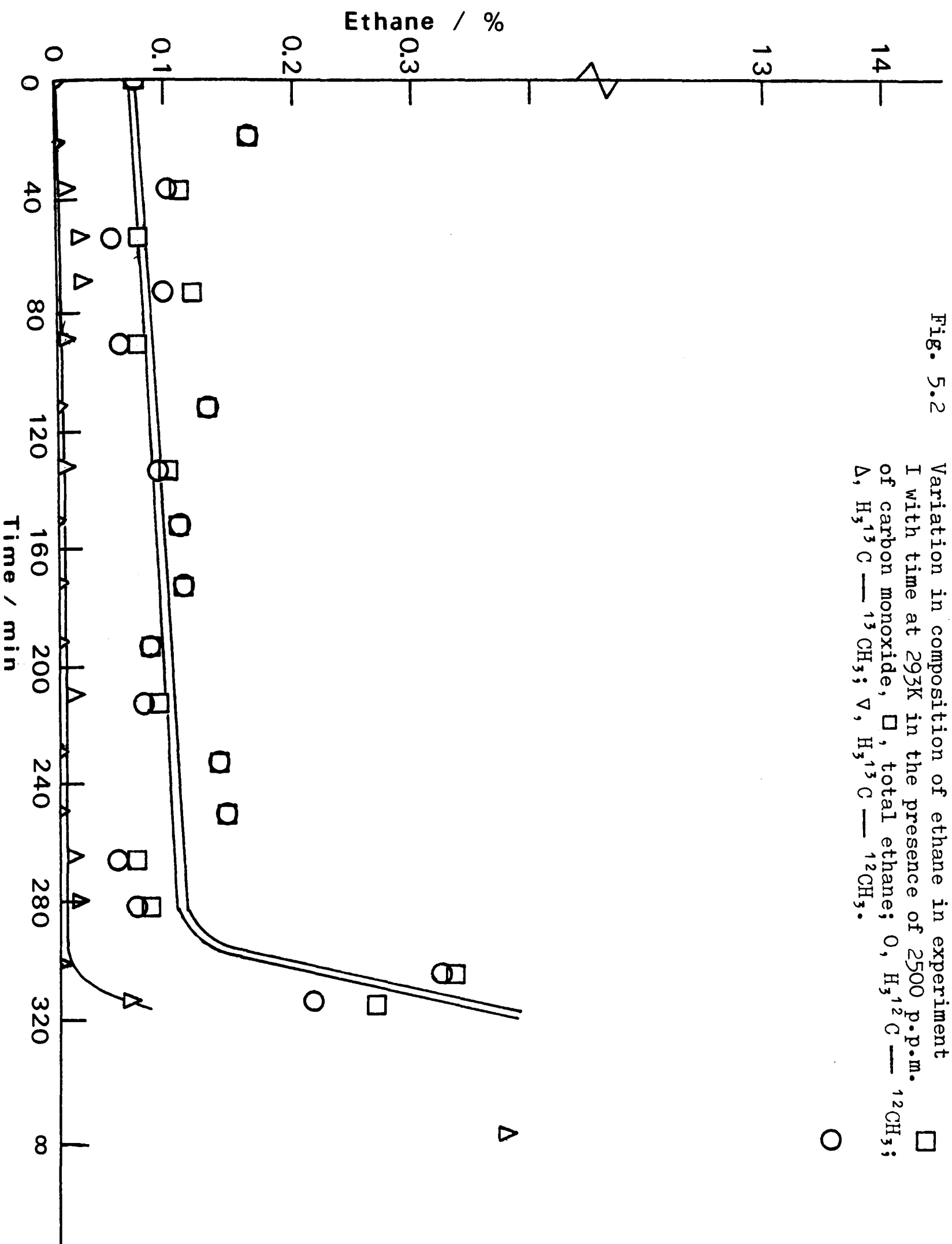

Fig. 5.2

Variation in composition of ethane in experiment
 I with time at 293K in the presence of 2500 p.p.m. of carbon monoxide, \square , total ethane; \circ , $H_3^{12}C$ — $^{12}CH_3$; Δ , $H_3^{13}C$ — $^{13}CH_3$; ∇ , $H_3^{13}C$ — $^{12}CH_3$.

Table 5.3: Variation in the Percentage of Gas Phase Hydrocarbon Containing a ^{13}C - ^{13}C Skeleton During the Reaction of 20% $^{13}\text{C}_2\text{H}_2$ in C_2H_4 , $\text{H}_2, \text{C}_2\text{H}_2 = 2:1$ at 293K

Time/Min	Percentage ^{13}C - ^{13}C
0	16.74
18	13.62
37	13.08
56	12.35
75	11.88
93	12.05
111	11.47
128	10.89
144	11.16
∞	11.28

When 2500 p.p.m. of carbon monoxide were present in a reaction mixture similar to that described in table 5.2 the rate of ethane production in region B was greatly reduced. The composition of the ethane produced as a fraction of time is shown in fig. 5.2. Because of the very small amount of ethane present analysis of the ethane was very difficult but the same general characteristics as in the absence of carbon monoxide were present. The vast majority (>90%) of the ethane contained ^{12}C - ^{12}C skeletons with very little evidence of ^{13}C - ^{13}C incorporation until after complete disappearance of the acetylene at ~280 min. whereupon ethylene hydrogenation took place.

5.3.2 Tracer Studies Using Deuterium

Typical fragmentation and sensitivity factors in experiments involving 'light'

Fig. 5.3

Variation in composition of acetylene, the percentages of acetylene, ethylene and ethane present in experiment III with time at 313K. \diamond , acetylene - d_0 ; \bullet , acetylene - d_1 ; \circ , acetylene - d_2 ; expressed as percentages of total acetylene. \square , acetylene; Δ , ethylene; ∇ , ethane; expressed as percentages of total gas phase hydrocarbon.

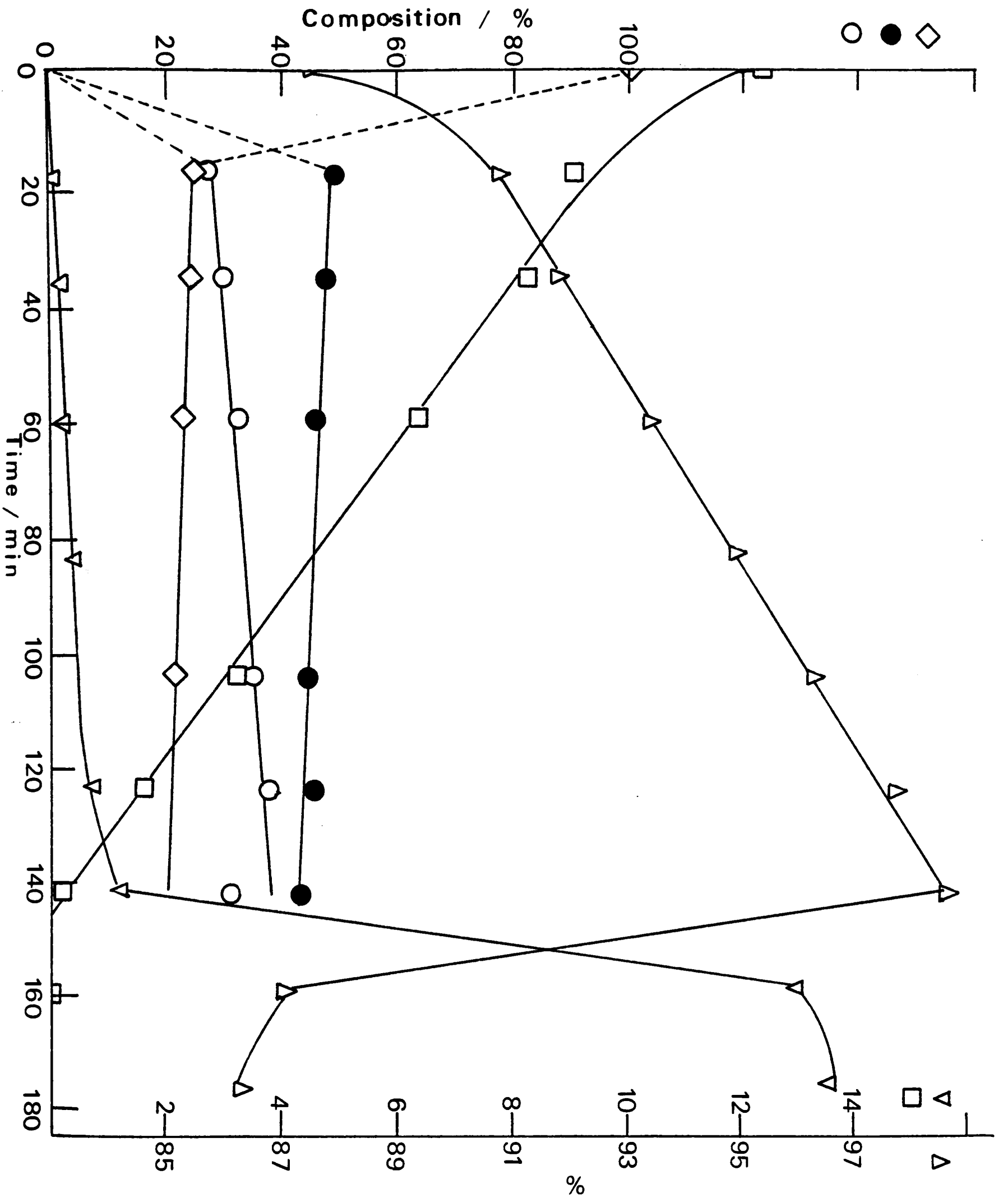

acetylene and ethylene and deuterium are shown in table 5.4. These factors are very similar to those employed during the carbon -13 experiments, see table 5.1.

The composition of the acetylene present and the percentages of acetylene, ethylene and ethane present in a typical experiment are shown in fig. 5.3. The characteristics of the reaction were identical to those observed in kinetic experiments. It may be observed that very rapid formation of acetylene -d₁ and -d₂ occurred during the first 18 min. of reaction with a corresponding decrease in the percentage of acetylene -d₀. The exchange of acetylene with deuterium continued very slowly until all the acetylene had disappeared.

Table 5.4: Typical Fragmentation and Sensitivity Factors used in Deuterium Tracer Studies

Gas		f ₁	f ₂	f ₃	f ₄	Parent Ion Sensitivity
Ethane	Light	0.4597	2.3623	0.1498	0.1374	0.343
	Heavy	0.2988	1.5354	0.0973	0.0893	
Ethylene	Light	0.1400	0.2124	0.0210	0.0027	1.000
	Heavy	0.0910	0.1380	0.0136	0.0017	
Acetylene	Light	0.0402	0.0231	-	-	1.180
	Heavy	0.0261	0.0150	-	-	

* 'light' fragmentation factors correspond to loss of H from parent. Loss of D is given by 'heavy' factors and are calculated as 0.65 f light, see Dowie et al⁸¹.

The incorporation of deuterium into the ethylene is shown in fig. 5.4 where the composition of the ethylene as expressed as a percentage of the total ethylene is plotted against time. There was an initial production of ethylene -d₁

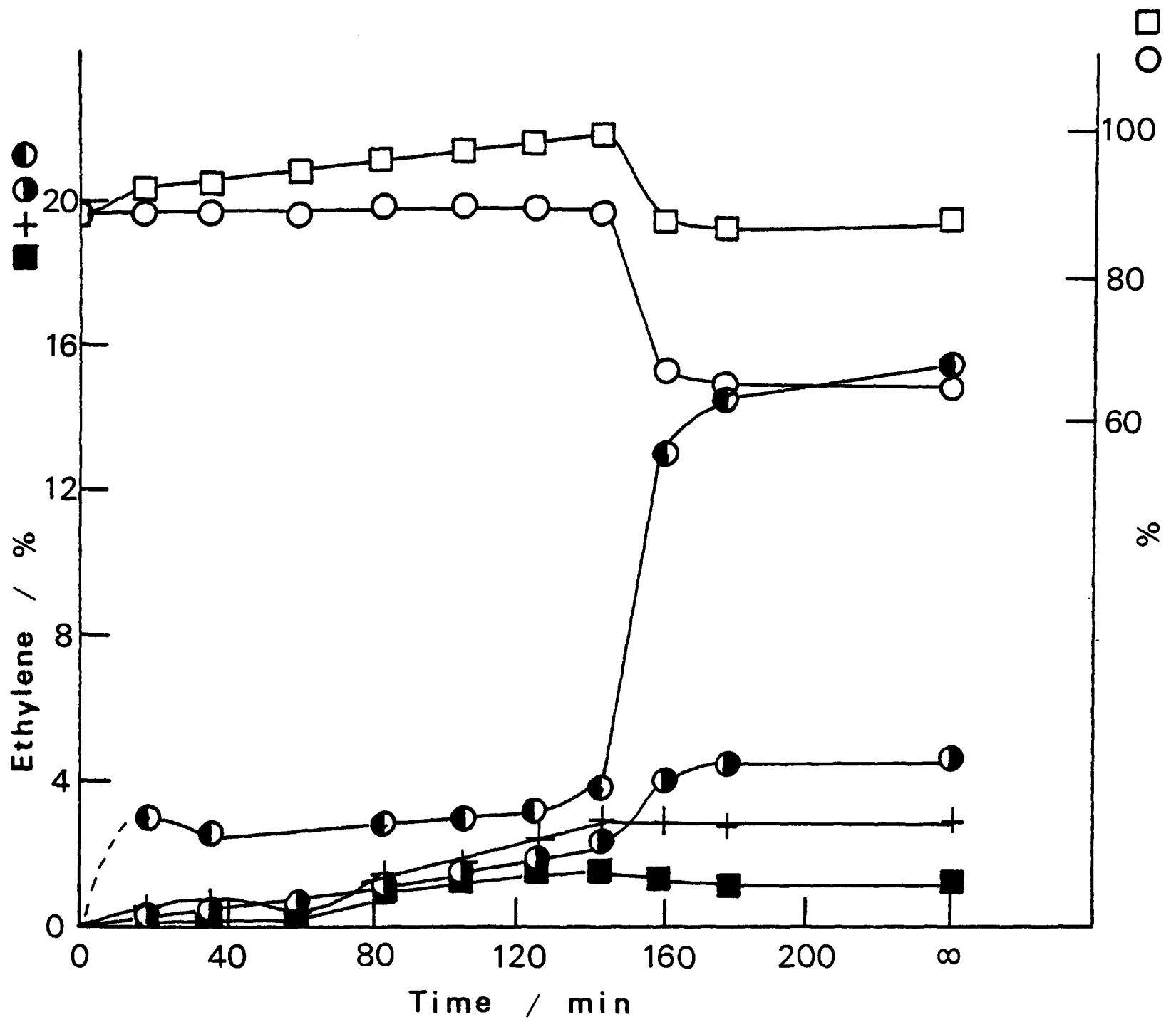
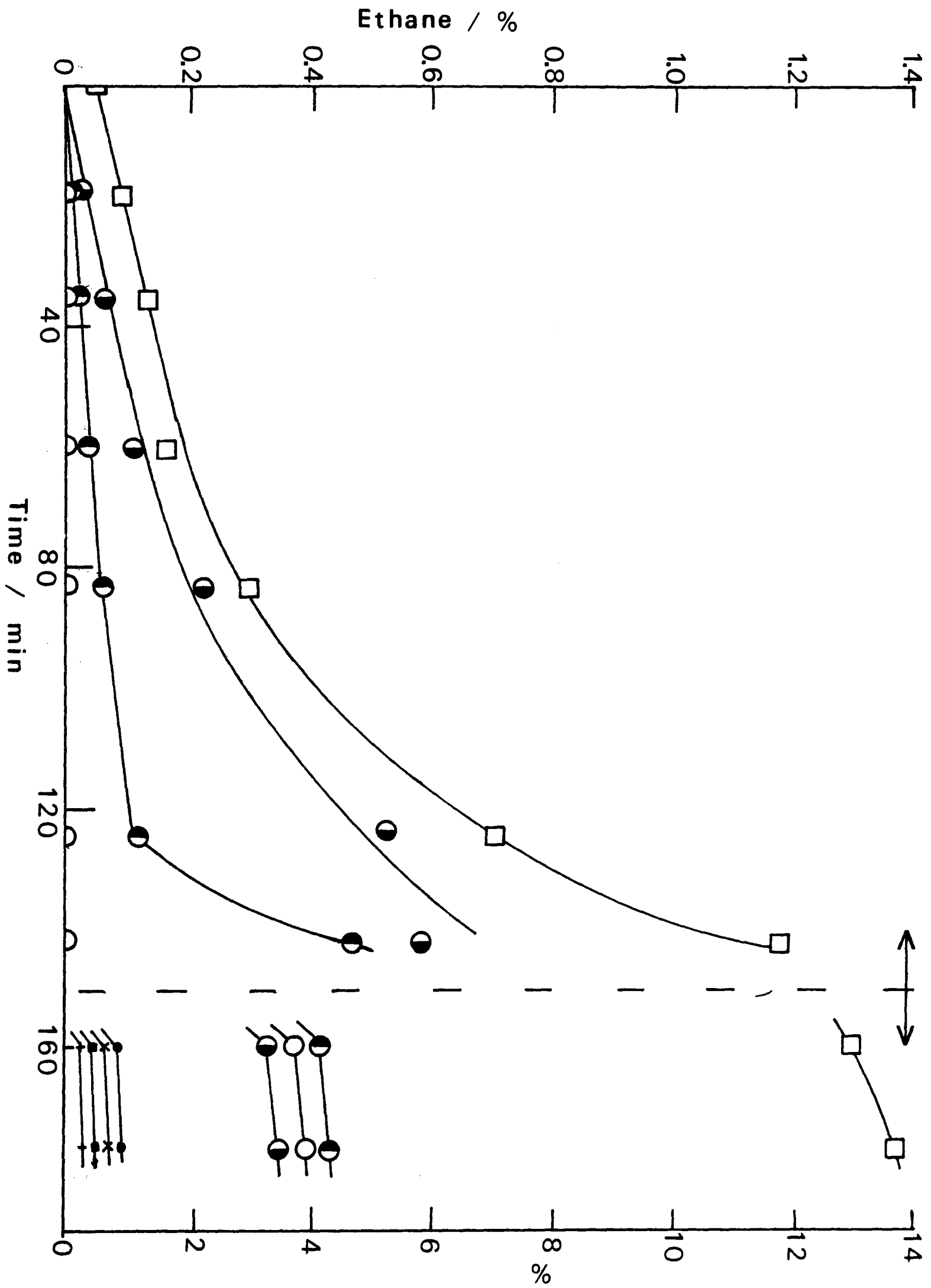

Fig. 5.4 Variation in composition of ethylene with time in experiment II at 313K. □, total ethylene; ○, ethylene - d₀; ○, ethylene - d₁; ●, ethylene - d₂; + ethylene = d₃; ■, ethylene - d₄; expressed as percentages of total ethylene.

Fig. 5.5 Variation in composition of ethane with time in experiment II at 313K.
□, total ethane; O, ethane - d₀;
⊙, ethane - d₁; ⊖, ethane - d₂;
●, ethane - d₃; ■, ethane - d₄;
+, ethane - d₅; X, ethane - d₆;
expressed as percentages of total
gas phase hydrocarbon.



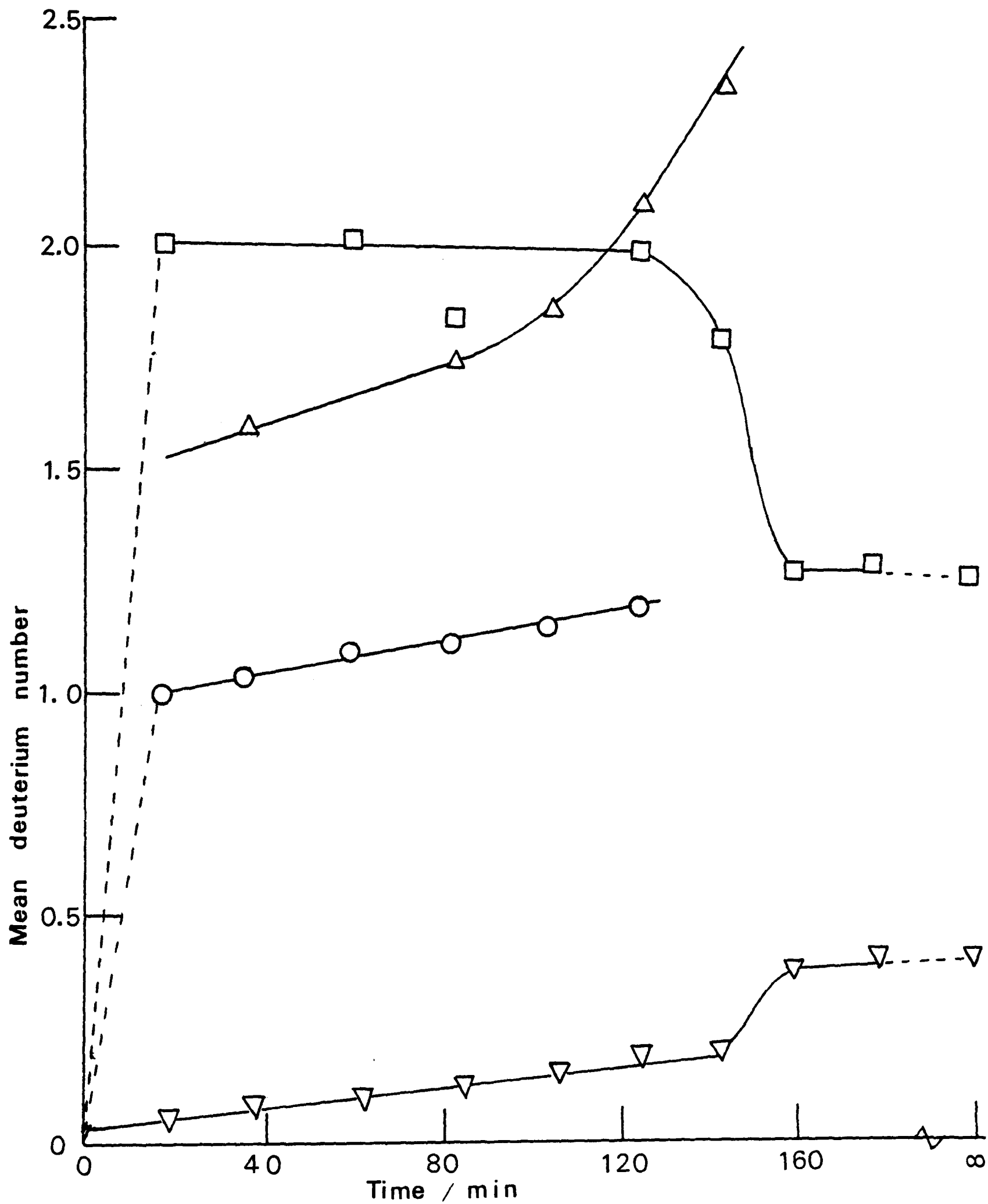

Fig. 5.6 Variation in the mean deuterium number of reactants and products with time in experiment II at 313K. O, C_2X_2 ; ∇ , C_2X_4 (total); Δ , C_2X_4 (produced after initial fast stage); \square , C_2X_6 .

in region A which then ceased until the disappearance of the acetylene at ~145 min., whereupon rapid exchange of ethylene with deuterium occurred. The production of ethylene $-d_2$, $-d_3$ and $-d_4$ progressed steadily during region B with an increase in the production of ethylene $-d_2$ on disappearance of the acetylene.

The deuterium content of the ethane produced is shown in fig. 5.5 as a function of time. In the presence of acetylene, i.e. until 145 min, the majority of the ethane was ethane- d_2 with some ethane- d_1 . There was no production of ethane- d_0 until the acetylene had disappeared whereupon there was appreciable formation of ethane $-d_0$, $-d_1$ and $-d_2$.

The mean deuterium number of the reactants and products are shown in fig. 5.6 as a function of time. In the first 18 min. of reaction the rapid exchange of acetylene with deuterium meant that acetylene rapidly attained a deuterium number of 1.0. As the slow exchange of acetylene with deuterium continued the deuterium number of the acetylene rose gradually as the reaction proceeded. From figs 5.4 and 5.6 ethylene exchange was only important when the acetylene concentration became very low and the deuterium number of the ethylene rose rapidly on disappearance of the acetylene. On the assumption that no ethylene exchange was taking place in region B it was possible to calculate the mean deuterium number of the ethylene which had been produced from the hydrogenation of acetylene after the initial fast exchange. This is also shown in fig 5.6. Any ethane produced had a mean deuterium number of 2.0 which rapidly fell to 1.3 on acetylene removal.

5.3.3. Reaction of Acetylene with Deuterium over the Alumina Support

In order to investigate the effect of the support in the initial rapid exchange of acetylene with deuterium over the palladium - alumina catalyst experiments were carried out on the acetylene - deuterium reaction in the absence of ethylene over the alumina support. The change in acetylene composition with

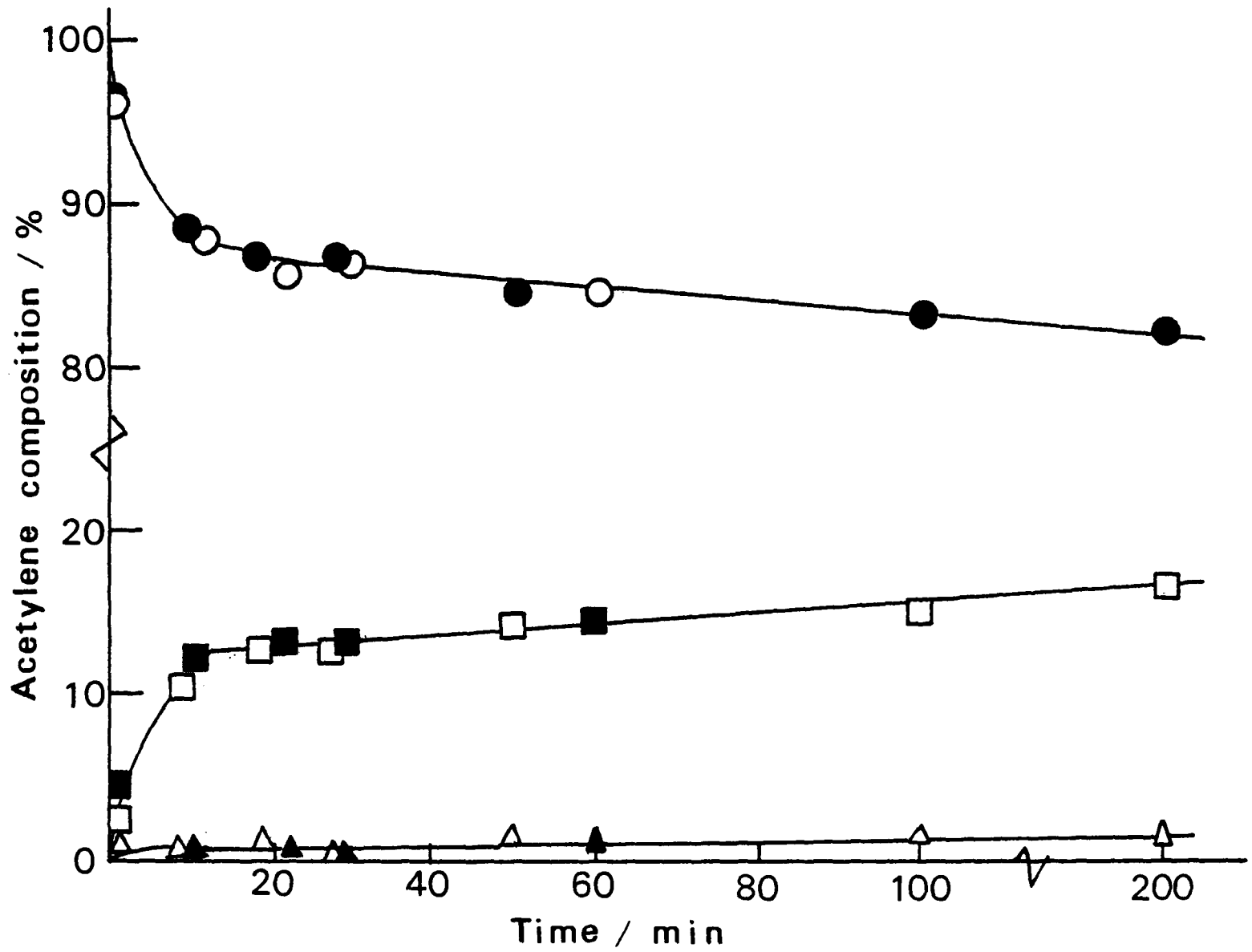

Fig. 5.7 Variation in composition of acetylene with time in experiment III at 293K and 313K. ●, acetylene - d₀; □, acetylene - d₁; Δ, acetylene - d₂; all at 293K. ○, acetylene - d₀; ■, acetylene - d₁; ▲, acetylene - d₂; all at 313K.

time in a typical experiment is shown in fig. 5.7. There was a fast initial exchange producing acetylene -d₁ with a small amount of acetylene -d₂ which was virtually complete after 12 min. Evacuation at 473K followed by the introduction of a new reaction mixture at 313K gave no apparent increase in rate over that observed at 293K. Only acetylene was detected in the gas phase so no hydrogenation occurred on the support at 293K or 313K.

5.4 Discussion

The experiments on carbon -13 labelled acetylene show unambiguously that the ethane produced by the hydrogenation of a mixture of acetylene and ethylene comes predominantly from the ethylene. This contrasts markedly with previous assumptions in which any ethylene present during the hydrogenation of acetylene is treated as inert⁹². Therefore the nature of the selectivity for ethylene formation in region B cannot be attributed to kinetic selectivity as has been supposed previously⁴⁸. Two explanations may account for the production of ethane from ethylene on a surface where acetylene is adsorbed so strongly as to prevent ethylene competing for the same sites. One explanation is that two types of surface site exist on the metal, the other is that two distinct modes of adsorption of ethylene are possible.

Considering first the argument in terms of sites, it appears that most sites (type X) can hydrogenate both acetylene and ethylene but adsorb acetylene much more strongly than ethylene at 293K. When an appreciable quantity of acetylene is present, as in region B, acetylene is adsorbed in preference to ethylene since acetylene has a larger free energy of adsorption than has ethylene. Only when the acetylene concentration falls to a low value, as in region C, does ethylene adsorb on the catalyst in competition with acetylene and thermodynamic selectivity operates. It is the type X sites on which the competition between ethylene and acetylene was examined in chapter 4 and on which acetylene is adsorbed 2200 times as strongly as ethylene at 293K.

Type X sites are responsible for the rapid ethylene hydrogenation observed in region D. Type Y sites may be assumed to hydrogenate only ethylene or, alternatively, may hydrogenate ethylene and acetylene equally well. The second alternative would manifest itself as preferential ethylene adsorption in the system studied because of the large excess of ethylene present. The steady rate of ethane formation, in region B, as described in chapter 4 occurs on type Y sites and the rate of ethane formation is independent of the acetylene: ethylene ratio and suggests that competition between acetylene and ethylene for type Y sites does not occur to any great extent. Since the mathematical treatment of Langmuir competition in chapter 4 only applies to type X sites the subtraction of the steady rate of ethane formation on type Y sites in region C is justified since ethane formation on type Y sites will be occurring in regions C and D as well as region B.

Some evidence for the existence of two different types of surface site can be obtained from a consideration of the surface geometry of face-centred cubic metals such as palladium. The geometry of associatively adsorbed acetylene and ethylene has been studied by several workers, ^{11,12,64,93}, and optimum metal-metal distances have been calculated. These are 0.343 nm for acetylene and 0.294 nm for ethylene on palladium assuming carbon - palladium bond lengths of 0.210 nm. The short interatomic spacings in palladium are 0.275 nm⁹⁴. The longer interatomic spacings are longer by a factor of $\sqrt{2}$ at 0.389 nm. It seems likely, from geometric considerations, that ethylene will adsorb more strongly on the shorter spacings and acetylene on the longer spacings as postulated by Bond³⁹. The (100) and (110) crystal planes of palladium contain both the long and short spacings and are capable of accommodating both hydrocarbons. The (111) crystal plane, however, only contains short spacings and may only accommodate ethylene while not adsorbing acetylene. This may be the basis for type X sites, the (100) and (110) crystal planes, and type Y sites, the (111) crystal plane. The catalyst selectivity

in region B may therefore be termed structural selectivity and not kinetic selectivity as was previously supposed. The selectivity of the catalyst may therefore be attributed to the small number of type Y sites present on the surface. Perhaps other metals with lower selectivities such as platinum have a larger proportion of (111) crystal planes exposed but the thermodynamic factor cannot be ignored as this is thought to operate strongly in palladium⁵⁴.

The alternative to two different types of site is two different modes of adsorption of the ethylene. It may be possible that some ethylene may be $\alpha\alpha$ adsorbed

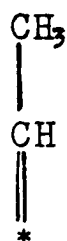

analogous to species proposed during butadiene hydrogenation⁹⁵. Such a species might be expected to be adsorbed with a strength comparable to that of acetylene. The adsorption of ethylene as an $\alpha\alpha$ adsorbed species as opposed to the normal $\alpha\beta$ adsorbed state could be a function of the catalyst such that type Y sites cause adsorption of ethylene as an $\alpha\alpha$ species but type X sites promote adsorption as the more common $\alpha\beta$ species. Therefore two alternative mechanisms for the selectivity for ethylene formation in region B may well be interrelated.

Further evidence for the presence of more than one site comes from the experiments where acetylene/ethylene mixtures were reacted with deuterium. Bond et al⁴⁴ found that the ethane produced by the reaction of deuterium with ethylene on palladium - alumina was almost totally ethane -d₀ and -d₁ at 310K. From fig. 5.5 it can be observed that any ethane produced in region B, i.e. in the presence of acetylene, from the reaction of ethylene with deuterium is predominantly ethane -d₂. Therefore a different mechanism must occur when ethylene is hydrogenated in the presence of acetylene than in its absence. The results may be reconciled since hydrogenation of ethylene in the absence of

acetylene would be likely to occur mainly on the large number of type X sites and in the presence of acetylene this hydrogenation would take place on the type Y sites of the catalyst. From fig. 5.5 it is seen that the composition of the ethane produced after disappearance of the acetylene is ethane -d₀ and -d₁ in agreement with Bond's findings.

The results on the acetylene/ethylene reaction with deuterium also support the alternative mechanism of two different adsorption modes for ethylene. The production of ethane -d₀ and -d₁ during the hydrogenation of ethylene with deuterium has been attributed to a disproportionation reaction between two ethyl species on the surface ⁴⁴.

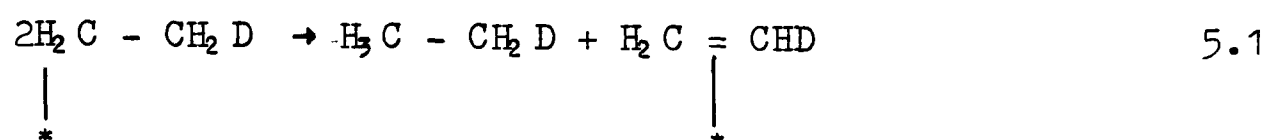

However, in the presence of acetylene, it may be difficult for two ethyl species to exist in close proximity to one another since the surface is covered predominantly by acetylene and so disproportionation may be impossible. The α adsorbed ethylene species would yield ethane -d₂ on reaction with deuterium as in equation 5.2.

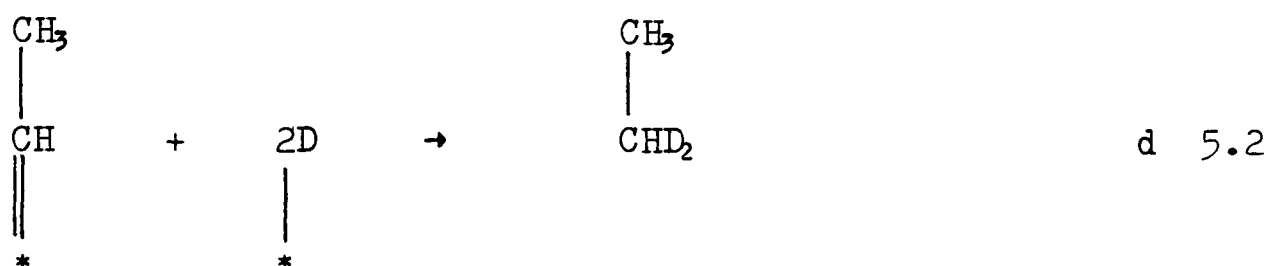

It would be interesting to determine whether the ethane -d₂ that is produced is CH₂D - CH₂D or CHD₂ - CH₃ but this could not be achieved on the apparatus available and the small amounts of ethane produced would make such a determination very difficult indeed.

The effect of carbon monoxide in reducing the rate of ethane production by a greater extent than reducing the rate of ethylene production has been demonstrated in chapter 4. In carbon -13 tracer experiments production of ethane

was greatly poisoned by the presence of carbon monoxide but, as in the absence of carbon monoxide, the ethane originated from ethylene and not from acetylene. The enhancement in selectivity caused by the presence of carbon monoxide may be attributed to carbon monoxide adsorbing in preference to ethylene on type Y sites or reducing the amount of ethylene which tends to α adsorb. This explanation is a reasonable alternative to those postulated elsewhere^{87,89,90}.

Tracer experiments involving carbon-13 labelled acetylene also enable a quantitative assessment to be made of the amount of acetylene which adsorbs as opposed to the amount which hydrogenates in region A. During the first 18 mins, of reaction there was a rapid loss of ^{13}C - ^{13}C skeletons from the gas phase and this must be attributed to adsorption of the acetylene. Thereafter a lesser rate of loss to the surface continued throughout the experiment. There is available metal surface area on the 0.54g of catalyst used to accommodate 1.73×10^{17} molecules at 0.2 nm^2 per molecule. The dose of reactants in carbon-13 tracer experiments contained 6.90×10^{19} molecules of acetylene and from table 5.3 it can be observed that 18.6% of the acetylene initially present disappeared from the gas phase and indicates that adsorption must occur on the alumina as well as on the palladium.

Experiments involving deuterium were also useful in examining the fate of hydrogen during the hydrogenation of mixtures of ethylene and acetylene. From fig. 5.3 it can be observed that rapid exchange of acetylene with deuterium occurs on admission of the reactants. Previous reports on the reaction of acetylene and deuterium over Group VIII metals have indicated that acetylene does not exchange readily with deuterium over palladium supported on kieselguhr⁵¹ or α -alumina⁵². These supports were of low surface area and may have imparted different characteristics to the catalyst than the high area alumina used in the present work. Bond et al⁵² have stated that exchanged acetylenic residues are probably formed over α -alumina supported palladium but are not desorbed and

and hence are not detected in the gas phase. Bond et al⁵³ found rapid acetylene exchange with deuterium over α - alumina supported ruthenium and osmium and have suggested that the acetylene exchange involved the interaction of acetylene with deuterium adsorbed on the alumina support.

Experiments involving the reaction of acetylene with deuterium over the alumina support were carried out to determine whether acetylene exchanged with deuterium on alumina in the absence of palladium. From fig 5.7 it can be seen that a rapid initial exchange takes place but not nearly to the same extent as over the supported metal. The support therefore probably does contribute to the initial exchange of acetylene with deuterium over alumina supported palladium but the support quickly becomes poisoned, possibly by the formation of adsorbed dimers. The fast adsorption of acetylene on the support during the first few minutes of reaction could also have the effect of self-poisoning the exchange reaction by preventing deuterium from adsorbing. The initial fast exchange of acetylene could be due in part to equilibration of surface species after the fast diffusion of deuterium to the active sites of the alumina and palladium on admission of the reaction mixture. This is a similar mechanism to that postulated for the initial fast production of ethane in chapter 4. Any poisoning of the support for acetylene exchange due to adsorption of acetylene or formation of dimers can be reversed by evacuation at 473K for 15 min. An increase in temperature from 293K to 313K had negligible effect on the rate of acetylene exchange over the alumina support so the rate of exchange may depend on the rate of diffusion of the acetylene to the active sites on which deuterium is adsorbed much more rapidly.

A similar attempt by Robertson⁹⁶ to exchange acetylene with deuterium over α - alumina failed because of the large amount of adsorption of acetylene on the catalyst which left very little acetylene in the gas phase for analysis.

Fig. 5.6 shows that there is a rapid decrease in the mean deuterium number of the ethane produced on disappearance of the acetylene and an increase in the deuterium content of the ethylene. This is due to the normal ⁹⁷ reaction of ethylene with deuterium on sites which have been previously covered with acetylene. From fig. 5.6 it also seems likely that no substantial ethylene exchange occurs until the acetylene has disappeared. Any incorporation of deuterium into the ethylene is due to the addition of deuterium to acetylene which itself contains appreciable quantities of deuterium from the initial fast exchange. The deuterium number of ethylene produced after the initial fast acetylene exchange, assuming no ethylene exchange, parallels the rise in the deuterium number of the acetylene in region B. When the acetylene concentration is very low ethylene exchange causes a rapid increase in the deuterium number of the ethylene that is produced. The formation of ethylene from acetylene may be written,

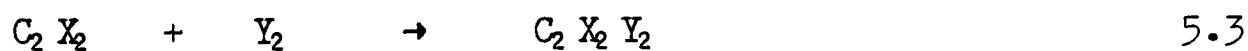

where X or Y = H or D. From fig 5.6 the formation of ethylene from acetylene, in region B, is seen to involve an increase in the deuterium number of 0.55. It follows therefore that Y₂ has an average composition of H_{1 .45} D_{0 .55}. Therefore more hydrogen than deuterium atoms are added to acetylene in producing ethylene despite the large excess of deuterium in the gas phase. This hydrogen which is reacting with acetylene to produce ethylene must have originated from the initial fast acetylene exchange since no other source of hydrogen atoms was present. This hydrogen must have been held on the surface since if it had entered the gas phase the hydrogen would have had a lesser chance of reacting with acetylene than the great excess of deuterium present and Y₂ would have been predominantly composed of deuterium on average. A similar phenomenon over nickel-kieselguhr and palladium - kieselguhr has been reported by Douglas and Rabinovitch ⁵¹ where hydrogen, once adsorbed on the

catalyst surface, did not return to the gas phase. Bond and Wells⁵² also reported that hydrogen desorption was negligible in the reaction of acetylene with deuterium over palladium - alumina. The amount of hydrogen involved necessitates adsorption on the support. The mechanism by which hydrogen, released in the exchange of acetylene with deuterium on the palladium, moves to the support has been termed hydrogen spillover⁹⁸. This process has mainly been observed in catalysts where the supported metal has been palladium or platinum and is believed to occur by a surface process rather than gas phase transport of hydrogen species⁹⁹. In order for hydrogenation of acetylene to ethylene to occur the reverse process must also occur since hydrogenation takes place on the palladium. Fewer examples of reverse spillover have been reported but it has been thought to be involved during alkene hydrogenation over silica - or alumina - supported platinum¹⁰⁰ and alumina-supported platinum, rhodium and palladium^{27,101,102}. Taylor et al¹⁰¹ have also suggested that the hydroxyl groups of the alumina support are the likely positions where hydrogen is stored during spillover.

CHAPTER 6

The Kinetics of Acetylene Hydrogenation in Excess Ethylene in a Flow System

6.1 Introduction

Chapters 4 and 5 described the kinetics and mechanism of the hydrogenation of small amounts of acetylene in ethylene in a static system at a pressure of 7.3 kN m^{-2} .

This chapter deals with studies carried out at atmospheric pressure using a stirred gas-solid reactor under conditions more similar to the industrial situation. Mann and Safo¹⁰³ described acetylene hydrogenation over pumice-supported nickel, platinum and palladium and found that the selectivity of the reaction for ethylene formation increased with increasing temperature and decreased on increasing the hydrogen: acetylene feed ratio. However, the feed gas used by Mann and Safo consisted only of a mixture of acetylene and hydrogen whereas the present investigation involves feed gases containing acetylene, hydrogen, ethylene, nitrogen and carbon monoxide similar to those employed in industrial ethylene purification plants. Industrially carbon monoxide is added to increase the selectivity for ethylene formation and to prevent temperature runaway caused by the exothermic hydrogenation of ethylene to ethane. In the static system experiments described previously no evidence was found for the production of C_4 compounds perhaps because any compounds also produced were held adsorbed on the catalyst surface since low gas pressures were involved. In this investigation the influence of carbon monoxide, hydrogen and ethylene on the kinetics of the hydrogenation of acetylene and the production of ethane are described as is the production and composition of the C_4 fraction.

6.2 Experimental Procedure

The apparatus and experimental techniques are described in chapter 2. Since the same sample of catalyst (14.04g) was used in all experiments, (excepting

Fig. 6.1 Reaction at 343K of mixtures of 25% H₂, 35% C₂H₄, 40%N₂, 1000 p.p.m. CO. Rates of O, acetylene removal; Δ, hydrogen consumption; □, ethane formation; ●, but-1-ene formation; ○, trans-but-2-ene formation; ⊙, cis-but-2-ene formation; +, buta -1,3-diene formation at various acetylene concentrations.

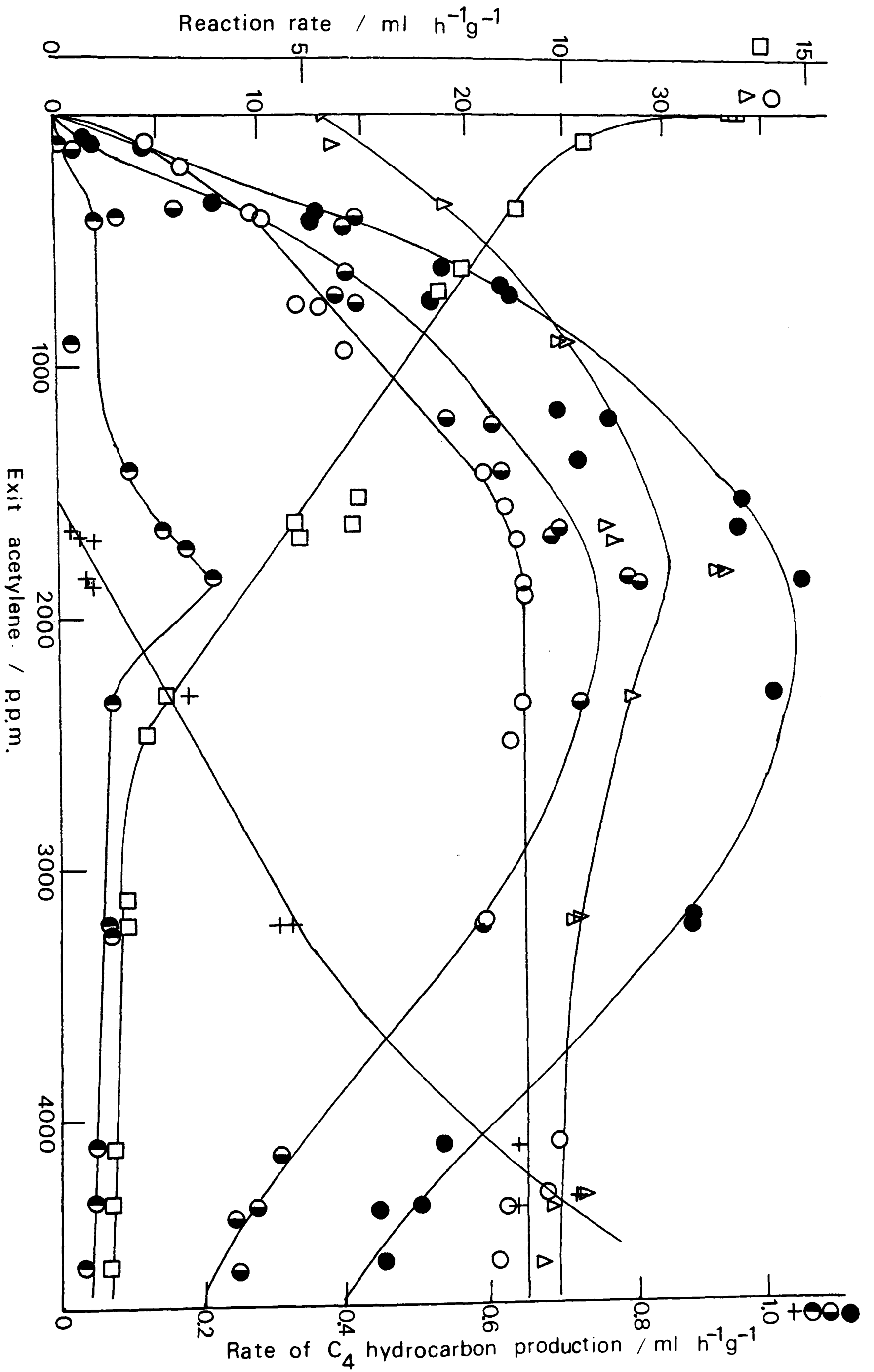
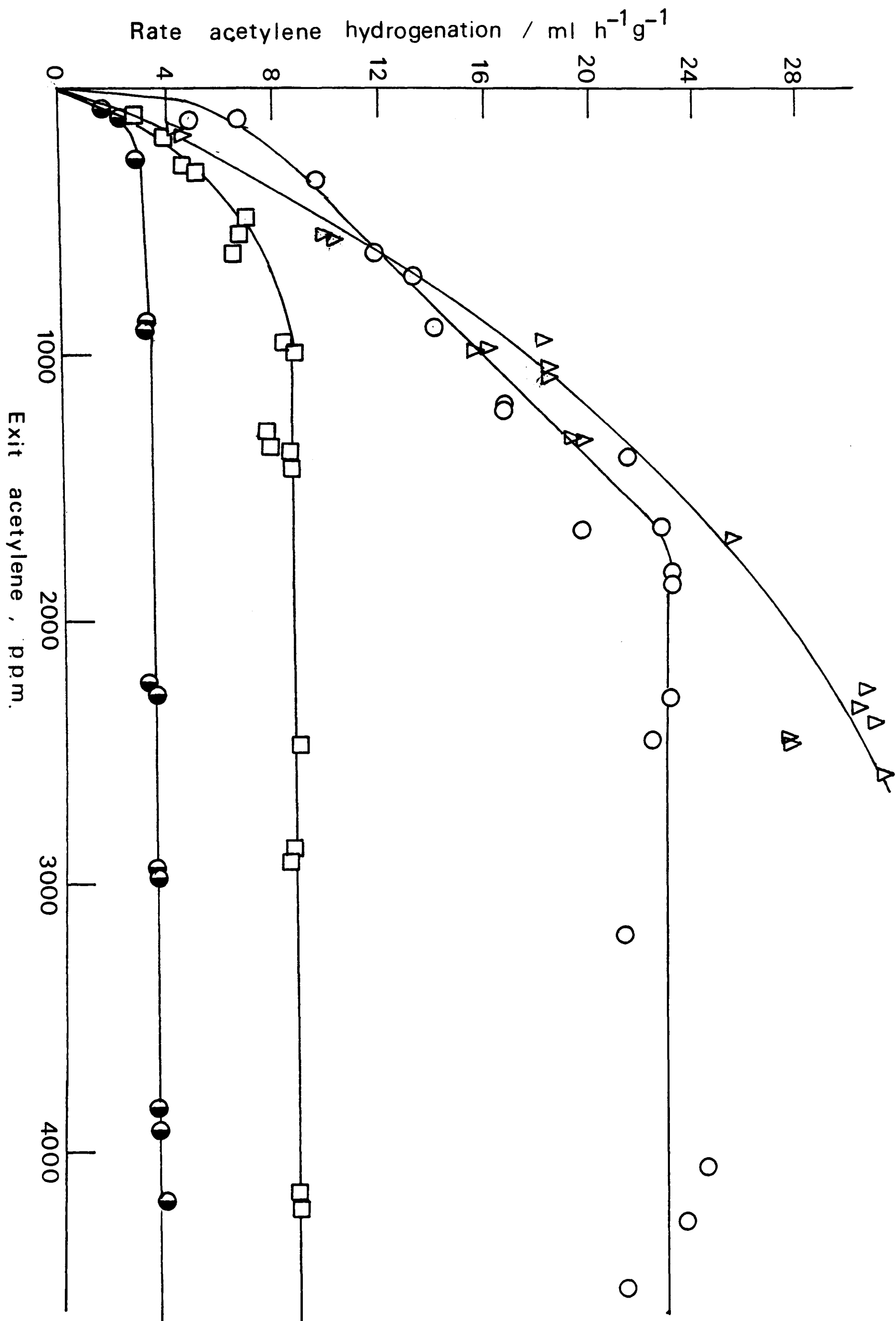

Fig. 6.2 Influence of hydrogen on the rate of acetylene removal at 343K in the presence of 35% C₂H₄ and 1000 p.p.m. CO. Exit hydrogen : Δ, 37.5%; ○, 22.8%; □, 9.4%; ●, 2.6%.



experiments on the influence of stirrer speed), checks were made at regular intervals to ensure that the activity of the catalyst remained constant.

In each run the technique employed was to keep all gas flows constant and to vary the inlet flow rate of the acetylene in order to give changes in the exit acetylene concentration.

The majority of experiments were performed at 343K and this necessitated the addition of 1000 p.p.m. of carbon monoxide to moderate the reaction rates and prevent temperature runaway. Some experiments were carried out in the absence of carbon monoxide at 273K.

6.3 Results

The general characteristics of a typical reaction, in which the rates of appearance or disappearance of reactants and products are plotted as a function of acetylene concentration, are shown in fig. 6.1.

6.3.1 Acetylene Hydrogenation

On increasing the acetylene concentration from zero the rate of acetylene removal at first increased until a point was reached after which it remained constant. The effect of varying the hydrogen concentration on the rate of acetylene hydrogenation is illustrated in fig. 6.2. All reactions had an inlet gas composition of 35% ethylene, 1000 p.p.m. of carbon monoxide and a reaction temperature of 343K. As the hydrogen concentration was increased the concentration of acetylene required to cause a constant rate of acetylene removal increased. From the data shown in fig. 6.2 a graph was drawn of \log [steady rate of acetylene removal] versus \log [hydrogen concentration]. This graph is shown in fig. 6.3 and had a gradient of 0.87 ± 0.05 which is equivalent to the reaction order in hydrogen at a steady rate of acetylene removal. For reactions in the absence of carbon monoxide at 273K the order in hydrogen was 1.30 ± 0.15 . No evidence was observed of a fall in the rate of

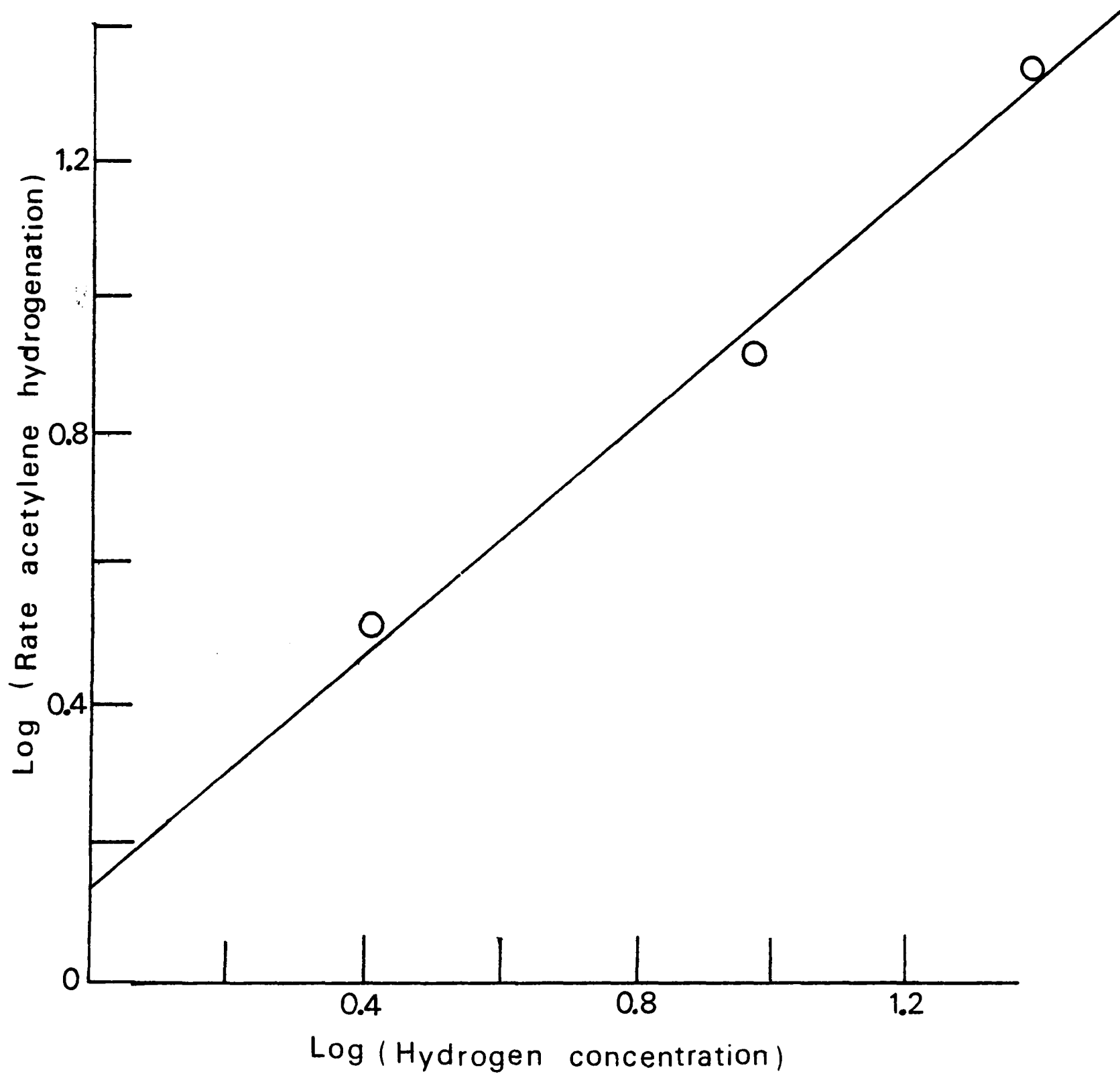

Fig. 6.3 Graph of log (steady rate of acetylene hydrogenation) against log (Hydrogen concentration) in the presence of 35% C_2H_4 and 1000 p.p.m. CO at 343K.

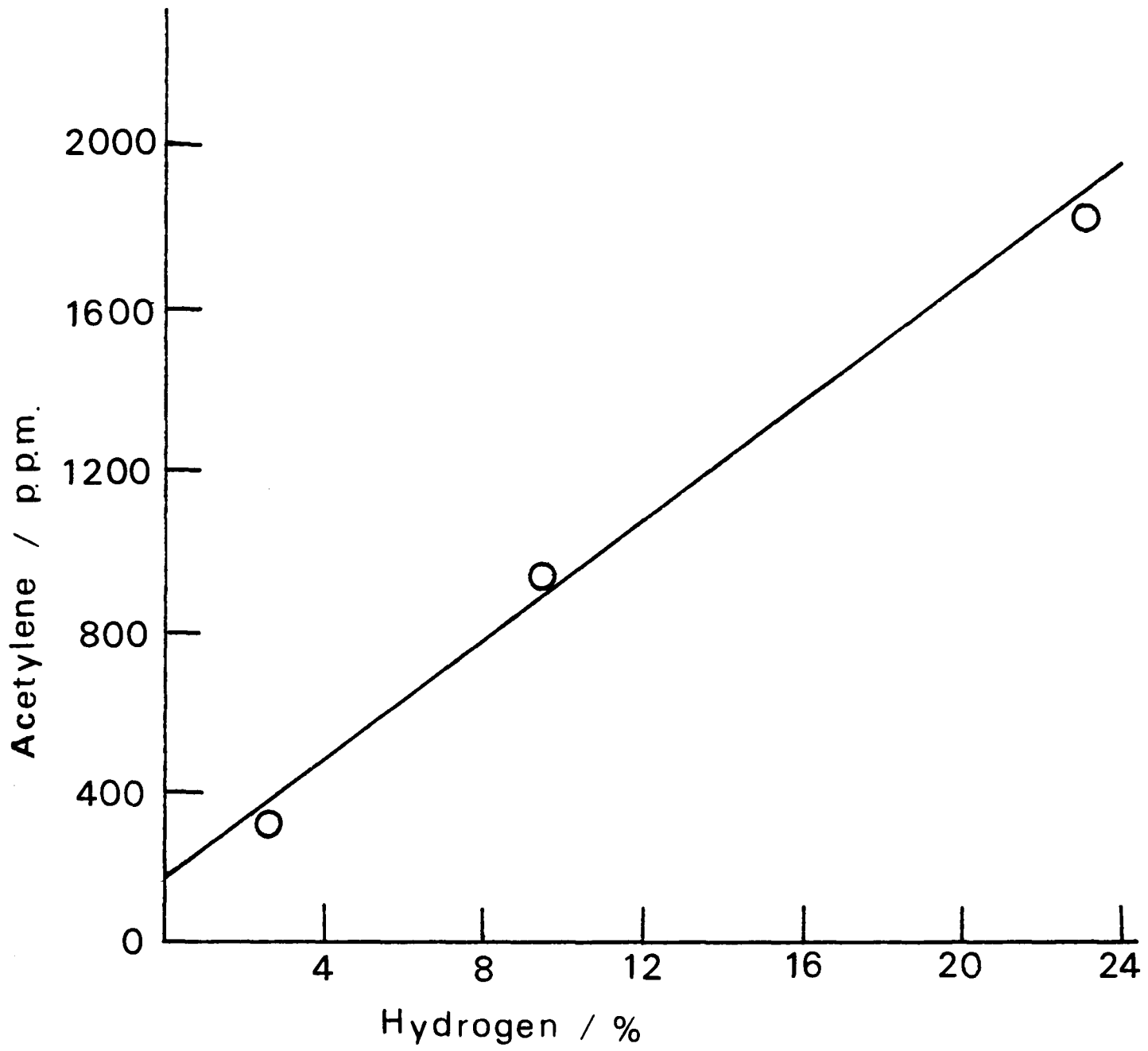

Fig. 6.4 Graph of the concentration of acetylene required to achieve a constant rate of acetylene removal against the concentration of hydrogen present in the presence of 35% C_2H_4 and 1000 p.p.m. CO at 343K.

Fig. 6.5 Influence of carbon monoxide on the rate of acetylene removal at 343K in the presence of 35% C₂H₄ and 25% H₂. Carbon monoxide concentrations : 0, 0%; □ , 1000 p.p.m., ●, 5000 p.p.m.

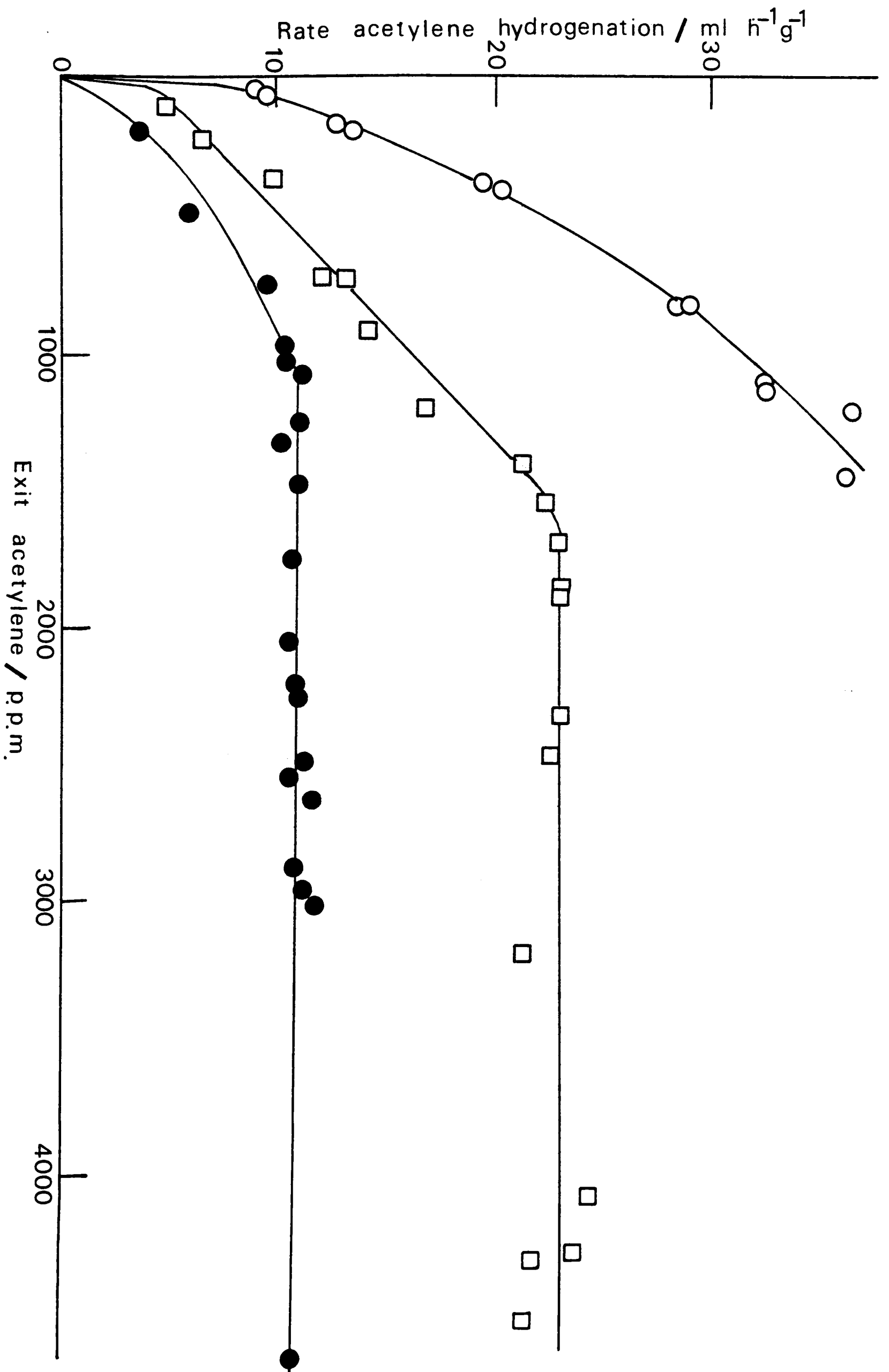
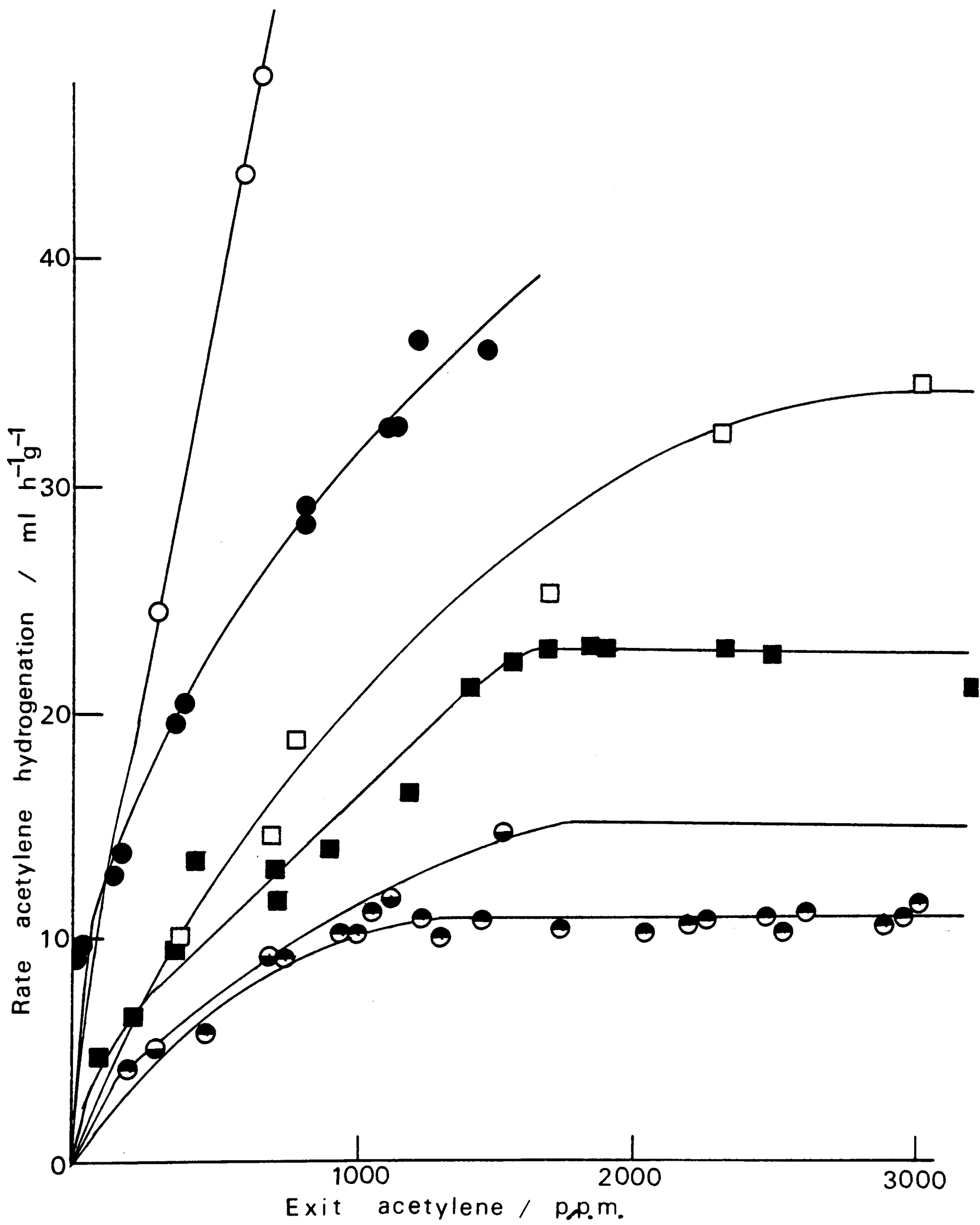

Fig 6.6

Influence of ethylene on the rate of acetylene removal at 343K in the presence of 25% H₂. Exit concentrations :
○, 0.2% C₂H₄ and 0% CO; ●, 28.7% C₂H₄ and 0% CO; □, 2.2% C₂H₄ and 1000 p.p.m. CO; ■, 34.4% C₂H₄ and 1000 p.p.m. CO; ●, 1.0% C₂H₄ and 5000 p.p.m. CO; ⊙, 34.7% C₂H₄ and 5000 p.p.m. CO.



acetylene hydrogenation after the constant rate was achieved on increasing the exit acetylene concentration. It has been noted that the more hydrogen that was present the greater the amount of acetylene that was required to achieve a constant rate of acetylene removal. **This** is illustrated in fig. 6.4 where the concentration of acetylene required to achieve a constant rate is plotted against the concentration of hydrogen present and it can be seen that the required acetylene concentration is proportional to the concentration of hydrogen present.

In fig. 6.5 the effect of carbon monoxide on the acetylene hydrogenation reaction is illustrated. Carbon monoxide has been shown in chapter 4 to be a poison for the acetylene hydrogenation reaction in a static system and this effect may be observed to hold in a flow system. Experiments in the absence of carbon monoxide had a very fast rate at 343K and did not achieve a steady rate of hydrogenation because of an experimental limitation on the amount of acetylene that could be introduced into the inlet gas stream. Therefore if a reaction had a rapid rate then most of the acetylene was removed from the system leaving small concentrations of acetylene which were not big enough to achieve zero order kinetics for the hydrogenation of acetylene. As the concentration of carbon monoxide was increased the rate of acetylene hydrogenation decreased and the first 1000 p.p.m. of carbon monoxide had a relatively greater effect than the addition of a further 4000 p.p.m. The amount of acetylene in the gas phase required to achieve a steady rate of acetylene hydrogenation also decreased as the carbon monoxide concentration was increased.

The effect of varying the ethylene concentration in the inlet gas is shown in fig. 6.6 for various carbon monoxide concentrations. When no ethylene was present in the inlet gas small amounts of ethylene were produced from acetylene hydrogenation. In all the experiments shown in fig. 6.6 the rate of acetylene removal was greater in the absence of ethylene in the inlet gas than in its

Fig 6.7

Influence of hydrogen on the rate of formation of ethane at 343K in the presence of 35% C₂H₄ and 1000 p.p.m. CO. Inlet hydrogen concentrations : 0, 40%; Δ, 25%; □, 10%; ▽, 2.8%

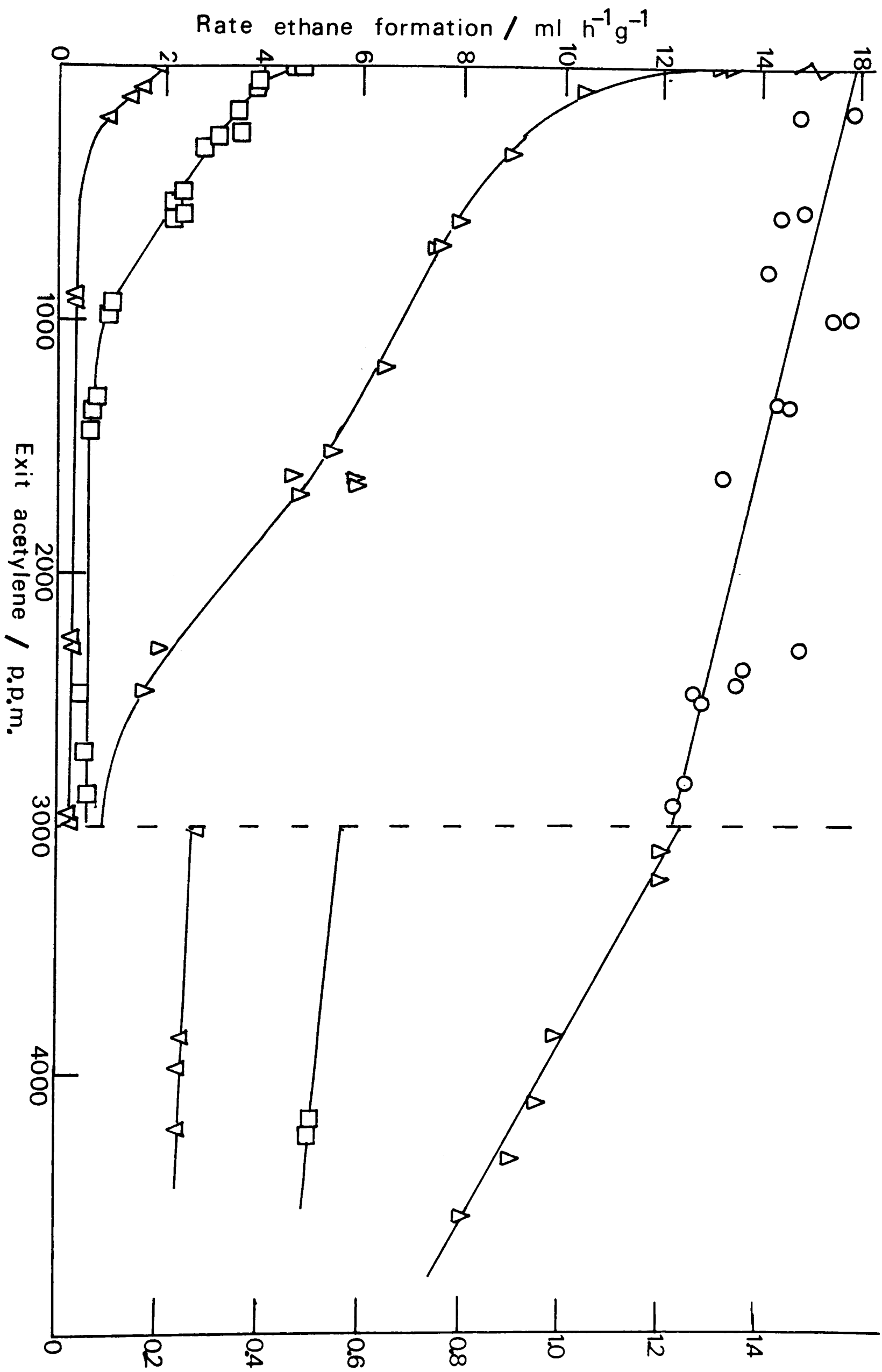

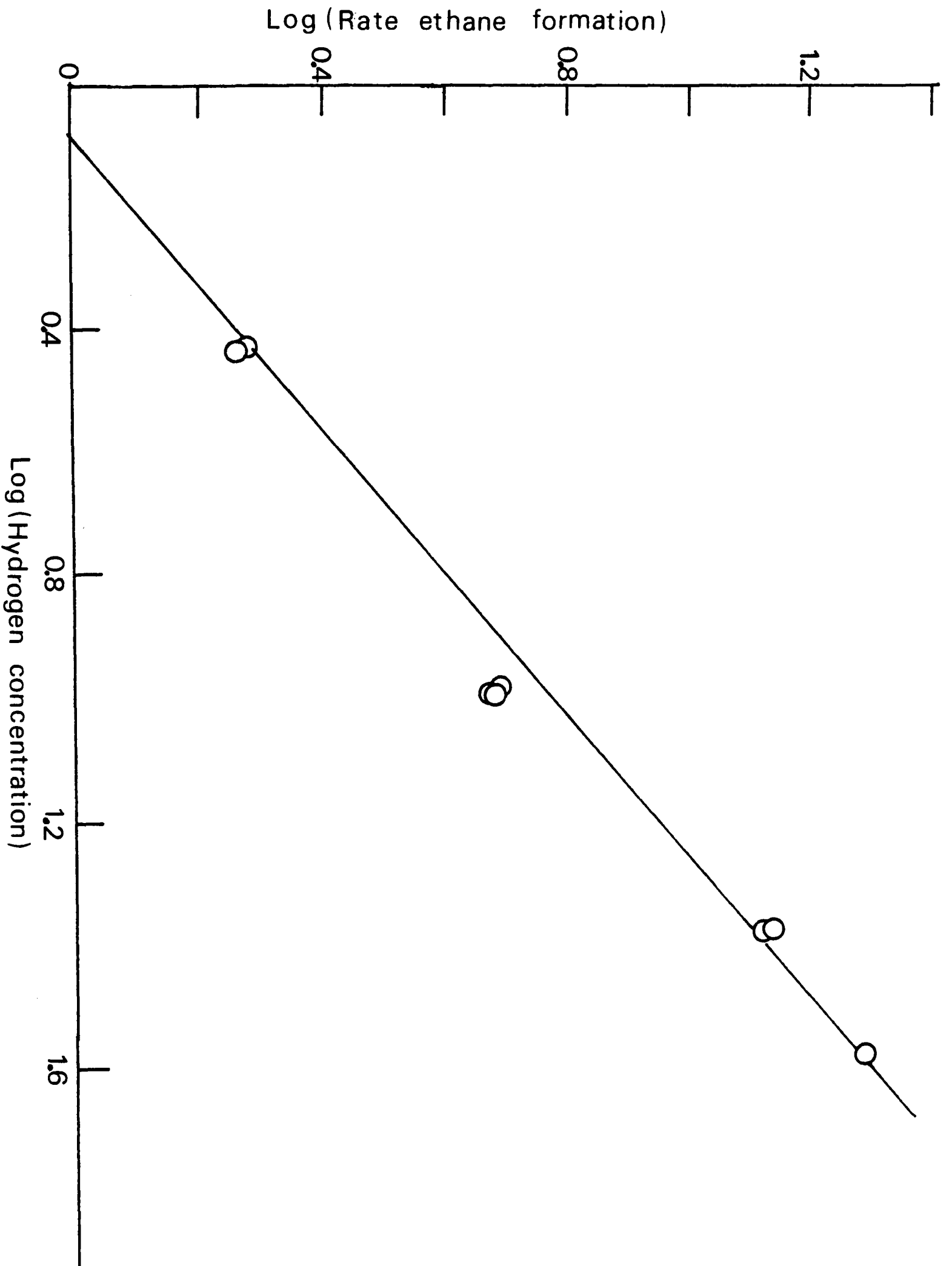

Fig. 6.8 Plot of log (Rate ethane formation) against log (Hydrogen concentration) for experiments in the absence of acetylene in the presence of 35% C_2H_4 and 1000 p.p.m. CO at 343K.

presence and the concentration of acetylene required to attain a steady rate of acetylene hydrogenation was also greater when ethylene was present in the inlet gas.

To summarise, a reduction in the rate of acetylene hydrogenation could be brought about by:

- (i) an increase in the concentration of carbon monoxide;
- (ii) an increase in the concentration of ethylene;
- (iii) a decrease in the concentration of hydrogen.

Also, whenever the steady rate of acetylene hydrogenation was decreased by any of the above factors, the concentration of acetylene required to achieve the steady rate of acetylene hydrogenation also decreased. Carbon monoxide had a relatively much greater effect on the rate of acetylene hydrogenation than had ethylene.

6.3.2. Ethane Formation

On increasing the acetylene concentration from zero the rate of ethane formation decreased and eventually attained a steady value as shown in fig 6.1.

In fig. 6.7 the rates of ethane formation at various hydrogen levels are presented as a function of acetylene concentration. All reactions had an inlet gas composition of 35% ethylene, 1000 p.p.m. carbon monoxide and a reaction temperature of 343K. The order in hydrogen concentration for ethane formation in the absence of acetylene was found from the gradient of a graph of \log [rate of ethane formation] versus \log [hydrogen concentration] as shown in fig. 6.8. The value of the gradient was 0.85 ± 0.05 . This value is of course the order in hydrogen for ethylene hydrogenation as no acetylene was present. At 273K in the absence of carbon monoxide the order in hydrogen was found to be 0.65 ± 0.05 . Similar plots were drawn to find the order in hydrogen for the steady rate of ethane formation at high exit acetylene concentration in the presence of 1000 p.p.m. carbon monoxide. Here the order in hydrogen was found to be 0.64 ± 0.07 at 343K

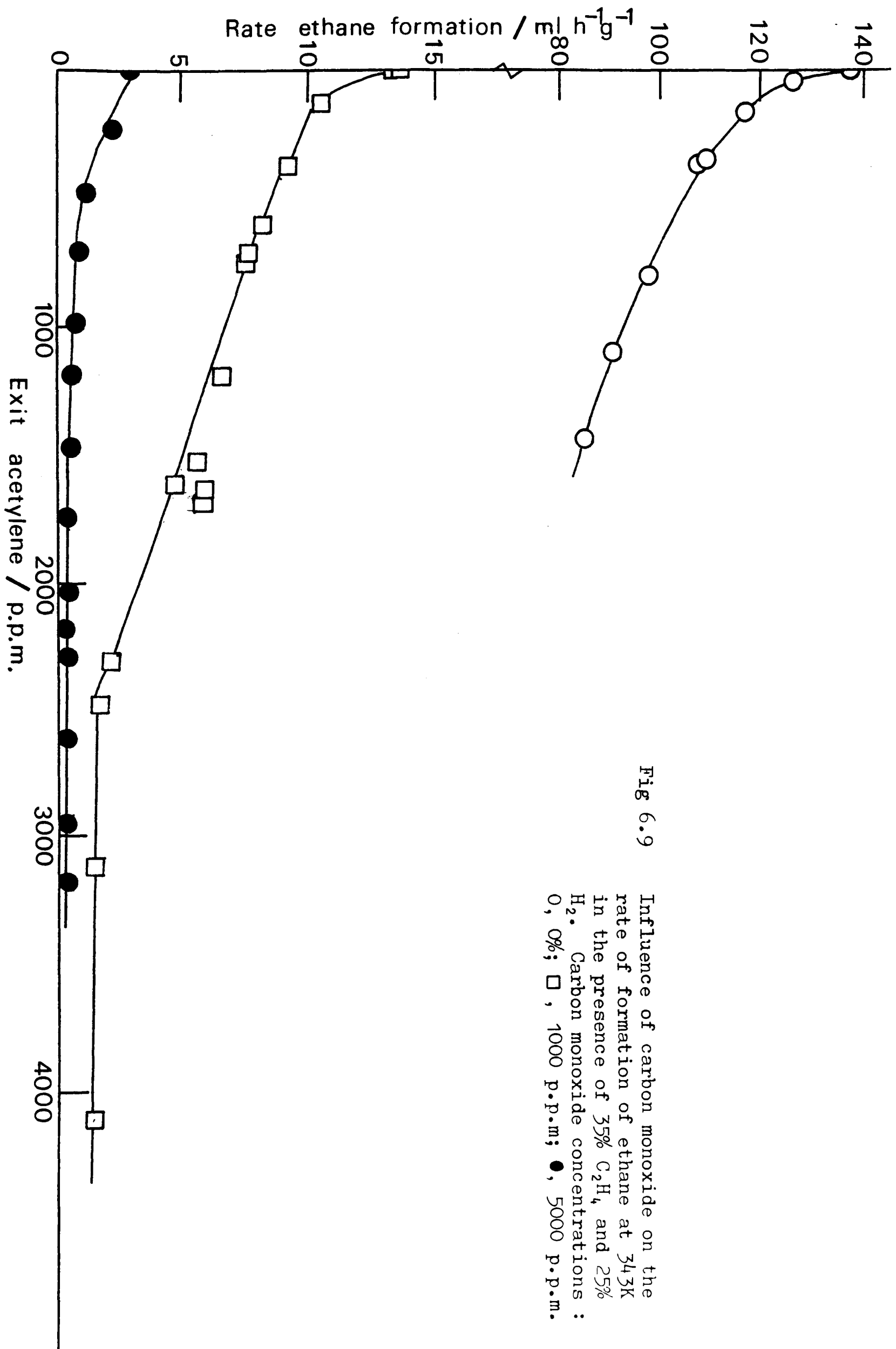

Fig 6.9

Influence of carbon monoxide on the rate of formation of ethane at 343K in the presence of 35% C_2H_4 and 25% H_2 . Carbon monoxide concentrations : 0, 0%; \square , 1000 p.p.m.; \bullet , 5000 p.p.m.

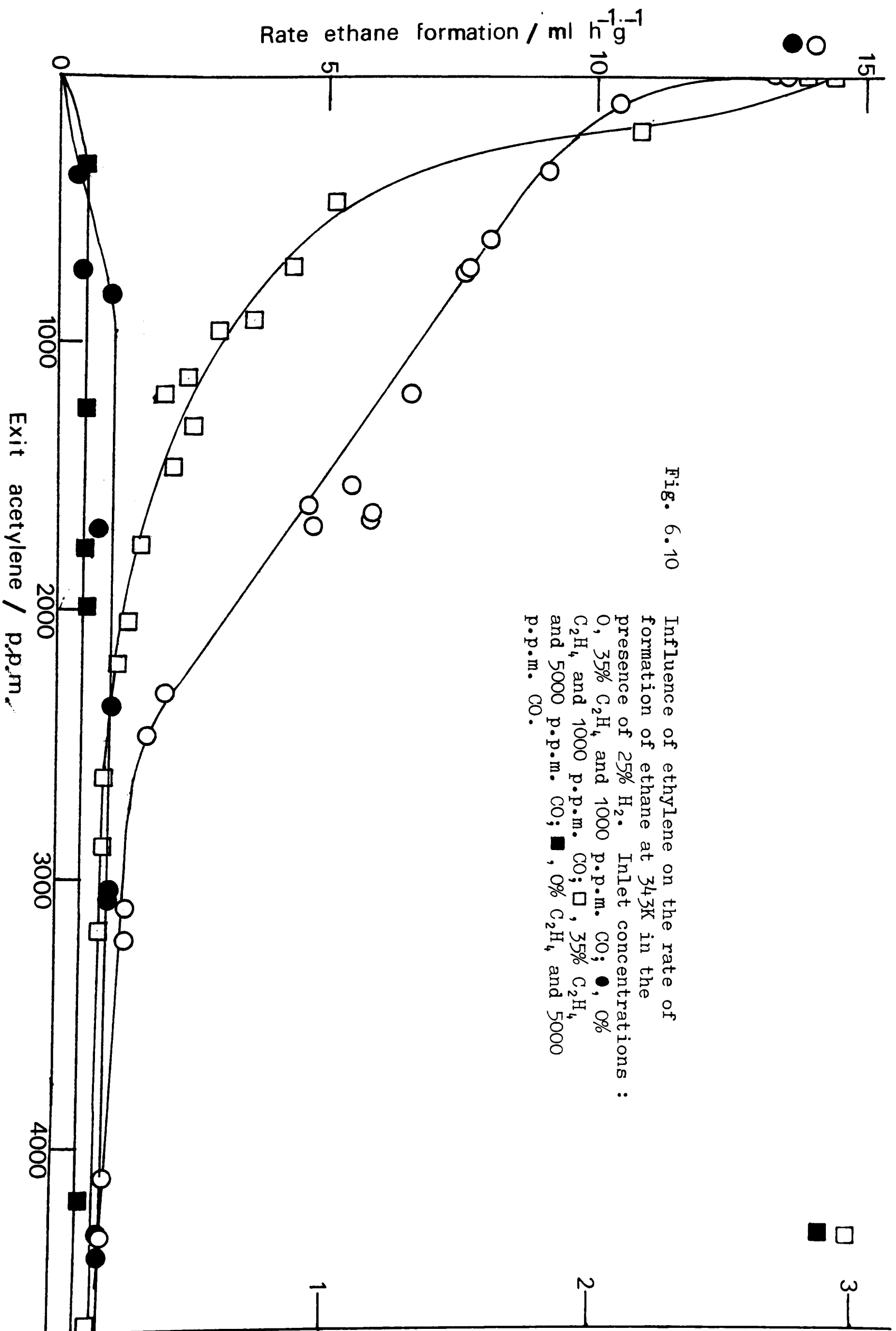

Fig. 6.10 Influence of ethylene on the rate of formation of ethane at 343K in the presence of 25% H₂. Inlet concentrations: O, 35% C₂H₄ and 1000 p.p.m. CO; ●, 0% C₂H₄ and 1000 p.p.m. CO; □, 35% C₂H₄ and 5000 p.p.m. CO; ■, 0% C₂H₄ and 5000 p.p.m. CO.

and 0.90 ± 0.05 at 273K in the absence of carbon monoxide.

Fig. 6.9 illustrates the effect of carbon monoxide on the rate of production of ethane and shows that the presence of carbon monoxide had a greater effect on the formation of ethane than on the disappearance of acetylene. It can be seen that the first 1000 p.p.m. of carbon monoxide had a disproportionately large effect on the rate of ethane formation.

The effect of ethylene on the rate of formation of ethane for experiments conducted in the presence of 1000 and 5000 p.p.m. of carbon monoxide is shown in fig. 6.10. When no inlet ethylene and 1000 p.p.m. of carbon monoxide was present increasing the acetylene concentration from zero produced an increase in the rate of ethane formation until about 1000 p.p.m. of acetylene was present; further increase in the acetylene level had no effect on the rate of ethane production. When 5000 p.p.m. of carbon monoxide was present the maximum rate of ethane formation occurred at an acetylene concentration of ~ 300 p.p.m. in the absence of ethylene in the inlet gas. From fig. 6.10 it may also be observed that the rate of formation of ethane, at acetylene levels > 3500 p.p.m., was identical for ethylene inlets of $\sim 35\%$ and zero ($\sim 2\%$ ethylene in exit) when 1000 p.p.m. of carbon monoxide was present. With 5000 p.p.m. of carbon monoxide coincidence in the rates of ethane formation occurred when the acetylene concentration was ~ 3000 p.p.m.

Therefore, at high acetylene concentrations, the rate of ethane formation was independent of both the acetylene and ethylene levels and varied only with the hydrogen and carbon monoxide concentrations.

6.3.3. Production of C_4 Hydrocarbons

The rates of hydrogenation of acetylene, production of ethane, hydrogen consumption and C_4 production in a typical experiment in the absence of carbon monoxide at 273K are shown in fig. 6.11. On increasing the acetylene level the rates of formation of but-1-ene, trans-but-2-ene, cis-but-2-ene and n-butane

Fig. 6.11 Reaction at 273K of mixtures of 25% H₂, 35% C₂H₄, 40% N₂, 0% CO. Rates of : O, acetylene removal; Δ, hydrogen consumption; □, ethane formation; ●, but-1-ene formation; ○, trans-but-2-ene formation; ⊙, cis-but-2 ene formation; +, buta-1,3-diene formation; ■, n-butane formation at various acetylene concentrations.

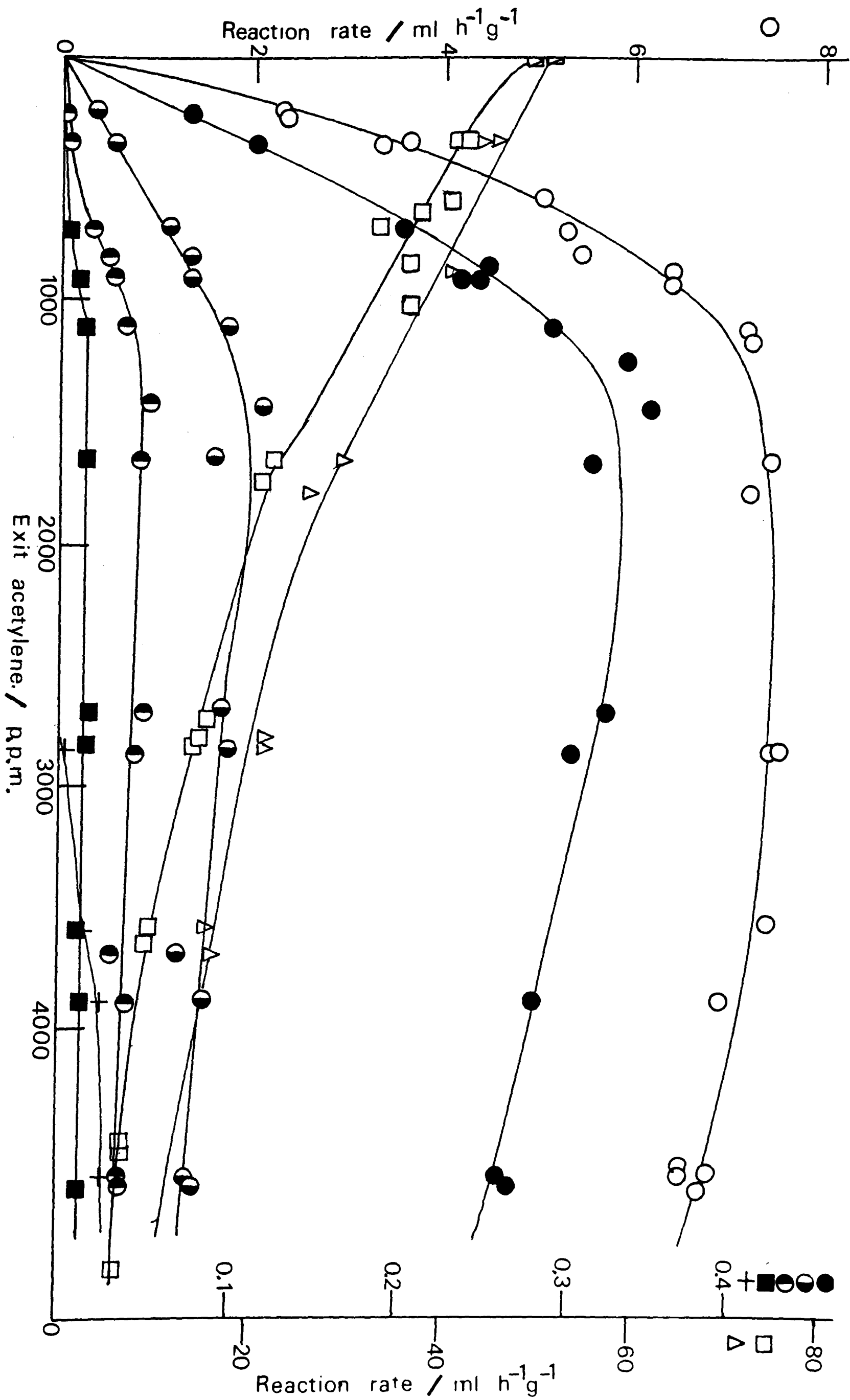
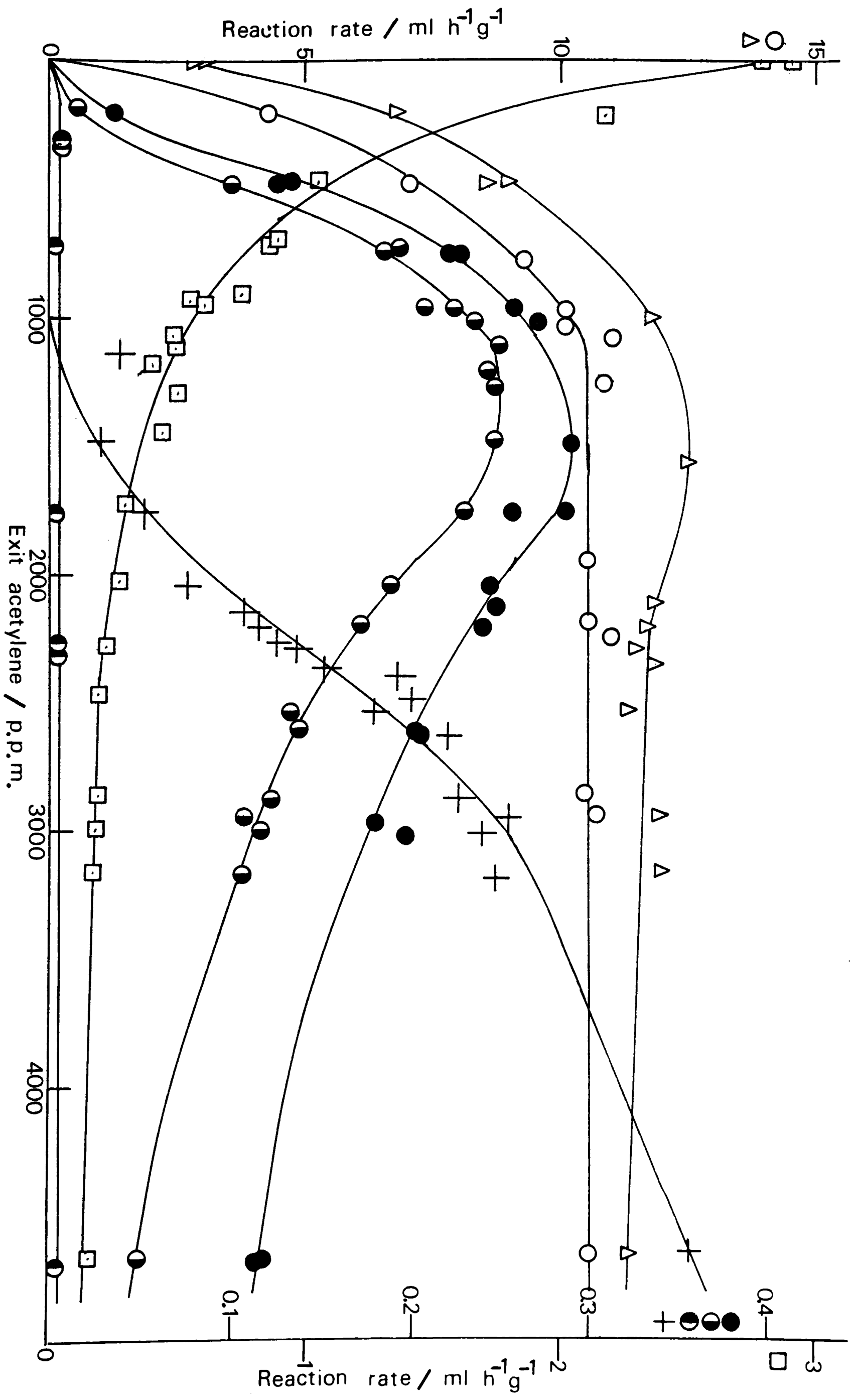

Fig. 6.12 Reaction at 343K of mixtures of 25% H₂, 35% C₂H₄, 40% N₂, 5000 p.p.m. CO. Rates of : O, acetylene removal; Δ, hydrogen consumption; □, ethane formation; ●, but-1-ene formation; ○, trans-but-2-ene formation; ⊙, cis-but-2-ene formation; +, buta-1,3-diene formation at various acetylene concentrations.



all increased initially. On increasing the acetylene concentration above ~1600 p.p.m. the rates of production of the butenes diminished and buta-1,3-diene began to appear in the gas phase. At the point where the reaction became zero order in acetylene the C_4 composition was but-1-ene 66.0%, trans-but-2-ene 22.1%, cis-but-2-ene 9.4% and n-butane 2.5%.

In the presence of 1000 p.p.m. of carbon monoxide at 343K the rates of C_4 production were as shown in fig. 6.1. Only very small traces of n-butane were detected when carbon monoxide was present. A much more pronounced maximum in the rates of formation of the butenes was found in the presence of 1000 p.p.m. of carbon monoxide and this maximum coincided with the position at which the rate of acetylene hydrogenation had just become constant. Cis-but-2-ene was only found in significant quantities around this point. The production of buta-1,3-diene was more apparent in the presence of 1000 p.p.m. of carbon monoxide.

Fig. 6.12 shows the rates of hydrogenation of acetylene, hydrogen consumption and C_4 production in the presence of 5000 p.p.m. of carbon monoxide at 343K.

The fraction of acetylene which was converted to C_4 species is shown in fig. 6.13 as a function of the acetylene concentration. All experiments were in the presence of 35% ethylene and 1000 p.p.m. of carbon monoxide at 343K. As the acetylene concentration was increased from zero the fraction of acetylene converted to C_4 compounds also increased until the point was reached where the disappearance of acetylene became zero order. The influence of hydrogen concentration on the fraction of acetylene being converted to C_4 compounds is also illustrated in fig. 6.13. At low acetylene levels the percentage of acetylene which was converted to C_4 species was reduced as the hydrogen concentration was increased. At high acetylene levels the converse was true. Under conditions where the rate of acetylene disappearance was independent of the acetylene concentration the fraction of acetylene which was converted to C_4

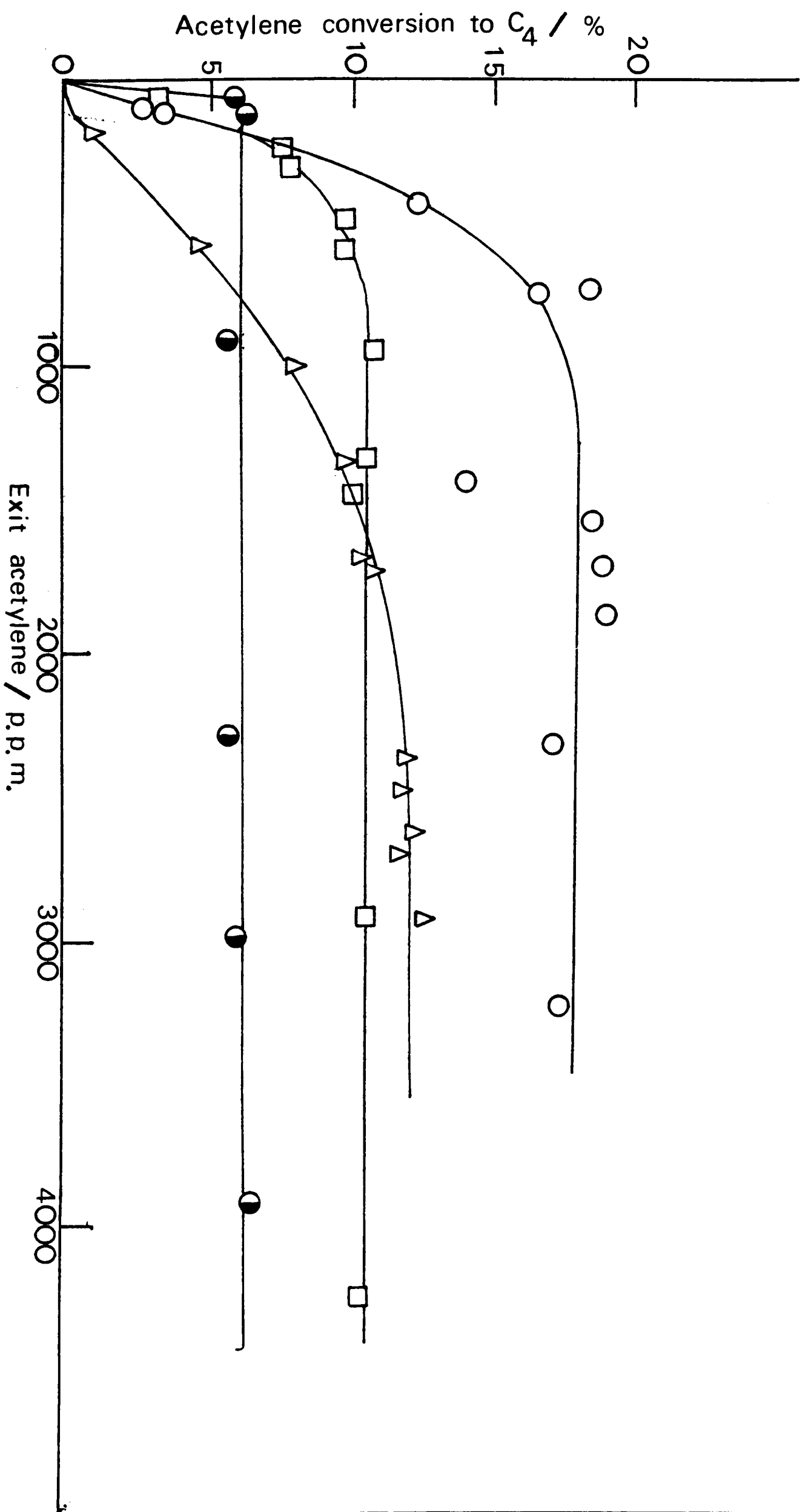

Fig. 6.13

Influence of hydrogen on the percentage conversion of acetylene into C₄ hydrocarbons.
 Exit hydrogen concentrations : ●, 2.6%;
 □, 9.4%; ○, 22.8%; Δ, 37.5%.

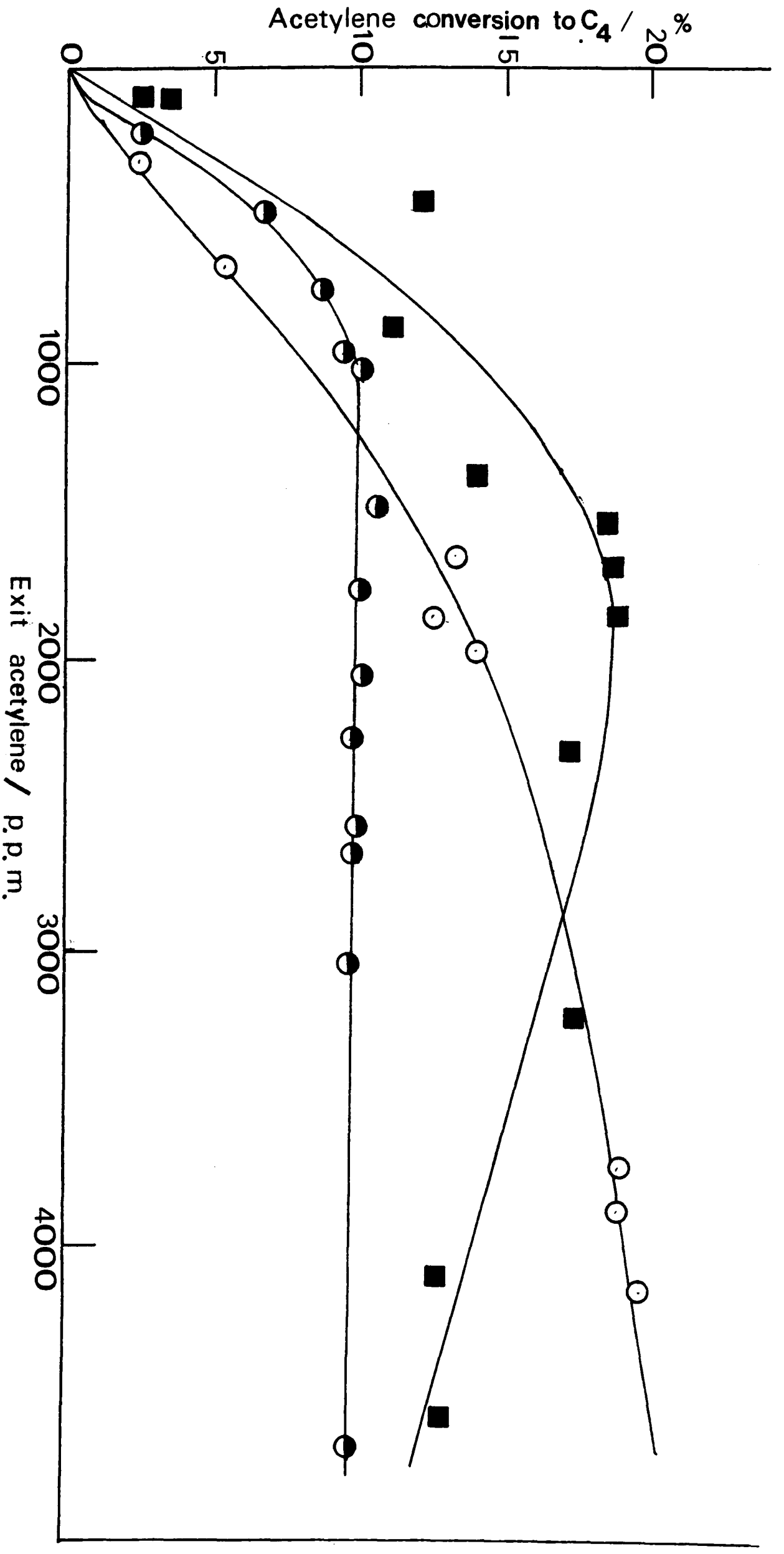
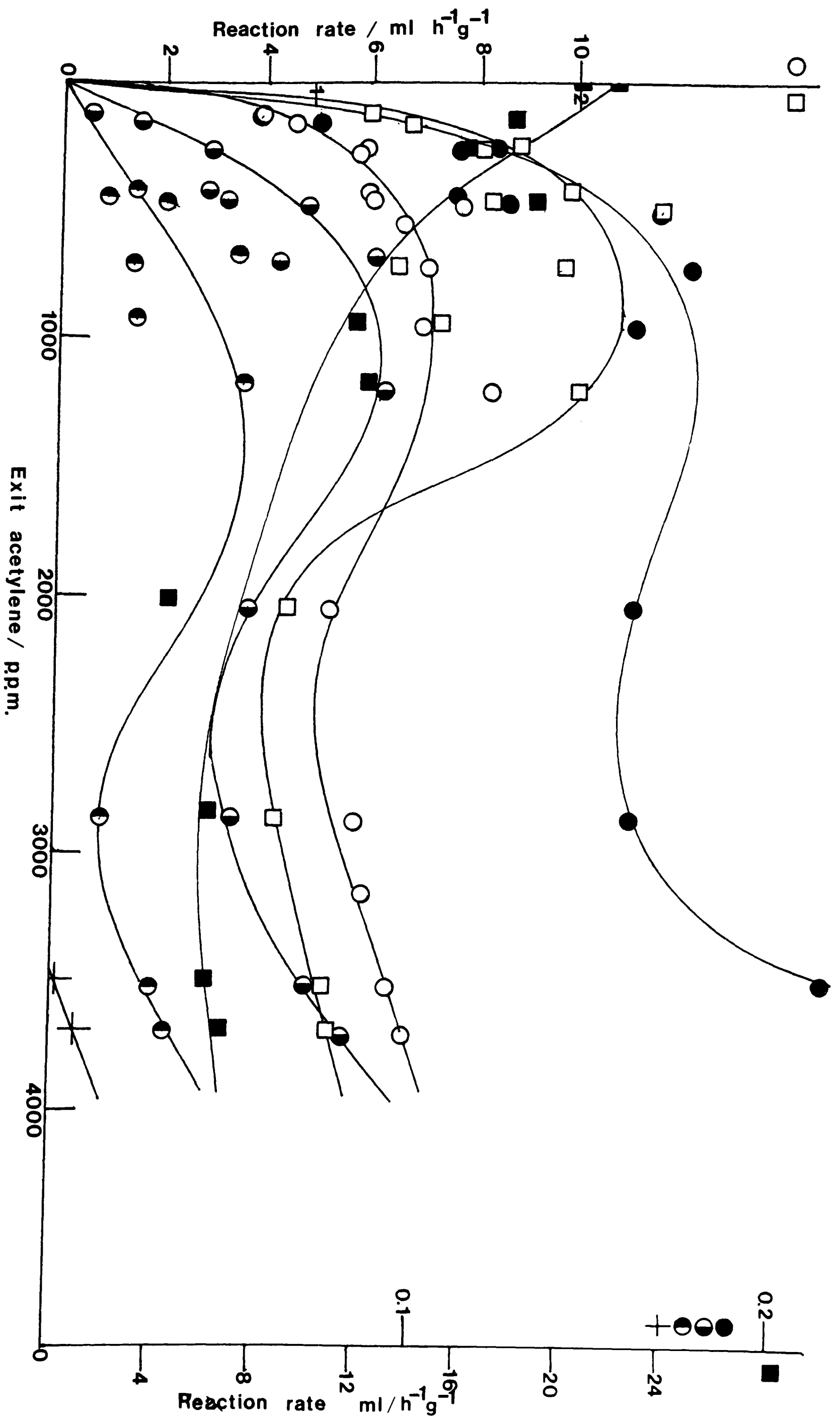

Fig. 6.14 Influence of ethylene and carbon monoxide on the percentage conversion of acetylene into C₄ hydrocarbons. Inlet concentrations : ■, 35% C₂H₄ and 1000 p.p.m. CO; ○, 0% C₂H₄ and 5000 p.p.m. CO; ●, 35% C₂H₄ and 5000 p.p.m. CO.

Fig. 6.15 Reaction at 273K of mixtures of 25% H₂, 35% C₂H₂, 40% N₂, 0% CO. Rates of :
○, acetylene removal; □, ethane formation; ■, propane formation; ●, but-1-ene formation; ◐, trans-but-2-ene formation; ◑, cis-but-2-ene formation; +, buta-1,3-diene formation at various acetylene concentrations.



compounds was also independent of the acetylene concentration.

Fig. 6.14 illustrates the effect of carbon monoxide and ethylene concentrations on the fraction of acetylene undergoing dimerization. When the carbon monoxide concentration was increased from 1000 to 5000 p.p.m. the yield of C_4 species that were produced from acetylene was almost halved. An increase in the ethylene concentration from $\sim 1\%$ to $\sim 34.7\%$ resulted in the fraction of acetylene dimerizing being reduced, except at low levels of acetylene.

An experiment was carried out to investigate whether the C_4 compounds were produced from two acetylene molecules, two ethylene molecules or from one acetylene and one ethylene molecule. To achieve this the acetylene hydrogenation reaction was carried out with 35% propylene present rather than ethylene at 273K in the absence of carbon monoxide. The product gas was analysed for C_4 , C_5 and C_6 fractions. Only C_4 compounds were detected at rates as shown in fig. 6.15. Comparison with fig. 6.11 shows that the rates of C_4 production in the presence of ethylene were similar to those in the presence of propylene. This experiment confirmed that the C_4 species were formed from two acetylene molecules.

6.3.4 Production of High Molecular Weight Hydrocarbons

After several weeks of operation it was observed that a brown oil had accumulated in the exit line from the reactor. The presence of an oily residue is common in commercial acetylene removal plants.

Gas chromatographic analysis of the oil in n-pentane solution indicated that at least sixteen different compounds were present. The analysis was performed on a Perkin-Elmer F-33 gas chromatograph with a 2m column of 11 $\frac{1}{2}\%$ Silicone Fluid MS 550 + Bentone 34 on Chromosorb W 80-100 mesh held at 150°C. Nitrogen at a pressure of 207 kN m⁻² was used as carrier gas.

A further sample in n-hexane solution was examined by High Speed Liquid Chromatography. The trace produced is shown in fig. 6.16. The column

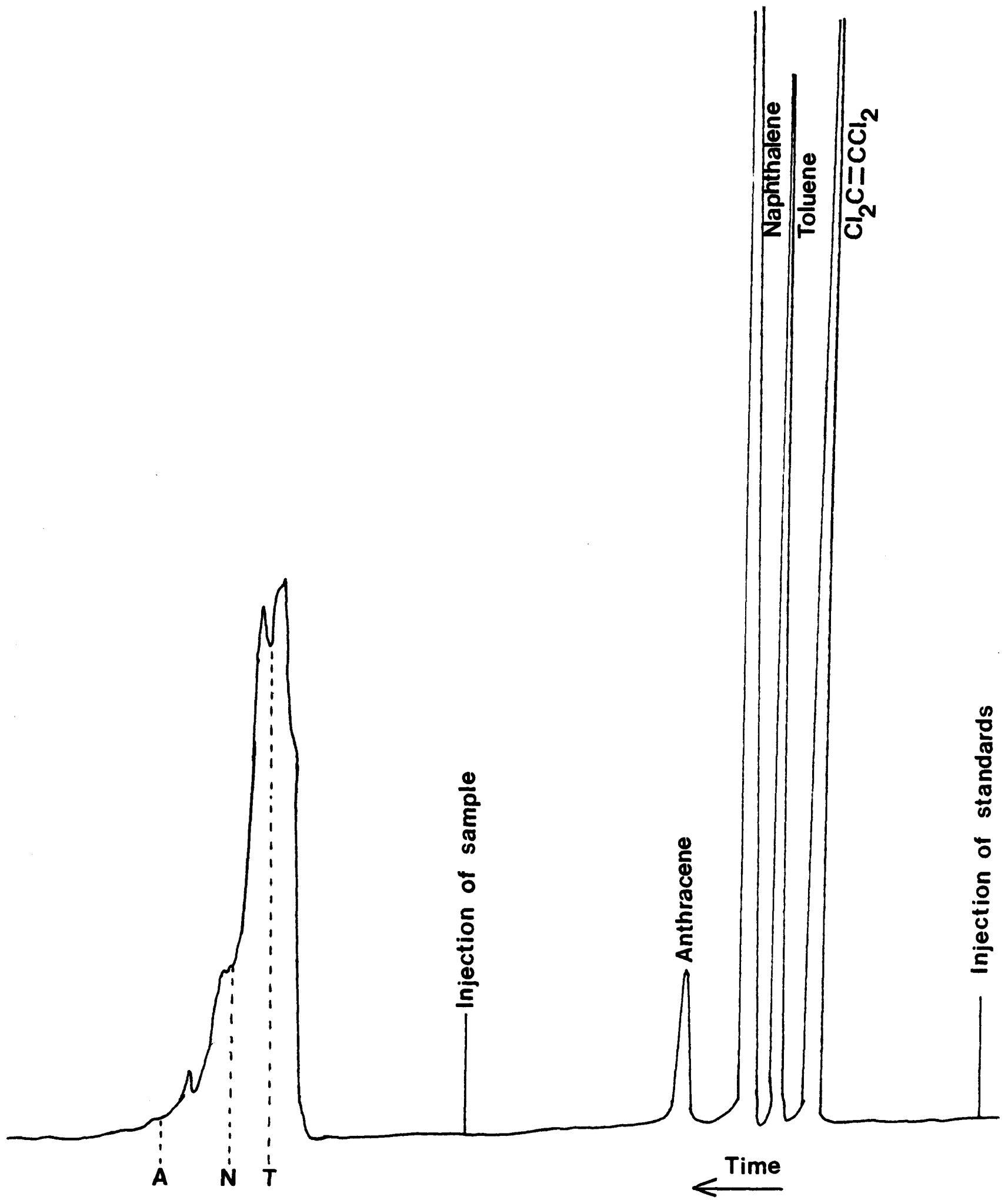

Fig. 6.16 High speed liquid chromatograph of polymeric oil with that of reference compounds.

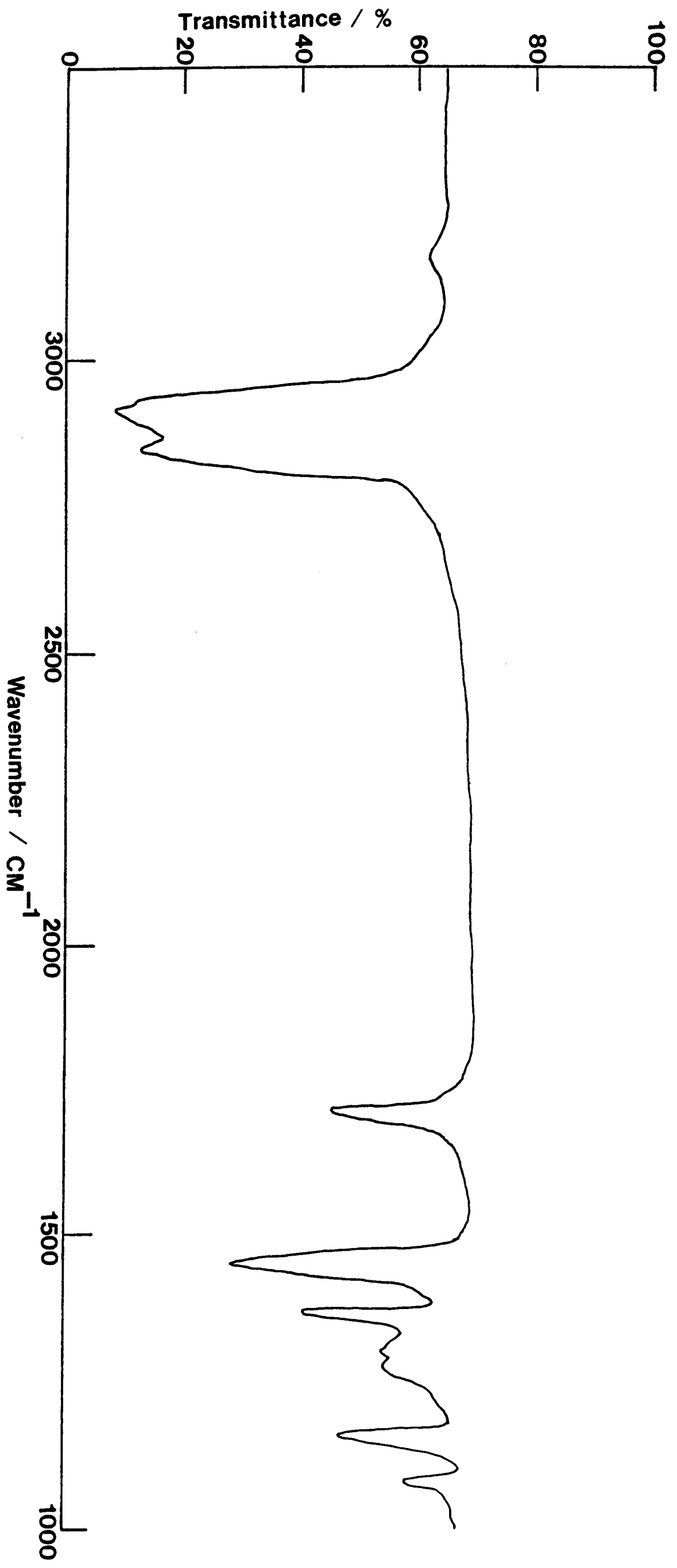

Fig. 6.17 Infra-red spectrum of polymeric oil.

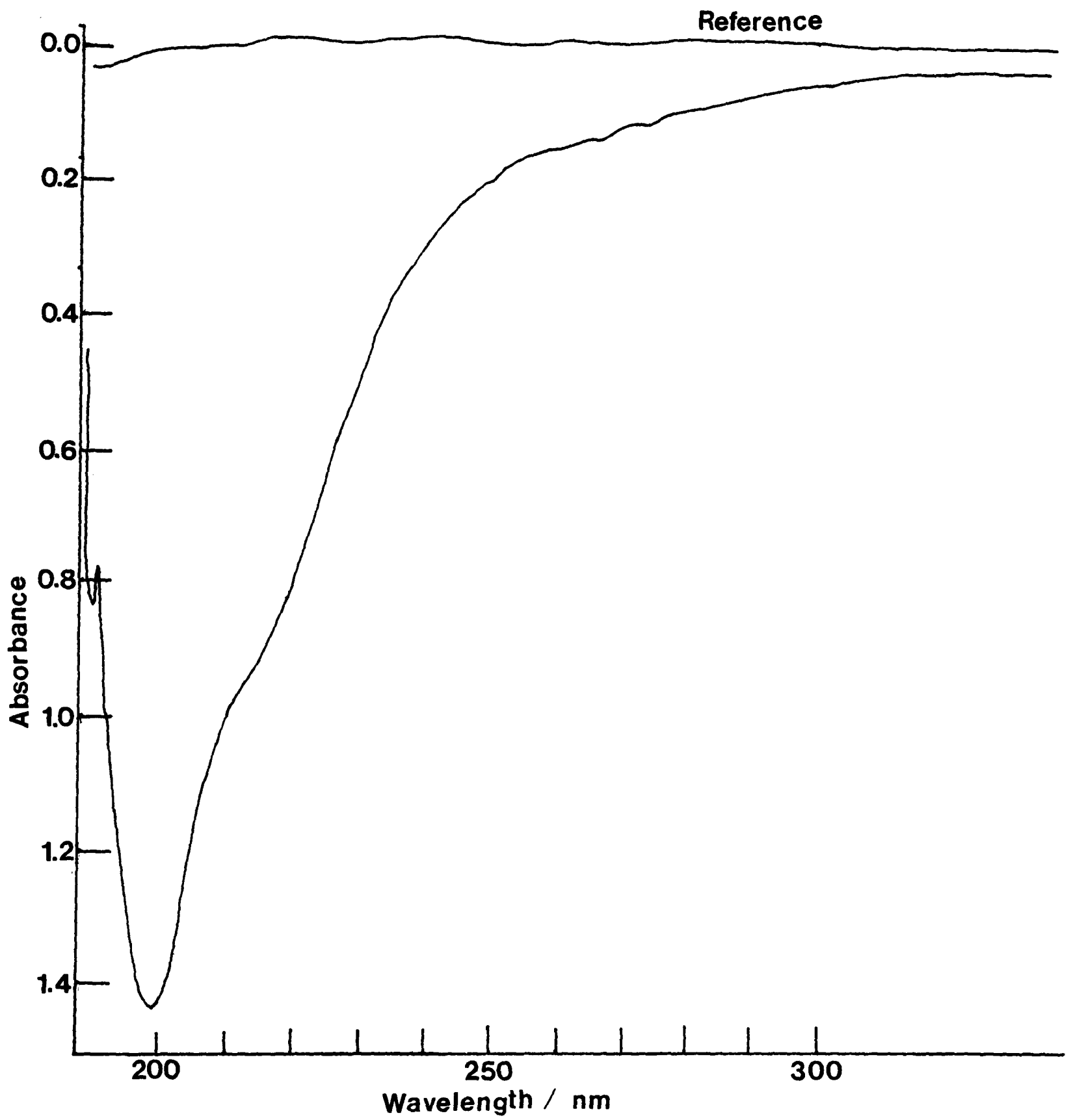

Fig. 6.18 Ultra-violet spectrum of polymeric oil.

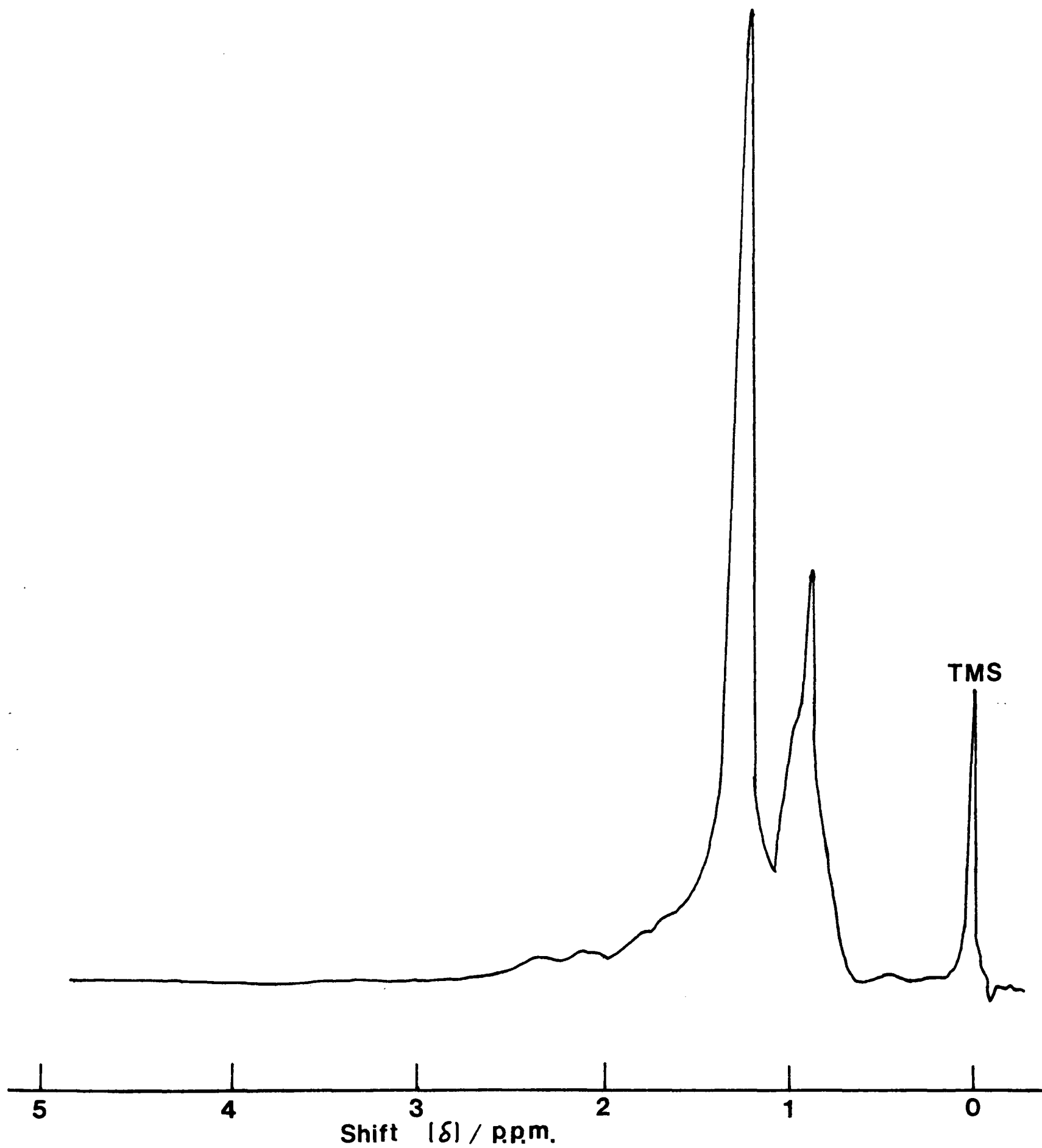

Fig. 6.19 Proton NMR spectrum of polymeric oil.

dimensions were 145 x 5 mm. containing silica of diameter 5.8 μm . The mobile phase was $\frac{1}{3}$ water - saturated hexane at a pressure of $2.76 \times 10^6 \text{ Nm}^{-2}$ at room temperature. Standards of anthracene, naphthalene and toluene were also run. From fig. 6.16 it can only be stated with certainty that anthracene was not present in the oil.

The infra-red spectrum of the oil taken as a smear is illustrated in fig. 6.17. The broad doublet at 2920 cm^{-1} and 2850 cm^{-1} indicated C - H stretching modes. The peak at 1712 cm^{-1} was rather weak for a carbonyl stretching vibration and the peaks at 1460 cm^{-1} and 1378 cm^{-1} were indicative of C - C stretching vibrations. No evidence of unsaturation above 3000 cm^{-1} or between 1600 and 1700 cm^{-1} can be observed. There existed no evidence for alkyne groups at $2100 - 2200 \text{ cm}^{-1}$ or at 3300 cm^{-1} .

The ultra-violet spectrum of the oil as a solution in n-pentane is shown in fig. 6.18. The peaks were at 189 nm (m), 198 nm (s), 216 nm (m), 265 nm (w) and 272 nm (w). The peak at 198 nm, with consideration of the infra-red results, indicated the presence of a carbonyl group although absorption due to C = C may also occur in this region of the spectrum.

A proton NMR spectrum was run with a sample of the oil in CDCl_3 solution. The trace is shown in fig. 6.19. The absence of peaks at δ values 2.5 - 10 ruled out the presence of aldehydic, aromatic or olefinic protons. The peak at δ 0.9 indicated methyl groups, that at δ 1.3 indicated methylene groups. The small peaks at δ 2.1 and δ 2.4 may have been due to traces of ketonic groups.

A single mass spectrum of the oil produced peaks with m/e values up to 310 indicating that the longest chain present would contain ~ 22 carbon atoms.

To summarise, the various analyses indicated that the oil consisted of saturated chains of up to 22 carbon atoms with traces of carbonyl groups. This analysis is in agreement with that of oil found in commercial practice¹⁰⁴.

6.4 Discussion

6.4.1 Kinetics of the Removal of Acetylene

The shape of the plots of the rate of removal of acetylene versus exit acetylene concentration, as shown in fig. 6.2 for example, may be explained in terms of an increase in the surface coverage of acetylene as the acetylene concentration in the gas phase is increased at low acetylene levels. On increasing the gas phase acetylene level the surface coverage in acetylene increases until the surface becomes saturated with acetylene. Beyond this point no increase in rate would be expected as the gas phase acetylene concentration increases and none is observed. Therefore the point at which the acetylene removal rate becomes independent of the gas phase acetylene concentration is a measure of the point at which the catalyst surface becomes saturated with acetylene.

Two mechanisms exist whereby the surface coverage in acetylene, at low acetylene levels, could increase with acetylene pressure. These are:

- (i) Competition between acetylene and other species for surface sites.
- (ii) Diffusional limitation on the rate at which acetylene can reach surface sites within the catalyst pores.

As described in chapters 4 and 5 competition between acetylene and ethylene proved to be a satisfactory explanation of the kinetics observed in static systems at lower pressures. This explanation does not account for the way the acetylene coverage increases with acetylene concentration in the flow system experiments for the following reasons. Firstly, the rise in rate of acetylene removal with acetylene concentration, as shown in fig. 6.1., has an approximately linear portion. On the basis of simple Langmuir competition a smooth curve would be expected. Secondly, if the amount of acetylene which can be adsorbed on the surface was governed solely by competition between acetylene and ethylene then the point at which the rate becomes zero order in acetylene should be similar for all experiments with the same acetylene/ethylene ratio. From

fig. 6.2 this is not the case since the point at which zero order kinetics in acetylene occurs is dependent on the amount of hydrogen present. Thirdly, although competition for surface sites between acetylene and hydrogen is inevitable, if competition for surface sites dominates the kinetics then it would be expected that the rate of removal of acetylene would fall at high acetylene concentrations due to the exclusion of hydrogen from the surface, no such fall is observed.

For these reasons it seems likely that diffusion limitation may explain the kinetics observed in the flow system experiments. For Knudsen flow of gases in catalyst pores the pore diameter must be smaller than the mean free path between the intermolecular collisions⁶⁶. The mean free path of acetylene molecules⁹⁴ at atmospheric pressure is ~50 nm. the mean pore diameter of I.C.I. 38-3 catalyst is 8 nm so Knudsen flow would certainly be expected.

The rate of diffusion of gases is given by¹⁰⁵

$$r_D = \frac{\Delta c \cdot D \cdot P}{d} \quad 6.1$$

where r_D is the rate of diffusion, Δc is the concentration gradient, D is the diffusion constant, P is the porosity and d is the distance over which diffusion is taking place. The porosity of type 38-3 catalyst is known to be: >25 nm pore radius, $0.12 \text{ cm}^3 \text{ g}^{-1}$; 3.7-25 nm, $0.07 \text{ cm}^3 \text{ g}^{-1}$; 1.0-3.7 nm, $0.16 \text{ cm}^3 \text{ g}^{-1}$. During Knudsen flow the diffusion constant is reduced below its value in the free gas. It is assumed that the diffusion constant in pores of radius >25 nm is 100%, 3.7-25 nm is 50% and 1.0-3.7 nm is 15% of the value in the free gas. The value for the diffusion constant of acetylene in air at atmospheric pressure is $0.1 \text{ cm}^2 \text{ s}^{-1}$ and, in the absence of a literature value for ethylene/nitrogen mixtures, this value is applied in the circumstances.

The product $D \cdot P$ is calculated to be $0.018 \text{ cm}^5 \text{ g}^{-1} \text{ s}^{-1}$ from these values quoted. A typical case is the situation where there is a gas phase concentration

of acetylene of 2000 p.p.m. The acetylene concentration decreases the deeper one proceeds into the palladium layer and may be expected to reach zero at the bottom of the palladium layer on the catalyst. If the depth of the palladium layer is 0.8 mm with a concentration difference of 2000 p.p.m. then substitution onto equation 6.1 yields a value for the rate of diffusion of acetylene of $2.2 \times 10^{-8} \text{ mol cm}^{-2} \text{ s}^{-1}$.

From fig. 6.1, when the concentration of acetylene was 2000 p.p.m., the rate of removal of acetylene was $24 \text{ ml h}^{-1} \text{ g}^{-1}$. This is equivalent to $\sim 3 \times 10^{-8} \text{ mol cm}^{-2} \text{ s}^{-1}$ for pellets with a superficial area of $8 \text{ cm}^2 \text{ g}^{-1}$. Therefore the observed rate of acetylene removal was within an order of magnitude of the calculated rate of acetylene removal suggesting that the rate of removal of acetylene at low acetylene levels is controlled by the rate of diffusion of acetylene within the catalyst pores. When the concentration of acetylene is increased the corresponding increase in concentration gradient would result in an increase in the rate of diffusion of acetylene and the rate of acetylene hydrogenation would be controlled by the kinetics of the reaction eventually.

An experiment was carried out to determine whether bulk diffusion in the gas phase was rate limiting. This involved measurement of the rates of acetylene hydrogenation and ethane formation as a function of basket speed. The results are illustrated in figs. 6.20 and 6.21 where it may be seen that the rates of acetylene hydrogenation and ethane formation were independent of basket speed confirming that bulk diffusion in the gas phase was not rate limiting.

Therefore, as the acetylene concentration increases, three regions may be identified. These will be subsequently referred to as (i) the region of diffusion control, (ii) the turning point and (iii) the "steady" region where the rate is kinetically controlled and is approximately zero order in acetylene.

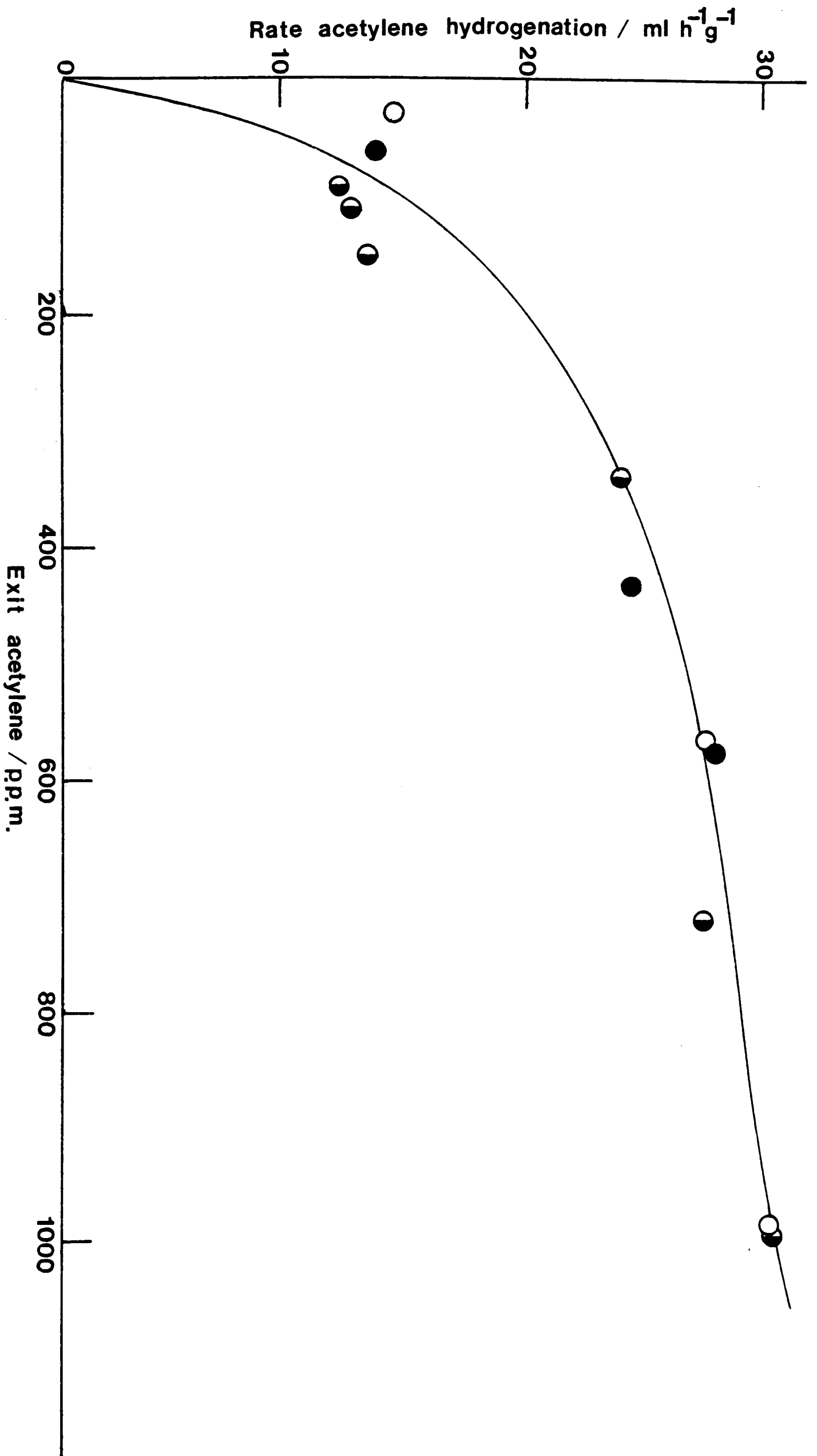

Fig 6.20 Influence of stirrer speed on the rate of acetylene removal for reaction at 343K of mixtures of 30% H_2 , 35% C_2H_4 , 35% N_2 , 1000 p.p.m. CO . Stirrer speeds :
 ●, 2000 r.p.m.; ○, 3000 r.p.m.; ◐, 3500 r.p.m.; ○, 4000 r.p.m.

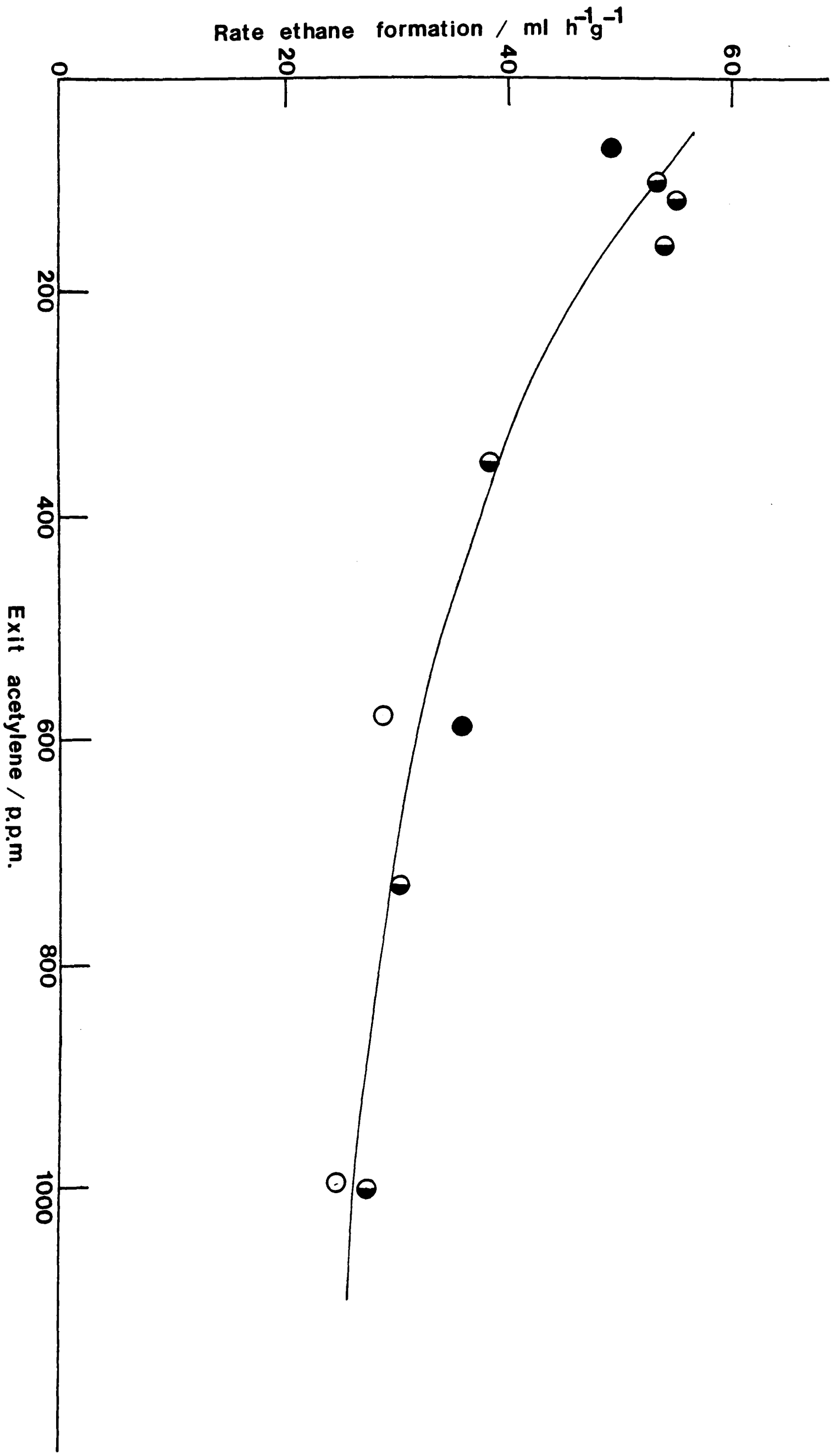

Fig. 6.21

Influence of stirrer speed on the rate of ethane formation for reaction at 343K of mixtures of 30% H₂, 35% C₂H₄, 35% N₂, 1000 p.p.m. CO. Stirrer speeds : ●, 2000 r.p.m.; ●, 3000 r.p.m.; ○, 4000 r.p.m.

6.4.2 Effects of Hydrogen, Carbon Monoxide and Ethylene on the Rate of Removal of Acetylene

It can be seen from fig 6.3 that the reaction is approximately first order in hydrogen at high acetylene levels when the rate is not diffusion limited. The concentration of acetylene required to achieve surface coverage and a steady rate of acetylene removal increases as the amount of hydrogen is increased. In the experiment with 40% of hydrogen, as shown in fig. 6.2. the region of diffusion control extended throughout the range of the whole experiment and no steady rate was achieved. Outside the diffusion controlled region the kinetic order in hydrogen was slightly less than unity. This may indicate some limited competition between acetylene and hydrogen for the surface.

The effects on the rates of acetylene hydrogenation of carbon monoxide and ethylene are qualitatively similar in that the region of diffusion control is curtailed and the subsequent steady rate of acetylene removal is reduced in the presence of these gases. The magnitude of these effects is greater in the case of carbon monoxide than with ethylene and may be thought of as equivalent to a reduction in the hydrogen concentration. From figs. 6.5 and 6.6 it appears that competition between carbon monoxide or ethylene with acetylene is not important at high acetylene levels since doubling the acetylene concentration from 2000 to 4000 p.p.m. has no detectable effect on the rate of acetylene hydrogenation. The reduction in both the effect of diffusion control and the steady rates caused by the presence of carbon monoxide or ethylene must be due to a reduced availability of hydrogen on the surface, probably on sites between the fairly close packed acetylene molecules. The influence of carbon monoxide on the adsorption of acetylene is known to be minor^{89, 90}.

6.4.3 The Formation of Ethane

The general shape of the graphs for the rate of formation of ethane as a function of acetylene concentration, illustrated in fig. 6.7, may be interpreted on the

basis of competition between ethylene and acetylene for the surface at low acetylene pressures, but there is probably some distortion caused by the diffusional limitation of rates. In chapter 5 it was postulated that such competition occurs on type X sites on which acetylene is adsorbed with a strength 2200 times that of ethylene at 293K. The rate of formation of ethane initially falls with an increase in acetylene concentration due to decreasing ethylene coverage of type X sites.

Once the surface has become saturated with acetylene the rate of production of ethane becomes independent of the acetylene and ethylene concentrations as shown in fig. 6.10 for experiments in the presence of 1000 and 5000 p.p.m. of carbon monoxide. The steady rate of production of ethane at high acetylene levels may be regarded as further evidence for type Y sites which can hydrogenate ethylene even in the presence of large quantities of acetylene. This is confirmed by fig 6.10 where the rate of production of ethane in the steady region (i.e. non diffusion controlled) is identical for experiments with zero and 35% ethylene in the inlet gas to the reactor. These results reinforce the conclusions obtained from the static system experiments discussed in chapter 4 and 5.

The effect of carbon monoxide is to depress the rate of formation of ethane to a much greater extent than the rate of hydrogenation of acetylene. This implies exclusion of ethylene from the surface by carbon monoxide. A comparison of results in fig. 6.9 at carbon monoxide levels of 1000 and 5000 p.p.m. suggests that carbon monoxide can compete effectively with ethylene for both type X and type Y surface sites.

6.4.4 Production of C₄ Molecules

Figures 6.1, 6.11 and 6.12 show the rate of production of C₄ species in the presence of 1000 p.p.m., zero and 5000 p.p.m. of carbon monoxide. The increase in the rate of formation of C₄ compounds at low acetylene levels may be explained by the increasing surface coverage in acetylene which increases the

probability of acetylene molecules occupying adjacent sites, which is a reasonable prerequisite for dimerization.

This may be represented by equation 6.2.

$$\text{Rate of } C_4 \text{ production} = k \theta_{C_2H_2}^n \quad 6.2$$

where k is a constant and $\theta_{C_2H_2}$ is the fraction of the surface covered by acetylene. An indication of the value of this fraction may be obtained from

$$\theta_{C_2H_2} = \frac{\text{Rate of } C_2H_2 \text{ disappearance}}{\text{Limiting rate of } C_2H_2 \text{ disappearance at surface saturation}} \quad 6.3$$

Values of n obtained from graphs of \log [rate of C_4 production] versus $\log [\theta_{C_2H_2}]$ for experiments at various gas compositions are shown in Table 6.1.

Table 6.1: Dependence of Rate of C_4 Production on the Surface Coverage of Acetylene at 343K

H_2 /%	C_2H_4 /%	N_2 /%	CO/p.p.m.	n
25	35	40	1000	1.64
25	35	40	5000	2.00
25	0	75	1000	2.05
10	35	55	1000	2.00

From table 6.1 it appears that in the majority of experiments n had a value of ~ 2 confirming that C_4 production required the adsorption of acetylene molecules on two adjacent sites. This conclusion is reinforced by the results shown in fig. 6.13 where the proportion of acetylene resulting in C_4 compounds becomes independent of the acetylene concentration once saturation has been attained.

The composition of the butenes, at the point of surface saturation with acetylene, is similar to that reported by Bond and Wells²⁹. This is markedly different from the thermodynamic equilibrium composition which is but-1-ene 2.4%,

trans-but-2-ene 74.4% and cis-but-2-ene 23.2% at 298K. This suggests that when a butene molecule is formed it is immediately desorbed without having sufficient time to undergo isomerization; this is understandable in view of the presence of acetylene and large quantities of ethylene.

Sheridan has suggested ¹¹ that the free radical form of an adsorbed vinyl group reacts with an adsorbed acetylene molecule to produce buta-1,3-diene which subsequently hydrogenates to yield butenes. Hydrogenation of buta-1,3-diene over palladium - alumina ⁶³ at 273K produced a butene composition of but-1-ene 64.4%, trans-but-2-ene 33.2% and cis-but-2-ene 2.4%. This composition agrees very closely with the butene analysis reported during acetylene hydrogenation in section 6.3.3, in confirmation of Sheridan's mechanism. Bond ⁶³ has proposed that but-1-ene is produced by a 1,2 addition of two hydrogen atoms to buta-1,3-diene whilst the but-2-enes are formed by a 1,4 addition process over palladium.

The conformation of the adsorbed buta-1,3-diene species resulting from the dimerization of adsorbed acetylene may well differ from that produced by gas phase buta-1,3-diene. The conformation of the adsorbed buta-1,3-diene determines the configuration of the but-2-ene which is produced. The trans : cis ratio for the but-2-enes produced during acetylene hydrogenation is 2.4 but is 13.8 during buta-1,3-diene hydrogenation. The proportions of cis and trans buta-1,3-diene in the gas phase is between 1:10 and 1:20 ¹⁰⁶ and would explain the trans : cis ratio for the but-2-enes produced during buta-1,3-diene hydrogenation if the conformations of adsorbed buta-1,3-diene do not readily interconvert. However, during acetylene hydrogenation, the conformation of the adsorbed buta-1,3-diene intermediate will depend on the stacking geometry of the two acetylene molecules which combine to form the diene ²⁹ and a different trans : cis ratio might be expected. Bond and Wells ⁶⁴ have reported that the most favoured steric arrangement of acetylene molecules on palladium is a form

of staggered packing which would be expected to form the transoid buta-1,3-diene on dimerization and subsequently the trans-but-2-ene on hydrogenation.

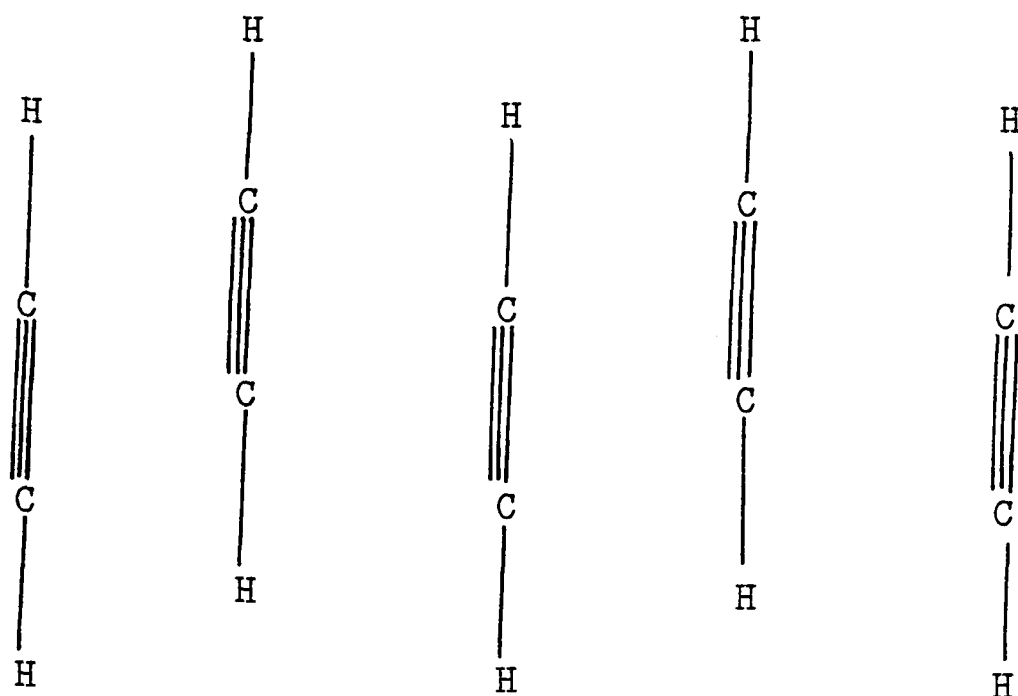

At low acetylene levels the majority of the but-2-ene formed has the trans configuration as shown in fig. 6.1. As the surface concentration of acetylene approaches monolayer saturation the mode of packing of acetylene may change to a closer packed form with geometry:

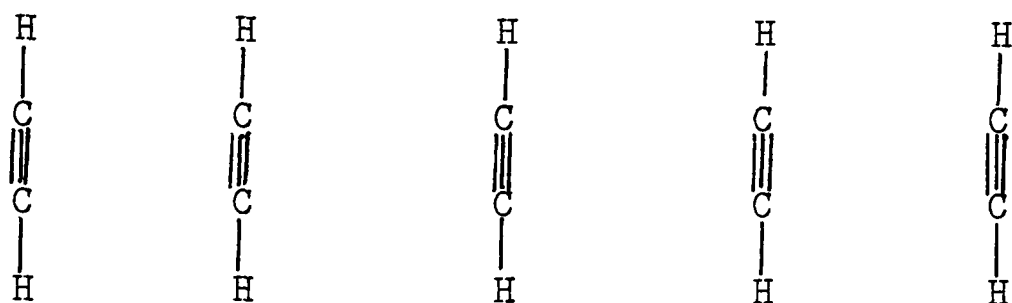

This form of packing would be expected to ultimately yield cis-but-2-ene. Fig. 6.1 shows that the amount of cis-but-2-ene formed does increase considerably when the acetylene coverage is close to saturation.

At high acetylene concentrations the yield of C_4 olefins falls and the principle C_4 product becomes buta-1,3-diene. This suggests that either the availability of surface hydrogen becomes less, although this is not reflected in a change in the rate of acetylene hydrogenation, or that the increasing acetylene bombardment of the surface with acetylene pressure displaces the buta-1,3-diene molecules before they have time to hydrogenate.

Carbon monoxide almost entirely eliminates n-butane production from butenes. This is equivalent to the effect of carbon monoxide on the production of ethane from ethylene where the selectivity of acetylene hydrogenation to ethylene is increased when carbon monoxide is added. The degree of saturation of the C₄ molecules is reduced in the presence of carbon monoxide due to a reduction by competition in the availability of adsorbed hydrogen.

6.4.5 Recent Publications

Recently published results ¹⁰⁷ have suggested that the presence of palladium hydride phases may influence the hydrogenation of acetylene. The thermodynamics of the palladium/hydrogen system ¹⁰⁸ give the following equation

$$\log P_{H_2} = 7.65 - \frac{2039}{T} \quad 6.4$$

where P is the dissociation pressure of palladium hydride. When equation 6.4 is applied to the flow system experiments it appears that the percentages of hydrogen required in the gas phase for hydride formation are 6.7% at 343K and 0.6% at 293K. Therefore in many of the experiments reported hydride formation is feasible. However Borodzinski et al ¹⁰⁷ report that hydride formation did not occur to any appreciable extent in catalysts where the dispersity of the palladium on the γ -alumina support was less than 1% wt. palladium. Since the I.C.I. 38-3 catalyst used in this work had a dispersity of 0.04% wt. palladium it is very unlikely that hydride formation contributed to the overall reaction.

In the static system experiments the pressures of hydrogen present were only $\sim 281 \text{ Nm}^{-2}$ and the required hydrogen pressure for hydride formation at 293K as calculated from equation 6.4 is 654 Nm^{-2} so hydride formation was unlikely in these experiments irrespective of the dispersity of the palladium.

References

1. LAM W.K. and LLOYD, L., Oil and Gas Journal, March 1972, 66.
2. PAAL, C. and HOHENEGGER, C., Ber, 1915, 48, 275.
3. ROSS, W.H., CULBERTSON, J.B. and PARSONS, J.P., J. Ind. Eng. Chem., 1921, 13, 775.
4. MORRIS, V.N., and REYERSON, L.H., J. Phys. Chem., 1927, 31, 1332.
5. YOSHIKAWA, K., Bull, Chem. Soc. Japan, 1932, 7, 201.
6. ACKERMANN, P., Brenstoff-Chem., 1937, 18, 357.
7. FISCHER, M. and KNORR, C.A., Z. Elektrochem., 1937, 43, 608.
8. FARKAS A. and FARKAS, L., J. Am. Chem. Soc., 1939, 61, 3396.
9. CREMER, E., KNORR, C.A., and PLIENINGER, H., Z. Electrochem., 1941, 47, 737.
10. SHERIDAN, J., J. Chem. Soc., 1944, 373.
11. SHERIDAN, J., J. Chem. Soc., 1945, 133.
12. SHERIDAN, J., J. Chem. Soc., 1945, 301.
13. SHERIDAN, J., J. Chem. Soc., 1945, 305.
14. SHERIDAN, J., J. Chem. Soc., 1945, 470.
15. BOND, G.C., and WELLS, P.B., Adv. Catalysis, 1964, 15, 171.
16. JENKINS, G.I., and RIDEAL, E., J. Chem. Soc., 1955, 2490.
17. BEECK, O., SMITH, A.E., and WHEELER, A., Proc. R. Soc. Lond. A., 1940, 177, 62.
18. PICKERING, H.L. and ECKSTROM, H.C., J. Phys. Chem., 1959, 63, 512.
19. BEECK, O., Discuss. Faraday Soc., 1950, 8, 118.
20. SELWOOD, P.W., J. Am. Chem. Soc., 1961, 83, 2853
21. STEPHENS, S.J., J. Phys. Chem., 1958, 62, 714.
22. CORMACK, D., THOMSON, S.J., and WEBB, G., J. Catalysis, 1966, 5, 224.
23. LITTLE, L.H., 'Infra-red spectra of adsorbed species', Academic Press, London and New York, 1966.
24. MORROW, B.A. and SHEPPARD, N., J. Phys. Chem., 1966, 70, 2406.
25. SHEPPARD, N., Discuss, Faraday Soc., 1966, 41, 177.

26. MORROW, B.A., and SHEPPARD, N., Proc. R. Soc. Lond. A., 1969, 311, 391.
27. TAYLOR, G., THOMSON, S.J. and WEBB, G., J. Catalysis, 1968, 12, 150.
28. BOND G.C. and WELLS, P.B., J. Catalysis, 1965, 4, 211.
29. BOND, G.C., and WELLS, P.B., J. Catalysis, 1966, 5, 65.
30. LITTLE, L.H., SHEPPARD, N. and YATES, D.J.C., Proc. R. Soc. Lond. A., 1960, 249, 242.
31. SHEPPARD, N. and WARD, J.W., J. Catalysis, 1969, 15, 50.
32. SOKOLOVA, N.P., KAZAKOVA, L.A. and BORISENKO, L.A., Russ. J. Phys., Chem., 1970, 44, 1515.
33. RANDHAVA, S.S. and REHMAT, A., Trans. Faraday Soc., 1970, 66, 235.
34. INOUE, Y. and YASUMORI, I., J. Phys. Chem., 1969, 73, 1618.
35. ROONEY, J., J. Catalysis, 1963, 2, 53.
36. ROONEY, J. and WEBB, G., J. Catalysis, 1964, 3, 488.
37. MIGNOLET, J.C.P., Discuss. Faraday. Soc., 1950, 8, 105.
38. SCHUIT, G.C.A., and VAN REIJEN, L.L., Adv. Catalysis, 1959, 10, 242.
39. BOND, G.C., 'Catalysis by Metals', Academic Press London and New York, 1962.
40. POLANYI M. and HORTIUTI, J., Trans Faraday, Soc., 1934, 30, 1164.
41. TWIGG, G.H., Discussions Faraday Soc., 1950, 8, 152.
42. BOND, G.C., and TURKEVICH, J., Trans. Faraday Soc., 1953, 49, 281.
43. BOND, G.C., Trans. Faraday Soc., 1956, 52, 1235.
44. BOND, G.C., PHILLIPSON, J.J., WELLS, P.B., and WINTERBOTTOM, J.M., Trans. Faraday Soc., 1966, 62, 443.
45. TAMARU, K., Bull. Chem. Soc., Japan, 1950, 23, 64.
46. SHERIDAN, J. and REID, W.D., J. Chem. Soc., 1952, 2962.
47. BOND, G.C., and SHERIDAN, J., Trans Faraday Soc., 1952, 48, 651.
48. BOND, G.C., DOWDEN, D.A., and MACKENZIE, N., Trans Faraday Soc., 1958, 54, 1537.
49. BOND, G.C., J. Chem. Soc., 1958, 2705.

50. BOND, G.C., and MANN, R.S., J. Chem. Soc., 1959, 3566; 4738.
51. DOUGLAS, J.E., and RABINOVITCH, B.S., J. Am. Chem. Soc., 1952, 74, 2486.
52. BOND, G.C., and WELLS, P.B., J. Catalysis, 1966, 6, 397.
53. BOND G.C., WEBB, G and WELLS, P.B., J. Catalysis, 1968, 12, 157.
54. WELLS, P.B., Chem and Ind., 1964, 1742.
55. WELLS, P.B., Surface and Defect Properties of Solids, 1972, 1, 236.
56. BOND, G.C., and WELLS, P.B., J. Catalysis, 1966, 5, 419.
57. MANN, R.S., and TO, D.E., Canad. J. Chem., 1968, 46, 161.
58. MANN, R.S., and TIU, D.E., Canad. J. Chem., 1968, 46, 3249.
59. MANN, R.S., and NAIK, S.C., Canad. J. Chem., 1967, 45, 1023.
60. MANN, R.S., and KHULBE, K.C., J. Catalysis, 1968, 10, 401; 1969, 13, 25.
61. WEBB, G. and WELLS, P.B., Trans. Faraday Soc., 1965, 61, 1232.
62. PHILLIPSON, J.J., WELLS, P.B., and WILSON, G.R., J. Chem. Soc., 1969, 1351.
63. BOND, G.C., WEBB, G., WELLS, P.B., and WINTERBOTTOM, J.M., J. Chem. Soc., 1965, 3218.
64. BOND, G.C., and WELLS, P.B., Actes Deuxieme Congr. Int. Catalyse, Paris, 1960, (Technip, Paris, 1961), 1159.
65. KARANTH, N.G., and LUSS, D., Chem. Eng. Sci., 1975, 30, 695.
66. WHEELER, A., Adv. Catalysis, 1951, 3, 250.
67. MARS, P. and GORGELS, M.J., Proc. 3rd European Symposium on Chemical Reaction Engineering, 1964, 55.
68. JAMES, J.L., and GREENWAY, D., Sixth World Petroleum Congress, Frankfurt, 1963, Section IV, paper 16.
69. ANDERSON, H.C., HALEY, A.J. and EGBERT, W., Ind Eng. Chem., 1960, 52, 901.
70. KILPATRICK, J.E., PROSEN, E.J., PITZER, K.S., and ROSSINI, F.D., J. Research Natl. Bur. Standards, 1946, 36, 359.
71. DOWIE, R.S., Ph.D, Thesis, University of Edinburgh, 1973.

72. DOWIE, R.S., KEMBALL, C., KEMPLING, J.C., and WHAN, D.A., Proc. R. Soc. Lond. A., 1972, 327, 491.
73. KEMBALL, C., NISBET, J.D., ROBERTSON, P.J., and SCURRELL, M.S., Proc. R. Soc. Lond. A., 1974, 338, 299.
74. WATSON, J.T. and BIEMANN, K., Anal. Chem., 1964, 36, 1135.
75. MS20 Series Instruction Manual, Associated Electrical Industries Ltd.
76. ROBERTSON, P.J., Ph.D. Thesis, University of Edinburgh, 1976.
77. BRISK, M.L., DAY, R.L., JONES, M. and WARREN, J.B., Trans Instn. Chem. Engrs., 1968, 46, T3.
78. CARBERRY, J.J., and GILLESPIE, B.M., Ind Eng. Chem., 1966, 58, 164.
79. DOWIE, R.S., 'Computer Programs for Catalytic Studies', Chemistry Department, University of Edinburgh, 1973.
80. RALSTON, A. 'A First Course in Numerical Analysis', McGraw-Hill, New York, 1965.
81. DOWIE, R.S., WHAN, D.A. and KEMBALL, C., J.C.S. Faraday I, 1972, 68, 2150
82. WEINBERG, W.H., DEANS, H.A. and MERRILL, R.P., Surf. Sci., 1974, 41, 312.
83. LANGMUIR, I., J. Am. Chem. Soc., 1915, 37, 417.
84. LANGMUIR, I., J. Am. Chem. Soc., 1916, 38, 2221.
85. LANGMUIR, I., J. Am. Chem. Soc., 1918, 40, 1361.
86. LANGMUIR, I., Trans. Faraday Soc., 1922, 17, 621.
87. TRAPNELL, B.M.W., Proc. Roy. Soc. Lond. A., 1953, 218, 566.
88. WHEELER, A., Adv. Catalysis, 1951, 3, 265
89. TAKEUCHI, A., TANAKA, K., and MIYAHARA, K., Chem. Letters, Chem. Soc. Japan, 1974, 171
90. TAKEUCHI, A., TANAKA, K., and MIYAHARA, K., Chem. Letters, Chem. Soc. Japan, 1974, 411.
91. HALLIDAY, M.M., Ph.D. Thesis, University of Edinburgh, 1975.
92. KABE, T., and YASUMORI, I., Nippon Kagaku Zasshi, 1965, 86, 385.

93. HERINGTON, E.F.G., Trans. Faraday Soc., 1941, 37, 361.
94. WEAST, R.C., 'Handbook of Chemistry and Physics', C.R.C. Press, Cleveland, Ohio, 1974.
95. WELLS, P.B., Private Communication.
96. ROBERTSON, P.J., Unpublished Results.
97. KEMBALL, C., J. Chem. Soc., 1956, 735.
98. SERMON, P.A. and BOND, G.C., Catalysis Reviews, 1973, 8(2), 211.
99. BENSON, J.E., KOHN, H.W., and BOUDART, M., J. Catalysis, 1966, 5, 307.
100. ALTHAM, J.A., and WEBB, G., J. Catalysis, 1970, 18, 133.
101. TAYLOR, G.F., THOMSON, S.J., and WEBB, G., J. Catalysis, 1968, 12, 191.
102. WEBB, G. and MACNAB, J.I., J. Catalysis, 1972, 26, 226.
103. MANN, R.S., and SAFO, S.Y., Chem. Eng. Prog. Symp. Ser., 1969, 65, 71.
104. DOWDEN, D.A., Private Communication.
105. SATTERFIELD, C.N., and SHERWOOD, T.K. "Role of Diffusion in Catalysis", Addison-Wesley, Reading, England, 1963.
106. SMITH, W.B., and MASSINGILL, J.L., J. Amer. Chem. Soc., 1961, 83, 4301.
107. BORODZINSKI, A., DUS, R., FRAK, R., JANKO, A., and PALCZEWSKA, W., Proc. 6th Int. Cong. on Catalysis., London, 1976.
108. WICKE, E., and NERNST G., Ber. Bunsen. Physik. Chem., 1964, 68, 224.

Hydrogenation of Acetylene in Excess Ethylene on an Alumina Supported Palladium Catalyst in a Static System

BY WILLIAM T. MCGOWN, CHARLES KEMBALL, DAVID A. WHAN*
AND (IN PART) MICHAEL S. SCURRELL

Department of Chemistry, University of Edinburgh,
West Mains Road, Edinburgh EH9 3JJ

Received 22nd March, 1976

Studies have been made of the kinetics of the hydrogenation of mixtures containing 2 % of acetylene in ethylene on an alumina supported palladium catalyst in a static system. Information has been obtained about the nature of the selectivity of the reaction of acetylene. Detailed analyses of the kinetics have been made as the ratio of the pressure of acetylene to ethylene decreases and subsequently as the remaining hydrogen is used up.

The poisoning action of carbon monoxide, which selectively inhibits the hydrogenation of ethylene, has also been studied.

Tracer studies using carbon-13 labelled acetylene, light ethylene and hydrogen with analysis by combined gas chromatography-mass spectrometry, have shown unambiguously that ethane produced from the hydrogenation of a mixture of acetylene in ethylene comes predominantly from the ethylene.

The reaction between acetylene, ethylene and deuterium gives a greater understanding of the surface processes involved and produces ethane which is mainly [²H₂]ethane.

It is postulated that two types of site exist on the surface, type X which hydrogenates both acetylene and ethylene and on which acetylene is adsorbed ~2200 times more strongly than ethylene at 293 K and type Y which is easily poisoned by carbon monoxide and can hydrogenate ethylene even in the presence of acetylene.

The selective hydrogenation of the small amounts of acetylene present in streams of ethylene from naphtha crackers is of commercial importance, especially in the purification of ethylene to be used for the manufacture of polythene, where acetylene quantitatively destroys the polymerization catalyst. The majority of work on acetylene hydrogenation has been carried out with acetylene as the sole initial hydrocarbon¹⁻⁵ and is thus removed from the industrial situation.

Palladium is known to be active for the hydrogenation of acetylene at room temperature² and is also highly active for the hydrogenation of ethylene to ethane. The nature of the selectivity for acetylene hydrogenation in the presence of a large excess of ethylene is not clearly understood. The aim of this work was to examine, using detailed kinetic studies, the reason for the selectivity and the factors influencing it.

The presence of carbon monoxide increases the selectivity⁶ of the reaction but its manner of action is not known with certainty and is also examined here.

In this paper we also report tracer studies involving carbon-13 labelled acetylene and deuterium used to investigate the mechanism of the reaction. Previous work involving the reaction of acetylene with deuterium on platinum foil by Farkas and Farkas⁷ showed that no deuterated acetylene was produced. Douglas and Rabinovitch⁸ also used catalytic hydrogenation over palladium and nickel in an attempt to prepare [²H₂]cis-ethylene but the product was a mixture of all possible deuterioethylenes. More recently Bond and Wells⁹ reacted acetylene with deuterium

over α -alumina supported rhodium, iridium, platinum and palladium and again reported no acetylene exchange. They found that [$^2\text{H}_2$]ethylene was the most abundant ethylene isomer but did not analyse the deuterium content of the ethanes which were produced. A succeeding paper reported very rapid exchange between acetylene and deuterium on ruthenium and osmium supported on γ -alumina.¹⁰

This work differs from past investigations because of the initial presence of excess ethylene; this more clearly resembles the situation found in industrial ethylene purification plants where traces of acetylene are hydrogenated, preferably with minimum ethane production.

EXPERIMENTAL

The catalyst used was type 38-3 (I.C.I., Agricultural Division) and consisted of 0.04 % palladium on pellets (5.4 mm \times 5 mm) of a transitional alumina.

The total surface area of the catalyst was 90 m² g⁻¹ and the metal surface area, as determined by carbon monoxide adsorption, was 160 m² g⁻¹ of palladium. Impregnation of the support with the solution containing palladium was carried out in such a manner that the bulk of the palladium was deposited near the outside of the pellets.

Matheson C.P. grade hydrocarbon gases were used and, where appropriate, distilled under reduced pressure the middle third being retained. Hydrogen (B.O.C.) was purified by diffusion through a heated palladium-silver alloy thimble. Carbon monoxide for use in poisoning experiments was obtained from I.C.I. as a 3 % mixture in hydrogen and was purified by passage through a liquid nitrogen trap. In poisoning experiments at higher concentrations of carbon monoxide, Matheson C.P. grade carbon monoxide was used after similar purification.

All non tracer experiments were conducted in a Pyrex reaction vessel (200 cm³) connected by an evacuable gas sampling valve to an F11 gas chromatograph fitted with a flame ionization detector. Analyses were carried out using either a 2 m column of 3 % squalane on alumina followed by a 0.75 m column of silica gel or a 2 m column of silica gel held at 333 K. Peak areas were integrated using a Hewlett Packard 3373 B integrator.

The majority of reactions was carried out on fresh samples of catalyst (0.35 g) which were activated by evacuation, followed by two successive reductions in 13.3 kN m⁻² of hydrogen at 473 K for a total of 17 h, and pumping at 473 K for 30 min prior to admission of the reactants. Some experiments, as indicated in the text, were performed on catalysts which had previously been used, the catalyst being pumped at 473 K for 30 min between runs.

The normal reaction mixture for kinetic measurements consisted of 19.6 kN m⁻² of ethylene, 0.4 kN m⁻² of acetylene and 0.8 kN m⁻² of hydrogen. This gave a mixture of 2 % acetylene in ethylene having a hydrogen to acetylene ratio of 2 : 1. The mixture was expanded from the mixing volume (126 cm³) to the reaction vessel giving a total pressure of 7.3 kN m⁻² in the reaction vessel. The composition of the contents of the reaction vessel was determined immediately on admission of the reactants and at appropriate intervals thereafter.

For experiments with labelled molecules, carbon-13 labelled acetylene (B.O.C.) of composition 84.3 % $\text{H}^{13}\text{C}\equiv^{13}\text{CH}$, and 15.0 % $\text{H}^{13}\text{C}\equiv^{12}\text{CH}$, was purified by a freeze-pump-thaw cycle at 77 K. Deuterium (Matheson) was purified by diffusion through a heated palladium-silver alloy thimble. Reaction mixture analysis, using combined gas chromatography-mass spectrometry (GC-MS) coupled with an "on-line" PDP-11 computer for data processing was that employed by Kemball *et al.*¹¹ Separation of the hydrocarbons was provided by a Perkin-Elmer F11 gas chromatograph fitted with a 2 m column of silica gel maintained at 363 K; helium was used as a carrier gas.

To examine the ethane produced by GC-MS the initial proportion of acetylene present was increased to 10-20 %. This was necessary to produce sufficient ethane to reduce background error in the ethane peaks of the mass spectrometer.

Three types of experiments involving tracers were carried out. (I) Mixtures containing carbon-13 labelled acetylene in ethylene were reacted over 0.54 g of catalyst at 293 K. The reaction mixtures consisted of 4.00 kN m⁻² acetylene, 16.00 kN m⁻² ethylene and 8.00 kN m⁻²

hydrogen. On expansion from the mixing volume this gave a pressure in the reaction vessel of 9.76 kN m^{-2} . (II) Mixtures of acetylene in ethylene were reacted over 0.58 g of catalyst at 313 K . The reaction mixtures consisted of 2.40 kN m^{-2} acetylene, 17.60 kN m^{-2} ethylene and 4.80 kN m^{-2} deuterium giving a pressure in the reaction vessel of 8.64 kN m^{-2} . (III) Experiments were carried out involving the reaction of deuterium and acetylene mixtures over 0.54 g of alumina support at 293 and 313 K . The reaction mixture consisted of 4.00 kN m^{-2} acetylene and 8.00 kN m^{-2} deuterium giving a pressure in the reaction vessel of 4.48 kN m^{-2} . After carrying out a reaction at 293 K , the reaction vessel was evacuated for 15 min at 473 K and the reaction was repeated at 313 K .

Fragmentation factors were found by analysing equal quantities (1.33 kN m^{-2} in the mixing volume) of ethane, ethylene and acetylene by GC-MS. In experiments II and III allowance was made for natural isotope occurrence as well as for background but in I no allowance for natural isotopes was made since non-natural acetylene was used.

RESULTS

KINETICS MEASUREMENTS

The general characteristics of a typical reaction are illustrated in fig. 1 where amounts of acetylene, ethylene and ethane are presented as percentages of the total gas phase hydrocarbon as a function of time at 293 K . Four distinct behavioural regions can be identified.

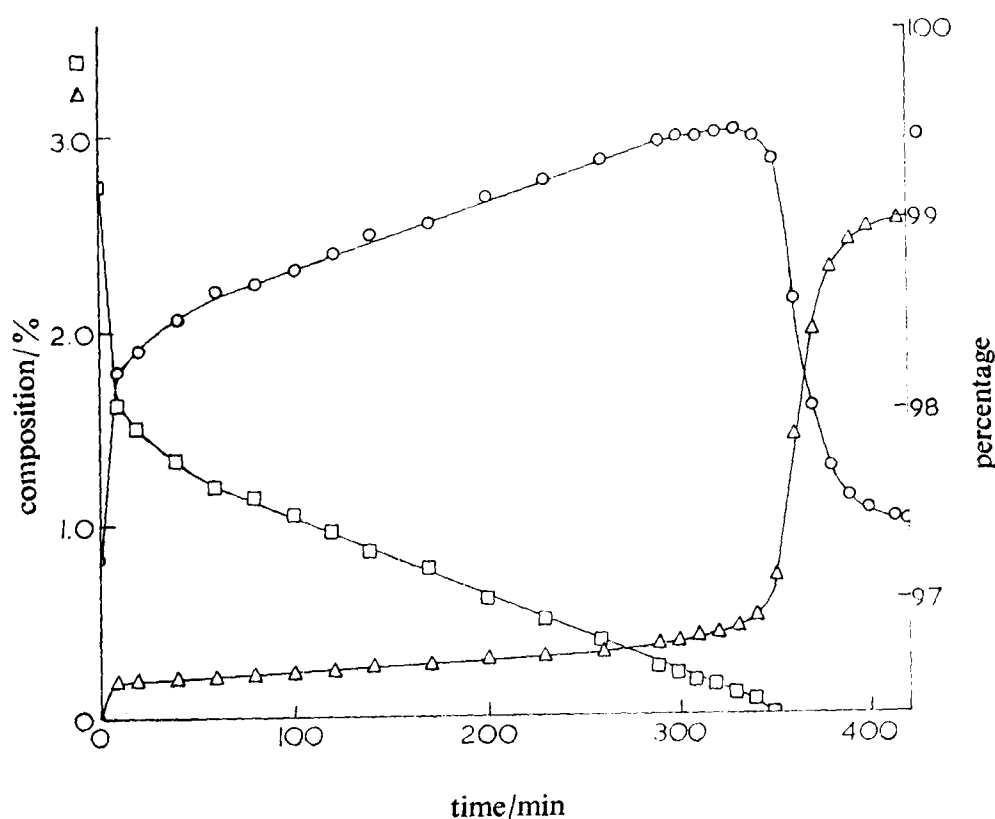

FIG. 1.—Variation in composition of gas phase hydrocarbon with time for a second reaction on a sample of catalyst at 293 K . \square , acetylene; \circ , ethylene; \triangle , ethane.

A. An initial rapid process, extending from the admission of reactants to $\sim 10 \text{ min}$ in fig. 1, during which the amount of acetylene in the gas phase diminishes and the percentages of ethylene and ethane increase.

B. A region, ~ 30 to $\sim 250 \text{ min}$ in fig. 1, where the rate of acetylene hydrogenation is constant, as are the rates of production of ethylene and ethane.

C. A region, ~ 250 to ~ 355 min in fig. 1, where the rate of production of ethylene decreases as the acetylene pressure approaches zero. The onset of region C corresponds to the point referred to by Bond *et al.*⁵ as the onset of the premature breakdown of selectivity.

D. A region, > 360 min in fig. 1, in which the rate of production of ethane falls off until all available hydrogen has been consumed.

REGION A

In the initial stages up to 40 % of the acetylene was removed from the gas phase in the first ten minutes of reaction and this fraction did not vary as the $H_2 : C_2H_2$ ratio was changed. The ethane produced during this period, which amounted to up to 0.2 % of the gas phase hydrocarbon, did not vary significantly over the temperature range 293-323 K. The rapid initial reaction was observed, although generally to a lesser extent, on catalysts which had been merely evacuated following a previous reaction as well as on freshly reduced catalysts.

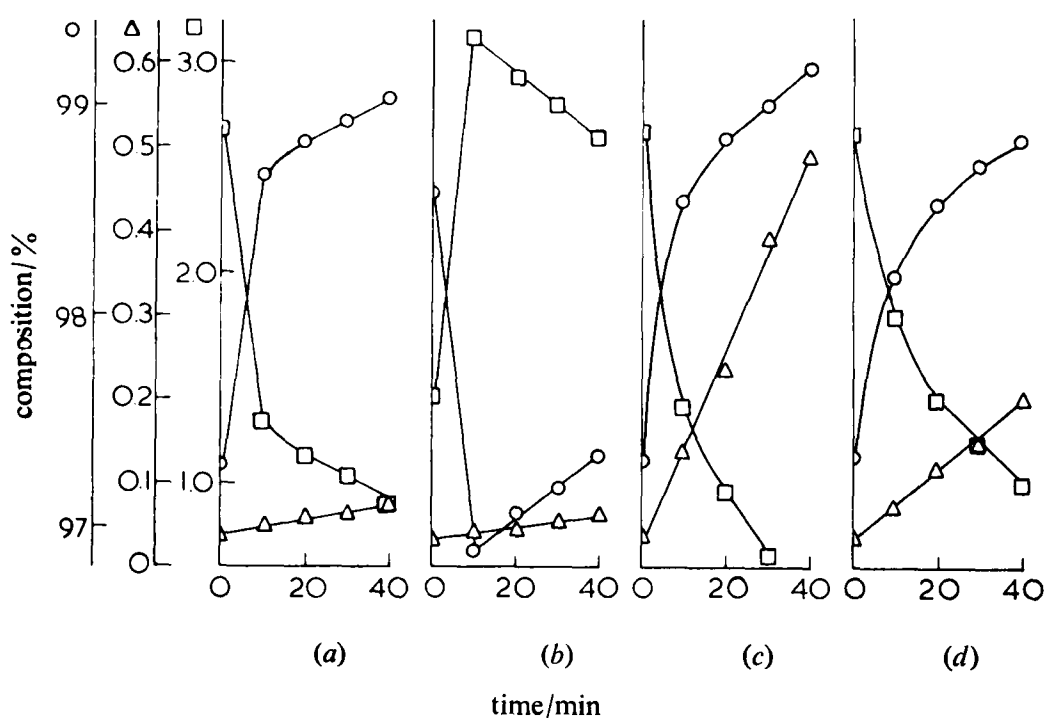

FIG. 2.—Effect of presorbed reactants on the initial stage of reaction at 293 K. Symbols as in fig. 1. (a) 1.2 kN m^{-2} of ethylene presorbed, (b) 0.13 kN m^{-2} of acetylene presorbed, (c) 0.27 kN m^{-2} of hydrogen presorbed, (d) all gases admitted simultaneously.

To investigate whether the initial fast stage was influenced by the order of admission of reactants, a series of experiments was conducted on a sample of catalyst in which the catalyst was first dosed with one of the reactants or products prior to admission of the remaining constituents of a normal reaction mixture. The results are illustrated in fig. 2. Between each run the catalyst was evacuated at 473 K for 30 min. The prior admission of ethylene had little effect on the characteristics of the reaction [*cf.* fig. 2(a) and (d)] whilst the prior admission of hydrogen resulted in a much greater rate of production of ethane [*cf.* fig. 2(c) and (d)]. Fig. 2(b) shows that when the surface is pretreated with acetylene the percentage of acetylene in the gas phase appears to increase on admission of the remaining reactants.

REGION B

Experiments were conducted in which different pressures of hydrogen were used for each reaction, the catalyst sample being evacuated at 473 K between runs. Results are expressed in table 1.

TABLE 1.—VARIATION OF RATES ^a OF PRODUCTION OF ETHYLENE AND ETHANE WITH INITIAL HYDROGEN/ACETYLENE RATIO

temperature/K	P_{H_2}/P_3	ethylene formation $R_2/10^3$ % min ⁻¹	ethane formation $R_1/10^3$ % min ⁻¹	S
293 ^b	2	9.03	3.79	2.4
293	1	4.60	0.48	9.6
293	8	33.70	14.70	2.3
293	4	14.90	7.68	1.9
293	2	9.47	3.27	2.9
293 ^c	2	3.50	0.22	15.9
323	2	15.63	0.82	19.1
293	8	11.01	1.06	10.4
292	1	1.18	0.06	19.7

^a rates expressed in terms of percentages of total gas phase hydrocarbon; ^b reactions on a single sample of catalyst evacuated at 473 K for 30 min between runs; ^c reactions on freshly reduced catalysts.

The selectivity of the hydrogenation of acetylene may be expressed in terms of the ratio of the rate of formation of ethylene, R_2 , to the rate of formation of ethane, R_1

$$S = R_2/R_1.$$

S decreased with repeated use of a sample of catalyst, typically from 15 to 20 for a fresh catalyst to 2 or 3 for a catalyst being used for the fourth time at 293 K, but did not depend on whether a catalyst was treated with hydrogen or simply evacuated between runs. The experiment illustrated in fig. 1, the second experiment on a sample of catalyst, had an S value of 7.3 in region B compared with a value of 16.8 for the first experiment. The dependence of S for freshly reduced catalysts on the ratio of hydrogen pressure, P_{H_2} , to acetylene pressure, P_3 , is also shown in table 1.

Measurements of the rate of disappearance of acetylene, R_3 , at temperatures between 273 and 323 K, showed that the reaction rate could be expressed as $R_3/\text{molecules s}^{-1} \text{ m}^{-2} = 1.27 \times 10^{21} \exp(-46.8 \times 10^3/RT)$ where R is in $\text{J K}^{-1} \text{ mol}^{-1}$.

In industrial service it is known that supported palladium catalysts cause the formation of butenes and higher molecular weight compounds. No such hydrocarbons were detected in our experiments, probably because of the much lower pressures used.

REGION C

At acetylene to ethylene ratios below about 4×10^{-3} the rate of production of ethane increased and the rate of production of ethylene diminished with falling acetylene pressure. Although not particularly apparent in fig. 1, it has been repeatedly observed that R_3 increases as the acetylene pressure falls in the portion of an experiment where acetylene is <0.1 % of the total gas phase hydrocarbon.

REGION D

After complete removal of acetylene the hydrogenation of ethylene was rapid and found to be first order in hydrogen. The rate of reaction of ethylene in this

region was not significantly influenced by temperature between 293 and 323 K, the rate constant having a value of 10^{-1} min^{-1} .

EXPERIMENTS WITH ADDED CARBON MONOXIDE

The presence of carbon monoxide reduced reaction rates to an extent which necessitated raising the standard reaction temperature from 293 to 323 K. Table 2 shows the effect of added carbon monoxide on the amount of acetylene removed and ethane formed during the first ten minutes of reaction, region A. Carbon monoxide has a much more severe effect on the rate of production of ethane than on the rate of removal of acetylene.

TABLE 2.—EFFECT OF ADDED CARBON MONOXIDE ON REGIONS A AND B

temperature /K	concentration of carbon monoxide /p.p.m.	REGION A		REGION B		S
		decrease in acetylene/% in first 10 min	increase in ethane/% in first 10 min	ethylene formation $R_2/10^4 \text{ \% min}^{-1} \text{ g}^{-1}$	ethane formation $R_1/10^4 \text{ \% min}^{-1} \text{ g}^{-1}$	
323	0	0.95	0.114	4.42	23.2	19.1
323	578	0.74	0.002	3.63	10.6	34.2
323	1155	0.66	0.032	1.34	2.77	48.5
343	5000	0.55	0.006	1.06	<0.15	>707

The influence of carbon monoxide on region B is also presented in table 2. It is seen that the rate of production of ethylene falls with increasing concentration of carbon monoxide to a lesser extent than the rate of ethane formation. The consequent increase in *S* is also quoted in table 2.

In region B the rate of hydrogenation of acetylene in the presence of 1155 p.p.m. of carbon monoxide could be expressed as

$$R_3 = 4.66 \times 10^{20} \exp(-45.4 \times 10^3/RT)$$

where the rate is expressed as molecules $\text{s}^{-1} \text{ m}^{-2}$ and *R* is in $\text{J K}^{-1} \text{ mol}^{-1}$.

TABLE 3.—EFFECT OF CARBON MONOXIDE ON THE HYDROGENATION OF ETHYLENE IN THE ABSENCE OF ACETYLENE AT 413 K

concentration of carbon monoxide/ p.p.m.	$10^3 R_1/\text{\% min}^{-1a}$	order in sequence of runs
1000	10.5	4
2000	9.2	1
2000	8.8	5
5000	5.6	3
10 000	2.8	6
20 000	2.6	2
0	11 800 ^b	—
0	100 ^c	—

^a rate of production of ethane expressed in terms of total hydrocarbon at a hydrogen concentration equivalent to 1 % total hydrocarbon; ^b extrapolated from 293 K with an activation energy ¹² of 40 kJ mol^{-1} ; ^c diffusion controlled rate at 293 K.

Amounts of carbon monoxide < 578 p.p.m. had little effect on the rate of acetylene removal in region C or the rate of hydrogenation of ethylene in region D. Levels of carbon monoxide > 1155 p.p.m. resulted in a very slow rate of production of ethane after the acetylene had been removed from the system.

Experiments were carried out to investigate the effect of carbon monoxide on the hydrogenation of ethylene in systems where acetylene was absent. In these reactions,

mixtures of 2 % hydrogen in ethylene were reacted in the presence of varying amounts of carbon monoxide at 413 K. The rates of hydrogenation of ethylene are quoted in table 3 for experiments carried out on the same sample of catalyst which was evacuated at 473 K between runs.

Experiments were performed to investigate the removal of carbon monoxide by evacuation of the catalyst at various temperatures. It was found that evacuation at 373 K for 30 min restored the original activity whereas evacuation at 323 K did not.

TRACER STUDIES

The ethane composition as a function of time in a typical experiment of type I is shown in fig. 3, where it can be observed that the rate of formation of $\text{H}_3^{12}\text{C}-^{12}\text{CH}_3$ is six times that of the rate of formation of $\text{H}_3^{13}\text{C}-^{13}\text{CH}_3$ in the steady region of ethane production, *i.e.* before the disappearance of acetylene at ~ 120 min. During the initial 18 min of reaction there was a loss of 3.1 % of $^{13}\text{C}-^{13}\text{C}$ skeletons (expressed as a percentage of total gas phase hydrocarbon) from the gas phase. As the reaction proceeded a further 2.3 % of $^{13}\text{C}-^{13}\text{C}$ skeletons were removed from the gas phase without forming gaseous products.

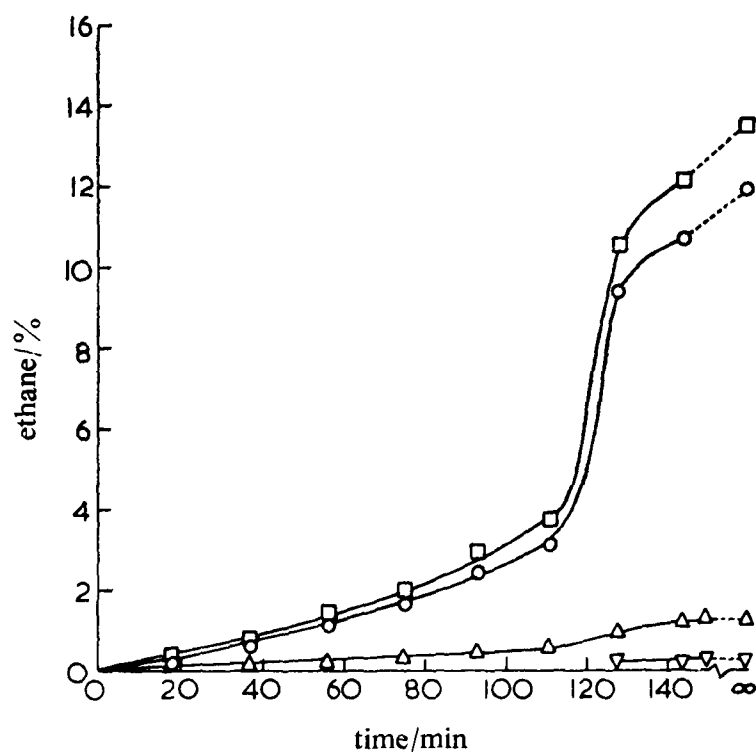

FIG. 3.—Variation in composition of ethane in experiment I with time at 293 K. \square , total ethane; \circ , $\text{H}_3^{12}\text{C}-^{12}\text{CH}_3$; \triangle , $\text{H}_3^{13}\text{C}-^{13}\text{CH}_3$; ∇ , $\text{H}_3^{13}\text{C}-^{12}\text{CH}_3$.

Fig. 4 shows the composition of the acetylene and the percentage of acetylene, ethylene and ethane present in a type II experiment. Very rapid formation of $[\text{}^2\text{H}_1]$ - and $[\text{}^2\text{H}_2]$ acetylene occurred during the first 18 min of reaction.

Fig. 5 illustrates the incorporation of deuterium into the ethane produced in experiment II. In the presence of acetylene, *i.e.*, until 145 min, the majority of the ethane was $[\text{}^2\text{H}_2]$ ethane with some $[\text{}^2\text{H}_1]$ ethane. There was no production of $[\text{}^2\text{H}_0]$ ethane until the acetylene had disappeared; after disappearance of the acetylene there was appreciable formation of $[\text{}^2\text{H}_0]$ -, $[\text{}^2\text{H}_1]$ - and $[\text{}^2\text{H}_2]$ ethane.

The mean deuterium numbers of reactants and products in experiment II are shown in fig. 6 as a function of time. The acetylene rapidly attained a deuterium

number of 1.0 and then more deuterium was slowly incorporated as the reaction continued. Ethylene exchange became important as the acetylene concentration fell and the deuterium number of the ethylene rose rapidly after disappearance of the acetylene. Any ethane produced had a mean deuterium number of 2.0; this rapidly dropped to 1.3 at the point when all the acetylene had been consumed.

The change in acetylene composition with time in experiments of type III is shown in fig. 7. There was a fast initial exchange, producing $[^2\text{H}_1]$ acetylene with a little

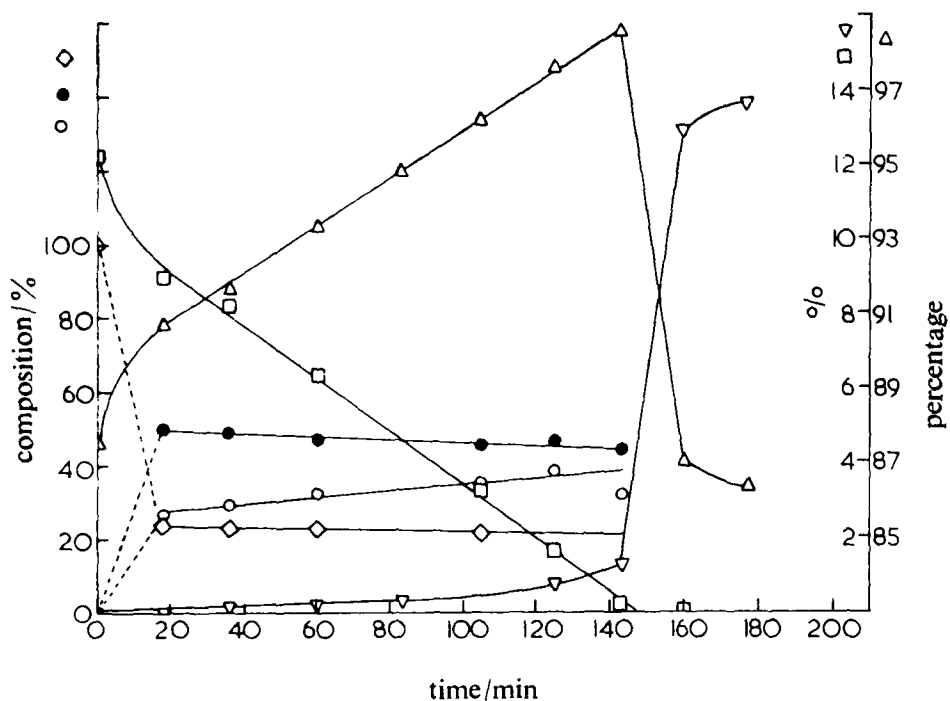

FIG. 4.—Variation in composition of acetylene and the percentages of acetylene, ethylene and ethane present in experiment II with time at 313 K. \diamond , $[^2\text{H}_0]$ acetylene; \bullet , $[^2\text{H}_1]$ acetylene; \circ , $[^2\text{H}_2]$ acetylene; expressed as percentages of total acetylene. \square , acetylene; \triangle , ethylene; ∇ , ethane; expressed as percentages of total gas phase hydrocarbon.

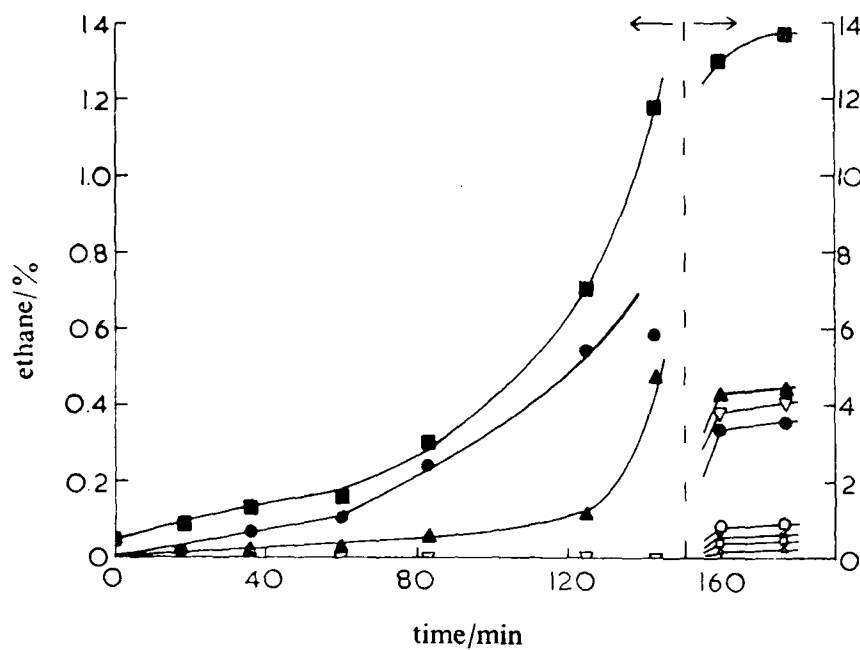

FIG. 5.—Variation in composition of ethane in experiment II with time at 313 K. \blacksquare , total ethane; ∇ , $[^2\text{H}_0]$ ethane; \blacktriangle , $[^2\text{H}_1]$ ethane; \bullet , $[^2\text{H}_2]$ ethane; \circ , $[^2\text{H}_3]$ ethane; \square , $[^2\text{H}_4]$ ethane; \triangle , $[^2\text{H}_5]$ ethane; \times , $[^2\text{H}_6]$ ethane.

HYDROGENATION OF ACETYLENE

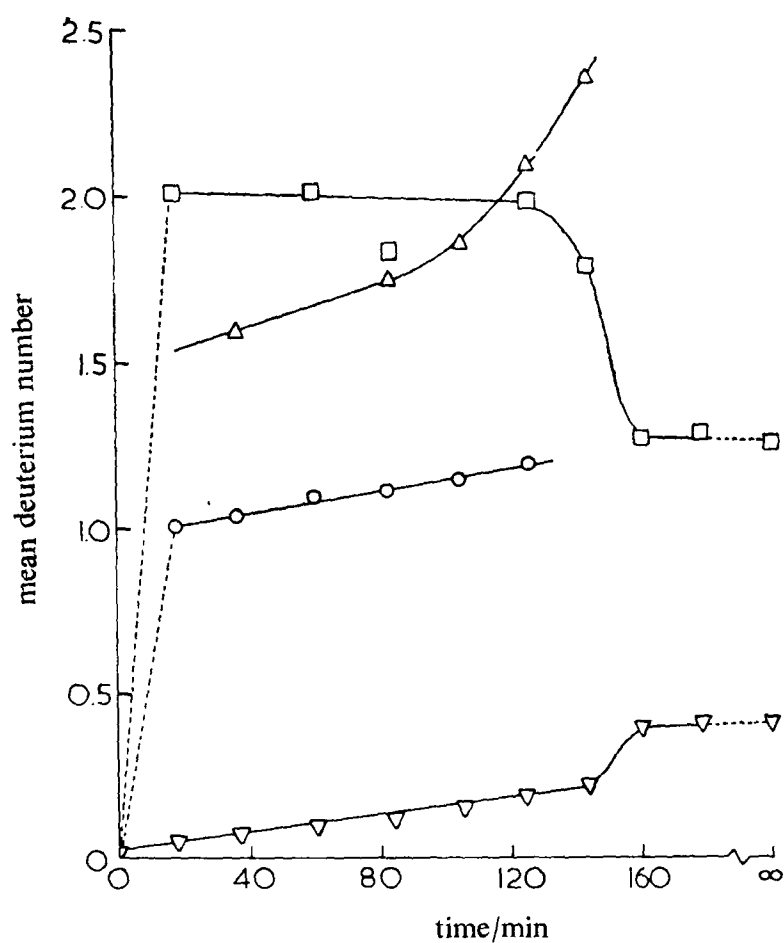

FIG. 6.—Variation in the mean deuterium numbers of reactants and products in experiment II with time at 313 K. \circ , C₂X₂; ∇ , C₂X₄ (total); Δ , C₂X₄ produced after initial fast stage; \square , C₂X₆.

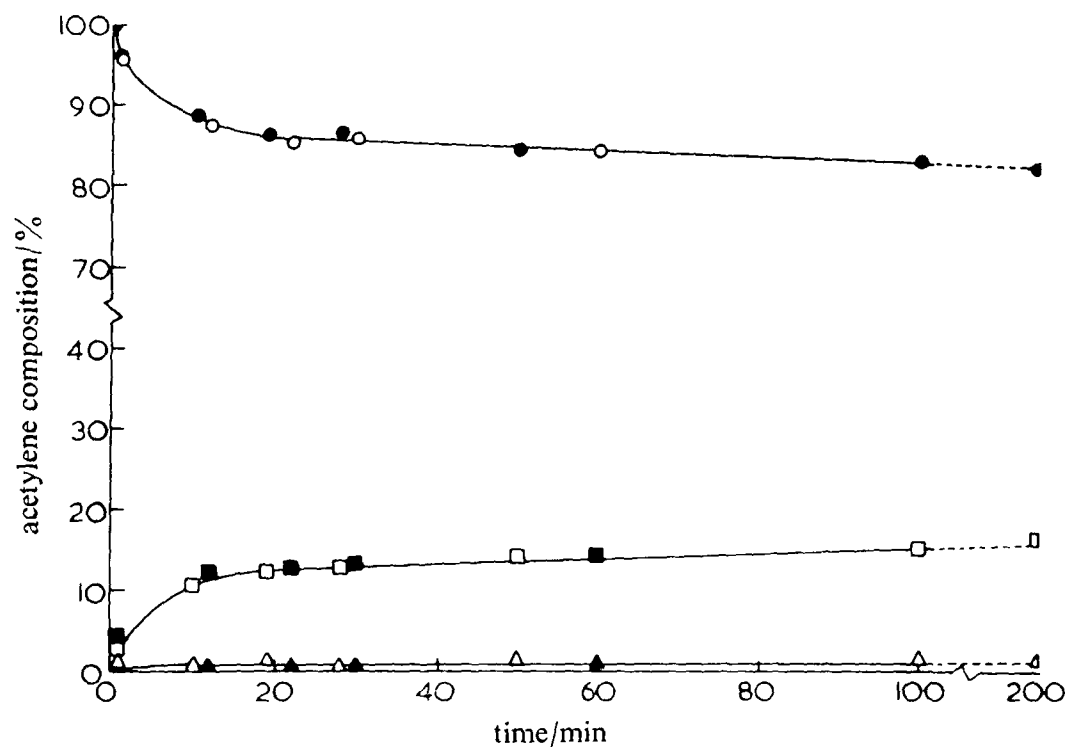

FIG. 7.—Variation in composition of acetylene in experiment III with time at 293 K and 313 K. \bullet , [²H₀]acetylene; \square , [²H₁]acetylene; Δ , [²H₂]acetylene; all at 293 K. \circ , [²H₀]acetylene; \blacksquare , [²H₁]acetylene; \blacktriangle , [²H₂]acetylene; all at 313 K.

$[^2\text{H}_2]$ acetylene, which was virtually complete after 12 min. There then followed a very slow exchange lasting for >200 min. Evacuation at 473 K followed by the introduction of a new reaction mixture at 313 K gave no apparent increase in rate over that observed at 293 K. Only acetylene was detected in the gas phase so no hydrogenation occurred on the support at 293 or 313 K.

An experiment of type I at 313 K with 2500 p.p.m. carbon monoxide added produced much less ethane than in the absence of carbon monoxide. Examination of the small amount of ethane produced showed that at least 90 % had come from ethylene.

DISCUSSION

The most striking result to emerge from this work is that the carbon-13 tracer studies have unambiguously shown that the majority of ethane produced by the hydrogenation of a mixture of acetylene and ethylene under region B conditions comes predominantly from the ethylene. This is confirmed by the observation that the ethane produced by reaction of ethylene and acetylene with deuterium is mainly the $[^2\text{H}_2]$ product. This finding contrasts markedly with the assumption, normally made when considering alkene + alkyne mixtures, that the surface is fully, or almost fully, covered with alkyne molecules and that any added ethylene behaves as an inert diluent during acetylene hydrogenation on palladium.¹³

We believe that the tracer studies can only be interpreted on the basis of two types of sites on the catalyst, or on two different modes of adsorption of ethylene, and will show that either of these postulates provides an adequate ground for interpreting the results from the kinetics experiments.

Consider first the argument in terms of different types of sites. The first type of site (type X), constituting the majority of sites, is capable of hydrogenating both ethylene and acetylene, but adsorbs acetylene much more strongly than ethylene at 293 K. The observation that ethane is formed from ethylene and not acetylene, despite the fact that acetylene would be expected to exclude ethylene almost completely from the metal,² requires the existence of a second type of site (type Y). Type Y sites must be responsible for the hydrogenation of ethylene in the presence of acetylene and may be assumed to adsorb only ethylene or, alternatively, may adsorb ethylene and acetylene equally well; the second alternative would also manifest itself as preferential ethylene hydrogenation in our system due to the large excess of ethylene present.

Further evidence for the presence of more than one type of site comes from the observations of Bond *et al.*,¹⁴ who found that the ethane produced by the reaction of deuterium with ethylene on alumina supported palladium was almost totally $[^2\text{H}_0]$ and $[^2\text{H}_1]$ at 310 K. In the presence of acetylene we find $[^2\text{H}_2]$ ethane as the predominant product of this hydrogenation. These results may be reconciled, since hydrogenation in the absence of acetylene would occur mostly on the large number of type X sites and could well proceed by a different mechanism from hydrogenation in the presence of acetylene, which must take place on the type Y sites of the catalyst. Fig. 5 shows that after the disappearance of the acetylene production of $[^2\text{H}_0]$ - and $[^2\text{H}_1]$ ethane occurs in agreement with Bond's findings.

Arguments based on the geometry of the adsorbed state¹⁵ have suggested that acetylene is unlikely to be adsorbed on the (111) plane of the face centred cubic metals although ethylene should adsorb with ease on this surface. It is thus possible that (111) faces are those responsible for type Y sites.

The alternative to two different types of site is two different modes of adsorption of the ethylene. The production of $[^2\text{H}_0]$ - and $[^2\text{H}_1]$ ethane during the hydrogenation

of ethylene with deuterium has been attributed to a disproportionation between two ethyl species on the surface.¹⁴ It is possible however that some ethylene may be $\alpha\alpha$ adsorbed analogous to

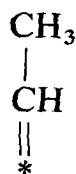

species proposed during butadiene hydrogenation.¹⁶ Such a species might be expected to be adsorbed with a strength comparable with that of acetylene and would yield [²H₂]ethane on reaction with deuterium. In this respect it would be interesting to determine whether the [²H₂]ethane produced is CH₂D—CH₂D or CHD₂—CH₃, but this can not readily be done with the apparatus available to us.

Catalyst selectivity, defined as the ratio of the rates of ethylene production to ethane production may thus be attributed to the relative numbers of the two types of sites and is not thermodynamic² in nature. Thermodynamic selectivity would involve competition between acetylene and ethylene for the same surface sites and would depend on the relative pressures of the two gases; the rate of production of ethane in region B is constant even though the ratio of acetylene to ethylene pressures is reduced by a factor of up to 10 during a reaction. In region B, because of the appreciable quantity of acetylene present in the gas phase, type X sites hydrogenate acetylene in preference to ethylene.

Reaction kinetics in region C, where the rate of production of ethane increases and the rate of production of ethylene diminishes as the acetylene pressure falls, can be explained by assuming that an increasing fraction of the type X sites are becoming covered with ethylene at the expense of acetylene. If it is assumed that the total rate of production of ethane in this region is the sum of the steady rate of ethane production, as observed in region B, plus production due to the continually increasing ethylene coverage, then it should be possible to interpret the latter on the basis of simple Langmuir competition between ethylene and acetylene.

Thus

$$R_1 = R_{1S} + R_{1C} \quad (1)$$

The steady rate, R_{1S} , may be measured directly from region B and subtracted from the rate of ethane formation in region C to give R_{1C} , the rate of ethane production on sites where competition between ethylene and acetylene is possible. If it is assumed that R_{1C} is proportional to the fraction of the surface covered with adsorbed ethylene, θ_2 , and that two hydrogen atoms are required to convert ethylene to ethane then

$$R_{1C} = k \cdot \theta_2 (\theta_H)^2. \quad (2)$$

Applying Langmuir considerations

$$\theta_H = a_H P_{H_2}^{1/2} / X \quad (3)$$

where $X = 1 + a_H P_{H_2}^{1/2} + a_2 P_2 + a_3 P_3$ and a_H , a_2 and a_3 are constants relating to the strengths of adsorption of hydrogen, ethylene and acetylene respectively and the P terms are the corresponding pressures. The equation assumes that competition occurs amongst all three gases for the same sites.

Similarly

$$\theta_2 = a_2 P_2 / X \quad (4)$$

substitution into eqn (2) from (3) and (4) yields

$$R_{1C} = k \cdot a_H^2 \cdot P_{H_2} \cdot a_2 P_2 / X^3. \quad (5)$$

As acetylene and ethylene are more strongly adsorbed on metals than hydrogen it may be assumed that $a_H P_{H_2}^{1/2} \ll 1 \ll a_2 P_2$ and $a_3 P_3$. Therefore

$$R_{1C} = k \cdot a_H^2 P_{H_2} / (a_2 P_2)^2 + (a_3 P_3 / a_2 P_2)^3. \quad (6)$$

For region D, where no acetylene is present, eqn (6) simplifies to

$$R_1 = k \cdot a_H^2 P_{H_2} / (a_2 P_2)^2. \quad (7)$$

If ethylene is assumed to be strongly adsorbed compared with hydrogen then eqn (7) reduces to

$$R_1 = k' \cdot P_{H_2} \quad (8)$$

where $k' = k a_H^2 / (a_2 P_2)^2$ and corresponds to the rate constant in region D. The rate of reaction in region D was found to be proportional to the hydrogen pressure thus lending weight to the assumptions made in deriving the equation.

The use of eqn (2) for the rate of reaction, leading to the detailed eqn (6), implies that three sites are required for the reaction to take place, one for ethylene and two for the hydrogen atoms. Other descriptions of the mechanism may be considered involving either (a) two sites, one for ethylene and one for adsorbed hydrogen, or (b) only one site for ethylene which is assumed to react with hydrogen coming directly from the gas phase or a physically adsorbed layer. A general equation may be derived to cover these different descriptions of the mechanism which takes the form

$$\frac{P_{H_2}^{1/n}}{R_{1C}} = \frac{1^{1/n}}{k'} + \frac{a_3}{a_2} \frac{1^{1/n}}{k'} \frac{P_3}{P_2} \quad (9)$$

where n corresponds to the number of sites required for the reaction. Eqn (6) corresponds to the special case where $n = 3$.

The appropriate plots to test eqn (9) for values of $n = 1, 2$ or 3 are presented in fig. 8 where it is seen that a straight line is obtained only when competition is assumed between acetylene molecules, ethylene molecules and hydrogen atoms, *i.e.*, for $n = 3$. Region D, where no acetylene was present, corresponds to the intercept in fig. 3. Values of the gradient and intercept in fig. 8 indicate that acetylene is 2200 times more strongly adsorbed than ethylene at 293 K.

It should be emphasized that the above kinetic analysis is only valid when the rates used are those after subtraction of the steady rate of ethane production, measured from region B. This is confirmation that there are on the catalyst two different types of site or that two independent mechanisms for hydrogenation of ethylene are operating.

Note that the reaction rate may depend on the probability that a site neighbouring an adsorbed hydrocarbon contains a hydrogen atom and thus θ_H itself may not be a completely adequate description of hydrogen availability.

We conclude that there is thus a change in the type of selectivity as the pressure of acetylene falls. Structural selectivity is observed at higher acetylene pressures (region B) and the loss of selectivity on entering region C may be attributed to the thermodynamics of the adsorption of ethylene and acetylene on type X sites. The ratio of the strengths of adsorption of acetylene and ethylene may be expressed as

$$a_3/a_2 = \exp(\Delta G_2 - \Delta G_3)/RT. \quad (10)$$

Applying this equation to the competition between ethylene and acetylene on a metal surface, Bond² concluded that if selectivity arose because of the stronger adsorption of acetylene then this would simply be a most improbable value for $(\Delta G_2 - \Delta G_3)$. While this conclusion is correct for region B, if the ratio of the fractions of the surface covered by acetylene and ethylene is 2200 when the pressures of the two gases are

equal then the value for the difference between the free energies of adsorption is 18.7 kJ mol^{-1} . In our opinion this value is not unreasonable.

After all the acetylene has been consumed the hydrogenation of ethylene continues (region D) until the supply of hydrogen is exhausted. Changing the temperature from 293 to 323 K makes negligible difference to the very fast rate of this reaction. We believe that the rate of ethylene hydrogenation in region D is determined by the rate of diffusion of reactants through the gas phase to the surface of the catalyst and have calculated the rate of diffusion as within an order of magnitude of the rate of ethylene hydrogenation.

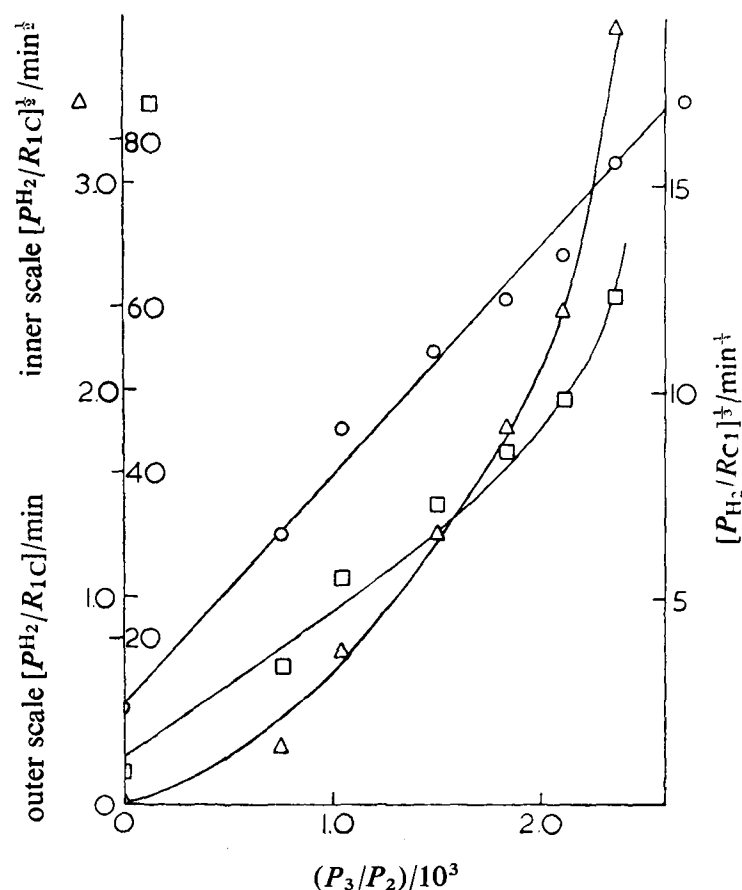
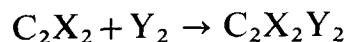

FIG. 8.—Plots of $(P_{H_2}/R_{1C})^{1/n}$ against P_3/P_2 for reaction at 293 K. Δ , $n = 1$; \square , $n = 2$; \circ , $n = 3$. Values of intercepts obtained from region D.

Fig. 6 shows that there is a rapid decrease in the mean deuterium number of the ethane produced on disappearance of the acetylene and an increase in the deuterium content of the ethylene. This may be attributed to the commencement of the normal ¹⁷ type of reaction of ethylene with deuterium on type X sites which had been previously covered with acetylene. Fig. 6 also shows that the deuterium number of ethylene produced after the initial fast acetylene exchange parallels the trend in the deuterium number of the acetylene. The formation of ethylene from acetylene may be written



whose X or Y = H or D. Formation of ethylene from acetylene is seen to involve an increase in deuterium number of 0.55, therefore it follows that Y_2 has an average composition of $H_{1.45}D_{0.55}$. This indicates that more hydrogen than deuterium atoms are added to acetylene in giving ethylene despite the large excess of deuterium in the gas phase. This hydrogen must have come from the original acetylene exchange

and have been held on the surface. A similar phenomenon has been reported by Douglas and Rabinovitch⁸ where hydrogen adsorbed on the catalyst did not return to the gas phase. The amount of hydrogen involved necessitates adsorption on the support and may involve the concept of hydrogen spillover¹⁸ from the metal to the support on adsorption and reverse spillover^{19, 20} in the case of hydrogenation.

ADDED CARBON MONOXIDE

That the presence of carbon monoxide has a marked retarding effect on the hydrogenation of ethylene in the absence of acetylene is clear from the results presented in table 3 for reactions at 413 K. The information in table 3 may be correlated by the equation

$$R_1 \propto (P_{\text{CO}})^x \quad (11)$$

if the value for zero carbon monoxide is excluded, and the value of x which satisfies the results is -0.54 .

If the rates of production of ethane in table 2 are plotted against the amount of carbon monoxide present then fig. 9 is obtained. This shows that a small amount of carbon monoxide has a disproportionately large influence on the rate of ethane production. Fig. 9 suggests that ~ 1000 p.p.m. of carbon monoxide are required to poison the type Y sites with corresponding increase in S . It is not possible to use the turning point in fig. 9, as the basis for a count of the first type of sites as the apparatus used did not permit determination of the amount of gas phase carbon monoxide present and it would be unreasonable to assume that all added carbon monoxide was adsorbed. The enhancement in selectivity caused by the presence of carbon monoxide may be attributed either to carbon monoxide adsorbing in preference to ethylene on type Y sites, or reducing the amount of ethylene which tends to $\alpha\alpha$ adsorb. This explanation seems a reasonable alternative to that put forward elsewhere.^{21, 22}

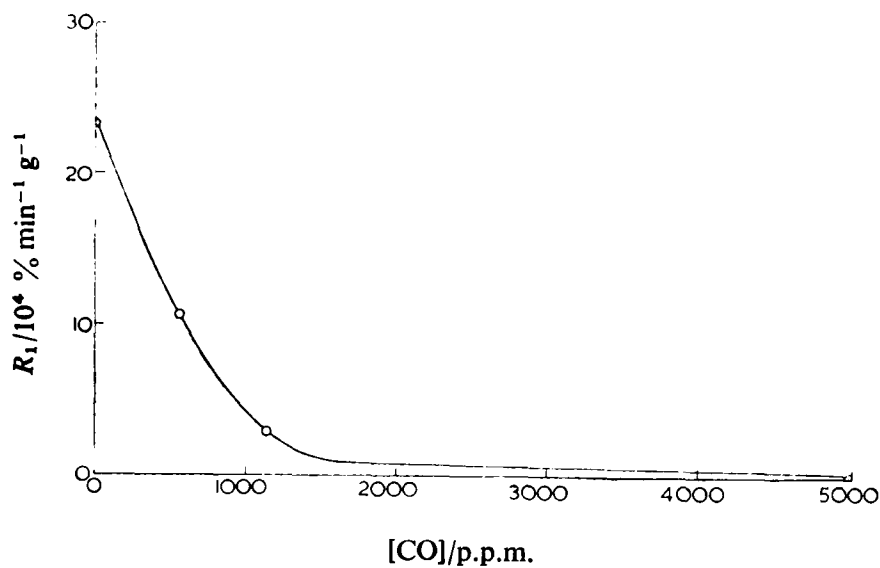

FIG. 9.—Graph of rate of production of ethane in region B against amount of carbon monoxide added. All reactions at 323 K.

An experiment in which 578 p.p.m. of carbon monoxide was added to a standard mixture of acetylene, ethylene and hydrogen at 323 K yielded a value of $9 \times 10^{-2} \text{ min}^{-1}$ for the rate constant for the hydrogenation of ethylene in region D. As this value is similar to the rate constant in the absence of carbon monoxide it seems reasonable

to assume that the rate of ethylene hydrogenation in the presence of small amounts of carbon monoxide is, as in the case of no carbon monoxide, diffusion controlled. Addition of 1155 p.p.m. of carbon monoxide caused a marked reduction in the rate of ethylene hydrogenation indicating that the reaction itself, rather than diffusion, becomes rate determining at higher concentrations of carbon monoxide.

The activation energy for the rate of hydrogenation of acetylene in region B was similar to that found in the absence of carbon monoxide but the pre-exponential factor was lower by a factor of ~ 2 to correspond to the slower rate observed. This suggests that the presence of carbon monoxide merely reduces the number of sites which are available but does not alter the mechanism of acetylene hydrogenation.

REGION A

An examination of fig. 2 shows that the extent of the initial rapid reaction is increased by the presence of hydrogen on the surface prior to the admission of the other reactants. It is possible that, in a standard experiment, hydrogen, because of its rapid rate of diffusion, reaches the active centres on the catalyst before the hydrocarbons. We thus believe that the initially observed rapid reaction (region A) is due to the removal of this excess hydrogen and the equilibration of surface species. Similarly the initial rapid exchange of acetylene with deuterium on the catalyst (fig. 4) or, to a lesser extent, on the support (fig. 7) is a transitory phenomenon associated with the equilibration of adsorbed species.

Fig. 2 and the ^{13}C tracer studies show that a substantial amount of hydrocarbon is adsorbed upon admission of reactants to the catalyst. When acetylene is pre-adsorbed subsequent admission of the remainder of the gas mixture displaces some of this acetylene into the gas phase, thus explaining the increase in acetylene in fig. 2(b). The extent of this adsorption, of the order of 6×10^{18} molecules, is such that the hydrocarbon could not be situated on the metal (which could accommodate only 1×10^{17} molecules), but adsorption must also have taken place on the support. Also, although ethylene and acetylene will be adsorbed with not widely different strengths on the alumina, it is unlikely that ethylene would be able to displace acetylene from the metal. The possibility of hydrocarbon upon hydrocarbon adsorption²³ can not be excluded but could not account for all the uptake from the gas phase.

The possibility of there being a number of highly active sites which rapidly poison was also considered as an explanation for the behaviour observed in region A. Since the initial stage is reproducible on catalysts which have been merely evacuated at room temperature and subjected to no further reduction it seems unlikely that region A is attributable to poisoning. Such poisoning would be reversible only under more drastic conditions of surface cleaning.

The authors thank the S.R.C. and the Agricultural Division, Imperial Chemical Industries, Ltd. for support.

¹ J. Sheridan, *J. Chem. Soc.*, 1944, 373.

² G. C. Bond, D. A. Dowden and N. Mackenzie, *Trans. Faraday Soc.*, 1958, **54**, 1537.

³ G. C. Bond, J. Newham and P. B. Wells, *Actes Deuxieme Congr. Int. Catalyse, Paris*, 1960 (Technip, Paris, 1961), p. 1177.

⁴ G. C. Bond, *Catalysis by Metals* (Academic Press, New York, 1962), p. 281.

⁵ G. C. Bond and P. B. Wells, *J. Catalysis*, 1966, **5**, 65.

⁶ H. C. Anderson, A. J. Haley and W. Egbert, *Ind. and Eng. Chem.*, 1960, **52**, 901.

⁷ A. Farkas and L. Farkas, *J. Amer. Chem. Soc.*, 1939, **61**, 3396.

⁸ J. E. Douglas and B. S. Rabinovitch, *J. Amer. Chem. Soc.*, 1952, **74**, 2486.

⁹ G. C. Bond and P. B. Wells, *J. Catalysis*, 1966, **6**, 397.

¹⁰ G. C. Bond, G. Webb and P. B. Wells, *J. Catalysis*, 1968, **12**, 157.

- ¹¹ C. Kemball, J. D. Nisbet, P. J. Robertson and M. S. Scurrrell, *Proc. Roy. Soc. A*, 1974, **338**, 299.
- ¹² G. C. Bond, *Catalysis by Metals* (Academic Press, New York, 1962), p. 242.
- ¹³ T. Kabe and I. Yasumori, *Nippon Kagaku Zasshi*, 1965, **86**, 385.
- ¹⁴ G. C. Bond, J. J. Phillipson, P. B. Wells and J. M. Winterbottom, *Trans. Faraday Soc.*, 1966, **62**, 443.
- ¹⁵ G. C. Bond, *Catalysis by Metals* (Academic Press, New York, 1962), p. 283.
- ¹⁶ P. B. Wells, personal communication.
- ¹⁷ C. Kemball, *J. Chem. Soc.*, 1956, 735.
- ¹⁸ P. A. Sermon and G. C. Bond, *Catalysis Reviews*, 1973, **8(2)**, 211.
- ¹⁹ G. F. Taylor, S. J. Thomson and G. Webb, *J. Catalysis*, 1968, **12**, 150 and 191.
- ²⁰ G. Webb and J. I. Macnab, *J. Catalysis*, 1972, **26**, 226.
- ²¹ A. Takeuchi, K. Tanaka and K. Miyahara, *Chem. Letters, Chem. Soc. Japan*, 1974, 171.
- ²² A. Takeuchi, K. Tanaka and K. Miyahara, *Chem. Letters, Chem. Soc. Japan*, 1974, 411.
- ²³ W. H. Weinberg, H. A. Deans and R. P. Merrill, *Surf. Sci.*, 1974, **41**, 312.

(PAPER 6/555)

Hydrogenation of Acetylene in Excess Ethylene on an Alumina-Supported Palladium Catalyst at Atmospheric Pressure in a Spinning Basket Reactor

WILLIAM T. MCGOWN, CHARLES KEMBALL, AND DAVID A. WHAN

*Department of Chemistry, University of Edinburgh, West Mains Road,
Edinburgh, EH9 3JJ, Scotland*

Received May 30, 1977

The hydrogenation of acetylene in the presence of ethylene and carbon monoxide has been investigated in a spinning-basket reactor on a commercial supported palladium catalyst. The rate of disappearance of acetylene was found to be controlled by pore diffusion at low acetylene concentrations and was independent of acetylene at high acetylene pressures. In the non-diffusion-controlled region the reaction of acetylene was first order in hydrogen, and the rate of ethane formation was independent of both the acetylene and ethylene pressures. This latter observation is consistent with the presence of sites which can hydrogenate ethylene even in the presence of acetylene. The nature of the C₄ products has been shown to be dependent on the packing of adsorbed acetylene molecules and on the availability of surface hydrogen. The analysis of a heavy involatile product is also reported.

INTRODUCTION

Mann and Safo (1) have described the hydrogenation of acetylene over pumice-supported nickel, platinum, and palladium and found that the selectivity of the reaction depended on the temperature and feed ratio. In commercial practice the hydrogenation of acetylene is normally performed as a method to remove C₂H₂ from ethylene cracker streams. It has been shown (2) that the characteristics of the hydrogenation of mixtures of ethylene and acetylene in a static system at a pressure of 7.3 kN m⁻² are different from those of each gas studied individually.

In that work (2), no evidence was found for the production of C₄ compounds, probably because of their retention on the surface of the support, but a mechanism for acetylene polymerization during hydrogenation over nickel and platinum has been

reported by Sheridan (3-5). Analysis of the C₄ fraction produced by the reaction of acetylene over palladium (6) has shown that the butenes were not produced in their equilibrium proportions.

These observations prompted us to investigate the kinetics of the hydrogenation of mixtures of acetylene in ethylene in a flow system at atmospheric pressure with a view to interpreting the mechanisms of hydrogenation and polymerization. The effect of carbon monoxide, added in commercial practice to improve the selectivity of the hydrogenation, is also reported.

EXPERIMENTAL

The reactor consisted of a stainless-steel catalyst basket which could be rotated at speeds up to 6000 rpm, the speed being indicated on a tachometer. The drive unit was completely sealed from, and magneti-

cally coupled to, the reactor shaft. The details of this type of reactor have been described elsewhere (7). Rotation of the basket at sufficiently high speeds caused the gas phase to be perfectly mixed and the composition of the gas phase to be identical over every catalyst pellet. Under conditions employed in this work the inflowing gas was almost instantaneously mixed with the gas already in the reactor, and the exit gas composition was assumed to be identical with the bulk gas composition in the reactor. The reaction rate was thus not dependent on inlet concentrations but on the bulk reacting gas concentration.

Cylinder gases, supplied by British Oxygen Corp. or Imperial Chemical Industries, were fed via two-stage pressure regulators, Brooks flow controllers and rotameters, or capillary flow meters into a container full of glass chips which acted as a premixer. The composition of the inlet gas was determined by gas chromatography using a 2-m silica gel column at 333 K. After measurement by rotameter, the flow to the reactor was split into two, 20% of the gas being passed down the reactor shaft to prevent damage to the reactor bearings by catalyst dust. The pressure in the reactor was marginally greater than atmospheric.

The analysis of the exit flow from the reactor was performed by gas chromatography. Two sample valves allowed material to be passed to a silica gel column, for C₂ analysis, and to a 10-m propylene carbonate on Chromosorb P column at 273 K which analyzed for C₄ compounds.

Throughout this work normal conditions used were a stirrer speed of 3000 rpm, a total gas flow rate of 20 liters hr⁻¹ and a temperature of 343 K. Nitrogen was used as an inert diluent so that, in experiments where the ethylene or hydrogen concentrations were varied, the total gas flow rate could be maintained at 20 liters hr⁻¹.

The catalyst used, I.C.I. type 38-3, was identical to that described previously (2)

and was reduced for 2 hr at 473 K in a 20-liter-hr⁻¹ flow of 30% hydrogen in nitrogen. The catalyst had a mean pore diameter of 8 nm and a pore volume distributed as follows: >25-nm pore radius, 0.12 cm³ g⁻¹; 3.7-25 nm, 0.07 cm³ g⁻¹; 1.0-3.7 nm, 0.16 cm³ g⁻¹. The geometric surface area of the catalyst pellets was 8 cm² g⁻¹. All reactions were performed on the same catalyst sample; checks made at frequent intervals indicated that constant activity was maintained throughout the period of this work.

RESULTS

The reaction rates, in units of milliliters per hour per gram of catalyst, were calculated from the inlet concentration I and exit concentration E , expressed as parts per million, using the equation

$$\text{rate} = (I - E)F/10^6 W$$

where F is the flow rate in milliliters per hour and W the catalyst weight in grams. A positive rate corresponded to a loss of reactant and a negative rate indicated the formation of a product.

The general characteristics of a typical reaction, in which the rates of appearance or disappearance of various compounds are plotted as a function of acetylene concentration, are illustrated in Fig. 1.

Disappearance of Acetylene

On increasing the acetylene concentration from zero, the rate of acetylene removal first increased and then remained constant.

The effects of change in hydrogen concentration on the rate of acetylene removal are illustrated in Fig. 2. Two points are worthy of note. First, the magnitude of the steady rate of acetylene removal increased with increasing hydrogen concentration and, for the experiments illustrated, had an order in hydrogen of 0.87 ± 0.05 . Second, the acetylene concentration required to

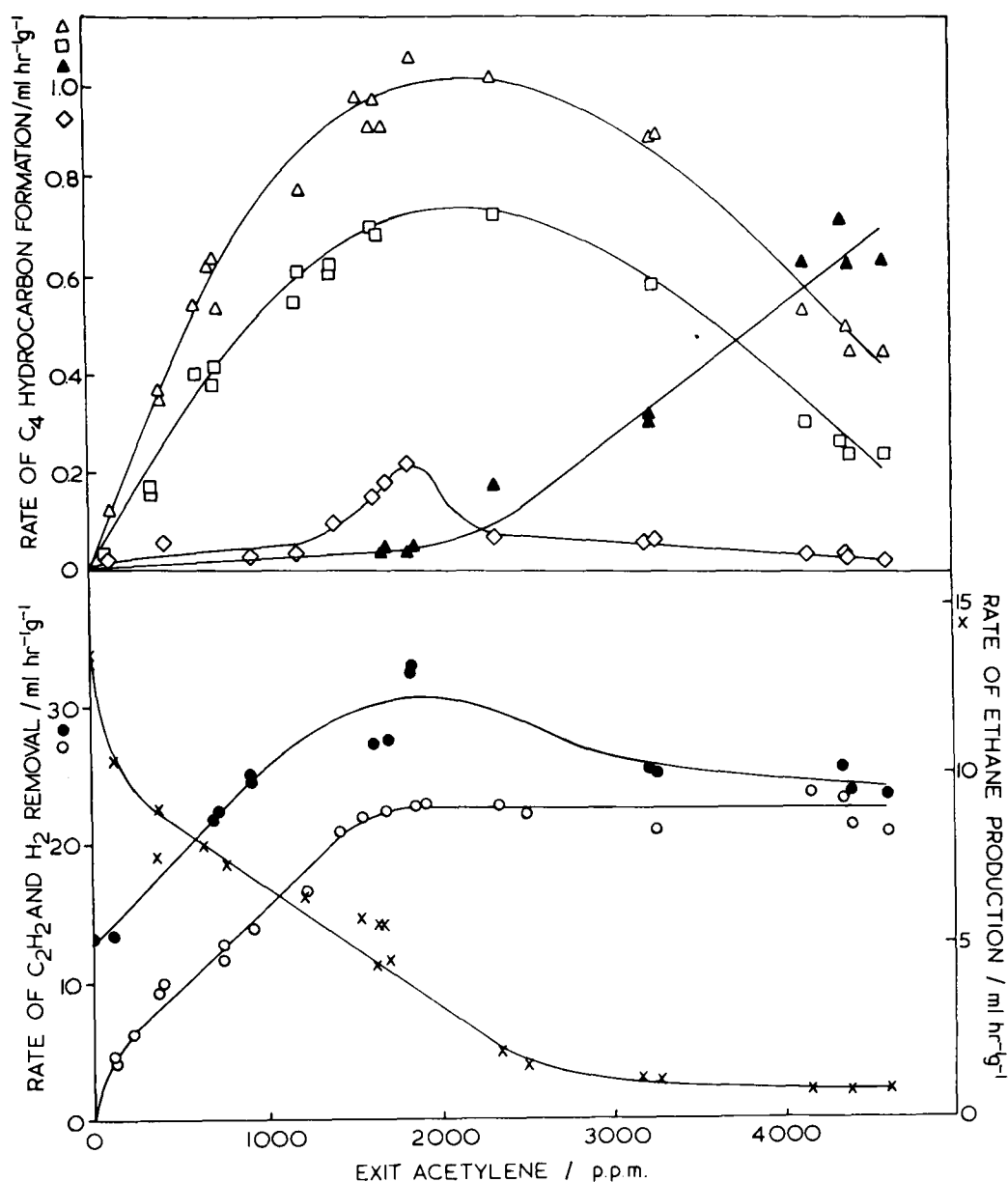

FIG. 1. Reaction at 343 K of mixtures of 25% H_2 , 35% C_2H_4 , 40% N_2 , and 1000 ppm of CO. Rates of: \circ , acetylene removal; \bullet , hydrogen consumption; \times , ethane formation; Δ , but-1-ene formation, \square , *trans*-but-2-ene formation; \diamond , *cis*-but-2-ene formation; and \blacktriangle , buta-1,3-diene formation at various acetylene concentrations.

achieve the point beyond which the reaction became zero order in acetylene moved to higher acetylene levels as the hydrogen level increased.

In Fig. 3 the effects of changing the concentrations of carbon monoxide and ethylene on the rate of removal of acetylene are presented. Comparison of experiments with the standard 35% ethylene in the inlet to the reactor showed that as the level of carbon monoxide was increased so the rate of acetylene removal decreased and the steady rate was established at lower concentrations of acetylene. The first 1000 ppm of carbon monoxide had a relatively

greater effect than the addition of a further 4000 ppm. For experiments in the absence of carbon monoxide it was, for experimental reasons, not possible to introduce sufficient acetylene into the reactor to observe the turning point where the reaction would become zero order in acetylene.

The results of changing the inlet level of ethylene from 35% to zero, at three different concentrations of carbon monoxide, can be seen in Fig. 3. It is apparent that both the rate of hydrogenation of acetylene and the point at which the reaction became zero order in acetylene are affected by the amount of ethylene present.

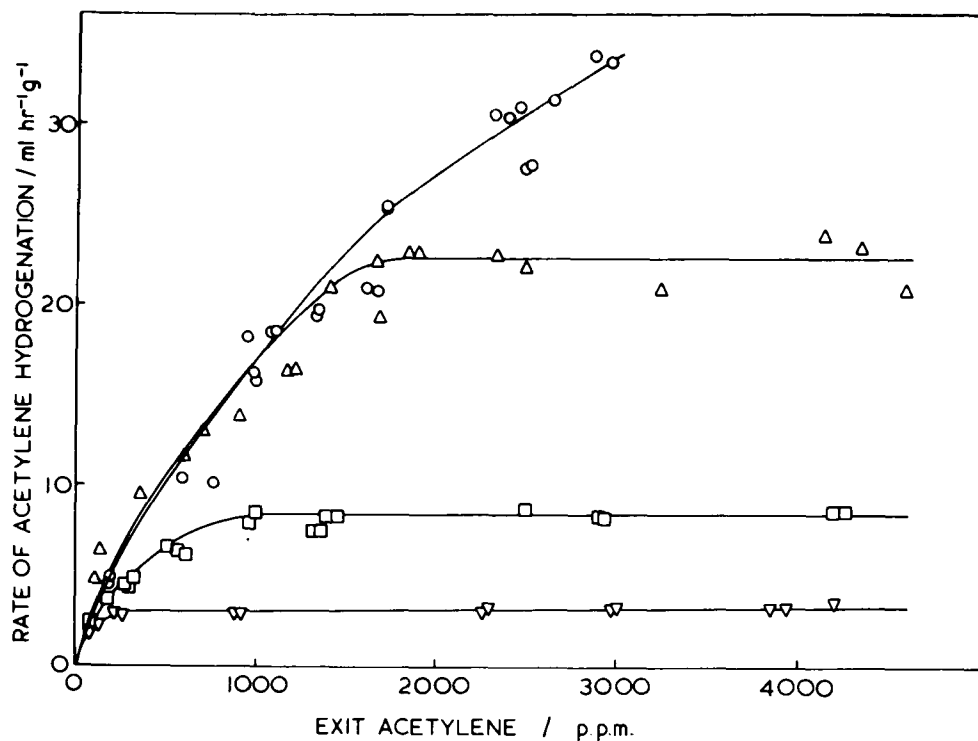

FIG. 2. Influence of hydrogen on the rate of acetylene removal at 343 K in the presence of 35% C_2H_4 and 1000 ppm of CO. Exit hydrogen: \circ , 37.5%; \triangle , 22.8%; \square , 9.4%; ∇ , 2.6%.

Formation of Ethane

The rates of formation of ethane at various hydrogen levels are presented as a function of acetylene concentration in Fig.

4. In the absence of acetylene the order in hydrogen was approximately unity.

Figure 5 illustrates the effect of carbon monoxide on the rate of production of

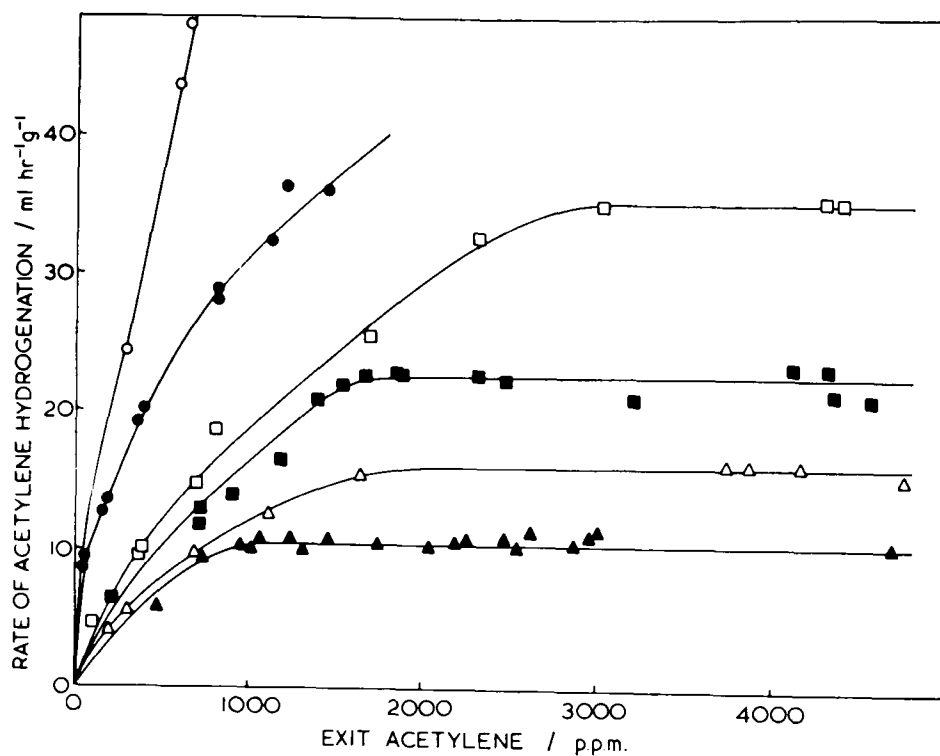

FIG. 3. Influence of ethylene and carbon monoxide on the rate of acetylene removal at 343 K in the presence of 25% H_2 . Exit concentrations: \circ , 0.2% C_2H_4 and 0% CO; \bullet , 28.7% C_2H_4 and 0% CO; \square , 2.2% C_2H_4 and 1000 ppm of CO; \blacksquare , 34.4% C_2H_4 and 1000 ppm of CO; \triangle , 1.0% C_2H_4 and 5000 ppm of CO; \blacktriangle , 34.7% ethylene and 5000 ppm of CO.

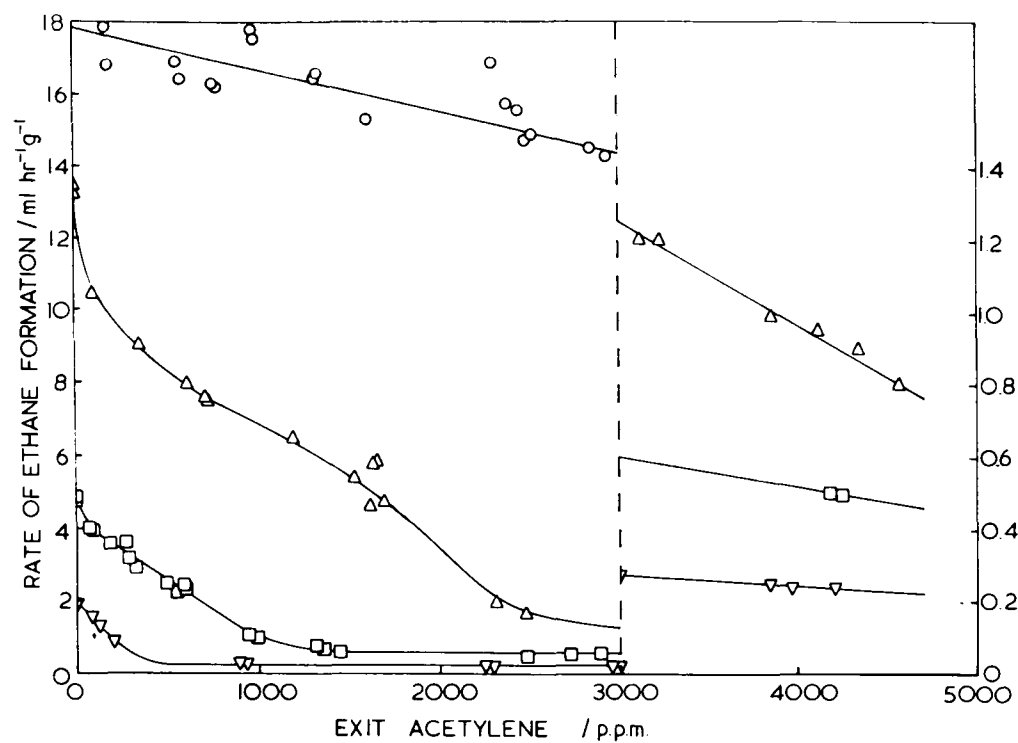

FIG. 4. Influence of hydrogen on the rate of formation of ethane at 343 K in the presence of 35% C₂H₄ and 1000 ppm of CO. Inlet hydrogen concentration: ○, 40%; △, 25%; □, 10%; ▽, 2.8%.

ethane and shows that the presence of carbon monoxide has a greater effect on the formation of ethane than on the disappearance of acetylene. It is seen that the first 1000 ppm of carbon monoxide has a disproportionately large effect on the rate of ethane formation.

Also presented in Fig. 5 is the effect of ethylene on the rate of formation of ethane for experiments conducted in the presence of 1000 ppm of carbon monoxide. With no inlet ethylene present, increasing the acetylene concentration produced an increase in the rate of ethane formation until about

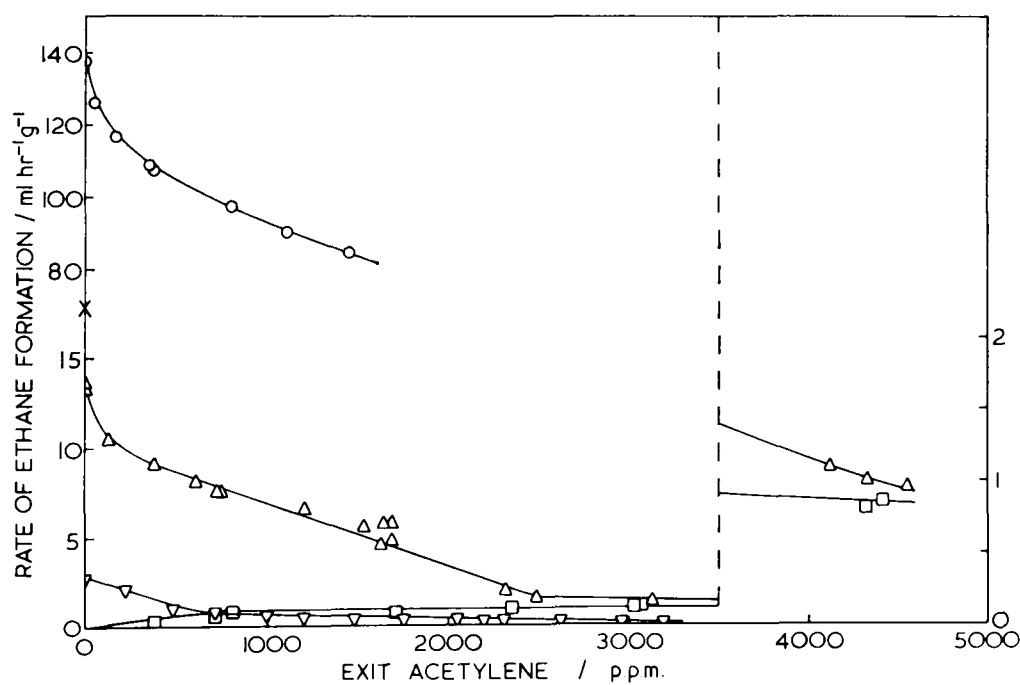

FIG. 5. Influence of ethylene and carbon monoxide on the rate of formation of ethane at 343 K in the presence of 25% hydrogen. ○, 35% C₂H₄ and zero CO inlet; △, 35% C₂H₄ and 1000 ppm of CO inlet; ▽, 35% C₂H₄ and 5000 ppm of CO inlet; □, zero C₂H₄ and 1000 ppm of CO inlet.

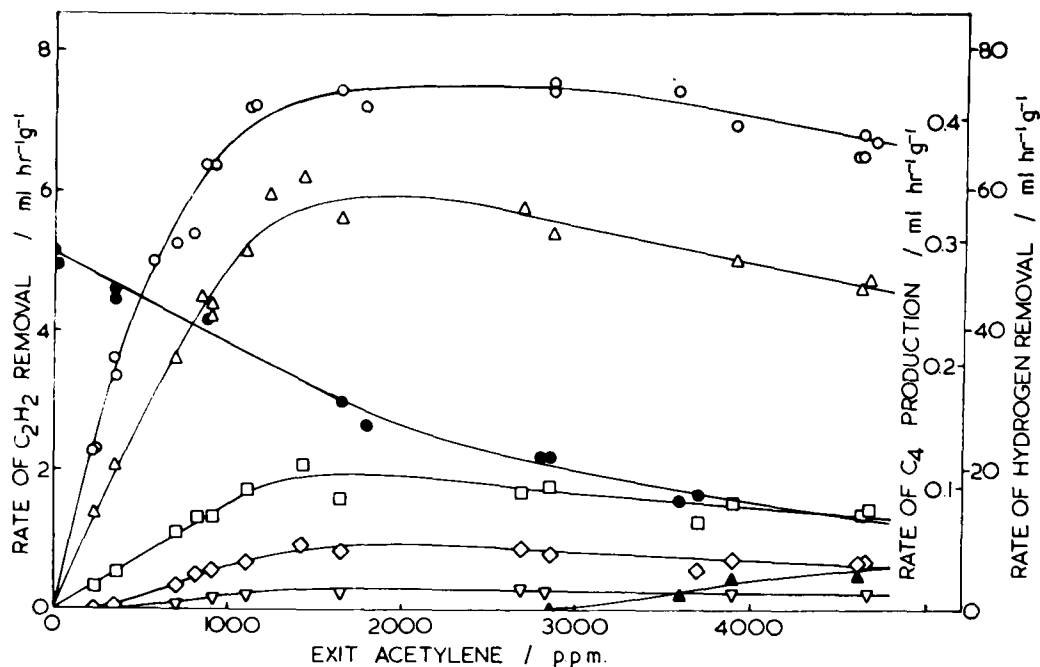

FIG. 6. Production of C_4 hydrocarbons from an experiment at 273 K with 25% H_2 , 35% C_2H_4 , and 40% N_2 in the absence of CO. ∇ , n -butane; other symbols as Fig. 1.

3500 ppm of acetylene was present; further increase in the acetylene level had no effect on the rate of ethane production. It is seen that the rate of formation of ethane, at acetylene levels >3500 ppm, was identical for ethylene inlets of $\sim 35\%$ and zero ($\sim 2\%$ ethylene in exit). At high acetylene concentrations the rate of ethane formation was thus independent of both the ethylene and acetylene levels and varied only with the hydrogen concentration.

Production of C_4 Hydrocarbons

Figure 6 shows the rates of hydrogenation of acetylene, hydrogen consumption, and C_4 production in a typical experiment in the absence of carbon monoxide at 273 K. As the acetylene level was increased so the rates of formation of but-1-ene, *trans*-but-2-ene, *cis*-but-2-ene, and n -butane also increased initially. When the acetylene concentration was increased above ~ 1600 ppm the rates of production of the butenes diminished and buta-1,3-diene began to appear in the gas phase. At the point where the reaction became zero order in acetylene, the C_4 composition was: but-1-ene, 66.0%; *trans*-but-2-ene, 22.1%; *cis*-but-2-ene, 9.4%; and n -butane, 2.5%.

The results shown in Fig. 6 for reaction in the absence of carbon monoxide may be compared with those in Fig. 1 for reaction in the presence of 1000 ppm of carbon monoxide. The temperature in the latter case was 343 K so that rates of reactions were comparable. Only traces of n -butane were detected in the presence of carbon monoxide. *cis*-But-2-ene was present in significant quantities only at the point where the rate of removal of acetylene had just become constant, and this point coincided with maxima in the production of but-1-ene and *trans*-but-2-ene.

The fraction of acetylene which was converted to C_4 species is plotted in Fig. 7 as a function of the acetylene concentration. It is seen that the fraction of acetylene thus converted initially increased as the acetylene in the gas phase increased until the point where the disappearance of acetylene became zero order. Figure 7 also illustrates the influence of hydrogen on the percentage of acetylene being converted into C_4 molecules. At low acetylene levels the production of C_4 species was reduced by increasing the amount of hydrogen but the converse was true at high acetylene concentrations.

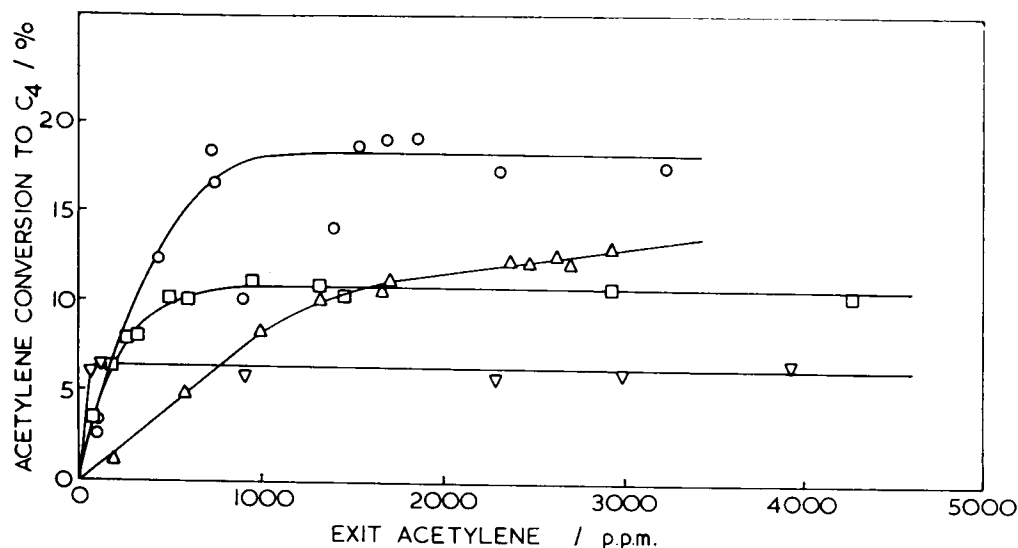

FIG. 7. Influence of hydrogen on percentage conversion of acetylene into C_4 hydrocarbons. Exit hydrogen concentration: ∇ , 2.6%; \square , 9.4%; \circ , 22.8%; \triangle , 37.5%.

The influence of carbon monoxide and ethylene on the fraction of acetylene forming dimer is illustrated in Fig. 8. It is seen that an increase from 1000 to 5000 ppm in the carbon monoxide concentration almost halves the yield of C_4 species. When the exit ethylene concentration was increased from ~ 1 to $\sim 34.7\%$ the fraction of acetylene dimerizing was also reduced, except at low levels of acetylene.

An experiment was carried out in an attempt to determine if the C_4 compounds were produced from two acetylene molecules, two ethylene molecules, or one acetylene molecule and one ethylene molecule. This involved carrying out reactions

of acetylene in propylene and analyzing the products for C_4 , C_5 , and C_6 fractions. Only C_4 compounds were detected, in amounts similar to those found in experiments with ethylene, confirming that C_4 species are formed from two acetylene molecules.

After the reactor had been running for some weeks it was observed that a brown oil, probably similar in nature to the oil found in commercial acetylene removal plants, had accumulated in the exit line from the reactor. Gas chromatographic analysis of the oil showed that it consisted of at least 16 different compounds. Infrared spectra gave some evidence for the presence of some carbonyl groups and suggested that

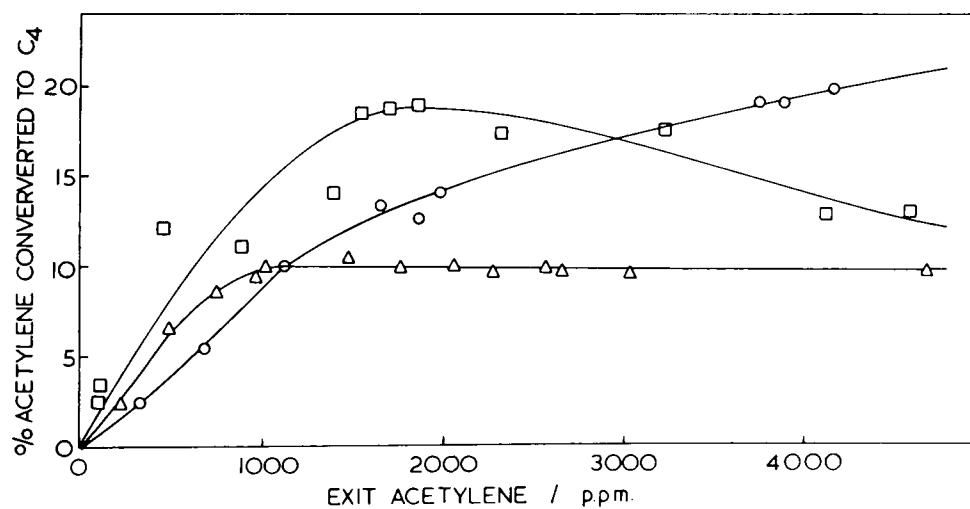

FIG. 8. Influence of ethylene and carbon monoxide on percentage of acetylene converted into C_4 hydrocarbons. \square , 1000 ppm of CO, 35% C_2H_4 ; \circ , 5000 ppm of CO, zero C_2H_4 ; \triangle , 5000 ppm of CO, 35% C_2H_4 .

no olefinic unsaturation was present. The ultraviolet absorption spectrum of a solution of the oil in *n*-pentane confirmed the presence of carbonyl groups. A proton magnetic resonance spectrum had two main peaks at $\delta = 0.9$ and 1.3 indicating methyl and methylene groups, respectively. Small peaks at $\delta = 2.1$ and 2.4 may be due to traces of ketonic groups. The absence of peaks at δ values between 2.5 and 10 ruled out the presence of aldehydic, aromatic, or olefinic protons. A mass spectrum of the oil produced peaks with m/e values up to 310 indicating that the longest chain present would contain 22 carbon atoms. Overall, the various analyses indicated that the oil consisted of saturated chains of up to 22 carbon atoms with traces of carbonyl groups. This analysis is consistent with that of oil found in commercial practice elsewhere (8).

DISCUSSION

Kinetics of the Removal of Acetylene

The shape of the plots of rate of removal of acetylene against acetylene concentration, for example in Fig. 1, may be explained on the reasonable assumption that at low acetylene levels the surface coverage in acetylene increases as the pressure of acetylene in the gas phase increases. Beyond the point when the surface becomes saturated with acetylene, no increase in rate would be expected with further increase in acetylene pressure and, indeed, none is observed.

There are two possible reasons as to why surface coverage in acetylene, at low acetylene levels, could increase with acetylene pressure. These are: (i) competition between acetylene and other species for surface sites and (ii) diffusional limitation on the rate at which acetylene can reach surface sites within catalyst pores.

Although competition between acetylene and ethylene proved to be a satisfactory explanation of the kinetics observed in

static systems at lower temperatures [(9) and references therein], we believe that it is not the principal factor governing the surface coverage of acetylene under the conditions presently reported for the following reasons. First, the rise in rate of acetylene removal with acetylene concentration (Fig. 1) has an approximately linear portion rather than the smooth curve predicted on the basis of simple Langmuir competition.

Second, if competition between acetylene and ethylene was the most important factor governing the amount of adsorbed acetylene, then the point at which the rate became zero order in acetylene should be similar for all experiments with the same acetylene/ethylene ratio; that this is not so is evident from Fig. 2 where it is apparent that the turning point is markedly dependent on the amount of hydrogen present. Third, although competition for surface sites between acetylene and hydrogen is inevitable, if it is assumed that such competition dominates the kinetics, then it would be reasonable to expect the rate of removal of acetylene to fall at high acetylene pressures due to exclusion of hydrogen from the surface; no fall is observed.

For Knudsen flow of gases in catalyst pores the pore diameter must be smaller than the mean free path between intermolecular collisions (9). At atmospheric pressure the mean free path of acetylene molecules is ~ 50 nm (10). The catalyst used in the present work had a mean pore diameter of 8 nm, so Knudsen flow would be expected.

The rate of diffusion of gases is given (11) by

$$r_D = \frac{\Delta c DP}{d}$$

where r_D is the rate of diffusion, Δc is the concentration gradient, D is the diffusion constant, P is the porosity, and d is the distance over which diffusion is taking

place. During Knudsen flow the diffusion constant is reduced below the value in the free gas. We make the assumption that the diffusion constant in pores of radius >25 nm is 100%, that for 3.7- to 25-nm pores it is 50%, and for 1.0- to 3.7-nm pores it is 15% of the value in the free gas. The value for the diffusion constant of acetylene in air at atmospheric pressure is $0.1 \text{ cm}^2 \text{ s}^{-1}$ and, in the absence of a literature value for ethylene/nitrogen mixtures, we have applied this in the present circumstances.

From the values quoted above and the porosity distribution cited earlier in the paper, the magnitude of the product $D \cdot P$ was calculated to be $0.018 \text{ cm}^5 \text{ g}^{-1} \text{ s}^{-1}$. For conditions where the concentration difference was 2000 ppm and the depth of the layer of palladium on the catalyst was 0.8 mm, the rate of diffusion of acetylene was calculated to be $2.2 \times 10^{-8} \text{ mol cm}^{-2} \text{ s}^{-1}$. For the experiment presented in Fig. 1, when the concentration of acetylene was 3000 ppm the rate of removal of acetylene was $24 \text{ ml hr}^{-1} \text{ g}^{-1}$; this is equivalent to $\sim 3 \times 10^{-8} \text{ mol cm}^{-2} \text{ s}^{-1}$ for pellets with a superficial area of $8 \text{ cm}^2 \text{ g}^{-1}$. These calculations suggest that the rate of acetylene hydrogenation at low acetylene levels is controlled by the rate of diffusion within the catalyst pores. At high acetylene levels, with correspondingly high concentration gradients, diffusion is fast and the rate is controlled by the kinetics of the reaction.

It was confirmed that bulk diffusion in the gas phase was not rate limiting as the rate of reaction did not alter when the basket speed was changed within the range 2000 to 4000 rpm.

Three regions may thus be identified as the acetylene pressure increases. These will be subsequently referred to as (i) the region of diffusion control, (ii) the turning point, and (iii) the "steady" region where the rate is kinetically controlled and is approximately zero order in acetylene.

Effects of Hydrogen, Carbon Monoxide, and Ethylene on The Rate of Removal of Acetylene

It is seen from Fig. 2 that the reaction is approximately first order in hydrogen at high acetylene levels when the rate is not diffusion limited. The concentration of acetylene required to establish surface coverage and the steady rate of acetylene removal increases as the amount of hydrogen is increased, and in the experiment with 40% hydrogen, the region of diffusion control extended throughout the range of the whole experiment and no steady rate was achieved. It is interesting to note that the diffusion-controlled regions are common to all experiments in Fig. 2, such regions being intersected by horizontal lines corresponding to the different kinetic rates for each hydrogen concentration. Outside the diffusion controlled region the kinetic order in hydrogen was slightly less than unity, perhaps indicating some limited competition between acetylene and hydrogen for the surface. Further evidence for such competition is available from the pattern of C_4 products, *vide infra*.

The effects on the rates of acetylene hydrogenation of carbon monoxide and ethylene are qualitatively similar in that the region of diffusion control is curtailed and the subsequent steady rate of acetylene removal is reduced, although the magnitude of those effects is much greater in the case of carbon monoxide. In the non-diffusion-affected region the effects of added carbon monoxide and ethylene are equivalent to those from reducing the hydrogen pressure. The information presented in Fig. 3 suggests that competition between carbon monoxide or ethylene and acetylene is not important at high acetylene levels since doubling the acetylene concentration from 2000 to 4000 ppm has no detectable effect on the rate of its reaction. The reduction in both the extent of diffusion-control and the steady rates caused by the presence of

carbon monoxide or ethylene may be interpreted as being due to a reduced availability of hydrogen on the surface. The influence of carbon monoxide on the adsorption of acetylene is known to be minor (12, 13).

The Formation of Ethane

The general shape of the graphs for the rate of formation of ethane as a function of acetylene concentration, illustrated in Fig. 4, may be interpreted on the basis of competition between ethylene and acetylene for the surface at low acetylene pressures, although it should be remembered that such a simple picture is considerably distorted by diffusional limitation of rates. It has been shown (2) that such competition occurs on type X sites, on which acetylene is adsorbed with a strength 2200 times greater than that of ethylene at 293 K. The rate of formation of ethane thus, at first, falls with increase in acetylene concentration due to decreasing ethylene coverage of type X sites.

Once the surface has become effectively saturated with acetylene, the rate of production of ethane becomes independent of the acetylene and ethylene concentrations as seen from experiments (Fig. 5) conducted in the presence of 5000 ppm of carbon monoxide. The steady rate of production of ethane at high acetylene levels may be regarded as further evidence for type Y sites which can hydrogenate ethylene even in the presence of considerable quantities of acetylene (2). It is particularly striking to note that the rate of production of ethane in the non-diffusion-controlled

region is identical for experiments with zero and 35% ethylene in the inlet to the reactor.

The effect of carbon monoxide on the rate of ethane formation is also presented in Fig. 5. The presence of carbon monoxide is seen to depress the rate of formation of ethane to a much greater extent than the rate of hydrogenation of acetylene (compare Fig. 3), implying exclusion of ethylene from the surface by carbon monoxide. A comparison of results in Fig. 5 at carbon monoxide levels of 1000 and 5000 ppm suggests that carbon monoxide can compete effectively with ethylene for both type X and type Y surface sites.

Production of C₄ Molecules

Figures 2 and 8 show that both the rate of production of and the fraction of reacted acetylene converted to C₄ species at first increase with acetylene pressure and then become constant at the point where the rate of disappearance of acetylene becomes constant. The increase in the rate of formation at low acetylene levels may be explained by the increasing surface coverage in acetylene which increases the probability of acetylene molecules occupying adjacent sites, a reasonable prerequisite for dimerization. This concept may be represented by

$$\text{rate of C}_4 \text{ production} = k\theta_{\text{C}_2\text{H}_2}^n$$

where k is a constant and $\theta_{\text{C}_2\text{H}_2}$ is the fraction of the surface covered by acetylene. An indication of the value of this fraction may be obtained from

$$\theta_{\text{C}_2\text{H}_2} = \frac{\text{rate of C}_2\text{H}_2 \text{ disappearance}}{\text{limiting rate of C}_2\text{H}_2 \text{ disappearance at surface saturation}}$$

Values of n obtained from graphs of log rate of C₄ production against log $\theta_{\text{C}_2\text{H}_2}$ for experiments at various gas compositions are shown in Table 1. In the majority of

experiments n had a value close to 2 confirming that C₄ production required the adsorption of acetylene molecules on two adjacent sites.

TABLE 1
Dependence of Rate of C₄ Production on the Surface
Coverage of Acetylene at 343 K

Inlet gas composition				<i>n</i> ^a
H ₂ (%)	C ₂ H ₄ (%)	N ₂ (%)	CO (ppm)	
25	35	40	1000	1.64
25	35	40	5000	2.00
25	0	75	1000	2.05
10	35	55	1000	2.00

^a As defined in text.

The composition of butenes, at the point of surface saturation with acetylene, is similar to that reported by Bond and Wells (6) and is markedly different from the thermodynamic equilibrium composition. This suggests that when a butene molecule is formed it is immediately desorbed, without having sufficient time to undergo isomerization; this is understandable in the presence of acetylene and large quantities of ethylene.

Sheridan has suggested (4) that the free radical form of an adsorbed vinyl group reacts with an adsorbed acetylene molecule to produce buta-1,3-diene which subsequently hydrogenates to butenes. On hydrogenation of buta-1,3-diene on palladium (14) at 273 K, the butene composition was found to agree favorably with values observed during acetylene hydrogenation (6) in confirmation of Sheridan's mechanism. Bond *et al.* (14) have proposed that but-1-ene is produced by 1,2 addition of two hydrogen atoms to buta-1,3-diene, while the but-2-enes are formed by a 1,4 addition process, the particular geometric isomer of but-2-ene being determined by the conformation of the adsorbed buta-1,3-diene. The conformation of adsorbed buta-1,3-diene resulting from the dimerization of adsorbed acetylene may well differ from that produced by gas phase buta-1,3-diene. It has been reported (15) that the most favored steric arrangement for acetylene

molecules on palladium is a form of staggered packing,

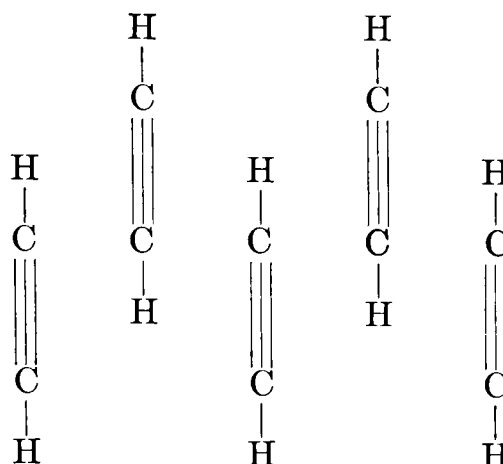

which would be expected to form the *transoid* buta-1,3-diene on dimerization and subsequently the *trans*-but-2-ene on hydrogenation. At low acetylene levels the majority of the but-2-ene formed has the *trans* configuration (see Fig. 1). As the surface concentration of acetylene approaches monolayer saturation, the mode of packing of acetylene may change to a closer packed form with the following geometry:

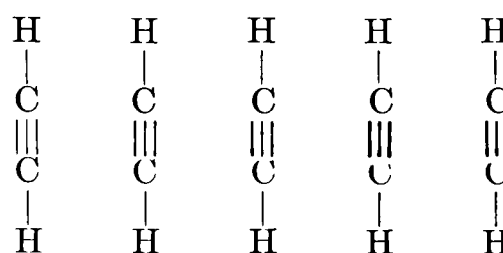

This form of packing would be expected to ultimately yield *cis*-but-2-ene. Figure 1 shows that the amount of *cis*-but-2-ene formed does increase considerably when the acetylene coverage is close to saturation.

At high acetylene concentrations the yield of C₄ olefins falls and the principal C₄ product becomes buta-1,3-diene. This suggests that either the availability of surface hydrogen becomes less, although this is not reflected in a change in the rate of acetylene hydrogenation, or that the increasing intensity of acetylene bombardment of the surface with acetylene pressure displaces the buta-1,3-diene molecules before they have time to hydrogenate.

Comparison of Figs. 1 and 6 shows that the presence of carbon monoxide has the effect of decreasing the degree of saturation of the C₄ molecules produced at a given acetylene concentration, presumably by reducing by competition the availability of adsorbed hydrogen.

Recently published results (16) have suggested that the presence of palladium hydride phases may influence the hydrogenation of acetylene. The thermodynamics of the palladium/hydrogen system (17) suggest that hydride formation is, in principle, possible under the conditions used in this work. It is, however, reported (16) that hydride formation does not occur to any significant extent on catalysts where the palladium loading is less than 1%, and we are of the opinion that hydride formation is of no importance in this work.

ACKNOWLEDGMENTS

The authors acknowledge with thanks support from the Science Research Council and from Agricultural Division, Imperial Chemical Industries, Ltd. We are also indebted to B. M. Collins and D. Lobleby for much helpful advice and discussion.

REFERENCES

1. Mann, R. S., and Safo, S. Y., *Chem. Eng. Progr. Symp. Ser.* **65**, 71 (1969).
2. McGown, W. T., Kemball, C., Whan, D. A., and Scurrell, M. S., *J. Chem. Soc. Faraday Trans. I* **73**, 632 (1977).
3. Sheridan, J., *J. Chem. Soc.*, 373 (1944).
4. Sheridan, J., *J. Chem. Soc.*, 133 (1945).
5. Sheridan, J., *J. Chem. Soc.*, 305 (1945).
6. Bond, G. C., and Wells, P. B., *J. Catal.* **5**, 65 (1966).
7. Brisk, M. L., Day, R. L., Jones, M., and Warren, J. B., *Trans. Inst. Chem. Eng.* **46**, T3 (1968).
8. Dowden, D. A., private communication.
9. Wheeler, A., *Advan. Catal.* **3**, 249 (1951).
10. West, R. C., "Handbook of Chemistry and Physics," C. R. C. Press, Cleveland, Ohio, 1974.
11. Satterfield, C. N., and Sherwood, T. K., "Role of Diffusion in Catalysis," Addison-Wesley, Reading, England, 1963.
12. Takeuchi, A., Tanaka, K., and Miyahara, K., *Chem. Lett.*, 171 (1974).
13. Takeuchi, A., Tanaka, K., and Miyahara, K., *Chem. Lett.*, 411 (1974).
14. Bond, G. C., Webb, G., Wells, P. B., and Winterbottom, J. M., *J. Chem. Soc.*, 3218 (1965).
15. Bond, G. C., and Wells, P. B., *Actes Congr. Int. Catal.*, 1159 (1960).
16. Borodzinski, A., Dus, R., Frak, R., Jaulso, A., and Palczewska, W., in "Proceedings Sixth International Congress on Catalysis," London, 1976.
17. Wicke, E., and Nernst, G., *Ber. Bunsenges. Phys. Chem.* **68**, 224 (1964).