

RELIGIOUS ATTITUDES OF ROMAN CATHOLIC SECONDARY
SCHOOL PUPILS IN STRATHCLYDE REGION

by

JOSEPH RHYMER

Thesis presented for the degree of
Doctor of Philosophy
at the
University of Edinburgh
1983

ABSTRACT OF THESIS

Joseph Rhymer: "Religious Attitudes of Roman Catholic Secondary School Pupils in Strathclyde Region".

The research tested the hypothesis that Roman Catholic pupils in Roman Catholic schools have a more positive attitude towards religion than Roman Catholic pupils in non-denominational schools.

Part I: Recent official Roman Catholic statements on religious education are found mainly in the documents of the Second Vatican Council, Pope Paul VI's "Credo of the People of God", the General Catechetical Directory, the Directory for Masses with Children, Pope John Paul II's "Catechesis in our Time", and his address on Education given during his 1982 pastoral visit to Great Britain.

Part II: Most Roman Catholic religious education in Scotland takes place within the denominational sector of publicly funded schools, established in their present form by the 1918 Education [Scotland] Act. It has been influenced by catechetical work in mainland Europe and the United States, syllabuses by D. Konstant and D. Lance, syllabuses for Ireland and for Liverpool, and Scottish syllabuses for Glasgow and for Motherwell. A Scottish national syllabus has been drafted.

Part III: The empirical research began with the construction of a stratified sample, representing the distribution of Scottish Roman Catholic pupils between Roman Catholic and non-denominational secondary schools, and drawn from areas of Strathclyde Region typical of geographical and economic conditions in Scotland as a whole.

A Likert-scale questionnaire was used, designed and tested by L.J. Francis, with slight modifications for Scottish Roman Catholics. It identified religious attitude by responses to 24 sentences; related information was obtained about the respondents' previous schooling, school year, sex, church attendance, social class, type of school, general literacy level, involvement with public examinations



in religious studies, contact with specialist teachers, and the syllabus in use. 2,122 questionnaires were processed, 1,113 from Roman Catholic pupils, first for simple correlations, and then by path analysis to identify the relative strengths of variables and causal relationships.

Conclusions: The results of the simple correlations were confirmed by the more rigorous path analysis, to show that there is no significant difference between the religious attitudes of Roman Catholic pupils in Roman Catholic and non-denominational schools. Furthermore, Roman Catholic pupils receiving Roman Catholic religious education in non-denominational schools show a more positive attitude than those who receive none.

The study ends with comments on ecclesiastical, educational and political implications, comparisons with other research, and with a bibliography.

DECLARATION

I declare that the accompanying thesis, "Religious Attitudes of Roman Catholic Secondary School Pupils in Strathclyde Region", has been composed by me, and is the result of my own work.

Joseph Rhymer
14th January 1983

Joseph Rhymer

RELIGIOUS ATTITUDES OF ROMAN CATHOLIC SECONDARY
SCHOOL PUPILS IN STRATHCLYDE REGION

by

JOSEPH RHYMER

Thesis presented for the degree of
Doctor of Philosophy
at the
University of Edinburgh
1983

CONTENTS

Abstract	i
Declaration	iii
Title Page	iv
Contents	v
Acknowledgements	vii
<u>PART I: Official Roman Catholic Statements on</u>	
<u>Religious Education</u>	1
A. The Second Vatican Council	1
References	23
B. The Credo of the People of God	25
References	32
C. The General Catechetical Directory	33
References	46
D. The Directory for Masses with Children	47
References	52
E. Catechesis in our Time	53
References	58
F. Pope Paul II's Address on Education	59
References	68
<u>PART II: Roman Catholic Religious Education in</u>	
<u>Scotland</u>	70
References	85
<u>PART III: The Empirical Enquiry</u>	88
1. The Sample	88
References	105
2. The Method of Enquiry	106
References	127

3. The Results	128
A. Univariate Correlations of the Whole Sample	131
B. Multivariate Correlations by Type of School	152
C. Multivariate Correlations by Type of School and Religious Education	186
D. Multivariate Correlations Using Path Analysis	221
Reference	233
<u>PART IV: Conclusions</u>	234
References	275
<u>Bibliography</u>	280

ACKNOWLEDGEMENTS

Many people contributed to this study, and their help is gratefully acknowledged: Dr. Ian Gray, Dr. Robin Gill and Dr. Ian McDonald of New College in the University of Edinburgh for their supervision; Dr. Ian Moir of New College and Dr. Leslie Francis of Culham College Institute for their advice and help with the computer programming and analysis, and Dr. Francis for allowing the use of his research questionnaire; officials of Strathclyde Regional Council Department of Education, particularly Mr. John Mulgrew, Assistant Director of Education, and Miss Jean Coghill, Advisor in Religious Education, and Archbishop T.J. Winning of Glasgow, Bishop S. McGill of Paisley, and Bishop C. Macpherson of Argyll and the Isles, for their help and for permission to conduct the research in schools within their jurisdiction; Sr. Francis Ellen, S.N.D., for arranging to finance the earlier stages of the work; Sr. Margaret Sheridan, S.N.D., Fr. James McShane and Sr. Helen Murphy, S.N.D., for their encouragement and for accepting the research as part of the College's work; Miss Judith Wright for help with the tedious task of preparing data for computer processing; Mrs. Elizabeth Burchell and Mrs. Carol Cormack for the final typing. In a category of their own are the staff, pupils and local clergy associated with the schools in which the research was conducted, who willingly participated in enquiries into such a sensitive and personal area of the school curriculum. Finally, I am deeply grateful to my wife for her help with the processing of the data, and for advice and encouragement at every stage of the project.

Joseph Rhymer
St. Andrew's College of Education,
Bearsden, Scotland.

PART I: OFFICIAL ROMAN CATHOLIC STATEMENTS ON RELIGIOUS
EDUCATION

The research reported in this work had as its main objective an evaluation of the religious attitudes of Roman Catholic secondary school pupils, and particularly to see what differences, if any, might be found between Roman Catholics who attended Roman Catholic schools and Roman Catholics who attended non-denominational schools. As a working hypothesis it seemed reasonable to assume that Roman Catholic pupils in Roman Catholic schools would have a more positive attitude towards the Christian religion than Roman Catholic pupils in non-denominational schools, and the research was designed to test this hypothesis. The method used was a Likert-type questionnaire administered to a stratified sample of Roman Catholic secondary school pupils in the Strathclyde Region of Scotland and it is fair to say at this point that the results obtained from the research did not support the hypothesis. The broader context for the research consisted of the provisions made by the Roman Catholic Church in Scotland for the religious education of its members of secondary-school age. These provisions in turn reflect the official position expressed by the central authorities of the Roman Catholic Church from the time of the Second Vatican Council.

A. THE SECOND VATICAN COUNCIL

The Second Vatican Council changed the face of the Roman Catholic Church and its attitudes towards its place in the contemporary world. The views it expressed about education stimulated a marked change in approach in religious education.

The Roman Catholic Church's thinking about education had never before been stated as thoroughly and authoritatively as it was in the official statements of the Second Vatican Council, which met from 11th October 1962 to 8th December 1965.^[1] The Council promulgated its statements in Latin, in the form of sixteen documents, between 4th December 1963 and 7th December 1965, the day before its formal closure. A Declaration on Christian Education (Gravissimum Educationis)^[2] was promulgated on 28th October 1965 after a majority vote of 2290 to 35, and contains the Council's major pronouncements on the topic, although the theme also occurs in a number of the other documents.

Vatican II laid the foundations for all of the Roman Catholic Church's subsequent thinking, particularly on the attitudes its members should adopt towards the societies in which they live. Education has been no exception, as may be seen from the norms, instructions and official comments issued by the popes, or authorised by them, since the Council closed. Six issued to date (August 1982) have been supplemented by statements by the Scottish Roman Catholic bishops, to apply to the particular needs of Roman Catholic education in Scotland. All have referred directly to Vatican II as their basis, and have quoted from its documents. There had been many official statements on education before Vatican II, of course, but at least implicitly the Council's statements superseded them, as may be seen by the changes made in the draft proposals, changes both of principle and of detail, before they reached the stage of official acceptance and promulgation^[3].

From Pope John XXIII's announcement that he intended to convoke an 'ecumenical' council, to the formal opening of Vatican II near the end of 1962, there were nearly four years of preparation of the agenda and draft documents by a number of preparatory commissions. It was widely expected that much of this preparatory documentation, theologically conservative in tone, would be accepted by the bishops with little modification, and that the Council would not need very long for its deliberations. As the Council was to be composed of all the Roman Catholic bishops of the world, it could hardly have been anticipated that they would spend a quarter of each year in Rome for four years, and take up an approach so different from that suggested to them in the preliminary documentation.

The main pronouncement on education was no exception to this unexpectedly new attitude adopted by the great majority of the Council members. Pope John himself drew up a list of questions for consideration by the Council, which were to form the basis of draft documents drawn up by a Preparatory Commission. Among these questions were a series on the topic of Roman Catholic schools - the rights of the Roman Catholic Church and of parents, and the duty of the State towards them - prompted by difficulties being experienced by Roman Catholic schools in some parts of the world, and the belief by Church authorities that a growing number of Roman Catholic parents were not sending their children to Roman Catholic schools even where they were available. Consequently, the first schema concentrated on the importance, maintenance and organisation of Roman

Catholic schools; their relationship to the family and the Church; and the provision of teachers for them. These aspects of Roman Catholic education were placed within the context of general principles, and two further sections were added on Roman Catholic universities and on obedience to the ecclesiastical authorities in everything concerned with theological studies, particularly biblical interpretation and the unique place of St. Thomas Aquinas.

This approach to the question of education was maintained well into the middle of the actual meetings of Vatican II at the end of its second year. By then the proposed schema had been considered by five different Council commissions and had reached its fifth draft. The fourth draft had even been sent out to all the bishops attending the Council. At this point the commission responsible for the progress of the Council's business asked for the whole proposal to be reduced to a general statement of principles about education and Roman Catholic schools, which the Council could pass, leaving all the details to the canon law revisions to be made after the Council had ended. It was further proposed to reduce this general statement to seventeen propositions about Roman Catholic schools, and these were the basis of the sixth draft sent out to the bishops before the third session of the Council in its third year of meetings. But the whole question had by then been so reduced in importance that the bishops and the commission responsible for the presentation of this topic strongly reacted to the curtailments and insisted that it be given adequate space in the Council's

agenda. The delays and changes of format had not in fact been a waste of time, for when the topic did come before the Council it was with a very different approach from anything that might have been anticipated from initial proposals or from the official attitude towards Roman Catholic education before the Council began.

Instead of a statement on Roman Catholic schools, the Council in its third session (on 17th November 1964) received as the seventh draft a Declaration on Christian Education, which it discussed for two days during which twenty-one of the Council members spoke to it and a further thirteen would have done so if there had been time. Before being issued in an authoritative version, the Council now voted on the main substance of the text which had been presented to it, with the understanding that there would be opportunity for written comments and revision in commission before it was asked to approve a final version. In the voting on this seventh draft, more than 25% voted against accepting the whole schema on principle, mainly because it was felt that it did not sufficiently emphasise the importance of Roman Catholic schools or provide a sufficiently strong defence of them for use in parts of the world where they were forbidden or under threat. Lesser, but substantial, minorities voted against sections of the schema, but in every case the majorities were large enough to allow the seventh draft to go forward for revision and final presentation^[4].

Nearly a year elapsed before the final, eighth, draft was put to the Council, when the Declaration on Christian

Education [Gravissimum Educationis] was accepted with only 35 votes against it and more than 2000 votes for it. Many suggestions had been received for emendation since the presentation of the seventh draft, and the eighth draft was double the length; moreover the Council knew that there would be a thorough review of the Roman Catholic Church's central organisation after the Council, and this would include adequate provision for controlling and influencing educational matters. In fact, when the reforms of the Roman Curia (the central administration of the Church) came into effect on 1st January 1968, they included a 'Congregation for Catholic Education', one of the ten permanent commissions for conducting the Roman Catholic Church's life and work, with three sections for seminaries, Roman Catholic universities, and Roman Catholic schools respectively [5]. Implementation of the general educational principles and recommendations enunciated by the Council would be the responsibility of the bishops of each province or 'episcopal conference' for their own area. In the case of Scotland, the two provinces (St. Andrews and Edinburgh, and Glasgow) operate as one episcopal conference with a single education commission [6].

In its final form Vatican II's Declaration on Christian Education contained twelve articles with an introduction and a conclusion [7]. The first four articles enunciate educational principles, beginning with the universal right of every person to education, irrespective of race, condition and age, ". . . corresponding to his proper destiny and suited to his native talents, his sex,

his cultural background, and his ancestral heritage"[8], and then identifying the distinctive nature of Christian education, the duties and rights of the people responsible for education, and the means used by the Roman Catholic Church for achieving its educational aims.

The next three articles [5 - 7] are concerned with schools in general, their importance, the rights of parental choice and the limits of State control, and the Roman Catholic Church's duty to provide for the moral and religious education of those of her members who are school children. It is worth noting here that these sections emphasise the pluralistic nature of modern society, in which the State should make provision for the range of cultural needs under its jurisdiction, and ensure that its educational provisions do not ". . . militate against the native rights of the human person, the development and spread of culture itself, the peaceful association of citizens, and the pluralism which exists today in very many societies"[9].

When, in the next two sections, this document turns to Roman Catholic schools, it is thus able to do so within the wider context of the rights of all groups within a pluralistic society. Articles 8 and 9, then, deal with Roman Catholic schools: the Roman Catholic Church's right to establish and control them; their distinctive characteristics; what is expected of teachers and parents; and the wide range of kinds of school needed to meet the range of situations that exist within societies and in different localities. Again, the rights of Roman Catholic schools

are argued within the wider context of the protection of general human rights: ". . . this sacred Synod proclaims anew . . . the Church's right freely to establish and to run schools of every kind and at every level . . . the exercise of this right makes a supreme contribution to freedom of conscience, the protection of parental rights, and the progress of culture itself"[10].

Articles 10 and 11 are concerned with Roman Catholic institutions for higher education and with faculties of theological studies. The final Article, 12, urges cooperation in educational work, so that there is coordination of all the various activities within Roman Catholic provisions for education, "and that between these [Roman Catholic] schools and others that kind of collaboration develops which the well-being of the whole human family demands"[11]. The introduction to the Declaration and its brief conclusion emphasise how large and urgent is the world-wide need for education, "implore" young people to consider becoming teachers, and express the "profound gratitude" and encouragement of the Council towards those who have accepted this vocation.

As this study is mainly concerned with the religious attitudes of Roman Catholic secondary school pupils, it is appropriate here to examine the Vatican II Declaration on Christian Education for the light it throws on this particular aspect of education and the needs of this particular age group. The starting point is to be found in Article 2, which derives specifically Christian educational needs from the nature of baptism, which is the

means by which "every Christian has become a new creature by rebirth from water and the Holy Spirit"; from this beginning he has then to "grow into manhood according to the mature measure of Christ, and devote himself to the upbringing of the Mystical Body"[12]. As by far the larger number of Roman Catholics are baptised shortly after birth, Christian education includes the period of formal education as well as the years that precede and follow it. From this very general (and biblical) description of the Christian growth to Christ-like maturity, this part of the Declaration derives more specific aims. The Christian education received by the baptised person should provide a steady introduction "into a knowledge of the mystery of salvation"; opportunity to "daily grow more conscious of the gift of faith"; the means for learning "to adore God the Father in spirit and in truth, especially through liturgical worship"; and training for the conduct of personal life "in righteousness and in the sanctity of truth, according to his new standard of manhood"[13]. This new standard for the baptised Christian is, of course, Christ.

Christian education, then, aims to provide knowledge, consciousness, adoration and personal conduct all of the kind revealed by Jesus Christ. The ultimate aim remains "that Christian transformation of the world by which natural values . . . contribute to the good of society as a whole"[14]. No mention has yet been made of Roman Catholic schools, and it is clear from the way the Declaration is constructed that the Council did not

consider that these aims could only be achieved through such schools. The whole emphasis is on the use and transformation of natural values and the general nurture provided by society in such a way as to develop specifically Christian values, for the Christian believes that the world itself is redeemed by Christ and capable of being penetrated and perfected by him [cf. Vatican II Decree on the Apostolate of the Laity, Section 5].

Christian education is neither something separate from other kinds of education, nor a mere addition, but the transformation of education to lead to the kind of full humanity exemplified by Christ.

"Pastors of souls" must make it their duty to see that this kind of education is available, but the primary responsibility rests with the parents. They have conferred life on their children, and it is they who have "a most solemn obligation to educate their offspring . . . as the first and foremost educators of their children. Their role as educators is so decisive that scarcely anything can compensate for their failure in it"[15]. They are to build on the child's baptism ["according to the faith received in baptism" - loc. cit.] so that he may be taught the knowledge of God, habits of worship, and love of neighbour, aims which are condensations of the general aims of Christian education expressed earlier in the Declaration.

The document's line of thought can now lead to the role of society and the State. It is through the family that children begin to discover their place and

responsibilities within the larger society to which they belong, so the rights and duties of the State in education derive from its responsibilities towards the families which constitute it, as well as from its responsibilities "to arrange for the temporal necessities of the common good". It fulfils these duties in three ways: by oversight of the way parents and other people with responsibilities in education go about their task, such as ensuring that children do in fact have an adequate education and are given the freedom to benefit from it; by active assistance, such as making provision for education through State-funded schooling; and "by implementing the principle of subsidiarity"[16]. This passage in Article 3 recognises that the State has a vital role in education, not merely as the parents might delegate part or all of their duties to it, but as part of its responsibility towards the larger society and its good. This Article also asserts the responsibility of the Roman Catholic Church in education, not only to its members but to all mankind "because she has the responsibility of announcing the way of salvation to all men" as well as providing its members with the means of growing into the fullness of Christ[17]. This broader claim need only be noted here, since this study is specifically concerned with Roman Catholic children, but it is interesting to see that it establishes a three-way co-responsibility involving parents, the State and the Roman Catholic Church.

Although it is mentioned in only one other of the Council's documents, the particularly influential Gaudium

et Spes [usually referred to as 'The Church in the Modern World'], the Declaration on Christian Education invokes a principle with far-reaching consequences when it refers to "the principle of subsidiarity" in connection with the State's responsibilities in education. Abbott's edition of the English translation of the Documents of Vatican II provides a useful footnote which gives something of the history of this principle^[18]. The principle was formulated in 1931 by Pope Pius XI [1922-1939], whose main energies were directed towards establishing more credible relationships between the Roman Catholic Church and the secular states of the modern world. He established the modern papal view of its role in world affairs not as a sovereign state, nor indeed as having the duty to regulate secular society, but as head of the Roman Catholic Church, and from this stance he was able to negotiate practical relationships with a number of states regarding the Roman Catholic Church's activities within their jurisdiction. Most important of these was the Lateran Treaty of 1929 between the papacy and the Italian government, which established the modern status of the Vatican. The Second Vatican Council was a logical and necessary consequence of Pius XI's initiatives, for it was able to survey the whole consequences of this new attitude of the Roman Catholic Church towards its members' role in society and of the attitude it thought the State should adopt. The "principle of subsidiarity" goes to the heart of what should be expected from the State, and was enunciated in the encyclical Quadragesimo Anno: "Just as it is wrong to withdraw from the individual and commit to the community at large what private enterprise and endeavour can accomplish,

so it is likewise unjust and a gravely harmful disturbance of right order to turn over to a greater society of higher rank functions and services which can be performed by lesser bodies on a lower plane"[19]. Pope John XXIII reasserted this principle himself in the encyclical Mater et Magistra [1961]. Applied to education, it can be interpreted to mean that the State should not take over functions which can be performed satisfactorily by groups within the State or organisations in which the actual parents can participate or which they can influence, for the primary responsibility for education remains always with the parents. It might be noticed also, perhaps, that there is a sense in which the principle could be applied to the Church itself, as an organisation analogous to a state, if it overrides parental rights in ways which make it impossible for them to exercise their proper responsibilities. It will be necessary to return to this point.

The place of the Roman Catholic school in implementing the general principles of education is only approached in the Declaration after a consideration of schools as such. In Article 7 it sees schools performing seven interrelated functions: cultivating the intellect; developing the capacity for right judgement; introducing pupils to their cultural heritage; promoting a sense of values; preparing pupils for earning their living; fostering understanding between people of different temperaments and backgrounds by bringing them together; and creating a centre of cooperation and activity for the many groups and individual members of "the entire human community"[20]. These functions

are taken for granted when the Declaration moves on to consider the schools directly organised or controlled by the Roman Catholic Church, and underlie all that it has to say about the distinctive purpose of such schools. It is first expected that they will effectively perform the general functions of schools as such and transform these functions by the particular insights of the Christian gospel. If they fail to perform these basic functions, they necessarily fail to perform the more specific functions for which they exist as religious institutions.

The specific functions of Roman Catholic schools are stated in Article 8, which says of "the Catholic school" that "it has several distinctive purposes". They are:

- a) "to create for the school community an atmosphere enlivened by the gospel spirit of freedom and charity";
- b) "to help the adolescent in such a way that the development of his own personality will be matched by the growth of that new creation which he became by baptism"; a statement which applies the belief in Christ's redemption of the natural order to the particular circumstances of the school;
- c) "to relate all human culture eventually to the news of salvation, so that the light of faith will illuminate the knowledge which students gradually gain of the world, of life, and of mankind"; which again presents Christian education not as a substitute for other kinds of education, with a different curriculum, but as one which relates all 'natural' knowledge to a full understanding of the world's relationship to God;

- d) "to promote effectively the welfare of the earthly city" through the education of its students, for which task "the Catholic school fittingly adjusts itself to the circumstances of advancing times";
- e) to prepare its pupils "to serve the advancement of the reign of God".

So the overall purpose of the specifically Roman Catholic school is to make formal education's contribution to the natural and spiritual development of its pupils, not only for their own personal needs but also that they "can become, as it were, the saving leaven of the human family"(21). The Article continues with assertions of the Roman Catholic Church's "right freely to establish and to run schools of every kind and at every level", with the quality of teacher needed for them to be effective, and it again asserts the importance of the parents. The teachers are to perform their duties in partnership with the parents. The Article concludes with a reminder to parents that they have a duty to support and help Roman Catholic schools, and to send their children to them "when and where this is possible".

The Article on Roman Catholic schools is the longest individual section in the Declaration, and reflects the deep concern many members of the Council felt that the importance of such schools might be diminished by placing them so completely within statements about the importance and functions of all education. By the time the Council finally voted on this document, more than three years after the Council had opened, the first draft of this part had been expanded to four times the original length. The proposals

first put to the Council had concentrated specifically on Roman Catholic educational provisions, and almost until the final vote on this document there were many members who still wanted any official document to go out in this form. Although all but thirty-five of the Council members voted for the document as it was finally promulgated, the whole Council was being circularised up to the last moment to urge rejection of it. Even the substitution of 'Christian' for 'Catholic' in the title was thought a watering down of the 'Church's' position on education, for all the official statements assume or assert that 'Catholic' means Roman Catholic, that the 'Church' is the Roman Catholic Church, and that "it is through Christ's Catholic Church alone, which is the all-embracing means of salvation, that the fullness of the means of salvation can be obtained"(22).

With the Article on Roman Catholic schools, the main relevance of the Declaration for this study has been reached. The remaining articles list the main types of Roman Catholic schools needed to meet the range of situations and pupils in modern society, and continue with universities and faculties of theology. As has already been noted, the final Article enjoins that "every effort should be made" not only to coordinate the various elements in Roman Catholic education, but also "that between these schools and others that kind of collaboration develops which the well-being of the whole human family demands"(23). The right to separate schools, asserted earlier in the Declaration, is not intended to encourage Roman Catholics to avoid establishing the closest possible relationships

with other sectors of the educational system in any society.

On the specific question of the aims and functions of Roman Catholic schools, and their effectiveness for the children entrusted to them, Articles 7 and 8 of the Declaration can now be seen as the ones most directly relevant, for they deal with the aims and functions all schools should fulfil, and the special contribution Roman Catholic schools make to these aims and functions for their pupils. It might be helpful to say at this point that within the limitations of this study the empirical enquiry looked at Roman Catholic pupils both in Roman Catholic schools and in other schools, and was concerned with the pupils' attitudes towards six interrelated aspects of the Christian faith as Roman Catholic children might be expected to experience it, whether through their schools, their families, or the parishes in which they live. These are their attitudes towards God, Jesus Christ, prayer, the Bible, public religion (including religious education in the schools), and the Roman Catholic Church itself. Below [pp.31,35] it will be shown that these are in fact aspects of the Christian faith which the Roman Catholic Church considers vital in the religious formation of its members, even though this may perhaps be taken for granted.

The broad theological foundations which the Declaration on Christian Education builds on could be illustrated from many of the Council documents, but some of them make such explicit statements that it is worth noting them here. The general aims of education are expounded in Article 61 of The Church in the Modern World

[Gaudium et Spes] in terms of the need to reassert the unity of human culture and of human nature: "For while the mass and diversity of human cultural factors are increasing, there is a decline in the individual man's ability to grasp and unify these elements . . . Nevertheless, it remains each man's duty to preserve a view of the whole human person, a view in which the values of intellect, will, conscience and fraternity are pre-eminent. These values are all rooted in God the Creator and have been wonderfully restored and elevated in Christ." It goes on to speak of opportunities available for education, in the widest sense, in the modern world, and how these should be used to relate all aspects of culture to the value of the human person. This particular Article also affirms the importance of the family in this educative process, particularly as the chief means of effecting the synthesis of the various aspects of human knowledge by the family's practical relating of them to its everyday needs and testing their value: "The family is the primary mother and nurse of this attitude. There, in an atmosphere of love, children can more easily learn the true structure of reality. There, too, tested forms of human culture impress themselves upon the mind of the developing adolescent in a kind of automatic way"⁽²⁴⁾. The general aim of education is related to conscience in Article 31, as an aim of all education and not as an aim specific to religious formation. Knowledge is here seen as essential for the proper operations of conscience, to enable the individual to discharge his obligations most effectively both to himself and to the society to which he belongs.

The education of youth is particularly important from this point of view[25].

The same document of Vatican II firmly asserts that it is the parents who have the primary responsibility for the education of their children, both for their general education and for their growth to religious maturity, and it is the parents who have the responsibility to make decisions about this. They will be able to make right decisions, of course, only if they realise that they are instruments of God's creative love, and are submissive to his will, but their responsibilities derive from their natural relationship to their children, and are not dependant on their Christian profession[26].

The fundamental responsibility of parents in education is pressed again in the Decree on the Apostolate of the Laity [Apostolicam Actuositatem], where it is derived from God's plan of creation: "Since the Creator of all things has established the conjugal partnership as the beginning and basis of human society and, by his grace, has made it a great mystery in Christ and the Church . . ." parents are cooperators in God's creative grace, particularly towards their children and their education. To this end, they should do all they can to ensure that government policies recognise this need of their families and their parental rights, along with such other needs as housing, working conditions, social security and their right to live together as a family[27].

References to religious education have already been noted in documents from Vatican II, and the document on

the Laity, mentioned above, sees this as an essential part of the formation of lay people to enable them to understand and discharge their apostolic responsibilities. It will be an important part of the curriculum in Roman Catholic schools, and should be provided for all Roman Catholic children who do not attend Roman Catholic schools - for whatever reason: "If young people lack this formation [the development of "a Catholic sense and apostolic activity"] either because they do not attend these [Roman Catholic] schools or because of any other reason, parents, pastors of souls, and apostolic organisations should attend to it all the more"(28). This is a point of particular relevance to this study, where provision for the religious education of Roman Catholic children in non-Roman Catholic schools will prove to be a significant factor in relationship to their religious attitudes.

The most important reference for our present purpose occurs in the Decree on the Bishops' Pastoral Office in the Church [Christus Dominus] for this is the only place where there is explicit listing of the appropriate primary source materials and experiences for religious education. The brief Article 14 of this document deals with 'Catechetical training' in a way which makes it clear that this is meant to be seen as religious education in the widest sense. After stating that its aim is "to make men's faith become loving, conscious, and active", and that it is needed by people throughout their lives, the Article goes on to make two points of particular relevance to religious education in schools. The first is that "In this

instruction a proper sequence should be observed as well as a method appropriate to the matter that is being treated and to the natural disposition, ability, age, and circumstance of life of the listener." Very serious efforts have been made in the years following the Council - and will continue - to design syllabuses and curricula of religious education which are as professionally effective as any of the best in other subjects, and as attractive to the pupils. But the second point is equally relevant: the bishops are to ensure that religious education "is based on sacred Scripture, tradition, the liturgy, the teaching authority, and the life of the Church"(29). This list of sources covers what the Roman Catholic Church understands to be "the deposit of faith", public worship, and the experience of full participation in the faith community and its hierarchical structure. Whether or not they are in Roman Catholic schools, children being brought up in this tradition should receive a religious education drawn from the full range of these sources, and if it is not available in their schools it should be provided for them in some other way. At first sight it may seem strange that the documents issued by the Council give so little detailed guidance about the implementation of responsibilities such as religious education which it clearly considers to be so important, but this need is met in a more practical way than would have been possible for the Council itself, by it ordering that practical directories should be produced, one of which would be concerned with "the catechetical instruction of the Christian people. It

should deal with the fundamental principles of such instruction, its arrangement, and the composition of books on the subject"[30]. This was implemented in 1971 by the Vatican's Sacred Congregation for the Clergy, and was translated into English as the General Catechetical Directory.

References Vatican II Section

- [1] Abbott, W.M. [Ed] The Documents of Vatican II
[Geoffrey Chapman, London 1967]
- [2] Only the Latin text, approved by a majority vote of the bishops and signed by the Pope and the bishops before being promulgated, is official, but here the documents will be referred to by the English titles of the translation edited by Walter M. Abbott, which will also be used for any quotations. See Abbott 1967.
- [3] Pohlschneider 1969
- [4] Ibid.
- [5] The Catholic Directory 1969
- [6] The Catholic Directory for Scotland 1982
- [7] Abbott 1967
- [8] Ibid., p. 639
- [9] Ibid., p. 644
- [10] Ibid., p. 646
- [11] Ibid., p. 650
- [12] Ibid., p. 640
- [13] Ibid., p. 640
- [14] Ibid., p. 640
- [15] Ibid., p. 641
- [16] Ibid., p. 642
- [17] Ibid., p. 642
- [18] Ibid., p. 300
- [19] Acta Apostolicae Sedis 23, quoted in the translation published by the Catholic Truth Society under the title 'Reconstructing the Social Order' (London, 1931).

References Vatican II Section

- [20] Abbott 1967, p. 643
- [21] Ibid., p. 646
- [22] Ibid., Article 3, Decree on Ecumenism, Unitatis
Redintegratio
- [23] Ibid., p. 650
- [24] Ibid., p. 267
- [25] Ibid., Article 31, p. 229
- [26] Ibid., Articles 48, 50, pp. 251f., 254
- [27] Ibid., Article 11, p. 502
- [28] Ibid., Article 30, p. 518
- [29] Ibid., p. 406
- [30] Ibid., Article 44, p. 428, Decree on the Bishops'
Pastoral Office, Christus Dominus

B. THE CREDO OF THE PEOPLE OF GOD.

As has already been noted [p.21, above], the Second Vatican Council in its instructions to bishops on the discharge of their pastoral office, required them to ensure that religious education is based on "sacred Scripture, tradition, the liturgy, the teaching authority, and the life of the Church"^[1]. Part of this list covers the contents of the 'deposit of faith', which it understands is referred to in I Timothy 6:20, where Timothy is enjoined to keep safe what "has been entrusted to you" (the phrase used by both the Jerusalem Bible and the New English Bible).

For the sake of clarity, it is worth noting the specifically Roman Catholic understanding of the phrase 'deposit of faith', as described in Vatican II's Dogmatic Constitution on Divine Revelation (Dei Verbum). This document states that "the apostolic preaching . . . was to be preserved by a continuous succession of preachers until the end of time." It included "everything which contributes to the holiness of life, and the increase in faith of the People of God; and so the Church, in her teaching, life, and worship, perpetuates and hands on to all generations all that she herself is, all that she believes." But it is not a static tradition, fixed once and for all in form and content: "This tradition which comes from the apostles develops in the Church with the help of the Holy Spirit. For there is a growth in the understanding of the realities and the words which have been handed down. . . . the Church constantly moves forward towards the fullness of

divine truth until the words of God reach their complete fulfilment in her." The 'deposit of faith' is the unity of sacred Scripture [in which "the apostolic preaching is expressed in a special way"] and this developing tradition: "Sacred tradition and sacred Scripture form one sacred deposit of the word of God, which is committed to the Church". Through those authorised to teach, the Church "draws from this one deposit of faith everything which it presents for belief as divinely revealed"(2).

A little over two years after the close of the Second Vatican Council, Pope Paul VI, who had succeeded John XXIII at his death in 1963, proclaimed a 'Year of Faith' to commemorate the nineteenth centenary of the martyrdom of the Apostles Peter and Paul. At its close, on the 30th June, 1968, Paul VI said that he had dedicated the year to the memory of the apostles "with the express purpose of witnessing to our determination to guard undiminished the 'deposit of faith' which they delivered to us" and to relate it to the present day(3). He went on to state that he was declaring "a profession of faith" which, although not a dogmatic definition in the strict sense when the Roman Catholic Church believes the Pope is speaking infallibly, would be an expression of the 'deposit of faith' in terms which interpret it "in accordance with the spiritual requirements of our times"(4). It would be faithful to the Council of Nicaea, but would reassure those who were unsettled in their faith by the changes occurring in the world, and by some of the research in theology which has undermined the Church's teaching. To this end this

post-Vatican II summary of the 'deposit of faith' was "sufficiently comprehensive and explicit to satisfy convincingly the need for light which is felt so strongly by so many of the faithful and by all those in the world - whatever be their religious affiliation - who search for the truth"[5]. Paul VI thus intended this statement of the 'deposit of faith' not only for 'the faithful' [which in the course of his statement he makes clear means the members of the Roman Catholic Church], but for all others, including other Christians.

The statement itself, well over two thousand words long in its English translation, is cast in the form of the Nicene Creed but expanded to ten times its length. It takes in and amplifies the main and distinctive Roman Catholic doctrinal positions, and anchors its statements with some forty references to official statements of the Roman Catholic Church, including those of Vatican II. It might reasonably be expected, therefore, that it would play an important part in the content of Roman Catholic religious education and, indeed, provide that Church with powerful arguments for the need for the distinctive religious education of its members. The Roman Catholic beliefs about the nature of the Church are central to its position on the religious education of its members, whether children or adults, and whether the religious formation of children takes place within the school or through some other means.

The statement sets out with care, the position regarding the Church. The Church is "a visible society, hierarchically structured, . . . the Church on earth,

the People of God on pilgrimage, the Church enriched with heavenly blessings, the germ and beginning of the Kingdom of God". It is formed by Jesus "through the Sacraments which derive from his own plenitude", and is built on the foundation of the apostles. In particular, the apostles are the basis of the Church's authority to teach: "Their ever-living word and their pastoral powers she [i.e. the Church] hands on faithfully in every century to the Successor of Peter and to the Bishops in communion with him. The Holy Spirit unfailingly assists her in her charge of guarding, teaching, explaining, and spreading that truth which was foreshadowed in the prophets and which God fully and completely revealed to men in the Lord Jesus . . . We believe that the Church which Christ founded and for which he prayed is indefectibly one in faith and in worship, and one in the communion of a single hierarchy"[6]. The statement goes on to recognise diversity of heritage and custom within this unity, and to recognise that "many elements of holiness and truth" are to be found "outside the framework of the Church of Christ", but the central assertion is crystal clear: the 'Church' is the Roman Catholic Church, identified by its hierarchical structure culminating in the See of Rome. Any person or organisation outside this can only have at best a limited access to "that truth . . . fully and completely revealed to men in the Lord Jesus".

In other places, the statement expands the classical creeds of Christianity to incorporate further developments of belief. Of Mary, there is asserted her freedom from all stain of sin, her perpetual virginity, that "she was

redeemed in a more exalted manner . . . , outstripping in excellence all other creatures by reason of the grace given her"[7], and her bodily assumption into heaven.

Original sin is described in terms of the inheritance of human nature by descent from Adam, and not by means of mere imitation of Adam. It is proper, says the statement, to give baptism to infants "in order that, though born deprived of supernatural grace, they may be reborn of water and the Holy Spirit to divine life in Christ Jesus"[8].

In two long sections, the statement is explicit about the theology of the Mass, which "is indeed the Sacrifice of Calvary sacramentally realized on our altars". Christ's presence "is a true, real and substantial presence", and this presence is described explicitly in terms of 'transubstantiation': ". . . in this Sacrament there is no other way in which Christ can be present except through the conversion of the entire substance of bread into his Body and through the conversion of the entire substance of wine into his Blood, leaving unchanged only those properties of bread and wine which are open to our senses . . . Any theological explanation intent on arriving at some understanding of this mystery, if it is to be in accordance with Catholic faith, must maintain, without ambiguity, that in the order of reality which exists independently of the human mind, the bread and wine cease to exist after the consecration"[9].

In a more incidental way, the statement also refers to Purgatory, angels, and the efficacy of prayer to the saints and holy angels who "in different degrees and ways

. . . share . . . in that exercise of divine power which belongs to Christ in his glory when they intercede for us and come to the aid of our weakness in brotherly care"(10).

In this document Paul VI paved the way for more explicit official consideration of the Roman Catholic Church's religious formation of its members, and in particular for the implementation of Vatican II's requirement, already noted, that the Church should issue a practical directory on religious education. He himself issued an Apostolic Exhortation, Evangelii Nuntiandi, in 1976; he established an International Council for Catechesis in 1975, and made it the subject for the General Assembly of the Synod of Bishops which met in October 1977. To these should be added the Directory for Masses with Children, issued by the Vatican's Congregation for Divine Worship in 1973, which asserts the importance of worship as a pedagogical force. It may fairly be claimed that Paul VI, who succeeded John XXIII as Pope shortly after the Second Vatican Council had started its work, made religious education one of the main concerns of his pontificate, and tried to ensure that the attitudes of Vatican II were faithfully expressed in detailed guidance and directions for this field. At the same time - and for some people to too great an extent - he was anxious to preserve continuity with the attitudes characteristic of the Roman Catholic Church before Vatican II. This latter may perhaps be seen in his Credo of the People of God, where many of the Roman Catholic beliefs associated with the period before Vatican II are expressed in quasi-credal form.

Whether or not Paul VI's statement of the contents of the 'deposit of faith' is seen as a return to the Roman Catholic Church's stance before Vatican II, it is a powerful and comprehensive summary of a modern pope's officially expressed understanding of the nature of the Church, its membership and its beliefs. If this kind of understanding is effectively taught, it might be expected to encourage positive attitudes towards the Church, participation in public celebrations of the Mass, the Bible as a vital source of information about Jesus Christ and the period when the Church was founded under the leadership of Peter and the other apostles, and even of positive attitudes towards the kind of lessons devoted specifically to religious education in Roman Catholic schools. More generally, there would be positive attitudes towards the aspects of Christianity accepted as vital by all Christians, whether Roman Catholics or not, particularly the importance of God, the need for a strong personal relationship with God, the need for prayer, and the relevance of Jesus Christ to the lives of people immersed in the world of today. The survey associated with this study aimed to evaluate the strengths of such attitudes, and relate them to the schools to which the pupils belonged and the kind of religious education they received.

References Pope Paul VI Credo of the People of God

- [1] Decree on the Bishops' Pastoral Office in the Church,
14, p. 406
- [2] Vatican II, Dogmatic Constitution on Divine
Revelation 8, 10, pp. 115-18
- [3] Pope Paul VI, 1968, p. 3
- [4] Ibid., p. 4
- [5] Ibid., p. 5
- [6] Ibid., pp. 10F
- [7] Ibid., p. 8
- [8] Ibid., p. 9
- [9] Ibid., pp. 12F
- [10] Ibid., pp. 14F

C. THE GENERAL CATECHETICAL DIRECTORY.

In the field of religious education, the most important official Roman Catholic document to date, since the end of the Second Vatican Council, has been the General Catechetical Directory issued by the Vatican's Sacred Congregation for the Clergy in 1971 to give detailed directions for implementing Vatican II's teaching about religious education. In this context, 'religious education' is meant in the broadest sense as the responsibility "to proclaim and promote the Faith in contemporary society"⁽¹⁾, and presumably explains why it comes within the province of the Sacred Congregation of the Clergy. In other words, the Directory is concerned with the whole area of pastoral theology, of which religious education in the narrower sense is to be seen as a part, and the religious education of children of school age as but one aspect of religious education. This approach does have the advantage of tackling the whole social context of religious education: the family, parish, and school in a particular locality, and the broader ecclesiastical and secular social structures of which they are members.

It is beyond the purpose or needs of this study to examine the Directory in all the areas it tackles, so it will be sufficient to note its general structure and then observe its comments on the religious education of children at school. The whole Directory is divided into six parts, the first of which examines the nature of the problems facing Christianity in contemporary, pluralistic human society with its rapid rate of change amidst religious

indifferentism and atheism. The following two parts deal with the ministry of the word, beginning with the nature of divine revelation; and with the Christian message as Trinitarian and Christocentric, expressed in the sacraments and Christian moral response to God, as well as by teaching the message of salvation explicitly. The Directory then turns, in part four, to a general statement of the principles of methodology, and in part five, applies these to the needs of the various age levels from infancy to old age. Finally, in part six, it points out the need for comprehensive planning related to the local situation, which develops and coordinates the resources needed for each particular area. Normally, such planning will be the responsibility of the 'Conferences of Bishops', where a 'Conference of Bishops' means the bishops of a particular locality recognised as having corporate responsibility for its pastoral needs. Scotland is the responsibility of a single Conference of Bishops, which has established a Catholic Education Commission as its advisory body for this aspect of its pastoral work.

The consideration already given in this study to the 'deposit of faith' makes it unnecessary to spend undue time on the first three parts of the Directory, which reaffirm the teaching on this already given by Vatican II and Pope Paul VI when describing the content of the Christian message. But it is worth noting a passage on 'sources of catechesis' in the Directory's part three, 'The Christian Message', for it shows the range of sources the Roman Catholic Church has in mind, and also has an important link with the general

method of teaching recommended in the next part.

The passage occurs in Paragraph 45: "The content of catechesis is found in God's word, written or handed down; it is more deeply understood and developed by the people exercising their Faith under the guidance of the Magisterium, which alone teaches authentically; it is celebrated in the liturgy; it shines forth in the life of the Church, especially in the just and in the saints; and in some way it is known too from those genuine moral values which, by divine providence, are found in human society"(2).

This description of the primary sources of religious education lists six forms of experience or activity available for an understanding of the message of salvation and full acceptance of it so that people may be formed by it. Firstly, there is 'God's word, written or handed down', by which, as we have seen in the consideration of the concept 'deposit of faith', the Roman Catholic Church understands the combination of the Bible - 'Sacred Scripture' - and the Church's explicitly identified and promulgated tradition as it has accumulated down the centuries and which is at least implicit, the Roman Catholic Church claims, in the contents of the Bible. Secondly, there is faith. An earlier paragraph has drawn a distinction between faith "as the total adherence given by man under the influence of grace to God revealing himself, (the Faith by which one believes)" and faith "as the content of revelation and of the Christian message (the Faith which one believes)"(3). As a primary source for understanding the message of salvation, it is clear that it is faith in the first sense of

the word that is meant here, and it is worth noticing that this is seen as an active, rather than merely passive, attitude towards the other sources available: "By faith man accepts revelation, . . . consciously becomes a sharer in the gift of God, . . . with full homage of his mind and will, freely assents to the Gospel, . . . [is led] to full discernment of the divine will . . . and to cooperation"[4]. In this sense, faith is itself one of the means of access to the knowledge of God. Thirdly, there is the authoritative guidance of the 'Magisterium', which the Roman Catholic Church understands to be the teaching authority located corporately in the Pope and the bishops as successors of the apostles, or uniquely in the Pope, who "enjoys supreme, full, immediate, and universal authority . . . , a primacy of ordinary power over all the churches"[5].

For its fourth primary source for religious education or formation, the Directory lists the 'liturgy', which for Roman Catholics means participation in the celebration of the Mass or Eucharist and which, as has been noted from the Credo of the People of God, is seen as a special means of access to the central events of the Gospel in the death and resurrection of Jesus Christ. Fifthly, the history of the Church down to the present day is another source, particularly - but not exclusively - the lives of its members who are identified as saints or as 'just'. And finally, human society itself is a primary source of information through the evidence it provides of moral values. This particular passage in the Directory then warns that these sources differ in status and value, and

that people responsible for religious education or formation "must first and always look to the unquestionable pre-eminence of revelation, written or handed down, and to the authority of the Magisterium of the Church"[6]. But it remains of first importance that the Directory lists such a range of sources, that they include the active contribution of faith and of worship, and secular experience of life in the world.

Turning, then, to methodology, the kind of sources identified for religious education leads the Directory to point to the inductive method of teaching as the most appropriate way of growing into a full understanding of the Christian message of salvation. Experience needs to be crystallised in formulae and generalisations, but these need to follow from the evaluation of experience rather than precede it. The inductive method is described as "one of the fundamental processes of the human spirit . . . that comes to grasp intellectual realities through visible things", and with particular reference to spiritual formation, it is "a knowing through signs", and "the active exercise of the spiritual faculties and the constant reference to concrete things in the explanation of intellectual concepts"[7]. Experience is itself a dynamic process, in which the questions, hopes, anxieties, reflections and judgements interact with each other and merge into a pattern which forms a way of life. Religious education should direct attention to the "more significant experiences, both personal and social", so that they can be related to the Christian gospel and lead to an active response to

God. Approached in this way, the Christian message itself becomes more intelligible, just as Jesus in the parable method of teaching "recalled to mind certain human situations . . . in order to explain eschatological and transcendent realities, and then to teach the way of life which these realities demand of us". But revelation is itself an aid to understanding experience, for "by recalling to mind the action of God who works our salvation" the faithful are helped in their efforts "to explore, interpret, and judge their own experiences, and also to ascribe a Christian meaning to their own existence"[8].

For such an approach to be effective, the subjects of religious education, whatever their age, need to be actively and deeply involved both in the secular world and in the religious community, for they are members of both, and their experiences in the one will not make full sense without the other. There are fundamental principles here for decisions about the kind of school organisation most appropriate for spiritual development. It can be argued that church members of school age can best be guided in the development of their full personal potential where secular and religious experience are being constantly related to revelation within a school which is controlled by the local religious community. On the other hand it can also be argued that such a school, by its separate existence, prevents its members from having full access to the secular experience they need for a complete understanding of the Christian message, and isolates them. This present study must have this problem in mind in its

attempts to identify the religious attitudes of Roman Catholic secondary school pupils in Roman Catholic and other schools, and in its evaluation attempt to identify and explain any differences.

The Directory implicitly returns to the question of primary sources for religious education when it relates the experiential approach to "the economy of revelation and salvation", that is, the ways in which people should normally express their relationship with God. Religious education should stimulate an active response in those who are taught, and this "is in harmony with the general condition of the Christian life in which the faithful actively respond to God's gift through prayers, through participation in the sacraments and the sacred liturgy, through acceptance of responsibilities in the Church and in social life, and through the practice of charity"^[9]. For the Roman Catholic of school age, these activities will normally be exercised in his or her home locality, and in the religious sense, locality here means the parish. Again, a dilemma can arise where there is a local Roman Catholic school, for it can be argued (as the present Pope, John Paul II, has said) that there is need to make the school "a community of faith centred on the Eucharist" and provide it with a Chaplain 'above all' for this purpose^[10]. Religion should be integral to all the school's activities, it is argued, and the Mass is then seen as the most perfect and logical expression of this integration. But such a provision can also discourage the pupils from normal participation in the liturgical activities of the parish,

and so further isolate them from the full range of normal experience. Nevertheless, these considerations are secondary to the more fundamental point, that religious formation needs to draw on the whole range of activities and experiences, both religious and secular, and can never be the mere transmission of knowledge in the narrower sense, still less the learning of formulae divorced from experience.

The Directory makes an important point when it draws attention to the importance of the peer group in the life of adolescents. It is "a vital necessity" to them, not just an escape from involvement in the larger social organisation, for they find support and stimulation in the group to which they belong. It also enables them to develop the sense of cooperation and co-responsibility which they will fully exercise when adults, and to grow into an appreciation of the wider meaning of membership of the Church. The religious education of adolescents should therefore be seen as a group activity "exploring the mutual relationships and ties between the content of the Christian message, which is always the norm for believing and acting, and the experiences of the group"^[11]. Here again, it should be noted that the natural structure determines the religious approach; it is not a case of establishing groups for religious reasons, but of recognising that at this stage of development adolescents in fact form and need groups, and that this experience is an important beginning for the development of religious understanding. This perception can be used as an argument either for or against establishing

distinct schools controlled by the local religious community, but it will clearly be more convenient to integrate religious education into the adolescents' natural social structure if this is expressed within the context of a school closely related to a parish, than if parochial life and school life belong to different social structures.

Parents receive surprisingly little attention in the Directory, although their importance is emphasised for the early years of the child, and it is recognised that parents themselves need support and formation "given to them by competent educators" to help them with their responsibilities^[12]. But once the child goes to school their responsibilities diminish as they are shared with others now concerned in the child's religious education. This is not because the child has entered a Roman Catholic school - the Directory is concerned throughout with the general world-wide situation, where it is not normal for Roman Catholic schools to be available - but applies to all schools: "When the child goes to school he enters a society of adults in an intensive way that absorbs a great part of his resources and concerns . . . Before this point, the family served a mediating role between the child and the People of God. But now the child is ready to begin sharing directly in the life of the Church"^[13].

Two main consequences flow from this, one of them already mentioned. This is that the religious development of the child becomes more and more the responsibility of 'catechists' - specialist religious educators, whether priests or lay, and whether within the school or outside

it - and less and less that of the parents. There must be close cooperation between these people and parents, about the syllabus, methods and the difficulties encountered, to ensure that the process is suitable for the child and that there is no clash between home and other agencies, but it is clear that the parents no longer have the necessary level of competence and training for fully effective religious education of children of school age. Where the parents are indifferent about religion, the religious educators must do all they can to establish a dialogue with them, so that [as always] the programme of religious education for their children may be presented in a way that really responds to the concrete situation.

The other consequence concerns the child's full entry into the life of the local religious community, through admission to the sacraments. Normally, the Roman Catholic Church baptises children of its members at infancy, so 'admission to the sacraments' means admission to receive communion at Mass [there is no bar to children of any age being present throughout the Eucharist] and to the Sacrament of Penance, 'confession'. A long addendum to the Directory sets out guidelines about the appropriate age and sequence for children to become communicants and penitents, and rules that it should be the age "at which the child begins to reason, that is, about the seventh year, more or less. From that time on the obligation of fulfilling the precepts of Confession and Communion begins"⁽¹⁴⁾. In the Scottish system of education this means the second or third year of the primary school, where much of the

religious education programme is occupied with preparation for 'First Confession' and 'First Communion'. In view of the role of the liturgy as a primary source of religious education through the experience of full participation, this custom within the Roman Catholic Church is an important element in religious formation, particularly as there is laid on members a serious moral obligation to be present at Mass every Sunday and on certain other days which are major festivals. By the time children enter the secondary school in Scotland they will normally have been regular communicants for five years.

For the sake of completeness, and because the practice is so markedly different from that of some other churches, it should be noted that the Sacrament of Confirmation is normally administered three or four years after children have been admitted to full communion, during their last years in the primary school, where it functions as a 'rite of passage' for the transition to the secondary school. The change of experience is a deep one for the children, from a primary school which is normally comparatively small and near to the child's home, where it serves a very localised community, to the larger and often more remote secondary school. Where these are Roman Catholic schools, the primary school will normally be associated solely with the child's own parish, while the secondary school will serve a number of parishes. Confirmation is administered by the diocesan bishop, an aspect of the rite which brings the child into personal relationship with the wider religious community, and the rite lays emphasis on

the acceptance by the child of adult responsibilities. Even so, it is very probable that 'First Communion' makes the more vivid impression, if only because it leads to the visible difference in status of being able to receive communion at Mass.

The General Catechetical Directory was produced to make more explicit the teaching of the Second Vatican Council about education, and to lay down guidelines for its implementation in the wide range of circumstances where the Roman Catholic Church has members. For the purposes of this study of Roman Catholic secondary school pupils in part of Scotland, five aspects of the Directory's contents have been considered particularly relevant. It sets out the primary sources of religious formation: the information available in the Bible and tradition; the experience of faith as active response to God; the guidance of the Pope and bishops; participation in the liturgy; the history of the religious community and its members, including the experiences of the present day; and the moral values of secular society. It identifies an approach from concrete experience as the most effective and appropriate method for religious education. It clarifies the relationship of parents and specialist religious educators. It identifies the fundamental importance of the group and the school for adolescents. It lays special emphasis on participation in the liturgy - the Mass or Eucharist. This last point makes it appropriate to consider next another official Vatican publication which amplified the teaching of the Second Vatican Council for practical

purposes: the Directory For Masses with Children,
published by the Congregation for Divine Worship in 1973.

References General Catechetical Directory

- [1] General Catechetical Directory 1, p.13. Quotations are from the approved English translation commissioned by the United States Catholic Conference; references are to the original paragraph number, and to the page number in the edition published by the Incorporated Catholic Truth Society, London, in 1972. The Latin original is entitled Directorium Catechisticum Generale.
- [2] Ibid., p.42.
- [3] Ibid., 36, p.36; the italics are in the original.
- [4] Ibid., 15. p.25.
- [5] Vatican II, Decree on the Bishops' Pastoral Office in the Church, 2; Abbott p.397.
- [6] General Catechetical Directory 45, p.42.
- [7] Ibid., 72, 73, p.63.
- [8] Ibid., 74, p.64.
- [9] Ibid., 75, p.65.
- [10] John Paul II, 1982, 5.
- [11] General Catechetical Directory 76, p.66.
- [12] Ibid., 78, p.68.
- [13] Ibid., 79, p.69.
- [14] Ibid. Addendum 1, p.100, quoting from a Papal Decree of 1910.

D. THE DIRECTORY FOR MASSES WITH CHILDREN.

The Directory for Masses with Children, issued by the Vatican's Sacred Congregation for Divine Worship in 1973, has a specific purpose: to give rules and guidelines for adaptations of the Roman Catholic eucharistic rite when the majority of people present are children aged between five and eleven years. After that age, it is assumed that the forms of the Mass authorised for use with adults should be used, and this is therefore the case for children of secondary school age in Scotland where children normally pass from primary school to secondary school in their twelfth year. But in the explanations offered by the Directory for its rulings, it refers to the educational dimensions of the liturgy, and these educational principles apply to the later years of compulsory schooling in Scotland as much as to the earlier ones. For a Roman Catholic in Scotland, 'going to church' now almost invariably means attending Mass, so a statement about going to church can be used to elicit attitudes towards the public celebration of Mass. If, as is already evident in this study, the Mass is so important for Roman Catholics, it is essential for their religious formation that they should have a positive attitude towards participating in it. The Directory for Masses with Children makes it clear that the Roman Catholic Church holds the Mass to be an important primary source for the religious formation of children as well as older people, and not a form of worship appropriate only for adults.

The educational effects of the Mass are incidental to its main purpose, but they are nevertheless of great importance. The Directory refers to its "innate pedagogical force", and states that "even in the case of children, the liturgy itself always exerts its own proper didactic force"[1]. This is set out most clearly in the final words of the Directory, which speaks not only of the fundamental reason for children participating in the Mass, to encounter Christ and "to stand in the presence of the Father with him", but also of their 'formation' by the Mass: "If they are formed by conscious and active participation in the eucharistic sacrifice and meal, they should learn day by day, at home and away from home, to proclaim Christ to others among their family and their peers, by living the 'faith, which expresses itself through love'"[2]. Moreover, the Mass is seen as a means of formation in secular values as well as specifically religious ones, for the religious formation is continuous with the secular one, and perfects it. Consequently, "It is not right to separate such liturgical and eucharistic formation from the general human and Christian education of children. Indeed it would be harmful if liturgical formation lacked such a foundation"[3].

The human values expressed in the Mass, and experienced by children who are actively participating, are the cooperation of people in community for achieving a corporate objective; communication between people; the value of listening to others; the importance of seeking pardon from and granting pardon to others in the community; the

expression of gratitude; the importance of symbolic actions which express a deeper meaning than their immediate one; the use of meals as a means of expressing friendship; and the importance to the community of festive celebration^[4]. The religious dimension of the Mass is made possible by these human dimensions, which open the children's minds to the further Christian values and make it possible for them to appreciate the religious significance of the activity.

As a primary source for specifically religious formation, The Directory points to the Mass as the celebration of "the great deeds of God in creation and redemption", "to encounter Christ . . . and to stand in the presence of the Father with him", and the celebration of the paschal mystery^[5]. Children are particularly brought into contact with the foundations of the Christian faith through the recitation of the Apostles' Creed in the course of the Mass. From there, the Directory moves into the opportunity afforded for appreciating the importance of 'the word of God', by which it means in this case the contents of the Bible experienced in direct relationship to the central beliefs of Christianity expressed through the life, death and resurrection of Jesus Christ. It warns that the integrity of the Bible needs to be guarded by avoiding mutilation of passages or unsatisfactory translations and paraphrases, for "Christ himself is present through his word in the assembly of the faithful". Just as parents have a responsibility to teach their children the beginnings of personal prayer, so the Mass takes this further by teaching them to pray in the

liturgical community. The periods of silence introduce children to the experience of meditation, and also give them the opportunity to learn to express themselves silently in praise of God and in other forms of prayer "in their hearts". They learn about intercession through the general prayers of intercession, which they are encouraged to help compose and to recite. They should be allowed to play their part in the various activities associated with the celebration of Mass, to assist their "internal participation", but above all they should learn that "all the forms of participation reach their high point in eucharistic communion when the body and blood of Christ are received as spiritual nourishment". Properly utilised, the Mass can help children to see the liturgy "as an activity of the entire man" in relationship with God^[6].

Where, then, is the most appropriate place for children to participate in the eucharistic liturgy of the Roman Catholic Church? Not in their schools, but in their parish churches. This is because "the Christian community is the best school of Christian and liturgical formation for the children who live in it", and this is explicitly the one "to which the individual families belong or in which the children live", where the children grow up in a community "giving witness to the Gospel, living fraternal charity, actively celebrating the mysteries of Christ". Catholic schools have their place in the religious formation of children, in association with the local religious community, but "the eucharist is always the action of the entire Church community" and it is always desirable that

adults should be taking part along with the children, "not as monitors but as participants", and "the primary place for the eucharistic celebration for children is the church"[7]. The Directory is clearly anxious to affirm that nothing should hinder the children's religious development as integral members of the whole religious community. They are to be given their appropriate place in the eucharistic activity, but not in such a way that their sense of membership of the whole is impaired. There is a place for the celebration of Mass within the school community, but it must not become a substitute for the children's discovery and expression of their proper place in the wider one. Nothing said about 'the Catholic school' in the Vatican publication with that title[8], nor Pope John Paul II's reference to "the school as a community of faith centred on the eucharist"[9] detracts from this principle.



References Directory For Masses with Children

- [1] Directory For Masses with Children 2, 12, pp.174, 177. Quotations are from the English translation issued by the International Committee on English in the Liturgy in 1973. References are to the original paragraph number, and to the page number in Matthews, E., Celebrating Mass with Children (London 1975), where the text of the Directory is printed in an appendix.
- [2] Ibid. 55, p.191. The biblical quotation is from Galations 5:6.
- [3] Ibid. 8, p.176.
- [4] See especially Ibid. 9, p.176.
- [5] Ibid. 35, 55, 8, pp.185, 191, 176.
- [6] Ibid. 49, 45, 10, 37, 22, pp.189, 188, 177, 186, 181.
- [7] Ibid. 11, 24, 25, pp. 177, 182.
- [8] Sacred Congregation for Catholic Education, The Catholic School, Rome, 1977.
- [9] Pope John Paul II, 1982, 5.

E. CATECHESIS IN OUR TIME.

The main official statements other than the two Directories discussed above, which gave the rules and guidelines for implementing the educational principles enunciated by the Second Vatican Council have so far been Pope Paul VI's Apostolic Exhortation Evangelii Nuntiandi (1971); the Sacred Congregation for Christian Education's document The Catholic School (1977); the official message of the Synod of Bishops which met towards the end of 1977, De catechesi hoc nostro tempore praesertim pueris atque iuvenibus, Ad Populum Dei Nuntius, to give it its full title, which was confusingly translated as 'Catechesis in our Time' and which is best referred to as 'the Synod message'; Pope John Paul II's Apostolic Exhortation Catechesi Tradendae (1979), published in English translation under the title Catechesis in our Time (hence the danger of confusion with the Synod message); and John Paul II's address on education during his pastoral visit to Britain in 1982.

The General Catechetical Directory remains the definitive document, which subsequent statements reaffirm while emphasising various aspects of it in the light of developments during the decade since it was issued. The cumulative contents of these statements were summarised, in effect, by Pope John Paul II in his address on education given in Scotland at St. Andrew's College of Education, Bearsden, on 1st June 1982, to which detailed attention will be given below. Before that a minimum needs be said

here, for the purposes of this study, about the other statements.

The document on The Catholic School asserted the importance of such schools for the development of the whole personality of their pupils, so that their religious development could be seen by the pupils as the proper end of their total development rather than as a separate aspect of it. In this connection, therefore it is central to the concept of a 'Catholic' school that "its task is fundamentally a synthesis of culture and faith, and a synthesis of faith and life"^[1]. The Eucharist is an appropriate focus and expression for the school as "a community of faith" which integrates a wide range of human activities, but the fundamental and normal centre for the pupil's eucharistic participation remains the wider religious community, particularly the parish. It urges that parents should be closely involved in the school's expression of the spiritual dimension of education, as indeed should also be the other members of the faith community in their proper degree, and it lays emphasis on the importance of the commitment and witness of teachers in the religious formation of the pupils.

The Synod of Bishops emphasised the need for religious education to be a synthesis of "word, memory and witness", where 'memory' is here used in the more extended meaning it carries in eucharistic theology as "the manifestation in our day of the 'mystery which was hidden in God before all times'", and which was expressed most fully in the life and work of Jesus Christ^[2]. It applied

this principle to pedagogy as an integration of "knowledge of the word of God; celebration of faith in the sacraments; the profession of faith in daily life"^[3], which again has relevance for the attitudes which pupils taught in this way might be expected to have.

Pope Paul II's Catechesis in our Time need only be noted here for two points relevant to this study. The first is a discussion, mainly in two paragraphs or sections, on the ecumenical dimension and on ecumenical collaboration in religious education. The stance taken, which is supported by a reference to a passage in the Second Vatican Council's Decree on Ecumenism, is best stated in a passage from paragraph 32 of Catechesis in our Time: "Catechesis will have an ecumenical dimension if, while not ceasing to teach that the fullness of the revealed truths and of the means of salvation instituted by Christ is found in the Catholic Church, it does so with sincere respect, in words and in deeds, for the ecclesial communities that are not in perfect communion with this Church"^[4]. The paragraph continues with the importance of giving a correct and fair presentation of "the other Churches and ecclesial communities that the Spirit of Christ does not refrain from using as means of salvation", and with the need to foster amongst Roman Catholics "a true desire for unity . . . with a view not to facile irenics made up of omissions and concessions on the level of doctrine, but to perfect unity"^[5].

In the next paragraph, Pope John Paul II warns against accepting a common syllabus for the religious

education of Roman Catholics which reduces it to areas of agreement between Roman Catholics and other Christians:

". . . the communion of faith between Catholics and other Christians is not perfect and complete; in certain cases there are even profound divergences. Consequently, this ecumenical collaboration is by its very nature limited; it must never mean a 'reduction' to a common minimum"⁽⁶⁾.

Where there is such common religious education in schools, of Roman Catholics and others, care must be taken, says this paragraph that "a specifically Catholic catechesis" is also given to the Roman Catholic pupils. It points out, moreover, that religious formation is initiation into the whole Christian life, "bringing full participation in the sacraments of the Church", and the mere teaching of doctrine - even where it includes the full range of Roman Catholic beliefs - is inadequate if this dimension is missing. In view of the importance of this point for this study, which is of Roman Catholic pupils in Roman Catholic schools and in other schools, it has to be given prominence; but in this context it is also important to maintain the distinction between 'religious education', in the widest meaning of that phrase as synonymous with 'religious formation' or 'catechesis', and 'religious studies', the much narrower area concerned indeed with a thorough and sympathetic understanding of religion but not with the religious commitment of the student. There can be no objection by Roman Catholics, on the basis of official statements, to a fair and objective common syllabus of religious studies, provided it is not thought to be adequate

for the religious education of Roman Catholics. Other churches would presumably take a similar position about the religious formation of their own members.

The other point of immediate relevance made in this statement by John Paul II concerns Roman Catholic schools. The case for such schools rests on the creation within such schools of an organic relationship between the religious dimension of the curriculum and the other elements in the pupils' education: "The special character of the Catholic school . . . is precisely the quality of the religious instruction integrated into the education of the pupils"; and later in the same paragraph, ". . . those who study are bound to bear the stamp of their studies, to be introduced to cultural or moral values within the atmosphere of the establishment in which they are taught, and to be faced with many ideas met with in school". Where religious education is fully integrated into the curriculum "the Gospel will impregnate the mentality of the pupils in the field of their learning, and the harmonization of their culture will be achieved in the light of faith"^[7]. If this integration of religious and secular culture does not exist, 'the Catholic school' does not deserve its distinctive title, says this passage, no matter how competent it may prove to be in teaching non-religious areas. It also goes without saying, from the whole context of this document and of every other official Roman Catholic document on education, that a school cannot be considered 'Catholic' if its religious education is not faithful to the whole range of Roman Catholic belief and practice.

ReferencesCatechesis in our Time

- [1] Sacred Congregation for Catholic Education, The Catholic School, Rome, 1977, 37.
- [2] Synod message, 1977, 7f.
- [3] Ibid. 11.
- [4] Catechesis in our Time 32, p.33. Quotations and references are from the English translation of Catechesi Tradendae published by St. Paul Publications and Catholic Information Services, undated. The Apostolic Exhortation was issued in 1979.
- [5] Ibid. Loc. cit.
- [6] Ibid. 33, p.34.
- [7] Ibid. 69, pp.63f.

F. POPE JOHN PAUL II'S ADDRESS ON EDUCATION.

During his 1982 pastoral visit to the Roman Catholics of England, Scotland and Wales, Pope John Paul II made a number of official statements in English on central issues, with the intention of clarifying the attitudes appropriate for Roman Catholics in contemporary Britain. He delivered an address on education at the Bearsden campus of St. Andrew's College of Education, the national Roman Catholic College of Education for Scotland, which, like the other Scottish colleges of education, specialises in pre-service and in-service courses for the professional training of teachers in schools. As with all the other Scottish colleges of education, it is entirely financed from public funds, and its site and buildings are owned by the State, circumstances which help put the Pope's comments on Roman Catholic education in context. The address was delivered to an invited audience, composed mainly of people actively involved with Scottish education in all its dimensions, not all of whom were Roman Catholics. On the previous day he had addressed a gathering of Roman Catholic secondary school pupils.

After a brief general survey of the history and structure of Scottish Education, and its contribution to educational developments in other countries, the Pope noted the role played by the established Church of Scotland in education at all levels, and welcomed its collaboration with the Roman Catholic Church, particularly in the field of religious education^[1]. He then mentioned the Education [Scotland] Act of 1918, which established Roman Catholic

schools as part of the Scottish education system, financed in the same way as the other schools in the public sector but giving the Church freedom to control religious education in Roman Catholic schools and providing it with guarantees about the appointment of teachers.

At this point, the address began to identify the danger of narrowness where educational aims are confined to the acquiring of qualifications for careers without concern for "the whole person, his inner self as well as his outer prospects"[2]. The Pope had by now laid the ground for an examination of the general philosophy underlying all education, which he identified as "the completing of the person" and "the development of the whole person"[3]. He noted that this philosophy is already being given due emphasis in Scotland by educationalists and educational authorities, and is a prominent theme in official reports on education. Such proposals as the distinction between 'core' subjects and 'electives' in the Munn and Dunning reports[4] on secondary education in Scotland here come to mind. But not only has there to be a clear identification of the subject areas and approaches appropriate to "integrated, personal and social education"[5], the Pope asserted that there must also be full realisation that the spiritual dimension is involved. He here gave his warm approval to the united approach of the Education Committee of the General Assembly of the Church of Scotland and the Roman Catholic Education Commission towards the Scottish education authorities' initiatives about specialist teachers of Religious Education, national examinations and making available the

services of the Inspectorate. In this he continued the ecumenical theme so conspicuous in other addresses he gave during this pastoral visit, but his remarks had equally important implications for the role of the State in religious education^[6]. In fact, a distinction has been drawn between Religious Education and Religious Studies in the relevant documents published by the Scottish Central Committee on Religious Education and the Scottish Certificate of Education Examination Board^[7], but the Pope did not draw attention to this.

With the identification of the spiritual dimension, the Pope then applied the Church's understanding of this dimension to man's relationship with Jesus Christ, ". . . since, in Christ, the Perfect Man, all human values find their fulfilment and unity." It is ". . . a faith relationship with Christ in whom all values find fulfilment," because ". . . the ultimate meaning of life and its fundamental values are indeed revealed in Jesus Christ"^[8]. Christian education differs from other educational philosophies, the Pope implied. It extends the concept of development and completion of the whole person by seeing education in terms of the individual's personal relationship with Jesus Christ. Christianity asserts that it is possible for all people to establish and develop this personal relationship and thus reach their fulfilment, and that it is God's will that all should attain to it. Christian education is concerned with identifying these aims and achieving them.

The other strand in the address was a consideration

of the means and agencies by which specifically Christian educational aims are to be realised. The primary responsibility, said the Pope, rests with the children's parents, and here he quoted directly from Vatican II's Declaration on Christian Education: "Since it is the parents who have given life to their children, it is they who have the serious obligation of educating their offspring. Hence parents must be recognised as the first and foremost educators of their children"[9]. The school is necessary, but complements rather than replaces the responsibility of the parents. At this point he stated the official Roman Catholic view of "what precisely is the identity and purpose of the Catholic school", by quoting from The Catholic School, published in 1977 by the Vatican's Sacred Congregation for Christian Education, the permanent central commission for educational matters. Again, the emphasis was on Jesus Christ as the focus of human values, and therefore as the key figure in the achievement of the full development of human potential. The overriding aim of the Catholic school, and the distinctive feature of all its activities, should be to bring its pupils into a living relationship with Christ and to dependence on him as the source of their personal fulfilment: "The Catholic school is committed to the development of the whole man, since in Christ, the Perfect Man, all human values find their fulfilment and unity. Herein lies the specifically Catholic character of the school. Its duty to cultivate human values in their own legitimate right in accordance with its particular mission to serve all men has its origin in the figure

of Christ"[10]. Later in the same section, the Pope made this point again with all the emphasis he could command: "In reflecting on the value of Catholic schools and the importance of Catholic teachers and educators, it is necessary to stress the central point of Catholic education itself. Catholic education is above all a question of communicating Christ, of helping to form Christ in the lives of others"[11].

In all this it is legitimate to ask whether the Pope was using 'Catholic' in its wider sense or as synonymous with 'Roman Catholic'. As an early passage in the address mentioned the statutory provisions for 'Roman Catholic' schools in Scotland, and went on to refer to 'Catholic' education and 'Catholic' schools, it may be inferred that he was using the two terms interchangeably, and that he consistently intended 'Catholic' to mean 'Roman Catholic'.

By this stage in his address, Pope John Paul had already referred to the role of teachers in Roman Catholic schools, and how important their Christian commitment is, because "faith is principally assimilated through contact with people whose daily life bears witness to it", and it is the teachers in the Roman Catholic schools who have the direct contact with the pupils whom they are training "to live the newness of Christian life in justice and in the holiness of truth"[12]. Again, to avoid any possibility of ambiguity here, the Pope immediately made it clear that pupils who are being led to 'Christian commitment' and the 'Christian life' have a right to what the Roman Catholic Church considers to be the whole range of Christian teaching,

"not in mutilated, falsified or diminished form but whole and entire". The teacher must not "make a selection of what he considers important in the deposit of faith as opposed to what he considers unimportant, so as to teach the one and reject the other"[13]. In this passage, John Paul II was quoting from the work he published on religious education, in 1979, Catechesi Tradendae (translated as Catechesis in our Time). Roman Catholic pupils in Roman Catholic schools should be able to enjoy the whole of the Church's teaching, taught and exemplified by committed Roman Catholic teachers, so that they have full opportunity to develop the potentially new life in Christ begun at their baptism.

The Pope completed his survey of education with remarks about the universities. Their purpose is to seek "a scientific knowledge of the truth, of the whole truth" to meet man's need for knowledge, but this need cannot be fully met if this level of enquiry "ignores or belittles the spiritual essence of man, his aspirations to the fullness of being, his thirst for truth and the absolute, the questions that he asks himself before the enigmas of sorrow and death"[14]. As the university is the final stage of formal education and its 'high point' for young people, said the Pope, they look to it for their confidence "not only about the legitimacy and finality of science but also about higher moral and spiritual values"[15]. By implication, the attitudes adopted towards the pursuit of truth by the universities determines the attitudes adopted by the schools. There is no Roman Catholic university in Scotland,

nor indeed elsewhere in Great Britain, so it is impossible to tell whether the Pope would have developed a specific philosophy of education for such an institution, distinct from other universities, as he had done for Roman Catholic schools.

Pope John Paul II in this address worked from the general to the specific, from the broad background of Scottish education, to the Roman Catholic part of it, and from the broad responsibilities of parents to the specific aims of the Roman Catholic sector and the conditions necessary for the achievement of these aims by the teachers. These aims and their realisation he presented as inseparable from the strictly Roman Catholic understanding of Christianity and its expression by the Roman Catholic Church in the modern world.

But one other point was made by the Pope, which may perhaps be seen as a warning against interpreting his remarks in too separatist a way, with rigidly exclusive claims for Roman Catholic educational institutions as the only way a child can safely reach personal fulfilment. In the passage where he spoke about "the specifically Catholic character of the [Roman Catholic] school", the Pope made remarks about "its duty to cultivate human values in their own legitimate right", and "its task is fundamentally a synthesis of culture and faith, and a synthesis of faith and life"^[16]. At least implicit in this is a recognition that Roman Catholic education cannot achieve its aims in isolation from the wider culture of the society to which both teachers and pupils belong.

Moreover, the relationship is one of 'synthesis', in which the "understanding of the realities" of the faith - in the phrase of Vatican II's document on Divine Revelation - develops through the need to relate faith to life and to express it within the framework of a particular culture. Faith has a social context to which it is a debtor as well as a contributor. This point may prove to be of particular importance when we compare the religious attitudes of Roman Catholic pupils in Roman Catholic schools with those of Roman Catholic pupils in non-Roman Catholic schools. It might be concluded that the cultural context of schools seems to be at least as significant a factor as their denominationalism.

Finally, in these comments on the Pope's Address on Education, his remarks may be summed up in a phrase he used towards the end of his section on Roman Catholic schools: "The cause of Catholic education is the cause of Jesus Christ and of his Gospel at the service of man"^[17]. By this it was clear that the Pope was thinking more deeply than at the level of social service, of evangelisation or of any narrow concept of adherence to Roman Catholicism. Within the limits of a comparatively short address, and within the context of a Roman Catholic institute mainly concerned with training teachers for Roman Catholic schools and serving those already teaching in them, he related Roman Catholic education to the universal mission of Jesus Christ. One main result of the education of Roman Catholic children, therefore, if it is to be effective, should be the inculcation in them of a positive attitude towards

Jesus Christ, whether or not they have attended Roman Catholic schools. Christians believe that God is the source and sustainer of all human potential and its actualisation, whether or not the individual is aware of this in his or her own life, but where Christian parents provide a specifically Christian education for their children they naturally look for conscious acceptance of Christ by them and for their response to him in a faith relationship.

References Pope John Paul II's Address on Education

- [1] Pope John Paul II, Address on Education, 1/6/1982, Section 2, [Source: Vatican Press Office]
- [2] Op. cit., Section 3
- [3] Op. cit., Section 4
- [4] The Munn Report: The Structure of the Curriculum in the Third and Fourth Years of the Scottish Secondary School, [Edinburgh, 1977];
The Dunning Report: Assessment for All. Report of the Committee to review Assessment in the Third and Fourth Years of Secondary Education in Scotland, [Edinburgh, 1977]
- [5] Pope John Paul II, Address on Education, Section 4
- [6] Op. cit., Section 4
- [7] Scottish Central Committee on Religious Education, A Curricular Approach to Religious Education [Edinburgh, 1978], p. 22;
Scottish Examination Board, Scottish Certificate of Education Religious Studies Ordinary Grade Syllabus [Dalkeith, 1982] pp. 3F.
- [8] Pope John Paul II, Address on Education, Sections 5,7
- [9] Op. cit., Section 4, quoting Declaration on Christian Education 3, see Abbott p. 641
- [10] Pope John Paul II, Address on Education, Section 5, quoting Vatican Sacred Congregation for Christian Education, The Catholic School [1977] 35-37
- [11] Loc. cit.; the italics are in the original
- [12] Loc. cit.
- [13] Loc. cit., quoting from Pope John Paul II, Catechesi Tradendae [Rome, 1979], 30-31, translated under the title Catechesis in our Time

References Pope John Paul II's Address on Education

[14] Pope John Paul II, Address on Education, Section 6

[15] Loc. cit.

[16] Op. cit., Section 5, quoting The Catholic School
[Rome, 1977], 37

[17] Loc. cit., Section 5

PART II: ROMAN CATHOLIC RELIGIOUS EDUCATION IN SCOTLAND

This section will not attempt to give a full account of the origins and development of present-day Roman Catholic education in Scotland; it is necessary, however, to provide sufficient information about it to indicate the background to this present enquiry. Particular attention must be given to Roman Catholic provisions for religious education, but this aspect cannot be separated from the more general situation because there is a substantial Roman Catholic sector within the publicly funded education system of Scotland. Moreover, the Roman Catholic Church in Scotland has directed most of its energies in religious education towards its publicly funded schools rather than towards the provision of religious education outside the school situation.

Two key dates stand out prominently in the history of Roman Catholic education in Scotland: 1872 and 1918, when important Acts of Parliament made regulations about the state system of education throughout Scotland and established the denominational schools as a substantial separate sector within the state system. Before 1872, the effects of the proscription of Roman Catholicism were still evident as the Roman Catholic Church in Scotland found itself transformed by large numbers of immigrants from Ireland and by the need to provide for the education of their children. The actual suppression of Roman Catholicism had in effect ceased from 1793 when Parliament acted to protect the property of Roman Catholics, and the first Roman Catholic church since the

Reformation was opened in Glasgow in 1797. The Emancipation Act of 1829, which removed the ban on Roman Catholic teachers and schools, opened the way for the first extensive efforts to provide Roman Catholic schools, and there was even a small measure of state funds made available for them; before that date some Roman Catholic schools had existed in the more remote parts of Scotland but in great poverty and under constant threat of implementation of the laws against them⁽¹⁾.

The Education [Scotland] Act of 1872 was the first modern attempt to make systematic provision for schooling throughout Scotland, as the preamble to the measure indicates: "An Act to amend and extend the provisions of the Law of Scotland on the subject of education in such a manner that the means of procuring efficient education for their children may be furnished and made available to the whole people of Scotland"⁽²⁾. Before this date a wide range of voluntary organisations and local government bodies had provided schooling, with the help of some state grants made available to supplement the funding from voluntary sources or school rates. The Act set up nearly a thousand school districts, each one managed by a School Board, and established the Scottish Education Department to administer it all. Voluntary schools, including Roman Catholic ones, could transfer into the state system if they so wished, and come under state control and financing. Unlike the provisions made for England in an Act passed two years before the Scottish one, the Scottish Act stated that denominational schools in Scotland which transferred into

the state system could retain their distinctive religious education.

In the event, the Roman Catholic authorities decided not to transfer their schools into the new state system of education, but to continue their voluntary status, which still attracted some funding from the state. Significantly, after the Act there could no longer be public funding towards the building costs of voluntary schools. In making this decision the Roman Catholics were swayed by the fear that they would be in such a minority position on the new, elected school boards that they would be unable to insist on the provision of distinctively Roman Catholic religious education for the Roman Catholic children attending the schools controlled by the boards. Seven years after the passing of the Act, the 1878-79 Report of the Scottish Education Department stated clearly that the religious education provided in the state schools was in fact Presbyterian:

"The mass of the Scotch people are Presbyterians, and for these the national schools may be said to exist, just as the Roman Catholic and Episcopal schools exist for these denominations. The public schools are to all intents and purposes denominational schools. Public and Presbyterian are practically interchangeable terms"⁽³⁾. This is not to say that the public schools would necessarily have been "to all intents and purposes denominational schools" and thus Presbyterian, if the Roman Catholic and Episcopal Churches had transferred their voluntary schools into the public system and done all they could to guard the denominational needs of their pupils through the school

boards. But these two churches did not in fact transfer their schools, and their fears about religious education in the state system were confirmed. Moreover, the Act made education compulsory, and children who did not go to schools in the public sector had to attend the voluntary schools. The decision not to transfer into the public sector forced the Roman Catholic Church to make voluntary provision for all Roman Catholic children, whom it forbade to attend the board schools. The financial cost of providing voluntary schools for all Roman Catholic children proved to be far greater than had been expected, particularly as the schools had to meet the educational requirements of the Scottish Education Department and its inspectors, and so be comparable to the public sector in the education they provided. There was much resentment amongst Roman Catholics that they helped finance the board schools through the rating system, while at the same time they also provided most of the money for their own voluntary system. The situation was exacerbated by the numbers and poverty of the Irish immigrants. For whatever reasons, the burden of providing a separate voluntary Roman Catholic system of education became intolerable during the forty years following the 1872 Act.

The changes which provided a solution and which created the present situation were brought in by the Education [Scotland] Act of 1918. From as early as 1900, the Roman Catholic authorities had pressed for Roman Catholic schools to be given the same financial provisions from public funds as the board schools, as may be seen in

a Pastoral Letter from the Archbishop of Glasgow which called for "the raising of our own Elementary Schools to an equal financial position with that of the Schools that are under the management of the Schools Boards, so that they may have what our neighbours have"[4]. The 1918 Act did exactly that, by giving the voluntary schools the opportunity of transfer into the public sector with safeguards for their distinctive approach to religious education and the right to ensure that teachers appointed to Roman Catholic schools were acceptable to the Church's authorities. All but three of the 228 Roman Catholic schools were transferred into the state system where [unlike similar provisions for England] all their financial needs were met from public funds. From 1918 onwards new schools have been built and maintained from public funds to meet Roman Catholic needs wherever the local situation has justified such provision.

Until the Second Vatican Council, and in many places for long after it, Roman Catholic religious education was firmly based on the 'Catechism of the Council of Trent', issued in 1566, which in more recent times was [and to some extent still is] used in schools in a condensed version, 'The Penny Catechism' as it is affectionately called, and which was the dominant influence on the programmes of religious education which existed in Britain before the 1960s[5]. With the publication and translation of the documents issued by the Second Vatican Council [the first full English edition was published in 1966 within months of the close of the council] a new era began in Roman

Catholic religious education as the principles enunciated by Vatican II were elaborated by Roman Catholic writers. When the older methods and materials were used by confident, informed and imaginative teachers they could be very effective, but all too few of the teachers in Roman Catholic secondary schools were trained to specialist level in religious education, and in any case Scottish (as distinct from English) regulations for the employment of teachers did not make provision for specialist teachers of religious education until the middle 1970s. In all this, it must not be forgotten that the school is not even the main source of religious formation. For this, as has been noted in the documents of the Second Vatican Council and subsequent official publications, pride of place must be given to the home and the liturgy. It could be argued that the liturgy of the Roman Catholic Church, even (or particularly) in its 'traditional', Tridentine form, more than compensates for any defects in formal religious education, and that the changes since Vatican II - the change from Latin to the vernacular, more participation by the congregation, revisions of the lectionary and of the main prayers, and changes in the physical arrangements in church buildings - have increased the effectiveness of public worship as a source of religious formation.

The best and most thorough account to date of the changes in Roman Catholic religious education has been provided by R.M. Rummery^[6], following research in Britain, who analyses the main trends and the work of the most influential theologians in this field. Most of the Roman

Catholic theologians in the field of religious education were working in the United States or the western countries of mainland Europe, and many of them were influential behind the scenes in the Second Vatican Council as officially accredited expert advisers to the bishops. Of these theologians, whose works were published in English, mention should be made of Hofinger, Jungmann, Moran, Sloyan, Stone and Van Caster^[7], while in England much of the early work in this field must be credited to Drinkwater and (as editor) to Branigan and the Catholic Teachers' Federation of England and Wales^[8]. Not only was emphasis placed on the need to relate religious education closely to the actual experience, the 'life situation' of the pupils (the 'inductive method' which was to be urged upon Roman Catholic teachers of religious education by the General Catechetical Directory), there was also a change of theological approach. Where the older forms of religious education tended to concentrate on doctrinal formulations, supported by isolated quotations from the Bible, incidents from church history and the lives of the saints, and was related to the round of festivals in the liturgical year, the new approach urged teachers to lead their pupils to an appreciation of 'salvation history'. This involved using the primary sources of information and experience in religion in ways which brought out the unfolding of God's plan of salvation to show how the saving love of God may be recognised and shared in the world of today.

If such an approach to religious education is applied to the six forms of experience or activity mentioned in the

General Catechetical Directory⁽⁹⁾, and noted already in this present work, it means applying it to the content of catechesis found in God's word, written or handed down; understood and developed by the people exercising their Faith; illuminated by the guidance of the Magisterium; celebrated in the liturgy; recognised in the life of the Church; and known too from those genuine moral values which, by divine providence, are found in human society. This means using the Bible in its entirety, with an understanding of the way Christians see its teachings and experiences developing throughout the Old Testament to reach their fulfilment in the life and work of Jesus Christ as it is presented in the New Testament. The Church, both in its authoritative statements and in its life, is to be seen as a continuation of this development, which continues the plan of salvation as 'the body of Christ'. Faith is an active participation in this process of understanding, rather than a passive acceptance of what is taught; the Magisterium is the focus for all the diverse and developing insights of the members of the Church, rather than an authoritarian teaching body; and the liturgy is seen as a means of identifying with the whole process of salvation, rather than as a means of receiving grace. Finally, the Church and her members do not stand in stark contrast to a secularised or evil world, but recognise its 'genuine moral values' as further evidence of God's creative presence.

The change of approach was analysed and expressed with great thoroughness at the level of the theologians and their readers, but it could not become a practical basis

for religious education in the school classroom until it had been translated into forms which could be understood and used by the teachers, most of whom were not specialists in religious education. However willing the majority of teachers to implement the insights of Vatican II in their teaching, they found that they did not possess the kind of knowledge they needed to do it. The older approach, based on the catechism, at least provided a clear body of systematic knowledge which could be taught and tested in the classroom. By comparison the new approach appeared vague and impracticable. There can be no doubt that this judgement still lingers in the hearts of many teachers.

The new approach began to be made practicable with the production of detailed syllabuses of religious education in schools, of which the first to be published in Britain following the Second Vatican Council were written for secondary schools by David Konstant and Derek Lance⁽¹⁰⁾. At the time, Konstant was Adviser on Religious Education for the Roman Catholic Archdiocese of Westminster, and states that the syllabus was "prepared in committee" composed of teachers in four Roman Catholic secondary schools in or near London, under his chairmanship. Lance was a layman teaching in a secondary school in Birmingham, where as Deputy Headmaster he was responsible for the school's programme of religious education. Both syllabuses were thus firmly tested in the school situation before publication, and were followed by more detailed material to provide teachers with more background information at their own level for use with the syllabus.

These two syllabuses were immediately influential throughout Britain, including Scotland, sometimes as a basis for adaptations to meet the needs of a local situation [as occurred in the Scottish Diocese of Galloway], and sometimes used without change. For teachers, their attraction undoubtedly lay in the way each syllabus provided a broad practical framework for teaching each section of the syllabus using the new approach to religious education. Konstant provided a framework of 'Theme', 'Content', 'Approach', 'Daily Experience', 'Scripture', and 'Background Material'; Lance's framework was 'Attitude', 'Experience', 'Material', 'Liturgy', 'Doctrine', and 'Something To Do'. Both Konstant and Lance gave detailed lists of the kinds of material [whether from religious or secular sources] which might be found useful for each unit or week of the religious education programme throughout the school.

More importantly, each syllabus turned the principles of the salvation history approach to religious education into a practical programme of development, from the first year through to the fifth year of the secondary school. Although the two syllabuses differ in the detail of how they arrange this, they agree in their general schemes, and the plan followed by Lance shows how this approach was worked out for practical use:

First Year

Advent Term: What is a Christian? The Christian life;
The Christian community centred on Christ.

Easter Term: Christ our Lord. Christ grows up; Christ

acts and teaches; Christ defeats evil.

Pentecost Term: Christ lives on. Resurrection; Pentecost;
The Church now.

Second Year

Advent Term: The promise. Abraham - Joseph.

Easter Term: God forms and rescues his people. Edoxus
- Samuel.

Pentecost Term: God prepares his people for Christ.
Kings - Christ.

Third Year

Advent Term: The coming of Christ - our openness to Christ.

Easter Term: Christ our redeemer. Luke 2 - 24.

Pentecost Term: Christ continued in his Church - the new
people of God.

Fourth Year

Advent Term: The Church - the little flock - the nucleus
of the new Israel. Pentecost - the early
councils.

Easter Term: Christ is shown to the world in the growing
Church. AD 320 - Reformation.

Pentecost Term: New life and growth in the Spirit; the
Church in the modern world. 1500 - the
present day.

Fifth Year

Generally: Life Themes: e.g. work, love, marriage, colour
bar, poverty, loneliness, old-age, science,
renewal of the Church: Vatican II^[11].

Since then, there have been new editions of these syllabuses, but more importantly, the work begun by Konstant and Lance has been developed much further, particularly in Ireland and in Liverpool, to produce particularly attractive syllabuses with detailed pupil books and material to help teachers and pupils to make the best use of the syllabus at classroom level. Two dioceses in Scotland, Glasgow and Motherwell, have developed their own syllabuses with detailed material for teachers and for pupils, and both syllabuses have been used widely both within these dioceses and in other parts of Scotland. In theory at least, Roman Catholic secondary school pupils should have experienced well designed programmes of religious education, whether or not they have been taught by specialist teachers of the subject. In practice, one knows that the picture is much more patchy, for religious education has not been subject to inspection and there have been no public examinations which might have been related to it (in both of these areas the situation has been changed very recently by the Secretary for State in Scotland), so it has tended to be a cinderella subject starved for time and resources.

Some five years ago the Scottish Roman Catholic hierarchy set up a group to plan a national syllabus of religious education for all Roman Catholic secondary schools in Scotland. To date, the scheme has reached the stage of piloting drafts through selected schools to test them before proceeding to the point of producing the full range of materials which would be needed for teachers and pupils. Teachers in Roman Catholic secondary schools in Scotland

have become used, by now, to syllabuses with good pupil materials as well as excellent presentation at the teachers' own level, and the national syllabus will have to be good to replace the respect felt in schools for such syllabuses as those available from Liverpool and Ireland. The draft national syllabus published earlier this year [1982] does, however, start with a valuable list of the features which should be contained in a modern religious education syllabus for Roman Catholic secondary school pupils:

1. It should consolidate, deepen and extend the religious education of the primary school years.
2. It will be forward looking and based on solid educational principles, building on good curricular work already done and incorporating what has been proved relevant and helpful.
3. It should be sensitive to the state of development, personal experience and social environment of the young people for whom it is designed.
4. It must take cognisance of the pressures and problems of today's world and the present and future needs of the pupils who have to confront and cope with it.
5. It must present the Christian message as an organic and living whole, and bring out the inter-relationship and harmony of the different events and features.
6. The doctrinal sub-structure underpinning the whole syllabus should stress the mystery of the one God who reveals himself as Father, Son and Holy Spirit and should give more outstanding elements of the Christian faith their rightful place.

7. It must comprise and integrate - knowledge of the word of God; celebration of the faith in sacraments; the profession of faith in daily life.
8. It should be related closely but not exaggeratedly to the Christian year and the liturgical cycle.
9. In each successive year major themes will recur, knowledge . . . extended, understanding . . . deepened, and new insights . . . gained.
10. It should provide a progressive formation in prayer.
11. It should have access to modern educational books, and an adequate library.
12. It should provide an adequate and appropriate vocabulary which will enable pupils to express, understand, and articulate their Catholic faith and their Christian principles^[12].

If these features can in fact be incorporated into an effective syllabus which can be used successfully by non-specialist teachers of religious education, the Roman Catholic Church in Scotland will have cause to be deeply grateful to the people who are working on it. Meanwhile, the material already produced, and in particular the list of aims and features just listed, do show something of what is being attempted for Roman Catholic secondary school pupils.

This brief survey of the position in Scotland has shown that the principles enunciated by the Second Vatican Council and in the General Catechetical Directory have been recognised, and that there is a strong and professional movement to implement them at a practical level in the schools. Knowing this, it is practicable to investigate

the religious attitudes of the pupils themselves against this background of the approach to religious education adopted by the Roman Catholic Church since Vatican II. As will be shown in the next part, which deals with the empirical enquiry, the investigation was conducted by means of a well-tested research instrument which sought information from the pupils about their attitudes towards statements about God, Christ, the Bible, Prayer, the Church, and School Religion.

References Part II

- [1] Throughout this section, particular use has been made of the following sources of information:
- The Catholic Directory for Scotland [Glasgow, 1982];
- Anson, P.F., Underground Catholicism in Scotland [Montrose, 1970];
- Burleigh, J.H.S., A Church History of Scotland [London, 1960];
- Drummond, A.L. and Bulloch, J., The Church in Late Victorian Scotland [Edinburgh, 1978];
- Drummond, A.L. and Bulloch, J., The Church in Victorian Scotland [Edinburgh, 1975];
- Drummond A.L. and Bulloch, J., The Scottish Church 1688-1843 [Edinburgh, 1973];
- Highet, J., The Churches in Scotland Today [Glasgow, 1950];
- Kenneth, Br., Catholic Schools in Scotland 1872-1972 [Glasgow, 1972];
- McRoberts, D. [Ed.], Modern Scottish Catholicism 1878-1978 [Glasgow, 1979];
- Scotland, J., The History of Scottish Education [London, 1969];
- Scott-Moncrieff, G., The Mirror and the Cross [London, 1960].
- [2] Quoted in Scotland, J., op. cit., Vol I p. 364.
- [3] Quoted in Kenneth, Br., op. cit., p. 9.
- [4] Eyre, C., Pastoral Letter dated 25th September 1900.
- [5] Its proper title is A Catechism of Christian Doctrine and its most recent edition was published by the Catholic Truth Society in 1971.

References Part II

- [6] Rummary, R.M., Catechesis and Religious Education in a Pluralist Society, [Sydney, 1975].
- [7] Hofinger, J., The Art of Teaching Christian Doctrine [Indiana, 1957, 1962];
- " - The ABC of Modern Catechetics [New York, 1962];
- " - [ed.] Teaching All Nations [London, 1961];
- Hofinger, J., and Stone, T.C., Pastoral Catechetics [New York, 1964];
- Jungmann, J.A., Handing on the Faith: A Manual of Catechetics [London, 1959];
- Moran, G., Design for Religion [New York, 1970];
- " - God Still Speaks [London, 1967];
- " - Theology of Revelation [London, 1967];
- " - Visions and Tactics [London, 1968];
- Sloyan, G.S., [ed.], Modern Catechetics: Message and Method in Religious Formation [London, 1964];
- " - [ed.], Shaping the Christian Message: Essays in Religious Education [New Jersey, 1958];
- " - Speaking of Religious Education [New York, 1968];
- Van Caster, M., The Structure of Catechetics [New York, 1965];
- " - Themes of Catechesis [London, 1967].
- [8] Drinkwater, F.H., Teaching the Catechism, [London, 1958];
- " - Telling the Good News, [London, 1960];
- Branigan, J.J. [ed.], The Teaching of Religion in Catholic Schools [London, 1954].

References Part II

- [9] The General Catechetical Directory, p. 42.
- [10] Konstant, D., A Syllabus of Religious Instruction for Catholic Secondary Schools [London, 1967];
Lance, D., Eleven to Sixteen: A Complete Course for Religious Education at the Secondary School Level [London, 1967].
- [11] Lance, D., op. cit., p. 21.
- [12] Catholic Education Commission, Religious Education Draft Syllabus [Glasgow, 1982], Vol I, p. 4.

PART III: THE EMPIRICAL ENQUIRY

1. The Sample

The purpose of this enquiry is to investigate the religious attitudes of three categories of Roman Catholic Secondary School pupils: those attending Roman Catholic schools; those attending non-Roman Catholic schools who receive specifically Roman Catholic religious education, whether or not it is provided within the school timetable or on the school premises; and those who attend non-Roman Catholic schools and who do not receive any specifically Roman Catholic religious education. As a working hypothesis, it is assumed that the first category of pupil - those attending Roman Catholic schools - will generally show higher scores in a quantitative measure of religious attitudes than the other two categories of pupil, those attending non-Roman Catholic schools. For these latter, no notice has been taken of the circumstances in which they receive Roman Catholic religious education. For some it may be given within the school timetable by separating the Roman Catholic pupils from the others for their religious education periods, and giving them a specifically Roman Catholic curriculum, taught by Roman Catholic members of staff or by priests, 'religious' or lay people who go into the schools just for those periods. ['Religious' in this context refers to monks or nuns who are members of religious orders.] For others religious education may be provided in the parish church, the church hall, a local convent or the priest's house at some time outside

school hours in the evening or at weekends. These two kinds of provision may possibly lead to differences in attendance, as the school situation provides an assumption that pupils will participate (and in any case are required by statute to receive some form of religious education in school), while provision outside school and school hours competes with other activities and depends more on the good will of the pupils and parents. Nevertheless, it did not prove practicable to take this factor into account in the present enquiry, as the attendance records for religious education, even in schools, were either unreliable or had not been separated from more general attendance records.

Ideally, the enquiry might have covered the whole of a country such as Scotland, but the resources required for such a blanket coverage were not available, so the enquiry was restricted both geographically and numerically. As will be explained, the sample was taken in such a way that the results might be considered useful beyond the strict limits of the sample itself, although in the most rigorous sense the generalisations obtained from the information collected apply only to the limited number of pupils investigated. In practice, it was decided to restrict the enquiry to one region of Scotland, Strathclyde, and to a stratified sample of Roman Catholic pupils within the secondary schools of Strathclyde Region.

At first sight this might seem unduly restrictive, for Scotland is divided into eleven administrative regions for local government: Borders, Central, Dumfries and Galloway, Fife, Grampian, Highlands, Lothian, Strathclyde,

Tayside, Orkney and Shetland, and the Western Isles. But Strathclyde Region is by far the largest, both geographically and in terms of its population; moreover, it contains nearly 75% of the Roman Catholic population of Scotland, according to the figures in The Catholic Directory for Scotland, 1980^[1]. The actual figures are illuminating. Expressed in terms of the nearest thousand for the eleven regions, the total Scottish population consists of: Borders, 100,000; Central, 271,000; Dumfries and Galloway, 142,000; Fife, 340,000; Grampian, 472,000; Highland, 192,000; Lothian, 749,000; Strathclyde, 2,419,000; Tayside, 399,000; Orkney and Shetland, 40,000; and the Western Isles, 30,000. Only Strathclyde Region [which includes the 'central belt' from Gourock and Greenock, through Paisley and Glasgow, to Coatbridge and Motherwell, together with such centres as Kilmarnock, Irvine New Town and Ayr] reaches seven figures for size of population; it has more than three times the population of its nearest rival, Lothian, which contains Edinburgh, and nearly half of the total population of Scotland^[2]. Strathclyde also contains within its borders a surprisingly wide range of geographical areas with very different ways of life. Its nineteen administrative districts range in character from Argyll and Bute, which includes such Hebridean islands as Coll, Tiree, Mull, Jura and Islay, as well as an area of mainland Scotland stretching from Appin, north of Oban to the Mull of Kintyre; to the City of Glasgow district, one of the most densely populated in Europe.

The Roman Catholic Church in Scotland is organised in

two provinces, St. Andrews and Edinburgh, and Glasgow, each with an archbishop, and eight dioceses divided between the two provinces, each with a bishop. The dioceses of St. Andrews and Edinburgh, and Glasgow, each give their name to a province, and in each case the archbishop is in charge of the diocese as well as the province. The diocesan boundaries do not coincide with the regional boundaries, and the Roman Catholic population of Strathclyde is under the jurisdiction of six different dioceses: St. Andrews and Edinburgh, Argyll and the Isles, Galloway, Glasgow, Motherwell, and Paisley. The Catholic Directory for Scotland gives figures for the estimated Roman Catholic population of every parish in Scotland, so it is possible, by identifying the Roman Catholic parishes located in the Strathclyde Region to obtain figures for the Roman Catholic population of the region. In the 1980 Directory, the totals for the Strathclyde parishes of the various dioceses yielded the following figures: St. Andrews and Edinburgh, 5,400; Argyll and the Isles, 4,300; Galloway, 43,000; Glasgow, 290,000; Motherwell, 189,000; Paisley, 89,000; all of which total 623,000. The total number of Roman Catholics in the whole of Scotland, obtained by the same process, was 820,000 in 1980. But it is only right to add a word of caution about these statistics. The figures for individual parishes are derived from the quarterly returns of the parochial clergy to their various diocesan offices, and should be obtained by a head count of the number of people attending Mass on particular, designated Sundays. In theory this is arguably the most reliable ecclesiastical

statistic of church attendance on a national scale for any denomination in Scotland, but one's suspicions are aroused by instances where precisely the same figures appear for a parish over a number of years. In many parishes there is no doubt that the statistics are obtained with meticulous care; in others it is clear that a rough guess is made, the same figures are returned as in previous years, or no return is made at all and the diocesan authorities repeat the last figure available.

It does seem probable that the Strathclyde Region has a higher proportion of Roman Catholics to the rest of the population than has the rest of Scotland (a little over 37% of the total population of the region, compared with less than 8% of the total population for the other Scottish regions). This is only to be expected from the proximity of the region to Ireland, just as the Liverpool, Preston and Manchester areas in the north-west of England have high Roman Catholic populations and contain the main ports for the routes to Ireland. The warnings must be repeated, however, against setting too much store by apparently precise proportions, for the figures being compared are obtained by different methods - information from parochial clergy on the one hand, and local government returns on the other hand - and do not have the same level of reliability. Within this context it is illuminating to see the statistics for Roman Catholic church membership in Scotland in 1980 provided by the 1983 edition of the U.K. Christian Handbook, where the figure given is 310,000, compared with the Catholic Directory for Scotland's figure of 820,000⁽³⁾.

This surprising discrepancy is explained by a note which indicates the problems which arise when attempts are made to compare membership figures for different religious groups: "Definitions of membership vary according to the church denomination or religious group in question. Adult church membership is defined as appropriate to each particular group, so that for example the Electoral Roll (not to be confused with the Local Authority Electoral Roll) has been used for the Church of England, the Easter Communicant figure has been used for the Church in Wales, whilst estimates, comparable to the Protestant definitions of membership, have been used for the Roman Catholic churches"(4).

These statistical considerations are an essential preliminary to establishing a method for obtaining a stratified sample for the present enquiry, and for evaluating its reliability for extrapolation purposes. From the considerations so far, it seems reasonable to conclude that the Strathclyde Region is a useful area from which to obtain a sample, for it contains a high proportion of the Roman Catholic population of Scotland; moreover, the range of economic and social situations within the region is reasonably representative of Scotland as a whole. The next stage is to try to relate these figures to the distribution of school population amongst the Roman Catholic secondary schools of Scotland.

According to figures provided by the Catholic Education Council for Scotland during the discussions of the merging of Notre Dame College of Education, Bearsden, and Craiglockhart College of Education, Edinburgh, in 1980

there were 78,574 pupils in the Roman Catholic secondary schools of Scotland, and 63,454 of these were attending Roman Catholic secondary schools in the Strathclyde Region. On the face of it, this would appear to be far too high a proportion for Strathclyde Region when it is related to the Roman Catholic population distribution between Strathclyde and the other Scottish regions. But four of the eleven Scottish regions have no Roman Catholic secondary schools; Grampian, Highland, Western Isles, and Orkney and Shetland, because the Roman Catholic population is so sparsely distributed that there are insufficient concentrations of Roman Catholic secondary school pupils to warrant the existence of separate schools. In those regions, therefore, the Roman Catholic pupils of secondary school age attend the non-denominational schools, and do not appear in Roman Catholic statistics.

This then raises another type of problem about using Strathclyde Region for an enquiry such as this one: that it has too few Roman Catholic pupils in non-denominational schools to make it possible to make useful comparisons with other parts of Scotland. Two factors mitigate this particular problem. Firstly, as has already been noted, Strathclyde Region covers a very large area, much of which is rural in character with a sparsely distributed population. In these rural parts, Roman Catholic secondary school pupils find themselves with no Roman Catholic school within reasonable reach and so attend the local non-denominational school. Only the central belt of Strathclyde Region, from Dumbarton to Ayr, and from the Clyde coast to Wishaw and Lanark can provide separate Roman Catholic secondary schools.

The region has ample Roman Catholic pupils in non-denominational secondary schools for comparison with Roman Catholic pupils in Roman Catholic secondary schools; indeed, as will be shown, even where there are Roman Catholic secondary schools a significant proportion of the local Roman Catholic pupils attend non-denominational schools in the same catchment area.

More difficult is the problem of deciding how many Roman Catholic pupils there actually are. Correlations of statistics for marriages in Roman Catholic churches and of baptisms (in a denomination where infant baptism is the norm) suggest that there is now little difference in the birth rate between Roman Catholics and others in Scotland, but, again, there is far too much uncertainty in the figures to be able accurately to estimate the total Roman Catholic population of secondary school age. Taking into account the Roman Catholic Church's repeated insistence that her members should send their children to Roman Catholic schools, and the distribution of school provision, an informed estimate would suggest that the proportion of Roman Catholic secondary pupils in Roman Catholic schools and non-denominational schools is about 4 to 1: that about 80% are in Roman Catholic schools and 20% in non-denominational schools. Such a proportion would allow for about 10% in non-denominational secondary schools where there is also a Roman Catholic secondary school in the same catchment area (a result actually obtained), and more than 20% in areas where there is no Roman Catholic secondary school available.

One obvious point of ambiguity may be cleared up without difficulty: it is notoriously difficult to decide exactly what constitutes a 'Roman Catholic' when membership is conferred by infant baptism and a proportion then do not become practising members as they grow up. It is not satisfactory to designate a pupil 'Roman Catholic' merely because the parents have decided to send him or her to a Roman Catholic school. Self identification was therefore adopted as the criterion in this present enquiry, by including a question asking the pupils [anonymously] to say what kind of church, if any, they go to; a proportion of the pupils in the Roman Catholic secondary schools answered this question with 'none' or with the name of a church other than Roman Catholic, and were thus excluded from the enquiry. Similarly, account was only taken of the pupils in non-Roman Catholic secondary schools who identified themselves as Roman Catholic, whether or not they had attended a Roman Catholic primary school.

There remained only the questions of stratification and of geographical distribution. A clear principle of stratification was needed in order to establish a norm for comparison. In theory it would have been possible to use attitudes for non-Roman Catholic pupils as a norm for comparison of the attitudes of the various categories of Roman Catholic pupils, but this would have created difficulties both of sensitivity and of ensuring that the non-Roman Catholic sample was distributed similarly to the Roman Catholic one. The former difficulty was reason enough for rejecting this method; religious attitudes are

already a sensitive enough area of enquiry, without the risk of appearing to be making invidious comparisons between pupils of different religious persuasion or of none at all. It was decided, therefore, to use the total Roman Catholic sample as the norm, and to draw conclusions by the variations from the norm exhibited by the three categories of pupil which contributed to the total sample: those in Roman Catholic schools, and those in non-denominational schools who were, or who were not, receiving specifically Roman Catholic religious education by some means or other. In the event, the sample was drawn from nine schools in the Strathclyde Region, all of them comprehensive [i.e. non-selective and drawing their pupils from a local catchment area], and four of them with rural catchment areas.

Confidentiality requires that the schools concerned may only be identified by a code number, but five of them were Roman Catholic schools, and four of them non-denominational. School 1 was a single-sex [boys] school in a large conurbation served by a number of Roman Catholic and non-denominational secondary schools, and School 4 was a single sex [girls] school of comparable size and range of studies, chosen to balance School 1 in the sample. School 2 was a large Roman Catholic school, coeducational [as were all the other schools except the two already mentioned], situated in the densely populated heart of a large conurbation with a number of other schools nearby. School 3 was a Roman Catholic secondary school of comparable size to School 2, but serving all of the Roman Catholic

population of a medium sized town. It thus contained a cross section of the wide range of social classes represented in the town, whereas School 2 tended to contain mainly the children of semi-skilled or unskilled parents. School 5 was again a large comprehensive school, situated in the outer fringes of the main conurbation. It contained pupils from a range of social classes but its main value lay in the existence of School 10 within its catchment area. School 10 was a non-denominational secondary school of comparable size to School 5 which proved to have a significant number of Roman Catholics amongst its pupils, even though there was a Roman Catholic secondary school in the same catchment area. It was impracticable to enquire why these pupils had not gone to the Roman Catholic school; one could only guess that the parents may have been influenced by such factors as convenience, more modern buildings, belief that it offered a better education [for which there seems to be little real evidence], or sheer indifference. Again, it is worth repeating that the Roman Catholic pupils in this school identified themselves as such, so the category was not attributed to them on the basis of parental opinion or of the kind of primary school they had attended.

The foregoing schools, the first five of which were Roman Catholic and the remaining one non-denominational, were all in urban areas. The remaining three were non-denominational schools in more rural or isolated areas, even though all of them were in towns sufficiently large to be centres for an extensive catchment area. School 6 was a secondary school of about two thirds the size of

the urban schools, with a very large rural catchment area and pupils from a wide range of social backgrounds. The area contained very few Roman Catholics, but there were sufficient Roman Catholic pupils for them to be taken as a separate group for Religious education. School 7 was situated in a town with quite a large Roman Catholic section in its population and a catchment area covering a considerable rural area. It also catered for the secondary pupils from a number of the islands of the Inner Hebrides, who lived in special school hostels in the town during the week, or for longer periods in the case of pupils from some of the further islands and at times when gales prevented the ferries from sailing. Local Roman Catholic clergy, and Roman Catholic teachers on the staff of the school provided the Roman Catholic pupils with specifically Roman Catholic religious education during the normal school timetable. Finally, School 8 was a smaller secondary school in a coastal town on the western side of the Clyde estuary, with a small Roman Catholic population, nearly all of whom lived in the town itself. The religious education needs of the Roman Catholic pupils were met by the local Roman Catholic parish priest outside school hours.

The sample of Roman Catholic pupils totalled 1,113, divided in the proportion of 882 in Roman Catholic schools and 231 in non-denominational schools. But to obtain this sample [since it was composed of pupils who identified themselves as Roman Catholic], it was necessary to obtain information from nearly double that number of pupils, 2,122 to be exact. In the process, 504 identified themselves as

Church of Scotland; 71 as Episcopalian (Church of England, or Anglican); 91 as 'other'; 357 as 'none'; and 40 (a surprisingly low 2%) provided no answer. The remaining 1,113 were the ones who identified themselves as Roman Catholics. It is tempting to draw conclusions from these figures, but it would be seriously wrong to attempt to do so, for these figures are wildly distorted by the fact that five of the nine schools were specifically Roman Catholic and provided 882 pupils who identified themselves as Roman Catholics. These figures give no indication of the proportions of Roman Catholics and other affiliations in the population as a whole. It is, however, of interest to note that more than 11% of the pupils questioned in the Roman Catholic schools claimed that they attended a church of another denomination, none at all, or declined to answer - and very few of these declined to answer.

As analysis of the answers of the Roman Catholic sample proceeded, it proved necessary to refine the stratification, and the final distribution of the stratified sample was 882 in Roman Catholic schools (where Roman Catholic religious education was a normal part of the curriculum); 121 in non-denominational schools but receiving Roman Catholic religious education; and 110 in non-denominational schools who were not receiving any specifically Roman Catholic religious education. In view of the Roman Catholic Church's expressed concern for the religious education of its members of school age, it is strange that a group of pupils could be left without provision for specifically Roman Catholic religious education; but local

churches do sometimes fear that to make such provision for Roman Catholic children who could have gone to a Roman Catholic school but chose not to do so, might undermine the position of the local Roman Catholic schools when such are available. Regrettable though it might seem, it can be a matter of deliberate policy not to provide religious education under such circumstances.

When a decision had been reached about the desired size and distribution of the sample it was then possible to set about obtaining the permissions needed to conduct the enquiry in the schools selected and by the particular methods to be used. In some cases close relationships had been established with schools during many years of contact with them as a member of the staff of a Scottish college of education concerned with the professional training of teachers of religious education. It was also helpful that the Roman Catholic Church authorities were aware that the enquiry was being conducted by someone whom they knew to be a member of their church. Religious education itself, and the existence of a large, separate, State-funded Roman Catholic education system, are particularly sensitive areas in Scotland, so it was particularly important that everyone with responsibility for the schools used in the enquiry, and for the religious formation of the pupils, should know what was planned and should give their full permission.

All the schools used were within the jurisdiction of one local authority, Strathclyde Region, where careful consideration of the enquiry, including the details of the questionnaire and the method of administering it, was given

by the Director of Education, the Assistant Director with particular responsibility for Religious Education, and the Adviser for Religious Education in the districts in which the schools were located. Permission was given, subject only to the removal from the questionnaire of a question about parental church attendance, and to assurances about parental consent for the questionnaire to be administered to their children. It had been made clear in the requests for permission that the results of the enquiry would be presented in a way which did not identify the schools used, and that everything possible would be done to safeguard the anonymity of the pupils who completed the questionnaire. The latter point was also relevant to the reliability of the answers given in response to the questionnaire. Permission was then formally obtained from the rectors (the Scottish term for headmaster) of the schools, and arrangements made to explain the purpose of the enquiry to the teaching staff of the schools. As it was intended that the questionnaire should be administered by class teachers, their sympathetic cooperation - which was readily given - and their understanding of what was involved, were important for the success of the enquiry. Parental consent was obtained by each school sending a letter to the parents of every pupil asked to complete the questionnaire, in which the purpose of the enquiry was explained and the parents were asked to let the rector know if they did not wish their children to take part. In the event, only ten out of more than two thousand pupils were withdrawn by parents from the enquiry. The questionnaires were administered by

class teachers in the Spring Term of 1981; the pupils were assured of their anonymity by being given unnumbered questionnaires, by being told, verbally and on the questionnaire, not to put their names anywhere on the questionnaire, and by the questionnaires being put into envelopes and sealed in the presence of the pupils as soon as they were completed. Parental and pupil confidence was particularly important in the non-denominational schools, where the questionnaire had to be administered to pupils with many different church affiliations (and none) in order to find which of them (by self-identification) were Roman Catholics.

From the ecclesiastical point of view, the schools actually used fell within three Roman Catholic dioceses: Glasgow, Paisley, and Argyll and the Isles. Permission had to be sought from the relevant authorities in each, and was readily given by the three bishops, the diocesan religious education advisers and (perhaps most importantly) by the clergy of the parishes to which the pupils belonged. In a number of parishes the parochial clergy gave invaluable assistance to the enquiry by explaining it from the pulpit, and by reassuring individual parents who were worried about their children being asked such personal questions about their religious attitudes. But for these reassurances there is no doubt that many more parents would have withdrawn their children from the enquiry.

When the questionnaires had been completed, the envelopes containing them were coded to identify the school year, and the school, to which the pupils belonged, the

individual questionnaires were numbered, and the information they contained was coded for computer processing.

References The Sample Section

- [1] The Catholic Directory for Scotland 1980, by Authority of the Archbishops and Bishops of Scotland, (Glasgow, 1980).
- [2] The Municipal Year Book 1980 [London, 1980].
- [3] U.K. Christian Handbook 1983 Edition [London, 1982] p. 25.
- [4] Op. cit. p. 39. [The italics are not in the original.]

2. The Method of Enquiry

The two main methods for conducting an enquiry of this nature are, broadly, by interview or by questionnaire. The two methods are not totally different, for interviewers need to follow a consistent line of questioning with all of the people interviewed, or at least to identify common areas of response, if any generalisations are to be drawn from the interviews; and where the enquiry is conducted by questionnaire it is necessary to establish the validity and clarity of the form of questionnaire used, by administering it to a pilot group and then remove any ambiguities through some form of interviewing. In this present enquiry the questionnaire method was employed, administered anonymously, for three main reasons: it required less labour to administer, so that questionnaires could be administered to a large number of pupils, in different schools, at much the same time; secondly, a well-proven questionnaire was available which could be used in the Scottish Roman Catholic situation with very little modification and which had been designed for rigorous statistical analysis; finally, the present writer had experience of successfully administering questionnaires and analysing the results for earlier research into religious education in Roman Catholic schools, although for a different purpose from the present enquiry. For the earlier enquiry [1] a comparatively simple form of analysis was employed for evaluating the results obtained from the thousand secondary school pupils questioned. In this present enquiry, the use [in a form slightly modified to make it easier for pupils more used to Roman Catholic

idioms] of a questionnaire designed and proved practicable by Dr. L.J. Francis of the Culham College Institute, made it possible to take advantage of path analysis, a more sophisticated mode of assessing the results.

During the earlier stages of the planning there was also the intention of using this particular questionnaire because it might make it possible to compare the results with similar research conducted in other parts of the United Kingdom. In the event, three factors militated against this: the first was the condition laid down by the local education authority, Strathclyde Region, that information could not be sought from the pupils about their parents' church affiliation or church attendance. To have sought this information from the parents themselves would have destroyed the anonymity of the survey, complicated it to an unacceptable degree, and increased the risk of parents refusing to allow their children to take part in the survey, with possible distortion of the sample. Secondly, other surveys of this type had also obtained the Intelligence Quotients of the pupils, and related them in each case to the answers provided to the questionnaire. Unlike other parts of Britain, it is understood, Scotland does not permit its secondary schools to have information (normally available within the primary schools) about the Intelligence Quotients of their pupils; in any case, this also could have jeopardised the anonymity of the individual answers, which was considered an important aspect of the information they conveyed. A possible solution might have been to add a selection of questions to the questionnaire, designed to

provide an Intelligence Quotient, but this possibility was rejected on the grounds that it might lengthen the questionnaire to the extent that pupils gave less attention to the answers they were giving, and that the extra time it occupied might intrude too much into the busy timetables of the schools. In any case there are sufficient doubts about the value of Intelligence Quotients obtained in this way to justify rejecting the extra complication the operation would have caused. The third main factor was the difference in age-range between Scottish schools and the rest of the United Kingdom. Scottish secondary schools do not admit pupils until a year later than schools in the rest of the United Kingdom, so the pupils in First Year are a year older than First Year pupils in other parts, and so on throughout the school [there is a separate Scottish system of public examinations for Fourth and Fifth Year, and it has not been normal for pupils to stay on in secondary education beyond the Fifth Year]. More is at stake here than the physical age of the pupils, for they are also affected by the transition from primary to secondary school, and by their year-status within the secondary school. There is sufficient uncertainty here to cast doubts on the value of solving the problem by, say, comparing First Year Scottish secondary school pupils with Second Year pupils in other parts of the United Kingdom, and so on. It was therefore reluctantly concluded that there would be little value in comparing the results from this enquiry with the results obtained from "apparently similar enquiries elsewhere. [2]

These considerations do not reduce the value of the

questionnaire itself as an instrument for investigating the religious attitudes of school pupils. Francis describes in a number of places the procedures he adopted for the construction of the series of statements which are the essential feature of this type of questionnaire [3]. The initial stage was the collection of a large number of statements drawn from a wide range of sources: attitude scales used by other sociologists of religion, reports of children's conversations about religion and published examples of children's written work, and Francis' own collection of statements gained by his own interviewing of children and reading their essays specially written for the purpose. During this, 160 school pupils were each interviewed for three half-hour sessions, and more than two hundred pupils each wrote essays on six consecutive school days about God, Jesus, the Bible, Prayer, Church, and School Prayer. Before writing their essays on each day, the pupils were encouraged to discuss their attitudes about the topic with the class teachers supervising the exercise, but they were assured of the confidentiality of the opinions they expressed in their written work, which was sealed into envelopes immediately they had completed it and not read by anyone in the school.

This initial stage provided a large collection of information about school pupils' attitudes about religion, both in denominational and non-denominational schools, which formed the basis for the compilation of 110 brief statements. Two main criteria were used in the compilation of this list. The first of these was their relevance to a definition of religion formulated by Francis in the light of the debate

on the definition of religion which has been so prominent in the sociology of religion over the past hundred years, and expressed in terms of phenomena associated with Christianity: "Evaluative concepts or beliefs learned about the characteristics of God, Jesus, the Bible, Church Services, and School Religion" (where the latter is confined explicitly to schools in a predominantly Christian context, whether they are denominational or non-denominational). Behind this definition there lies another one, which distinguishes between attitudes and other psychological predispositions, such as opinions, beliefs, traits, and behavioural intentions. After an analysis of possible areas of confusion, Francis uses 'attitude' in the sense of "a relatively permanent and enduring evaluative predisposition to a positive or negative response of an affective nature"; this response "reflects evaluative concepts and beliefs" about specific areas - in this case Christianity.

The second criterion is one of item clarity: that the statements must be free from ambiguity. At this stage of the compilation of a reliable set of statements, freedom from ambiguity is tested by presenting statements to a panel of judges working independently of each other, who sort them into eleven categories, ranging from most favourable through neutral to least favourable; statements which are placed in roughly similar categories by the judges are deemed unambiguous, while statements placed in widely different categories by a large number of the judges are rejected as ambiguous^[4]. The 110 statements selected by Francis at this stage of the process of compiling an attitude scale are as follows:

1. The best story I ever heard is in the bible.
2. Man has invented the idea of God.
3. The bible helps me.
4. I think it is a waste of time to say prayers.
5. Church services always bore me and they are difficult to follow.
6. It seems to make very little difference whether I believe in God or not.
7. I think the bible is very difficult to read.
8. I like going to church services.
9. I think bible stories are some of the best stories ever told.
10. Most church-goers seem to me to be narrow minded and kill joys.
11. I only know a little about the bible but it has helped me to believe in God.
12. Going to church makes me feel good.
13. It is stupid to insist that there is a God.
14. God loves us even when we're not good.
15. I find it boring to listen to the bible.
16. Church services may help some people but they don't help me.
17. I like starting the school day with school prayers.
18. Religion is as necessary for my soul as food is for my body.
19. I don't think there should be rich churches when there are poor people.
20. Man does not need God.
21. I think praying to God is a good way to start the school day.
22. I believe the church has the greatest influence for right living.
23. I don't really know why I believe in God.
24. I think God is a harsh judge.
25. Jesus was a man who never did wrong things.
26. I know that Jesus helps me.
27. I don't like the sort of people who go to church regularly.

28. Jesus is the Son of God.
29. I believe the church is hopelessly out of date.
30. I find it difficult to believe in God because there is no real proof.
31. I go to church because I feel better for having done so.
32. The other school lessons are more important for me than lessons about God.
33. Saying my prayers helps me a lot.
34. The church is very important to me.
35. I don't know whether I believe in the bible or not.
36. Going to church makes me feel sad and gloomy.
37. I fail to see any connection between the bible and my own life.
38. Going to church is a waste of my time.
39. It seems absurd to me that thinking people should go to church.
40. I want to love Jesus.
41. I think church services are boring.
42. I do not read the bible because it is out of date.
43. I think people who pray are stupid.
44. Trust in God gives me a deep sense of security.
45. God is good to us.
46. I believe that you must belong to a church to live life at its best.
47. I hate anything to do with religion.
48. School prayers help me with my work.
49. Belief in God has no interest for me.
50. The church upholds the spirit and teaching of Jesus and deserves my loyal support.
51. God helps us to lead a better life.
52. I like school lessons about God very much.
53. My church is the best influence in my life.
54. I think Jesus was God in another form.
55. I think the church is stupid.
56. I think it is a waste of time to pray.
57. My church has my highest loyalty and respect.
58. I think the bible has a lot of zip to it.

59. At church I enjoy the singing and the music best.
60. God means a lot to me.
61. If I do not attend church I feel that something is missing.
62. I believe that God helps people.
63. Prayer helps me a lot.
64. I am afraid of God.
65. Sometimes God listens to prayers and sometimes He doesn't.
66. I think praying is a good thing.
67. I think the bible is out of date.
68. I like going to school assembly because you pray.
69. People should read the bible every day.
70. I believe that God listens to prayers.
71. Sometimes I believe in God and sometimes I don't.
72. Scientists have proved the bible to be wrong.
73. I think going to church is an unpleasant way to spend a Sunday.
74. I think church assemblies are very nice.
75. Jesus doesn't mean anything to me.
76. I believe every word of the bible is true.
77. God is very real to me.
78. I doubt if the church fulfils any useful purpose.
79. Saying prayers in school does me no good.
80. There is a great deal of truth in the bible.
81. I know that Jesus is very close to me.
82. My religion is a source of great joy.
83. Sometimes I like school prayers but sometimes I don't.
84. The idea of God means much to me.
85. I like going to church services because I get something worthwhile to think about.
86. Sometimes school assemblies are very exciting.
87. I think religion is out of date.
88. Church is all right but it could do with better music.
89. Everyone should pray at least once a day.

90. I believe that Jesus still helps people today.
91. We often do wrong things but God still loves us.
92. Sometimes I believe in Jesus and sometimes I don't.
93. I think that school assemblies are not necessary.
94. The more I understand the bible the more help I get from it.
95. I know that God helps me.
96. Jesus has no importance for us today.
97. The books of the bible are a hopeless tangle of fact and fiction.
98. I find it hard to believe in God.
99. School prayers are helpful to us.
100. I think religion is an essential part of man's being.
101. I don't like praying with other children in school assembly.
102. Sometimes I like going to church and sometimes I don't.
103. I dislike the word God and all that goes with it.
104. I think the church is a sad place because all the people are buried there.
105. I think school prayers are boring.
106. I regard the church as the most important thing in the world outside my home.
107. We ought to talk to Jesus every day.
108. Whatever I pray for comes true.
109. You can pray but God won't hear you.
110. I enjoy singing hymns.

These statements were then subjected to further testing by groups of school pupils and, as a further check, by a group of school teachers. The same basic technique was employed for detecting ambiguity: each judge, whether a child or an adult, was required to sort the statements into categories of favourable, neutral, and unfavourable; the sorting was done in two stages, so that nine categories were

available by the end of the sorting process. Statements from the full pool of 110 items were then rejected where a comparison of the decisions reached by the judges showed that the statements had been placed in different categories to an unacceptable degree. The decisions were thus reached on the basis of 'Q sorting' methodology, with the use of a standard coefficient of correlation as the criterion of ambiguity; basically, such a coefficient provides a quantitative method of comparing the extent to which judges agree or disagree about the categories to which the statements belong, and the researcher decides that beyond a selected degree of ambiguity - expressed as a correlation coefficient - a particular statement is too ambiguous for reliable use. It is worth pointing out that the test of ambiguity in such an evaluation of the reliability of the basic statements has to be whether the statements are found to be ambiguous by the kind of people (school children in this case) with whom they are to be used in the enquiry.

By this stage, 50 of the original 110 statements had been judged too ambiguous for use. The remaining 60 were administered to groups of children in the format, and under the conditions, in which they would be used for actual empirical research: a questionnaire in which the pupils were required to express their reactions to the statements by indicating a particular point on a five-point scale ranging from 'agree strongly' to 'disagree strongly': that is, a Likert Scale. Statistical analysis of the responses given by a hundred of these pupils, using tests for consistency of correlations between on the one hand the

responses to each of the 60 statements, and on the other hand the cumulative scores of the responses to all the statements, suggested that a further 34 of the statements should be excluded on the grounds that the responses were not sufficiently consistent to be able to use statistical techniques which depend for their validity on every statement being strictly compatible with all the others. Again, it should be noticed that the statistical information, however refined, does not relieve the researcher of the responsibility of deciding what constitutes an unacceptable degree of ambiguity or of incompatibility of a statement or item; it only provides a precise measurement of compatibility, and it still has to be decided what degree of compatibility is most appropriate for the particular research being undertaken and for the methods which it is proposed to use for the analysis and evaluation of the results obtained. In this particular case, Francis chose to use a particularly rigorous level of compatibility, so that the analytical technique he employed on the results - path analysis - would be highly reliable and capable of identifying precise differences in the correlations between the variables in the situation under investigation. This was to prove particularly valuable for the present enquiry, where it eventually became important to identify the difference between two of the variables: on the one hand, Roman Catholic pupils in non-denominational schools who were receiving specifically Roman Catholic religious education; and on the other hand, Roman Catholic pupils in non-denominational schools who were not catered for, neither

in school nor outside it, for their religious education needs as Roman Catholics.

24 statements remained at the end of the whole process of judging and testing, and these formed the item content of the 'dependent' (or 'attitude') variables in the questionnaire. For the present enquiry, these 24 statements were administered as a pilot scheme to pupils in a Scottish Roman Catholic secondary school, and very slight changes in wording were made (and checked with L.J. Francis) to eliminate any danger that Scottish Roman Catholic pupils might stumble over the statements because they seemed to have a non-Roman Catholic flavour about them. The 24 statements used in this present enquiry were as follows:

1. I find it boring to listen to readings from the Bible.
2. I know that Jesus Christ helps me.
3. Saying my prayers helps me a lot.
4. The Church is very important to me.
5. Going to Church is a waste of my time.
6. I want to love Jesus Christ.
7. I think Church services are boring.
8. I think people who pray are stupid.
9. God helps me to lead a better life.
10. I like school lessons about God very much.
11. God means a lot to me.
12. I believe God helps people.
13. Prayer helps me a lot.
14. I know that Jesus Christ is very close to me.
15. I think praying is a good thing.
16. I think the Bible is out of date.
17. I believe that God listens to prayers.
18. Jesus Christ doesn't mean anything to me.

19. God is very real to me.
20. Saying prayers in school does me no good.
21. The idea of God means much to me.
22. I believe that Jesus Christ still helps people today.
23. I know that God helps me.
24. I find it hard to believe in God.

It may be noticed that eight of the above statements [1, 5, 7, 8, 16, 18, 20, and 24] are negative in tone when compared with the remaining sixteen, e.g. "I find it boring to listen to readings from the Bible", or "Jesus Christ doesn't mean anything to me". This device of mixing 'positive' and 'negative' statements was employed to detect instances where a pupil merely went through the list selecting precisely the same response for each statement, without real thought. In the event, there were hardly any completed questionnaires which showed any evidence of this indifference, so there was no need to take account of it in the analysis process. Evidently, the pupils gave the questionnaire the full attention that had been hoped for, and they deserve full credit for their helpfulness. But one consequence of using this 'reversing' device does have to be noticed, for it can cause confusion when examining how the analysis was actually done: the results for these 'negative' statements were reversed when they were read off the completed questionnaires, to make them easily compatible for statistical purposes with the 'positive' statements. In each of these eight cases, 'disagree strongly' was read as 'agree strongly', 'disagree' was read as 'agree', 'not certain' remained the same, 'agree' was read as 'disagree',

and 'agree strongly' was read as 'disagree strongly'. Care was taken at the coding stage, by the use of a transparent overlay with the appropriate code for each of the twenty-four statements, to ensure that this reversal was identified and observed during the long process of transferring the results from the 2,122 completed questionnaires onto the coding forms for entering the raw information into the computers.

The responses given to the twenty-four statements constituted the 'dependent' or 'attitude' variables in the enquiry, that is the ones which were designed as directly dependent on the religious attitudes of the participants in the survey and which could be used as indicators of, or evidence of, their religious attitudes. It remained to design a section of the questionnaire which would provide information from each participant about the 'independent' variables: the characteristics of their behaviour or situation which might reveal correlations with their religious attitudes. As has already been mentioned, two kinds of information which might have provided significant correlations with religious attitudes were excluded by the education authorities: parental church attendance and pupils' intelligence quotients, but other kinds of information could be obtained without difficulty or fear of offence: the school year of the participant pupils; whether or not they had attended a Roman Catholic primary school before going on to a secondary school (in some areas in which the survey was conducted there were Roman Catholic primary schools but no Roman Catholic secondary schools); their sex;

how often they attended church (on a four-point scale of 'weekly', 'at least once a month', 'sometimes', and 'never'); what kind of church they attended (Church of Scotland, Roman Catholic, Episcopalian or Church of England, 'other', and 'none'), from which information, in all cases - including the questionnaires completed by pupils in the Roman Catholic schools - the Roman Catholic sample was compiled; and the social class of the pupil, determined by the social class of the father or guardian. Previous experience of such an enquiry had shown that it was necessary to ask for a description of the father's or guardian's trade or profession, as the name of the occupation (e.g. 'engineer') meant little in many cases. For this enquiry, the social class groupings followed were the five-fold scheme used since 1911 by the British national population census, in which the many different socio-economic groups are collected into five broad categories, each of which is termed a 'social class', ranging from Class I allocated to 'professional occupations', to Class V allocated to the 'unskilled', with Class III subdivided into 'non-manual' and 'manual'. The grouping of occupations into these categories is regulated by the belief of the Office of Population Censuses and Surveys that "so far as possible, each category is homogeneous in relation to the basic criterion of the general standing within the community of the occupations concerned"⁽⁵⁾. Despite the subjective element in this classification, and the very broad nature of the five categories, the scheme is convenient for enquiries such as this because it provides a widely

used and clear method of classification with recognised limitations.

Further information was obtained from a brief set of questions fastened to the envelopes into which the completed questionnaires were placed, for completion by the teachers administering the questionnaires to the particular groups of pupils. These questions asked for information about the literacy level of the group ('mixed ability', 'above average', 'average', 'below average'); whether or not the group was being prepared for a public examination in Religious Studies, such as the 'O Level' of one or other of the English examination boards (there being no Scottish 'O Grade' examination in Religious Studies at the time of the survey); whether the group was taught by a specialist teacher of Religious Education; and what syllabus of religious education, if any, was in use. General information about each school was noted from personal contact: whether there was a Roman Catholic secondary school in the same catchment area (in the case of non-denominational schools); whether the school was coeducational, boys only or girls only; and whether the school was a Roman Catholic school or non-denominational.

The final form of the three-page questionnaire administered to each pupil is given in the following three pages.

The questionnaires were administered to the pupils in the Spring Term of 1982, and the completed questionnaires from each group of pupils were placed in large

[Text continues on Page 125]

Religious Attitude Research Project

This project is part of a study of the way young people feel about religion. We would like you to help by answering some questions.

The whole project is confidential. No one will connect you with the answers you give. Not even your teachers will see them.

DO NOT WRITE YOUR NAME ON THIS

Part 1

This part of the questionnaire contains a number of sentences about religion and school. They look like this:-

	Agree Strongly	Agree	Not Certain	Disagree	Disagree Strongly
1. <u>I believe in God all the time</u>	AS	A	NC	D	DS

AS means I Agree Strongly

A means I Agree

NC means I am Not Certain

D means I Disagree

DS means I Disagree Strongly

Read the sentence carefully and think, "Do I agree with it?"

If you <u>Agree Strongly</u> , put a ring round	(AS)	A	NC	D	DS
If you <u>Agree</u> , put a ring round	AS	(A)	NC	D	DS
If you are <u>Not Certain</u> , put a ring round	AS	A	(NC)	D	DS
If you <u>Disagree</u> , put a ring round	AS	A	NC	(D)	DS
If you <u>Disagree Strongly</u> , put a ring round	AS	A	NC	D	(DS)

Now try this one:-

2. I think God helps me	AS	A	NC	D	DS
-------------------------	----	---	----	---	----

THIS IS NOT A TEST. THERE ARE NO RIGHT OR WRONG ANSWERS.

ANSWER AS YOU REALLY THINK. YOUR ANSWERS WILL BE CONFIDENTIAL

Now please turn to the next page for the rest of the sentences.

	Agree Strongly	Agree	Not Certain	Disagree	Disagree Strongly
1. I find it boring to listen to readings from the Bible	AS	A	NC	D	DS
2. I know that Jesus Christ helps me	AS	A	NC	D	DS
3. Saying my prayers helps me a lot	AS	A	NC	D	DS
4. The Church is very important to me	AS	A	NC	D	DS
5. Going to Church is a waste of my time	AS	A	NC	D	DS
6. I want to love Jesus Christ	AS	A	NC	D	DS
7. I think Church services are boring	AS	A	NC	D	DS
8. I think people who pray are stupid	AS	A	NC	D	DS
9. God helps me to lead a better life	AS	A	NC	D	DS
10. I like school lessons about God very much	AS	A	NC	D	DS
11. God means a lot to me	AS	A	NC	D	DS
12. I believe God helps people	AS	A	NC	D	DS
13. Prayer helps me a lot	AS	A	NC	D	DS
14. I know that Jesus Christ is very close to me	AS	A	NC	D	DS
15. I think praying is a good thing	AS	A	NC	D	DS
16. I think the Bible is out of date	AS	A	NC	D	DS
17. I believe that God listens to prayers	AS	A	NC	D	DS
18. Jesus Christ doesn't mean anything to me	AS	A	NC	D	DS
19. God is very real to me	AS	A	NC	D	DS
20. Saying prayers in school does me no good	AS	A	NC	D	DS
21. The idea of God means much to me	AS	A	NC	D	DS
22. I believe that Jesus Christ still helps people today	AS	A	NC	D	DS
23. I know that God helps me	AS	A	NC	D	DS
24. I find it hard to believe in God	AS	A	NC	D	DS

Please turn to the next page for the final questions.

(ASC43/LJF78) JR 81)

Part 2

The questions in this part ask for some information about yourself. This part is also confidential. No one will connect you with the answers you give, and no one in the school will see it.

Please answer by ticking the box which fits your answer.

Which school year are you in?

First year	1	
Second year	2	
Third year	3	
Fourth year	4	
Fifth year	5	
Sixth year	6	

Did you go to a Roman Catholic Primary School?

Yes	2	
No	1	

Sex

Male	1	
Female	2	

How often do you go to Church?

Weekly	4	
At least once a month	3	
Sometimes	2	
Never	1	

What kind of Church do you go to?

Church of Scotland	1	
Roman Catholic	2	
Episcopalian or Church of England	3	
Other	4	
None	5	

What is the trade or profession of your father or guardian?

Please describe it.....

THANK YOU FOR YOUR HELP.

envelopes and sealed in their presence, after which they were collected or sent from the various schools for processing. At the processing centre the questionnaires were all numbered consecutively and identified with a group and school code conveying the information obtained about the group and school to which each questionnaire related. The information on each questionnaire was then translated into a numerical code and the coded information transferred onto coding sheets for the use of the punch-card operators. Once on a set of punch-cards, the information was fed into computers in Edinburgh and Cambridge, which were programmed for the comparatively simple analysis in terms of univariate correlations, and the more complex multi-variate correlations programme needed for path analysis. At this stage the enquiry was most fortunate to be able to take advantage of the programming services of Dr. Moir in Edinburgh and Dr. Francis in Cambridge, who were most generous of their time and expertise. For coding purposes a simple numerical code was devised which allocated a number, or combination of numbers, to each variable and its subdivisions. The information asked for through the computer programmes would be given in terms of these numbers, and would then need to be translated back into the variables which they represented. The code was as follows, and indicates the range of information obtained. Not all of this information was actually used in the subsequent analysis for this particular enquiry.

Coding Key: Religious Attitudes Research ProjectColumn

1-4	Questionnaire numbers.		
5-28	<u>Dependent Variables.</u> (Page 2 of questionnaire)		
	Positive questions: (All questions except QQ. 1, 5, 7, 8, 16, 18, 20, & 24.)	Agree Strongly Agree Not Certain Disagree Disagree Strongly	5 4 3 2 1
	Negative questions:	<u>Reverse</u> of above coding.	
29-45	<u>Independent Variables</u>		
29-34	<u>Personal Information</u>		
29	Year in school:	1st. Yr., 4th. Yr...	1,4,5,6
30	Roman Catholic Primary School:	Yes No	2 1
31	Sex:	Male Female	1 2
32	Church Attendance:	Weekly Monthly Sometimes Never	4 3 2 1
33	Church Affiliation:	Church of Scotland Roman Catholic Anglican Other None	1 2 3 4 5
34	Social Class:	Registrar General's Groups Unemployed	1,2,3,4, 6
35-38	<u>School Information</u>		
35	School code number:		1,2,3, e
36	Type of School:	Roman Catholic Non-denominational	2 1
37	Type of Pupils:	Coeducational Boys only Girls only	1 2 3
38	Roman Catholic School in Area:	Yes No	1 2
39-45	<u>Group Information</u>		
39-40	Year Group code number:	1st. Yr. groups: 4th. Yr. groups: 5th. & 6th Yrs:	11, 12, 41, 42, 51, 61,
41	Literacy Level:	Mixed ability Above average Average Below average	1 2 3 4
42	Public Religious Studies Exam.:	Yes No	2 1
43	Contact with Specialists:	Yes No	2 1
44-45	Syllabus in use:	Teachers' own School's own Other	1 2 1,2,3,

References The Method of Enquiry Section

- [1] Rhymer, J., The Use of the Bible in Modern Catholic Catechesis, unpublished M.Th. Thesis for the University of Edinburgh, 1975.
- [2] Francis, L.J., An Enquiry into the Concept 'Readiness for Religion', unpublished Ph.D. Thesis, University of Cambridge, 1976;
- " - School Influence and Pupil Attitude in Religious Education, Unpublished M.Sc. Dissertation, University of London, 1977;
- 'Attitude and Longitude: As Study in Measurement', in Character Potential, Vol 8, pp. 119-130, Schenectady, 1978.
- [3] This process is described succinctly by J. Gahagan in the chapter on "Attitudes" in Radford, J. & Govier, E. [Eds.], A Textbook of Psychology, London, 1980.
- [4] Office of Population Censuses and Surveys, Classification of Occupations 1970 (London, 1979), p. 114-119.

3. The Results

The analysis of the results obtained about the sample of 1,113 Roman Catholic pupils at secondary schools in the Strathclyde Region of Scotland will now be presented in four stages, mainly by tables and graphs, but also with explanations of the way in which conclusions might be drawn from these statistics. It should be made clear that the first three stages of this presentation are at a lower level of analysis than the fourth stage. The questionnaire was designed for use with path analysis of the information it provided, and this rigorous form of analysis is employed for the final, fourth stage of presentation. The first three stages of presentation are based on a simpler form of analysis, by straight comparison of the various kinds of information yielded by the questionnaire and by the other enquiries associated with it. Of these first three stages, the first simply examines the information obtained from the responses to the 24 sentences in the questionnaire, and suggests what conclusions might be drawn about the religious attitudes of the whole sample of 1,113 pupils. The second stage of presentation distinguishes between the pupils in the sample who were at Roman Catholic schools, and those attending non-denominational schools. The third stage then distinguishes between three situations: pupils attending Roman Catholic schools, the Roman Catholic pupils at non-denominational schools who were receiving specifically Roman Catholic religious education lessons (whether in school hours or not), and those for whom such a provision was not available. Finally, as has already been said, the

fourth stage of presentation employs path analysis, in a way which is statistically more rigorous than the approach used for the first three stages. By using path analysis it was possible to isolate the various kinds of information and identify the factors which had the strongest correlations with the religious attitudes shown by the three categories of pupil within the sample. This final stage provided confirmation of the conclusions reached by the preceding, simpler examination of the information.

In the presentation, 'dependent variable' refers to the information obtained from the responses to the 24 sentences, which indicated the religious attitudes of the pupils. 'Independent variables' refers to all the rest of the information, such as the kind of school they attended, their social class, etc. 'Univariate correlations' are comparisons between the religious attitudes and only one of the independent variables at a time. 'Multivariate correlations' relate the religious attitudes to more than one of the independent variables (particularly whether the pupils concerned were attending Roman Catholic schools or non-denominational ones, and what kind of religious education they were receiving) and evaluates the significance of the differences detected. Clearly, these multivariate correlations, which are taking into account the effects of more than one independent variable at a time, are difficult to evaluate by the simpler methods of comparison employed for stages two and three of the presentation. Path analysis proved to be more valuable for this kind of complex analysis, but the simpler approach of the earlier stages

did provide useful indications of the results which might be expected. The results, then, are presented below in four stages, under the following headings:

- A: Univariate Correlations of the Whole Sample;
- B: Multivariate Correlations by Type of School;
- C: Multivariate Correlations by Type of School and Religious Education;
- D: Multivariate Correlations Using Path Analysis.

The main function of the first of these, which was a simple analysis of the whole sample, was to provide a norm so that differences could be identified by comparison with it in the more complex analysis of the multivariate correlations.

A: Univariate Correlations of the Whole Sample

The results for the total Roman Catholic sample of 1,113 pupils constituted the norm for comparison purposes in the analysis when subsections of the sample came under consideration; it is therefore appropriate to begin this examination of the results by looking at the characteristics of this norm. It provides a picture of the religious attitudes of all the Roman Catholic pupils in the enquiry, whether or not they were in Roman Catholic schools. Table 1 gives the results, as percentages, of the responses of the pupils to each of the 24 sentences on the questionnaire, and the following pages present these same results in graphical form. The reader is reminded that the results for the eight 'negative' sentences (1, 5, 7, 8, 16, 18, 20, and 24) have been reversed to facilitate comparison with the 'positive' sentences, the remaining sixteen. There are six percentages for each sentence, corresponding to the five categories from 'disagree strongly' through to 'agree strongly' together with a sixth category of pupils who provided no answer. The results are given to the nearest whole number, and it will be noticed that the 'no answer' category never amounts to more than 1%.

The first point of interest is that the responses to these sentences all show a positive attitude towards religion, with one notable exception: the response to Sentence 10: "I like school lessons about God very much". The extent of this overall positive attitude towards religion may be seen by combining the figures in the

[Text continues on page 143]

Table 1

Roman Catholic Pupils:
Total Number Sampled (N = 1113).

Sentence 1: "I find it boring to listen to readings from
the Bible."*

	DS	D	NC	A	AS	[NA]
All RC pupils:	8	23	21	37	11	[1]
						(X ² sig. 0.01)

Sentence 2: "I know that Jesus Christ helps me."

	DS	D	NC	A	AS	[NA]
All RC pupils:	2	5	28	41	24	[1]
						(X ² sig. 0.01)

Sentence 3: "Saying my prayers helps me a lot."

	DS	D	NC	A	AS	[NA]
All RC pupils:	4	13	28	35	19	[1]
						(X ² sig. 0.01)

Sentence 4: "The Church is very important to me."

	DS	D	NC	A	AS	[NA]
All RC pupils:	3	14	26	34	23	[0]
						(X ² sig. 0.01)

Sentence 5: "Going to Church is a waste of my time."*

	DS	D	NC	A	AS	[NA]
All RC pupils:	4	9	15	34	38	[1]
						(X ² sig. 0.01)

Sentence 6: "I want to love Jesus Christ."

	DS	D	NC	A	AS	[NA]
All RC pupils:	2	3	19	35	39	[1]
						(X ² sig. 0.01)

Sentence 7: "I think Church services are boring."*

	DS	D	NC	A	AS	[NA]
All RC pupils:	9	27	21	28	15	[1]
						(X ² sig. 0.01)

Sentence 8: "I think people who pray are stupid."*

	DS	D	NC	A	AS	[NA]
All RC pupils:	1	1	5	32	60	[0]
						(X ² sig. 0.01)

*See note, p. 151

[Table continues]

Table 1 [Cont.]

Roman Catholic Pupils:
Total Number Sampled (N = 1113).

<u>Sentence 9:</u> "God helps me to lead a better life."						
	DS	D	NC	A	AS	[NA]
All RC pupils:	3	8	27	38	24	[1]
						[X ² sig. 0.01]
<u>Sentence 10:</u> "I like school lessons about God very much."						
	DS	D	NC	A	AS	[NA]
All RC pupils:	13	30	28	22	7	[0]
						[X ² sig. 0.01]
<u>Sentence 11:</u> "God means a lot to me."						
	DS	D	NC	A	AS	[NA]
All RC pupils:	2	8	21	38	31	[0]
						[X ² sig. 0.01]
<u>Sentence 12:</u> "I believe God helps people."						
	DS	D	NC	A	AS	[NA]
All RC pupils:	2	3	16	41	38	[0]
						[X ² sig. 0.01]
<u>Sentence 13:</u> "Prayer helps me a lot."						
	DS	D	NC	A	AS	[NA]
All RC pupils:	4	14	28	33	21	[1]
						[X ² sig. 0.01]
<u>Sentence 14:</u> "I know that Jesus Christ is very close to me."						
	DS	D	NC	A	AS	[NA]
All RC pupils:	3	7	31	34	25	[1]
						[X ² sig. 0.01]
<u>Sentence 15:</u> "I think praying is a good thing."						
	DS	D	NC	A	AS	[NA]
All RC pupils:	2	6	19	44	29	[1]
						[X ² sig. 0.01]
<u>Sentence 16:</u> "I think the Bible is out of date." *						
	DS	D	NC	A	AS	[NA]
All RC pupils:	6	13	19	34	28	[1]
						[X ² sig. 0.01]

*See note, p. 151

[Table continues]

Table 1 [Cont.]

Roman Catholic Pupils:
Total Number Sampled [N = 1113].

Sentence 17: "I believe that God listens to prayers."

	DS	D	NC	A	AS	[NA]
All RC pupils:	2	5	25	33	34	[1]
						[X ² sig. 0.01]

Sentence 18: "Jesus Christ doesn't mean anything to me."*

	DS	D	NC	A	AS	[NA]
All RC pupils:	1	3	8	28	59	[0]
						[X ² sig. 0.01]

Sentence 19: "God is very real to me."

	DS	D	NC	A	AS	[NA]
All RC pupils:	2	8	27	35	28	[1]
						[X ² sig. 0.01]

Sentence 20: "Saying prayers in school does me no good."*

	DS	D	NC	A	AS	[NA]
All RC pupils:	8	21	23	31	17	[1]
						[X ² sig. 0.01]

Sentence 21: "The idea of God means much to me."

	DS	D	NC	A	AS	[NA]
All RC pupils:	2	7	23	40	27	[1]
						[X ² sig. 0.01]

Sentence 22: "I believe that Jesus Christ still helps people today."

	DS	D	NC	A	AS	[NA]
All RC pupils:	3	3	17	38	39	[0]
						[X ² sig. 0.01]

Sentence 23: "I know that God helps me."

	DS	D	NC	A	AS	[NA]
All RC pupils:	3	6	27	39	26	[1]
						[X ² sig. 0.01]

Sentence 24: "I find it hard to believe in God."*

	DS	D	NC	A	AS	[NA]
All RC pupils:	6	18	12	33	31	[0]
						[X ² sig. 0.01]

*See note, p. 151

DS

D

NC

A

AS

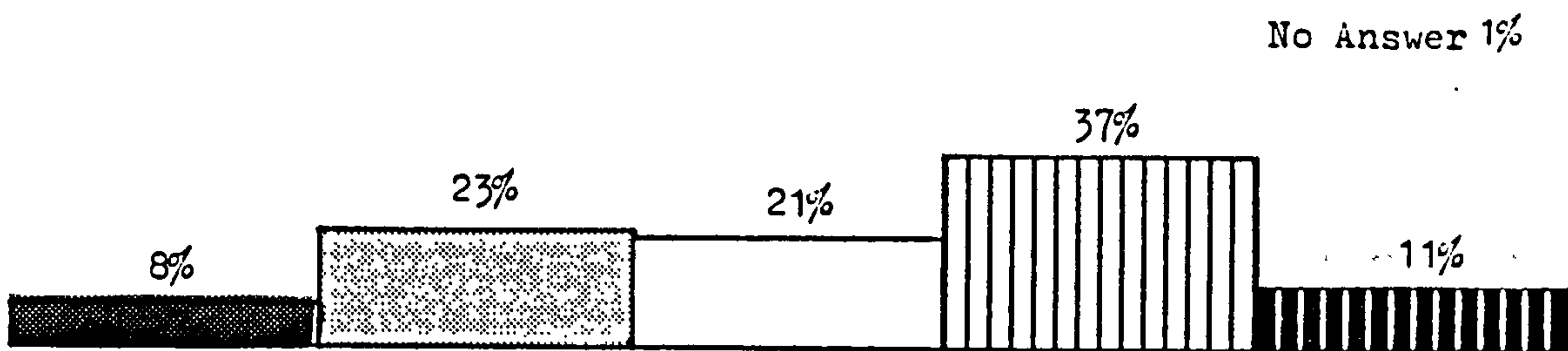

1.

"I find it boring to listen to readings from the bible"

No Answer 1%

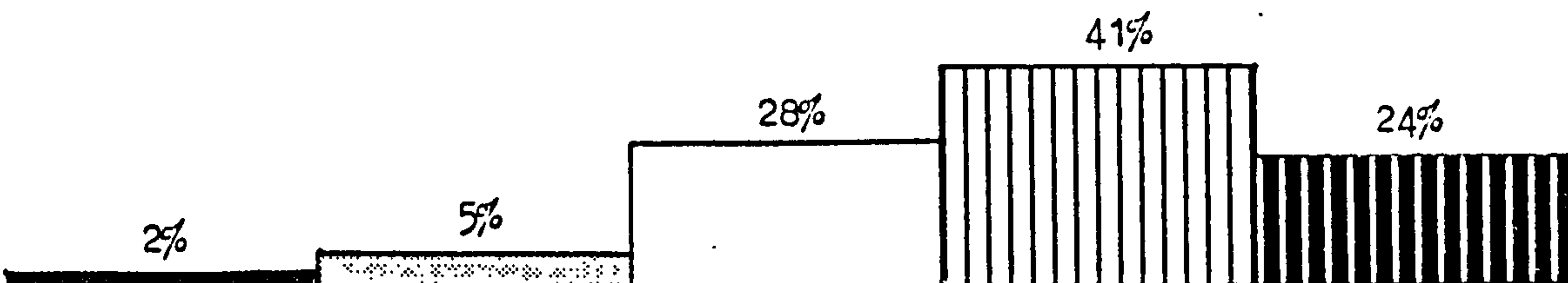

2.

"I know that Jesus Christ helps me"

No Answer 1%

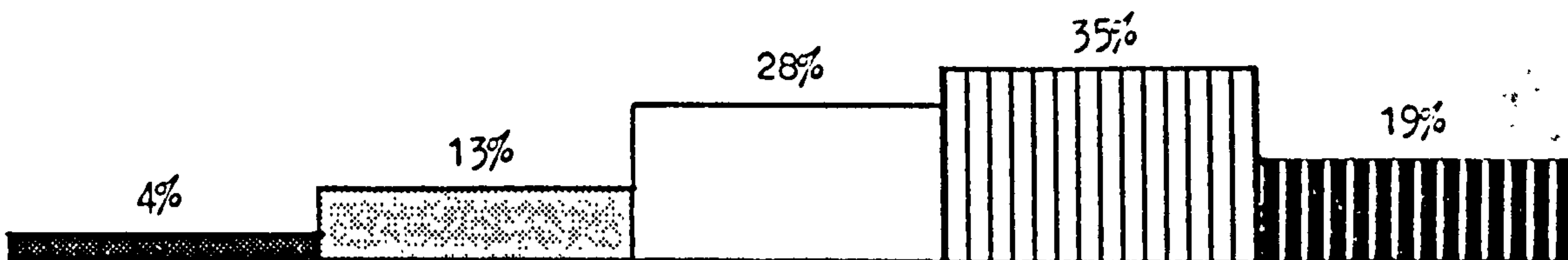

3.

"Saying my prayers helps me a lot"

DS

D

NC

A

AS

No Answer 0

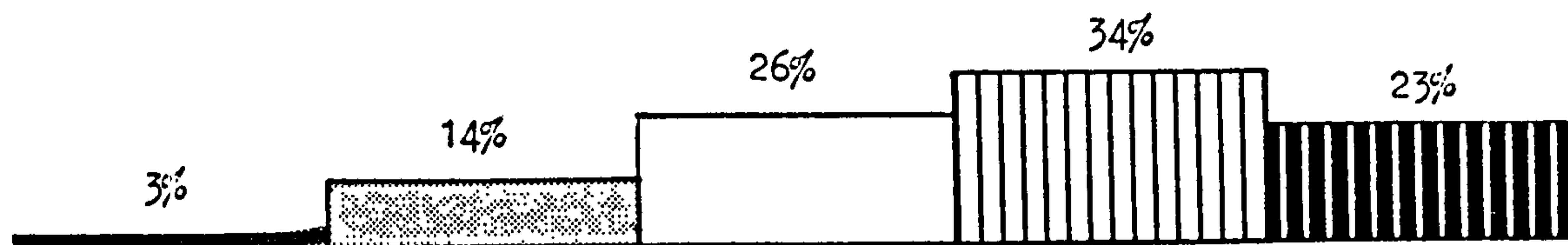

4.

"The church is very important to me"

No Answer 1%

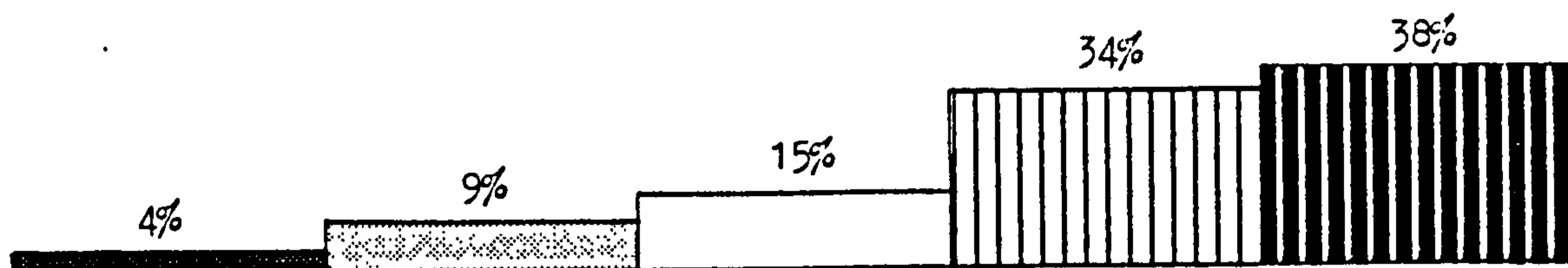

5.

"Going to church is a waste of my time"

No Answer 1%

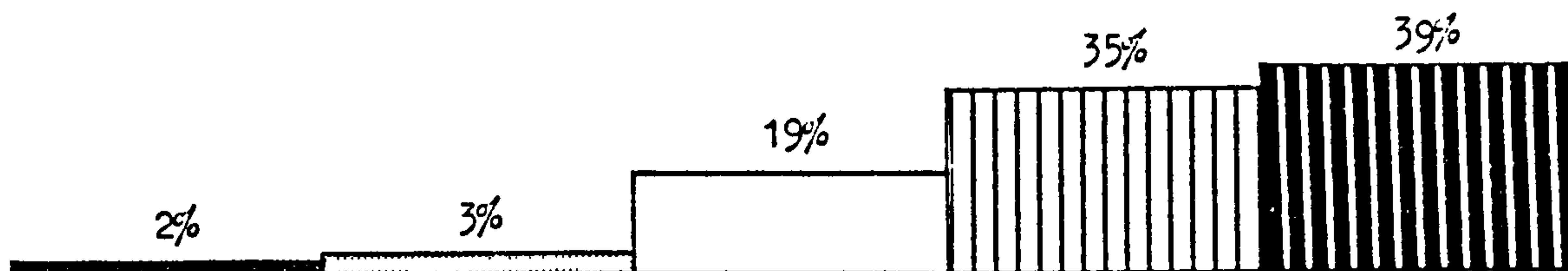

6.

"I want to love Jesus Christ"

DS

D

NC

A

AS

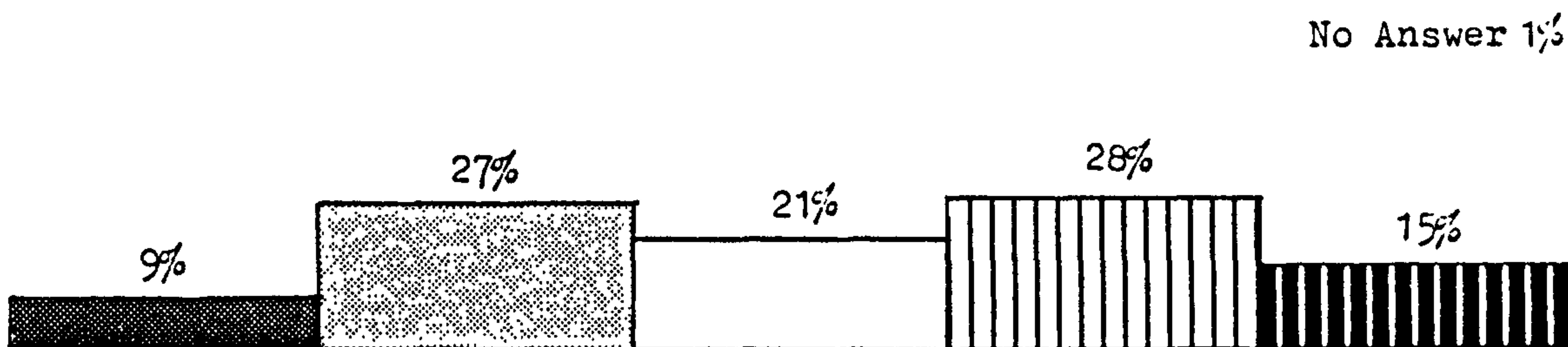

No Answer 1%

7.

"I think church services are boring"

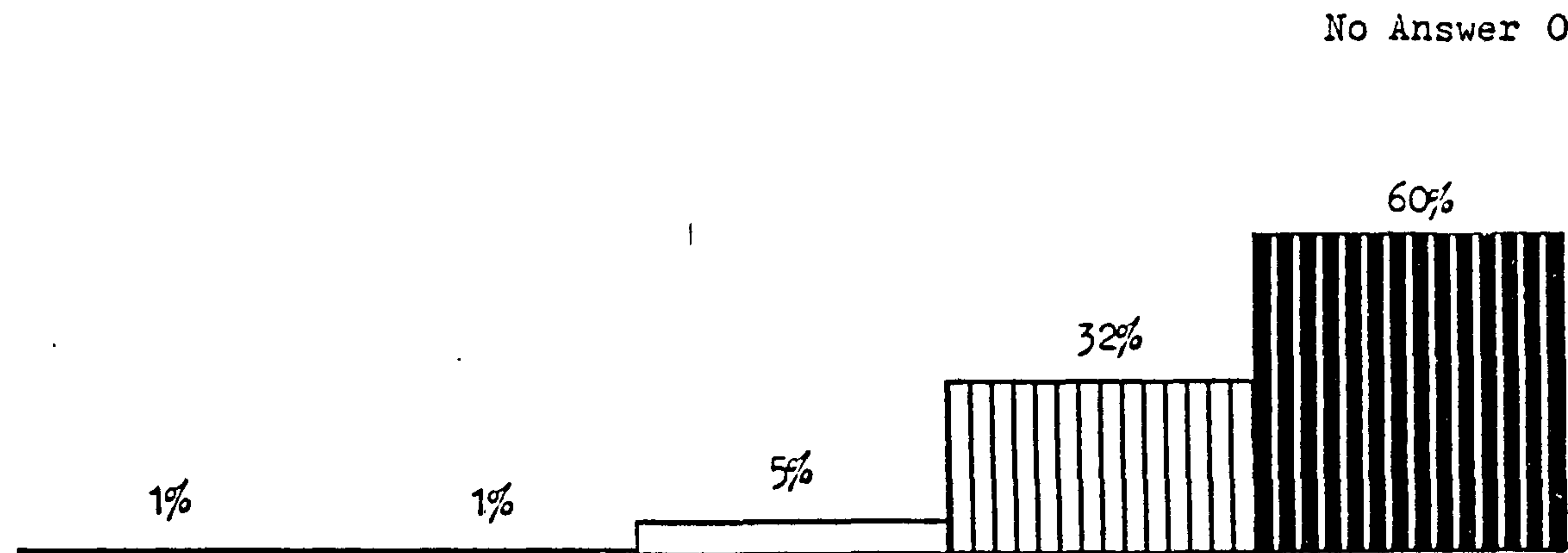

No Answer 0

8.

"I think people who pray are stupid"

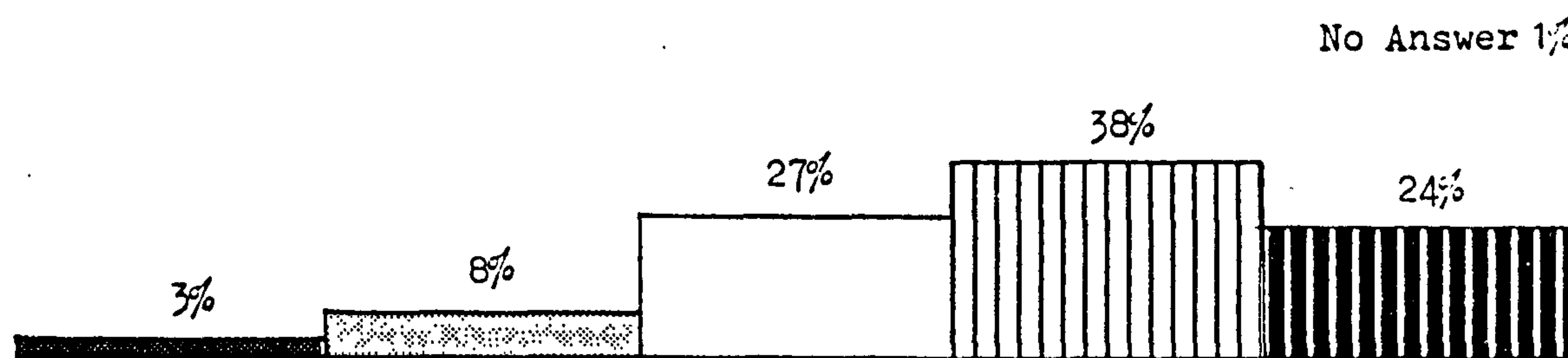

No Answer 1%

9.

"God helps me to lead a better life"

DS

D

NS

A

AS

No Answer 0

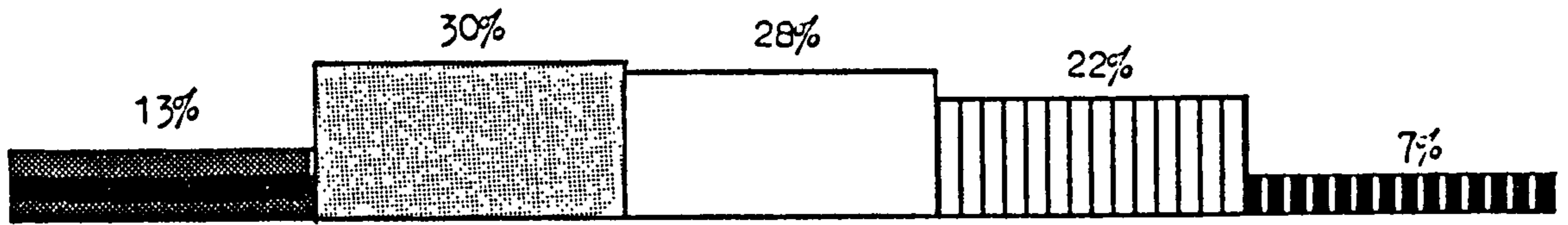

10.

"I like school lessons about God very much"

No Answer 0

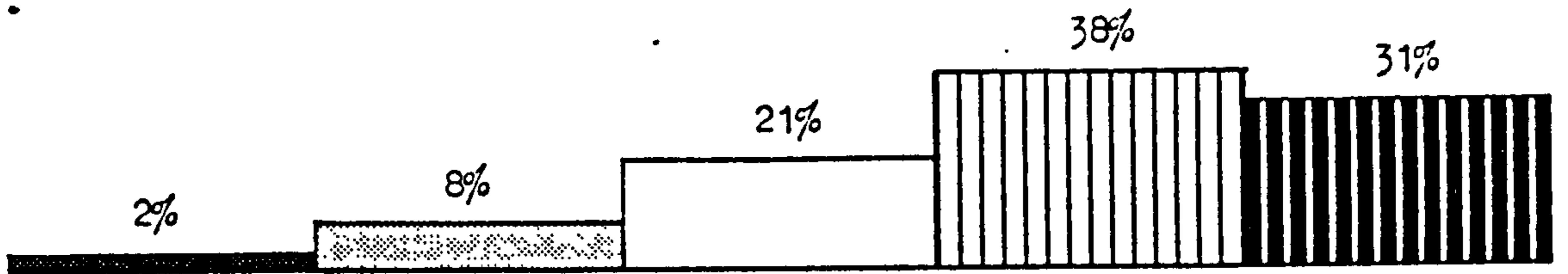

11.

"God means a lot to me"

No Answer 0

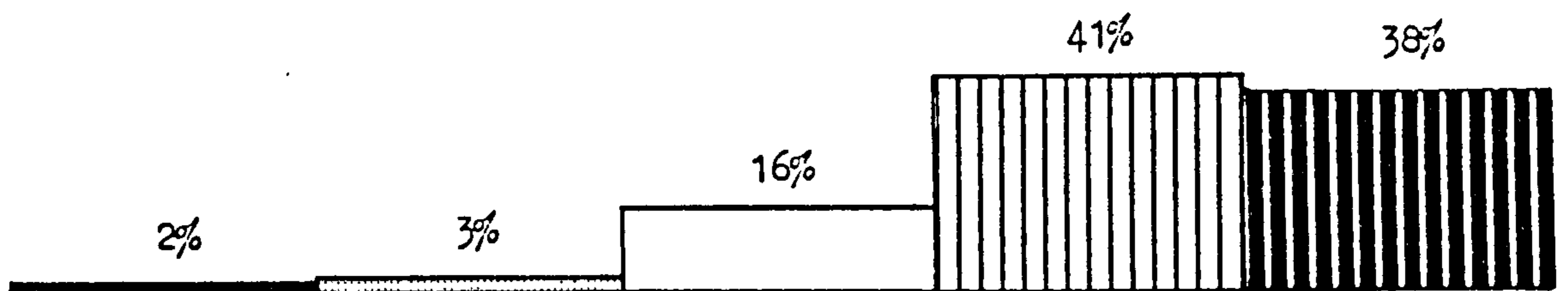

12.

"I believe God helps people"

DS

D

NS

A

AS

No Answer 1%

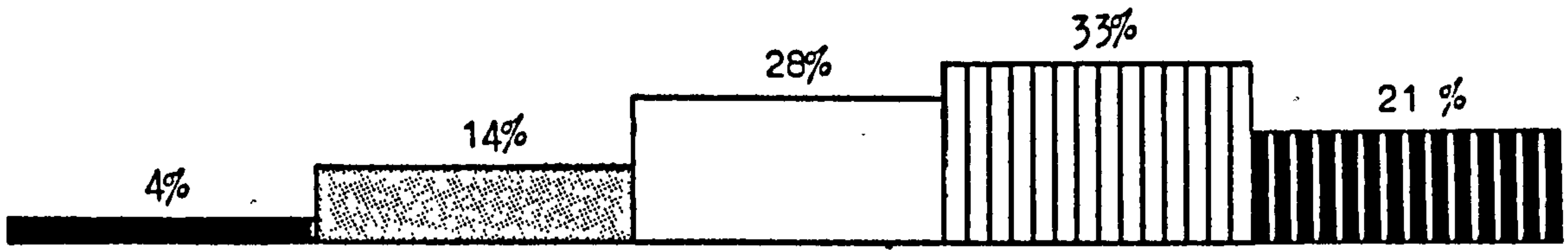

13.

"Prayer helps me a lot"

No Answer 1%

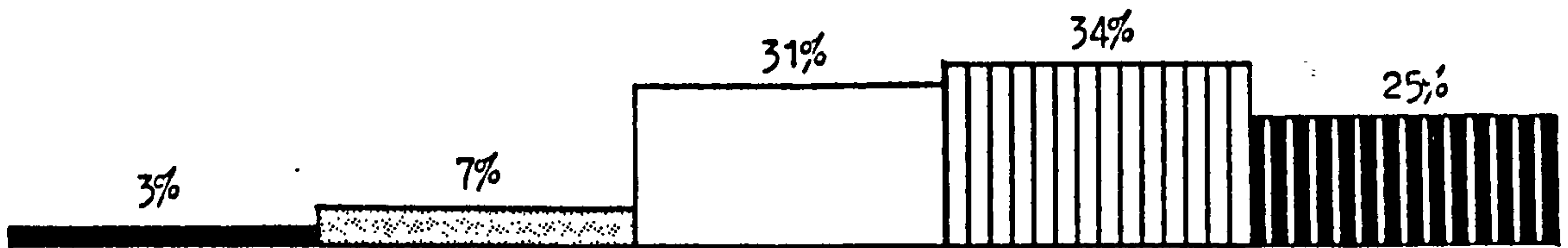

14.

"I know that Jesus Christ is very close to me"

No Answer 1%

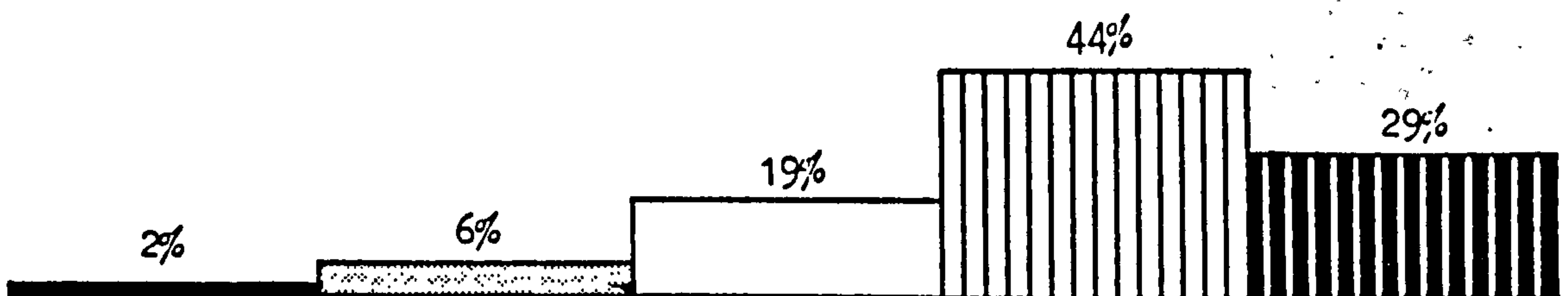

15.

"I think praying is a good thing"

DS

D

NS

A

AS

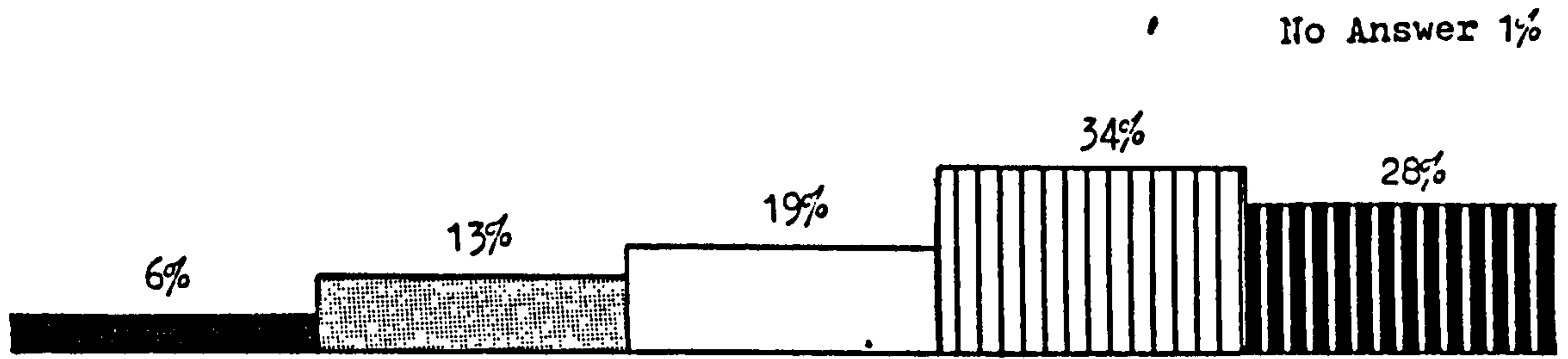

16.

"I think the bible is out of date"

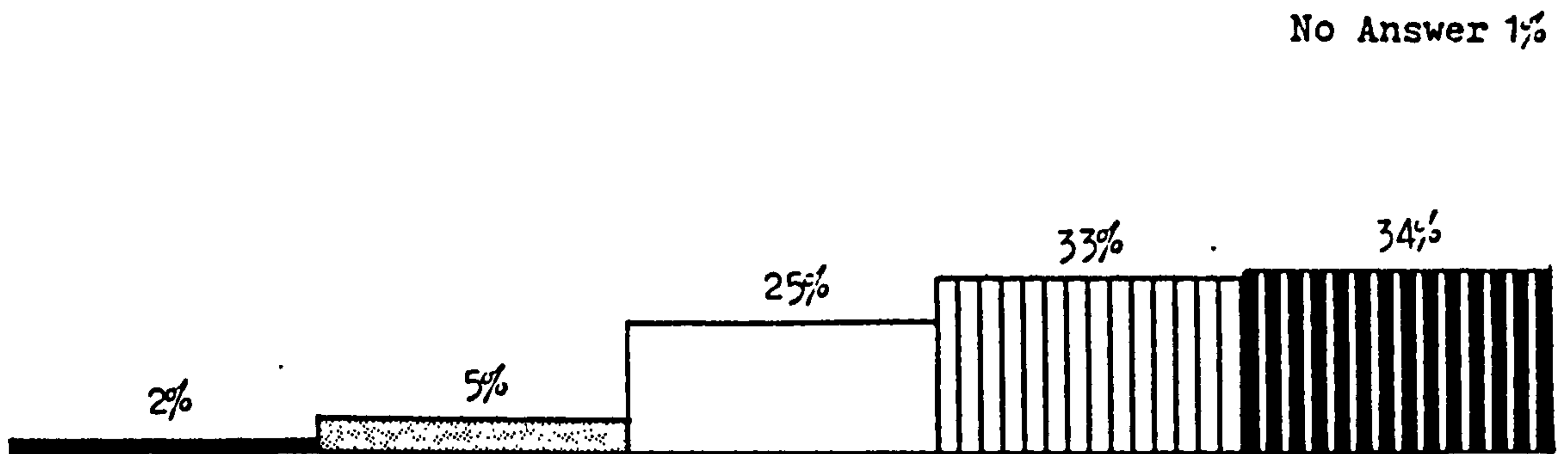

17.

"I believe that God listens to prayers"

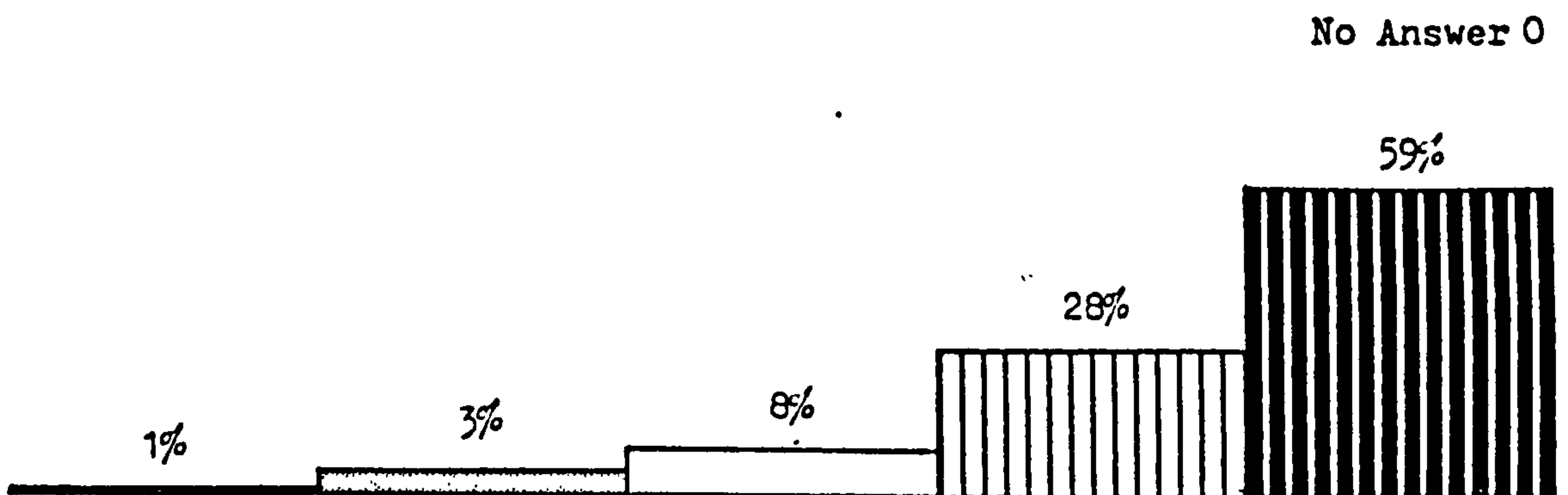

18.

"Jesus Christ doesn't mean anything to me"

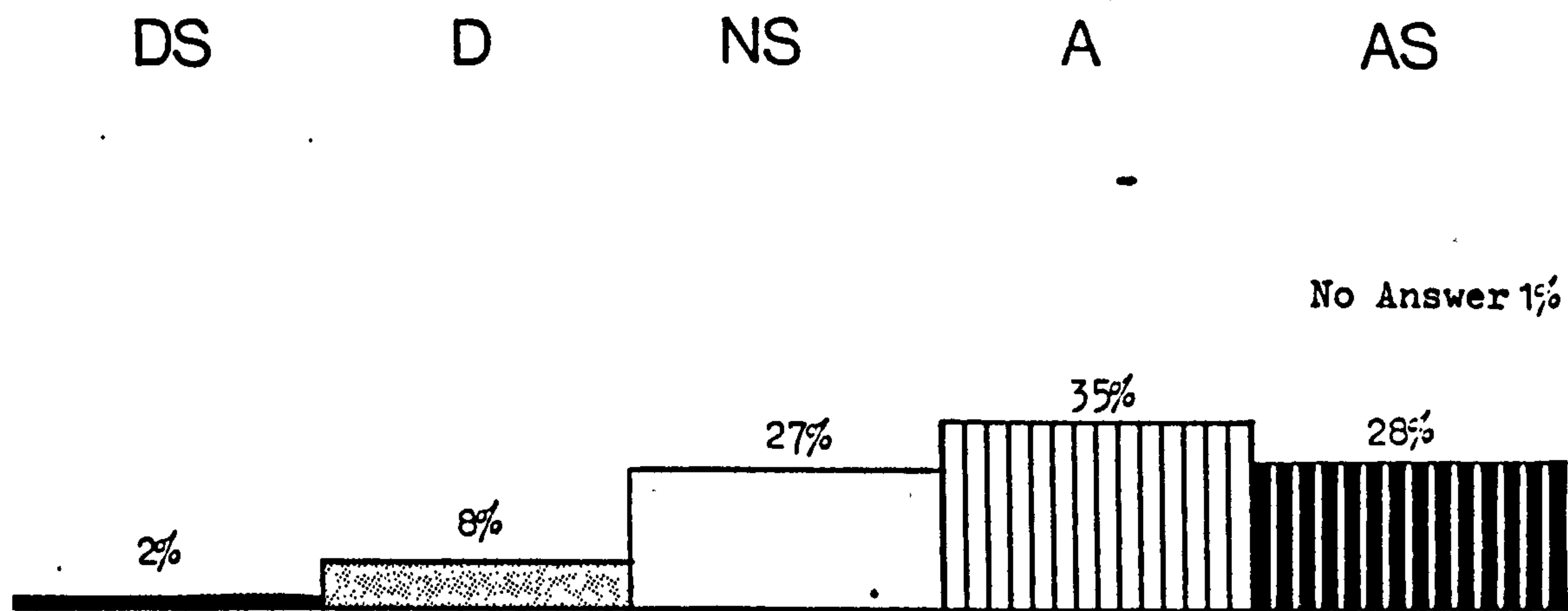

19.

"God is very real to me"

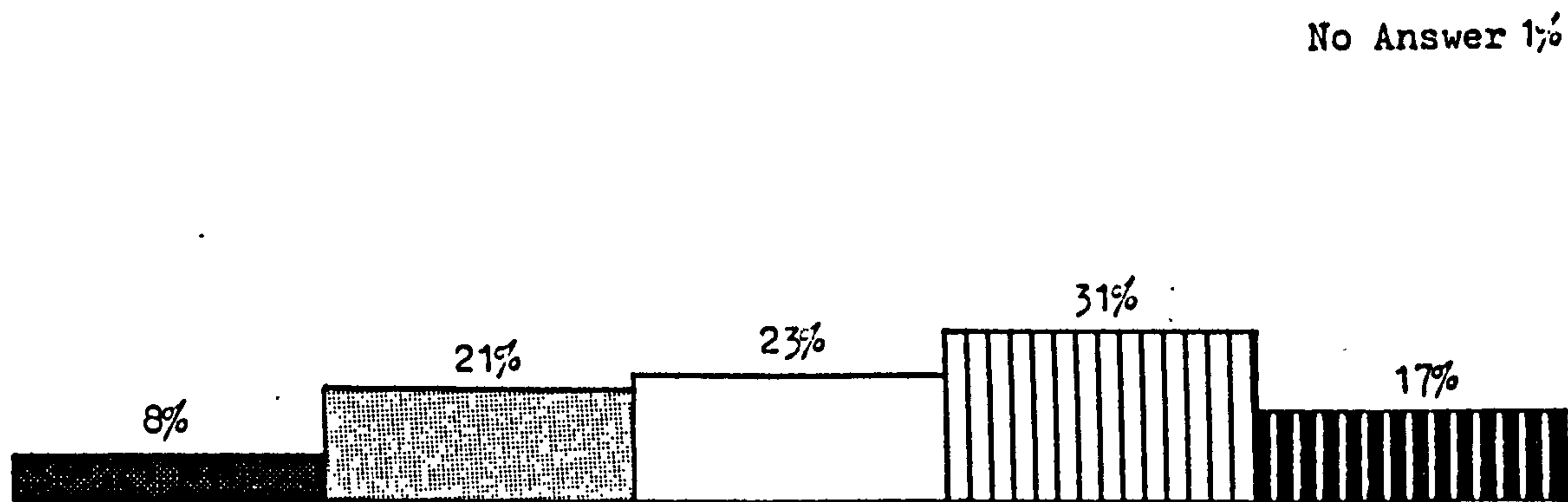

20.

"Saying prayers in school does me no good"

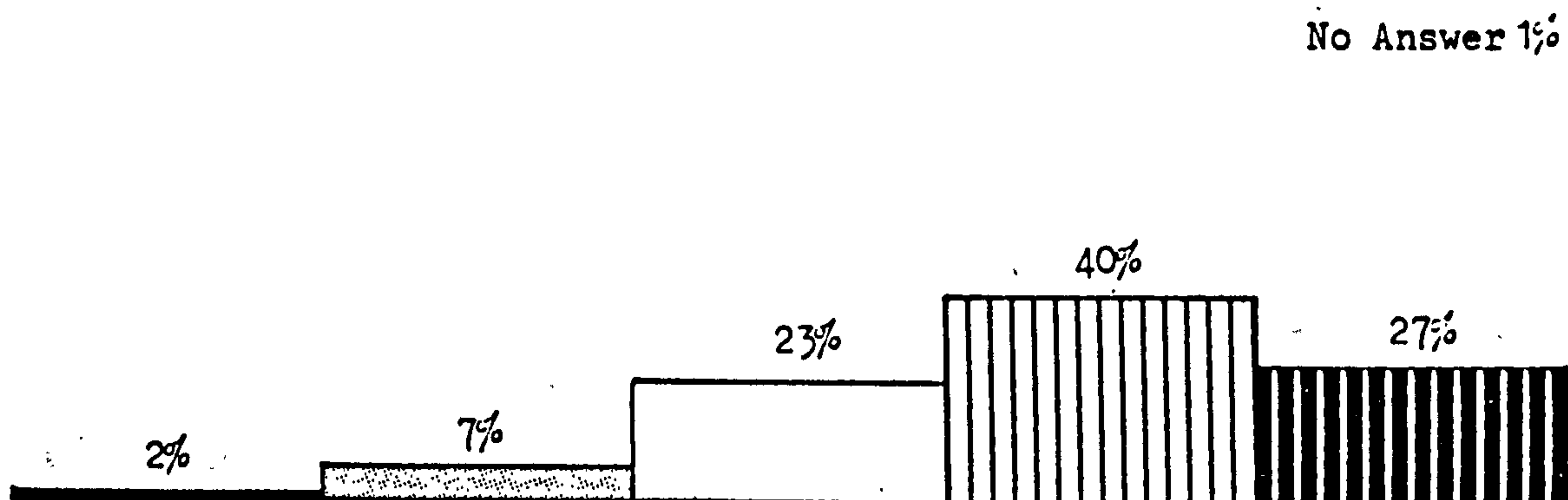

21.

"The idea of God means much to me"

DS

D

NS

A

AS

No Answer 0

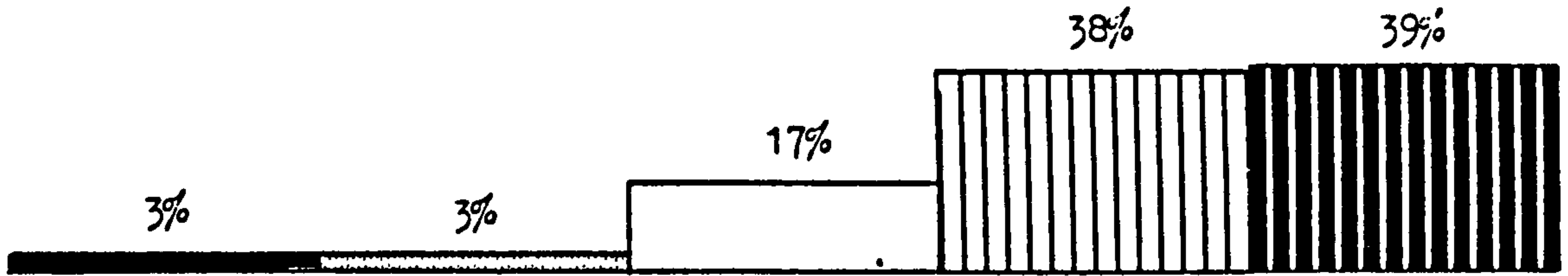

22.

"I believe that Jesus Christ still helps people today"

No Answer 1%

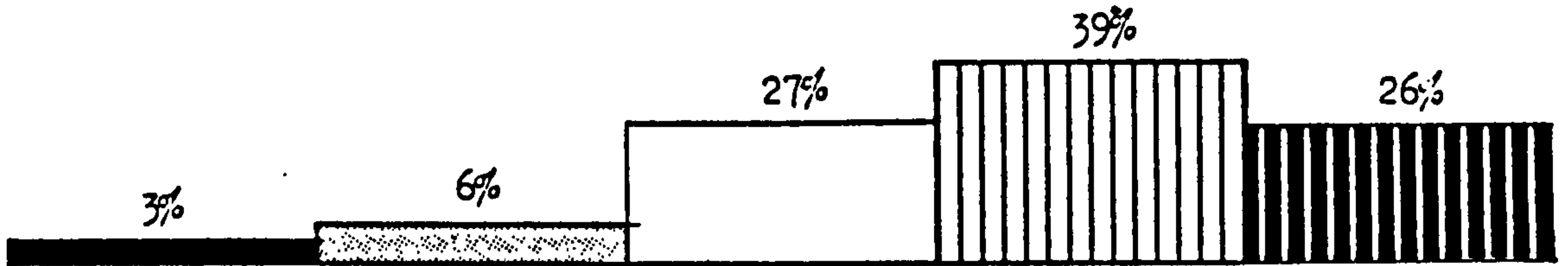

23.

"I know that God helps me"

No Answer 0

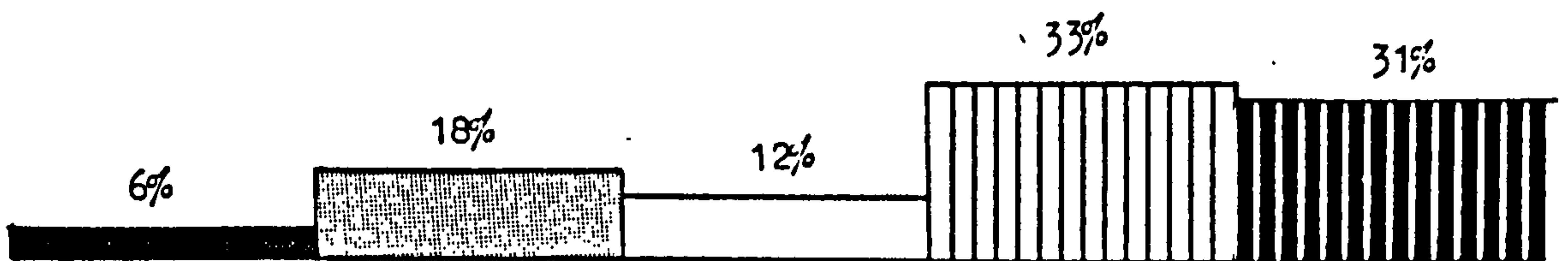

24.

"I find it hard to believe in God"

'agree strongly' and 'agree' categories, and comparing them with the combined figures for the 'disagree strongly' and 'disagree' categories. The results are as follows:

<u>Sentence</u>	<u>Agreement</u>	<u>Disagreement</u>
1:	48%	31%
2:	65%	7%
3:	54%	17%
4:	57%	17%
5:	72%	13%
6:	74%	5%
7:	43%	36%
8:	92%	2%
9:	62%	11%
10:	29%	43%
11:	69%	10%
12:	79%	5%
13:	54%	18%
14:	59%	10%
15:	73%	8%
16:	62%	19%
17:	67%	7%
18:	87%	4%
19:	63%	10%
20:	48%	29%
21:	67%	9%
22:	77%	6%
23:	65%	9%
24:	64%	24%

In view of the fact that Roman Catholic children have their religious affiliation ascribed to them by their parent or guardians (by being baptised as infants), and that there are still quite strong pressures on them from family sources and institutional inertia to continue to accept this ascription during their time as children of school-age, the

Roman Catholic church authorities may take comfort from these figures. The children's religious affiliation, however involuntary or unthinking, is associated with a positive personal attitude towards religion. It is all the more significant, therefore, that they so dislike their experience of lessons about religion in school as expressed in their responses to Sentence 10. To anticipate a later stage of this analysis, there is no evidence that this result for the overall sample comes from the proportion of Roman Catholic pupils in non-denominational schools; quite the reverse in fact: 45% in Roman Catholic schools disliked school lessons about God, compared with 37% in non-denominational schools; and only 27% in Roman Catholic schools said they liked their school lessons about God, compared with 32% in non-denominational schools. Nor is it 'school' which is the significant factor here, for there was only one other statement which mentioned school, Sentence 20. Here there was a positive response of agreement, but it is significant that this was a sentence about prayer in school. In general, the survey revealed a very strong positive attitude towards prayer, and it is evident that this attitude persists even in the school situation where the pupils so disliked their religious education lessons. One of the reasons for this may be that at the time of this enquiry (and for the foreseeable future) most Roman Catholic secondary school pupils in Roman Catholic schools in Scotland received their religious education from teachers who were not as highly trained in this subject as in their main teaching subject, and so, perhaps,

fall back on less attractive methods of teaching or were unable to engage the pupils' interest in the information they were conveying compared with other subjects in the school curriculum. Ironically, the Roman Catholic pupils in non-denominational schools who receive specifically Roman Catholic religious education are likely to be taught by specialists in the subject just because special arrangements have to be made for them.

A detailed analysis of the total sample of Roman Catholic pupils is not the main purpose of this enquiry, but rather a comparison of those in Roman Catholic and non-denominational schools; nevertheless brief comments are appropriate at this point about the broad impressions given by the overall results.

The positive attitudes shown towards 23 of the 24 sentences (when the 'negative' ones are reversed) has already been noted, and the one sentence to which strong exception was taken was seen to be Sentence 10: "I like school lessons about God very much". For clarification of the pupils' attitudes, the 24 sentences can be divided into six groups according to various aspects of Christianity mentioned in them: God, Jesus, the Bible, Prayer, Church (without distinguishing between the Church as a theological concept and Church as a place for worship), and School Religion.

Seven of the sentences fall into the first category, 'God':

- 9. God helps me to lead a better life;
- 11. God means a lot to me;

- 12. I believe God helps people;
- 19. God is very real to me;
- 21. The idea of God means much to me;
- 23. I know that God helps me;
- 24. I find it hard to believe in God. (Results read in reverse)

Strongly positive attitudes were shown to all of these [the detailed figures are given in the Table 1 and its associated graphs], with the exception of the final one. Although there was a positive attitude of similar strength to this sentence, it was accompanied by an unusually strong [24%] combined attitude of difficulty about belief in God, while none of the other sentences in this category attracted more than 11%. Even Sentences 11, 19 and 21 attracted strongly positive attitudes [69%; 63% and 67%] and weak negative ones [10%; 10%; and 9%], although it might be thought that these three are similar in content to Sentence 24. The most likely explanation is that 'belief' within the Roman Catholic Church covers a very wide range of statements about God, some of which would certainly be beyond the capacity of most school pupils, yet they will have encountered them in the course of the liturgical year.

The next category is 'Jesus', which contains the following sentences:

- 2. I know that Jesus Christ helps me;
- 6. I want to love Jesus Christ;
- 14. I know that Jesus Christ is very close to me;
- 18. Jesus Christ doesn't mean anything to me; (Results reversed)
- 22. I believe that Jesus Christ still helps people today.

There were positive attitudes towards all of these, some of

them [particularly Sentence 18] very strong, and no strongly expressed negative attitudes. The only one of the above sentences with a slightly lower positive attitude was Sentence 14, where it may reflect expectations about personal experience in religion. But it is clear that this group of sentences reveals a particularly strong attachment to Jesus Christ by the overwhelming majority of all the pupils.

The third category is 'the Bible', which contained only two sentences:

1. I find it boring to listen to readings from the Bible; [Results reversed]

16. I think the Bible is out of date. [Results reversed]

There were markedly contrasting results for these two sentences. The first evoked a comparatively low positive attitude, and a comparatively high negative one [48% and 31% respectively], showing that these pupils were not enthusiastic about listening to the Bible being read to them. This may reflect either their attitude towards religious education lessons in school [vividly reflected in the results for Sentence 10], or towards Church services [clearly, although less vividly, expressed in the results for Sentence 7]. On the other hand, there was a much stronger set of responses about Sentence 16 [62% and 19%], which showed that the pupils did not consider the Bible to be out of date. There is a lesson here for the way school pupils in Roman Catholic schools normally come into contact with the Bible, for there are still very few schools where the pupils have a Bible of their own to keep and use as

they wish. Modern Roman Catholic religious education is more concerned with the Bible as a whole than used to be the case when texts tended to be used out of context, but it would seem that the pupils are not very enthusiastic about having it read to them. Nor is the experience of hearing it read during services as helpful as it could be, for it usually takes the form of three short passages read during the first part of the Mass, often without any very obvious connection between them.

The fourth category is 'Prayer', which contains six of the sentences:

- 3. Saying my prayers helps me a lot;
- 8. I think people who pray are stupid; [Results reversed]
- 13. Prayer helps me a lot;
- 15. I think praying is a good thing;
- 17. I believe that God listens to prayers;
- 20. Saying prayers in school does me no good. [Results reversed]

The results here were less even, although all were more strongly positive than negative. Sentence 8 evoked the strongest response [for that matter, it was also the strongest response to any of the 24 sentences], where 92% were positive and only 2% negative. The pupils thus rejected very strongly the idea that people who pray are stupid, and only 5% were uncertain about this statement, the lowest figure for uncertainty for any of the 24 sentences. There were lower positive responses to Sentences 3 and 13, showing, perhaps, less certainty about personal prayer than about the general importance and value of prayer. This may have reflected a lack of growth in prayer, or a failure to use informal methods of prayer more appropriate to the pupils' growth

towards maturity. The lowest positive scores, and the highest negative ones, were recorded for Sentence 20, about prayers in school (48% and 29% respectively), but the positive responses still outweighed the negative ones. As prayer is such an important aspect of what is normally meant by religion, this category is an important indicator of pupil attitude, and shows that their positive attitude towards religion is strong about a really essential element.

The fifth category is 'Church', which contains three sentences:

4. The Church is very important to me;
5. Going to Church is a waste of my time; (Results reversed)
7. I think Church services are boring. (Results reversed)

Here the pupils did not think going to Church is a waste of their time (72% to 13%) but nothing like as high a proportion found the services other than boring (43% to 36%).

The more abstract sentence about the importance of the Church attracted support somewhere between the figures for the other two sentences (57% to 17%). There would seem to be real danger, here, of pupils finding their hopes unfulfilled if such a high proportion think it useful to go to Church but find the experience unsatisfactory.

Finally, there is the category of 'School Religion', which contains two sentences:

10. I like school lessons about God very much;
20. Saying prayers in school does me no good. (Results reversed)

The response to Sentence 10 has already been noted: it is the only sentence of the 24 to which there was an overall

negative attitude, 29% liked their school religious education lessons but 43% disliked them. The response to the other sentence, about prayers in school, was not overwhelmingly enthusiastic, but the positive attitudes did outweigh the negative: 48% thought prayer in school did them good, while 29% thought not.

To sum up these results, the pupils showed an encouragingly strong attitude towards the personal aspects of their religion, particularly towards Jesus Christ and towards prayer. This might indicate something of the topics which should be given emphasis in religious education: the person of Jesus Christ, and the practice of prayer. On the other hand, pupils actively disliked their religious education lessons, and were less than enthusiastic about their public experience of religion: hearing the Bible read to them, Church services, and saying prayers in school. The first of these might be met by making available to pupils Bibles which they can own, particularly now that there are versions which present the text more attractively and intelligibly than used to be the case. For the second, many Roman Catholic churches now present at least one of the Sunday Masses in a form more attractive to young people and give them more responsibility for parts of the service; moreover, an increasing number of schools encourage their pupils to plan school Masses for their class or peer group, celebrated in the school itself by a school chaplain or at least by a local priest closely associated with the school and its pupils. Finally, there is a distinct move away from set forms of prayer, learned by heart and repeated without

variation in school, day after day. The 'charismatic movement' has gained much support in the Roman Catholic Church, particularly amongst young people, and most schools now have an informal prayer group. It would be unfortunate, perhaps, if the old traditional forms of prayer were to be abandoned entirely, but at least they are being used in Roman Catholic schools in conjunction with more informal modes of prayer in the pupils' own language and related by them to their immediate needs.

Note: The asterisks in the tables and graphs indicate 'negative' sentences for which the results have been reversed to facilitate comparison with the 'positive' sentences.

B: Multivariate Correlations by Type of School

This enquiry was designed to test the hypothesis that Roman Catholic children of secondary school age who attended Roman Catholic schools would have a more positive attitude towards their religion than would comparable children in non-denominational schools, that is, Roman Catholic children of the same age-group who for one reason or another were not attending Roman Catholic schools. With this general purpose in mind, schools were selected which would provide a stratified sample of Roman Catholic pupils, divided so that the proportion of those attending Roman Catholic schools and those attending non-denominational schools would reflect a reasonable estimate of the distribution of these two groups in the secondary school population of Scotland. The Roman Catholic pupils were sorted out from the rest (even in the Roman Catholic schools) by the answer they provided to the question asking what kind of church they attended, if any. Of the 1,113 pupils who thus identified themselves as Roman Catholics, 882 attended Roman Catholic secondary schools and 231 attended non-denominational ones.

The religious attitudes of these two groups of Roman Catholic pupils can be compared by comparison of the percentage responses given by each group to the 24 sentences which comprise the dependent variables in the questionnaire. Again, five kinds of response were possible to each sentence, ranging from 'disagree strongly' through 'not certain' to 'agree strongly', and in a very small

number of cases (only reaching 2% in the case of responses of one of the groups to one of the sentences) no response was given. As an aid to comparison, the figures obtained for these two groups of pupils were compared with the figures for the whole sample of 1,113 Roman Catholic pupils. The results are presented in Table 2 and its associated graphs, with an asterisk marking the 'negative' sentences for which the results have been reversed.

Visual comparison of the results for the two groups, similar to the method of comparison used for the univariate correlations of the whole sample, is an inexact method of analysis, but it is sufficiently accurate to provide a useful first impression, particularly when the results for the two groups are seen in close conjunction with the results for the whole sample. More exact results, obtained by path analysis, will be presented later. Such a comparison of the religious attitudes of the Roman Catholic children in Roman Catholic schools and the ones in non-denominational schools reveals hardly any differences at all in their responses to the bulk of the 24 sentences. Even where there are differences of attitude, they never amount to a reversal of attitude between one group and the other, and in only two instances are the differences sufficiently large to be surprising.

In seventeen of the dependent variables, that is, the responses to seventeen of the sentences in the questionnaire, such differences as appear are so slight that they do not warrant attention. These cases are the

[Text continues on page 183]

Table 2

Roman Catholic Pupils:

Total Number Sampled [N = 1113];
 In Roman Catholic Schools [N = 882];
 In Other Schools [N = 231].

Sentence 1: "I find it boring to listen to readings from
 the Bible."*

	DS	D	NC	A	AS	[NA]
All RC pupils:	8	23	21	37	11	[1]
In RC schs:	8	24	23	34	10	[1]
In other schs:	10	16	15	46	13	[0]
						[X ² sig. .01]

Sentence 2: "I know that Jesus Christ helps me."

	DS	D	NC	A	AS	[NA]
All RC pupils:	2	5	28	41	24	[1]
In RC schs:	2	5	28	42	25	[1]
In other schs:	2	4	36	36	21	[0]
						[X ² sig. = 0.11]

Sentence 3: "Saying my prayers helps me a lot."

	DS	D	NC	A	AS	[NA]
All RC pupils:	4	13	28	35	19	[1]
In RC schs:	4	13	28	36	19	[1]
In other schs:	4	14	28	32	21	[1]
						[X ² sig. = 0.86]

Sentence 4: "The Church is very important to me."

	DS	D	NC	A	AS	[NA]
All RC pupils:	3	14	26	34	23	[0]
In RC schs:	3	14	25	34	23	[1]
In other schs:	4	14	27	33	22	[0]
						[X ² sig. = 0.99]

Sentence 5: "Going to Church is a waste of my time."*

	DS	D	NC	A	AS	[NA]
All RC pupils:	4	9	15	34	38	[1]
In RC schs:	4	9	15	34	38	[1]
In other schs:	4	7	16	33	40	[0]
						[X ² sig. = 0.92]

*See note, p. 151

[Table continues]

Table 2 (Cont.)

Roman Catholic Pupils:

Total Number Sampled (N = 1113);

In Roman Catholic Schools (N = 882);

In Other Schools (N = 231).

Sentence 6: "I want to love Jesus Christ."

	DS	D	NC	A	AS	[NA]
All RC pupils:	2	3	19	35	39	[1]
In RC schs:	2	3	18	35	41	[1]
In other schs:	2	4	25	36	33	[0]

(X² sig. = 0.02)

Sentence 7: "I think Church services are boring."*

	DS	D	NC	A	AS	[NA]
All RC pupils:	9	27	21	28	15	[1]
In RC schs:	9	29	21	27	15	[0]
In other schs:	11	20	20	33	15	[1]

(X² sig. = 0.03)

Sentence 8: "I think people who pray are stupid."*

	DS	D	NC	A	AS	[NA]
All RC pupils:	1	1	5	32	60	[0]
In RC schs:	1	1	5	33	60	[0]
In other schs:	2	2	5	29	62	[0]

(X² sig. = 0.54)

Sentence 9: "God helps me to lead a better life."

	DS	D	NC	A	AS	[NA]
All RC pupils:	3	8	27	38	24	[1]
In RC schs:	3	8	26	38	25	[1]
In other schs:	2	8	32	35	22	[1]

(X² sig. = 0.56)

Sentence 10: "I like school lessons about God very much."

	DS	D	NC	A	AS	[NA]
All RC pupils:	13	30	28	22	7	[0]
In RC schs:	14	31	27	22	5	[0]
In other schs:	10	27	30	21	11	[1]

(X² sig. = 0.01)

*See note, p. 151

[Table continues]

Table 2 (Cont.)

Roman Catholic Pupils:

Total Number Sampled [N = 1113];

In Roman Catholic Schools [N = 882];

In Other Schools [N = 231].

Sentence 11: "God means a lot to me."

	DS	D	NC	A	AS	[NA]
All RC pupils:	2	8	21	38	31	[0]
In RC schs:	2	7	22	37	32	[0]
In other schs:	3	9	18	41	29	[0]

[X² sig. = 0.61]

Sentence 12: "I believe God helps people."

	DS	D	NC	A	AS	[NA]
All RC pupils:	2	3	16	41	38	[0]
In RC schs:	2	3	15	41	39	[1]
In other schs:	2	5	20	41	33	[0]

[X² sig. = 0.14]

Sentence 13: "Prayer helps me a lot."

	DS	D	NC	A	AS	[NA]
All RC pupils:	4	14	28	33	21	[1]
In RC schs:	4	14	26	34	20	[1]
In other schs:	4	13	34	27	21	[1]

[X² sig. = 0.21]

Sentence 14: "I know that Jesus Christ is very close to me."

	DS	D	NC	A	AS	[NA]
All RC pupils:	3	7	31	34	25	[1]
In RC schs:	3	8	29	35	25	[1]
In other schs:	3	7	36	31	24	[0]

[X² sig. = 0.41]

Sentence 15: "I think praying is a good thing."

	DS	D	NC	A	AS	[NA]
All RC pupils:	2	6	19	44	29	[1]
In RC schs:	2	6	19	44	29	[1]
In other schs:	2	6	21	43	27	[0]

[X² sig. = 0.97]

[Table continues]

Table 2 (Cont.)

Roman Catholic Pupils:

Total Number Sampled (N = 1113);

In Roman Catholic Schools (N = 882);

In Other Schools (N = 231).

Sentence 16: "I think the Bible is out of date."*

	OS	D	NC	A	AS	[NA]
All RC pupils:	6	13	19	34	28	[1]
In RC schs:	6	14	20	34	25	[1]
In other schs:	4	11	14	33	37	[1]
						(X ² sig. 0.01)

Sentence 17: "I believe that God listens to prayers."

	OS	D	NC	A	AS	[NA]
All RC pupils:	2	5	25	33	34	[1]
In RC schs:	2	5	24	33	35	[2]
In other schs:	3	5	26	33	33	[0]
						(X ² sig. = 0.70)

Sentence 18: "Jesus Christ doesn't mean anything to me."*

	OS	D	NC	A	AS	[NA]
All RC pupils:	1	3	8	28	59	[0]
In RC schs:	1	4	8	29	58	[0]
In other schs:	3	2	9	23	64	[0]
						(X ² sig. = 0.10)

Sentence 19: "God is very real to me."

	OS	D	NC	A	AS	[NA]
All RC pupils:	2	8	27	35	28	[1]
In RC schs:	2	7	28	34	28	[1]
In other schs:	2	9	21	39	29	[0]
						(X ² sig. = 0.20)

Sentence 20: "Saying prayers in school does me no good."*

	OS	D	NC	A	AS	[NA]
All RC pupils:	8	21	23	31	17	[1]
In RC schs:	7	21	21	32	18	[1]
In other schs:	8	21	29	27	15	[0]
						(X ² sig. = 0.17)

*See note, p. 151

[Table continues]

Table 2 (Cont.)

Roman Catholic Pupils:

Total Number Sampled (N = 1113);

In Roman Catholic Schools (N = 882);

In Other Schools (N = 231).

Sentence 21: "The idea of God means much to me."

	DS	D	NC	A	AS	[NA]
All RC pupils:	2	7	23	40	27	[1]
In RC schs:	2	7	23	40	27	[1]
In other schs:	2	8	24	42	23	[1]

[X² sig. = 0.88]

Sentence 22: "I believe that Jesus Christ still helps people today."

	DS	D	NC	A	AS	[NA]
All RC pupils:	3	3	17	38	39	[0]
In RC schs:	3	3	17	38	39	[1]
In other schs:	3	4	17	38	38	[0]

[X² sig. = 0.87]

Sentence 23: "I know that God helps me."

	DS	D	NC	A	AS	[NA]
All RC pupils:	3	6	27	39	26	[1]
In RC schs:	2	6	27	39	25	[1]
In other schs:	3	5	26	39	26	[0]

[X² sig. = 0.98]

Sentence 24: "I find it hard to believe in God."*

	DS	D	NC	A	AS	[NA]
All RC pupils:	6	18	12	33	31	[0]
In RC schs:	5	20	11	33	30	[1]
In other schs:	9	13	13	30	34	[0]

[X² sig. = 0.05]

*See note, p. 151

" I FIND IT BORING TO LISTEN TO READINGS FROM THE BIBLE "

DS

D

NC

A

AS

No Answer 1%

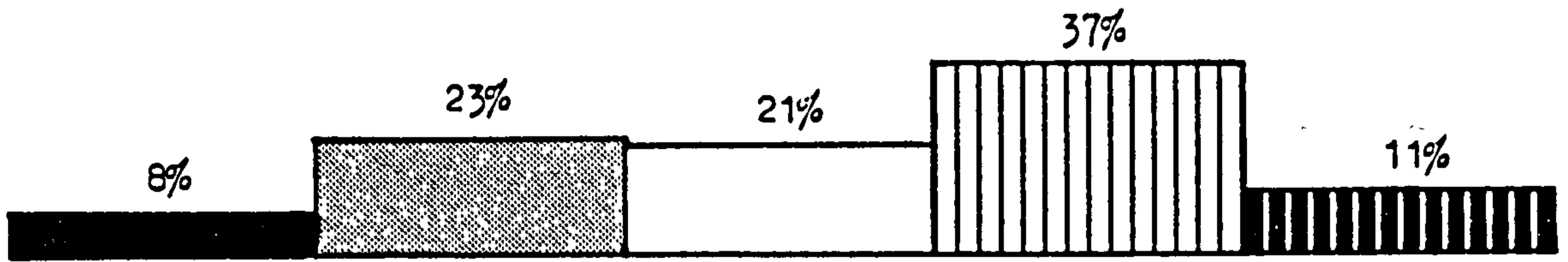

No Answer 1%

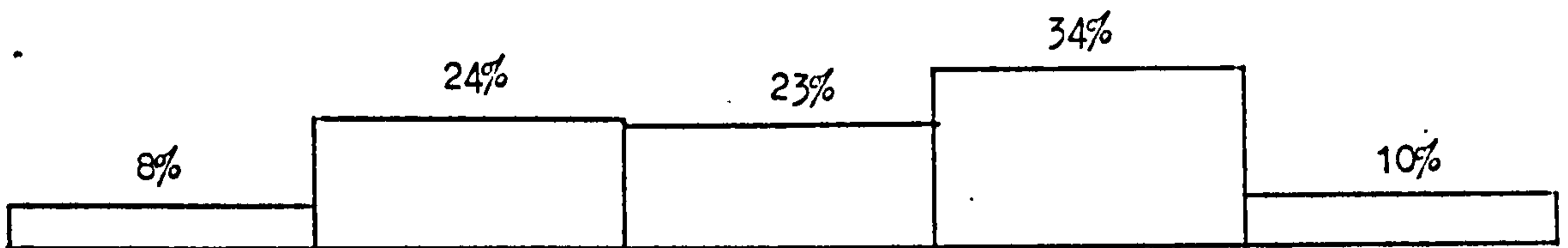

No Answer 0

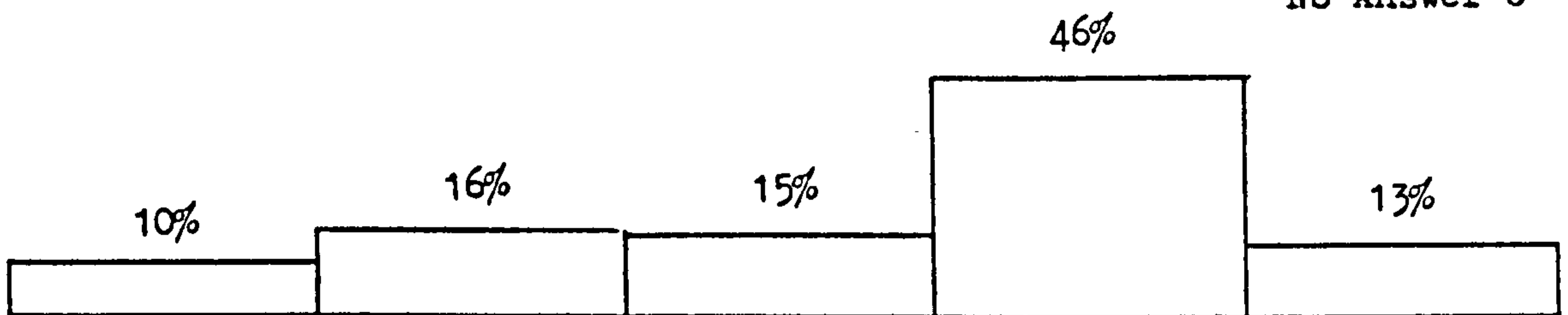

2. " I KNOW THAT JESUS CHRIST HELPS ME A LOT "

DS D NC A AS

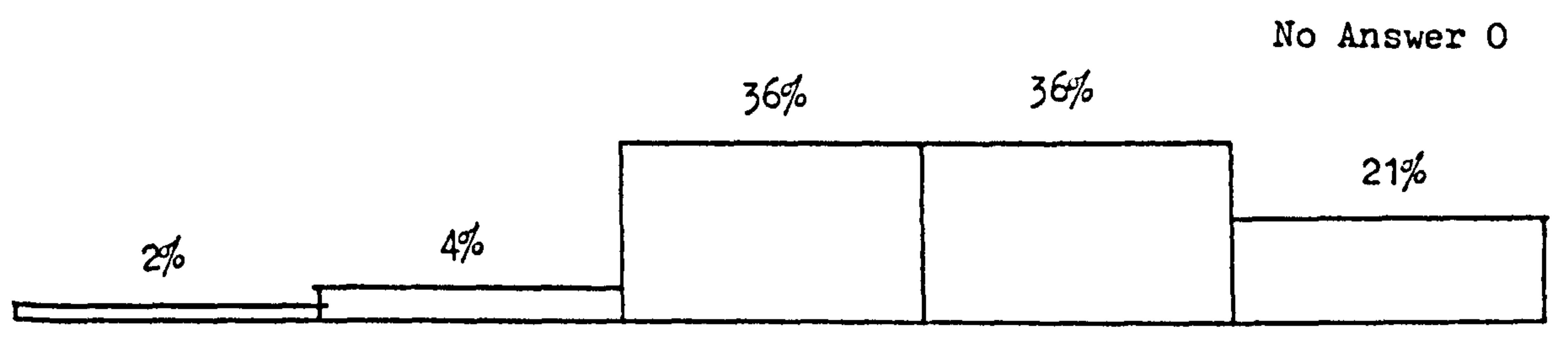
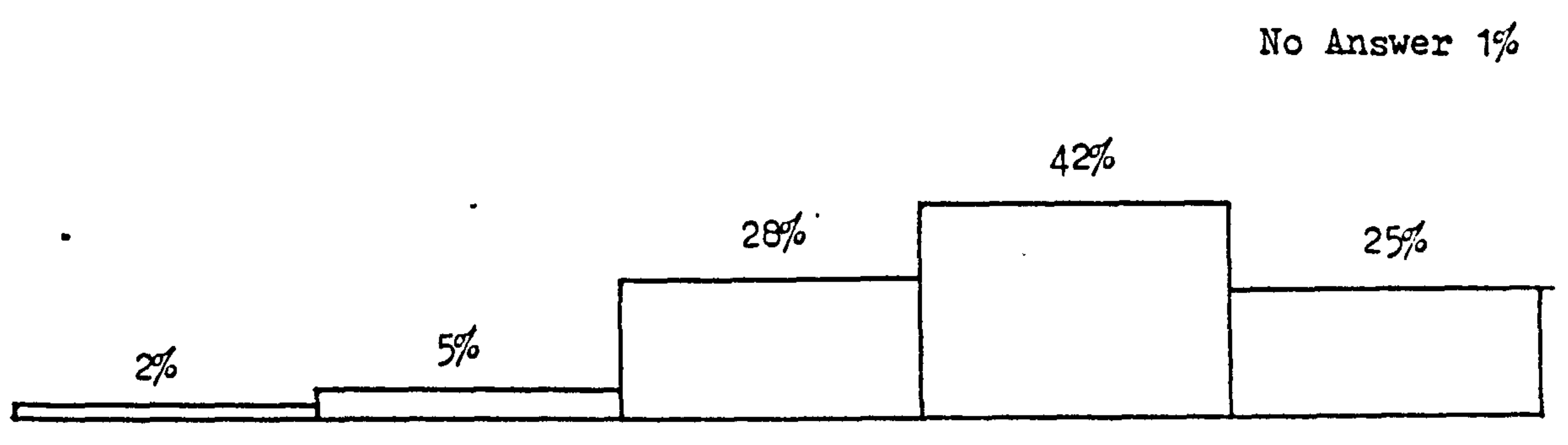
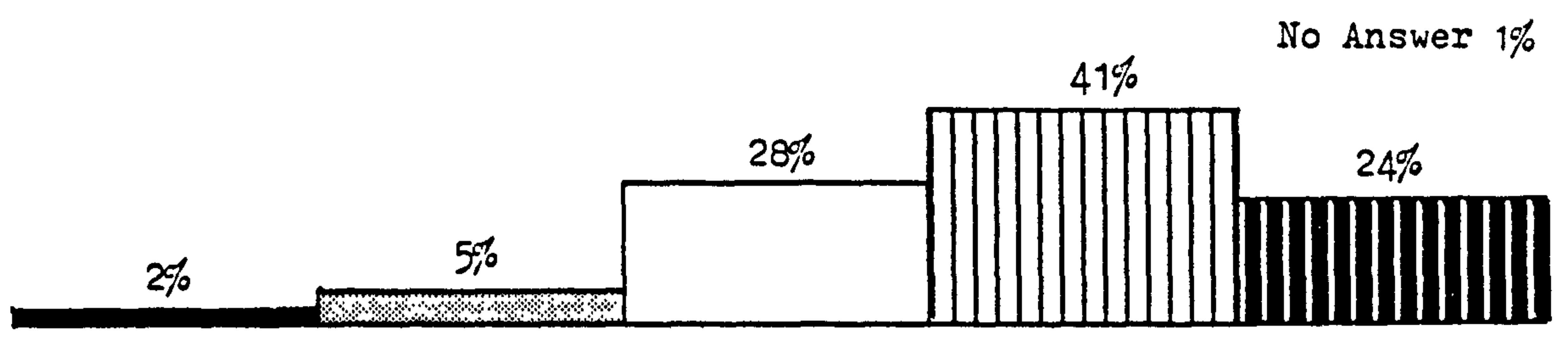

3. " SAYING MY PRAYERS HELPS ME A LOT "

DS D NC A AS

No Answer 1%

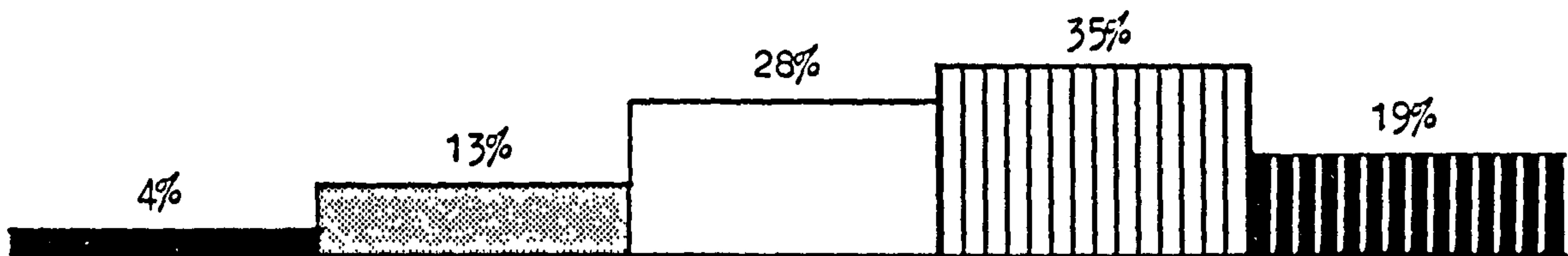

No Answer 1%

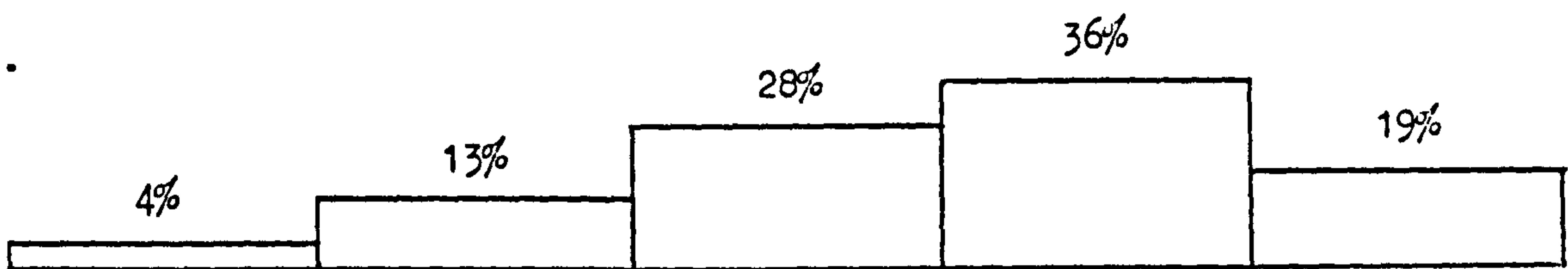

No Answer 1%

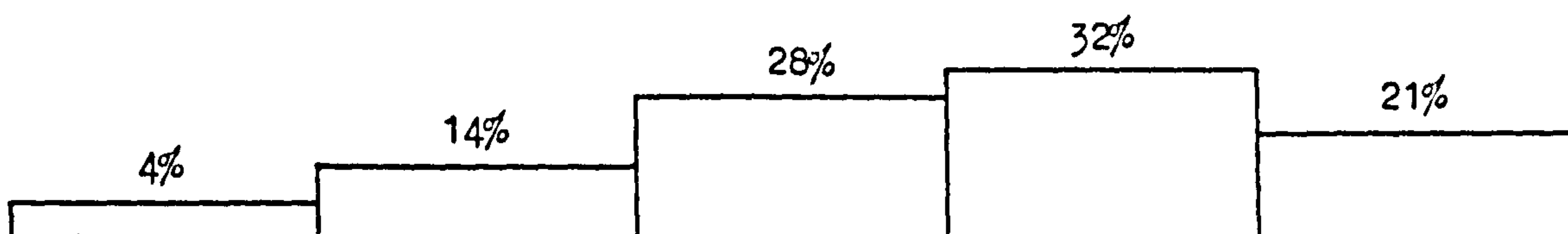

4. " THE CHURCH IS VERY IMPORTANT TO ME "

DS D NC A AS

No Answer 0

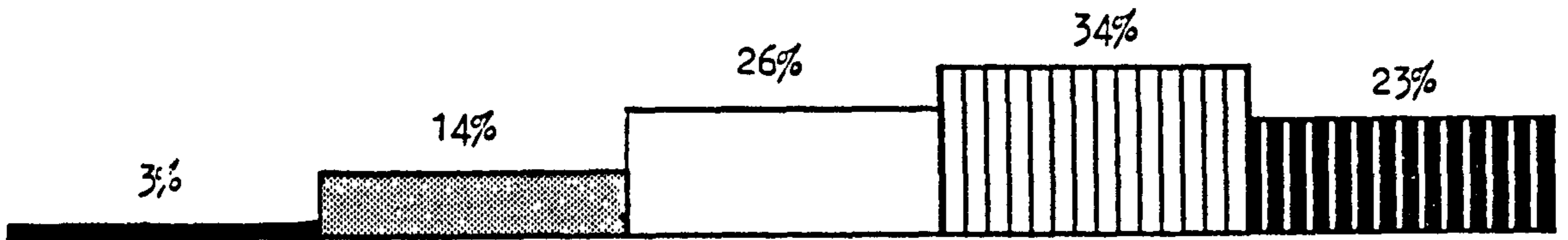

No Answer 1%

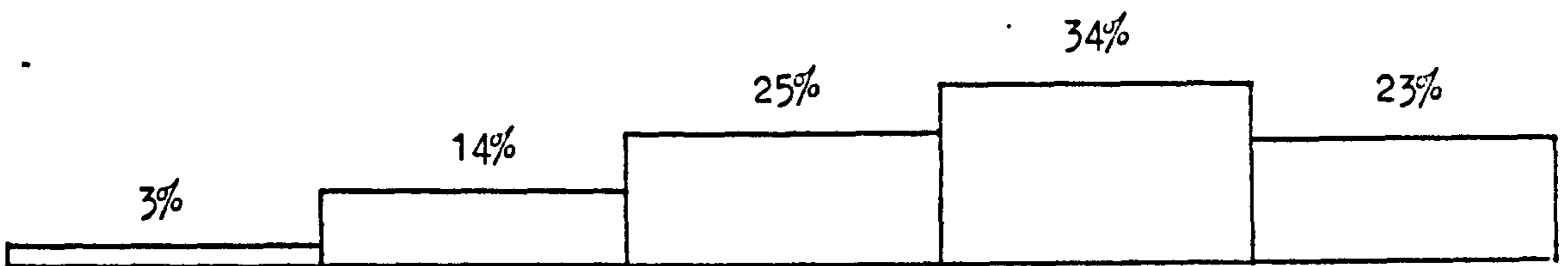

No Answer 0

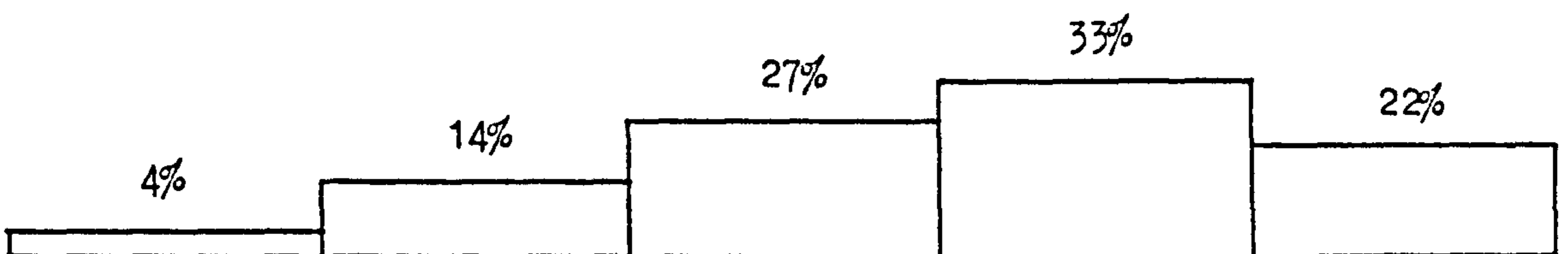

5. " GOING TO CHURCH IS A WASTE OF MY TIME "

DS D NC A AS

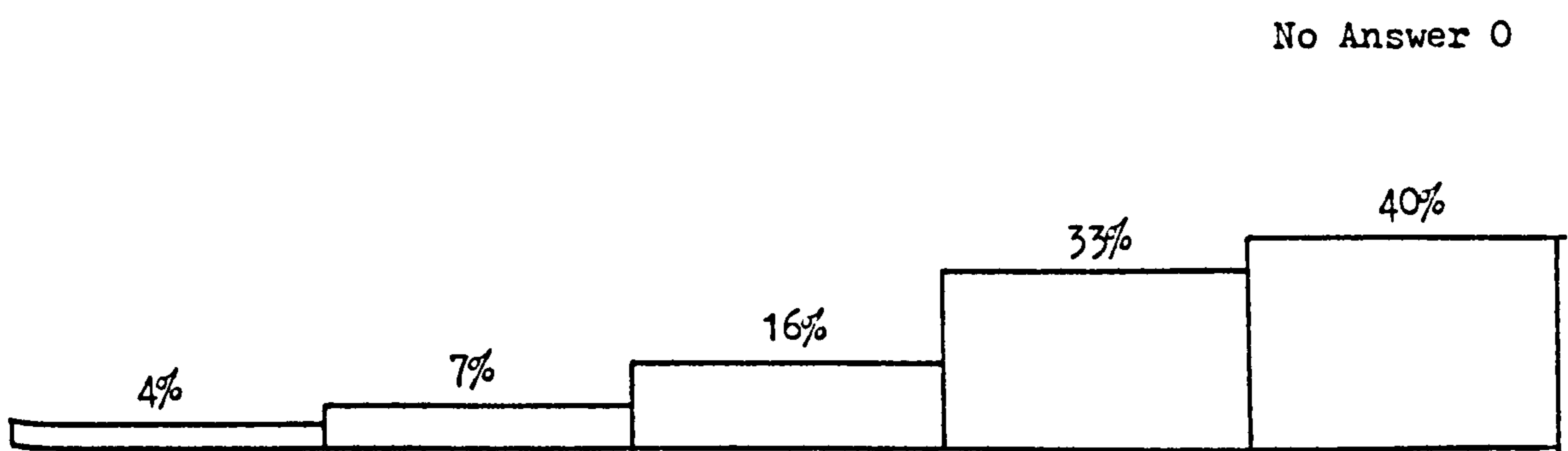
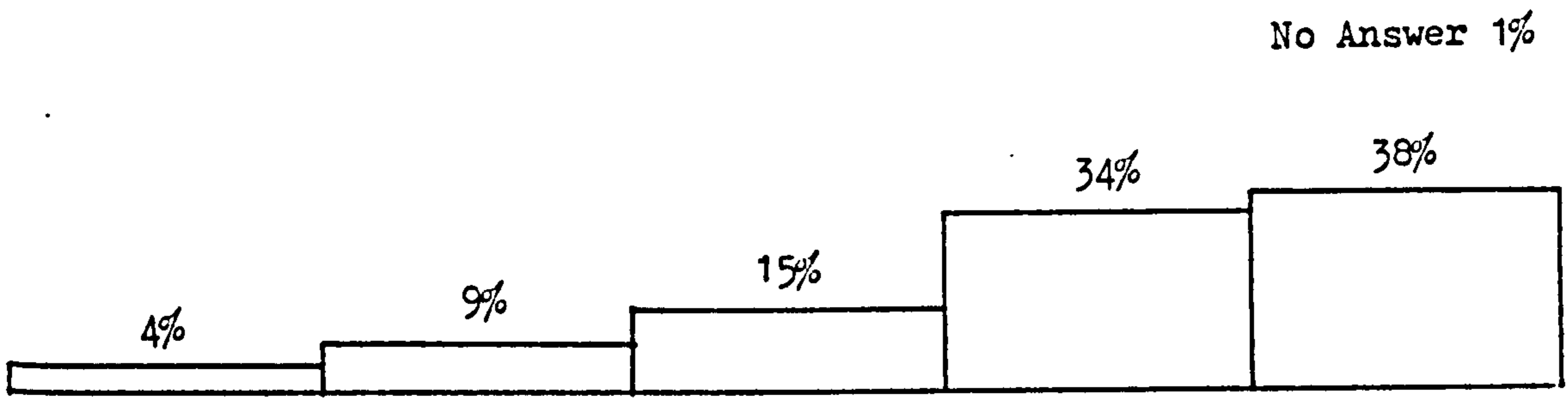
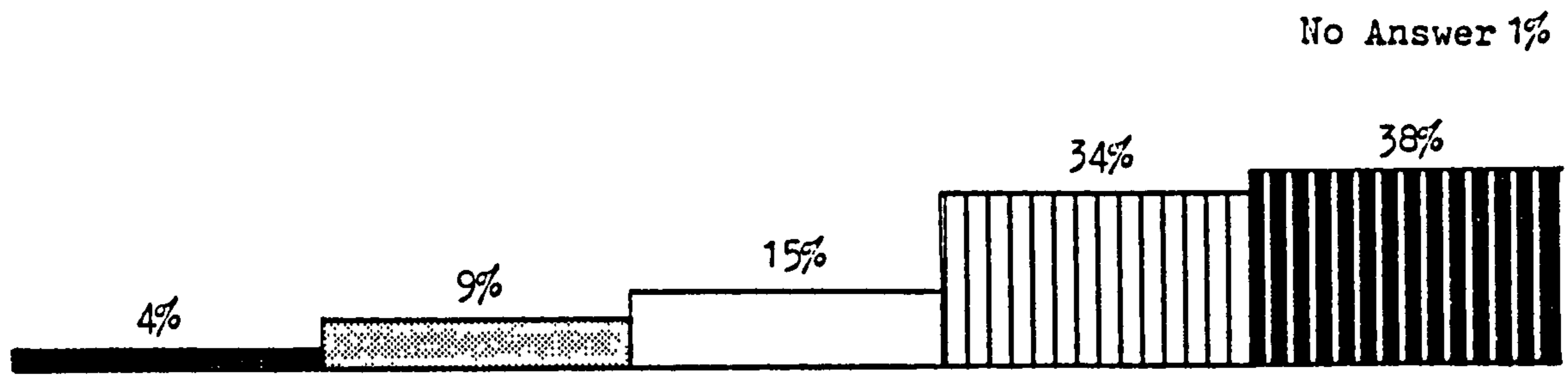

6. " I WANT TO LOVE JESUS CHRIST "

DS

D

NS

A

AS

No Answer 1%

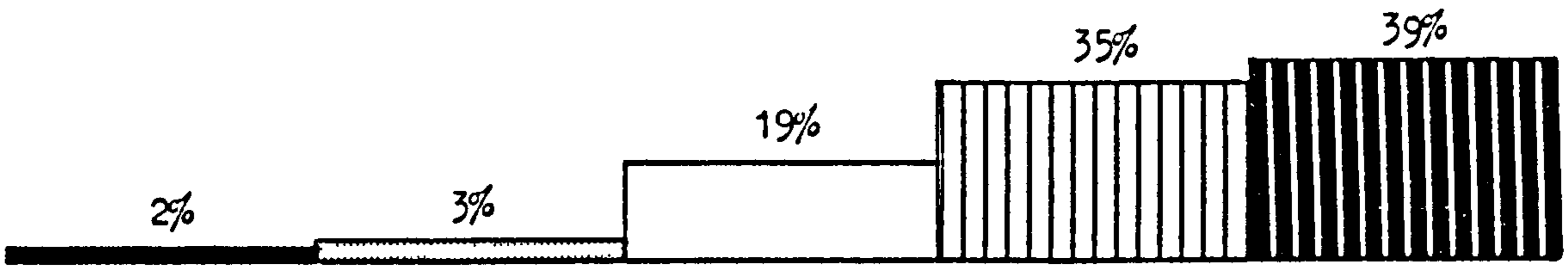

No Answer 1%

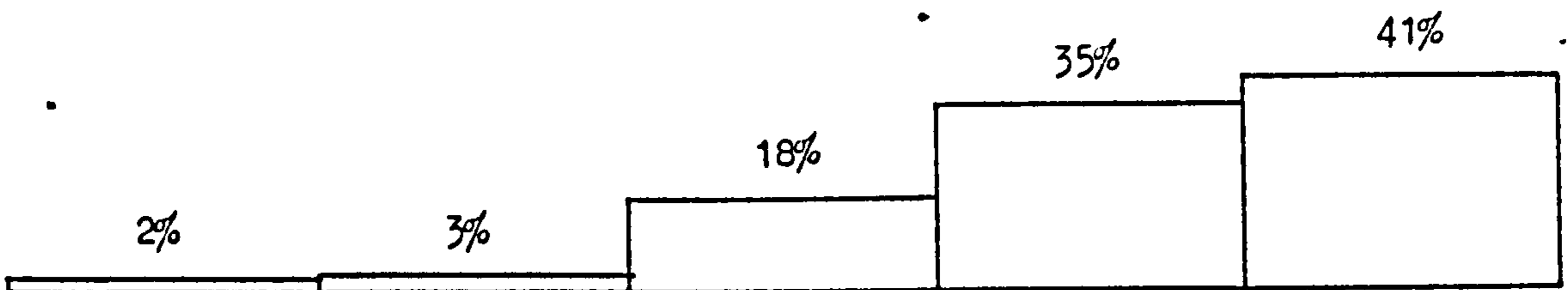

No Answer 0

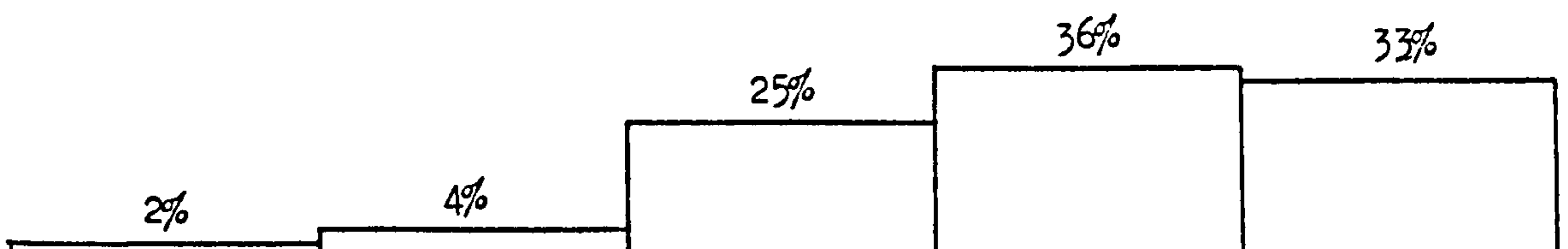

7. " I THINK CHURCH SERVICES ARE BORING "

DS

D

NC

A

AS

No Answer 1%

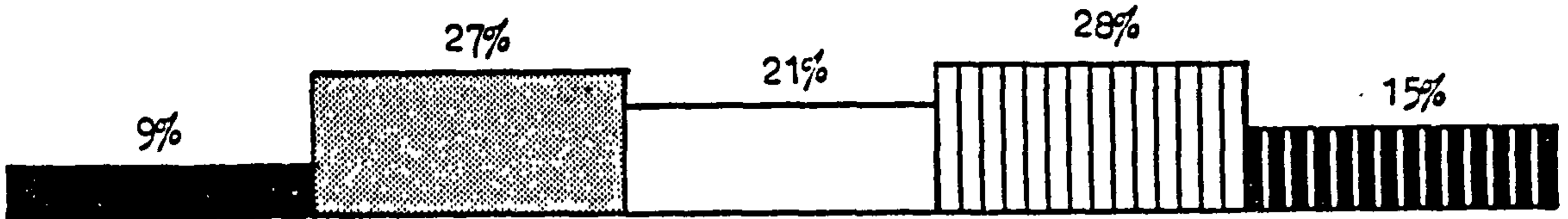

No Answer 0

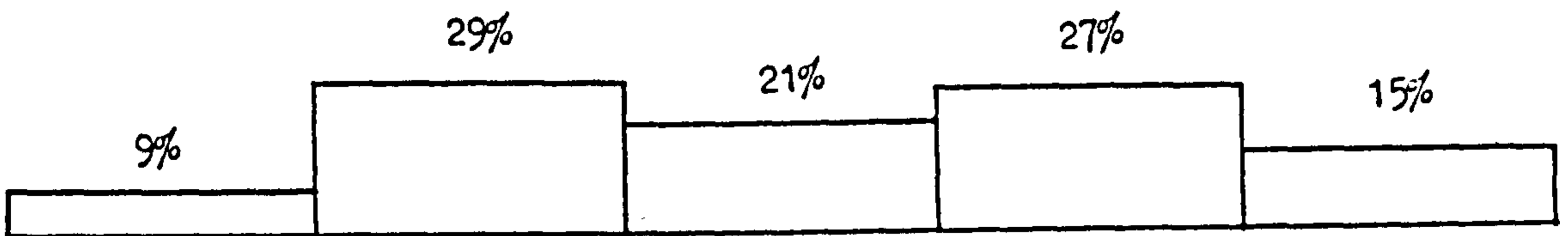

No Answer 1%

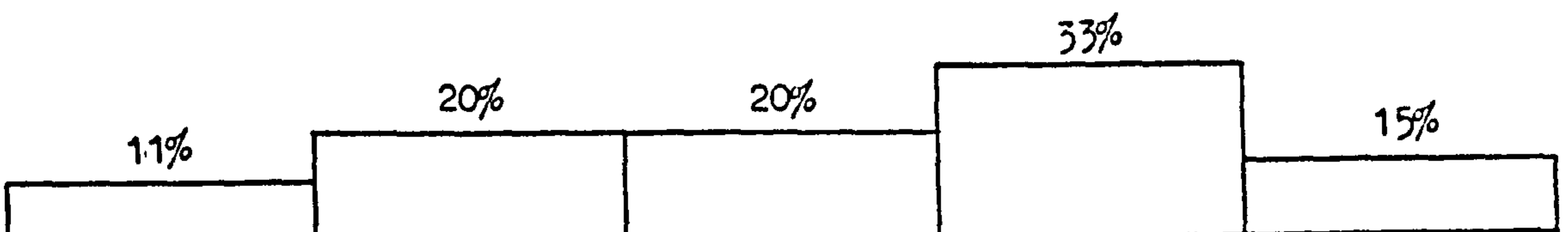

DS D NC A AS

No Answer 0

60%

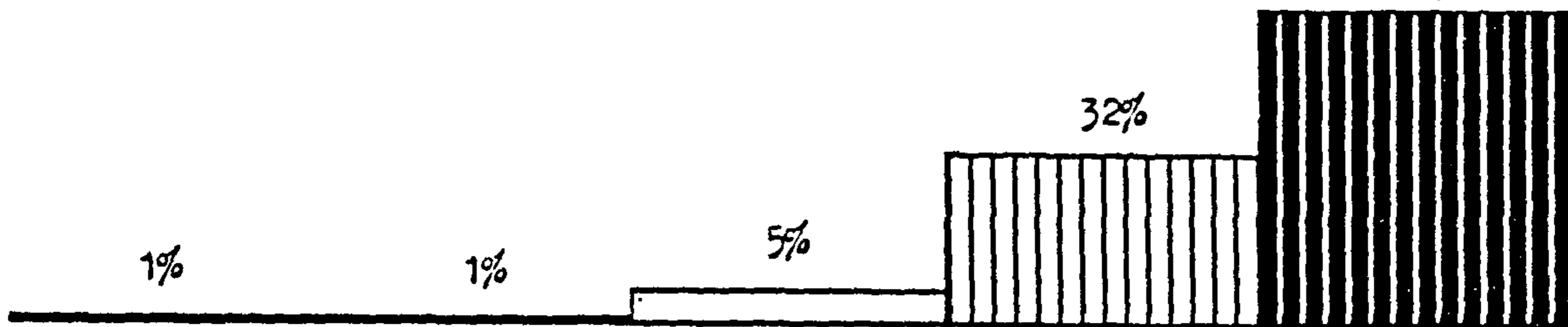

No Answer 0

60%

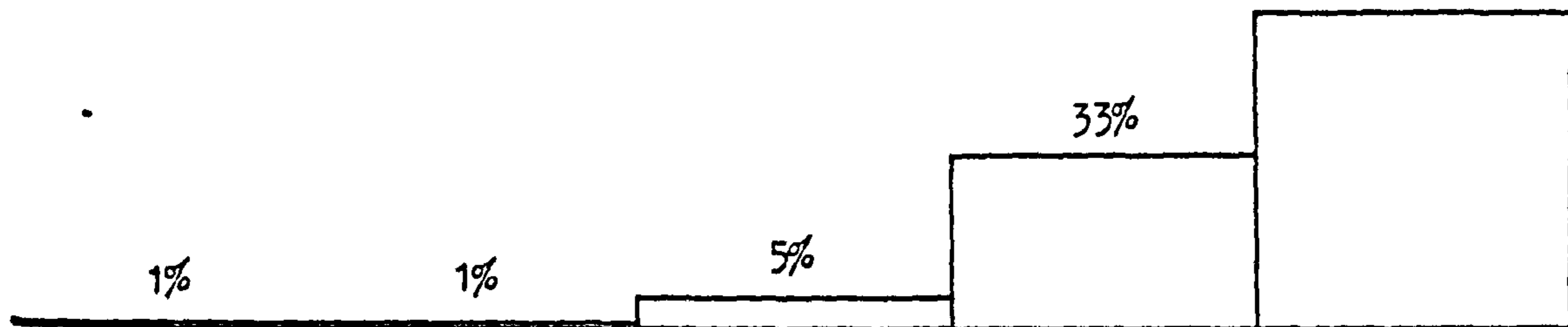

No Answer 0

62%

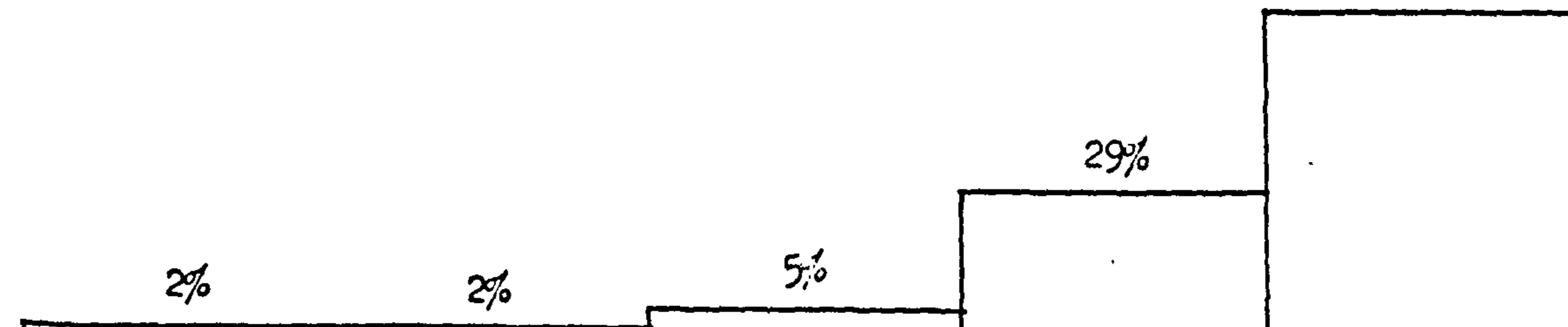

9. " GOD HELPS ME TO LEAD A BETTER LIFE "

DS

D

NC

A

AS

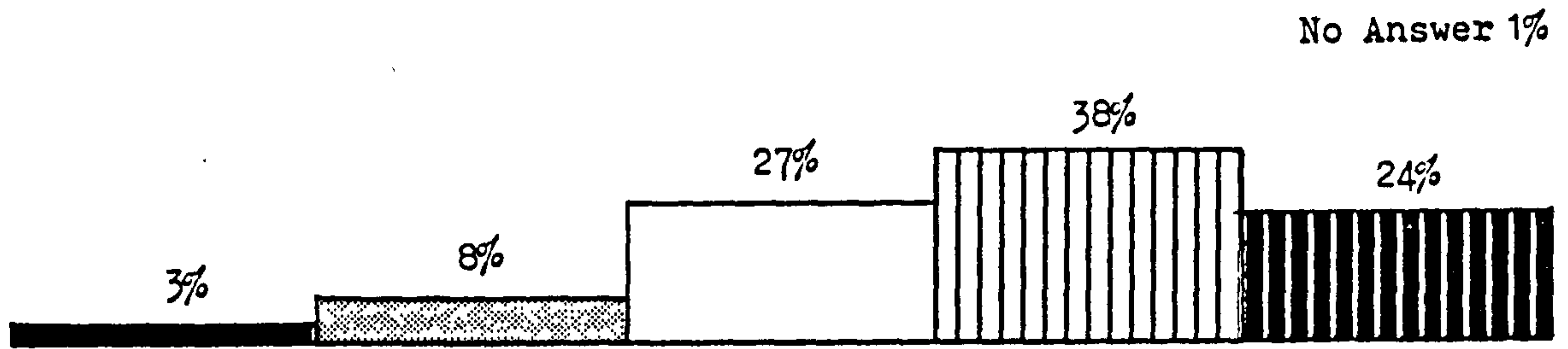

No Answer 1%

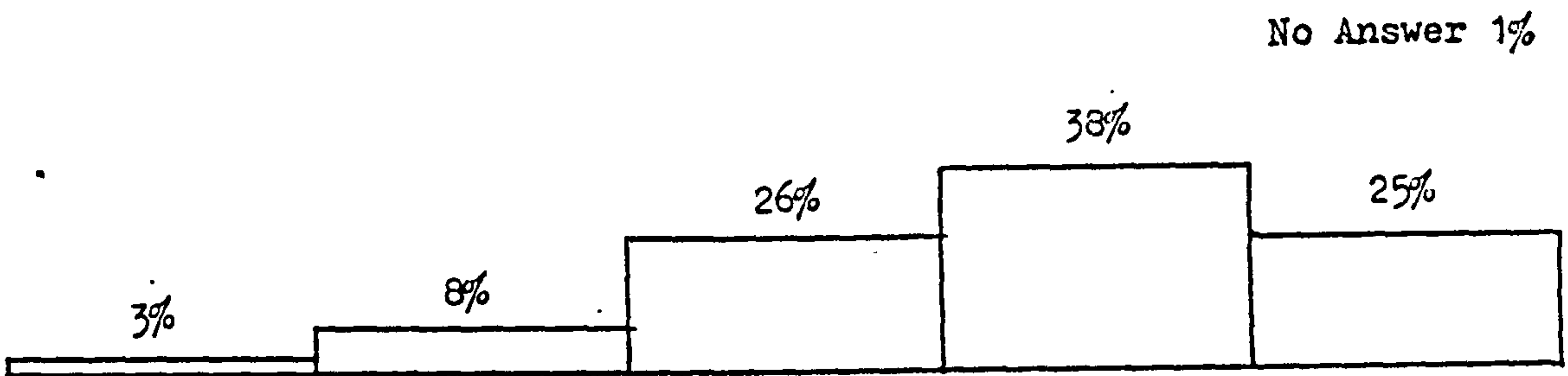

No Answer 1%

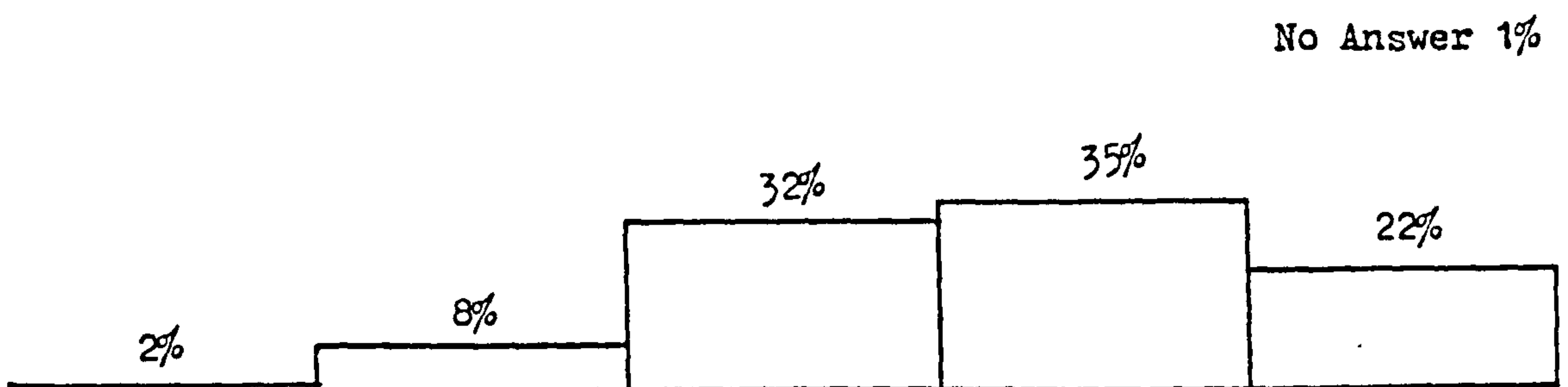

No Answer 1%

DS D NS A AS

No Answer 0

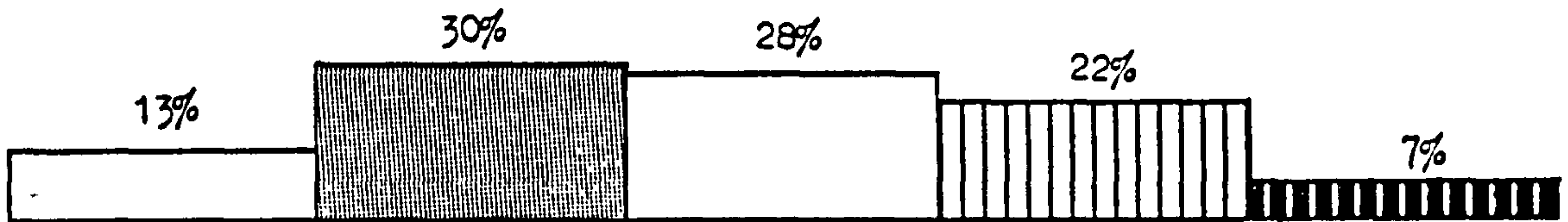

No Answer 0

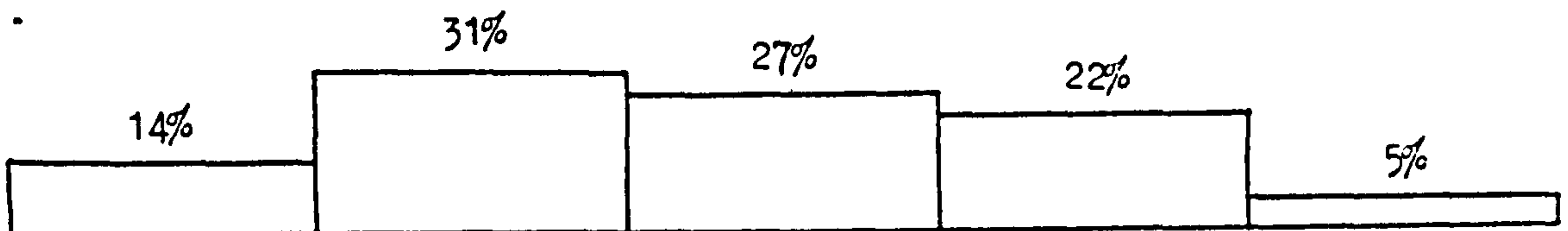

No Answer 1%

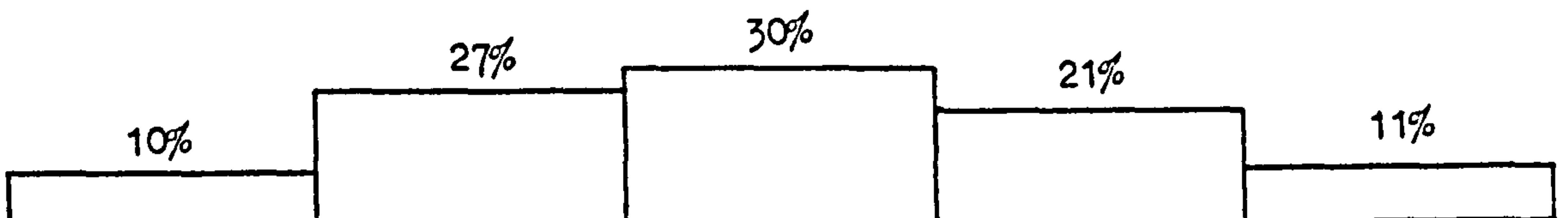

DS

D

NC

A

AS

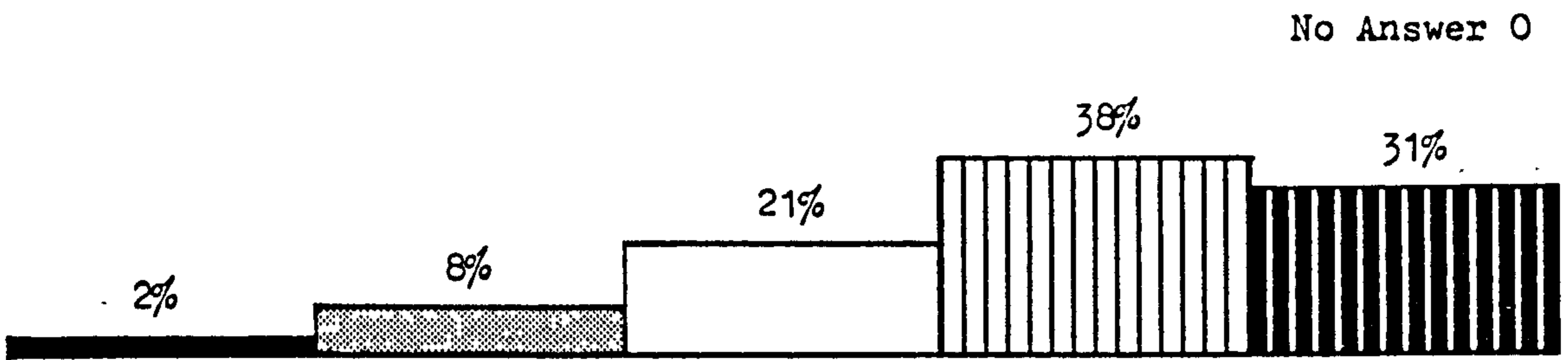

No Answer 0

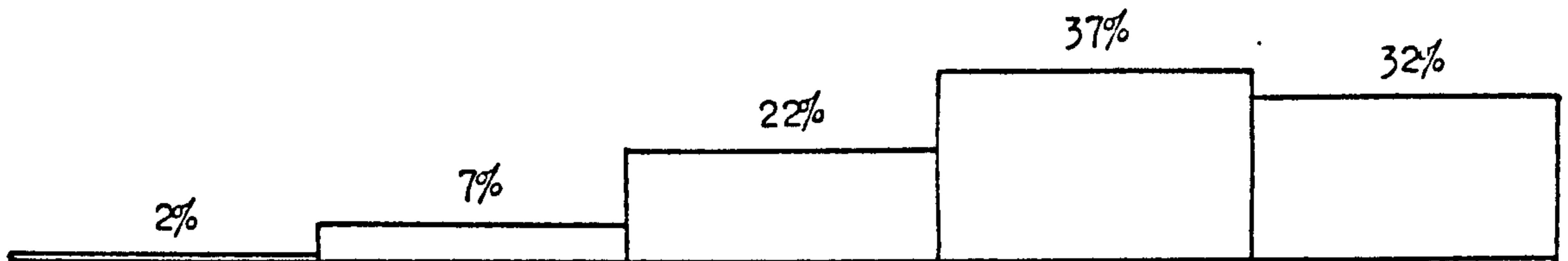

No Answer 0

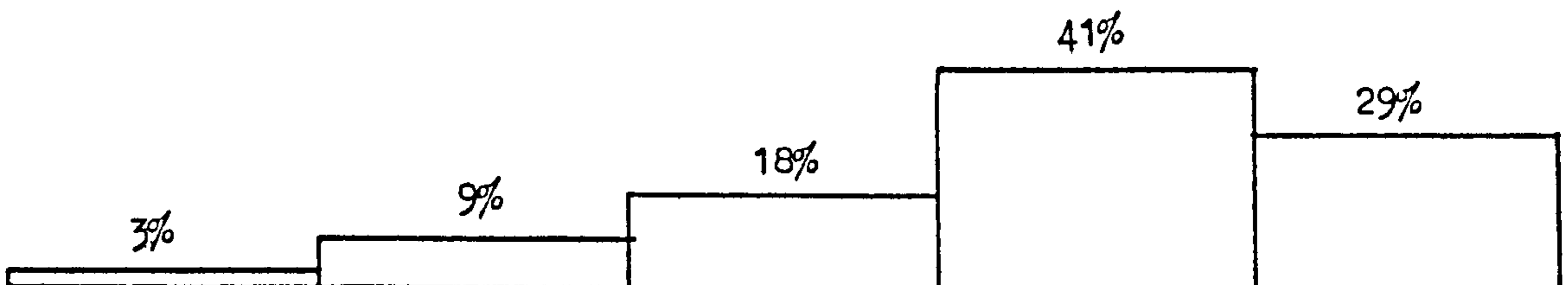

DS

D

NC

A

AS

No Answer 0

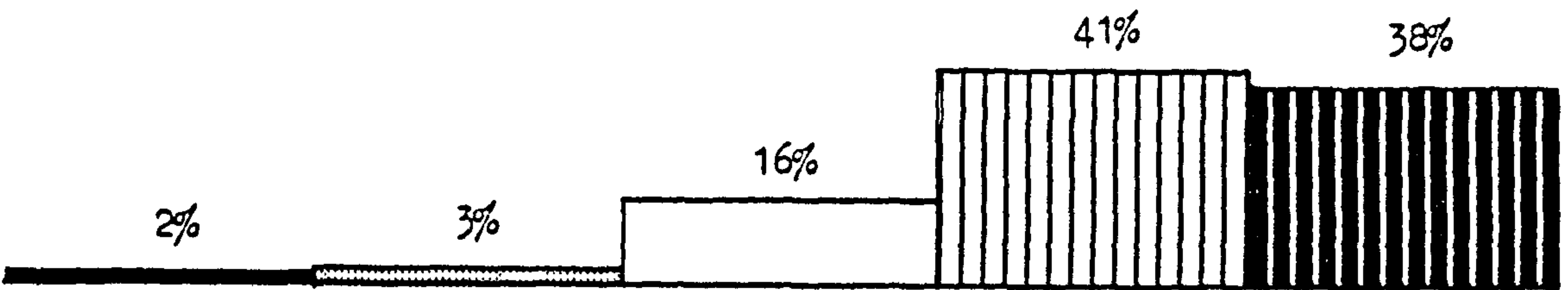

No Answer 0

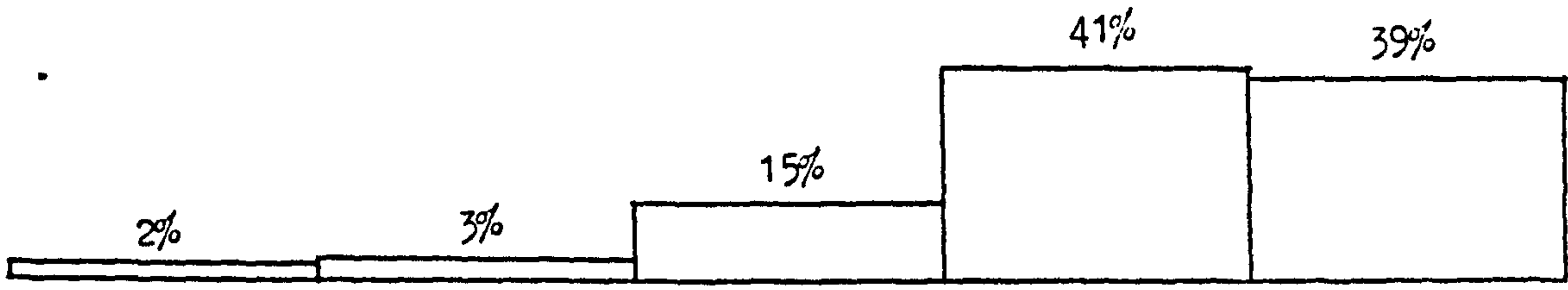

NO Answer 0

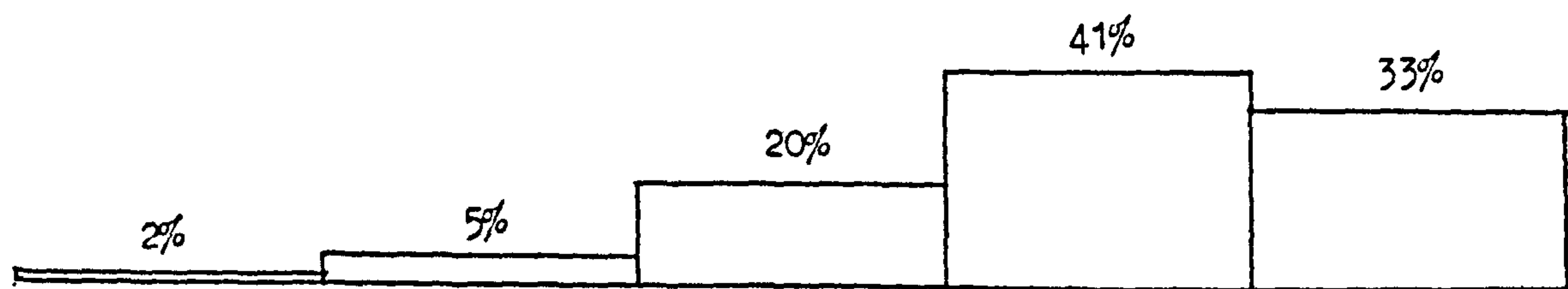

DS D NS A AS

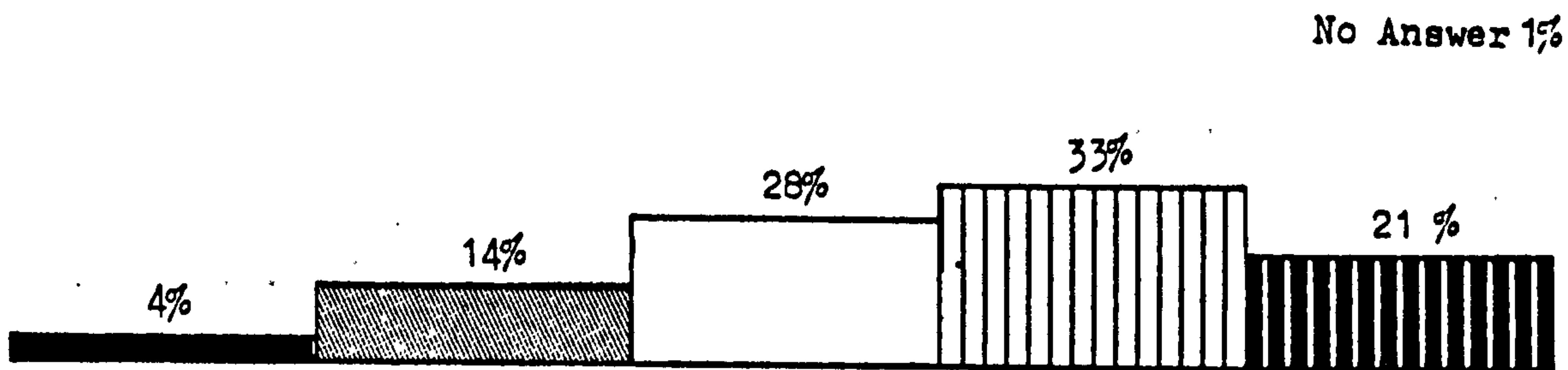

No Answer 0

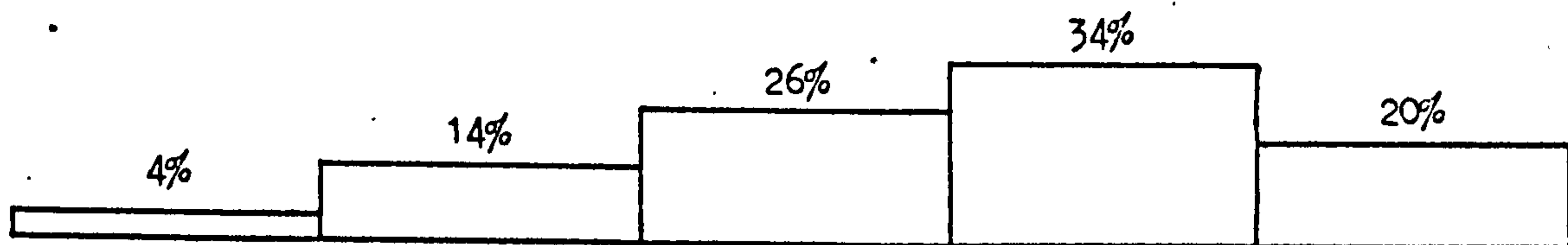

No Answer 1%

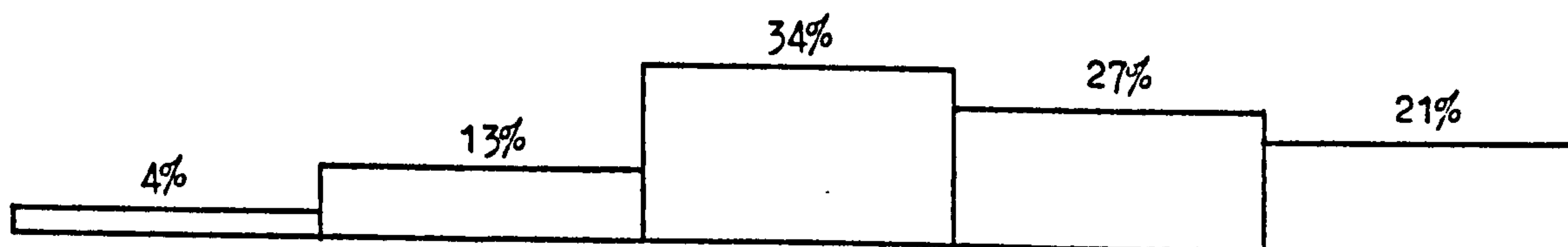

DS

D

NC

A

AS

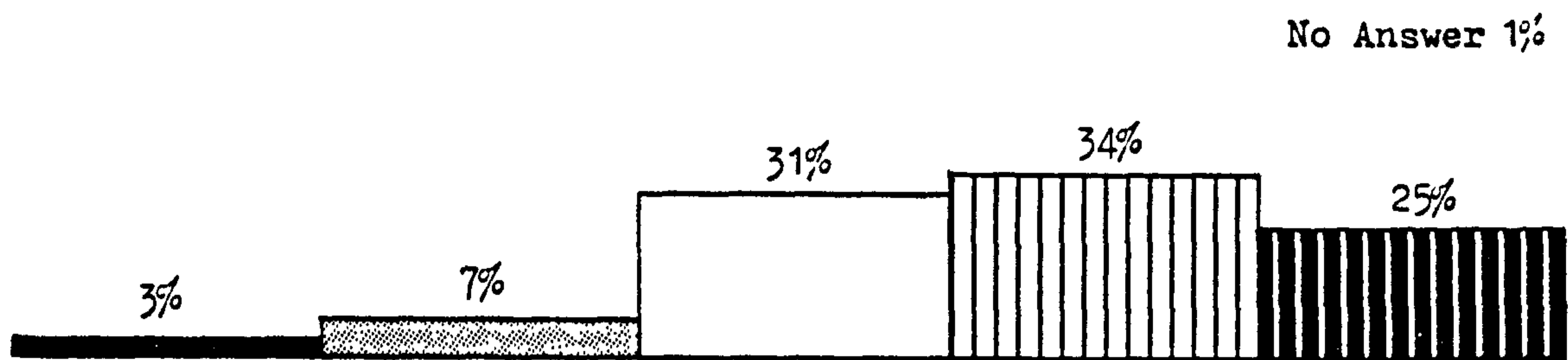

No Answer 1%

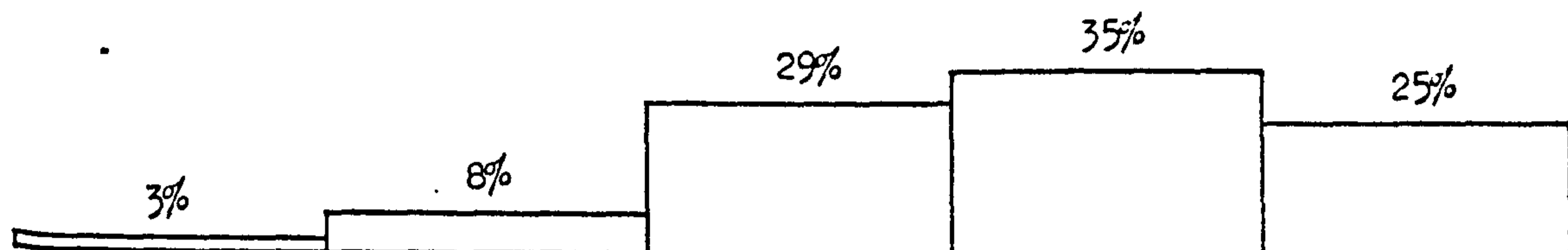

No Answer 0

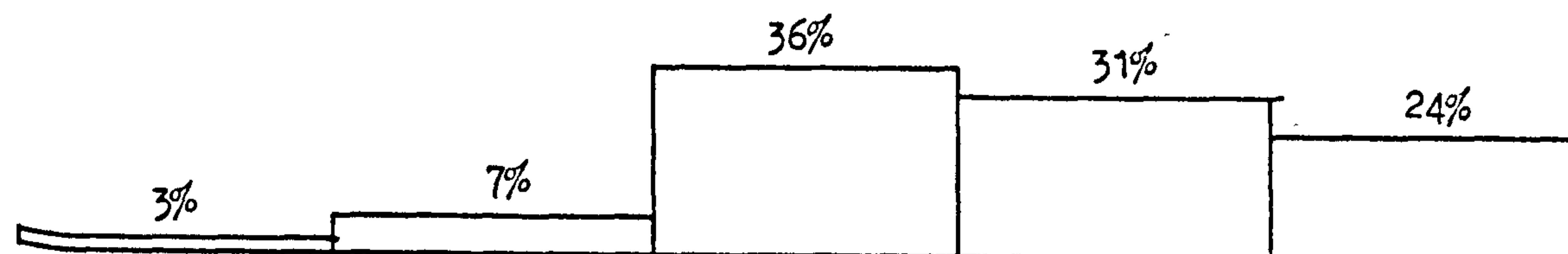

DS

D

NC

A

AS

No Answer 1%

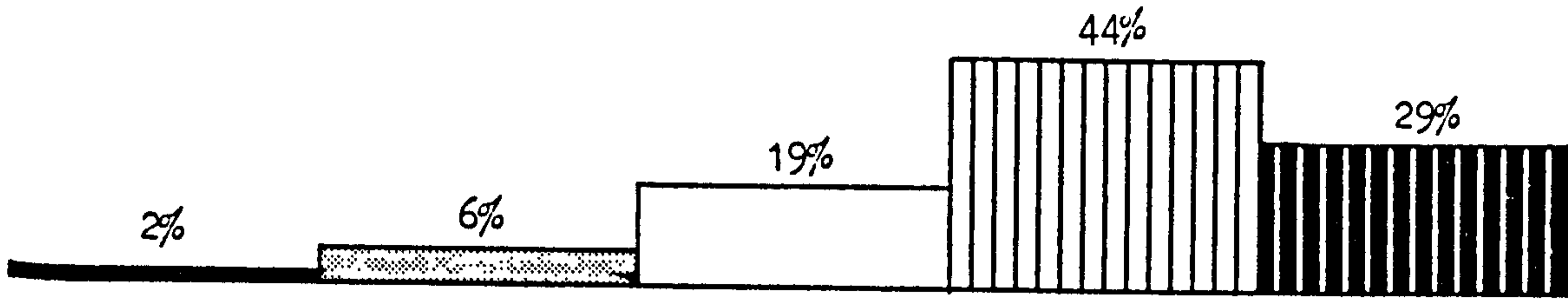

No Answer 1%

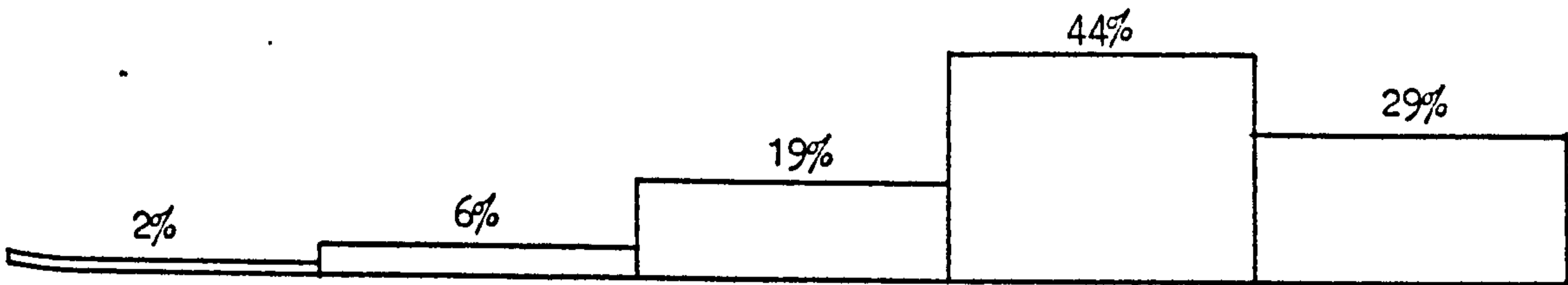

No Answer 0

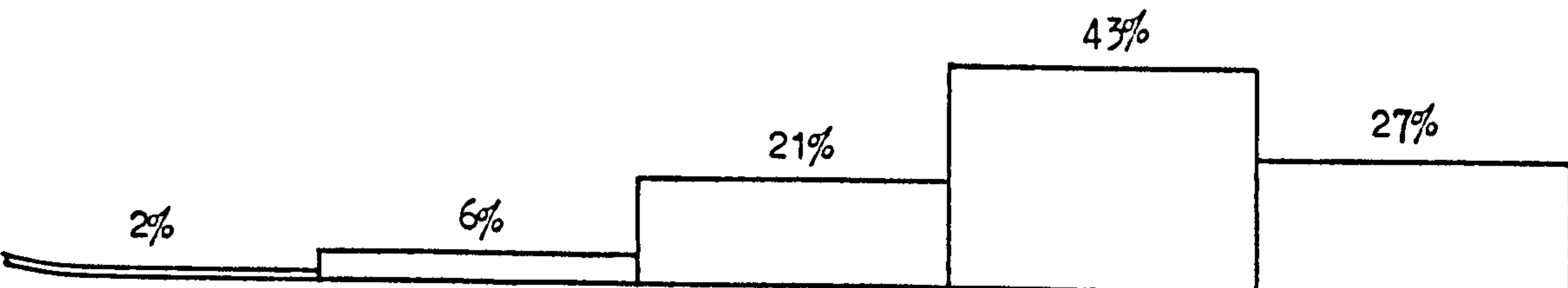

DS D NS A AS

No Answer 1%

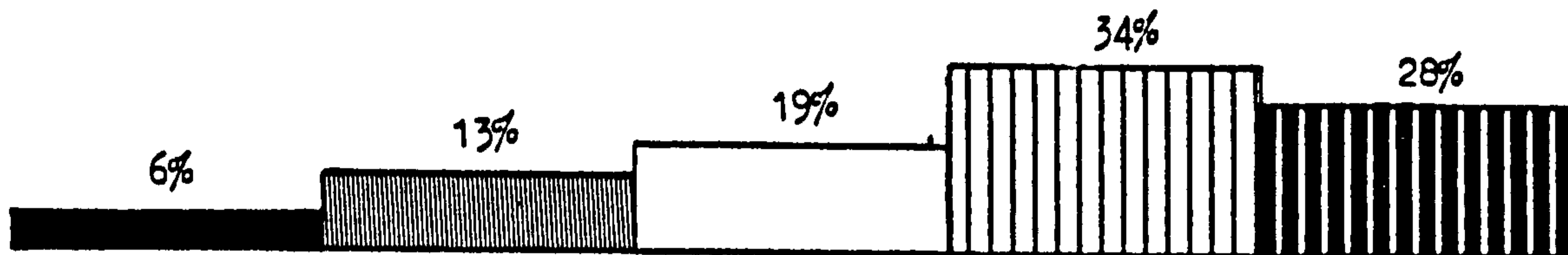

No Answer 1%

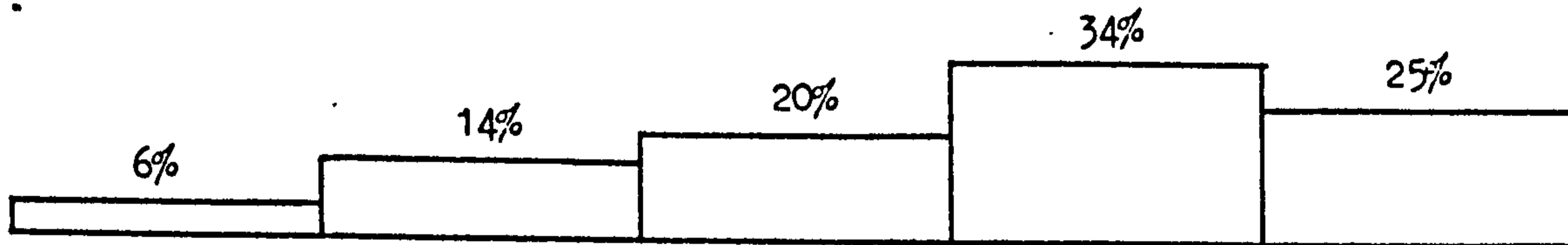

No Answer 1%

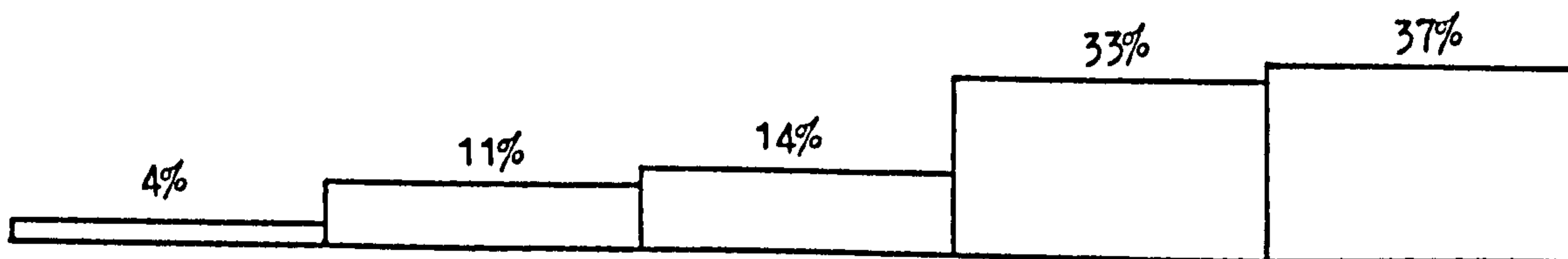

DS D NC A AS

No Answer 1%

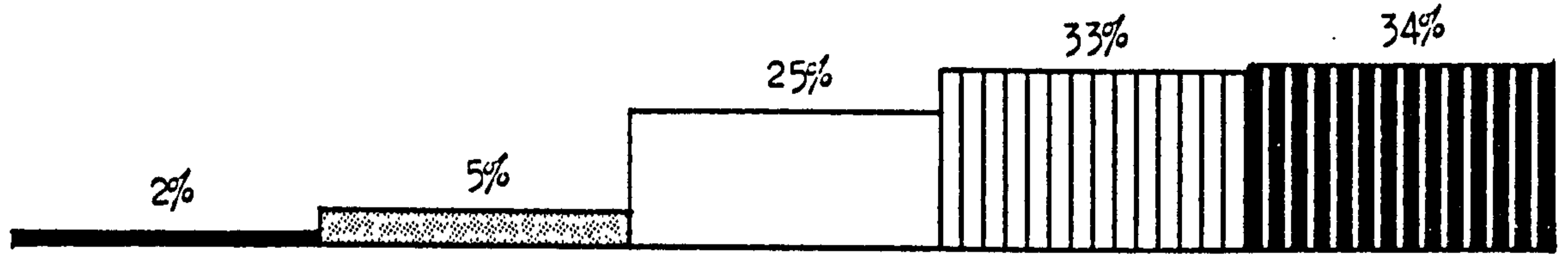

No Answer 2%

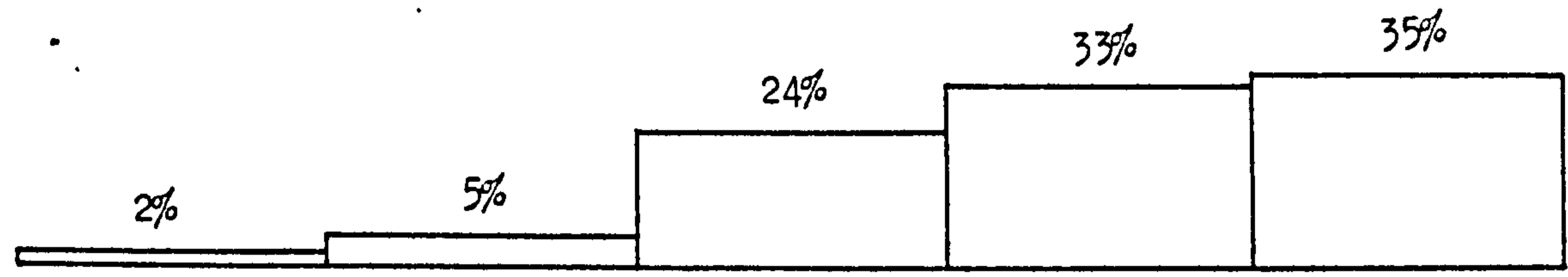

No Answer 0

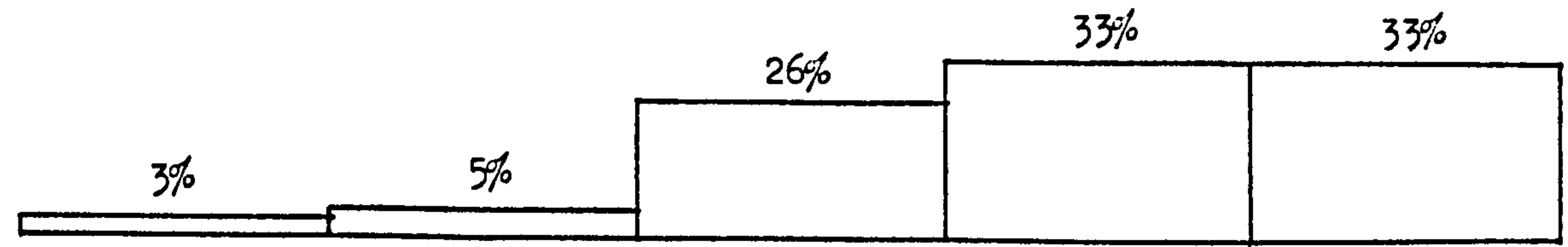

DS

D

NC

A

AS

No Answer 0

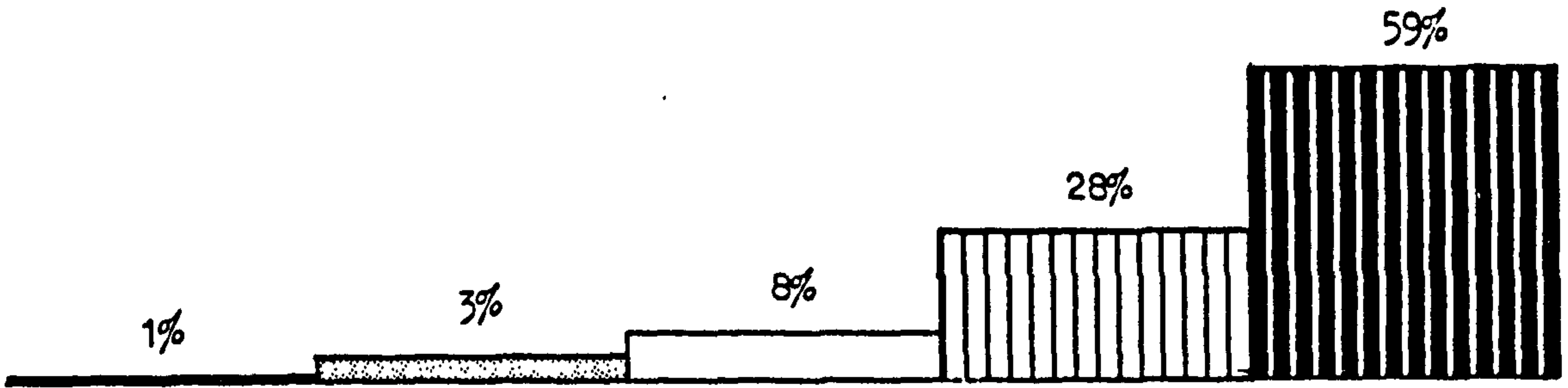

No Answer 0

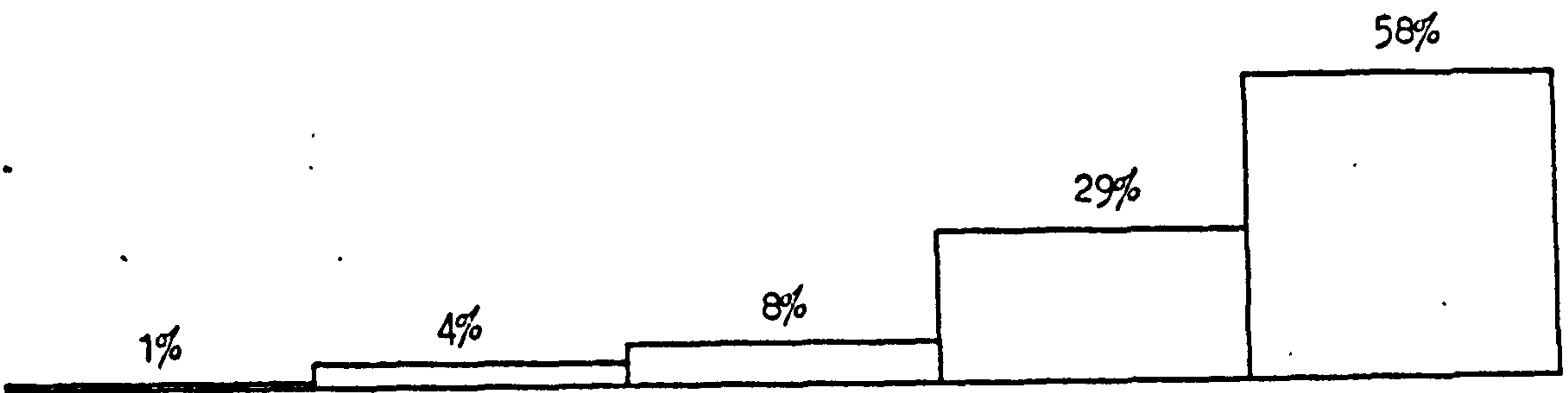

No Answer 0

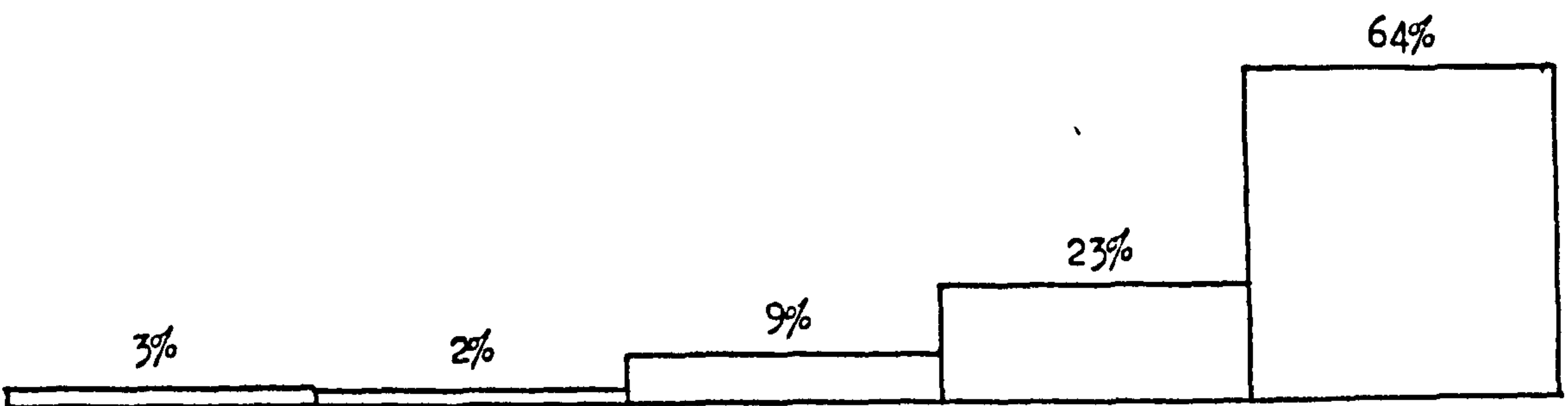

DS D NS A AS

No Answer 1%

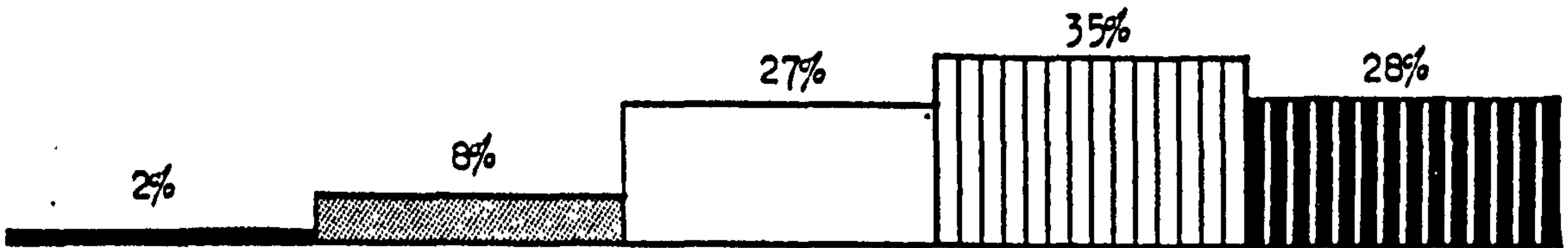

No Answer 1%

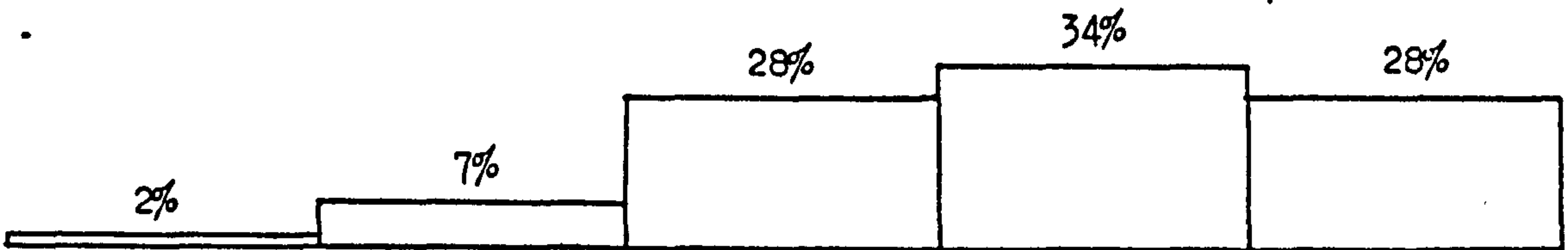

No Answer 0

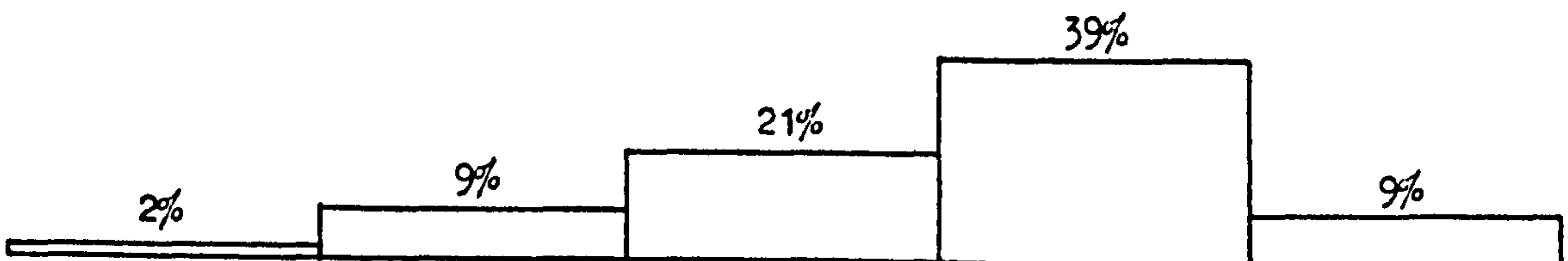

DS

D

NS

A

AS

No Answer 1%

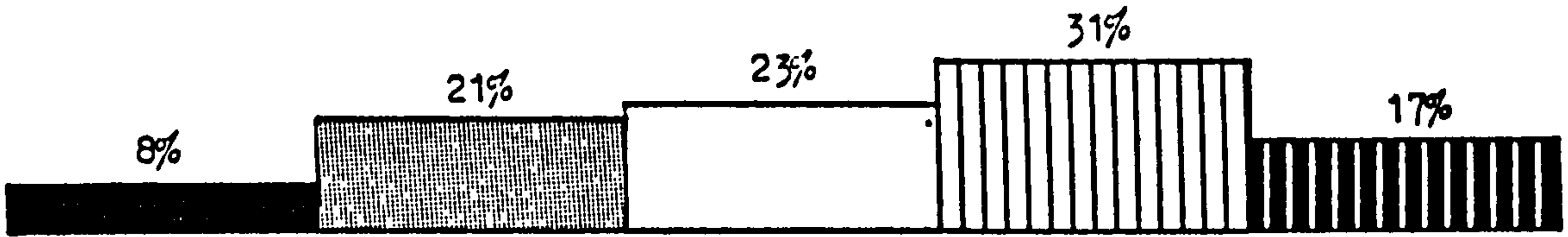

No Answer 1%

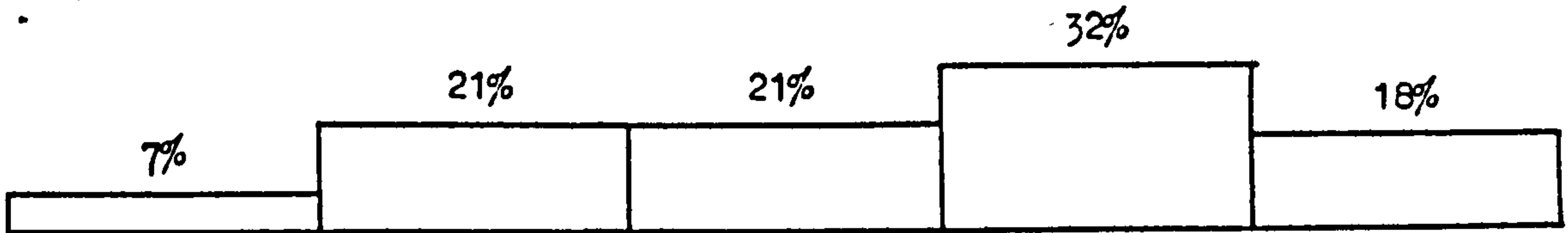

No Answer 0

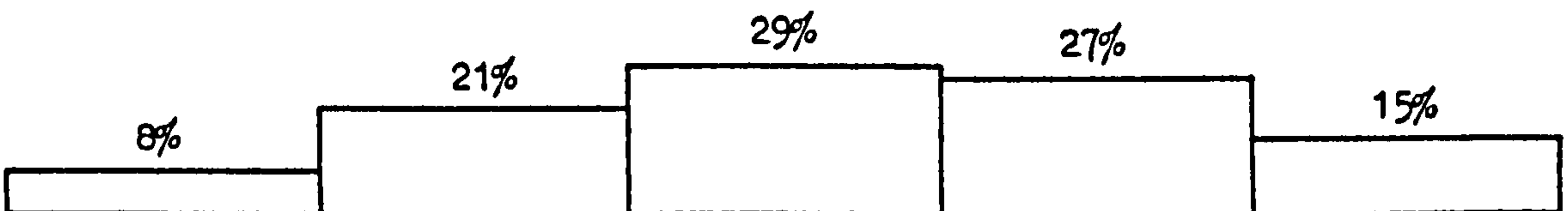

DS

D

NS

A

AS

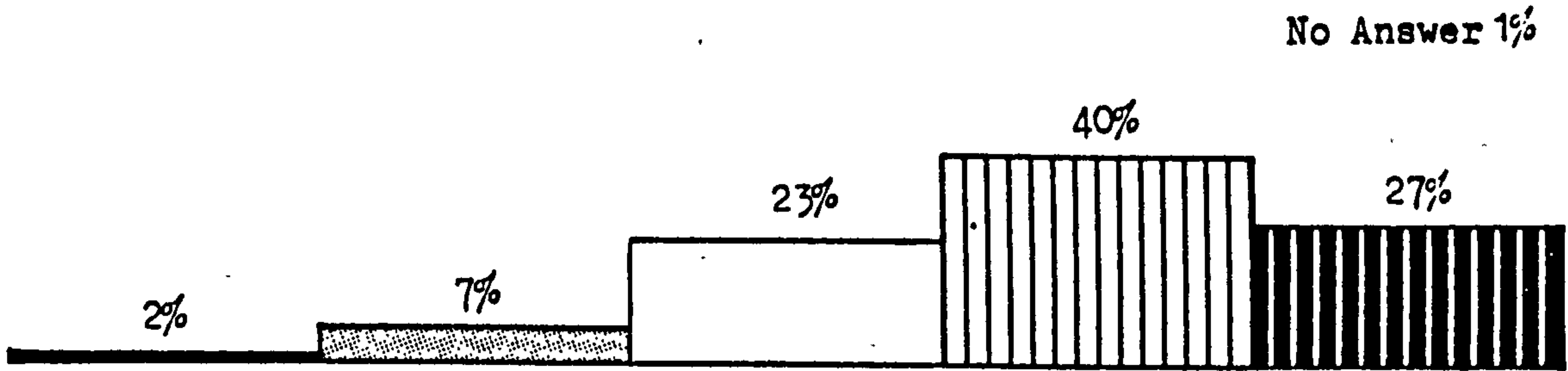

No Answer 1%

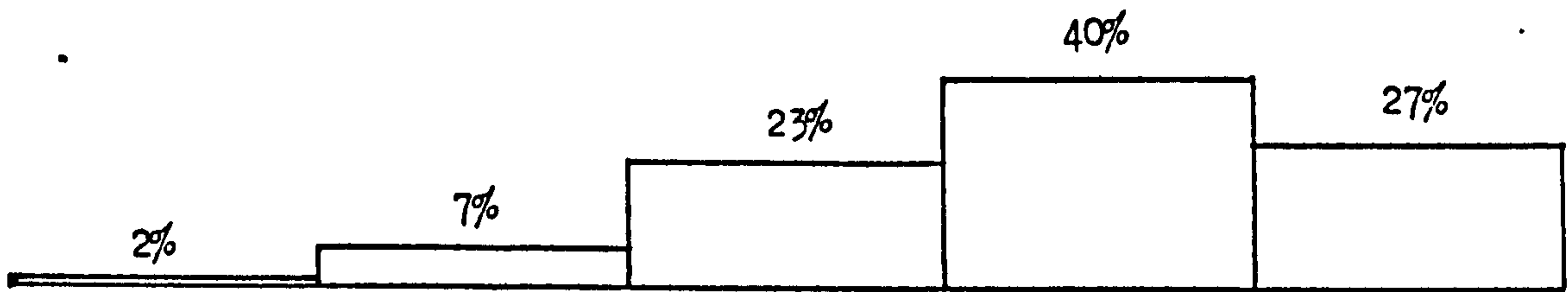

No Answer 1%

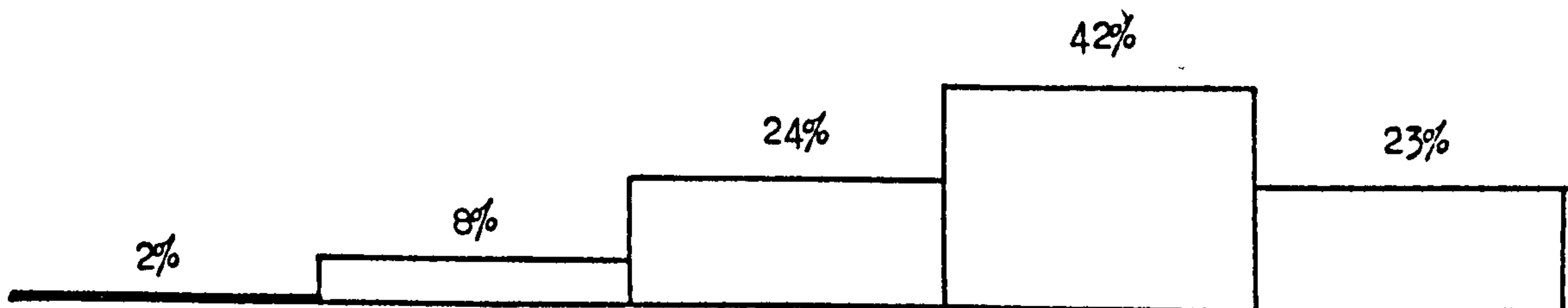

22. " I BELIEVE THAT JESUS CHRIST STILL HELPS PEOPLE TODAY "

DS D NS A AS

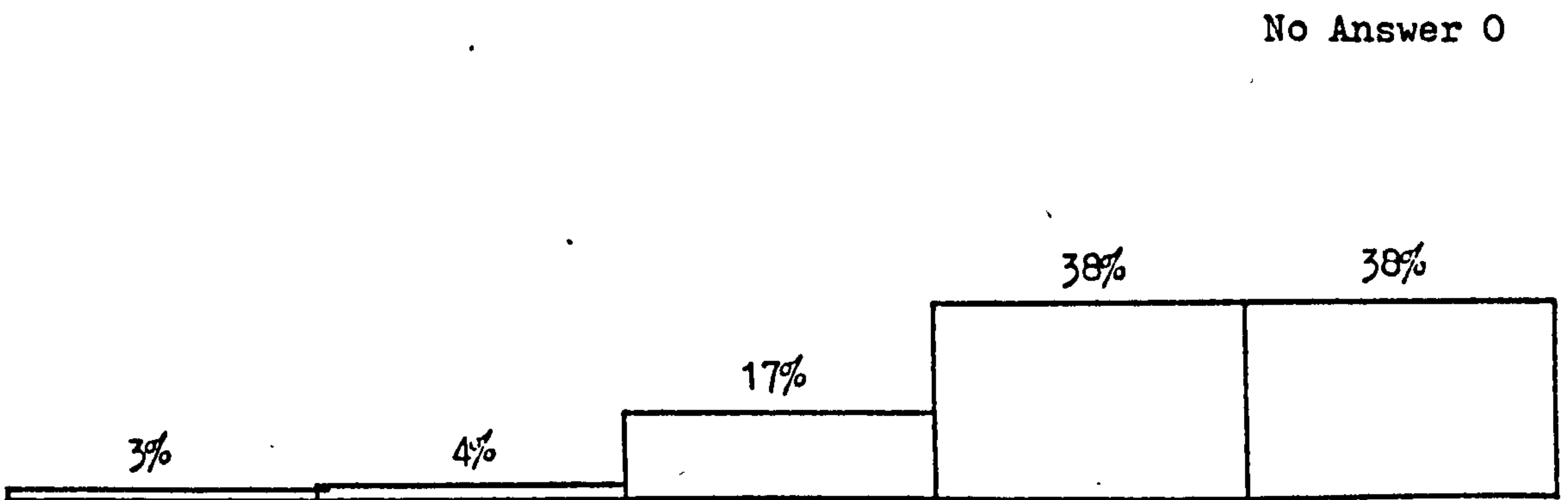
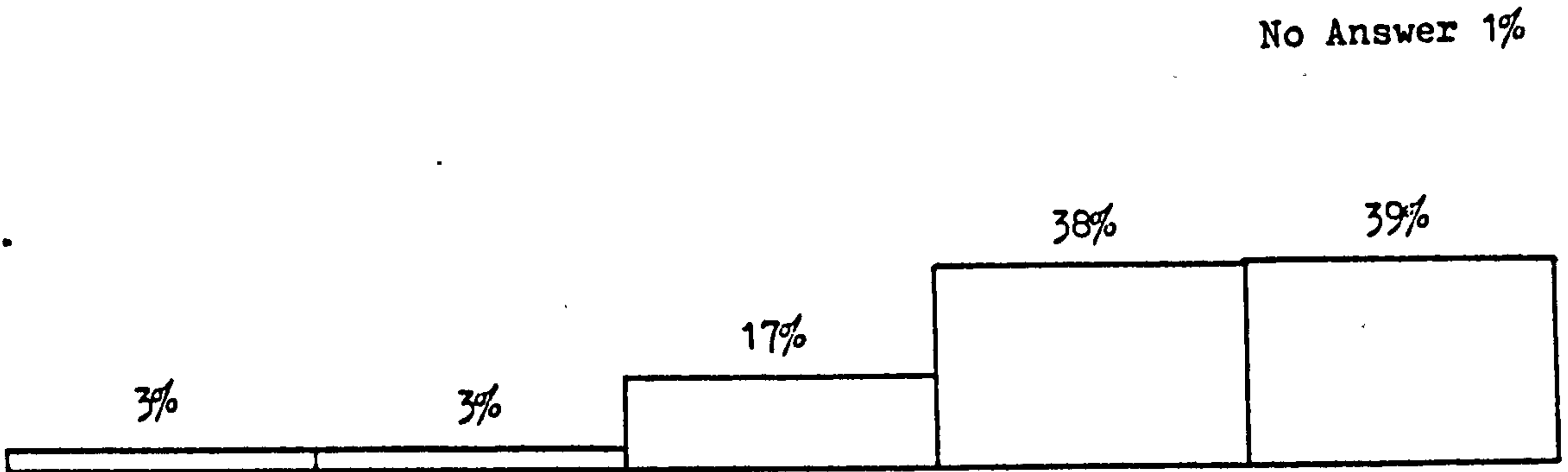
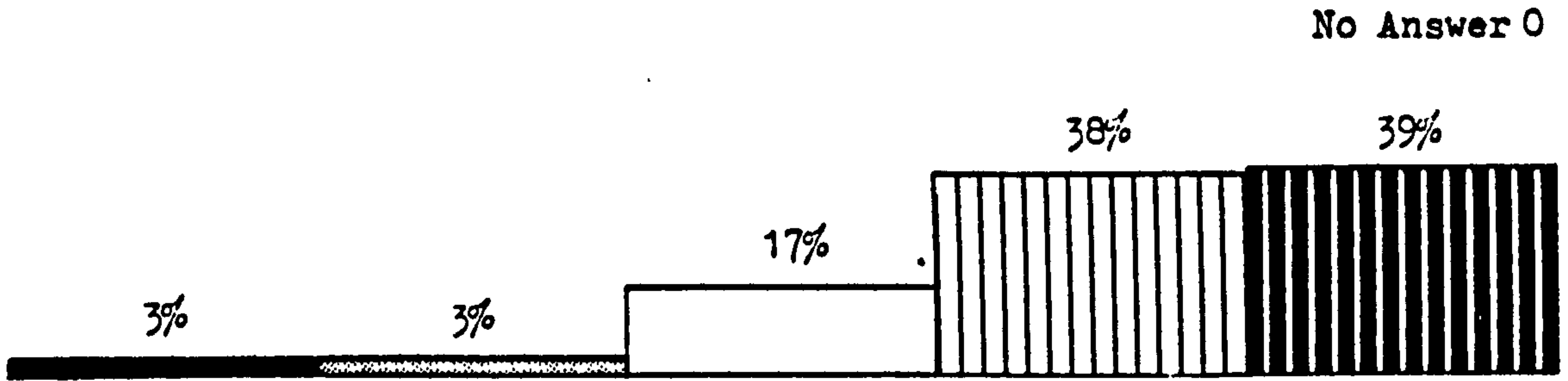

23. " I KNOW THAT GOD HELPS ME "

DS

D

NS

A

AS

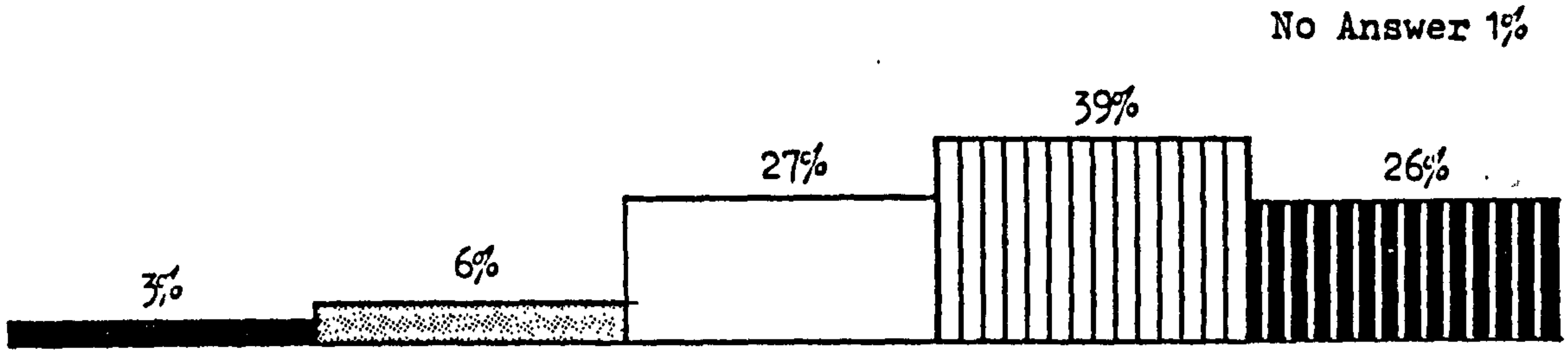

No Answer 1%

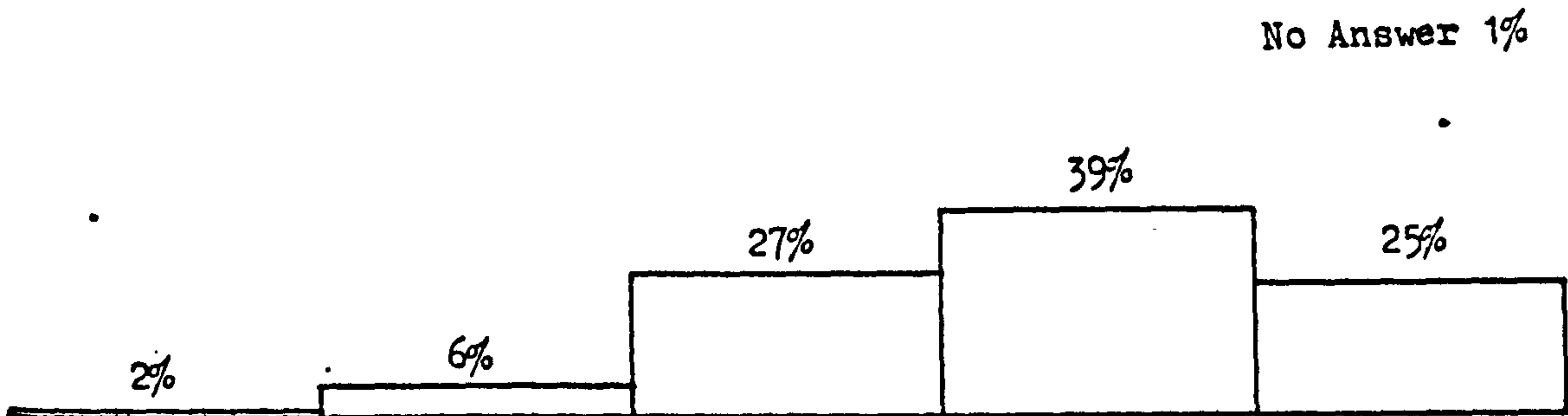

No Answer 1%

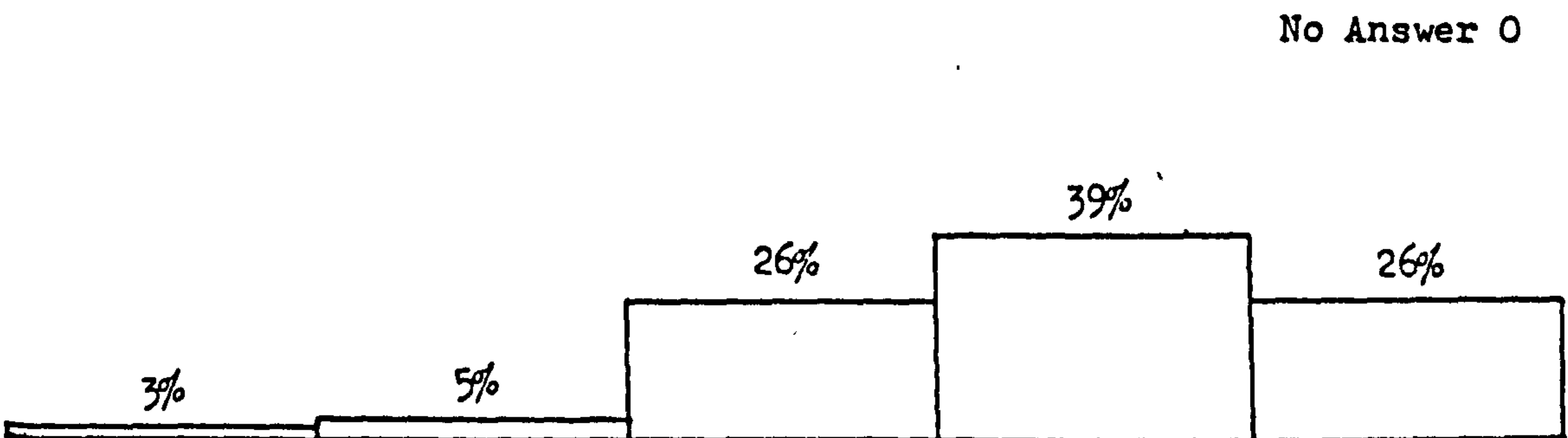

No Answer 0

24. " I FIND IT HARD TO BELIEVE IN GOD "

DS D NS A AS

No Answer 0

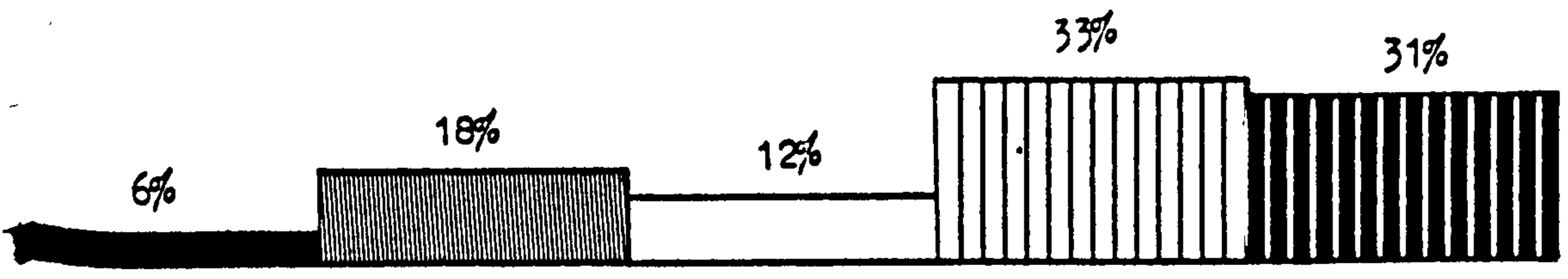

No Answer 1%

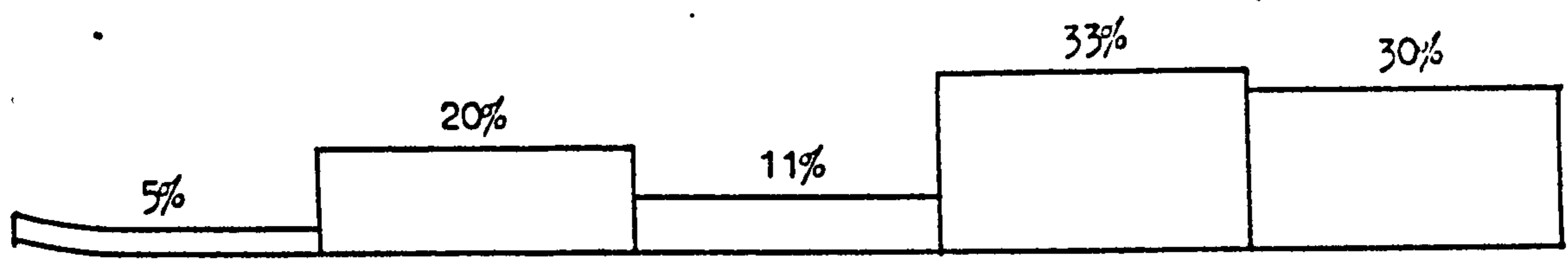

No Answer 0

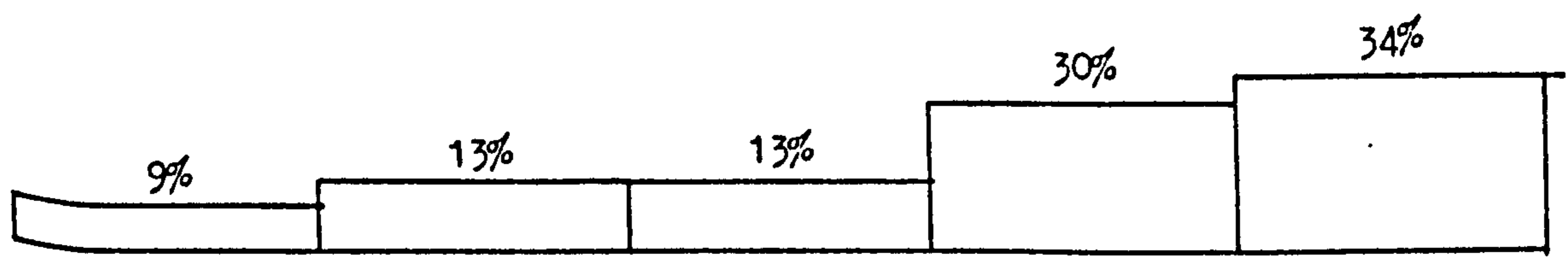

responses to the following sentences:

3. Saying my prayers helps me a lot;
4. The Church is very important to me;
5. Going to Church is a waste of my time;
8. I think people who pray are stupid;
9. God helps me to lead a better life;
10. I like school lessons about God very much;
11. God means a lot to me;
12. I believe God helps people;
13. Prayer helps me a lot;
14. I know that Jesus Christ is very close to me;
15. I think praying is a good thing;
17. I believe that God listens to prayers;
18. Jesus Christ doesn't mean anything to me;
21. The idea of God means much to me;
22. I believe that Jesus Christ still helps people today;
23. I know that God helps me;
24. I find it hard to believe in God.

The two instances where the differences are large enough to attract immediate attention are both concerned with the Bible, and are the responses to Sentences 1 and 16. For Sentence 1: I find it boring to listen to readings from the Bible, 59% of the pupils in non-denominational schools were not bored by the Bible read to them, compared with 44% in Roman Catholic schools (it should be remembered that all the pupils were Roman Catholics); and the figures for boredom were 26% and 32% respectively. For Sentence 16: I think the Bible is out of date, 70% of the pupils in non-denominational schools found the Bible up to date, compared with only 59% in Roman Catholic schools, while the obverse figures were 15% and 20% respectively. It would seem that being a pupil in a non-denominational school goes with having a more positive attitude towards

the Bible. This is a finding which would be worth exploring further, but was not pursued in this present enquiry.

The other five dependent variables where there were noticeable, but smaller, differences were the responses to the following sentences:

2. I know that Jesus Christ helps me;
6. I want to love Jesus Christ;
7. I think Church Services are boring;
19. God is very real to me;
20. Saying prayers in school does me no good.

In three of these, Sentences 2, 6 and 20, the pupils in the Roman Catholic schools showed a rather more positive attitude than those in non-denominational schools. In the other two instances, Sentences 7 and 19, it was the other way round: the pupils in the non-denominational schools showed a slightly more positive attitude. It might be concluded from this that the ethos of a Roman Catholic school helps the pupils towards a more positive personal relationship with Jesus Christ, and that they find school worship more attractive or helpful than their fellows in non-denominational schools, but the differences in the figures are not very large. It is interesting to note that Roman Catholic pupils in non-denominational schools are less bored by their attendances at Church services; this may reflect the experience of being part of the small congregations of country parishes [where there are no Roman Catholic secondary schools], and the enhanced social significance of the Sunday Mass for such groups; but again, there is not all that much difference in the figures. For Sentence 20 [God is very real to me] the difference between

the two groups is even smaller, even though it is just sufficient to attract attention.

If all this were to be the only result of the enquiry, the hypothesis with which it began would be unsubstantiated: there appears to be no significant difference between the religious attitudes of Roman Catholic children who attend Roman Catholic secondary schools and those who attend non-denominational ones. This broad conclusion stands, and will be confirmed by the more rigorous path analysis method of correlating the dependent and independent variables. But the range of information obtained for this enquiry made it possible to take account of another independent variable, another factor in the education of this sample of Roman Catholic children. This variable was the type of religious education received by the children in the non-denominational schools: whether it was specifically geared to their membership of the Roman Catholic Church. The results obtained when this factor was taken into account are reported in the next section.

C: Multivariate Correlations by Type of School
and Religious Education

Amongst the Roman Catholic pupils in non-denominational schools, some were provided with specifically Roman Catholic religious education lessons and some were not; this difference could be entered into the calculations as another independent variable, and so divide the total sample into three groups and compare the results. These statistics are presented in Table 3 and its associated graphs. The percentages represent the dependent variables, the responses to each of the 24 sentences, which are the evidence for religious attitude. The first line of statistics gives the results for the whole sample, as an aid to comparison. The other three lines give the results for Roman Catholic pupils in Roman Catholic schools (882 in number), for those in non-denominational schools who receive Roman Catholic religious education (121 in number), and for those in non-denominational schools who do not (110 in number). No account was taken of whether the Roman Catholic religious education provided for the pupils in non-denominational schools was received in school or not, for in either case it would be given by similar people: the local priest, or a Roman Catholic teacher on the staff of the school. The graphs follow a similar format for each sentence. The analysis at this stage is again based on the impression gained from a visual comparison of the statistics, but it will be followed in the next stage by the more dependable method of path analysis.

[Text continues on page 217]

Table 3

Roman Catholic Pupils:

- Total Number Sampled [N = 1113];
- In Roman Catholic Schools [N = 882];
- In Other Schools, receiving Roman Catholic Religious Education [N = 121];
- In Other Schools, not receiving Roman Catholic Religious Education [N = 110].

Sentence 1: "I find it boring to listen to readings from the Bible."*

	DS	D	NC	A	AS	[NA]
All RC pupils:	8	23	21	37	11	[1]
In RC schs:	8	24	23	34	10	[1]
In other schs, with RC RE:	5	13	15	50	17	[1]
In other schs, without RC RE:	15	19	16	43	8	[0]
						[X ² sig. 0.01]

Sentence 2: "I know that Jesus Christ helps me."

	DS	D	NC	A	AS	[NA]
All RC pupils:	2	5	28	41	24	[1]
In RC schs:	2	5	26	42	25	[1]
In other schs, with RC RE:	0	4	33	39	24	[0]
In other schs, without RC RE:	5	5	38	34	18	[1]
						[X ² sig. 0.06]

Sentence 3: "Saying my prayers helps me a lot."

	DS	D	NC	A	AS	[NA]
All RC pupils:	4	13	28	35	19	[1]
In RC schs:	4	13	28	36	19	[1]
In other schs, with RC RE:	1	10	28	37	23	[2]
In other schs, without RC RE:	7	19	23	26	19	[1]
						[X ² sig. 0.14]

Sentence 4: "The Church is very important to me."

	DS	D	NC	A	AS	[NA]
All RC pupils:	3	14	26	34	23	[0]
In RC schs:	3	14	25	34	23	[1]
In other schs, with RC RE:	3	12	26	38	23	[0]
In other schs, without RC RE:	4	16	27	31	21	[1]
						[X ² sig. 0.96]

*See note, p. 151

Table 3 (Cont.)

Roman Catholic Pupils:

Total Number Sampled (N = 1113);

In Roman Catholic Schools (N = 882);

In Other Schools, receiving Roman Catholic Religious Education (N = 121);

In Other Schools, not receiving Roman Catholic Religious Education (N = 110).

Sentence 5: "Going to Church is a waste of my time."*

	DS	D	NC	A	AS	[NA]	
All RC pupils:	4	9	15	34	38	[1]	
In RC schs:	4	9	15	34	38	[1]	
In other schs, with RC RE:	2	8	16	35	39	[0]	
In other schs, without RC RE:	6	6	16	30	42	[1]	
							(X ² sig. 0.88)

Sentence 6: "I want to love Jesus Christ."

	DS	D	NC	A	AS	[NA]	
All RC pupils:	2	3	19	35	39	[1]	
In RC schs:	2	3	18	35	41	[1]	
In other schs, with RC RE:	0	3	19	39	39	[0]	
In other schs, without RC RE:	5	6	32	32	26	[0]	
							(X ² sig. 0.01)

Sentence 7: "I think Church services are boring."*

	DS	D	NC	A	AS	[NA]	
All RC pupils:	9	27	21	28	15	[1]	
In RC schs:	9	29	21	27	15	[0]	
In other schs, with RC RE:	9	25	17	32	17	[0]	
In other schs, without RC RE:	13	15	24	34	13	[3]	
							(X ² sig. 0.20)

Sentence 8: "I think people who pray are stupid."*

	DS	D	NC	A	AS	[NA]	
All RC pupils:	1	1	5	32	60	[0]	
In RC schs:	1	1	5	33	60	[0]	
In other schs, with RC RE:	1	2	5	31	62	[0]	
In other schs, without RC RE:	3	3	5	28	62	[0]	
							(X ² sig. 0.27)

*See note, p.151

[Table continues]

Table 3 (Cont.)

Roman Catholic Pupils:

Total Number Sampled (N = 1113);

In Roman Catholic Schools (N = 882);

In Other Schools, receiving Roman Catholic Religious Education (N = 121);

In Other Schools, not receiving Roman Catholic Religious Education (N = 110).

Sentence 9: "God helps me to lead a better life."

	DS	D	NC	A	AS	[NA]
All RC pupils:	3	8	27	38	24	[1]
In RC schs:	3	8	26	38	25	[1]
In other schs, with RC RE:	1	5	34	33	26	[2]
In other schs, without RC RE:	4	11	30	37	18	[0]
						[X ² sig. 0.38]

Sentence 10: "I like school lessons about God very much."

	DS	D	NC	A	AS	[NA]
All RC pupils:	13	30	28	22	7	[0]
In RC schs:	14	31	27	22	5	[0]
In other schs, with RC RE:	5	22	32	25	15	[1]
In other schs, without RC RE:	15	32	28	17	7	[1]
						[X ² sig. 0.01]

Sentence 11: "God means a lot to me."

	DS	D	NC	A	AS	[NA]
All RC pupils:	2	8	21	38	31	[0]
In RC schs:	2	7	22	37	32	[0]
In other schs, with RC RE:	1	6	20	42	31	[0]
In other schs, without RC RE:	6	12	16	40	26	[1]
						[X ² sig. 0.08]

Sentence 12: "I believe God helps people."

	DS	D	NC	A	AS	[NA]
All RC pupils:	2	3	16	41	38	[0]
In RC schs:	2	3	15	41	39	[1]
In other schs, with RC RE:	1	3	18	42	36	[0]
In other schs, without RC RE:	3	6	21	40	30	[0]
						[X ² sig. 0.45]

[Table continues]

Table 3 (Cont.)

Roman Catholic Pupils:

Total Number Sampled [N = 1113];

In Roman Catholic Schools [N = 882];

In Other Schools, receiving Roman Catholic Religious Education [N = 121];

In Other Schools, not receiving Roman Catholic Religious Education [N = 110].

Sentence 13: "Prayer helps me a lot."

	DS	D	NC	A	AS	[NA]
All RC pupils:	4	14	28	33	21	[1]
In RC schs:	4	14	26	34	30	[1]
In other schs, with RC RE:	2	10	35	31	21	[2]
In other schs, without RC RE:	7	16	32	26	18	[1]
						[X ² sig. 0.24]

Sentence 14: "I know that Jesus Christ is very close to me."

	DS	D	NC	A	AS	[NA]
All RC pupils:	3	7	31	34	25	[1]
In RC schs:	3	8	29	35	25	[1]
In other schs, with RC RE:	2	4	36	33	26	[0]
In other schs, without RC RE:	5	9	36	29	22	[0]
						[X ² sig. 0.60]

Sentence 15: "I think praying is a good thing."

	DS	D	NC	A	AS	[NA]
All RC pupils:	2	6	19	44	29	[1]
In RC schs:	2	6	19	44	29	[1]
In other schs, with RC RE:	1	4	21	44	30	[0]
In other schs, without RC RE:	4	8	20	43	25	[1]
						[X ² sig. 0.79]

Sentence 16: "I think the Bible is out of date."*

	DS	D	NC	A	AS	[NA]
All RC pupils:	6	13	19	34	28	[1]
In RC schs:	6	14	20	34	25	[1]
In other schs, with RC RE:	2	10	17	31	39	[1]
In other schs, without RC RE:	6	12	12	34	35	[2]
						[X ² sig. 0.16]

Table 3 (Cont.)

Roman Catholic Pupils:

Total Number Sampled (N = 1113);
 In Roman Catholic Schools (N = 882);
 In Other Schools, receiving Roman Catholic Religious
 Education (N = 121);
 In Other Schools, not receiving Roman Catholic Religious
 Education (N = 110).

Sentence 17: "I believe that God listens to prayers."

	DS	D	NC	A	AS	[NA]
All RC pupils:	2	5	25	33	34	[1]
In RC schs:	2	5	24	33	35	[2]
In other schs, with RC RE:	0	7	21	36	36	[0]
In other schs, without RC RE:	6	4	31	31	28	[1]
						(X ² sig. 0.05)

Sentence 18: "Jesus Christ doesn't mean anything to me."*

	DS	D	NC	A	AS	[NA]
All RC pupils:	1	3	8	28	59	[0]
In RC schs:	1	4	8	29	58	[0]
In other schs, with RC RE:	2	1	7	21	69	[0]
In other schs, without RC RE:	3	3	10	26	58	[0]
						(X ² sig. 0.20)

Sentence 19: "God is very real to me."

	DS	D	NC	A	AS	[NA]
All RC pupils:	2	8	27	35	28	[1]
In RC schs:	2	7	28	34	28	[1]
In other schs, with RC RE:	1	7	18	43	32	[0]
In other schs, without RC RE:	3	11	25	36	26	[0]
						(X ² sig. 0.42)

Sentence 20: "Saying prayers in school does me no good."*

	DS	D	NC	A	AS	[NA]
All RC pupils:	8	21	23	31	17	[1]
In RC schs:	2	21	21	32	18	[1]
In other schs, with RC RE:	7	22	34	31	16	[0]
In other schs, without RC RE:	10	20	34	22	14	[1]
						(X ² sig. 0.01)

*See note, p. 151

Roman Catholic Pupils:

Total Number Sampled [N = 1113];

In Roman Catholic Schools [N = 882];

In Other Schools, receiving Roman Catholic Religious Education [N = 121];

In Other Schools, not receiving Roman Catholic Religious Education [N = 110].

Sentence 21: "The idea of God means much to me."

	DS	D	NC	A	AS	[NA]	
All RC pupils:	2	7	23	40	27	[1]	
In RC schs:	2	7	23	40	27	[1]	
In other schs, with RC RE:	0	6	26	45	24	[0]	
In other schs, without RC RE:	5	10	22	39	23	[2]	
							[X ² sig. 0.25]

Sentence 22: "I believe that Jesus Christ still helps people today."

	DS	D	NC	A	AS	[NA]	
All RC pupils:	3	3	17	38	39	[0]	
In RC schs:	3	3	17	38	39	[1]	
In other schs, with RC RE:	0	2	18	38	42	[0]	
In other schs, without RC RE:	6	6	16	38	34	[0]	
							[X ² sig. 0.22]

Sentence 23: "I know that God helps me."

	DS	D	NC	A	AS	[NA]	
All RC pupils:	3	6	27	39	26	[1]	
In RC schs:	2	6	27	39	25	[1]	
In other schs, with RC RE:	1	4	26	43	26	[0]	
In other schs, without RC RE:	6	6	26	35	27	[0]	
							[X ² sig. 0.62]

Sentence 24: "I find it hard to believe in God."*

	DS	D	NC	A	AS	[NA]	
All RC pupils:	6	18	12	33	31	[0]	
In RC schs:	5	20	11	33	30	[1]	
In other schs, with RC RE:	8	11	14	31	36	[0]	
In other schs, without RC RE:	9	16	13	30	33	[0]	
							[X ² sig. 0.47]

*See note, p. 151

1. " I FIND IT BORING TO LISTEN TO READINGS FROM THE BIBLE "

DS

D

NC

A

AS

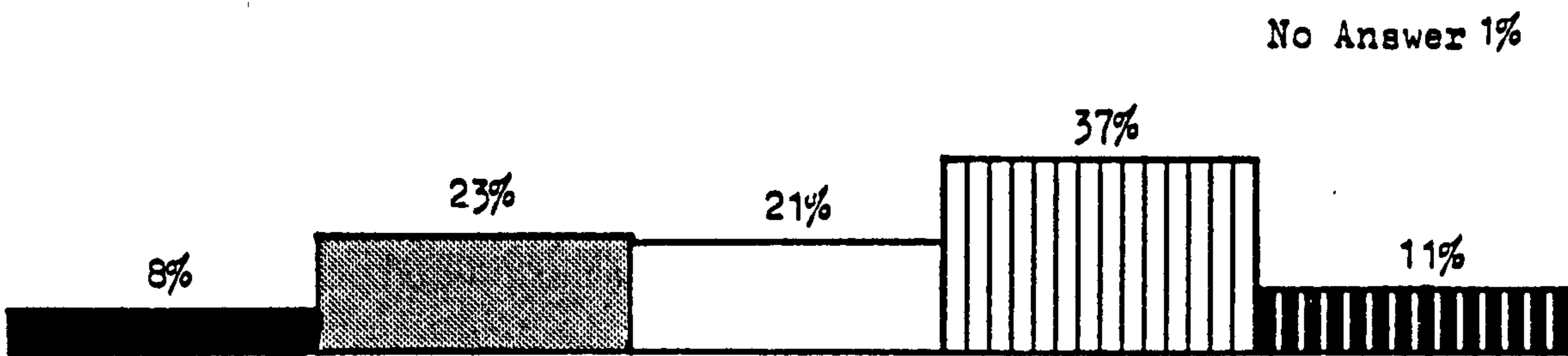

No Answer 1%

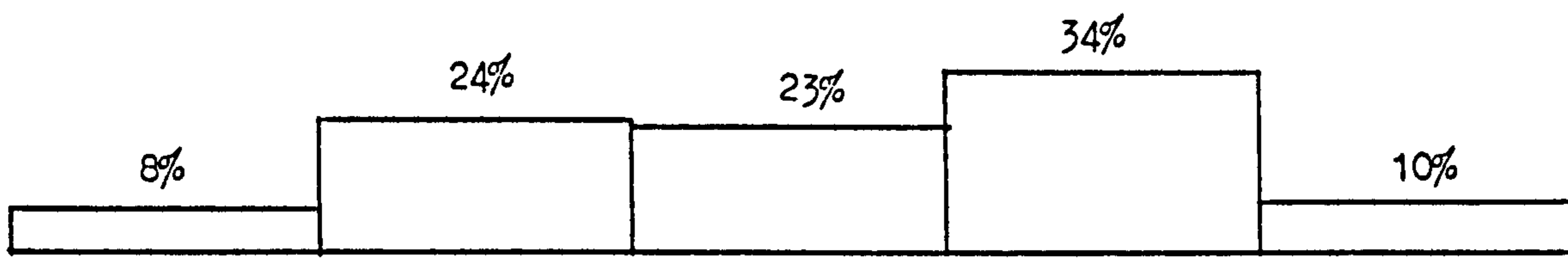

No Answer 1%

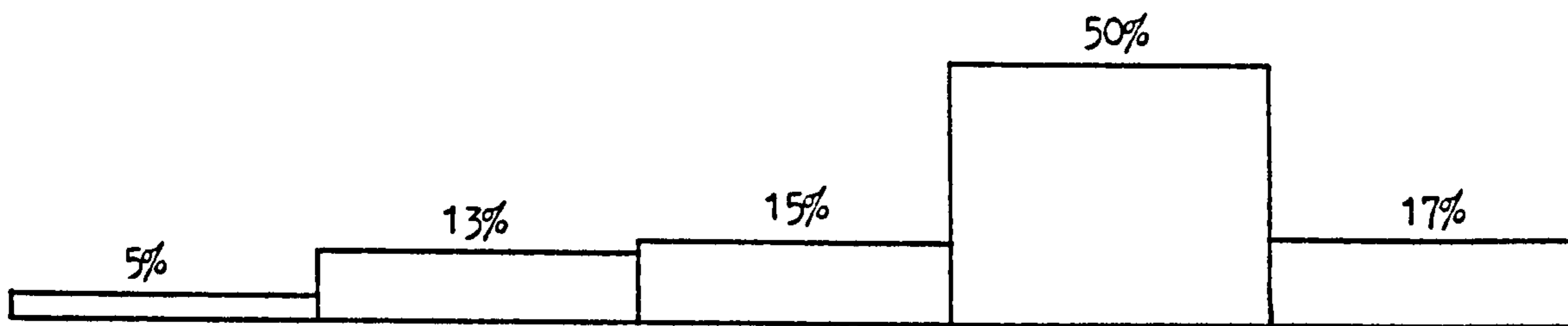

No Answer 0

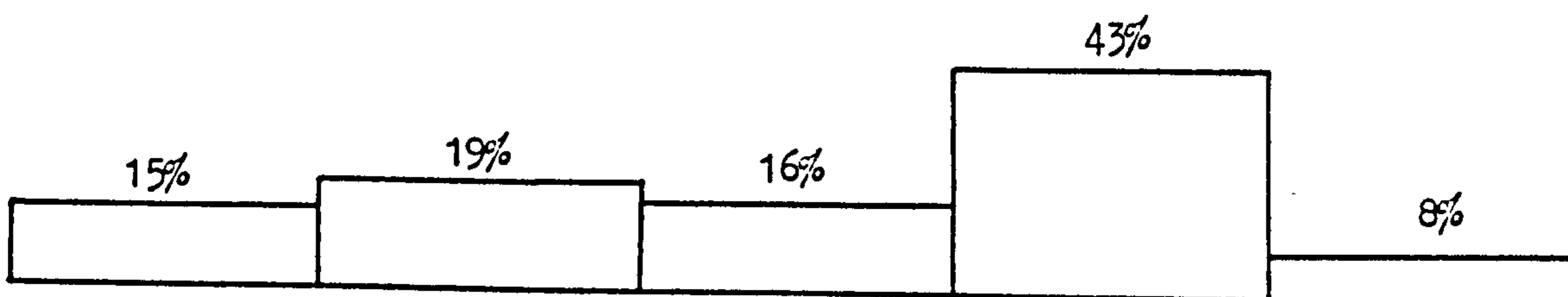

2. " I KNOW THAT JESUS CHRIST HELPS ME A LOT "

DS

D

NC

A

AS

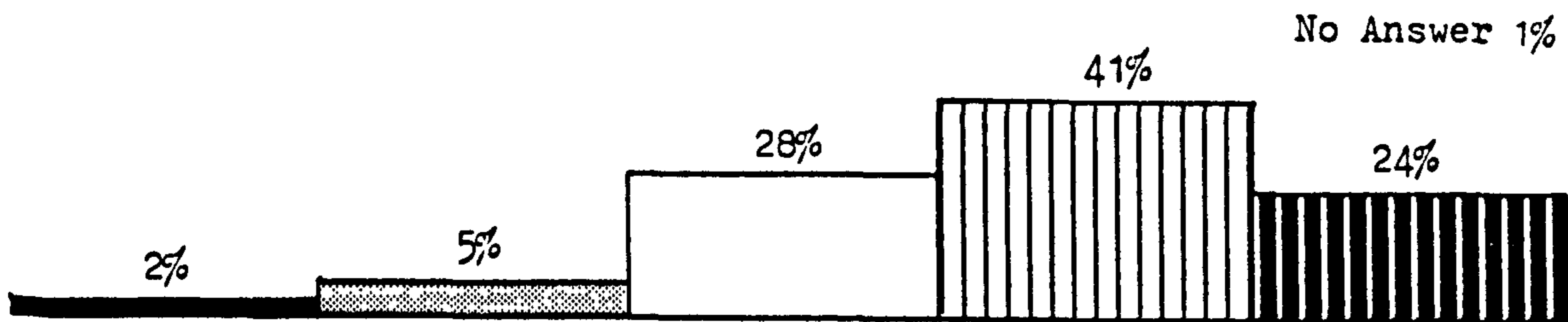

No Answer 1%

No Answer 1%

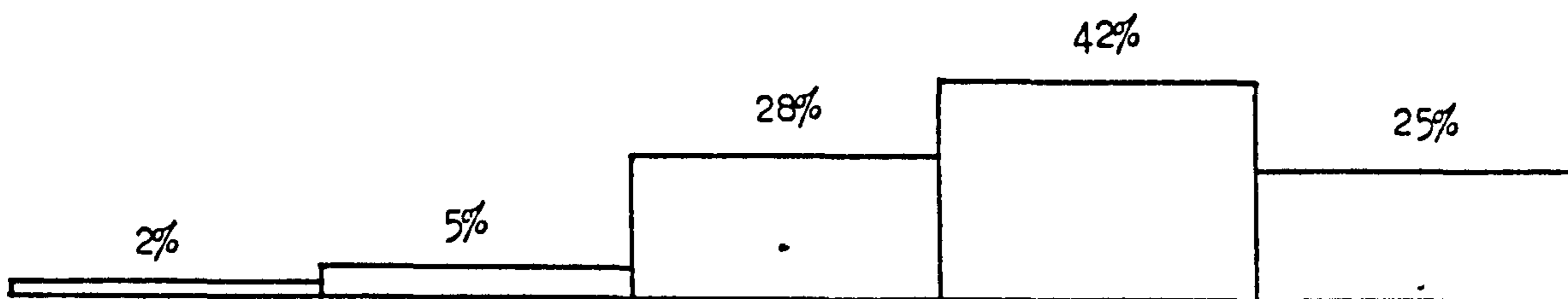

No Answer 0

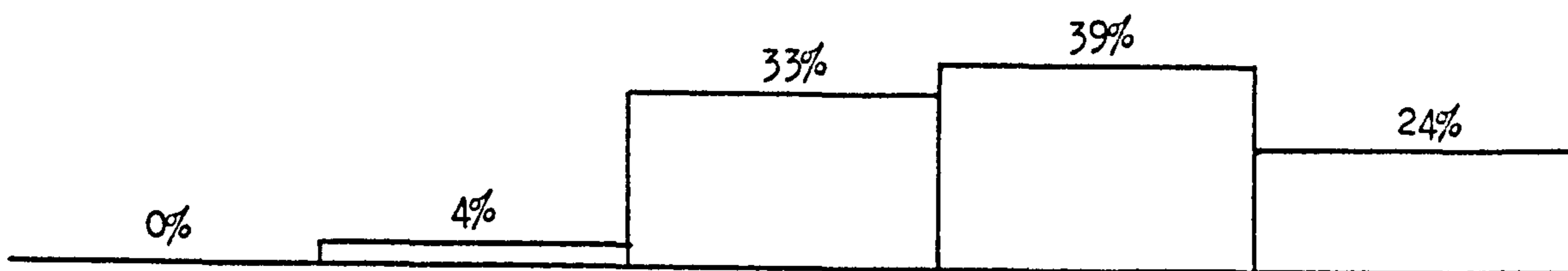

No Answer 1%

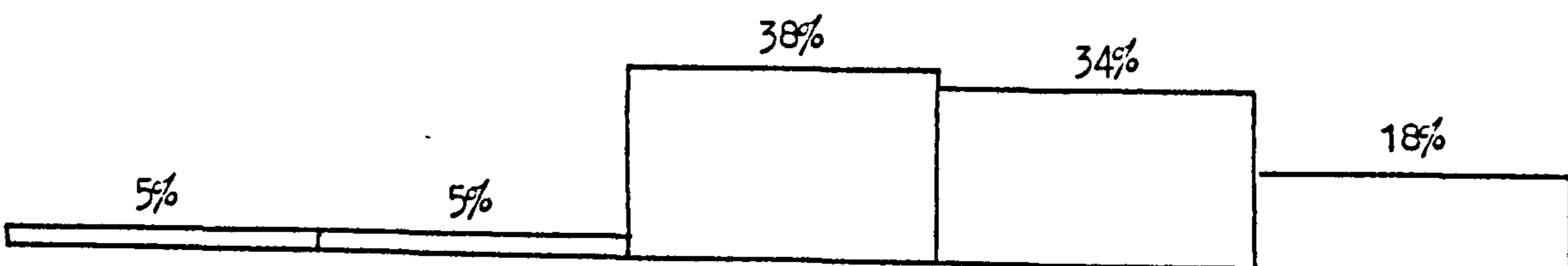

3. " SAYING MY PRAYERS HELPS ME A LOT "

DS

D

NC

A

AS

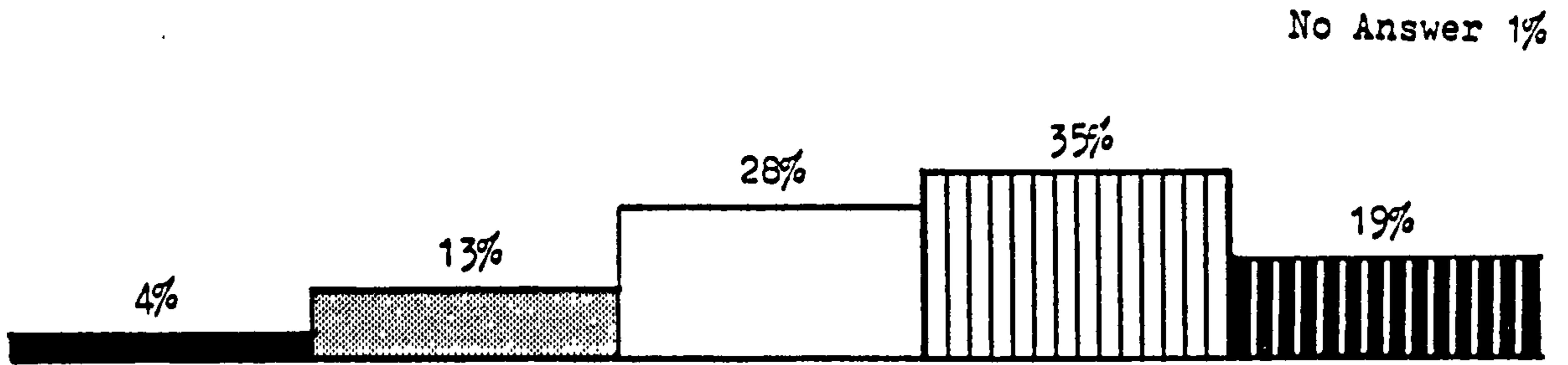

No Answer 1%

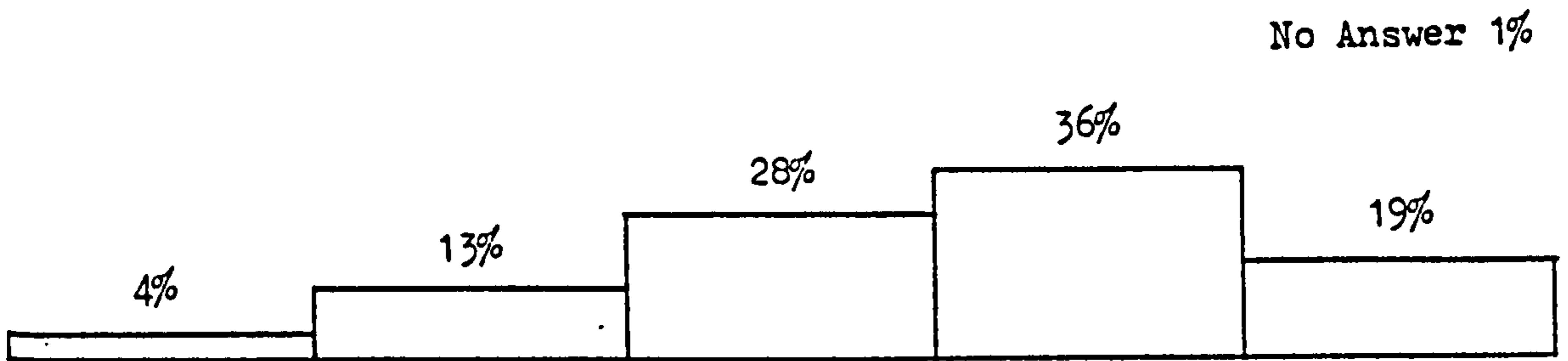

No Answer 1%

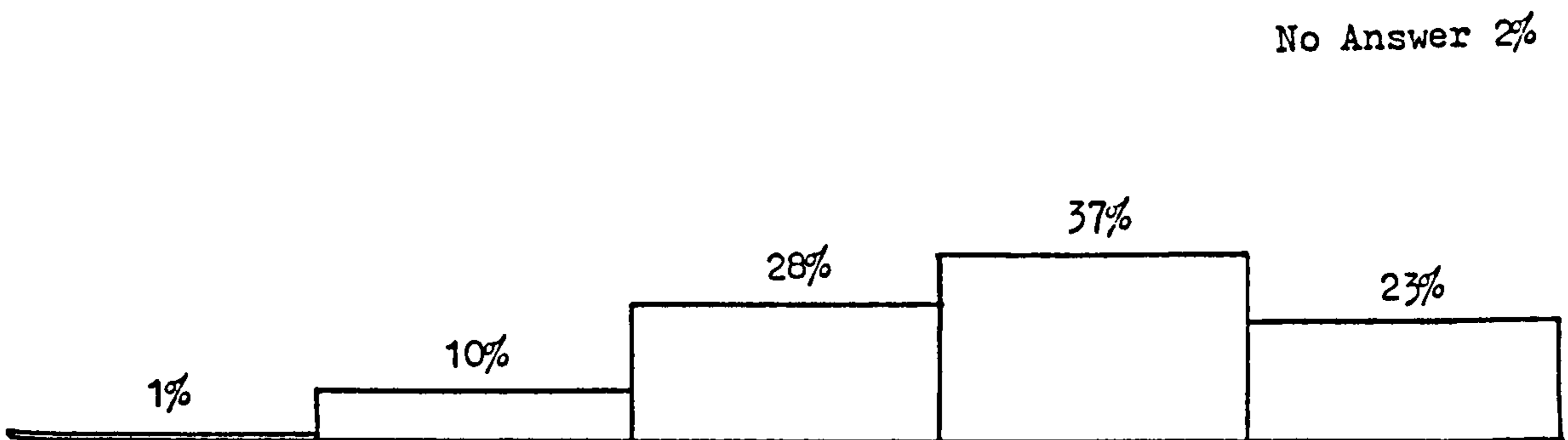

No Answer 2%

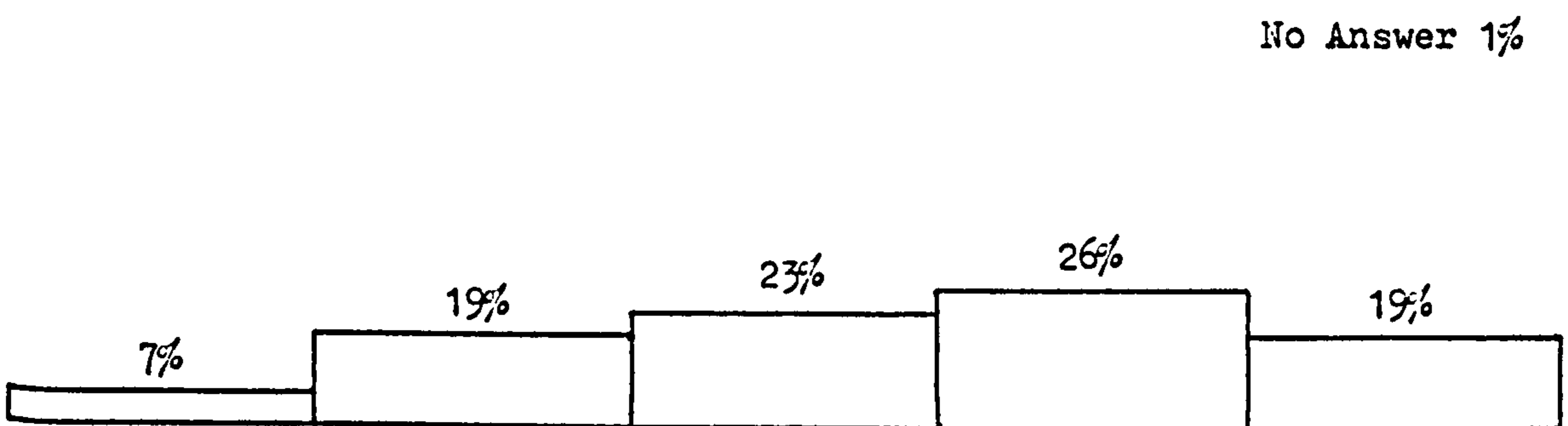

No Answer 1%

4. " THE CHURCH IS VERY IMPORTANT TO ME "

DS D NC A AS

No Answer 0

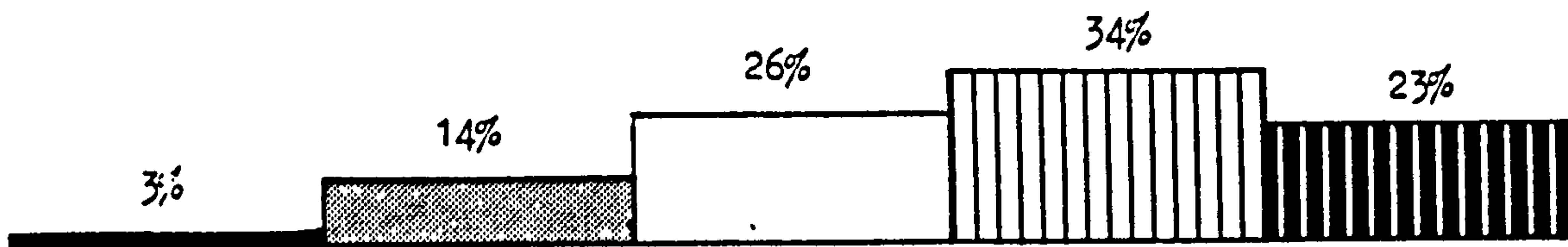

No Answer 1%

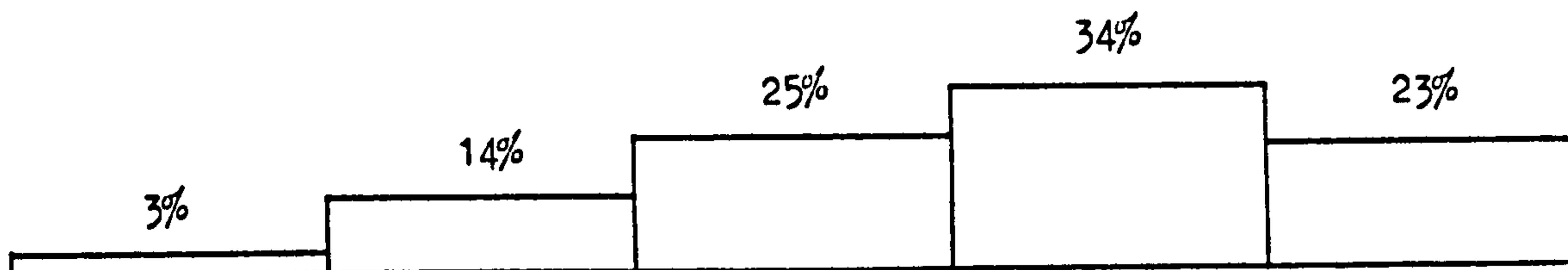

No Answer 0

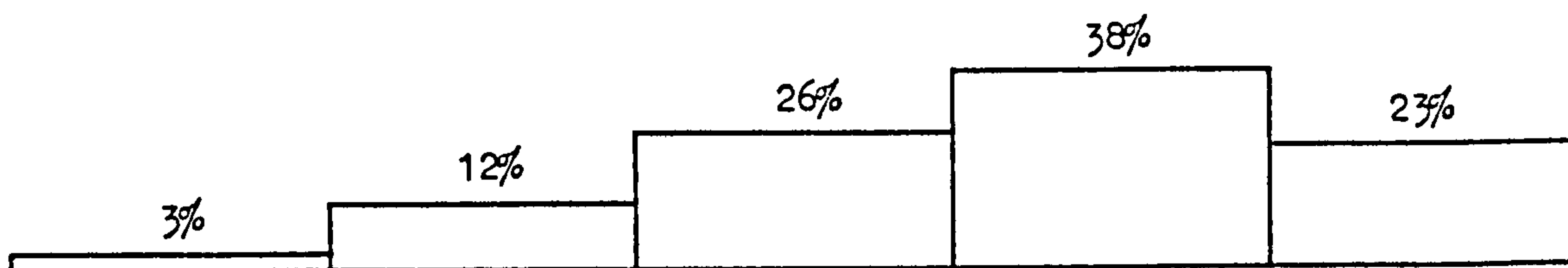

No Answer 1%

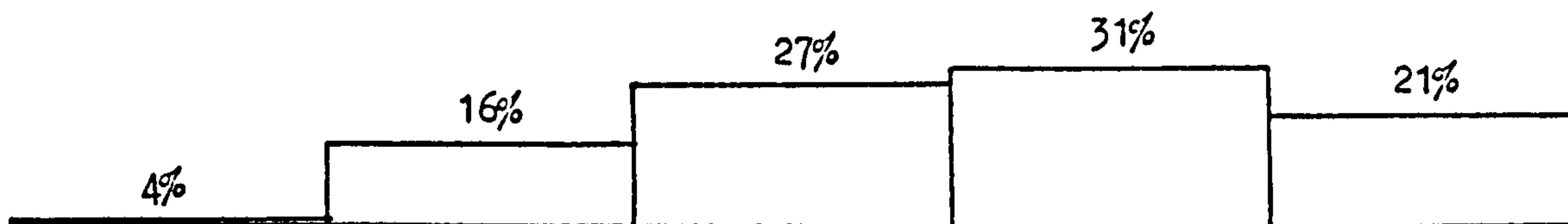

5. " GOING TO CHURCH IS A WASTE OF MY TIME "

DS D NC A AS

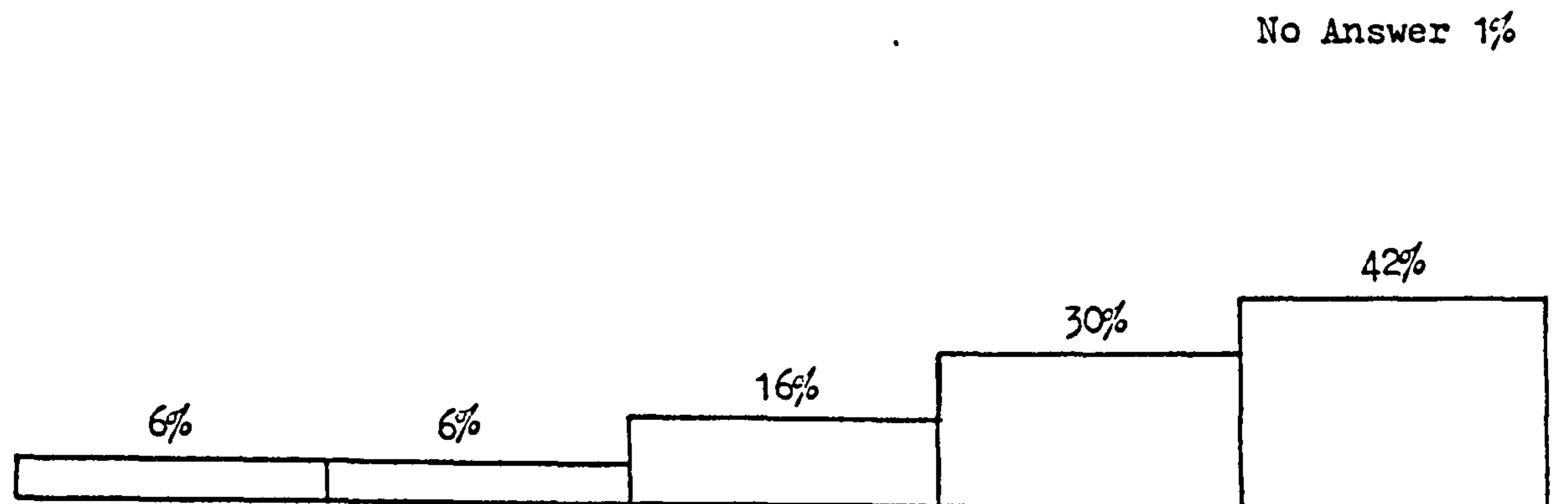
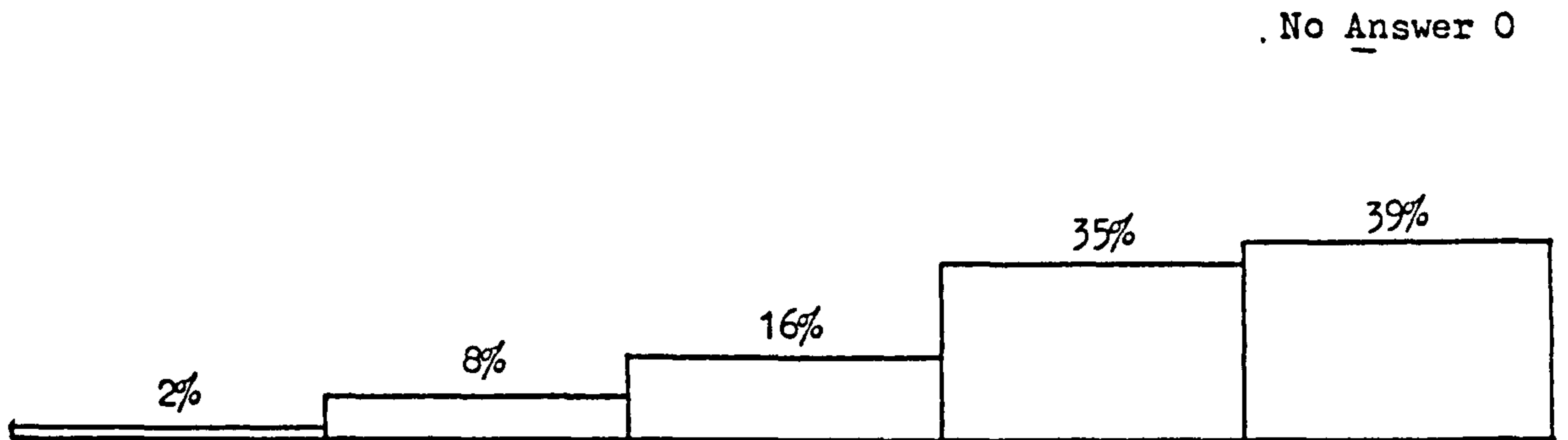
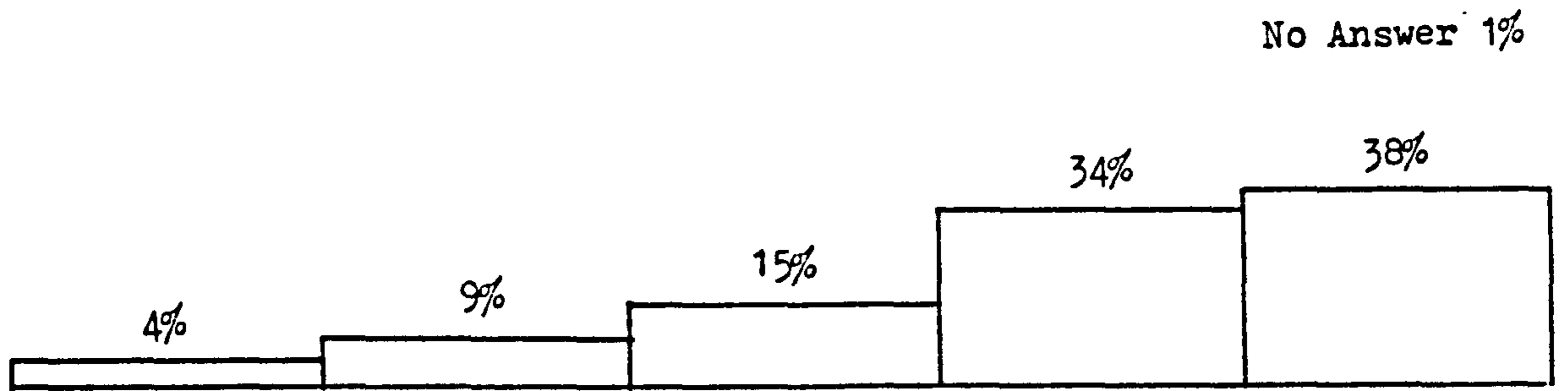
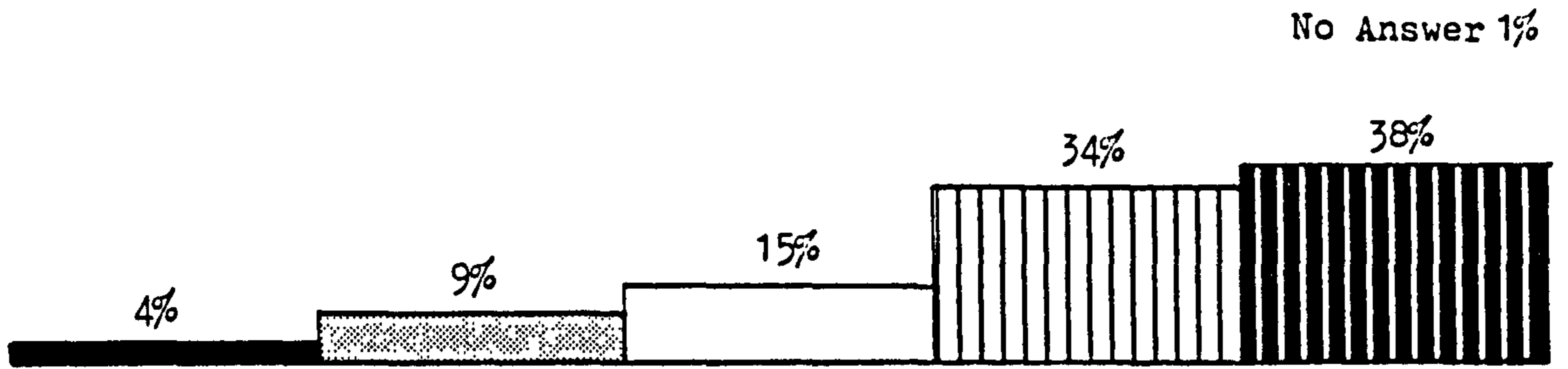

6. " I WANT TO LOVE JESUS CHRIST "

DS D NS A AS

No Answer 1%

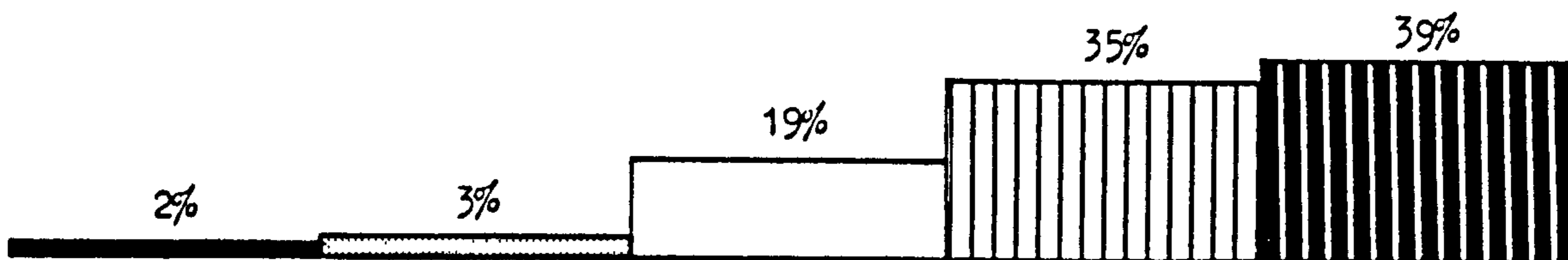

No Answer 1%

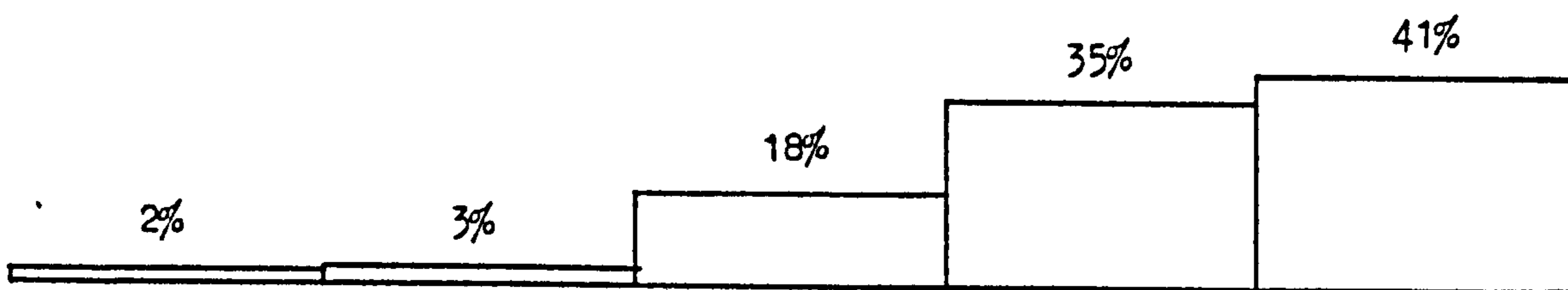

No Answer 0

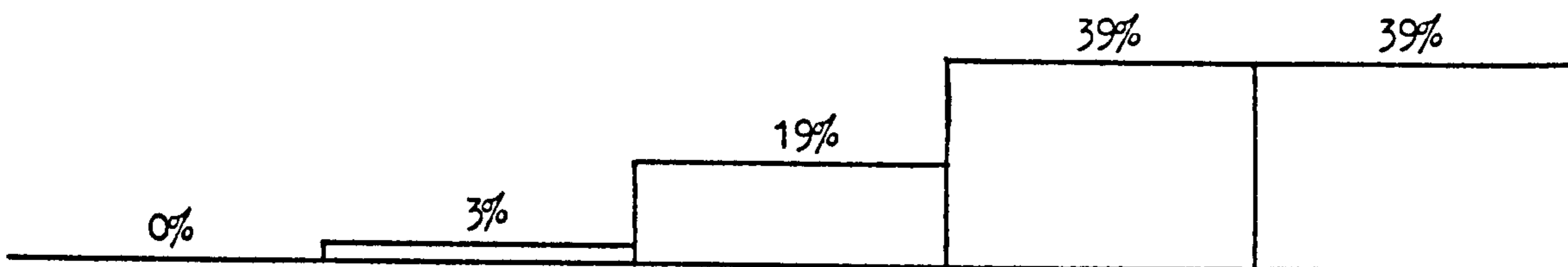

No Answer 0

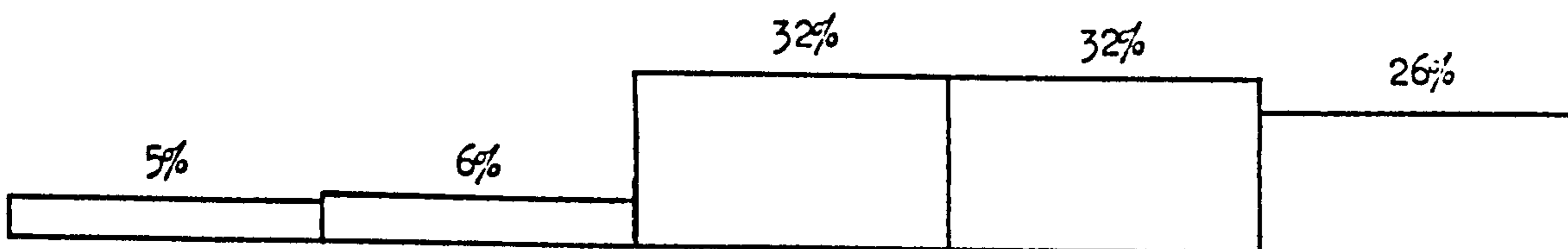

7. " I THINK CHURCH SERVICES ARE BORING "

DS

D

NC

A

AS

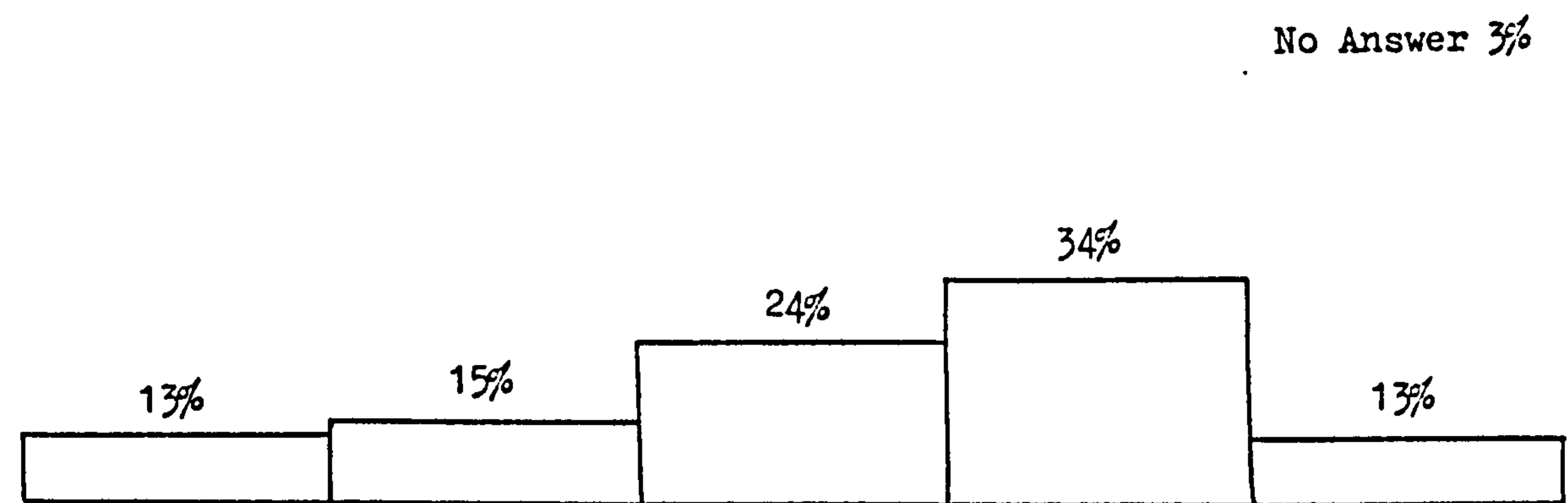
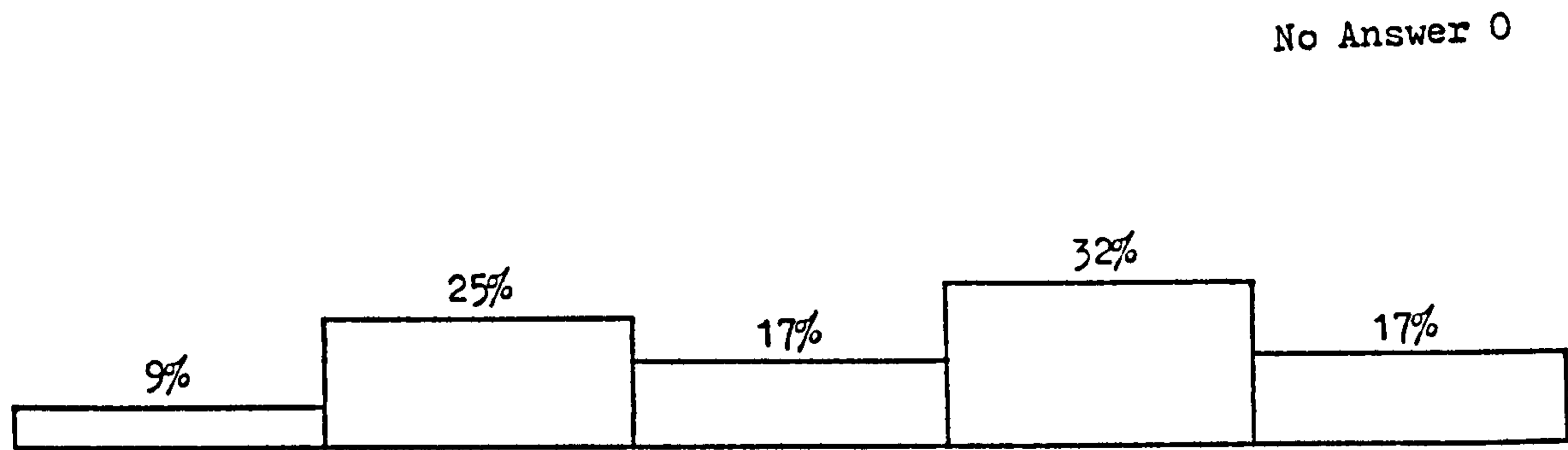
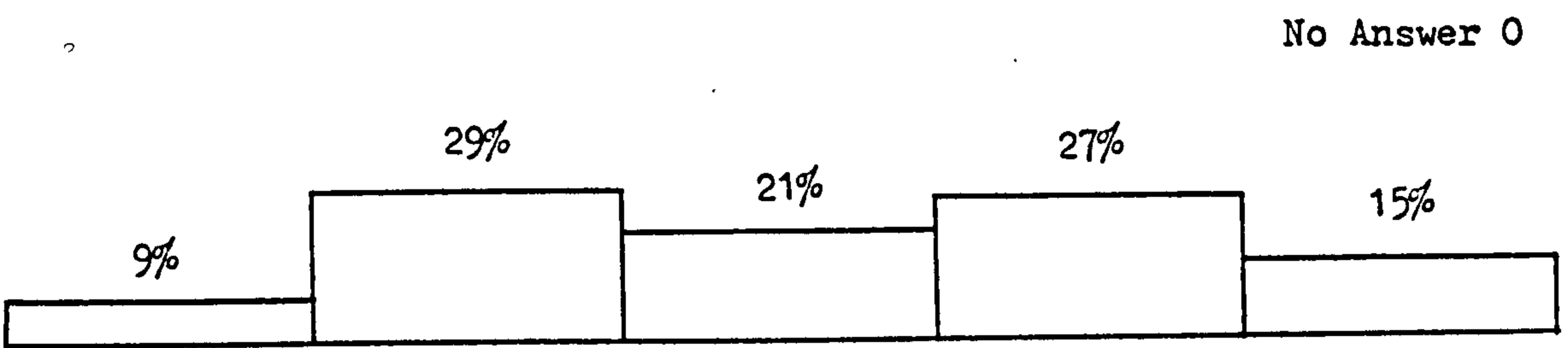
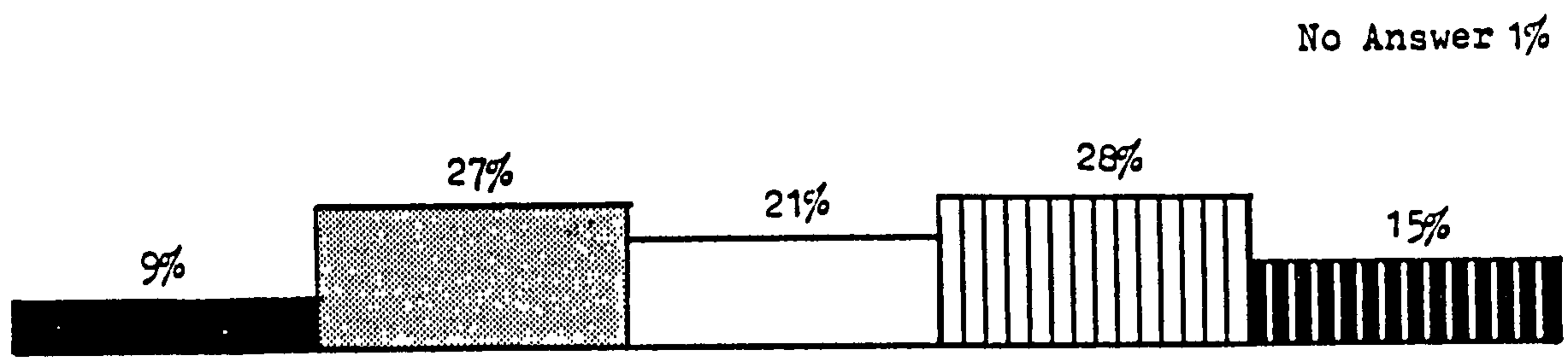

8. " I THINK PEOPLE WHO PRAY ARE STUPID "

DS D NC A AS

No Answer 0

60%

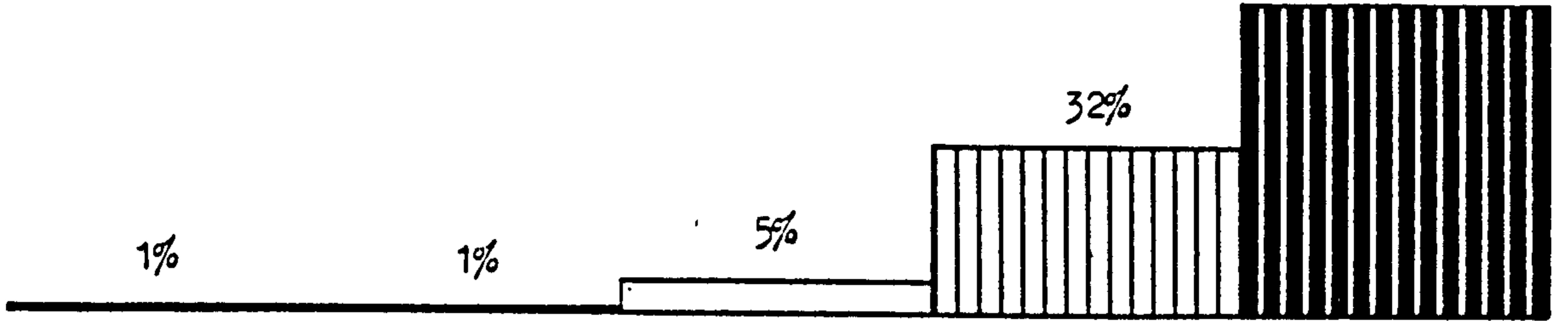

No Answer 0

60%

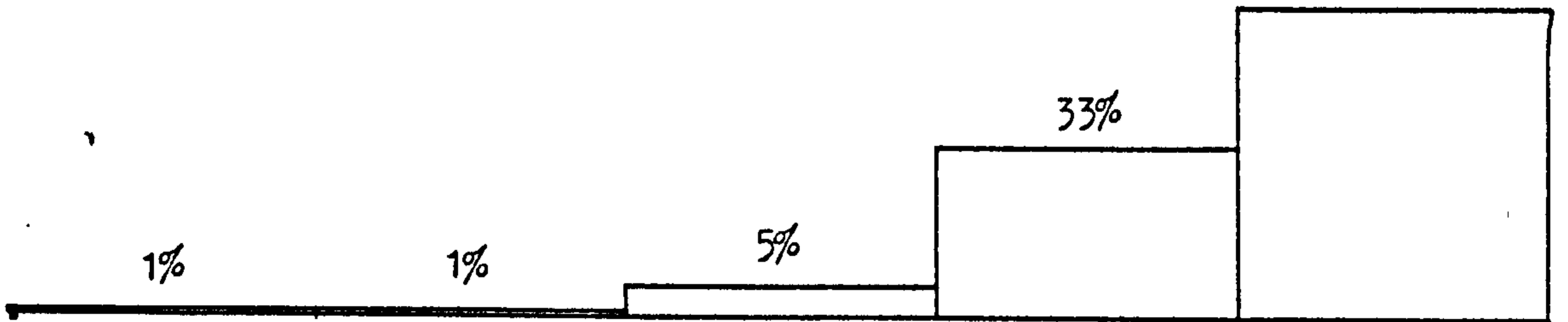

No Answer 0

62%

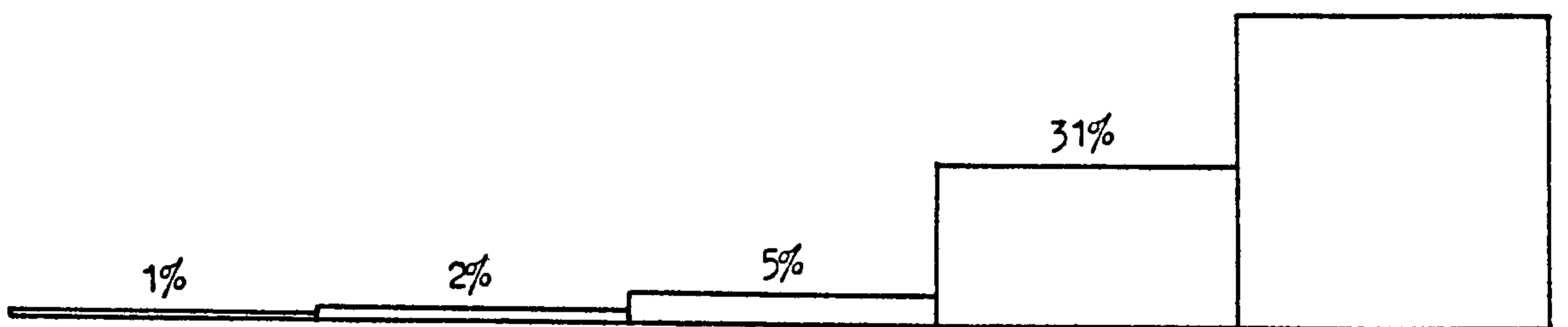

No Answer 0

62%

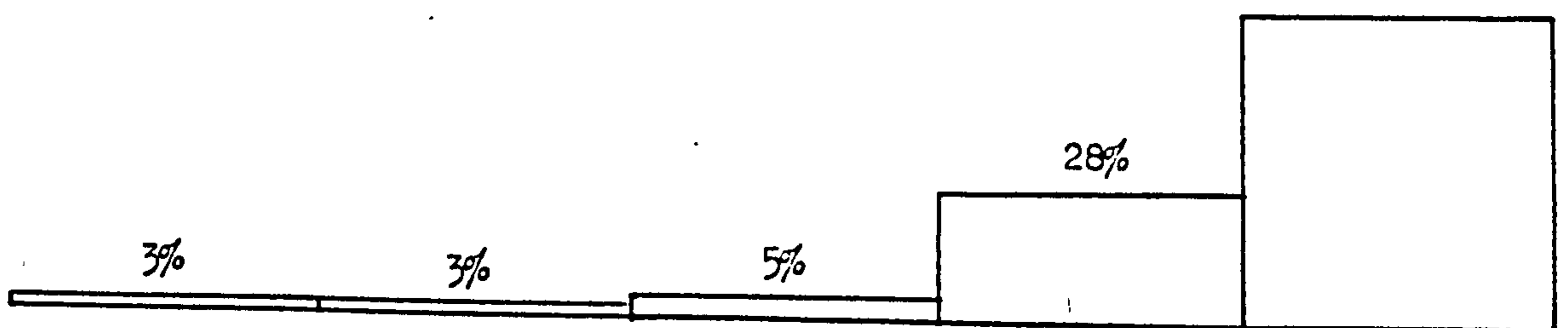

9. " GOD HELPS ME TO LEAD A BETTER LIFE "

DS D NC A AS

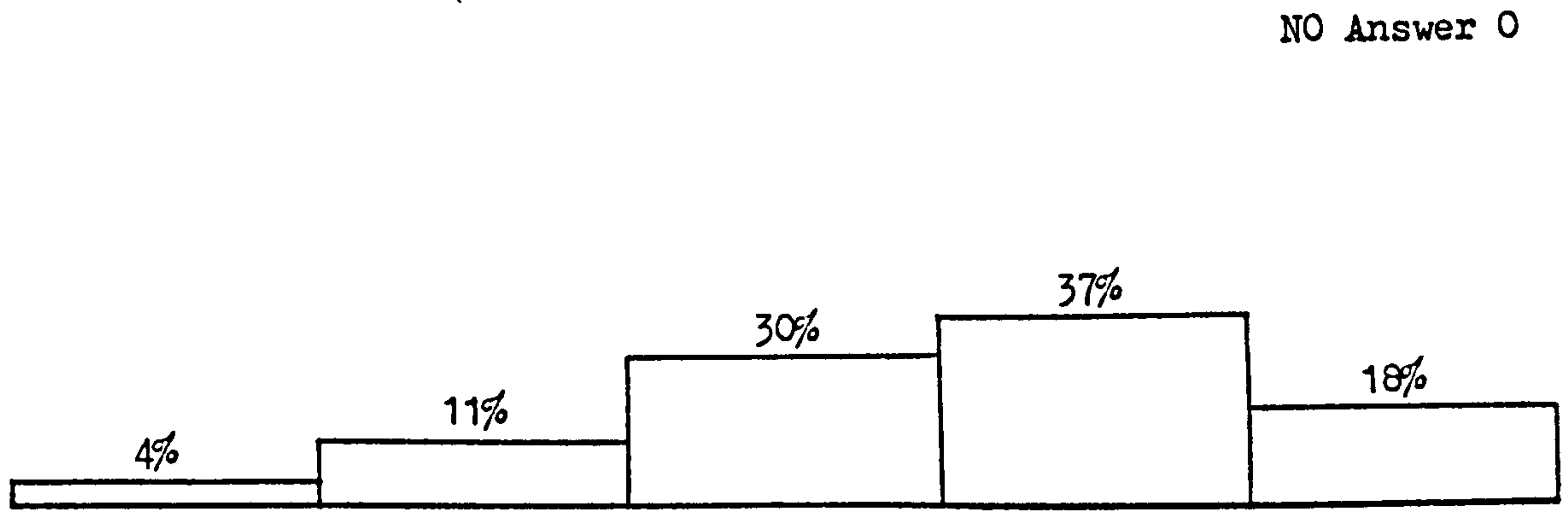
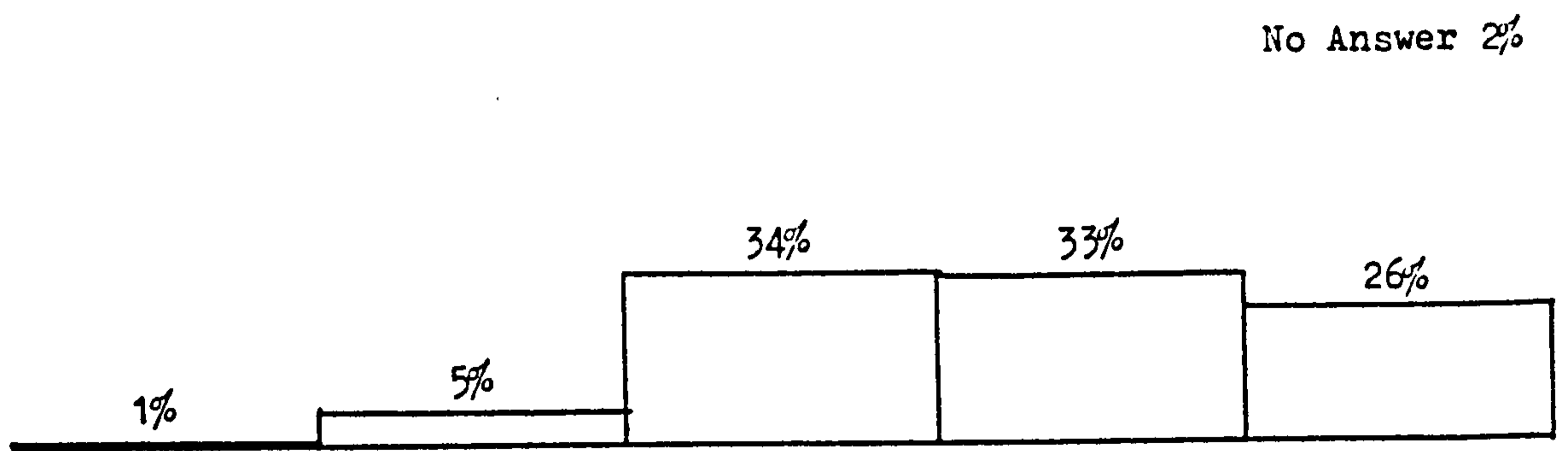
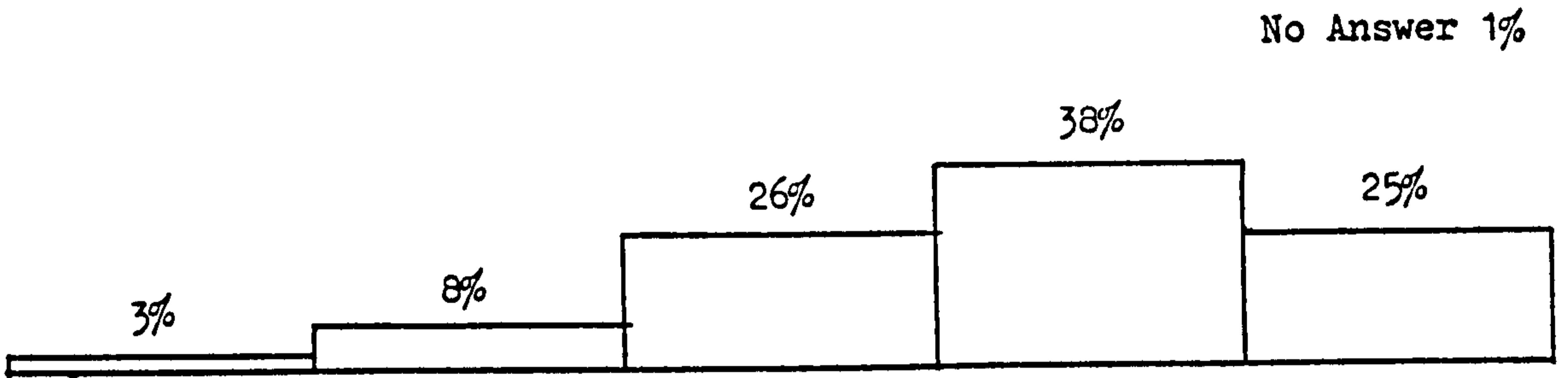
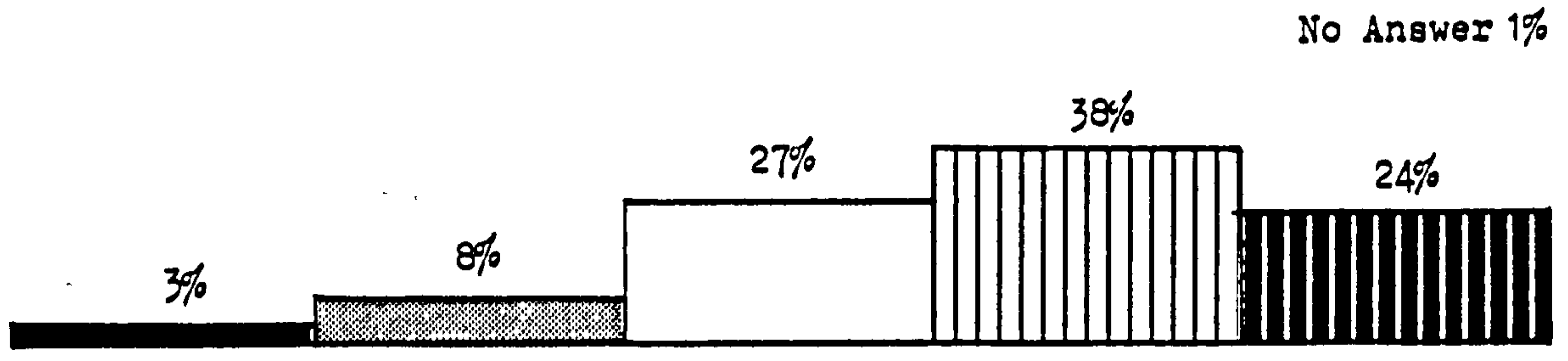

10. " I LIKE SCHOOL LESSONS ABOUT GOD VERY MUCH "

DS D NS A AS

No Answer 0

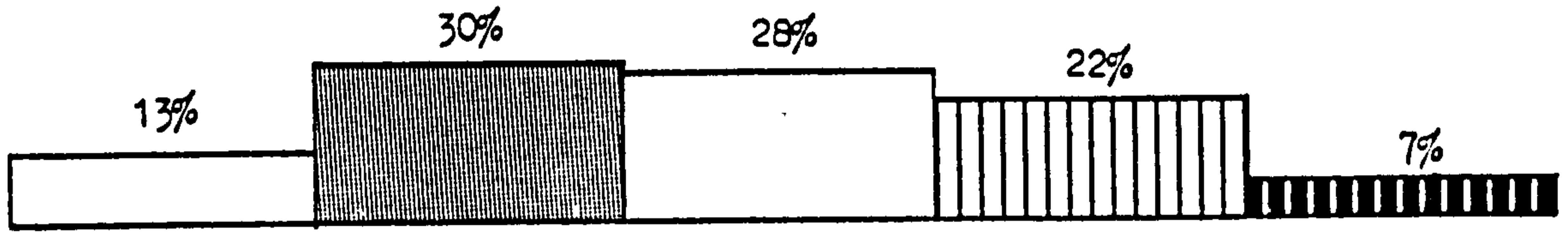

No Answer 0

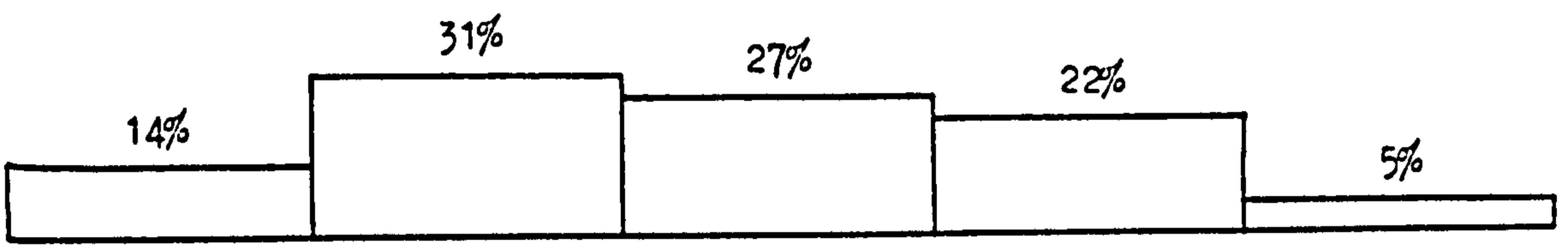

No Answer 1%

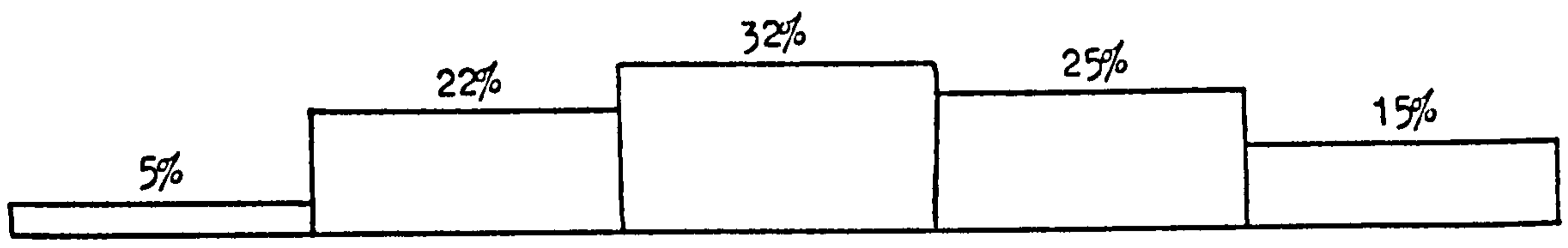

NO Answer 1%

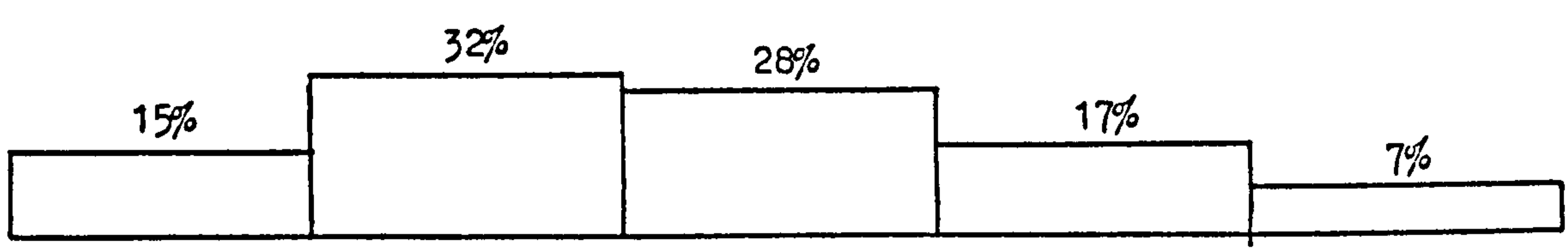

11. " GOD MEANS A LOT TO ME "

DS D NC A AS

No Answer 0

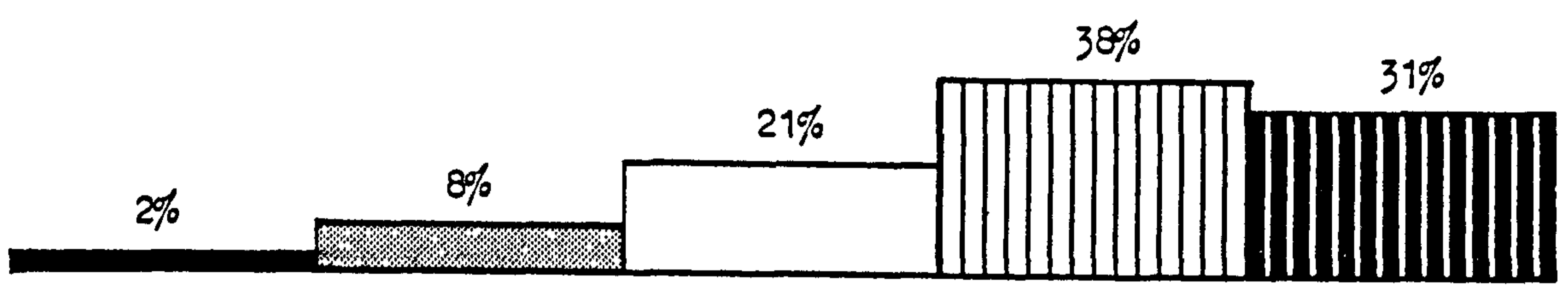

No Answer 0

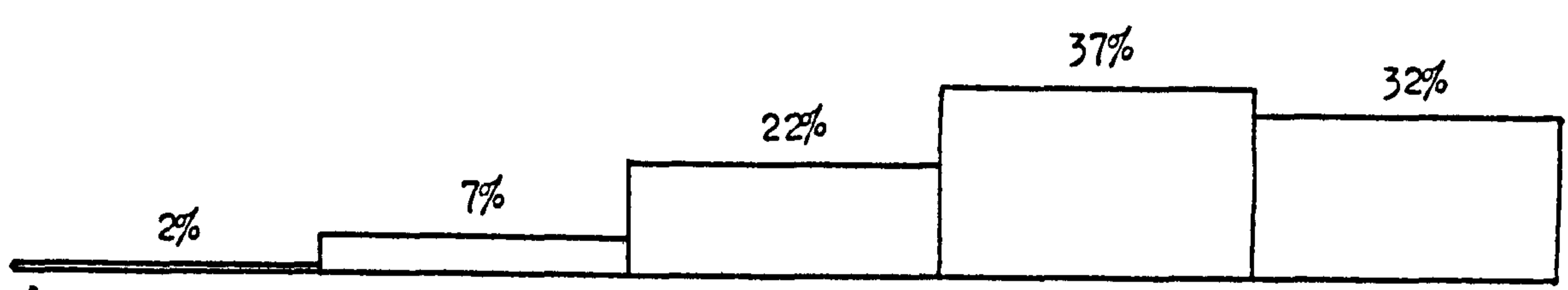

No Answer 0

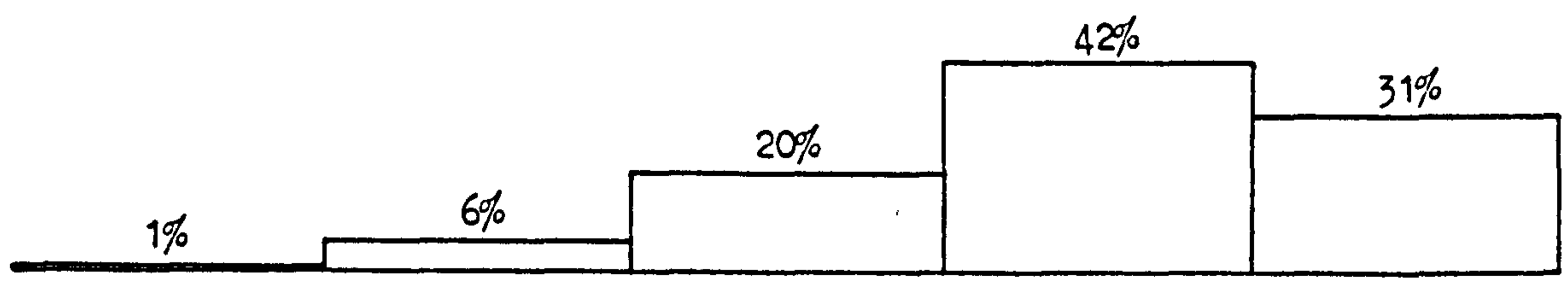

No Answer 1%

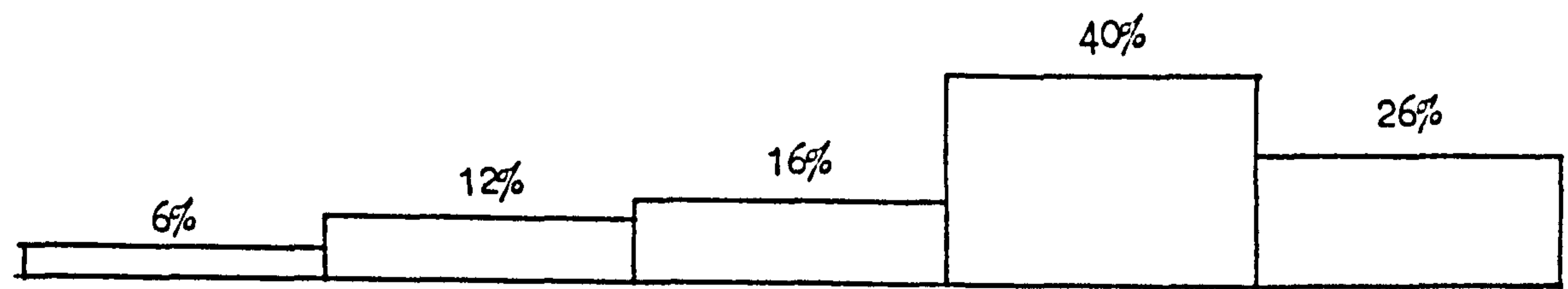

12. " I BELIEVE GOD HELPS PEOPLE "

DS

D

NC

A

AS

No Answer 0

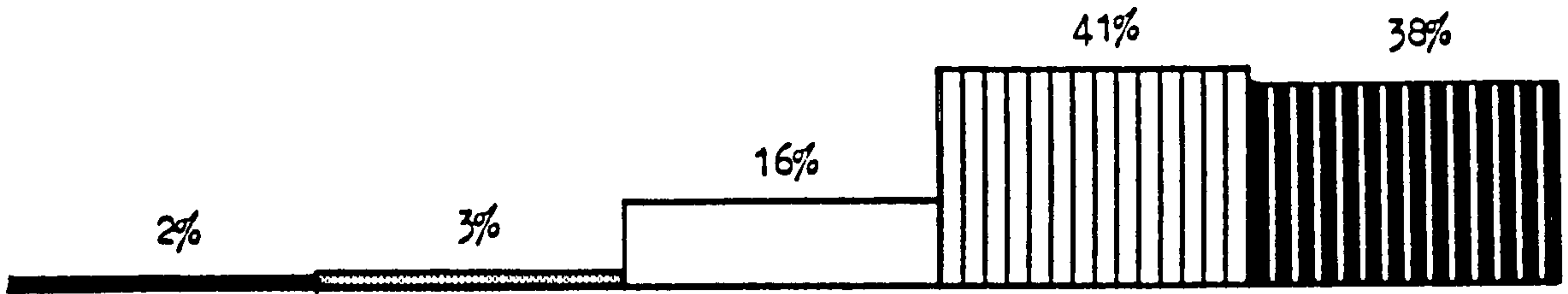

No Answer 0

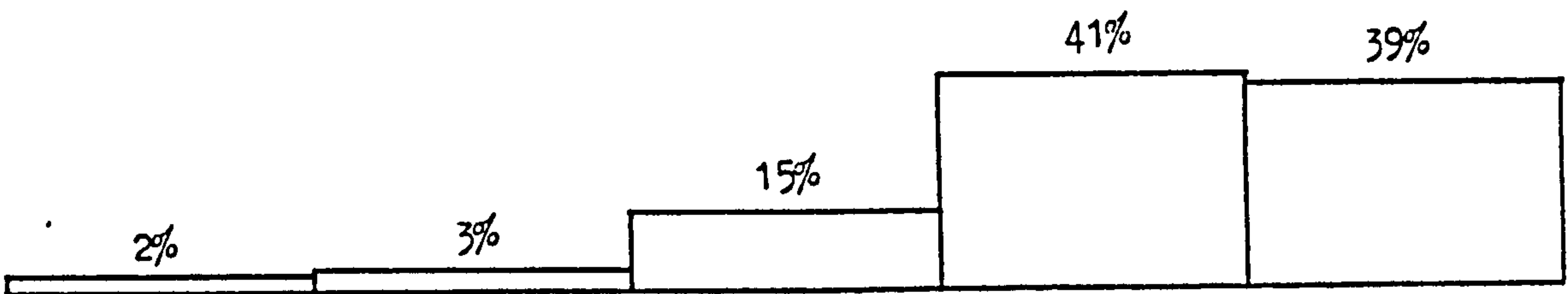

No Answer 0

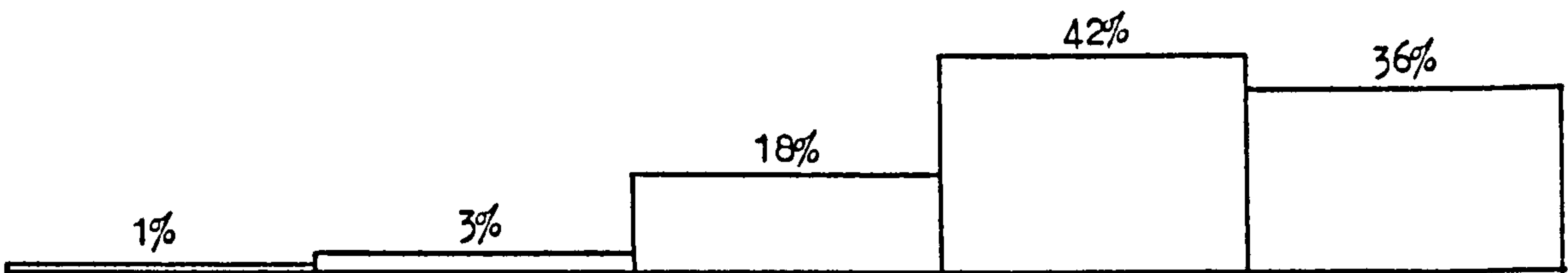

No Answer 0

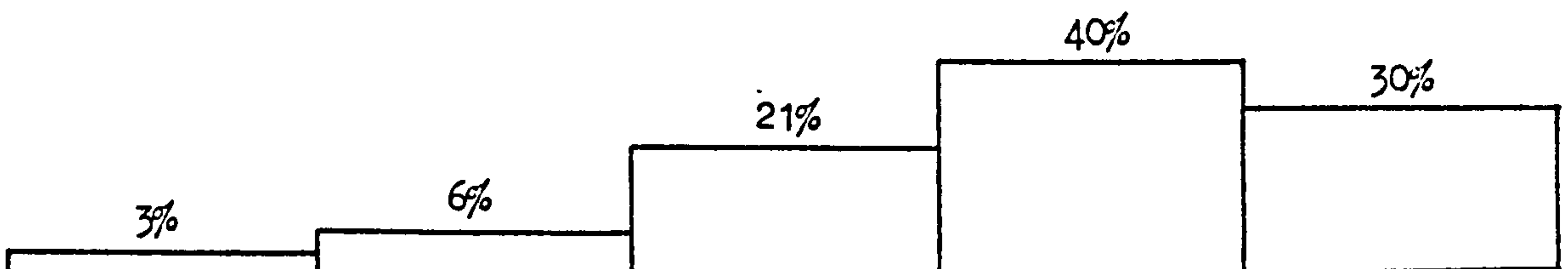

13. " PRAYER HELPS ME A LOT "

DS

D

NS

A

AS

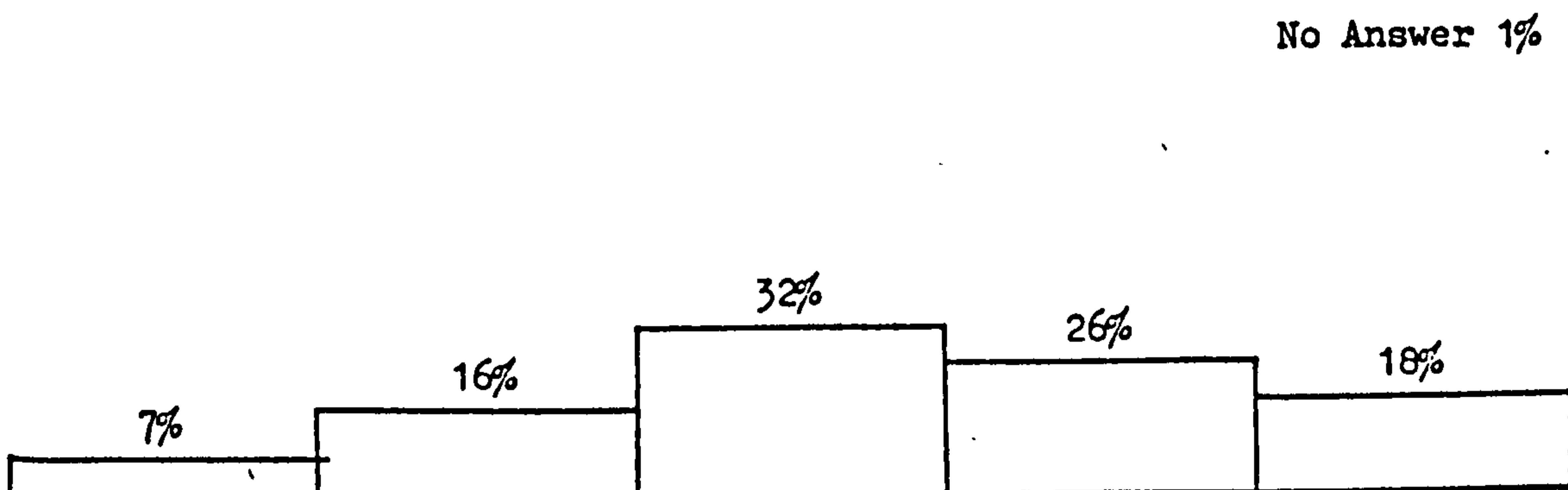
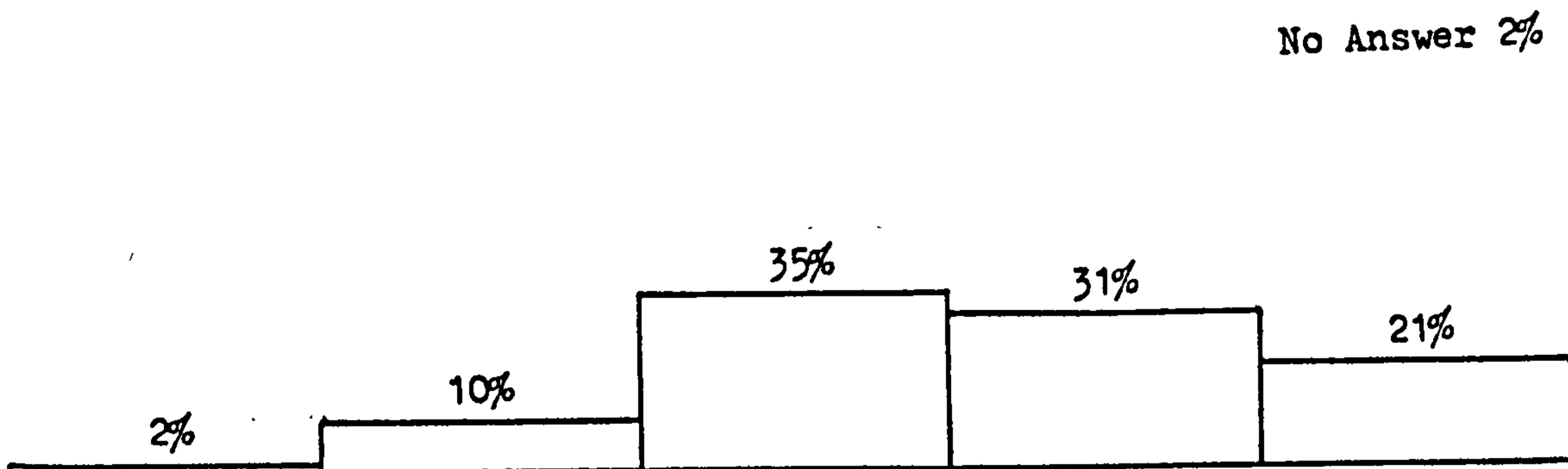
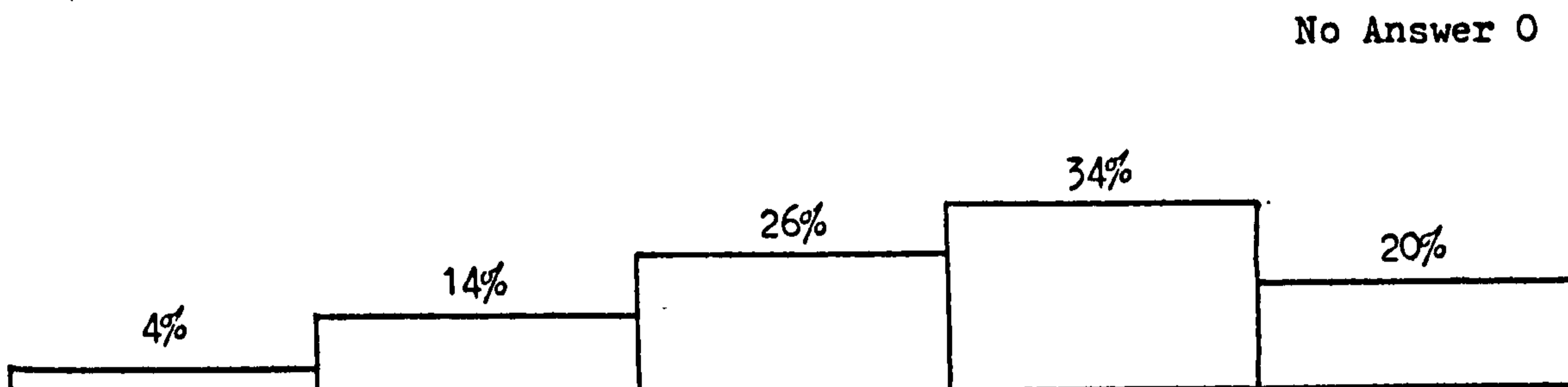
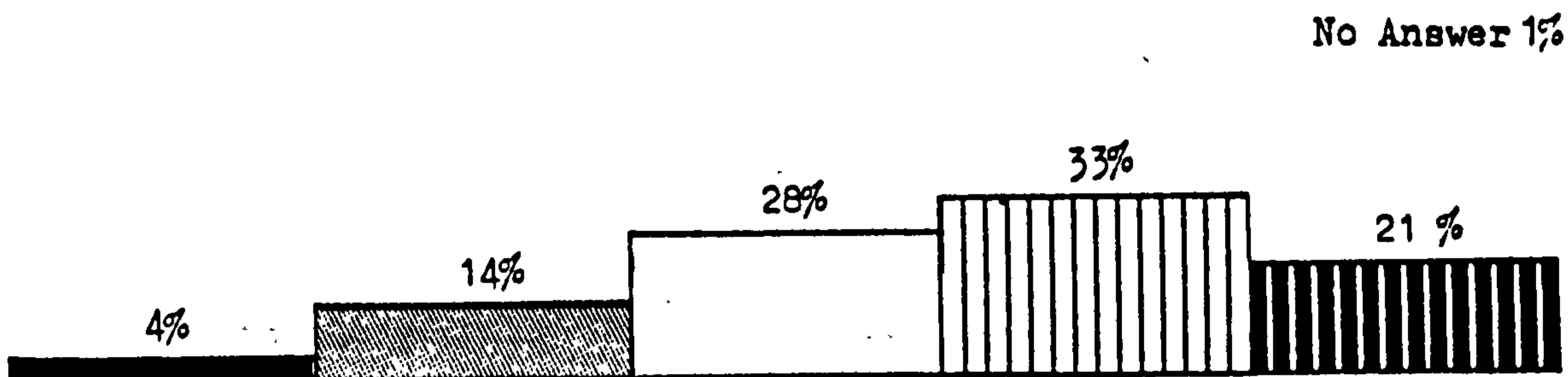

14. " I KNOW THAT JESUS CHRIST IS VERY CLOSE TO ME "

DS

D

NC

A

AS

No Answer 1%

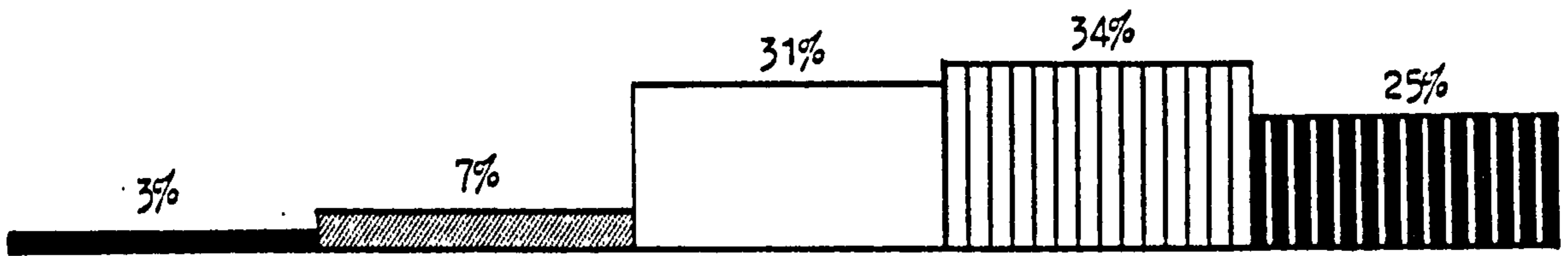

No Answer 1%

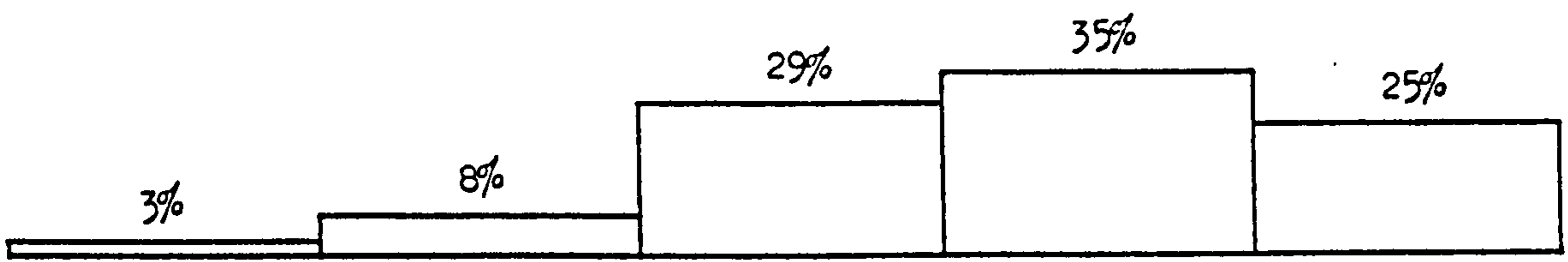

No Answer 0

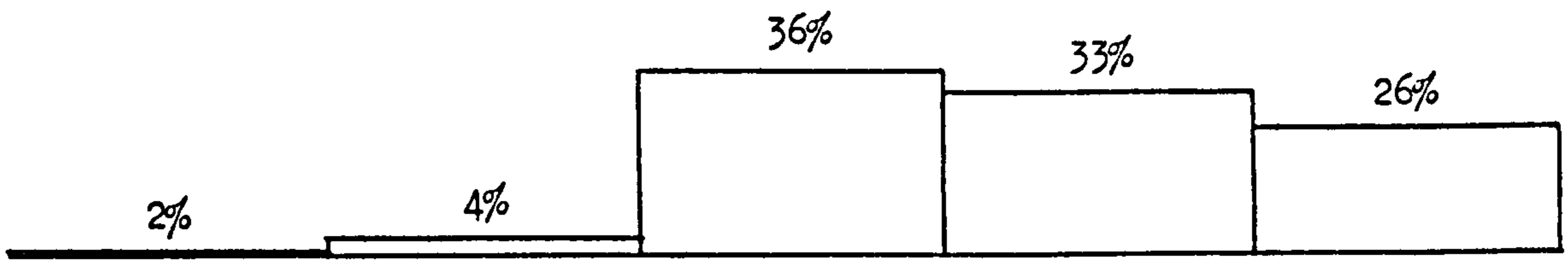

No Answer 0

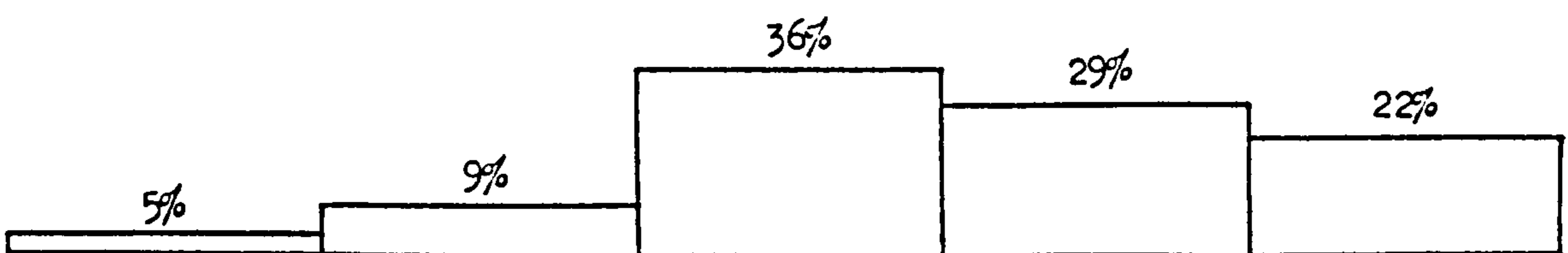

15. " I THINK PRAYING IS A GOOD THING "

DS

D

NC

A

AS

No Answer 1%

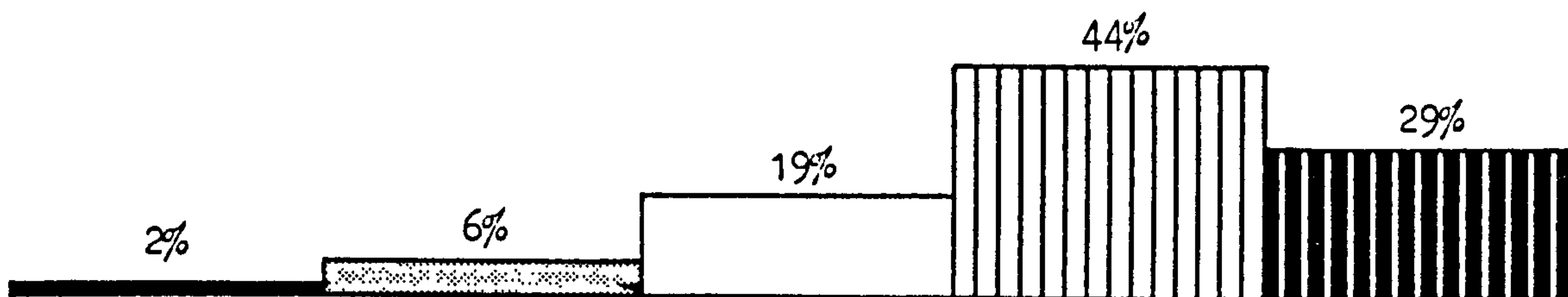

No Answer 1%

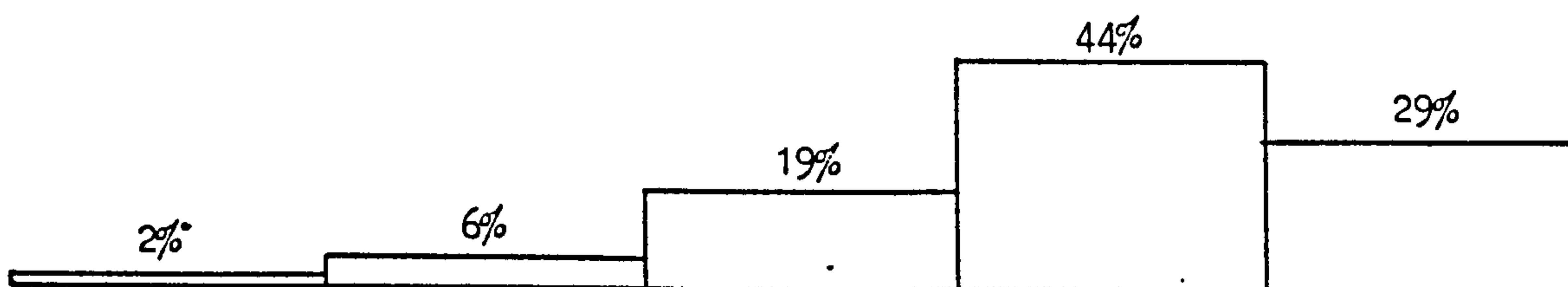

No Answer 0

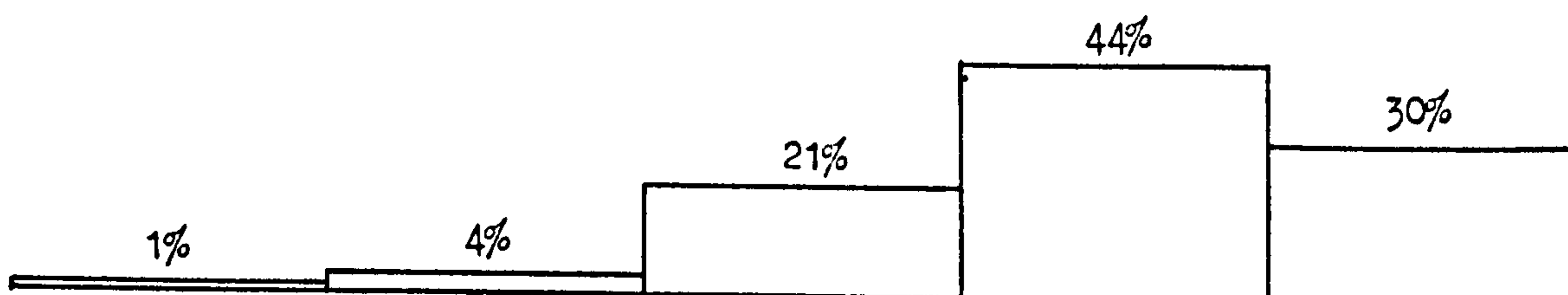

No Answer 1%

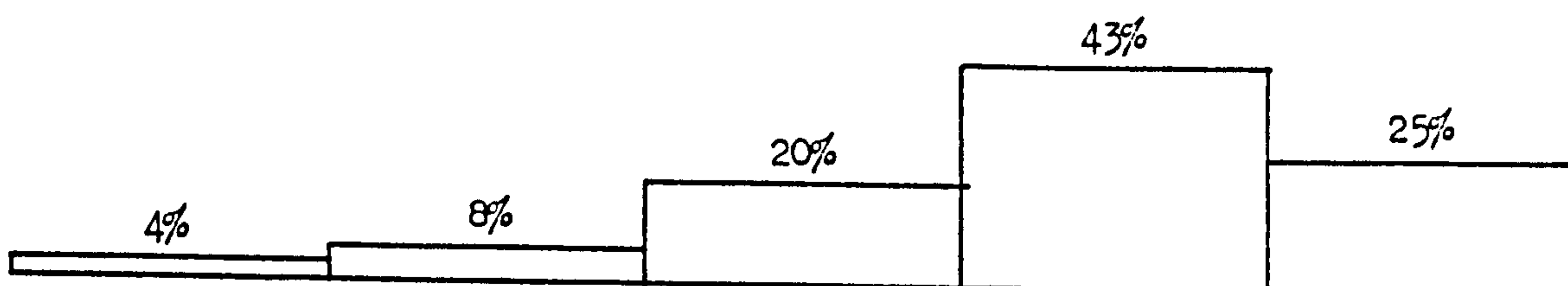

16. " I THINK THE BIBLE IS OUT OF DATE "

DS

D

NS

A

AS

No Answer 1%

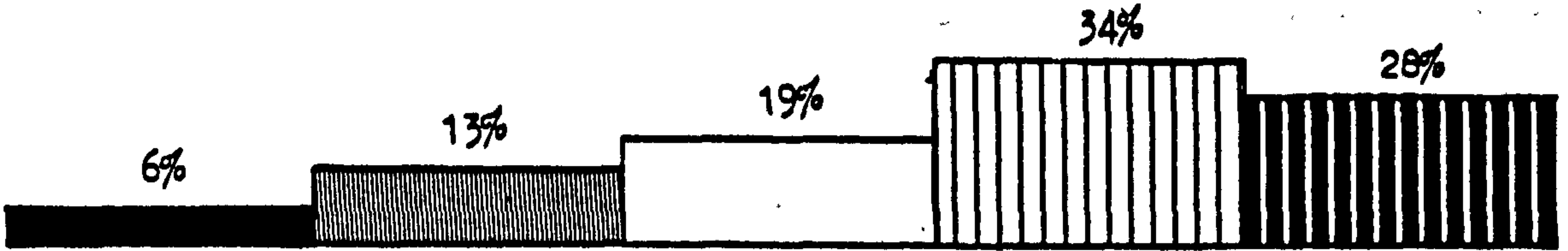

No Answer 1%

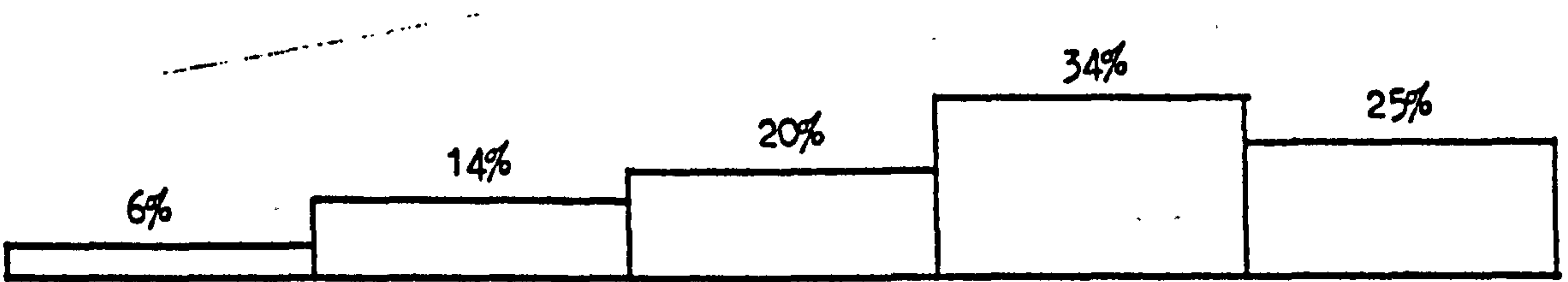

No Answer 1%

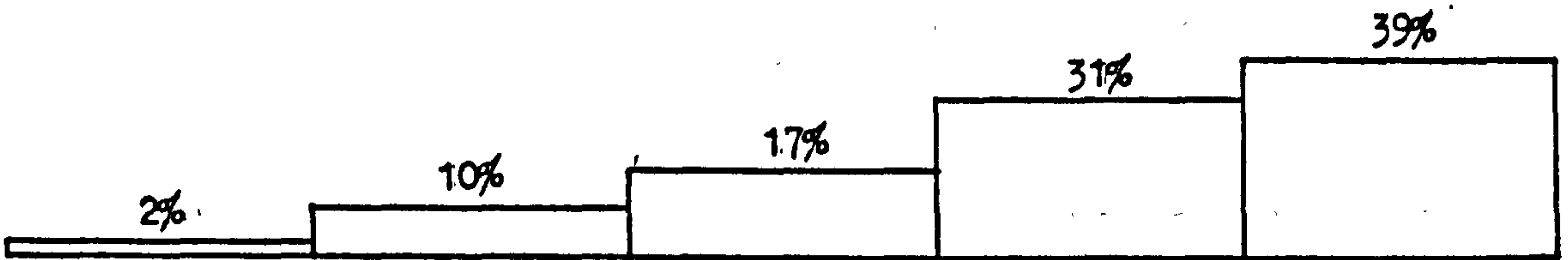

No Answer 2%

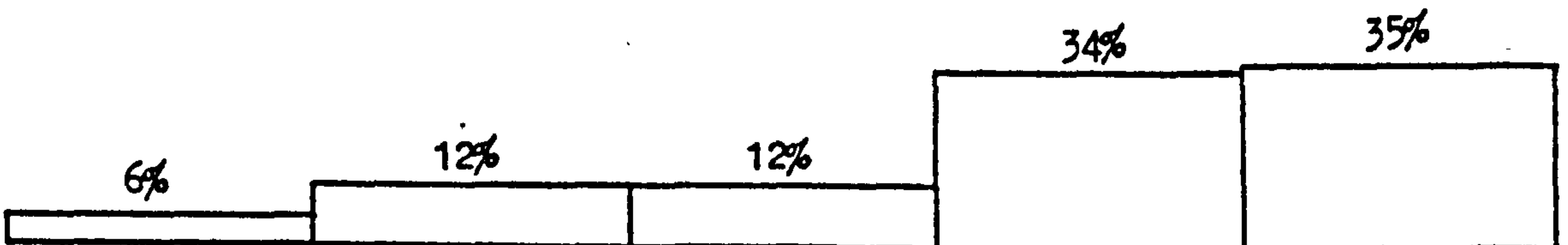

17. " I BELIEVE THAT GOD LISTENS TO PRAYERS "

DS D NC A AS

No Answer 1%

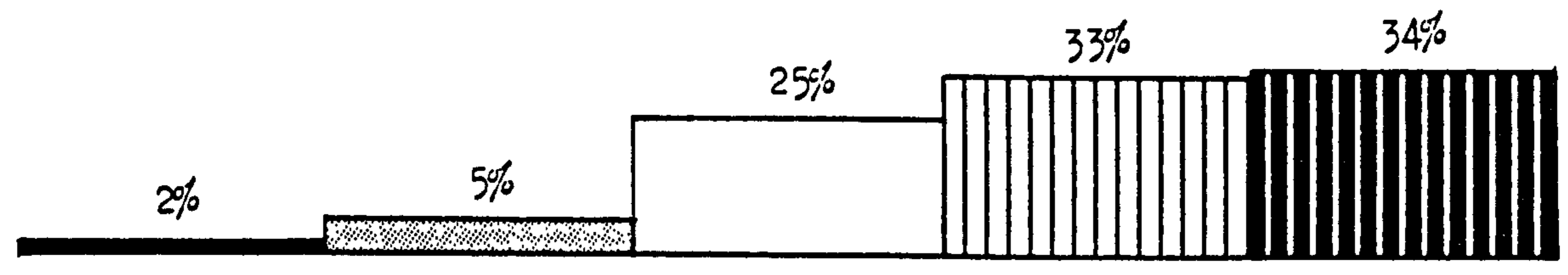

No Answer 2%

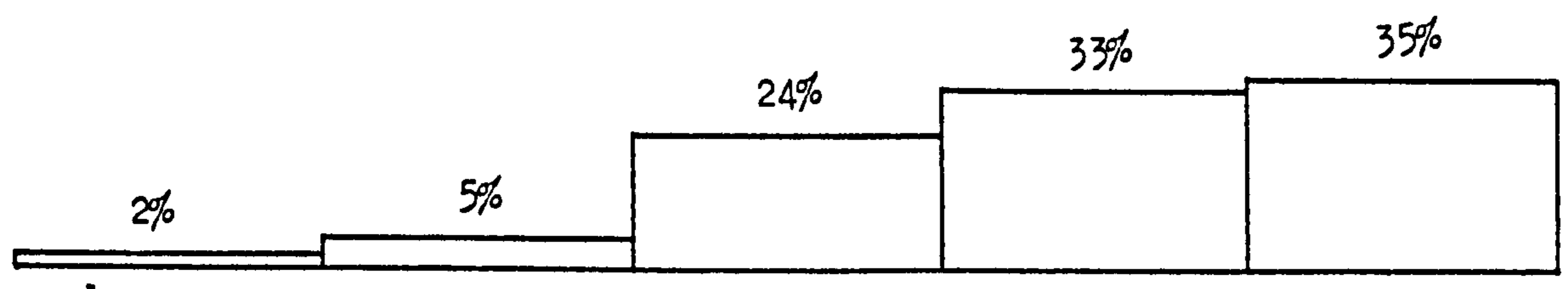

No Answer 0

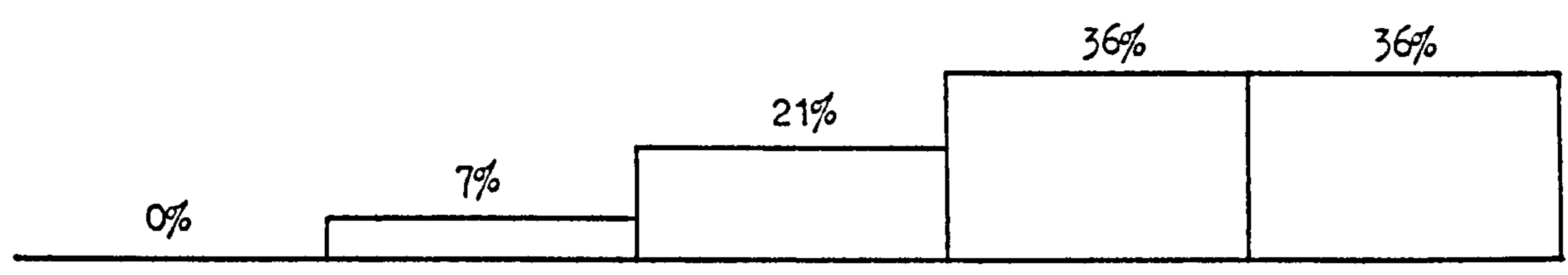

No Answer 1%

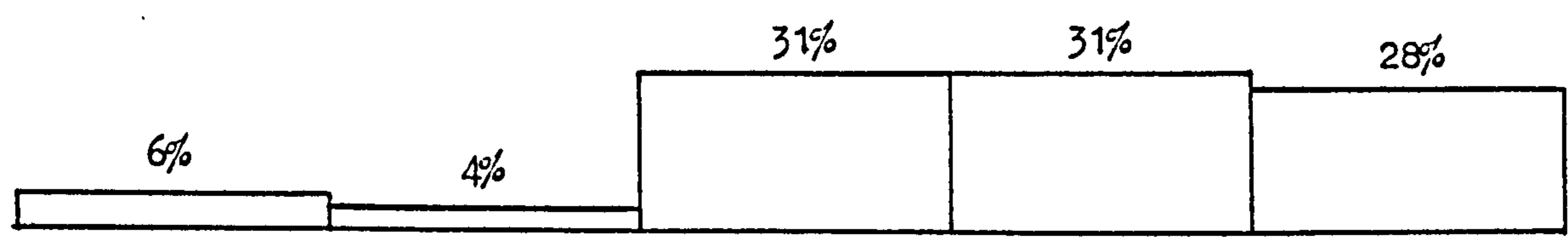

18. " JESUS CHRIST DOESN'T MEAN ANYTHING TO ME "

DS D NC A AS
No Answer 0

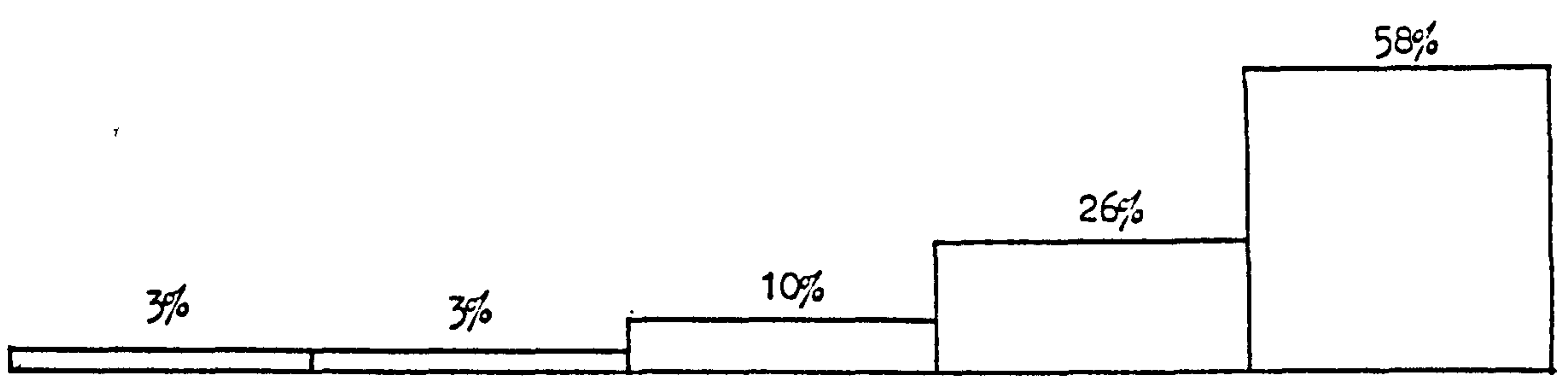
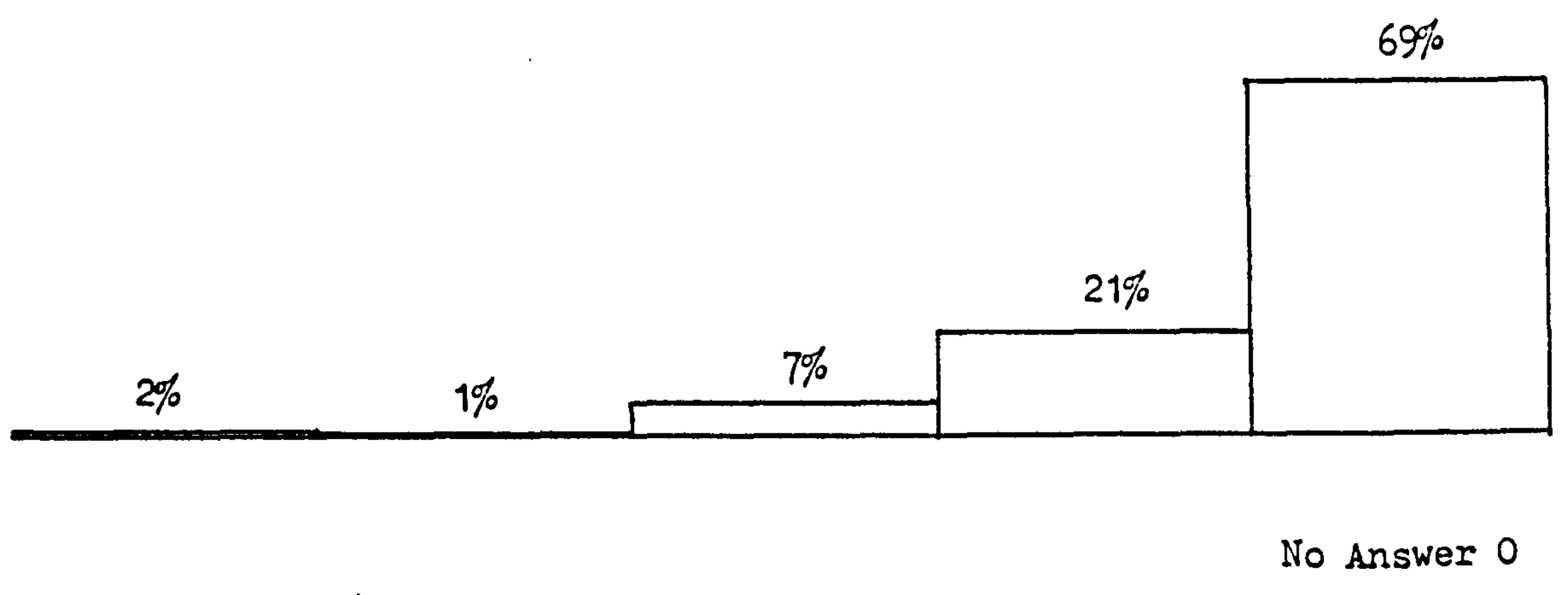
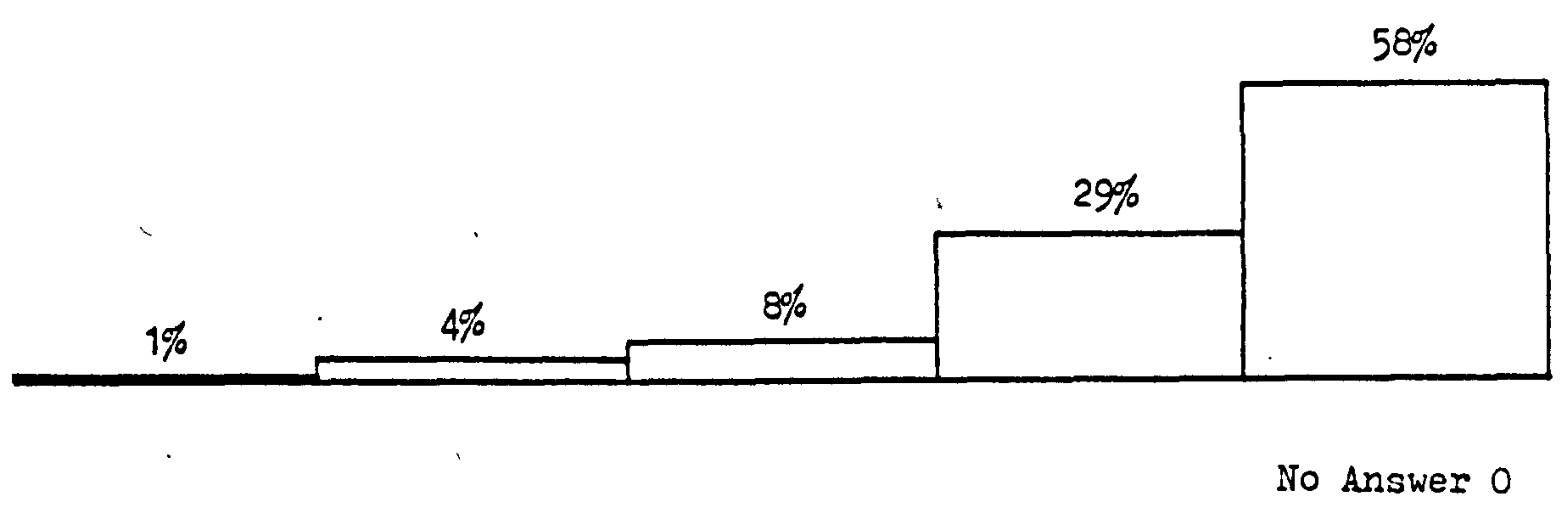
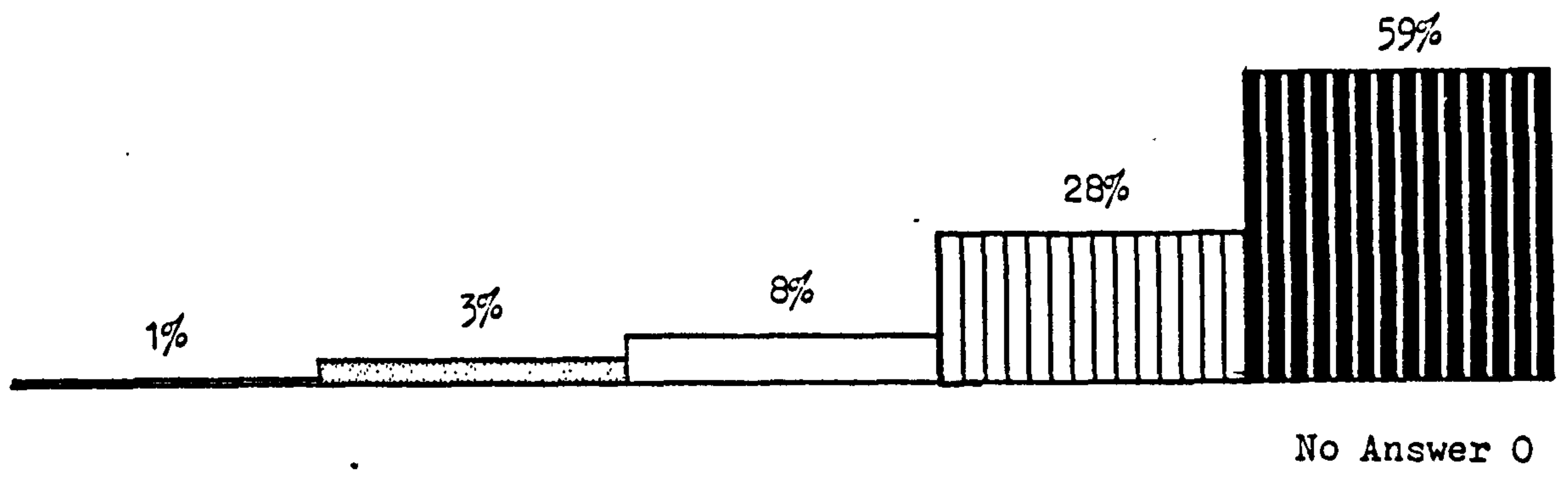

19. " GOD IS VERY REAL TO ME "

DS D NS A AS

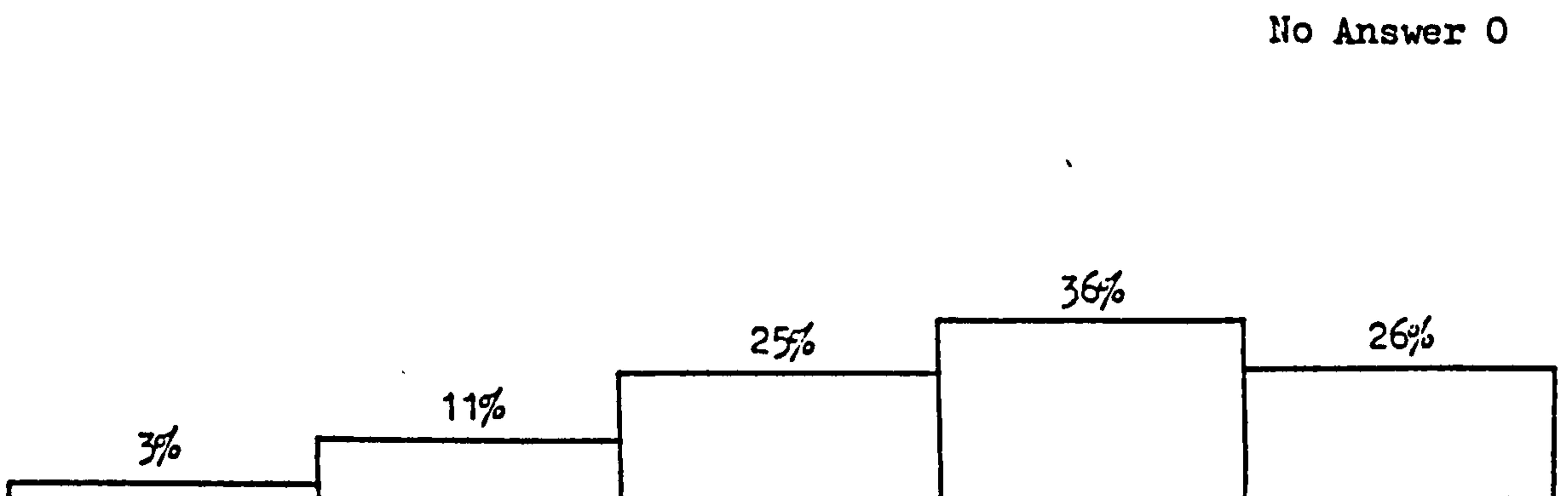
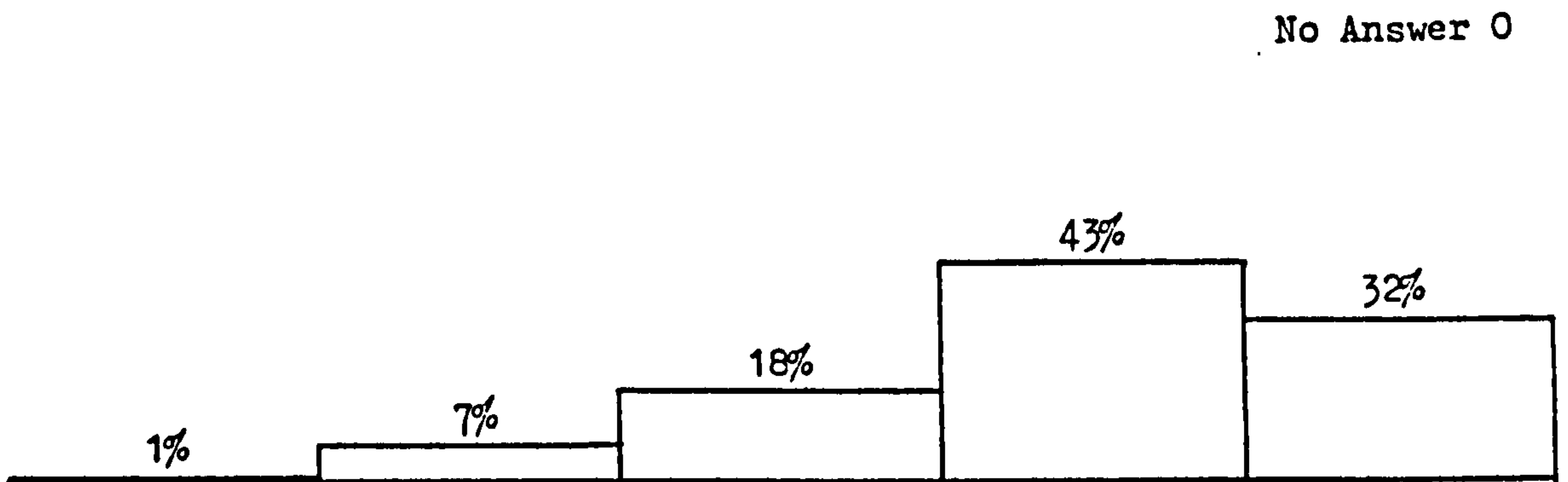
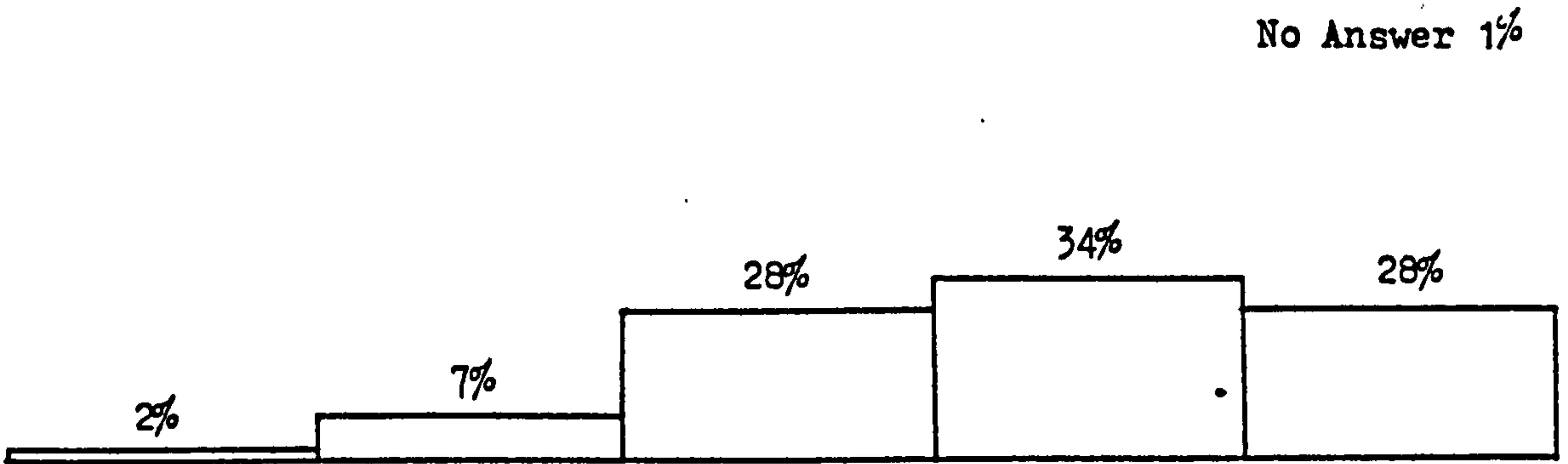
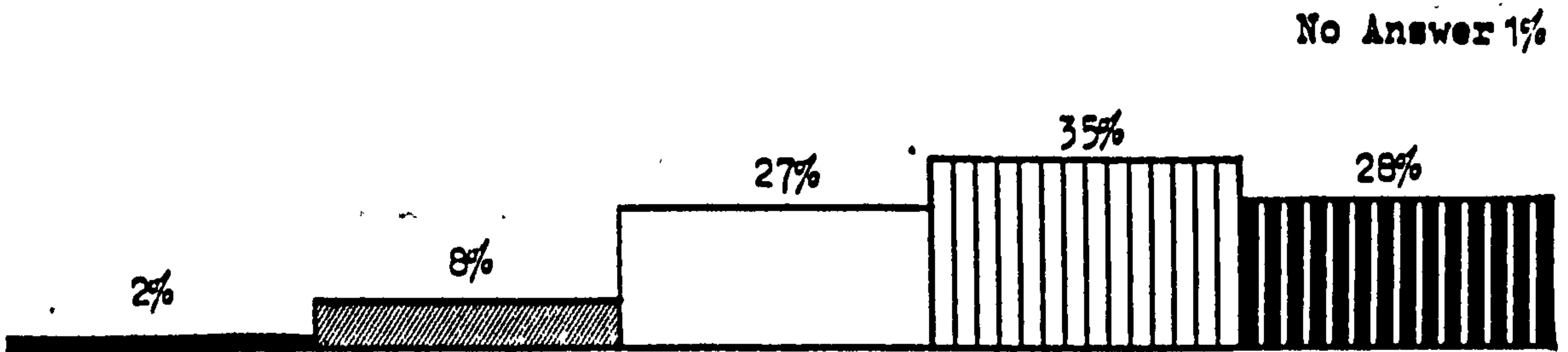

20. " SAYING PRAYERS IN SCHOOL DOES ME NU GOOD "

DS D NS A AS

No Answer 1%

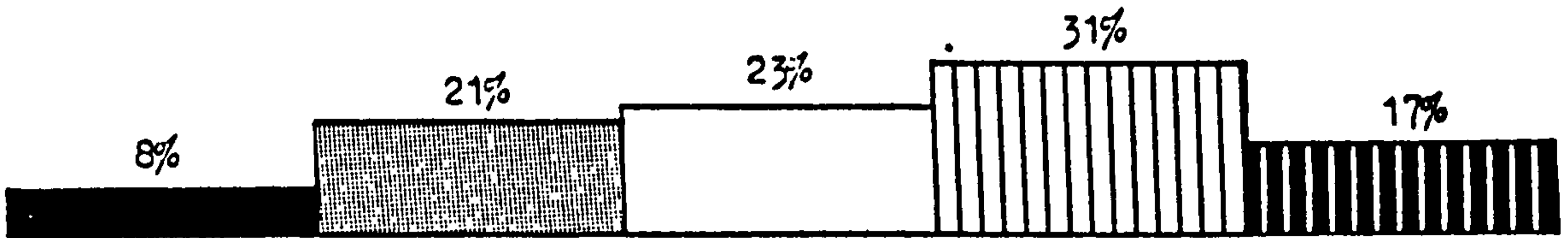

No Answer 1%

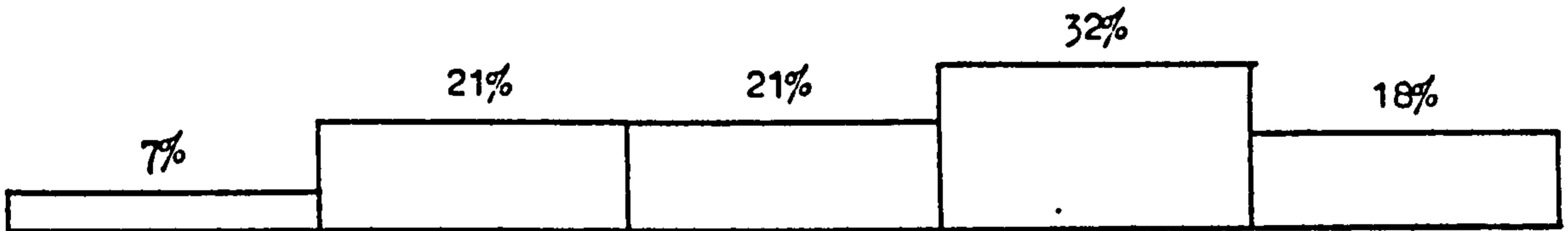

No Answer 0

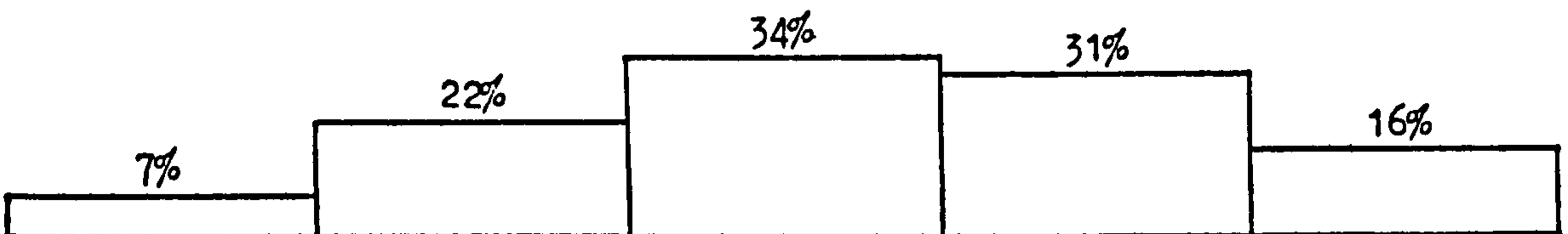

No Answer 1%

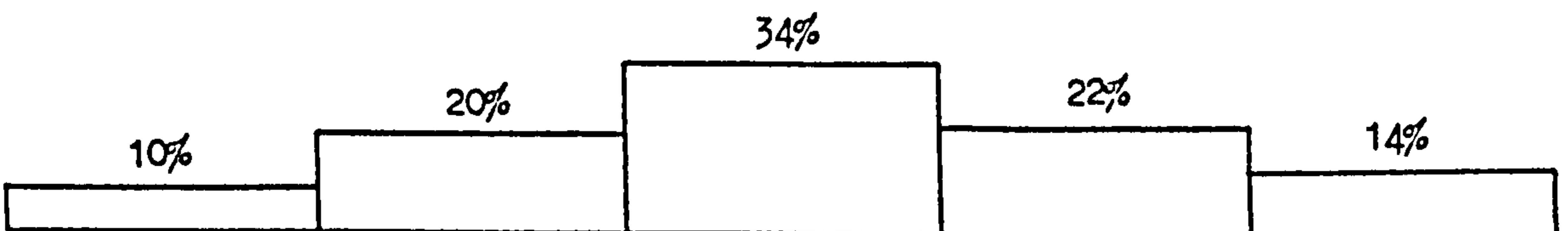

21. " THE IDEA OF GOD MEANS MUCH TO ME "

DS

D

NS

A

AS

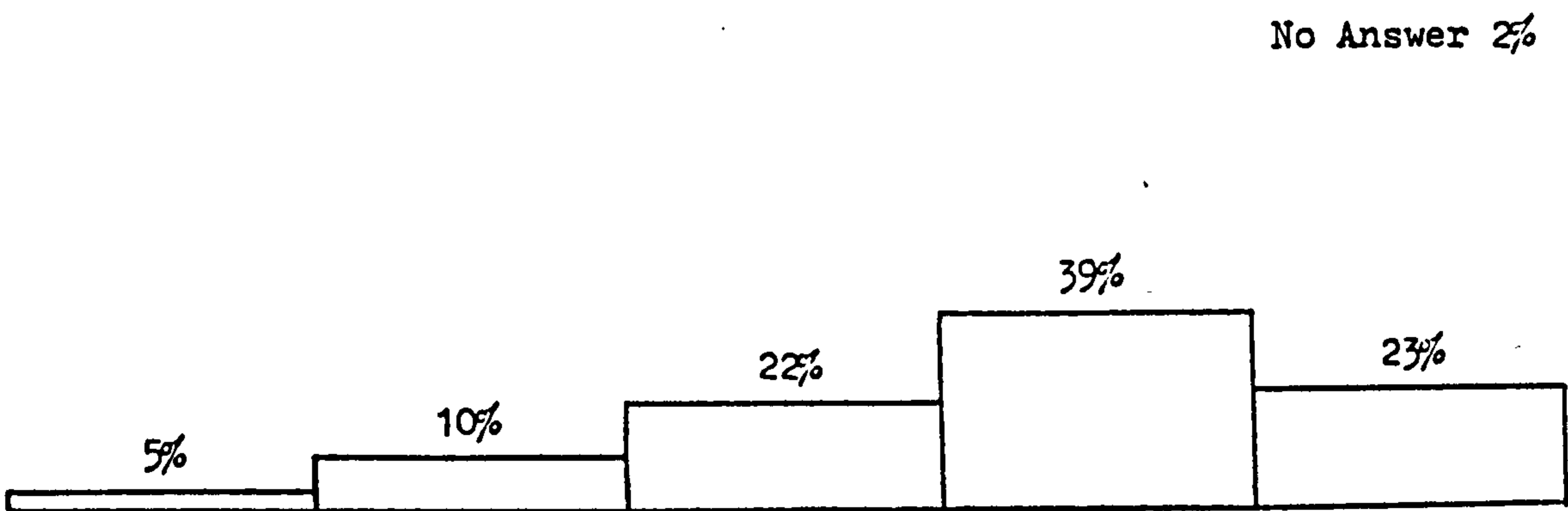
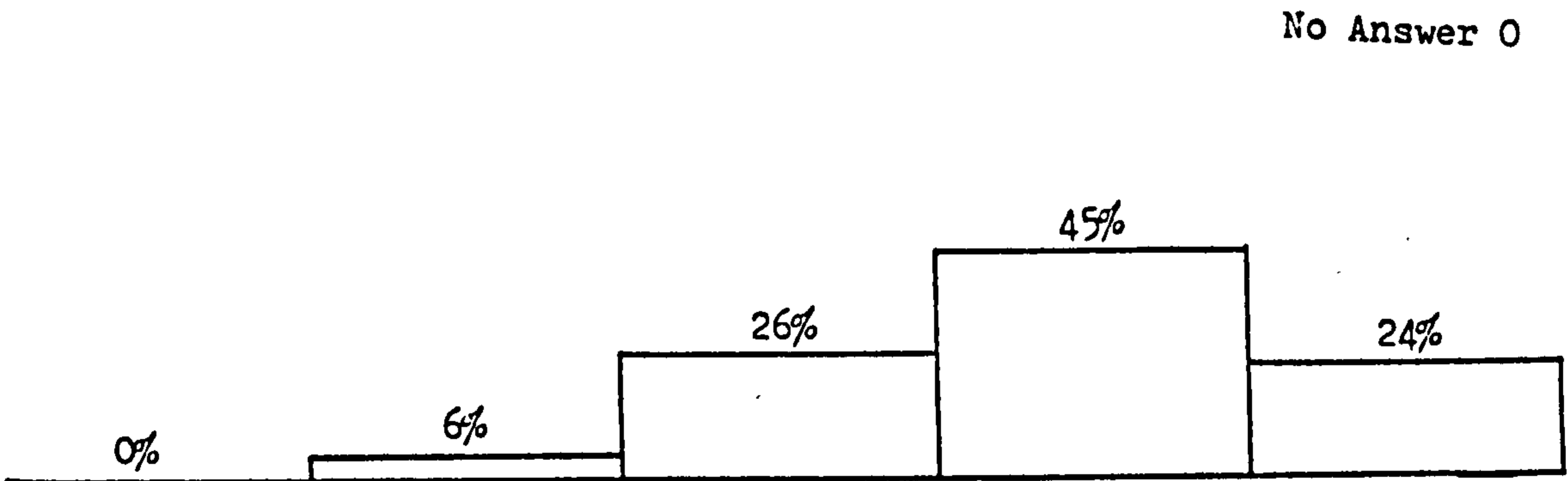
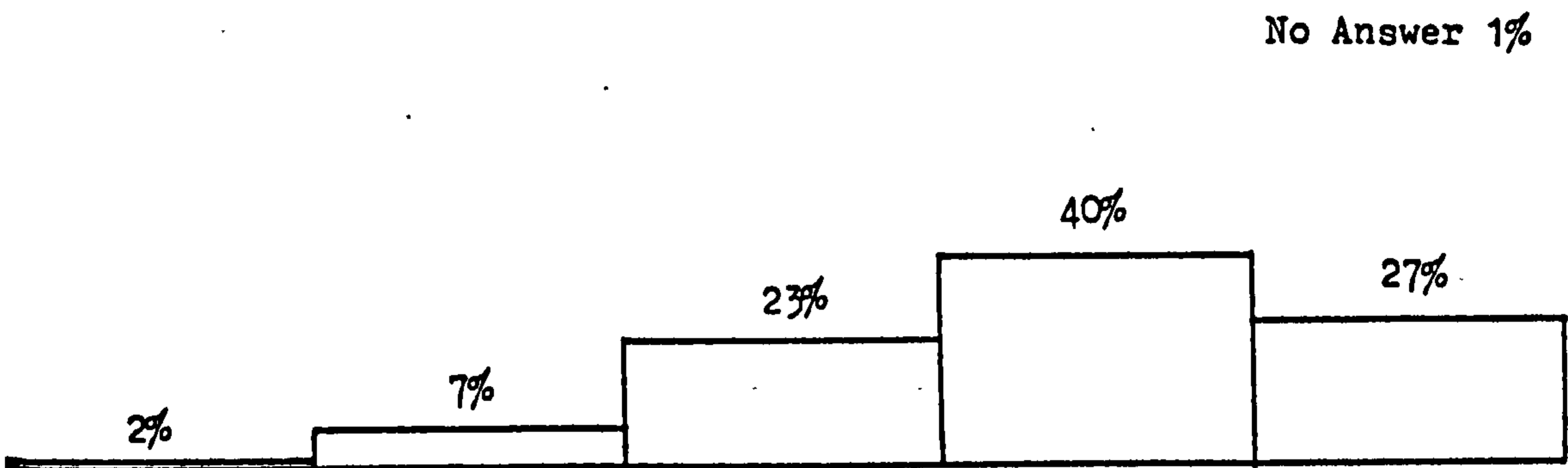
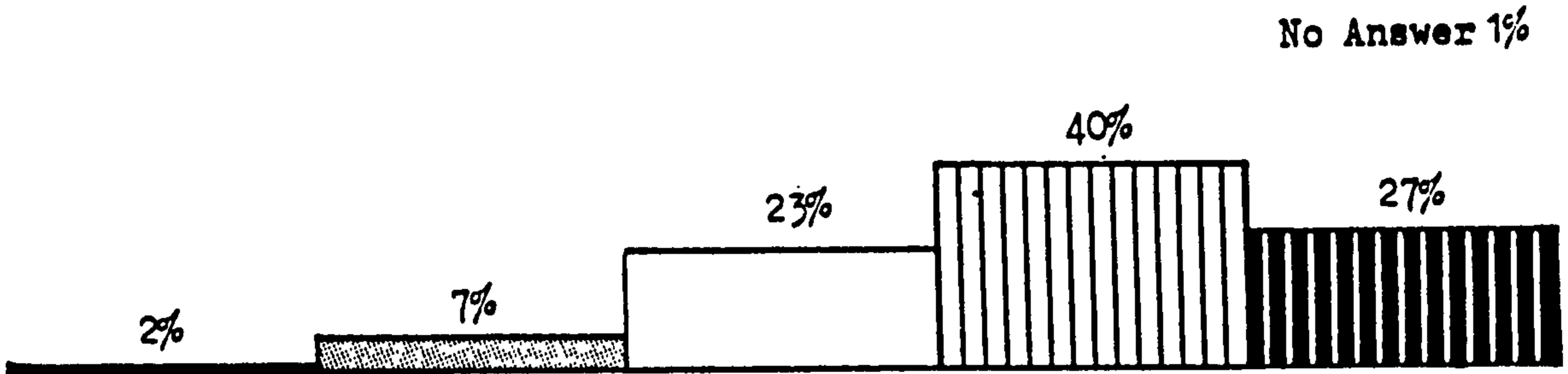

22. " I BELIEVE THAT JESUS CHRIST STILL HELPS PEOPLE TODAY "

DS

D

NS

A

AS

No Answer 0

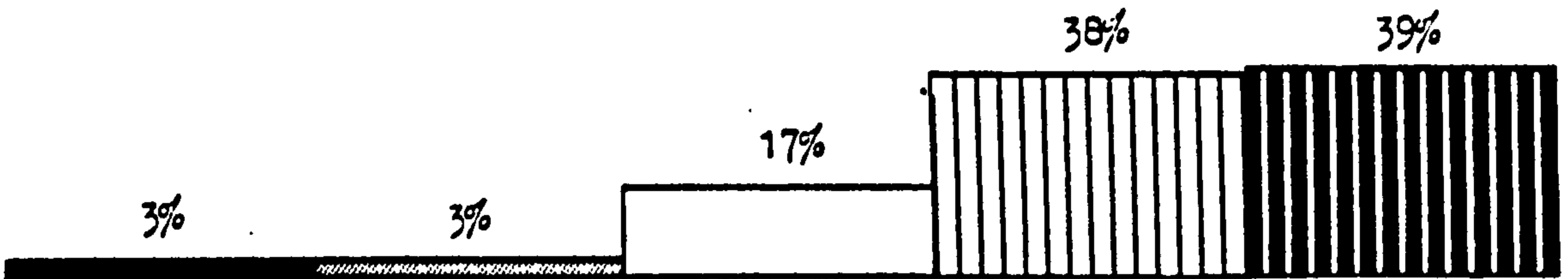

No Answer 1%

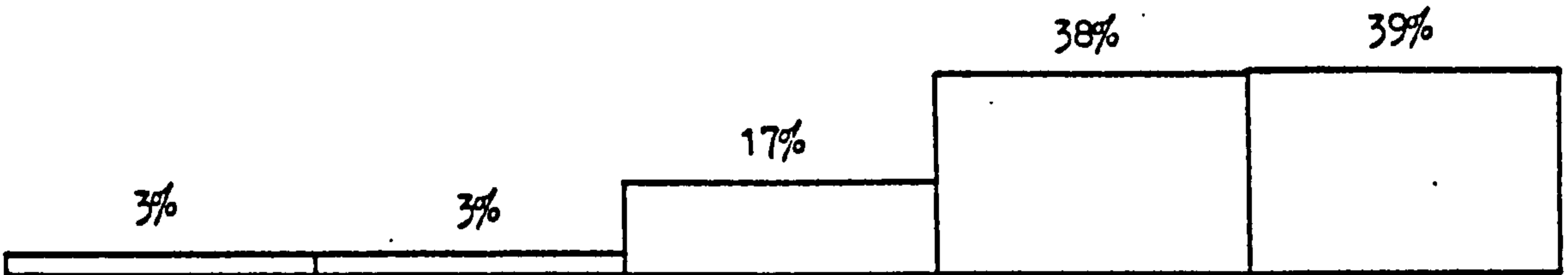

No Answer 0

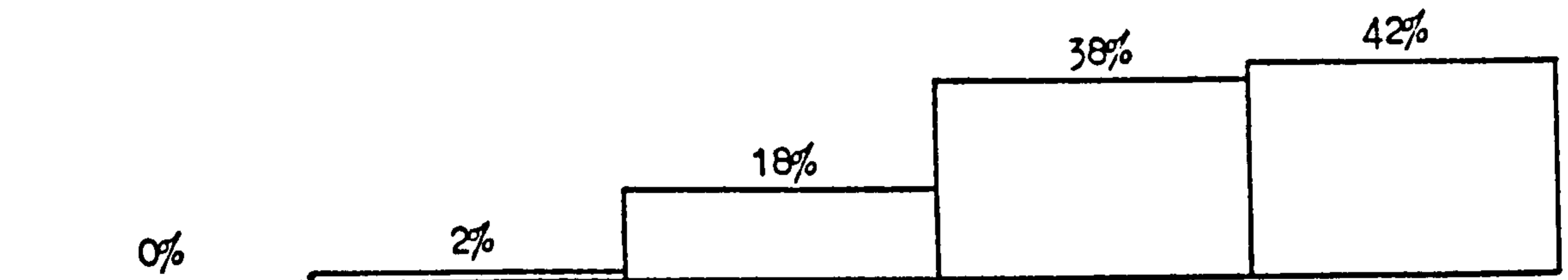

No Answer 0

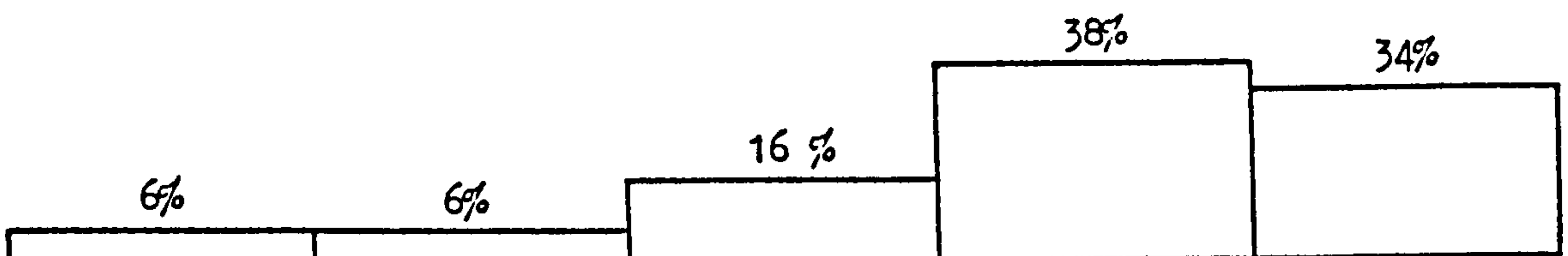

23. " I KNOW THAT GOD HELPS ME "

DS

D

NS

A

AS

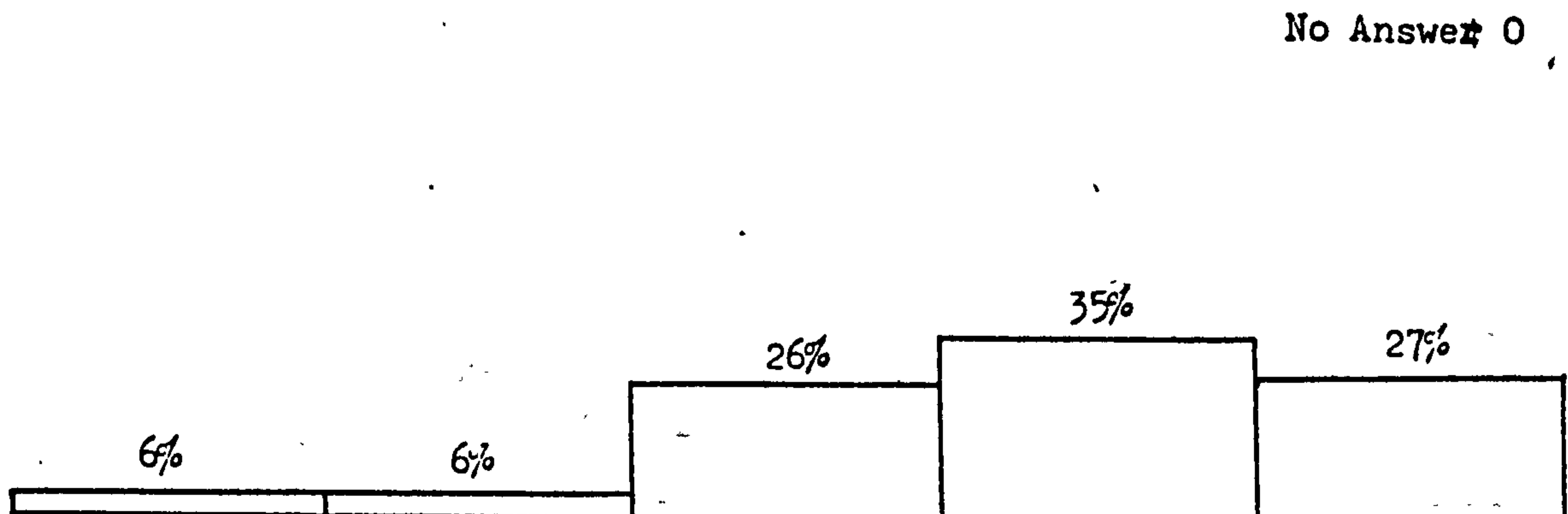
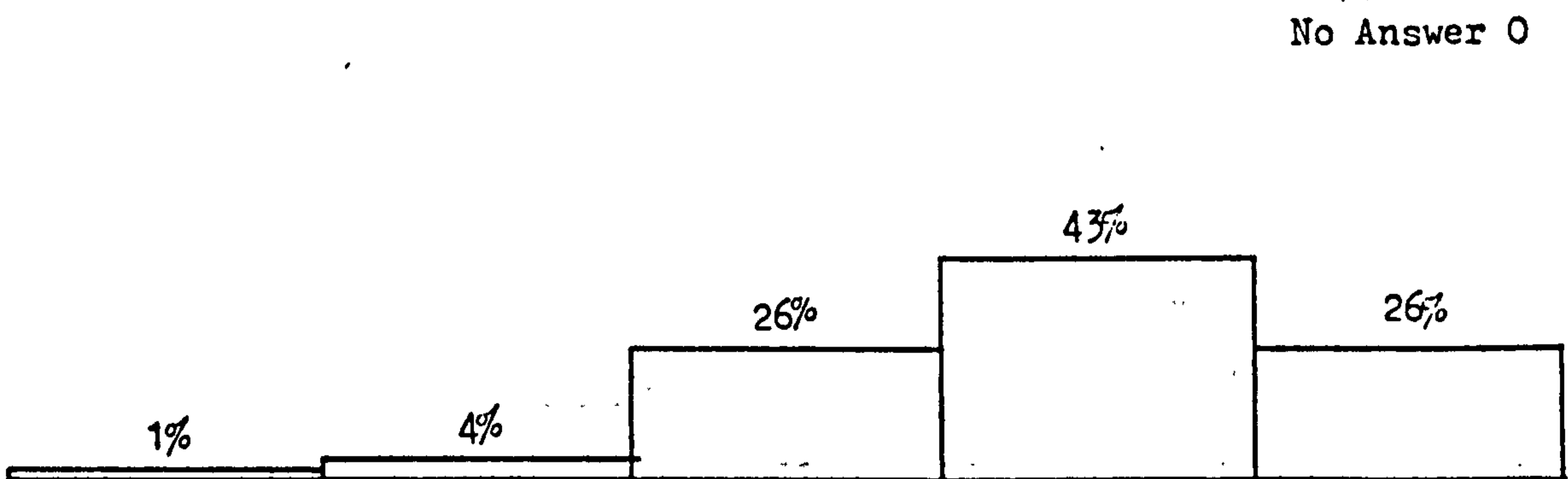
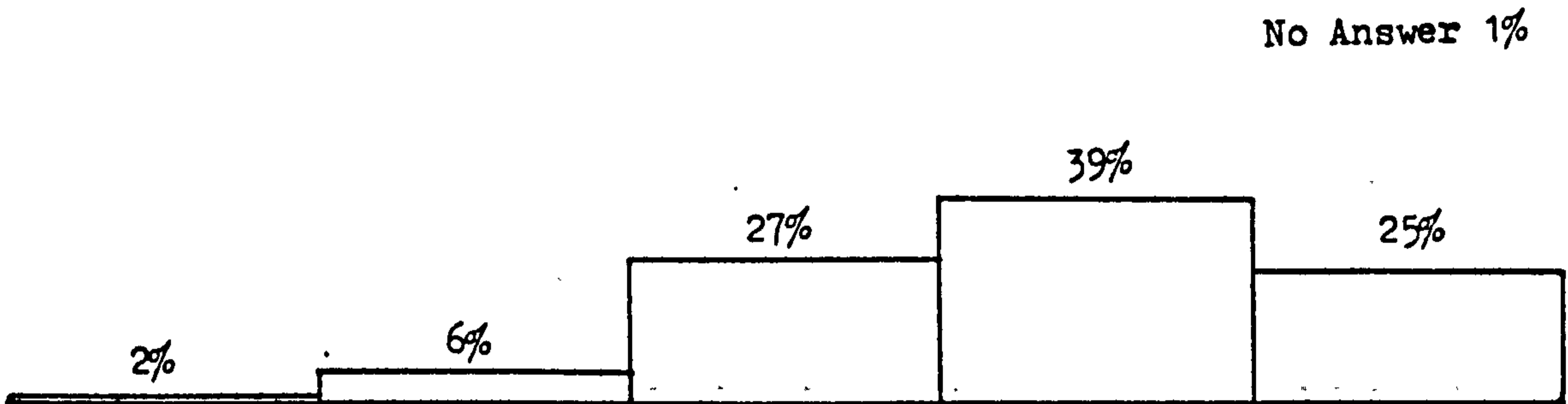
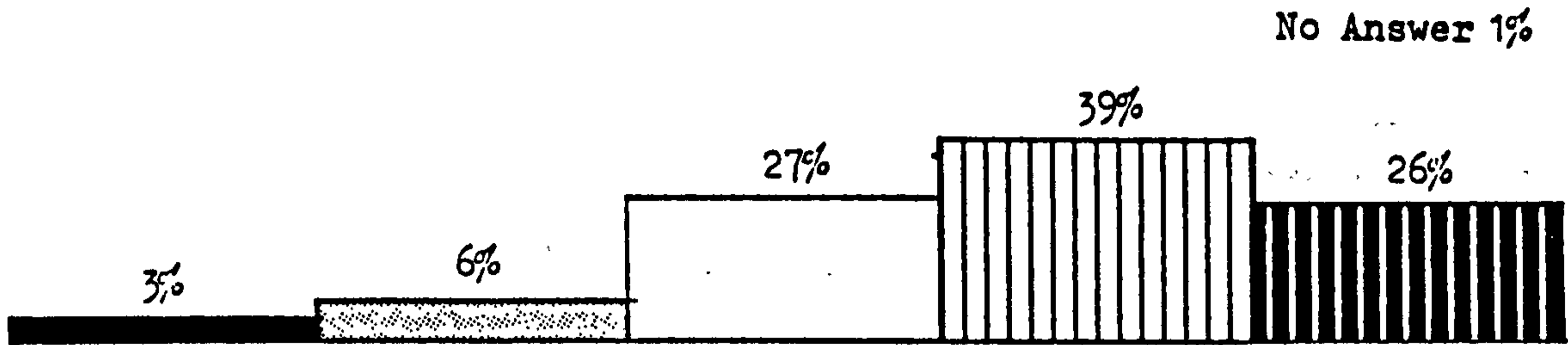

24. " I FIND IT HARD TO BELIEVE IN GOD "

DS

D

NS

A

AS

No Answer 0

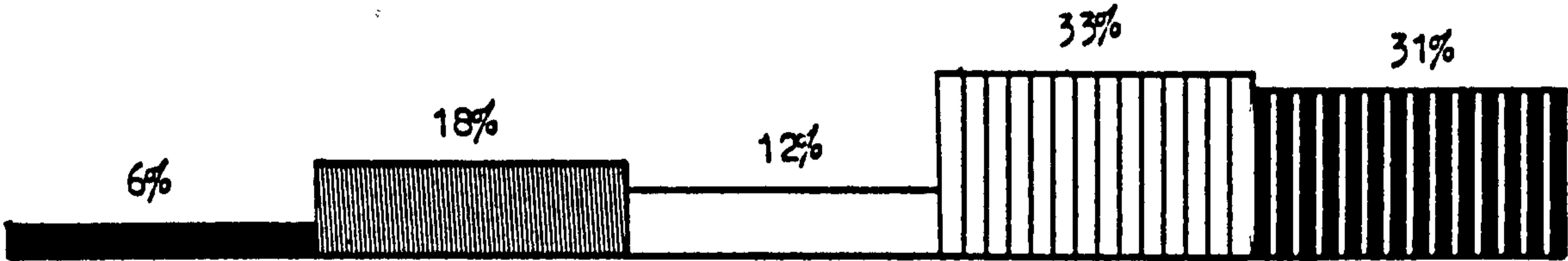

No Answer 1%

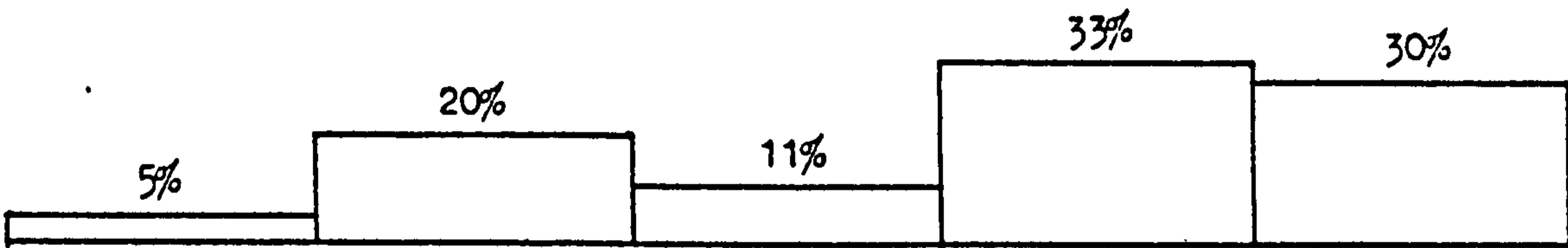

No Answer 0

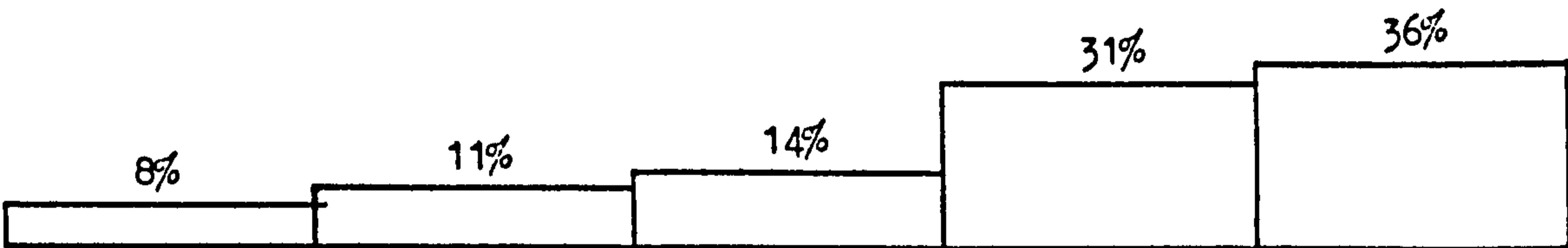

NO Answer 0

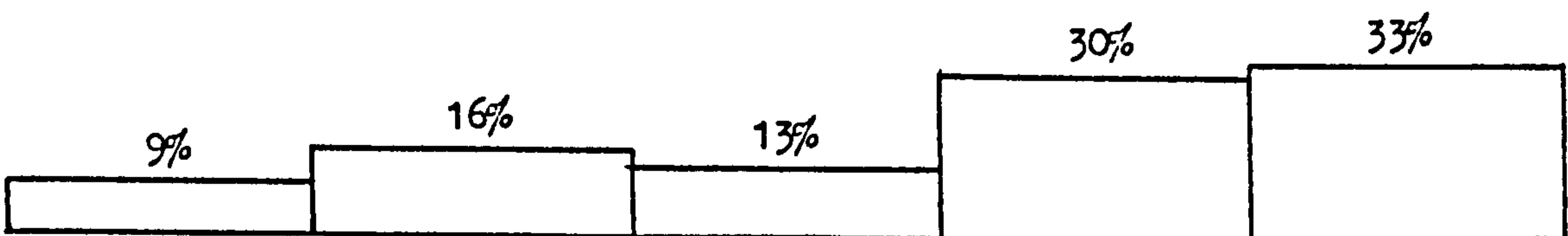

The impression given by the statistics is again more easily recognised by combining the 'agree' and 'agree strongly' figures on the one hand, and the 'disagree' and 'disagree strongly' figures on the other hand, as was done in earlier stages of the presentation of results. The figures for the 24 sentences, in this simplified form, are as follows:

<u>Sentence</u>	<u>RC Schools</u>		<u>Others with RC RE</u>		<u>Others without RC RE</u>	
	<u>Pos.</u>	<u>Neg.</u>	<u>Pos.</u>	<u>Neg.</u>	<u>Pos.</u>	<u>Neg.</u>
1.	44%	32%	67%	18%	51%	34%
2.	67	7	63	4	52	10
3.	55	17	60	11	45	26
4.	57	17	61	15	52	20
5.	72	13	74	10	72	12
6.	76	5	78	3	58	11
7.	42	38	49	34	47	28
8.	93	2	93	3	90	6
9.	63	11	59	6	55	15
10.	27	45	40	27	24	47
11.	69	9	71	7	66	18
12.	80	5	78	4	70	9
13.	64	18	52	12	44	23
14.	60	11	59	6	51	14
15.	73	8	74	5	68	12
16.	59	20	70	12	69	18
17.	68	7	72	7	59	10
18.	87	5	90	3	84	6
19.	62	9	75	8	62	14
20.	50	23	47	29	36	30
21.	67	9	69	6	62	15
22.	77	6	80	2	72	12
23.	64	8	69	5	62	12
24.	63	25	67	19	63	25

These figures, in which the most relevant comparisons

are between non-denominational schools whose Roman Catholic pupils receive Roman Catholic religious education and those schools where this does not pertain, present a very different picture of the religious attitudes of Roman Catholic pupils in non-denominational schools. They reveal a marked contrast between the ones who receive specifically Roman Catholic religious education by some means or other, and those who do not. In the responses to every sentence there is a larger positive attitude in the former, and in all but one of the responses to the 24 sentences there is a larger negative attitude in the latter. The exception in the pattern of negative attitudes occurs in connection with Sentence 7: I think Church services are boring, where the pupils who do not receive any Roman Catholic religious education are less bored by the Church services they attend. The differences are striking in the responses to six of the sentences:

1. I find it boring to listen to readings from the Bible;
3. Saying my prayers helps me a lot;
6. I want to love Jesus Christ;
10. I like school lessons about God very much;
17. I believe that God listens to prayers;
19. God is very real to me;

of which the responses to Sentence 10 are particularly conspicuous for their divergence. The pupils for whom no specifically Roman Catholic provision is made show far greater dislike of their religious education, possibly because it is in such lessons that they are most aware of their religious difference from other pupils rather than because of anything defective in the lessons themselves.

There are easily identifiable but less striking differences of attitude shown in the responses to a further ten of the sentences as well: Sentences 2, 4, 9, 11, 12, 13, 14, 20, 21. and 22. Between them these sentences belong to all six categories identified earlier: God, Jesus, the Bible, Prayer, Church, and School Religion, which indicates that the difference in religious attitude, as measured by the responses to this particular set of 24 sentences, applies to all six aspects of religion mentioned in the sentences.

By the same token, the Roman Catholic pupils in non-denominational schools with provision for Roman Catholic religious education tend to have a more positive religious attitude than their fellows in Roman Catholic schools, but only conspicuously so in their responses to four of the sentences:

1. I find it boring to listen to readings from the Bible;
10. I like school lessons about God very much;
16. I think the Bible is out of date;
19. God is very real to me.

In one instance the difference is conspicuous in the other direction; the pupils in Roman Catholic schools show a markedly more positive attitude towards Sentence 13: Prayer helps me a lot.

The provisional conclusion to be drawn from the results so far is that the enquiry has shown that Roman Catholic pupils in non-denominational schools have a general religious attitude every bit as positive as pupils in Roman Catholic schools, provided they are receiving specifically Roman Catholic religious education. Indeed, in some respects their attitude is more positive than is the attitude of those

in Roman Catholic schools. Where, however, there is no specifically Roman Catholic provision for religious education, the pupils' attitude is definitely less positive. A word of warning is appropriate, however, that the differences should not be over-emphasized. The figures show that even the pupils identified as scoring lowest in this attitude scale are still showing a strongly positive attitude towards their religion.

It only remains now, in the presentation of results, to consider the results of the path analysis.

D: Multivariate Correlations Using Path Analysis

So far, in the presentation of results, the correlations between the various values obtained for the dependent variable, religious attitude, and the independent variables, have been assessed by the impression gained by a simple examination of the statistics, without using any of the more rigorous analytical techniques available for such a task. This final stage of the presentation of results now turns to one of these techniques, path analysis. Religious attitude, the main subject of this enquiry, is designated the 'dependent' variable because it is assumed that it is this which is affected by any changes in the other factors under observation, the 'independent' variables, of which the most important for this enquiry is the kind of school involved - whether it is Roman Catholic or non-denominational.

Path analysis is an extension of the linear multiple regression method of identifying the relative strengths of the various variables in a multivariate situation, by employing a correlation coefficient for each set of relationships between variables. The main relationships of interest are those which are identified between the dependent variable and the independent variables, but at certain stages in the analysis it is also necessary to take account of the correlations between the independent variables themselves. The correlation coefficient employed in this analysis is the one in most general use: the Pearson product-moment coefficient of correlation, symbolised by 'r', which is expressed numerically as a decimal fraction between zero

and one, and is qualified by a positive or negative sign. 'One' signifies perfect correlation between two variables, where one of them changes exactly in step with the other; 'zero' signifies that there is no correlation between the two variables. The positive sign indicates that an increase in the value of one variable is accompanied by an increase in the value of the other; conversely, the negative sign indicates that one decreases as the other increases. The extension of linear multiple regression referred to, which characterises path analysis, is the technique of using the correlation coefficient to treat a number of independent variables as constant, while at the same time introducing a further independent variable and identifying the change of value (if any) in the dependent variable. By this means it is possible to isolate the correlation pattern between a particular independent variable and the dependent variable in a multivariate enquiry and quantify it. It is also possible to identify a 'causal' relationship, in terms of the effect that change in the independent variable has on the dependent variable. Fortunately, there are standard computer programmes published for obtaining the necessary coefficients^[1], for in a multivariate situation it is also necessary to evaluate the relative importance of a number of independent variables in their effect on the dependent variable.

The first stage in the path analysis is the construction of a correlation matrix, using Pearson's correlation coefficient to express the strength of the co-relationship between any two of the variables, together with the

probability proportion for significance. The correlation matrix for this present enquiry is given on the next page, where it expresses the characteristics of the total sample. This yields the following information about the information obtained from, and about, this total sample of Roman Catholic secondary school pupils, reading across the matrix line by line:

- a) Religious attitude decreases with age (as shown by the negative sign);
- b) Girls (who were coded '2') have higher attitude scores than boys (coded '1');
- c) Pupils who attend church more often have a more positive attitude;
- d) The social class of the pupil (ascertained by parental occupation), is not significant;
- e) The denominational affiliation of the school is not significant. In other words, much the same religious attitude scores were obtained for Roman Catholic pupils in Roman Catholic schools as for Roman Catholic pupils in non-denominational ones. It is this correlation which is to be the main subject of the path analysis.

Then, reading across the next line, about the denomination of the school:

- f) The Roman Catholic schools (coded '2') have slightly more older pupils in this sample than the non-denominational schools (coded '1');
- g) The Roman Catholic schools have slightly more girls in the sample than boys;

[Text continues on page 225]

Correlation Matrix of Total Sample

	Year	Sex	Church Attend.	Social Class	Denom. of School
Attitude	-.1576 p .001 (a)	+.1689 p .001 (b)	+.3079 p .001 (c)	-.0501 NS (d)	+.0001 NS (e)
Denomination of school	+.1714 p .001 (f)	+.0735 p .01 (g)	+.0701 p .01 (h)	+.0286 NS (i)	
Social Class	-.1967 p .001 (j)	-.0121 NS (k)	-.1481 p .001 (l)		
Church attend- ance	+.1075 p .001 (m)	+.1437 p .001 (n)			
Sex	+.0918 p .001 (o)				

The letters in brackets below each set of figures refer to points made about this matrix in the text.

h) Pupils in Roman Catholic schools attend church more often than those in non-denominational schools. This may show the influence of the rural pupils in the sample, for whom a Roman Catholic church is not so accessible;

i) Social class is not significant: there is much the same distribution of social classes in Roman Catholic and non-denominational schools.

Then, on the next line, about social class:

j) The social class of the parents increases (in terms of status of their occupations) with the age of the pupils in the sample. (The negative sign appears here because social class was coded with classification I as '1', II as '2', etc.);

k) There is no significant difference of social class between boys and girls;

l) Increase in social class (i.e. classes I and II) goes with increased church attendance.

Then, on the next line, about church attendance:

m) This shows that older pupils in this sample attend church more frequently than do younger pupils. It may be that this result is affected by o) below, which shows that there were more girls in the higher age-ranges of the sample, combined with the point about to be made:

n) Girls (coded '2') attend church more frequently than boys (coded '1').

Finally, on the line about the sex of the pupils in the sample:

o) There were more girls than boys in the higher age-ranges

of the sample.

Linear multiple regression analysis (of which path analysis is an extension) requires not only an evaluation of the strengths of the various correlations, but also an evaluation of the relative strength of two variables in their combined effect on a third one. In the case of this enquiry, it is an evaluation of any two of the independent variables (such as church attendance and social class) on the dependent variable, religious attitude. The coefficient which expresses this relative strength is the Beta weight, the standardised regression coefficient, which takes into account the range of scores within the variables. It is this which is used as the all-important path coefficient to express the predictive, or 'causal' strengths of the various independent variables in their influence on religious attitude. The significance of any particular independent variable, in terms of its path coefficient, can then be ascertained by controlling for the variables introduced at earlier stages in the calculation. For this final purpose, a further coefficient is relevant, a multiple coefficient of alienation, 'R', more usually referred to as the 'residual', which is a measure of the error component. Fortunately, again, the use of a computer and reliable published programmes, brings this method of analysis within reach of an investigator who is not a specialist in statistics.

To sum up so far: 'path analysis' is so named because it represents the system of relationships between variables by means of diagrams in which the variables are connected

by lines or 'paths', which also indicate the effect of one variable on another. The strength of the relationship between variables can be indicated numerically on the path by means of a coefficient of correlation, the Beta weight, which indicates how changes in the independent variable match changes in the dependent variable. By entering the path strengths into the calculations in strict order it is possible to make allowance for the independent variables (age, sex, social class, church attendance) which are not the first concern of this enquiry, and isolate the independent variable in which it is particularly interested: the type of school, whether it is Roman Catholic or non-denominational. The correlational matrix has already shown that the effects of this aspect of the situation on the religious attitude of the pupils seems to be negligible, but it remains to be seen whether this remains the case when the effects of the other independent variables, the other factors, are taken into account.

The first of the path-model diagrams, Path Model 1, shows the correlations, respectively, of age, sex, and social class, with the religious attitude scores of all the Roman Catholic secondary school pupils in the sample, without any consideration of their church attendance or of the type of school they attend. The analysis starts with these three independent variables because they are not within the children's own choice, and thus can be considered to be outside the pupil's control. Obviously this is so for age and sex, but it is also the case for social class as social class is here defined in terms of the occupation of the

[Text continues on page 229]

Path Model 1

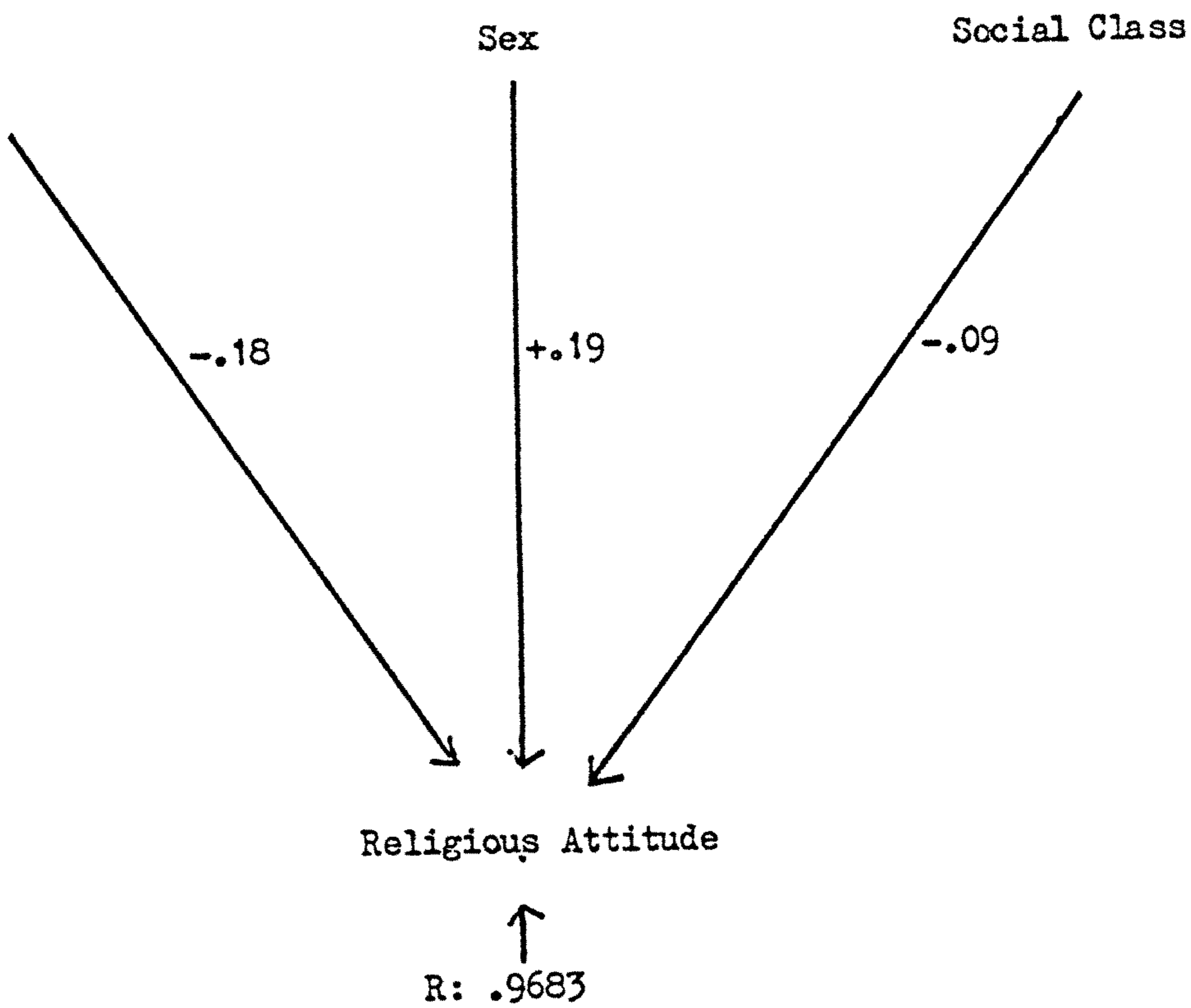

Path Model 1A

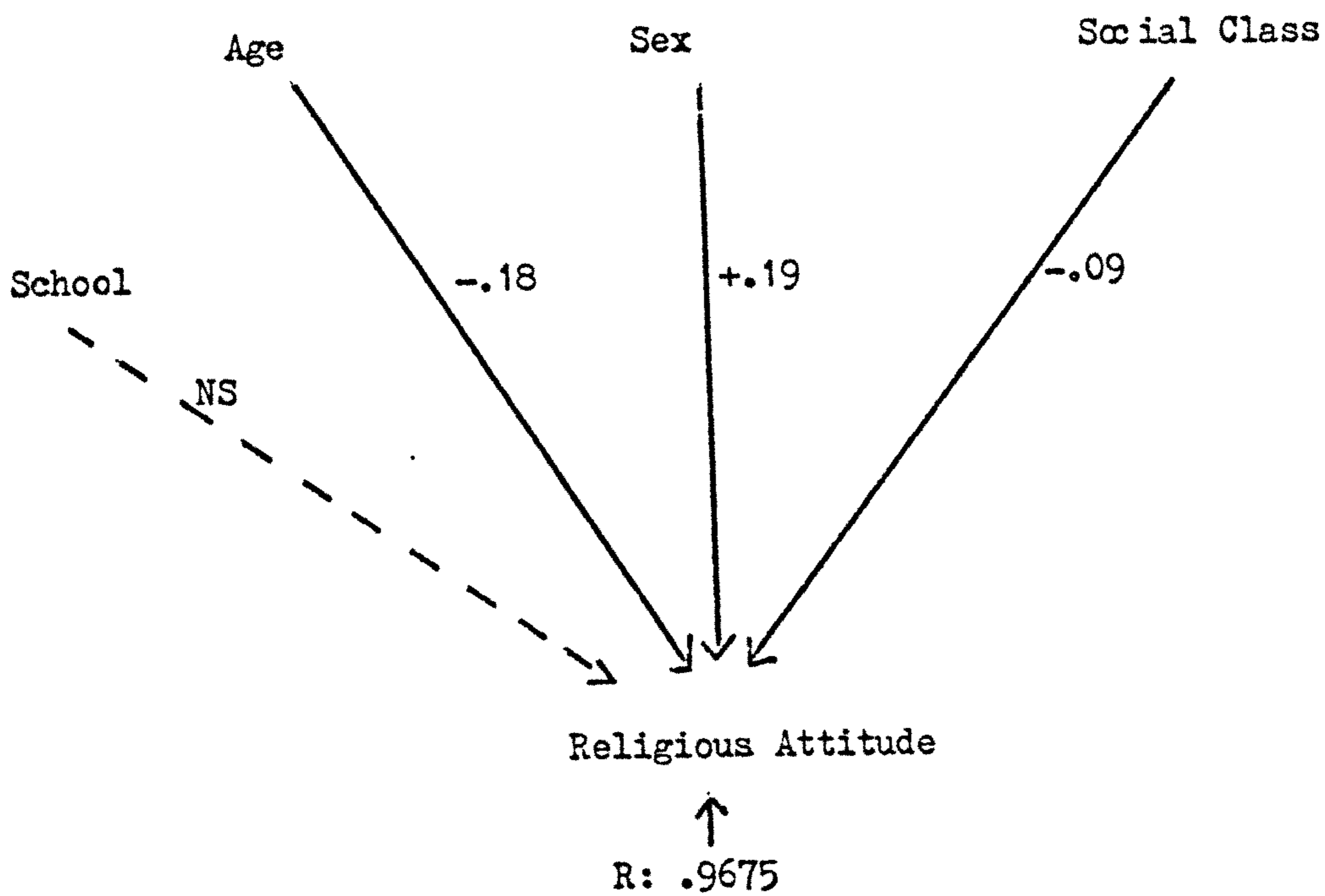

pupil's father or guardian.

The next stage, represented by Path Model 1A, is to introduce a fourth independent variable, attendance at a Roman Catholic school, to see if this makes any difference to the predicted religious attitude, having now controlled for sex, age and social class. It proves not to make any significant difference but this result is still insecure until the effects of church attendance have been taken into account.

Path Model 2 expresses the correlations between the three independent variables outside the pupil's control, sex, age and social class, and the independent variable which is a matter of choice for them, church attendance. The path model shows that sex and social class are significant here, but not the age of the children in this particular sample. So far, then, it has been found that age is a predictor of religious attitude but not of church attendance.

Path Model 3 brings together Path Models 1 and 2, to show the correlations of four of the independent variables, sex, age, social class and church attendance, with the dependent variable, religious attitude, when their effects are considered together. This model shows that social class only affects attitude through the effect it has on church attendance, not directly. The sex of the pupil has a significant effect on both church attendance and attitude. The age of the pupil only affects attitude. This means, incidentally, that the girls are more religious

[Text continues on page 231]

than the boys on two accounts: their church attendance and their religious attitude, but this is not the main concern of this enquiry.

Path Model 4 represents the point in the analysis when it is possible to evaluate the effects of the independent variable with which this enquiry is particularly concerned: attendance at a Roman Catholic school. This now tests the hypothesis from which the enquiry started, that attendance at a Roman Catholic secondary school goes with ['causes'?] a more positive attitude towards religion amongst Roman Catholic pupils, than when Roman Catholic pupils attend a non-denominational school. The result is well below the level chosen as a criterion of significance. This means that when all the other factors examined have been taken into account, it makes very little difference to the religious attitudes of Roman Catholic pupils whether they attend a Roman Catholic secondary school or not. In both types of school, religious attitudes are much the same for Roman Catholic pupils of similar age, sex, social class and level of church attendance.

Only when a further independent variable is introduced is there any evidence of significant difference in attitude. This further variable is obtained by subdividing the category 'non-denominational school' into those where Roman Catholic pupils received specifically Roman Catholic religious education in some way, and those whose Roman Catholic pupils did not. Path Models 1 - 4 take no account of this distinction. When it is introduced, in Path Model 5, it emerges that there is a marked difference between

[Text continues on page 233]

Path Model 4

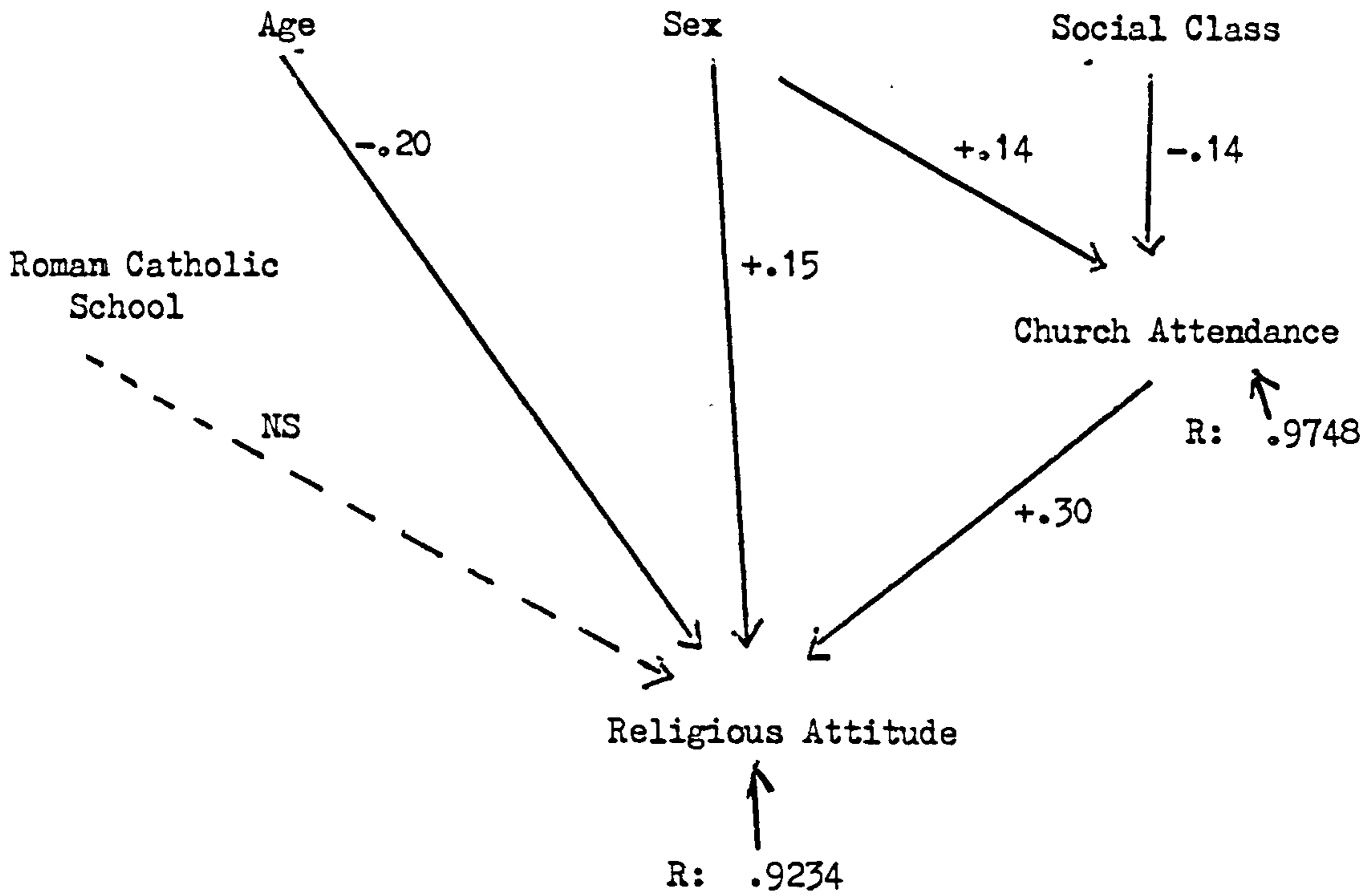

Path Model 5

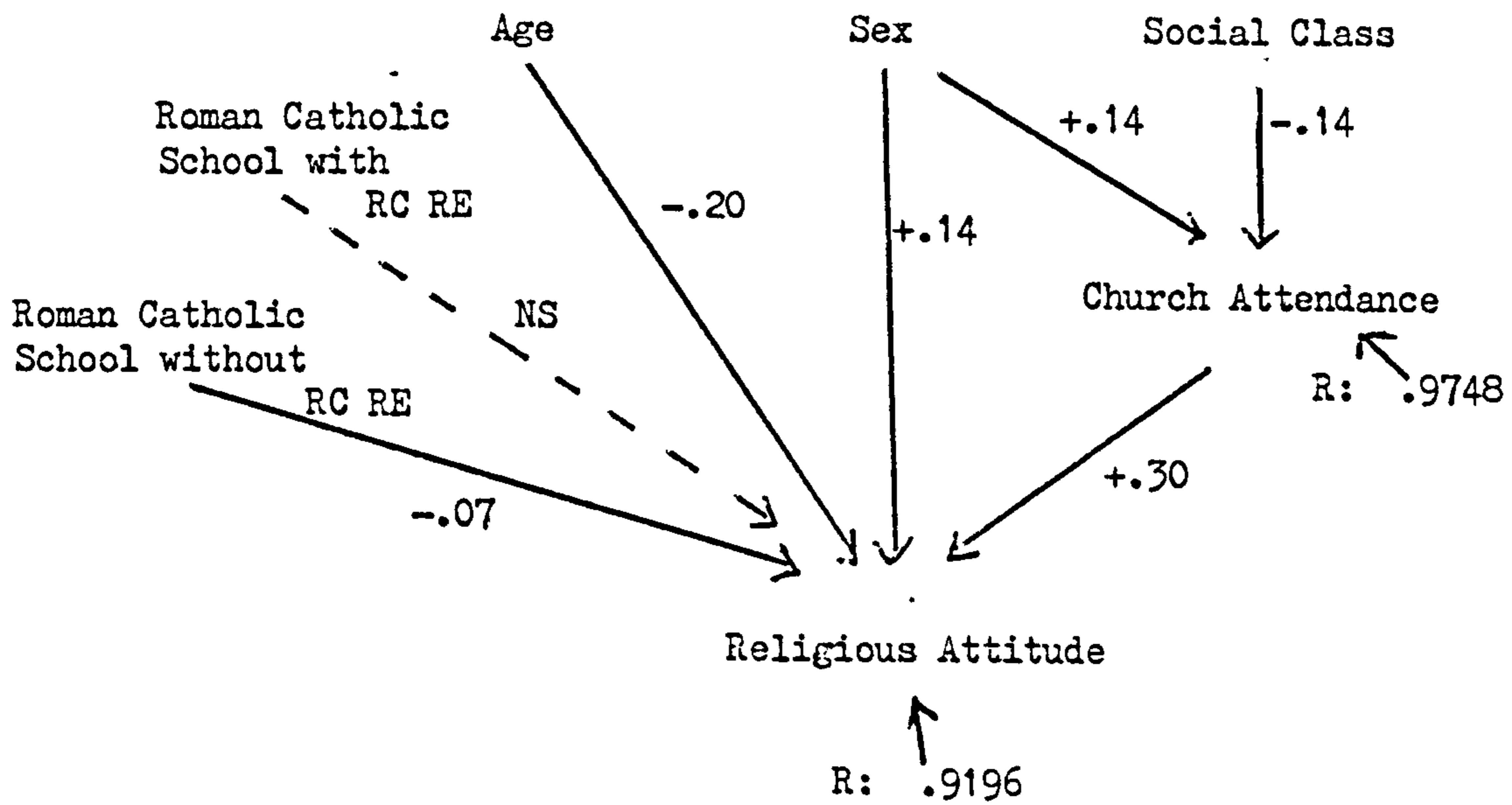

the two kinds of Roman Catholic pupils in non-denominational schools. Those who received no specifically Roman Catholic religious education showed a significantly lower score in their responses to the sentences about religious attitude than those who did have special Roman Catholic provision made for them. The impression gained earlier by visual inspection of the statistics is thus confirmed by the much more rigorous method of analysis provided by path analysis.

Reference D: Multivariate Correlations Using Path
 Analysis section

- [1] Nie, N.H., SPSS: Statistical Package for the Social Sciences (New York, 1975), pp. 384ff.

CONCLUSIONS

The main conclusion of this study can be stated clearly: the working hypothesis that Roman Catholic pupils in Roman Catholic secondary schools have a more positive attitude towards religion than Roman Catholic pupils in non-denominational schools has not been established. The test instrument used, a 24 sentence Likert-scale questionnaire, has detected no significant difference between the two kinds of school. When the analysis was refined to identify any significant differences between Roman Catholic pupils in non-denominational secondary schools who received specifically Roman Catholic religious education, and those who did not, it was found that those who did have specifically Roman Catholic provisions made for them scored more highly than those who did not. It would even follow, therefore, that Roman Catholic pupils in non-denominational schools who have Roman Catholic religious education show a slightly more positive overall attitude towards religion than the pupils in the Roman Catholic schools.

This conclusion must now be refined. Firstly, the conclusion only applies with the strictest rigour to the information obtained about the 1,113 Roman Catholic pupils within the Strathclyde Region of Scotland who provided answers to the questionnaires. It could be argued that no really firm conclusions can be drawn from these results about any other pupils in Strathclyde, still less about pupils elsewhere. But care was taken to get as

representative a sample as possible, which reflected the probable distribution of Roman Catholic secondary school pupils in Scotland, between Roman Catholic and non-denominational schools. Moreover, although the pupils in the sample were all located within the Strathclyde Region, they came from parts of the region which reflected the very wide range of geographical and economic conditions to be found in Scotland as a whole. Sex, Age and Social Class were all reasonably well reflected in the sample; the questionnaires were all administered during the same part of the School Year, and under the same conditions of confidentiality. None of the groups of questionnaires showed any signs of doubt about the secrecy of the operation, or any differences in the seriousness and care with which they had been completed. Under these circumstances, it might reasonably be concluded that similar results would be obtained for other Roman Catholic pupils in Strathclyde Region and also in other parts of Scotland. On the basis of this particular test instrument, the religious attitudes of Roman Catholic secondary school pupils are not affected by whether or not they are at a Roman Catholic or a non-denominational school - except that if they are at a non-denominational school they seem more likely to have a more positive religious attitude if they are being provided with Roman Catholic religious education lessons.

Secondly, these conclusions can be analysed in more detail when attention is turned to the responses given to individual sentences. The most encouraging fact to emerge

is that the overall results showed positive responses to all but one of these sentences, for the only exception was found to be the responses to Sentence 10, which concerned school lessons about God. The responses to this particular sentence showed that not only did all categories of Roman Catholic pupils dislike school religious education lessons; the ones in Roman Catholic schools disliked them a good deal more than their Roman Catholic counterparts in non-denominational schools. Possible explanations might be the insecurity felt by many non-specialist teachers of this subject compared with their competence in their main subjects, for which they have degree-level qualifications, and the personal nature of religious education. Moreover, compared with other subjects in the school curriculum, there is as yet no clearly recognised and used national syllabus, and less resources tend to be allocated to religious education. This is an area where the Roman Catholic educational authorities might feel there is need for deeper evaluation of the training and support given to teachers, and of the way the subject is planned, taught and allocated resources. With the exception of this one aspect of religious attitude, Roman Catholics can feel reassured about the religious attitudes of their members of secondary school age. Their religious affiliation has for the main part been ascribed to them by their parents and guardians, but their attitude to religion is clearly positive at an age when they might be expected to be rejecting it.

Thirdly, when the sentences are considered under the

categories of God, Jesus, the Bible, Prayer, Church, School Religion, it becomes evident that the pupils whole had strongly positive attitudes towards God, Jesus and Prayer, tempered only by a measure of personal dissatisfaction about their own practices and the strength of their own relationships with God and Jesus, which might reflect unrealistic expectations about religious experience. The overall positive responses about Prayer were the strongest of all, with signs of less certainty about personal prayer than about the general importance and value of prayer. Strong rejection of the suggestion that the Bible is out of date was accompanied by less enthusiasm (though still not a negative attitude) for listening to the Bible being read to them. Similarly, the pupils did not think it a waste of their time to go to Church, and agreed that the Church is very important to them, but found the actual experience of Church services boring. It might be valuable to explore further their feelings about Church services, to find how the needs of young people could be better met. School Religion met with the least enthusiasm, as has already been noted, and here the more positive attitude towards prayers in school may reflect the very strong attitude towards prayer shown in other contexts, rather than very much appreciation of school worship.

Turning to the results obtained when a distinction is drawn between Roman Catholics in Roman Catholic schools and Roman Catholics in non-denominational schools, there was hardly any difference in the responses of the two groups to most of the sentences. The non-denominational

group had a more positive attitude towards the Bible sentences, and this again is an area which could be explored further. Lesser differences were detected about personal relationship with Jesus and about prayers in school, where the pupils of Roman Catholic schools were more positive than the others; while pupils in non-denominational schools were more enthusiastic about Church services, and to a slight extent found that God was more real to them. As has already been noted [p. 184], the pupils in non-denominational schools would be more likely to belong to rural parishes where Church services may fulfil a social need for scattered Roman Catholic families, but again this would need further investigation.

The most marked contrasts in the whole enquiry were between the attitudes of the Roman Catholic pupils in non-denominational schools for whom Roman Catholic religious education was provided - whether in school or in some other way - and those for whom there was no such provision. The results here, which are considered in more detail in pages 217-20 above, point strongly to the importance of the religious education of Roman Catholic children in non-denominational schools. In a situation such as pertains in Scotland, where the areas of high population density have a State-funded Roman Catholic school system alongside the non-denominational one, it is right and natural that the Roman Catholic Church authorities should strongly emphasise the duty of Roman Catholic parents to send their children to Roman Catholic schools when they are available in their area. But in many cases, one consequence is a

refusal by the Church to make any provision for the religious education of children whose parents choose these circumstances to send them to non-denominational schools. It is argued that such parents have voluntarily refused the religious education facilities available in their local Roman Catholic school and so must shoulder responsibility themselves for the religious formation of their children. However logical such an attitude may seem it is not the stance taken by Vatican II, which considered that the needs of the children override any other consideration. The most relevant passage is worth quoting again [as well as above, p. 20]: "If young people lack this formation . . . either because they do not attend these [Roman Catholic] schools or because of any other reason, parents, pastors of souls, and apostolic organisations should attend to it all the more". To do so with the energy, professional expertise and resources comparable to those deployed within the Roman Catholic schools in Scotland would call for a radical change in the Church's attitude towards such Roman Catholic pupils attending non-denominational schools in areas where Roman Catholic schools are available, but it would appear that the Roman Catholic Church in Scotland should make this change. It would call for money to be raised or allocated to this purpose, and for people to be found with the time and training to undertake the work; both of these are provided within Roman Catholic schools as part of the publicly funded education system, but the needs of Roman Catholic pupils in non-denominational schools are just as real, and

this study has shown that when there is special provision for their needs it is particularly effective.

At this point it would be appropriate to recognise the limitations of an enquiry such as this, in terms of the limited aspect of religious involvement that it has in fact investigated. Religious attitude is an important aspect of a group's religious involvement, but it is only one of them. In terms of what can be measured, it can be argued that the method used in this enquiry gives a reasonably sound indication of the level of belief amongst the group, but it does not provide information about religious practice, knowledge, identifiable religious experience, or about the way the group applies its religious involvement to the problems of everyday life. Information was obtained about the church attendance of this group, which showed that the Roman Catholic pupils in Roman Catholic schools had a somewhat higher level of attendance than those in non-denominational schools; but as has already been observed about attitude towards church services, this may reflect travel problems in rural areas rather than differences in religious commitment, and in any case attendance at services is only one aspect of religious practice. On this point, however, it is worth noticing that attendance was higher, amongst all categories in the sample, than is normally thought to be the case by many Roman Catholics. Furthermore, it would be a mistake to assume that religious development proceeds at a steady rate, even if it could be measured comprehensively and accurately. It is more probable that many people, particularly pupils of secondary

school age, go through periods of doubt and lapsing from religious practice as a normal part of their development to religious maturity. This does not affect a comparison of groups of pupils with similar backgrounds and of the same age, which has been the object of this enquiry, but the consideration does apply to any more general interpretation of church attendance statistics, and it would have been a factor of first importance if the enquiry had been conducted over a number of years to identify a trend. Empirical research into such a sensitive area as religious involvement soon reaches a point where some people - including school pupils - are reluctant to reveal their knowledge, attitudes or behaviour, and the information then loses its value for interpretation. It has to be faced that conclusions such as those in this enquiry are drawn from only a limited part of the totality of religious involvement.

Equally to the point for such an organisation as the Roman Catholic Church is the place of the school within the wider ecclesiastical context of its members' families and the local ecclesiastical community, the parish. As has been noted [e.g. pp. 19, 41f, 62, above], official ecclesiastical statements stress again and again the primary responsibilities of the parents in religious nurture, and the parish as the religious community within which young people discover their proper place as members of the Church and grow towards religious maturity. As their children grow, parents share their responsibilities for the religious development of their children with others,

some of whom are specially trained and appointed. Denominational schools have to be seen in this larger context, not as the sole agency responsible for the religious education of the pupils, but as only one of the religious influences. Sometimes the impression is given that the Church, both locally and more widely, has delegated its responsibilities for religious education to the schools, and that schools feel that they should provide for all the religious needs of their pupils. Not only is such an assumption impracticable, it can also distort the natural balance of formative religious influences in pupils' lives, and can leave them with the assumption that the discipline, assessment of achievement and ascription of status appropriate to school life applies equally to the religious dimension of their lives. In this context it is appropriate to note official ecclesiastical statements that the school should not replace the parish as the proper place for children to worship, however desirable it might be to give an important place to worship within school life, particularly the Mass [see above, pp. 48-50]. Children in non-denominational schools should not feel deprived of help in their religious development because they are not at a Roman Catholic school, and where they receive such help [as we have seen] their religious attitudes are every bit as positive as those who do go to a denominational school.

The assessment of religious education is a particularly difficult aspect of the assessment of the effectiveness of the school curriculum. For the most part, it can

only be done at all extensively by assessing the level of knowledge and of understanding of the knowledge, achieved by pupils; even to extend this into an assessment of pupils' evaluation of religious knowledge is to move into realms of difficulty. It is practicable to assess skills such as interpretation of information, analysis, application and evaluation, provided there is a clear recognition of how limited such assessment is for measuring personal religious involvement; even a denominational school cannot have as an assessable objective the development of its pupils' religious commitment. The main methods of assessment of religious education will be the methods used in other subjects in the curriculum: question papers, projects, essays, appreciation of set texts. None of these should leave the pupil with the impression that his or her religious commitment is being evaluated. With caution, the assessment can be extended by the use of such methods as those employed in this enquiry, for the contribution that the identification of the attitudes of a group might make to a diagnostic assessment. The limitations are that in practice it can only be applied to a group and in a way that preserves the confidentiality of the answers given. But it could be of particular use in helping to evaluate the effectiveness of various syllabuses. One of the findings of the present enquiry related religious attitude to the particular syllabus in use with the pupils. It was found that the most effective syllabuses of religious education [in terms of their correlations with positive religious attitudes] were those which schools had designed

for themselves; this finding was consistent with earlier research into religious knowledge conducted by the present writer. As the Roman Catholic Church in Scotland works on the development of a national syllabus of religious education for use in Roman Catholic secondary schools, it might find it useful to include this method amongst its evaluation techniques, particularly when it has to decide whether such a national syllabus is preferable to other syllabuses available, or even to ones produced within individual schools.

The separate denominational sector is a sensitive political issue in Scotland, and it is to be hoped that the limitations of such an enquiry as this will show that it has little to contribute to the general question of whether it is desirable that there should be separate Roman Catholic schools. One effect of having a large, separate denominational sector with its own national college of education is the opportunity it provides for developing expertise and resources in religious education. The days are long past when such a sector operated in isolation from the rest of the education world in Scotland (if it ever did). At least since Vatican II the Roman Catholic Church has acknowledged its need to share in the experience and competence of other Christians, not least in the field of religious education. To give but one instance, Pope Paul VI, who presided over most of the Second Vatican Council's deliberations, called on the Bible Societies for help very soon after the council closed, and such collaboration has continued and developed in very many

fields. In Scotland, close collaboration exists between people concerned with religious education, whatever their religious affiliations, but the Roman Catholic schools and the national college have been able to devote more people and resources to this area of the school curriculum because it is expected that all Roman Catholic teachers in Roman Catholic schools will contribute to the religious education teaching, whatever their main subject might be. It might reasonably be expected that the rest of the Scottish educational world might draw on Roman Catholic experience where it is found appropriate, if only to avoid less successful aspects of it.

Parental choice in schooling is again a prominent issue in British education, and in Scotland has already stimulated a lively public debate about the effects of publishing the performance of individual schools in public examinations, and constructing 'league tables' of schools' achievements. It might reasonably be argued that parental choice should be respected with regard to such an important area as the religious environment within which their children receive their formal education: whether it intends to do so or not, a school does communicate an attitude towards religion, and parents are entitled to take this into account. Moreover, it is still claimed that Christianity makes a fundamental, distinctive and continuing contribution to contemporary Scottish life, and so it might be claimed that there should be schools which are explicitly Christian wherever there is a demand for them and it is practicable (on educational and financial

grounds] to provide them. In making such a claim, the Roman Catholic Church must do all it can to ensure that its schools are not religiously divisive, by ensuring that the pupils in them give sympathetic and appreciative attention to other forms of Christian commitment, and to religious beliefs and practices other than Christianity itself. That such schools are socially divisive is a matter for debate, within the context of the present system of comprehensive education. The controversy about public examination achievements has shown that the comprehensive schools which draw their pupils from small, densely populated catchment areas show marked differences in achievement (judged in terms of the number of 'O' Grade and 'Higher' Grade passes obtained), and this is popularly attributed to the social class distribution of the various neighbourhoods in which the schools are located. As the denominational schools normally draw their pupils from wider geographical areas than the non-denominational schools (to achieve viable numbers), it could well be that they contain a wider social mix. This, too, would be an interesting subject for research. But if a separate school sector is to be defended, it might be more reasonable in today's ecumenical climate if it were seen in terms of Christian schools, rather than schools serving members of specific denominations such as the Roman Catholic Church. Such sharing is already beginning in the use of places of worship, and there would seem to be good reason to apply the same thinking to the provision of schools.

Although there is a growing volume of research into

religious education in Scottish schools, particularly in Jordanhill College of Education and Dundee College of Education, there has not yet been time to accumulate the kind of statistics available for other parts of Great Britain. As was explained earlier in this study, differences in school organisation, particularly the age of transfer from primary to secondary school, complicate comparisons with other parts of Britain, making it all the more desirable to have information for comparison within Scotland itself. It would be particularly valuable if there were studies of pupils extending over a period of time to help identify changes and long-term effects, and it would be useful to have more information about the effectiveness of the various syllabuses and syllabus models in use in Scottish schools. It will also be useful to have information about the effects of the introduction of the new 'O' Grade syllabus and examination in Religious Studies, particularly as Scotland moves towards implementing the recommendations of the Munn and Dunning reports by appropriate changes in the school curriculum, in inspection, in assessment and in the public examination system.

Within the Roman Catholic sector of public education there has been discussion of the relationship of the religious education of pupils in Roman Catholic schools and of Roman Catholic pupils in non-denominational schools where no Roman Catholic school is available, but there has not yet been any systematic study. It is comparatively easy to obtain information about the syllabuses in use for religious education within Roman Catholic schools (where

there are many variations]), but much more difficult to find what is being done for Roman Catholic pupils attending non-denominational schools. As this study has shown, provisions for the latter are important for the religious attitude of the pupils, and it would be useful to know what materials and methods are most effective; such enquiries should also be extended to cover provisions and opportunities for the parents of such pupils.

Early in this study, mention was made of seven functions of schools in general, and of five functions of Roman Catholic schools in particular, as listed in Vatican II's Declaration on Christian Education (see above, pp. 13-15). It may be appropriate to end this present study with a brief summary of these functions, as a reminder of the fundamental aims for education as they are understood by the Roman Catholic Church. The general functions mention the development of intellect, right judgement, and a sense of values; preparation for earning a living; fostering understanding between people of different temperaments and backgrounds; and the school as a centre of cooperation for different groups and individuals within the whole community. The aims specific to Roman Catholic schools (which are presented as a Christian view of the school, not as a Roman Catholic view in any exclusive or denominational sense), mention the gospel spirit of freedom and charity; the development of personality in terms of redemption and the new creation; relating knowledge 'of the world, of life, and of mankind' - the whole school curriculum - to the news of salvation; promoting the welfare of the contemporary

world; and serving the advancement of the reign of God. When The General Catechetical Directory lists the primary sources of religious education, as part of the implementation of the general principles enunciated by Vatican II, it does so with the understanding that they will serve such general and specific aims of education as have just been listed. The primary sources it lists as God's word, written or handed down; faith under the guidance of the Church's teaching authority; the liturgy; the life of the Church, in the past and the present; and "those genuine moral values which, by divine providence, are found in human society" [see above, pp. 35-40]. These sources - including the last one mentioned - are the raw materials for programmes of Christian religious education, as the Roman Catholic Church understands it, whether in specifically Christian schools or for Christians in other schools. Syllabuses of religious education, at least for Roman Catholic children, should be designed to use these primary sources in explicit relationship to the general and specific aims of education just listed, if they are to be faithful to the most authoritative statements on education made by the Roman Catholic Church in the present day. Research into Roman Catholic education in Scotland could usefully be related to such basic statements about aims and primary sources, particularly if it is research into the effectiveness of syllabuses.

It is appropriate, in a study such as this, to indicate the extent to which comparisons might be made between this study of Roman Catholic pupils of secondary

school age, and analogous research studies, particularly in the British Isles, the United States of America, and Australia. Some of the problems associated with comparing the results of the present study with those of other research have already been mentioned (pp. 107f.). In a useful article reviewing studies of children's attitudes towards religion over the period from 1940 to 1978⁽¹⁾, Francis observes that for exact comparison of results "it is necessary for the same instrument of attitude measurement to be employed in the same manner to samples constituted on the same basis"⁽²⁾. In that article, Francis lists a number of studies which provide information about the place of religious education in children's evaluation of their school subjects, but these studies cannot be used to provide explanations of the placing. Interpretations of anecdotal material obtained by interviewing school children suggest that children have considerable interest in religion but they conclude that schools fail to make proper use of this interest. Nearer to the present study are psychometric studies using various attitude scales to measure personal, social, environmental and educational aspects and relate them to the children's religious attitudes. By this means, studies have investigated the relationship between attitudes towards religion and the children's age, sex, intelligence, church attendance, type of school, style of teaching and of syllabus of religious education in use, main school subject taken, social class and geographical area. The distinction between the psychometric type of study and the descriptive type is important, for the

former better lends itself to more exact evaluation of the influence of various factors on children's attitude towards religion.

Most research into religious attitudes has been concerned with non-Roman Catholic samples, or has compared Roman Catholics with members of other religious organisations. In the course of identifying the pupils who considered themselves to be Roman Catholics, the present study also obtained information about an almost equal number of pupils who said that they belonged to other churches or none at all. This information is not used in this study, and is not made available, because it was only obtained incidentally to the information required, and it is haphazard and unstratified. Moreover, permission was only given to use information about Roman Catholic pupils, and use of any other information was expressly excluded by the education authorities. Exact comparisons with other research is further limited by lack of information about parental background and the children's intelligence (for both of which, permission was withheld), actual curricula being taught and school location related to density of population. An attempt was made to find what was being taught, but there were serious doubts about the relationship between the named syllabuses and what was actually being taught in the classroom, which raised problems about the reliability of this information. In this connection, attention is drawn to research currently being conducted by E. Spencer, of the Scottish Centre for Research in Education, Edinburgh. No account has been taken in this

study of distinctions between rural and urban schools because of the difficulty of defining with sufficient accuracy the gradations between urban and rural for the various pupils and schools; one school, for example, contained pupils from outlying islands who lived in school hostels during the working week, and pupils from one of the most densely populated housing estates in Europe.

Within the British Isles, the closest comparisons are with the studies made by L.J. Francis of the Culham Institute, Abingdon, W.K. King, of the University of Reading, and J.E. Greer, of the New University of Ulster, all of whom have used the same Francis religious attitude scale used (with minor modifications noted below) in this present study. The pilot study for the present research showed the need for minor changes to some of the statements in the Francis scale, and these were made after consulting L.J. Francis to ensure that they would not compromise the statistical analysis of the results obtained. The changes consisted of the addition of the word 'Christ' after 'Jesus' in sentences 2, 14, 18 and 22, and the addition of the words 'readings from', in sentence 1: "I find it boring to listen to readings from the Bible".

The available results of the studies made by Francis, King and Greer do not give a sentence-by-sentence breakdown of the information obtained, but Francis does comment on the results obtained for groups of sentences arranged by topic⁽³⁾, similarly to the present study (pp. 145ff. and 237), under the categories Belief in God; Belief in Jesus; The Bible; Prayer; The Church; and Religious Education.

Francis' interest was in change in attitude with age, and his results are the ones he obtained from a predominantly non-Roman Catholic sample of children in the south-east of England, approximately seven to seventeen years old. In all but two of these categories, that of the Bible and Religious Education, the attitude scores in the Francis sample are conspicuously lower than those obtained in the present study, even though the average age of the present study sample is so much higher than for Francis' sample. For Belief in God, for example, those in Francis who agree with "I know that God helps me" ranges from 46% in First Year Secondary to only 27% in Fifth Year, compared with the present study's 65%; while those who disagree range from 18% to 48% compared with the present study's 9%. "I want to love Jesus" yields 38% agreement in Francis (at age 14) compared with the present study's 74%. Agreement figures at age 16 in Francis for four sentences about prayer are 20%, 20%, 29% and 37%, while the comparable figures for the present study are 54%, 67%, 73% and 92% respectively. For "The Church is very important to me" Francis obtained 27% agreement at aged 12, and 17% at aged 16, while the present study gave 57%. Francis's 15 year-olds are almost the same in their attitude towards "the Bible as boring" when compared with the present study (32% compared with 31%), and the figures are similar in the two studies for those who think the Bible is out of date. 32% of the total population of the secondary schools in Francis like school lessons about religion, a result very similar to the 29% of the present study's Roman Catholic pupils. If the two

samples are at all comparable, Roman Catholic secondary school pupils in Scotland show a much more positive attitude towards personal religion, and have much the same attitude towards the Bible and their experience of religious education in their schools, than Francis' mixed English sample.

The mean scores correlated with independent variables for the present study and Francis^[4] are tabulated below, bearing in mind that these are for a mixture of religious affiliations and aged 7 to 16 years for Francis, while in the present study they are for Roman Catholics aged 12 to 18 years. The responses to each of the 24 sentences were given a code between 1 and 5; so the lowest possible total score was 24, and the highest possible was 120.

	<u>Present Study</u> [1981]	<u>Francis</u> [1974]
1. SEX		
Male:	86.52 [45.1%]	77.96 [50%]
Female:	92.43 [54.1%]	89.34 [50%]
	N = 1113	N = 900
2. CHURCH ATTENDANCE		
Never:	63.20 [1.8%]	88.51 [33.5%]
Seldom:	83.09 [25.0%]	93.47 [29.1%]
Monthly:	85.37 [4.7%]	98.88 [22.7%]
Weekly:	93.13 [68.4%]	104.70 [14.7%]
	N = 1113	N = 1826
3. SOCIAL CLASS		
1:	90.03 [3.1%]	90.85 [9.2%]
2:	91.02 [19.0%]	90.37 [19.7%]
3:	92.90 [7.4%]	89.34 [61.9%]
4:	89.94 [38.9%]	88.91 [8.2%]
5:	88.62 [15.2%]	91.00 [1.0%]

[No answer: 16.5%]

N = 1113

N = 1713

4. YEAR IN SECONDARY SCHOOL

1:	95.43 [34.5%]	82.01 [20%]
2:	88.43 [10.5%]	83.01 [20%]
3:	81.16 [8.6%]	79.05 [20%]
4:	84.52 [24.2%]	78.81 [20%]
5:	90.73 [16.1%]	66.03 [20%]
6:	89.99 [6.0%]	Not Given

N = 1113

N = 500

5. RELIGIOUS AFFILIATION

[Age range: 9-11 yrs.]

Roman Catholic:	89.74 [N = 1113]	101.59 [N = 302]
Church of England:		86.09 [N = 711]
Non-denominational:		89.48 [N = 1260]

Comparing the results obtained by Francis with those obtained in the present study, the first set of figures, for male and female pupils, shows a similar swing towards girls, who record higher scores for religious attitude than boys: an 11.34 difference of mean score in Francis and a 5.91 difference in this study [possible score ranges from 24 to 120 in the Francis scale used by both studies]. The difference in age range in the two studies suggests that the difference between boys and girls is more marked in the early years.

The mean scores for the four categories of frequency of church attendance show the same trend in the two studies, where more frequent attendance is associated with higher attitude score, as might be expected. It should be noticed that differences in the samples are reflected in these figures: the only figures readily available for Francis

relate to pupils in the two top years of primary schools, where the younger age-range is reflected in higher attitude scores, and there are also large differences in sample distribution between the four categories of frequency of attendance.

Social class comparisons show close similarity between the two studies, but comparisons between the various age-groups does show a difference in trend. A similar, declining pattern of mean scores emerges for the first three years of the secondary school pupils in the two studies, but thereafter the figures diverge. Francis found a consistent decline in attitude scores with increase in age; the present study found that this decline in attitude applied only to the first three years for Roman Catholic pupils in secondary schools, after which the mean scores rose again in Years 4 and 5, and only declined very slightly again in Year 6 (aged approximately 16, 17 and 18 years, respectively). Although these results run counter to Francis' findings that religious attitudes decline steadily as school pupils grow up, an earlier study by K.E. Hyde⁽⁵⁾ also found a more positive attitude score in Year 4. Results for the present study may have been affected by the fact that the survey was conducted during the Spring Term, when some of the Year 4 pupils had left school at Christmas; compared with Years 1 to 3, Year 4 therefore contained a higher proportion of pupils who intended to stay on into Year 5 and, possibly, Year 6. There still remains, however, the marked increase in scores in Years 5 and 6, in sharp contrast to Francis' findings.

This finding merits further research, to find whether it is replicated, and if it is, what other factors are related to it. The final figures given for Francis and this study show a considerably higher mean score for Roman Catholics in Francis, which is interesting, but it should be borne in mind that Francis' figures here are for the top two forms of the primary school (ages 9 to 11, approximately), while the present study is confined to pupils of secondary school age (12 to 18, approximately).

The overall decline in religious attitude with increased age of school pupil was also found by W.K. Kay, who compared attitude scores, using the Francis scale, in Roman Catholic schools in England, Ulster and Eire, and made the results available in 1981[6]. Kay's results for the three countries, by year, are given in the following table [mean scores for the present study, by school year, will be found in the previous table. As before, when the answer to each sentence is coded between 1 and 5, the minimum possible score for 24 sentences is 24 and the maximum possible is 120.];

	<u>England</u>	<u>Ulster</u>	<u>Eire</u>
Age: 11 yrs:	91.54 [11.3%]	108.63 [8.6%]	Not available
12:	89.30 [34.9%]	105.12 [26.2%]	101.40 [5.4%]
13:	87.78 [21.2%]	98.24 [27.2%]	101.99 [21.2%]
14:	85.17 [12.7%]	94.70 [27.2%]	99.10 [28.4%]
15:	81.00 [18.5%]	87.70 [10.8%]	93.98 [22.5%]
16:	Not available	Not available	88.56 [22.5%]
	N = 189	N = 279	N = 373

The other indication from these figures concerns the

interpretation to be placed on the higher scores for Ulster and Eire, where scores were higher than for the present study, and considerably higher than those for England. More would need to be known about the composition of the samples than is at present available, for it is not indicated whether the English Roman Catholic figures are for pupils in Roman Catholic schools, or simply for pupils who identify themselves as members of the Roman Catholic Church. If this is not the case, it would be worth asking if a sense of belonging to an ethnic minority, in the case of Ulster, or a sense of extensive community support, in the case of Eire, accounts for the more positive scores in the English situation.

J.E. Greer used the Francis scale in 1978 to collect information about pupils in twelve Belfast secondary schools, six of which were Roman Catholic. In a carefully designed random selection, it was originally intended that the sample should consist of twenty-six schools, but fourteen either refused to participate or sent in their information too late for inclusion in the study. The study was designed to compare the religious thinking and religious attitudes of Roman Catholic and Protestant pupils, and the published information included information about religious attitude related to school year⁽⁷⁾. Greer's findings confirm those of Francis and Kay, by showing that the decline in attitude score continues into Year 4 of the secondary school. Girls score more highly than boys, and Roman Catholics considerably more highly than Protestants, but this latter finding is not relevant to the present study. In contrast

with Kay, Greer's mean score by school year are much lower [for Roman Catholic pupils], and are lower (by amounts varying from about 10 points to 5 points) than the mean scores obtained in the present study. It is interesting to find that two studies of pupils in the same geographical area (Ulster) and of the same religious affiliation (Roman Catholic), using the same scale and method of analysis, obtain such different results. These results merit further research.

Moving away from the Francis scale, M.P. Hornsby-Smith has published the results of research mainly undertaken in 1973^[8]. The main sample consisted of 573 Year 5 pupils in three Roman Catholic and one non-denominational secondary schools near London, investigated by means of a self-completion questionnaire supplemented by interviews; Hornsby-Smith made no comparison between Roman Catholic pupils in Roman Catholic and non-denominational schools. His work was published in 1978, before that of Francis, Kay and Greer, and it is relevant to note that he draws attention to "the complete absence of research data in this area"^[9] at that time. Hornsby-Smith concluded that many pupils, even in Roman Catholic schools, considered that religion had no relevance in their lives or to the forming of their moral and social values and beliefs, a conclusion which runs counter to the present study, in which it was found that attitude towards religion is high among pupils in Year 5.

An earlier study of Roman Catholic education in Liverpool published in 1964 by J. Brothers^[10], was based

on research conducted amongst adults who had been at Roman Catholic grammar schools in Liverpool during the 1950s. Brothers identifies with commendable clarity the exact nature of the sample studied; it consisted entirely of Roman Catholics who had left Roman Catholic Grammar schools in Liverpool three years before the fieldwork was carried out; they had all left in the same year; they had spent two or more years in the Sixth Form [i.e. Years 5 and 6, normally containing pupils who are 16 years old or more]; their address at the time of leaving school was within the city of Liverpool; and they were still resident within the city boundaries at the time of the fieldwork^[11]. In the event, 84 people were interviewed, equally divided between men and women. Brothers concluded that "there is considerable room for examining the methods of religious instruction which have resulted not only in defensive, and even hostile, attitudes towards the wider society, but in a concept of Christianity as little more than a set of spiritual beliefs, of faith as something to be 'kept', and a view of the social life of the Church identified with outdated parochial associations"^[12]. These conclusions do not find support from the present study, but it should be noted that Brothers studied a differently constituted, adult sample more than twenty years before the present study, and that the interview schedule contained no questions explicitly about religious attitudes.

Research into Roman Catholic education in the United States of America has come to be associated mainly with the work of A.M. Greeley, whose two studies, done in association

with other people, have become standard works of reference^[13]. Like Hornsby-Smith in 1978 about the research situation in Great Britain, it is asserted in Greeley and Rossi [1966] that no relevant empirical research had been done on Roman Catholic schools in the United States: "In view of the general emphasis on education in American society and the size and importance of the Catholic school system, it is surprising that systematic studies of the Catholic school have never before been undertaken"^[14]. Five years later, Greeley and Gockel^[15] stated that only three studies met the criteria that they focus on the question of religious development, provide data by which comparisons can be made among groups who vary in the amount of parochial education they receive (including those with no parochial education), and are carried on with sufficient methodological rigour to merit the name 'research'^[16]. Another Roman Catholic contributor to the same collection of essays, A. Godwin, makes a similar point^[17]. There had in fact been many earlier publications, before Greeley and Rossi or at much the same time, of which mention might be made of work by J. Burns and B. Kohlbrenner, H. Carrier, J. Fichter, R.A. Neuwien, T.F. O'Dea, and M.P. Ryan^[18], which provide valuable information, but they are mainly descriptive and generalised, rather than statistical and specific. Fichter, for example, gives a detailed description of a particular [unidentified] Roman Catholic parochial school, obtained by systematic observation of the whole school and its activities throughout an academical year, but does not give statistical material which could be used as a basis

for comparison.

Useful information about Roman Catholic schools in the United States is to be found in a descriptive book by Greeley⁽¹⁹⁾, which leads one to conclude that the situation in the United States is very different from that of Scotland. In sharp contrast to Scotland, where the Roman Catholic educational sector is financed entirely from central or local government funds, the American Roman Catholic 'parochial' schools have to be financed by the Roman Catholic population, in addition to their contribution to the financing of the State system of education. The average cost of the parochial schools in 1974 was 3.32% of parental income, supplemented by subsidies from general parochial funds. In 1974 only 29% of Roman Catholic pupils of secondary school age attended Roman Catholic schools, while the other 71% went to State 'public' schools, and Greeley states that increasing costs of providing parochial schooling is leading to an increasing proportion of pupils going to the State schools. In Scotland, so far as the present study could determine, the proportion of Roman Catholic pupils of secondary school age in non-denominational schools was only of the order of 10%. Such differences make it difficult to make valid comparisons.

The foundations of modern studies of Roman Catholic education in the United States were laid in the academical year 1963-64, just as the Second Vatican Council was beginning, by means of two surveys. The first was the nation-wide Notre Dame Study of Catholic Education, in which all but one of the dioceses (New Jersey) cooperated in

providing answers to questionnaires sent to all Roman Catholic schools, administrative officers and teachers in the United States; the general questionnaires were supplemented by more detailed studies of a number of diocesan school systems. The more general findings were reported in Neuwien, in the book already mentioned, and the survey is also conveniently described by G.N. Shuster⁽²⁰⁾. The other survey was the one conducted by Greeley and Rossi, also mentioned already.

The Notre Dame survey provided information directly related to the effectiveness of religious education teaching in Roman Catholic secondary schools, but it was not designed to enable comparisons to be made with Roman Catholic pupils in the 'public' [i.e. State] schools. Girls' attitudes towards their religion were found to be more affirmative than boys, as was also the attitudes of children both of whose parents had received a Roman Catholic education. Shuster concludes from the Notre Dame data that "the Catholic school has succeeded in its task of introducing young people not merely to some knowledge but also to some understanding of the basic tenets of the Catholic faith"⁽²¹⁾, but in the absence of material for comparison it is not possible to evaluate this finding.

Greeley and Rossi studied nearly three thousand Roman Catholic adults in the United States, aged between 23 and 57 years, by interview, to ascertain the effects of their education, whether in Roman Catholic institutions or otherwise. In one aspect, this study resembled that of Brothers in Liverpool, mentioned above, for it was concerned

with adults who had left school for at least some years. Greeley and Rossi, however, also obtained some information from adolescents still at school, by means of unsupervised questionnaires completed by the children at home. The most relevant findings of Greeley and Rossi relate church attendance, doctrinal orthodoxy and religious knowledge to the various kinds of school attended and to religious education classes for Roman Catholic children attending 'public' schools. The results are expressed in figures which quantify the answers to groups of questions on similar topics. [Each answer was allocated a numerical value to indicate the extent of agreement or disagreement with the question; the figures below merely combine the responses to several questions for convenience of comparisons. They are not percentages.][22]:

	<u>School(s) Attended</u>			<u>Attended Parish</u>
	<u>All R.C.</u>	<u>Some R.C.</u>	<u>None R.C.</u>	<u>R.E. Classes</u>
Church Attendance:	80	47	20	47
Doctrinal Orthodoxy:	75	57	41	59
Religious Knowledge:	61	20	2	17
	[N = 147]	[N = 192]	[N = 211]	[N = 175]

From these figures, Greeley and Rossi drew a conclusion about parish religious education classes as a substitute for the religious formation given by Roman Catholic schools: "We asked our adolescent respondents who were not in Catholic schools whether they were presently attending any kind of religious instruction class. A little less than

one-third of those not in Catholic schools were in such classes, but it does not appear that the classes were having much impact on their religious attitudes and behaviour. The young people in the CCD (i.e. parish) programmes are much more like those in public schools with no religious instruction than they are like those in Catholic schools. At their present level of success, not only are CCD classes not a functional alternative to Catholic schools, they do not seem to accomplish very much at all"^[23]. The findings of the present study do not support any such conclusion for Scotland. Ten years later in 1973-74, Greeley replicated the earlier enquiry in cooperation with two other people^[24], but this later study did not include an adolescent questionnaire. The later study detected a decline in parochial (i.e. Roman Catholic) school enrolments, a reduction in 'religious' personnel (monks, brothers and nuns) for staffing, the abandonment of devotional practices, and a decline in the acceptance of authority. On the positive side, the study identified the emergence of the charismatic movement amongst Roman Catholics, and rising expectations of what Roman Catholics expected of their church. Looking back on their education, the adults who constituted the sample thought that parochial schools were more effective than the provisions made by parishes for Roman Catholic pupils in 'public' schools.

Research published in 1976 by R.H. Potvin and others^[25], from an analysis of two sets of data collected by Gallup, concluded that there was a progressive decline in traditional beliefs and practices amongst Roman Catholics between the

ages of 13 and 29, a conclusion reached by other studies, as we have seen, but not by the present one.

As with Francis in England, and Greer in Ulster, there have been a number of studies in the United States comparing Roman Catholic pupils with pupils of other denominations^[26]. Hoge and Petrillo investigated the development of religious thinking amongst Roman Catholic, Baptist and Methodist 10th Grade pupils (about equivalent to British 4th Form 15 to 16 year-olds), and found that a high level of abstract religious thinking is associated with rejection of doctrine and of church associations, except amongst Roman Catholics attending parochial schools. Some five years earlier, Fox and Elton concluded that there were no clear differences between Roman Catholics and others, but the results were derived from non-attitudinal information. No such research has been conducted in Scotland comparing members of different denominations, and this is an area of research which would be well worth developing. There would be much to be gained from comparative studies of school pupils belonging to different religious groups, and from research amongst adults into the effectiveness of their religious education.

Turning to Australia, the situation in Roman Catholic education is similar, in some respects, to the United States, and in consequence very different from Scotland. Although not as rigidly excluded from public funding as in the United States, Australia enjoys nothing like the extensive public funding of Roman Catholic schools in England and Wales, let alone the total public funding of the Roman Catholic

educational system in Scotland. State support has been increased in Australia following parental action in the 1960s, but the proportion of pupils attending Roman Catholic schools has declined sharply. Ironically, by the end of 1982, when most Roman Catholic schools were receiving substantial help from state or federal government funds, there had been a marked increase in small, private, Roman Catholic schools where parents could feel that they had more control over policy and curricula^[27].

Three Australian studies by J.R. Prince, D. Hyde, and D.A. de Vaus^[28] have yielded results of interest to the present enquiry. Prince published the results of research amongst six groups in two State schools, two private Protestant schools and two groups studied outside the school context. It is not clear from the report what proportion of the membership of the sample was Roman Catholic, but Prince states that there was "a relative lack of Roman Catholics", so there must have been some. Girls scored higher than boys in almost all the religious attitudes tested, and Prince found that "State school students display significantly more religious zeal than do the independent (i.e. Church) school students"^[29]. In the absence of information about provisions for religious education by churches for their pupils in State schools it is not clear whether this conclusion is different from the present study, but it seems probable that de Vaus reached conclusions about Australia opposite to those of the present study.

Hyde investigated pupils' religion in three Melbourne

schools, one of which was a Roman Catholic girls school "in a working-class to middle-class area" of the city, and he compared the results he obtained with conclusions drawn from a survey four years earlier about the religious beliefs, habits and moral attitudes of the Australian community in general, conducted by H. Mol^[30]. The questionnaire used by Hyde is very different from that of the present study, and Hyde found it difficult to generalise from the figures he obtained, but the Roman Catholic girls registered scores considerably higher than those of pupils in the other two schools, and he states that "comparing percentages from the schools with the community in general, it would appear either that school pupils are definitely less 'religious' than the average person in the community, or that there has been a marked decline in 'religiousness' in Australia over the past four years"^[31]. The value given to these conclusions must depend to some extent on the validity of generalisations drawn from so restricted a sample, but if they are valid they run counter to findings such as those of Greeley and his associates, that religiosity diminishes with age. It would be interesting to compare the religious attitudes of Scottish Roman Catholic pupils with that of the Scottish community as a whole, or even of the Scottish Roman Catholic community, but the more general information required does not exist.

D.A. de Vaus' research conclusions were based on a study of 1,735 pupils in Years 11 and 12 (i.e. 16 to 18 year-olds) in twelve Victoria secondary schools: six Roman Catholic schools (3 boys-only, 3 girls-only, as

Roman Catholic school education in Australia is segregated), and six coeducational State schools. The method of research utilised a self-administered questionnaire with questions about God, Jesus, the devil, miracles, and religious practice; the results were then grouped under categories of Orthodoxy, Church Attendance, and Devotional Practice, after the example, to some extent of Greeley and Rossi. de Vaus' results are as follows, first for all pupils [including Roman Catholics] and then for Roman Catholic pupils alone[32]:

	<u>Type of School</u>	
	<u>R.C.</u>	<u>State</u>
1. <u>ALL PUPILS</u>		
Highly Orthodox:	60%	31%
Regular Attenders:	83%	41%
Highly Devotional:	40%	29%
	(N = 921)	(N = 814)
2. <u>ROMAN CATHOLICS</u>		
Highly Orthodox:	61%	51%
Regular Attenders:	84%	57%
Highly Devotional:	41%	35%
	(N = 899)	(N = 144)

From these results de Vaus concludes [as does the present study] that there is little difference between the two school systems so far as they affect Roman Catholic pupils, and "any impact of Catholic schools is on church attendance more than on beliefs and even less on having private devotions"[33]. Surprisingly, de Vaus found little difference between boys and girls in Roman Catholic schools, although the expected higher scores by girls shows with

Roman Catholic pupils in State schools. As in the present study, de Vaus was unable to obtain related information about the pupils' parents' practice of religion, and was unable, therefore, to estimate the extent to which the differences between Roman Catholics in State schools and Roman Catholics in Roman Catholic schools were due to the influence of the home.

An extensive and thorough study of Sixth Form pupils (aged approximately 16 to 18 years), staff and parents associated with 21 Roman Catholic boys' high schools in Australia was published by M. Flynn in 1975^[34]. Flynn used a Likert-type questionnaire with a section on "Moral and Religious Attitudes and Values". Six of the questions related directly to religious values, with the following results^[35]:

<u>Religious Value</u>	<u>Responses</u>		
	<u>Sentence</u>	<u>Positive</u>	<u>Negative</u>
1. Christ is a very real person to me in my daily life:	48.5%	30.0%	2.74
2. As far as I can, I intend to base my life on the teachings and example of Christ:	50.6%	21.4%	2.63
3. I like to take an active part in the liturgy of the Mass:	28.0%	55.2%	3.45
4. I would not go to Mass on Sundays if I were really free to stay away:	26.7%	58.0%	3.47
5. I think Catholics should go to the sacraments regularly:	51.2%	23.6%	2.63
6. I think that Catholics should go to Mass at least on Sundays:	51.7%	33.0%	2.69

[The 'mean' here relates to a Likert scale coding of 1 to

5, where 1 represents the most positive response and 5 the most negative.)

Answers to similar questions [14, 6, 7, and 5] in the present study were markedly more positive than these, but Flynn's study is confined to Sixth Form pupils, and only to boys, while the present study covers pupils in all six years of the secondary school, and includes both boys and girls. Flynn also obtained interesting responses to a question asking pupils to say what they thought had most influenced their religious development^[36]:

<u>Influence</u>	<u>Responses</u>			<u>Rank</u>
	<u>Positive</u>	<u>Negative</u>	<u>Mean</u>	
1. Instruction and example of parents:	55.6%	16.8%	2.41	1
2. Example and guidance of teachers:	28.3%	34.4%	3.10	2
3. School's religious instruction:	25.3%	37.4%	3.18	3
4. Influence of friends:	23.0%	47.2%	3.39	4
5. Guidance of some priest:	22.8%	51.7%	3.50	5
6. Religious Instruction provided by the Church:	9.7%	64.4%	3.85	6

The results shown in the above table reveal an overwhelming respect for parental influence and minimal respect for the religious instruction provided by the Church. It must be remembered, however, that these are pupils in Roman Catholic schools who may have had little experience of the religious instruction provided by the Church for Roman Catholic pupils in State schools; it is also possible that there is ambiguity of relationship with priests if they are in schools where at least some of the teachers

are priests and where priests are closely involved in the schools' expressions of authority.

Before leaving the Australian scene, mention must be made of a study by H. Praetz^[37] into the factors which influence Roman Catholic parents when they are deciding whether to send their children to State schools or to Roman Catholic ones. Praetz, herself a Roman Catholic parent in Australia, produces some important conclusions which deserve attention in any country where Roman Catholic parents have to choose between a Roman Catholic and a non-denominational school for their children; for example:

"It is apparent that there are marked differences between Catholic-school and government-school parents. Although, on average, parochial school families are large and parents have low income, low educational attainment and semi- or unskilled occupational status, it is clear that, on average, Catholic-school parents are better off than are government-school parents and that high-school parents are better off than technical-school parents"^[38]. In a country such as Australia, where parents and/or the parish must make substantial financial contributions to Roman Catholic schooling, the situation is radically different from the position in Scotland, so any comparison would be complicated. Nor is there any Scottish study of Roman Catholic parents related to the schools to which their children go and to the opportunities in the locality for sending children to Roman Catholic schools. Such research would be valuable. It should be added that Praetz's book contains an appendix on the experimental methodology employed in the research

which is a model of the kind of information needed for proper evaluation of the findings^[39].

It is useful, at the conclusion of a review of analogous research, to refer again to the problems associated with comparisons of various studies of religiosity. Some dangers are obvious: marked differences in sample, methodology, analysis and social context; attention has been drawn to such differences where it has been thought appropriate. But there are more subtle problems, which may best be indicated by brief quotations from two perceptive articles by D.B. Gray and A.R. Gualtieri^[40]. Gray writes, "Most attempts to measure attitudes towards the church have been inadequate because referents have not been defined. Scale writers have assumed too easily that the label 'church' was affixed to a single or unidimensional referent and that its meaning was the same for all readers"^[41]. And Gualtieri writes, "The employment of the quantifier 'religious' raises considerable problems. The word 'religious' (and its cognates) is used in such contradictory ways as to suggest that its retention as a cashable term is a futile procedure"; and "When we apply evaluative criteria to religious persons and communities we appraise not only them but also their religious tradition"^[42]. The present study tries to meet these problems of definition and tradition with its opening 70 pages on the Vatican II and post-Vatican II Roman Catholic religious tradition within which the sample studied was located. L.J. Francis, as has been indicated, gave considerable attention to the semantic context of the Francis scale which has been used

as the research instrument here. Comparison with other research is only meaningful and reliable when similar, related information is available and is taken into account.

References Part IV

- [1] Francis, L.J., "The Child's Attitude Towards Religion: A Review of Research", in Educational Research, Vol. 21, No. 2 [1979], pp. 103-108.
- [2] Ibid., p. 106.
- [3] Francis, L.J., Christianity and the Child Today [Oxford: Farmington Institute for Christian Studies; "Occasional Paper Nu. 6", 1980], pp. 3f.
- [4] - " - An Enquiry into the Concept "Readiness for Religion", Unpublished Ph.D. Thesis for the University of Cambridge, 1976.
- " - School Influence and Pupil Attitude in Religious Education, Unpublished M.Sc. Dissertation for the University of London Institute of Education, 1977.
- [5] Hyde, K.E., A Study of Some Factors Influencing the Communication of Religious Ideas and Attitudes among Secondary School Children, Unpublished Ph.D. Thesis for the University of Birmingham, 1959.
- [6] Kay, W.K., Religious Thinking, Attitudes and Personality amongst Secondary Pupils in England and Ireland, Unpublished Ph.D Thesis for the University of Reading, 1981.
- [7] Greer, J.E., "Religious Attitudes and Thinking in Belfast Pupils", in Educational Research, Vol. 23, No. 3 [1981], pp. 177ff.

References Part IV

- [8] Hornsby-Smith, M.P., Catholic Education: The Unobtrusive Partner (London, 1978).
- [9] Ibid., p. 60.
- [10] Brothers, J., Church and School (Liverpool: 1964).
- [11] Ibid., pp. 21f.
- [12] Ibid., pp. 171f.
- [13] Greeley, A.M., and Rossi, P.H., The Education of Catholic Americans (Chicago, 1966).
- Greeley, A.M., McCready, W.C., and McCourt, K., Catholic Schools in a Declining Church (Kansas City, 1976).
- [14] Greeley, A.M., and Rossi, P.H., op. cit. p. vi.
- [15] Greeley, A.M., and Gockel, G.L., "The Religious Effects of Parochial Education", in Strommen, G.L. (ed), Research on Religious Development (New York, 1971) pp. 264-301.
- [16] Ibid., p. 265.
- [17] Godin, A., "Some Developmental Tasks in Christian Education", in Strommen, op. cit. pp. 109-154. On this particular point, see p. 111.
- [18] Burns, J. and Kohlbrenner, B., A History of Catholic Education in the United States (New York, 1937).
- Carrier, H., "La Religion des Etudiants Américains", in Archives de Sociologie des Religions, Vol. 12 (1961), pp. 89-106.
- Fichter, J.H., Parochial School: A Sociological Study (Notre Dame, Ind., 1958).

References Part IV

- [18] [Cont.] Neuwien, R. [ed.], Catholic Schools in Action [Notre Dame, Ind., 1966].
- O'Dea, T.F., The American Catholic Dilemma [New York, 1958].
- Ryan, M.P., Are Parochial Schools the Answer? [New York, 1964].
- [19] Greeley, A.M., The American Catholic [New York, 1977].
- [20] Shuster, G.N., Catholic Education in a Changing World [Notre Dame, Ind., 1967].
- [21] Ibid., p. 102.
- [22] Greeley, A.M. and Rossi, P.H., op. cit. pp. 185 and 190. The basis of the figures, or "indices", is explained on p. 19.
- [23] Ibid., pp. 190f.
- [24] Greeley, A.M., McCready, W.C., and McCourt, K., op. cit.
- [25] Potvin, R.H., Hoge, D.R., and Nelson, H.M., Religion and American Youth, with Emphasis on Catholic Adolescents, [Washington, D.C., 1976].
- [26] Hoge, D.R. and Petrillo, G.H., "Development of Religious Thinking in Adolescence", in Journal for the Scientific Study of Religion, Vol. 17 [1978], pp. 139-154.
- Fox, W.S. and Elton, F.J., "Protestant-Catholic Differences in Educational Achievement and Persistence in School", in Journal for the Scientific Study of Religion, Vol. 12 [1973], pp. 65-84.
- Weigert, A.J. and Darwin, L.T., "Parental Support,

References Part IV

- [26] [Cont.] Control and Adolescent Religiosity", in Journal for the Scientific Study of Religion, Vol. 11 [1972], pp. 389-393.
- Smith, C.B., Weigert, A.J., and Thomas, D.L., "Self-Esteem and Religiosity: An Analysis of Catholic Adolescents from Five Cultures", in Journal for the Scientific Study of Religion, Vol. 18 [1979], pp. 51-60.
- [27] Manion, B.C., "The Future of Christian Schools", in Journal of Christian Education, [Sydney], Paper 75 [Nov. 1982], pp. 24-30.
- [28] Prince, J.R., "Religious and Social Attitudes in Church and State Schools in Western Australia", in Journal of Christian Education [Sydney], June 1972, pp. 34-55.
- Hyde, D., "Relating God to the World of Secondary Students", in Journal of Christian Education [Sydney], June 1977, pp. 48-54.
- de Vaus, D.A., "Education and Religious Change Among Senior Adolescents: I Questioning Some Research Assumptions", and ". . . II Findings of An Enquiry", in Journal of Christian Education [Sydney], Dec. 1980, pp. 13-24, and April 1981, pp. 33-45 respectively.
- " - "The Impact of Catholic Schools on the Religious Orientation of Boys and Girls", in Journal of Christian Education, [Sydney], July 1981, pp. 44-51.

References Part IV

- [29] Prince, J.R., op. cit. pp. 51ff.
- [30] Mol, H., Religion in Australia [Melbourne, 1971].
- [31] Hyde, D., op. cit. p. 49.
- [32] de Vaus, D.A., "The Impact of Catholic Schools etc.,"
pp. 47f.
- [33] - " - op. cit. p. 47.
- [34] Flynn, M., Some Catholic Schools in Action [Sydney,
1975].
- [35] - " - op. cit. p. 162.
- [36] - " - op. cit. p. 167.
- [37] Praetz, H., Where Shall We Send Them? [Melbourne, 1974].
- [38] Ibid., p. 70.
- [39] Ibid., pp. 103ff.
- [40] Gray, D.B., "Measuring Attitudes towards the Church",
in Journal for the Scientific Study of Religion, Vol.
9 [1970], pp. 293-297.
- Gualtieri, A.R., "What is Comparative Religion
Comparing?", in Journal for the Scientific Study of
Religion, Vol. 6 [1967], pp. 31-39.
- [41] Gray, D.B., op. cit. p. 293.
- [42] Gualtieri, A.R., op. cit. pp. 35 and 39 respectively.

BIBLIOGRAPHY

Main sources, including sources referred to and cited in the text.

Abbott, W.M. (Ed.), The Documents of Vatican II (London, 1966).

Alves, C., The Christian in Education (London, 1972).

Anson, P.F. Underground Catholicism in Scotland (Montrose, 1970).

Association of Municipal Authorities, The Municipal Year Book 1980 (London, 1980).

Attfield, D.G., Religious Education in Church Schools (Farnham, 1975).

Beales, A.C.F. Education under Penalty (London, 1963).

Berridge, M.N. The Religious Development of Children (London, 1966).

Birnie, I.H. (Ed.), Religious Education in Integrated Studies (London, 1972).

Bless, W. (Ed.), Fundamentals and Programs of a New Catechesis (Pittsburgh, 1966).

Blood, H., A Manual of Instruction in Christian Doctrine (London, 1914).

Boudon, R., The Logic of Sociological Explanation (London, 1974).

Branigan, J.J. (Ed.), The Teaching of Religion in Catholic Schools (London, 1954).

Brierley, P. (Ed.), The United Kingdom Christian Handbook 1983 (London, 1982).

- Brothers, J. Church and School (Liverpool, 1964)
- Bullen, A. Parents, Children and God (London, 1972).
- " - What's Happening to our Children? (London, 1974).
- Burleigh, J.H.S. A Church History of Scotland (London, 1960).
- Burns, J. and Kohlbrenner, B., A History of Catholic Education in the United States (New York, 1937).
- Carrier, H., "La Religion des Etudiants Américains", in Archives de Sociologie des Religions, Vol. 12 (1961).
- Carter, G.E. The Modern Challenge to Religious Education (New York, 1961).
- Catholic Education Commission for Scotland, Religious Education Draft Syllabus for Secondary Schools (Glasgow, 1982).
- Conran, U.M. New Life in Christ Jesus (Slough, 1977).
- Conway, W.J. The Child and the Catechism (Maynooth, 1959).
- Cox, E. Changing Aims in Religious Education (London, 1966).
- Cully, I.V. Christian Worship and Church Education (Philadelphia, 1967).
- Cully, K.B. The Search for a Christian Education since 1940 (Philadelphia, 1965).
- Currie, R., and others, Churches and Church-Goers (Oxford, 1977).
- de Vaus, D.A. "Education and Religious Change Among Senior Adolescents: I Questioning Some Research Assumptions", and ". . . II Findings of an Enquiry", in Journal of Christian Education (Sydney), Dec. 1980, and April 1981.

- de Vaus, D.A. "The Impact of Catholic Schools on the Religious Orientation of Boys and Girls", in Journal of Christian Education, [Sydney], July 1981.
- de Waal, J. Why Catholic Schools? [Wellington, undated but later than 1977].
- Donaldson, M. Children's Minds [London, 1978].
- Drinkwater, F.H. The Abbreviated Catechism with Explanations [London, 1969].
- " - Educational Essays [London, 1951].
- " - Teaching the Catechism [London, 1958].
- " - Telling the Good News [London, 1960].
- Drummond, A.L. and Bullock, J. The Church in Late Victorian Scotland 1874-1900 [Edinburgh, 1978].
- " - - " - The Church in Victorian Scotland 1843-1874 [Edinburgh, 1975].
- " - - " - The Scottish Church 1688-1843 [Edinburgh, 1973].
- Dunning, J. (Chairman), Assessment for All [Edinburgh, 1977]:
 "Report of the Committee to review Assessment in the Third and Fourth Years of Secondary Education in Scotland", the "Dunning Report".
- Durham, the Bishop of, The Fourth R [London, 1970].
- Dutch Episcopal Conference, A New Catechism [London, 1970].
- English and Welsh Episcopal Conference, A Catechism of Christian Doctrine [London, 1971].

- Evening, M. Approaches to Religious Education (London, 1972).
- Eyre, C. [Archbishop of Glasgow], Pastoral Letter (Glasgow, 1900).
- Feeney, J.H. [Chairman], Falling Rolls in Catholic Secondary Schools (Glasgow, 1982).
- Fichter, J.H. Parochial School: A Sociological Study (Notre Dame, Ind., 1958).
- Fletcher, J. Bearing Witness to Christ (London, 1966).
- Flynn, M. Some Catholic Schools in Action (Sidney, 1975).
- Fox, W.S. and Elton, F.J., "Protestant-Catholic Differences in Educational Achievement and Persistence in School", in Journal for the Scientific Study of Religion, Vol. 12 [1973], pp. 65-84.
- Francis, L.J. "Attitude and Longitude: A Study in Measurement", in Character Potential Vol. 8, 1978 pp. 119-30 [Schenectady, 1978].
- " - "The Child and Christianity" in The Tablet, 22.11.80, pp. 1152-4 [London, 1980].
- " - "The Child's Attitude Towards Religion: A Review of Research", in Educational Research, Vol. 21, No. 2 [1979].
- " - Christianity and the Child Today (Oxford: Farmington Institute for Christian Studies; "Occasional Paper Nu. 6", 1980).
- " - An Enquiry into the Concept 'Readiness for Religion', Unpublished Ph.D. Thesis for the University of Cambridge, 1976.
- " - His Spirit with Us (London, 1981).

- Francis, L.J. "The Psychology of Religion: Revived, not yet Reborn", in Bulletin of the British Psychological Society, Vol. 31, 1978, pp. 44-5 [London, 1978].
- " - "Psychometrics and Christian Belief", in Bulletin 26 of the National Association of Teachers in Further and Higher Education, pp. 5-8 [London, 1978].
- " - "Research and the Development of Religious Thinking" in Educational Studies, Vol. 5 Nu. 2, 1970, pp. 109-15 [London, 1979].
- " - School Influence and Pupil Attitude in Religious Education, Unpublished M.Sc. Dissertation for the University of London, 1977.
- " - "School Influence and Pupil Attitude towards Religion", in British Journal of Educational Psychology, Vol. 49, 1979, pp. 104-23 [London, 1979].
- " - "Theology and Education: a Research Perspective", in Scottish Journal of Theology, Vol. 32 Nu. 1, 1979, pp. 61-70 [Edinburgh, 1979].
- " - "The Young Person's Religion: a Crisis of Attitude?", in Scottish Journal of Theology, Vol. 33, Nu. 2, 1980, pp. 159-69 [Edinburgh 1980].
- Francis, L.J. and Carter, M. "Church Aided Secondary Schools, as an Examination Subject, and Pupil Attitude Towards Religion", in British Journal of

Educational Psychology, Vol. 50, 1980,
pp. 297-300 (London, 1980).

Fry, C. (Ed.), Assessment and Examinations in Religious Education (Dundee, 1982).

Fuller, E. The Christian Idea of Education (New Haven, 1960).

Gaffney, C. and Trenchard, J. The Illustrated Catechism
(Alton, 1980).

German Episcopal Conference, A Catholic Catechism
(London, 1958).

Gibbert, K. Teaching Religion in Schools (London, 1970).

Glasgow Archdiocesan Religious Education Centre, Religious Education Programme for Secondary Schools
(Glasgow, 1975).

Godin, A., "Some Developmental Tasks in Christian Education",
in Strommen, op. cit. pp. 109-154.

Goldman, R., Readiness for Religion (London, 1965).

- " - Religious Thinking from Childhood to Adolescence (London, 1964).

Gray, D.B., "Measuring Attitudes towards the Church",
in Journal for the Scientific Study of Religion, Vol. 9 (1970).

Gray, J., What About the Children? (London, 1970).

Greeley, A.M., The American Catholic (New York, 1977).

Greeley, A.M. and Gockel, G.L., "The Religious Effects of Parochial Education", in Strommen, G.L. (ed.), Research on Religious Development (New York, 1971).

Greeley, A.M., McCready, W.C., and McCourt, K., Catholic Schools in a Declining Church (Kansas City, 1976).

- Greeley, A.M. and Rossi, P.H., The Education of Catholic Americans (Chicago, 1966).
- Green, M.R. (Chairman), Report of the Working Party on Religious Education and Religious Observance (Glasgow: Strathclyde Regional Council Education Committee, 1981).
- Greer, J.E. "Religious Attitudes and Thinking in Belfast Pupils", in Educational Research, Vol. 23, No. 3 (1981).
- Grimmitt, M. What Can I do in R.E.? (Great Woking, 1973).
- Gualtieri, A.R. "What is Comparative Religion Comparing?" in Journal for the Scientific Study of Religion, Vol. 6 (1967).
- Hardyck, C.D. and Petrinovich, L.F. Introduction to Statistics for the Behavioural Sciences (London, 1976).
- Haring, B. Acting on the Word (Tenbury Wells, 1975).
- Heenan, J. Teaching the Faith (London, 1972).
- Hofinger, J. The Art of Teaching Christian Doctrine (London, 1962).
- " - Teaching All Nations (Freiburg, 1961).
- Hofinger, J. and Reedy, W.J. The A.B.Cs. of Modern Catechetics (New York, 1962).
- Hofinger, J. and Stone, T.C. Pastoral Catechetics (New York, 1964).
- Hoge, D.R. and Petrillo, G.H., "Development of Religious Thinking in Adolescence", in Journal for the Scientific Study of Religion, Vol. 17 (1978),

Holm, J. Teaching Religion in Schools (London, 1975).

Hornsby-Smith, M. Catholic Education: the Unobtrusive Partner (London, 1978).

Hulmes, E. Commitment and Neutrality in Religious Education (London, 1979).

Hyde, D., "Relating God to the World of Secondary Students", in Journal of Christian Education (Sydney), June 1977.

Hyde, K.E., A Study of Some Factors Influencing the Communication of Religious Ideas and Attitudes among Secondary School Children, Unpublished Ph.D. Thesis for the University of Birmingham, 1959.

Irish Episcopal Commission on Catechetics, The Irish Catechetical Programme (Dublin, 1972).

- " - The Christian Way (Dublin, 1982); the revised Irish syllabus.

Italian Episcopal Conference, Teaching the Faith the New Way (Slough, 1973); the original Italian edition was published in 1970.

Jebb, P. (Ed.), Religious Education (London, 1968).

- " - (Ed.), Catholic Education: Drift or Decision (London, 1968).

John Paul II, Pope, Catechesis in our Time (Slough, 1979); "Catechesi Tradendae".

- " - The Pope in Britain: Collected Homilies and Speeches (Slough, 1982).

Johnston, L. Teaching the Faith (London, 1974).

Jungmann, J.A. Handing on the Faith (Freiburg, 1959).

- Jungmann, J.A. Pastoral Liturgy (London, 1962).
- Kay, W.K., Religious Thinking, Attitudes and Personality amongst Secondary Pupils in England and Ireland, Unpublished Ph.D. Thesis for the University of Reading, 1981.
- Kenneth, Br., Catholic Schools in Scotland 1872-1972 (Glasgow, 1972).
- King, J.D. Religious Education in Ireland (Dublin, 1970).
- Klecka, W.R. and others, Statistical Package for the Social Sciences Primer (New York, 1975).
- Konstant, D. R.E. for R.Cs. (London, 1968).
- " - Religious Education for Secondary Schools (London, 1976).
- " - A Syllabus of Religious Instruction for Catholic Secondary Schools (London, 1967).
- Konstant, D. (Chairman), Signposts and Homecomings (Slough, 1981).
- Lance, D. Eleven to Sixteen (London, 1967).
- " - Till Christ be Formed (London, 1964).
- Liverpool Archdiocesan Religious Education Centre, A Religious Education Scheme for Secondary Schools (Slough, 1979).
- Manion, B.C., "The Future of Christian Schools", in Journal of Christian Education, (Sydney), Paper 75 (Nov. 1982), pp. 24-30.
- Marthaler, B.L. Catechetics in Context (Huntingdon, Ind., 1973).
- Matthews, E. Celebrating Mass with Children (London, 1975).
- " - Children Give Thanks (London, 1976).

- Miller, S. Experimental Design and Statistics [London, 1975].
- Mol, H., Religion in Australia [Melbourne, 1971].
- Moran, G. Design for Religion [New York, 1970].
- " - God Still Speaks [London, 1967].
- " - Theology of Revelation [London, 1967].
- " - Vision and Tactics [London, 1968].
- Motherwell Diocesan Religious Education Centre, Growing Faith [Edinburgh, 1973]; the Motherwell diocesan secondary religious education syllabus.
- " - Religious Education Programme [Motherwell, 1982]; the revised Motherwell diocesan syllabus.
- Munn, J. [Chairman], The Structure of the Curriculum [Edinburgh, 1977]; the "Munn Report".
- McDonald, C.D.P. "Researching the Effectiveness of Catholic Religious Education", in Catholic Education Today, Vol. 10, Nu. 1, 1976, pp. 2f.
- McRoberts, D. [Ed.] Modern Scottish Catholicism [Glasgow, 1979].
- Neuwien, R. [Ed.] Catholic Schools in Action [Notre Dame, Ind., 1966].
- Nichols, K. Cornerstones [Slough, 1978].
- " - Orientations [Slough, 1979].
- " - Pastoral Catechetics in Action [Slough, 1977].
- Nichols, K. and Cummins, J. Into His Fulness [Slough, 1980].
- Nie, N.H. and others, Statistical Package for the Social Sciences [New York, 1975].
- O'Dea, T.F., The American Catholic Dilemma [New York, 1958].

Office of Population Censuses and Surveys, Classification of Occupations [London, 1970].

Paul VI, Pope, The Credo of the People of God [London, 1968].

Pius XI, Pope, The Christian Education of Youth [London, 1929]; "Divini Illius Magistri".

- " - On Reconstructing the Social Order [London, 1931]; "Quadragesimo Anno".

Pohlschneider, J. "Commentary on Vatican II Declaration on Christian Education" in Vorgrimler, H. [Ed.], Commentary on the Documents of Vatican II Vol. 4, pp. 1-48 [New York, 1969].

Potvin, R.H., Hoge, D.R., and Nelson, H.M., Religion and American Youth, with Emphasis on Catholic Adolescents [Washington, D.C., 1976].

Praetz, H. Where Shall We Send Them? [Melbourne, 1974].

Prince, J.R. "Religious and Social Attitudes in Church and State Schools in Western Australia", in Journal of Christian Education [Sydney], June 1972,

Radford, J. and Govier, E. [Eds.] A Textbook of Psychology [London, 1980].

Rahner, H. A Theology of Proclamation [New York, 1968].

Reid, W.G. [Chairman], Religious Education in Lothian Schools [Edinburgh, 1979].

Rhymer, J. The Use of the Bible in Modern Catholic Catechesis, unpublished M.Th. Dissertation for the University of Edinburgh, 1975.

Rummary, R.M. Catechesis and Religious Education in a Pluralistic Society [Sydney, 1975].

Ryan, M.P., Are Parochial Schools the Answer? [New York, 1964].

The Schools Council, Journeys into Religion [St. Albans, 1977]; the Schools Council Religious Education in Schools Project.

Scobie, G.E.W. Psychology of Religion [London, 1975].

- " - "The Psychology of Religion: a Religious Revival?", in Bulletin of the British Psychological Society, Vol. 30, 1977, pp. 142-4 [London, 1977].

Scotland, J. The History of Scottish Education [London, 1969].

Scotland, J. and Fairweather, I.C.M. [Eds.], A Good Education [Edinburgh, 1982].

Scott-Moncrieff, G. The Mirror and the Cross [London, 1960].

Scottish Education Department, Issues in Educational Assessment [Edinburgh, 1979].

- " - - " - A Curricular Approach to Religious Education [Edinburgh, 1977]; Bulletin 2 of the Scottish Central Committee on Religious Education.

Scottish Episcopal Conference, The Catholic Directory for Scotland 1980 [Glasgow, 1980].

Scottish Examination Board, Scottish Certificate of Education Religious Studies Ordinary Grade Syllabus [Dalkeith, 1982];

since published in the
Board's Regulations 1983.

Sheehan, M. Apologetics and Christian Doctrine (Dublin, 1960).

Shuster, G.N., Catholic Education in a Changing World
[Notre Dame, Ind., 1967].

Sloyan, G.S. Modern Catechetics: Message and Method in
Religious Formation (London, 1964).

- " - Shaping the Christian Message (New Jersey, 1958).

- " - Speaking of Religious Education (New York, 1968).

Smart, N. and Horder, D. (Eds.), New Movements in Religious
Education (London, 1975).

Smith, C.B., Weigert, A.J. and Thomas, D.L., "Self-Esteem
and Religiosity: An Analysis of Catholic
Adolescents from Five Cultures"; in Journal
for the Scientific Study of Religion, Vol. 18
[1979].

Trent, Council of, Catechism of the Council of Trent (New
York, 1934); translated by McHugh,
J.A. and Callan, C.J. with an intro-
duction, notes and index; the original
was first published in 1566.

Tucker, B. (Ed.) Catholic Education in a Secular Society,
[London, 1968].

van Caster, M. The Structure of Catechetics (New York, 1965).

- " - Themes of Catechesis (London, 1967).

Varrillon, F. Announcing Christ (London, 1963).

Vatican: Sacred Congregation for Catholic Education, The
Catholic School (London, 1977).

- " - Lay Catholics in Schools: Witnesses to Faith
[London, 1982].

- Vatican: Sacred Congregation For the Clergy, The General Catechetical Directory (London, 1972).
- Vatican: Sacred Congregation For Divine Worship, The Directory for Celebrating Mass with Children (London, 1975); see Matthews, E., above.
- Vatican: Secretariat For Promoting Christian Unity, Ecumenical Directory Part II: Ecumenism in Higher Education (London, 1967).
- Weigert, A.J. and Darwin, L.T., "Parental Support, Control and Adolescent Religiosity", in Journal For the Scientific Study of Religion, Vol. 11 [1972].
- Winter, M. Mission and Maintenance (London, 1973).
- Woodhall, R. Followers of Christ (Slough, 1974).
- Youngman, M.B. Analysing Social and Educational Research Data (London, 1979).
- Zimmer, L. Apostolic Renewal (New York, 1973).