THE EVALUATION
OF
OESOPHAGEAL REFLUX

David L Stoker MBChB FRCS(Ed) FRCS

Thesis submitted for the degree of Doctor of Medicine

University of Edinburgh.

1989



CONTENTS

Abstract

1. History

2. Aetiology

3. Epidemiology

4. pH monitoring

5. Quantitation

6. External probe

7. Internal probe

8. Conclusions

9. Appendices - 1

- 2

- 3

- 4

- 5

10. References

Acknowledgements

Papers

DECLARATION

I hereby declare that all the experimental studies contained within this thesis were conducted personally by the author during the tenure of a Research Fellowship at The Royal Naval Hospital, Haslar, and Queen Alexandra Hospital, Portsmouth.

This manuscript was prepared and printed solely by the author, using an Amstrad PCW8512 wordprocessor and Hewlett Packard Laserjet II laserprinter.

Ethics approval for these studies was obtained from the Medical Research Sub-Committee of the Naval Medical Research Committee.

This thesis initially reviews the ancient and modern literature on the oesophagus, and its investigation. The current literature on reflux oesophagitis is evaluated, and modern concepts of aetiology are discussed.

The five year endoscopic experience of reflux disease for the Portsmouth gastroenterologists is quantified, and it is shown that this is a widespread condition affecting all adult age groups, with a predilection for the elderly.

The current gold standard test for acid reflux - 24 hour pH testing - is evaluated. A new method of interpreting pH test results (the area under the curve) is compared with the more usual cumulative acid index. It is shown that the new method is no more accurate than the old, when trying to separate normal from abnormal pH test results, suggesting that factors other than acid may also be involved in the aetiology of reflux disease.

Measurements are performed on samples of human oesophageal refluxate, looking at three other factors which may be implicated in reflux oesophagitis, namely bile salts, trypsin and pepsin. These factors are compared with the pH of the refluxate. It is shown that significant quantities of all three substances are present in the samples, across the pH range, rather than in the narrow pH bands expected. Bile salts are selected for further study.

The development of a system for measuring bile reflux using an external gamma detector and $^{75}\text{SeHCAT}$ labelled bile is outlined, and tested. It is shown that this system is insensitive as a measure of bile reflux, but is capable of monitoring the enterohepatic circulation.

The developmental program for a new, internal gamma probe and portable monitoring system for use within the gastrointestinal tract is outlined. *In vitro* studies show this to be highly sensitive to $^{75}\text{SeHCAT}$, and $^{99}\text{Tc}^{\text{m}}\text{HIDA}$, despite its small size.

The internal gamma probe is validated as a measure of bile reflux in human volunteers using a gamma camera for comparison of results. In all cases studied, correlation between counts from the internal probe and gamma camera are shown to be positive, and are strongly suggestive that bile reflux is being measured. This system can therefore be regarded as the first effective portable bile reflux detector, with significant potential for the further study of reflux related disease.

Of the Heart-burn

"What is commonly called the heart-burn, is not a disease of that organ, but an uneasy sensation of heat, or acrimony, about the pit of the stomach, which is sometimes attended with anxiety, nausea, and vomiting.

It may proceed from debility of the stomach, indigestion, bile, the abounding of an acid in the stomach,"

Domestic Medicine

William Buchan 1784

The discovery of acid and bile

The aetiology of reflux oesophagitis is intimately related to both hydrochloric acid and bile salts. Both of these substances have long been known to man, although their relevance to disease has only become clear in the 20th century. A very full account of the history of bile salts is given in K W Heaton's paper "Bitter Humour", and the following outlines this.

The ancient Greeks evolved a medical doctrine based on four humours - blood, phlegm, black bile and yellow bile. Yellow bile had the attributes of fire, and was hot, dry and tasted bitter, while black bile was cold and melancholic (*the greek word "melan" means black, and "chole" means bile*). Gastric digestion of food was thought to be brought about by heat, supported by black bile, which was regarded mainly as an excretion product until the seventeenth century AD. In 1683, the Dutch anatomist Diemerbroeck suggested for the first time that bile may have digestive qualities "dissolving and separating the thinner parts of the chyle from the thicker ones so that they may easily be taken up by the lacteal vessels".

In the eighteenth century the physicians John Arbuthnot and Thomas Coe both noted that ox bile was sometimes used as an alternative to soap for washing clothes. There followed in the nineteenth century some important experiments by a number of individual German scientists, who by creating biliary-cutaneous fistulae in animals, showed that large excesses of fat were thereby excreted in the stools. These demonstrations of steatorrhoea proved the digestive qualities of bile.

The individual glycocholic and taurocholic acids were isolated by chemists in

the mid nineteenth century, and during the same period it was noted that there was a continuous recirculation of these bile salts between the bowel and the liver.

Hydrochloric acid is first mentioned in the literature of the late fifteenth century when it was distilled from alum and salt, and used for the softening of bones (unknown Italian author - cited by Reti 1965). One hundred years later Paracelsus (cited by Pagel 1956) described acid in the stomachs of animals, but thought that this was ingested rather than being excreted by the stomach.

In the early seventeenth century the Belgian doctor and chemist Van Helmont made the important observation that gastric secretions were themselves acidic, and noted the similarity with "spirit of sea salt" or hydrochloric acid, which he could make by distilling sea salt and potters clay. He compared the action of gastric juice with the action of "liquor of sulphur" or sulphuric acid on leather (cited by Reti 1965, Pagel 1956), although he also regarded the spleen as the source of the digestive agent.

It was the development of acid/base indicators in the late seventeenth century which led to the final proof that gastric juice contained acid. Viridet (cited by Baron 1979) poured heliotrope extract down the throat of a pig, and demonstrated that the oesophageal mucosa was stained blue by it, indicating alkaline, whereas the stomach lining was stained a deep red, indicating acid. He also described acid regurgitation into the oesophagus and mouth.

The Italian physiologist Spallanzani (cited by Prescott 1929) isolated "marine acid" or hydrochloric acid from the stomachs of crows by feeding them retrievable sponges and analysing the extracts. He also showed that these juices would only digest food adequately when kept at body temperature. Spallanzani was involved in an animated correspondence with the Scottish anatomist and surgeon John Hunter,

who believed that digestion was mainly independent of body heat, and that gastric acidity was due to decomposition of sugar in food. Misconceptions such as this continued on into the early nineteenth century when many still believed that gastric juice was saliva, and any acid present was secondary to the digestive process.

It remained for William Prout, the father of British biochemistry, to resolve the problem once and for all. In 1823, he quantified "muriatic acid" (HCl) from the stomachs of a large variety of mammals and also from humans using an early titration technique. He also postulated that chloride was secreted from the blood to the gastric lumen by the power of electricity, and that as hydrochloric acid was secreted, so the blood became alkaline.

In 1825, William Beaumont (cited by Rosen 1943) also isolated hydrochloric acid from human stomach using the gastric fistula of his well known patient Alexis St Martin. A few years later in 1834, it was noted by Eberle in Germany that hydrochloric acid and a neutral gastric mucosal extract were inactive alone, and would only cause digestion when mixed together. The following year Schwann isolated the mucosal extract and called it pepsin.

A History of Oesophageal Investigations

2500BC to 1800AD

The first medical records relating to the oesophagus date back to approximately 2500BC. The "Edwin Smith Surgical Papyrus" of ancient Egyptian times describes the fistula created by a "wound of the throat piercing the gullet", and contains the first known description of wound suture (Breasted 1930, Brewer 1980).

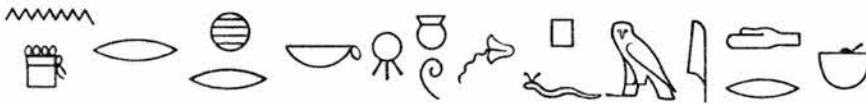

Translation:

Thou shouldst draw together that wound with stitching.

THE EDWIN SMITH SURGICAL PAPYRUS

The writer goes on to describe binding the wound with fresh meat, honey and lint, with further dressings leading to patient recovery.

Until the 15th century AD there are no further medical references to the oesophagus, but in 1490, Avenzoar described cannulation of the upper oesophagus in patients with dysphagia. The next references were again to surgery and occurred in 1672, when Wiseman described suturing a tear in the oesophagus of a child who had

fallen onto a wooden dagger. By the early 18th century, cervical oesophagotomy was occasionally being performed for treatment of stricture formation, and the removal of foreign bodies. Thomas Willis, the physician who described the sweet taste of diabetic urine, also described the first known case of achalasia in 1679, and performed dilatation of the cardia using a whalebone rod.

Bouginage for oesophageal stricture was first described by Vareliaud in 1801, and Lanelongue described an instrument with a cutting blade for the same purpose in 1867, although, not surprisingly, blind division of oesophageal strictures was associated with a high mortality rate. Balloon dilatation was first performed by Russell in 1887, on a case of achalasia, using a rubber balloon covered in silk on the end of a bougie. The technique was successful in the five cases on which it was attempted.

The procedures outlined above were all hampered by the fact that the oesophagus itself could not be visualised, although there were many early attempts at this. The next section describes the evolution of endoscopic techniques in relation to the upper GI tract.

The development of endoscopy.

Philipp Bozzini is credited with inventing the first simple endoscopic instrument for viewing the pharynx, although it was primarily intended for examining the vagina, the rectum, and the female urethra and bladder. It was called the "Lichtleiter" and it used a beeswax candle as its light source. This unfortunately provided insufficient illumination for it to be of any true diagnostic value.

Several further designs of "candle powered" endoscope were used in the first half of the nineteenth century, mainly for examining the bladder and rectum. The

Désormeaux lamp of 1865 was a considerable improvement on the candle, and utilised a burning mixture of alcohol and turpentine (gasogen) as its light source. John Bevan described upper oesophagoscopy in 1868 in the Lancet, and although his main light source was the candle, he also described a "limelight" based on a burning mixture of hydrogen and oxygen, and a Magnesium lamp based on a burning Magnesium wire, neither of which could have been very pleasant for the patient.

In the same year of 1868, the first gastroscopy was performed by Adolph Kussmaul in Germany (cited by Schindler 1937). He succeeded in passing a rigid open tube, with obturator, down the length of the oesophagus of a sword swallower, into the stomach. Even using the Désormeaux lamp, little could be visualised, but his demonstration proved that rigid instruments could traverse the natural curves of the thorax, and paved the way for the development of further rigid oesophagoscopes (MacKenzie) and gastroscopes.

The most significant advances of the nineteenth century were made by the cystoscopists, with the advent of electrical illumination, which allowed a light source to be placed at the distal tip of the examining instrument. Nitze and his optical assistant, Leiter are credited with making the first cystoscope with an electric light source in 1879, and Nitze also constructed a gastroscope, although this proved unsuccessful, due to the complicated cooling systems required by the hot platinum loop electrode used to provide light.

In his celebrated paper of 1881 Johann von Mikulicz described the first adequate endoscopic examinations of the stomach, using morphine narcosis, and diagnosed carcinoma and gastric ulcer using this technique. His work was not followed up however, due to technical difficulties, and it is thought that accidents may have occurred (Schindler 1950).

In 1896, Rosenheim was the first to use an Edison light bulb for illumination of the oesophagus and stomach, but his and several other rigid endoscopes of the 1890s were all very impractical, and were not widely used (cited by Walk 1966). In 1902, Einhorn perfected a rigid oesophagoscope, with an electric light source at its distal tip (Fig 1), which he had some success with. In his book "Diseases of the Stomach", he described examination of his patients in the "sword swallowing" position (Fig 2), without anaesthesia, but went on to say that gastroscopy using the same technique was both difficult and dangerous.

It was in the early 1900s, that the technique of endoscopy came into its own, with the development of better optics. Chevalier Jackson was one of the earliest surgeons to regularly examine the stomach. He emphasised the safety aspects,

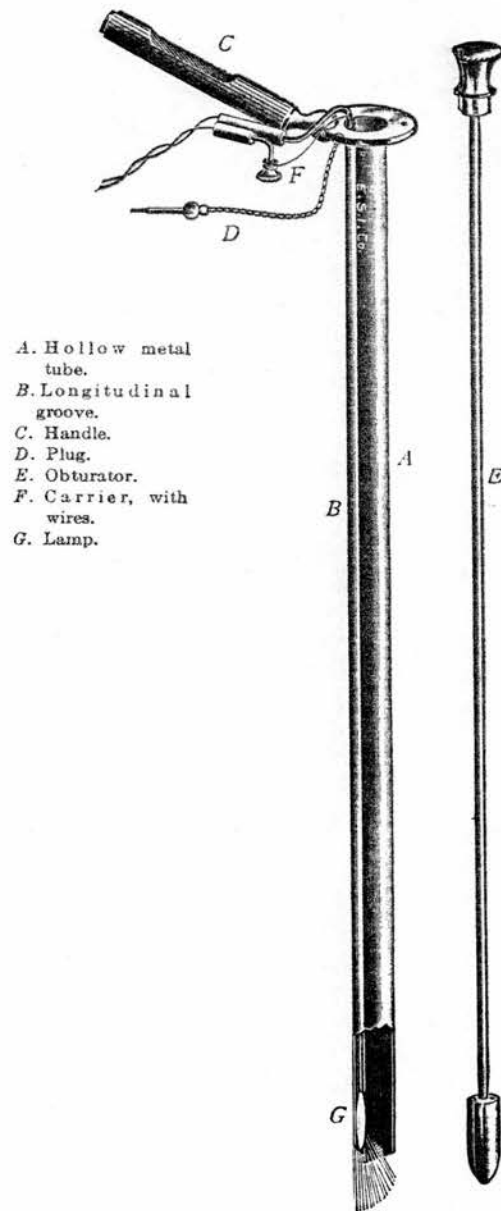

Figure 1

and stated that although the examination of the oesophagus could be performed with only local cocaine anaesthesia, viewing the stomach required general anaesthesia with chloroform or ether. He described the prone, neck extended position for the patient, and by simultaneous palpation of the abdomen, could examine one half to three-quarters of the gastric mucosa. In later papers, he described examination of the pylorus (pyloroscopy), and also use of gastric biopsy for the diagnosis of benign and malignant ulcer.

The real architect of modern endoscopy was Rudolf Schindler, who first experimented with rigid endoscopes, in the 1920's, and then invented the first semi-flexible instrument in 1932. This was based on a system of more than fifty lenses to



Fig 2. Rigid oesophagoscopy 1902
A tribute to the endurance of the Edwardian Lady

transmit the image through an arc of up to 34° (Davies 1972). The addition of controls to flex the distal tip of the instrument was a further major advance (Taylor 1941) and not only enhanced examination of the distal stomach, but also added to the safety of the technique.

The invention of a coherent glass fibre bundle capable of transmitting an optical image along a flexible path was made by the physicist, Harold Hopkins at Imperial College, London in 1953. (Hirschowitz 1958, Burnett 1962, Salmon 1972). The technology was adapted, and developed into a prototype fiberoptic gastroscope by a South African, Basil Hirschowitz in the USA, but it was several years before he could persuade an American Company (American Cystoscope Makers Inc.) to produce a commercially viable instrument. These became available in 1960, and were first used in Alabama, USA. The first flexible instruments were wide, ($\frac{1}{2}$ inch diameter) and although they made examination of the whole of the stomach possible, they could not enter the duodenum (Burnett).

The potential for these early flexible instruments was quickly recognised by the Japanese, and within a few years, Olympus were producing the high quality fiberoptic endoscopes, which have so dramatically changed our practice of gastroenterology today. A further refinement of the instrument in the early 1970's was the side viewer, which has led to our present techniques of endoscopic retrograde cholangio-pancreatography (ERCP), with its potential for non-operative removal of stones, and stenting of biliary strictures (Cotton 1972).

X-Ray techniques.

The rigid endoscope was then, the first truly diagnostic tool to be used, and predated the first use of X-Rays by some thirty years. Wilhelm Röntgen discovered the phenomenon of the X-Ray in 1895, and two years later in 1897 Cannon carried

out the first X-Ray contrast series, looking at the passage of bismuth subnitrate down the gullet of a goose. In the same year, Bliss reported using X-Rays to examine a foreign body lodged in a patient's upper oesophagus.

By 1908 the techniques of barium meal, follow through, and enema were being used regularly in man (Carman 1913, Harrington 1928), and sporadic reports of diaphragmatic hernia began to appear in the literature soon afterwards (Abbott 1924, Friedenwald 1925, Kirklin 1947).

In the first half of this century, radiology was felt to complement endoscopy in the study of the oesophagus (Auguste 1951), and was certainly better at diagnosing functional abnormalities such as spasm and disordered peristalsis. Barium studies also proved effective in the diagnosis of gross lesions of the oesophagus such as carcinoma, ulceration and stricture formation, but have always been less useful for diagnosing oesophagitis. The barium cine-oesophagogram provided an objective measurement of gastro-oesophageal reflux in the 1950's and '60s, and the combination of acid and barium mixtures was used with some effect for the evaluation of oesophagitis, by looking at motility patterns (Donner 1966). Screening Barium swallows have provided much useful information about the incidence of diaphragmatic and hiatus hernia. (Giffin 1912, Stein 1960).

Although to a great extent, X-Ray techniques have now been superseded by endoscopy and manometry, they are still useful, and as recently as 1976, barium sulphate tablets were used to demonstrate the delayed passage of potentially corrosive medications through the oesophagus (Evans 1976).

Surgery of the oesophagus.

The development of endoscopic and X-Ray techniques made accurate examination of the oesophagus possible. This, together with important developments in anaesthesia (Long 1849), and antisepsis (Lister 1867) enabled surgeons to perform more major surgery than had previously been attempted.

The first effective oesophageal surgery, other than simple esophagotomy, was for achalasia, and was described by Heller in 1913. He performed an anterior and posterior longitudinal myotomy over the cardia with excellent effect.

Sporadic cases of oesophageal resection for carcinoma were being reported as early as 1877 (Czerny), but safe and effective techniques were not developed until after the Second World War, when Brewer, and Ivor Lewis in 1946 pioneered the high gastric replacement, which involved mobilising the stomach up into the thorax, for anastomosis to the cervical oesophagus.

Surgery for hiatus hernia was originally much the same as repair of any hernia - a simple reduction and repair of the defect. Harrington (1928, 1930) described phrenic nerve division to relax the diaphragm either on its own or with a simple overlap repair of the crus as being effective, but the more major procedure had a 17% mortality rate, due to respiratory problems. In 1946 Allison described a similar operation, and by 1951 he had performed 33 such procedures, with only one death. Allison also advocated distal oesophagectomy with oesophagojejunostomy for patients with refractive oesophageal ulceration, and achieved good results from operations on 15 patients.

These techniques were superseded, when in 1956 Nissen described a more

effective anti-reflux procedure, which involved mobilising the oesophagus into the abdomen for 6cms and then wrapping the fundus of the stomach around it (Fig 3). He named the procedure fundoplication, and with modifications, this is still one of the most commonly performed anti-reflux operations. Modifications of Nissen's procedure were introduced by Hill, and Belsey. They have been shown not only to increase lower oesophageal sphincter pressure but also to increase the amplitude of peristaltic contractions (Fisher 1978, Gill 1986).

Fig 3 - The Nissen Fundoplication.

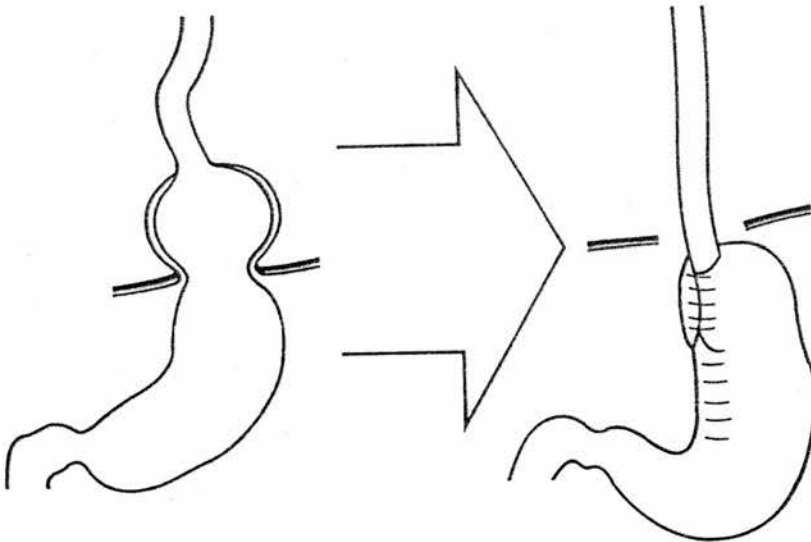

The recognition in recent years that biliary and pancreatic secretions can cause oesophagitis, especially after gastrectomy, has led to biliary diversion procedures being performed with good results. In particular the long-limb Roux-en-Y, with a 45cm between the oesophageal anastomosis and the afferent segment, has proved useful in some cases (Spencer Payne 1983).

Modern investigative techniques.

The pH test

Prior to the 1950's, estimations of gastric acidity were usually performed using the phenolphthalein end point titration method, but in situ electrodes were in preliminary use mainly for gastric/duodenal secretion studies in 1939 (Eyerley, Flexner). In 1952 Rovelstad described measuring oesophageal pH with a shielded glass electrode, but these were only short recordings, with the emphasis of his tests being on the stomach and duodenum.

In 1958 two tests for oesophageal pathology were described, both of which have had a profound effect on our present understanding of reflux oesophagitis, and which in modified form, are still in frequent use today. The first of these was the "Acid Perfusion Test for Oesophagitis" described by Bernstein. He perfused the oesophagus of 55 patients with 0.1N HCl, using Normal Saline as a control, and showed conclusively that in those patients with oesophagitis, he could elicit their symptoms with the acid perfusate. He showed that the test would confirm the oesophageal origin of symptoms in patients without oesophagitis, and concluded that this would be particularly useful in differentiating between pain of cardiac origin, and that of oesophageal origin.

Eyerly's miniature glass pH electrode was first used in the oesophagus by Tuttle and Grossman, in 1958. They described placing the pH electrode via the nose into the mid oesophagus to directly measure acid regurgitation. They did not, in their initial experiments, record the patients symptoms during the test, but they were the first to directly measure gastro-oesophageal reflux of acid. The pH test has undergone an almost continuous process of refinement since then, and is now regarded as the Gold Standard test for reflux (Silverstein 1980, Evans 1987,

Schindlbeck 1987, Johnsson 1987). Prolonged pH studies were started during the 1960's (Spencer 1969, Miller 1964, 1967), and in 1974, Johnson and DeMeester described a mobile system consisting of a glass electrode and cable attached to a strip chart recorder on a movable trolley which facilitated ambulatory recordings of up to 72 hours. The first truly portable systems appeared in 1980 (Falor), when pH sensitive radiotelemetry capsules were used, with the results being stored on a tape recorder worn on a waistbelt. It was as recently as 1984, that Vitale first described our present system of recording on portable microprocessors, with direct computer analysis of results. Several of these systems are now available (Vertec, Synectics, Gaeltec, Oxford)

Motility studies.

Oesophageal transit time was traditionally measured by listening with a stethoscope over the cardia for deglutition sounds as the patient swallowed liquid. This technique was really only useful for the diagnosis of strictures and achalasia. (Kronecker & Meltzer 1883, Winklestein 1935).

Manometry was first performed in Germany in 1883 by Kronecker and Meltzer, using rubber air balloons in the pharynx and oesophagus to study normal swallowing. They described peristalsis, as well as refuting the idea of anti-peristaltic waves in the oesophagus, and also demonstrated oesophageal dysmotility after swallowing a carbonic acid mixture. Sixty six years elapsed however, before Kramer and Ingelfinger used a "balloon kymograph" to examine motility in the abnormal oesophagus.

In 1943, Wetterer invented a miniature electromagnetic pressure transducer

small enough to be placed in the trachea, or internal jugular vein, and in 1956 this technique was modified by Fyke et al for measuring pressures in the GI tract. They discovered "a zone or band of high pressure interposed between the stomach below, and the oesophagus above ... detectable for distances of 2 to 3cms", and concluded that this was a functioning sphincteric mechanism - a fact not previously recorded. These findings were confirmed the following year by Atkinson et al using an air perfused open ended tube system for pressure measurement.

Radioisotope studies

The use of radionuclides to examine the oesophagus was first described in 1972 by Kazem. He studied the oesophageal transit time of a Tc^{99m} labelled pertechnetate drink, using gamma camera imaging, producing a test for transit time which was both accurate and involved a very low radiation dose. He called his test the "radioesophagram" or REG. Tolin quantified this test in 1979, by collecting the scintiscanner data on a digital computer. This was then analysed using an "area of interest" over the oesophagus, to calculate the exact rate of transit of the labelled fluid.

Fisher et al first described the use of a gamma camera to detect and quantitate gastro-oesophageal reflux of a Tc^{99m} sulphur colloid, but it could not be described as wholly physiological as an artificial pressure gradient was used to induce reflux during the limited time of the test. Although this test is still in use for the measurement of reflux (Krog 1982, Kaul 1985, 1986), it is not thought to be so useful in the study of oesophageal motility disorders (Mughal 1986).

The development of a modern perspective on reflux oesophagitis

Diaphragmatic hernia

Although the relationship between hiatus hernia and oesophageal reflux remains a controversial one, the history of diaphragmatic herniae in general, forms an interesting and important background to our present day view of the subject.

The first description of diaphragmatic hernia is attributed to Ambroise Paré in 1610. He described two cases of hernia, both of which were traumatic in origin. The first involved a Capitaine Francois d'Alon of Xaintonge, who was shot in the chest by an arquebus. He survived the injury only to die of intestinal obstruction eight months later. At post-mortem a large part of his colon was found "distended with gas" in the thorax, having herniated through a hole in the diaphragm no larger than the base of the little finger. In the second case, stomach and small intestine were found to have herniated into the chest of a soldier at post-mortem, thirteen days after a wound to the membranous portion of the diaphragm.

The congenital type of diaphragmatic hernia was first described in 1698 by Riverius (cited by Unger & Speiser), and until the 20th century it was regarded as a rare condition, with only 10 live cases being reported prior to 1908 (Harrington), and 15 prior to 1912 (Giffin).

Andrew in the Lancet in 1903 is thought to have described the first case of herniation of the cardia through the oesophageal hiatus. Over the next 20 years or so, with the increasing use of X-Ray techniques, it was gradually realised that hiatus hernia was quite a common phenomenon (Abbott 1924, Friedenwald 1925)

Early thoughts on aetiology

Ulcers and inflammation of the oesophagus were described by Quinke as early as 1879, but the aetiology of heartburn and oesophagitis remained obscure until 1884 when Reichmann performed an experiment on three patients with heartburn, and three normal subjects. He persuaded them to swallow small gelatin coated sponges attached to silk thread, placing them in the mid oesophagus. On withdrawing them, he found that those sponges from patients with heartburn contained fluid which gave an acid reaction, while those from the asymptomatic subjects were alkaline. Reichmann believed that the cardia was a factor in the aetiology of heartburn, and that its degree of contraction was related to the extent of a patient's symptoms.

The vomiting of bile stained fluid associated with heartburn after gastrectomy was described by Hartman in 1921, but no relationship between the two was suggested. Jones and Richardson in 1926 described heartburn as being due to oesophageal spasm as a result of exposure to acid, alkaline, or gastric contents, a finding which was corroborated by Payne and Poulton. Two years later, Chevalier Jackson reviewed 88 patients with "peptic oesophageal ulcers", using the rigid oesophagoscope. He came to the interesting, but somewhat erroneous conclusion that infection was the chief aetiological factor in the development of the disease, with the infective focus commonly being the tonsil. He regarded retrograde flow of gastric contents as being a perpetuating factor only, but a certain cause of pain. Jackson also stated quite categorically that there was no evidence for a sphincter mechanism at the anatomical cardia, and that the diaphragmatic pinchcock was normal in all his patients with oesophageal ulcer. Kofler, in 1928, reported relief of heartburn by tonsillectomy, and put the symptoms down to absorbed toxic substances causing a vagus neuritis.

Post-mortem studies by Mallory and Weiss in 1932 described acute lacerations of the oesophagus following prolonged vomiting, and in the same paper they described the formation of chronic ulcers at the cardia. They postulated that these were caused by "regurgitation of gastric juice and the corrosive effect of alcohol".

The in vivo condition of reflux oesophagitis was first described as recently as 1935, by Winkelstein. He listed the causes of oesophagitis as:

1. Irritative (mechanical, thermal and chemical).
2. Specific (Syphilis, TB, actinomycosis).
3. Secondary, as a complication of cardiospasm, diverticula or neoplasm.

To these he added a fourth category which he presented as a separate clinical entity - a "peptic" oesophagitis which he suggested was due to "the irritant action on the mucosa of free hydrochloric acid and pepsin". He concluded that "heartburn may be due to peptic oesophagitis", and in doing so made a significant contribution to our modern understanding of the condition.

Over the next twenty years there was a gradual realisation that peptic oesophagitis was not just a terminal condition seen in debilitated patients, but was in fact a common disease (Allison 1946, 1951), although its relationship to heartburn was still seldom considered (Beaconsfield 1953).

The presence of hiatus hernia, and incompetence of the gastro-oesophageal junction were both recognised as predisposing to reflux (Allison 1951, Aylwin 1953, Flood 1953, Stewart 1955) but it was also shown that acid reflux could occur in the absence of a demonstrable hernia (Flood 1953, 1955). The spasm theory of oesophageal pain was still widely accepted (Moersch 1943) until questioned by Bernstein who in 1958 showed a direct relationship between mucosal acid exposure

and heartburn. The prolonged pH and manometry recordings that can now be performed have still failed to uncover the exact cause of oesophageal pain, although they can now help to differentiate oesophageal pain from that of cardiac origin (Janssens 1986).

Even in the 1950's, the origin of oesophagitis was still often thought to derive from infections such as cholecystitis, tonsillitis or pneumonia, with bacterial dissemination via veins and lymphatics (Auguste 1951, Allison 1946). Auguste also mentions an "allergic" type of oesophagitis, although he does not expand on this. Moffat in 1965 listed vitamin deficiencies, vascular aberrations and inherent susceptibility to the trauma of ingested food among the possible causes of the disease. The mechanism for production of the lesion remained far from clear however. The "acid/pepsin theory" could not explain the observations of Helsingen (1958), Palmer (1960), Windsor (1964) or Morrow (1976) that oesophagitis occurred in patients who had undergone gastrectomy, or in whom there were other causes for achlorhydria such as pernicious anaemia (Orlando 1973). Histological evidence (Palmer 1955, Lodge 1955) pointed to the submucosa as the site of origin of the lesion, with only secondary spread upwards to the epithelial surface - an unlikely sequence of events if hydrochloric acid alone were to blame.

Animal studies also produced conflicting evidence. Ferguson (1950) showed the damaging effect of acid alone on six species of animal oesophagus, including cats and dogs. These studies were confirmed by Redo in 1958 and 1959, using a dog model. However, a much quoted paper by Cross & Wangenstein (1957) suggested that bile and pancreatic juice were the main factors causing oesophageal erosions in cats and dogs. This work was confirmed by Moffat et al. in 1965, again using a dog model.

By the 1960's concepts of aetiology were starting to crystallize. Treatment of oesophagitis was firmly based on the acid/pepsin reflux theories of Hale (1957), Redo (1959), Casten (1967), and Goldberg (1969). Medical treatment consisted of antacids, anticholinergics, and sedatives, with surgery designed to reduce gastric acid secretion, reduce and repair hiatus hernia and reconstruct the gastro-oesophageal sphincter mechanism.

There was growing evidence however that this was insufficient to explain the problems in all cases. Skinner in 1966 pointed out that there was little correlation between symptoms and severity of reflux disease in many cases, and reiterated that oesophagitis and its complications could occur in the absence of a hiatus hernia. With the use of the investigations outlined above, there was therefore increasing evidence that a large number of other factors were involved in creating the clinical picture of oesophagitis.

Further studies in the 1970's and 1980's have increased our understanding of the condition immensely, and these will be examined in more detail in the next chapter.

Present views on aetiology

Non-reflux oesophagitis

Our modern concepts on the aetiology of oesophagitis are still far from complete. Winkelstein's classification into four groups still holds true, but has been modified. Trauma of a mechanical or caustic nature is a factor in some cases, and to this we can now add drug induced inflammation (Heller 1982, Kikendall 1983, Collins 1979, Bova 1987). Infection can still be a problem, although the organisms have changed in the era of the antibiotic. Syphilis and Tuberculosis are rare, but *Candida albicans* (Sheft 1970, Kodsi 1976, Mathieson 1983) can be a problem in the debilitated patient, and Herpes simplex infection may be quite common in those who are immunocompromised (Morrissey 1978, Shortsleeve 1981, Byard 1987).

Unlike the situation in the stomach and duodenum, there is little evidence that *Campylobacter pylori* has any detrimental effect on oesophageal mucosa, although it has been cultured from both healthy and inflamed oesophageal biopsy specimens (Zimbalist 1988), and Barrett's oesophagus (Talley 1988, Hazell 1988, Paull 1988).

A "stagnant" oesophagitis, due to lactic acid produced by fermentation of food debris, is certainly seen in achalasia, and above some strictures, but is not a serious problem in itself (Smart 1987, Passmore 1975).

Crohn's disease of the oesophagus has been described (Gelfand 1968, Dyer 1969, Freedman 1984, Geboes 1986, Maffei 1987), and oesophagitis may even rarely be associated with ulcerative colitis (Rosendorff 1967).

Reflux oesophagitis

It is now accepted that the vast majority of cases of oesophagitis are due to the effect of refluxing gastric contents on the oesophageal mucosa, either in the presence or absence of an incompetent lower oesophageal sphincter (LOS). It is also accepted that the symptom of heartburn may bear little relationship to either the presence of oesophagitis or its complications. The aetiology of reflux oesophagitis can be conveniently divided into two parts:

- 1.) Mechanical causes for reflux of fluid into the oesophagus (Fig 4).
- 2.) The mechanism of damage to the oesophageal mucosa.

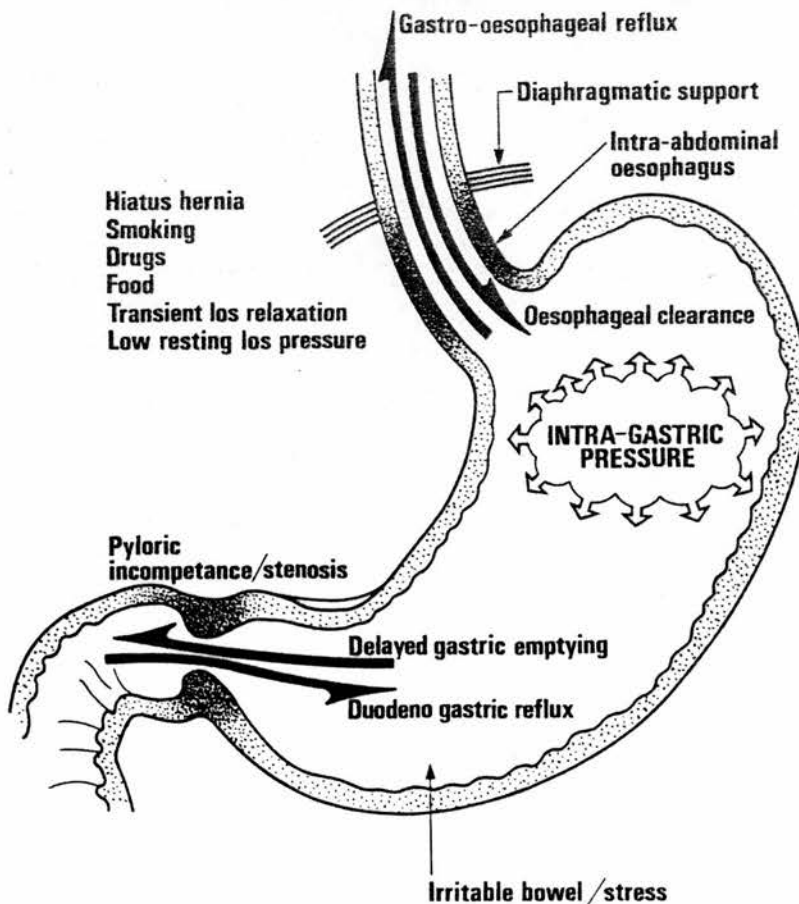
Fig 4**THE DYNAMICS OF REFLUX**

Normal reflux

Oesophageal reflux occurs in normal healthy people. It is mainly post prandial, and of short duration, due to rapid oesophageal emptying. It is usually, but not always asymptomatic, and rarely occurs in the supine position (DeMeester 1976). There is some evidence to suggest that it is not affected by advancing age (Spence 1985, DeMeester 1976, Sadek 1985), although oesophagitis is more common in the elderly, possibly due to decreased tissue resistance, oesophageal motor function (Eypasch 1988), and slower cell regeneration (McHardy 1972, Dodds 1981, Pries 1982).

Reflux becomes pathological when it produces undue symptoms, or signs of oesophageal damage, and for this to occur, one or more of the following mechanisms must be compromised. Firstly, the antireflux mechanisms may be impaired, allowing undue reflux to occur. Secondly, there may be decreased oesophageal clearance due to motility dysfunction. Thirdly, the oesophageal mucosal protection mechanism may be deranged.

Failure of protective mechanisms

The physiological protective responses to acid in the oesophagus are increased frequency of swallowing (Orr 1984), with increased saliva production (Helm 1982, 1983, 1987) - a form of oesophagosalivary reflex in subjects with heartburn. The opossum oesophageal submucosal glands have been shown to secrete bicarbonate intraluminally, which may have a protective role, although this has not been shown in man (Hamilton 1988).

These mechanisms may become deranged in patients with oesophagitis. For example it has been shown that there is an age related loss of salivary response to

oesophageal acidification, which may explain why erosive lesions are more common in the older age group (Sonnenberg 1982, Helm 1987).

Although it was described some thirty years ago, the physiology of the main anti-reflux mechanism - the lower oesophageal sphincter (LOS) - is still not fully elucidated. Much of the work has been performed on the opossum sphincter, which physiologically, is similar to that of man. It is thought that there are two main elements to the generation of resting sphincter pressure. Firstly, there is a calcium dependant low membrane potential in LOS smooth muscle (Fox 1978), which produces an intrinsic myogenic tone not affected by neurotransmitter blocking agents such as tetrodotoxin (Goyal 1976, Daniel 1976). Secondly, there is also a neural element. Dividing the vagi in the opossum causes sphincter hypertension, and stimulating the distal ends cause sphincter relaxation, suggesting that the neural control is mainly inhibitory (Rattan 1974).

In the cat, excitatory and inhibitory pathways have been reported (Gonella 1977). Martin in 1986 showed that transient LOS relaxations could be abolished in dogs by vagal blockade, although there was no effect with atropine. This suggests that there may be both cholinergic and sympathetic pathways involved. Hormonal mechanisms have also been explored, with emphasis on the pharmacological effects of pentagastrin, which has been shown to increase sphincter pressure (Giles 1969). The physiological effects of gastrin, however, have been shown to be negligible (Sturdevant 1974, Higgs 1974, Dodds 1975).

Until recently, low resting LOS tone was the major factor implicated in allowing reflux to occur (DeMeester 1976, Dodds 1982, McCallum 1986, Kahrilas 1986). The length of the sphincter zone, and the length of the intra-abdominal segment of the oesophagus are also important in determining gastro-oesophageal

competence (DeMeester - unpublished data, BSG 1988). Welch confirmed in 1982 that the diaphragm also has its part to play in the anti-reflux mechanism of the sphincter zone.

There are other ways in which it is now thought that the LOS mechanism fails to prevent reflux. Firstly, inappropriate, or transient total relaxation of a normal sphincter is known to occur as a separate entity from the physiological relaxation seen associated with swallowing (Dent 1980, Wyman 1984, Dent 1988). This has been shown to be under vagal control in dogs (Martin 1986). Secondly, transient rises in intra-abdominal pressure can overcome either a normal or low pressure sphincter (Dodds 1982). It is now thought that physiological reflux is independent of sphincter tone, and is instead the result of these transient inappropriate sphincter responses. They may also be relevant in pathological reflux. In 1987, Kruse-Anderson suggested that inappropriate responses are more likely to occur after non-propagated contractile activity of the oesophagus, and are more often related to non-propagated waves in those with severe acid reflux. Also in 1987, Gill showed that reflux is more likely to occur during fasting in relation to the gastric component of the migrating motor complex (MMC), which is known to increase intra-gastric pressure. The relative importance of low resting pressure and transient falls in LOS pressure is not yet known. One of the problems encountered when measuring sphincter pressures is the large variation in normal levels (Russell 1987), but mean LOS pressures have been shown to be lower in refluxers than non refluxers (DeMeester 1976, Dodds 1982).

Hiatus hernia - a common finding in patients with severe oesophagitis (Edwards 1973) - may predispose to reflux in some individuals because the extrinsic diaphragmatic support for the LOS is reduced. In 1987, Mittal suggested that part of

the reason for delayed oesophageal clearance in reflux patients was that gastric contents are retained within a hernial sac, and reflux back into the oesophagus as the LOS relaxes, so delaying the overall acid clearance time. In 1988, he suggested that a reflex diaphragmatic contraction occurs as well as increased LOS tone in response to increased intragastric pressure.

There are a number of other factors involved in increasing the exposure of the oesophagus to gastric contents. In 1963, Siegel noted that acid perfusion of the oesophagus in patients with heartburn induced motor abnormalities, and more recently, these have been described by Kjellén (1985) and others (Baldi 1985, Maddern 1986 & Kahrilas 1986), all of whom showed that in patients with oesophagitis, motor activity was impaired, with slower clearance of oesophageal contents. *In vitro* studies on cat oesophagus have shown that oesophageal acid perfusion decreases LOS muscle tone (Biancani 1984), although this has not been shown in man. More recently still, Eriksen (1988) has questioned whether the oesophageal motility disorder is secondary to reflux, and has suggested that it may be a primary disorder leading to reflux, rather than an effect of reflux.

Acid in the oesophagus has been shown to stimulate increased gastric acid secretion (Ward 1970, Giles 1968), with a greater response in patients with severe reflux disease. Most recently, Mulholland (1988) has shown in a small group of reflux patients, that basal acid secretion may also be raised.

Smart in 1986, suggested that in some cases there may be a more widespread motility disorder present, and that there is a relationship with the irritable bowel syndrome.

The role of delayed gastric emptying in patients with oesophagitis is controversial, but has been described in up to 57% of reflux cases (McCallum 1981).

Keshavarzian (1988) has shown that although delayed gastric emptying is common in refluxers, it is not well correlated with the degree of reflux present. There is conflicting evidence that pyloric incompetence may also be involved in increasing bile reflux (Kaye 1974, Matikainen 1981, Krog 1982).

Gastric distension has been shown to increase the frequency of LOS relaxations, with a greater frequency of relaxations in those patients with oesophagitis (Holloway 1985).

The sensory pathways in the oesophagus which lead to the above reflexes occurring are still poorly understood (Howard 1988). It is known that there are mechanoreceptors, thermoreceptors and chemoreceptors present in the oesophageal mucosa, and that most, but not all are under parasympathetic control. A few mechanoreceptors excite sensory pathways passing through dorsal root ganglia in the cat, and are almost certainly sympathetic in origin (Christensen 1984).

The pH sensitivity of the oesophageal mucosa in man remains unproven, and indeed, a recent study by Thompson (1988) showed no difference in oesophageal clearance response in human volunteers following acid or normal saline infusion.

Extrinsic factors

Extrinsic factors are also implicated. The most important of these is undoubtedly cigarette smoking. Nicotine has been shown to reduce LOS pressure and predispose to gastro-oesophageal reflux (Dennish 1971, Staniciu 1972, Schindlbeck 1987). Smoking has also been shown to delay gastric emptying of solids (Miller 1987), and decrease the neutralising effects of saliva, leading to reduced oesophageal acid clearance (Gupta 1988).

Dietary constituents can also have an adverse effect on sphincter competence.

Fat lowers sphincter pressure (Nebel 1972), and leads to increased postprandial reflux (Becker 1988), and so do caffeine, chocolate (Dennish 1972), and the carminative oil containing foods such as onion (Mellow 1988), garlic and peppermint (Chernow 1979).

Alcohol not only reduces upper and lower oesophageal sphincter pressures significantly, but also produces impairment of peristalsis (Hogan 1972).

In 1983, Clouse suggested that psychiatric illness may have a detrimental effect on oesophageal motility.

The effects of psychological stress on oesophageal motility have been studied only in the last few years, and so far results are contradictory, with Richter (1987) showing increased amplitude of oesophageal waves induced by stress, and Soffer (1988) showing no abnormalities of oesophageal contraction, induced by the same stressful stimuli.

The mechanism of damage to the oesophagus

Acid

When gastric fluid is allowed to remain in contact with oesophageal mucosa for a prolonged period, damage occurs. Historically the noxious agent is acid, and most of the studies throughout the 1950's and 60's (Ferguson, Casten, Giles, Goldberg, all quoted in Ch 1) pointed to hydrochloric acid and pepsin as the guilty agents. Few papers, some of which have been mentioned, questioned this, and the belief is still widespread today, despite growing evidence that acid is only one of several factors involved. The other major factors implicated are bile, and the pancreatic enzymes trypsin, and lysolecithin.

Bile

The noxious qualities of bile were first noted in the late nineteenth century by Rywosch on a number of different tissues, including those of the gastrointestinal tract, in animals. It is now thought that some of his results may have been due to laboratory artefact.

Smith in 1914, showed that bile would damage mucosal surfaces but evidence of specific damage to oesophageal mucosa did not begin to accumulate until within the last 25 years. Levrat, and Lambert in 1962, showed that diverting duodenal juices to the oesophagus of rodents produced a severe oesophagitis, although they implicated pancreatic enzymes as the major damaging factor. Davenport, using a dog model, in 1968 demonstrated the disruption of gastric mucosal cell membranes by 10mMolar bile salts, and showed increase flux of Sodium and Hydrogen ions was occurring.

Indirect evidence for bile reflux occurring in hiatus hernia patients was given by Gillison in 1969, when he demonstrated duodenogastric reflux occurring in a large proportion of cases. He carried out some studies on monkeys in 1972, and produced severe oesophagitis and stricture formation by enhancing gastro-oesophageal reflux of bile. Henderson, in 1972 and 1973, produced similar results in dogs by oesophageal perfusion with bile, and bile salt/acid mixtures. Further clues as to a mechanism of damage were given by Safaie-Shirazi et al. in 1975, They used ionic permeability of oesophageal mucosa to hydrogen ion as a measure of mucosal damage, and demonstrated, first in dogs, and then in man that perfusion of acid, and to a greater extent bile/acid mixtures caused massive increases in mucosal permeability. Similar work showing the toxic synergism between acid and bile has been performed by a number of other workers using a rabbit or dog model (Chung 1977, Harmon 1978, Kivilaakso 1980, Lillemoe 1982, 1983, Kidder 1983,

Schweitzer 1984, Lalyre 1984, Kiroff 1987).

In 1978, Pellegrini, using pH monitors, confirmed the presence of alkaline reflux in man, and emphasised the importance of mixed acid and alkaline reflux.

Other aspects of bile damage have also been studied. Bachir in 1976 refined Bernstein's original test and showed that mixtures of bile and acid produced far more symptoms than acid alone, although this is contrary to Pellegrini's findings.

Hopwood in 1981, and Bachir in 1982, demonstrated the cellular disruption caused in human oesophageal mucosa, using bile acid solutions. Salo in 1984 pinpointed the cell membrane and intracellular organelles as the areas primarily damaged by bile.

The biochemical mechanisms are now also being studied. Biancani showed in 1984, in the cat, that calcium pathways of oesophageal sphincter muscle are disrupted by acid perfusion. More recently still, in 1987, Manning has shown that calcium homeostasis is massively disrupted in the oesophageal mucosa of rabbits by bile perfusion. He also found an analogy with the human condition in that it was the deeper layers of the epidermis (Stratum germinativum) which were damaged first due to their higher concentrations of calcium sensitive phospholipases. Also in 1987, Kiroff produced similar findings using the rabbit model, showing damage to the deeper layers of the oesophageal mucosa occurring first, in response to acidified taurocholate solutions.

Disruption of calcium metabolism would also be expected to have effects on the calcium mediated intrinsic LOS muscle tone, and in 1988, Szewczak has produced some evidence for this in cat oesophagus.

Enzymes

The effects of trypsin on the oesophageal mucosa are not so well documented, but were recognised as far back as 1951 by Cross, and by Lambert in 1962. The most interesting recent data on trypsin comes from Lillemoe again. In 1983, he showed that in rabbits, trypsin perfusion at an alkaline pH (7.5), produced oesophageal mucosal erosions and ulceration without significant changes in hydrogen ion flux across the mucosa. This suggested a different mechanism of damage to either bile or hydrochloric acid. The most likely effect is a proteolytic action on the epithelial surface itself, rather than on the deeper layers of the mucosa.

There is indirect evidence that lysolecithin may also be toxic to oesophageal mucosa. Duane, in 1980, showed that this was significantly more damaging to gastric mucosa than bile acid mixtures, producing large sodium and hydrogen ion transmucosal fluxes.

In conclusion

From the above review, the evolution of oesophageal investigations can be seen to have accelerated sharply in the past twenty years, and with it, our understanding of reflux disease has deepened and broadened. However, as with all new investigations, fresh insights into the pathophysiology of a disease inevitably pose new questions. As the "gold standard", 24hour pH studies tell us a great deal about acid reflux, and possibly something about alkaline reflux, but very little about reflux of the actual constituents of gastroduodenal fluid. Correlation between acid reflux,

and either symptoms or endoscopic findings has been shown to be poor (Johansson 1986). Bile, thought to be damaging to the oesophagus, cannot be measured easily by pH study unless its pH is above 7, and the range of pH for bile reflux is an unknown quantity. Any alkaline pH reading has also to be differentiated from swallowed saliva. The way in which 24hour pH studies are assessed is also far from standardized, with a number of different indices being used.

This thesis will develop the theories which have been discussed and following an epidemiological review, will examine present techniques of 24hour pH testing, and look at the different ways of interpreting the data. In particular the various indices in present usage will be compared with a more statistically exact measurement - the area under the curve. The limitations of pH testing will be examined and delineated, with emphasis on the inability to measure bile reflux. Bile salts, and the pancreatic enzymes in refluxate will then be examined in more depth. As little information is available on bile in the human oesophagus, direct measurements will be undertaken with a view to establishing a range for concentration and pH.

As direct aspiration techniques are inappropriate for long term monitoring, methods of indirectly measuring bile reflux will be investigated in the subsequent chapters with emphasis on the use of portable gamma probes to measure radioactively labelled bile reflux. In this way it is hoped that a new technique may be developed enabling ambulatory bile monitoring to be performed.

Oesophagitis - a clinical review

The importance of oesophagitis in late twentieth century medical practice cannot be emphasised enough. To illustrate this point, the upper GI endoscopy records in the Portsmouth region between 1983 and 1988 have been examined. The results of these examinations have been comprehensively stored on a dedicated computer database (Micromed System).

A total of 12,652 examinations were performed up until March 1988. Of these, 8445 were new referrals, and it is from this group that the following figures were obtained. In 1,928 cases (22.8% of the new patient total), a diagnosis of oesophagitis was made (including Barrett's oesophagitis). This compared with 1,573 cases of gastritis (18.6%), with only 777 duodenal ulcers (9.2%), and 504 gastric ulcers (6%). There were also 254 benign oesophageal strictures (3%) and 247 cases of benign ulceration (2.9%). (Fig 5).

When examined by decade (Fig 6), oesophagitis was most commonly diagnosed in the 60 - 70 age group, and the actual numbers diagnosed in the 5th, 6th and 8th decades were very similar. There was a steady increase in the incidence of the disease from the second decade (14.7%) to the eighth decade (26.6%), with a decreased incidence in the over 80's, which may in part be a reflection of the lower number of patients endoscoped in this age group (Fig 7).

These data show that oesophagitis is the commonest disease of the upper gastrointestinal tract seen at endoscopy. It also suggests that although there is an increasing incidence of the disease with age, it is common in all age groups of the

adult population.

The figures represent only the tip of a very large iceberg of disease, as a significant proportion of patients will be treated only by their General Practitioner, or by self medication, and a further unspecified number of asymptomatic cases will remain undiagnosed and untreated in the community.

Assessment of reflux disease is at present performed not only by endoscopy, but by intra-oesophageal pH testing, and the effectiveness of this technique will be evaluated in the following chapter.

Figure 5

New Endoscopic Diagnosis of Upper GI Disease – QA/RNH – 1983–1988

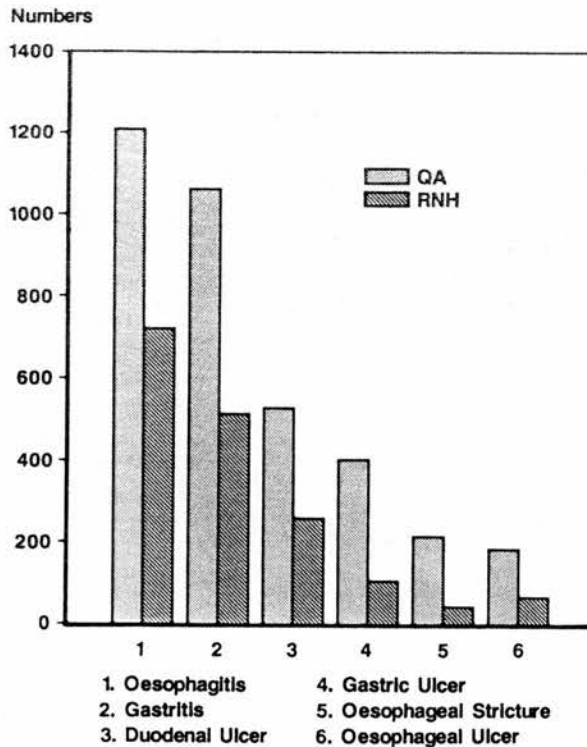

Numbers of Patients with Oesophagitis by Decade - QA/RNH - 1983-1988

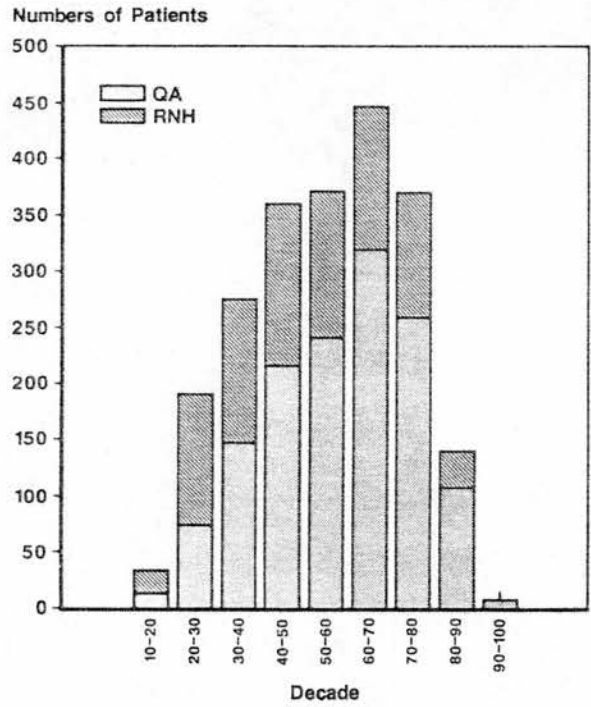

Figure 6

Incidence of Oesophagitis at Endoscopy by Decade - QA/RNH - 1983-1988

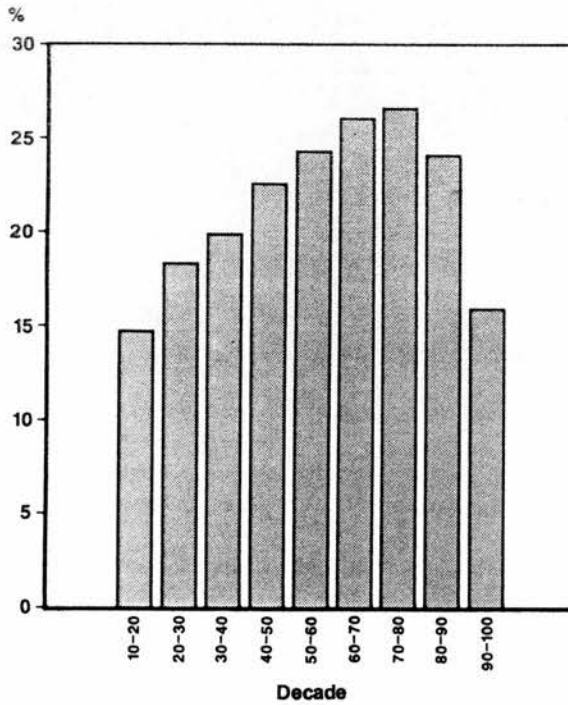

Figure 7

24 hour pH monitoring - the state of the art

Introduction

Monitoring of intra-oesophageal acid reflux using pH electrodes and recording equipment is now the "gold standard" (Silverstein 1980) against which all other tests for reflux have to be compared. It is itself, however, far from standardised, and has certain drawbacks. Schindlbeck, in an outstanding paper in 1987, showed sensitivities as high as 93.3% and specificities up to 92.9% for 24 hour pH testing using percentage time pH < 4 as the only criteria, and other recent studies (Johnsson 1987a) have shown similar results. However, when one examines the protocols in detail, one finds varying criteria for normality, and abnormality. These and similar studies tend to select subjects from the extreme ends of the health/disease spectrum in order to obtain statistical differences between "normal" and "abnormal" groups, and produce high sensitivities and specificities. In particular, by excluding from the normal range those with only occasional symptoms of heartburn, or the asymptomatic volunteer with erythema at the lower end of the oesophagus, it is possible that one may be artificially skewing the normal range for pH values towards zero. For example Schindlbeck takes as his normal subjects those with no symptoms of gastro-oesophageal reflux, excluding even those with occasional symptoms, while Johnsson added a normal endoscopy to these already strict criteria. Schindlbeck's abnormal subjects were selected on symptoms alone, and a number had normal endoscopies. Johnsson's on the other hand, all had proven grade II or III oesophagitis as well as reflux symptoms.

The vexing question of what is, and what is not normal is particularly difficult to answer when severe disease does not correlate well with symptoms, and equally,

symptoms do not always point to actual disease being present.(Johnsson 1987b)

As in many other conditions there is no doubt a continuous spectrum from the normal to the diseased state. Donald, in *The Lancet* in 1987, described diagnostic yields for oesophagitis from 24 hour pH testing of 47%, and in a general hospital setting, these figures probably represent a more realistic expectation.

As a way of comparing a patient's response to therapy pH testing may not be accurate, as it has also been shown that there is a large inter-test variability for individual patients (Wiener 1987, Donald 1987). Shorter testing intervals, using 12 hours or a post-prandial sample also have a lower diagnostic yield (Bianchi 1985).

The pH test will give information about the time exposure of the oesophageal mucosa to acid reflux. It does not, however, tell us anything about the response of the mucosa to the acid (Vitale 1984, Branicki 1984) has shown, along with many other centres, that an abnormal pH test does not correlate well with abnormal endoscopic findings or hiatus hernia. Going one step further than this, Lacey Smith (1989) has shown no correlation between oesophageal pain, and acid reflux episodes. The reason for this remains obscure, but it does strengthen the hypothesis that other factors are involved in the condition.

The most obvious problem with a pH probe is that it will only measure the pH of fluid in the lumen of the oesophagus, and therefore tells us nothing about the volume, or the exact constituents of either refluxate, or swallowed material. It is also possible that luminal pH does not accurately represent pH at the mucosal surface, which may be different due to the effects of surface mucus and saliva. As these factors may all be relevant to the aetiology of oesophagitis, any results obtained on pH data alone may in some cases be severely compromised.

Positioning a tube in the oesophagus is itself unphysiological, and has been claimed to decrease oesophageal pH (Vinnik 1964). However the frequency of swallowing has also been shown to increase with intubation (Evans 1985), thereby reducing the duration of reflux episodes. Salivation may also be increased, with a consequent increase in intra-oesophageal pH.

Having outlined the many drawbacks of the procedure, it is clear, however, that pH testing will give a higher diagnostic yield than other tests of oesophageal function such as manometry, endoscopy/biopsy or barium studies, when used alone, but that combinations of tests will still provide the best results (Behar 1976, Benz 1972).

Materials and techniques.

Electrodes

There are two main types of electrode in use. Firstly the combined glass/reference type (Fig 8), in which a glass and integral KCl reference electrode are housed in the same assembly, and secondly a monocrystalline antimony type, which utilises a separate silver/silver chloride cutaneous reference electrode. Both types are reliable if handled correctly, with the antimony one showing a slightly inferior performance, and shorter working life due to corrosion of the metals used (McLauchlan 1987). They may both soon be superseded by electrodes based on plastic (Evans 1987, Rawlings 1985, Oesch 1986), Vanadium, or ISFETs (Ion sensitive field effect transistors - Duroux 1988).

Positioning

pH recordings are arbitrarily taken from a point 5cms above the lower oesophageal sphincter, as measured by manometry. Other techniques for placing the

probe such as using the acid/alkali junction (Dehn 1986), or an endoscopic measurement, are less accurate (Stoker 1987). Some workers have suggested that the positioning is not important (Walker 1986, Dehn 1987), but recent evidence suggests that, as in the stomach, there is a concentration gradient for gastric contents between distal and proximal oesophagus (Crumplin - bile 1974, Sondheimer 1987, Shaker 1987, Cravens 1987), which would certainly account for the fact that oesophagitis tends to be a distal oesophageal disease. It has now been well proven that out-patient, ambulatory monitoring is both more physiological, and more accurate in predicting abnormality, as well as saving on hospital in-patient facilities (Branicki 1982, Falor 1980, Schlesinger 1985).

Interpretation

There is controversy over how the results of the test are to be interpreted, and these hinge on the exact definition of a reflux episode. There are a number of scoring systems in use. DeMeester, in 1980, described a scoring system based on six different criteria of reflux, each criteria being weighted according to its sensitivity for determining reflux. A final score was obtained by adding the weighted values together. This had the advantage of high sensitivity and specificity, but the disadvantage of being unwieldy. It was also based on small numbers of hospitalized "normal" subjects, whose actual results were not normally distributed.

In 1984, Branicki introduced a frequency/duration index, based on mean frequency, and mean duration of reflux episodes. This was easy to calculate, and produced good discrimination between normal subjects, and those with reflux. It has the theoretical disadvantage that if there are a large number of short repetitive crossings of the pH 4 threshold (as are often seen on testing), then overestimation of mean frequency, and underestimation of mean duration is likely to occur.

Figure 8 - The Radiometer glass pH electrode

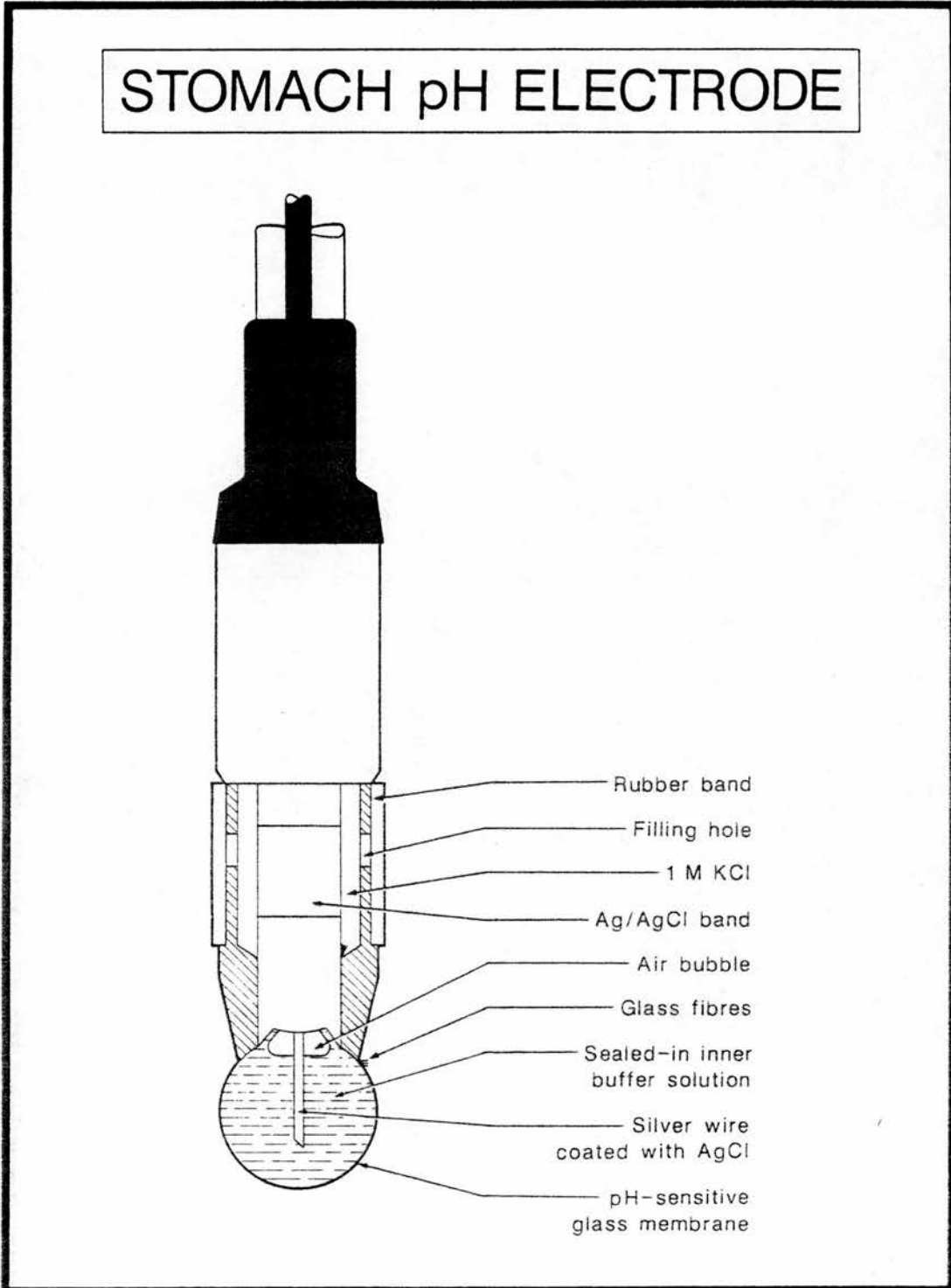

Jenkinson, in 1987, described the use of percentiles to express his normal range for pH testing, and showed high degrees of sensitivity and specificity, but the technique has not found favour in gastroenterology circles.

The simplest measurement of acid reflux, and the most commonly used today, is the cumulative acid index, which is the percentage time during the test that the pH is less than 4. Schindlbeck's paper in 1987 showed that this is in fact more accurate than any of the other scoring systems in discriminating between normal and abnormal. All of these indexes differentiate between reflux occurring in the erect, and the supine positions, with supine reflux being a more sensitive indicator than erect.

The cumulative acid index is purely a measure of the time to which the oesophagus is exposed to acid. It tells us nothing about the volume of acid present, and will not for example differentiate between exposure of the oesophagus to fluid of pH 3.8, or a more acidic, and possibly more damaging solution of pH 1.2.

Aims

As a logical extension to the concept of the cumulative acid index, it is proposed to examine the area under the curve on the graph of pH against time, and more specifically to examine the area under the pH 4 line (Fig 10). This should literally add depth to the former index, indicating the degree of acidity as well as the time exposure of the oesophagus to acid. The hypothesis is raised that, if acid is the only factor involved in the production of oesophagitis, the Area of the curve under the pH 4 line should be a better predictor of abnormality than the Cumulative Acid Index.

As well as studying the area under the curve, it is proposed to examine the

cumulative acid index, and a number of other variables in normal subjects, and those with reflux disease to decide on the best criteria for differentiating between normal and abnormal.

Method

A full medical history was obtained, and a symptom questionnaire (DeMeester 1980, Greatorex 1983, see Appx 1) was filled in for all participants giving a score of 0 to 9 for reflux symptoms.

Normal subjects were a volunteer group, who had no history of gastrointestinal disease, and were allowed a symptomatic score of 0 or 1. As most of the adult population experience occasional heartburn, this was not therefore an exclusion from our normal group. Patients were a consecutive group being investigated for reflux disease or atypical chest pain with a normal exercise ECG.

Most patients underwent upper gastrointestinal endoscopy with the Olympus Q10 endoscope, and a visual grading for oesophagitis was obtained, using a modified grading based on Savary and Miller.

Modified Savary and Miller grading of oesophagitis

- Grade 0 - Normal oesophagus.
- Grade 1 - Minimal oesophagitis - Non-confluent erosions just proximal to mucosal transition zone.
- Grade 2 - Moderate oesophagitis - Confluent, non-circumferential erosions.
- Grade 3 - Severe oesophagitis including ulceration - Confluent, circumferential erosions, and/or ulceration.
- Grade 4 - Benign stricture formation.

The procedures were not all performed by the same operator.

45% (53/118) of patients also had biopsies taken. Initially it was planned to give all biopsies a histological grading, but this proved impractical for two reasons. Firstly, not all endoscopists remembered to take biopsies, and when biopsies were taken, they were often insufficient in number, or not taken from the exact area of oesophagitis. Secondly, as the Q10 endoscope has only a narrow biopsy channel, the specimens were small and rarely included the lamina propria and submucosa, which is necessary for accurate grading. None of the normal volunteers underwent endoscopy.

Manometry technique.

With each subject, prior to passing the pH electrode, oesophageal manometry was carried out in order to ascertain the exact position of the lower oesophageal sphincter (LOS). 1% Xylocaine jelly was used to anaesthetise the nasopharynx, and a 4mm diameter triple lumen manometry catheter passed into the stomach. The catheter contained three lateral openings at its distal end, with a 120° radial orientation to each other, and being situated 5cms apart. The tube was attached via pressure transducers (Lectromed Type 524-1) to a triple perfusion pump (Perfusor VI, B. Braun). A perfusion rate of 1ml per minute was used. Recordings were taken on a chart recorder (Lectromed MX6), calibrated to 2.5mmHg per millimetre, with a chart speed of 50 divisions per minute.

Having taken basal pressure measurements from the stomach, the catheter was withdrawn in 1cm increments, remaining at each point for approximately one minute. In this way the lower oesophageal sphincter was mapped using the station pull-through technique (Dodds 1976). Measurements of wave amplitude, duration and propagation were also taken from the body of the oesophagus, following dry and wet

(5ml water) swallows.

The 24 hour pH test

Prior to use, all pH testing equipment was calibrated at room temperature, using phosphate buffer solutions of pH 1.67, and 6.97.

Following accurate mapping of the position and length of the LOS, and withdrawal of the manometry catheter, the pH electrode was passed via the nose into the stomach, and then gently withdrawn to be placed 5cms above the upper margin of the lower oesophageal sphincter. The position at which the pH readings altered from gastric acidity to oesophageal neutrality (Acid/Alkaline junction) was also measured, in cms from the external nares. The wire was passed behind the ear and beneath clothing to prevent snagging, to the recorder carried on a waistbelt.

Two types of equipment were used. The principal type was a Radiometer GK 280IC combined glass pH electrode attached to a Novo Memolog™ 2A solid state portable 24 hour recorder, with a 12Kbyte memory. This translates to 12,000 data points, with a capability of sampling at 7.5 second intervals for 24 hours. The electrode is 4.5mm in diameter, with a length of 25mm. The cable is of 2.5mm diameter low noise coaxial type, 2.5m in length.

In some patients a Digitrapper Mk.II with antimony electrode was used. This has a 24kByte memory, enabling a 4 second sampling interval to be used. In order that the measurements be kept as physiological as possible, patients (initially fasted overnight) were allowed to carry out normal daily work or leisure activities during the test, and were allowed to eat and drink normally apart from dietary restriction on foods of pH <5 and >7 about which guidance was given in the form of a list of forbidden foods (Appx 2/Jenkinson).

All subjects were asked to refrain from smoking, and taking antacid preparations during the test period. H₂ receptor antagonists were discontinued 2 days prior to testing. During the test each patient kept a log (Appx 3) of activities including eating, drinking and sleeping, as well as recording symptoms as they occurred.

Processing of data

At the end of the 24 hour period, the pH electrode was withdrawn and recalibrated in buffer solutions as above. The information was fed via an RS232 interface unit into computer memory (Ericsson PC). This could then be processed and numerical and graphic hardcopy obtained using an attached printer (Mannesmann Tally MT85). All data was backed up onto floppy disc, with two copies made, and stored on different sites. The basic data on the printout for the two types of recorder were similar:-

- Graph of pH against time, also showing event markers.
- Total time of reflux
- Cumulative Acid Index (% time below pH 4 during 24hours)
- % reflux while erect.
- % reflux while supine.
- Total number of reflux episodes
- Duration of longest reflux (secs).

Although two sets of computer software were used (Vertec and Synectics), the criteria for a reflux episode was the same for both. A reflux was defined as starting when the pH fell below 4, and finishing when the pH had risen above 5 again. In this way, small fluctuations around the pH 4 mark could not produce artefactual readings. Illustrations of typical normal and abnormal pH recordings are shown in Fig 9.

Figure 9 - Normal and Abnormal pH graphs.

NORMAL 24hr pH RECORDINGS

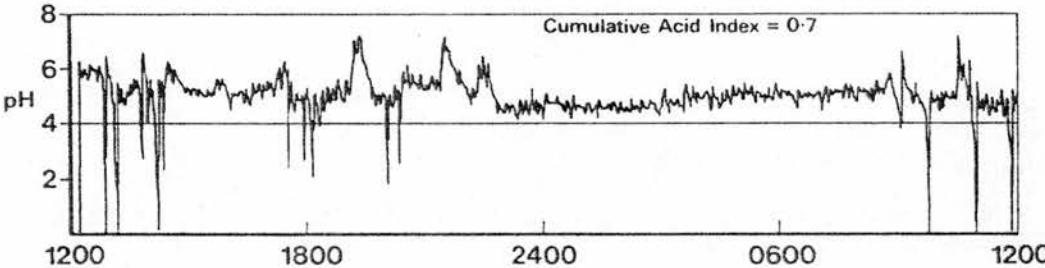
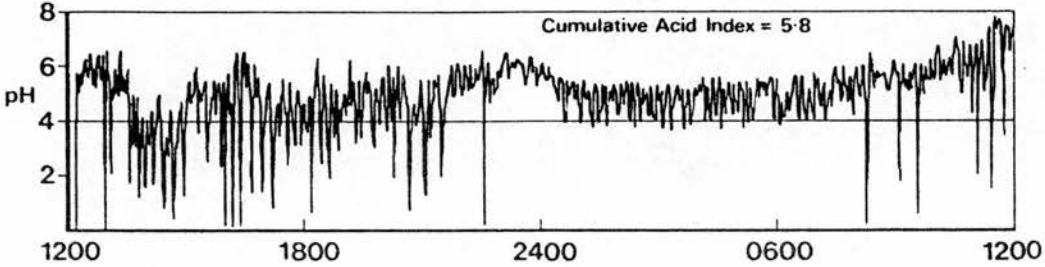

ABNORMAL 24hr pH RECORDINGS

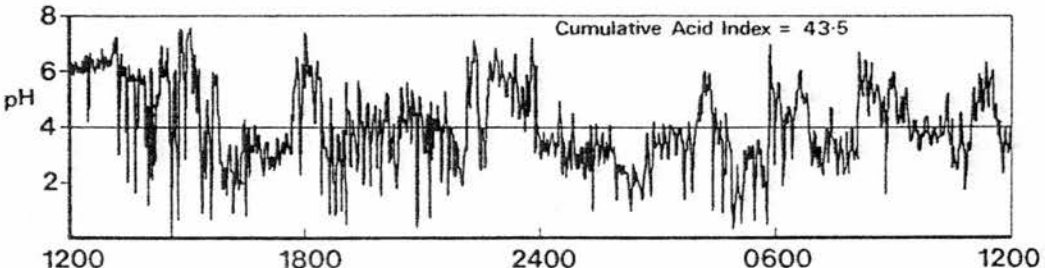
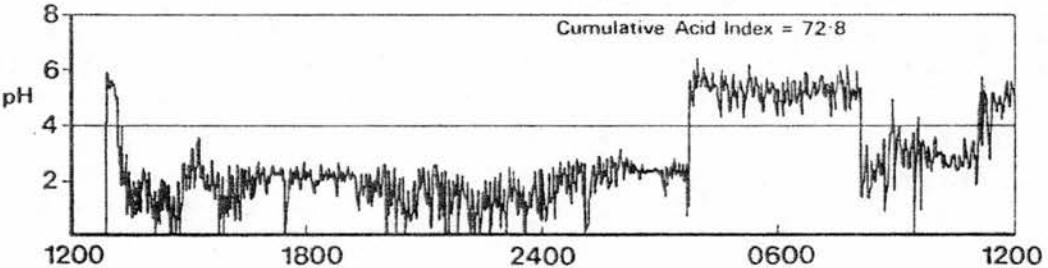

The Area under the Curve

By writing our own additions to the Basic program on the Vertec software, and using a modification of Simpson's rule, the total area of the graph under the pH 4 line (Fig 10) and the erect and supine areas under pH 4 were also calculated. The mean pH was measured also.

Simpson's rule requires division of the area to be measured into an even number of vertical strips, of height y (Fig 10). By adding the sum of the areas of each strip together, the total area can be obtained. The narrower the strip, the more accurate the calculation.

$$\text{The summed area} = h(Y_1 + Y_n + 4 Y_e + 2 Y_o).$$

Where h = width of each strip (the smaller this is, the more accurate the result)

Y_e = sum of all even ordinates

Y_o = sum of all odd ordinates, leaving out Y_1 and Y_n .

All relevant patient data, manometric data, pH data, endoscopic, and symptomatic scores were filed on a computer database (DBase II, Amstrad PCW8512) for optimum collation.



Figure 10 - AUC and Simpsons Rule

The Area of the Curve Under the pH4 Line

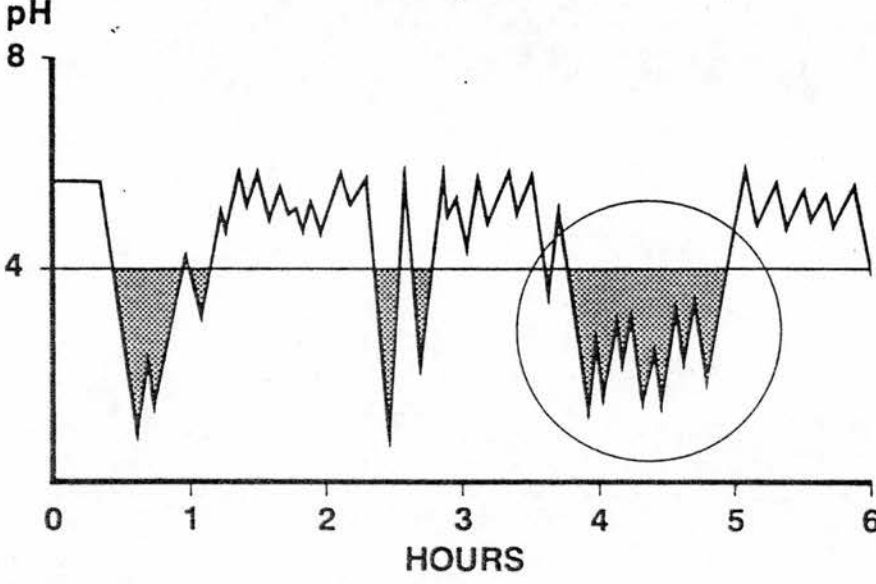
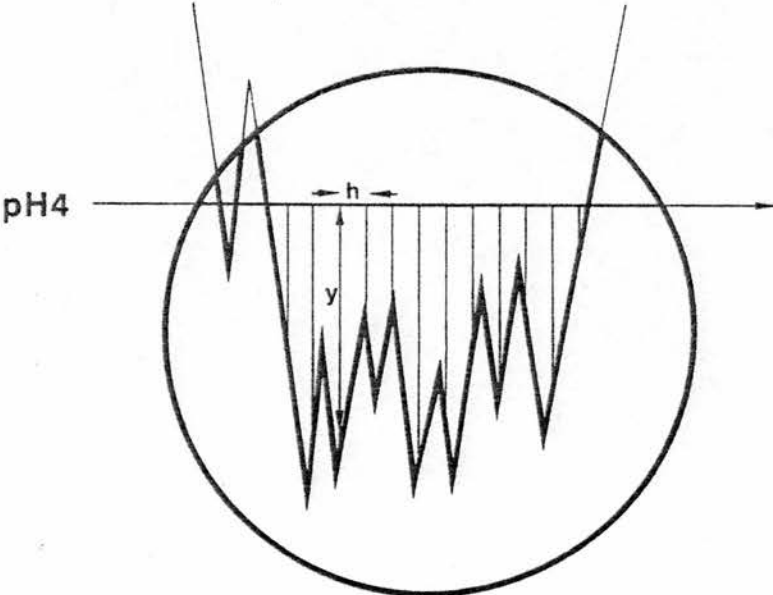

Illustration of Simpson's Rule



Each trapezium of Height y and Width h .

Results

207 combined manometry/24 hour pH tests were performed by the author. There was a 7.7% failure rate for the procedure. 4 patients (1.9%) failed to tolerate the pH electrode, while in 12 patients (5.8%) equipment malfunction led to artefactual recordings.

10 patients who underwent testing while on H₂ receptor blockers, and 22 patients who did not undergo endoscopy were excluded from the statistical calculations.

118 patients, and 41 normal subjects were therefore included in the study. The male:female ratio for the normal group was 25:16, and that of the patients was 64:54. There was no significant difference in the sex ratios (Chi squared = 2.823, $p > 0.1$).

The mean age of the normal subjects (\pm SD) was 34 ± 11.4 , and that of the patients was 49.4 ± 15.0 . There was a statistically significant difference between the two means ($p < 0.001$). There was however, only a very weak correlation between age and CAI ($r = +0.185$ $p < 0.05$), and the age difference between the two groups was therefore thought to be of little importance.

pH electrode drift.

The Radiometer glass electrode was checked for drift over 24 hours by calibration before testing, and recalibration afterwards. Buffers of pH 1.68, and 6.97 were used at room temperature. Mean drift (\pm SD) at 1.68 was $+0.28$ (1.96 ± 0.59) and mean drift at 6.97 was $+0.02$ (6.99 ± 0.19) These are within acceptable limits for pH testing, and will lead to only a very minor reduction in CAI/AUC measurements.

The Synectics antimony electrode was calibrated before each recording, and

showed little change over the 24 hours, as long as the electrode was polished with fine emery paper initially.

Positioning of the pH electrode.

pH probes should be placed in a reproducible anatomical position in the oesophagus in order to make valid comparisons between patients. The acid/alkaline junction (AAJ) is often used to determine the position of the LOS when placing oesophageal pH probes if manometry is not available. I have examined 125 subjects, comparing the manometrically determined position of the LOS with the AAJ. The techniques used to map the LOS and AAJ have already been described.

The mean (\pm 1SD) length of the LOS was 3.5cm \pm 1.3 (Range 1-7cms). In most cases there was a rapid change from pH 1-2 to pH 6-7 within 1cm. The AAJ occurred within the sphincter zone in 72 subjects (57.6%). In 34 of these subjects the transition was at the lower end of the sphincter. In 53 cases (42.4%) the AAJ fell outside the manometrically determined LOS by 1cm or more. 44 (34%) cases were below the LOS (Range 1-13cms, mean 3.4 \pm 2.3), while 8 were above (Range 1-6cms, mean 2.8 \pm 1.8).

The variability of the AAJ in relation to the LOS makes it an unreliable technique for accurately placing pH probes. The probable reasons for this are pH changes in the fundic gas bubble (Emde 1987), and the occurrence of acid reflux during withdrawal of the pH probe through the sphincter zone.

Mean oesophageal pH.

The mean oesophageal pH (\pm SD) over 24 hours was 6.00 \pm 0.33, using the 24 hour readings from normal subjects only.

Multivariate analysis.

Multivariate analysis of two groups of data was performed, to ascertain which criteria were most useful for the discrimination between normality and abnormality. For this purpose, only those patients with endoscopically proven oesophagitis (n = 73) were included in the abnormal group (i.e. those with an endoscopic score of 1 - 4). The normal group consisted of the volunteer subjects with a symptomatic score of 0 or 1 (n = 41).

A full description of the statistical method and results is included in Appendix 4, but the following is a list of the variables tested:

- 1.) Cumulative acid index (CAI%)*
- 2.) Erect CAI*
- 3.) Supine CAI*
- 4.) Area under the curve (AUC)
- 5.) Erect AUC
- 6.) Supine AUC
- 7.) Total number of reflux episodes (Reflux)
- 8.) Duration of longest reflux (Length)
- 9.) Smoker or Non-Smoker
- 10.) LOS pressure (Pressure)
- 11.) Endoscopy score
- 12.) Symptom score

Some items of data (*) were \log_e transformed to fulfil the statistical functions of the parametric tests.

CAI%

Using multivariate analysis (Appx 4), it was shown that there were significant differences between the controls and patients using the criteria (variates) Reflux, Length, Pressure and CAI%. The best discriminators between normality and abnormality were CAI% and Length. Combinations of two or more variates did not increase the discriminatory power of the test. Results of the normal and abnormal pH tests are presented as a cumulative % graph in Fig 11.

There were similar numbers of smokers in the control and patient groups, and this therefore had no discriminatory value when tested.

The Area under the Curve

When the variate AUC was added to the equation, it was found that it had a very similar discriminatory value to CAI%. It was not a better discriminator between normality and disease than CAI%. Fig 12 is a cumulative % graph showing the results of normal and abnormal subjects in whom AUC was measured.

Endoscopy score

The variates CAI%, Length, Reflux, Pressure and AUC were compared for the group of patients with minimal oesophagitis (Endoscopy score 1) and those with moderate to severe disease (Endoscopy score 2 - 4). It was not possible to discriminate between the two groups using any of these variables (Appx 4).

Figure 11

Cumulative Acid Index – Cumulative % Normal v Abnormal curve

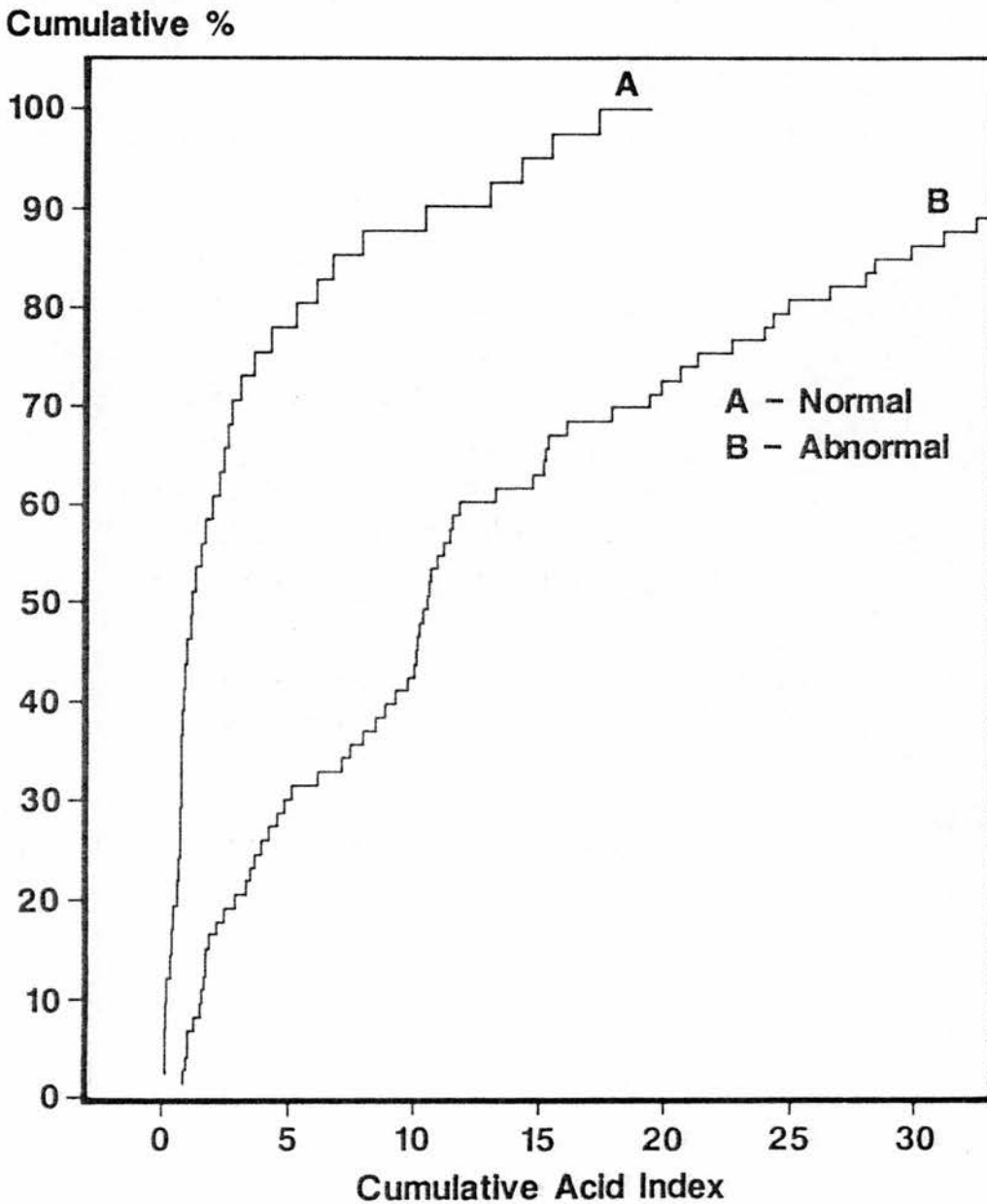
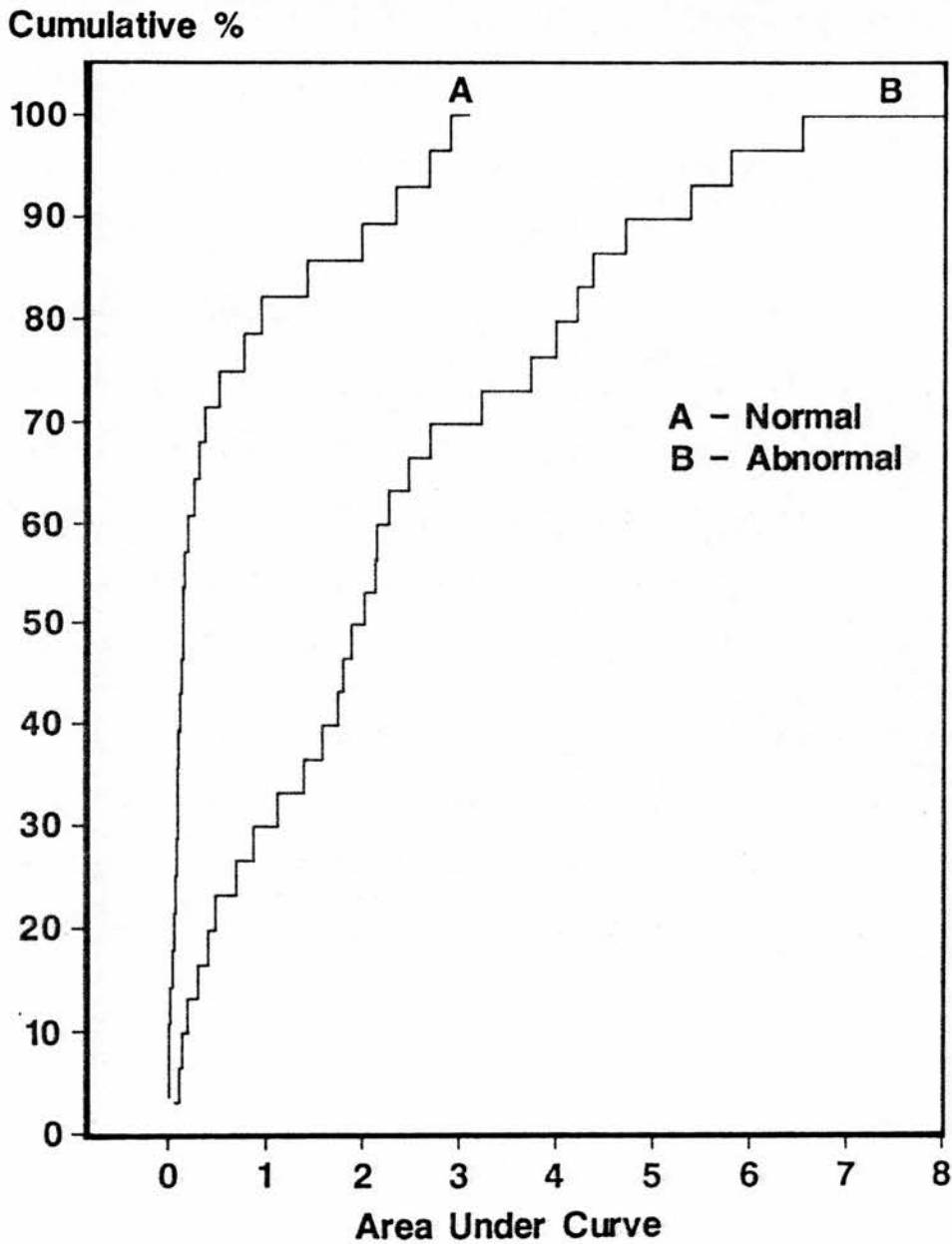

Figure 12

Area Under Curve – Cumulative % Normal v Abnormal



Erect and Supine data

Because of the skewness of the Erect and Supine data, this was not used in the multivariate analysis, but in a separate non-parametric test, the separate erect and supine CAI% data were both good discriminators between control and patient groups. The smaller amount of Erect and Supine AUC data was not tested.

Conclusions

As in a number of other studies, the Cumulative Acid Index has proved to be the best discriminator between normality and disease, although there was a considerable overlap between the normal and abnormal results. Acid is therefore an important factor in reflux disease. However, despite the fact that AUC gives a better indication of the degree of acid exposure, it is not a better discriminator for the presence of reflux disease than CAI.

If the degree of acidity is no more important than the time of acid exposure, then reflux at, for example, pH 3.8 should be just as damaging as reflux at pH 1.2. The pH of refluxing fluid depends on the amount of acid present, and on neutralizing alkalies such as food, saliva (pH 5.45 - 6.06 - Pellegrini 1978), bile and the pancreatic secretions. This study therefore suggests that these factors may have a role to play in the production of the disease.

The poor correlation between the pH test results and endoscopic findings may indicate a fault with either the pH testing technique, or endoscopic assessment but it does confirm Branicki's similar findings in 1984, and also tends to reinforce the idea that factors other than acid are involved in the disease process.

The endoscopy scores were deliberately kept simple, and as only a few

experienced endoscopists were involved, it is not thought likely that major errors in interpretation were made.

If the pH test itself is at fault, then a patient's true reflux status is not being reflected. Some problems with the technique have already been highlighted, but that of reproducibility has only been touched upon. There are few studies of the day to day variations in pH test results. Donald (1987) showed the magnitude of reflux varying by up to a factor of two in six patients undergoing repeat tests. Wiener (1987) showed variations up to a factor of 3.2 in 46 patients. Conversely, Johnsson (1988) showed a reproducibility of 77% in 20 patients undergoing 2 pH tests on consecutive days. Undoubtedly, testing each patient on several occasions and taking a mean would produce a more accurate result for an individual patient, but this would be unacceptable to most patients, and would be very time consuming. The problem of reproducibility can be overcome to some extent by using large numbers of patients. For this pH/endoscopy correlation study 71 subjects were used, and this is thought to be a large enough number for valid interpretations to be made.

The results of these pH studies are dependant on the the efficacies of the tests themselves, but the evidence presented strongly suggests that constituents of oesophageal refluxate other than acid are contributing to the overall picture, and these will be examined in more detail in Chapter 5.

The constituents of oesophageal refluxate.

With the advent of 24 hour pH testing, much is now known about acid reflux into the oesophagus. The evidence outlined in previous chapters suggests that bile and enzymes may also be important in the aetiology of reflux disease, although little is known about the amounts present in the oesophagus, or their patterns of reflux.

Bile salts are normally present in the human stomach with mean concentrations varying from 50 to 500microM/l, and ranges up to 9mM/l (Table 1). In patients with upper gastrointestinal disease, mean gastric bile salt concentrations tend to be somewhat higher, and they are highest in patients who have undergone gastric surgery where they can rise to 19mM/l (Table 2). There is a shallow concentration gradient of bile salts between the pylorus and the oesophagus (Crumplin 1974), but it is still reasonable to conclude that the levels of bile salts in oesophageal refluxate should bear a close relationship to stomach levels.

There is very little data available on intra-oesophageal bile salt levels during reflux, and no work has been performed on the pH of such material. Smith, in 1984, used a four hour continuous aspiration technique to obtain samples of oesophageal refluxate in 40 patients with known acid reflux, and showed mean bile salt concentrations of only 8.9microM/l with a range of 0-100microM/l. More recently Mittal showed negligible bile salt levels in oesophageal samples from 16 patients with oesophagitis. In 1988, Gotley used a Salem sump aspiration method to measure bile salts in 50 patients with reflux disease. He found levels in excess of 200microM/l in 25% of his series. Also in 1988, Johnsson, in Sweden, showed low levels of bile salts

in continuously aspirated samples of oesophageal reflux, varying from 0.8 to 64 microM/l (mean 9.6microM/l).

Apart from the work outlined above, this the full extent of the literature on oesophageal bile concentrations, and clearly is inadequate. Bile salts in the range of 100 - 200microM/l have been shown to be damaging to oesophageal mucosa, when mixed with acid, by Hopwood, and Bateson. In 1988, Gotley showed cytopathic changes to *in vitro* samples of human oesophagus with bile salt levels as low as 50microM/l. This range of levels appears to be well within physiological limits in the stomach, but needs further investigation in the oesophagus.

The "raison d'être" of this thesis is to investigate new ways of evaluating oesophageal reflux, but it was thought necessary to also examine bile reflux using a variation on the more conventional aspiration method, in order to ascertain the range of levels likely to be encountered in our subjects.

Both the proteolytic pancreatic enzymes (Levrat 1962, Mud 1982, Salo 1988) and also pepsin (Goldberg 1969, Kivilaakso 1980) have been implicated in the causation of reflux oesophagitis, but their presence in human oesophageal reflux has not been quantified. Therefore, in order to confirm their presence in human reflux, tryptic and peptic activity were also measured.

Total serum conjugated bile acid assays are available, and have been used successfully on gastro-oesophageal aspirates. The studies by Smith and Mittal were based on continuous suction sampling of the oesophagus over periods varying from 30mins to 4 hours, with the resulting samples being assayed. It is possible that this technique may be diluting any bile present, due to swallowed saliva, and intermittent reflux of non bile containing gastric secretions. Mittal's results were affected by the

presence of food, which produced bile acid-like activity in his assay.

It is difficult to obtain satisfactory samples of oesophageal reflux, due to its intermittent and unpredictable nature, and the dilution effects mentioned. At endoscopy, bile stained fluid is quite commonly seen lying in the oesophagus, often in relation to oesophagitis, or a hiatus hernia. In order to avoid the problems outlined, direct aspiration of oesophageal fluid was undertaken via the suction channel of an endoscope for total bile salt assay, trypsin assay, pepsin assay, and pH measurement.

In the following chapters, the measurement of radioactively labelled bile reflux with gamma probes will be discussed. In order to ascertain the levels of radioactivity likely to be encountered, selected patients with known reflux problems were given $^{75}\text{SeHCAT}$ 10microCi orally 24 hours prior to routine endoscopy, and aspirates were counted for $^{75}\text{SeHCAT}$ as well as being assayed for bile salts. By using known standard concentrations of SeHCAT it was then possible to calculate a specific activity for $^{75}\text{SeHCAT}$ in bile.

The bile assay used was based on an enzymatic, colorimetric system for quantitation of bile acids in serum (Enzabile, Nycomed (UK) Ltd.). 3 Alpha-Hydroxy-steroid dehydrogenase (3 Alpha-HSD), in the presence of NAD oxidises hydroxy bile acids to their corresponding 3-keto steroids under formation of NADH (Fig 13). A yellow tetrazolium salt Nitro Blue is reduced to its coloured formazan in the presence of NADH. Formazan is blue, with a maximum absorption at 540nm.

Tables 1 and 2

TABLE 1
INTRAGASTRIC BILE ACID CONCENTRATIONS
IN NORMAL SUBJECTS

	MEAN ($\mu\text{M/l}$)	MAX ($\mu\text{M/l}$)
Rhodes et al. 1969	100	680
Crumplin et al. 1974	120	580
Goldner et al. 1976	500	2,300
Dewar et al. 1982	51	112
Poxon et al. 1986	430	9,370

TABLE 2
INTRAGASTRIC BILE ACID CONCENTRATIONS
IN UPPER GI DISEASE

	MEAN ($\mu\text{M/l}$)	MAX ($\mu\text{M/l}$)
Oesophagitis (Crumplin)	360	1,800
Gastritis (Goldner)	510	2,900
Duodenal ulcer (Dewar)	514	906
Gastric ulcer (Rhodes)	1,480	5,730
Vagotomy + antrectomy (Poxon)	2,730	21,820
Billroth I (O'Connor)	4,490	17,000
Billroth II (O'Connor)	7,020	19,000

Due to the sensitivity of the test, and the large variations in expected bile concentrations in oesophageal aspirates, most aspirates were diluted with Bovine serum albumen (BSA, Ortho Diagnostic Systems, 22% protein concentration and used in a 1:10 dilution with N Saline (22g/litre)) prior to testing to keep within the range of the test standards. BSA has been shown to enhance the reactivity of the enzyme 3 alpha-HSD from *Pseudomonas testosteroni* (Scholmerch), and is the same diluent used for the bile standards used in the assay. BSA contains measurable quantities of bile acids, and prior to setting up the procedure BSA was run through the assay on its own to assess the efficiency of the industrial bile depletion process (alcohol fractionation). Negligible amounts of bile acid were found in the BSA concentration used of 22g/l. Collins has shown that the pH of the sample does not affect the outcome of the assay, due to the buffering effect of the reagents used.

Method:

Oesophageal sampling was performed on 51 patients undergoing routine endoscopy either at the Royal Naval Hospital, Haslar, or at Queen Alexandra Hospital, Cosham. Gastric samples were aspirated from a further group of 17 patients. The procedures were performed by myself, and other gastroenterologists.

The patient lay in the left lateral position, and intravenous Midazolam or Diazemuls (5-10mg) was administered. Prior to intubation the suction channel was flushed with water and then cleared and dried with air. No suction was performed in the oesophagus prior to sampling. When bile stained fluid was seen within the oesophagus or a hiatus hernia following a straightforward intubation which did not involve excessive retching, a sample of the fluid was taken. The endoscope used in most cases was the Olympus Q10. An endoscopic grading of oesophagitis was performed using the modified Savary and Miller grading described in Chapter 4.

Samples were collected into a sputum trap, connected in series with the suction apparatus. Usually between 2 and 20mls of fluid was obtained.

The pH of each sample was tested using a Standard pH Meter (Radiometer Copenhagen, PHM82). The samples were then spun down in a centrifuge for fifteen minutes to remove any contaminants and solid material, prior to freezer storage at minus 20°C.

Total bile salt levels, tryptic activity and peptic activity were then measured in batches of 12 to 18. For the Bile salt estimations, depending on the colour of the specimens, 1:11, or 1:51 dilutions were found to be most appropriate using BSA as above. 1:100 dilutions are considered to be the maximum practical using the Enzabile kit, and these were only necessary in samples taken from post-gastrectomy patients.

The bile salt assay

This was a manual procedure, performed by myself, and consisted of adding 500microl of buffered enzyme to 200microl of paired samples (BSA diluted), with 500microl blank reagent added to identical paired samples. Three bile standards (again paired) were run through with each assay (5microM/l, 25microM/l and 100microM/l). In order to calculate intertest variability, one paired patient sample was repeated for each assay. After mixing, cuvettes were incubated at 37°C for 15 minutes. A "stop" reagent was then added (500microl of 0.1M/l HCl) to arrest the enzymatic process, and the absorbance of samples tested in a colorimeter (LKB 2074 Calculating Absorptiometer) at a wavelength of 540nm. The mean absorbance of the paired samples was then taken as the final reading. Bile salt concentrations were calculated using a standard curve.

Figure 13 - The Enzabile reaction

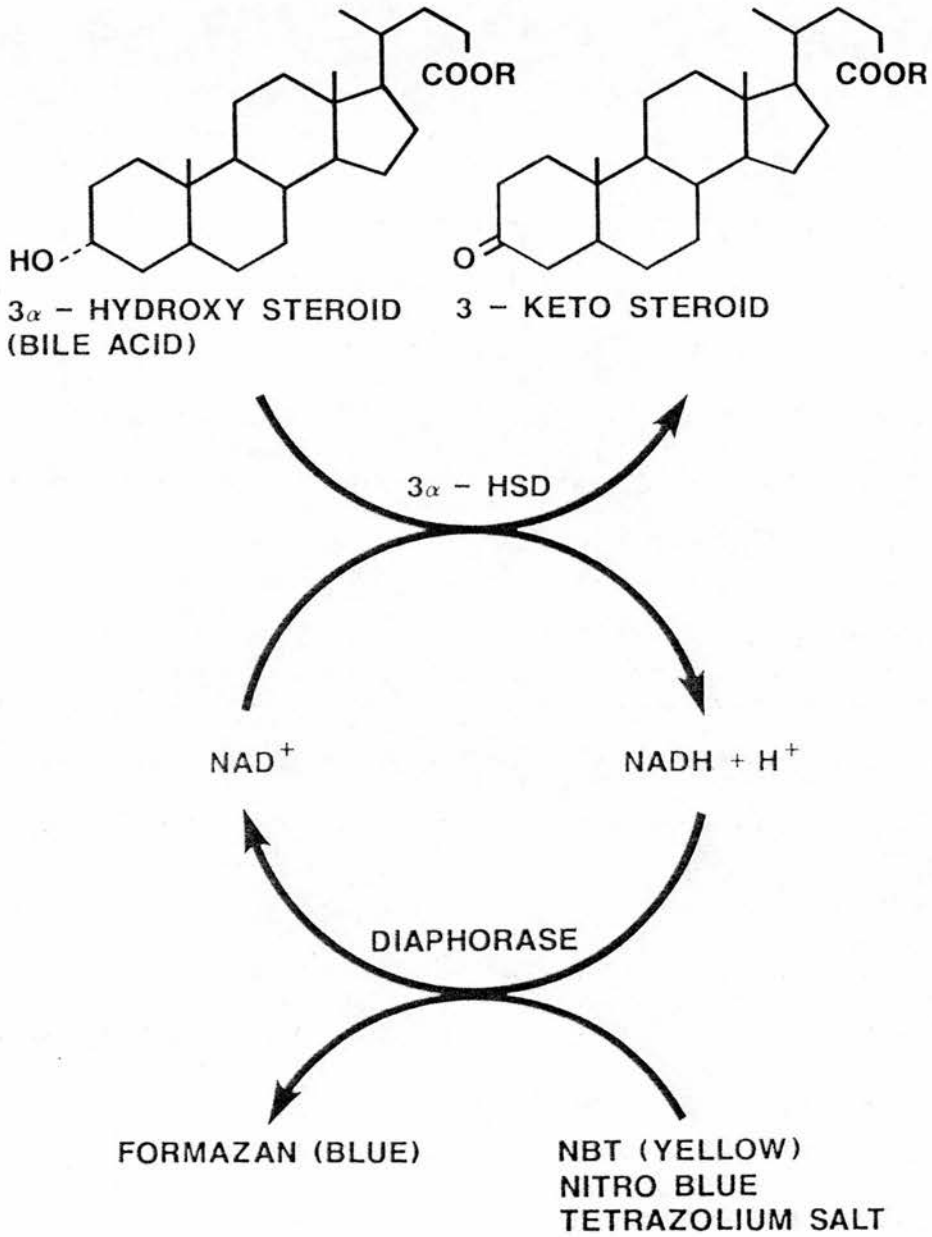

The trypsin assay

The trypsin assay was also based on an enzymatic, colorimetric method, first devised by Lundh in 1957. The assay is based on the principle that trypsin can act as an esterase, and hydrolyse benzoylarginine ethyl ester (BAEE) to benzoylarginine. This reaction can be monitored directly by measuring the increase in absorbance at 253nm which accompanies the formation of benzoylarginine.

The assay was performed at standard pH 8, using a Lambda 5 spectrophotometer (Perkin Elmer), by the Department of Chemical Pathology at Queen Alexandra Hospital, Portsmouth. 10microl samples were added to 3mls BAEE and incubated for 3 minutes at 30 C, and the change of absorbance at 253nm measured over this period. Trypsin standards were run through with each assay. Trypsin activity is proportional to the change in absorbance, and can be calculated using a standard curve, in IU/l.

Normal levels of trypsin in duodenal aspirates are greater than 10IU/l (Bramwell Cook 1967, Murthy 1980).

The pepsin assay

The pepsin assay was developed at The Royal Naval Hospital, Haslar, and is a kinetic method based on the degradation of albumen complexed with bromphenol blue (BPB). Pepsin degrades the complex, releasing increasing quantities of dye, with a colour change which can be measured colorimetrically (Gray 1982).

This assay was performed using a centrifugal analyser (Cobas Bio, Roche), in the Department of Biochemistry at The Royal Naval Hospital, Haslar. 20 μ l samples

were added to 200 μ l of albumen/BPB substrate, and incubated at 37°C for 5 minutes. The change in absorbance at 605nm is measured at 10 second intervals over this period, and is proportional to the pepsin activity of the sample.

Mean peptic activity in samples taken from the normal stomach (including stimulated and unstimulated periods) is 62IU/l (Deakin 1985).

Gamma counting

Six patients had taken oral ⁷⁵SeHCAT 24 hours previously. Samples (100microl) from these patients were counted on an automatic gamma counter (Gamma Master 1277 - 10 head version) as well as undergoing chemical assay. In this way concentrations of radioactivity could be measured in the samples, as compared with standard dilutions of SeHCAT. This fulfilled two purposes. Firstly, it enabled me to obtain accurate quantitative measurements of radioactivity in refluxed material in microCi/ml, in order to put numerical values on the sensitivity range of both the internal and external probes. Secondly it enabled me to obtain a specific activity for SeHCAT, from which, theoretically a total body conjugated bile pool size could be obtained.

Statistical Analysis

Bile salt concentration and tryptic activity were correlated with pH using standard linear regression analysis and Student's t test. Oesophageal samples from post gastric surgery patients were compared with the remaining oesophageal samples, and also gastric samples, using one way analysis of variance (See Appendix 4).

Patients were also divided into two groups. Group A with an oesophagitis

grading of 0 or 1, and Group B with a grading of 2, 3 or 4. Multivariate analysis was performed on the two groups using the three variables pH, peptic activity and tryptic activity, utilising the 2-sample Hotelling's T^2 statistic (Hotelling 1931) in order to examine the relationship of the variables to severity of oesophagitis.

Results.

Study numbers

Fifty one oesophageal samples were taken, and 17 gastric samples. Eight samples were excluded from the oesophageal correlation studies as the patients had undergone gastrectomy or a gastric drainage procedure.

In 32 out of the 43 patients (74.4%) with intact stomachs, there was related, macroscopic oesophagitis. Due to limited volumes of specimen, one patient sample was not assayed for trypsin, and two for pepsin.

Inter/intra test variation

As the bile salt assay was a manual technique, within run, and between run analysis was performed.

The standard error of the difference between two means (SEDM) was calculated for 50 paired samples, measuring the absorbance of each sample. The two means were 1001.11nm and 993.65nm. The SEDM was 7.31. There was therefore no significant difference between the two means for the paired samples ($p > 0.3$), and intra test variation was insignificant.

Seven runs were performed, with a sample of known concentration in each run. The coefficient of variation between tests was 4.7%, which is acceptable for a steroid assay.

The standard curve was linear within the range of bile concentrations used ($r = +0.998$, Fig 14)

Bile

There was a positive correlation between bile salt concentration and pH ($r = +0.427$, $p < 0.002$, Fig 15). Twenty-one out of the 43 samples fell in the pH range 4 - 7. Bile salt concentrations are shown in Table 3.

Trypsin

Forty two samples were assayed for trypsin. The levels ranged from 0.1 - 19.6iu/l, with a median of 1.5iu/l. There was a strong positive correlation between tryptic activity and pH as shown in Fig 16 ($r = +0.589$, $p < 0.001$). Twenty-one out of 42 (50%) samples fell into the pH range 4 - 7.

Pepsin

Forty samples were assayed for pepsin, with a range 1 - 250iu/l, and a median of 27iu/l. Linear regression analysis was not performed on these results, for reasons which will be explained, but the results are shown graphically in Figure 17.

Specific activity of $^{75}\text{SeHCAT}$ in bile

Six patients had previously taken oral $^{75}\text{SeHCAT}$, and samples were counted in an automatic gamma counter to compare with standard dilutions of $^{75}\text{SeHCAT}$.

<u>Bile activity</u>	<u>Bile conc.</u>	<u>Specific Act.</u>
1. 0.015microCi/ml	96microM/l	0.14microCi/microM
2. 0.003microCi/ml	163microM/l	0.01microCi/microM
3. 0.021microCi/ml	409microM/l	0.035microCi/microM
4. 0.002microCi/ml	68microM/l	0.024microCi/microM
5. 0.001microCi/ml	49microM/l	0.023microCi/microM
6. 0.0006microCi/ml	4microM/l	0.1microCi/microM

Figure 14 and Table 3

Bile Standard Reference Curve (5, 25, and 100microM/l)

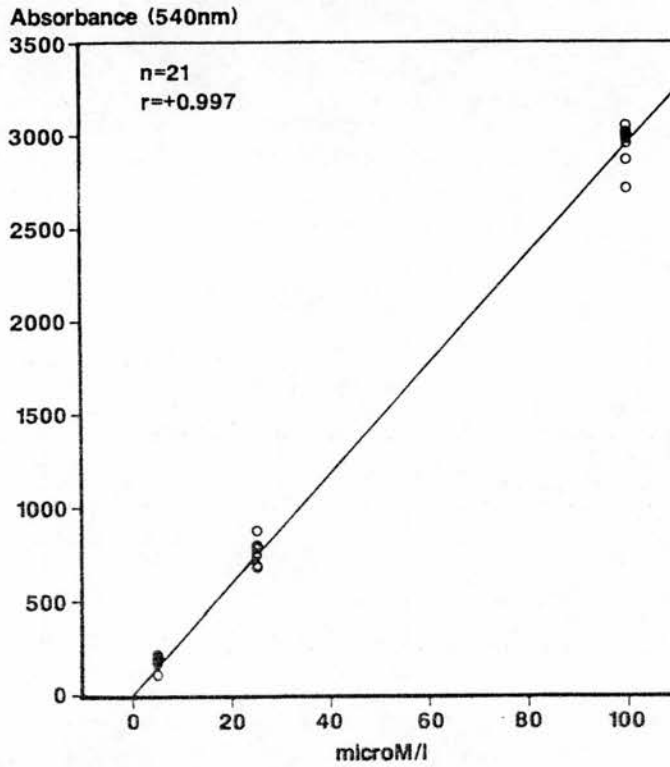

pH and Bile Salt Concentrations

	OESOPHAGEAL ASPIRATE (INTACT STOMACH)	OESOPHAGEAL ASPIRATE (POST SURGERY)	GASTRIC ASPIRATE
NUMBER OF ASPIRATES	43	8	17
BILE SALT CONCENTRATION MEDIAN (RANGE)	133(15-5404)	1390(230-7453)	157(4-6736)
pH MEAN (± 1 SD)	4.2(± 2.0)	5.8(± 1.8)	3.3(± 2.1)

Figure 15 - Graph Bile

pH and Concentration of Oesophageal Bile (Excluding Gastric Surgery Cases)

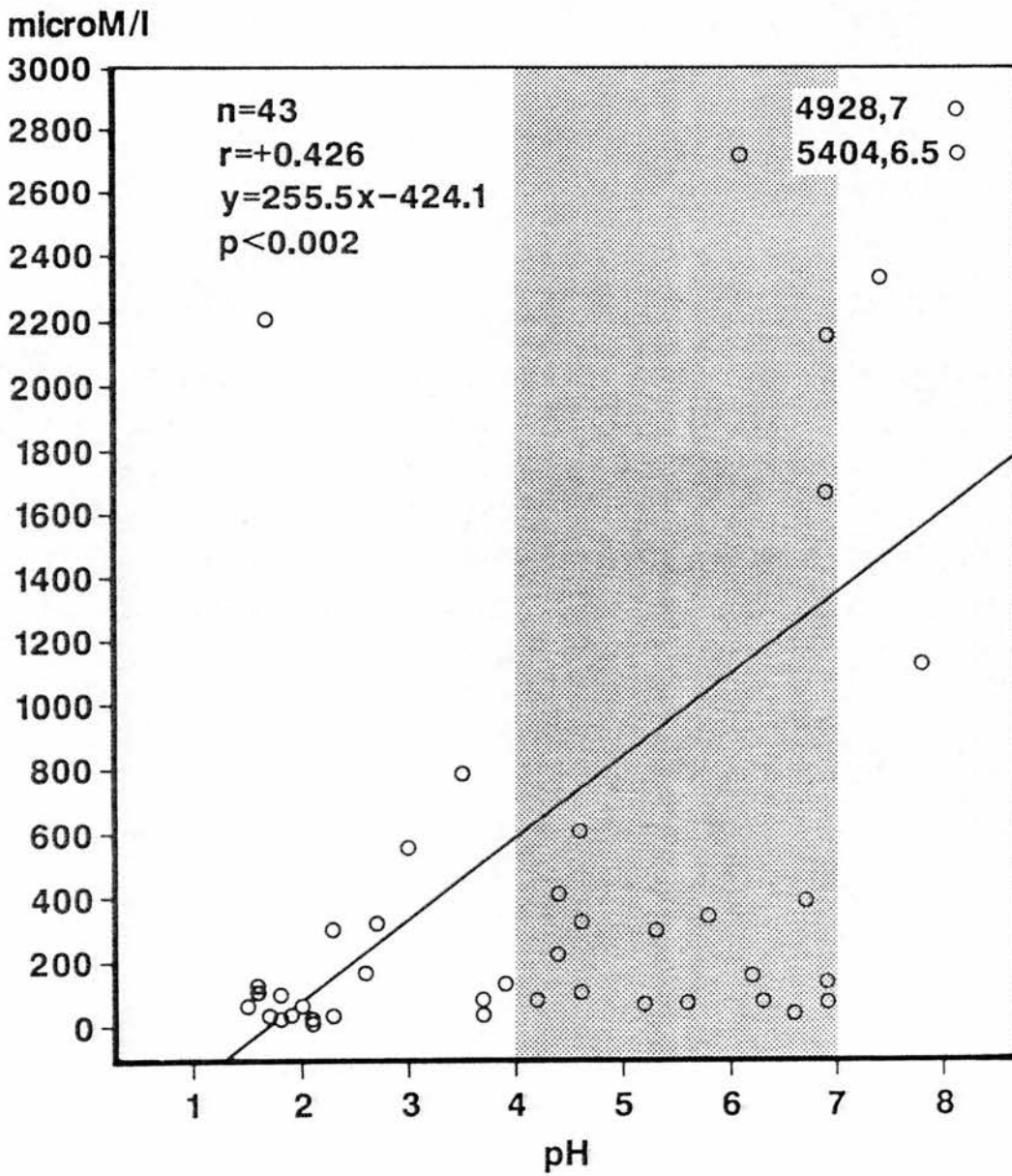

Figure 16 - Graph Trypsin

Trypsin Activity in Oesophageal Reflux Measured Against pH

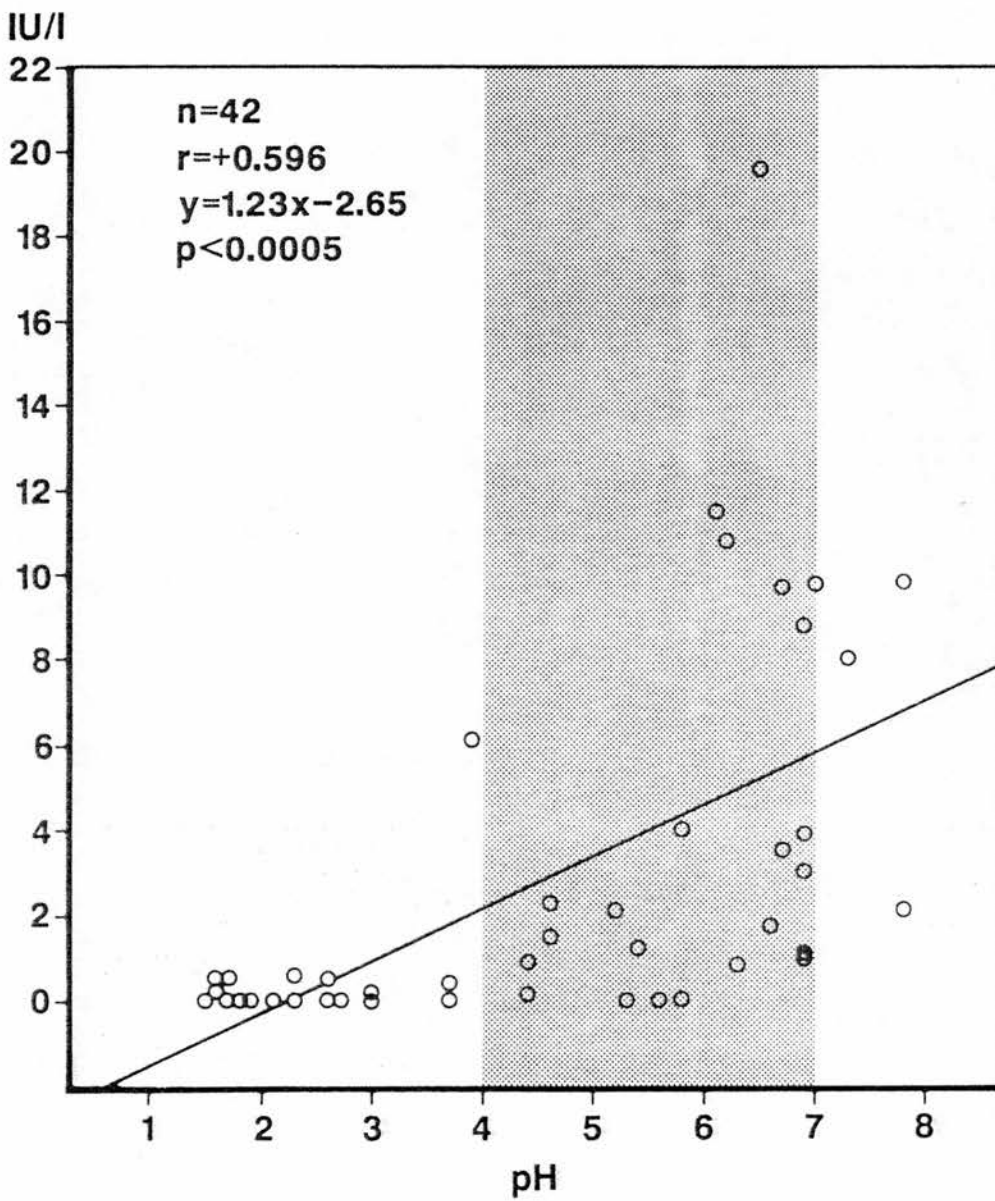
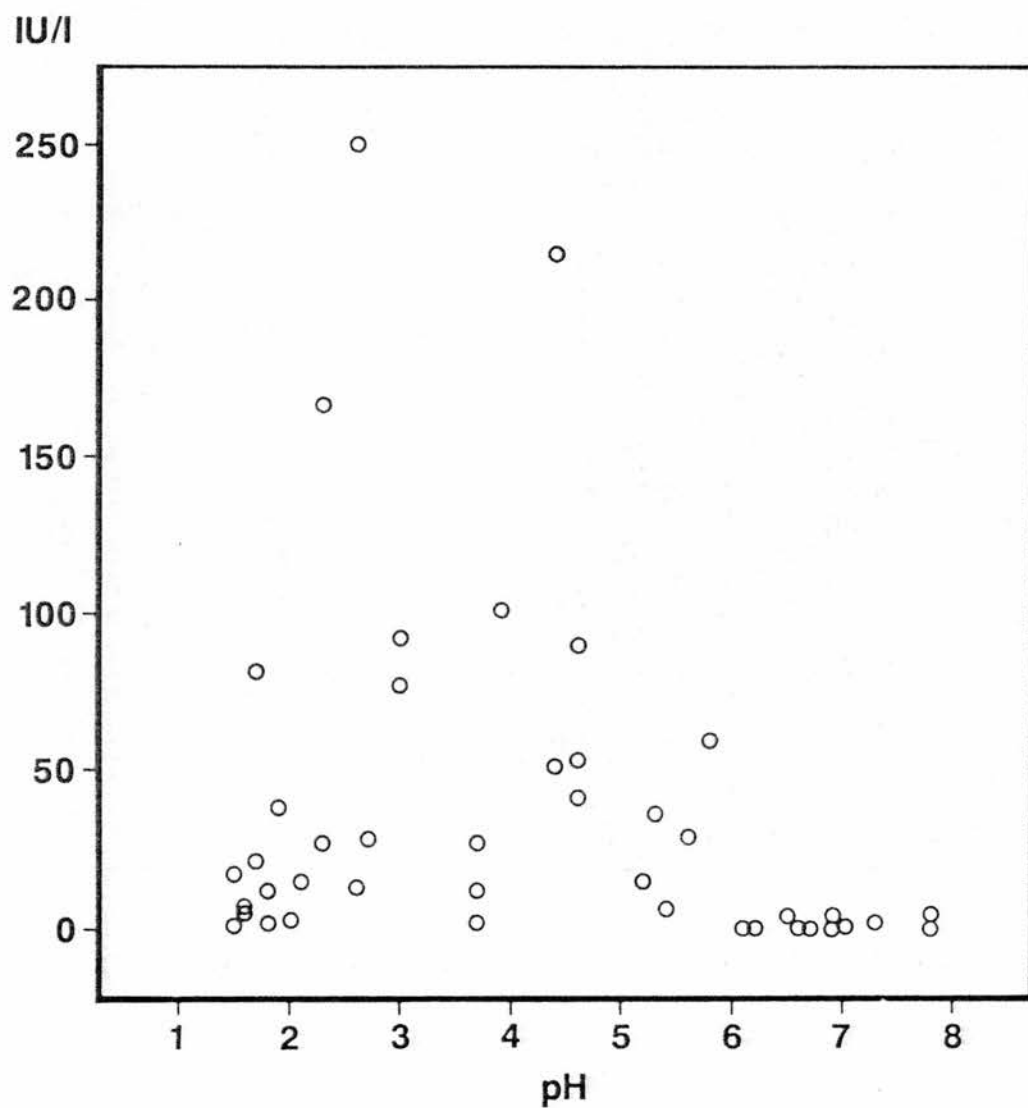

Figure 17 - Graph Pepsin

Pepsin Activity in Oesophageal Reflux Measured Against pH



Comments:

This study was performed in order to ascertain the probable levels of bile salts, tryptic activity and peptic activity likely to be encountered in oesophageal refluxate. The technique of endoscopic aspiration is not one that has been used before, but for our purposes it is thought to be valid. Although the reflux seen may not be totally physiological, i.e. it may in some cases be secondary to intubation - it nevertheless will have the same constituents as true reflux, and at worst represents levels and pH of bile seen in the fundus of the stomach during the fasting state.

Bile Salts

The wide range of bile salt concentrations reported here are greater than those previously found in the oesophagus. However it does tend to bear out the hypothesis that bile salt levels in refluxate should be similar to levels in the stomach. The levels reported are well within the range which can cause oesophageal mucosal damage, which was evident in 74% of the endoscopies.

The highest levels encountered are comparable with hepatic duct bile salt levels (10 - 20mM/l, pH 7.8 - 8.6), but not gallbladder bile (50 - 200mM/l, pH 7 - 7.4) (Ganong 1979)

It can be seen that the bile salt concentrations in the post surgery samples were considerably higher than in the remainder, and they were also more alkaline. There were significant differences between the mean values of oesophageal samples from the post-gastrectomy group, and the intact stomach group. There was no significant difference between the mean values of the oesophageal samples/intact stomach group and the the gastric samples group (One way analysis of variance / Appx 4)

pH

Duodenogastro-oesophageal reflux is often described as "alkaline reflux", but these results suggest that this is a complete misnomer. Bile salts were found in samples throughout the pH range from 1.5 to 7.8, with the mean pH being 4.2. Only a very small proportion of the samples had a pH above that found in the normal lower oesophagus (Normal pH 6.00 ± 0.33).

The accepted level below which acid reflux is measured during pH monitoring is pH 4. Alkaline reflux has also been measured in this way using pH 7 - 7.5 as the lower limit. 49% of the above samples, on bile salt assay, and 50% of samples on trypsin assay fell into the range between pH 4 and pH 7, and so would have been totally missed as reflux episodes, by a standard 24 hour pH test, despite their potentially damaging nature. The results suggest therefore, that pH testing is very insensitive to bile/trypsin reflux, and emphasises the need for a separate way of monitoring what seems to be a common phenomenon.

From the previous chapter, it could be seen that there was a considerable overlap between the normal and abnormal ranges for pH tests, and one of the reasons for this could well be the potentially damaging "missed" bile reflux between pH 4 and pH 7.

Trypsin

Pancreatic enzymes have been implicated in the aetiology of oesophagitis, and we have therefore measured trypsin as being a representative enzyme in our samples. There was very little enzyme activity when the pH of the aspirate was below 4. This was to be expected, as trypsin is inactivated at acid pH. There was a strong positive correlation between increasing pH, and increasing trypsin activity, and the highest

enzyme activity levels were seen when the pH was above 6.

In some samples, trypsin activity was very low, even when the bile concentrations rose above 1mM/l. This may in part have been due to enzyme degradation occurring during freezer storage, especially in the lower pH range.

It is unlikely that trypsin plays any part in the production of oesophagitis, when reflux is acid. However, when duodenal contents reflux into the oesophagus in higher concentrations, and the pH is also higher, tryptic activity can approach that in the normal duodenum, and may lead to a form of autodigestion of the oesophageal mucosa.

Pepsin

The results of the pepsin assay are more difficult to interpret, and linear regression analysis was not thought to be a valid test on these measurements. Small numbers of endoscopic specimens were collected weekly over a several month period, making freezer storage necessary, although it is known that this may lead to enzyme degradation, especially when the pH is below 1.5 (Deakin 1984). This has almost certainly lead to artefactually low peptic activity in many of the samples in which the pH was low. This can be seen on the scattergram (Fig 17), where there is a cluster of low readings in the pH band 1-2. There is a further cluster of low readings when the pH is above 5, and this is due to physiological inactivation of enzyme in the alkaline pH range.

There are two reasons justifying presentation of the results of pepsin assay. Firstly, pepsin has not been measured before in the oesophagus, and secondly, despite the underestimates caused by storage artefact, peptic activity was still found to be present above pH 4, in the area missed by pH testing.

There are at least seven pepsin isoenzymes (Etherington 1967, Samloff 1969), some of which are active in the higher pH bands. Little is known about the ratios of pepsinogen 1, and the other isoenzymes. It may be that some patients with oesophagitis have higher concentrations of the higher pH band isoenzymes (Ref - personal communication - S Gray).

Peptic activity was in most samples inversely proportional to pH, and gastric levels were seen in a number of cases, where the pH was below 5. The proteolytic nature of this enzyme again makes it a possible factor in the causation of oesophagitis.

Endoscopy Score

We have shown no correlation between the degree of oesophagitis and concentration of bile salts, tryptic activity or pH in oesophageal refluxate. This suggests that other factors, such as the sensitivity of the oesophageal mucosa to noxious agents, are also involved.

Specific activity

In practice, there are a number of factors which make measurement of specific activity inaccurate using oesophageal sampling. The main variable is the physiological $\frac{1}{2}$ life of $^{75}\text{SeHCAT}$, which although on average is about 2.4 days, is unpredictable between patients, with a normal seven day retention range varying from 15-80%. The amount of retained $^{75}\text{SeHCAT}$ would need to be measured immediately prior to aspiration of the sample to overcome this problem.

Another variable is much more difficult to quantify. On spinning down each sample, there appeared to be a green residue which was thought to consist of food residue. However a sample run through the gamma counter produced a higher reading for radioactivity than its supernatant, showing that it contained $^{75}\text{SeHCAT}$ labelled bile. It is likely that this residue contained mainly dissolved bile salts mixed with it, but also small amounts of precipitated bile salts, the amount of precipitate depending on the acidity of the sample. The more bile salts are precipitated the lower the concentration of remaining bile/radioactivity there is to be measured in the supernatant. As concentrations are low, this makes specific activity readings unreliable. For the accurate measurement of total bile salt pool, these measurements would be better carried out on duodenal bile, or gallbladder bile.

Due to the problems outlined above, specific activity of $^{75}\text{SeHCAT}$ in the samples varied, although three samples were of comparable activity. It is clear however from these measurements that there are only very small amounts of $^{75}\text{SeHCAT}$ in bile reflux, as is only to be expected, when the oral dose is as low as $10\mu\text{Ci}$, most of which will be distributed in the small bowel and gallbladder at any one time. The relevance of these results will become clearer in the next chapter.

Conclusions

It has been shown that at least three potentially damaging agents are present in oesophageal reflux other than hydrochloric acid. Enzyme activity is pH dependant, and it has been shown that in the relevant pH bands, gastric and pancreatic enzymes are often present in sufficient quantity to cause damage.

Bile reflux is often described as "alkaline reflux", but these results suggest that this is a misnomer. Bile was found in samples throughout the pH range, with the mean pH being 4.5. Only a very small proportion of the samples had a pH above that found in the normal lower oesophagus.

Half of these samples would have been missed as reflux episodes by conventional oesophageal pH-metry. These results therefore cast some doubt on the true value of pH testing for measurement of the reflux of duodenal contents into the oesophagus, and suggest that further techniques are required for the separate monitoring of bile and trypsin.

In Chapter 6, a new concept in measurement of bile reflux will be described.

The external detection of gamma labelled bile

"We have examined the hypothesis that a portable external gamma probe, placed over the sternum, facing the oesophagus, can be used to measure radioactively labelled bile reflux."

Introduction.

Having ascertained that bile reflux cannot usefully be measured using presently available techniques, the above hypothesis was raised.

Radioactive labelling of bile has been used for diagnostic purposes for some years, but the techniques all use whole body counters or gamma cameras rather than portable equipment, to detect gamma emissions.

Oesophageal reflux has been detected using scintiscanning techniques (Fisher 1975 & 1976, Kaul 1985 & 1986), but these have all involved ingestion of a $^{99}\text{Tc}^m$ labelled colloid, rather than using an intrinsically labelled bile acid. Radiolabelled bile has been detected in the stomach (Nicolai 1980), but has not been looked for in the oesophagus.

Small portable solid state gamma detectors based on Cadmium Telluride have been available in the clinical field for some time (Walford 1973, Entine 1974), but have not been widely used. They have been shown to be effective in detecting early loss of renal function following transplant surgery (Smith 1981), but until now, have not been used to detect radiolabelled bile.

By combining radiolabelling techniques with portable gamma monitoring equipment it is hoped that a more accurate method may be developed for the measurement of bile reflux, in the ambulatory subject.

Aim

The aim of this chapter is to combine the techniques outlined above, and to ascertain whether the new method will accurately measure bile reflux. The possibility of combined pH and gamma monitoring will also be examined.

More specifically, the sensitivity of an external gamma detector will be examined with reference to radiolabelled bile, initially in a phantom model, and then in human subjects.

Prior to human studies, certain basic information had to be obtained, and techniques needed to be developed.

Firstly a suitable radiolabel had to be chosen, and a suitable gamma detector obtained. The Memolog computer software discussed in the previous chapter had to be adapted to read gamma counts either as a single data set, or as data in parallel with pH monitoring. For program manipulation, I had the invaluable help of Dr Alec Houston, Consultant Physicist to the Department of Nuclear Medicine, RNH Haslar, and with his help, the necessary program modifications were made, and improved upon, over the period of initial development of the technique.

Vertec Scientific, who provided me with the Memolog 600 System, were able to provide a compatible, portable CdTe gamma detector.

Before choosing a radiolabel, the relative advantages of $^{75}\text{SeHCA}$ T and $^{99\text{m}}\text{Tc}$ -HIDA were studied.

The Cadmium Telluride gamma detector

Cadmium Telluride (CdTe) is a complex synthetic semiconductor crystal, which behaves in a similar way to a diode. It is energized by a bias voltage of 60-80Volts, (unlike scintillator/photomultiplier tubes which need a bias voltage of 1500Volts). Gamma photons hitting the crystal matrix produce small voltage alterations technically known as "free drift of mobile holes and electrons" (Bell 1971, Sinclair 1986) which are directly proportional to the amount of radioactivity being measured. Different crystals are sensitive to different photon energies, depending on the growth characteristics of the crystal matrix, and also its dimensions. The larger the crystal the more sensitive it is to the higher gamma energies. The range of detection for CdTe crystals is from 20KeV up to 300KeV.

As very small currents are involved, in the region of nanoamps, the signal from a crystal needs to be boosted by a charge sensitive preamplifier. Current is then fed to an amplifier, which converts the signal from analogue to digital form for display, or information storage purposes. Unlike scintillation detectors, CdTe will function well at room temperature, and also at body temperature, making it ideal for prolonged internal or external counting in human subjects.

The gamma detector available to me was purpose built for use with the Memolog 600 system, and consisted of a 16mm diameter, 2mm thick disc of CdTe, encased in a lead lined aluminium housing. Within the same housing, the CdTe crystal was connected to a miniature preamplifier. The preamplifier was powered

from the Memolog batteries, and signals from it were fed by 2 metres of coaxial cable, back to the Memolog for storage in the ROM memory, in the same way as pH data. Storing counts from a gamma detector in this way is a relatively new, but reliable technique (Davies 1985). (Fig 18 - 20)

Figure 18

EXTERNAL
CdTe GAMMA PROBE

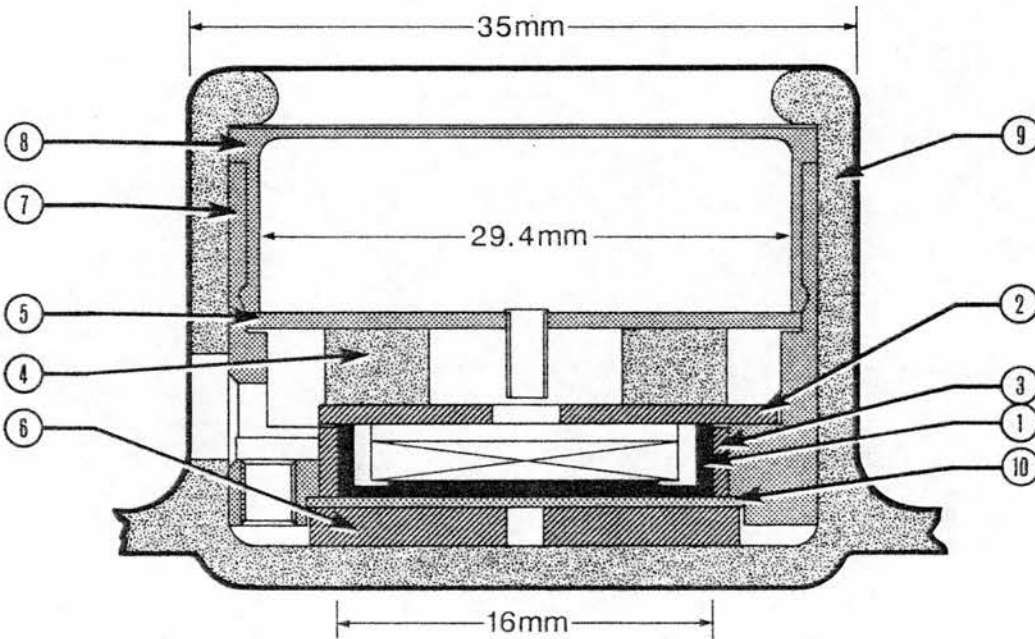

- LEGEND:
- | | |
|---------------------------|----------------------------|
| 1. CdTe CRYSTAL | 6. LEAD COLLIMATOR |
| 2. 1mm LEAD SHIELDING | 7. STAINLESS STEEL HOUSING |
| 3. 1mm LEAD SHIELDING | 8. HEADPLATE |
| 4. RUBBER MOUNTING BLOCKS | 9. RUBBER COLLAR |
| 5. PREAMPLIFIER | 10. ALUMINIUM PLATE |

Figure 19

Typical Wiring of a Cadmium Telluride (CdTe) Detector

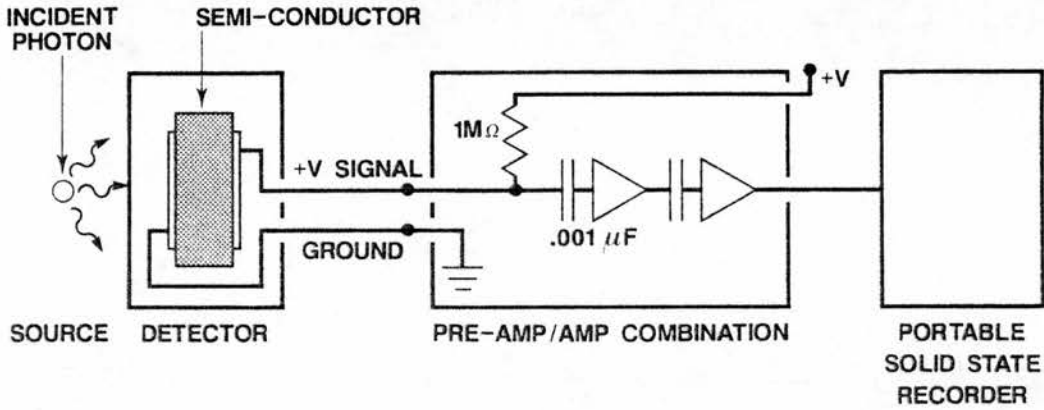
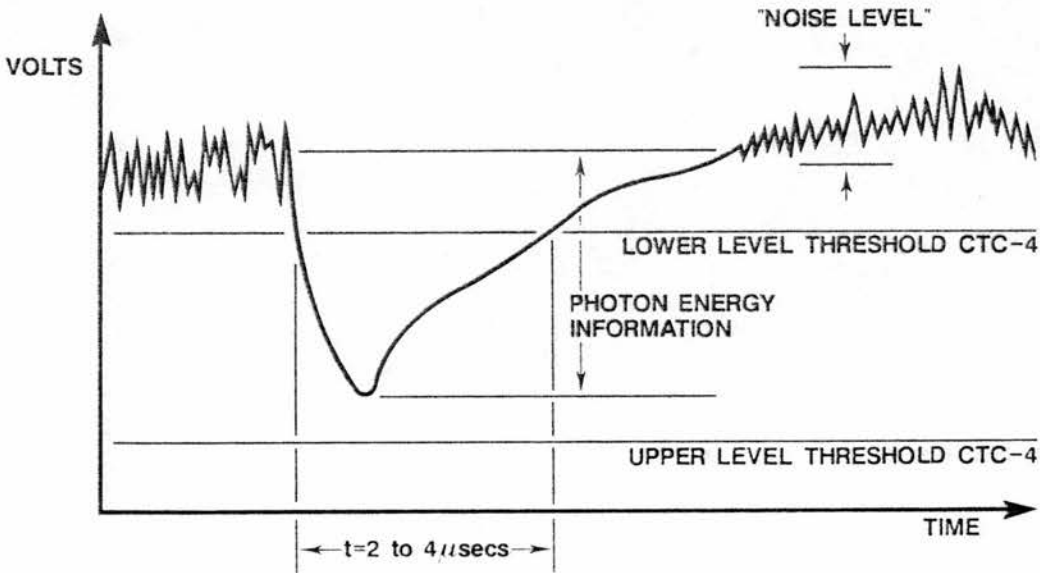

Figure 20

Pre-Amp Output Signal



The Radiolabels

1.) ^{75}Se HCAT (Selenium HomoCholic Acid Taurine)

This substance is a synthetic bile analogue (Homocholic acid taurine) to which a $^{75}\text{Selenium}$ label has been attached. It has been shown to behave in an identical fashion to the naturally occurring bile conjugate taurocholic acid (Delhez 1982, Merrick 1982), and mixes fully with the endogenous bile pool after oral ingestion. At present it is used mainly as a test for bile malabsorption from the small bowel (Nyhlin 1980, Meller 1981, Merrick 1985, Sciarretta 1986), and has also been used to study faecal bile loss in non ileal disease (Van Tilburg 1987).

^{75}Se has a physical half-life of 123 days, but although ^{75}Se HCAT takes part in the enterohepatic circulation, its biological half-life is only 2.6 days (Merrick 1982), as in each pass of the terminal ileum, a part is lost into the colon and excreted.

Figure 21

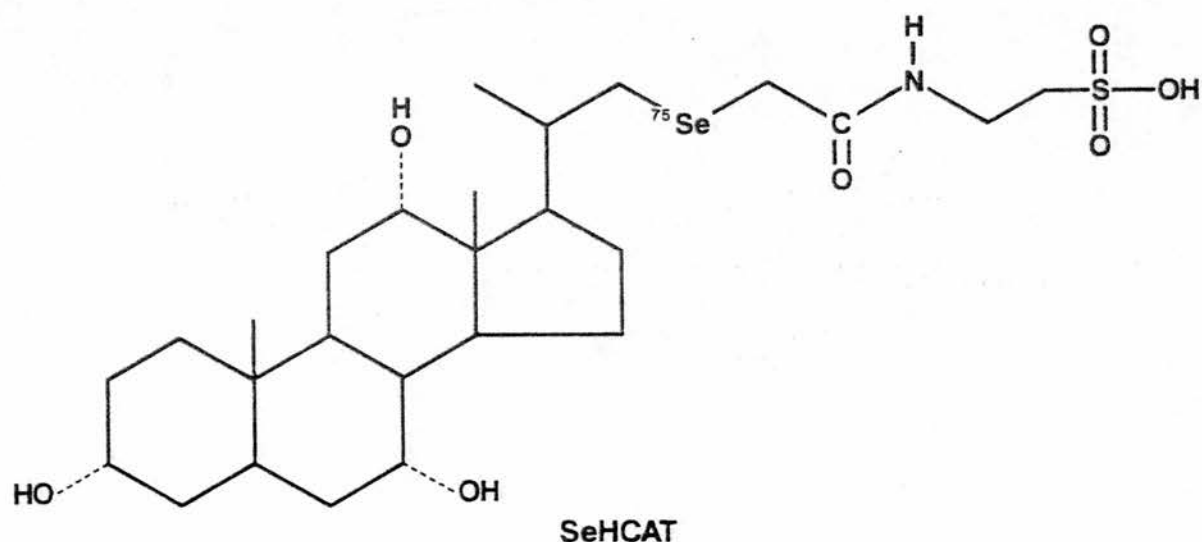

2.) ^{99m}Tc -HIDA (Technetium N IminoDiacetic Acid)

^{99m}Tc -HIDA has been used in the diagnosis of liver and gallbladder disease since the late 1970's (Harvey 1975, Harvey 1979, Eikman 1979, Van der Linden 1984). It is another radiolabelled bile analogue (Loberg 1976) and is used routinely as a test for gallbladder function (Eikman 1979, Van der Linden 1984), and has also been used to examine duodenogastric reflux (Nicolai 1980, Mackie 1982). It is given intravenously rather than orally, and is rapidly taken up by the liver, and excreted in bile. A small proportion is also excreted by the kidneys. Unlike ^{75}Se HCA, it is not reabsorbed by the terminal ileum, and so is quickly lost from the system. It also has a far shorter physical half-life, of six hours. This means that considerably larger doses of radiolabel can be administered without affecting the total absorbed radiation dose (Brown 1981). The corollary of this is that it cannot be used for long term monitoring, unless repeated doses are given.

Figure 22

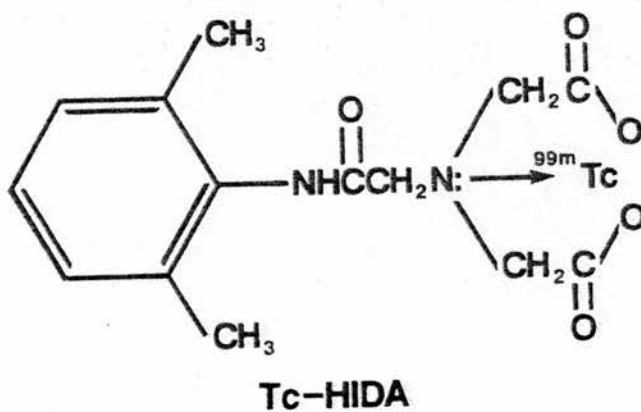

Absorbed radiation dose to man for $^{75}\text{SeHCAAT}$ and $^{99}\text{Tc}^m\text{-HIDA}$

The higher recommended oral dose of $^{75}\text{SeHCAAT}$ (25microCi) is used here to illustrate the maximum radiation dose in a healthy human subject. It is anticipated that a 10microCi dose will be adequate for the purpose of the study.

Total body	0.025rads (1.0mrad/microCi)
Liver	0.035rads (1.4mrad/microCi)
Gallbladder	0.300rads (12mrad/microCi)
Small intestine	0.275rads (11mrad/microCi)
Upper large int.	0.205rads (8.2mrad/microCi)
Lower large int.	0.203rads (8.1mrad/microCi)
Ovaries	0.103rads (4.1mrad/microCi)

In order to calculate the maximum absorbed radiation dose from $^{99}\text{Tc}^m\text{-HIDA}$ in a healthy humansubject, an intravenous dose of 5mCi of $^{99}\text{Tc}^m\text{-HIDA}$ will be assumed.

Total body	0.080rads (16mrad/mCi)
Liver	0.380rads (76mrad/mCi)
Gallbladder	4.540rads (908mrad/mCi)
Small intestine	0.945rads (189mrad/mCi)
Upper large int.	1.510rads (302mrad/mCi)
Lower large int.	0.995rads (199mrad/mCi)
Ovaries	0.310rads (62mrad/mCi)

The above figures can be compared with the "average total background radiation dose to man" which is 0.257rads/year. The radiation dose received by the ovaries during a standard oral cholecystogram is 0.078rads.

It can be seen, therefore, that despite the long physical half-life of $^{75}\text{Selenium}$,

and the higher dose of $^{99}\text{Tc}^m$, the absorbed dose of radiation from either compound to subjects in this study is likely to be small and within the limits of background radiation (Soundy 1982, Brown 1981).

Having compared the merits of the two radiolabels in common usage, $^{75}\text{SeHCAAT}$ was chosen as most appropriate for monitoring of bile reflux. The absorbed radiation dose is smaller, and it has the advantage of being given orally. It has a longer biological half-life ($T^{1/2}_{\text{biol}}$) than $^{99}\text{Tc}^m\text{-HIDA}$, mainly due to its property of being reabsorbed in terminal ileum, and this would enable it to be monitored for a longer period. $^{75}\text{SeHCAAT}$ has its main photon peak at 260KeV, as opposed to 140KeV for $^{99}\text{Tc}^m\text{-HIDA}$. Both these energies are well within the range which can be measured by CdTe detectors.

The high energy and long $T^{1/2}_{\text{biol}}$ of $^{75}\text{SeHCAAT}$ are also the causes of its major drawbacks. Firstly, the higher energy means less Compton scatter, and a higher background count from tissues adjacent to those being studied. Secondly, the $T^{1/2}_{\text{biol}}$ of the compound in the human body means that it can only be given in microCurie quantities to avoid overdose of radiation.

The remainder of this chapter is devoted to the experimental work with $^{75}\text{SeHCAAT}$, performed to ascertain whether the hypothesis raised is tenable. It is divided into three parts - initial phantom studies, clinical phantom studies, and lastly clinical bile reflux studies.

 PHANTOM STUDY 1
Aim

The aim of this study was to ascertain the relative contributions of the liver and oesophagus during a bile reflux test using $^{75}\text{SeHCAT}$. A simple model of the organs in their anatomical positions was used (Fig 23). The model was immersed in water to simulate soft tissue, and a gamma camera used to measure counts.

At this early stage in the work a large number of assumptions had to be made, but using Soundy's data (1982), approximate tissue concentrations of $^{75}\text{SeHCAT}$ could be calculated, and also approximate concentrations in bile, using the levels obtained in Chapter 5.

Mean concentration of $^{75}\text{SeHCAT}$ in bile	- 0.0084microCi/ml
Mean bile concn in oesophagus	- 671micromol/l
Mean specific activity of $^{75}\text{SeHCAT}$ in bile	- 0.046microCi/micromol
>>> Mean $^{75}\text{SeHCAT}$ concn = 0.031microCi/ml of oesophageal bile.	

Of a 10microCi dose of $^{75}\text{SeHCAT}$, only 4% is distributed throughout the body. 96% remains within the enterohepatic circulation. The liver retains 5%, while the gallbladder on average retains 15%, although this must vary considerably, depending on the volume of bile it contains. This leaves 76% in bile itself.

Assuming a liver volume of 1500mls, overall liver concentration will be 0.0003microCi/ml. The gallbladder will on average contain 1.5microCi of $^{75}\text{SeHCAT}$, but in the initial study, as the gallbladder is a considerable distance from the lower oesophagus, its contribution was not considered.

Figure 23

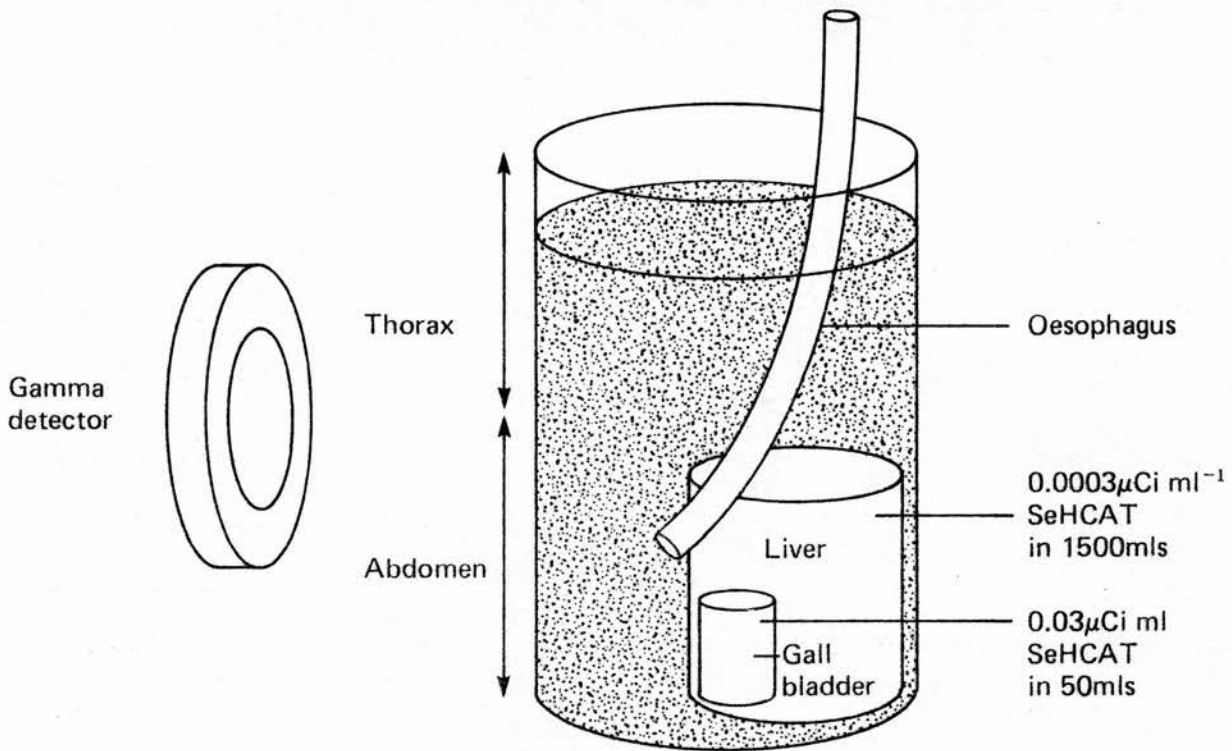

PHANTOM MODEL

A 5ml bolus of refluxing "bile" was assumed for the phantom, at a concentration of 671micromol/l.

Due to the large number of variables described, the "physiological" $^{75}\text{SeHCAAT}$ concentrations in the model oesophagus were bracketed by a factor of 5 above and below:

0.006microCi/ml in 5mls water (0.03microCi total)

0.03microCi/ml in 5mls water (0.15microCi total)

0.15microCi/ml in 5mls water (0.75microCi total)

Method

The liver model was filled with $^{75}\text{SeHCAAT}$ labelled water at a concentration of 0.0003microCi/ml. The "oesophagus", which consisted of a hollow plastic tube of 1.5cms internal diameter, contained 5mls of $^{75}\text{SeHCAAT}$ labelled water in three different concentrations - 0.0006, 0.03 and 0.15microCi/ml.

The model described, was then placed up against a gamma camera (Siemens Large Field of View, 37 ZLC head, with parallel hole, low energy, all purpose (LEAP) collimator) in its vertical mode, with its centre exactly 10cms from the "lower oesophagus".

Firstly, background counts were measured over a 90 second period. Counts were then measured with the labelled liver model in situ. The oesophageal model was then added with the three concentrations of $^{75}\text{SeHCAAT}$ described, thoroughly washing the tube between measurements, and counts measured over an identical period.

Results: These are shown graphically in Fig 24.

Figure 24

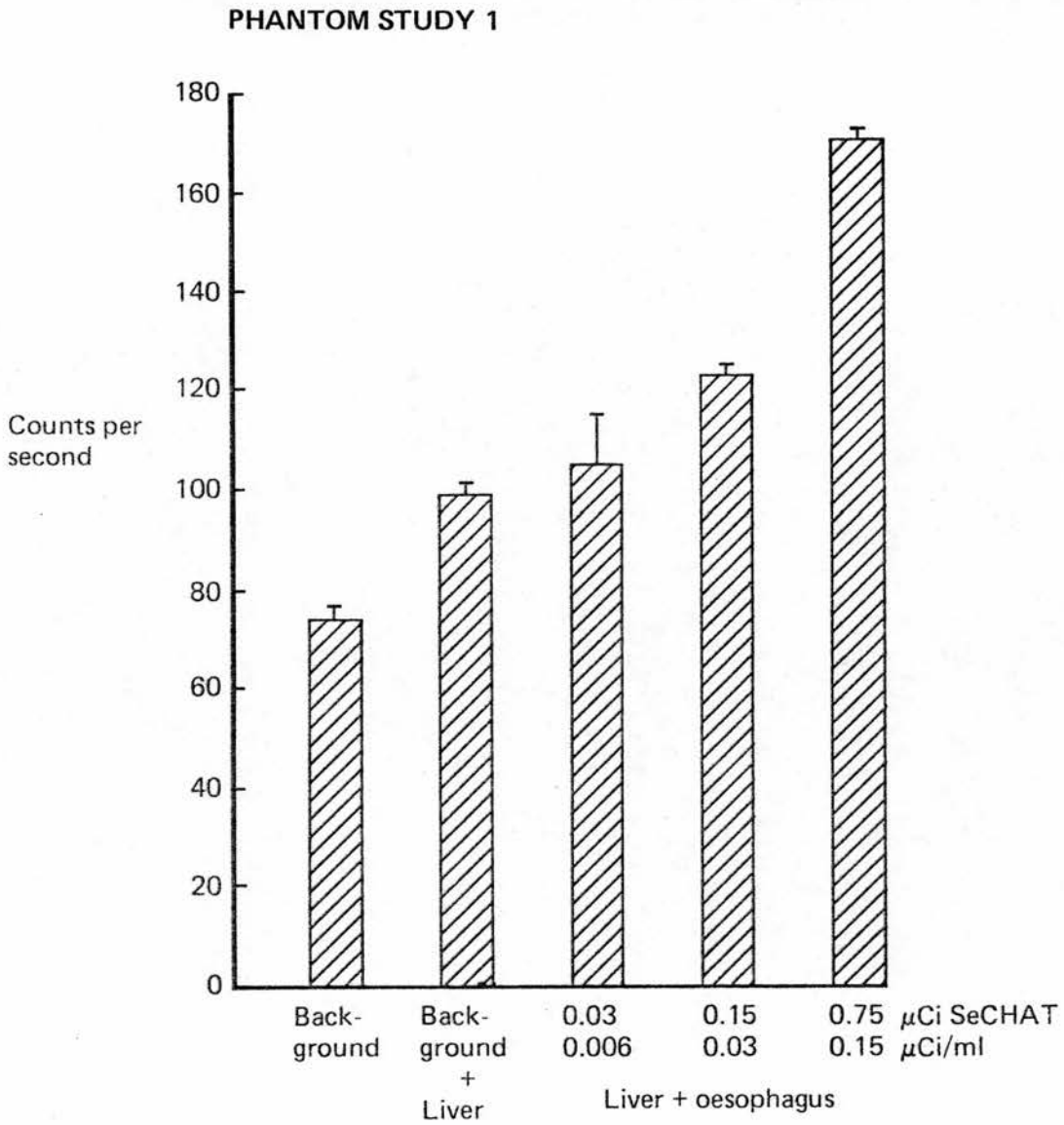

Conclusions:

The following conclusions can be drawn from this experiment. Firstly, the background count throughout is very high, and together with liver background adds up to more than half the overall counts, even with the higher concentration of $^{75}\text{SeHCAT}$. The high background count may be due to the fact that the experiment took place within the confines of the Department of Nuclear Medicine, in the presence of other patients being scanned, and all further tests were performed outwith the department.

Secondly, despite the high background count, adding increasing concentrations of $^{75}\text{SeHCAT}$ to the oesophageal model did in fact produce a stepwise increase in counts.

The results suggest that even at the very small concentrations of "bile" ($^{75}\text{SeHCAT}$) being measured, the oesophageal component of the scan is significant.

PHANTOM STUDY 2

Aim

The aim of this second phantom study was to examine the sensitivity of the external gamma probe to physiological levels of $^{75}\text{SeH}\text{CAT}$, using the same model as above. At the same time a simple measurement of increasing volumes of "reflux" was also performed.

Method

The portable gamma probe was placed exactly 10cms from the "lower oesophagus" model, in the horizontal plane (Fig 23). For this experiment, a 2mm thick straight bore single hole (7mm diameter) lead collimator was used. The gamma probe was connected directly to the Memolog portable recorder for data collection. For this experiment, five one minute sample intervals were used. As before, background counts were initially measured, and counts were then measured with the labelled liver model in situ. The oesophageal model was then added with increasing volumes of $^{75}\text{SeH}\text{CAT}$, starting with 0.04microCi in 1ml of water, and serially adding 1ml increments to a maximum of 5mls, to mimic reflux of between 1 and 5mls of bile containing fluid.

Results:

Shown graphically in Fig 25

Figure 25

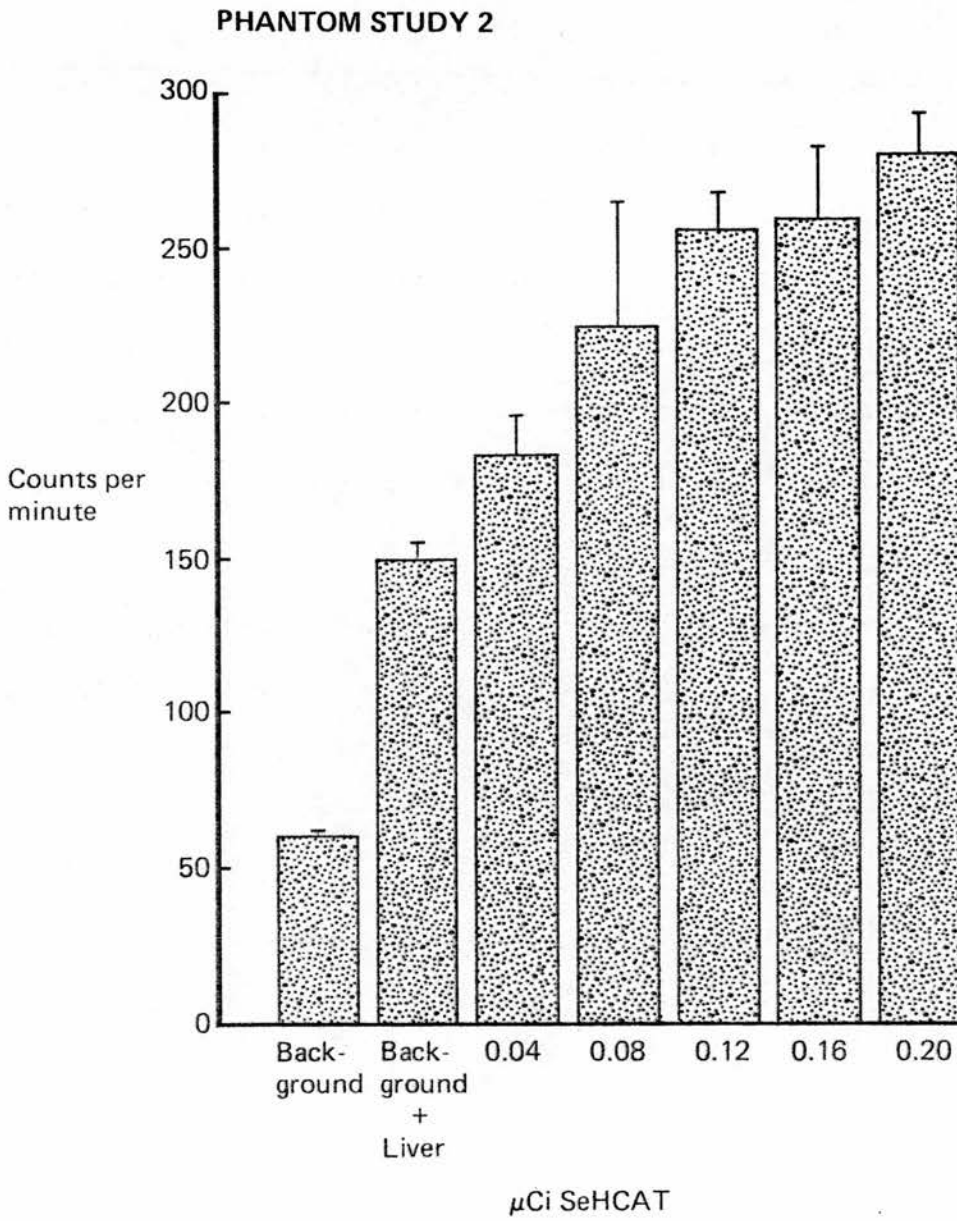

Conclusions

Firstly, it was again clear that background levels of radiation accounted for a significant proportion of all measurements, and that the liver model was also producing a large contribution.

The experiment showed that the external gamma probe was capable of measuring the small amounts of radiation present, and that it could also measure incremental rises in "oesophageal" levels of $^{75}\text{SeHCAT}$.

The counts were very low in all cases, and it should be noted that results are in counts per minute, rather than counts per second. It was noted during the experiment that counts could be boosted by a factor of 10 by removing the collimator, at the expense of losing a degree of directionality.

The next step in the investigation was to replace the phantom model with a human model.

CLINICAL STUDY 1

Aim

To examine the sensitivity of the external gamma probe to an oral dose of 10microCi of $^{75}\text{SeHCAT}$ in a human subject, using measurements over the small bowel, liver and mid oesophagus.

Method

A 60 year old male subject was given a 10microCi dose of $^{75}\text{SeHCAT}$ orally. Five hours was allowed for absorption of the dose, and the uncollimated external

gamma probe was then fixed to the anterior abdominal wall with adhesive tape, and left in situ, with the patient ambulant, for 24 hours. The Memolog portable recorder was used for data collection, using a sample interval of 15 seconds.

The position of the external probe was changed three times during the 24 hours, in order to collect counts over the small bowel (3cms below umbilicus), liver (8th intercostal space in mid-clavicular line) and oesophagus (mid-sternum). Mean counts (in counts per second) were then calculated for each area.

Results

Shown graphically in Fig 26

Conclusions

This experiment confirmed the sensitivity of the uncollimated external gamma probe to a standard dose of oral $^{75}\text{SeHCAT}$ administered to a human subject. It also showed a high gradient in counts between the three areas examined, suggesting that directionality is maintained despite lack of collimation, and that background counts over the oesophagus in a non bile refluxing patient are relatively low. From the standard deviation measurements, and from the graphic printout, it was clear that there were considerable fluctuations in counts over the small bowel and the liver.

Figure 26

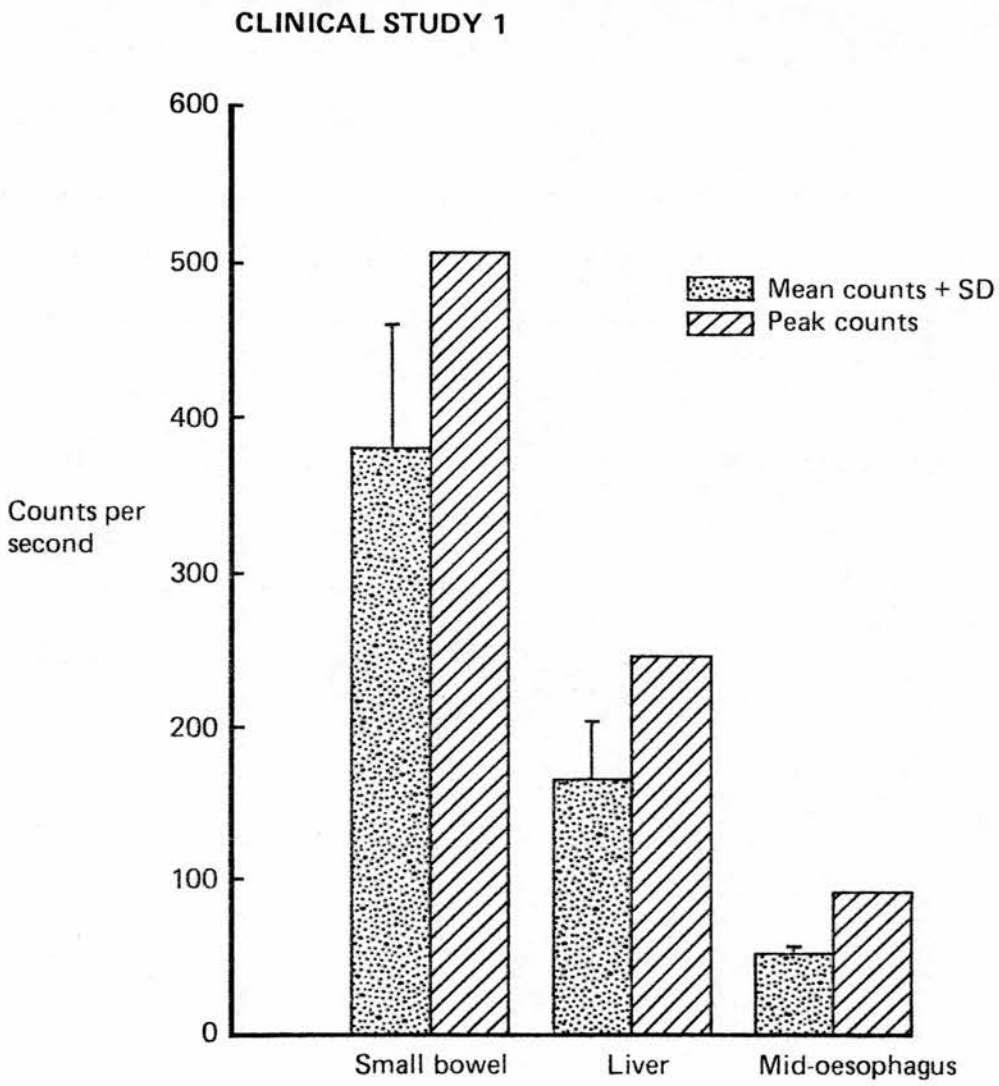

As with the phantom studies, predetermined "physiological" amounts of $^{75}\text{SeHCAT}$ labelled water were now measured in the human oesophagus.

CLINICAL STUDY 2

Aim

The aim of this study was to simulate bile reflux in a human subject, and to further assess the directionality of the uncollimated probe. For this purpose, pilot studies were performed, and a technique was developed in which a Fogarty catheter and balloon containing a measured amount of $^{75}\text{SeHCAT}$ could be passed down the oesophagus, and into the stomach. Initially, it was not intended to simulate any of the effects of background radiation produced by $^{75}\text{SeHCAT}$ in the liver or small bowel, but simply to assess the sensitivity of the external gamma probe.

Method

A normal subject first underwent oesophageal manometric pressure testing to determine the position of the lower oesophageal sphincter (LOS). Having done this, a Fogarty catheter (Size 10) was passed via the nose to position the balloon exactly 5cm above the LOS. Metal skin markers were then placed over the sternum and a chest X-ray (plain pa) taken. In this way an exact surface marking was obtained for the intra-oesophageal balloon, and the gamma probe could be accurately placed facing it. The Memolog recorder was used to collect data from the probe.

Background counts were taken using a 15 second sampling interval, over a ten minute period.

The Fogarty catheter was then emptied as far as possible of air by applying suction via a syringe/two way tap. It was found in pilot studies that a significant volume of $^{75}\text{SeHCAT}$ labelled fluid remained in the Fogarty catheter itself, and added a "false background" level. This was also accounted for here by counting over a " $^{75}\text{SeHCAT}$ primed" Fogarty, with the balloon empty. The catheter was filled with a predetermined concentration of $^{75}\text{SeHCAT}$ - in this case, 0.04microCi/ml - without blowing up the balloon. Further background counts were then taken.

A 0.5ml, then 1ml increments of $^{75}\text{SeHCAT}$ were sequentially injected into the balloon up to a total of 0.2microCi (5mls). A 15 second sample interval was used for measuring counts over a ten minute period for each increment. The procedure was repeated, having moved the balloon 5cm down, to the level of the LOS, and then again to a position in the fundus of the stomach, 5cm below the LOS.

Two problems were encountered with this technique. Firstly, the subjects tended to experience some discomfort and tugging in the nose, when the Fogarty balloon contained the full 5mls of fluid, caused by oesophageal peristalsis. Secondly, when moving the collapsed balloon down to the cardia, and on into the stomach, measurements were necessarily from the external nares, and on one or two occasions, it is thought that coiling of the tip of the catheter may have taken place.

Results:

These are shown graphically in Fig 27

Figure 27

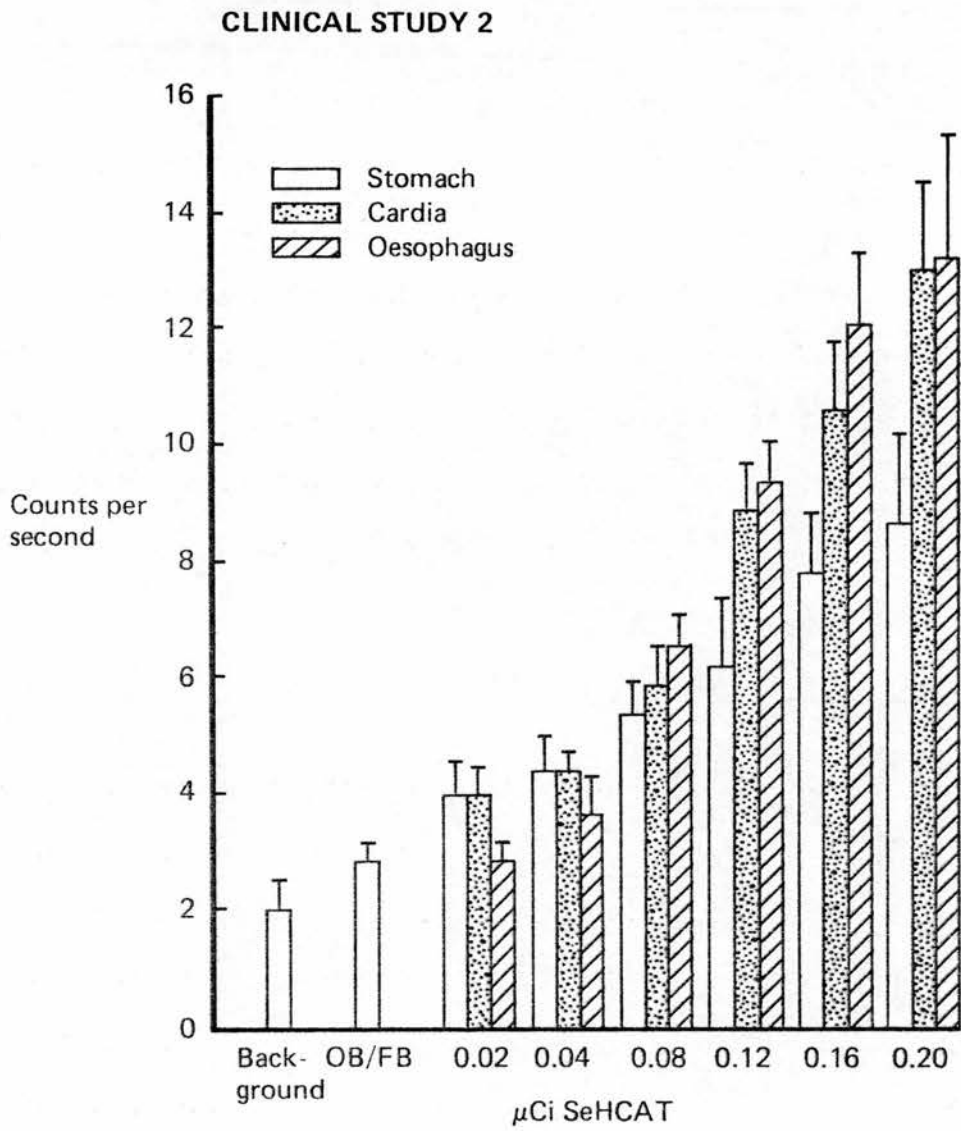

OB/FB – Oesophageal background/Fogarty primed

Conclusions:

The above study showed stepwise increases in gamma counts as the amount of $^{75}\text{SeHCAT}$ was increased in the Fogarty balloon. Moving the radioactive source out of direct line with the probe produced a reduction in counts with the larger amounts of $^{77}\text{SeHCAT}$. It is not immediately obvious why, with the lower concentrations, and the gamma probe directly opposite the balloon, the counts dropped rather than increased. One explanation is that the balloon may not have been properly aligned with the probe due to looping of the catheter tip.

At this stage a problem became apparent. Although readings were being obtained with the very small quantities of $^{75}\text{SeHCAT}$ being used, when these were compared with the counts obtained in Clinical Study 1 - a patient who had taken oral $^{75}\text{SeHCAT}$, it was clear that background readings over the oesophagus (50 - 100cps) were of a greater order of magnitude than the artificial reflux in the latter study (5 - 15cps).

With some interest, the effect of simulated bile reflux using the Fogarty catheter technique was therefore tested on a volunteer who had taken oral $^{75}\text{SeHCAT}$.

CLINICAL STUDY 3

Aim

The aim of this study was again to simulate bile reflux in a human subject, and to further assess the directionality of the uncollimated probe. The important background effects of systemically administered $^{75}\text{SeHCAT}$ were now taken into

consideration.

Method

Three normal volunteers took part in this study. Twenty four hours prior to intubation, each volunteer was given 10microCi of $^{75}\text{SeHCAT}$ orally. Manometry, X-Ray screening and Fogarty catheter intubation was then performed as before. A higher incremental range of $^{75}\text{SeHCAT}$ was used in the Fogarty catheter (0.05microCi/ml), and six increments, up to a total dose of 0.5microCi in 5mls water were measured with the probe facing a point 5cm above the LOS, and the balloon in the three positions as before (LOS + 5cm, LOS, LOS - 5cms).

Results

Data obtained was comparable in all three cases, and results of one subject are shown graphically in Fig 28.

Conclusions

As expected, background levels of radiation were considerably higher due to the ingested $^{75}\text{SeHCAT}$ in the liver, gallbladder and small bowel, and although counts were higher as increasing increments of $^{75}\text{SeHCAT}$ were injected into the mid-oesophageal balloon, they were only really measurable above 0.4 μCi in 4ml water. This represents 2.5-5% of the standard ingested dose - almost certainly too large a proportion as studies in Chapter 4 have shown 0.01 - 1% is a more realistic percentage of ingested dose occurring in actual oesophageal bile reflux.

Figure 28

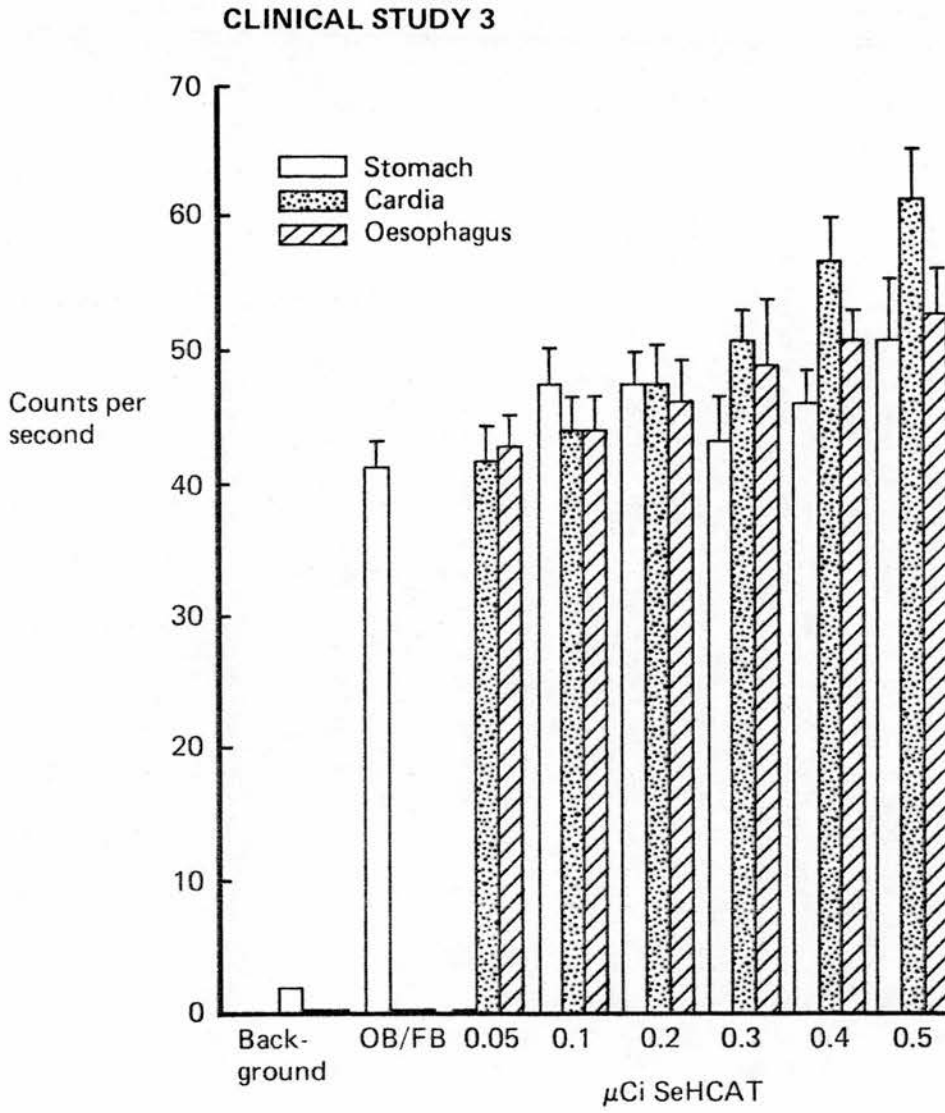

OB/FB – Oesophageal background/Fogarty primed

Discussion

The main problem highlighted by the above investigations is that counts from the small quantities of $^{75}\text{SeHCAT}$ which may be expected in refluxing bile are being swamped by background from the liver, gallbladder, and small bowel.

There are a number of ways in which counts from labelled oesophageal reflux may be selectively enhanced.

Increasing the directionality of the probe by collimation will tend to cut down on liver and small bowel background, but in this case, the lead shielding reduced the sensitivity of the probe to such a large extent, that the low levels of $^{75}\text{SeHCAT}$ present became almost immeasurable. Other workers have overcome this problem by using a more sophisticated collimator, with up to 80 holes in the lead disc (Washington 1988).

Angulation of the gamma probe upwards, away from the liver should also decrease background counts, and in 10 subjects this was tested. A 30° angle was found to decrease background counts by 30%. The probe was difficult to keep at the required angle in ambulatory subjects, and in view of the small increase in sensitivity, was felt to be impractical.

Gamma radiation obeys the inverse square law, and distance is therefore of prime importance when measuring it. The oesophagus is a deep structure throughout most of its length, and on measurements from 105 lateral chest X-Rays is an average of 13.7cms from the skin overlying the mid sternum. The gamma probe could be placed closer to the oesophagus in two positions.

Firstly, in the neck, where distance would be reduced to three or four centimetres, and background radiation would also be reduced due to the larger

distance from the abdomen. Unfortunately, there would be correspondingly less reflux higher up in the oesophagus. This position is therefore not viable.

The second feasible position for the probe would be on the back, facing directly forward. Rather surprisingly, X-Ray measurements showed that the lower third of the oesophagus is almost equidistant from the skin overlying the sternum and vertebral spines (A/P ratio 13.7 : 13.4).

Another important adverse factor was touched upon in Clinical Study 1. It was noted during this 24 hour study that background counts from $^{75}\text{SeHCAT}$ were not steady, but fluctuated. The fluctuations in counts were of the same order of magnitude as the $^{75}\text{SeHCAT}$ artificial reflux, and could not be differentiated from it.

Fluctuations in gamma counts

Although not directly relevant to this thesis, the phenomenon of the fluctuations in gamma counts is briefly discussed as it has not previously been reported.

The fluctuations in counts seen as background over the oesophagus were a reflection of far larger fluctuations seen over the liver and small bowel. These were too high to have been due to reflux, and were investigated as 24 hour studies, in 8 normal volunteers.

By comparing small bowel transit time of lactulose (The hydrogen breath test), with the small bowel transit time of a $^{75}\text{SeHCAT}$ capsule, as measured by a gamma probe over the terminal ileum, it became clear that initial peaks in counts were due to passage of $^{75}\text{SeHCAT}$ through the small bowel, and that further peaks in counts were due to the enterohepatic circulation of bile, together with gallbladder filling and emptying (Stoker 1987).

A further interesting finding was that in half the patients gamma counts dropped below the mean and levelled out during sleep, suggesting that bile ceased to circulate, and remained in the gallbladder. In the other half there were continuing large fluctuations in counts overnight, despite the fasting state. This suggested that bile continued to circulate during sleep in some subjects, while in others it did not.

The subject merits further study, as major differences in the enterohepatic circulation may be relevant in a number of disease states such as bile malabsorption diarrhoea and gallstones.

Summary

To reiterate the first paragraph of this chapter, the hypothesis that a portable gamma probe, placed over the sternum, can be used to measure radioactively labelled bile reflux, has been examined. The results of the above experiments show that the hypothesis is non-tenable, using $^{75}\text{SeHCAAT}$.

At this stage, two options were explored. Firstly, the above experiments could be repeated using $^{99}\text{Tc}^m\text{-HIDA}$ as the bile label. The lower energy Technetium would be expected to have higher tissue attenuation, and therefore, proportionately less background effect over the oesophagus. At the same time, the milliCi doses of $^{99}\text{Tc}^m$ given, would increase overall counts, and allow collimation to be used with an increase in probe directionality.

The second, and more interesting option was to abandon the external gamma probe in favour of a detector which could be placed within the oesophagus. In theory, this would negate the directionality, and distance factors, as the measuring instrument would be bathed in refluxing fluid.

These options will be combined, and discussed in the next chapter.

THE DEVELOPMENT AND USE OF AN INTERNAL GAMMA PROBE

"We have examined the hypothesis that an internal gamma probe, placed within the oesophagus, can be used to measure radiolabelled bile reflux."

Introduction

Many of the problems associated with use of the external gamma probe could be overcome if the detector crystal was placed closer to the radioactive source, in this case, radiolabelled bile salts. The most efficient way to do this would be to place the probe within the oesophagus, so that readings were taken from the same position as a pH probe, being intermittently bathed in refluxate. The hypothesis discussed in the previous chapter was therefore modified to encompass this possibility.

Internal gamma probes have so far received very limited use in the medical field. True internal probes have in fact only been used to trace bronchogenic tumours labelled with $^{57}\text{Cobalt}$ -bleomycin (Barber 1980). This was achieved by passing a probe down the biopsy channel of a bronchoscope, and placing it, under vision, adjacent to suspicious lesions labelled with radioactive tumour marker.

Small portable gamma probes have been developed for use during surgery (Harvey 1981) and have been used to detect parathyroid adenomas (Ubhi 1984), and osteogenic tumours (Szypryt 1986) per-operatively.

Internal gamma probes have never been used in gastrointestinal investigations, and prior to testing the above hypothesis, a period of development was undertaken.

Phase I - DEVELOPMENT

Specifications

As shown in previous chapters, the oesophagus forms a relatively hostile environment for any measuring instrument, which will be intermittently bathed in acid, bile, and enzyme mixtures, as well as food and saliva. The initial specifications for such a device were as follows:

- 1.) Dimensions small enough to be passed nasally (maximum diameter 5mm).
- 2.) Durable, and waterproof to allow prolonged monitoring (up to 24 hours) whilst being bathed in acid and bile.
- 3.) Cable of sufficient length to attach it to an external preamplifier.
- 4.) Sensitivity to ^{75}Se and $^{99}\text{Tc}^{\text{m}}$ in the varying amounts previously noted in refluxed bile.

Aim

The aim was to build a CdTe probe to these specifications, for use with the Novo Memolog portable monitoring equipment. The requirements were discussed with Radiation Monitoring Devices Inc. (RMD) of Watertown, Massachusetts, USA. This is a small company with a unique knowledge of the production and use of Cadmium Telluride gamma detectors. They are the sole commercial source for crystals used in a multitude of fields throughout the world and it was they who produced a 2.5mm diameter experimental probe for use in the lung. Collaboration with this company was arranged, and their laboratory and workshops in Boston, USA

were visited, in order to view the equipment and its manufacturing process at first hand.

The following is a description of the developmental problems encountered and how they were overcome.

The probe

The dimensions of the probe were set at 5mm diameter - this being the maximum that could be comfortably passed via the nose - and 14mm length. This is approximately the size of an antibiotic capsule, and much the same size as a glass pH electrode.

Complete electronic isolation from the gastro-oesophageal mucosa was deemed essential, due to the fact that the Cadmium Telluride crystal was activated by a voltage bias of 60 volts, albeit with a minute leakage current in the range 10 - 300 nanoAmps. It was therefore embedded in epoxy-resin, with a Teflon coated aluminium casing. The probe was rounded at both ends to facilitate entry and exit from the nasal passages. It was then rigorously tested in the laboratory in a fluid environment.

A Cadmium Telluride crystal was picked for sensitivity to photon peaks at 140 and 260 keV, these being the peaks associated with ^{75}Se , and $^{99}\text{Tc}^m$.

Collimation of a probe this size was not possible, but it was requested that a small amount of lead or tungsten shielding be inserted into the nose of the probe, to reduce background counts from the liver and small bowel - a problem previously encountered when using the external probe.

The prototype CdTe oesophageal probe took three months to build, and the result is shown diagrammatically in Figure 29. The crystal dimensions were 2mm x

2mm - considerably smaller than the 16mm diameter, 2mm thick disc used in the external probe. Only two major problems were encountered during its construction. Firstly, the small size of the housing meant that there was no extra room for lead/tungsten shielding, or for any form of vibration damping mechanism. Secondly, on final testing the connections between the probe and its cable were found to be weakened by any bending at the junction between the two. As this would be unavoidable in passing the probe through the nose, extra strengthening was added at this joint.

The probe and its cable assembly were capable of being sterilized chemically for internal use.

The cable

To be sensitive, and to avoid problems with background noise, the length of lead between the gamma detector and the preamplifier had to be as short as possible. In the external gamma detector (Fig 18), the preamplification circuits were built in to the shielded detector housing, with only a few millimetres between the two. Increasing cable length leads to rising capacitance within the system, with reduced signal to noise ratio. Even low inductance cable tends to act like an aerial, picking up any extraneous electromagnetic radiation in the vicinity, and increasing background electronic noise.

RMD advised that, ideally the cable length should be less than 50cms. This was not long enough for oesophageal use, as to be placed in the lower oesophagus or the fundus of the stomach, approximately 35 - 40cms of wire needed to be passed. A compromise of 60cms of cable was decided upon. This still meant that the preamplifier needed to be close to the face, probably slung around the neck.

Figure 29



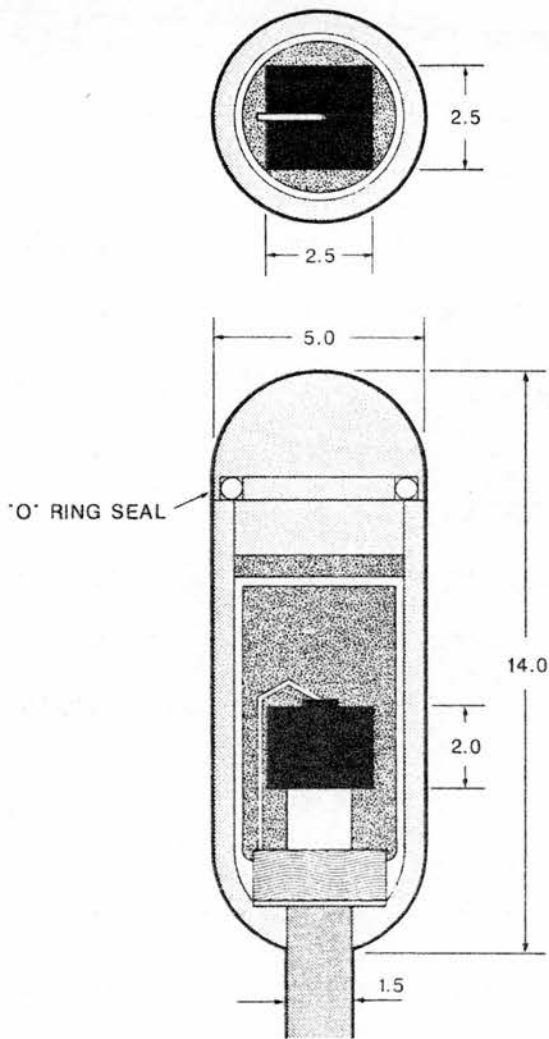



INTERNAL GAMMA PROBE

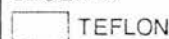

NOTES:

- (1) Not to scale.
- (2) All dimensions in mm.
- (3) Wire lead length 60cm.

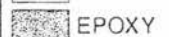
LEGEND:

 TEFLON	 CdTe CRYSTAL
 ALUMINIUM	 BRASS STRAIN RELIEF
 EPOXY	 COAXIAL CABLE

The preamplifier

Due to the small size of the internal gamma probe, a built in charge sensitive preamplifier was not feasible, and a separate external device was necessary. A tailored preamplifier (Baxter 1976) could be supplied by RMD, with the prototype internal probe, but this would not necessarily have been compatible with our Memolog equipment. It was therefore decided to utilise the preamplifier stage of the external probe, which was already compatible with the Memolog system.

On receiving the probe, it was initially connected to our external gamma detector preamplifier, which was dismantled for the purpose. The internal probe was found to function with these circuits after adjusting the voltage bias, and signal threshold levels of the Gamma Module section of the Memolog. A convenient mount for the preamplifier was made by utilising the housing and rubber cover for the external detector too. This could easily then be stuck in position on a patient's neck, shoulder or chest, depending on the length of lead available after passing the probe.

(For circuit diagram see appendix 5)

The power sources

For initial bench testing of the internal probe, the Memolog recorder batteries provided the necessary power source for the preamplifier and crystal. At a later stage, with an RMD preamplifier, a small mains driven power pack was purchased, and later still, this was replaced by a portable battery pack.

The battery pack reduced background noise even further, by eliminating "mains hum".

The computer software

The software developed for use with the external gamma probe was used with little further modification for transferring and storing data from the internal probe.

Solving developmental problems

Following delivery of the prototype, it became clear that there were still several problems to overcome. These stemmed from the different characteristics of the new probe.

At rest on the bench with no radioactive sources close by, the probe produced a variable amount of background counts. These were due mainly to electronic noise induced in the crystal and its cable by a number of factors. CdTe crystals are microphonic (they act as very effective microphones at certain frequencies), and simply tapping the crystal housing produced increased counts. This microphonic effect is brought about by the fact that the crystal is piezo-electric - that is, pressure distortion of the crystal causes current to flow within it.

CdTe is also a semiconductor, and behaves like a radio diode. Moving the cable through an electromagnetic field (e.g. past a mains lead) will induce current, as will simply bending the cable. When the whole apparatus was immobile, concentrations of $^{75}\text{SeHCAAT}$ down to 0.01microCi/ml could be detected, at levels 2 - 3 times natural background levels, suggesting that in these very controlled circumstances the crystal was sensitive enough for our purposes.

The effect of background radiation from small bowel and gallbladder $^{75}\text{SeHCAAT}$

were not accounted for initially.

Ways to overcome the above problems fell into two groups. Firstly, the radioactive label could be changed to one of a lower energy ($^{99}\text{Tc}^m$ - 140KeV, or even lower still ^{125}I - 20KeV). This would reduce actual radioactive background counts, due to increased tissue attenuation, with a consequently higher signal to noise ratio. Secondly, ways of reducing the inherent "noisiness" of the crystal/cable assembly were examined, by altering signal threshold levels, and by considering changing the cable itself for one with ultra-low inductance characteristics.

After consultation with the manufacturers, and after extensive electronic testing by Vertec with their own preamplifier, the conclusion was reached that the more advanced RMD preamplifier was needed. This was specifically designed to be insensitive to the inductance of the cable, and the microphonics of the crystal, but at the same time was capable of picking up a gamma photon induced signal from the CdTe crystal. It had the disadvantage that it was a little larger than the Vertec model, and for our prototype, was initially mains driven, making a fully ambulatory system impractical.

The preamp/powerpack system purchased was equipped with several feet of cable, so that subjects would be ambulatory around the bedside if necessary.

Further electronic modifications by Vertec were necessary to the CdTe Module in the Memolog system in order to make it compatible with the RMD preamplifier. Several adjustments were made to the voltage bias on the crystal, and the voltage threshold levels on the module (which also contained pulse shaping circuits). The result of this was a fully compatible system, allowing preliminary, and human studies to begin.

The more sophisticated preamplifier proved an effective screen for extraneous electronic noise produced by cable inductance, and crystal microphonics. This enabled me to embark on phantom studies using the probe, to measure its in vitro sensitivity prior to use in vivo.

Phase 2 - PHANTOM STUDIES

Study 1 - In vitro.

Aim:

The aim of the initial studies with the new probe was to assess its sensitivity to ^{75}Se and $^{99}\text{Tc}^{\text{m}}$.

From the previous bile salt studies, it was apparent that the detector had to be sensitive enough to pick up between 0.01 and 1% of the administered radioactivity - in the case of $^{75}\text{SeHCAAT}$ this meant in the range of 0.001 - 0.1microCi.

Due to its smaller cubic capacity, the internal probe was expected to be less sensitive to gamma photons than the external probe (i.e. it would produce less counts per unit of radiation). In anticipation of this reduced sensitivity, the alternative radiolabel, $^{99}\text{Tc}^{\text{m}}\text{HIDA}$ was also examined.

Method:

A range of concentrations (microCi/ml) of $^{75}\text{SeHCAAT}$ and $^{99}\text{Tc}^{\text{m}}\text{HIDA}$ in water were prepared in test tubes (Volume 5mls). The internal gamma probe was placed in each tube for one minute, using a 5 second sample interval, and the mean counts for each sample was taken. Concentrations tested were from 0.01 to 10microCi/ml.

Results:

The probe proved sensitive down to concentrations of 0.1microCi/ml above background counts for both $^{99}\text{Tc}^m$ and ^{75}Se . Background counts consisted of natural radiation, and electronic noise (Fig 30).

Conclusions:

With the RMD preamplifier, the overall sensitivity of the crystal to gamma photons was slightly diminished, but it still proved possible to measure very small doses of radioactivity. As previously explained, however, it was felt that $^{75}\text{SeHCA}$ T would not reflux in even these small amounts, and for reflux studies, a radioactive label with better counting characteristics required. Technetium 99m , in the form of $^{99}\text{Tc}^m\text{HIDA}$ was a suitable alternative, and bearing in mind the advantages and disadvantages discussed in the previous chapter, it was decided to continue in vivo studies with the internal probe using this alternative.

Figure 30

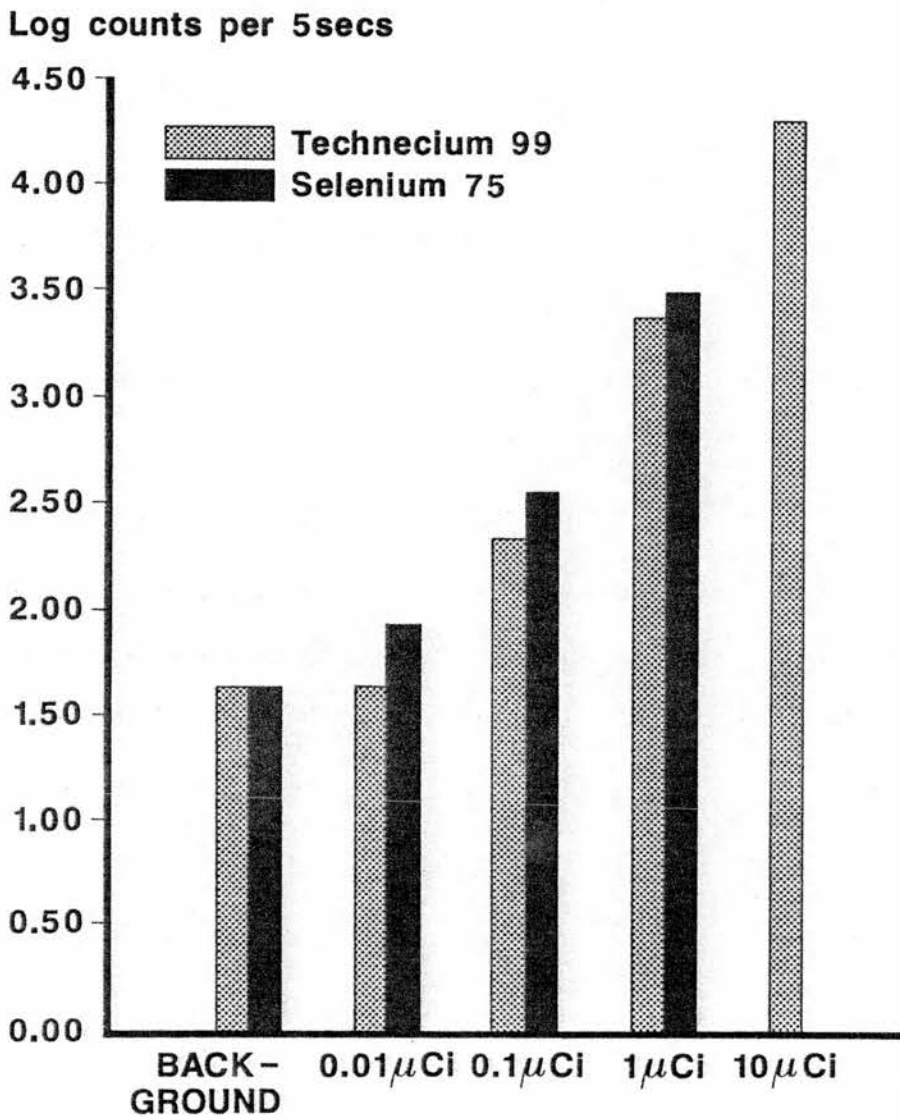
**INTERNAL GAMMA PROBE -
Tc⁹⁹/Se⁷⁵ COMPARISON**

Study 2 - In vivo.

Aim:

To study probe sensitivity in the human oesophagus, in the presence of systemically administered $^{99}\text{Tc}^{\text{m}}\text{HIDA}$.

Having assessed the probe in vitro, the next important step was to assess it in the oesophagus itself. This was a more demanding test, with a number of other factors coming into play. Firstly, the operating temperature of the probe would be higher at 37°C rather than room temperature. Secondly, the cable was unlikely to remain still, due to neck and pharyngeal movements. Thirdly, the all important effect of background radiation from systemically administered radiolabel had to be assessed.

Method:

A normal human subject underwent oesophageal manometry, to ascertain the position of the lower oesophageal sphincter. The gamma probe was then passed via the nose to a position 5cm above the upper margin of the sphincter, and taped in position, with the preamplifier slung around the neck, and connected to the Memolog recorder, using a 0.5 second sample interval.

Four milliCi of $^{99}\text{Tc}^{\text{m}}\text{HIDA}$ were administered intravenously, one hour prior to the test. Five millilitre boluses of pertechnetate ($^{99}\text{Tc}^{\text{m}}\text{O}_4^-$) labelled water were then swallowed by the subject at intervals. The concentrations used were 2microCi/ml, 5microCi/ml and 10microCi/ml. Two swallows were performed at each of the selected concentrations.

With the probe still in position, a standard oesophageal transit study was then performed, with the subject lying under a gamma camera, using a 1milliCi bolus of

$^{99}\text{Tc}^{\text{m}}\text{O}_4^-$ in 10mls of water.

Results:

On initially passing the probe, very high counts were recorded. This was due to changes in the operating temperature of the probe. By reducing the threshold voltage by a small amount, the probe could be brought back into the gamma detection range.

There were peaks in gamma counts after each pertechnetate swallow, which could be seen above a low background count produced by radiolabel in the gallbladder and small bowel. The peaks were small for the 2microCi/ml swallows, and large for the 10microCi/ml swallows. Following the test, the patient regurgitated a small amount of fluid, and this too was picked up by the probe - the first time an actual reflux event had been monitored (Fig 31).

The gamma camera readings obtained from a region of interest over the lower third of the oesophagus during the oesophageal transit study correlated well (visual only) with readings taken simultaneously from the internal probe (Fig 32).

Conclusions:

The conclusion from these initial studies was that the gamma probe functioned adequately in vivo, and was capable of monitoring very low levels of $^{99}\text{Tc}^{\text{m}}$ labelled material, above background radiation from $^{99}\text{Tc}^{\text{m}}$ HIDA in the liver, gallbladder and small bowel.

The probe may also have a use in the measurement of oesophageal clearance, having the advantage of portability, and the disadvantage that it will only measure clearance from one "region of interest" at a time.

What these studies could not tell us was whether the probe would measure dynamic bile reflux in a patient with known reflux disease. The third phase of this

chapter will deal with measuring actual bile reflux events.

Figure 31

Internal Gamma Probe – Comparison of Tc Labelled Liquid Swallows

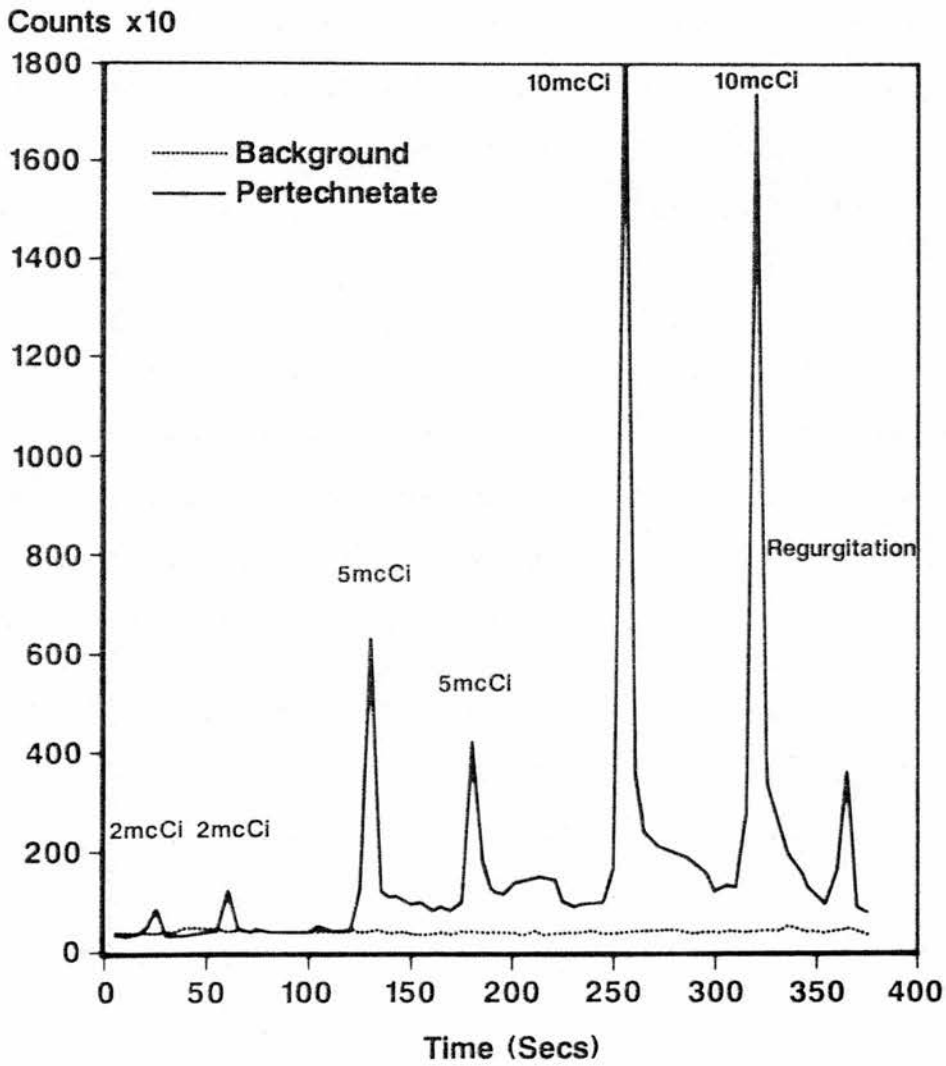
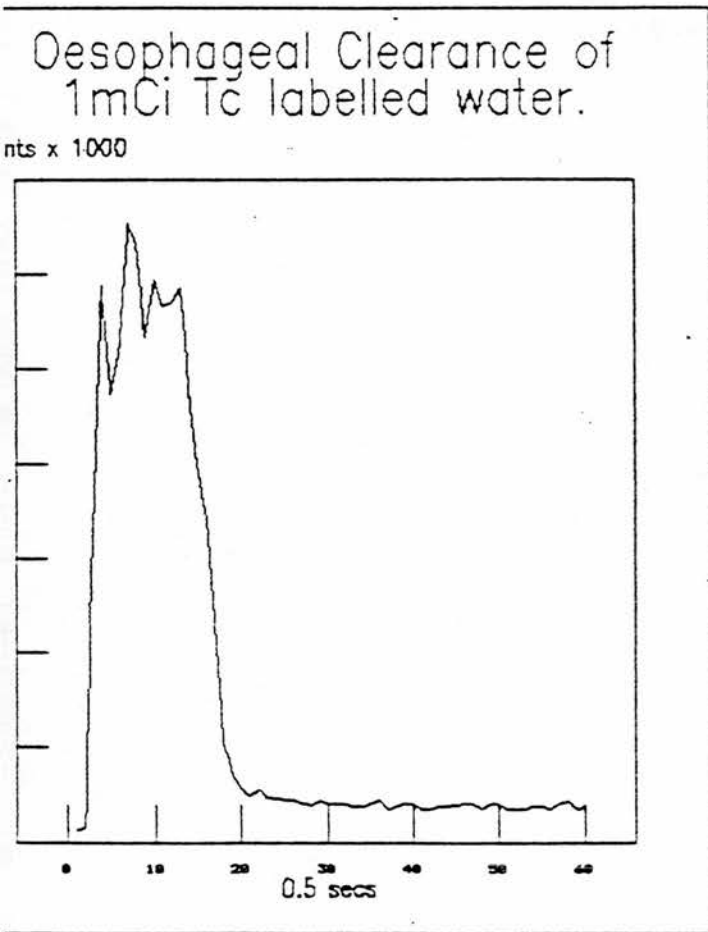
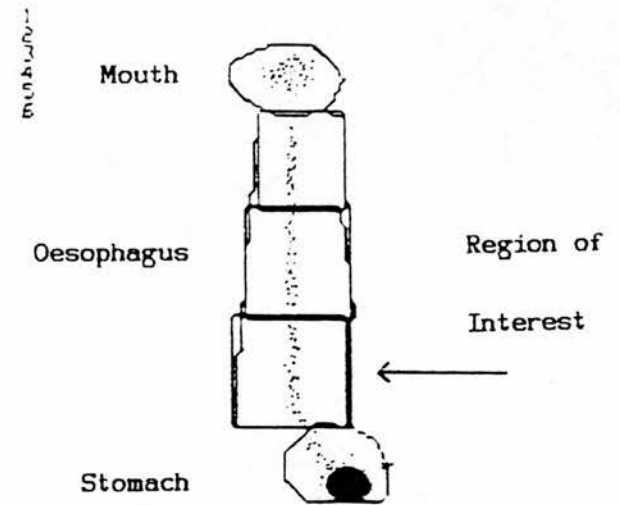

Figure 32



Counts from internal probe

Gamma camera scintigram



view number 2

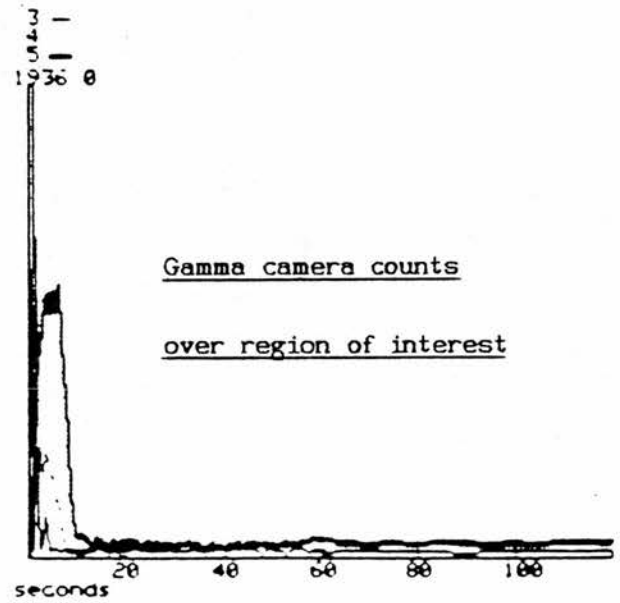

Phase 3 - BILE REFLUX STUDIES

Introduction:

Having established that the probe functioned adequately in the human upper gastro-intestinal tract, a number of patients with known bile reflux, and an equal number of normal volunteers were examined.

Aim:

The aim of this study was to validate the measurement of pathological and physiological bile reflux in human volunteers using the internal gamma probe.

In order to validate the readings taken from the probe, two parallel methods of measuring reflux were performed simultaneously. Firstly, as with the oesophageal transit test, simultaneous scintiscanning was performed, but with the camera centred over the body of the stomach. Secondly, aspiration of refluxate was performed at 5 minute intervals, from the area adjacent to the probe, using a fine (8 French Gauge) Ryles tube. This was taped to the gamma probe cable, to ensure specimens were taken from as close to the crystal as possible. Fine tubing was found to be ideal, as it easily passed with the probe, and enabled small specimens of 1ml to be taken for separate gamma counting. Larger Ryles tubes were also tried, but could not be passed along with the probe, and so the exact positioning of the tip in relation to the probe was less predictable.

The feasibility of simultaneous pH monitoring was also explored. This was

abandoned in favour of direct aspiration for the following reasons. Firstly, there did not appear to be any correlation between acid reflux, and peaks in the gamma readings - a finding which was not unexpected in view of the results described in Chapter 5. Secondly, it was not practical to pass an aspiration tube, pH probe, and gamma probe simultaneously.

It was initially hoped to perform all validation studies with the probe in the lower oesophagus. However, during test runs in patients with known severe bile reflux, it became clear early on that this would be very inefficient. Even the severe oesophageal refluxers, when under test conditions, lying under a gamma camera, would not reflux to order.

Various techniques were tried to enhance reflux, including Valsalva manoeuvre, abdominal binders, and raising the foot of the bed. The results of this were unpredictable, and unphysiological. Reflux of bile into the fundus of the stomach was found to be a far more predictable phenomenon. In practice the furthest the probe could be passed with the length of cable available was 10 - 15cms below the LOS. For the patient's comfort, and for reproducibility, the studies were all performed with the probe placed 5cm below the manometrically determined LOS.

Method:

Patients and normal subjects underwent identical procedures. A total of ten examinations were performed. The first three patients were bile refluxers, as shown on endoscopy (PB, ED and LA), and were pilot studies to assess the optimum position for the probe, and the feasibility of performing simultaneous pH monitoring.

Each subject was fasted for 12 hours prior to testing. Any drugs affecting

gastric secretion (antacids, H2 blockers) were stopped 24hours prior to the procedure.

The nasal passages were anaesthetised with 1% Xylocaine jelly. Oesophageal manometry was performed to map the LOS. The gamma probe, previously sterilized by soaking in 1% Gigasept, with attached aspiration tubing or pH electrode, was then passed via the nose into the oesophagus or fundus of the stomach and positioned as described above. The cable/tube assembly were taped to the nose, and the cable connected to the preamplifier, powerpack and Memolog with the subject supine, under a gamma camera (Siemens Large Field of View, 37 ZLC head, with parallel hole, low energy, all purpose (LEAP) collimator). For aspiration purposes a sterile 10cc syringe was attached to the tubing.

A counting interval of 5 seconds was used for the internal probe, while the scintiscanner counted over 15 second intervals.

The reasons for the difference in counting intervals were as follows. The Memolog maximum sample size was 99,990 counts. Using a 5 second sample interval, counts sometimes rose to 60 - 70,000 counts per 5 seconds. Increasing the sampling interval would have taken the readings outside the range of the recorder. The external gamma camera was capable of counting over 5 second intervals, but would not plot or calculate regions of interest on more than 180 data points. This would mean recording for 15 minutes only, before having to download the data onto tape, and starting again. A compromise of 15 second sampling on the gamma camera was decided upon as this would allow a 45 minute recording.

At time 0, with the subject lying under the gamma camera, 4milliCi $^{99}\text{Tc}^m\text{HIDA}$ was administered intravenously. Data acquisition was initiated for internal and external gamma counting simultaneously, and gastric aspirations were started. Two or

three consecutive 45 minute acquisitions were performed for each subject. The progress of the labelled bile was also followed closely by visual screening.

Information from the Memolog was transferred to an Ericsson PC computer, and a printout of the raw data obtained. For storage purposes, the internal probe results were also downloaded from computer onto floppy disc. Gamma camera data was transferred to a Nodecrest Micas III computer, and also stored separately on magnetic tape

A program (CORRDLS) was written for the Nodecrest computer enabling the gamma camera acquisitions (45mins each) to be merged, and then correlated with the synchronised Memolog data. In each case the readings from the Memolog were compared with the readings taken from a gamma camera region of interest over the fundus of the stomach. It was possible to map the position of the stomach from its relation to the liver during the $^{99}\text{Tc}^{\text{m}}$ HIDA scan.

The results were plotted out graphically for visual correlation. Mathematical correlation was performed using mean counts per minute for both sets of data.

Samples of gastric juice were aspirated at 5 - 10 minute intervals during tests 4 to 10. In order to compensate for radioactive decay during the test, 1ml aliquots of all samples were measured simultaneously on a gamma counter (Nuclear Enterprise, Edinburgh 8311), immediately after the test was concluded.

Results:

The main problem encountered with the above proforma was the difficulty in obtaining aspirated gastric secretions from every subject. Satisfactory samples were only achieved in 5 subjects. In the last two normal subjects, minimal or no aspirate

was achieved during most of the acquisition time.

The results will be presented in chronological order, by subject, and then tabulated. The first four cases should be regarded as pilot studies.

Subject 1 (PB, male, age 61) - Internal probe/pH test.

History of reflux symptoms, and endoscopically proven oesophagitis. No previous surgery.

Two 45 minute gamma camera acquisitions performed for monitoring purposes, with internal probe/pH electrode 5cm above the LOS. Internal monitoring was continued for 100 minutes, until $^{99}\text{Tc}^{\text{m}}$ HIDA reflux had occurred. The patient became symptomatic with heartburn in the 87th minute, and this corresponded with a rise in internal gamma counts, and a fall in oesophageal pH to around 3.9.

Subject 2 (ED, female, age 59) - Internal probe/pH test.

History of severe reflux symptoms, and endoscopically proven oesophagitis. No previous surgery.

Four 45 minute gamma camera acquisitions performed for monitoring purposes. The position of the probe and pH electrode were adjusted on four occasions to measure activity above and below the LOS.

Subject 3 (LH, male, age 74) - Internal probe/pH test

No history of acid reflux, but of waterbrash. The patient had undergone a Billroth I gastrectomy for peptic ulcer disease in 1948.

Three 45 minute gamma camera acquisitions performed for monitoring purposes. Probe and pH electrode initially placed in stomach, and then withdrawn into oesophagus. Gastric and oesophageal pH remained in the range 6 - 8 throughout the recording.

Subject 4 (SC, female, age 66) - Internal probe/aspiration test.

History of heartburn and regurgitation, associated with severe oesophagitis, and achlorhydria, suggesting bile reflux. No previous surgery.

Two 45 minute gamma camera acquisitions performed for monitoring purposes. Probe assembly withdrawn into oesophagus following measurement of possible reflux into stomach.

Mathematical correlation was not performed in the first four cases due to the changes in probe position during the recording. For the remaining six cases the probe was kept stationary in the fundus of the stomach, 5cm below the LOS, to enable the computer correlations to be performed.

Subject 5 (RH, male, age 42) - Internal probe/aspiration test (Fig 33)

History of mild heartburn and anaemia. Gastroenterostomy for peptic ulcer many years ago. Copious bile reflux into the stomach on endoscopy.

Two consecutive 45 minute acquisitions were performed. Graphs were obtained of the gamma camera region of interest, but the data was compromised due to a computer system failure, prior to measurement of mathematical correlation. There was good visual correlation between internal and external gamma counts during TcHIDA reflux events.

Subject 6 (JR, male, age 77) - Internal probe/aspiration test (Fig 34)

History of heartburn and regurgitation, with oesophageal ulceration. No previous surgery.

Two 45 minute gamma camera acquisitions were performed. The second was correlated with internal probe readings. $^{99}\text{Tc}^{\text{m}}\text{HIDA}$ reflux occurred, with good visual and mathematical correlation between internal and external counts ($r=+0.7937$, $p < 0.01$, $n=45$).

Subject 7 (FH, male, age 59) - Internal probe/aspiration test (Fig 35).

This patient had minimal reflux symptoms, but a Barrett's oesophagus on endoscopy, and a highly abnormal pH test suggesting severe acid reflux. Two 45 minute gamma camera acquisitions both of which were correlated with internal probe readings. Minimal $^{99}\text{Tc}^{\text{m}}\text{HIDA}$ reflux occurred during the test, in keeping with his symptoms, and internal/external gamma counts tailed off, with no rise after the initial liver concentration of radioisotope. There was good visual and mathematical correlation between the two sets of counts ($r=+0.8922$, $p < 0.01$, $n=90$).

Subject 8 (MC, male, age 25) - Internal probe/aspiration test (Fig 36).

Normal asymptomatic volunteer. Two 45 minute gamma camera acquisitions both of which were correlated with internal probe readings. Two $^{99}\text{Tc}^{\text{m}}\text{HIDA}$ reflux events occurred during monitoring, with good visual and mathematical correlation between the two sets of counts ($r=+0.5292$, $p > 0.01$, $n=77$). Aspiration was not possible.

Subject 9 (TE, male, age 25) - Internal probe/aspiration test (Fig 37).

Normal asymptomatic volunteer. Two 45 minute gamma camera acquisitions, both of which were correlated with internal probe readings. No TcHIDA reflux occurred on screening, although there was a late peak on the internal gamma probe readings (55mins), which may represent some bile reflux. There was fair visual correlation, and good mathematical correlation between the two sets of counts ($r=+0.7493$, $p > 0.01$, $n=90$).

Subject 10 (RG, male, age 23) - Internal probe/aspiration test (Fig 38).

Normal asymptomatic volunteer. Two 45 minute gamma camera acquisitions both of which were correlated with internal probe readings. There was significant $^{99}\text{Tc}^{\text{m}}$ HIDA reflux on screening, and good visual and mathematical correlation between the two sets of counts ($r=+0.5372$, $p > 0.01$, $n=90$).

Lapse and lag test

In order to examine the reliability of the correlation program, and the synchronization of the above double sets of data, a lapse/lag test was performed on two data sets (JR and FH). This test involved deliberately desynchronizing the data set prior to correlation, by introducing a lag factor of one minute, then a lapse factor of one minute. This produces two further correlation coefficients, both of which should be less than that for the correctly aligned data (ie malaligned data should not correlate as well as aligned data).

Lapse/lag correlation coefficients

	<u>FH</u>	<u>JR</u>
Lag	- r=.6712	.5515
Sync	- .8922	.7937
Lapse	- .6798	.4824

In each case the synchronized data produced the highest correlation coefficient, suggesting that the data is well aligned.

Table 4

**Summary of Results Comparing
Internal Probe Counts and Gamma Camera Counts in Ten Subjects**

NAME	AGE	SEX	CLINICAL REFLUX	PROBE POSITION	pH TEST	ASPIRATION	PROBE/GAMMA CAMERA CORRELATION
Peter BEESON	61	M	BILE	STOMACH/OESOPH	YES	NO	_____
Elsie DIXON	59	F	BILE	STOMACH/OESOPH	YES	NO	_____
Lawrence HEALY	74	M	BILE	STOMACH/OESOPH	YES	NO	_____
Sylvia CLEEVE	66	F	BILE	STOMACH/OESOPH	YES	NO	_____
Raymond HUGHES	42	M	BILE	STOMACH	NO	YES	_____
James ROBINSON	77	M	BILE	STOMACH	NO	YES	r = +0.7937 n = 45
Frank HOUGHTON	59	M	ACID	STOMACH	NO	YES	r = +0.8922 n = 90
Mark CHURCHER	25	M	NIL	STOMACH	NO	YES	r = +0.5292 n = 77
Tim ETHERTON	25	M	NIL	STOMACH	NO	DRY	r = +0.7493 n = 90
Roger GOSLING	23	M	NIL	STOMACH	NO	DRY	r = +0.5372 n = 90

Fig 33

Duodenogastric Bile Reflux – A Comparison of Internal versus External Gamma Counting

A) INTERNAL PROBE READINGS (PROBE LYING IN FUNDUS OF STOMACH)

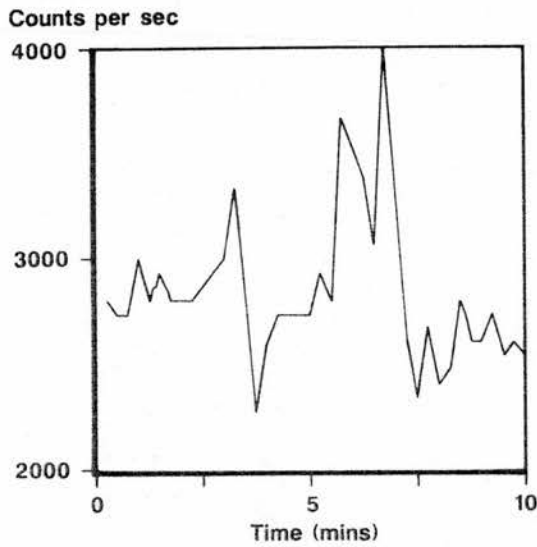

B) GAMMA CAMERA COUNTS (REGION OF INTEREST OVER FUNDUS)

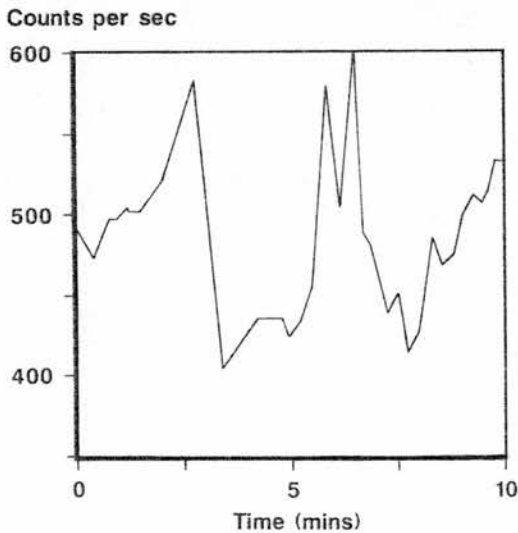
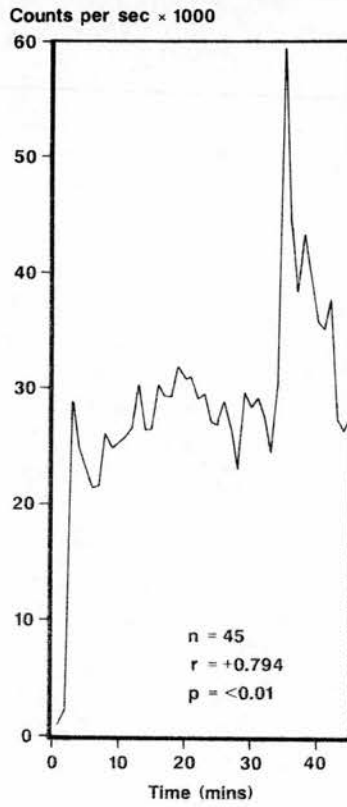

Fig 34

Duodenogastric Bile Reflux – A Comparison of Internal versus External Gamma Counting

**A) INTERNAL PROBE READINGS
(PROBE LYING IN FUNDUS OF STOMACH)**



**B) GAMMA CAMERA COUNTS
(REGION OF INTEREST OVER STOMACH)**

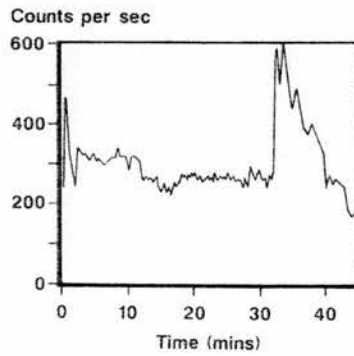
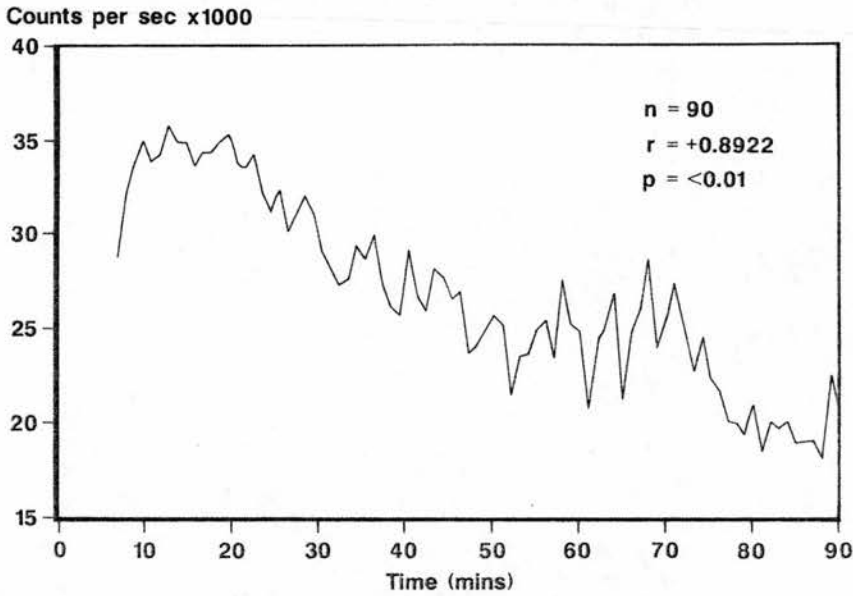

Fig 35

Duodenogastric Bile Reflux – A Comparison of Internal versus External Gamma Counting

A) INTERNAL PROBE READINGS (PROBE LYING IN FUNDUS OF STOMACH)



B) GAMMA CAMERA COUNTS (REGION OF INTEREST OVER STOMACH)

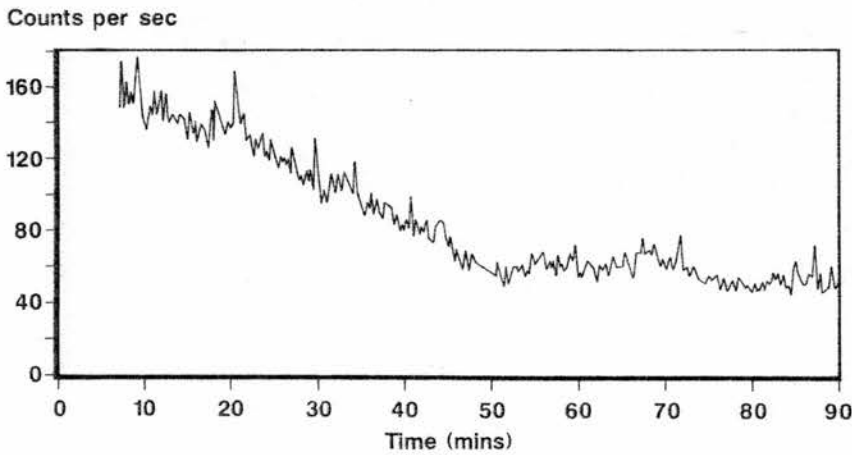
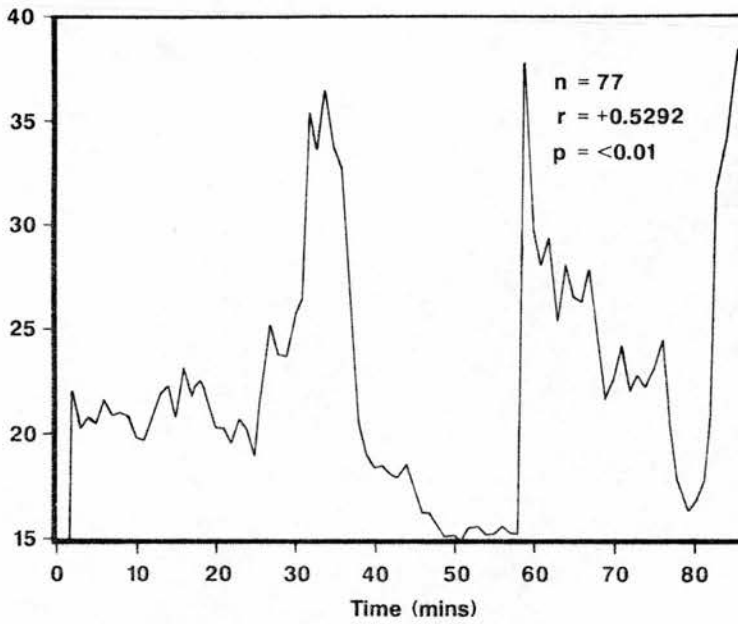

Fig 36

Duodenogastric Bile Reflux - A Comparison of Internal versus External Gamma Counting

A) INTERNAL PROBE READINGS (PROBE LYING IN FUNDUS OF STOMACH)

Counts per sec x1000



B) GAMMA CAMERA COUNTS (REGION OF INTEREST OVER FUNDUS)

Counts per sec

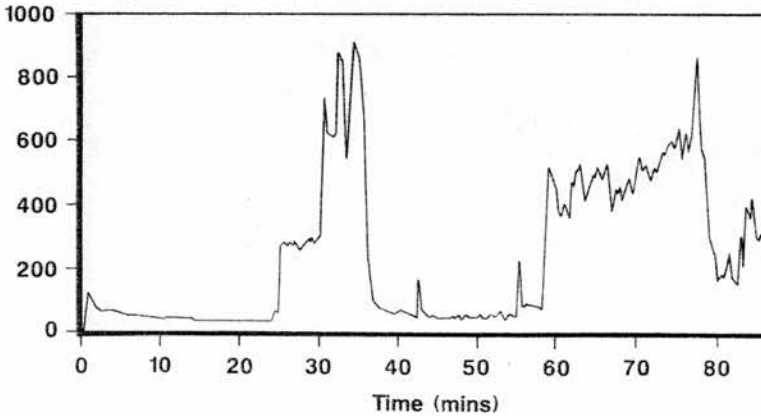
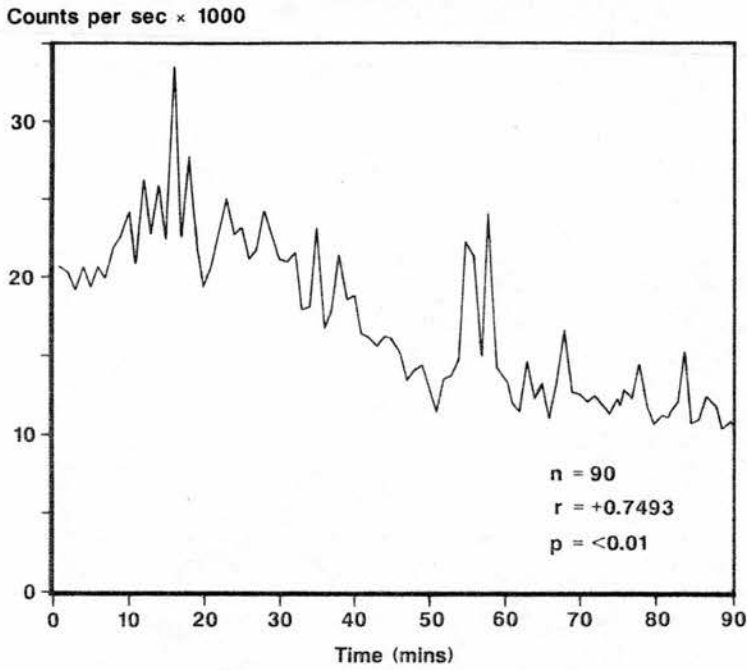

Fig 37

Duodenogastric Bile Reflux – A Comparison of Internal versus External Gamma Counting

A) INTERNAL PROBE READINGS (PROBE LYING IN FUNDUS OF STOMACH)



B) GAMMA CAMERA COUNTS (REGION OF INTEREST OVER STOMACH)

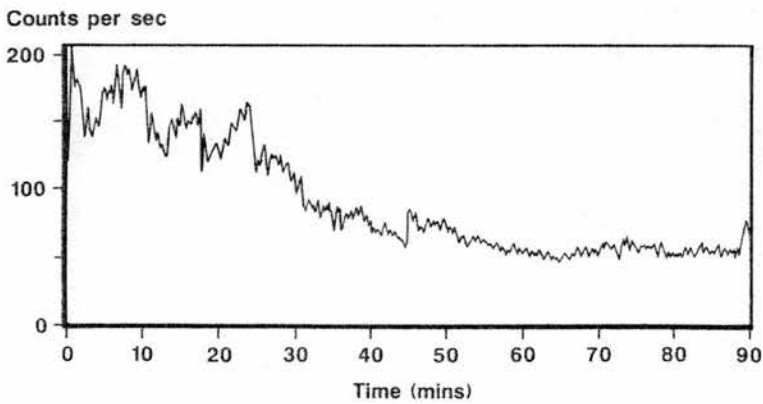
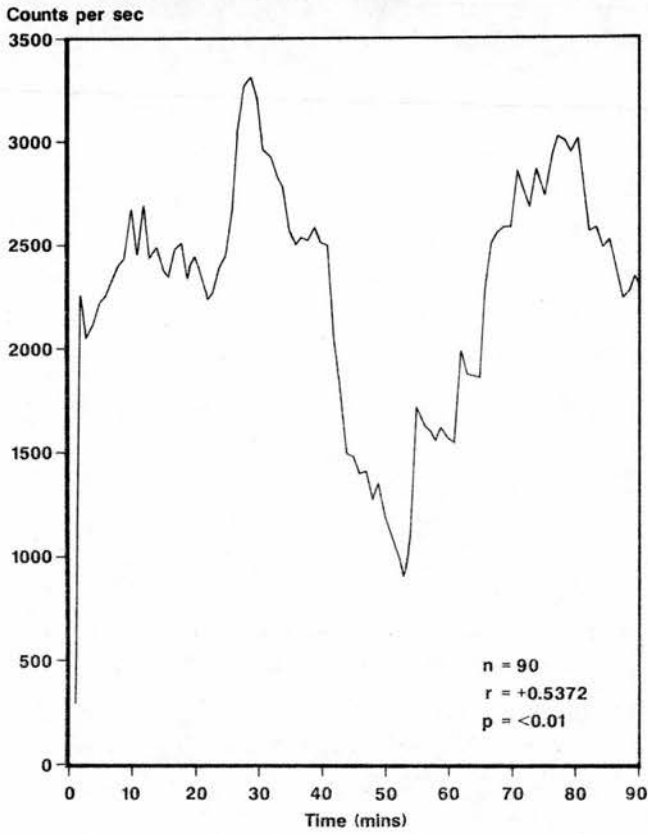

Fig 38

**Duodenogastric Bile Reflux – A Comparison of
Internal versus External Gamma Counting**

**A) INTERNAL PROBE READINGS
(PROBE LYING IN FUNDUS OF STOMACH)**



**B) GAMMA CAMERA COUNTS
(REGION OF INTEREST OVER STOMACH)**

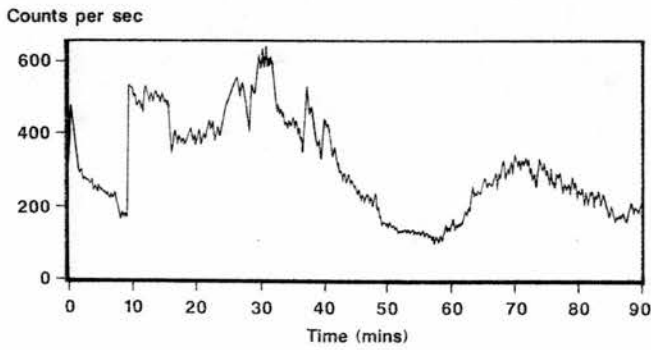

Discussion

Examination of all the internal/external gamma count curves reveals some interesting similarities. During the first 30 to 40 minutes of each test, TcHIDA is concentrated in the liver, excreted into bile, and then concentrated in the gallbladder. Both the internal and external gamma detectors registered very high counts immediately after intravenous injection of $^{99}\text{Tc}^{\text{m}}\text{HIDA}$, as the concentrated bolus passed through the circulation. This initial peak rapidly declined due to dilution within the circulation, and rapid uptake of $^{99}\text{Tc}^{\text{m}}\text{HIDA}$ by the liver. A smaller, shallower peak then appeared, as the radioisotope became concentrated in the liver substance, then this too declined as the $^{99}\text{Tc}^{\text{m}}\text{HIDA}$ was excreted in bile, and stored in the gallbladder.

Ejection of $^{99}\text{Tc}^{\text{m}}\text{HIDA}$ labelled bile into the duodenum had little effect on the counts in the fundus of the stomach, but on screening, as soon as bile refluxed into the stomach, the fundal counts started to rise. This is an inherent problem with the internal probe - that it will not only measure counts when immersed in bile, but also bile lying in a pool close by, for example, in the antrum of the stomach. The large peaks in counts seen thereafter, were thought to be due to radiolabelled antral fluid washing back towards the fundus of the stomach, and bathing the probe in bile. Visual screening confirmed these events during testing.

The curve shape varied in those patients in whom no bile reflux occurred. In these cases, after the initial rise in counts due to liver concentration of the TcHIDA, there was a steady decline in counts, with no further rise, as no bile entered the stomach, but drained distally into the small bowel.

The above observations have been further reinforced by mathematical correlation between the internal probe counts and the gamma camera counts. These

Figure are all highly positive with a range of +0.5292 to +0.8922, and a mean correlation coefficient of $+0.7003 \pm 0.1611$, $p < 0.01$).

Aspiration curves - visual correlation only

Subject This proved a less useful method of validation, as only small numbers of samples (5 - 10) could be taken during testing. In two subjects, aspirations were "dry", possibly due to the aspiration tubing impinging on the gastric mucosa.

In the three of the five cases where aspiration of bile from the region adjacent to the gamma probe was successful, there was good visual correlation between high probe counts, and high counts in the gastric aspirates, suggesting that the internal probe was measuring refluxing bile (Figure 39). However in two cases there was poor correlation, which may have been due to the aspiration tube slipping further down into the stomach (Figure 40).

Mathematical correlations were not performed with these results

Possible artefacts

Enterohepatic circulation artefact can be ruled out as this does not occur when using $^{99}\text{Tc}^{\text{m}}\text{HIDA}$. Other forms of artefact have also to be considered. These might include interference from labelled bile in the small bowel and the colon.

Count
60
50
40
30
20
10
0
0

Figure 39

Duodenogastric bile reflux - gamma counts from
internal probe and aspirated gastric samples

Subject 5

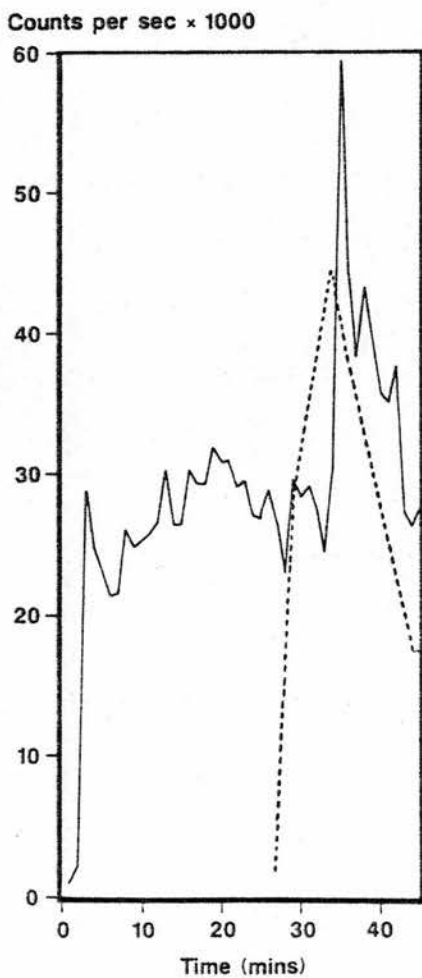

Counts x1000

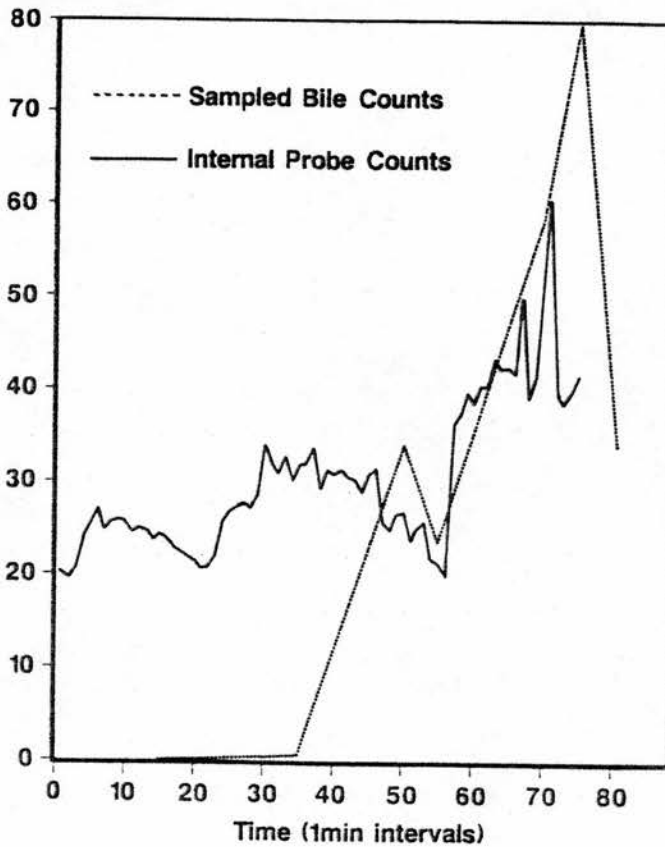

Subject 6

Figure 40

Duodenogastric bile reflux - gamma counts from
internal probe and aspirated gastric samples

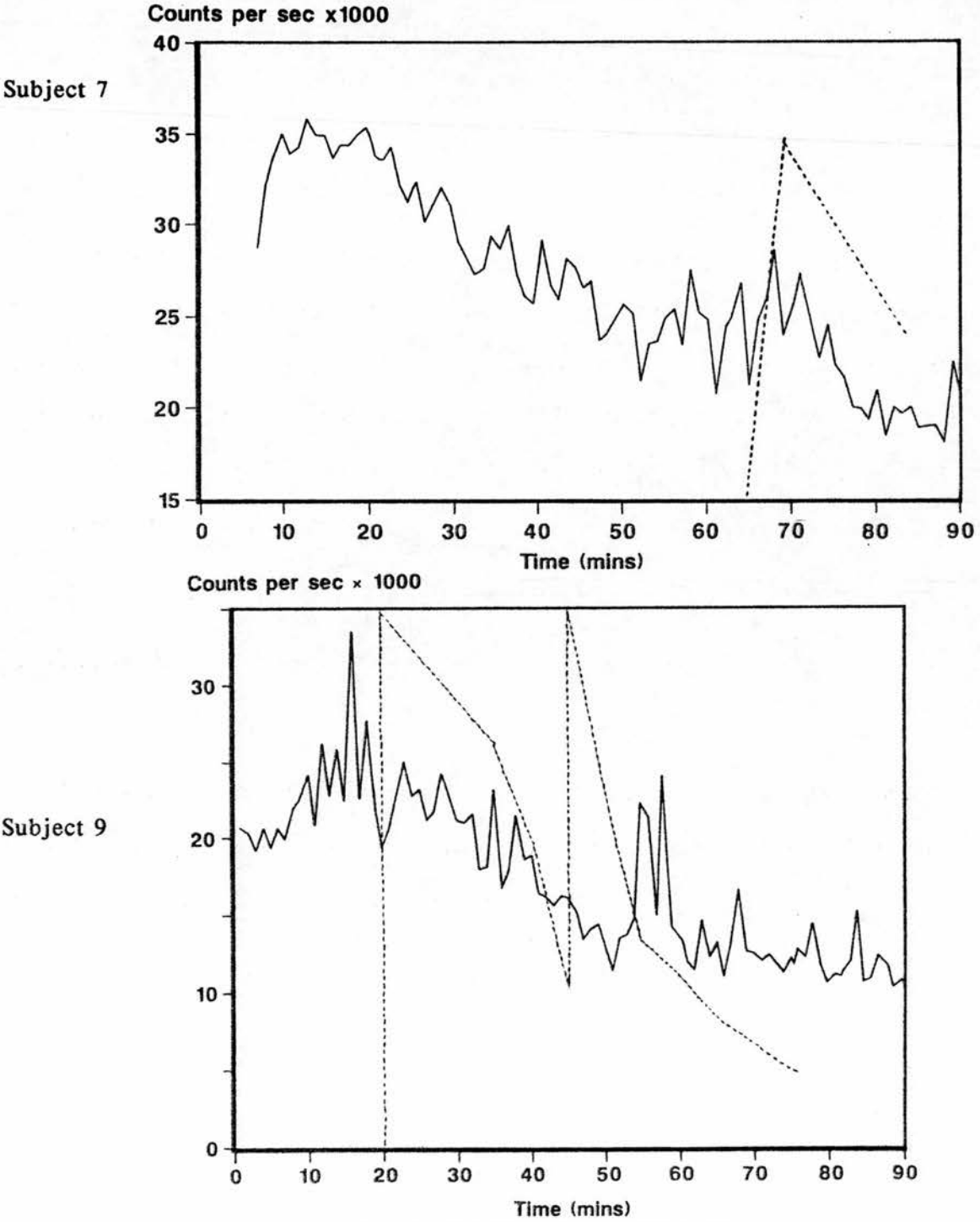

SUMMARY AND CONCLUSIONS

In summary, this thesis has reviewed the literature, ancient and modern, on the oesophagus, and its investigation. The current literature on oesophagitis has been evaluated, and further ways of investigating the condition have been developed and assessed.

From the historical and modern concepts review, it is clear that oesophagitis was poorly understood until Winkelstein's classification of the condition in 1935. Since then, the idea of oesophageal reflux as an abnormal phenomenon has been developed, and enlarged upon in a multitude of studies. Despite this, oesophagitis is still an incompletely understood "*dis-ease*", and many questions regarding aetiology are yet to be answered. In the late 1980s, we are still not clear as to why some patients present with severe symptoms, and minimal reflux disease, and conversely, why some patients present late, with minimal symptoms, and severe disease. The mechanism of oesophageal pain, and its relationship to pain of cardiac origin is still being explored, and may yet reveal unexpected relationships between these two closely apposed structures.

In particular, the question of mucosal acid damage versus bile salt damage has been discussed, and the present controversies regarding this have been highlighted. There is no question that acid is an important factor in the aetiology of oesophagitis, but bile salts and enzymes also have a part to play which is as yet undetermined, due to lack of accurate measurement techniques.

Oesophageal function can be quantified in a number of different ways, and the

developments leading to present day techniques of oesophageal measurement have been outlined. Tests fall into two categories. Firstly, those measuring structure, such as endoscopy and X-Ray investigations. Secondly, there are the tests measuring function. These include manometry, oesophageal transit studies, and pH testing. Patterns of normal and abnormal oesophageal function are now well documented, but measurements are far from standardized, making comparisons between groups of subjects from different laboratories difficult.

In chapter 3, the five year endoscopic experience of reflux disease for one group of gastroentgologists, was quantified, showing that it is a widespread condition, affecting all adult age groups, with a predilection for the elderly. It is likely that there is a large undiagnosed pool of asymptomatic disease in the community some of which may present late with symptoms of stricture or oesophageal ulceration.

The "Gold Standard" test for gastro-oesophageal reflux today - 24 hour pH testing - has been discussed, and critically assessed in chapter 4. pH testing reveals a great deal about the patterns of acid reflux into the normal and abnormal oesophagus, but from the studies on normal volunteers it is clear that there is a large overlap between these, and the selected patient population. Some patients with severe reflux symptoms, or proven oesophagitis had normal pH tests, while others with no symptoms had severely deranged pH tests.

By examining the area under the curve of the pH 4 line on ph testing it was hoped to create a better delineation between the normal and abnormal tests. This proved not to be the case, with the AUC being no better at separating the normal from the abnormal than the cumulative acid index. It therefore seemed that the quantity, or concentration of acid present in the oesophagus was no more important

than the time that the acid was lying in contact with oesophageal mucosa, when attempting to predict whether a subject would fall into a normal or abnormal group. This was surprising, as one might expect reflux at a lower pH to be more damaging to mucosa than reflux at a higher pH.

The final conclusion from the chapter on pH monitoring was that, although it may be the best available test for oesophageal reflux at the present time, it is far from perfect. It was felt likely that other factors, unrelated to pH, may also be playing a part in reflux disease, and that it was these unknown factors which were decreasing the sensitivity of the pH test.

The constituents of oesophageal refluxate include not only acid, but also food, drink (including alcohol), saliva, and varying amounts of duodenal secretions. These have not been widely studied, and with the exception of bile salts, their combined effects on oesophageal mucosa are unknown. One of the reasons for the lack of quantitation of the constituents of reflux is that there is no completely satisfactory technique for measuring it in its entirety. Various aspiration techniques have been attempted, some in combination with pH monitoring, but none have been fully satisfactory. Continuous aspiration of lower oesophageal contents is open to criticism, as this will also measure swallowed saliva, and oesophageal secretions. In chapter 5, the technique of endoscopic aspiration of oesophageal contents was utilized. This again has its drawbacks, in that "spot" sampling only is performed. Also the presence of the endoscope itself in the oesophagus introduces a further abnormal variable, predisposing to reflux. Care was taken to avoid sampling from cases where retching occurred during intubation, and this method is thought to be no less valid than other aspiration techniques.

Measurements were performed on a number of samples of oesophageal

refluxate, looking at other factors likely to cause damage to oesophageal mucosa, namely bile salts, and the proteolytic enzymes, trypsin and pepsin. These were compared with the pH of the refluxate. The results were revealing, in that significant quantities of all three substances were found to be present in aspirated samples of refluxate. More interestingly still, they were not just present and active in narrow pH bands, but across a whole range from pH 1.5 to 7.5. Bile concentrations and tryptic activity correlated with increasing pH.

These results raised the interesting concept of "non-acid" reflux as a cause of oesophagitis. The idea of "alkaline" reflux leading to inflammation of the oesophagus has been put forward many times over the years as described in chapter 2, but none of the specimens tested were in the true alkaline range above pH 7.5. It therefore seems possible that damage may occur in the oesophagus when refluxing fluid is in the mid range of pH from 4 to 7. This would explain the poor discrimination between normal and abnormal subjects using pH testing, programmed only to measure changes below a set pH level (pH 4 in most cases). The results may also help to explain the poor correlation between symptoms and signs of reflux, and pH test results. It may be that measuring the time spent in different pH bands (pH 3-4, 4-5, 5-6 etc.) would improve the sensitivity of pH testing. DeMeester in the USA (personal communication) is at present studying this concept, and his results are awaited with interest.

Having demonstrated that oesophageal reflux in the mid pH range is occurring, and may be causing inflammation, it is necessary to postulate a mechanism of damage. As has already been mentioned, pH electrodes can only measure hydrogen ion concentration in the oesophageal lumen, and tell us little about what is happening at the cellular surface. The oesophageal mucosa is protected by a thin layer of

mucus, and damage to this by enzymic action or bile salts may lead to greater penetration of hydrogen ions to the cell surface, and an increased mucosal cell/hydrogen ion contact time. Breakdown of the mucus protection layer would also allow an increased bile salt, and proteolytic enzyme contact time with the mucosal cell. At present this is a difficult concept to test, but if the aetiology of oesophagitis is to be fully understood, further methods have to be found to examine the pathological processes at a cellular level.

Some of the theories of biochemical and cellular damage were discussed in Chapter 2, but these were mainly studies involving *in vitro* models. In order to decide finally the relative importance of acid and bile in oesophageal reflux, a method of studying *in vivo* damage in the human oesophagus is needed. One possible way of achieving this would be to monitor electrolyte flux across the oesophageal mucosal membrane, by measuring transmucosal potential difference changes. A damaged mucous membrane becomes "leaky" to sodium, potassium and hydrogen ions and reduces the transmucosal potential difference. It has to be recognised that damage may occur to oesophageal mucosa which does not involve changes in electrical potentials across mucosal surfaces, but this is a method which has been used in animals with some success, and also in studies of the human stomach.

An alternative to continuing the study of reflux exclusively by pH testing, which, after all can only measure hydrogen ion concentration, was to measure concentration of other damaging factors in reflux. In this thesis, bile was chosen for further study. The advantage of measuring acid reflux was that pH testing equipment, suitably miniaturized and computerized was readily available. No such equipment was available for bile testing.

Some limited studies of a "bile probe" have been performed at Guy's Hospital

(Armstrong 1987) using an enzyme (3-alpha hydroxysteroid dehydrogenase) based system. The aim of Armstrong's study was to produce a system for continuous ambulatory monitoring of bile reflux. The probe built proved capable of measuring bile acid concentrations down to 100microMol/l. There were problems with the system however. Firstly, the probe was too large to be passed into the stomach. Secondly, the probe would only measure bile acids within a fixed, narrow pH range around 6. Outside this pH band the measurements became inaccurate due to enzyme degradation, especially in acid environments. Thirdly, the enzyme tended to degrade with time, although it was pointed out that this could be corrected for. Bearing in mind the acidic nature of the stomach, the system was not therefore suitable for gastric or oesophageal monitoring purposes, and it seemed unlikely to lead to an effective clinical system. In chapter 6, an alternative method of bile monitoring was investigated.

The radiolabelling of human bile has been possible for several years, and has been used to investigate gallbladder disease ($^{99}\text{Tc}^{\text{m}}\text{HIDA}$) and bile malabsorption ($^{75}\text{SeHCAT}$). By combining bile labelling techniques with a portable external gamma monitoring system, it was felt that an alternative method of detecting bile reflux could be developed. In practice the system, based on $^{75}\text{SeHCAT}$ and the Memolog 600 external gamma detector, proved insensitive as a measure of bile reflux. The reasons for this were insensitivity and lack of directionality of the gamma detector, associated with high background counts from the liver and small bowel. It would have been possible to increase the dose of radiolabel given, to counteract the insensitivity of the detector, but this would have led to increasing problems with background radiation "noise" within the system. Conversely, reducing the dose of $^{75}\text{SeHCAT}$ given would reduce the background problems, but at the same time

decrease the reflux detection rate still further. This "Catch 22" situation led to the abandonment of the technique as a method of reflux detection.

The external probe studies did have positive aspects. In examining the reasons for the high background radiation levels, it was realized that there were large fluctuations in gamma counts over the liver and small bowel, and that these were due to the enterohepatic circulation of radiolabelled bile. Ambulatory studies of enterohepatic circulation patterns in man have not previously been recorded, and although not directly relevant to the thesis it was felt that this was a useful finding, and worthy of further study.

The modification of the external gamma monitoring concept to that of internal gamma monitoring was not difficult. Bathing a detector in refluxing oesophageal fluid seemed the ideal way to overcome the problems encountered with the external system, which were mainly distance related. The practical application of this modification proved more problematic, although eventually also more rewarding. Apart from a single mention in the literature (Barber 1980) internal gamma detectors for human use were unheard of, and unobtainable commercially. The first part of chapter 7 outlines the successful development of a prototype internal gamma probe, with its associated monitoring equipment. The probe itself was built with specialized help from Radiation Monitoring Devices Inc. in the USA. The design specifications were achieved, but initially portability proved a problem, with a mains preamplifier limiting the mobility of the patients. A battery pack and holster were acquired late on in the project, which made the equipment truly ambulatory.

Following the developmental program, *in vitro* studies showed the internal probe to be highly sensitive to gamma photons, despite the tiny Cadmium Telluride crystal it contained. The electronic problems associated with having a CdTe crystal at

some distance from its preamplifier were overcome by a sophisticated preamplification system. In practice, with the prototype used, this limited the cable length to around 60cms, enabling the probe to be passed only as far as the fundus of the stomach.

Having proved that the internal probe was capable of measuring the small amounts of radiolabelled bile expected in oesophageal reflux, it was tested in human volunteers (initially the author). Its performance was validated by comparing and correlating internal probe counts with counts obtained from a gamma camera focussed on the area occupied by the probe. For validation purposes, the ideal testing site of lower oesophagus proved impractical, due to the unpredictability of reflux events occurring during the limited monitoring time. The site chosen for validation studies was therefore the gastric fundus, where duodenogastric reflux could reliably be expected to occur in most subjects within the two hour period of testing.

In the limited number of cases studied, results were encouraging, and suggested that the internal probe was indeed measuring bile reflux into the fundus of the stomach, while avoiding to a large extent the problems of background radiation encountered using the external probe. Bile aspiration studies were less conclusive, but it was felt that the equivocal results obtained from some subjects were secondary to developmental problems with the aspiration technique itself, rather than any intrinsic defect in the gamma monitoring system.

The technique developed is not perfect, but at present is the only known method for measuring bile reflux in ambulatory patients.

It is accepted that the number of patients tested is small, and that before the system is developed further for clinical studies of bile reflux, a larger number of validation studies needs to be performed, preferably with a refined technique for

separate bile aspiration studies in parallel with gamma camera scanning.

The monitoring system as it stands is only a qualitative measure of bile reflux, in effect measuring "ebb and flow" of radiolabelled bile into the stomach or oesophagus. By comparing bile salt concentrations from aspirated refluxate samples with gamma counts it may be possible to make it semi-quantitative, with high gamma counts indicating high concentrations of bile salts, and low counts indicating low bile salt concentrations.

The relationship between acid reflux and bile/trypsin reflux is complex. Bile salts have been shown to reflux throughout the pH range, but a comprehensive comparison of the patterns of bile reflux with those of acid reflux will only be possible with further development of the techniques described. It may be that in a subject, oesophageal reflux may be predominantly acid at one time of the day, and mainly bile/trypsin at another time of the day. This would be shown by combined pH and bile monitoring - a technique which would be quite practicable with few modifications to the equipment used.

One of the main drawbacks of the internal gamma monitoring technique is that the recording time is limited by the radioactive half life of $^{99}\text{Tc}^{\text{m}}\text{HIDA}$, and also the fact that this radiolabel does not participate in the enterohepatic circulation. This limits studies to two or three hours duration. The isotopic and physiological characteristics of $^{75}\text{SeHCAT}$ make monitoring possible over considerably longer periods, but because it can only be given in such small quantities, the internal probe is not sensitive enough to measure it. There are several possible ways around this problem. Firstly, $^{99}\text{Tc}^{\text{m}}\text{HIDA}$ could be given as an intermittent bolus, or a continuous infusion over a longer period of time - for example 2mCi intravenous boluses at three hour intervals for a total of twelve hours. One would have to allow for the

artefact produced by the intermittent liver uptake and excretion of the isotope if this method was used.

The ideal radiopharmaceutical would both take part in the enterohepatic circulation, and be given in large enough quantities to be detected by the CdTe crystal. One cannot rely on developments in radiopharmaceutical technology to produce such a compound, although this is not outwith the realms of possibility. From a more practical point of view, there are a number of ways in which the gamma probe itself may be improved, possibly increasing its sensitivity enough to measure $^{75}\text{SeHCAAT}$, and certainly increasing its signal to noise ratio.

On completion of the research described in this thesis, a visit was arranged to the facility of Radiation Monitoring Devices in Massachusetts, USA, to discuss modifications which could be incorporated into a Mark II probe. A large number of possibilities were discussed including the use of twin probes, in series, for the measurement of bile flow rates. It is anticipated that the following modifications will be made as a second stage in this ongoing project. Firstly, the initial fears about electromagnetic induction creating excessive noise in the cable assembly proved unfounded. Tests in the RMD laboratory showed that the cable length could effectively be extended to 2 metres without undue interference occurring. This was largely due to the high specification and characteristics of the preamplifier which needed no further alterations itself. Although increasing cable length does not increase the sensitivity of the probe, it does extend the uses to which it can be put, for example, passing the probe on into the antrum of the stomach, and even the duodenum and small bowel. Also the preamplifier could be placed at a distance from the face, for example on a waistbelt.

The size of the probe could be reduced further. In a few patients it proved

difficult to either pass the probe, or more often, remove it, due to impingement on the turbinate processes. A reduction of 1mm in the diameter of the probe was possible, and would overcome this problem.

Increasing the sensitivity of the probe proved possible by two methods. A slightly larger CdTe crystal could be used (2mm wide by 4mm long), to increase sensitivity to gamma irradiation selectively from sources lateral to the probe (ideal for a probe immersed in radiolabelled fluid). Secondly, although collimation was still not practical in such a small device, an element of shielding could be introduced. Gamma irradiation from the liver and duodenum undoubtedly produced some artefact in the recordings described in Chapter 7. By incorporating a tungsten, or lead tip onto the probe, measurements from radiation "straight ahead" of the probe would be reduced. These combined measures of a larger crystal, and shielded tip would be expected to increase overall sensitivity to radiolabelled bile reflux.

One further possibility proved viable, and this was the incorporation of the RMD preamplifier into the CdTe module attached to the Memolog recorder. Having the electronics in one compact package would make the equipment as easy to carry as pH monitoring equipment.

In conclusion, this thesis highlights the wide range of pH of oesophageal reflux, as shown by 24 hour pH, and aspiration studies, and has developed the concept of non-acid reflux as a cause of oesophagitis. A means of measuring bile salt reflux has been devised, using a new gamma monitoring technique. With further development, it is expected that this technique will clarify the position of bile reflux in particular in the overall picture of oesophageal reflux.

The concept and availability of a truly internal gamma monitoring device also raises the exciting possibility of internal measurement of other radiolabelled fluids, including blood constituents, and also solid organs and tumours.

In 1784 William Buchan noted in his "Treatise on the Prevention and cure of Disease" that bile was one of the culprits causing heartburn, and suggested "a dose or two of rhubarb and an infusion of Peruvian bark in wine" as a cure. He had no means of corroborating his statements, or measuring the results of his treatment, but now, two hundred years on, although the cause of heartburn and the aetiology of the disease is still unclear, we are one step nearer to the answers.

Appendix 1 - QUESTIONNAIRE

1.) HEARTBURN

- None - 0 - No heartburn
- Minimal - 1 - Occasional episodes
- Moderate - 2 - Reason for medical visit
- Severe - 3 - Interference with daily activities

2.) REGURGITATION

- None - 0 - No regurgitation
- Minimal - 1 - Occasional episodes
- Moderate - 2 - Predictable on position/straining
- Severe - 3 - Episodes of pulmonary aspiration

3.) DYSPHAGIA

- None - 0 - No dysphagia
- Minimal - 1 - Occasional episodes
- Moderate - 2 - Require liquids to clear
- Severe - 3 - Episode of meat impaction
requiring medical treatment

NOTE: Value for heartburn + regurgitation + dysphagia = Total symptomatic score.

Appendix 2 - Dietary exclusions - foods with a pH below 5.

PLEASE EXCLUDE THE FOLLOWING ACIDIC FOODS
FROM YOUR DIET

DRINKS: Orange juice/squash, grapefruit juice, lemon barley water, Ribena and Lucozade. Also black tea or coffee.

SOUPS: Oxtail and Tomato.

DESSERTS: Tinned apricots, pineapples, pears and peaches. Fruit salad, fruit jellies, trifles, stewed apple, rhubarb tart. Fresh oranges, apples and tangerines. Blackcurrant pie, apricot crumble and lemon meringue.

SALADS: Tomatoes.

MISCELLANEOUS: Vegetable curry.

Appendix 3 - PATIENT LOG

PROFORMA NUMBER:

FILENAME: b:

PARAMETERS: pH Ext probe Int probe

NAME: **UNIT NO.** **DATE OF BIRTH:**

ADDRESS:

DATE OF TEST: **TIME STARTED:** **TIME STOPPED:**

MANOMETRIC LOS: **LOS PRESSURE:** **PH LOS:**

POST STUDY PH CALIBRATION: 1.68/ 6.97/

PLEASE RECORD IN THIS LOG ANY EVENTS OCCURRING DURING MONITORING. THIS SHOULD INCLUDE:

TIMES OF DRINKS AND MEALS

NOTE ALL TIMES WHEN LYING DOWN (eg bedtime/getting up in morning)

EPISODES OF HEARTBURN, INDIGESTION OR PAIN

AT THE SAME TIME DO NOT FORGET TO PRESS THE "EVENT" BUTTON ON YOUR MONITOR.

INSTRUCTIONS ON DIET ARE OVERLEAF

DO NOT SMOKE DURING MONITORING.

AVOID USING ANTACIDS, BUT IF ABSOLUTELY NECESSARY, PLEASE RECORD THE TIME AND AMOUNT TAKEN

IF THERE ARE ANY PROBLEMS, PLEASE PHONE:

Dept. of Gastroenterology. Gosport 584255 ext 2530

or Dr Stoker. Fareham 281662

Appendix 4PART 1 Statistical analysis of pH data (Chapter 4)

The statistical techniques employed in this thesis for analysing multivariate data are described in standard texts on multivariate analysis (Anderson, Mardia et al, Morrison, Rao).

Sets of observations are available for two groups of patients - one group was considered to have oesophageal reflux disease, and the other group was considered "normal". The data for the two groups ($I=1,2$) can be summarised in terms of sample means and covariance matrices. The mean vector \underline{x}_I denotes $x_{I1}, x_{I2} \dots x_{Ik}$, the set of means corresponding to the k variables being considered.

We have asked the question; are the mean vectors for the two groups different? If differences do occur, is it possible to allocate an individual (on the basis of his experimental data) to one of the two groups?

The first question can be answered by evaluating the 2-sample Hotelling T^2 statistic provided the sample covariance matrices $\underline{S}_1, \underline{S}_2$ are equal and the distribution of observations are multinormal. Equality of covariances can be assessed by Box's M test, and Mardia has proposed a test of multinormality based on the multivariate measures of skewness and kurtosis.

The second question involves methods of discriminant analysis. When the forms of the distributions of the two groups are known (e.g. multinormal) but their

parameters are unknown, the "sample maximum likelihood discriminant rule" can be used. Assuming the two groups of data are samples from multinormal distributions with different means (estimated by \bar{x}_1, \bar{x}_2) and the same covariance matrix (estimated by \underline{S}), the sample maximum likelihood discriminant rule allocates an individual with data \underline{x} to group 1 if and only if

$$(\bar{x}_1 - \bar{x}_2)' \underline{S}^{-1} (\underline{x} - 0.5(\bar{x}_1 + \bar{x}_2)) > 0$$

The expression $y = (\bar{x}_1 - \bar{x}_2)' \underline{S}^{-1} \underline{x}$ is referred to as the linear discriminant function or discriminant score (when \underline{x} is assigned values) and can be evaluated for all individuals in the two groups. A plot of the sample cumulative distribution function for the two groups can illustrate the amount of separation between the two groups.

In considering the discrimination problem between two multinormal populations with different means and common covariance matrices there may be some variables that have no discriminatory power once other variables have been taken into account, and these can safely be discarded. Procedures for doing this have been described by Rao.

Statistical method

1.) Hotelling's T^2 test.

This is the multivariate equivalent of the Student t^2 test and will agree in value when only one variate is being studied. An "F" variate with degrees of freedom 1 and m is equivalent to a "t" variate squared with m degrees of freedom.

Results have been presented in terms of the multivariate tests even when one variate only is under study.

2.) Elimination of variables having no discriminatory power

The 2 sample Hotelling's T^2 statistic can be expressed as:

$$\frac{n_1 n_2}{n} (\bar{x}_1 - \bar{x}_2)' S^{-1} (\bar{x}_1 - \bar{x}_2)$$

for any number of variables. For p variables let the statistic be T_p^2 (say).

(n_1 and n_2 are the two sample sizes, and $n = n_1 + n_2$)

A test for considering if (p - k) variables can be discarded in the presence of k other variables uses the statistic:

$$\frac{(n_1 + n_2 - p - 1)}{(p - k)} \cdot \frac{(T_p^2 - T_k^2)}{(n_1 + n_2 - 2 + T_k^2)} \quad (\text{with } p > k)$$

Under the null hypothesis of no useful additional information from the (p - k) extra variables, the statistic has the F_{p-k, n_1+n_2-p-1} distribution and is rejected for large values of this statistic.

The variables tested in this case were as follows:

- 1.) Cumulative acid index (CAI%)
- 2.) Erect CAI%
- 3.) Supine CAI%
- 4.) Area under the curve (AUC)
- 5.) Erect AUC
- 6.) Supine AUC
- 7.) Total number of reflux episodes
- 8.) Duration of longest reflux
- 9.) Smoking
- 10.) LOS pressure
- 11.) Endoscopy grading
- 12.) Symptom score

Results:

- 1.) Controls v. Patients (Variables: Reflux, Length, Pressure, CAI%)

Data analysis have been conducted on 41 "controls" and 73 "patients" (endoscopy score 1, 2, 3 or 4). Summaries of the multivariate tests underlying the analyses are given in Table A. It has been necessary to apply a \log_e transformation to various variates in order to reduce skewness. It is readily apparent that for combinations of variates, the statistical assumptions are not fulfilled entirely. Broadly speaking, in the presence of non-normality, the normal theory tests on means are influenced by skewness, whereas the tests on covariances are influenced by kurtosis. Skewness appears mostly with the "patient" data and inequality of covariances generally arises as the number of variates increase. In these situations the Hotelling's T^2 statistic is considered as "approximate" in testing for differences in sample means for the two groups of subjects.

For the combinations, or single variates shown in Table A, it can be concluded that the groups of "controls" and "patients" can be considered as having significantly different mean values, with some of the variates illustrating higher levels of separation (or discrimination) between the two groups.

Of the four single variates reflux, length, pressure and CAI%, CAI% and length are the best two discriminators. Of the combinations of the three variates reflux, length, and CAI%, either (i) reflux and length, or (ki) reflux and CAI% can be dropped with a single variate CAI%, or length, being the discriminatory variate.

Figures 11 and 12 illustrate the separation between the two groups presented in terms of the cumulative distributions. Table C provides summary statistical measures for the two groups of subjects.

2.) Controls v. Patients (Variables: Reflux, Length, CAI% and AUC)

The area under the curve (AUC) has been calculated for 28 "controls" and 31 "patients". The corresponding data for reflux, length, and CAI% have been co-examined to indicate the best discriminators (if any) between the two groups of subjects. Summaries of the multivariate tests are given in Table B.

Similar findings to that described above in (1.) are found relating to statistical assumptions. From this limited set of data either CAI% or AUC can be considered as the best discriminator. Other variates indicate significant differences in mean values for the two groups, but not to the same degree as CAI% or AUC. Table D shows the summary statistical measures for the two groups of subjects.

Patients: Endoscopy score 1 versus endoscopy score 2,3 or 4.

Using the same methodology as described previously, the two groups of patients have been compared on the basis of endoscopy score. Endoscopy score of zero has been excluded. Summary multivariate tests are shown in Table E.

For combination and single variates analysed there are no significant differences in average values between the two endoscopy groups. The pressure variate suggests there is a significant difference between average values, but in view of the skewness and kurtosis for the second endoscopy group, the result should be left open for question and further investigation in a larger study.

The sample sizes for the AUC variate are small and further investigation of AUC in larger groups may be advisable before firm conclusions can be drawn in this case about the difference between the two endoscopy groups. Table F provides summary statistical measures for the variates studied.

CAI% erect/supine data

In view of the large proportion of zero values, particularly in the "controls", and the moderate to severe skewness of observations, it was not practical to apply a statistical test based on "normal" theory (i.e. a parametric test). Comparison between these two interdependent sets of data was possible using a non-parametric test known as the Kolmogorov-Smirnoff 2 sample test, which finds the maximum differential between 2 sets of non-parametric data.

The difference between control and patient data was significant at the 1% level for both Erect CAI%, and Supine CAI%. The maximum differential for the Erect CAI% was at 2.5%, while the maximum differential for Supine CAI% was at 0.2%

cumulative acid index.

PART 2 Bile, trypsin and pepsin analysis (Chapter 5)

Endoscopy score

Information for 47 patients on endoscopy score, pH, bile concentration and tryptic activity has been analysed by the techniques already described, by generating two groups of patients according to endoscopy score - Group A, with a score of 0 or 1, and Group B, with a score 2,3 or 4.

Table G summarises the statistical tests and summary measures. There is no significant difference in the average values for the two endoscopy groups (based on the multivariate test for the three variables pH, bile concentration and tryptic activity. The two variables bile concentration and tryptic activity required a \log_e transformation to fulfill the statistical assumptions of the tests. If there had been a progressive increase or decrease in the three variables with endoscopy score, then the above analysis using two endoscopy groups should have yielded significant differences in average values.

Bile in post-gastrectomy/normal stomach/oesophagus

Bile concentrations (\log_e transformed) for the above three groups of patients (sizes 8, 17, and 43) have been compared by the one way analysis of variance method. Log transformation was again necessary to fulfill the normality assumption

employed in the analysis of variance test. Average (log) values for the post-gastrectomy, normal stomach and oesophagus groups are 7.39, 5.31 and 5.29 respectively. These values are significantly different ($p > 0.01$) with the post-gastrectomy group having a significantly higher average value compared to the other two groups. The normal stomach and oesophagus groups are not significantly different. The post-gastrectomy group is relatively small and does not contain any very low values, but does contain the two highest values of all three groups.

Table A.
Multivariate Tests for Various Variables in the
Comparison of Controls (G₁) and Patients (G₂)

VARIABLES CONTROL (G ₁) v PATIENTS (G ₂)	GROUP NUMBERS (N ₁ , N ₂)	EQUALITY OF COVARIANCES		NORMALITY TESTS						HOTELLING'S T ² STATISTIC	F STATISTIC (d,f)	SIGNIFICANCE (p)	
		BOX'S M TEST	$\chi^2(d,f)$	SKEWNESS $\chi^2(d,f)$		KURTOSIS N(0,1)		G ₁	G ₂				
				G ₁	G ₂	G ₁	G ₂						
REFLUX (L)	(41,73)	0.07 (1)		1.11 (1)	6.86 (1)	0.33	2.01			15.04	15.04	(1,112)	<.01
LENGTH (L)	(41,73)	0.00 (1)		0.00 (1)	0.08 (1)	0.12	-1.26			48.39	48.39	(1,112)	<.01
LOS PRESSURE	(41,73)	10.51 (1)		1.30 (1)	20.07 (1)	-0.62	3.03			6.17	6.17	(1,111)	<.05
CAI% (L)	(41,73)	5.04 (1)		2.07 (1)	1.38 (1)	0.66	-1.22			54.48	54.48	(1,112)	<.01
REFLUX (L) LENGTH (L)	(41,73)	11.11 (3)		3.47 (4)	15.32 (4)	-0.32	1.11			51.68	25.61	(2,111)	<.01
REFLUX (L) CAI% (L)	(41,73)	21.52 (3)		7.07 (4)	27.81 (4)	0.00	2.08			56.12	27.81	(2,111)	<.01
LENGTH (L) CAI% (L)	(41,73)	11.35 (3)		5.58 (4)	4.15 (4)	-0.29	-1.13			55.92	27.71	(2,111)	<.01
REFLUX (L) LENGTH (L) CAI% (L)	(41,73)	27.53 (6)		11.74 (10)	38.51 (10)	-0.05	1.11			56.34	18.44	(3,110)	<.01

NOTE: Variables showing (L) after name indicates logarithm (e) of data has been used.
d,f = Degrees of Freedom

Table B.
Multivariate Tests for Various Variables in the
Comparison of Controls (G₁) and Patients (G₂)

VARIABLES CONTROL (G ₁) v PATIENTS (G ₂)	GROUP NUMBERS (N ₁ , N ₂)	EQUALITY OF COVARIANCES BOX'S M TEST X ² (d,f)		NORMALITY TESTS				HOTELLING'S T ² STATISTIC	F STATISTIC (d,f)		SIGNIFICANCE (p)
		SKEWNESS X ² (d,f)		KURTOSIS N(0,1)							
		G ₁	G ₂	G ₁	G ₂						
AUC (L)	(28,31)	2.74 (1)	2.70 (1)	0.00 (1)	2.70 (1)	-0.86	-0.74	27.07	27.07	1.57	<.01
* CAI% (L)	(28,31)	6.08 (1)	2.81 (1)	1.31 (1)	2.81 (1)	0.37	-0.69	28.59	28.59	1.57	<.01
* LENGTH (L)	(28,31)	2.50 (1)	0.36 (1)	0.05 (1)	0.36 (1)	0.38	-1.02	29.30	29.30	1.57	<.01
* REFLUX (L)	(28,31)	2.72 (1)	2.86 (1)	0.30 (1)	2.86 (1)	-0.42	-0.64	18.47	18.47	1.57	<.01
AUC (L), CAI% (L)	(28,31)	9.93 (3)	24.68 (4)	45.06 (4)	24.68 (4)	5.37	2.92	28.67	14.08	2.56	<.01
AUC (L), REFLUX (L)	(28,31)	6.56 (3)	3.79 (4)	5.10 (4)	3.79 (4)	-1.10	-1.18	27.33	13.42	2.56	<.01
AUC (L), LENGTH (L)	(28,31)	3.74 (3)	7.21 (4)	0.63 (4)	7.21 (4)	-0.33	-0.58	30.79	15.12	2.56	<.01
AUC (L) REFLUX (L) LENGTH (L)	(28,31)	7.37 (6)	12.23 (10)	24.55 (10)	12.23 (10)	0.86	-1.18	30.79	9.90	3.55	<.01
AUC (L) CAI% (L) REFLUX (L) LENGTH (L)	(28,31)	17.32 (10)	51.05 (20)	64.48 (20)	51.05 (20)	2.00	1.23	31.40	7.44	4.54	<.01

NOTE: Variables showing (L) after name indicates logarithm (e) of data has been used.

* Given that AUC is known.

Table C.
Summary Statistical Measures for 3 Variates
in the Comparison of 41 'Controls' and 73 'Patients'

		REFLUX (LOG _e)	LENGTH (LOG _e)	CAI% (LOG _e)
MEANS				
CONTROLS		3.19	1.58	0.28
PATIENTS		4.00	3.33	2.22
COVARIANCES				
CONTROLS	REFLUX (LOG)	1.20	0.91	1.55
	LENGTH (LOG)	0.91	1.65	1.83
	CAI% (LOG)	1.55	1.83	2.57
PATIENTS	REFLUX (LOG)	1.11	0.16	0.61
	LENGTH (LOG)	0.16	1.65	1.29
	CAI% (LOG)	0.61	1.29	1.39

Table D.
Summary Statistical Measures for 4 Variates
in the Comparison of 28 'Controls' and 31 'Patients'

		REFLUX (LOG)	LENGTH (LOG)	CAI% (LOG)	AUC (LOG)
MEANS					
CONTROLS		3.14	1.42	0.10	-1.61
PATIENTS		4.37	2.99	2.03	0.34
COVARIANCES					
CONTROLS	REFLUX (LOG _e)	1.59	1.09	1.93	1.81
	LENGTH (LOG _e)	1.09	1.63	1.88	1.81
	CAI% (LOG _e)	1.93	1.88	2.83	2.69
	AUC (LOG _e)	1.81	1.81	2.69	2.75
PATIENTS	REFLUX (LOG _e)	0.85	0.58	0.85	0.99
	LENGTH (LOG _e)	0.58	0.89	0.83	0.93
	CAI% (LOG _e)	0.85	0.83	1.10	1.21
	AUC (LOG _e)	0.99	0.93	1.21	1.47

Table E.
Multivariate Tests for Some Variables
in the Comparison of Patients with
Endoscopy Score 1 (G₁) Versus Endoscopy Score 2, 3 and 4 (G₂)

VARIABLES CONTROL (G ₁) v PATIENTS (G ₂)	GROUP NUMBERS (N ₁ ,N ₂)	EQUALITY OF COVARIANCES		NORMALITY TESTS				HOTELLING'S T ² STATISTIC	F STATISTIC (d,f)
		BOX'S M TEST	χ^2 (d,f)	SKEWNESS χ^2 (d,f)		KURTOSIS N(0,1)			
				G ₁	G ₂	G ₁	G ₂		
REFLUX (L)	(30,41)	0.86 (1)		0.03 (1)	8.31 (1)	-1.18	2.24	0.00	0.00 (1,69)
LENGTH (L)	(30,41)	1.05 (1)		0.04 (1)	0.34 (1)	-1.21	-0.56	1.10	1.10 (1,69)
PRESSURE	(30,41)	0.62 (1)		3.55 (1)	26.08 (1)	0.23	5.43	7.43	7.43 (1,69)
CAI% (L)	(30,41)	0.37 (1)		0.43 (1)	1.00 (1)	-1.15	-0.62	0.63	0.63 (1,69)
REFLUX (L) LENGTH (L)	(30,41)	1.93 (1)		4.28 (4)	11.70 (4)	-1.11	1.33	1.12	0.55 (2,68)
AUC (L)	(10,20)	0.09 (1)		0.49 (1)	3.44 (1)	-0.91	0.04	1.07	1.07 (1,28)

Table F.
Summary Statistical Measures for Variates
in the Comparison of Patients with
Endoscopy Score 1 Versus
Endoscopy Score 2, 3 and 4

	MEANS		VARIANCES	
	ENDO 1	ENDO 2+	ENDO 1	ENDO 2+
REFLUX (LOG)	4.01	4.00	0.94	1.30
LENGTH (LOG)	3.16	3.49	2.02	1.41
PRESSURE	22.5	14.9	112.6	148.5
CAI% (LOG)	2.12	2.34	1.56	1.27
AUC (LOG)	0.08	0.56	1.25	1.49

NOTE: Sample sizes of the 2 groups are 30 and 41 for all variates except AUC where sizes are 10 and 20.

Table G.
Bile Study: Statistical Tests and Measures
for pH, Bile Con (Log), Trypsin (Log)

		ENDOSCOPY GROUP	
		SCORE 0+1	SCORE 2+3+4
	SAMPLE SIZE	27	20
NORMALITY TESTS (MULTIVARIATE FOR 3 VARIABLES)	SKEWNESS $\chi^2(d,f)$	4.08 (10)	3.55 (10)
	KURTOSIS N(0,1)	-1.59	-1.79
EQUALITY OF COVARIANCES BOX'S TEST		$\chi^2 = 7.07$	d,f = 6
HOTELLING'S T ²		1.11	
EQUIVALENT F STATISTIC (d,f)		0.35 (3,43)	

	pH	BILE CON (LOG)	TRYPsin (LOG)	
MEANS				
ENDOSCOPY 0+1	4.24	5.60	-1.69	
ENDOSCOPY 2+3+4	4.77	5.61	-1.15	
COVARIANCES				
ENDOSCOPY 0+1	pH	4.29	1.63	3.40
	BILE CON (LOG)	1.63	2.53	3.14
	TRYPsin (LOG)	3.40	3.14	8.95
ENDOSCOPY 2+3+4	pH	4.56	2.60	6.02
	BILE CON (LOG)	2.60	3.56	3.80
	TRYPsin (LOG)	6.02	3.80	10.76

Statistics References:

ANDERSON T W. An introduction to multivariate statistical analysis. J Wiley & Sons (1958)

BOX G E P. Problems in the analysis of growth and wear curves. Biometrics 1950; 6: 362-389

HOTELLING H. The generalisation of Student's ratio. Annals of Mathematical Statistics 1931; 2: 360-378

MARDIA K V, KEAT J T & BIBBY J M. Multivariate analysis. Academic press 1979

MORRISON D F. Multivariate statistical methods. McGraw Hill 1976

RAO C R. Linear statistical inference and its applications. J Wiley & Sons 1965

Appendix 5 - Circuit diagram of internal probe preamplifier

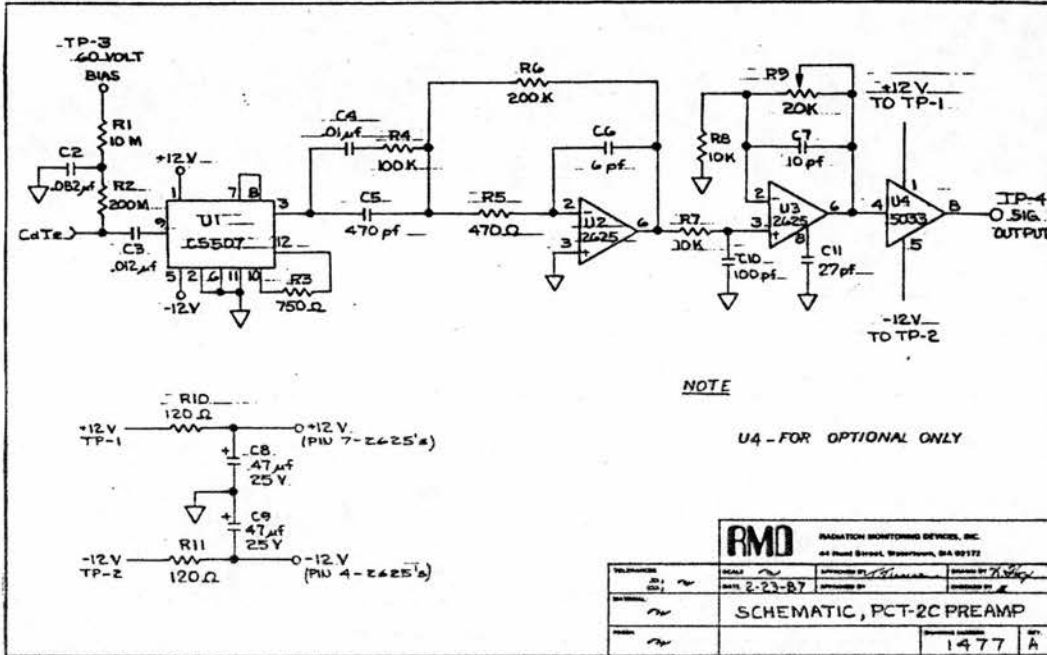

PCT 2C PREAMPLIFIER
REV. C PARTS LIST

MAY 14, 1987

PART	DESCRIPTION	VALUE	RATING
R 1	CARBON COMP.	10 M	1/4 W
R 2	CARBON COMP.	200 M	1/4 W
R 3	CARBON COMP.	750	1/4 W
R 4	CARBON COMP.	100 K	1/4 W
R 5	CARBON COMP.	470	1/4 W
R 6	CARBON COMP.	200K	1/4 W
R 7	CARBON COMP.	10 K	1/4 W
R 8	CARBON COMP.	10 K	1/4 W
R 9	SINGLE TURN POT	20 K	1/4 W
R 10	CARBON COMP.	120	1/4 W
R 11	CARBON COMP.	120	1/4 W
C 1	MONOLITHIC	0.1	UF 100 V
C 2	MONOLITHIC	0.082	UF 100 V
C 3	MONOLITHIC	0.012	UF 100 V
C 4	MONOLITHIC	0.01	UF 500 V
C 5	CERAMIC NPO	470	PF 300 V
C 6	CERAMIC NPO	6	PF 100 V
C 7	MONOLITHIC	10	PF 100 V
C 8	TANTALUM	47	UF 25 V
C 9	TANTALUM	47	UF 25 V
C 10	MONOLITHIC	100	PF 100 V
C 11	MONOLITHIC	27	PF 1 KV
U 1	CONNECTOR	6 PIN	
U 2	CONNECTOR	BNC FEMALE PANEL MOUNT	
IC 1	HYBRID PREAMP	CS-507-1	
IC 2	OP AMP	HA-2625-100	
IC 3	OP AMP	HA-2625-100	
IC 4	LINE DRIVER	HA-5033 *	
B 1	CASE		
	PANEL BEARINGS		
	STANDARD CABLE		
*	OPTIONAL		

REFERENCES

- ABBOTT D P. The early diagnosis of true hernia of the diaphragm. *JAMA* 1924; 83: 1898-1899
- ALLISON P R. Peptic ulcer of the oesophagus. *J Thor Surg* 1946; 15: 308-317
- ALLISON P R. Reflux oesophagitis, sliding hiatal hernia, and the anatomy of repair. *Surg Gynae Obs* 1951; 92: 419-431
- ANDREW C T. The height of the diaphragm in relation to the position of certain abdominal viscera. *Lancet* 1903; i: 790-792
- ARMSTRONG D, LENNOX B, ALBERY J et al. Is continuous ambulatory monitoring of duodenogastric reflux feasible? *In vitro* assessment of an enzymatic amperometric bile acid electrode. *Proc of the BSG*. Sept 1987. TH101; 139
- ATKINSON M, EDWARDS D A W, HONOUR A J & ROWLANDS E N. Comparison of cardiac and pyloric sphincters - a manometric study. *Lancet* 1957; ii: 918-922
- AUGUSTE C. Les Oesophagites. *Arch Mal App Digestif* 1951; Supp: 110-137
- AYLWIN J A. The physiological basis of reflux oesophagitis in sliding hiatal hernia. *Thorax* 1953; 8: 38-45
- BABEY A M. Observations on the nature of heartburn. *Am J Dig Dis*. 1937; 4: 600-602
- BACHIR G S & COLLIS J L. Effect of perfusion of bile salts solutions into the oesophagus of hiatal hernia patients and controls. *Thorax* 1976; 31: 271-277
- BACHIR G S, COLLIS J L & JOFFE S N. The toxicity of bile salt conjugates on human oesophageal epithelium grown in tissue culture. *J Surg Res* 1982; 32: 547-554
- BALDI F, FERRARINI F, BALESTRA R et al. Oesophageal motor events at the occurrence of acid reflux and during endogenous acid exposure in healthy subjects and in patients with oesophagitis. *Gut* 1985; 26: 336-341
-

BARBER H B, WOOLFENDEN J M, DONAHUE D J et al. Small radiation detectors for bronchoscopic tumour location. *IEEE Trans Nuc Sci* 1980; NS-27/1: 496-502

BARON J H. The discovery of gastric acid. *Gastroenterology* 1979; 76: 1056-1064

BATESON M C, HOPWOOD D, MILNE G et al. Oesophageal epithelial ultrastructure after incubation with gastrointestinal fluids and their components. *J Path* 1981; 133: 33-51

BAXTER R D. Miniature hybrid preamplifier for CdTe detectors. *IEEE Trans Nuc Sci* 1976; NS-23: 493-497

BEACONSFIELD P. Reflux oesophagitis: its diagnosis and treatment. *Gastroenterology* 1953; 24: 369-377

BECKER D J, SINCLAIR J W, WU W C & CASTELL D O. Fatty foods and reflux: Evidence of increased oesophageal acid exposure after a high fat meal. *Gastroenterology* 1988; 94(5): A29

BEHAR J, BIANCANI P & SHEAHAN D G. Evaluation of oesophageal tests in the diagnosis of reflux oesophagitis. *Gastroenterology* 1976;71:9-15

BELL R O. Calculation of gamma-ray pulse height spectrum in a semiconductor detector in the presence of charge carrier trapping. *Nuc Instruments and Methods* 1971; 93: 341-348

BENZ L J, HOOTKIN L A et al. A comparison of clinical measurements of gastro-oesophageal reflux. 1972; 62: 1-5

BERNSTEIN L M & BAKER L A. A clinical test for oesophagitis. *Gastroenterology* 1958; 34: 760-781

BEVAN J A. New Inventions - Oesophagoscope. *Lancet* 1868; April 11th: 470

BIANCANI P, BARWICK K, SELLING J & McCALLUM R. Effects of acute experimental oesophagitis on mechanical properties of the lower oesophageal sphincter. *Gastroenterology* 1984; 87: 8-16

BIANCHI PORRO G , PACE F, BARONI S et al. Comparison between three methods of oesophageal pH recording in the diagnosis of gastro-oesophageal reflux disease. Gut 1985; 26: A1104

BLISS A A. Foreign body (iron staple) in the oesophagus, removed after having been located by means of the Röntgen rays. Int Med Mag 1897; 2: 83-84

BOVA J G, DUTTON N E, GOLDSTEIN H M & HOBERMAN L J. Medication induced esophagitis: Diagnosis by double contrast esophagography. Am J Rad 1987; 148: 731-732

BOZZINI P. Lichtleiter, eine Erfindung zur Anschauung innerer Theile und Krankheiten nebst der Abbildung (Light Assembly, an invention for inspecting internal parts and diseases accompanied by an illustration). J der Praktischen Arzneykunde und Wundarzneykunst 1806; 24: 107-124

BRAMWELL COOK H, LENNARD-JONES J E, SHERIF S M & WIGGINS H S. Measurement of tryptic activity in intestinal juice as a diagnostic test of pancreatic disease. Gut 1967; 8: 408-414

BRANICKI F J, EVANS D F, JONES J A et al. A frequency-duration index (FDI) for the evaluation of ambulatory recordings of gastro-oesophageal reflux. Br J Surg 1984; 71: 425-430

BRANICKI F J, EVANS D F, OGILVIE A L et al. Ambulatory monitoring of oesophageal pH in reflux oesophagitis using a portable radiotelemetry system. Gut 1982; 23: 992-998

BREASTED J H. The Edwin Smith Surgical Papyrus - Translation and commentary. Vol 1. University of Chicago Press 1930.

BREWER L A. History of Surgery of the Oesophagus. Am J Surg 1980; 139: 730-743

BREWER L A. One stage resection of carcinoma of the cervical oesophagus with subpharyngeal esophagostomy - report of a successful case. Annals of Surgery 1949; 130: 9-20

BROWN P H, KRISHNAMURTHY G T, BOBBA V V R & KINGSTON E. Radiation dose calculation for Tc-99m HIDA in health and disease. J Nuc Med 1981; 22: 177-183

BUCHAN W. Domestic Medicine (or A Treatise on the Prevention and Cure of Disease by Regimen and Simple Medicines). W Strahan, London. 1784; 8th Edition: 462

BURNETT W. An evaluation of the gastroduodenal fibroscope. Gut 1962; 3: 361-365

BYARD R W, CHAMPION M C & ORIZAGA M. Variability in clinical presentation and endoscopic findings of Herpetic oesophagitis. Endoscopy 1987; 19: 153-155

CANNON W B. The movements of the stomach studied by means of the Röntgen rays. Am J Physiol 1898; 1: 359-382

CASTEN D F, Peptic oesophagitis, hiatal hernia, and duodenal ulcer - a unified concept. Am J Surg 1967; 113: 638-641

CANNON W B. The movements of the intestines studied by means of Röntgen rays. Am J Physiol 1902; 6: 251-277

CARMAN R D. The technic of Röntgen-ray examination of the gastro-intestinal tract, and the interpretation of screen and late findings. J Am Med Assoc 1913; 61: 321-326

CHERNOW B & CASTELL D O. Diet and heartburn. JAMA 1979; 241: 2307-2308

CHRISTENSEN J. Origin of sensation in the oesophagus. Am J Physiology 1984; 246: 221-225

CHUNG R S, JOHNSON G F & DENBESTEN L. Effect of sodium taurocholate and ethanol on hydrogen ion absorption in rabbit esophagus. Dig Dis 1977; 22: 582-588

CLOUSE R E & LUSTMAN P J. Psychiatric illness and contraction abnormalities of the oesophagus. New Eng J Med 1983; 309: 1338-1342

COLLINS B J, WATT P C H, O'REILLY T et al. Measurement of total bile acids in gastric juice. J Clin Path 1984; 37: 313-316

COLLINS B J, CROTHERS G, MCFARLAND R J & LOVE A H G. Bile acid concentrations in the gastric juice of patients with erosive oesophagitis. Gut 1985; 26: 495-499

-
- COLLINS F J, MATTHEWS H R, BAKER S E & STRAKOVA J M. Drug induced oesophageal injury. *BMJ* 1979; 23 June: 1673-1676
- COTTON P B, BLUMGART L H, DAVIES G T et al. Cannulation of papilla of Vater via fiber-duodenoscope. *Lancet* 1972; 8th Jan: 53-58
- CRAVENS E, LEHMAN G, O'CONNOR J et al. Placement of oesophageal pH probes 5cm above the LES : Can we get closer? *Gastroenterology* 1987; 92(5) A1357
- CROSS F S & WANGENSTEEN O H. Role of bile and pancreatic juice in production of oesophageal erosions and anaemia. *Exp Biol Med* 1957; 77: 862-866
- CRUMPLIN M K H, STOL D W, MURPHY G M & COLLIS J L. The pattern of bile salt reflux and acid secretion in sliding hiatal hernia. *Br J Surg* 1974; 61: 611-616
- CZERNY Prof. Neue Operationen - Resection des Oesophagus. *Centralblatt für Chirurgie*. 1877; 28: 28-29
- DANIEL E E, TAYLOR G S & HOLMAN M E. The myogenic basis of active tension in the lower oesophageal sphincter. *Gastroenterology* 1976; 70: 874
- DAVENPORT H W. Destruction of the gastric mucosal barrier by detergents and urea. *Gastroenterology* 1968; 54: 175-181
- DAVIES A B. Rudolf Schindler's role in the development of gastroscopy. *Bull Hist Med* 1972; 46: 150-170
- DAVIES L, WEXLER J P, RABINOWITZ A et al. Data acquisition using a scintillation detector interfaced to a personal microcomputer. *J Nuc Med* 1987; 26: 85-87
- DEAKIN M, RAMAGE J, PAUL A et al. Don't freeze pepsin! *J Roy Nav Med Serv* 1985; 71: 96-97
- DEHN T C B. 24-hour ambulatory pH recording in gastro-oesophageal reflux. *GI Futures* 1986; 1(issue 2): 10-12
- DEHN T C B & KETTLEWELL M. 24-hour monitoring of oesophageal pH in out-patients. *Lancet* 1987; March 14: 625-626
-

DELHEZ H, VAN DEN BERG J W O, VAN BLANKENSTEIN M & MEERWALDT J H. New method of the determination of bile acid turnover using ⁷⁵Se-Homocholeic Acid Taurine. *Eur J Nuc Med* 1982;7:269-271

DEMEESTER T R, JOHNSON L F, JOSEPH G J et al. Patterns of gastro-oesophageal reflux in health and disease. *Ann Surg* 1976; 184: 459-469

DEMEESTER T R, WANG C-I, WERNLY J A et al. Technique, indications, and clinical use of 24 hour oesophageal pH monitoring. *J Thorac Cardiovasc Surg* 1980; 79: 656-670

DENNISH G W & CASTELL D O. Inhibitory effect of smoking on the lower oesophageal sphincter. *New Eng J Med* 1971; 284: 1136-1137

DENNISH G W & CASTELL D O. Caffeine and the lower oesophageal sphincter. *Dig Dis* 1972; 17: 993-996

DENT J F, DODDS W J, FRIEDMAN R H et al. Mechanism of gastro-oesophageal reflux in recumbent asymptomatic human subjects. *J Clin Invest* 1980; 65: 256-267

DENT J, HOLLOWAY R H, TOOULI J & DODDS W J. Mechanisms of lower oesophageal sphincter incompetence in patients with symptomatic gastro-oesophageal reflux. *Gut* 1988; 29: 1020-1028

DEWAR P, KING R & JOHNSTON D. Bile acid and lysolecithin concentrations in the stomach in patients with duodenal ulcer before operation and after treatment by highly selective vagotomy, partial gastrectomy, or truncal vagotomy and drainage. *Gut* 1982; 23: 569-577

DODDS W J. Instrumentation and methods for intraluminal oesophageal manometry. *Arch Int Med* 1976; 136: 515-523

DODDS W J, HOGAN W J, HELM J F & DENT J. Pathogenesis of reflux oesophagitis. *Gastroenterology* 1981; 81: 376-394

DODDS W J, HOGAN W J, MILLER W M et al. Relationship between serum gastrin concentration and lower oesophageal sphincter pressure. *Dig Dis* 1975; 20: 201-207

DODDS W J, DENT J, HOGAN W J et al. Mechanisms of gastro-oesophageal reflux in patients with reflux oesophagitis. *N Eng J Med* 1982; 307: 1547-1552

DONALD I P, FORD G A & WILKINSON S P. Is 24 hour ambulatory oesophageal pH monitoring useful in a District General Hospital? *Lancet* 1987; Jan 10; 89-91

DONNER M W, SILBIGER M L, HOOKMAN P & HENDRIX T R. Acid-Barium swallows in the radiographic evaluation of clinical oesophagitis. *Radiology* 1966; 87: 220-225

DUANE W C, WIEGAND D M & GILBERSTADT M L. Intra-gastric duodenal lipids in the absence of a pyloric sphincter: Quantitation, physical state, and injurious potential in the fasting and postprandial states. *Gastroenterology* 1980; 78: 1480-1487

DUROUX P, EMDE C, BAUERFEIND P et al. Intraluminal pH-metry of the future with ISFET electrodes. *Gastroenterology* 1988; 94(5): A107

DYER N H, COOK P L & KEMP HARPER R A. Oesophageal stricture associated with Crohn's disease. *Gut* 1969; 10: 549-554

EDWARDS D A W, THOMSON H, SHAW D G et al. Symposium on gastro-oesophageal reflux and its complications. *Gut* 1973; 14: 233-253

EIKMAN E A. Radionuclide hepatobiliary procedures: When can HIDA help? *J Nuc Med* 1979;20:358-361

EINHORN M. Diseases of the Stomach. 5th Ed. New York. William Wood & Co. 1911 Ch 2; 30-36

EMDE C, GARNER A & BLUM A L. Technical aspects of intraluminal pH-metry in man: current status and recommendations. *Gut* 1987; 28: 1177-1188

ENTINE G & SERREZE H B. High spatial resolution CdTe Medical probes. *IEEE Trans Nuc Sci* 1974; NS-21: 726-730

ERIKSEN C A, SADEK S A, CRANFORD C et al. Reflux oesophagitis and oesophageal transit: evidence for a primary oesophageal motor disorder. *Gut* 1988; 29: 448-452

ETHERINGTON D J & TAYLOR W H. Nomenclature of the pepsins. *Nature* 1967; 216: 279-280

-
- EVANS K T & ROBERTS G M. Where do all the tablets go? *Lancet* 1976; Dec 4th: 1237-1239
- EVANS D F, PRIEST M S, CLARK A G & HARDCASTLE J D. Effect of oesophageal pH sensors on patterns of swallowing. *Gut* 1985; 26: A574
- EVANS D F. Twenty-four hour ambulatory oesophageal pH monitoring: an update. *Br J Surg* 1987; 74: 157-161
- EYERLY J B & BREUHAUS H C. A method of measuring acidity and protein digestion within the human stomach. *Am J Dig Dis* 1939; 6: 187-191
- EYPASCH E P, BAILEY R T, DGMEESTER T R et al. Age influences capsule entrapment in the esophagus. *Gastroenterology* 1988; 94(2): A120
- FALOR W H, HANSEL J R, CHANG B et al. Out-patient 24 hour pH monitoring by telemetry. *Gastroenterology* 1980; 78 part II: 1163
- FERGUSON D J, SANCHEZ-PALOMERA E, SAKO Y et al. Studies on experimental oesophagitis. *Surgery* 1950; 28: 1022-1039
- FISHER R S, ROBERTS G S, LOBIS I F & MALMUD L S. Use of gastro-oesophageal (GE) scintiscan to evaluate anti-reflux maneuvers. *Gastroenterology* 1975; 68: A893
- FISHER R S, MALMUD L S, LOBIS I F & MAIER W P. Antireflux surgery for symptomatic gastro-oesophageal reflux - Mechanism of action. *Dig Dis* 1978; 23: 152-160
- FISHER R S, MALMUD LS, ROBERTS G S & LOBIS I S. Gastro-oesophageal (GE) scintiscanning to detect and quantitate GE reflux. *Gastroenterology* 1976; 70: 301-308
- FLEXNER J, KNIAZUK M & NYBOER J. A method for the continuous recording of gastric pH *in situ*. *Science* 1939; 90: 239-240
- FLOOD C A, WELLS J & BAKER D. Insufficiency of cardia in hiatus hernia. *Gastroenterology* 1953; 25: 364-374
- FLOOD C A, WELLS J & BAKER D. Oesophageal reflux in simple heartburn. *Gastroenterology* 1955; 28: 28-33
-

-
- FOX J E & DANIEL E E. The role of Ca^{++} in the genesis of lower oesophageal sphincter tone and contraction. *Gastroenterology* 1978; 74: 1035
- FREEDMAN P G, DIETRICH D T & BALTHAZAR E J. Crohn's disease of the oesophagus: Case report and review of the literature. *Am J Gastroenterol* 1984; 79: 835-838
- FRIEDENWALD J & FELDMAN M. Report of an interesting case of diaphragmatic hernia of the cardia of the stomach through the oesophageal orifice. *Am J Med Sci* 1925; 170: 263-271
- FYKE F E, CODE C F & SCHLEGEL J E. The gastro-oesophageal sphincter in healthy human beings. *Gastroenterologia* 1956; 86: 135-150
- GEBOES K, JANSSENS J, RUTGEERTS P & VANTRAPPEN G. Crohn's disease of the oesophagus. *J Clin Gastroenterol* 1986; 8: 31-37
- GELFAND M D & KRONE C L. Dysphagia and oesophageal ulceration in Crohn's disease. *Gastroenterology* 1968; 55: 510-514
- GIFFEN H Z. The diagnosis of diaphragmatic hernia. *Ann Surg* 1912; 55: 388-397
- GILES G R, CLARK C G & BUCHAN R. Effect of oesophageal perfusion with acid on basal gastric secretion. *Gut* 1968; 9: 52-56
- GILES G R, MASON M C, HUMPHRIES C & CLARK C G. Action of gastrin on the lower oesophageal sphincter in man. *Gut* 1969; 10: 730-734
- GILL R C, KELLOW J E & WINGATE D L. Gastro-oesophageal reflux and the migrating motor complex. *Gut* 1987;28: 929-934
- GILL R C, BOWES K L, MURPHY P D et al. Oesophageal motor abnormalities on gastro-oesophageal reflux and the effects of fundoplication. *Gastroenterology* 1986; 91: 364-9
- GILL R C, KELLOW J E & WINGATE D L. Gastro-oesophageal reflux and the migrating motor complex. *Gut* 1987; 28: 929-934
- GILLISON E W, CAPPER W M, AIRTH G R et al. Hiatus hernia and heartburn. *Gut* 1969; 10: 609-613
-

GILLISON E W, DE CASTRO V A, NYHUS L M et al. The significance of bile in reflux oesophagitis. *Surg Gynaecol Obst* 1972; 134: 419-424

GILLISON E W, KUSAKARI K, BOMBECK C T & NYHUS L M. The importance of bile in reflux oesophagitis and the success in its prevention by surgical means. *Br J Surg* 1972; 59: 794-798

GOLDBERG H I, DODDS W J, GEE S et al. Role of acid and pepsin in acute experimental esophagitis. *Gastroenterology* 1969; 56: 223-230

GOLDNER F H & BOYCE H W. Relationship of bile in the stomach to gastritis. *Gast Endosc* 1976; 4: 197-199

GONELLA J, NIEL J P & ROMAN C. Vagal control of lower oesophageal sphincter motility in the cat. *J Physiol* 1977; 273: 647-664

GOTLEY D C, MORGAN A P & COOPER M J. Bile acid concentrations in the refluxate of patients with reflux oesophagitis. *Br J Surg* 1988; 75: 587-590

GOYAL R K & RATTAN S. Genesis of basal sphincter pressure: effect of tetrodotoxin on lower oesophageal sphincter pressure in opossum *in vivo*. *Gastroenterology* 1976; 62: 62-67

GRAY S P & BILLINGS J A. Kinetic assay of human pepsin with albumin-bromphenol blue as substrate. *Clin Chem* 1983; 29: 447-451

GREATOREX R & THORPE J A C. Clinical assessment of gastro-oesophageal reflux by questionnaire. *Br J Clin Pract* 1983; 37: 133-135

GUPTA R R, KAHRILAS P J. The acute effect of smoking on oesophageal acid clearance time and salivation. *Gastroenterology* 1988; 94(5): A161

HALE H W, & DRAPANAS T. Reflux oesophagitis. *Am J Surg* 1957; 93: 228-233

HAMILTON B H, TOBEY N A, SCHREINER V J & BROCKINGTON J C. *In vivo* bicarbonate (HCO_3) secretion by mammalian oesophagus. *Gastroenterology* 1988; 94(5): A170

-
- HARMON J W, JOHNSON L F & MAYDONOVITCH C L. Effects of different bile salts on the hydrogen ion permeability of the rabbit esophagus. *South Sect Gastroent* 1978; 26: 17a
- HARRINGTON S W. Diaphragmatic hernia. *Arch Surg* 1928; 16: 386-415
- HARRINGTON S W. Diaphragmatic hernia associated with traumatic gastric erosion and ulcer. *Surg Gynecol & Obst* 1930; 51: 504-521
- HARTMAN H R. Blood changes in a gastrectomized patient simulating those in pernicious anaemia. (Heartburn/biliary vomiting post gastrectomy). *Am J Med Sci.* 1921; 62: 201-206
- HARVEY E, LOBERG M & COOPER M. ^{99m}Tc - HIDA: A new radiopharmaceutical for hepatobiliary imaging. *J Nuc Med* 1975 ;16: 533.
- HARVEY E, LOBERG M, RYAN J et al. Hepatic clearance mechanism of ^{99m}Tc -HIDA and its effect on quantitation of hepatobiliary function. *J Nuc Med* 1979; 20: 310-313
- HARVEY W C & LANCASTER J L. Technical and clinical characteristics of a surgical biopsy probe. *J Nuc Med* 1981; 22: 184-186
- HAZELL S L, CARRICK J & LEE A. *Campylobacter pylori* can infect the oesophagus when gastric tissue is present. *Gastroenterology* 1988; 94(5): A178
- HEATON K W. Bitter Humour: The development of ideas about bile salts. *J Roy Coll Phys Lond* 1971; 6: 83-97
- HELLER S R, FELLOWS I W, OGILVIE A L & ATKINSON M. Non-steroidal anti-inflammatory drugs and benign oesophageal stricture. *BMJ* 1982; 285: 167-168
- HELM J F, DODDS W J, HOGAN W J et al. Acid neutralizing capacity of human saliva. *Gastroenterology* 1982; 83: 69-74
- HELM J F, DODDS W J, RIEDEL D R et al. Determinants of oesophageal acid clearance in normal subjects. *Gastroenterology* 1983; 85: 607-612
-

HELM J F, DODDS W J & HOGAN W J. Salivary Response to oesophageal acid in normal subjects and patients with reflux oesophagitis. *Gastroenterology* 1987; 93: 1393-1397

HELSINGEN N. Oesophagitis following total gastrectomy. *Acta Chir Scand* 1959; 118: 190-201

HENDERSON R D, MUGASHE F L, JEEJEEBHOY K N et al. The role of bile and acid in the production of oesophagitis and the motor defect of oesophagitis. *Ann Thor Surg* 1972; 14: 465-473

HENDERSON R D, MUGASHE F L, JEEJEEBHOY K N et al. Synergism of acid and bile salts in the production of experimental esophagitis. *Can Med J* 1973; 16: 12-17

HIGGS R H, SMYTH R D & CASTELL D O. Gastric alkalinization - effect on lower oesophageal sphincter pressure and serum gastrin. *New Eng J Med* 1974; Sept 5: 486-490

HILL L D. An effective operation for hiatal hernia - an eight year appraisal. *Ann Surg* 1967; 166: 681-692

HIRSCHOWITZ B I, CURTISS L E, PETERS C W & POLLARD H M. Demonstration of a new gastroscope, the "fibrescope". *Gastroenterology* 1958; 35: 50-53

HOGAN W J, VIEGAS de ANDRADE S R & WINSHIP D H. Ethanol-induced acute oesophageal motor dysfunction. *J Appl Physiol* 1972; 32: 755-760

HOLLOWAY R H, HONGO M, BERGER K & McCALLUM R W. Gastric distension: A mechanism for post-prandial gastro-oesophageal reflux. *Gastroenterology* 1985; 89: 779-784

HOPKINS H H & KAPANY N S. A flexible fibrescope, using static scanning. *Nature* 1954; 173: 39-41

HOPWOOD D, BATESON M C, MILNE G & BOUCHIER I A D. Effects of bile acids and hydrogen ion on the fine structure of oesophageal epithelium. *Gut* 1981; 22: 306-311

HOWARD P J & HEADING R C. Oesophageal pain. *Hosp Update* 1988; 1st Jan: 1381-1390

JACKSON, Chevalier. Peptic ulcer of the oesophagus. *J Am Med Assoc* 1929; 5: 369-372

JACKSON, Chevalier. Gastroscopy: Report of additional cases. *J Am Med Assoc* 1907; 49: 1425-1428

JACKSON C & JACKSON C L. Peroral gastroscopy - including examination of the supradiaphragmatic stomach. *J Am Med Assoc* 1935; 104: 269-274

JANSSENS J, VANTRAPPEN G & GHILLEBERT G. 24-hour recording of oesophageal pressure and pH in patients with noncardiac chest pain. *Gastroenterology* 1986; 90: 1978-1984

JENKINSON L R, NORRIS T L & WATSON A. Dietary guidelines for ambulatory oesophageal pH monitoring. *Gut* 1986; 27: 594-595

JENKINSON L R, NORRIS T L & WATSON A. Expression of normal ranges in 24 hour intra-oesophageal pH monitoring. *Gut* 1987; 28: 1378

JOHANSSON K E, ASK P, BOERYD B et al. Oesophagitis, signs of reflux, and gastric acid secretion in patients with symptoms of gastro-oesophageal reflux disease. *Scand J Gastroenterology* 1986; 21: 837-847

JOHNSSON F, JOELSSON B, GUDMUNDSSON K & GREIFF L. Symptoms and endoscopic findings in the diagnosis of gastro-oesophageal reflux disease. *Scand J Gastroenterol* 1987; 22: 714-718

JOHNSSON F, JOELSSON B & ISEBERG P-E. Ambulatory 24 hour intraoesophageal pH monitoring in the diagnosis of gastro-oesophageal reflux disease. *Gut* 1987; 28: 1145-1150

JOHNSSON F & JOELSSON B. Reproducibility of ambulatory oesophageal pH monitoring. *Gut* 1988; 29: 886-889

JOHNSSON F, JOELSSON B, FLORÉN C-H, & NILSSON A. Bile salts in the esophagus of patients with esophagitis. *Scand J Gastroenterol* 1988; 23: 712-716

JOHNSON L F & DEMEESTER T R. Twenty-four hour pH monitoring of the distal oesophagus. *Am J Gastro* 1974; 62: 325-332

JONES C M & RICHARDSON W. Observations on the nature of heartburn. *J Clin Inv.* 1926; 2: 610

KAHRILAS P J, DODDS W J, HOGAN W J et al. Oesophageal peristaltic dysfunction in peptic oesophagitis. *Gastroenterology* 1986; 91: 897-904

KAUL B, HALVORSAN T, PETERSEN et al. Gastro-oesophageal reflux disease - Scintigraphic, endoscopic, and histologic considerations. *Scand J Gastroenterol* 1986; 21: 134-138

KAUL B, PETERSEN H, GRETTE K et al. Scintigraphy, pH measurement, and radiography in the evaluation of gastro-oesophageal reflux. *Scand J Gastroenterol* 1985; 20: 289-294

KAYE M D & SHOWALTER J P. Pyloric incompetence in patients with symptomatic gastro-oesophageal reflux. *J Lab & Clin Med* 1974; 83: 198-206

KAZEM I et al. A new scintigraphic technique for the study of the oesophagus. *Am J Roentgen* 1972; 115: 681-688

KESHAVARZIAN A, BUSHNELL D L, YEGELWEL E J et al. Effect of gastric emptying on gastro-oesophageal reflux. *Gastroenterology* 1988; 94(2): A223

KIDDER G W, LILLEMOR K D, HARMON J W et al. Evaluation of *in vivo* measurement of transoesophageal electrical resistance as an indicator of early experimental oesophageal mucosal injury. *J Lab Clin Med* 1983; 102: 477-486

KIKENDALL J W, FRIEDMAN A C, OYEWOLE M A et al. Pill induced esophageal injury: Case reports and a review of the medical literature. *Dig Dis Sci* 1983; 28: 174-182

KIRKLIN B R & HODGSON J R. Roentgenologic characteristics of diaphragmatic hernia. *Am J Roentgenol* 1947; 58: 77-101

KIROFF G K, DEVITT P G, DeYOUNG N J & JAMIESON G G. Bile salt induced injury of rabbit oesophageal mucosa measured by hydrogen ion disappearance. *Aust N Z J Surg* 1987; 57: 111-117

KIROFF G K, MUKERJHEE T M, DIXON B et al. Morphological changes caused by exposure of rabbit oesophageal mucosa to hydrochloric acid and sodium taurocholate. *Aust N Z J Surg* 1987; 57: 119-126

-
- KIVILAAKSO E, FROMM D & SILEN W. Effect of bile salts and related compounds on isolated oesophageal mucosa. *Surgery* 1980;87:280-285
- KJELLÉN G & TIBBLING L. Oesophageal motility during acid-provoked heartburn and chest pain. *Scand J Gastroenterol* 1985; 20: 937-940
- KOFLER K. Sodbrennen und chronische Tonillitis (Heartburn and chronic tonsillitis). *Wiener Klin Woch* 1928; 41: 768-777
- KODSI B E, WICKREMESINGHE P C, KOZINN P J et al. *Candida* oesophagitis - a prospective study of 27 cases. *Gastroenterology* 1976; 71: 715-719
- KRAMER P & INGELFINGER F J. I. Motility of the human oesophagus in control subjects and in patients with oesophageal disorders. *Am J Med* 1949; 7: 168-173
- KRAMER P & INGELFINGER F J. II. Cardiospasm, a generalized disorder of oesophageal motility. *Am J Med* 1949; 7: 174-179
- KROG M, GUSTAVSON S & JUNG B. Studies on oesophagitis - no evidence for pyloric incompetence as a primary etiological factor. *Acta Chir Scand* 1982; 148: 439-442
- KRONECKER H & MELTZER S. Der Schluckmechanismus, seine Erregung und seine Hemmung (The mechanism of swallowing, its stimulation and its inhibition. *Arch Anat Physiol (Suppl)* 1883; 328-362
- KRUSE-ANDERSON S, WALLIN L & MADSEN T. Relationship between spontaneous non-propagating pressure activity in the oesophagus and acid gastro-oesophageal reflux in pathological and non-pathological refluxers. *Gut* 1987; 28: 1478-1483
- LACEY SMITH J, OPEKUN A R, LARKAI E & GRAHAM D. Sensitivity of the oesophageal mucosa to pH in gastro-oesophageal reflux disease. *Gastroenterology* 1989; 96: 683-689
- LALYRE Y, SUBACH C, SCHMIDT L et al. Mechanism of combined bile salt and acid induced esophageal injury. *Gastroenterology* 1984; 86: A1149
- LAMBERT R. Relative importance of biliary and pancreatic secretions in the genesis of oesophagitis in rats. *Am J Dig Dis* 1962; 7: 1026-1033
-

LANELONGUE. Observation avec quelques considerations pour servir l'histoire de l'oesophagotomie interne. Mem Soc Chir Paris 1867; 6: 547-560

LEVRAT M, LAMBERT R & KIRSHBAUM G. Oesophagitis produced by reflux of duodenal contents in rats. Am J Dig Dis 1962; 7: 564-573

LEWIS I. The surgical treatment of carcinoma of the oesophagus with special reference to a new operation for growths of the middle third. Br J Surg 1946; 34: 18-31

LILLEMoe K D, JOHNSON L F & HARMON J W. Role of the components of the gastroduodenal contents in experimental acid oesophagitis. Surgery 1982; 92: 276-284

LILLEMoe K D, KIDDER G W, HARMON J W et al. Tauroursodeoxycholic acid is less damaging than taurochenodeoxycholic acid to the gastric and esophageal mucosa. Dig Dis Sci 1983; 28: 359-363

LILLEMoe K D, JOHNSON L F & HARMON J W. Alkaline esophagitis: A comparison of the ability of components of gastroduodenal contents to injure the rabbit esophagus. Gastroenterology 1983; 85: 621-628

LISTER J. On the antiseptic principle in the practice of surgery. Lancet 1867; Sept 21: 353-356

LOBERG M D, COOPER M, HARVEY E et al. Development of new radio-pharmaceuticals based on N-substitution of Iminodiacetic acid. J Nuc Med 1976; 17: 633-638

LODGE K V. The pathology of non-specific oesophagitis. J Path Bact 1955; 69: 17-24

LUNDH G. Determination of Trypsin and Chymotrypsin in human intestinal content. Scand J Clin & Lab Investigation 1957; 9: 229-232

MACKENZIE M. A New Oesophagoscope. Br Med J 1881; 1: 813

MACKIE C R, WISBEY M L & CUSCHIERI A. Milk TcHIDA test for enterogastric bile reflux. Br J Surg 1982; 69: 101-104

-
- MADDERN G J & JAMIESON G G. Oesophageal emptying in patients with gastro-oesophageal reflux. *Br J Surg* 1986; 73: 615-617
- MAFFEI V J, ZAATARI G S, McGARITY W C et al. Crohn's disease of the oesophagus. *J Thorac Cardiovasc Surg* 1987; 94: 302-311
- MAJOR R H. *Classic Descriptions of Disease*. Charles C Thomas. Springfield, Illinois 1932: Ch 10; 591-593
- MANNING R G, HEUSKEN J E, HARMON J W et al. Bile salts disrupt Calcium homeostasis before inducing oesophagitis. *Gastroenterology* 1987; 92(5): A1516
- MARTIN C J, PATRIKIOS J & DENT J. Abolition of gas reflux and transient lower oesophageal sphincter relaxation by vagal blockade in the dog. *Gastroenterology* 1986; 91: 890-896
- MATHIESON R & DUTTA S K. Candida esophagitis - Review article. *Dig Dis Sci* 1983; 28(4): 365-370
- MATIKAINEN M, TAAVISAINEN M, & KALIMA T V. Duodenogastric reflux in patients with heartburn and oesophagitis. *Scand J Gastroenterology* 1981; 16: 253-255
- McCALLUM R W, BERKOWITZ D M & LERNER E. Gastric emptying in patients with gastro-oesophageal reflux. *Gastroenterology* 1981; 80: 285-291
- McCALLUM R W. Gastro-oesophageal reflux - Update on diagnosis, pathophysiology & medical therapy. *Curr Con Gastroenterol* 1986; 4: 6-11
- McHARDY G & BALART L. Reflux esophagitis in the elderly, with special reference to antacid therapy. *J Am Ger Soc* 1972; 7: 293-304
- McLAUHLAN G, RAWLINGS J M, LUCAS M L et al. Electrodes for 24hour pH monitoring - a comparative study. *Gut* 1987; 28: 935-939
- MELLER S T, KUPFER R M, JAZWARI R P, et al. Dynamic Imaging of the enterohepatic circulation with SeHCAT. *Proc Br Inst Rad* 1981; 54: 702-703
- MELLOW M H, ALLEN M, ROBINSON M G & ORR W C. The effect of raw onions on acid reflux and reflux symptoms. *Gastroenterology* 1988; 94(5): A298
-

MERRICK M V, EASTWOOD M A, ANDERSON J R & ROSS H M. Enterohepatic circulation in man of a Gamma emitting bile-acid conjugate, 23-Selena-25-Homotaurocholic Acid (SeCHAT). *J Nuc Med* 1982; 23: 126-130

MERRICK M V, EASTWOOD M A & FORD M J. Is bile acid malabsorption underdiagnosed? An evaluation of accuracy of diagnosis by measurement of SeHCAT retention. *BMJ* 1985; 290: 665-668

MIKULICZ J. Ueber gastroskopie und oesophagoskopie. *Wiener Medizinische Presse* 1881; 45: 1405-1408

MILLER F A, NEB O, DoVALE J et al. Utilization of inlying pH probe for evaluation of acid-peptic diathesis. *Arch Surg* 1964; 89: 199-203

MILLER F A, DOBERNECK R C. Diagnosis of the acid-peptic diathesis by continuous pH analysis. *Surg Clin N Am* 1967; 47: 1325-1334

MILLER G, FARRINGTON C, SMITH V et al. Smoking delays gastric emptying of solids. *Gut* 1987; 28: 1406

MITTAL R K, REUBEN A, MAGYAR L & McCALLUM R W. Identification of bile acids in the oesophagus during gastro-oesophageal reflux in man. *Gastroenterology* 1984; 86: 1184

MITTAL R K, REUBEN A, WHITNEY J et al. Do bile acids reflux into the oesophagus? *Gastroenterology* 1987; 92: 371-375

MITTAL R K, LANGE R C & McCALLUM R W. Identification and mechanism of delayed oesophageal acid clearance in subjects with hiatus hernia. *Gastroenterology* 1987; 92: 130-135

MITTAL R K, FISHER M, ROCHESTER J et al. Characteristics of human lower oesophageal sphincter pressure response to abdominal compression. *Gastroenterology* 1988; 94(5): A305

MOERSCH H J & MILLER J R. Oesophageal pain. *Gastroenterology* 1943; 1: 821-831

MOFFAT R C & BERKAS E M. Bile esophagitis. *Arch Surg* 1965; 91: 963-966

MORRISSEY J F. Endoscopic evaluation of gastro-oesophageal sphincter dysfunction. *Southern Med J* 1978; 71(suppl 1): 56-61

MORROW D & PASSARO E R. Alkaline reflux esophagitis after total gastrectomy. *Am J Surg* 1976; 132: 287-291

MUD H J, KRANENDONK S E, OBERTOP H et al. Active trypsin and reflux oesophagitis: an experimental study in rats. *Br J Surg* 1982; 69: 269-272

MUGHAL M M, MARPLES M & BANCEWICZ. Scintigraphic assessment of oesophageal motility: what does it show and how reliable is it? *Gut* 1986; 27: 946-953

MULHOLLAND M W, MELENDEZ R L, REID D S et al. Stimulated gastric acid secretion in patients with reflux esophagitis. *Gastroenterology* 1988; 94(2): A314

MULLER-LISSNER S A. Bile reflux is increased in cigarette smokers. *Gastroenterology* 1986; 90: 1205-9

MURTHY S N S, KOSTMAN J & DINOSO V P. Effect of pH, substrate, and temperature on tryptic activity of duodenal samples. *Dig Dis Sci* 1980; 25: 289-294

NEBEL O T & CASTELL D O. Lower oesophageal sphincter pressure changes after food ingestion. *Gastroenterology* 1972; 63: 778-783

NICOLAI J J, SILBERBUSCH J, VAN ROON F et al. A simple method for the quantification of biliary reflux (into the stomach). *Scand J of Gastroent.* 1980; 15: 775-780

NISSEN R. Gastropexy and "fundoplication" in surgical treatment of hiatal hernia. *Am J Dig Dis* 1961; 6: 954-961

NYHLIN H, MERRICK M V & EASTWOOD M A. SeHCAT can detect ileal malfunction. *Gut* 1980; 21: 914

O'CONNOR H J, WYATT J I, WARD D C et al. Effect of duodenal ulcer surgery and enterogastric reflux on *Campylobacter pyloridis*. *Lancet* 1986; Nov 22: 1178-1181

OESCH U, BRZOZKA Z, XU A et al. Design of neutral hydrogen ion carriers for solvent polymeric membrane electrodes of selected pH range. *Analytical Chem* 1986; 58: 2285-2289

ORLANDO R C & BOZYMSKI E M. Heartburn in pernicious anaemia - a consequence of bile reflux. *New Eng J Med* 1973; 125: 522-523

ORR W C, JOHNSON L F & ROBINSON M G. Effect of sleep on swallowing, oesophageal peristalsis, and acid clearance. *Gastroenterology* 1984; 86: 814-819

PAGEL W. Van Helmont's ideas on gastric digestion and the gastric acid. *Bull Hist Med* 1956; 30: 524-536

PALMER E D. Subacute erosive ("peptic") oesophagitis - Histopathologic study. *A M A Arch Path* 1955; 59: 51-57

PALMER E D. Subacute erosive ("peptic") oesophagitis associated with achlorhydria. *New Eng J Med* 1960; 262: 927-929

PARÉ A. Les oeuvres d'Ambroise Paré - Conseiller et premier chirurgien du Roy. Claude Rigaud et Claude Obert, Lyon. 9th Ed 1633 (1st Edition Paris 1575)

PASSMORE R & ROBSON R. *A Companion to Medical Studies*. Blackwell Scientific Publications 1975. Vol 3i; 19: 23

PAULL G & YARDLEY J H. Gastric and esophageal *Campylobacter pylori* in patients with Barrett's esophagus. *Gastroenterology* 1988; 95: 216-218

PAYNE W W & POULTON E P. Experiments on visceral sensation. Part 1. The relation of pain to activity in the human oesophagus. *J Physiol* 1927; 63: 217-241

PELLEGRINI C A, DEMEESTER T R, WERNLY J A et al. Alkaline gastro-oesophageal reflux. *Am J Surg* 1978; 135: 177-184

POXON V A, MORRIS D L, YOUNGS D J et al. Exposure to bile acids and bacteria over 24 hours following partial gastrectomy, vagotomy, and pyloroplasty. *World J Surg* 1986; 10: 981-989

PRESCOTT F. Spallanzani on spontaneous generation and digestion. *Proc Roy Soc Med* 1929; 23: 495-510

-
- PRIES J M. Coping with reflux oesophagitis in the elderly. *Geriatrics* 1982; 9: 57-67
- PROUT W. On the nature of the acid and saline matters usually existing in the stomachs of animals. *Phil Trans Roy Soc* 1824; 1: 45-49 (facsimile in *Gut* 1974; 15: follows p82)
- QUINCKE H. Ulcus Oesophagi ex digestionem. *Deutsche Arch Klin Med* 1879; 24: 72-79
- RATTAN S & GOYAL R K. Neural control of the lower oesophageal sphincter - influence of the vagus nerves. *J Clin Inv* 1974; 54: 899-906
- RAWLINGS J M & LUCAS M L. Plastic pH electrodes for the measurement of gastrointestinal pH. *Gut* 1985; 26: 203-207
- REDO S F & BARNES W A. Effects of the secretions of the stomach, duodenum, jejunum, and colon on the esophagus of the dog. *Surg, Gynecol & Obs* 1958; March: 337-342
- REDO S F, BARNES W A & ORTIZ DE LA SIERRA A. Perfusion of the canine esophagus with the secretions of the upper gastro-intestinal tract. *Ann Surg* 1959; 149: 556-564
- REICHMANN M. Ueber sogenannte "dyspepsia acida". *Berlin Klin Woch* 1884; 21: 768-771
- RETI L. How old is hydrochloric acid? *Chymia* 1965; 10: 11-23
- RHODES J, BARNARD D E, PHILLIPS S F et al. Increased reflux of bile into the stomach in patients with gastric ulcer. *Gastroenterology* 1969; 3: 241-252
- RICHTER J E, ANDERSON K O, DALTON C B et al. Effects of psychological stress on oesophageal pressures in chest pain patients and healthy volunteers. *Gastroenterology* 1987; 92(5): C1595
- RIVERIUS - cited by UNGER A S & SPEISER M D. Congenital diaphragmatic hernia. *Am J Radiol*. 1926; 15: 135-143
- ROSEN G. Notes on the reception and influence of William Beaumont's discovery. *Bull Hist Med* 1943; 13: 631-642
-

ROSENDORFF C & GRIEVE W T. Ulcerative oesophagitis in association with ulcerative colitis. *Gut* 1967; 8: 344-347

ROVELSTAD R A, OWEN C A & MAGATH T B. Factors influencing the continuous recording of *in situ* pH of gastric and duodenal contents. *Gastroenterology* 1952; 20: 609-624

RUSSELL C O H & WHELAN G. Oesophageal manometry: how well does it predict oesophageal function. *Gut* 1987; 28: 940-945

RUSSEL J C. Diagnosis and treatment of spasmodic stricture of the oesophagus. *Br Med J* 1898; June 4th: 1450-1451

RYWOSCH D. Vergleichende versuche über die giftige wirkung der gallensäuren (Attempts at a comparison of the poisonous effects of bile). *Arb Pharmacol Inst Zu Dorpat* 1888; 2: 102-140

SADEK S, CHEADLE W C, VITALE G et al. Normal distal oesophageal pH profile. *Gut* 1985; 26: A555

SAFAIE-SHIRAZI S S, DENBESTEN L & ZIKE W L. Effect of bile salts on the ionic permeability of the oesophageal mucosa and their role in the production of oesophagitis. *Gastroenterology* 1975;68:728-733

SALMON P R, BROWN P, HTUT T & RGAD E. Endoscopic examination of the duodenal bulb: clinical evaluation of forward and side-viewing fiberoptic systems in 200 cases. *Gut* 1972; 13: 170-175

SALO J A & KIVILAAKSO E. Contribution of trypsin and cholate to the pathogenesis of experimental alkaline reflux oesophagitis. *Scand J Gastro* 1984; 7: 875-881

SALO J A, LEHTO V P, MYLLARNIEMI H et al. Morphological alterations in experimental tryptic esophagitis in the rabbit. *Gastroenterology* 1988; 94: A396

SAMLOFF I M. Slow moving protease and the seven pepsinogens: Electrophoretic demonstration of the existence of eight proteolytic fractions in human gastric mucosa. *Gastroenterology* 1969; 57: 659-669

SAVARY M & MILLER G. The Esophagus - Handbook and Atlas of Endoscopy. Gassmann A G, Solothurn, Switzerland 1978

-
- SCHINDLBECK N E, HEINRICH C, KONIG A et al. Optimal thresholds, sensitivity, and specificity of long-term pH-metry for the detection of gastro-oesophageal reflux disease. *Gastroenterology* 1987; 93: 85-90
- SCHINDLBLECK N E, HEINRICH CHRISTINE, DENDORFER A et al. Influence of smoking and oesophageal intubation on oesophgeal pH-metry. *Gastroenterology* 1987; 92: 1994-1997
- SCHINDLER R. *Gastroscopy - The endoscopic study of gastric pathology*. 2nd Ed. Illinois: University of Chicago Press 1950
- SCHLESINGER P K, DONAHUE P E, SCHMID B & LAYDEN T J. Limitations of 24-hour intra-oesophageal pH monitoring in the hospital setting. *Gastroenterology* 3985: 89: 797-804
- SCHOLMERICH J & DELUCA M. Affinity of different bile acids for Hydroxy steroid dehydrogenases - influence of enzyme immobilization and presence of albumen (Bovine). *Gastroenterology* 1987; 92(5): A1771
- SCHWEITZER E J, HARMON J W, BASS B L & BATZRI S. Bile acid efflux precedes mucosal barrier disruption in rabbit oesophagus. *Am J Physiol* 1984; 5(1): G480-G485
- SCIARRETTA G, VICINI G, FAGIOLA G et al. Use of 23-Selena-25-Homocholytaurine to detect bile acid malabsorbtion in patients with ileal dysfunction or diarrhoea. *Gastroenterology* 1986; 91: 1-9
- SHAKER R, DODDS W J, HELM J F, HOGAN W J & ARNDORFER R C. Regional oesophageal distribution and clearance of refluxed acid. *Gastroenterology* 1987; 92(5): A1635
- SHEFT D J & SHRAGO G. Oesophageal moniliasis - The spectrum of the disease. *JAMA* 1970; 213: 1859-1862
- SHORTSLEEVE M J, GAUVIN G P, GARDNER R C & GREENBERG M S. Herpetic oesophagitis. *Radiology* 1981; 141: 611-617
- SIEGAL C I & HENDRIX T R. Esophageal motor abnormalities induced by acid perfusion in patients with heartburn. *J Clin Inv* 1963; 42: 686-695
-

-
- SILVERSTEIN B D & POPE C E. Role of diagnostic tests in oesophageal evaluation. *Am J Surg* 1980; 139: 744-748
- SINCLAIR F. Some consequences of the dipole model. *Radiation Monitoring Devices - Report*; 1986; 13th May: 1 - 11
- SKALHEGG B J. On the 3-Hydroxysteroid Dehydrogenase from *Pseudomonas testosteroni* - Purification and properties. *Eur J Biochem* 1974; 46: 117-125
- SKINNER D B. Symptomatic oesophageal reflux. *Am J Dig Dis* 1966; 11: 771-779
- SKINNER D B & BELSEY R H. Surgical management of esophageal reflux and hiatus hernia. *J Cardiovasc Surg* 1967;53: 33-54
- SMART H L, NICHOLSON D & ATKINSON M. Gastro-oesophageal reflux in the irritable bowel syndrome. *Gut* 1986; 27: 1227-1131
- SMART H L, FOSTER P N, EVANS D F et al. Twenty four hour oesophageal acidity in achalasia before and after pneumatic dilatation. *Gut* 1987; 28: 883-887
- SMITH G M. An experimental study of the relation of bile to ulceration of the mucous membrane of the stomach. *J Med Res* 1914; 30: 147-183
- SMITH M R, BUCKTON G K & BENNETT J R. Bile acid levels in stomach and oesophagus of patients with acid gastro-oesophageal reflux. *Gut* 1984; 26: A556
- SMITH R S, SAMPSON W F D & WARREN D J. Evaluation of miniaturised CdTe detectors in renal transplant renography. *Nuc Med Comm* 1981; 2: 21-25
- SOFFER E E, SCALABRINI P, POPE C E & WINGATE D L. Effect of stress on oesophageal motor function in normal subjects and in patients with the irritable bowel syndrome. *Gut* 1988; 29: 1591-1594
- SONDHEIMER J M, HAASE G M. Simultaneous multiple site oesophageal pH monitoring in children with and without gastro-oesophageal reflux. *Gastroenterology* 1987; 92(5): A1649
- SONNENBERG A, STEINKAMP U, WEISE A et al. Salivary secretion in reflux oesophagitis. *Gastroenterology* 1982; 83: 889-895
-

SOUNDY R G, SIMPSON J D, ROSS H M & MERRICK M V. Absorbed dose to man from the 75m Selenium labelled conjugated bile salt 75m SeHCAT. *J Nuc Med* 1982;23:157-161

SPENCE R A J, COLLINS B J, PARKS T G & LOVE A H. Does age influence normal gastro-oesophageal emptying? *Gut* 1985; 26: 799-801

SPENCER J. Prolonged pH recording in the study of gastro-oesophageal reflux. *Br J Surg* 1969; 56: 912-914

SPENCER PAYNE W. Prevention and treatment of biliary-pancreatic reflux oesophagitis. *Surg Clin N Am* 1983; 63: 851-858

STANCIU C & BENNGTT J R. The effect of smoking on gastro-oesophageal reflux. *Gut* 1972; 13: 318

STEIN G N & FINKELSTEIN A. Hiatal hernia - Roentgen incidence and diagnosis. *Am J Dig Dis* 1960; 5: 77-87

STEWART J D, CHARDACK W M & ALFANO G S. Reflux oesophagitis. *Ann Surg* 1955; 141: 627-636

STOKER D L & WILLIAMS J G. 24-hour monitoring of oesophageal pH in out-patients. *Lancet* 1987; Feb 7: 332

STOKER D L & WILLIAMS J G. Enterohepatic circulation patterns in man. *Gut* 1987; 28: 1385

STURDEVANT R A L. Is gastrin the major regulator of lower oesophageal sphincter pressure? *Gastroenterology* 1974; 67: 551-553

SZEWCAK S, HILLEMEIER C, LEWIS A et al. Calcium and inositol phospholipids in the cat esophagus and lower esophageal sphincter (LES). *Gastroenterology* 1988; 94(5): A451

SZYPRYT E P, HARDY J G & COLTON C L. An improved technique of intraoperative bone scanning. *J Bone Joint Surg (Br. Ed)* 1986; 68b: 643-646

TALLEY R, WEINSTEIN W M, MARIN-SORENSEN M et al. *Campylobacter pylori* colonization of Barrett's oesophagus. *Gastroenterology* 1988; 94(5): A454

TAYLOR H. A New Gastroscope with controllable flexibility. *Lancet* 1941; Sept 6th: 276-277

THOMPSON D G, ANDREOLLO N A, McINTYRE A S & EARLAM R J. Studies of the oesophageal clearance responses to intraluminal acid. *Gut* 1988; 29: 881-885

TOLIN R D, MALMUD L S, REILLY J & FISHER R S. Oesophageal scintigraphy to quantitate oesophageal transit (Quantitation of oesophageal transit). *Gastroenterology* 1979; 76: 1402-1408

TUTTLE S G & GROSSMAN M I. Detection of gastro-oesophageal reflux by simultaneous measurement of intraluminal pressure and pH. *Proc Soc Exp Biol Med.* 1958; 98: 225-227

UBHI C S, HARDY J G & PEGG C A S. Mediastinal parathyroid adenoma: a new method of localization. *Br J Surg* 1984; 71: 859-860

VAN DER LINDEN W & KEMPI V. Filling of the gallbladder as studied by computer assisted ^{99m}Tc -HIDA scintigraphy. *J Nuc Med* 1984; 25: 292-298

VAN TILBURG A J, van BLANKENSTEIN F W, de ROOIJ F W & van den BERG J W. Use of SeHCAT as a marker of faecal bile acid loss in non ileal disease. *Gastroenterology* 1987; 92(5): A1681

VINNIK I E & KERN F. The effect of gastric intubation on oesophageal pH. *Gastroenterology* 1964; 47: 388-394

VITALE G C, CHEADLE W C, SADEK S et al. Computerized 24-hour ambulatory oesophageal pH monitoring and oesophagogastroduodenoscopy in the reflux patient. *Ann Surg* 1984; 200: 724-728

WALFORD G V & PARKER R P. The development and application of coaxial CdTe Medical probes for use in the clinical environment. *IEEE Transactions on Nuc Med.* 1973; NS20(N1): 318-328

WALK L. The History of Gastroscopy. *Clio Medica* 1966; 1: 209-222

WALKER S J, HOLT S, SANDERSON C J et al. Does the position of the probe affect the results of oesophageal pH monitoring. *Gut* 1986; 27: A1242

- WARD A S. Oesophageal reflux and gastric secretion. *Gut* 1970; 11: 738-742
- WASHINGTON N. Department of Physiology and Pharmacology, Nottingham. Personal communication at BSG, Autumn 1988.
- WEISS S & MALLORY G K. Lesions of the cardiac orifice of the stomach produced by vomiting. *J Am Med Assoc.* 1932; 98: 1353-55
- WELCH R W & GRAY J E. Influence of respiration on recordings of lower esophageal sphincter pressure in humans. *Gastroenterology* 1982; 83: 590-594
- WETTERER E. Eine neue manometrische sonde mit elektrischer transmission. *Zeit Biol* 1943; 101: 332-350
- WIENER G J, MORGAN T M, COPPER G B, WU W C et al. Ambulatory 24 hour pH monitoring: Is it a reproducible test for gastro-oesophageal reflux? *Gastroenterology* 1987; 92(5): A1695
- WILLIS T. *Pharmaceutice rationalis. Diatriba de Medicamentum Operationibus in Human Corpore*, Editio tertia, Oxford 1679. Ch 1, p.23. (Original Latin copy in Wellcome Museum of History - English translation by Major).
- WINDSOR C W. Gastro-oesophageal reflux after partial gastrectomy. *BMJ* 1964; 2: 1233-1234
- WINKLESTEIN A. Inflammation of the lower third of the oesophagus. *J Am Med Assoc.* 1935; 104: 906-909
- WISEMAN R. Eight surgical treatises. Treatise V - of wounds. 1719; Fifth Edition: p81 (Treatise of Wounds first published 1672) London.
- WYMAN J B, DENT J, HEDDLE R et al. Belching: A clue to understanding of pathological gastro-oesophageal reflux? *Gastroenterol* 1984; 86: A1303
- ZIMBALIST E H, DREZNICK E B & GOTTENBERG G S. *Campylobacter pylori* and its relation to the development of oesophagitis. *Gastroenterology* 1988; 94(5): A517
-

ACKNOWLEDGEMENTS

The work for this thesis could not have been performed without the considerable help and encouragement I received from my supervisors, Professor John Williams, and Dr Duncan Colin-Jones, and I am greatly indebted to them for their advice, patience and support.

I wish to acknowledge the late Bill Burland, and his successor Mark McMahon of Smith, Kline and French Laboratories, for providing generous funds for my Research Fellowship.

The following list consists of a large number of people and Departments, all of whom helped to make this work possible.

- Alec Houston, Consultant Physicist at Haslar, for his considerable help with the computer programs needed to interpret both the pH and the gamma probe data.
- Roger Pethybridge, Consultant Statistician to the Institute of Naval Medicine, for his invaluable work in helping to interpret my data.
- Surgeon Commander Roger Leicester, Consultant Surgeon, for his help with computer hardware, and pH testing equipment.
- Surgeon Captain Murdo McLeod, and the Staff of the Department of Nuclear Medicine, for their advice and encouragement throughout my stay at Haslar.
- Dr Russell Young, Consultant Chemical Pathologist, for his essential tuition in the

laboratory techniques of bile salt assay.

- Mr J Billings and Mr L Chubb, Chief Laboratory Technicians, for performing the pepsin and trypsin assays.
- Miss Jane Sayle, Chief Librarian to the Royal Navy, for her diligence and help in tracking down obscure references.
- The Defence Research Information Centre (DRIC), Glasgow, for translating the above references from the original, and sometimes very dated German.
- The Nursing Staff of the Departments of Gastroenterology of the Royal Naval Hospital, Haslar, and Queen Alexandra Hospital, Cosham, with special thanks to Ms Jill Powers, as both assistant and research volunteer.
- The Department of Medical Graphics, for producing most of the graphs and diagrams for my thesis (Harold and Steve).
- The Department of Medical Photography, for making up the numerous slides needed for presentations at meetings (Ted).

Last, but not least, I wish to acknowledge the assistance I have received from two Companies. Firstly, Radiation Monitoring Devices Inc., Boston, Massachusetts, for building the internal gamma probe to my exact specifications, and following this up with technical support. Secondly, Vertec Scientific, Aldermaston, for help in initiating the pH monitoring program, and latterly, for electronic assistance in making their equipment compatible with the RMD probe.

PAPERS

The following papers concerned with this thesis have been presented at local, national, and international meetings:

- Grey Turner Travelling Surgical Club - Sept 86
"New ways of looking at oesophageal reflux"
- British Nuclear Medicine Society - April 1987
"Small bowel transit studies with SeHCAT - a preliminary study"
- Triservice Surgical Meeting - June 1987
"Small bowel transit studies with SeHCAT"
- British Society of Gastroenterology Jubilee meeting - Sept 87
"Enterohepatic circulation patterns in Man"
- SK & F Gastroenterology Symposium - November 1987
"Modern methods of examining the oesophagus"
- Wessex Gut Club - December 1987
"Oesophageal Bile reflux - is it alkaline?"
- Guy's Hospital Gastroenterology meeting - Jan 1988
"New ways of looking at oesophageal reflux"
- Wessex Physicians Club - March 1988
"New approaches to detecting bile reflux"
- British Society of Gastroenterology Spring meeting - March 1988
"The pH and concentration of bile in the oesophagus"
- British Nuclear Medicine Society - April 1988
"A Microdetector for bile reflux"
- The 1921 Surgical Club of Great Britain - May 1988
"The development and assessment of a bile probe"
- American Gastroenterological Association - New Orleans - May 1988
"Oesophageal bile reflux - Is it alkaline?" - Oral presentation

XIII International Congress of Gastroenterology - Rome - Sept 1988

"The importance of oesophagitis - a survey of 12,652 upper gastrointestinal endoscopies"

British Society of Gastroenterology Autumn meeting - September 1988

"Tryptic and Peptic Activity in Oesophageal Refluxate"

British Society of Gastroenterology Autumn meeting - September 1988

"Comparison of the acid/alkaline junction with the manometrically determined lower oesophageal sphincter"

British Society of Gastroenterology Autumn meeting - September 1988

"Oesophagitis - a five year endoscopic review"

XXIV Congress of the European Society for Surgical Research - Brussels - May 1989 "The Internal Gamma Probe - A New Concept in Bile Reflux Detection"

The following papers concerned with this thesis have been published or submitted for publication:

STOKER D L & WILLIAMS J G. 24 hour monitoring of oesophageal pH in out-patients. Lancet 1987; Feb 7th: 332

STOKER D L, WILLIAMS J G, YOUNG R M, BILLINGS J A, CHUBB L & COLIN-JONES D G. Proteolytic enzyme activity and bile in human oesophageal refluxate (Gastroenterology).

STOKER D L, WILLIAMS J G, McCLEOD M & COLIN-JONES D G. The internal gamma probe - a new concept in bile reflux detection (Gut).