

ANATOMICAL AND PHYSIOLOGICAL STUDIES
OF THE VASCULAR, NERVOUS AND
MUSCULAR TISSUES OF THE
MAMMARY GLANDS

by

J. L. LINZELL

being a dissertation submitted to the
University of Edinburgh for the degree
of Doctor of Philosophy.

1951



PREFACE

Except for the preparation of photomicrographs and the copying of records, all the work described in this thesis was done in the Department of Physiology at the University of Edinburgh, during the period January 1948 to July 1950, whilst in receipt of a personal grant from the Agricultural Research Council. My thanks are due both to the University and to the Council for thus enabling me to carry out my studies.

The work was started under the supervision of Professor I. de Burgh Daly, F.R.S. and after he left Edinburgh, continued under the guidance of Dr. Catherine O. Hebb.

The vascular, nervous and muscular tissues of the mammary gland have received relatively little attention and in essence this thesis describes some investigations made into the control of the blood flow through the organ and into the methods whereby the secreted milk is extracted from it.

Most of the work has already been published in the following papers:-

- (1) Vasomotor nerve fibres to the mammary glands of the cat and dog. *Quart. J. exp. Physiol.* 1950, 35, 295.
- (2) Some conditions affecting the blood flow through the perfused mammary gland, with special reference to the action of adrenaline. (With C.O.Hebb.) *Quart. J. exp. Physiol.* 1951, 36, 159.
- (3) The silver staining of myoepithelial cells particularly in the mammary gland and their relation to the "ejection" of milk. *J. Anat. Lond.* 1951, in press.
- (4) The blood and nerve supply to the mammary glands of the cat, dog, rabbit, guinea pig, rat and mouse. Submitted to *J. Anat. Lond.*

I have received most generous help and advice at all times from my supervisors to whom I should like to express my

most sincere thanks. In addition I am very grateful for the helpful discussions I have had with Drs.G.Fegler and P.Eggleton.

I also wish to thank Mr.S.D.Carlill, who helped me with the electrical apparatus used in plotting dermatomes, Dr.J.A.Watt, who kindly let me use his apparatus and helped me prepare the stereoscopic photograph in Fig.23, Dr.A.W.B.Cunningham, who enabled me to obtain some human tissue for histological purposes and Dr.G.J.Romanes for allowing me to use a new staining method devised by him, some time before it was published.

I received technical assistance during some experiments and at various times in the assembling and cleaning of apparatus from Messrs.T.B.Black, Frank D.Collier and Margaret Forfar and during the preparation of photomicrographs from Mr.S.B.Cross.

The routine histological sections were prepared by Mr.A.Marshall, M.B.E., and I greatly benefited from his help and practical experience during my histological studies of the mammary myoepithelial cells.

Apart from the experiments in Section III done in collaboration with my supervisor Dr. Catherine O. Hebb and the assistance already acknowledged, all the work reported in this thesis was done by myself, and has not been submitted for any degree to any other University.

J. L. LINZELL.

August 1951.

CONTENTSPART I

	<u>Page</u>
<u>A general review of the physiology of the mammary gland</u>	
<u>Section I. Historical Introduction.</u>	4
" II. Comparative Anatomy.	7
" III. Embryology.	10
" IV. Normal Post-Natal Development.	12
" V. Control of Mammary Development.	17
(a) The role of the ovaries.	17
(b) " " " " anterior pituitary.	19
(c) " " " " adrenal cortex.	22
(d) " " " " placenta.	22
(e) " " " " thyroid.	23
" VI. Initiation and Control of Lactation.	24
(a) The role of the anterior pituitary.	24
(b) " " " " adrenal cortex.	26
(c) " " " " thyroid.	27
(d) Initiation of lactation.	27
" VII. Secretion and Synthesis of Milk.	31
" VIII. The Nervous System and Lactation.	42

PART II

<u>Account of work done.</u>	51
<u>Introduction.</u>	51
<u>Section I. Blood and Nerve Supply to the Mammary Glands.</u>	56
Summary.	71
" II. Vasomotor Nerves to the Mammary Glands.	73
Summary.	99
" III. Conditions affecting the Blood Flow through the Perfused Mammary Gland.	100
Summary.	113
" IV. Muscular Tissues in the Mammary Glands and their Relation to the "Ejection" of Milk.	155
Summary.	126
<u>General discussion and summary.</u>	127.
<u>Addendum.</u>	
I. Litter size, birth weight and the number of teats in the cat.	136
II. Anatomical nomenclature.	139.
<u>References.</u>	140

SECTION I

HISTORICAL INTRODUCTION

Our knowledge of the physiology of the mammary gland has been mainly acquired during the last 20 years. This is perhaps surprising in view of the fact that the possession of this important organ is one of the reasons for classifying some 18,000 species into one class (Mammalia) and in view of its commercial importance to the farmer and its social importance to man, particularly in the days before the artificial feeding of infants was perfected. Being largely controlled by endocrine organs, however, the elucidation of some of the mechanisms of the control of mammary growth and lactation had to await the birth of the science of Endocrinology.

During the 19th century the organ received most attention from Zoologists and Anatomists, but the former only in so far as it concerned the classification of species and provided information as to their evolution. This work has been reviewed by Owen (1868) and Bresslau (1920).

The gross and microscopical anatomy of the mammae of man and domesticated animals, particularly of the cow, was extensively studied by German anatomists in the latter half of the 19th century, but with little emphasis on the changing morphology shown during the sexual cycle. In spite of these adequate descriptions of the fully developed and quiescent organ published 70-80 years ago, the subject is poorly dealt with in many contemporary standard texts.

The discovery of secretory nerves to the salivary glands by Ludwig in 1851 and later to the pancreas and stomach, naturally led to the search for similar nerves to the mammary

gland. This research was also fostered by the consideration of the highly yielding dairy cow. Although it was obvious that milk was secreted between milkings, in that the udder increased in size, it was not considered possible that all the milk obtained at one milking could possibly be stored in the udder. Hence the conclusion that most of the milk obtained was rapidly secreted during milking, via secretory nerves. It was not until 1926-1932 that four papers, using improved methods, finally demonstrated that in fact, milking only removed 80% of the milk present, and that the udder could easily store even 20 litres of milk (see Gaines and Sanmann, 1926). Earlier work on mammary nerves has been summarised by Basch (1903). Although opinions were divided, the demonstration by Ribbert (1898) that the gland functioned normally when transplanted to another part of the body, was generally accepted as final proof of the absence of specific secretory nerves.

Early in this century it was realised that hormones must be concerned with mammary growth and function but attempts to isolate them were failures due to inadequate methods (see Lane-Clayton and Starling, 1906), and matters thus rested until successful means were devised for the extraction of the sex hormones in the 1920's and 30's, after which there was a great increase in our knowledge, chiefly due to an immense amount of endocrinological studies carried out mainly in the U.S.A.

The second world war decreased the output of papers on the mammary gland but a number of experiments and field trials were carried out into possible means of initiating lactation in heifers and of increasing the yield in lactating dairy cows, particularly in Britain, where milk became a very important commodity during wartime.

Since the war European workers have paid increasing attention to the mammary gland, with greater emphasis on milk secretion. Already radioactive tracer substances are being usefully employed in these studies and they will doubtless be used considerably more often in the future.

The mammary gland is a highly specialized organ for the secretion of milk. It is composed of a network of ducts and alveoli. The alveoli are the sites of milk production, and the ducts transport the milk to the nipple. The mammary gland is innervated by the sympathetic nervous system, and its function is regulated by hormones, particularly prolactin and oxytocin.

The mammary gland is a highly specialized organ for the secretion of milk. It is composed of a network of ducts and alveoli. The alveoli are the sites of milk production, and the ducts transport the milk to the nipple. The mammary gland is innervated by the sympathetic nervous system, and its function is regulated by hormones, particularly prolactin and oxytocin.

The mammary gland is a highly specialized organ for the secretion of milk. It is composed of a network of ducts and alveoli. The alveoli are the sites of milk production, and the ducts transport the milk to the nipple. The mammary gland is innervated by the sympathetic nervous system, and its function is regulated by hormones, particularly prolactin and oxytocin.

SECTION II

COMPARATIVE ANATOMY

The concern of all living things being to reproduce their kind in sufficient numbers to maintain their species, two methods are adopted. Lower animals and plants tend to produce large numbers of fertile eggs, most of which perish in a hostile external environment, but sufficient survive for the purpose. Higher animals, particularly the mammals, achieve the same level of replacement by exhibiting greatly increased parental care to a smaller number of offspring, which are fed and protected until almost mature. The mammary gland and the placenta are intimately concerned with this process.

The mammary glands are seen in their simplest form in the Monotremata as a collection of enlarged skin glands (100-200), collected together into 2 areas of the abdomen and each opening at the base of a large hair. In *Echidna* and *Proechidna* (the Australian anteaters) a pouch or incubatorium develops in the female during pregnancy enclosing these 2 gland areas, into which the egg is placed and where the young remain after hatching until quite large. After weaning, the incubatorium disappears again. In *Ornithorhynchus* (Duck-bill platypus) no incubatorium is found and the young are reared in a nest like a bird.

Teats are absent in both families and young merely lick off the fatty secretion which exudes from the base of the hairs. Males also possess glands but play no part in the rearing and feeding of the young.

In Didelphia or Marsupials teats are found for the first time and the ducts of the compound tubulo-alveolar glands drain

into them. The number of teats and teat ducts is not constant, and although the number of teats varies in an obvious manner with the number of young born and reared, there is no known significance in the variation (up to 24) in the number of teat ducts. In those species possessing the permanent pouch or marsupium the teats are found in close rows (Kangaroos, Wallabies, Koala bears, Bandicoots, etc.). When the marsupium is absent (several species of Opossum) the teats are found in 2 and sometimes 4 rows along the ventral surface of the body. Due to the absence of a placenta the young are born extremely immature, and are transferred to a teat, where they remain more or less permanently attached until weaned.

The mammary glands of the Monodelphia or Placentalia (which sub-class embraces 95% of all mammals) are essentially similar to those of the Marsupials but no Marsupium is found, as the young are born in an advanced stage of development, especially in herbivores likely to be the victims of predatory carnivores. The mammary gland has yielded to the placenta the important function of early care of the developing embryo and in at least one species (guinea pig) the new born young can survive without mother's milk. There is a similar variation in the number of teats (2-22) and teat ducts (1-16). The glands are arranged in 2 rows along the ventral (occasionally dorsal) surface of the body, but the exact number and position varies, as is well known.

The fully active organ in the placentalia is a compound tubulo-alveolar gland broken up into lobes and lobules by an elastic connective tissue, which separates it from the skin on one side and the surface body muscles on the other. The alveoli are similar to those of other secretory glands, but

only one type of secretory cell is present, surrounded by a distinct basement membrane. The alveoli are very closely packed, being separated only by scanty connective tissue, blood vessels, nerves and lymphatics. The ducts collect together and finally drain into a variable number of capacious cisterns at the base of the teat, which connect to the teat ducts and to the exterior. The larger ducts are lined by a 2-layered epithelium which is believed to have some secretory propensity. There is a considerable amount of smooth muscle in the teat, running in bundles in different directions and also some running along the interlobar and interlobular ducts in some species. In addition myoepithelial cells (Körbzellen or basalzelle) lie between the alveolar cells and the basement membrane, and there is now strong circumstantial evidence that these cells are contractile (Richardson, 1949), (see also Section IV, Part II).

The active gland has a rich blood supply, an extensive lymph drainage and receives nerves. The latter have been inadequately studied, although Arnstein (1895) claims that individual cells (type and location doubtful) receive small branched knobby nerve endings as in the secretory cells of the salivary gland.

SECTION III

EMBRYOLOGY

The first primordium in very young embryos of all mammals is a hairless area of the abdominal wall, where the ectoderm is thickened and the mesoderm possesses a rich blood supply.

In the Monotremes there are 2 such circumscribed areas (within the future incubatorium in Echidna), in which 100-200 stout hairs later develop from ectodermal ingrowths, each with an associated large modified sweat gland.

In the Marsupials and Placental animals the area is elongated, and extends a variable distance between the limb buds - as the milk line. The line later disappears leaving lens-shaped ectodermal thickenings (mammary buds) corresponding in number and distribution to the teats of the adult.

In both sub-classes, by a complicated process of differential growth of the surrounding tissues, teats are formed in at least 5 different ways, but the primary milk ducts are always derived from the original mammary bud, simply as in growing cores of cells which later become canalized.

In Marsupials hairs and sebaceous glands develop for a short time with the primary milk ducts, and later disappear. Even in higher mammals these rudiments may appear in some species (horse, cat), stressing the common evolutionary history of the mammary gland of all mammals as modified sweat glands.

On the basis of his embryological studies Bresslau (1920) has suggested the glands were originally evolved from the "brooding spots" (Brutflecken) found in primitive and some modern birds. These areas, which are richly supplied with

blood vessels and are devoid of hairs are used for hatching purposes and are found in both sexes. The presence of mammae in both sexes of mammals and the similar structure of the primary primordia in the early mammalian embryo to these "brooding spots" are cited in favour of this theory.

SECTION IVNORMAL POST-NATAL DEVELOPMENT

The mammary gland resembles other sexual organs in that it requires constant stimulation to develop from the inconspicuous thing it is in the quiescent state and continual stimulation to function once it has developed. When these stimuli are removed it ceases to work, an accelerated atrophy of disuse ensues and it relapses again to its state of obscurity, ready to repeat the same cycle again.

No adequate account is available of the post-natal development of the glands in the Monotremes, but Burrell (1927) states that the mammary glands in the Platypus are not fully active (i.e. milk cannot be expressed) until at least a week after the young are hatched.

Of the Marsupials mammary changes during pregnancy and lactation have been described for the American opossum (*Didelphys virginiana*) by Hartman (1923) and for the Australian native cat (*Dasyurus viverrinus*) by Hill and O'Donoghue (1913). In both species the gland consists merely of a teat and a few branched ducts before ovulation, but during pro-oestrus and oestrus extensive and rapid duct growth occurs and during the very short gestation period alveoli are rapidly formed, so that lactation commences just after birth of the young without any further mammary proliferation. The fact that pregnancy (12-13 days) in this opossum lasts only half the duration of the normal cycle (28 days) emphasises how extremely rapid mammary growth must be.

In the Native cat, the gestation period is also short (8-14 days). As in some placental mammals, sterile coitus is followed by pseudo-pregnancy (complete) in both species,

in which the same mammary development recurs as in pregnancy.

The involutionary processes have not been described but in the opossum they do not necessarily follow the weaning of the young/as successive litters often overlap and it is common to find young of various ages attached to teats at the same time.

Placental mammals. In the relatively few species that have been studied, the mammary growth between birth and puberty follows general bodily growth and merely entails slight growth of the teat and some extension of the primary ducts which, although branched, rarely extend beyond the base of the teat. The duct system at puberty is rather more extensive in the heifer, but in this as in some other species (e.g. man) the subsequent increase in size of the udder before the first pregnancy is chiefly due to an increase in the amounts of connective tissue and fat.

Mammary growth after puberty varies with the species, sex and type of sexual cycle exhibited.

In the males of all the placentalia the infantile condition remains although some species (man, rat and guinea pig) show quite extensive primary ducts. The mammary tissue is capable of responding to artificial stimulation with hormones and spontaneous mammary growth and even lactation have been noted in the goat by Aristotle, and in the ram, bull, steer, ass, deer and roe-deer (see Velich, 1926).

In polyoestrous females growth of the duct system tends to occur during pro-oestrus and oestrus in preparation for pregnancy and where the cycle is long (fox, sheep, goat, horse guinea pig and man) some regression tends to occur again during met-oestrus and dioestrus.

In animals such as the mouse and rat, where the oestrous cycle is short (5-6 days) there is obviously less time for

much regression to take place and in all species in the absence of conception there is a gradual extension of the milk ducts, up to a maximum which is only exceeded during pregnancy. In the rabbit, cat and ferret, ovulation is not spontaneous and oestrus continues more or less indefinitely until ovulation is induced by copulation. In the rabbit and to a lesser extent in the cat, a prolonged oestrous period, which presumably would not occur in nature, leads to some expansion of the duct system, but this is not the case in the ferret.

Although in the species mentioned so far, no alveoli are formed during normal cycles, a condition of pseudo-pregnancy can be induced in some (rat, mouse, rabbit, ferret and cat) by sterile copulation with a vasectomised male or by mechanical stimulation of the anterior vagina and cervix. This condition which lasts for about half the normal duration of pregnancy in the rat, mouse and rabbit (incomplete pseudo-pregnancy) and for a period equal to the gestation period in the ferret (complete pseudo-pregnancy), is characterised by persistence of the corpus luteum. This is associated with all the uterine and other changes preparing for nidation and pregnancy, including further growth of the mammary ducts and the formation of alveoli. These changes reverse when the corpus luteum regresses and a new cycle commences.

Selye and his workers have shown that a somewhat similar condition can also be induced by sucking the nipples of the rat and mouse, but this only lasts whilst regular suckling is continued (see section on the nervous system).

The dog, which normally has only 2 sexual cycles a year, ovulates spontaneously, and if not fertilized shows a complete pseudo-pregnancy which, even in virgin animals at first oestrus, may be so intense as to be accompanied by abdominal distension,

nest making, and lactation sufficient to rear puppies (Marshall, 1922; Velich, 1926).

If conception occurs, further mammary growth quickly ensues in all species under the influence of a functional corpus luteum, whose removal in early pregnancy leads to abortion and mammary regression. The changes consist of marked lengthening and branching and rebranching of ducts to form a complex tree-like structure. Later, alveoli bud from the terminal ducts like grapes from a vine and by about mid-pregnancy the development of the gland in preparation for lactation is almost complete. The fact that this entails only a slight increase in the total size of the gland has misled many into thinking that mammary growth occurs in the latter half of pregnancy, when the great increase in size seen during that period is mainly due to an increase in the size of the alveoli owing to commencing secretion (see Altman, 1945). This is borne out by the fact that abortion or the process of milking are both capable of inducing lactation during the last third of the gestation period.

Lactation normally starts of course at parturition and once initiated requires to be maintained by the process of sucking or milking. The length of lactation and the amount of milk secreted varies with the species. A small animal such as a rat, whose young grow exceedingly quickly, secretes more milk per unit body weight than larger, more slowly maturing animals such as the horse, ox and man (Brody and Nisbet, 1938). The milk of all species has the same qualitative chemical composition, but the amount of protein in particular, varies directly as the rate of growth of the young. Thus the piglet, which doubles its birth weight in 6 days, has milk containing 7.23%

protein, whilst the calf, which doubles its birth weight in 6 weeks, has only 3.4%.

The rate of milk secretion is not well known for animals suckling their young. The growth curves of young rats are sigmoid, with the greatest rate of increase occurring during the middle of the lactation period (Cowie and Folley, 1947 a). In the domestic cow and goat, which may well be abnormal in this respect, the yield gradually increases for 5-6 weeks, is maintained there for a few weeks only and then declines exponentially. Although involution of the gland can be delayed by the continuation of milking or suckling, this cannot be prolonged indefinitely. Once suckling has stopped the involution is hastened, the alveoli slowly atrophy and are resorbed, and the gland eventually regresses to the pubertal condition of a teat and a few major branched ducts only.

The cow and the goat, which have been selectively bred for high milk production by man, although they conform to the above scheme in general, provide the most exceptions. Thus the dairy breeds give milk far in excess of what is required for the young, occasionally lactate spontaneously in the virgin state (Shoshan, 1935; Velich, 1926), and many cases of prolonged lactation following a single parturition are on record (up to 15 years in the cow) (Linton, 1929, 1934).

SECTION VTHE CONTROL OF MAMMARY DEVELOPMENT
IN THE PLACENTALIA(a) The role of the ovaries

A consideration of the normal activity of the mammary gland during the sexual cycle shows that although the types of cycles differ considerably, in all species some extension of the immature duct system occurs during the follicular phase of the ovarian cycle. In addition it is only during the presence of an active corpus luteum that the formation of alveoli takes place. This obviously suggests that the ovarian hormones are intimately concerned with mammary growth, which is supported by the fact that ovariectomy prevents all mammary development.

The isolation and identification of oestrogens provided fresh impetus to the study of mammary growth and all workers agree that oestrogens, natural and synthetic, produce marked duct growth in normal, immature and ovariectomized animals, and also in normal and castrated males. In most animals duct proliferation alone is produced, but in the guinea pig, goat, cow, monkey and possibly man, alveoli are formed as well (see reviews by Turner, 1939 a; Folley, 1940, 1944, 1947 a; Petersen, 1944).

It was also to be expected that the formation of alveoli would be associated with the hormone of the corpus luteum. When this substance was isolated it was employed to determine whether it had any power of promoting growth of alveoli in those species in which oestrogens alone produced only duct growth.

At first all results were negative (Corner, 1930), but Turner and Frank (1931, 1932) discovered that extensive alveolar

formation occurred in the rabbit when injected with oestrogen and progestin or corpus luteum extract together. This has been amply confirmed for many species. The growth of alveoli is more prompt if the animal has been pretreated with an oestrogen to promote duct growth and there is an ideal ratio of oestrogen to progestin for optimal results (Lyons and Pencharz, 1936; Lyons and McGinty, 1941; [Lyons and Sharf,] 1941).

The fact that oestrogens alone produce duct and alveolar growth in some species, even in ovariectomized animals, does not necessarily mean that progesterone is not required in these species. This can only be proved when other sources or progesterone are removed as well. It has for example been isolated from the adrenal cortex and in addition other cortical hormones (e.g. desoxycorticosterone) have been shown to have a progesterone-like action.

Oestrogens (natural and synthetic) will produce their effects when applied to the skin around the nipple. In high dosage the effect is not confined to the treated gland, but this is the case with minimal doses. In view of this and also considering the evidence showing that oestrone has a vasodilator action, Mixner and Turner (1942) postulate that its chief function is to make tissues more accessible to progesterone by producing localised hyperaemia and increasing vascular permeability. This is supported by the fact that sufficiently large doses of progesterone will in fact produce alveolar formation without oestrogens. However, the important paper by Bullough (1946) showing that oestrogens have the important function of stimulating the rate of mitosis in all organs, throws some doubt on this theory.

(b) The role of the anterior pituitary

In general, treatment with oestrogen and progestin produces mammary growth equivalent only to that found by mid-pregnancy and it is evident that other factors are probably concerned in producing the full effect as normally seen by the end of the gestation period.

Although several workers (Corner, 1930; Evans, 1933) produced evidence to show that anterior pituitary extracts could promote mammary growth and lactation, attention was really focussed on the hypophysis when attempts were made to produce results with oestrogen and progesterone in hypophysectomized animals. Up to about 1935, several papers indicated that this could be done (Asdell and Seidenstein, 1935; Nelson, 1935), but since then they have been outnumbered by results showing that the pituitary had to be intact to allow oestrogen and progesterone to produce mammary growth. The finding of Gomez, Turner, Gardner and Hill (1937) that as little as 2% of the anterior lobe allowed a normal response of the mammary glands of male mice to oestrogen suggests that earlier workers did not completely remove the anterior pituitary in their experiments.

Whilst it is now generally admitted that the anterior pituitary does play a part in mammary growth during pregnancy, it is not certain whether the ovarian hormones act via the pituitary or with it.

The former view is held by Turner and his co-workers at Missouri, who have published a series of papers since 1937 in support of the theory that oestrogens and progestin act indirectly by stimulating the anterior pituitary to produce

2 hormones, mammogen I and II respectively, which in turn produce duct and alveolar growth respectively. This theory was originally based on a widely quoted experiment using only 4 hypophysectomized male guinea pigs. One of the animals which received daily implants of whole male rat pituitaries showed no mammary growth, but the other 3 responded to similar daily implants from rats that had been pretreated with oestrogen (Gomez, Turner and Reece, 1937).

The experimental basis for the existence of mammogen II appears to be a report by Mixner (1940) that pregnant cattle pituitaries caused lobulo-alveolar growth in spayed virgin mice and that this factor could be separated from mammogen I. Other reports from these workers indicated that duct growth could be produced in hypophysectomized rabbits and rats with pituitary implants from pregnant but not non-pregnant cattle (Gomez and Turner, 1938).

Methods of assay were described for both mammogen I and II, but a surprising feature was that mammogen I, unlike all other pituitary hormones including mammogen II, was claimed to be lipid in nature (Mixner and Turner, 1941 a, 1942). Greep and Stavelly (1941) were unable to find a duct promoting factor in a lipid extract of the anterior pituitary and even the Missouri workers themselves have since reversed their opinion, and now believe that mammogen I is a protein (Trentin, Lewis et al., 1943).

This theory has not gone without criticism from other endocrinologists. Nelson (1938, 1939) and Reece and Leonard (1939) have been unable to detect any difference in the pituitaries of oestrogen treated and non-treated animals. White (1943) has analysed the methods of the Missouri workers

and points out that these do not preclude the extraction of steroids from the pituitaries. In view of the fact that Turner's test animals (male mice for mammogen I and spayed virgin mice for mammogen II) have their own pituitaries intact, and that very large doses of the extracts had to be given, it is quite possible that the active agent was a steroid hormone.

There is also the well documented fact that oestrogens can have localised action by percutaneous application confined to the gland treated, which Mixner and Turner (1943) explain as being due to localised hyperaemia making the gland more sensitive to circulating sub-threshold amounts of mammogen (see Folley, 1947 a). Non-specific rubifacients such as turpentine (Kudryavtsev and Glebina, 1941), (Mixner and Turner, 1941 b; Lewis and Turner, 1942), and even massage can produce mammary hypertrophy but an entirely different interpretation can be applied (cf. Section VIII).

Even the Missouri workers themselves in their 1943 paper admit that since the two mammogens are now believed by them to be proteins, they may even be identical.

Whilst it is apparent that the anterior pituitary is concerned in mammary growth, recent reviews suggest alternatively that the ovarian hormones act peripherally in conjunction with pituitary factors, most probably prolactin (Lyon, Simpson and Evans, 1941, 1943).

Hypophysectomy causes such a profound metabolic upset that it is not surprising that mammary growth is difficult to induce. Even inanition can have a non-specific inhibitory action (Astwood, Geschickter and Rausch, 1937) and it is reasonable to assume that a fairly complete replacement therapy would be required before the ovarian hormones could be expected to work. This is in fact the trend of modern work. Although

Mixner, Bergman and Turner (1942) report that mammogen II is distinct from prolactin, thyrotropin and gonadotropin, fairly extensive but not complete mammary growth with oestrogen in hypophysectomized animals has been obtained by simultaneously administering prolactin by Lyons (1943) and prolactin and adrenocorticotropin (Gardner and White, 1941, 1942) and growth hormone (Reece and Leonard, 1941, 1942).

Jacobsohn (1948) has recently shown in parabiotic rats that the ovarian hormones act both directly on the mammary glands and also indirectly by causing the release of anterior pituitary hormones, which in turn act synergistically with the ovarian hormones on the mammary glands. In the author's opinion there is no convincing evidence that any special pituitary mammary growth factors are involved. It is to be hoped that this problem may be settled in the future with the 6 purified hormones isolated from the anterior pituitary by Evans and his school in California.

(c) The role of the adrenal cortex

Although desoxycorticosterone can produce duct and alveolar growth in some species and progesterone has been isolated from the gland, there is little evidence to indicate that the gland plays an important part in mammary development during pregnancy, except in so far as it is essential to life itself.

(d) The role of the placenta

The fact that the placenta in the absence of the hypophysis and ovaries can prevent mammary involution has been interpreted as evidence for the placenta producing a mammogenic hormone. However, most of these experiments have been carried out in the latter half of pregnancy when mammary development is complete, and it seems more likely that, if anything, the placenta is producing hormones which can maintain the early

secretory activity of the formed gland (Newton and Richardson, 1941).

(e) The role of the thyroid

There is conflicting evidence as to the need for a functioning thyroid in mammary development, the earlier experiments indicating that the process is independent of the thyroid (Dragstedt, Sudan and Phillips, 1924) were probably due to the fact that the developing foetus or foetuses can produce enough thyroxine after midterm, at least in the heifer, to correct the deficiency in the mother.

It now seems probable that the thyroid is necessary for normal mammary development during pregnancy, but that its action is an indirect one, in exerting its well known effects on general body metabolism.

SECTION VI
INITIATION AND CONTROL OF LACTATION IN THE
PLACENTALIA

(a) The role of the anterior pituitary

The importance of the anterior pituitary in lactation has never been in doubt since Stricker and Grueter (1928, 1929) first produced lactation in ovariectomized pseudo-pregnant rabbits by injecting an aqueous extract of the anterior hypophysis (see also Evans, 1933; Houssay, 1935 b; McPhail, 1935 a and b). It is also well known that lactation cannot be initiated or maintained in the hypophysectomized animal (McPhail, 1935 a, b; Nelson, 1934, 1935). Riddle et al. (1932, 1933) discovered that a pituitary factor which could initiate lactation could also be easily assayed by the production of enlargement and secretion of the crop glands of the pigeon and dove (see Bates, 1937; Bergman, Meites and Turner, 1940; Folley, Dyer and Coward, 1940). This substance they called prolactin (also known as galactin, mammotropin, lactogen and lactogenic hormone), and it was then assumed that this was the only lactogenic hormone of the anterior pituitary, since it showed remarkable properties in inducing lactation in animals whose glands were suitably prepared (i.e. developed) (Bergman and Turner, 1937, 1940).

However, even before prolactin was fully purified (it was the first anterior pituitary hormone to be obtained in a crystalline form) it was discovered that it could not initiate lactation in the hypophysectomized guinea pig, in which adrenal cortex hormones or adrenocorticotropin were required as well (Gomez and Turner, 1936; Nelson and Gaunt, 1936, 1937; Pencharz and Lyons, 1938; Gomez, 1942; Lyons, 1943). In the

rabbit, however, pure prolactin was sufficient to induce lactation in the hypophysectomized state and in addition in the intact animal when injected into one of the six milk ducts, each of which drains only one sector of the gland to the exterior, lactation was induced only in the sector injected. In addition, hypertrophy and hyperplasia of the alveoli can be demonstrated by this technique (Lyons, 1942; Meites and Turner, 1947).

The specificity of the lactogenic hormone has also been doubted by Asimov and Krauze (1937), who showed that for increasing the milk yield of cows (galactopoiesis) as opposed to lactogenesis, which is the initiation of lactation, crude pituitary extracts were more effective than purified prolactin (see also Folley and Young, 1941 a, 1945; Folley, Malpress and Young, 1945 b; Fawns, Folley and Young, 1945). Folley and Young (1940, 1941) noted that the effectiveness of such extracts showed more parallelism to their glycotropin content than to their prolactin content (see also Gomez and Turner, 1937 a, b).

The present trend is towards the view that there is more than one anterior pituitary hormone concerned in lactogenesis of which prolactin is certainly one and it must be pointed out that many experiments with prolactin in mammals have concerned animals with intact pituitaries, which would give no indications as to the specificity of this hormone (Riddle, 1940; Folley and Young, 1945).

It is also interesting to note that prolactin (i.e. a factor capable of stimulating growth of the pigeon crop) has been detected in appreciable amounts in the hypophysis of male mammals, and also in those of birds, reptiles, amphibians and fish, and even in their brains and livers, so that either the

the specificity of the hormone is in doubt or else it has a wider importance in vertebrate physiology than its name would suggest (Riddle and Bates, 1939).

Several workers have assayed the pituitaries of animals in various states, and found more of the hormone during lactation than during other parts of the sexual cycle and there have also been reports that oestrogens increase the prolactin content of the pituitaries of male and female rabbits (Reece, Hathaway and Davis, 1939; Meites and Turner, 1942 d).

However, it is not known whether these findings indicate increased production or storage of the hormone.

(b) The role of the adrenal cortex

Lactation is seriously impaired by adrenalectomy and several attempts have been made to restore it with adrenal cortex extracts and some of the other numerous steroids isolated from the gland (Carr, 1931; Gaunt, 1933; Britton and Kline, 1935; Cowie and Folley,^{1945 b} 1947 b, c; Cowie, Folley, French and Greenbaum, 1947, 1949; Cowie, 1949).

Whilst complete replacement therapy is effective in restoring lactation (Swingle and Pfiffner, 1932; Gaunt and Tobin, 1936), no one of the steroids tried has been successful (Gaunt, 1941; Gaunt, Eversole and Kendall, 1942; Cowie and Folley, 1947 a, b). This is not surprising in view of the fact that recent work by Vogt (1943) and Bush (1951) has shown that at least two hormones are normally secreted into the blood in all the species studied.

The claims for the existence of a specific lactational hormone in the adrenal cortex, cortilactin (Brownell and Lockwood, 1933; Spoor, Hartman and Brownell, 1941), which stimulates the pigeon crop glands like prolactin, have not been substantiated.

(c) The role of the thyroid

Although the thyroid is difficult to remove completely without simultaneously removing the parathyroids, and any operative interference non-specifically decreases milk secretion for a few days, there is evidence that thyroidectomy does reduce the efficiency of lactation (Trautmann, 1919; Nelson, 1939; Spielman, Petersen and Fitch, 1944).

The administration of thyroxine, thyroid extracts, or iodinated proteins (containing thyroxine) to lactating cows have all had significant galactopoietic effects, but the fact that this is accompanied by adverse symptoms (increased heart and respiratory rate, hyperthermia, sweating, etc.) due to the greatly increased metabolic rate, suggests that the thyroid only affects lactation non-specifically as a part of its action on all bodily processes (Folley and White, 1936; Ralston and Herman, 1938; Reineke and Turner, 1942; Blaxter, 1945 a, b, 1946; Owen, 1948 a, b; Bailey, Bartlett and Folley, 1949, Leech, 1950).

The possibility of parathyroid tissue being removed during thyroidectomy and non-specifically inhibiting lactation should not be overlooked (Folley, Scott-Watson and Amoroso, 1942; Cowie and Folley, 1945 a).

(d) The initiation of lactation

Although histological and other studies have shown that individual secretory cells are capable of secretion by about the middle of pregnancy, lactation only typically begins at parturition.

A detailed consideration of the several theories that have been postulated to account for the initiation of lactation will not be given, but brief reference will be made to the more

important. Many theories are based upon the idea of removal at parturition of inhibitory influences.

Thus removal of the corpus luteum in the latter half of pregnancy in the goat (Drummond-Robinson and Asdell, 1926) and rat (Selye, Collip and Thomson, 1934) results in lactation and suggests that it was previously inhibiting it. However, progesterone does not inhibit lactation when injected into animals and this theory does not account for the fact that many animals can lactate during pregnancy (woman, cow and goat), which also disposes of the theory that the placenta inhibits lactation (cows may retain the placenta after parturition for several weeks and yet still lactate).

Selye (1934 a) postulated that the mechanical distension of the uterus accounted for the absence of lactation during pregnancy because he was able to inhibit lactation by filling the uterus of rats with paraffin after Caesarian section. However Bradbury (1941) showed that lactation occurred in such animals if they were allowed sufficient time to recover from the operation.

The most widely held theory is that oestrogen, partly of placental origin, inhibits the production of prolactin by the anterior pituitary (Nelson and Pfiffner, 1931; Nelson, 1932; 1934, 1936). This is largely based on the fact that in the guinea pig, removal of the ovaries in the pregnant animal frequently induces lactation and that it also often starts when oestrogens are withheld from virgin animals previously receiving it. Oestrogens in large doses have also been shown to inhibit mammary growth and lactation in small and large mammals (Gardner, 1941), and are widely used to suppress lactation in the human. However, the clinical reports are generally invalid because suckling was discontinued as well, which alone

would suppress lactation. It is now known that women can lactate whilst receiving large doses of synthetic and actual oestrogens, and there are numerous reports showing that oestrogens can not only produce mammary growth, but also initiate and maintain lactation, particularly in the cow and goat (with pituitary but not necessarily ovaries intact) (Frazier and Mu, 1935; de Fremery, 1936; Ralston and Herman, 1938; Folley, Scott-Watson and Bottomley, 1940, 1941; Walker and Stanley, 1940, 1941; Folley and Young, 1941 b; Lewis and Turner, 1941, 1942;^a Cockburn, 1942; Meites and Turner, 1942 a, b, c, d; Kochan, 1943, Reece, 1943; Parkes and Glover, 1944; Folley, Stewart and Young, 1944; Hammond and Day, 1944; Folley and Malpress, 1944 a, b, c; Folley, Malpress and Young, 1945 a; Spriggs, 1945; Peeters and Massart, 1947 a; Peeters, Massart, Coussens and Vandeplassche, 1949). Meites and Turner (1942a, b, c,d) believe that the secretion of prolactin during pregnancy is suppressed by progesterone, overriding the influence of oestrone, which tends to increase the prolactin content of the pituitary. Their methods have been criticised experimentally by Hall (1944), but are supported by the work of Curtis (1949).

Folley (1941) and Malpress (1947) have attempted to explain the anomalous findings with oestrogens by postulating that there are two threshold levels for them in regard to prolactin, between which prolactin output is increased, whilst oestrogen levels below have no action and above actively inhibit the process. Although there is some experimental evidence to support this supposition it is clear that these threshold levels must vary considerably between individuals and much further work is needed to put it on a sound footing.

An entirely different theory, which postulates not the removal of an inhibitory influence, but requires the application of a stimulus, is that of Petersen (1944). He believes that the release of oxytocin at parturition causes the expulsion of preformed milk from the alveoli and ducts, and thus starts the process, which, as is well known, requires the regular removal of milk formed for its continuation. This theory, although still a theory, has much in its favour and will be discussed further under the nervous system (Section VIII).

SECTION VIISECRETION AND SYNTHESIS OF MILK IN THEPLACENTALIA

A consideration of the microscopical anatomy of the mammary gland suggests that milk is a secretion and not merely a plasma filtrate produced by mechanical means. The alveolar lining cells are typical secretory cells similar to those found in other glands. In addition a comparison of the composition of plasma and milk shows that although the osmotic pressures are the same (6.6 atmospheres) there is a great difference in the ratio of various constituents and that milk fat, lactose, casein, lactalbumin and citric acid being peculiar to milk must have been manufactured in the gland.

Histological studies have also shown that the alveolar cells go through a cycle of activity. When the alveolus is empty these cells are greatly elongated and secretory granules, of which fat is the most easily demonstrated, accumulate between the nucleus and the lumen border, from whence they pass into the alveolar lumen. As milk accumulates in the alveolus the secretory cells become stretched and may become cuboidal or even squamous in appearance (Hammond, 1927; Richardson, 1947). Secretory activity ceases once the pressure rises above a critical level. Experiments in which air or fluid have been injected into the mammary gland under pressure suggest that this value is 25-40 mm. Hg (Petersen and Rigor, 1932 a; Petersen, 1944).

Once secretion ceases, the milk within the alveolus tends to come into equilibrium with the blood, when a fluid exactly resembling colostrum in its high protein and mineral content and low lactose content eventually results (Ragsdale, Turner and Brody, 1924; Davidson, 1924, 1926; Porcher and Muffet,

1930; Petersen and Rigor, 1932 b, c). Evidence that milk is normally not in equilibrium with the blood has been obtained from numerous studies on physiological and pathological factors altering the composition of milk in the cow. It is surprising that many different things including the intra-mammary infusion of hyper-, hypo- and iso-tonic solutions of electrolytes and non-electrolytes, mastitis and even leaving formed milk in the gland, all have a similar result and upset the normal disequilibrium between blood and milk producing a colostrum-like fluid. Mastitis (Espe, 1946) and some drugs like dinitro-phenol (Brouwer and Martin, 1938) sufficiently damage the gland to allow new blood constituents like bicarbonate, which are normally absent, to enter the "milk".

The gland is permeable to some substances, particularly those foreign to the body, but a discussion of this subject is outside the scope of this review. The excretion of drugs in the milk has been reviewed by Kolda (1926) and Burn (1947).

The method by which milk constituents leave the cell has been the subject of controversy for nearly a century, and has been critically reviewed by Richardson (1947). At one time it was thought that the gland was holocrine and that the cells were bodily extruded, with their contents, into the alveolar lumen, but the relative infrequency of mitoses in the active gland excludes this process. The fact that in most histological sections of the lactating gland pieces of cytoplasm containing milk precursors can be easily found in the lumen apparently detached from the secretory cells had led many into thinking that the gland is apocrine. However, this may just as easily be an artefact due to sectioning or to the fact that the tall cylindrical cells in the phase of active secretion may become bent or twisted, when part of them may appear in successive sections.

Therefore it is just as possible that the secretory cells of the mammary gland are merocrine like many other secretory glands.

The fact that milk secretion ceases if the pressure within the gland rises too high would suggest that the milk yield will be optimum only when milk is so frequently removed that this critical pressure is never reached. This is in fact the case. Thus milking cows three times daily instead of twice, increases the milk yield 10-25% and four times daily a further 5-15% (see Espe, 1946). The actual increase depends on the milk yield and the elasticity of the udder, and of course in an animal suckling its young the milk is removed fairly frequently and it is unlikely that back pressure ever hampers the milk yield under natural conditions (see also Section VIII).

The biochemical studies of milk secretion have been chiefly directed towards the identification of the precursors of the particular substances manufactured by the gland. However it is now becoming increasingly obvious that it is misleading to refer to a particular substance being manufactured from any other particular substance, since the flexibility and degree of overlap in biochemical processes has been considerably underestimated in the past (see Kay, 1947). The following methods have been used:-

(1) Arterio-venous changes in blood composition

This method of comparing the arterial blood going to the gland and the venous blood leaving it has been chiefly applied to the goat and cow, but it took some time to evolve a suitable technique applicable to unanaesthetised animals (see Meigs, Blatherwick and Cary, 1919; Cary, 1920; Blackwood and Stirling, 1932 a, b, c; Blackwood, 1932, 1934) which did not unduly disturb the animal and thus produce concentration or

dilution of the blood during its passage through the gland (Graham, Kay and McIntosh, 1936; Shaw and Petersen, 1939.) American workers claim that Nembutal anaesthesia is suitable for this method, since it does not interfere with the process of milk secretion (Reineke, 1940, Reineke, Williamson and Turner, 1941 a; Shaw, 1946). However the method suffers from the disadvantage that it is not suitable for quantitative work and does not allow for the lymph drainage, which although it is considerably less than the blood flow may well be greater than the milk production. No measurements of lymph flow have been made but anatomical studies suggest that it is considerable in the active gland (El Hagri, 1945).

(2) Perfusion of the isolated organ

This method has been used by Petersen, Shaw and Visscher (1939, 1941) and by Peeters and Massart (1947 b, 1950), but in this case it is difficult to supply the blood with the correct amounts of milk precursors, hormones, etc. The normality of the organ under these conditions has been questioned by the finding of a respiratory quotient lower than in the normal functional gland, and the fact that the gland does not react normally to blood sugar changes.

(3) Mammary gland slices

The incubation of slices of tissue under suitable conditions has been used to indicate the metabolic potentialities of the gland (Grant, 1935, 1936; Smith and Levy, 1943; Knodt and Petersen, 1945, 1946 a), and to a great extent recently by Folley and French (1948 a, b, c, 1949 a, b, c, d, 1950) in studies of intermediate metabolism, particularly of fat.

(4) Use of isotopes

This method is being increasingly applied to problems of mammary gland metabolism (Aten and Hevesy, 1938; Kleiber,

Smith and Ralston, 1948; Popjak and Beeckmans, 1949; Kleiber, Smith and Tolbert, 1950; Sternberg, 1950; Cowie, Duncombe et al., 1950; Aten and Heyn, 1950) and will doubtless be extensively used in the future.

(5) Biochemical examination of the mammary gland and milk under various conditions

This method has been used in a variety of ways to study particular problems such as the effect of diet, hormones, etc. (see Meigs, 1922; Kay, 1945, 1947).

It is obvious that no one method is suitable for all purposes but in general the results obtained are fairly consistent. The following is a brief summary of present knowledge:-

Most workers point to the great metabolic activity of the lactating mammary gland and to its efficiency. Graham et al. (1938) in the cow, calculated that of the total energy uptake as determinable from A-V differences, 90% reappeared in the milk, so that only 10% was used in the gland for energy purposes. Gaines (1928) has similarly calculated that 52.6% of the extra food required above maintenance for lactation in the cow was returned in the milk. The rate of blood flow through the active gland has also been stressed as being very great. This has been estimated from measurements of the total quantity of a given substance in the milk, and the average amount of the same substance or its precursor removed from the blood in the same time. Such calculations have given values of between 250 and 500 volumes of blood for each volume of milk produced, but their accuracy depends upon quantitative conversion of the blood precursor to the milk substance. It is probable that 400-500 : 1 is the correct ratio of blood flow to milk production in the cow (Lintzel, 1934; Graham, Jones and Kay, 1936; Shaw and Petersen, 1938 a, 1940 a, b; Shaw, Powell and Knodt, 1942). In the

unanaesthetised goat, Graham (1937), using a thermostromuhr and Jung (1932 a, b), using a stromuhr, found a ratio of 250 : 1, but in each case there are technical reasons for believing this value is too low.

During the passage of the blood through the gland the following substances are removed:- glucose, inorganic phosphate, neutral fat, calcium, β hydroxy butyric acid, amino acids, a plasma globulin, a glycoprotein and oxygen (Graham, Kay and McIntosh, 1936; Shaw and Petersen, 1939, 1943; Shaw and Knodt, 1941).

At the same time carbon dioxide is added (more than oxygen removed) and also probably urea (Graham, Houchin and Turner, 1937; Shaw and Petersen, 1938 b; Petersen and Shaw, 1942). There is no detectable change in phospholipids, cholesterol, haemoglobin and haematocrit values and pyruvic and lactic acids (Shaw and Petersen, 1938 a; Powell and Shaw, 1942).

The mammary gland respire actively at a rate per unit of tissue inversely proportional to the size of the animal (Folley and French, 1949 d). The metabolic activity in the rat is less than that of the kidney cortex and nervous tissue but about equal to that of the liver, and as would be expected, it greatest during lactation.

In the normal undisturbed cow the gland removed 4-5 volumes of oxygen and adds 5-7 volumes of carbon dioxide, giving a respiratory quotient above 1 (Shaw, 1939). This figure is often arrived at by allowing for carbon dioxide retained in the gland for the manufacture of urea and for this and other considerations this finding has been open to criticism. However, it has been repeatedly reported by a number of workers that the R.Q. normally is 1.1 - 1.3 and recently an even higher figure (1.54) has been obtained for gland slices in vitro (Folley and

French, 1948 a). It is only in the fasting whole animal or when the gland slices are incubated without the glucose as a substrate that the R.Q. falls below one.

It is not yet known what the gland uses for energy, but there is evidence that it can oxidise glucose, long-chain fatty acids, β hydroxybutyric and acetic acids.

Modern views on the methods of formation of the substances peculiar to milk will now be briefly indicated.

LACTOSE

The fall in blood sugar is usually 25-30% of the arterial value and this is sufficient to account for the lactose formed assuming a quantitative conversion. The assumption that glucose is one of the main precursors of lactose is borne out by the fact that lowering of the blood sugar (starvation, insulin or phlorizin administration Gowen and Tobey, 1931 a, b) reduces milk lactose and raising the blood sugar (glucose administration intra-venously or by mouth, or by thyroxine or adrenaline administration) increases the amount of milk sugar (Whitnah, Riddell and Hodgson, 1933; Bottomley et al., 1939). Mammary gland slices in vitro can form lactose from glucose, maltose and glycogen (Grant, 1935, 1936; Knodt and Petersen, 1945) and other hexoses, absorbed from the blood as glycoprotein may supplement the carbohydrate supplies (Reineke, Williamson and Turner, 1941 b).

Glycogen is present in the mammary gland (Knodt and Petersen, 1945, 1946 b) in disputed amounts, but it is not yet known whether it is an intermediate substance in the formation of lactose or a carbohydrate reserve. Mammary glycogen levels can be increased by perfusing with hyperglycaemic blood, particularly in the presence of insulin. The incubation of such perfused tissue results in a fall in the glycogen content and a rise in

the amount of lactose (Knodt and Petersen, 1946 b).

Since there is no uptake of galactose from the blood this part of the lactose molecule must be formed in the gland. There is no evidence as to how this is carried out, but Folley (1949 a) in an extensive review of the biochemical aspects of mammary gland function, has suggested a possible scheme for lactose synthesis from glucose via galactose phosphate. It is of interest to note in this connection that the mammary gland contains acid and alkaline phosphatases (Folley and Kay, 1935; Dempsey, Bunting and Wislocki, 1947; Mullen, 1950 a, b). The latter has been studied by Folley and Greenbaum (1947 a), who found that the enzyme concentration increased during late pregnancy, was maintained at a high level during lactation and fell quickly after weaning. The histochemical studies of Dempsey, Bunting and Wislocki (1947) showed that this enzyme is located in the outer cuboidal cell layer of the ducts. They therefore suggested that it is concerned with the transport of metabolites.

MILK FAT

There is a considerable uptake of blood fat by the active gland (Lintzel, 1934; Shaw and Petersen, 1938 a, 1940 a, b; Shaw, Powell and Knodt, 1942), and the amount is probably sufficient to account for the milk fat formed. A lipase is present in mammary tissue (Kelly, 1942) and according to Kelly and Petersen (1939) free fatty acids can be demonstrated histochemically in the basal portion of the epithelial cell. This may indicate that lipolysis is involved in fat absorption.

It is well known that the milk fat of herbivores, particularly ruminants, contains characteristic short-chain fatty acids ($C_4 - C_{14}$) and their origin has aroused much interest and speculation. These theories cannot be considered in detail,

but briefly until recently two theories had been put forward. Hilditch (see Hilditch and Paul, 1936; Hilditch and Thompson, 1936; Achaya and Hilditch, 1950) suggested that the short-chain fatty acids arose by oxidative degradation of the long-chain deo-glycerides and Reineke, Ston^ecipher and Turner (1941) thought they might arise from carbohydrate and thus explain the higher R.Q. of active mammary tissue. There was some evidence to support both theories, but recent discoveries in the field of ruminant digestion led the way to a new and more likely theory. It is now known that the chief end products of rumenal fermentation are acetic, butyric and propionic acids which are readily absorbed into the blood and that the mammary gland removes acetic acid from it (McClymont, 1949). A series of important papers from the National Institute for Research in Dairying have shown that the ruminant mammary tissue differs from that of other species in that it can oxidise acetate with or without glucose, with a high R.Q., whereas other animals can only oxidise acetate, if glucose is present (Folley and French, 1948 a, b, c, 1949 a, b, c, d, e; Balmain, French and Folley, 1950; Balmain and Folley, 1951). The utilization of acetate for fat synthesis would account for the characteristically high R.Q. of active mammary tissue, and recent tracer studies have demonstrated in a simple and direct manner that blood acetate is indeed incorporated quickly into milk fat (Popjak and Beeckmans, 1949; Kleiber, Smith and Tolbert, 1950; Popjak, French and Folley, 1950, 1951; French et al., ¹⁹⁵⁰ 1951).

MILK PROTEINS

The amino acids taken up from the blood are too few to account for the milk proteins, but a blood globulin, a glycoprotein containing 9% galactose - mann^{ose}, glucosamine complex, is taken up in quantity by the cow's udder (Reineke, Williamson and Turner, 1941 b).

There is only 0.05% globulin in milk and this is identical with blood globulin (possibly antibody γ globulin) so that some of the glycoprotein is likely to contribute to the formation of casein and lactalbumin. Moreover, during starvation, when some milk secretion still persists, the amino-acid absorption ceases. The phosphate radical in casein has been shown by using radioactive phosphorus to be derived from the inorganic phosphate of the blood (Kleiber, Smith and Ralston, 1948; Aten and Hevesy, 1938; Sternberg, 1950).

It may be that the amino acids removed by the udder are deaminated because mammary tissue contains arginase (Shaw and Petersen, 1938 b; Folley and Greenbaum, 1946; 1947 a), and also excretes urea into the blood (Graham, Houchin and Turner, 1937; Graham, Houchin, Petersen and Turner, 1938). Mammary gland arginase levels have been extensively studied by Folley and Greenbaum (1946, 1947 a, b, 1948 a, b, c, 1949 a, b). Its concentration is greatest in the rat and mouse, but low in the guinea pig, rabbit, cow and goat. There is an increase in the amount during lactation in the rat, but adrenalectomy decreases it again. Since adrenalectomy is known to decrease the capacity of the liver for gluconeogenesis and also decreases its arginase content, it may be that the deamination of amino-acids through arginase is an important metabolic activity in the mammary gland, at least in the rodent.

Non-protein nitrogenous substances are not removed from the blood so that those in milk are presumably derived from the gland itself.

CITRIC ACID

This substance which is present in almost immeasurable quantities in blood is present in quantity in milk and recent

in vitro studies have shown that gland slices can manufacture it from glucose, pyruvic acid, lactic acid, maltose and glycogen. The central position of citric acid in the intermediate metabolism of carbohydrate, fatty acids and amino acids emphasises the opening remarks of this section about the inadvisability of referring to specific precursors of any one substance in milk.

SECTION VIII

NERVOUS SYSTEM AND LACTATION

The rapid and spectacular rise of the science of endocrinology swung attention away from the relation of the nervous system to the mammary gland, but in spite of the demonstration that the auto-transplanted gland apparently functions normally, evidence is slowly accruing of the intimate relationship between the nervous system and mammary function.

Before this subject can be adequately discussed it must be made clear that the total process of producing milk involves three distinct phenomena.

The synthesis of milk occurs within the alveolar cells, and the process of its extrusion into the lumen of the acinus constitutes milk secretion. Although some of the milk formed passes out of the alveoli into the ducts, cisterns and teat, once these are full any more milk formed remains within the alveoli. Owing to the elasticity of the connective tissue, this distension results in a visible swelling of the gland. The high surface tension of the milk, particularly of the fat globules, favours the retention of the milk in the distensible alveoli, so that its speedy removal requires an active muscular process. This occurs reflexly within a minute of the commencement of suckling or milking and is variously known by a number of lay names ("draught in women, "let down" in cows and goats). The German name "Einschiessen" (Tgetgel, 1926) and that proposed by Petersen, "ejection", describe the process more accurately.

Of course once the milk in the teat and cistern is removed, milk would tend to run down from the smaller ducts to replace it, but without the ejection reflex this would be far too slow for the needs of the suckling animal.

It must be emphasised that this process does not involve any increase in the rate of milk secretion, as was thought at first, but merely the transference of preformed milk from the alveoli, where it was formed, to the teat and cisterns, where it can be removed.

From a theoretical point of view the nerves going to the mammary gland could be:- (a) sensory from the skin of the teat and the gland and from the gland itself; (b) vasomotor from the autonomic nervous system; (c) secretory to the alveolar cells; (d) motor to the smooth muscle around the large ducts and to the myoepithelial cells. Unfortunately no thorough histological study of the mammary nerves has been made. The absence of secretory nerves is now generally accepted. Several workers (Emmerson, 1929; Jung, Tagard and Pierre, 1934; Espe, 1947) have shown that milk secretion was unaffected by nerve section in various species, and Goltz and Freusberg (1874) and Goltz and Ewald (1896) showed that this also applied when the thoracic and lumbar parts of the spinal cord were completely removed in the dog. Ribbert (1898), Pfister (1901) (see Basch, 1903) and Stricker (1930) all noted normal milk secretion in auto-transplanted glands in the guinea pig and rabbit. These findings are difficult to reconcile with the report by Arnstein (1895) that there are nerve endings on the secretory cells of the gland, but he gives too few details to decide really which cells are concerned.

The question of the presence of vasomotor nerves and their function has not been studied previously per se; this subject is dealt with in this thesis.

Evidence for the existence of sensory nerves and nerves to the gland muscle elements will be discussed as part of the

next two sections, and has also been investigated in this thesis.

Nervous stimuli arising from the teats and the effects of suckling

Whilst it appears that centrifugal nervous impulses to the mammary gland may be of secondary importance to the normal control of lactation, evidence is accumulating that centripetal ones are of great consequence.

Kuramitsu and Loeb (1921) showed that suckling in the rat and guinea pig prevents mammary involution, which normally follows ovariectomy in the lactating state. However it was not until 1934 that a series of papers by Selye and his co-workers (Selye, 1934 b; Selye, Collip and Thomson, 1934; Selye and McKeown, 1934 a, b, c) drew attention to the important effects of suckling. Previously it was thought that suckling delayed mammary involution because it removed formed milk sufficiently frequently to prevent the pressure within the gland rising to the critical level, above which secretion cannot occur. However Selye (1934 b) showed that suckling could delay involution considerably in rats, in which the escape of milk was prevented by tying the main ducts. Involution was also prevented in glands not suckled, because the teat had been removed, if one or more teats were left for suckling. This retardation of involution not confined to the gland suckled led him to postulate that the act of suckling led to a release of prolactin from the anterior pituitary. Of course the accumulation of milk eventually leads to involution but it occurred much later than in unsuckled controls, and lactation can be prolonged in normal mice by providing fresh litters after each batch is weaned (Selye, Collip and Thomson, 1934).

The same workers have also shown that suckling in rats could reinstate lactation after weaning. Even in virgin animals prolonged dioestrous periods could be induced, accompanied by progestational uterine changes, by mammary development and even by lactation, but only in the presence of the ovaries and pituitary. These dioestrous periods, called suckling pseudo-pregnancy, were due to the presence of persistent corpora lutea. These observations assume great significance in view of the fact that luteotrophin, the anterior pituitary hormone responsible for maintaining functional corporea lutea, has recently been identified with prolactin (see Desclin and Gregoire, 1937; Hisaw and Astwood, 1942; Hooker, 1946; Desclin, 1946, 1947).

Stimulation of the teats by the chemical irritation of periodically applied turpentine has also been shown to delay involution (Mixner and Turner, 1941 a), and so also does prolactin administration (Hooker and Williams, 1941; Williams, 1945).

Further evidence in support of this theory came from C.W. Turner and his school at Missouri who showed that suckling after a short period of non-suckling reduced the prolactin content of the pituitary of rats with the teat duct tied (Holst and Turner, 1939; Reece and Turner, 1936, 1937 a, b), but that the long term result of regular suckling was to increase the prolactin content of the pituitary and thus the output (Meites and Turner, 1942 e).

It has also been shown that suckling caused degranulation of the acidophils of the anterior pituitary which are generally agreed to produce prolactin (Dawson, 1946; Friedman and Hall, 1941).

Whilst it does appear that suckling sets up a neuro-hormonal reflex, the nervous afferent side had not been extensively studied.

There have been a few attempts to cut the pituitary stalk in an effort to break the final nervous link with the adeno-hypophysis. The technical difficulty of damaging the pituitary stalk only and the fact that the last link between the hypothalamus and the anterior pituitary may be humoral and not nervous (see Green and Harris, 1947) makes these experiments difficult to interpret.

It must also be pointed out that there is evidence that prolactin is not the only anterior pituitary hormone concerned in initiating and maintaining lactation, but the reviews by Folley (1947, 1949 b) should be consulted for further discussion of this subject.

The ejection reflex

It is interesting to note that a similar neuro-hormonal reflex has been postulated to account for the ejection reflex, also produced by the process of suckling or manipulating the teats.

It is generally agreed that the ejection of the milk is an active process, contrary to the widely held view that a cow "holds up" her milk until induced to relax and "let it down", which was even held by Zietzschmann as late as 1922 (see Gaines, 1915; Tgetgel, 1926; Hammond, 1936). If a cannula is inserted into the teat of a cow, only the milk which has accumulated in the teat, cisterns and large ducts since the previous milking will run out, and it requires manual manipulation of the teat or other associated milking procedures to which cows quickly become conditioned, to induce the ejection reflex, after which the rest of the stored milk can also be obtained. Gaines (1915) and Hammond (1936) think that this is an entirely nervous reflex, the former postulating that the smooth muscle around the milk ducts is induced to contract and the latter that vasomotor nerves produce a state of erection similar to that in the penis, which indirectly forces out the stored milk.

However, Ely and Petersen (1940, 1941) showed that the "let down" occurred normally in a denervated half of the cow's udder when the other innervated teats were manipulated and on the basis of this and other experiments postulated their theory. This holds that suckling and manipulation of the teat reflexly causes the release of oxytocin from the posterior pituitary which in turn causes the smooth muscle or myoepithelial cells of the udder to contract and squeeze out the stored milk. Petersen did not clearly state what he considered to be the effector tissue. This is considered in the thesis.

It has long been known that an extract of the posterior lobe of the pituitary contains a factor which upon injection exactly simulates the ejection reflex (Mackenzie, 1911; Schäfer and Mackenzie, 1911; Ott and Scott, 1910, 1912; Gavin, 1913; Hammond, 1913; Heaney, 1913; Schäfer, 1913, 1914; Simpson and Hill, 1914 a, b, 1915; Maxwell and Rothera, 1915; Turner and Slaughter, 1930). Although it is now believed to act by stimulating the myoepithelial cells in the gland, because its action is so fleeting, some earlier workers thought it was actually secretagogue. However, it only acts when there is milk stored within the gland and in the albino rabbit the glands can actually be seen to contract under the influence of pituitrine through the unpigmented skin (Turner and Cooper, 1941).

Ely and Petersen (1941) also showed that oxytocin could cause the "let down" of milk in the cow after section of the inguinal nerve to the gland and also that adrenaline had an inhibiting effect. This is of interest in view of the well known fact that a cow "holds up" her milk if frightened or disturbed in any way during milking. Petersen and Ludwick (1942) and Peeters, Massart and Coussens (1947) state that the blood from a cow, in which the reflex has just been evoked,

causes ejection of milk from an isolated perfused udder, whereas the blood from an unstimulated cow has no effect.

The latent period of the ejection reflex in the cow (Ely and Petersen, 1941) and man (unpublished observations) is 40-60 seconds, which fits in well with the time that would be needed to travel from the pituitary to mammary gland by the blood (see also Vercruyssen, Peeters and Coussens, 1950).

Gomez (1939, 1940) reported that rats hypophysectomized just after parturition and receiving adrenal cortex extract and glucose were unable to lactate unless given injections of pituitrine as well.

Experiments have been reported in which the posterior pituitary has been removed (Dott, 1923; Smith, 1932; Houssay, 1935 a; Fisher, Ingram and Ranson, 1938), or the hypophyseal stalk cut (Herold, 1939; Dandy, 1940; Dempsey and Uotila, 1940; Desclin, 1940; Jacobsohn and Westman, 1945; Maranon, 1947). In some of these experiments a normal lactation has been noted but no attempt has been made to study the ejection reflex itself after these operations. The numbers of animals in which these difficult operations have been completely and thoroughly carried out is very small and it may be that part of the hypothalamus (e.g. median eminence) can secrete post-pituitary hormones. In a more recent study, Jacobsohn (1949 a, b) cut the pituitary stalk of rabbits and found that although there was histological evidence of lactation persisting for some weeks, the young died, suggesting that they were unable to obtain the milk through failure of the ejection reflex.

Turner and Cooper (1941) compared the activity of oxytocin and pitressin, which are only partly separated, and found that pitressin had a greater ejecting activity than would be expected on the basis of its oxytocin content. This suggests that

possibly the erection type of mechanism postulated by Hammond (1936) may perhaps be concerned as well. Peeters, Coussens, Bouckaert and Oyaert (1949), Peeters and Coussens (1950) and Cross (1950, 1951) have shown that suckling also releases the anti-diuretic hormone from the posterior pituitary and Cross and Harris (1950) have now reported that ejection took place in anaesthetised rabbits upon electrical stimulation of the pituitary stalk.

Petersen has extended his theory to account for some cases of lactational failure in cows due, he believes, to the incomplete ejection of milk leading to the gland never being completely emptied, thus hastening involution (Miller and Petersen, 1940, 1941; Knodt and Petersen, 1944). He states that such cases are benefited by pituitrine injections after milking when the remainder of the stored milk can be obtained. He has also contended that the release of oxytocin at parturition is responsible for the commencement of lactation, causing the ejection of milk which although formed sometime during the last third of pregnancy remains in the alveoli and small ducts. This fits in with the fact that milk retained unduly long in the alveoli eventually comes into equilibrium with blood, leaving a fluid in all respects similar to colostrum and also with the fact that manipulation of the teats induces lactation in many cases even before parturition.

Finally, the widely quoted experiment of Inglebrecht (1935) may be quoted here as further evidence for the importance of afferent nervous stimuli from the teats in maintaining lactation. He cut the spinal cord of lactating rats between the last dorsal and first lumbar vertebrae, thus denervating the last six of the twelve glands present in this species. He

found that when he covered up the six innervated glands and allowed successive litters of young access to the denervated glands they were unable to obtain milk and died of starvation. If on the other hand even only two of the innervated glands were suckled, a copious milk flow resulted from all glands, and the young could be reared. Although this experiment probably concerns the release of prolactin from the anterior pituitary and oxytocin from the posterior lobe, it is an elegant method of demonstrating the neuro-hormonal mechanisms involved in lactation.

PART IIACCOUNT OF WORK DONEINTRODUCTION

Whilst reading the literature reviewed in Part I of this thesis, I was struck by the paucity of papers dealing with the blood and nerve supply to the mammary glands. This is true of the latter half of the nineteenth century, when much of the work done was anatomical, and also of work done in this century, which has mostly been endocrinological and biochemical. Although there was indirect evidence suggesting that the active organ had a relatively large blood flow through it, there were very few actual figures and no investigations into its variation and control. This is perhaps surprising, when one considers that the rate of milk secretion is bound to depend upon the mammary blood flow, because all the milk precursors come from the blood. The work reported here was begun in an attempt to remedy these omissions, but was later extended to include a study of the muscular tissues of the mammary gland as well.

Most of the work has been done on the lactating cat and unless otherwise stated, refers to this animal. Other species have, however, been studied, whenever practicable, as they became available.

Unfortunately the only clear accounts of the gross mammary blood and nerve supply are those for the human, the cow and the horse. The smaller mammals in particular have none. It was necessary, therefore, to study this first.

The anatomical texts of Mivart (1881), Reighard and Jennings (1925, 1951) for the cat, and Krause (1868) and Gerhardt (1909) for the rabbit, make no reference to the blood



and nerve supply to the mammary gland. Those of Greene (1931) for the rat, and Sisson (1940), Ellenberger and Baum (1943), Bradley (1948) and Miller (1948) for the dog, give the major blood vessels supplying the mammae, the most complete being the accounts of Miller and Greene. Similar information is given for the dog and cat by Turner and Gomez (1934) and Turner and de Moss (1934), for the rabbit by Wahl (1915) and all the named species in the monograph by Turner (1939 b).

Of the authors named only Ellenberger and Baum (1943) and Miller (1948) give any information on the nerve supply to the mammary glands of these laboratory animals.

The literature dealing with vasomotor nerves is equally scanty. Laffont (1879) in an attempt to discover secretory nerves, noted that stimulation of the distal cut end of the external spermatic nerve, supplying the inguinal mammary gland in the curarised bitch, caused congestion of the same gland. However, Goltz and Ewald (1896) found that suckling produced a similar congestion in a dog whose spinal cord had been removed below T III, so that a vasomotor reflex ~~may~~ not have been concerned. When Ribbert (1898) in the guinea pig and Stricker (1930) in the rabbit succeeded in transplanting the mammary glands of the young animal to the back of the ears and later obtained normal milk secretion, it was assumed that nerves were unnecessary for mammary function. However, Kahn (1925) noted some changes in the milk of guinea pigs after mammary denervation, and Ernst (1929) found that complete denervation but not sympathectomy alone caused atrophy of the resting gland in the dog and rabbit. Cannon and Bright (1931) found that one dog and 2 cats showed lactational deficiencies as a belated result of Cannon's famous experiments on complete sympathectomy. Bacq (1932), in Cannon's laboratory, reinvesti-

gated the problem in the rat, but got no conclusive results. Clark (1933) made an examination of the tissues after sympath-ectomy but reported no significant changes in the mammary glands. Simeone and Ross (1938) returned to the effect of partial and complete sympathectomy on gestation and lactation in the cat, but again the results were quite inconclusive. In general the mammary glands were normally developed at parturition but the maternal instinct was lacking and the kittens were not suckled.

Graham, Kay and McIntosh (1936) and Shaw and Petersen (1939) when using a technique of obtaining simultaneous arterial and venous blood samples from the udder of the unanaesthetised cow, found that these were useless from a biochemical viewpoint if the animal was seriously disturbed or upset during sampling. Such an effect produced either a great concentration or dilution of the blood during its passage through the udder, as well as a temporary cessation of milk secretion. These sudden changes in vascular permeability occurring in response to fear or pain, might well be due to the release of adrenaline and/or sympathetic nerve activity.

St.Clair (1942) noted that cutting the inguinal nerve (external spermatic) to the udder or removal of the lumbar sympathetic chain, caused an increase in the temperature of the udder in the cow, and since this work was started Peeters, Coussens and Sierens (1949) briefly reported that stimulation of the same nerve decreased the venous outflow of the isolated cow's udder, perfused at constant pressure.

The arrangement of the blood vessels within the mammary gland has been determined for the larger vessels in the cow (see Turner, 1939 b), but the only studies of the minute vascular distribution in relation to the gland structure have been those of Wahl (1915) for the rabbit and Dabelow (1933) for the

rabbit, rat, mouse and guinea pig.

Wahl (1915) followed the pattern of the blood vessels in whole mounts of the mammary glands from the 23 mm. embryo up to the animal in full lactation and during involution. He describes the gradual increase in number and complexity of the capillary plexuses along the ducts, which are most developed at the ends where the growth is taking place. More and more arterioles and venules are formed from the surrounding tissues to supply these capillary plexuses as pregnancy proceeds, although some arterioles and venules also form within them.

Dabelow (1933) examined the injected vessels (Indian ink) in thick sections and compared the vascular pattern in the mammary glands with that of the fat, in which they develop during pregnancy. In contrast to Wahl, he states that as the glands develop during pregnancy they merely take over the pre-existing fat capillaries. The latter become wider and some arterioles and venules are formed from them, but no new vessels are formed, the gland retaining in principle the same vascular pattern as the fat in which it developed.

It was concluded therefore from the literature, just quoted, that direct proof for the existence of vasomotor nerves to the mammary gland was lacking and that there was no knowledge as to how many of the vessels were innervated and to what extent the blood flow could be altered by their activation. The physiological experiments were designed to attempt to answer these problems and anatomical investigations were carried out concurrently on the arrangement of blood vessels and nerves in the species studied physiologically (cat and dog).

After it had been accidentally discovered that some nerve stains, employing silver, stained the muscular and myoepithelial cells of the mammary glands, observations were also made

upon these tissues in the anatomical and physiological studies and their relationships to the ejection of milk.

[The following text is extremely faint and largely illegible. It appears to be a detailed scientific or medical report, possibly describing anatomical and physiological studies related to milk ejection. The text is organized into several paragraphs, with some lines appearing to be section headers or sub-headers. The content is too light to transcribe accurately.]

SECTION I

THE BLOOD AND NERVE SUPPLY TO THE MAMMARY GLANDS

Animals and methods:-

I. Gross anatomy

Detailed dissections were made of the blood vessels and nerves supplying the lactating mammary glands of 6 dogs, 17 cats, 6 rabbits, 4 guinea pigs, 3 rats and 5 mice. The recognition of the **smaller** vessels was facilitated in the majority of cases by the injection of Indian ink, or coloured solutions of Neoprene latex or gelatin. The Neoprene injected specimens (2 dogs; 3 cats) were completely macerated after dissection, for the confirmation and detection of anastomoses between the larger vessels. It was possible to inject completely all the larger vessels from either end of the mammary tissue, thus stressing the functional significance of these intra-glandular anastomoses. Attempts were made to stain nerves macroscopically a greenish tinge by the method of Lim Boon Keng (1893) for cardiac nerves, but it was unsuccessful for the cutaneous mixed nerves studied.

II. Microscopic anatomy

(a) Blood vessels - These were injected in the mammary glands of cats and dogs with Indian ink, Neoprene latex or coloured gelatin solutions, after previously washing the blood from the vessels with warm Ringer solution via the artery. With Neoprene and gelatin simultaneous injection of the arteries and veins was carried out at the same pressure (120-200 mm. Hg), in an attempt to colour them differently. This was unsuccessful at first, in that the different coloured solutions did not necessarily meet in the capillaries, leaving the arteries and vein injected in different colours. This condition was

obtained, however, by incorporating into the injection medium 1-5% of arrowroot starch. The size of the starch granules (9.5 - 44.2 μ , Mean 22.7 \pm 8.25) was such that most of the medium was held up in the arterioles and venules, and ensured that the different colours met in the capillaries. In some specimens the milk ducts were also injected with Neoprene in a third colour. After injection, the majority of Neoprene injected specimens (from 6 cats and 2 dogs) were macerated, and the casts studied under a dissecting microscope, whilst the gelatin (11 glands from 5 cats and 1 dog gland) and Indian ink (2 cat glands) injected tissues were usually studied in thick (150-250 μ) serial frozen sections with a stereoscopic microscope (\times 5 - \times 120). However, much information was also obtained by the dissection under the stereoscopic microscope (magnification \times 20) of 5 cat glands cleared in 50% glycerol in which the blood vessels had been injected with red and blue gelatin and some of the milk ducts had been injected with Indian ink. The cat has 3-6 main milk ducts which, it was shown by injecting each with a different coloured dye are separate and drain a definite sector of the gland, as in the rabbit (Lyons, 1942). The scanty interlobar and interlobular connective tissue in the cat mammary gland is rendered transparent and easily dissected. The nerves show up a glistening white and can be followed considerable distances.

The histological structure of the vessels was studied in routinely prepared sections stained by Van Gieson (Marshall, 1946), Marshall and Trowell's (1943) "Haurab" method, or Romanes's (1950) method which stains smooth muscle as well as nerve.

(b) Nerves - Attempts to stain the nervous tissue within the mammary glands of the dog, cat, rabbit and rat, with

methylene blue by the methods of Schabadasch (1935), Meyling, (1948), Feindel, Sinclair and Weddel (1947), and Feindel, Allison and Weddell (1948), and with gold chloride by the methods of Garven (1925) were unsuccessful in that, in the specimens that were sufficiently deeply stained it was not possible to distinguish with certainty the nerve fibres from reticular fibres. However the finer nerve fibres within the gland were stained by the silver method of Romanes (1950) in tissue fixed in Carnoy or acetic-formal-alcohol and the larger sensory nerve endings in the nipple and areolar were stained by Gros-Bielschowsky's method in formal fixed tissue.

III. Dermatomes

The areas of skin supplied by the lateral cutaneous branches of the lumbar and some thoracic spinal nerves was determined in 6 female cats (5 under anaesthesia, 1 decerebrate). Electrodes were placed under the uncut nerves and the action potentials, produced by stroking the hairs of the innervated areas, were picked up, amplified and recorded with an oscillograph and loudspeaker. By this method the dermatome of each nerve could be quickly determined and plotted.

Results

Gross blood supply to the mammary glands

This is essentially the same in the dog, cat, rabbit, rat, mouse and guinea pig. The dog and cat, with which this work has been most concerned, have been studied in detail, and the other species only from a comparative point of view. Unfortunately the literature shows no uniformity of nomenclature, and several vessels and nerves to be described have not been mentioned before in anatomical texts of the species. The I.N.A. system used by Miller (1948) has been followed because he is the only author to name all the vessels encountered. The alternative

names that have been used by other authors are given in Addendum II.

Cat and dog. (Figs.1 and 5)

In the lactating state the mammary glands in these species form a continuous band of tissue running from the axilla to the inguinal region. (The cat normally has 4 pairs of glands and the dog 4-6). There is an extensive network of large arteries and veins permeating the mammary tissue, supplied from 3 main sources:-

(a) Caudally the subcutaneous abdominal or caudal superficial epigastric artery and vein which originate from the external pudendal vessels in the inguinal canal, and pass forward on the dorso-lateral aspect of the abdominal and inguinal mammary glands to join,

(b) The cranial superficial epigastric vessels, which emerge through the abdominal wall just behind the xiphoid cartilage in the midline and originate from the internal thoracic or internal mammary vessels.

(c) The lateral (or external) thoracic vessels, originating from the axillary vessels, travel caudally on the lateral side of glands 1 and 2, to which they supply branches. These vessels are smaller than (a) and (b).

In addition to these main vessels there are, in order of size:-

(d) Several branches (2-4) from the internal thoracic vessels, which pass between the costal cartilage near the sternum, to enter the first pair of glands medially.

(e) A series of parallel vessels running ventro-laterally around the body beneath the panniculus carnosus muscle in company with the lateral cutaneous thoracic and lumbar nerves, to anastomose with the superficial epigastric and external

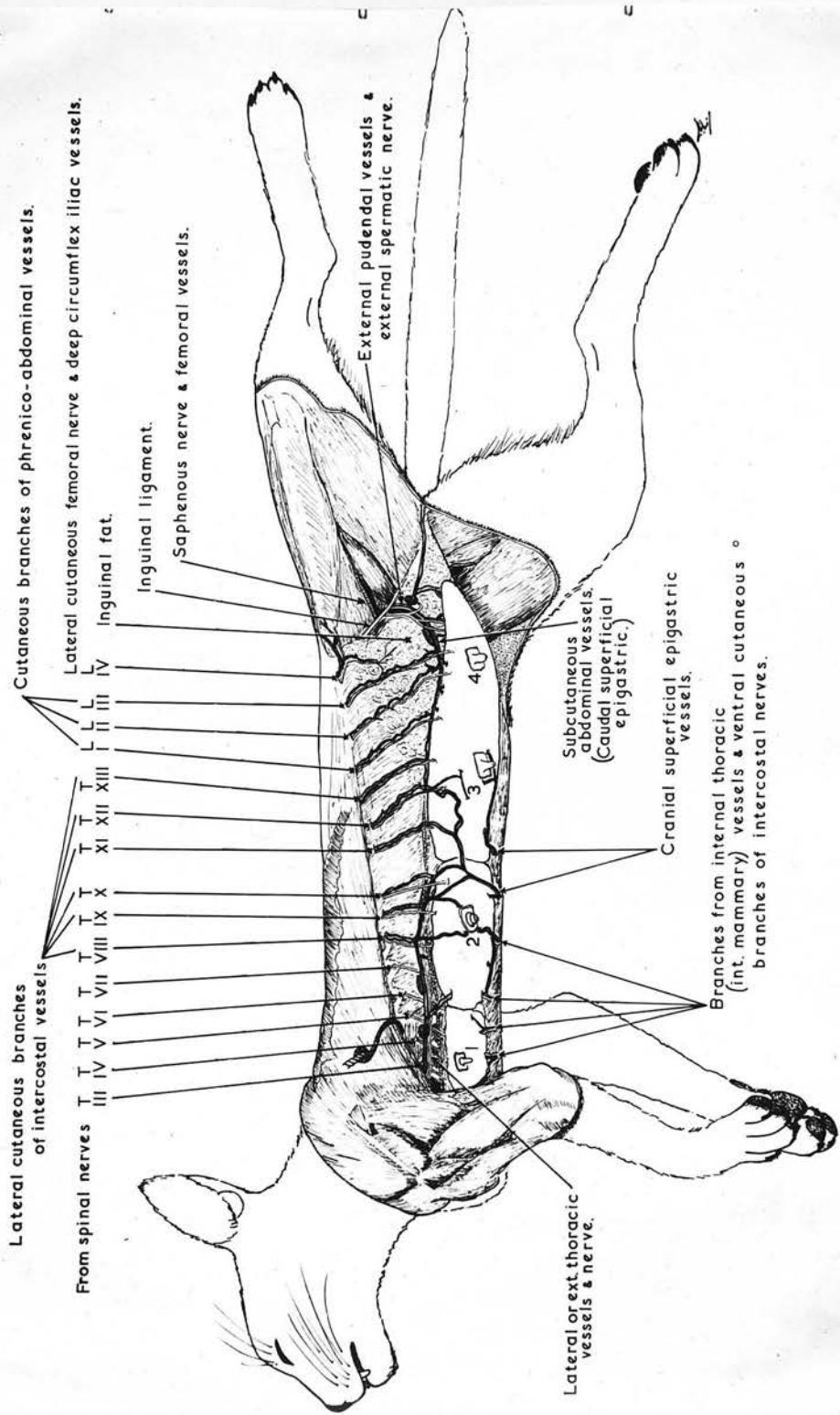

FIG. 1. Drawing of the blood and nerve supply to the mammary glands of a lactating cat.

thoracic vessels. The vessels travelling with the lateral cutaneous femoral nerve (L IV) arise from the deep circumflex iliac vessels, those with nerves from L I, II and III from the phrenico-abdominal vessels, and the rest from the intercostal vessels. The latter usually extend as far forward as T VII, but branches from T VIII or IX are sometimes missing.

(f) A few small twigs from the epigastric vessels within the abdominal wall passing through it to enter glands 3 and 4 dorsally.

(g) A variable number of vessels (often only veins) crossing the midline between glands 3 and 4.

A valve is usually present in the external pudendal vein just outside the inguinal canal. This is the only valve encountered in the mammary veins.

Gross nerve supply

Cat and dog. (Fig.1)

The nerve supply is also multiple. The mammary glands lie between the skin and the panniculus carnosus muscle and are innervated by the lateral cutaneous branches of the ventral divisions of the thoracic and lumbar spinal nerves, which enter the glands laterally. The glands receive branches from the nerves from T III to L III inclusive. T II does not send macroscopically visible fibres to the first gland and L IV (lateral cutaneous femoral nerve) has medial branches which enter the inguinal fat but which cannot usually be seen entering the inguinal mammary gland with the naked eye, although physiological evidence was obtained later that vasoconstrictor fibres in this nerve may reach the inguinal gland. The inguinal gland receives in addition most of its vasomotor innervation from the external spermatic nerve, reaching it in company with caudal superficial epigastric vessels from the inguinal canal. The ventral

cutaneous branches of the intercostal nerves, which emerge through the interchondral spaces, in company with vessels from the internal thoracic artery and vein, also send some branches to the thoracic glands. A few small nerves have also occasionally been found entering glands 3 and 4 on the dorsal aspect from the overlying abdominal wall. These originate from the muscular branches of the ventral spinal nerves supplying the abdominal muscles.

The lateral thoracic nerve, which accompanies the vessels of the same name along the lateral edges of glands 1 and 2, does not, as far as can be seen, send any branches to the mammary glands, although it apparently sometimes anastomoses with the lateral cutaneous nerves travelling across it. It has been shown by Langworthy (1924) to innervate the panniculus muscle in the cat and dog, and by Wilson (1913) to innervate in man the Achselbogen muscle, which is the homologue of the panniculus. Stimulation of the nerve causes contraction of the panniculus muscle; that of the lateral cutaneous nerves does not.

Gross blood and nerve supply in other species

Rabbit. (Figs. 2 and 6)

The rabbit has 3-5 pairs of mammary glands arranged as in the dog and cat. The caudal superficial epigastric vessels do not come from the external pudendal vessels however, but leave the femoral vessel in the thigh, and anastomose with the external pudendals within the inguinal gland. The lateral thoracic vessels are relatively larger than in the dog and cat, and appear to play a greater part in supplying the cranial glands over the thorax than the vessels from the internal thoracics. The vessels which exactly correspond in origin and position to the deep circumflex iliacs in the cat and dog are called the ilio-lumbar by Krause (1868) and Gerhardt (1909). They are

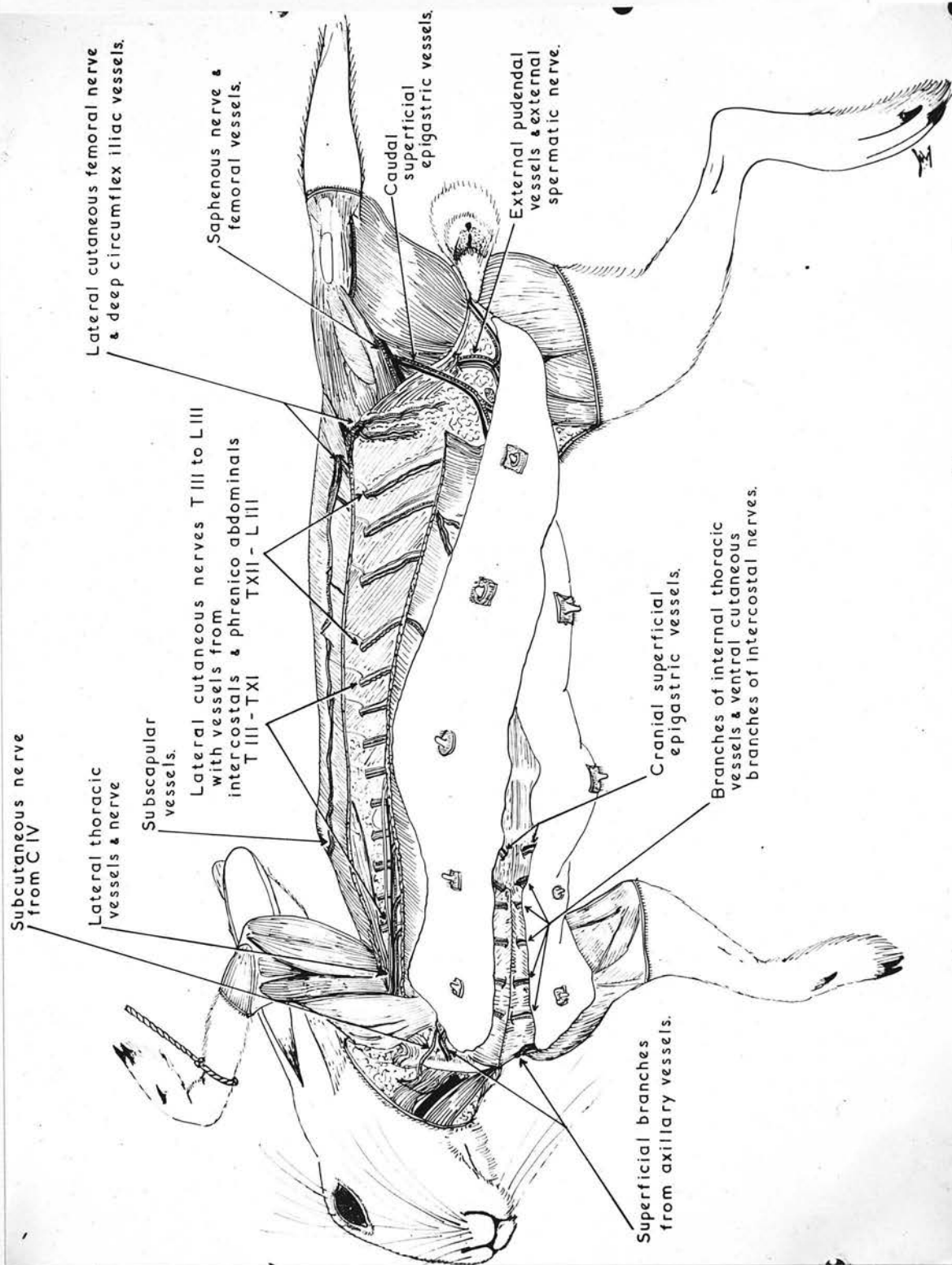

FIG. 2. Drawing of the blood and nerve supply to the mammary glands of a lactating rabbit.

also relatively larger and anastomose with the caudal superficial epigastrics and the subscapular vessels. Superficial extensions of the latter are very prominent in this species, and also join the lateral thoracic vessels. In addition, gland 1 receives a pair of vessels not present in the cat and dog. These arise either from the axillary (emerging just behind the clavicle) or less commonly from the subclavians in front of the clavicle (superficial cervical). They are accompanied by a superficial nerve from C IV. The phrenico-abdominal vessels supplying lateral cutaneous branches to the abdominal and inguinal glands are called the lateral abdominal by Krause (1868).

Rat and mouse. (Figs.3 and 7)

In these species the glands are arranged in 2 groups around the axilla (3 pairs) and inguinal region (3 pairs in the rat and 2 pairs in the mouse), so that the middle region of the abdomen is devoid of glands. Unlike the cat, dog and rabbit, the mammary glands of the rat and mouse lie beneath the panniculus carnosus muscle and not between it and the skin. The blood and nerve supply more resembles the rabbit than the dog and cat. However, there is no vessel corresponding to the cranial superficial epigastric of the other species and this area of the abdominal skin is supplied by a branch of the lateral thoracic. The anastomosis between the caudal superficial epigastrics and the external pudental is less conspicuous than in the rabbit.

The subscapular vessels are not prominent.

Guinea pig. (Fig.4)

The guinea pig has only 2 mammary glands situated in the inguinal region, and the blood is supplied almost entirely by the external pudental vessels, although some branches extend beyond the glands anteriorly. Some very small branches also reach the glands from vessels which correspond to the caudal superficial epigastrics of the rabbit, rat and mouse.

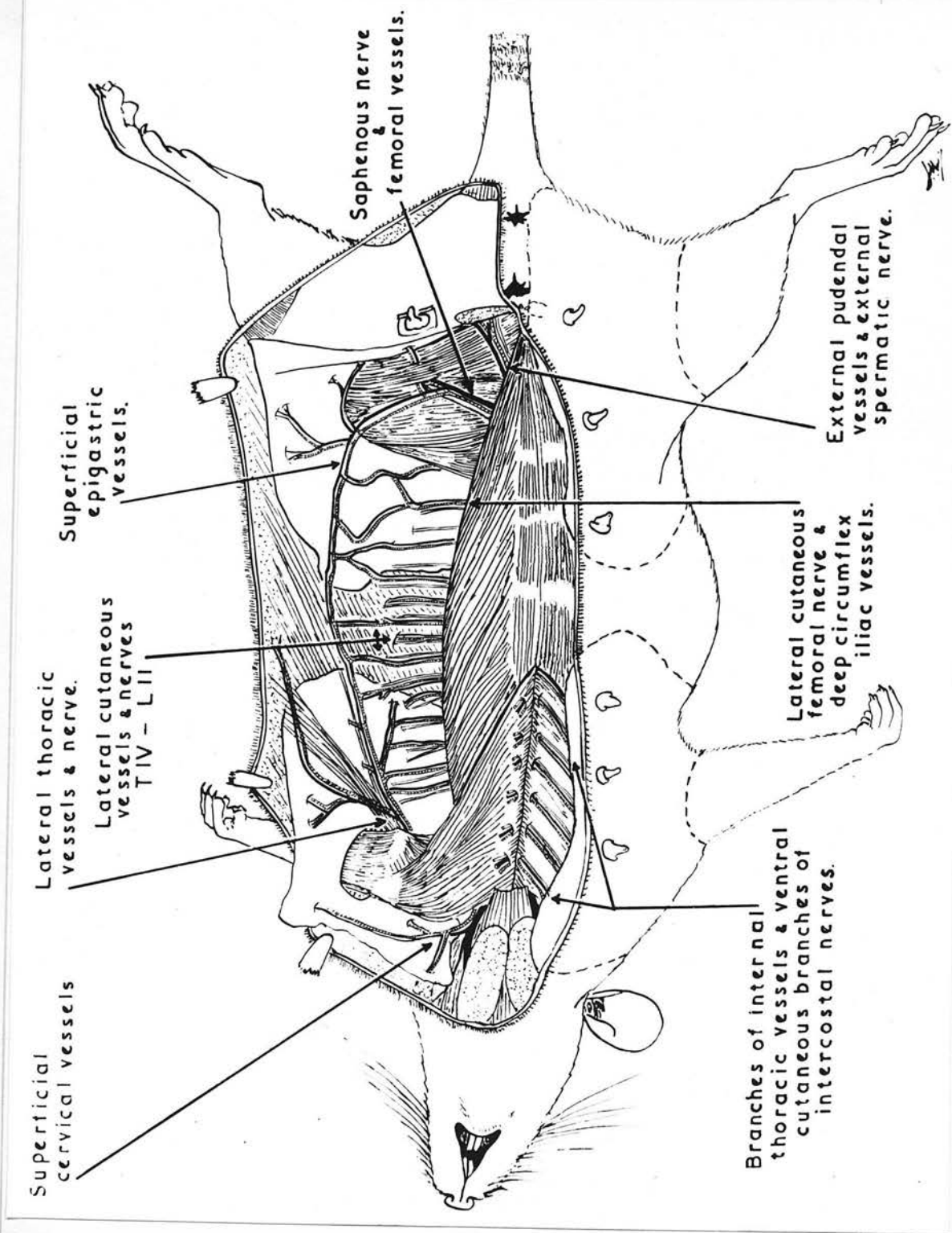

FIG. 3. Drawing of the blood and nerve supply to the mammary glands of a lactating rat.

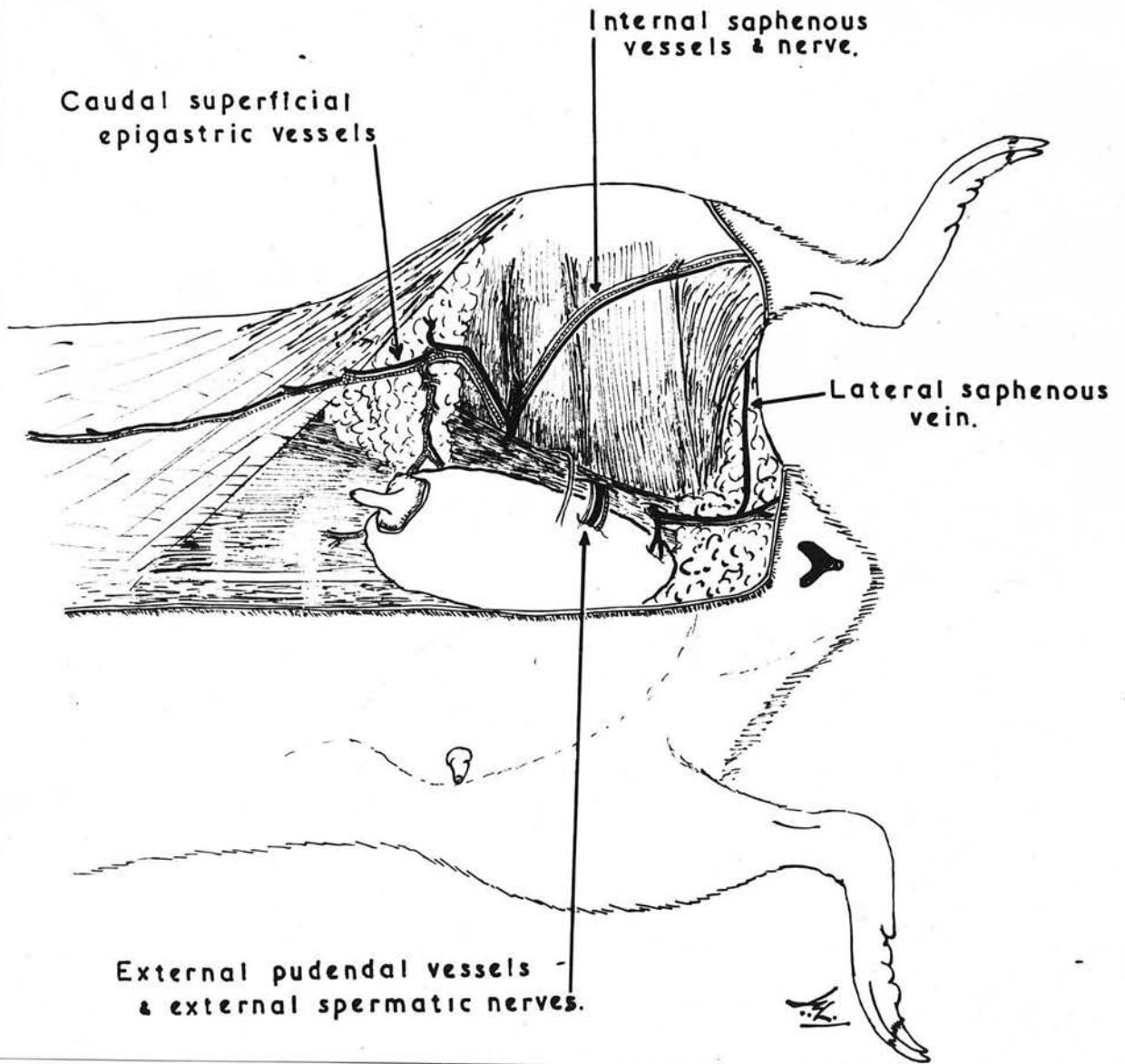

FIG.4. Drawing of the blood and nerve supply to the mammary glands of a lactating guinea pig.

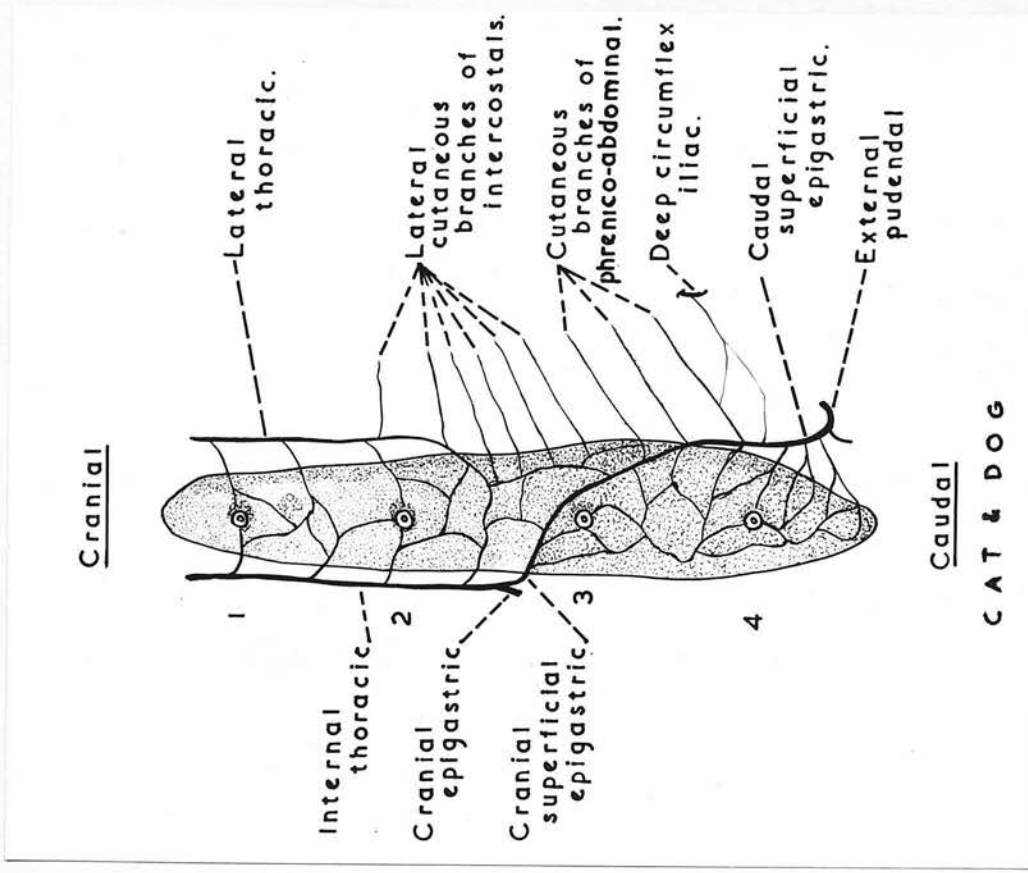

FIG. 5.

Diagrams of the arterial supply to the mammary glands. The veins are similar.

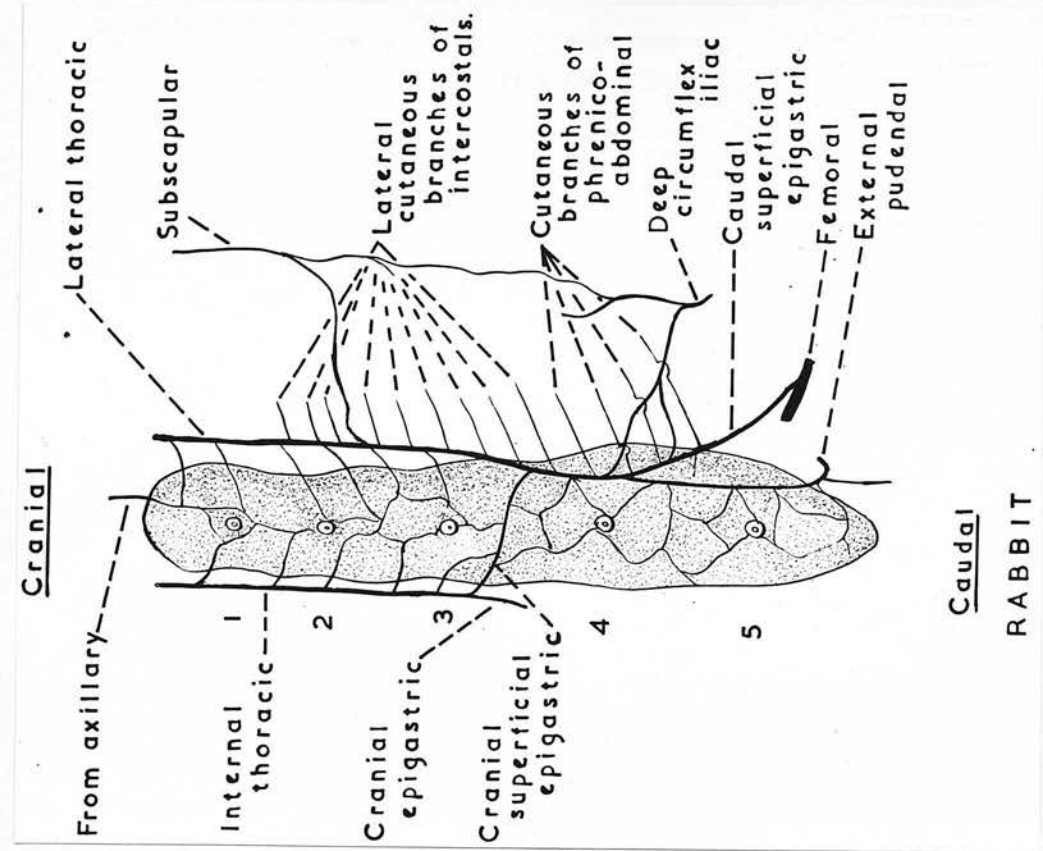
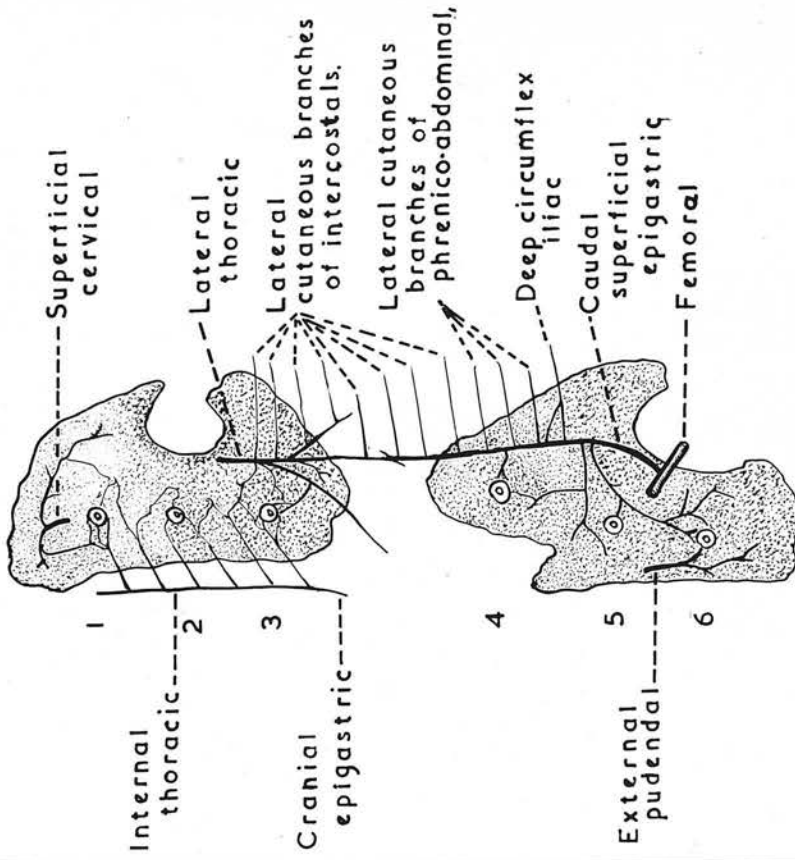

FIG. 6.

Cranial



Caudal

RAT & MOUSE

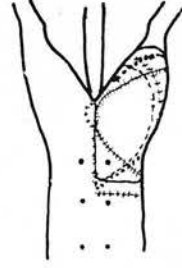
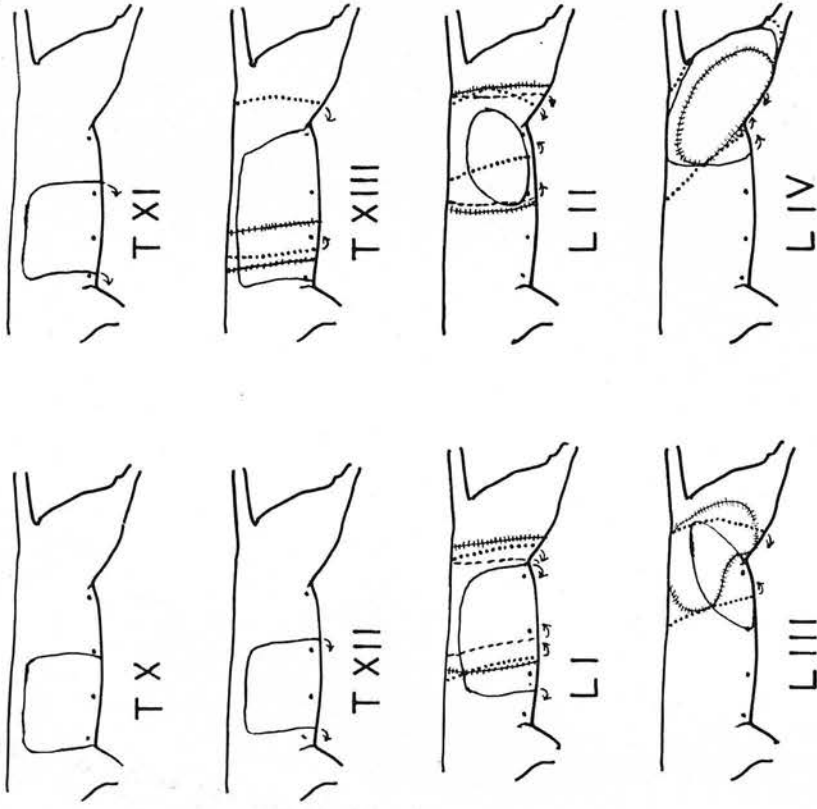

External spermatic.

FIG. 7.

Same as Figs. 5 and 6.

FIG. 8.

The skin areas supplied by the lateral cutaneous branches of some spinal nerves in 6 female cats.

The external spermatic nerve sends 2 large branches to the gland. One accompanies the external pudendal vessels as in the other species but the other leaves the abdominal cavity laterally above the inguinal ligament and enters the gland a little way in front of the other vessels and nerves.

The posterior part of the gland is drained by an additional vein (unaccompanied by an artery) which joins the perineal branch of the external pudendal vein.

Anomalous findings

In 7 of 102 cats examined an extra large vein was present joining the caudal superficial epigastric to the femoral vein low in the thigh. In two cases the condition was bilateral, in one case on the left side and the rest on the right. In 3 animals the right external pudendal vein was double as well. This anomaly is of interest as this form of venous drainage of the posterior glands is found normally in the rabbit, rat and mouse, and suggests that this more complicated system has been lost by the cat.

Dermatomes

For physiological purposes it was required to know the approximate areas of the mammary tissue supplied with vasomotor fibres by the different spinal nerves. Since Bellini (1948) has shown that the sympathetic fibres and sensory fibres in spinal nerves supply approximately the same areas in the cat, the sensory dermatomes covering abdominal and inguinal glands were plotted by the method described. The results shown in Fig.8 indicate that any one area is innervated by at least 5 adjacent nerves and that there is considerable variation from cat to cat and even on the 2 sides of the same animal. Later physiological experiments showed that the inguinal gland received vasomotor constrictor fibres from nerves T XIII - L IV (i.e. the same as

sensory innervation) and thus confirmed Bellini's findings.

Vessels and nerves within the glands

Nerves

Macroscopically visible nerves can usually be traced as far as the teat, in company with large blood vessels. Riederer (1905) describes nerve nets in ~~the~~ cow's teat and Cathcart, Gairns and Garven (1948) have made a thorough study of the quiescent human nipple stained by ~~the~~ Gros-Bielschowsky method and describe a number of complex nervous networks of sensory origin, particularly around the mouths of the milk ducts, and an all pervading sympathetic ground plexus in the smooth muscle and connective tissue of the nipple. Arnstein (1895) described the existence of nerve endings on the cells in the mammary gland of a pregnant cat stained with methylene blue. Dempsey, Bunting and Wislocki (1947) describe lightly myelinated nerves entering the interlobar septa and accompanying the arteries and some ducts. The silver methods of Romanes (1950) and Richardson (1949) chiefly used in this study stained the large myelinated nerve fibres in macroscopically visible nerves entering the gland and in between the smooth muscle bundles in the teat (Fig.12). Less regularly Romanes's method also stained fine unmyelinated fibres along the walls of arterioles which presumably are the sympathetic vasoconstrictor nerves demonstrated in subsequent physiological experiments, (Figs.9, 10 and 11). The latter, which were seen to accompany interlobular arterioles as small as 24μ , were the only nerves ever seen in the actual mammary gland of the lactating cat stained by silver methods.

Blood vessels

The mammary glands develop in an area already possessing a definite blood supply. The arrangement of large blood vessels is retained at all stages of mammary activity, and the examination

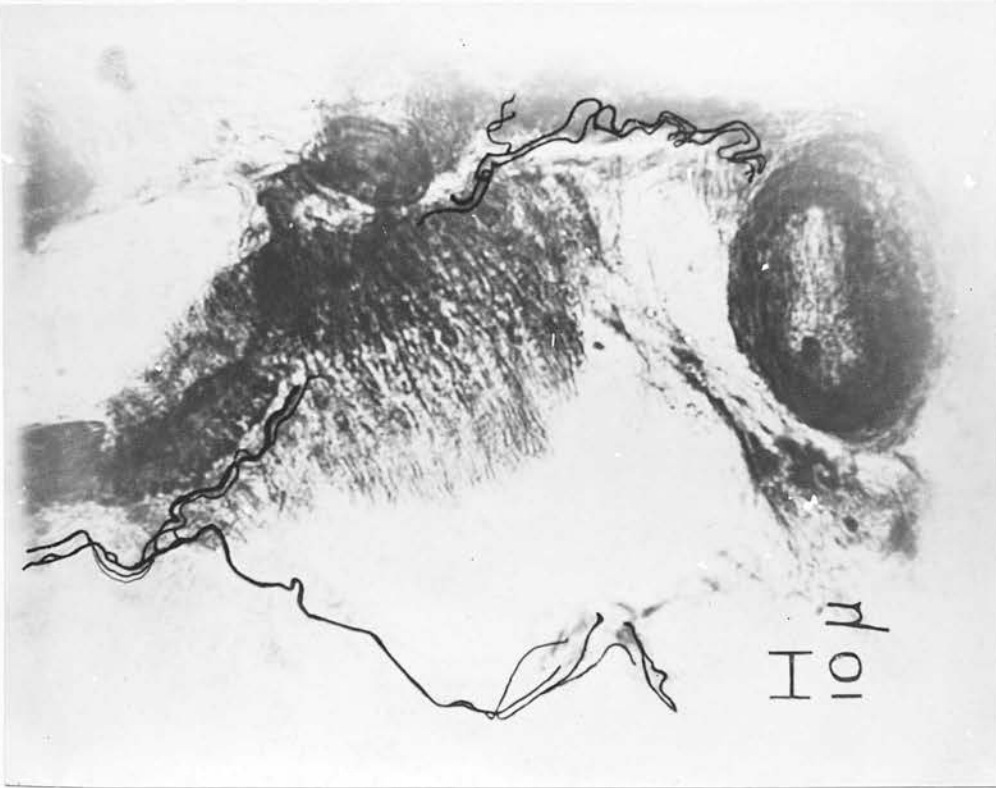

FIG. 9.

Photodiagrams of nerve fibres accompanying arterioles in the lactating mammary glands of a cat.

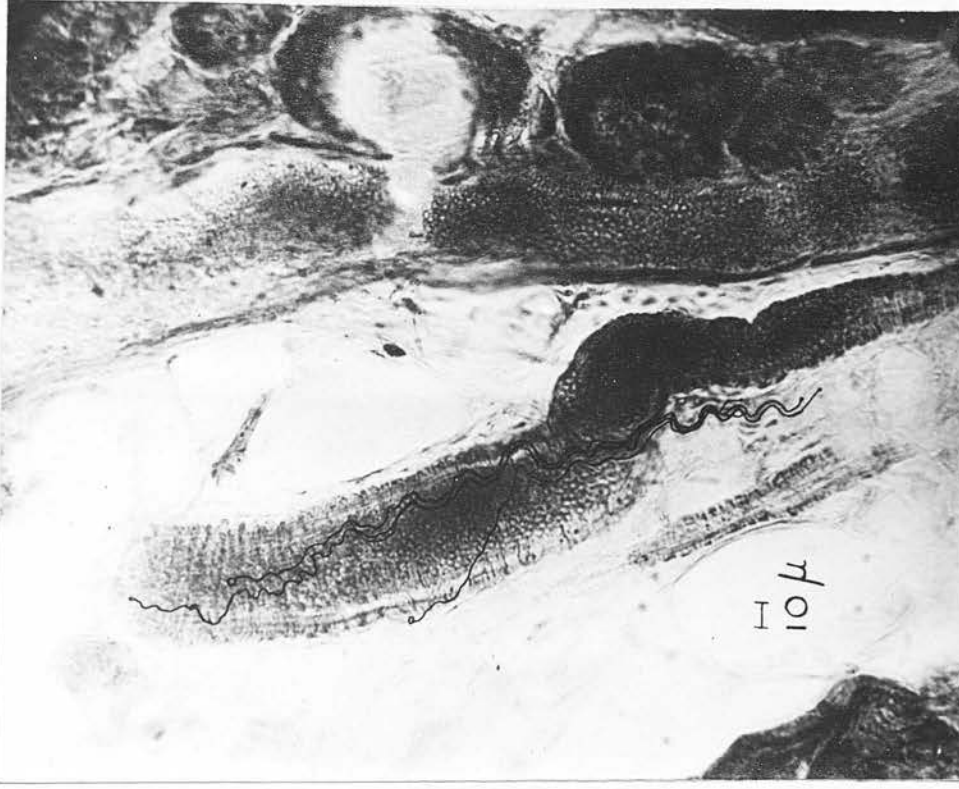

FIG. 10.



FIG.11. Photomicrograph of nerve fibres entering an arteriole wall in the mammary gland of a cat. Romanes's (1950) method.



FIG.12. Photomicrograph of a nerve (N) lying between the smooth muscle bundles in the teat of a cat. Strands of the panniculus muscle are frequently found passing through the mammary glands and in this animal striated muscle fibres were widely distributed throughout the nipple. Richardson's (1949) method.

of glands of pregnant animals and of involuting glands shows that as the mammary ducts spread outwards and develop alveoli there is a considerable increase in the size and apparent number and complexity of the small blood vessels. This has been confirmed in greater detail for the rabbit by Wahl (1915) who followed the vascular distribution in all stages from the embryo to the involuting gland after lactation. Dabelow (1933) compared the mammary blood vessels in the rat, mouse, guinea pig and rabbit with those in the subcutaneous fat in which the mammary glands develop, as seen in 120μ sections of Indian ink injected tissue. He stated that the distribution of mammary blood vessels is basically the same as those in the mammary fat (Fig.13), and that as the gland grows during pregnancy fat capillaries are taken over by the developing ducts and alveoli as they are formed. Some capillaries become transformed into arterioles and venules but according to Dabelow no new vessels are formed. He described three types of blood supply to individual fat lobules, which are later transformed into mammary lobules:-

(I) arteriole and venule entering intra-lobularly; (II) arteriole and venule entering and leaving peripherally but from the same side; (III) arteriole and venule approaching from completely different places (Fig.14). He also found that neighbouring mammary lobules shared capillary nets and believed that the inter-communicating fat capillaries enable blood to be shunted from an inactive (i.e. full) lobule to an active (i.e. empty) neighbour. (Fig.15).

In this study, examination of 150μ serial sections of cat mammary glands revealed lobules apparently possessing the different types of vascular distribution of Dabelow, but many others in which the exact arrangement could not be determined. Examination was much easier with even thicker sections (up to 250μ)

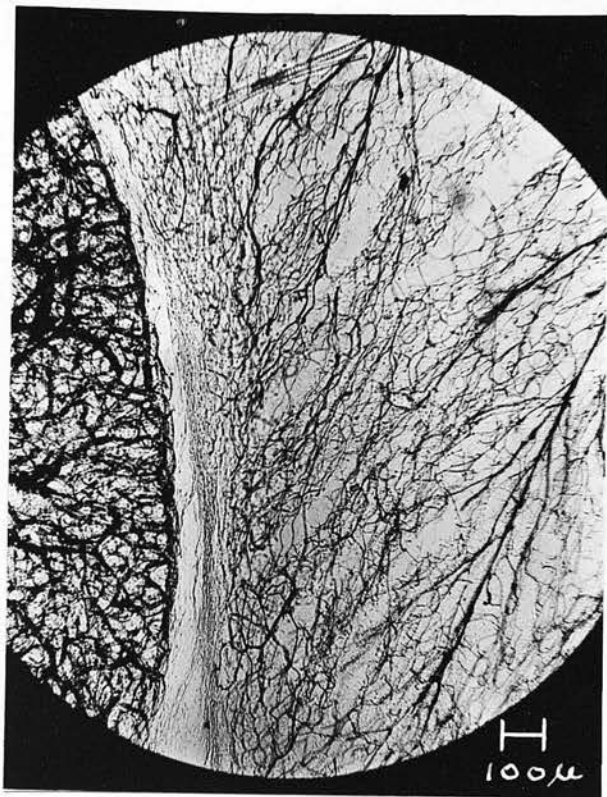

FIG. 13. Photomicrograph of section at the junction of the inguinal mammary gland (left) and inguinal fat (right), with blood vessels injected with Indian ink. The mammary vessels are no more extensive than the fat vessels but there are relatively more arterioles and venules than in the fat.



Abb. 2.

Abb. 2. Gefäßverzweigung im Fettlappchen des Mammarfettkörpers. I. Arterie und Vene intralobulär.

Abb. 3. Gefäßverzweigung im Fettlappchen des Mammarfettkörpers. II. Arterie und Venenstamm liegen dem Lappchen peripher an.

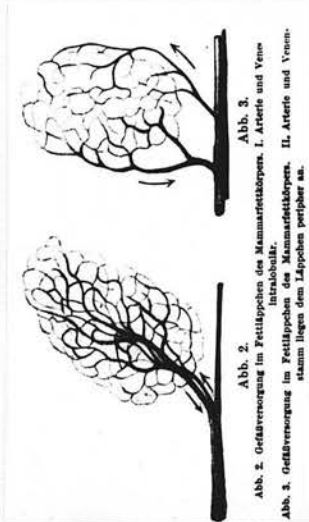

Abb. 4.

Abb. 4. Gefäßverzweigung im Fettlappchen des Mammarfettkörpers. III. Arterie und Vene weit voneinander entfernt, ohne klare Lagebeziehungen zueinander.

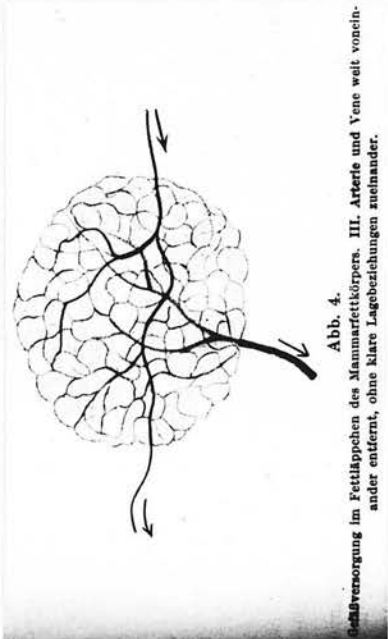

Abb. 18.

Abb. 18. Blutstromverzweigung (Schemata) von getriebenen Milchkanälen (Milch) zum Lumen (rechts) durch die Anastomosen der umgebenden Fettgewebe.

FIG. 14.

FIG. 15.

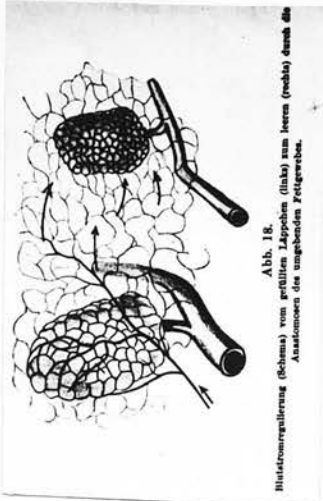
Diagrams from Dabelow (1933) showing the 3 different types of blood supply to mammary fat lobules, and the method of shunting blood from a full to an empty lobule.

and with tissue in which arteries were injected red and veins blue, but it became apparent that even these thick sections did not necessarily include an entire lobule, and that some of them received more than one arteriole and venule.

The dissection of glands with vessels and milk ducts injected and of Neoprene casts of the vessels and ducts confirmed that individual lobules are very variable in shape and size. Although irregular, they usually measured 200-300 μ along each axis and did not exceed 600 μ in any one. Each lobule is drained by a milk duct (60-70 μ) which is formed by the convergence of smaller ducts (40-50 μ) draining various sections. The alveoli (30-60 μ) are tightly packed but small clefts or fissures between each sector further subdivide the lobule. Some 30-60 lobules are tightly packed into a lobe, so that they have many sharp edges and corners like the lobes of the liver and lungs. The lobes are also irregular and measure 1-3 mm. The milk ducts from the lobules form within the lobe at obtuse angles to form a common duct (150 μ) draining the lobe into the main duct system of the gland.

In the network of large vessels already described, arteries (200-400 μ) and veins (500-700 μ) lie closely together and give off branches every 1 - 1.5 mm. (arteries 75-100, veins 100-200 μ). Where these vessels lie on the surface of a gland the nerves often lie closely to them, but nerve branches could not always be seen to follow the branches mentioned. These larger arterioles and venules meander through the gland giving branches to lobes lying next to them and forming a complicated secondary network in which a pair of vessels, whilst running in the same general direction, do not usually lie close together. There was no obvious relationship between these large arterioles and venules and the mammary gland structure. They do not for example

regularly follow the milk ducts, or bear any constant relationship to the gland lobes (Figure 22).

From 2 to 7 arterioles (50-70 μ) and venules (70-120 μ) supply each lobe and although the numbers are usually equal, they do not always travel together but are often equally spaced around it, entering by passing in between the lobules or breaking up into capillaries on the surface. Within the lobes the arterioles and venules also take very variable courses and enter the lobules from every conceivable position. For this reason there were more lobules with arteriole and venule approaching from different places (Dabelow's type III, Fig. 16, Nos. 9, 10), than those with both vessels entering from the same side (type II, Fig. 16, No. 8) or both vessels together with or without the duct (type I, Fig. 16, Nos. 2, 5). The last type were in fact uncommon, and were outnumbered by a further type of lobule in which one vessel (more often venule than arteriole) enters intralobularly with the duct and the other approaches from another position (Fig. 16, No. 6; Fig. 18). There were also a number of lobules that received more than one arteriole or venule (Fig. 16, Nos. 1, 3 and 4; Fig. 17).

The dissection of whole glands and Neoprene casts of vessels and ducts, revealed a feature that was not apparent in the careful microscopical examination of thick serial sections of the same injected material. The arterioles and venules enter the lobules via the clefts or fissures between the sections of the lobule, where they break up and supply the capillary network in the secretory tissue. This means that only true capillaries are found between the alveoli and on no occasion were capillaries ever seen passing from one lobule to another as described by Dabelow (1933).

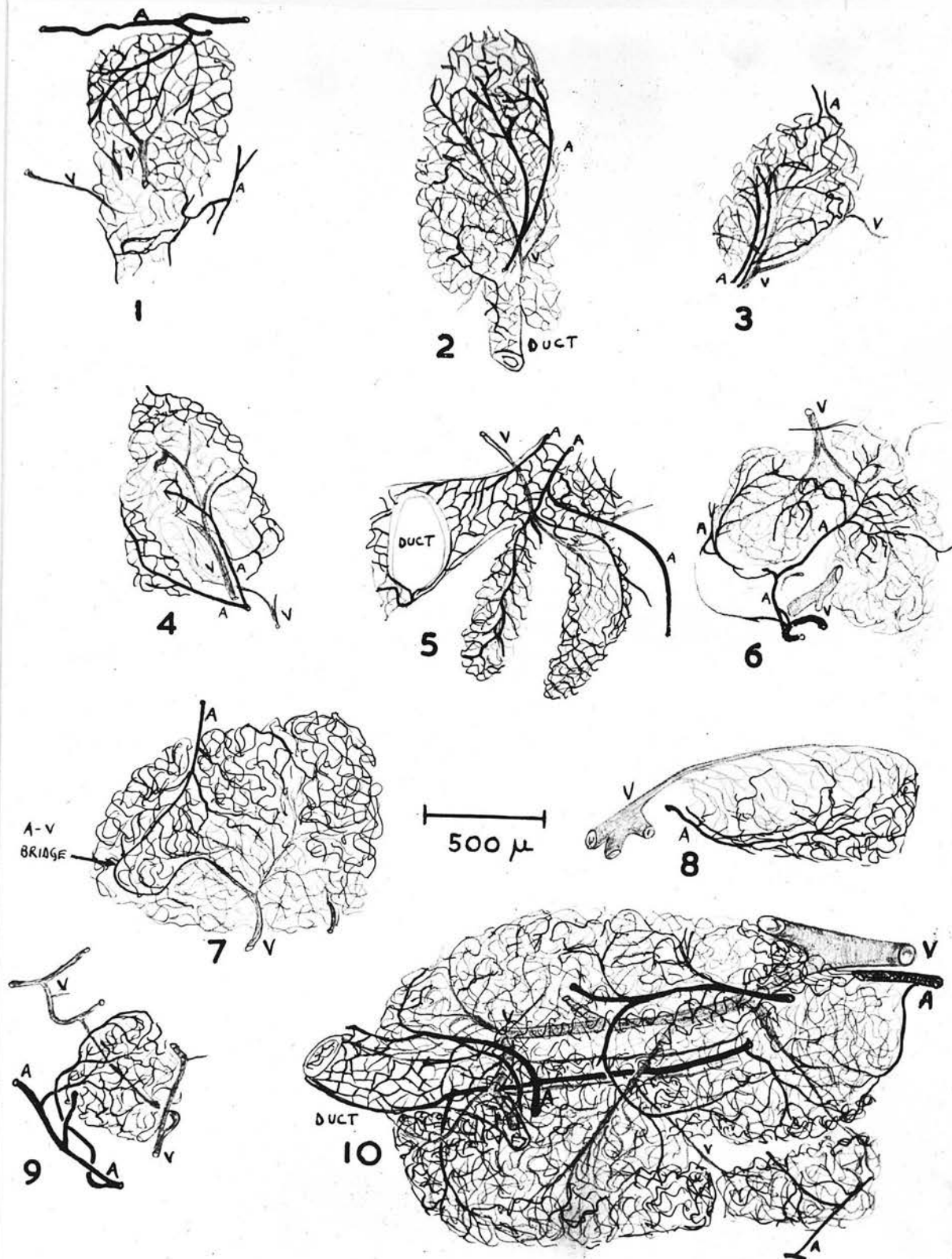

FIG.16. Diagrams of the different types of arrangement of the arterioles and venules supplying individual lobules (1-9) and a small lobe (10) seen in 150 μ sections of lactating mammary glands (cat) injected with different coloured media. Arterioles - black; venules - grey.

Photographs of the lobules Nos.4 and 6 are shown in Figs.17 and 18 respectively.

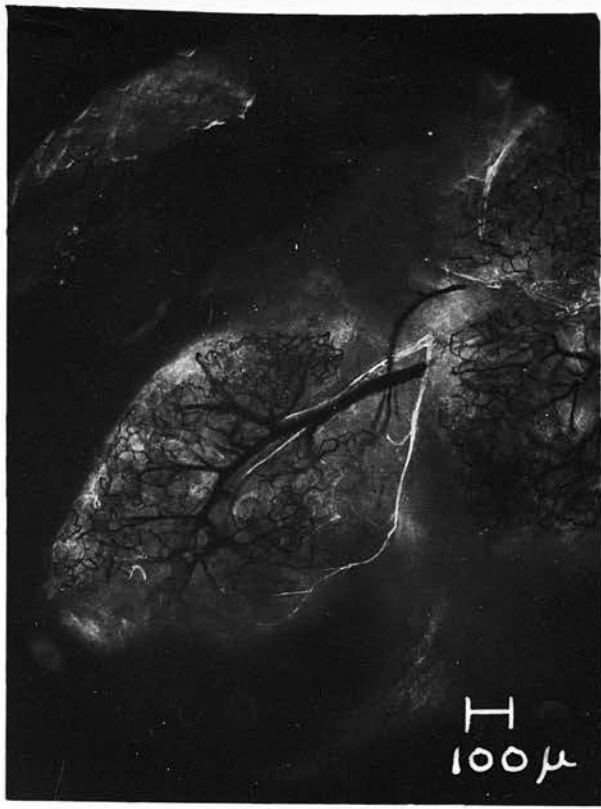

FIG. 17.

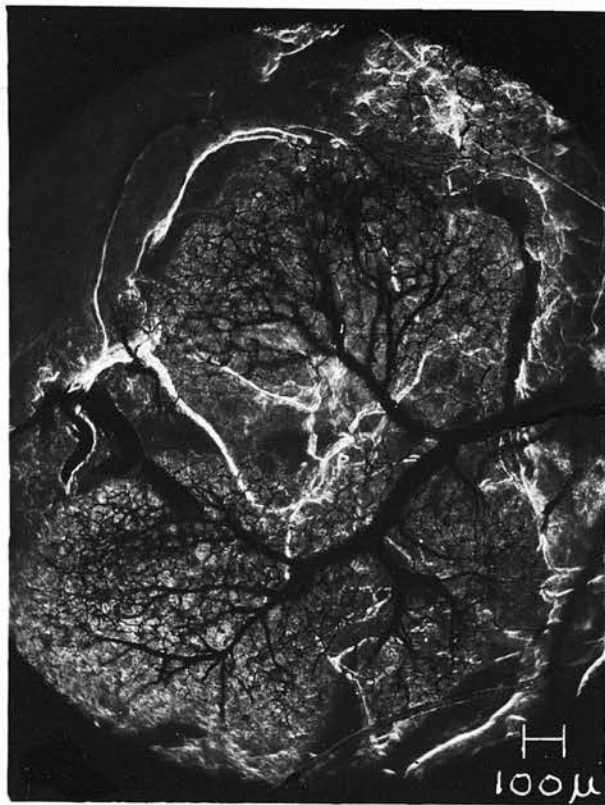

FIG. 18.

Photomicrographs from 150μ sections of lactating cat mammary glands, with arteries (red) and veins (blue) injected.

In these photographs arteries show up white and veins black.

Histological examination of the mammary blood vessels by routine smooth muscle stains showed their structure to be quite typical. Smooth muscle cells could not for certain be detected in arterioles smaller than 18μ and venules smaller than 75μ (paraffin sections). However in sections^{of} the same tissue stained by Romanes's (1950) silver method, a few muscle cells were clearly detected in interlobular venules as small as 45μ , and some circular smooth muscle cells were found to persist in arterioles of 12μ .

A distinctive arrangement of blood vessels was seen in two parts of the mammary glands studied:-

(a) Milk ducts. The smallest milk ducts within the lobules received their blood supply from the capillary network of the alveoli around them as also did the slighter larger ones between the lobules (i.e. draining them) (Fig.16). However, all milk ducts of 150μ in diameter or larger possessed a characteristic capillary network surrounding them, joined at intervals by arterioles and venules, of $20-40\mu$ (Figs.19, 21 and 22). This capillary network was continuous throughout the duct system of the gland, right up to the mouths of the ducts at the tip of the nipple, where it joined the dermal network giving rise to the capillary loops of the skin. The larger ducts and cisterns had an additional vascular network outside the capillaries formed by the supplying arterioles and venules ($20-40\mu$) (Fig.20).

(b) The teat. The blood vessels in the teat were also characteristic. The 3-6 primary milk ducts, embedded in an interlacing meshwork of smooth muscle bundles, form the core of the nipple through which long straight arteries ($20-30\mu$) pass, parallel to the ducts. These arteries branch little and supply the capillary beds around the ducts and in the dermis (Figs.22, 23, 27, 28 and 29). Larger thin walled tortuous veins ($50-120\mu$)

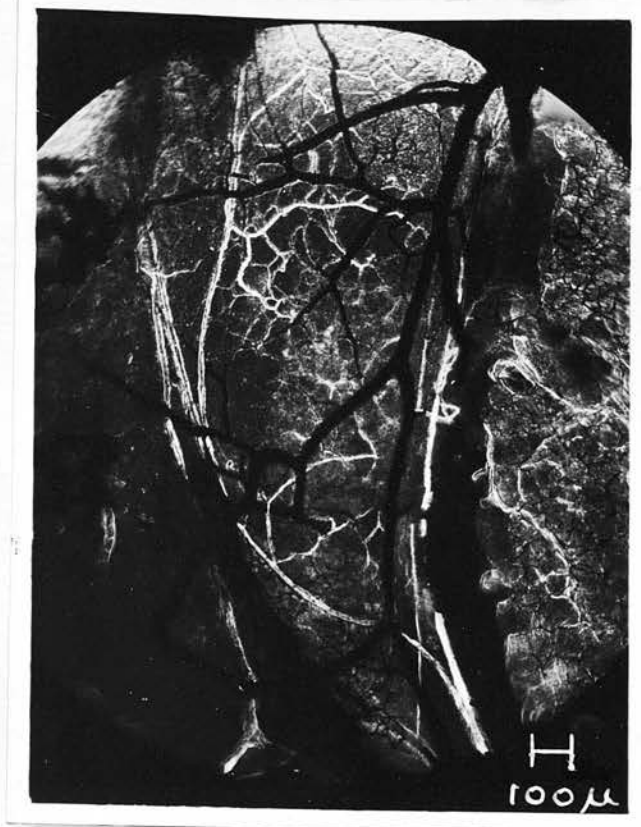

FIG. 19. - Large duct



FIG. 20. - Cisterns

Photomicrographs from 150μ sections of lactating cat mammary glands with arteries (red) and veins (blue) injected. In these photographs the arteries show up white and the veins black.

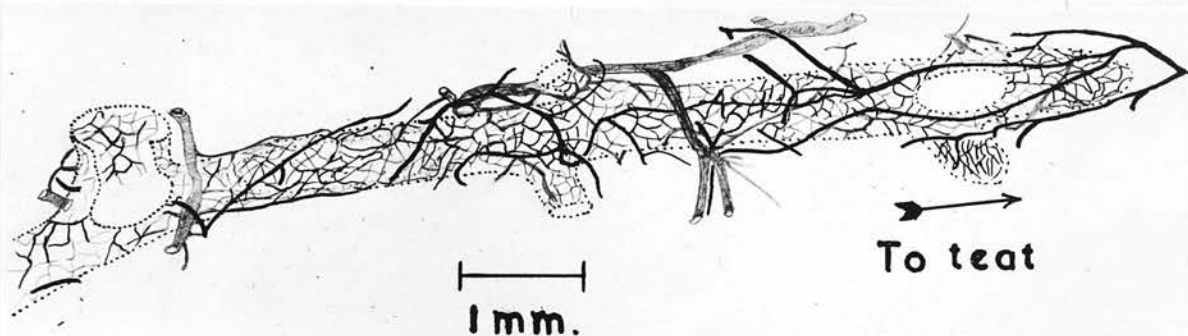

FIG. 21. Diagram of the blood vessels around a large duct as seen in a 150μ section of a lactating cat mammary gland. Arteries - black; veins - grey.

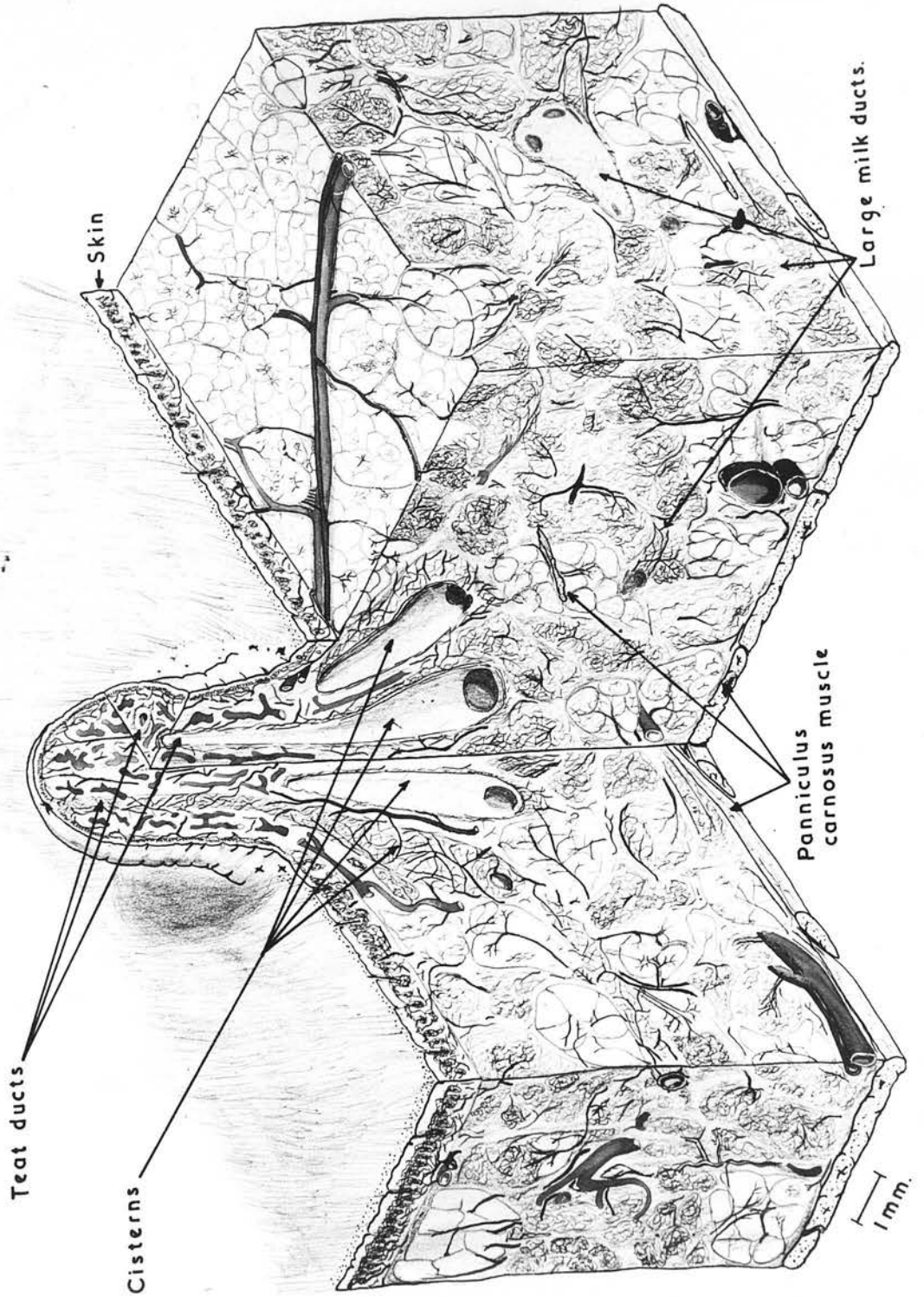

FIG. 22. Isometric diagram of the blood vessels in the lactating mammary gland of the cat as seen in dissections of injected tissue.

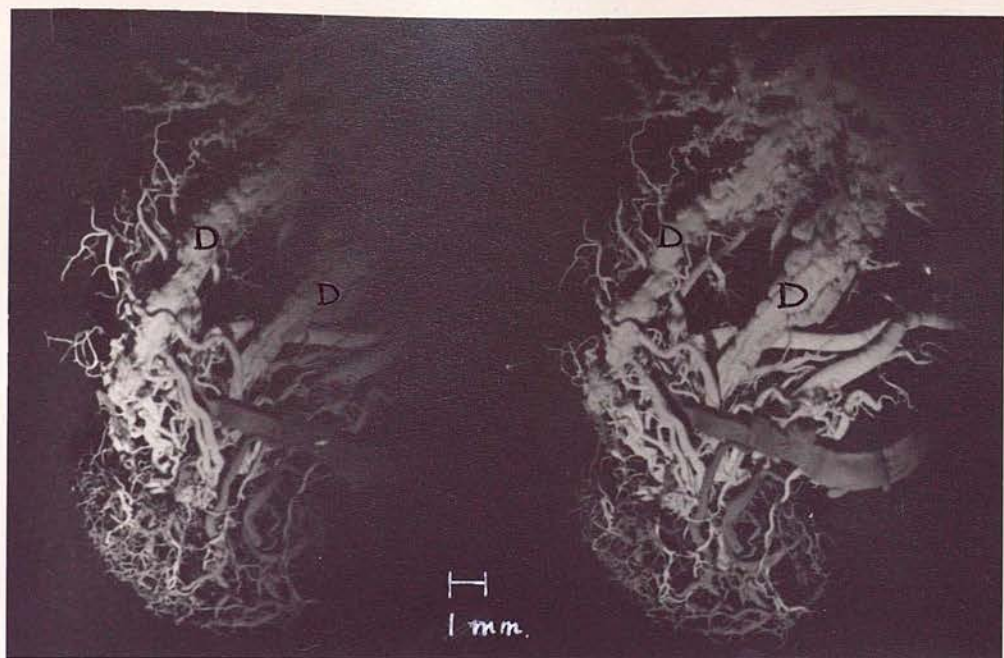

FIG. 23. Stereoscopic photograph of a Neoprene cast of the arteries (light), veins (dark) and 2 milk ducts (D) of the teat of a lactating dog.

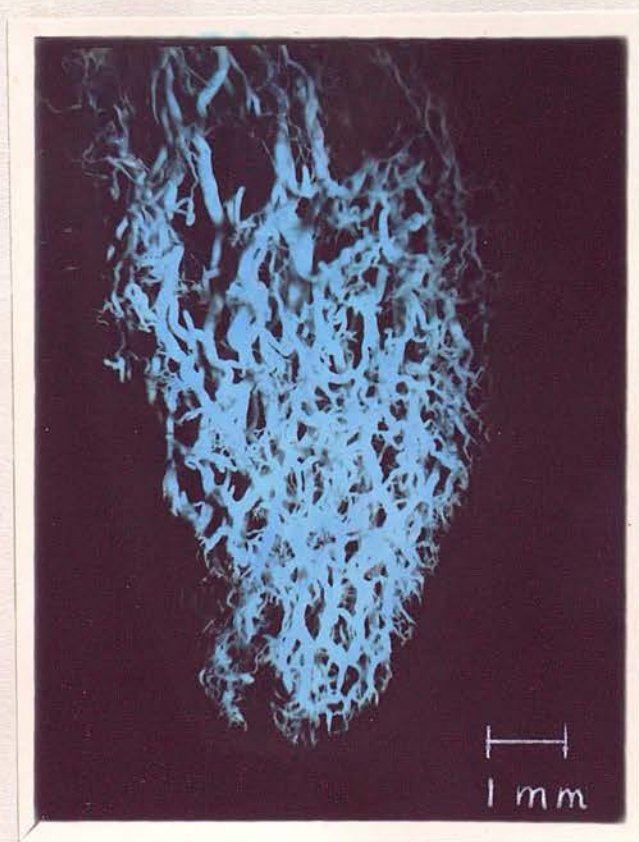

FIG. 24. Neoprene cast of veins in teat of a lactating cat.

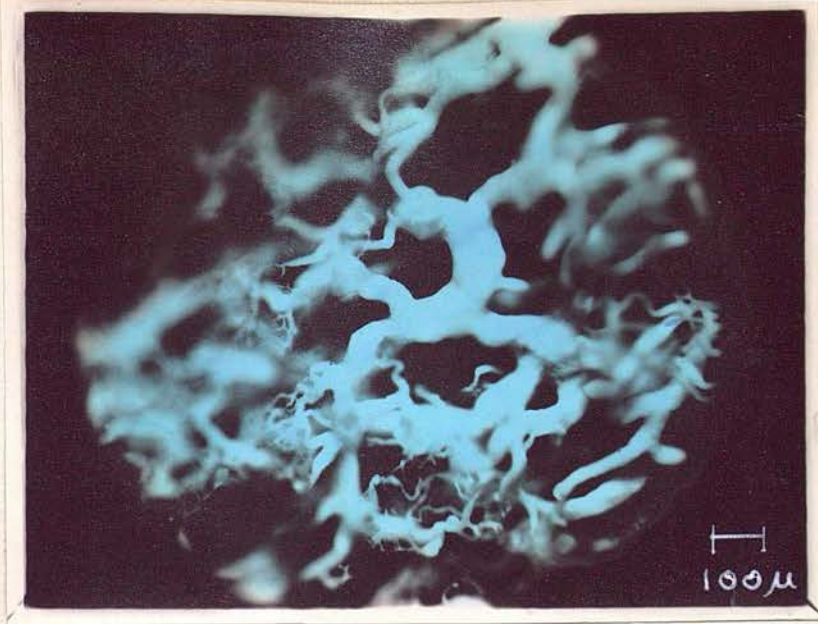

FIG.25. Photomicrograph of part of cast in Fig. 24.



FIG.26. Photomicrograph of part of cast in Fig.24.



FIG.27. Photomicrograph of 150 μ section of cat's teat with arteries injected with Indian ink.

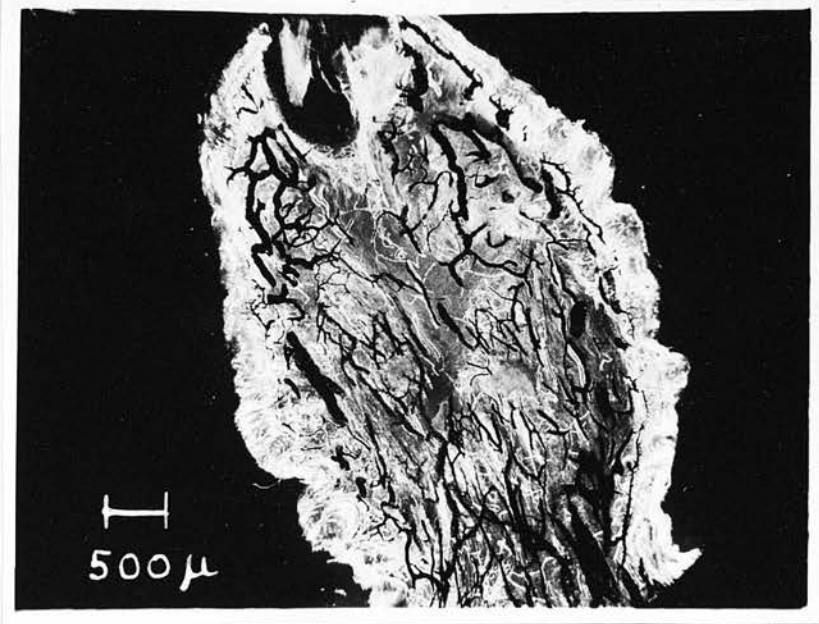

FIG. 28. Photomicrograph of 150 μ section of cat's teat with blood vessels injected. Arteries - white; veins - black.

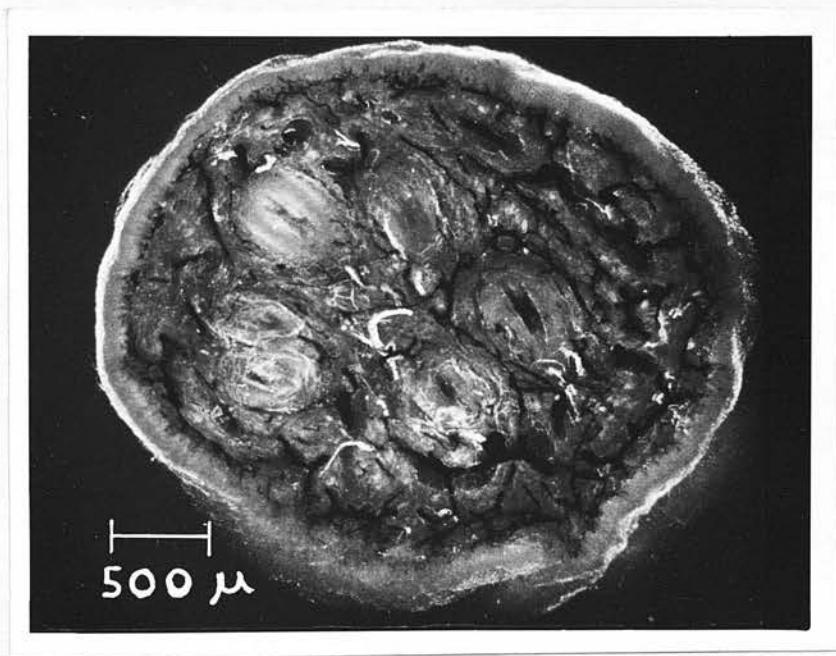

FIG. 29. Photomicrograph of 250 μ cross section of cat's teat, with blood vessels injected. Arteries - white; veins - black.

collect blood from the same sources and form a close network throughout the whole nipple (Figs. 22, 23, 24, 25, 26, 28 and 29). The teat vessels are supplied direct from large primary blood vessels entering the gland and it is probably for this reason as well as their size that it is much easier to inject the teat vessels with any medium than is the case with the gland proper. A similar venous network has been described for the teat of the cow by Furstenburg (1868), Riederer (1903) and Rubeli (1916).

Arterio-venous anastomoses

What might be considered arterio-venous anastomoses were seen between some arterioles and venules on the large ducts and cisterns in 6 sections from one gland of a cat (simultaneous injection of arteries and veins at 180 mm. Hg). These consisted of direct communicating vessels (20-40 μ) between arterioles (containing red injection medium) and venules (blue) (Fig. 30). However, in view of the fact that both arterioles and venules in these regions form part of a network, it is possible that the vessels described really joined two arterioles or two venules, which had become differently coloured by chance. In other parts of the same injected tissue the colours definitely met in the capillaries but some of the terminal duct venules were mauve in colour, so that this morphological evidence for the existence of arterio-venous anastomoses on the mammary milk ducts in this gland cannot be considered conclusive. It is hoped to reinvestigate this problem.

Much more commonly smaller direct pathways between the arterioles and venules were seen in many lobules and occasionally on the ducts. These vessels were 400-1,000 μ in length and in frozen sections mounted in Dammar measured 15 μ in diameter. They directly joined an arteriole and venule and were either straight or gently curved. Typical capillaries joined them

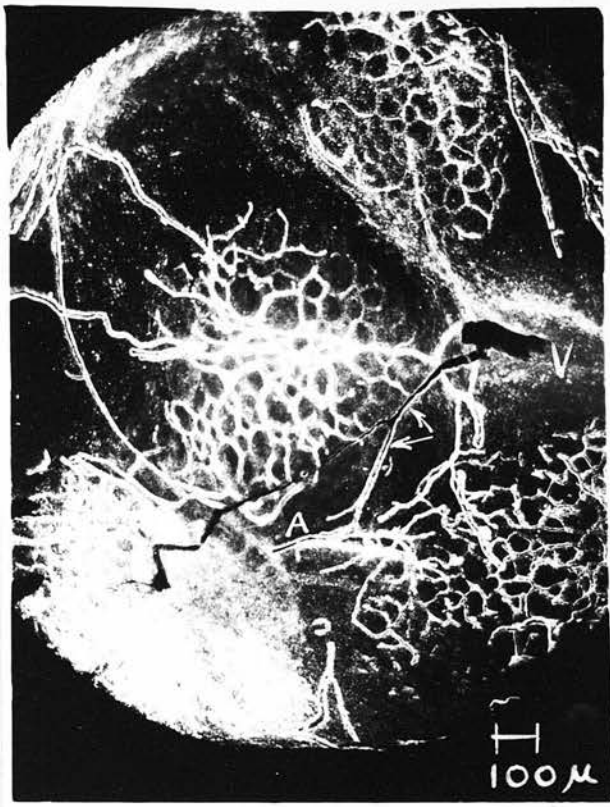

FIG. 30. Photomicrograph of lobules beside large duct (in section above this one). The venule (V) draining the lobule (bottom left) is apparently joined (\blacktriangleright) by an arteriole (A). Arterioles - white; venules - black.



FIG. 31. Arteriole-venular (\blacktriangleright) near wall of duct, forming a direct passage for blood between an arteriole (A) and venule (V).

(Fig.16, No.7; Fig.31). It is probable that they correspond to the arteriole-venular bridge described by Zweifach (1939) in the mesentery of the mouse and frog. He suggested that these structures carried most of the blood passing through the area when the tissue was inactive.

Discussion

Unlike any other organ the mammary glands develop in the adult animal by growing into their surrounding tissues (fat and subcutaneous connective tissue). The invaded tissues already have a complicated multiple blood and nerve supply so that to a great extent the mammary glands take over the existing vascular and nervous structure. The studies of Wahl (1915) show that the capillaries around the growing ends of the ducts become enlarged and as is well known in areas having a great blood flow, some capillaries become differentiated into arterioles and venules, whilst retaining the basic characteristics of the vascular pattern of the area (Dabelow, 1933).

In the fully formed organ of the cat and dog, with which this work has been concerned, the large blood vessels are revealed as forming an anastomosing network throughout the tissue, from which the smaller vessels leave to wander between the lobes at random. The terminal arterioles and venules enter the lobules from almost every direction, to join the capillary network around the alveoli. The smaller arterioles and venules do not lie close together, but travel in the same general direction, and it is only the small arteries and veins (i.e. those that can just be seen with the naked eye) that lie side by side.

In theory, the nerve supply to any organ might comprise secretory, motor, sensory and vasomotor components. The mammary

glands lying in the subcutaneous tissues have been shown to be innervated by the cutaneous nerves and it has to be determined what types of nerve fibres they carry to the glands. The anatomical studies reviewed and described in this section show that there is an extensive sensory innervation of the teat and that its smooth muscle and that in the areola receive motor fibres. However, the only nerve fibres that have been detected in the gland proper have been the nerves accompanying the arteries and arterioles, and the report of Arnstein (1895) that there are secretory nerve endings on the mammary cells has not been confirmed.

The remainder of this thesis deals with physiological studies of the blood flow through the mammary glands and its control by vasomotor nerves and other means, and some observations on structure and function of the muscular tissue of the glands.

Summary of Section I

1. The gross blood and nerve supply to the mammary glands of the dog and cat are described and compared with that of the rabbit, rat, mouse and guinea pig.

2. The mammary blood supply is derived mainly from the external pudendal, lateral thoracic and internal thoracic vessels, but the network of vessels within the glands is joined by many other smaller sources of supply.

3. The mammary glands are innervated by the lateral cutaneous branches of the spinal nerves.

4. The arrangement of the vessels within the glands of the cat and dog in the lactating state has been described. This includes a description of the different methods whereby individual lobules are supplied with blood, and accounts of the vascular

networks around the milk ducts and within the teats.

5. Histological investigations have revealed sensory nerve endings in the teat and nerves to the smooth muscle, but in the gland proper only fine nerve fibres accompanying the arterioles.

SECTION II

VASOMOTOR NERVES TO THE MAMMARY GLANDS

The physiological experiments described here provide evidence of the extent and type of vasomotor innervation of the mammary vessels. The latter's reaction to drugs and other vascular phenomena are also discussed.

Methods

Animals used

Some preliminary experiments were carried out in an attempt to demonstrate vasomotor nerves to the mammary glands of the rabbit, guinea pig and rat, but these were inconclusive because the responses obtained were only equal to the experimental error of the apparatus available. For this reason the cat was chosen as the main experimental animal. It was not possible to obtain sufficient numbers of dogs or goats, which were generally more suitable than cats.

Pregnant cats were selected by abdominal palpation (possible from the 3rd week of the gestation period) from all the female animals entering the laboratory, and used at various stages after parturition (1-73 days. Mean \pm S.D. 16 ± 14). A smaller number of cats which arrived with kittens or just after weaning were also used. Nine dogs were obtained; one lactating at the end of pseudo-pregnancy and eight just after weaning (2-7 days) their puppies following a normal lactation of 6-8 weeks. Two milking goats were used, one was suckling a kid aged 15 days, and the other, at an unknown stage of lactation, was milked by hand.

Anaesthesia

To avoid undue excitement, the cats were anaesthetised before being separated from their kittens. The anaesthetic,

which was injected into the right cephalic vein in the cat and dog and into the external jugular in the goat, was one of the following: (a) 6.45% pentobarbitone in 10% alcohol (Nembutal, Abbott); (b) 2% chloralose in normal saline; (c) pentobarbitone induction followed by 20% urethane in normal saline; (d) a mixture of 3.3% chloralose and 33% urethane in normal saline. By this method the dosage required to induce deep anaesthesia varies with the condition of the animal and the rate of injection (the first two thirds of the computed dose was injected quickly to avoid the stage of excitement in light narcosis and the rest very slowly, taking 10-15 min. in all), and the dosage used in these experiments was:-

Pentobarbitone -	Cat	31.8 \pm 13.3 mg./kg.
	Dog	33.9 \pm 4.5 mg./kg.
Chloralose -	Cat	95.9 \pm 15.2 mg./kg.
	Dog	108.5, 122.5, 109.5 mg./kg. (only used thrice)
	Goat	86.9 mg./kg.
Chloralose and urethane	Cat	61.7 \pm 11.3 and 617 \pm 113 mg./kg.
	Dog	58.2, 54.2, 65.0 and 582, 542, 650 mg./kg. (only used thrice)
	Goat	44.6 and 446 mg./kg. (only used once)

The vasomotor effects of the anaesthetics employed are given in Table II, where it will be seen that chloralose is constrictor and urethane and pentobarbitone dilator of the mammary vessels when injected intra-arterially in single doses. On this evidence the mixture of chloralose and urethane would, in theory, be a suitable anaesthetic for studying vasomotor responses. Other advantages which led to its being used more than the other anaesthetics were (a) it did not possess the property of chloralose of inducing extreme hyperaesthesia; (b) it was not such a powerful depressant of the respiratory centre as pentobarbitone; and (c) it was long lasting, so that the inducing dose was sufficient for an experiment lasting up to 12 hours.

General preparation of the animal for all experiments. After anaesthetisation, cats were suspended in a canvas sling by which they were partially submerged in a bath of Ringer solution at 37°C. and tracheal and venous cannulae were then inserted. Under these conditions the majority of animals that were good surgical risks lived 9 hours and several had to be destroyed after surviving 12 hours. Owing to the small numbers available, saline baths were not constructed to hold dogs and goats. These animals were kept warm on the usual electrically heated operating table, which, although less efficient than the saline bath, was adequate for the purpose. Further preparation depended upon the type of experiment to be made, but the long survival time of the animals frequently allowed more than one type to be carried out.

Histological methods

At the end of all perfusion experiments and of many others the tissue was immediately placed in a fixative (10% formol saline, Carnoy or acetic-formol-alcohol), together with another gland, generally the opposite one, which was used as a control. Both pieces of tissue were subsequently carried through together. As a routine, sections (10 μ) were cut from paraffin blocks and stained with Haematoxylin and Eosin, Van Gieson (Marshall, 1946), and by the "Haurab" method of Marshall and Trowell (1943). For special purposes blood vessels were stained in some formalin fixed tissue (frozen sections) by Pickworth's method (1934), and nerves by Romanes's (1950) method.

Perfusion of the isolated mammary gland

This was based on the method of Richards and Plant (1916), in which a pump was placed in series with the animal and the mammary gland, using the animal's own arterial blood as the perfusate (see Fig.32). It was adopted in an effort to overcome

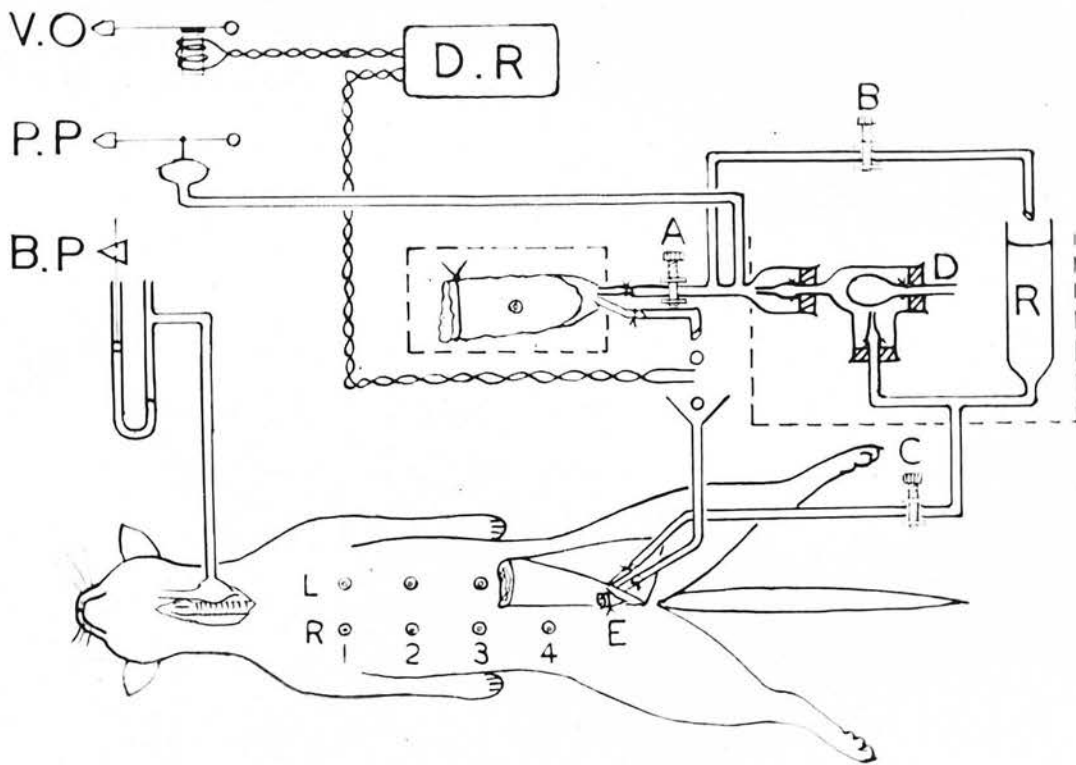

in perfusion
 FIG. 32. Diagram of apparatus used by Richards and Plant's ~~perfusion~~ method, indicating perfusion of inguinal mammary gland, L 4.

- B.P. - Blood pressure recorder from carotid artery.
- V.O. - Venous outflow recorder.
- D.R. - Drop recorder.
- P.P. - Perfusion pressure recorder.
- E. - Stump of external pudendal vessels.
- D. - Rubber pulsator connected to Dale-Schuster pump (not shown).
- R. - Blood reservoir.
- A, B and C - Screw clips (see text).

The dotted lines indicate the parts enclosed in warmed chambers.

the objections to the methods dispensing with the animal (Petersen, Shaw and Visscher, 1941; Peeters and Massart, 1947 b), in which it is difficult to provide, in the correct quantities, the milk precursors and hormones, etc. required by the active mammary gland. Since vasoconstriction occurred in the gland as a result of the trauma associated with dissection, it seemed preferable to use a pump giving nearly constant volume output over a wide range of pressure. For this purpose a Dale-Schuster pump with valves and pump chamber of reduced size was employed. It had a capacity of about 30 c.c. (including connections), and could be readily adjusted to deliver less than 1 c.c. of blood per min. There was the disadvantage that, as is shown in Fig.33, the output diminished by 0.2 c.c. per 10 mm. Hg rise in pressure. In this, however, it was more efficient than the other constant volume output pumps designed for a similar purpose, which were tested. Thus one of a similar design to that used by Gaddum, Peart and Vogt (1949) showed a fall in output of 0.4 c.c. for each 10 mm. Hg rise in pressure, while a simple pump activated by a piston made from a ground-glass syringe (see Brodie, 1903) was even less efficient. The effect of this factor could be assessed in the analysis of the experiments by reference to the calibration shown in Fig.33, or by the simultaneous measurement of the venous outflow during perfusion.

The further preparation of the animal for perfusion consisted of dissecting one of the inguinal mammary glands (R or L IV) free from all its surrounding structures, including skin, and leaving it in contact with the animal by only the external pudendal vessels and lymphatics, and the anastomotic vessels reaching it through the penultimate gland 3 (see Figs.1 and 5). After the administration of heparin (1,000 I.U. per kg.), the

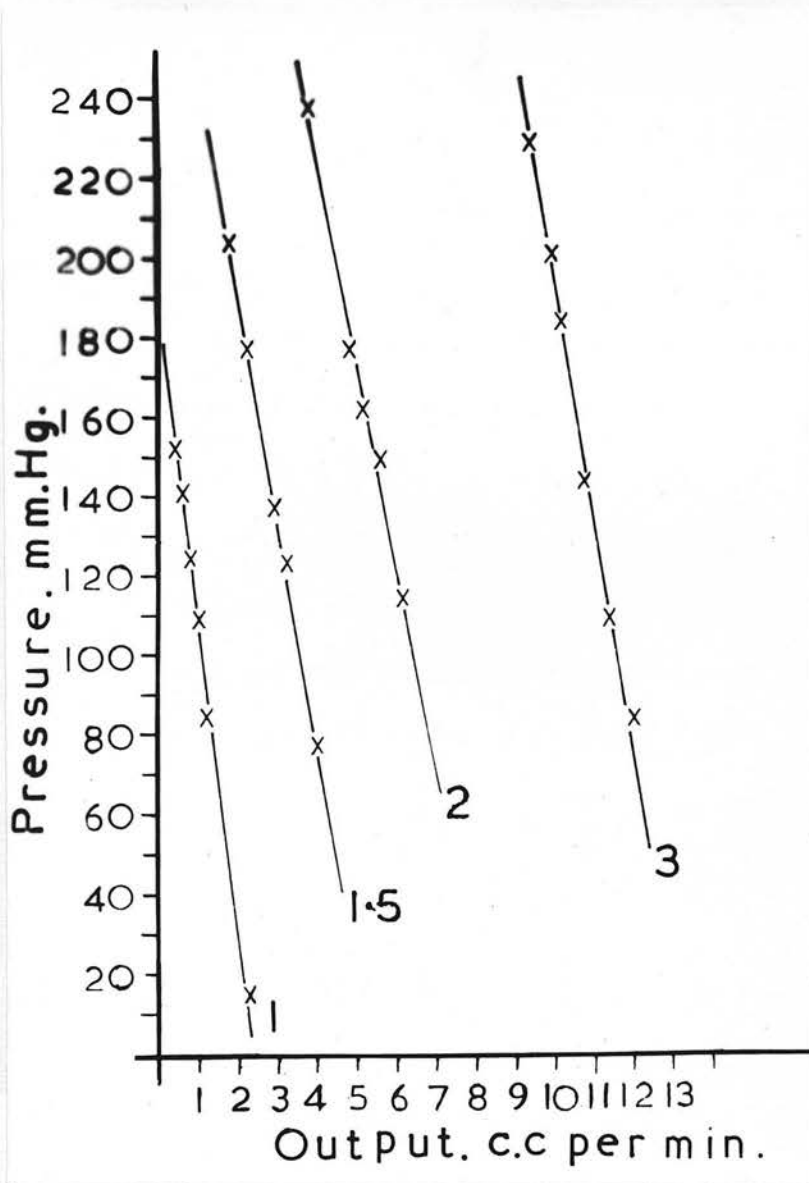

FIG. 33. Calibration of perfusion apparatus used showing the fall in output with the rise in peripheral resistance. The arabic numerals by each graph refer to the stroke calibrations on the Dale-Schuster pump.

carotid blood pressure record was started. The left femoral artery and vein were then cannulated for the respective purposes of supplying blood to the pump reservoir (R) and receiving it back again from the perfused gland. The reservoir and pump were then filled with blood from the animal, whilst blood or 6.5 per cent. gum Ringer was injected intravenously to maintain the blood volume, Heparin (100 I.U.) was placed in the reservoir before filling, and liquid paraffin was used to diminish the loss of gases from the surface of the blood. The external pudendal vessels were then cannulated, care being taken not to ligate the lymphatics, which otherwise became quickly distended. During this procedure the anastomotic vessels were still intact, but immediately afterwards they were quickly ligated and severed and the gland transferred to the gland chamber. The cannulated artery was connected to the pump and perfusion begun. The period during which the tissue was completely without a blood supply, that is before the circulation was re-established, was 3 to 5 minutes. At the outset the stroke volume of the pump was minimal, and it was gradually increased until the perfusion pressure was about 120 mm. Hg. For 15 to 20 minutes thereafter the organ was left undisturbed in its warm chamber, and was kept moist throughout the experiment by a covering of cotton wool saturated with Ringer solution. In a few experiments glands 3 and 4 were perfused together in this way, since the blood-supply to gland 3 from the external pudendal artery is sufficient for this purpose.

Sources of error - Certain irregularities in the pressure tracing were found to be related to artefacts arising from the method itself. The factors thought to be concerned were:-

(a) Fibrin formation - This was frequently found upon microscopical examination of the blood in the perfusion system in early cat experiments, in spite of the liberal use of heparin,

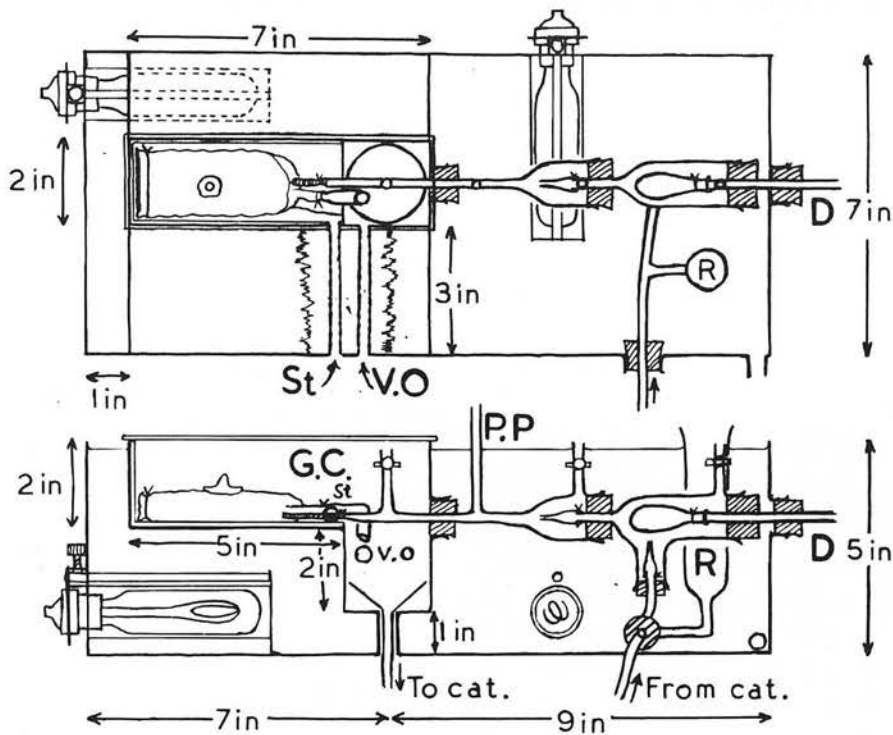

FIG. 34. Scale diagram of improved water bath enclosing gland chamber and the perfusion pump. The tank is made of copper and heated by two 16 candle-power carbon filament lamps. The thermoregulator (mercury-toluene) is not shown.

- G.C. - Gland chamber, lined and covered with Perspex and filled with air but surrounded on all sides by water at 38.5°C. Blood from the pump enters via tubing passing through a sealing bung and the blood leaving the gland is caught in a funnel passing through the bottom of the gland chamber and the tank, to return to the cat.
- St and V.O. - Metal tubes joining the gland chamber to the outside, used for inserting stimulating electrodes and electrodes recording venous outflow respectively.
- D. - Tube from rubber pulsator passing through the tank to a Dale-Schuster pump (not shown).
- R. - Blood reservoir.
- P.P. - Tube to manometer recording perfusion pressure.

The sensitivity of the mammary blood vessels to cold was further confirmed in one experiment on a cat, in which the water was let out of the improved water bath during perfusion and replaced by cold. As the temperature in the gland chamber fell to 25°C., the perfusion pressure steadily rose from 62 to 87 mm. Hg (43.2 per cent.), and the venous outflow decreased from 0.67 to 0.28 c.c./min. (58.2 per cent.), and some pressure irregularities were also seen. Upon replacing the cold water by water at 39°C. these changes were reversed, the perfusion pressure falling to 50 mm. Hg. and the venous outflow increasing to 0.9 c.c./min.

(c) Blood sedimentation - This occurred in the pump and tubing leading to the gland in a high proportion of experiments and estimation of the blood sedimentation rate in standard Westergreen tubes confirmed the great variation encountered in these lactating cats (0.5 - 135 mm./hour). When the flow was slow, high B.S.R. was accompanied by the formation of large clumps of corpuscles, both in the perfusion tubing and within the cat's skin blood vessels. In both cases it was reminiscent of the "sludging" of blood described by Knisely, Elliott and Bloch (1945). This was ^{also} observed in apparently healthy non-lactating adult cats of both sexes, in vessels where the flow was slow, and, since many perfusion experiments were encountered in which the perfusion pressure was quite steady and yet the blood was sedimenting and clumping to a marked degree, it was concluded that this factor was not concerned with the irregularities. No sedimentation was seen in the dog experiments, in which the B.S.R. was 0.0 - 0.5 mm./hr., but which nevertheless did show some spontaneous perfusion pressure changes.

(d) Mechanical - The mammary gland is in anastomotic connection with all contiguous tissue and after dissection,

which was carried out before giving heparin, it was left covered with numerous ligatures encircling the many cut vessels, in which, presumably, clots were also formed. Although the great irregularities in the perfusion pressure were eliminated, occasional sudden changes were seen in some experiments. It is felt that these were due to the slipping of either clot or ligature in one or more of the severed vessels. Such changes were abrupt and easily distinguished from biological responses; they decreased in number as the technique of dissection improved with practice. It is also possible to obtain a partial obstruction to the blood flow due to ill positioning of the gland in relation to the arterial and venous cannulae within the gland chamber. This may only manifest itself by an increase in the number of the abrupt changes described above, which cease when the arrangement of the gland is altered. This factor is particularly true of the very small gland of the cat. Further, by the addition of a shunt to the outflow of the pump (screw clip A in Fig.32 closed and B adjusted to bring the P.P. to its previous value) it was possible to show that the irregularities were not related to mechanical errors in the pump itself.

It is considered that of the factors discussed as possibly leading to artefacts, the most important have been fibrin formation and the effects of cooling of the perfusate.

General results of perfusion - Depending upon the survival of the animal, perfusion was continued for 1 to 6 hours, the tissue being considered "alive" as long as responses could still be obtained, and the arterio-venous difference in the colour of the blood gave evidence of active tissue respiration. The experiments were frequently stopped because of the death of the animal, at which stage the perfused gland was still

viable on the above criteria. In one experiment on a dog, after perfusing for 6.3 hours using an artificial oxygenator (the dog having died after a perfusion of 2 hours), the gland was stored overnight at $-4^{\circ}\text{C}.$, and upon perfusing again 15 hours later, responses to drugs (vasoconstriction to adrenaline and the ejection of milk with oxytocin) were still obtained.

Some milk secretion apparently continued during perfusion. This was suggested by the fact that if all the preformed milk was expelled from the ducts and alveoli with oxytocin at the beginning of perfusion, more milk was ejected from the gland if oxytocin were given again after a sufficiently long interval (1 hour). It is well known that oxytocin has no action on the milk flow if repeated soon after a first dose, because there is little or no milk left to be ejected (see section IV, part II). The positive response after 1 hour indicated that some milk had probably been secreted during this time.

Macro- and microscopical examination of the perfused tissue was carried out using the opposite unperfused gland as a control. In general the only pathological lesions demonstrable by a variety of staining methods were interlobular oedema and distension of the perivascular lymphatics, particularly if the main efferent lymphatics were accidentally tied during cannulation of the external pudendal vessels. Sections from glands, which for a variety of reasons (usually fibrin embolism) were perfusion failures, showed in addition interalveolar congestion and even haemorrhage.

The chief criticism of the method was that the blood flow was probably low. This was suggested by the following considerations:-

(1) Cannulation of either the main artery or vein appeared to decrease the blood flow, irrespective of whether this entailed perfusion. Thus the mean blood flow through the perfused glands in these experiments was 3.6 ± 1.2 c.c./100 g./min. in the dog and 2.5 ± 1.0 in the cat (maximum flows 4.6 ± 1.54 and 3.33 ± 2.5 respectively). An equally low flow was recorded when the venous outflow was measured with a cannula (2 ± 1 c.c./g./min. However, indirect blood flow measurements by Brodie's plethysmographic method (clamping the vein for 5 sec. and measuring the increase in gland volume/^{Fig.41}) gave much high figures. Although there was also some tendency for the flow to fall during the experiments, the average figures were 19.5 ± 16 c.c./100 g./min. (maximum flows 23.8 ± 10.4).

(2) The number of capillaries open at the end of perfusion was determined by injecting a small quantity of Indian ink intrarterially immediately before stopping the pump, or by staining sections by Pickworth's (1934) benzidine method. Comparison with sections from glands that had been totally injected with Indian ink revealed that only about half the total number of capillaries were open (Figs.35, 36 and 37).

(3) The amount of blood left in the organ at the end of perfusion was determined by washing through the gland with a known amount of saline and comparing photoelectrically the amount of haemoglobin collected in the saline with that in an equal volume of saline to which a known amount of the same blood had been added. It was found to be only about 30 per cent. of the total capacity of the gland, as estimated by the volume of a complete Neoprene cast of the vessels (made at 200 mm. Hg. injection pressure).

Plethysmography and blood-flow measurements

These experiments were confined to a study of glands 4 or

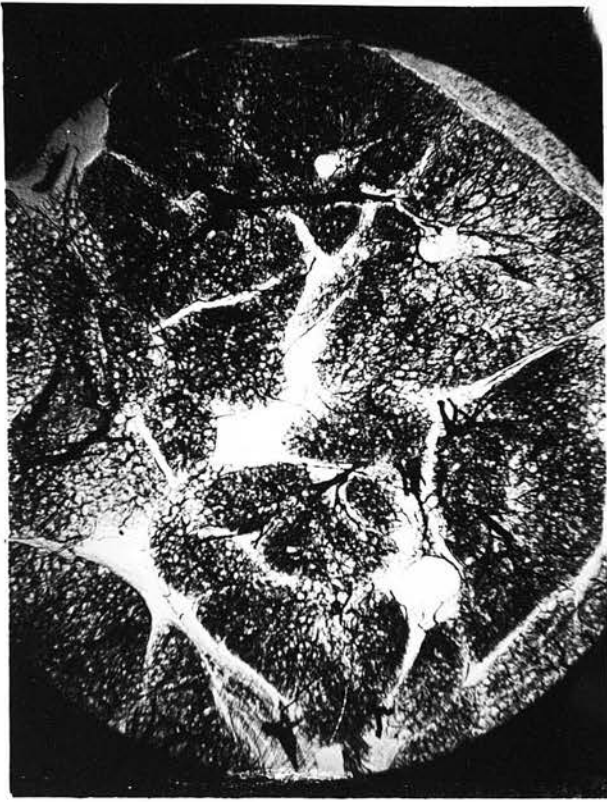

FIG. 35. Mammary tissue with blood vessels completely injected with Indian ink. ($\times 15.5$)

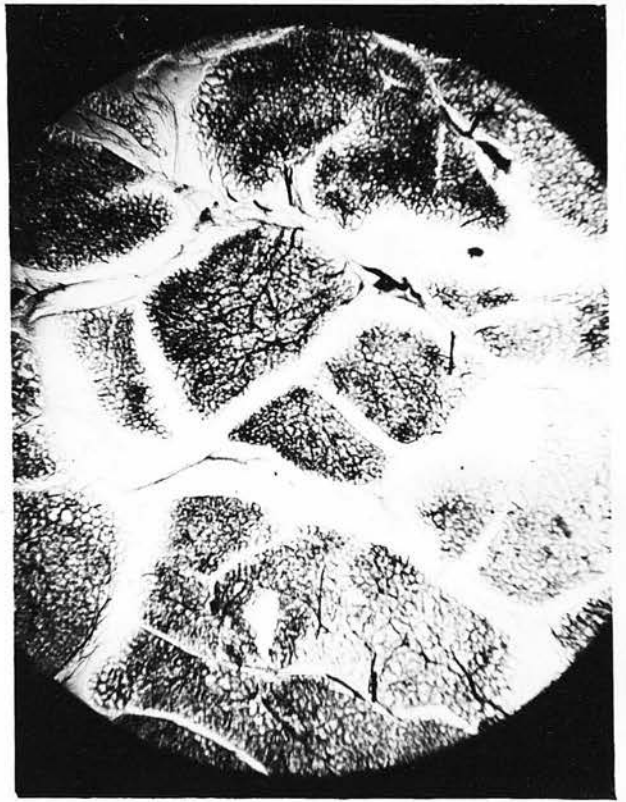

FIG. 36. Mammary tissue in which Indian ink was injected with the perfusate just before ending perfusion. ($\times 15.5$)

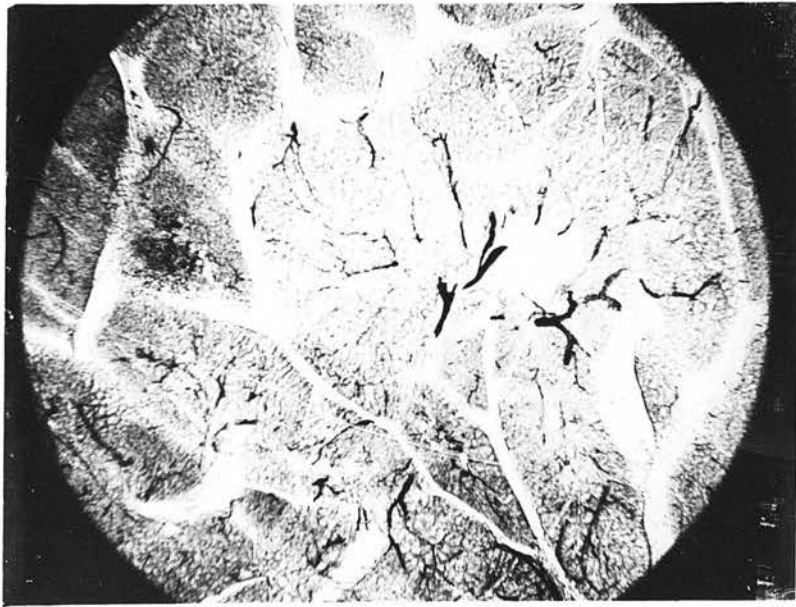

FIG. 37. Perfused mammary tissue stained by Pickworth's (1934) benzidine method. ($\times 15.5$)

3 and 4 together, which were completely isolated from all surrounding structures and left connected to the cat by only the external pudendal vessels and lymphatics. The separated tissue was then enclosed in a plethysmograph of 30-40 c.c. capacity for gland volume recording, and this was connected to a Brodie volume recorder (3.c.c. capacity). It was possible to record gland volume changes of 0.01 - 0.02 c.c. by using a smaller version of the free swing lever described by Afford (1948), weighing only 100 mg. The blood flow was measured by cannulating the external pudendal vein and recording the venous outflow with a drop recorder (designed by Professor A.E.Ritchie). In both types of experiments the general systemic blood pressure was recorded with a mercury or small membrane manometer.

When attempts were made to record mammary gland volume and the venous outflow simultaneously, it was found that this was unsuccessful because of the passive shrinkage in gland volume which occurred when the external pudendal vein was opened for cannulation (venous pressure about 4-5 cm. blood). (Fig.41). Presumably there was then less blood in the organ to be squeezed out by an active vasoconstriction, and so the response to nerve stimulation was smaller than when the vein was intact. Later it was found in one experiment that if the animal were placed prone instead of supine, so that the gland hung down below the abdomen in approximately the normal position, opening the vein did not induce this passive shrinkage of the gland, and the vasoconstrictor effect of nerve stimulation could still be effectively demonstrated.

The microscopical examination of living blood vessels

For these experiments the tissue was quickly exposed with a minimum of dissection, and prevented from drying and cooling by a constant stream of 1 per cent. gelatin in Ringer at 38.5°C.

TABLE I. - RESPONSES TO NERVE STIMULATION

Numbers of positive responses to stimulation of various spinal nerves.

Type of experiment	Species	Vasoconstriction	Vasodilatation
Perfusion	Cat	115	(16) 2 (1)
	Dog	104	(7)
Plethysmography ..	Cat	212	(22) 20 (3)
	Dog	13	(1)
Blood flow measurement	Cat	16	(5)
Microscopy	Cat	50	(7)
Total	Cat	393	22
	Dog	117	..

The numbers in brackets refer to the number of experiments involved.

(see Zweifach, 1948). Indirect cool illumination was used after the quartz rod technique of Knisely (1934, 1936), but using instead a polished Perspex rod ($\frac{1}{2}$ inch diam.) opposite a hole of similar size in the lamp-house. The rod was cut at 45° at the tissue end to focus the light, which was thus reflected through its convex side. A 100-W. bulb was sufficient for magnifications up to 50 times, but a 750-W. Photoflood bulb No.1 was used for photography.

General

Nerve stimulation. - This was carried out in the majority of experiments with the Ritchie-Sneath square wave stimulator, Multitone (Ritchie, 1944), with which one can independently vary the voltage, frequency and pulse length. An induction coil was occasionally used for comparison with the electronic stimulator.

Drugs. - These were made up in Ringer or normal saline, and when injected into the gland intra-arterially, the volume of fluid was kept at 0.1 c.c.

Results

Stimulation of the distal cut end of the external spermatic nerve usually caused vasoconstriction (see Table I). In the case of the intact mammary gland in situ this was evidenced by a diminution in gland volume of 5.3 per cent. or less (average about 1 per cent.), persisting for 0.5 to 7 minutes, together with a simultaneous decrease in the venous outflow of 10-100 per cent. (Figs. 38, 39 and 40). These responses were observed in both cats and dogs and were unaccompanied by any change in general blood pressure. Results from perfusion experiments confirmed these findings. Thus nerve stimulation produced a rise in perfusion pressure of up to 37 per cent. of the mean resting value (average about 9 per cent.) in cats, and up to 59 per cent. (average about 20 per cent.) in dogs, lasting 0.5

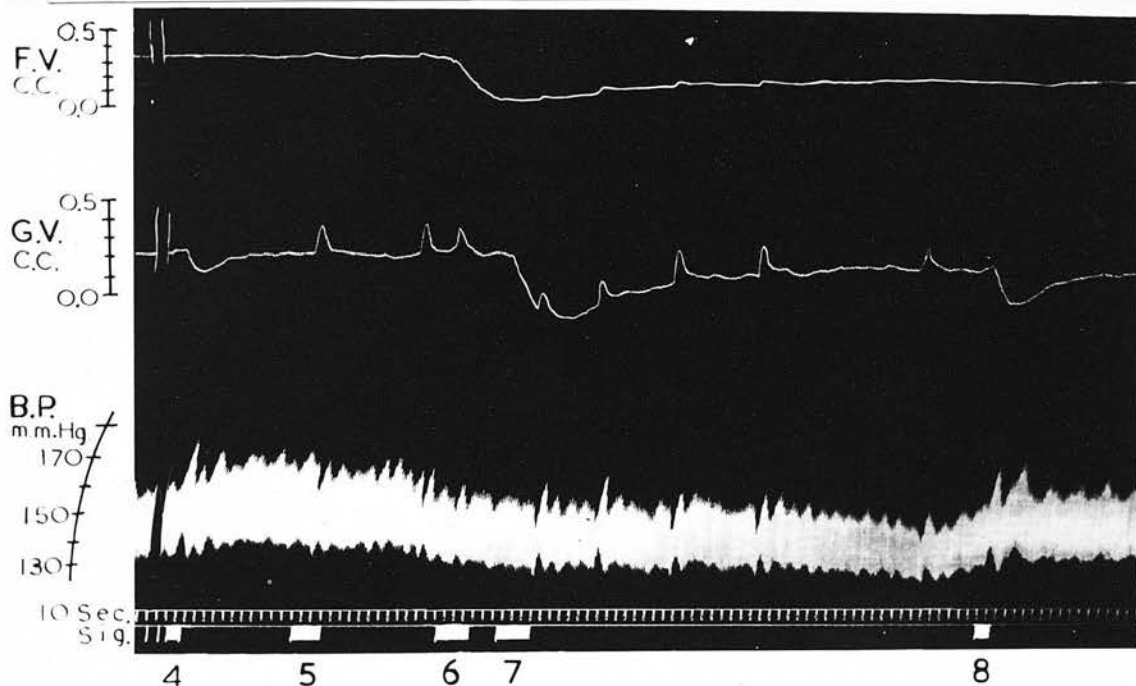
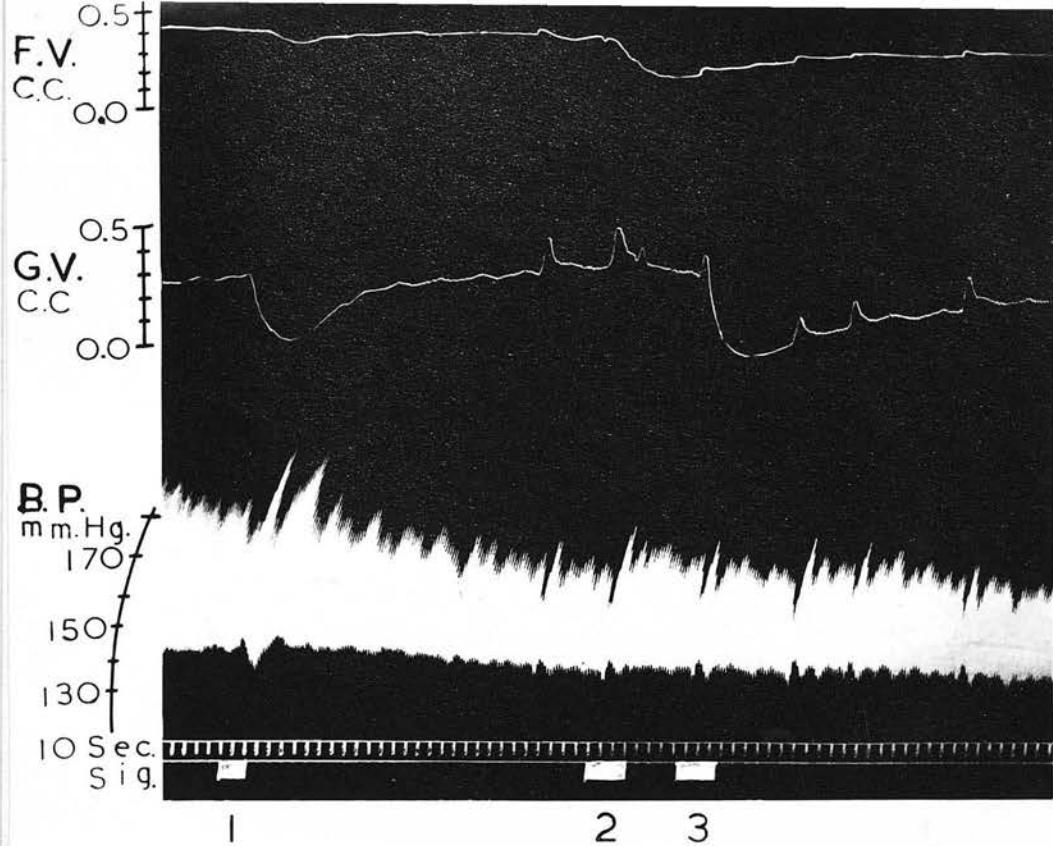

FIG. 38. Expt. C 39. Cat. 2.77 kg. Lactating 3 days. Pentobarbitone anaesthesia. Left inguinal fat and R 4 in plethysmographs at 11.10 and 1.00 p.m. resp. Fat volume 11 c.c. (F.V.). Gland volume 19.5 c.c. (G.V.). B.P. membrane manometer. Cat supine.

- 1 - 3.32 p.m. Adrenaline 1 μ g. intravenously.
- 2 - 3.37 " Stimulation of distal cut end of external spermatic nerve 10/50/1/30. Left side.
- 3 - 3.38 " Ditto - Right side.
- 4 - 3.54 " Adrenaline 0.1 μ g. intravenously.
- 5 - 3.56 " Tannic acid 2.5 mg. intravenously.
- 6 - 3.58 " Stimulation left 10/50/1/30.
- 7 - 3.59 " " right "
- 8 - 4.08 " Adrenaline 0.1 μ g. intravenously.

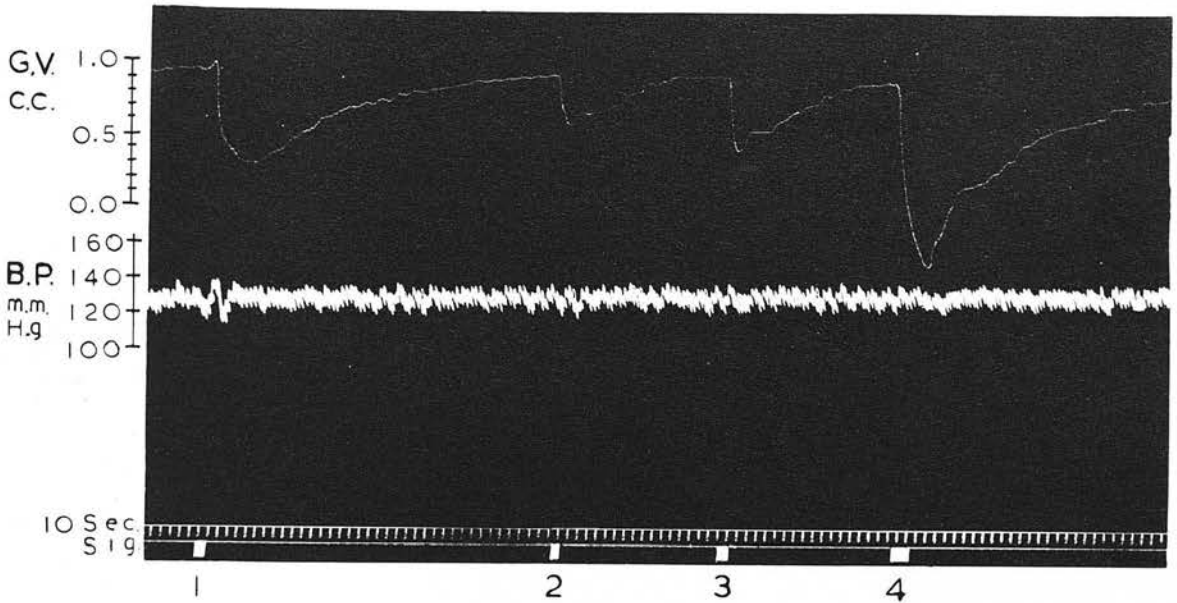

FIG. 39. Expt. D 1; Dog. 17.2 kg. 4 days involution. Pentobarbitone anaesthesia. L 5 in plethysmograph at 12.31 p.m. Gland volume 90 c.c. (G.V.) B.P. mercury manometer. Dog supine.

- | | |
|---------------|--|
| 1 - 1.53 p.m. | Adrenaline 2 μ g. intravenously. |
| 2 - 1.59 " | Stimulation of distal cut end of external spermatic nerve, 10/5/1/5. |
| 3 - 2.02 " | Ditto 10/5/1/10. |
| 4 - 2.05 " | Ditto 10/5/1/15. |

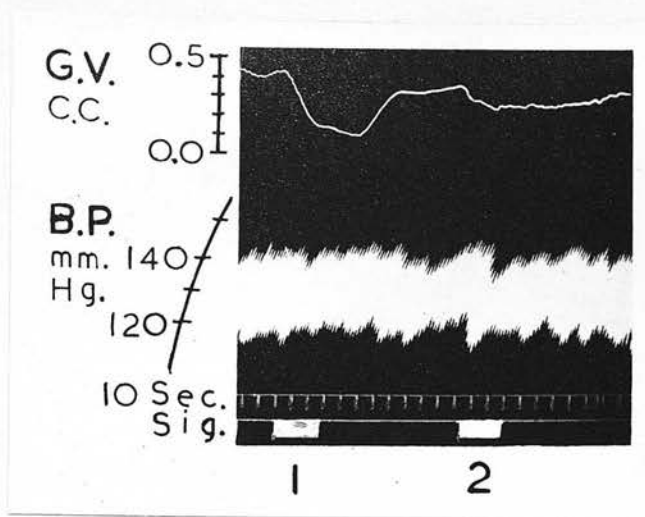

FIG. 40. Expt. C 43. Cat. 3.06 kg. Lactating 6 days. Pentobarbitone anaesthesia. R 4 in plethysmograph at 1.39 p.m. with circulation intact. Gland volume (G.V.) 13 c.c.
 1 - 3.22 p.m. Stimulation of external spermatic nerve 10/50/1/20.
 2 - 3.25 " Same stimulation of nerve L II.

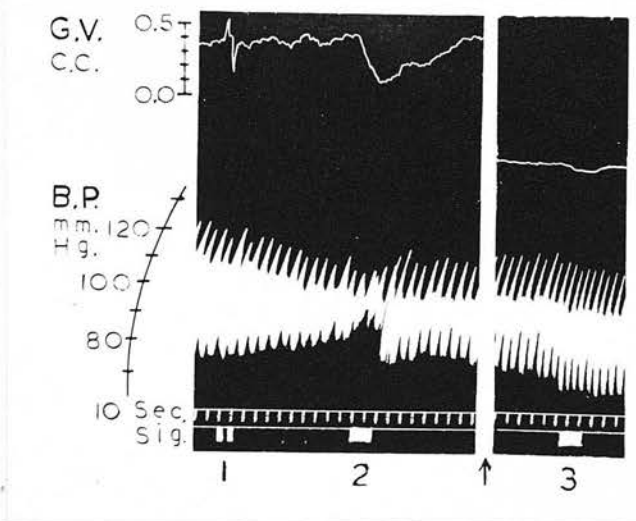

FIG. 41. Expt. C 50. Cat. 2.5 kg. Lactating 15 days. Chloralose and urethane anaesthesia. R 4 in plethysmograph at 2.45 p.m. Gland volume 16.5 c.c. Cat supine.
 1 - 3.42 p.m. External pudendaL vein and then artery clamped for 5 sec.
 2 - 3.44 " Stimulation of the distal cut end of the external spermatic nerve, 10/50/10/12.
 ↑ - 3.50 " External pudendaL vein cannulated; open to the exterior.
 3 - 4.14 " Nerve stimulation repeated, 10/50/10/12.

N.B. The apparent decrease in the pulse pressure was due to a clot in the blood pressure cannula partially obstructing it.

to 4 minutes. In both species there was also a decrease in the venous outflow, an observation indicating that the rise in pressure itself did not fully reflect the intensity of the vasoconstriction produced (Fig.42, 43, 46). The responses were obtained at all level of the resting perfusion pressure, and also at the height of a pressor response to a moderate dose of adrenaline. In the dog there was frequently a temporary increase in the venous outflow, occurring at the time when the perfusion pressure was rising, which was followed by the usual decrease (Fig.54). This was not seen in cat perfusions, but was observed in one cat experiment in which the venous outflow was recorded from the intact gland. In three cat perfusion experiments the pressure curve to nerve stimulation showed a flattening or even a second rise succeeding the initial peak (Fig.44 and 45).

In all types of experiment the size and duration of response could be increased by lengthening the time of stimulation (up to a maximum of about 15 sec.) (Figs.39 and 46), and to a more variable extent by increasing the voltage (up to a maximum of 0.5 - 10 V.), pulse length (up to 1-10 msec.) and the frequency (up to 5-50/sec.). A maximal response could invariably be obtained by a stimulus of 10 volts, 50 stimuli/sec., each of 1 msec. lasting 15 sec. (signified 10/50/1/15). A strength-duration curve of the vasoconstrictor fibres in the external spermatic nerve is shown in Fig.47.

In addition to the external spermatic nerve, the mixed spinal nerves thoracic XIII to lumbar IV, supplying mammary glands 3 and 4, were also found to include vasoconstrictor fibres (Fig.40). The inguinal glands 4, which have been given the most attention in the present study, receive fibres from cutaneous lumbar nerves II, III and IV, but most of their innervation from the external spermatic nerve, which also

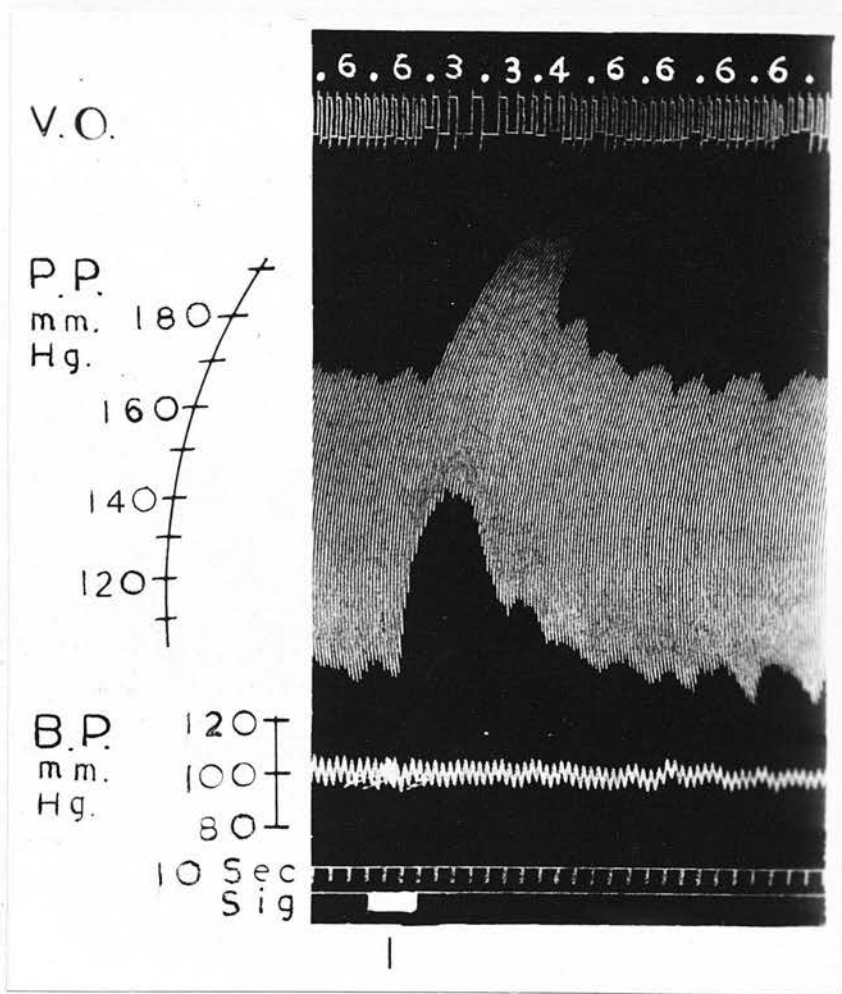

FIG. 42. Expt. C 49. Cat. 2.8 kg. Lactating 13 days. Chloralose and urethane anaesthesia. Perfusion of R 4, started at 2.50 p.m. Defibrinated heparinized blood. V.O. 17 drops per c.c.

1 - 3.21 p.m. Stimulation of distal cut end of external spermatic nerve, 0.5/50/10.

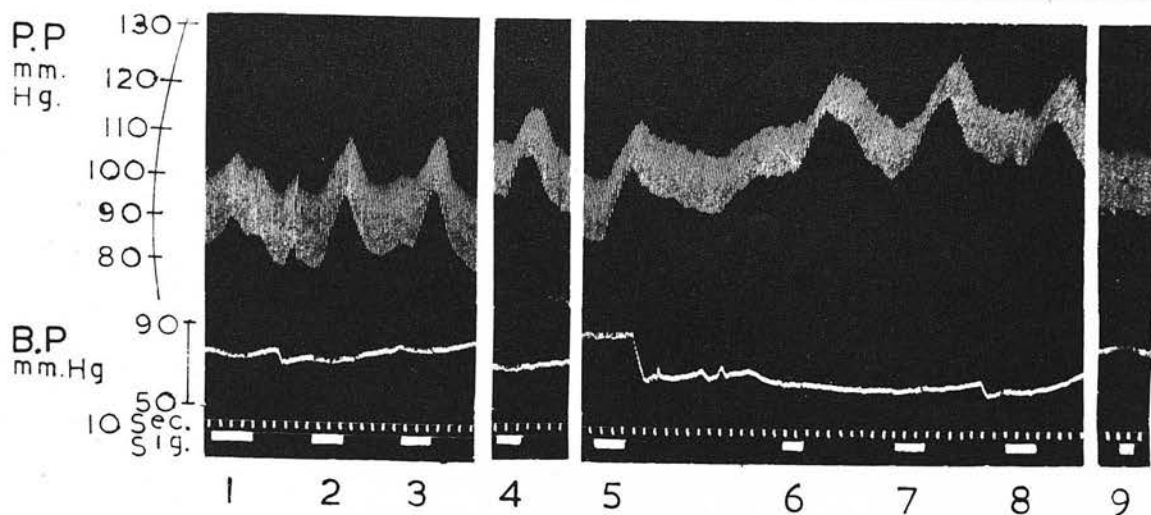

FIG. 43. Expt. C 18. Cat. 2.83 kg. Lactating 7 days.
 Pentobarbitone and urethane anaesthesia. Perfusion
 of L 4 started at 5.31 p.m.

- | | | |
|--------------------------|---|--------------|
| 1 - 6.30 p.m. | Stimulation of external spermatic nerve | 0.5/50/0.01. |
| 2 - 6.32 " | " " main mammary vessel | 10/50/1. |
| 3 - 6.33 $\frac{1}{2}$ " | " " " " " " | " " |
| 4 - 6.38 " | " " nerve | 10/50/1. |
| 5 - 6.41 " | " " " " | " " |
| 6 - 6.43 " | " " " " | 2/5/0.1. |
| 7 - 6.44 " | " " " " | 0.5/5/0.01. |
| 8 - 6.46 " | " " " " | 0.5/1/0.01. |
| 9 - 6.47 " | Control. No response to pulling nerve over forceps
instead of over electrodes. | |

N.B. The sudden falls in the B.P. tracing were due to removing blood from the cat to fill the pump blood reservoir.

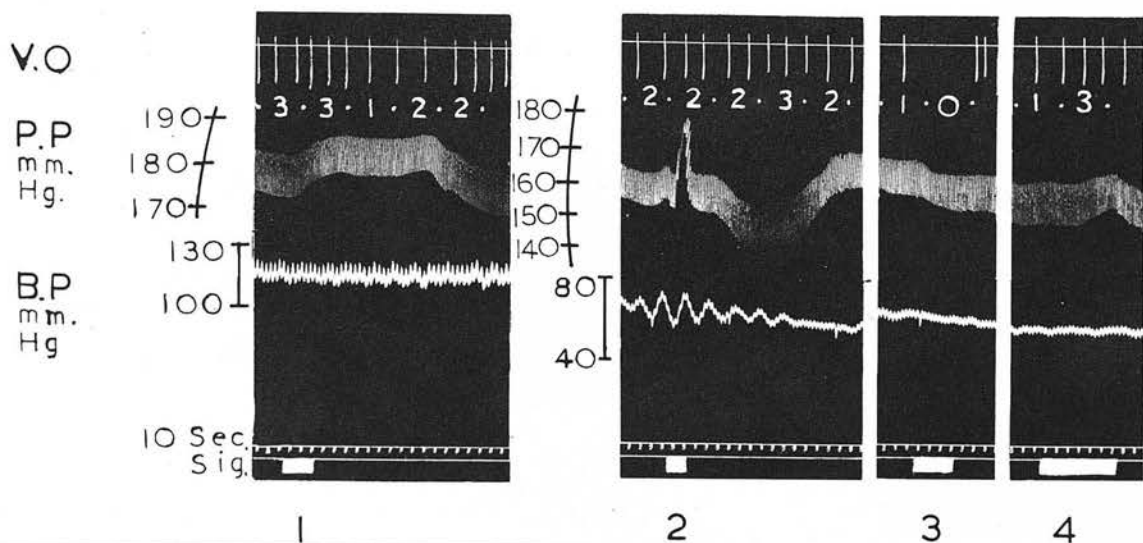

FIG. 44. Expt. C 28. Cat. 3.2 kg. Lactating 4 days.
Chloralose and urethane anesthesia. Perfusion
of R 4 started at 11.25 a.m. V.O. 20 drops per c.c.

- 1 - 1.44 p.m. Stimulation of the distal cut end of the external
spermatic nerve, 10/50/1.
- 2 - 3.42 " Acetylcholine 1.0 μ g.
- 3 - 3.47 " Nerve stimulation 0.5/5/0.1.
- 4 - 3.49 " " " " for 20 sec. and then
voltage increased to 5.

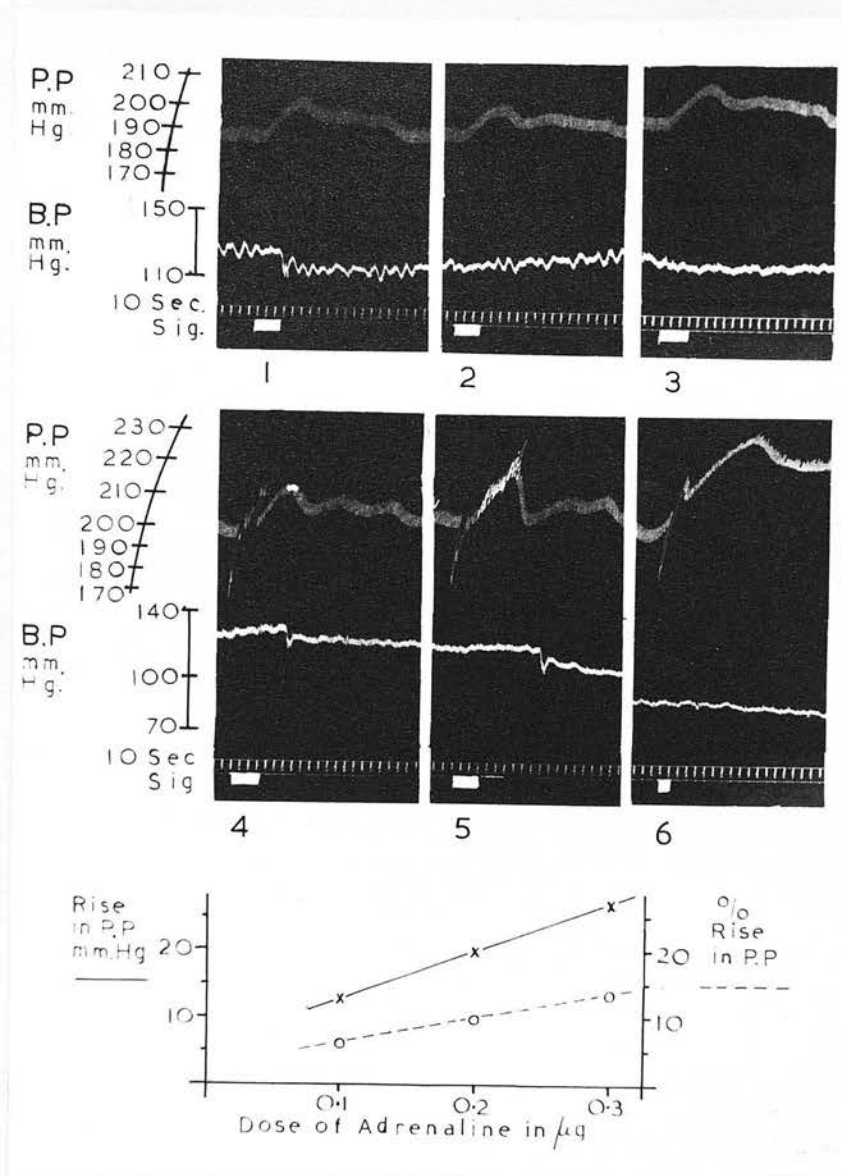

FIG. 45. Expt. C 19. Cat. 3.4 kg. Lactating 13 days. Pentobarbitone and urethane anaesthesia. Gland R 4 perfused at 2.44 p.m.

Prolonged and multiphasic responses to nerve stimulation and to adrenaline.

1 - 3.13 p.m.	Stimulation of external spermatic nerve	2/5/0.01.
2 - 3.19 "	" " " " "	" " 0.5/5/0.01.
3 - 3.30 "	" " " " "	" " 5/5/1.
4 - 3.36 "	Adrenaline 0.1 μ g. intra-arterially.	
5 - 3.42 "	" 0.2 μ g. "	
6 - 3.55 "	" 0.3 μ g. "	

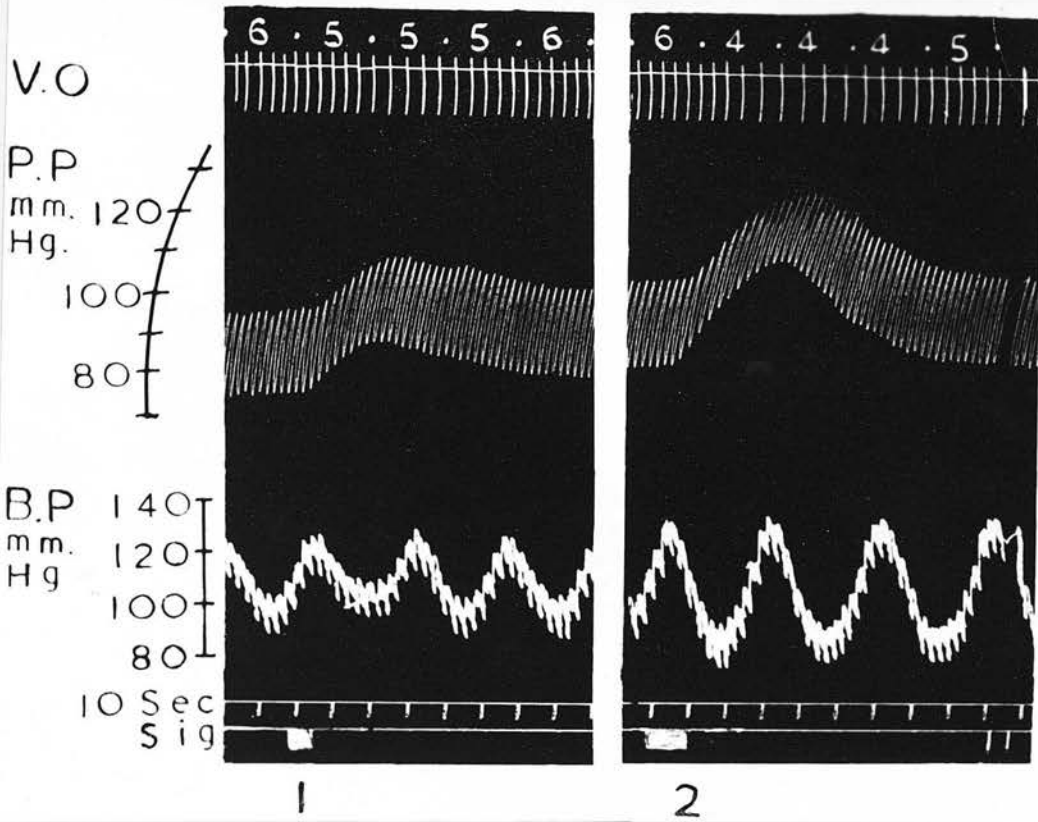

FIG. 46. Expt. D 5. Dog. 17.2 kg. 8 days involution.
Chloralose and urethane anaesthesia. Perfusion of
R 5 started at 3.20 p.m. V.O. 15 drops per c.c.

- 1 - 6.36 p.m. Stimulation of the distal cut end of the external
spermatic nerve, 10/50/1/5.
2 - 6.38 " Ditto, 10/50/1/10.

N.B. Hering-Traube waves in B.P.

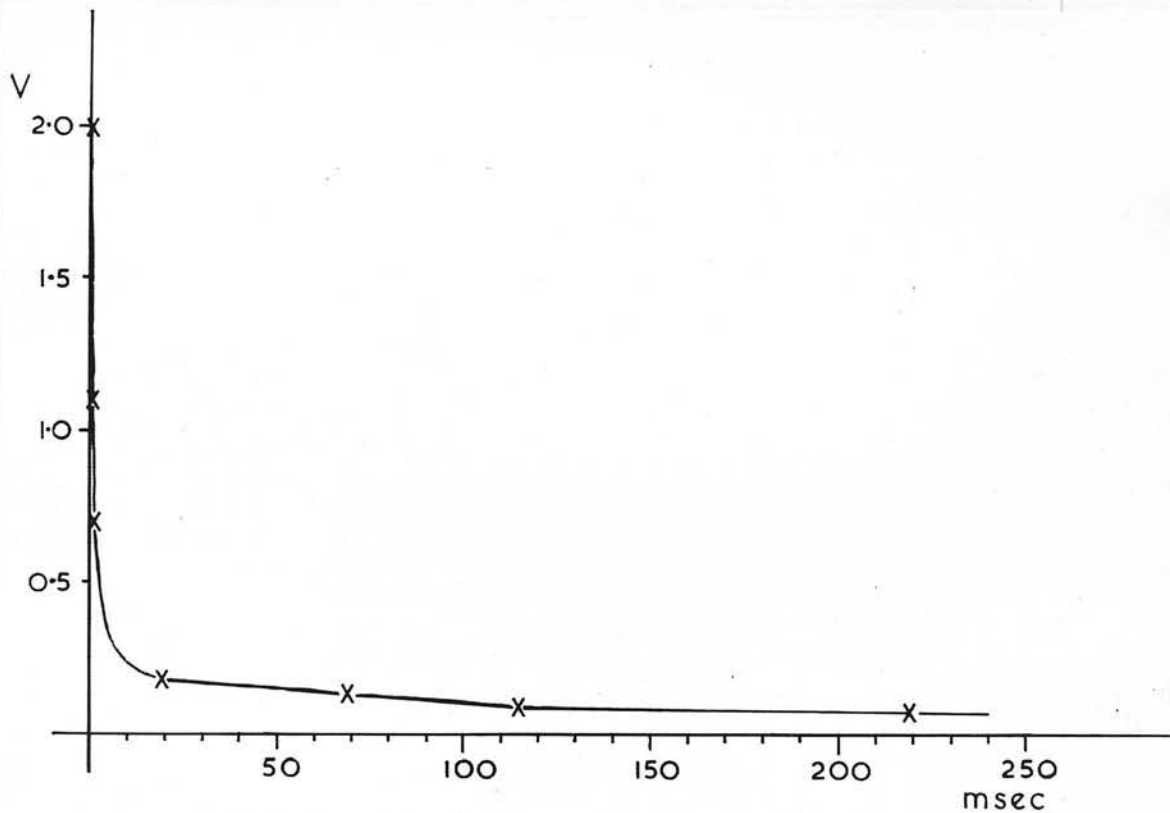

FIG. 47. Expt. C 70. Cat. 3.2 kg. Lactating 2 days. Chloralose and urethane anaesthesia. Glands R and L 4 in plethysmograph at 12.15 p.m. Strength duration curve of vasoconstrictor fibres in the left external spermatic nerve. Condenser discharge, 10 stimuli per sec. 3.07 to 5.30 p.m.

arises from lumbar IV. The peripheral distribution has not been worked out in detail, but from microscopical examination it appeared that there is considerable overlap in the areas innervated by adjacent nerves.

Bellini (1948) has shown that the sympathetic fibres and sensory fibres in the spinal nerves in the cat, supply approximately the same skin areas, so that by plotting the sensory dermatomes more information was obtained on this point. It was confirmed that lumbar nerves II, III and IV supply the skin over the inguinal mammary glands, but showed that nerves L I and T XIII may send some fibres as well in some animals (Fig.8). Although the vasomotor nerves were actually demonstrated in the mammary glands just beneath the skin, it is clear that these results broadly confirm Bellini's findings and stress still further the intimate relationship between the mammary glands and the skin.

These results were not in themselves conclusive proof for the existence of vasoconstrictor nerve fibres to the mammary glands as such, because they referred to mammary tissue (inguinal gland 10-20 g.), plus 1-2 g. (5-10 per cent. by weight) of adipose tissue and the superficial inguinal lymph glands (about 300 mg.) The fat and lymph glands were the tissues that it was not practicable to separate from the mammary glands because they were so intimately related to the branches of vessels and nerves entering the gland. Possibly the responses recorded represented the activity of vasoconstrictor nerves to the large vessels outside the gland and to the fat between them. Indeed, on actual test, it was shown that the volume of the inguinal fat, when measured separately, shrank on nerve stimulation (Fig.38), thus providing further evidence for the existence of vasomotor fibres in adipose tissue (see Wertheimer and

Shapiro, 1948). However, in four experiments, in which the mammary gland was completely separated from all fat and lymph tissue, it too showed positive responses to nerve stimulation (Fig. 38). The decrease in gland volume then recorded was usually about equal to the volume of a Neoprene cast of all the large vessels outside the gland proper, and since these vessels contracted only very slightly during nerve stimulation, it was concluded that the smaller vessels within the gland were mainly responsible for the responses recorded.

To be quite certain that the deductions from these experiments were correct, microscopic examination of the living vessels on or near the surface of the mammary glands was carried out. This revealed that nerve stimulation produced visible constriction of small arteries (20-100 μ), but little if any change in the calibre of the accompanying vein (50-150 μ) and capillaries (Fig. 48), although the application of a small dose of adrenaline to the capillaries on the surface of a lobule did produce blanching. To nerve stimulation (10/50/1/15) there was a latent period of about 2 seconds, after which the artery rapidly contracted and the blood flow in the artery and vein slowed or even stopped. During the response, which lasted 1 to 2 minutes, the blood corpuscles in the vein could be seen proceeding in a series of jerks, and even going backwards on occasions. Serial sections of such a pair of vessels that had been observed in the living state (artery 50 μ and vein 100 μ) showed that smooth muscle could only be detected in the medial coat of the artery and that three very fine nerve fibres ran between its media and adventitia.

The vasoconstriction produced by nerve stimulation was shown to be unaffected by eserine sulphate (0.1 mg./kg. into the whole animal or 50-100 μ g. intra-arterially), by atropine

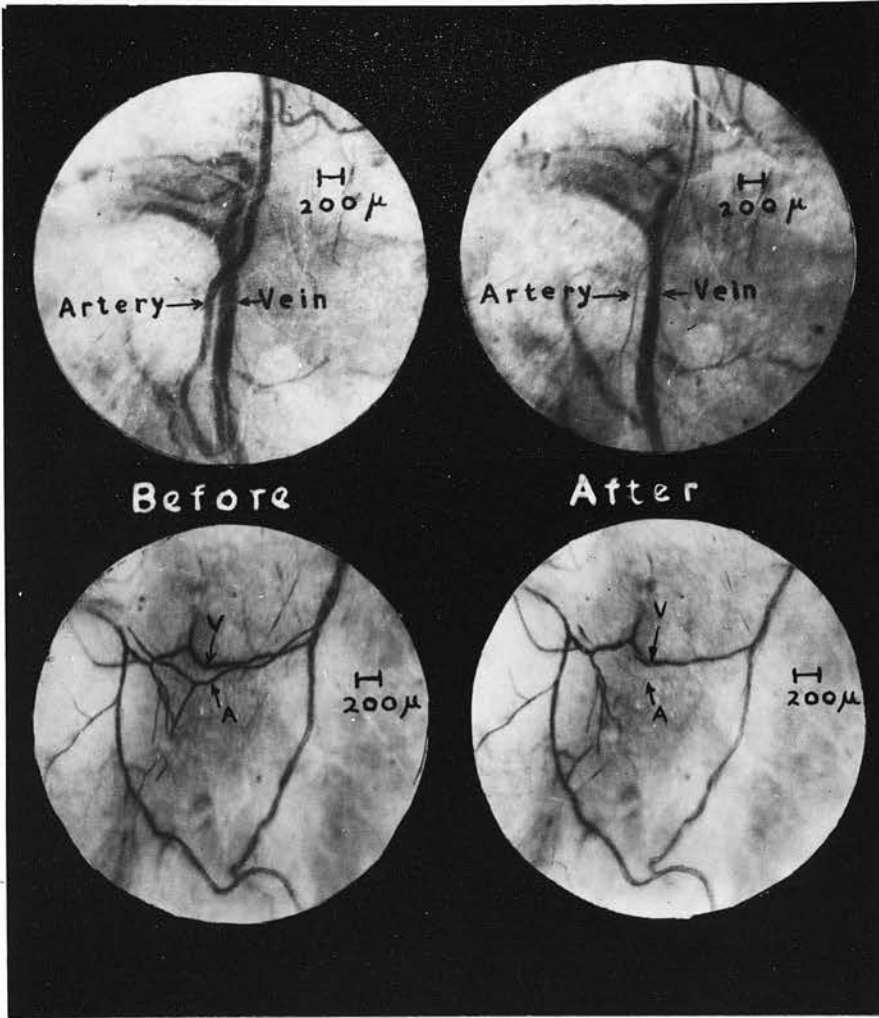

FIG. 48. Expt. C 68. Cat. 2.8 kg. Lactating 24 days. Chloralose and urethane anaesthesia. Photomicrographs of living vessels on surface of gland R 4, ($\times 21.5$) before and just after stimulation of external spermatic nerve.

sulphate (0.3 mg./kg. intra-venously or 50-100 µg. intra-arterially) and by nicotine (0.5 mg. intra-arterially), but was abolished by ergotoxine, ergotamine and dihydro-ergotamine (0.3 mg./kg. intra-venously or 0.1 - 1.0 mg. intra-arterially) (Figs.49, 50 and 51). Reversal of the response with ergot preparations was seen in only 7 out of 14 experiments, and in these the vasodilation^{ta} produced by nerve stimulation was small and transient. In four perfusion experiments (3 cats and 1 dog) dihydroergotamine, in addition to abolishing the effects of nerve stimulation, produced a marked and lasting vasodilation^{ta}, as shown by a permanent fall in perfusion pressure and a rise in the venous outflow. The significance of this finding is discussed in section III. (p.113) Cocaine hydrochloride was administered intravenously to the whole cat according to the method of Rosenblueth and Schlossberg (1931), and, in conformity with their findings, potentiated (50-100 per cent.) and prolonged (up to 10 times) the vasoconstrictor response to nerve stimulation, but only when sufficient had been injected to produce toxic effects on the heart (Fig.52). Tannic acid (0.5 mg. intravenously and 10 µg. intra-arterially) also potentiated (20-100 per cent.) and prolonged (30-110 per cent.) the responses to nerve stimulation in 6 out of 8 experiments in the dog and cat (plethysmography and perfusion) (Fig.38). This was of interest in view of the recent finding of Konzett (1948) that this drug has the same effects on the physiological actions of adrenaline, an action also found in these experiments. These findings showed that the nerve endings concerned were adrenergic.

Reflex vasoconstriction. - This was demonstrated in the cat by comparing the responses of the intact gland with that of its opposite control, which was denervated. In this preparation, anoxia, produced by clamping the trachea or by rebreathing

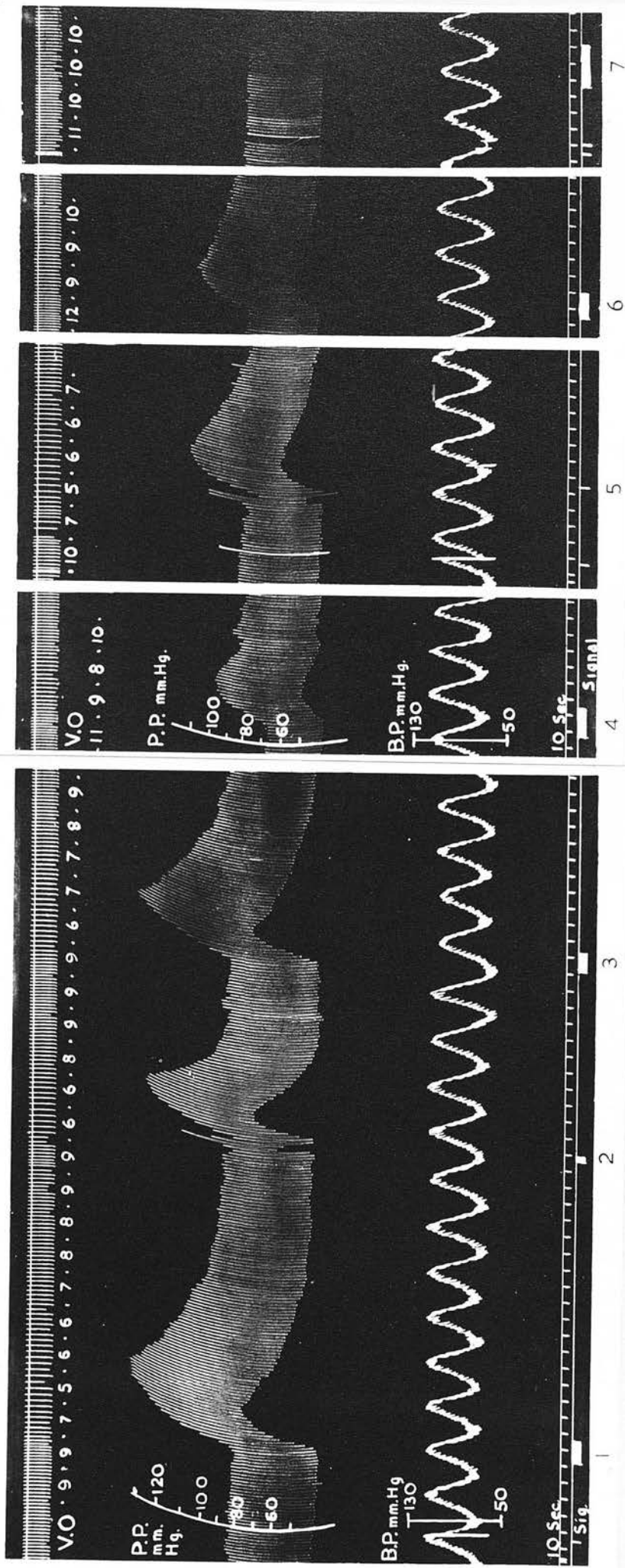

FIG. 49. Expt. D 4. Dog. 23.13 kg. 7 days involution. Chloralose and urethane anaesthesia. Perfusion of R 5 started at 3.13 p.m. V.O. 14 drops per c.c.

- | | |
|---------------|--|
| 1 - 5.01 p.m. | Stimulation of distal cut end of the external spermatic nerve, 10/50/1/12. |
| 2 - 5.03 " | Eserine sulphate 100 μ g., intra-arterially. |
| 3 - 5.06 " | Stimulation repeated 10/50/1/12. |
| 4 - 5.08 p.m. | " " 10/50/1/17. |
| 5 - 5.15 " | Atropine sulphate 100 μ g., intra-arterially. |
| 6 - 5.18 " | Stimulation repeated 10/50/1/17. |
| 7 - 5.24 " | Control. Nerve pulled over electrodes with no current flowing. |

N.B. The Traube-Hering type waves in the B.P. tracing.

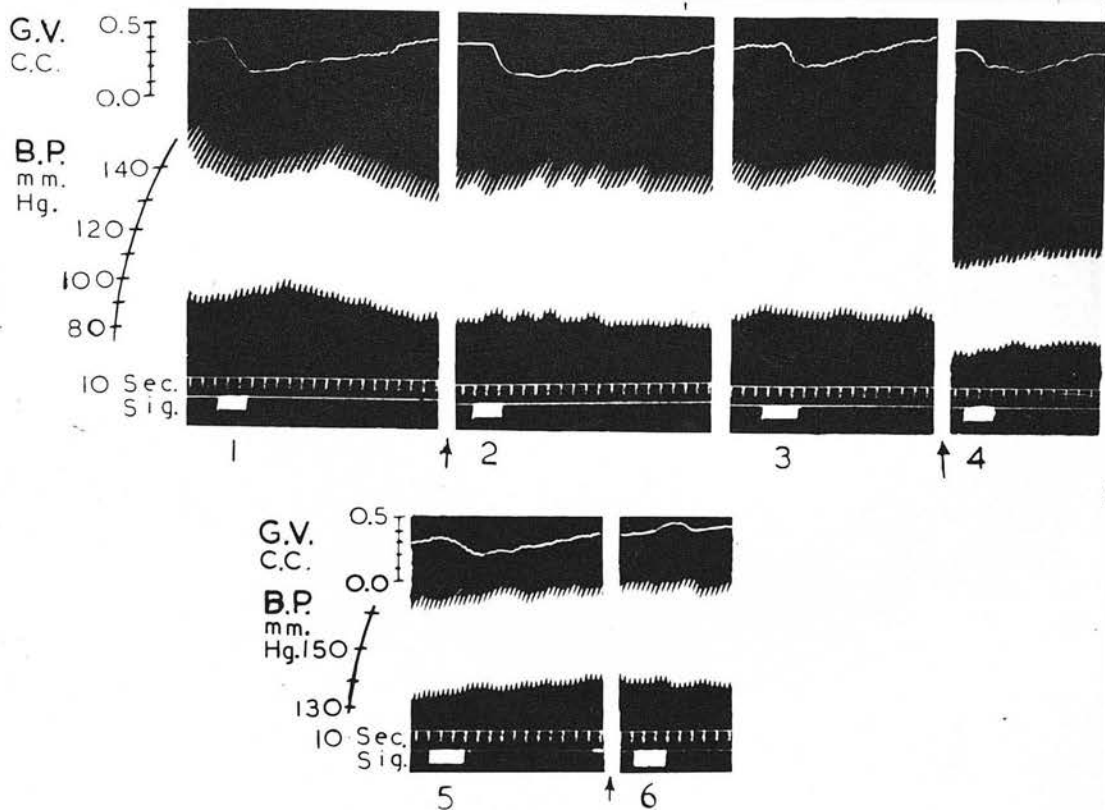

FIG. 50. Expt. C 44. Cat. 3.3 kg. Lactating about 10 days. Chloralose and urethane anaesthesia. R 4 in plethysmograph at 1.25 p.m. Gland volume 21.5 c.c. B.P. membrane manometer.

- | | | | |
|---|---|-----------|--|
| 1 | - | 2.12 p.m. | Stimulation of the distal cut end of the external spermatic nerve, 10/50/1/15. |
| ↑ | | 2.23 | " Eserine sulphate 0.3 mg. intravenously. |
| 2 | - | 2.36 | " Stimulation repeated, 10/50/1/15. |
| 3 | - | 2.47 | " " " |
| ↑ | | 2.52 | " Atropine sulphate 1.0 mg. intravenously. |
| 4 | - | 2.59 | " Stimulation repeated, 10/50/1/15. |
| 5 | - | 5.50 | " " " |
| ↑ | | 5.52 | " Dihydroergotamine 0.5 mg. intravenously. |
| 6 | - | 5.56 | " Stimulation repeated, 10/50/1/15. |

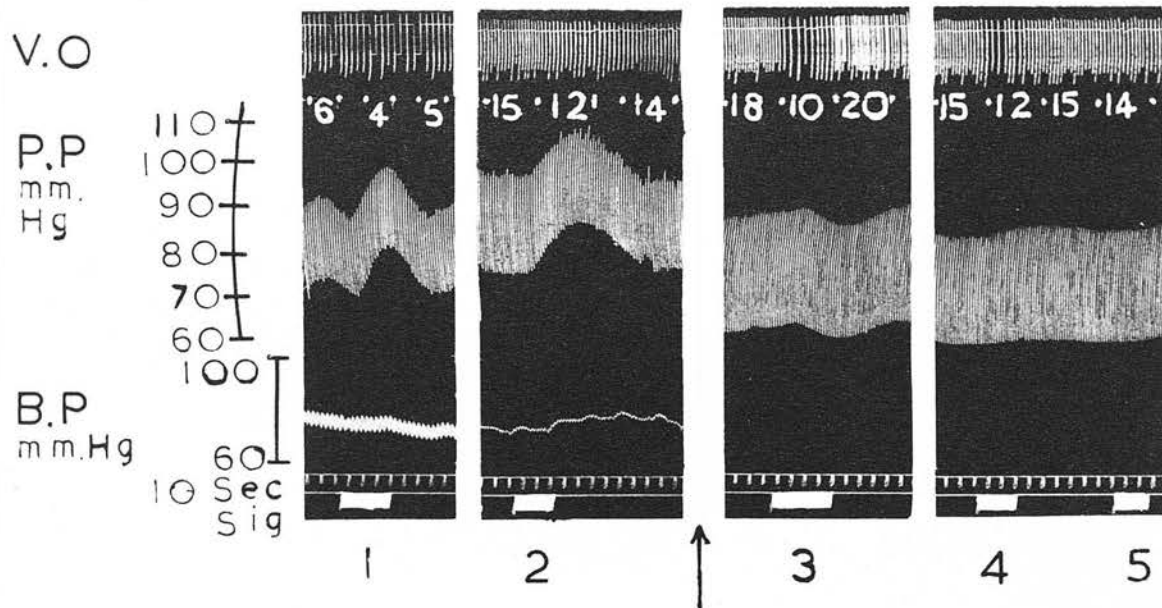

FIG. 51. Expt. C 24. Cat. 2.6 kg. Lactating 2 days. Chloralose and urethane anaesthesia. Perfusion of R 3 and 4 started at 1.50 p.m. V.O. 30 drops/ c.c.

Responses to nerve stimulation before and after ergotamine.

- | | | |
|----------|------|---|
| 1 - 2.04 | p.m. | Stimulation of external spermatic nerve 5/50/1. |
| 2 - 3.33 | " | " " " " " " |
| ↑ 3.54 | " | Dihydroergotamine 100 µg. intra-arterially. |
| 4.05 | " | " " " " |
| 4.21 | " | " " " " |
| 3 - 4.24 | " | Nerve stimulation 10/50/1. |
| 4 - 4.26 | " | " " " " |
| 5 - 4.27 | " | Control. No response to pulling nerve over forceps. |

N.B. A clot stopped the B.P. tracing just before responses 3, 4 and 5.

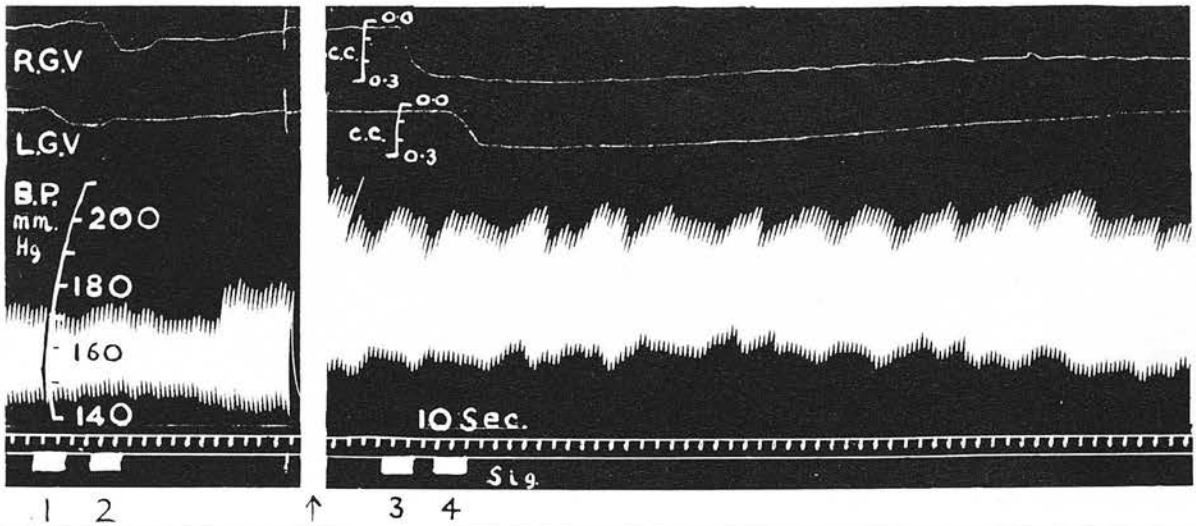

FIG. 52. Expt. C 56. Cat. 2.4 kg. Lactating 6 days.
Chloralose and urethane anaesthesia. Both inguinal
glands in plethysmographs at 12.23 p.m.

Effect of cocaine on nerve stimulation

- | | | | |
|----------|------|-----------------------------------|-------------|
| 1 - 2.40 | p.m. | Left external spermatic nerve | 10/50/1/10. |
| 2 - 2.41 | " | Right " " " " | " |
| ↑ 2.44 | " | Cocaine HCl 15 mg. intravenously. | |
| 3 - 3.05 | " | Right nerve stimulated as before, | 10/50/1/10. |
| 4 - 3.25 | " | Left " " " " | " |

nitrogen, caused a passive increase in the volume of the denervated gland coinciding with the rise in B.P., but a decrease in the volume of the innervated side. When the latter was also denervated a passive response to anoxia was then seen in both glands. The vasoconstriction of the innervated gland, which must have been central or reflex in origin, was of the same magnitude as was subsequently produced when the distal cut end of the same nerve was maximally stimulated.

Vasodilatation. - Nerve stimulation occasionally produced small vasodilator responses in the cat (Table I), usually with weak stimuli (0.5 - 1.0 volt, 0.1 - 0.01 msec.). (Fig. 44).

In many other experiments such weak stimuli produced either no effect at all or vasoconstriction. There was no greater tendency for vasodilator responses to appear when the vessels were in a more constricted state, as judged by a high resting perfusion pressure or a poor blood flow through the intact gland.

In one experiment, weak electrical stimuli which regularly produced a diminution in gland volume had the opposite effect after tannic acid administration.

In two experiments the external spermatic nerve of a cat was sectioned aseptically in the inguinal canal 72 and 24 hours before the experiment, in the hope that if any vasodilator fibres were present they might be unmasked as the vasoconstrictor fibres degenerated. In both cases no responses were obtained in the cut nerves to electrical or mechanical (mercury drops) stimulation, although the opposite controls gave vasoconstrictor responses as usual. These results indicate that the vasoconstrictor fibres degenerate within 24 hours of sectioning, but failed to demonstrate the existence of active vasodilator fibres.

TABLE II. - RESPONSES TO DRUGS

Substance	Species	Response	Minimum effective dose used	
			Whole animal	Isolated gland
Adrenaline	Cat	Vasoconstriction	0.01 $\mu\text{g.}^+$	0.005 $\mu\text{g.}^+$
	Dog	"	1.0 $\mu\text{g.}$	0.0001 $\mu\text{g.}^+$
DI Noradrenaline	Cat	"	0.5 $\mu\text{g.}$	
Acetylcholine	Cat	Vasodilatation	1.0 $\mu\text{g.}$	0.2 $\mu\text{g.}^+$
	Dog	"	1.0 $\mu\text{g.}$	0.1 $\mu\text{g.}$
Histamine	Cat	"	0.1 $\mu\text{g.}$	0.1 $\mu\text{g.}$
	Dog	"	..	0.1 $\mu\text{g.}$
Urethane	Cat	"	10 mg.	0.3 mg.
	Dog	"	..	1.0 mg. ⁺
Pentobarbitone	Cat	"	..	0.05 mg.
	Dog	"	..	0.01 mg.
Chloralose	Cat	Vasoconstriction	..	1.0 mg. ⁺
	Dog	"	..	1.0 mg. ⁺
Pitocin (oxytocin)	Cat	Usually a vasoconstriction, sometimes vasodilatation with smallest doses.	0.01 unit ⁺	0.001 unit ⁺
	Dog		..	0.0001 unit ⁺
		Cat	Ejection of milk	0.01 unit ⁺
	Dog	"	..	0.001 unit ⁺
Pitressin	Dog	Vasoconstriction, no ejection.	..	0.01 m. unit
Pilocarpine	Cat	Vasodilatation	0.5 mg.	..
Eserine	Cat	Vasoconstriction	..	50 $\mu\text{g.}$
	Dog	"	..	50 $\mu\text{g.}$
Atropine	Cat	Varied	..	50 $\mu\text{g.}$
	Dog	"	..	50 $\mu\text{g.}$
Nicotine	Cat	Vasodilatation	..	100 $\mu\text{g.}$
	Dog	"	..	10 mg. (only once)
Dihydroergotamine	Cat	Varied	0.5 mg.	100 $\mu\text{g.}$
	Dog	"	1.0 mg.	100 $\mu\text{g.}$
Barium chloride	Cat	Vasoconstriction	21 mg. (only once)	..
	Dog	"	..	1 mg.

Only those figures marked with an asterisk⁺ represent threshold doses.

The motor actions of drugs on the mammary blood vessels

Table II summarises the results obtained, and particular reference will be made to only adrenaline and acetylcholine.

Adrenaline. - The sensitivity to this substance was great. By intra-arterial injection into the perfused gland the threshold dose varied between 0.05 and 0.005 $\mu\text{g.}$ in the cat and 0.001 and 0.0001 $\mu\text{g.}$ in the dog. Since the glands weighed 10-20 g. in the cat and 40-90 g. in the dog, it appeared that the dog's mammary vessels were more sensitive to adrenaline than were the cat's (but see section III). The duration of the response in both species varied between 1 and 20 minutes according to the dose (see Figs. 53 and 54). The smallest amounts occasionally caused a fall in perfusion pressure which was often followed by the usual pressor response (Figs. 55, 56). Diphasic responses similar to those described as occasional effects of nerve stimulation were also observed a few times with adrenaline (Fig. 45). By intra-venous injection into the whole animal, the threshold dose that produced a shrinkage in mammary gland volume accompanied by a slight rise or no change in B.P. was 0.01 - 0.1 $\mu\text{g.}$ in the cat (Fig. 38). Adrenaline was tested in this way in only two dogs (11.6 and 17.3 kg.); 1 $\mu\text{g.}$ produced vasoconstriction in each case (Fig. 39). In all experiments the size of response varied with the dosage. Typical dose-response curves are shown in Figs. 45, 53 and 57. The ergot preparations listed, used in the dosage required to suppress the results of nerve stimulation, also abolished (3 experiments) or temporarily reversed (7 experiments) the effects of adrenaline (Fig. 63).

In three plethysmographic experiments dl noradrenaline was compared with adrenaline when given intra-venously. In all cases it was less active than adrenaline in inducing mammary

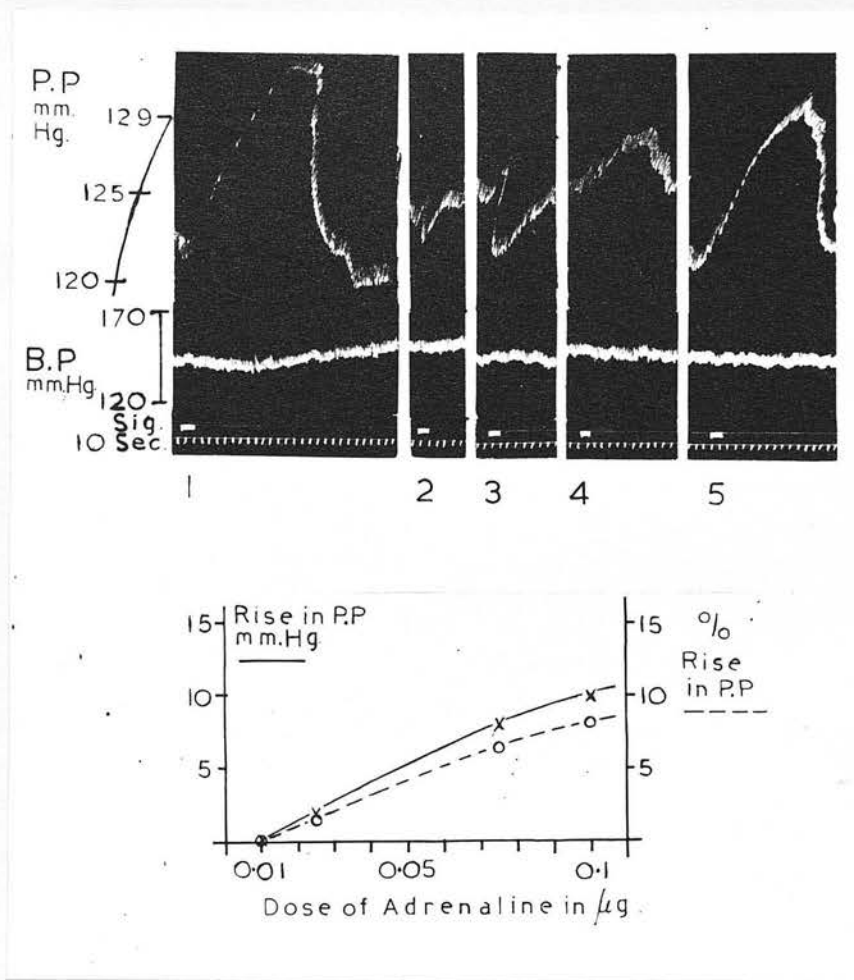

FIG. 53. Expt. C 16. Cat. 3.8 kg. Lactating 5 days. Pentobarbitone and urethane anaesthesia. Perfusion of L 4 started at 1.03 p.m.

Dose response curve to adrenaline

1 - 2.01 p.m.	Adrenaline 0.1 μg.	intra-arterially.
2 - 2.17 "	" 0.01 μg.	"
3 - 2.21 "	Saline control 0.1 ml.	"
4 - 2.28 "	Adrenaline 0.025 μg.	"
5 - 2.35 "	" 0.075 μg.	"

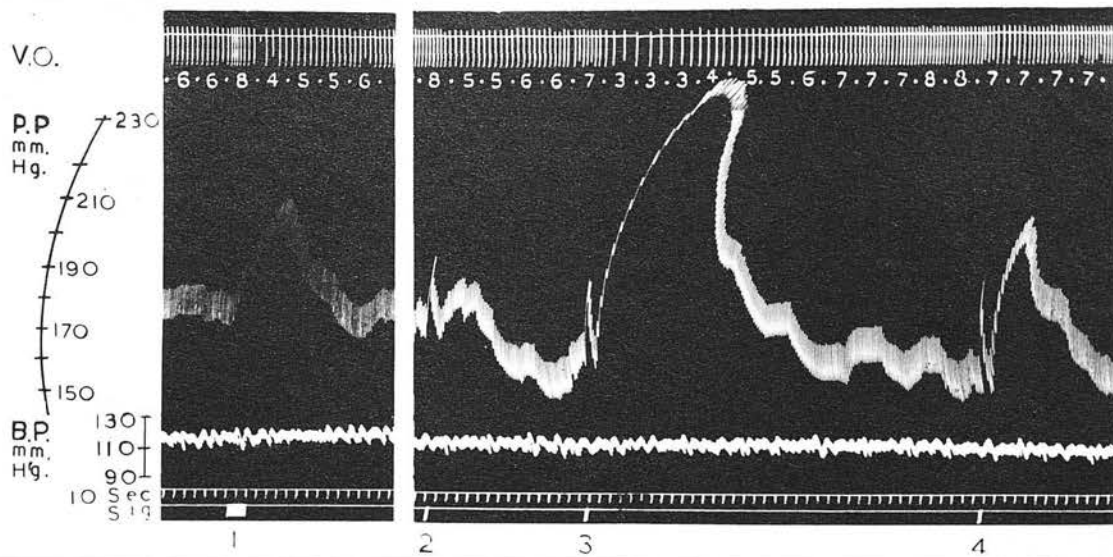

FIG. 54. Expt. D 3. Dog. 14.5 kg. 2 days involution. Chloralose anaesthesia. Perfusion of R 4 started at 2.51 p.m. V.O. 14 drops per c.c.

- 1 - 4.22 p.m. Stimulation of the distal cut end of the external spermatic nerve 10/50/1.
- 2 - 4.32 " Adrenaline 0.001 $\mu\text{g.}$, intra-arterially.
- 3 - 4.35 " " 0.1 $\mu\text{g.}$, "
- 4 - 4.41 " " 0.01 $\mu\text{g.}$, "

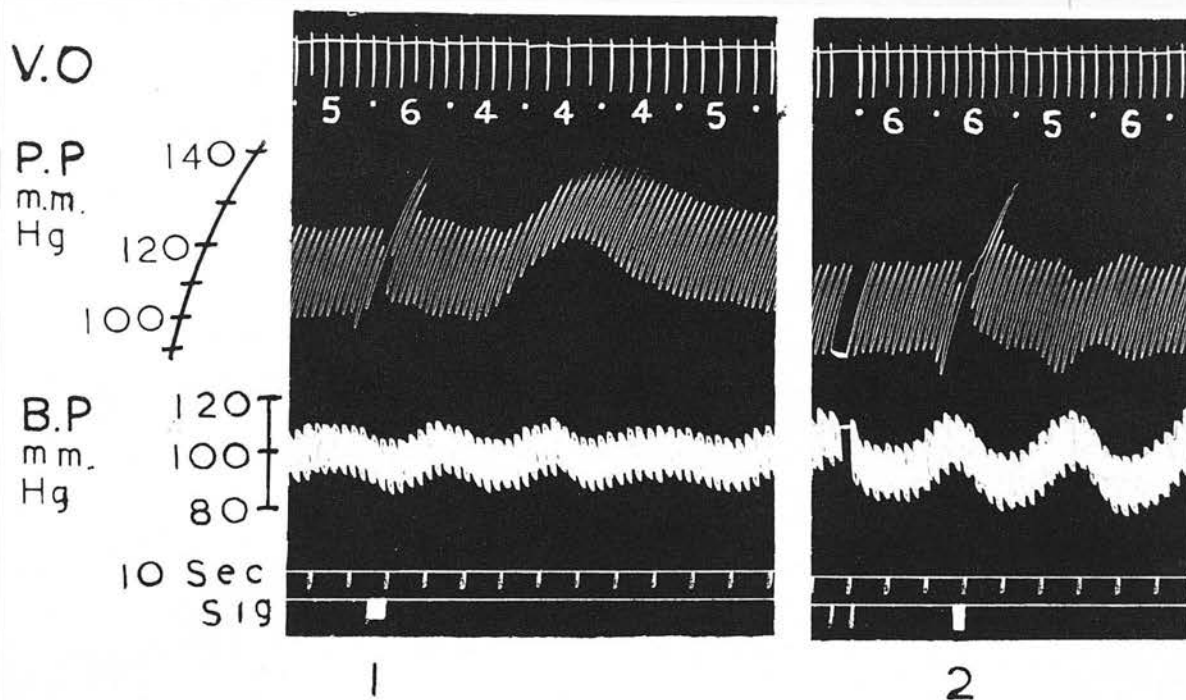

FIG. 55. Expt. D 5. Dog. 17.2 kg. 6 days involution. Chloralose and urethane anaesthesia. Perfusion of gland R 5 started at 3.20 p.m. V.O. 15 drops per c.c.

- 1 - 5.08 p.m. Adrenaline 0.001 $\mu\text{g.}$ intra-arterially.
- 2 - 5.13 " " 0.0001 $\mu\text{g.}$ "

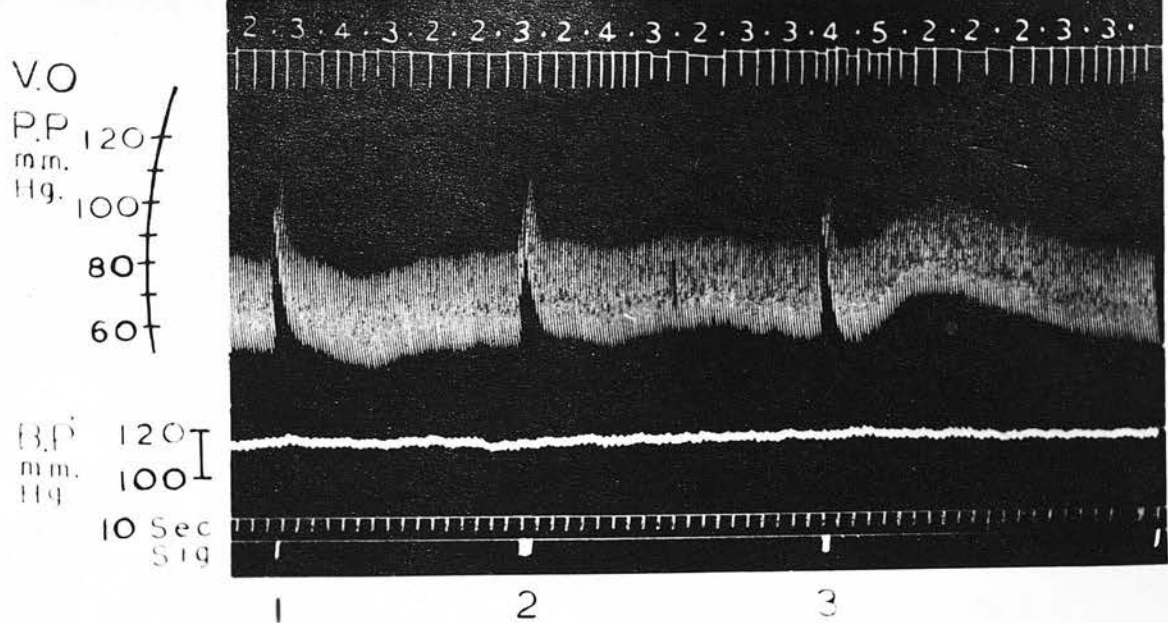

FIG. 56. Expt. C 46. Cat. 2.26 kg. Lactating 56 days. Chloralose and urethane anaesthesia. Perfusion of gland R 4 started at 2.48 p.m. V.O. 18 drops per c.c.

- | | | | |
|---------------|------------|----------------|-------------------|
| 1 - 4.29 p.m. | Adrenaline | 0.001 μ g. | intra-arterially. |
| 2 - 4.31 " | " | 0.01 μ g. | " |
| 3 - 4.35 " | " | 0.1 μ g. | " |

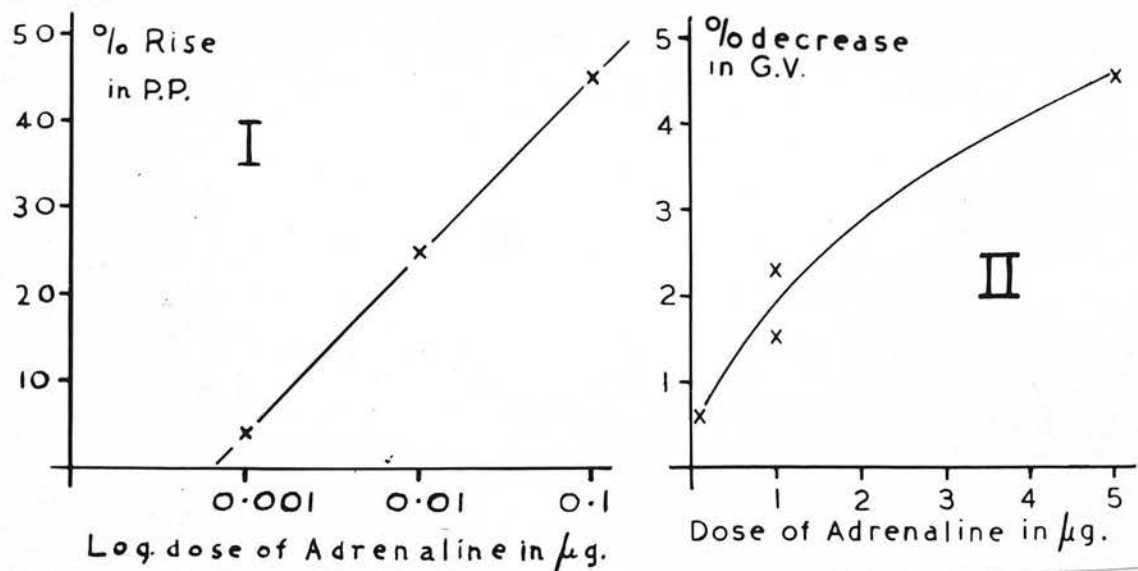

FIG. 57. Dose-response curves to adrenaline.

- I - Expt. D 3. Dog. 14.5 kg. Same experiment at Fig. 54.
 II - Expt. C 39. Cat. 2.8 kg. Same experiment as Fig. 38.

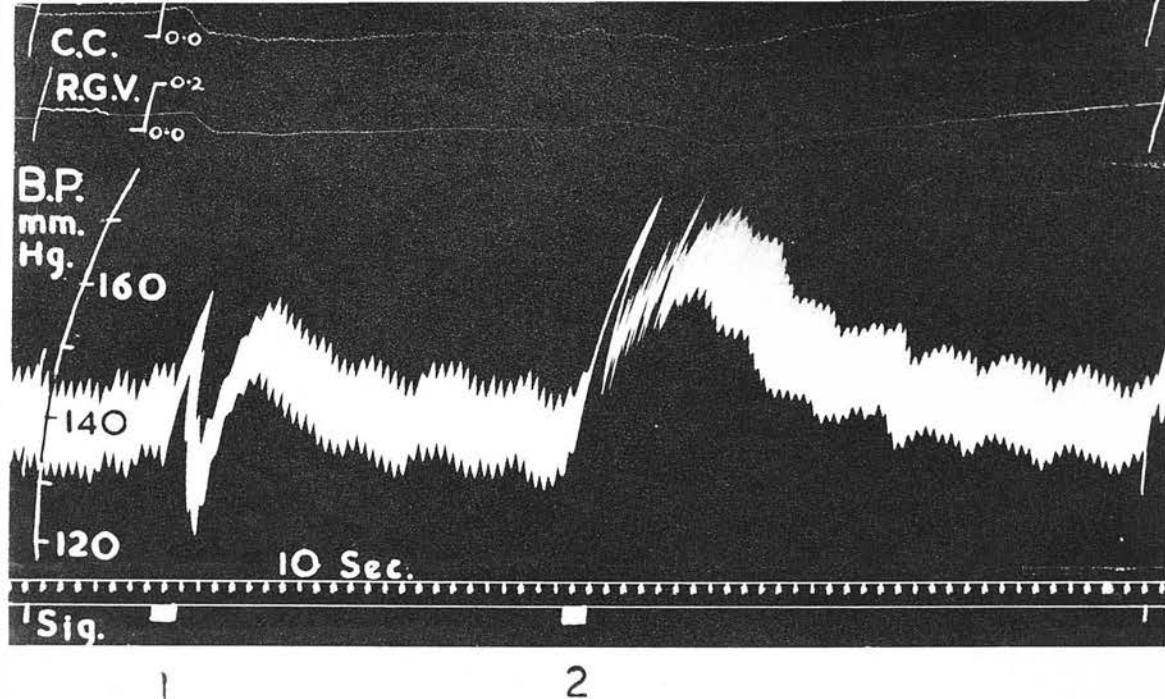

FIG. 58. Expt. C 72. Cat. 2.4 kg. Lactating 2 days. Chloralose and urethane anaesthesia. Glands R and L 4 in plethysmographs at 12.20 p.m. Cat supine.

- 1 - 4.11 p.m. Adrenaline 2.0 μ g. intravenously.
 2 - 4.15 " \bar{d} Noradrenaline 20.0 μ g. "

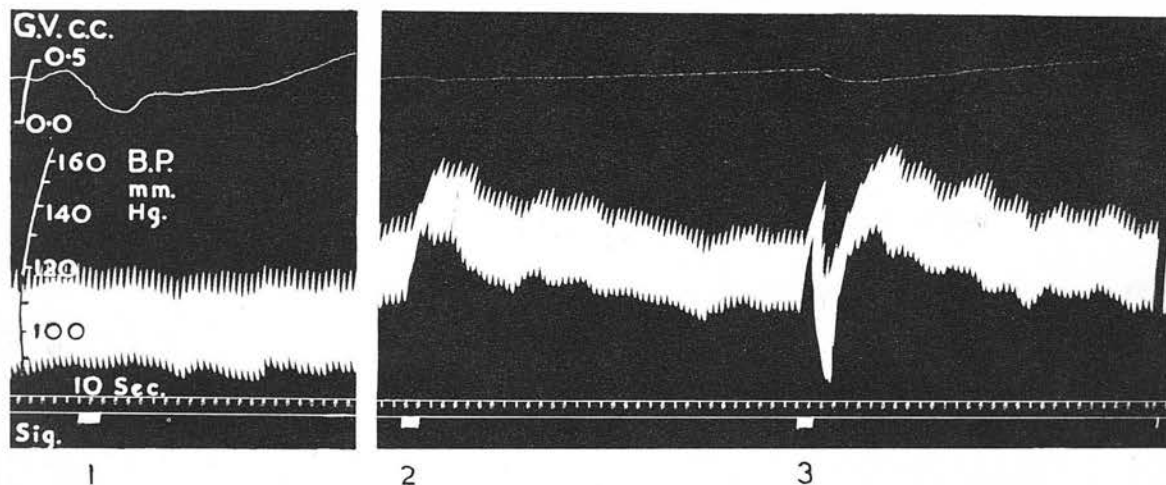

FIG. 59. Expt, C 70. Cat. 3.2 kg. Lactating 2 days. Chloralose and urethane anaesthesia. Gland L 4 in plethysmograph at 12.15 p.m. Cat supine.

- 1 - 1.32 p.m. Stimulation of external spermatic nerve, with induction coil. 2 v. primary C. 0.10 cm.
 2 - 2.34 " \bar{d} Noradrenaline 2 μ g. intravenously.
 3 - 2.39 " Adrenaline, 2 μ g. "

vasoconstriction but the ratio of its activity to that of adrenaline was 1 : 7.5; 1 : 5 and 1 : 10 in each case. Noradrenaline produced a pure rise in blood pressure unlike adrenaline which produced a di- or tri-phasic response (see Figs. 58 and 59).

Acetylcholine. - This produced vasodilatation in doses of 0.1 - 1.0 $\mu\text{g.}$ in the isolated gland of the dog and cat (unesterified) (Figs. 60 and 61), but in the whole animal the results were more variable and the individual sensitivity to the drug covered a wide range. Small doses (1 $\mu\text{g.}$) usually produced a fall in B.P. and an increase in mammary gland volume, but a fall in the latter was also sometimes seen, which was interpreted as being due to a fall in inflow pressure. A similar variation was encountered in one experiment in which 1 $\mu\text{g.}$ intra-arterial injection either increased or decreased the venous outflow from the intact gland. The fact that this dose regularly produced vasodilatation in the perfused gland suggests that the results in the whole animal were due to capacity effects.

Spontaneous gland volume changes

The spontaneous pressure changes met with in early perfusion experiments have been discussed under Methods, where it was suggested they were largely due to artefacts arising from imperfections in technique. However, in the plethysmography experiments, a greater or lesser amount of spontaneous variation in mammary gland volume was seen in 20 out of 21 experiments in the cat and in 1 out of 2 dogs. Although these variations did not preclude the recording and interpretation of responses produced experimentally, an attempt was made to determine their origin and cause.

In addition to pulse and respiratory waves, which were not always shown on the volume records, two types of spontaneous wave could be distinguished. Type I consisted of large, sudden

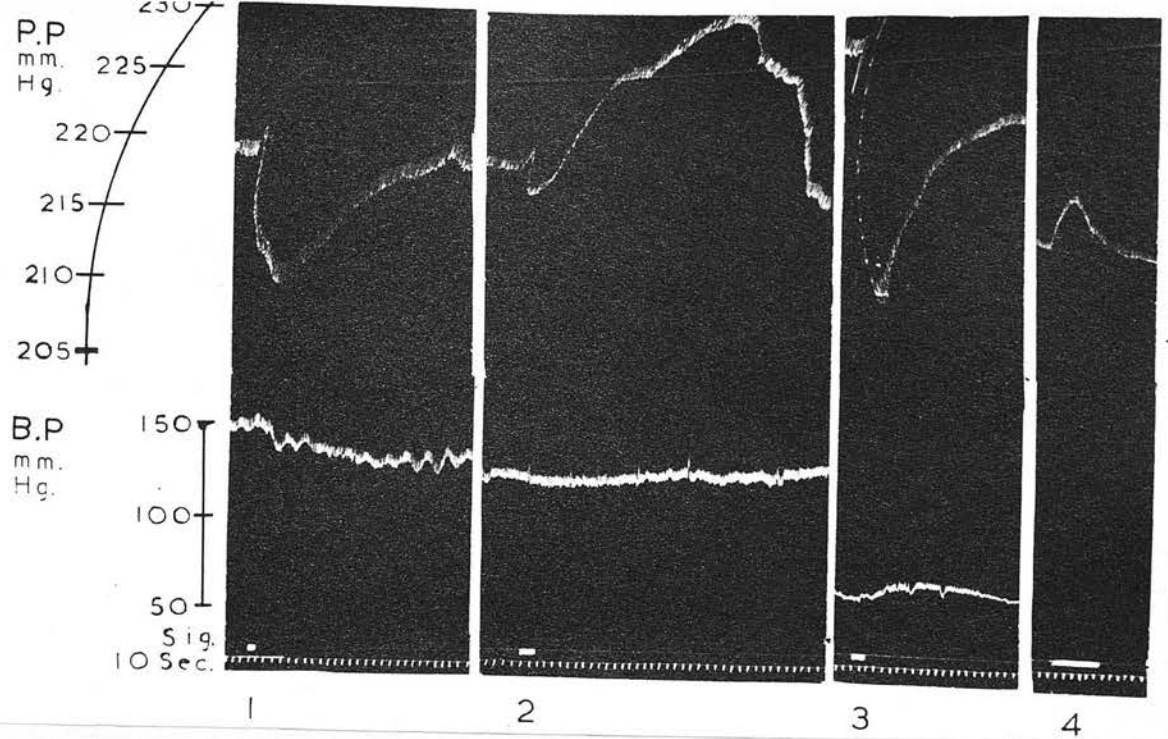

FIG. 60. Expt. C 16. Cat. 3.8 kg. Lactating 5 days. Pentobarbitone and urethane anaesthesia. Perfusion of gland L 4 started at 1.03 p.m.

- 1 - 3.13 p.m. Acetylcholine 1 μ g. intra-arterially.
- 2 - 3.51 " Adrenaline 0.1 μ g. " "
- 3 - 4.20 " Urethane 100 mg. " "
- 4 - 4.29 " Nerve stimulation 5/50/1.

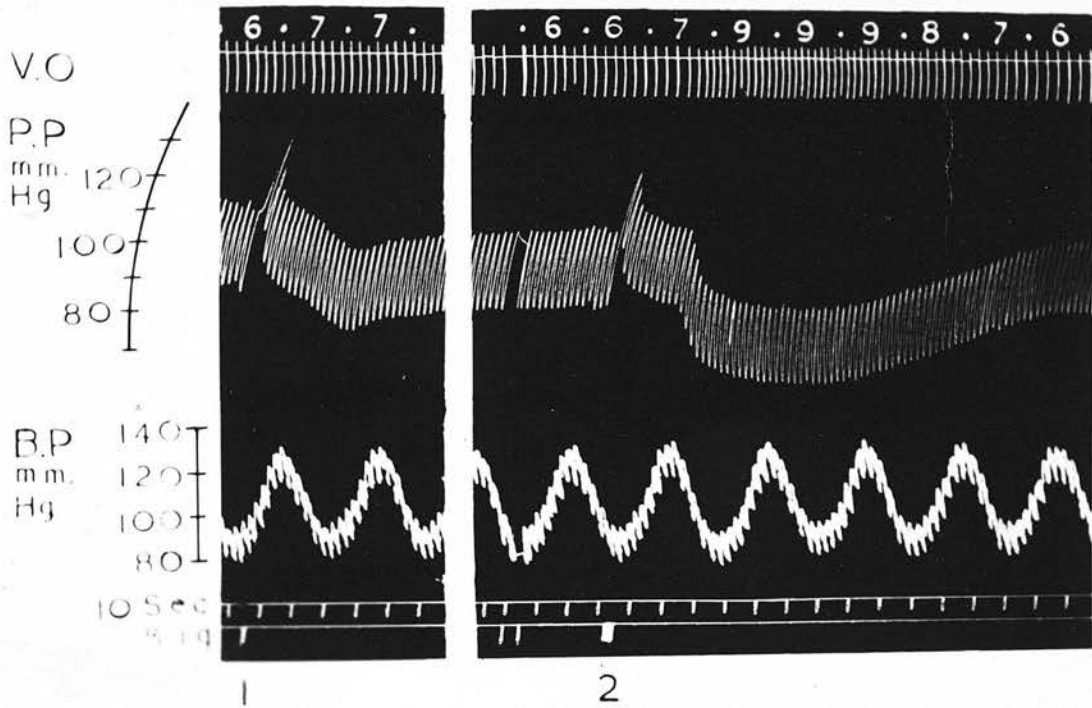

FIG. 61. Expt. D 5. Dog. 17.2 kg. 6 days involution. Chloralose and urethane anaesthesia. Perfusion of gland R 5 started at 3.20 p.m. V.O. 15 drops per c.c.

- 1 - 6.27 p.m. Acetylcholine 0.1 μ g. intra-arterially.
- 2 - 6.30 " Histamine acid phosphate 0.1 μ g. "

regular increases in gland volume, which subsided quickly. Each response lasted 20-60 seconds. They were usually only seen for limited periods in any one experiment (Figs. 38, 62 and 63). Type II had a similar wave-length, but were smaller and less regular. It was difficult to decide whether the primary change was a contraction or dilatation of the gland. They were usually present throughout an experiment, but tended to disappear as the gland deteriorated in its responses to nerve stimulation and drugs (Figs. 65, 66, 67, 68).

Type I waves were usually accompanied by a slight fall in B.P. and were unaffected by cutting the external spermatic nerve, by bilateral vagotomy, by bilateral adrenalectomy, or by clamping the carotid arteries. They were also unaffected by liberal application of procaine, cocaine, phenol and formalin to the external pudendal vessels and lymphatics (the only connections with the cat). They were sometimes caused by moving the rectal thermometer, again after thorough denervation. In yet another experiment spontaneous increases of this type in the volume of the inguinal fat on one side, and the inguinal mammary gland on the other (both denervated), steadily increased in size as the urinary bladder became more and more distended during the experiment. These changes were accompanied by opposing changes in the B.P., the general level of which fell as the bladder filled (Fig. 63). Opening the abdomen partially and puncturing the bladder completely reversed the fall in B.P. and likewise abolished the spontaneous volume changes. They could be reproduced, however, by gently pressing on the abdomen before and on the posterior vena cava after relieving the distended bladder (Fig. 63). They also reappeared spontaneously when the bladder was refilled with saline to its original state of tension. Thus it was concluded that, in this experiment at

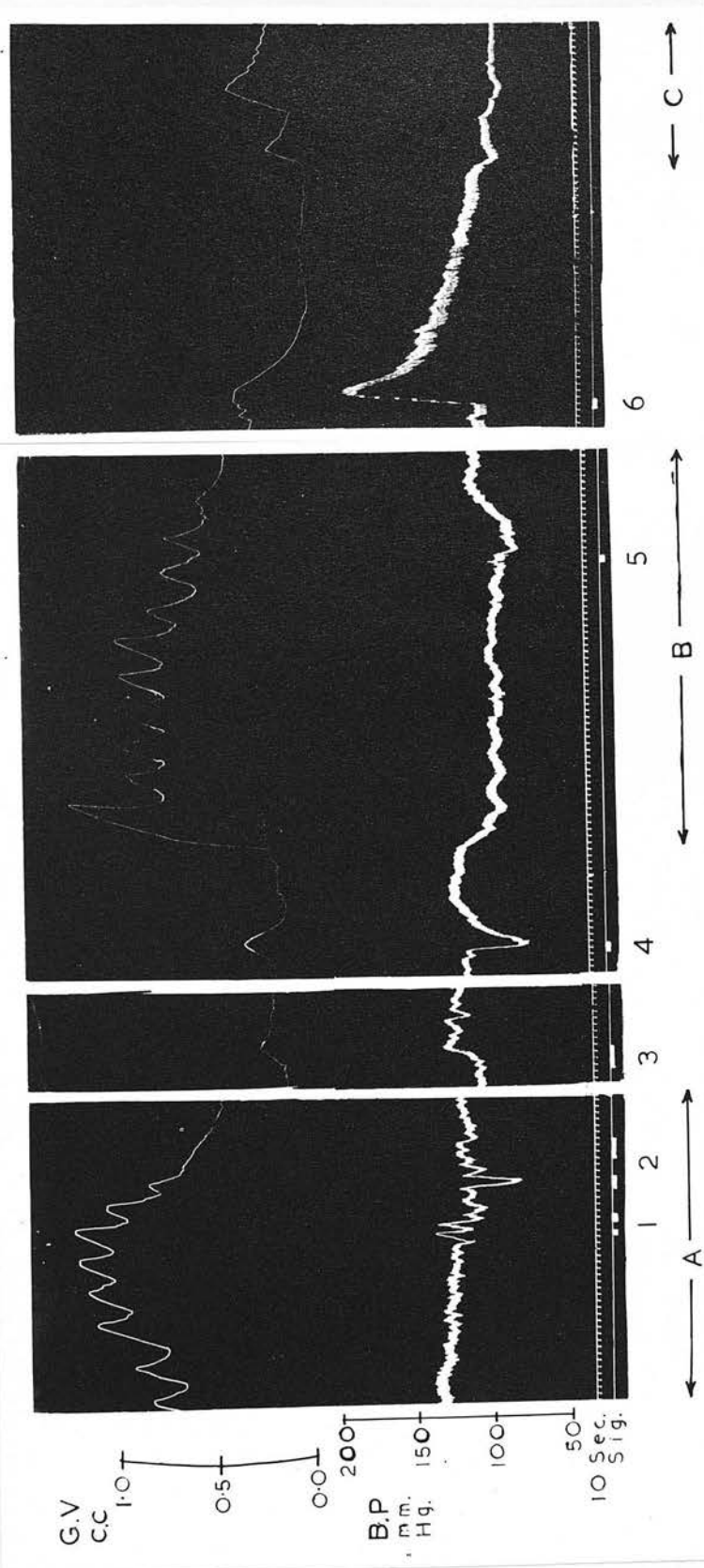

FIG. 62. Expt. C 1. Cat. 3.2 kg. Lactating 73 days. Pentobarbitone anaesthesia. R 4 in plethysmograph at 12.30 p.m. Volume of gland and fat 35 c.c. External spermatic nerve cut. B.P. mercury manometer.

Comparison of spontaneous and experimental responses.

- A - 3.55 p.m. Spontaneous response, unaffected by:-
 - 1 - Clamping the left carotid artery (twice).
 - 2 - Pulling the left sympathetic and vagus nerve (twice).
- 3 - 4.22 p.m. Adrenaline 10 µg., intravenously.
- 4 - 4.28 " Pilocarpine 0.5 mg. "
- B - 4.30 " Second spontaneous response after cutting the left vagus.
 - 5 - Right vagus cut.
- 6 - 5.52 p.m. Adrenaline 50 µg., intravenously.
- C - 5.58 " Fifth spontaneous response after stripping the subcutaneous abdominal vessels and after bilateral adrenalectomy.

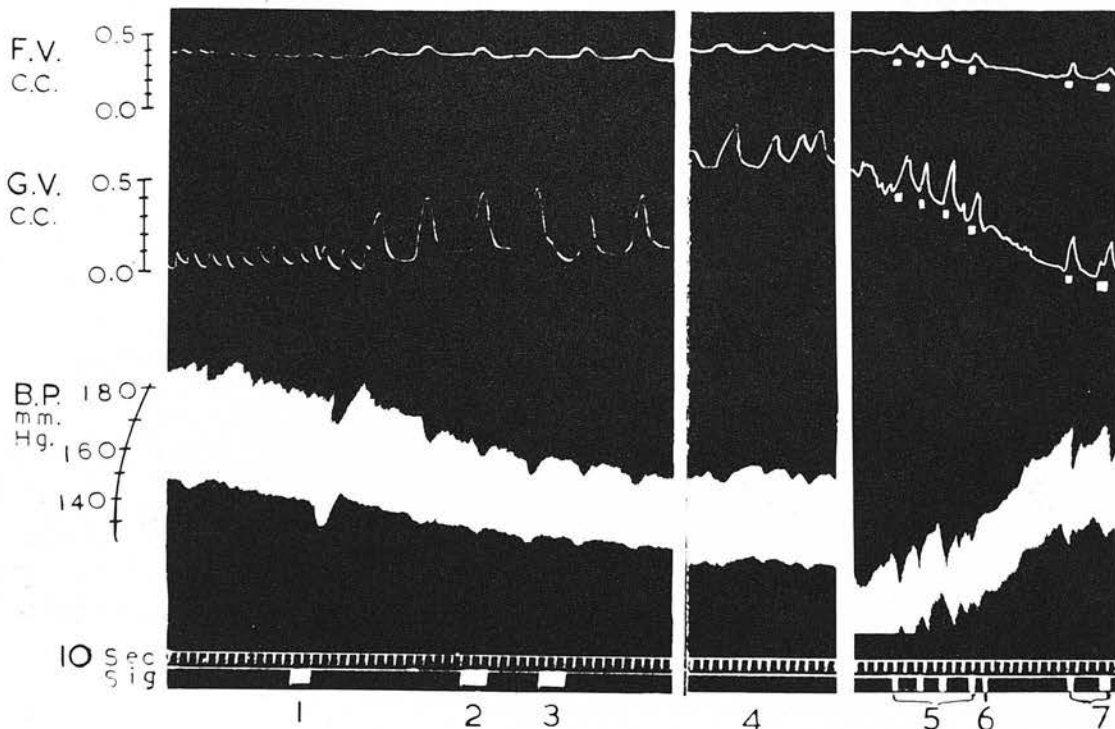

FIG. 63. Expt. C 39. Cat. Same experiment at Fig. 38. Spontaneous changes in fat volume, mammary gland volume and blood pressure.

- | | | |
|-----|-----------|---|
| | 4.17 p.m. | Dihydroergotamine 1 mg., intravenously. |
| 1 - | 4.26 " | Adrenaline 1.0 μ g., " |
| 2 - | 4.29 " | Stimulation of the distal cut end of the external spermatic nerve, 10/50/1., left side. |
| 3 - | 4.30 " | Ditto - right side. |
| 4 - | 5.35 " | Continued spontaneous responses in F.V., G.V., and B.P. |
| 5 - | 6.14 " | Abdomen opened and the very full bladder gently pressed 4 times. |
| 6 - | 6.15 " | Bladder punctured. |
| 7 - | 6.17 " | Posterior vena cava pressed gently twice. |

least, the spontaneous changes in B.P., fat volume and mammary gland volume were due to pressure on the vena cava, damming blood up peripherally and decreasing the venous return to the heart. In this particular case it appeared that the efforts of the bladder to evacuate its contents were the motive force, but in other experiments it appeared to be either bladder, uterine (Fig.64) or rectal movements. Such effects were only entirely abolished by a complete evisceration, thus stressing the fact that any slight pressure on the abdominal veins can cause such phenomena.

When the venous pressure was recorded as well as the mammary gland volume, it was confirmed that type I waves were accompanied by a rise in venous pressure (Figs.65 and 66), but that the smaller spontaneous waves called type II were independent of venous pressure variations, both when it was measured in the femoral vein and in the external pudental vein itself (Figs.65 and 66). Type II waves were also seen in other experiments in which the abdomen was open and the bladder empty, and occurred in the mammary gland on one side of the cat when there was no such change in the inguinal fat on the other. The recent finding of Peeters, Coussens and Oyeart (1949), Peeters, Coussens and Sierens (1949), and Peeters, Massart, Oyeart and Coussens, (1948) that the cow's teats undergo rhythmical contractions under certain conditions, suggested that this factor might be concerned here. However, removal of the teat and areola had no effect upon the spontaneous volume changes, and since these tissues weigh only about 100 mg. in the cat, it is probable that if teat movements were taking place they would be too small to be recorded by the apparatus used. Another explanation might have been that uterine movements produced the small waves of type II by pulling on the round ligament and thus compressing

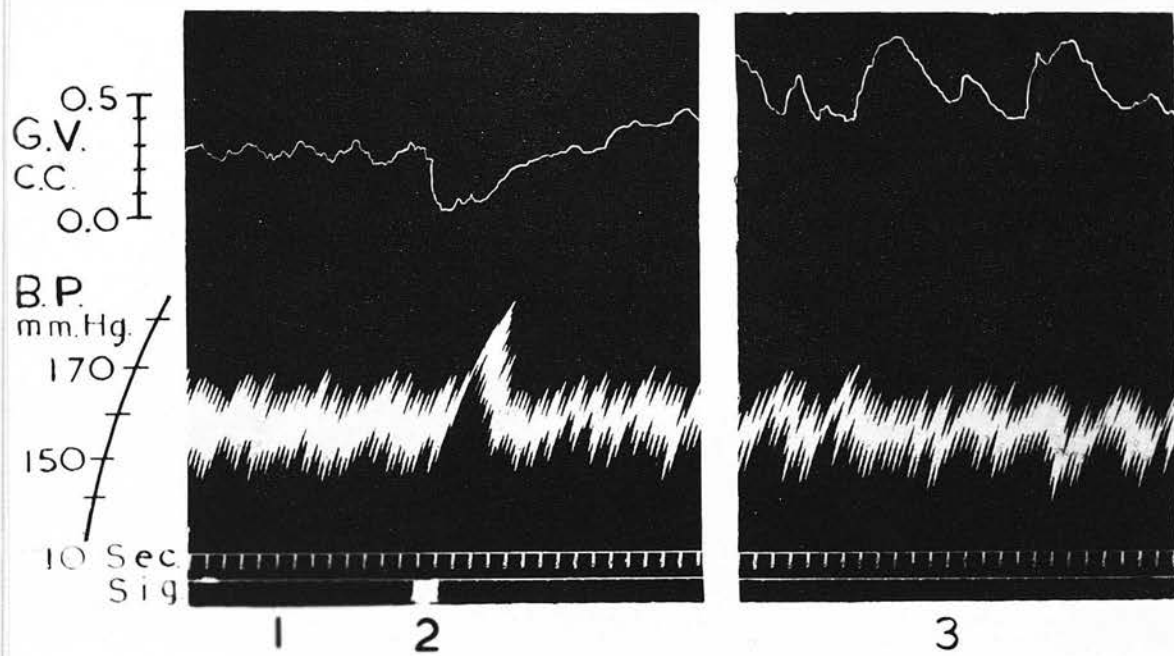

FIG. 64. Expt. C 40. Cat. 2.3 kg. Lactating 5 days. Pentobarbitone anaesthesia. Gland R 4 in plethysmograph at 12.00 p.m. Cat supine. B.P. by membrane manometer.

Spontaneous gland volume changes believed to be due to uterine movements.

- 1 - 3.29 p.m. Spontaneous G.V. responses before
- 2 - 3.30 " Pitocin 1.0 unit intravenously.
- 3 - 3.35 " And after.

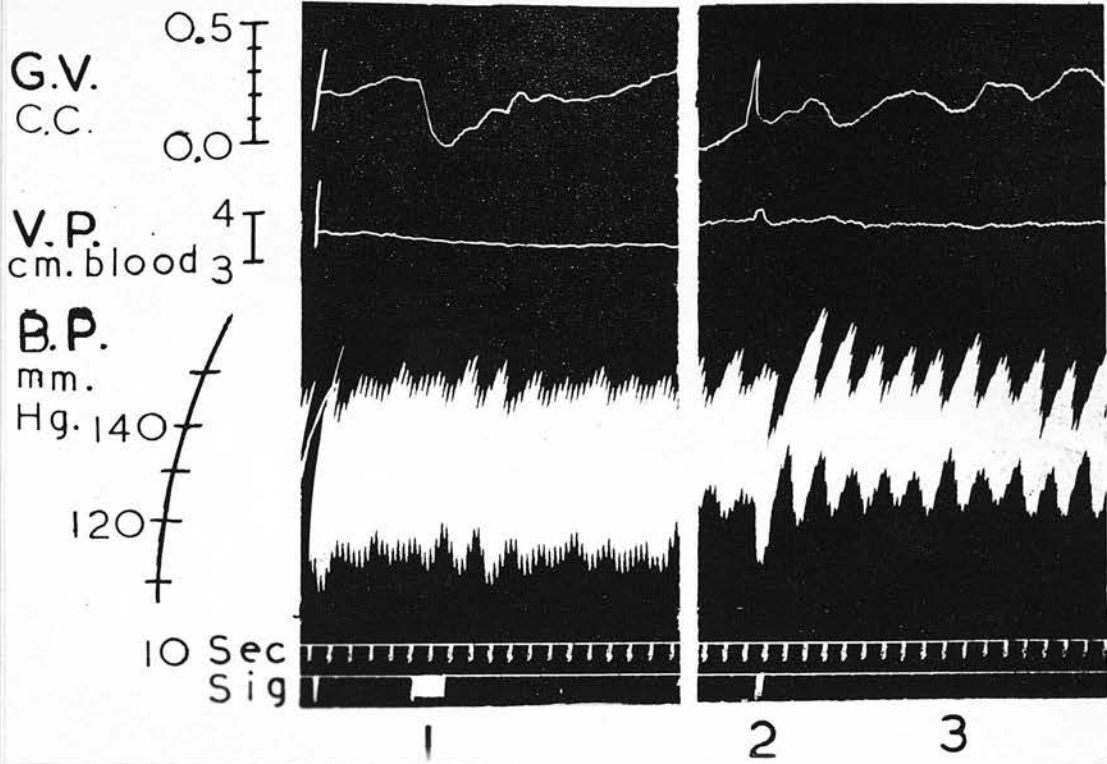

FIG. 65. Expt. C 45. Cat. 3.2 kg. Lactating 15 days. Chloralose and urethane anaesthesia. L 4 in plethysmograph at 1.50 p.m. Gland volume 12 c.c. Venous pressure recorded in left femoral vein. B.P. membrane manometer.

- 1 - 3.23 p.m. Stimulation of the distal cut end of the external spermatic nerve, 10/50/1.
- 2 - 3.54 " Pressure on the abdomen just behind the xiphoid.
- 3 - 3.56 " Spontaneous gland volume changes.

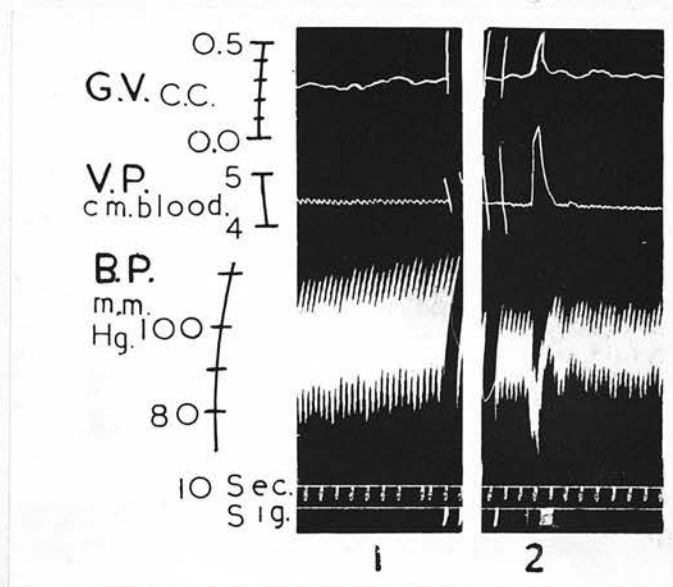

FIG. 66. Expt. C 52. Cat. 2.2 kg. Lactating 16 days. Gland R 4 in plethysmograph at 5.00 p.m. Venous pressure (V.P.) recorded in external pudendal vein. B.P. membrane manometer.

- 1 - 5.50 p.m. Spontaneous G.V. responses without similar changes in V.P.
- 2 - 6.23 " Pressure on abdomen for 5 secs.

the external pudendal vein as it passed through the inguinal canal. However, removal of the round ligament had no effect on the gland volume changes. Histological examination revealed no smooth muscle cells in the interlobular connective tissue of the gland, but it was found that some bundles of striated muscle from the panniculus carnosus muscle traverse the glands (even penetrating into the teat in one case), but it was not considered that this could easily produce the mammary gland volume changes in question.

Finally, it was discovered that type II waves frequently occurred simultaneously in both inguinal mammary glands (L and R 4 in Fig. 1) and in a kidney (Figs. 67 and 68), and usually bore a simple relationship to Traube-Hering type waves in the blood-pressure tracing (one gland volume wave corresponding to 1 or 2 B.P. waves). These B.P. waves were similar to those described by Barcroft and Nisimaru (1932) and by Barcroft, Nisimaru and Steggerda (1932), which were attributed to contraction and relaxation of the spleen and intestines and were abolished by clamping the splenic and intestinal vessels. These procedures, on the contrary, had no effect on the B.P. or organ volume waves encountered in the present experiments. However, when the respiration was recorded in addition, it was seen that the waves in the B.P. and the mammary gland volume could be correlated with rhythmical fluctuations in the depth of respiration (Fig. 68, 69), and that they disappeared when the chest was opened and the animal put on artificial respiration (Starling Ideal Pump).

It was concluded, therefore, that neither type of spontaneous mammary gland volume changes met in these experiments was specifically concerned with the mammary glands: type I were due to compression of the great veins in the abdomen by the abdominal viscera, and type II were due to changes in the blood

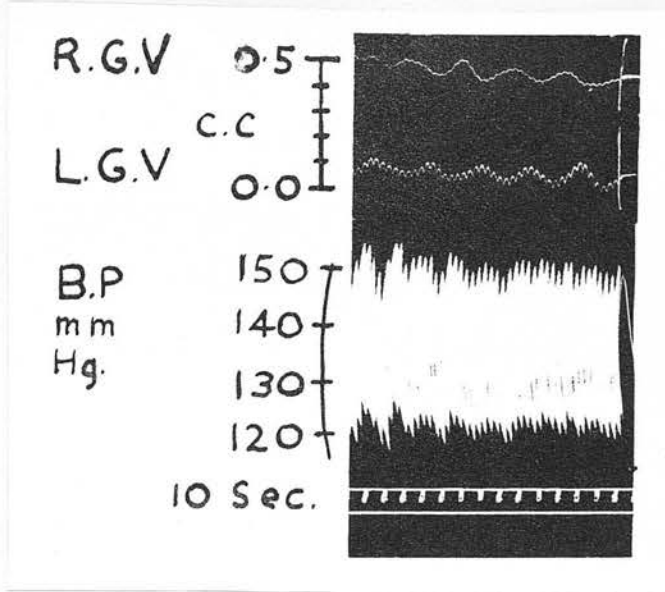

FIG. 67. Expt. C 57. Cat. 2.6 kg. Lactating 7 days. Chloralose and urethane anaesthesia. Glands R and L 4 in plethysmographs at 12.25 p.m. Cat supine.

Showing spontaneous changes (type II) in G.V. tracings.

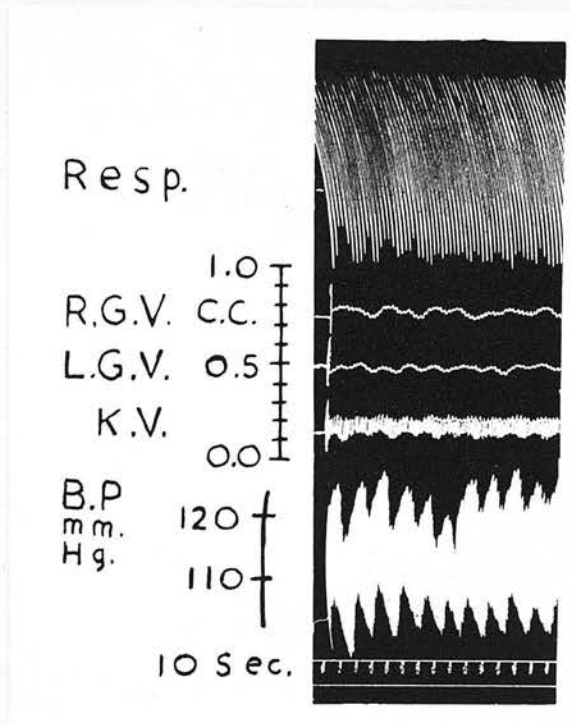

FIG. 68. Expt. C 61. Cat. 2.95 kg. Lactating 8 days. Chloralose and urethane anaesthesia. Mammary glands L 4 and R 4 and left kidney in plethysmographs. Organ volumes 16, 16 and 11 c.c. respectively. Respiration recorded by volume recorder and oesophageal tube ending over the base of the heart. B.P. by membrane manometer. Started at 1.14 p.m.

1.45 p.m. Spontaneous changes.

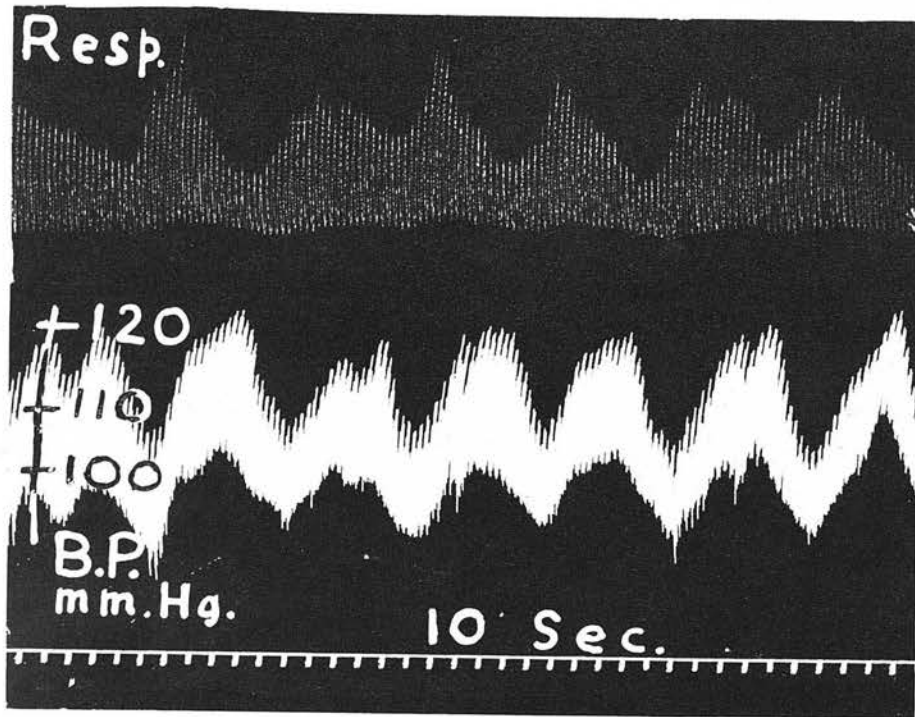

FIG. 69. Expt. C 58. Cat. 1.9 kg. Chloralose and urethane anaesthesia. Spontaneous fluctuations in B.P. following similar changes in depth of respiration.

flow through the glands, which was of central origin and probably connected with variations in the depth of respiration.

Discussion

From these experiments it is apparent that the mammary glands receive vasomotor fibres from the cutaneous mixed spinal nerves. The usual response to electrical stimulation of the distal cut ends of these nerves is a vasoconstriction of the small arteries and arterioles in the mammary glands, the vessels which histological examination reveals have a well formed muscular medial coat and two or three fine nerves between the media and adventitia. It can also be shown that the vasoconstrictor nerves concerned are adrenergic, because (a) adrenaline has the same action, (b) the vasoconstriction is unaffected by eserine and atropine, (c) it is potentiated by cocaine and tannic acid, and (d) abolished or reversed by ergot preparations.

It is well known that the mixed spinal nerves contain sympathetic vasomotor fibres. There can be little doubt that the vasoconstrictor fibres in the lumbar nerves, which have been shown in these experiments to extend to the mammary glands, skin and subcutaneous fat, are sympathetic in origin and pass to the spinal nerves in the grey rami. The location of the cell stations of the fibres concerned is beyond the scope of this thesis, but many careful dissections have failed to reveal any connections between the abdominal sympathetic plexuses and the spinal nerves studied. This confirms the finding of St. Clair (1942), who noted an increase in the temperature of the cow's udder when he removed the inguinal nerve or the lumbar sympathetic chain, but no change when the posterior mesenteric plexus was ablated.

In the ruminant the perineal nerve, which is the continuation of the pudic nerve arising from sacral nerves II, II and IV also sends fibres to the back of the mammary glands (St.Clair,

1942), but this has not been found in any dissections of the mammary glands in the dog and cat. The fact that nicotine has no action upon the vasoconstriction produced by stimulating the lumbar nerves shows that there are no ganglia in the course of these nerves in the mammary glands (confirmed by a similar finding by Peeters, Coussens and Sierens (1949) in the cow and much histological work). For these reasons it is difficult to agree with the suggestion of Petersen (1942) that the mammary gland probably receives parasympathetic innervation, although the evidence on which it is based, that the gland responds to parasympathomimetic drugs, is confirmed.

No convincing evidence was found of vasodilator fibres to the mammary glands in these experiments. It may be that the small and inconstant responses observed were in fact due to the stimulation of either sympathetic or antidromic vasodilator fibres, although the latter hypothesis is unlikely, since the time relations and characteristics of the responses recorded were not typical of antidromic vasodil^{ta}ation. It could be sugges-
ted that vasodila^{ta}tion was not readily demonstrated because the innervated vessels were already fully dilated, but all the observations made point to the opposite conclusion. In fact, the major difficulty of the preparation for all experiments reported here was to reduce spontaneous vasoconstriction, and the conditions should have been ideal for the demonstration of vasodilatation.

Although it has not been directly shown that sympathetic vasoconstrictor fibres play any part in controlling the blood flow through the mammary glands of the unanaesthetised animal, the vasoconstriction to anoxia demonstrated in the anaesthetised state is as great as can be subsequently produced by maximal stimulation of the external spermatic nerve, and this

severely curtails the blood flow through the gland for 1 to 2 minutes or more. It seems very likely, therefore, that the fall in milk yield, which is so well known to occur in the cow when subjected to fear or pain, is a direct consequence of a poor blood flow through the organ resulting from reflex vasoconstriction, and the action of adrenaline released into the circulation under these circumstances.

Vasomotor nerves have been demonstrated in these experiments only in lactation and in commencing involution. In view of the rapid growth of the mammary gland in the first half of pregnancy, and its equally rapid involution at the end of lactation, accompanied in the rabbit, according to Wahl (1915), by the formation of new vessels, it would appear that it might be a suitable tissue for following the growth and degeneration of vasomotor nerves. However, this may not be the case. Dabelow (1933) believes that the mammary glands of the mouse, rat, guinea pig and rabbit, developing in the subcutaneous fat, take over the pre-existing capillaries, which become enlarged in the region of the mammary tissue (some become differentiated into arterioles and venules), and that no new vessels are formed. It has been shown in the present experiments that the mammary fat also receives sympathetic vasoconstrictor fibres, so that the vessels taken over by the developing mammary gland are presumably already innervated, and the growth of nerves may be as limited as the growth of vessels in these species. Dabelow also states that the capillaries in the fat between the lobules, which are continuous with the vessels within the mammary lobules themselves, in the laboratory rodents, may serve as shunts for the transfer of blood from an inactive (full of milk) to an active (empty) lobule, assuming that the distended alveoli

would mechanically compress the capillaries in the inactive lobules. If this hypothesis is correct, vasomotor nerves to the anastomotic vessels may be of importance for this phenomenon, although in the cat and dog, in which no evidence for intercommunicating lobular capillaries was found (Section I, p. 67), it is more likely that the nervous control of local blood flow would be carried out via the vasomotor nerves to the supplying arterioles.

The difficulties and sources of error encountered in the methods used for these experiments need little comment. The changes in mammary gland volume produced by extrinsic factors merely emphasise the care necessary in the interpretation of plethysmograph records, and the analysis of their causes may be of wider interest in view of similar spontaneous volume waves detected by the sensitive finger plethysmographs (see Burch, 1948). The difficulties met with in trying to perfuse the mammary glands also illustrate the great care required in discovering how far the conditions obtaining during perfusion approach the normal. It is not sufficient to assume, as has been done by other workers in this field, that the mammary tissue remains/merely because it carries out one or more functions as in the intact unanaesthetised animal. The implications from these experiments, that the blood flow may be reduced in the perfused state on account of the vasoconstriction so easily induced by handling and cooling, shows that misleading findings may result from the use of such preparations in biochemical studies of milk secretion without some independent means of assessing their value. The perfusion method is further considered in Section III.

Summary of Section II

1. The existence of sympathetic vasoconstrictor fibres in the spinal nerves to the mammary glands of the cat and dog has been demonstrated in experiments involving blood flow measurements, plethysmography, perfusion of the isolated gland, and microscopical examination of the living vessels.

2. In the cat, vasoconstriction was only observed in the small arteries and arterioles, vessels which, on histological examination, were found to have much smooth muscle in the medial coat and were innervated by fine unmyelinated nerve fibres.

3. The nerve endings concerned are thought to be adrenergic because:-

(a) adrenaline has the same action in very small doses;

(b) their effects are unaffected by eserine, atropine and nicotine;

(c) are potentiated by cocaine and tannic acid;

(d) abolished or reversed by ergot preparations.

4. No convincing evidence has been obtained of the existence of active vasodilator fibres in the spinal nerves studied, or of parasympathetic innervation of the mammary gland.

5. The mammary gland blood vessels are very sensitive to cooling, to which they react by vasoconstriction.

6. Two types of spontaneous volume waves seen in plethysmograph experiments are described and their causes discussed.

7. Some difficulties encountered in the perfusion method used are described and the method is criticised on account of the low blood flow encountered.

8. Figures are given for the mammary blood flow under various experimental conditions.

SECTION III

SOME CONDITIONS AFFECTING THE BLOOD FLOW THROUGH

THE PERFUSED MAMMARY GLAND

In the previous section the experiments employing perfused mammary tissue were criticised because the blood flow was only about one-tenth of that through the intact glands of anaesthetised animals. This is also true of the isolated perfused cow's udder (Peeters, 1950).

The experiments reported here were undertaken to see if the blood flow through the perfused mammary gland could be improved by incorporating the lungs in a circulatory system serving the otherwise isolated gland, since in the experience of other workers (Eicholtz and Verney, 1924; Hemingway, 1931; Newton, 1932; Bayliss and Ogden, 1933) the passage of shed blood through lungs reduces its vasoconstrictor properties.

Methods

Procedure. - In 15 experiments, the lactating mammary glands of 2 dogs, 2 goats and 11 cats were perfused. The animals were anaesthetised by intravenous injection (cephalic vein in dogs and cats, jugular in the goat) of chloralose either alone or in combination with pentobarbitone or urethane (see Table III). The most satisfactory anaesthesia was obtained with a 1 : 10 mixture of chloralose and urethane.

After insertion of tracheal and venous cannulae, one inguinal mammary gland was carefully separated from the skin and other surrounding tissues except for the main artery and vein. In the goat the whole udder ~~was~~ thus separated but it was not skinned.

Artificial respiration (Starling Ideal Pump) was then begun and the chest opened widely by splitting the sternum. Bleeding from small vessels was controlled with the aid of

"Fibrin foam" (Lister Institute). A loose ligature was passed around the pulmonary artery, then a wide bore cannula was tied into the tip of the left auricular appendage and its free end closed. Loose ligatures were put in place around the tissues connecting the lungs to other thoracic structures so that they could be tied off later to prevent any leakage through the lungs' systemic vessels. (A small part of the oesophagus was left attached to the trachea). Heparin (Liquemin Roche, 1000 I.U. per kg. body weight) was injected intravenously and the animal bled out from a carotid artery. Glucose (0.5 c.c. 20%/100 c.c.) and heparin (500 I.U./100 c.c.) were added to the shed blood which was then placed in the perfusion apparatus. Immediately following death the pulmonary artery was cannulated, the prepared ligatures in the thorax tied, the heart tightly bandaged to compress the ventricles and the lungs removed from the chest and placed in the respiratory chamber. The cannula in the left auricle (venous) was opened and perfusion via the pulmonary artery begun. A few minutes later perfusion of the mammary gland was also started.

Subsequently it was found more satisfactory in the case of cats to use a donor animal (large male cat with compatible blood) to supply the lungs and blood for the perfusion. In this case the mammary gland was not removed from the lactating cat until lung perfusion was well established. The mammary circulation could then be re-established in 3 to 6 minutes.

In one experiment the gland of a cat was perfused in a system in which the lungs were replaced by an artificial oxygenator (Hooker-Drinker type). In two other experiments (1 cat and 1 goat) the Richards and Plant (1915) technique used previously was again employed (Section III, p. 75), but with the difference that the pump was working at constant pressure and not

as before at constant volume inflow. The pump was fed with blood from the femoral artery. The overflow from the constant pressure shunt and the venous effluent were both returned to the animal through its femoral veins.

Mammary gland-lung perfusion circuit. - It will be observed from Fig.70 that the lungs and mammary gland were perfused not "in series" but "in parallel" from a large common reservoir. This proved to be a practicable arrangement for perfusion of the mammary glands of the cat because in this case the rate of flow through the lungs was so much larger than that through the gland that the blood in the reservoir at any given time approximated very nearly (in gas concentration) to pure pulmonary venous blood (80-100% saturated with oxygen). In the case of the dog or goat, in which the disparity between the mammary gland ~~the~~ lung blood flows was not so great, two blood reservoirs were used. These were joined by tubing which prevented the blood from accumulating on one side of the circuit and allowed only minimal mixing of "arterial" and "venous" bloods. Closure of the connecting tube between the two reservoirs resulted in a strictly "in series" perfusion (Fig.71).

and

Except in one experiment in which a positive pressure pump (Starling Ideal) was used, ventilation of the lungs was by negative pressure, using the modified respiratory chamber described by Hebb and Nimmo-Smith (1946). Either air or a mixture of CO₂ (5 or 7%) in O₂ was respired. The tidal air (T.A.) was recorded with a small spirometer. A CO₂ absorber could be switched into the respiratory circuit if desired.

The blood entering and the air surrounding the mammary gland were maintained thermostatically at 38.5°C., while the blood entering the lungs was at 32 to 34°C. and the respiratory chamber at approximately 35°C.

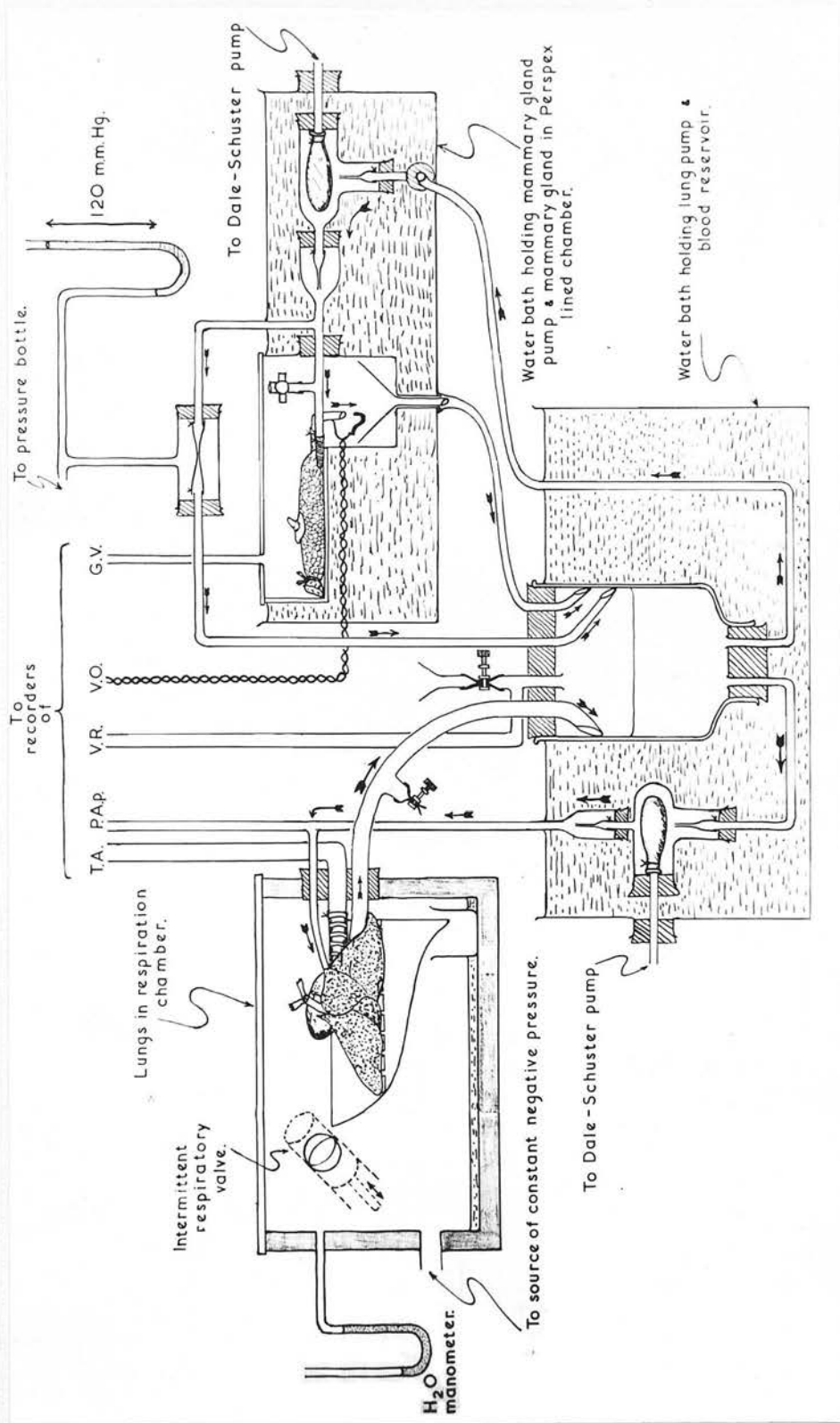

FIG. 70. Diagram of the apparatus used for perfusing the lungs and mammary gland of the cat. Mammary perfusion at constant pressure. For further details and abbreviations see text. In the actual apparatus the positions of the tubes returning blood to the reservoir were reversed so that lung venous blood was on the side supplying the mammary pump and vice versa. The course taken by the blood is indicated by arrows.

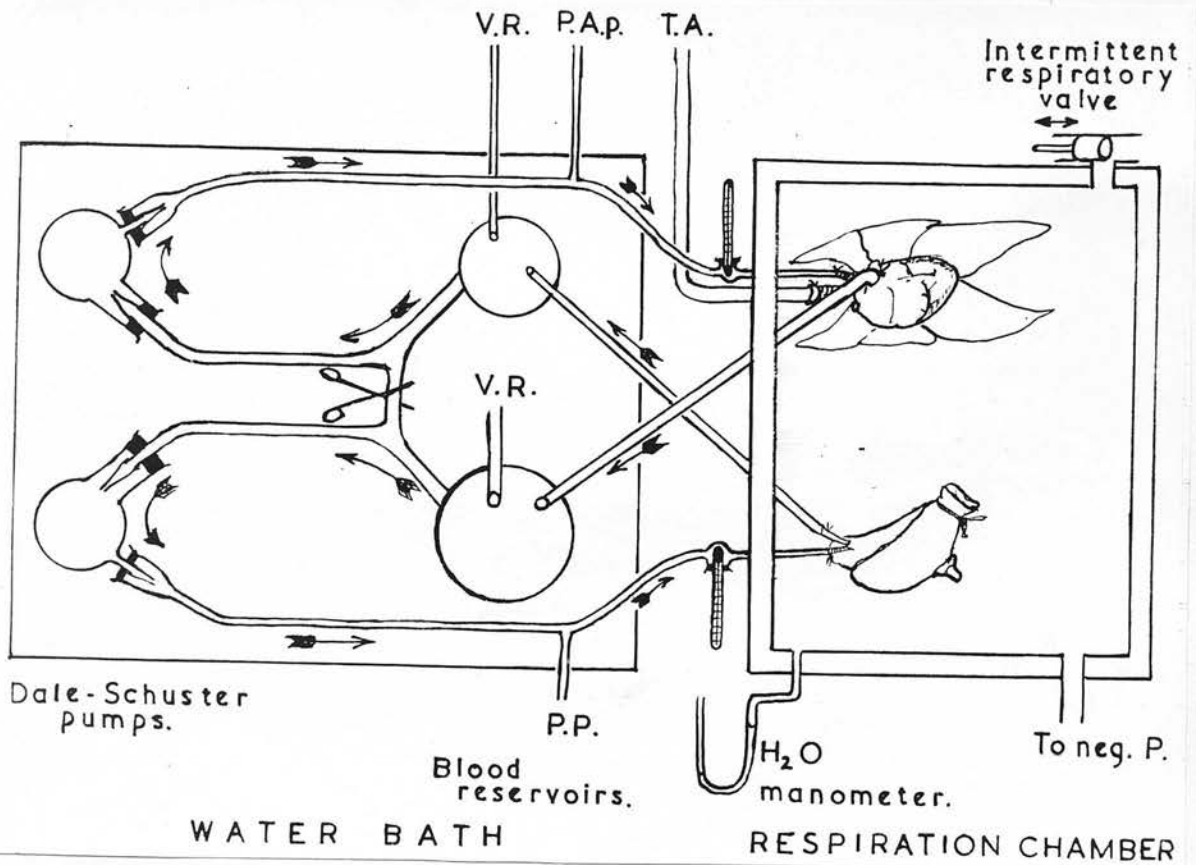

FIG. 71. Apparatus for perfusion of the lungs and mammary gland of dog or goat. Constant volume mammary perfusion. Also see text.

Continuous records were taken of:- The pulmonary arterial pressure (P.A.p.); the mammary venous outflow (V.O.) with the simple drop recorder used previously or with the Fleisch type Pulszeitschreiber (ordinate recorder) used by Gaddum and Kwiatkowski (1938); the volume of the blood reservoir or reservoirs (V.R.); and, when perfusing at constant volume inflow, the mammary perfusion pressure (P.P.). Since the circulations were closed, the V.R. recorders reflected inverse changes in the blood volume of the organs supplying the reservoirs. With mammary perfusion at constant pressure, records were also sometimes made of the mammary gland volume (G.V.).

All glassware that came in contact with blood at any time during the experiment was siliconed with a 5% solution of "Teddol" (B.T.H.) in CCl_4 before use. Glucose 0.25 c.c. of 20% solution and heparin 250 I.U. per 100 c.c. of blood were added to the perfusate approximately every hour throughout the perfusion.

It should be emphasised that particular care was taken during all perfusion experiments to overcome the errors (discussed in Section II, p. 77) that can be introduced by fluctuations in temperature, the formation of fibrin, blood sedimentation and mechanical obstructions to flow.

Analyses were made to determine the blood content of:-

- (1) glucose (Hagedorn and Jensen, see Peters and Van Slyke, 1932);
- (2) O_2 and CO_2 (Peters and Van Slyke, 1932); and (3) haemoglobin (cyanhaemoglobin method used by Daly, Eggleton, Elsdon and Hebb, 1946).

Results

Events occurring at the outset of the first mammary gland-lung perfusion (Table III, D 8) seemed to provide an immediate demonstration of the efficiency of the lungs in improving the

TABLE III. - SUMMARY OF EXPERIMENTS PERFORMED

No.	Anaesthetic		Type Expt.	Blood flow cc/100g/min.		Initial µg.	Adrenali ne µg.	ne threshold Maximum g/g, tissue	Length perfusion. hours	Oedema lungs	Remarks	
	mg./kg.			Initial	Max.							
D 8	C P	122.5 6.3	CV	< 1	14.2		10^{-5}	1.65×10^{-14}	6	+		
D 9	C P	109.5 64.8	CV	2.0	55.4		10^{-6}	7.1×10^{-15}	6.5			
C 71	C	83.3	CV	1.75	3.75				4.5	++++	+ P. ventilation of lungs.	
C 74	C	123.5	CV	0.03	0.96		10^{-4}	4.34×10^{-12}	3.25	-	Some haemolysis of blood.	
C 75	C U	43.2 432	CP	0.97	6.83		10^{-4}	8.8×10^{-12}	2	-	Air embolism of lungs terminated expt.	
C 76	C U	43.7 437	CP	1.45	21.5		10^{-3}	5.8×10^{-11}	7	-		
C 77	C U	60.6 606	CP D	4.3	23.4	10^{-4}	10^{-6}	1.73×10^{-13}	10	-		
C.78	C U	53.6 536	CP D	0.7	7.75	10^{-2}	10^{-4}	5.72×10^{-12}	9	++++	Donor's splanchnics cut before bleeding.	
C 79	C U	62.4 624	CP D	0.425	5.38	10^{-5}	10^{-6}	4.25×10^{-14}	5.5	+	? incompatible blood added to system.	
C 80	C U	46.2 462	CP D	3.4	14.8	10^{-5}	10^{-7}	1.1×10^{-14}	7	+	5 p.c. CO ₂ /O ₂ respired continuously.	
C 83	C U	39.3 393	CP D	0.7	30		7.5×10^{-6}	3.75×10^{-13}	5.5	-	7 p.c. CO ₂ /O ₂ respired continuously. Donor's splanchnics cut before bleeding.	
G I	C P	86.9 7.9	CV CV	2.0	13.0		10^{-4}	7.45×10^{-14}	6.75	++++		
G II	C U P	44.6+31.8 446 + 318 16.9	CP	Richards and Plant's method 3.88 3.88 †						4.5		
C 81	C U	33.35 333.5	CP	9.37	9.37 *	0.1	10^{-4}	1.22×10^{-11}	5			
C 82	C U	76.8 768	CP	1.02	Artificial oxygenator 1.02		10^{-2}		5.5		Donor's splanchnics cut before bleeding.	

C = Chloralose; U = Urethane; P = Pentobarbitone;
 CP = Constant Pressure; CV = Constant Volume;
 D = Donor lungs.

† Initial flow only; after 3 hours perfusion flow fell to 1.2 c.c./100 g./min.
 * Initial flow only; it fell to 4.5 in next half-hour and then rose to 7.3 c.c./100 g./min. in 2.5 hours.

blood flow through the mammary tissue. When perfusion started the pump supplying the gland contained blood which had not yet been passed through the lungs and the perfusion pressure quickly rose to 180/220 mm. Hg with a blood flow of less than 1 c.c./100 g./min. However, when blood which was being returned from the lungs began to enter the mammary gland (this could be detected because it was a brighter red), there was an abrupt fall in the perfusion pressure to 70/110 mm. Hg and this pressure was maintained while the flow was increased to 7.6 cc./100 g./min. The flow was nearly doubled in the next half hour and then kept at this rate until lung perfusion was stopped because of pulmonary oedema.

In subsequent experiments lung perfusion preceded mammary perfusion long enough to ensure that all the blood had traversed the pulmonary vessels before it reached the gland. With this precaution the blood flow in the second dog perfusion (Table III, D 9) was initially higher than in the first and was afterwards increased to the very much higher figure of 55 c.c./100 g./min. without increase of perfusion pressure above physiological limits. No pulmonary oedema developed and the mammary blood flow was maintained at this level for $6\frac{1}{2}$ hours. The maximum rates of blood flow in these two experiments were much larger than the previous maximum values of 3.1 to 7.54 c.c./100 g./min. (mean \pm S.D. = 4.59 ± 1.54) obtained for this species with the Richards and Plant technique, and they fall within the range of values observed in glands with their normal blood supply intact.

An experiment on a goat mammary gland-lung preparation (Table III, G 1) was not satisfactory since pulmonary oedema had developed before dissection of the lungs was begun. However, the maximum blood flow (constant volume inflow) of 13 c.c./100 g./min. was 3 to 10 times higher than that in another goat udder

perfused by the Richards and Plant technique at constant pressure inflow (Table III, G 2).

In the first two experiments on cat glands (Table III, C 71 and C 74) perfusion at constant volume inflow was used but owing to the small dimensions of the gland this proved to be impracticable since the rate at which blood was replaced in the pump was so slow (once every 20-30 mins) that it was nearly stagnant and its vasotonin content increased. This accounted for the low flows observed. To eliminate such effects, a constant pressure shunt back to the reservoir was arranged, so that the gland was now perfused at constant pressure inflow adjusted between 120 and 140 mm. Hg and vasomotor effects were signalled by changes in V.O. (venous outflow). With this arrangement the flow through the pump was more than 200 c.c./min. (of which less than 3 c.c. was diverted to the mammary gland) and the rate of replacement was about 10 times per min.

In this way, much better results were obtained. After an initially high vascular resistance (spasm of the main artery along a length of 1 to 2 mm. was often seen after cannulation), there ensued a fairly rapid rise in venous outflow, which continued for 1.5 to 3 hours (Figs. 72, 73 and 74). The maximum flow achieved in three experiments which for technical reasons were the least satisfactory was between 5.38 and 7.75 cc./100 g./min. In one of these there was gross pulmonary oedema (Table III, C 78); in another accidental pulmonary air embolism cut short the perfusion (Table III, C 75); while in the third, blood, later found to be incompatible with that of the lactating cat, had been introduced into the system (Table III, C 79). However, in four other experiments with constant pressure perfusion, in which no accidents occurred and pulmonary oedema was absent or not serious, the maximum flows were 14.8, 21.5, 23.4 and 30.0

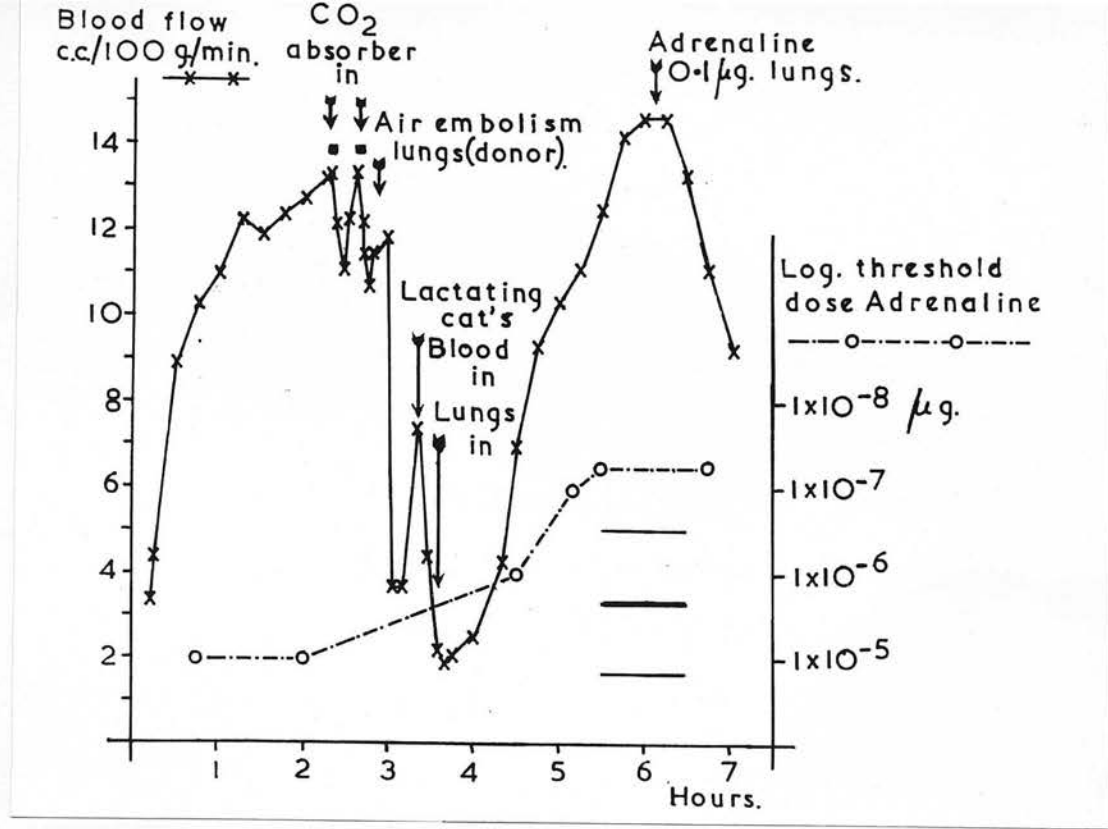

FIG. 72. Graph of mammary blood flow for Expt. C 80. Note the falls in mammary blood flow when the CO_2 absorber was switched into the respiratory circuit for two five minute periods after two and half hours perfusion. Also the marked fall as soon as the lung perfusion was stopped because of air embolism, the further fall when 60 c.c. of the lactating cat's blood was put in the reservoir and the gradual recovery when the same cat's lungs were perfused in place of the donor's. The three horizontal lines show the mean (thick) \pm twice the standard error of the mean (thin), blood flows for cat mammary gland perfusions by Richards and Plant's method as used in Section II.

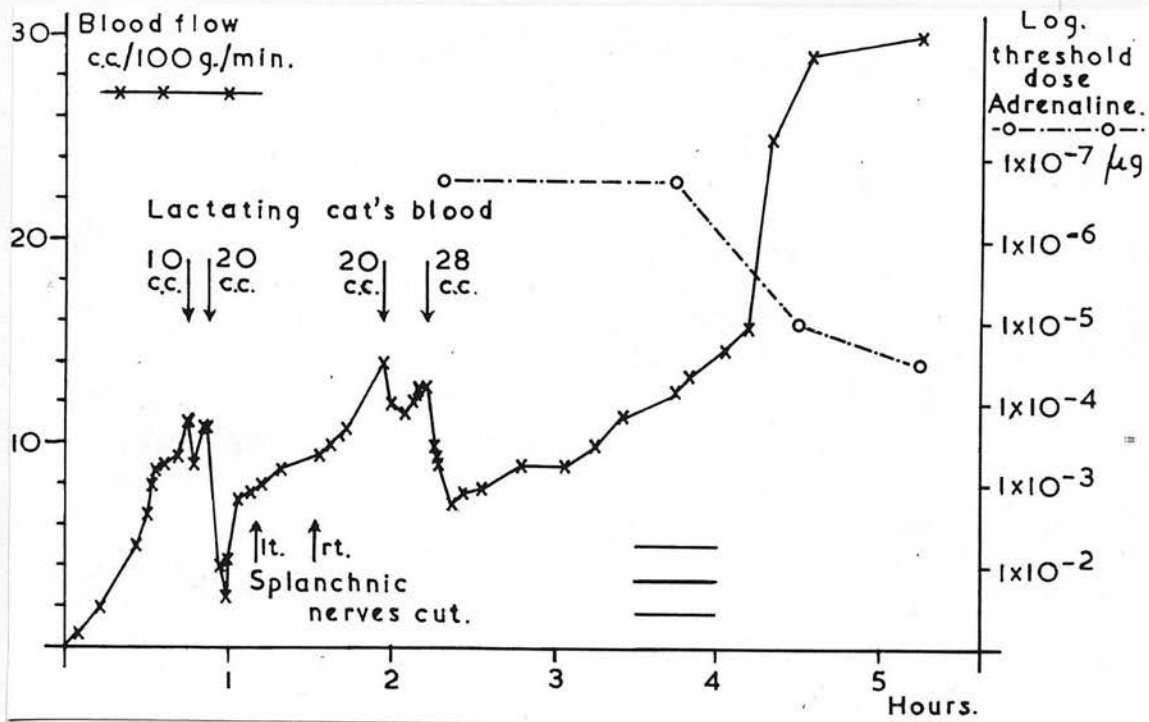

FIG. 73. Graph of mammary blood flow for Expt. C 83, showing the effect of adding to the reservoir blood withdrawn from the lactating cat before and after cutting its splanchnic nerves. The reason for the fall in sensitivity to adrenaline observed later may have been a fall in blood glucose. The gland was not "dying" because at the end of perfusion the arterio-venous difference for glucose was 13 mg.% and for O_2 3.95 vols.% (R.Q. = 1.2). For the meaning of the horizontal lines see legend of Fig. 72.

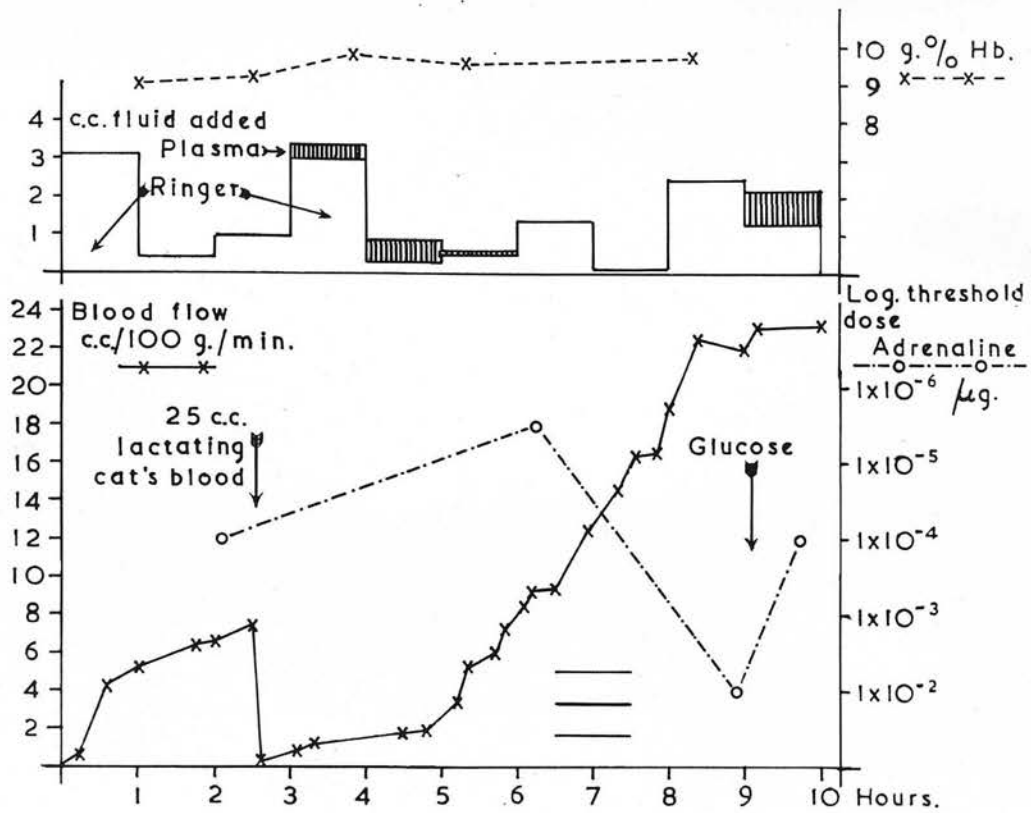

FIG. 74. Graph of mammary blood flow for expt. C 77 showing the gradually increasing blood flow throughout the experiment and the vasoconstrictor effect of lactating cat's blood. The increasing blood flow was not due to a lowered blood viscosity because in spite of the Ringer added to the perfusate (180 c.c. blood) the haemoglobin level increased slightly. Note the effect of glucose upon the falling sensitivity to adrenaline.

c.c./100 g./min. (C 80, 76, 77 and 83 respectively). These compare favourable with the range of maximum values 6.6 to 55 c.c. (mean 23.8 ± 10.41) found for intact glands of the anaesthetised cat and show a considerable improvement over the maximum values, 0.48 to 7.13 (mean 3.33 ± 2.5) obtained for cat glands perfused according to the Richards and Plant technique, with constant volume inflow.

The experience gained from the mammary gland-lung preparations suggested that the poor flows encountered in the experiments just quoted from Section II might also have been due to the formation of vasotonins in the blood during too slow a passage through the connecting pump. Accordingly the Richards and Plant method was retested but the pump was arranged to work at constant pressure inflow (as described above) so that the blood in the apparatus would be continuously and rapidly replaced from the arterial system of the animal. In this experiment (Table III, C 81) a considerable improvement in mammary blood flow was realised. As compared with previous experiments the maximum was higher but it is more significant that the flow was well maintained for 5 hours. Previously it had been found to drop as the experiment progressed (see Fig.75).

In the mammary gland-lung preparations as in isolated perfused lungs, the blood CO_2 was very low unless the lungs were ventilated with CO_2 mixtures. In early experiments measures of this kind to prevent hypocapnia were not taken since it was thought that CO_2 might produce too severe pulmonary vasoconstriction (see Duke, 1949, 1951) but later on, ventilation with 5% CO_2 in O_2 (in one experiment 7% CO_2 was used) was tried and found to maintain the blood CO_2 at about 30 vol. %. This precaution proved to be important for mammary blood flow since tests showed (see Fig.72) that interruption of CO_2 ventilation

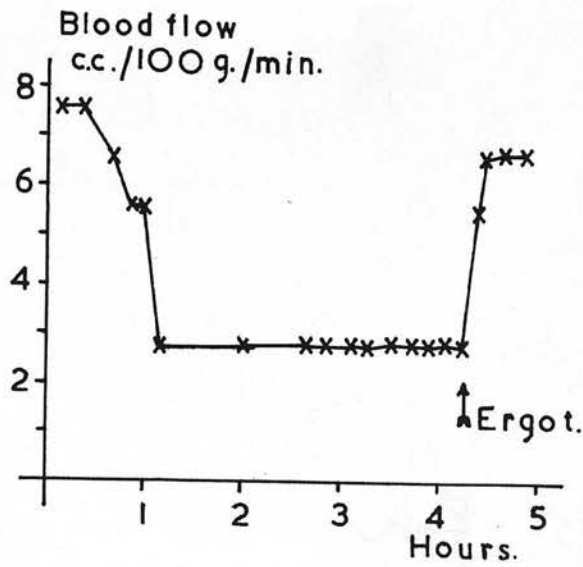
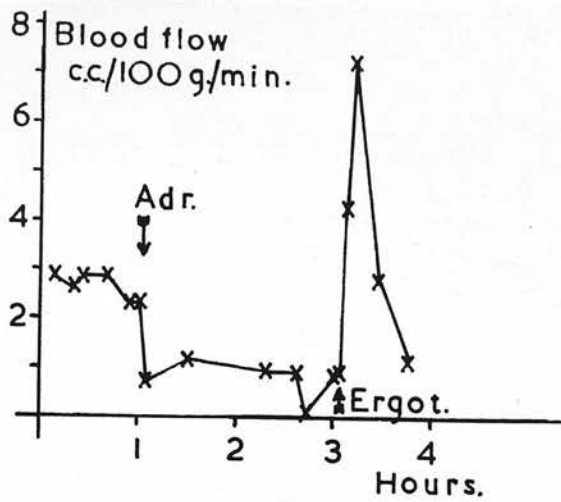

FIG. 75. Graphs of mammary blood flow from two typical experiments (cat C 49 above and dog D 5 below) of perfusion at constant volume by Richards and Plant's method. Shows the improvement in blood flow after the administration of dihydroergotamine. Also shows the effect of 10 μ g. adrenaline given intravenously to the donor in the upper experiment (indicated by arrow at 1 hr.).

was followed by a reduction in blood flow through the gland while recovery occurred after CO₂ ventilation had been resumed. The improvement in mammary blood flow due to CO₂ (given continuously in some other experiments was achieved without any ill-effects to the lungs and the pulmonary arterial pressure was at about its usual level (ca + 20 cm. blood).

Although the increase in mammary blood flow associated with increased blood CO₂ was of significant dimensions it was small when compared with the total improvement in flow which was originally gained by incorporating the lungs in the perfusion system. In a control experiment with the substitution of an artificial oxygenator (aerated with 5% CO₂ in O₂) for the lungs, the blood was fully saturated with O₂ and its CO₂ content kept at 30 vol.%. Nevertheless the maximum blood flow was only 1 c.c./100 g./min. and it was clear that any improvement in flow due to CO₂ was more than offset by the constrictor effect of vasotonins (Fig.76).

Sensitivity of the mammary vessels to adrenaline

It has already been noted that the mammary vessels respond to the vasoconstrictor action of adrenaline in threshold doses of as little as 0.005 µg. for the cat and 0.0001 µg. for the dog. In mammary gland-lung perfusions however, the threshold doses of adrenaline approximated to these values only at the beginning of perfusion, while as the experiment went on and the blood flow reached maximal proportions, the sensitivity of the vessels increased 100- to 1000-fold (Figs.72, 77, 78 and 79). Then it was such that the minimum effective doses required to produce vasoconstriction were found to be 10⁻⁷, 10⁻⁶ and 10⁻⁴ µg. for the mammary glands of the cat, dog and goat respectively. Expressed as g. of adrenaline per g. of tissue these doses were, in the same order, 1.1 × 10⁻¹⁴, 7.1 × 10⁻¹⁵ and 7.45 × 10⁻¹⁴, values which give fairly close agreement for the sensitivity of the three species.

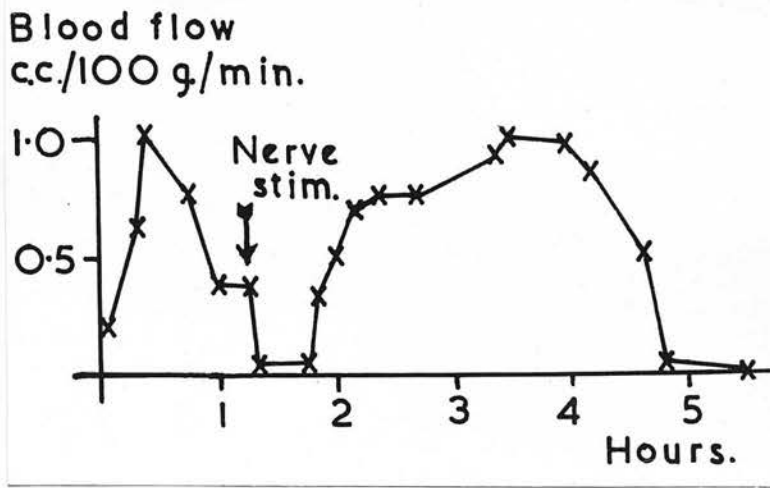

FIG. 76. Graph of mammary blood flow in Expt. C 82. Perfusion of mammary gland with an artificial oxygenator instead of the lungs. The blood flow remained low throughout the experiment and nerve stimulation had a prolonged effect.

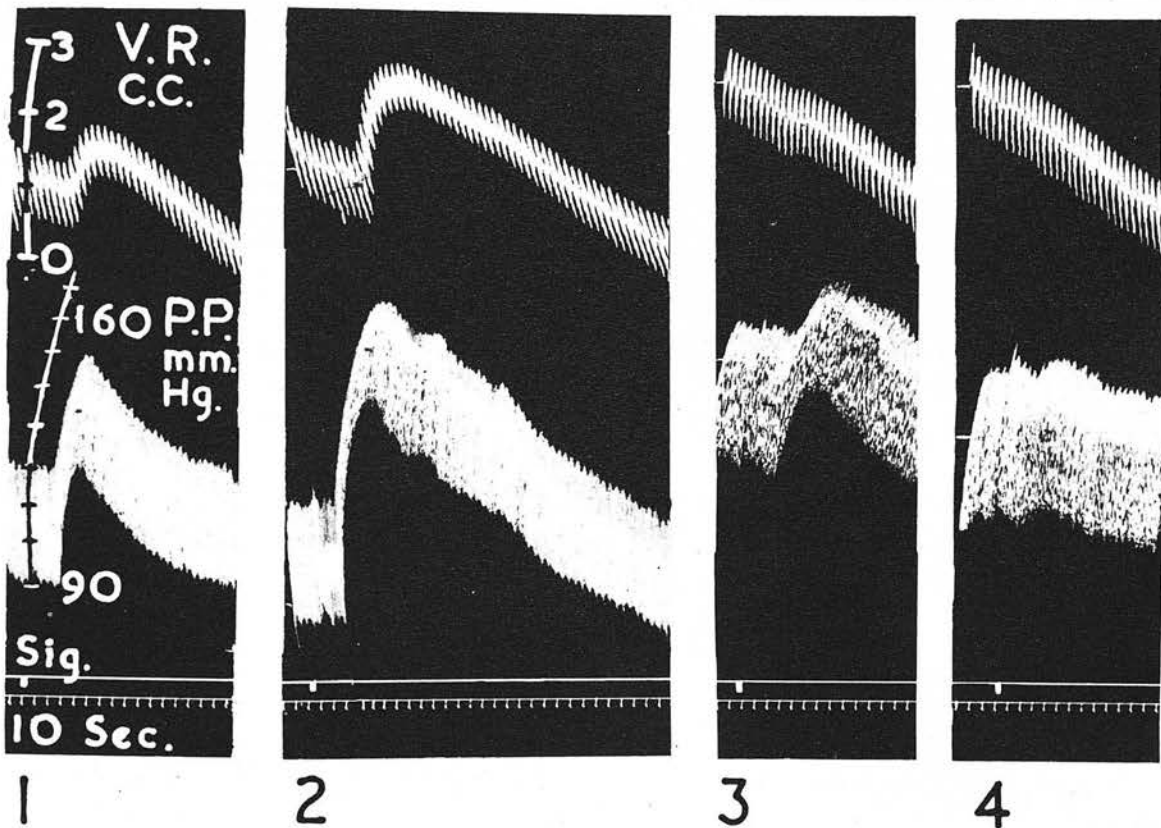

FIG. 77. Expt. D 9. Dog. 20.0 kg. Lactating 56 days. Chloralose anaesthesia. Mammary gland-lung perfusion. Mammary gland perfusion at constant volume inflow started at 2.42 p.m.

Mammary responses to adrenaline and noradrenaline.

- | | | |
|---------------|------------------|-----------------|
| 1 - 4.00 p.m. | dl Noradrenaline | 0.01 μ g. |
| 2 - 4.05 " | Adrenaline | 0.01 μ g. |
| 3 - 5.00 " | " | 0.0001 μ g. |
| 4 - 5.06 " | dl Noradrenaline | 0.0001 μ g. |

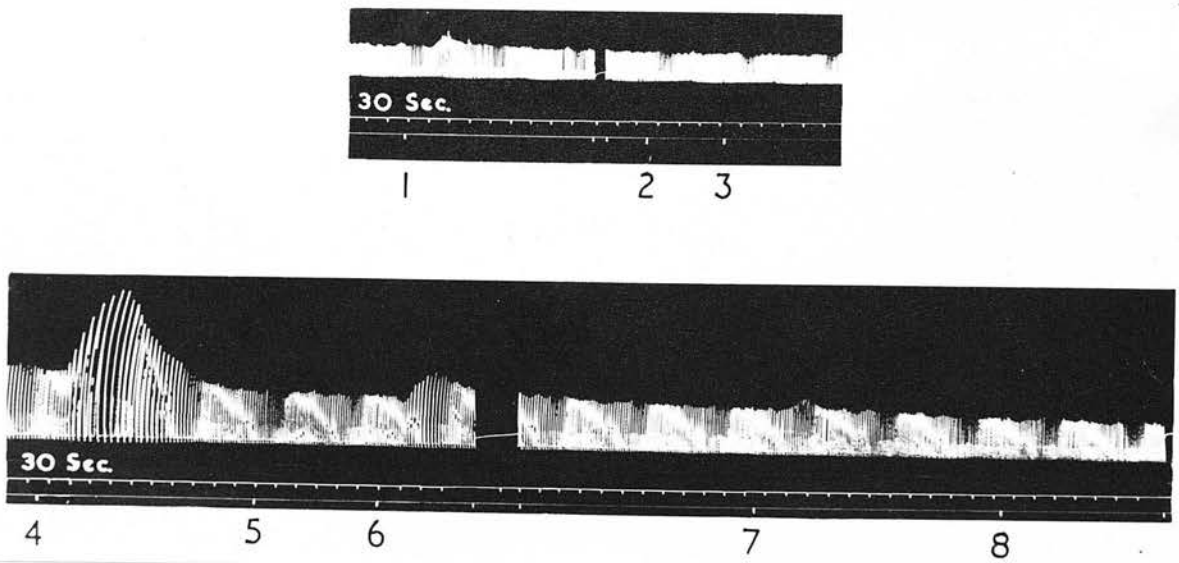

FIG. 78. Expt. C 80. Cat. 2.6 kg. Lactating about 7 days. Chloralose and urethane anaesthesia. Mammary gland-lung perfusion. Mammary perfusion at constant pressure started at 12.00 noon.

Sensitivity to adrenaline. Mammary venous outflow (Ordinate recorder).

1 - 12.40 p.m.	10^{-5} μ g.) Blood flow 10.36 c.c./100 g./min.			
2 - 12.46 "	Ringer control 0.1 c.c.				
3 - 12.47 "	10^{-6} μ g.				
4 - 4.19 "	10^{-5} μ g.	" "	4.44	"	"
5 - 4.24 "	Ringer control 0.1 c.c.				
6 - 4.27 "	10^{-6} μ g.				
7 - 4.35 "	10^{-7} μ g.	" "	7.03	"	"
8 - 4.41 "	Ringer control 0.1 c.c.	" "	9.00	"	"

N.B. The height of the tracing is proportional to the interval between successive drops of blood.

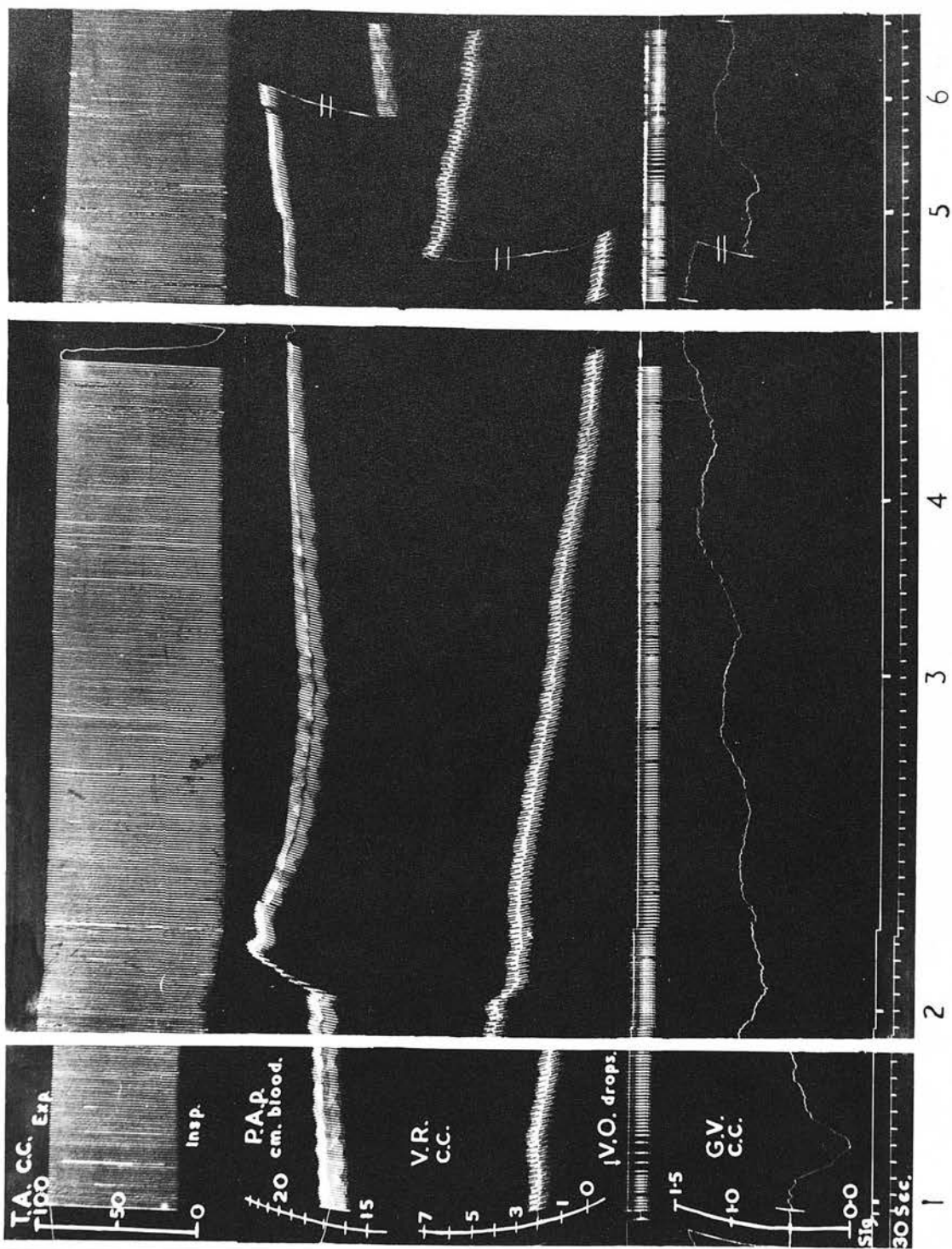

FIG. 79. Expt. C 75. Cat. 1.8 kg. Lactating 47 days. Chloralose and urethane anaesthesia. Cat's own lungs on negative P. Ventilation and mammary perfusion at constant pressure. Started 12.42 p.m. V.O. 18 drops per c.c.

- | | | |
|---------------|-------------------------------------|----------------|
| 1 - 1.35 p.m. | Adrenaline 0.0001 $\mu\text{g.}$, | mammary gland. |
| 2 - 1.53 p.m. | " 0.5 $\mu\text{g.}$, | lungs. |
| 3 - 2.03 p.m. | Saline control 0.1 c.c., | mammary gland. |
| 4 - 2.08 p.m. | Adrenaline 0.00001 $\mu\text{g.}$, | " " |
| 5 - 2.16 p.m. | " 0.0001 $\mu\text{g.}$, | " " |
| 6 - 2.19 p.m. | Saline control 0.1 c.c., | " " |

The lower sensitivity to adrenaline which the mammary vessels exhibited continually in the experiments in Section II and at the beginning of the present experiments may have been the result of pre-existing vasoconstriction. In the mammary gland-lung perfusions it was also observed that when the blood glucose was allowed to fall much below its normal level (this could easily occur since the gland consumption of glucose was fairly high) the sensitivity to adrenaline also fell and could be increased again by injecting more glucose into the blood (Fig. 74). The meaning of this relation is not at present clear.

The threshold for noradrenaline was generally higher than that for adrenaline, but the ratio varied from 1 : 1 to 37.5 : 1.

In the course of these experiments some tests were made to determine whether adrenaline released during bleeding would be present in the shed blood in sufficient quantities to affect the mammary vessels independently of vasotonins. The results of these tests were not decisive, however, mainly because the concentration of vasotonins was large enough to mask the action of any other vasoconstrictor principle which might be present. As little as 0.05 c.c. of some samples of plasma (the red blood cells had no activity) produced a fall in mammary venous outflow; while only double this quantity had an equivalent effect on the lung vessels (rise in P.A.p.). This second effect must have been due solely to vasotonins since the lungs were relatively insensitive to adrenaline and noradrenaline (see below). It was possible, however, that some of the effect of the mammary vessels was due to adrenaline since dihydroergotamine (1 mg.) which reversed the action of adrenaline and that of noradrenaline on the mammary vessels also reduced by about 50% their vasoconstrictor response to injected blood or plasma. It was also found that blood withdrawn from an anaesthetised

lactating animal after section of its splanchnic nerves was only about half as active in causing mammary vasoconstriction as samples taken before the operation (Fig.73).

The functional state of the mammary tissue.

It could be shown in each experiment that some milk was secreted by the perfused tissue. Each gland was emptied of its milk before perfusion began and at the end of the experiment oxytocin was given and the ejection of milk again observed. It was a deficiency of the method that in the dog and cat we had no means of regularly removing the milk without disturbing the perfusion, because in these smaller animals milk does not readily flow along cannulae which are sufficiently fine to be inserted in the milk ducts, so that even after oxytocin administration only a small fraction of the milk that a suckling animal would remove could be obtained. The disadvantage was that in a long perfusion, milk secretion would eventually stop from back pressure and there was some evidence that filling of the gland contributed to an increased resistance which in turn may have promoted the oedema (usually slight) detected by histological examination as an end effect in all experiments.

Measurements of arterio-venous differences in O_2 , CO_2 , glucose and haemoglobin were carried out in some experiments. The tissue removed 3.7 to 8 vols. per cent O_2 from the blood. In the unanaesthetised cow and goat arterio-venous differences for O_2 are generally 3 to 5 vols. per cent., and in the actively secreting state the R.Q. is now known to be above unity (Folley, 1949 a). The R.Q. was estimated by measuring A-V differences in O_2 and CO_2 . Values over one (e.g. 1.2 in C 83, Table III) were encountered although in some experiments they were below. The A-V difference for glucose varied with the rate of blood flow from 13 to 60 mg. per cent., but the estimated glucose

consumption of the gland was more nearly constant (1.8 - 3.1 mg./100 g./min.).

The amount of water taken up by the tissues usually caused haemoconcentration of about 1%. Generally, when this value was exceeded oedema of the gland was more marked than usual. In the goat mammary gland-lung perfusion, water losses were sufficient to produce severe haemoconcentration in the later stages of the experiment. Although there was pulmonary oedema as well, the secretion of 360 c.c. of milk alone contributed in large measure to this because the total blood in the system was only 1400 c.c. In dog and cat experiments in which the volume of blood used was much greater in relation to the weight of mammary tissue haemoconcentration due to milk formation was negligible.

Vasoconstrictor nerve fibres carried by the external spermatic nerves retained their excitability throughout perfusion (Figs.80 and 81).

The response of the lungs to adrenaline and noradrenaline

The threshold doses of adrenaline and noradrenaline for pulmonary vasomotor responses were 1,000 to 10,000 times greater than those for mammary gland reactions. The pulmonary vasomotor responses were tested in only a few instances because, with doses large enough to produce any effect, sufficient adrenaline passed through the lungs to affect the mammary blood flow (Fig.72) for a very long time. The results obtained can be briefly summarised. Adrenaline and noradrenaline, in doses ranging from 0.1 to 15 µg., caused a decrease in the lung blood volume (not significant in the cat). The P.A.p. responses varied: there was either a rise (C 75, C 78 and G 2), or a fall (C 74 and C 79), or a rise followed by a fall (C 75 and D 9),

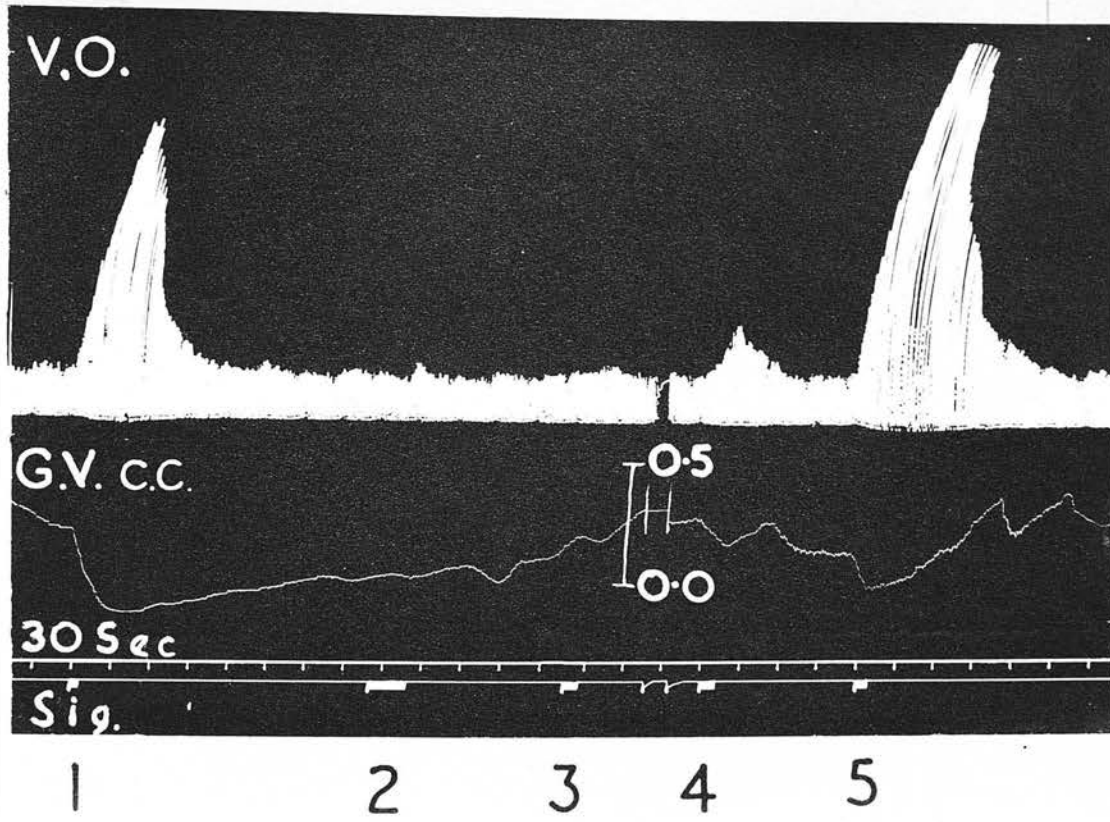

FIG. 80. Expt. C 83. Cat. 3.75 kg. Lactating 7 days. Chloralose and urethane anaesthesia. Mammary gland-lung perfusion. Mammary perfusion at constant pressure started at 1.48 p.m.

Mammary responses to sympathetic stimulation

Stimulation of the external spermatic nerve with a Ritchie-Sheath square wave stimulator. Blood flow 25 c.c./100 g./min. (Ordinate recorder).

- | | |
|---------------|---|
| 1 - 6.07 p.m. | 10 volts/50 stimuli per sec./1 msec./3 sec. duration. |
| 2 - 6.10 " | 1/1/0.01/30 |
| 3 - 6.12 " | 2/5/0.01/15 |
| 4 - 6.16 " | 10/1/1/10 |
| 5 - 6.18 " | 10/50/1/10 |

N.B. The height of the V.O. tracing is proportional to the interval between successive drops. (G.V. = gland volume).

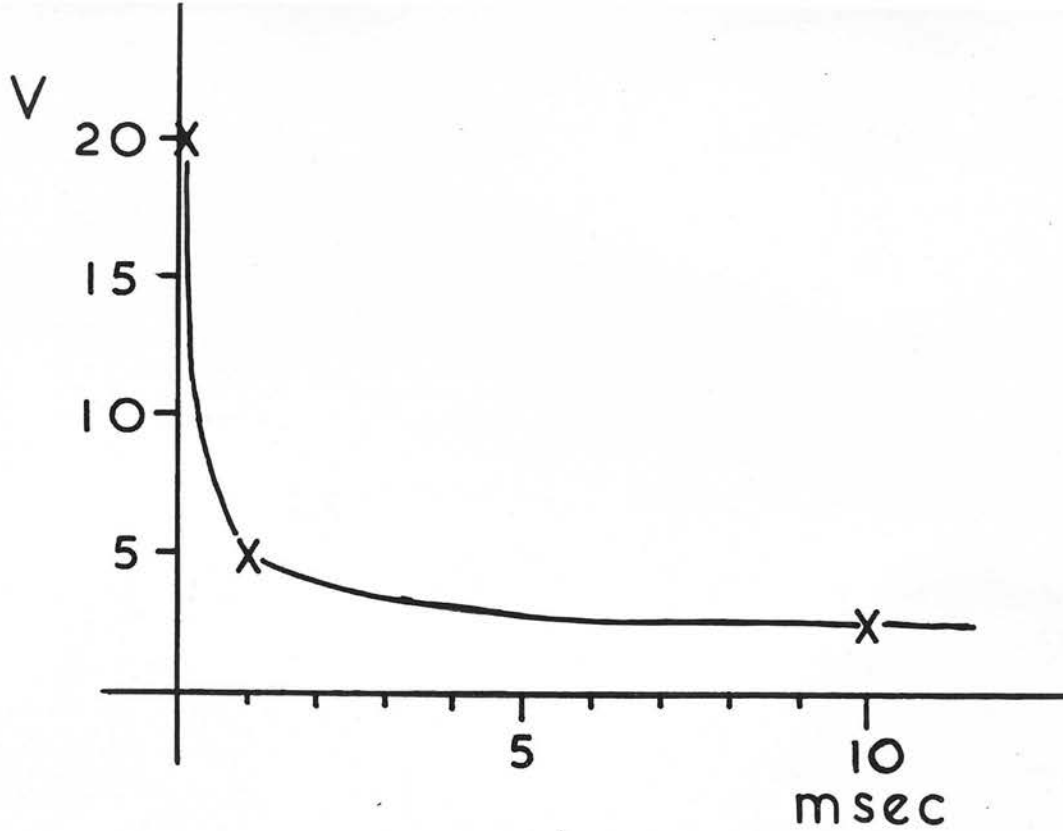

FIG. 81. Expt. C 76. Cat. 1.9 kg. Mammary gland-lung perfusion started at 12.20 p.m.
 Strength duration curve of vasoconstrictor fibres in the external spermatic nerve to the mammary gland 6.43-7.00 p.m.
 Ritchie-Sneath stimulator 50 stimuli per sec. 5 sec. duration.
 Compare with Fig.47.

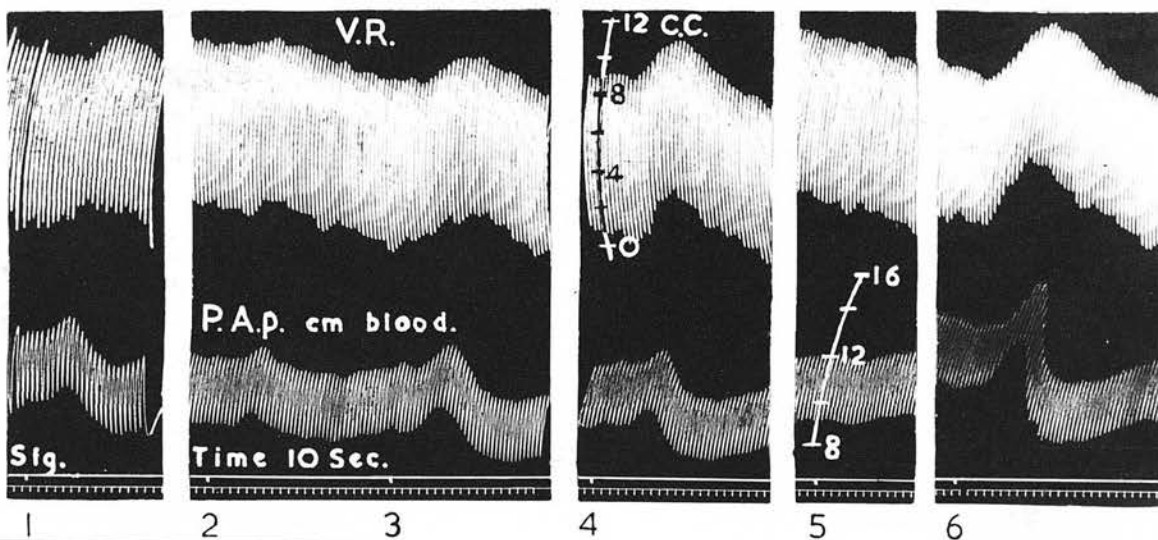

FIG. 82. Expt. D 9. Dog. Same expt. as Fig.5. Lung perfusion started at 2.29 p.m.

Lung responses to adrenaline and noradrenaline.

- 1 - 8.20 p.m. dl Noradrenaline 1.0 µg.
- 2 - 8.27 " Adrenaline 0.1 µg.
- 3 - 8.30 " " 0.3 µg.
- 4 - 8.36 " dl Noradrenaline 3.0 µg.
- 5 - 8.42 " Saline control 0.3 c.c.
- 6 - 8.52 " Adrenaline 1.0 µg.

or different responses at different times in the same experiment (C 76 and C 77). The diphasic, predominately vasodilator, responses to these substances in the dog are shown in Fig.82, and vasodilator responses in the cat in Fig.83. The fall in P.A.p. to noradrenaline has only been observed previously in ergotoxinised lungs (Konzett and Hebb, 1949) and is of interest since it is often thought that noradrenaline has pure vasoconstrictor properties. Adrenaline was about three times as active as noradrenaline in promoting pulmonary responses.

Adrenaline and, to a lesser extent, noradrenaline produced bronchodilatation throughout these experiments, (Figs.79 and 83) and broncho-constriction was not observed although the latter response is observed in isolated dog lungs after perfusion of 1.5 to 2 hours (Daly, Hebb and Petrovskaia, 1941).

Discussion

From the evidence reviewed here it is clear that, as a method for perfusing the mammary gland, the mammary gland-lung preparation gives better and more uniform results than perfusion in series with the whole animal or with an artificial oxygenator. The maximum blood flows in such a system compare favourably with the maximum flows measured with a plethysmograph in the intact glands of anaesthetised dogs and cats and are significantly higher than those obtained with other perfusion methods. The increased sensitivity to adrenaline and noradrenaline is an interesting association with the better blood flow. It is encouraging too, that even after perfusion for some hours, the mammary gland is still viable because milk is ejected in response to oxytocin, and arterio-venous differences in glucose, O_2 and CO_2 are evidence of an active metabolism.

It appears that the larger blood flows obtained in the mammary gland-lung preparations depend upon the effectiveness

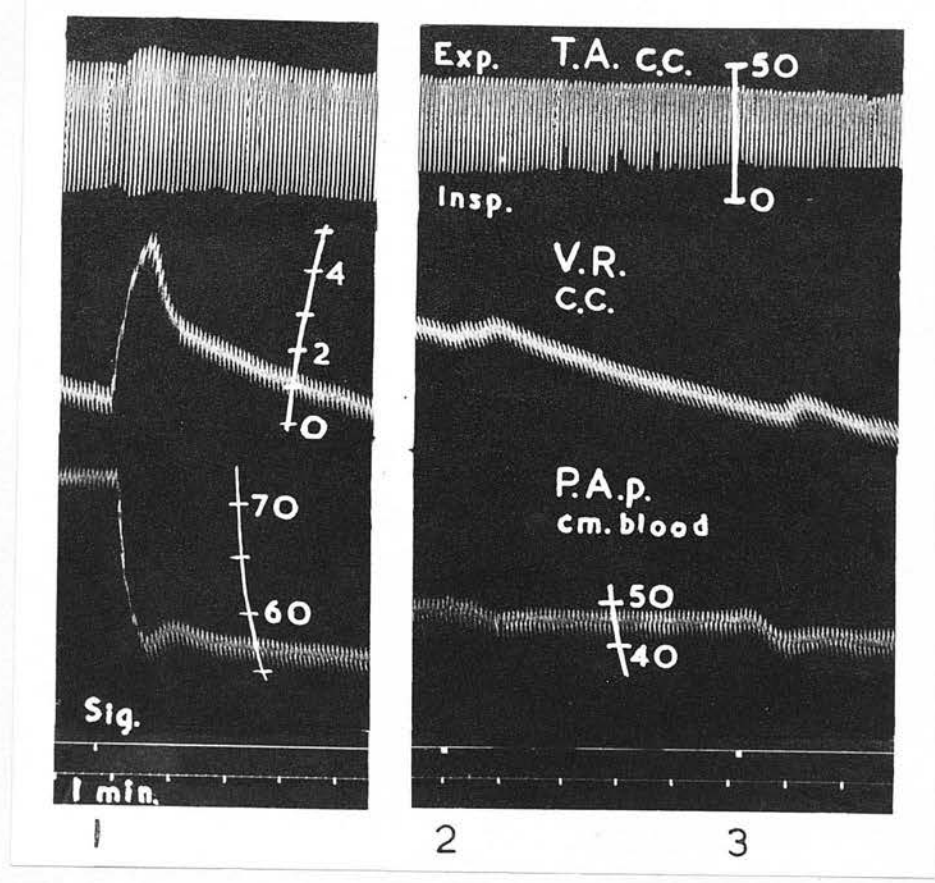

FIG. 83. Expt. C 74. Cat. 2.7 kg. Lactating 6 days. Chloralose anaesthesia. Mammary gland-lung perfusion started at 1.09 p.m. Negative P ventilation of lungs; some haemolysis of blood.

- 1 - 3.05 p.m. Adrenaline 5 μ g. lungs.
- 2 - 4.11 " 1 Noradrenaline 15 μ g. lungs.
- 3 - 4.16 " Adrenaline 5 μ g. lungs.

of the lungs in reducing the vasotonin content of the perfusate. Recently some light has been thrown upon the mechanisms by which this action of the lungs is brought about. The experiments of Rapport, Green and Page (1948 a, b) have shown that a vasoconstrictor substance isolated from serum and partially purified is inactivated by a protein extract of lung tissue. According to Bradley, Butterworth, Reid and Trautner (1950) the enzyme concerned may be a monoamine oxidase.

In practice, provision has to be made for the fact that fresh vasotonins may form if, after leaving the lungs, the circulation of the blood outside the living tissue is sufficiently sluggish. Failure to maintain good flows through cat glands perfused at constant volume inflow was probably dependent upon this fact, as we have seen. There can be little doubt too, that the slow blood flow through the pump in earlier experiments also promoted the formation of vasotonins. Arterial blood from the whole animal having just left the lungs should contain little or no vasoconstrictor substances, and when steps are taken to pass most of it quickly through the pump and back to the animal (constant pressure technique) we now find that a better blood flow is obtained.

Even when difficulties arising from vasotonin formation have been met in this way, there remains the possibility which has not yet been properly tested that because of the extreme sensitivity of the mammary blood vessels to adrenaline and noradrenaline, vasoconstriction will be produced in the gland by release of these hormones into the blood during haemorrhage. It is possible that an initial adrenalinaemia may not seriously affect conditions in the mammary gland-lung perfusions but in the mammary gland-whole animal preparations the risk that adrenaline may be released into the blood at any time during

the experiment must be given more serious consideration. If so, denervation of the adrenals may provide the remedy. In this connection it is of interest that in earlier experiments it was sometimes found that dihydroergotamine greatly improved the blood flow through the gland (Fig. 75). The fact that Heymans, Bouckaert and Moraes (1932) and Bayliss and Ogden (1933) have reported that ergot preparations abolish the vasoconstrictor properties of defibrinated blood does not necessarily detract from this evidence since in neither of these investigations were the animals' adrenal medullas inactivated before bleeding.

Summary of Section III

In an attempt to discover the cause for the low blood flows encountered previously in the perfused mammary gland, experiments have been carried out in dogs, cats and goats, in which the mammary glands have been perfused in conjunction with (a) isolated perfused lungs, (b) the whole living animal (Richards and Plant's method) and (c) an artificial oxygenator.

Approximately normal blood flows were obtained only in the mammary gland-lung preparations, whilst with an artificial oxygenator the flow was exceedingly small. In order to maintain optimum blood flow rates through perfused mammary tissue, it is necessary that the perfusing blood should spend as little time as possible outside living tissue and should pass repeatedly through the lungs (as in methods (a) and (b)) to remove the vasotonins that form in shed blood. The blood flow in perfusion by Richards and Plant's method can be improved if the time spent by the blood between the animal and the perfused gland is reduced to a minimum, but the technique still suffers from the disadvantage that the release of adrenaline or noradrenaline into the blood from the animal's adrenal glands may seriously

decrease the mammary blood flow. The mammary blood vessels of the species tested were found to be extremely sensitive to these substances and when tests were made on mammary gland-lung preparations vasoconstrictor responses were observed with doses of adrenaline equivalent to 10^{-14} g./g. of mammary tissue.

SECTION IVTHE MUSCULAR TISSUES OF THE MAMMARY GLANDS AND
THEIR RELATION TO THE EJECTION OF MILK

The ejection reflex has been described in Section VIII, Part I of this thesis, where it was pointed out that there is a considerable amount of evidence to show that this is due to the release of oxytocin from the posterior pituitary gland. There has been, however, a great deal of doubt and confusion as to how this hormone brought about the transference of the milk from the alveoli and small ducts, where it is stored, to the larger ducts and cisterns, from which it can be easily removed by suckling (see Figs. 84 and 85). It is obvious that some active process is required to bring this about.

Hammond (1936) postulated that the "let down" phenomenon was due to a vascular erection process, similar to the penis, since early German anatomists had described a network of veins in the cow's teat, which they thought was cavernous erectile tissue (see Furstenberg, 1868; Riederer, 1903; Rubeli, 1916; Zietzschmann, 1917). Subsequent histological studies have failed to demonstrate any vascular arrangement that could erect the mammary gland itself, and the majority of workers believed that the smooth muscle in the gland was probably responsible, although several doubted whether there was enough present (Richardson, 1947).

It is well known that there is a large amount of smooth muscle in the teat and areola and it is generally stated that a few sparsely distributed cells extend along the main ducts and to some extent mingle with the connective tissue of the interlobular septa. There have also been some reports of smooth muscle cells around the alveoli (Swanson and Turner,



Photomicrograph of the living mammary gland of an anaesthetised lactating mouse with blood and nerve supply intact, 10 hours since last suckled.

FIG. 84. Normal appearance of distended gland showing evenly distributed alveoli as white dots and white milk filled ducts.

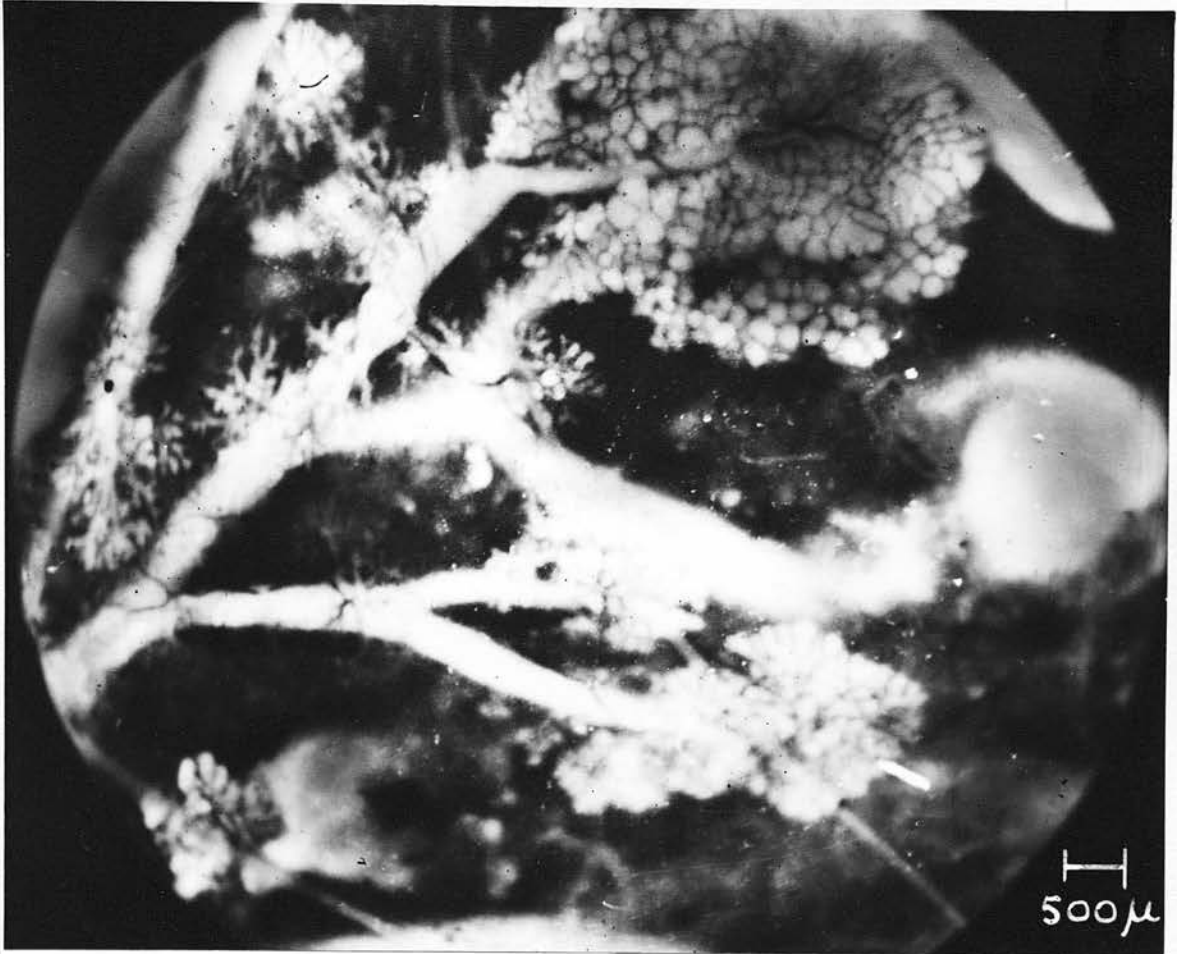

Photomicrograph of the living mammary gland of an anaesthetised lactating mouse with blood and nerve supply intact, 10 hours since last suckled.

FIG. 85. Same field 2 minutes after applying 0.01 U of oxytocin (Pitocin P.D. and Co.). Note that the majority of alveoli have been emptied of milk and can no longer be seen, whilst the ducts have become greatly distended. Two most superficial lobes have not been emptied, probably because the milk could not escape as the ducts were distended to capacity.

1941), but there is little doubt that many people have confused smooth muscle with myoepithelial cells in this position (see Turner, 1939 b).

The existence of myoepithelial cells (Basket cells, Korbzelle, Basalzelle) lying between the secretory cells and the basement membrane has long been known in salivary, lacrymal, sweat and mammary glands. They were accurately described and illustrated by German histologists during the 19th century.

Kölliker (1850) described long spindle shaped muscle cells along the outside of sweat ducts and Henle (1850) referred to a sheath of muscle cells accompanying the milk ducts deep into the gland substance. Kölliker (1855) could not for certain find muscle along milk ducts as in sweat glands but Henle (1866) quite definitely described and illustrated stellate cells on the basement membrane of the stomach, mammary and salivary glands, which he distinguished from smooth muscle but thought might be nerve cells, which they certainly resemble. Other clear accounts of the mammary myoepithelial cells were given by Langer (1871), Langhans (1873), Moullin (1880), Dreyfuss (1888) and Benda (1893). Two types of myoepithelial cells were distinguished, stellate around the alveoli and spindle shaped along the outside of the ducts. It was also thought that both types were contractile and aided the escape of the glandular secretions by squeezing the alveoli and widening the ducts. These early accounts of their structure and function have been reviewed by Zimmerman (1898, 1927), Bertkau (1907), Lenfers (1907), Retterer and Lelièvre (1911) and Babkin (1944).

For the past 40 years almost the only interest in the mammary myoepithelium has been that of pathologists, who were concerned with its metaplastic activities in mammary tumours (see Hamperl, 1939; Kuzma, 1943) and the only workers

considering the normal tissue were apparently unaware of the earlier German work, and confused the cells with smooth muscle (Swanson and Turner, 1941), or considered them capillary adventitial cells (Dieckmann, 1925; Hammond, 1927), so that at the time when Ely and Petersen (1941) put forward the current theory of the ejection mechanism, it is probably true to say that the majority of workers in the field considered that the sparsely distributed smooth muscle was the effector tissue. The balance was ably restored by Richardson (1949), who, aware of the true nature of the myoepithelial cells, and the difficulty of staining them by conventional methods, devised a silver staining method which dramatically demonstrated the extensive network of cells around all the alveoli and ducts of the mammary gland. He also again clearly differentiated the cells from smooth muscle, and produced circumstantial evidence for their contractibility and participation in the "let down" reflex.

At a time (May 1948) when I was unaware of Richardson's work on the goat, or that Zimmerman (1898) had previously used a chrome silver staining method, the myoepithelium of the mammary gland of a lactating cat was accidentally stained with silver when trying to stain nerve endings. This discovery was followed up and provides independent confirmation of the work of Richardson by showing the existence of these silver staining cells (which can be identified as the myoepithelium) in the mammary, salivary and sweat glands of other species.

Histological Methods

The lactating mammary glands of 26 cats, 5 dogs, 1 rabbit, 1 rat, 1 goat and 2 humans were used. The animal tissues were taken and fixed (frequently by perfusion) before death from anaesthetised animals used in the experiments described in Sections I and II. The human material was obtained 10 and 24

hours after death and fixed immediately. The submaxillary and salivary glands and pancreas of a day old kitten and of 2 cats were also used.

The following fixatives were used:- 10% formalin in N saline (neutral and acidified); 15% neutral formalin and 2% ammonium bromide; 25% chloral in 50% alcohol; formalin 1 part and saturated mercuric chloride 9 parts; Carnoy (absolute alcohol 6 parts, glacial acetic acid 1 part and chloroform 3 parts); Helly's fluid, Bouin; Weber's (1944) fluid and acetic-formal alcohol (glacial acetic acid 5% and formalin 5% in 80% alcohol).

Frozen and paraffin embedded (dehydrated and cleared with isopropyl alcohol, ethyl alcohol and chloroform) sections were stained, in many cases from the same piece of tissue. A routine thickness of 25 μ was generally employed. No advantages were found in thicker sections (up to 100 μ) as recommended by Richardson (1949) and thinner sections were less suitable because whole myoepithelial cells were less frequently included in a section.

For myoepithelium the silver staining methods of Gros-Bielschowsky, Rogers (1931), Nonidez (1939), Holmes (1942, 1943), Silver (1942), Richardson (1949) and Romanes (1950) were tried.

Some paraffin sections were also routinely stained for muscle by Van Gieson (Marshall, 1946) and by Marshall and Trowell's "Haurab" method.

Incidental observations on the ejection of milk

During the work reported in Sections I, II and III some incidental observations were made upon the mechanisms involved in the ejection of milk.

The procedure of anaesthetising the cats with their kittens made it possible to confirm Gaines's (1915) discovery

that the reflex is abolished by anaesthesia. The cat's litters frequently continued to suck during and after the anaesthetisation of the mother, but in spite of vigorous efforts on their parts could obtain little or no milk. For example one kitten belonging to a cat that was anaesthetised with chloralose and urethane at 9.45 a.m., sucked actively from then until the experiment started. Repeated weighing showed that it was getting no milk. Whilst it was still on the teat, the mother was given 0.1 U oxytocin intravenously at 10.15 a.m. and within 30 sec. it ceased suckling and pummelling the gland and began to swallow quickly and violently. It had gained 4 g. by 10.18 a.m. and would have obtained more still had it not been removed to allow the experiment to start. The response to oxytocin shows that there was some stored milk in the gland, but that under anaesthesia the reflex ejection had been inhibited, thus confirming the original observation of Gaines on the dog.

It has already been mentioned that the response to oxytocin was employed as one means of testing the vitality of the gland under perfusion conditions. The simple procedure used by Mackenzie (1911) and Schafer and Mackenzie (1911) was employed for recording the flow of milk in all experiments. A small incision was made into the region of the main milk ducts. After the initial flow due to the milk in the ducts running out, there was never any further escape whilst the tissue was undisturbed, however long the experiment.

Of the substances given, either intravenously to the whole animal or intra-arterially to the perfused tissue (see Table II), the only one that produced any flow of milk was the posterior pituitary hormone oxytocin (Pitocin, P.D. and Co.). This product always produced an immediate flow of milk from

the opened duct and was unaffected by the previous administration of atropine, eserine and ergot preparations. Pitressin, on the other hand, in the very small doses that could be given on account of its marked vasoconstrictor action, produced no milk ejection. Neither did nerve stimulation or venous congestion of the gland produced by clamping the vein for blood flow measurements. These last two observations may be cited as further evidence against the theory of Hammond (1936) that ejection is due to vascular erection.

Ely and Petersen (1941) in their original paper suggesting that the release of oxytocin from the posterior pituitary was concerned in the "let down" of milk, also stated that the injection of adrenaline or fright, prevented it, but that injected oxytocin could still produce the phenomenon. In this study it was repeatedly noticed that oxytocin was effective in causing ejection when given immediately after adrenaline (i.e. during the vasoconstriction) and even when the two substances were given together. This suggests that the inhibiting effect of adrenaline in the whole animal is due to an interference with the release of oxytocin rather than with an antagonistic action on the mammary gland.

Histological Results

The findings of Richardson (1949) were confirmed. It was possible to stain the myoepithelial cells with silver in the mammary glands (Figs.86-96, 102 and 103), in the sweat glands of the mammary skin (Fig.99), and in the submaxillary salivary gland (Figs.100 and 101), but nothing resembling these cells was seen in the pancreas. The routine muscle stains tried did not stain the myoepithelium.

the ground that was unaltered by the previous staining...
...of staining, resulting in a very small amount of...
...of its nature...
...of the gland... by staining the... with the...
...of the gland...

Photomicrographs of lactating mammary tissue stained
by Romanes's method. Sections 25 μ .

Fig.86. General low power view showing abundance of
myoepithelium. Background unstained. Tissue
No.32. Cat. Carnoy. Frozen section.

Fig.87. General low power view showing different
appearance when collagen and reticulin stained.
This could not be confused with the specific
myoepithelial staining in Fig.86. Tissue No.52.
Cat. Acetic-formal-alcohol. Frozen section.

Fig.88. Simultaneous staining of smooth muscle of an
artery (A) and vasomotor nerves in nerve bundle
(N) as well as myoepithelium. Tissue No.32.
Cat. Carnoy. Frozen section.

Fig.89. Same section as Fig.88, showing longitudinal
myoepithelium on surface of large interlobar
duct.

Discussion

The findings of Romanes (1921) were confirmed. It was
possible to stain the myoepithelial cells with silver in the
mammary glands (Figs. 86-88, 102 and 103), in the sweat glands
of the mammary skin (Fig. 89), and in the subcutaneous salivary
gland (Figs. 100 and 101), but nothing resembling these cells
was seen in the pancreas. The routine muscle stains tried did
not stain the myoepithelium.

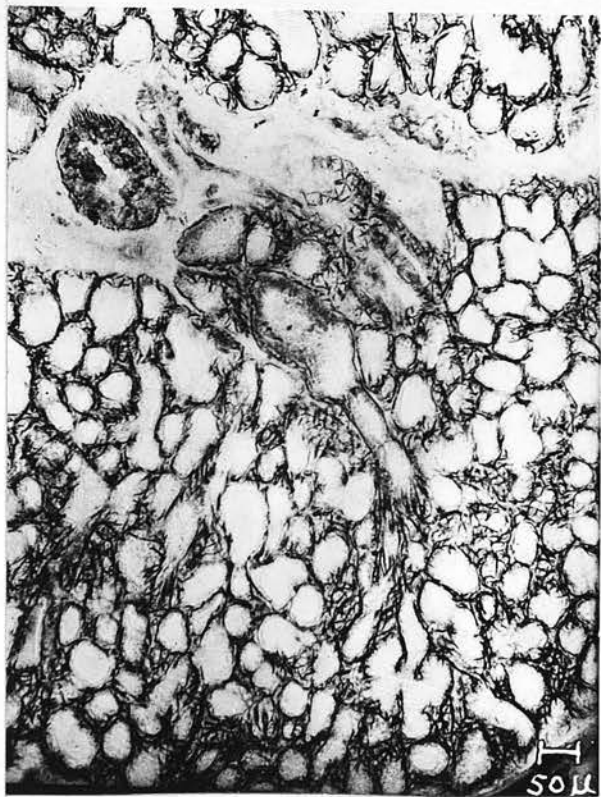

FIG. 86.

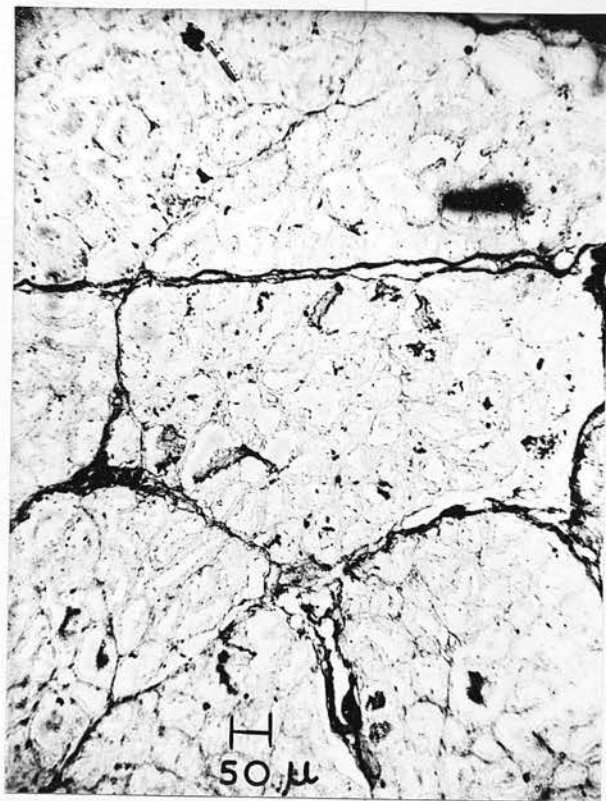

FIG. 87.

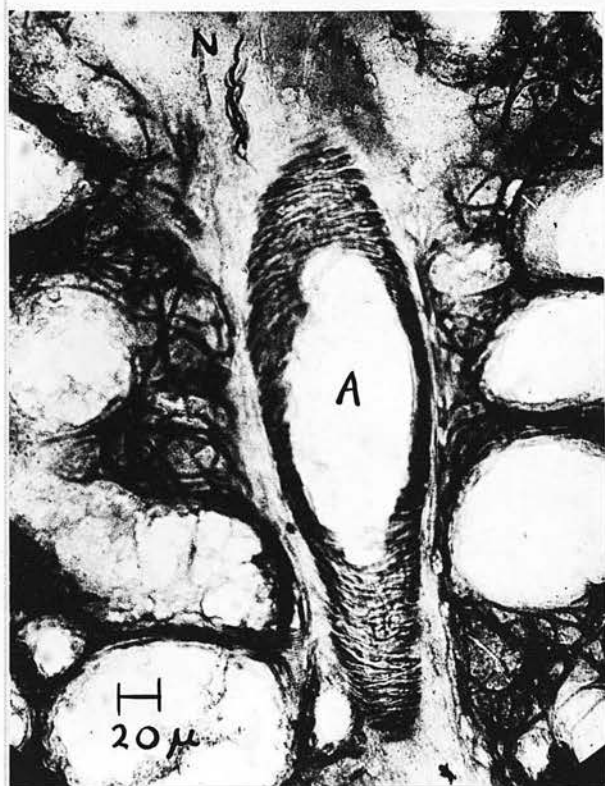

FIG. 88.



FIG. 89.

Of the fixatives and staining methods tried, success was only obtained with tissues fixed in Carnoy, acetic-formal-alcohol or formalin (acidified) and with the staining methods of Romanes and Richardson.

Richardson's method was not used as extensively as that of Romanes and failed to stain the myoepithelium of the goat udder, fixed in Weber's fluid (not perfused as Richardson recommended), and also failed on dog and cat tissue fixed by perfusion with Weber's fluid. However, it did stain the myoepithelial cells and other cell nuclei of 4 pieces of cat tissue, two fixed in acetic-formal-alcohol (one by perfusion), one in acidified formalin, and one in Carnoy's fluid (by perfusion).

The technique of Romanes (1950) using a weak solution of colloidal silver chloride at pH 8.0 (16 hours at 56°C. in the dark) gave better but not completely reliable results. After staining, the sections were developed in hydroquinone and sodium sulphite solution but the toning in gold chloride was omitted as it was often found to increase the density of background staining. With this method only Carnoy and acetic-formal-alcohol fixatives gave positive results, and in the case of the former, immersion in 10% formalin overnight before cutting frozen sections or embedding was found to be essential. The addition of 5% formalin to the Carnoy did not have the same effect.

In addition to the myoepithelial cells (brown to black), smooth muscle (golden brown) and nerves (black) were also stained, (Figs. 86 and 88) whilst the background was either unstained or showed only the outlines of secretory cells, particularly their nuclei and nucleoli. Failure to obtain this specific staining of myoepithelial cells, smooth muscle and nerve was encountered, in which case either the result was a

of the alveolar and staining methods tried, the most
only obtained with fixation fluid in Carnoy, acetic-formal-
alcohol or formalin (acidified) and with the staining methods
of Romanes and Richardson.
Richardson's method was used as alternatively as that
of Romanes and with it to stain the myoepithelium of the
mammary gland (not fixed in Carnoy) as described in Richardson
(1907) and also tried on dog and cat mammary gland by
Richardson's method.

Photomicrographs of lactating mammary tissue stained
by Romanes's method.

FIG. 90. Network of stellate myoepithelial cells over
surface of alveoli. Tissue No.52. Cat.
Acetic-formal-alcohol. Frozen section.

FIG.91. Myoepithelial cells from a dog. Tissue No.81.
Carnoy. Paraffin section.

FIG.92. Myoepithelium in the human breast over alveolus
(A) and small duct (D). Tissue No.79, 10 hours
post mortem. Carnoy. Frozen section. Death
during first stage of labour from heart failure
and Hodgkins' disease.

FIG.93. Myoepithelial cells in an empty gland showing
a fibrillar internal structure. Tissue No.76.
Cat. Carnoy. Frozen section.

staining with this method only Carnoy and acetic-formal-
alcohol fixatives gave positive results, and in the case of the
former, fixation in 10% formalin overnight before cutting
frozen sections or embedding was found to be essential. The
addition of 2% formalin to the Carnoy did not have the same
effect.
In addition to the myoepithelial cells (brown to black),
smooth muscle (golden brown) and nerves (black) were also
stained. (Figs. 88 and 89) whilst the background was either un-
stained or showed only the outlines of secretory cells, partition
large dark nuclei and nucleoli. Failure to obtain this
specific staining of myoepithelial cells, smooth muscle and
nerves was encountered, in which case either the result was a



FIG. 90.



FIG. 91.



FIG. 92.



FIG. 93.

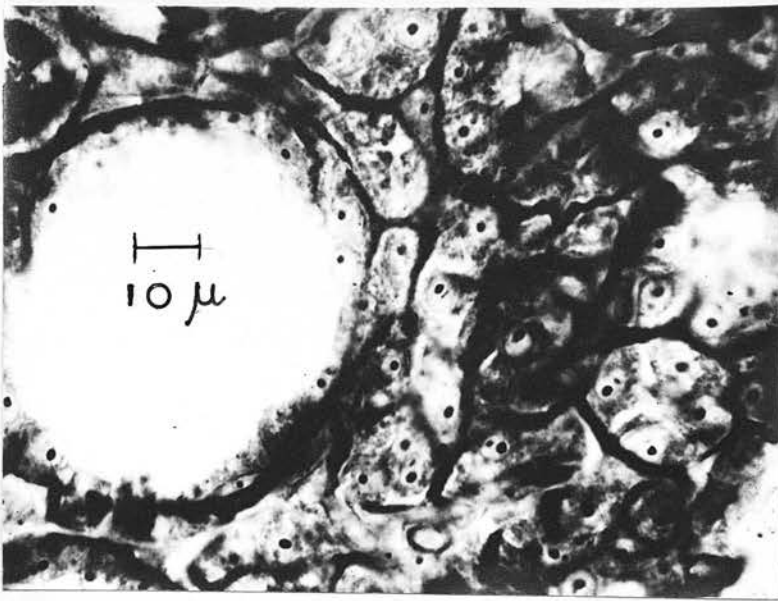

FIG. 94. Myoepithelial cells in the mammary gland of a cat, lying over the alveolar cells. Same tissue as Fig.90.

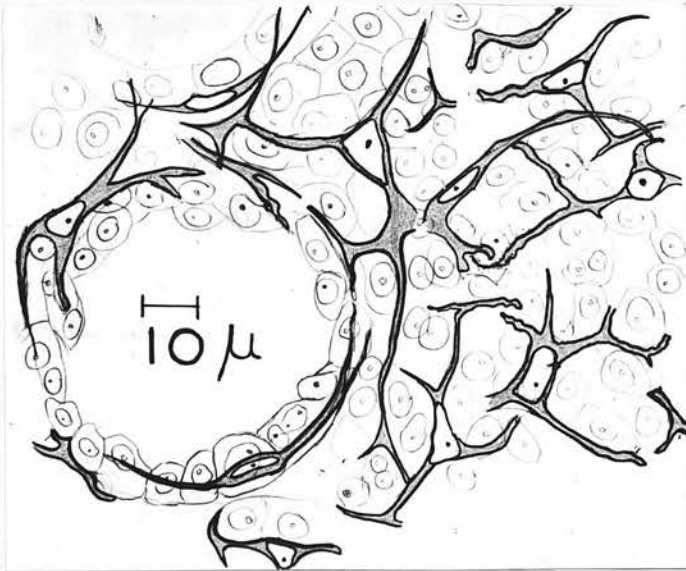

FIG. 95. A free hand drawing of the area in Fig.94 showing that the myoepithelial cells as seen in section and from the surface do not form a true syncytium.

TABLE IV. - RESULTS OF STAINING LACTATING MAMMARY GLANDS BY ROMANES'S METHOD FOR THE DEMONSTRATION OF MYOEPIHELIAL CELLS.

No.	Species	Frozen sections		Paraffin sections	
		No pretreatment	K ₂ Cr ₂ O ₇ pretreatment	No pretreatment	K ₂ Cr ₂ O ₇ pretreatment
<u>Carnoy fixed tissues followed by formalin</u>					
27	Cat			++	-
30	Cat			++	++
32	Cat	++		-	++
39	Dog	+ -	++	+ -	-
60	Cat	+ -	+	+ -	-
61	Cat	++			
62	Cat	++	++	++	++
69	Cat	+ -			
74	Human	+ -	+	+	+ -
75	Rabbit	-	+ -	+ -	+
76	Cat	++			
79	Human	-	++	++	-
81	Dog	++	++	++	++
86	Dog	+ -	-	- ?	++
87	Rat	+	-	+ - ?	-
90	Goat	+	+		

Acetic-formal-alcohol fixed tissues

50	Cat	++		++	++
52	Cat	++		++	++
59	Dog	- -	+ -		
69	Cat	+ -	+ -	++	+
67	Cat	-	-	-	-
71	Cat	-	-	+	+
72	Cat	-	+ -	+ -	++
73	Cat	-	++	-	-
74	Human	-	+	+ -	-
75	Rabbit	-	+	-	+
78	Cat	-	+	+	+
79	Human	-	+ -		

- ++ Myoepithelial cells distinctively stained on faint background.
- + Positive, but not so easy to see since background stained more.
- + - Cells faintly stained.
- Negative. Myoepithelium unstained.

Photomicrographs of lactating mammary tissue stained by Romanes's method. Sections 25 μ .

FIG. 96. Myoepithelium (marked by arrows) lying outside two cell layered wall of milk duct (D). Tissue No.52. Cat. Acetic-formal-alcohol. Paraffin section.

FIG. 97. Section of distended mammary gland showing long drawn out myoepithelium.

FIG. 98. Section of gland from same animal after emptying with the aid of oxytocin. Tissue No.60. Cat. Carnoy. Frozen section.

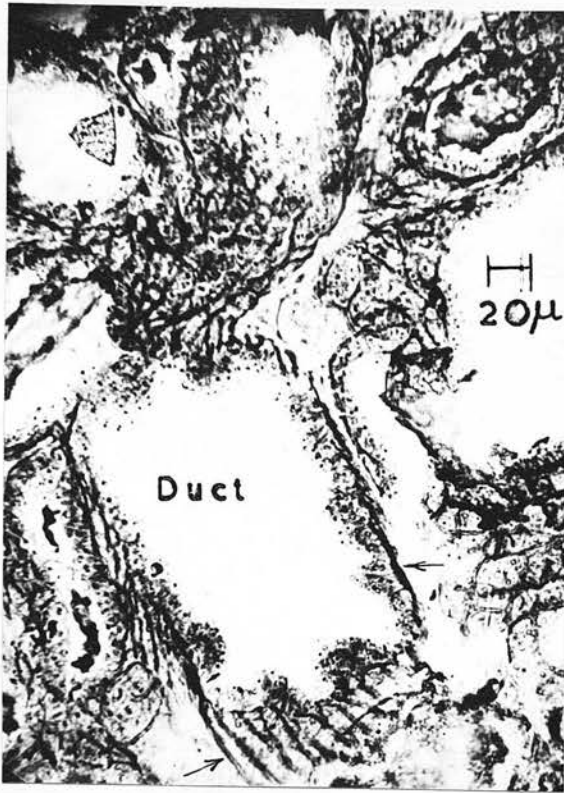

FIG. 96.

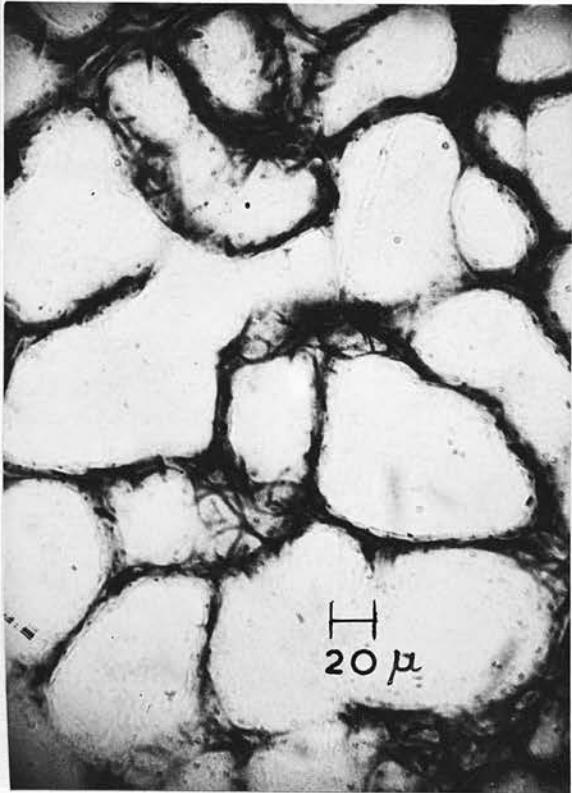

FIG. 97.

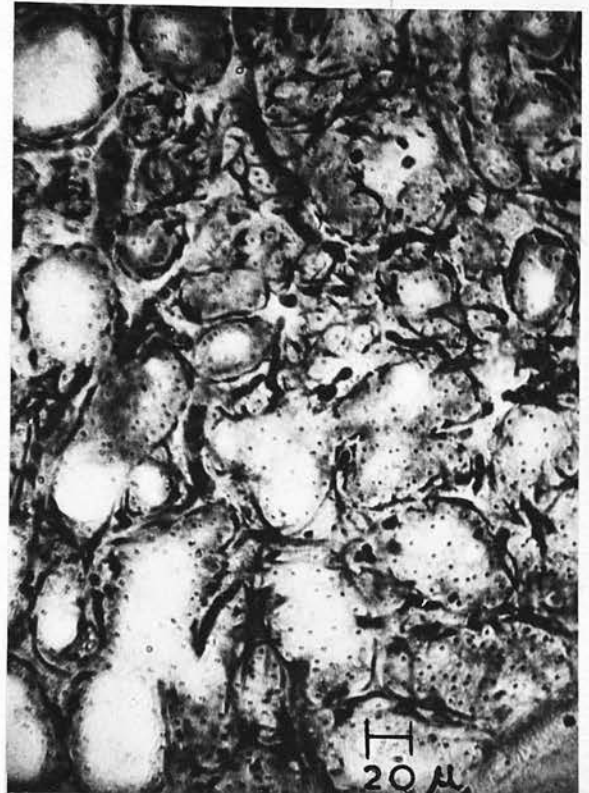

FIG. 98.

faint general brown colour or collagen and reticular fibres were stained (Fig.87). The immersion of the sections in 5% potassium dichromate for a few hours before staining was sometimes found to alter completely the pattern of staining from the latter to the former (particularly in acetic-formal-alcohol fixed tissues), but paradoxically also sometimes change it from one showing myoepithelium, muscle and nerve to that showing collagen and reticulin (see Table IV). Many variations were made in unsuccessful attempts to find a reliable method of ensuring the specific staining required along the lines suggested by Kubie and Davidson (1928), Foot (1929 a, b, c), Foley (1939), Landau (1940), Silver (1942), Holmes (1942) and Weber (1944), but these will not be given as no radical alteration to Romanes's method was made. Its reliability as used may be judged from Table IV.

As noted by Richardson the capillaries were also occasionally stained in parts of otherwise satisfactorily stained sections.

There can be no doubt that the silver stained cells seen in the tissues studied are the myoepithelial cells, as previously described and illustrated by the early German histologists. The stellate variety lie as a complicated irregular network around the alveoli at the base of the secretory cells (Figs.86, 88, 90, 91, 92 and 93), and sweep uninterruptedly over onto the ducts where they become spindle shaped (Fig.96) and are found lying longitudinally outside the normal two cell lining (Figs. 89 and 96), right up to the cisterns and teat ducts. The silver method used does not stain the basement membrane, so that its relationship to the cells cannot be seen in these preparations, but in this connection it is interesting to note

that general brown pigment in collagen and reticular fibers
 were stained (Fig. 98). The absorption of the eosin in the
 surrounding fibrous tissue was a few hours before staining was com-
 plete. It is interesting to note that the pattern of staining from
 the latter to the former (particularly in nuclei-formaldehyde
 fixed tissues), but not in the latter, was different. It
 was more granular and fibrous, and more intense in that staining
 was more extensive (Fig. 99). This was particularly true
 in the case of the latter (Fig. 99).

FIG. 99. Myoepithelial cells lying outside cells of
 sweat gland in dermis over mammary gland.
 Tissue No.27. Cat. Carnoy. Paraffin
 section.

FIGS. 100 and 101. Submaxillary salivary gland of
 cat showing smaller, less numerous myoepi-
 thelial cells. Carnoy. Paraffin section.

to examine the method and the reliability of the method as used in the
 subject from which it was obtained.

As noted by Robinson the epithelial cells are also occasion-
 ally stained in parts of otherwise unstained tissue.

There can be no doubt that the silver stained cells seen
 in the present study are the myoepithelial cells, as previously
 indicated and illustrated by the only other histologist.
 The stained cells are a scattered irregular network
 around the alveoli at the base of the secretory cells (Figs. 98,
 99, 100, 101, 102 and 103), and were uniformly over onto the
 ducts where they become spiral shaped (Fig. 98) and are found
 lying longitudinally outside the normal wall lining (Figs.
 99 and 100), right up to the alveolar and duct ducts. The
 silver stained cells are not seen in the basement membrane, so
 that the relationship to the cells cannot be seen in these
 preparations, but in this connection it is interesting to note



FIG. 99.



FIG. 100.



FIG. 101.

that pathologists (Hamperl, 1939; Kuzma, 1943) have studied the myoepithelium in an indirect manner by staining the basement membrane with silver. Their studies confirm that the myoepithelium lies between the secretory cells and the basement membrane. However it was not until silver nerve stains were applied to the mammary gland that it was accidentally and independently discovered that the myoepithelium itself could be stained with silver. It should also be pointed out here that it is misleading to refer to the outer cell layers of the ducts as myoepithelium (Dempsey, Bunting and Wislocki, 1947), because the myoepithelial cells in fact lie outside as a third layer (Fig.96).

The spindle shaped cells lying along the periphery of the ducts are clearly separate, but the complicated network of stellate cells over the alveoli often appears syncytial. However in these cases careful drawings have been made at the highest magnification (see Elias, 1950), following out the finest ramifications. Although cell processes do sometimes meet and often cross over, no evidence that the myoepithelium is a true syncytium was obtained, and the opinion was formed that it is probably not (Figs.95 and 104).

The capillaries lie very close to the myoepithelial cells (Fig.102) and in some cases appear to be joined to some of the myoepithelial processes (Fig.103). Careful examination in the same way, however, shows there is no direct union (Fig.104).

Although the silver method stains the finest nerve endings accompanying arterioles, no nerves have ever been seen to enter either the secretory cells or the myoepithelial cells in this study.

Richardson's finding that the cells differ in appearance in distended and empty glands, being long and drawn out in the



FIG. 102. Myoepithelial cells (M) and capillaries (C) stained by silver. Tissue No.50. Cat. Acetic-formal-alcohol. Paraffin section.

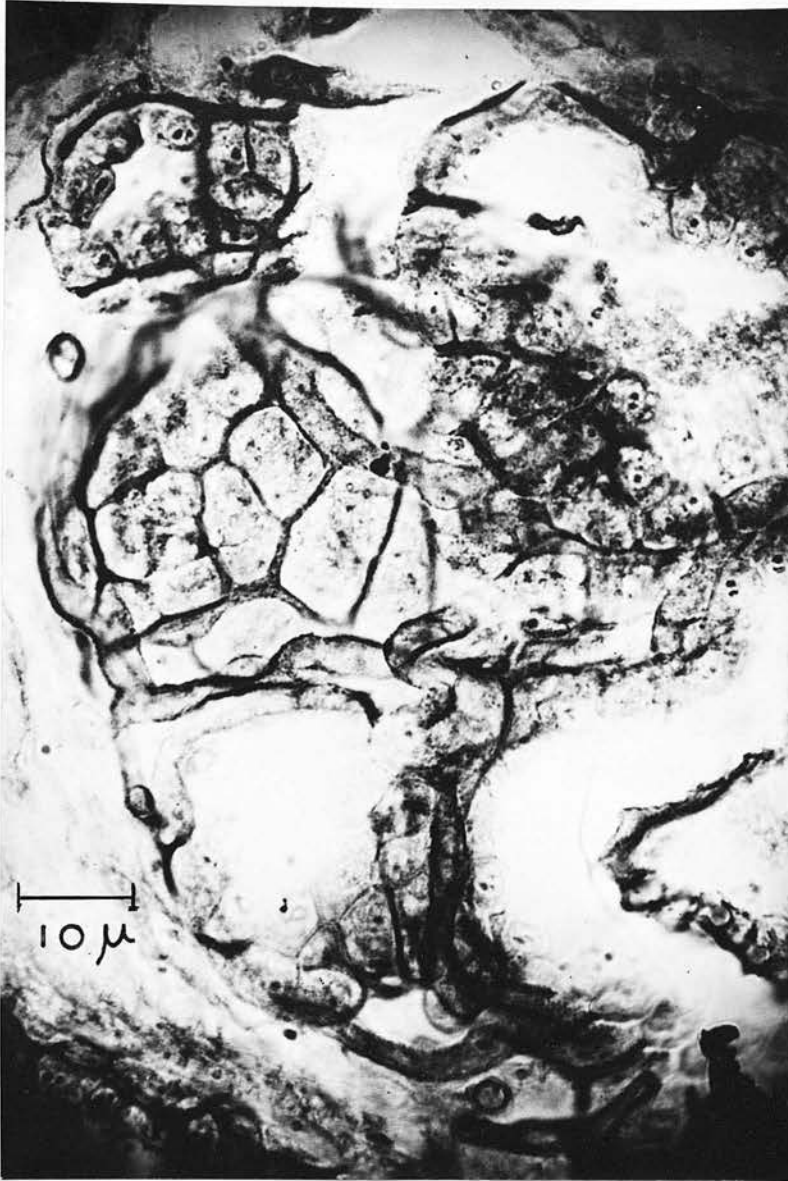

FIG. 103. Same section as Fig.102, showing the close relationship between the myoepithelium and the capillaries over a mammary alveolus.

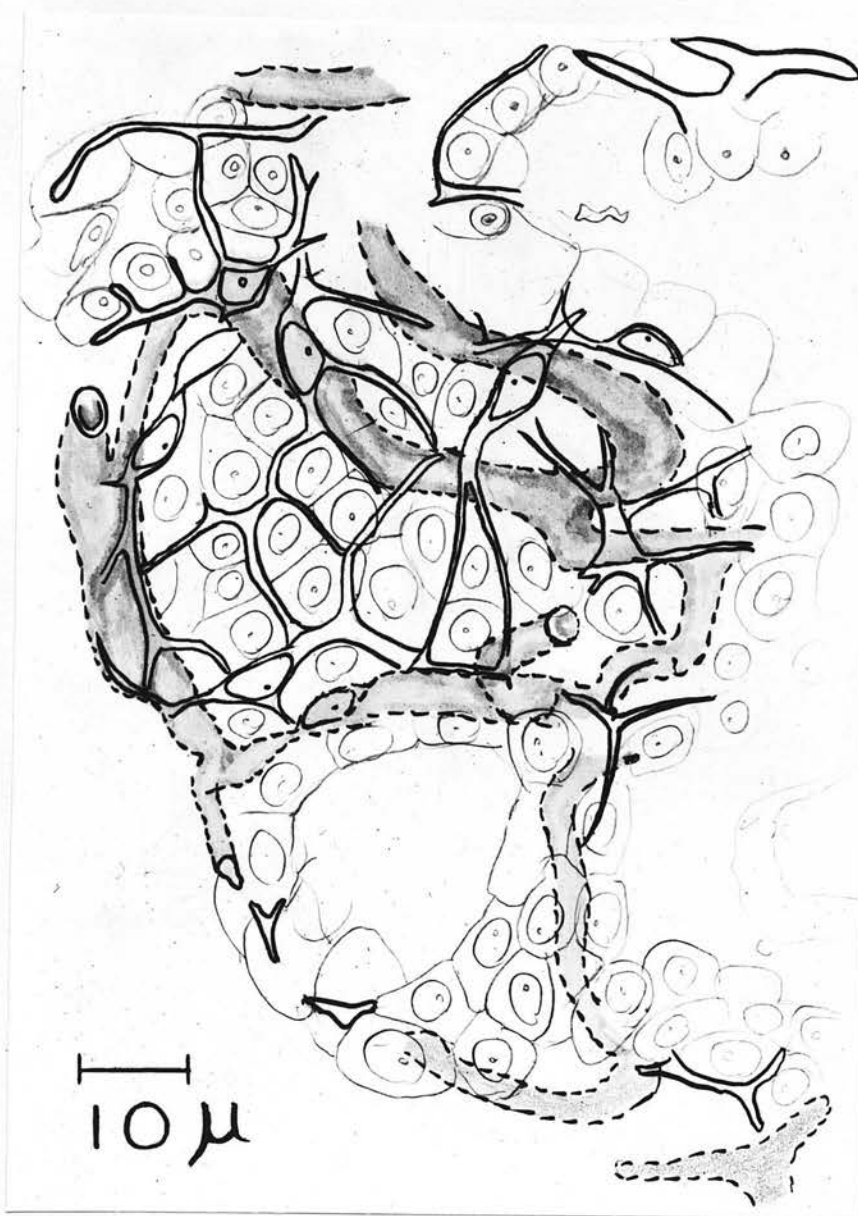

FIG. 104. A free hand drawing of the field photographed in Fig. 103.

former and short and squat in the latter has been confirmed. The cells in a distended specimen in Fig.97 should be compared with those in Fig.98, in which the gland was thoroughly emptied by oxytocin injected intravenously before fixing. The cells around completely collapsed alveoli appear much broader and it is often possible to make out a distinctly fibrillar internal structure in this state (Fig.93).

The fact that the silver method also stains smooth muscle made it possible to reinvestigate the distribution of smooth muscle in the mammary glands and clearly distinguish it from myoepithelium. The presence of many interlacing bundles of smooth muscle fibres in the teat and areola was confirmed and it was also noticed that strands of the panniculus carnosus muscle pass between the lobes, actually extending into the teat of one cat gland. However, in the particular samples of the species studied, in no instance was any smooth muscle found either between the lobes, lobules or alveoli and in fact the only smooth muscle fibres ever seen in the mammary glands proper were those in the walls of the blood vessels.

Discussion

The discovery that silver, can under certain circumstances be used to obtain a fairly selective staining of myoepithelial cells has, in the case of the mammary gland, helped to clear up a number of points which have previously caused confusion as to the peripheral mechanism of the "letting down" or ejection of milk. The following facts are offered in support of the view that the mammary myoepithelium is the sole effector tissue concerned in the process:-

(a) The silver staining methods reveal the extreme abundance of the myoepithelial tissue and emphasise that it is ideally arranged around the alveoli and along the ducts, for squeezing

the milk out of the acini and small ducts into the large ducts and cisterns (Figs. 84 and 85).

(b) The new method which also selectively stains smooth muscle and nerves, reveals that in the species studied, there is no inter-alveolar smooth muscle and that the myoepithelial cells in the mammary gland are not innervated. The effector tissue could not therefore be smooth muscle, as was suggested for the cow by Swanson and Turner (1941), and the absence of innervation fits in with the finding that ejection can be obtained in a denervated (Ely and Petersen, 1941) or isolated perfused mammary gland (Petersen, Shaw and Visscher, 1941; Peeters and Massart, 1947) (Sections II and III) and rules still further against Gaines's (1915) theory of a purely nervous reflex.

(c) There is no anatomical evidence to support the theory that a vascular "erection" causes milk ejection. Furthermore it has been shown that neither vasomotor nerve stimulation nor venous congestion produces it. However the very close proximity of the myoepithelial cells to the capillary network around alveoli and ducts means that any circulating oxytocin would reach them quickly and would probably affect all the myoepithelial cells almost simultaneously.

(d) The myoepithelial cells stain when smooth muscle stains and have what appear to be myofibrils inside them. The distinct shortening and thickening of the cells occurring when the alveoli empty, naturally in response to milking (Richardson, 1949) or artificially in response to oxytocin (Figs. 97 and 98), strongly suggests that their role in the process is active and not passive, when folding of the long cell processes would be expected.

(e) The mammary myoepithelial cells are much longer and more extensive than those in the sweat glands or salivary glands, in which secretion is mainly controlled by secretory nerves. Milk secretion is not controlled in this way and is believed to be a more or less continuous process, depending upon intramammary pressure and hormonal and metabolic factors. Some active muscular process is therefore essential for removing the stored milk, and it is significant that the myoepithelium is so extensive in the mammary gland.

Summary of Section IV

The finding of Richardson (1949) that the myoepithelial cells of the mammary gland of the goat can be selectively stained with silver has been independently confirmed for other species and extended to the same cells in the sweat glands and the submaxillary salivary glands.

The appearance of the myoepithelium in silver stained sections is described and evidence discussed in favour of the view that this tissue in the mammary gland is responsible for the phenomenon of the "letting down" or ejection of milk in response to suckling or milking.

GENERAL DISCUSSION AND SUMMARY

It is not necessary to reiterate in detail the gross blood and nerve supply to the mammary glands given in Section I, Part II. The glands extend along the ventral thorax and abdomen and receive a multiple blood and nerve supply in common with the other subcutaneous tissues.

The fact that many cutaneous nerves of thoracic and lumbar origin innervate the glands, stresses the difficulty of thoroughly denervating them for experimental purposes, without actual transplantation.

The multiple blood supply is understandable in the case of such a widely dispersed tissue, but it may have additional significance for maintaining the blood flow under all conditions. For example, it has been shown that the anastomoses within the tissue are such that it is possible for blood to reach all parts from any one main source of supply. It is conceivable that in certain positions of the body some of the mammary vessels, which are very superficial, might be sufficiently compressed to reduce the blood flow through them. However the vascular anastomoses mean that it is very unlikely that this would affect the total flow through the tissue as a whole.

The microscopical examination of the small blood vessels shows that, whilst the lobes have a multiple blood supply, the individual lobules do not generally receive more than one arteriole and venule. The capillaries around the alveoli form part of a complete network confined to the individual lobules but also embracing the smallest milk ducts draining them. The larger ducts also have an encircling capillary net, which is supplied at intervals by arterioles and venules, and continues right up to the mouths of the ducts, when it joins that of the

skin. The largest ducts and cisterns have in addition a second layer of vessels, formed by the supplying arterioles and venules.

The arteriole-venular bridges of Zweifach (1939), seen in some lobules and the arterio-venous anastomoses doubtfully recorded on some of the ducts, probably serve to maintain the overall blood flow through the tissues, whilst allowing greater control of the flow through small parts of it.

The significance of the venous network in the teat is not clear. It was first thought by Furstenberg (1868), Riederer (1903) and Rubeli (1916) to form a cavernous erectile tissue in the cow and that it was concerned in the flow of milk. Furstenberg for example, thought that a cow held up her milk by holding her breath and actually obliterating the teat lumen by venous turgescence, whilst Rubeli believed that the latter was produced by vasomotor nerves. As has been shown in Section VIII, Part I and in Section IV, Part II of this thesis, it is no longer thought that the holding up of milk is an active process, but that the "letting down" is. The teat vessels have received no mention in modern theories, neither have they in the recent studies of the erection of the teat and its behaviour during milking by Peeters, Massart, Oyeart and Coussens (1948). They have shown that the smooth muscle in the nipple undergoes rhythmical contractions when it is distended, and suggested that the compression of the veins at this time aids the return of the blood to the heart.

One could imagine that the filling of the venous network with blood would help the muscular erection to make the teat a firm structure for the young animal to grasp in its mouth, and that the capacious veins would to some extent stabilise the teat circulation by filling up during the negative pressure phases

of the suckling process. However it is likely that the exact significance of the venous network will remain obscure until we have exact knowledge of its behaviour and of the blood flow through the glands during suckling.

Histological studies have demonstrated a wealth of sensory nerve endings in the teat, particularly around the mouths of the ducts. Their presence ties up nicely with the investigations showing that suckling acts as an important stimulus for maintaining active milk secretion in general, and for starting the ejection reflex in particular. The smooth muscle in the teat is innervated (Cathcart, Gairns and Garven, 1948), and nerve stimulation causes contraction of the teat in the isolated perfused cow's udder (Peeters, Coussens and Sierens, 1949). Vasomotor nerves have been demonstrated histologically in the mammary gland proper and the physiological experiments show that these are in all probability sympathetic adrenergic vasoconstrictor fibres. No secretory fibres have been detected and no sensory fibres either in the gland itself, although the human breast is generally considered to be more sensitive to pressure than its surrounding structures. Of course this may depend upon pressure endings in the overlying skin, or it may mean that some of the nerves lying with or near the blood vessels in the gland are sensory fibres.

In cases of large wounds into the udder of the cow, it is found that the mammary tissue away from the teat is relatively insensitive to pain, but that the teat region is extremely perceptive (Professor L.P.Pugh, 1951, personal communication), so that this bears out the histological findings. However, in view of the one isolated report of Arnstein (1895), describing specialised nerve endings on the cells of the mammary gland of a pregnant cat stained with methylene blue, it would seem

desirable to restudy the innervation of the mammary glands, using the improved modern methylene blue methods.

These anatomical facts give no indication of the actual blood flow through the mammary glands and it is somewhat surprising that there are very few report^s that do.

Milk secretion studies using simultaneous sampling of arterial and venous blood have shown which substances are removed from the blood. By knowing the amount of these substances in the milk, it is possible to calculate the ratio of blood flow to milk secreted over a given period (generally 24 hours). The ratio is usually accepted as being 400-500 : 1 and has been used in attempts to conduct quantitative balance experiments on milk secretion. The numerous criticisms that can be levied against the method have been fully discussed by Folley (1949 a). One has been that, on the only occasion on which it was checked against the actual flow as measured by the thermostromuhr, the theoretical value was about twice the actual (Graham, Houchin, Petersen and Turner, 1938).

Few other workers have measured mammary blood flow. Jung (1932 a, b, 1933) used the stromuhr in one dry and two lactating goats, under ethyl chloride anaesthesia. He thought his figures might be a little low; they were 5.5 to 7.2 c.c./100 g./min. in the lactating state. He was surprised to find that these values were lower than the flow through the resting parotid salivary gland (17.2 c.c./100 g./min.). In actual fact the ruminant parotid gland secretes continuously, so that his figures really represent the active tissue. Lintzel (1934, quoted by Graham, Jones and Kay, 1936) states that the blood flow through the udder of a high yielding goat is 800 c.c./min. Assuming an udder weight of 2 kg. this is 40 c.c./100 g./min. Graham (1937), using the thermostromuhr, obtained values of

only 90-200 c.c./min. in the same animal (4.5 - 10 c.c./100 g./min. for a 2 kg. udder). If we assume a blood/milk ratio of 500/1, it is probable that values for the cow's udder would lie between 25 c.c. (6 kg. udder giving 4.5 kg. milk daily) and 60 c.c./100 g./min (14 kg. udder giving 25 kg. milk daily).

Comparable figures for other tissues given by Starling (1945) are for the thyroid 560 c.c., kidney and liver 150 c.c., brain 130 c.c., heart (coronary) 100 c.c., intestines 70 c.c., and the hand 13 c.c./100 g./min., whilst the flow for the whole body (man) is about 5 c.c./100 g./min.

It appears that the mammary blood flow is certainly less than that through more vital organs and that attempts to make actual measurements have invariably given lower values than those expected on more theoretical grounds.

The figures found in this work for the glands of anaesthetised cats using Brodie's plethysmographic method (6.6 - 55.0 Mean \pm S.D. 23.8 ± 10.4 c.c./100 g./min.) are more in accord with the values calculated from blood/milk ratios, whilst those obtained in situ by cannulating the vein are very much lower (1 - 4.6, Mean 2 ± 1.3). In both cases the glands had been skinned and dissected out (i.e. handled considerably), so that this suggests that it is the cannulation that profoundly decreases the flow. Spasm of the vessels was in fact frequently seen, and in perfusion experiments, in which both artery and vein had to be cannulated, the initial perfusion flow was low and increased as the experiment progressed. It is probable that the spasm of the large vessels (due to direct stimulation of the smooth muscle in their walls or to local reflexes) was also accompanied by vasoconstriction due to adrenalinaemia and by reflex vasoconstriction of the small arteries and arterioles. Such a vasoconstriction was also produced by anoxia.

Thus it has been shown in the dog and cat that, whilst the blood flow through the lactating mammary glands is similar to that through the udder of milking cows and goats, any attempt to make direct measurements by cannulation of the vessels appreciably decreases the flow. It is reasonable to assume that the same applies to other species and explains the lower values obtained when this was applied to farm animals.

Apart from the vascular constriction due to manipulation, perfusion of the isolated mammary gland introduces other artificial conditions which may seriously curtail the blood flow. These have been found to be :-

(a) the formation of minute fibrin emboli due to the contact of blood with glass, etc.;

(b) cooling of the tissue or perfusate;

(c) the release of adrenaline or noradrenaline into the blood during bleeding or at any time during the experiment, since the mammary vessels are so extremely sensitive to these substances;

(d) the formation of vasotonins in the blood under artificial conditions and their accumulation, if not removed by the passage of the blood through the pulmonary vascular bed.

The observations reported in Section IV on the ejection of milk all support the theory that this is brought about by the reflex release of oxytocin from the posterior pituitary gland.

There is good histological evidence for the existence of sensory receptors in the teat and it has been confirmed that anaesthesia abolishes the reflex. It is still possible, however, to produce ejection under anaesthesia by administering the hormone, showing that the peripheral mechanism is still working.

It is also probable that the inhibitory action of adrenaline is due to its blocking the release of oxytocin, as in the case of the posterior pituitary anti-diuretic hormone, because adrenaline does not abolish the action of oxytocin on the mammary gland itself.

As regards the effector tissue in the mammary gland, all the evidence now points to the myoepithelium as being responsible.

Direct examination of the living tissue confirms that oxytocin produces a sudden transference of milk from the small ducts and alveoli, into the larger ducts (Fig. 84 and 85), and that this is unaccompanied by any vascular phenomenon resembling "erection", for which there is no anatomical evidence anyway. There are no demonstrable secretory nerves, nerve stimulation does not produce ejection and oxytocin acts equally on the isolated perfused tissue, so that it is not a question of the sudden secretion forcing the preformed milk into the ducts, as was once thought. Moreover microscopical examination shows in addition, that the alveoli are actually emptied of milk, thus confirming Schafer's conclusion that a second dose of pituitrine was ineffective immediately after the first because there was no more milk left to be squeezed out.

It has been suggested that the ejection phenomenon is due to the elastic recoil of the gland tissue, the milk being held in previously by sphincters around the mouths of the large ducts. However this could hardly account for the observed increase in the diameter of the ducts and on histological examination no such sphincters can be found.

The exclusion of the above theories means that only a muscular mechanism is left for consideration and it has to be decided what type of muscle is involved.

Striated muscle strands can be found traversing the mammary glands in those species with a well developed cutaneous musculature. However they are very variable in extent and are by no means constantly found in all the glands of one animal or in all individuals of a species. Striped muscle therefore, cannot be seriously considered.

Smooth muscle is usually stated to be sparsely distributed in the mammary glands. Richardson (1947) has considered the evidence for this and concludes (a) that it is so scant as to be insignificant and (b) that in his own preparations (Richardson, 1949), all the smooth muscle in the goat's udder is associated with blood vessels. My own investigations have been equally definite for the mammary glands of the goat, dog, cat, rabbit, rat, mouse and guinea pig. There is certainly no intra-lobular smooth muscle.

This further reduces the field to myoepithelial cells and here the evidence is positive instead of negative. The new silver stains abundantly confirm the work of the old German histologists. The myoepithelium is revealed as a luxuriant network of stellate and aciculate cells completely covering all the secretory and ductile tissue. The stellate variety are ideally situated for quickly and efficiently squeezing the alveoli and the spindle shaped cells are equally well placed for widening the ducts. They are all in very close contact with the capillaries.

Myoepithelial cells resemble muscle cells in their appearance and staining properties, but since no-one has seen them contract, it is not proven that they are indeed muscle cells. However there is some circumstantial evidence in favour of this. In the full gland the myoepithelial cells are long and drawn out, whilst in the gland that has been emptied, either

naturally or artificially with injected oxytocin, they are short and squat. If they had been inert structures like collagen fibres it would have been expected that, instead of changing shape they would have merely folded or wrinkled.

It has already been noted that the myoepithelium is very much more developed in the mammary gland than in the salivary or sweat glands, which, it was suggested, was due to the fact that the latter have additional means (i.e. secretory nerves) of expressing their secretions. There appears to be a further difference. Babkin (1944) thinks that the salivary myoepithelial cells are innervated by sympathetic nerves and says they contract to histamine. Mammary myoepithelial cells are affected by neither, so that it looks as if they have evolved into a more specialised as well as more developed tissue.

ADDENDUM ILITTER SIZE, BIRTH WEIGHT AND THE NUMBEROF TEATS IN THE CAT

Few figures are available with regard to litter size, birth weight and number of teats in the cat, in spite of the frequent use of this animal for scientific research and of its popularity as a household pet. The animals considered here were obtained from an animal dealer in Edinburgh.

Litter size

According to Gros (1936) this is just over 4 whilst Hall and Pierce (1934) found an average of 3.88 in a study of 33 litters. In this study 71 cats of unknown age and parity were obtained in various stages of pregnancy. The frequency distribution curve of the litters born to these animals is shown in Fig.105. The mean (\pm S.E.) number of kittens in a litter was 3.76 ± 0.2 . Hall and Pierce also found that small cats had significantly smaller litters than large ones. In this series cats having 4 kittens or less (59) weighed 2.69 ± 0.45 kg. (mean \pm S.D.) after parturition, whilst those (12) that gave birth to 5 or more weighed 2.99 ± 0.44 kg. Statistical analysis showed that this difference would probably have occurred by chance only once in 20 trials, but in view of the differences of condition of the cats on purchase and the possible effects of age and parity, it is not felt that these figures fully support the findings of Hall and Pierce, without further study.

Birth weight

Hall and Pierce (1934) found that the birth weight varied from 70-144 g. with an average \pm S.D. of 106.4 ± 13.5 g. Since many of these animals were not weighed until up to 20

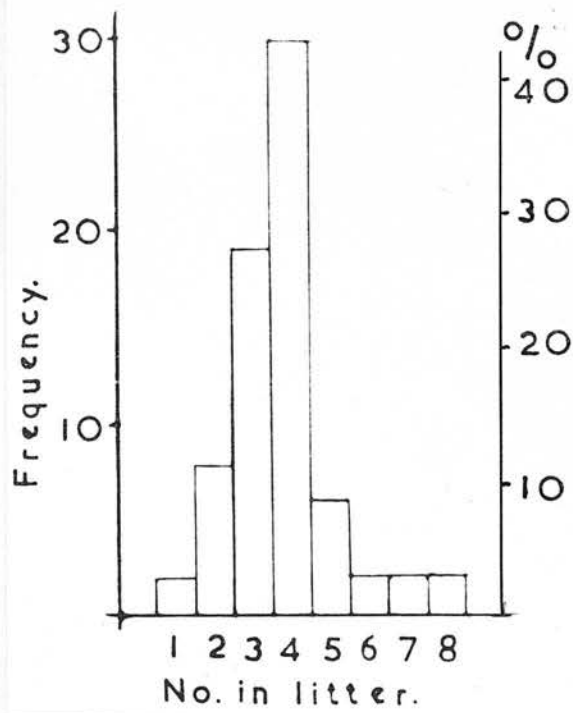

FIG. 105. Frequency diagram of litter size.

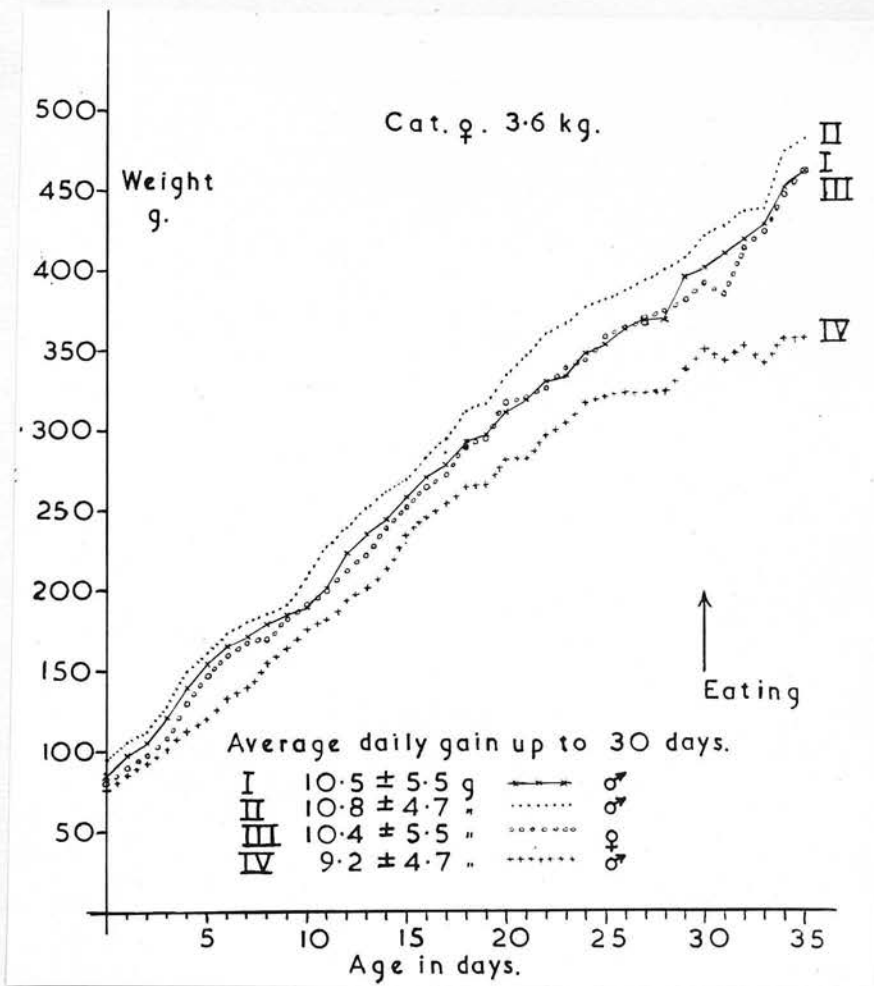

FIG. 106. Growth curves of 4 kittens in one litter. Kitten No. IV although in perfect health, remained persistently smaller than his litter mates, under identical environmental conditions.

hours after birth, they thought some may have gained up to 10 g. in that time. This has been confirmed. In the case of kittens weighed before suckling the range was 76 to 127 g. Mean \pm S.D. 94.6 ± 11.9 g., whereas those weighed some hours after birth (e.g. early in the morning after having been born during the night) ranged from 68-135 g. Mean \pm S.D. 103.2 ± 19.1 . There was no significant difference between the sexes in either case.

A few observations were made on the post-natal growth rate of the kittens until the time they started supplementing their suckling by eating the mother's solid food as well (at about 30 days). Suckling was not finally stopped until 60-75 days. The growth curves on the purely milk diet were approximately linear, (Fig.106) the average daily gain of individual kittens varying from 9.2 ± 4.7 to 11.9 ± 6.4 g. In one litter of 2 kittens, in which the mother underwent Caesarian section for the delivery of a third, there was no increase in weight for 4 days, and a faster growth rate thereafter (13.2 ± 4.5 g. and 13.1 ± 5.38 daily). Apart from this one case, no loss in weight after birth was ever seen. There was no significant difference between the sexes over the period covered.

The number of teats

According to Reighard and Jennings (1951), the cat possesses 5 pairs of mammary glands, but Mivart (1881) and Turner and de Moss (1934) state that there are only 4 pairs. Of 102 female cats examined in this series all but 15 were found to possess 4 pairs ($1\frac{1}{2}$ pairs thoracic; $1\frac{1}{2}$ pairs abdominal and 1 pair inguinal). The first thoracic pair were infrequently sucked and usually involuted within a few days after birth. Even when sucked they were smaller than the other glands. Of the 15 cats possessing supernumerary nipples,

10 had 9 teats, 4 had 10 and 1 had 15. Only 11 of these 25 extra teats were functional in that milk could be expressed from them during lactation, and all the functionless ones were either between glands 3 and 4 or behind glands 4 (inguinal).

Supernumerary teats were not encountered in front of the second pair of teats.

DOG							CAT	RABBIT			RAT	MOUSE	GUINEA PIG
Miller (1948)	Bradley (1948)	Ellenberger and Baum (1943)	Sisson (1940)	Turner (1939)	Mivart (1881)	Reighard Jennings (1925)	Turner (1939)	Krause (1868)	Gerhardt (1909)	Wahl (1915) Turner (1939)	Greene (1931)	Turner (1939)	Turner (1939)
<u>BLOOD VESSELS</u>							Internal mammary	Internal mammary	Internal mammary	Internal mammary	Internal mammary	Internal mammary	Internal mammary
Internal thoracic	Internal thoracic	Internal thoracic	Internal thoracic	Internal thoracic	Internal mammary	Internal mammary							
Cranial epigastric	Cranial epigastric	Cranial epigastric	Anterior abdominal	Anterior abdominal	-	-		Superior epigastric	Superior epigastric	Epigastric	Superior epigastric	Epigastric	Epigastric
Cranial superficial epigastric	-	-	-	Anterior abdominal	-	-	Ant. or ext. mam.			-	-		
Lateral thoracic	External thoracic	External thoracic	External thoracic	-	Long thoracic	Long thoracic		Long thoracic	Long thoracic	Thoraco- epigast. or ext. mam.	Lat. thoracic Long. " Ext. mam.	Thoraco- epigast. or ext. mam.	Thoraco- epigast. or ext. mam.
Phrenico- abdominal	Phrenico- abdominal	Phreno- abdominal	Phrenico- abdominal	-	Supra- renal	Adreno- lumbar		Lateral* abdominal	(off renal)	-	Supra- renal		
Deep cir- cumflex iliac	Deep cir- cumflex iliac	Deep cir- cumflex iliac	Circumfl. iliac	-	-	Ilio- lumbar		-	-	-	Ilio- lumbar		
External pudendal	External pudendal	External pudendal	Ext. + pudic	External pudic	-	External spermatic		External sperm. off	External spermatic		Pudic- epigast.		Superficial epigastrics
Caudal superficial epigastric	-	Caudal mammary	Subcut. abdominal	Posterior mammary	-	-	Post. mam. or epigast.			Superficial epigastric	-		Superficial epigastrics
Superficial cervical	-					Anterior thoracic?.		Superficial cervical	Superficial cervical		Superficial cervical		
Caudal epigastric	Caudal epigastric	Caudal epigastric	Posterior abdominal	-	Epigastric	-	Hypo- gastric ?	Inferior epigastric	Inferior epigastric		Pudic epigastric trunk		Hypogastric ?
+ Mammary artery is branch of it in ♀ * 12th intercostal off renal as well.													
<u>NERVES</u>													
External spermatic	External spermatic	External spermatic	External spermatic	-	Genito crural	Medial branch genito- femoral		External spermatic	External spermatic				External spermatic
Lateral thoracic	Pectoral	Lateral ^x thoracic	External thoracic	-	-	Anterior thoracic		Long ** pectoral	Long pectoral				Lateral thoracic
Lateral cutaneous femoral	Lateral cutaneous femoral	Lateral cutaneous femoral	Lateral cutaneous femoral	-	Ilio- inguinal ?	-		Lat. cut. fem.	Lateral cutaneous femoral				Lateral cutaneous femoral
								Supra- clavicular	Supra- clavicular				Middle supra- clavicular

* Running with abdominal vein ?
x or thoraco-ventralis.

REFERENCES

- Achaya, K.T. and Hilditch, T.P. (1950). Proc. Roy. Soc. B, 137, 187.
- Afford, A.E. (1948). Proc. Soc. Exp. Biol. N.Y. 67, 296.
- Altman, A.D. (1945). Vestn. Zhivotnov. No.1, 85. Abs. in Vet. Bul. 1950, 20, 108.
- Arnstein, C. (1895). Anat. Anz. 10, 410.
- Asdell, S.A. and Seidenstein, H.R. (1935). Proc. Soc. Exp. Biol. N.Y. 32, 931.
- Asimov, G.J. and Krauze, N.K. (1937). J. Dairy Sci. 20, 289.
- Astwood, E.B., Geschickter, C.F. and Rausch, E.O. (1937). Am. J. Anat. 61, 373.
- Aten, A.H.W. and Hevesy, G. (1938). Nature, 142, 111.
- Aten, A.H.W. and Heyn, C.B. (1950). Amer. J. Physiol. 162, 579.
- Babkin, B.P. (1944). Secretory mechanism of the digestive glands. N.Y. Paul B.Hoeber.
- Bacq, Z.M. (1932). Amer. J. Physiol. 99, 444.
- Bailey, G.L., Bartlett, S. and Folley, S.J. (1949). Nature, 163, 800.
- Balmain, J.H. and Folley, S.J. (1951). Biochem. J. 48, i.
- Balmain, J.H., French, T.H. and Folley, S.J. (1950). Nature, 165, 807.
- Barcroft, J. and Nisimaru, Y. (1932). J. Physiol. 74, 311.
- Barcroft, J., Nisimaru, Y. and Steggarda, F.R. (1932). J. Physiol. 74, 491.
- Basch, K. (1903). Ergebn. Physiol. 2, 326.
- Bates, R.W. (1937). Cold Spring Harbor Symp. Quart. Biol. 5, 191.
- Bayliss, L.E. and Ogden, E. (1933). J. Physiol. 77, 34F.
- Bellini, E. (1948). Sperimentale, 99, 42.
- Benda, C. (1893). Derm. Z. 1, 94.
- Bergman, A.J., Meites, J. and Turner, C.W. (1940). Endocrinology, 26, 716.
- Bergman, A.J. and Turner, C.W. (1937). J. Biol. Chem. 120, 21.

- Bergman, A.J. and Turner, C.W. (1940). *J. Dairy Sci.* 23, 1229.
- Bertkau, F. (1907). *Anat. Anz.* 30, 161.
- Björk, V.O. (1948). *Acta Chirurgica. Scand.* 96, Suppl. 137.
- Blackwood, J.H. (1932). *Biochem. J.* 26, 772.
- Blackwood, J.H. (1934). *Ibid.* 28, 1346.
- Blackwood, J.H. and Stirling, J.D. (1932 a). *Ibid.* 26, 362.
- Blackwood, J.H. and Stirling, J.D. (1932 b). *Ibid.* 26, 778.
- Blackwood, J.H. and Stirling, J.D. (1932 c). *Ibid.* 26, 1127.
- Blaxter, K.L. (1945 a). *J. Endocrinol.* 4, 237.
- Blaxter, K.L. (1945 b). *Ibid.* 4, 266.
- Blaxter, K.L. (1946). *J. agric. Sci.* 36, 117.
- Bottomley, A.C., Folley, S.J., Walker, F.H.A. and Scott-Watson, H.M. (1939). *J. Endocrinol.* 1, 287.
- Bradbury, J.T. (1941). *Endocrinology*, 29, 393.
- Bradley, O.C. (1948). *Topographical anatomy of the dog.* 5th Edn. Edinburgh. Oliver and Boyd.
- Bradley, T.R., Butterworth, R.F., Reid, G. and Trautner, E.M. (1950). *Nature*, 166, 911.
- Bresslau, E. (1920). *The mammary apparatus of the mammalia.* London. Methuen and Co. Ltd.
- Britton, S.W. and Kline, R. (1935). *Amer. J. Physiol.* 113, 178.
- Brodie, T.G. (1903). *J. Physiol.* 29, 266.
- Brody, S. and Nisbet, R. (1938). *Mo. Agr. Res. Sta. Res. Bull.* No.285.
- Brouwer, E. and Martin, J. (1938). *Lait*, 18, 337.
- Brownell, K.A., Lockwood, J.E. and Hartman, F.A. (1933). *Proc. Soc. Exp. Biol. N.Y.* 30, 783.
- Bullough, W.S. (1946). *Phil. Trans. B.* 231, 453.
- Burch, G.E. (1948). In - *Methods in medical research*, Vol.I. (Ed. Van R. Potter). Chicago. The Year Book Publishers, Inc.
- Burns, J.H. (1947). *Brit. Med. Bull.* 5, 190.
- Burrell, H. (1927). *The Platypus.* Sydney. Angus and Robertson, Ltd.
- Bush, I.E. (1951). *J. Physiol.* May meeting Physiol. Soc.

- Cannon, W.B. and Bright, E.M. (1931). *Amer. J. Physiol.* 97, 319.
- Carr, J.L. (1931). *Proc. Soc. Exp. Biol. N.Y.* 29, 131.
- Cary, C.A. (1920). *J. Biol. Chem.* 43, 477.
- Cathcart, E.P., Gairns, F.W. and Garven, H.S.D. (1948). *Trans. Roy. Soc. Edin.* 61, 699.
- Clark, S.L. (1933). *J. Comp. Neurol.* 58, 553.
- Cockburn, R.S. (1942). *Vet. Rec.* 54, 467.
- Corner, G.W. (1930). *Amer. J. Physiol.* 95, 43.
- Cowie, A.T. (1949). *J. Endocrinol.* 6, 145.
- Cowie, A.T., Duncombe, W.G., Folley, S.J., French, T.H., Glascock, R.F., Massart, L., Peeters, G. and Popják, G. (1950). *Biochem. J.* 48, xxxix.
- Cowie, A.T. and Folley, S.J. (1945 a). *Nature*, 156, 719.
- Cowie, A.T. and Folley, S.J. (1945 b). *J. Endocrinol.* 4, 375.
- Cowie, A.T. and Folley, S.J. (1947 a). *Ibid.* 5, 9.
- Cowie, A.T. and Folley, S.J. (1947 b). *Endocrinology*, 40, 274.
- Cowie, A.T. and Folley, S.J. (1947 c). *J. Endocrinol.* 5, 14 and 24.
- Cowie, A.T. and Folley, S.J. (1948). *Ibid.* 5, 282.
- Cowie, A.T. and Folley, S.J. (1949). *Ibid.* 6, VI.
- Cowie, A.T., Folley, S.J. and French, T.H., and Greenbaum, A.L. (1947). *Ibid.* 5, XXXIII (proc.).
- Cowie, A.T., Folley, S.J., French, T.H. and Greenbaum, A.L. (1949). *Ibid.* 6, ii (proc.).
- Cross, B.A. (1950). *Nature*, 166, 612.
- Cross, B.A. (1951). *J. Physiol.* 114, 447.
- Cross, B.A. and Harris, G.W. (1950). *Nature*, 166, 994.
- Curtiss, C. (1949). *Endocrinol.* 45, 284.

- Dabelow, A. (1933). *Morph. Jb.* 73, 69.
- Daly, I. de Burgh, Eggleton, P., Elsdon, S.R. and Hebb, C.O. (1946). *Quart. J. exp. Physiol.* 33, 215.
- Daly, I. de Burgh, Hebb, C.O. and Petrovskaia, B. (1941). *Quart. J. exp. Physiol.* 31, 129.
- Dandy, W.E. (1940). *J. Amer. Med. Ass.* 114, 312.
- Davidson, F.A. (1924). *J. Dairy Sci.* 7, 267.
- Davidson, F.A. (1926). *J. Agric. Res.* 33, 873.
- Dawson, A.B. (1946). *Amer. J. Anat.* 78, 347.
- Dempsey, E.W., Bunting, H. and Wislocki, G.B. (1947). *Ibid.* 81, 309.
- Dempsey, E.W. and Uotila, U.U. (1940). *Endocrinology*, 27, 573.
- Desclin, L. (1940). *C.R.Soc. Biol. Paris*, 134, 267.
- Desclin, L. (1946). *Ibid.* 140, 1182.
- Desclin, L. (1947). *Endocrinology*, 40, 14.
- Desclin, L. and Grégoire, C. (1937). *C.R.Soc. Biol. Paris*, 126, 250.
- Dieckmann, H. (1925). *Virchows. Arch.* 256, 321.
- Dott, N.M. (1923). *Quart. J. exp. Physiol.* 13, 241.
- Dragstedt, L.R., Sudan, A.C. and Phillips, K. (1924). *Amer. J. Physiol.* 69, 477.
- Dreyfuss, R. von (1888). *Virchows. Arch.* 113, 535.
- Drummond-Robinson, G. and Asdell, S.A. (1926). *J. Physiol.* 61, 608.
- Duke, H.N. (1949). *Quart. J. exp. Physiol.* 35, 25.
- Duke, H.N. (1951). *Ibid.* 36, 75.
- Eicholtz, F. and Verney, E.B. (1924). *J. Physiol.* 59, 340.
- Elias, H. (1950). *Scientific monthly*, April, p.229.
- Ellenberger, W. and Baum, H. (1943). *Handbuch der Vergleichenden Anatomie der Haustiere*. 18th Edn. Berlin. Julius Springer.
- Ely, F. and Petersen, W.E. (1940). *J. Dairy Sci.* 23, 536.
- Ely, F. and Petersen, W.E. (1941). *Ibid.* 24, 211.
- Emmerson, M.A. (1929). *J. Amer. Vet. Med. Ass.* 74, 372.

- Ernst, M. (1929). Deut. Zeit. f. Chirurgie. 215, 302.
- Espe, D. (1946). Secretion of milk. 3rd Edn. Iowa State College Press.
- Espe, D. (1947) J. Dairy Sci. 30, 9.
- Evans, E.I. (1933). Proc. Soc. Exp. Biol. N.Y. 30, 1372.
- Fawns, H.T., Folley, S.J. and Young, F.G. (1945). J. Endocrinol. 4, 205.
- Feindel, W.H., Allison, A.C. and Weddell, G. (1948). J. Neurol. 11, 227.
- Feindel, W.H., Sinclair, D.C. and Weddell, G. (1947). Brain, 70, 494.
- Fisher, C., Ingram, W.R. and Ranson, S.W. (1938). Diabetes insipidus and hypothalamus. Edward, Bros.
- Foley, J.O. (1939). Anat. Rec. 73, 465.
- Folley, S.J. (1940). Biol. Rev. 15, 421.
- Folley, S.J. (1941). Lancet, 240, 40.
- Folley, S.J. (1944). Vet. Rec. 56, 9.
- Folley, S.J. (1947 a). Brit. Med. Bull. 5, 130.
- Folley, S.J. (1947 b). Ibid. 135.
- Folley, S.J. (1947 c). Ibid. 5, 142.
- Folley, S.J. (1949 a). Biol. Rev. 24, 316.
- Folley, S.J. (1949 b). J. Endocrinol. 6, XVI.
- Folley, S.J., Dyer, F.J. and Coward, K.H. (1940). Ibid. 2, 179.
- Folley, S.J. and French, T.H. (1948 a). Nature, 161, 933.
- Folley, S.J. and French, T.H. (1948 b). Biochem. J. 42, XLVII.
- Folley, S.J. and French, T.H. (1948 c). Ibid. 43, LV.
- Folley, S.J. and French, T.H. (1949 a). Nature, 163, 174.
- Folley, S.J. and French, T.H. (1949 b). Biochem. J. 44, XLV.
- Folley, S.J. and French, T.H. (1949 c). Proc. 1st Int. Congr. Biochem. p.606.
- Folley, S.J. and French, T.H. (1949 d). Biochem. J. 45, 117.
- Folley, S.J. and French, T.H. (1949 e). Ibid. 45, 270.
- Folley, S.J. and French, T.H. (1950). Ibid. 46, 465.

- Folley, S.J. and Greenbaum, A.L. (1946). *Biochem. J.* 40, 46.
- Folley, S.J. and Greenbaum, A.L. (1947 a). *Ibid.* 41, 261.
- Folley, S.J. and Greenbaum, A.L. (1947 b). *Nature*, 160, 364.
- Folley, S.J. and Greenbaum, A.L. (1948 a). *J. Endocrinol.* 5, 236.
- Folley, S.J. and Greenbaum, A.L. (1948 b). *Biochem. J.* 43, 537.
- Folley, S.J. and Greenbaum, A.L. (1948 c). *Ibid.* 43, 581.
- Folley, S.J. and Greenbaum, A.L. (1949 a). *J. Endocrinol.* 6, x.
- Folley, S.J. and Greenbaum, A.L. (1949 b). *Proc. 1st Int. Congr. Biochem.*, p.409.
- Folley, S.J. and Kay, H.D. (1935). *Biochem. J.* 29, 1837.
- Folley, S.J. and Malpress, F.H. (1944 a). *J. Endocrinol.* 4, 1.
- Folley, S.J. and Malpress, F.H. (1944 b). *Ibid.* 4, 23.
- Folley, S.J. and Malpress, F.H. (1944 c). *Ibid.* 4, 37.
- Folley, S.J., Malpress, F.H. and Young, F.G. (1945 a). *Ibid.* 4, 181.
- Folley, S.J., Malpress, F.H. and Young, F.G. (1945 b). *Ibid.* 4, 212.
- Folley, S.J., Scott-Watson, H.M. and Amoroso, E.C. (1942). *Ibid.* 3, 178.
- Folley, S.J., Scott-Watson, H.M. and Bottomley, A.C. (1940). *J. Physiol.* 98, 15P.
- Folley, S.J., Scott-Watson, H.M. (Mrs. C.C.Thiel) and Bottomley, A.C. (1941). *Ibid.* 100, 7P.
- Folley, S.J., Stewart, D.L. and Young, F.G. (1944). *J. Endocrinol.* 4, 43.
- Folley, S.J. and White, P. (1936). *Proc. Roy. Soc. B*, 120, 346.
- Folley, S.J. and Young, F.G. (1940). *J. Endocrinol.* 2, 226.
- Folley, S.J. and Young, F.G. (1941a). *Lancet*, 1, 380.
- Folley, S.J. and Young, F.G. (1941 b). *Nature*, 148, 563.
- Folley, S.J. and Young, F.G. (1945). *J. Endocrinol.* 4, 194.
- Foot, N.C. (1929 a). *Amer. J. Path.* 5, 215.
- Foot, N.C. (1929 b). *Ibid.* 5, 223.
- Foot, N.C. (1929 c). *Ibid.* 5, 365.
- Frazier, C.N. and Mu, J.W. (1935). *Proc. Soc. Exp. Biol. N.Y.* 32, 997.

- de Fremery, P. (1936). *J. Physiol.* 87, 50P.
- French, T.H., Hunter, G.D., Martin, A.J.P. and Popjak, G. (1951). *Biochem. J.* 48, vi.
- Friedman, M.H. and Hall, S.R. (1941). *Endocrinology*, 29, 179.
- Fürstenberg, M.H.F. (1868). *Die Milchdrüsen der Kuh.* Leipzig. W.Engelmann.
- Gaddum, J.H. and Kwiatkowski, H. (1938). *J. Physiol.* 94, 87.
- Gaddum, J.H., Peart, W.S. and Vogt, M. (1949). *Ibid.* 108, 467.
- Gaines, W.L. (1915). *Amer. J. Physiol.* 38, 285.
- Gaines, W.L. (1928). *Science*, 67, 353.
- Gaines, W.L. and Sanmann, F.P. (1926). *Amer. J. Physiol.* 80, 691.
- Gardner, W.V. (1941). *Endocrinology*, 28, 53.
- Gardner, W.V. and White, A. (1941). *Proc. Soc. Exp. Biol. N.Y.* 48, 590.
- Gardner, W.V. and White, A. (1942). *Anat. Rec.* 82, 414.
- Garven, H.S.D. (1925). *Brain*, 48, 380.
- Gaunt, R. (1933). *Amer. J. Physiol.* 103, 494.
- Gaunt, R. (1941). *Proc. Soc. Exp. Biol. N.Y.* 47, 28.
- Gaunt, R., Eversole, W.J. and Kendall, E.C. (1942). *Endocrinology*, 31, 84.
- Gaunt, R. and Tobin, C.E. (1936). *Amer. J. Physiol.* 115, 588.
- Gavin, W. (1913). *Quart. J. exp. Physiol.* 6, 13.
- Gerhardt, U. (1909). *Das Kaninchen.* Leipzig. W.Klinkhardt.
- Goltz, F. and Ewald, J.R. (1896). *Pflüg. Arch. ges. Physiol.* 63, 362.
- Goltz, F. and Freusberg, A. (1874). *Ibid.* 9, 552.
- Gomez, E.T. (1939). *J. Dairy Sci.* 22, 488.
- Gomez, E.T. (1940). *Ibid.* 23, 537.
- Gomez, E.T. (1942). *Endocrinology*, 31, 613.
- Gomez, E.T. and Turner, C.W. (1936). *Proc. Soc. Exp. Biol. N.Y.* 35, 365.
- Gomez, E.T. and Turner, C.W. (1937 a). *Ibid.* 36, 78.
- Gomez, E.T. and Turner, C.W. (1937 b). *Ibid.* 36, 80.
- Gomez, E.T. and Turner, C.W. (1938). *Ibid.* 37, 607.
- Gomez, E.T., Turner, C.W., Gardner, W.V. and Hill, R.T. (1937). *Ibid.* 36, 287.
- Gomez, E.T., Turner, C.W. and Reece, R.P. (1937). *Ibid.* 36, 286.
- Gowen, J.W. and Tobey, E.R. (1931 a). *J. Gen. Physiol.* 15, 45.
- Gowen, J.W. and Tobey, E.R. (1931 b). *Ibid.* 15, 67.

- Graham, W.R. (1937). *J. Biol. Chem.* 122, 1.
- Graham, W.R., Houchin, O.B., Petersen, V.E. and Turner, C.W. (1938). *Amer. J. Physiol.* 122, 150.
- Graham, W.R., Houchin, O.B. and Turner, C.W. (1937). *J. Biol. Chem.* 120, 29.
- Graham, W.R., Jones, T.S.G. and Kay, H.D. (1936). *Proc. Roy. Soc. B*, 120, 330.
- Graham, W.R., Kay, H.D. and McIntosh, R.A. (1936). *Ibid.* 120, 319.
- Graham, W.R., Peterson, V.E., Houchin, O.B. and Turner, C.W. (1938). *J. Biol. Chem.* 122, 275.
- Grant, G.A. (1935). *Biochem. J.* 29, 1905.
- Grant, G.A. (1936). *Ibid.* 30, 2027.
- Green, J.D. and Harris, G.W. (1947). *J. Endocrinol.* 5, 136.
- Greene, E.C. (1935). *Trans. Amer. Phil. Soc.* 27. Anatomy of the rat.
- Greep, R.O. and Stavely, H.E. (1941). *Endocrinology*, 29, 18.
- Gross, G. (1936). The care and breeding of laboratory animals. (Ed. E.J.Farris). N.Y. John Wiley and Sons.
- El Hagri, M.A.A.M. (1945). *Vet. J.* 101, 27, 51, 75.
- Hall, S.R. (1944). *Endocrinology*, 34, 14.
- Hall, V.E. and Pierce, G.N. (1934). *Anat. Rec.* 60, 111.
- Hammond, J. (1913). *Quart. J. exp. Physiol.* 6, 311.
- Hammond, J. (1927). *The Physiology of reproduction in the cow.* Camb. Univ. Press.
- Hammond, J. (1936). *Vet. Rec.* 48, 519.
- Hammond, J. (Jr) and Day, F.T. (1944). *J. Endocrinol.* 4, 53.
- Hamperl, H. (1939). *Virchows Arch. f. path. Anat.* 305, 171.
- Hartman, C. (1923). *Amer. J. Anat.* 32, 353.
- Heaney, N.S. (1913). *Surg. Gynec. and Obstet.* 17, 103.
- Hebb, C.O. and Nimmo-Smith, R.H. (1946). *J. Physiol.* 105, 1.
- Hemingway, A. (1931). *Ibid.* 71, 201.
- Henle, J. (1850) (Constatt's) *Jahresber. ges. Med.* p.41.
- Henle, J. (1866). *Handbuch der systematischen Anatomie des Menschen.* Vol. II. *Eingeweidelehre.* Braunschweig. F.Wilweg u. Sohn.
- Herold, L. (1939). *Arch. Gynaek.* 168, 534.
- Heymans, C., Bouckaert, J.J. and Moraes, A. (1932). *Arch. Int. Pharmacodyn.* 43, 468.
- Hilditch, T.P. and Paul, H. (1936). *Biochem. J.* 30, 1905.
- Hilditch, T.P. and Thompson, H.M. (1936). *Ibid.* 30, 677.
- Hill, J.P. and O'Donoghue, C.H. (1913). *Quart. J. micr. Sci.*, 59, 133.

- Hisaw, F.L. and Astwood, E.B. (1942). *Ann. Rev. Physiol.* 4, 536.
- Holmes, W. (1942). *J. Path. Bact.* 54, 132.
- Holmes, W. (1943). *Anat. Rec.* 86, 157.
- Holst, S. and Turner, C.W. (1939). *Proc. Soc. Exp. Biol. N.Y.* 42, 479.
- Hooker, C.W. (1946). *Ann. Rev. Physiol.* 8, 480.
- Hooker, C.W. and Williams, W.L. (1941). *Endocrinology*, 28, 42.
- Houssay, B.A. (1935 a). *C.R. Soc. Biol. Paris*, 120, 496.
- Houssay, B.A. (1935 b). *Ibid.* 120, 502.
- Inglebrecht, P. (1935). *Ibid.* 120, 1369.
- Jacobsohn, D. (1948). *Acta. Physiol. Scand.* 17, Suppl. 57.
- Jacobsohn, D. (1949 a). *Ibid.* 19, 10.
- Jacobsohn, D. (1949 b). *Ibid.* 19, 19.
- Jacobsohn, D. and Westman, A. (1945). *Ibid.* 9, 284.
- Jung, L. (1932 a). *C.R. Soc. Biol. Paris*, 109, 737.
- Jung, L. (1932 b). *Ibid.* 109, 1052.
- Jung, L. (1933). *Lait*, 13, 307.
- Jung, L., Tagard, R. and Pierre, M. (1934). *C.R. Soc. Biol. Paris*, 115, 1538.
- Kahn, R. (1925). *Klin. Wschr.* 4, 2256.
- Kay, H.D. (1945). *Nature*, 156, 159.
- Kay, H.D. (1947). *Brit. Med. Bull.* 5, 149.
- Kelly, P.L. (1942). *J. Dairy Sci.* 25, 709.
- Kelly, P.L. and Petersen, W.E. (1939). *J. Dairy Sci.* 22, 7.
- Kleiber, M., Smith, A.H. and Levy, P. (1943). *Proc. Soc. exp. Biol. N.Y.* 53, 94.
- Kleiber, M., Smith, A.H. and Ralston, N.P. (1948). *Ibid.* 69, 354.
- Kleiber, M., Smith, A.H. and Tolbert, B. (1950). *Proc. 18th Int. Physiol. Congr.*
- Knisely, M.H. (1934). *Anat. Rec.* 58, 73.
- Knisely, M.H. (1936). *Ibid.* 64, 499.
- Knisely, M.H., Eliot, T.S. and Block, E.H. (1945). *Arch. Surg.* 51, 220.
- Knodt, C.B. and Petersen, W.E. (1944). *J. Dairy Sci.* 27, 449.
- Knodt, C.B. and Petersen, W.E. (1945). *Ibid.* 28, 415.
- Knodt, C.B. and Petersen, W.E. (1946 a). *Ibid.* 29, 115.
- Knodt, C.B. and Petersen, W.E. (1946 b). *Ibid.* 29, 121.
- Kochan, W.F. (1943). *Vet. Rec.* 55, 449.
- Kolda, J. (1926). *Lait*, 6, 12, 88, 180, 269.

- Kölliker, A. (1850). Mikroskopische Anatomie der Gewebelehre des Menschen. Bd.II. Leipzig. W.Engelmann. p.556.
- Kölliker, A. (1855). Handbuch der Gewebelehre des Menschen für Aertze und Studuriende. 2nd Edn. Leipzig. W.Engelmann.
- Konzett, H. (1948). *Experientia*, 4, 443.
- Konzett, H. and Hebb, C.O. (1949). *Arch. int. Pharmacodyn.* 78, 210.
- Krause, W. (1868). Die Anatomie des Kaninchens. In topographischer und operativer rücksicht. Leipzig. W.Engelmann.
- Kubie, L.S. and Davidson, D. (1928). *Arch. Neurol. Psychiat.* 19, 888.
- Kudryavstev, P.N. and Glebina, E.I. (1941). *Vestn. sel'skokhoz. Nauki Zhivotn.* 2, 136. Abs. in *Vet. Bul.* 1947, 17, 558.
- Kuramitsu, C. and Loeb, L. (1921). *Amer. J. Physiol.* 56, 40.
- Kuzma, J.F. (1943). *Amer. J. Path.* 19, 473.
- Laffont, M. (1879). *C.R. Acad. Sci. Paris*, 89, 649.
- Landau, E. (1940). *Bull. Histol. Tech. Micr.* 7, 65.
- Lane-Clayton, J.E. and Starling, E.H. (1906). *Proc. Roy. Soc. B*, 77, 505.
- Langer, C. (1871). In *Handbuch der Lehre von den Geweben des Menschen und der Thiere.* (Ed. S.Stricker). Leipzig. W.Engelmann.
- Langhans, T. (1873). *Virchow's Arch. f. path. Anat.* 58, 132.
- Langworthy, O.R. (1924). *J. Mammol.* 5, 49.
- Leech, F.B. (1950). *J. Endocrinol.* 7, 42.
- Lenfers, P. (1907). *Z. Fleisch. Milchhygiene*, 17, 340, 383, 424.
- Lewis, A.A. and Turner, C.W. (1941). *J. Dairy Sci.* 24, 845.
- Lewis, A.A. and Turner, C.W. (1942). *Ibid.* 25, 895.
- Lim Boon Keng (1893). *J. Physiol.* 14, 467.
- Linton, R.G. (1929). *Vet. Rec.* 2, 652.
- Linton, R.G. (1934). *Vet. Rec.* 14, 691.
- Lintzel, W. (1934). *Lait*, 14, 1125.
- Lyons, W.R. (1942). *Proc. Soc. exp. Biol. N.Y.* 51, 308.
- Lyons, W.R. (1943). *Essays in Biology.* Univ. Calif. Press, Berkeley.
- Lyons, W.R. and McGinty, D.A. (1941). *Proc. Soc. exp. Biol. N.Y.* 48, 83.
- Lyons, W.R. and Pencharz, R.I. (1936). *Ibid.* 33, 589.
- Lyons, W.R. and Scharf, G. (1941). *Ibid.* 48, 86.
- Lyons, W.R., Simpson, M.E. and Evans, H.M. (1941). *Ibid.* 48, 634.
- Lyons, W.R., Simpson, M.E. and Evans, H.M. (1943). *Ibid.* 52, 134.

- Mackenzie, K. (1911). *Quart. J. exp. Physiol.* 4, 305.
- McClymont, G.L. (1949). *Biochem. J.* 45, i.
- McPhail, M.K. (1935a). *Proc. Roy. Soc. B*, 117, 34.
- McPhail, M.K. (1935 b). *Ibid.* 117, 45.
- Malpress, F.H. (1947). *Brit. Med. Bull.*, 5, 161.
- Maranon, G. (1947). *Brit. Med. J.* 1, 769.
- Marshall, F.H.A. (1922). *The physiology of reproduction.* 2nd Edn. London; Longmans, Green.
- Marshall, A. (1946). *J. Physiol.* 105, 35P.
- Marshall, A. and Trowell, O.A. (1943). *Ibid.* 102, 9P.
- Maxwell, A.I. and Rothera, A.C.H. (1915). *Ibid.* 49, 483.
- Meigs, E.B. (1922). *Physiol. Rev.* 2, 204.
- Meigs, E.B., Blatherwick, N.R. and Cary, C.A. (1919). *J. Biol. Chem.* 37, 1.
- Meites, J. and Turner, C.W. (1942 a). *Endocrinology*, 30, 711.
- Meites, J. and Turner, C.W. (1942 b). *Ibid.*, 30, 719.
- Meites, J. and Turner, C.W. (1942 c). *Ibid.*, 30, 726.
- Meites, J. and Turner, C.W. (1942 d). *Proc. Soc. exp. Biol. N.Y.* 49, 193.
- Meites, J. and Turner, C.W. (1942 e). *Ibid.* 49, 190.
- Meites, J. and Turner, C.W. (1943). *Endocrinology*, 31, 340.
- Meites, J. and Turner, C.W. (1947). *Amer. J. Physiol.* 150, 394.
- Meyling, H.H. (1949). *J. Anat. Lond.* 83, 78.
- Miller, M.E. (1948). *Guide to the dissection of the dog.* 2nd Edn. Ithaca, N.Y.
- Miller, K. and Petersen, W.E. (1940). *J. Dairy Sci.* 23, 539.
- Miller, K. and Petersen, W.E. (1941). *Ibid.* 24, 225.
- Mivart, St.G. (1881). *The Cat - an introduction to the study of backboneed animals especially mammals.* London. John Murray.
- Mixner, J.P. (1940). *J. Dairy Sci.* 23, 542.
- Mixner, J.P., Bergman, A.J. and Turner, C.W. (1942⁹). *Endocrinology*, 31, 461.
- Mixner, J.P. and Turner, C.W. (1941a). *Ibid.* 29, 324.
- Mixner, J.P. and Turner, C.W. (1941b). *Proc. Soc. exp. Biol. N.Y.* 46, 437.
- Mixner, J.P. and Turner, C.W. (1942). *Endocrinology*, 30, 591.
- Mixner, J.P. and Turner, C.W. (1943). *Mo. Agr. Exp. Sta. Res. Bull.* 378.
- Moullin, C.W.M. (1880). *J. Anat. Physiol.* 15, 346.
- Mullen, J.E.C. (1950 a). *J. Dairy Res.* 17, 288.
- Mullen, J.E.C. (1950 b). *Ibid.*, 17, 306.

- Nelson, W.O. (1932). *Anat. Rec.* 54, 51 (Suppl.).
- Nelson, W.O. (1934). *Endocrinology*, 18, 33.
- Nelson, W.O. (1935). *Proc. Soc. exp. Biol. N.Y.* 33, 222.
- Nelson, W.O. (1936). *Physiol. Rev.* 16, 488.
- Nelson, W.O. (1938). *Anat. Rec.* 72, 117 (Suppl.).
- Nelson, W.O. (1939). *Amer. J. Physiol.* 126, 592P.
- Nelson, W.O. and Gaunt, R. (1936). *Proc. Soc. exp. Biol. N.Y.* 34, 671.
- Nelson, W.O. and Gaunt, R. (1937). *Ibid.* 36, 136.
- Nelson, W.O. and Pfiffner, J.J. (1931). *Anat. Rec.* 51, 51.
- Newton, W.H. (1932). *J. Physiol.* 75, 18.
- Newton, W.H. and Richardson, K.C. (1941). *J. Endocrinol.* 2, 322.
- Nonidez, J.F. (1939). *Amer. J. Anat.* 65, 361.
- Ott, I. and Scott, J.C. (1910). *Proc. Soc. exp. Biol. N.Y.* 8, 48.
- Ott, I. and Scott, J.C. (1912). *Ibid.* 9, 63.
- Owen, R. (1868). *On the anatomy of vertebrates. Vol.III. Mammals.* London. Longmans, Green and Co.
- Owen, E.C. (1948 a). *Biochem. J.* 43, 243.
- Owen, E.C. (1948 b). *Ibid.* 43, 235.
- Parkes, A.S. and Glover, R.E. (1944). *J. Endocrinol.* 4, 90.
- Peeters, G. (1950). Personal communication.
- Peeters, G. and Coussens, R. (1950). *Arch. int. Pharmacodyn.* 84, 209.
- Peeters, G., Coussens, R., Bouckaert, J.H. and Oyaert, W. (1949). *Ibid.* 80, 355.
- Peeters, G., Coussens, R. and Oyaert, W. (1949). *Ibid.* 77, 113.
- Peeters, G., Coussens, R. and Sierens, G. (1949). *Ibid.* 79, 75.
- Peeters, G. and Massart, L. (1947 a). *J. Endocrinol.* 5, 166.
- Peeters, G. and Massart, L. (1947 b). *Arch. int. Pharmacodyn.* 74, 83.
- Peeters, G. and Massart, L. (1950). *Research*, 3, 217.
- Peeters, G., Massart, L. and Coussens, R. (1947). *Arch. int. Pharmacodyn.* 75, 85.
- Peeters, G., Massart, L., Coussens, R. and Vandeplassche, M. (1949). *Ibid.* 78, 548.
- Peeters, G., Massart, L., Oyaert, W. and Coussens, R. (1948). *Ibid.* 75, 243.
- Pencharz, R.I. and Lyons, W.R. (1938). *Proc. Soc. exp. Biol. N.Y.* 38, 388.
- Peeters, J.P. and Van Slyke, D.D. (1932). *Quantitative clinical chemistry. Vol.2. Methods.* Baltimore. Williams and Wilkins.

- Petersen, W.E. (1942). Proc. Soc. exp. Biol. N.Y. 50, 298.
- Petersen, W.E. (1944). Physiol. Rev. 24, 340.
- Petersen, W.E. and Ludwick, T.M. (1942). Fed. Proc. 1, 66.
- Petersen, W.E. and Rigor, T.V. (1932 a). Proc. Soc. exp. Biol. N.Y. 30, 254.
- Petersen, W.E. and Rigor, T.V. (1932 b). Ibid. 30, 257.
- Petersen, W.E. and Rigor, T.V. (1932 c). Ibid. 30, 259.
- Petersen, W.E. and Shaw, J.C. (1942). J. Dairy Sci. 25, 708.
- Petersen, W.E., Shaw, J.C. and Visscher, M.B. (1939). Ibid. 22, 439.
- Petersen, W.E., Shaw, J.C. and Visscher, M.B. (1941). Ibid. 24, 139.
- Pickworth, F.A. (1934). J. Anat. Lond. 69, 62.
- Popják, G. and Beeckmans M.L. (1949). Biochem. J. 44, XXXVII.
- Popják, G., Folley, S.J. and French, T.H. (1949). Arch. Biochem. 23, 509.
- Popják, G., French, T.H. and Folley, S.J. (1950). Biochem. J. 46, XXVIII.
- Popják, G., French, T.H. and Folley, S.J. (1951). Ibid. 48, 411.
- Porcher, C. and Muffet, E. (1930). Lait, 10, 394 and 528.
- Powell, R.C. and Shaw, J.C. (1942). J. biol. Chem. 146, 207.
- Ralston, N.P. and Herman, H.A. (1938). J. Dairy Sci. 21, 120 (Proc.)
- Ragsdale, A.C., Turner, C.W. and Brody, S. (1924). J. Dairy Sci. 7, 249.
- Rapport, M.M., Green, A.A. and Page, I.H. (1948 a). J. biol. Chem. 174, 735.
- Rapport, M.M., Green, A.A. and Page, I.H. (1948 b). Proc. Soc. exp. Biol. N.Y. 68, 582.
- Reece, R.P. (1943). Proc. Soc. exp. Biol. N.Y. 52, 145.
- Reece, R.P., Hathaway, I.L. and Davis, H.P. (1939). J. Dairy Sci. 22, 1.
- Reece, R.P. and Leonard, S.L. (1939). Proc. Soc. exp. Biol. N.Y. 42, 200.
- Reece, R.P. and Leonard, S.L. (1941). Endocrinology, 29, 297.
- Reece, R.P. and Leonard, S.L. (1942). Proc. Soc. exp. Biol. N.Y. 49, 660.
- Reece, R.P. and Turner, C.W. (1936). Ibid. 35, 367.
- Reece, R.P. and Turner, C.W. (1937 a). J. Dairy Sci. 20, 411.
- Reece, R.P. and Turner, C.W. (1937 b). Proc. Soc. exp. Biol. N.Y. 35, 621.
- Reighard, J. and Jennings, H.S. (1925, 1951). Anatomy of the cat. 2nd Edn. 1925; 3rd Edn. 1951. N.Y. Henry Holt and Co.
- Reineke, E.P. (1940). J. Dairy Sci. 23, 543.
- Reineke, E.P., Stonecipher, W.O. and Turner, C.W. (1941). Amer. J. Physiol. 132, 535.

- Reineke, E.P. and Turner, C.W. (1942). *J. Dairy Sci.* 25, 393.
- Reineke, E.P., Williamson, M.B. and Turner, C.W. (1941 a).
 Ibid. 24, 317.
- Reineke, E.P., Williamson, M.B. and Turner, C.W. (1941 b).
J. Biol. Chem. 138, 83.
- Retterer, E. and Lelièvre, A. (1911). *J. Anat. Paris*, 47, 101.
- Ribbert, H. (1898). *Arch. EntwMech. Org.* 7, 688.
- Richards, A.N. and Plant, O.H. (1915). *J. Pharm.* 7, 485.
- Richardson, K.C. (1947). *Brit. Med. Bull.* 5, 123.
- Richardson, K.C. (1949). *Proc. Roy. Soc. B*, 136, 30.
- Riddle, O. (1940). *J. Amer. med. Ass.* 115, 2276.
- Riddle, O. and Bates, R.W. (1939). In - Sex and internal secretions; Chap.XX, p.1088. (Ed. E.Allen). London.
- Riddle, O., Bates, R.W. and Dykshorn, S.W. (1932). *Proc. Soc. exp. Biol. N.Y.* 29, 1211.
- Riddle, O., Bates, R.W. and Dykshorn, S.W. (1933). *Amer. J. Physiol.* 105, 191.
- Riederer, T. (1903). *Arch. Tierheilk.* 29, 593.
- Ritchie, A.E. (1944). *J. Scil Inst.* 21, 64.
- Rogers, W.M. (1931). *Anat. Rec.* 49, 81.
- Romanes, G.J. (1950). *J. Anat. Lond.* 84, 104.
- Rosenblueth, A. and Schlossberg, T. (1931). *Amer. J. Physiol.* 97, 365.
- Rubeli, O. (1916). *Schweiz. Arch. Tierheilk.* 58, 357.
- St.Clair, L.E. (1942). *Amer. J. Vet. Res.* 3, 10.
- Schabadasch, A. (1935). *Acta Morphologica*, 1. Staatsverlag,
 Gorkij. Theoretische und experimentelle studien zur Methylenblaufärbung
 des nervengewebes.
- Schäfer, E.A. (1913). *Quart. J. exper. Physiol.* 6, 17.
- Schäfer, E.A. (1914). Ibid. 8, 379.
- Schäfer, E.A. and Mackenzie, K. (1911). *Proc. Roy. Soc. B*,
84, 16.
- Selye, H. (1934 a). *Proc. Soc. exp. Biol. N.Y.* 31, 488.
- Selye, H. (1934 b). *Amer. J. Physiol.* 107, 535.
- Selye, H., Collip, J.B. and Thomson, D.L. (1934). *Endocrinology*,
18, 237.
- Selye, H. and McKeown, T. (1934 a). *Anat. Rec.* 60, 323.
- Selye, H. and McKeown, T. (1934 b). *Surg. Gynec. Obstet.* 59, 886.
- Selye, H. and McKeown, T. (1934 c). *Proc. Soc. exp. Biol. N.Y.*
31, 683.
- Shaw, J.C. (1939). *J. Dairy Sci.* 22, 438.
- Shaw, J.C. (1946). Ibid. 29, 183.

- Shaw, J.C. and Knodt, C.B. (1941). *J. Biol. Chem.* 138, 287.
- Shaw, J.C. and Petersen, W.E. (1938 a). *Amer. J. Physiol.* 123, 183.
- Shaw, J.C. and Petersen, W.E. (1938 b). *Proc. Soc. exp. Biol. N.Y.* 38, 631.
- Shaw, J.C. and Petersen, W.E. (1938 c). *Ibid.* 38, 632.
- Shaw, J.C. and Petersen, W.E. (1938 d). *J. Dairy Sci.* 21, 122.
- Shaw, J.C. and Petersen, W.E. (1939). *Proc. Soc. exp. Biol. N.Y.* 42, 520.
- Shaw, J.C. and Petersen, W.E. (1940 a). *J. Dairy Sci.* 23, 538.
- Shaw, J.C. and Petersen, W.E. (1940 b). *Ibid.* 23, 1045.
- Shaw, J.C. and Petersen, W.E. (1943). *J. Biol. Chem.* 147, 639.
- Shaw, J.C., Powell, R.C. and Knodt, C.B. (1942). *J. Dairy Sci.* 25, 909.
- Shoshan, A. (1935). *Vet. J.* 91, 280.
- Silver, M.L. (1942). *Anat. Rec.* 82, 507.
- Simeone, F.A. and Ross, J.F. (1938). *Amer. J. Physiol.* 122, 659.
- Simpson, S. and Hill, R.L. (1944 a). *Quart. J. exp. Physiol.* 8, 103.
- Simpson, S. and Hill, R.L. (1944 b). *Ibid.* 8, 377.
- Simpson, S. and Hill, R.L. (1945). *Amer. J. Physiol.* 36, 347.
- Sisson, S. (1940). *The anatomy of the domestic animals.* 3rd Edn. Philadelphia. W.B.Saunders and Co.
- Smith, P.E. (1932). *Amer. J. Physiol.* 99, 345.
- Spielman, A.A., Petersen, W.E. and Fitch, J.B. (1944). *J. Dairy Sci.* 27, 441.
- Spoor, H.J., Hartman, F.A. and Brownell, K.A. (1941). *Amer. J. Physiol.* 134, 12.
- Spriggs, D.N. (1945). *Vet. Rec.* 57, 519.
- Starling, E.H. (1945). *Principles of human physiology.* 9th Edn. C.C.Evans. London. Churchill.
- Sternberg, J. (1950). *Proc, 18th int. Physiol. Congr.*
- Stricker, P. (1930). *C.R. Soc. Biol. Paris*, 102, 1076.
- Stricker, P. and Grueter, F. (1928). *Ibid.* 99, 1978.
- Stricker, P. and Grueter, F. (1929). *Pr. Med.* 37(2). 1269.
- Swanson, E.W. and Turner, C.W. (1941). *J. Dairy Sci.* 24, 635.
- Swingle, W.W. and Pfiffner, J.J. (1932). *Med.* 11, 371.
- Tgetgel, B. (1926). *Schweiz. Arch. Tierheilk.* 68, 335, 369.
- Trautmann, A. (1919). *Pflug. Archiv. ges. Physiol.* 177, 239.
- Trentin, J.J., Lewis, A.A. and Bergman, A.J. and Turner, C.W. (1943). *Endocrinology*, 33, 67.
- Turner, C.W. (1939 a). *In - Sex and internal secretions.* (Allen, Danforth and Doisy). 2nd Edn. Chap XI, p.740.

- The comparative anatomy of the mammary glands.
- Turner, C.W. (1939 b). / Univ. Coop. Store Columbia, Missouri.
- Turner, C.W. and Cooper, W.D. (1941). *Endocrinology*, 29, 320.
- Turner, C.W. and Frank, A.H. (1931). *Science*, 73, 295.
- Turner, C.W. and Frank, A.H. (1932). *Mo. Agri. Exp. Sta. Res. Bul.* 174.
- Turner, C.W. and Gomez, E.T. (1934). *Mo. Agr. Exp. Sta. Res. Bul.* 207,
- Turner, C.W. and de Moss, W.R. (1934). *Mo. Agr. Exp. Sta. Res. Bul.* 207.
- Turner, C.W. and Slaughter, E.S. (1930). *J. Dairy Sci.* 13, 8.
- Velich, A. (1926). *Lait*, 6, 1, 102.
- Vercruyssen, R., Peeters, G. and Coussens, R. (1950). *Arch. int. Pharmacodyn.* 82, 93.
- Vogt, M. (1943). *J. Physiol.* 102, 341.
- Wahl, H.M. (1915). *Amer. J. Anat.* 18, 515.
- Walker, S.M. and Stanley, A.J. (1940). *Anat. Rec.* 78, 142 (Suppl.).
- Walker, S.M. and Stanley, A.J. (1941). *Proc. Soc. exp. Biol. N.Y.* 48, 50.
- Weber, H. (1944). *Bull. Histol. Tech. micr.* 21, 45.
- Wertheimer, E. and Shapiro, B. (1948). *Physiol. Rev.* 28, 451.
- White, A. (1943). *Ann. N.Y. Acad. Sci.* 43, 365.
- Whitnah, C.H., Riddell, W.H. and Hodgson, R.E. (1933). *J. Dairy Sci.* 16, 347.
- Williams, W.L. (1945). *Anat. Rec.* 93, 171.
- Wilson, J.T. (1913). *J. Anat. Lond.* 47, 8.
- Zietzschmann, O. (1917). *Deut. Tieraztl. Wschr.* 25, 361.
- Zietzschmann, O. (1922). *Lait*, 2, 229.
- Zimmermann, K.W. (1898). *Arch. f. Mikroskop. Anat.* 52, 552.
- Zimmermann, K.W. (1927). *Handbuch der Mikroskopischen anatomie des Menschen.* (Ed. V.Möllerndorff). Bd.5, p.130.
- Zweifach, B.W. (1939). (~~1939~~). *Anat. Rec.* 73, 475.
- Zweifach, B.W. (1948). In - *Potter's Methods in medical research.* Vol.I, p.13.