

The Circulation of Cypriot Pottery in the Middle Bronze Age

Louise C. Maguire

**Doctor of Philosophy
University of Edinburgh
1990**



VOLUME II

CONTENTS

Volume II

Section I	Text Illustrations	1
Section II	Catalogue Text	53
Section III	Catalogue Illustrations (Figures)	175
	Catalogue Illustrations (Plates)	238

- | | |
|----|--------------------|
| 1 | Milia |
| 2 | Kouklia |
| 3 | Katydhata |
| 4 | Dhiorios |
| 5 | Stephania |
| 6 | Lapithos |
| 7 | Krini |
| 8 | Dhenia |
| 9 | Dhikomo |
| 10 | A. Paraskevi |
| 11 | Kythrea |
| 12 | Leondari Vouno |
| 13 | Yeri |
| 14 | Politiko-Lambertis |
| 15 | Dhali |
| 16 | Alambra |
| 17 | Livadhia |
| 18 | Klavdhia |
| 19 | Arpera |
| 20 | Kalopsidha |
| 21 | Enkomi |
| 22 | A. Iakovos |
| 23 | Paleoskoutella |
| 24 | Nitovikla |

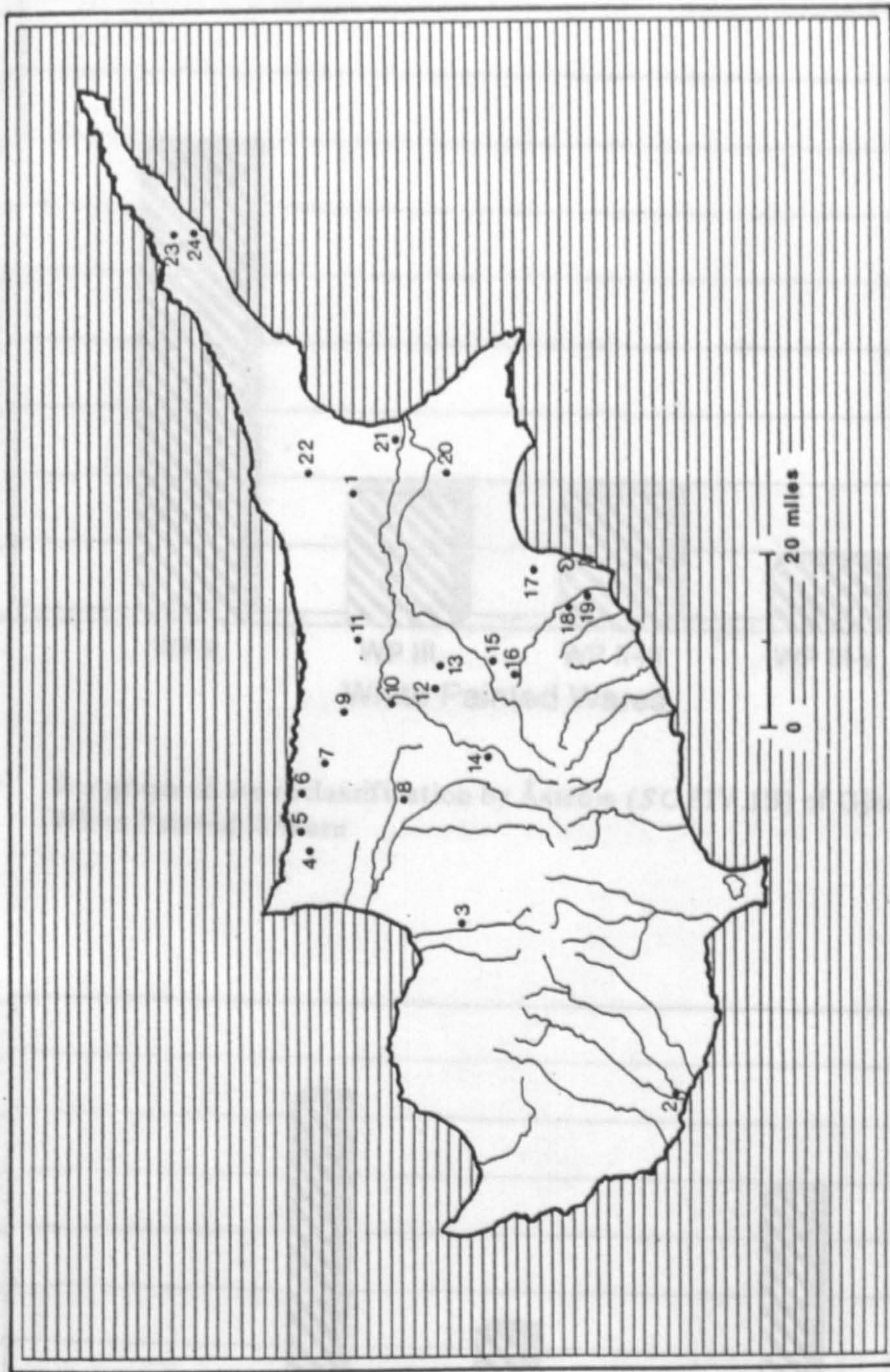

Figure 1: Map of Cyprus indicating those sites mentioned in the text

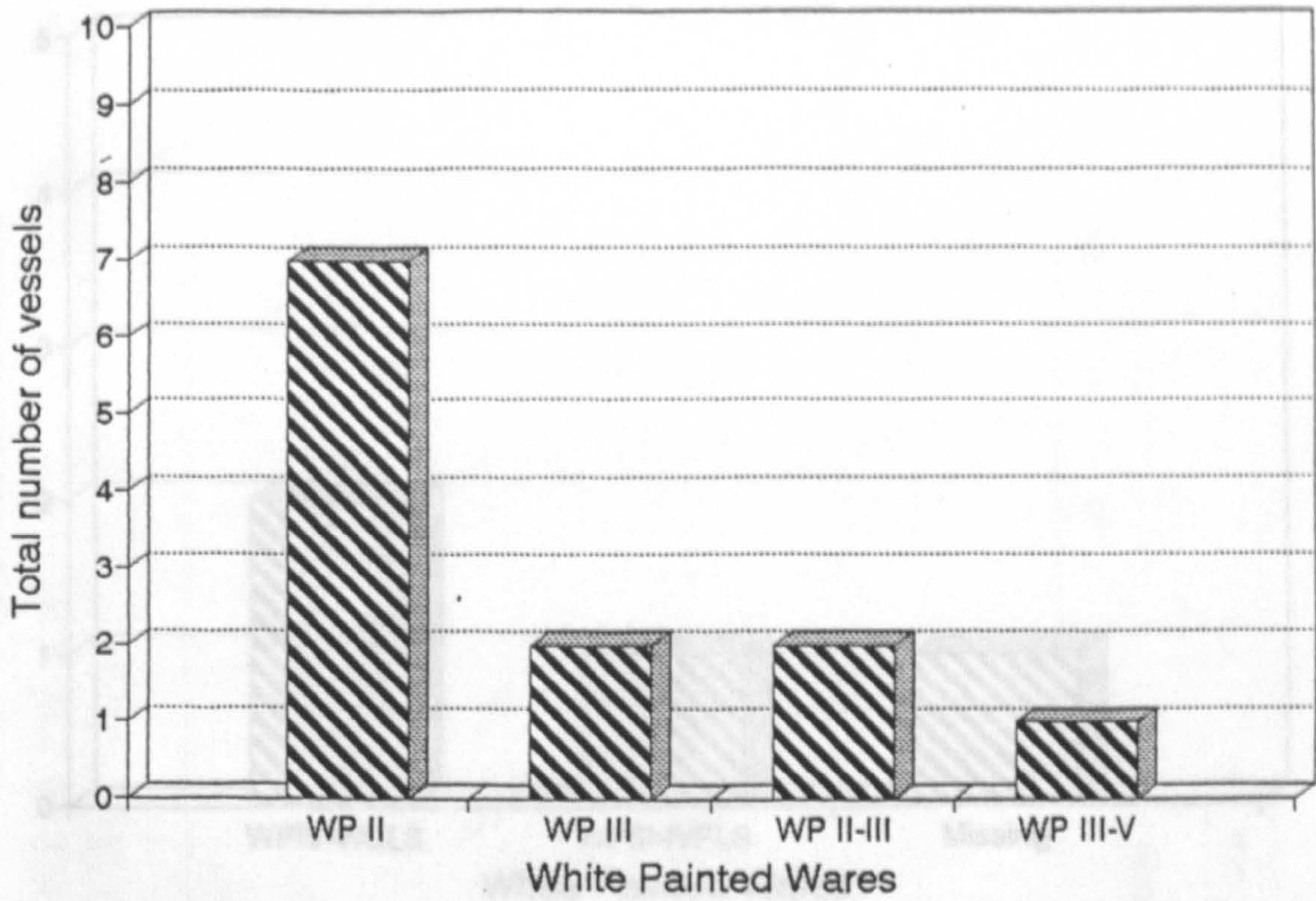

Figure 2: Bar graph of the reclassification by Åström (SCEIV.1B) of Gjerstad's (1926) White Painted II Ware

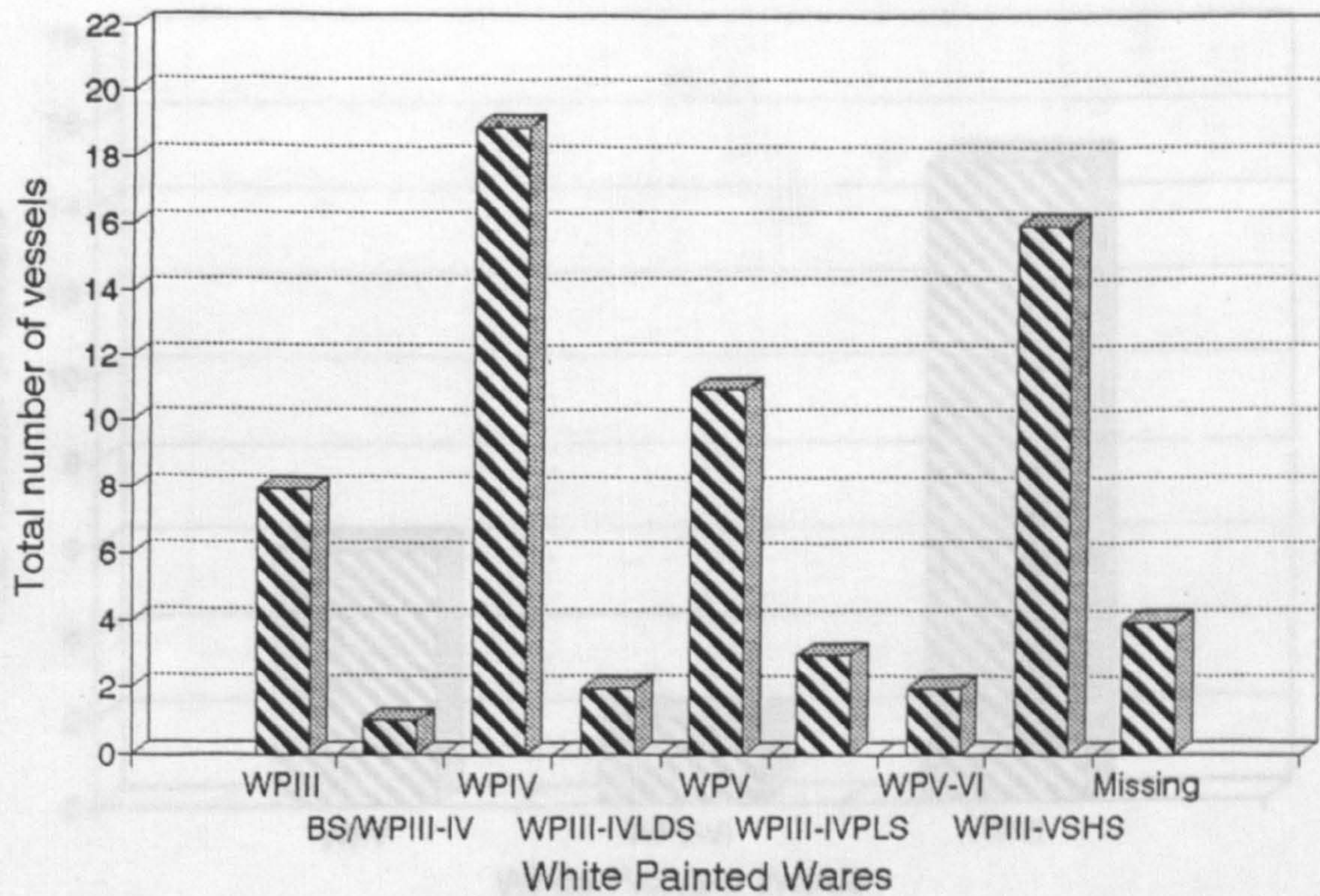

Figure 3: Bar graph of the reclassification by Åström (SCEIV.1B) of Gjerstad's (1926) White Painted III Ware

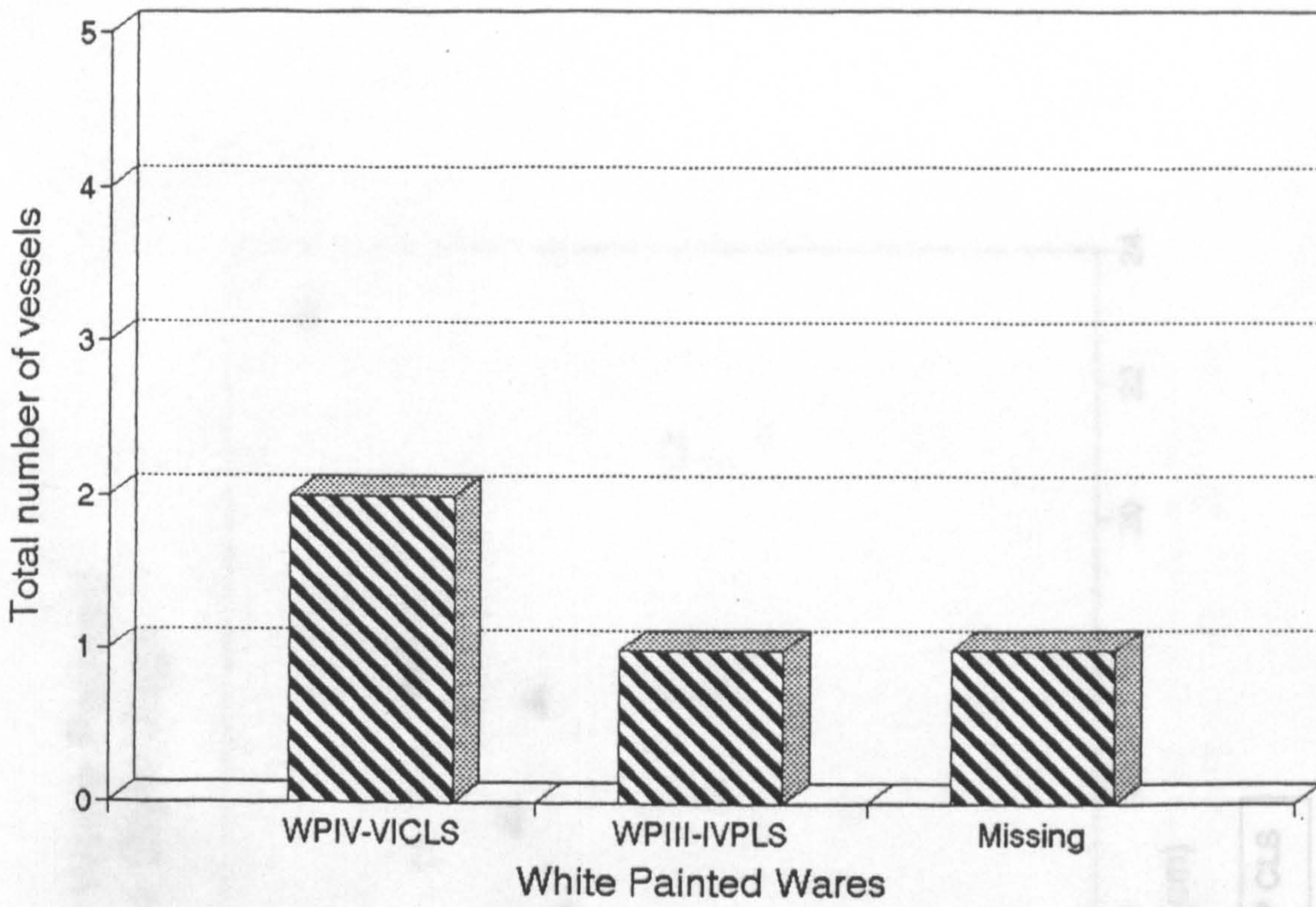

Figure 4: Bar graph of the reclassification by Åström (SCEIV.1B) of Gjerstad's (1926) White Painted IV Ware

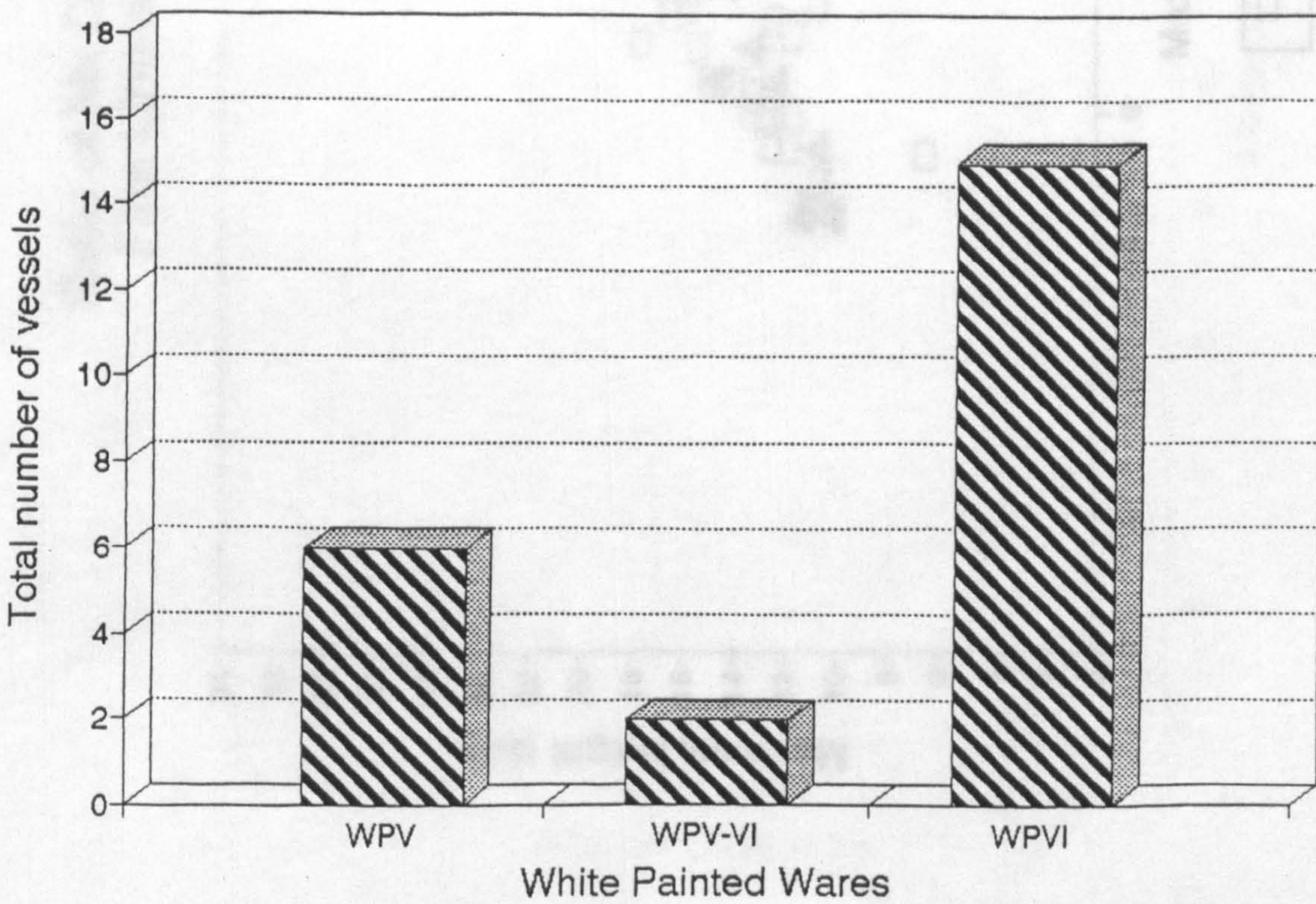

Figure 5: Bar graph of the reclassification by Åström (SCEIV.1B) of Gjerstad's (1926) White Painted V Ware

Ratio of Mx Diam/Mx Ht of White Painted Fine Line and Cross Line Style Jugs

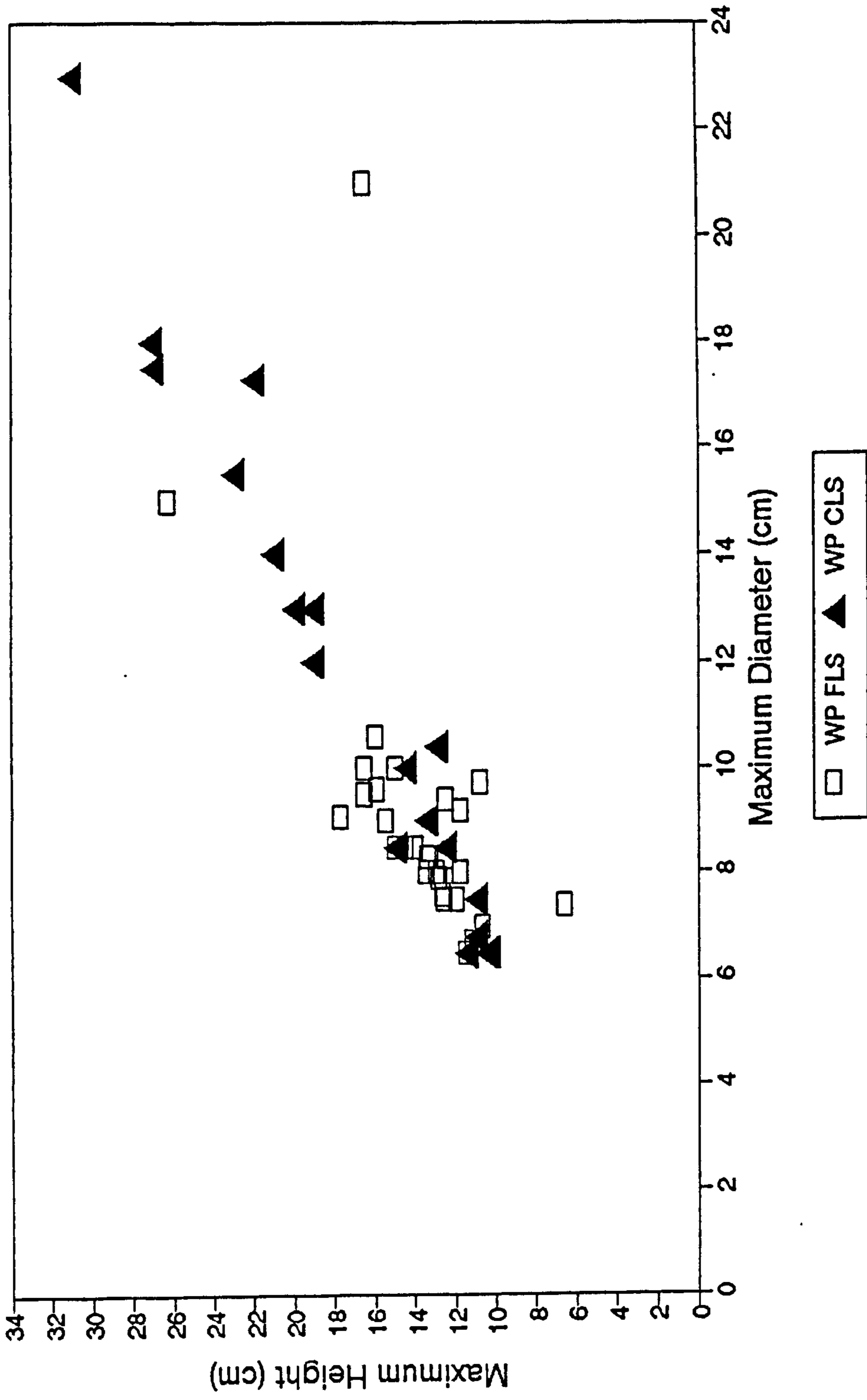

Figure 6: X-Y plot of the ratio of the maximum diameter to the maximum height of White Painted V Fine Line Style and White Painted Cross line Style jugs and juglets

Ratio of Mx Diam/Ht of Mx Diam of White Painted FLS and CLS Juglets

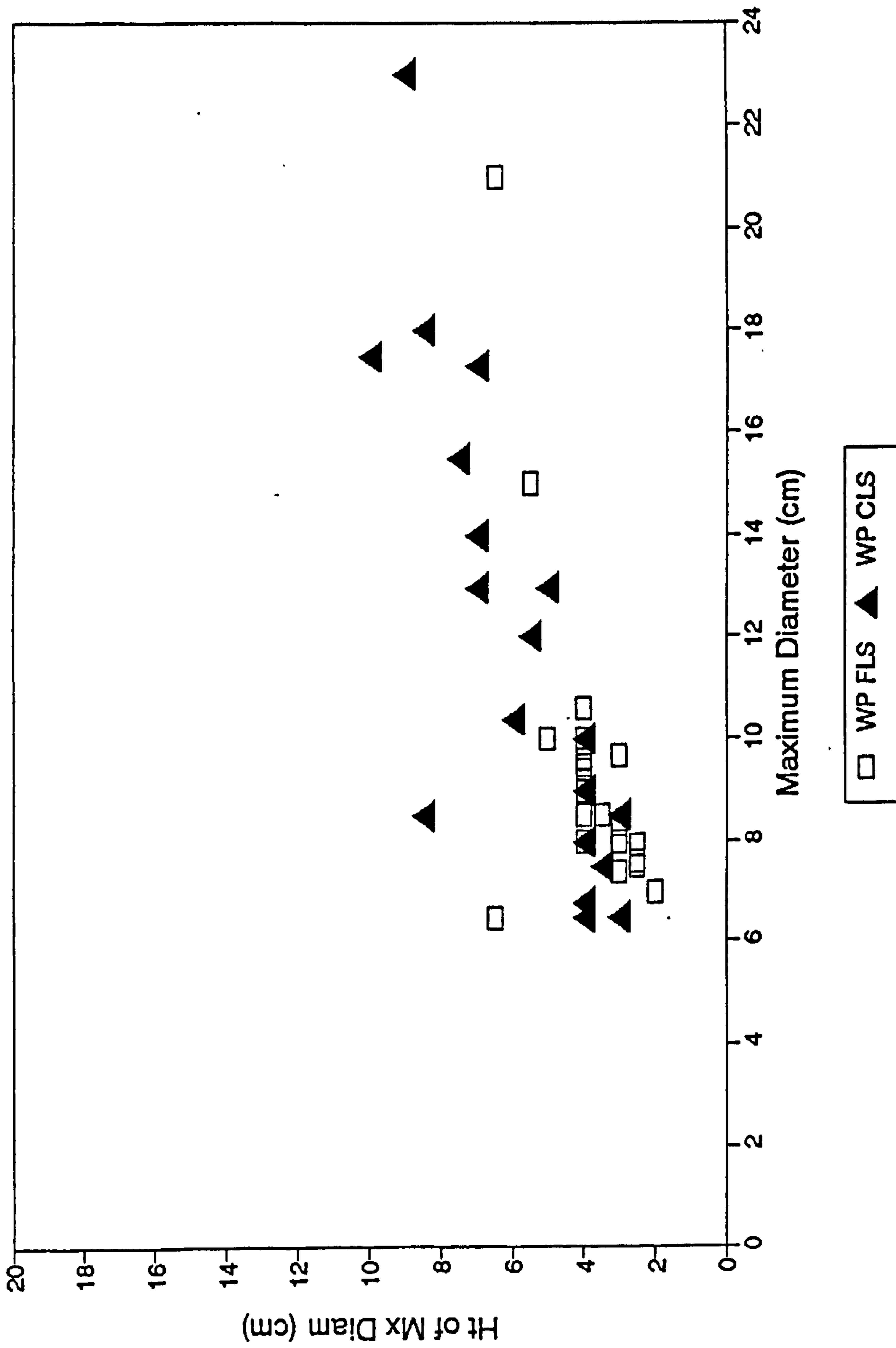

Figure 7: X-Y plot of the ratio of the maximum diameter to the height of the maximum diameter of White Painted V Fine Line Style and White Painted Cross Line Style jugs and juglets

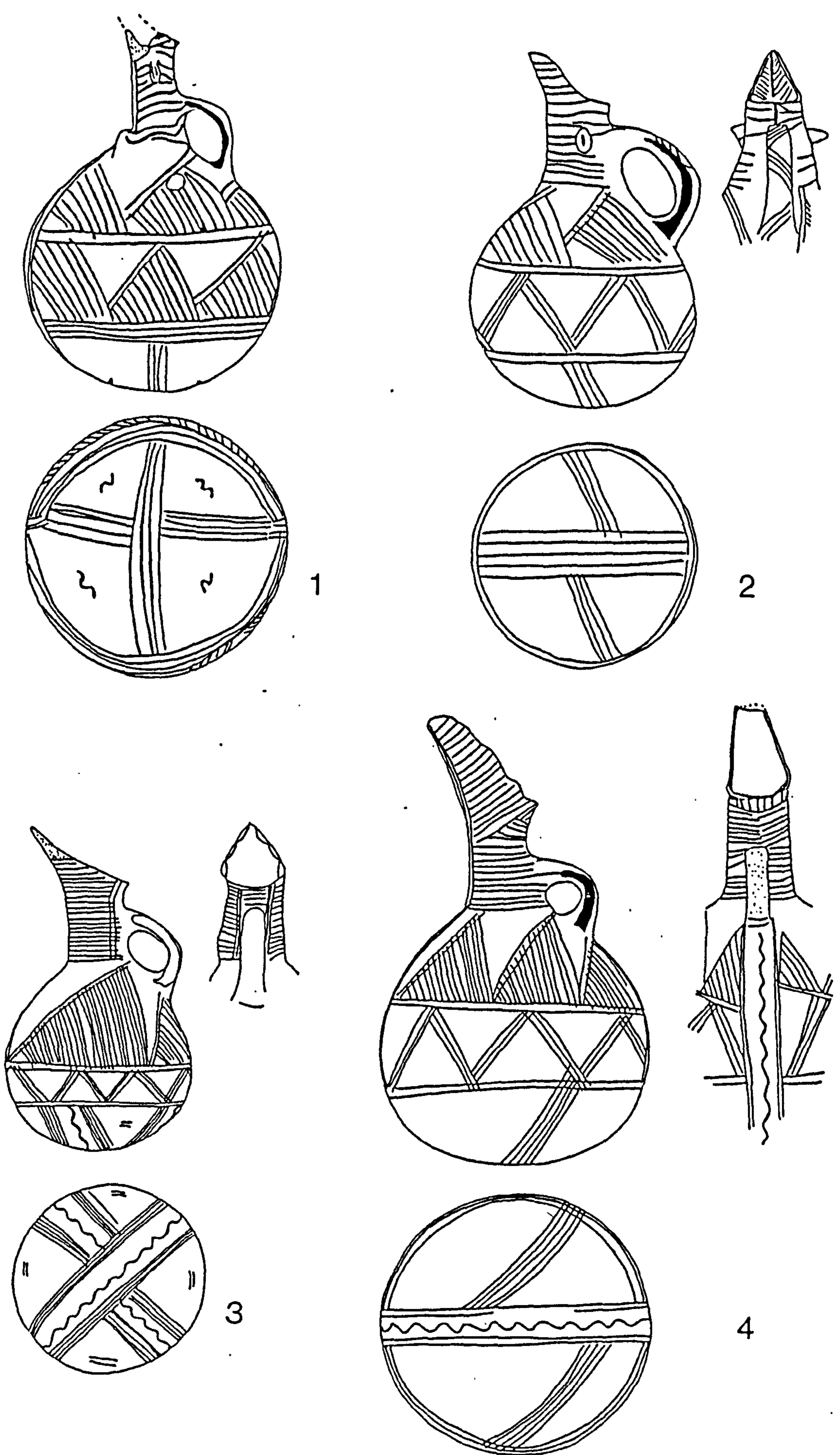

Figure 8: White Painted V Fine Line Style (1. A. Paraskevi 2. A. Paraskevi 3. unknown 4. unknown after Frankel 1983)

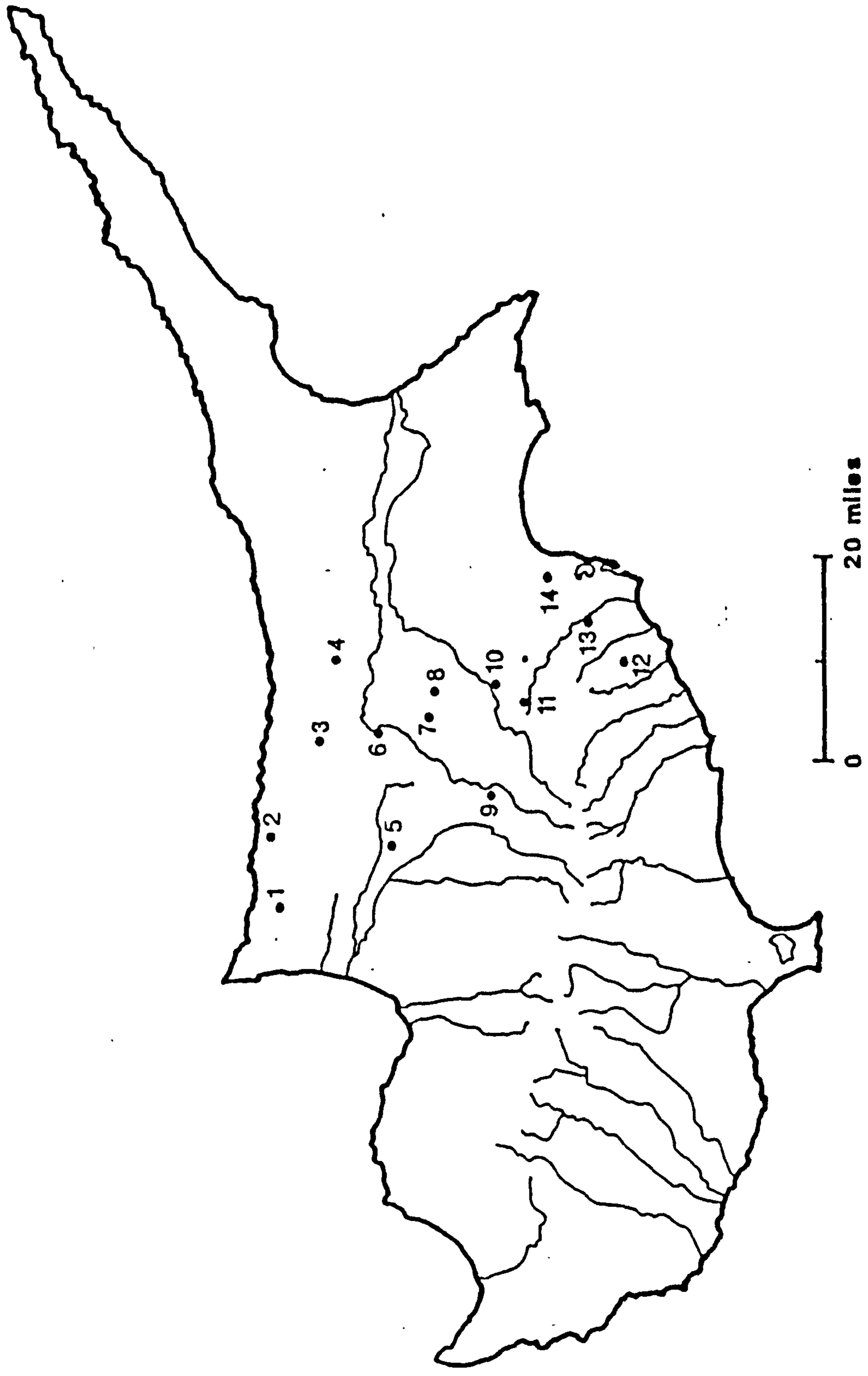

Figure 9: Distribution within Cyprus of White Painted V Fine Line Style

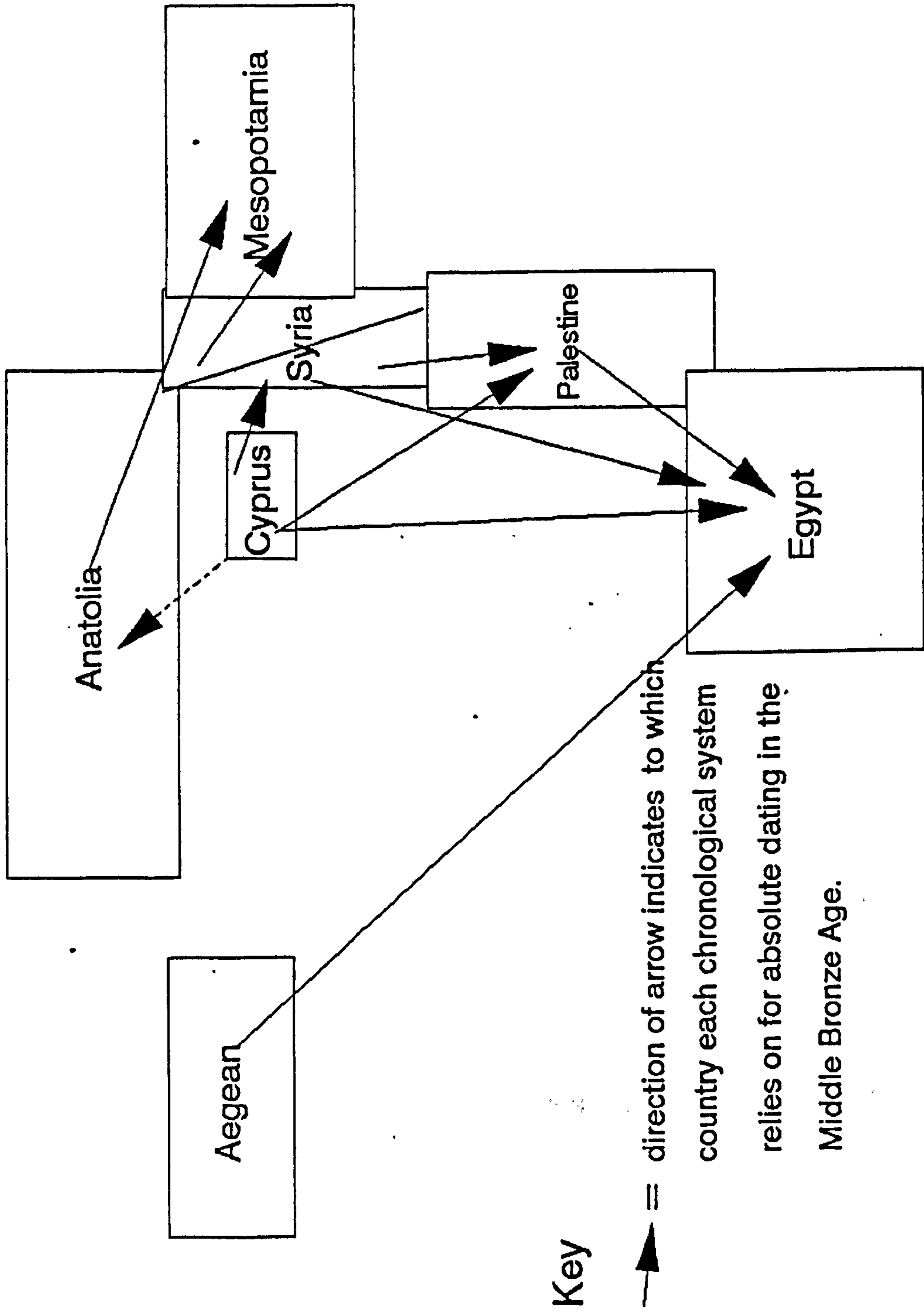

Figure 10: An overview of the interdependency of Near Eastern chronological systems

Distribution of WP III and IV (after Åström SCE IV.1B)

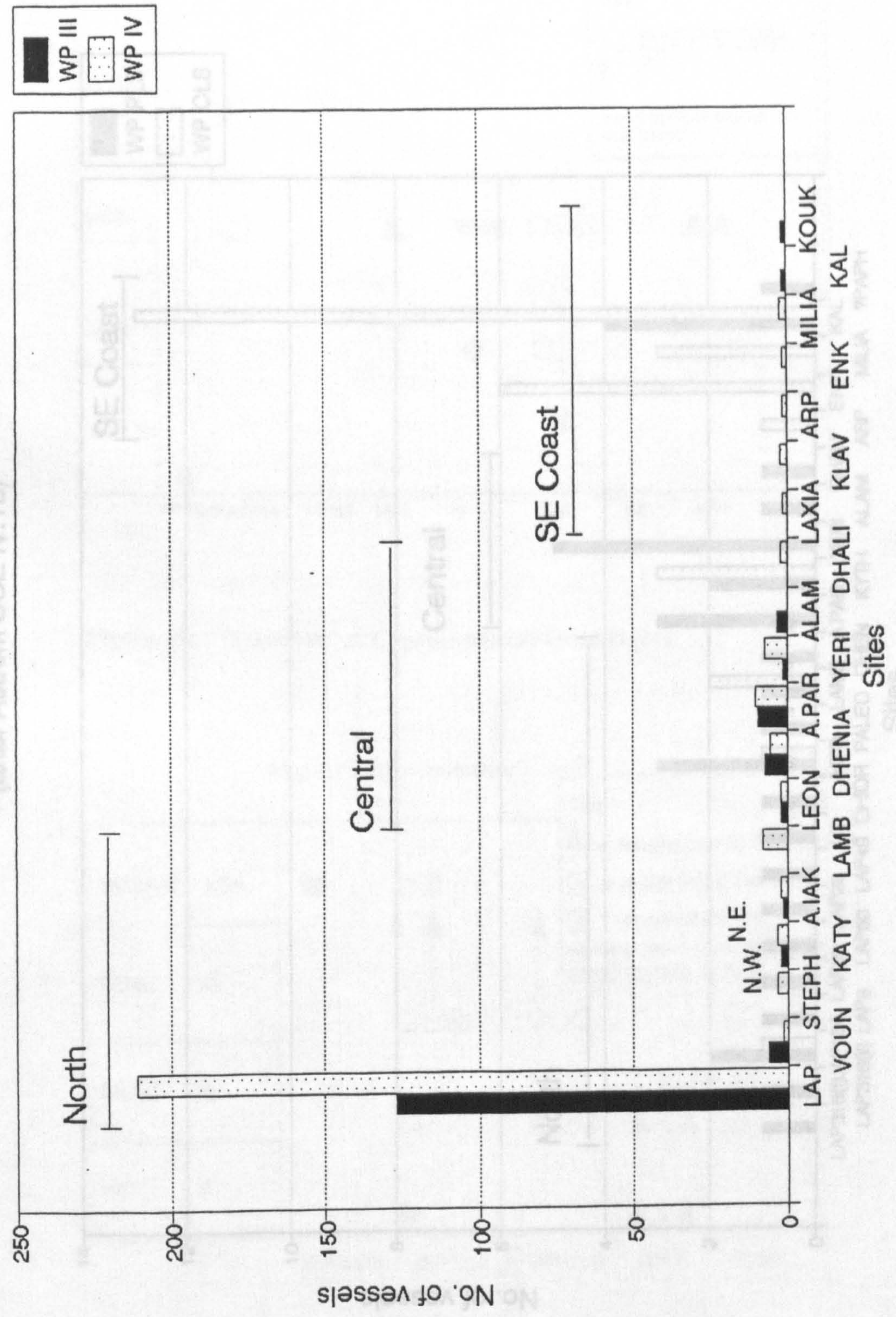

Figure 11: Bar graph of the distribution of White Painted III and IV within Cyprus, using information compiled by Åström (SCE IV.1B)

Distribution of WP PLS and WP CLS (after Astrom SCE IV.1B)

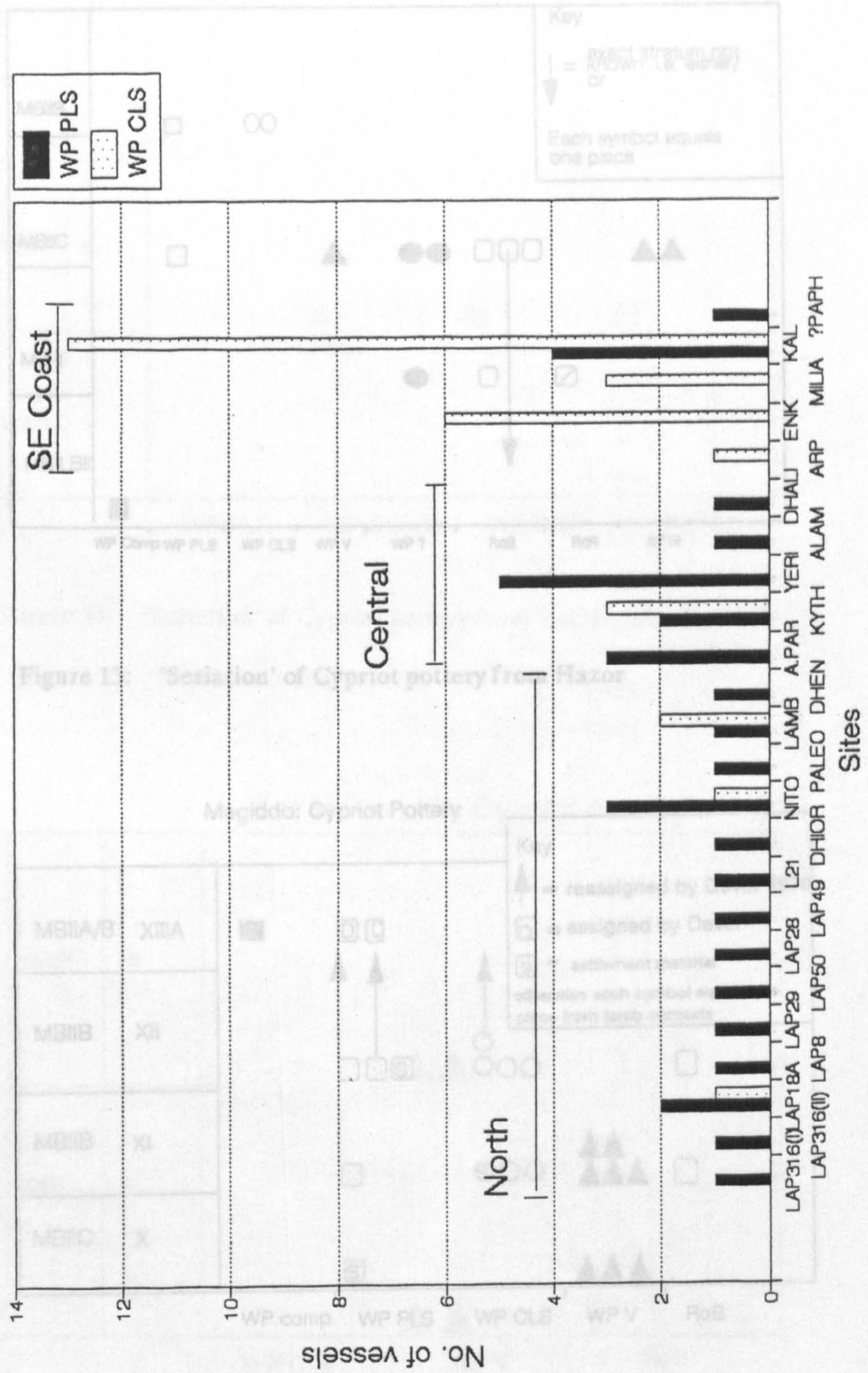

Figure 12: Bar graph of the distribution of White Painted Pendent Line Style and Cross Line Style within Cyprus, using information compiled by Åström (SCEIV.1B)

Hazor : Cypriot pottery

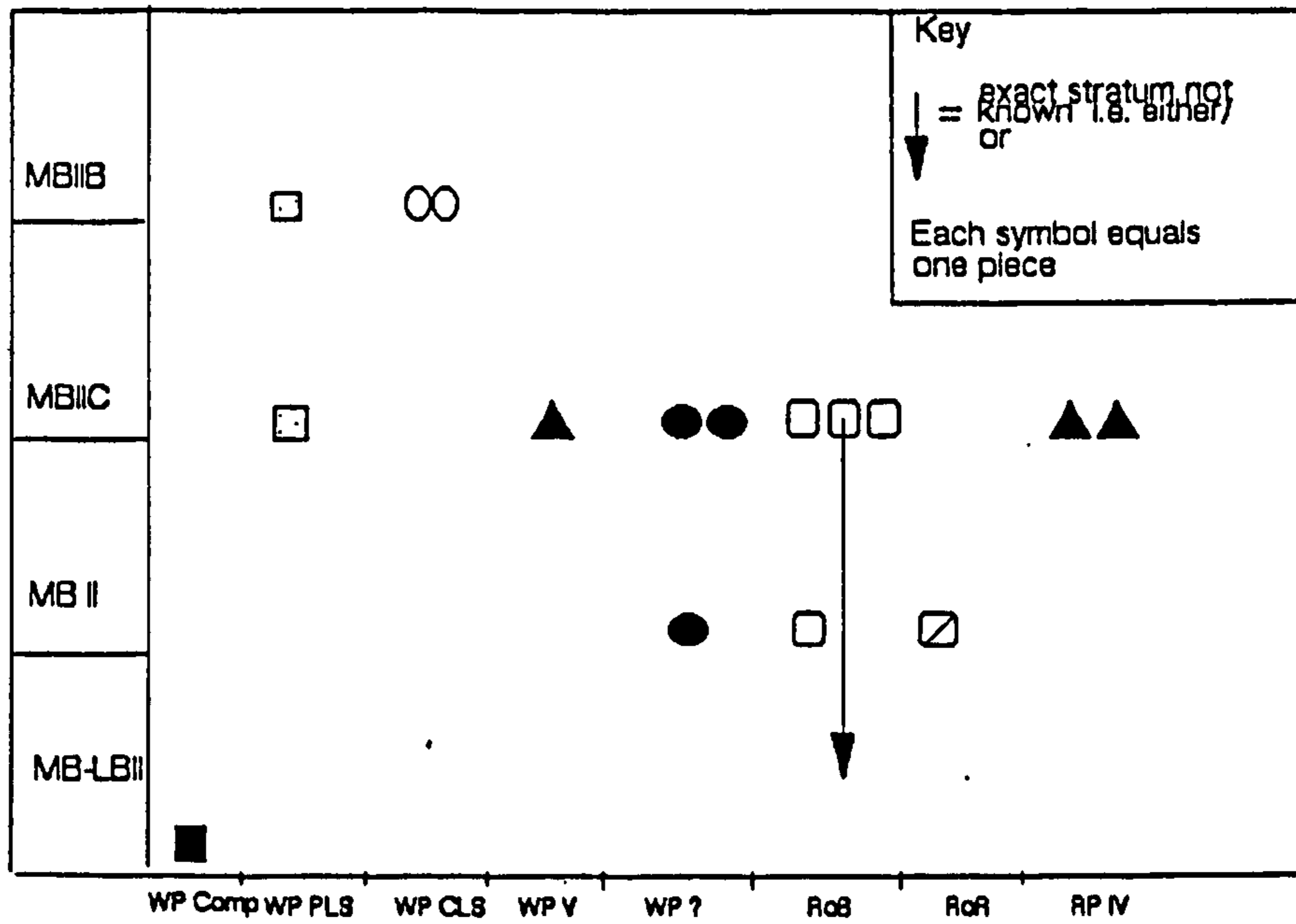

Figure 13: 'Seriation' of Cypriot pottery from Hazor

Megiddo: Cypriot Pottery

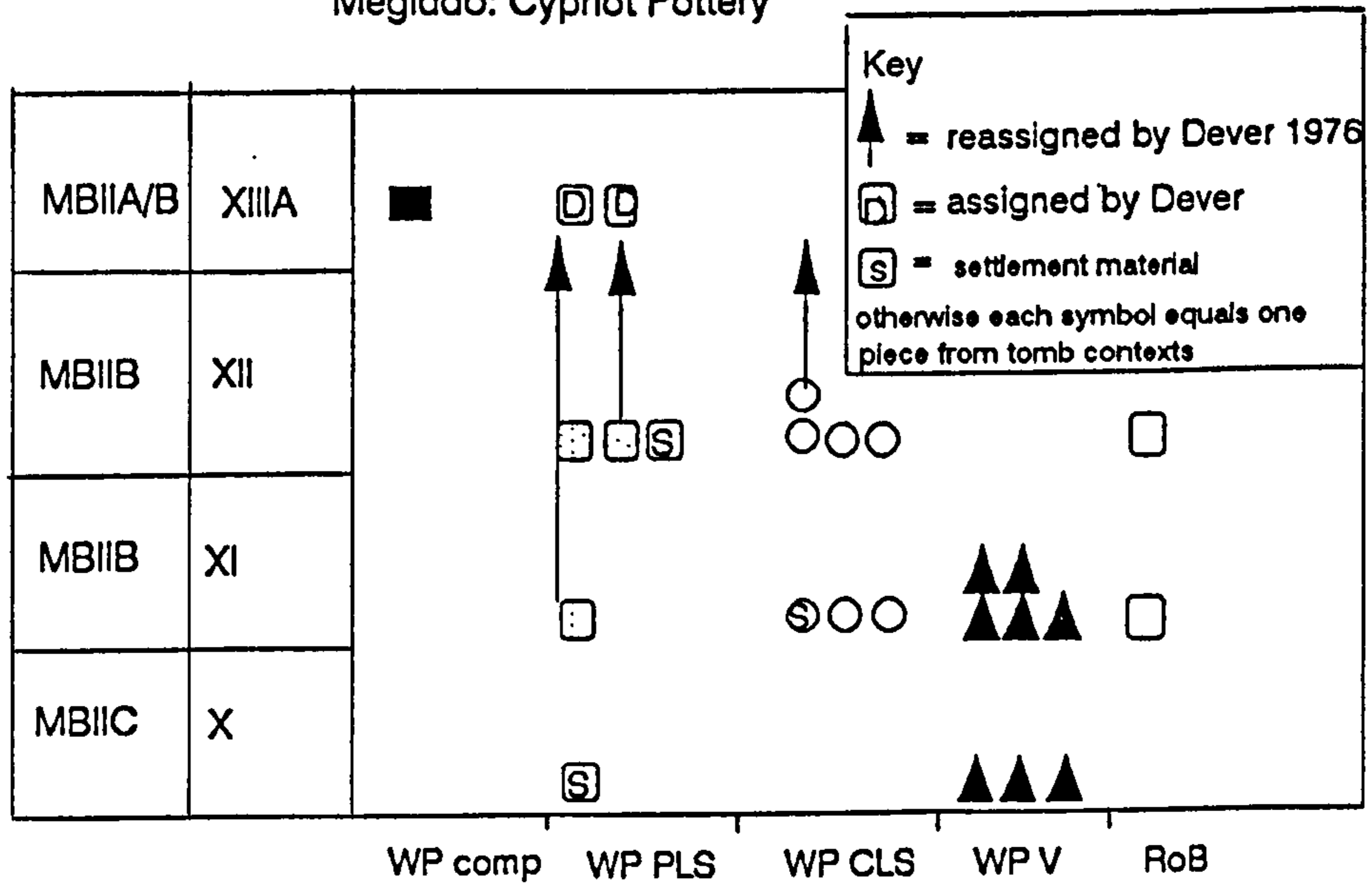

Figure 14: 'Seriation' of Cypriot pottery from Megiddo

Tell Jerishe: Cypriot pottery

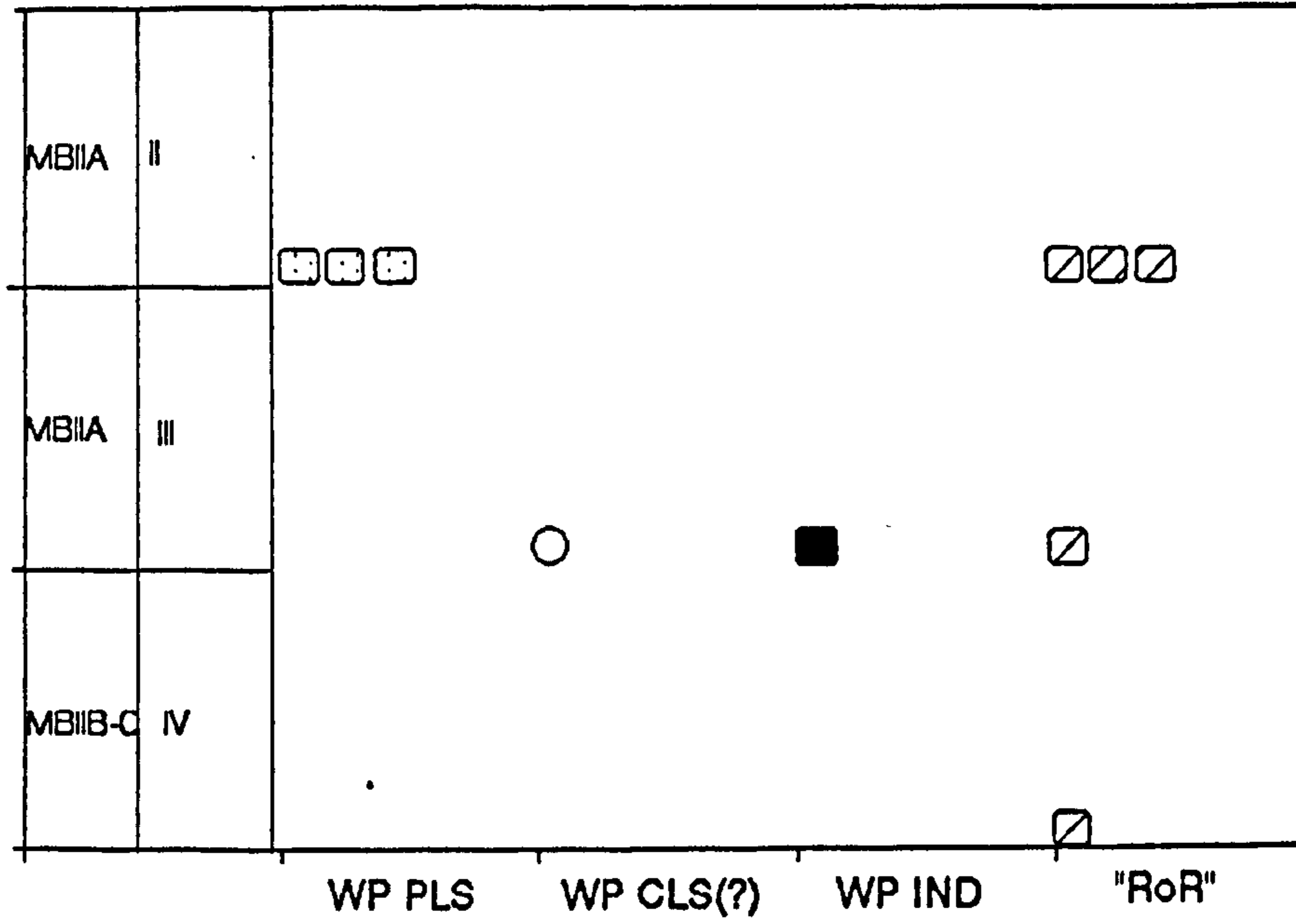

Figure 15: 'Seriation' of Cypriot pottery from Tell Jerishe

Tell Mevorakh: Cypriot pottery

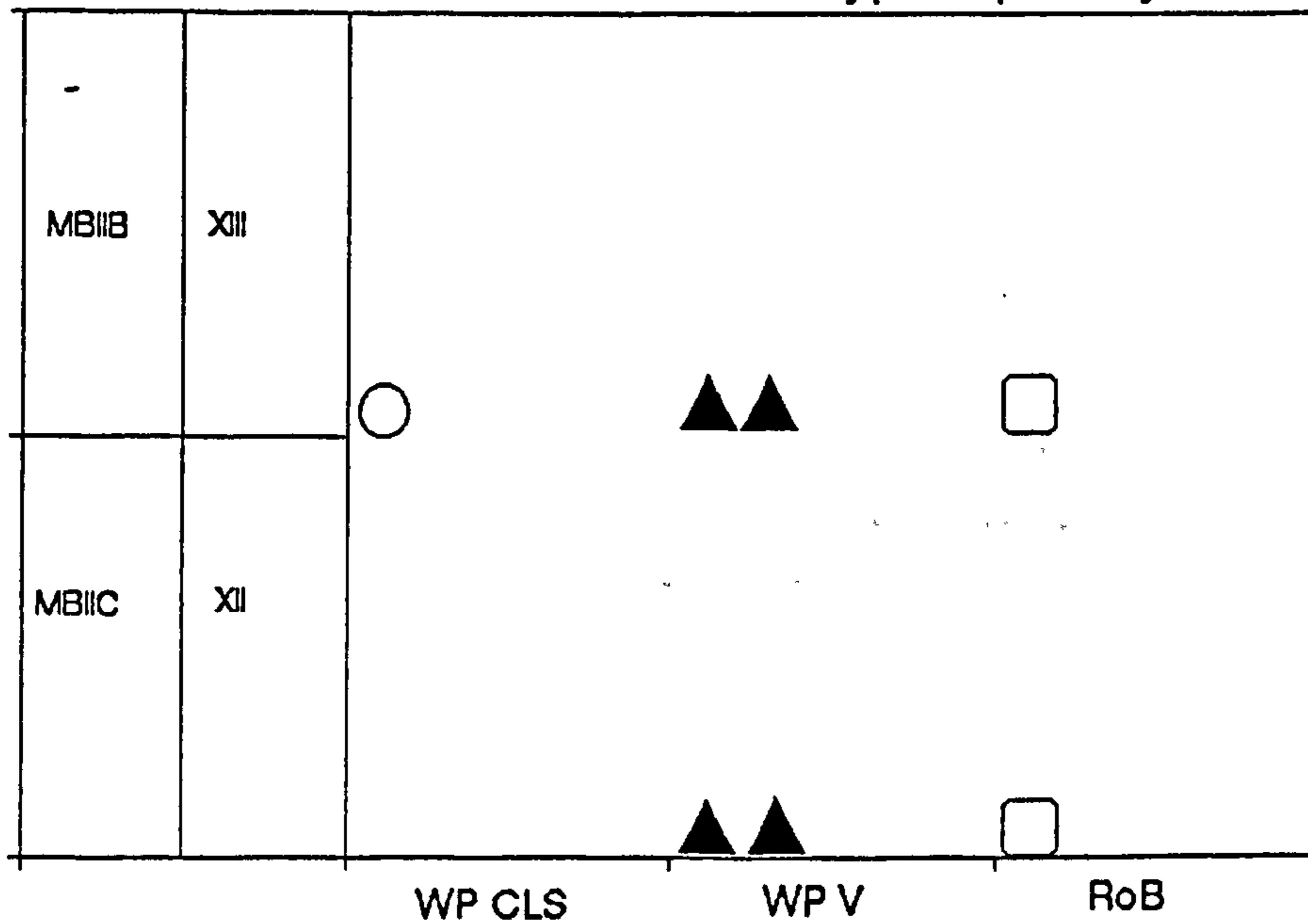

Figure 16: 'Seriation' of Cypriot pottery from Tell Mevorakh

Distribution of WP PLS, WP CLS and WP V

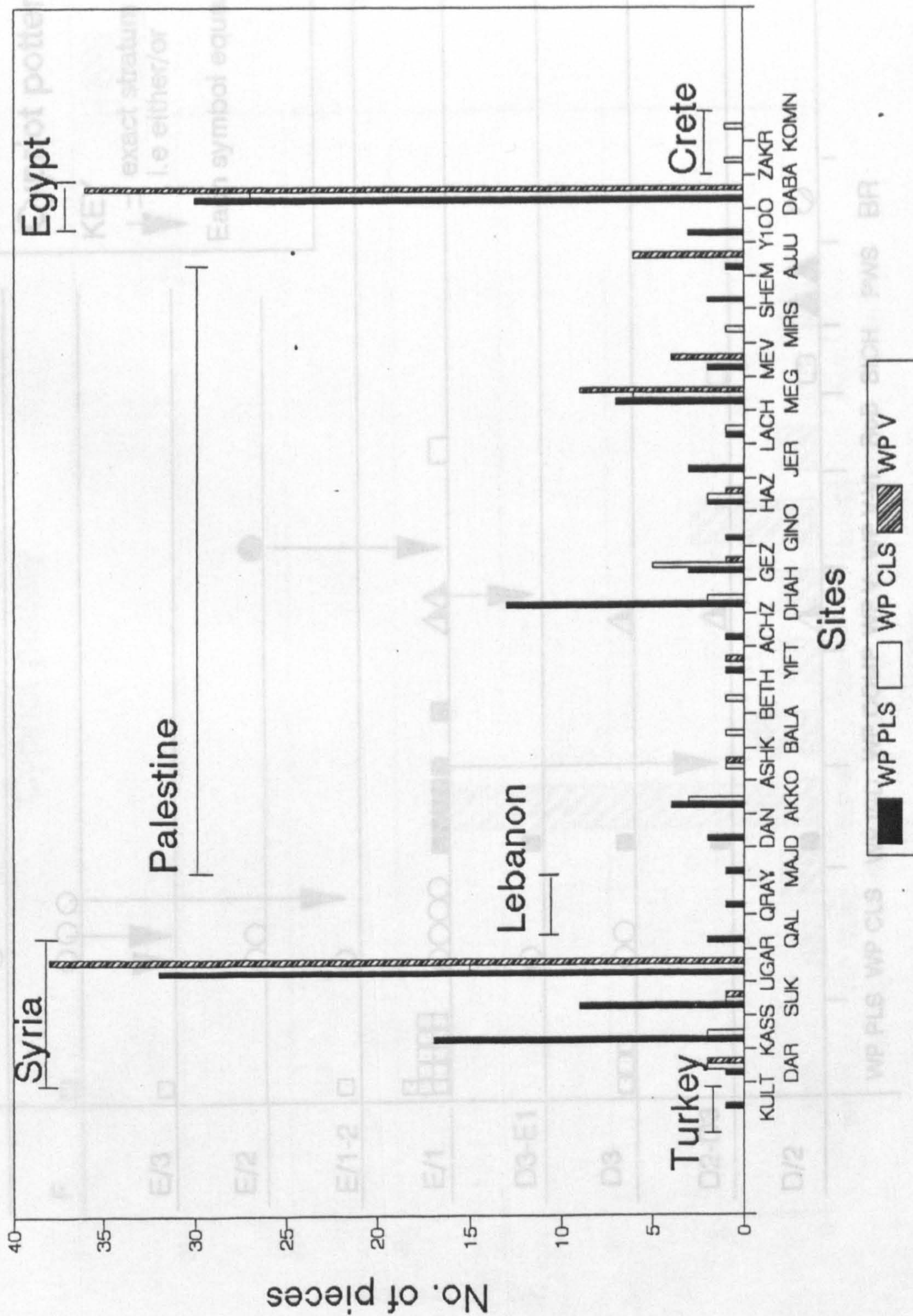

Figure 17: Distribution of White Painted Pendent Line Style, White Painted Cross Line Style and White Painted V in the East Mediterranean

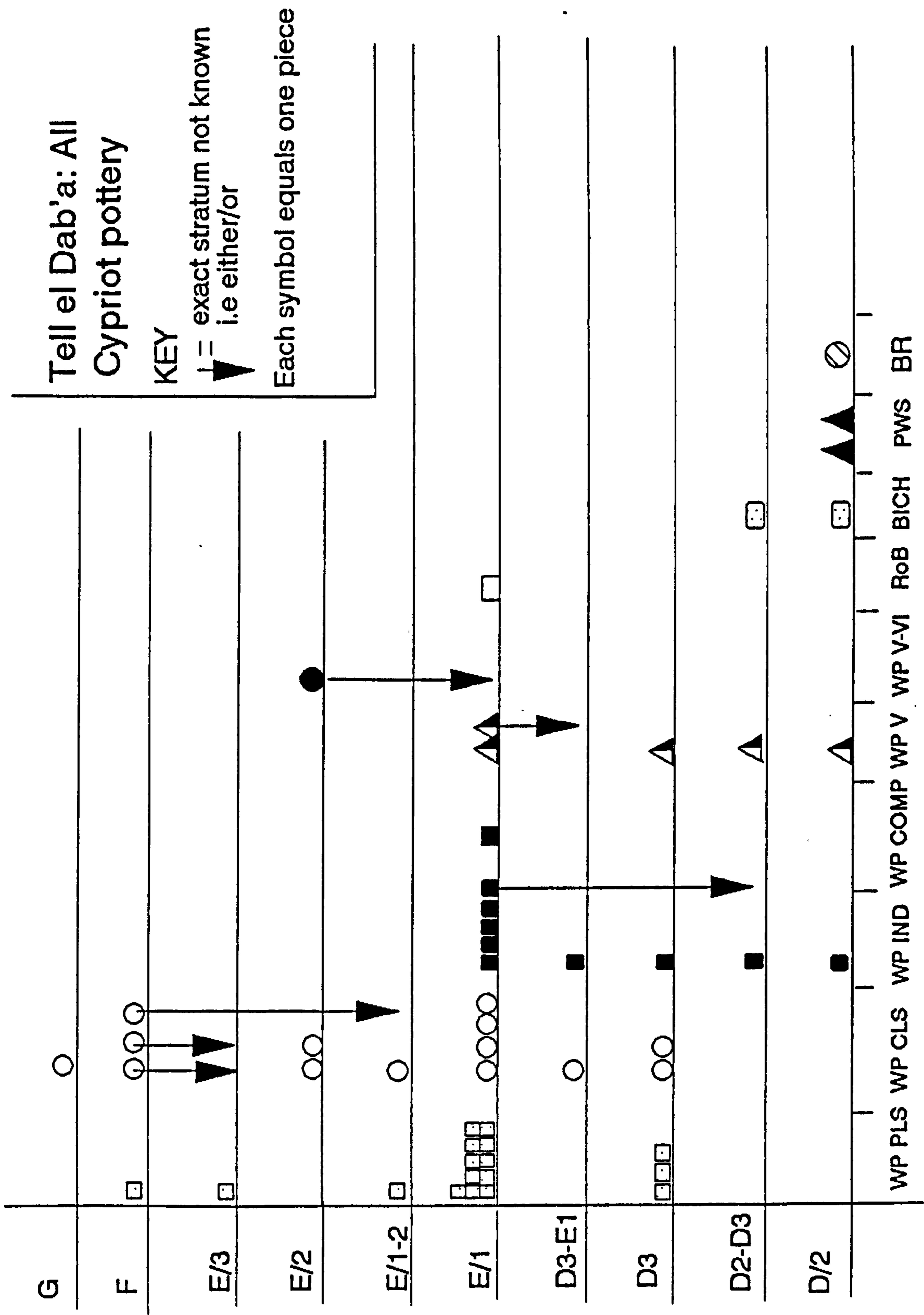

Figure 18: 'Seriation' of Cypriot pottery from the tell (AII), Tell el Dab'a

Tell el Dab'a: Area AV-p19
 Cypriot pottery

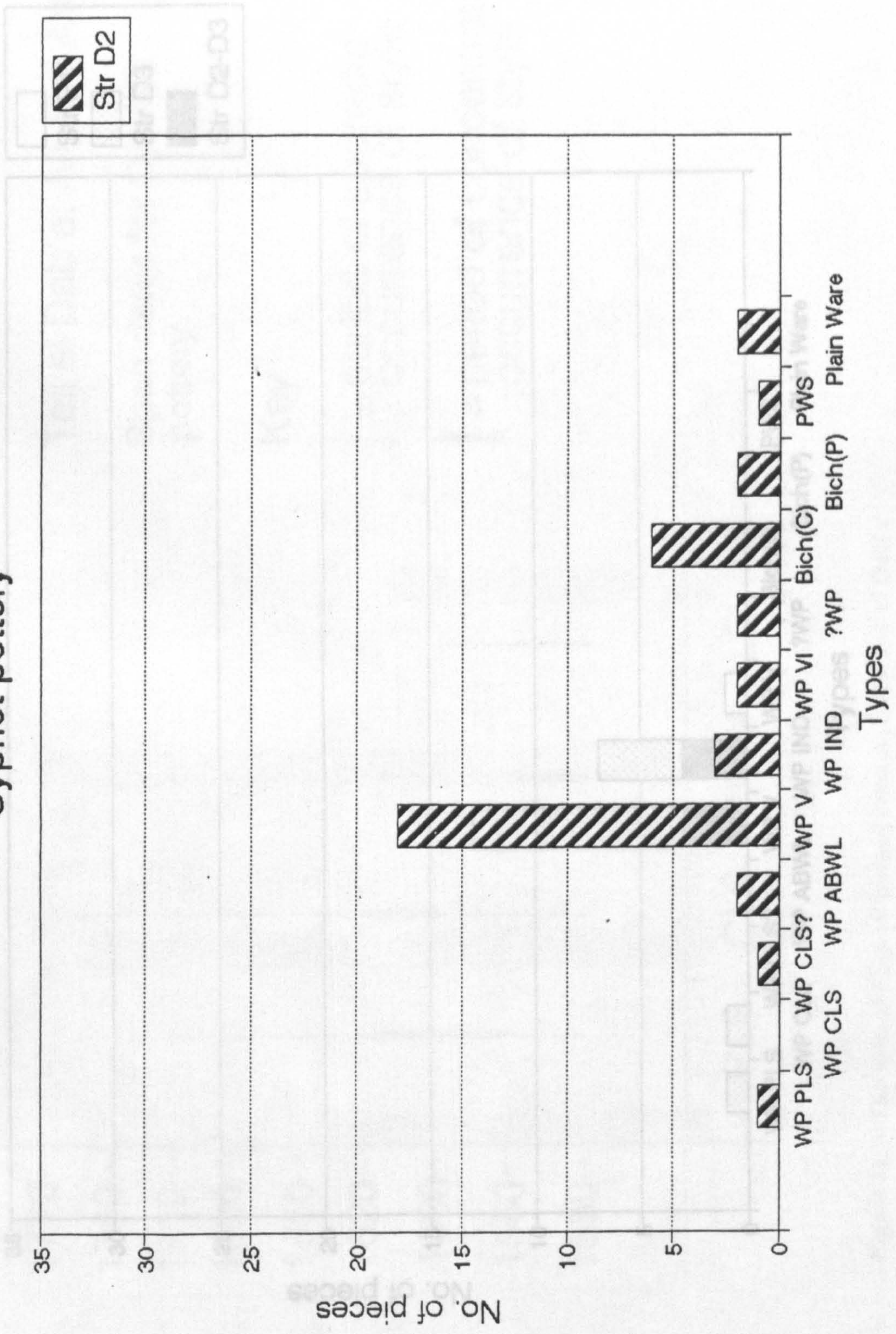

Figure 20: Distribution of Cypriot pottery from Area AV, square p19 Tell el Dab'a

Figure 19: Distribution of Cypriot pottery from Area AV, Tell el Dab'a

Tell el Dab'a: Area AV-p19 Cypriot pottery

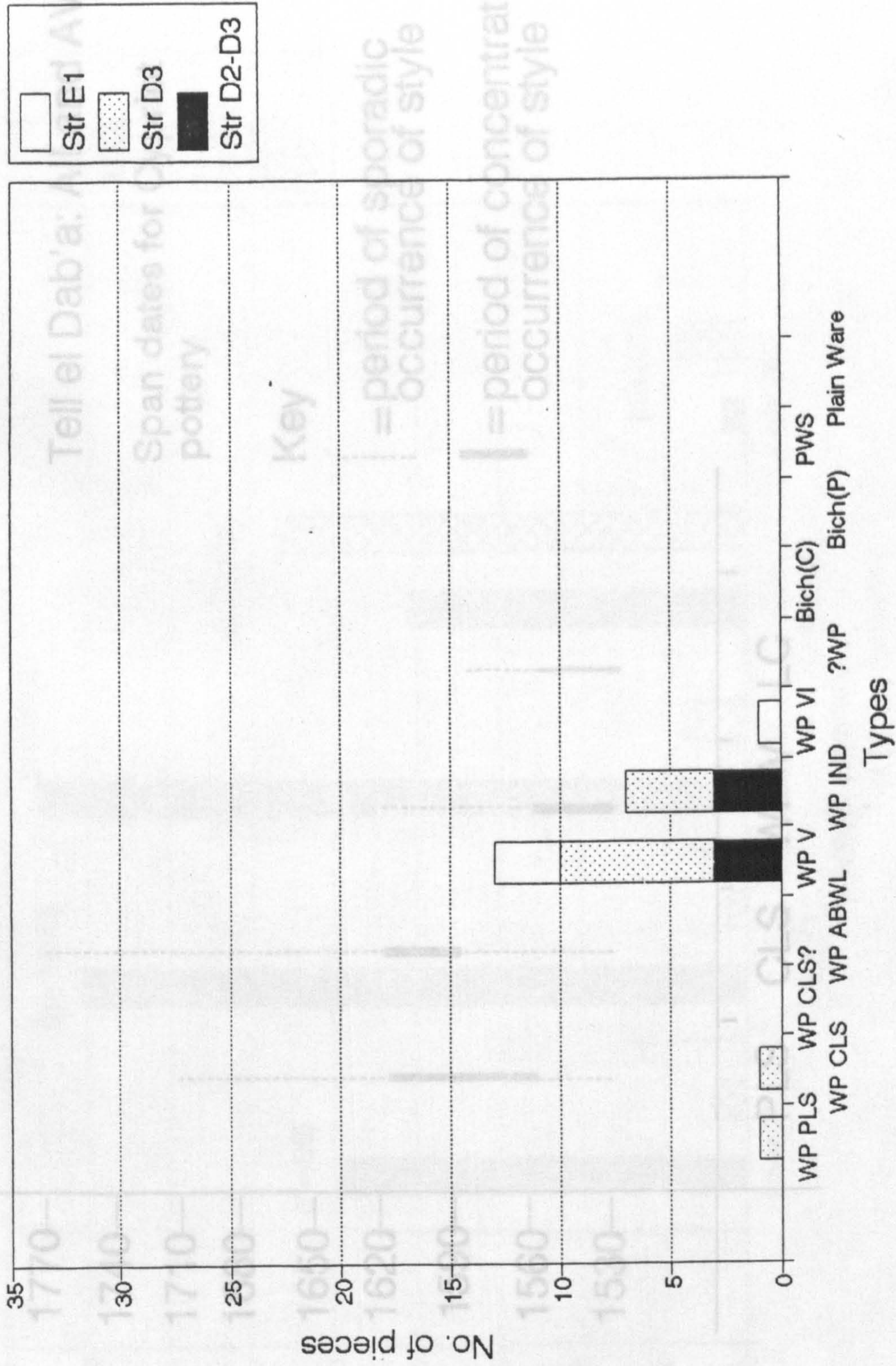

Figure 20: The span of Cypriot pottery from Area AV, square p19 Tell el Dab'a

Figure 20: Distribution of Cypriot pottery from Area AV, square p19 Tell el Dab'a

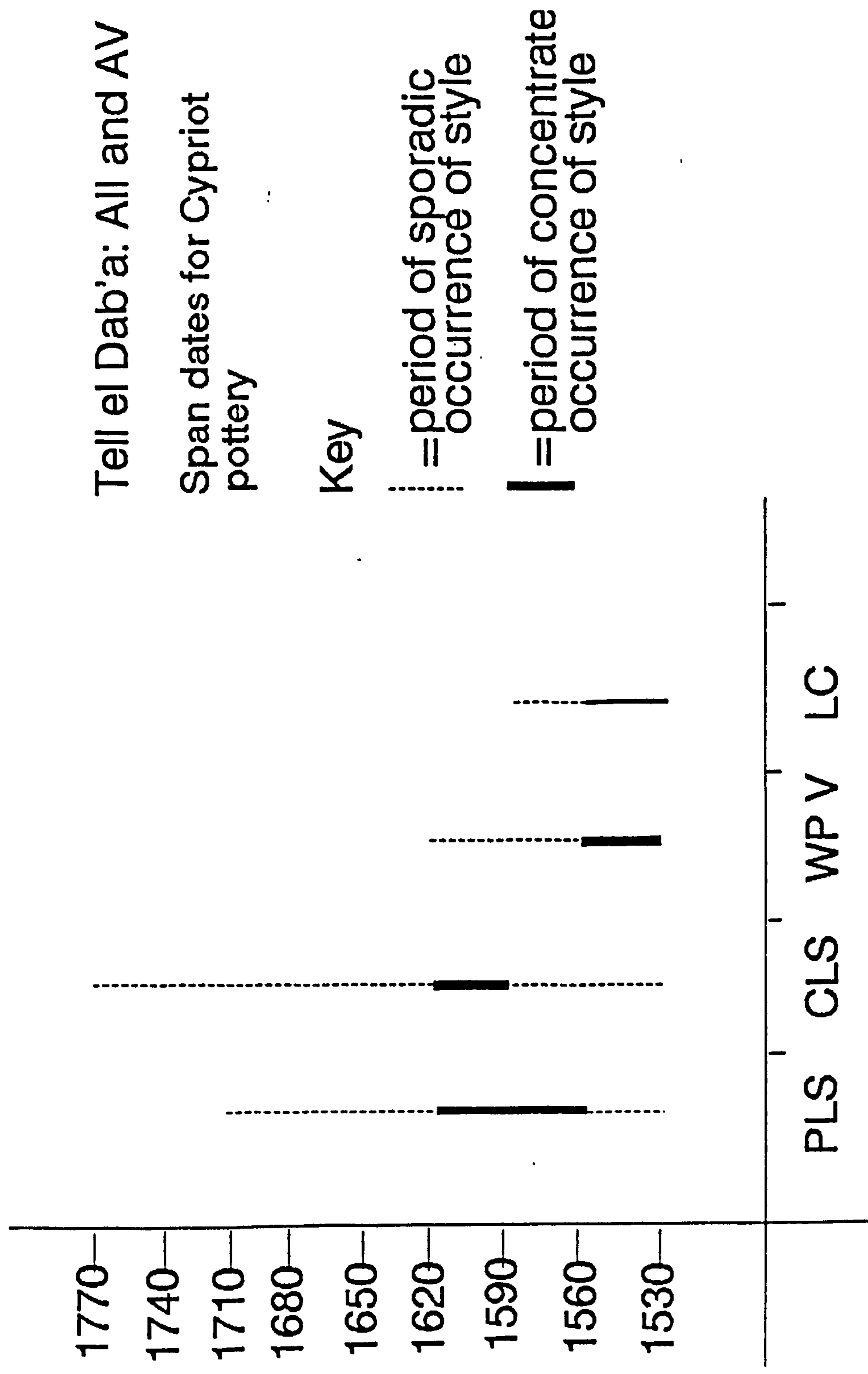

Figure 21: The span of Cypriot pottery from All, AV Tell el Dab'a

Kalopsidha
Trench 9: North pit

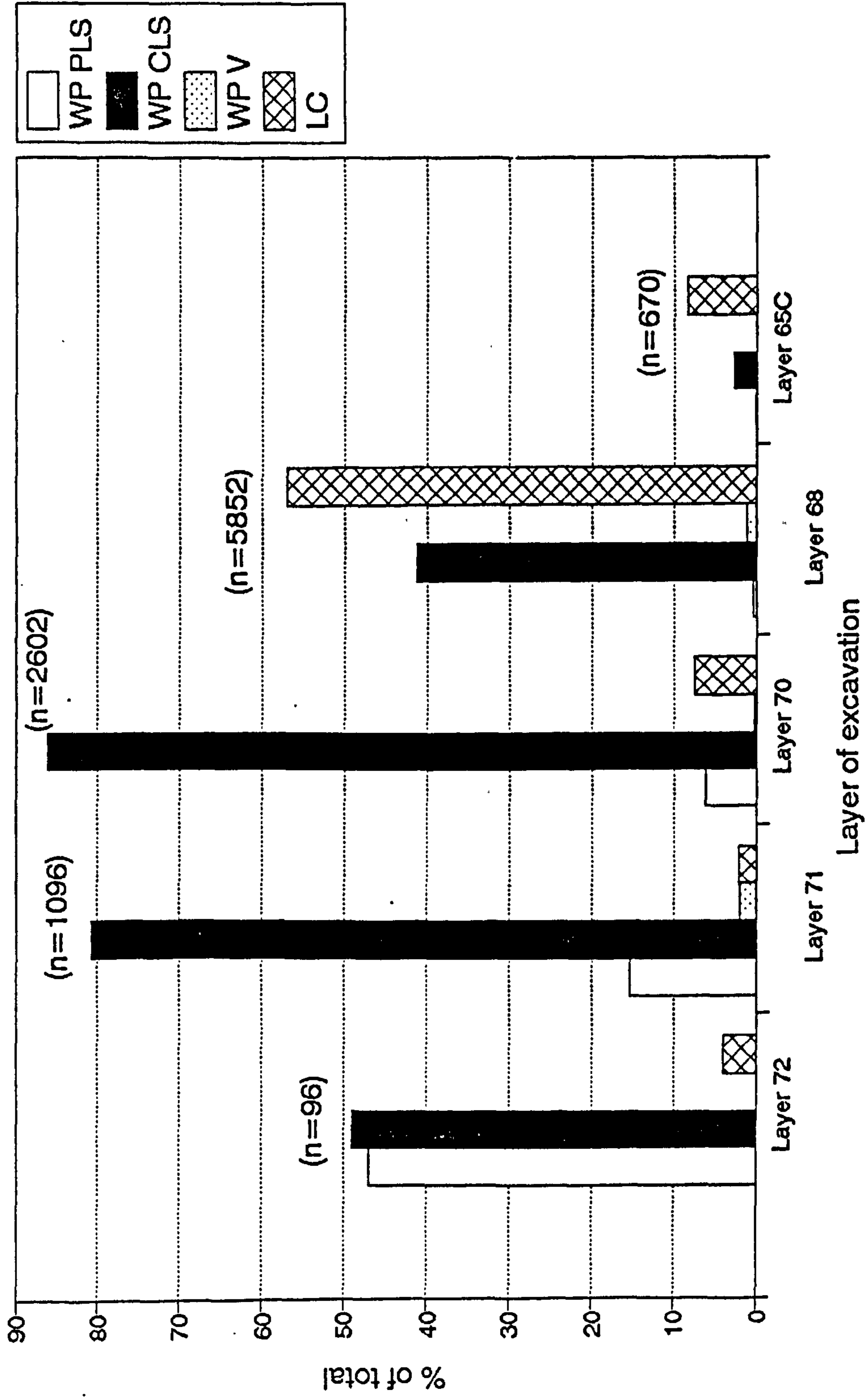

Figure 22: The juxtaposition of White Painted Pendant Line Style, White Painted Cross Line Style, White Painted V and Late Cypriot pottery from Kalopsidha, Trench 9, North pit

Kalopsidha: Trench 9
Squares A-J 19-23 (30)

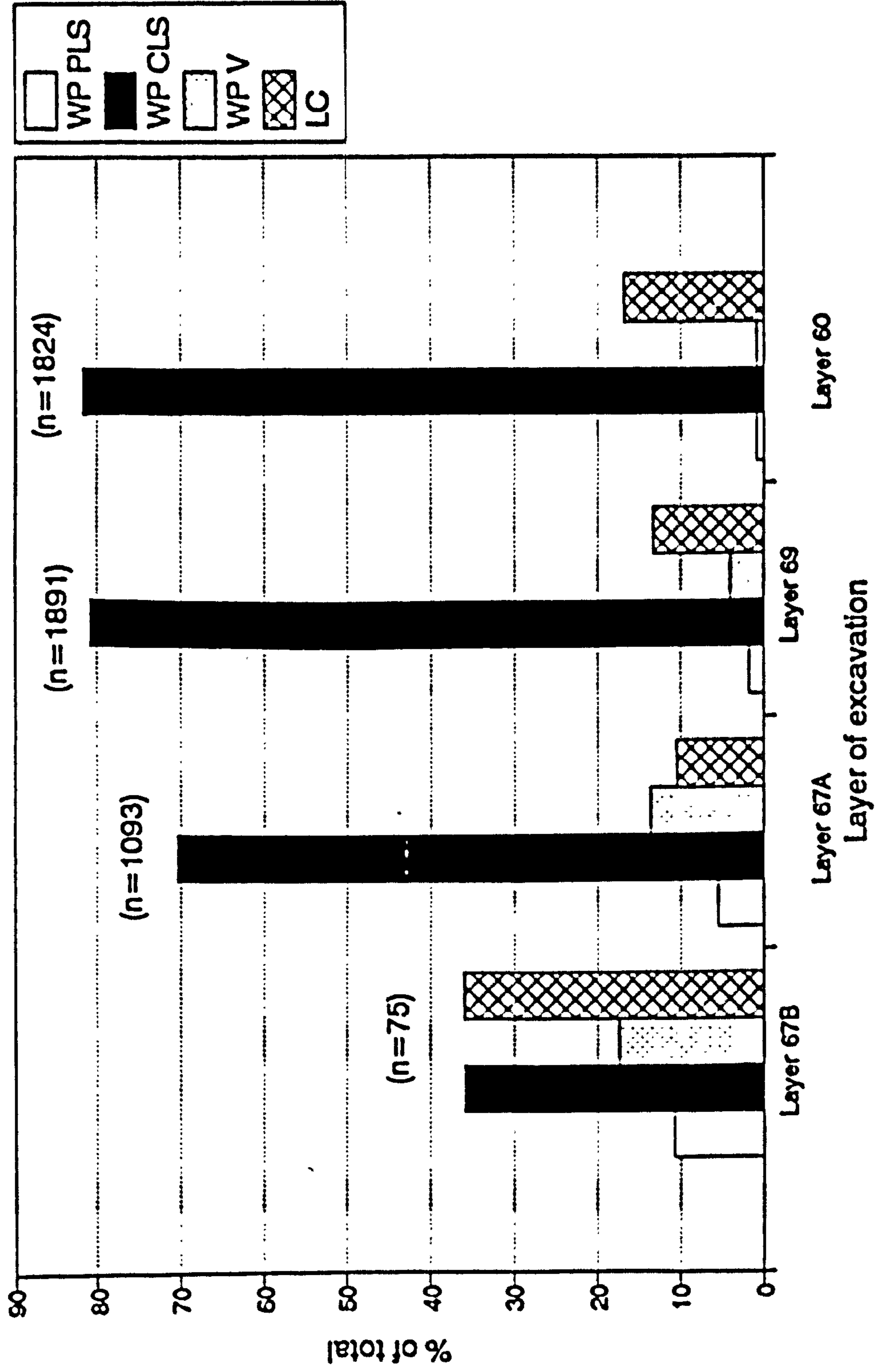

Figure 23: The juxtaposition of White Painted Pendent Line Style, White Painted Cross Line Style, White Painted V and Late Cypriot pottery from Kalopsidha, Trench 9, Squares A-J19-23(30)

Kalopsidha: Trench 9
Southern part

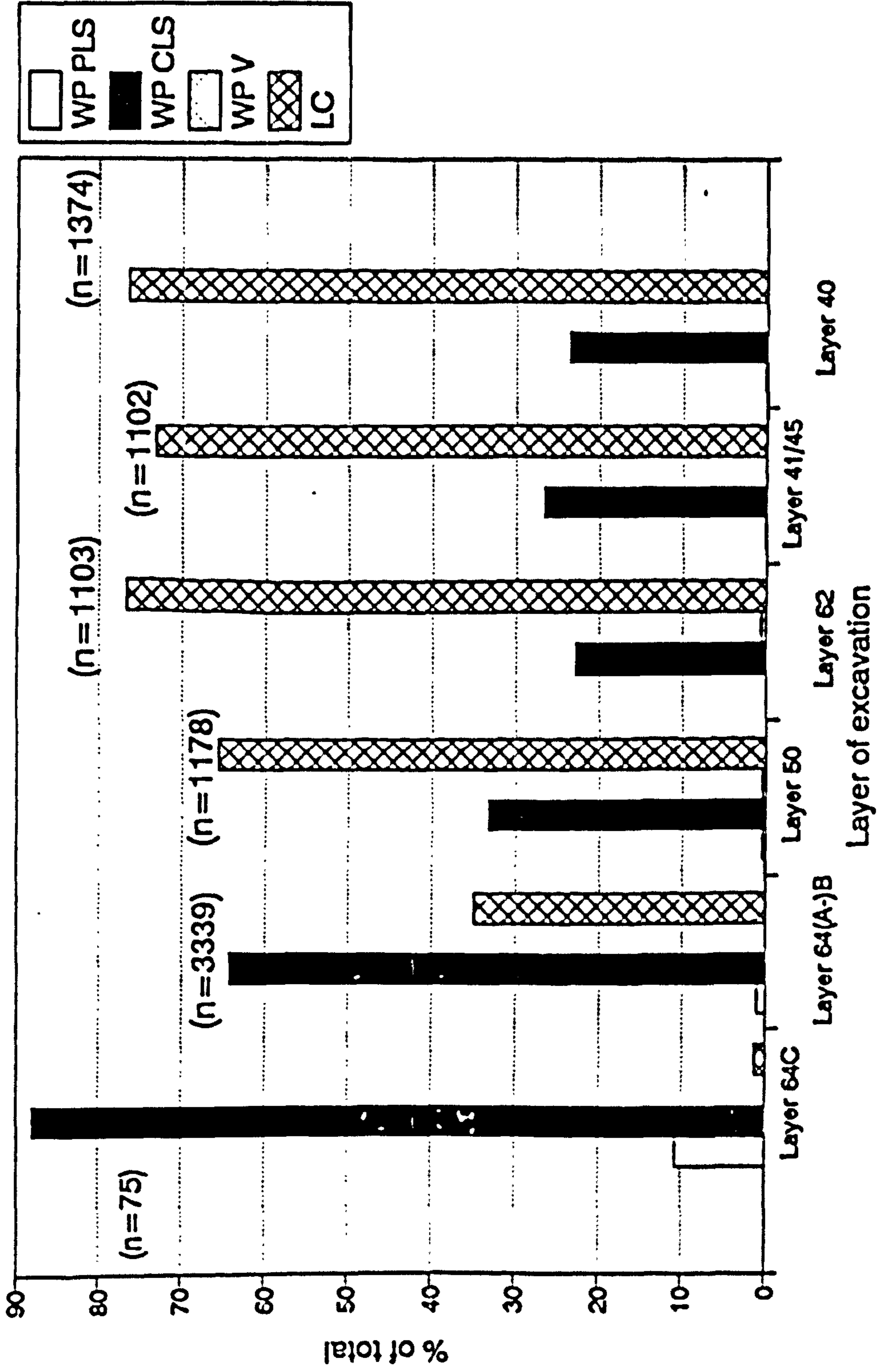

Figure 24: The juxtaposition of White Painted Pendant Line Style, White Painted Cross Line Style, White Painted V and Late Cypriot pottery from Kalopsidha, Trench 9, Southern part

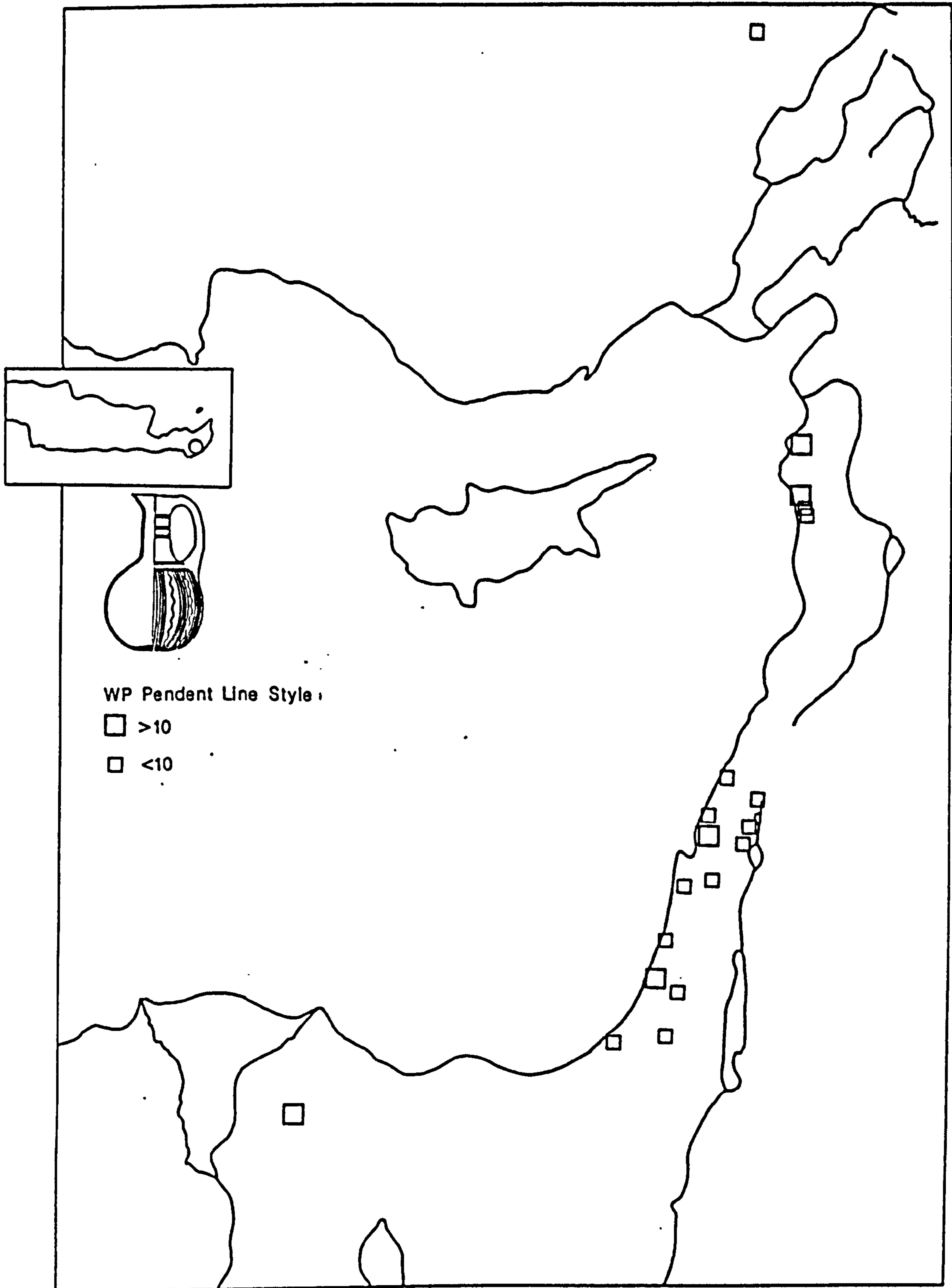

Figure 25: Distribution of White Painted Pendant Line Style

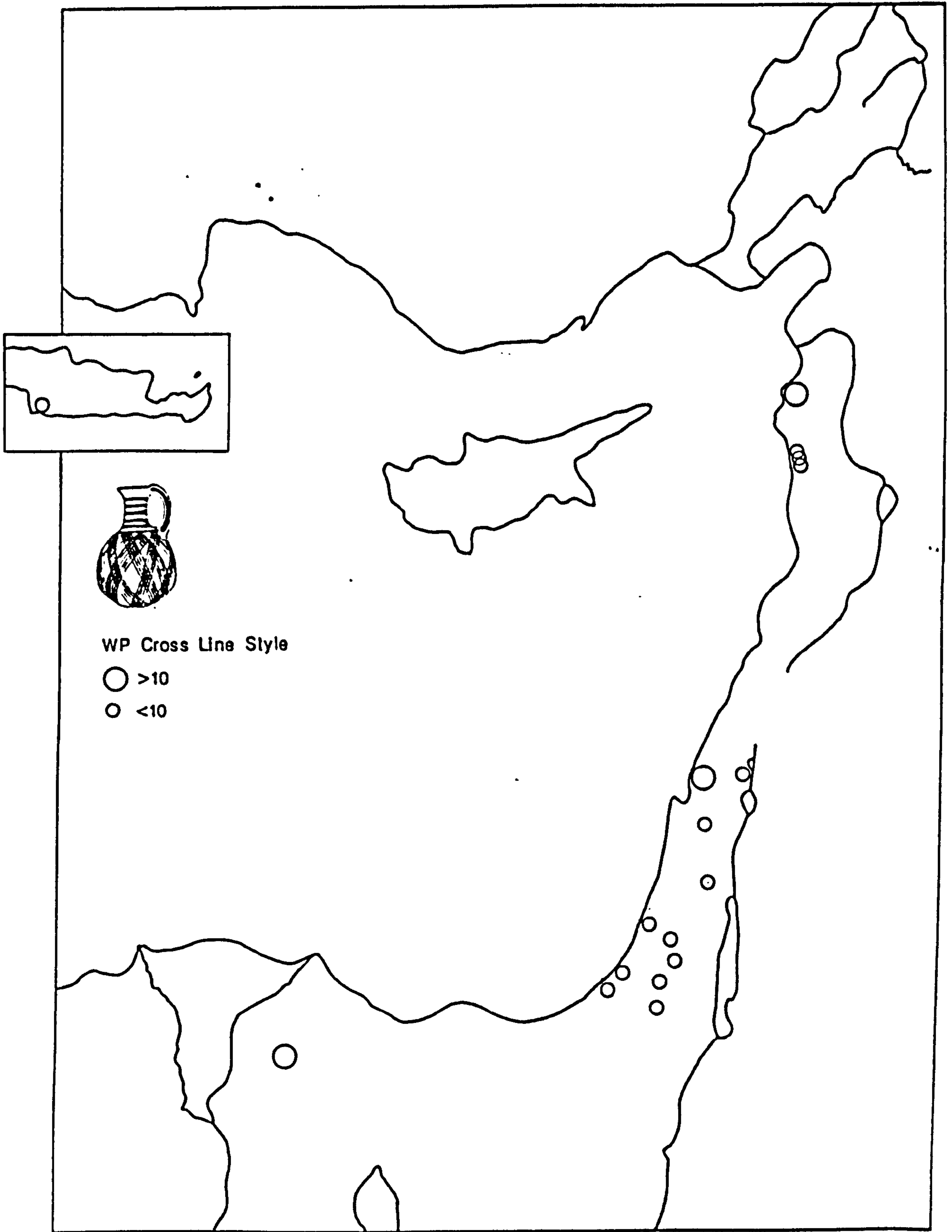

Figure 26: Distribution of White Painted Cross Line Style

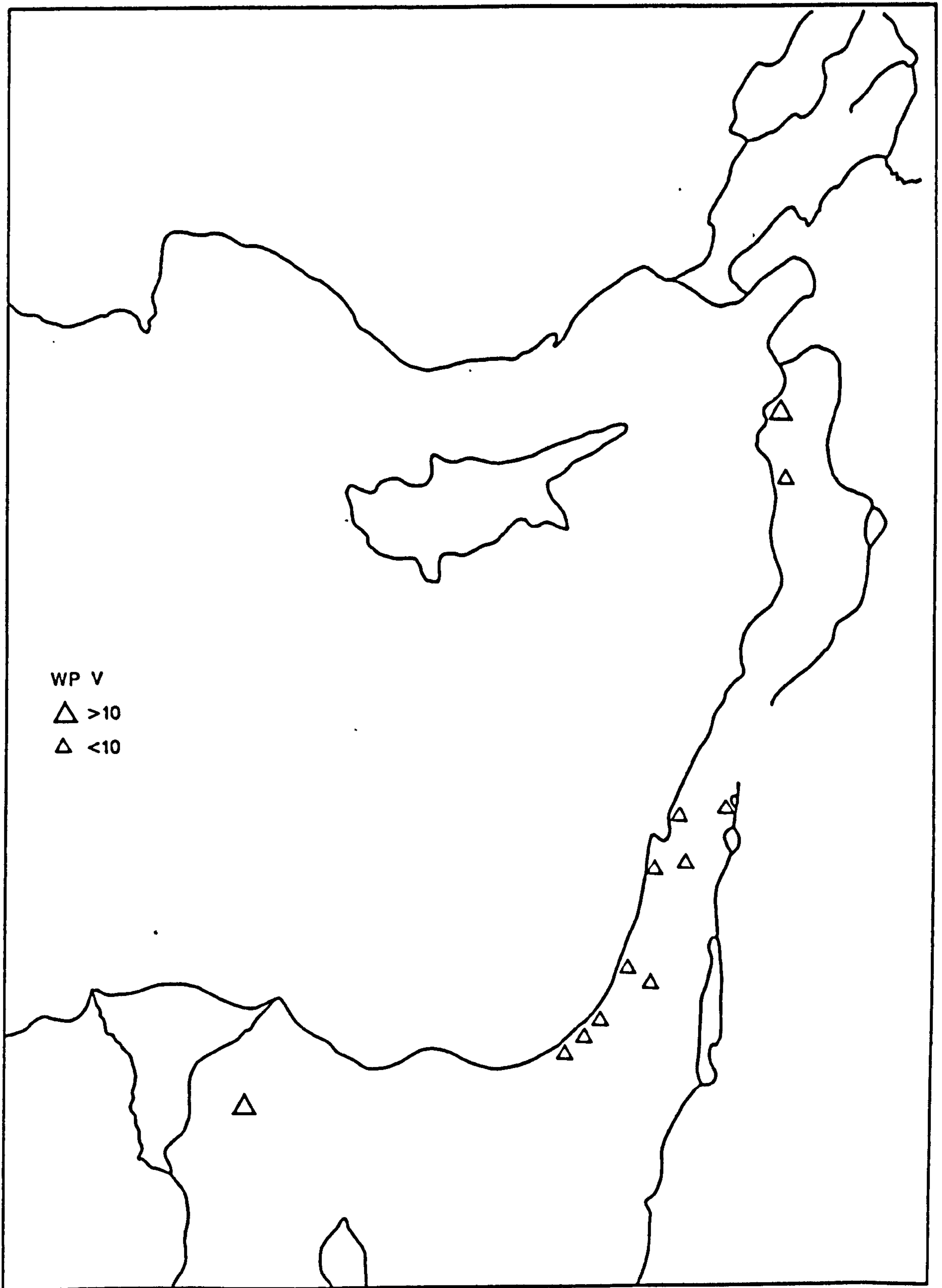

Figure 27: Distribution of White Painted V

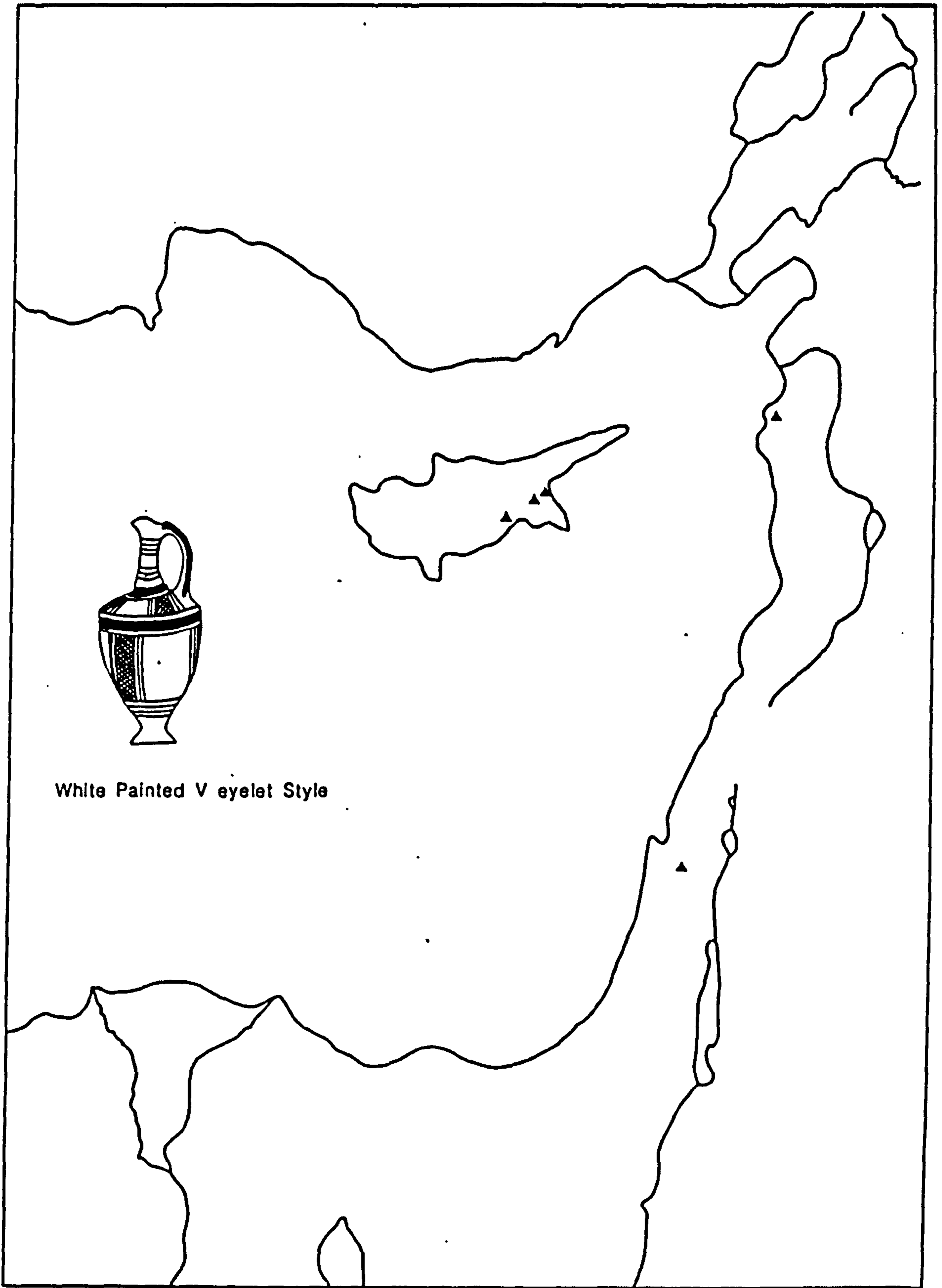

Figure 28: Distribution of White Painted V Eyelet Style

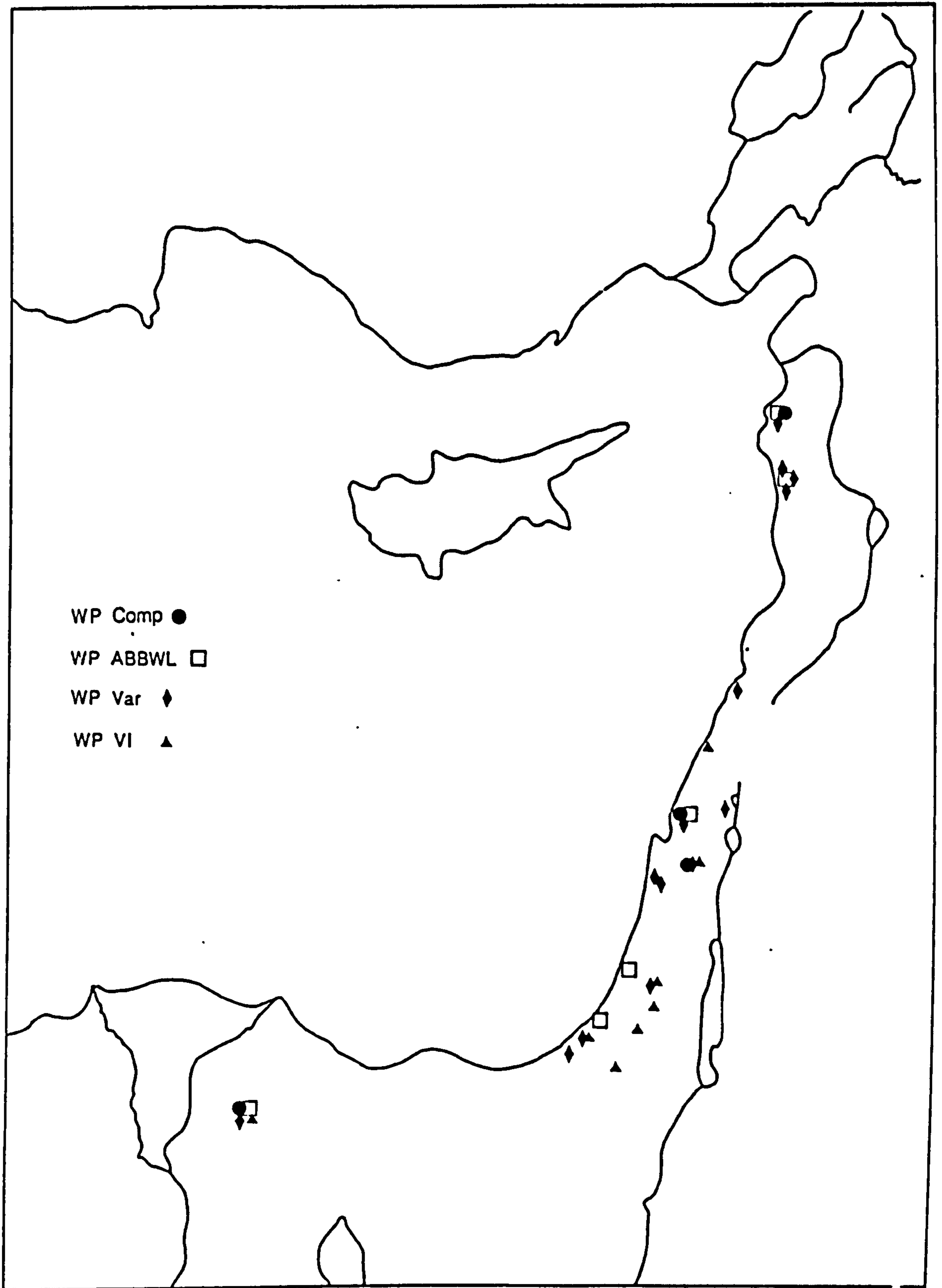

Figure 29: Distribution of White Painted Composite, White Painted Alternating Broad Band and Wavy Line Style, White Painted various

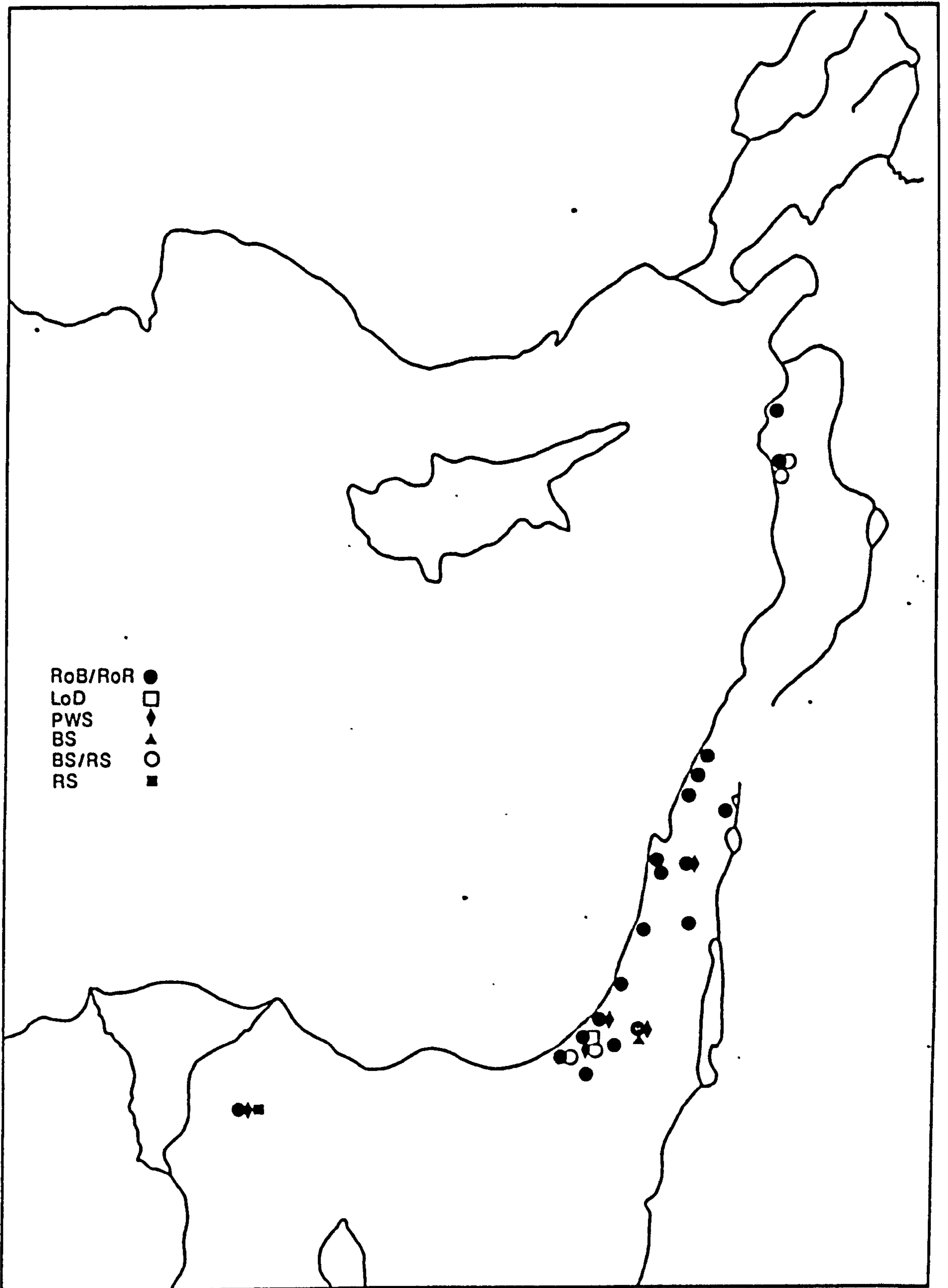

Figure 30: Distribution of Red on Black/Red on Red, Light on Dark, Proto White Slip, Black Slip, Reserve Slip

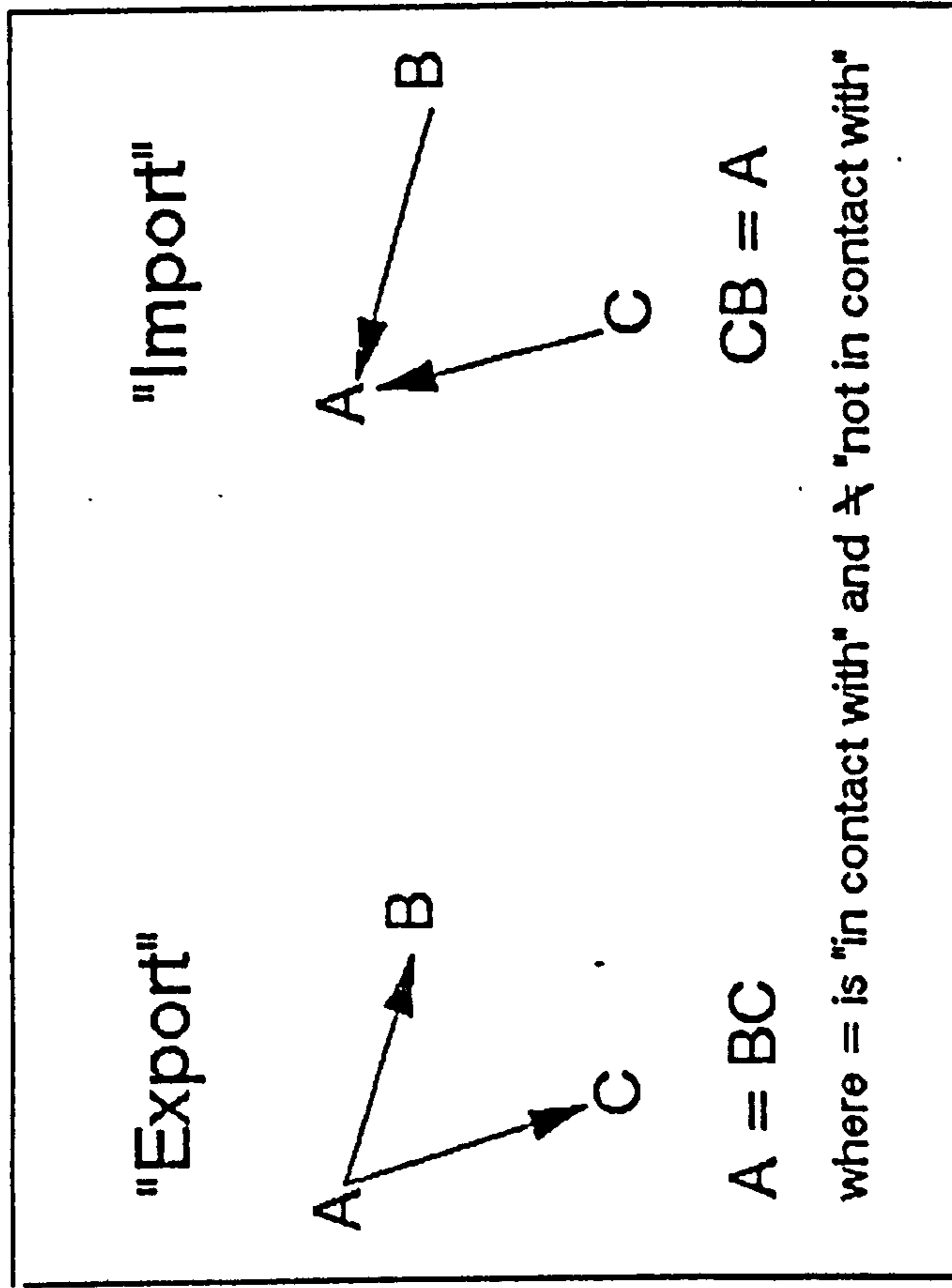

Figure 31: An overview of idealised interpretations on the distribution of Cypriot pottery abroad

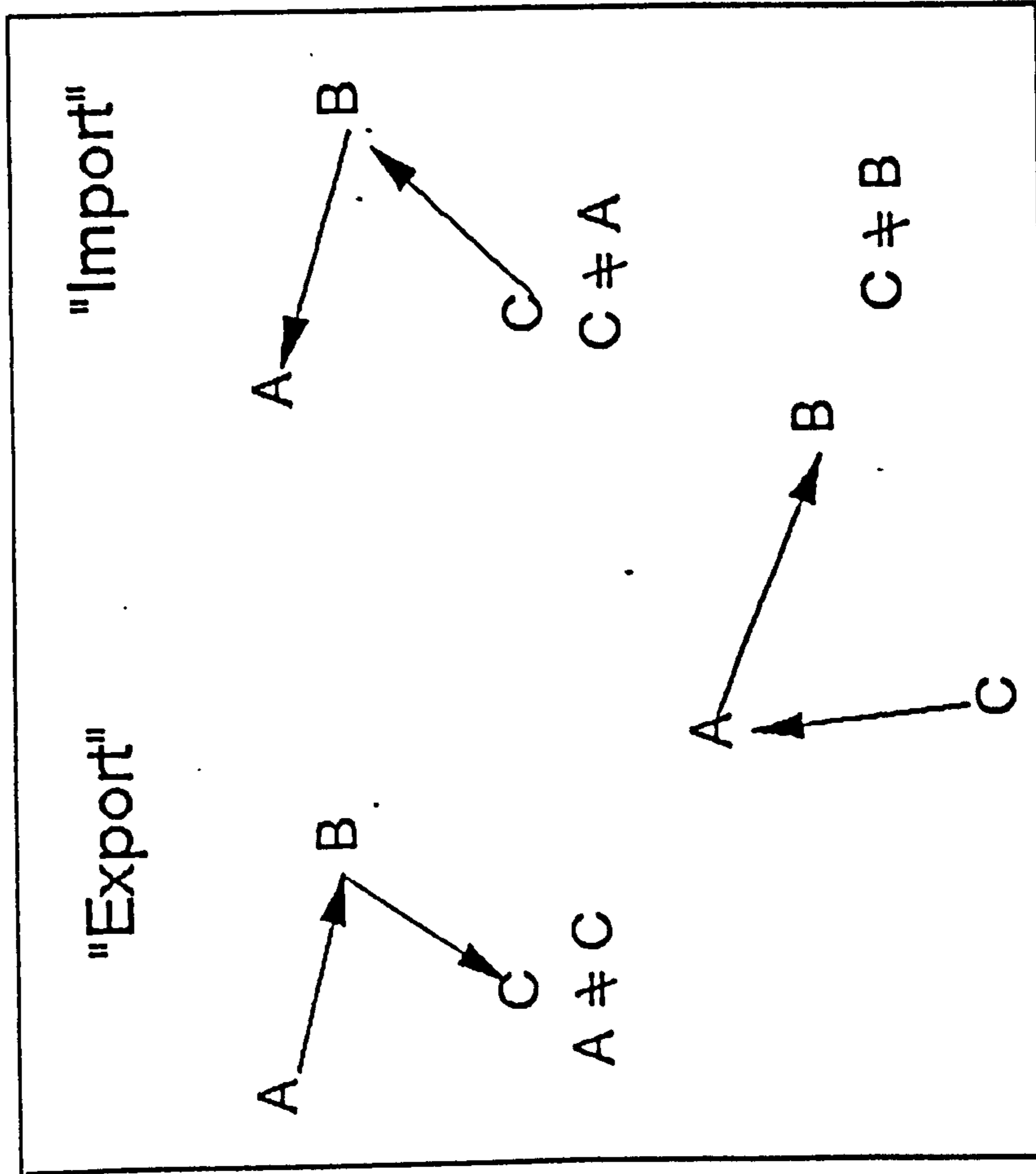

Figure 32: Idealised interpretations of Cypriot pottery found abroad

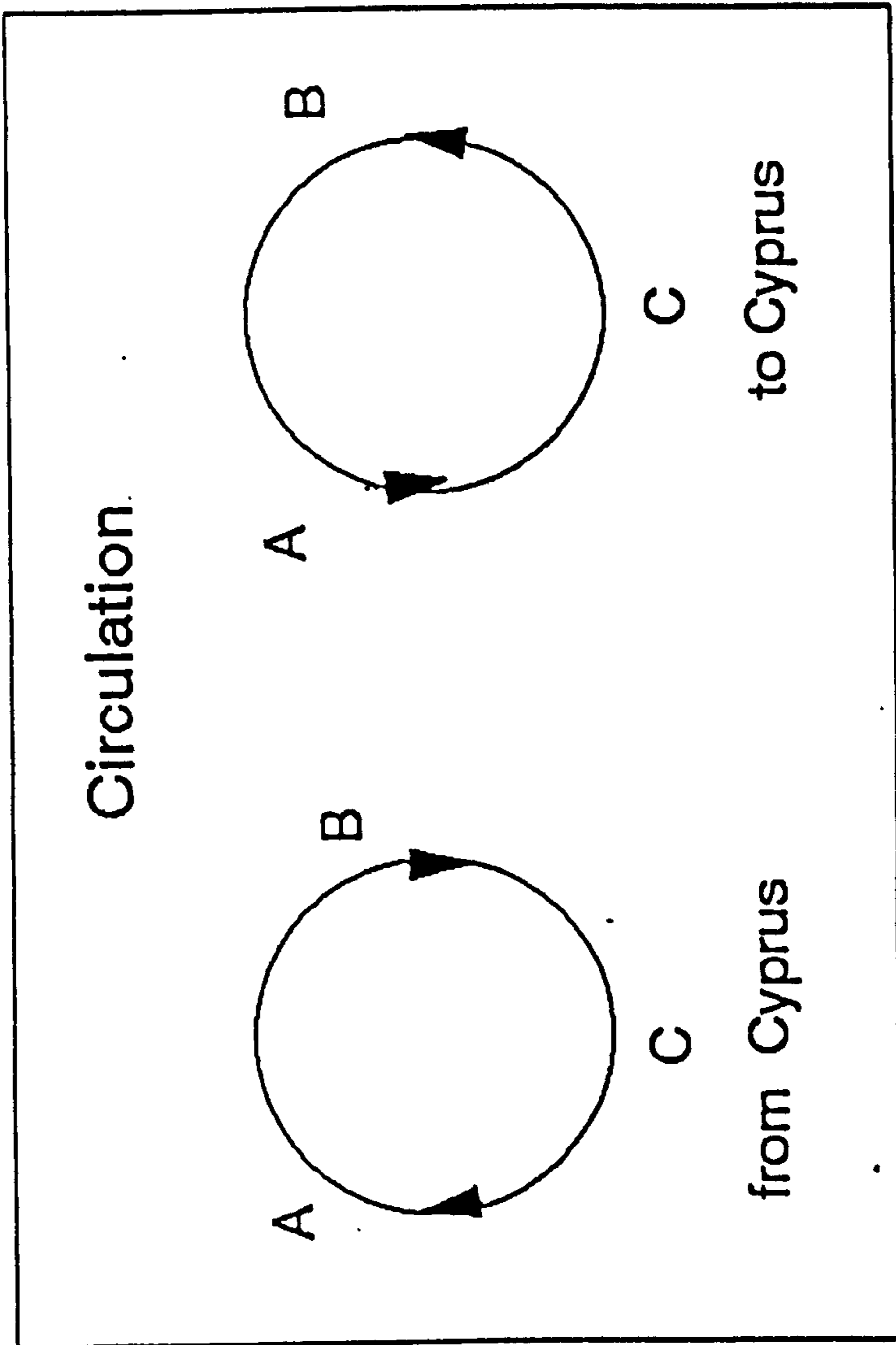
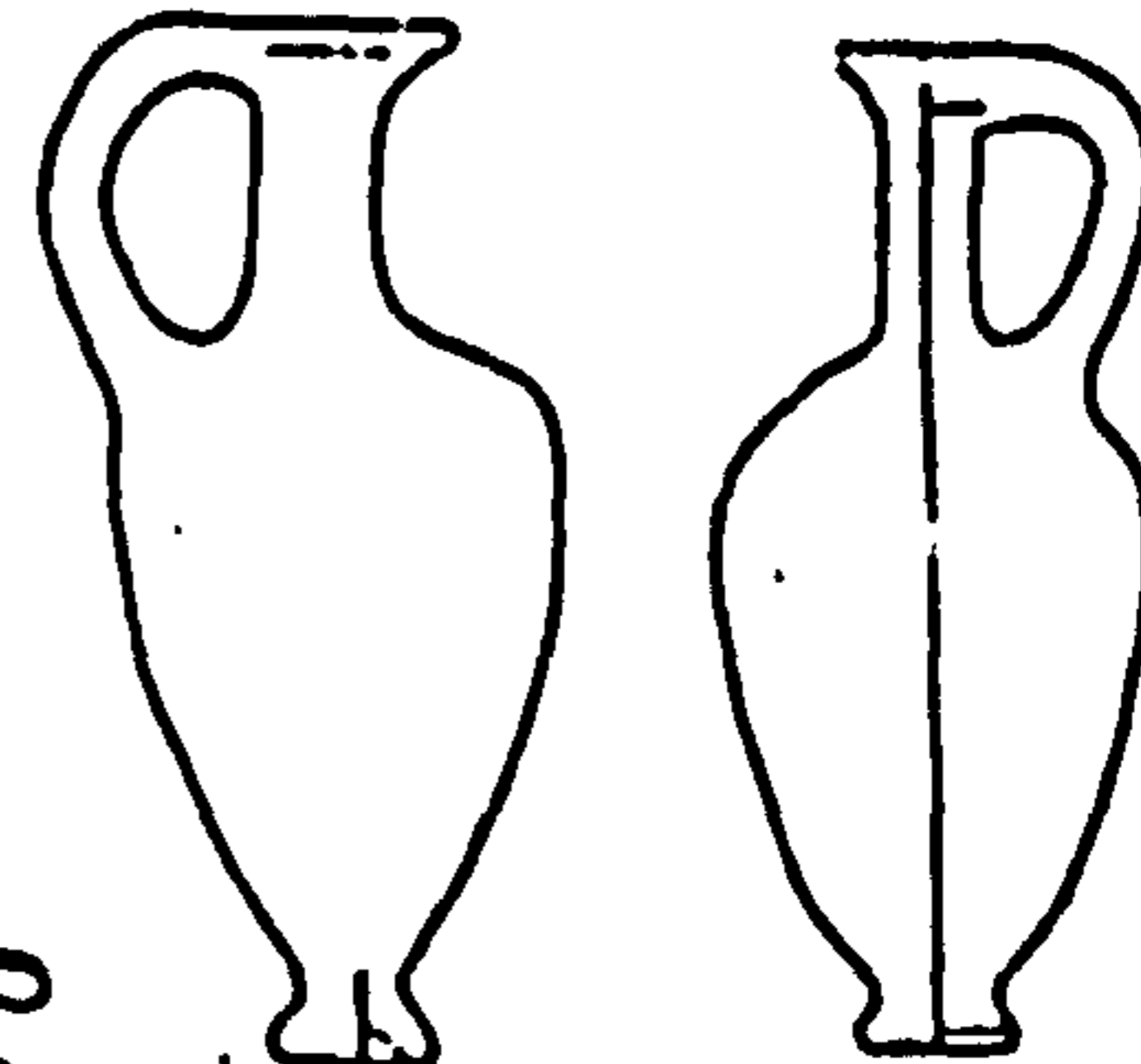

Figure 33: A description of the distribution of Cypriot pottery abroad

N. Syria (Ras Shamra): Red (/Black/Brown) Burnished Ware

RB collared

- *collared rim
- *carinated shoulder
- *pedestal base
- *handle from rim to shoulder



RB trefoil

- *trefoil mouth
- *carinated shoulder
- *ring/pedestal base
- *handle from rim to shoulder

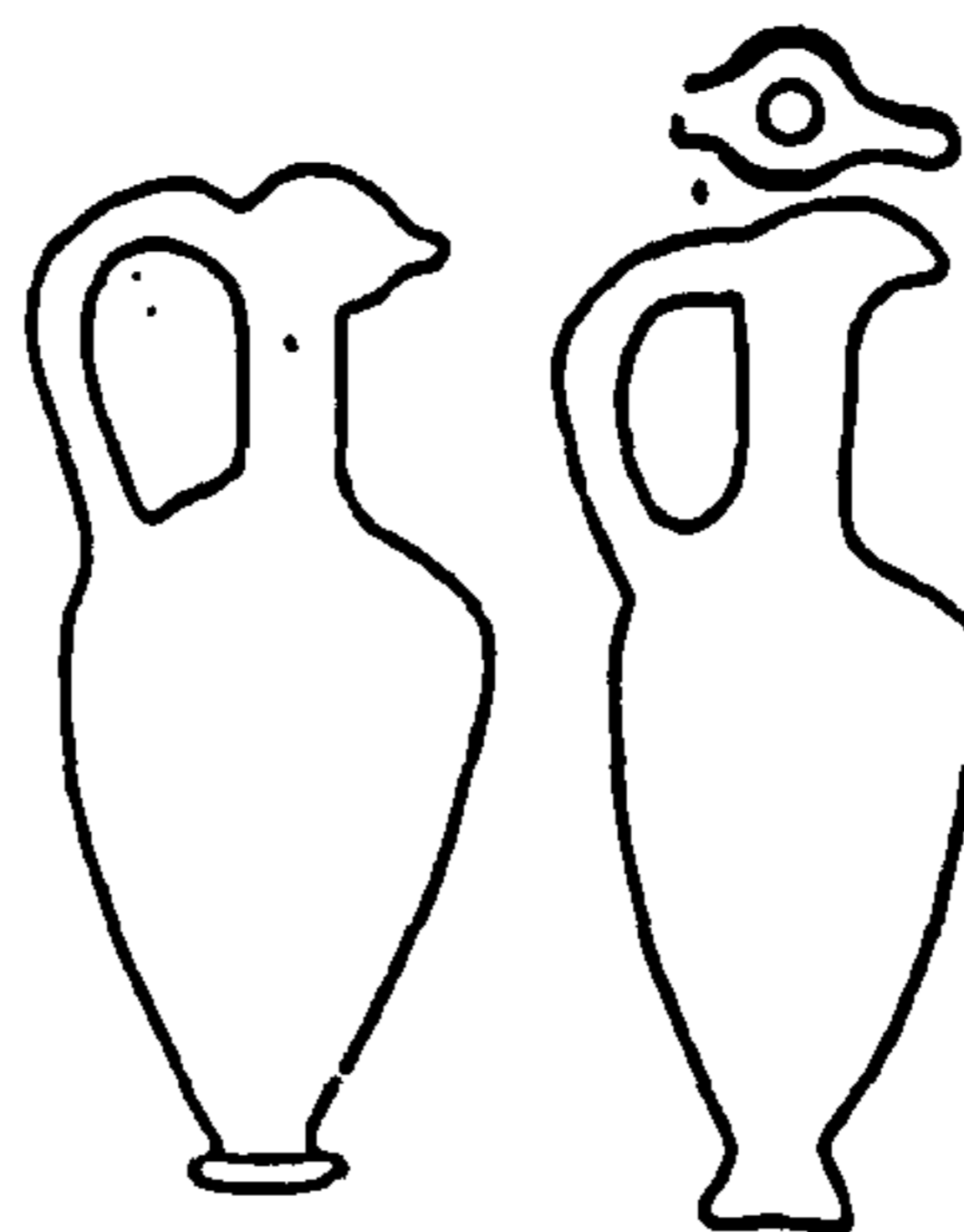

Palestine: Red Polished

RP Piriform

- *rolled lip
- *piriform body
- *button base
- *handle from below rim to shoulder
- *bipartite handle

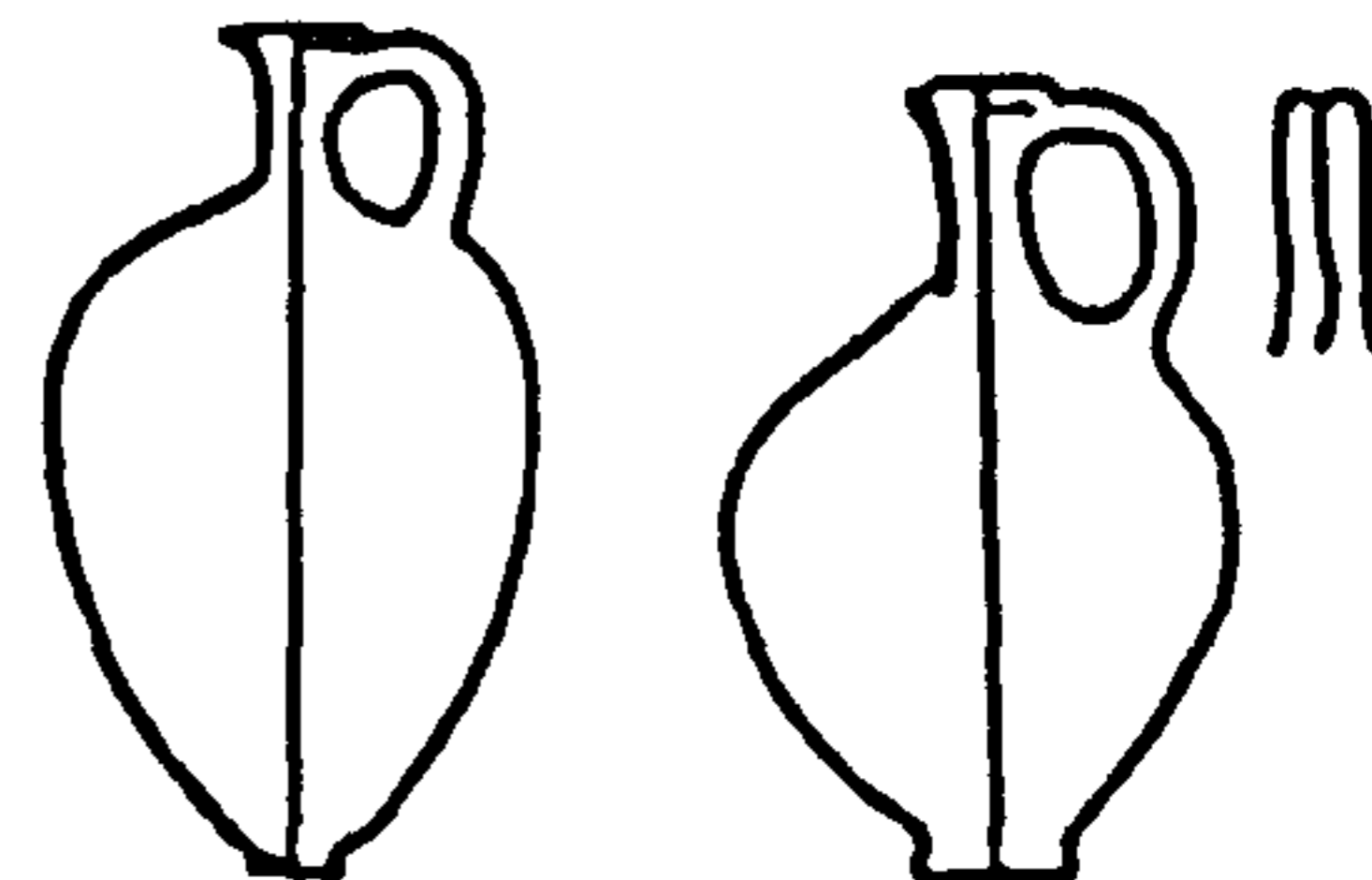

RP cylindrical

- *rolled rim
- *squat cylindrical body
- *flat base
- *handle from below rim to shoulder
- *bipartite handle

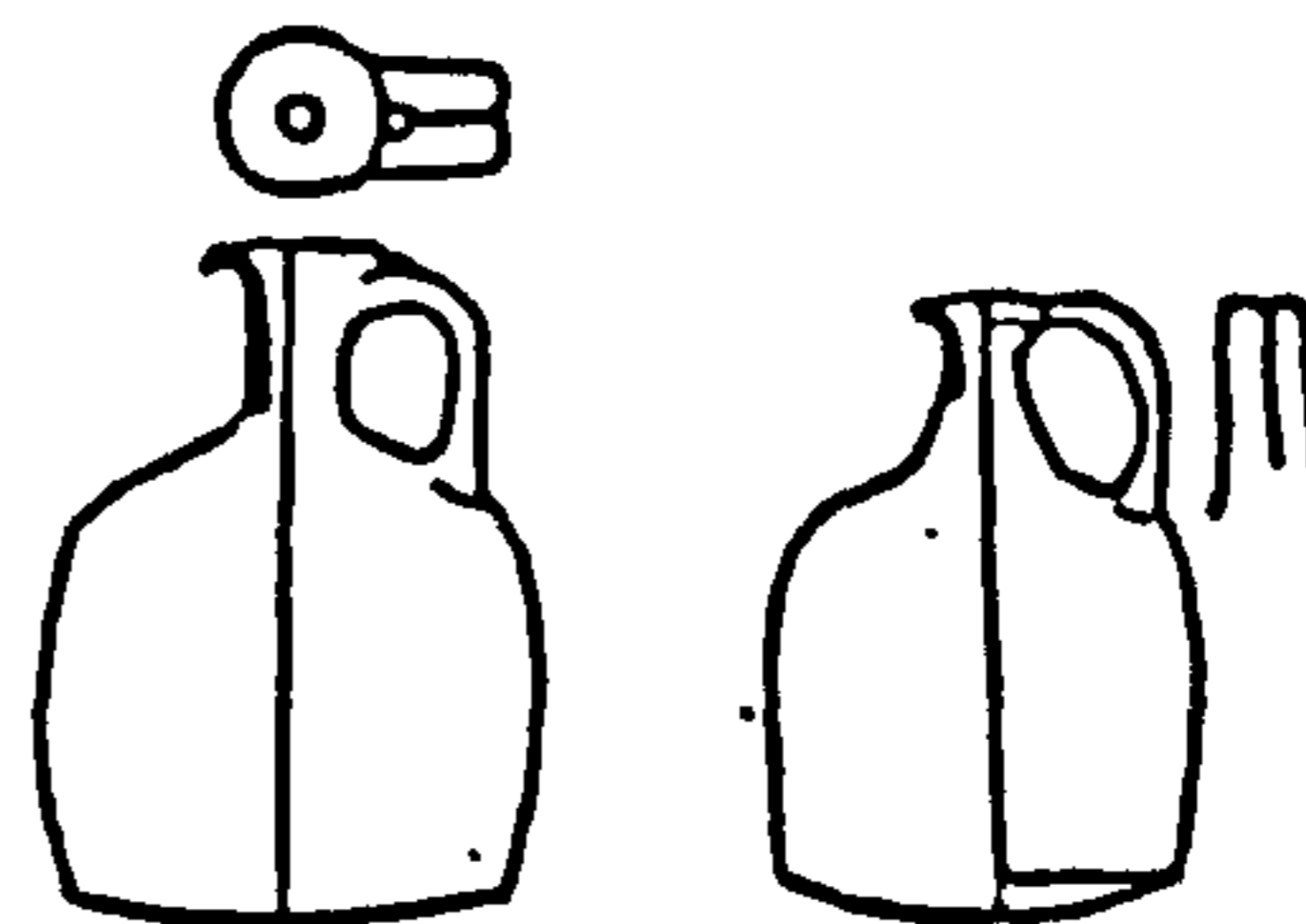

Figure 34: 'Easy reference' classification of Red Polished and Red Burnished juglets (PCC's)

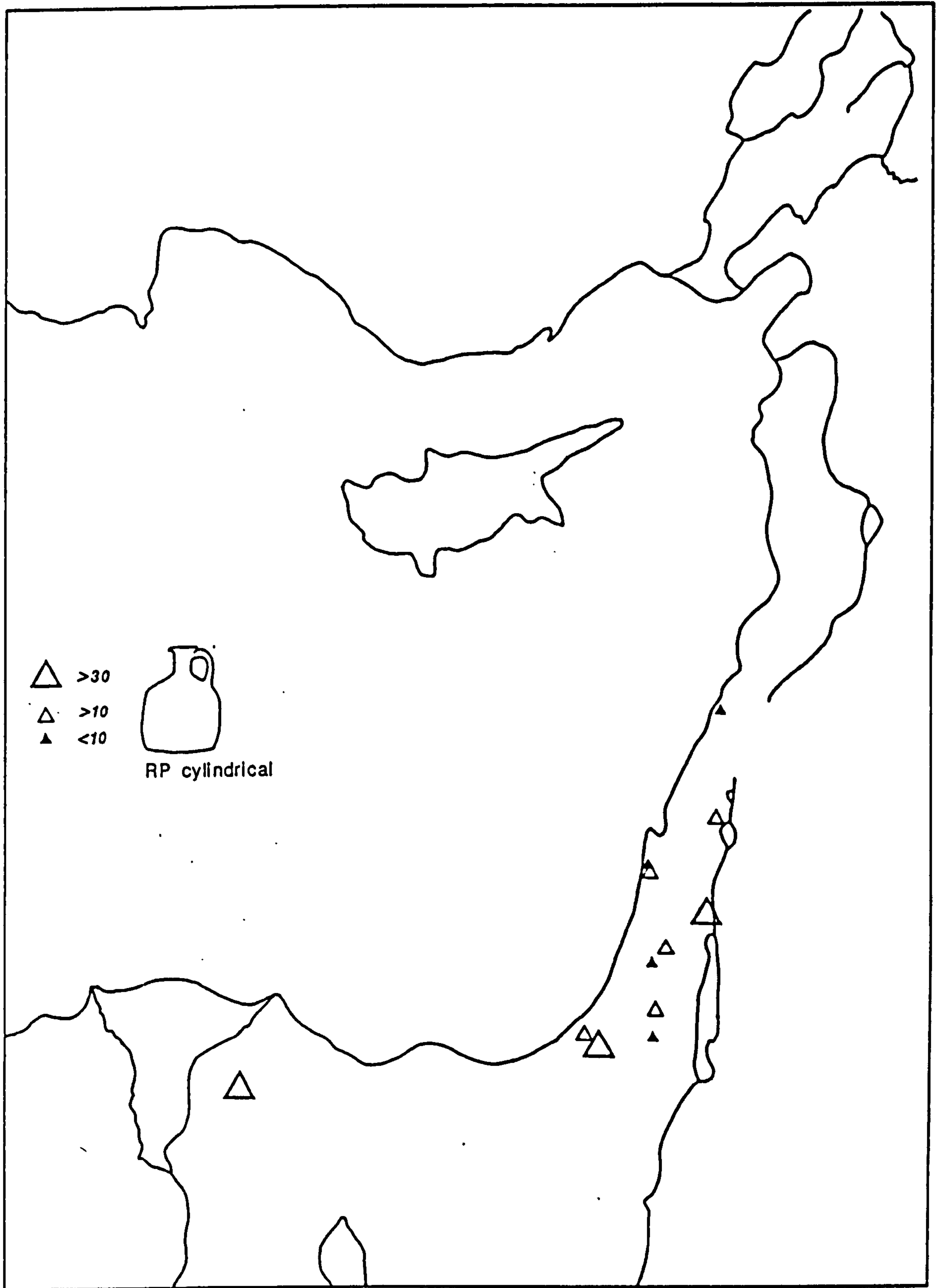

Figure 36: Distribution of Red Polished and Red Burnished juglets (cylindrical)

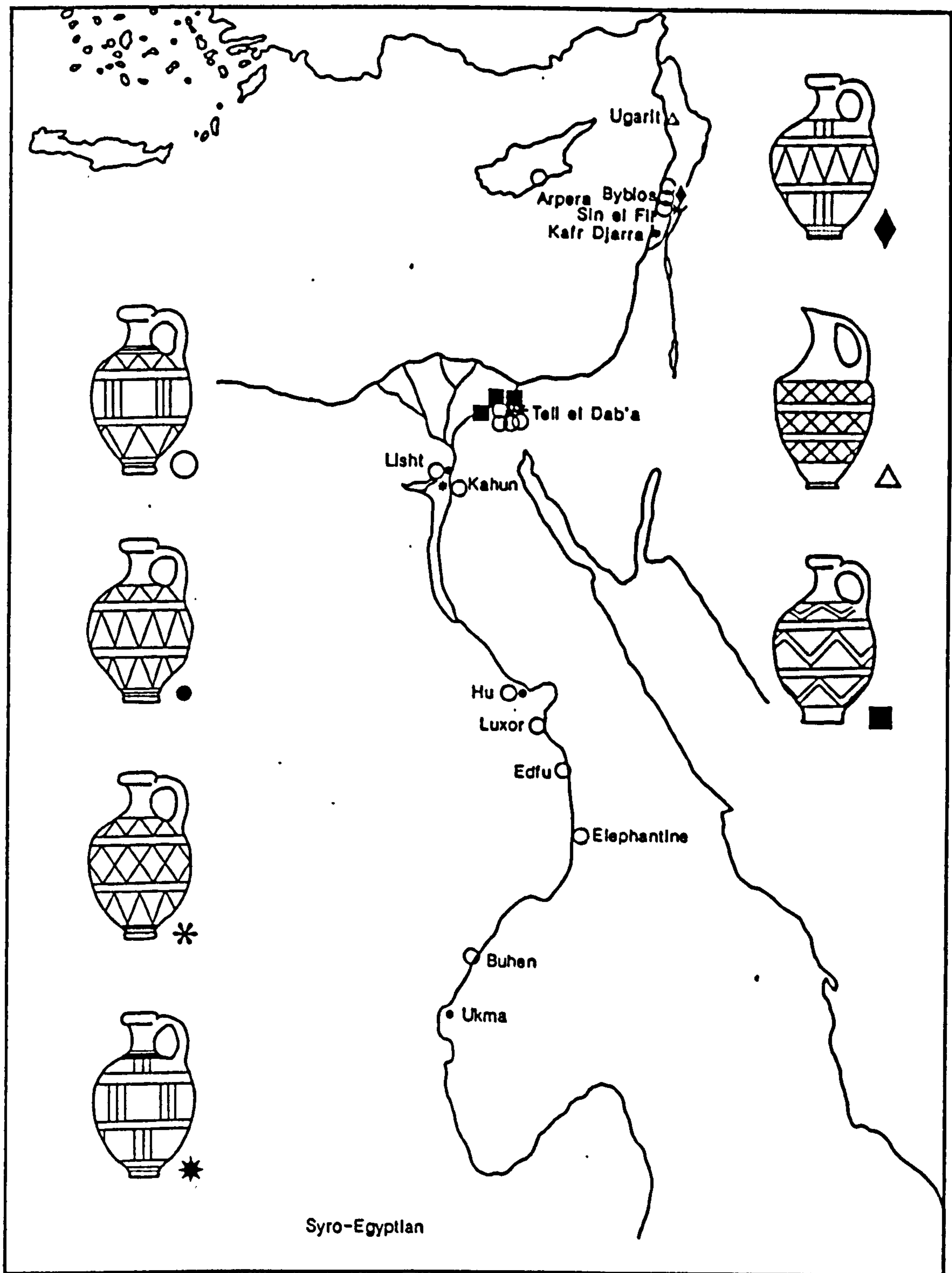

Figure 37: Distribution of Tell el Yahudiyeh Ware: Syro-Egyptian group (after Bietak 1985)

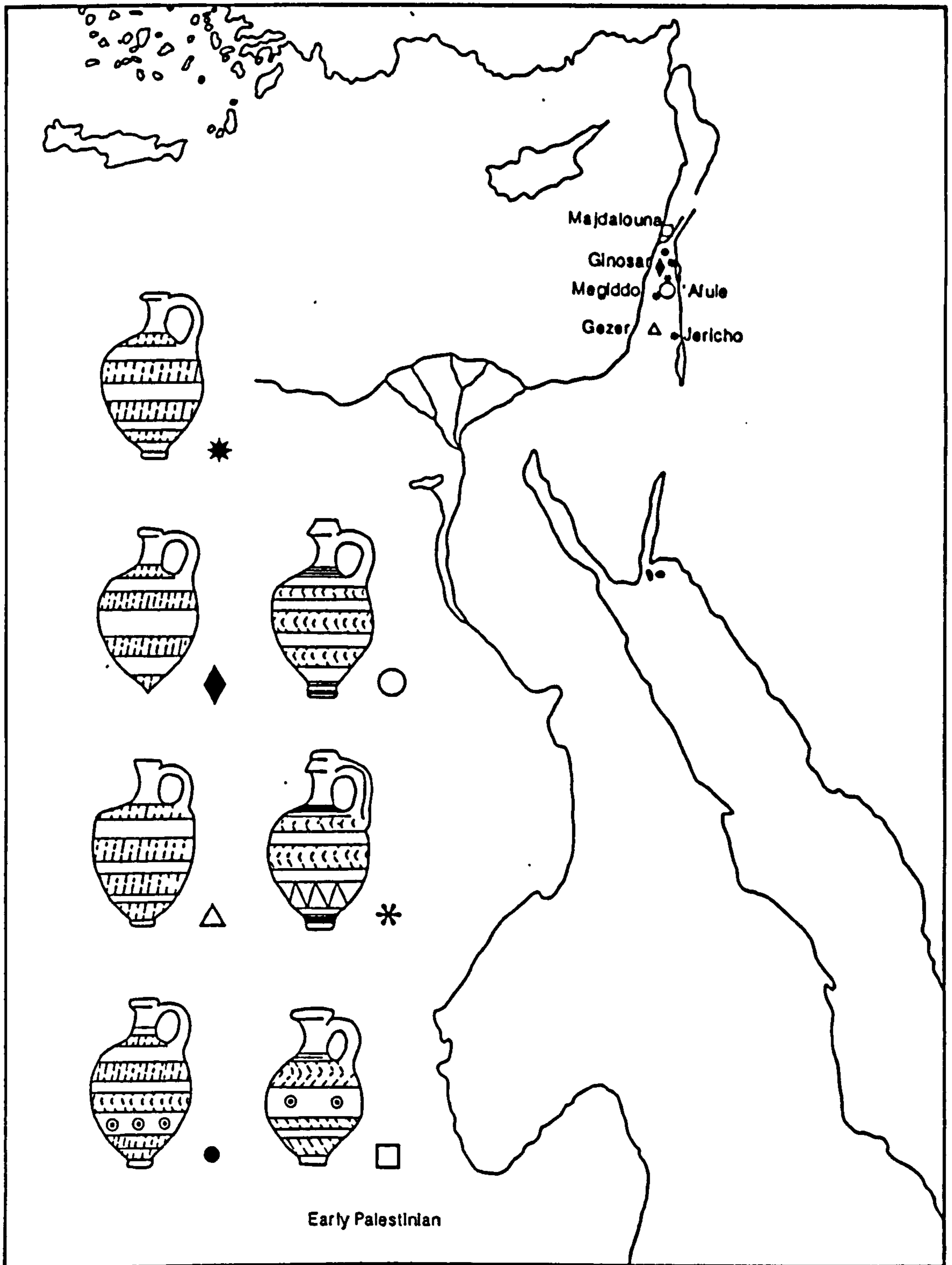

Figure 38: Distribution of Tell el Yahudiyeh Ware:Early Palestinian group (after Bietak 1985)

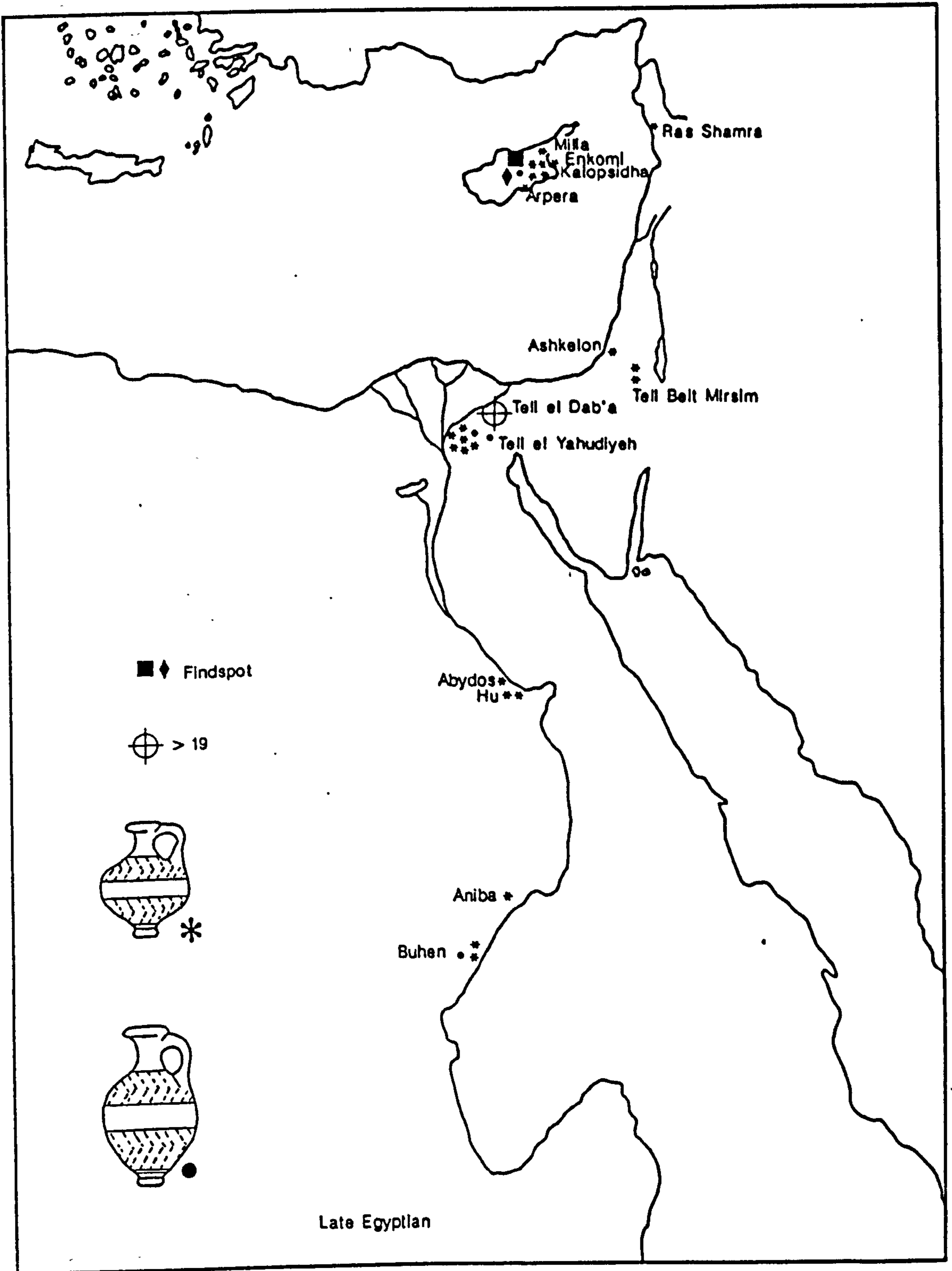

Figure 39: Distribution of Tell el Yahudiyeh Ware: Late Egyptian group (after Bietak 1985)

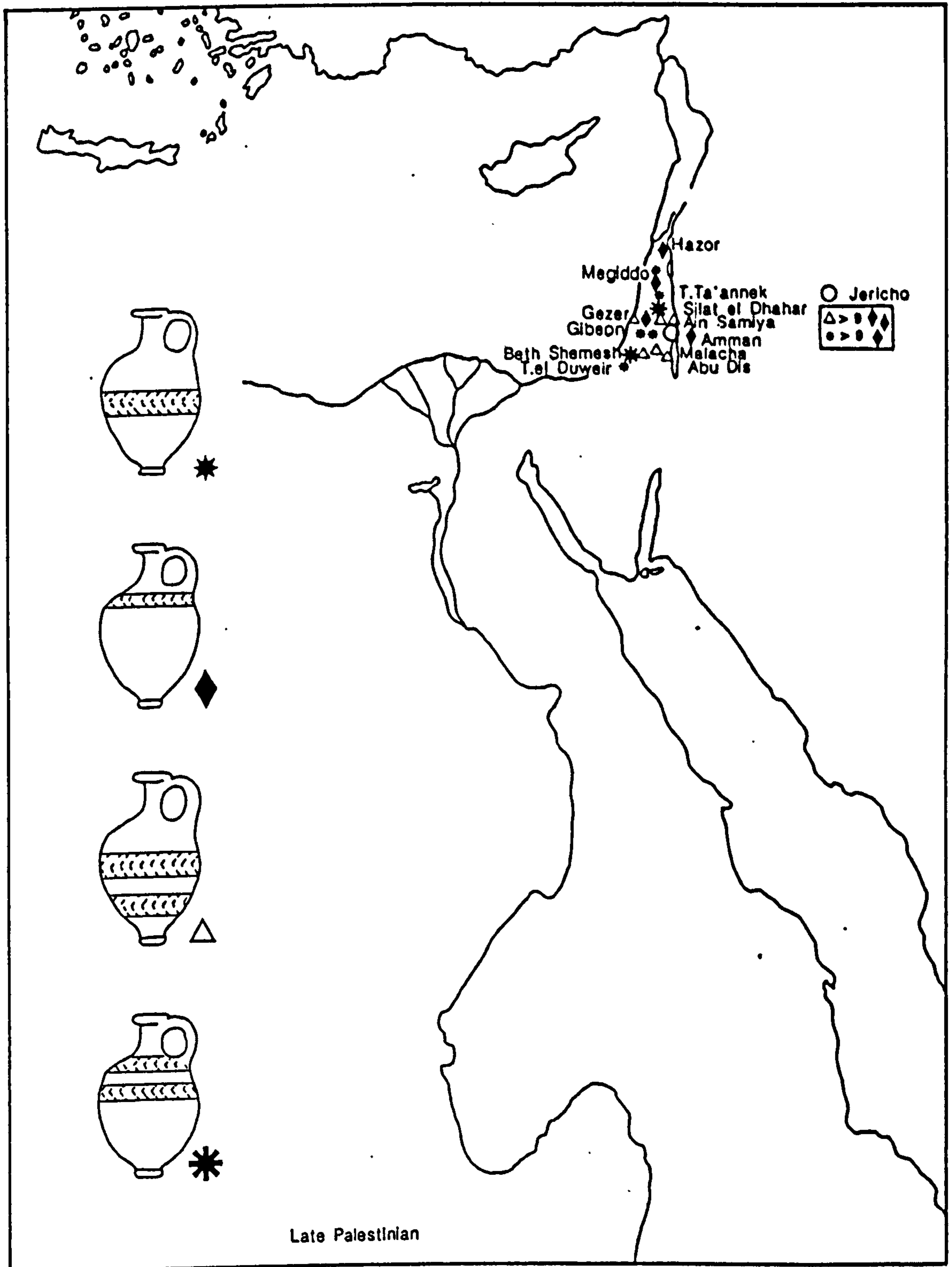

Figure 40: Distribution of Tell el Yahudiyeh Ware:Late Palestinian group (after Bietak 1985)

WP V eyelet
(RB trefoil or collared shape)

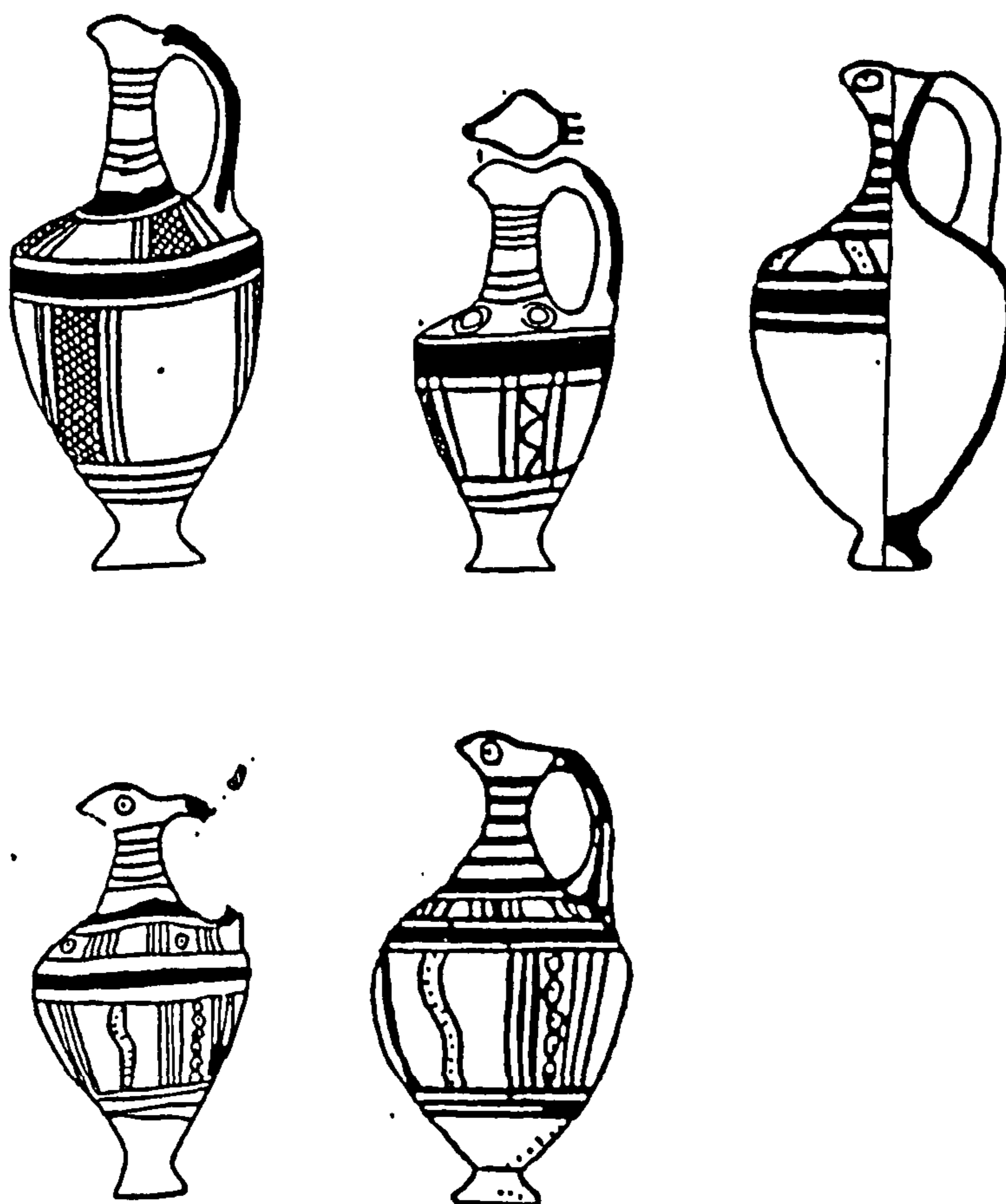

Figure 41: White Painted V Eyelet style juglets

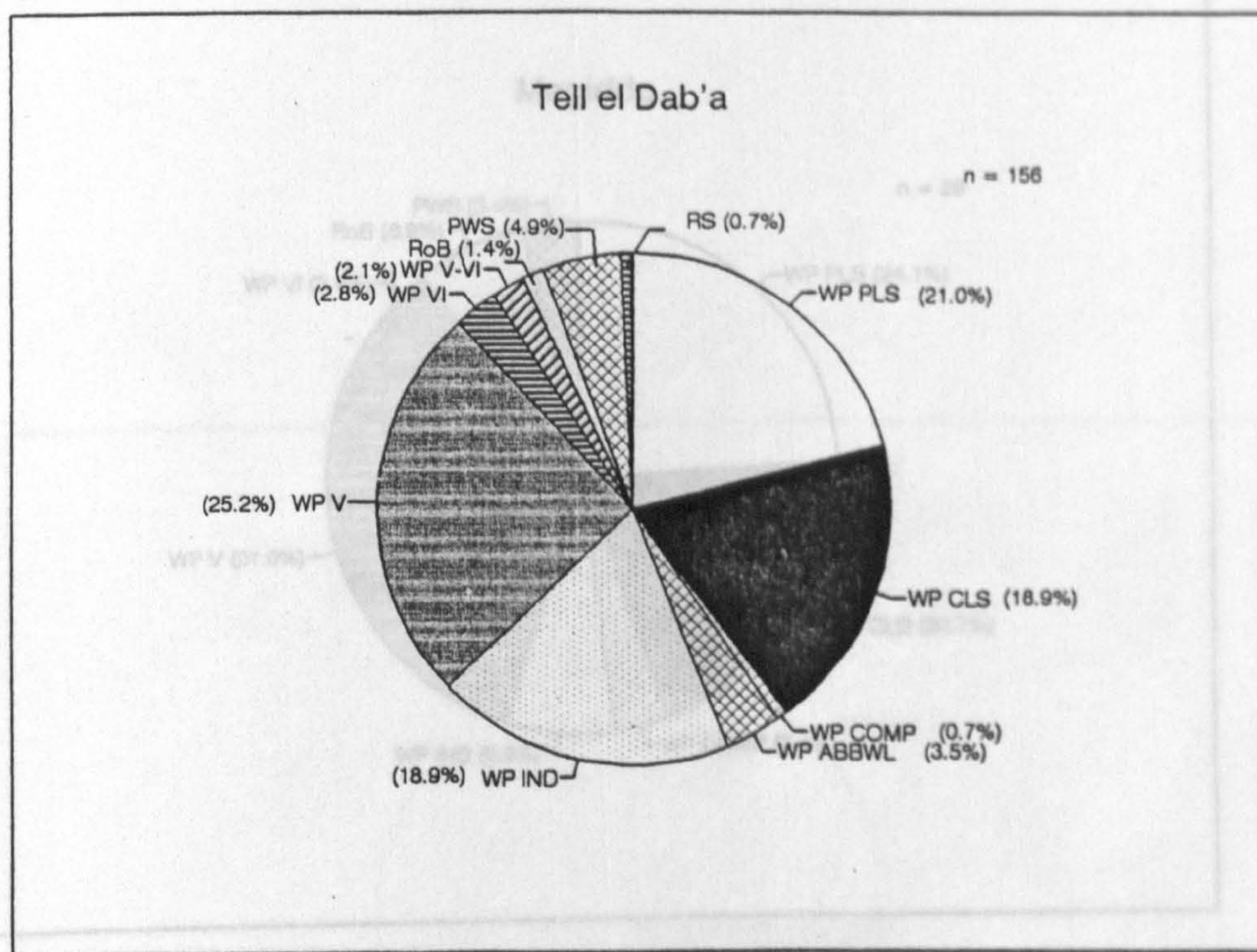

Figure 42: Pie chart of the relative proportions of Cypriot pottery at Tell el Dab'a

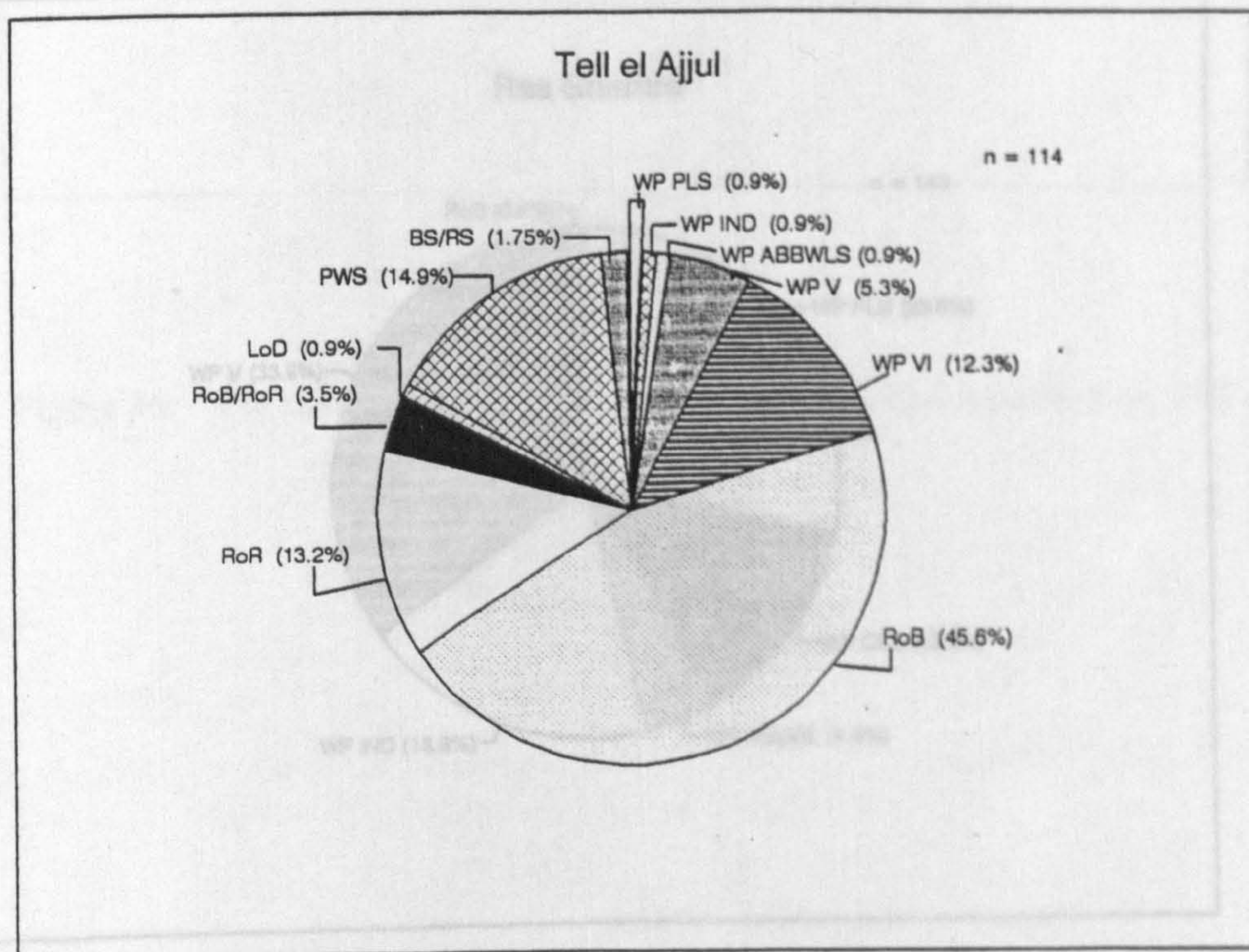

Figure 43: Pie chart of the relative proportions of Cypriot pottery at Tell el Ajjul

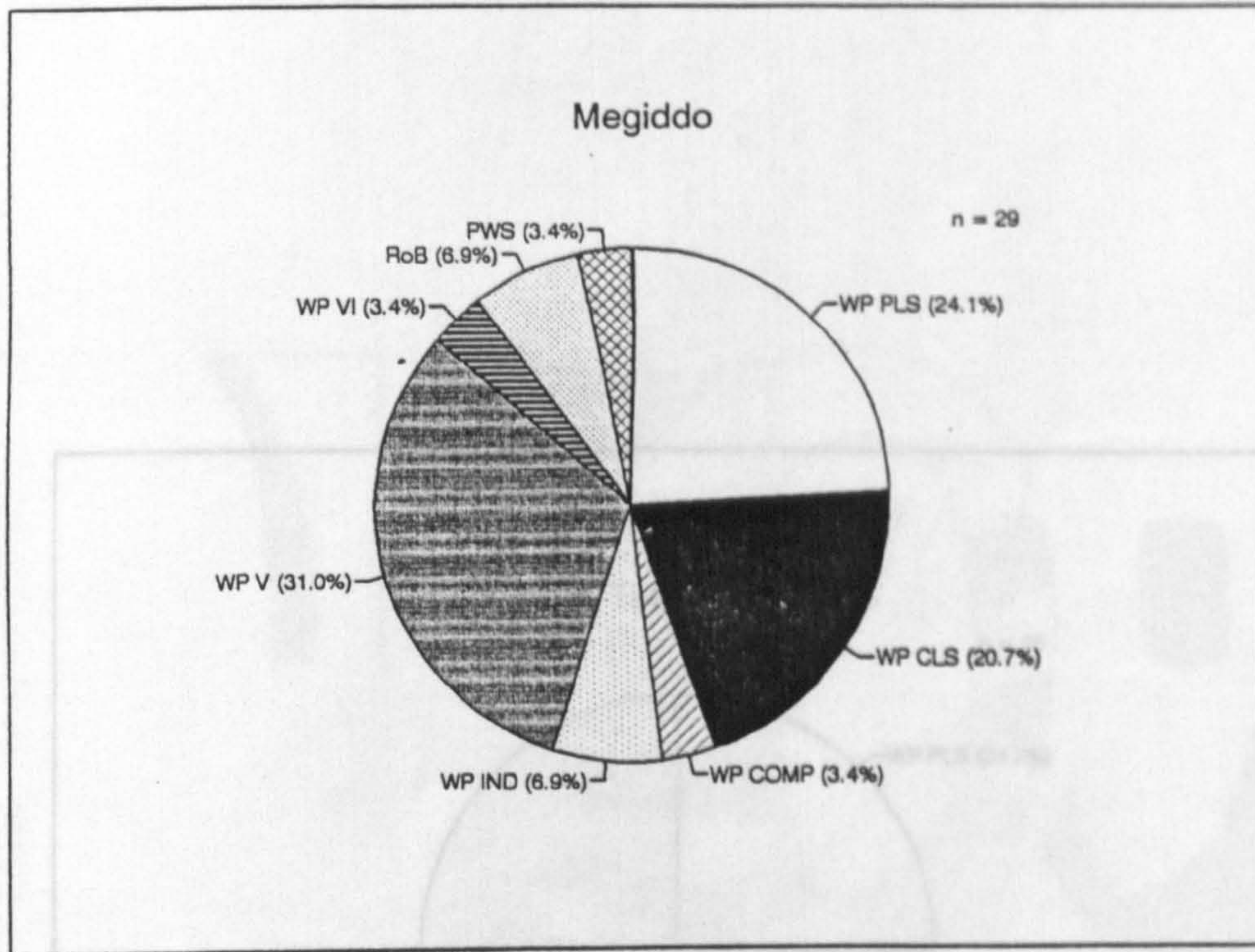

Figure 44: Pie chart of the relative proportions of Cypriot pottery at, Megiddo

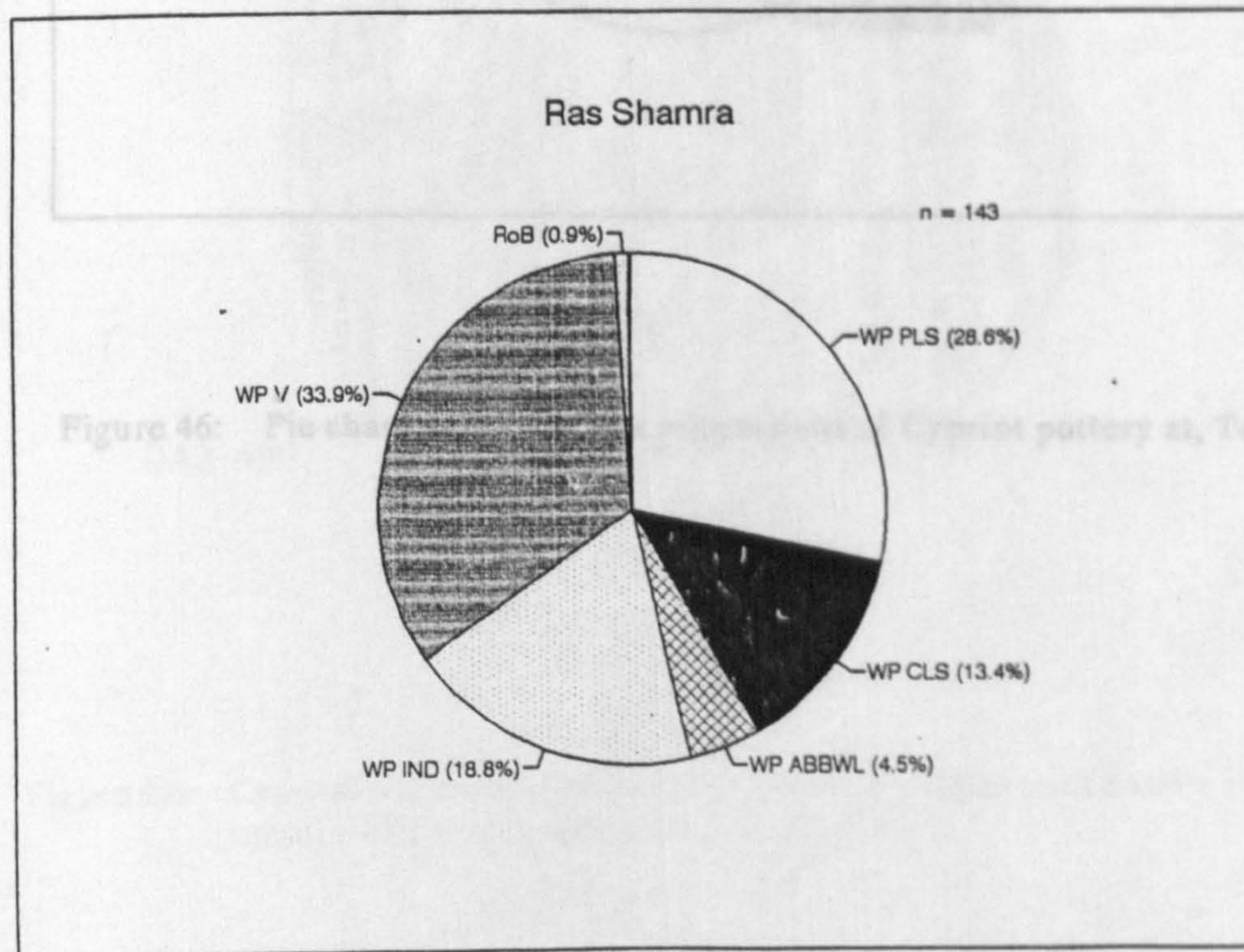

Figure 45: Pie chart of the relative proportions of Cypriot pottery at, Ras Shamra

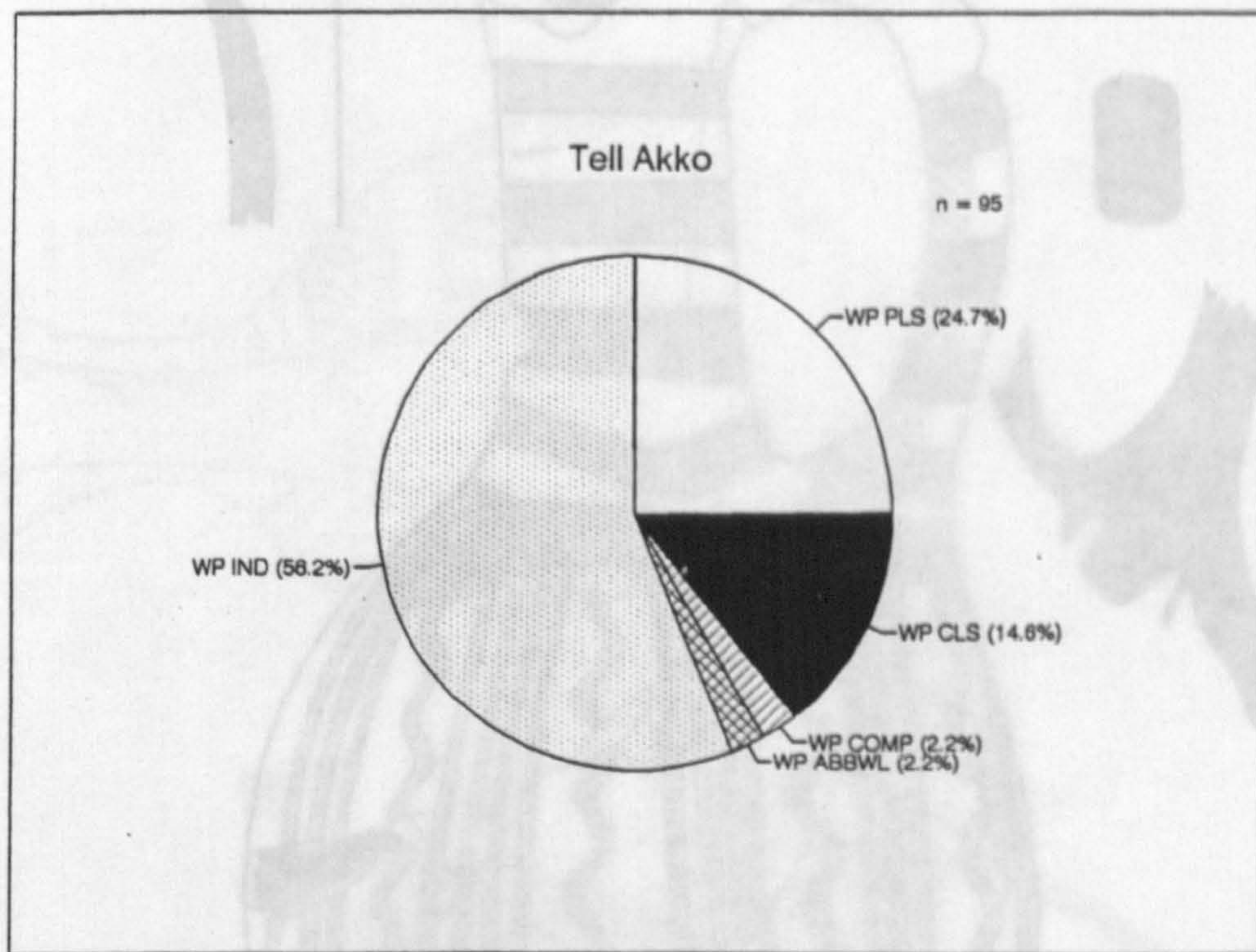

Figure 46: Pie chart of the relative proportions of Cypriot pottery at, Tell Akko

Figure 47: Cypriot pottery fragment showing a handle inserted into a hole in the rim of a vessel.



DAB 490

Figure 47: Cypriot White Painted Pendant Line Style juglet with handle inserted into vessel wall (plug handle), from Tell el Dab'a

Figure 48: Tell el Yahudiyyah Ware (globular bandmade juglet) with handle inserted into vessel wall, from Tell el Dab'a

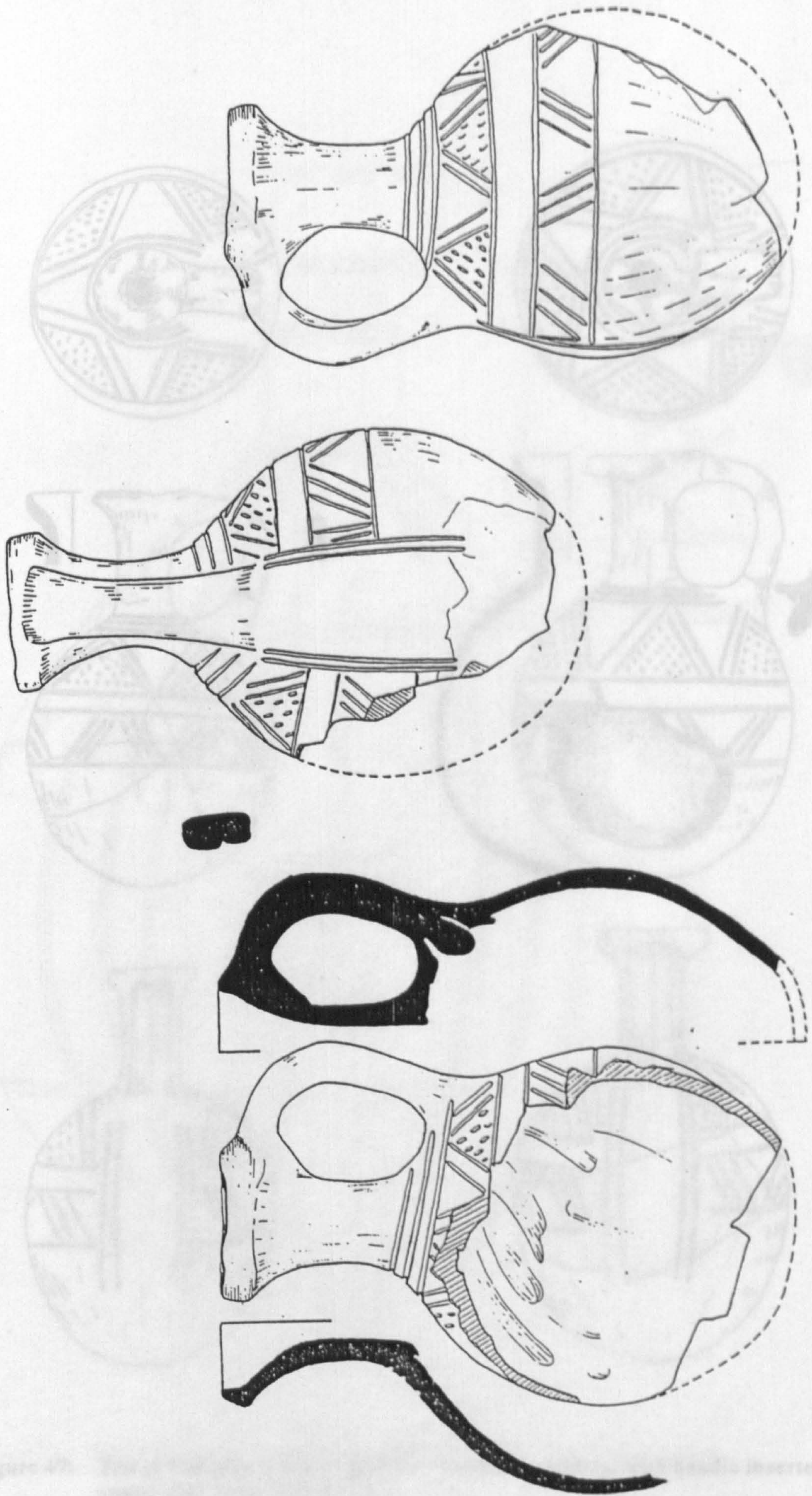

Figure 48: Tell el Yahudiyeh Ware (globular handmade juglet) with handle inserted into vessel wall, from Tell el Dab'a

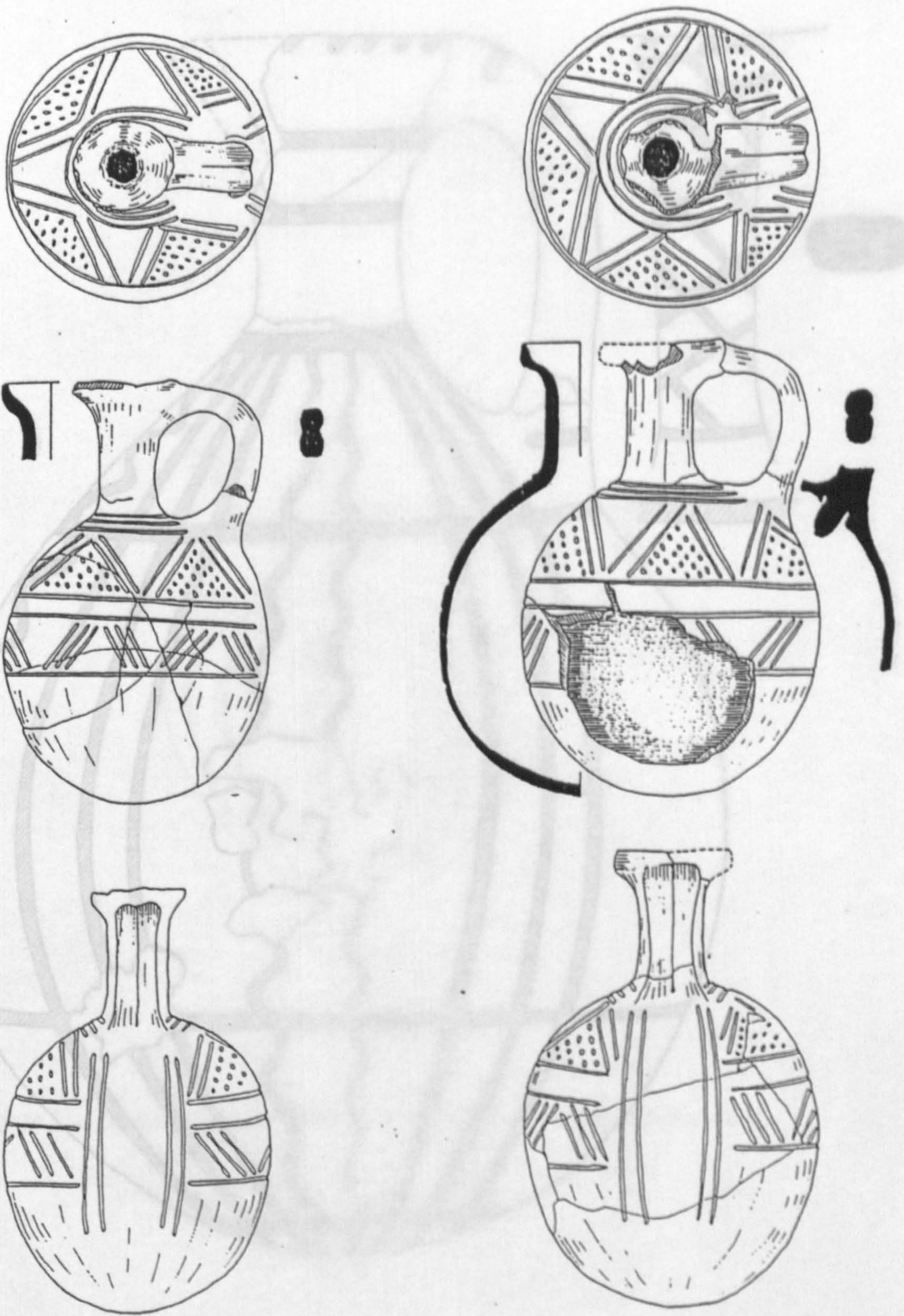

Figure 49: Tell el Yahudiyeh Ware (globular handmade juglets) with handle inserted into vessel wall, from Tell el Dab'a

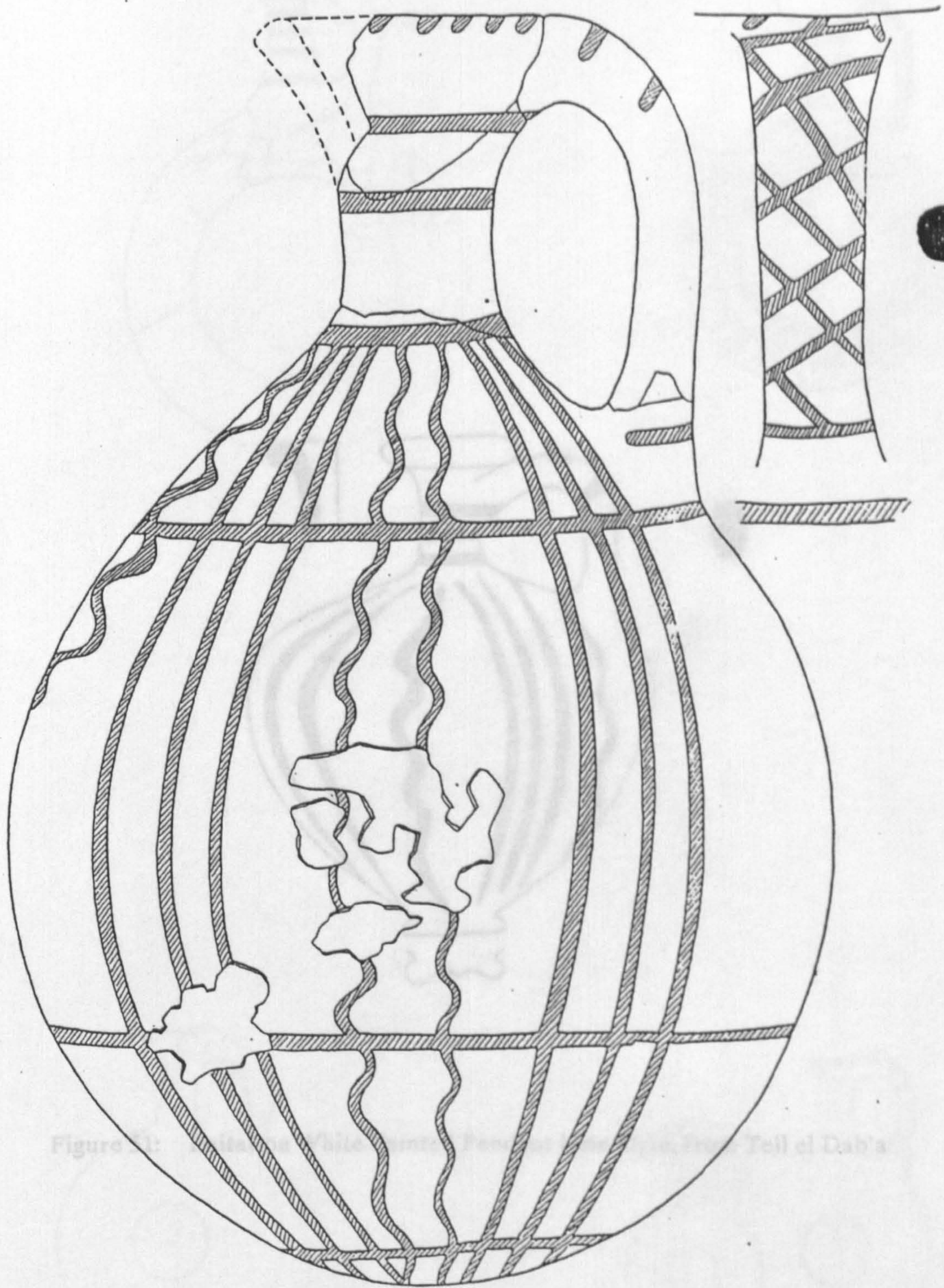

Figure 50: Imitation White Painted Pendent Line Style, from Tell el Dab'a

Figure 50: Imitation White Painted Pendent Line Style, from Tell el Dab'a

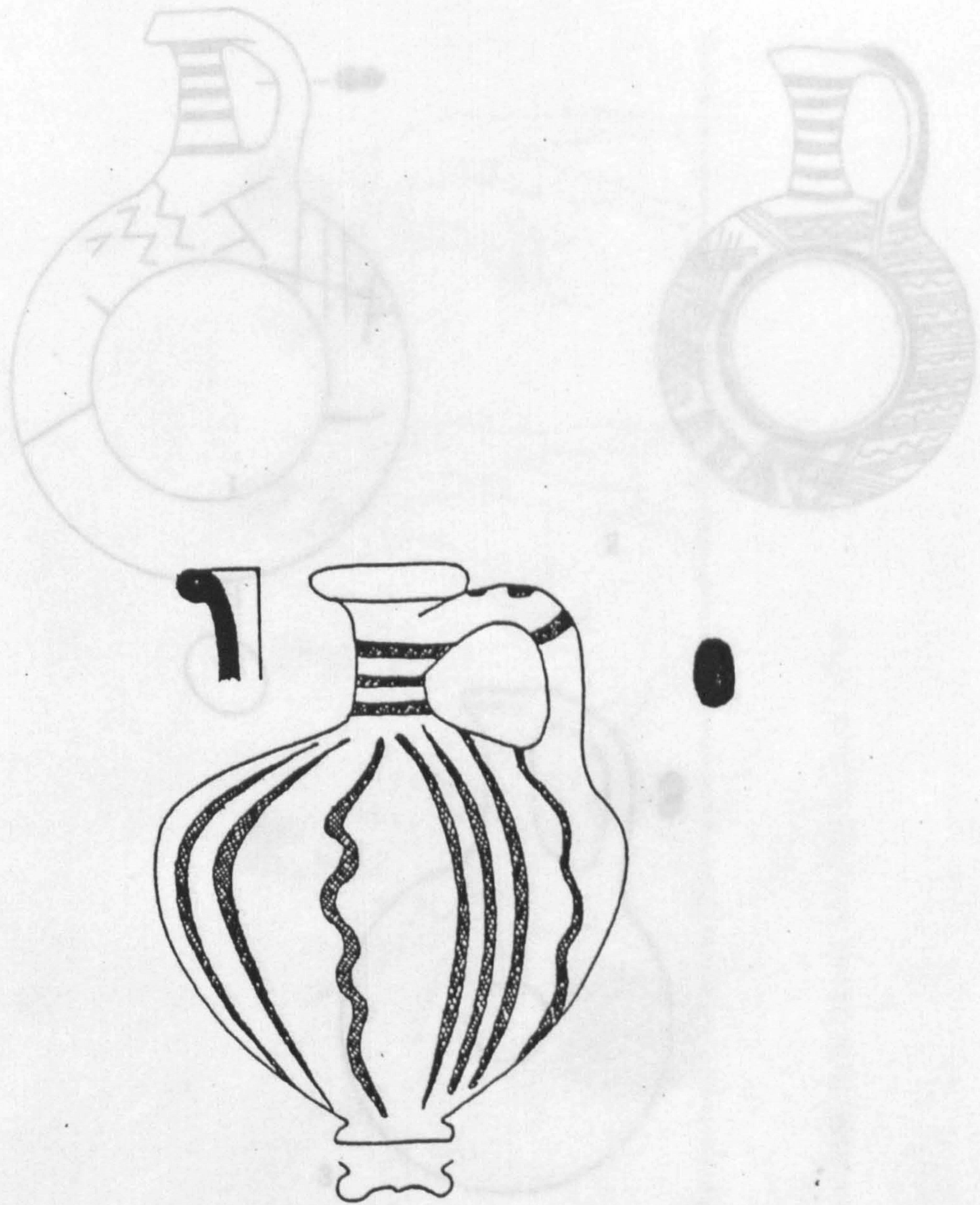

Figure 51: Imitation White Painted Pendent Line Style, from Tell el Dab'a

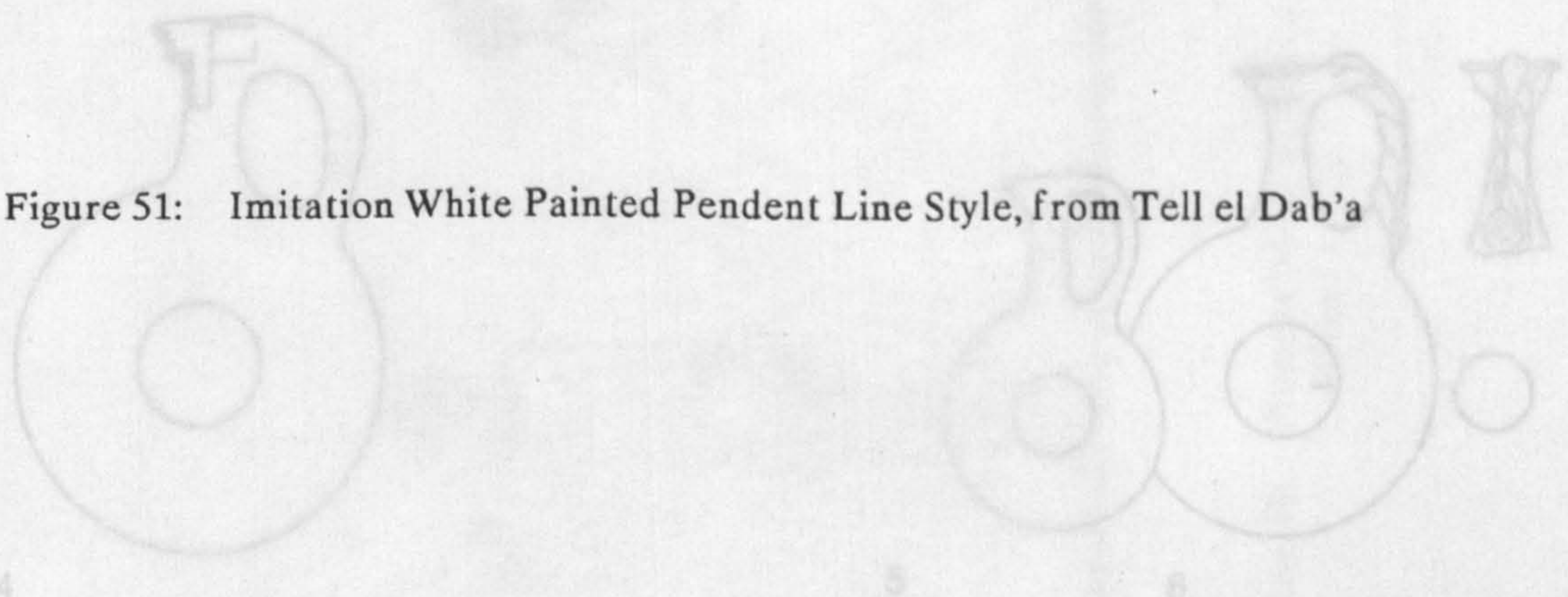

Figure 52: Ring-necked vessels (1-3, 5-7) 1. Tell el Dab'a 2. Tell el Dab'a 3. Tell el Dab'a 4. Ras Shamra 5. Ras Shamra 6. Ras Shamra 7. Ras Shamra

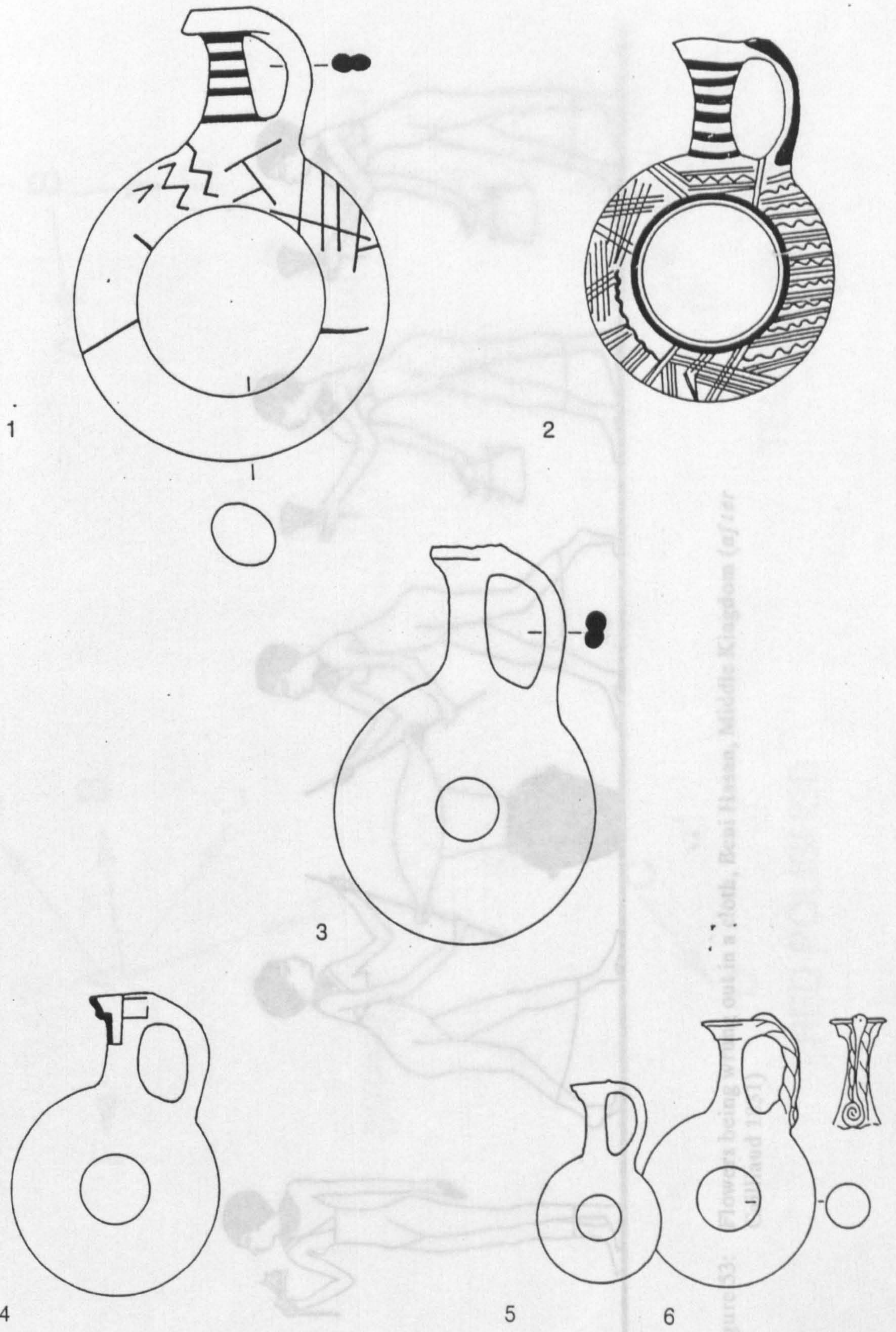

Figure 52: Ring vases - 1. Byblos 2. Cyprus (A. Iakovos) 3. Tell el Dab'a 4. Ras Shamra 5. Ras Shamra 6. Ras Shamra

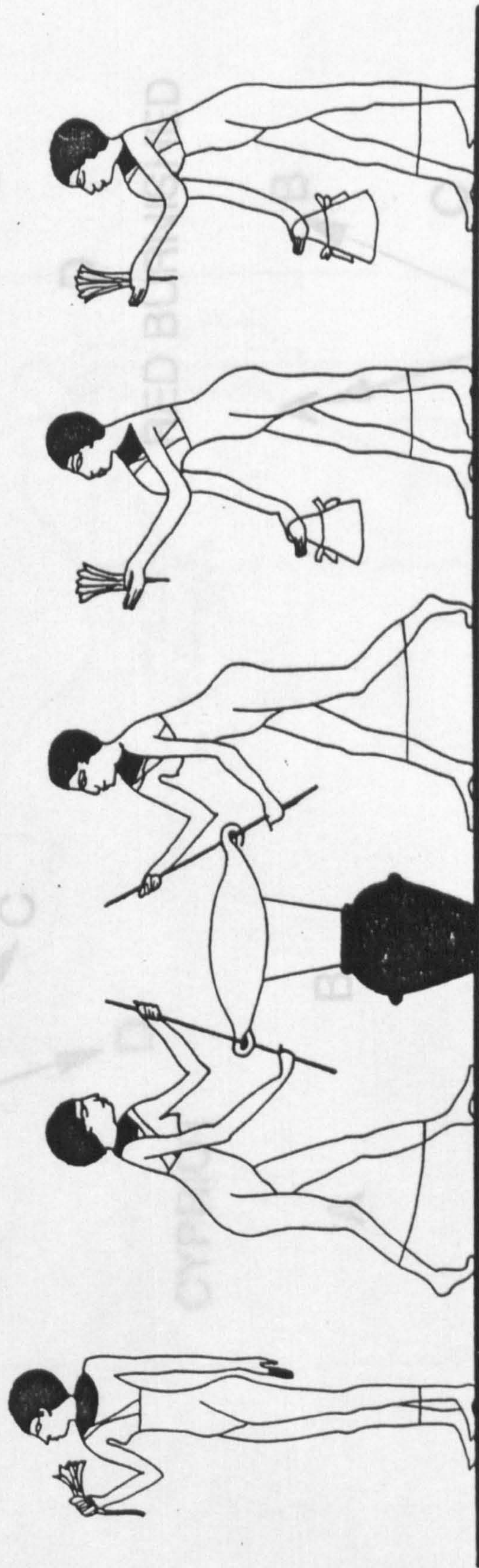
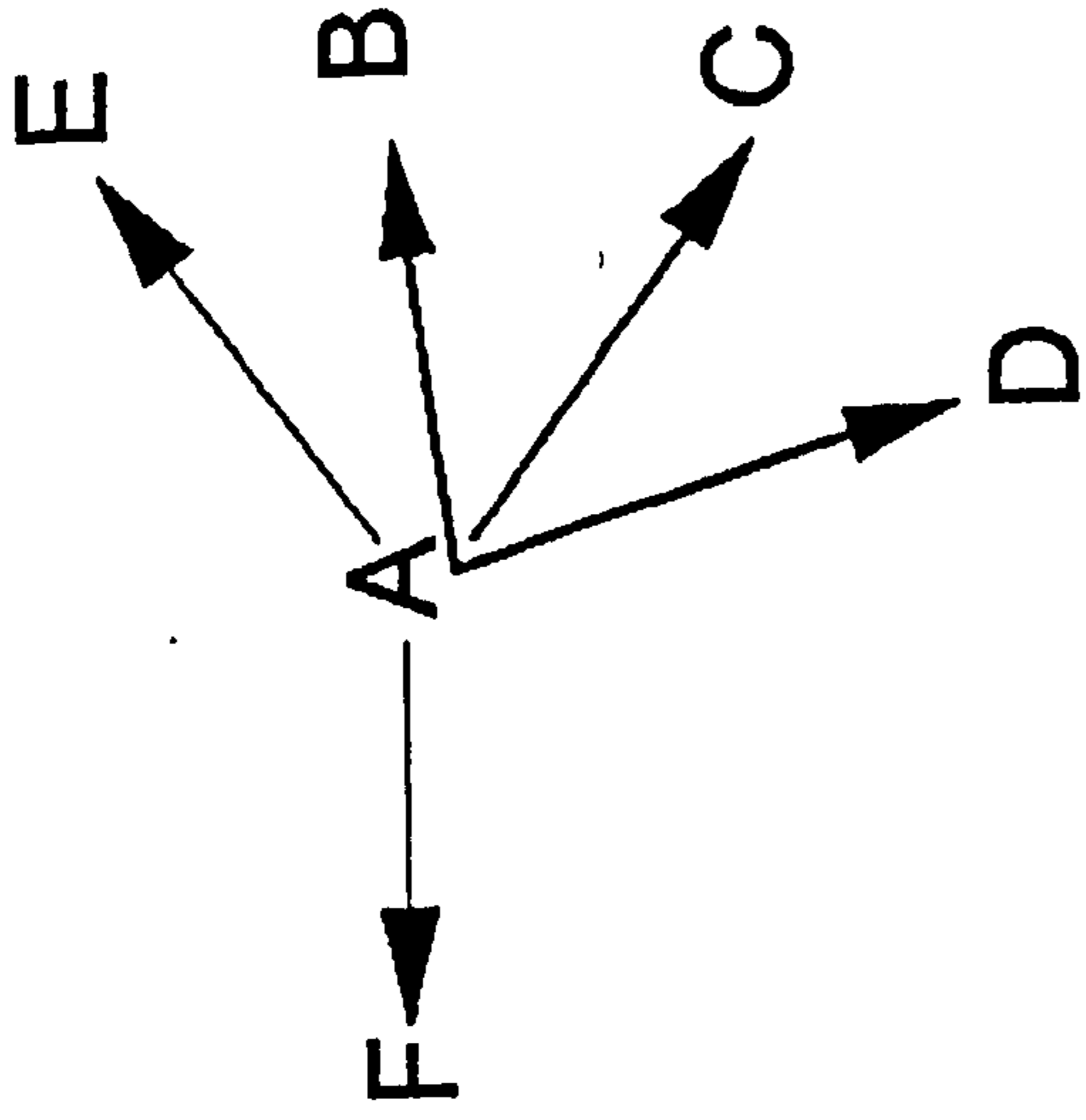
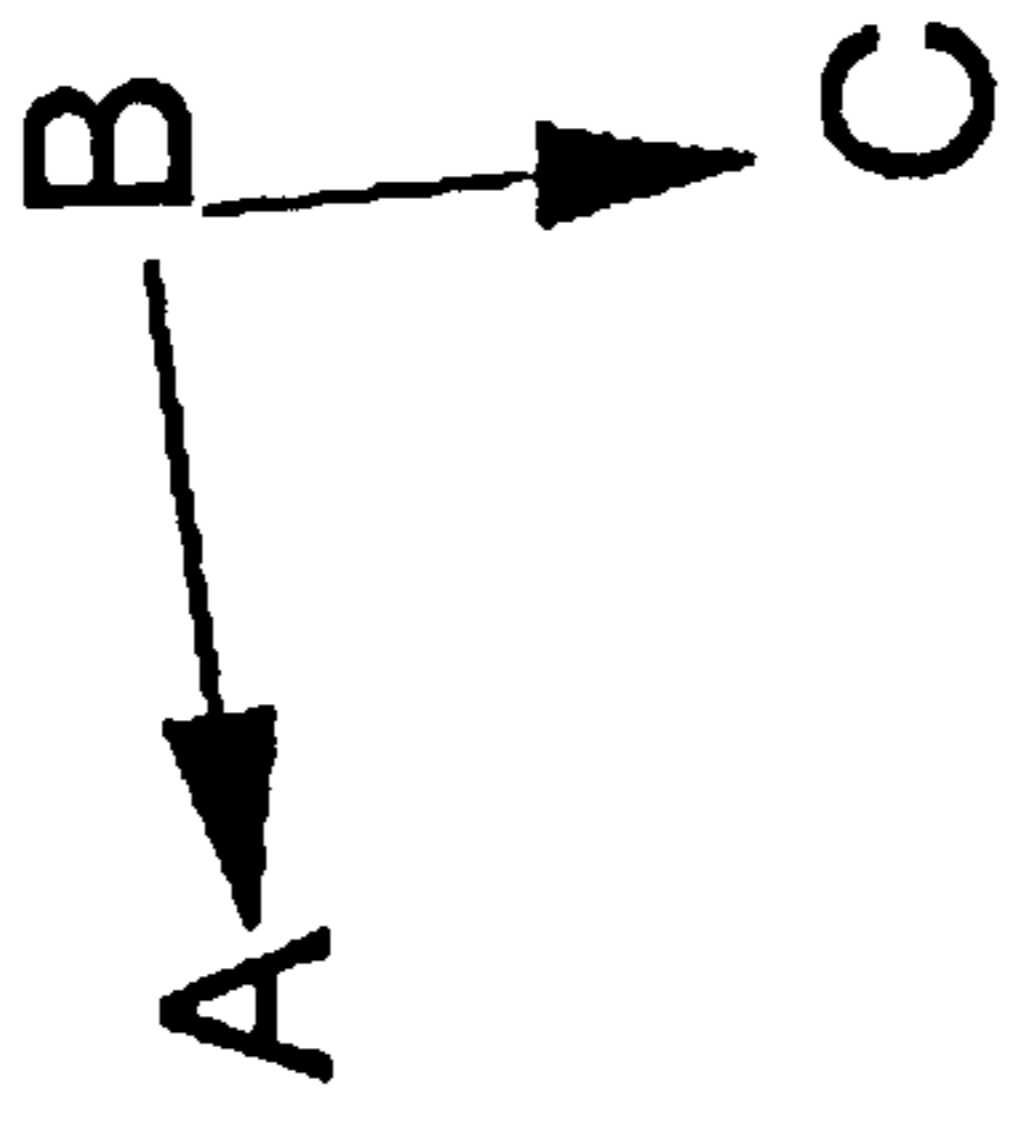

Figure 53: Flowers being wrung out in a cloth, Beni Hasan, Middle Kingdom (after Cailliaud 1831)

Figure 54: The directional flow of FCC's - A Cyprus, B Syria, C Palestine, D Egypt, E Anatolia, F Crete



CYPRIOT



D

RED BURNISHED

A B

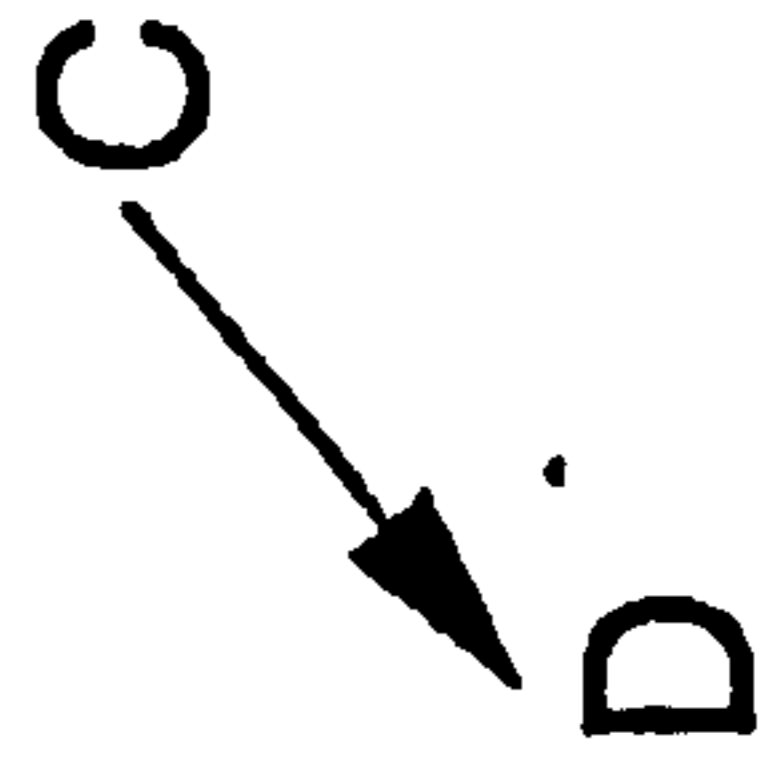

RED POLISHED

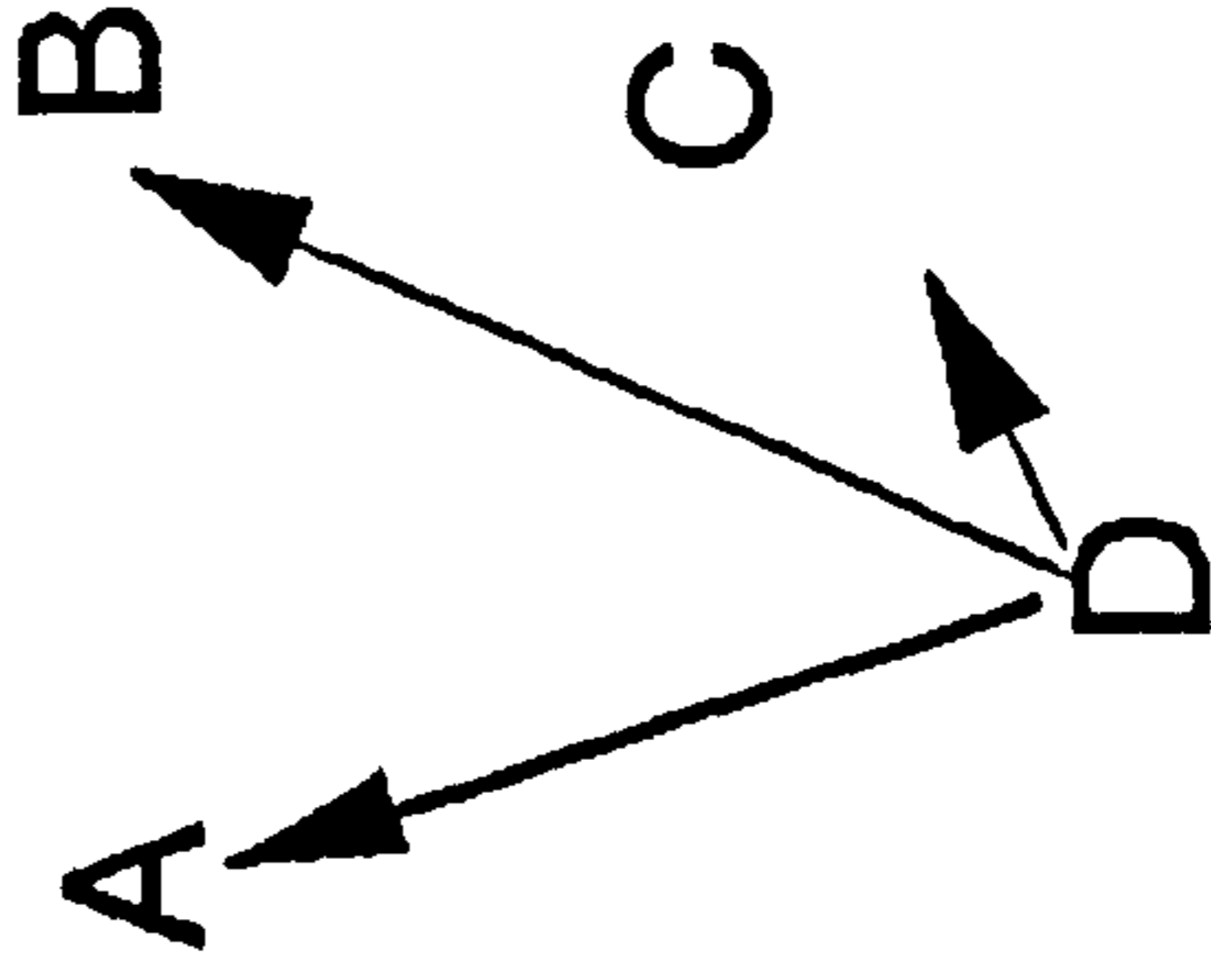

TELL EL YAHUDIYEH

Figure 54: The directional flow of PCC's - A Cyprus, B Syria, C Palestine, D Egypt, E Anatolia, F Crete

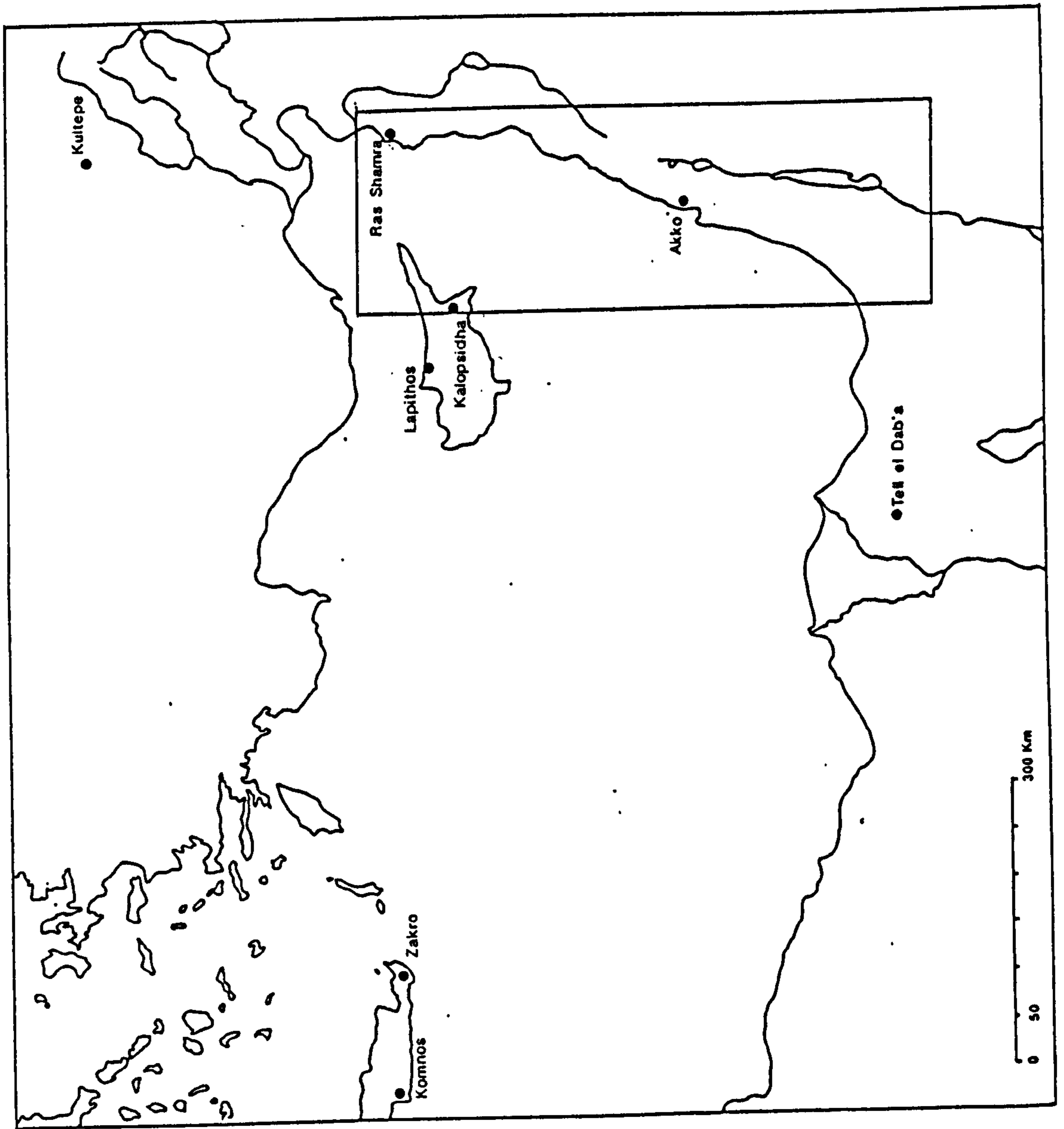

Figure 55: Map of sites mentioned in the text

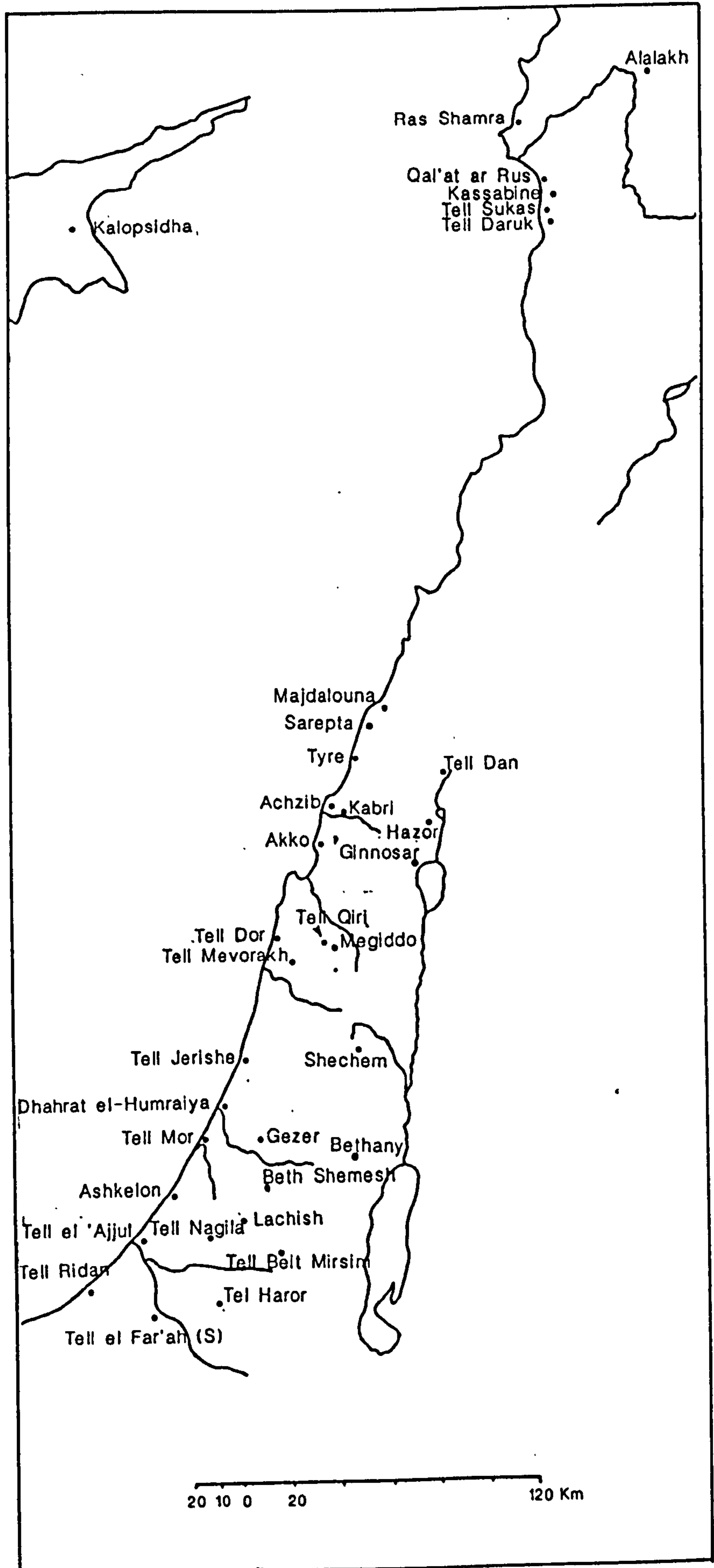

Figure 56: Map of sites mentioned in the text

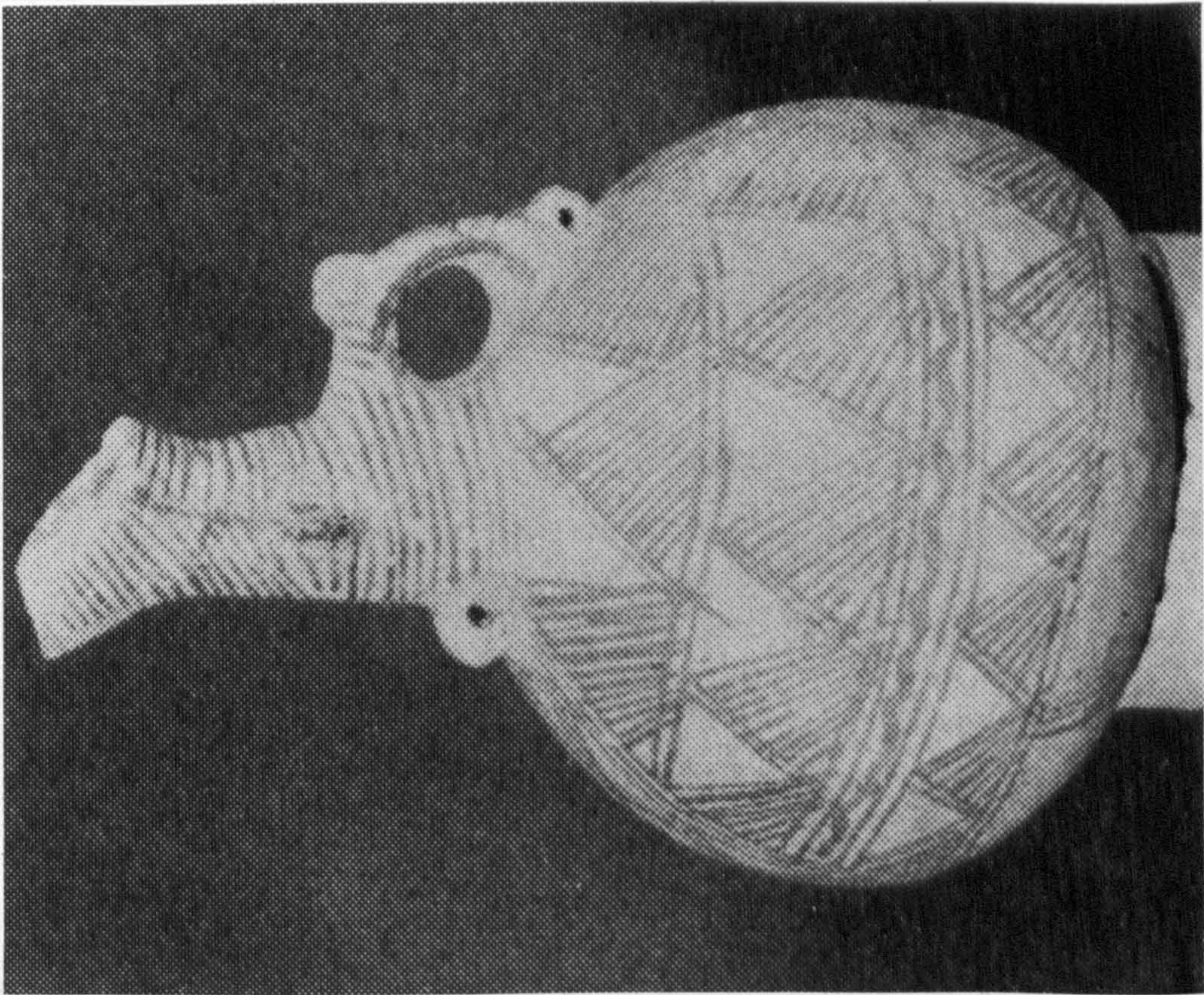

Plate 1: White Painted Fine Line Style: (?Alambra, Villa 1969 Pl.XIV.63)

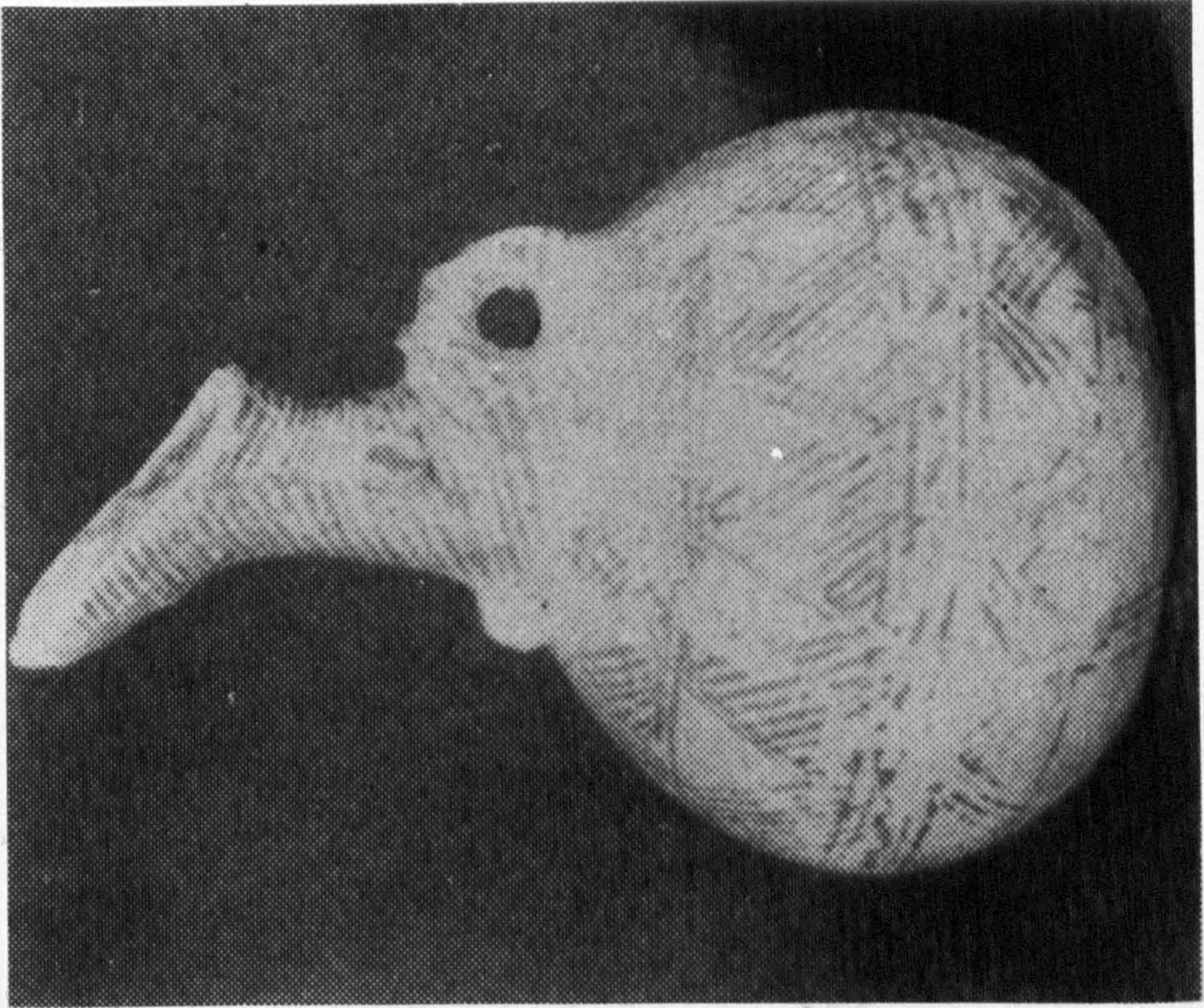

Plate 2: White Painted Fine Line Style: (?Alambra, Villa 1969 Pl.XIV.62)



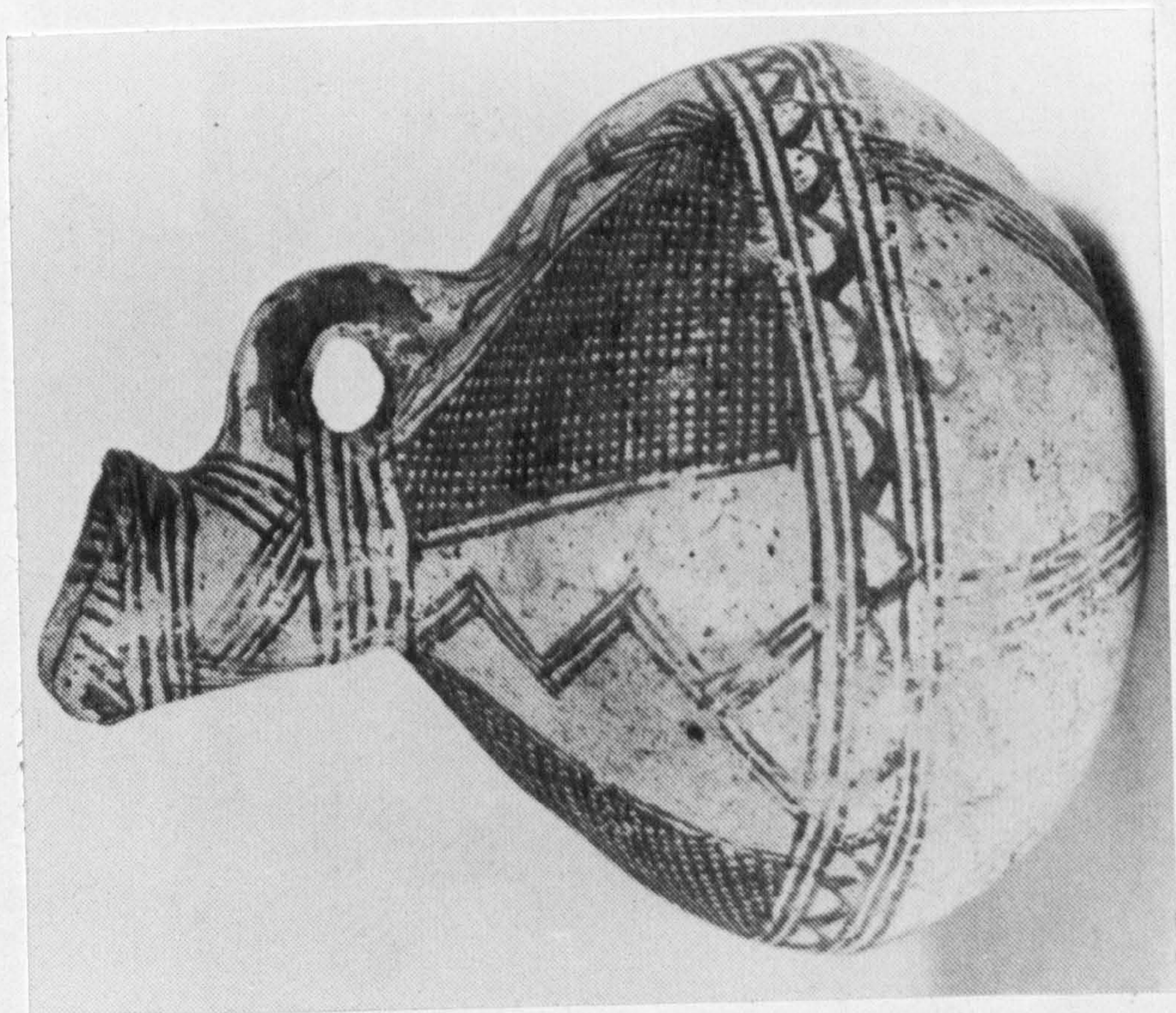

Plate 3: White Painted Fine Line Style: (Unknown, Åström 1979, 46.25)

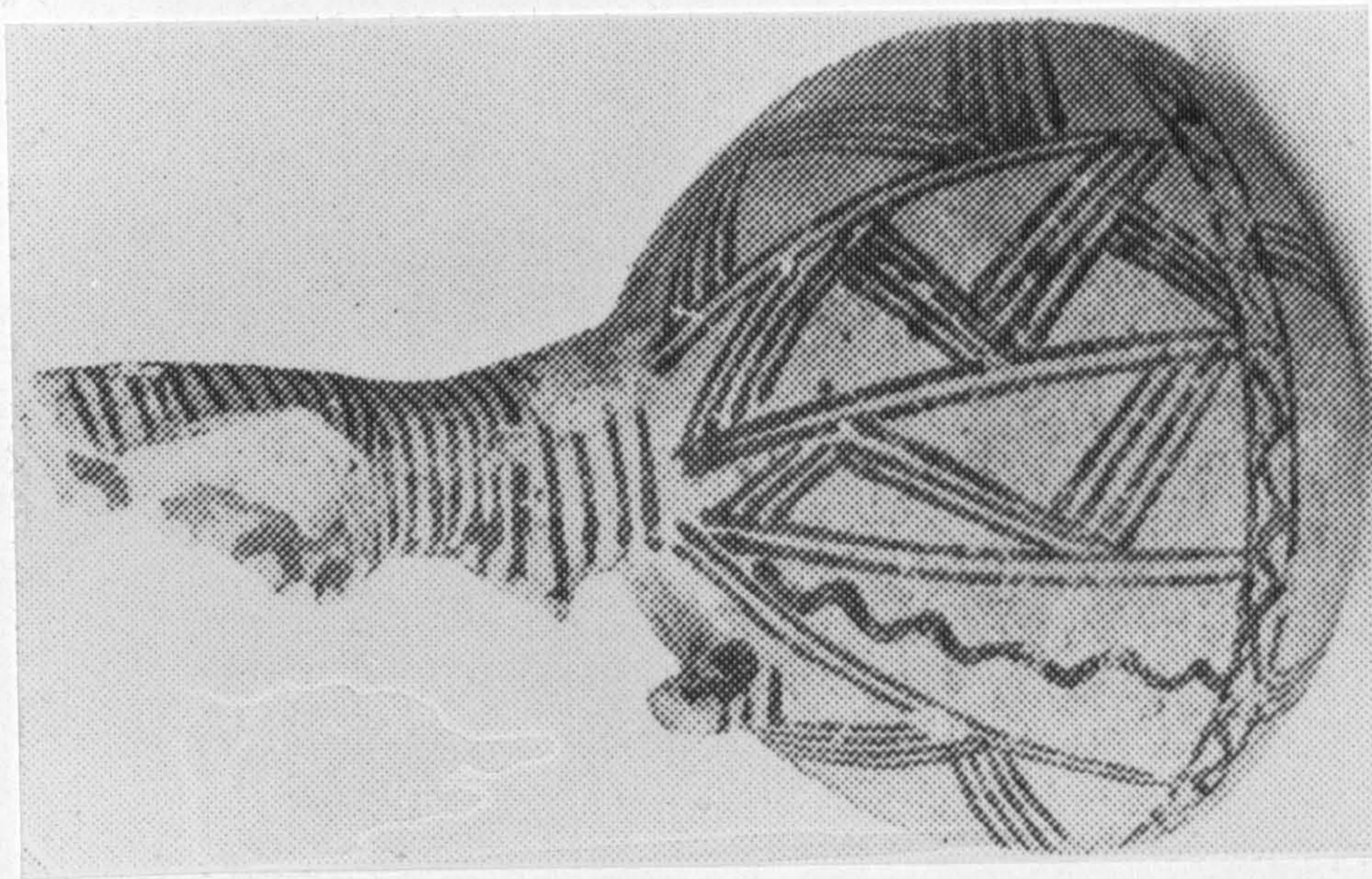

Plate 4: White Painted Fine Line Style: (A. Paraskevi, Frankel 1983, Pl 35.1267)

CATALOGUE

Preface to the Catalogue

This catalogue comprises the bulk of data used in the main body of the thesis. It derives from three resources of research. Johnson (1982) compiled a catalogue of exported Cypriot pottery to the Levant and Egypt from published sources: this catalogue has been updated to include unpublished pieces and information gathered from first hand analysis of Cypriot material in Palestine. In the case of material from Syria it was possible to study the Cypriot pottery from Schaeffer's excavations now stored in the Louvre, mostly unpublished. In very rare cases material was studied but could not be used in the catalogue since it was "unpublished". Professor Bietak has kindly allowed me access to all the unpublished material from Tell el Dab'a, Egypt. All the material from Tell el Dab'a is included in the catalogue. However, a small sample (100) has been previously documented (Maguire 1986). Where necessary, subsequent information about these pieces has been included here.

The sites are arranged according to geographical location in eg Palestine, Syria and Egypt, and within these groups are arranged alphabetically. Each pottery style is dealt with in order.¹

¹ *Red Polished *White Painted Pendent Line Style, *White Painted Cross Line Style, *White Painted Alternating Broad Band and Wavy Line Style, *White Painted Composite Ware, *White Painted V Ware (Tangent, Eyelet etc), *White Painted VI Ware, *White Painted Various *Red on Black (Red on Red) Ware, *Light on Dark *Composite Ware *Plain Ware *Bichrome *Proto White Slip *White Slip *Base Ring.

SITE		
TYPE/STYLE		
CAT NO.	CONTEXT	DESCRIPTION ILLUSTRATION LOCATION REFERENCE

The Catalogue numbers run consecutively through the whole catalogue, and are prefixed with a suitable three-letter abbreviation made up from the site name (eg Megiddo MEG; Ras Shamra RSH). In three instances, however, numbers were not assigned until the catalogue had been compiled, and these are included in addenda but are also referenced within their relevant site and pottery style allocation. For ease of reference the illustration (ILL) numbers are also numbered consecutively throughout the figures and plates. Where an illustration is provided this is indicated in the catalogue entry. It has not been possible to see all the material first hand and the relevant information for certain material has been extracted from the publications and is differentiated in the catalogue by inverted commas. The details of the context are given in the second column, where available. In the cases of Ras Shamra and Tell el Ajjul, for example, many annotations remain obscure but in order to maintain a consistency in detail of available information, everything has been included for future reference. A concordance of Catalogue and Museum numbers has been included at the end for reference.

The descriptions provide information on shape, technique, fabric and surface treatment at macro level. While the Munsell system (1975) is a common tool used by archaeologists to measure colour, it was found that because of certain conditions the Munsell system could not be used consistently. In the first instance, nearly all the

pottery identified is handmade and non-standardised. With regard to pottery firing temperatures appear to have varied due to the position of vessels within the firing compartment and parts of the vessels produced different colours. Therefore, when dealing with sherds there is no certainty that the variation in hue and chroma necessarily reflects the conditions of firing for the whole vessel. Similarly, limitations are imposed on the system where the light under which the objects are analysed is not consistent. Conditions vary from natural midday sunlight to artificial electric lamps or neon lights - all presenting variations in the measurement of the colour. Distortion in readings is likewise as a result of post-depositional concretion or water/lime staining.

This catalogue has limitations which should be addressed. Initially it was thought that the catalogue might be used as a descriptive basis for the identification of individual pieces of Cypriot pottery as exported. The distinctive properties of each style in terms of decoration allowed for ease of recognition and comparison with the distribution within Cyprus itself. However, through an analysis of the wares as they are classified within Cyprus, certain difficulties in using White Painted Ware categories emerged. It has become quite evident that the superficial classification based on the decorative style is far from satisfactory, especially in the case of White Painted III and IV, where fabric characteristics are used in a general, subjective classification to order the different types of pottery. It was advocated that the study of each style be addressed on a descriptive level and subjected to a further analytical test in order to assess the variability in independent attributes, spatially and temporally.

In order to attempt this analytical classification, the descriptive classification must be constructed along specific lines, and this could not be undertaken for this collection of Cypriot pottery; we must know, in the first instance

"..how detailed our examination or analysis of material should be, and what level of variability we should regard as significant" (Frankel forthcoming).

and secondly, how to go about the examination.

"A descriptive classification may aim to deduce the structural order underlying an assemblage and give as clear a picture as possible of the relationships between entities making up an assemblage, in order that assessment of the nature of relationships or future analytical classifications or future analytical reclassification may be carried out to maximum effect" (Baird forthcoming).

However, in order to assess the interaction of attributes of specific styles eg WP PLS, the starting point must be within the make-up of the Cypriot ceramic classification itself, rather than purely on the *export* of the Cypriot material. It could be suggested that recording systems such as Baird forthcoming should be attempted.

A revision or reclassification of the individual styles used here is not undertaken in this present study, but nevertheless it must be stressed that ultimately it is needed if we are to pinpoint production locales and redistribution within Cyprus and certainly before we can fully understand any export of Cypriot pottery. The information accumulated in this catalogue enables discussions on classification, chronology and circulation to be confidently undertaken. The catalogue now comprises over 40 sites, and deals with over ten types of Cypriot pottery exported in the Middle Bronze Age.

A macroscopic examination of the Cypriot material suggests the following differentiations in the colour of the fabric and a pilot X-Ray Diffraction study² was undertaken to assess the nature of the inclusions in the White Painted Wares.

Two obvious colour differentiations exist within the WP styles, though no consistent percentages of fabric colour in relation to each style have been detected. A light brown³ medium to well-levigated, well-oxidized fabric is consistently obtained through the

² The X-Ray Diffraction analysis was carried out at the Department of Geology, University of Edinburgh by Ed Follows and Andy Poole.

³ 10YR 8/3-4 very pale brown (Munsell 1975); "buff" would appear to be synonymous with light brown cf Merrillees 1974, Dothan 1974 infra Catalogue.

pottery production process, which is especially pale in the White Painted V and White Painted VI varieties. The inclusions most predominant are sparse concentrations of fine white grit, red nodules and dark angular grit and some quartz, and a medium concentration of fine dark angular grits, predominantly black (possibly derived from the Troodos massif). Occasionally there is a sparse concentration of medium to coarse sized vegetable matter. The fabric displays a high relief fracture surface leading to clast-like features and is highly porous.

While there exists an overall homogeneity in colour and inclusion content, slight variation in the above features suggests that within a general region, several clay sources are used and, equally, different tempering and firing processes alter the appearance of the clays.

The second variation is a light red brown⁴ fabric, well-levigated and oxidized. The inclusions most common are dense concentrations of fine white grit (which include possible planktonic foraminifera sourced from the original clay), medium concentrations of fine to medium dark grits and sparse to medium concentrations of fine quartz grains and red sand nodules, and little organic matter. In contrast to the 'light brown' fabric, the surface fracture is much more compact and uniform and may represent a more defined clay source.

A third variation of the White Painted Ware fabric exists but is not common in the exported varieties. The clay is fired to a greenish colour⁵, which dominates both fabric and slip. It displays similar characteristics to the 'light brown' fabric, including high concentrations of dark grits (again Troodos derived) and high porosity.

⁴ 7.5YR 8/6-5YR varying to 5YR 7/6-8 reddish yellow

⁵ 5Y 7.5/3 pale yellow

Red on Black Ware fabric is a consistent light red brown fabric, very hard and fine, well-levigated with a sparse concentration of fine red sand, white grits, and dark grits.

Where possible, any cross reference or parallels have been cited for specific pieces. The distributions of the wares have been discussed in previous chapters and most are illustrated Figs 25-30. The illustrations have been arranged according to styles and wares rather than catalogue entry, the figure drawings are followed by plates. The sherds are drawn at 1:1 and complete pots at 1:2 unless otherwise stated.

In many cases the material remains unpublished and to this extent the catalogue remains incomplete. The following sites have not been included in the catalogue, since the Cypriot pottery remains unpublished, but the author was kindly allowed to examine them and take some preliminary notes. Tell Ridan, Tell Haror and Site Y-100 in the Southern Negev have produced Cypriot sherdage⁶ (pers.comm. E. Oren), as has Tell Dor⁷ (pers.comm. E. Stern). Only a small sample of the Cypriot pottery from Tell Akko is published (Dothan 1974), while over 200 sherds are recorded (Saltz 1977).

⁶ Site Y-100 WP Various, WP PLS and WP PLS/CLS; Tell Ridan - RoR/RoB, WP/RS, WP Indeterminate, WP V-VI, WP ABBWLS; Tell Haror WP VI (possibly Cypriot imitations).

⁷ Tell Dor - Cypriot pottery (mainly WP and RoB) from MBA contexts.

CATALOGUE

Abbreviations

c. concentration

dec. decoration

frag. fragment

ILL illustration (figure or plate)

med. medium

misc. miscellaneous

sp. sparse

str. stratum

tb tomb

RF Rockefeller Museum

IDAM Israel Department of Antiquities and Museums

WFA W.F. Albright Institute of Archaeological Research, Jerusalem

AO Antiquités Orientales, Louvre, Paris

KHM Kunsthistorisches Museum, Vienna

φ diameter

CATALOGUE

SITES

Palestine

ACHIZIB

White Painted Pendent Line Style

ACH 1 Stone Body sherd form closed vessel; handmade. Very hard and fine
packing on red brown fabric. Med. c. of very fine and coarse white
MBIIA/B grits, especially on the exterior surface. Sp. c.
Glacis of fine red sand. Light red brown slip. Red paint. Polished

ILL 3
IDAM 63.Ach D114/21
Oren 1975, Fig 4:90

Red on Red

ACH 2 Rim sherd from bowl; handmade. Fine and soft light red brown
fabric. Sp. c. of very fine white grits. Pitted surface
especially on interior. Surface very badly abraded.
Originally red pinkish slip on interior and exterior.

φ 21cm

IDAM 63.Ach D.305/221/1

ACH 3 Rim sherd from bowl; handmade. Hard and fine red brown
clay. Sp. c. of fine black grits, red sand and white grits.

φ < 10% remaining
IDAM 63.Ach D.45/11

AIN SIHEMS (Beth Shemesh)

White Painted Pendent Line Style

AIS 4 Room 479 Fragment. from jug; "orange-brown ware, very well levigated,
Str.VI cream slip, decoration in brown paint."
MBIIA

Grant and Wright 1938, 97 Pl.XXIV:8

AIS 5 T.3 Jug; "greenish drab paste, friable, decoration in dark
(Cemetery 3) brown or bistre on cream white slip."

Grant 1929, 126-7 no. 649

White Painted VI

AIS 6 "Teapot" vessel; handmade. Fine and hard light brown fabric. Med. c. of fine dark sand. Sp. c. of fine white grits. Spout forced into vessel wall. Slightly everted rim. Cream slip and black paint. Matt. Shaved.

RF I.6005

AKKO

White Painted Pendent Line Style

AKK 7 Glacis
MBIIA "Body sherd from jug; Buff core, brown on buff, burnished outside, buff inside."

Dothan 1976, Fig 8:6

AKK 8 Glacis
MBIIA "Body sherd from jug; Pinkish core, reddish brown on pinkish cream outside, buff inside, burnished."

Dothan 1976, Fig 8:10

AKK 9 Glacis
MBIIA "Body sherd from jug; Cream core, black on cream, burnished outside."

Dothan 1976, Fig 8:1

AKK 10 Glacis
MBIIA "Body sherd from jug; Buff core, brown on cream buff, burnished."

Dothan 1976, Fig 8:2

White Painted Cross Line Style

AKK 11 Glacis
MBIIA "Body sherd from jug; Pinkish core, reddish brown on pink, burnished."

Dothan 1976, Fig 8:12

AKK 12 Glacis
MBIIA "Body sherd from jug; Pink core, red on pinkish cream outside, buff inside."

Dothan 1976, Fig 8:13

AKK 13 M/9
MBIIA "Body sherd from jug; Buff core, reddish brown on

cream outside, burnished."

Dothan 1976, Fig 8:16

White Painted Alternating Broad Band and Wavy Line Style

AKK 14 Glacis "Body sherd from jug; Pink core, reddish brown on
MBIIA cream, burnished."

Dothan 1976, Fig 8:14

AKK 15 Glacis "Body sherd from jug;
MBIIA Pink core, reddish brown on cream"

Dothan 1976, Fig 8:15

White Painted Composite Ware

AKK 16 Glacis "Rim sherd from bowl;
MBIIA Pinkish core, red on
 cream outside, black on cream inside."

Dothan 1976, Fig 8:7

AKK 17 Area C "Juglet; Buff core etc"
Dothan 1976, Fig 17.6

White Painted Various

AKK 18 Glacis "Body sherd from jug;
MBIIA Buff core, brown on cream,
 burnished."

Dothan 1976, Fig 8:3

AKK 19 Glacis "Body sherd from jug;
MBIIA Buff core, dark brown on
 cream outside."

Dothan 1976, Fig 8:4

AKK 20 Glacis "Body sherd from jug;
MBIIA Buff core, dark brown on buff outside,
 cream inside, burnished."

Dothan 1976, Fig 8:5

AKK 21 Glacis "Body sherd from jug;
MBIIA Pink core, reddish brown
 on cream, burnished."

Dothan 1976, Fig 8:8

AKK 22 Glacis "Body sherd from jug;
MBIIA Buff core, red on cream
 slip, burnished."

Dothan 1976, Fig 8:9

AKK 23 Glacis
MBIIA "Neck fragment from jug;
No location, no description."

Dothan 1976, Fig 9:left

AKK 24 Glacis
MBIIA "Body sherd from bowl;
Buff core, brown slip on
outside, brown on buff inside, burnished."

Dothan 1976, Fig 8:11

TELL EL 'AJJUL

White Painted Pendent Line Style

AJJ 25 TT860
TA870? 860? Shoulder frags. from jug; handmade.
Red brown fabric. Hard and fine. Dense c. of fine white
grits, med. c. of fine dark and red sand. Cream slip. All
over burnish. Red paint.

ILL 1, 121 row 2.4

RF 40.1?

White Painted IV

AJJ 26 MBII-LBI Handle fragment of jug; handmade. Hard and fine red brown
clay. Sp. c. of fine and coarse white, dark, red angular
grits. Purple red paint on brown slip.

ILL 122 row 3.1

WFA 1471 -5.69

AJJ 27 Handle fragment from bowl; handmade. Hard and fine red brown
fabric. Sp. c. of coarse white grit and fine red sand. Red
paint on light brown slip.

ILL 122 row 2.1

WFA 142 -5.56

White Painted Alternating Broad Band and Wavy Line Style

AJJ 805 TCT 829 Shoulder frag. from jug; handmade. Red brown fabric. Sp. c.
of fine white grits. Thick white slip. Red paint. Burnished all over.

ILL 121

RF 40.133/12

White Painted V

AJJ 28 AQ710
(= 1010)
LB city Bowl; handmade. Light brown greenish fabric. Fine and hard
clay. Sp. c. of fine and coarse white grits. All
over burnish. Brown to black paint. Reconstructed without
handle.

φ 18cm

ILL 93, 121
RF 33.1386,
RF 47.303 ILL 201, DR poss sherd from same bowl.
AG III Pl.XLIV:75 (with handle fragment.)

AJJ 29 R6 Rim sherd from bowl; handmade. Hard and fine pinkish light fabric. Sp. c. of fine red sand and fine white to med, grits (especially on the surface.) Med. c. of fine dark sand. Matt black to red paint on interior and exterior. Cream slip inside and out.

φ c.17cm <10% remaining

ILL 33, 121
RF-

AJJ 30 LB Body sherd from jug; handmade. Hard and fine pinkish light brown fabric. Dense c. of fine to coarse white grits (especially on surface). Sp. c. of fine red sand.

ILL 122 row 1.2
WFA 1449 -5.76

AJJ 31 P.II "Sherd of closed vessel. Hardish, thickening, orange and orange-brownish fabric with lighter core; creamy-white or white slip, matt as preserved, and matt friable black painted decoration."

Merrillees 1974, Fig 4:77

AJJ 32 P.I "Sherd. Hardish, relatively thick, buff fabric; matt buff slip or wash and lustrous black painted decoration."

Merrillees 1974, Fig 4:102

AJJ 33 Misc. "Sherd of vase. Thick, handmade brown and orange brown fabric; matt buff slip and matt friable dark red painted decoration."

Merrillees 1974, Fig 7:211

White Painted VI

AJJ 34 ATQ41/6
Exc 1007B Complete jug; handmade. Fine and hard light brown fabric. Med. c. of fine black and red sand. Matt dark brown paint. Trefoil mouth. Handle from neck to shoulder. Cream slip.

ILL 128
RF 38.651

AJJ 35 TCK 820
no481 Juglet; handmade. Trefoil mouth. Handle from neck to shoulder. Almost flat base. Fine and hard light brown, fine greenish fabric. Sp. c. of dark sand. Greenish cream slip. Faint traces of burnishing. Badly abraded with remnants of black paint. Shaved.

ILL 129
RF 35.4159

- AJJ 36 Grp1007 noC Trefoil mouth. Handle from neck to shoulder. Round base. Hard and fine light brown fabric. Thick cream slip. Smooth. Shaved. All over burnish. Black paint.
- ILL 132
RF 38.652
- AJJ 37 Tb 363 no 560 Fragment of juglet; handmade. Trefoil mouth. Handle from neck to shoulder. Hard and fine light brown fabric. Med. c. of red and black sand. Sp. c. of limestone. Very badly abraded, traces of black paint.
- LB
RF 33.1448
Type 89A Petrie AGIII PIXXXIX
- AJJ 38 TO,b 632 Fragment of juglet; handmade. Globular juglet almost flat base. Plug handle. Fine and hard light brown fabric. Med. c. of fine dark sand. Black paint. Very badly abraded.
- RF 31.206
Petrie Corpus Type 89A
- AJJ 39 Tb 369 Fragment of juglet; handmade. Globular juglet almost flat base. Handle from neck to shoulder. Fine and hard light brown fabric. Med. c. of fine red and black grits. Shaved. Very little decoration remaining. Black and brown paint visible on cream slip.
- RF 33.1450
AGIII PIXXXVIII Type 52 E2
- AJJ 40 Tb 363 no 560 Fragment of juglet; handmade. Globular, almost flat base. Handle from neck to shoulder. Hard and fine fabric fired light brown all through. Med. c. of fine red and dark sand. Cream slip.
- LB
RF 33.1442
AGIII PIXXXIX Type 89A
- AJJ 41 E890 no2546 Bull vase, complete; handmade. Trefoil mouth. Strap handle. Light brown fabric. Hard and fine. Sp. c. of fine dark sand and red igneous matter. Cream slip. Friable drab black paint.
- RF 36.1490
- AJJ 42 Tomb 257 Bull vase; handmade. Light brown fabric. Hard and fine. Sp. c. of fine dark grits. Light brown slip. Badly abraded. Very faint traces of black paint.
- RF I.10199
AG I Pl.L:257
- AJJ 43 Juglet fragment.; handmade. Hard and fine light brown fabric. Sp. c. of fine white grits. Matt red paint on light brown slip.
- RF I10125

- AJJ 44 Bull vase; handmade.
AG III Pl.XL:408
- AJJ 45 Bull vase; handmade.
AG V Pl.XXVIII:101S
- AJJ 46 P.II "Sherd of WP VI animal shaped vase with handle ends pushed through wall of body. Hardish, thick, light brown fabric; matt creamy-light brown slip and matt red painted decoration, though there does appear to be faint traces of lustre."

Merrillees 1974, Fig 5:130
- AJJ 47 Misc. "Sherd of WP VI animal shaped vase with trefoil spout. Soft buff fabric; slip almost entirely worn off, but perhaps light brown or creamy-buff, and matt friable black painted decoration."

Merrillees 1974, Fig 7:210

White Painted Various

- AJJ 48 Body sherd from bowl; handmade. Hard and extremely fine red brown fabric. Sp. c. of fine to coarse white grit and fine red sand. Matt black to dark brown paint on orange to cream burnished slip.

ILL 122 row 3.2
WFA 1483 -5.67

Red on Red

- AJJ 49 Spout fragment. of bowl; handmade. Very fine and hard red brown clay. Sp. c. of very fine white grits. Red slip and pinkish paint.

RF 31.219
Representative selection made by Petrie
AGI PIXXI
- AJJ 50 no2167
MH 995
MBII Bowl fragment. with spout; handmade. Very hard and very fine red brown fabric. Thin red slip and paint. All over burnish.

ø 21cm

ILL 136
RF 32.2118
AG II Pl.XXVII:10U
- AJJ 51 A'F 710 Spout fragment. from bowl; handmade. Very hard and very fine red brown clay. Sp. c. of coarse red sand and grit. Sp. c. of very fine white grits. Matt red paint on red burnished slip on interior and exterior.

φ c.25cm

ILL 143, 144 row 1.2

.RF 33.1759

Exc 1933 File ATQ/41/6

AJJ 52

Rim sherd and handle stub from bowl; handmade. Very hard and very fine red brown fabric. Sp. c. of coarse igneous and fine white grits. Burnished red slip on exterior. Faint red matt paint on red brown burnished slip on interior.

ILL 122 row 1.1

WFA 1469 -5.78

AJJ 53 AII
MBII-LBI

Body sherd from bowl; handmade. Very hard and very fine red brown fabric. Sp. c. of fine white grits and dark sand. Matt red paint on red brown burnished slip on exterior. Pinkish red matt paint on dark red brown slip on interior.

ILL 138 row 5.2

WFA 1430 -5.59

AJJ 54 A/II

"Sherd of bowl with curving side with rim in the same contour. Hard, orange-buff fabric; on exterior and interior, burnished lustrous red slip and matt friable creamy-white painted decoration."

Merrillees 1974, Fig 2:26

AJJ 55 A/II

"Sherd of bowl with curving side with rim in the same contour. Hard thick, buff fabric; lustrous red slip and matt drab whitish painted decoration."

Merrillees 1974, 91:27

AJJ 56 A/II

"Sherd of bowl with open spout. Hard, thick, orange fabric; on exterior, dark red slip, somewhat lustrous, as preserved; on interior, lustrous red slip, friable in parts, and matt cream and pink decoration."

Merrillees 1974, Fig 2:28

AJJ 57 N.N.

"Sherd of Red-on-Red(?) bowl with loop handle. Hard, thick, orange-buff fabric; on exterior, burnished, lustrous, blotchy orange-red brown and black slip; on interior, friable orange red and black slip, slightly lustrous, as preserved. Much of slip is worn off."

Merrillees 1974, Fig 2:29

AJJ 58 P.II

"Sherd of bowl with open spout. Hard, thick orange fabric; on exterior, burnished, somewhat lustrous, dull red slip and matt painted decoration, some of which has been burnished and is lustrous; on interior, burnished, pinkish red slip, faintly lustrous in spots, with black border on inside of rim and matt red and plum painted decoration, faintly lustrous where slip has been burnished."

Merrillees 1974, Fig 4:78

- AJJ 59 P.II "Sherd of bowl with loop handle. Hardish, thick, orange fabric; on exterior, slightly lustrous, friable blotchy red and reddish brown slip; on interior, somewhat lustrous, friable reddish slip and matt creamy-white painted decoration with faint pink tinge in places."
- Merrillees 1974, Fig 4:79
- AJJ 60 OY952 P.I "Sherd of bowl with open spout. Hard orange fabric; very faintly lustrous, friable red slip, inside and out."
- Merrillees 1974, Fig 4:107
- AJJ 61 OY930 P.I "Sherd of bowl, probably Red on Red, with everted rim. Soft, thick orange buff fabric; lustrous red slip inside and out but no trace of painted dec.."
- Merrillees 1974, Fig 4:108
- AJJ 62 OE1020 P.II "Sherd of bowl; curving sides with rim in the same contour. Thick softish, slightly orange-buff fabric; burnished lustrous red slip and matt painted decoration, light red, as preserved."
- Merrillees 1974, 107:179
- AJJ 63 misc. "Sherd of bowl. Hard, orange fabric; on exterior, red slip, slightly lustrous, as preserved; on interior, slightly lustrous red slip, streaked all over with black lines, and matt red and pink painted decoration."
- Merrillees 1974, Fig 7:192
- Red on Black**
- AJJ 64 LA970 Body sherd from bowl; handmade. Red brown fabric. Very hard and fine. Med. c. of fine and coarse red sand, and fine white grits. Brown burnished slip. Pink paint, matt.
- ILL 48, 107 row 2.2
RF 47.354
- AJJ 65 TA870? Handle fragment from bowl; handmade. Red brown fabric. Hard and fine. Med. c. of fine dark red and white grits. Brown slip. Red to red brown paint.
- ILL 141, 142 row 1.3
RF 40.134/2
- AJJ 66 TA870?
1933/4
LB Body sherd from bowl; handmade. Red brown fabric with subtle peach core. Hard and fine. Med. c. of fine red, white and dark grits. Brown slip. Pink to red paint. Matt.
- ILL 141, 142 row 2.1
RF 47.353

- AJJ 67 TA870
1933/4 Rim sherd from bowl; handmade. Orange light brown fabric. Hard, fine. Sp. c. of red grits. Brown and red slip, difference in firing. Pink paint.
- φ 28cm.
- ILL 141, 142 row 1.1
RF 40.134
- AJJ 68 TA870 Rim sherd from bowl; handmade. Buff fabric. Hard and fine Med. c. of fine white, red and dark grits. Almost black slip and pink paint.
- φ 19cm
- ILL 141, 142 row 1.2
RF 40.134/1
- AJJ 69 MT998
Exc 1933 no23 Bowl fragment with handle; handmade. Buff fabric with subtle peach core. Very hard and very fine. Sp. c. of dark coarse angular grits. Med. c. of fine dark and red sand. Burnished brown slip. Lilac paint. Badly abraded.
- φ > 30cm
- ILL 135 row 1.2
RF 33.1534
(68 QAJJ 10W2)
AGIII PIXXX Type 10U2
- AJJ 70 Body sherd from bowl; handmade. Red brown fabric. Very hard and fine. Sp. c. of med. white grits and coarse igneous matter. Med c. of fine dark and red sand. Brown slip. All over burnish before matt paint applied.
- ILL 47
RF 32.2?
Representative selection made by Petrie
Exc 1931 A/II-AGI PIXXXIX
- AJJ 71 Body sherd from bowl; handmade. Red brown fabric. Very hard and very fine. Sp. c. of med. white grits. Med. c. of fine dark and red sand. Brown slip and red to pink paint.
- ILL 47
RF 31.220/14
- AJJ 72 Rim sherd from bowl; handmade. Extremely hard and fine light brown fabric. Sp. c. of med. white grits and fine dark sand. Drab.
- φ < 10% remaining
- RF 31.219
Representative selection made by Petrie
MBA-EIA
- AJJ 73 Rim sherd from bowl; handmade. Very hard and very fine light

brown fabric. Med. c. of white grits and red sand. Drab.
Red paint on exterior and pinkish on interior.

φ 22cm

RF 31.219

Representative selection by Petrie
Exc 1931 MBA

AJJ 74 MN 1020
MB-LB

Body (basal) sherd from bowl; handmade. Very hard and very fine red brown fabric. Med. c. of fine white grits and sp. c. of coarse red igneous. High % of glimmer. Matt red paint on dark brown burnished interior and red/ brown exterior.

ILL 143, 144 row 2.2

RF 32.2189/2

Exc. 1932

AJJ 75 1020
MB-LB

Body sherd from bowl; handmade. Very hard and very fine red brown fabric. Sp. c. of coarse white grits and med. c. of very fine white grit. Sp. c. of red sand. Matt red paint on dark brown burnished exterior; matt lilac paint on dark brown burnished interior.

ILL 143, 144 row 2.3

RF 32.2189/4

Exc.1932

AJJ 76 OM 943
MB-LB

Rim sherd of bowl; handmade. Very hard and very fine red brown. Sp. c. of fine and coarse white grits and med. c. of dark red sand. Red matt paint on dark brown (faintly) burnished exterior and interior.

φ 22cm c.20% remaining

ILL 139, 140 row 2.1

RF 32.2189/3

AJJ 77 PH980
Exc 1932
MB-LB

Rim sherd from bowl; handmade. Very hard and very fine red brown fabric. Sp. c. of coarse red sand and fine white grit and red sand. Uneven surface external surface. Lilac to red matt paint on dark brown burnished slip.

ILL 139, 140 row 3.1

RF 32.2189/1

AJJ 78 973 LC
Exc 1933
LB

Rim sherd from bowl; handmade. Very hard and fine red brown fabric. Sp. c. of fine white grits. Abraded surface. Pinkish matt red on dark to med. brown burnished slip on exterior and faint traces of red paint on interior.

φ 26cm

ILL 139, 140 row 2.2

RF 33.1756

AJJ 79 LB
Exc 1933

Rim sherd from bowl; handmade. Very hard and very fine red brown fabric. Sp. c. of coarse red sand and fine white grit. Matt pinkish red on brown surface on interior and exterior.

Highly burnished exterior and interior.

φ 26cm

ILL 139, 140 row 1.3
RF 33.1754

AJJ 80 LB
Exc 1933

Body sherd (basal) from bowl; handmade. Very hard and fine red brown fabric. Sp. c. of fine white grits and red sand. Matt red paint on black to dark brown burnished slip in interior and exterior.

ILL 139, 140 row 3.2
RF 33.1758

AJJ 81

Rim sherd from bowl; handmade. Very hard and fine red brown fabric. Sp. c. of fine white grits. Red to lilac matt paint on black burnished slip on interior and exterior.

φ c.24cm < 10% remaining

ILL 139, 140 row 1.2

RF 33.1755
File ATQ/14/6 Exc 1933

AJJ 82

Rim sherd from bowl; handmade. Very hard and very fine red brown fabric with subtle pink core. Sp. c. of fine dark sand and med. c. of fine to coarse light brown grits especially on surface. Badly abraded surface. Red brown matt paint on dark brown burnished slip on interior and exterior.

φ c.25cm < 10% remaining

ILL 143, 144 row 2.1
ILL 207B row 2.1
RF 33.1760 Exc 1933

AJJ 83 LB
Exc 1933

Handle and rim fragment. of bowl; handmade. Very hard and very fine red brown fabric. Sp. c. of red grit and fine white sand. Matt pinkish red paint on dark brown burnished slip on interior, exterior and handle.

ILL 139, 140 row 1.1

RF 33.1758

AJJ 84 PT980
MBII-LBI

Rim sherd from bowl; handmade. Very hard and fine light brown fabric. Sp. c. of fine white grits. Badly abraded surface. Red brown paint on dark brown slip on exterior. Rich red matt paint on dark brown slip.

φ 22cm

ILL 138(B) row 3.1
WFA 1425 - 5:51

AJJ 85 MN1000

Rim sherd from bowl; handmade. Very hard and very fine light red brown fabric. Sp. c. of fine white grits and coarse red

grits. Wet smoothed interior. Lilac paint on dark brown slip on exterior. No paint visible on interior.

φ < 10% remaining

ILL 138(B) row 1.1
WFA 1466 -5:52

AJJ 86 MP 982 MBII-LBI Rim sherd from bowl; handmade. Very hard and very fine red brown fabric. Sp. c. of fine and coarse white grits. Med. c. of fine to coarse dark grits. Matt lilac paint on dark brown burnished slip on exterior and interior.

φ < 10% remaining

ILL 138(B) row 1.2
WFA 1467 -5.53

AJJ 87 "f" MBII-LBI Body sherd from bowl; handmade. Very hard and very fine red brown fabric. Sp. c. of very fine and fine white grits and med. red grits. Faint lilac to red matt paint on dark brown to black burnished slip on exterior. Matt red paint on brown burnished slip on interior.

ILL 138 (A) row 1.1
WFA 1426 -5.55

AJJ 88 AII MB-LBI Body sherd from bowl; handmade. Very hard and very fine red brown fabric. Sp. c. of fine and coarse white grits, and fine dark sand. Matt red paint on lightly burnished dark brown slip on exterior. Red to lilac matt paint on almost black low burnished slip.

ILL 138 (A) row 3.1
WFA 1428 -5.56

AJJ 89 OX 180 MBII-LBI Body (basal) sherd from bowl; handmade. Very hard and very fine red brown clay. Sp. c. of fine white grits, coarse red grits and fine dark sand. Lilac red paint on dark brown burnished slip on exterior and interior.

ILL 138 (B) row 2.1
WFA 1431 -5.57

AJJ 90 AIIAA MB-LBI Body sherd from bowl; handmade. Very hard and fine red brown fabric. Sp. c. of coarse black and red grits, and fine white grits. Pink paint on dark brown low burnished slip on interior and exterior.

ILL 138 (B) row 2.2
WFA 1429 -5.58

AJJ 91 IIAW Body sherd form jug; handmade. Red brown, very hard and very fine clay. Sp. c. of fine white, red and dark grits. Abraded red brown paint on dark brown slip on exterior. Lilac paint on almost black slip on interior.

ILL 138 (B) row 4.1
WFA 1433 -5.60

- AJJ 92 II Body sherd from bowl; handmade. Very hard and very fine orange red brown fabric. Sp. c. of fine white grits and fine dark sand. Matt red paint on dark brown burnished slip on exterior. Red brown slip on interior.
- ILL 138 (B) row 2.3
WFA 1435 -5.61
- AJJ 93 ML 980 Body sherd from bowl; handmade. Very hard and very fine light brown fabric. Med. c. of fine white grits. Matt red paint on dark brown burnished slip on interior and exterior.
- ILL 138 (B) row 4.2
WFA 1432 -5.62
- AJJ 94 II Body sherd from bowl; handmade. Very hard and very fine red brown fabric. Sp. c. of coarse red grits and fine cream sand. Abraded, faint red paint on dark brown slip on exterior. Lilac paint on dark brown burnished slip.
- ILL 138 (B) row 1.3
WFA 1434 -5.63
- AJJ 95 II Body sherd from bowl; handmade. Very hard and very fine red brown clay. Sp. c. of fine and coarse white grits, and fine and coarse red sand. Matt red paint on dark brown slip on exterior. Black burnished slip on interior.
- ILL 138 (B) row 3.3
WFA 1437 -5.64
- AJJ 96 Body sherd from bowl; handmade. Very hard and very fine light red brown fabric. Sp. c. of fine white grits. Matt red paint on dark brown slip on exterior and interior.
- ILL 138 (B) row 3.4
WFA 1438 -5.65
- AJJ 97 A/X Body sherd from bowl; handmade. Very hard and very fine dark red brown fabric. Sp. c. of angular red grits and dark igneous material. Abraded matt red on dark brown to brown slip on exterior and interior.
- ILL 138 (B) row 3.2
WFA 1436 -5.66
- AJJ 98 A/II "Sherd of closed vessel. Hard, thin orange and orange-brown fabric; lustrous friable black slip and matt red painted decoration, on exterior only."
- Merrillees 1974, 91:25
- AJJ 99 A
SF716
Type 10K8 "Sherd of bowl with curving sides. Hard, relatively thick, light orange-brown fabric; burnished, somewhat lustrous red-brown slip and thin matt red painted decoration."
- Merrillees 1974, 95:66

- AJJ 100 P.I "Sherd of bowl. Thick, hard buff fabric; somewhat lustrous black slip inside and out, and matt purplish-red painted decoration inside and out."
Merrillees 1974, 98:88
- AJJ 101 OZ973 "Sherd of spouted bowl, with curving sides and rim in the same contour. Softish orange fabric; mottled, slightly lustrous brown, red and black friable slip and matt painted decoration on the exterior; on interior, friable almost matt, patchy brown slip of several shades and matt red painted dec.."
originally
OZ963
(under PIII)
Merrillees 1974, Fig 4:103
- AJJ 102 ODB1003 "Sherd of spouted bowl, with curving sides and light orange-brown fabric; on exterior, faded, somewhat lustrous, black slip and matt red painted dec.; on interior, slightly lustrous red slip and matt red painted decoration."
P.III
Merrillees 1974, 99:104
- AJJ 103 OM980 "Sherd of bowl. Hard, thick, orange buff fabric; on exterior, streaky lustrous, black, brown and red slip; on interior, lustrous black-brown slip and matt red painted decoration."
P.III
Merrillees 1974, 99:105
- AJJ 104 OY950 "Sherd of bowl, curving sides with rim in same contour. Hard, thick, orange fabric with brown core; drab red slip, almost matt, as preserved, shading up to black and traces of matt red painted decoration, on exterior; on interior, lustrous streaky red and brown slip and matt slightly lighter red painted decoration."
P.I
Merrillees 1974, 99:106
- AJJ 105 PF930 "Sherd of bowl. Hard, thick, orange fabric; on exterior, friable, very faintly lustrous black slip and matt red painted decoration: on interior, slightly lustrous black slip and matt red painted decoration."
P.I
Merrillees 1974, 102:131
- AJJ 106 PF936 "Sherd of bowl with open spout. Hard, thick, orange and orange-buff fabric; slightly lustrous, patchy black and dark brownish slip and matt red painted decoration on exterior; on interior, friable, slightly lustrous black slip and matt red painted decoration."
originally
PF926
P.I
Merrillees 1974, Fig 5:132
- AJJ 107 OE1005 "Sherd of bowl. Thick, hard, buff fabric; faintly lustrous black slip outside on interior, almost matt as preserved, and drab red and red-brown on exterior; on interior surfaces matt red painted decoration."
P.III
Merrillees 1974, 107:178

AJJ 108 MS984 "Sherd of bowl. Hard, thick, buff fabric; on exterior,
EX11.12b/3 faintly lustrous black slip, on lower part overfired to red,
PII and matt red painted decoration, which becomes
invisible in area; on interior, faintly lustrous, overfired friable
red slip, much worn off."

Merrillees 1974, Fig 7:191

AJJ 109 Bowl fragment.
AG I Pl.XXXV: 102

AJJ 110 Rim sherd from bowl;
AG I Pl.XXXV: 103

AJJ 111 Bowl.
AG III Pl.XXX: 10U2 City I

AJJ 112 Bowl.
Spouted bowl with handle.
AG III Pl.XXX: 10W City I

AJJ 113 Bowl fragment with handle;
AG III Pl.XXX: 10W2 City I

AJJ 114 Spouted bowl with handle;
AG III Pl.XXX: 10W3

AJJ 115 Jug.
AG IV Pl.LVI:89J0 ?

Black Slip/Reserved Slip

AJJ 116 K770 no128, Large jug; handmade. Everted rim. Ovoid body. Handle from
Grave 1505 neck to shoulder. Round base. Fine and hard light brown
fabric. All matt. Brown slip. Reserve slip on upper
shoulder.

Max. Ht. = 46.5cm

ILL 123
RF 33.1396
AG III Pl.XXXIX Type 68R3

AJJ 117 A/IIA/IIAA "Two sherds of closed vessel. Hard, thick, gritty, greenish-grey fabric; matt, friable black slip, a band of which has been wiped off, reslipped light brown with greenish tinge, and a black zigzag painted over it."

Merrillees 1974, Fig 2:30

Red on Black/Red on Red

AJJ 118 MV980 Body sherd from bowl; handmade. Very hard and very fine light red brown fabric. Sp. c. of fine white grits. Pink matt paint on red brown and dark brown slip on exterior. Lilac matt paint on dark brown abraded slip on interior.

ILL 138 (A) row 2

WFA 1427 -5.54

AJJ 119 Spout fragment from bowl; handmade. Very hard and very fine red brown fabric. Sp. c. of white grits. Pinkish matt paint on red burnished slip on exterior. Pinkish red paint on dark red brown burnished slip on interior.

φ c.22cm <10% remaining

ILL 138 (B) row 5.1

WFA 1440 -5.50

AJJ 120 PH950 "Sherd of Red-on-Black or Red-on-Red bowl. Hardish, thick, originally buff fabric; on exterior, burnished lustrous patchy black PH935 P.I brown, reddish brown and orange-red slip; on interior, friable red slip somewhat lustrous, as preserved."

Merrillees 1974, Fig 5:133

AJJ 121 PF950 "Sherd of Red-on-Black or Red-on-Red bowl. Hardish, thick, originally buff fabric; on exterior, friable, burnished, lustrous slip, PF935 [P.I] shading up through red brown and red to black; on interior, slightly lustrous slip, as preserved shading up through red to brown and black."

Merrillees 1974, Fig 5:134

Light on Dark

AJJ 122 LZ 852 Rim sherd from bowl; handmade. Very hard and very fine light brown fabric. Sp. c. of fine white grits. Matt light brown paint on brown to dark brown burnished slip on exterior and interior.

φ 28cm

ILL 143, 144 row 1.1

RF 33.1757

Exc 1933 File ATQ/41/6

WFA photo

Proto-White Slip

- AJJ 123 E820 no2922 Bowl; handmade. Hard, coarse rust to grey coloured fabric. Dense c. of fine white grits and high % of igneous material. Thick white slip. Discolouration in firing process. Red brown paint.
- φ 19cm
ILL 146, ILL 149
RF 40.113
- AJJ 124 E799TA Bowl fragment; handmade. Hard and coarse rusty red fabric. Sp. c. of white grits and glimmer and med. c. of fine red and black sand. Thick off-white slip. Orange paint.
- φ 19cm
- ILL 51, 110 row 1.1
RF 47.517
- AJJ 125 LB frags. Rim sherd from bowl; handmade. Red brick fabric. Hard and coarse. Dense c. of igneous material. Med. c. of fine white grits and fine dark and red sand. Thick white slip. Red brown paint, polished.
- φ c.19cm-<10% remaining
- ILL 51, 110 row 2.1
RF 47.303/19
- AJJ 126 LB frags. Rim sherd from bowl; handmade. Fired red brown all through. Dense c. of igneous matter. Dense c. of coarse white and black grits. White slip. Matt. Black paint. Metallic ring.
- φ c.19cm-<10% remaining
- ILL 51, 110 row 2.2
RF 47.303/13
- AJJ 127 LB frags. Body sherd from open vessel; handmade. Hard and fine dark grey fabric. Med. c. of white grits and igneous matter. Sp. c. of coarse veg. material. Thick white slip on interior and exterior. Black paint and all over burnish.
- ILL 51, 110 row 2.3
RF 47.303(134)
- AJJ 128 F840
LB Body sherd from open vessel; handmade. Hard and fine. Red and brown sandwiched core. Med. c. of fine white grits. Thin white slip. Red brown paint.
- ILL 110 lower left
RF 47.306
- AJJ 129 LB Rim sherd from bowl; handmade. Hard and fine fabric. Rusty red clay. Med. c. of fine white grits and glimmer. Thin white slip. Red brown paint. All over burnish.

- ILL 49, 110 lower centre
RF 47.303/37
- AJJ 130 E799 Body sherd with handle piece; handmade. Hard and fine, almost black core. Sp. c. of coarse angular red grits. Med. c. of very fine white grits. Quite coarse. Thick cream slip. Red paint. All over burnish.
- ILL 110 lower right
RF 47.518
- AJJ 131 LB Rim sherd from bowl; handmade. Hard and fine clay. Rusty red and light brown sandwiched core. Dense c. of fine white grits and dark sand. Dense c. of igneous matter. Thin cream slip. Black paint. All over burnish.
- RF 47.303/33
- AJJ 132 E808 2924 Rim sherd and body fragments from bowl; handmade. Hard and fine brown fabric. Med. c. of fine to med. black grit. Thick white slip on interior and exterior. Dark brown to orange matt, slightly friable paint. Faint burnish.
- φ 20cm
- ILL 50, 110 row 1
RF -
- AJJ 133 E750 1470
LB Rim fragment with handle piece; handmade. Hard and coarse rusty brown fabric. Sp. c. of fine quartz particles. Dense c. of black grit. Matt orange brown paint on thin white slip. All over burnish.
- φ 19cm
- ILL 133 lower
RF 35.4333
Exc 1933
- AJJ 134 J750
J740 Rim and handle fragment. from bowl; handmade. Hard and coarse and rusty brown sandwich core. Sp. c. of coarse white grits and dense c. of igneous matter. Matt black paint on thin brown white slip (inside and out). Burnished.
- φ c.19cm < 10% remaining
- ILL 110 row 3.1
RF-
- AJJ 135 A/II "Sherd of bowl. Hard, gritty, orange-brown fabric; creamy-white slip with slight sheen and faintly lustrous, almost matt black and light orange-brown painted decoration."
- Merrillees 1974, Fig 2:31
- AJJ 136 A/II "Sherd of bowl. Hard, gritty orange fabric; creamy-buff slip with marked sheen and matt black and brown dec.."
- Merrillees 1974, Fig 2:36

(classed as WS I)

AJJ 137 A/II "Sherd of bowl. Hard, gritty, reddish-brown fabric; cream slip with marked sheen and matt black and brown painted decoration."

Merrillees 1974, Fig 2:37
(classed as WS I)

AJJ 138 Two rim sherds from bowls.

AG I Pl. XXXV:92,93

AJJ 139 Complete bowl; handmade.

RF 35.3935 (display)
ILL 145
AG IV Pl. XLVI 33 T1469

ASHKELON

White Painted Cross Line Style

ASH 140 "Bottom stratum" Fragment. of jug; handmade. Red brown fabric. Hard and fine. Sp. c. of coarse white grits. Dense c. of fine black sand. Red brown slip. Red brown and black paint. Paint polished.

ILL 82
RF P2152a
Bergoffen 1988, Fig 1:2

White Painted Alternating Broad Band and Wavy Line Style

ASH 141 "Bottom stratum" Body sherd from jug; handmade. Very hard and very fine grey light brown fabric. Sp. c. of very fine white grits- some coarse especially near the surface. Light brown slip. Matt brown paint.

ILL 10, 121
RF P.2145
Bergoffen 1988, Fig 1.1

White Painted V

ASH 142 "Bottom stratum" Neck and shoulder fragment of jug; handmade. Hard and fine. Sp. c. of red grits and dense c. of fine white grits. Dense c. of fine grits on the surface. Cream slip. Black paint. Matt.

ILL 121 row 2.1
RF P.2153

Red on Black

ASH 143 "Bottom stratum" Rim sherd from bowl; handmade. Very hard and fine red brown fabric with subtle peach core. Med. c. of fine white grits and dark red sand. Some coarse red grits. Dark brown slip and red paint.

ILL 121 row 1.1
RF P2150
Bergoffen 1988, Fig 1.4 (P2148)

Red on Red

ASH 804 Body sherd from bowl; handmade.

ILL 121
RF P2106 n 6.T

Proto White Slip

ASH 144 Rim sherd from bowl; handmade. Rusty red fabric. Dense c. of fine white grits. Med. c. of very coarse red brown igneous. Hard and coarse fabric. Red and brown paint. All over burnish.

ILL 51
RF-
Bergoffen 1988, Fig 2.1

BALATA (Shechem)

White Painted Cross Line Style

BAL 145 AJQ15/6 LB Body sherd from jug; handmade. Hard and fine clay. Light brown and red sandwiched core. Sp. c. of fine white grits and dark sand. Thin cream slip and red brown paint. Diagonal polishing marks after slip and paint.

ILL 8
RF I.884

Red on Black

BAL 146 AJQ15/6 LB Body sherd from bowl; handmade. Hard and fine clay fired red all through. Sp. c. of very fine light brown sand. Very dark brown slip and red to pink decoration. Burnished prior to the application of paint.

ILL 48
RF I.865

TELL BEIT MIRSIM

White Painted Cross Line Style

- TBM 147 Str G and F
MBII Body sherds (articulated) from jug;
handmade. Fine and hard clay. Light brown greenish fabric.
Dense c. of fine dark sand. Thin cream slip. Black to brown
paint. Traces of polishing.
- RF 32.2820/2
Albright 1933 Pl.22:7

BETHANY

White Painted Cross Line Style

- BET 148 Locus 3a "Ten fragments of Cypriot pottery known as White Painted Ware.
MBIIB-LBI The decoration is dark brown on a light base."
- Loffreda 1974, 165 Fig 8:13

TELDAN

White Painted Pendent Line Style

- DAN 149 Tb 4663 Jug; handmade. Plug handle, neck and body sherds.
Hard and fine red brown fabric. Sp. c. of fine red sand and
fine white grits. Thin red brown red slip. Red lustrous
paint, friable in places. Surface badly abraded.
- Biran 1986, Fig 8: top left
- DAN 150 Tb 4663 Jug; handmade. Hard and fine greenish light brown to
light brown fabric. Sp. c. of fine to med. white grits
(visible also on surface). Greenish light brown slip. Black
to brown paint, friable in places. Very uneven interior
surface. All over burnish to low finish.
- Biran 1986, Fig 8:left middle

DIAHRAT EL-HUMRAIYA

White Painted Pendent Line Style

- DHA 151 Grave 38 Juglet; handmade. Handle from neck to shoulder. Slightly
omphalous base. Globular. Plug handle. Hard and fine light
brown fabric. Med. c. of fine dark and red grits. Cream
slip. Black to brown paint. All over burnish. Very badly
abraded.

- ILL 72
RF 47.47
Ory 1948, Pl.XXXII:8
- DHA 152 Grave 12 Jug; handmade. Hard and fine clay. Light brown green fabric. Light brown slip with reddish tint. Red to black paint. Sp. c. of fine dark and red grits. Matt paint, badly abraded and preserved.
- ILL 79
RF 47.17
Ory 1948, Pl.XXXII:19
- DHA 153 Grave 44 Jug; handmade. Hard and fine clay. Outside wall added later. Sandwich core of red brown and sandy brown. Med. c. of very fine white grits. Red brown slip. Red paint. All over burnish. Plug handle. Very fragile.
- RF 47.55
ILL 68
Ory 1948, Pl.XXXII:20
- DHA 154 Grave 50 Jug; handmade. Hard and fine red brown fabric. Dense c. of fine white grits. Red brown slip and red and black paint.
- ILL 69
RF 47.65
Ory 1948, 86 Pl XXXII:21
- DHA 155 Grave 18 "Juglet, yellowish-brown ware, slip, pattern in brown (worn off)".
- ILL 73
RF 47.24
Ory 1948, Fig 15 and Pl.XXXII:9
- DHA 156 Grave 34 "Painted juglet, pale brown ware, brown painting worn off."
- ILL 81
RF 47.43
Ory 1948, Pl.XXXII:24
- DHA 157 Grave 37 "Juglet; yellowish ware, creamy slip, painting in brown."
- ILL 78
RF 47.44
Ory 1948, Pl.XXXII:6
- DHA 158 Grave 38 "Painted juglet, brownish ware, pattern in red vertical bands alternating with groups of five lines crossing at bottom, in centre of base a blot of paint and two concentric bands, horizontal bars on neck and handle; two punctures at attachment to rim."
- ILL 75
RF 47.46

Ory 1948, Pl.XXXII:3

DHA 754 Grave 2

"Juglet, well levigated yellow ware, cream slip, painted in dark grey."

ILL 70
RF 47.1

Ory 1948, 79 Fig 4, Pl.XXXII.4

DHA 755 Grave 2

"Juglet, greenish ware with slip, grey to black pattern..but worn."

ILL 71
RF 47.2
Ory 1948, 80 Fig 5, Pl XXXII.5

White Painted Cross Line Style

DHA 159 Grave 55

Fragment of jug; handmade. Fine and hard light brown fabric. Sp. c. of black and red grits. Light brown slip and red paint. Paint very badly abraded and fragmentary vessel.

RF 47.67
Ory 1948, 86 "three fragmentary painted juglets, as Pl.XXXII:6"

DHA 160

"Juglet; painted with crossing bands of oblique parallel lines in brown."

ILL 80
RF 47.21
Ory 1948, Fig 14 and Pl.XXXII:14

White Painted Alternating Broad Band and Wavy line Style

DHA 161 uncertain
provenance

Body sherd from jug; handmade. Hard and fine light brown fabric with greenish core. Light brown slip and red paint. Sp. c. of fine white and dark grits. All over burnish.

ILL 10, 97, 121
RF 47.84
Ory 1948, 87
This sherd was previously classed as
WP Pendent Line Style. After reexamination it was found to
be of WP Alternating Broad Band and Wavy Lines.

TELL FAR'A (south)

Red on Black

FAR 162 Tomb 551 Jug.
"XVth Dynasty

Price Williams 1977, Fig 13:17, 9, 31

FAR 163 Sherds "associated with a Hyksos gateway
appear to be Red on Black or Red on Red
Ware."

SCE IV.1B, 227
Beth Pelet II Pl.LXXII:6,10

GEZER

White Painted Pendent Line Style

GEZ 164 Juglet; handmade. Complete. Handle from rim to shoulder.
Globular. Round base. Cylindrical neck. Everted rim. Fine
and hard light brown fabric. Med. c. of very fine dark
sand. Thin cream slip and red paint. All over burnish.

ILL 76
RF V.1713

GEZ 165 L.8010 "Sherd; handmade. Paste: 10YR "very pale brown" 8/3; no
Field I inclusions visible. No core. Hard. Interior as paste,
Glacis 8012 of organic paint-5YR "dark reddish grey" 4/2."
Tower 5017
pre-MBIC

Dever *et al* 1974, Pl.20:39

GEZ 166 Second Jug fragment.
Semitic
Period Macalister 1912 Vol III Pl.CXLV:1,
Vol II, 172

White Painted Cross Line Style

GEZ 167 Tomb No 1 Jug;
"decorated with black basket-work upon
a yellow slip and black horizontal
bands round the neck."

Macalister 1912 Vol III Pl.LXII:51,
Vol I, 302

GEZ 168 Second Jug fragment.
Semitic
Period Macalister 1912 Vol III Pl.CXLV:2

Vol II, 172

GEZ 169 Second
Semitic
Period

Basal(?) sherd.

Macalister 1912 Vol III Pl.CXLV:3
Vol II, 173

GEZ 170

Sherd; red on pink.

Macalister 1912 Vol III Pl.CXL:5,
Vol II, 173

GEZ 171

Sherd; brown on light brown slip.

Macalister 1912 Vol III Pl.CXL:7,
Vol II, 173

White Painted V

GEZ 172 Second
Semitic
Period

Jug;

Macalister 1912 Vol III Pl.CLVII:4
Vol II, 161

White Painted VI

GEZ 173

Animal figurine. No description.

Macalister 1912 Vol III Pl.CXXVI:22
Vol II, 2

GEZ 174

Animal figurine. No description.

Macalister 1912 Vol III Pl. CXXVI:25,
Vol II, 2

GEZ 175

Animal figurine. No description.

Macalister 1912 Vol III Pl. CXXVI:26,
Vol II, 2

GEZ 176 Locus 402
Field I

"Juglet; handmade. Paste: 7.5YR "pink" 7/4. No inclusions
visible. No core. Hard. Surface as paste. External as paste,
MBII and LBII organic painted decoration "10R "weak red" 4/4."

Dever *et al* 1974, Pl.38:9

White Painted Various

GEZ 177

Neck fragment; black on light brown.

Macalister 1912 Vol III Pl.CXL:9,
Vol II, 159

GEZ 178 Handle fragment.
"dark Indian red on a yellow ground."

Macalister 1912 Vol III Pl.CLII:9,
Vol II, 156

Red-on-Black

GEZ 179 Spouted bowl.

Macalister 1912 Vol III Pl.CXL:8,
Vol II, 169,173

GEZ 180 Second Spout fragment from bowl.

Semitic

Period

Macalister 1912 Vol III Pl.CLV:2,
Vol II, 169.

GINOSAR

White Painted Pendent Line Style

GIN 181 Tomb 4 Jug; handmade. Handle from rim to shoulder. Round
MBIIA/B to base. Globular body. Plug handle. Light brown, green clay.
MBIIB Hard and fine. Porous. Sp. c. of med. sized white and dark
grits. Light brown slip and brown paint. Polished.

IDAM 56848 EKY 430
Epstein 1974, Fig 15:9

HAZOR

White Painted Pendent Line Style

HAZ 182 Two sherds from jug?;

Yadin *et al* 1961 Pl.CCCXII:5

HAZ 183 Locus 5005 "Sherd; yellow clay, few black
Str 3 (small) grits, burnished. Dec.
MBIIB dark brown."

Yadin *et al* 1961 Pl.CCLXXXVII:23

White Painted Pendent Line Style (?)

HAZ 184 "Bowl(?); light brown levigated
clay, red slip. Dec. "Black on red"."

Yadin *et al* 1958 Pl.XCVIII:18

White Painted Cross Line Style

HAZ 185 Locus 9010 "Sherd; pinkish clay, grey grit
Str 4 (small), whitish slip. Dec."
MBII

Yadin *et al* 1958 Pl.C:13

HAZ 186 Locus 9010
Str 4
MBIIB
"Sherd; pinkish levigated well
fired clay, yellow burnished slip.
Decoration in brown."

Yadin *et al* 1958 Pl.C:14

White Painted V

HAZ 187 Locus 9037
Str 3
MBII
"Sherd from jar; buff clay, smoothed surface. Decorated."

Yadin *et al* 1958 Pl.XCIV:21

White Painted Various

HAZ 188 Locus 9009
Str 3
MBII
"Sherd; coarse pinkish clay.
Yellow external slip. Decorated."

Yadin *et al* 1958 Pl.C:27

HAZ 189 Locus 9043
Str 4
MBII
"Sherd; reddish well-fired clay,
yellow core, isolated white (small) grits. Light red slip.
Decorated."

Yadin *et al* 1958 Pl.XCIII:21

HAZ 190 Locus 6212
Str 3
MBII
"Handle fragment; Yellowish
levigated clay. Decorated."

Yadin *et al* 1960 Pl.CXV:10

HAZ 191 Locus Q14
"Pilgrim Flask (Cypriote). Greenish
clay, black grit (small). Decorated."

Yadin *et al* 1958 Pl.CXIII:6

Red-on-Black

HAZ 192 Locus 76
Str 6
"Bowl; pink levigated well-fired
clay, burnished in and out. Dec. (red paint on rim)."

Yadin *et al* 1958 Pl.LI:28

HAZ 193 Locus 6305
Str 3
MBII
"Bowl; pink levigated clay, red
slip. Dec. ("black on red")."

Yadin *et al* 1960 Pl.CXV:11

HAZ 194
"Body sherd;

Yadin *et al* 1961 Pl.CCLXXXVII:24

HAZ 195 Locus 9039 Body sherd;
Str 2 "Yellowish levigated clay, interior
MBII black slip. Decorated ("black on red").

Yadin *et al* 1958 Pl.CII:20

KABRI

White Painted Pendent Line Style

KAB 196 Locus 441 Body sherd from jug; handmade. Very hard and very fine red brown fabric.
Sp. c. of fine white grits and dark sand. Light red brown slip and lustrous red
brown paint. All over vertical burnishing.

KAB 47/86

ILL 2

White Painted Alternating Broad Band and Wavy Line Style

KAB 197 Locus 441 Jug; handmade. Plug handle from below rim to shoulder. Globular body.
Roughly cylindrical neck with everted circular rim. Very hard, fine and porous
green buff fabric. Sp. c. of fine white and dark grits, and red sand. Light brown
slip. Matt, friable black to dark brown paint.

KAB 47/86

KAB 198 Locus 441 Shoulder fragment from jug; handmade. Very hard and very fine red brown
fabric. Sp. c. of fine white and dark grits. Light red brown slip and lustrous dark
red paint. All over burnish.

KAB 47/86

ILL 11

KAB 199 Locus 441 Body sherd from jug; handmade. Very hard and fine light red brown clay. Sp. c.
of fine white grits and fine dark sand. Matt light red brown slip. Lustrous red
brown paint.

KAB 47/86

ILL 11

KAB 200 Locus 441 Body sherd from jug; handmade. Very hard and very fine medium brown clay.
Dense c. of fine black grits and sp. c. of fine white grits. Matt, light brown slip.
Lustrous brown paint.

KAB 47/86

ILL 11

White Painted V

KAB 201 Locus 446 (TLS) Jug; handmade. Plug handle from rim to shoulder. Globular body almost
flat base. Roughly cylindrical neck. Everted circular rim. Very hard and fine
greenish light brown fabric. Very porous. Sp. c. of coarse and fine white and
black grits, and red sand. Light brown slip. Matt, friable brown to black paint.

KAB 47/86

KAB 202 Locus 431 (TLS) Shoulder fragment from jug; handmade. Very hard and fine light brown

and red brown sandwiched core. Sp. c. of fine red and dark sand. Cream slip. Matt, friable black paint applied after burnishing.

KAB 47/86

ILL 16

Red Slip and White Painted Composite Ware

KAB 203 Locus 453 Rim sherd from wide bowl; handmade. Very hard and fine red brown clay. fired brown on exterior. Light brown slip and lustrous red brown paint on interior. Point burnished all over.

KAB 47/86

ILL 12

White Painted Various

KAB 204 Body sherd from jug; handmade. Very hard and fine light brown fabric. Dense c. of fine to medium white grits. Few fine dark and red grits. Cream slip. No decoration.

KAB 47/86

KAB 205 Locus 441 Body sherd from jug; handmade. Very hard and fine light brown clay. Sp. c. of fine white grits. Cream slip. All over burnish. Possibly WP ABBWLS. Decoration consists of two horizontal bands. Red brown paint.

KAB 47/86

KAB 206 Locus 441 Body sherd from jug; handmade. Hard and very fine red brown clay. Sp. c. of fine white and dark grits. Light red brown slip and red brown paint. Possibly WP ABBWLS. Decoration consists of two horizontal bands.

KAB 47/86

KAB 207 Locus 441 Handle fragment from jug; handmade. Hard and very fine light brown fabric. Med. c. of fine white grits. Smooth cream slip. Black friable paint. Decoration consists of two vertical bands on side and three oblique bands across the back of the handle.

KAB 47/86

KAB 208 Locus 441 Handle fragment from jug; handmade. Hard and very fine greenish light brown fabric. Sp. c. of med. white and dark grits. Abrade black paint.

KAB 47/86

KAB 209 Plug handle fragment from jug; handmade. Hard and very fine light brown fabric. Dense c. of fine light brown fabric. Sp. c. of red sand. Light brown slip. Black, friable matt paint. Decoration consists of two vertical bands on each side. Badly abraded.

KAB 47/86

LACHISH

White Painted Pendent Line Style

LAC 210 Locus 129 MBII-III "Juglet; handmade. Buff, medium firing, buff slip, dark brown paint on body. Handle from rim to shoulder, round base."

Tufnell 1958 Pl.79:813, 197-8

White Painted Cross Line Style

LAC 211 MB fill of NE section of glaxis "Part of juglet; fine pink section pink slip, smooth burnish out, worn buff surface in, lustrous paint."

Tufnell 1958, 197, Fig 3:174

White Painted VI

LAC 212 Tb 1986 (Quarry) no2680 M-LB Spout fragment. from "teapot" vessel; handmade. Fine and hard clay. Peach coloured core. Sp. c. of dark sand and coarse red angular grits. Cream slip. Abraded drab black paint.

RF 34.3004

LAC 213 Two "teapot" fragments from the one vessel; handmade. Fine and hard fabric fired light brown all through. Sp. c. of fine white grits, red and dark sand. Cream slip. Black paint. Shaved. Drab.

RF 34.3004

LAC 214 Tb1968 (Quarry) no2680 M-LB Handle fragment of "teapot" vessel; handmade. Plug handle. Very fine and hard clay. Buff fabric with subtle grey core. Sp. c. of red and black fine sand. Cream slip. Drab black paint. Shaved.

RF 34.3004

LAC 215 as LA 3 Handle fragment from "teapot" vessel; handmade. Fine and hard clay. Buff fabric. Dense c. of fine red and black sand. Plug handle very clearly exposed in section.

RF 34.3004

LAC 216 Tb216,no4600 LBII Juglet; handmade. Handle from rim to shoulder. Almost spindle shaped. Pointed base. Shaved. Hard and fine light brown fabric. Sp. c. of fine dark and red sand. Black paint. Matt. Cream smooth slip.

RF 36.1490

Tufnell 1958 Pl.79:824, Pl.53:9

LAC 217 Jug; "Fine buff fabric. Soft firing. Buff slip. Black decoration. Scraped."

Tufnell 1940 Pl.LIB:282

Red-on-Black

LAC 218 Temple area "Rim sherd; soft firing, black slip, red decoration."
"anterior to
building of
Temple"

Tufnell *et al* 1940 Pl.LXIV:3, 81

Red-on-Black/ Black Slip

LAC 219 Locus 4004 "Open spouted bowl, of buff ware, covered by a dark slip,
MBIII-LBIII fired black outside and reddish-brown in. Not certain if bowl
was originally painted."

Tufnell 1958 Pl.79:816 ,197

Black Slip III

LAC 220 Locus 7011 "Jug; buff, soft fire, black slip. Incised lines and zigzags,
round body. Ribbon handle, neck to shoulder, flat base."

Tufnell 1958 Pl.79:814

Proto-White Slip

LAC 221 Temple Area "Body sherd; fine grey, medium firing. White slip inside
"Attribution and out. Black decoration"
to Structure I?"

Tufnell *et al* 1940 Pl.LXIV

TEL JERISHE

White Painted Pendent Line Style

JER 222 II "Jug; Cypriot, pink clay."
MBIIA

Geva 1982 Fig 32:11

JER 223 Str II "Jug; Cypriot, white clay, white slip, black painted design."

Geva 1982 Fig 32:12

JER 224 Str II "Jug; Cypriot, cream clay, inner surface pink, white slip,
MBIIA black painted design."

Geva 1982 Fig 32:14

White Painted Cross Line Style(?)

JER 225 Str III
MBIIA "Jug; Cypriot, pink clay, grey and white grits."

Geva 1982 Fig 31:6

White Painted Various

JER 226 Str III
MBIIA "Jug; Cypriot, grey clay, white grits, wheel marks, light grey slip, grey painted stripes."

Geva 1982 Fig 31:8

Red on Red

JER 227 Str IV
MBIIB-C "Jug; Cypriot, cream clay, outer surface pink, painted decoration." From the illustration this sherd may well be WP Cross Line Style.

Geva 1982 Fig 27:7

JER 228 Str II
MBIIA "Jug; Cypriot, pink clay." This sherd resembles WP Pendent Line Style.

Geva 1982 Fig 32:10

JER 229 Str II
MBIIA "Jug; Cypriot, pink clay." Possibly WP Pendent Line Style.

Geva 1982 Fig 32:11

JER 230 Str II
MBIIA "Jug; Cypriot, grey clay, outer surface light pink, two-toned red stripe."

Geva 1982 Fig 32:13

JER 231 Str II
MBIIA "Juglet; Cypriot, light pink clay, white slip, black painted design."

Geva 1982 Fig 31:7

TEL KURDANE

White Painted Alternating Broad Band and Wavy Line Style

KUR 232 Jug.

Åström 1966, 81
(On display in Haifa Museum)

TEL NAGILA

Red on Black

NAG 233 Tomb DT2
MBIIB Jug:

Amiran and Eitan 1963, 334
1965, 113-23 Fig 18

MEGIDDO

White Painted Pendent Line Style

MEG 234 Tomb 24
no 2831 Juglet; handmade. Handle from rim to shoulder. Plug handle. Part of rim missing. Slightly omphalous base. Squat globular shape. Hard and fine light brown fabric. Sp. c. of fine dark sand. Pitting visible on surface. Cream slip and red paint. Very badly abraded.

ILL 77
RF I.3060
Guy 1938 Pl.103:10, 48-50

MEG 235 Tomb 3128
Str XII
MBIIB Juglet; handmade. Handle from rim to shoulder. Round base. Hard and fine light brown fabric. Med. c. of med. sized dark sand and white grits. Cream slip. Black to red paint. Plug handle.

ILL 67
RF 37.935
Loud 1948 Pl.26:13

MEG 236 Tomb 4107
Str XII
MBIIB Jug; handmade. Hard and fine red brown fabric. Dense c. very coarse white grits and dark sand. The white grits have all come to the surface and are visible in large quantities around the handle and the rim. Light brown slip and red and black paint.

Notes: This piece seems to be a very crude form of a Cypriot jug. Very weak lines painted alternately red and black and are quite irregular. The fabric appears to be coarser than that of typical Cypriot vessels. The handle is from rim to shoulder and is unusually thick. Round base. Thick everted rim. Short neck and globular body.

Mx. Ht. = 22.2cm.

ILL 74
RF 38.994
Loud 1948 Pl.26:17

MEG 237 Locus 5048 "Fragmentary jug; handmade. Fine, buff, grey and white grits, burnish, decoration."

Loud 1948 Pl.26:16

MEG 238 T.3076
Str XI
MBIA/B "Complete jug; Cream buff, minute white grits, well fired, burnish outside, black decoration."

Loud 1948 Pl.34:12

MEG 239 Locus N = 3174
Str X
MBIIC "Flask fragment; well handmade. Fine, buff, well burnished outside, brown-red decoration."

Loud 1948 Pl.46:11

White Painted Cross Line Style

MEG 240T.5068
Str XII
MBIIB

"Jug; well handmade. Fine, pink buff, few minute white grits, well fired. Vertical burnish outside, red decoration."

Loud 1948 Pl 26:15

MEG 241T.3086
Str XII
MBIIB

"Fragmentary jug; pink-buff, gray and white grits, wet smoothed black decoration."

Loud 1948, Pl 26:15

MEG 242T.3111
Str XII
MBIIB

"Intact jug; buff, gray grits, well fired, white wash outside, black decoration."

Loud 1948, Pl 26:15

MEG 243Locus = 4093

"Jug; well handmade. Fine, cream buff, few minute black grits, burnished outside, black decoration."

Loud 1948, Pl.34:8

MEG 244T.4109
Str XI
MBIIB

"Jug; handmade. Intact but chipped. Fine, buff, few minute grits, well fired, spaced burnished outside, black decoration."

ILL 83

RF 38.1004

Loud 1948, Pl.34:9

MEG 245T.5243
Str XI
MBIIB

"Jug; well handmade. Fine, pink-buff to green-cream, minute white grits, well fired, well burnished outside, black (fired red in places) decoration."

Loud 1948, Pl.34:4

White Painted V

MEG 246Tomb 39
Str IX
LB

Bull vase; handmade. Trefoil mouth. Strap handle and modelled tail and legs. Hard and fine light brown fabric. Dense c. of fine red sand. Thin cream slip. Black paint. Shaved all over.

RF 37.853

MEG 247Tomb 4109
c656
Str XI

TLS Jug; handmade. Complete. Fine and hard light brown fabric. Sp. c. of med. sized red, white and dark grits. Cream slip. Red and black paint. All over burnish.

ILL 89

RF 38.1003

Loud 1948, Pl.34:13

MEG 248Locus = 5037

Jar; handmade. Large fragment with originally two handles

Str XI
MBIIB (strap). Everted rim. Hard and fine light brown green fabric. Med. c. of fine white and dark grits. Cream slip and black paint. All matt.

φ 21cm.

ILL 92
RF 39.520
Loud 1948, Pl.36:3

MEG 249Locus = 3180 "Jug; well handmade. Fine, pink-buff, numerous minute pink
Str X and white grits, green-buff slip and burnish outside, dark
MBIIC red decoration."

Loud 1948 Pl.42:1

White Painted V (Eyelet Style)

MEG 250T.3065 "Fragmentary jug; well handmade. Fine, pink-buff, minute
Str X white grits, well fired, burnish outside, red decoration."
MBIIC

Loud 1948, Pl.41:29

MEG 251T.3046 "Jug; well handmade. Fine, green-buff, minute black grits,
Str X wet-smoothed, black decoration, thrust through handle."
MBIIC

Loud 1948, Pl.41:30

MEG 252T.5050 "Jug; handmade? Fine, green buff, burnish outside, black
Str XI decoration."
MBIIA/B

Loud 1948, Pl.34:16

MEG 253T.5343 "Fragmentary jug; well handmade. Fine, cream buff, few grits,
Str XI well fired. Burnish outside, black decoration. Thrust
MBIIA/B through handle.

Loud 1948, not illustrated

White Painted VI

MEG 254Tomb 77 "Teapot" vessel; handmade. Plug handle. High handle. Flat
LBI base. Spout. Hard and fine buff fabric. Med. c. of red and black sand. Cream slip. Black drab paint. Shaved.

ILL 133
RF I.3423
Guy 1938, Pl.41:28

White Painted Various

MEG 255T.1178 Body sherd from jug; handmade. Hard and fine red fabric.
Med. c. of fine red and dark sand. Red brown slip and red paint. All over vertical burnishing.

RF 34.2410

Black Slip/White Painted Composite Ware

MEG 256 Locus = 5061 "Bowl sherd; well handmade. Fine, cream-buff, heavily fired,
Str XIII A black to red wash outside, burnish inside and out, black
MBIIA/B decoration."

Loud 1948, Pl.19:15

Red on Black

MEG 257 Tomb 5134 Jug; handmade. Fine and hard red brown fabric. Med. c. of
Str XI coarse red and white grits. Red brown slip and pink to red
MBIIB paint.

ILL 134

RF 39.582

Loud 1948, Pl.26:14

MEG 258 Locus 3068 "Bowl; well handmade. Fine, buff, minute white grits,
Str XI lustrous black slip inside and out, red decoration."
MBIIB

φ c.24cm

Loud 1948, Pl.38:16

Proto White Slip Ware

MEG 259 Locus 4021 "Fragmentary bowl; well handmade. Fine, red buff, minute white
Str X grits, well fired, white slip and burnish inside and out,
MBIIC brown decoration."

Loud 1948 Pl.45:21

TELL MEVORAKH

White Painted Cross Line Style

MEV 260 Locus 283 "Fragments of the body of a jug. Buff, finely levigated;
Str XIII white slip; surface polished after painting; many minute
MBIIB black and white grits; paint of fine crossing lines varies
from orange-red to charcoal-brown with firing; broad painted
bands on body vary from brick-red to blackish-brown; at base
broad black lines; handmade."

Stern 1984, Pl.26A, 143

MEV 261 Fragment. of jug; no description. "From mixed post-MBA
levels."

Stern 1984, 145

White Painted V

- MEV 262 Locus 336
Str XIII
MBIIB
Amphora; pinkish-beige; few med. black and white grits, many small black and white grits; painted dec. varies from orange-red to charcoal brown with firing; handmade body; neck and rim made separately on a wheel; attachment at base of neck visible; entire outer surface wet-smoothed after joining neck and handles to body.

Ht 41cm.

Stern 1984, Pl.25:A-B, Fig 2, 140
- MEV 263 Locus 316
Str XII
MBIIB
"Fragment of an amphora; greenish buff; many small black and white grits; black paint; handmade."

Stern 1984 Pl.25:C top, 142-3
- MEV 264 Locus 317
Str XII
MBIIC
"Fragment of a closed vessel; greenish-buff; many small black and white grits; black paint; handmade."

Stern 1984 Pl.25:C centre 143
- MEV 265 Locus 22
Str XII
MBIIC
"Fragment of a closed vessel; pinkish-buff; very many small black and white grits; black paint; handmade."

Stern 1984, Pl.25:C bottom, 143

White Painted Various

- MEV 266
White Painted fragments found in post- MBA fills. No description.

Stern 1984, 145

Red on Black

- MEV 267 Locus 316
Str XII
MBIIB
"Rim sherd of a bowl; rose-buff; minute to med. black and white grits; black slip ; purplish-red paint applied with a multiple brush apparently of many elements; handmade."

Stern and Saltz 1978, 144
- MEV 268 Locus 205
Str XII
MBIIC
"Fragment of a bowl; pinkish-buff, finely levigated; occasionally med.-sized, fairly minute to small black and white grits; med. lustrous black slip; red paint applied with a multiple brush of at least 11 elements; handmade."

Stern and Saltz 1978
- MEV 269
One fragment. No description from mixed post MBA fills.

TELL MOR

Red on Red

- MOR270 StrXIIB
Bowl; handmade. Hemispherical bowl with hz. spout and

end of MBIIC handle. Red brown fabric. Hard and fine. Sp. c. of fine white and coarse grits. Red brown slip and red paint.

φ 16cm

IDAM 60.615

Dothan 1973 Fig 4:4, 8-9

YIFTAHEL

White Painted Pendent Line Style

YIF 271 Body sherds (3) of same jug; handmade. Hard and fine red brown clay. Sp. c. of fine white and black grits. Red brown Red paint. All over burnish.

ILL 1

1382:410 RF

White Painted V "Eyelet" Style

YIF 272 Juglet; handmade. Rounded shoulder, pedestal base (hollow), plug handle. Hard and fine red to pink fabric. Med. c. of very fine to med. white grits. Sp. c. of dark grits. Cream slip fired red in places. Red to brown paint.

ILL 18

1382:236 RF

Syria

TELL DARUK

White Painted Pendent Line Style

DAR 273 Layer 26 "handmade sidesherd of fine light clay. Matt black
M/LBA painted decoration consisting of parallel lines on both sides of a broad wavy band. 4.0 X 3.5cm."

Oldenburg & Rohweder 1981, 32:95 Fig 39

White Painted Cross Line Style

DAR 274 Layer 26 "Sidesherd of fine buff (exterior) and red (interior)
clay. Black lustrous decoration consisting of lines crossing each other in three directions, and bordered by a black area."

Oldenburg & Rohweder 1981, 32:94 Figs 31, 38

DAR 275 Layer 24 "Sidesherd of red clay with small white particles and
M/LBA creamy slip. Matt dark brown bands on exterior. 2.2 X 2.0cm."

Oldenburg & Rohweder 1981, 32:96 Fig 39

White Painted V

DAR 276 Layer 24
M/LBA "Sidesherd of fine light brown porous clay with creamy slip. Brown painted bands on exterior. 3.2 X 2.0 cm."

Oldenburg & Rohweder 1981, 32;97 Fig 39

DAR 277 Layer 24
M/LBA "Sidesherd of fine light clay (with slip?). Matt black-painted bands on exterior. 2.7 X 4.0 cm"

Oldenburg & Rohweder 1981, 32;98 Fig 39

White Painted Various

DAR 278 Layer 30
MBA "Sidesherd of light yellow clay with three horizontal red painted bands."

Oldenburg & Rohweder 1981, 31;85 Fig 38

KAFER ED-GARRA

White Painted Cross Line Style/Pendent Line Style

KAF 279 Tomb 57 "Près de la surface nous avons recueilli un col de cruche cylindrique, un autre à bec pincé et pourvu d'une anse, tous deux ornés de bandes bruns."

Guiges 1938 Fig 48 right

KASSABINE

KAS 280 Unpublished tomb-group, East of Djebélé (= N. of Arab el Moulk)

White Painted Pendent Line Style (c 17 pieces)

White Painted Cross Line Style (2 pieces)

White Painted (other) (5 pieces)

Åström 1966, 139 and n 2

QAL'ATER-RUS

?White Painted V

QAL 281

Ehrich 1939

?White Painted Pendent Line Style

QAL 282 Layer 3 "a black on cream sherd with vertical wavy lines alternating with groups of four straight ones... cf Beth Shemesh no649, on p.127, similar pattern;"

Ehrich 1939

QAL 283 Layer 2 "another of the wavy line sherds."

Ehrich 1939, 47 n.7

Red on Black

QAL 284 Layer 2 "a piece of typically Cypriote red-on-black, and a very interesting red on red."

Ehrich 1939, 47

Red on Red

QAL 285 Layer 2 "a fragment of a bowl with band handle, once highly burnished. The traces of multiple lines of dull paint are on the inside."

Ehrich 1939, 47

Black Slip II (Reserved Slip) Ware?

QAL 286 Ehrich 1939, 75 Pl XXI, Fig XIX

QRAYE

White Painted Pendent Line Style

QRA 287 "caractérisée par un décor rouge-ocre ou lie de vin sur fond clair. Sur la panse le décors, toujours géométrique, consiste en faisceaux de lignes longitudinales encradant parfois des lignes ondulées parfois aussi recoupées par des lignes horizontales"

Guiges 1940, 59 Pl XII.b

MAJDALOUNA

White Painted Pendent Line Style

MAJ 288 Tomb Jug;

Chéhab 1940, 50 Fig 3c

SAREPTA

Red Polish IV-V

SAR 289 II-K-21 "Rim of shallow bowl. Red slip irregular hand
Level 31 burnish to high luster; slip flakes off easily."
"J/H" Deposit

Anderson 1979, 775 Pl 24.25

White Painted Pendent Line Style

- SAR 290 II-L-21 "Body sherd from (handmade) closed vessel
basin Very slightly lustrous slip; matt painted
Stratum G decoration: four narrow parallel lines,
"intrusive" a wavy line on either side."

Pritchard 1975, 86-7 no 2; Fig 51:2
Anderson 1979, 791.1 Pl 29.1
- SAR 291 II-K-21 "Body sherd from (handmade). Monochrome
Level 32 exterior; irregular hand burnish to low luster."
Stratum L

Anderson 1979, 763 Pl 21.7
- SAR 292 II-K-20 "Body sherd from lower wall of juglet.
Level 29-4 Exterior irregular hand burnish; monochrome paint.
Stratum J

Anderson 1979, 771 Pl 23.28
- SAR 293 II-K-21 "Body sherd from handmade juglet. Light
level 31 irregular hand-burnish after paint; surface bloom;
"J/H" Deposit matt monochrome decoration; worn."

Anderson 1979, 776 Pl 24.27

White Painted IV-V

- SAR 294 II-K-21 "Rim and body sherd from (handmade) juglet. Cross Line
Level 32 Style or Tangent Line Style. Fugitive white slip; matt
Stratum L black paint.

Anderson 1979, 763 Pl 21.5

White Painted V-VI

- SAR 295 II-K-20 "Body sherd from large (handmade) vessel. Traces of
Locus 32-1 irregular hand-burnish; matt monochrome decoration;
(K2) orientation of fragment unclear."
Stratum K

Anderson 1979, 767 Pl 22.18

- SAR 296 Animal shape vase.

Pritchard 1971, 61

White Painted VI

- SAR 297 II-K-20 "Handle stub from juglet. Shaved; matt monochrome
Locus 29-1 decoration; possibly "Soft Triglyphic Style".
Stratum II

Anderson 1979, 780 Pl 25.30

Red on Black

- SAR 298 II-K-20
Locus 30-1
Stratum K
"Body sherd from open vessel. Slightly lustrous slip; matt monochrome decoration, worn on interior."
Anderson 1979, 768 Pl 22.25
- SAR 299 II-L-20
Level 28-1
mixed
Stratum G
(probable)
"Rim sherd from open vessel. Handmade; plain vertical rim; diam. of rim: 19cm. Slightly lustrous slip, black on the exterior, red on interior except for a narrow black band around the interior rim; matt painted decoration: vertical lines on the exterior, short horizontal lines on the interior."
Pritchard 1975, 86 no 1 Figs 26:1, 51:1
Anderson 1979, 791 Pl 29.1

TELL SUKAS

White Painted Pendent Line Style

- SUK 300 Tomb IV
Level 1
MBA
"Jug, type C8, bottom up, mouth facing towards south, handle to west, close to skull 9. Handmade (?), burnished with matt lustrous black paint on cream."
-H.20.5cm Diam 14.8cm"
Thrane 1978, 51.10 Fig 55
context Fig 4. Plan 3
- SUK 301 Tomb IV
Level 1
MBA
"Jug, type C8, south of skull, just west of stone layer, spout towards south, handle down. Handmade, burnished creamy slip with red paint."
Thrane 1978, 51-2.19 Fig 56
- SUK 302 Tomb IV
Levels I & II
MBA
"Sherd of jug; type C8; (other sherds join to complete pot). Handmade, reddish buff, glossy paint on milky white slip (burnished)?
-H.27.6cm Rim Diam 4.2cm"
Thrane 1978, 54.170 Figs 43-44 & 62
- SUK 303 G 11 SW
layer 11
"Fine reddish clay with buff slip on which are vertical lines of red paint and remains of one parallel, wavy (Period H)¹ line.
-H.2.65cm, W.2.46cm."
Buhl 1983, 52.259 Pl XIV
- SUK 304 E 8 NWXL
layer 5
(Period F)
"Two side sherds. Reddish clay with some particles and mica; black to red lustrous paint on burnished slip.
-H.1) 4.0cm 2) 3.3cm W.1) 4.8cm 2) 4.2 cm"

¹ Buhl 1983, 110 "...the deposits from Periods K-E showed certain lacunae and complicating circumstances because they have been exposed to severe destruction."

Buhl 1983, 52.262 Pl XVI

SUK 305 F 11 NW
Layer 2
"Side sherd. Light buff greenish clay, vertical lines and one parallel wavy line in bluish-black paint.
-H.4.3cm, W.3.2cm"

Buhl 1983, 52.263 Pl XVI

SUK 306 G 11
layer 1
(Period A)
"Shoulder sherd. Red gritty micaceous clay with small black particles. Red to brown painted vertical lines and two parallel wavy lines on buff polished slip.
-H.5.5cm, W.7.9cm."

Buhl 1983, 52.264 Pl XVI

SUK 307 G 11 SE
layer 9
(Period H)
"Side sherd. Brown clay with white particles. Vertical lines and parallel wavy lines in paint on light brown slip.
-H.9.0cm, W.9.0cm."

Buhl 1983, 52.265 Pl XVI

SUK 308 surface
"Side sherd. Buff clay with some grits and particles of mica. Vertical lines and parallel wavy lines in black and red matt paint.
-H.5.2cm, W.7.5cm."

Buhl 1983, 52.266 Pl XVI

White Painted Cross Line Style

SUK 309 L 13 SE
Room XXIV
"Reddish-yellowish clay with particles of mica. Net pattern in matt black paint.
layer 4-H.3.2cm, W.4.0cm."
(Periods D-A)

Buhl 1983, 52.267 Pl XVI

White Painted Alternating Broad Band and Wavy Line Style

SUK 310 H 11 NE
layer 19
(Period J)
"Light brownish clay with lighter brownish slip, polished brown paint. Horizontal broad bands separated by parallel wavy lines.
-H.3.0cm, w.5.0cm"

Buhl 1983, 52.271 Pl XVI

White Painted V

SUK 311 G 11 SW
layers 9,10,11
CXXVI
(Periods H2-G3)
"Neck slightly everted. Red clay, somewhat porous, grits. black core. Decoration in red matt paint. A broad band on the inside of the rim; outside on the neck three horizontal bands, on the shoulder a wavy line enclosed by two horizontal bands, below this three vertical stripes grouped together and joining a

horizontal band.
-H.8.2cm, diam c.9.2cm, th. 0.5-1.0cm"

Buhl 1983, 54.278 Pl XVII

White Painted Various

SUK 312 G 14 "Grey-brown clay, buff on exterior with black and white
layer 2 particles. Red-brown matt paint: vertical lines and
(period B-A) remains of a dot (?).
-H.5.6cm, w.7.7cm"

Buhl 1983, 52.268 Pl XVI

SUK 313 Layer 3 "Jug and handle fragment; trefoil mouth. Horizontal
encircling bands around neck."

Ehrich 1939 Pl XXIII.1.P7.1, 82, 84

Black Slip/Reserve Slip

SUK 314 G 15 NE "Light yellowish clay with many dark and white
layer 18 particles and mica. Remains of dark paint on exterior.
(period H2) Two horizontal bands separated by a parallel wavy
line.
-H.5.0cm, w.5.5cm."

Buhl 1983, 52.270 Pl XVI

Red on Red/Red on Black

SUK 315 Layer 3 Ehrich 1939, 84 Table

TYRE

White Painted V-VI

TYR 316 Grave 2 "Juglet; handmade. Pale yellow fabric. Dark grey paint."
Str XVIII
Bikai 1978, Pl LIII; Pl LXXXVII.7

TYR 317 Grave 2 "Juglet; pale yellow fabric; very dark grey paint."
Str XVIII
Bikai 1978, Pl LIII.4

TYR 318 Grave 3 "Animal shaped vase; pale brown fabric; dark grey paint."
Bikai 1978, Pl LIIA.3 and note 3

Red on Black

- TYR 319 IC-11 A "Rim sherd from bowl. Very pale brown fabric. Very dark grey (lustrous) surface. Weak red paint."
 . Bikai 1978, Pl.LB.16
- TYR 320 IC-6 D "Rim and handle fragment from wide shallow bowl Pink fabric." very dark grey (lustrous) surface; Red paint.
 . Bikai 1978, Pl LB; Pl LXXXVI.1

RASSHAMRA

Red Polished

- RAS 321 RS 1934 "Deux fragments de vases en t.c. lustrée rouge, décor incisé et incrusté de blanc."
 prés du temple Dagon,
 pt top.11
 prof. 1m et 1m 70.

Ugaritica II Fig 102.15,16

White Painted Pendent Line Style

- RSH 322 Juglet; handmade. Handle from rim to shoulder. Globular body. Slightly porous, red brown hard, fine fabric. Med. c. of fine black grits. Dense c. in patches of very fine white grit. Yellow to red brown matt smooth slip. Slight horizontal burnishing all over. Bright red to red brown paint. Differentiation in firing conditions.
 H. 12.4cm
 AO 19188 RS 8075
- RSH 323 RS 1932 Jug; handmade. Handle from rim to shoulder. Globular body round base. Slightly everted rim. Light brown to red brown hard, fine fabric. From surface only - dense c. of porous. Very sp. c. of fine white limestone. Med. c. of round and angular black grits. Light brown to yellow slip. All over burnish. Lustrous red paint. Evenly and accurately executed, very regular.
 H. 30.2cm
 ILL 64
 AO 16103
Ugaritica II Pl XXXIX centre
cf CM 31 1970 X-7 12 Kotsiatis
 Frankel 1974, Fig 19
- RSH 324 2e niveau Juglet; handmade. (WP V) Wide neck (4.7cm), flat base.
 cendue feinte Handle from rim to shoulder. From surface - light brown
 Iv.v.II very hard, fine fabric. Sp. c. of med. voids from burnt out vegetable matter. Sp. c. of fine white and fine dark grits. Well fired (high). Matt finish. Light brown to cream slip, matt self slipped. Matt, black to dark brown paint, smudged in places, loosely applied.

H. 13.4cm
AO 17224
Ugaritica II Fig 131.10; Fig 102.3

RSH 325 Fragmentary juglet; handmade. Handle from rim to shoulder. Plug handle. Slightly flat base. Light brown to red brown, slightly porous. Med. c. of dark brown (fine) grit. Sp. c. of dark red matter. Med. c. of dark angular fine grit. Sp. c. of fine white on surface and of med. to coarse red lumps of very fine clay or sand in section. Light brown slip, vertical and horizontal point burnishing all over, especially visible on paint, matt. Red brown paint, matt.

H.12.5cm
AO 18639 (on object) AO 18571 (on tag) both in register

RSH 326 RS 1931 Restored jug; handmade. Handle from rim to shoulder. Ovoid
niv tr n.1 w 81 body, almost flat but grooved base which creates a slight
necropole du indent. Light brown, very hard. fine fabric. From surface
2e niveau- med. c. of fine white grit to dense c. in some areas. Med.
c. of angular fine black and fine dark brown grits. Sp. c.
of angular fine red particles. Light brown slip. Slightly
burnished all over. Fired red brown in patches (3) slight
warping in one position. Matt black to dark brown, slightly
friable paint evenly applied.

ILL 65
AO 14.934
Ugaritica II Pl XLIII.4

RSH 327 Body sherd from jug; handmade. Pale green, med. hard, fine
fabric. Dense igneous. Dense c. of fine to med. dark rounded
grits. Sp. c. of white chalk/limestone. Greenish brown slip,
matt. Matt black to dark brown paint, slightly friable.

ILL 66 row 4.5
AO 84 176

RSH 328 RS 62 5.07W Body sherd from jug; handmade. Red brown, hard, fine. Sp. c.
(on sherd) of coarse deep red/black flecks or clay nodules?. Sp. c. of
fine white/dull white chalk. Med. c. of fine dark/black
grits. Red brown paint, burnish all over.

ILL 66 row 4.8
AO 81 1853 (in register RS 62 Sud Acropole 3922 3.06W &
5.03/7W)

RSH 329 RS 1939 Shoulder fragment from jug; handmade. Red brown, hard, very
E.2180 fine fabric. Sp. c. of fine black and dark brown grits. Sp.
c. of fine red grit. Burnished all over red brown slip.
Lustrous red brown paint.

ILL 66 row 4.7
AO 80 753

RSH 330 RS 1939 C.EST Body sherd from jug; handmade. Light brown hard, fine
Sondage B11 fabric. Dense c. of fine white grits, especially near
de 2.15m à 2.80 surface and dense c. of fine black grits. Pale reddish brown
slip. Slight diagonal point burnishing. Weak matt brown to black paint.

- ILL 66 row 3
AO 80 709
- RSH 331 RS 1939
Tb LXXXVI Basal sherd from jug; handmade. Red brown hard, fine fabric.
Sp. c. of fine dark grit, slightly porous. Sp. c. of fine
chalk. Red brown slip. Diagonal all over point burnishing.
Red to dark red matt paint.
- ILL 66 row 4.6
AO 84 177
- RSH 332 RS s/482 2m50 Body sherd from juglet; handmade. Red brown, hard, fine
fabric. Med. c. of fine dark grits. Light red brown slip,
lustrous red brown to dark brown paint.
- ILL 66 row 6.3
AO 84 240
- RSH 333 1938/9?
S.Rés 2199 Basal sherd from jug; handmade. Red brown hard, fine fabric.
Sp. c. of fine white grits. Pale red brown abraded slip.
Diag. point burnishing. Brown paint, lustrous, surface
abraded.
- ILL 66 row 5.5
AO 81 277 (poss from same vessel as AO 80 305)
- RSH 334 RS 1938
pt 2060
vers 2.5m Body sherd from jug; handmade. Red brown hard, fine fabric.
Sp. c. of fine white grits. Pale red brown abraded slip.
Brown paint, lustrous, surface abraded.
- ILL 66 row 5.6
AO 80 305 (poss from same vessel as AO 81 277)
- RSH 335 RS 1938
pt 2060
vers 2.5m Body sherd from jug; handmade. Light brown, med. hard, fine
clay. Sp. c. of fine white grits. Med. c. of very fine dark
grits. Sp. c. of very fine red/ dark nodules. Pale brown
slip, all over burnish. Lustrous black paint.
- ILL 66 row 4.4
AO 80 306
- RSH 336 RS 1938
sondage C3
4m05 à 4m20 Two body sherds from same vessel (jug); handmade. Dark red
hard, fine fabric. Dense surface c. of very fine
white chalk/limestone. Dense c. of fine black grit. Sp. c.
of white glimmer. Red brown even well preserved slip.
Vertical, horizontal and diagonal point burnishing. Lustrous
red brown paint.
- ILL 66 row 2.5,6
AO 80 541
AO 80 541
- RSH 337 RS 1938
PW 1802
or CW 2184
Tranche Body sherd from jug; handmade. Red brown, hard, fine
(metallic), finely porous. Sp. c. of fine white chalk. Sp.
c. of fine dark brown and black angular grits. Light brown,
vertical, horizontal diagonal burnishing all over. Red brown
even lustrous paint.

ILL 66 row 2.4
AO 81 456

RSH 338 RS 1939 Two sherds from same jug; handmade. Red, dark brown fabric.
Bibliothèque-H Dense igneous content. Med. c. of med. white to fine chalk.
Bibliothèque Dense c. of fine dark and dark brown grits. Red brown slip,
-sud diagonal point burnishing. Red brown paint.

ILL 66 row 5.4, row 5.3
AO 84 164
AO 80 485

RSH 339 RS 1939 Basal(?) sherd from jug; handmade. Red brown (faint grey
Bibliothèque-H uneven core) hard, fine fabric. Sp. c. of fine rounded
quartz, rusty red brown med, clay nodules and veg.
striations. Med. c. of fine dark grits. Self slip.
horizontal point burnishing all over. Lustrous red brown
paint.

ILL 66 row 5.7
AO 84 165

RSH 340 RS 1939 C.EST Body sherd from jug; handmade. Pale brown med. fine fabric.
sondage B11 Sp. c. of fine rounded dark grits. Sp. c. of fine shell (?)
de 2m15 à white matter. Pale brown almost green slip, matt. Lustrous
2m80 dark brown/black paint.

ILL 66 row 6.1
AO 80 711

RSH 341 RS 1939 (WP PLS/WP CLS) Three sherds (two articulated) from one jug;
sondage handmade. Very hard, med. fabric. Banded section - light
dans tranchée brown, light red brown, light brown, dark red brown. Dense
1937 le de c. of white grit. Med. c. of dark angular grit. Sp. c. of
21.12.1938 coarse white grit. Matt yellow to light brown slip. Matt
3m40 à 3m80 friable red brown to black paint.

ILL 66 row 2.2 AO 80 638-articulated
ILL 66 row 1.1 AO 80 641-articulated
ILL 66 row 2.1 AO 80 639

RSH 342 RS 1939 Body sherd from jug; handmade. Red brown, metallic, hard,
Chantier fine clay. Sp. c. of fine to med. white grit. Med. to dense
Est 2170 c. of very fine black particles. Light brown to red brown
slip. Point burnishing, all over. Bright red lustrous evenly
applied paint.

ILL 66 row 5.1
AO 80 81

RSH 343 RS 1939 Body sherd from jug; handmade. Dark brown, hard (metallic)
Tb LXXXV? fine fabric. Med. c. of fine white and fine dark grit.
Sp. c. of fine red grits. Light brown slip, slight
burnishing all over. Weak brown paint. Very metallic finish
all over.

ILL 66 row 4.1
AO 81 848

- RS 344 Body sherd from jug; handmade. Hard, metallic fine clay. Red brown. Sp. c. of fine to med. sized white grits. Med. c. of fine dark grits and sp. c. of fine red particles. Greenish light brown slip. All over faint point burnishing. Dark black matt paint.
- ILL 66 row 5.2
AO 81 850
- RS 345 RS 62 5.07W Two body sherds from same jug; handmade. Red brown, med. fine clay, porous. Sp. c. of med. dark angular grit. Sp. c. of angular (fine) quartz. Red brown slip. Point burnished all over. Self slip. Lustrous even, red paint.
- RS 62 sud
Acropole
- ILL 66 row 1.5
ILL 66 row 1.4
AO 81 1844 (RS 62 4.02W)
AO 81 1898
- RSH 346 RS 62 5.0W Very worn sherd from jug; handmade. Used for burnisher? Red brown metallic, med. fine clay. Sp. c. of med. white grit. Med. c. of fine dark grit. Very sp. c. of fine mica. Yellow matt to red brown slip. Red brown to matt black paint.
- RS 62 sud
disc? Acropole
- ILL 66 row 4.2
AO 81 1851
- RSH 347 RS 1939 Body sherd from jug; handmade. Sandwiched pale brown/pale red/almost pink fabric. Sp. c. of fine and med. limestone. Med. c. of dark and brown grits. Slightly porous. Pale brown slip, diagonal point burnishing all over. Matt black paint.
- chantier Est
2179 devant
porte
ouvrant sur
pièce su dessus
de tombe LXXV
- ILL 66 row 6.2
AO 80 155 2179-2
- RSH 348 RS 62 3922 Shoulder fragment from jug; handmade. Brown hard, fine fabric. Dense. c. of fine dark grit. Sp. c. of fine red and fine white rounded quartz. Light brown matt metallic slip. faint burnishing, dark brown to black matt paint.
- ILL 66 row 1.2
AO 81 1847
- RSH 349 Body sherd from jug; handmade. Light brown, hard, fine fabric. med. c. of fine dark grit. Sp. c. of med. yellow sand. Sp. c. of fine red and fine white sand. Light brown matt slip. Dark brown to black matt paint. Slight burnish all over.
- ILL 66 row 1.3
AO 84 767 (mis-numbered)
- RSH 350 Niveau II "Cruche en t.c. rose, peinte en rouge foncé.
Nécropole

Ht 16cm.5.1931 Tr.N, vers 2m."
Ugaritica II Fig 100.19

RSH 351 Niveau II "Cruche en t.c. crème peinte en rouge brique. Ht 12cm.5 Tr.
coud. près pt.top.55"

Ugaritica II Fig 100.25

RSH 352 Tb LXXXV "19 et 20. Cruches à panse sphérique, en t.c. chamois
peintes en rouge. Inv M.11.646 (72) Ht 14cm. Inv M11.738
(1) Ht 15cm.5"

Ugaritica II Fig 108, 19,20

White Painted Cross Line Style

RSH 353 2e niveau Juglet; handmade. High handle from rim to shoulder. Globular
body; slightly flat base. Red brown, med. fine fabric. Dense
c. of very fine black grit. Very sp. c. of fine white
matter, and irregular red brown fine matter. Yellow slip,
all over burnish (slight) but especially marked on the
paint. Bright red paint.

H. 10.1cm
AO 19206 RS 8527

RSH 354 no 507 Juglet; handmade. Red brown, hard, fine, porous fabric.
RS 2e niveau Dense c. of fine dark grits (angular and rounded). Very sp.
of med. to fine white grit. Matt red brown surface, dark red
brown paint.

H.11.4cm
AO 14889
(possibly *Ugaritica* II Fig 107.12)

RSH 355 RS 1932 Juglet, handmade. From surface hard, fine green, also light
tr.7.vi pt 8 brown fabric. Dense c. of very fine white grits and black
especially near to the surface.

H.11.5
AO 16102
Ugaritica II Fig 131.4; Fig 100.21

RSH 356 RS 2e niveau Jug; handmade. Handle from rim to shoulder. Globular body,
round base. Hard, fine red brown clay. Very well levigated.
Very sp. c. of fine white grits and angular quartz. Light
brown to yellow slip, smooth, slight burnishing all over.
Red lustrous paint, to dark brown and orange. Double
encircling bands on base, with double cross in centre.

H.15cm
6.117 RSAO 18646
Ugaritica II Fig 100.21

RSH 357 Animal vase; handmade. Trefoil mouth. Concave neck. Handle
from rim to shoulder (tail). Head stump and four feet. Pale

brown hard, fine fabric. Sp. c. of angular grey to white quartz. Dense c. of fine black and grey angular and rounded grits. Sp. c. of nodules of orange clay (?). Slightly porous. Pale brown slip, all over burnish. Black matt paint, patch where fired red.

H.10.6cm
AO 19183 RS 8439
Ugaritica II Fig 106.10

RSH 358 RS 61 T.3709 Juglet fragment.; handmade. Handle from rim to shoulder. Trefoil mouth. Red brown clay. Dense c. of fine dark grits. Sp. c. of fine white, grit, very sp. c. of fine rounded dull grey quartz. Med. c. of dark brown angular grits. Very badly abraded surface, matt light brown slip, red brown paint.

AO 81 1881 RS.61 T.3709 (on object)
RS 62 sud acropole 3922 3.06w, 5.03/0.7w 2m70/2m80(register)

RSH 359 RS 11753 Fragmentary jug; handmade. Globular body round base. Handle from rim to shoulder. Sandwiched, hard, fine outer light brown, inner light grey brown core. Dense igneous content. Sp. c. of angular red brown grits and fine white grits. Sp. c. of rounded quartz. Cream to yellow slip, diagonal point burnishing all over, but especially visible over paint. Very vivid red brown lustrous paint. Full round dot, almost flattened base.

H.16.7cm
AO 84 123 (LBL 30)

RSH 360 RS 8.267 Juglet; handmade. Handle from rim to shoulder, globular body round base. Light brown fabric. Indeterminate cream surface, matt. Matt black paint.

H.8.85cm
AO

RSH 361 RS 1939 Body sherd from jug; handmade. Red brown fabric.
chantier Est Dense c. of fine white grit. Med. c. of fine black.
2320 à 4.55m Light brown slip, horizontal burnishing. Black to dark red paint.

ILL 96 row 5.3
AO 80 82

RSH 362 RS 1938- Body sherd from jug; handmade. Light brown fabric. Pale
1939 Pt 2217 light brown slip. Red brown matt paint.

ILL 96 row 5.2
AO 80 341

RSH 363 RS 1938 Basal sherd from jug; handmade. Red brown fabric, red brown
sondage C3 slip, slight burnishing. Red paint.
4m05 à 4m20

ILL 96 row 3.1
AO 80 540

- RSH 364 RS 1938
porte ouest
1828a(?)
Body sherd from jug; handmade. Red brown fabric, red brown slip. Slight burnishing. Red paint.
ILL 96 row 5.1
AO 80 292
- RSH 365 RS 1938
sud residence
1906?pt 1938
Body sherd from jug; handmade. Light brown fabric. Light brown slip. Matt black paint.
ILL 96 row 1.5
AO 80 756
- RSH 366 Niveau II
"Cruche en t.c. verdâtre, peinte en noir. Inv. M.9116
Ht.4cm5 RS 1937 UM"
Ugaritica II Fig 110.33
- RSH 367 UM2
Juglet
Ugaritica II Pl XXXIX left
- RSH 368 U.R
Palastanlage
Schicht I
"aus feinem, rötlichem Ton, hart gebrannt; cremefarbiger, matter Überzug, rotbraune Bemalung"
Ugaritica IV, Pl II.10
- RSH 369 Palastanlage
Schicht I
Hof III
"aus porösem, sandig-quarzigem Material mit geglätteter Oberfläche schwarz auf rosiger Cremefarbe"
Ugaritica IV 268.10 Pl III

White Painted Cross Line Style/V

- RSH 370 RS 8379
(WP V) Jug; handmade. Almost flat base. ovoid body. Handle from rim to shoulder. Perforation at top of handle facing mouth, possibly deliberate. Red brown hard and very fine clay. Sp. c. of med. sized rounded dark/grey to black grits. Patches of dense c. of fine white grits. Red brown very smooth self slip. Red brown to dark red brown paint. Diagonal point burnishing especially on paint. Faint on body. Fine porosity on surface.
H.30cm
AO
- RSH 371 RS 2e niveau
Tranchée
N2 point 32
Jug; handmade. Ovoid body, flat base, handle from rim to shoulder. Red brown, hard, med. fabric. Dense c. of fine white, red, dark black grits especially at the surface. Lustrous red brown paint, slightly friable. All over faint burnishing, but otherwise red brown slip.
H.20.2cm
AO 14.935 (p32)
(possibly *Ugaritica* II Fig 105.40; drawing incomplete)

RSH 372 "Tombe
Hyksos" Fragment. of jug; handmade. Handle from rim to shoulder. Knob at base of neck diametrically opposite handle. Plug handle, not protruding. Light red brown, hard. med. fabric. Dense igneous. Med. c. (especially surface) of fine to med. white grits. Med. c. of fine dark angular and dark grey angular grits. Light brown to red brown slip. Red brown paint to dark brown.

AO 84 124 RS 193(9?)

White Painted V (eyelet)

RSH 373 T.LXXXV.63 Juglet; handmade. Handle from rim to shoulder. High carinated shoulder. Pedestal base. Red brown, hard, fine fabric fired to pale brown. Med. c. of fine dark grits. Sp. c. of dull white grits. Dense c. of pitted white matter. Very badly abraded pale brown slip. All over slight burnish. Red brown, friable, to red paint.

ILL 87 right

AO 83 854

RSH 374 Juglet; handmade. Handle from rim to shoulder. Trefoil mouth, plug handle. Carinated shoulder, pedestal base. Red brown to yellow brown hard, fine fabric. Sp. c. of fine white grit and angular red brown nodules of clay. Med. c. of fine dark angular. All over faint burnishing. Red brown to dark brown lustrous paint.

ILL 87 left

H. 14.9cm

AO 81 844

RSH 375 Jug; handmade. Handle from rim to shoulder. Piriform body, splayed pedestal base. Thick everted rim. Surface visibility - pale brown, hard fine fabric. Dense c. of fine dark angular grits. Sp. c. of fine angular quartz. Densely porous (fine pockets). Pale light brown matt self slip. All over faint burnish. Dark brown to black paint.

ILL 86 right

H.16.6cm

AO 20 372

RSH 376 T.LXXXV no69 RS 11645 Jug; handmade. Handle from rim to shoulder. Trefoil mouth, Pedestal base. Very pale brown, well levigated hard to med. hard and fine clay. Sp. c. of very fine dark grits. Extremely fine pitting. Sp. c. of white mica. Slightly shaved, matt pale brown slip. Red to dark brown to black matt paint. Slightly friable.

ILL 86 left

H. 15.4

AO 20 373

Ugaritica II, Fig 108.15; Fig 130.21

- RSH 377 UM2-3 "Cruches en t.c. chamois, peintes en rouge foncé. 15cm.5, 14cm"
Ugaritica II, Figs 108.16,17
- RSH 378 Tombe LXXXIII "Cruche en t.c. chamois, peinte en rouge Ht 19cm.5 1929 Tr.C.pt.top 2295 Inv M.11.591. La tombe a été anciennement détruite, elle remonte à l'UM 2 ou début de 3"
Ugaritica II, Fig 108.1
- RSH 379 "tombe du niveau IIe" "Cruche en terre peinte en rouge et brun"
Ugaritica I, Fig 17.10

White Painted Alternating Broad Band and Wavy Line Style

- RSH 380 RS 1939 Est. Shoulder fragment from jug; handmade. Light brown internal matt slip. Lustrous dark red to black paint. Exterior - mottled red brown to dark brown.
Rés pt 2376 à 2m60 ou RS 1938 Rés. de à 3m 65
ILL 94 row 2.8
AO 81 258
- RSH 381 Bibliothèque 2256a à 1.2m sous mayelles du puits Body sherd from jug; handmade. Red brown fabric. Light brown to red brown slip. Lustrous red paint.
ILL 94 row 4.8
AO 80 495
- RSH 382 RS 1938 Pt 1833 Body sherd from jug; handmade. Dark red brown fabric. Light brown to cream slip. orange red brown paint. All over point burnishing.
ILL 94 row 3.8
AO 80 545
- RSH 383 RS PW 2400 Tell Yahudiyeh 2m10 2^e 2.40m Body sherd from jug; handmade. Light brown fabric. Light brown slip. Lustrous black slip.
ILL 94 row 3.7b
AO 81 769
- RSH 384 RS 1939 Bibliothèque 2256a à 1m20 sous mayelle du puits. Body sherd from jug; handmade. Red brown clay. Dense c. of fine white striations (seaweed?). Dense c. of round black round black grits. Red brown slip and matt red brown paint.
ILL 94 row 1.8
AO 80 482

White Painted Composite Ware

RSH 385 RS 1938 Sherd fragment from bowl; handmade. Red brown
chantier ouest fabric, light brown internal slip. Very hard, fine fabric.
2101 (à 3m) Sp. c. of fine white grits. Med. c. of fine dark grits. Red
brown to dark brown matt paint. External deep red to dark
red paint. Diagonal burnishing.

ILL 94 row 2.7
AO 80 361

RSH 386 RS 1938 Rim sherd from bowl; handmade. Red brown fabric. Dense c.
PW 1802 ou of white grit. Matt red brown slip in interior. Matt mottled
CW 2184 brown and dark brown on exterior. Friable on exterior.
Tranche CW
profondeur 2m50

ILL 94 row 3.8
AO 81 455

RSH 387 RS 1927 Spout and rim fragment from bowl; handmade. Red brown
Tombe XLIII fabric. Red brown slip. Red lustrous paint interior,
exterior dark red brown paint.

ILL 94 row 4.7
AO 80 406

RSH 388 RS 1939 Bowl fragment; handmade. Light brown fabric. Light brown
PW 2048 à internal matt slip. Lustrous dark red to black paint.
3m80 Exterior - mottled red brown to dark brown.

ILL 94 row 2.7
AO 81 744

White Painted V

RSH 389 Charnier 26 Jug; handmade. Handle from rim to shoulder, ovoid body, flat
Banquette base. Very hard, fine light brown fabric, from surface
visibility - sp. c. of fine white limestone, overall
distribution of fine burnt out voids. Sp. c. of fine rounded
quartz. Handle - dense c. of fine white, dark, grits and
porous. Matt light brown to yellow slip. Matt black to dark
brown paint, brown paint especially on lower part of vessel.

H.29.6cm
AO 16105
Ugaritica II Figs 107.28, 131.17

RSH 390 RS 9652 Jug; handmade. Handle from rim to shoulder. Trefoil mouth.
Red brown slightly orange med. fine fabric. Dense c. of fine
white grit. Dense c. of fine angular and rounded black grit.
Sp. c. of fine nodules of deep and bright red clay. Sp. c.
of coarse white grit. Pale light brown slip; fired bright
orange in patches. Very red to dark red (orange in patches)
matt, evenly applied paint.

ILL 91 left
H.31.7cm
AO 19 253

- RSH 391 RS 11746 Jug; handmade. Handle from rim to shoulder. Ovoid body, flat T.LXXXV.no7 base. Light red brown med. fine fabric. Dense c. of fine angular dark grits. Dense c. of fine to med. soft white limestone. Med. to sp. c. of fine dark red angular grits especially at handle. Light brown self slip. Red brown to dark brown to black evenly applied black paint (friable where black).
- H. 25.1cm
AO 20370
Ugaritica II Fig 108.23; Fig 131.14
- RSH 392 "d'une tombe du IIe niveau" "Cruche en terre peinte en rouge et brun" Combines WP V and WP PLS motifs².
- Ugaritica* I, Fig 17.9
- RSH 393 Tombe Tr.Est Cône pt. top.19.plat. 1930 "Grande cruche en t.c. crème, peinte en rouge; fond Ht 28.5cm5 Inv M.7521"
- Ugaritica* II, Fig 105.37
- RSH 394 Palastanlage Shicht I Hof III WP V TLS "aus feinem, rötlichen Ton, hartgebrannt; cremefarbiger, matter Überzug rotbraune Bemalung"
- Ugaritica* IV, 266.13 Pl.II
- RSH 395 RS 61 T.3709 Neck and sherd fragments (4) from jug; handmade. Dark red hard, med. fine fabric. Very dense c. of fine white chalk or limestone. Dense c. of black/brown rounded grits. Dense c. of dark red fine nodules of clay. Two perforations where handle joins body, innermost of section is light brown, outermost dark red.
- ILL 96 row 4.3 AO 81 427
ILL 94 row 2.4 AO 81 1911
ILL 94 row 1.3 AO 81 1967
ILL 94 row 1.4 AO 81 1867
ILL 94 row 2.3 AO 81 1870
- RSH 396 RS 1938 PW 1802 (ou CW 2184 profondeur 2m50) (WP V TLS) Shoulder fragment with handle stub attached; handmade. Sandwiched light brown core with red brown to pink Tranche CW exterior. Med. c. of fine black grits. Sp. c. of fine white. Pale brown to yellow matt slip. Matt red to dark red paint.
- ILL 94 row 3.6
AO 81 452
- RSH 397 RS 1939 Tombe LXXXVI (WP V TL/WLS) Body sherd from jug; handmade. Light brown fabric. Light brown slip, matt black paint.
- ILL 94 row 1.2
AO 84 186
- RSH 398 RS 1938.1939 Neck fragment from jug; handmade. Red brown, hard fine

² "this variation of the WP PLS has not yet been found in Cyprus" SCE IV.1B, 215

- pt 2217 fabric. Sp. c. of fine chalk and fine dark grits. Red brown to yellow brown slip. Point burnishing. Red lustrous brown paint.
- ILL 94 row 1.7
ILL 95 row 2.5
AO 80 338
- RSH 399 RS 62 3909 Neck fragment from jug; handmade. Light brown, hard, fine fabric. Sp. c. of fine dark grits and fine white grit. Pale brown to cream slip. Lustrous red brown to dark red paint.
- ILL 94 row 5.6
ILL 95 row 2.6
AO 81 1922
- RSH 400 Bibliothèque Body sherd from jug; handmade. Red brown fabric. Dense c. of
2256a à 1.2m fine white limestone. Med. c. of fine dark red clay nodules.
sous mayelles Med. c. of fine dark brown and black particles. Red brown
du puits slip. Red brown slightly lustrous paint.
- ILL 94 row 4.5
AO 80 496
- RSH 401 RS 1939 Body sherd from jug; handmade. Dark rusty red brown fabric.
pt 2060? Very hard and very fine fabric. Dense igneous. Dense c. of
vers 2.5m fine round black and angular brown grits. Sp. c. of round
dark brown clay nodules. Sp. c. of fine white grits. Very
homogeneous clay matrix.
- ILL 94 row 5.5
ILL 95 row 1.6
AO 80 299
- RSH 402 RS 62 3922 (WP V TLS) Body sherd from jug; handmade. Red brown, med.
RS sud hard, med. fine fabric. Dense c. of fine to med. white
acropole limestone. Med. c. of fine dark grits. Light brown slip,
3922 3.06W slightly burnished. Dark red matt paint.
& 5.03/.07W,
2m 70/2m80
- ILL 94 row 3.5
ILL 95 row 1.3
AO 81 1845
- RSH 403 RS 1934 2nd Body sherd from jug; handmade. Light brown clay. Med. c. of
Pal. 8.30m fine black and dark brown grits. Med. hard to med. fabric.
Est 66 Light brown slip, matt. Matt black to dark brown paint.
- ILL 95 row 4.6
ILL 94 row 5.3
AO 81 413
- RSH 404 RS 1938 (WP V TLS) Body sherd from jug; handmade. Light brown, med.
PW 1802 hard, fine fabric. Sp. c. of fine chalk. Dense c. of fine
(as 81 452) cream red particles. Sp. c. of fine dark brown. Light brown
to slip. Orange to red brown burnished paint.
- ILL 94 row 4.3
ILL 95 row 4.6
AO 81 462

- RSII 405 MB 1931 (WP V TLS) Body sherd from jug; handmade. Red brown fabric.
Tr 8.14 Med. c. of fine white striations (seaweed). Dense c. of
point 63 fine white chalk/limestone. Light brown to cream slip. Dark
brown paint, slightly friable paint. Horizontal point
burnishing.
- ILL 94 row 4.6
AO 81 385
- RSII 406 RS 1939 (WP V TLS/WL) Body sherd from jug; handmade. Red brown to
C.EST to light brown, hard, fine fabric. Dense c. of fine to
sondage coarse white matter, dense c. of fine black and dark grits.
B11 de 2m15 Sp. c. of fine red particles. Light brown to yellow slip.
à 2m 80 Red brown to dark brown and matt black paint. Radial point
burnishing, metallic finish.
- ILL 95 row 3.4
AO 80 706
- RSII 407 PW (WP V/CLS) Body sherd from jug; handmade. Dark red brown
Tell fabric. Hard, fine fabric. Med. c. of round dark grit. Sp.
Yahudiyeh c. of fine white grits. Red brown slip, red brown paint. All
2m10 2^e over burnish. Slightly lustrous paint. Metallic finish.
2m40m
- ILL 94 row 2.6
ILL 95 row 3.1
AO 81 762
- RSII 408 RS 1935 Body sherd from jug; handmade. Light red brown, hard,
sondage nord fine fabric. Med. c. of fine black grits. Sp. c. of fine
28iv 35 angular red grits. Sp. c. of fine white limestone. Sp. c. of
depuis med. red brown clay nodules. Light brown slip, matt. Dark
8m85 prof brown matt paint.
jusqu'à totale
9m75
- ILL 94 row 5.1
ILL 95 row 3.5
AO 80 1083
- RSII 409 RS 62 sud Two handle frags. from jug; handmade. Red brown, hard, fine
acropole 3922 fabric. Dense. c. of fine angular grit. Sp. c. of fine red
3.06W & 5.03/ brown nodules of clay. Med. c. of fine dark brown and black
.07W 2m 70/ angular and rounded grits. Light brown to cream slip. Slight
2m80 vertical burnishing. Matt dark brown to almost black slip,
friable paint.
- ILL 94 row 1.1
ILL 94 row 2.1
ILL 95 row 1.1
ILL 95 row 2.1
AO 81 1859 RS 62 5.07W
AO 81 1859
- RSII 410 Bibliothèque Body sherd from jug; handmade. Pale brown, med. hard fabric.
2256A à 1.20m Med. c. of fine black grits. Sp. c. of fine white limestone.
sous mayelle Sp. c. of fine red brown clay nodules. Sp. c. of fine to
du puits med. quartz grains. Dense c. of fine white grits on the
surface. Pale brown matt self slip. Matt black friable

- paint.
- ILL 94 row 4.1
ILL 95 row 4.1
AO 80 488
- RSH 411 Tb LXXVIII** **Shoulder fragment from jug. Pale green fabric. Med. hard, fine, lightly porous.**
suites **Med. c. of fine to med. pockets of pale orange matter. Med. c. of fine black angular grits. Sp. c. of elongated thin white fragments. Sp. c. of coarse pale orange nodules of clay/ sand texture. Pale green self slip. Slight burnishing. Dark brown to black matt friable paint.**
- ILL 94 row 3.2
ILL 95 row 4.2
AO 80 21
- RSH 412 RS 61 T.3709** **Body sherd from jug; handmade. Pale green fabric, med. hard med. fine. Dense c. of fine pockets of light orange clay. porous. Dense c. of fine black grits. Sp. c. of pale brown fine chalk. Self slip, matt. Matt black friable paint.**
- ILL 94 row 5.2
ILL 95 row 4.3
AO 81 1876
- RSH 413 RS 1938** **Body sherd from jug; handmade. Hard, fine red brown fabric.**
pt 1892 **Inner 25% red brown, outer 75% light brown. Inner - med. c. of med. sized rounded dark nodules. Slightly porous. Outer - med. c. of fine dark. Sp. c. of fine white. Cream, light brown slip. Slightly burnished. Matt thick dark brown to black paint.**
1^{er} niveau
- ILL 94 row 4.2
ILL 95 row 4.5
AO 80 608
- RSH 414 RS 1938** **Body sherd from jug; handmade. Light brown, med. hard fabric. Sp. c. of fine white grit, med. c. of fine dark brown and black grit. Pale green slip. Slightly burnished. Abraded lustrous friable black paint.**
pt 1982
1^{er} niveau.
- ILL 94 row 3.1
ILL 95 row 4.4
AO 80 290
- RSH 415 RS 1938** **(WP V FBB) Body sherd from jug; handmade. Very hard metallic fine clay, dark red. Dense c. of fine dark brown, black, white grits. Very homogeneous fine clay matrix. Red brown matt slip. Red brown matt paint.**
sondage
pt 21014.4m
à 4.88m
- ILL 94 row 2.5
ILL 95 row 3.2
AO 80 345
- RSH 416 Porte ouest** **Body sherd from jug; handmade. Sandwiched light brown inner 2072 mélange dark brown outer. Outer - very dense c. of fine to score, RS 1939 med. white grits. Dense c. of fine black. Sp. c. of fine grey. Dense igneous. Inner- less white grits more dark grit.**

Light red brown slip. Dark red brown paint. Burnished slightly. Slightly lustrous paint.

ILL 94 row 1.5

ILL 95 row 3.3

AO 81 228

RSII 417 RS sondage
nord. Rés pt
1870 de 5.8m
à 6m.
T.LXXXI

Body sherd from jug; handmade. Red brown fabric. Hard, med. fine. Dense c. of fine to med. white grit and dark and black fine grit. Light brown to cream burnished slip. Dark red brown friable lustrous paint.

ILL 94 row 3.4

ILL 95 row 2.4

AO 81 216

RSII 418 RS 1939

Large body sherd from jug; handmade. Sandwiched inner light brown core (outer surfaces 25% red each). Sp. c. of fine white. Sp. c. of dark red round clay nodules. Med. c. of fine round black grits. Sp. c. of fine bright red sand. Light brown matt slip but diagonal point burnishing visible radiating over the surface. Dark brown matt paint.

ILL 94 row 3.3

ILL 95 row 2.3

AO 80 640

RSII 419 RS 1961
Tombe 3709

Handle from jug (WP V-VI); handmade. Pale brown hard, fine fabric. Sp. c. of very fine black and white grits. Pale brown self matt slip. Black paint.

ILL 94 row 5.4

AO 81 130

RSII 420 RS 1939
Tombe
LXXXVI

Body sherd from jug; handmade. Red brown hard, med. fine fabric. Porous. Sp. c. of fine white limestone. Med. c. of fine dark grits. Yellow, light brown slip. Slight point burnishing. Weak red paint (matt). Abraded.

ILL 94 row 4.5

ILL 95 row 1.7

AO 84 180

RSII 421 BM 86
brunes.

Cruchette WP V (rather WP CLS). Terre beige à particules blanche et Décor géométrique peint brun. Intacte.

80/5105

Mallet 1990, Fig 1.4 Pl XIV. 4,5

RSII 422 BM 86

Cruchette (panse). "Six tessons de la mince panse d'une cruchette (WP VI CLS) en pâte verdâtre très fines, décorée de bandes droites peintes en brun rouge et croisées."

80/5408

Mallet 1990, 49

- RSH 423 BM 86** **Cruchette col. "amputé du bec et de la partie inférieure de l'anse fixée au bord, en terre blanc verdâtre, décoré de bandes droites peintes en brun horizontales autour du col et verticales sur l'anse."**
- 80/5410
Mallet 1990, 49
- RSH 424 BM 1260** **Cruche (col) WP V. "Des tessons du type WP V illustrent la peterie chypriote, 81/3457, col de cruche décoré de bandes peintes brunes (Pl. BM 1246XVI,2)"**
tombe
- 81/3457
Mallet 1990, 51 Pl.XVI.2
- RSH 425 BM 1260** **Cratère (?panse) "trois morceaux de panse d'un cratère (?) en terre beige rose, avec un engobe beige jaune et un décor peint en noir de lignes obliques en séries et horizontales, et de bandes ondulées."**
tombe
BM 1246
- 81/3458
Mallet 1990, 51
- RSH 426 BM 1260** **"anse verticale de cruchette en terre verdâtre, décorée de bandes verticales peintes noires."**
tombe
BM 1246
- 81/3493
Mallet 1990, 52
- RSH 427 BM 1260** **"un tesson de vase décoré de bandes peintes brunes du type WP V."**
- 81/3328
Mallet 1990, 53

White Painted V (Composite, eyelet, ABBWLS motifs)

- RSH 427 RS 7429** **Jug; handmade. Trumpet mouth, handle from base of neck to mid shoulder. Globular body, round base. Red brown hard, fine fabric. Dense c. of fine white grits. Dense c. of elongated angular rounded black and dark brown grits. Densely igneous. Sp. c. of fine (bluish) grit. Sp. c. of veg. striations (fine).
H. 32.8**
- ILL 90
AO 20 375

White Painted V (VI)

- RSH 429 Cendu feinte** **Jug; handmade. Long cylindrical neck, flat base, thin strap no VII** **handle, flat mouth. Shaving on neck and handle. Very pale brown fabric. Well levigated. Med. fine fabric. Very sparse c. of fine dark grits. Very sp. c. of white irregular (rounded) med. quartz grains. Pale light brown almost white slip, matt. Irregular diagonal point burnishing in patches. Deep red to dark brown and black paint, lustrous.**
- ILL 131
AO 19233 RS 9706

cf RSH 70 AO 19249 9802RS same potter
Ugaritica I Fig 53.V
Ugaritica II Pl XL bottom.left

RSH 430 Jug; handmade. Trefoil mouth, Handle form mid neck to shoulder. Neck slightly shaved (vertical). Elsewhere irregular shaving. Ovoid body. Shaved to form a shallow pointed base. Only clear from surface - pale red brown med. hard, fine clay. Very well levigated. Sp. c. of coarse irregular nodules of dark red (rusty brown) matter (clay). Sp. c. of very fine dark grit. Pale red brown slip, matt. Red brown to brown to dark brown paint. Patches (2) of orange, from position in firing.

ILL 130
H. 20.1
AO 19249 9802 RS
cf RSH 429 AO 19233 RS 9706
Ugaritica I Fig 53.S

White Painted Various (likely V)

RSH 431 RS 1936 Neck and handle (plug) fragment from jug; handmade.
 Tb XXIX Rusty red brown, hard, fine fabric. Dense igneous. Dense c. of fine angular black and brown grits. Sp. c. of blue nodules (?). Sp. c. of white limestone and fine rounded grey grits. Badly corroded, some decoration visible. Red brown self slip. Red brown lustrous paint.

ILL 96 row 4.2
AO 81 819

RSH 432 Palastanlage "scherben aus feinem, rötlichem Ton, hartgebrannt;
 Schicht I cremefarbiger, matter Überzug schwarze Bemalung."
 Hof III

Ugaritica IV, 266 Pl II

White Painted Various

RSH 433 Tombe Body sherd from jug; handmade. Light brown clay.
 LXXV? Weak brown to dark brown paint. Possibly WP PLS.
 RS 1939

ILL 96 row 1.3
AO 81 849

RSH 434 RS 33 Body sherd from jug; handmade. Light brown clay.
 Tessons Matt dark brown to black paint. Possibly WP V.
 "Obeid"
 sous tranchée
 Tablette

ILL 96 row 1.4
AO 81 1972

RSH 435 Tombe Neck fragment from jug; handmade. Red brown fabric.
 ?LXVII? Yellow brown slip, red brown lustrous paint.
 RS 1939

- ILL 96 row 2.5
AO 81 167
- RSH 436 RS 1938 Body sherd from jug; handmade. Red brown, dense c. of white
Pt SR 1906 grit. Pale light brown slip, brown matt paint. Burnished.
av. minoen Possibly WP PLS/WP CLS
Fragments
Region minoens ?
"Saurtunnen" ILL 96 row 3.2
AO 81 676
- RSH 437 RS 1938 Body sherd from jug; handmade. Light brown fabric. Light
pt 2720 brown slip, matt black paint. Point burnished. Possibly WP V.
(or 2790)
ILL 96 row 2.2
AO 80 618
- RSH 438 RS 1938 Body sherd from jug; handmade. Red brown fabric. Yellow
pt 2720 to red brown slip. All over burnish. Orange to red brown
(or 2790) paint. Metallic. cf WP CLS/V AO 84 124
AO 80 618
- RSH 439 RS 1939 Body sherd from jug; handmade. Light red brown fabric.
Pt ouest 1889 Light red brown surface. Dark red to black paint. Point
burnished on paint.
ILL 96 row 2.4
AO 80 219
- RSH 440 sondage nord. Body sherd from jug; handmade. Dark brown clay. Light brown
Rés Pt 1870 de slip. Weak brown to dark brown paint. Diagonal point
5.67 à 5.75m burnishing.
(5.65m sous mur)
ILL 96 row 2.7
AO 81 187
- RSH 441 RS 1938/39 Body sherd from jug; handmade. Light brown sandwiched red
SR 1878 brown core. Dense white. Red brown surface, red brown matt
sondage vers paint. Point burnishing.
2.80m
AZIZ 18/xi
ILL 96 row 3.8
AO 80 690
- RSH 442 RS 1939 Body sherd from jug; handmade. Light brown fine fabric.
C.EST Light brown slip. Dark red brown to brown black matt paint.
sondage Possibly WP V
BII de 2.15m
à 2m 80 ILL 96 row 2.3
AO 80 705
- RSH 443 RS 1936 Tr Body sherd from jug; handmade. Red brown and light brown
Est Gdlone? sandwiched core. Pale brown slip. Friable red to black matt
paint.
ILL 96 row 3.6

AO 81 561

- RSII 444 RS 1939 Body sherd from jug; handmade. Red brown fabric. Yellow
pt 2071 point burnished slip. Red to orange paint.
suite/sous
la couche
brûlée des ILL 96 row 3.7
glacis AO 80 62
- RSII 445 RS 1938 ou 39? Body sherd from jug; handmade. Red brown fabric. Abraded
Ch.Est 2158 surface. Red brown paint.
ILL 94 row 1.6
ILL 96 row 1.1
AO 80 177
- RSII 446 RS 1938 Neck fragment from jug; handmade. Red brown fabric.
sud residence Red brown slip, red paint.
1906? pt 1938
ILL 96 row 1.8
AO 80 758
- RSII 447 RS 1939 Neck fragment from jug; handmade. Red brown fabric. Light
Tranchée C.W red brown slip, red paint.
près Pt 1583
entre 2.10
et 2.75
le 27-12-38 par
laffort au luv.
mur voisin
ILL 96 row 2.6
AO 80 669
- RSII 448 RS 1938 Body sherd from jug; handmade. Red brown fabric.
sondage Dense c. of med. white fabric. Red brown slip, red paint.
C3 4m os à Point burnishing.
4m20
AO 80 541
- RSII 449 Bibliothèque Body sherd from jug; handmade. Red brown fabric. Dense c.
2256a à 1.2m of med. white grits. Red brown slip, red paint. Horizontal
sous mayelles burnishing.
de puit
ILL 96 row 1.2
AO 80 495
- RSII 450 RS 1938 Body sherd from jug; handmade. Red brown fabric. Red brown
PW 2400 slip, red paint. Burnished.
2.10m 2^e niv.
ILL 96 row 3.4
AO 81 760

- RSII 451 RS 1938.39
porte ouest
pt 1889 Body sherd from jug; handmade. Red brown fabric. Dense
c. of white grit. Red brown slip. Diagonal point burnishing
Red paint.
- ILL 96 row 3.3
AO 80 218
- RSII 452 RS 1938
sondage
nord Rés
de 5.8 à 6m Body sherd from jug; handmade. Red brown metallic fabric.
Dense c. of white grit. Sandwiched light brown core. Light
brown slip, matt. cf AO 84 124
- ILL 96 row 4.2
AO 81 228
- RSII 453 Palastanlage
Schicht I
Hof III "aus porösem, sandig-quarzigem Material mit
rauher, schwarz und rot auf grünlicher Cremefarbe"
- Ugaritica* IV 268.10 Pl III
- RSII 454 UM2"
IV, à 5m au N
de T.II Prof.
2m 20" Cruche t.c. crème, peinte en marron. Ht 5cm RS 1932 Tr 7
- RSII 455 Palastanlage
Schicht I
Hof III "aus porösem, sandig-quarzigem Material mit geglätteter
Oberfläche, schwarz und braun auf dunkler Cremefarbe"
- Ugaritica* IV 268.13 Pl III
- RSII 456 Palastanlage
Schicht I
Hof III "aus porösem, sandig-quarzigem Material mit geglätteter
Oberfläche, schwarz und braun auf dunkler Cremefarbe"
- Ugaritica* IV 268.14 Pl III
- Red on Black Ware**
- RSII 457 RS 1939 2449 Rim and handle fragment from bowl; handmade. Light brown
very hard and very fine fabric. Red brown to black matt slip. Dark red to violet
paint.
- ILL 137 A row 1.3
AO 80 298
- RSII 458 RS sans
indications Spout and rim fragment from bowl; handmade. Very hard and
very fine dark red brown fabric. Mottled red and dark brown
matt slip.
- ILL 137 A row 1.1
AO 83 924
- RSII 459 RS 1939 porte
ouest 2072
mélanges Rim and handle fragment from bowl; handmade. Very hard
and very fine red brown fabric. Dark brown slip, red paint
exterior. Dark brown slip and red brown paint interior.

ILL 137 A row 2.1
AO 80 227

RSH 460 RS sud Spout fragment from bowl; handmade. Red brown fabric. Black
acropole matt slip on exterior and interior. Purple paint exterior.
4.12w-2m20/40 Red paint interior.

ILL 137 A row 2.2
AO 81 2049

RSH 461 RS 1939 porte Handle fragment from bowl; handmade. red brown fabric. Red
ouest 2075 brown slip- burnished. Red brown paint, matt.

ILL 137 B row 1.2
AO 80 68

RSH 462 Bibliothèque Rim sherd from bowl; handmade. Exterior black slip, no
2256E paint, interior black slip, red paint.

ILL 137 B row 1.2
AO 84 251

RSH 463 RS 1938 Rim sherd from bowl; handmade. Red brown fabric.
CW 2152 3m55 Exterior and interior black slip and red paint.
Fouilles sur
palier escalier
coudé PW

ILL 137 B row 1.3
AO 80 365

RSH 464 RS 62 4.02w Rim sherd from bowl; handmade. Red brown fabric.
sud acropole Exterior and interior black slip and red matt paint.
3922 3.06w
& 5.03/07W
2m70/2m80

ILL 137 B row 2.2
AO 81 1863

RSH 465 RS 1938 Rim sherd from bowl; handmade. Red brown fabric. Pt 1833 Exterior black slip
Pt 1833 Exterior black slip burnished, and red to purple matt paint.
Interior dark brown slip and red paint.

ILL 137 B row 2.1
AO 80 543

RSH 466 RS 1938 Rim sherd from bowl; handmade. Exterior and interior black
CW 2152 3m55 slip burnished, red matt paint.
Fouilles sur
palier escalier
coudé PW

ILL 137 B row 1.1
AO 80 365

RSH 467 RS 62 4.02w Rim sherd from bowl; handmade. Red brown fabric. Exterior
sud acropole and interior red brown slip burnished and matt red paint.
3922
3.06w & 5.03/07W

2m70/2m80

ILL 137 B row 2.3
AO 81 1864

RSII 468 RS 1938 Rim sherd from bowl; handmade. Light red brown fabric.
sondage nord Exterior and interior brown slip and matt red brown paint,
Rés pt1970 abraded on interior.
de 5.87 à 6m
T.LXXXI

ILL 137 B row 3.1
AO 81 212

RSII 469 RS1939 Rim sherd from bowl; handmade. Light red brown fabric.
Tranchée Exterior brown slip burnished and abraded paint. Red brown
CW Près Pt interior abraded paint.
1583 entre
2m10 et 2.75
le 27-12-38
par laffort au
niv mur voisin

ILL 137 B row 3.2
AO 80 659

RSH 470 as 469 Rim sherd from bowl; handmade. Light red brown fabric.
Brown slip, burnished on exterior, abraded paint. Red paint
on interior.

ILL 137 B row 2.3
AO 80 659

RSH 471 RS 1938 Body sherd from bowl; handmade. Red brown fabric..
pt 2720 Black burnished slip on exterior and purple paint.
(or 2790) Black burnished slip on interior and red paint.
2m15 à 2m80.

ILL 137 B row 5.2
AO 80 615

RSH 472 RS 1938 Body sherd from bowl; handmade. Red brown fabric. Dark brown
pt 1833 burnished slip on exterior, faint paint. Internal burnished
black slip, red paint.

ILL 137 B row 4.2
AO 80 547

RSH 473 RS 1939 C.EST Body sherd from bowl; handmade. Light grey fabric. Black
sondage B11 burnished slip and weak dark red paint on interior. Black
de burnished slip on interior.
2m15 à 2m80

ILL 137 B row 5.3
AO 80 712

RSH 474 RS 33 tessons Body sherd from bowl; handmade. Dark brown to black slip and
"obeid" sous matt red paint on exterior, interior brown slip and red
Tranchée paint.
Tablette

ILL 137 B row 4.3
AO 81 2013

RSH 475 RS s482 2m 50 Body sherd from bowl; handmade. Black slip, burnished, matt

- purple paint on exterior. Interior black slip, burnished, orange matt paint on interior.
- ILL 137 B 5.1
AO 84 236
- RSH 476 RS pt 1833 Body sherd from bowl; handmade. Red brown fabric. Mottled brown dark red to brown slip, burnished, faint paint on exterior. Interior, dark brown, burnished, faint paint.
- ILL 137 B row 4.1
AO 81 705
- RSH 477 RS 1939
Tb LXXXII Body sherd from jug; handmade. Light brown fabric. Lustrous black slip, matt red paint.
- ILL 137 A row 3.1
AO 81 843
- RSH 478 RS 1939 porte Handle (plug) from jug; handmade. Light brown fabric. ouest 1828a à Slightly shaved, matt black slip. Weak red matt 2.5m sous le paint. linteau de l'en corbellement du glacis
- ILL 137 A row 3.3
AO 80 332
- RSH 479 Tb LXXVIII
RS1939 Body sherd from jug; handmade. Light brown fabric. Red lustrous slip, faint red matt paint.
- ILL 137 A row 3.2
AO 80 20
- RSH 480 RS 1938
pt 1892
1er niveau. Body sherd from jug; handmade. Red brown fabric. Black lustrous slip. Matt red paint.
- ILL 137 A row 4.1
AO 80 607
- RSH 481 RS1938
chantier
ouest 2136
(prof 2m55) Body sherd from jug; handmade. Light brown paint. Black lustrous slip, matt red to violet paint.
- ILL 137 A row 4.2
AO 80 382
- RSH 482 RS 1939
Tranchée
CW près pt
1583
entre 2m10 et
2m75 Body sherd from jug; handmade. Lustrous black slip. No paint visible. abraded in places.
- ILL 137 A 4.3
AO 80 660
- RSH 483 NII-III Body sherd "situé au sud du temple de Dagon" Ugaritica IV, 416 Fig 1 2.2 (some fragments are possibly White Painted V-VI)

RAS SHAMRA (MINET EL BEIDHA)

White Painted V (Tangent Line Style)

RSH 484 Jug; handmade. Ovoid body, handle from rim to shoulder. Flat base. Narrow long cylindrical neck. Pale brown, hard, med. fabric. Dense c. of igneous matter. Dense c. of fine to med. black angular grit. Sp. c. of fine to med. dark red angular grit and clay particles. Sp. c. of coarse rounded angular grits. Sp. c. of rounded (med) grey quartz. Extremely pale brown, almost white matt slip. Abraded but some burnishing (vertical and diagonal). Lustrous, evenly applied red paint.

H. 25cm

ILL 88

AO 18640 (Minet el Beidha on jug, Ras Shamra on inventory)

Egypt

ABYDOS

White Painted VI (Soft Triglyphic Style)

ABY 485 *Abydos* II Pl XXXIX

TELL EL DAB'A

White Painted Pendent Line Style

DAB 486 3272 Jug; handmade.

AI-g4

E/1

cf Johnson 1982, Fig 1; H3

Bietak 1979, Pl. XXXIIIb

Maguire 1986, Fig 2.14

DAB 487 6982 Sherd from jug.

AI-k11-111

E/1

Maguire 1986 Fig 2.26

DAB 488 7057H Body sherd from jug; handmade. Light brown clay.

AI-k16 Pl 2/3 very hard, very fine; white slip, brown red paint.

E/1

Maguire 1986 Fig 1.8

DAB 489 6462P Body sherd from jug; handmade. Mottled green and dark grey

AI-k17 clay, med. hard, med. fine fabric. Dense c. of red and

E/1 brown sand with pitting. Sp. c. of black grits. Greenish

slip. All over burnish. Weak brown to black paint. Very

- badly abraded interior.
- ILL 5
- DAB 490 4014 Juglet; handmade. Plug handle.
 AII-1/17
 Gr 5
 D/3
- ILL 4
 Maguire 1986 Fig 2.16
- DAB 491 153 Body sherd from jug; wheelmade(?) Reddish yellow clay, red
 AII-112 P10/1 paint. Polished.
 E/1
- Maguire 1986 Fig 2.20
- DAB 492 4107F Body sherd from jug; handmade. Light brown grey clay, very
 AII-m18 P12/3 fine, very hard, white slip, dark brown paint.
 E/1
- Maguire 1986 Fig 1.12
- DAB 493 830 Body sherd from jug; handmade.
 AII-m10 P1 4/5
 E/3 or F
- ILL 3
 Maguire 1986, Fig 2.22
- DAB 494 1704 Jug; handmade. Surface pink brown.
 AII-m11
 Gr 7
 E/1
- ILL 5
 Maguire 1986, Fig 2.15
 cf Johnson 1982, Fig 1: H2
- DAB 495 1329 Body sherd from jug; handmade. Med. to hard orange
 AII-m11 P1 1 to light brown fabric. All over burnish. Cream slip. Red to
 D/3 dark brown lustrous paint.
- ILL 3
 KHM A2908
 Maguire 1986 Fig 2.19
- DAB 496 1434 Body sherd from jug; handmade.
 AII-n12 P1 2
 near Tb 2
 E/1
- ILL 5
- DAB 497 2879d Body sherds from jug; handmade. Light brown grey clay.
 AII-n18 P1 4/5 Fine, hard. Cream slip, dark brown paint. Polished.
 E/1-2
- Maguire 1986 Figs 1.6,7,10,11
- DAB 498 4128F Body sherds from jug; handmade. Light red, brown clay.

- All-n19 Pl 2/3 Very fine, hard; light red brown slip. Red paint.
E/1
Maguire 1986 Figs 1.3,9
- DAB 499 2067c Body sherd of small jug; black paint on yellow
All-o12 Pl 2/3 background.
E/1 or D/3
Maguire 1986 Fig 2.18
- DAB 500 4107J Body sherds from jug; handmade. Red brown clay, very
All-o/18-m/19 fine, hard. Red brown slip, red paint.
K2325
E/2-D/3-2
Maguire 1986 Figs 1.2,4,5
- DAB 501 2072 Small globular juglet, round base and strap handle;
All-o15 Pl 0/1 handmade. Light brown fabric. Porous. Hard and fine. Sp. c.
D/3-E/1 of fine white grits. Dense c. of fine black grit. Sp. c. of
coarse vegetable matter. Light brown slip. Black friable
paint. Matt all over.

ILL 4
KHM A3394
Maguire 1986 Fig 2.27
- DAB 502 3263I Shoulder fragment from jug; hard polished, brown wavy
All-p16 lines.
intrusive pit
G

ILL 2
cf Åström SCE IV.1B Fig IX:4
cf Johnson 1982 Fig 1:42

Maguire 1986 Fig 2.17
- DAB 503 3275y Body sherd from jug; handmade. Light brown clay, very
All-q21 Pl 1 hard, very fine. Brown slip, brown paint. Burnished.
E/1 Irregular interior surface.

cf Åström 1957 Fig IX:4
cf Johnson 1982 Fig 1:II2
Maguire 1986 Fig 1.1
- DAB 504 6486E Shoulder fragment from jug; handmade. Light brown, hard,
AV-p19 Pl 4/5 densely porous fabric. Sp. c. of fine white grit. Light
brown slip. Dark brown friable paint.

ILL 2
ILL 119 row 2.2
- DAB 505 6472O Body sherd from jug; handmade. Light brown hard, fine, well
AV-p19 Pl 5/6 levigated fabric. Sp. c. of fine white limestone and fine
shell. Sp. c. of fine black grit. Self slip, dark brown to
black paint. All over burnish.

ILL 2, 85 left
- DAB 506 6461F Body sherd from jug; handmade. Light brown to greenish

AV-p19 P14 d hard, med., porous fabric. Med. c. of med. angular dark grits, rusty red residue within pitting. Sp. c. of fine limestone. Grey white to cream slip. Dark brown, slightly lustrous and friable paint. All over burnish.

ILL 5

DAB 507 4498g FI-k21 P1 1/2 a/2-b/3 Body sherd from jug; wheelmade? Light brown clay, hard, fine; brown slip, dark grey paint.

Maguire 1986 Fig 1.13

DAB 508 6088 FI-o21 Opfergrube 9 a/2 Body sherds from jug; handmade. Red brown fabric hard, fine. Sp. c. of fine dark sand. Sp. c. of med. white grit. Red brown slip, red paint. Burnished.

ILL 6

DAB 509 2437 All-m16 P1 2/3 ?WP PLS. Small shoulder fragment and handle of a large jug; yellow grey surface. Black paint. Decoration of wavy line and vertical line.

Maguire 1986 Fig 2.28

DAB 510 (5051) o16 K688 WP PLS? Body sherd from jug; handmade. Red brown core with greenish interior. Brown to black paint. Light brown slip. All over burnish.

DAB 756 3154C Shoulder fragment from jug; handmade.

ILL 2

White Painted Cross Line Style

DAB 511 (5049) FI-k21 P1 0/1 b1(-b2) (CLS) Body sherd from jug; handmade. Red brown fabric, very hard. Dense c. of coarse veg temper. Sp. c. of med. sized white grit. Cream brown slip, black and brown paint, all over light burnish but fairly light in appearance.

DAB 512 6461 AIV near Kalkblocks (CLS) Neck or shoulder fragment; handmade. Light brown clay. Sp. c. of fine white grit. Med. c. of dark sand. Dense c. of light brown sand. Dense igneous content; esp. dark brown grit. Light brown slip, black paint, faint vertical burnishing.

DAB 513 6460S FI-p19/o19 P1 0/1 (CLS) Base fragment from jug; handmade. Light brown hard, fine clay. Sp. c. of limestone; med. c. of fine black grit. Light brown to cream slip, dark brown, black paint. All over burnish.

ILL 9

ILL 114 row 2.2

- DAB 514 3260c Base sherd from large jug; handmade. Grey
 AII o15-16 red fabric. Round based.
 F or E/3
- Maguire 1986 Fig 5.21
- DAB 515 7057o Globular juglet; handmade. Handle from rim to shoulder
 Cemetery NE Flat mouth; concave neck. Plug handle. Light brown, med.
 of Area AII hard, fine fabric. Sp. c. of fine limestone. Sp. c. of
 Surface dark fine grits and red sand. Light brown abraded slip.
 Black slightly lustrous paint.
- H. = 12cm
 Max Diam = 8.1cm
 Rim Diam = 2.4cm
- DAB 516 7057F Body sherd from jug; handmade. Cream, very hard and
 AII-i11 P16 very fine clay. Brown white slip. Black paint.
 f-0/2 = E?
- Maguire 1986 Fig 3.5
- DAB 517 308 Shoulder fragment from jug; handmade. Light brown
 AII-k17 P11 clay and slip. Very hard very fine clay. Black and
 dark brown paint. Lightly polished.
- Maguire 1986 Fig 3.3
- DAB 518 7057E Two (articulated) body sherds from jug; handmade. Very
 AII-k17 P13 hard and very fine dark brown clay, cream brown slip. Red
 E/1 to red brown paint.
- Maguire 1986 Fig 3.6
- DAB 519 4124 Jug. Round base, plug handle for insert into vessel
 AII-l/17 P14/5 wall; handmade rather crudely. Hard, fine pale yellow
 E/2 clay, greenish slip. Red and brown paint.
- Notes: The outside wall has been added later, clay has
 been added to the base of the handle to reinforce
 it. The interior is very irregular. The vessel is
 very fragmentary and fragile. Three substantial
 articulated sections remain but several decorated
 and undecorated fragments were not drawn.
 cf Johnson 1982 FigJ3 (Gezer)
 A9 (Accho)
 E1 (Tell Beit Mirsim)
 01 (Tell Mevorakh)
- Maguire 1986 Fig 3.9
- DAB 520 527 Basal sherd from jug; handmade. Hard, fine light brown
 AII-m13 P10/1 clay. Light brown greenish slip. Sp. to med. c. of fine to
 surface coarse grits. Black matt paint.
 post E/1
- ILL 8
 KHM A2372
 Maguire 1986 Fig 2.24

- DAB 521 1990f Body sherd from jug. Red fabric, light red decoration.
 AII-n/15 Pl 1
 E/1-E/2
 Maguire 1986 Fig 5.20
- DAB 522 3416k Body sherds (5) from jug; handmade. Very fine light orange
 AII-n17 Pl 2/3 fabric. White slip with red brown and black decoration.
 E/2-F
 ILL 7
 Maguire 1986 Fig 5.10
- DAB 523 3274i Two body sherds from jug; wheelmade(?) Very fine, very
 AII-n19 Pl 1/2 hard light grey clay. Black paint.
 dist Tb 1
 D/2
 Maguire 1986 Fig 5.12
- DAB 524 4128D Body sherd from jug, handmade. Very hard, very fine
 AII-n19 Pl 2/3 light brown clay. Light brown slip. The surface is
 E/1? very badly corroded.
 Maguire 1986 Fig 3.7
- DAB 525 4148B Shoulder fragment from jug; handmade. Fine, hard light brown
 AII-o/20 Pl 4/5 reddish fabric, dark red paint, well polished. Irregular interior
 later temple surface
 phase
 K2533
 E/1
 Maguire 1986 Fig 3.1
- DAB 526 4148B Body sherd from jug; handmade. Reddish brown, fine, hard
 AII-o20 Pl 4/5 clay. Red paint. Well polished. Very uneven interior
 Str E/1 surface.
 Maguire 1986 Fig 3.8
- DAB 527 2056a Body and neck fragments from jug; yellow slip and black
 AII-o12 Pl 4 lines, broad bands encircling neck.
 D/3
 Maguire 1986 Fig 5.22
- DAB 528 (5055) Two articulated body sherds from jug; handmade.
 AII-p21 Pl 4/5 Sandwiched pinkish brown core with light brown. Dense
 K2321 igneous content. Dense c. of fine white, black grit. Med.
 d = G c. of red sand. Orange red to red brown matt paint.
 Slightly abraded.
- DAB 529 819b Body sherd from jug; handmade. Brown fabric, outer section
 AIII Pl 1/2 red brick. Hard and fine. Thick cream slip. Black and red
 suchgraben friable paint. Dense c. of black grit. Sp. c. of fine white
 b-c? grit. All over burnish.
 KHM A2598b

DAB 530 6486B Handle fragment (plug) from small globular juglet;
AV-p19 Pl 4/5 handmade. Red brown to light green hard, porous but fine
fabric. Sp. c. of coarse veg matter and fine limestone.
Dense c. of fine/angular dark brown grits. Very sp. c. of
fine red sand. Light brown slip, black to red brown
friable paint.

ILL 8
ILL 119 row 2.3

DAB 531 6472P Body sherd from jug; handmade. Light red brown, hard
AV-p19 Pl 5/6 porous but well levigated fabric. Sp. c. of fine white .
K3495 grit. Med c. of fine black grits. Light brown slip, red
brown lustrous paint. All over diagonal point burnishing.

ILL 8, 85 right

DAB 532 3404F Body sherd from jug; handmade. Very hard and very fine
FI-i/21 red and light brown sandwich core. Brown orange slip.
disturbed Very red paint.
by Naville
b/1-2

Maguire 1986 Fig 3.4

DAB 533 3556k Body sherd from jug; handmade. Very fine light brown
FI-i/23 Pl 1/2 fabric and surface; black and red paint.
disturbed
by Naville
a/2-b/2

Maguire 1986 Fig 5.11

DAB 534 (5064) Body sherd from jug; handmade. Red brown, very hard
FI-i22 and fine fabric. Self slipped red brown. Friable black
Gr.40 paint. Dense c. of fine white grits, red sand and black
K2527 grit. Highly burnished all over.
d

DAB 535 4305D Shoulder fragment from jug; handmade. Very light brown,
FI-j23N very hard, fine clay. Light brown clay and slip. Red and
disturbed brown paint.
by Naville
c-b/3

Maguire 1986 Fig 3.2

DAB 536 6460K WP CLS
FI-123
Gr 26
b1

ILL 117, 118 row 3.1

DAB 537 6460R Body sherds from jug; handmade. Light brown hard, fine
FI-123 fabric. Sp. c. of fine white grit. Med. c. of fine black
grit. Med. c. of yellow brown sand. Light brown to cream
slip. Dark brown to black paint to red paint. Faint
burnishing.

ILL 8, 84

- DAB 538 (5050) Four articulated body sherds from jug; handmade.
o15 Pl2/3 Mottled green fabric and slip.. Fairly porous. Dense c. of
K613 red sand and med. c.. of veg. matter. Uneven interior
surface. Matt dark brown, friable paint.
- DAB 539 (5071) Body sherds (3) from jug; handmade. Red brown fabric. Sp. c. of
FI-j27 Pl 1/2 fine white black and red grits. Light brown slip. Orange red to dark brown paint.
K2536b
c2/3

ILL 116 row 3.2

- DAB 540 (5061) CLS ? Four articulated body frags. from jug;
FI-i22 handmade. Light brown fabric. Dense c. of fine black
Gr.29 grit. Sp. c. of red med. sand. Sp. c. of fine white
K2488 limestone. Mottled cream slip. Matt. Pitted all over. Very
c badly abraded. Black friable paint.

ILL 115 row 1.2

White Painted Cross Line or Pendent Line Style

- DAB 541 (5070) WP CLS/PLS Body sherd from jug; handmade. Red brown
AII-p21 Pl 6/7 fabric, very hard and fine. Dense c. of dark grits and fine white grits,
K2451 especially near the surface. Orange red slip. All over burnish.
e

- DAB 542 6460P WP CLS/PLS Body sherd from juglet; handmade.
FI-p20 Light brown to green, porous, hard, med fabric.
Navillegrube 4 Sp. c. of fine white grit; dense c. of fine black grit.
Self slip. Black matt paint.

ILL 8

- DAB 543 3043 WP CLS? Jug; handmade. Strap handle, round base. Very
AII-p20 fine core. Brown red lines.
Grave 3
E/2-E/1

ILL 9

Maguire 1986 Fig 5.14

- DAB 544 6462L WP CLS?
AV-p19 Pl 4/5
K3429

ILL 34

ILL 109 row 2.2

- DAB 545 341 WP PLS/CLS. Jug; handmade? Very light brown clay, fine to
AI-g4 med.; reddish yellow slip. Red and brown stripes on
Grave3neck.
E/1 Classed as WP Pendent Line Style.

Maguire 1986, Fig 2.23

- DAB 546 2653 WP PLS or CLS. Shoulder fragment from jug; handmade.
AII-o16 Pl 1/2 Very hard and fine red brown, grey sandwiched core. Sp. c.

F-E/3 of fine white grit and black grit. Cream slip. Lustrous red brown paint. Burnished on paint only.

ILL 34

KIIM .

Maguire 1986 Fig 8.22

White Painted Alternating Broad Band and Wavy Line Style

DAB 547 6461H Body sherd from jug; handmade.
AV-p19 Pl4 Hard, med. to fine clay. Sandwiched porous pale green (outer) and red brown (inner) core. As 6461G in technique.

ILL 11

DAB 548 6015A Body sherd from jug; handmade. Med. very fine red
FI-o20 brown/light brown sandwiched core. Sp. c. of fine
Gr 12 yellow/white sand and sp. c. of fine to med. dark grits. Yellow light brown slip and black, friable matt paint.

ILL 11, 100

DAB 549 6486D Body sherd from jug; handmade. Light brown, hard, fine
AV-p19 Pl 4/5 densely porous fabric. Med. c. of fine white limestone. Med. c. of angular black sand. Light brown slip, black friable matt paint.

ILL 11

ILL 119 row 1.1

DAB 550 6859B Shoulder fragment from jug; handmade.
AV-n17 Pl 2 Hard, fine and porous light brown fabric. Med. c.
within room of fine black grit and sp. c. of red sand. Light brown/cream slip, matt black paint and all over burnish.

ILL 109 row 1.1

DAB 551 6137J Body sherd from jug; handmade. Red brown
AV-p16 Pl 1/2 med. fine fabric, orange core. Med. c. of black grit. Sp.
Grube c. of fine white sand.

ILL 16

DAB 552 6461E Body sherd from jug; handmade. Med. hard and fine brown
AV-p17 clay. Sp. c. of fine red and white sand/stone. Sp. c. of
P10/1-2 fine dark grits. Light brown slip; dark brown matt paint.
K34425

ILL 19

DAB 553 6461S Neck fragment from jug; handmade. Med. fine, green to light
AV-p16 P11/2 brown densely porous fabric. Sp c. of fine white grit
(some shell). Dense c. of fine dark grits and med. c. of
fine red sand. Greenish brown slip. Black friable matt
paint.

White Painted V Ware

DAB 554 1249 WP V TL/WLS Body sherd from jug; handmade.
AII-114 P1 3 Light brown greenish fabric. Sp. c. of fine white and
E or D/3 dark grit. Cream/light brown slip. Black paint.

KHIM A2836
Maguire 1986 Fig 2.21

DAB 555 (5060) WP V/RS Light brown, hard, fine fabric. Dense c. of fine
AII-n19 black grit. Sp. c. of fine white limestone. Red brown
K2006 friable paint, all over burnish.

DAB 556 (5076) Body sherd from jug; handmade. Dense c. of black and white
FI-k23 P1 1 grits. Thin peach core. Some vegetable matter. Very hard and fine.
K2729 Red paint. Burnished slip. Matt paint.
b1/b2

ILL 116 row 3.1

DAB 557 6461V Body sherd from jug; handmade.
AV-p18 P1 1-2

ILL 5

DAB 558 6489G WP (Kal). Rim fragment from bowl; handmade.
AV-p19 P1 7 Light red brown med. hard, very fine well levigated
E1/2 fabric. Sp. c. of very fine limestone and very fine red
sand and black grit. Red brown slip, red to red brown
paint. Abraded surface but some point burnishing visible.

$\phi < 10\%$ remaining

ILL 12
ILL 117, 118 row 1.2

DAB 559 6489O WP (Kal). Body sherd from jug; handmade. Dark grey, very
AV-p19 P1 7 hard and very fine fabric. Sp. c. of fine white grit. Dark
E1/2 brown to black paint.

ILL 12

DAB 560 6462T WP (Composite BS/RS/WP) bowl fragment; handmade.
AII-k17 P1 3 Self slipped red brown fabric, very hard and very fine.
K3360 Sp. c. of white angular quartz, dark grit and fine red
d/E1 sand. Red paint.

ILL 12, 104 row 2.1

- DAB 561 94 Body sherd from jug; handmade. Light brown green fabric with light brown internal sandwiched core. Hard and fine. Slightly porous. Sp. c. of fine white and black grits. Greenish light brown slip. Black friable paint.
- AI-g/3
17 aus
Oberbau2
sec depos
- ILL 21
KIIM A2191
Maguire 1986 Fig 8.26
- DAB 562 819 Handle from bowl; handmade. Light brown fabric. Hard and fine. Sp. c. of fine dark and white grits. Greenish light brown slip. Black friable paint.
- AIII PL 1/2
suchgraben
- KHIM A2598a
- DAB 563 6461R3 WP V Handle fragment; handmade. Light brown hard, med. fabric. Sp. c. of fine white limestone and red sand. Dense c. of fine white quartz and dark grey black and brown grits. Yellow brown, red to dark brown matt, friable paint.
- AV-p16 P11/2
b2 E1-D2
- ILL 24
ILL 106 row 2.2
- DAB 564 6461G Body sherd from jug; handmade. Very hard fabric. Outer section pale green, inner core red brown. Sp. c. of surface limestone. Outer: porous, voids from pitting of red matter. Inner: dense igneous, white, red angular quartz grains. Sp. c. of white matter possibly shell. Pale green surface weak matt black, slightly friable paint. All over burnish.
- AV-p19 P14
- ILL 34
- DAB 565 (5331) Neck fragment from jug; handmade. Light green fabric, porous, high fired. Med. c. of fine black grit and sp. c. of med. white grit. Light green slip, black paint and brown.
- AII-a/21
K565
- ILL 115 row 2.3
- DAB 566 6461R2 (CLS) Base fragment (flat) of jug; handmade. Red brown, hard, very fine fabric. med. c. of med. veg matter on external surface. Sp. c. of fine white limestone. Sp. c. of fine angular dark grits. Yellow brown slip, red paint.
- AV-p16 P11/2
- ILL 9
ILL 110 row 1.1
- DAB 567 6462Q (WP V BB) Body sherd from jug; handmade. Med. fine red brown fabric. Very sp. c. of fine white grit. Med. c. of fine angular grits, very sp. c. of fine red sand.
- AII-k17
d E/1
- ILL 30

- DAB 568 6799G (WP V BB) Body sherd from jug; handmade. Hard, fine light red brown clay. Dense c. of fine red sand and fine white limestone and dark grit: Light red brown surface, red as 6799H paint and all over burnish.
AV-p18 P13
rel b2/3
ILL 30
- DAB 569 518 Body sherd from jug; handmade. Red brown, hard and fine fabric. Sp. c. of fine to med. grits. Dense c. of angular black grit and red grit. Cream slip. Black friable matt paint. Burnished before paint applied.
All-m13 P13 surface
D/3
KIIM A2365
ILL 31
Maguire 1986 Fig 5.15
- DAB 570 580 Body sherd from jug; handmade. Fine hard clay. Fine All-m13 P1 3/4 cream slip. Painted black stripes.
D/3-E/1
ILL 31
Maguire 1986 Fig 8.23
- DAB 571 6486G Large handle fragment; handmade. Light brown hard fabric. Med. AV-n17 P10/1 c. of fine black grit and angular dark brown. Sp. c. of fine white limestone. Self slipped black friable paint.
ILL 22, 113
- DAB 572 6855F Handle fragment.; handmade. Very hard and fine red brown AV-n17 P10/1 fabric. Sp. c. of fine limestone. Yellowish cream slip. Grube Dull black paint. Point burnish prior to painting.
ILL 23
- DAB 573 6474 Possibly WP V TLS. Juglet (incomplete); handmade. AV-n17 P1 1/2 Neck fragment to rim. Everted rim, handle from mid neck to shoulder, crude plug handle, flat base; globular body. Very uneven interior surface. Neck made separately; cylindrical. In very fragment condition. Badly eroded through salts. Black encrustation on main body. Hard, fine well levigated, slightly porous fabric. Sp. c. of coarse red 'sand' nodules. Very badly abraded faint yellow slip. Thick friable but abraded lustrous red paint.
Ht. c 16cm
ILL 17
- DAB 574 6461R1 Possibly WP V TLS. Shoulder fragment from jug; handmade. AV-p16 P11/2 Dark brown, hard, very fine clay. Dense c. of porous fine to med. white grit. Sp. c. of coarse brown sand. med. c. of fine black grit and fine red sand. Slightly porous. Dense surface c. of fine pitting. Yellow brown slip; dark red paint, matt.
ILL 30
ILL 105 row 2.2

- DAB 575 6500v Possible WP V TLS. Body sherd from jug; handmade. Med. AV-o17 Pl 0/1 fine, light brown clay. Sp. c. of med. red sand and fine white limestone. Med. c. of fine quartz and fine black mica. Light brown slip, dark brown to black matt paint. Vertical point burnishing (3cm strips).
ILL 21, 105 row 2.3
- DAB 576 6859A1-2 Body sherds (2) from jug; handmade. Hard, fine light brown AV-n17 Pl 2 clay. Dense c. of fine igneous matter. Med. c. of fine within room grits and red sand. Densely porous. Light brown self slip. Matt light red brown to dark brown slightly friable paint.
ILL DR 19
ILL 109 row 3.1,2
- DAB 577 6856E Part handle and neck fragment from jug; handmade. AV-o18 Pl 1/2 Light brown, hard, med. clay. Dense c. of igneous. Med. c. of white shell/or limestone and fine dark grits. Med. c. med. red sand. Sp. c. of coarse dark grit. Porous. Light brown-greenish slip. Black, matt friable paint.
ILL 25
ILL 106 row 3.3
- DAB 578 6486M Handle stub and shoulder fragment from jug; handmade. AV-o19 Red brown, inner core dark brown, Med. c. of black grit. Grube 7 Sp. c. of med. white foraminifera. Red brown and cream (in K3422 firing) slip. Red matt paint; all over burnish (vertical) before painting.
ILL 21
ILL 112 left
- DAB 579 6856M Body sherd from jug; handmade. Grey to greenish light AV-o19 Pl 2/3 brown, hard, med. fabric. Med. c. of fine round quartz. Sp. c. of fine limestone. med. c. of fine black grit. Light brown, with greenish tinge to slip. Black matt paint.
ILL DR 6
- DAB 580 6857C Handle fragment; handmade. Red brown very hard and very AV-p16 Pl1/2 fine fabric. Sp. c. of fine red, fine white and med. c. of K3561 fine black grits. Light brown slip, dark brown paint and slight burnishing.
ILL 27
- DAB 581 6462 Body sherd from closed vessel; handmade. Very hard and AV-p17 Pl 2 very fine light brown clay (and slip). Sp. c. of very fine white grits and coarse dark brown grits. Dark brown to black paint; all over burnish.
ILL 39
ILL 117, 118 row 2.2
- DAB 582 6472M Handle fragment from jug; handmade. Greenish light brown AV-p19 Pl 4 fabric. Very porous. Hard, med. to fine fabric. Med. c. of

- K3449/1-5 orange matter (sand?). Dense c. of surface black grits.
c? Self slip, weak grey friable paint.
- ILL 24
ILL 107 row 2.3
- DAB 583 6472I Handle and shoulder fragment from jug; handmade.
AV-p19 Pl 4/5 Hard, med. porous, and densely igneous, light brown to red
K3478 brown fabric. Sp. c. of fine white grits and rounded
D/3 orange quartz. Med. c. of fine angular black and dark red
grits.
- ILL 25
ILL 107 row 2.1
- DAB 584 6486A Rim and neck fragment from large jug; handmade.
AV-p19 Pl 4/5 Light brown, hard, fine slightly porous but well levigated
clay. Sp. c. of med. black rounded grits and fine white
limestone on surface. Cream slip, dark brown to black matt
friable paint. Light burnishing all over.
- ø 11cm
ILL 26, 102
- DAB 585 6486L Strap plug handle from jug of tankard; handmade.
AV-p19 Pl 5/6 Light brown med. to fine clay. Sp. c. of fine white grit.
e? med. c. of surface pitting from limestone explosion. Much
burnt out porous area on surface. Sp. c. of fine red sand and
black grit. Self slipped (light brown). Dark brown to black,
friable matt paint. Point, vertical burnishing before paint applied.
- ILL 23, 98, 99
- DAB 586 6857A Neck fragment from jug; handmade. Red brown, hard, med.
AV-p19 Pl 5/6 porous fabric. Sp. c. of med. grains of rounded quartz.
K3504 Med. c. of fine red sand and sp. c. of fine white grit. Red brown slip
and paint, all over burnishing.
- ILL 20
ILL 110 row 2.1
- DAB 587 6857B Neck and rim fragment from large jug; handmade. Greenish
AV-p19 Pl 5/6 hard, med., very porous fabric. Dense c. of fine black
K3504 grit. Sp. c. of fine limestone and fine red sand. Matt
greenish surface, black, friable matt paint and vertical point burnishing.
- ILL 25
ILL 108 row 1.1
- DAB 588 6461T Handle fragment from jug; handmade. Greenish light brown (as
AV-p19 PL 5/66857B) med. fine densely porous fabric. Med. c. of fine to
med. quartz. Med. c. of fine red sand and fine black
grits.
- ILL 24
ILL 107 row 1.3

- DAB 589 (5062)³
FI-i22 Gr.28
Raubgrube
K2424
Base fragment from jug; possibly wheelmade. Hard, fine pink exterior core, brown interior. Med. c. of angular brown grits. Sp. c. of white grits. Med. c. of veg. temper. Dark brown paint. Burnishing.
- DAB 590 (5078)
FI-j23 Pl 0/1
K2526
a/2-b/1
WP V Body sherd from jug; handmade. Light brown fabric. Very hard and fine. Med. c. of med. sized black grit. Med. c. of med. sized black grit and med. to coarse white grit. Sp. c. of fine red sand. Dark brown to red paint. All over burnish. Light brown slip.
- DAB 591 (5075)
FI-122 Pl 1/2
c1
WP V. Body sherd from jug; handmade. Porous light brown fabric. Sp. c. of fine black grit. Friable black paint. Cream, light brown slip. Slip burnished.

ILL 116 Row 3.3
- DAB 592 7051A
FI-p20
Grab 2
Large handle fragment from jug; handmade. Light brown hard, fabric. med. c. of fine dark grits and fine red sand. Originally yellow burnished slip, dark brown to light brown paint.
- DAB 593 6473A
AV-p19 Pl 5/6
K3495
d/e
Possibly WP V TLS; Body sherd from juglet; handmade. Hard, fine, quite porous dark grey/brown. Sp. c. of fine foraminifera and fine black grit. Grey brown surface, dark red, friable paint. All over burnish.

ILL 15, 85 centre
ILL 109 row 1.2
- DAB 594 6461I
AV-o18
Grube 7
Body sherd from jug; handmade. Dark brown, hard; med. clay. Dense c. of fine black and dark brown grits. Dense surface pitting. Very sp. c. of fine white grit and redLight brown slip; dark brown to light brown paint. Faint burnishing.

ILL 45
ILL 108 row 1.3
- DAB 595 6489N
AV-p19 Pl 7
E1/2
Body sherd from jug; WP V/Bichrome weak colours. Handmade. Med. fine red brown clay. Sp. c. of med. red sand and fine white limestone. Sp. c. of rounded orange quartz. Med. c. of fine black dark grit. Light brown, dark brown to black matt paint. Diagonal point burnishing.

ILL 45
ILL 111 row 1.1
- DAB 596 6489M
AV-p19 Pl 7
E1/2
Basal sherd from jug; handmade. Light brown hard, med. fabric. Sp. c. of surface fine limestone. Med. c. of fine black grit and red sand. Sp. c. of coarse veg. temper. Light brown abraded slip, red paint, abraded.

ILL 20
ILL 110 row 1.2

³ These numbers in brackets are temporary numbers allocated by the author while awaiting confirmation of Tell el Dab'a catalogue numbers.

DAB 597 6472W Neck fragment from jug; handmade. Light green
AV-p19 Pl 5/6 fabric, hard. Sp. c. of fine white grit, poss shell;
K3492 fine red and med. c. of fine black grits. Self slip,
black, dark grey paint.

ILL 20

DAB 598 1974 Bowl; handmade. Very fine and very hard orange red core.
m11 nol Well fired. Fine limestone inclusions. No slip. Brown
D/2 and red paint. Very smooth both inside and out. Rim 17cm.

MX diameter 18°

ILL 14

SCE IV.1B, Fig XV. 1/7,8. P.68.

DAB 599 6461X Possibly WP V TLS. Badly abraded body sherd from jug;
AV-p18 Pl 1/2 handmade. Med. and very fine light red brown fabric.
Med. c. of fine to med. red sand. Sp. c. of very fine
white grit. Med. c. of dark grit. Yellow slip, red
paint abraded.

ILL 15

DAB 600 6856t Possibly WP V TLS as 6500v. Body sherd from jug;
AV-p19 Pl 4-5 handmade. Hard. med. slightly porous light red brown
Navelle clay. Med. c. of fine white grit and fine red sand.
disturbance Yellow brown, slip, bright red to dark brown matt paint.
Faint burnishing.

ILL 32

ILL 105 row 2.1

DAB 601 (5058) Amphora fragment; handmade. Very hard orange red fabric.
AII-i11 Pl 6/7 Dense c. of coarse red sand and black grit. Dense c. of
f-g coarse white to light brown grit. Light brown slip. Rusty
red friable paint. Burnish all over. Pitted surface.

ILL 115 row 1.1

DAB 602 3423C Amphora? fragment Body sherd; handmade. Red clay, no
AII-p21 Pl 2/3 slip. Red paint.
robbers' pit
Tb 3

Maguire 1986, Fig 19.2

White Painted V Tangent Line Style

DAB 603 1008 Body sherd from jug; handmade. Red brown, very hard,
AII-n11 Pl 1 fine fabric. Dense c. of fine white grit. Sp. c. of med. to
coarse red sand and fine black grit. Cream slip. Black matt
friable paint.

ILL 13

KHM A2699

DAB 604 6472Y WP V TLS. Handle (plug) and neck fragment, including part of shoulder.
AV-o19 handmade. Light red brown fabric. Hard. Dense ifneous. Sp. c. of med.
Grube 7 black grits, white limestone. Med. c. of fine red sand. Sp. c. of rounded

& 6486N quartz. Light brown to cream slip. Black friable matt paint.
K3422

ILL 26, 103 = 6472Y, 112 = 6486N

DAB 605 6461W Shoulder fragment from small jug; handmade.
AV-p18 P11/2 Med. fine light grey clay. Med. c. of fine black grit, sp. c. of fine white grits.
Slightly porous. Very sp. c. of fine white limestone. Light brown
slip to cream. Black matt paint.

ILL 15
ILL 108 row 2.2

DAB 606 6486F Body sherd from jug; handmade. Cream hard, porous fabric.
AV-p19 P14/5 Sp. c. of fine black and white grit. Self slip, cream.
Black friable to dark brown matt paint. Diagonal
burnishing.

ILL 15
ILL 119 row 2.1

DAB 607 6461N Body sherd from jug; handmade.
AV-p19 P15/6 Red brown fabric. Sp. c. of fine white limestone and med.
to fine red sand; med. c. of angular dark grits.
Light brown surface, matt red paint, all over faint burnish.

ILL 15
ILL 105 row 1.1

DAB 608 6023A Body sherd from jug; handmade. Light brown, hard, porous
FI-o20 fabric. Med. c. of fine dark grits. Sp. c. of rounded red sand
Gr.14 white shell, and limestone. Light brown lustrous slip.
Dark brown to black friable paint. Highly burnished all
over to give a very soapy feel.

ILL 16, 101
cf KAB 202

White Painted V Fine Line Style

DAB 609 7057q Rim fragment from small bowl or cup;
surface handmade. Bevelled rim. Very hard and
Friedhof very fine. Sp. c. of fine angular grit and fine
red sand. Self slip. Matt black friable paint.

φ 7.4 cm

ILL 12
ILL 117, 118 row 1.1

White Painted V Broad Band Style

DAB 610 6500u Body sherd from jug; handmade.
AV-o17 P10/1 Light brown hard, fine clay. Med. c. of fine red sand and
rel a/b fine dark brown, grits and sp. c. of fine to med.
limestone. Light brown slip; dark, matt paint.

ILL 31
ILL 105 row 1.3

- DAB 611 6486C (ABBWLS) Body sherd from jug, near shoulder;
AV-p19 P1 4/5 handmade. Light brown hard, porous fabric. Sp. c. of fine
white limestone. Very sp. c. of red sand; med. c. of
angular black grit.
- ILL 34
ILL 119 row 1.2
- DAB 612 6460L Body sherd from jug; handmade. Hard, fine, red brown
AII-k15 P11 fabric. Sp. c. of fine white limestone; med. c. of fine
K3223 dark grit, dark brown and yellow sand. Self slip, red
D2/3 paint. Horizontal burnishing except on paint.
- ILL 20
ILL 114 row 1.1
- DAB 613 6137M Body sherd from closed vessel; handmade. Light brown med.
AV-p17 P1 1/2 clay. Med. c. of fine black grit. Sp. c. of fine to
Grube 17 med. sand and white limestone. Light brown slip. Black
matt thickly applied paint.
- DAB 614 6462M Body sherd from jug; handmade.
AV-p19 P1 4/5 Outer most surface of the section light green,
K3429 75% red brown, hard, med. fine fabric. Sp. c. of med,
limestone and fine red sand. Med. c. of fine black and
dark brown grit. Cream slip, dark brown, matt friable paint.
- ILL 16
ILL 109 row 2.1
- DAB 615 6472H2 Body sherd from jug; handmade. Light brown hard,
AV-p19 P1 5/6 fine porous fabric. Sp. c. of med. sized red grit
K3480 (rounded). Sp. c. of fine veg. temper. Light brown matt
E1-D3 slip to cream. Black to dark brown matt friable paint.
Faint diagonal point burnishing.
- ILL 19
ILL 109 row 3.3
- DAB 616 6461M Body sherd from jug; handmade. Med., fine light brown
AV-p19 fabric. med. c. of fine dark sand and sp. surface c. of
Gr 27 fine white limestone. Light brown, almost white slip; dark
brown to black abraded paint. Burnishing all over, except
paint.
- ILL 16
ILL 108 row 2.1
- DAB 617 6462K Body sherd from closed vessel; handmade.
AV-p19 P1 6 Hard, med. fabric. Sp. c. of med black grit and
fine white limestone. Med. c. of dark angular grits. Light
red brown slip. Lustrous deep red paint. All over point
burnishing. Well preserved surface.
- ILL 32
ILL 105 row 1.2

- DAB 618 6034B Body sherd from jug; handmade. Hard, med. red brown
 FI-o21 fabric. Dense c. of fine black grit; sp. c. of light brown
 Gr 4/Sit 2 quartz. Sp. c. of coarse veg. burn out. Sp. c. of fine
 a/2 b/1d white limestone. Self slip. Red and black friable paint.
- ILL 34
- DAB 619 6460Q WP IND Body sherd from jug; handmade. Light brown to green
 FI-p20 hard, fine fabric. Dense c. of fine black grit, light
 Navillegrube 4 brown sand. Med. c. of dark brown grit. Light brown to
 green slip. Black to dark brown friable paint.

White Painted V-VI

- DAB 620 740 Neck and shoulder fragment from juglet; handmade.
 AII-k11 P13 Very fine, hard greenish light brown clay. Sp. c. of fine
 from well dark grit and fine white. Cream slip. Black matt paint. All
 over burnish. Light shaving or wet smoothing.

ILL 27
 KHM A2544
 Maguire 1986, Fig 8.15

- DAB 621 749 Body sherd from jug; handmade.
 AII-k11 P13 Light red brown , hard and fine fabric. Med. c. of fine
 E/1 or E/2 dark grits and red angular med. to coarse grits. Sp. c. of
 fine white grits. Light brown slip. Dark brown to light
 orange paint. Matt paint and slip.

KHM A2552
 Maguire 1986, Fig 2.25

- DAB 622 6462N Handle fragment with plug handle; handmade.
 AV-q18 Light brown, hard and very fine well levigated fabric.
 PI(1)/2 Sp. c. of fine limestone and fine black angular grits.
 Yellow to cream slip, dark brown matt paint. Slight
 incisions on back of handle. Slight shaving technique used
 all over surface.

ILL 28
 ILL 106 row 2.1

- DAB 623 (5059) Handle fragment from jug; handmade. Green core
 AN-z21 and slip. Matt. Dense c. of fine to med. sized black grits.
 K2222 Dense c. of fine red sand. Small c. of fine white grit.
 Black to brown friable paint, fairly weak.

ILL 115 row 2.2

- DAB 624 6461L WP VI CLS. Body sherd from jug; handmade. Grey very
 AV-p16 P11/2 hard and fine fabric. Sp. c. of med. black grit and
 rounded quartz. Light green slip, dark brown to black
 paint. Horizontal burnishing all over the vessel.

DAB 625 3402a WP VI CLS. Large body sherd from jug; wheelmade.
FI-i/20 P12 Dark red brown, very hard. Dense c. of
?drw = i/21 fine glimmer. Med. c. of fine dark grits. Well levigated
pit dist Dense c. of white discoloured schisms. Red brown, black
paint applied after point burnishing

Maguire 1986 Fig 5.18

White Painted Wheelmade

DAB 626 (5052) Rim frags from jug?; wheelmade. Greenish light brown
AII-k/9 P18/9 fabric, slightly porous, med. density of fine to coarse
K3178 black grits. Some fine red sand. Greenish slip. Black to
g = D/3 brown matt abraded paint. Pitted surface. Sp. c. of fine
white grit.

ILL 115 row 2.1

DAB 627 306 Jug; wheelmade. Hard, fine porous clay fired to
AII-k9 P1 7 greyish green. Greenish slip. Paint is black and matt.
D/2

Maguire 1986, Fig 19.1

DAB 628 4634A WP/Bichrome?CLS Sherd with handle fragment; wheelmade.
FI-k22 P1 1 Red brown clay, very fine, hard; original white cream
Neville pit 20 slip has become a mottled brown red. Large wheelmarks
on interior.

Maguire 1986, Fig 19.3

DAB 629 4769A Rim sherd of BS/WP Composite Ware bowl; handmade.
FI-120 Very hard finely levigated clay fired light brown; black
Pit 8 Navillian brown slip on the outside; lightly burnished to a
low remaining finish; black brown painted on interior.

Maguire 1986, Fig 11

DAB 630 7057C WP/WS Body sherd from bowl? handmade; Fine hard brown
AII-k9 and grey sandwiched core. Thick white slip. Dark brown to
Grave 35 red paint. Lightly burnished. Very smooth interior.
D3

Maguire 1986 Fig 6.3

DAB 631 908a Shoulder fragment from jug; handmade. Very hard and fine
AII-114 greenish light brown fabric. Sp. c. of fine white grit.
surface Dense c. of fine black grit. Greenish buff slip and friable
black paint.

KHM 2654a

Maguire 1986 Fig 8.20

DAB 632 908b Body sherd from jug; handmade. Very hard and fine light brown
AII-114 to red (on internal section). Sp. c. of fine white grit and fine
surface dark sand. Cream slip. Friable black paint.

KHM 2654b

Maguire 1986 Fig 8.20

DAB 633 (5267) WP V-VI teapot. Fragments of small juglet; handmade. Light brown
FI-k23 core. Sp. c. of veg (coarse) matter. Sp. c. of fine black grit. Cream slip.
K3045 friable black to brown paint. Matt all over.
a2/D2?

ILL 116 row 3.4

White Painted Various

DAB 634 3179c Body sherd from jug; handmade. Very fine hard clay. Very
FI-i21 Pl 2 light brown surface. Dark brown bands.
G/4

Maguire 1986, Fig 8.25

DAB 635 6472H1 (BS/RS) or WP V BB. Shoulder fragment from jug; handmade.
AV-p19 Pl 5/6 Grey, hard, med. fine and porous fabric. Med. c. of
K3480 fine dark grits. Sp. c. of fine white grits. Black to dark E1-D3 brown
friable matt paint.

ILL 19 109 row 1.3

DAB 636 6858G Body sherd from jug; handmade. Light brown
AV-p19 Pl 6 med., hard, finely porous fabric. Surface pitting. Sp c.
of med. veg. temper. Cream smooth slip. All over burnish.

DAB 637 6461A Body sherd from jug; handmade. Light brown hard, fine
FI-i20 Pl 2 fabric. Very sp. c. of fine white grit; fine red sand. Med. c. of fine dark grit.
Light brown to cream slip, dark brown to black paint. All over diagonal point
burnishing.

ILL 20, 87 row 1.2

DAB 638 2680e Body sherd with handle stump from juglet;
AII-o16 possibly wheelmade. Very fine and very hard red brown
pit dist clay.

Maguire 1986, Fig 6.10

DAB 639 1096 Body sherd from jug. Brown paint
AII-m11/m12
D/3

DAB 640 (5072) Body sherd from jug; handmade. red brown fabric. Sp. c. of fine
AII-i17 Pl 1/2 and coarse white grit. Slightly porous. Pitting. Brown paint. Greenish cream slip.
nr Gr. 3 All over burnish.
K2410
c/d

DAB 641 6461C Body sherd from jug; wheelmade. Light brown to
AII-m/n 36/37 green fabric. Sp. c. of very fine red sand and dark grit.
Green slip, matt. Weak grey matt paint.

ILL 54

DAB 642 (5053) Fragment from small juglet with slightly everted rim;
AII-p20 Pl 3 handmade. Light red brown med. hard fabric. Dense c. of

- K2143
c = E27 black grit. Red paint, white to cream slip. All over
burnish.
- ILL 116 row 2.2
- DAB 643 6799II Handle fragment (plug) from jug; handmade. Light brown med.
AV-p18 P13 fine slightly porous fabric. Dense c. of fine dark
(slightly angular) red grit. Sp. c. of fine white shell or
limestone. Med. c. of fine black grit especially towards
the surface. Abraded surface. Black friable matt paint.
- ILL 29, 107 row 1.2
- DAB 644 6461Y Body sherd from jug; handmade.
AV-p18 P11/2 Red brown, hard and very fine. Sp. c. of dark and fine
white grit. Yellow slip, dark brown paint. All over
burnish.
- ILL 31
- DAB 645 6856S Red brown, very hard, fine slightly porous fabric.
AV-p19 P1 4 Sp. c. of fine white grit and coarse red sand. Sp. c. of
coarse pitting. Med. c. of fine red sand. Sp. c. of fine
dark brown grits.
- ILL 32
- DAB 646 6856x Rim and handle fragment from small jug; handmade.
AV-p19 P1 4 Red brown med. hard, fine porous fabric. Med. c. of fine
white grit and fine black grit. Sp. c. of fine red grit.
Red brown self slip. Red friable paint.
- ILL 34, 106 row 1.3
- DAB 647 6856u (WP V). Body sherd from jug; handmade.
AV-p19 P1 4/5 Grey green hard, med. fabric. Sp. c. of coarse pitting on
K3633 exterior surface. Dense c. of fine black grit. Sp.
c. of fine limestone and fine red sand. Dark grey to light
green slip. Black matt abraded paint. All over burnish.
- ILL 16
ILL 108 row 2.3
- DAB 648 6856v1 (WP V). Body sherd from jug; handmade. Light green.
AV-p19 P1 4/5 med. hard, med. fine fabric. Dense c. of fine black grit.
K3633 Sp. c. of fine limestone and fine red sand.
- DAB 649 6856v2 Body sherd from jug; handmade. Badly abraded.
AV-p19 P1 4/5 Light green, med. hard, med. fine fabric.
K3633
- DAB 650 6472X Very abraded neck fragment. Red brown fabric, med. hard
AV-p19 P1 5/6 clay. Sp. c. of red sand. Surface abraded.
K3492
rel d/e

- DAB 651 6858J AV-p19 Pl 6 Body sherd from jug; handmade. Light brown, med. hard fabric. Dense c. of surface igneous inclusions. Sp. c. of fine white grit. Dense c. of med. sized black grits. Cream to light brown slip. Dark brown to red abraded matt paint.
- ILL DR 11
ILL 110 row 1.3
- DAB 652 6137Q AV-q19 Pl 1/2 Body sherd from jug; handmade. Red brown fabric. Dense igneous content. Dark angular grit, black grit. Med. c. of angular grey/white quartz. Very sp. c. of fine limestone grits. Red brown slip, red paint.
- ILL 32
ILL 120 right
- DAB 653 (5068) FI-k21 Pl 1/2 K2734 b2 nrG.15 Neck fragment from jug; handmade. Light brown, very hard and very fine well levigated fabric. Sp. c. of igneous matter. Med. c. of fine to med. sized white grit. Cream slip, all over burnish, red to dark red paint, badly abraded.
- ILL 116 row 2.3
- DAB 654 (5067) FI-k23 K2709 Shoulder fragment from jug; handmade. Red brown fabric. Sp. c. of med. sized grits. Slightly porous. Very hard and fine fabric. Some veg. temper. All over burnish. Thick cream slip. Brown black paint.
- DAB 655 6460N FI-123 Pl2 Grube Neck fragment from jug; handmade. Light red brown, hard, fine fabric. Sp. c. of fine limestone, shell and black grits. Greenish to light brown slip. Dark brown to black paint. All over burnish bar paint.
- ILL 34, 114 row 1.2
- DAB 656 7057L FI-p20 Spout fragment of jug; handmade. Light brown med. hard, to med. fine fabric. Sp. c. of fine white grits, dense igneous-med. c. of fine black grits; very porous. Sp. c. of fine grey quartz. Light brown slip, black paint.
- DAB 657 6460W3 AII-i11 Pl 6/7 D/2 Handle fragments and one body sherd; handmade Very abraded pieces. Possibly matt black paint on one handle. Light brown fabric. Sp. c. of limestone; med. c. of dark brown grits. Sp. c. of light brown med. grains. Med., fine fabric.
- ILL 28, 29
- DAB 658 7057J AII-k16 Pl 2/3 E/1 Body sherd from jug; handmade. Very hard, fine, light brown clay, light brown slip. Brown paint.
- Maguire 1986, Fig 6.5

- DAB 676 6858K
AV-p19 P16 Body sherd from jug; handmade. Red brown (exterior) to light brown (interior) core. Med. hard, fine very porous fabric. Sp. c. of med. white sand/chalk. Med. c. of fine red sand. Red brown self slip, red, matt friable paint, all over burnish.
- DAB 677 6137P
AV-q16 P10/1
K3344 (PLS). Body sherd from jug; handmade. Light green hard, med. porous fabric. Dense c. of fine red brown sand. Sp. c. of fine white grit and black grit. Sp. c. of fine to med. white vegetable temper (elongated impressions).
- ILL 34
ILL 120 left
- DAB 678 2680F
All-p17
pit dist Body sherd from jug; handmade. Very fine light brown clay. Grey white slip with orange-red paint. Polished.
- ILL 31
Maguire 1986, Fig 7.12
- DAB 679 4812A
FI-120
Grave 23
b3 (CLS). Body sherd from jug; handmade. Red brown med. clay. Red orange surface. Possibly Cross Line Style.
- Maguire 1986, Fig 7.13
- DAB 680 3223a
FI-i20 P10/1
a/2? (CLS/PLS). Neck and handle fragments from jug; handmade. Concave neck; handle from rim to shoulder. Slightly backward sloping mouth; everted rim; base of handle includes insert for wall of the vessel. Very hard and very fine light brown grey clay. Brown slip. Black paint, abraded in places.
- cf Johnson 1982 Fig 3, N11
cf Alasia II (Enkomi) 1981 P21 Fig 3:8
Maguire 1986, Fig 7.11
- DAB 681 3585B
FI-i22
surface (V 'zig-zag' bowl). Rim sherd from bowl; handmade. Very light brown clay, light brown slip. Brown paint polished.
- Maguire 1986, Fig 7.14a
- DAB 682 6461K
AV-o18
Grube 7 Body sherd from jug; handmade. Red brown fabric. Med. c. of fine to med. white grits. Sp. c. of fine mica and med. dark red sand. Self slip. Red lustrous paint, all over burnish.
- ILL 30
ILL 110 row 2.2
- DAB 683 6856y
AV-p19 P15/6 Body sherd from jug; handmade. Light brown fabric with greenish tinge. Hard, porous. Dense c. of igneous, interspersed by even mud matrix. Med. c. of coarse to med.

quartz. Med. c. of red sand and black grit. Matt black friable paint. All over burnish.

- DAB 684 6855II WP VI(?) Shoulder fragment with plug handle stub.
AV-n19 Pl 1? Handmade. Possibly from a globular jug/teapot. Very pale brown, med. hard and well levigated clay. Sp. c. of fine black grit and red orange sand. Cream slip, matt black friable paint. Abraded.
- ILL 29
ILL 107 row 2.2
- DAB 685 (5057) WP (poss Cyp Bichrome); wheelmade on a slow wheel. Light brown
AII-k/9 Pl 8/9 hard core. Small c. of med. red sand. Burnished all over.
K3185 abraded cream slip. No paint visible.
f-g = D2
- DAB 686 7057D WP ? Possibly WP V-VI. Body sherd from jug; handmade.
AII-k15 Pl 3 Light brown fabric, very porous very hard and fine.
K3220 Cream white slip. Black paint.
b2-3
- DAB 687 7057A Tail fragment of fish piece; handmade. Fine, hard, light
AII-k9 brown grey clay, white slip, black paint.
Grave 35
D3
- Maguire 1986 Fig 6.1
- DAB 688 6472G (WP V-VI). Handle fragment from jug; handmade.
AV-n18 Pl 1/2 Light brown, porous fabric. Sp. c. of fine veg.
K3448 striations and med. to coarse rounded quartz. Light
b/c D2 brown to green slip. Black to dark grey matt paint.
- ILL 25
ILL 107 row 1.1
- DAB 689 6472V Handle stub from small jug; handmade.
AV-p19 Pl 5/6 Dark brown fabric, med. texture. Sp. c. of fine shell,
K3492 limestone. Med. c. of fine veg tempering. Porous. Dark
brown to black paint. Abraded.
- ILL DR 38
- DAB 690 3228a (WP ?) Fragment of bowl. Round base. Very hard, fine dark
FI-i20 Pl 1/2 grey clay. White slip. Black lines and latticed band.
dist pit Possibly WPV or VI.
- Maguire 1986, Fig 17.2
- DAB 691 6014 (WP ?) Handle fragment from jug; handmade. Potter's mark?
AII-k15 Pl 4 Brown clay hard and fine, green white slip. Brown paint.
E/1
- cf SCE IV.1B, 251
Maguire 1986 Fig 19.4

Red on Black Ware

- DAB 692 64 Handle (plug) from a large jug; handmade.
AI-g5(?g13) Light brown fabric. Black slip. Sp. c. of fine white grits.
secondary Lilac matt paint. Burnished surface.
deposition
- ILL DR 52
cf SCE IV.1B , Fig 33 and 34
cf Johnson 1982, Fig 6:Q1
Maguire 1986, Fig 10.1
- DAB 693 6462R Neck fragment from jug; handmade. Light red brown
AII-k17 Pl 3 very hard and very fine light red brown fabric. Sp. c. of
K3360 very fine red sand and dark grits. Dark brown, black paint
E/1 (slip). Matt lilac dark brown paint. All over burnish bar
paint.
- ILL 49, 104

Red Slip Ware

- DAB 694 6814H BS/RS Neck and handle fragment from large jug; handmade.
AV-p18 Pl 2 Light brown to dark brown fabric, hard, med. fine. Dense
im S Profil igneous content. Dense c. of dark grit. Sp. c. of fine to
med. white grits. Med. c. of round and angular quartz.
Handle denser content-especially quartz. Red brown to
dark brown slip, matt friable. (Handle from mid neck to
shoulder, strap handle. 2 punctured holes on shoulder- ϕ
0.7cm)
- ILL 35, 124

Plain Ware

- DAB 695 6461P Rim sherd, everted lip, from large jug or amphora;
AV-p16 Pl 1/2 handmade. Light brown to light grey fabric, very
K3417 hard and very fine. Sp. c. of fine to med. red sand and
fine limestone. Sp. c. of fine yellow sand. Light brown to
light pink slip.
D/2 Possibly of the same vessel as 6794A (below)
- ϕ 16.6cm
- ILL 36, 126
- DAB 696 6794A Flat base of large jar or amphora; handmade. Red brown.
AV-p16 Pl 1/2 very hard and very fine fabric. Sp. c. of coarse dark red
sand. Sp. c. of fine yellow sand and red sand. Med. c. of
very fine dark grits. Sp. c. of fine and med. limestone.
Self slip, red brown. Weak black to dark grey matt paint.
Possibly from the same vessel as 6461P (above).
- ϕ 13.3cm
- ILL 38, 123

DAB 697 6809E Plain White Ware. Neck and shoulder fragment of pithos or
AV-p19 Pl 4 large jug; handmade. Very hard and fine. Red brown and
light brown core. Dense c. of fine to med. limestone. Sp.
c. of yellow fine sand. Sp. c. of fine, med and coarse red
sand. Dense c. of black charcoal like material, med. to
coarse. Med. c. of rounded quartz fine (white). Yellowish,
light brown slip.

ILL 37, 125

DAB 698 6813A ?Plain White Ware. Incised amphora fragment; handmade.
AV-p19 Pl 5/6 Light brown, very hard and very fine fabric. Dense c. of
K3492 fine to med. red sand. Sp. c. of fine dark grits. Very sp.
c. of white sand. Incised decoration of parallel diagonal
strokes.

Proto White Slip Ware

DAB 699 2100 Bowl; hemispherical, round base. Very fine and hard
AII-n10 Pl 2/3 well fired clay. Dusky red core; white slip.
Gr I Decoration red paint on a very smooth crudely point
D2 polished surface.

ILL 52

Maguire 1986, Fig 15a.1

DAB 700 1319 Body sherd from bowl; handmade. Rusty red and brown
AII-n11 Pl 1 sandwiched fabric. Dense c. of igneous. Sp. c. of fine
pit dist white grits. Hard and fine. Thick smooth white slip, inside
D/2 and out. Orange matt paint. Surface burnished.

ILL 52

KHM A2902

Maguire 1986 Fig 17.3

DAB 701 974 Rim sherd from milk bowl.
AII-n11 Pl1 dist area
D/1

ILL 52

DAB 702 6461Z Fragment of a wishbone handle from bowl; handmade.
AV-m18 Pl 2 Dark brown hard, med fabric. Dense c. of angular igneous
matter.

ILL 52

ILL 111 row 2.2

DAB 703 1559 Rim sherd from milk bowl; handmade. Red brown to rusty red
AII-m14 sandwiched core. Very hard and fine. Dense c. of fine white
grit and sp. c. of coarse white grit. Sp. c. of coarse red
angular and black grit. Dense c. of igneous. orange red
paint. White slip on interior and exterior. All over
burnish.

ILL 52
KHM A1749

DAB 704 3154B Body sherd from bowl; handmade.
FI-i21 P12
K1583

White Slip Ware

DAB 705 1073 WS Handle fragment from milk bowl; handmade. Very hard and fine
AII-o12 fabric. Dense c. of igneous. Sp. c. of fine white grit.
surface Cream slip. Red brown paint. Matt. Slightly shaved.
Burnishing bar paint.

KHM A2750
Maguire 1986 Fig 17.4

DAB 706 (5079) WS. Handle stub from bowl; handmade. Grey fabric, blue
FI-j23 P1 0/1 core. Dense c. of white grits. Sp. c. of red sand. Some
K2526 veg temper. Thick white slip, remnants of brown to red
d/2-b/1 mottled paint.

DAB 707 (5079) (WS I) Body sherd from bowl; handmade. Grey green core. Dense c. of
FI-j23 P1 0/1 fine white grit. Dense c. of coarse black igneous, angular matter.
K2526 Some red grit. Thick white slip on interior and exterior. No decoration.
a/2-b/1 Burnished inside and out.

DAB 708 290 (WS I) Rim sherd from milk bowl. Dense igneous content.
AI-g5 P1 3 White slip interior and exterior. All over burnish. Sp. c.
D/2 of white grits. Red brown weak to strong paint.

KHM A1748
Maguire 1986 Fig 16.1

DAB 709 6461Q (WS I) Rim fragment from bowl; handmade. Dark grey core, rusty
AV-p17 P1 2 red towards exterior, hard and med. fabric. Dense c. of
sebakh pit fine grit and dark angular grits. Cream/white slip matt and thick. Dark
brown paint.

ILL 53
 $\phi = 15\text{cm}$

DAB 710 6462E (WS I) Rim fragment from bowl; handmade. Rusty red brown
AV-p19 hard, med. fine fabric. Dense c. of igneous matter; med.
Gr 10 c. of fine angular grit. Med. c. of fine white sand. Thick
white slip. Red brown to light orange paint. All over burnish.

ILL 53
ILL 111 row 2.1

DAB 711 7057p (WS I) Wishbone handle fragment from bowl; handmade.
surface Dark red to grey fabric. Dense igneous; med. c. of fine
angular dark, red brown and black grits.

Base Ring Ware

DAB 712 6137G Rim sherd from bowl; handmade. Red brown, hard, very
AV-p16 Pl 1/2 fine clay. Dark brown/black slip. Sp. c. of fine white
Grube grits. Horizontal burnishing.

DAB 713 6137J Rim sherd from bowl; handmade. Red brown clay,
AV-p16 Pl 1/2 Hard, very fine fabric. Sp. c. of fine white grit.
Grube Dark brown to black slip.

DAB 714 (5054) Body sherd from jug; handmade. Blue grey core. Dense
AII-p22 Pl 1/2 igneous content. Med. c. of med. white grit. Sp. c. of red
K2581 sand. Matt black surface. Very badly pitted interior and
exterior. Exterior red flecks on surface. Thin walled.
b = Rames Weak white matt paint.

ILL 116 row 1.4

Bichrome Ware

DAB 715 6794D Body sherd from juglet; wheelmade.
AV-n18 Pl 1/2 Grey brown and grey sandwiched core, very hard and
within hse very fine fabric. Sp. c. of fine limestone. Yellow to
light brown thick slip. Dark grey to dark red brown paint.
All over burnish bar paint.

ILL 111 row 1.3

ILL 42

DAB 716 1073 Bichrome fragment.; wheelmade. Rusty red sandwiched dark brown
AII-o12 fabric. Dense c. of igneous. Sp. c. of fine white matter
and grits. Brown slip. Alternating black and lilac paint.

KHMA2749

DAB 717 2530g Neck fragment from jug; wheelmade. Handle from neck to
surface find shoulder. Very hard fine light red brown
fabric. Cream brown slip. Red and brown paint. Polished.

Maguire 1986, Fig 12.1
cf Epstein 1966 Plate XIV:1

DAB 718 02 Globular jug; wheelmade. Carinated shoulder. Handle from
AII-i11 Pl 4 rim? to shoulder. Flat base. Red and brown very hard, very
18th Dyn fine clay. Pitting on surface. Very drab polished surface.
B/3 White green slip. Fine wheelmarks on interior. Discolouration in firing.

Maguire 1986, Fig 13.1
Epstein 1966, Pl VII:7

DAB 719 1186 Head and beak fragment from bird vessel. Spouted beak.
AII-m/14 Pl 1/2
D2/D3

Maguire 1986 Fig 8.14b

DAB 720 2359 Fragment of Bichrome painted vessel. Very fine and very
AII-m15 Pl 0/1 hard burnt light orange fabric. Same coloured slip. Black
painted bands. Fine wheelmarks on interior. Pitted
surface.

Maguire 1986, Fig 16.20

DAB 721 2010b Shoulder fragment from jug; wheelmade. Red brick clay very
AII-n10Pl 2 hard. Brown white slip and black paint.
D/2

Maguire 1986, Fig 12.5

DAB 722 03 Neck of jug; wheelmade. Red brick clay. Fine and hard.
All-n14 Brown slip. Brown and red paint. Hard surface.
secondary
deposition
K556
G

Maguire 1986, Fig 12.2

DAB 723 6486H Body sherd with handle stub; slow wheel. Light brown
AV-n17 Pl 0/1 core, exterior red brown. Very hard fabric. Sp. c. of med. red sand and round
quartz. Sp. c. of veg temper on inner surface. Med. c. of fine igneous on surface.
Light green matt slip. Black and red paint. All over burnish,
including thin grey to matt black paint. Red paint more
lustrous but still friable.

ILL 44

DAB 724 4436B Body sherd; wheelmade. Very hard and very fine grey
FI-k20 fabric. Grey brown surface. Cream slip. Brown and
Grave 9 red paint. Spoked wheel motif.
disturbed
a2/b1

ILL 151

cf Epstein 1966, Pl XIX,4 (Tell el-'Ajjul)

Pl XVIII,1 (Megiddo)

Pl XVIII,3 (Tell el-'Ajjul)

Pl XVI,5 (Jaffa)

Maguire 1986, Fig 13.11

DAB 725 5208G Shoulder fragment with handle stub from jug; wheelmade.
FI-k23 Pl 3/4 Red to light brown fabric; very fine and hard; brown
Pit 17 yellow surface. Fairly weak colours. Black and brown
disturbed paint. Wheelmarks on interior.
c

Maguire 1986, Fig 12.6

- DAB 726 5208f Handle and shoulder fragment from jug; wheelmade; very
 FI-k23 P1 8 hard very fine, red pink clay. Red pink slip. Lilac and
 intrusive black paint. Slightly polished.
- Maguire 1986, Fig 12.4
- DAB 727 (5066) Bichrome (?); Body sherd from closed vessel; wheelmade.
 AII-p21 P1 5 Well levigated fabric, orange to peach core. Sp. c. of fine
 K2419 white and black grit. Paint applied after firing. Sp. c. of
 f = F,E/3-2 fine white and black grit. Pinkish slip burnished. Friable
 matt paint.
- ILL 116 row 1.2
- DAB 728 2657 Bichrome (C) Body sherd of jug. Red and black paint. Bird
 AI-e24 P1 2/4 motif depicted.
 close to 2655
- ILL 39
- DAB 729 2655 Bichrome (C) Neck and handle fragment from jug; wheelmade.
 AII-a/11 P1 1 Handle from neck to shoulder. Cylindrical neck. Very thick
 dist context and heavy fabric. Flaky yet fine. Light red to yellow core. Cream slip. Pitted
 Secondary surface. Horizontal and vertical polish marks. Decoration on neck and handle.
 black mottling.
- ILL 40
- cf Amiran 1969, Pl 48:5,7
 Maguire 1986, Fig 14.15
- DAB 730 2891c Bichrome (C) Flat thick everted rim fragment of large
 AII-o19 P1 1/2 krater; wheelmade. Very hard and very fine brown clay;
 pit dist drab brown paint.
 External ϕ 24cm
 Internal ϕ 19cm
- cf Epstein 1966, Pl XVIII,163
 Maguire 1986, Fig 14.12
- DAB 731 2681 Bichrome (C) Body sherd from jug; wheelmade. Very hard
 AII-p17 dense yellow core. Decorative motif probably shoulder
 pit insertion. Part of bird depicted.
- ILL 39
- cf Epstein 1966, Pl XIV,11
 Maguire 1986, Fig 16.17
- DAB 732 6486K Bichrome (C) Neck fragment from juglet; wheelmade. Light
 AV-o19 P1 2 brown, hard and well levigated clay. Sp. c. of fine black
 grits and fine red sand. Cream to very pale brown chalky
 slip. Bright red and black paint. Black painted over the
 red.
- ILL 45

- DAB 733 6137B** Bichrome (C) Carinated shoulder fragment from large jug or
AV-p16 P11/2 wheelmade. Red brown, very hard and fine fabric. Sp. c. of fine white
on top of wall grit, fine to med. dark brown grits and med.
red sand. Faint yellow/light brown slip. Weak brown to
dark grey/black paint.
- ILL 42, 152
- DAB 734 6137L** Bichrome (Cyp) Body sherd from jug; handmade. Red brown, very
AV-p17 P1 1/2 hard and fine clay. Sp. c. of fine dark grits. Burnish,
except paint. Light brown slip, red and black matt paint.
- ILL 45
- DAB 735 6137N** Bichrome (Cyp) Shoulder fragment from large jug or krater; slow
AV-p18 P1 1 wheelmade. Light brown, very hard and very fine fabric.
Dense igneous. Med. c. of fine limestone. Sp. c. of fine
red angular grit; med. c. of med. yellow sand and fine dark brown grit. Sp.
c. of coarse angular red grit/sand. Cream slip. Burnish bar paint. Matt black
paint and red paint, red applied after black.
- ILL 41, 153
- DAB 736 6137U** Bichrome (Cyp) Shoulder fragment of large jug or krater; slow
AV-p18 P11/2 wheelmade. Light brown very hard and very fine fabric.
Well levigated. Dense c. of fine red sand. Sp. c. of fine
black grit. Sp. c. rounded white/yellow quartz. Med. c. of
fine pitting on external and internal surface. Yellow
slip, black matt friable paint and dark red. Burnish all
over bar paint.
- ILL 41, 152
- DAB 737 6137S** Bichrome (Cyp) Body sherd from jug; wheelmade.
AV-q16 P1 0/1 Light red brown to light green, hard, fine fabric. Med. c.
K3348 of fine black grit. Sp. c. of limestone. Cream to yellow
matt slip. Weak, black and dark red paint.
- ILL 19
ILL 109 row 2.3
- DAB 738 (5056)** Bichrome (C); Body sherd from jug; handmade. Red brown
All-p22 P11/2 core. Dense c. of med. sized white grit. Sp. c. of red
K2412 coarse sand. Pitted all over. Thick matt red and brown
b = B black paint. Burnished cream slip.
- ILL 116 row 1.3
- DAB 739 64620** Bich (Cyp) Body sherd from jug; handmade. Grey brown
AV-q18 P11?/2 very hard and very fine fabric. Sp. c. of coarse white
D2 limestone. Med. c. of med. to fine angular quartz grit.
Grey to light green slip. Black and dark brown friable
matt paint. Burnish only on unpainted slip.
- ILL 45
ILL 111 row 1.2

DAB 740 6472z Bichrome (P) Shoulder fragment from large jug or krater;
AV-n18 P10/1 wheelmade (fast and slow). Red brown, hard, fine fabric. Sp.
c. of fine limestone. Sp. c. of coarse striations from
burnt out veg. matter. Sp. c. of fine to med quartz
(rounded). Red brown slip, black, dark red matt paint. All
over burnish, except paint.

ILL 150

ILL 43

DAB 741 4506B Bichrome (P) Base fragment of jug; wheelmade. Very red, violet
FI-k23 P10/1 and deep grey core. Very fine and very hard. Lightly
surface polished surface. Possibly "Palestinian Bichrome".

Maguire 1986, Fig 13.10a

DAB 742 2656 Bichrome (CLS) Two sherds from jug; brown core, yellow slip.
AII-a/21 P11 Black painted lines. Diagonal and horizontal polishing
dist context marks.

ILL 46

Maguire 1986 Fig 5.16

DAB 743 6461U Bichrome (P) Shoulder fragment with handle stub; wheelmade.
AV-p18 P11/2 Sandwiched red brown and dark grey fabric, hard and very
fine. Sp. c. of fine to med. black grit. Light green slip,
dark brown and red paint; abraded but some burnishing
visible.

ILL 45

DAB 744 2681a? Bichrome/Levantine. Body sherd from jug; wheelmade. Fine
AII-m17 P12/3 and very fine clay. Polished surface. Black stripes.
E/1 or D/3

Maguire 1986, Fig 16.19

KAHUN

White Painted Pendent Line or Cross Line Style

KAH 745 deep chamber Petrie, Iahun and Gurob
PI 1:18 p10

SEDMENT

White Painted Cross Line Style (VI)

SED 746

Petrie and Brunton PI XLV.70

White Painted VI (Soft Triglyphic Style) Imitation?

SED 747

Petrie and Brunton Pl XVI.69

TARKHAN

White Painted Cross Line Style (VI)

TAR 748

Wheelmade;
Tarkhan II PL IX:25 p12

Crete

KOMNOS

White Painted Cross Line Style

KOM749 MMIII

Rm 51

Jug; handmade.

"Two thirds complete with parts of the body and rim missing.

Its height is 13.0cm and the maximum diameter is 8.7cm. The fabric is reddish yellow (5YR 6/6) and very gritty. The handmade vessel has a rounded base, a globular body, a cylindrical neck and round mouth. A vertical handle is thrust into the shoulder and joins the rim. The surface of the jug is covered with a white slip, and the body is decorated with groups of five oblique lines, matt red in color, which cross at the shoulder and at the widest part of the body. At the base of the handle are two short horizontal strokes. No decoration is preserved on

the

neck."

(C 6112)

Russell 1985, 42 and Fig 1

White Painted Various?

KOM750 MMIB

"Two sherds, probably from jugs, with a fabric very close to Cypriot examples."
..the surface on these sherds has completely worn away."

Russell 1985, 42

KNOSSOS

Red Polished Ware

KNO 751 S-E Kamares

Area Dove pit
OII₃ Box 15

"Fragmentary RP III amphora. Extant 0.15m Gtest d 0.152m.

Two joining fragments of neck (including both handles), shoulder and body. The rim-lop is lost all round. On the neck, off-centre, is a relief disk. Spurred handles. Light brown, rather soft with light brown to greyish-blue core in the thicker parts. Covered inside and out in a red wash ('slip'), polished and lustrous on the inside, particularly on the neck. The wash on the outside is

matt."

Stratigraphic Museum, Knossos, Box 1402

Catling and Macgillivray 1983, 1 and Fig 1, Pl 1 a,b

ZAKRO

White Painted Pendent Line Style

ZAK 752 "two adjoining fragments; joint size, 12 X 11 cm. with a maximum thickness of 0.7cm.; fabric, a hard-baked, rather cement-buff-coloured clay with fine white and black grits and covered with a matt, light-buff wash; hand-made; paint, matt, fugitive, and varying from dull rusty-brown to black; decoration, three encircling parallel broad bands at the top, at right angles to which are pendent groups of six uneven parallel lines alternating with a single vertical wavy line.

Haraklion Museum Box 72 Gamma
Popham 1963, 89 Fig 1, Pl 26a

Anatolia

KÜLTEPE

White Painted Pendent Line Style Jug

KÜL 753 Kültepe Fragment of jug.
Ib
Åström 1987, 62 and Fig 2

ADDENDUM

DHA 754 Grave 2 "Juglet, well levigated yellow ware, cream slip, painted in dark grey."

ILL 70
RF 47.1

Ory 1948, 79 Fig 4, Pl. XXXII.4

DHA 755 Grave 2 "Juglet, greenish ware with slip, grey to black pattern..but worn."

RF 47.2
ILL 71
Ory 1948, 80 Fig 5, Pl XXXII.5

DAB 756 3154C Shoulder fragment from jug; handmade.

ILL 2

ASHKELON

Red on Red

ASH 804 Body sherd from bowl; handmade.

ILL 121
RF P2106 n 6.T

TELLELAJJUL

AJJ 805 TCT 829

Shoulder frag. from jug; handmade. Red brown fabric. Sp. c.
of fine white grits. Thick white slip. Red paint. Burnished all over.

ILL 121

RF 40.133/12

APPENDIX TO CATALOGUE

IMITATION WHITE PAINTED WARE

White Painted Pendent Line Style

DAB 757 6856K Body sherd from jug; slow wheelmade. Sandwiched inner
AV-o18 grey core and rusty red outer core. Very hard and well
PI 1/2 levigated. Med. c. of fine white grits. Sp. c. of rounded
 quartz. Slightly porous. Mottled lilac brown to light
 brown slip. Dark (weakly applied) grey paint. Horizontal
 burnishing.

DAB 758 6460T Body sherd from jug; wheelmade. Red brown, hard, fine
AII-i11 fabric. Dense c. of fine white grit. Med. c. of fine
PI 5/6 black sand. Sp. c. of med. to fine red sand. Red brown to
D3 yellow slip. Grey to black paint.

ILL 59, 117, 118 row 1.3, 2.3

DAB 759 6460U PLS imit body sherd from jug; wheelmade. Red brown, hard, fine
AII-i11 fabric. Dense c. of fine white grit. Med. c. of fine
PI 5/6 black sand. Sp. c. of med. to fine red sand. Red brown to
D3 yellow slip. Grey to black paint.

ILL 59, 117, 118 row 2.3,

DAB 760 3392A *IVb, very fine-fine ox., mid.-hard; with little mica (golden). Core yellowish beige,
FI-i20 PI 1 outer light or. oxz. Or. burnished 5 YR 5/8 yellowish red, red dec. (closer and more
Tomb 2 irregular than shown on drawing, and some lines can be seen
str a/2 on the bottom part).*

Bagh 1988, Fig 45d

DAB 761 6115 *Id, fine, ox., hard; with quartz, feldspar, mica, lime (0.2-1.5mm). Core
AII-k17 grey, outer or. oxz. Burnished 7.5YR 7/4 pink, black dec.
str?
Tomb 20

Bagh 1988, no Fig (45e)

DAB 762 6114R WP PLS imit *Id?, fine, ox. med; with very fine
AII-117 Pl round quartz (to 0.2mm), little sand, golden mica,
str rel c/d lime. No core, light red through. Burnished pink to reddish yellow, red
dec.

Bagh 1988, Fig 49a

DAB 763 2510a WP PLS imit
AII n/15 Pl 3/4
K386
E3

ILL 57

DAB 764 4918? WP PLS?/imit
FI-k23 Body fragment with handle stub from jug.
surface
b/1

ILL 2

DAB 765 6855E WP imit. Neck and handle stub from jug; wheelmade. Red
AV-n17 brown purple very hard, fine fabric. Med. c. of med.
Pl 0/1 sized veg. matter. Sp. c. of med. sized red quartz. Sp. c.
of fine yellow and red sand. Surface c. (sp) of mica.

ILL 111 row 2.4

Painted Tell el Yahudiyeh

DAB 766 6461V Body sherd from juglet; wheelmade.
AV-p18 Hard, very fine dark grey brown fabric. Sp. c. of
Pl 1/2 fine mica. Dark brown self slip, dark brown paint.
Horizontal point burnishing.

DAB 767 3138 PLS motif *Ton VI, sehr fein, hart
FI-j/21 ox. wenig quartz, wenig Glimmer, Kalk."
Gr.8 Slip: 10YR 7.3 sehr bloss braun, rote farbe."
a/2 = D-E Wheelmade.

ILL 55

DAB 768 2307 PLS motif. Small juglet; rolled rim, handle from below rim to
AII-m/15 shoulder, pedestal base. *Id,?, ox., hard; with lime (to 0,5mm). Core ? Nat surf. 5 YR
Grab 3 5,5/6 reddish yellow, yellow burnished 2,5 Y 8/3 7,5 YR, brown-black dec.

ILL 5

CM 91710

Bagh 1988 Fig 42a

DAB 769 6114S *Id, fine, ox., mid.-hard; with much golden mica, quartz, ceram., lime. Core dark grey.
All-i11 Pl 6/7 outer pink oxz. Burnished 7,5 YR 7.6 reddish yellow, black
str d/2-3 dec.

Bagh 1988 no Fig (42b)

DAB 770 05 PLS motif. Globular jug; wheelmade. Red grey
All-k17 clay, brown pink slip. Wheelmarks visible on outside.
Gr 30 Polished.
E/1

Maguire 1986, Fig 18.4

DAB 771 4113 PLS motif. Juglet.
ILL 56

DAB 772 3301A PLS motif. Juglet
ILL 56

White Painted Cross Line Style

DAB 773 6114T *I a/b, fine, ox., mid.-hard; with round quartz (to 0,8mm), mica, little fine lime. Core
All-q21 Pl1/2 grey, outer or. oxz. Burnished 5 YR 7.6 reddish yellow, black
dec.*
c/d

Bagh 1988, Fig 49 b

DAB 774 61371 WP CLS ?imit. Body sherd from jug; wheelmade.
AV-p16 Red brown to lilac hard, med. fine fabric. Med. c. of
Pl1/2 fine white grits. Med. c. of fine to med sized red
Grube quartz. Self slipped, all over burnish bar paint. Black
paint.

ILL 58
ILL 111

DAB 775 6856P WP CLS imit. Base sherd, flat, of jug; slow wheelmade.
AV-p17 Light red brown fabric, hard slightly porous. Sp. c. of
Pl 1/2 fine red sand and rounded (dull glass) red grit. Thick
light green slip. Friable black to weak grey. Vertical
burnishing all over bar paint.

ILL SL 412/13 row 2.3

DAB 776 6460/O WP CLS imit. Body sherd from jug; wheelmade.
FI-n19 Red brown fabric, sandwiched grey core. Sp. c. of fine
Neville to coarse yellow pitted sand and fine white limestone.
grube Med. c. of dark grits. Light brown to green slip. Vertical
burnishing. Matt black paint.

White Painted VI

DAB 777 6114u
FI-122
P13/4
K2435

WP VI CLS. Body sherd from jug; wheelmade. Violet and dark grey section, hard, med. fabric. Med c. of med. sized vegetable matter, orange rounded quartz. Sp. c. of fine white limestone. Med. c. of fine med. red sand. Self slipped. Dark grey to black paint. Vertical point burnishing.

Bagh 1988, Fig 49c

DAB 778 6114p
FI-k21
K26897

Body sherd from jug; wheelmade. Red brown and dark grey, almost violet section. Med. c. of fine to medium black grits. Sp. c. of rounded dark grey quartz. Red brown, possibly burnished slip. Dark grey to black matt paint.

Bagh 1988, Fig 49d

Mycenaean

DAB 779 (5056)
AII-p22
P11/2
K2412

Mycenaean; shoulder fragment from jug; wheelmade. Very well levigated, hard and fine fabric. Slight peach core. Sp. c. of med. to coarse black grits. Red to red brown paint. Highly burnished all over.

ILL 116 row 1.1

TELLELYAHUDIYEH

Tell el Yahudiyeh Ware

DAB 780 4438
FI-k20
Grab 13

Juglet; handmade. Globular body with plug handle.

ILL 60-62
cf 4166-8 ILLS

Non Cypriot

DAB 781 7067A
FI-123
P13/4
over palace
K3639

?Ware. Rim fragment from jug; wheelmade. Very hard and very fine metallic, red brown fabric. Dense c. of coarse black angular grit. Sp. c. of coarse dark red grits (rounded). Sp. c. of fine yellow sand and fine angular grits. Dark red brown slip; hz burnishing abraded. Dark red paint.

DAB 782 6460X
AII-i11
D/2

?Ware. Base fragment of small cylindrical juglet; handmade. Porous light brown, hard, med. fabric. Very sp. c. of red and white sand. Med. c. of dark brown to black fine grits. Abraded red brown exterior.

- DAB 783 6855G ?WP. Shoulder fragment of jug; handmade. Red brown
AV-n17 fabric med. hard, med. fine. Med. c. of fine and coarse
P12 sand. Cream abraded slip, red friable abraded paint.
within room
K3612
- DAB 784 6472K ?WP. Body sherd from jug; wheelmade. Green to dark
AV-n18 grey well levigated fabric. Sp. c. of fine white grit. Med.
P1 1/2 c. of quartz (rounded) and black angular grits. Light brown
K3447 to green slip. Weak grey to black paint. All over
D/2 burnish.
- DAB 785 6461D ?WP late. Handle fragment from small jug; handmade.
AV-n19 Light brown very hard, and very fine fabric. Sp. c. of
n Profil med. light brown angular grits, quartz, fine red sand or
red clay nodules. Cream slip, dark brown lustrous to black and friable paint.
- ILL 58
ILL 106 row 1.2
- DAB 786 6855K ?WP Body sherd from jug; wheelmade slow. Light red brown
AV-n19 hard, fine. Sp. c. of white grit; med. c. of fine sand and
Grube 10 sp. c. of med. rounded quartz. Light green slip, dark brown
to weak black paint. All over burnish.
- DAB 787 6472L poss RP. Base fragment from jug; handmade. Red brown
AV-n18 P1 1/2 fabric to dark grey. hard, med and porous. Med. c. of fine
K3447/4 black grit and sp. c. of med. white grit. Sp. c. of veg.
striations. Sp. c. of fine quartz. Orange brown monochrome
paint. All over burnish.
- DAB 788 6856R Unlikely Cypriot. Possibly Levantine Painted Ware. Red
AV-p19 P1 2 brown hard fabric. Med. c. of fine black grit. Light grey
to white matt slip. Weak grey to dark brown paint. All
over burnish.
- DAB 789 6814D ?WP Rim fragment Handmade. Light green, hard, med. fabric.
AV-p19 P1 7 Porous. Dense. c. of med white to orange pitting. Med. c.
K3510 of coarse white quartz. Med. c. of fine black grits.
- DAB 790 105 ?WP Body sherd from jug; handmade. Very hard and very fine
AI-h/3 Red brown and dark grey sandwiched core. Sp. c. of fine
white grit and black grit. Smooth cream slip. Dark brown
paint to black lustrous. All over burnish. Possibly a
Bichrome piece, lilac stripe just visible.
- KHM A2195
Maguire 1986, Pl IV.105

KHATA'ANA

White Painted V Eyelet Style

- KHA 791 3369 Jug.
E/1/J "VI (??), very fine, ox., very hard; with very fine dark
str relb/1 sand and very fine quartz. No core, or./pink through (?). Burnished
 (horiz.) 7,5 YR 7,5/3 pink, red dec. 10 R 4/4 weal red."

 Bagh 1988 Fig 29

BUHEN

White Painted Pendent Line Style

- BUH 792 Tomb K45 "Rose pink ware covered with a slip of almost the same colour;
 the painted decoration (black?) consists of lines which run vertically down from a
 small circle painted round the neck; H ca. 8cm.

 Buhen 1921 Pl 92 no10886
 196, 237
 Bagh 1988, Fig 59b

TARKHAN

White Painted Pendent Line Style

- TAR 793 "XVth " "Light orange exterior surface; brown painted decoration. Dense and hard pink (7.5
Dynasty" YR 7/4) fabric with large white inclusions and a few medium-sized rectangular
 impressions from burnt-out vegetable matter. Handmade, rim and handle applied.
 Surface burnished and decoration applied in dark red pigment, viz. rim 'ticks',
 parallel diagonal lines on neck and alternate wavy lines and groups of straight lines
 down body" Bagh 1988, (Fig) 48d

 Petrie *Tarkhan* II 12 Pls IX, 23 PL LXXI (photo)
 Merrillees 1968, Pl I.2
- TAR 794 "XVth "Lustrous yellowish exterior surface; brown painted decoration
Dynasty" Bagh 1988 No Fig (Fig) 58e

 Petrie *Tarkhan* II 12 Pl LXXI
 Merrillees 1968, 30.2 as TAR

TELLELYAHUDIYEH

White Painted Pendent Line Style

TYH 795 without exact provenance Juglet; PLS motif

Bagh 1988, Fig 57d
HIC Pl.VIIIA,67

TYH 796 Grave 2 in the Gezira Juglet; PLS motif

Bagh 1988, Fig 57e
Griffith 1890, Pl.XI,9 and 9a

TYH 797 without exact provenance "in the debris" Juglet; PLS motif

Bagh 1988, Fig 57f
Adam (ASEA) 1958, Pl.XX.5

TYH 798 Grave 2 inside the "camp" Juglet; PLS motif.

"I a(d), fine, ox., hard; with little lime, golden mica. No core rose/beige through (maybe core a little more purple)" Bagh 1988, Fig 57g

HIC Pl VII.2

TYH 799 Grave 37

Juglet; PLS

"Id?, fine, ox., hard; with lime, mica, quartz, possibly dung.

Beige/rose burnished, black dec. -Clay under flaking slip looks much like marl." Bagh 1988, Fig 57 h

Tufnell 1978, Fig 4.20,98

HIC 13, Pl VIII.51

No provenance

"NUCLEUS CORPUS": Rockefeller Museum, Jerusalem.

White Painted Pendent Line Style

NUC 800

Body sherds from jug; handmade. Hard and fine clay. Orange and light brown sandwich core. Med. c. of fine white sand and fine dark and red sand. Red brown slip and red paint. Diagonal point polishing all over surface.

RF P.1230

NUC 801

Body sherd from jug; handmade. Hard and fine. Sandwiched red and grey core. Med. c. of fine white grits. Dense c. of dark grey coarse grits. Red brown slip and red paint. All over burnish.

ILL 3
RF P.1255

Red on Black

NUC 802

Rim sherd from bowl; handmade. Hard and fine red brown fabric. Dense c. of angular red grits. Med. c. of white limestone. Very dark brown slip and lilac paint. Burnished slip.

φ 23cm
RF P.1138

NUC 803

Rim sherd from bowl; handmade. Hard and fine red brown fabric. Sp. c. of coarse angular grits (red and black). Sp. c. of med. white grits. Brown slip, red to pink paint. Burnished slip and matt paint.

φ 19cm
RF P.1139

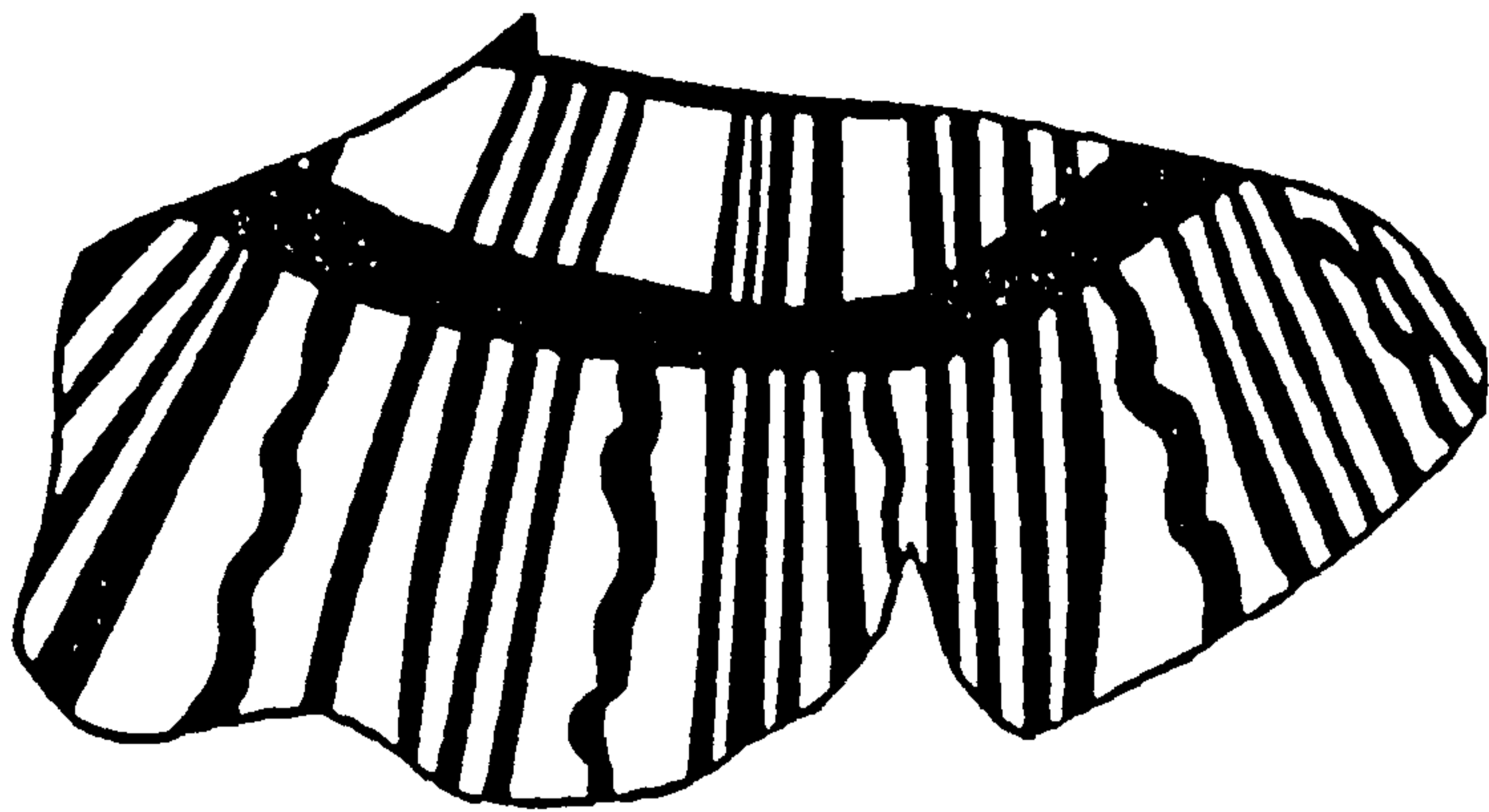

AJJ 25

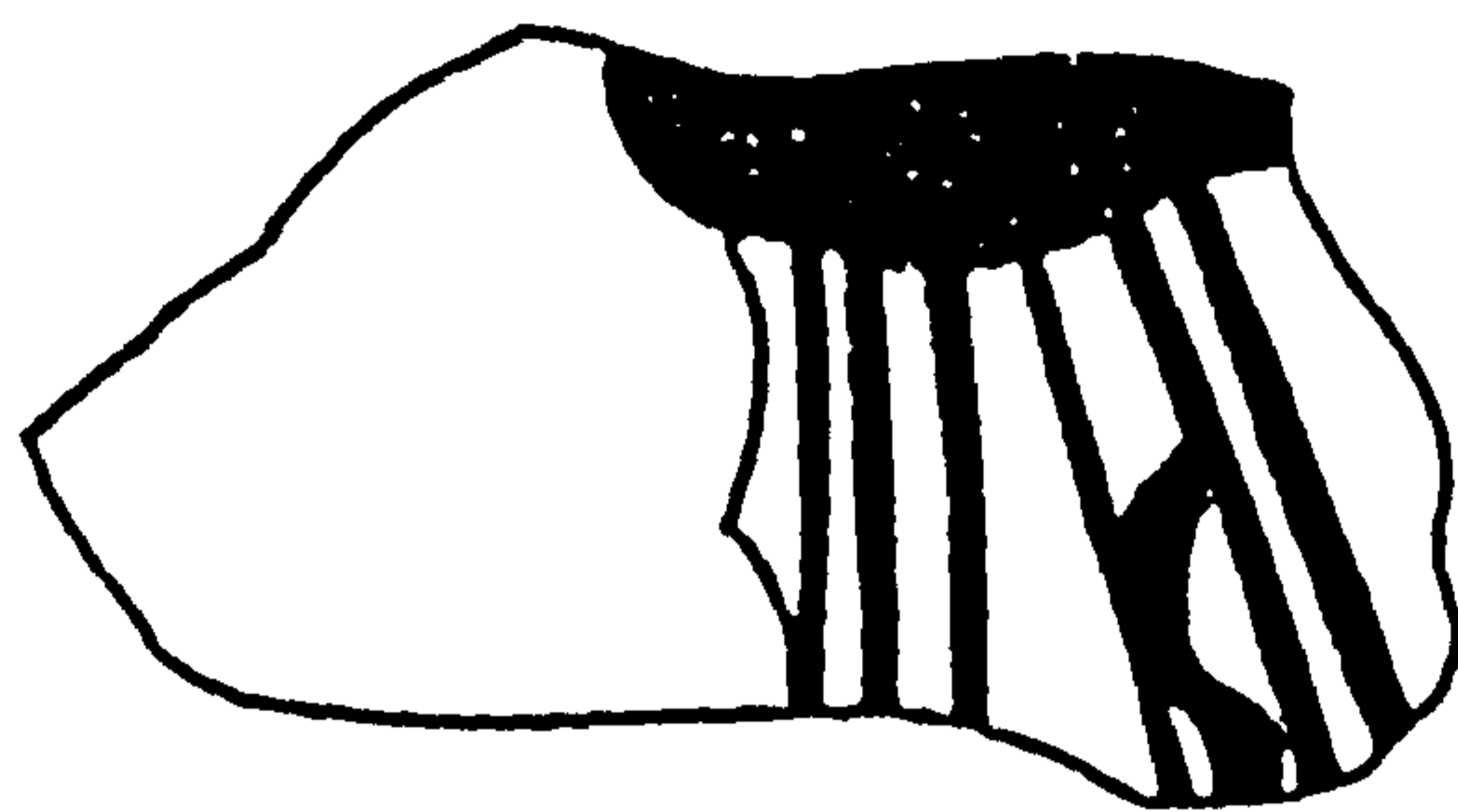

YIF 271

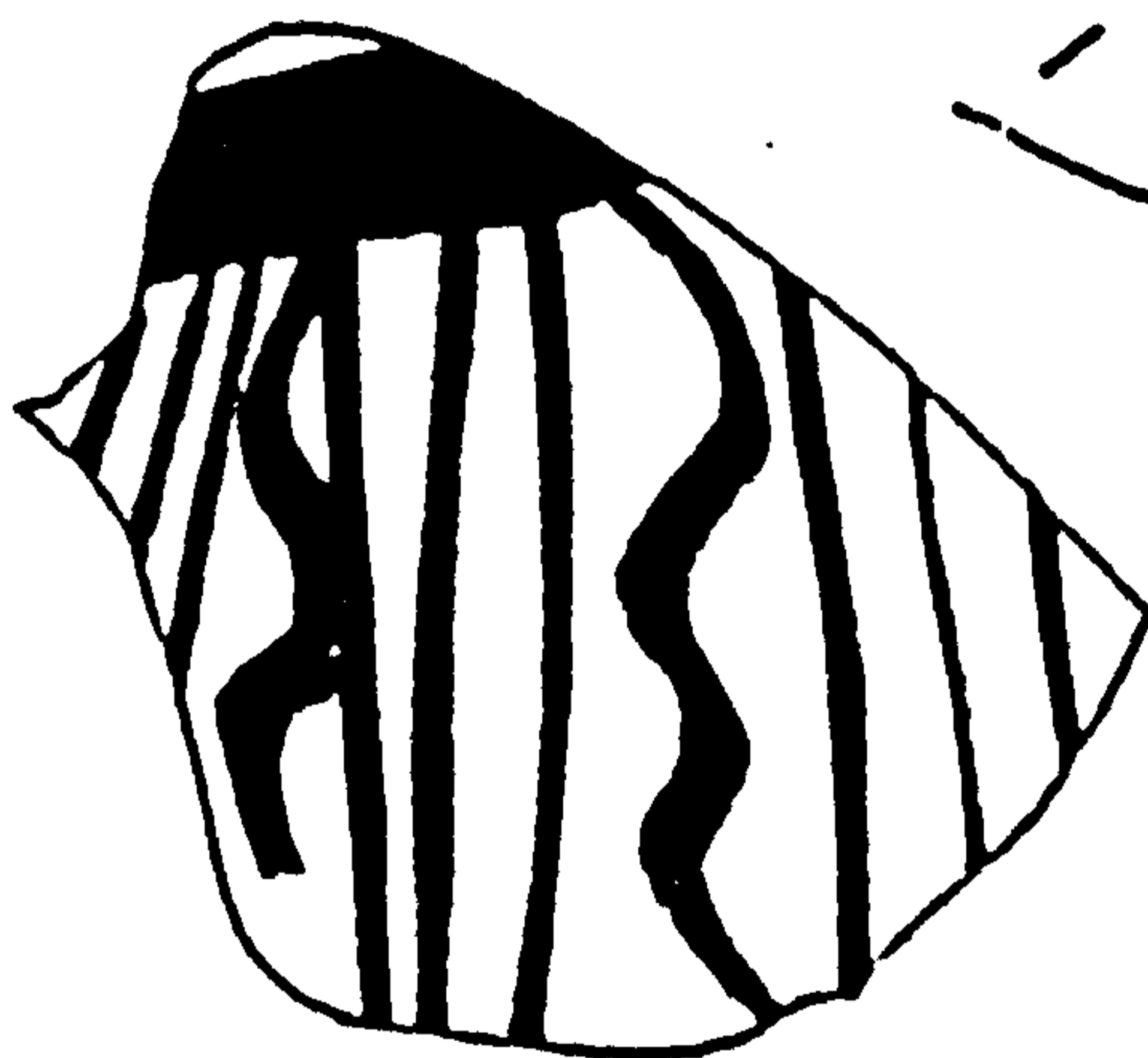
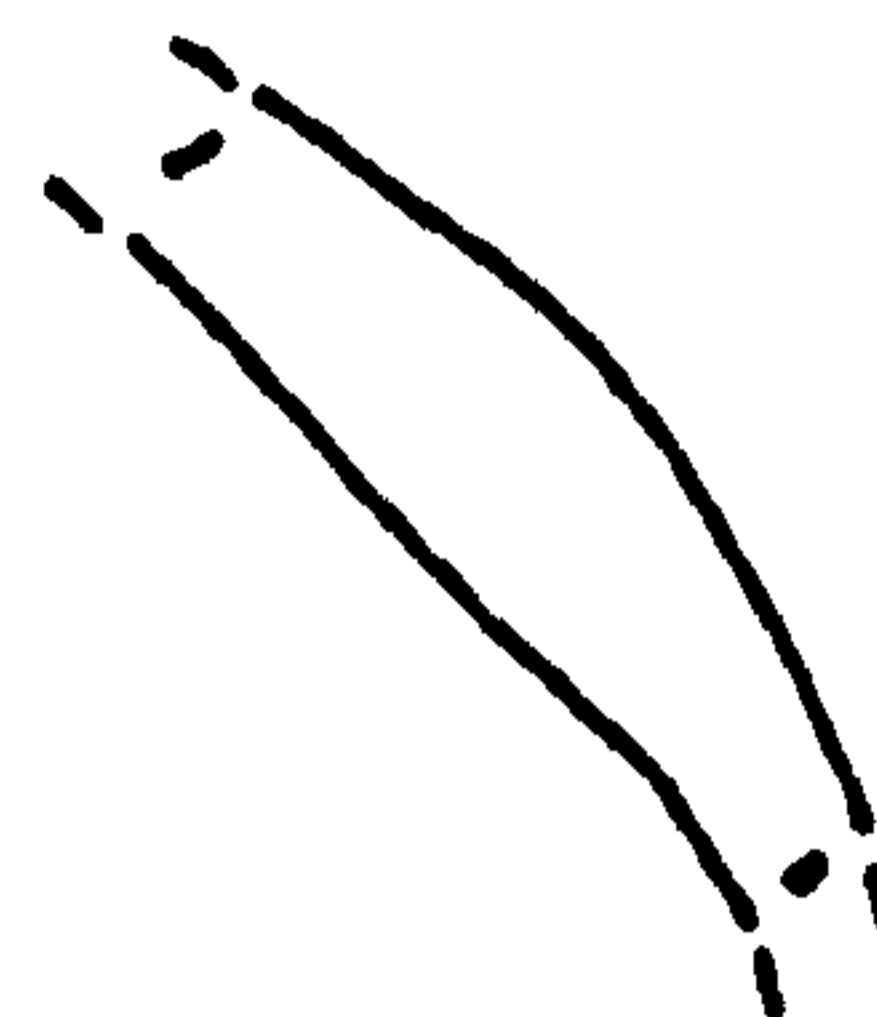

YIF 271

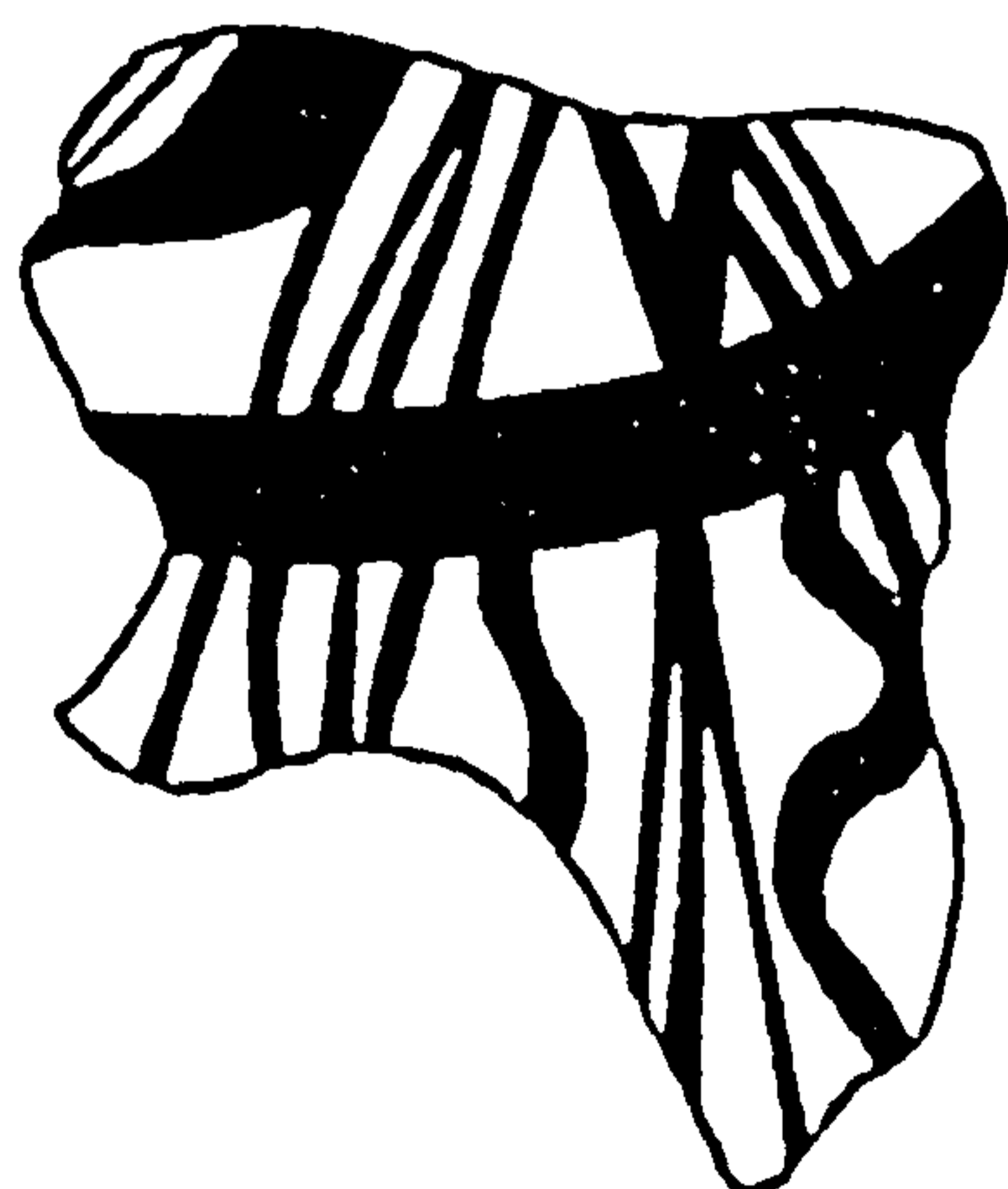

YIF 271

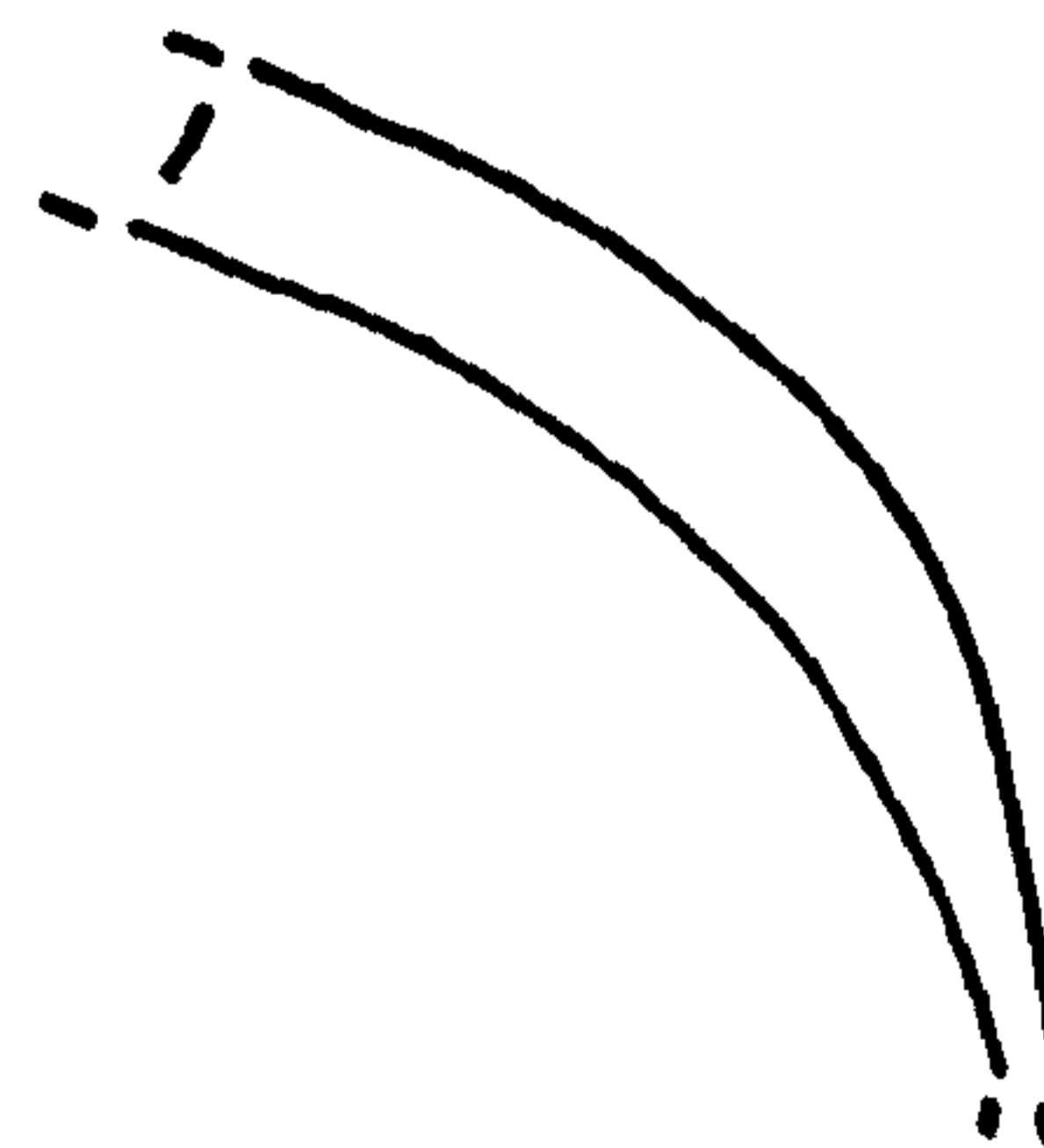

ILL 1

White Painted Pendent Line Style

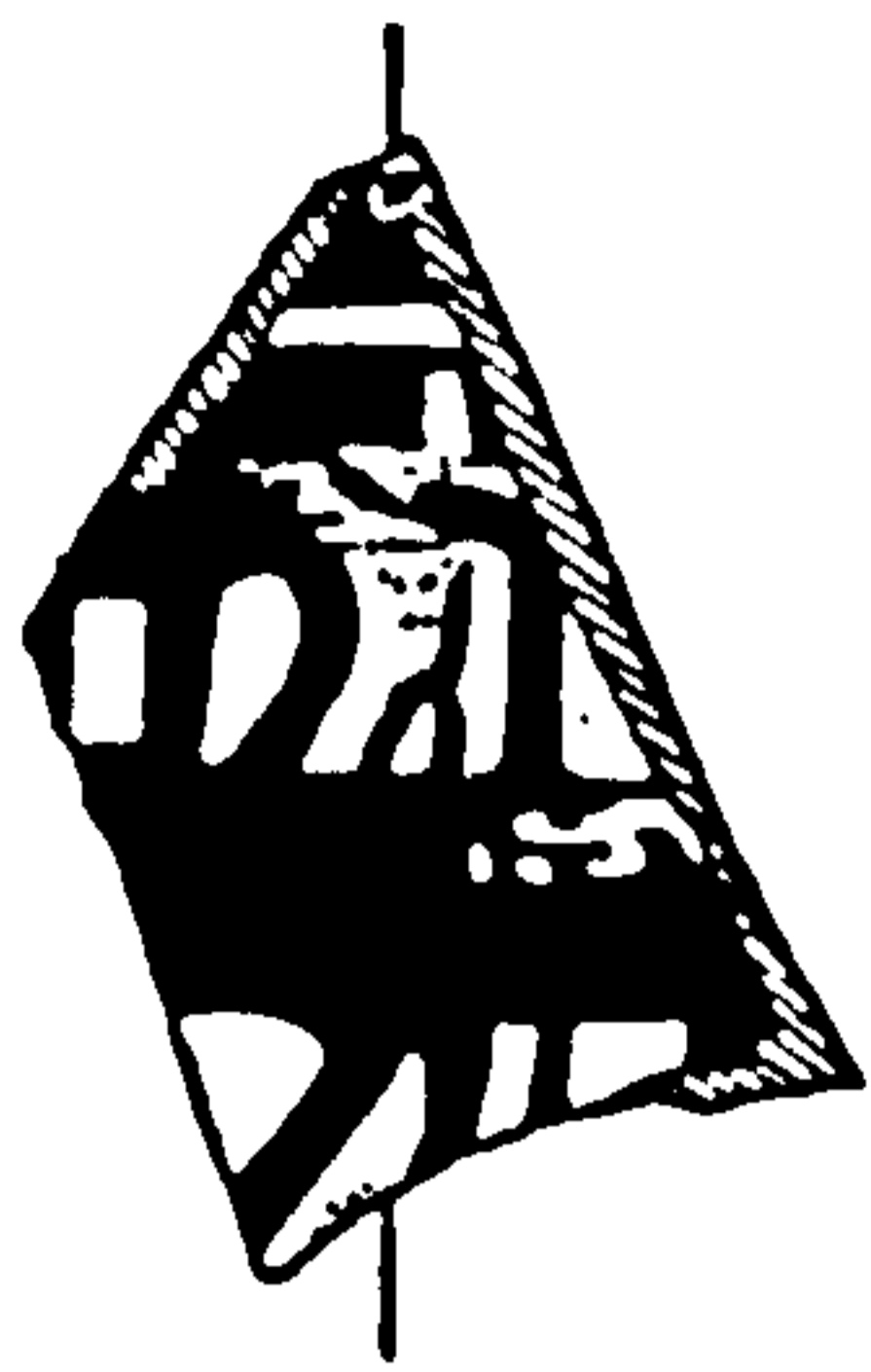

DAB 504

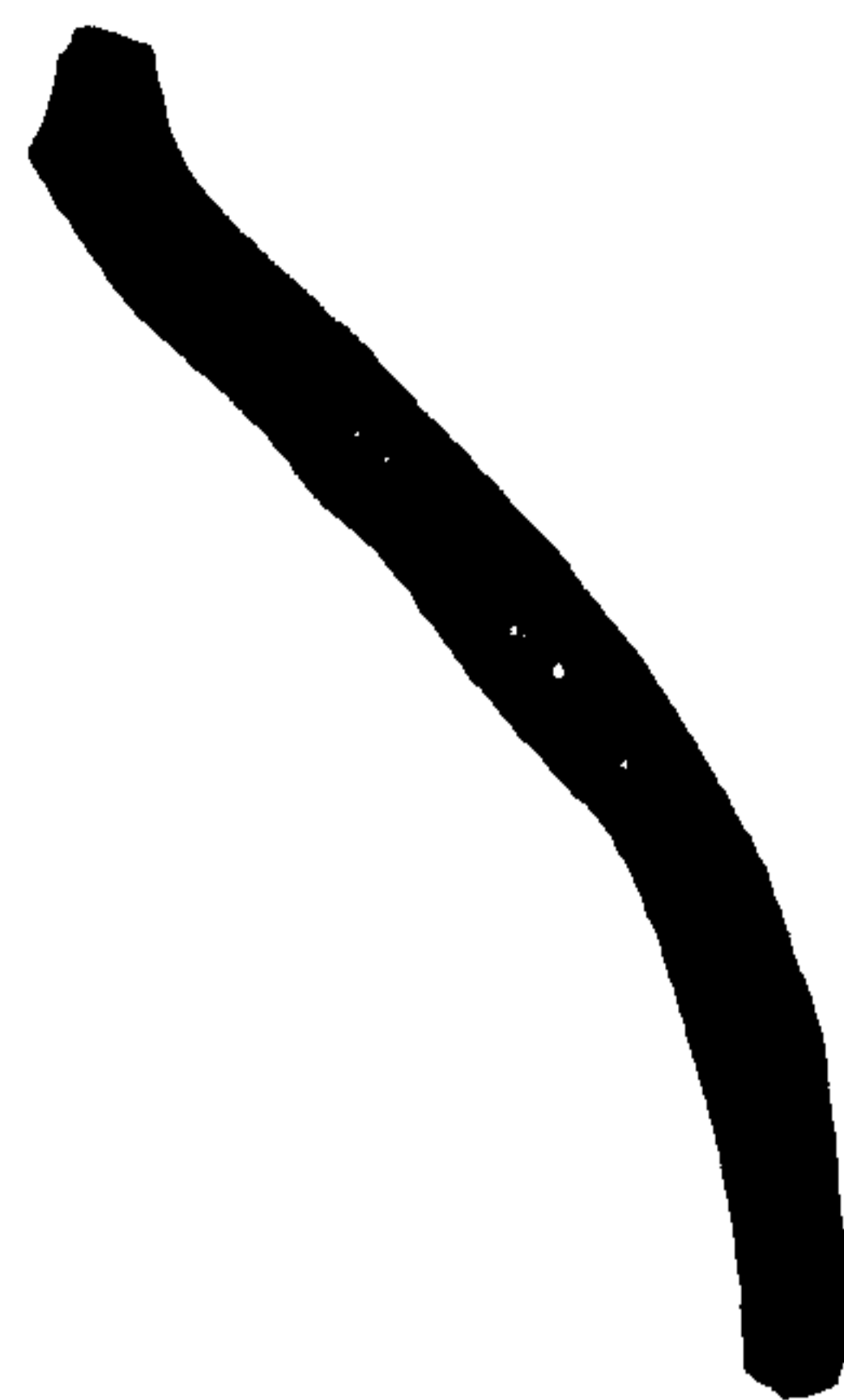
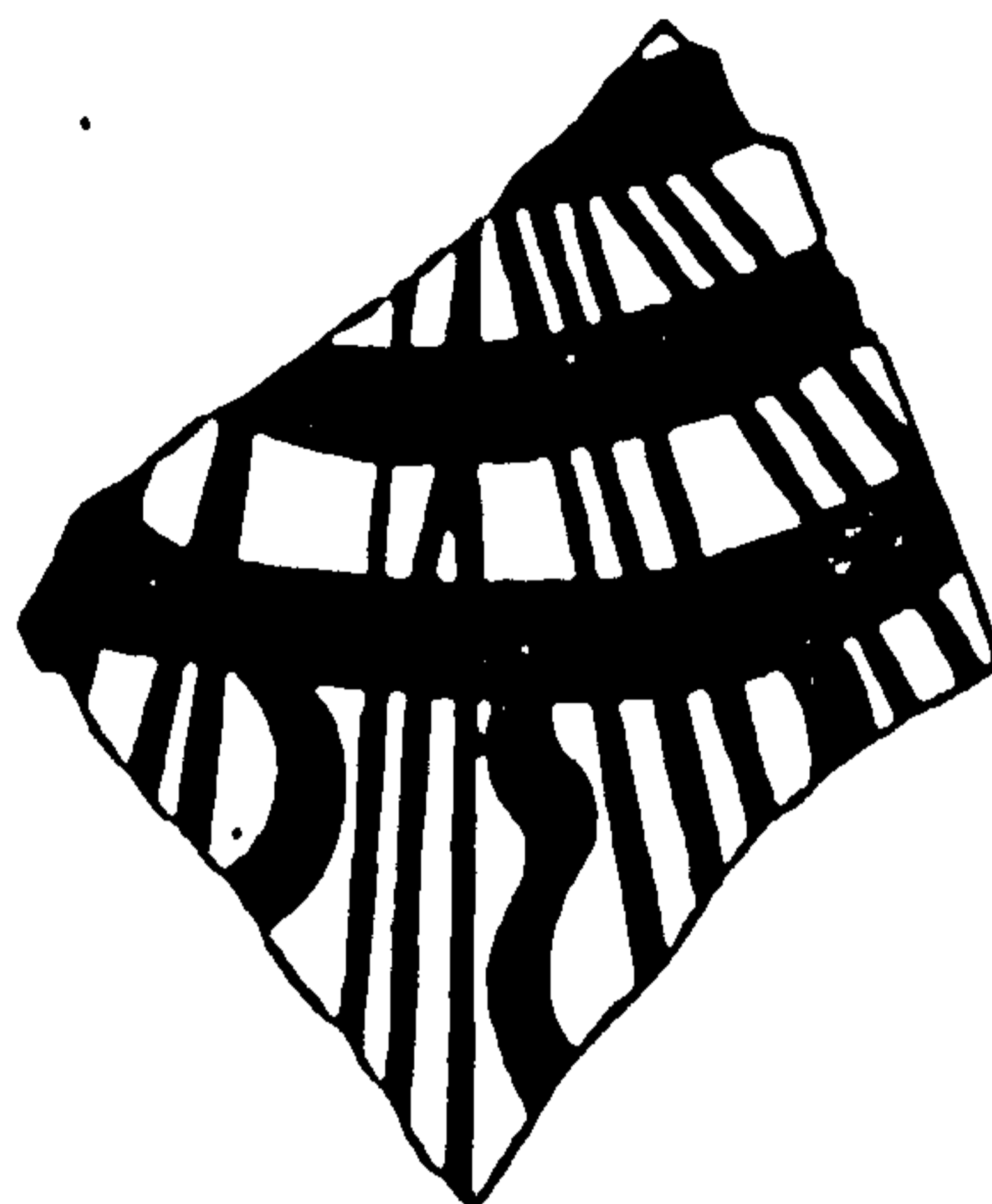
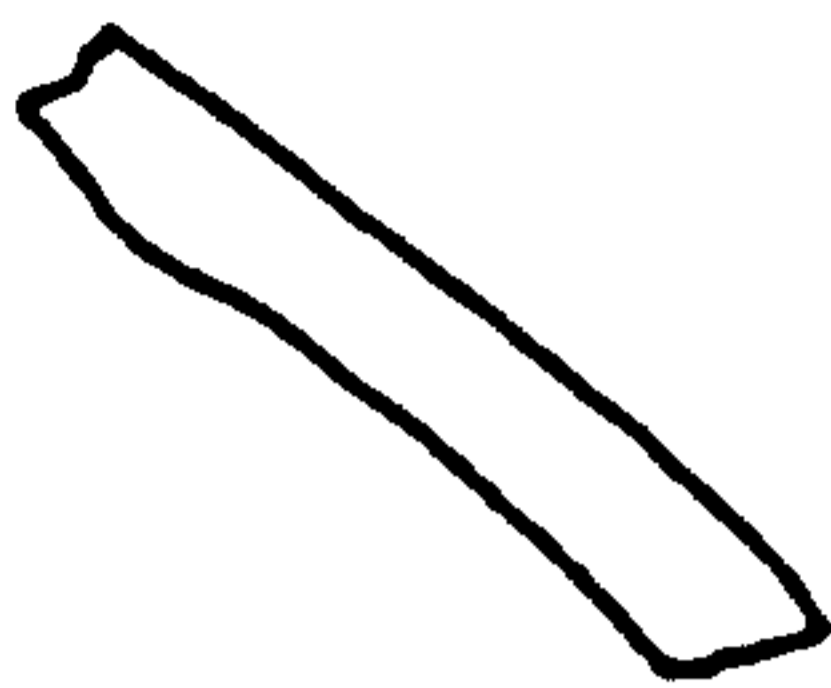

DAB 756

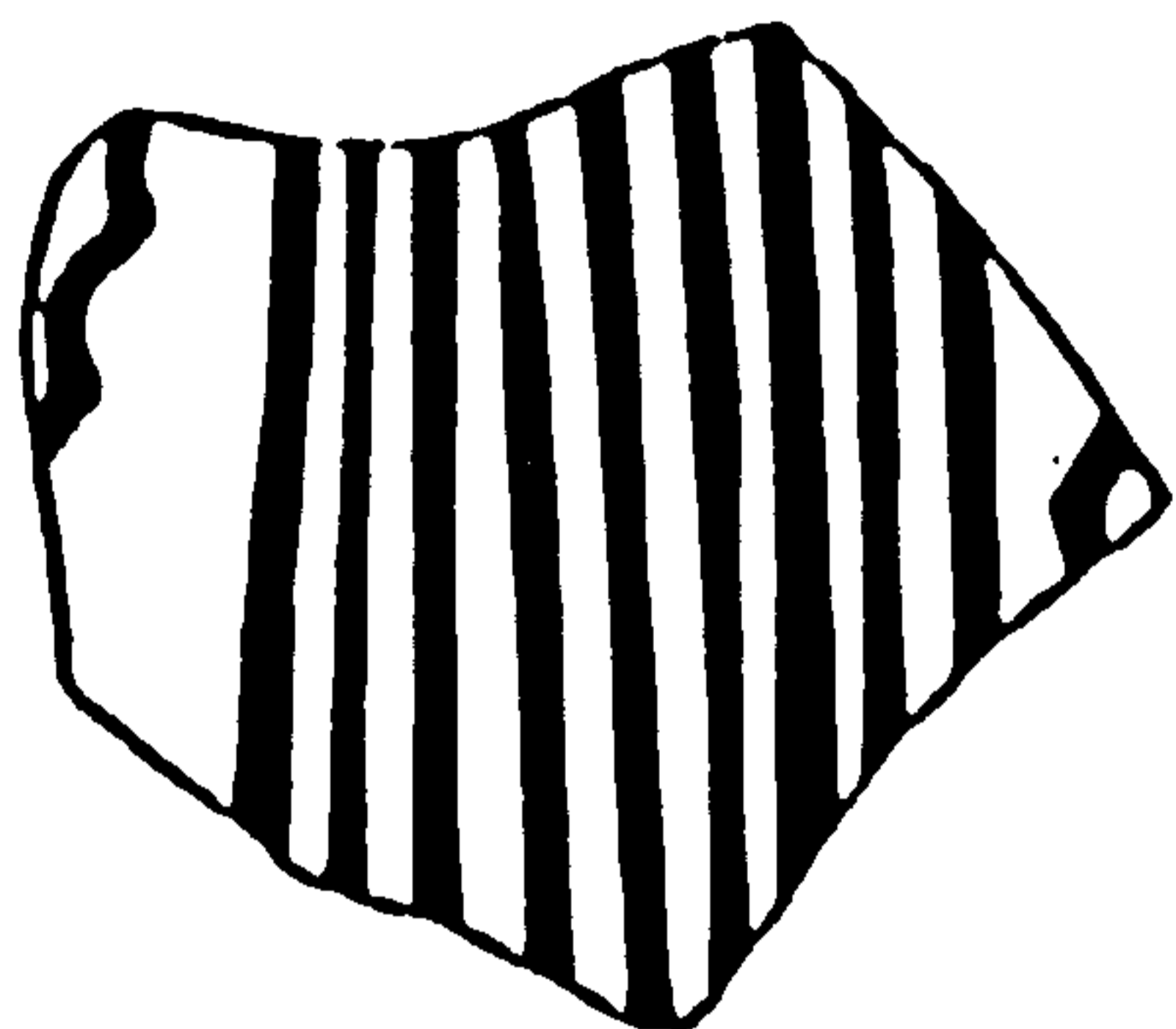

KAB 196

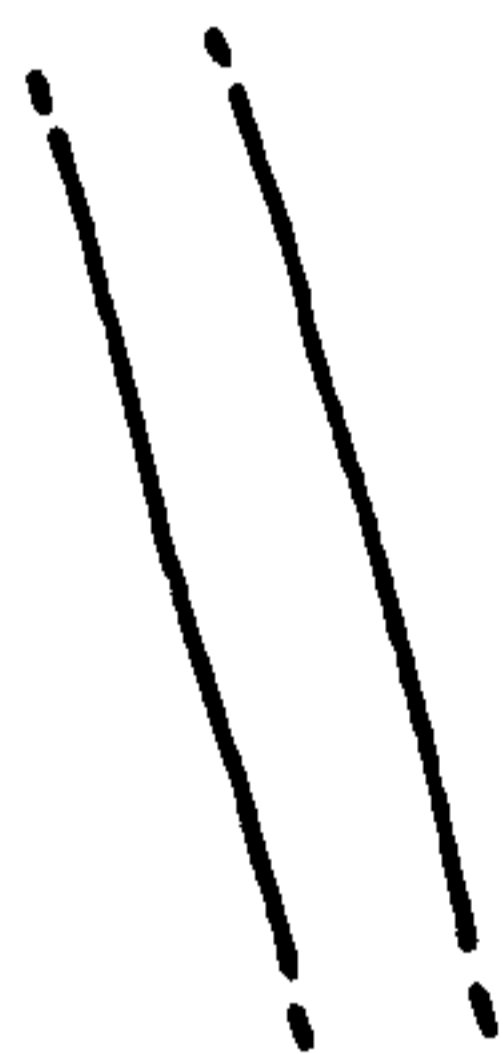

DAB 505

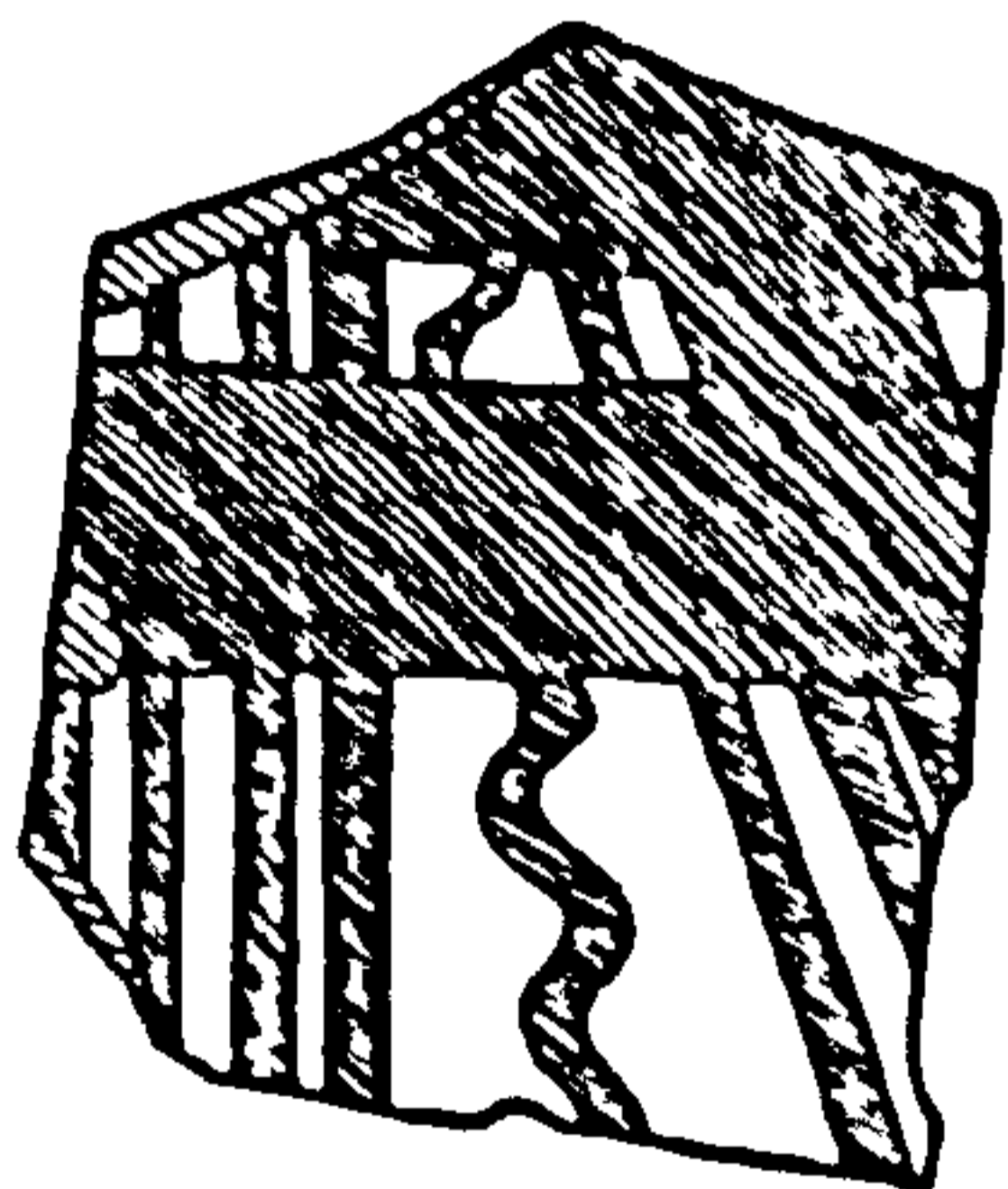

DAB 502

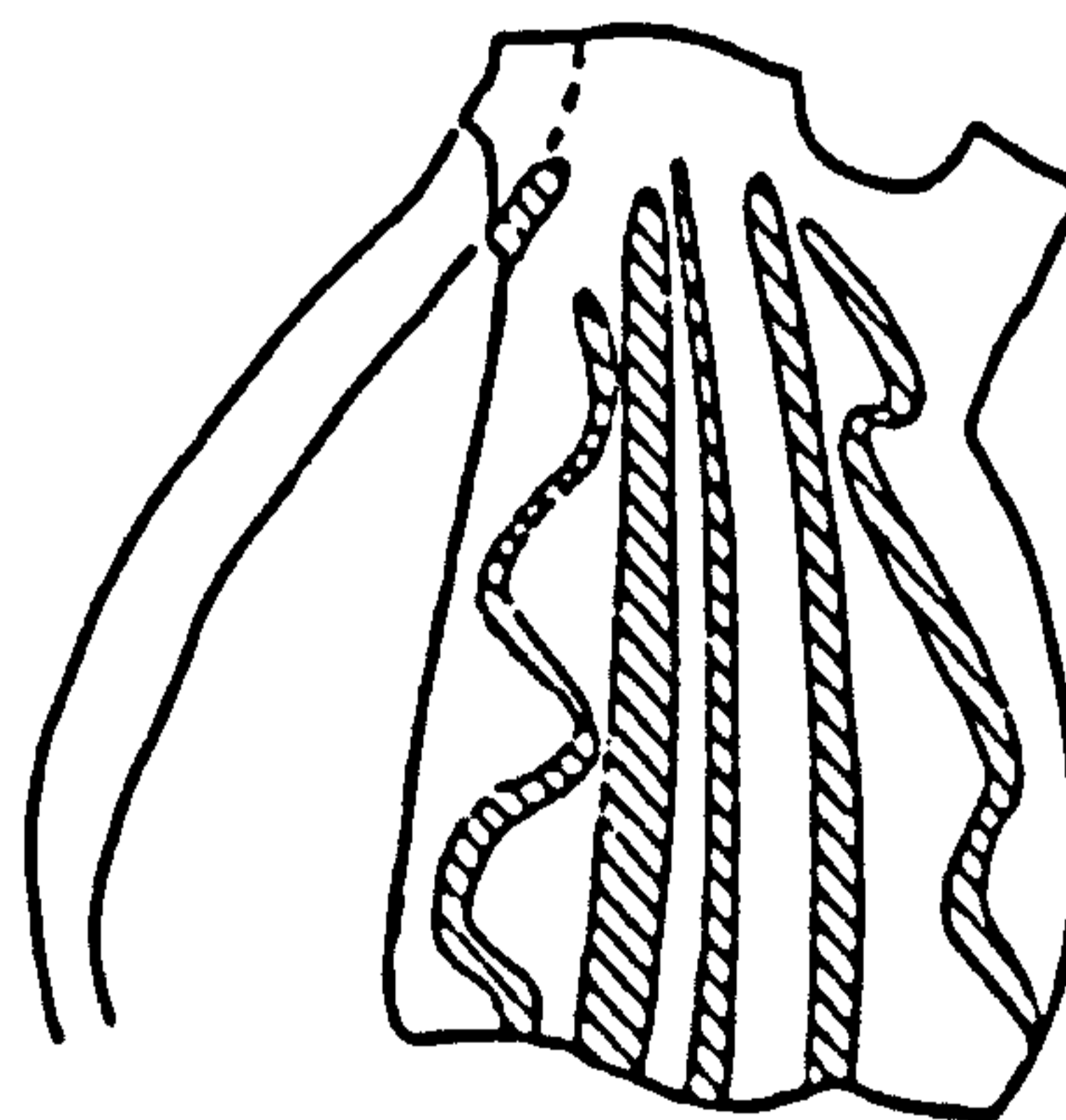

DAB 764
1:2

ILL 2

White Painted Pendent Line Style, Imitation White
Painted Ware (DAB 764)

NUC 801

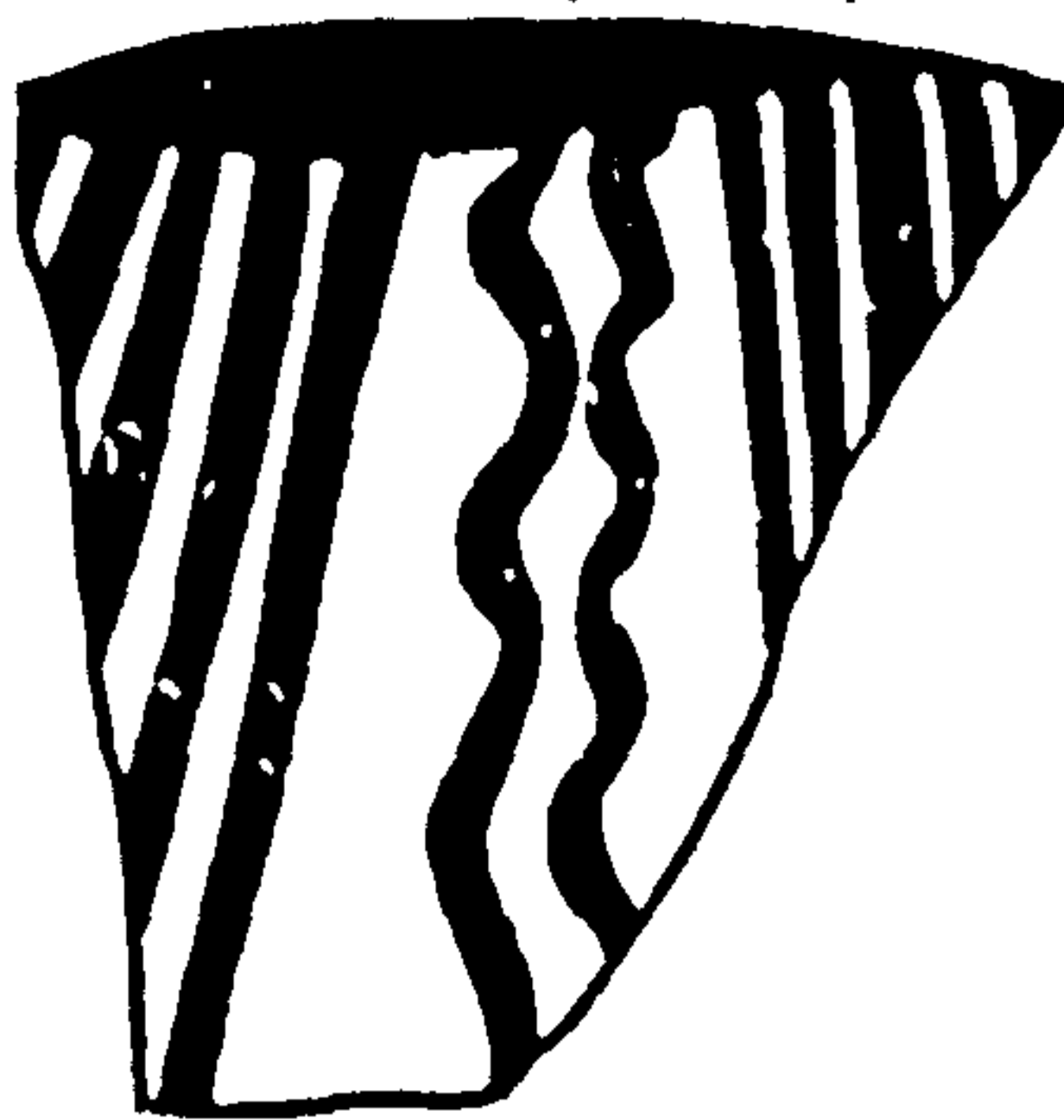

ACH 1

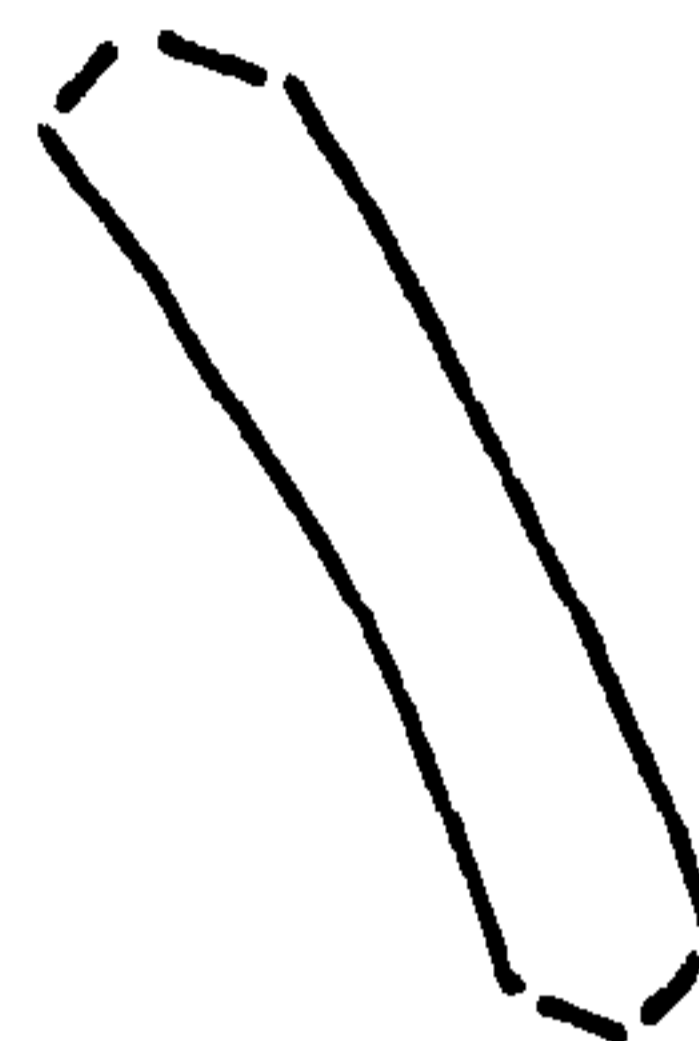
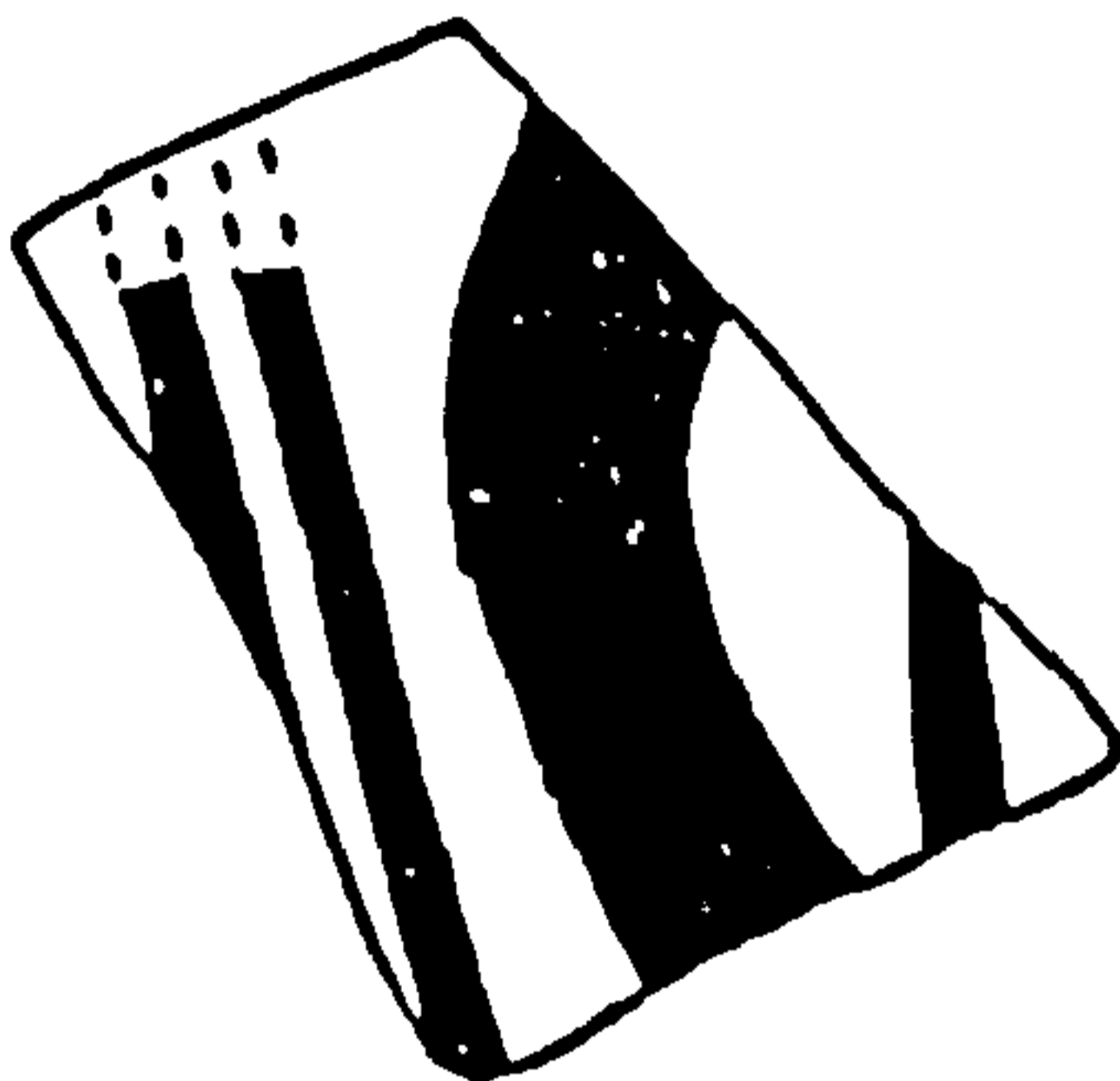

NUC 800



DAB 493

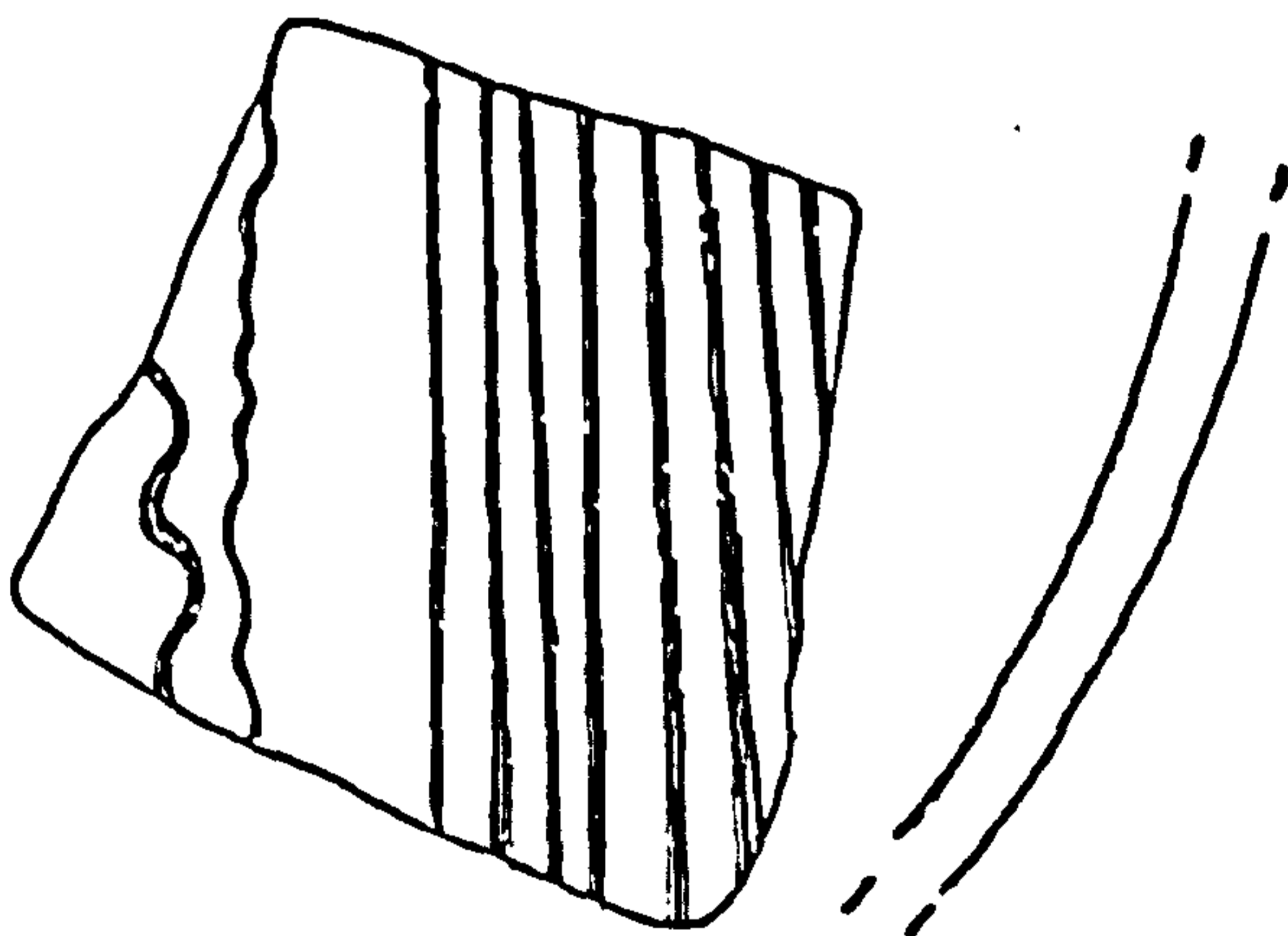

DAB 495

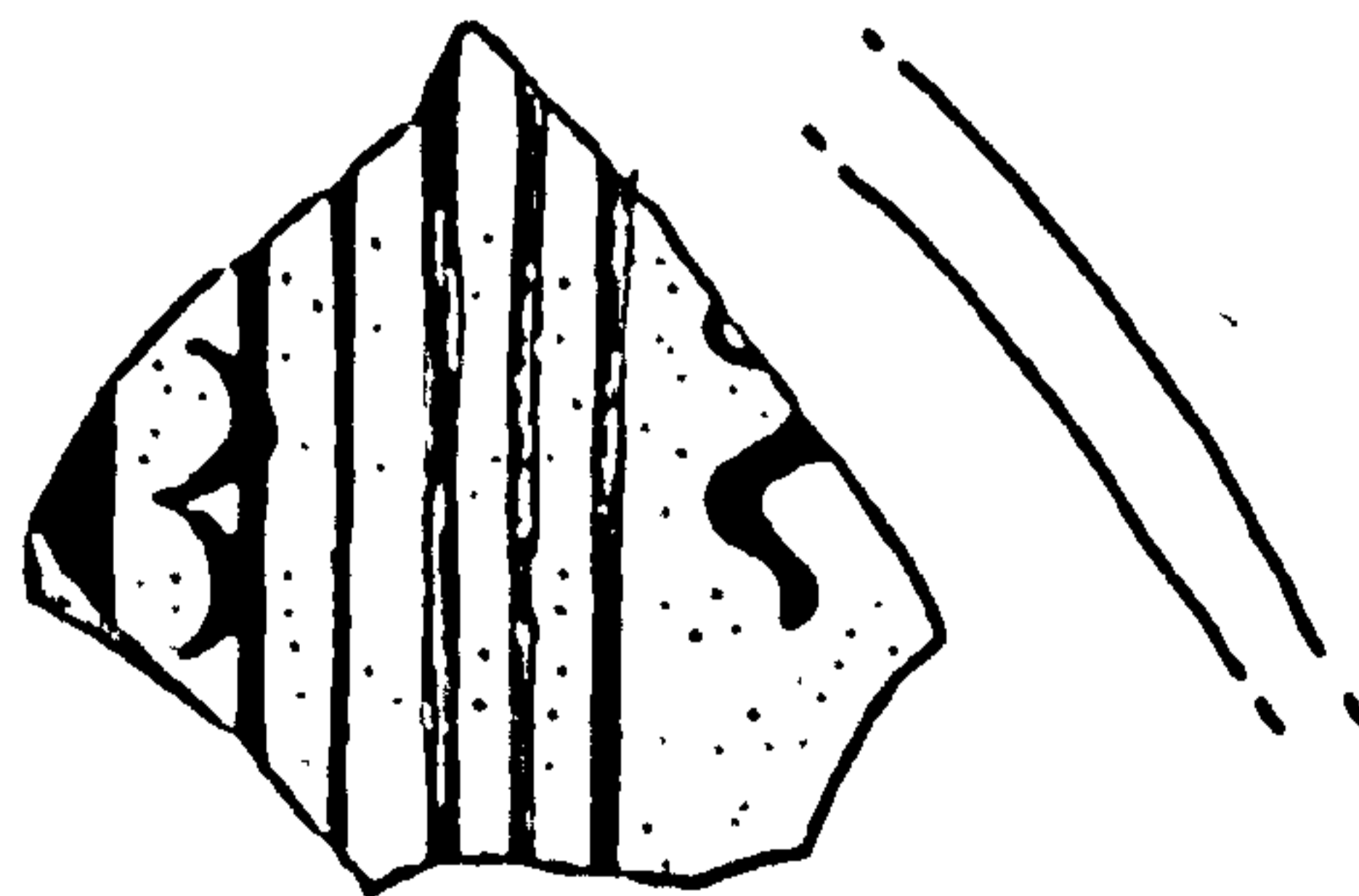

ILL 3

White Painted Pendent Line Style



DAB 490

DAB 788

DAB 557

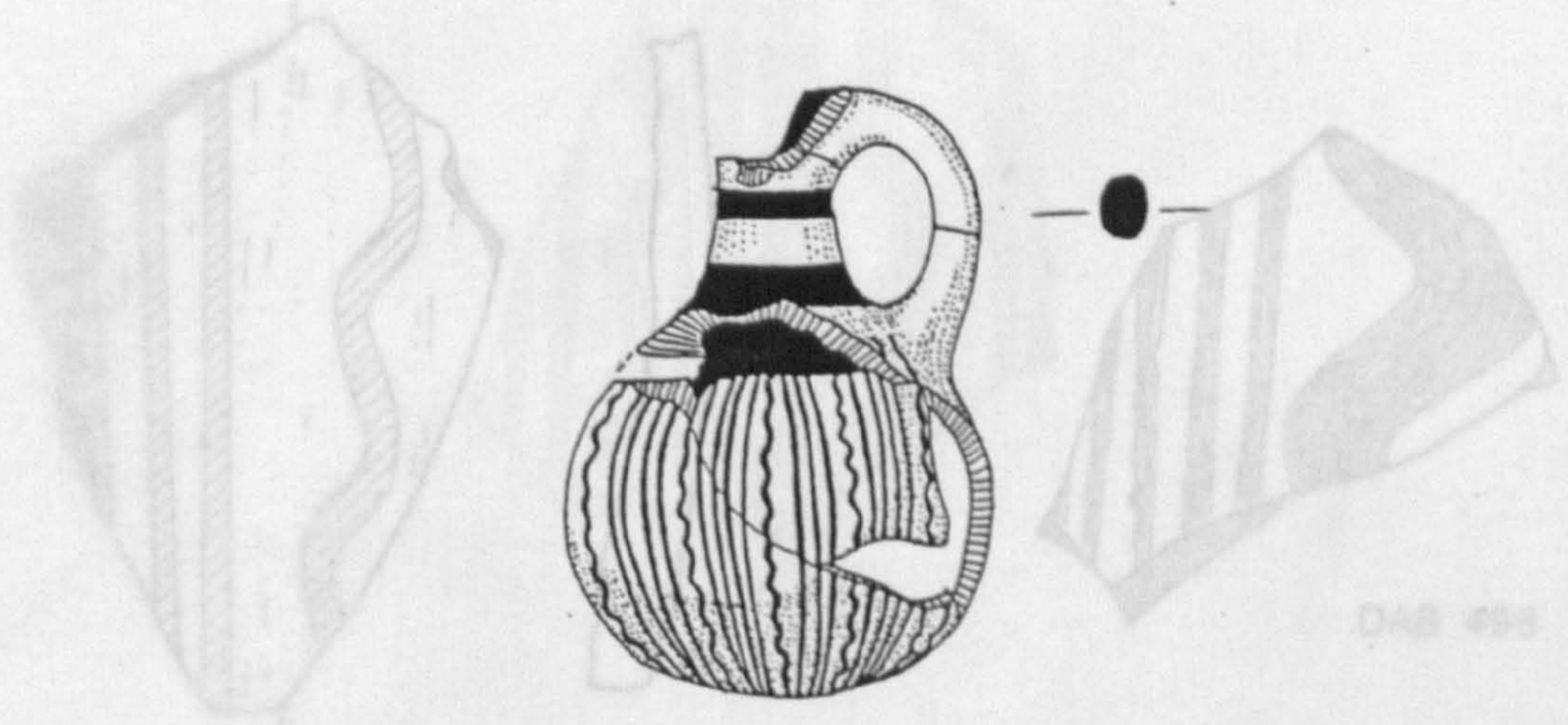

DAB 501

DAB 498

ILL 4

White Painted Pendent Line Style



DAB 494



DAB 768

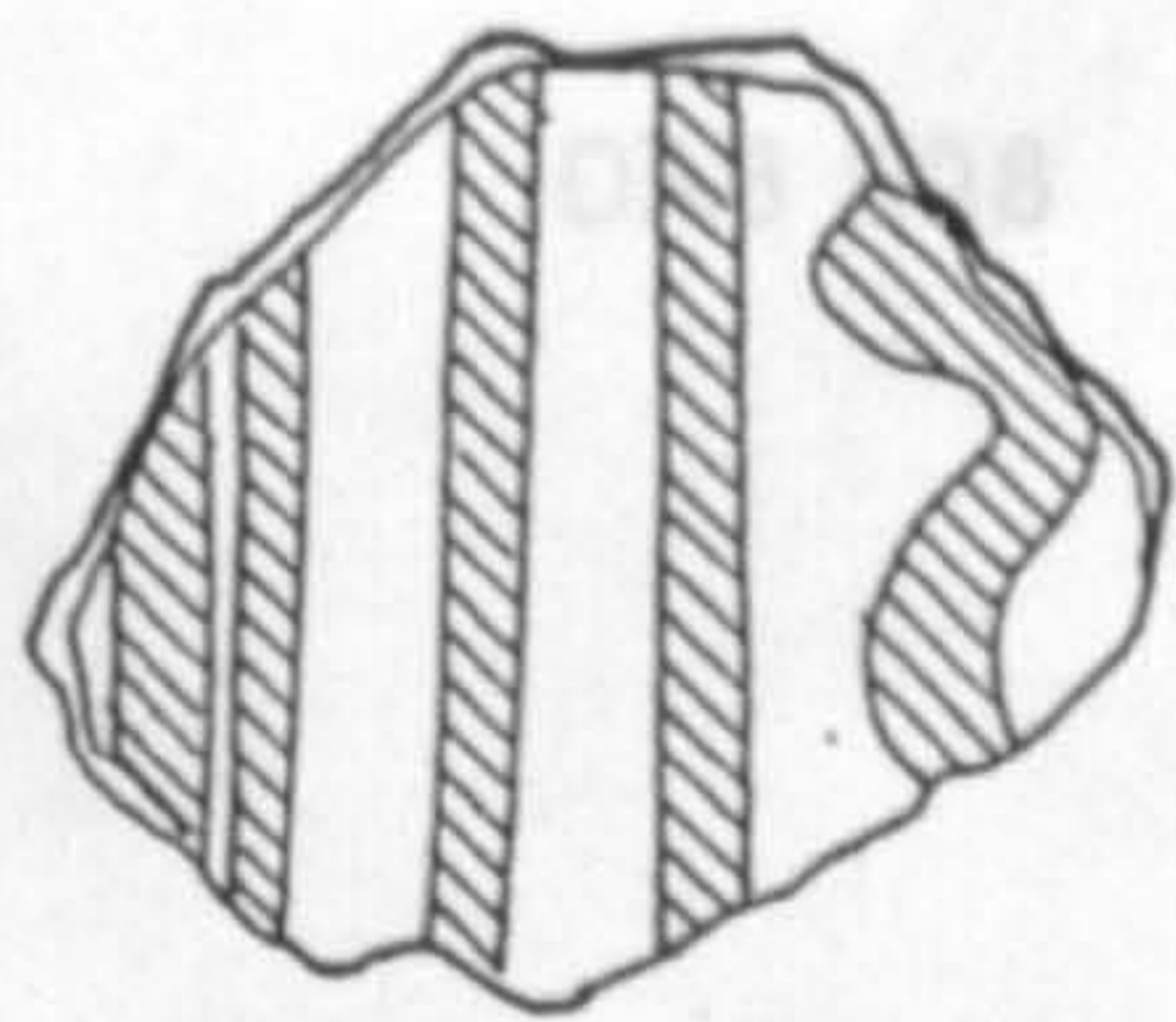

DAB 506



DAB 557

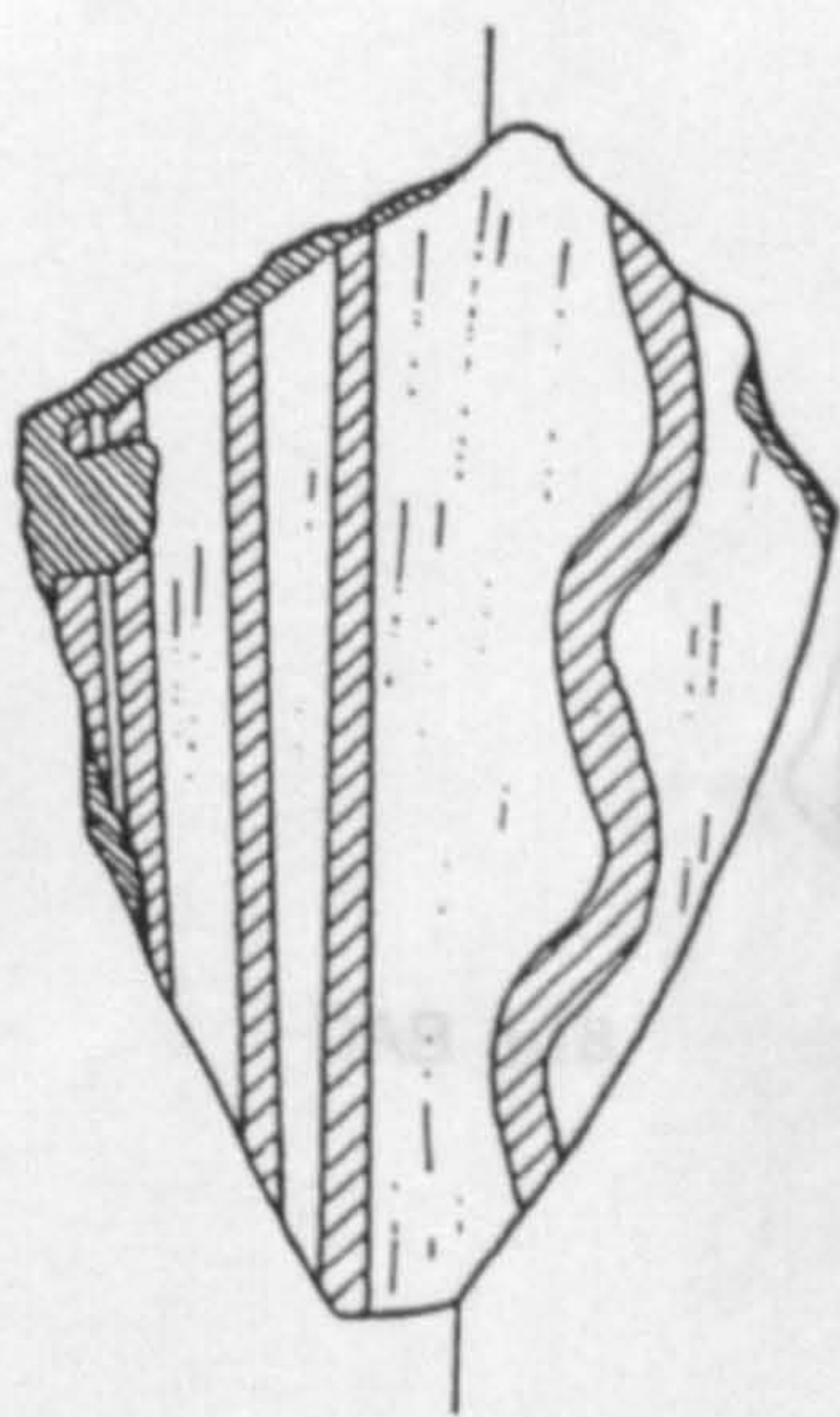

DAB 489

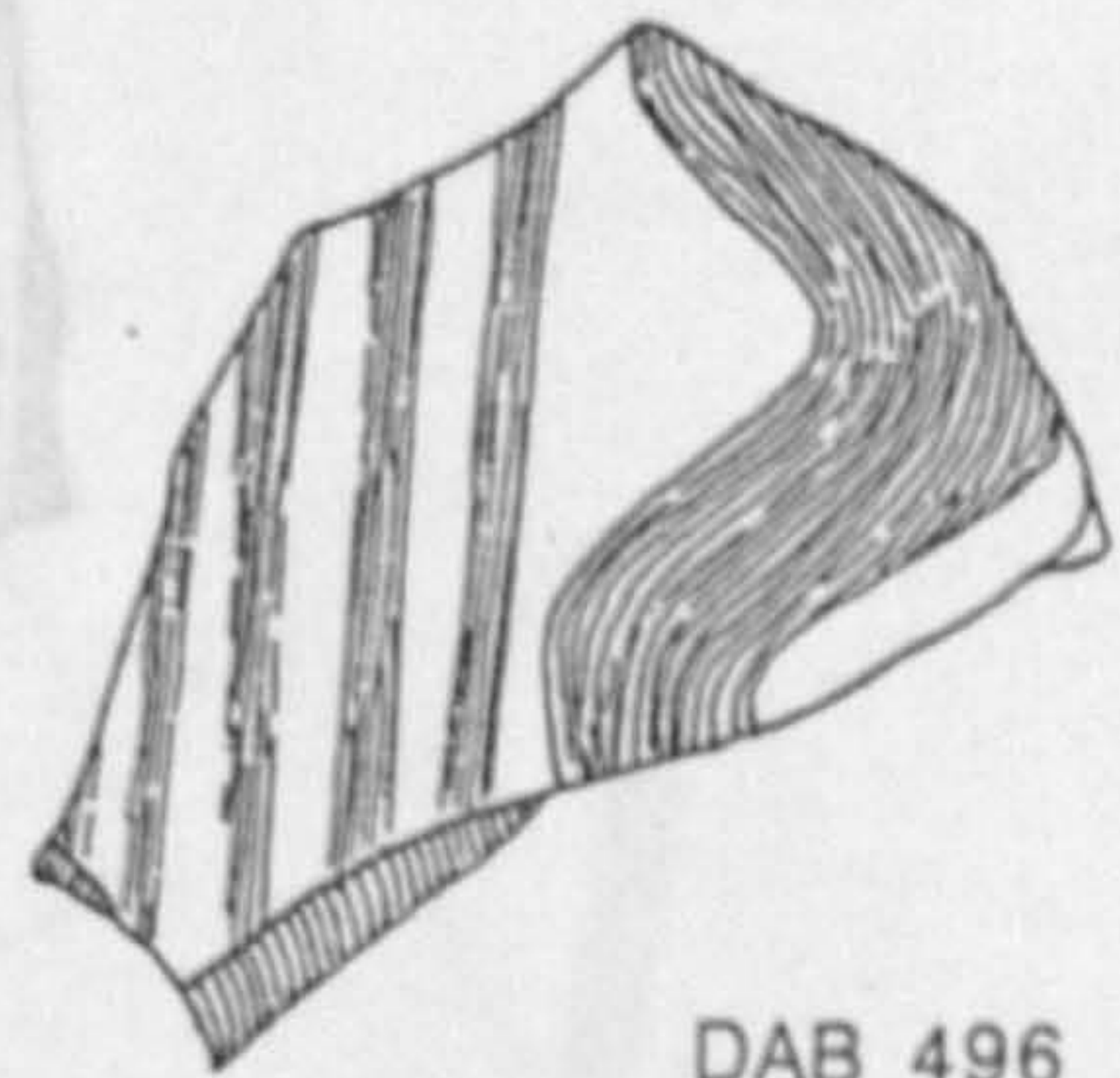

DAB 496

ILL 6
ILL 5

White Painted Pendent Line Style
White Painted Pendent Line Style, Imitation White
Painted Ware (DAB 768)

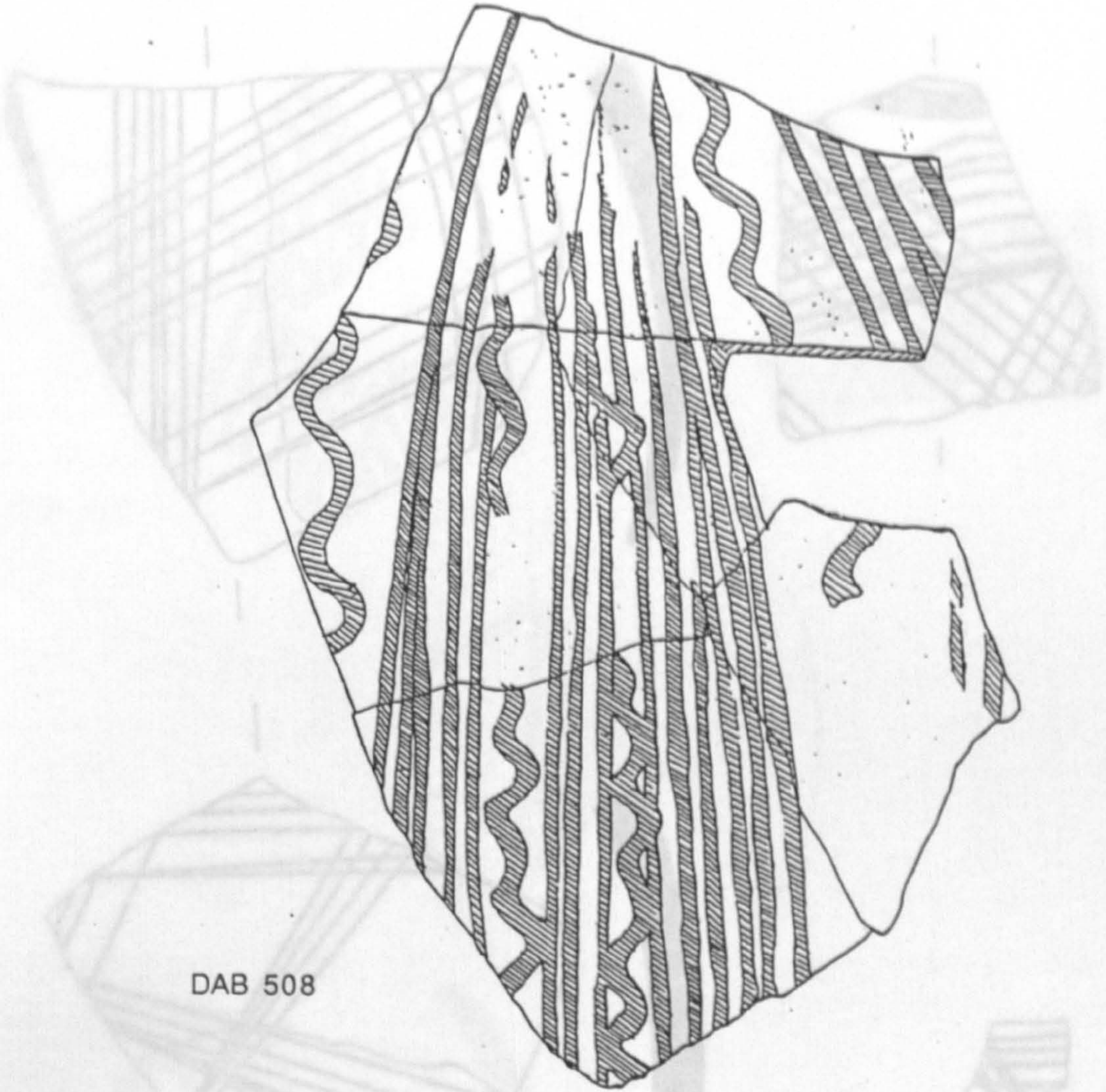

DAB 508

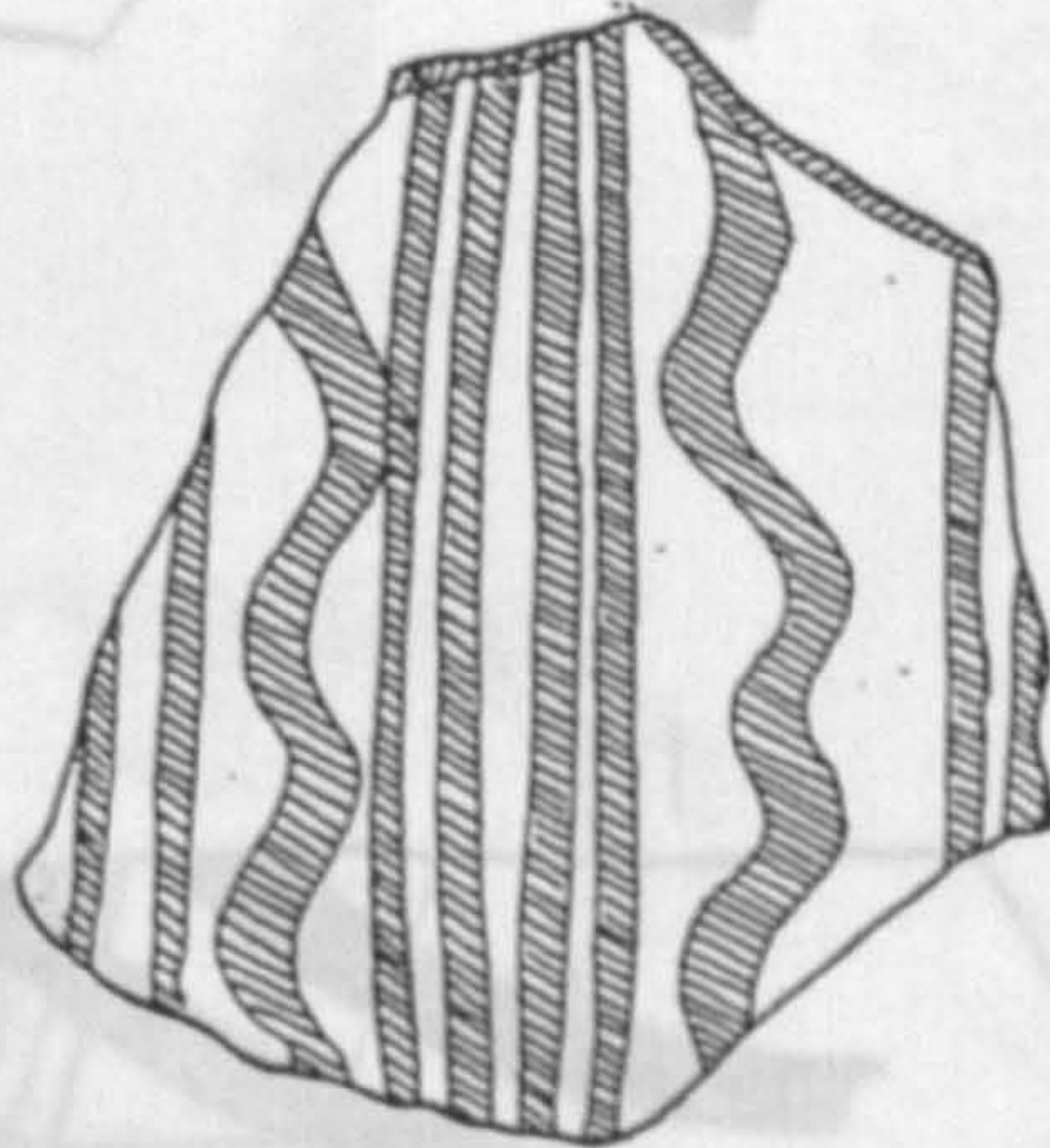

DAB 508

ILL 6

White Painted Pendent Line Style

ILL 7

White Painted Cross Line Style

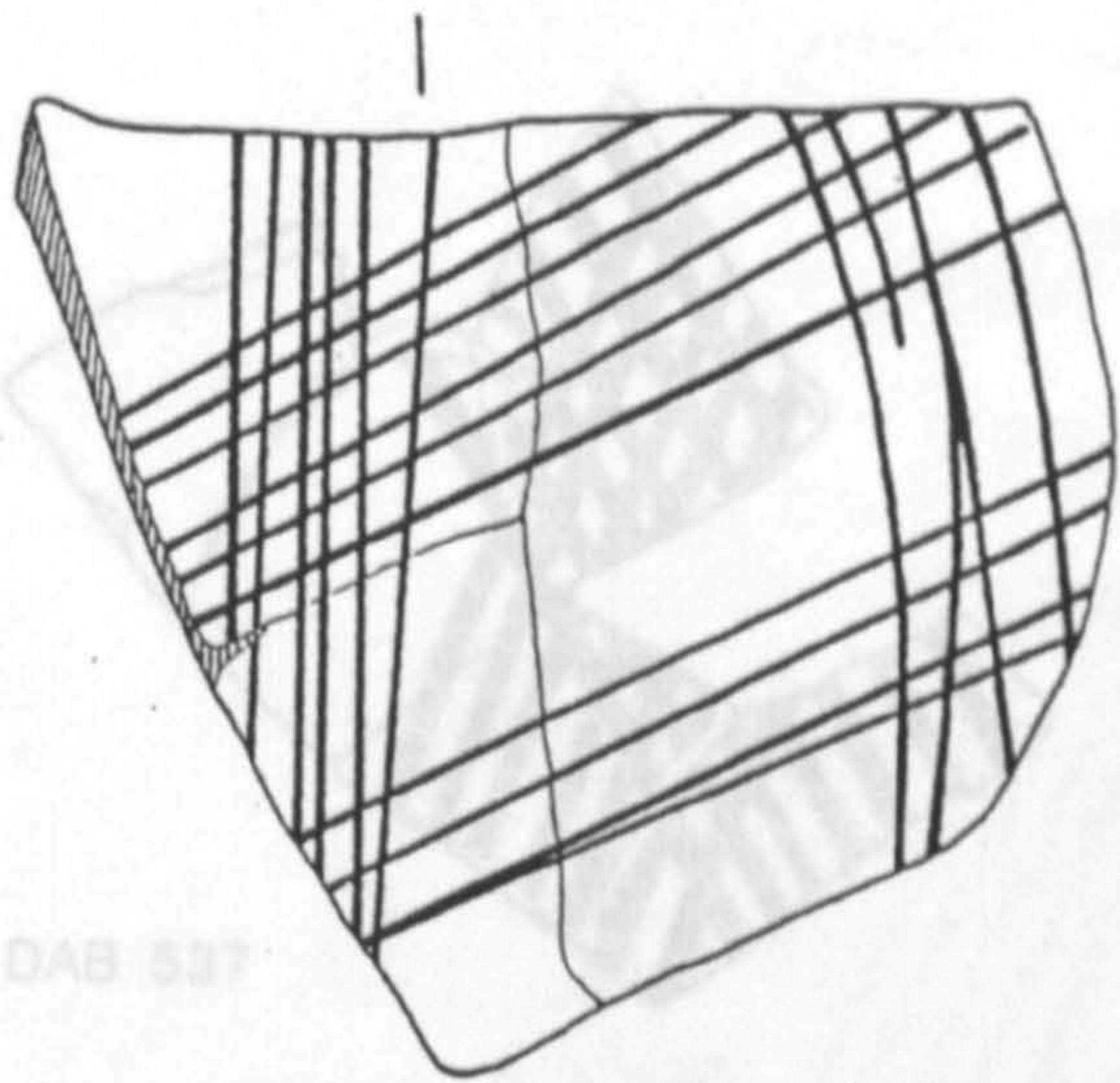

DAB 537

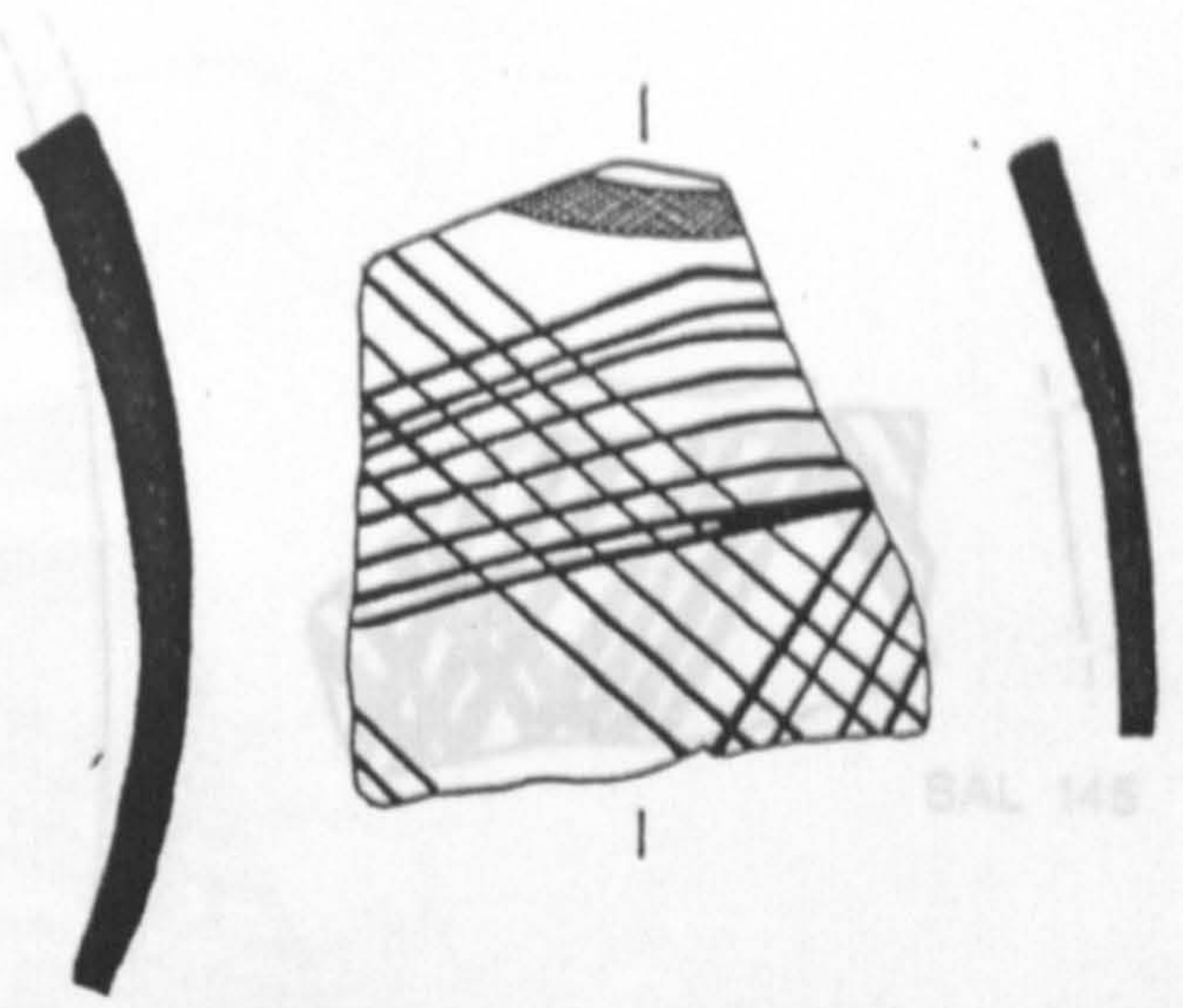

SAL 145

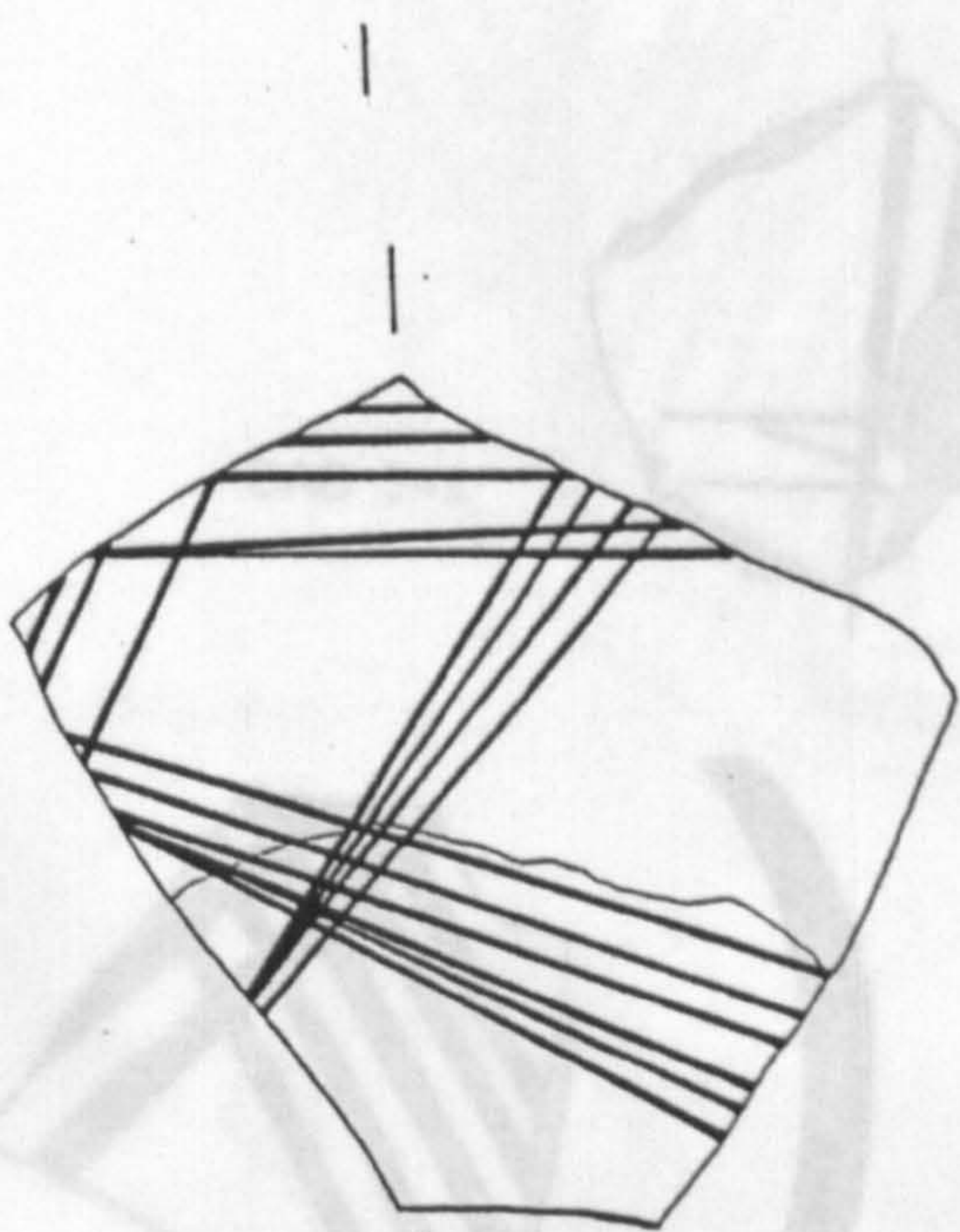

DAB 520



DAB 531

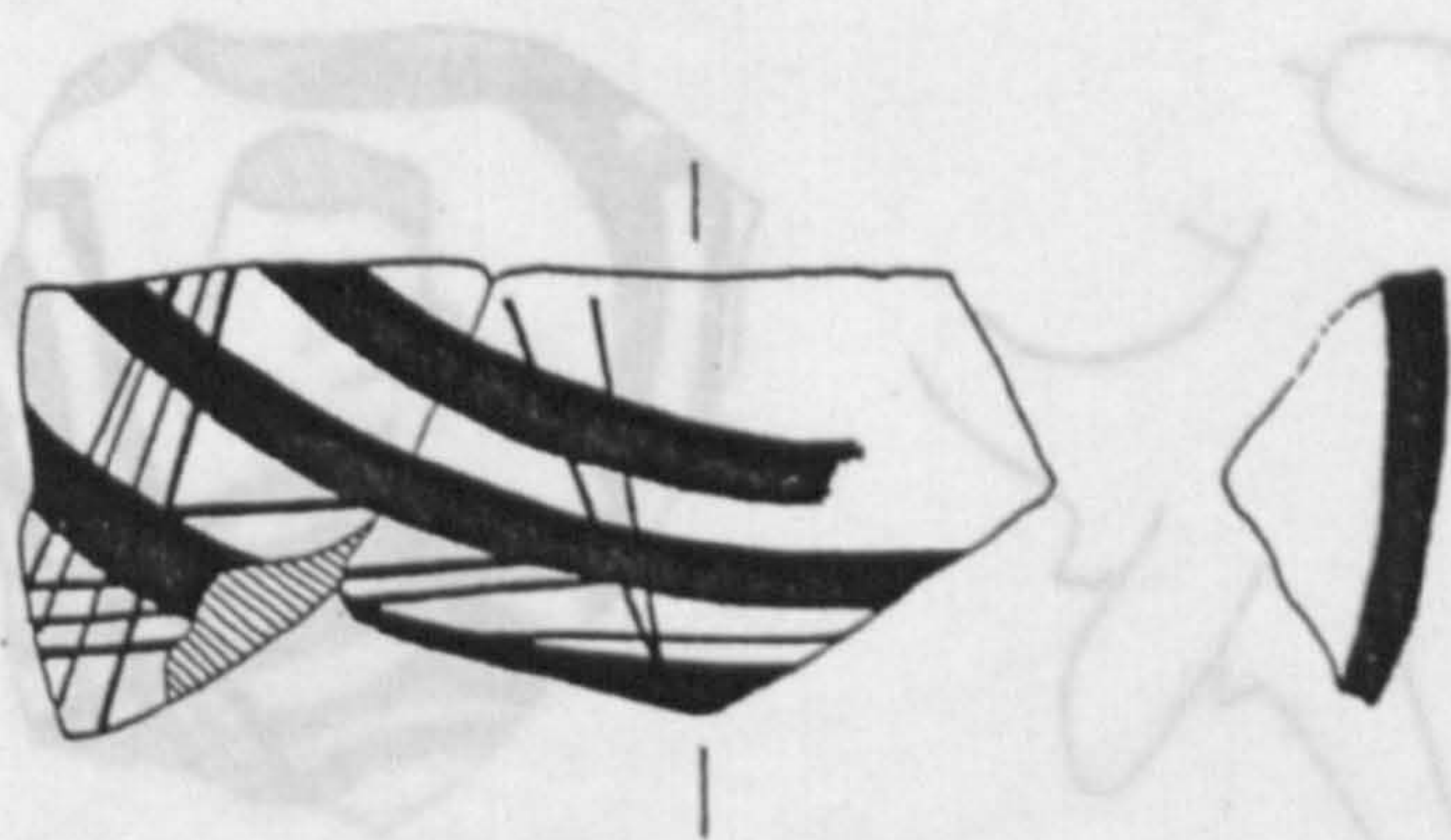

DAB 522

ILL 7

White Painted Cross Line Style

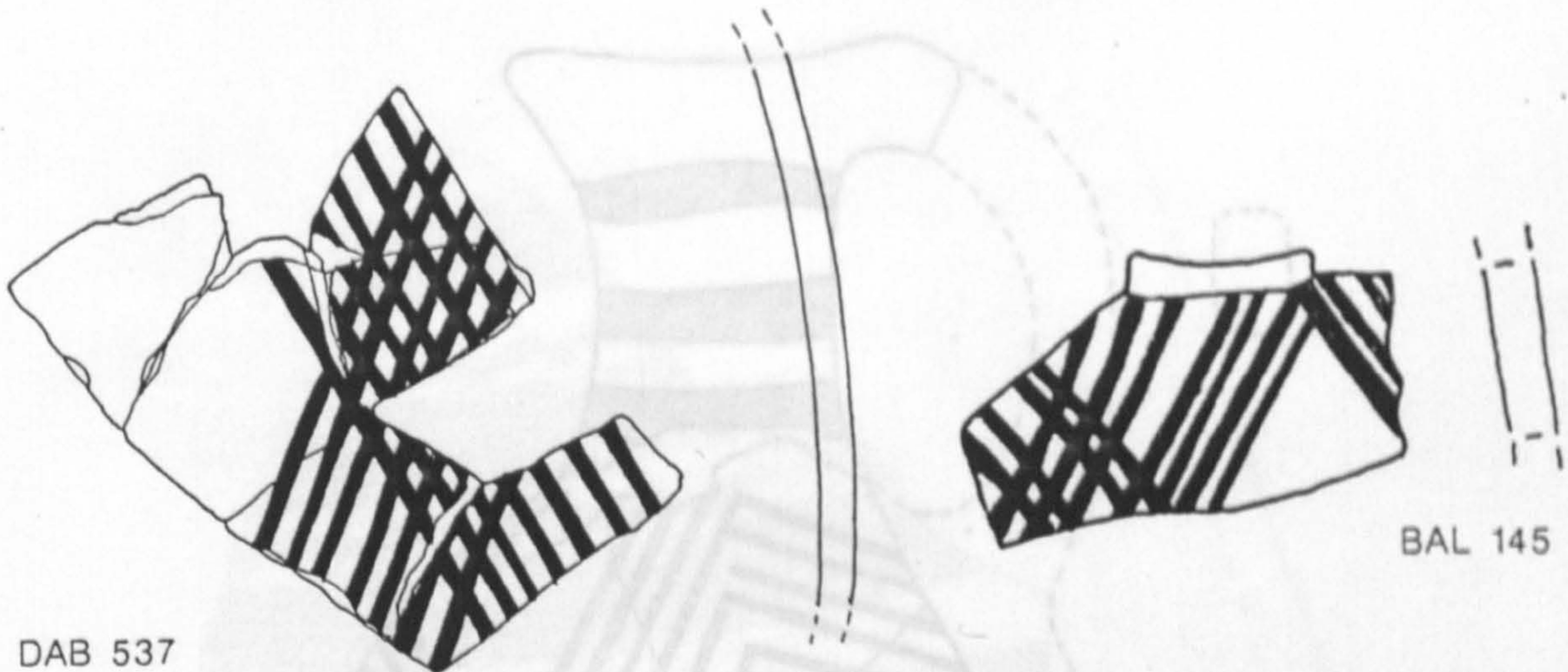

DAB 537

BAL 145

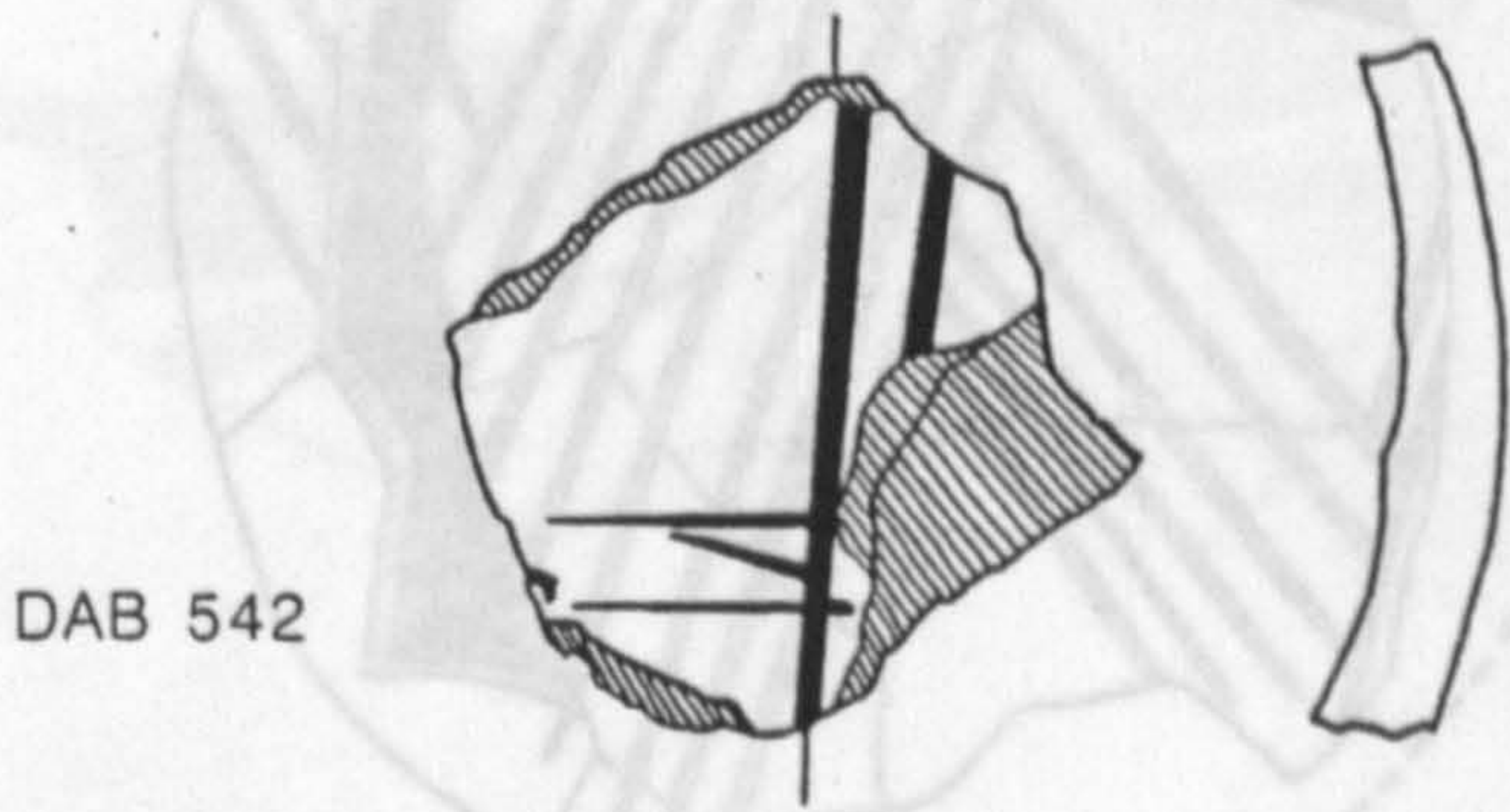

DAB 542

DAB 543

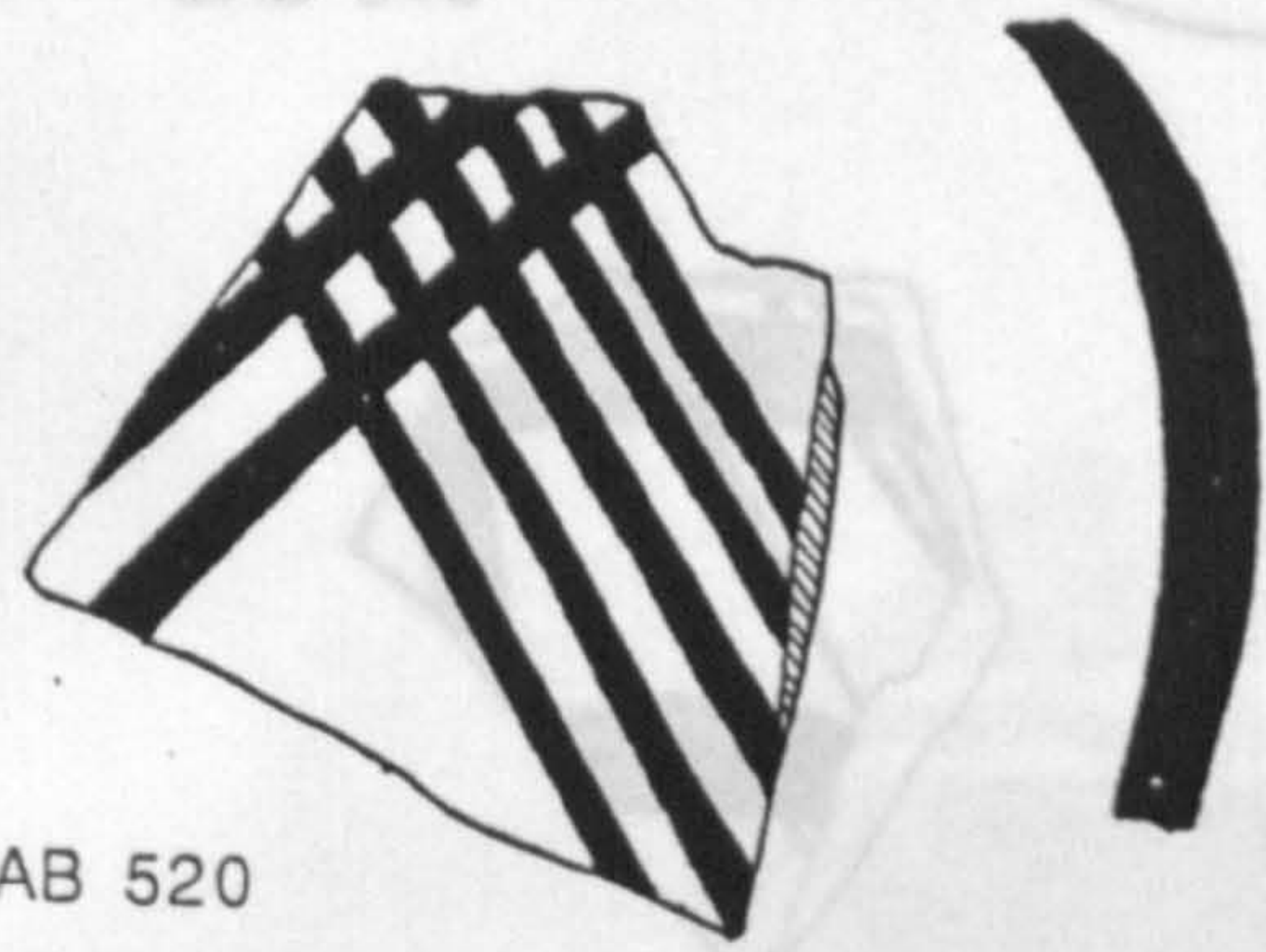

DAB 520

DAB 513

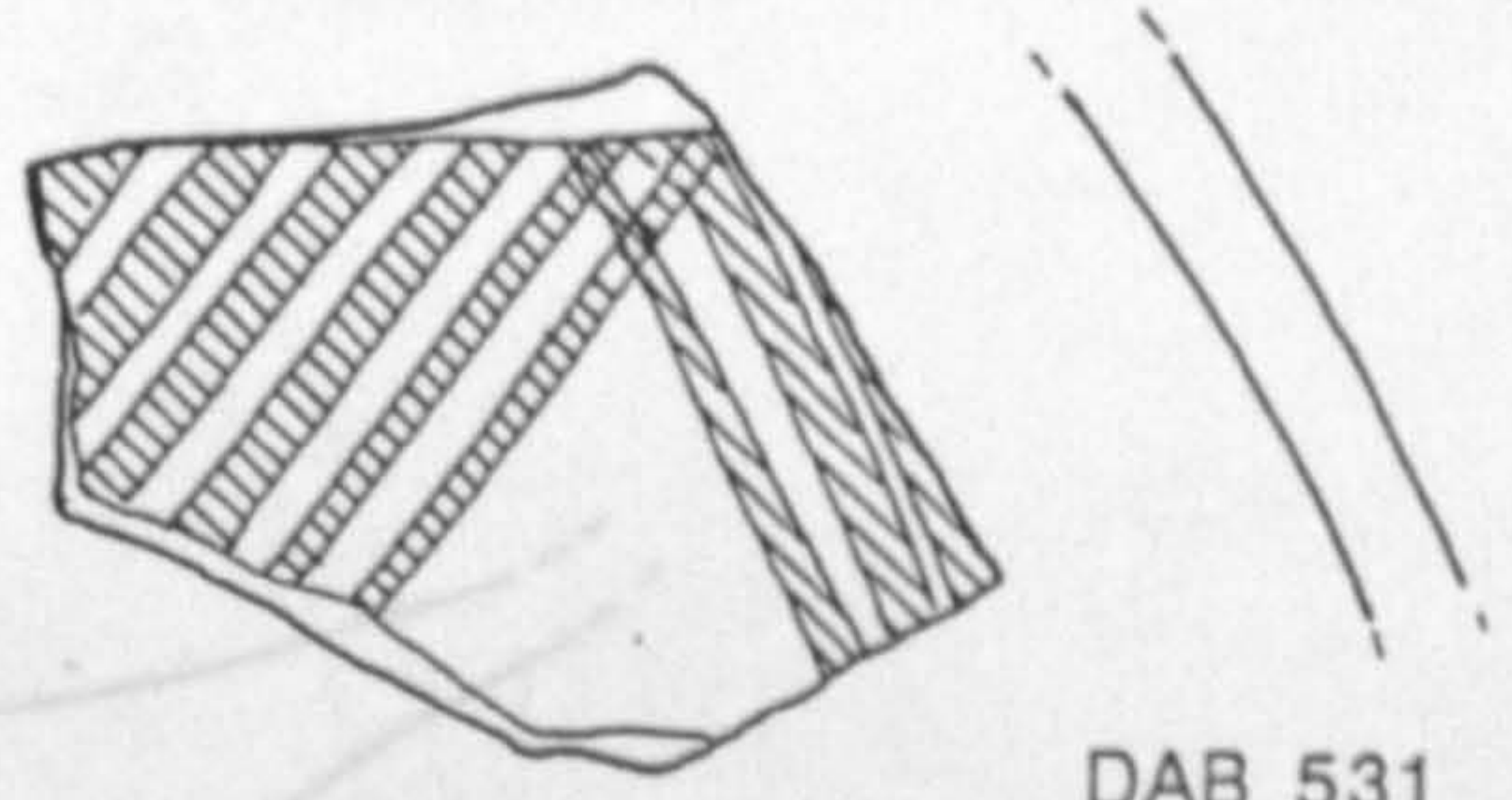

DAB 531



DAB 530

DAB 566

ILL 9

ILL 8

White Painted Cross Line Style / Topped Line Style
White Painted Cross Line Style

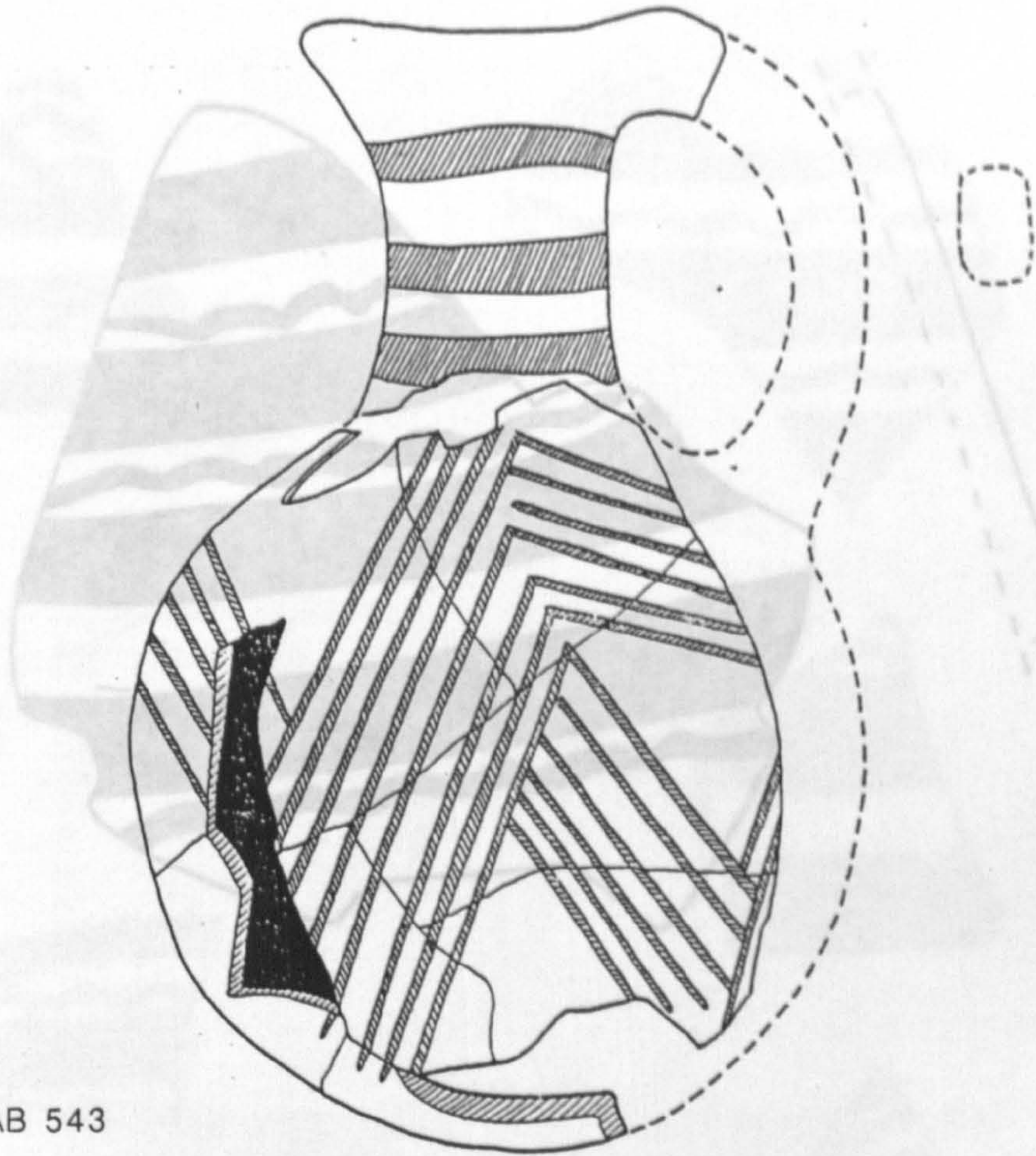

DHA 101

DAB 543

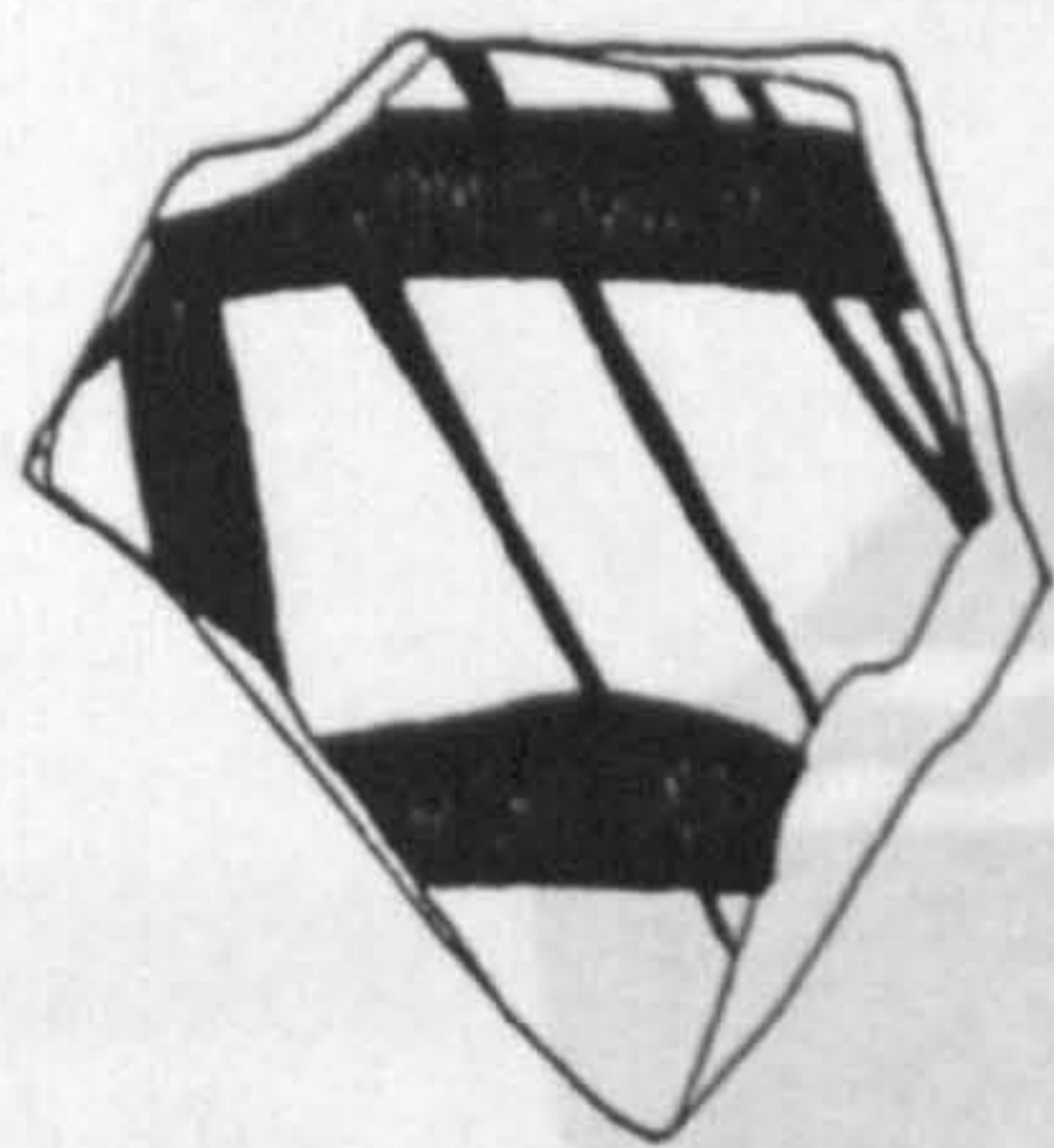

DAB 513

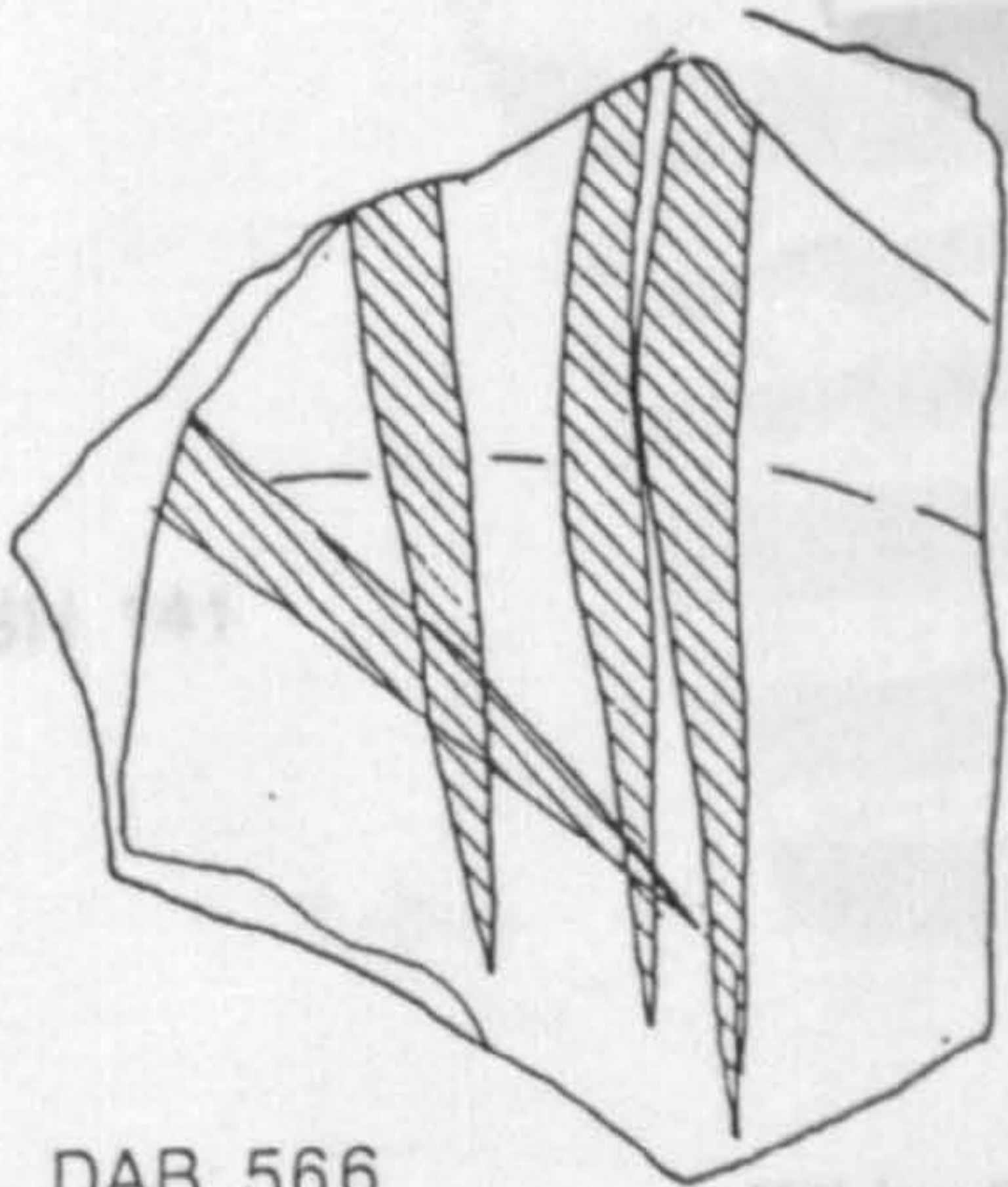

DAB 566

ILL 9

White Painted Alternating broad Band and Wavy Line Style

White Painted Cross Line Style/Tangent Line Style, White Painted V

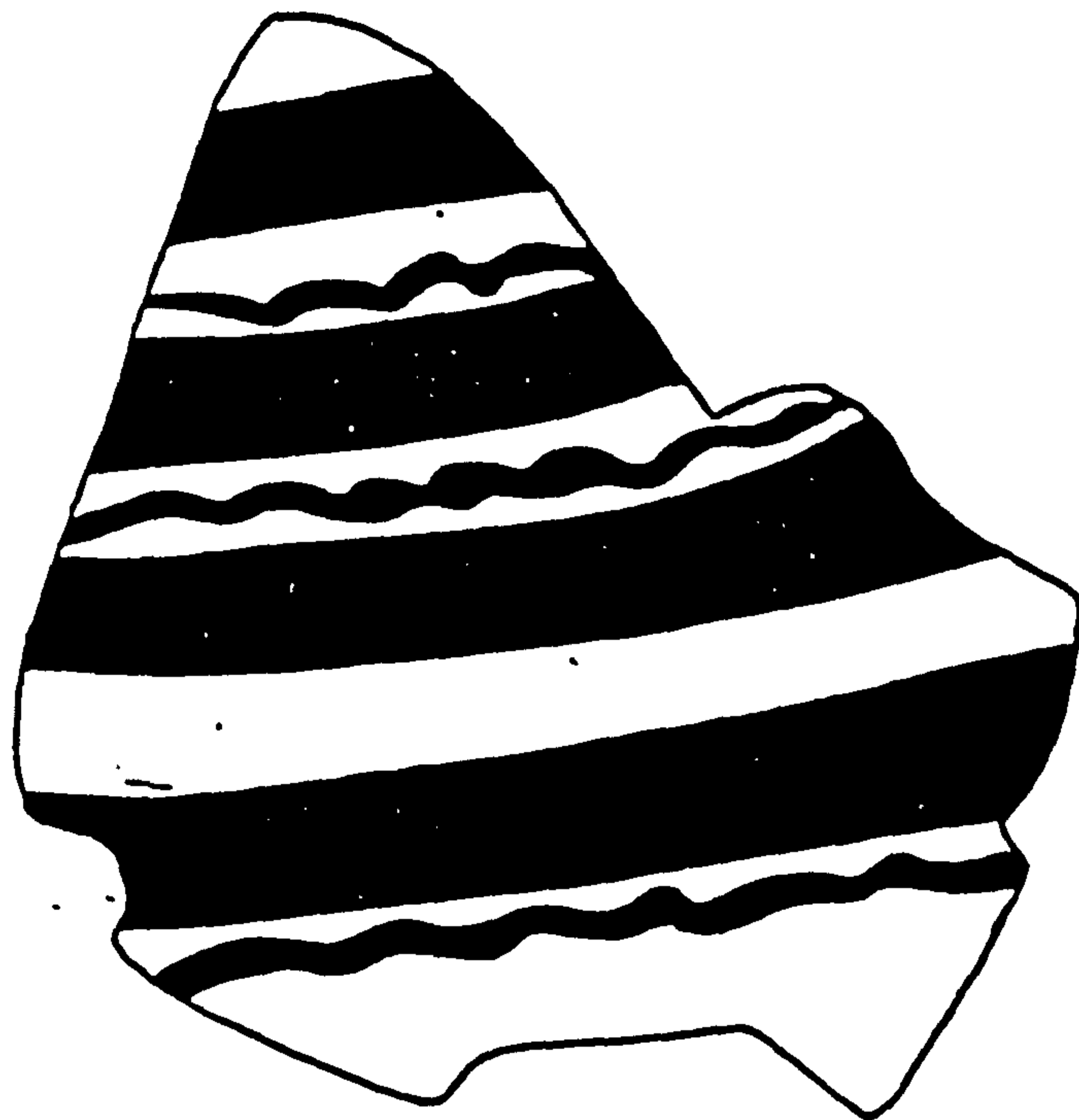

DHA 161

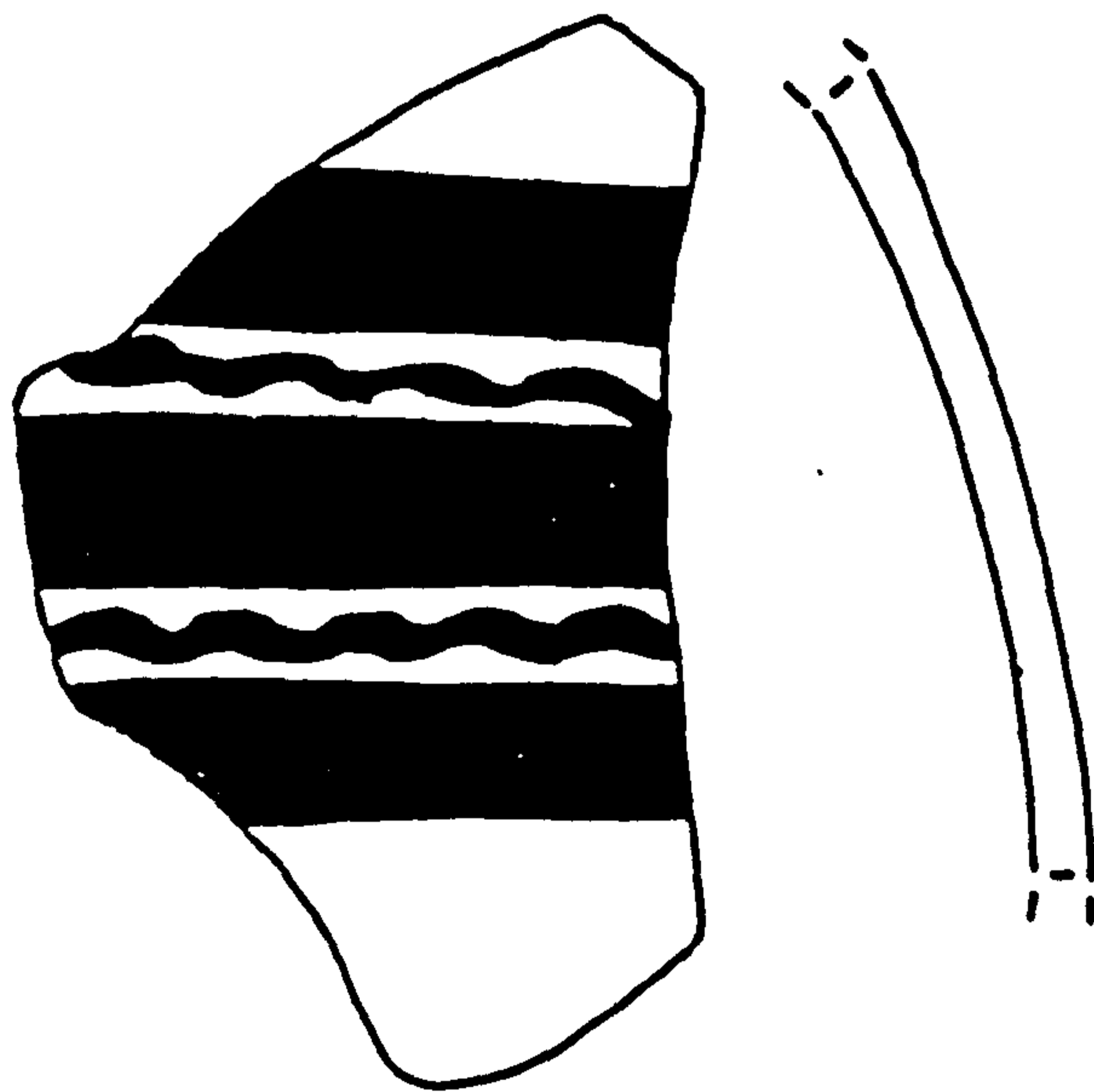

ASH 141

ILL 10

White Painted Alternating broad Band and Wavy Line Style

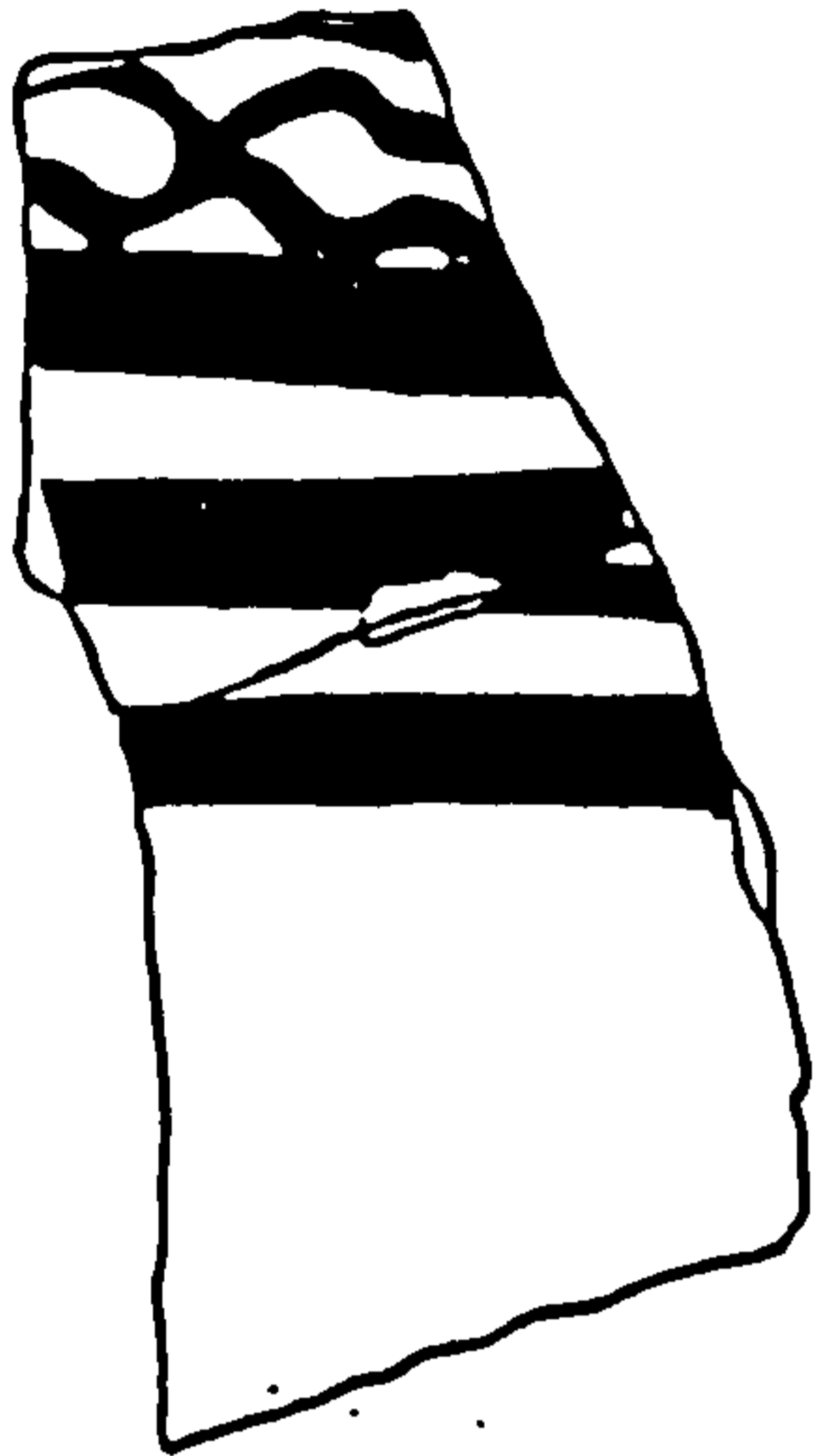

DAB 547



KAB 198

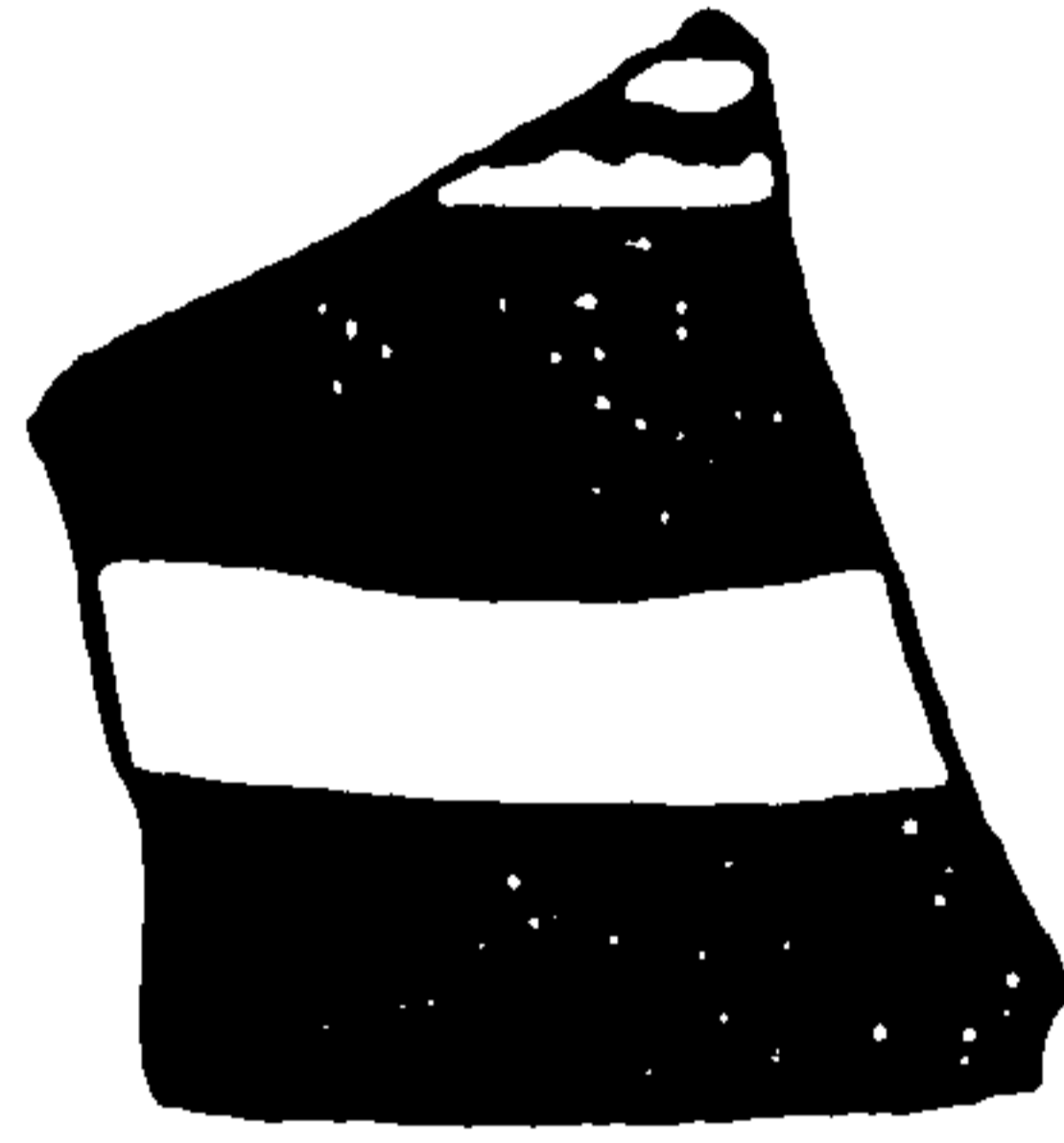
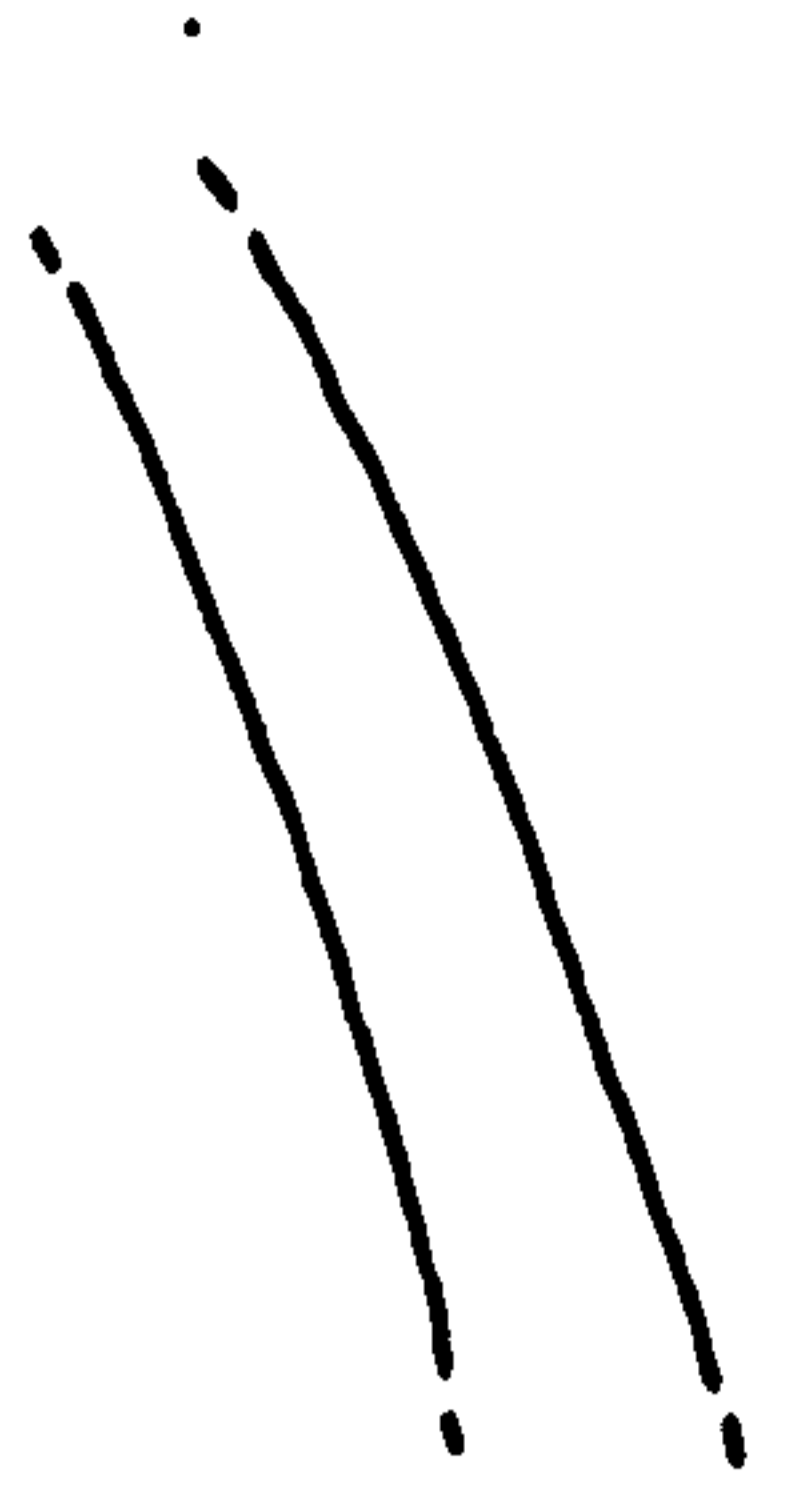

KAB 199

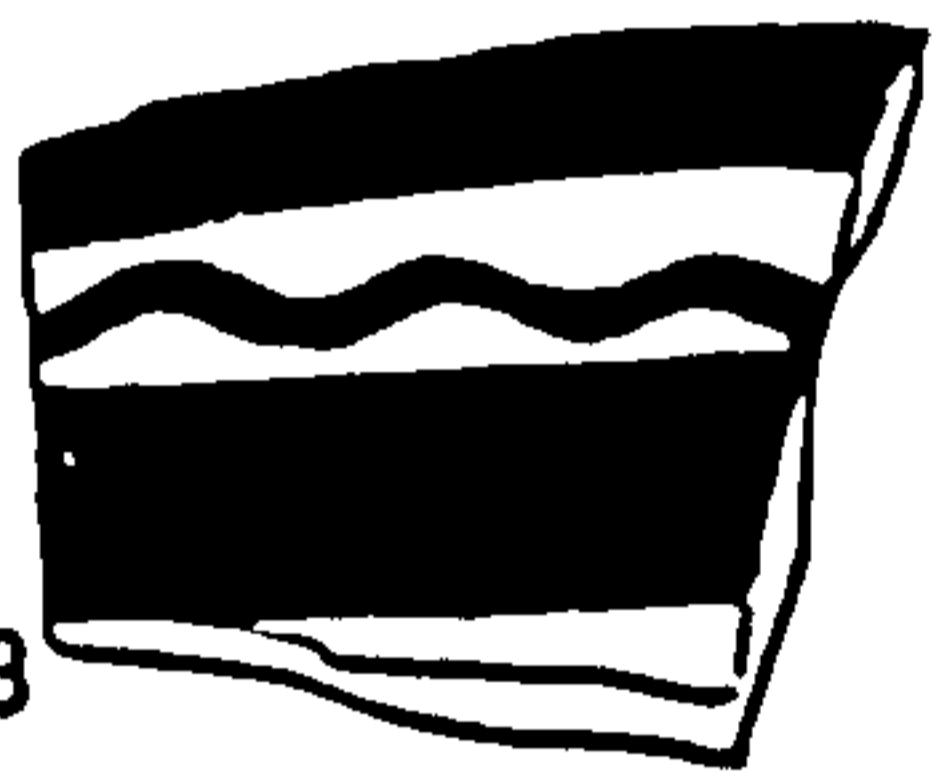
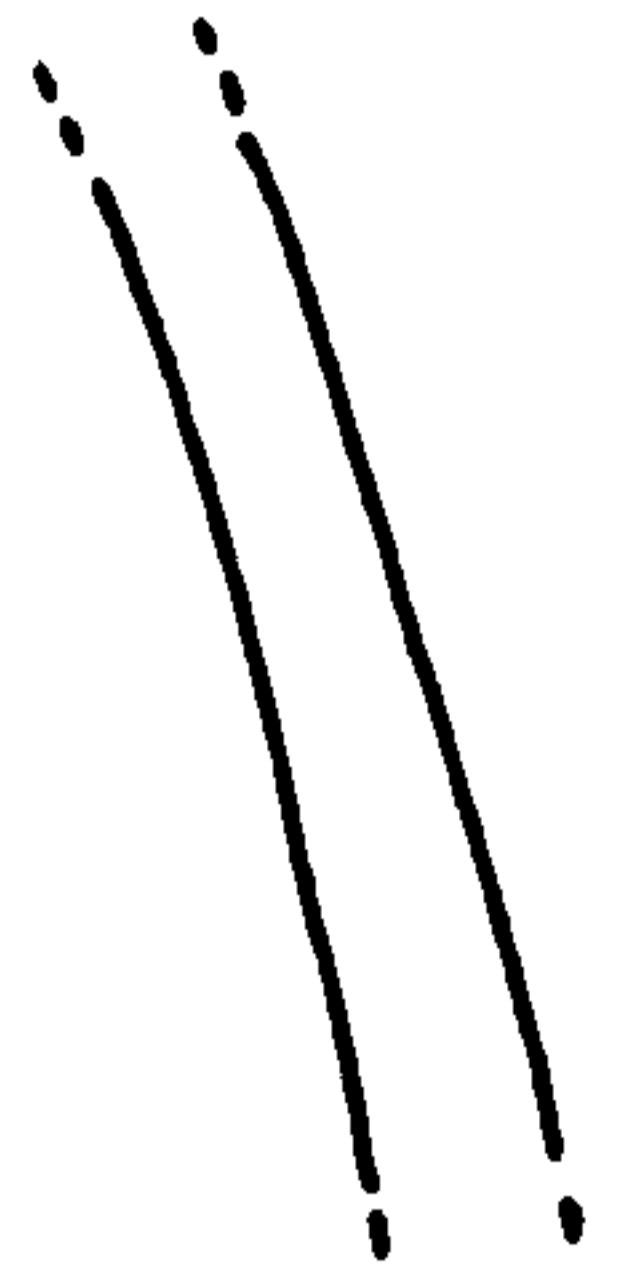

DAB 548

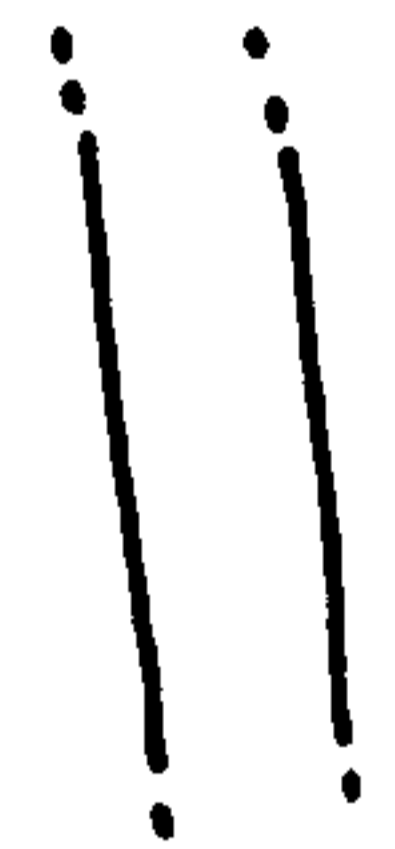
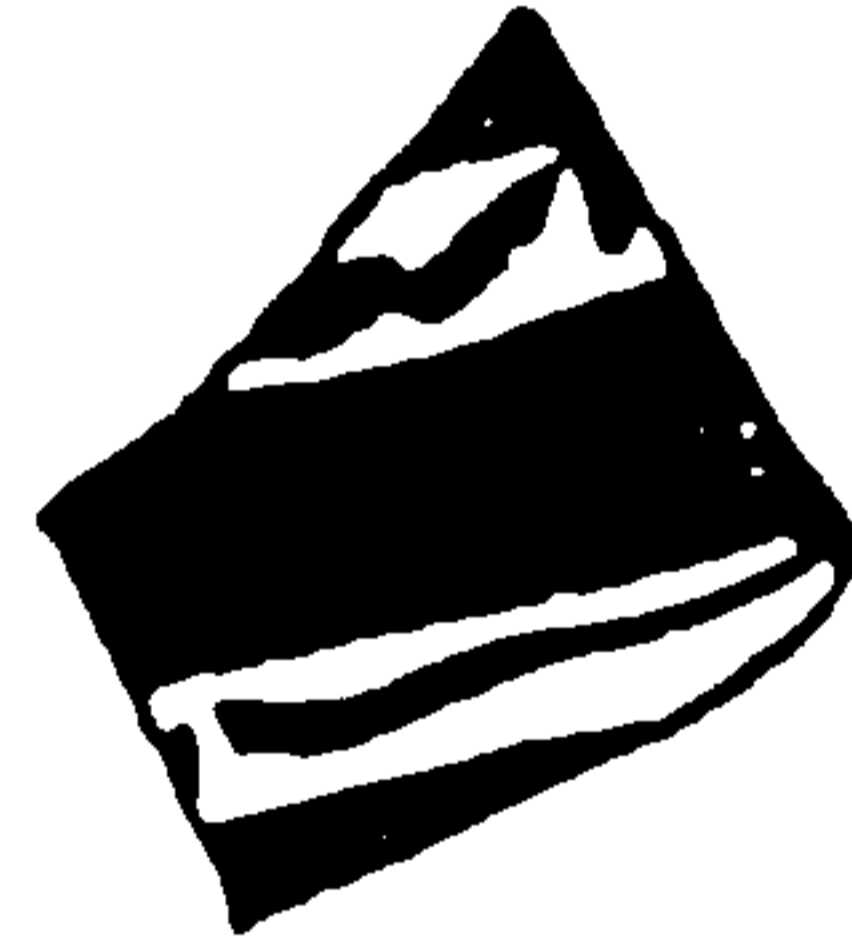

KAB 200

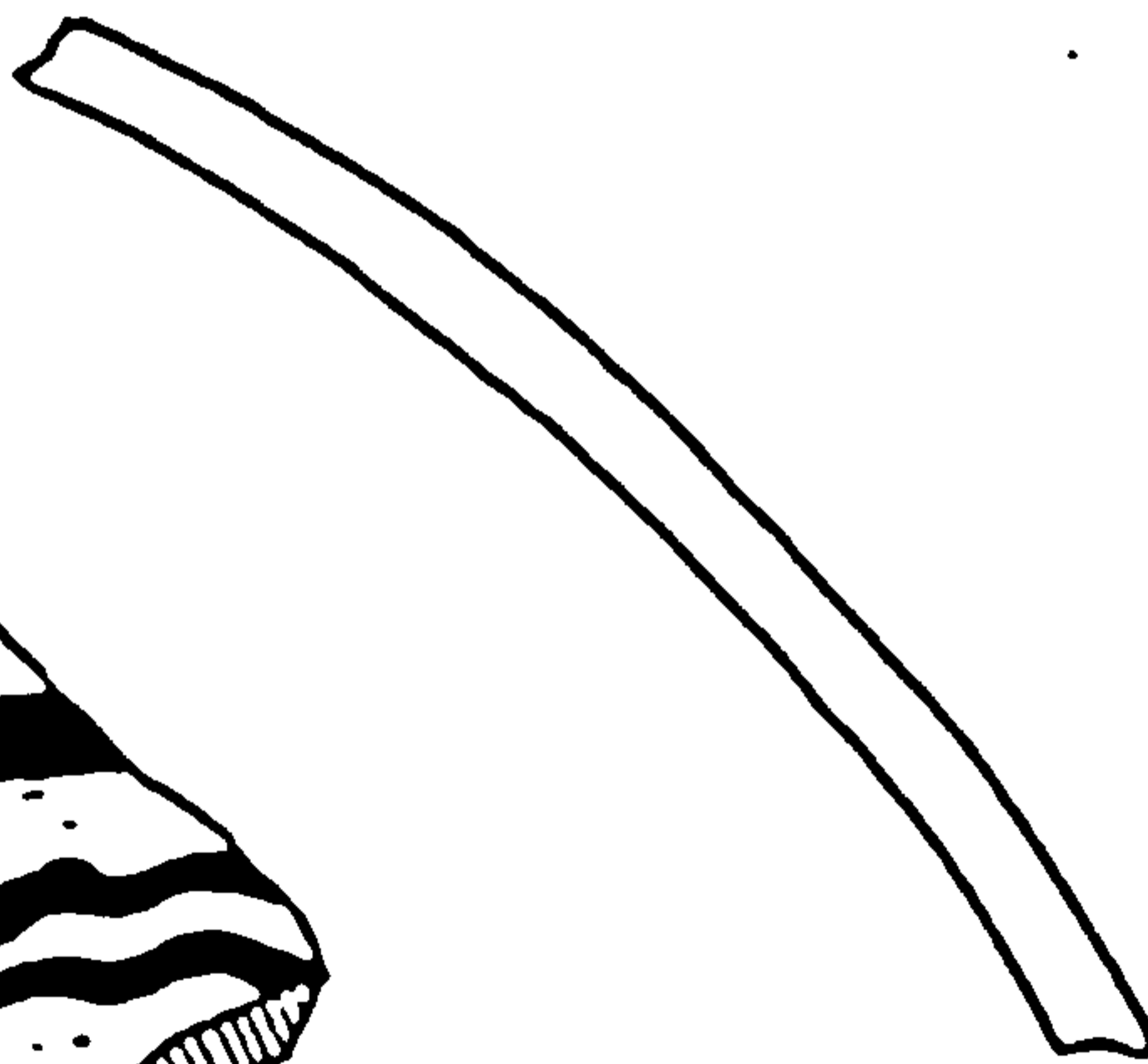

DAB 549

ILL 11

White Painted Alternating broad Band and Wavy Line Style

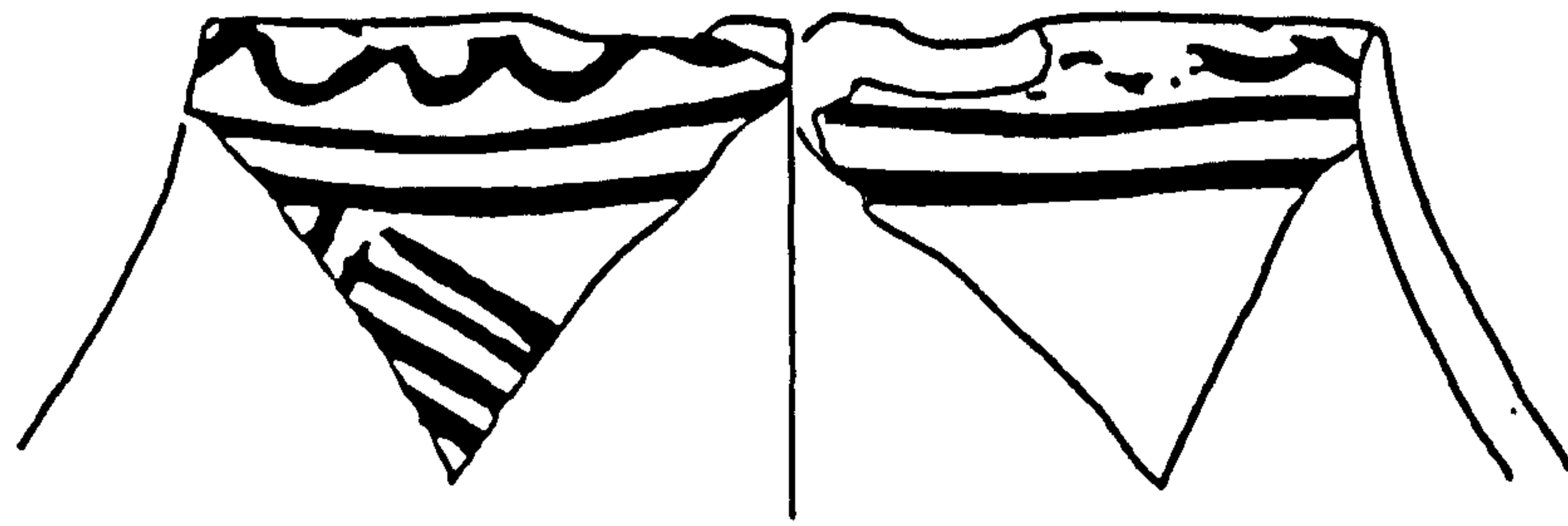

DAB 609

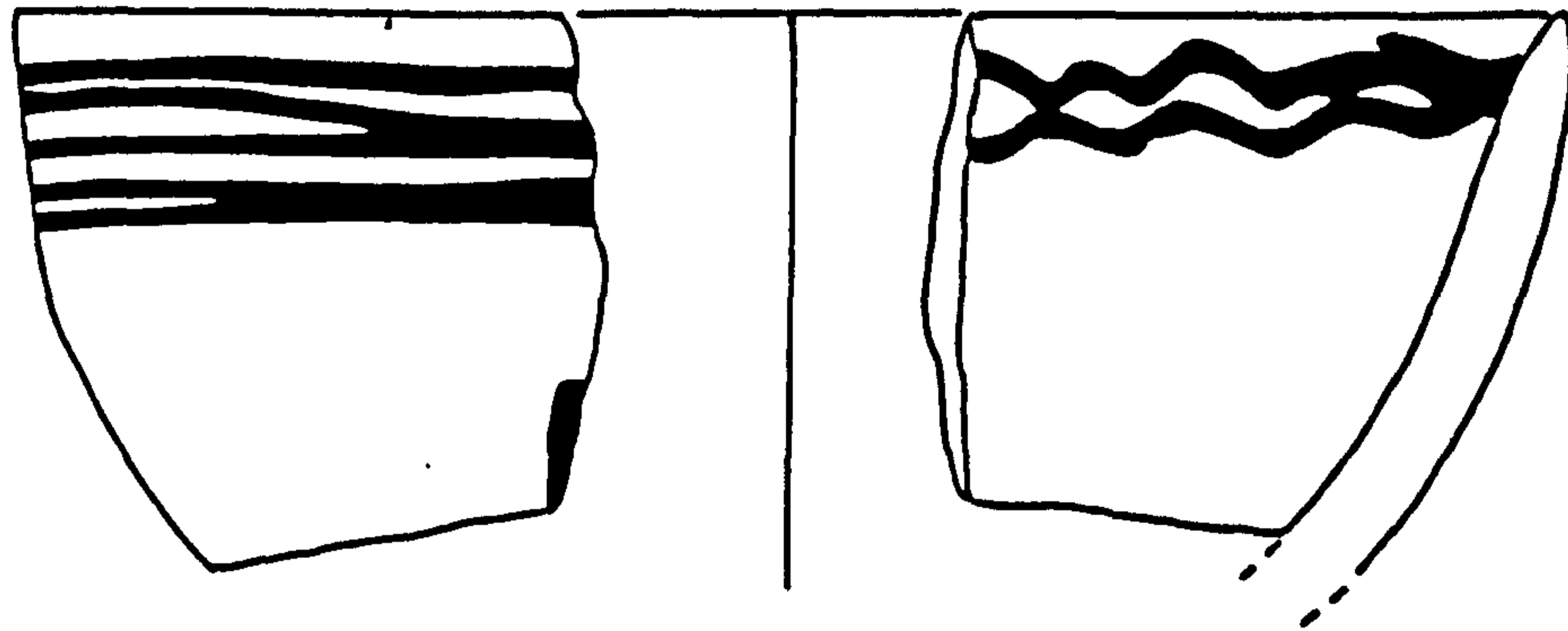

DAB 558

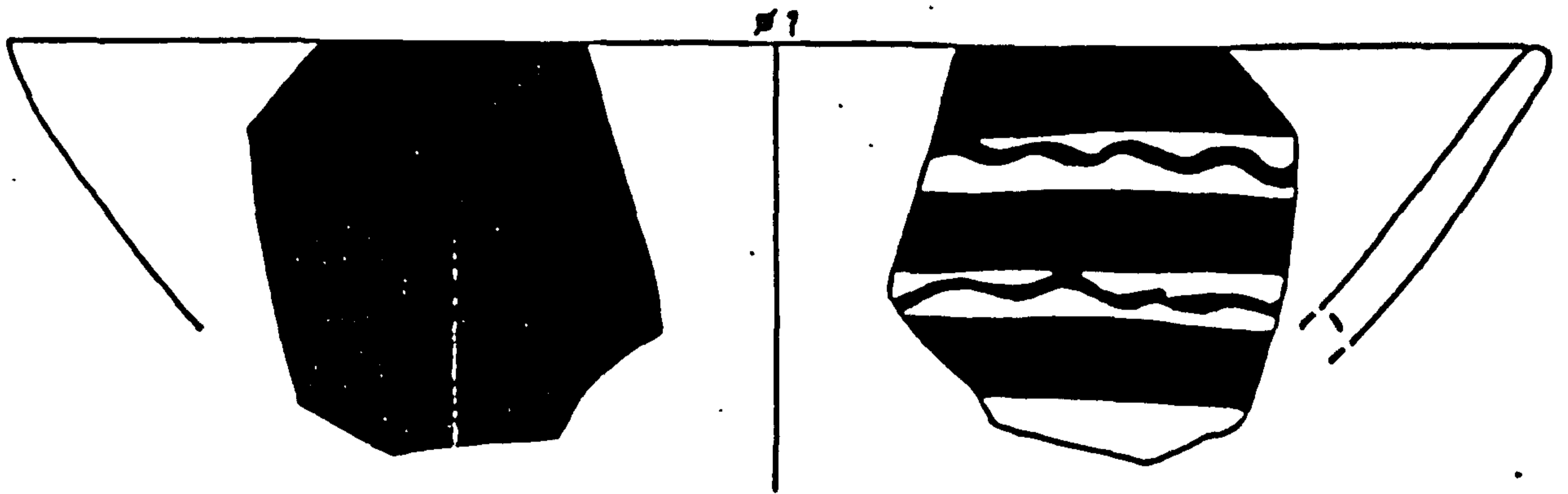

KAB 203

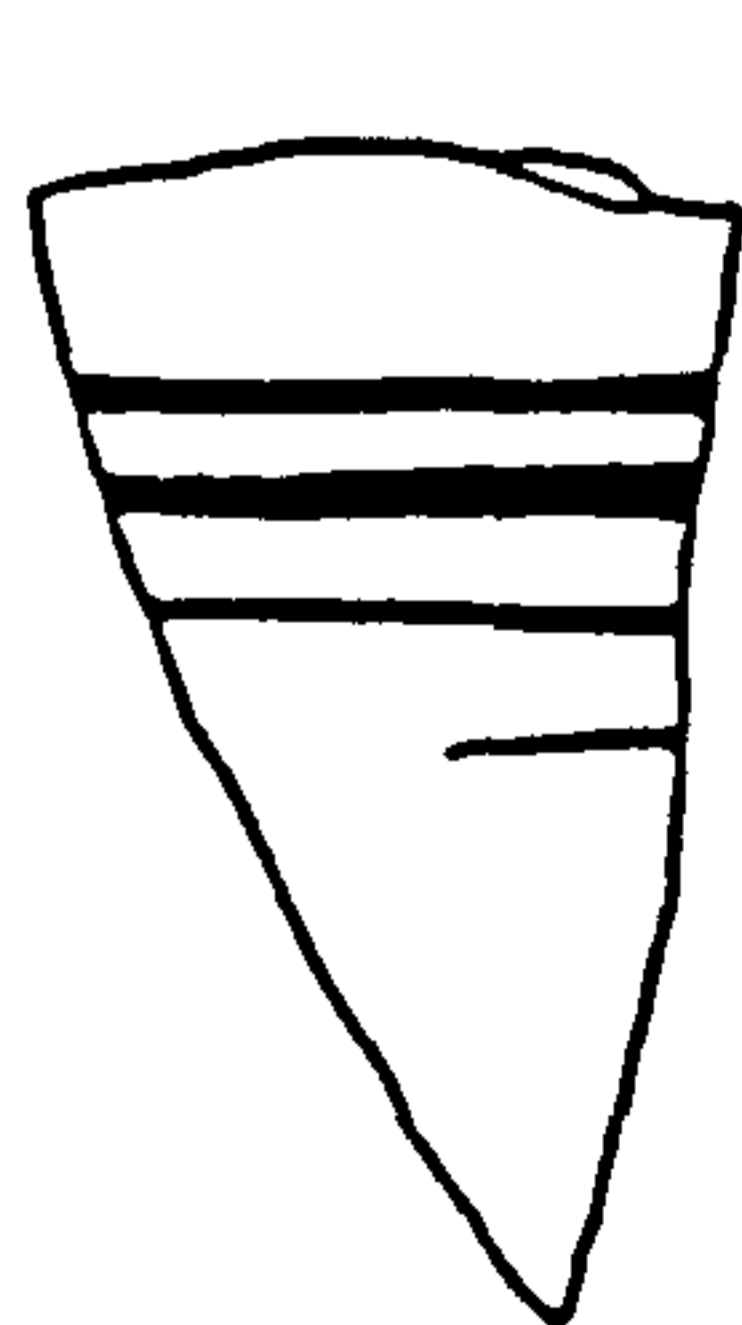

DAB 559

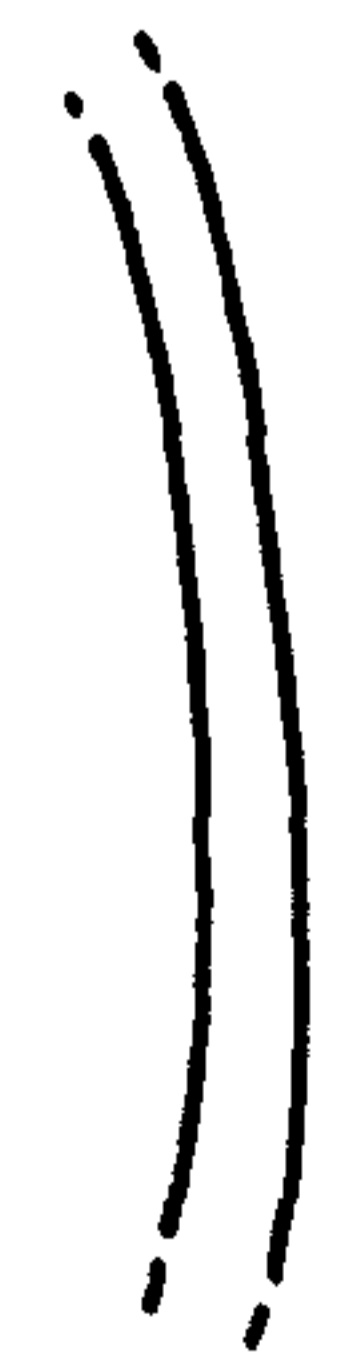
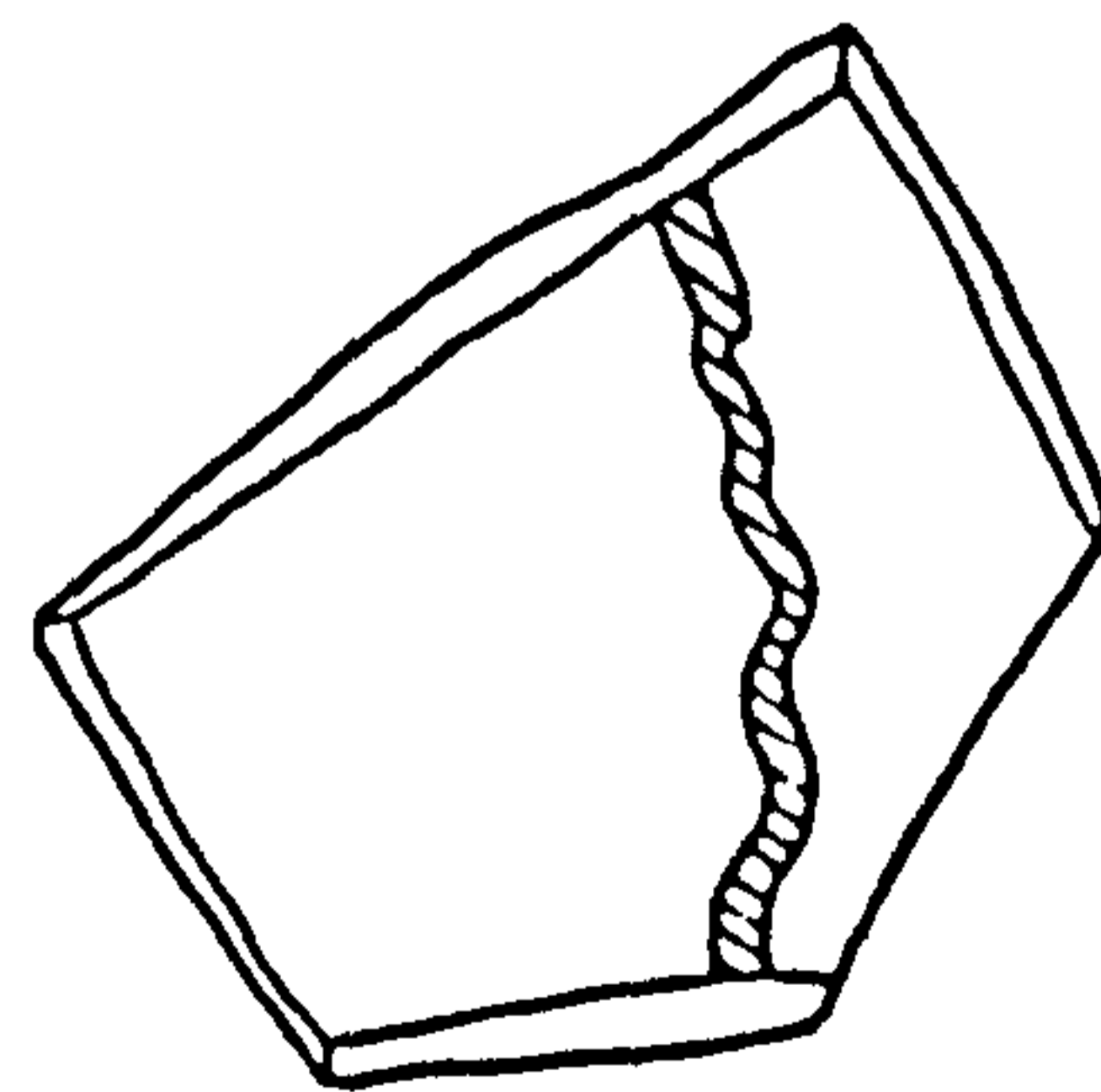

DAB 560

ILL12

White Painted V

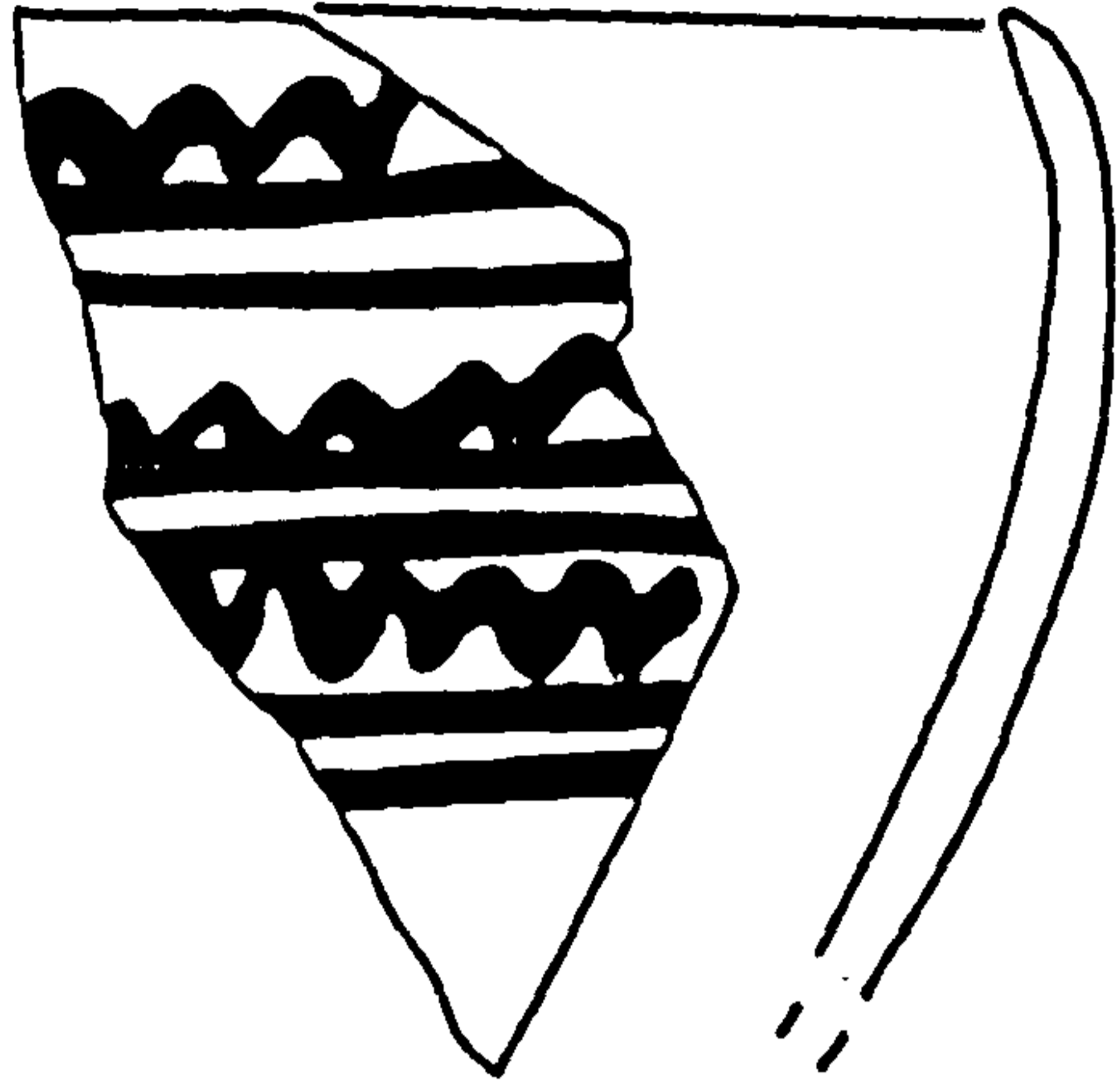

AJJ 28

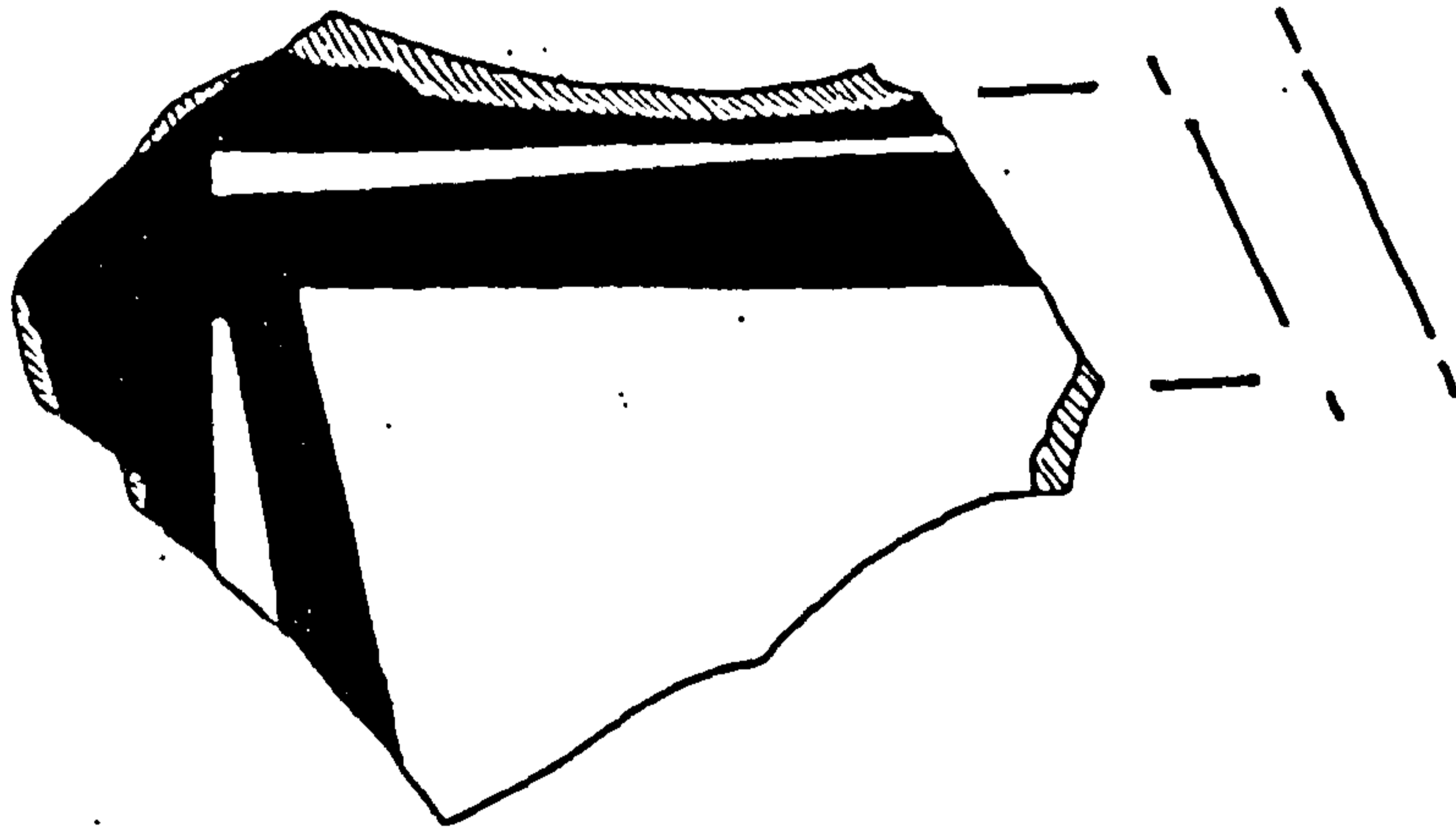

DAB 603

ILL 12

White Painted V

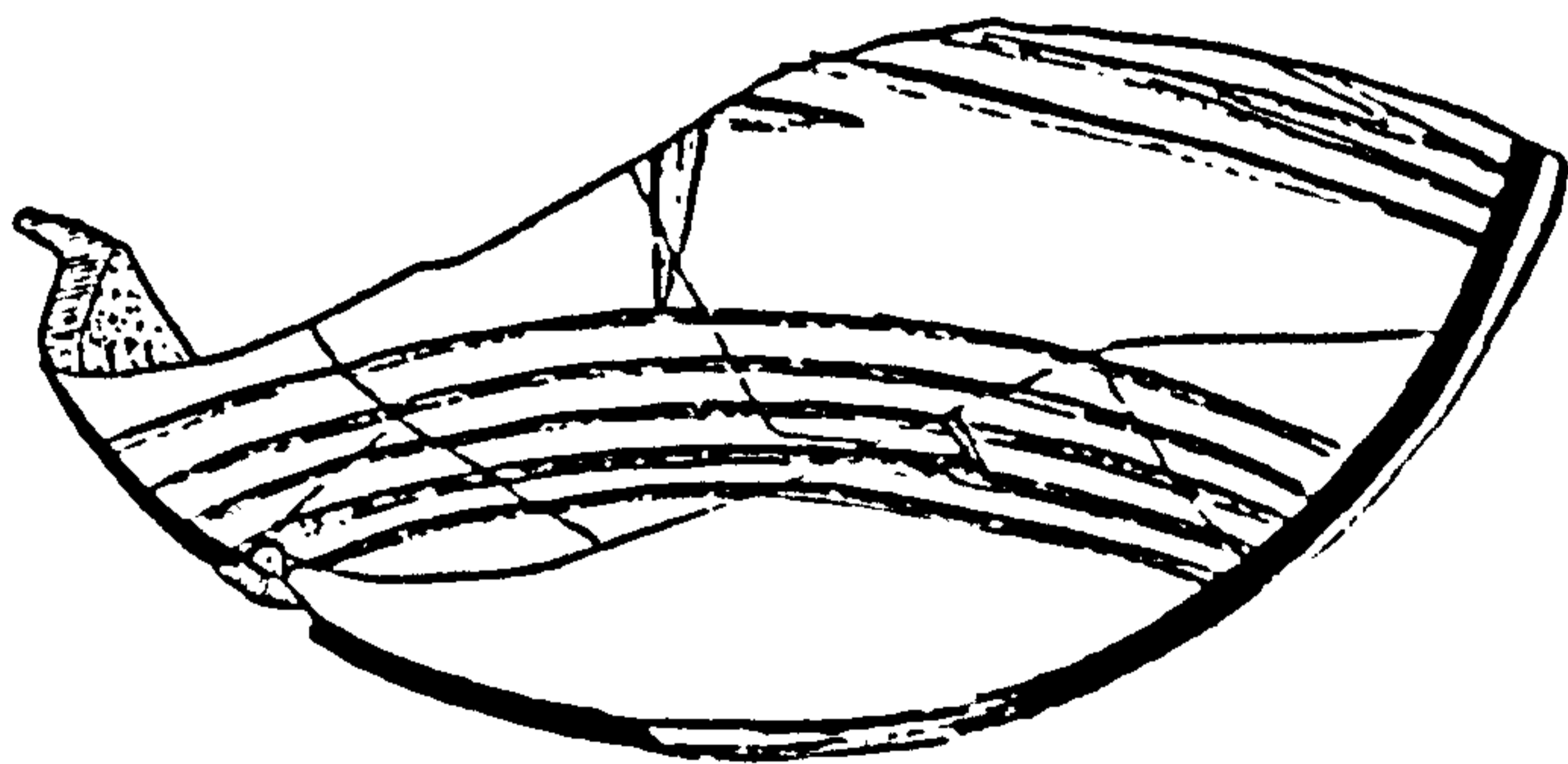
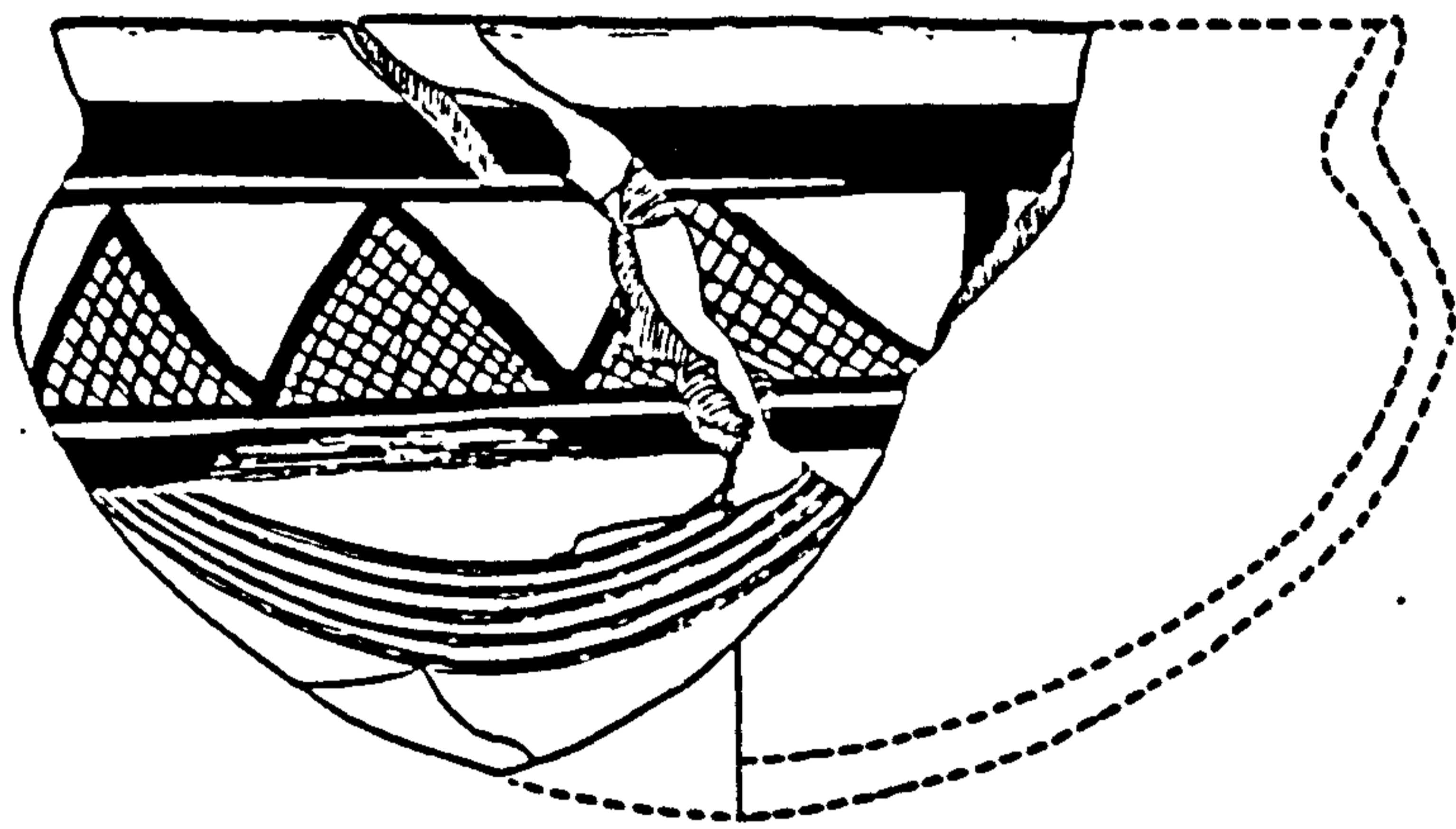
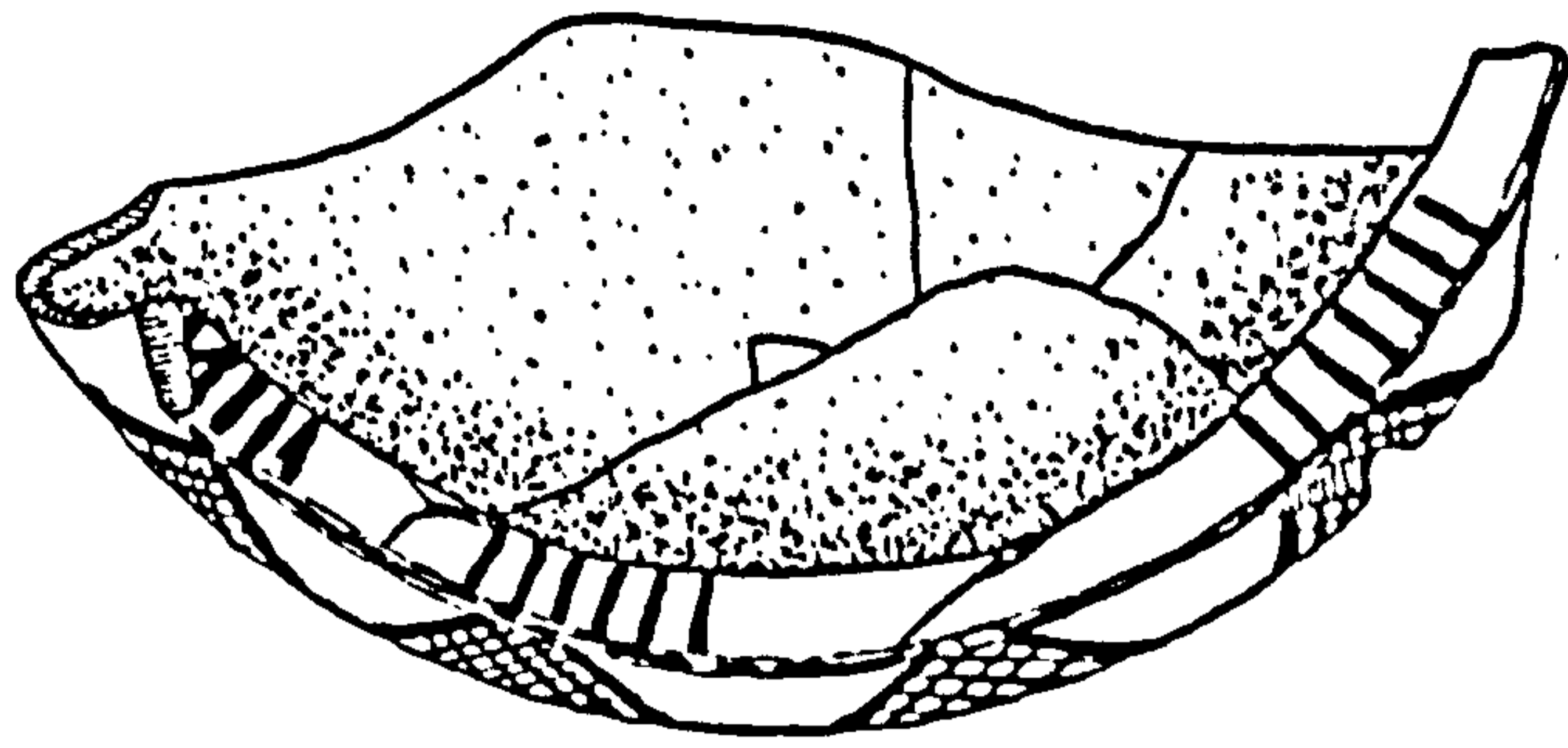

DAB 598

ILL 14

White Painted V

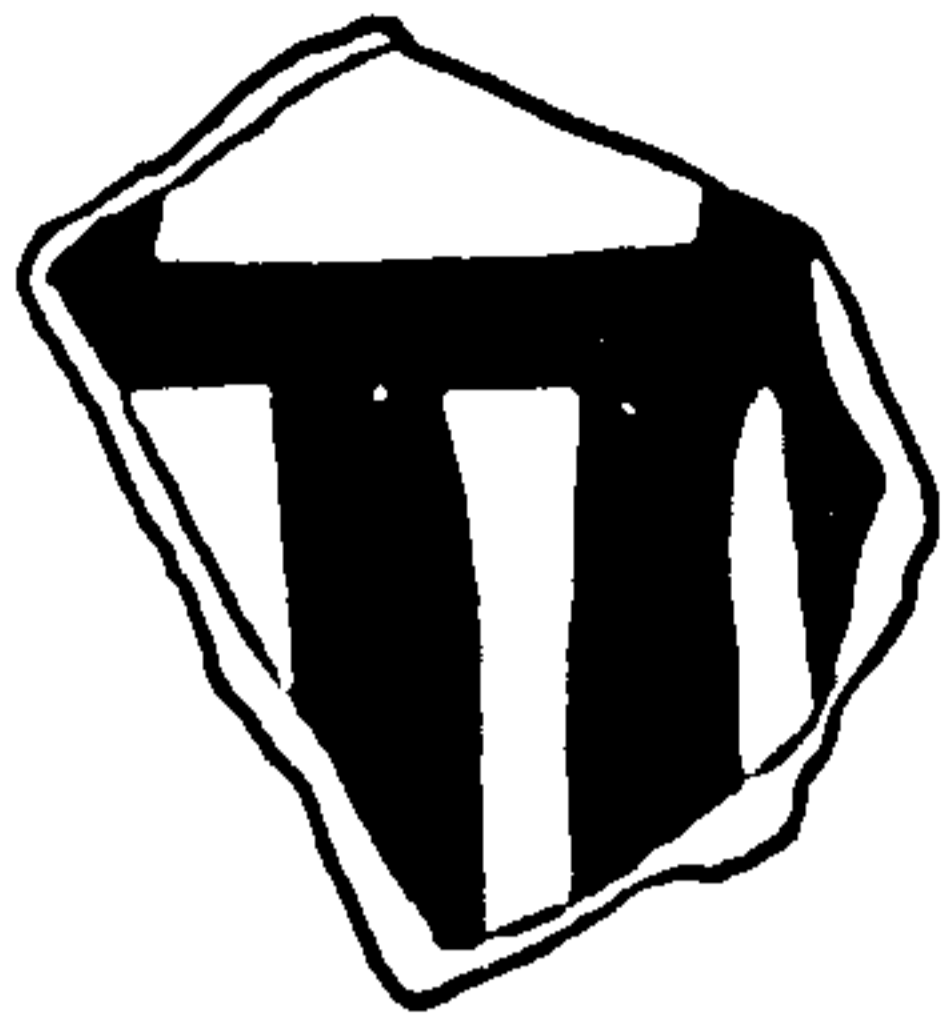

DAB 593

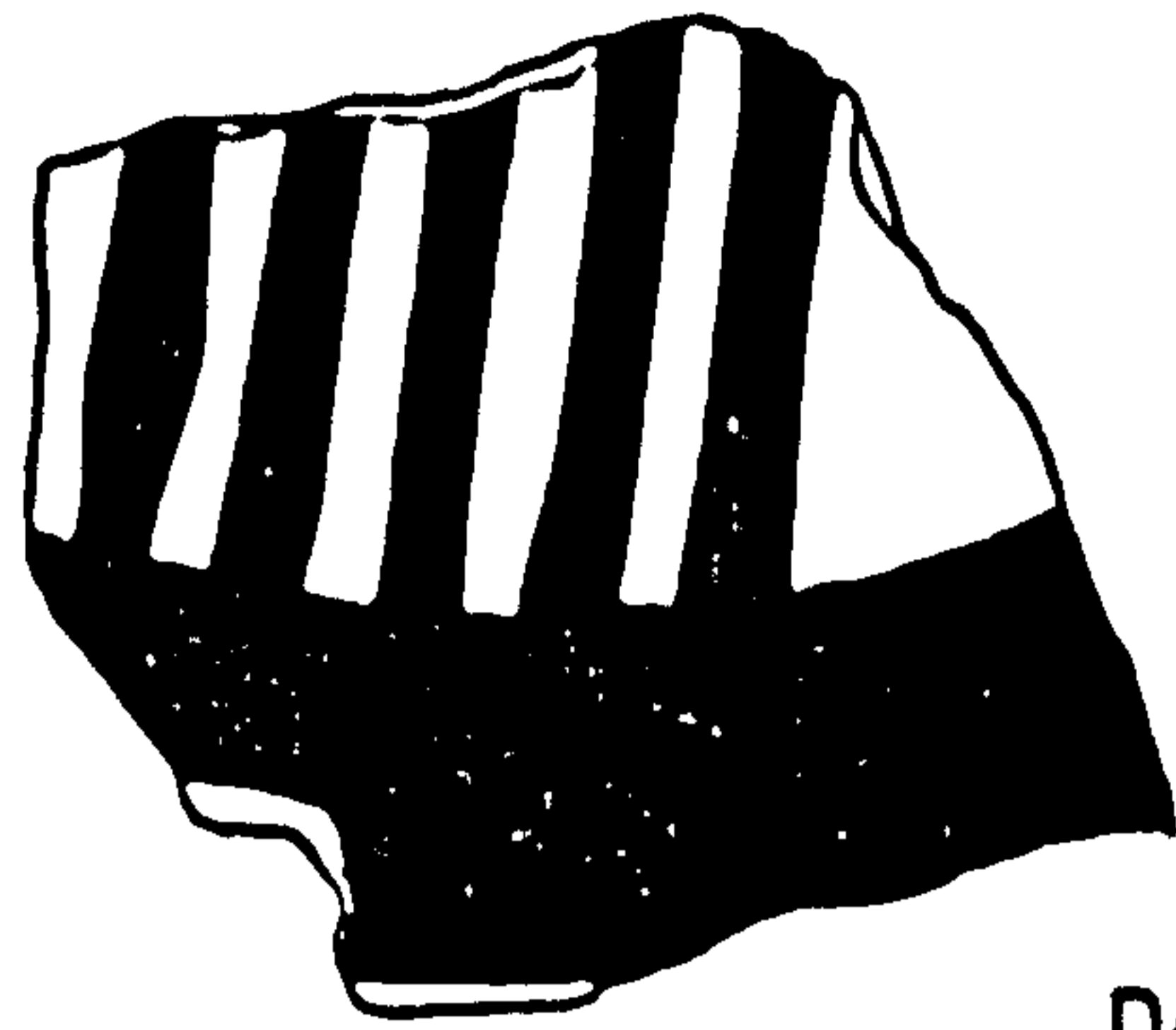
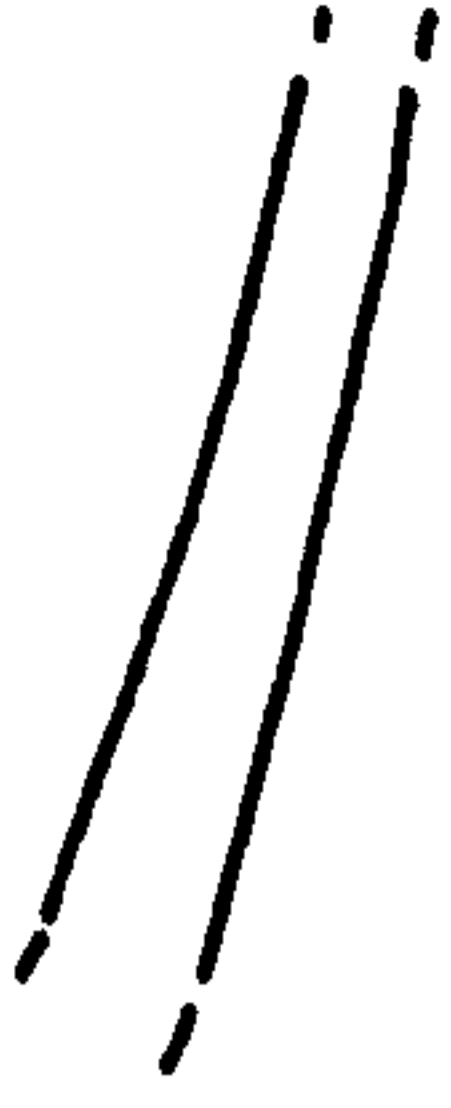

DAB 605

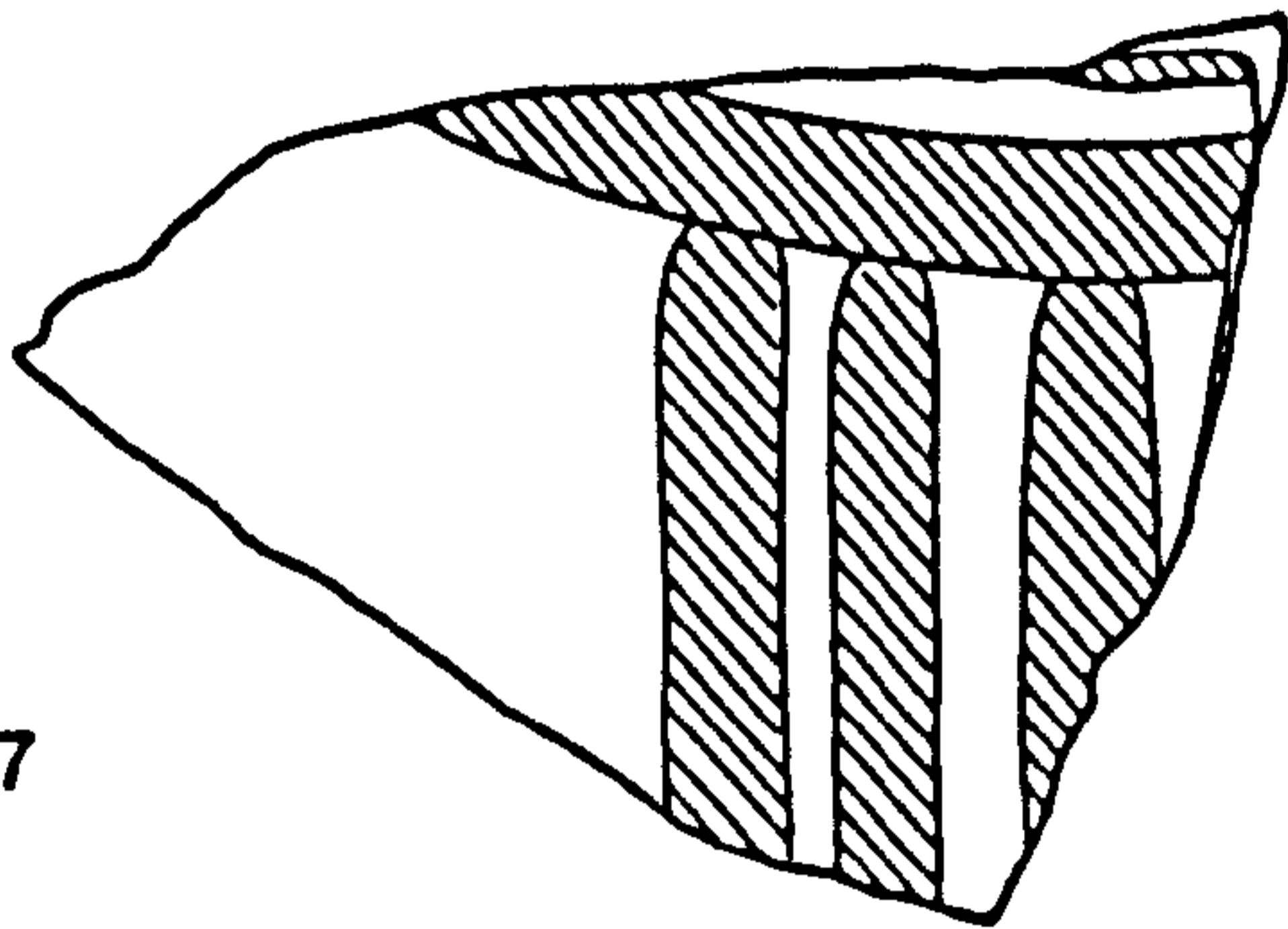

DAB 607

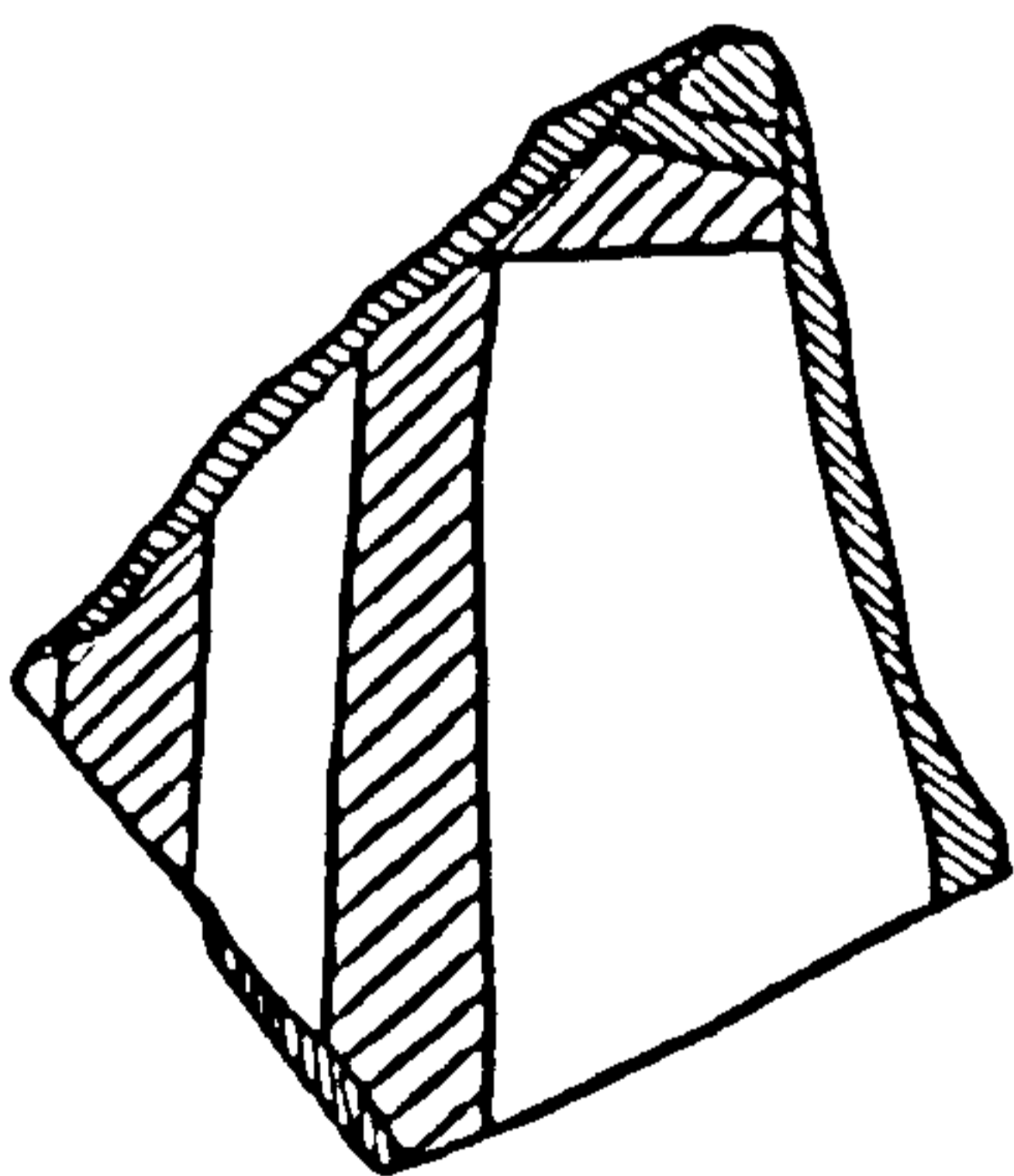
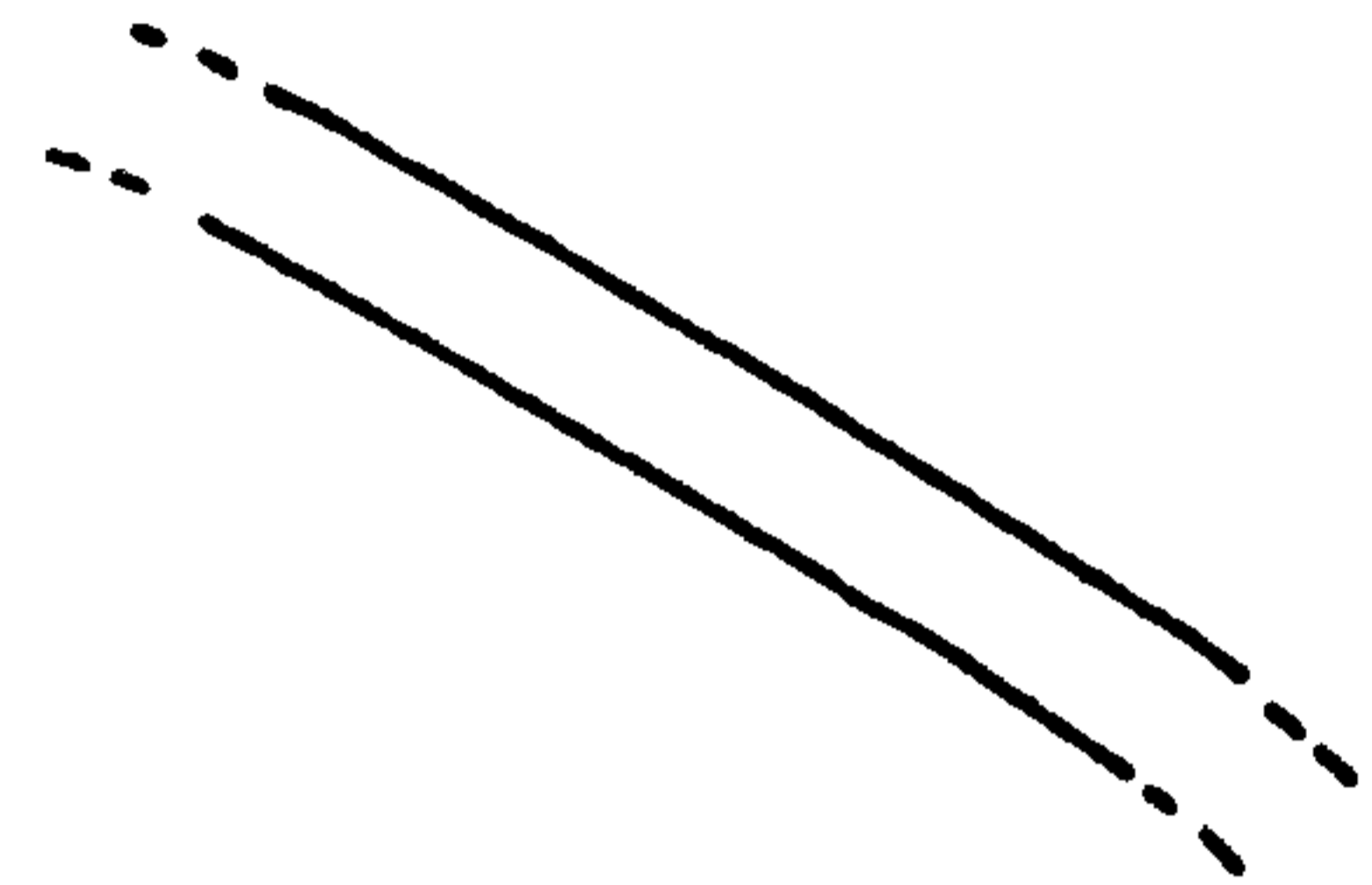

DAB 606

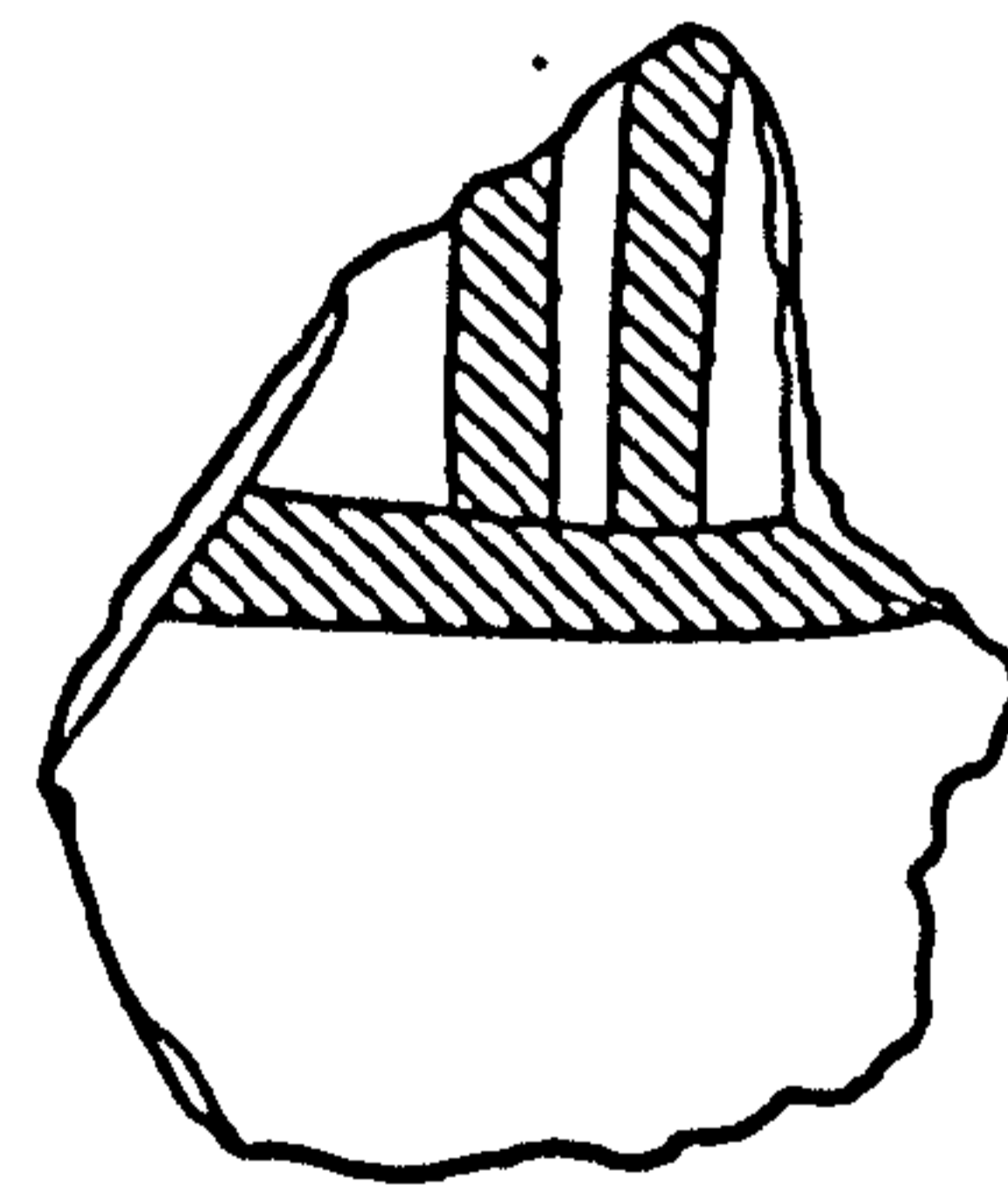

DAB 599



ILL 15

White Painted V

DAB 608

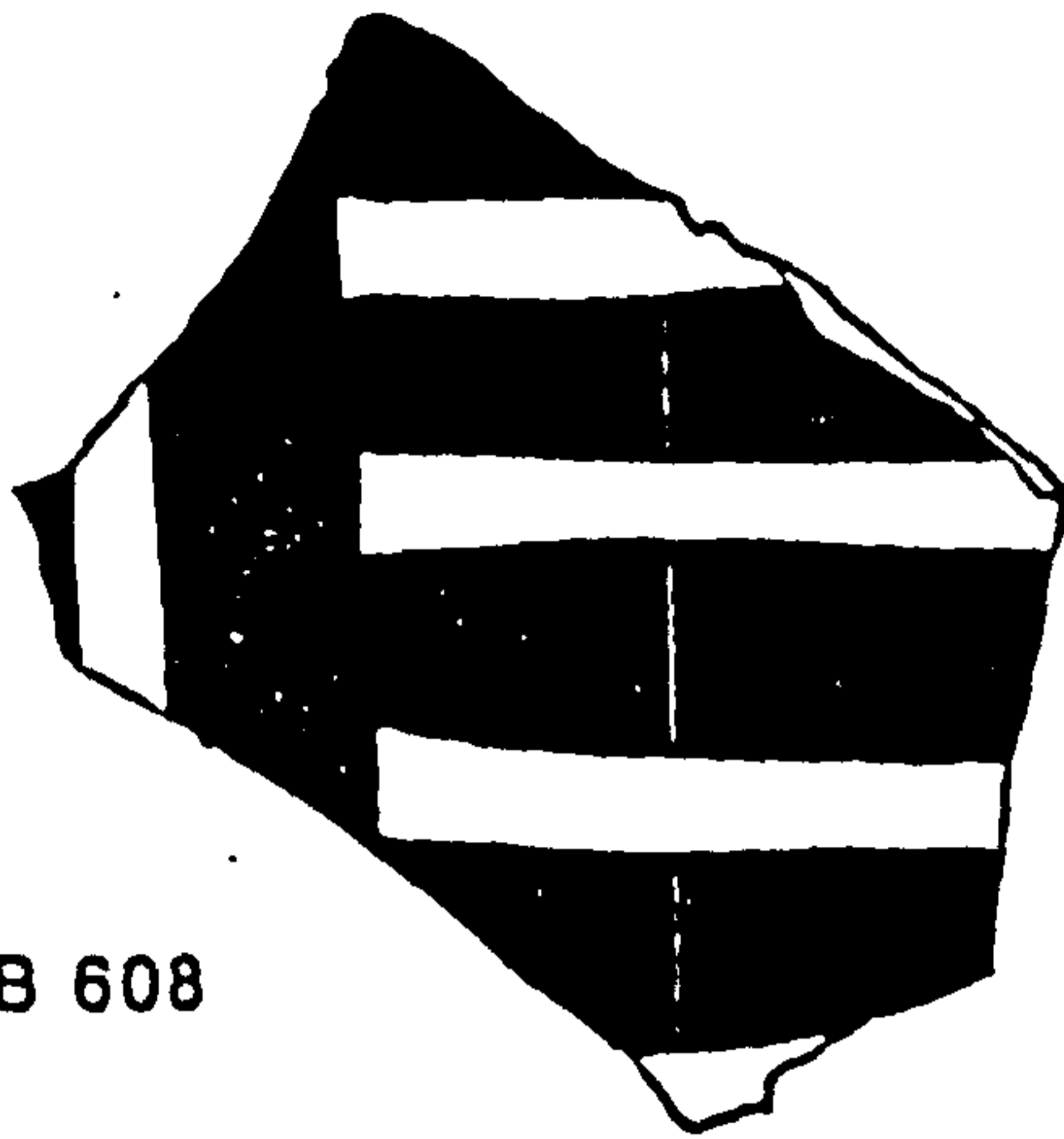

KAB 202

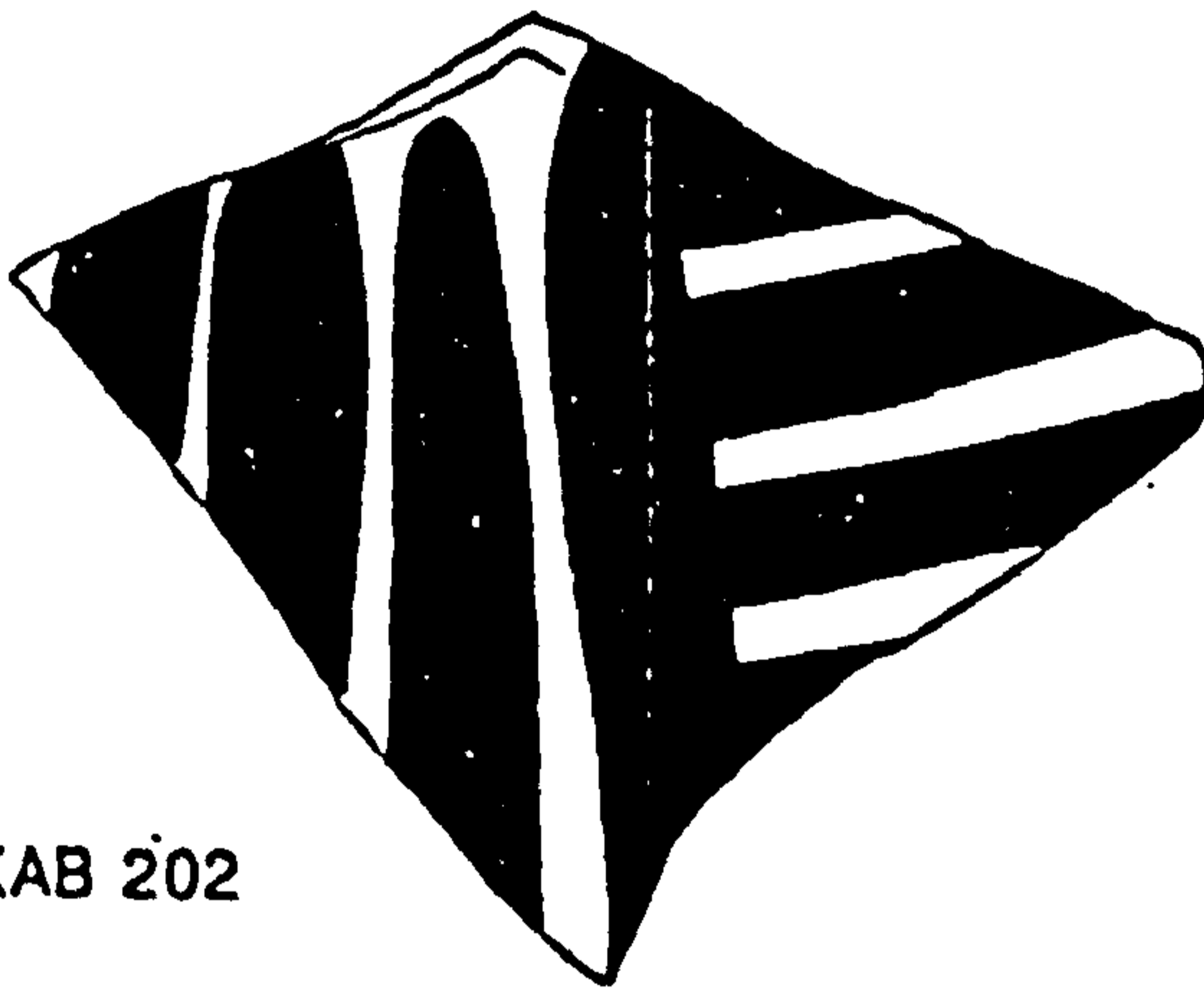

DAB 647

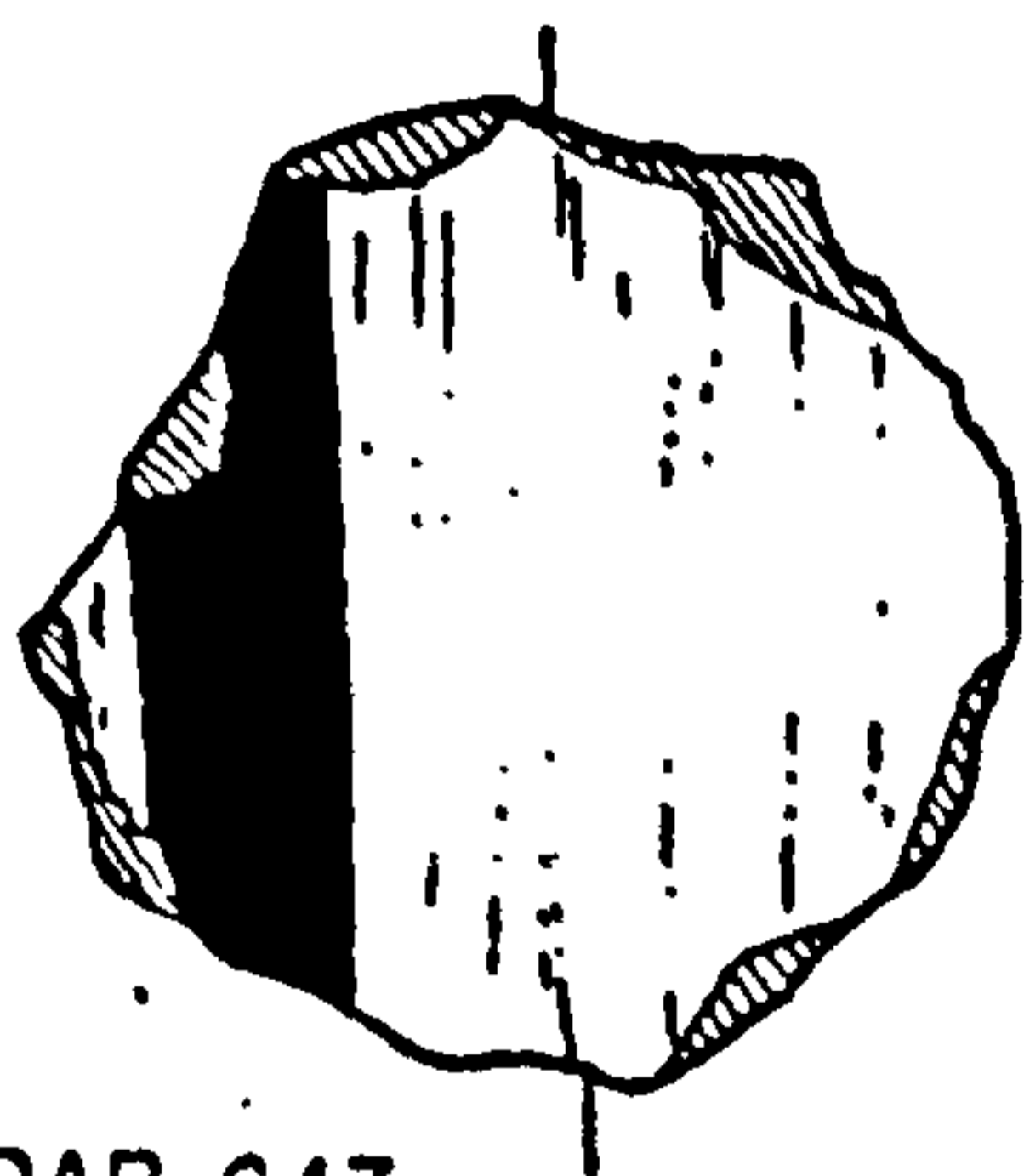

SF

DAB 616

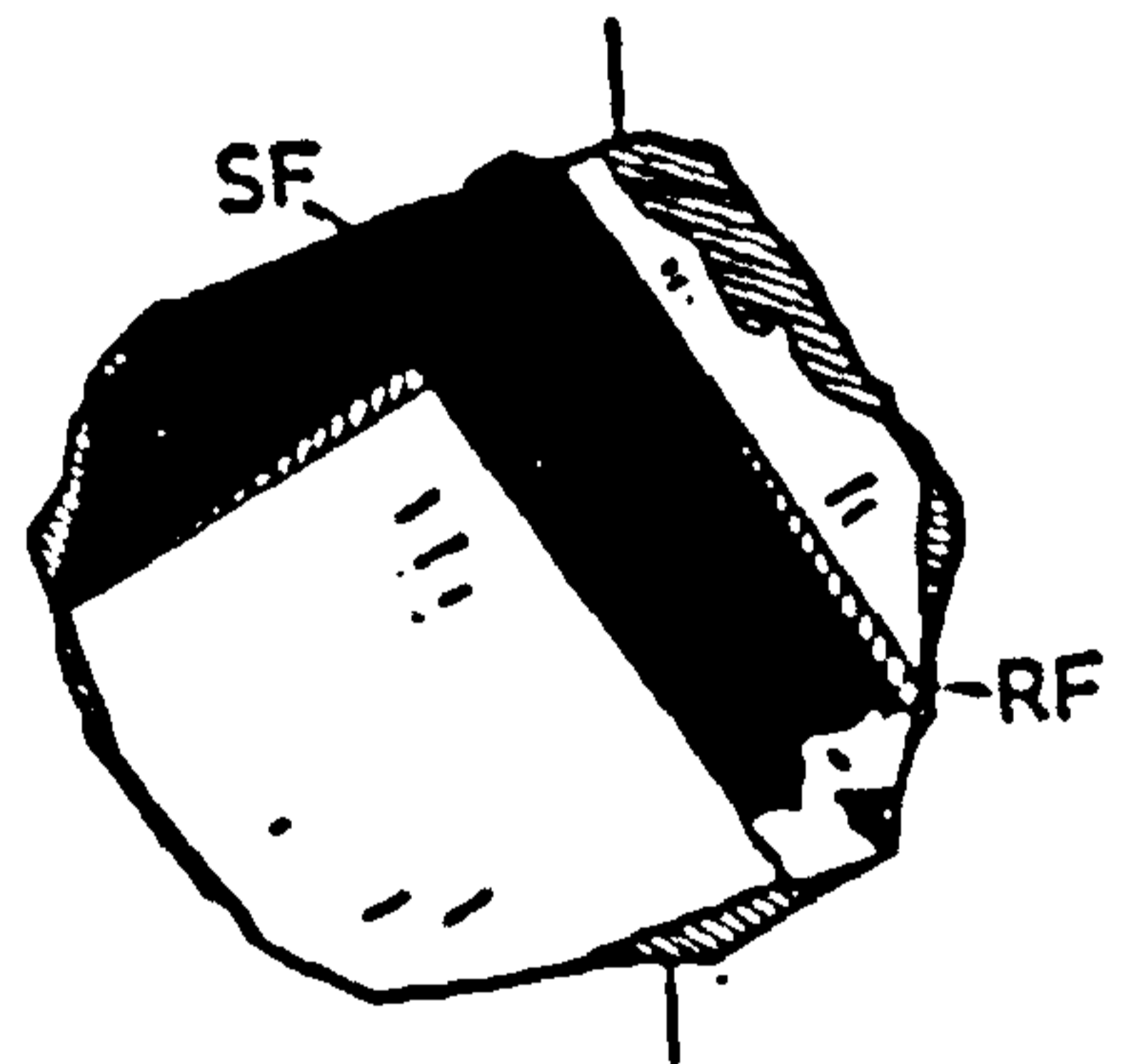

DAB 614

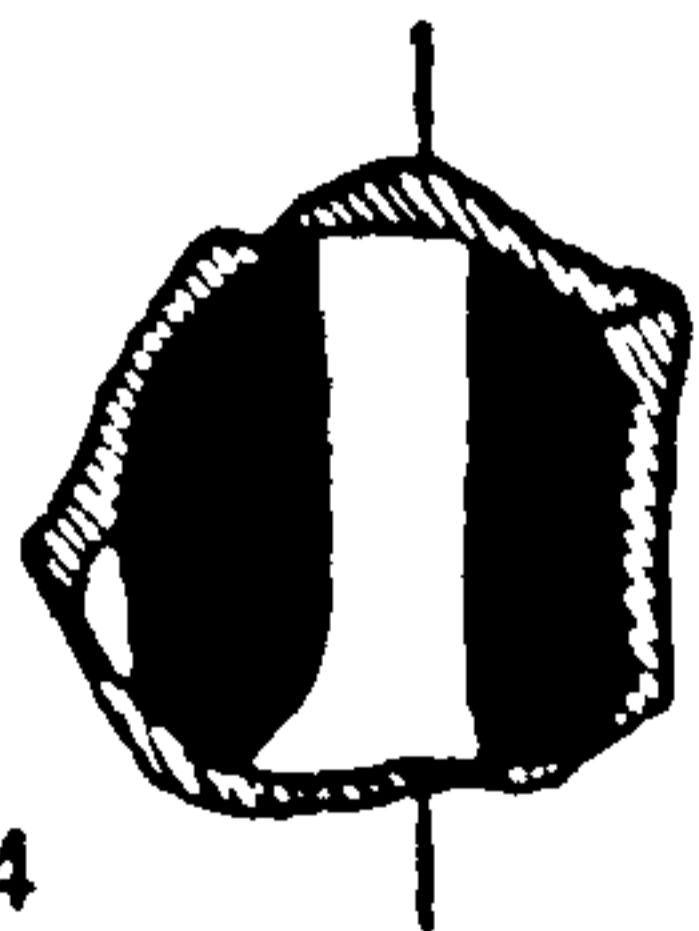

DAB 551

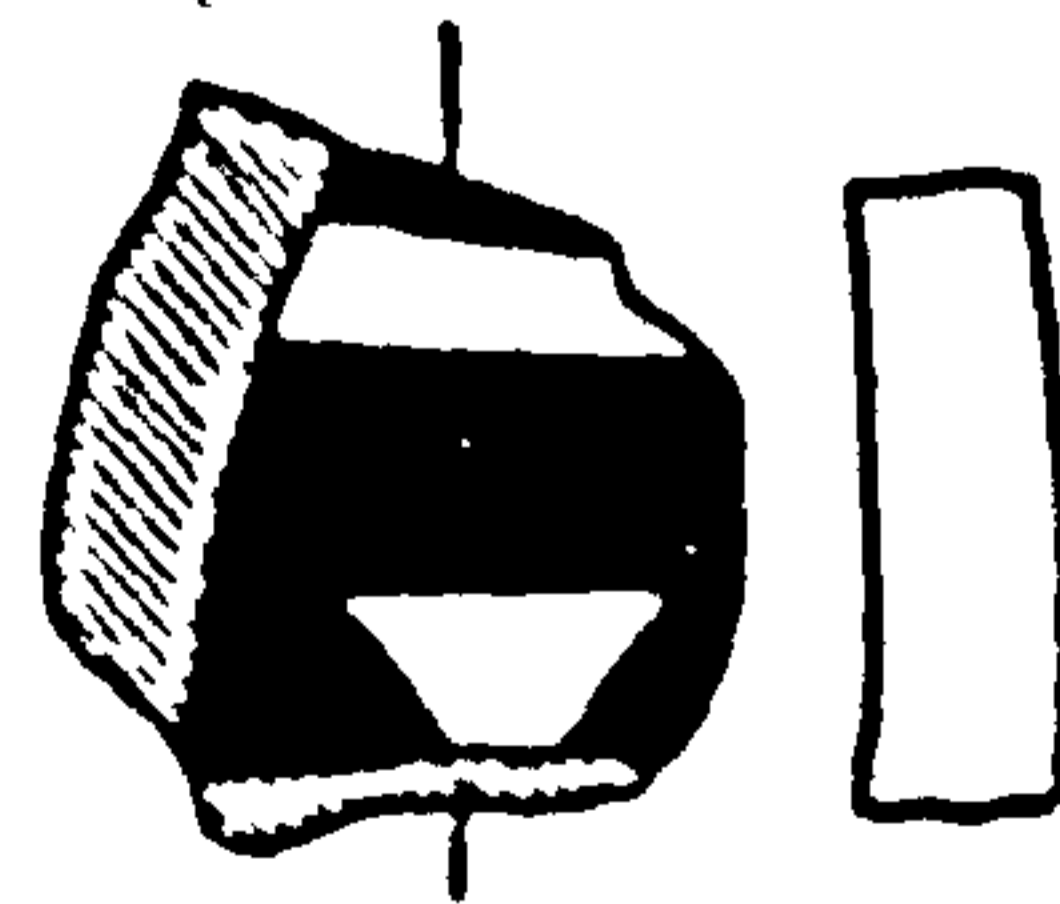

ILL 16

White Painted V

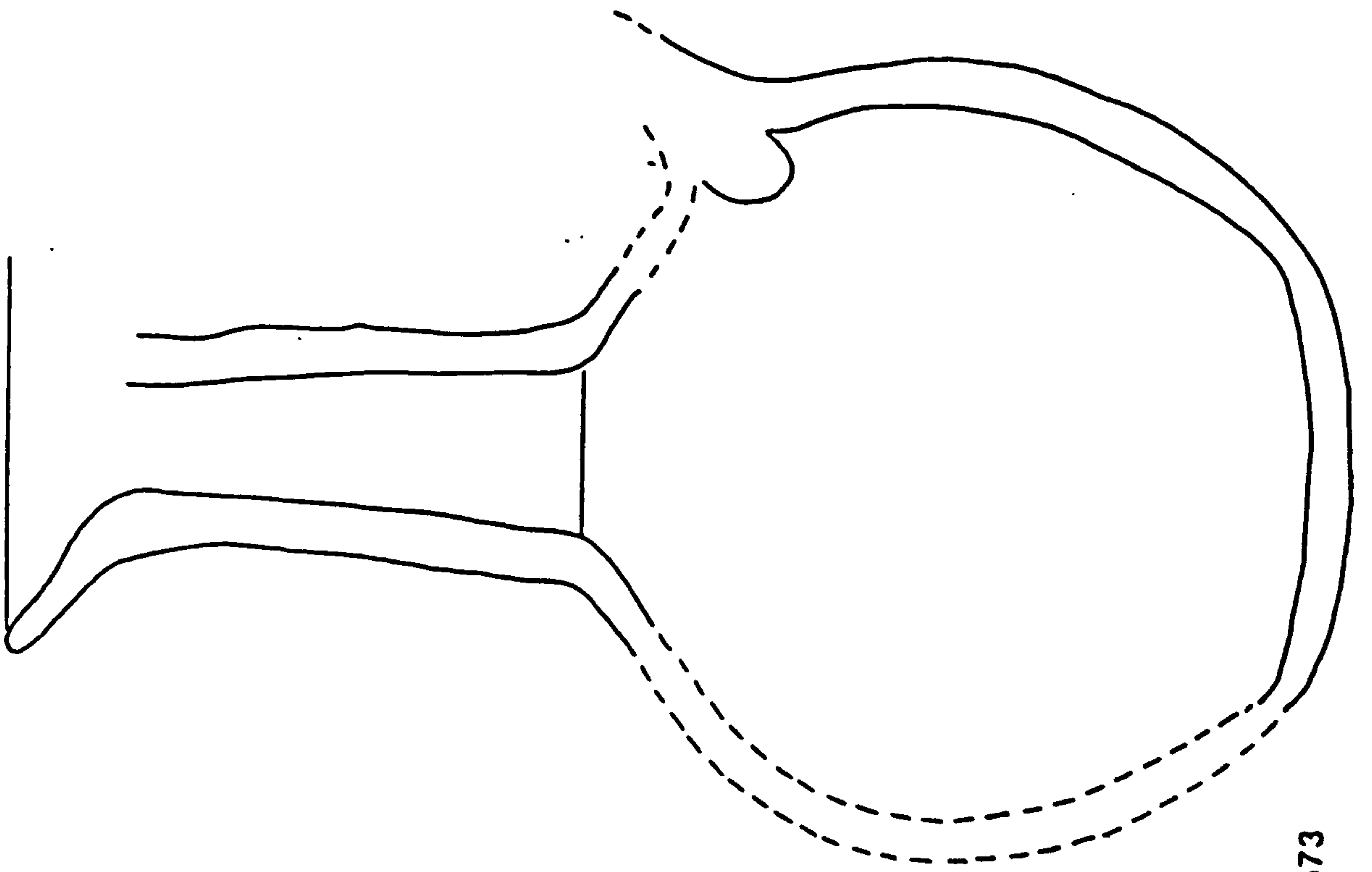
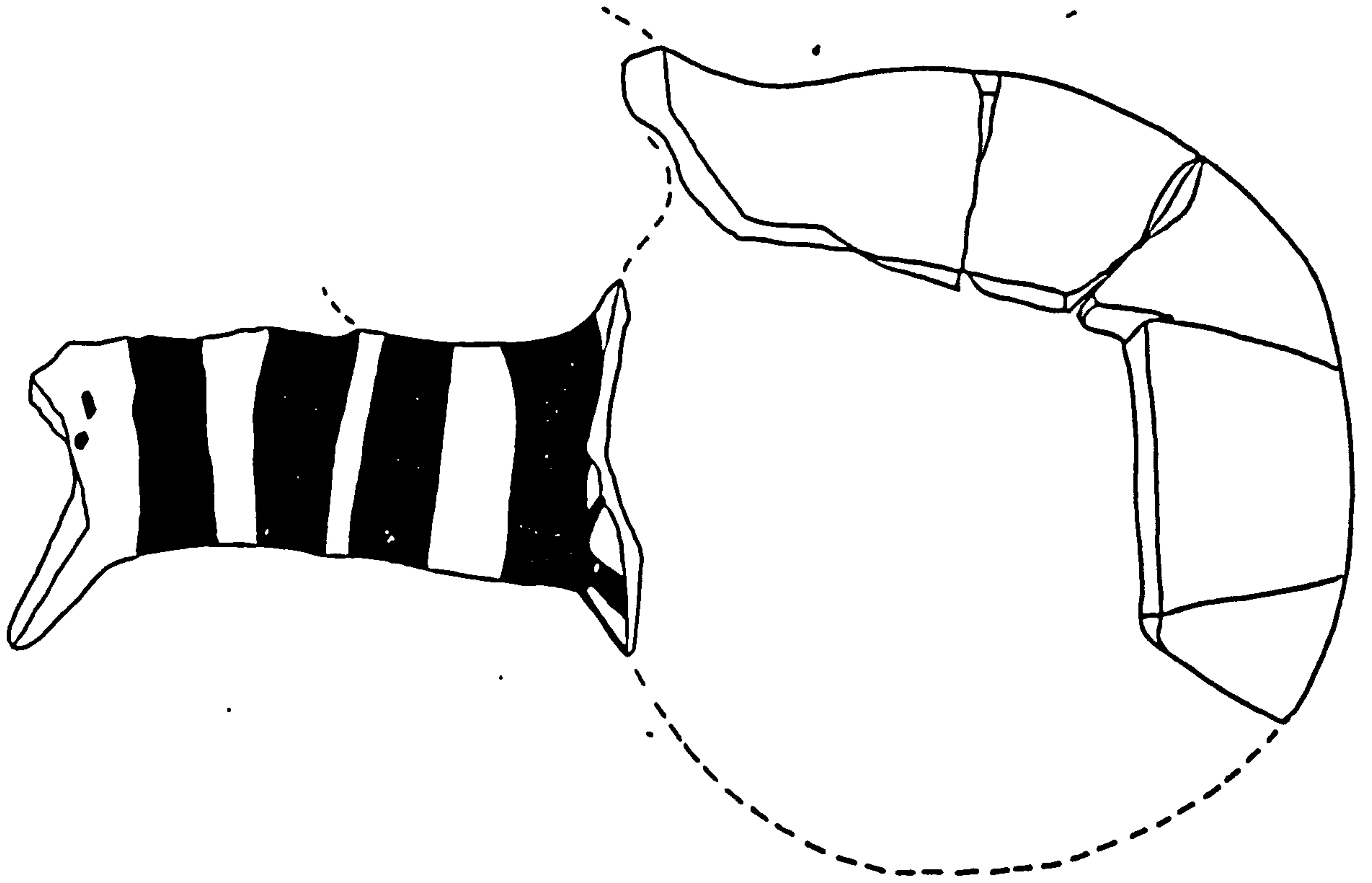

DAB 573

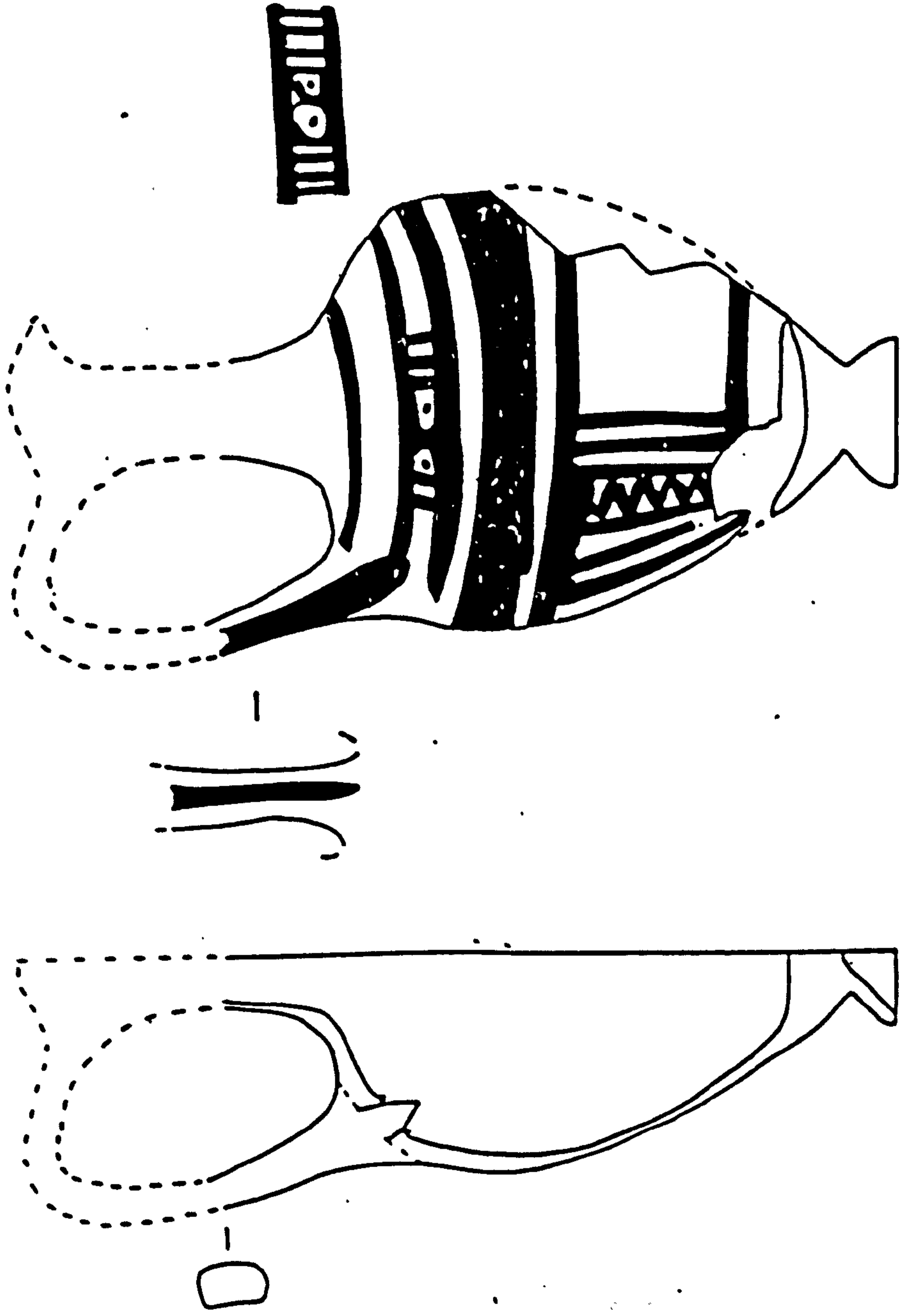

White Painted V Eyelet Style

ILL 18

YIF 272

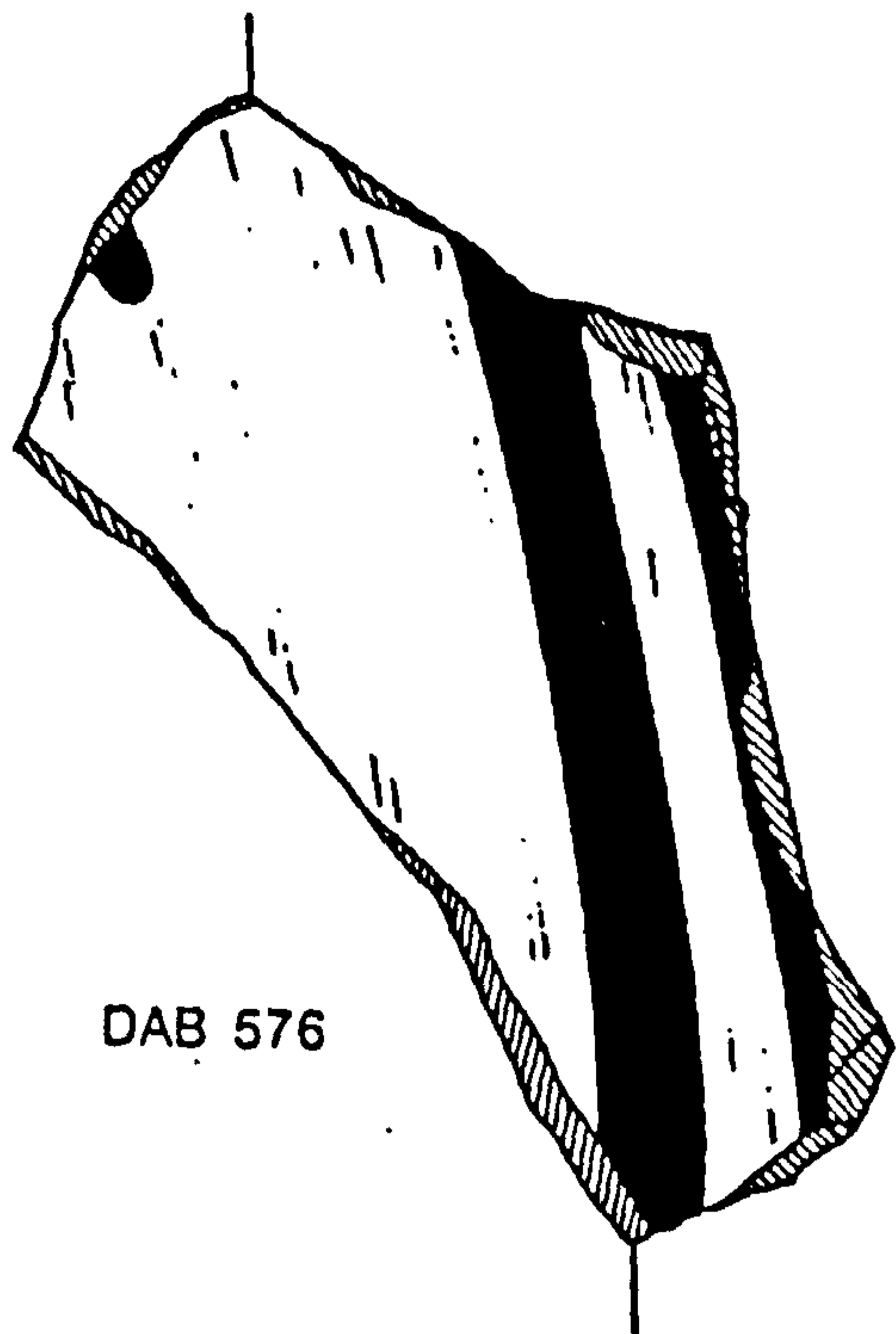

DAB 576

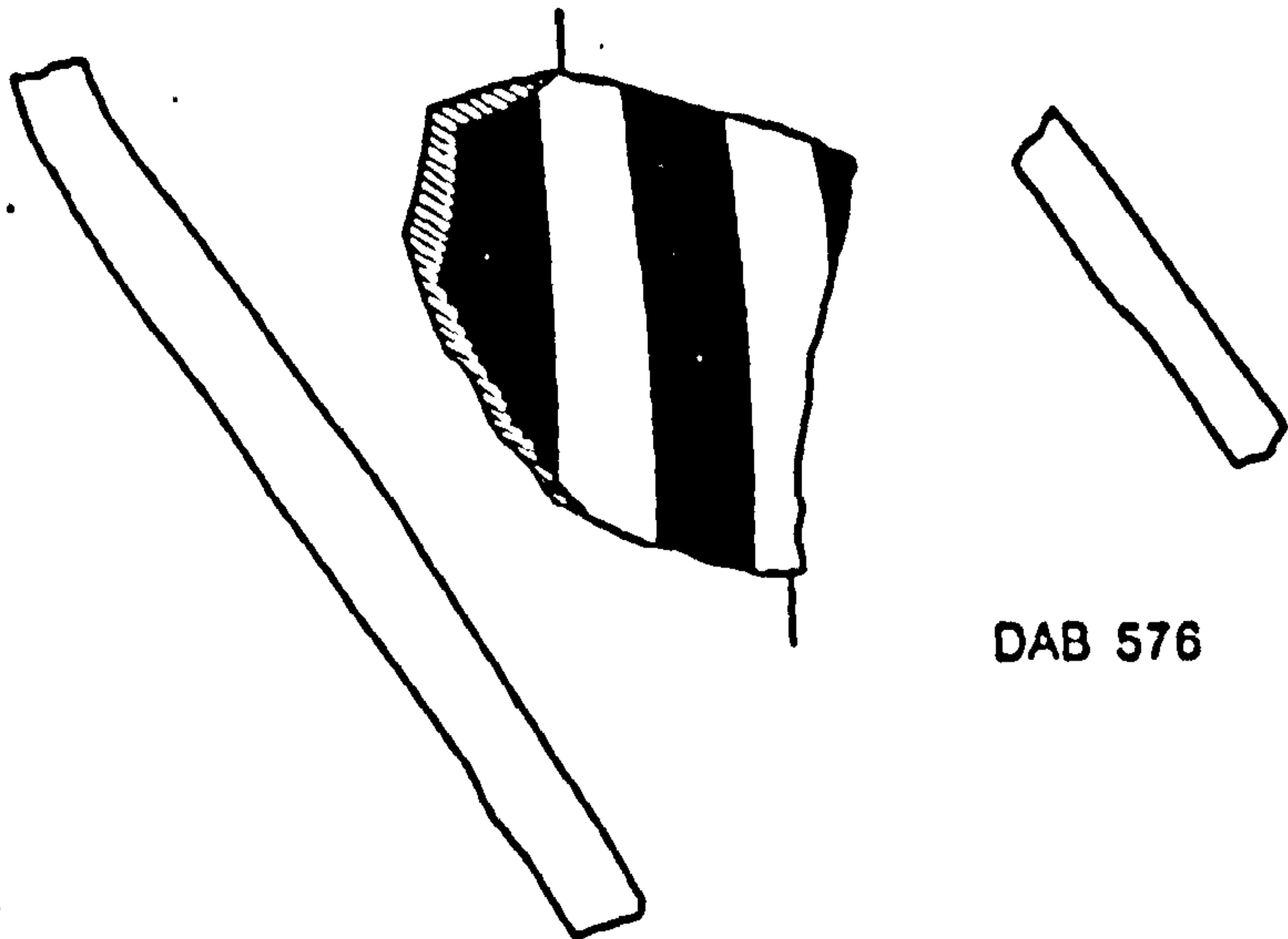

DAB 576

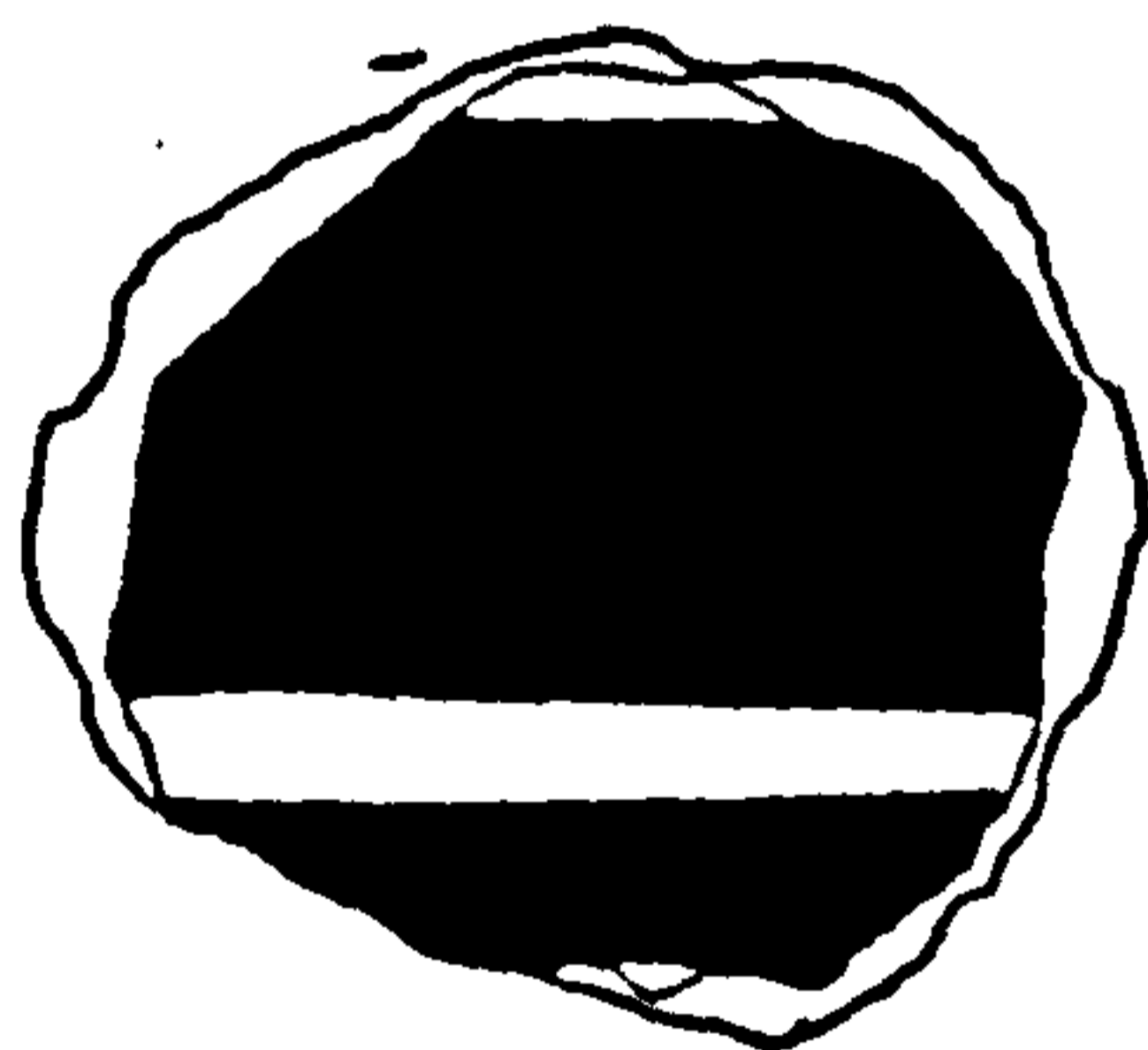

DAB 615

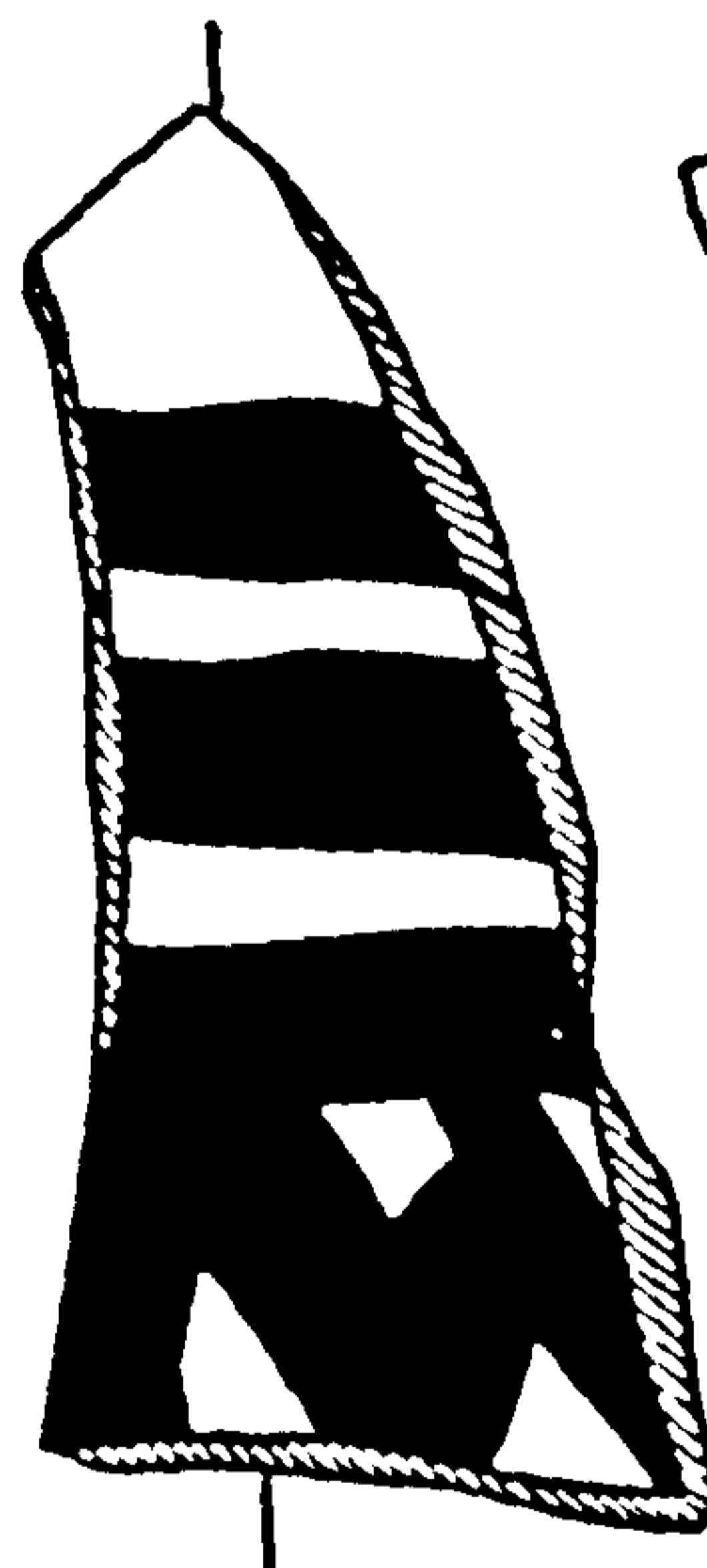

DAB 552

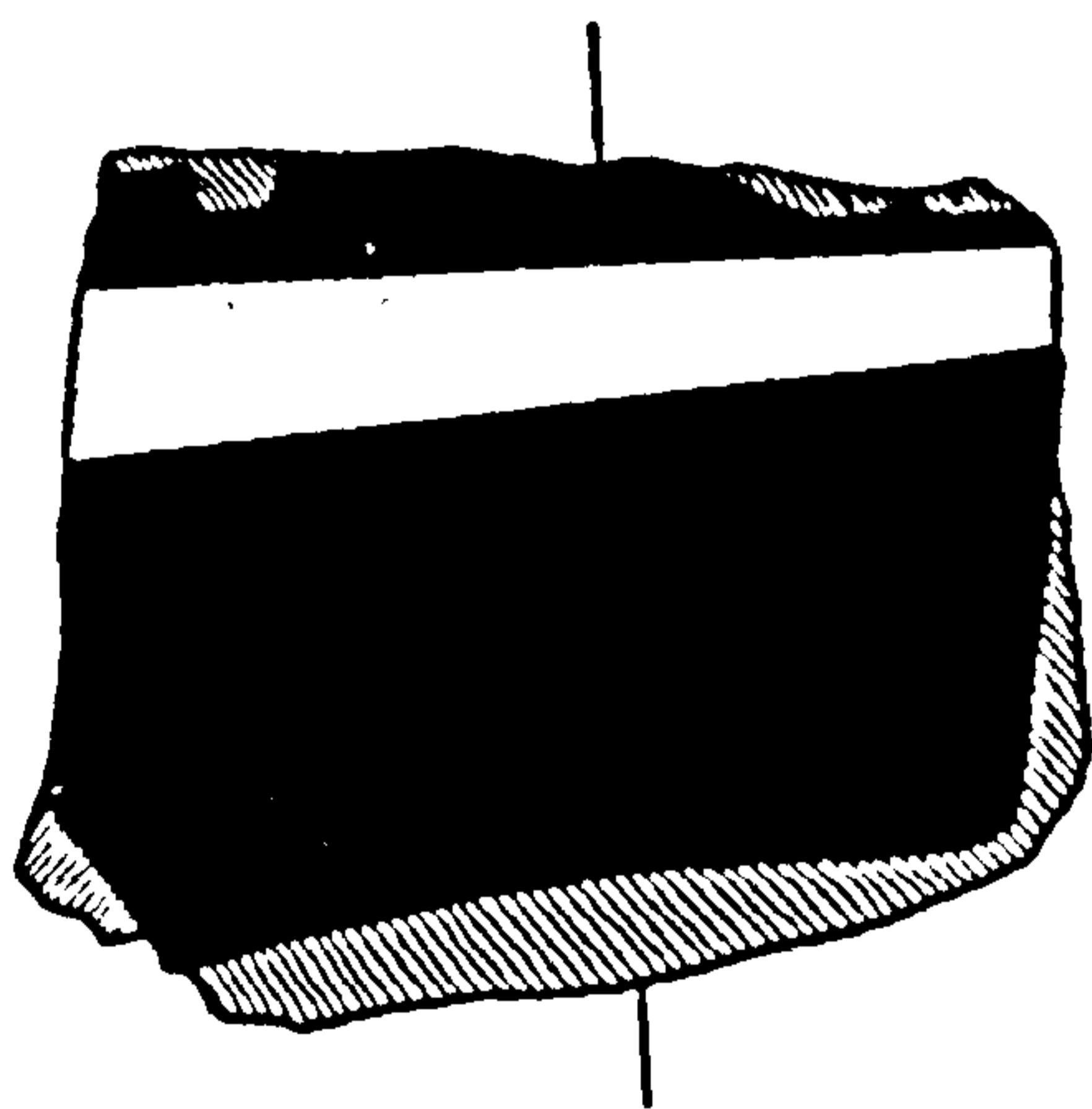
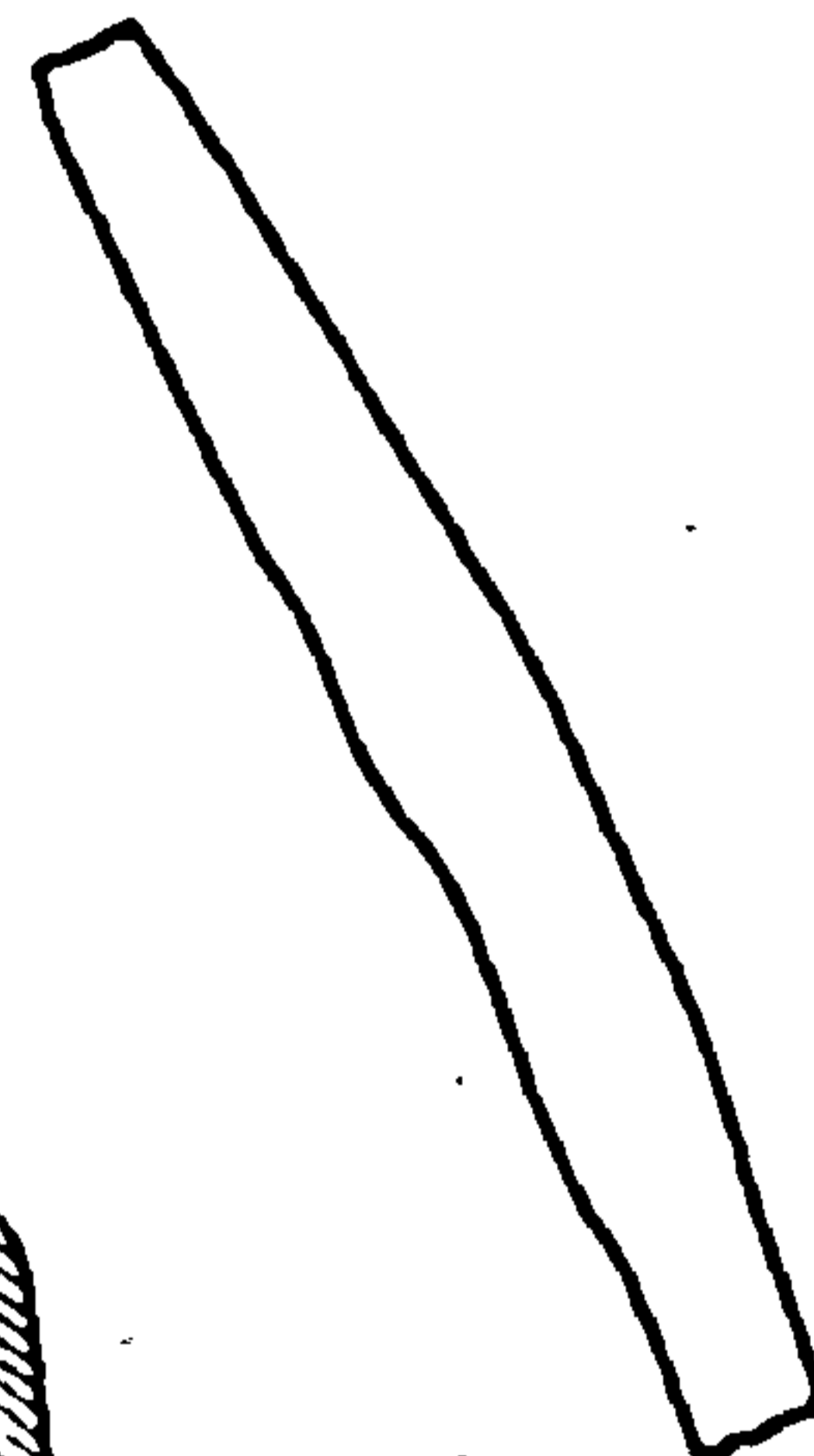

DAB 737



DAB 635

ILL 19

White Painted V



DAB 586

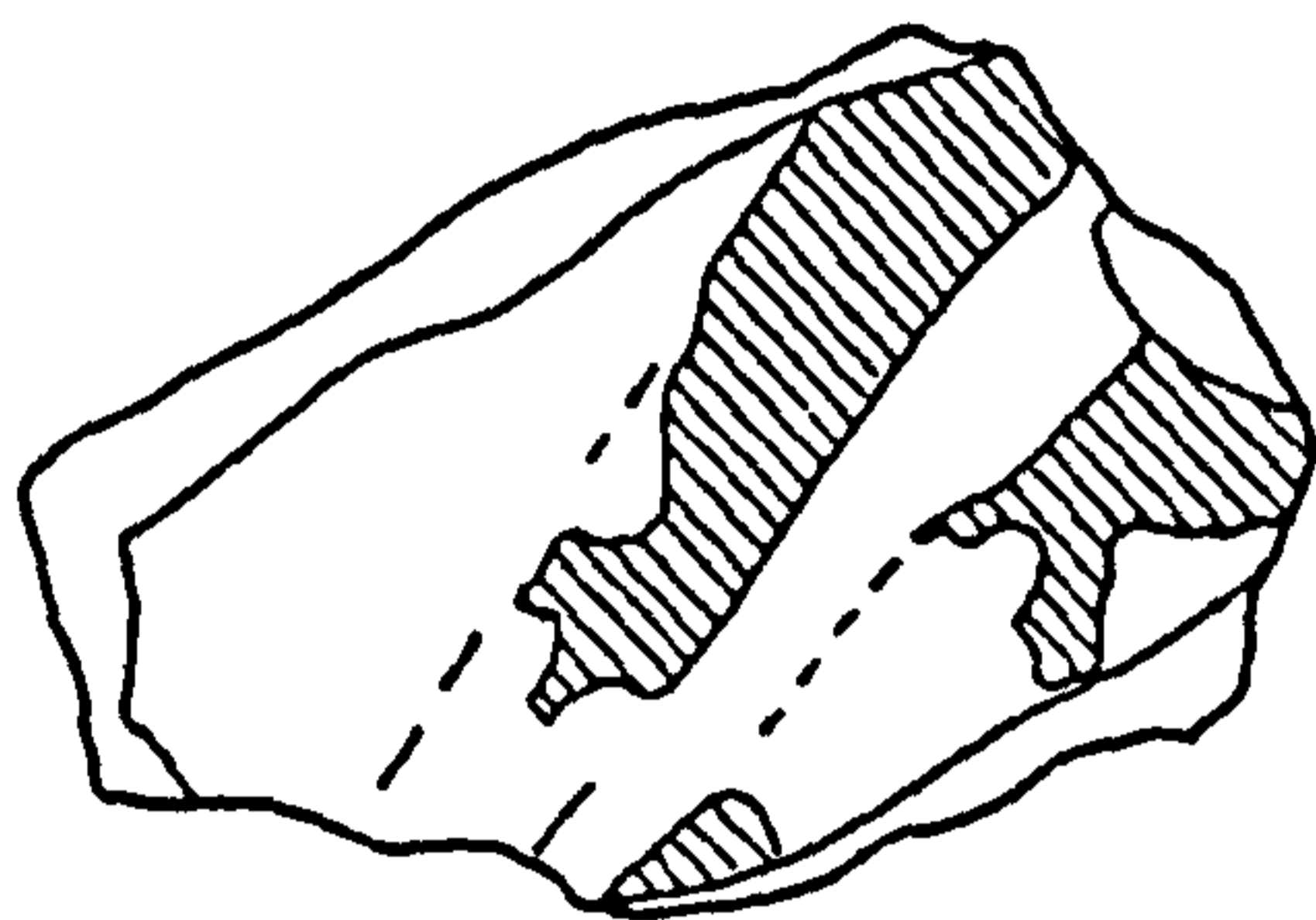
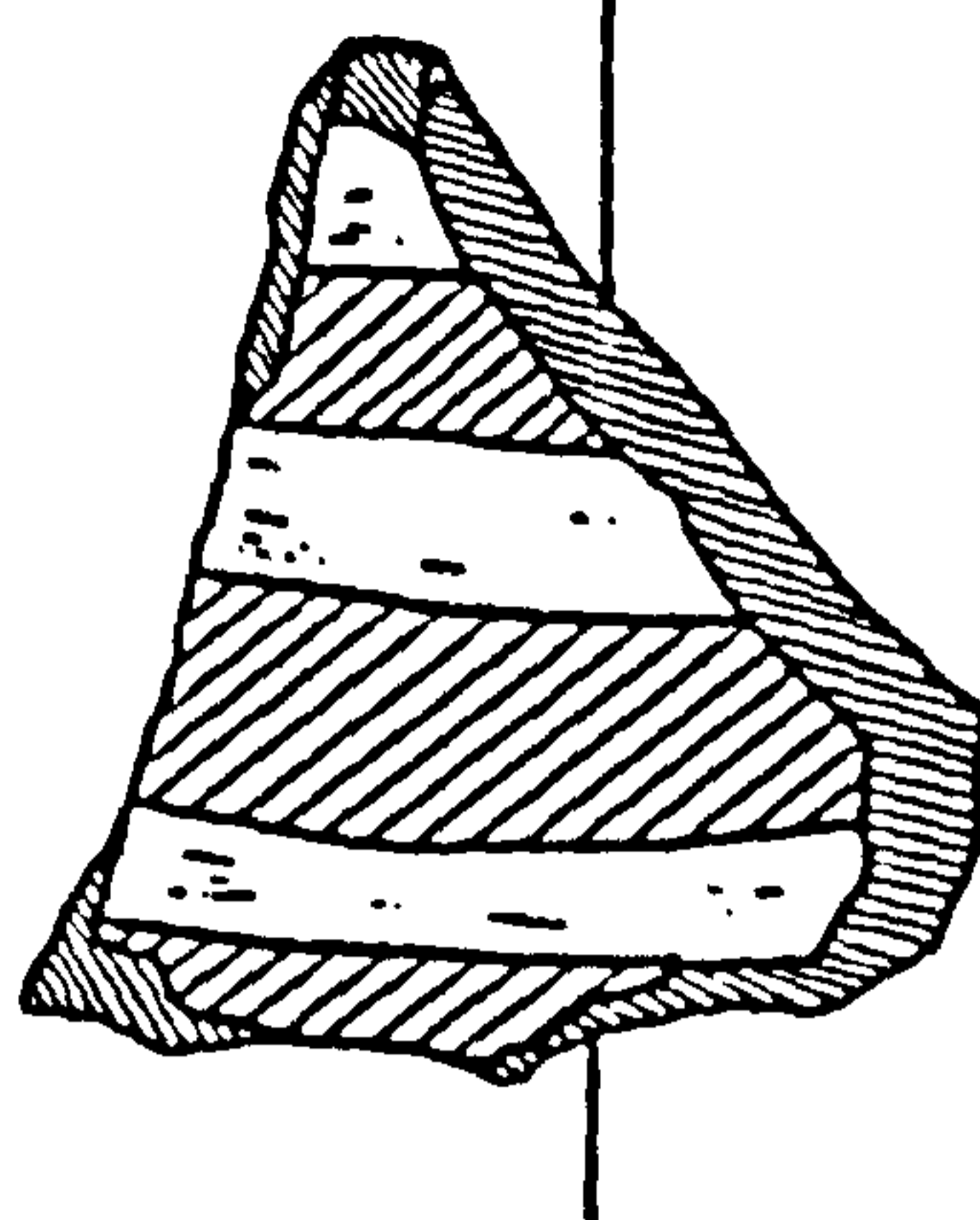

DAB 596

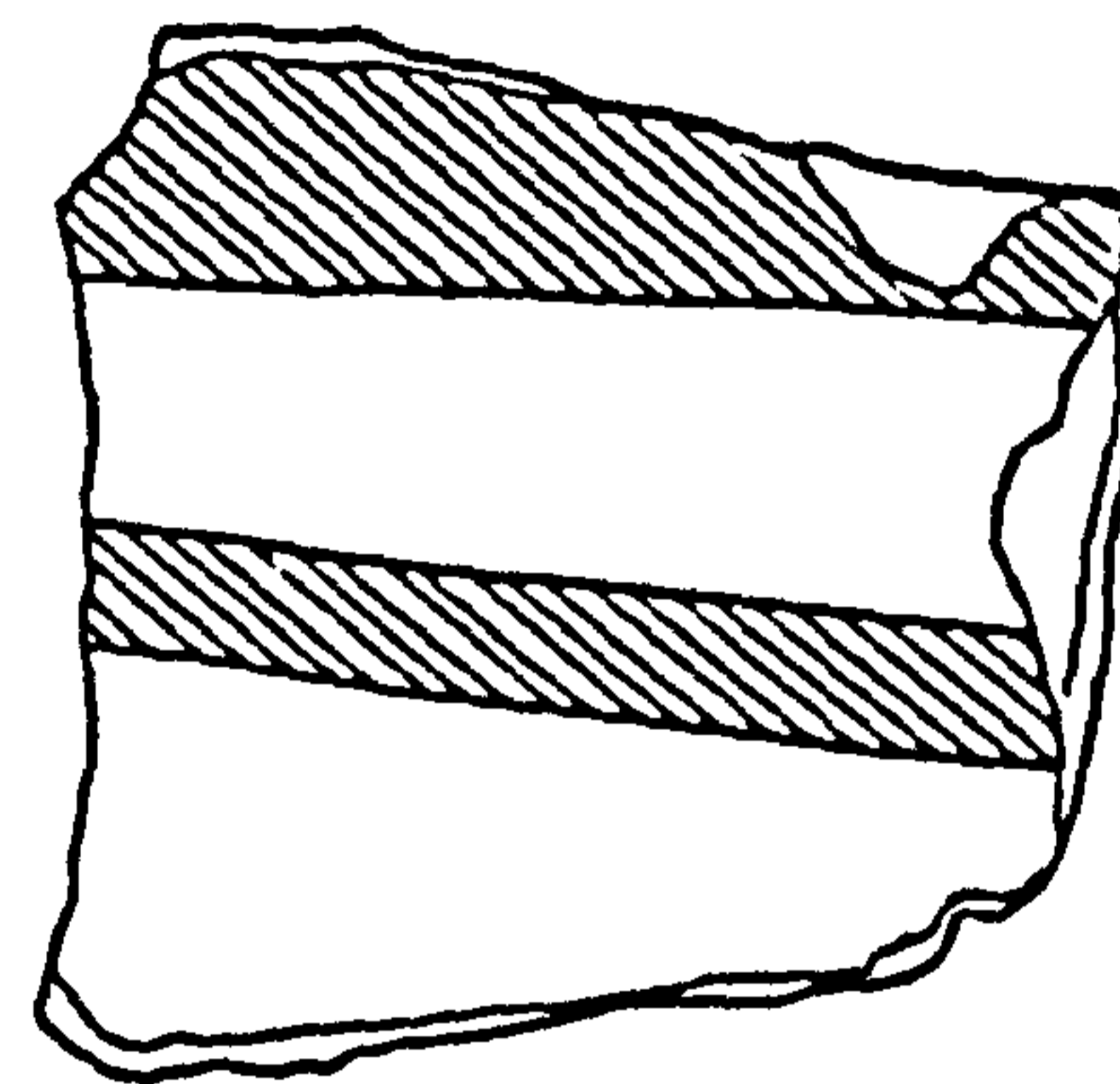

DAB 612



DAB 637

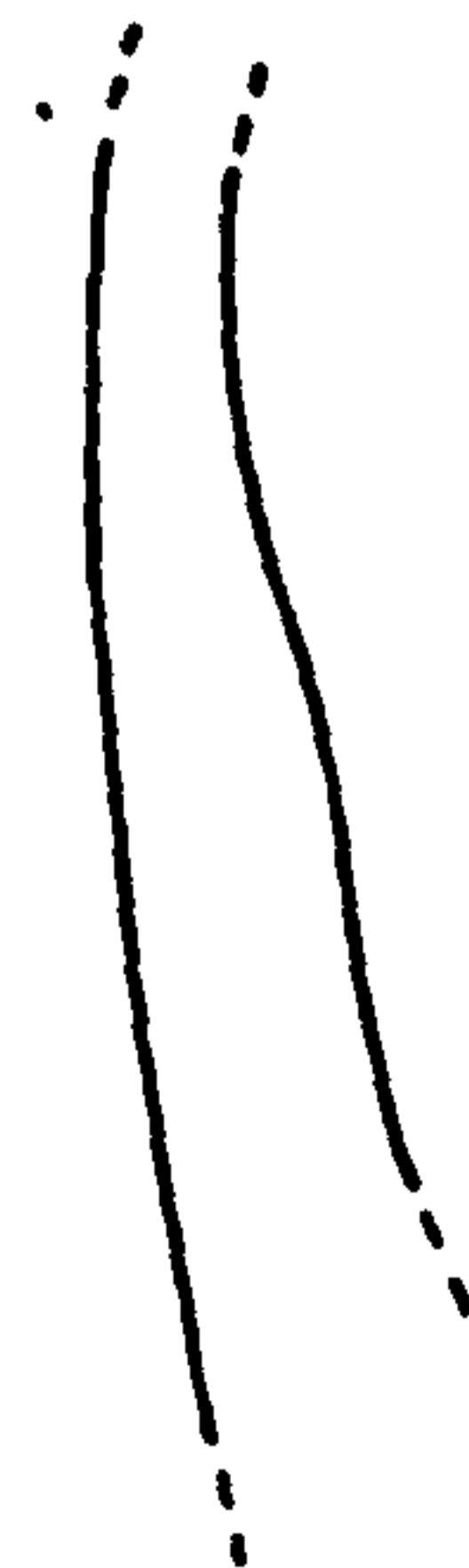

DAB 597

ILL 20

White Painted V

DAB 561

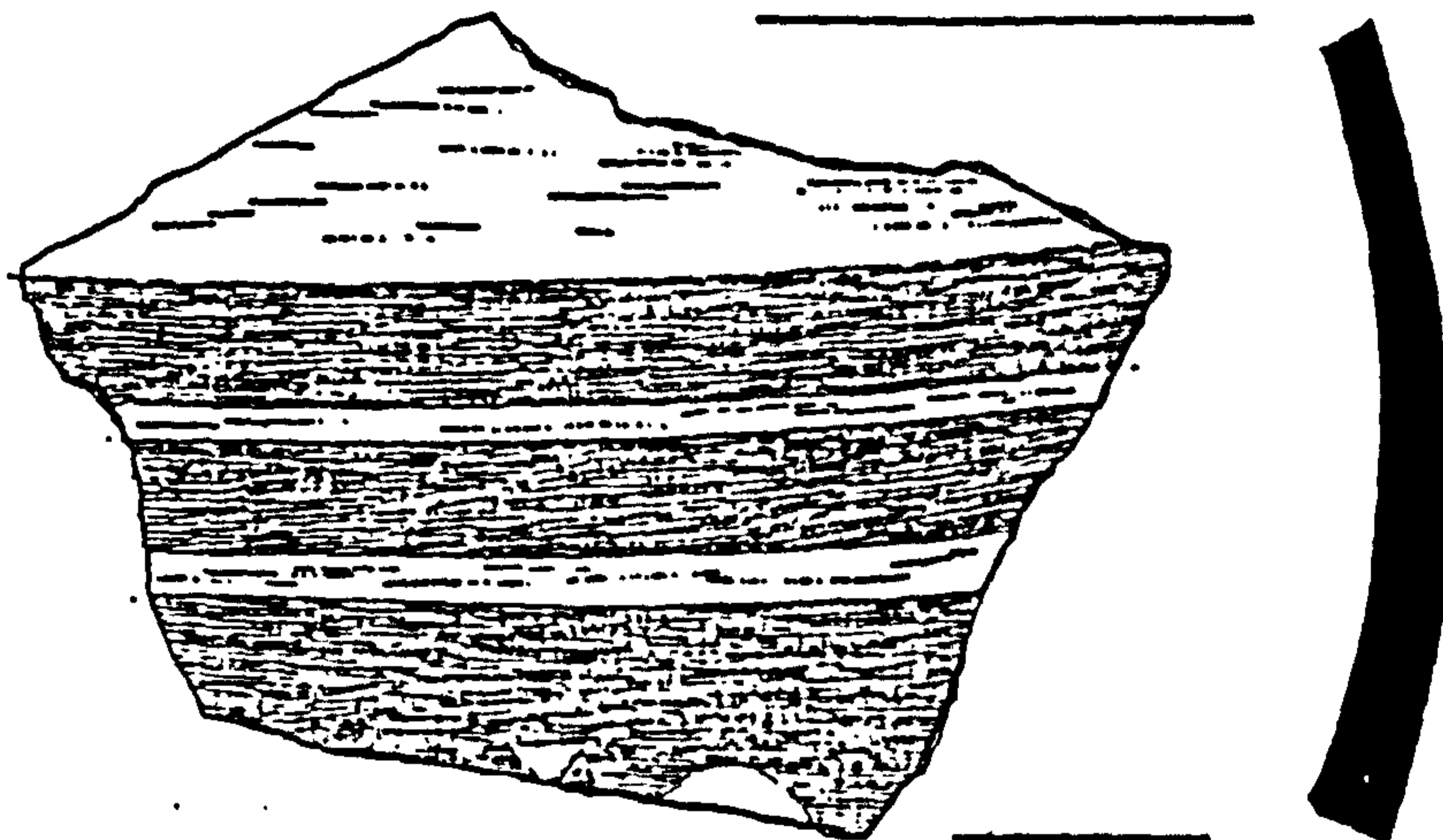

DAB 575

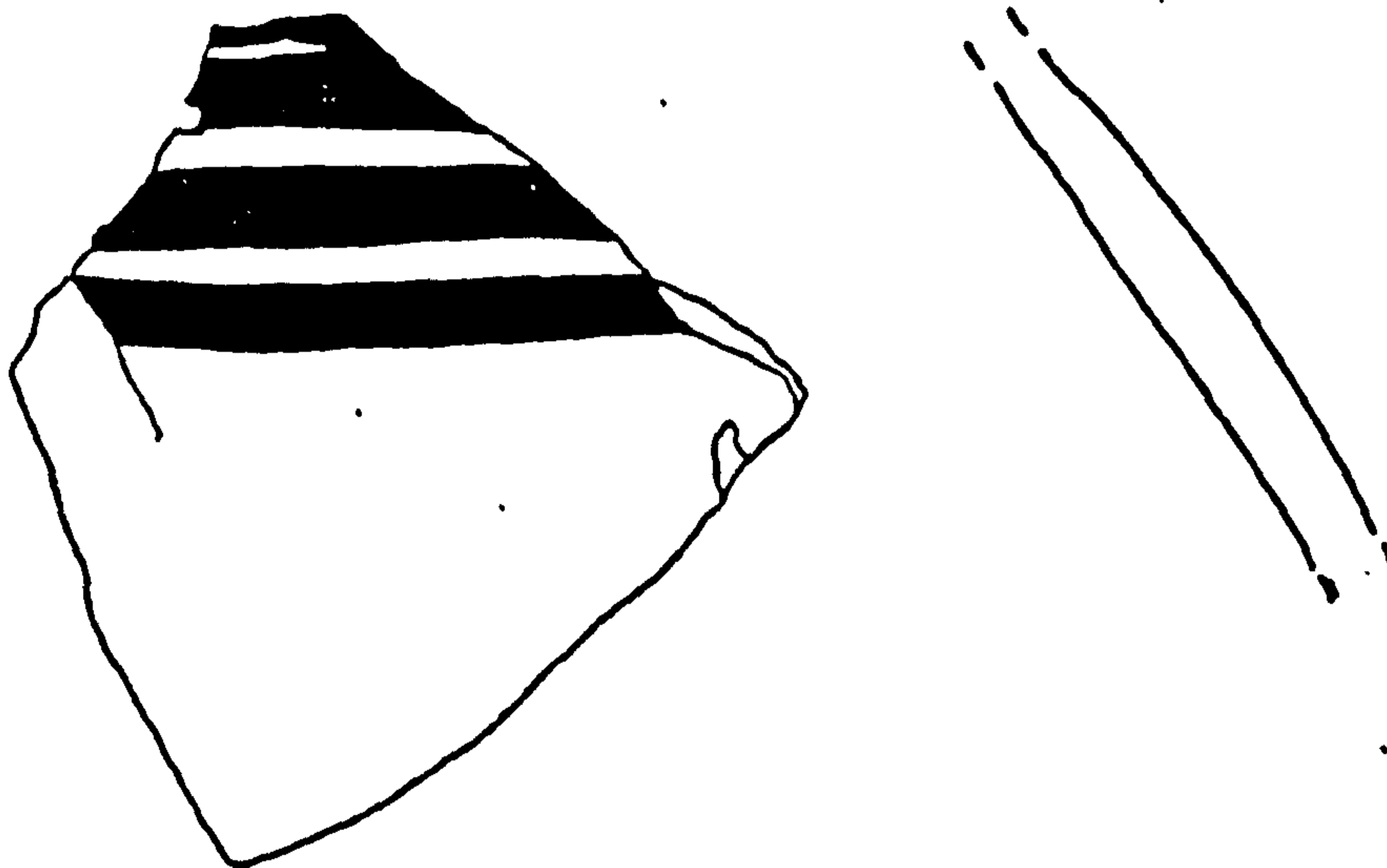

ILL 21

White Painted V



DAB 571

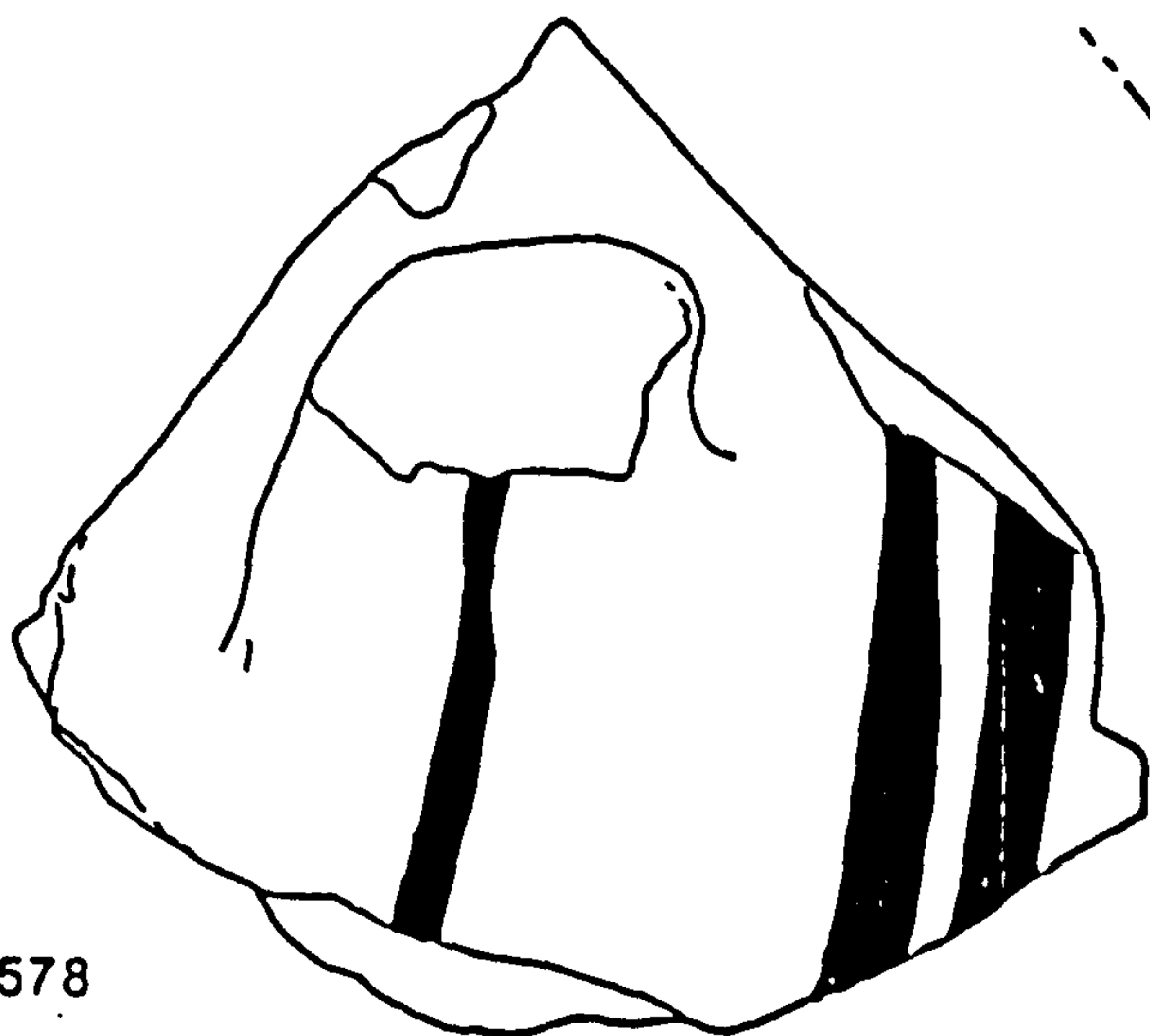

DAB 578

ILL 22

White Painted V



DAB 585

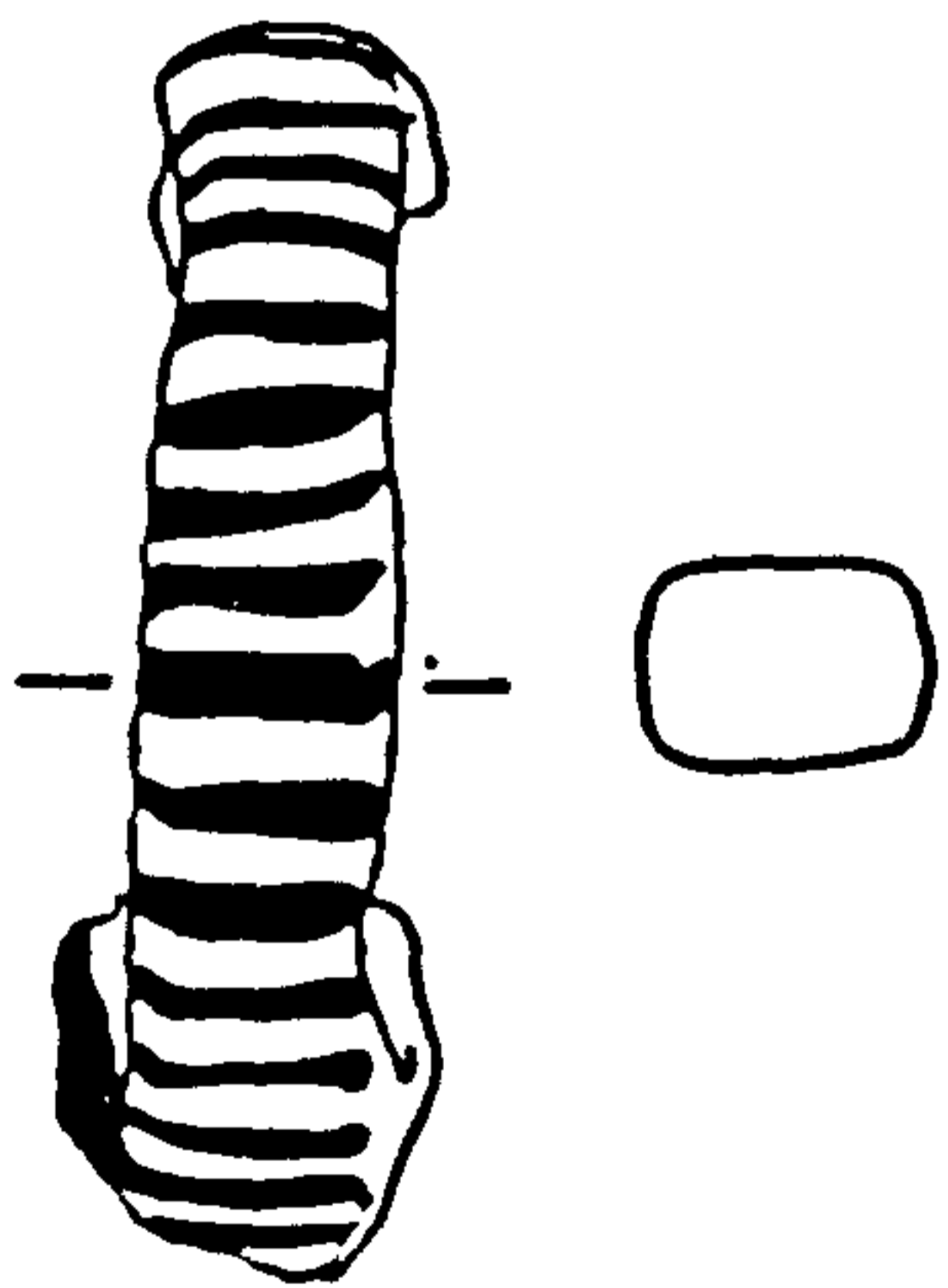
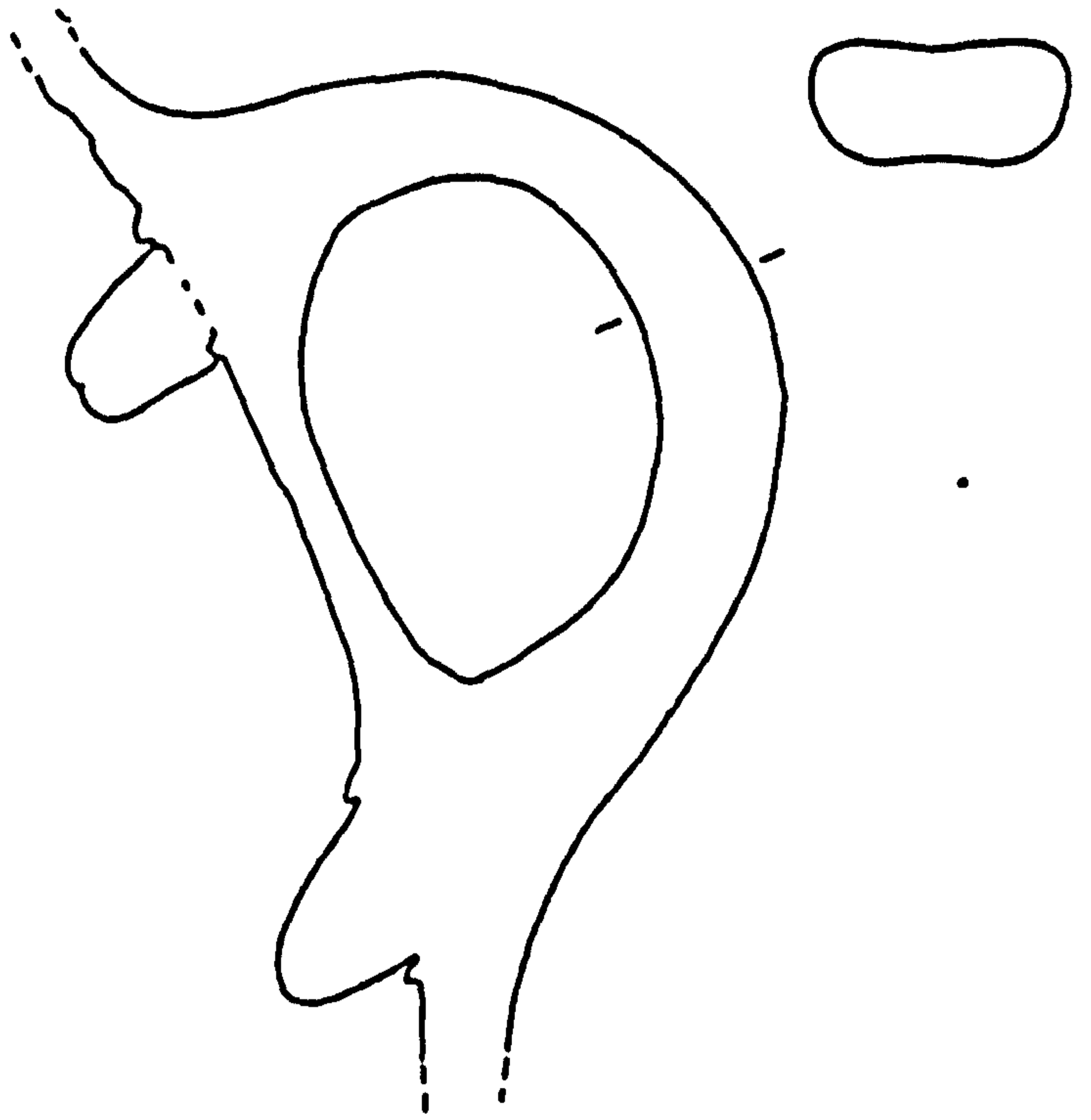

DAB 572

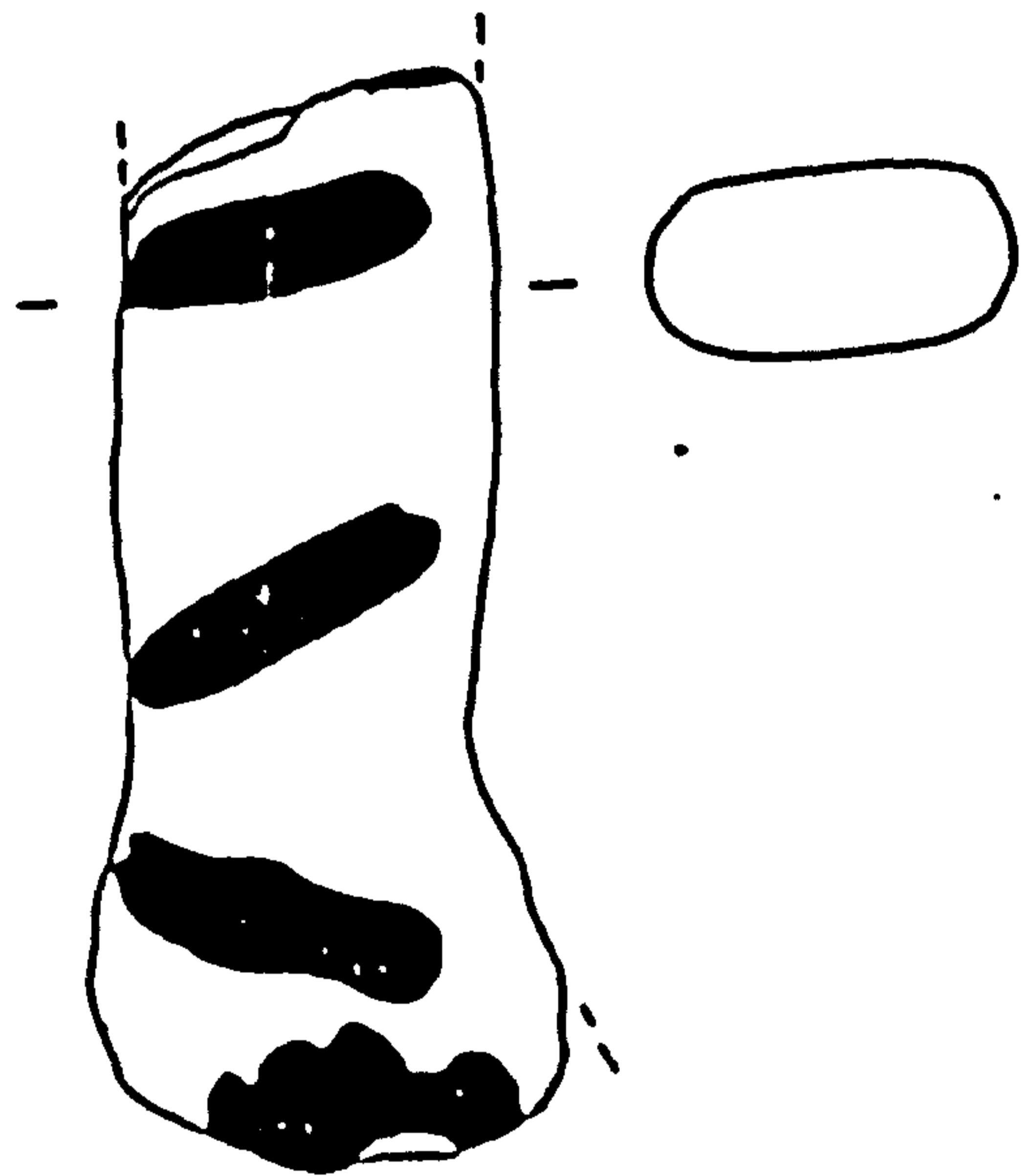

DAB 688

ILL 23

White Painted V

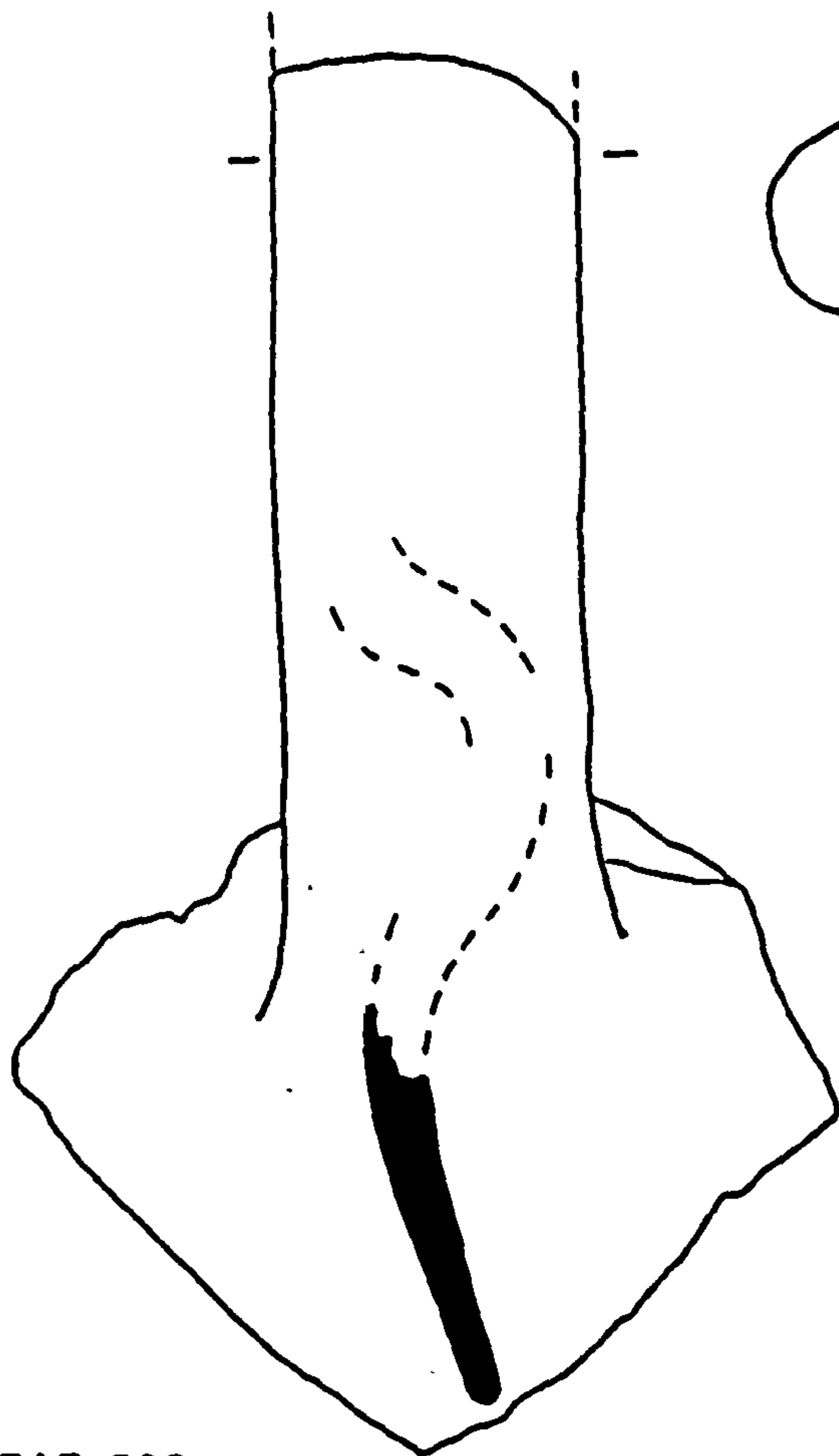

DAB 582

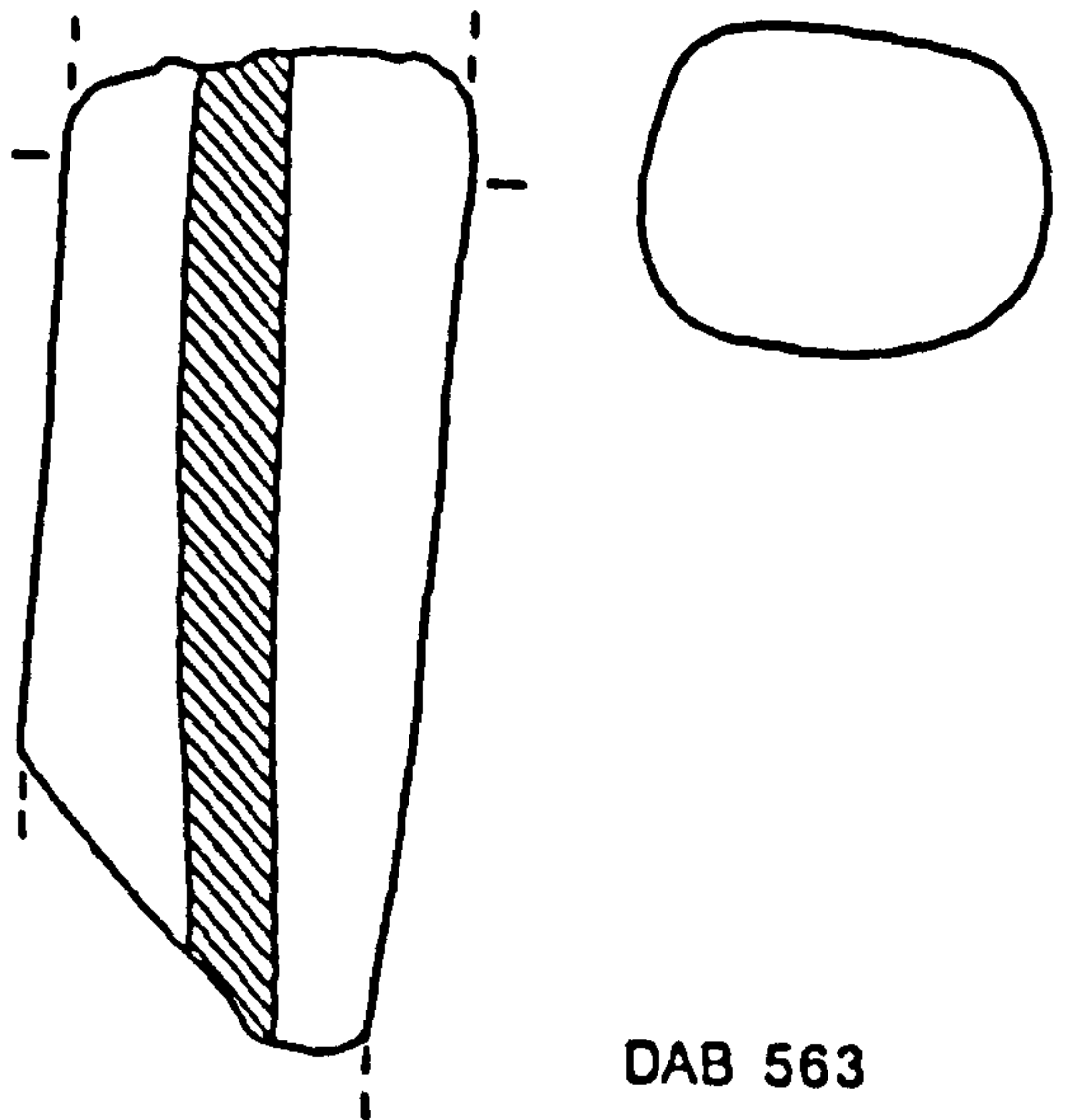

DAB 563



DAB 588



White Painted V

ILL 24

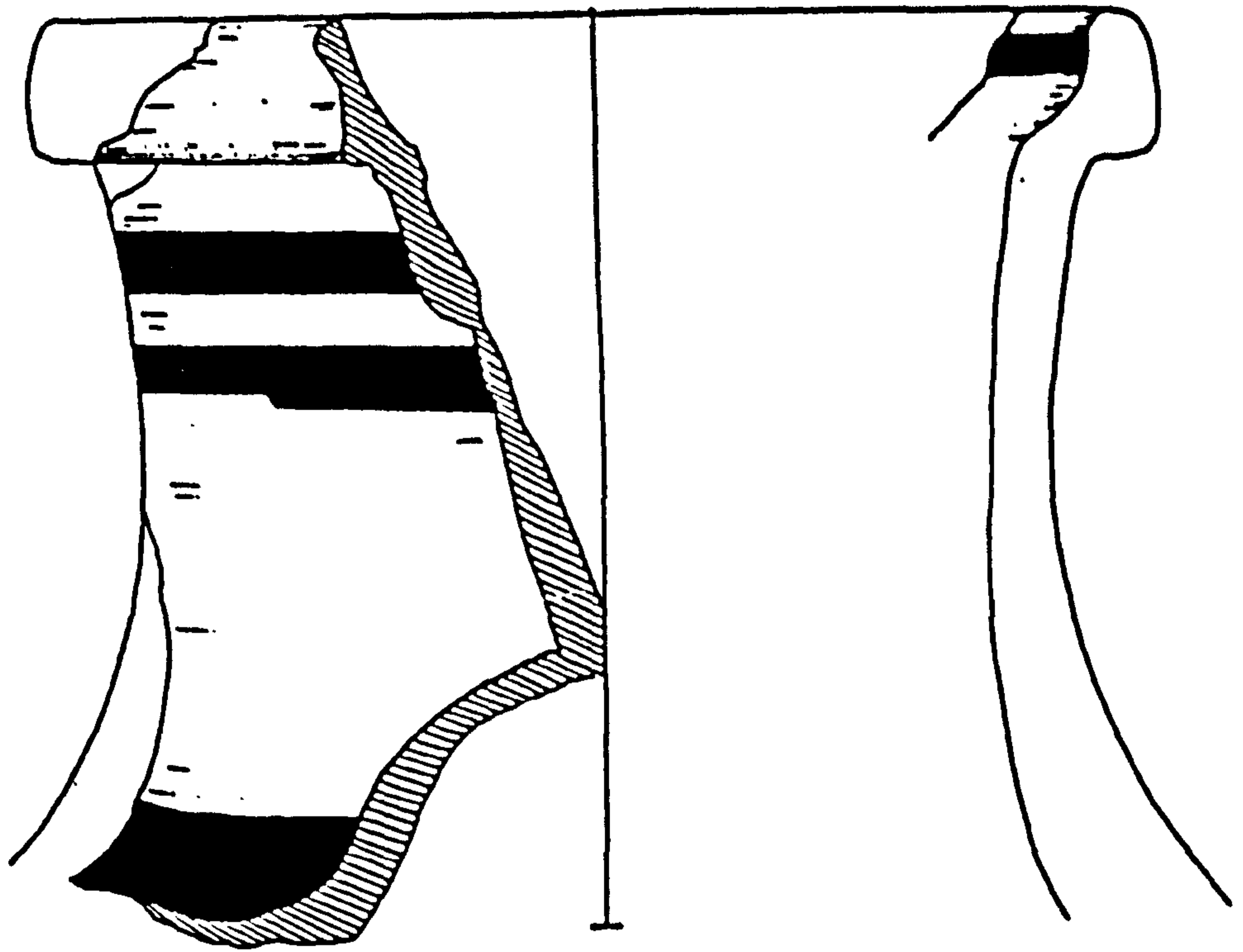

DAB 587

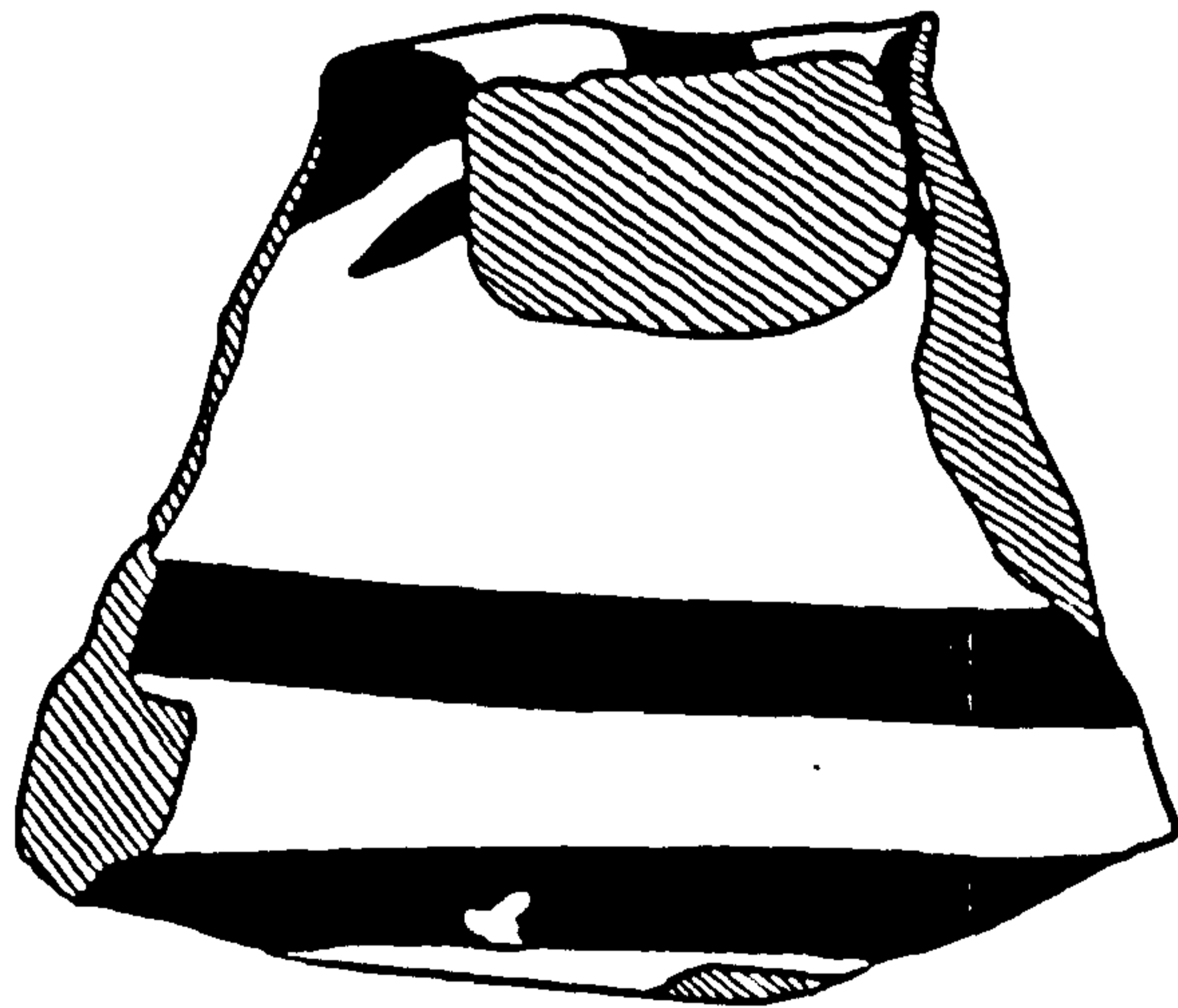

DAB 577

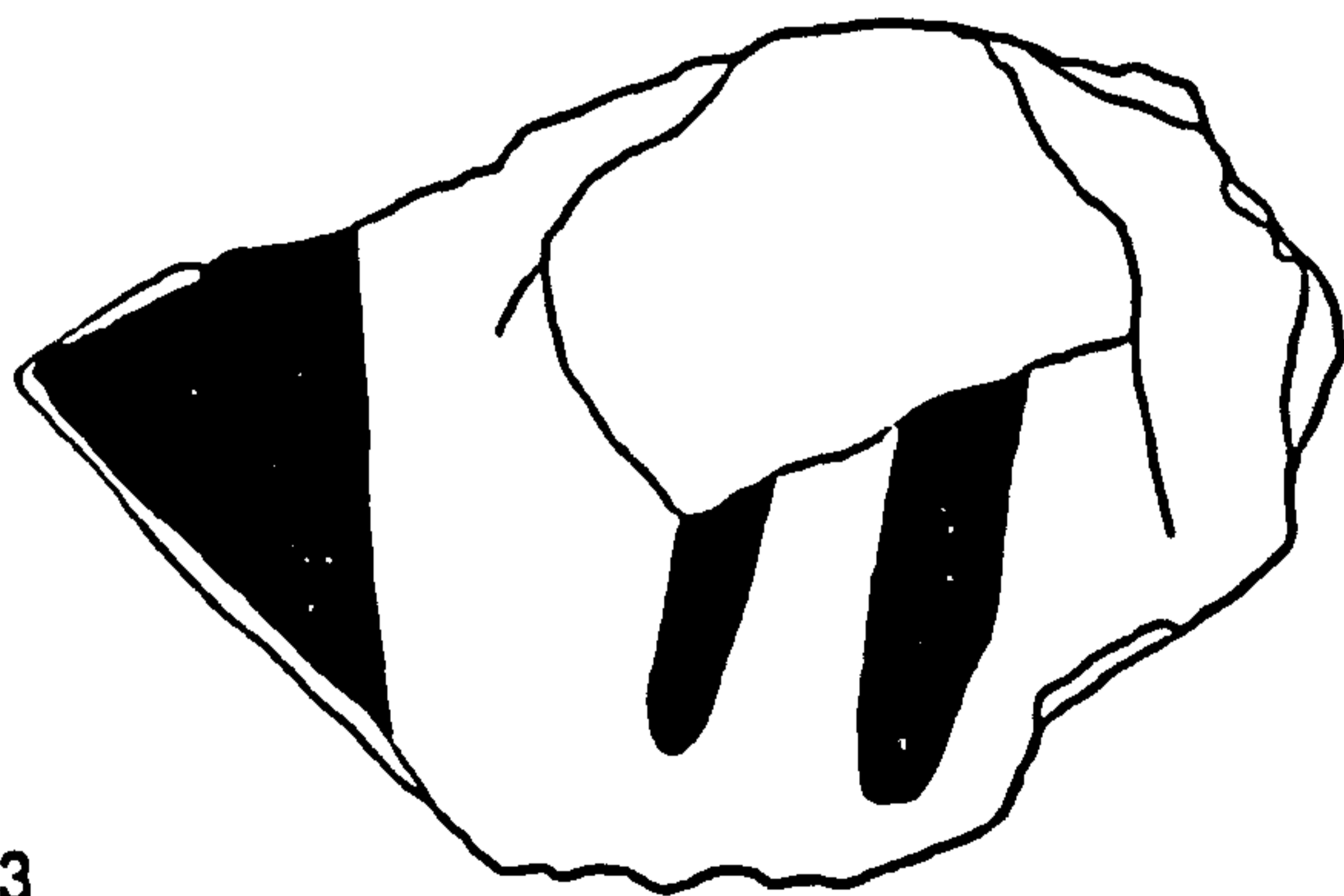
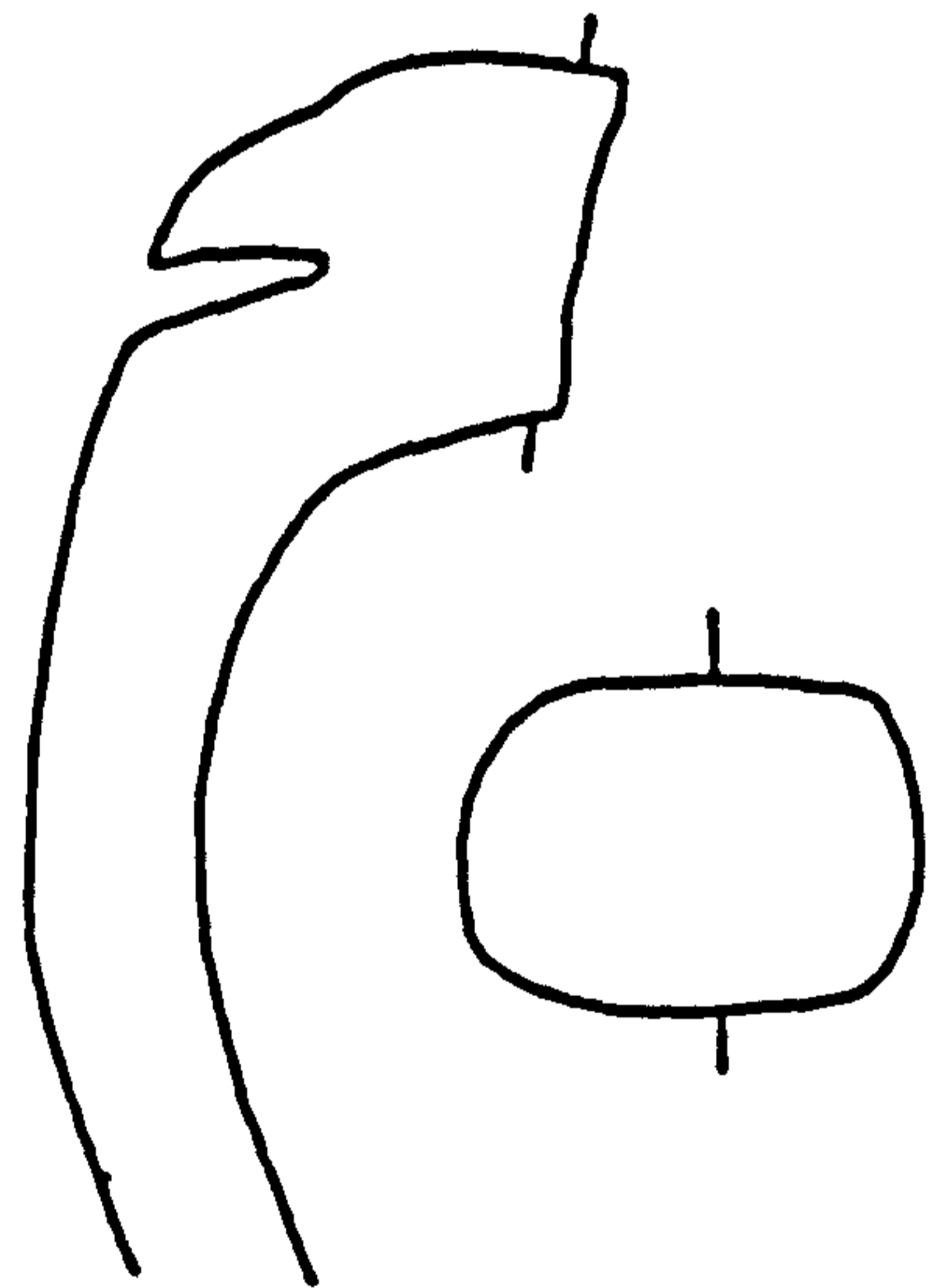

DAB 583

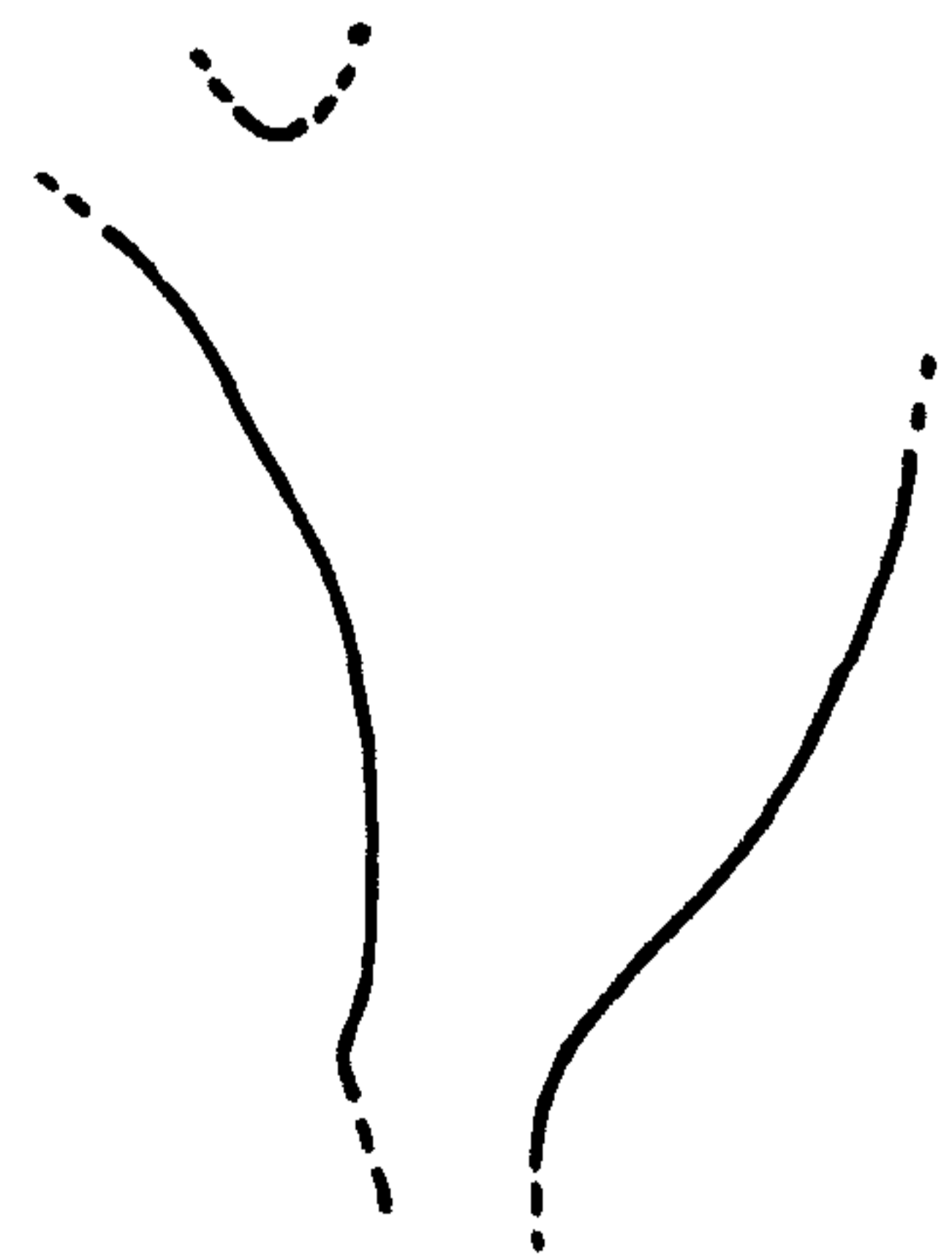

ILL 25

White Painted V

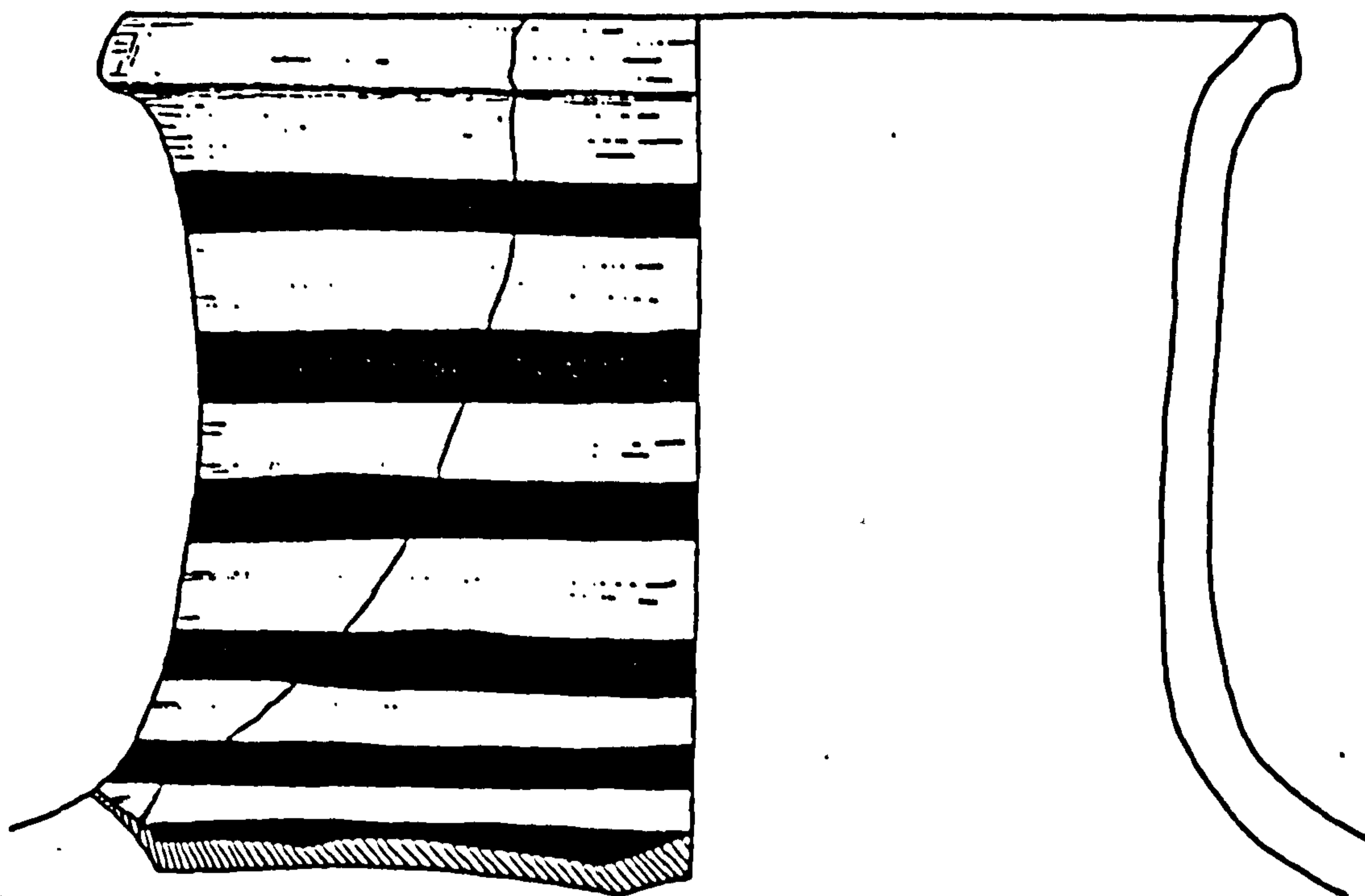

DAB 584

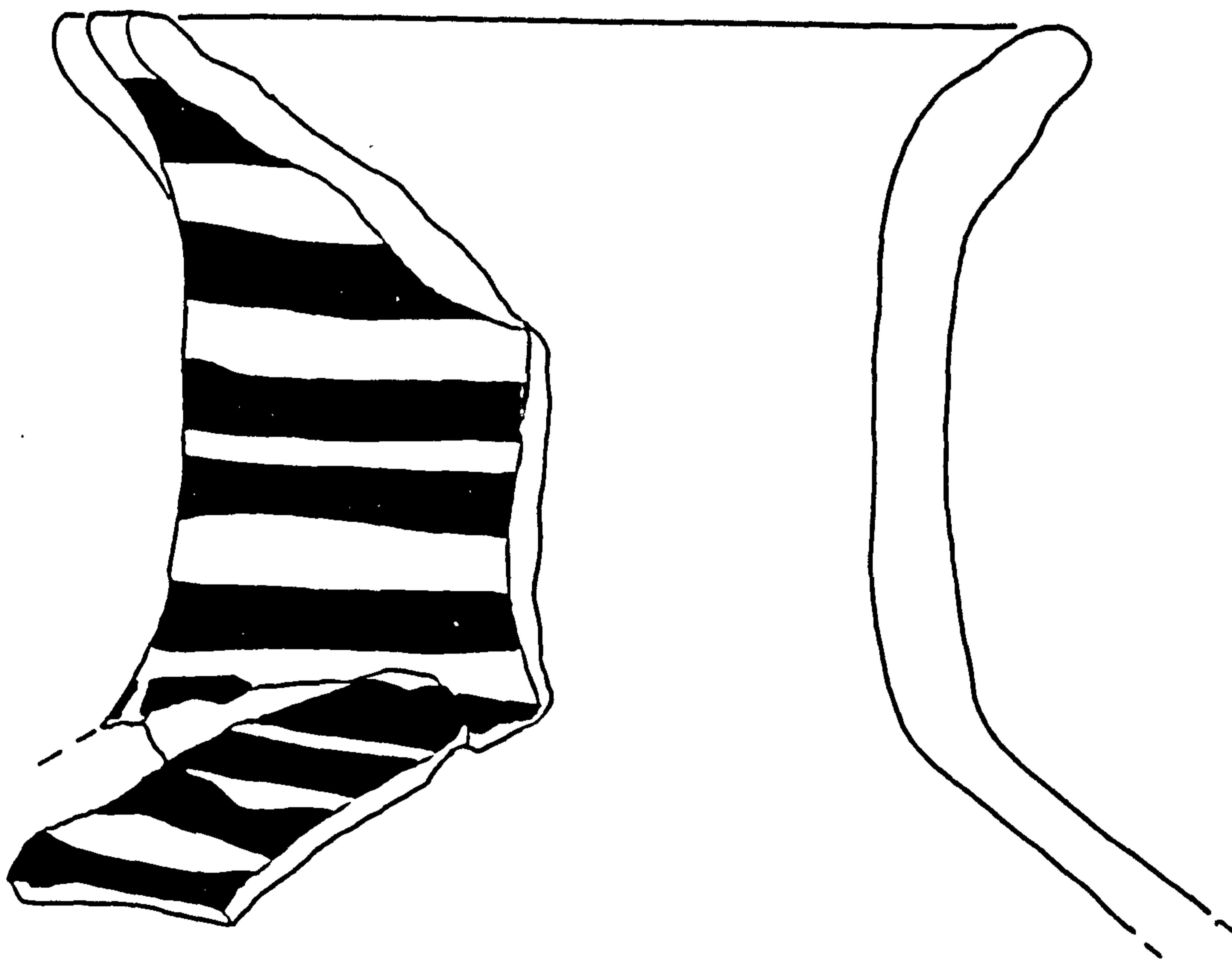

DAB 604

ILL 26

White Painted V

DAB 620

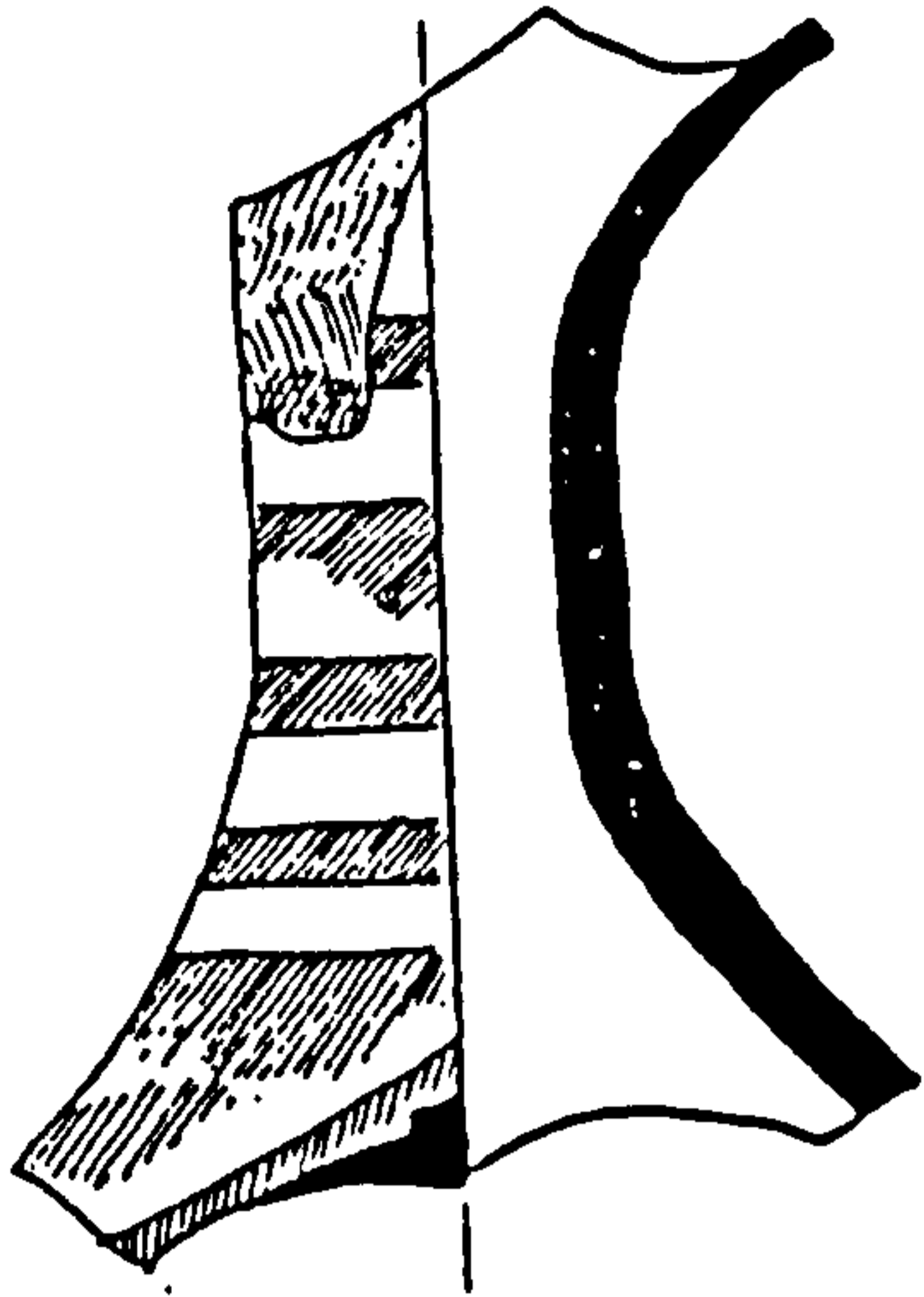

DAB 672

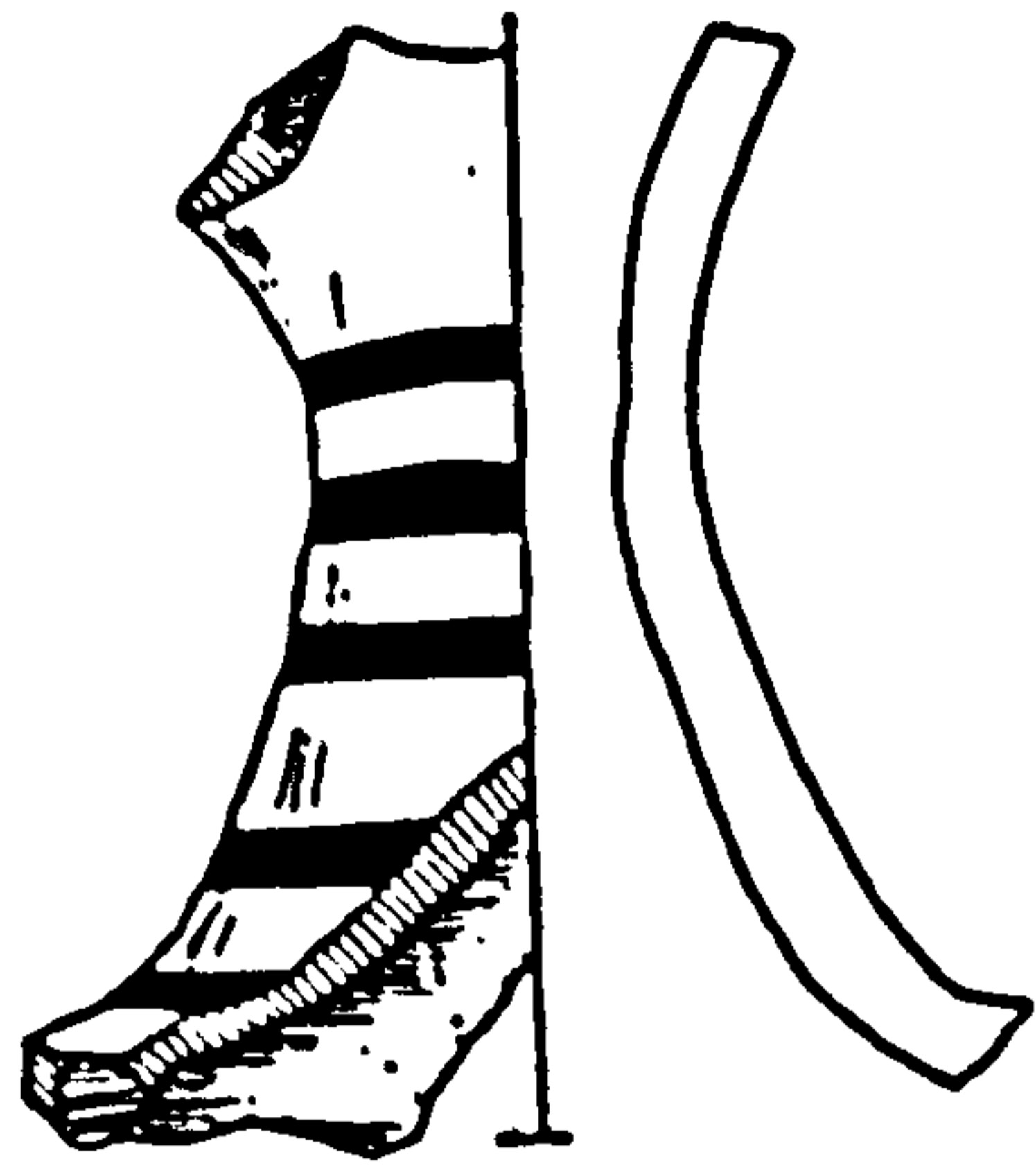

DAB 662

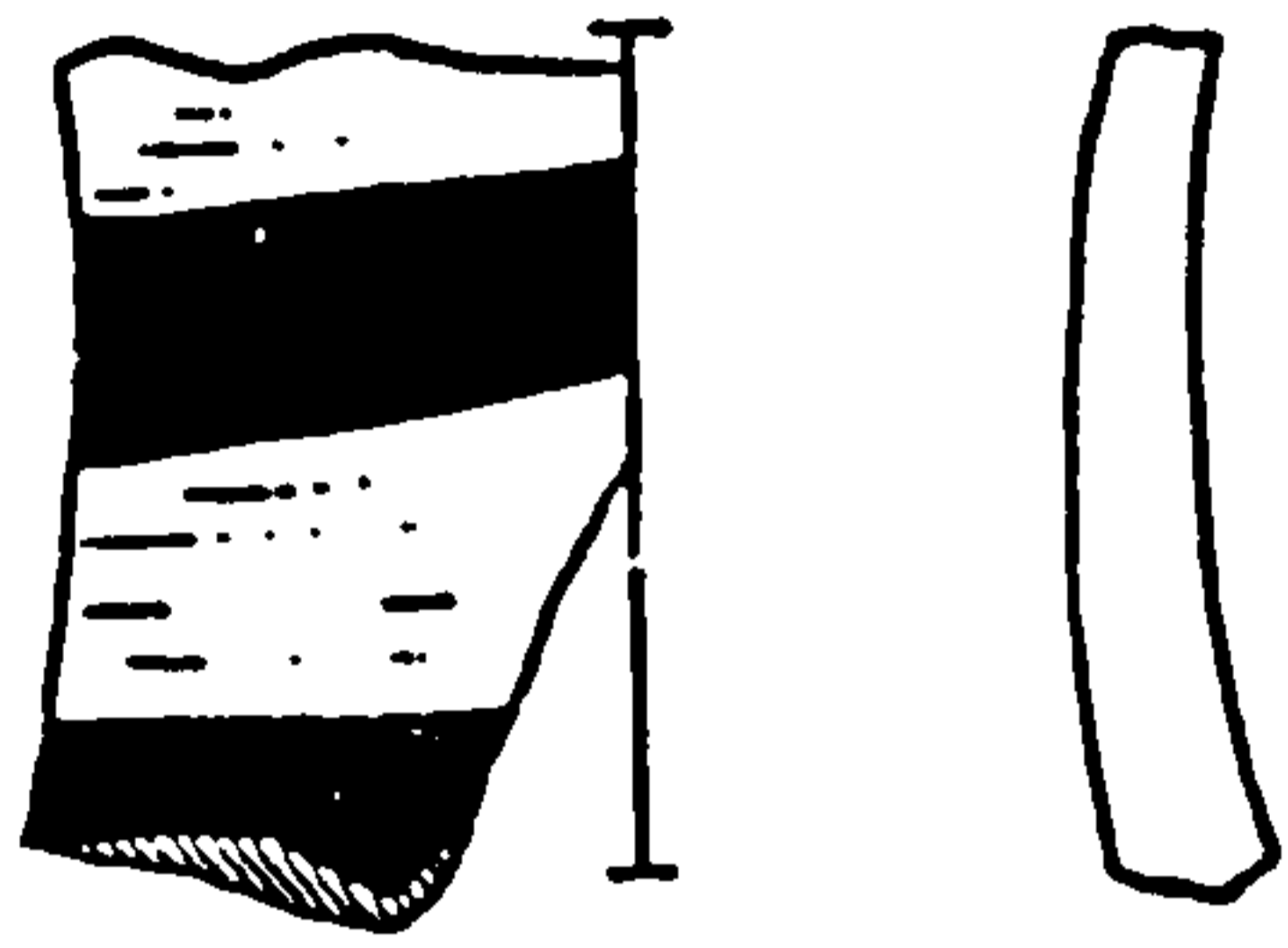

DAB 667
1:2

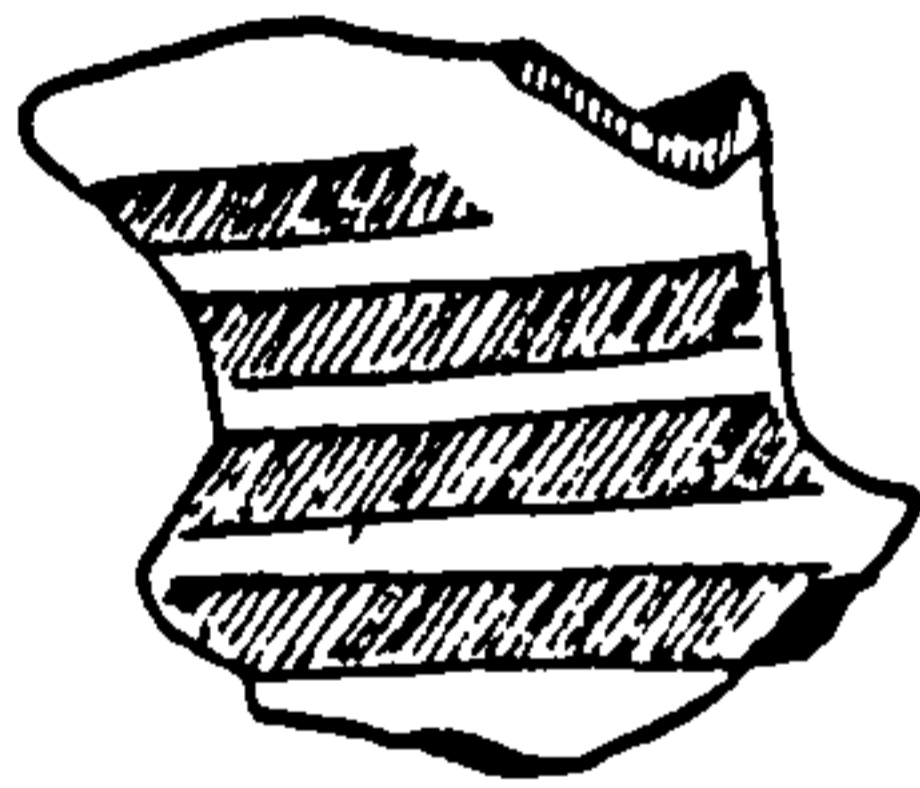

DAB 765

DAB 671

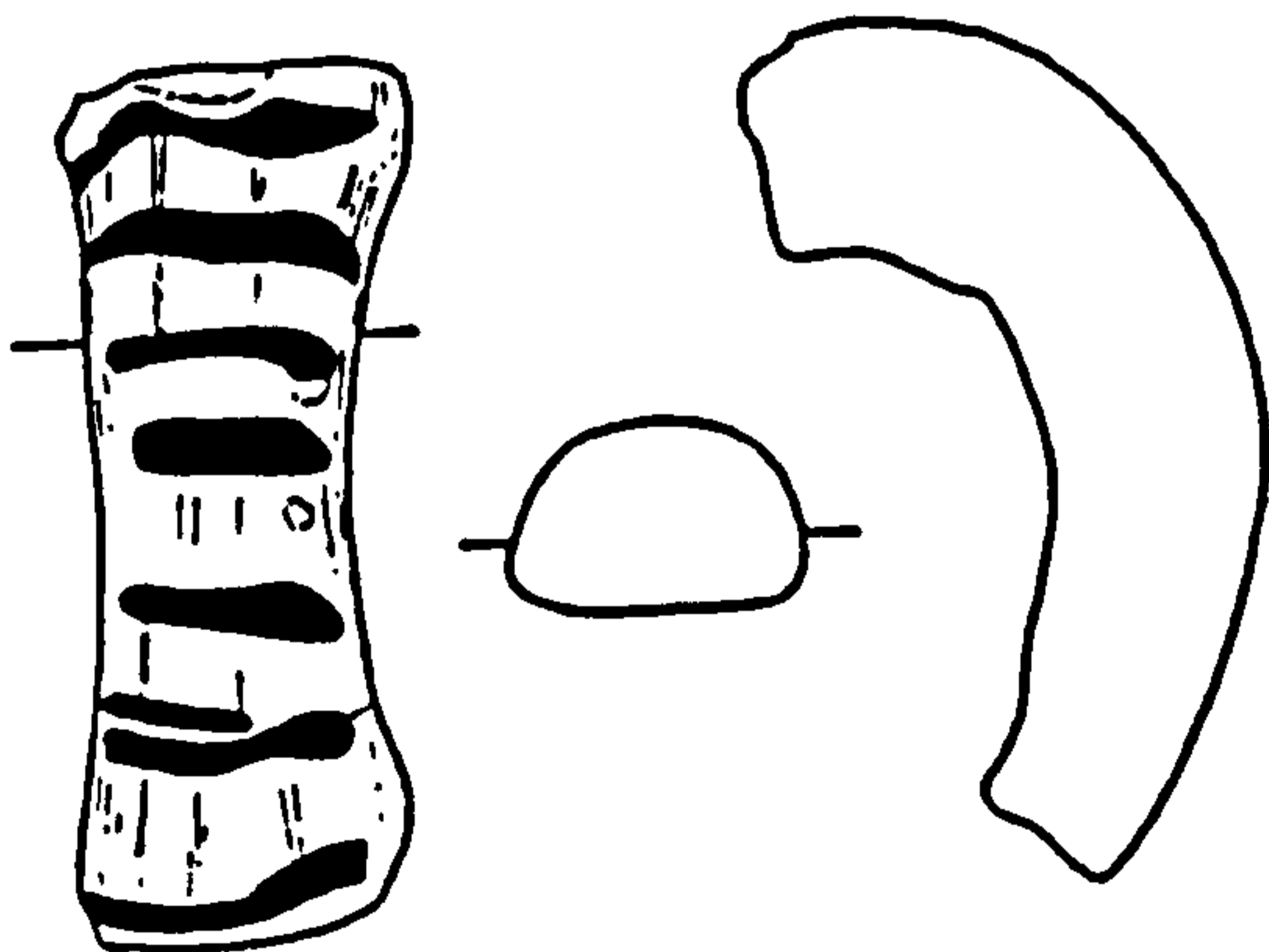

DAB 580

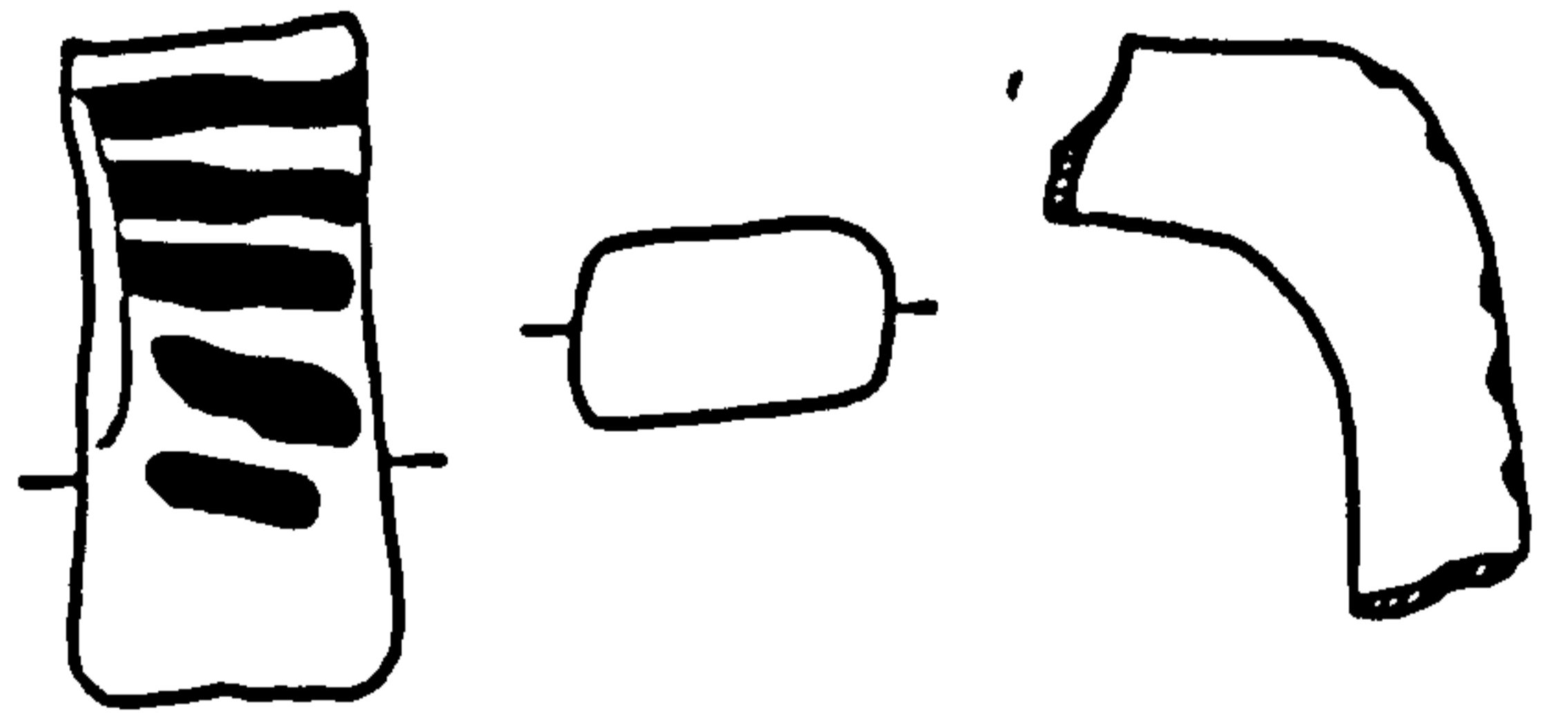

ILL 27

White Painted Various, Imitation White Painted
(DAB 765)

DAB 622

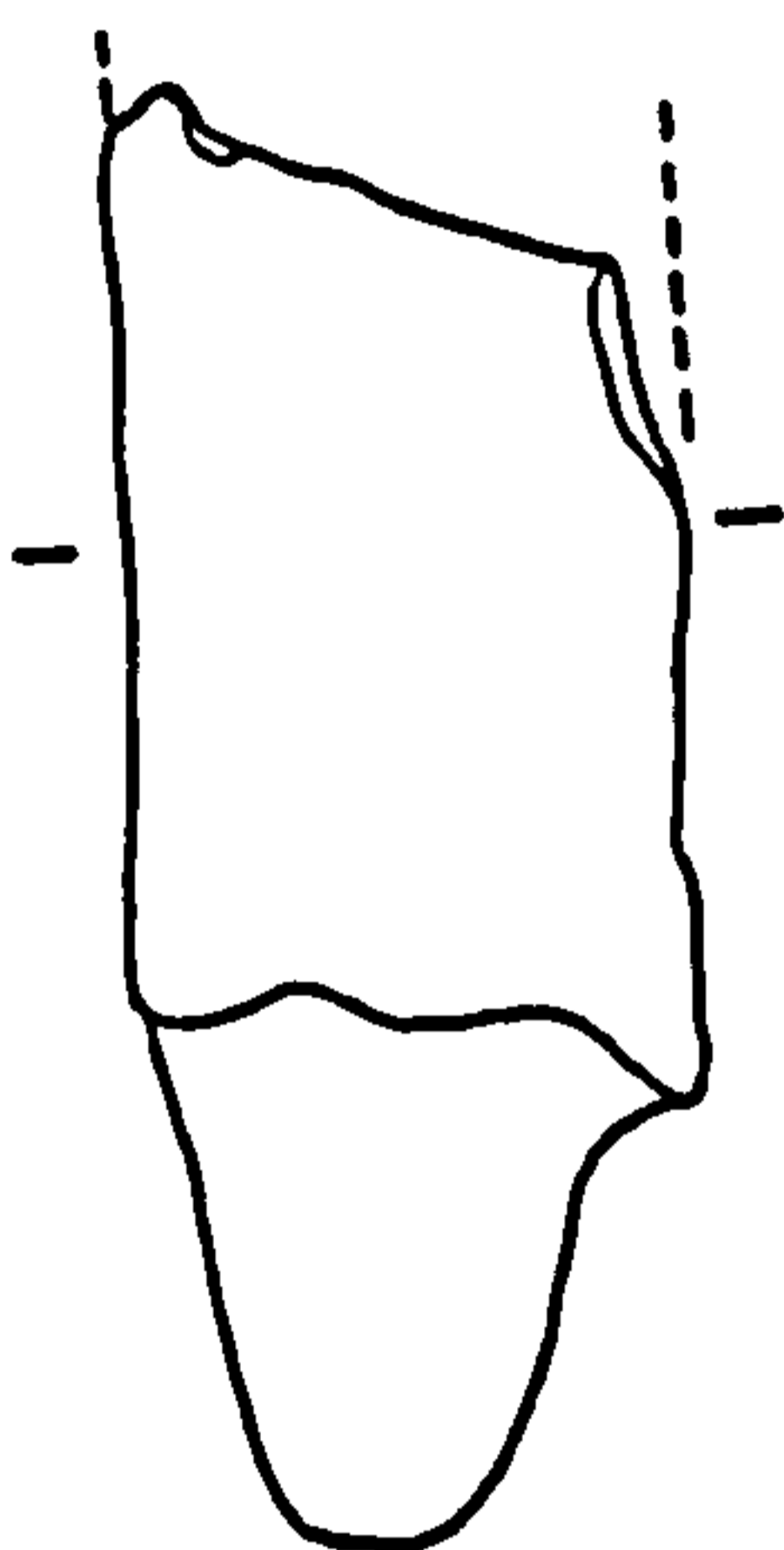
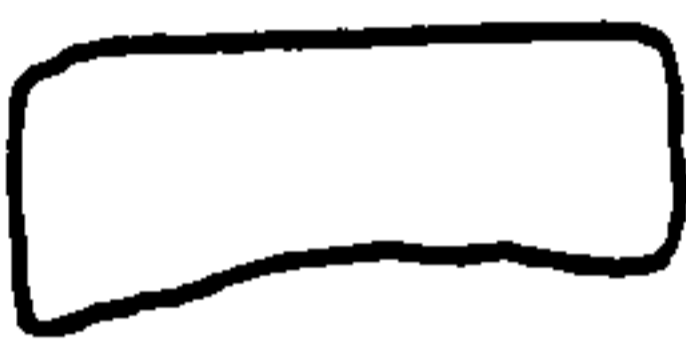
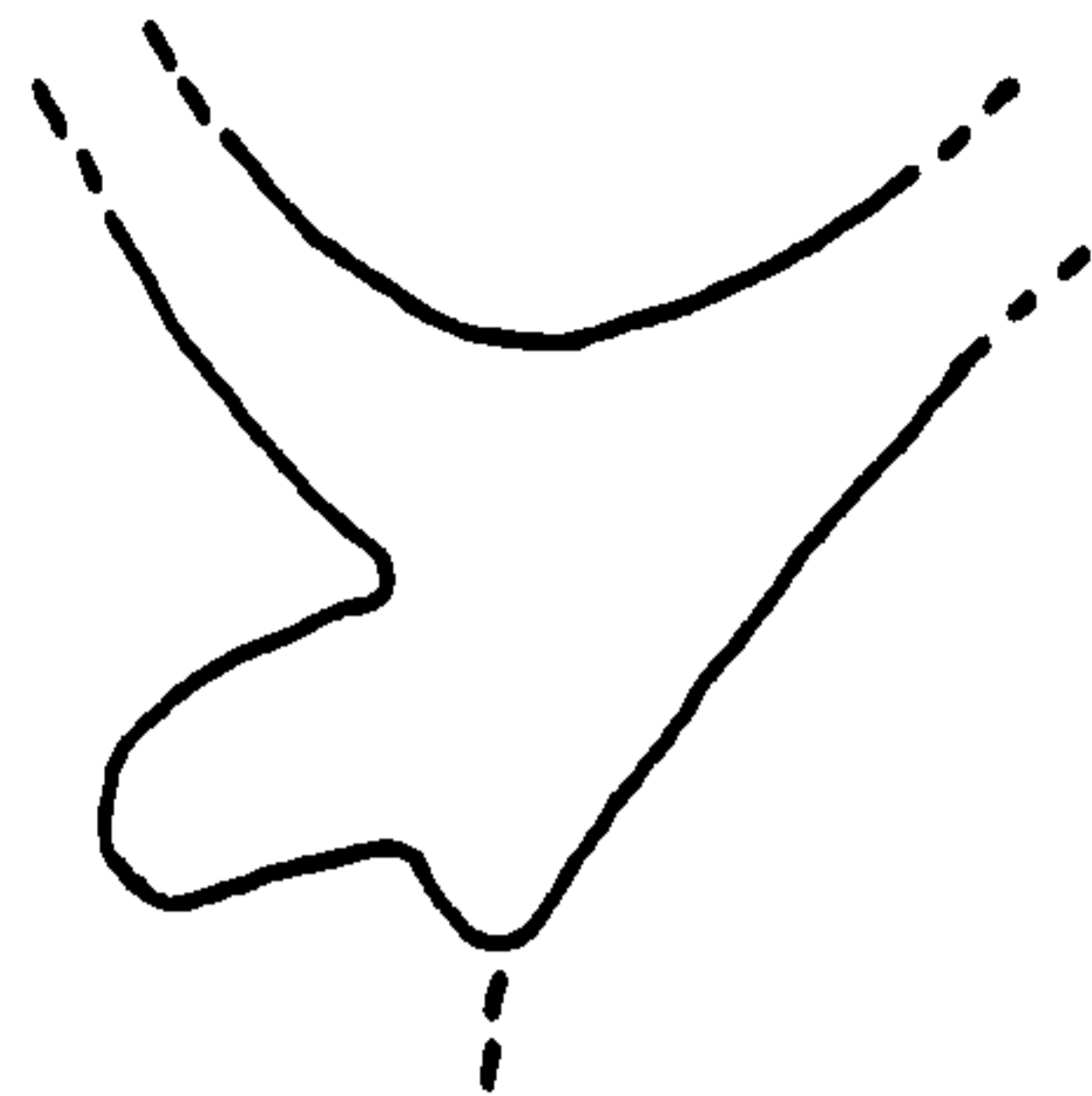
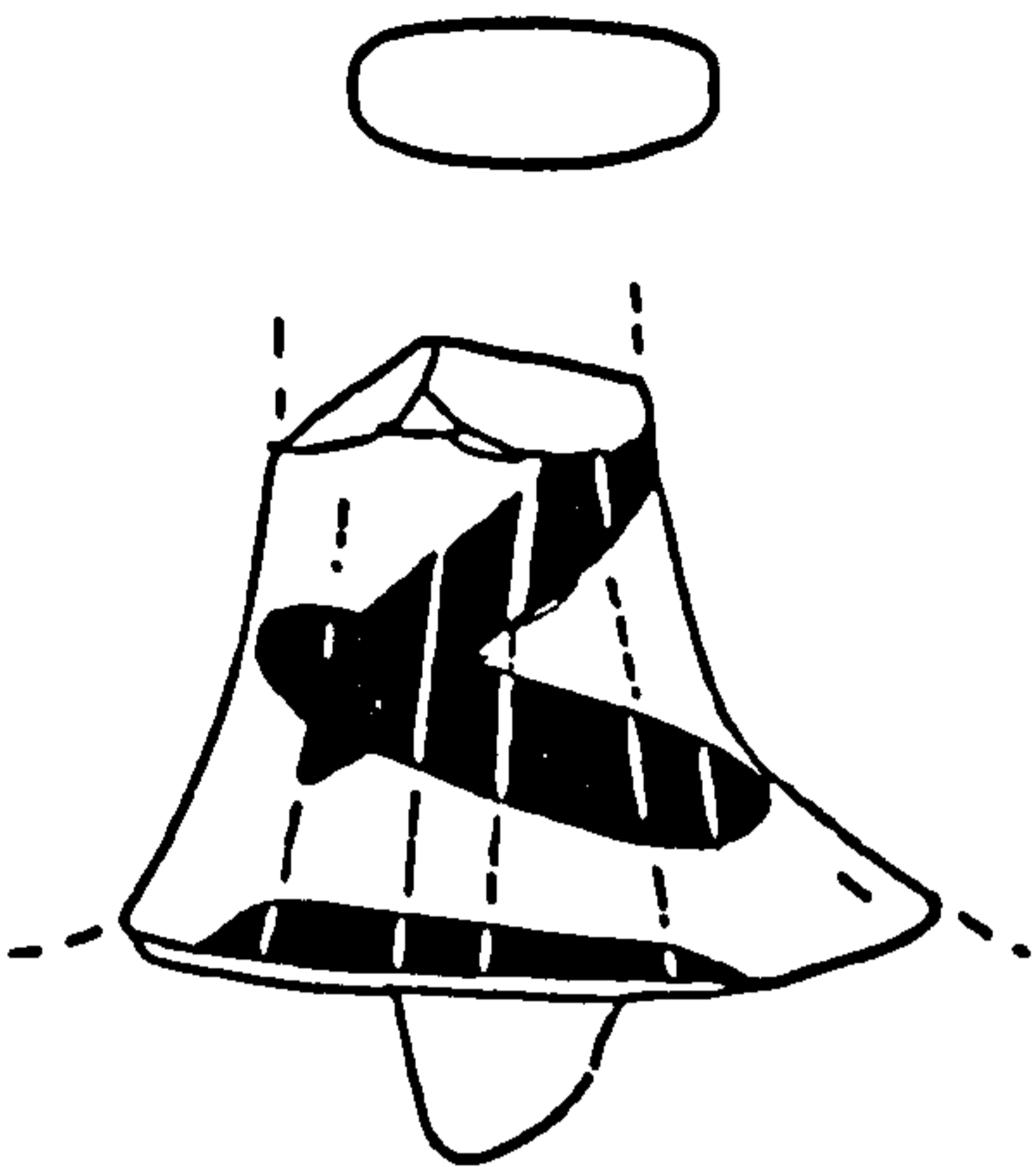

DAB 657

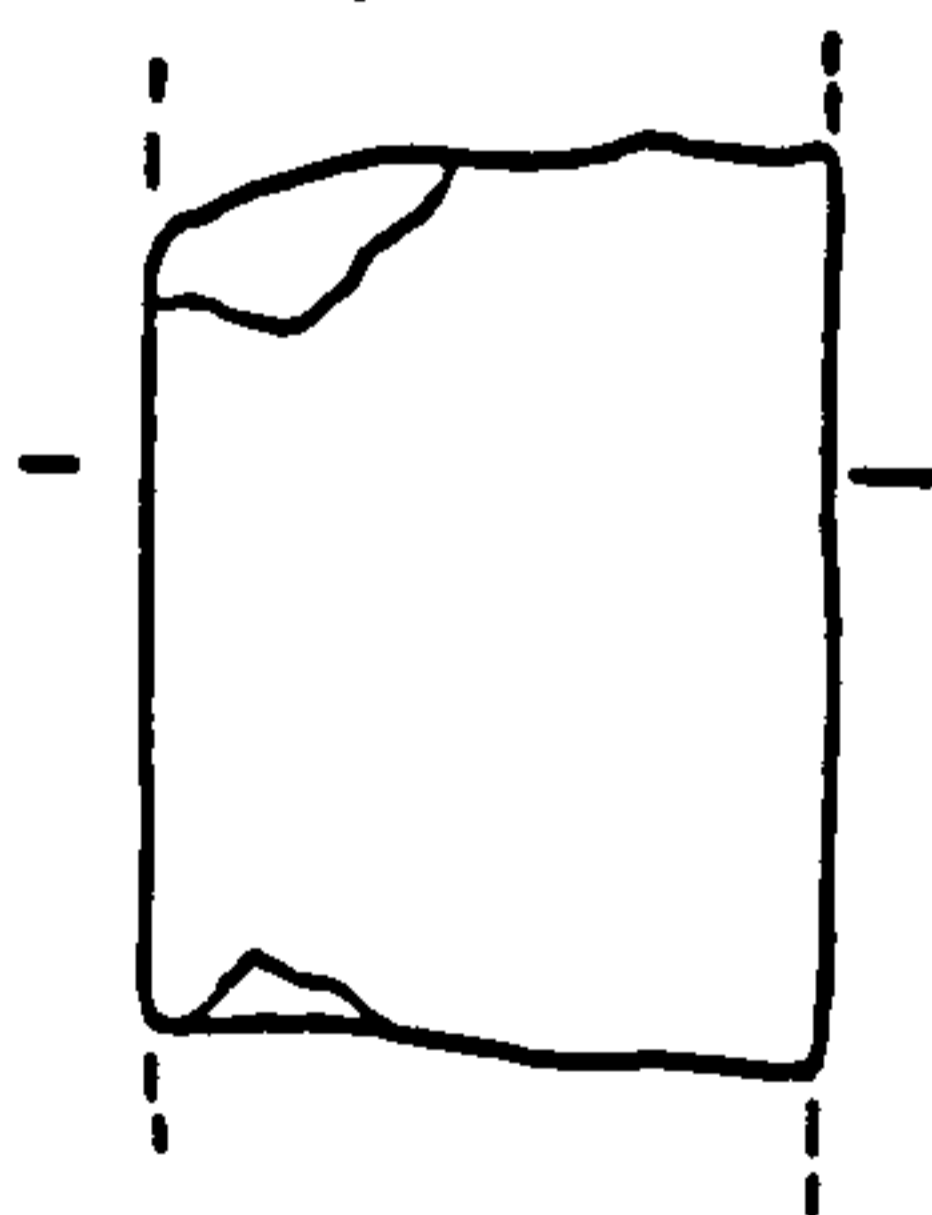

DAB 657

ILL 28

White Painted VI (DAB 622); White Painted Various

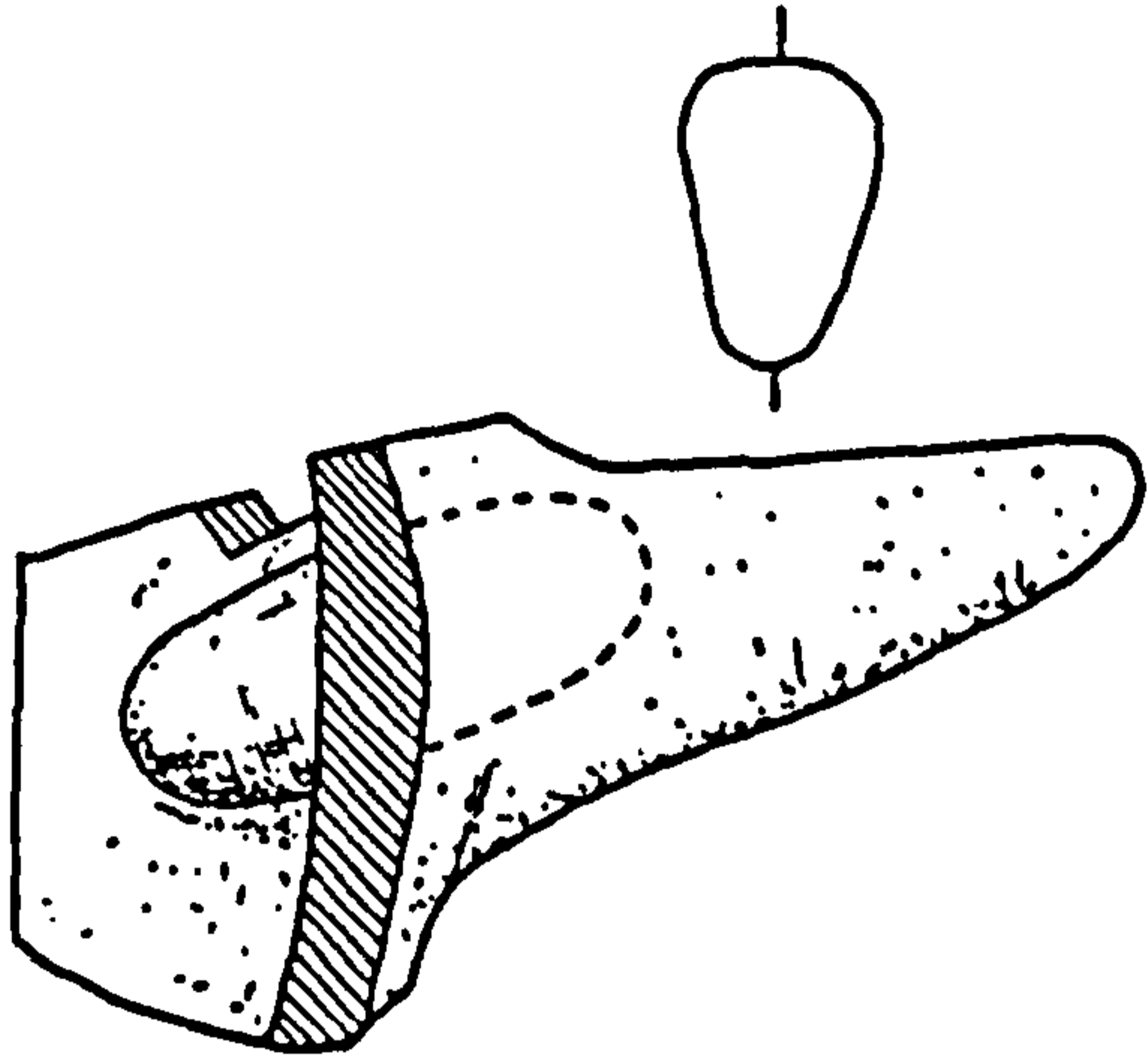

DAB 643

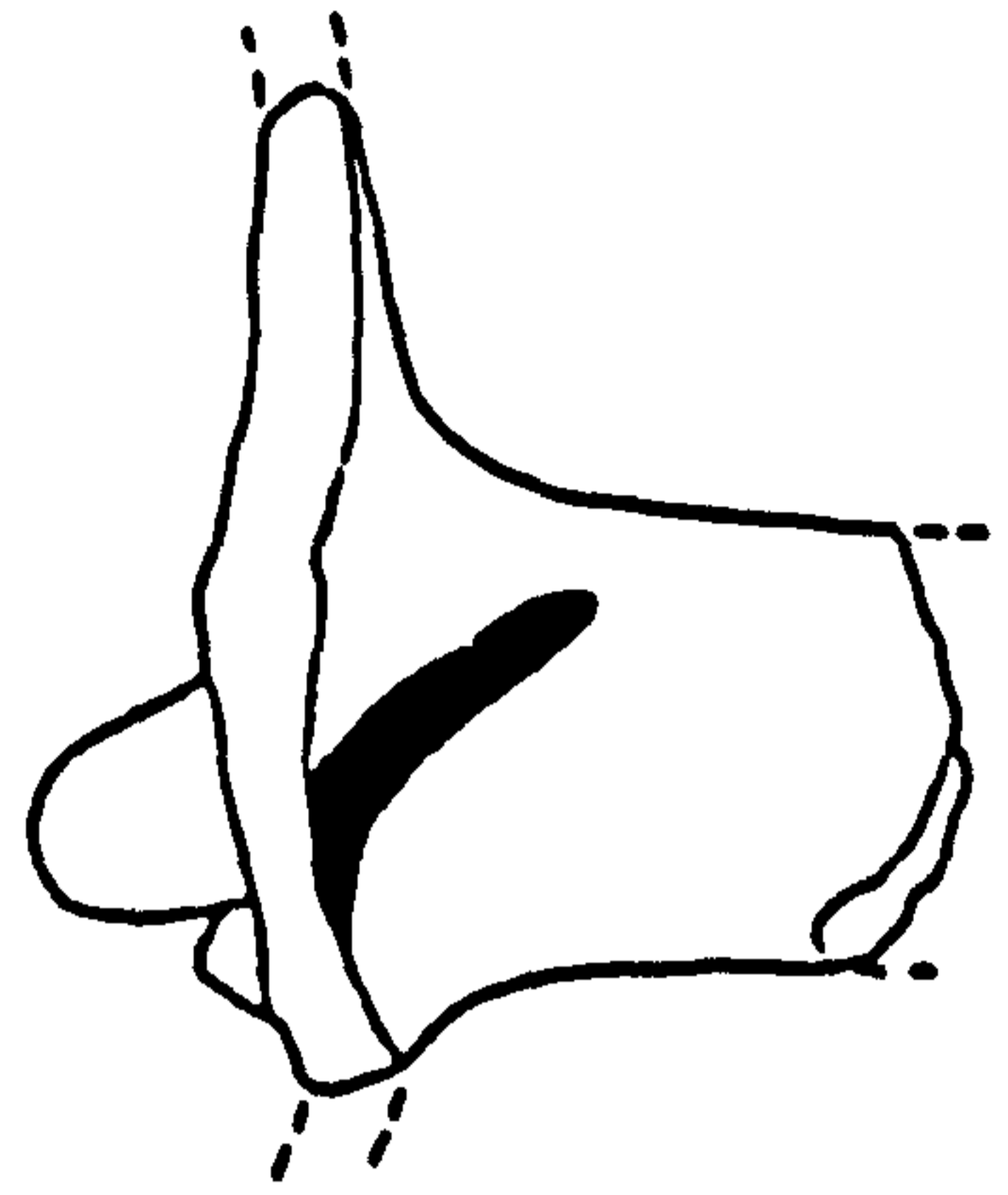
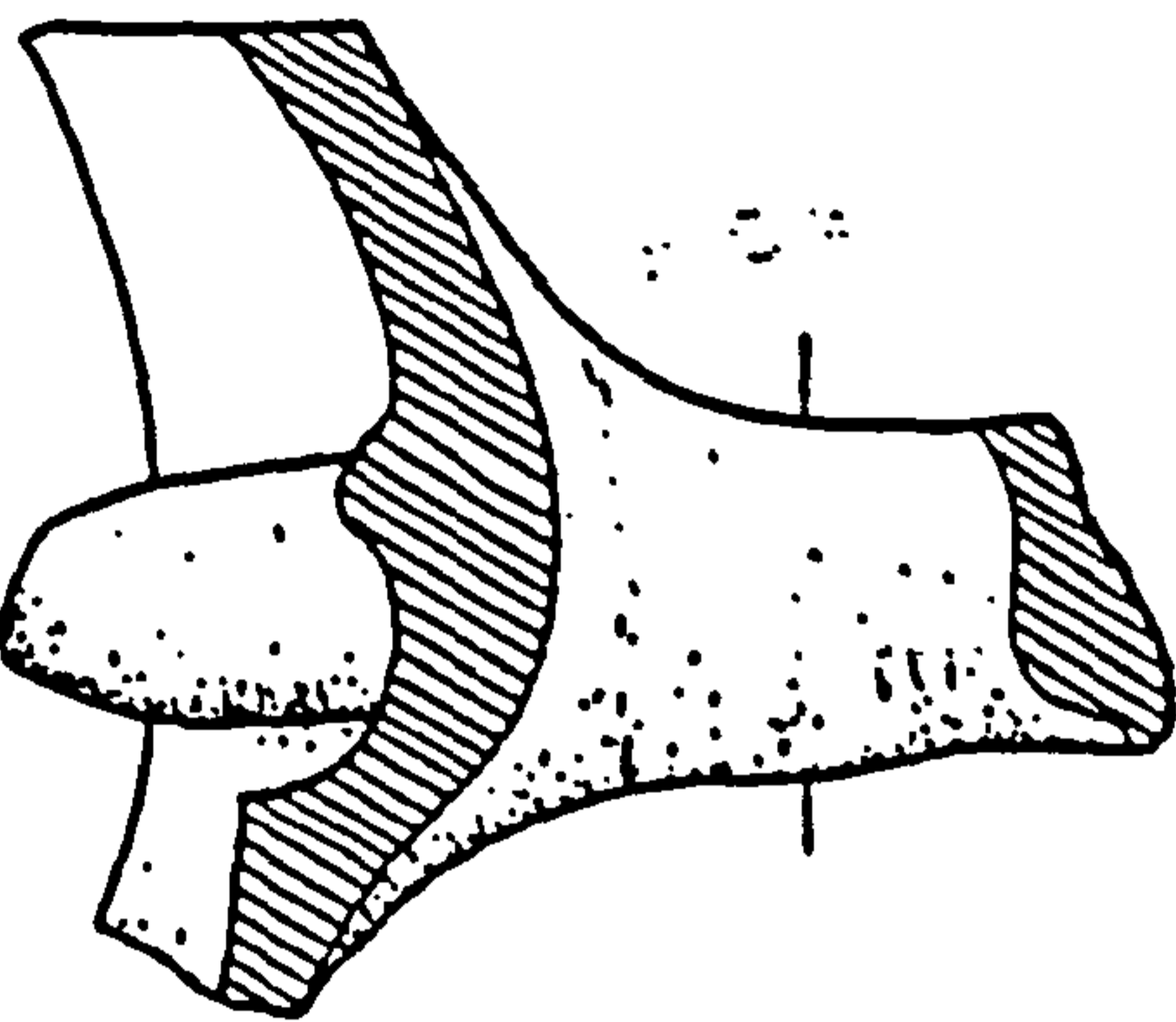

DAB 657

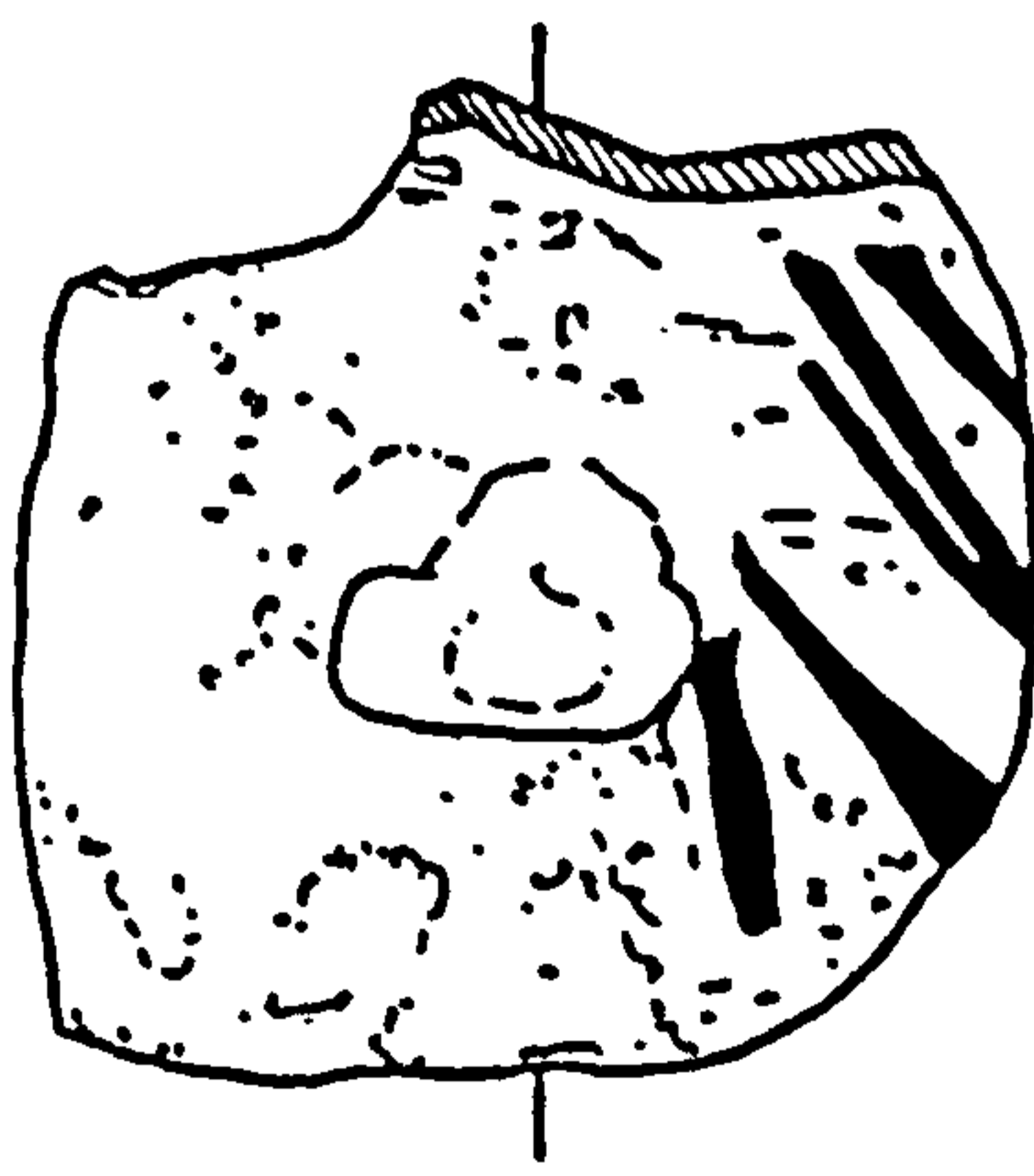
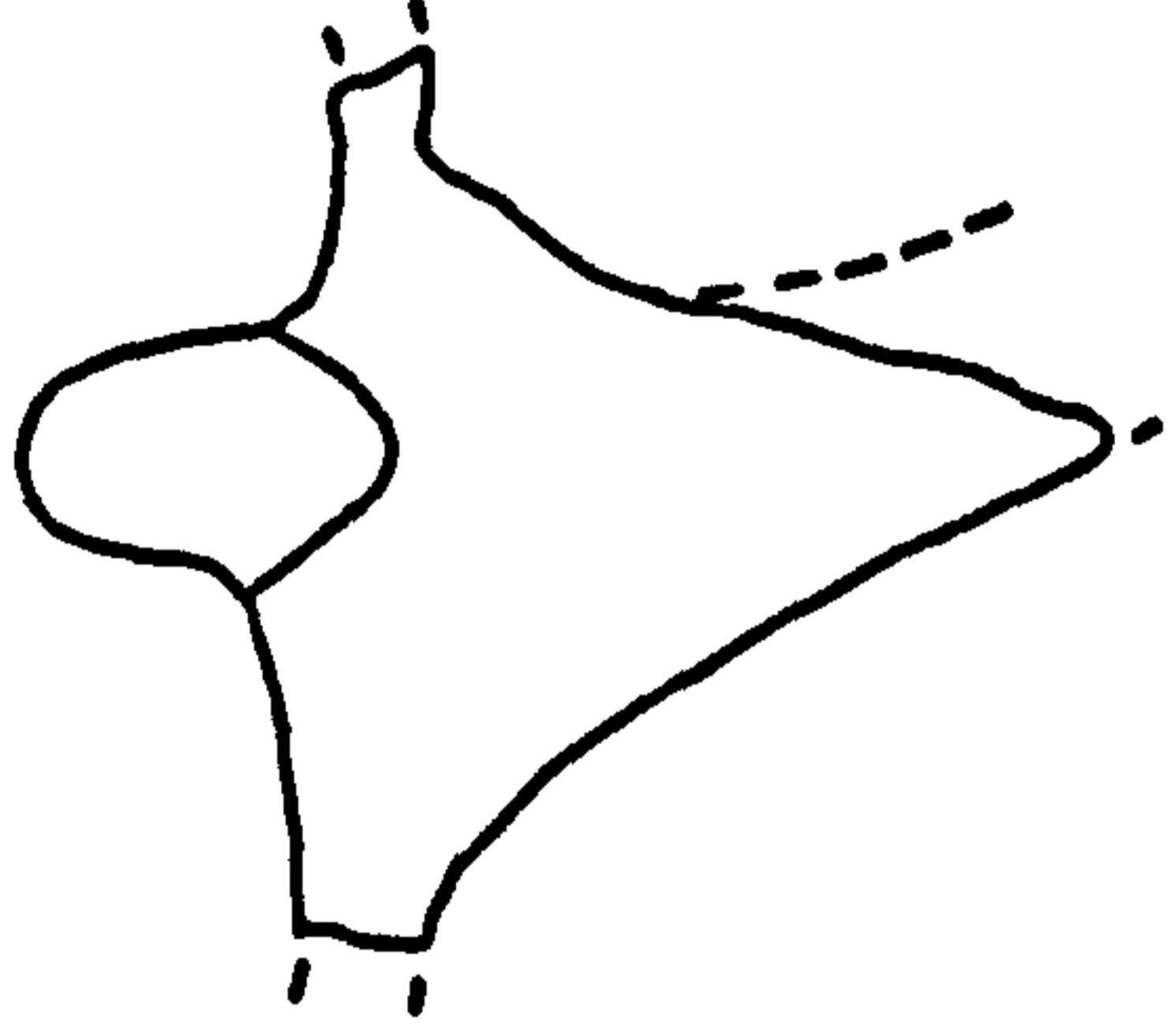

DAB 684



ILL 29

White Painted V/VI

DAB 574

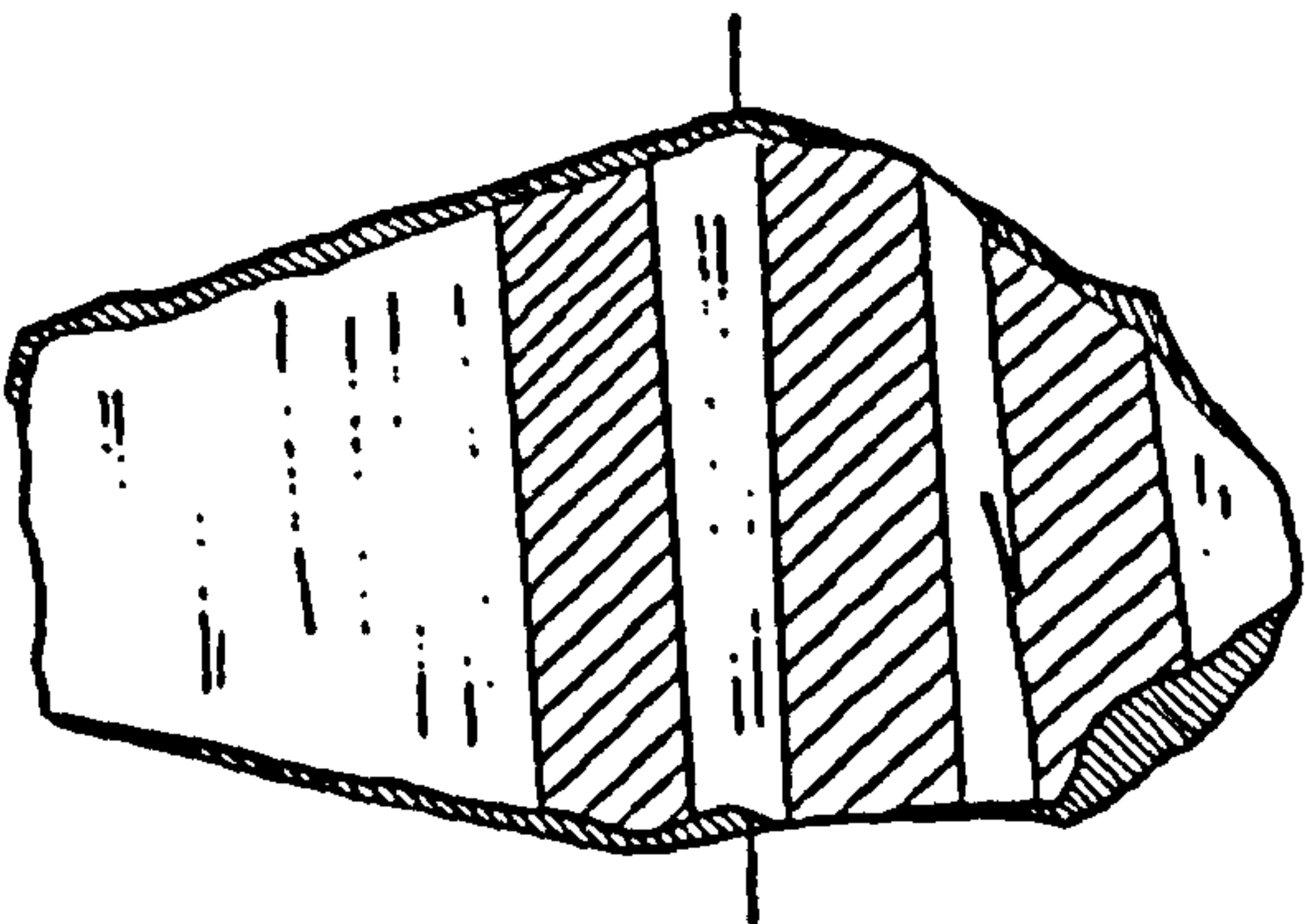
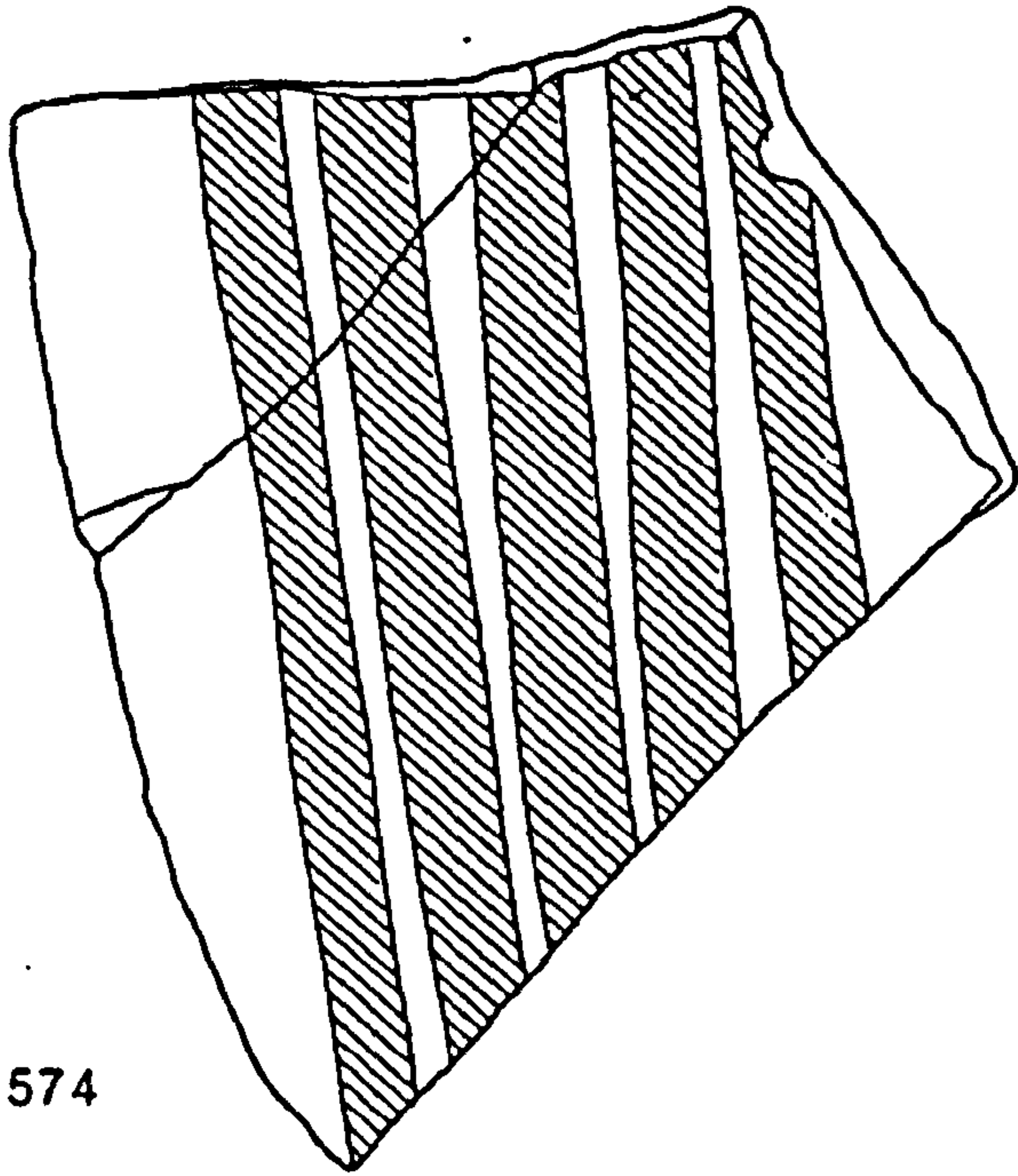

DAB 567

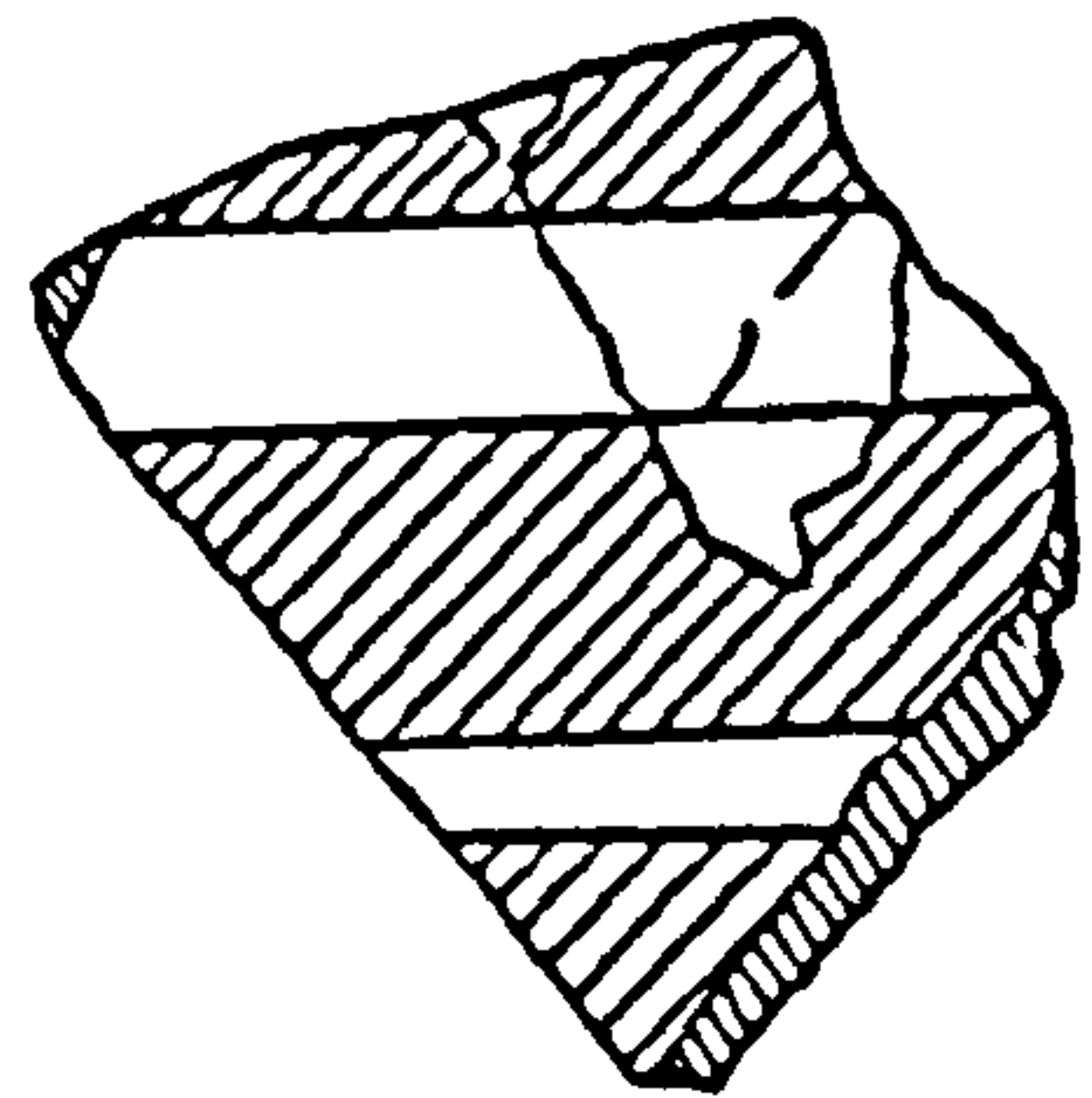

DAB 568



DAB 682

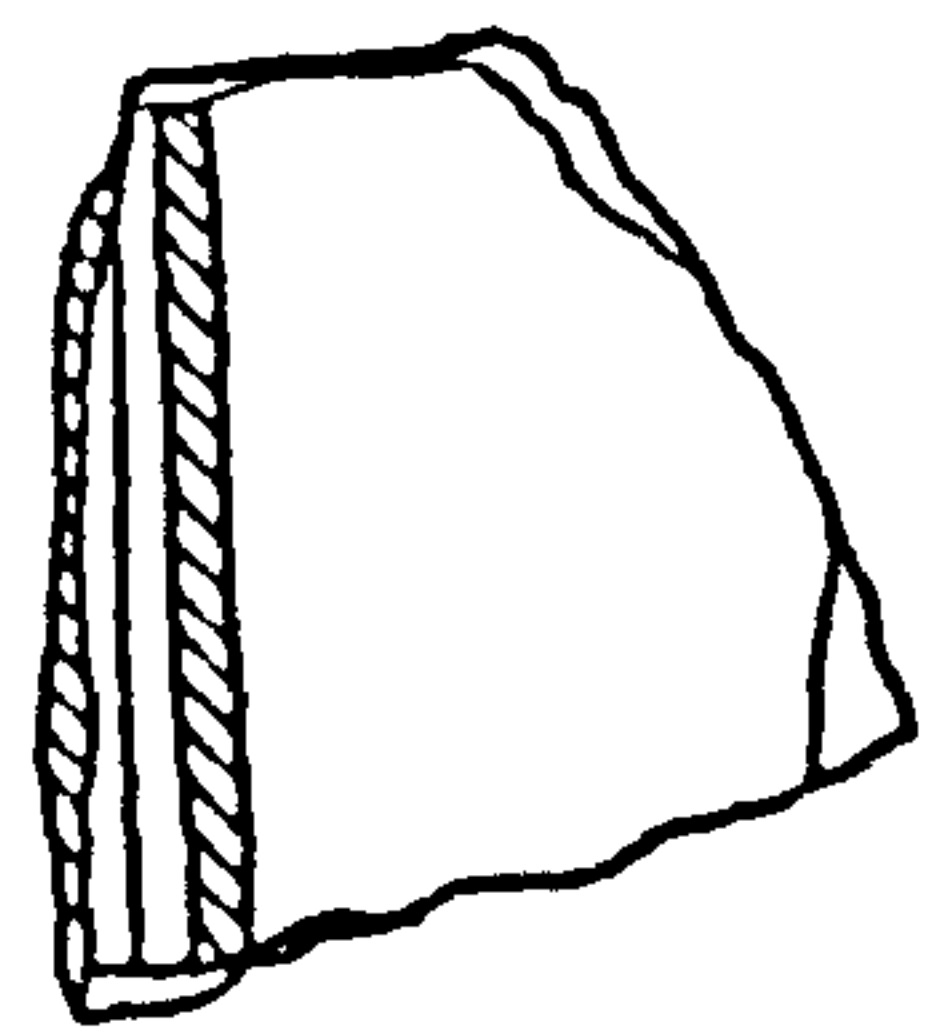
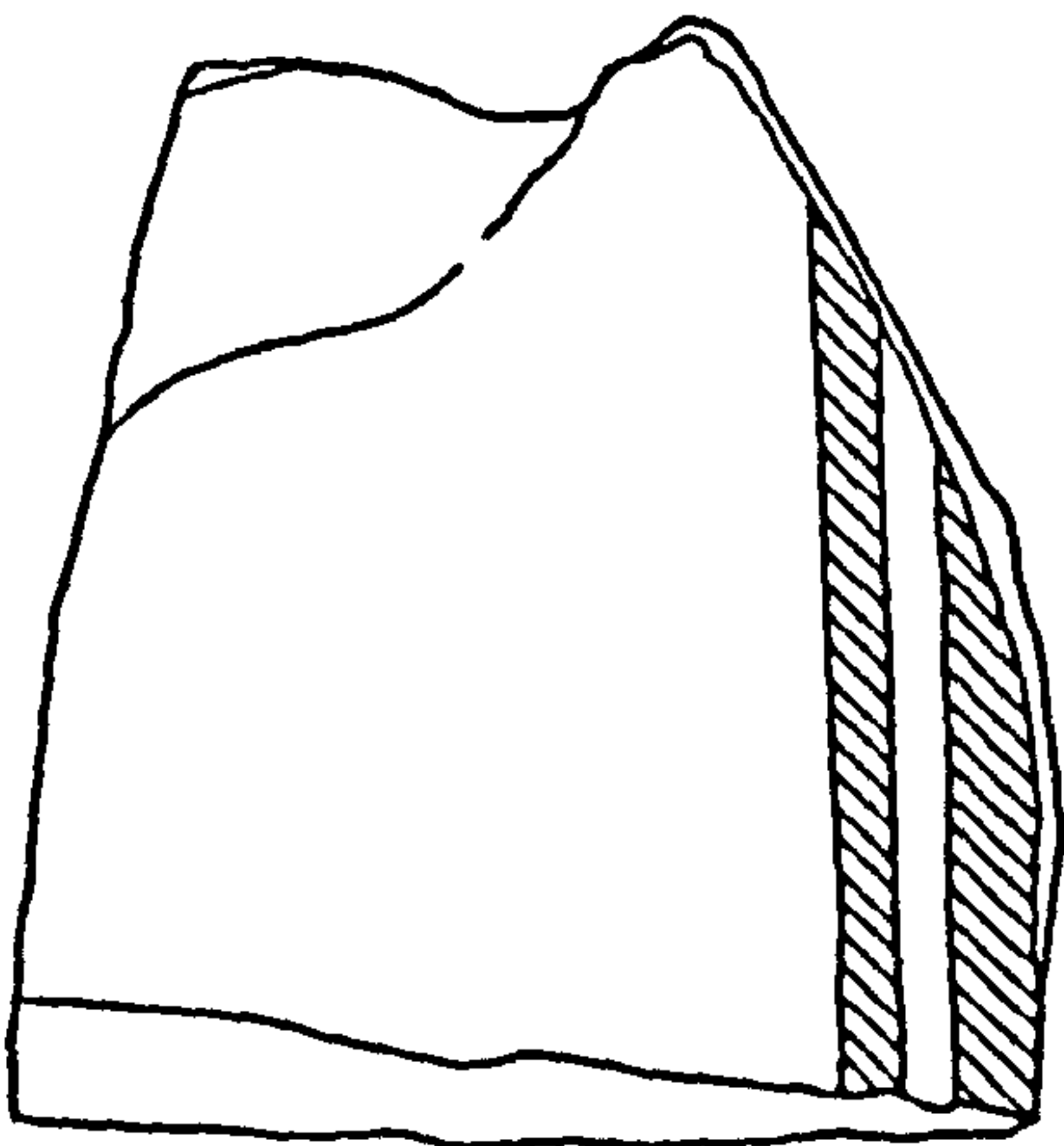

DAB 660



ILL 30

White Painted V

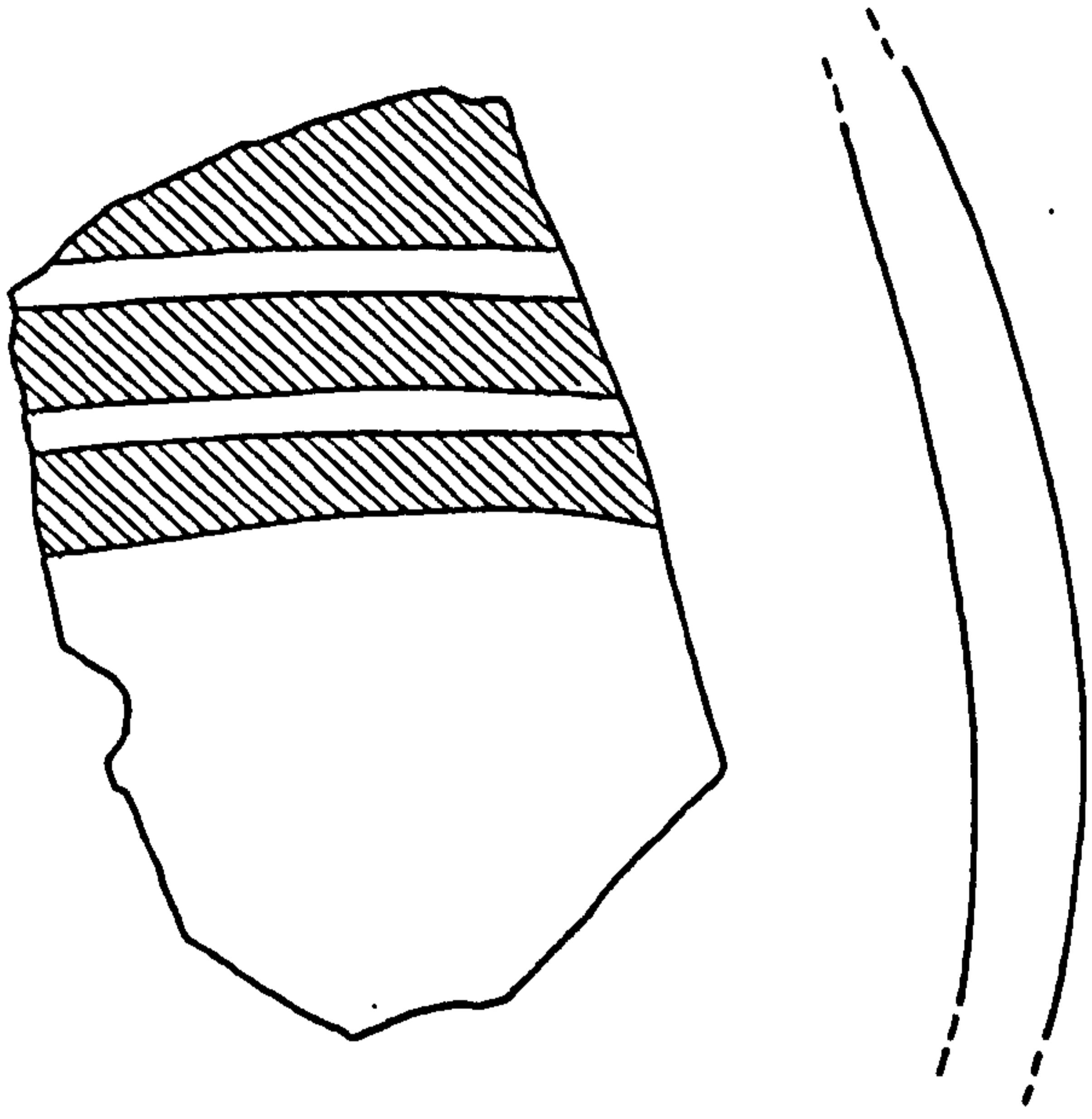

DAB 678

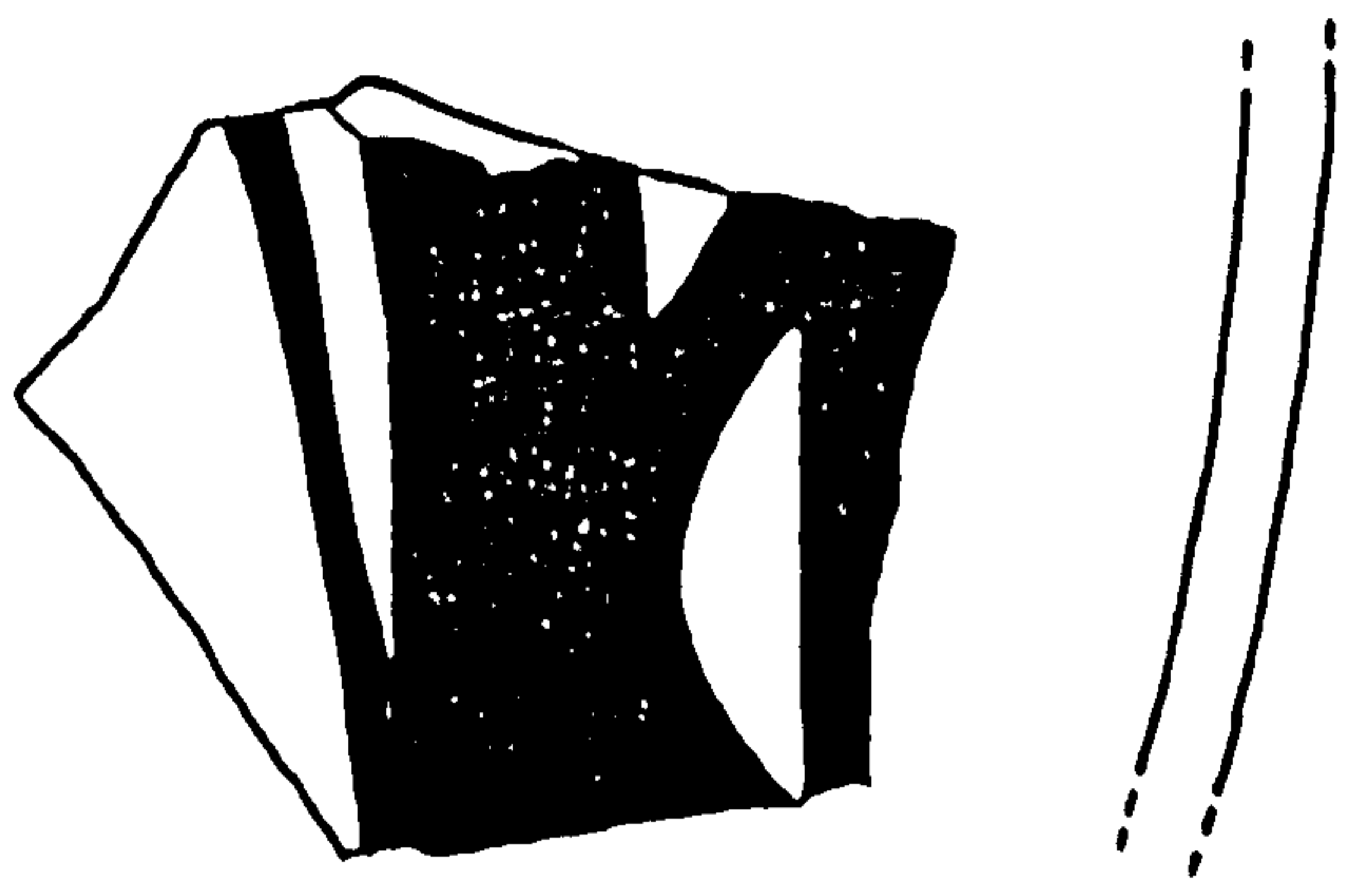

DAB 610

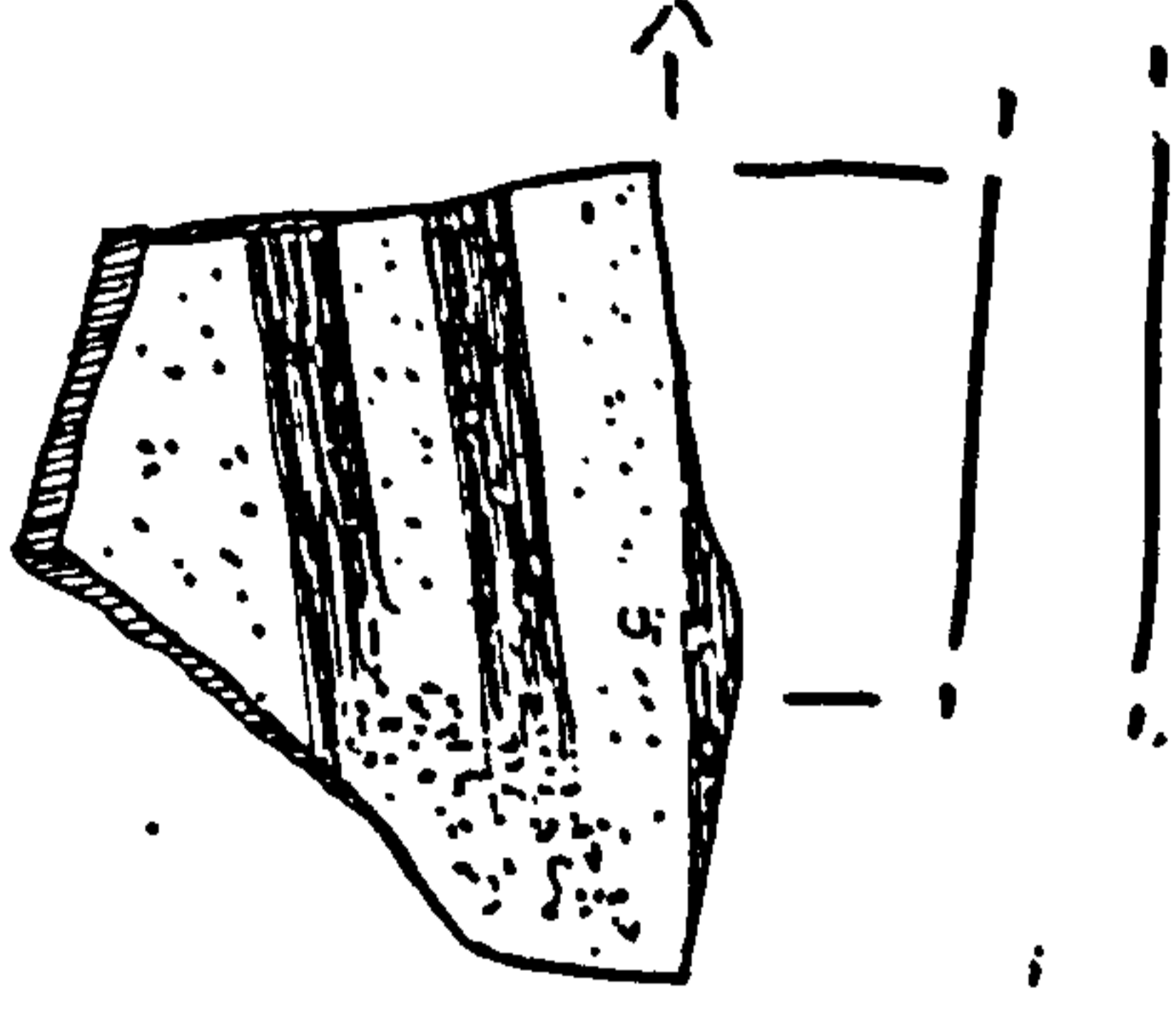

DAB 570

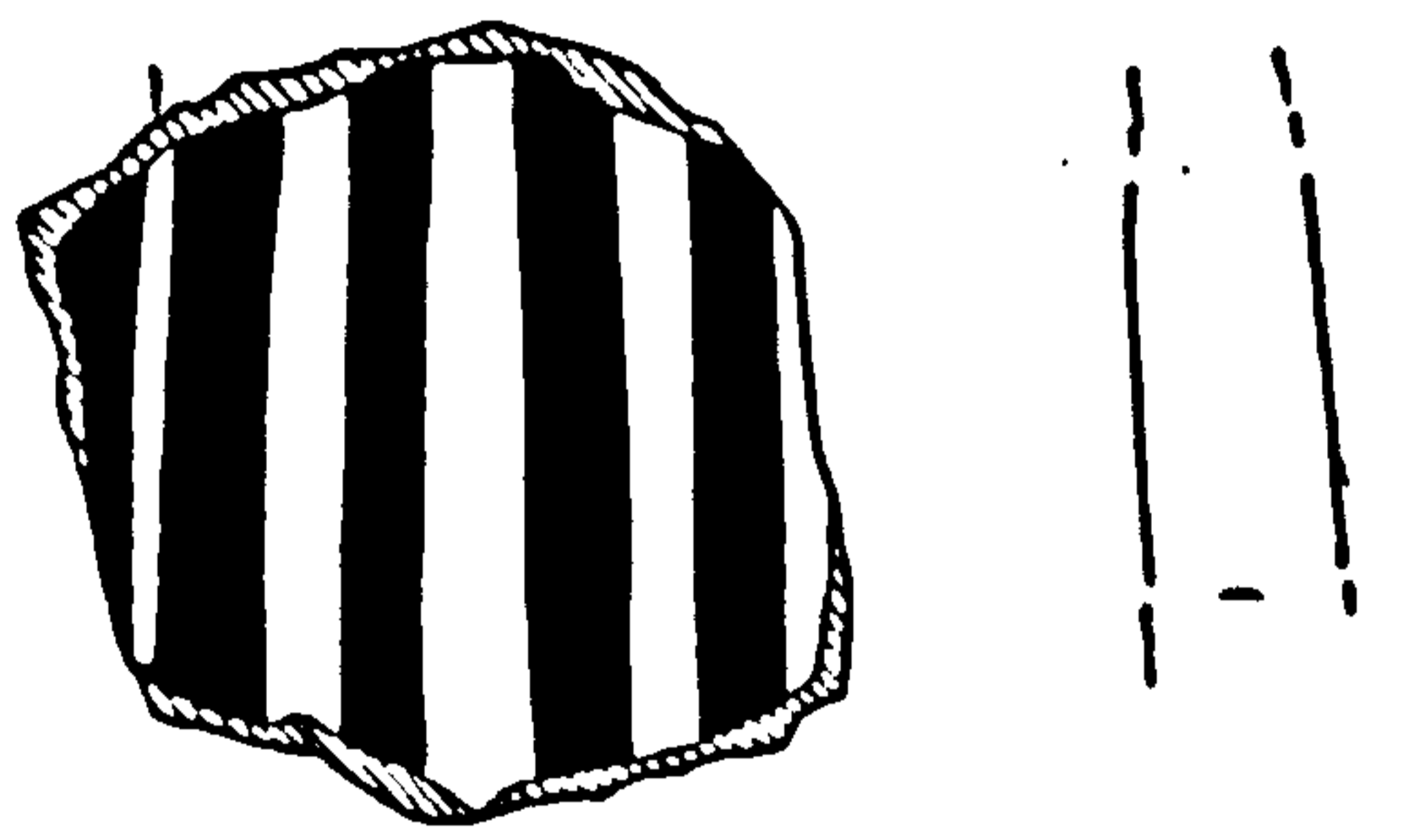

DAB 569

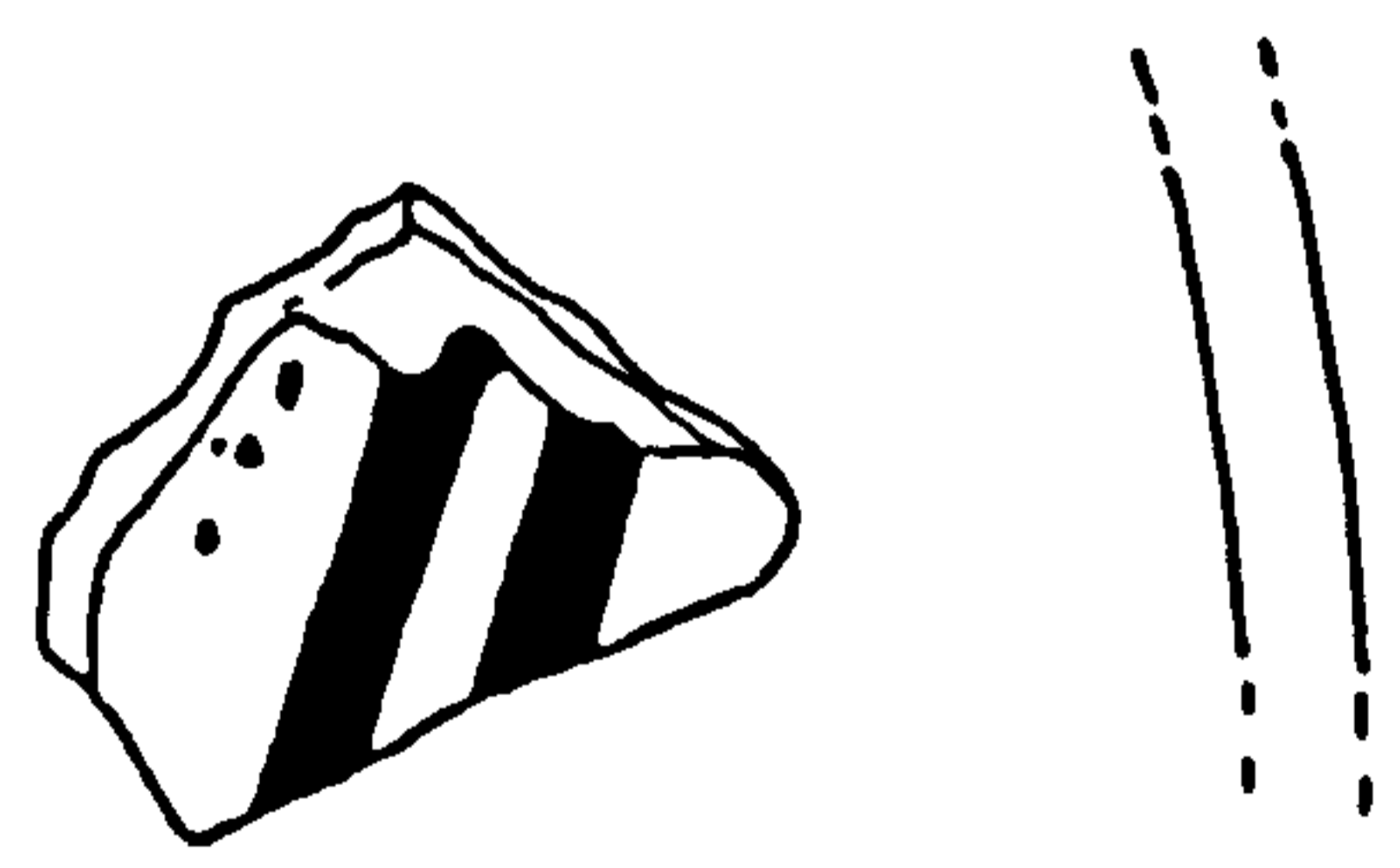

DAB 644

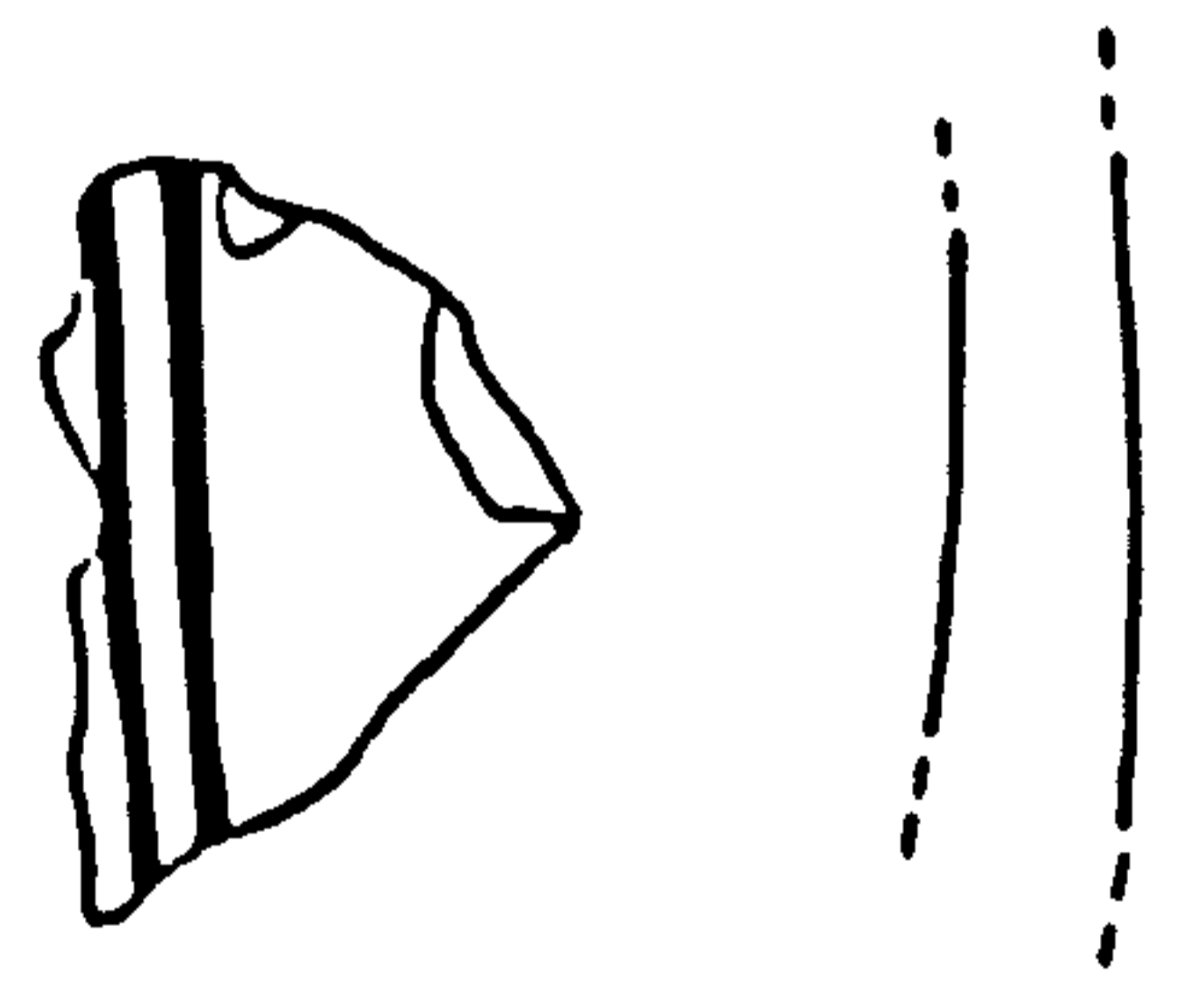

DAB 661

ILL 31

White Painted V

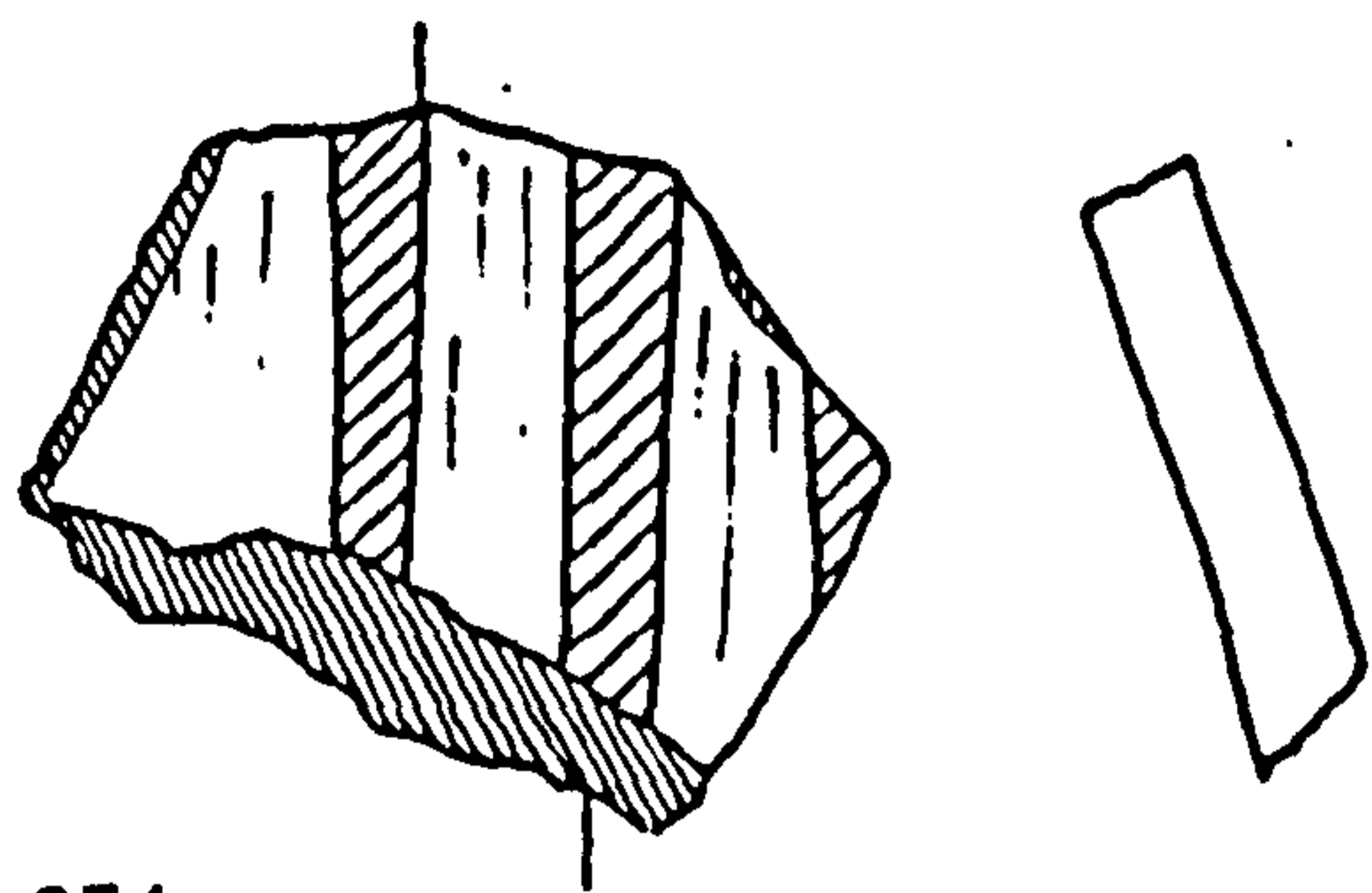

DAB 674

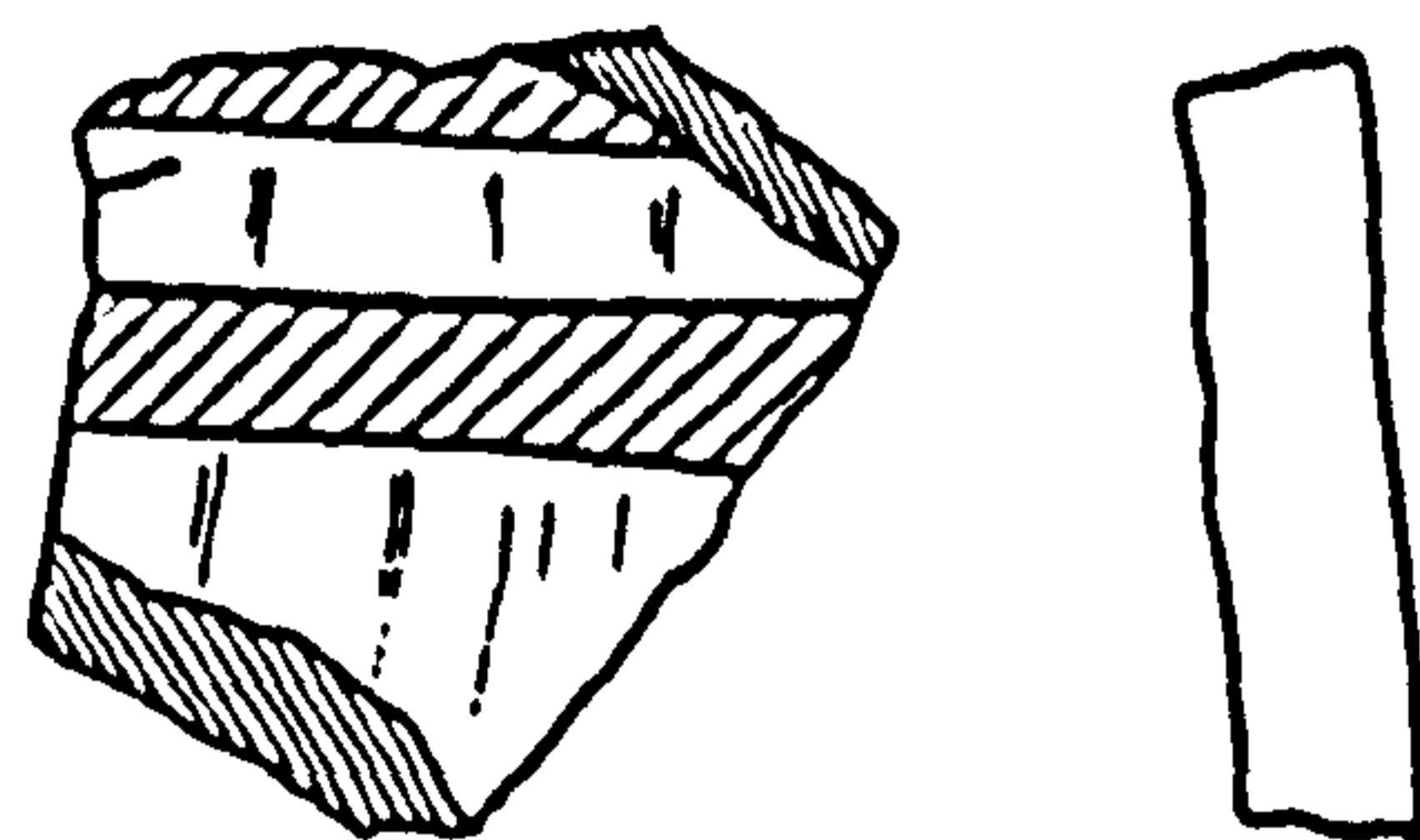

DAB 645

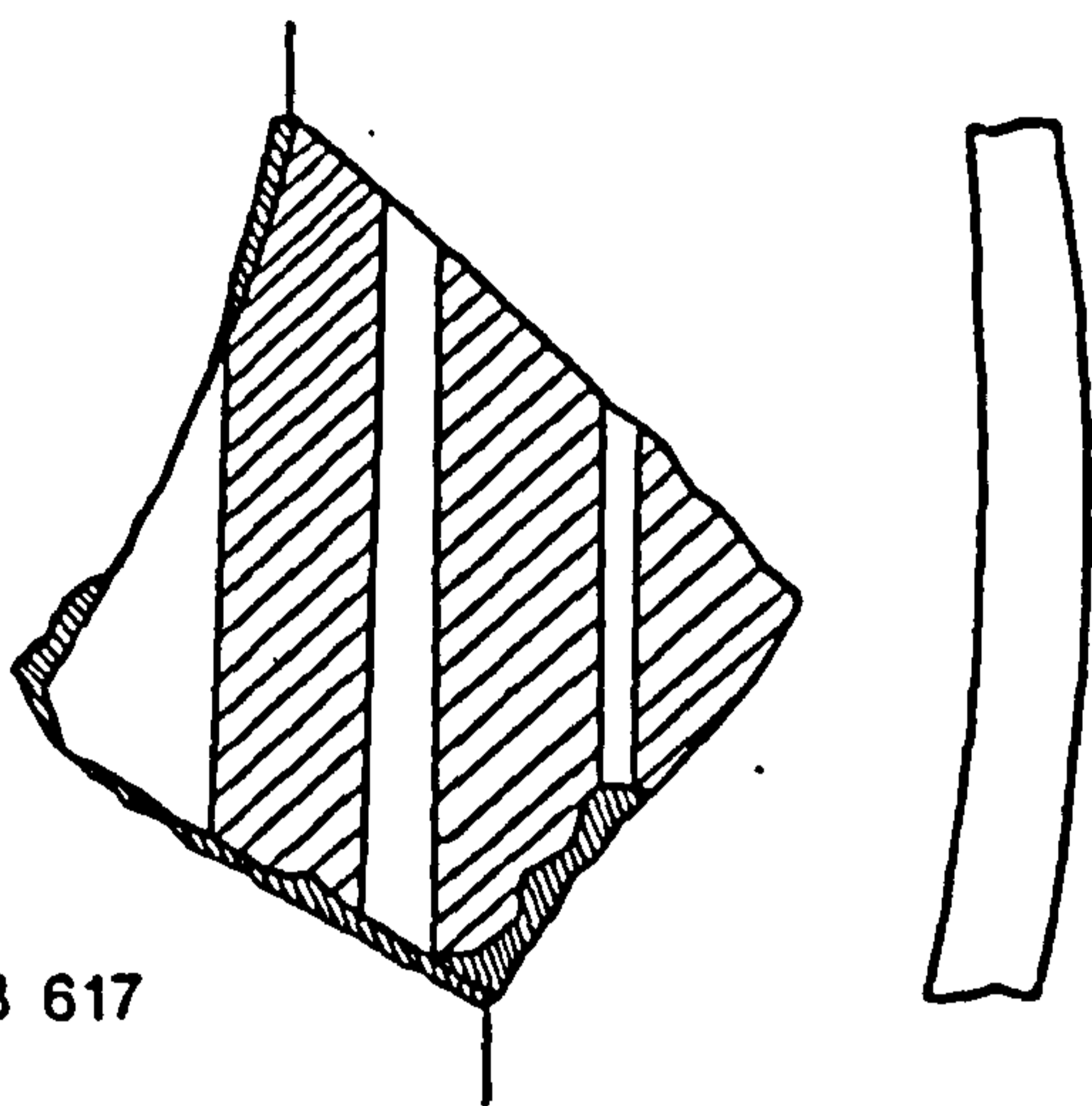

DAB 617

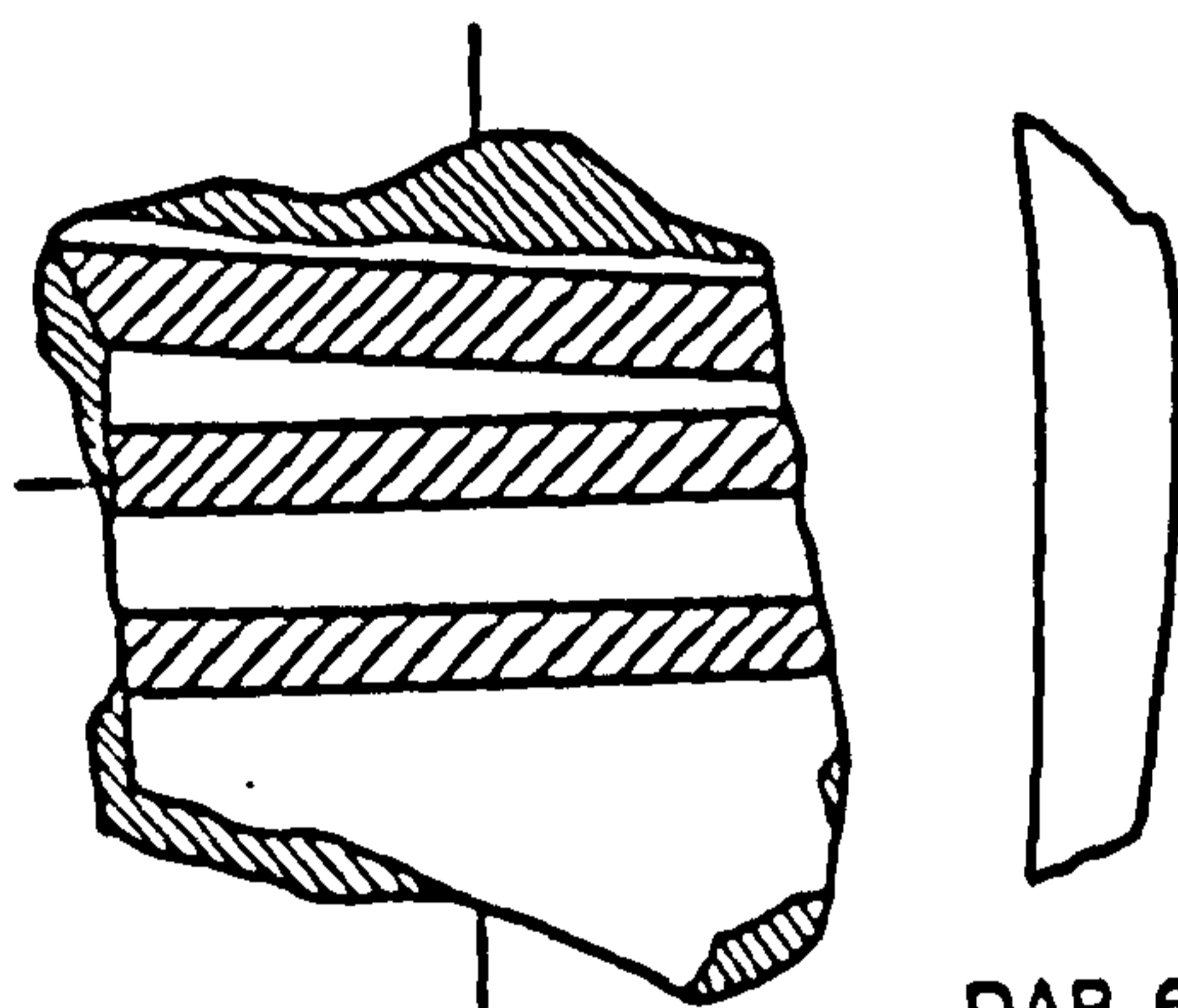

DAB 652

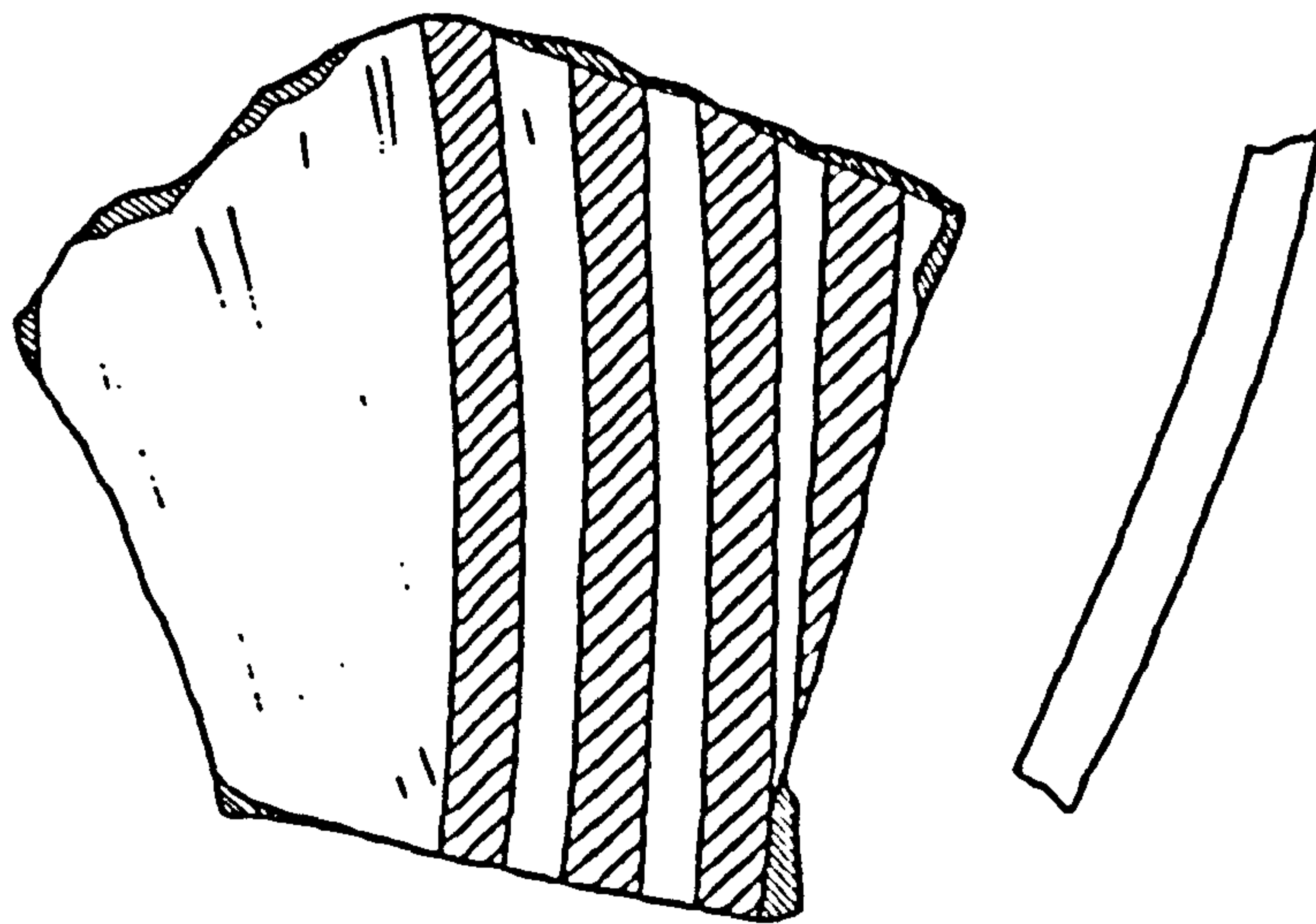

DAB 600

ILL 32

White Painted V

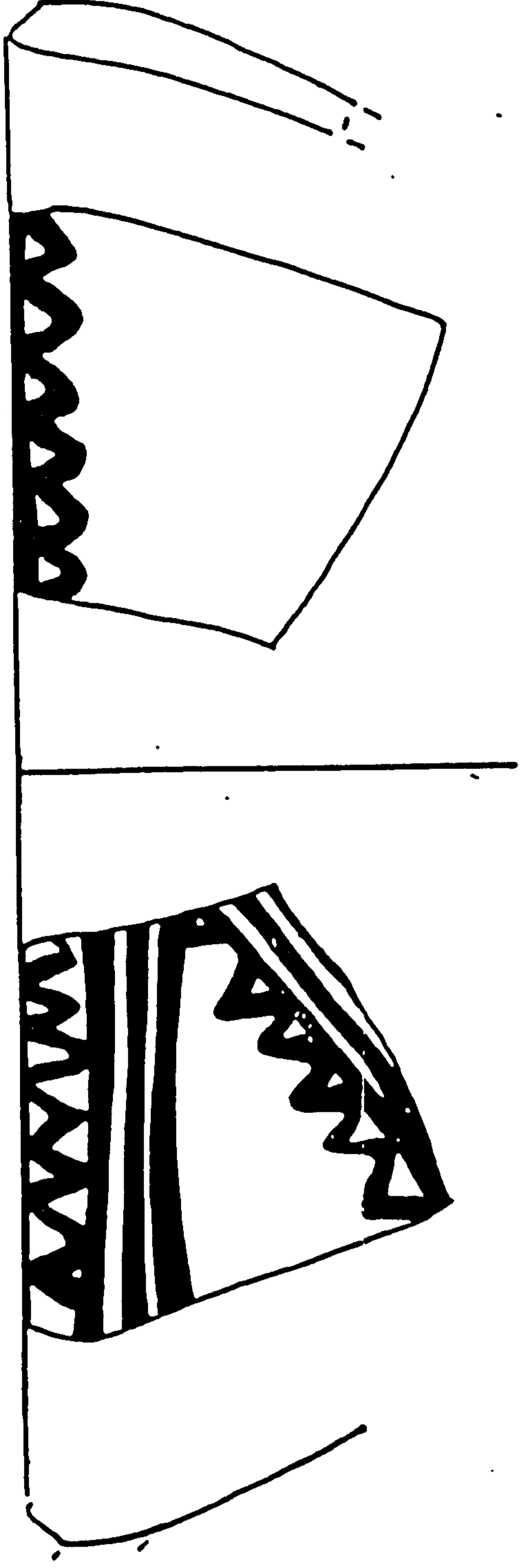

AJJ 29

White Painted V

ILL 33

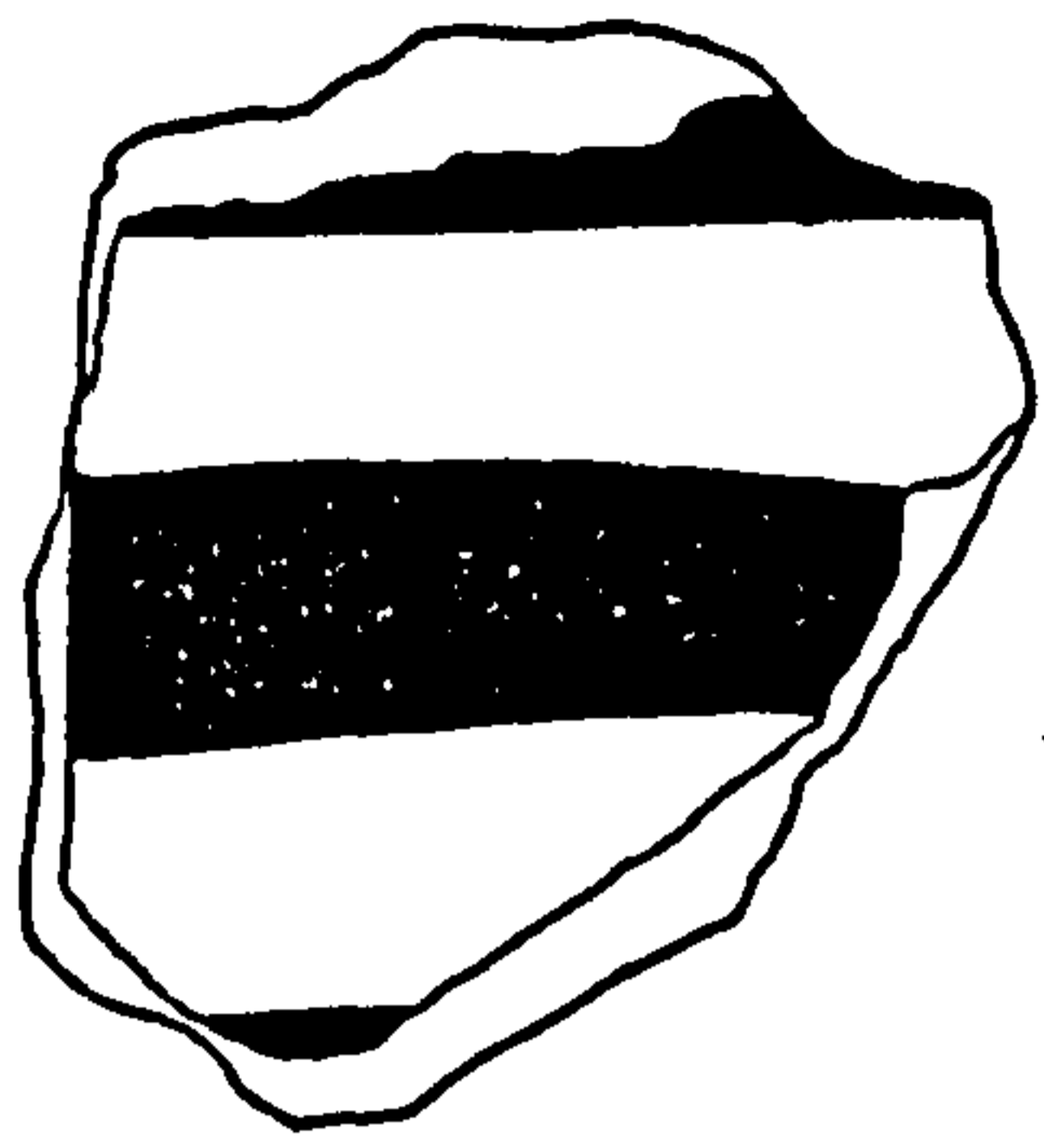

DAB 655

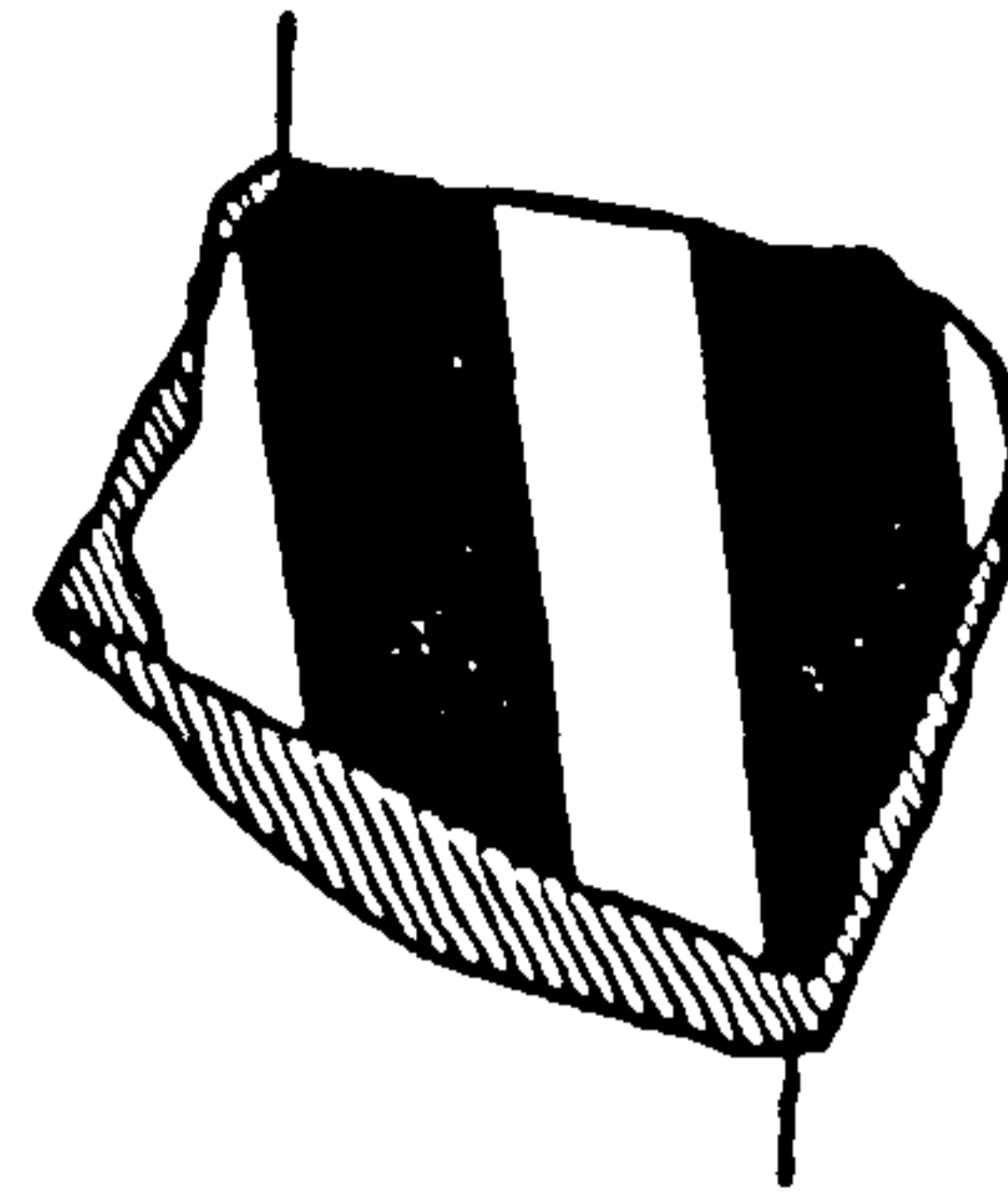
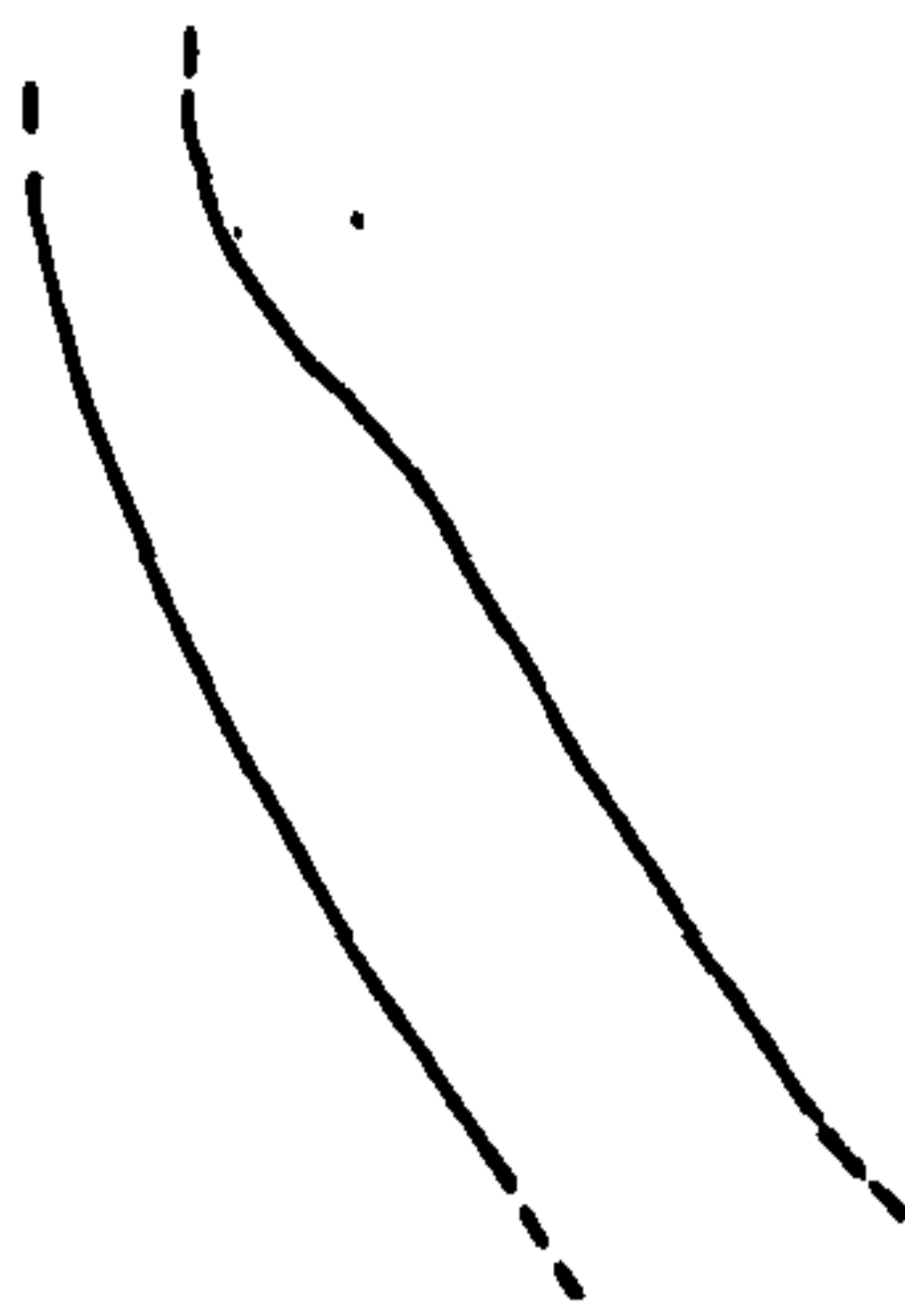

DAB 611

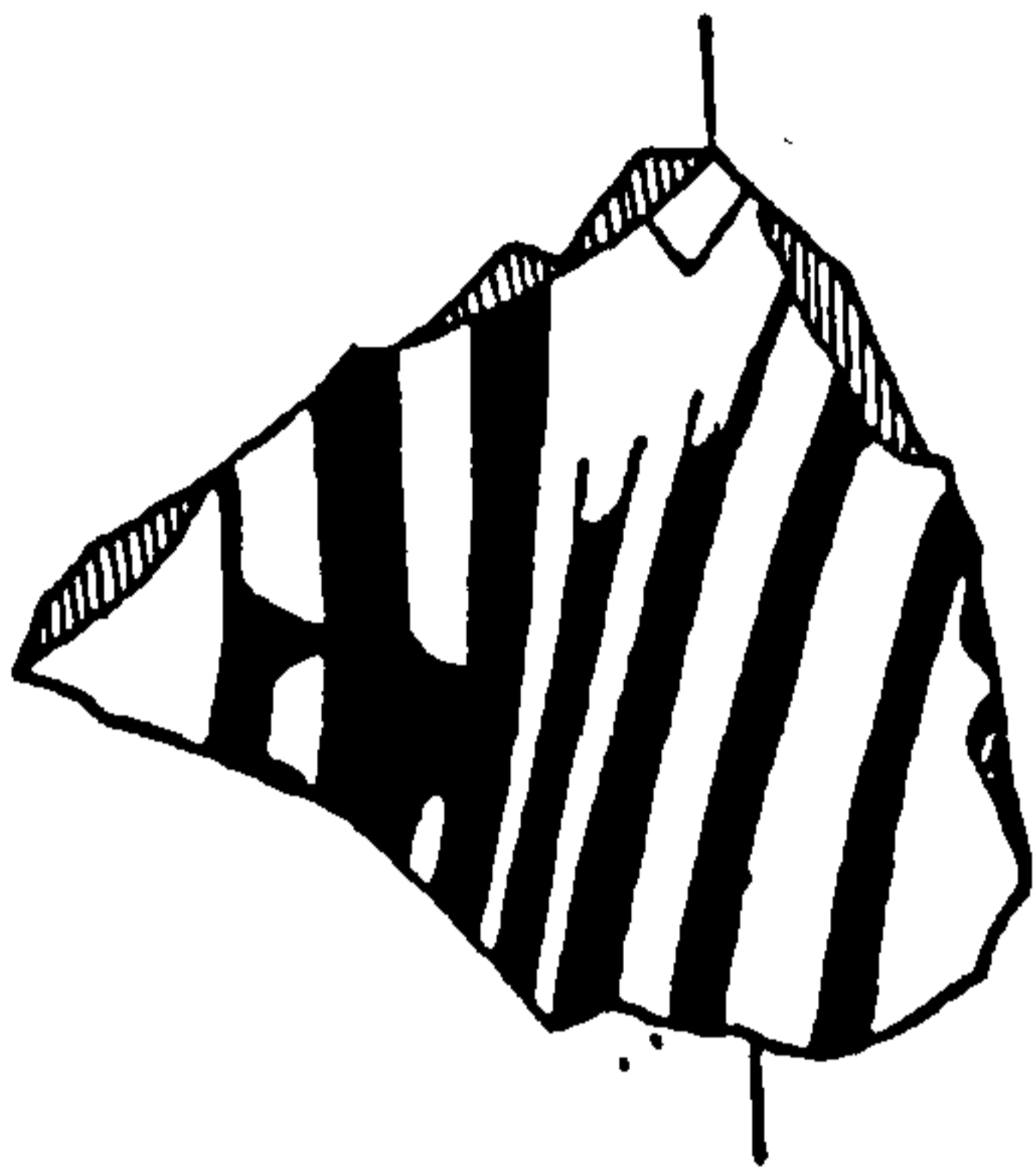

DAB 677

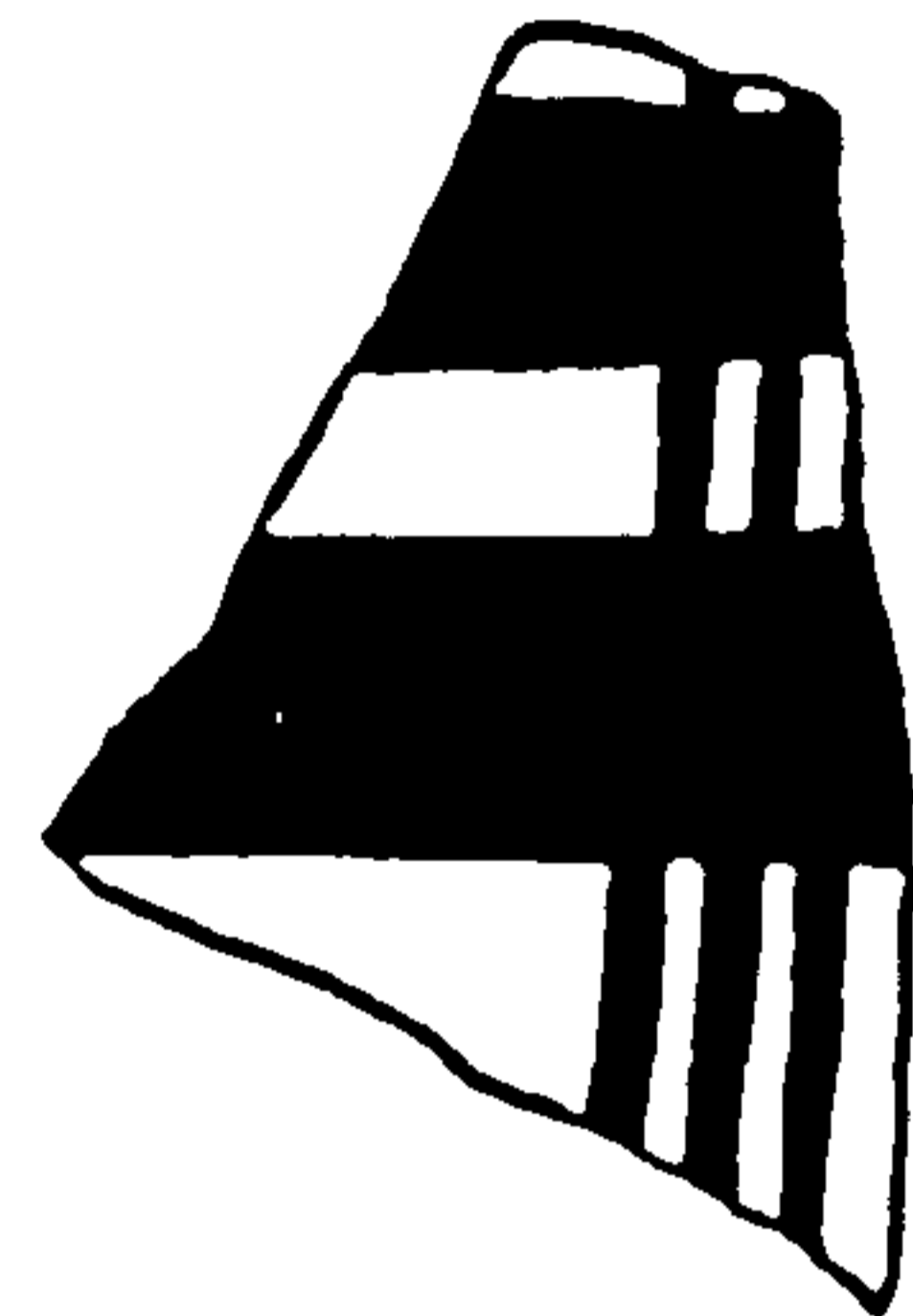
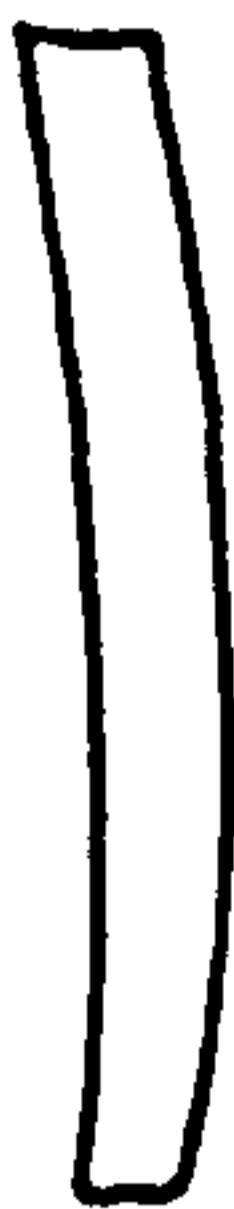

DAB 546

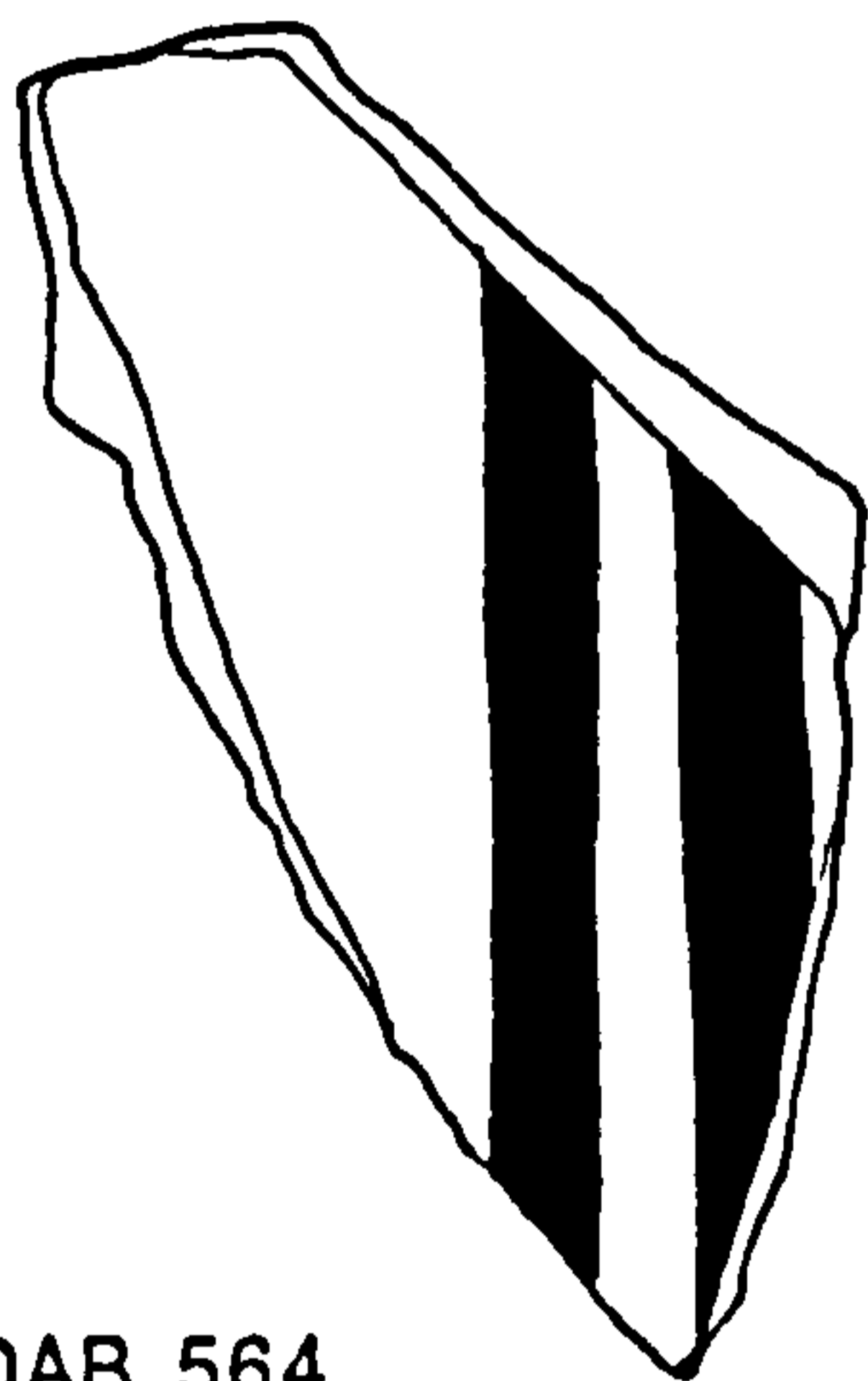

DAB 564

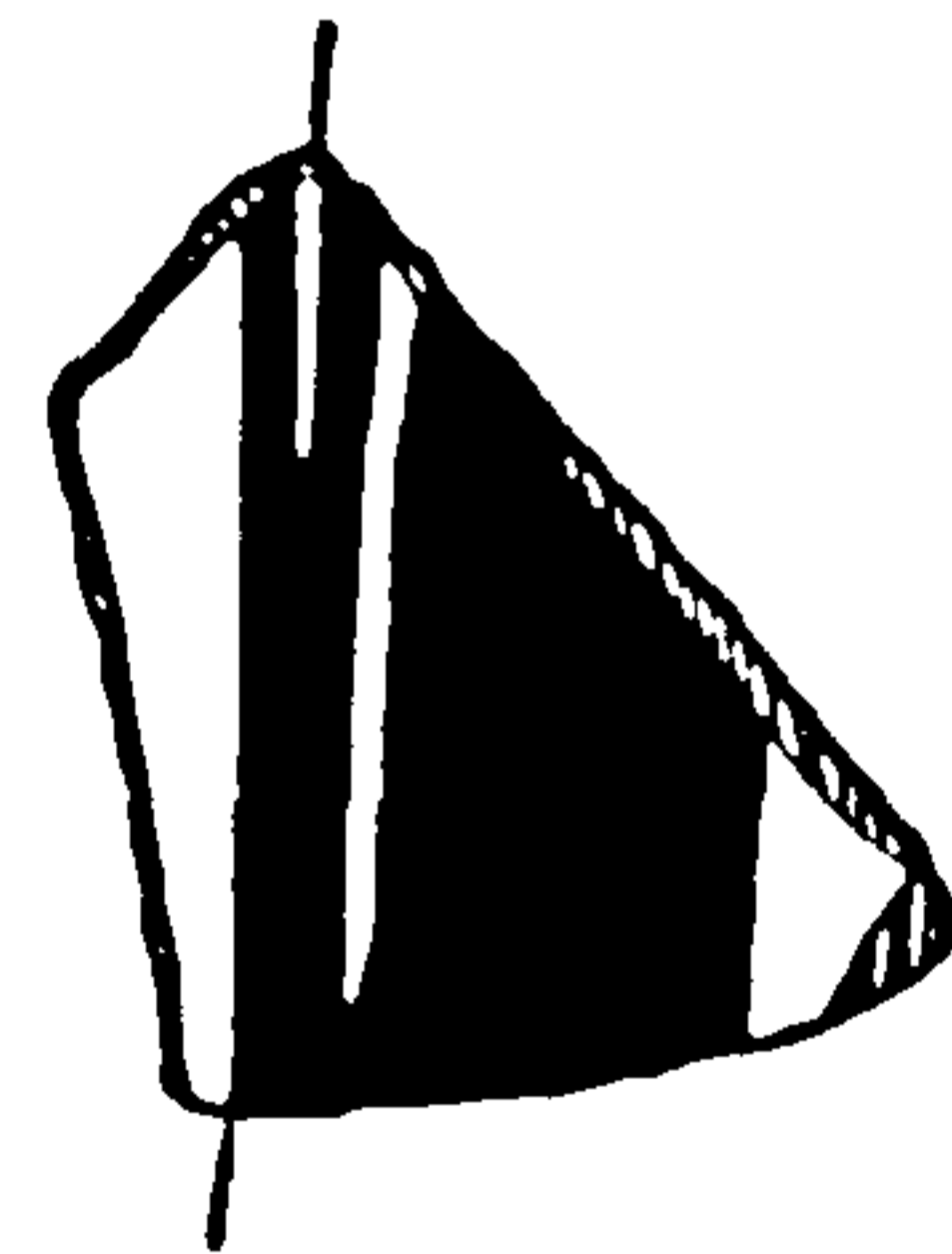
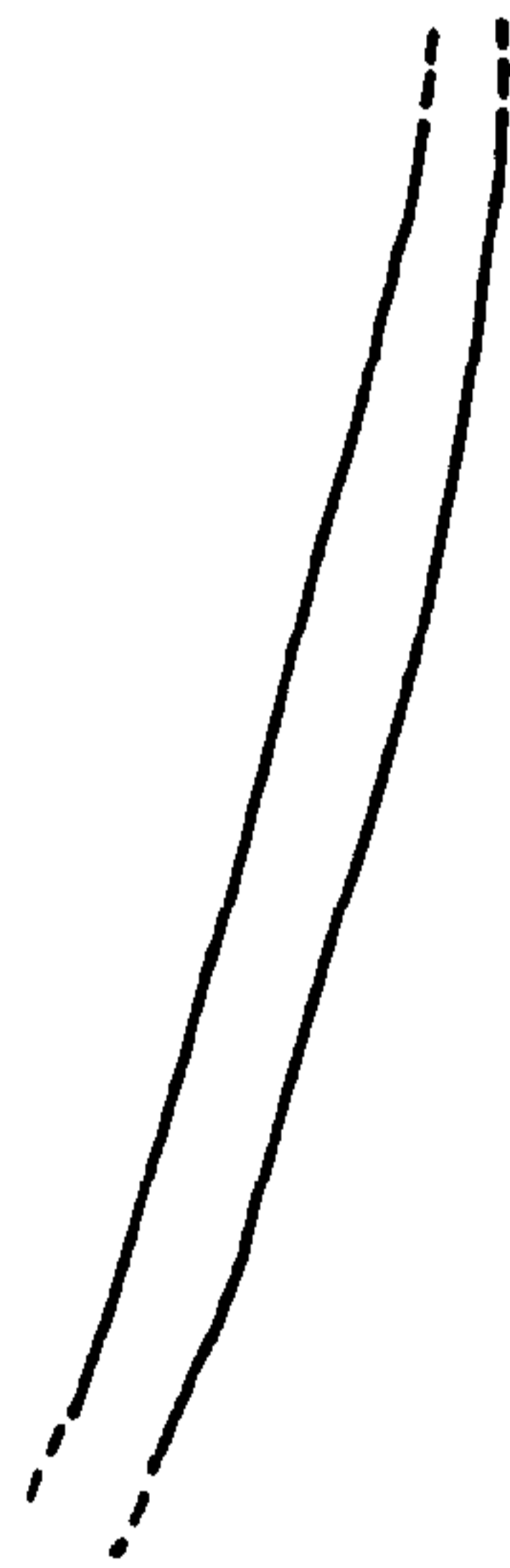

DAB 544

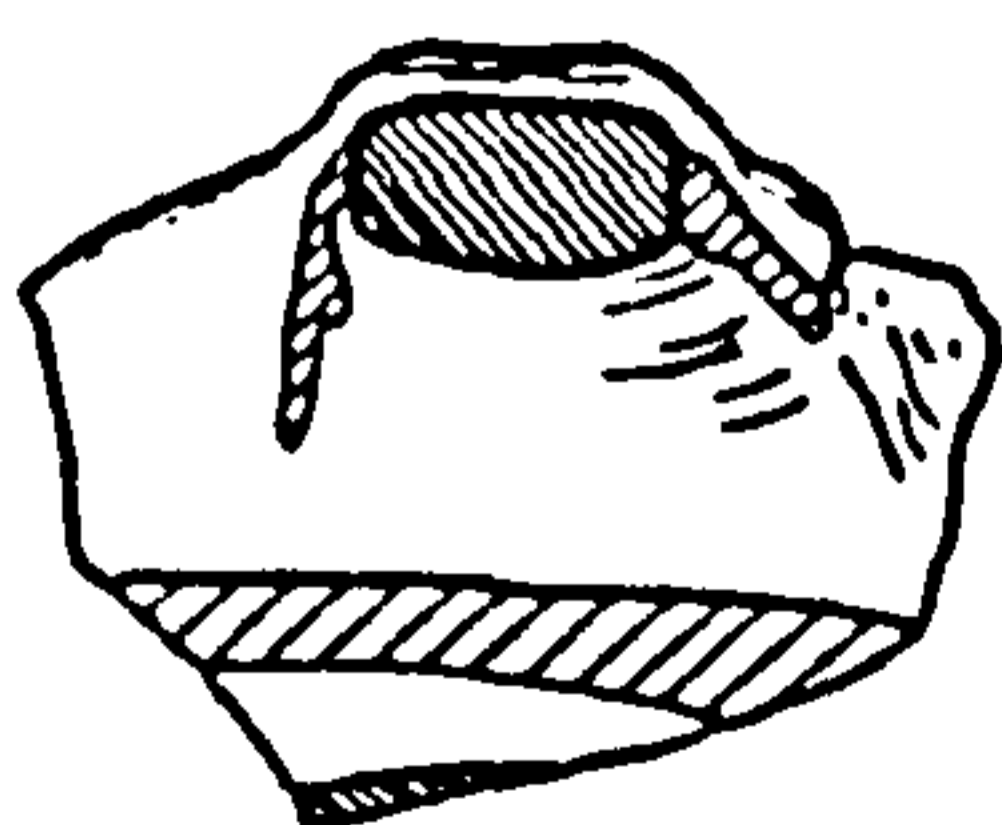

DAB 646

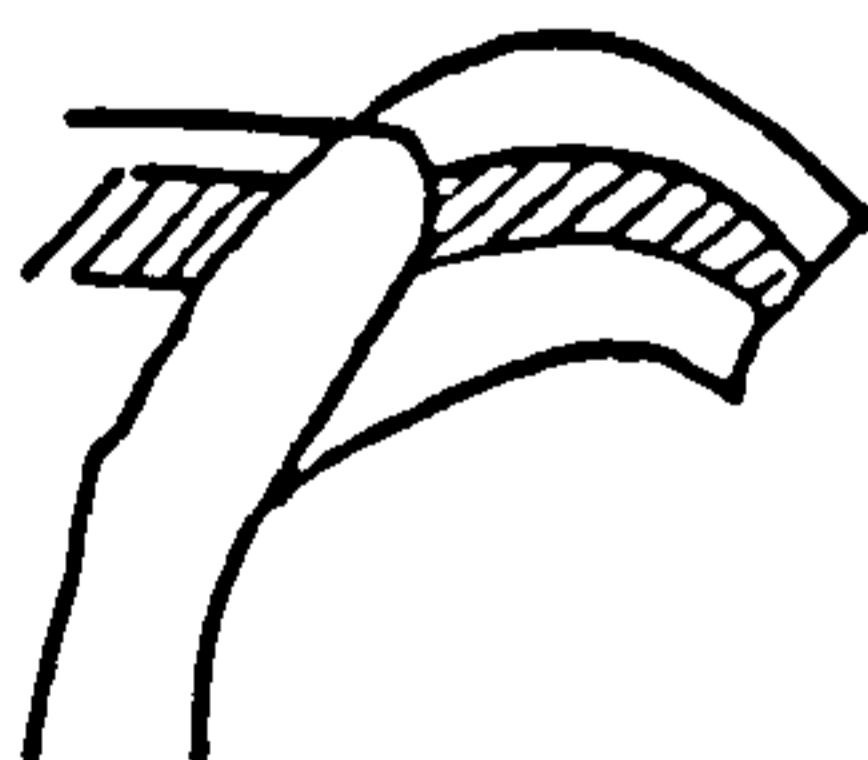

ILL 34

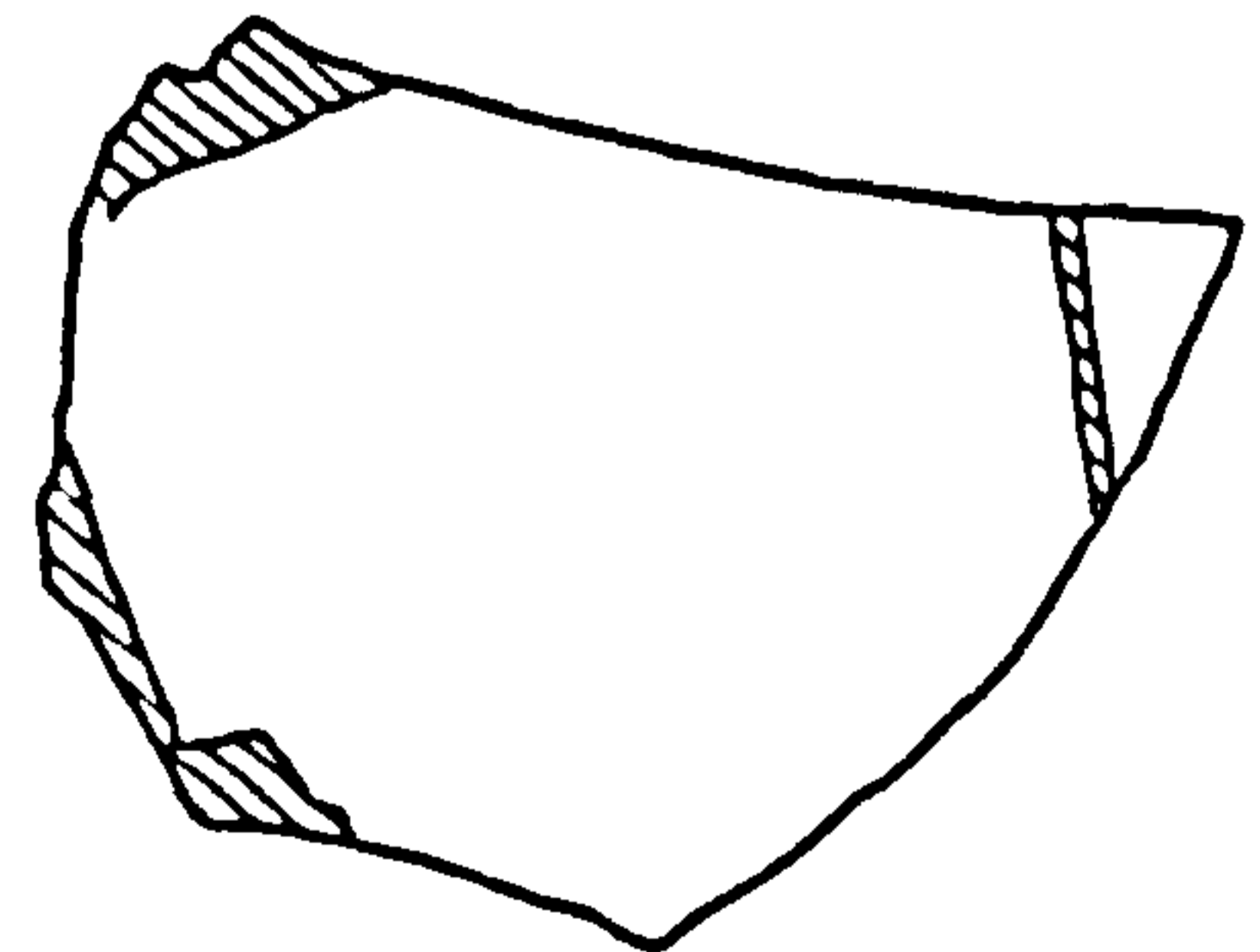

DAB 618

White Painted Various

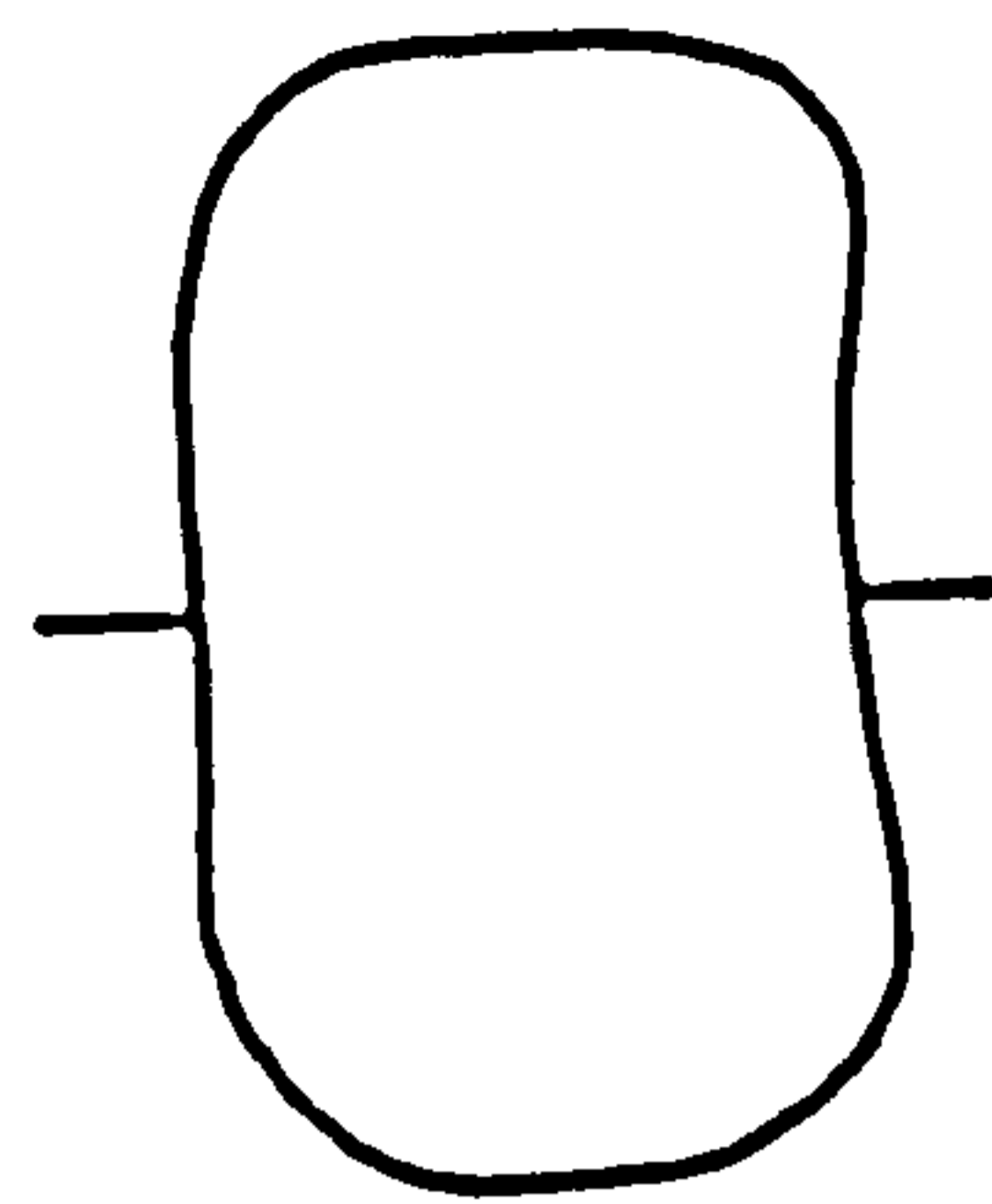
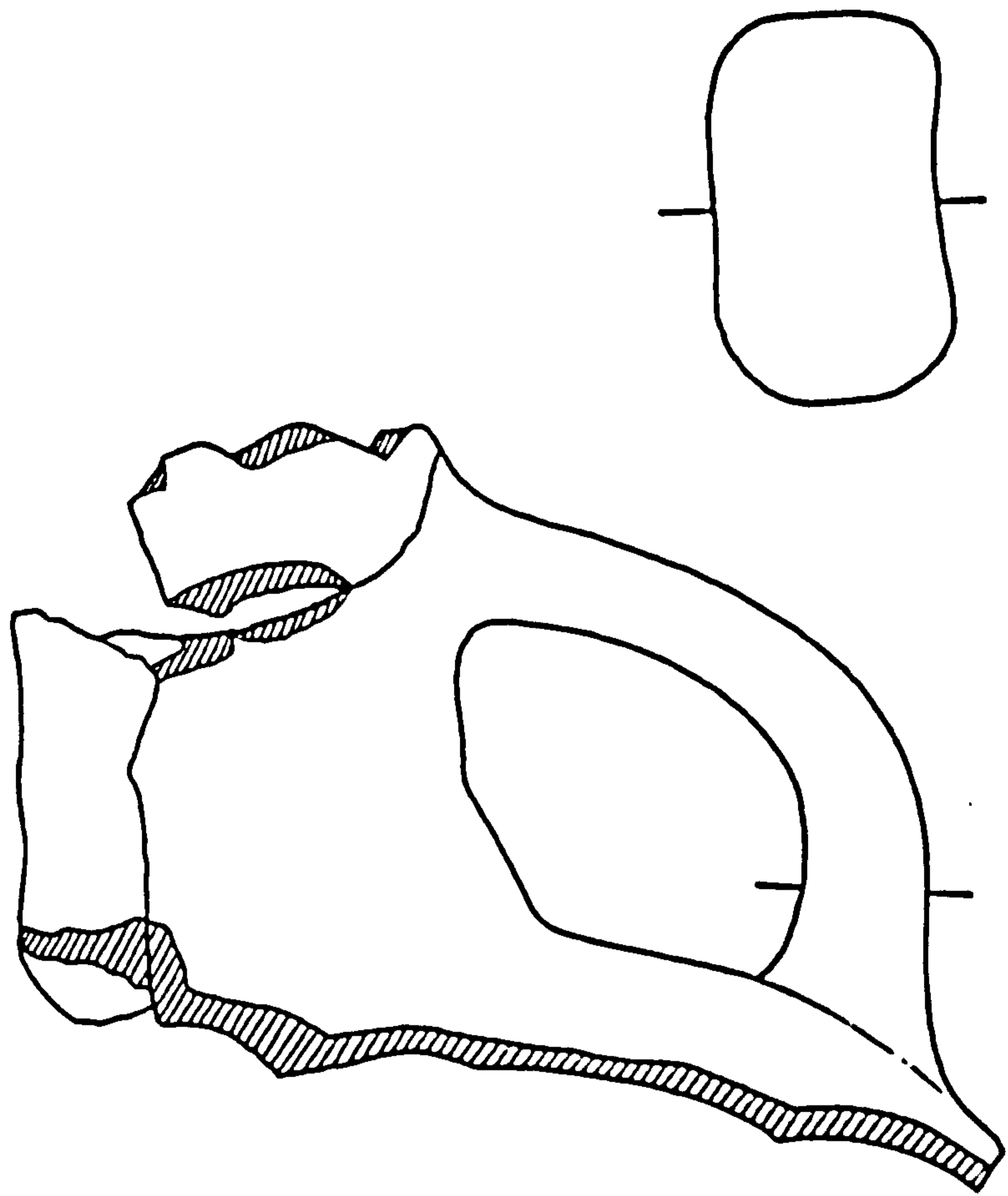

DAB 694
1:2

ILL 35

Red Slip

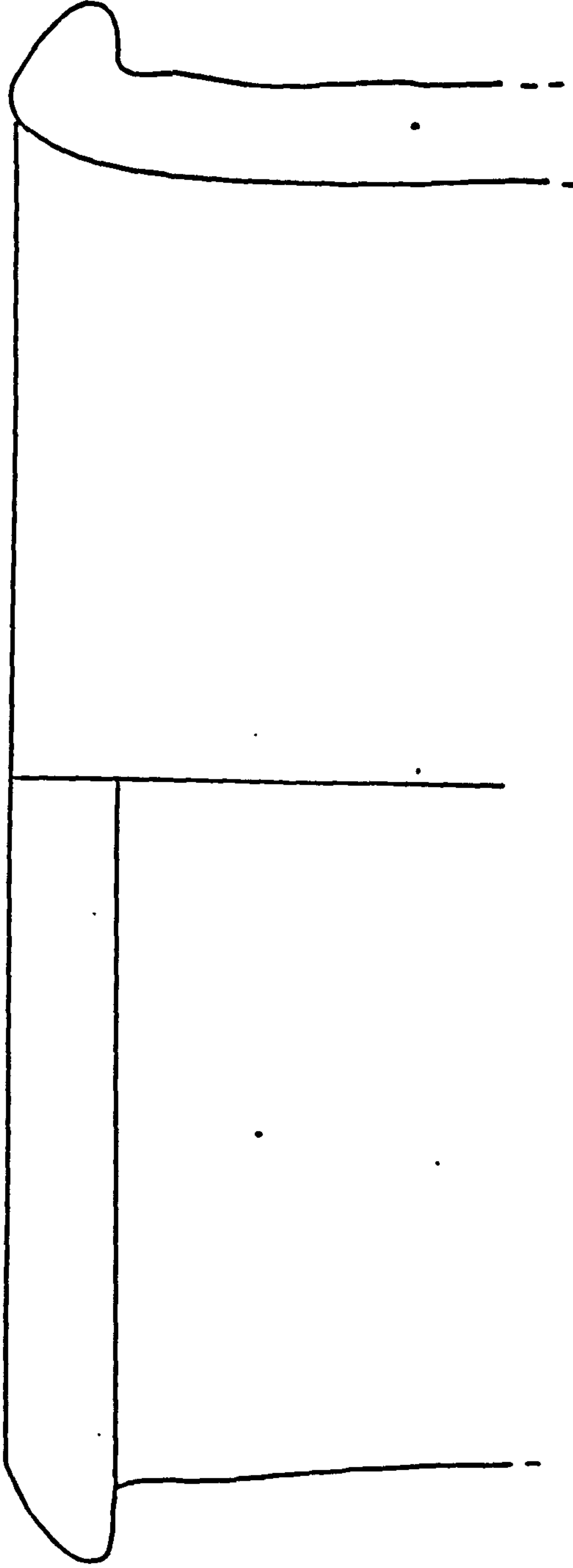

DAB 695

ILL 36

Plain Ware

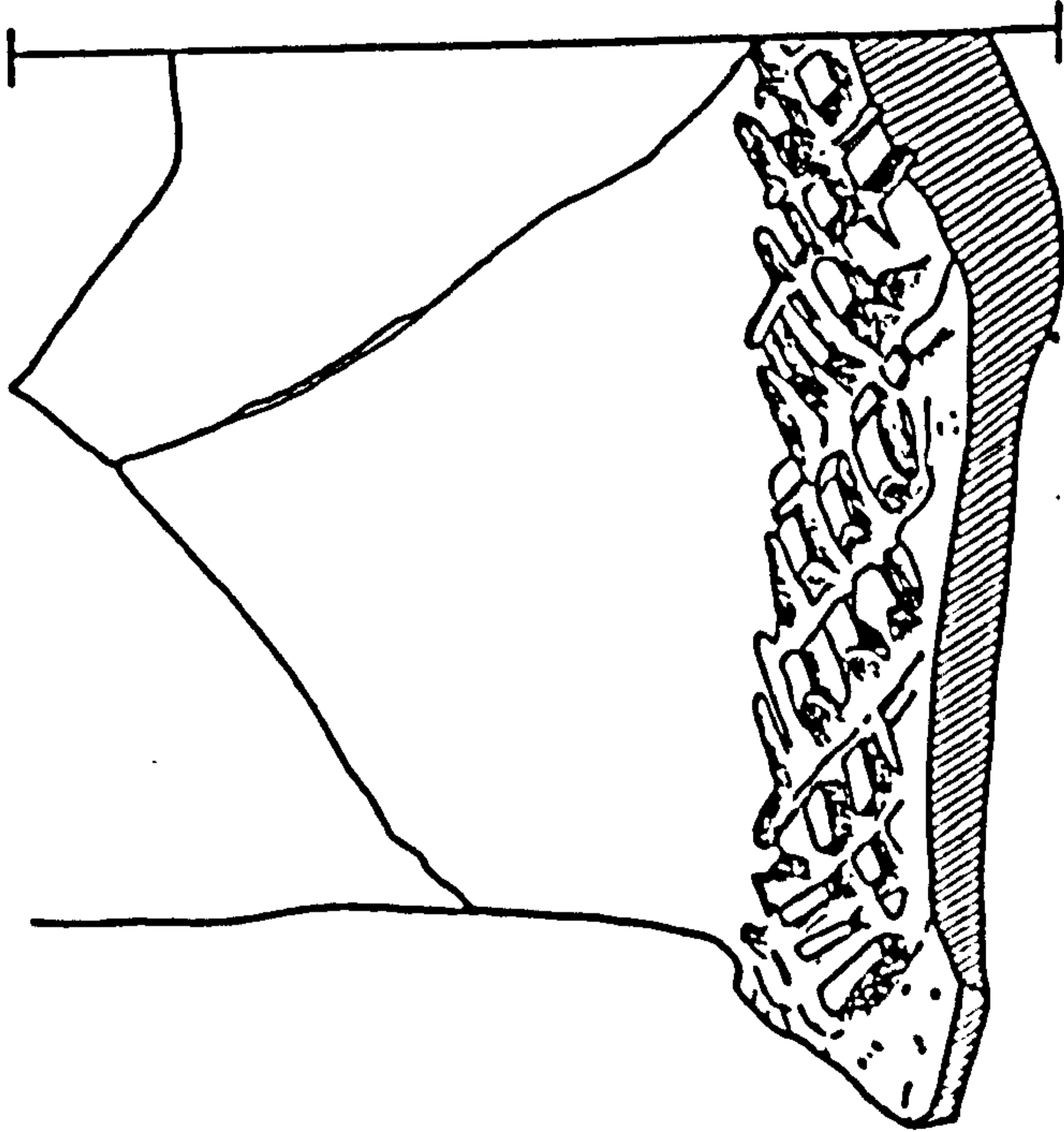
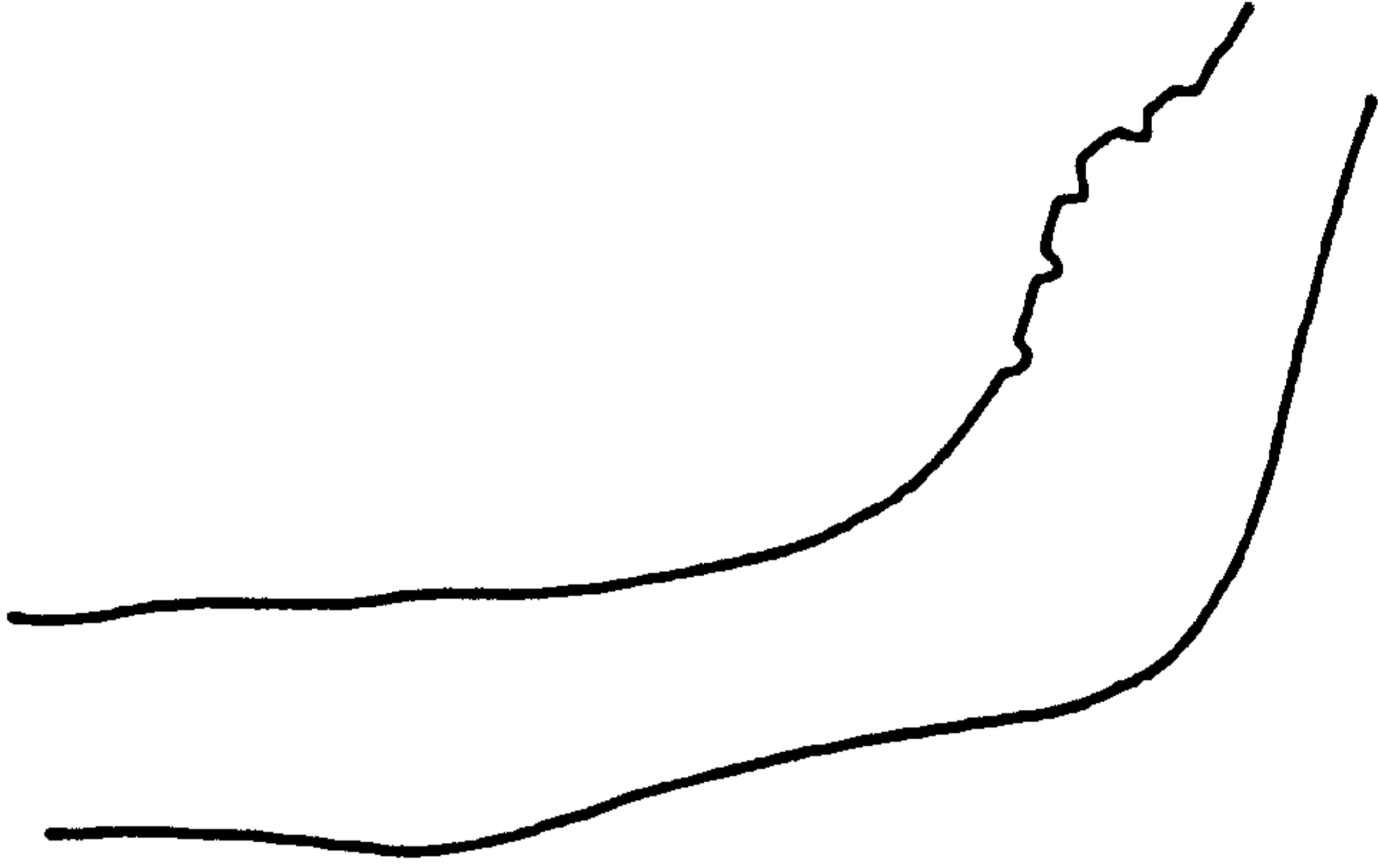

DAB 697

Plain Ware

ILL 37

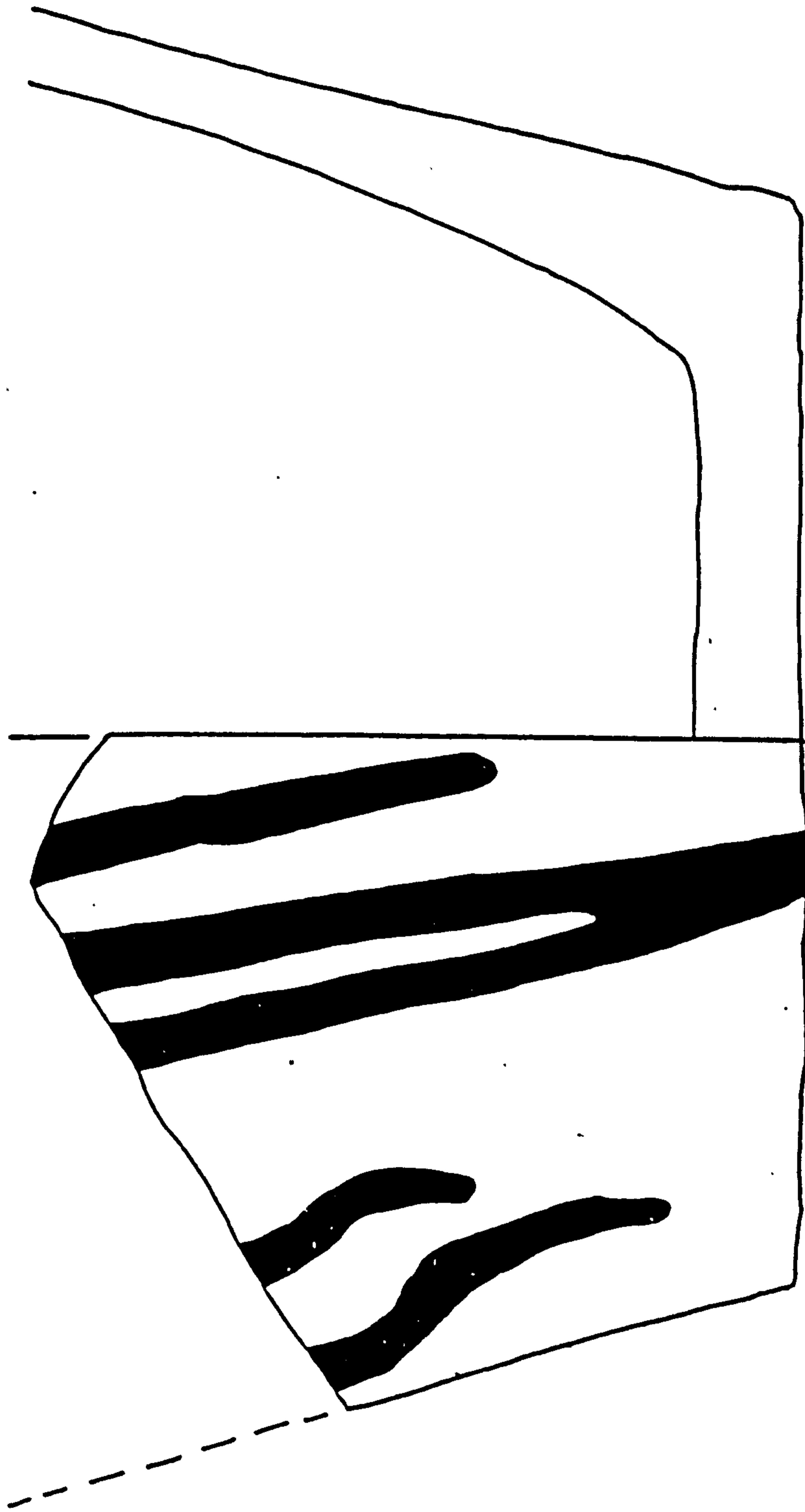

DAB 696

Plain Ware

ILL 38

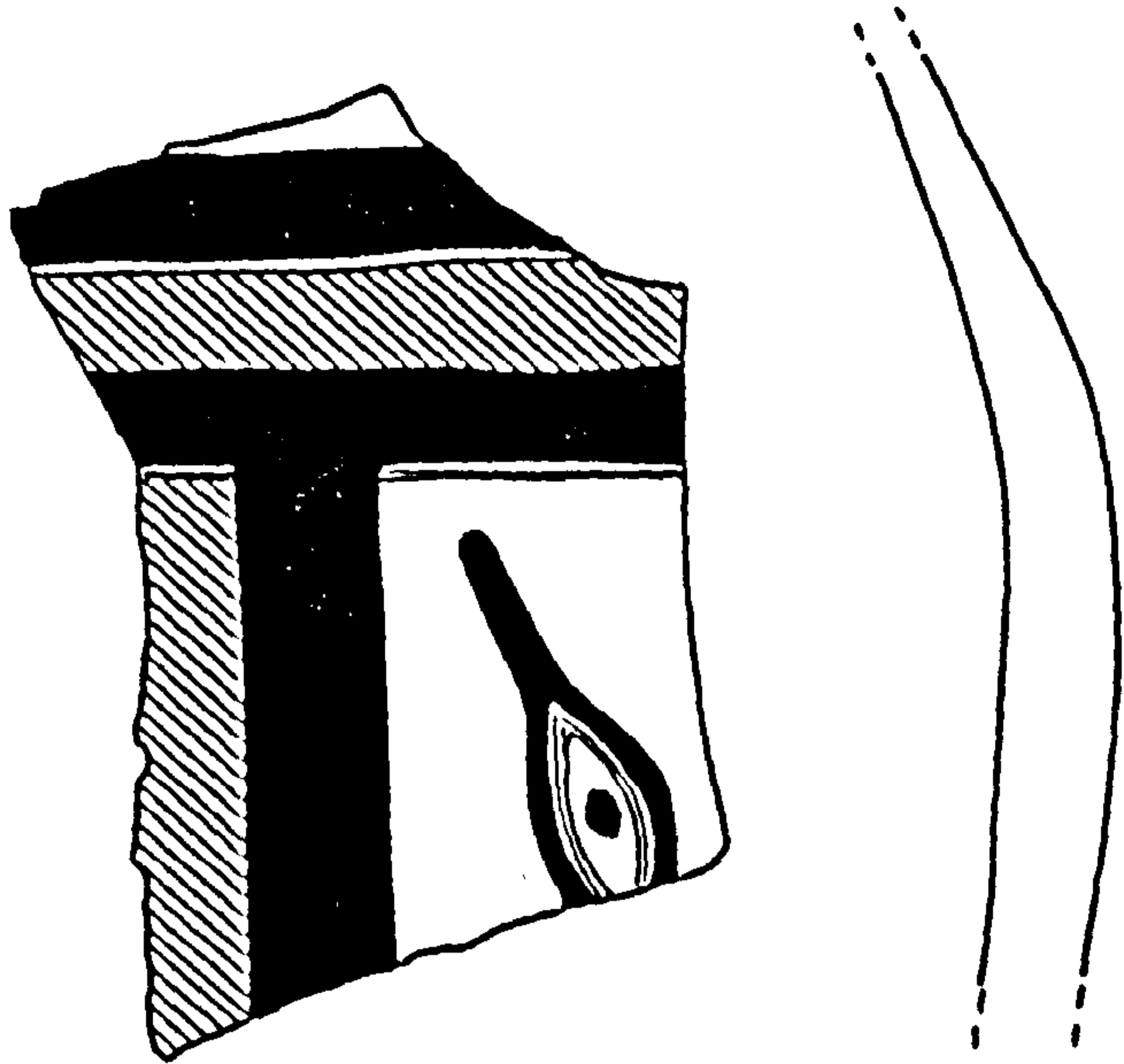

DAB 731

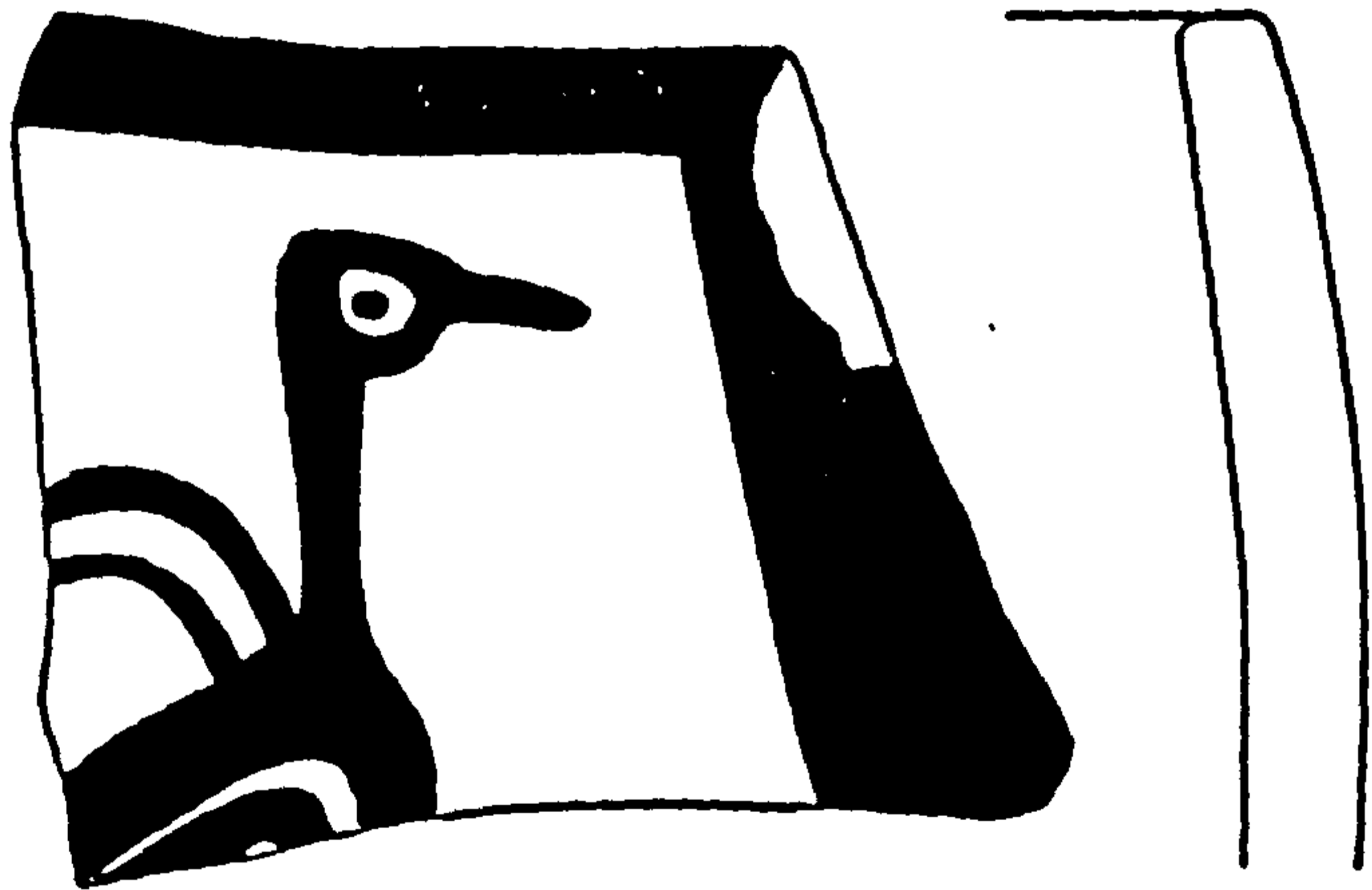

DAB 728

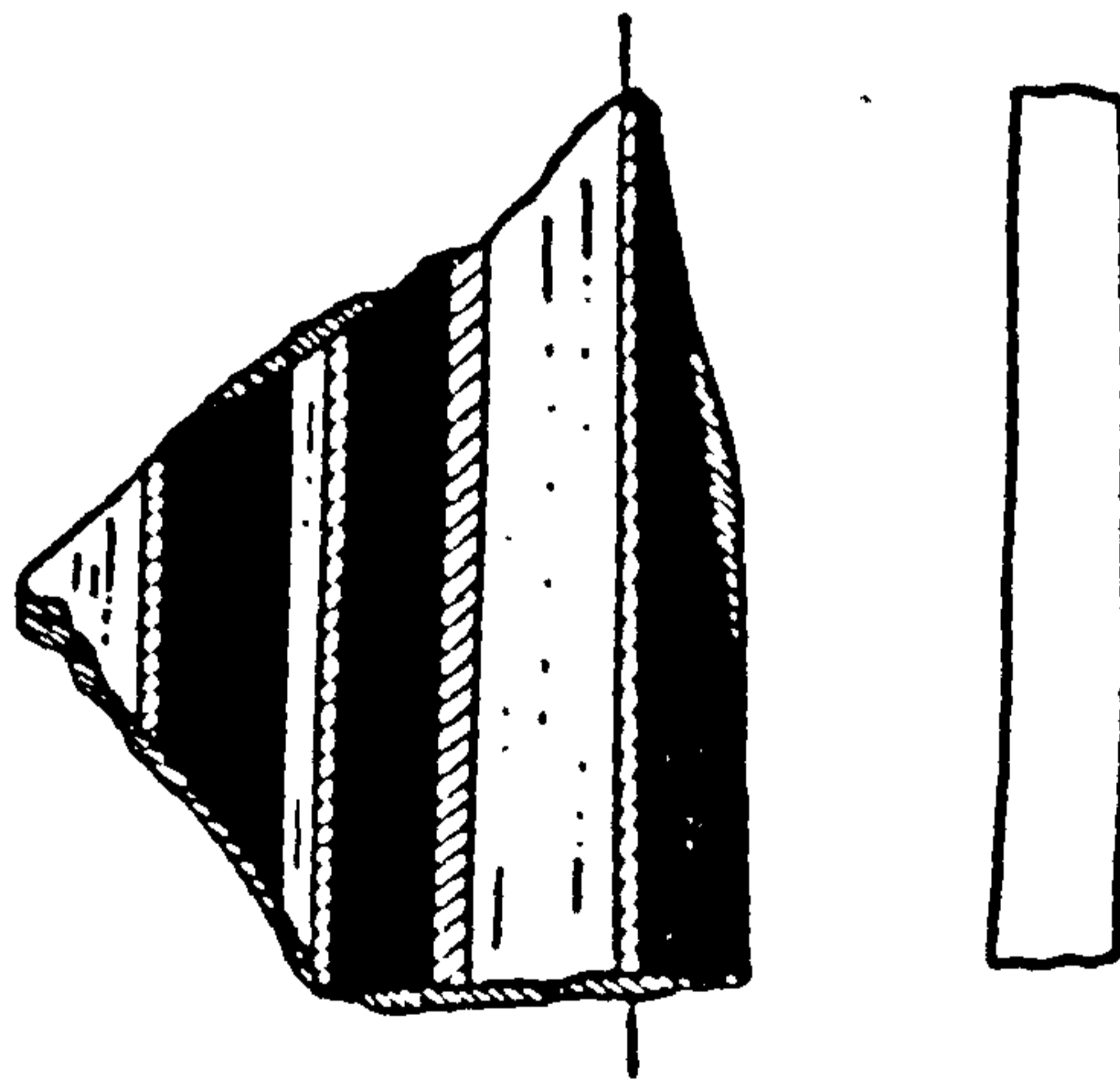

DAB 581

ILL 39

Bichrome Ware (Cyp)

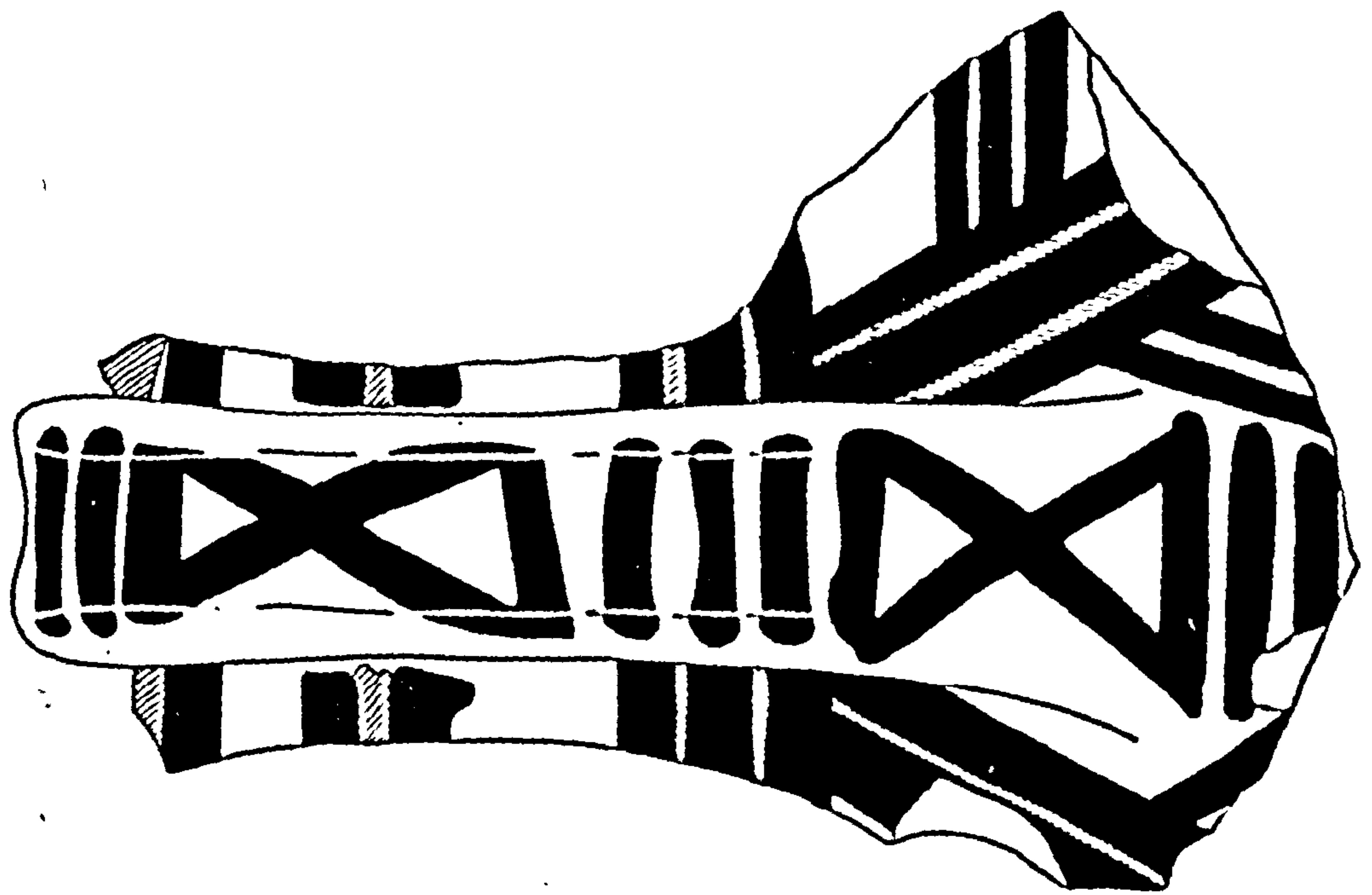

DAB 729

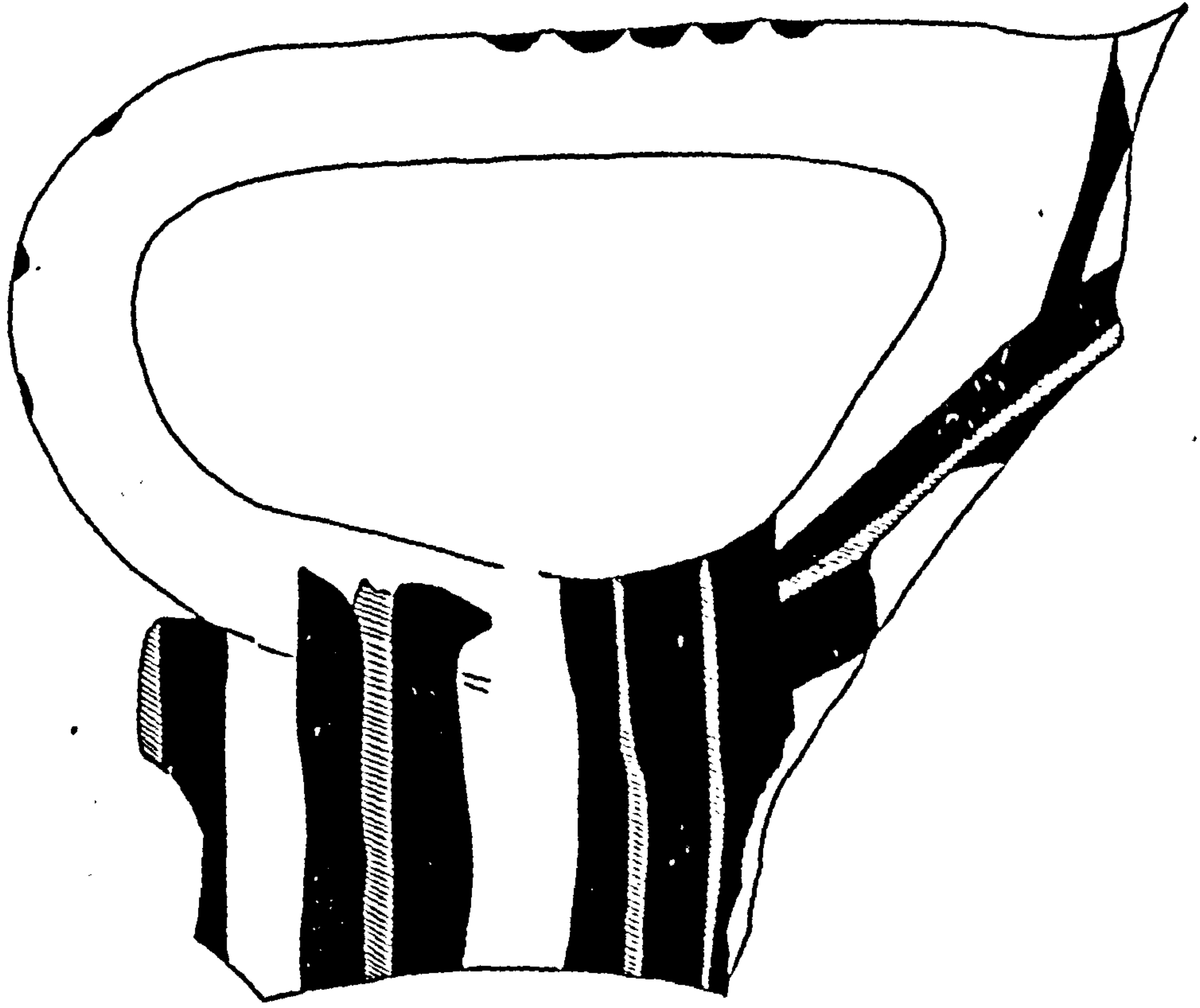

ILL. 40

Bichrome Ware (Cyp)

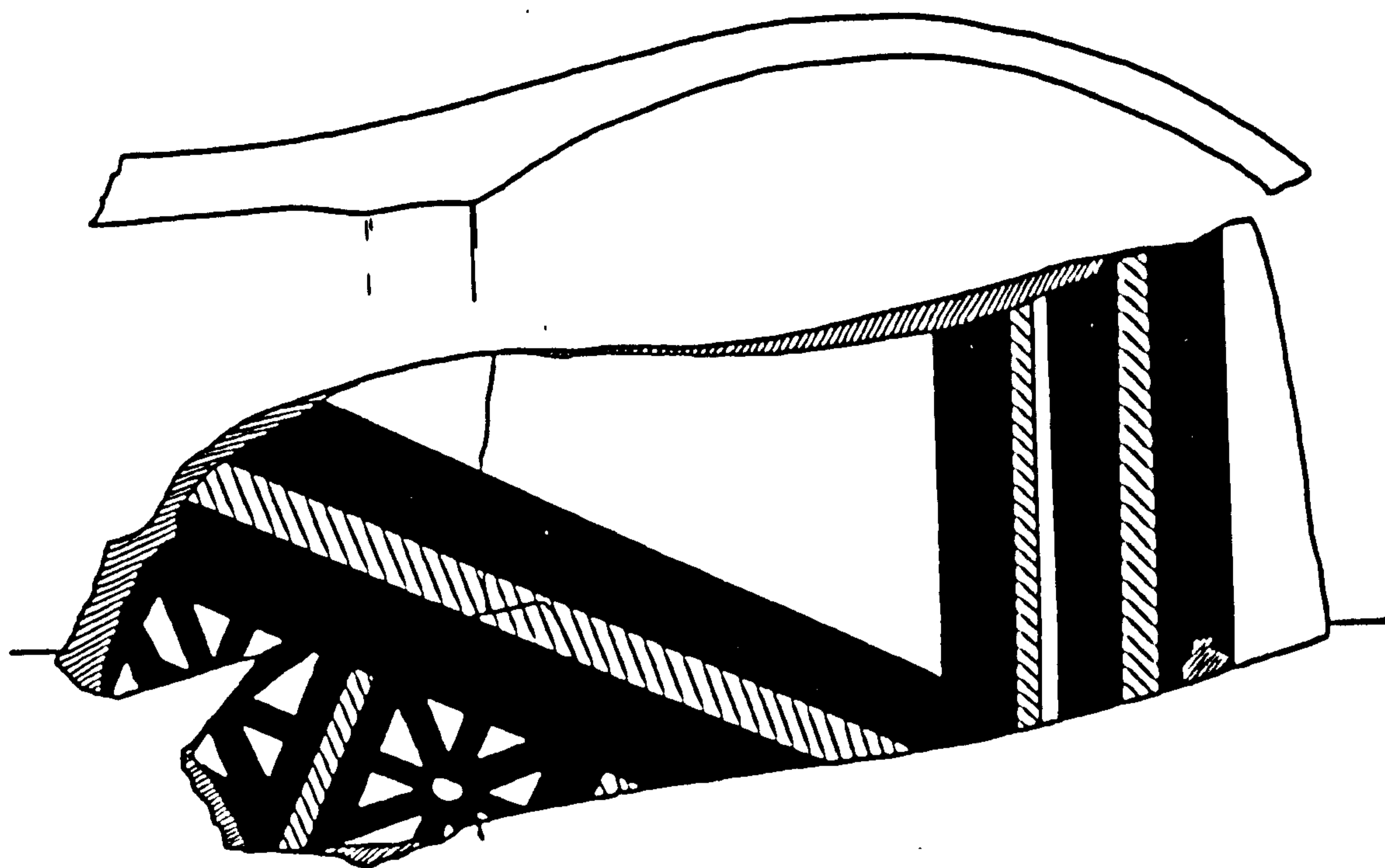

DAB 736

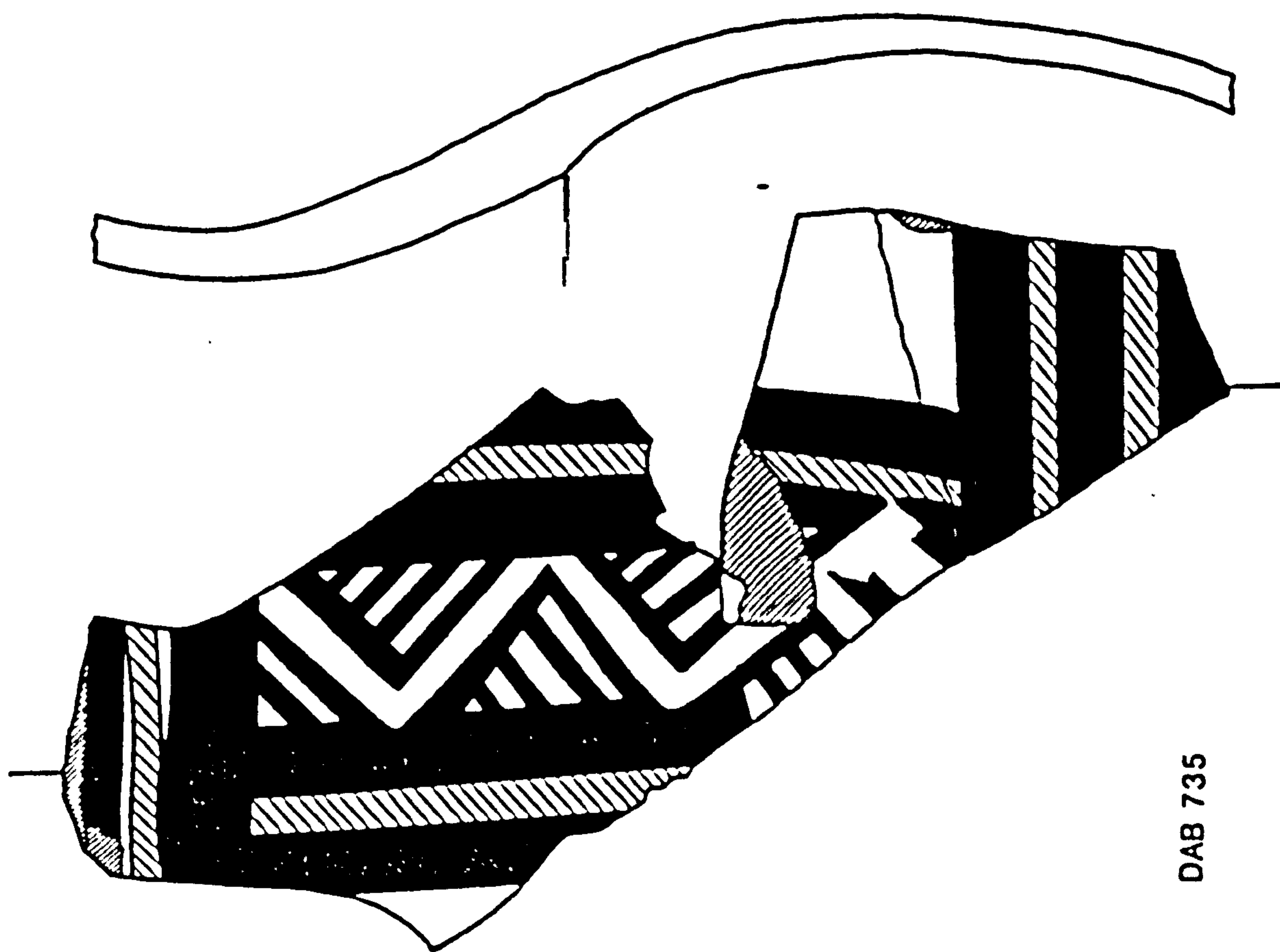

DAB 735

ILL 41

Bichrome Ware (Cyp)



DAB 733

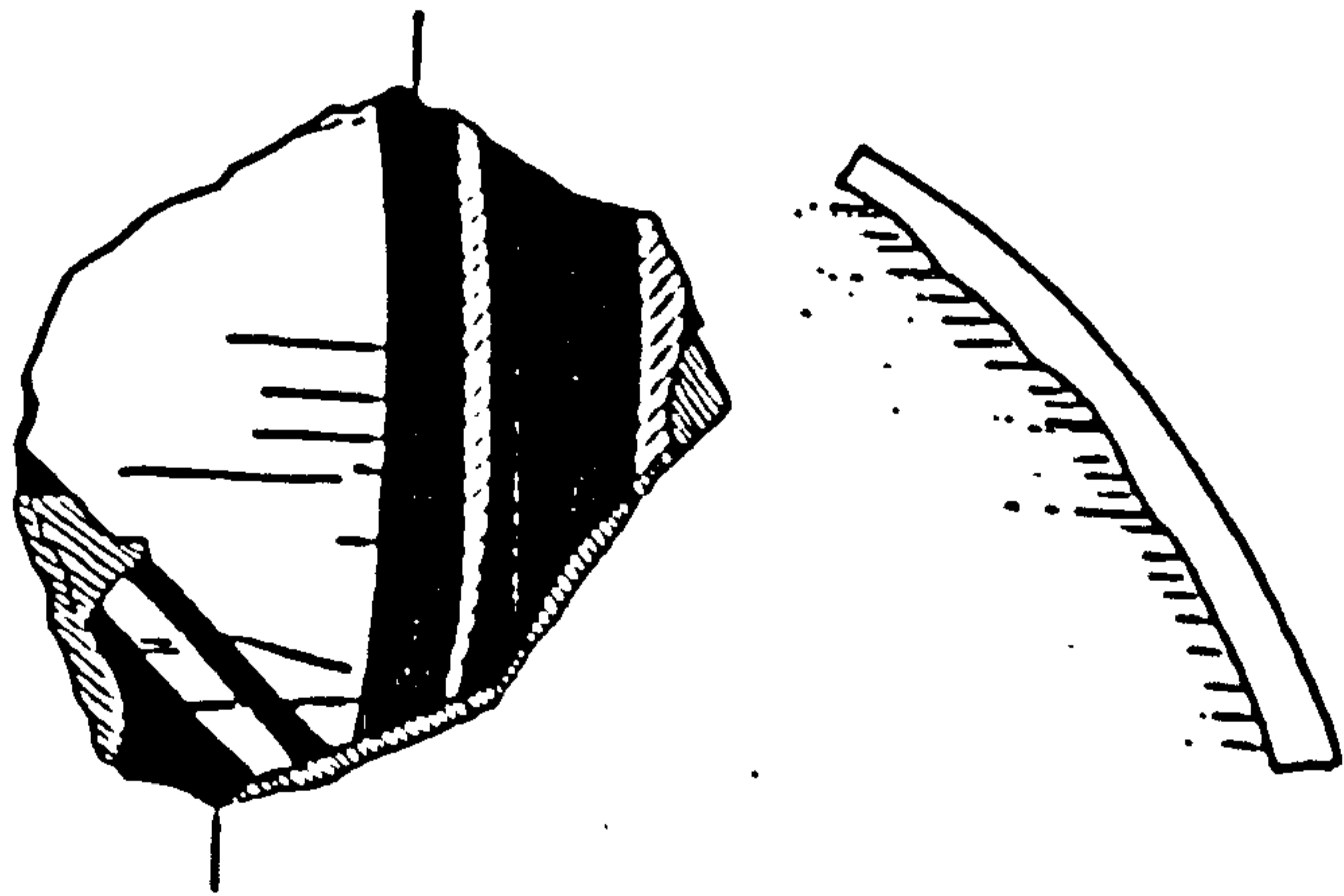

6794 D

ILL 42

Bichrome Ware (Cyp)

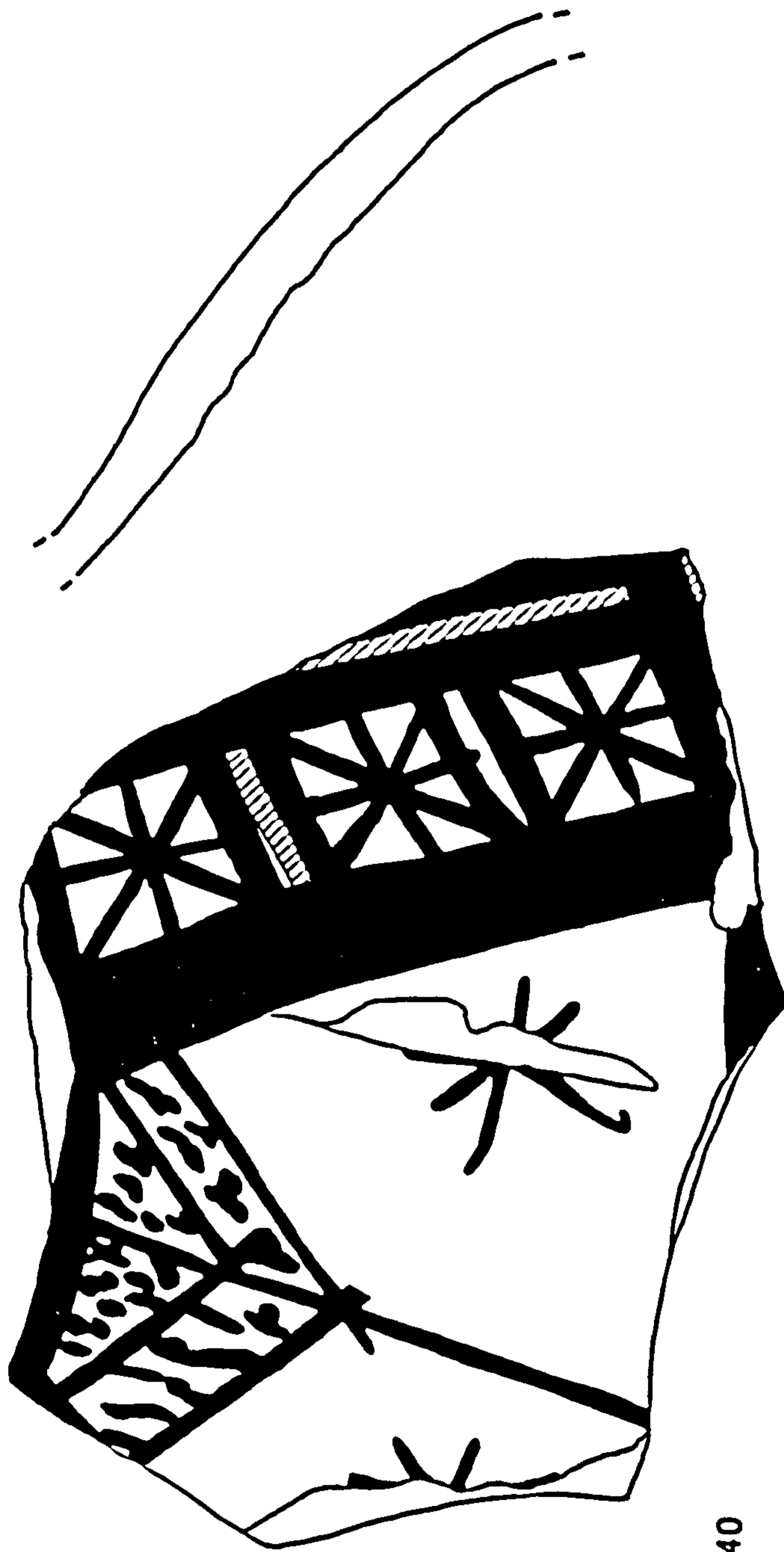

DAB 740

ILL 43

Bichrome Ware

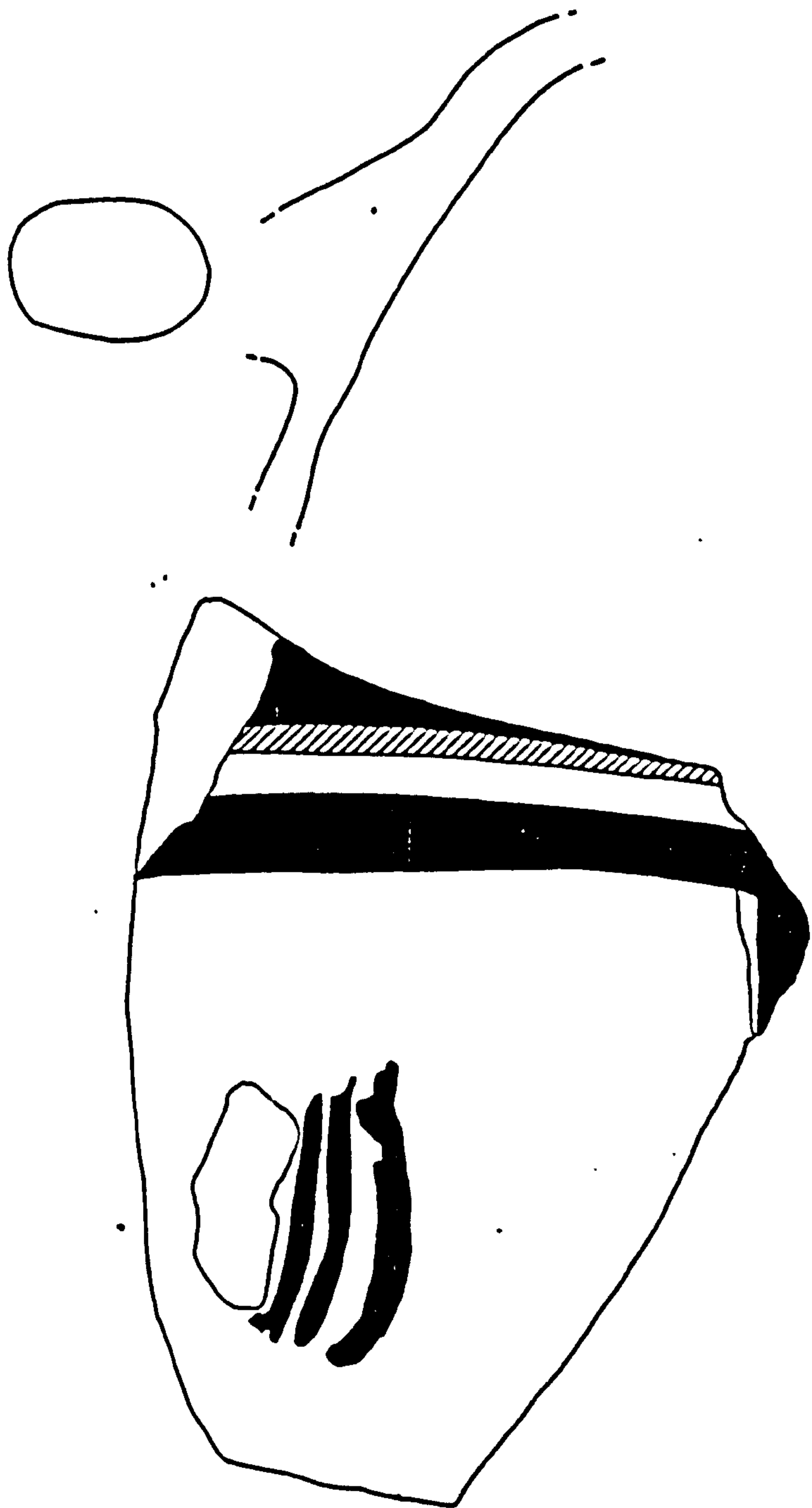

DAB 723

ILL 44

Bichrome Ware

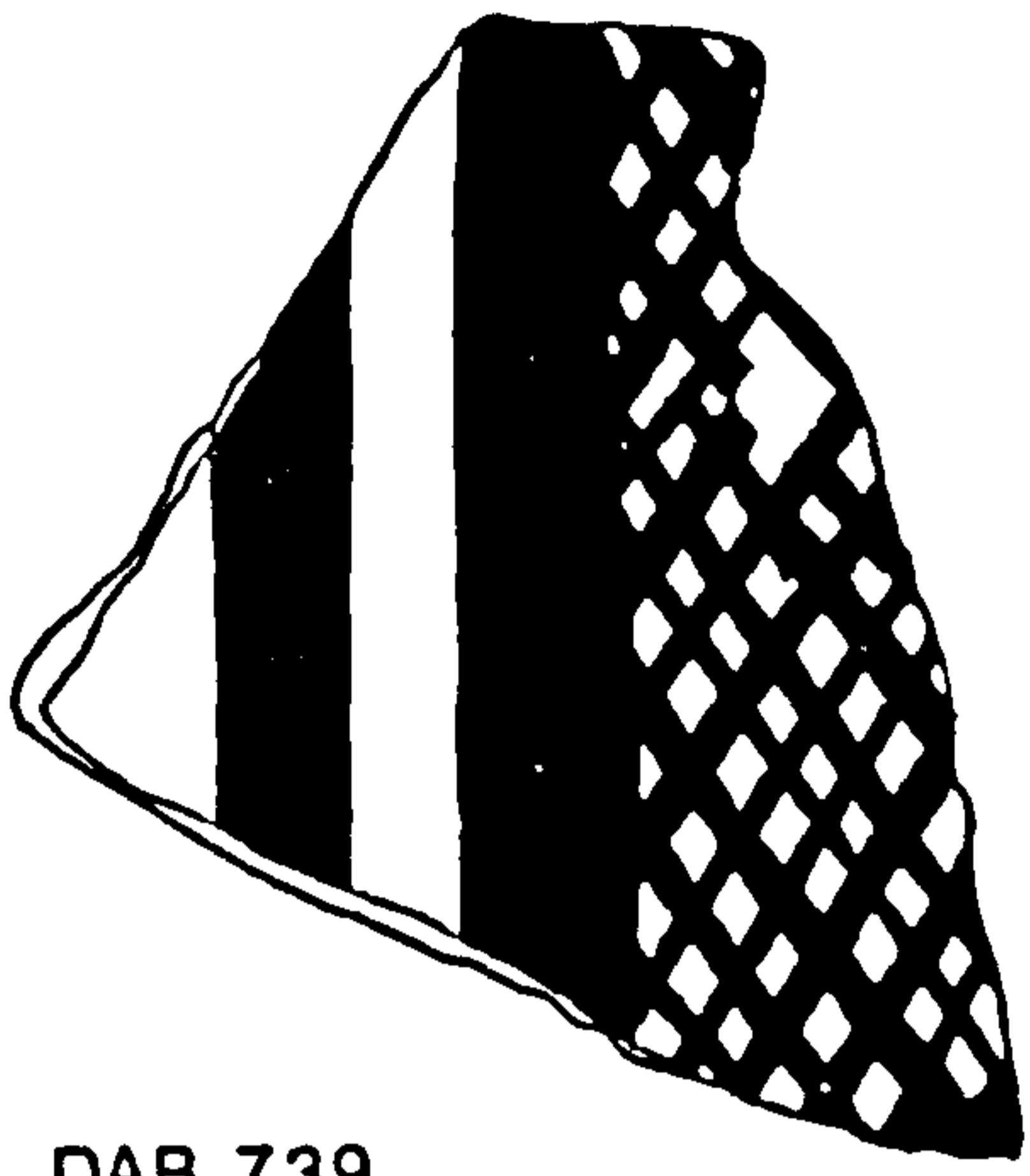

DAB 739

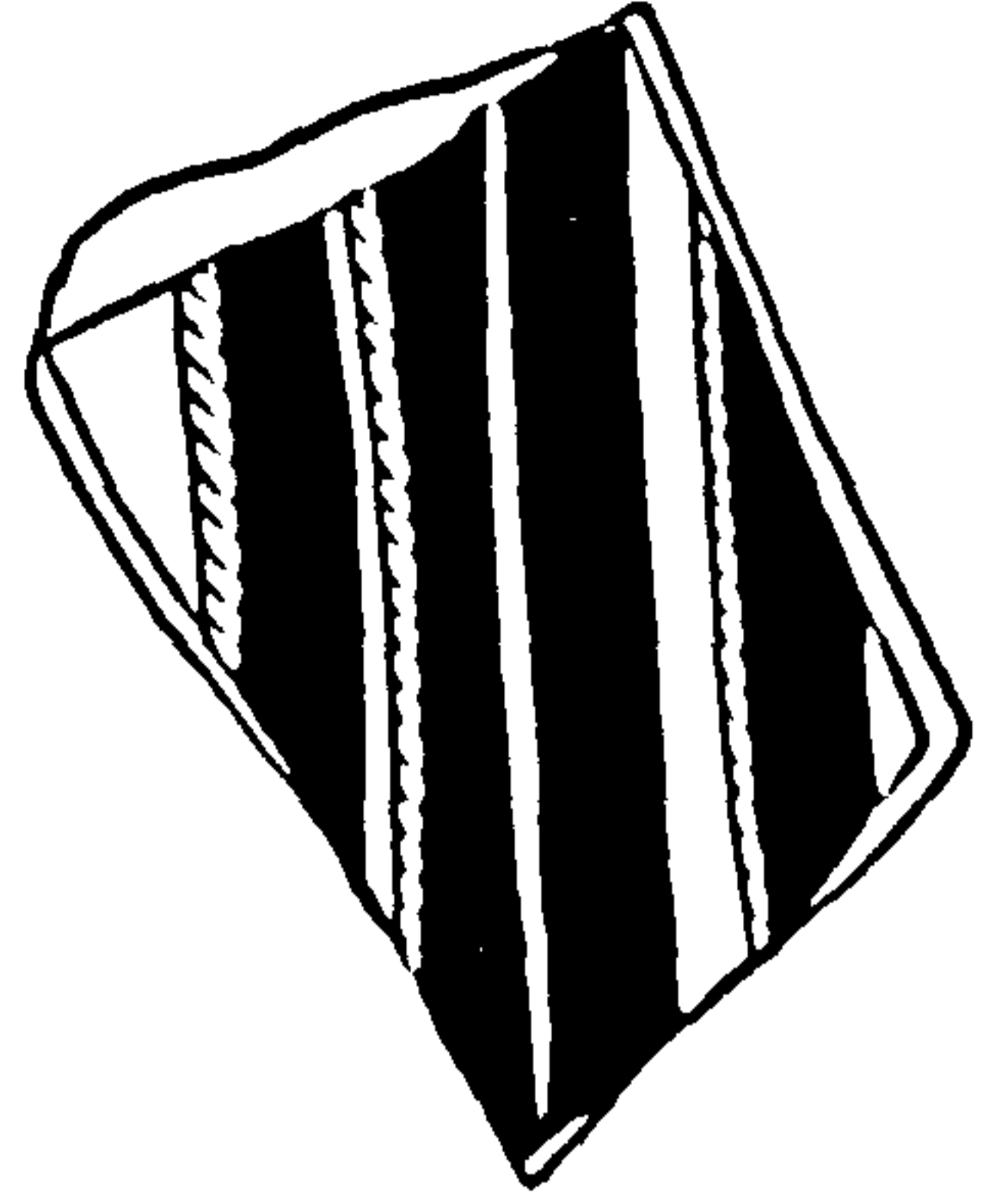
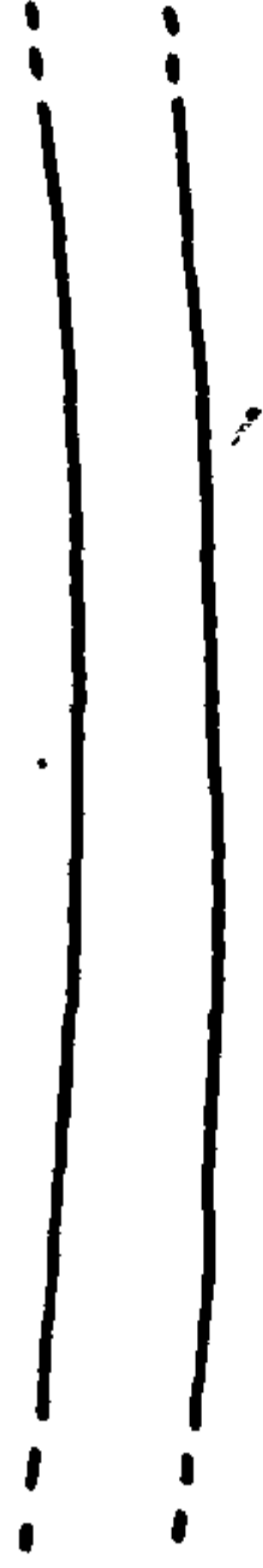

DAB 594

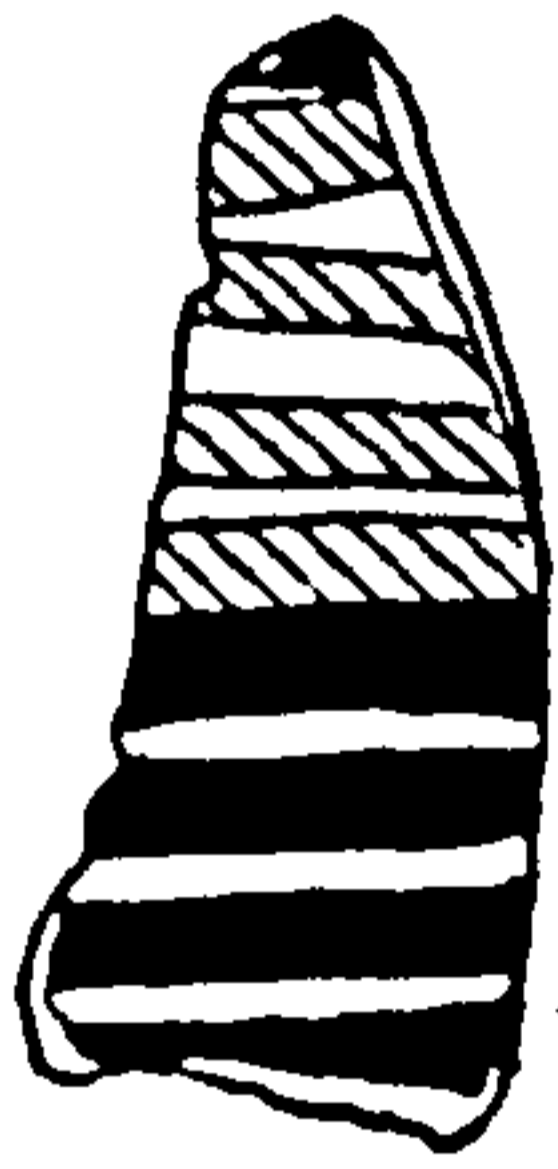

DAB 732

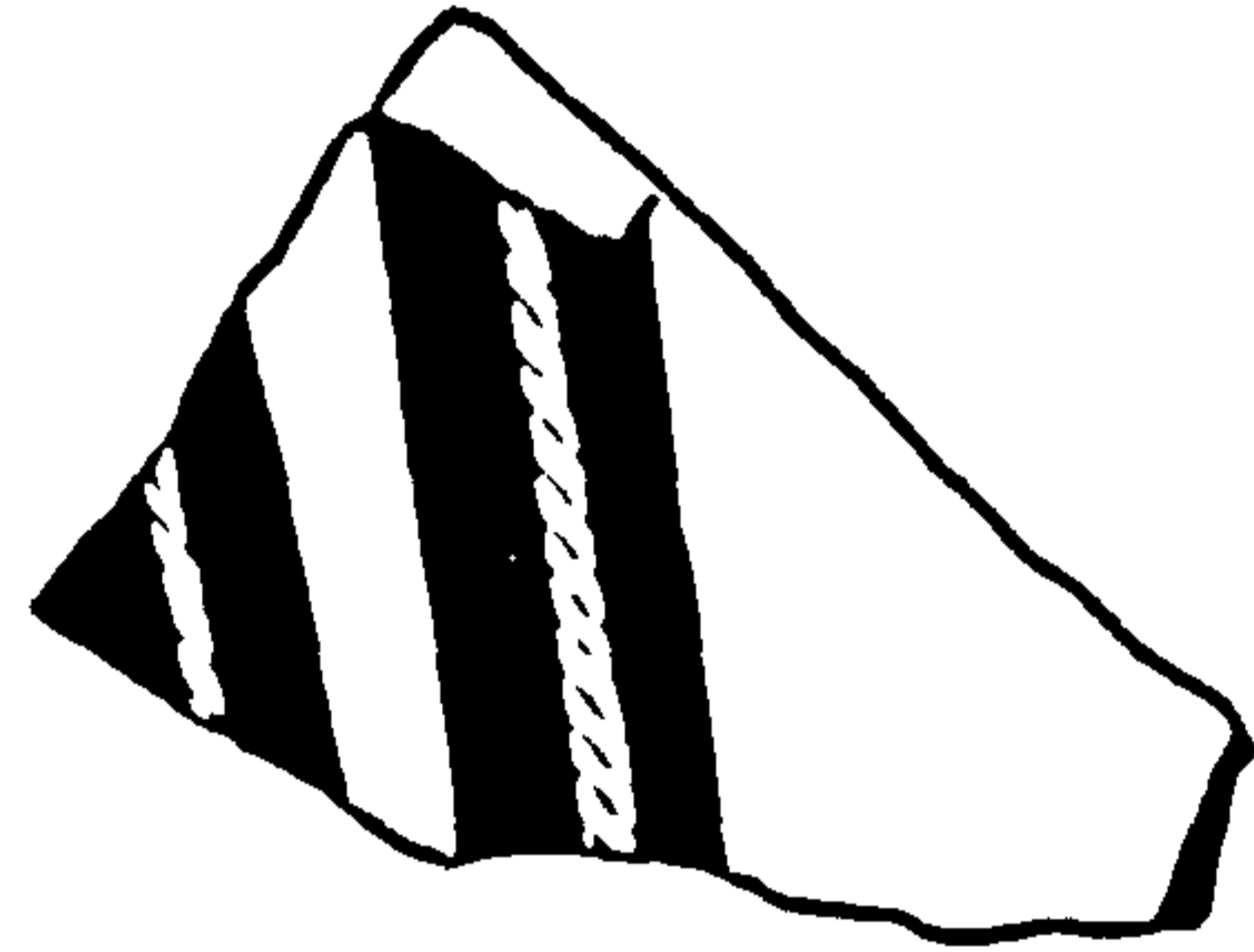

DAB 595

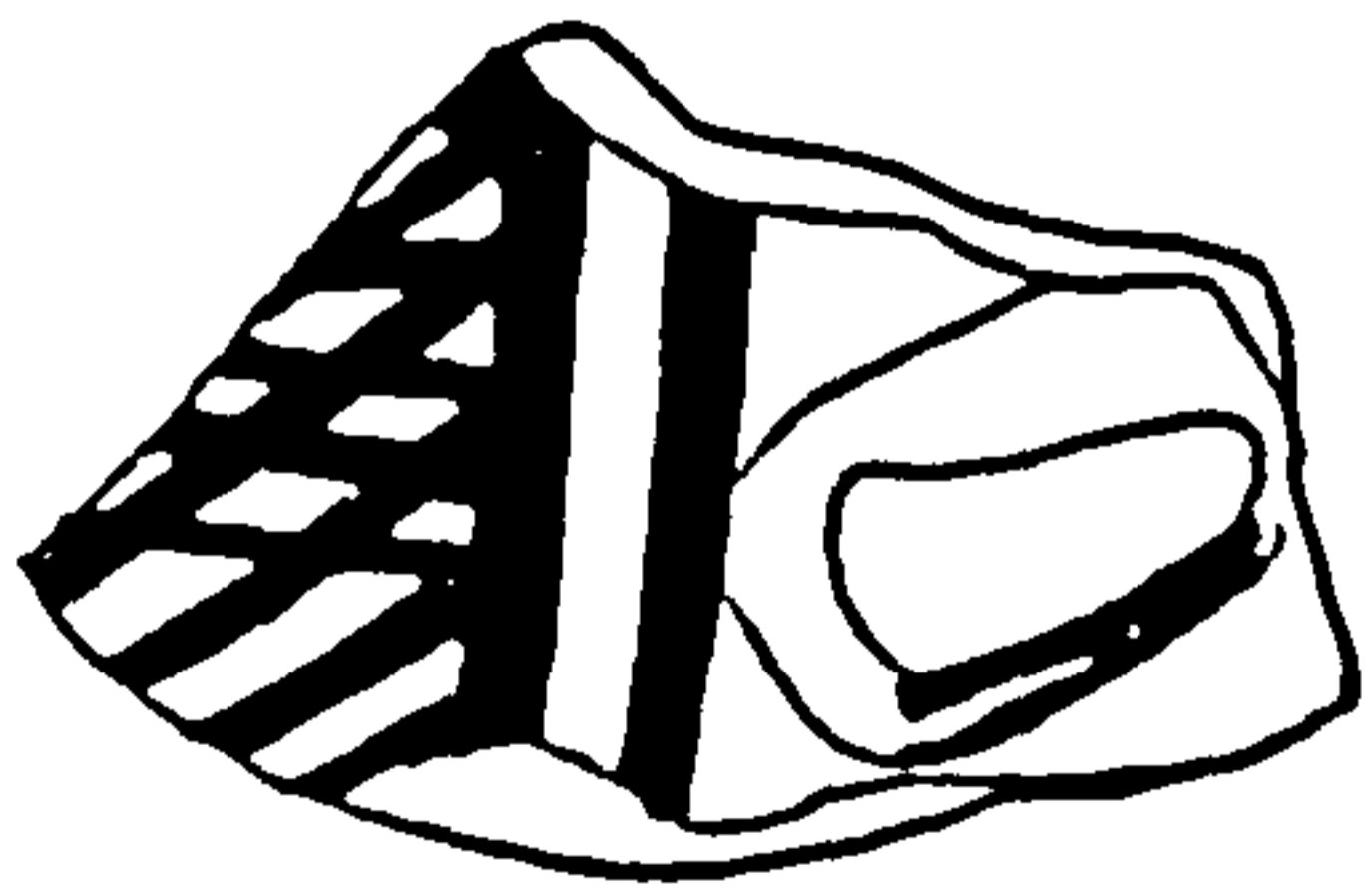
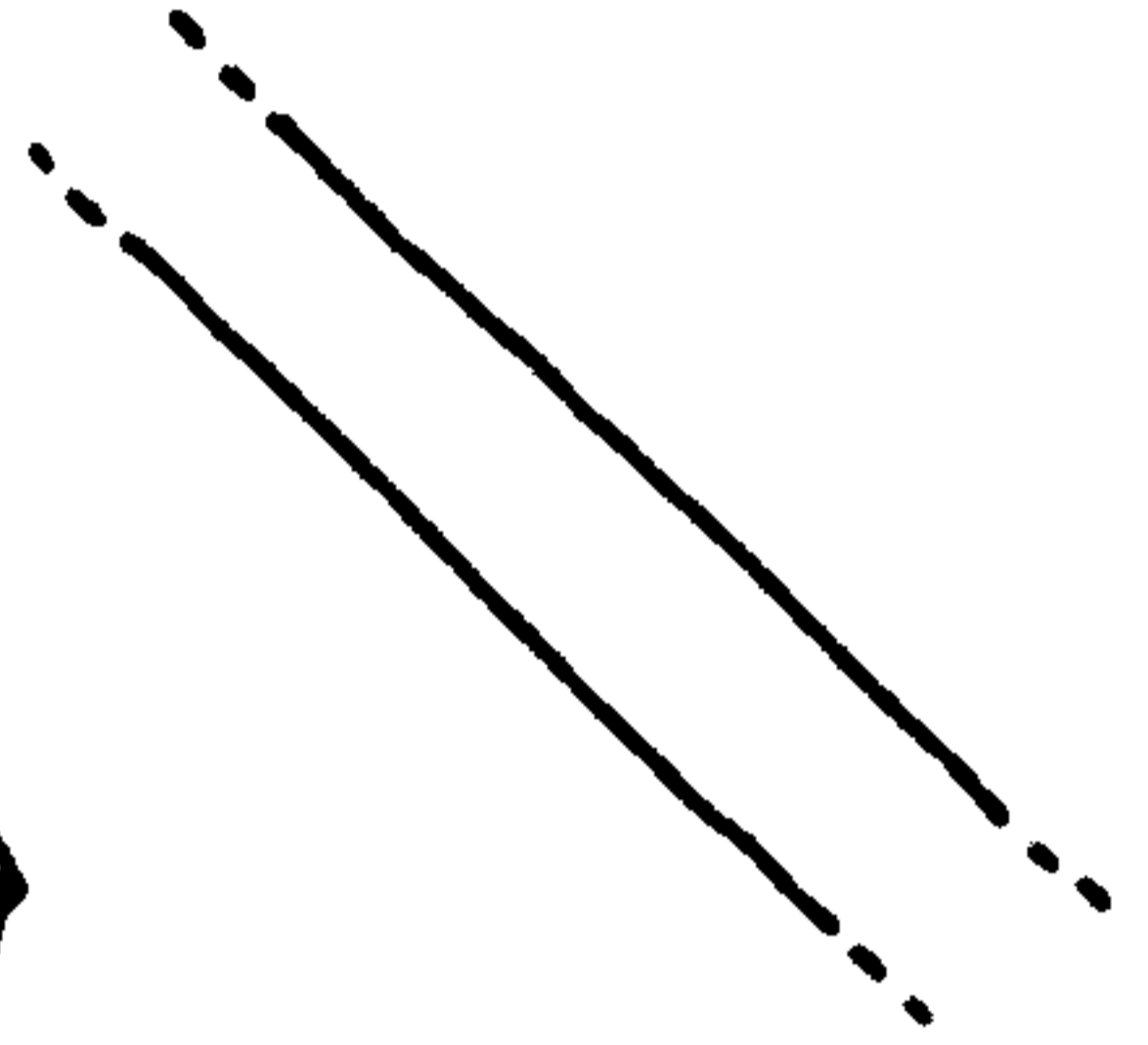

DAB 743

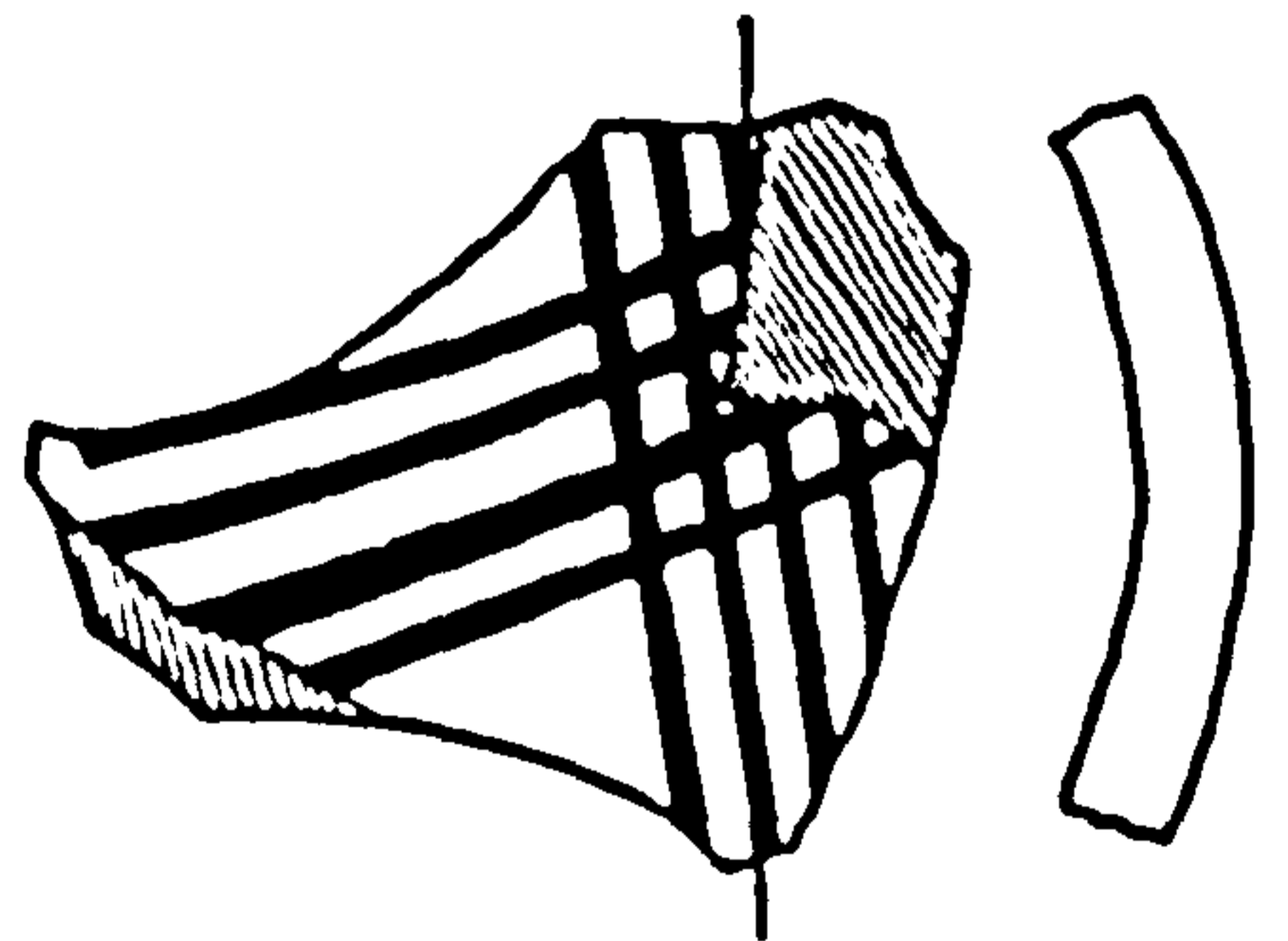
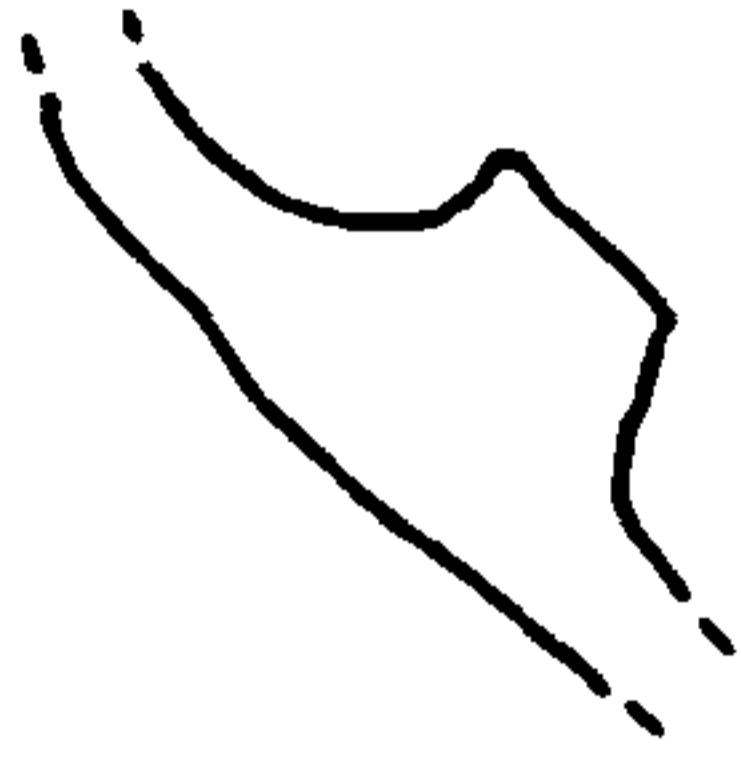

DAB 734

ILL 45

Bichrome Ware

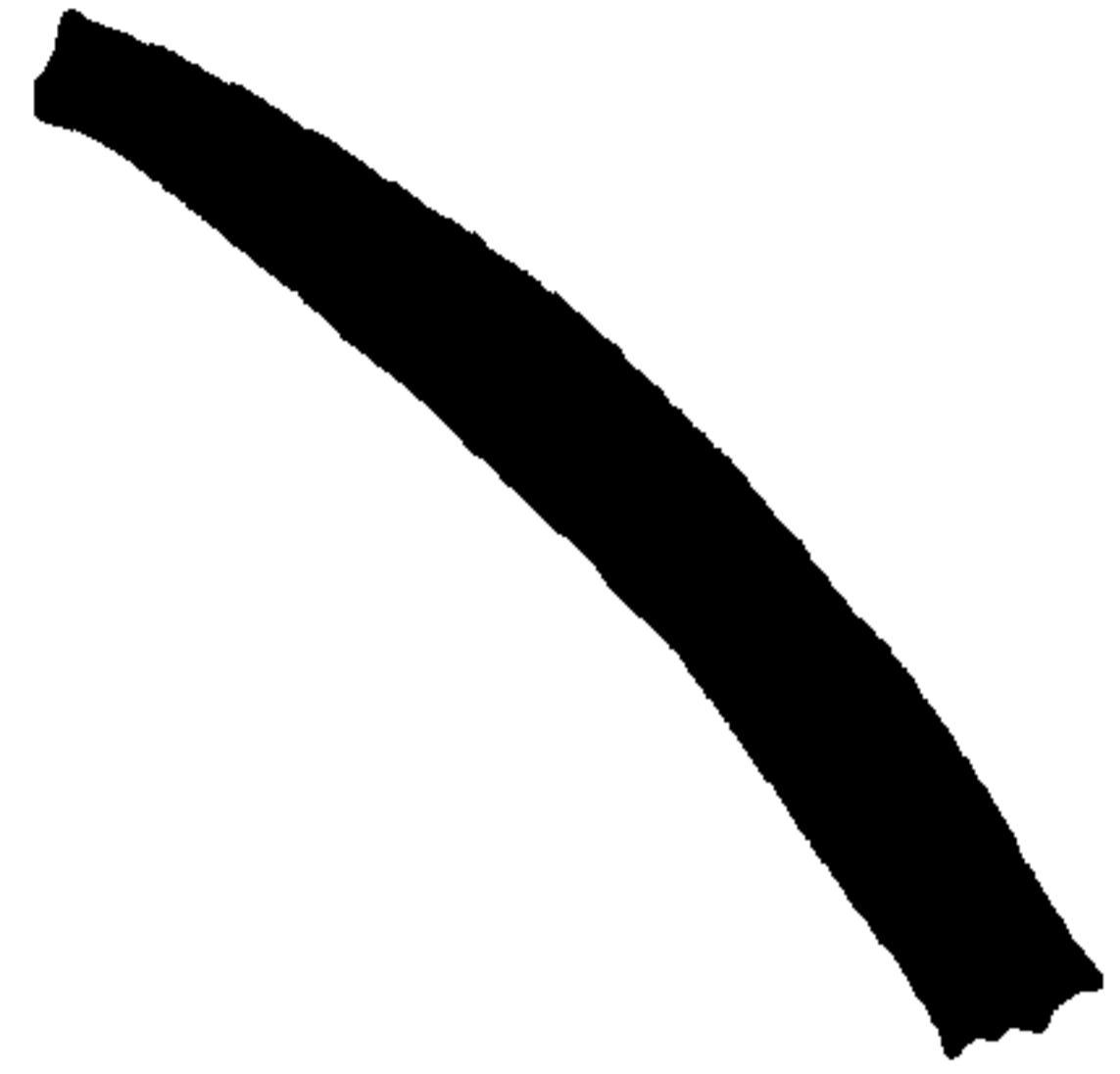
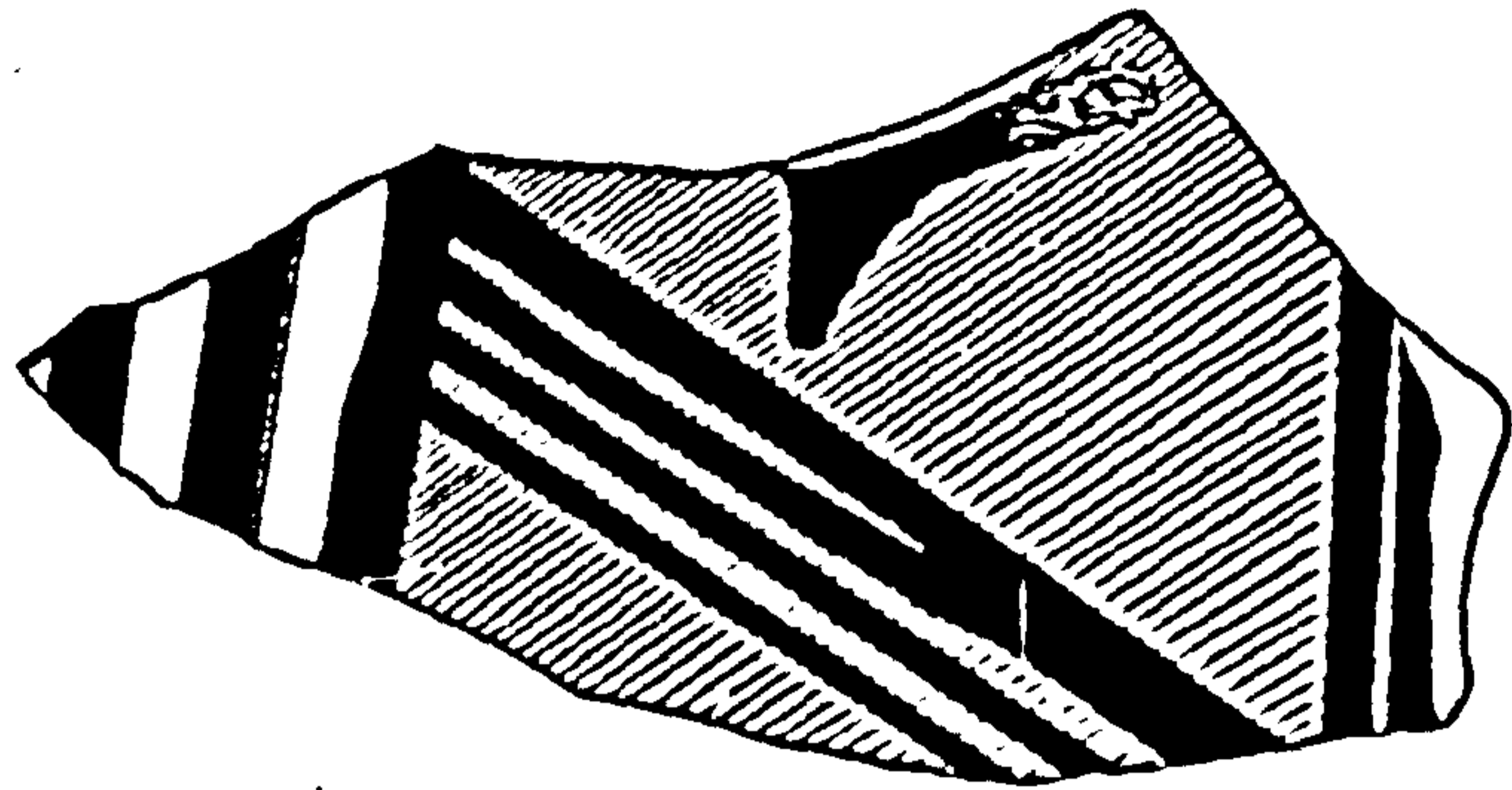

DAB 742

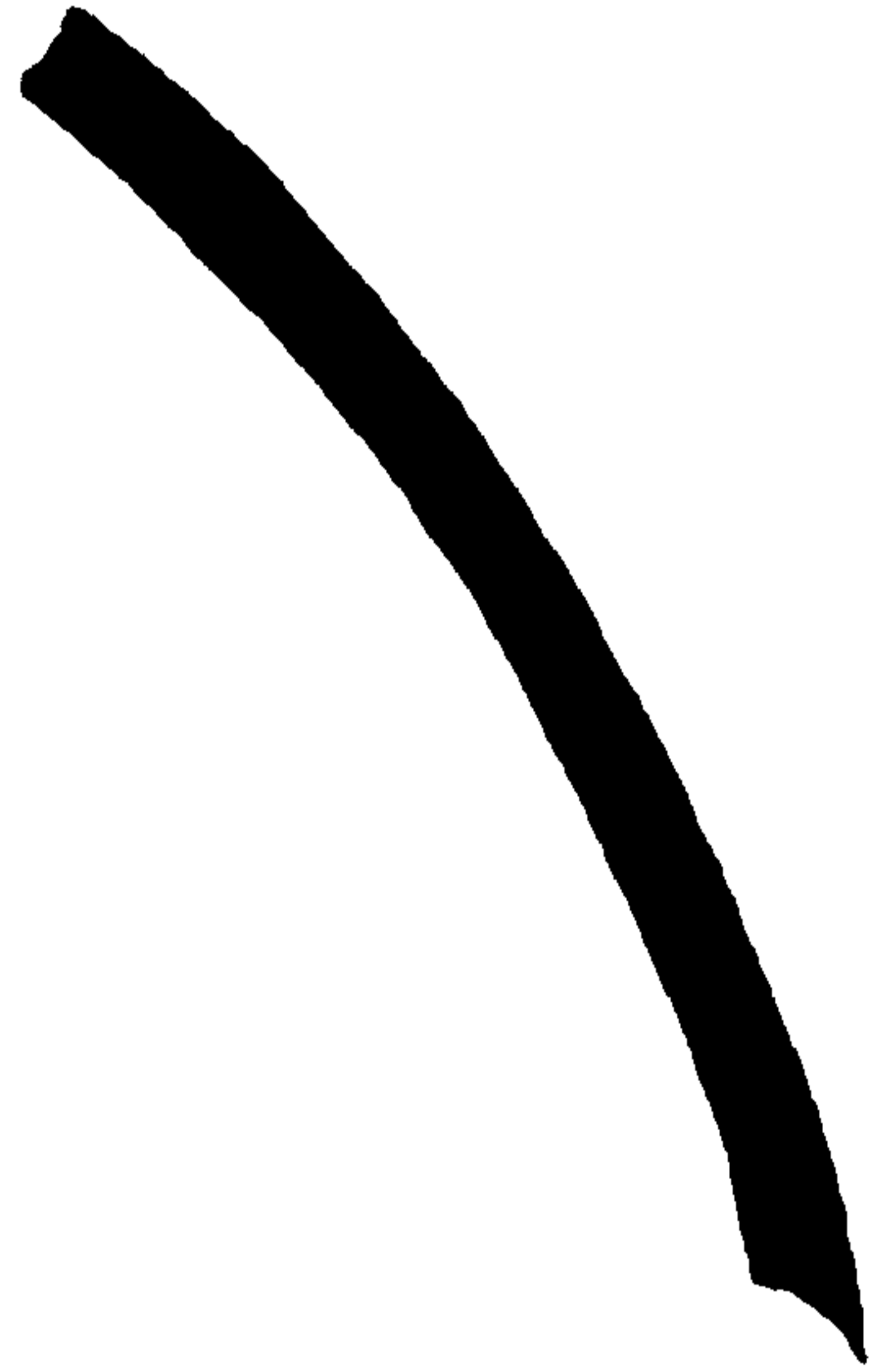
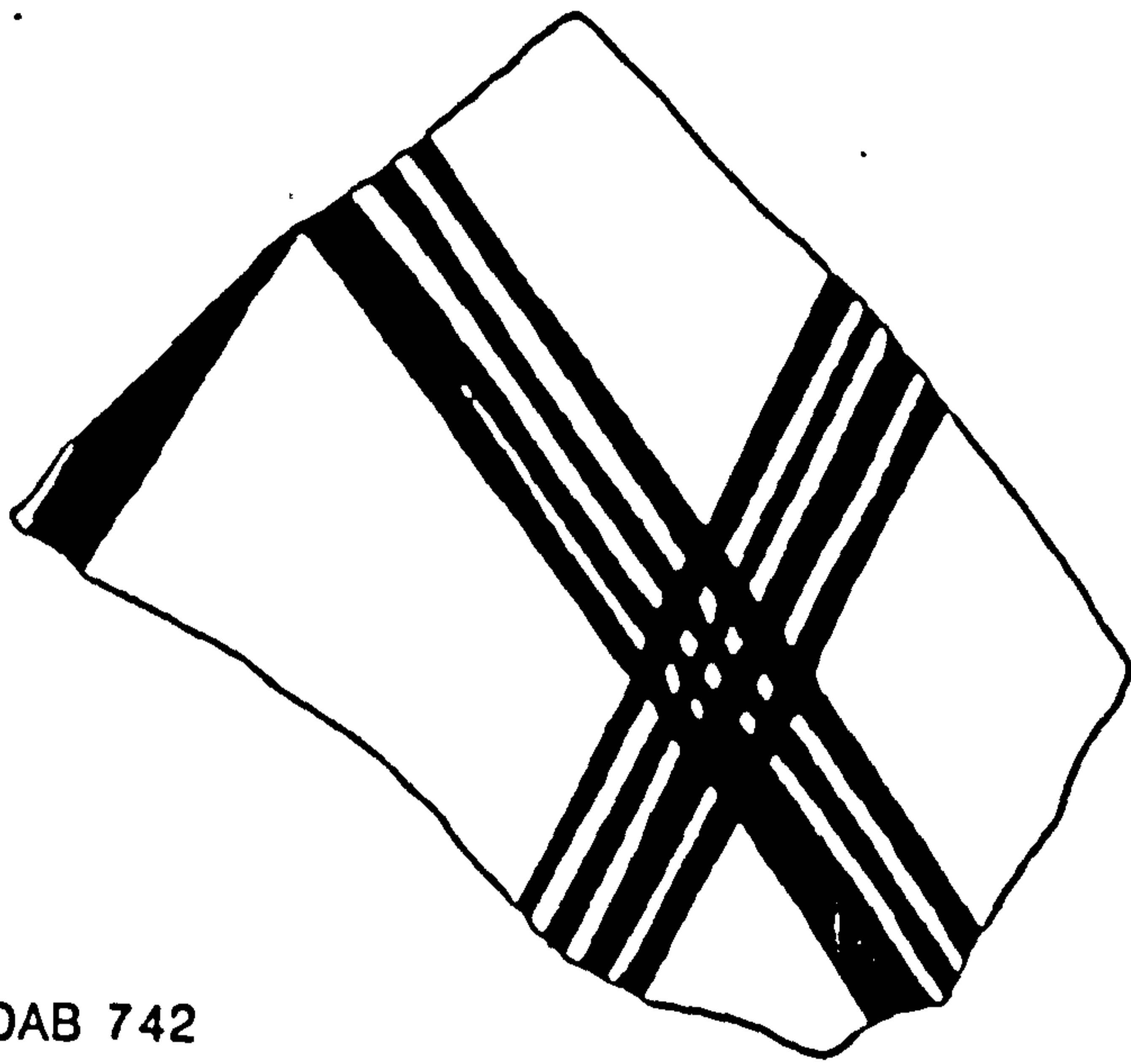

DAB 742

ILL 46

Bichrome Ware

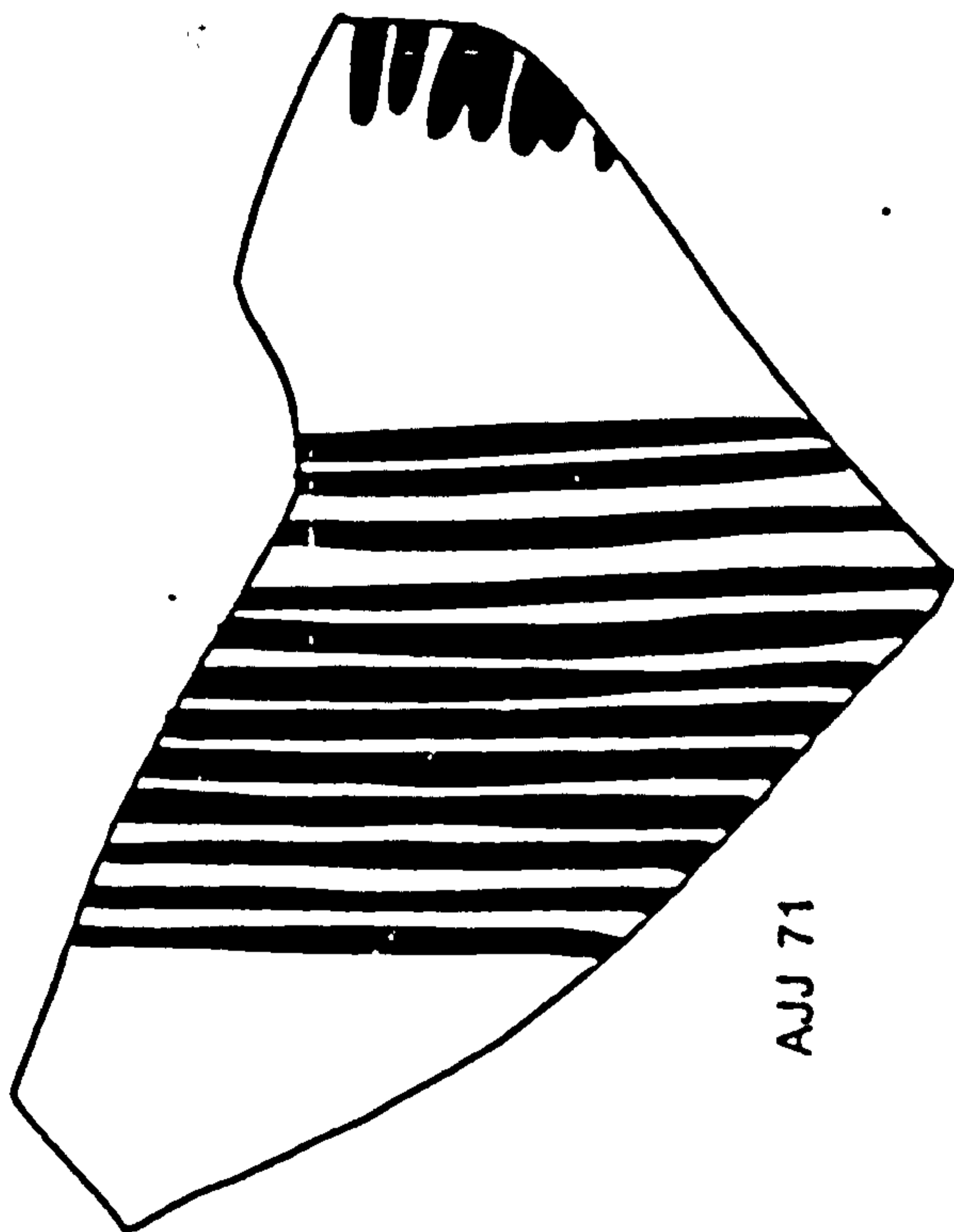
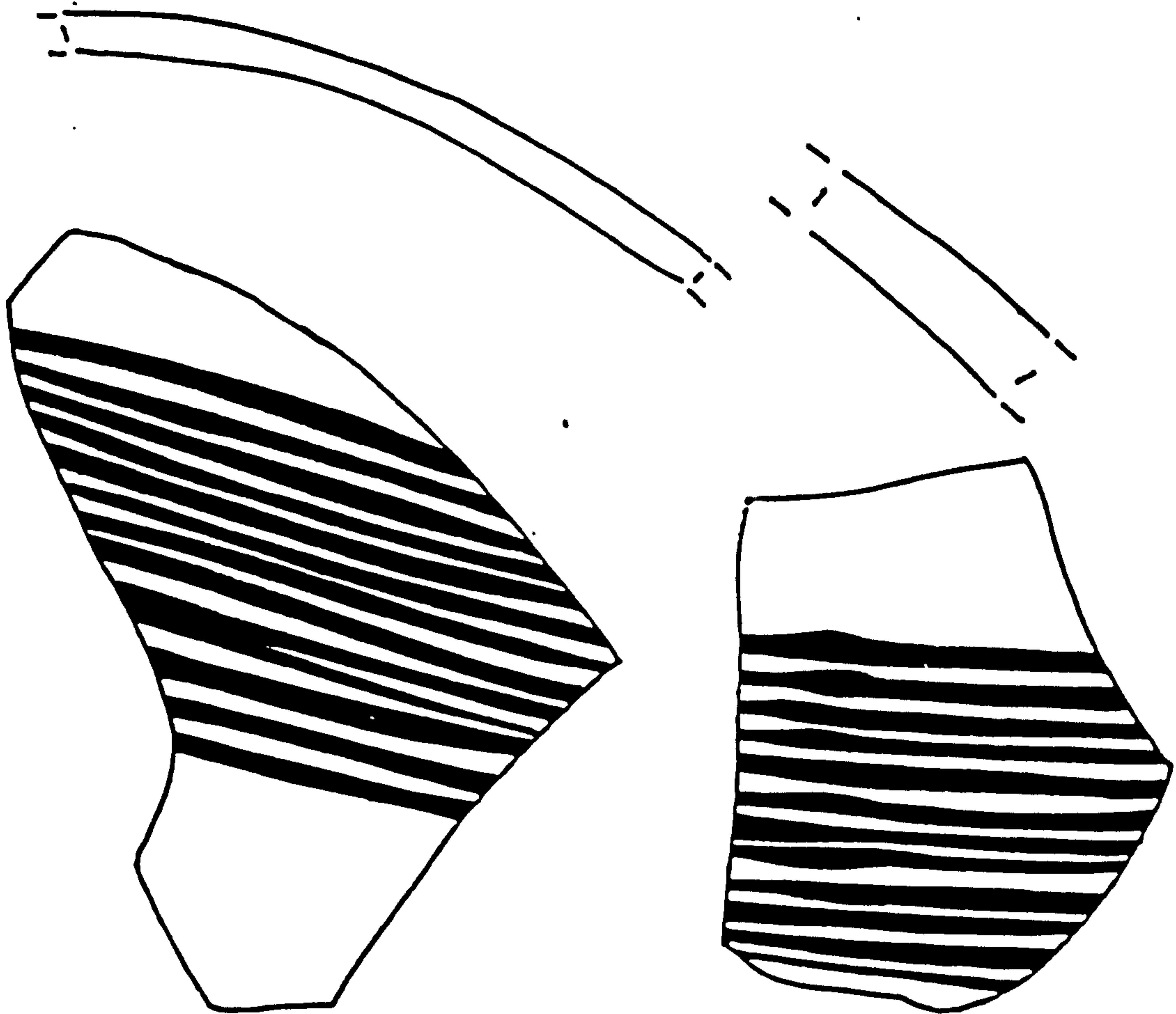

AJJ 71

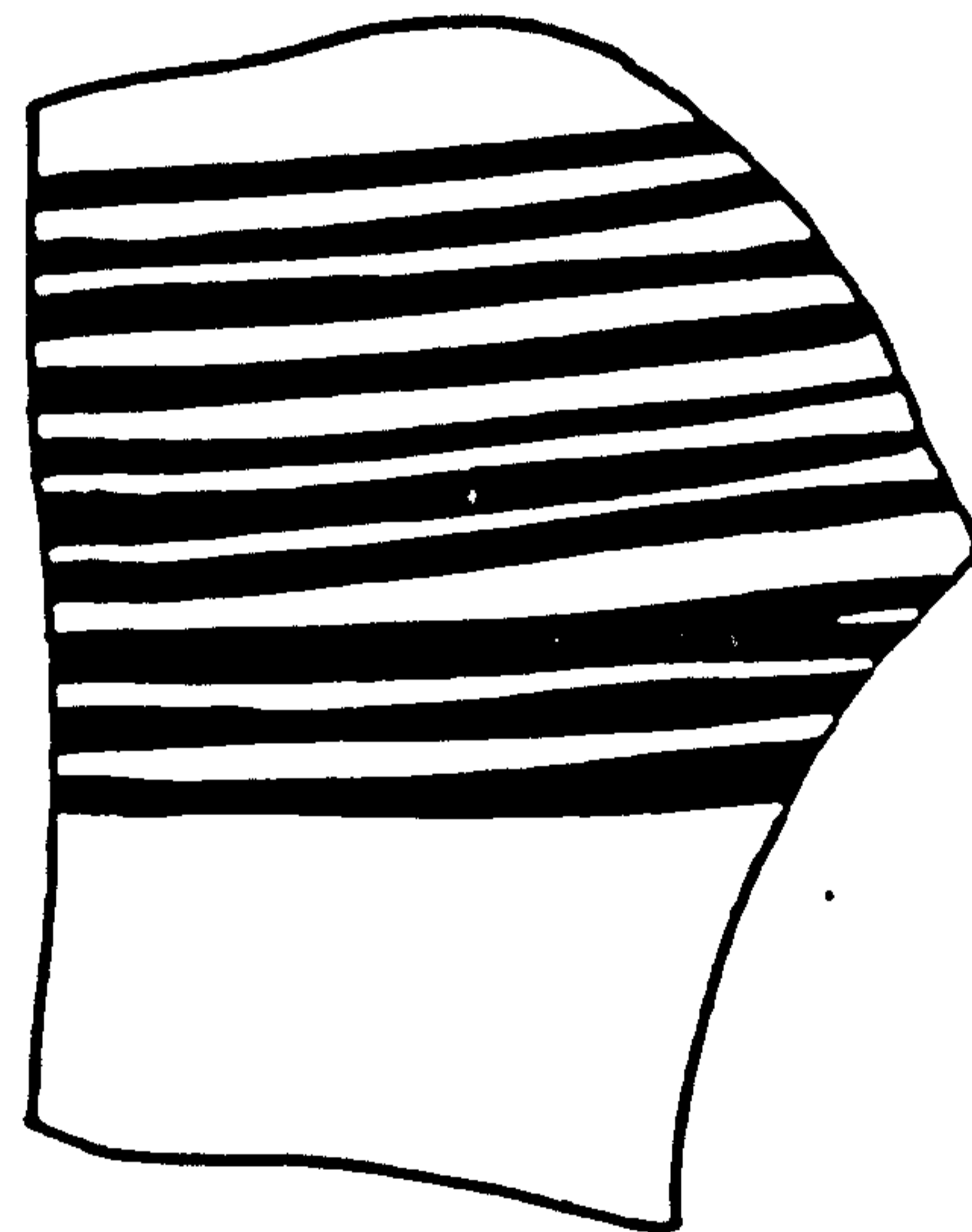

AJJ 70

ILL 47

Red on Black

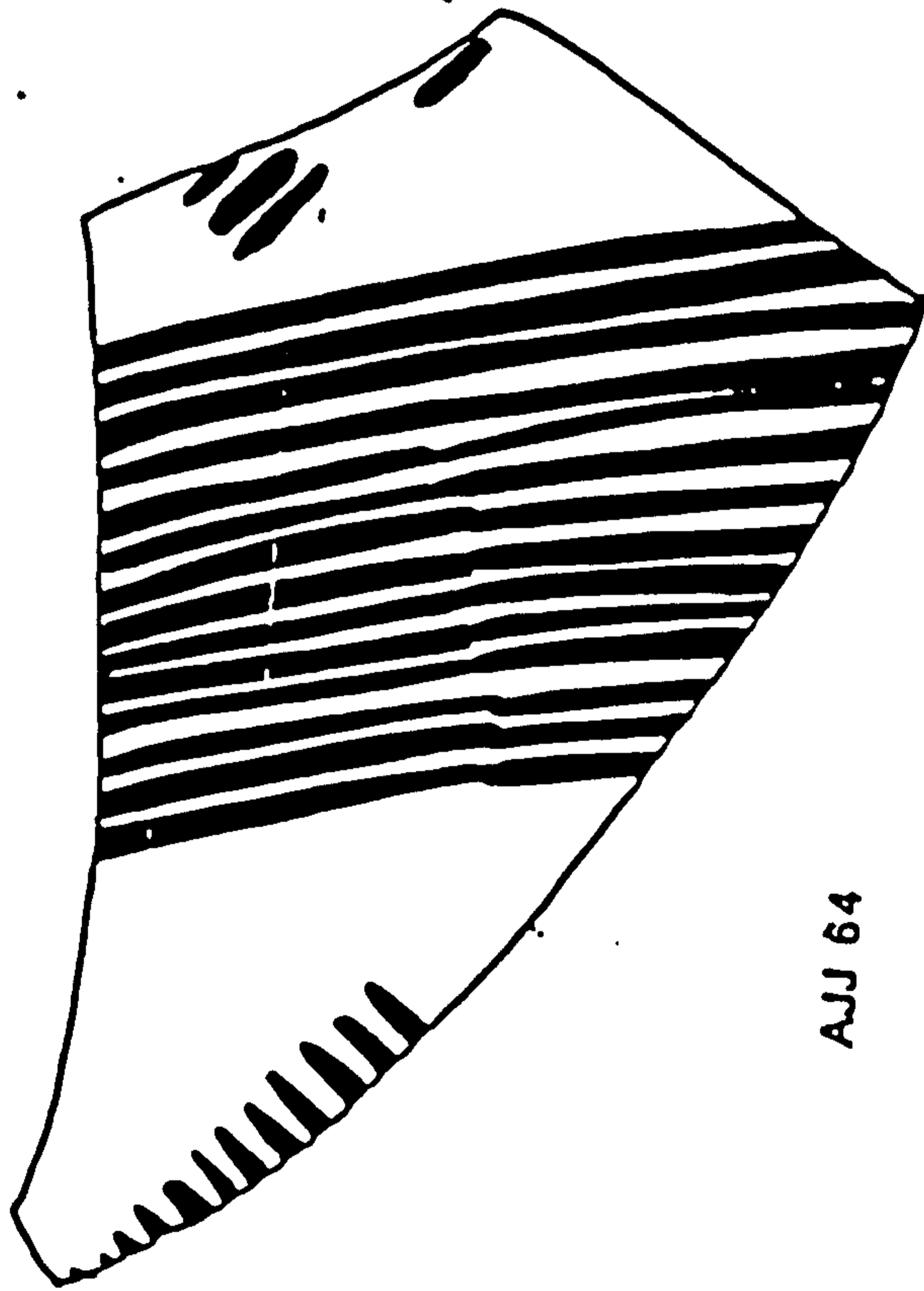
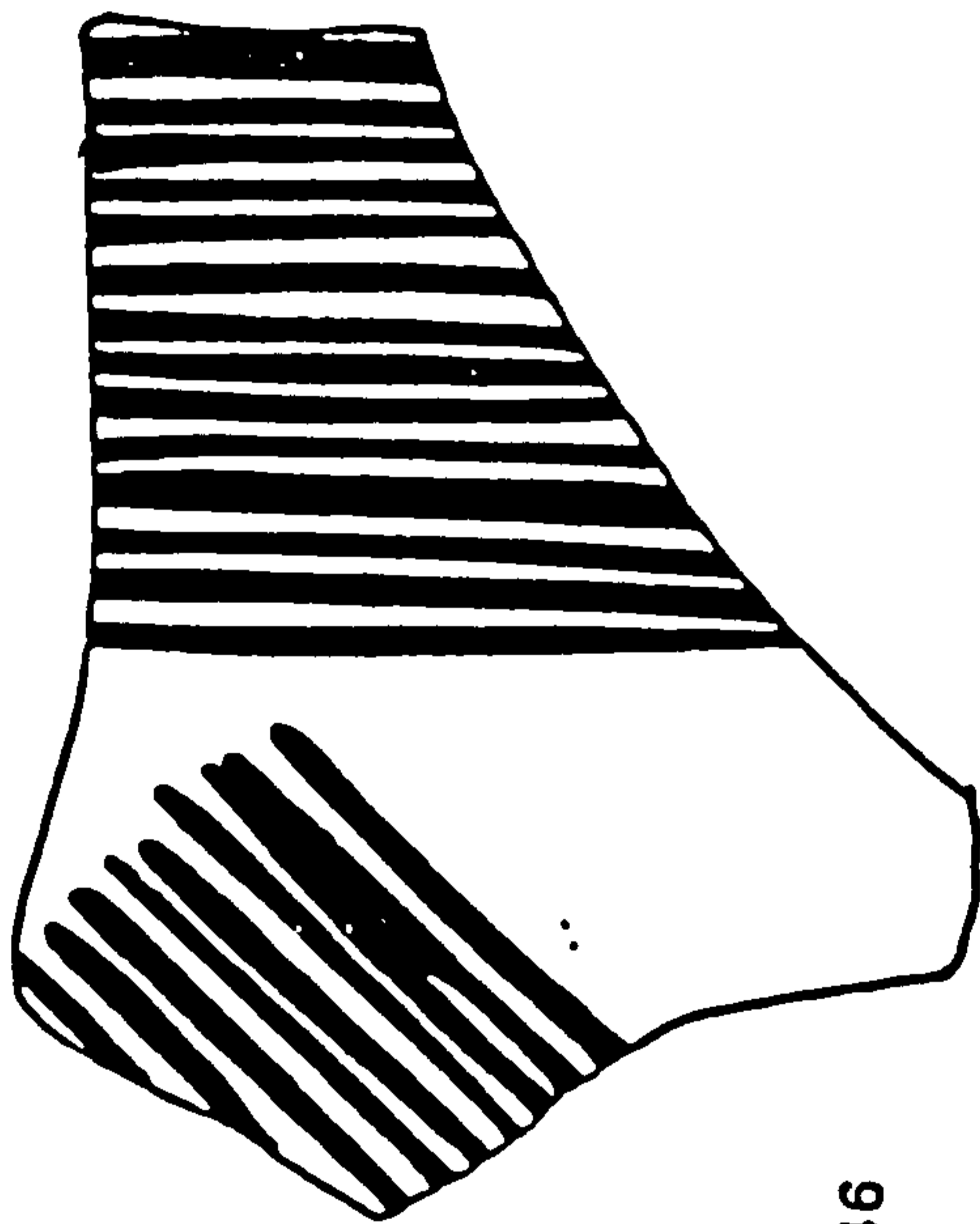
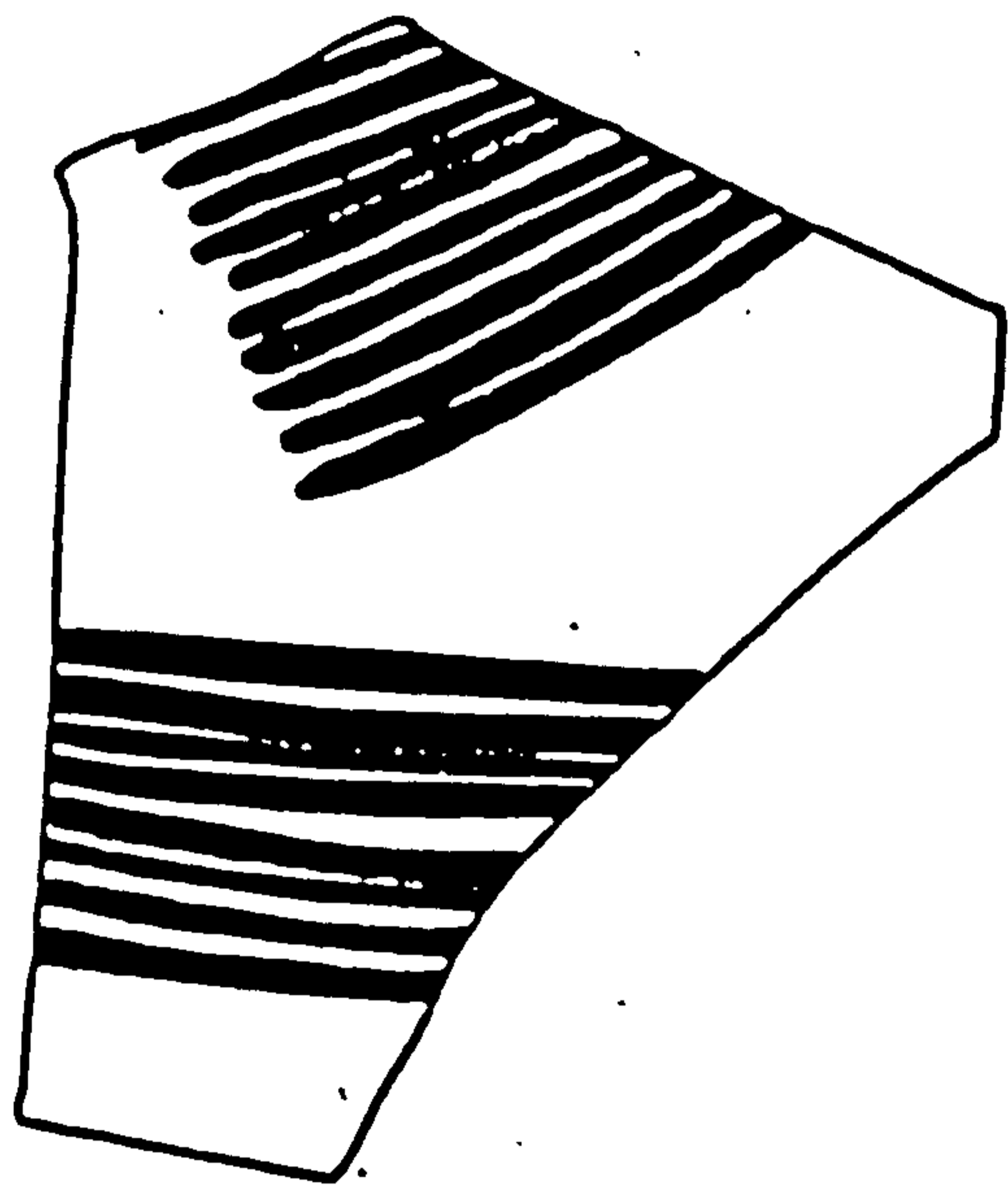
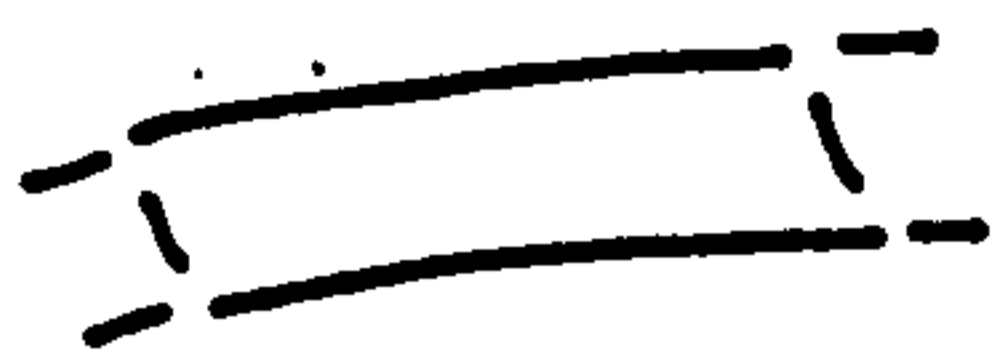

BAL 146

AJJ 64

ILL 48

Red on Black

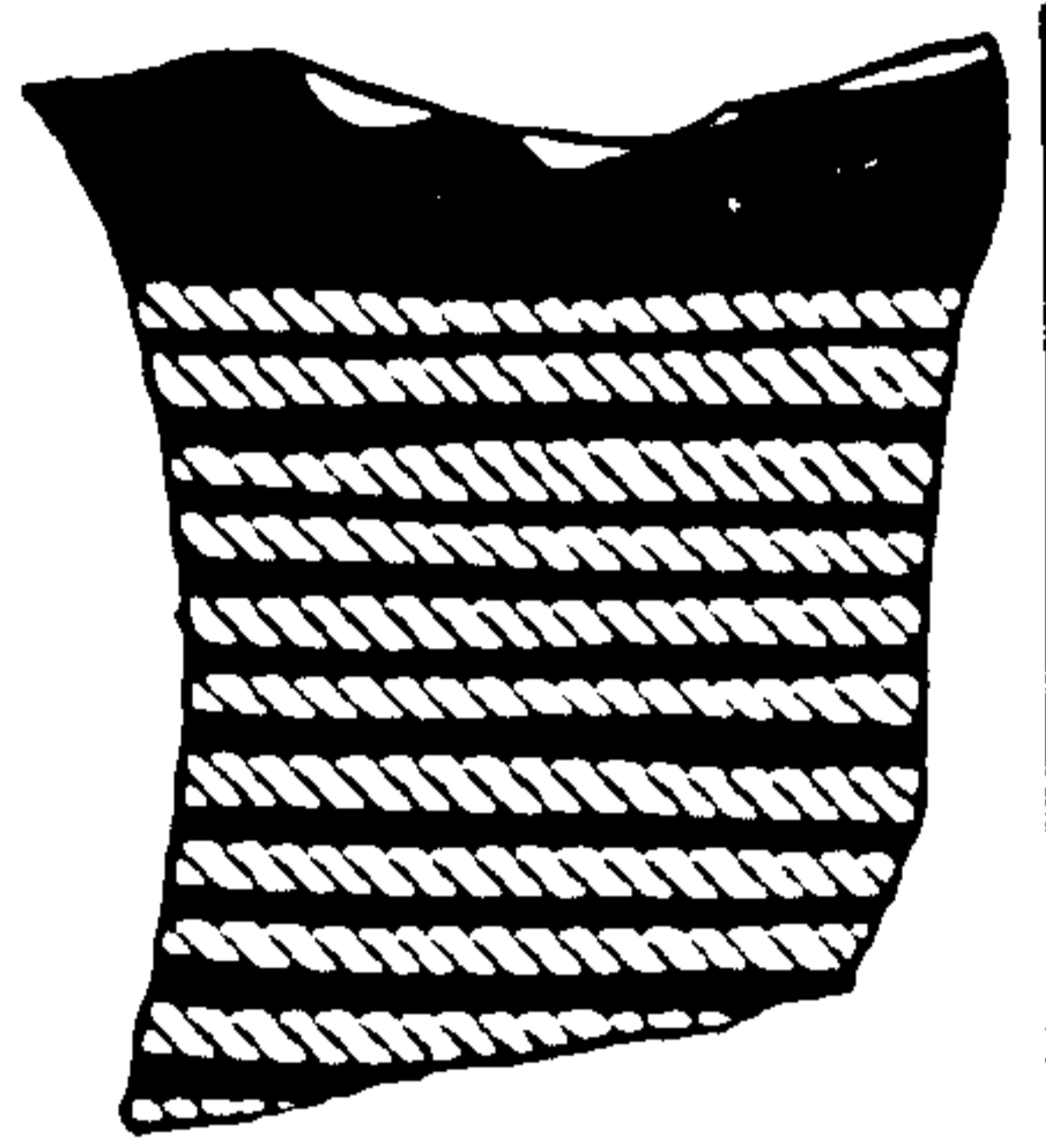

DAB 693

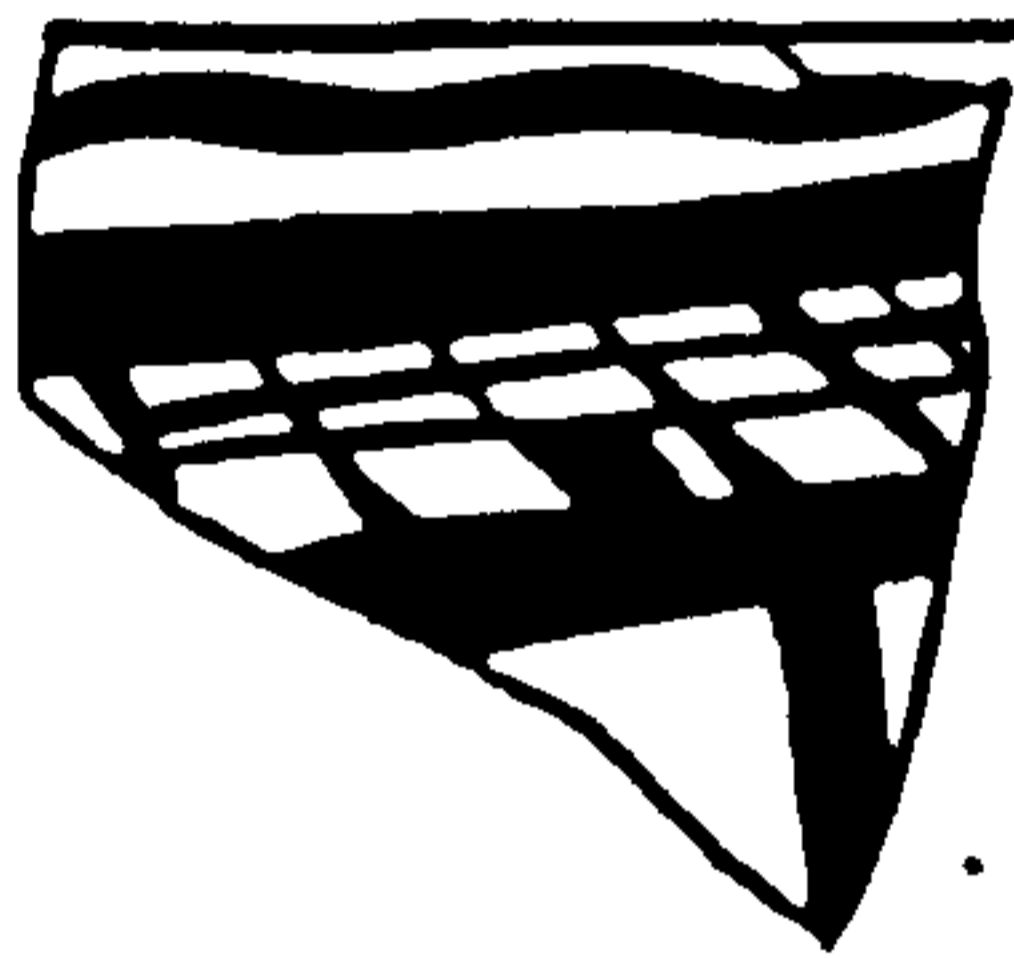

AJJ 129

ILL 49

Red on Black, Proto White Slip

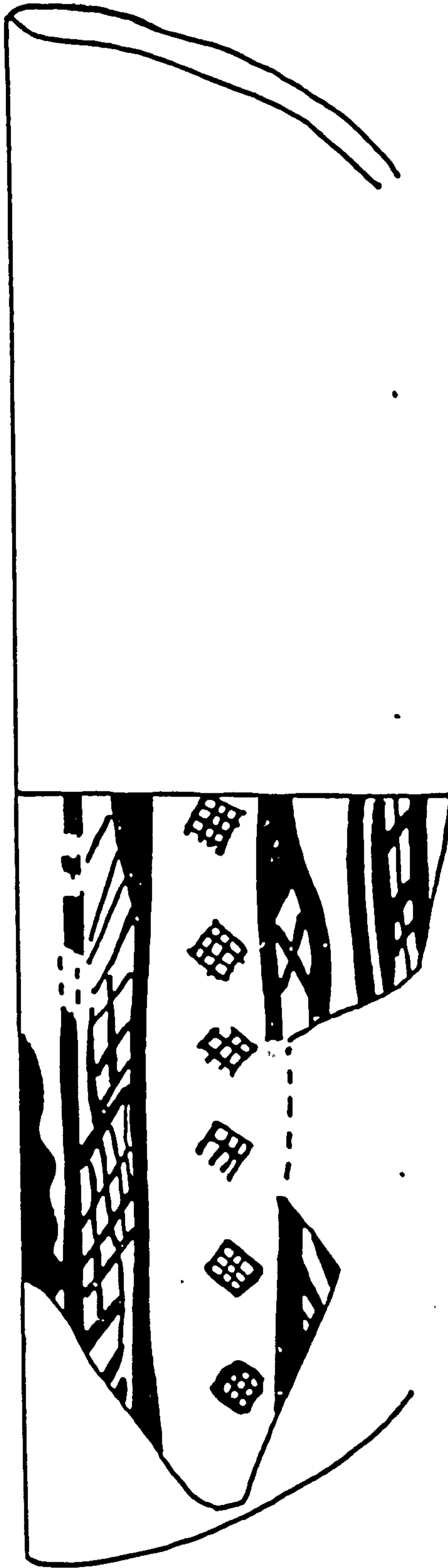

AJJ 132

Proto White Slip

ILL 50

AJJ 126

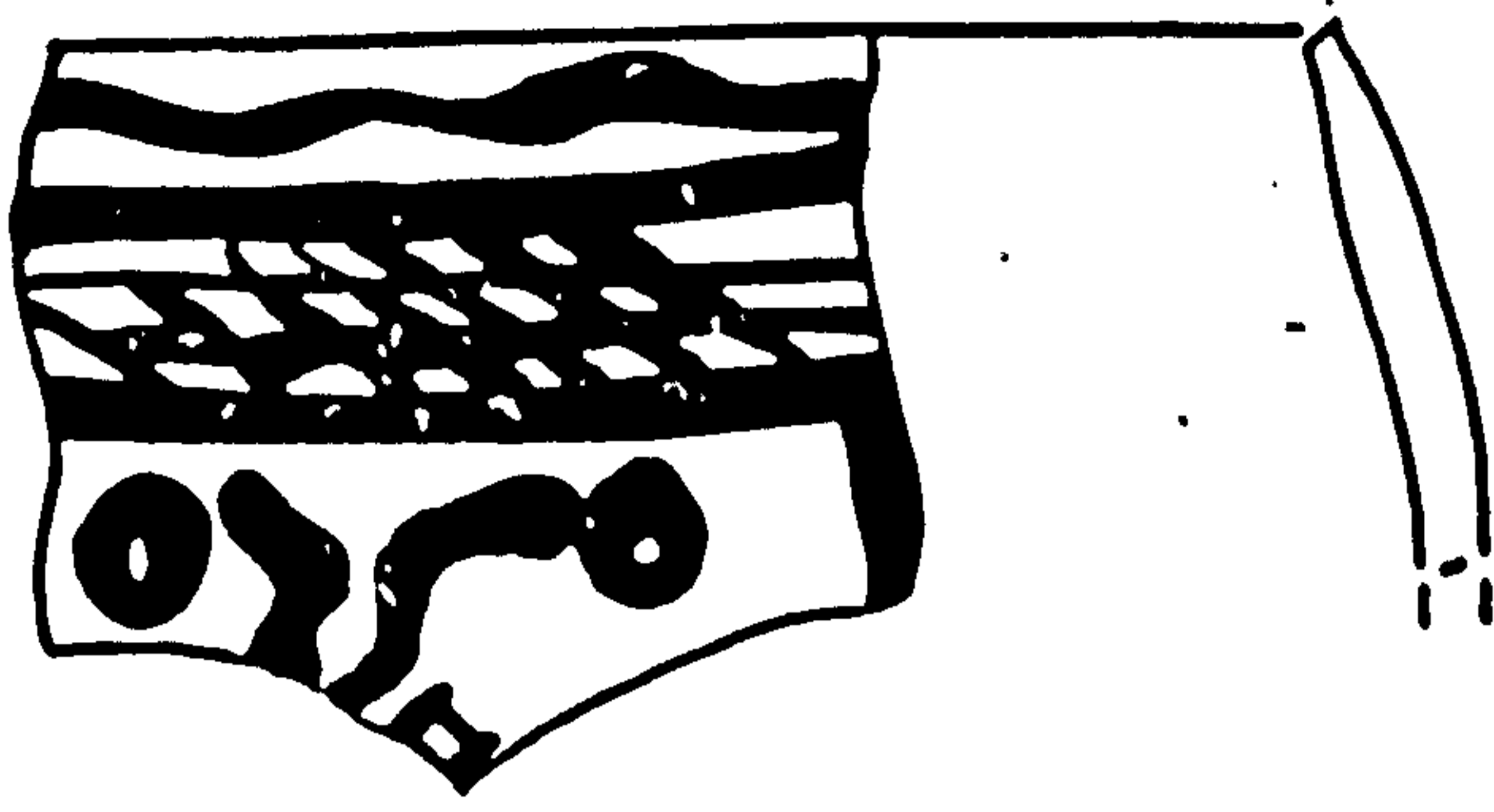

ASH 144.

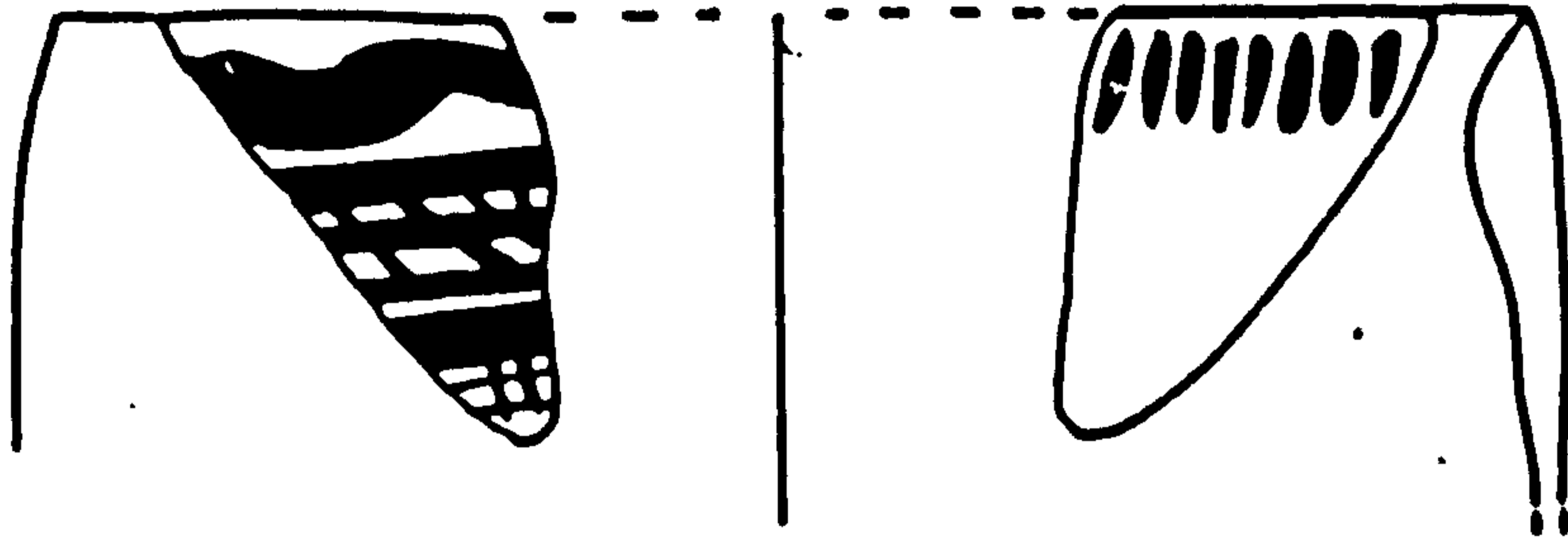

AJJ 125

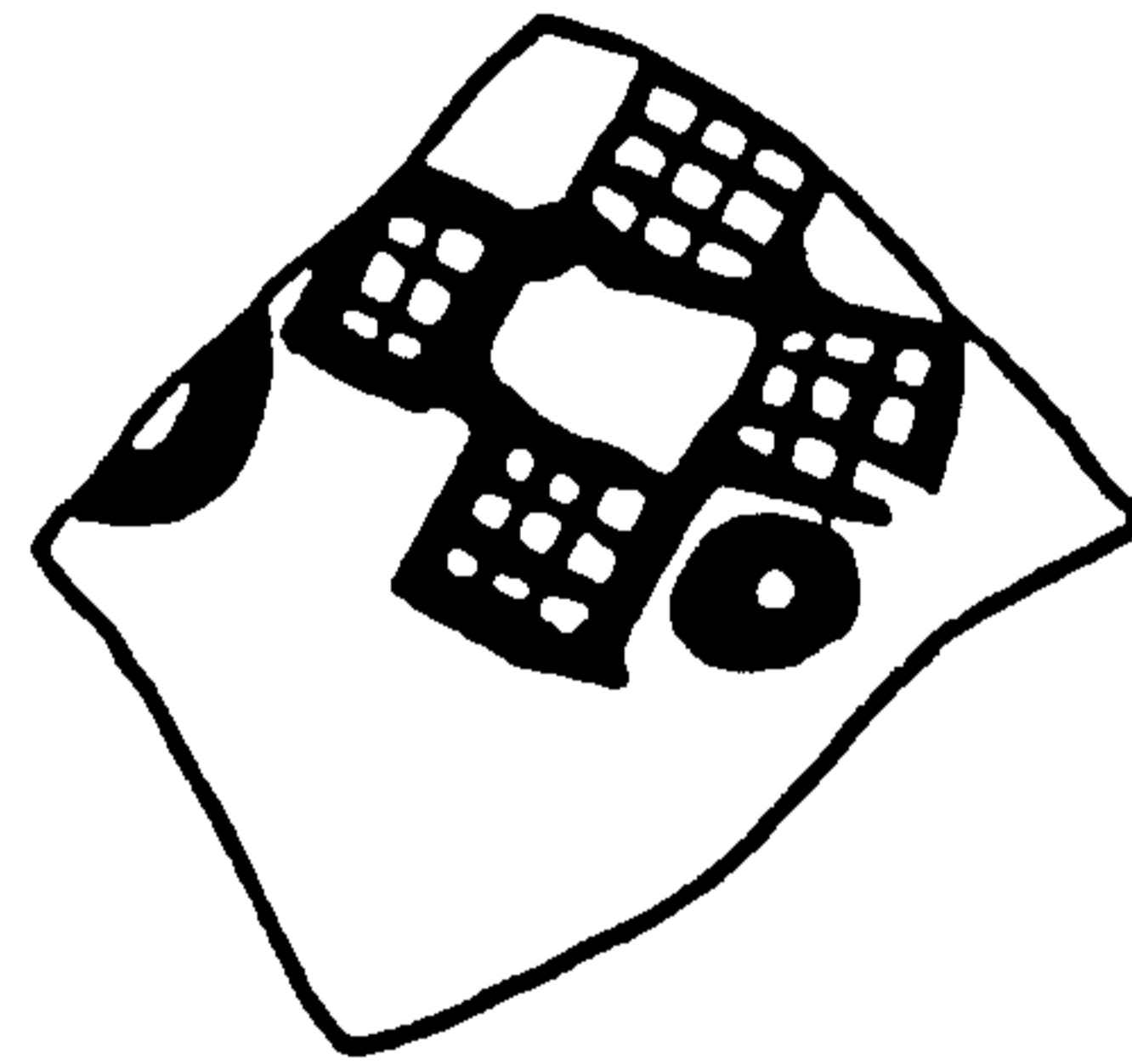
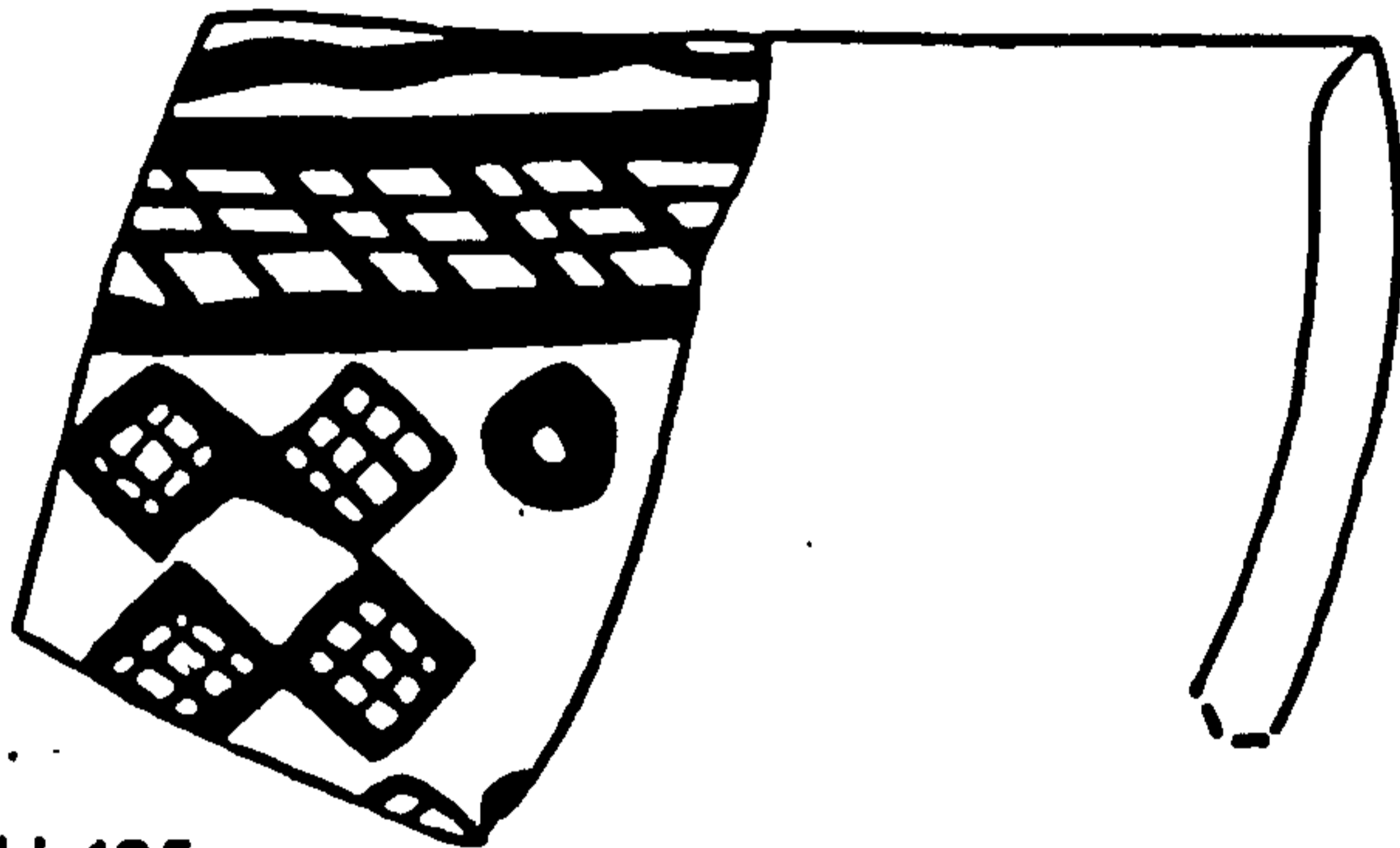

AJJ 127



AJJ 124

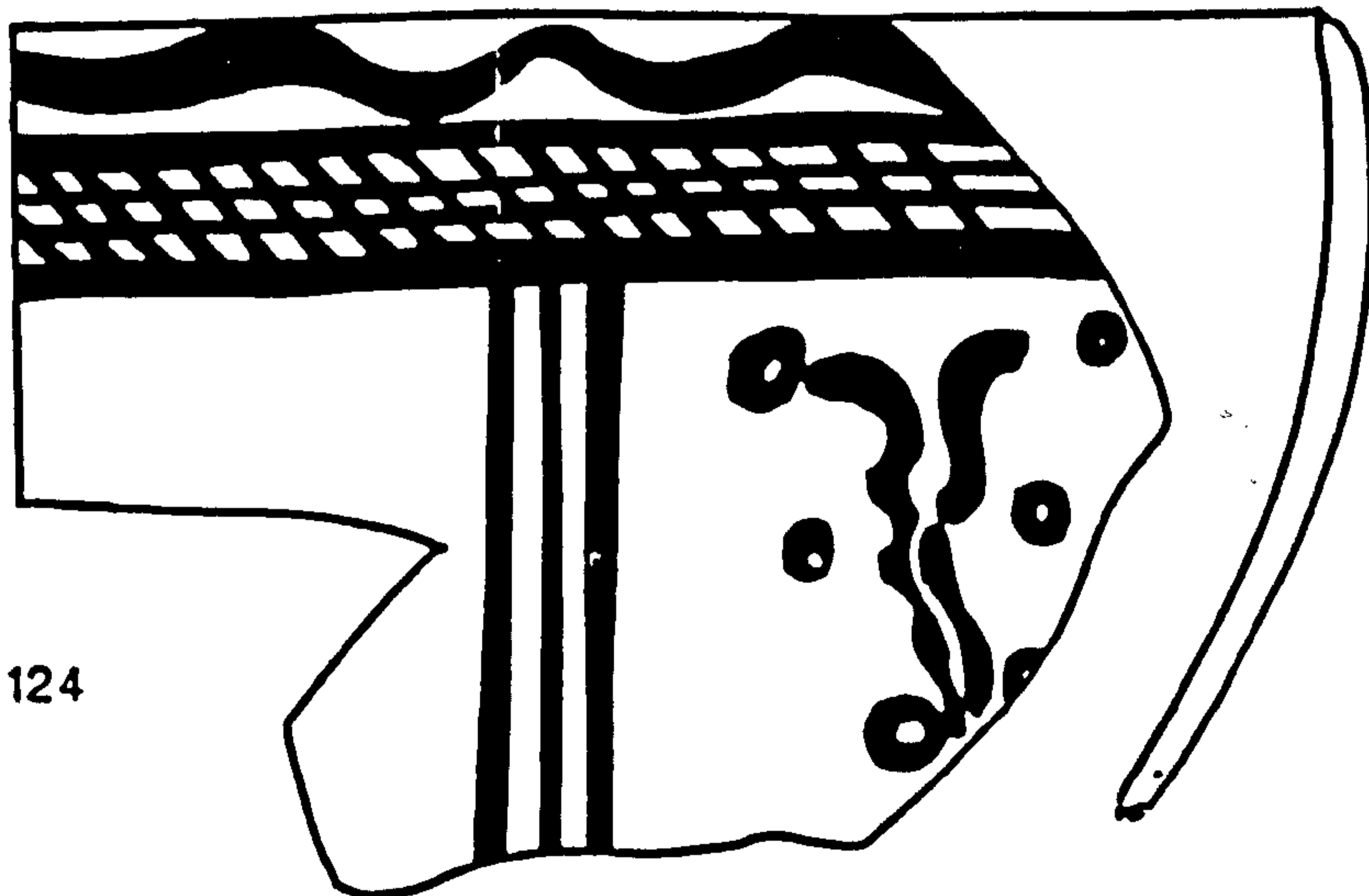

ILL 51

Proto White Slip

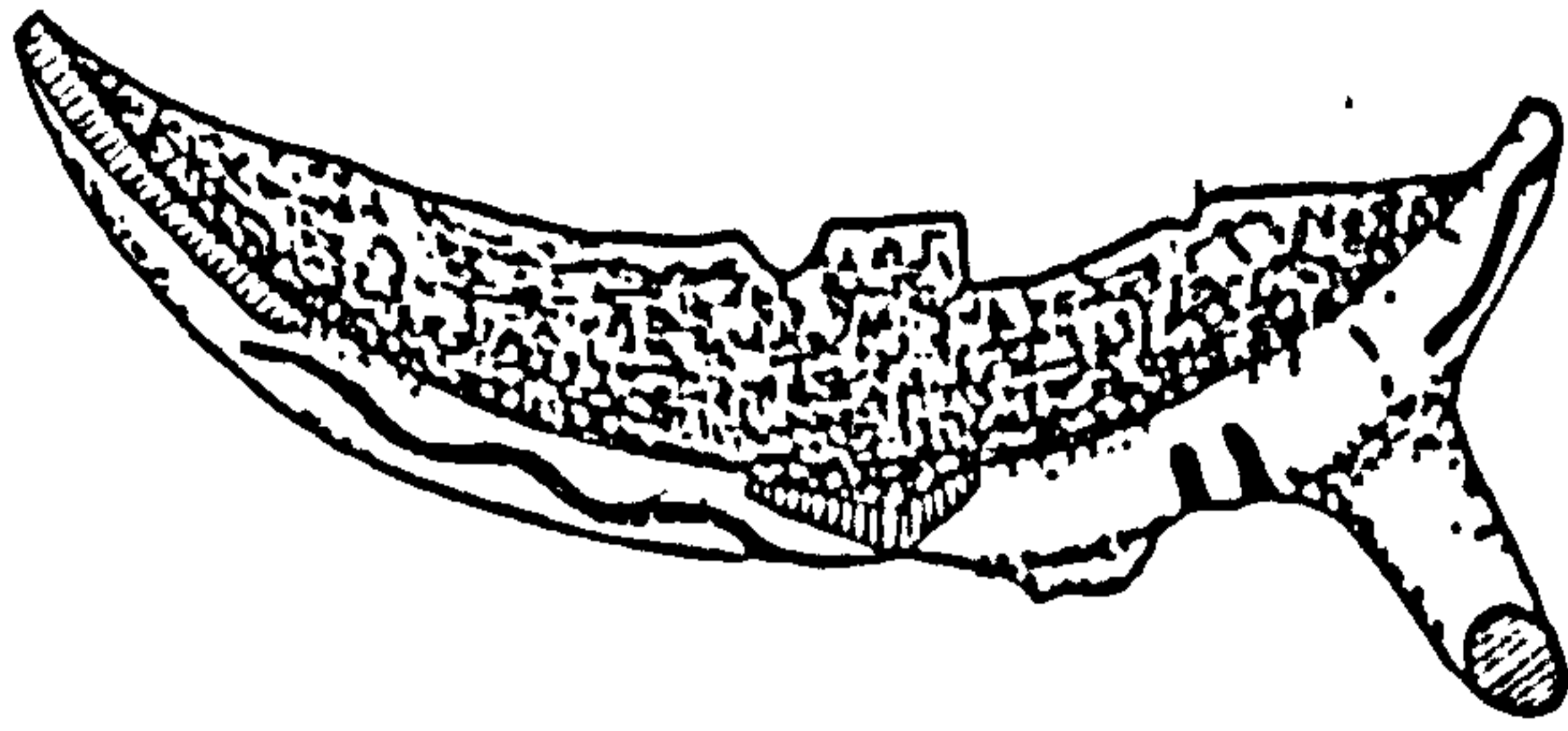

DAB 699

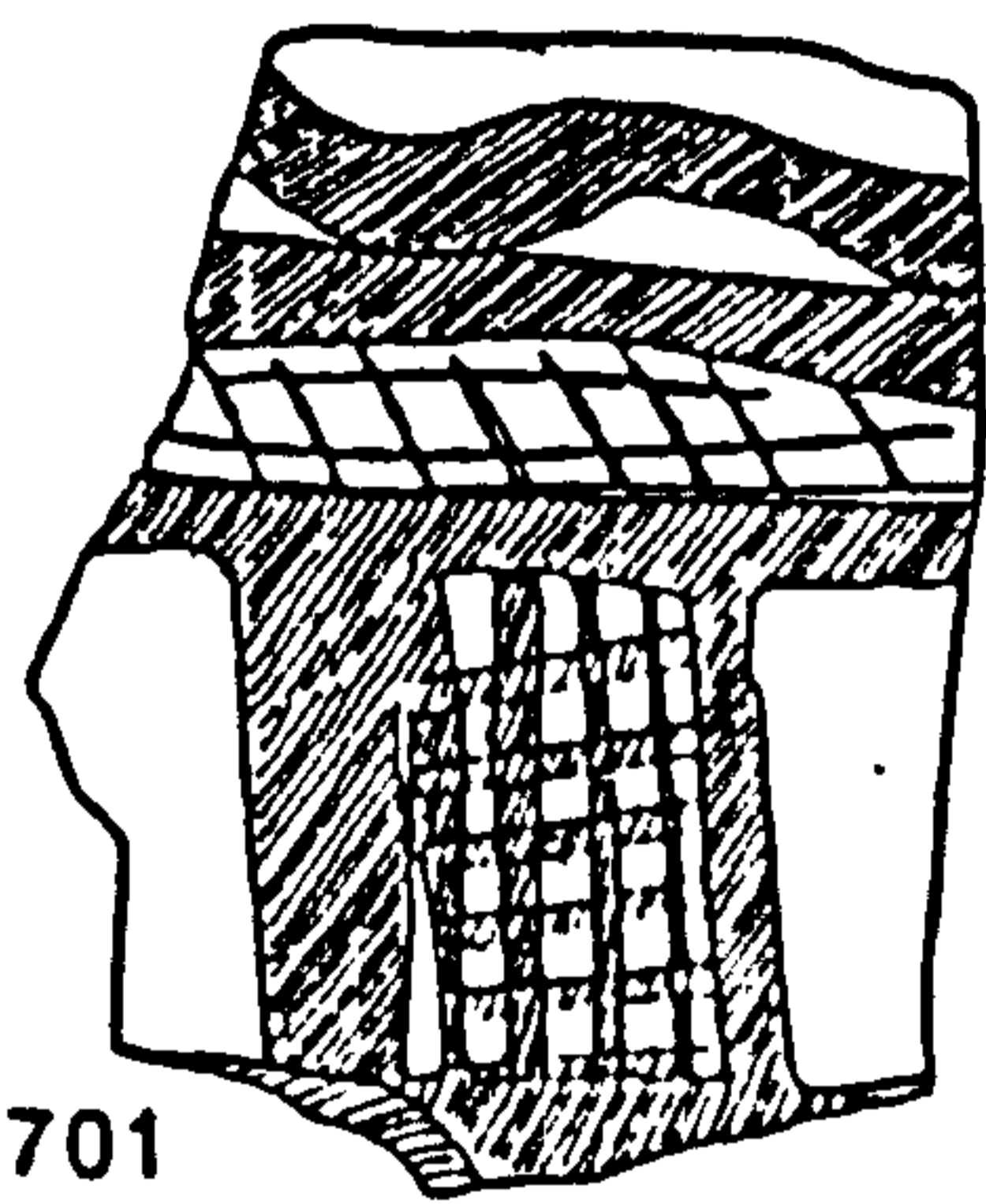
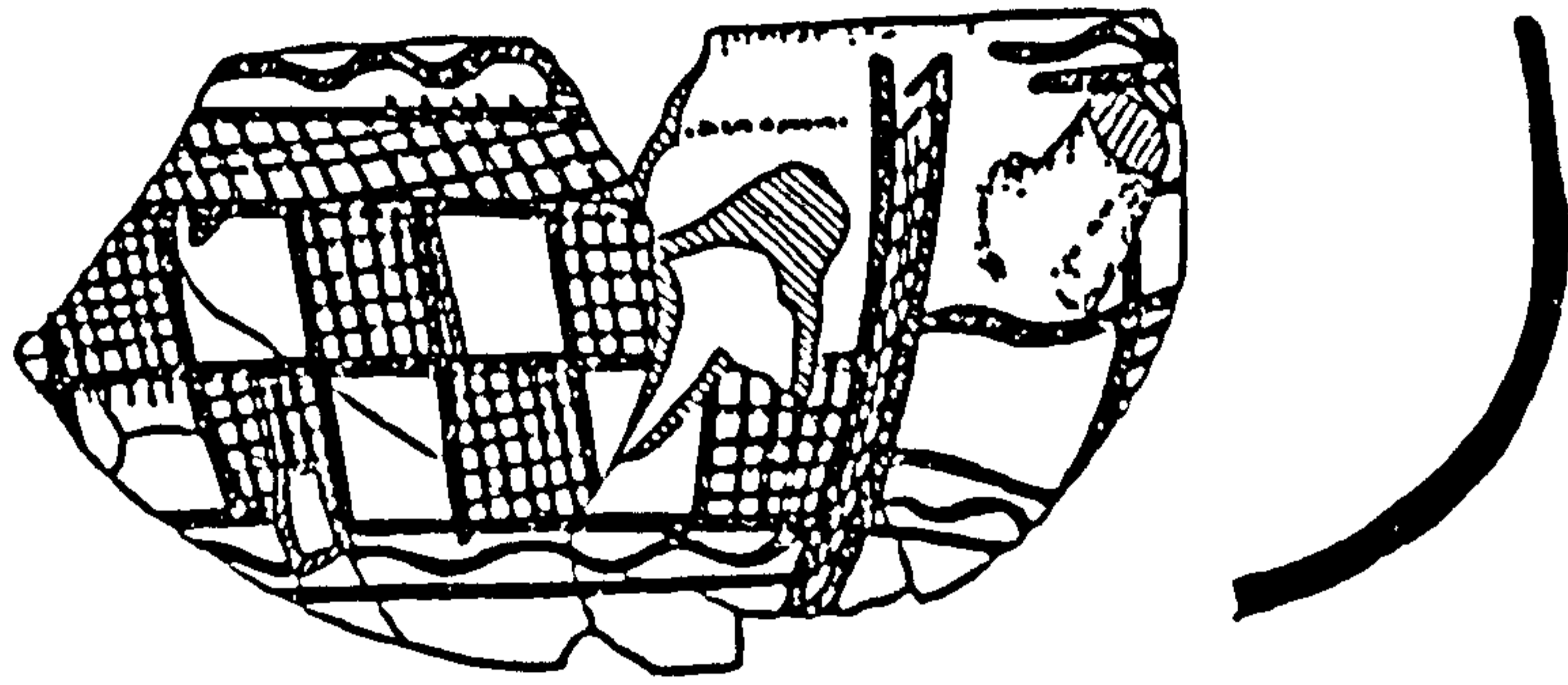

DAB 701



DAB 703

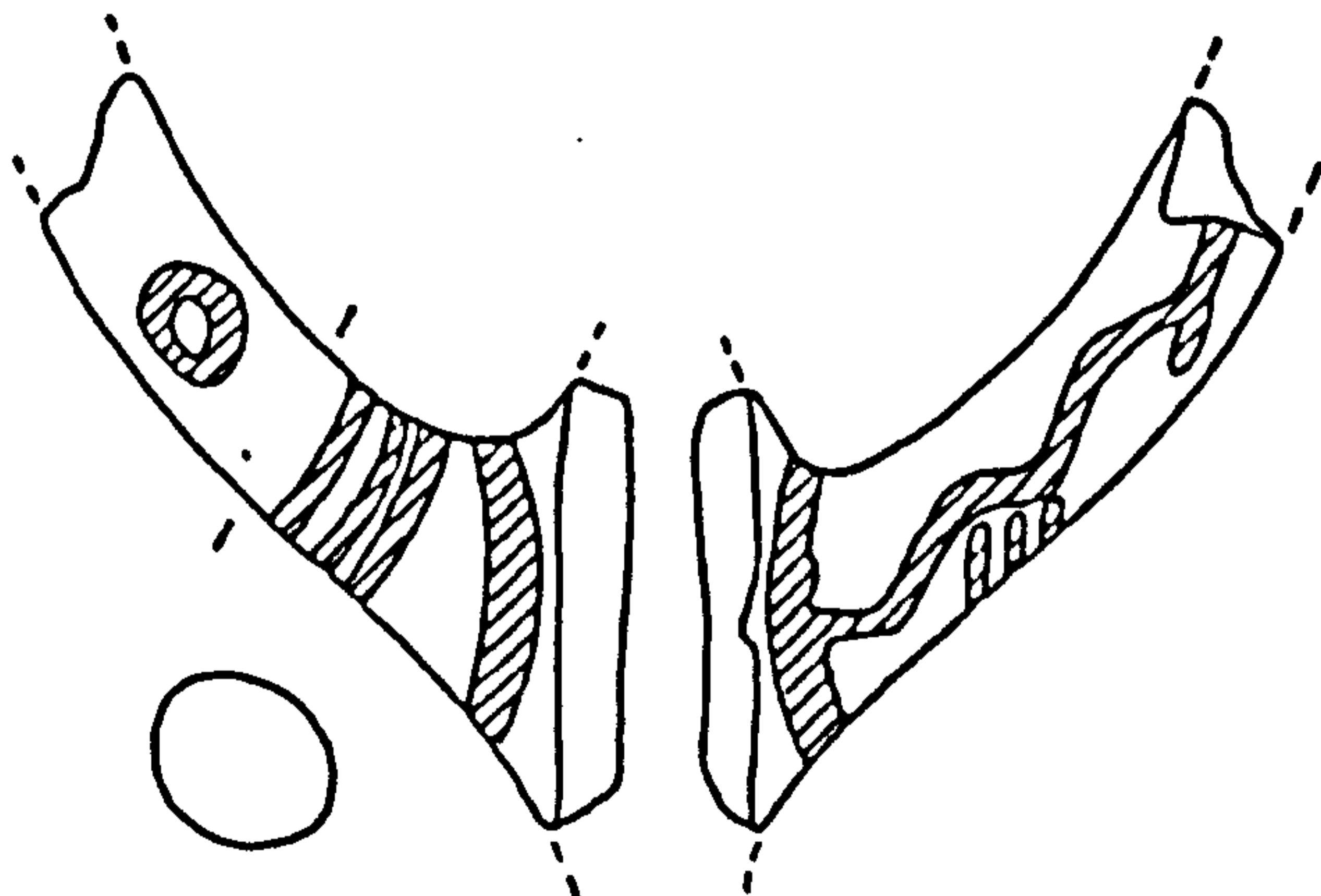

DAB 702

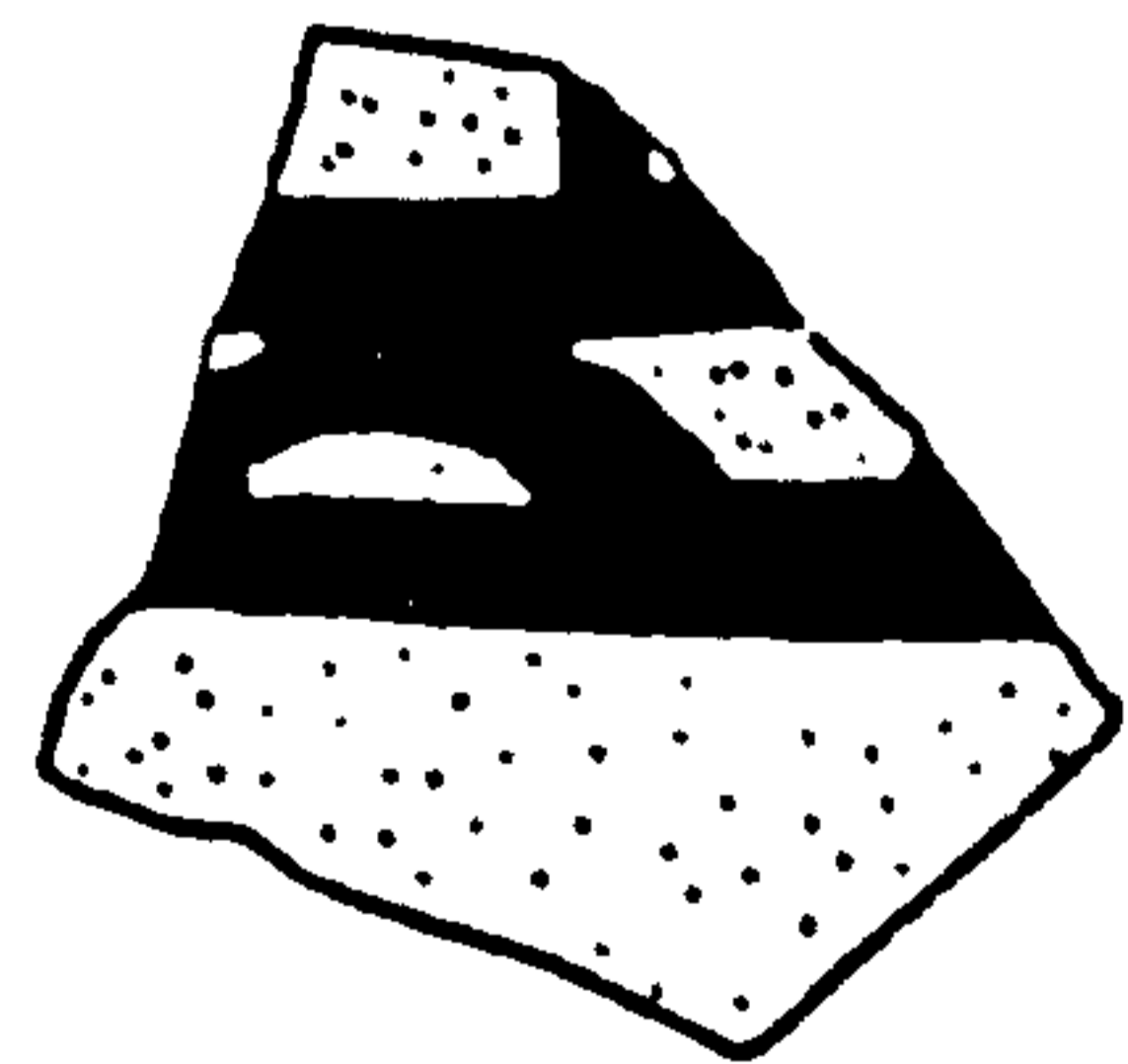

DAB 700

ILL 52

Proto White Slip

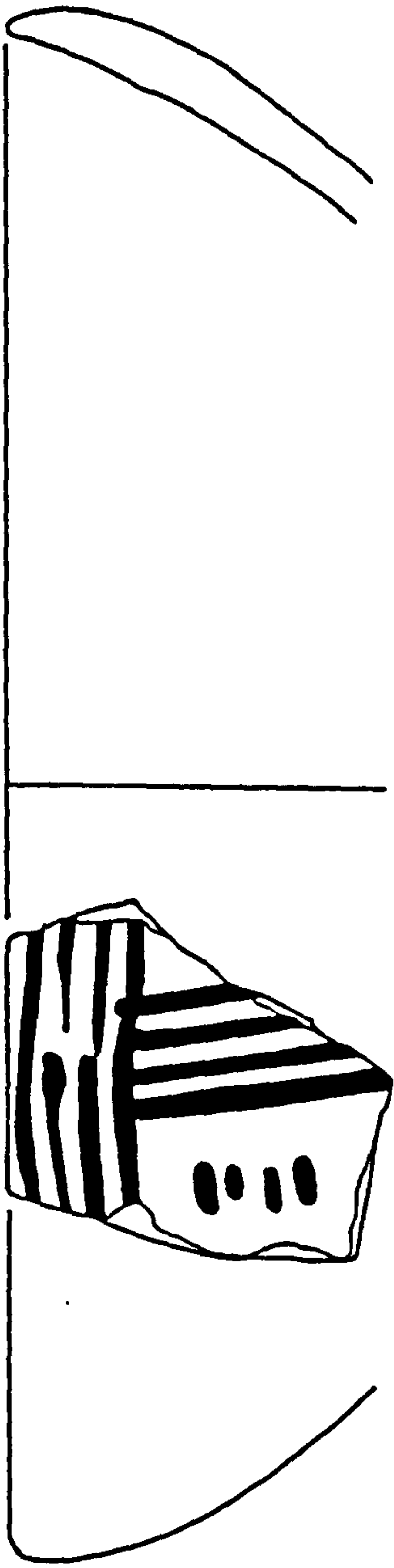

DAB 709

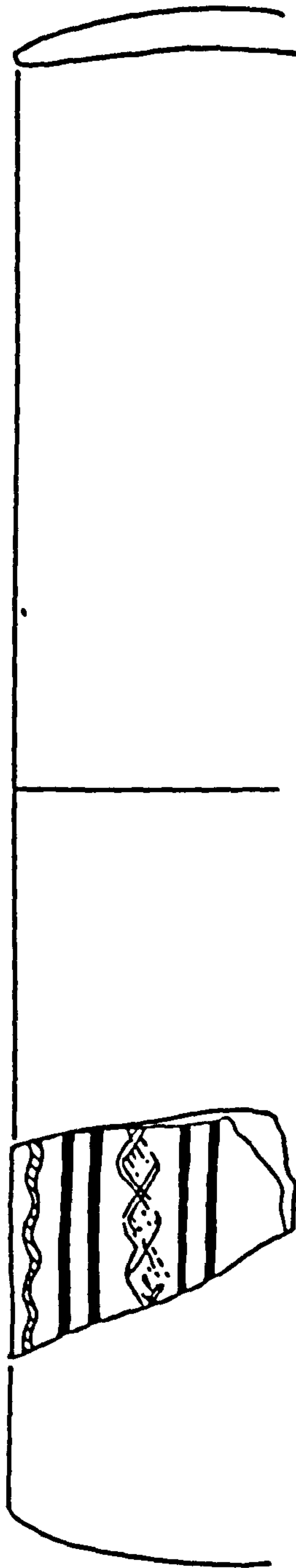

DAB 710

ILL 53

White Slip

DAB 675

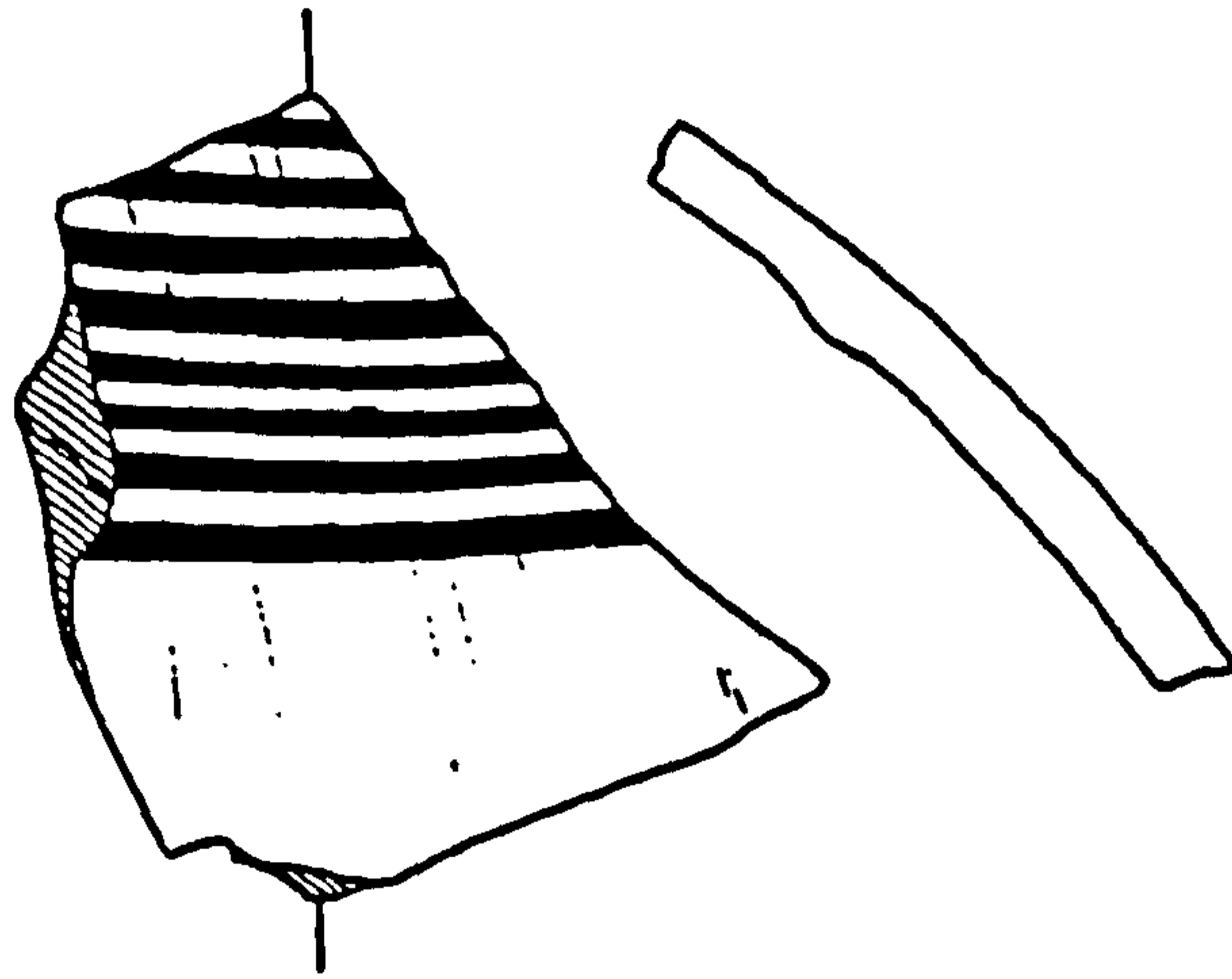

DAB 641



ILL 54

White Painted Wheelmade

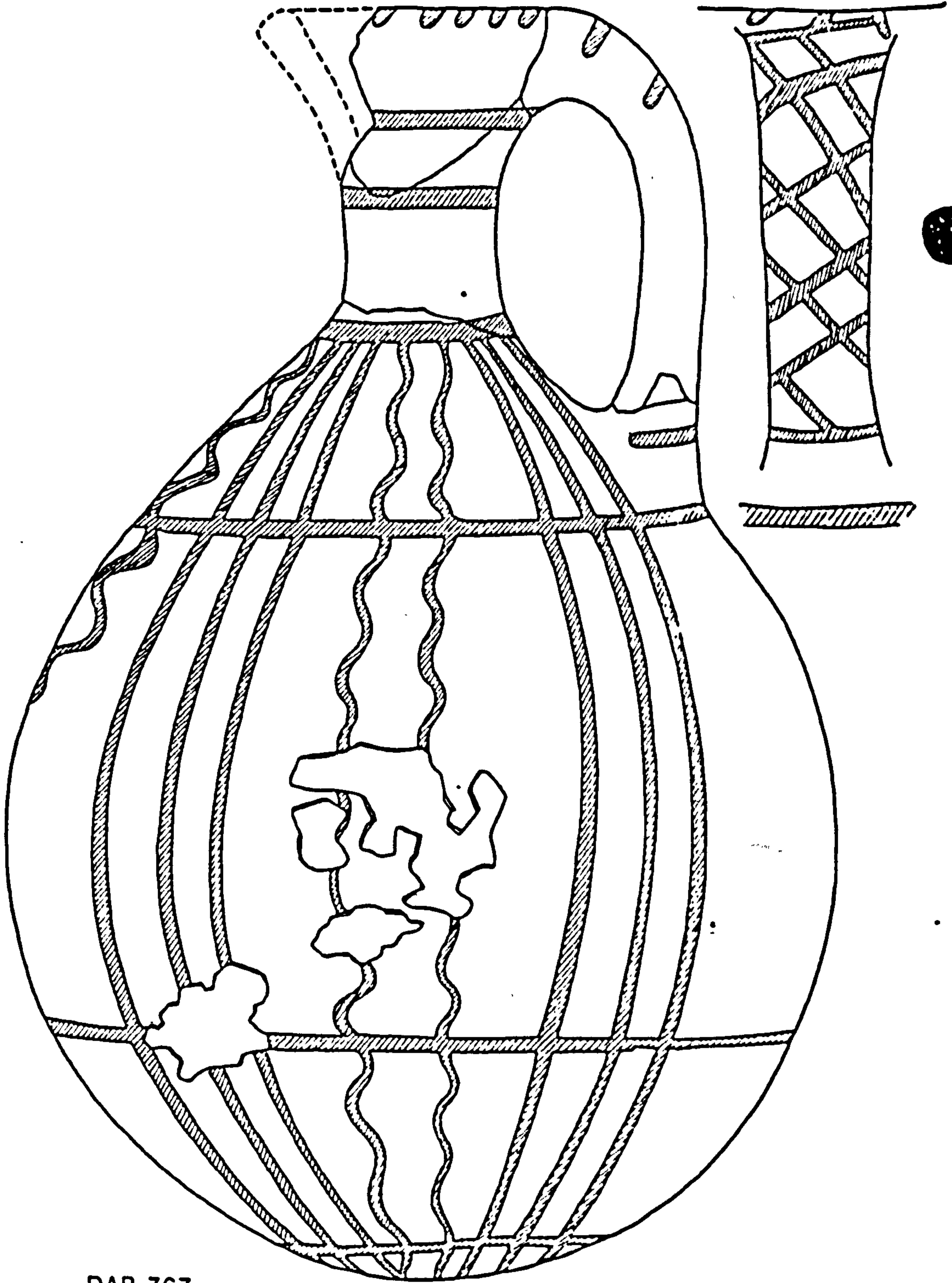

DAB 767
1:1

ILL 55

Imitation White Painted Pendent Line Style

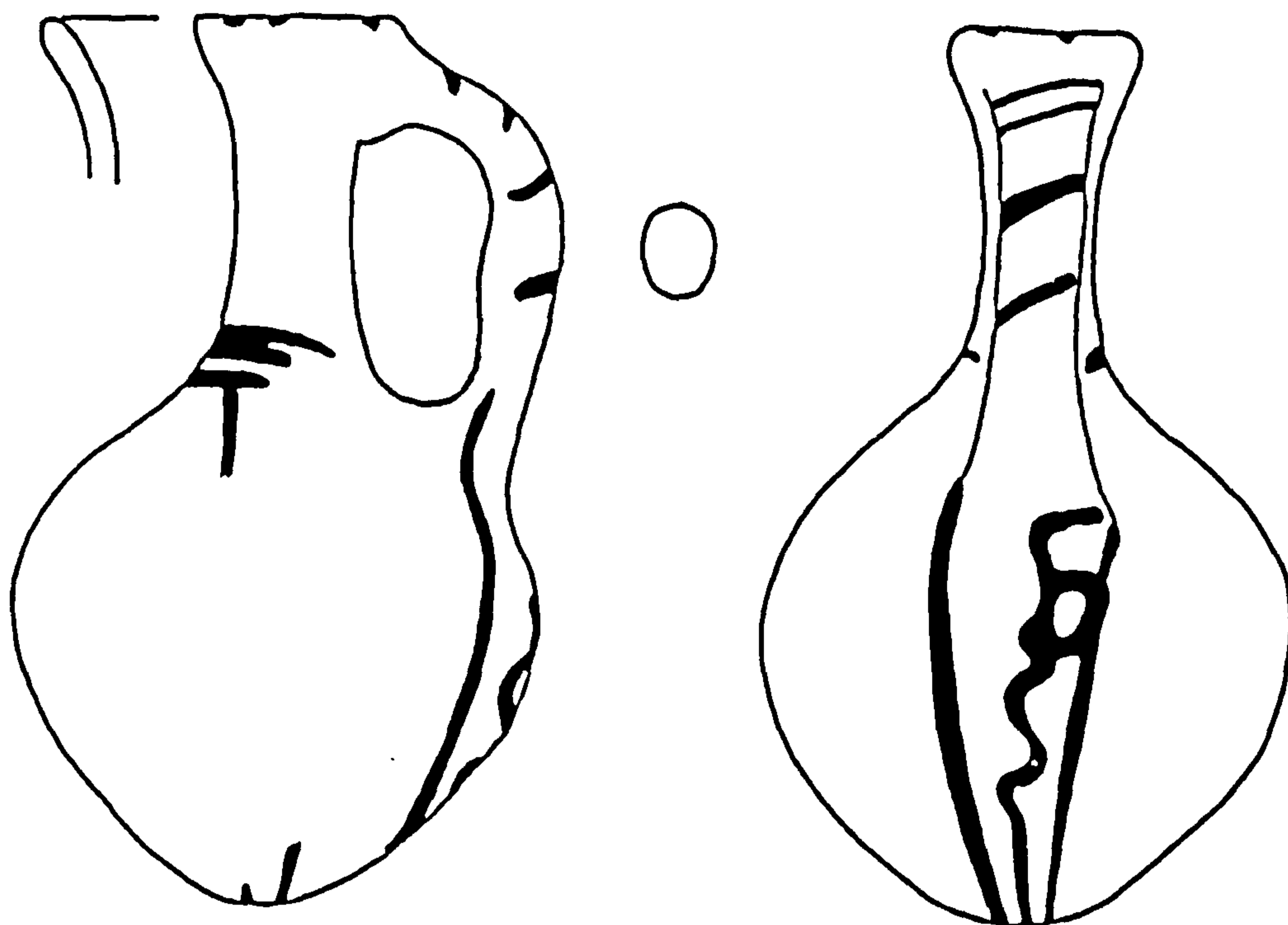

DAB 771

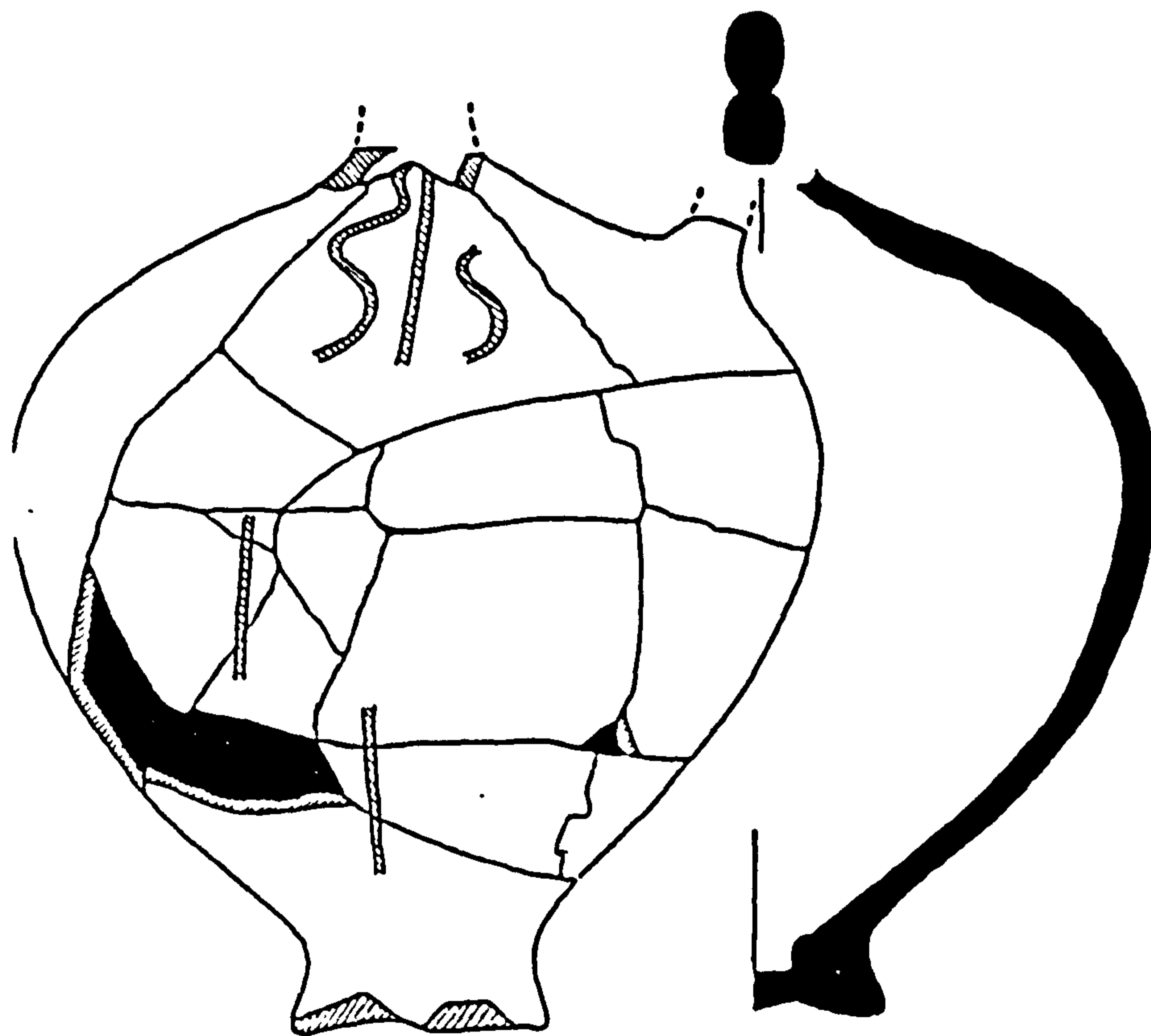

DAB 772

ILL 56

Imitation White Painted Pendent Line Style

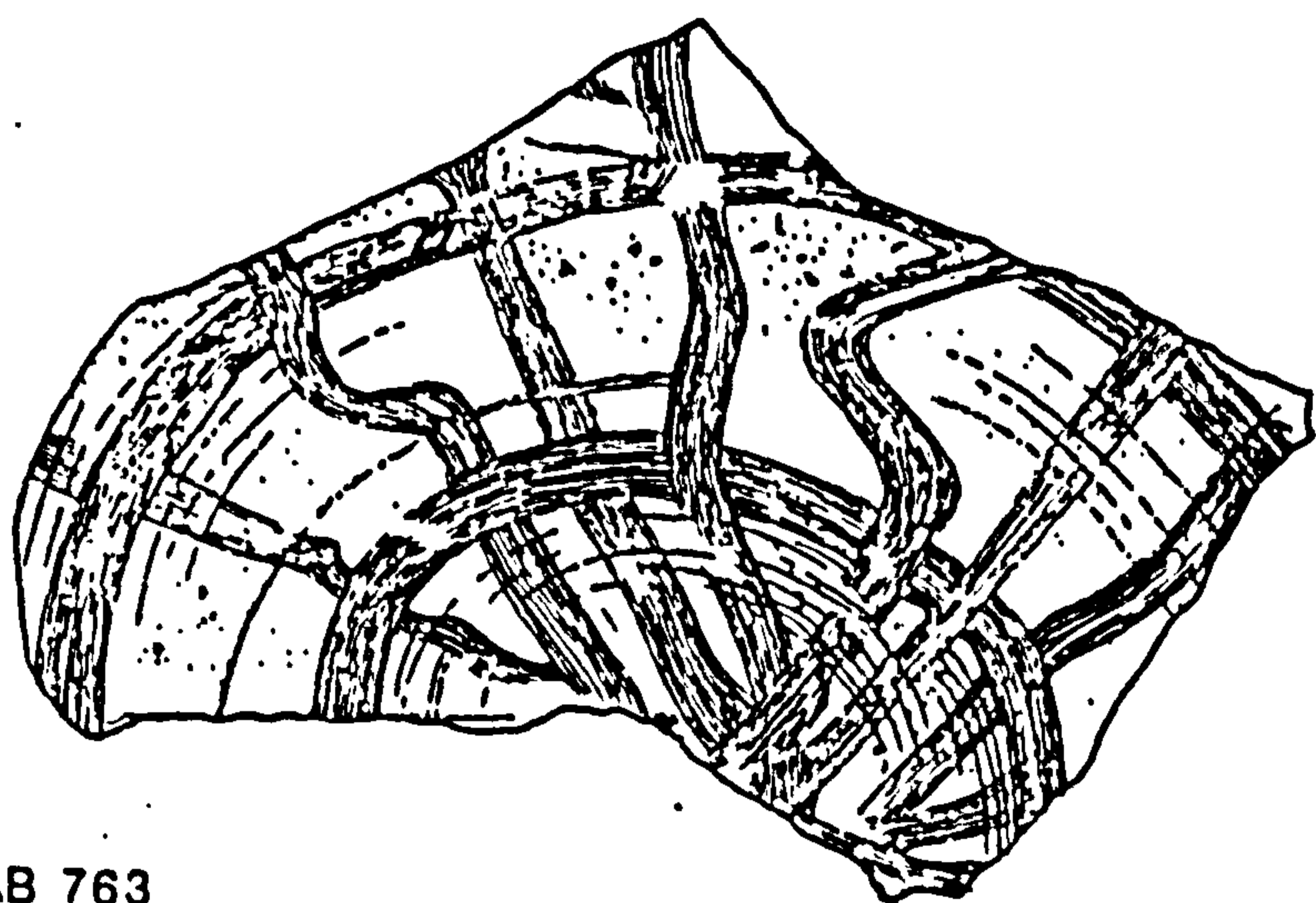

DAB 763

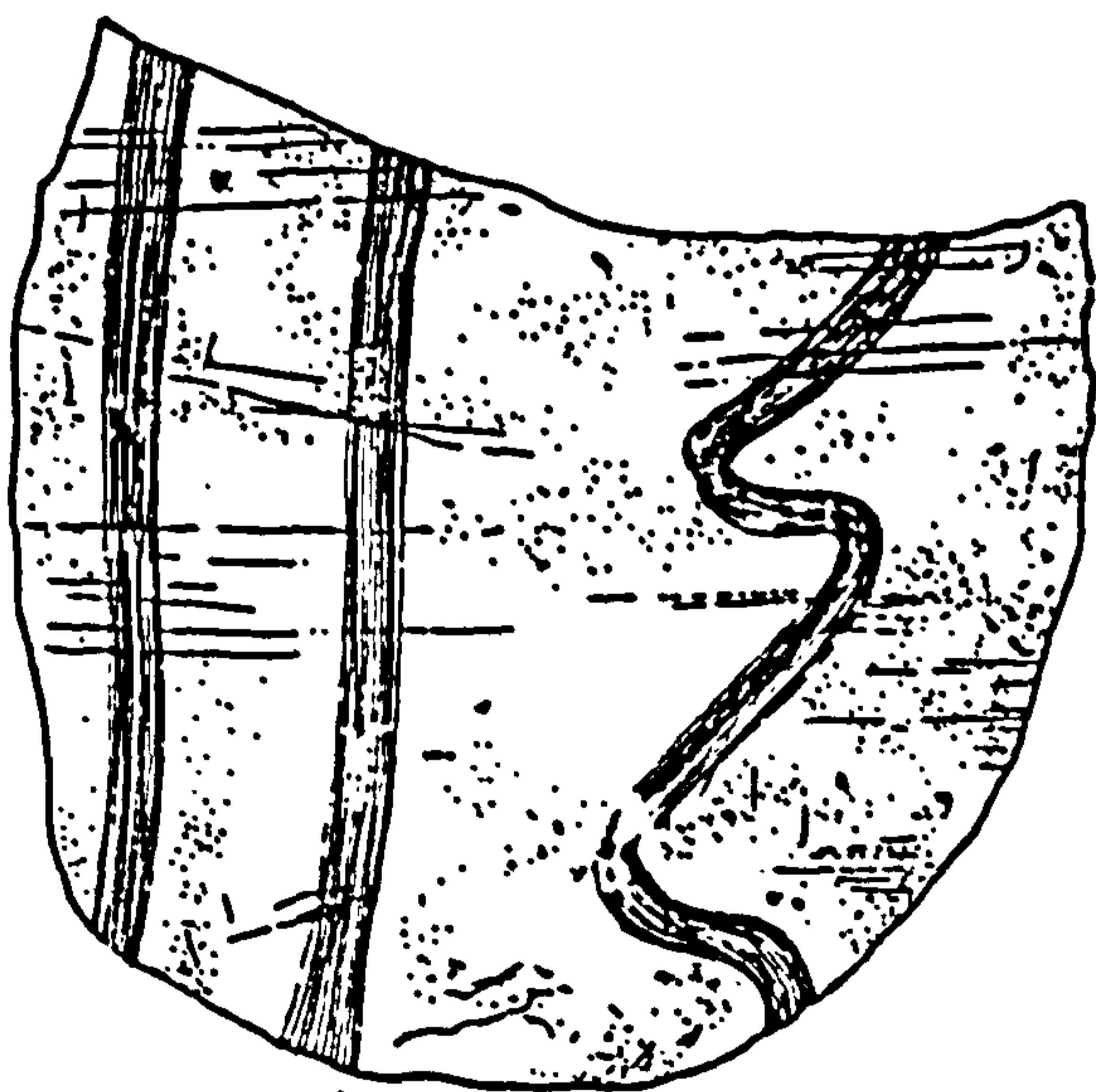

DAB 763

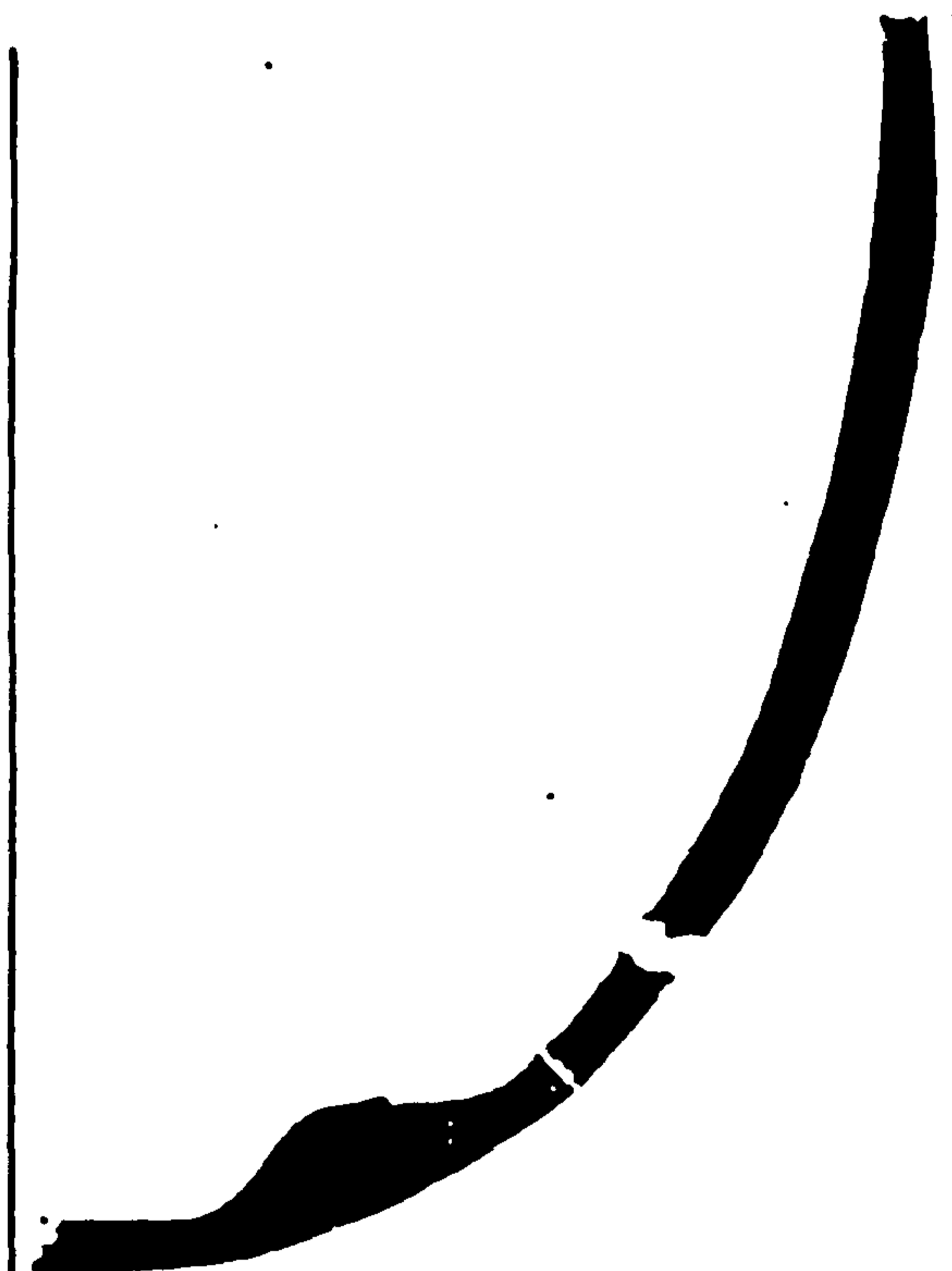

ILL 57

Imitation White Painted Pendent Line Style

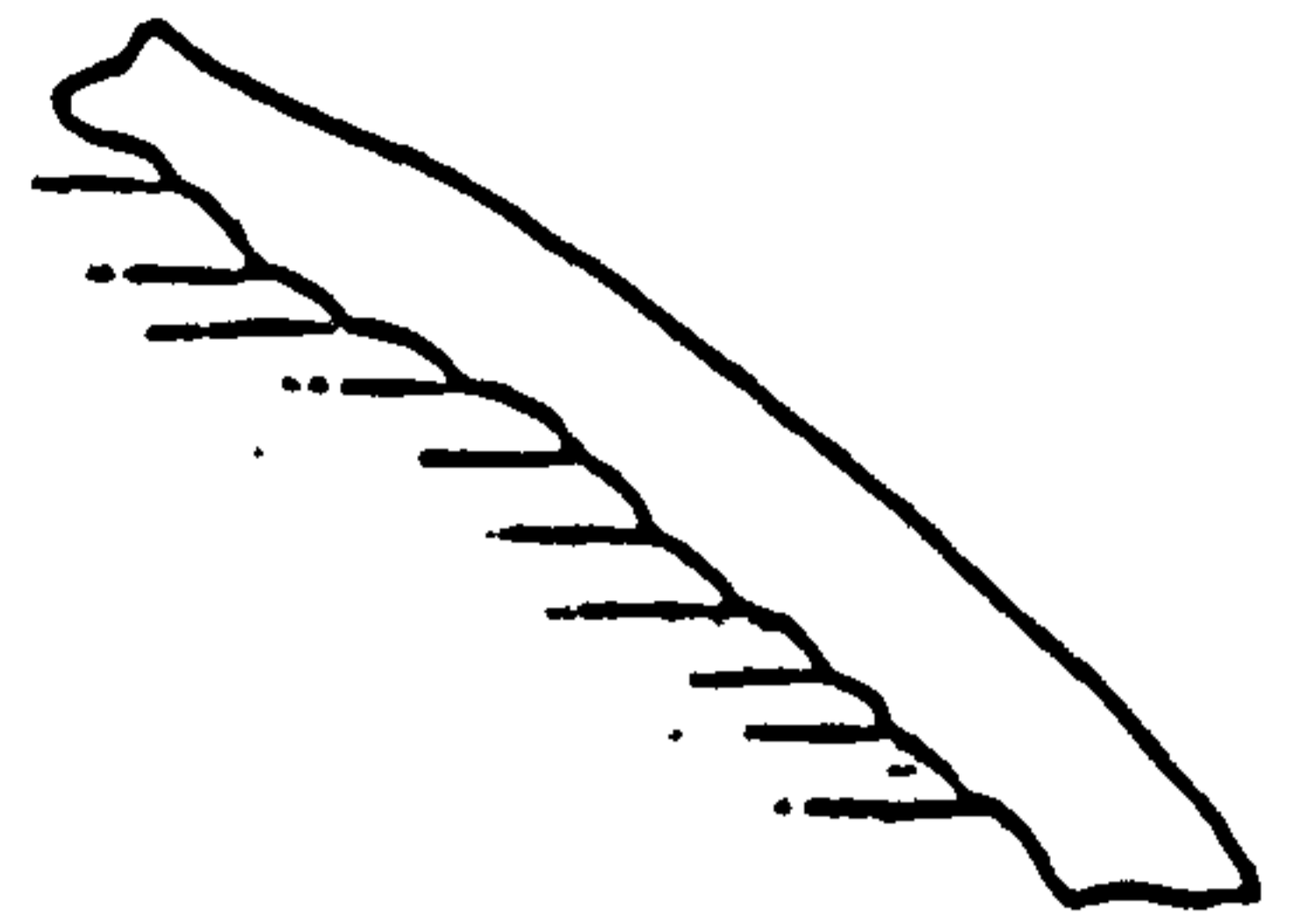
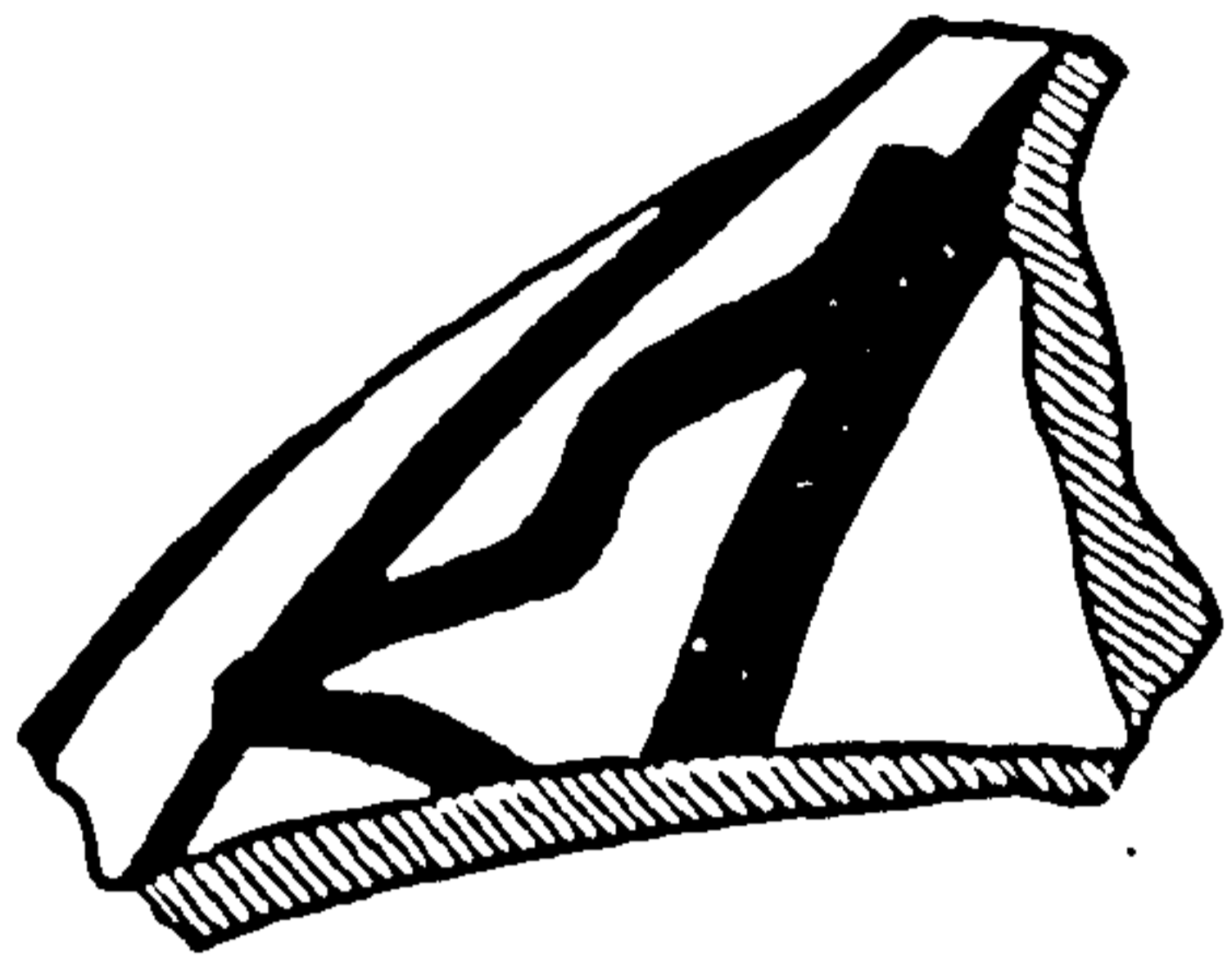

DAB 757

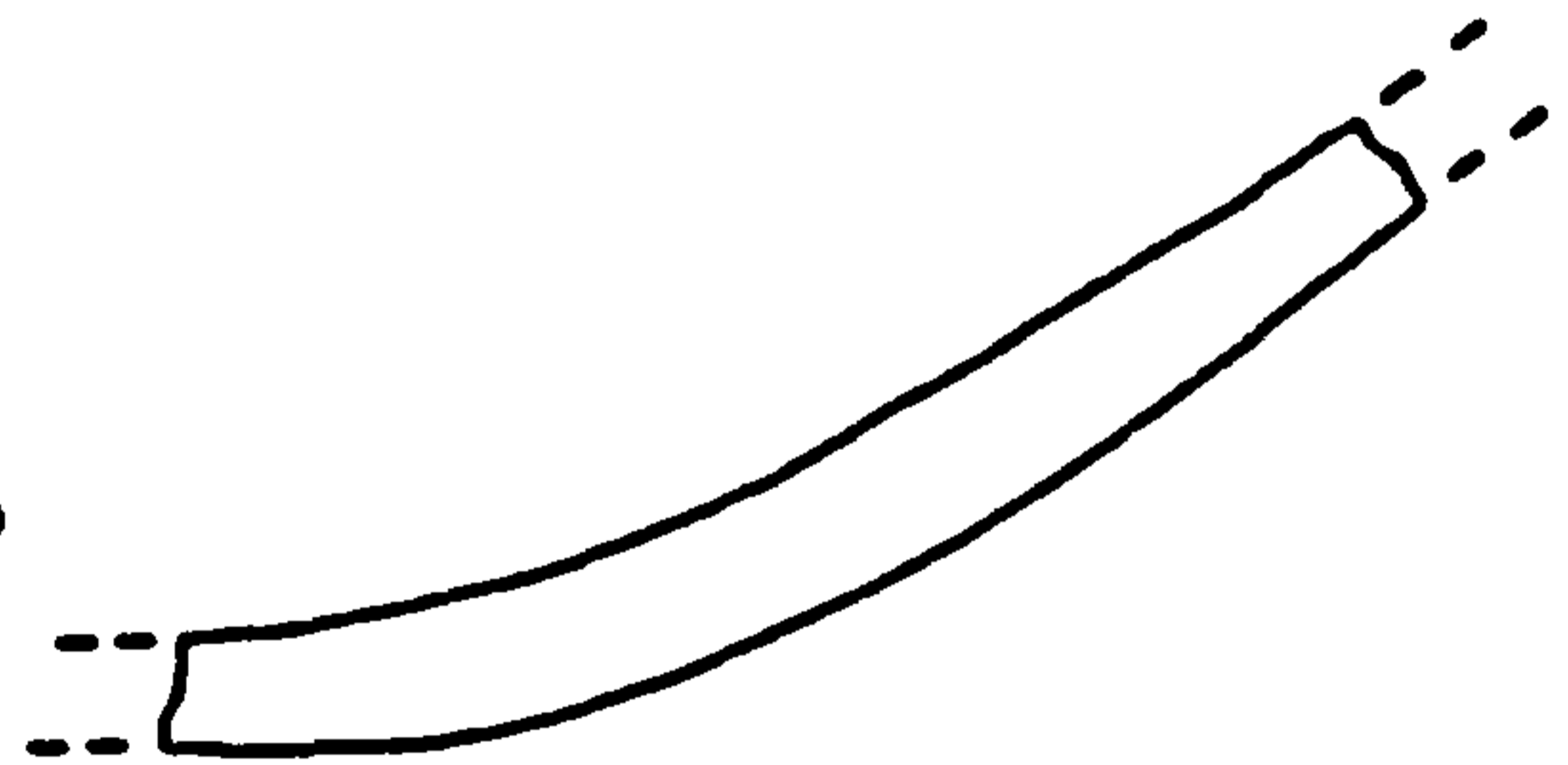
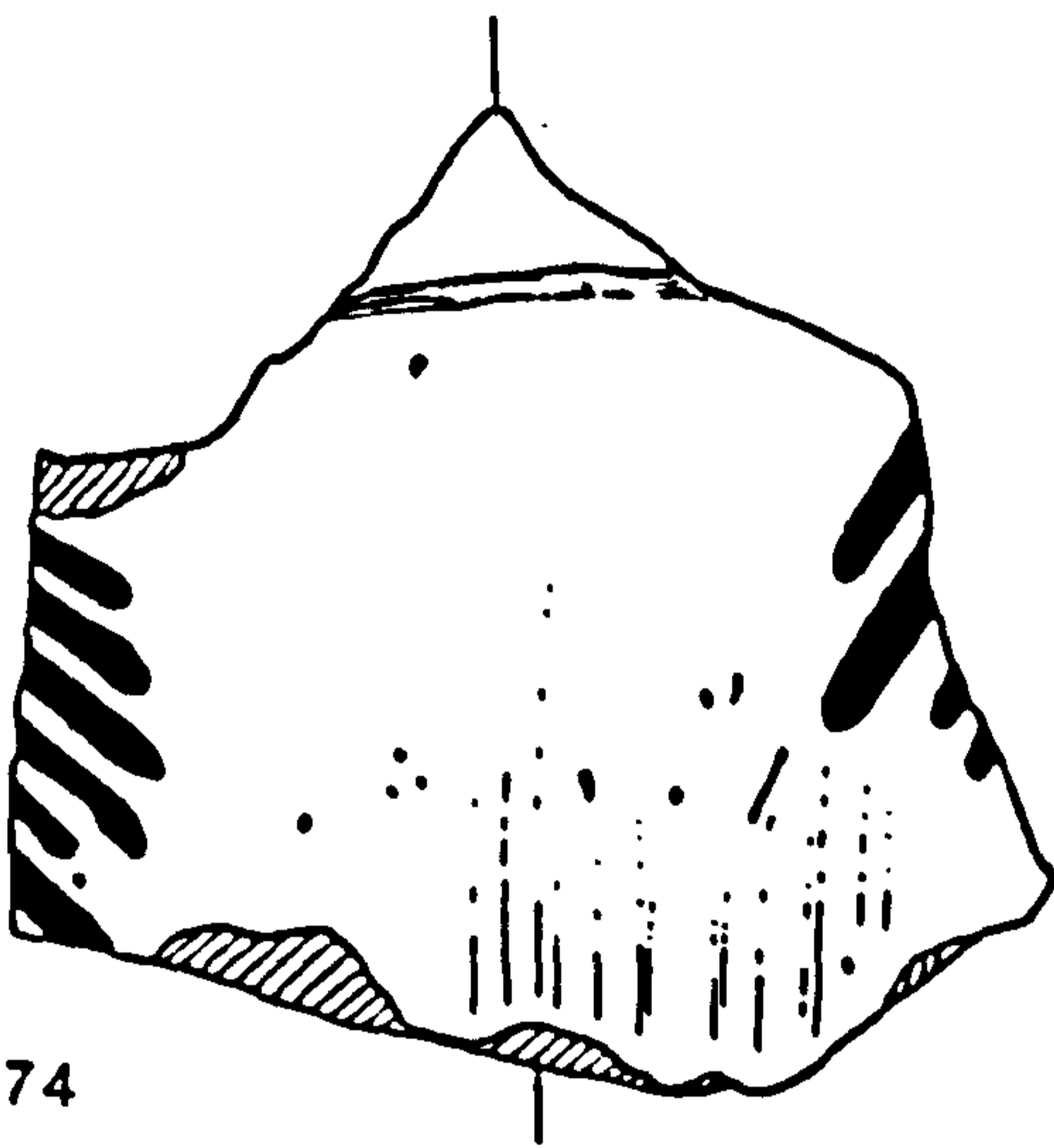

DAB 774

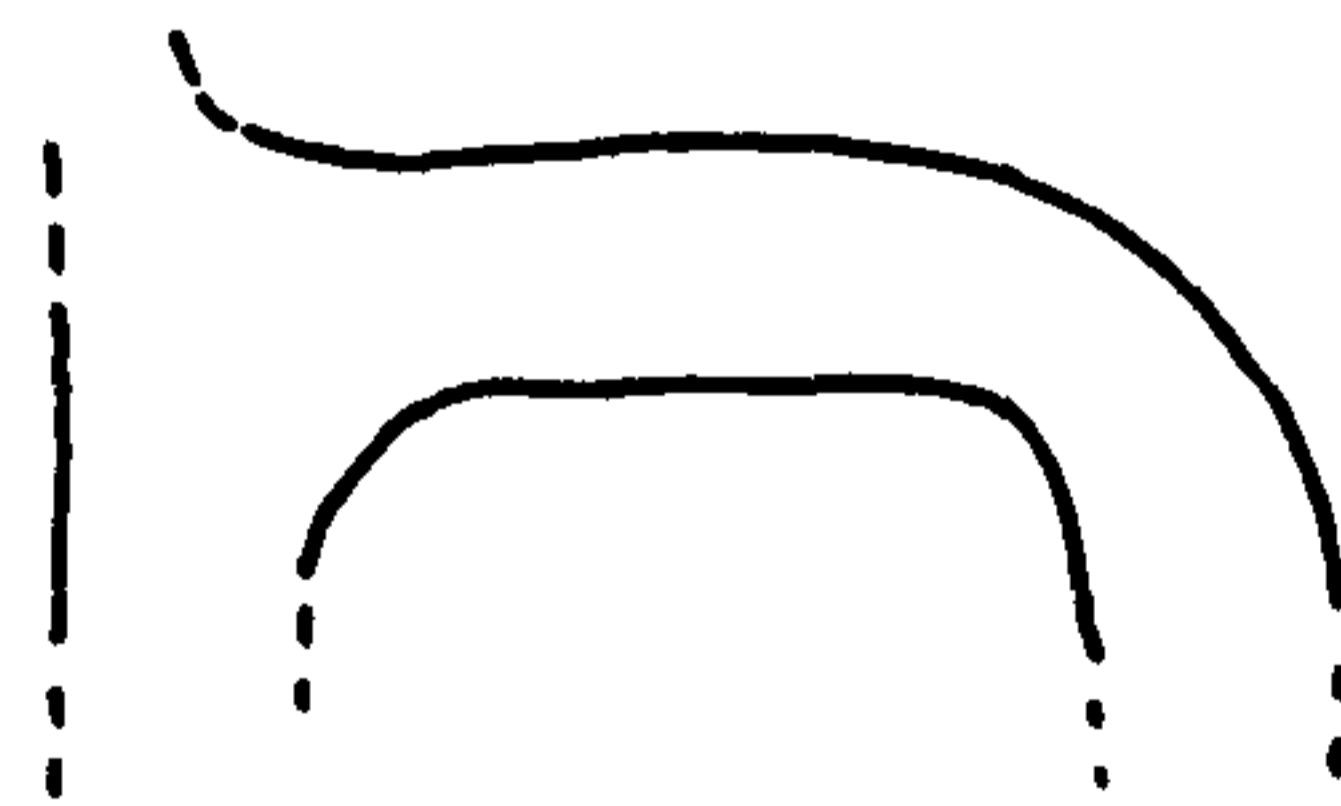
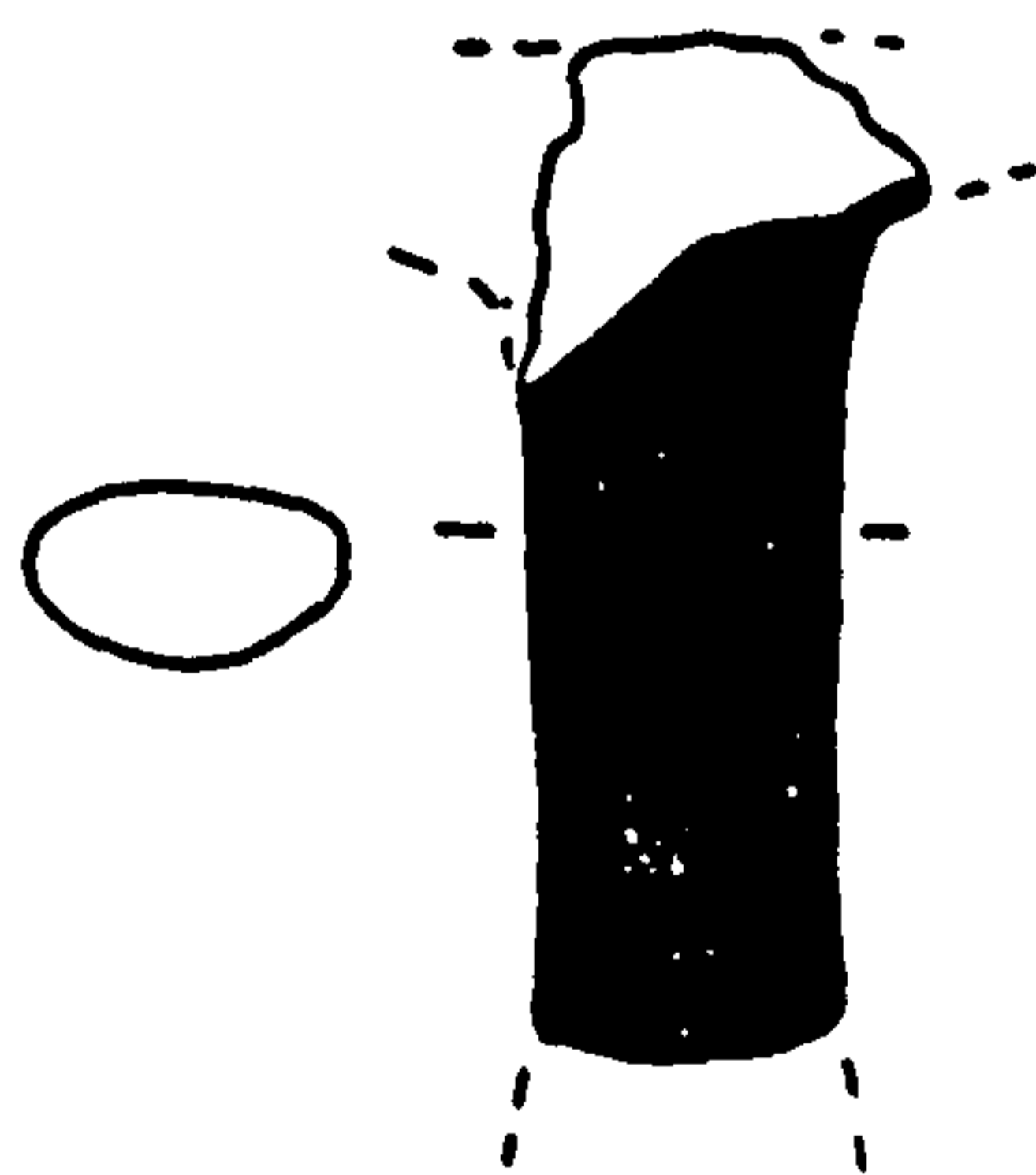

DAB 785

ILL 58

Imitation White Painted; ?White Painted

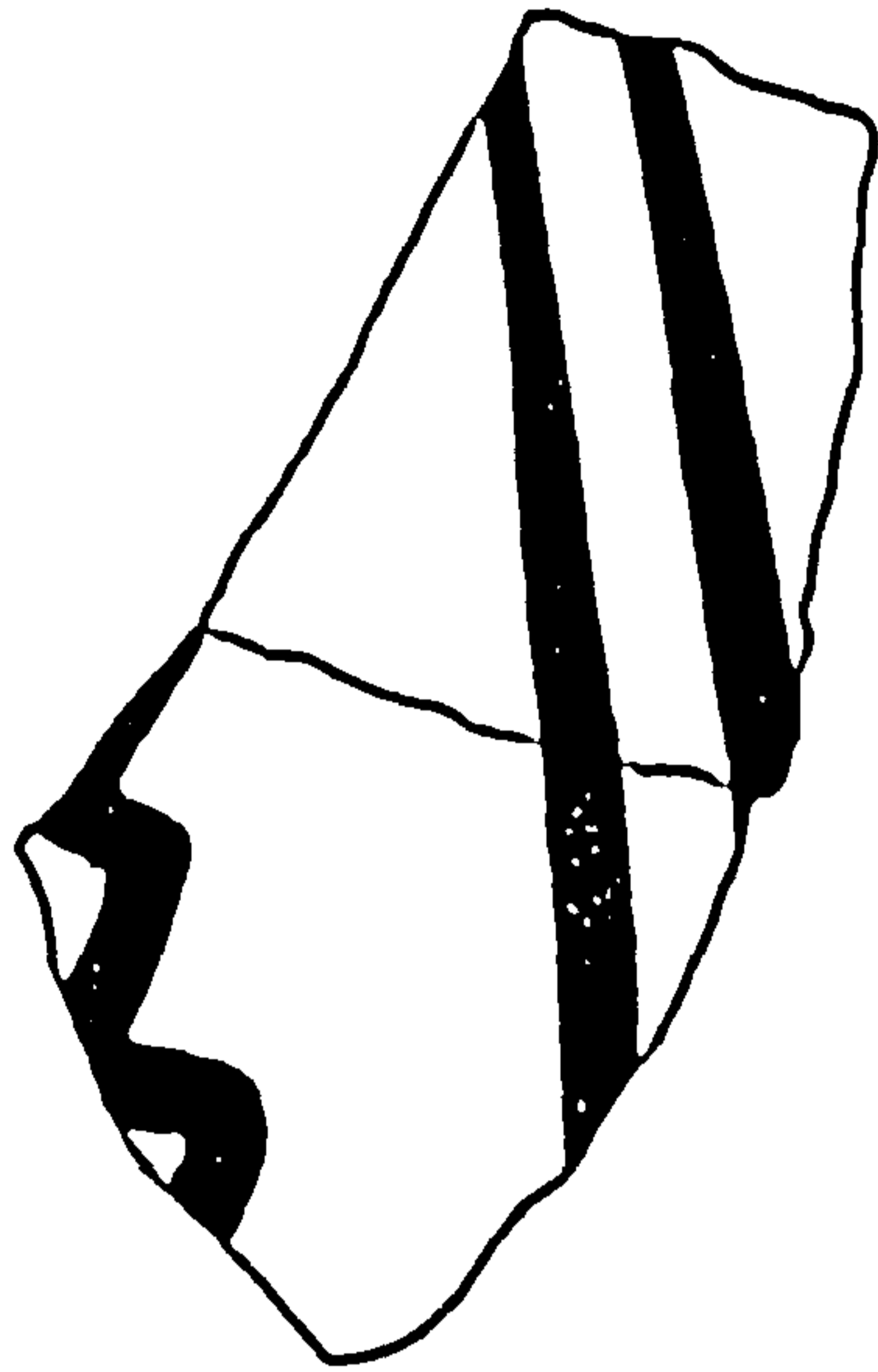

DAB 769



DAB 769

ILL 59

Imitation White Painted Pendent Line Style

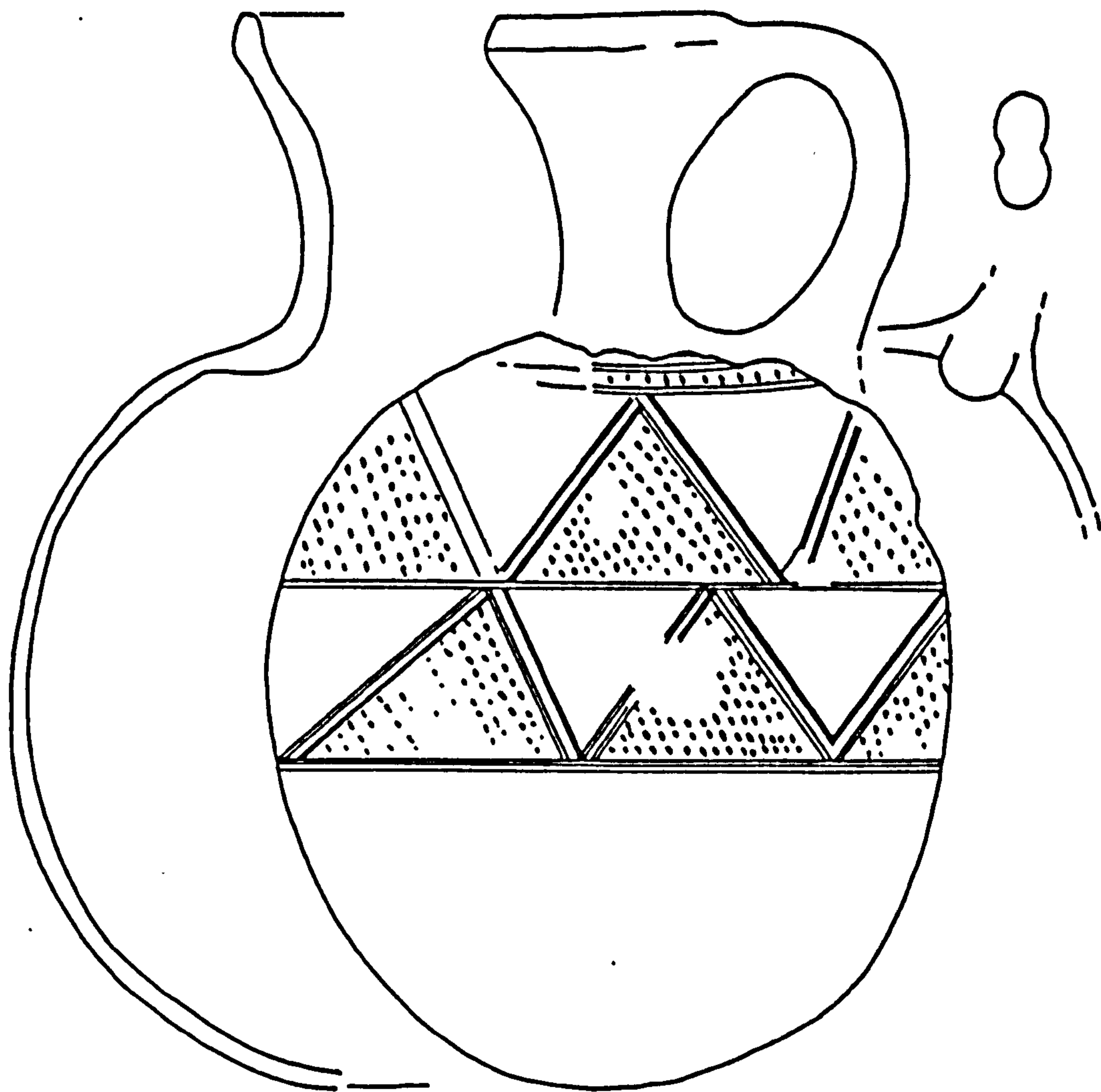

DAB (780)

1:1

ILL 60

Globular (handmade) Tell el Yahudiyeh Ware with
handle inserted into the vessel wall, Tell el Dab'a

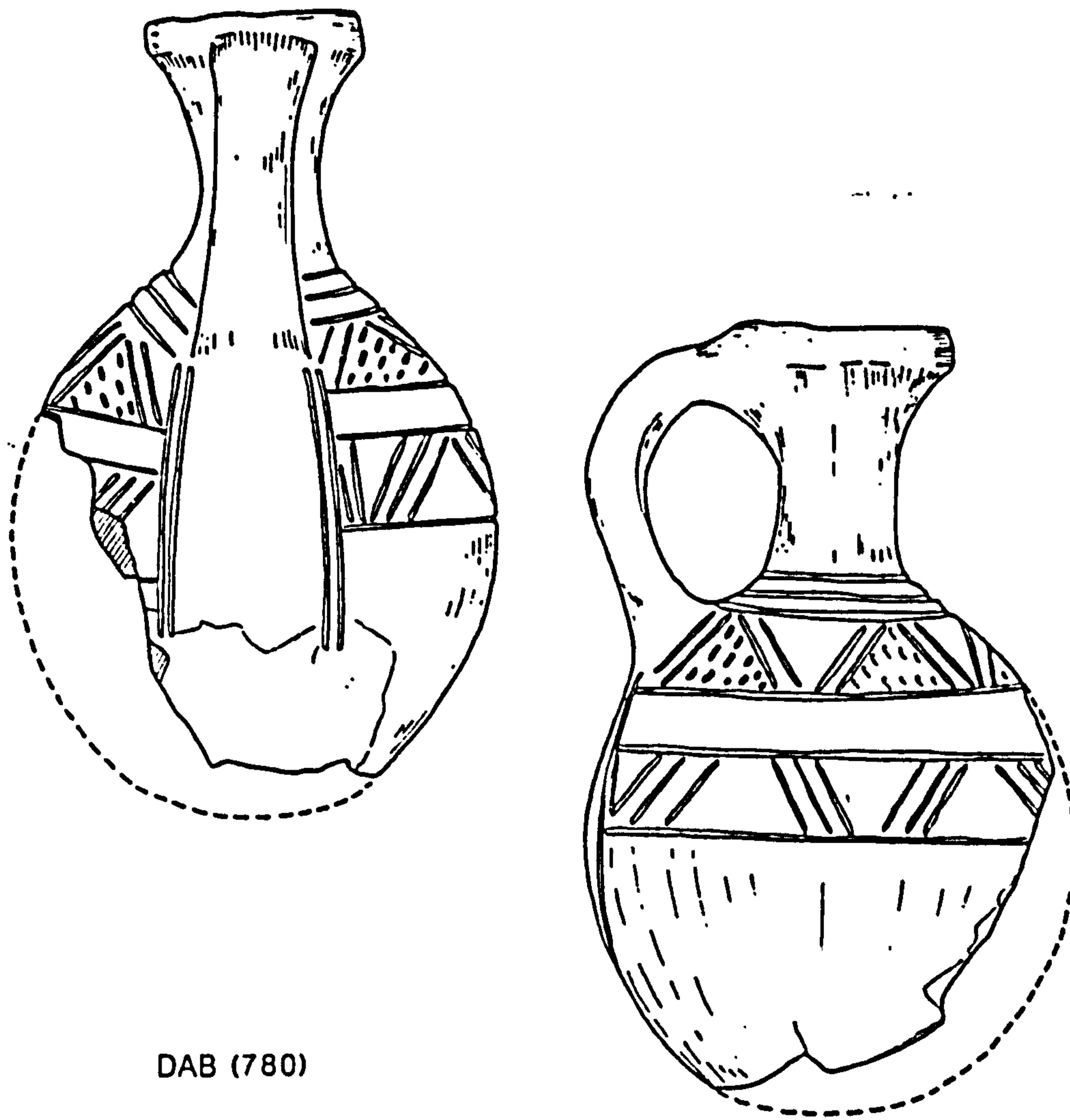
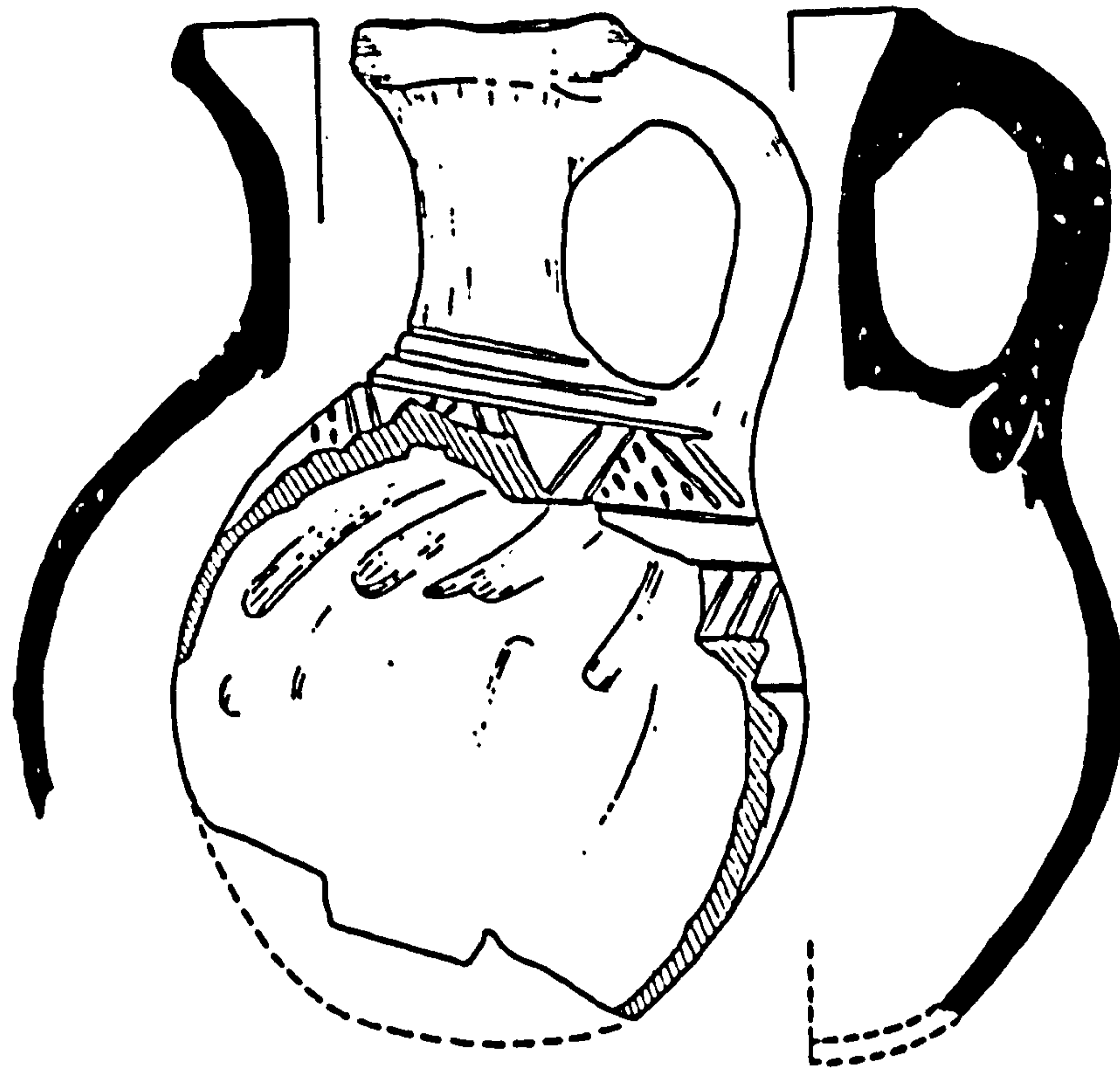

DAB (780)

ILL 61

Globular (handmade) Tell el Yahudiyeh Ware with handle inserted into the vessel wall, Tell el Dab'a

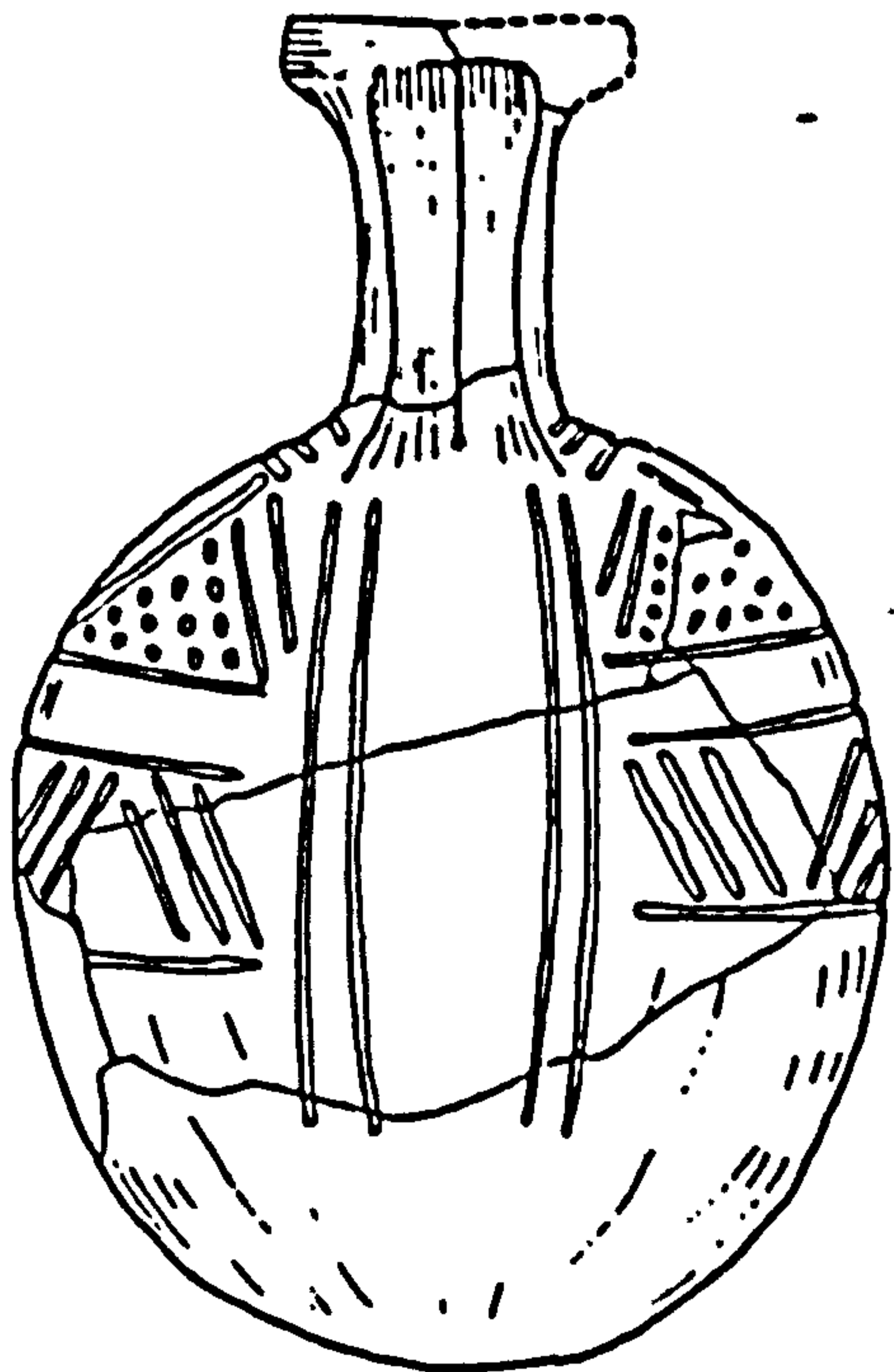
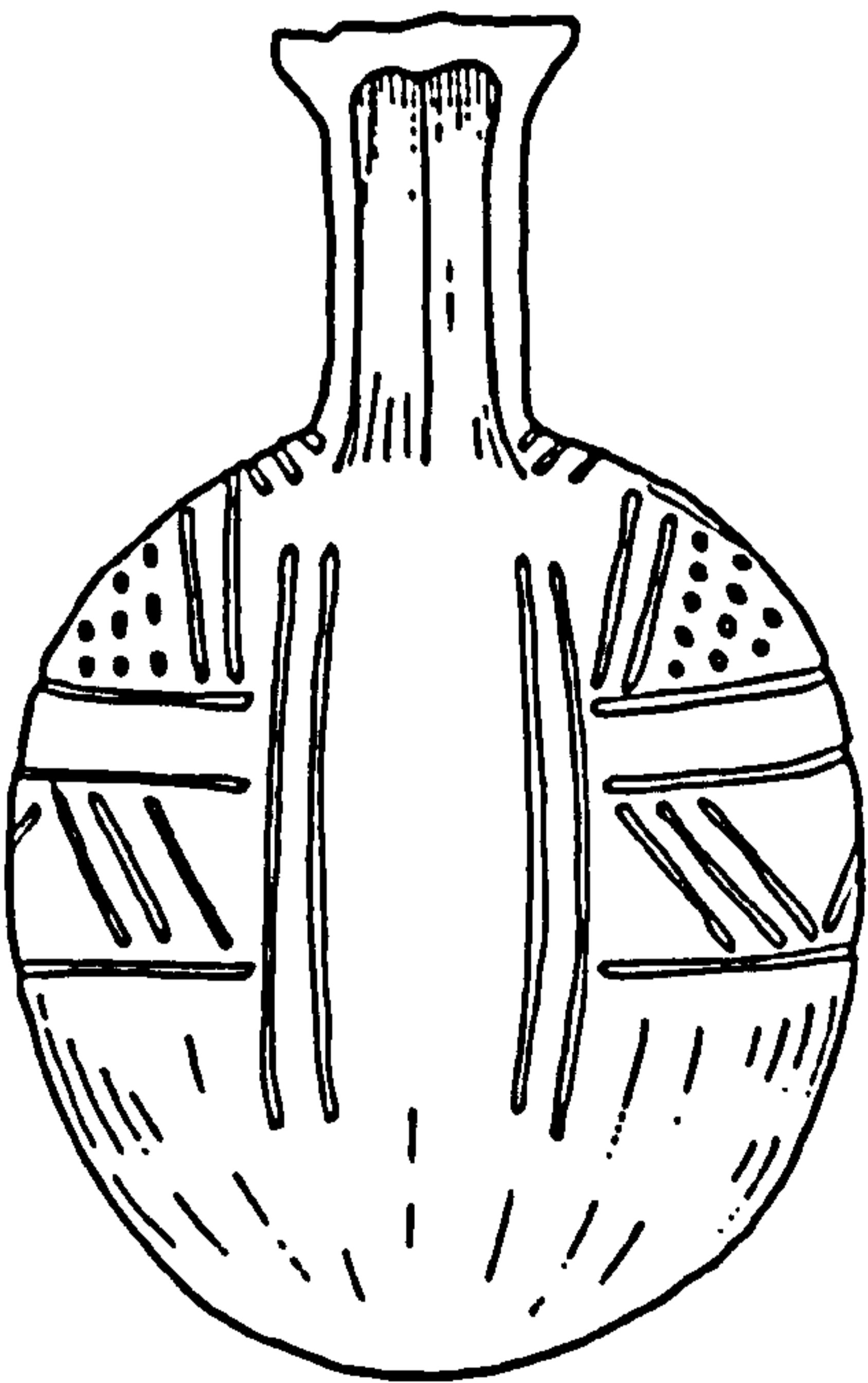
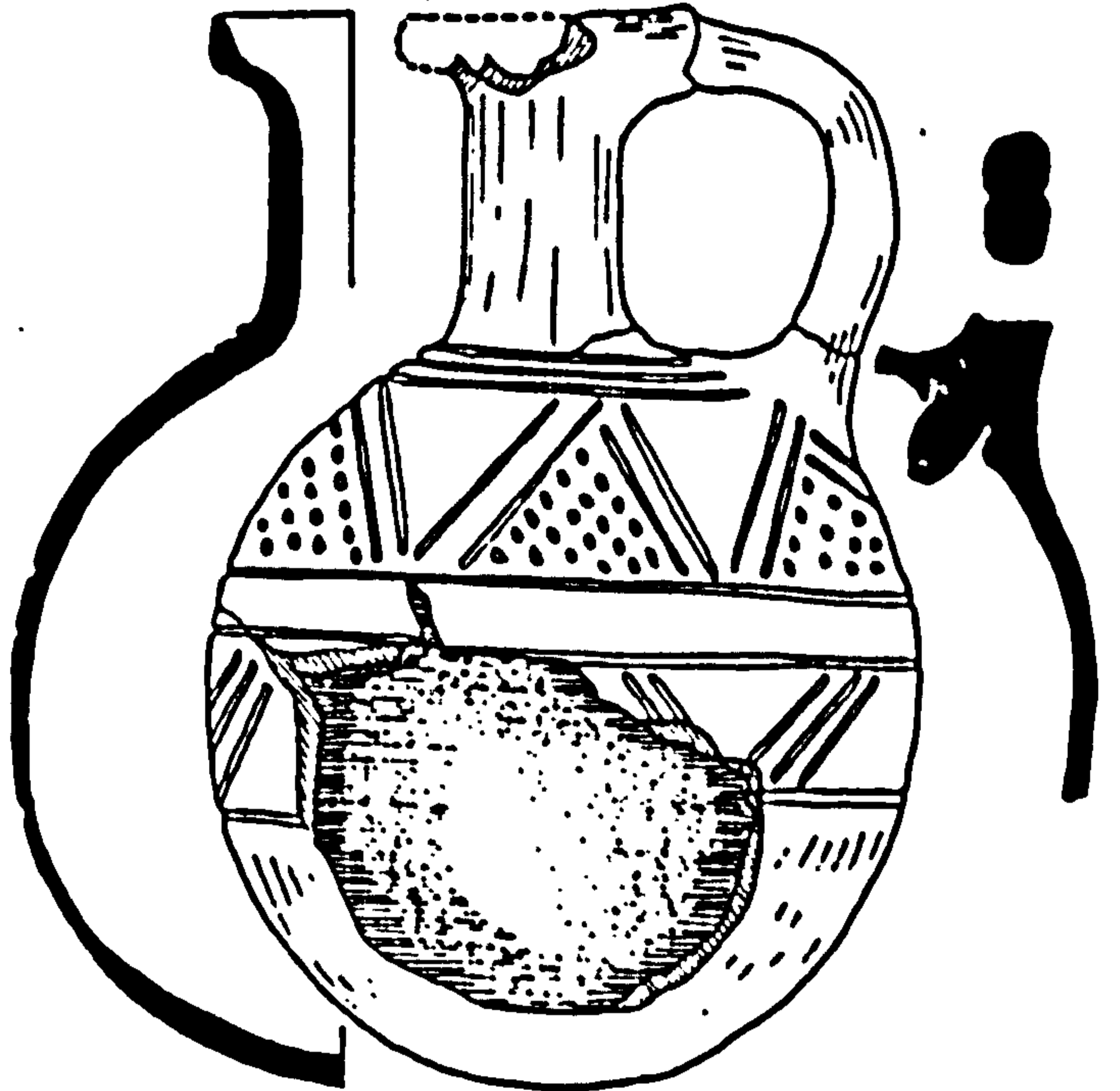
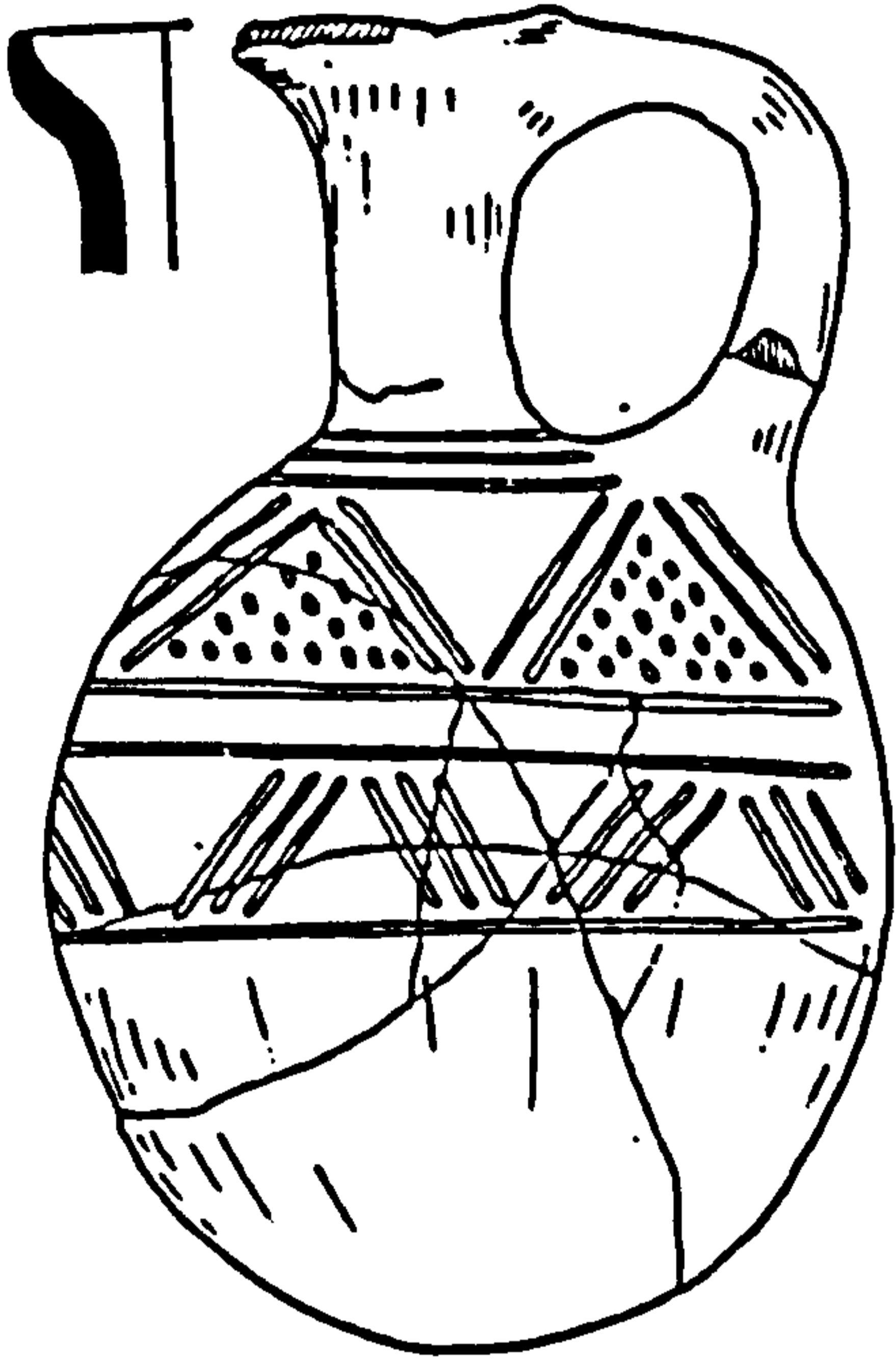
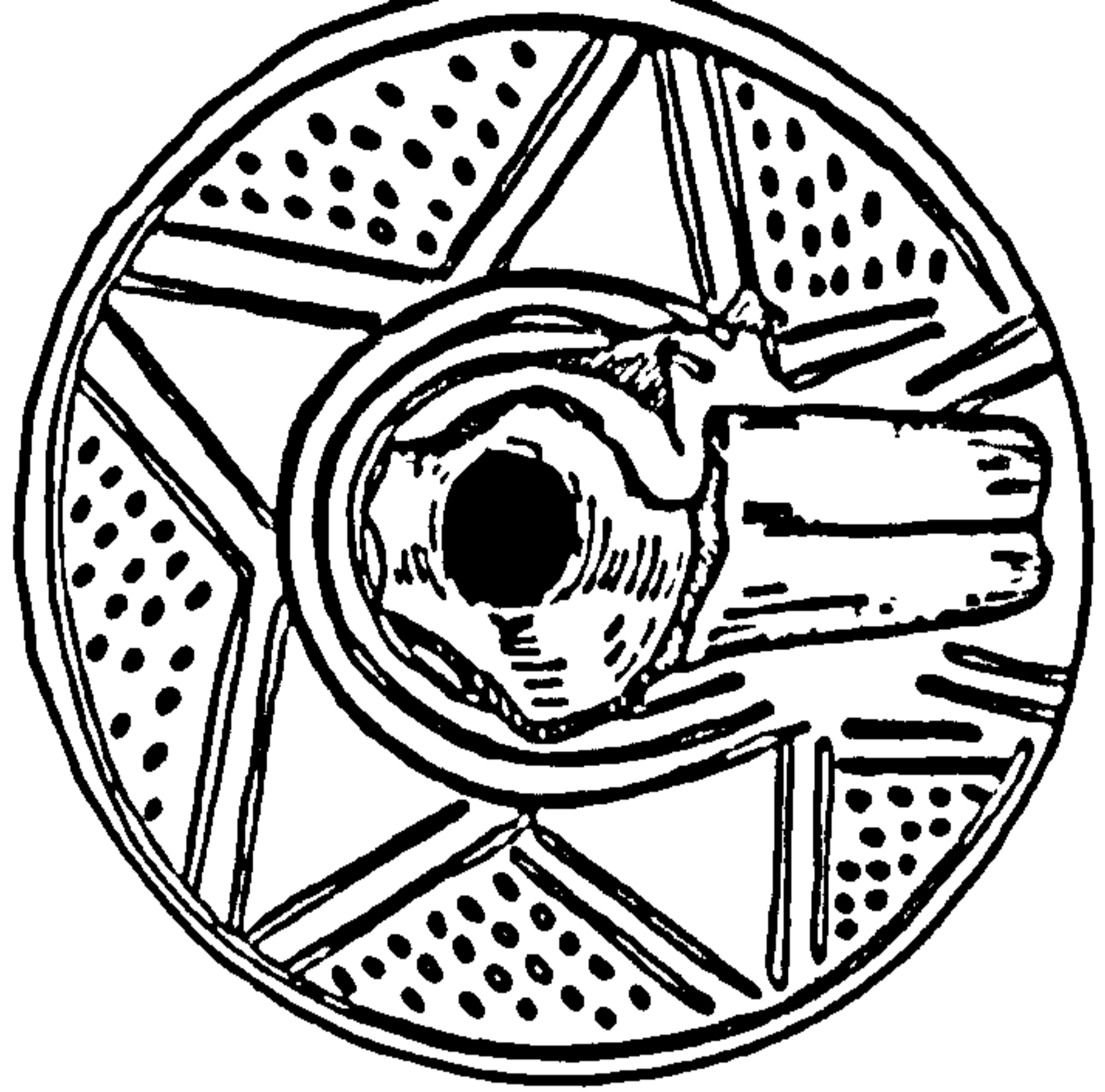
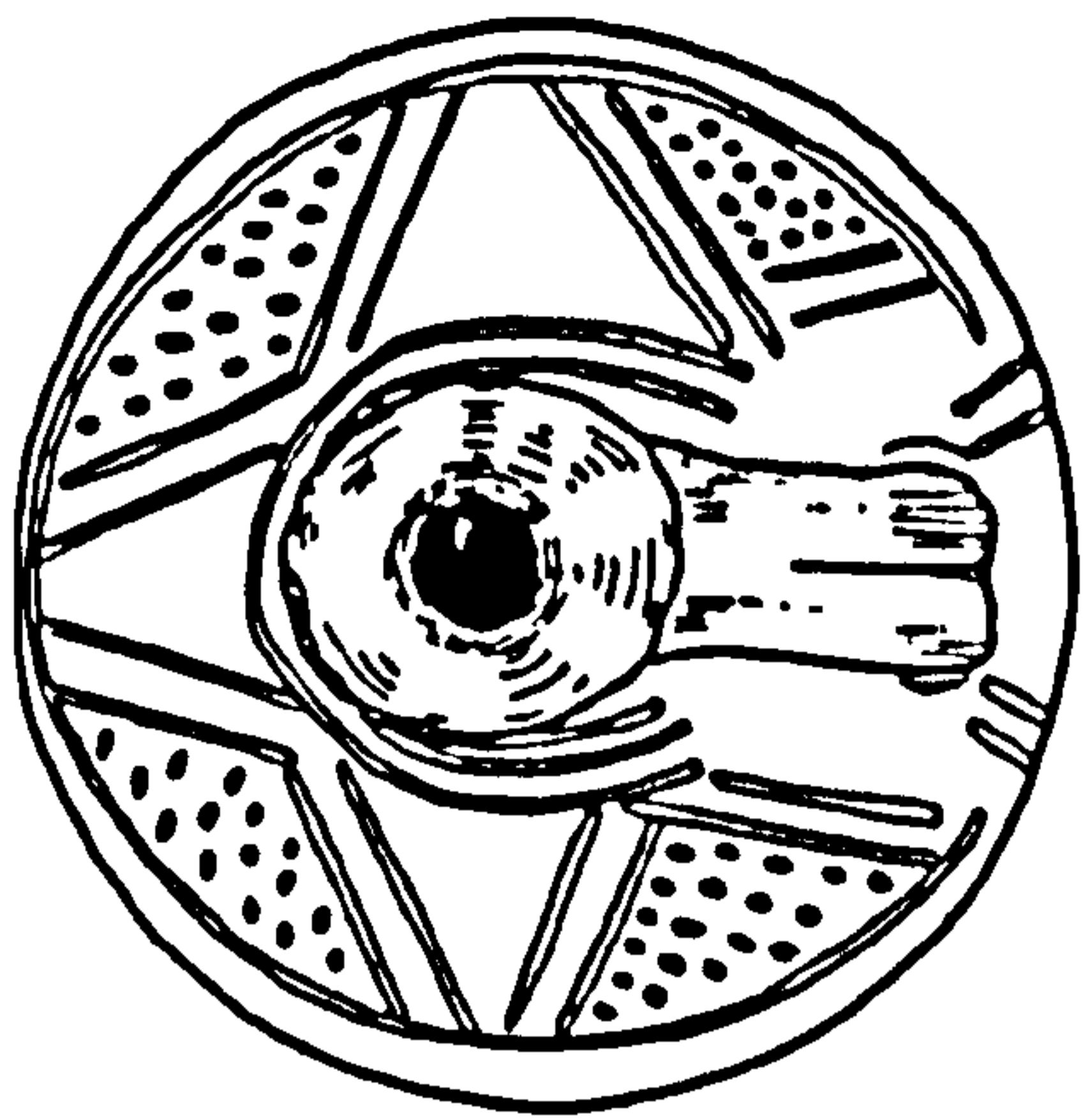

DAB 780

DAB (780)

ILL 62

Globular (handmade) Tell el Yahudiyeh Ware with handle inserted into the vessel wall, Tell el Dab'a

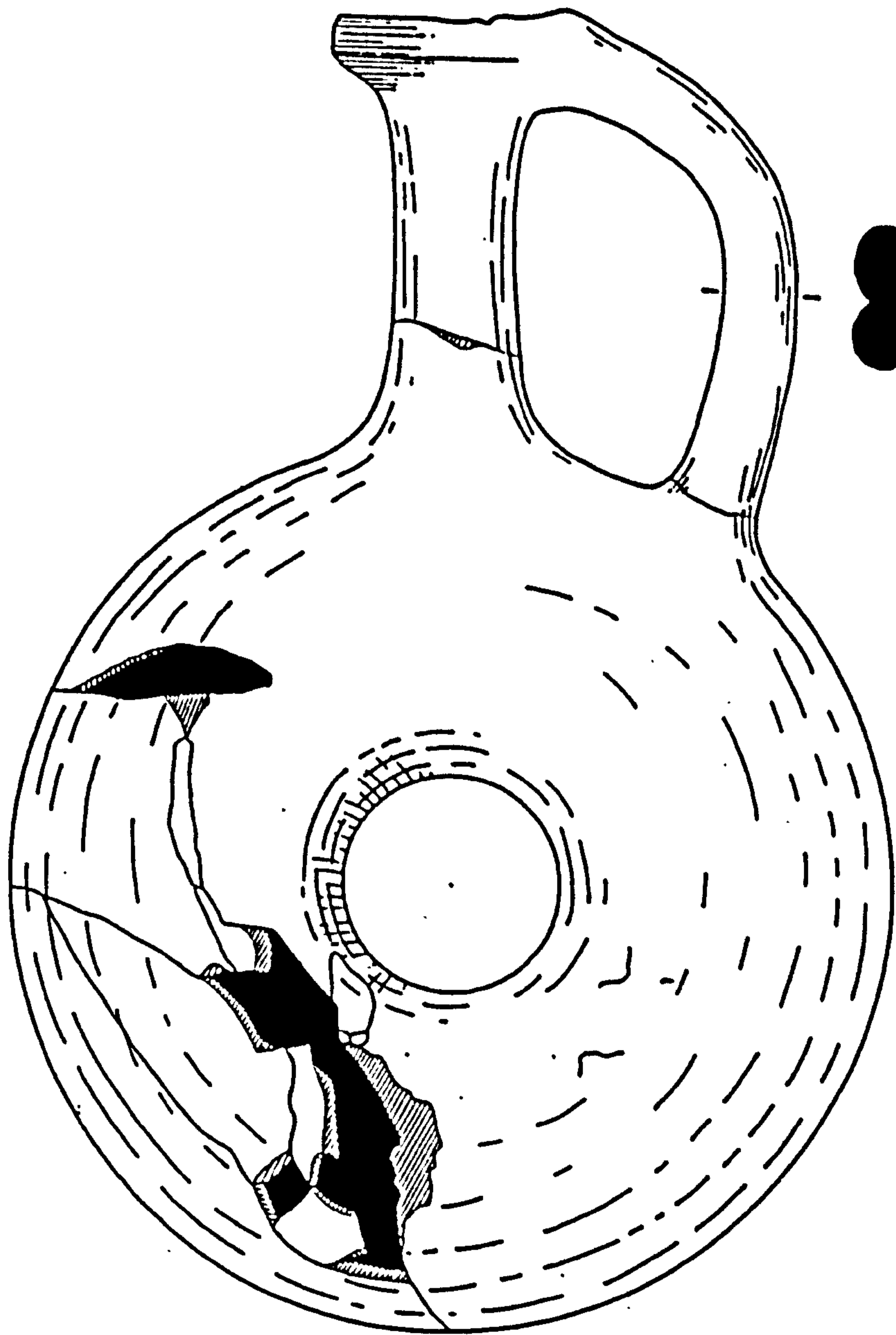

1:1

ILL 63

Ring vase from Tell el Dab'a



ILL 64 RSH 323 White Painted Pendent Line Style



ILL 65 RSH 326 White Painted Pendent Line Style



ILL 66

RSH

White Painted Pendent Line Style



ILL 67

MEG 235

White Painted Pendent Line Style



ILL 69

DHA 154

White Painted Pendant Line Style

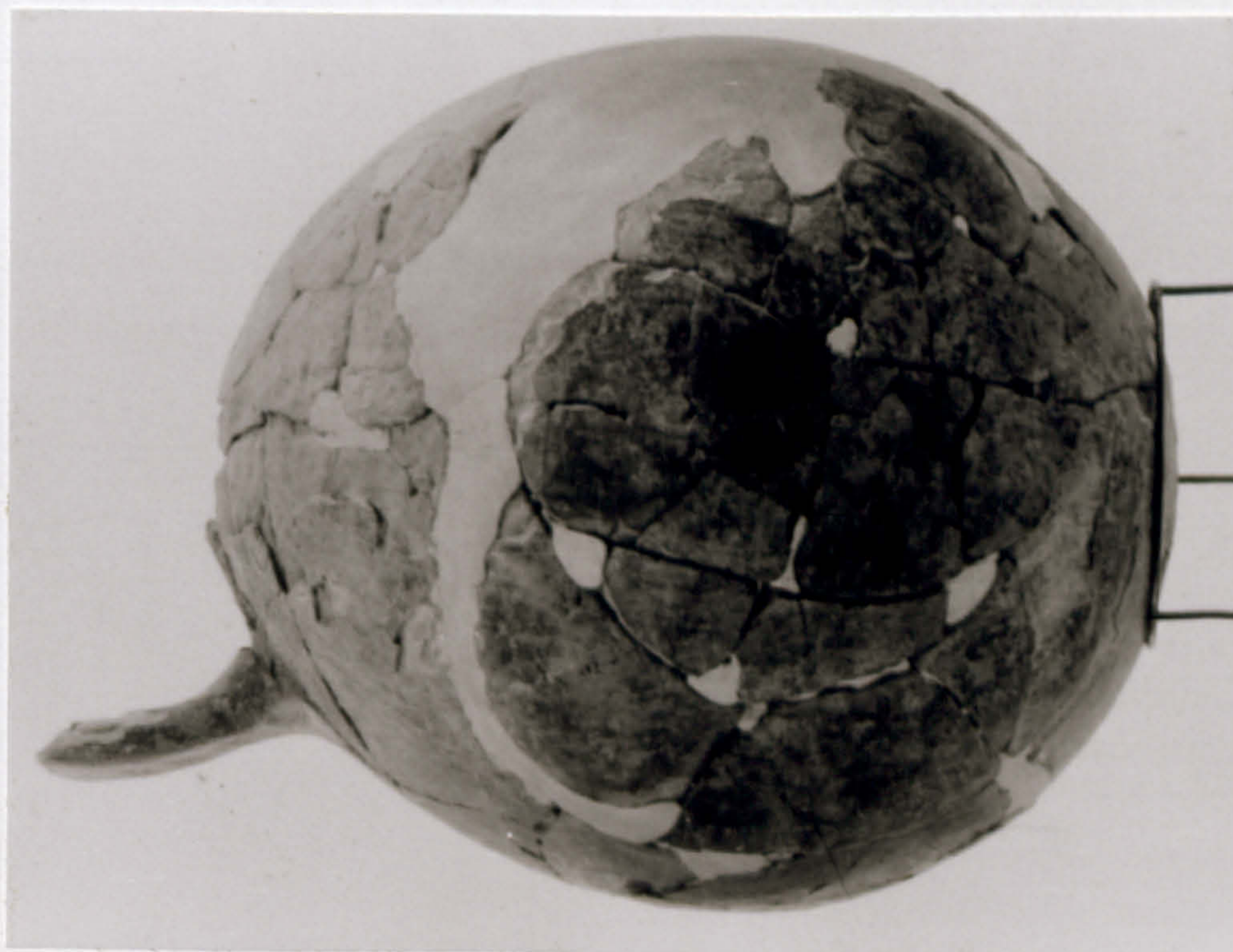

ILL 68

DHA 153

White Painted Pendant Line Style



ILL 70

DHA 754

White Painted Pendant Line Style

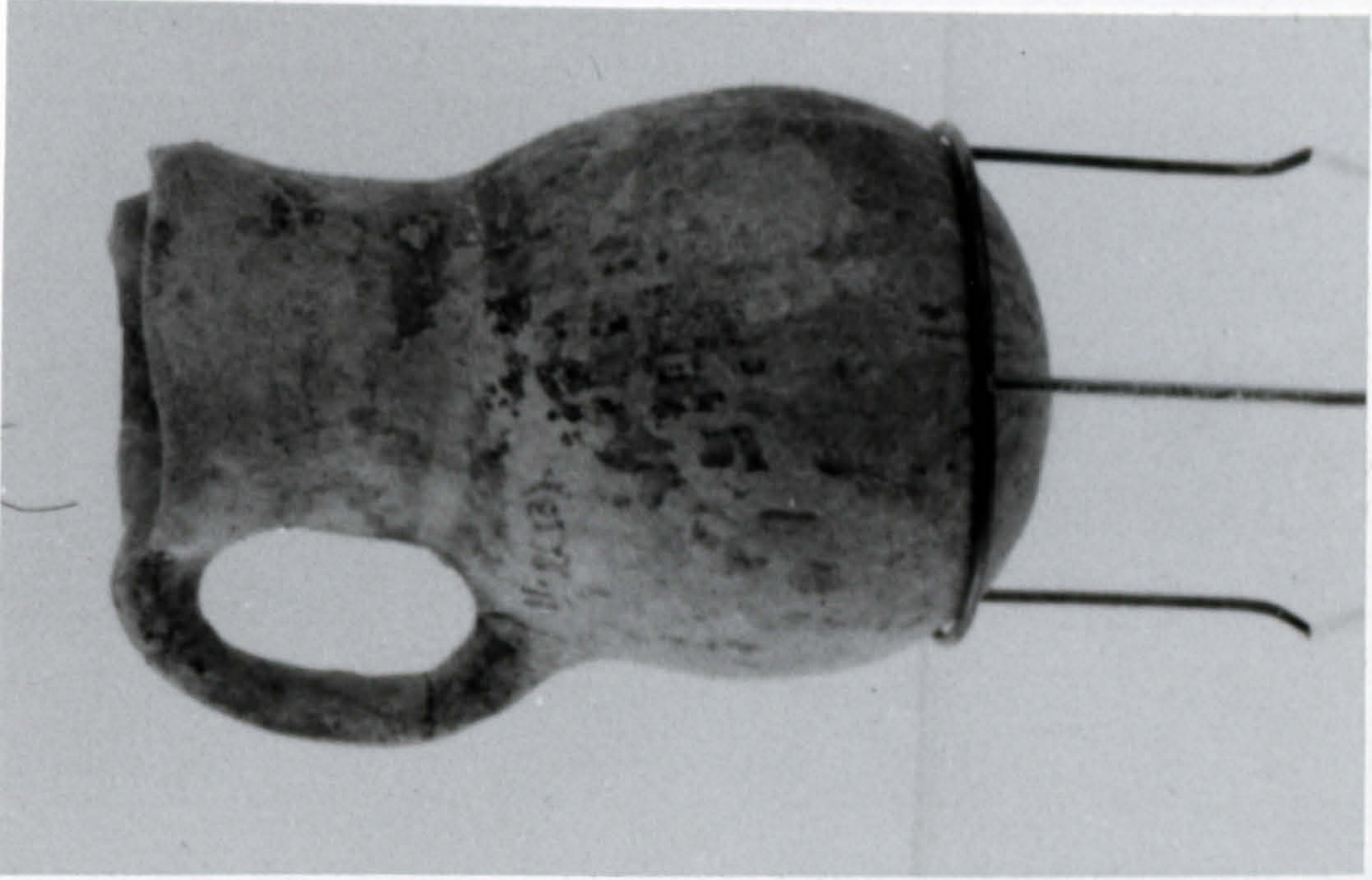

ILL 71

DHA 755

White Painted Pendant Line Style



White Painted Pendant Line Style

DHA 155

ILL 73



White Painted Pendant Line Style

DHA 151

ILL 72



ILL 75

DHA 158

White Painted Pendent Line Style



ILL 74

MEG 236

Imitation White Painted Pendent Line Style



ILL 76

GEZ 164

White Painted Pendant Line Style



ILL 77

MEG 234

White Painted Pendant Line Style



ILL 78

DHA 157

White Painted Pendent Line Style

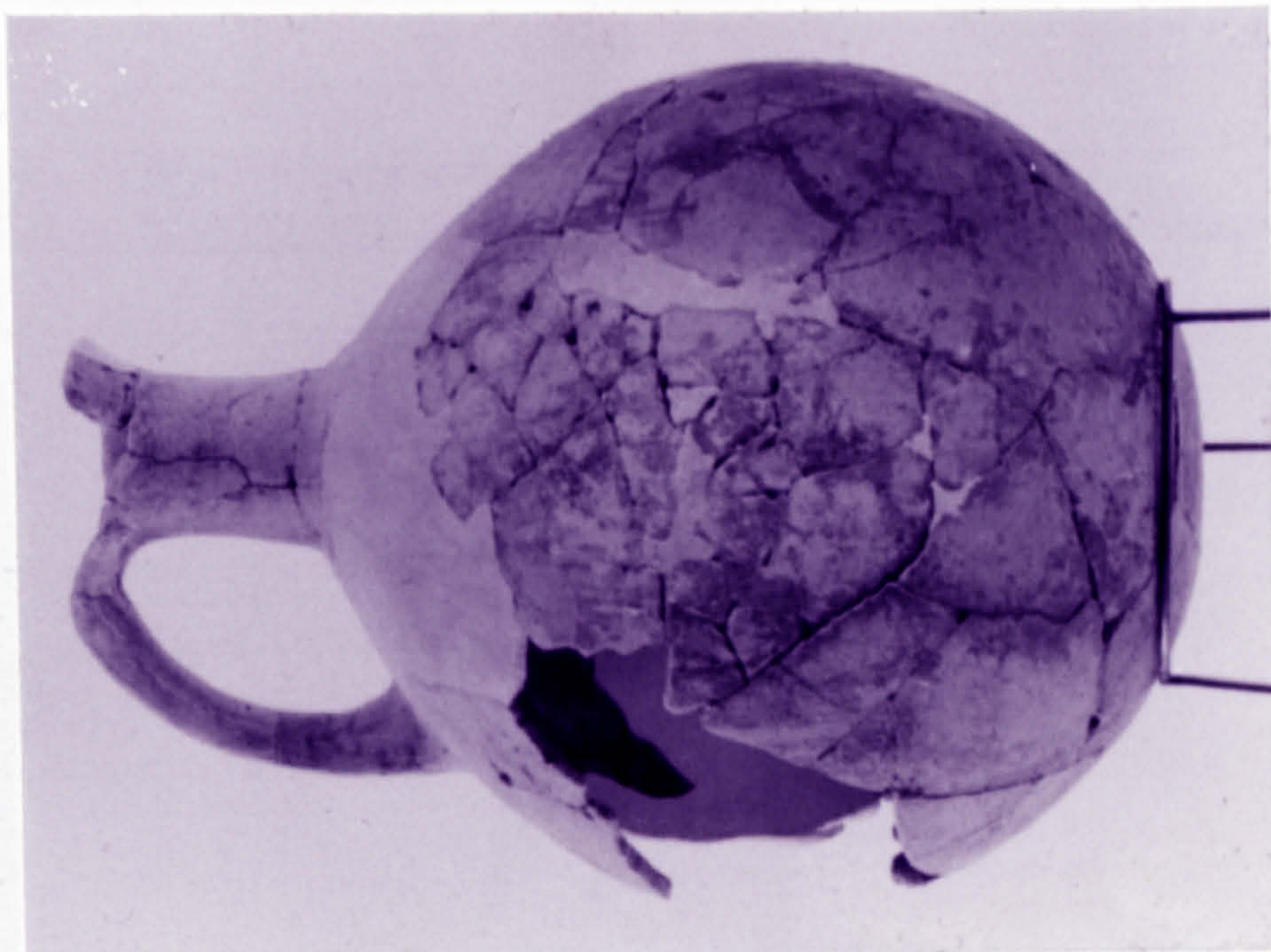

ILL 79

DHA 152

White Painted Pendent Line Style

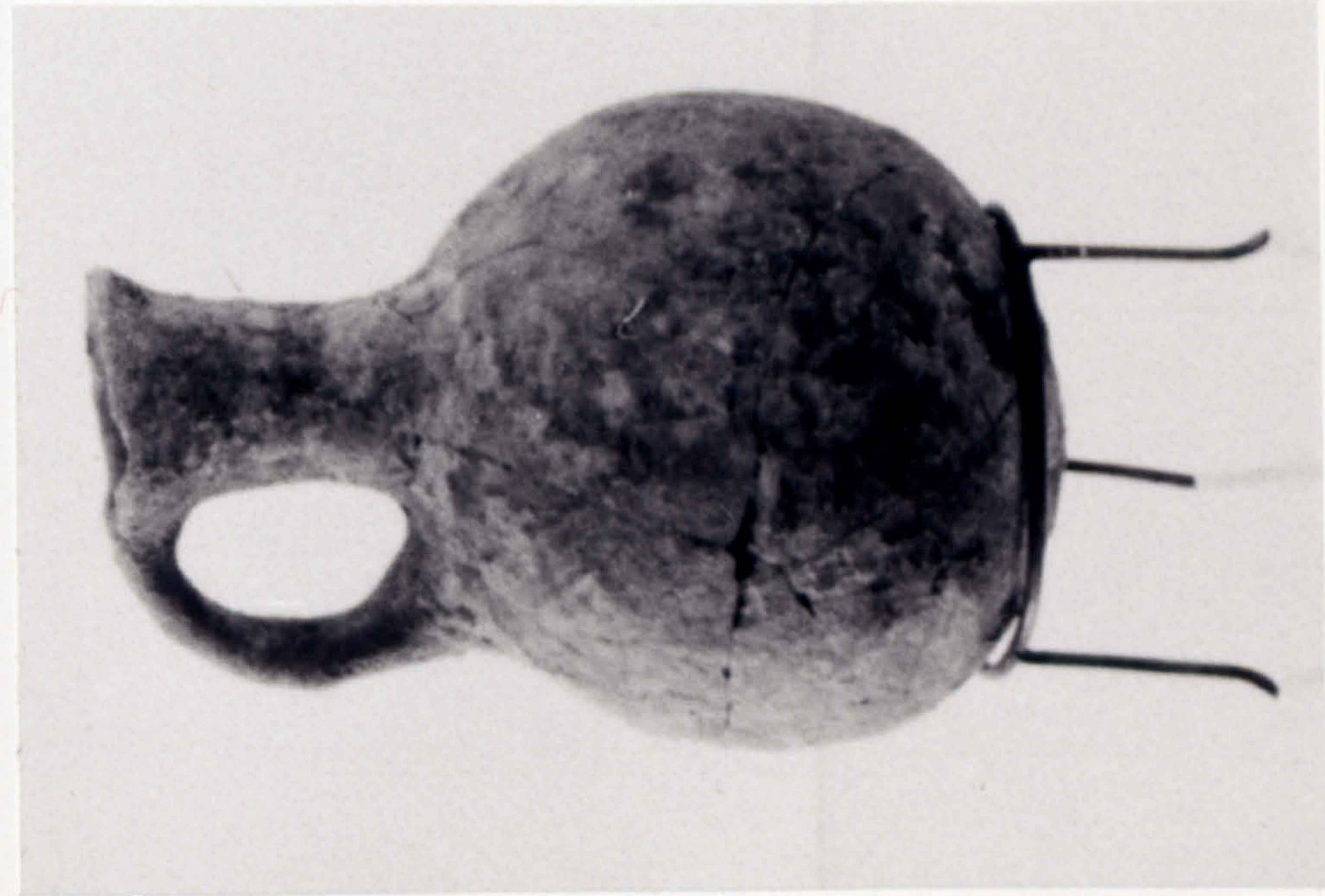

ILL 80

DHA 160

White Painted Cross Line Style



ILL 81

DHA 156

White Painted Pendant Line Style



ILL 82

ASH 140

White Painted Cross Line Style



ILL 83

MEG 244

White Painted Cross Line Style

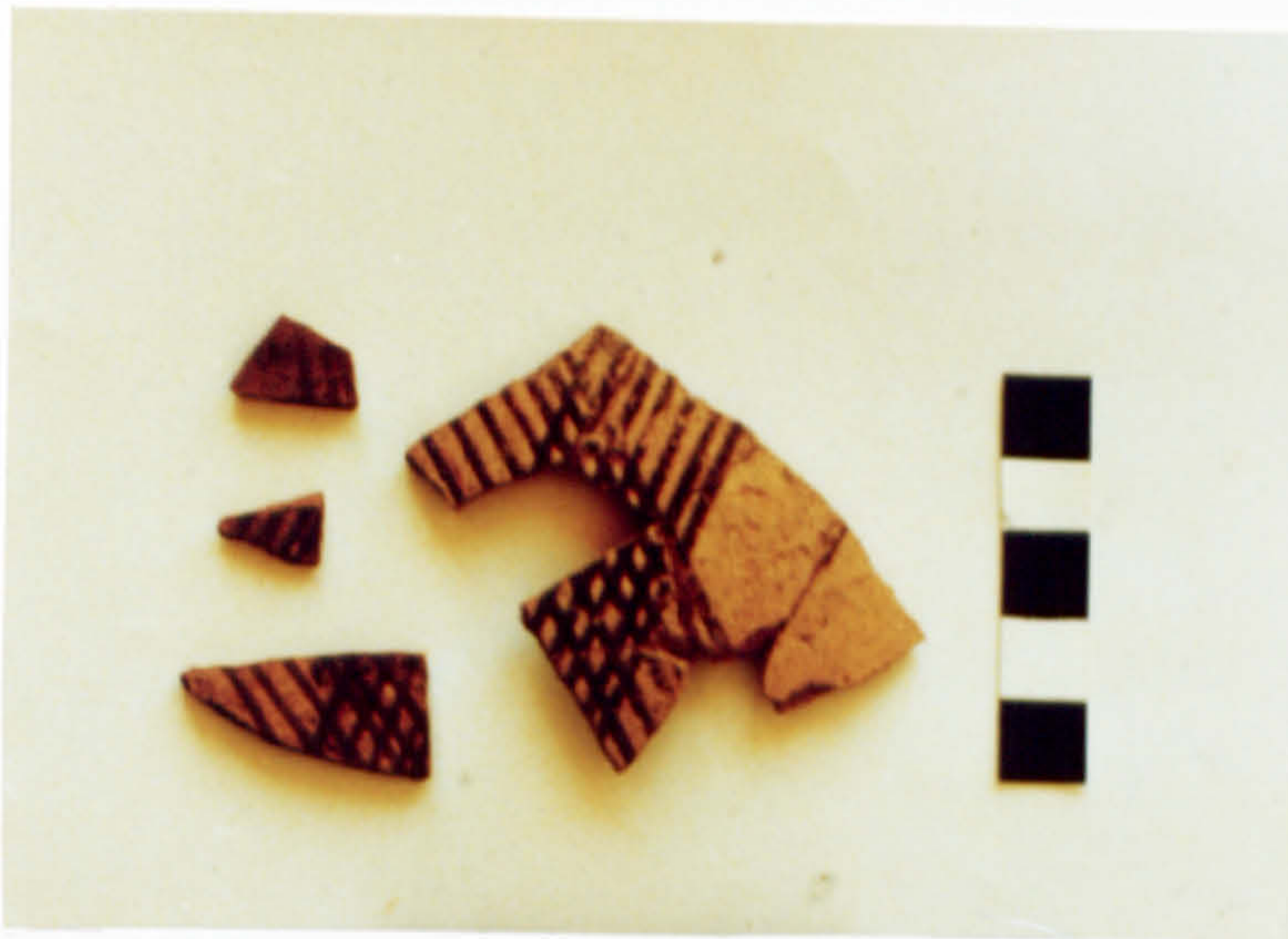

ILL 84 DAB 537 White Painted Cross Line Style

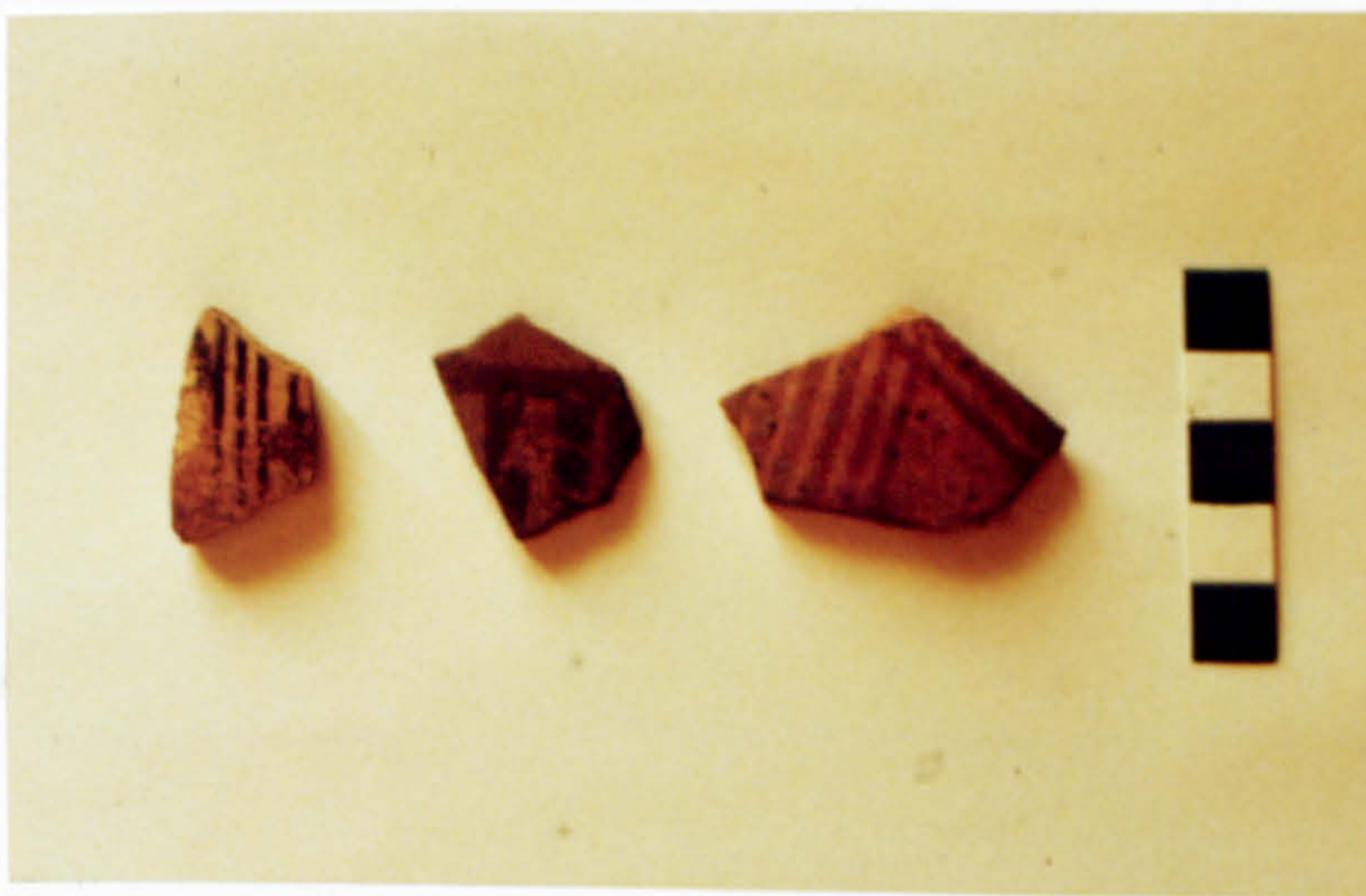

ILL 85 DAB 505: White Painted PLS/CLS
DAB 593: White Painted V Tangent Line Style
DAB 531: White Painted Cross Line Style



ILL 86

RSH 376
RSH 375

White Painted V Eyelet Style
White Painted V Eyelet Style



ILL 87

RSH 374
RSH 373

White Painted V Eyelet Style
White Painted V Eyelet Style

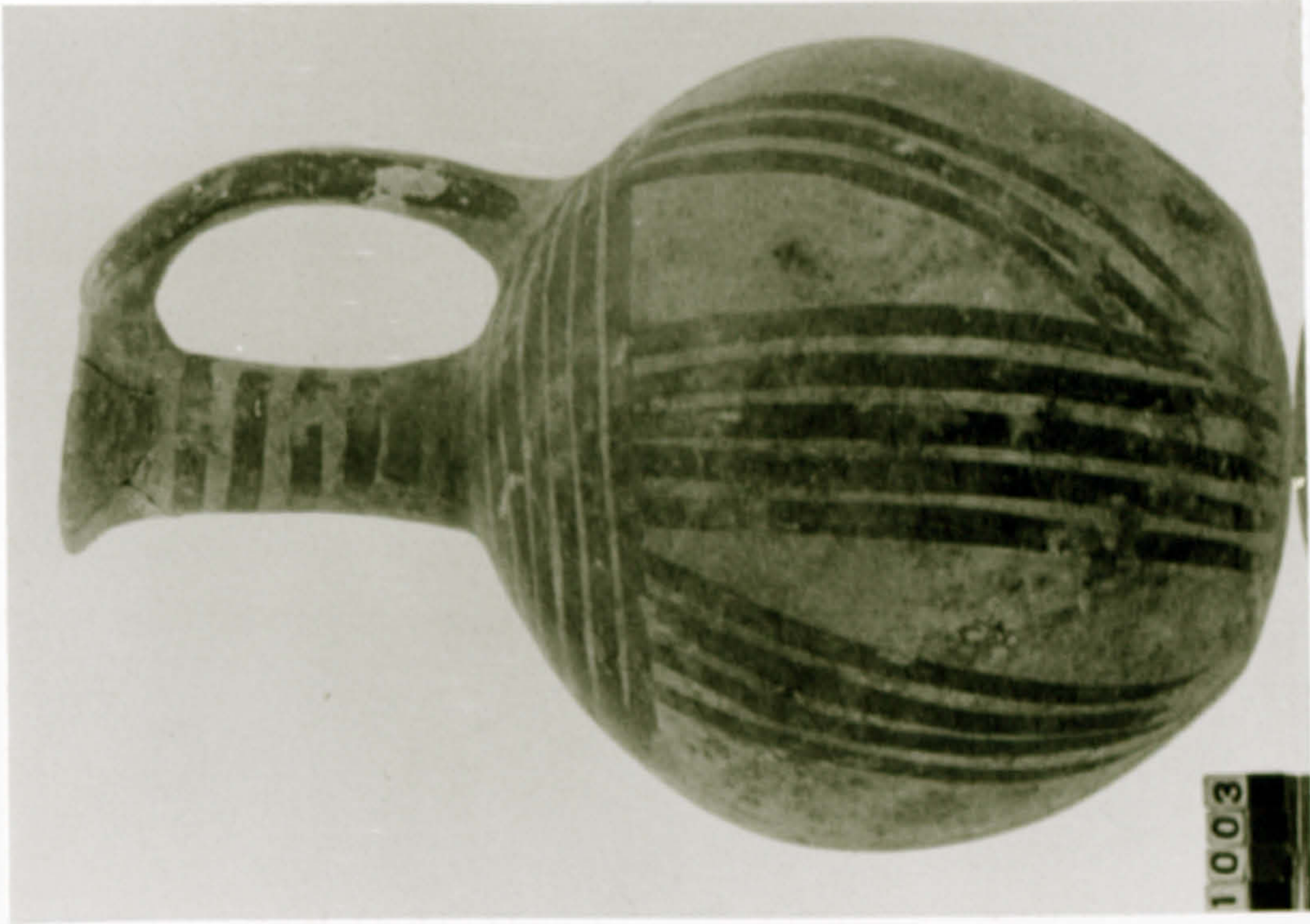

ILL 89

MEG 247

White Painted V Tangent Line Style



ILL 88

RSH 484

White Painted V Tangent Line Style



ILL 90

RSH 427

White Painted V (Composite motifs-EyeI, Tangent, Alternating Broad Band and Wavy Line Style)



ILL 91

RSH 390

White Painted V (Broad Band)



ILL 92

MEG 248

White Painted V (Broad Band)



ILL 93

AJJ 28

White Painted V (Zig zag)

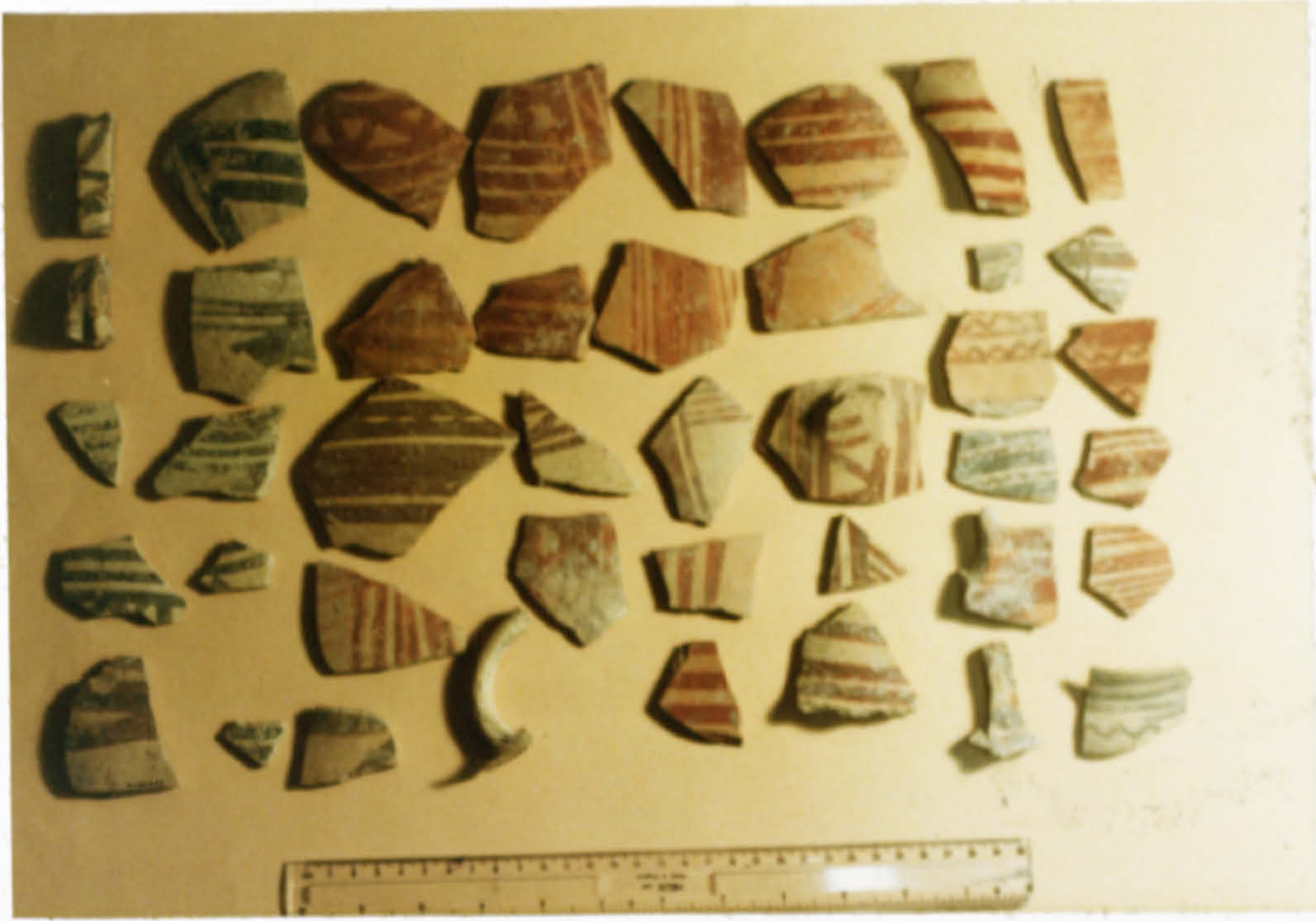

ILL 94 RSH - White Painted V (Wavy Line Style, Tangent Line Style), White Painted Alternating Broad Band and Wavy Line Style, White Painted Composite



ILL 95 RSH- White Painted V



ILL 96

RSH-

White Painted (Various)

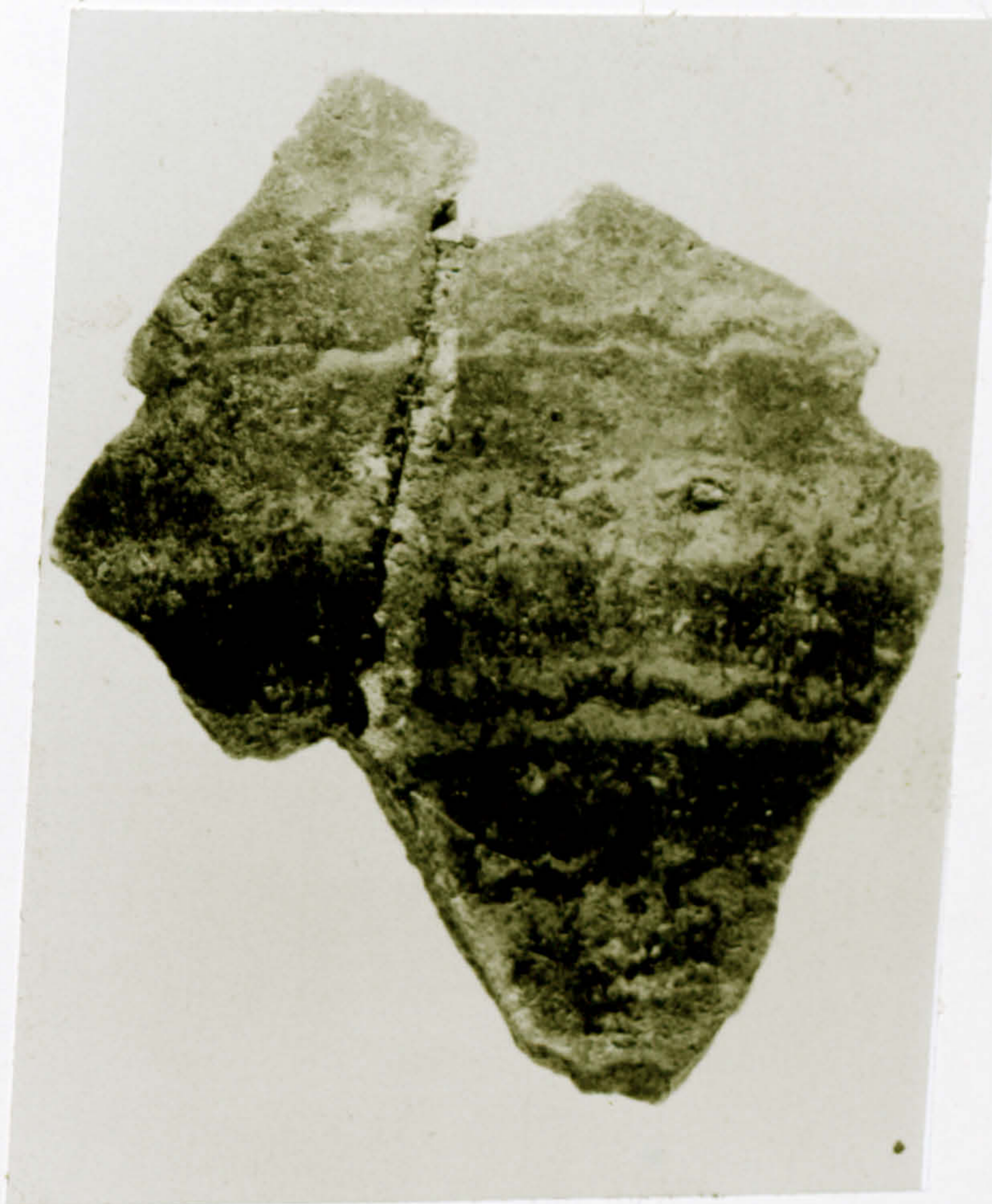

ILL 97

DHA 161

White Painted Alternating Broad Band and Wavy
Line Style



ILL 98

DAB 585

White Painted V



ILL 99

DAB 585

White Painted V

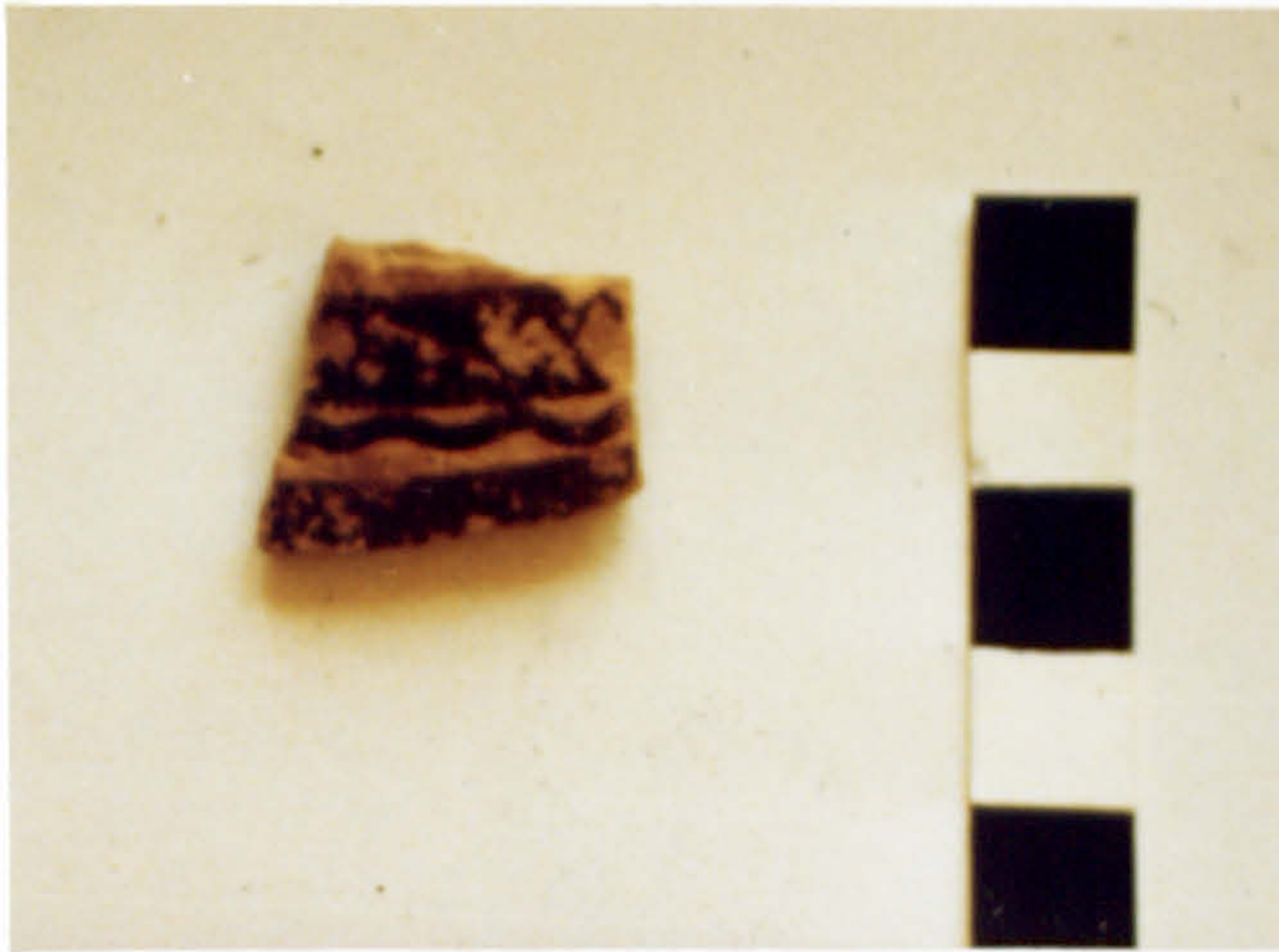

ILL 100

DAB 548

White Painted Alternating Broad Band and Wavy
Line Style

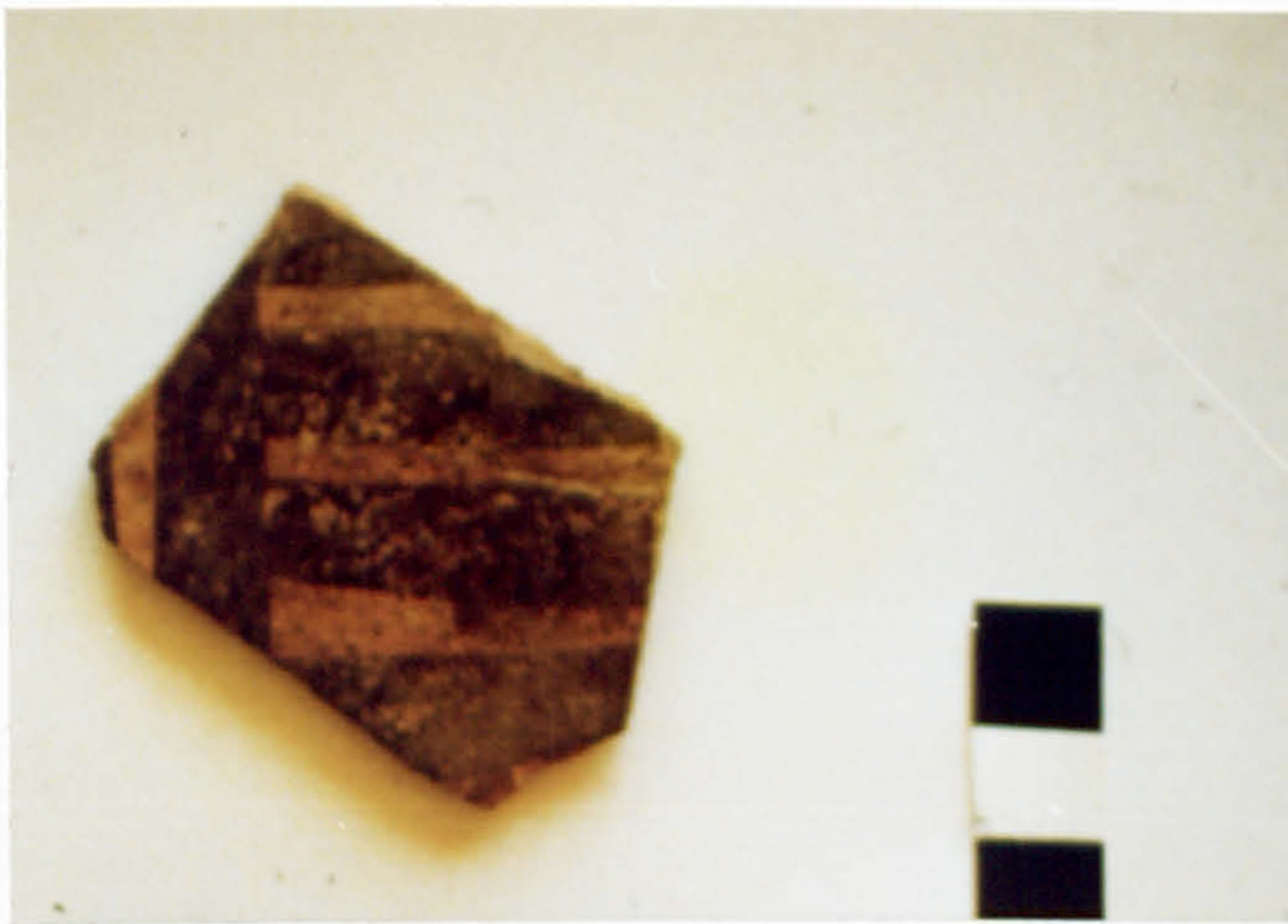

ILL 101

DAB 608

White Painted V Tangent Line Style

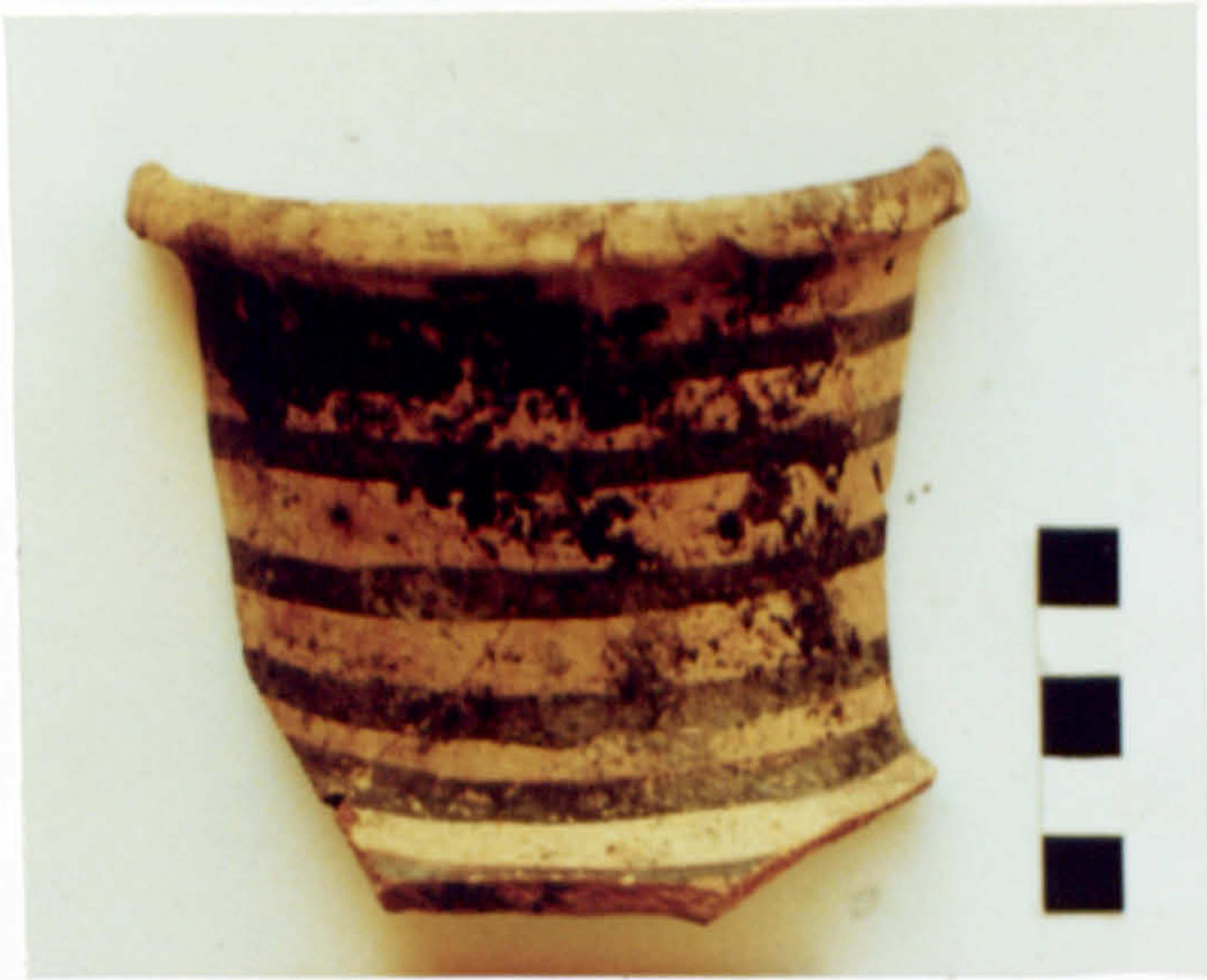

ILL 102

DAB 584

White Painted V

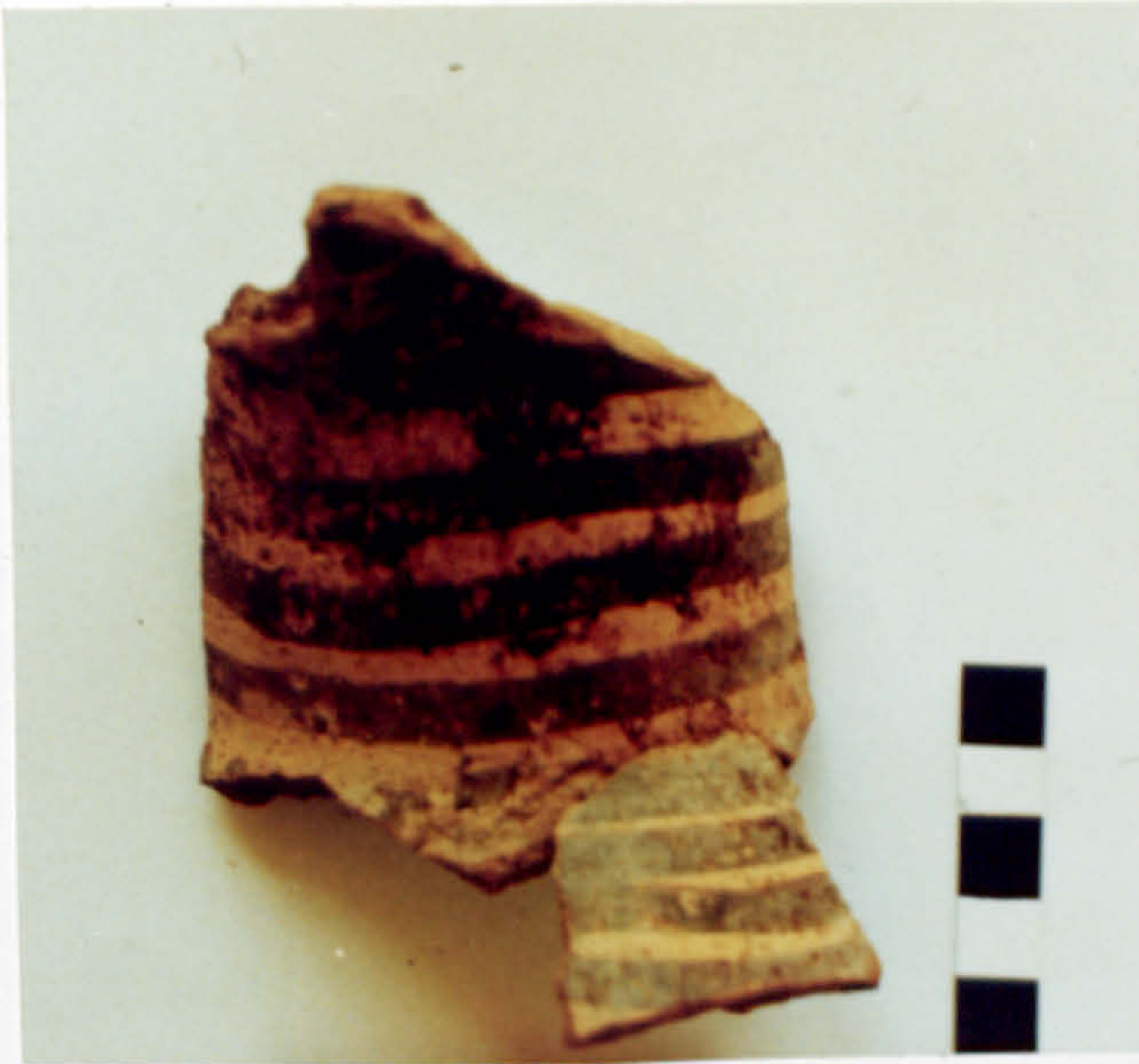

ILL 103

DAB 604

White Painted V Tangent Line Style



ILL 104

DAB -

White Painted

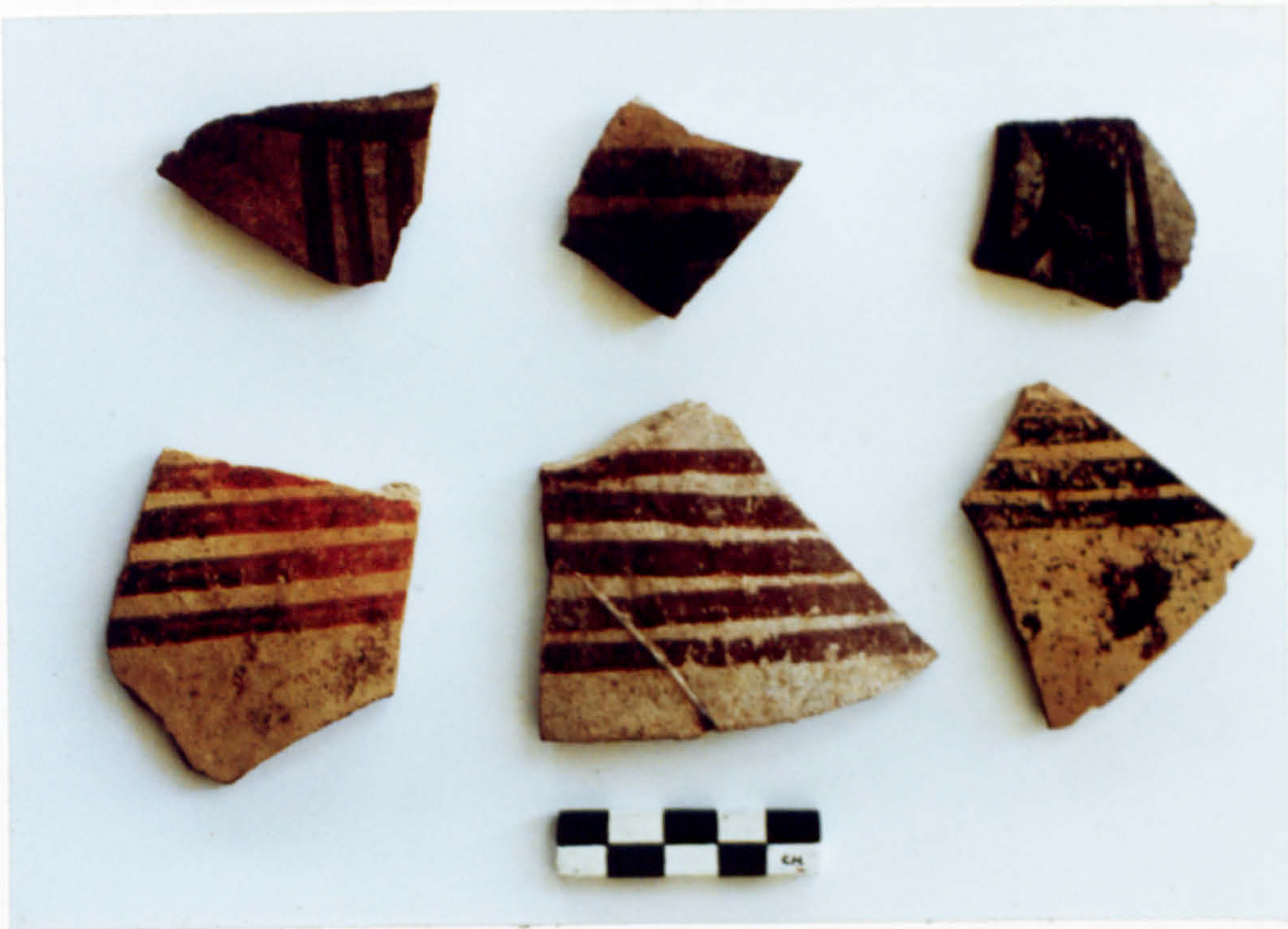

ILL 105

DAB -

White Painted V



ILL 106 DAB- White Painted V



ILL 107 DAB- White Painted V



ILL 108

DAB-

White Painted V



ILL 109

DAB-

White Painted V



ILL 110 DAB- White Painted V; White Painted various



ILL 111 DAB Bichrome Ware; Imitation White Painted Ware;
White Slip; Proto White Slip



ILL 112

DAB

White Painted V



ILL 113

DAB

White Painted V



ILL 114

DAB

White Painted V



ILL 115

DAB

White Painted V, White Painted Wheelmade Ware



ILL 116

DAB

Mycenaean, Bichrome Ware, White Painted V,
White Painted VI, Base Ring



ILL 117

DAB-

White Painted V Fine Line Style; White Painted V;
Imitation White Painted Pendent Line Style, White
Painted V Cross Line Style.



ILL 118

DAB-

White Painted V Fine Line Style; White Painted V;
Imitation White Painted Pendent Line Style, White Painted
V Cross Line Style.



ILL 119

DAB-

White Painted Alternating Broad Band and Wavy Line Style; White Painted V; White Painted Pendent Line Style; White Painted Cross Line Style



ILL 120

DAB-

White Painted Pendent Line Style; White Painted Various



ILL 121

ASH
AJJ
DHA

Red on Black; Red on Red; White Painted V; White
Painted Pendent Line Style; White Painted Alternating
Broad Band and Wavy Line Style



ILL 122

AJJ-

Red on Red; White Painted V; White Painted Various



ILL 123

AJJ 116

Black Slip/Reserve Slip



ILL 124 DAB 694 Red Slip Ware



ILL 125 DAB 697 Plain Ware



ILL 126

DAB 695

Plain Ware



ILL 127

DAB 696

Plain Ware



ILL 128

AJJ 34

White Painted VI



ILL 129

AJJ 35

White Painted VI



White Painted VI

RSH 429

ILL 131



White Painted VI

RSH 430

ILL 130



ILL 132

AJJ 36

White Painted VI



ILL 133

MEG 254

White Painted VI



ILL 134

MEG 257

Red on Black



ILL 135 AJJ 69 Red on Black



ILL 136 AJJ 50 Red on Black



ILL 137 RSH- Red on Black

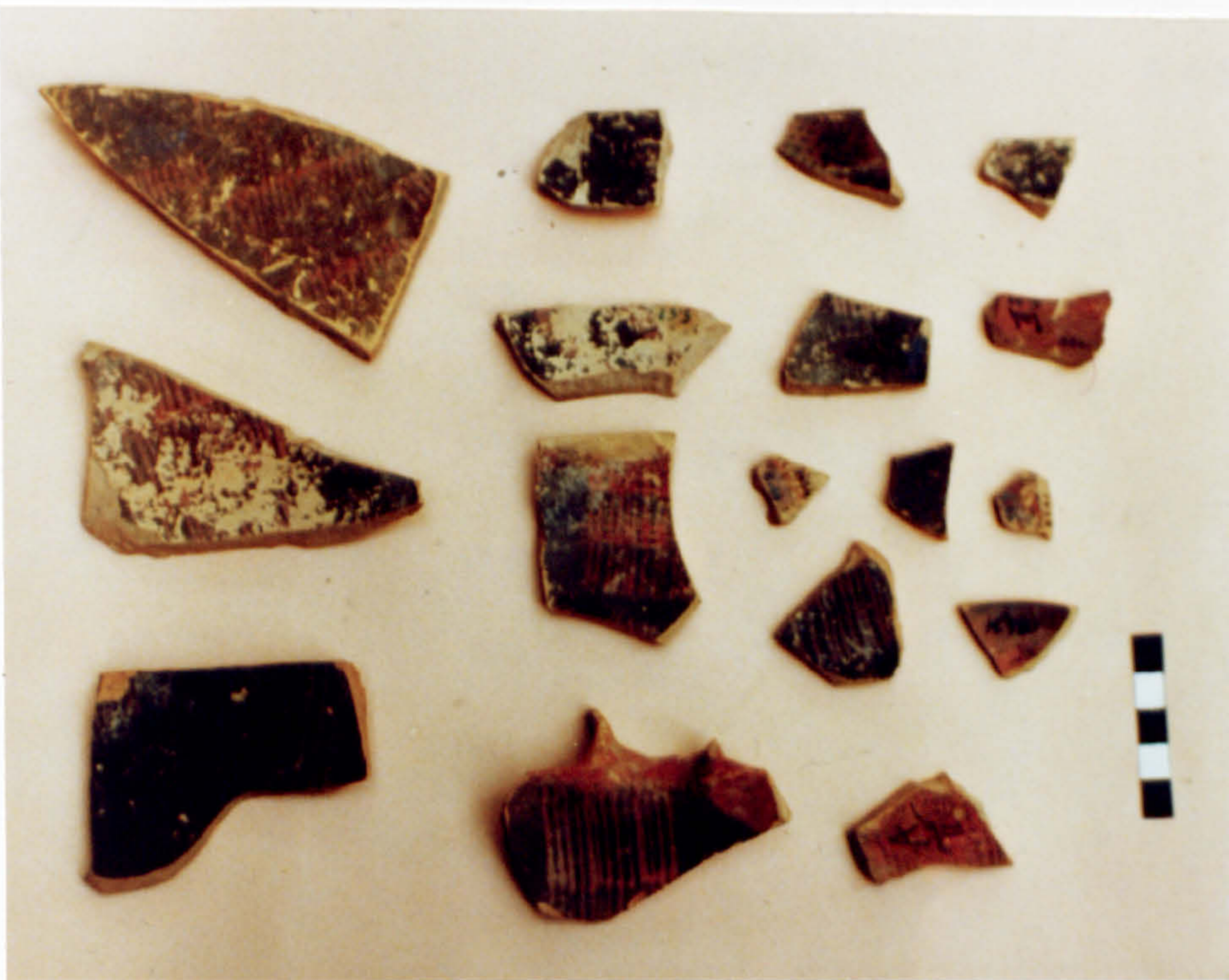

ILL 138 AJJ Red on Black

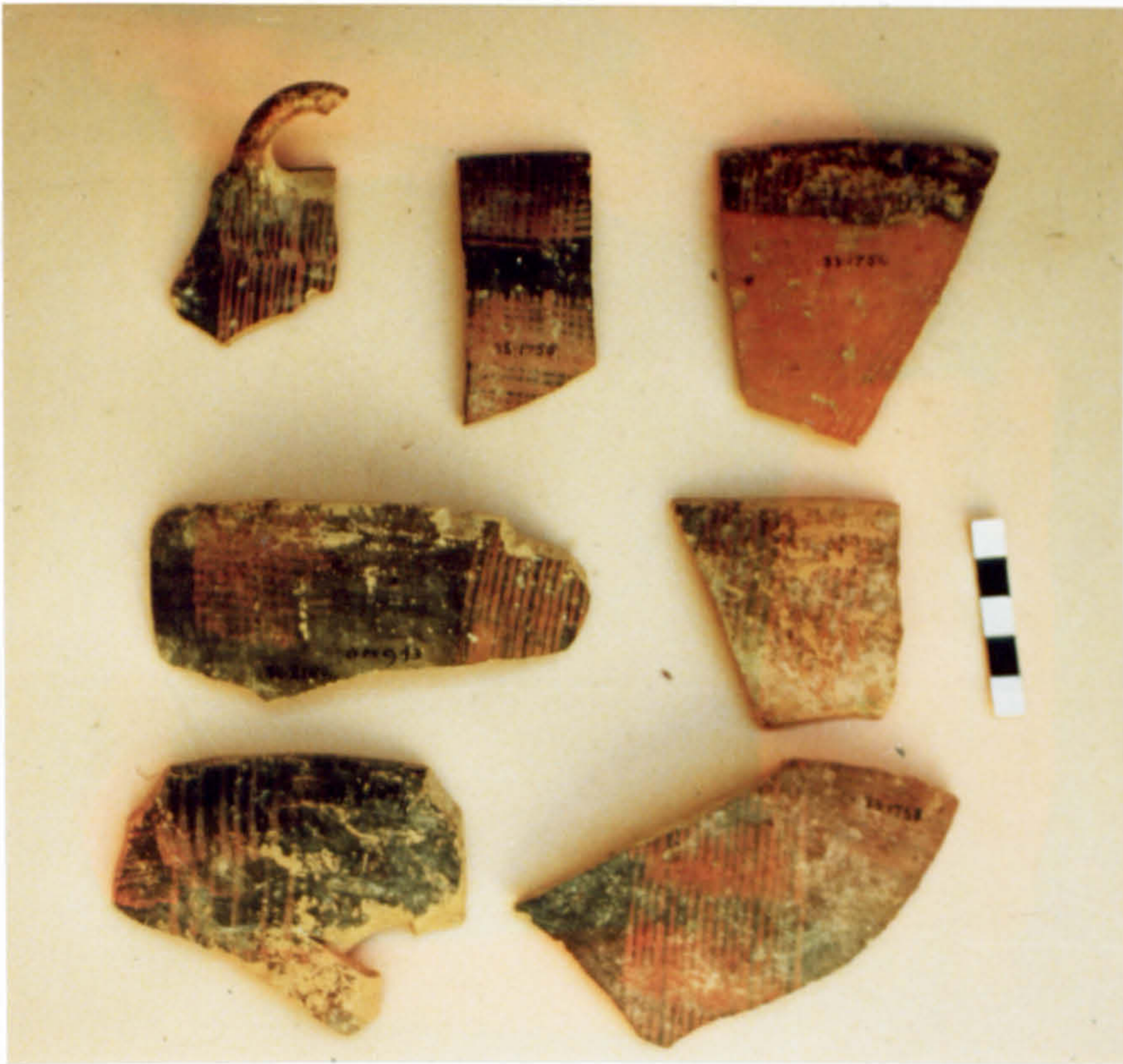

ILL 139 AJJ- Red on Black

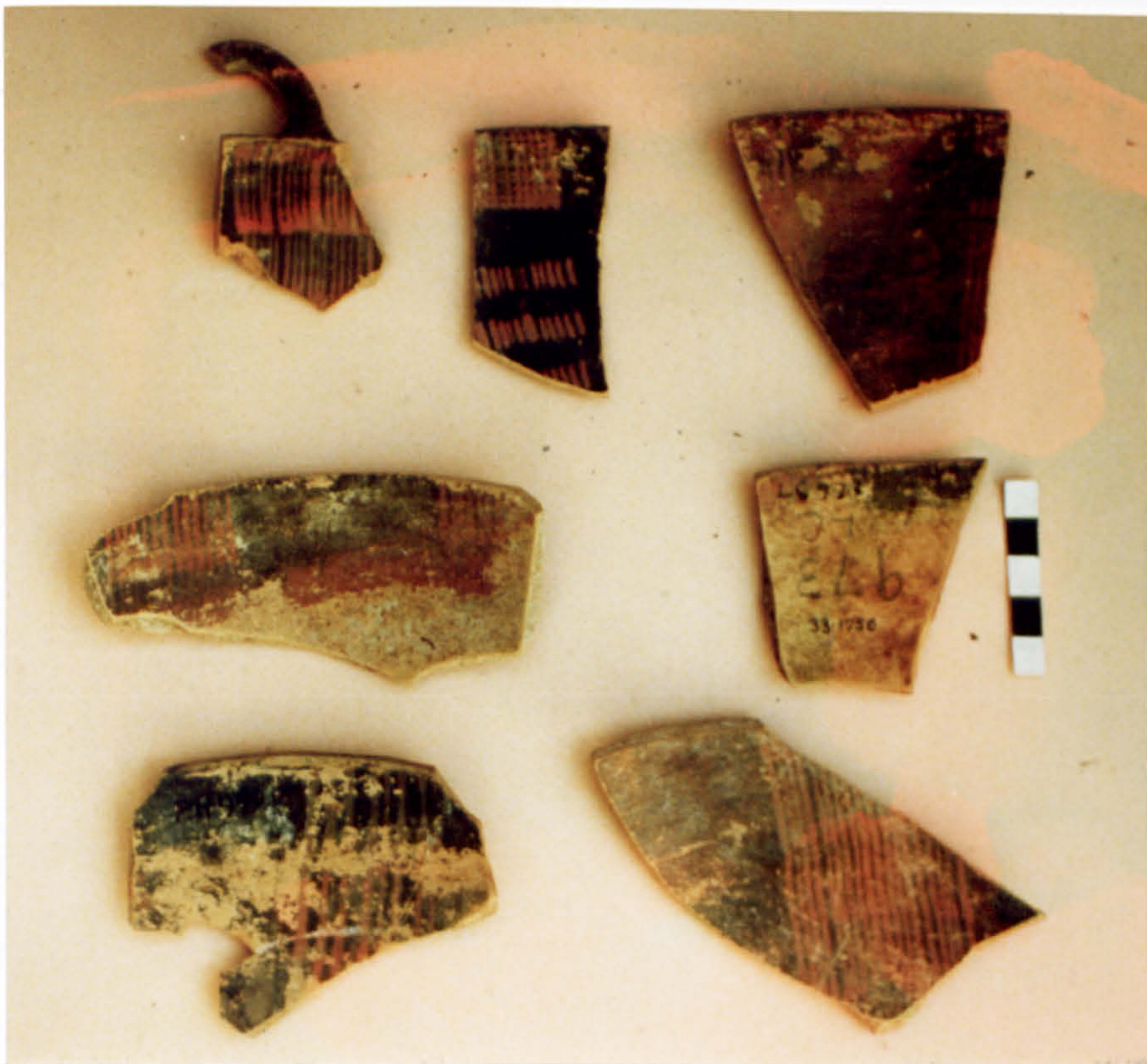

ILL 140 AJJ Red on Black



ILL 141

AJJ-

Red on Black

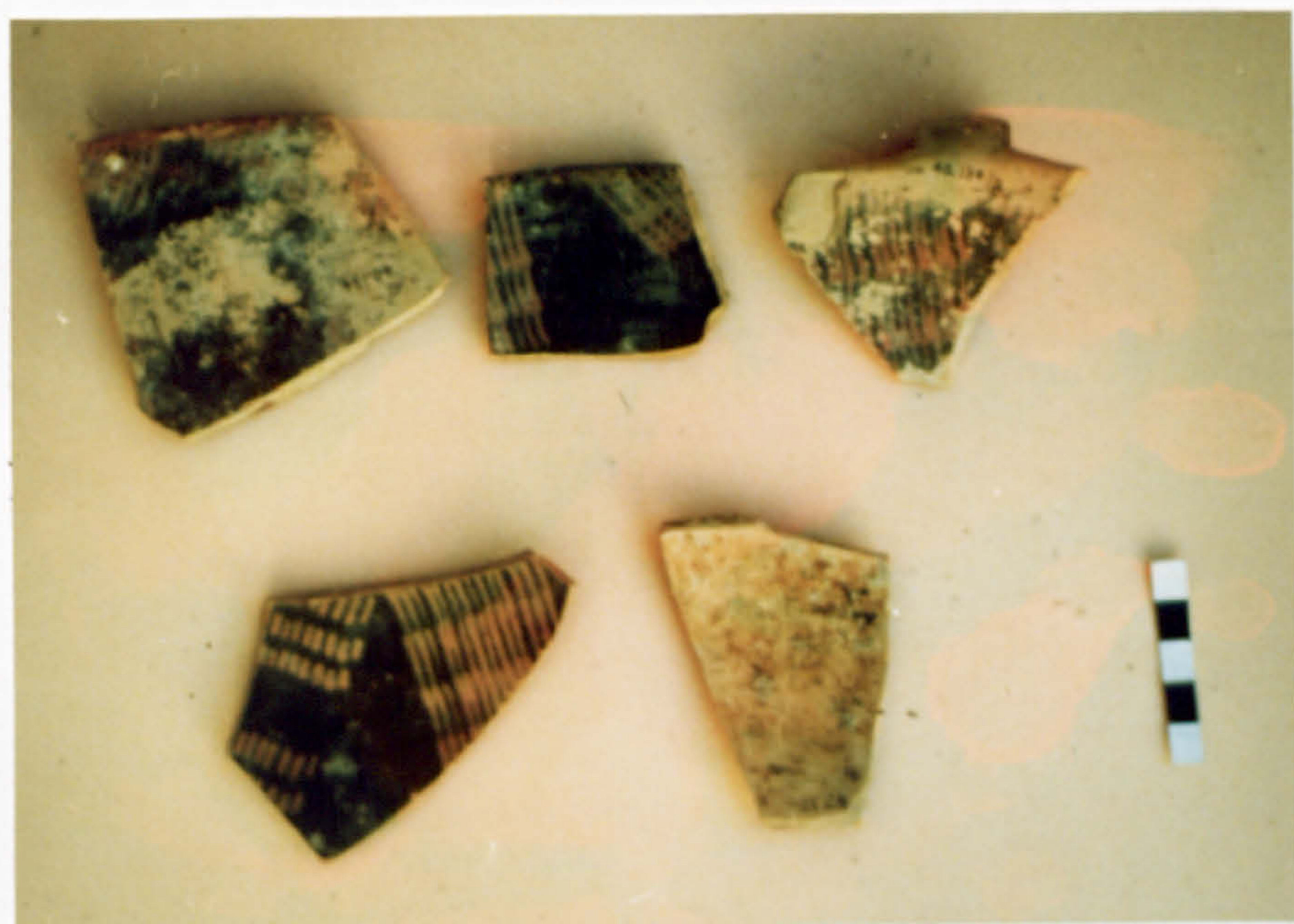

ILL 142

AJJ-

Red on Black

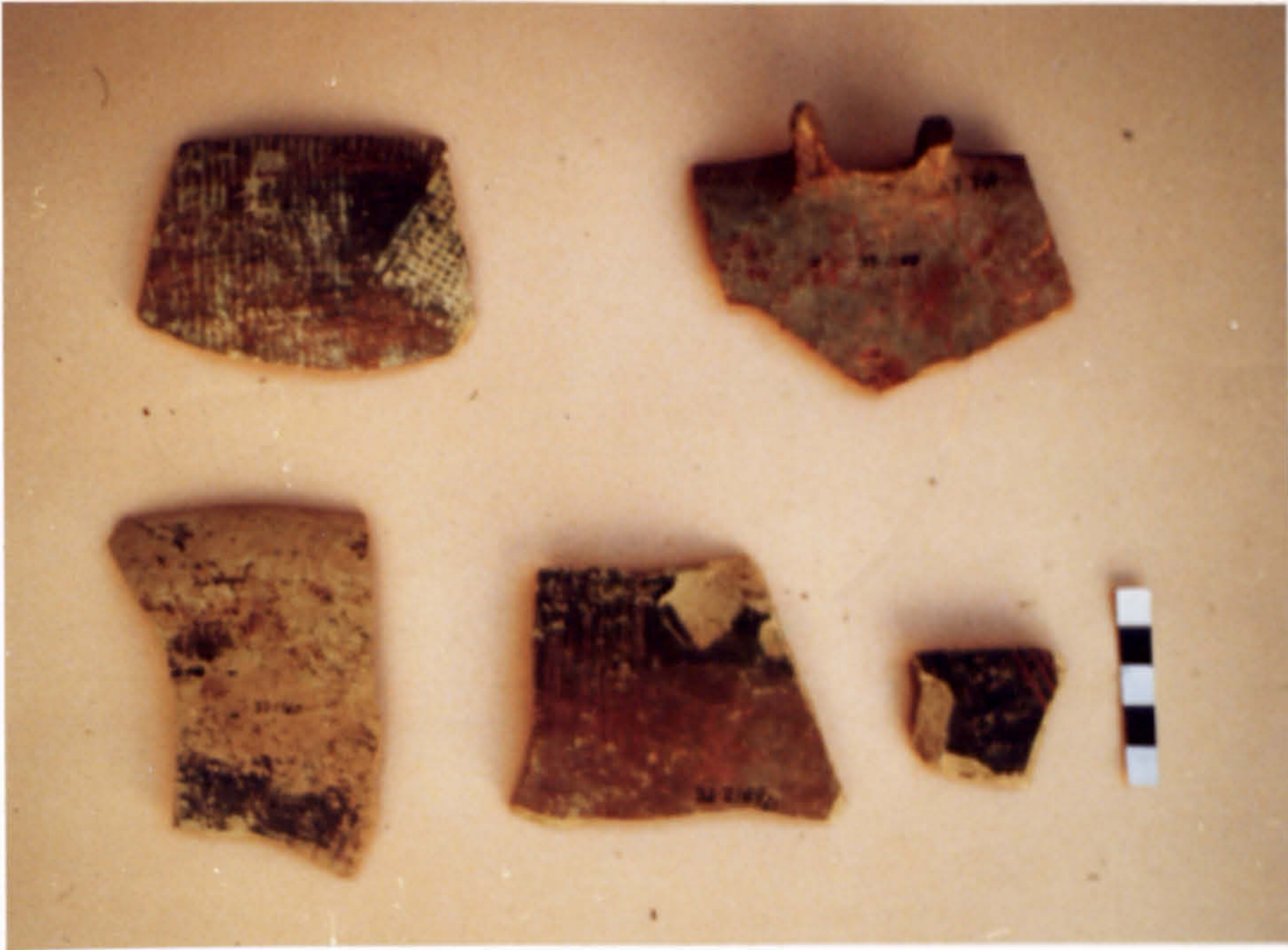

ILL 143

AJJ-

Light on Dark; Red on Black



ILL 144

AJJ-

Light on Dark; Red on Black



ILL 145

AJJ 139

Proto White Slip

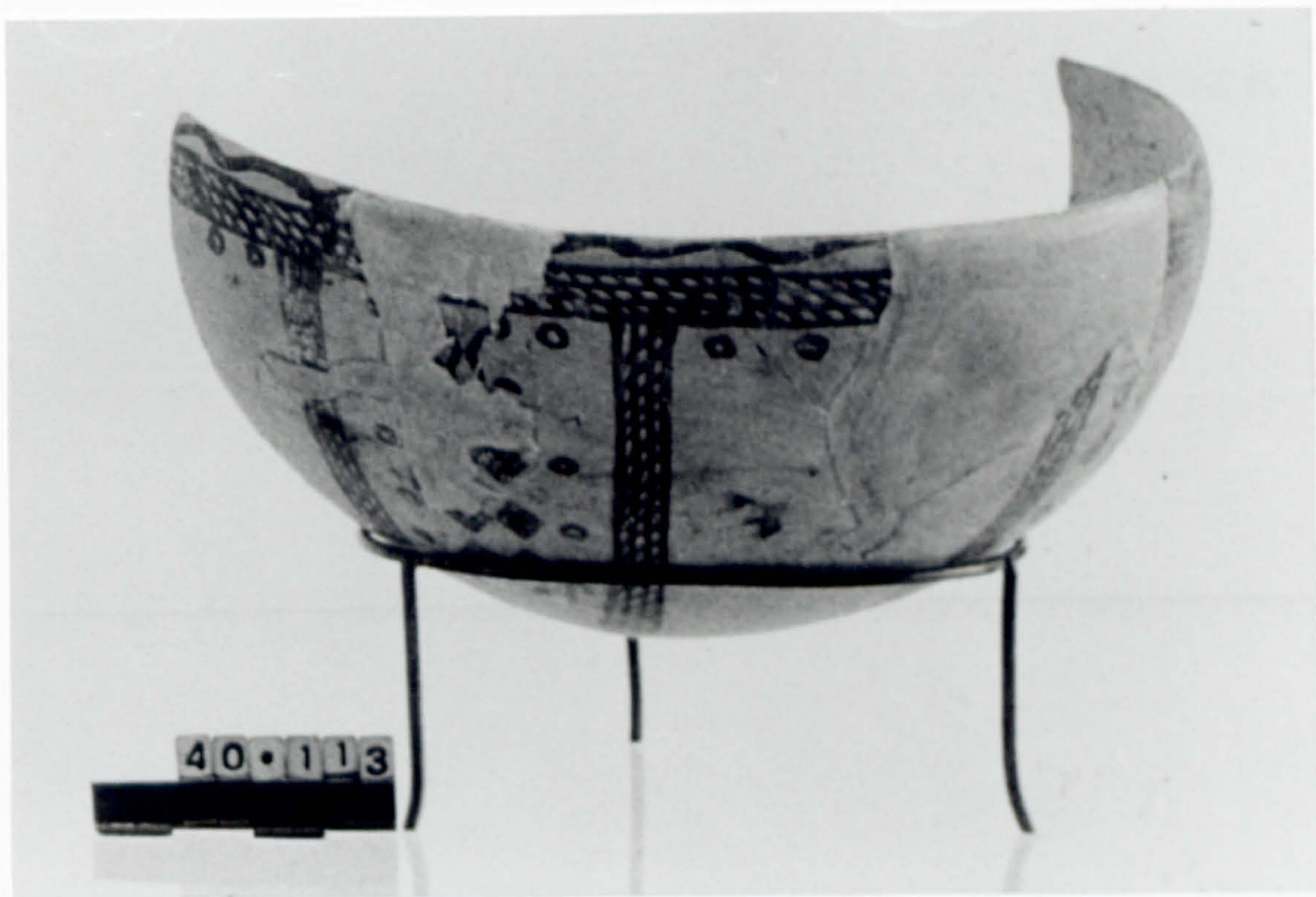

ILL 146

AJJ 123

Proto White Slip

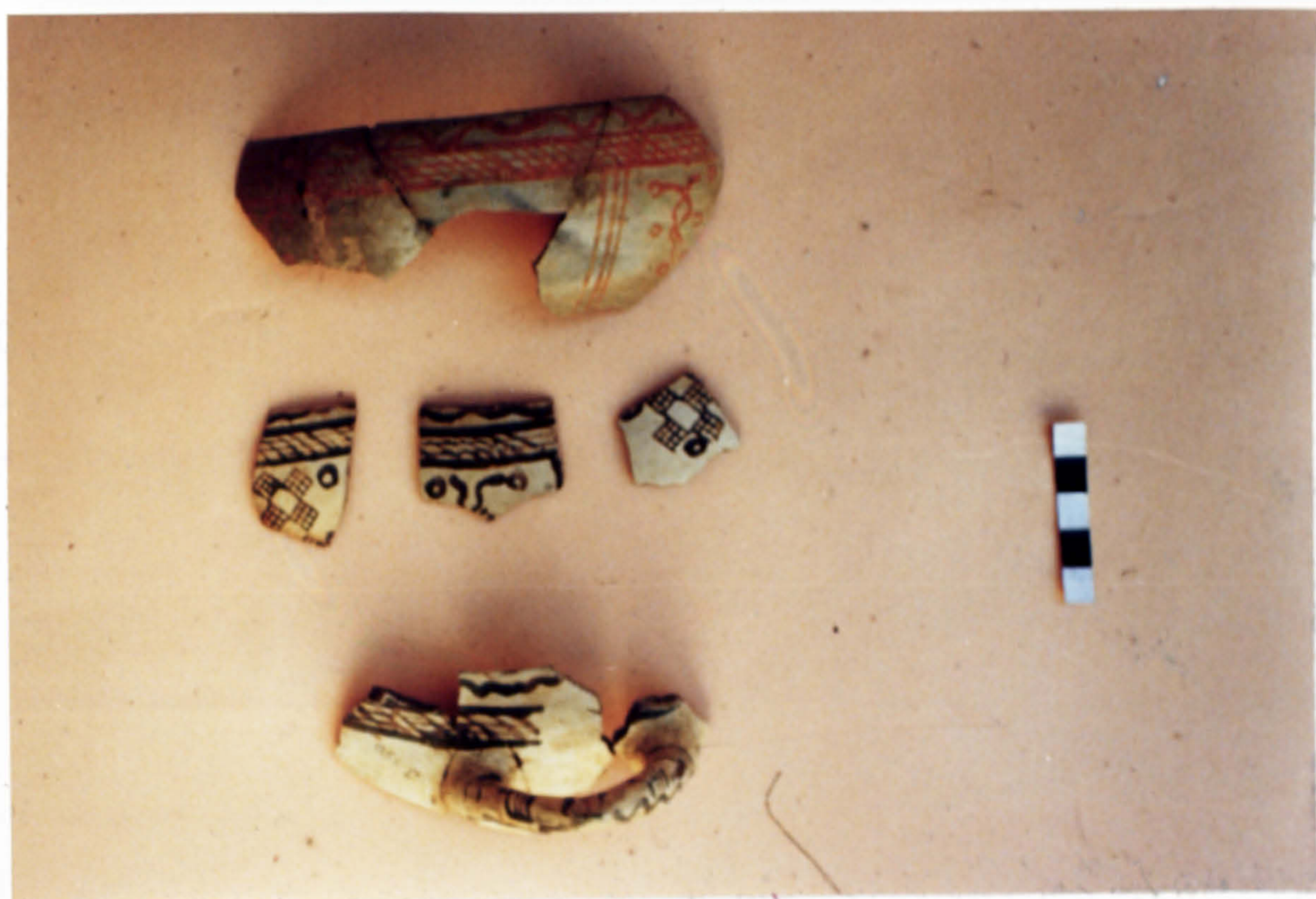

ILL 147 AJJ- Proto White Slip

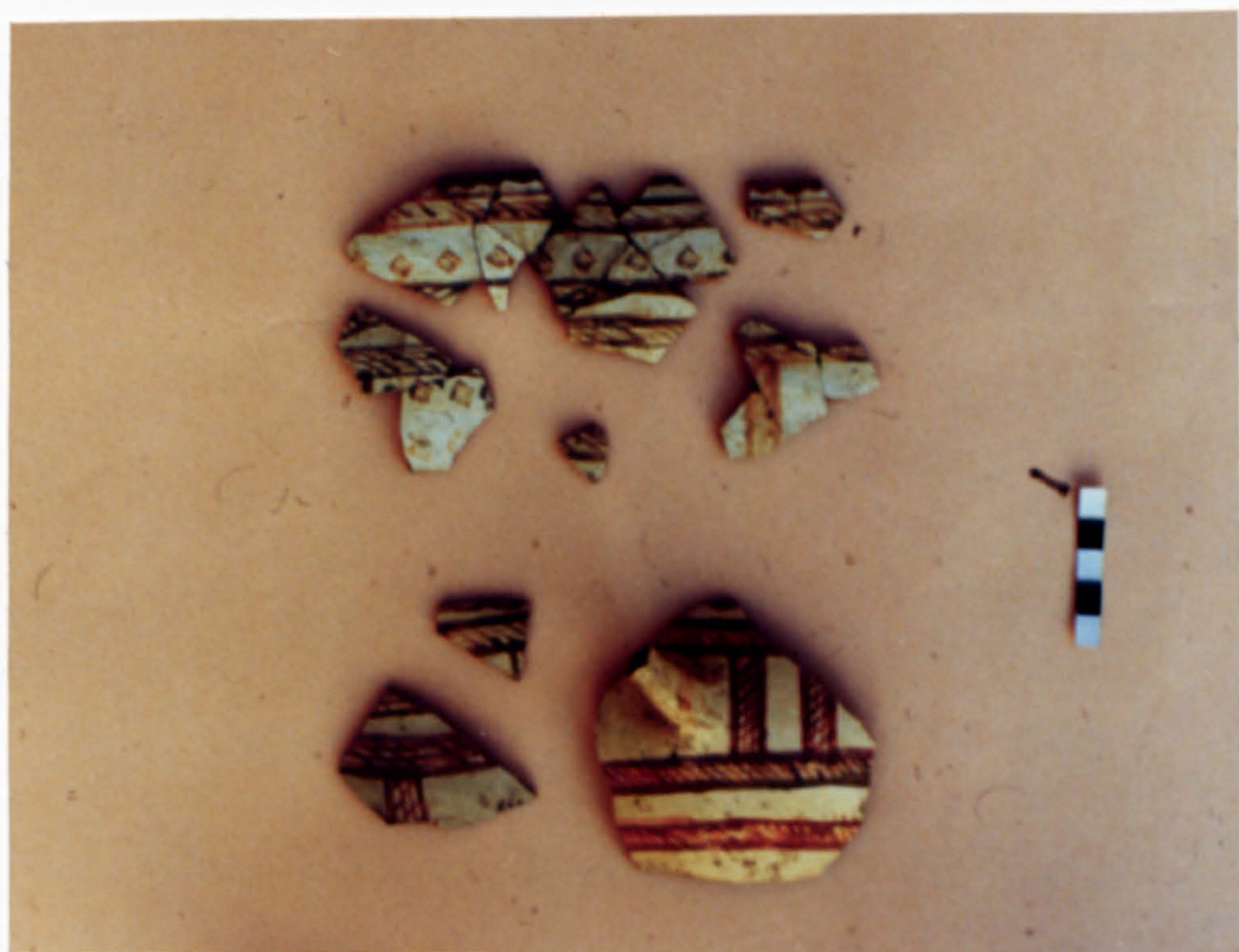

ILL 148 AJJ- Proto White Slip



ILL 149

AJJ

Proto White Slip

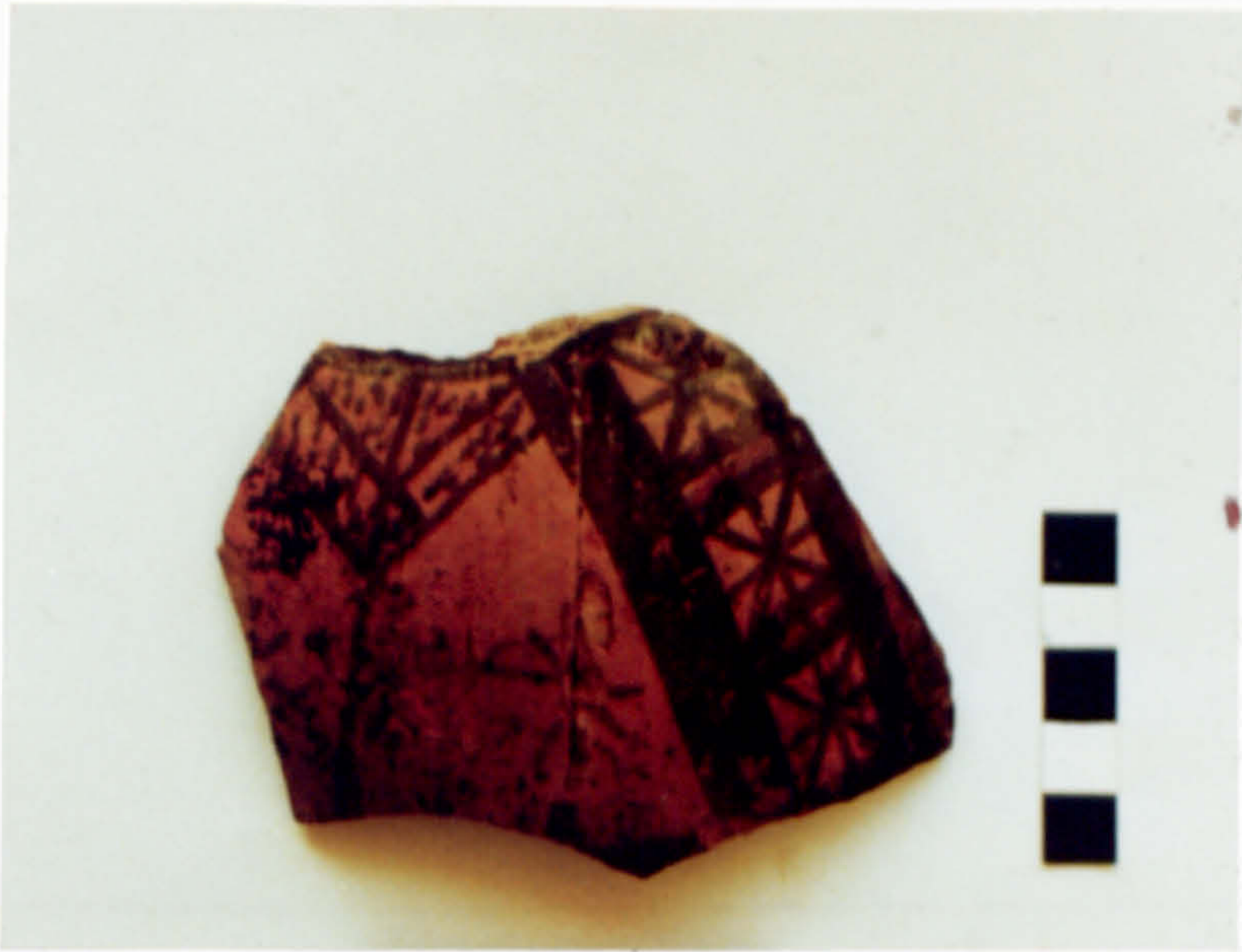

ILL 150

DAB 740

Bichrome Ware (Pal)



ILL 151

DAB 724

Bichrome Ware (Pal)



ILL 152

DAB-

Bichrome Ware (Cyp)



ILL 153

DAB 735

Bichrome Ware (Cyp)