

D. Drysdale

**H O M E O F F I C E
F I R E R E S E A R C H A N D
D E V E L O P M E N T G R O U P**



The Suppression and Extinction of Class 'A' Fires Using Water Sprays

By G B Grant
D D Drysdale

University of Edinburgh

FR/DG

The text of this
publication may
not be reproduced,

nor may talks or lectures based on material contained within the document be given, without the written consent of
the Head of the Home Office
Fire Research and Development Group.

This document was commissioned by the Home Office Fire Research and Development Group. The views expressed
are those of the authors and do not necessarily reflect the views of the Home Office.

FRDG Publication Number 1/97

Home Office Fire Research and Development Group
Horseferry House Dean Ryle Street
LONDON SW1P 2AW

© Crown Copyright

ISBN 1-85893-806-6

ABSTRACT

Water has long been the agent of choice for fighting Class 'A' fires. In fact the thermal characteristics of water make it ideally suitable as an extinguishing agent for most types of fire, whether it is used to extract heat directly from the flames, the hot products of combustion or from the surface of the fuel. The phase change from liquid water to water vapour (steam) is particularly effective in extracting thermal energy and the production of large quantities of water vapour may further contribute to fire extinguishment by inerting the surrounding atmosphere, especially where the fire is confined to some extent. The literature review which forms the basis of this report has been conducted in order to establish the current state-of-the-art regarding the use of water sprays for the suppression and extinction of Class 'A' fires. It is concluded that the current state-of-the-art is close to the point where a description of fire extinction can be given from the initiation of suppression to the point of final extinguishment, this is a stated FRDG objective. However, certain gaps in the knowledge base still exist and these are highlighted, provisional recommendations are made for the direction of future research in these areas.

MANAGEMENT SUMMARY

Introduction

The Fire Experimental Unit of the Home Office Fire Research and Development Group is seeking to produce a comprehensive description of the suppression and extinction of Class 'A' fires. The Fire Safety Engineering Group of Edinburgh University was asked to conduct a literature review to establish the current state-of-the-art regarding the use of water sprays to suppress and extinguish Class 'A' fires and to identify any gaps in the current knowledge base. This report presents the results of this exercise at a moderately technical level and concludes that the current state-of-the-art is close to achieving the stated FRDG objective.

and provisional recommendations are made for the direction of future research in these areas.

Although research output in the general area of 'fire safety science' has grown steadily over the past few decades, the subject of fire suppression has received relatively little attention. This situation has changed dramatically over the last few years with the interest in water mist as a replacement for Halon gas fixed fire protection systems. The current review is timely in this respect since many published works on the subject of fire suppression by water sprays are now available, although certain differences between fixed systems and manual fire suppression must be borne in mind.

Mechanisms of extinction of Class 'A' fires by water sprays

There are potentially three mechanisms by which water can effect the suppression and extinction of Class 'A' fires:

- *Cooling* of the combustible solid fuel surface, which reduces the rate of pyrolysis and hence the supply rate of fuel vapour to the flame zone. This reduces the rate of heat release by the fire; consequently the thermal feedback from the flame is also reduced and this augments the primary cooling effect of the suppression agent. The application of a water spray to the fuel bed is typical of this method,
- *Cooling* of the flame zone directly; this reduces the concentration of free radicals (in particular the chain-branching initiators of the combustion reaction). Some proportion of the heat of reaction is taken up by heating an inert substance (such as water) and therefore less thermal energy is available to continue the chemical break-up of reactive compounds in the vicinity of the reaction zone. One function of the new water mist technology is to act in this manner, the fine droplets providing a very large surface area per unit mass of spray in order to increase the rate of heat transfer;
- *Inerting* the air feeding the flame by reducing the oxygen partial pressure through the addition of an inert gas (e.g. N₂, CO₂, H₂O vapour). This is equivalent to removing the oxidiser supply to the flame. Large test fires in enclosures (mainly Class 'B' and 'C') have been rapidly suppressed and extinguished by water mists, primarily due to the atmospheric inerting which accompanies the production of large volumes of water vapour in confined spaces.

In order to ensure the final extinguishment of a Class 'A' fuel, it is essential to cool the fuel bed below some critical level, expressed either as a critical surface temperature or a heat flux (kW m^{-2}) to be removed from the bulk of the fuel. If this is not done then there is a high probability of re-ignition (or 'burnback') when water application ceases.

Types of water sprays used for firefighting

The nature of the water discharge from a firefighting branch may be broadly classified into one of two characteristic types: a *solid jet* or a *diffuse jet* ('*spray-jet*'). The advantages of the spray jet have been reported since the early 1900s and it has long been recognised that very efficient fire extinguishment is possible using only a small amount of water; the recent search for Halon alternatives has re-vitalised this area of fire suppression research. The development of nozzles for use in fixed-equipment Water Mist Fire Suppression Systems (WMFSS) has concentrated on the generation of populations of very small droplets ($\sim 10\text{-}200\ \mu\text{m}$) with the twin aims of promoting rapid droplet evaporation in the presence of a fire and mimicking as far as possible the transport characteristics of Halon gas to obtain an adequate dispersion of the mist within a fire compartment. The operating pressures of such systems vary widely from $\sim 5\text{-}300$ bar ($70\text{-}4400$ psig). In the UK, the Fire Service employ two distinct systems for delivering water to a fire: the main jet/spray branch supplied by a 70 mm diameter hose or, in the majority of cases, the more manoeuvrable 19 mm hosereel system fitted with an adjustable spray branch. The former operates at pressures of typically 7 bar (100 psig), delivering water at flow rates up to $\sim 1100\ \text{l min}^{-1}$, while hosereel systems generally operate above 10 bar (150 psig) providing flow rates of up to $\sim 150\ \text{l min}^{-1}$.

Choice of an 'optimum' droplet size for firefighting sprays

The possible existence of an 'optimum droplet size' for firefighting has been considered by several authors, taking into account the thermodynamic properties necessary to promote rapid cooling and the need to project such sprays into hot, energetic, gaseous atmospheres. The problem is compounded by the need to cool not only the compartment gases, but moreover the hot fuel surfaces in order to achieve final extinguishment of Class 'A' materials. Fuel cooling is essential, but the contribution of gas phase cooling is also important, not least to ensure a tolerable environment in which firefighters can operate, in addition, where ventilation is restricted, extremely rapid initial flame knockdown is possible as a result of gas phase cooling and the subsequent formation of an inerting water vapour atmosphere. The optimum drop sizes for efficient gas phase cooling and radiation absorption are much smaller than those required to reach the solid fuel surface, since the latter must possess sufficient momentum to traverse the buoyant fire gases without being deflected. The 'optimum' drop sizes proposed in the literature fall in the wide range from $2\ \mu\text{m}$ to $2\ \text{mm}$, for radiation attenuation and fuel bed cooling respectively. In practice it is usual to produce a wide range of drop sizes within 'polydisperse' sprays and for firefighting this is probably beneficial; some adjustment of spray characteristics at the nozzle is obviously advantageous however, given the foregoing discussion.

Theoretical models of suppression and extinction

Several theoretical models of suppression and extinction are discussed in this report and these fall broadly into two groups: those which attempt to describe the suppression and extinction problem in some 'local' sense (e.g. in the environs of the fuel surface and/or within the flame zone) and those which formulate the problem as part of a larger physical framework, typically a compartment containing a fire. Some interesting results have been published, for example in one case it was estimated that ~ 62% of the water applied to a room fire was required to cool the fuel below its characteristic ignition temperature; this was found to agree well with large scale experimental data. While some of the more 'fundamental' modelling approaches are mathematically elegant, they are not readily comparable to practical situations (e.g. to typical fire suppression test data). Unfortunately, it is also generally the case that such theoretical models have been subjected to insufficient independent scrutiny and have been used to solve only the particular problems devised by their originators. Additional independent testing of these models is required in order to assess the utility of the various modelling techniques.

Experimental fire suppression tests at small and large scales

An extensive review of fire suppression tests on confined and unconfined fires at a range of scales has been performed and several important points have emerged:

- For any given fire there exists a critical application rate of water, \dot{m}''_{wc} ($l \cdot m^{-2} \cdot min^{-1}$), below which the fire cannot be extinguished. In general, \dot{m}''_{wc} increases with increasing pre-burn time and also (for compartment fires) with the total area of ventilation openings (A_v). In practice, firefighters adopt a higher 'preferred rate' of water application, due in part to the need to cool their surroundings;
- There is also a 'minimum time to extinguishment', which is found to be very repeatable during tests if the firefighter is familiar with the experimental configuration;
- Values of \dot{m}''_{wc} determined in the laboratory are consistently some 10-100 times less than those required in practice, due in part to the additional cooling requirement of firefighters (as mentioned above);
- The primary function of water in Class 'A' fire suppression is to remove heat from the body of the fuel and therefore the water requirement depends on the 'heat content' of the fuel rather than the instantaneous heat release rate (HRR) of the fire. In fact, the rate of heat absorption from the fuel bed required to achieve extinguishment is generally far less than the HRR of the fire itself. Higher values of critical water application rate (\dot{m}''_{wc}) have been observed for 'densely-packed' fuel beds than for 'loosely-packed' ones;
- Based on small scale wooden crib fires, it has been postulated that the 'fundamental condition for total fire extinction' may be expressed as *reignition time* \geq *time required for sweeping the entire fuel surface with water*;
- Small water droplets generated by mist systems provide a more efficient heat sink than a spray comprised of large drops, due to the more rapid evaporative cooling;

- It has been observed that water mists are most effective velocity into the combustion zone, and preferably at low level;
- It has been noted that if a large confined fire is allowed to develop, heating the surroundings and depleting the compartment oxygen concentration, then rapid extinguishment is possible by water mist or sprays. This is due to the rapid cooling and production of water vapour and the combination of cooling and inerting effects results in extremely efficient extinguishment;
- In general, firefighting tactics are more important than variations in the characteristic droplet size or velocity. However, in the context of Fire Service operations, drop size has some relevance during the initial gas-phase cooling of compartment fires. A smaller drop size promotes more efficient cooling and therefore the influence of droplet size is greatest when the fire cannot be extinguished by fuel cooling (e.g. low firepoint liquids such as petrol).
- For Class 'A' fires, where solid-phase cooling is necessary, the efficiency of this process is expected to be less influenced by drop size, provided the water can reach the fuel surface. Recent work by the FEU, where high- and low-pressure hosereel systems (operating between 2-45 bar) were evaluated, has confirmed this hypothesis and it was concluded there that firefighting tactics are more decisive than any variations in characteristic droplet size or velocity;
- Regarding firefighting tactics for confined Class 'A' fires, initial flame knockdown is achieved faster and with less water using a spray nozzle. However final extinction requires the same volume of additional water, regardless of the application method (jet/spray), provided the water reaches the fuel surface. Pulsed spray application in the early (room-cooling) phase reduces the possibility of 'steam burns' to the firefighter since the rate of production of clouds of water vapour is more predictable and therefore more easily avoided by crouching at low level. Wide-angle fog is recommended during this phase, followed by a narrow-angle fog or solid jet, particularly for fuel cooling of deep-seated Class 'A' materials which require adequate cooling to ensure final extinguishment (thus precluding 'burnback'), although gas-phase cooling and inerting of the fire atmosphere are beneficial to the firefighters' comfort and also contribute some suppressive effect.

Class 'A' additives

Many diverse additives have been proposed over the last three decades or so, with the aim of improving the effectiveness achieve flame extinction and reducing the total volume of water required. Much of the research effort on Class 'A' additives has focused on the use of surfactant chemicals such as AFFF, AFFF-AR, FP, FP-AR, FFFP, FFFP-AR etc. which were originally developed for Class 'B' fires and were intended to be applied as aspirated foams. However, because of the three-dimensional nature of typical Class 'A' fires, a greater degree of agent penetration is required initially and therefore additive streams are generally applied un-aspirated in these situations. The surface tension (σ) of these solutions is less than that of plain water and hence the 'wettability' of the solution is increased; this improves both the fuel-bed penetration and rate of heat extraction of the

extinguishing water by conduction (since the contact area of individual water droplets is increased).

Thickening agents have been used to produce solutions of 'viscous water', which are reported to achieve faster knockdown, more rapid extinguishment and a reduced tendency to burnback; in addition, runoff and total water consumption were reduced. The literature contains much anecdotal evidence from forest fire operations where viscous water was seen to reduce the suppression time and prevent burnback. An additional benefit of viscous water is its ability to adhere to vertical surfaces.

Chemical inhibitor additives work by interrupting the chemical chain reactions required to sustain combustion. e.g. potassium carbonate solution is known to be effective against Class 'A' materials; the alkali metal salts in general are more effective as the atomic number increases, therefore potassium bicarbonate is better than sodium bicarbonate, which in turn is better than lithium bicarbonate. Remarkable (~ 70%) reductions in the total extinguishing water requirement have been reported from recent room and contents burns, using a 20% by mass diammonium-hydrogen phosphate solution.

Class 'A' foam is a relatively recent development and recent US test experience of a CAFS (compressed air foam system) against post-flashover compartment fires has shown that an aspirated 0.5% solution can promote very rapid cooling of compartment gases, up to ~ 500% faster than plain water over the range ~ 540 °C to 100 °C and this required only 18% of the total plain water application to achieve this result. The relatively low steam and smoke production gave better visibility throughout the attack. It has also been suggested that this agent could provide a more efficient attack on high heat release rate synthetics in domestic fires without incurring the logistical problems associated with merely increasing plain water delivery rates beyond ~ 350 l.min⁻¹.

Small scale tests of plastics fire suppression by 'wet water' have shown that increased adhesiveness is connected with ease of extinction and that wet water can be much more effective than plain water in many instances. Large scale plastics fires data have not been reported in the literature. Wet water applied as fog has been found to be better than solid stream application, but not in the case of foam plastic fires.

Conclusions

The main conclusions of this report are as follows:

1. The dominant mode of Class 'A' fire suppression has been identified as fuel cooling, although indirect cooling and inertion of the fire atmosphere may also play a role; the latter mechanisms are however more relevant to the initial knockdown of the fire than to its final extinguishment. There is general consensus in the literature that a Class 'A' fire cannot be finally extinguished until the fuel bed is cooled below some critical value, either expressed as a critical surface temperature or as a critical rate of heat flux to be abstracted.

2. Our present understanding of the processes involved during fuel cooling by water impingement is however, far from complete. This is particularly true for materials of low thermal conductivity, which are the most relevant to Class 'A' compartment fires. Although some progress has been made in recent years, much remains to be done, particularly in the case of textiles and composite materials.
3. The critical application rate of water ($l.m^{-2}.min^{-1}$) required to secure the extinguishment of a Class 'A' fire has been shown to be a highly variable quantity, which depends upon parameters such as fuel type, geometry and pre-burn period, compartment geometry and degree of ventilation, spray characteristics and application method etc.
4. Some objective 'consolidation' of the various semi-empirical models is required (together with some independent validation tests against more recent empirical data). It would be of interest to compare the predictions of these models by simulating some of the most recent FEU experiments on the suppression of Class 'A' compartment fires. A qualitative agreement between the FEU 'three phase' model of extinguishment and the published results from the 'Fire Demand Model' has been identified in this report. A particularly useful element of output from this model is an inventory of the suppression water applied, from which may be judged the efficiency of water application and the volume of water vapour generated etc. It is also claimed that the 'FD' model can predict levels of air entrainment during compartment fire suppression.
5. Given that there is a sudden transition to extinction from flaming combustion, the problem would appear to be amenable to analysis by non-linear modelling techniques (*i.e.* 'catastrophe theory'), which are now employed routinely in the study of various natural phenomena, including fire growth problems. Any future theoretical analysis of fire extinguishment should consider making use of this mathematical technique.
6. The interaction between water sprays and buoyant fire plumes has been widely studied, particularly in the case of sprays discharging vertically downwards (characteristic of sprinklers). Complex computer algorithms have been developed in order to track the progress of water droplets travelling in high temperature gaseous atmospheres and to estimate the magnitude of air entrainment into these sprays. At present however, there has been no comprehensive study of similar phenomena which occur during manual fire-fighting operations where the initial droplet trajectories are typically horizontal, or very nearly so. The existing drop size distributions for jet-spray branches are sparse and have not been used to assess the ultimate fate of water droplets during fire-fighting in compartments.
7. There does not appear to be a consensus emerging from the literature on the benefits, or otherwise, of adopting high pressure (> 10 bar, ~ 150 psig) hosereel systems for tackling compartment fires. Some writers cite the advantages of finer sprays coupled with increased 'throws' but others remain sceptical. There would appear to be some scope for further investigation and clarification in this area.
8. Regarding the use of additives in firefighting water, two areas have been identified which might repay further study. Firstly the effectiveness has been reported independently by several authors; the reported benefits included reduced water runoff, reduced time to extinguishment and delayed burnback. The

additive trials reported by the FEU to date have not investigated so-called 'viscous water' and it is recommended that future trials do include such agents. Secondly, the possibility that sprayed AFFF can produce chemical flame inhibition has been suggested to explain the rapid knockdown of certain Class 'B' fires in the US. Although FEU compartment fire tests have not confirmed this effect, that further research in this area is warranted.

9. Finally, in the longer term, a natural extension of this work would be to consider the suppression and extinction of other classes of fire.

TABLE OF CONTENTS

1. INTRODUCTION	1
2. DEFINITION OF CLASS 'A' FIRES	2
2.1 GENERAL	2
2.2 IMPLICATIONS FOR FIRE-FIGHTING OF CLASS 'A' FIRES	3
2.2.1 Heat transfer aspects	3
2.2.2 Mechanisms of flame	4
2.2.3 Fire spread in pre-flashover compartment	7
2.2.4 Typical (past-flashover) compartment fires attended by the Fire Service	8
2.2.5 Class 'A' fires in the open	9
2.3 SUMMARY	9
3. MECHANISMS OF EXTINCTION BY WATER OF CLASS 'A' FIRES.....	10
4. TYPES OF WATER SPRAYS.....	11
4.1 JETS, SPRAYS, FOGS AND MISTS: HYDRAULIC ASPECTS	11
4.1.1 Solid jets	11
4.1.1.1 The origins of jet instability	11
4.1.1.2 The optimum pressure head at the nozzle	12
4.1.1.3 Water flow through jet-pipe nozzles	12
4.1.1.4 Height of throw and width of spread	12
4.1.2 Diffuse jets	13
4.1.2.1 Definition of 'spray-jets'	14
4.1.2.2 Definition of droplet mean diameter	14
4.1.2.3 Determination of spray pattern	15
4.1.2.4 Methods of spray production	15
4.1.3 Fogs & mists	17
4.1.3.1 Water mist: definition, and examples of system specifications	18
4.2 METHODS OF WATER APPLICATION USED BY THE FIRE SERVICE.....	21
4.2.1 Jet/spray branches	21
4.2.2 High & low pressure	25
4.2.3 Speculative FEU research on fog & mists	25
4.3 SUMMARY	25
5. 'CHOICE' OF DROPLET SIZE (THEORETICAL ASPECTS).....	27
5.1 EFFECT OF PRESSURE ON DROPLET GENERATION.....	27
5.1.1 Droplet stability	27
5.1.2 Operating principles of water spray nozzles.....	28
5.1.2.1 Pressure atomisers	28
5.1.2.2 Gaseous atomisers	29
5.1.2.3 Rifling or swirl atomisers	30
5.1.2.4 Other types of atomisers	30
5.1.3 Drop size	31
5.2 ABILITY TO TRAVEL (SPRAY PENETRATION OR 'THROW')	37
5.2.1 Spray penetration in the absence of a fire	37
5.2.2 Spray penetration/interaction	47
5.3 ABILITY TO COOL.....	47
5.3.1 General	47
5.3.2 Heat transfer	58
5.3.3 Heat transfer	58
5.3.4 Attenuation of thermal radiation by water droplets	60
5.4 CONCEPT OF "OPTIMUM" DROPLET SIZE	65
5.5 MEASUREMENT OF DROPLET SIZE DISTRIBUTION IN PRACTICE	67
5.5.1 General	67
5.5.2 Sample size and standard distributions	68

5.5.3 Spatial and temporal sampling	68
5.5.4 Mechanical methods of drop size measurement.....	69
5.5.5 Light scattering by water droplets: the basis of optical techniques.....	70
5.5.6 Optical droplet sizing techniques.....	72
5.5.7 Limitations of optical systems	73
5.5.8 Photography and holography.....	73
5.5.9 Extinction systems	75
5.5.10 Fraunhofer diffraction systems	75
5.5.11 Single particle sizers.....	76
5.5.12 Phase doppler anemometry.....	76
5.5.13 Interferometric laser imaging of droplets.....	77
5.6 SUMMARY	78
6. PREDICTION OF SUPPRESSION & EXTINCTION USING MODELS.....	81
6.1 'FUNDAMENTAL' THEORETICAL MODELS OF THE SUPPRESSION/EXTINCTION PROCESS.....	81
6.1.1 General	81
6.1.2 The firepoint equation - fuel surface cooling	81
6.1.3 Thermal theory of solid fuel extinguishment - fuel surface cooling.....	86
6.1.4 Models of flame suppression and extinction - flame cooling, diluting and inerting.....	88
6.2 EMPIRICALLY-BASED MODELS OF COMPARTMENT FIRES.....	95
6.2.1 Compartment fire models in the absence of fire suppression.....	95
6.2.2 Compartment fire models with fire suppression.....	97
6.3 SUMMARY.....	99
7. LARGE SCALE AND SMALL SCALE SUPPRESSION TESTS	100
7.1 GENERAL.....	100
7.2 SUPPRESSION TESTS ON OPEN FIRES	101
7.2.1 Fire suppression tests involving a range of fuel types	101
7.2.2 Sprinkler suppression of warehouse fires	110
7.3 SUPPRESSION TESTS ON COMPARTMENT FIRES	117
7.4 TEST DATA ARISING FROM WMFSS DEVELOPMENT.....	128
7.4.1 General	128
7.4.2 Accounts of some notable WMFSS tests	128
7.4.2.1 SINTEF experiments - Norway	128
7.4.2.2 Ship protection	132
7.4.2.3 Telecommunications and utilities protection (live electrical equipment).....	133
7.4.2.4 Gas turbine enclosures.....	134
7.4.2.5 Gaseous combustion (explosions).....	136
7.4.3 Design considerations for water mist fire suppression systems (WMFSS).....	137
7.5 SUMMARY.....	142
8. USE OF ADDITIVES FOR CLASS 'A' FIRE SUPPRESSION.....	146
8.1 GENERAL.....	146
8.2 SURFACE TENSION ('WETTABILITY') MODIFIERS.....	147
8.3 VISCOSITY MODIFIERS	156
8.4 CHEMICAL FLAME INHIBITORS FOR FIRE-FIGHTING WATER	162
8.5 CLASS 'A' FOAM.....	165
8.6 SUMMARY.....	170
9. DISCUSSION.....	173
10. CONCLUSIONS AND PROPOSALS FOR FUTURE WORK.....	176
ACKNOWLEDGEMENTS.....	177
REFERENCES	178
LIST OF SYMBOLS.....	192

LIST OF TABLES

Table 1.	Extinguisher performance against different fire types	3
Table 2.	L_v values for some solid and liquid fuels	4
Table 3.	Summary of mean droplet diameters for specific applications	15
Table 4.	Typical jet/spray branch hydraulic performance data for branches operating as jets	22
Table 5.	Typical jet/spray branch hydraulic performance data for branches operating as sprays at 0° elevation	23
Table 6.	Droplet mean diameter d and total surface area for one litre of water distributed as a monodisperse spray of i droplets	32
Table 7.	Scattering modes associated with various scattering angles	72
Table 8.	Variation of critical application rate with surface area of fire	104
Table 9.	Classification of fire growth according to 'fire growth factor'	112
Table 10.	Convective heat release rate (HRR) values at sprinkler actuation for various sprinkler/fuel array configurations	115
Table 11.	Mass median drop size (microns) at a range of spray nozzle pressures	119
Table 12.	Field fire tests, Norfolk Virginia	158
Table 13.	Field fire tests, Onondaga County, New York	158
Table 14.	Viscous water fire extinguishment data for 12.8 m ² room	160
Table 15.	Viscous water fire extinguishment data for 21 m ² room	160
Table 16.	Quantities of loaded stream solutions (litres) required to extinguish 6 kg crib fires	164
Table 17.	Loaded stream fire extinguishment data for 12.8 m ² room	164

LIST OF FIGURES

Figure 1.	The Front Room Fire (Time from ignition = 30 s)	
Figure 2.	The Front Room Fire (Time from ignition = 1 min: 15 s)	
Figure 3.	The Front Room Fire (Time from ignition = 2 min: 15 s)	
Figure 4.	The Front Room Fire (Time from ignition = 3 min: 0 s)	
Figure 5.	The Front Room Fire (Time from ignition = 3 min: 15 s)	
Figure 6.	The Front Room Fire (Time from ignition = 3 min: 20 s)	
Figure 7.	Schematic of compartment fire growth history	

- Figure 8. Spectrum of droplet diameters
- Figure 9. Schematic illustration of fire-fighting nozzles
- Figure 10. Proposed classification of water sprays by drops size distribution
- Figure 11. Various commercial water mist nozzles
- Figure 12. Basic categories of fire-fighting branches
- Figure 13. Principal techniques of water atomisation by nozzles
- Figure 14. Number of droplets and total surface area produced by one litre of water, as monodisperse sprays with various mean droplet diameters, d
- Figure 15. Droplet size of impinging jets as a function of pressure and angle
- Figure 16. McCaffrey's 'first stage' (momentum conservation) model of water droplet-flame interaction
- Figure 17. The entrainment relationship for a water spray
- Figure 18. Thermal energy requirement for heating and phase changes of 1 litre (1 kg) of water
- Figure 19. Schematic heat transfer during surface cooling showing convergence (a) and divergence (b) of heat flux lines at droplet impact site
- Figure 20. Effect of droplet size on transmissivity
- Figure 21. Accuracy of mean diameter as a function of sample size
- Figure 22. Schematics of Malvern (a) and PDA (b) optical layout
- Figure 23. Interaction between parallel light and a single water droplet
- Figure 24. Water-based suppressibility correlation
- Figure 25. Thermal model of combustion process
- Figure 26. Variation of non-dimensional maximum temperature with 'boundary Damköhler number'
- Figure 27. Variation of non-dimensional maximum temperature with 'flame zone Damköhler number'
- Figure 28. Heat losses during a fully-developed compartment fire
- Figure 29. 'Fire Demand Model' suppression water inventory
- Figure 30. Time to extinguish a fire vs. agent application rate
- Figure 31. Suppression agent quantity/rate curve
- Figure 32. Schematic of phases of fire suppression and extinction

APPENDIX

Table A1. Summary of experimental data on water suppression and extinction of open fires

Table A2. Summary of experimental data on water suppression and extinction of compartment fires

The first part of the report describes the experimental conditions and the results of the tests. The second part of the report describes the theoretical background of the tests and the results of the theoretical calculations. The third part of the report describes the results of the tests and the theoretical calculations. The fourth part of the report describes the results of the tests and the theoretical calculations.

The report presents the results of the tests in a tabular form and also in a graphical form. The results of the tests are presented in Table A1 and Table A2. The results of the theoretical calculations are presented in Table A3 and Table A4. The results of the tests and the theoretical calculations are compared in Table A5 and Table A6.

The results of the tests and the theoretical calculations are compared in Table A5 and Table A6. The results of the tests and the theoretical calculations are compared in Table A5 and Table A6. The results of the tests and the theoretical calculations are compared in Table A5 and Table A6. The results of the tests and the theoretical calculations are compared in Table A5 and Table A6.

The report concludes by stating that the tests and the theoretical calculations have shown that the water suppression and extinction of open fires and compartment fires is a complex process. The results of the tests and the theoretical calculations are compared in Table A5 and Table A6. The results of the tests and the theoretical calculations are compared in Table A5 and Table A6. The results of the tests and the theoretical calculations are compared in Table A5 and Table A6.

I. INTRODUCTION

The Fire Experimental Unit of the Home Office Fire Research and Development Group is seeking to produce a comprehensive description of the suppression and extinction of Class 'A' fires. The Fire Safety Engineering Group of Edinburgh University were asked to conduct a literature review to establish the current state-of-the-art regarding the use of water sprays to suppress and extinguish Class 'A' fires and to identify any gaps in the current knowledge base.

This report presents the results of this exercise at a moderately technical level and concludes that the current state-of-the-art is close to achieving the stated FRDG objective. However, certain gaps in the knowledge base are also highlighted, and provisional recommendations are made for the direction of future research in these areas.

Although research output in the general area of 'fire safety science' has been steadily growing over the past few decades, the subject of fire suppression has received relatively little attention. This situation has changed dramatically over the last few years with the interest in water mist as a replacement for Halon gas fixed fire protection systems. The current review is timely in this respect since many published works on the subject of fire suppression by water sprays are now available, although certain differences between fixed systems and manual fire suppression must be borne in mind.

The report begins by defining Class 'A' fires and describing the development of a compartment fire, the mechanisms of extinction of Class 'A' fires by water are also discussed. Thereafter, the subjects of nozzle design, spray production and droplet characteristics are addressed and the possible existence of an 'optimum droplet size' for firefighting is considered. A review of theoretical models of suppression and extinction is included and is followed by a summary of notable experimental studies. Finally, the use of additives in connection with Class 'A' fire suppression is discussed.

2. DEFINITION OF CLASS 'A' FIRES

2.1 General

The current British/European Standard BS EN 2: 1992 *Classification of fires* (Reference 1) defines four categories of fire, according to the material undergoing combustion. This system has been used extensively in the research and development of fire fighting extinguishants and in discussions of other fire-related matters.

Class A: fires involving solid materials, usually of an organic nature, in which combustion normally takes place with the formation of glowing embers.

Class B: fires involving liquids or liquefiable solids.

Class C: fires involving gases.

Class D: fires involving metals.

Book 1 of the Home Office *Manual of Firemanship* (Reference 2) contains the following definition of Class 'A' fires:

"These are fires involving solid materials normally of an organic nature (compounds of carbon), in which combustion generally occurs with the formation of glowing embers. Class A fires are the most common and the most effective extinguishing agent is generally water in the form of a jet or spray."

(In addition, it should be noted that solid rubber is designated a Class 'A' fuel whereas molten rubber is defined as Class 'B'; these definitions have important implications for tackling fires involving vehicle tyres.) The present authors consider that there may be some ambiguity regarding the classification of some thermoplastics such as polyethylene etc. which burn as pool fires. The Class 'A' definition given above covers those solids which "generally" form glowing embers; most thermoplastics do not form glowing embers (PVC can produce a char) yet they do constitute a large proportion of the synthetic materials used in building construction. As they liquefy before burning, they would seem to fall into the Class B category, however the situation is more complex. Historically, Class B fires are associated with the most common form of liquid fire: the hydrocarbon pool fire. Hydrocarbons are less dense than water and are not efficiently cooled by water because of the ease with which combustible vapours are released (i.e. they possess a low "firepoint"). In contrast, thermoplastics generally have firepoints in excess of 200 °C, and in some cases 300 °C, and can be effectively cooled by water application.

Hirst (Reference 3) used the European fire classification to rank the effectiveness of various types of extinguishant media. Table 1, on page 3, shows Hirst's ranking of agent performance into the categories poor (P), good (G) or very good (VG); 'NO' indicates that the agent is unsuitable for that fire class. It can be seen that water is again identified as the best agent for Class 'A' fires, in agreement with Reference 2.

The emphasis of the present study is on the extinction and suppression of Class 'A' fires by water; however, other fire types are also mentioned in passing where a comparison of the extinction process is of interest.

Table 1
Extinguisher performance against different fire types (after Reference 3)

Fire Classification	Agent					
	Water	Foam	CO ₂	Halon 1211	Powder	Special powders
European classes						
A	VG	G	P	G¹	P	G¹
B	NO	VG	G	VG	VG	-
C	NO	NO	G	VG	VG	-
D	NO	NO	NO	NO	NO	G

¹ The designation 'G' is debatable here, since neither agent produces direct cooling of Class 'A' fuels

2.2 Implications for fire-fighting of Class 'A' fires

2.2.1 Heat transfer aspects

Cox (Reference 4) identified the essential feature of an "unwanted fire" as the control of the fuel supply by the positive feedback of heat from the products of its own combustion. Irrespective of whether the fuel is initially solid (Class 'A') or liquid (Class 'B'), the supply of gaseous volatiles is produced *via* this feedback of thermal energy; where the characteristic fire dimension is >0.3 m, the feedback is dominated by thermal radiation. Such fires are of the diffusion flame variety, and are usually turbulent in character (see also Reference 5). The more products of combustion that are released, the greater is the radiative heat feedback and the consequent rate of release of volatiles; the latter then burn and release an even greater quantity of products per unit time, and so on. This process is ultimately self-limiting however, since the flame emissivity cannot exceed unity and there is also a certain amount of radiation absorption by the vapour zone above the fuel surface.

Drysdale (Reference 6) discussed an expression of the form,

$$\dot{m}'' = \frac{\dot{Q}_G'' - \dot{Q}_L''}{L_v} \quad (1)$$

which described the rate of burning of solid and liquid fuels, where

$$\begin{aligned} \dot{m}'' &= \text{mass burning rate per unit area (g.m}^{-2}\text{.s}^{-1}\text{)} \\ \dot{Q}_G'' &= \text{rate of gain of thermal energy per unit area (kW.m}^{-2}\text{)} \\ \dot{Q}_L'' &= \text{rate of loss of thermal energy per unit area (kW.m}^{-2}\text{)} \end{aligned}$$

L_v = latent heat of evaporation (or 'heat of gasification' for solid fuels) (kJ g^{-1})

and \dot{Q}_G'' , \dot{Q}_L'' incorporate conduction, convection and radiation components of heat transfer. Drysdale (Reference 6) identified two major differences between flammable liquid fires and those involving solid fuels; in the latter both the surface temperature during burning and the magnitude of L_v tend to be significantly greater than those associated with Class 'B' materials. The relatively high surface temperature of burning solids ($\sim 400\text{-}500\text{ }^\circ\text{C}$) in turn leads to significant radiative heat losses, while high values of L_v are indicative of the additional thermal energy required for the chemical decomposition (pyrolysis) of solid fuels (see Table 2 below).

Table 2
 L_v values for some solid and liquid fuels (adapted from Reference 6)

Material	L_v (kJ.g^{-1})
Polycarbonate (solid)	2.07
Wood (Douglas Fir)	1.82
Polystyrene (solid)	1.76
Methyl alcohol (liquid)	1.20
Ethyl alcohol (liquid)	0.97
Heptane (liquid)	0.48

Although a value of L_v for 'wood' appears in Table 2, it was noted in Reference 6 that there was no clear consensus on the numerical value of this parameter in the literature, with reported values ranging from around $1.8\text{-}7.0\text{ kJ.g}^{-1}$. This was attributed to the complex nature of wood (inhomogeneous and anisotropic) and inherent differences between the various species.

The formation of a char layer on the burning surface of wood and some synthetic polymers has the initial effect of reducing the heat transfer rate to the unpyrolysed layers below and so reducing the pyrolysis rate. Consequently, an increased value of imposed heat flux \dot{Q}_G'' may be required to re-establish a flow rate of volatiles sufficient to sustain combustion. Higher surface temperatures will obtain, in order to maintain the required flow of heat through the char layer, and so the radiative component of \dot{Q}_L'' will also increase, although surface oxidation of the char layer will offset these losses to some degree (Reference 6). Wood discolours and chars at temperatures above $200\text{-}250\text{ }^\circ\text{C}$ and when burned or heated above $450\text{ }^\circ\text{C}$, only some $15\text{-}25\%$ of the original mass normally remains as char. The 'burning rate of wood' is commonly quoted in terms of the linear rate of formation of a char layer and the empirical expression,

$$R_w = 2.2 \times 10^{-2} I \quad (2)$$

was reported in Reference 6, where I is the external heat flux (kW m^{-2}) and R_w is the burning rate expressed in millimetres per minute. The 'standard' rate of burning of wood is often given as 0.6 mm.min^{-1} , derived from measurements of char depth on wooden beams and columns exposed to a standard fire test (Reference 6). However, it is known

that localised temperatures of $\sim 1100\text{ }^{\circ}\text{C}$ may be developed in compartment fires, with associated heat flux values of some $200\text{ kW}\cdot\text{m}^{-2}$; these conditions lead to predicted burning rates (*i.e.* char formation rates) as high as $4.4\text{ mm}\cdot\text{min}^{-1}$ from equation (2).

2.2.2 Mechanisms of flame spread in Class 'A' fires

The mechanisms of flame spread and fire growth are somewhat different for the different classes of fire. Solid fuels for example, may be burned in any orientation, unlike liquid fuels where the flame is always located above the horizontal free surface and flame propagation is likewise always horizontal; a notable exception to the latter is the 'running liquid fire', a hazard in the petrochemical industry, where a leak of burning liquid fuel at high level discharges onto the surfaces below. It is apparent that fire spread by flowing liquid is governed by the flow of the fuel under gravitational forces, which is quite different to conventional fire spread between Class 'A' solid fuels (see also the comments on the possible inclusion of thermoplastic materials as Class 'A' fuels in Section 2.1).

The spread of fire, whether on individual 'fuel elements' or between those 'elements' (such as items of furniture) in enclosures, has been the subject of much attention in fire science literature over the years. Historically, this research effort has been aimed at ranking the fire hazard posed by various types of building material, burning in different configurations (*e.g.* horizontal, upward and downward flame spread). Several workers have also endeavoured to produce theoretical models of flame spread in an attempt to understand the processes governing the spread of flame on individual 'fuel elements', and in particular to predict the *flame spread rate* V (either in $\text{m}\cdot\text{s}^{-1}$ or $\text{m}^2\cdot\text{s}^{-1}$). Although these models have had some success in specific circumstances it is true to say that, at present, no general model exists which can faithfully predict the development of a room fire containing arbitrary materials.

Williams (Reference 7) considered the concept of 'fire spread' to be meaningful only in situations where both burning and non-burning combustibles could be identified, where 'burning' was used in its most general context, to include all processes ranging from glowing combustion to vigorous flaming. Fire spread was deemed to occur only where some form of 'communication' existed between the burning region and the non-burning fuel. In all cases of practical interest, the 'communication' across the boundary separating these regions was perceived to be thermal in nature (*e.g.* conduction, convection, radiation, or flaming embers); the transfer of thermal energy from burning to non-burning (or 'virgin') fuel is necessary to promote chemical decomposition ('pyrolysis') and the associated production of fuel gases ('the volatiles'). Williams concluded that the first objective in describing the fire spread process was to identify the dominant mode of heat transfer across the so-called 'surface of fire inception'. Regarding the spread of fire among discrete elements, Williams (Reference 7) noted that the number of practical fire spread mechanisms would be reduced since heat conduction through the fuel can generally be dismissed as an option for item-to-item fire propagation. In this case the principal mechanisms are radiation, the convection of hot gases and the expulsion of burning particles.

2.2.3 Fire spread in pre-flashover compartment fires

Compartment fires in domestic or commercial premises represent by far the most common type of fire attended by the Fire Service in the UK; therefore the process of fire development in these cases has particular relevance to the present report. Drysdale (Reference 6) has presented an extensive account of the development of compartment fires, in both the 'pre-flashover' and 'post-flashover' regimes. In the context of the present study of Class 'A' fire extinguishment, a brief account of the development of compartment fires is useful, and can be made with reference to Figures 1-6, reproduced from the BRE video *The Front Room Fire*. This experiment, performed in the FRS Cardington test facility in 1989, employed a specially-constructed test compartment containing typical domestic 'front room' furniture and fittings. The ignition source was a single match placed on the seat of a settee, and the progress of the fire was observed and filmed from locations adjacent to the front wall, which remained absent during the test. The degree of confinement of the test room was therefore much less than would be typical of a 'real' compartment fire and consequently the fire was not ventilation-controlled.

In the latter case a deep smoke layer develops and its base gradually descends towards the floor; consequently the upper flame zone becomes enveloped in an increasingly vitiated atmosphere. At the same time, the compartment temperature tends to increase, since the reservoir of cool air available for entrainment into the flame and the upper smoke layer is depleted. Under these conditions the onset of flashover tends to be delayed due to a lack of oxygen and the rate of heat release from the fire is observed to fall off, although the compartment temperature remains high. Fire-fighters arriving at this point are faced with very hazardous conditions since the sudden admission of oxygen into the compartment, resulting from the opening of a door or window, is liable to result in an explosive *backdraught*. In contrast, the freely-ventilated geometry of the BRE 'front room' test precluded the formation of a deep smoke layer and probably led to an earlier transition to flashover since the supply of oxygen was unrestricted.

Drysdale (Reference 6) described three possible outcomes for the compartment environment, after localised burning has become established:

- the fire may burn itself out without involving other items of combustible material, particularly if the item first ignited is in an isolated position;
- if there is inadequate ventilation, the fire may self-extinguish or continue to burn at a very slow rate dictated by the availability of oxygen;
- if there is sufficient fuel and ventilation, the fire may progress to full room involvement, in which all combustible surfaces are burning.

The discussion which follows, and the figures which illustrate it, are associated with the last of these scenarios.

Figure 1: During the early growth stage of the fire, the flames remain confined to the item first ignited and the fire behaves as it would in the open. The initial (relatively slow) spread of flame over the settee is due principally to thermal conduction and convection; radiation effects are negligible at this stage.

Figures 2 & 3: As the fire grows more rapidly, radiative heat transfer becomes increasingly more significant, although the production of volatiles is still confined to fuel surfaces in the immediate environs of the ignition zone. A large amount of hot smoke begins to accumulate under the ceiling. The interior surfaces of the compartment and non-burning fuel elements become subjected to an increasing level of thermal radiation; smoke production increases rapidly.

Figures 4 & 5: As the rate of volatile production increases, the flame height increases proportionately. Radiation and smoke production also increase dramatically, with the latter's contribution to the former increasing as the smoke concentration, layer thickness and temperature all increase. The 'positive feedback' effect from the hot, stably-stratified smoke layer is proportional to the increasing 'view' that the fuel has of its own hot combustion products; for fires of size ~ 0.3 m and above, radiative feedback is the dominant mechanism of heat transfer (Reference 4). The increasing level of radiative heat transfer to the virgin fuel accelerates the rate of release of volatiles and flames are seen to extend into the smoke layer in transient bursts, where the entrained oxygen concentration is sufficient to sustain combustion.

Figure 6: 'Flashover' is the term given to the relatively abrupt change from a localised, and still relatively easily extinguished, fire to the complete involvement of all the combustible elements within the compartment. Any occupants who have not escaped the fire by this stage are unlikely to survive (Reference 6).

This sequence of fire development is depicted schematically in Figure 7, where the periods of growth, full development and final decay are identified. In this diagram 'flashover' is shown to occur over a finite period of time, which is the case in reality; although short in relation to the main stages of the fire history, the flashover period cannot be construed as an instantaneous 'event'. The lower (dashed) curve illustrates the course of a hypothetical fire where flashover does not occur, either because the available fuel has been consumed or due an insufficient supply of oxygen.

Attempts have been made to quantify the conditions associated with incipient flashover (Reference 6), such as a floor level heat flux of 20 kW.m^{-2} , ceiling temperatures of ~ 600 °C, and critical values of burning rate (\dot{m}) or heat release rate (\dot{Q}). Despite these attempts, and others, there still does not exist a general method to estimate the 'flashover potential' of an arbitrary compartment. Drysdale (Reference 6) also reported that the thermal inertia ($k\rho c$) of the compartment boundaries plays a major role in determining the time to incipient flashover. It has been found that if the internal surfaces of the compartment are comprised of an insulating material (*i.e.* low $k\rho c$) then the time to

flashover is reduced dramatically; Drysdale illustrated a four-fold reduction in flashover delay between walls lined with brick and those lined with fibre insulating board. It was stressed however, that this effect is only relevant when the insulation material forms the inner face of a compartment boundary, the usual practice of providing an inner wall of plasterboard tends to counteract this effect. The presence of wall insulation is also relevant to the post-flashover compartment fire, considered in the next section.

2.2.4 Typical (post-flashover) compartment fires attended by the Fire Service

Notwithstanding the threat to occupants posed by the pre-flashover compartment fire, the Fire Service generally do not attend fires in the early régime described above, arriving later when the behaviour is again quite different. Post-flashover compartment fires are typified by the total involvement of all combustible surfaces (Figure 6), leading to a maximum rate of heat release and gas temperatures up to ~ 1100 °C. Figure 7 shows this peak, which occurs during the 'fully developed' stage, and the subsequent 'decay period'. The details of the post-flashover fire history are dependent upon the quantity and disposition of the fuel elements and the geometry of any ventilation openings (Section 6.2). Thus, post-flashover fires may be classed broadly as 'fuel-controlled' (no restriction of combustion air supply) or 'ventilation-controlled' (restricted air supply). In general, fuel-controlled fires tend to be less severe; the presence of excess air (*i.e.* more than theoretically required for complete combustion of the fuel) moderates the compartment temperature and is therefore associated with lower rates of heat release.

Under conditions of poor ventilation, a compartment may fill with unburned and partially-burned fuel vapours. If ventilation is suddenly provided, when a door is opened or a window fails, the sudden inrush of air through these openings may produce an explosive *backdraught*, leading to external flaming (if a large quantity of hot unburned combustion products are released). The danger of structural elements failing is greatest during the fully developed phase of the fire when locally high temperatures exist. Fire spread to adjacent compartments is likely if external flaming persists or if the structural integrity of the original compartment is breached (see also Section 6.2).

A recent supplement to the *Manual of Firemanship* describes the growth of (Class 'A') compartment fires and the associated dangers posed by *flashover* and *backdraught* (Reference 8). The unpredictable nature of the transition to flashover may lead to fire-fighters within a compartment being cut off from their escape route by the sudden ignition of large areas of solid fuel surfaces. A backdraught is equally hazardous and three possible backdraught scenarios are discussed in Reference 8. One example may be illustrated by the dashed curve in Figure 7, where the compartment fire has not reached flashover and has 'died down' (*i.e.* the rate of heat release is much reduced), due to oxygen starvation. In this instance the fire may continue to burn at a reduced rate since a small amount of fresh air can still enter the room through gaps in the door or window seals. The important point to note is that no significant cooling occurs under these conditions and so vigorous combustion can be re-established immediately a new supply of oxygen becomes available. Hence the obvious danger for fire crews arriving at this stage of the fire, the opening of a compartment door or window may lead to a sudden

deflagration (backdraught) which could engulf the fire-fighters. Reference 8 also suggests practical strategies for reducing the potential danger to fire-fighters, such as how to identify dangerous situations and the use of smoke venting techniques. The injection of water spray pulses into the hot gases beneath the compartment ceiling has also been found to reduce the danger by cooling the gases and diluting them with water vapour.

Some further aspects of compartment fires are discussed in Sections 6.2 and 7.3 of the present report.

2.2.5 Class 'A' fires in the open

The behaviour of unconfined Class 'A' fires differs from the confined case in several important respects. In open fires the radiant feedback from solid 'boundaries' outwith the combustion zone and from a smoke layer under the ceiling are absent; the mass rate of burning depends on local heat transfer effects from the flame zone to the fuel bed (*i.e.* conduction, convection, radiation). The burning rate for a given fuel load (\dot{m}) will generally be lower than for the equivalent confined case, and is fuel-controlled (*i.e.* the controlling parameter is the fire area, A_f and the ventilation area A_v is not relevant). 'Ventilation-controlled' fires in the context of compartment fires are not encountered; however a strong wind may increase the burning rate of fires in the open by inducing vigorous turbulent mixing of excess combustion air. In general, open fires are characterised by a lower smoke and CO production, increased yields of CO₂ and water vapour and by lower product temperatures. Thus the combustion is more efficient than in the confined case and a given fuel load will generally burn longer in the open, if unchecked, although the maximum rate of heat release will generally be lower. Unconfined Class 'A' fires have no equivalent phenomena to *flashover* or *backdraught*. (The special problems associated with very large scale open air fires such as forest fires or *fire-storms* in urban areas are outwith the scope of this report.)

2.3 Summary

Class 'A' fires involve solid materials (usually of an organic nature) whose surface temperature during combustion is normally between 400-500 °C and which normally form glowing embers. The continuation of combustion requires that a certain amount of heat is continually transferred back to the fuel bed; for fires of characteristic size greater than ~ 0.3 metres this thermal feed-back is dominated by radiation. A compartment fire reaches *flashover* when all the combustible contents have become involved; most incidents attended by the Fire Service are so-called *post-flashover* compartment fires. Such fires are typified by high compartment gas temperatures (up to ~ 1100 °C) and poor ventilation, leading to a fuel-rich atmosphere; the sudden inrush of air caused by opening a door or breaking a window may lead to a sudden deflagration (or *backdraught*) which could engulf firefighters. It is essential that this hazard is appreciated, particularly during the early stages of fighting compartment fires before the compartment gases have been cooled and diluted by firefighting activities.

3. MECHANISMS OF EXTINCTION BY WATER OF CLASS 'A' FIRES

Fristrom (Reference 9) observed that water is by far the most common liquid extinguishant and that the principal action of liquid agents is the removal of heat from the fire through their heat capacity and latent heat of vapourisation (Section 5.3). The effects of fuel dilution (water-miscible liquid fuels only) and fuel blanketing (or inerting) were identified as auxiliary suppressant effects. Therefore, of the various physical and chemical mechanisms of fire suppression described previously in Reference 5, only three are relevant to the suppression of Class 'A' fires by water application:

- *Cooling* of the combustible solid fuel surface, which reduces the rate of pyrolysis and thus the supply rate of fuel to the flame zone. This reduces the rate of heat release by the fire, consequently the thermal feedback from the flame is also reduced and this augments the primary cooling effect of the suppression agent. The application of a water spray to the fuel bed is typical of this method;
- *Cooling* of the flame zone directly; this reduces the concentration of free radicals (in particular the chain-branching initiators of the combustion reaction). Some proportion of the heat of reaction is taken up by heating an inert substance (such as water) and therefore less thermal energy is available to continue the chemical break-up of compounds in the vicinity of the reaction zone. One function of the new water mist technology is to act in this manner, the fine droplets providing a very large surface area per unit mass of spray in order to increase the rate of heat transfer;
- *Inerting* the air feeding the flame by reducing the oxygen partial pressure by the addition of an inert gas (e.g. N_2 , CO_2 , H_2O vapour). This is equivalent to the removal of the oxidiser supply to the flame by the production of water vapour. This is the dominant mechanism by which water mists can suppress large confined fires.

In addition, fire spread may be controlled by pre-wetting adjacent combustible surfaces which in effect provides a heat-sink and delays the onset of ignition. The ability of water sprays to absorb thermal radiation has also been exploited as a fire protection and fire-fighting aid. While this could be perceived as an additional 'cooling mechanism', its application is principally as an 'indirect' fire-fighting measure, where shielding of personnel or property is required (Section 5.3.4).

Fristrom (Reference 9) noted that in practical situations, the problem of application is usually the critical factor determining the efficacy of water as a heat sink, since water which fails to reach the seat of the fire cannot contribute to its extinguishment. Although, as will be seen later, this statement is not always strictly true in the case of compartment fires, Fristrom's point is taken and the question of the optimum force and size dispersion of water jets has been debated extensively. In general terms, if the jet or spray distribution is skewed towards relatively large drop sizes, then only a small fraction will realise their maximum heat extraction potential by evaporating, while the majority will remain in the liquid phase and form run off. Conversely, if the water is delivered in the form of very fine droplets in order to promote rapid evaporation, the spray may lack the momentum required to penetrate the fire region, again the net result is that water is wasted and fire-fighting efficiency is compromised. The following section considers some of the physical characteristics of various jets, sprays and 'fogs' in more detail.

4. TYPES OF WATER SPRAYS

4.1 Jets, sprays, fogs and mists: hydraulic aspects

4.1.1 Solid jets

Herterich (Reference 10) published an early (*ca.* 1960), comprehensive discourse on the nature of solid water jets used for fire-fighting purposes. Many aspects relating to the physics of jet production were covered, including:

4.1.1.1 The origins of jet instability

Jet instability causes the inevitable transition from the initial 'enclosed' (or tube-like) flow to the separated flow characteristic of a 'diffuse jet'. The principal agents responsible for the break-up of the solid jet were identified by Herterich as the internal turbulence in the water stream and the steep velocity gradient generated between the jet and the ambient air. It was noted that smaller jet diameters and higher jet-nozzle pressures both promoted an accelerated break-up of the solid jet while air-foam jets, being initially less 'enclosed', were even more prone to break-up. Previous work on jet break-up (*ca.*1936) was discussed in Reference 10, where the characteristic non-dimensional parameter,

$$Z = \frac{\eta}{\sqrt{\sigma\rho D}} \quad (3)$$

had been formulated from a consideration of the Reynolds and Weber numbers (also non-dimensional). The criterion for the disintegration of a solid jet was given as,

$$Z \geq 2000 \left(\frac{\eta}{\nu\rho D} \right)^{4/3} \quad (4)$$

where the group $\eta/\nu\rho D$ is the reciprocal of the Reynolds number. The above two expressions were used to infer a critical condition for break-up of the jet in terms of the relative velocity between the jet and the surrounding air,

$$\nu \geq 300 \left(\frac{\eta}{\sigma} \right)^{1/4} \left(\frac{\sigma}{\rho D} \right)^{5/8} \quad (5)$$

where η , σ , ρ are the dynamic viscosity (Pa.s), surface tension (N.m⁻¹) and density (kg.m⁻³) of water respectively, D is the diameter of the jet (m) and ν is the relative (water-jet:air) velocity (m.s⁻¹). The contemporary research and development effort in this area strove to delay the onset of jet instability in order to maximise the height and 'throw' of fire-fighting jets. From equation (5) above it can be seen that the onset of critical conditions may be delayed by increasing the dynamic viscosity or surface tension and decreasing the jet diameter or fluid density.

4.1.1.2 The optimum pressure head at the nozzle

As suggested above, the pressure at the jet nozzle is intimately associated with the expected range and stability characteristics of the resulting jet. Herterich (Reference 10) noted that opinion was sharply divided over the operating pressure required to produce 'a good extinguishing water-jet'. It was argued that for any given nozzle diameter (D), a useful and economical pressure-head lay between an upper and lower bounding value. In relation to this subject, the Austrian notion of 'hard' and 'soft' solid water jets was introduced. Soft jets were defined as those with exit pressures which maintained the 'enclosed' nature of the jet while also ensuring an adequate 'throw'. In contrast, hard jets were characterised by a rapid break-down, initiated at a short distance from the nozzle exit. The latter were not designed to produce a greater throw than soft jets, but were considered to be 'richer in energy'. In practical terms, 'hard jets' provided deeper penetration of deep-seated, glowing fires and improved heat absorption following the shattering of the jet on impact. Herterich also included an illustrative table showing the division between 'hard' and 'soft' jet behaviour for nozzles of diameter 8-18 mm operating at gauge pressures of between ~ 7-12 bar (100-170 psig).

4.1.1.3 Water flow through jet-pipe nozzles

Herterich reported several pioneering studies of the discharge characteristics of jet-nozzles, performed during the latter half of the nineteenth century. The empirical formula,

$$Q \approx 0.2D^2\sqrt{h_s} \quad (6)$$

was given for estimating the nozzle flow rate, Q (in litres per minute) where D is the nozzle diameter (mm) and h_s is the static pressure-head upstream of the nozzle exit (metres water gauge). A table was also included which showed the expected flow rates for nozzle diameters of $4 \leq D \leq 40$ operating at pressures of $10 \leq h_s \leq 160$ (i.e. between 1-16 bar or 15-230 psig). In order to assess the capacity of fire extinguishing pumps in practice, it was recommended that equation (6) be used in conjunction with accurate measurements of h_s and the nozzle diameter.

4.1.1.4 Height of throw and width of spread

The problem of calculating the jet trajectory is considered in Reference 10, initially by assuming that the fluid stream behaves in a similar manner to a solid projectile. While this simple model is attractive, in practice the interaction of the jet with the ambient air introduces significant changes in the dynamics. It can be demonstrated that the maximum throw of a jet is achieved with an initial angle of $\sim 32^\circ$ while for a solid projectile the critical angle is 45° . In order to achieve the maximum vertical height of throw, an initial discharge angle of 80° was advised.

In addition to the above subjects, Herterich (Reference 10) also considered the effects of 'back-force' or 'back-pressure' on fire-fighters operating water jets, the impact force of the water jet on solid objects, and the design of jet pipe nozzles. Some of Herterich's closing remarks on the subject of solid jets are worth repeating: '*Bringing water to the*

seat of a fire is one of the main problems in fighting any fire. The easiest and most simple method is the solid jet process; however, the characteristics of the solid jet must be taken into consideration. According to Herterich, the use of solid jets enables the transport of large quantities of water to the seat of the fire with practically no loss of pressure, except that required to overcome wind resistance. The significant kinetic energy of the jet results in a general disintegration (or *atomisation*) of the water stream, which produces a good extinguishing effect at the point of impact, this applies particularly to the 'hard' jets described in Section 4.1.1.2, which are very effective on deep-seated fires at close range. However, the extinguishing effect is limited to the area around the point of impact. Herterich stressed that the direct heat transfer from the fire to the extinguishing water was of limited use due to the relatively small area of water presented to the flames; this fact inevitably led to the application of surplus water to secure extinguishment and the consequent danger of water damage through over-application. The solid jet was considered to be essential in fighting fires which developed rapidly, and for deep-seated fires such as fires in wood-stores, stacked packing materials etc., where 'a quick effect and lasting result' were required. Solid jets were also considered essential against fires where strong draughts were generated, although the selection of a wide-area spray jet with large (high momentum) water droplets was thought to be a pragmatic option in some cases. Finally, where a fire could only be fought from a distance, the solid jet remained the only method of ensuring success.

4.1.2 Diffuse jets

In the foregoing section, it was noted that the 'solid' jet represented an unstable régime of fluid flow, tending always to break-up and undergo transition to a diffuse jet. Writing in 1960, Herterich (Reference 10) remarked that the 'classical' solid-jet method of fire-fighting was being successfully augmented in some cases by the use of 'spray-jets'. The shift towards the latter was driven by an acceptance of technical arguments which showed that for certain types of fire, very efficient extinguishment could be achieved using only a small amount of water. Herterich traced the origins of spray-jet technology from as early as 1877, noting its recommended use for 'damping down gases' in 1925 and against Class 'B' fires in 1933. Clarke (Reference 11) also referred to the pioneering use of water sprays, and the recognition of their benefits during the 19th century. It was further noted by Clarke that the opinion was held by some in the early post-war years, that high-pressure sprays (which were believed to contain very fine drops) represented the ultimate in fire-fighting efficiency. However, an extensive study by D. Hird *et al.* (Reference 12) involving the London and Birmingham Fire Brigades showed no material advantage in increasing operational pressure above ~ 7 bar (100 psig) since any theoretical merit possessed by fine droplets was offset by their limited trajectory; these results are considered further in Section 7 of this report. Herein lies the dilemma posed by water spray (and water mist) technology; while the potential for very efficient and economic fire extinguishment increases (theoretically) with decreasing drop size, the problem of application becomes more difficult as the low-momentum droplets become more susceptible to up-draughts which may prevent them reaching the intended target area.

4.1.2.1 Definition of 'spray-jets'

Heiterich identified a need for consistent terminology when discussing fire-fighting sprays, especially when considering the characteristic 'size' of the droplets. Figure 8 of the present report is an amalgamation of Heiterich's droplet size data and those of Jones and Nolan (Reference 13), the latter adapted their spectrum of drop sizes from Lefebvre (Reference 14). The size categories in upper area of the figure ('Colloidal', 'Dust' etc.) are reproduced from Heiterich (Reference 10), who considered that the 'average' size range from 100-1000 μm was of most interest in fire-fighting terms. The text below the x-axis shows the range defined as 'fine sprays or mists' in Reference 13 ($\sim 20\text{-}120 \mu\text{m}$), together with the approximate locations of 'aerosols', 'nozzles' and 'sprinklers' in the droplet spectrum. The cut-off between 'sprays' and 'mists' remains somewhat arbitrary however, for example the US National Fire Protection Association has recently suggested a practical definition of 'water mist' as a spray in which 99% of the water volume is contained in droplets less than 1000 μm in diameter (Section 4.1.3.1).

4.1.2.2 Definition of droplet mean diameter

To simplify the calculations involved in problems of two-phase flow in the diffuse jet, it is conventional to quote a single *mean* or *representative* diameter; this practice avoids the rather unwieldy complexities involved in considering an entire distribution of sizes. Mean diameter measurements are unique to a given distribution and represent some physical attribute of the spray as a whole. The mean diameter used to describe a spray depends on the use to which it will be put: for example, the 'Sauter Mean Diameter', D_{32} is the sum of the droplet volumes divided by the sum of the droplet surface areas of a given spray. It is therefore the diameter of a droplet which will have the mean surface area and volume for the whole spray. This is useful in studies of fuel sprays, where the droplet surface area to volume ratio is a factor, along with others such as local vapour pressure and temperature, in determining the rate at which the droplet can evaporate. The rate at which such fuel droplets release vapour for combustion is a major factor governing the heat release rate. These physical attributes are equally relevant to water sprays used for fire-fighting, since efficient heat transfer and evaporative cooling are vital components of the extinguishment process.

For most situations, a measure of the range of drop sizes and a mean diameter value will be sufficient to describe the distribution. Mugele and Evans (Reference 15) formulated a standard notation for defining mean diameters:

$$D_{ab} = \left(\frac{\sum N_i D_i^a}{\sum N_i D_i^b} \right)^{1/(a-b)} \quad (7)$$

where the particular numerical values of the indices a , b depend on the phenomenon under investigation. Table 3, on page 15, contains examples of commonly-used mean diameters, whose definitions are based on the above equation.

Table 3
Summary of mean droplet diameters for specific applications

Mean Diameter	Symbol	Application
Length	D_{10}	Comparisons
Surface Area	D_{20}	Reaction area
Volume	D_{30}	Hydrology: volume control
Surface Area/Length	D_{21}	Absorption
Volume/Length	D_{31}	Molecular diffusion
Sauter	D_{32}	Mass transfer and reaction rates
De Brouckere or Herdan	D_{43}	Combustion equilibrium

Another commonly used representative diameter is the *volume median diameter*, often denoted by $D_{v,0.5}$. Half of a given volume of water will be in the form of droplets greater than this diameter and the other half in droplets smaller than this diameter.

Mean diameters are a measure of the central tendency of the distribution and will not reflect a relatively few extreme values at the 'tail ends' of the distribution. When quoting mean diameters, great care must be taken that equivalent measurements are being used to make comparisons, especially when data from different collection systems are being analysed, so as always to compare like-with-like (see also Section 5.5).

4.1.2.3 Determination of spray pattern

While a knowledge of the droplet size distribution within a spray is important, this information alone is insufficient to characterise the fire-fighting potential of a water spray. It is equally important to know how the spray spreads out after leaving the nozzle; this includes determining the 'spray angle', 'spray distance' and 'spray density' (the mass of water delivered per unit area, per unit time). A comprehensive discussion of the various spray pattern parameters and their experimental measurement is given in Reference 10. These techniques were employed by the Home Office Fire Experimental Unit (FEU) during their extensive appraisal of commercial jet/spray branches; some practical results from these tests are discussed in Section 4.2.

4.1.2.4 Methods of spray production

Some of the more technical aspects of spray production are discussed in Section 5.1; the present section presents a brief overview of the subject as a preamble for some of the topics to be addressed in subsequent sections. In general terms, the function of a spray nozzle is to accelerate and disintegrate (or *atomise*) a liquid (e.g. water, in the present case) and to disperse the resulting drops (Reference 16). Fraser and Eisenklam (Reference 16) defined three classes of spray nozzle (or *atomiser*) according to the type of energy used to effect the disintegration of the liquid stream. The three groups were: pressure energy atomisers, gaseous energy atomisers ('twin-fluid' type) and centrifugal energy atomisers (i.e. rotary atomisers). In Reference 10, Herterich dismissed the last of these as having no relevance to the fire-fighting sector, but defined the 'rifling nozzle' as

an intermediate design between the pressure and gaseous energy types. The following definitions were given in Reference 10:

- Pressure atomisers - the liquid to be atomised (water) is moved within the nozzle and the other medium (ambient air) is still,
- Gaseous atomisers - the liquid to be atomised is essentially stationary and the gaseous medium which effects the atomisation moves rapidly within the nozzle,
- Rifling nozzles - the nozzle remains stationary, while the liquid to be atomised is given a 'translatory' (*i.e.* forward) motion and also a rotational motion. After ejection at the nozzle, the leading edge of the liquid takes the form of a hollow cone, the opening angle of which may be large or small.

Herterich proceeded to discuss a classification system for fire-fighting nozzles based on the form of construction of the nozzle and it was noted that the most widely used models were based on the rifling principle while twin-fluid atomisers were rare. Figure 9 illustrates the main types of fire-fighting jets and sprays and their operating principles. Grimwood (Reference 17) has recently discussed the types of spray nozzles which have been in use since the 1940s; it was noted that they all relied on either stream impingement or 'fog teeth' to produce a wide fog pattern. A major problem associated with this design was the gaps produced in the spray pattern which allowed a significant amount of radiant heat to be transmitted to the operator (see also Section 5.3.4). Later designs, incorporating spinning teeth, were seen to greatly reduce this problem and also produce much finer droplets, capable of being suspended in the air '*for several seconds*'. Grimwood also considered the working pressures and practical implications of modern fog nozzles and some of these issues are discussed in Section 4.2.

In concluding his discussion of fire-fighting spray nozzles, Herterich stipulated the following practical requirements, which were to be '*satisfied where possible*':

- Since fire-fighting water is seldom 'clean', it is important that spray nozzle apertures should not be too small as blockages could occur, compromising the efficiency of the atomisation process;
- So-called 'multi-purpose' fire-fighting branches offer important advantages on the fire-ground, these nozzles permit the water stream to be issued as a solid stream, spray jet of varying angle or a combination of the two (Figure 9),
- The spray nozzle should provide a flow rate of 100 l.min^{-1} and 400 l.min^{-1} respectively, where small or large jet pipes are used and these flow rates must be attained at pressures of $\sim 5 \text{ bar}$ ($\sim 70 \text{ psig}$),
- At the above pressure-head, the mean droplet diameter must be between $0.5\text{-}1.5 \text{ mm}$ ($500\text{-}1500 \mu\text{m}$),
- Efficient nozzle design is important to minimise the energy required to achieve atomisation, in order to ensure satisfactory mean distances of throw at operating pressures of 5 bar (70 psig).

4.1.3 Fogs & mists

It is apparent from the foregoing that there has been a long-standing appreciation of the potential benefits of fine water sprays for fire-fighting applications. Despite this fact, the research effort in fire safety engineering over the last few decades has been dominated by studies of fire growth and development, rather than the dynamics of fire suppression and extinction. Recently however, this trend has been reversed somewhat, and there has been a marked resurgence of interest in fire suppression generally and in *water mist* technology in particular (see for example, the conference proceedings of References 18-20). Hence the emergence of commercially available water mist (fixed-installation) systems is a fairly recent phenomenon, despite the fact that the use of fine water droplets for gas-phase fire suppression has been studied for at least 50 years (Reference 21). Recent progress in the design of water mist systems has been stimulated by two global legislative acts, namely:

- The International Maritime Organisation (IMO) regulations which required the retrofit of fire suppression systems on most commercial maritime vessels;
- The Montreal Protocol on Substances that Deplete the Ozone Layer which required the phase-out of Halons as fire suppression agents.

The former led to the rapid development of lightweight, low impact, high efficiency (*i.e.* low water demand) mist systems to replace existing shipboard sprinkler systems; this application of water mist systems is now relatively well developed and commercialised. The intended phase-out of Halon fire suppressants prompted an ongoing search for alternative technologies which preserve all the benefits of a clean 'total flooding' agent yet are environmentally benign; in contrast to the maritime experience, the take up of water mist as a replacement for Halon 1301 (CF_3Br) total flooding agent has been sparse. Some 'perceived advantages' of water mist over traditional fire protection methods were identified by Back (Reference 21):

1. Water systems may be relatively inexpensive due to low/no agent costs;
2. Water is non-toxic and poses no environmental problems;
3. Water mist systems can suppress flammable liquid pool and spray fires;
4. Water mist systems utilise water flow rates significantly lower than conventional sprinklers, hence reducing the collateral damage;
5. Water mist systems may be made to perform functionally in some applications like total flooding gases (*i.e.* obstructed, enclosed fires);
6. Water mist systems can be activated by a variety of means (*e.g.* early detection using smoke detectors);
7. Water mist is non-electrically conductive;
8. Water mist may have applications as inerting or explosion suppression systems.

Although the above list is written from a fixed-installation standpoint, it could be argued that most of these advantages should apply equally where water mist used as an extinguishing agent during active fire-fighting against compartment fires. The following section considers some of the aspects of water mist systems in greater detail.

4.1.3.1 Water mist: definition, and examples of system specifications

The newly-formed NFPA (US National Fire Protection Association) Committee, NFPA 750 Water Mist Fire Suppression Systems Committee, have defined *water mist* as: 'A water spray for which the D_{v99} (99% volume diameter) as measured at the coarsest part of the spray in a plane 1 metre from the nozzle, at its minimum operating design pressure, is less than 1000 μm (1.0 mm)', (Reference 22). This implies that 99% of the water volume discharged must be in drops less than 1.0 mm in diameter, compared with conventional sprinkler systems where D_{v99} may be of the order of 5000 μm (5 mm) (Reference 21). It is argued (Reference 21) that water mist fire suppression systems rely on the production of relatively small (<500 μm) droplet sprays to extinguish fires and that the very low terminal velocities of the smallest droplets (~ 100 μm) allow the mist to circulate around obstructions and to extinguish fires in the manner of a total flooding gas. Ramsden (Reference 23) commented that in this respect the NFPA definition was regarded by some as being too loose, since it permitted relatively coarse droplet sizes, not dissimilar to those produced by conventional waterspray and sprinkler systems. An alternative definition was advanced in Reference 23: 'A water distribution of fine drops having a mean diameter of 80-200 microns and a D_{v99} less than or equal to 500 μm .' It was considered that the latter definition ensured a very small average drop diameter and would prevent manufacturers from offering slightly modified standard waterspray systems as 'mist' systems.

Mawhinney *et al.* (Reference 24) also advocated a more stringent classification terminology, in order to distinguish between "coarser" and "finer" water sprays. Figure 10 shows the "cumulative percent volume" distribution plot, proposed by Mawhinney *et al.*, which defines three categories of water spray. In the figure, the terms D_{v10} and D_{v90} refer to the diameters for which 10% or 90%, respectively, of the volume of the water spray is contained in droplets of smaller diameter, measured in a standard manner (Reference 24). It can be seen that for "Class 1" sprays, 90% of the volume is contained in droplets less than 200 μm in diameter while 10% of the volume is contained in droplets of less than 100 μm ; the cumulative % volume limits for Class 2 and Class 3 sprays are similarly derived from Figure 10. In this scheme, Mawhinney *et al.* defined the Class 1 and Class 2 sprays as "mist" since at least 90% of the water volume is contained in droplets with diameters smaller than 400 microns. It was argued that both these sprays were comprised almost entirely of the "fine" drop sizes which promote the rapid evaporation of water in the fire environment and facilitate the characteristic extinction mechanisms of water mist, *i.e.* flame cooling and inerting by the production of water vapour. In practice, Class 1 and Class 2 sprays are suited to the suppression of liquid fuel fires or where excessive surface wetting is undesirable. A potential advantage in the former is that serious splashing of the fuel is avoided, due to the reduced momentum of the water droplets and their propensity for rapid evaporation in the flame region. Class 3 sprays were seen as a better choice where fuel wetting was tolerable, or even necessary to achieve extinguishment, for example when tackling Class 'A' fires.

The design of water mist nozzles was discussed by Smith (Reference 25), who noted that due to its high surface tension, water is a relatively difficult liquid to atomise effectively. Nozzles which were initially designed for other uses, such as agricultural (crop spraying etc.) or industrial applications (*e.g.* spray painting, spray drying, spray

combustion), have been adopted or modified for fire protection; an early account of diverse agricultural nozzles is given in Reference 26.

The various types of nozzle were described by Smith (Reference 25) and subdivided into "single-fluid" and "twin-fluid" types.

Single Fluid Mist Nozzles

- *Hollow cone-single fluid*: a swirling motion is induced in the liquid within the nozzle and this produces a spray plume where most of the droplets are concentrated at the outer edge;
- *Solid cone-single fluid*: an approximately homogeneous concentration of droplets is contained within a spray pattern which may have a round, square or rectangular "footprint";
- *Flat spray -single fluid*: an elliptical orifice produces a sheet spray having a relatively uniform distribution of droplets. This design is not suitable for area protection, but has applications for protecting equipment located in narrow voids.

Single fluid systems are also known as "simplex" or "hydraulic" types and share the common feature that the mean droplet size in the resulting spray is influenced by the water pressure according to the following approximate relationship,

$$\frac{d_{m_1}}{d_{m_2}} \propto \left(\frac{p_2}{p_1} \right)^{0.3} \quad (8)$$

where d_m is the 'volume mean diameter', a mass-based measure of the average droplet diameter (D_{30} from Table 3, page 15) and p is the nozzle operating pressure. The increase in atomising efficiency with rising water pressure explains why some single fluid systems operate at around 100 bar (1450 psig) or even up to 300 bar (4350 psig).

Twin Fluid Mist Nozzles

The alternative to single fluid mist production is to use a dual fluid head, also known as "air atomising", "duplex" or "pneumatic" nozzles. These systems bring air (or more commonly nitrogen) and water together into the nozzle mixing chamber where a highly turbulent interaction takes place before a fine mist is expelled through a single or multiple outlets. The advantages of twin fluid nozzles are that effective atomisation occurs at low operating pressures (~ 5-6 bar or 70-90 psig), with average droplet diameter decreasing with increasing gas:liquid pressure ratio. They may also provide high initial droplet velocities and good horizontal projection characteristics. A disadvantage is that of high gas demand and the need for a twin supply manifold, resulting in an increased cost over single fluid systems.

According to Jones and Nolan (Reference 13), single fluid nozzles can produce droplets as small as 90-100 μm when operating at pressures around 5-6 bar (~ 70-90 psig), but to achieve smaller droplets (down to ~30 μm), twin-fluid systems must be used. It was also noted in Reference 13 that despite the theoretical and experimental evidence that

such small droplets are extremely effective at suppressing combustion, it was still proving difficult to produce sprays with the bulk of their water in droplets smaller than $\sim 30 \mu\text{m}$.

Smith (Reference 25) discussed some specific nozzle designs and some examples are shown in Figure 11. The Marioff 'Hi-Fog' system was developed for fire protection in machinery compartments and accommodation areas in ships. Sprinklers have not been a practical proposition for the latter due to their prohibitive size, weight and the problems of free-surface effects if adequate drainage is not provided. The Hi-Fog system is quite different in operation to conventional sprinklers, since a fine mist travelling at initially high velocity is produced using a high pressure manifold of small bore pipes incorporating a number of multiple orifice spray heads and operating at up to 300 bar (4350 psig). It was estimated by the manufacturer that an 800 cabin ferry would require a conventional sprinkler system weighing 100 tons compared with an equivalent Hi-Fog system weighing only 9 tons. Marioff have also developed a self-contained extinguisher based on a modular concept, comprising a multiple orifice spray head, a pressurised water container and an interconnecting pipe manifold. The stand-alone system is intended to provide fire protection for individual enclosed rooms in contrast to the pump driven systems designed for passenger cabins and other occupied spaces. Another variation is dedicated to engine room protection and features a sequential dual phase deployment of spray. An initial high velocity fog is introduced into the protected space to give a rapid fire knock-down, followed by a lower pressure mist which provides continuous cooling, thus preventing re-ignition of the fuel and maintaining a controlling atmosphere. During this second phase, an automatic pump recharges the pressure vessels to enable a further high pressure discharge to be applied if required.

Ginge-Kerr, a member of Securiplex Technologies, has developed a fine water spray system using nozzles originally designed by British Petroleum. The twin-fluid nozzles operate at modest air and water pressures of up to ~ 5 bar (~ 70 psig), and three commercial designs are available giving water delivery rates of 5, 10 and 20 l min^{-1} and with droplet diameters in the range 80-200 μm within a spray discharge angle of 60° or 90° . Applications have focused on specifically-designed systems for localised fire threats.

The Grinnell/Wormald AquaMist system uses two types of nozzles, designated AM5 and AM6, at operating pressures of 6-12 bar (~ 90 -175 psig) and corresponding flow rates of 11.5-16.3 l min^{-1} . The mean droplet diameter of the spray is given as 60-150 μm , dependent upon sampling location. Testing of the system at the Swedish National Testing and Research Institute has led to system design parameters for fire control in ships' cabins, corridors and public spaces.

The Unifog system was developed by the Norwegian Unitor company in collaboration with TBS of Germany and is designed to comply with new IMO regulations relating to sprinklers in marine passenger vehicles. A typical installation comprises a pump station supplying water from storage tanks to a narrow bore stainless steel manifold via a number of directional valves. Again a range of nozzles is available, made of bronze alloy or stainless steel and producing droplets of diameters in the range 20-150 μm . The HTC Micro-Fog system is intended for a variety of marine and land-based applications and

features a piston-type pump unit with a water flow capacity of 20-1000 l.min⁻¹. The water flows at ~ 4 m.s⁻¹ through stainless steel pipes to a number of multiple spray heads with 4, 5 or 6 narrow orifice nozzles, producing droplets in the range 20-50 µm.

4.2 Methods of water application used by the Fire Service

The first two subsections below provide a brief summary of the main classes of water delivery system currently available to the Fire Service; the last subsection describes some speculative research on the possible future application of 'water mist' technology to Fire service operations. The focus of Section 4.2 is on the hydraulic aspects of the delivery systems and the relative performance against real fires is not considered here; a more thorough discussion of the latter is given in Section 7, where the results of various large-scale test programmes are discussed.

4.2.1 Jet/spray branches

During the early 1980s, the UK Home Office Scientific Research & Development Branch (SRDB) conducted a practical appraisal of a wide range of commercially-available jet/spray branches; the results of these tests were published in a series of reports by Rimen (References 27-30). The broad aim of the study was: '*...to evaluate the range of hand-controlled branches available in order to give guidance on their cost effectiveness and efficiency.*' The initial phase of the study, reported in References 27-29, examined a total of 31 branches whose performance was assessed in terms of hydraulic criteria (jet throw and quality, spray patterns and flow vs. pressure characteristics), ease of handling, 'robustness' and general maintenance requirements. In addition, a further 6 branches were tested in a later, supplementary test series (Reference 30); however these tests were not as extensive as the original series and did not include any assessment of the robustness of the units. Neither phase of the study included the appraisal of the branch performance against test fires, nor were measurements of the drop size distribution within the sprays undertaken.

Discussing the background to the initial study, Rimen (Reference 29) noted that relatively few incidents attended by UK fire brigades required the use of a main jet to control and extinguish a fire, although such fires did account for a substantial proportion of fire losses in general. It was stressed that effective fire-fighting required a degree of control over both the volume and pattern of the water emerging from the branch; the versatility of the jet/spray branch design was perceived to be a major advantage during fire-fighting operations. Since the study was intended to provide practical guidance for fire officers, it was decided that the project should cover all jet/spray branches readily available in the UK and with delivery rates (through hoses of ~70 mm diameter) up to 1100 l.min⁻¹ at a pressure of 7 bar (100 psig); 'hosereel' branches (Section 4.2.2) were deliberately excluded from the survey. Despite the wide range of branches obtained for the trials, it was found that the six categories shown in Figure 12 (Reference 27) were sufficient to encompass all the design variants. In the context of the present report only

the findings of the hydraulic tests are of interest and some of the main points are now discussed briefly.

The hydraulic tests were designed to enable a comparison of jet throw and quality, the spray patterns and the flow vs. pressure characteristics of each branch. In order to achieve a degree of standardisation, the branches were tested sequentially in a specially designed experimental rig which incorporated the water supply, an electromagnetic flowmeter and a static pressure gauge just upstream of the branch coupling (Reference 27). Measurements of jets were made at elevations of 0°, 20° and 35° to the horizontal, while all spray measurements were conducted at 0° elevation only but over a range of cone angle settings. Where a branch permitted a simultaneous jet and spray discharge (Figure 9), tests were conducted with the jet control fully open and the spray cone at both its maximum angle and at half this value. All branches were tested at pressures of 3, 5 and 7 bar (44, 73, 100 psig) and all assessments of water distribution were based solely on visual observations or photographs taken during the tests. The test results were plotted as graphs of *throw vs. flow* (jets), *maximum spray breadth vs. flow* (sprays) at various pressures and *flow vs. pressure* for all branches. The 'throw' of a jet or spray was defined as the horizontal distance from the branch coupling to the point where most water was judged to fall onto the ground by observers. For branches operated as sprays, the 'breadth' of the spray pattern was defined as the maximum dimension of the spray 'footprint' impacting on the horizontal floor, measured normal to the branch centre-line. It was found that the horizontal range associated with this dimension was generally less than the observed throw of the spray branch concerned.

Rimen noted in Reference 29 that a wide range in hydraulic performance was evident from the initial batch of 31 branches tested; at a given pressure the flow rates varied by a factor of 10, the throw of jets by a factor of 2 and the width of sprays by a factor of ten. Table 4 below shows typical hydraulic data obtained from the tests on jet performance reported in Reference 27. In general the experimental data showed that jet throw was roughly proportional to flow rate, although there was considerable scatter; hence the 'maximum' and 'minimum' values shown in Table 4 are approximate extremes taken from the graphical data of Reference 27.

Table 4
Typical jet/spray branch hydraulic performance data for branches operating as jets
(after Reference 27)

Operating pressure (bar)	Elevation (°)	'Minimum' throw/flow (m)/(l.min ⁻¹)	'Maximum' throw/flow (m)/(l.min ⁻¹)
7	0	12/120	17/1030
7	20	23/120	42/1030
7	35	25/120	48/1050
3	0	8/100	11/700
3	20	17/100	32/700
3	35	18/100	40/700

The hydraulic performance data for branches operated purely as sprays were also presented in Reference 27; however here the situation was more complex, owing to the additional variables such as cone included angle and spray breadth. Two correlation plots were included for the sprays produced by branches at 7 bar, one of 'extreme spray width vs. flow rate' and the other of 'extreme spray width vs. maximum cone angle'. The first plot exhibited considerable scatter, with minimum spray widths between ~ 1-5 m obtained at flow rates between 100-200 l.min⁻¹ and maximum widths between 2-21 m at flows of around 700 l.min⁻¹. In contrast, the extreme spray width displayed an approximately linear dependence on the cone included angle; a minimum spray width of ~ 1 metre occurred with a spray angle of ~ 12 °, while a cone angle of 160° produced a spray some 21 metres wide. Some more examples of spray branch performance data are shown in Table 5 below, extracted from the extensive tabulated data provided in Reference 27.

Table 5

Typical jet/spray branch hydraulic performance data for branches operating as sprays at 0° elevation (after Reference 27)

Operating pressure (bar)	Flow (l.min ⁻¹)	Spray cone included angle (°)	Throw (m)	Breadth (m)	Range to breadth (m)	Comments (Reference 27)
7	224	20	14	0.9	6.0	Entrained fog visible to 20 m. measured 'throws' refer to large droplets.
7	278	158	2.2	16.5	2.0	Coarse, hollow spray, no visible entrainment.
3	296	28	9.8	2.4	6.0	Coarse spray, hollow cone.
3	311	180	1.8	14.3	1.0	Hollow cone, 'spoke effect'.

The wide variation in the hydraulic performance of branches was still evident in the subsequent tests reported in Reference 30. Rimen (Reference 29) concluded that it was impossible to distil the results to provide a simple 'best buy' recommendation for the following reasons:

- No performance specification exists for fire-fighting branches and there is no 'discernible measure of agreement between fire-fighters concerning the precise requirements of a jet/spray branch';
- Many different situations may arise, each requiring a different 'optimum' branch;
- The relative importance of various possible branch characteristics (*e.g.* long range jet, wide spray angle, solid or hollow spray cone, fine or coarse droplets, dense or sparse spray, jet/spray combination etc.) remains highly subjective.

In a complementary effort to improve upon the available range of jet/spray hardware, the Home Office commissioned a parallel research and development programme to develop a lightweight, all-purpose nominal 600 l.min⁻¹ jet and spray branch capable of delivering high performance 25 mm and 19 mm jets together with an independently-controlled, variable-angle spray discharge (Reference 31). A wide range of nozzles and branches were tested, including commercially-available units and computer-designed prototype

units which had been specially fabricated for the study. The critical factors affecting the performance were found to be: the nozzle shape, the contraction ratio (nozzle inlet diameter/nozzle outlet diameter), the diameter of the branch feeding the nozzle and the length of this section. As a result of the tests, a prototype jet and spray branch was developed which provided improvements in delivered water rates of up to 30% for both nominal 25 mm and 19 mm jets over ranges of 37.5 m and 32.5 m respectively. A concentric annular orifice was found to provide the best spray pattern, affording a homogeneous delivery adjustable from a parallel jet ($\sim 100 - 400 \text{ l min}^{-1}$) to a flat (180°) circular spray. It was considered that the operational flexibility of the branch would prove suitable for tackling a wide range of incidents, from fully developed severe fires in occupancies down to the 'mopping-up' of small areas of localised flaming.

4.2.2 High & low pressure hosereel systems

The main jet/spray branches described above are deployed only when it is necessary to deliver a large quantity of water at the fireground. However, the vast majority of fires, particularly those within residential buildings, are either attacked initially or extinguished solely with hosereel systems which are also carried on fire appliances (Reference 32). In 1960 it was observed that the use of hosereels had steadily increased to the point where 75% of the fires in which water was applied by the Fire Service were extinguished in this manner (Reference 33). Hosereel systems employ flexible rubber hoses of ~ 19 mm diameter and are faster to deploy and more flexible in operation than main jets, but deliver water at a much lower rate. The Joint Fire Research Organisation (JFRO) study reported in Reference 33 represents an early scientific investigation of the extinguishing efficiency of hosereels against fully developed room fires. The aim of the work was to optimise the delivery of the limited water supply on 'first-aid' appliances, and the effects of application rate, nozzle pressure and nozzle type (spray or jet) were examined (see also Section 7.3).

Rimen (Reference 32) noted that until the mid 1960s, the maximum pressure available for hosereel systems on fire appliances had been around 10 bar (~ 150 psig). This situation changed with the development of a new generation of 'high pressure' pumps, which could deliver pressures of up to $\sim 30-40$ bar (435-580 psig) at the hosereel outlet on the fire appliance. This advance in pump design encouraged the development of a wide range of hosereel guns incorporating a wider choice of droplet sizes, velocities, flowrates and spray patterns (Reference 32). In Rimen's 1990 study of hosereel systems, units operating up to the 10 bar pressure limit were defined as 'low pressure' and those operating at greater pressures were designated 'high pressure'. Advocates of high pressure hosereel systems cite the ability to produce a finer spray or 'fog' as a critical advantage during fire-fighting since this promotes evaporative cooling in the fire environment and produces water vapour which acts as an inerting agent. Rimen (Reference 32) tempered this view by highlighting the higher capital costs involved, the need for higher quality hoses and fittings and the more rigorous maintenance requirement. Grimwood (Reference 17) observed that despite the widespread availability of multi-stage pumps, high pressure tubing and guns, other elements of the pipework had failed to keep pace with modern flow requirements resulting in a restriction of high pressure flows. As an example of this restriction, Grimwood cited a

40 bar (580 psig) pump pressure delivering only 30 bar (435 psig) at the nozzle. Since the pressure drop along the line is inversely proportional to the internal diameter, one solution would be to increase hosereel tubing from 19 mm bore to, say, 25 mm. Such an increase would improve the flowrates, stream reach and pump efficiency but the negative effects would be the increased weight of the charged line and the additional storage space requirement on the appliance (Reference 17). The performance of high and low pressure hosereel systems against experimental fires is discussed in Section 7 of this report.

4.2.3 Speculative FEU research on fog & mists

The use of fine water mists or fogs as fixed fire protection systems has been mentioned in Section 4.1.3.1 of this report. The Fire Experimental Unit have understandably taken an interest in extending this technology to active fire-fighting operations and some practical tests have been undertaken to assess the uses and limitations of water mist systems (References 34, 35). Although the scope of the test programme was necessarily limited, some useful data were obtained; these experiments are discussed in more detail in Section 7 of this report.

4.3 Summary

The nature of the water discharge from a firefighting branch may be broadly classified into one of two characteristic types: a *solid jet* or a *diffuse jet* ('*spray-jet*'). In the case of the solid jet, some efforts have been made to delay the break-up of the water stream as far as possible in order to minimise the aerodynamic drag and thus maximise the range or 'throw' of the jet branch. Conversely, very high pressure solid jets have been proposed, where the coherency of the water stream is lost soon after exiting the nozzle; it has been claimed that the increased kinetic energy of these jets promotes better penetration of deep-seated glowing fires coupled with improved heat absorption following shattering of the jet on impact. The advantages of the spray jet have been reported since the early 1900s and it has long been recognised that very efficient fire extinguishment is possible using only a small amount of water; the recent search for Halon alternatives has re-vitalised this area of fire suppression research.

The development of nozzles for use in fixed-equipment Water Mist Fire Suppression Systems (WMFSS) has concentrated on the generation of populations of very small droplets ($\sim 10\text{-}200\ \mu\text{m}$) with the twin aims of promoting rapid droplet evaporation in the presence of a fire and mimicking as far as possible the transport characteristics of Halon gas to obtain an adequate dispersion of the mist within a fire compartment. The operating pressures of such systems vary widely from $\sim 5\text{-}300$ bar (70-4400 psig). In the UK, the Fire Service employ two distinct systems for delivering water to a fire: the main jet/spray branch supplied by a 70 mm diameter hose or, in the majority of cases, the more manoeuvrable 19 mm hosereel system fitted with an adjustable spray branch. The former operates at pressures of typically 7 bar (100 psig) and delivers water at up to $\sim 1100\ \text{l}\cdot\text{min}^{-1}$, while hosereel systems operate at over 10 bar (150 psig) and flow rates of

up to $\sim 150 \text{ l}\cdot\text{min}^{-1}$. The advent of the WMFSS 'boom' has recently led the Fire Service to conduct some preliminary assessments of the suppression/extinction effectiveness of very fine water sprays against typical test fires.

5. 'CHOICE' OF DROPLET SIZE (THEORETICAL ASPECTS)

5.1 Effect of pressure on droplet generation

5.1.1 Droplet stability

Lefebvre (Reference 14) defined the atomisation process as the conversion of bulk liquid into small drops, due to the disruption of the consolidating influence of surface tension by the action of internal and external forces. In the absence of such disruptive forces, an isolated liquid droplet in equilibrium assumes a spherical shape since this possesses the minimum surface energy. Any change in system geometry promoted by external distorting forces, such as aerodynamic forces, is resisted by a combination of stabilising internal viscous forces and surface tension; break-up of the drop occurs when the magnitude of the external forces just exceeds the surface tension force.

Under equilibrium conditions, the internal pressure at any point on the drop surface, p_1 is just sufficient to balance the external aerodynamic pressure p_A and the surface tension pressure p_σ so that,

$$p_1 = p_A + p_\sigma = \text{constant} \quad (9)$$

and for a spherical drop,

$$p_\sigma = \frac{4\sigma}{D} \quad (10)$$

where σ is the surface tension (N.m^{-1}) and D is the drop diameter (m). When subjected to aerodynamic forces, a drop will remain stable provided any changes in air pressure on its surface can be compensated for by a corresponding change in p_σ such that p_1 remains constant (Reference 14). On the other hand, if p_A is much greater than p_σ then significant changes in the former cannot be accommodated by changes in p_σ in order to maintain p_1 constant. In these circumstances, the aerodynamic forces may deform the drop to an extent that leads to a further reduction in p_σ and ultimately to fragmentation into smaller droplets. The increase in p_σ associated with the decrease in droplet diameter (equation (10)) may then be enough to resist further disruption by external aerodynamic forces, arresting the break-up process. If this is not the case then the 'aerodynamic shattering' process continues until p_σ is large enough to maintain a constant value of p_1 at all points on the surface of the drops; at this point the ensemble of drops is stable and no further break-up can occur. These considerations led Lefebvre (Reference 14) to introduce the concept of a 'critical drop size'. For drops slightly larger than this critical size, the break-up time increases for decreasing size; the limiting value is associated with the stable drop, which has an infinite break-up time. The viscosity of the liquid opposes droplet deformation and fragmentation and therefore tends to increase the break-up time. Herterich (Reference 10) presented some simple calculations on droplet stability and showed that as the droplet diameter decreases, so its resistance to external destructive forces increases.

5.1.2 Operating principles of water spray nozzles

The subject of water atomisation in fire-fighting equipment was introduced earlier in Sections 4.1.2 and 4.1.3. Three types of atomisation process were identified as being of practical use to the Fire Service (Section 4.1.2.4):

- Pressure atomisers - the liquid to be atomised (water) is moved within the nozzle and the other medium (ambient air) is still;
- Gaseous atomisers - the liquid to be atomised is essentially stationary and the gaseous medium which effects the atomisation moves rapidly within the nozzle;
- Rifling nozzles - the nozzle remains stationary, while the liquid to be atomised is given a 'translatory' (*i.e.* forward) motion and also a rotational motion. After ejection at the nozzle, the leading edge of the liquid takes the form of a hollow cone, the opening angle of which may be large or small.

Some of the more important features of these classes of atomisers are now considered, and in particular the effect of operating pressure on the characteristics of the resulting water spray.

5.1.2.1 Pressure atomisers

The most basic design of pressure atomiser is the *plain orifice*, which represents the easiest method of atomising a low-viscosity liquid (Reference 14). At low discharge velocity the liquid emerges as a coherent but distorted pencil, however if the liquid pressure exceeds the ambient pressure by some 1.5 bar (~ 22 psig or 150 kPa) then a high velocity jet is produced which readily disintegrates into a well-atomised spray. The break-up of the jet is promoted by an increase in flow velocity, which increases both the level of internal turbulence and the aerodynamic drag forces exerted by the ambient atmosphere. Typical sprays produced in this manner have cone angles in the range 5-15°; this parameter is found to depend mainly on the viscosity and surface tension of the liquid and the degree of jet turbulence (Reference 14). An increase in the latter tends to increase the ratio of the radial to the axial component of the jet velocity and so widens the cone angle. Lefebvre cited diesel injectors, jet engine afterburners and rocket engine injectors as examples of plain orifice atomisers.

A variation of the plain orifice nozzle is the *flat film* type (Figure 13), where a flat spray sheet is produced from a specially-shaped nozzle incorporating a long slot. The principle of this nozzle is identical to the impinging jet nozzle where jets of liquid are produced from separate orifices. The fluid streams collide and produce a fan-shaped sheet in a plane perpendicular to that containing the nozzles (Figure 13(a)). In this design it becomes increasingly more difficult to ensure effective jet impingement as the nozzle separation is increased, therefore practical flat film (or *fan spray*) nozzle designs have been developed which effectively incorporate both jets within a single nozzle (Figure 13(b)). According to Reference 26, flat film nozzles are usually used for low flow rates, a working pressure range of 1.7-8.6 bar (25-125 psig) was quoted by Fraser and Eisenklam (Reference 16). In the discussion section of Reference 16, D.J. Rasbash

commented that work by the Fire Research Station on impinging jets had shown that the mean droplet size of the spray was inversely proportional to jet pressure, but that this effect was seen to tail off at pressures in excess of 7 bar (100 psig). This observation had important implications for fire-fighting operations, since at the time (1956), high pressure fire-fighting sprays (41-55 bar, 600-800 psig) were being introduced in preference to existing equipment where the maximum operating pressure was ~ 10 bar (150 psig). It was noted in Reference 10 and Reference 16 that the impinging jet technique was widely used to produce fire-fighting sprays.

The *impact nozzle* shown in Figure 13(c) is similar in concept to the impinging jet type, but uses a solid surface to promote disintegration of the liquid stream. A central jet is directed against a metal plate forming a disk-like sheet of liquid which propagates radially and fragments into a fine mist at its boundary. The resulting spray trajectory is then mainly dictated by gravity; sprinkler heads are an obvious example of impact nozzle, corresponding to the inverted Figure 13(c) configuration. The most commonly used pressure atomiser for small volumes of liquid is the swirl spray nozzle (Figure 13(d)). The nozzle comprises a swirl chamber into which liquid enters through tangential ports and from which it exits through a central orifice (Reference 16). Inside the chamber the liquid swirls around an air core and is then discharged in the form of a hollow conical sheet; the latter subsequently disintegrates into smaller drops. If the formation of the central air core is suppressed, a 'drowned' or 'solid spray' is formed. Such solid cone sprays consist of much coarser droplets, particularly in the central core of the spray; however, solid cone sprays have a much greater throw range than hollow cone sprays (Reference 16). The development of the spray passes through several stages as the liquid injection pressure is increased from zero (Reference 14), and these are shown in Figure 13(e). The major limitation of swirl spray atomisers is that the flow rate is directly proportional to the square root of the injection pressure differential (above ambient); therefore in order to double the flow rate, a fourfold increase in nozzle pressure is required. The implications of this characteristic are either excessive demands on nozzle pressure at high flows, or poor atomisation at low flows if the swirl ports are sized to pass the maximum flow rate at the maximum injection pressure. Various refinements to the basic swirl spray nozzle have been devised for combustion applications, in order to avoid these difficulties; further discussion of these issues may be found in References 14 and 16.

5.1.2.2 Gaseous atomisers

Gaseous, or twin fluid, atomiser designs do not suffer from the problem of poor atomisation at low liquid injection rates, discussed above. In these nozzles, the atomisation process is enhanced through the introduction of a high-velocity gas stream, which impinges on a relatively low-velocity liquid stream (Reference 14). These designs are classed as either *internal* or *external* gaseous atomisers, depending on whether the gas stream is initially surrounded by, or surrounds, the liquid discharge respectively. Figure 13(f) shows a cross-section through a typical external twin fluid atomiser, where the air is passed through an annulus concentric with a plain orifice from which the liquid jet is discharged. In general, this type of atomiser produces relatively small drops and a wide spectrum of drop sizes.

5.1.2.3 Rifling or swirl atomisers

The main points relevant to this type of nozzle are discussed in Section 5.1.2.1 concerning swirl spray nozzles.

5.1.2.4 Other types of atomisers

Lefebvre (Reference 14) also discussed various novel types of atomiser design, including *effervescent* atomisers, *electrostatic* atomisers, *ultrasonic* atomisers and *whistle* atomisers. The principle of effervescent atomisers is that the gas is introduced, under pressure, directly into the bulk liquid at some point upstream of the nozzle. The method known as *supercritical injection* relies on the *flashing* of dissolved gas in the liquid, and this technique has been proposed to improve the atomisation of liquid fuels. The problems are those of forcing the gas to dissolve in the liquid initially and then to be released from solution when required to promote atomisation. Lefebvre commented that the problem of low bubble growth rate could prove to be a fundamental limitation to the practical application of flashing injection by dissolved gas systems. Electrostatic atomisers promote the fragmentation of water droplets by the mutual repulsion of like charges on the surface of individual drops. Hence, an electrical pressure is set up which tends to expand the surface area and this is resisted by the forces of surface tension, when the former exceeds the latter, the surface becomes unstable and droplet disintegration commences. Initial experiments with this method were limited to very low flow rates, and restricted its practical uses to painting and printing applications. However, the development of the 'spray triode' (Reference 14) was seen as a major step forward in realising high throughputs with electrostatic atomisers. Basically, the spray triode consists of a high density of very small tungsten fibres, embedded in a refractory material, at densities up to 10^7 cm^{-2} (Reference 14). Since each fibre can handle flow rates of up to 1 ml.s^{-1} , a 600 l.min^{-1} main branch supply would, in theory at least, require ten thousand (10^4) such electrodes, over a total area of $\sim 0.1 \text{ mm}^2$.

Ultrasonic atomisers promote the atomisation of liquids by their contact with a rapidly vibrating solid surface. Early use of the technique, between ~ 1960 -80, was restricted to the combustion area; latterly however, ultrasonic nozzle technology has found applications in semiconductor processing, humidification and the vapourisation of volatile anaesthetic agents in hospitals (Reference 14). Such nozzles can produce very fine atomisation at the extremely low flow rates required in certain pharmaceutical and lubrication processes. Drop sizes in the range 1 - $5 \mu\text{m}$ are produced by medical 'nebulisers', where inhaled drugs or water are required to penetrate to the extreme air passages of the lungs to provide medication or humidification. The very low spray velocity associated with this nozzle design is also a useful attribute in these applications, facilitating the entrainment of droplets in a moving air stream and their controlled conveyance as a fine mist. Ultrasonic atomisers are much less able to cope with flow rates at the higher end of the spectrum required by combustion or fire-fighting applications; maximum flow rates of around 7 l.h^{-1} are reported by Lefebvre (Reference 14). The *whistle atomiser* is essentially another form of gaseous atomiser, where a high pressure gas flow is focused into the centre of a liquid jet, causing liquid fragmentation

with the emission of strong sound waves. These designs normally operate at a sound frequency of about 10 kHz and produce droplets around 50 μm in diameter at liquid flow rates up to 1.25 l.s^{-1} . A deficiency of whistle atomisers is that the drop size cannot be easily controlled unless the nozzle diameter is altered. According to Lefebvre, no reliable or proven theoretical analysis of whistle atomisers is available, but the evidence suggests that the sound field is not a controlling factor in the atomisation process.

5.1.3 Drop size

The size of an individual droplet, or some mean drop size within a spray, is of great importance when discussing other attributes of the spray. For example, the kinetic energy associated with a droplet is proportional to its mass times its velocity squared ($\text{k.e.} = \frac{1}{2}mv^2$) and the former is proportional to the cube of its diameter. Similarly, the resistance offered by the surrounding air to the forward motion of the droplets is proportional to the droplet diameter. Therefore the carrying power, or penetration, of the spray is strongly dependent upon the drop size distribution (Section 5.2). The efficiency of heat transfer to water droplets, which is fundamental to their use in fire-fighting applications, is also dependent on droplet geometry and in particular the ratio of the total surface area of the spray to its volume; maximising this ratio is beneficial in promoting rapid absorption of heat from the environment and subsequent evaporation of the droplet (Section 5.3). In order to illustrate the relationship between droplet mean diameter and the total surface area of the spray, Herterich (Reference 10) considered the idealised atomisation of one litre of water into a number of droplets of equal diameter.

If one litre of water is subdivided into i droplets of equal volume then,

$$V_{\text{tot}} = i \frac{\pi d^3}{6} = 10^6 \text{ (mm}^3\text{)} \quad (11)$$

and so the diameter of each droplet is given by,

$$d = \sqrt[3]{\frac{6 \times 10^6}{i\pi}} \text{ (mm)} \quad (12)$$

and

$$S_{\text{tot}} = i\pi d^2 \text{ (mm}^2\text{)} \quad (13)$$

is the corresponding total surface area per litre volume of the resulting spray. Figure 14, plotted for a one litre volume of water and $10^3 \leq i \leq 10^{12}$, confirms the dramatic increase in surface area which may be achieved with effective atomisation and Table 6 (page 32) contains some extracts of data from Figure 14 which illustrate this trend.

Table 6

Droplet mean diameter d and total surface area for one litre of water distributed as a monodisperse spray of i droplets (data from Figure 14).

Number of droplets, i	Droplet mean diameter, d (mm)	Total surface area of spray, (m ²)
10^{12}	0.012	484
10^{11}	0.027	225
10^9	0.124	48
10^6	1.240	5
10^4	5.700	1

Sprays comprised of droplets of equal diameter are referred to as *monodisperse* and are quite rare in practice since specialised rotary atomisers are required for their production. If liquid is introduced onto a spinning disk or cup, the radial acceleration produces a thin sheet of fluid which is thrown off at the edge and disintegrates into 'main' droplets of a very uniform size which are well separated in space and are accompanied by two smaller 'satellite' droplets (Reference 16). Hoare (Reference 26) suggested that 20 μm droplets would be produced by a rotary atomiser (125 mm disk) spinning at 20 000 r.p.m. Fraser and Eisenklam (Reference 16) discussed some early experimental investigations of the factors affecting the main drop size d_M from rotary atomisers. The empirical equation,

$$d_M = \frac{360\,000}{S} \sqrt{\frac{\sigma}{D\rho_L}} \quad (14)$$

was found to be applicable to a spinning disk atomiser with a square edge profile, in this expression d_M is the main drop size (microns), S the rotation speed (r.p.m.), D the disk diameter (cm), σ the surface tension (dynes cm^{-1}) and ρ_L is the liquid density (g cm^{-3}). It was observed that the edge profile exerted a strong influence on d_M and that in general the liquid flow rate in rotary atomisers needed to be maintained within a critical range of flow rates to ensure reliable operation. Hoare (Reference 26) also noted that the rotary atomiser principle was used in mechanical fog production to generate very fine particle sizes ($\sim 5 \mu\text{m}$) at correspondingly low liquid injection rates.

In contrast to the somewhat idealised monodisperse sprays, most sprays of practical importance are *polydisperse* in nature, that is they consist of a wide range of droplet sizes, associated with some form of frequency distribution. Lefebvre (Reference 14) noted that the physical processes involved in atomisation are not yet sufficiently well understood for mean diameters to be expressed in terms of fundamental equations. Even the simplest case of the break-up of a liquid jet, which has been studied theoretically for over a century, cannot yet be satisfactorily explained by existing theories. It is not surprising then, that our understanding of the sprays produced by more complex atomisation techniques remains far from complete. Many experimental investigations of polydisperse spray production have been conducted however, and simple empirical equations have been sought to characterise the mean drop size (see also Section 4.1.2.2) and drop size distribution in terms of a few principal system variables. The most relevant liquid properties are the surface tension, viscosity and density; for liquids

injected into a gaseous atmosphere the gas density is also important. In addition the liquid and gas velocity fields and nozzle geometry must also be considered. Detailed discussions of how these factors affect the spray quality from various types of atomiser are found in References 10, 16 and most extensively in Reference 14. The liquid viscosity was identified in Reference 16 as being the most influential property affecting the drop size, a decrease in viscosity resulting in a more uniform spray of smaller drops.

Merrington and Richardson (Reference 36) performed a series of tests on sprays injected from a plain circular orifice into stagnant air, in order to investigate the performance of nozzles used in aircraft. The mean drop size (Sauter mean diameter, D_{32} in Table 3, page 15) was found to be related to the system variables by the equation,

$$D_{32} = \frac{500d^{1.2} \nu_L^{0.2}}{\nu} \text{ (m)} \quad (15)$$

where d_0 is the nozzle diameter, ν_L is the kinematic viscosity (absolute viscosity divided by density) of the liquid and ν is the injection velocity at the nozzle. Herterich (Reference 10) noted that at 'high air speeds', the above equation was found to reduce to,

$$D_{32} = \frac{500 \nu_L^{0.2}}{\nu} \text{ (m)} \quad (16)$$

where the mean droplet diameter becomes independent of the nozzle geometry for relative liquid:air velocities in excess of the atomisation level². Lefebvre (Reference 14) listed six additional empirical correlations for the mean droplet size produced by plain orifice atomisers, including some more recent expressions developed for diesel-type injectors.

Herterich (Reference 10) reproduced a graph of mean droplet size v. nozzle pressure from a previous investigation of impinging jet atomisation (Figure 15). This plot shows the effect of increasing jet pressure, nozzle diameter and interception angle (θ) on the mean droplet diameter (determined by the *Rosin-Rammler* method to be the diameter above which 36.8% of the spray volume resides); the tests employed nozzle diameters of 1.6–4.75 mm at pressures in the range ~ 1.4–8.3 bar (~ 20–120 psig). The general trends are that the droplet mean diameter decreases with both increasing pressure and interception angle; the throw of the spray however, was found to decrease as the angle of interception was increased. The uppermost ($\theta = 30^\circ$) curve however, appears to confirm the FRS supposition (see bottom of page 28) that a minimum mean droplet diameter is attained at some pressure; thereafter, a reversal of the trend is indicated, with droplet mean diameter tending to increase with increasing nozzle pressure. Given the similar shapes of the other curves, it is tempting to speculate that a similar behaviour would exist for jets striking at larger angles; unfortunately experimental data were not reported for pressures higher than ~ 8 bar (~ 120 psig).

² The critical relative velocity for onset of atomisation is $\nu \geq 300(\eta/\sigma)^{1/4}(\sigma/\rho D)^{5/8}$ (Reference 10)

Fraser and Eisenklam (Reference 16) reported drop size correlations for various nozzle designs, such as,

$$D_{32} = 15\,400 \frac{\sqrt{h^* \sigma}}{v} \text{ (}\mu\text{m)} \quad (17)$$

for commercially-available single hole fan spray nozzles, where h^* is the thickness of the liquid sheet at break-up (μm), σ is the surface tension (dynes cm^{-1}), v is the velocity of the liquid sheet (cm s^{-1}) and 15 400 is an empirical constant. It was noted that the mean drop sizes predicted by the above equation, and found in practice, are some 10-55 times larger than the thickness of the liquid sheet.

The pressure-swirl (or swirl-spray) atomiser has been the subject of numerous experimental and theoretical studies (Reference 14) because of its wide range of applications. Despite this research effort, the complexities of the system combined with uncertainties in the experimental data have so far prevented the development of a complete understanding of pressure-swirl atomisation. The parameters controlling the atomisation quality of these nozzles are once again the physical properties of the liquid and gaseous atmosphere, together with the liquid injection pressure and the size of the atomiser as indicated by its 'flow number',

$$FN_{UK} = \frac{Q}{\sqrt{p}} \quad (18)$$

where Q is the flow rate in UK gallons per hour and p is the injection pressure differential in pounds per square inch. Alternatively a metric flow number is sometimes used, defined as,

$$FN = \frac{\dot{m}}{\sqrt{p\rho_L}} \text{ (m}^2\text{)} \quad (19)$$

where \dot{m} is the flow rate (kg s^{-1}), and the units of p and ρ are N.m^{-2} (Pa) and kg m^{-3} respectively. The inclusion of the liquid density in equation (19) enables the flow number to be defined as the *effective flow area* of the nozzle in a dimensionally-correct expression; in contrast, comparisons of nozzle performance based on equation (18) are meaningful only where data are obtained with a standard calibration fluid. Fraser and Eisenklam (Reference 16) compared the performance of fan spray and swirl spray nozzles with water injection using empirical formulae for the Sauter mean diameter calculated over a range of flow numbers from 0.2-2.0 and nozzle pressures from ~ 2-7 bar (~ 25-100 psig). In general the drop size was predicted to decrease with increasing pressure for both nozzle designs. At low flow numbers the performance of the two designs was similar, but at higher FN , the swirl-spray nozzle gave smaller drop sizes, and particularly at higher pressures. For water, pressures in excess of 7 bar (100 psig) were not found to materially reduce the drop size, particularly for fan-spray nozzles. Lefebvre (Reference 14) presented a detailed discussion of the various factors which influence pressure-swirl atomisation, namely: surface tension, viscosity, liquid flow rate, flow number, nozzle pressure differential, air properties and atomiser dimensions.

Conventional, empirical, analyses of the pressure-swirl atomisation had led to correlations for Sauter mean drop size of the form,

$$D_{32} \propto \sigma^a \nu^b \dot{m}_L^c \Delta p_L^d \quad (20)$$

where the variables on the right hand side are those of surface tension, kinematic viscosity, liquid mass flow rate and nozzle pressure differential. The expressions discussed in Reference 14 contain various values for the exponents a-d, with variations attributed to differences in nozzle design or flow régime. Lefebvre proposed the following alternative expression for the mean drop sizes produced by pressure-swirl atomisers, derived from a 'first principles' consideration of the mechanisms involved,

$$D_{32} = 4.52 \left(\frac{\sigma \eta_L^2}{\rho_A \Delta p_L^2} \right)^{0.25} (t \cos \theta)^{0.25} + 0.39 \left(\frac{\sigma \rho_L}{\rho_A \Delta p_L} \right)^{0.25} (t \cos \theta)^{0.25} \quad (21)$$

where θ is half the spray cone angle ($^\circ$) and the 'spray film thickness', t , is given by,

$$t = 2.7 \left[\frac{d_o F N \eta_L}{(\Delta p_L \rho_L)^{0.5}} \right]^{0.25} \quad (22)$$

and d_o is the diameter of the final exit orifice of the nozzle. It was argued that this treatment of the problem captured all of the important physical processes involved and predicted trends in nozzle performance which were consistent with previously published findings.

The drops sizes from twin fluid atomisers are, in general, smaller than those produced by swirl-spray or fan spray nozzles. Fraser and Eisenklam (Reference 16) reported an early empirical equation based on several hundred experiments with small twin fluid nozzles operating at a high volumetric ratio of air to liquid,

$$D_{32} = \frac{585}{V} \sqrt{\frac{\sigma}{\rho_L}} + 597 \left(\frac{\eta}{\sqrt{\gamma \rho_L}} \right)^{0.45} \left(\frac{1000}{j} \right)^{1.5} \quad (23)$$

where D_{32} is the Sauter mean diameter (microns), V is the velocity of air relative to liquid at the nozzle exit (m.s^{-1}), σ is the surface tension (30-73 dynes.cm $^{-1}$), ρ_L is the liquid density (0.8-1.2 g.cm $^{-3}$), η is the absolute viscosity (0.01-0.3 poise) and j is the air/liquid volume ratio at air and liquid orifice respectively, *i.e.* at the ambient pressure. The above equation was originally developed for twin fluid *internal mixing* atomisers operating at subsonic relative velocities, but was found to apply equally to supersonic discharges; the difference between internal and external atomisers is discussed in Section 5.1.2.2 of this report. For any particular liquid, the drop size is determined by the air to liquid ratio and the relative velocity; drop size decreases as the air pressure and air to liquid ratio are increased and drop sizes of 20-30 μm (Reference 16) and even one micron (Reference 37) have been reliably produced.

Lefebvre (Reference 14) reported two empirical expressions for the Sauter mean diameter of droplets produced by external twin fluid atomisers (Figure 13(f)). Firstly,

$$\frac{D_{32}}{t} = \left[1 + \frac{16\,850\,Oh^{0.5}}{We(\rho_L/\rho_A)} \right] \left[1 + \frac{0.065}{(\dot{m}_A/\dot{m}_L)^2} \right] \quad (24)$$

where t is the initial film thickness ($= D_o h / D_m$), D_o is the outer diameter of the pressure nozzle, D_m is the diameter of the annular gas nozzle, h is the slot width of the pressure nozzle, Oh is the 'stability number' $(\mu_L^2 / \rho_L t \sigma)^{0.5}$ and We is the 'Weber number', $\rho_A U_A^2 t / \sigma$. Once again the mean droplet size is found to reduce with increasing air velocity U_A and with decreasing liquid viscosity. The alternative expression,

$$D_{32} = 51 d_o Re^{-0.39} We^{-0.18} \left(\frac{\dot{m}_L}{\dot{m}_A} \right)^{0.29} \quad (25)$$

where $Re = \rho_L v d_o / \mu_L$ and $We = \rho_L d_o v^2 / \sigma$, was also discussed in Reference 14. This equation was developed during a study of kerosene sprays and it was found that smaller droplets were produced when the spray was injected into higher ambient air pressures, for example $D_{32} \sim 70\ \mu\text{m}$ at $p_A \sim 200\ \text{kPa}$ (2 bar) while $D_{32} \sim 50\ \mu\text{m}$ at $p_A \sim 600\ \text{kPa}$ (6 bar). Lefebvre (Reference 14) summarised the behaviour of external twin fluid atomisers in the following four conclusions:

- For any given liquid, the key factors governing atomisation quality are the dynamic pressure of the atomising air and the relative velocity between the liquid and the surrounding air;
- For any particular air velocity, continual increase in liquid injection pressure from an initial value of zero produces an increase in the Sauter mean diameter (SMD) up to a maximum value, beyond which further increase in injection pressure causes the SMD to decline;
- The liquid injection pressure at which the SMD attains its maximum value increases with increase in atomising air velocity;
- Whereas increase in air velocity is usually beneficial to atomisation quality, increase in liquid velocity may help or hinder atomisation, depending on whether it increases or decreases the relative velocity between the liquid and the surrounding air.

For rifling nozzles more associated with fire-fighting applications, Herterich reported that the expression,

$$D_{10} = 3 \left(\sigma^4 / 4 p R^2 \right)^{1/3} \quad (26)$$

where D_{10} is the linear mean diameter (Table 3, page 15), σ is the surface tension, r is the radius of the tangential flow inlet, p is the pressure upstream of the nozzle and R is the radius of the turbulence chamber into which the tangential flow enters. The absence

of the nozzle diameter in the above equation was in agreement with previous findings (Reference 10). Herterich also reported a very simple expression for estimating drop diameters based on a consideration of droplet stability,

$$d \approx \frac{450}{v^2} \text{ (mm)} \quad (27)$$

where v is the discharge velocity of the water into still air (m.s^{-1}). While the simplicity of the expression is attractive, the general impression obtained from the above section is that droplet atomisation is rarely monodisperse and depends upon many system variables.

5.2 Ability to travel (spray penetration or 'throw')

5.2.1 Spray penetration in the absence of a fire

Lefebvre (Reference 14) defined the *penetration of a spray* as the 'maximum distance it reaches when injected into stagnant air'. The practical penetration achieved by a particular spray is governed by the relative magnitudes of the kinetic energy of the initial liquid jet and the degree of aerodynamic resistance offered by the surrounding gas. Although the initial velocity of the jet is usually high, the ensuing break-up into droplets rapidly increases the surface area of the spray and the kinetic energy is gradually dissipated by frictional losses. Once the initial kinetic energy has been expended, the spray trajectory is ultimately dictated by a combination of local air currents and the force of gravity. Lefebvre presumed that, in general, a compact narrow spray would have a high penetration while a well-atomised spray of wide cone angle would, by virtue of its increased air resistance, tend to have a low penetration. All other things being equal, the penetration of a spray is much greater than for an individual drop, since the leading droplets impart forward momentum to the surrounding gas, reducing the air drag on the following drops and promoting better penetration. According to Ranz (Reference 38), a single droplet has a 'stopping distance' which is an order of magnitude smaller than the ultimate penetration distance of the spray in which it resides. However, Ranz' analytical treatment of spray penetration was admittedly 'largely conjecture' and contained several unknown parameters; hence this work is of no practical value at present, although it was envisaged that the concepts presented might be of use in future experimental programmes.

Hoare (Reference 26) reported several examples of spray penetration in agricultural applications: 400-1500 μm drops produced by 400-600 psig nozzles could be projected to 30 feet (~ 9 m) into the air (tree spraying), 100-200 μm drops at 200-300 psig were thrown some 6-7 feet (~ 2 m) (vineyards), 80-150 μm drops at 40-100 psig were suitable for herbicidal spraying and for droplets < 80 μm there was a danger of the spray being picked up by the wind and deposited onto crops where they might cause damage. It appeared that a droplet size of ~ 180 μm was optimum for drift spraying and this system was a compromise, allowing the wind to carry the droplet a certain distance while the droplet also fell under gravity. The latter system was best produced by a 'high

speed air jet', but no other system details were given in relation to effective penetration distances.

Herterich (Reference 10) reported the theoretical analyses of Euteneuer (Reference 39), who utilised the simplified impulse theorem to calculate the horizontal throw ranges of single droplets and spray-jets. For the case of a single droplet, Euteneuer proposed the equation,

$$x = 2d \ln \left[1 + 0.5 \frac{v_0 t}{d} \right] \quad (28)$$

where x is the distance of throw (m), v_0 is the initial velocity of the drop (m s^{-1}), t is the 'flight time' (s) and d is the drop diameter (mm). Both theory and experiment indicated that the throw range could be increased by raising the initial discharge velocity (v_0), by employing a higher pressure at the nozzle, the experimental programme covered a range of nozzle diameters from 0.1-3 mm and pressure heads of 2.5-20 bar (~ 35 -300 psig). Euteneuer's equation, above, does indicate that the throw of a droplet may be increased by raising the initial velocity v_0 (through a corresponding increase in nozzle pressure), however this mechanism cannot be relied upon indefinitely, since the accompanying decrease in droplet diameter at higher pressures has the opposite effect on ' x ' in the equation, thus reducing the penetration. Euteneuer extended his theoretical analysis to the case of a spray-jet, comprised of multiple droplets, where the maximum distance of throw was defined as the horizontal distance from the nozzle to the point of greatest water delivery. These data (quoted by Herterich in Reference 10) showed that spray-jet penetration was expected to be significantly greater than for single drops and also confirmed the general fall-off in penetration at elevated nozzle pressures.

Herterich argued that it was often wrongly assumed that a sizeable increase in pressure will promote better atomisation or bring about a greater distance of throw. It was stated further that this misconception had led the fire-fighting industry to introduce high pressure pumps (up to ~ 60 bar, 900 psig) which was completely unnecessary, since the maximum throw for a spray-jet was attained at a much lower pressure.

On the other hand, Güttler (Reference 40) used the empirical formula developed by Thomas and Smart (Reference 41),

$$w = 2.15 \frac{Q^{0.36} H^{0.28}}{\theta^{0.58}} \quad (29)$$

to compare the performance of 'normal' and high pressure water sprays. In this formula, w is the 'average throw' of a spray-jet (m), Q is the flow rate (l min^{-1}), H is the nozzle operating pressure (metres of water equivalent) and θ is the included angle of the spray ($^\circ$); the formula is valid for $30^\circ < \theta < 90^\circ$. This formula was also discussed by Herterich (Reference 10), who noted that w is influenced more by changes in cone angle and flow rate than by the nozzle operating pressure. Güttler (Reference 40) used the above equation to demonstrate the increased penetration achieved by high pressure

sprays ($H_{hp} \sim 320$ metres w.g., ~ 30 bar, 450 psig) over normal pressure sprays ($H_{np} \sim 48$ m w.g., ~ 5 bar, 70 psig); thus,

$$\frac{w_{hp}}{w_{np}} = \frac{H_{hp}^{0.28}}{H_{np}^{0.28}} = 1.7 \quad (30)$$

indicates a 70% increase in spray penetration for these values of nozzle pressure. However, in the original paper by Thomas and Smart (Reference 41), equation (29) was derived from an analysis of photographs of the sprays produced by nozzles operating at pressures of $\sim 3, 7$ and 10 bar (50, 100 and 150 psig) and flow rates between ~ 45 -1955 l.min^{-1} (10-430 gallons per minute). Additional visual estimates of the throws produced by higher pressure sprays (~ 20 and 40 bar, 300 and 600 psig) showed that equation (29) tended to grossly overestimate w ; it was concluded that the extrapolation of this expression to high pressure cases was not reliable since the effect of pressure was reduced. Given this conclusion, Güttler's (Reference 40) assertion of a monotonic increase of throw with pressure must therefore be seen as questionable.

Herterich (Reference 10) concluded that the empirical and theoretical data on the throw of spray jets, available in 1960, were not adequate to define this parameter as a simple function of nozzle pressure. It was argued that any increase in nozzle pressure above 14 bar (~ 200 psig) was not justified since any increase in throw range would be offset by operational difficulties. Herterich therefore recommended that it would be more profitable to design improved spray nozzles with spray angles between 6 - 25° , more efficient atomisation and a better conversion of nozzle pressure into forward velocity.

Lefebvre (Reference 14) also discussed the penetration (x) of liquid sprays, and presented equations developed during research on diesel injectors, for example

$$x = 0.2d_o \left(\frac{v_L t}{d_o} \right)^{0.48} \left(\frac{v_L d_o}{v_L} \right)^{0.3} \left(\frac{\rho_L}{\rho_A} \right)^{0.35} \quad (31)$$

where d_o is the nozzle diameter and t represents the 'injection time'. The latter parameter is typically measured in milliseconds and therefore this type of correlation cannot be confidently extrapolated to the case of continuous fire-fighting sprays where the time of injection is essentially infinite; under these conditions the above equation would erroneously predict correspondingly infinite penetrations. At present there appears to be no widely accepted, practical methodology for predicting the throw range of typical fire-fighting sprays.

Yule *et al.* (Reference 42) described a technique based on laser Doppler anemometry (LDA) which allowed simultaneous particle size and velocity measurements in sprays. The method was developed for measuring fuel droplet data in vaporising or burning fuel sprays to assist in the development of spray combustion systems. Laboratory-scale twin-fluid atomised kerosene sprays ($Q_f \sim 0.1 \text{ ml.s}^{-1}$ and $Q_a \sim 63$ -126 ml.s^{-1}) were analysed using this technique; droplet mean diameters and velocities were found to range between ~ 20 -120 μm and ~ 2 -15 m.s^{-1} respectively. The possible extension of the method to

larger-scale sprays was not discussed, although in principle this would appear to be possible. The LDA technique is discussed further in Section 5.5 of this report, together with various other methods for estimating droplet size distributions

5.2.2 Spray penetration/interaction with fire plume convection currents

Rasbash (Reference 43) listed the factors controlling the penetration of a spray to the seat of a fire as the drop size and thrust (or force) of the spray, the thrusts of the flames and wind, gravity and the evaporation of the spray in the flames. Rasbash noted that during manual fire-fighting with water sprays, the combined dissipative effects of flame thrust, evaporation and ambient wind could be minimised by applying the spray directly through the base of the flames to the fuel from the upwind side of the fire; under these conditions the horizontal throw of the spray (dictated by the spray thrust and gravity) usually determines the degree of penetration. In cases where the spray is applied downward onto the fire however, all the aforementioned factors play a role, and in particular the relative thrusts of the flames and the water spray (Reference 43). The former is proportional to the buoyancy generated by the fire, and hence the rate of heat release, while the latter is a function of the reaction at the nozzle and the width of the spray. An appendix in Reference 43 considered these parameters in more detail; briefly, the upward thrust of a flame was shown to be correlated with the flame height while for water sprays the non-dimensional velocity profile was found to be similar to that for turbulent free jets. Experiments on the downward penetration of water sprays onto 0.3 m diameter kerosene pool fires showed that the penetration decreased as the spray pattern became more 'peaked' in the centre of the pool and as the thrust and the drop size of the spray decreased.

In a subsequent paper (Reference 44), Rasbash discussed a theoretical model of spray penetration into a flame based on equations describing the deceleration and evaporation of the drops. Results showing drop size and drop velocity histories for various initial conditions (*i.e.* droplet diameter and velocity) were presented, assuming a characteristic flame temperature of 1000 °C. Two flame velocities were used in the calculations, either zero or 2.5 m s⁻¹ in an upward direction. For the range of drop sizes examined (50-500 μm), the penetration distance was found to be approximately proportional to the square of the diameter for a given flame velocity and initial droplet velocity. The upward velocity of the flame was observed to have a significant effect on the penetration of the drop. The penetration into a stationary flame was some six times greater than that predicted for a flame with a vertical velocity of 2.5 m s⁻¹. Rasbash's model is discussed further in Section 5.3.2 in the context of heat transfer from flames to water sprays.

McCaffrey (Reference 45) separated the dynamics of the water droplet-flame interaction into three levels of complexity: simple momentum conservation between a non-evaporating particle and a flowing gas stream, a momentum and energy balance around a droplet (including an evaporation mechanism) and finally, the "Grand" model, incorporating a complete set of (solvable) governing equations describing the effects of radiation, turbulence and chemical kinetics. McCaffrey demonstrated the utility of a simple first stage (*i.e.* momentum conservation only) droplet-flame interaction model and presented a parametric plot of the droplet injection problem for a horizontally-

propelled droplet traversing an upward-flowing gas jet (Figure 16); the application under consideration was the suppression by water of jet diffusion flames associated with oil-well blow-offs. The density ratio ρ_A/ρ_W was assumed to be 0.001 (e.g. air:water) and curves were produced showing the non-dimensional trajectory ($x^* = x/D$, $y^* = y/D$) as a function of non-dimensional time $t^* = tv_o/D$ and the initial velocity ratio v_A/v_o (gas velocity:initial droplet velocity) where D is the droplet diameter. The plot was shown to be of use in estimating whether a particular drop size is likely to remain resident in the flame or pass straight through. Ideally in practice it is desirable to match the droplet size and momentum to the characteristics of the anticipated gas stream (i.e. its momentum and width) to guarantee a residence time which realises the heat extraction potential of the droplet. The dashed lines in Figure 16 illustrate the effect of different density ratios and each are drawn for the particular case where $v_A/v_o = 20$. The model (unspecified) allows the initial injection angle to vary and includes "flexible" models for the effects of buoyancy and drag forces on the particle. McCaffrey (Reference 45) also conceded that although a single droplet would not disturb the gas flow unduly, in practice a spray of particles would be expected to have a significant effect on the flow field of the fuel gas; a more general model would also need to incorporate statistical distributions of initial particle size and velocity.

One important aspect of spray interaction with fires is the expansion of the flame volume which sometimes accompanies the initiation of fire suppression activity. The increase in heat release rate is due to the air entrained within the spray envelope, which both increases the amount of oxygen available to the fire and promotes more intimate mixing of the reactants in the flame zone. McQuaid developed a method for estimating the volume of air entrained within water sprays and compared the predictions of this analysis with some experimental data obtained at realistic scales (Reference 46). The method was originally developed as a design aid for water-spray barriers intended to assist the dispersal of gas or vapour leakages in chemical plants (Reference 47). The air-entrainment relationship proposed by McQuaid is shown in Figure 17, where Q_a is the rate of air entrainment into the spray ($m^3 \cdot s^{-1}$), Q_w is the water flow rate ($l \cdot s^{-1}$), D is the width of the spray (m) and ρ is the density of water ($1000 \text{ kg} \cdot m^{-3}$). The flow number F is defined as $F = Q_w / \sqrt{P_w}$ where P_w is the water pressure at the nozzle (Pa). The method is used to estimate the total rate of air entrainment into the spray envelope from the nozzle to the plane where the spray width is D . However, the analysis is restricted to cases where F is a constant, which occurs when flow conditions in the nozzle are fully turbulent. McQuaid (Reference 46) noted that the spread of the original small-scale data used to construct Figure 17 was around $\pm 20\%$; for the comparisons with the large-scale data, the mean ratio of predicted to experimental air entrainment was 0.97 with a standard deviation of 36%. Given the uncertainties in the reported experimental data, McQuaid concluded that the accuracy of the method was acceptable for its intended practical application. Using the data for the first spray in Table 5 (page 23) of this report, $P_w = 700 \text{ kPa}$, $Q_w = 3.7 \text{ l} \cdot s^{-1}$ and $D = 0.9 \text{ m}$ which gives $F \sim 4.4 \times 10^{-3}$ and $Q_a/Q_w \sim 1.1$, leading to an estimate for the air entrainment rate of $Q_a \sim 4 \text{ m}^3 \cdot s^{-1}$.

Although the simplicity of McQuaid's method is attractive, it lacks the sophistication to model water sprays used within compartments in the presence of fire and has not been validated against more recent nozzle data. The more advanced modelling techniques

which are discussed below have the capability to provide a more accurate calculation of air entrainment rates, albeit at the expense of greater computational effort. The empirically-based compartment fire suppression model described in Section 6.2.2 strikes a balance between the two approaches and also has the capacity to generate air entrainment rate data.

There is a growing body of contemporary research concerned with the interaction between water droplets and buoyant fire plumes; this research has in large measure been driven by the desire to improve the design of fixed sprinkler systems (References 48-56). Beyler (Reference 48) described a 'unified mathematically expressed conceptual framework' for analysing the interaction of fires and sprinklers. For simplicity, the problem was partitioned into three sub-models: a sprinkler actuation model, a model of drop formation and dynamics and a fire suppression model. The drop size distribution was identified as a critical element in determining the effectiveness of a sprinkler system. Experiments had shown that although small drops were most effective in cooling the atmosphere, these were often transported away from the fire by convection currents and deposited on adjacent sprinkler elements. The cooling effect thereby produced was often found to result in delayed actuation of adjacent heads thus favouring the actuation of more remote heads (a phenomenon known as 'sprinkler skipping'). In contrast, large drops were not prone to deflection by the fire plume and were more able to penetrate to the seat of the fire, at the expense of reduced atmospheric cooling. Beyler's droplet-fire interaction model (Reference 48) included the effects of evaporation and drag forces on the droplet within a hot air plume with Gaussian distributions of velocity and temperature. It was found that the smaller drop sizes were more affected by evaporation than larger ones and evaporation had negligible effect on the dynamics of drops greater than ~ 2 mm diameter. Heat gain by thermal radiation was ignored since the residence times of the large drops within the combustion zone were short (~ 0.1-0.3 s). An analysis of the effect of heat release rate revealed a strong influence on the degree of plume penetration. In the case of a small fire (250 kW), the updraught from the fire was sufficient to carry a 1 mm diameter droplet away from the fire, preventing it from landing on the fuel surface. These results indicated that there may exist a critical heat release rate above which a given drop size would not contribute to fire extinguishment, although Beyler stated that further sensitivity studies would be required to validate this hypothesis.

Factory Mutual Research Corporation (FMRC) developed a computer simulation of water spray-fire plume interaction, to assist in identifying the controlling parameters affecting fire suppression and thereby to improve the cost-effectiveness of large-scale testing and sprinkler optimisation (Reference 49). It was also envisaged that the comprehensive data set produced by the FMRS model could be used to develop simplified correlations to aid the design process for sprinkler systems. Alpert and Delichatsios (Reference 49) described improvements to the computational algorithm for simulating the axisymmetric spray-plume interaction. Results were presented to illustrate the behaviour of a downward-facing droplet spray interacting with a buoyant fire plume, where both elements shared a common centreline; the more general case of a sprinkler head not centred on the fire is more complex and requires a three-dimensional modelling technique. The successful modelling of the fire suppression problem was seen as comprising two main areas: the simulation of water droplet dynamics prior to

impinging onto the fuel bed and the subsequent effect on fire development; only the former was considered in Reference 49. The study consisted of more than 100 numerical solutions for the flow field arising from the interaction of a point or ring monodisperse spray with a fire plume. Fire heat outputs ranged from 0.5-4 MW and spray variations included: median droplet size (0.6, 1.0, 1.4 mm), water flow rate (2.3, 4.6, 7.0 kg.s⁻¹) and injection velocity (8 and 16 m.s⁻¹); output data included gas streamlines, isotherms and droplet trajectories. The influence of the fire plume was characterised by a 'penetration ratio' (P_e), obtained by comparing the droplet trajectories under no-fire conditions with those modified by the fire plume. This ratio was defined as the amount of water reaching the base of the heat release zone under no-fire conditions to that obtained in the presence of a fire; a complex weighting procedure was adopted to take account of all droplets reaching floor level. Correlations were obtained for the variation in P_e from zero to unity, in terms of the functional relationship,

$$P_e = f(\dot{M}_s / \dot{M}_p + 4d/d_c) \quad (32)$$

where \dot{M}_s is the vertical thrust of the spray in the absence of a fire, \dot{M}_p is the plume vertical thrust at the elevation of the spray nozzle, d is the mass median droplet diameter and d_c is a 'critical droplet diameter'. The latter was defined as the approximate maximum size of an isolated droplet whose downward motion can be arrested by a particular plume flow on the plume axis at the spray nozzle elevation. The values of \dot{M}_p and d_c were deduced by calculation for each fire condition. Although the efficacy of equation (32) was confirmed and some general conclusions were drawn, it was considered that improvements in the numerical solution technique were necessary. In order to remove some of the instabilities observed in the model, a more accurate, fully transient computer code was being developed.

Heskestad (Reference 50) discussed the development of a submodel for sprinkler-hot layer interaction designed to be incorporated into two-layer zone models of compartment fires. The model considered the discharge of an isolated sprinkler into a quiescent upper hot layer of fire gases and the subsequent penetration of the jet into the cool air below. The goal was to simulate the initial cooling effect on the hot layer, the degree of spray penetration into the lower layer and the secondary cooling of the upper layer by the buoyant re-entry of the warmed water jet into the upper layer with cool air entrained from the lower layer. Details of the main elements of the model were described, including: the entrainment of air into a water spray, the penetration of spray induced flow into the lower layer, the entrainment of the lower layer fluid into the upper layer, the heat transfer to evaporating liquid drops and the heat balance within the upper layer (of uniform temperature); the fire plume itself was not simulated. The model was 'calibrated' with reference to a series of 25 sprinklered room fire experiments in order to determine the value of some empirical coefficients. The cooling predictions for the hot layer were found to agree well with the published results for fires in the range ~ 130-500 kW interacting with sprays from three different sprinkler nozzles at water flow rates between ~ 40-100 l.min⁻¹. The calculated penetration depths and associated entrainment rates from the cool lower layer were found to be negligible in all cases, although a lack of experimental data precluded the confirmation of these predictions.

Alpert (Reference 51) reiterated FMRC's goal of obtaining simple correlations for spray-plume interaction from an analysis of the results of more complex models of the types described above; this theme was previously introduced in Reference 49. The percentage penetration of a sprinkler spray through a fire plume, expressed as a function of easily measurable spray and plume characteristics was given as an example of such a correlation. Results from FMRC's steady-state finite difference model were analysed in terms of the penetration ratio, defined previously in this section by equation (32) (Reference 49). The controlling parameters were expressed as four non-dimensional ratios: $x_1 = \dot{M}_s/\dot{M}_p$, $x_2 = d_m/d_c$, $x_3 = V_s/V_p$, $x_4 = H/D_f$. The vertical thrust at the nozzle of the spray and plume were defined as,

$$\dot{M}_s = V_{m_j} \dot{M}_{m_j} \sin^2 \theta_o / [2(1 - \cos \theta_o)] \quad (\text{N}) \quad (33)$$

and

$$\dot{M}_p = 0.0733 \dot{Q}_c^{2/3} (H + 1.02 D_f - 0.083 \dot{Q}_c^{2/5})^{4/3} \cdot [1 + 0.026 \dot{Q}_c^{2/3} (H + 1.02 D_f - 0.083 \dot{Q}_c^{2/5})^{-5/3}] \quad (\text{N}) \quad (34)$$

respectively. In the above equations, V_{m_j} is the initial droplet velocity (m s^{-1}), \dot{M}_{m_j} is the mass flow rate of injected water (kg.s^{-1}), (θ_o) is the half-angle of the outer spray envelope close to the nozzle ($^\circ$), H is the height of the sprinkler nozzle above the floor (m), D_f is the effective diameter of the heat release zone (m) and \dot{Q} , \dot{Q}_c represent the total and convective rates of heat release (kW) respectively. The drop-size parameter x_2 is the ratio of the measured mass-median drop diameter for the spray to the critical drop size at the nozzle whose downward motion is just arrested by the plume. Alpert (Reference 51) assumed a constant drag coefficient (equal to 0.5 for the Reynolds number range of interest) and derived the expression,

$$d_c = 0.0406 \dot{Q}_c^{2/3} (H + 1.02 D_f - 0.083 \dot{Q}_c^{2/5})^{-2/3} \quad (\text{mm}) \quad (35)$$

for the critical drop diameter at the nozzle height. In addition, the expression,

$$d'_c = 0.1339 \dot{Q}_c^{2/5} \quad (\text{mm}) \quad (36)$$

was given for the critical drop size stopped by the plume at the height of the flame tip. The effect of the thrust ratio on the penetration ratio, P_e , was discussed by Alpert, for thrust ratios below ~ 1 , $0 < P_e < 0.8$ but for thrust ratios approaching unity, P_e was seen to rapidly attain a values in excess of 0.9, indicating a delivery of more than 90% of the spray volume to the seat of the fire. Three forms of correlation between P_e and x_1, x_2, x_3, x_4 were assessed; the best agreement was found using the rational polynomial equation,

$$\hat{y} = \hat{P}_e = \frac{a_0 + a_1 x_1^{n_1} + a_2 x_2^{n_2} + \dots + a_4 x_4^{n_4}}{1 + b_1 x_1^{n_1} + b_2 x_2^{n_2} + \dots + b_4 x_4^{n_4}} \quad (37)$$

because this expression tended to a limiting value of unity even for large values of the controlling non-dimensional parameters. Equation (37) was found to yield a satisfactory correlation of the data using only the ratios x_1, x_2, x_4 as defined above and the results differed little from the correlation employing all four parameters, implying that x_3 was negligible. Alpert discussed the possibility of a similar correlation describing the thermal energy absorption of the spray, since the numerical simulations were able to compute the heat energy absorbed either by evaporation or by an increase in the droplet temperature. A plot of the numerical results showed a gradual reduction in the 'thermal energy absorption ratio' of the spray with increasing value of thrust ratio \dot{M}_s/\dot{M}_p . It was stated that this did not imply that the cooling effect of the spray was any less at high values of the thrust ratio, merely that the cooling mechanism was modified from a droplet heating/evaporation mechanism to one involving dilution through increased spray air entrainment.

Yet another variant of the spray-plume interaction model has been described by Jackman and Nolan (Reference 52). This model (known as 'SPLASH') has been used to simulate the protection offered by water deluge systems to chemical plant installations subjected to external fire impingement. Output data include the total heat transfer from the fire gases to the spray, the complete physical and thermal drop histories throughout the spray and the changing properties of the fire gases. The computer simulations reported in Reference 52 were conducted to investigate the effects of wind and elevated temperatures on the spray protection of an LPG tank. The degree of water coverage was found to diminish with both increasing fire gas temperature and external wind velocity; the results were also found to be in general agreement with experimental investigations of LPG tank protection. The mathematical formulation of the 'SPLASH' code is described in more detail in Reference 53, together with representative output data from 22 simulations of a sprinklered corridor fire. For each simulation the ultimate fate of 12044 individual drops was determined, enabling both the percentage of water evaporated and the percentage of water reaching the interface between hot and cold gas layers to be estimated. It was concluded that the SPLASH program was able to model the interaction processes relevant to the specification of active and passive fire protection and smoke ventilation design.

Hoffmann and Galea also developed a two-phase fire-sprinkler interaction model which they compared with experimental data from a fire-sprinkler scenario (Reference 54). The predictions of time-dependent gas temperature were in reasonable agreement with experiment; however the efficiency of the computational algorithms and their implementation was poor. A total of 27 hours of CPU time were required to simulate the 175 seconds prior to sprinkler actuation while the subsequent 25 seconds required a further 63 hours, even though the computational grid was relatively coarse. It was envisaged that parallel computing techniques could provide a dramatic increase in calculation speed; early indications were that the 90 hour simulation described above could be reduced to ~ 7 hours by this method (Reference 54). In describing the mathematical basis for their model, Hoffmann and Galea (Reference 55) noted that in contrast to the compartment fire problem, the subject of fire suppression had received comparatively little attention from the modelling community and therefore remained in a relatively primitive state of development. These authors justified the development of fire suppression models in a similar manner to Alpert and Delichatsios (Reference 49) *viz.*

theoretical models of the fire-sprinkler interaction reduces the need for expensive large-scale testing and allows the effect of system variations to be assessed more rapidly than is possible by testing alone. Hoffmann and Galea (Reference 55) described in detail the formulation of their transient, three-dimensional model of the interaction between water droplets and the hot turbulent atmosphere in a fire compartment; the spray-flame and spray-fuel interactions were not considered and were seen as subjects for future research. The results obtained from the model for two distinct test geometries, one of which was discussed briefly in Reference 54, are presented in greater depth in Reference 56. It was concluded that although the technique was still in its 'early days', the model was capable of producing qualitatively correct simulations of the fire-sprinkler interaction. Given the massive computational effort required to solve such problems, it was seen as essential that future implementations of such models should run on parallel computers (as advocated in Reference 54). The authors also highlighted the urgent need for detailed experimental data on fire-sprinkler interaction to be used for model verification.

Fthenakis *et al.* (Reference 57) have also independently developed a computational model of water spray interaction with a gaseous plume, in the context of absorbing and dispersing an accidental release of toxic gas (hydrofluoric acid) in the atmosphere. Again the fundamental equations for momentum, mass and energy interchange between the gas and liquid phases were solved; the solution domain was two-dimensional in this case and the effects of turbulence were also included through modified laminar flow equations. Despite the different practical application intended for the model, some points of general interest emerged which are of relevance to the present study.

In Section 5.2.1 it was noted that the penetration of a spray is greater than for a single droplet under the same conditions. Fthenakis *et al.* considered the influence of the water droplets in two flow regions: a dense spray region close to the nozzle and further away from the nozzle where the droplet trajectories could be considered separate (sparse spray region). The dense spray region was defined as occurring where the drops occupied a significant fraction, ϕ , of the volume of the gas-phase (e.g. $\phi > 0.05$) and droplet trajectories were closely spaced. In this region, the expression,

$$\frac{C_D}{C_{DS}} = 1 + 3.5\phi \quad (38)$$

was adopted to relate the drop drag coefficient (C_D) to the single drop drag coefficient (C_{DS}). Previous research on the sparse sprays had showed that for sprays consisting of 300 μm drops, the maximum expected decrease in C_D would be $\sim 30\%$; Fthenakis *et al.* adopted a reduction in C_D of 15% for their sprays (consisting mostly of droplets in the 100–200 μm range). The ability of the model to predict air entrainment into the spray was also discussed in Reference 57; in order to produce an acceptable level of agreement between the model and experimental data it was necessary to adjust two of the 'constants' in the turbulence model. This highlights a perennial problem associated with such sophisticated modelling techniques: they lack true generality in their use and often require to be 'tweaked', 'tuned' or otherwise calibrated for a particular problem with reference to empirical data (ideally gleaned from large-scale experiments of the type they

are supposed to replace). The optimum representation of the drop size distribution of the spray was examined during sensitivity studies. It was found that for the nozzles being modelled (which produced droplets in the range 50-700 μm), input data based on only five representative drop sizes were sufficient to produce solutions which were insensitive to this parameter. Using a single mean size rather than a size distribution resulted in deviations in the range of 2-5%. The effectiveness of the water spray to remove hydrofluoric acid from the atmosphere was found to increase with increasing water flow rate and decreasing drop size; these trends were confirmed by large-scale experiments.

From the foregoing it is clear that there is a continuing interest in the interaction of water sprays with fires, although the main emphasis has to date been on the momentum, mass and energy exchanges between the liquid and gas phases. The current state-of-the-art is not mature enough to include the effects of direct flame cooling and water impingement onto burning fuels; hence a generalised fire suppression model is still remote. Moreover, the modelling philosophy appears to be divided into two camps: those who look to fundamental models as the way forward and those who aim to use the best available models in conjunction with experimental data to produce robust, simplified engineering correlations which may be used for design purposes. The subject of spray-fire interaction is addressed again in Sections 6 and 7 of the present report.

5.3 Ability to cool

5.3.1 General

It is impossible to say when water was first knowingly used to extinguish fire, since the origins of fire-fighting are inextricably linked with the primeval discovery of fire itself. However, in more recent times the effectiveness of water against various fire types has been well documented and subjected to much scientific analysis. As a result, various extinguishing mechanisms have been proposed and Section 3 of this report identified *fuel cooling*, *flame cooling* and *inerting* as the modes most relevant to Class 'A' fires. In discussing the action of water mists, Mawhinney (Reference 24) added the *blocking of radiant heat*, which aids fire suppression by reducing the thermal energy feedback to unburned fuel surfaces. A more quantitative discussion of these extinction mechanisms is given in Section 6.1. The present discussion considers the various routes by which water droplets may extract heat from their surroundings and the relative effectiveness of these *heat transfer* routes.

The principal action of liquid extinguishing agents identified by Fristrom (Reference 9) was the extraction of heat from the fire through the latent heat of vapourisation and heat capacity. Water was described as: "...a uniquely suitable liquid, being stable, non-combustible, non-toxic and having a very high heat of vapourisation." The specific heat capacity of water at constant pressure (c) is the amount of energy required to raise 1 kg of liquid by 1 $^{\circ}\text{C}$, while the specific latent heat of vapourisation (L_v) is the amount of energy required to convert 1 kg of liquid water at 100 $^{\circ}\text{C}$ to steam without a change in temperature. At 20 $^{\circ}\text{C}$ and atmospheric pressure, $c = 4.182 \text{ kJ}\cdot\text{kg}^{-1}\cdot\text{K}^{-1}$ and at 100 $^{\circ}\text{C}$

and the same pressure, $L_v = 2257 \text{ kJ.kg}^{-1}$ (Reference 58). Water in its vapour form can also absorb heat, as *super-heated steam*, with a corresponding specific heat capacity which tends to increase with ambient temperature³. Figure 18 illustrates the quantity of thermal energy which can be absorbed by 1 kg (~ 1 litre) of water as it is heated from solid phase (ice) to super-heated steam. In this diagram the specific latent heat of melting is taken to be $\sim 333 \text{ kJ.kg}^{-1}$ at 0 °C (Reference 58) and a representative constant specific heat capacity for water vapour (at 1150 K) is taken as $2.4 \text{ kJ.kg}^{-1} \text{ K}^{-1}$ (Reference 45). Two important temperatures are shown as dashed lines on Figure 18: a notional upper limit of 1100 °C for the mean temperature associated with typical compartment fires and a “representative flame temperature” of 1500 K (Reference 45). The implications of Figure 18 are discussed in greater depth in Section 6.1.

Herterich (Reference 10) considered the thermal characteristics of water and found that with the exception of helium and hydrogen, water possesses the greatest specific heat capacity of all naturally-occurring substances and has the greatest latent heat of vapourisation of all liquids. Coleman (Reference 59) compared the cooling effects of water and carbon dioxide and found that the former was some 6.5 times as effective as an equal mass of CO₂, despite the very cold temperature of CO₂ exiting from fire extinguishers (up to 45% of the discharge at $\sim -78.8 \text{ °C}$). The apparent anomaly was explained by the fact that the agent temperature is of secondary importance in cooling; water has specific and latent heat values of 5.3 and 3.9 times those of CO₂, respectively. From the above it is apparent that water is potentially a very powerful extinguishing agent, capable of absorbing vast amounts of heat from fires and providing a means for rapid fire suppression and extinguishment. However, in order to realise this great potential, heat must be efficiently transferred from fire and its environs to the water applied during fire-fighting; this goal forms a recurrent theme in the remainder of this report.

5.3.2 Heat transfer from hot gases to water droplets

In a recent appraisal of fire suppression by water mist, Ramsden (Reference 23) observed that the major cooling effect of water was due to its high latent heat of vapourisation. This may be illustrated with reference to Figure 18; it can be seen that 418 kJ of thermal energy are required to heat one litre of water from 0-100 °C, whereas a further 2257 kJ are subsequently required to convert this volume of water to water vapour (without further change in temperature). Moreover, since evaporation can only occur at the surface of a liquid, the greater the surface area achieved by a given volume of liquid, the greater will be its cooling ability; the production of sprays with large surface areas was discussed in Section 5.1.3.

The evaporation of drops within a spray involves simultaneous heat and mass transfer processes in which the heat for evaporation is transferred to the drop surface by conduction and convection from the surrounding hot gas, and vapour is transferred by

³However, steam at temperatures above 100 °C is stable only at pressures in excess of normal atmospheric levels, hence any additional heat capacity cannot be realised during typical firefighting operations

convection and diffusion back into the gas stream (Reference 14). Herterich (Reference 10) noted that the rate of vapourisation (or evaporation) of a droplet depended upon its surface area, the characteristic *heat transfer number* (α) and the relative velocity between the droplet and the surrounding gas.

For a spherical droplet in a quiescent atmosphere, the heat transfer number may be written,

$$\alpha = \text{constant} \times \frac{k}{d} \quad (\text{W.m}^{-2}\text{K}^{-1}) \quad (39)$$

where k is the thermal conductivity of the surrounding gas ($\text{W.m}^{-1}\text{K}^{-1}$) and d is the droplet diameter (m). This model of droplet heat transfer was employed as a simplifying assumption in Grin and Sergeev's model of explosion suppression by water sprays (Reference 60); the results obtained using this model are discussed further in Section 5.4.

As Herterich remarked however, in practical fire-fighting operations it cannot be assumed that the relative velocity between spray droplets and the surrounding air is zero, and more elaborate versions of the above equation are required to describe the heat transfer process. The measurement of droplet evaporation in moving airstreams has been studied using diverse and often ingenious techniques (*e.g.* References 61, 62). The resulting data are conventionally correlated using well-known non-dimensional heat transfer and fluid flow parameters:

$$\text{Nu} = \frac{\alpha d}{k} \quad (\text{Nusselt number}) \quad (40)$$

$$\text{Sc} = \frac{\nu}{D} \quad (\text{Schmidt number}) \quad (41)$$

$$\text{Pr} = \frac{c\eta}{k} \quad (\text{Prandtl number}) \quad (42)$$

$$\text{Re} = \frac{vd}{\nu} \quad (\text{Reynolds' number}) \quad (43)$$

$$\text{Pe} = \text{Re} \cdot \text{Pr} = \frac{vd}{K} \quad (\text{Péclet number}) \quad (44)$$

where α, d, k, ν, η have been defined previously and c is the specific heat capacity of air at constant pressure ($\text{J.kg}^{-1}\text{K}^{-1}$). In addition, the symbols D and K represent the *mass diffusivity* of water vapour in air (m^2s^{-1}) and the *thermal diffusivity* of air (m^2s^{-1}) respectively; the latter is defined by the expression,

$$K = \frac{k}{\rho c} \quad (45)$$

again using the above symbol definitions.

Herterich (Reference 10) described the early work by Ranz and Marshall (Reference 61), who performed experiments on droplet evaporation in air at temperatures up to 220 °C, using drop diameters in the range 0.6-1.0 mm and at $0 \leq Re \leq 200$. The expression,

$$Nu = 2 + 0.6 Pr^{1/3} Re^{1/2} \quad (46)$$

was found to correlate the experimental data well and also satisfied the theoretical requirement that $Nu = 2$ at $Re = 0$ (the zero relative velocity case); the range of validity has been given as $1 < Re < 70 \times 10^3$ and $0.6 < Pr < 400$ (Reference 61). Kincaid and Longley (Reference 62) used the above correlation to develop a theoretical model of spray evaporation in agricultural sprinkler irrigation. The droplet temperature was calculated as a function of time for a range of droplet sizes, velocities and initial temperature at ejection. It was found that the droplet size had a large effect on the rate of temperature change whereas the droplet velocity had a relatively minor effect. The model was also used to calculate the rate of droplet evaporation in terms of percentage mass loss per second. Here it was found that higher temperatures and lower relative humidity resulted in the greatest evaporation rates; conversely, lower temperatures and higher values of relative humidity tended to slow down the rate of evaporation. Droplet velocities were in the range 0-10 m.s⁻¹ and droplet diameters were between 0.3-2 mm. The range of ambient temperatures of agricultural interest was ~ 0-40 °C, much lower than in fire-fighting operations.

Using the model, Kincaid and Longley were able to determine that if the initial droplet temperature was not equal to the ambient wet-bulb temperature, then it could take some 8 seconds before this temperature was reached; during this stage heat is transferred by a combination of sensible and latent heat. Once the droplet attains the wet-bulb temperature however, all subsequent heat received by the droplet is dissipated as latent heat lost in the evaporation process; that is, the latent heat lost is exactly balanced by the sensible heat input to the droplet from the air. From an agricultural standpoint, since typical droplet flight times were of the order of 1-2 s, it was deemed unlikely that any but the smallest droplets would attain the wet-bulb temperature before reaching the ground. In the case of sprays used for fire-fighting, efficient droplet evaporation is required and the results of Reference 62 also show that reducing the droplet diameter reduces the time taken to reach the wet-bulb temperature; for droplets less than ~550 microns it is reasonable to assume that the time taken for this state to be reached is negligible.

Rasbash (Reference 44) discussed the limitations of equation (46) when applied to the evaporation of drops immersed in gaseous atmospheres at elevated temperatures (*i.e.* above the 220 °C maximum employed by Ranz and Marshall). It was found that, for droplets evaporating within Bunsen burner flames, the measured evaporation times were consistently 60% greater than predicted by equation (46). The discrepancy was attributed to the insulating effect of the water vapour as it passed through the boundary layer surrounding the drop, tending to reduce the rate at which heat was transferred to the surface of the drop. Although the thermal conductivity of air and steam is similar at 100 °C (~ 0.028 W.m⁻¹.K⁻¹), the specific heat capacity of steam is twice as high ($C_p \sim$

2000 J. kg⁻¹.K⁻¹, Reference 58) which would be consistent with the observed insulating effect. Rasbash proposed an alternative expression,

$$\text{Nu} = \frac{\lambda'}{\lambda' + 0.4\beta} \left[2 + 0.6 \text{Pr}^{1/3} \text{Re}^{1/2} \right] \quad (47)$$

to take account of this effect, where λ' is the total heat of vapourisation of the drops and β is the increase in enthalpy of the steam when raised from the surface temperature of the drop to the temperature of the flame.

Herterich reported an alternative "corrected" form of equation (46),

$$\text{Nu} = \frac{\alpha d}{k} = 2.83 + 0.6 \text{Pr}^{1/3} \text{Re}^{1/2} \quad (48)$$

which was derived in order to explain observed rates of heat transfer to droplets in excess of those predicted by equation (46) and where values of k , Re and Pr are calculated using the average physical properties of the air and the steam layer around the droplet. It should be noted however that this "correction" to equation (46) is in the opposite direction to that proposed by Rasbash, where reduced rather than enhanced experimental heat transfer rates were reported (Reference 44). It has not been possible to investigate this discrepancy within the timescale of the present project. Equation (48) was recently employed by Güttler (Reference 40) to estimate the total quantity of heat transmitted to high- and low-pressure monodisperse water sprays (Section 5.1.3) using the expression,

$$W = \alpha \cdot O \text{ (W.m}^{-3}\text{.K}^{-1}\text{)} \quad (49)$$

where α is the heat transfer number for an individual droplet, as discussed above and O is the total surface area of the spray per unit volume of water (m².m⁻³ or m⁻¹). Güttler's calculations were somewhat simplistic and used equation (27) to calculate a representative drop size from the notional discharge velocities of fire-fighting sprays. This expression yields predictions of droplet diameters which are inversely proportional to the square of the initial spray velocity; hence higher pressure sprays are predicted to produce ever smaller droplet sizes. Despite the rather approximate nature of Güttler's subsequent methodology, equation (49) remains a useful way to express the cooling capacity of water sprays. The application of this expression to practical polydisperse sprays, however, requires a detailed knowledge of the drop size distribution in order to calculate O , the spray area per unit volume. The practical situation is complicated further since the droplet diameter and velocity will both reduce with time and temporal variations have been ignored in the discussion thus far.

Rasbash (Reference 44) employed the modified Ranz and Marshall equation (47) to estimate the heat transfer between flames of freely-burning hydrocarbon fires and water sprays. Using this expression, Rasbash produced a plot of convective heat transfer rate (in cal.cm⁻².s⁻¹) against drop velocity (cm.s⁻¹) for drop sizes ranging from 50 microns to 2 mm, and assuming a flame temperature of 1000 °C. In general, higher droplet velocities and smaller droplet diameters were found to increase the heat transfer rates.

For example, a 2mm drop at $v \sim 0.07 \text{ m s}^{-1}$ (terminal velocity in still air) produced a heat transfer rate of $\sim 167 \text{ kW m}^{-2}$ while the same drop travelling at 2 m s^{-1} achieved a value of $\sim 293 \text{ kW m}^{-2}$. For a 50 micron drop at velocities of 0.01 m s^{-1} and 0.5 m s^{-1} the corresponding heat transfer rates were $\sim 1.7 \text{ MW m}^{-2}$ and 2.5 MW m^{-2} respectively. Curves representing these calculations for intermediate droplet sizes were also given in Reference 44. The model described by Rasbash also included the temporal variations in droplet velocity and diameter and was able to estimate the penetration distance of droplets into the flame prior to evaporation (see Section 5.1). The heat transfer from a unit volume of flame was defined as the product of the total surface area of the drops present, the heat transfer coefficient and the temperature difference between the drop surface and the flame. If the mass flux of the spray entering the flame is $\dot{m}_d'' (\text{kg m}^{-2} \text{ s}^{-1})$, consisting of drops of diameter d (m) travelling at $v_d (\text{m s}^{-1})$ then the total mass of drops per unit volume is given by \dot{m}_d''/v_d . From equations (11) and (13), the total surface area of these drops is,

$$O = \frac{6\dot{m}_d''}{\rho_w dv_d} (\text{m}^2 \cdot \text{m}^{-3}) \quad (50)$$

which can be compared with equation (49) and where ρ_w is the density of water. Rasbash (Reference 44) used this expression to define a "heat transfer capacity" for the spray,

$$X = \frac{6\dot{m}_d''}{\rho_w dv_d} \alpha \Delta T (\text{W} \cdot \text{m}^{-3}) \quad (51)$$

where α is the heat transfer number for a drop and ΔT is the temperature differential described above; this is equivalent to $W \cdot \Delta T$ in Güttler's terminology (Reference 40).

Rasbash constructed a parametric plot of the function $6\alpha\Delta T/\rho_w dv_d$ against v_d for a range of d ; these theoretical data were used in conjunction with empirical drop size distribution and mass flux data (from an impinging jet spray) to demonstrate the utility of the method. The calculation of the initial heat transfer capacity of the spray on contact with the flame was quite straightforward; the corresponding calculations as the spray progressively penetrated into the flame proved more laborious. The latter involved the calculation of updated drop size and drop velocity distributions based on the time-dependent equations also presented in Reference 44. The example calculation presented by Rasbash confirmed that drops of larger initial size were able to penetrate further into the flame before complete evaporation occurred. The calculation also highlighted the steady decay in the heat transfer capacity (X) with increasing spray penetration. It was found that X was not reduced to less than 50% of its initial value until the spray had penetrated to more than 0.2 m into the flame, despite the early evaporation of the fine droplets which formed the bulk of the initial heat transfer capacity of the spray. This relatively slow spatial decay of X was thought to be due to the deceleration of the coarser droplets over a similar distance, becoming more concentrated in space and therefore abstracting a greater amount of heat per unit volume of the flame than was possible initially. The use of Rasbash's model in predicting the conditions for flame extinguishment is considered further in Section 6.1.4.

A more recent implementation of this type of model has been reported by Jackman and Nolan (Reference 52), in the context of modelling the fire protection by water deluge of chemical storage vessels. This mathematical model is able to examine the detailed heat and mass transfer interactions using a three-dimensional particle-tracking algorithm, and has been applied to investigations of sprinkler systems and water mist protection. Output data from the program include the total heat transfer from the fire gases to the spray and thermal and physical histories of the drops within the spray. Input data include details of the hot gas layer and empirical drop size data from a range of commercial sprinklers and water mist nozzles. The main advance in such recent computational models is that individual droplet behaviour may be studied within an overall simulation of spray/fire interaction. The basic equations of heat and mass transfer are generally similar to those employed in older models, indeed Ranz and Marshall's equation (46) is incorporated in the SPLASH computer model.

During the course of the present survey a number of other papers concerning aspects of droplet evaporation were also obtained (60-63). Kucherov (Reference 63) presented a detailed mathematical description of droplet evaporation occurring in each of four "evaporation régimes". These were, in order of increasing rate of heat transfer: the diffusion régime, the diffusional-convective régime, the subsonic régime, the sonic régime and the explosive régime. The paper included example calculations of drop temperature and radius for all five evaporation régimes; however the theory presented was only valid for very small droplets, currently of little interest in fire-fighting ($d \sim 1-10 \mu\text{m}$). Ferron and Soderholm (Reference 64) estimated the evaporation of pure water droplets and the stabilisation times of particles containing salt. The life times of pure water droplets in air at 20 °C and various values of relative humidity were described; however the droplet size were again of the order of $\sim 10 \mu\text{m}$ as the study was concerned with the aerosols produced by nebulisers for medical applications.

Sadd *et al.* (Reference 65) described the results of an experimental investigation of the evaporation of water droplets doped with various soluble surfactants; the ultimate objective was to model the evaporation of aerosols contaminated with soluble, involatile surfactants. The experiments involved droplets of initial size $\sim 1200 \mu\text{m}$ whose evaporation could be observed with a micrometer microscope to an accuracy of $\sim 4 \mu\text{m}$. The experiments were conducted over a temperature range of 13-29 °C and with relative humidities from 3-92%. The work confirmed previous findings that surfactants are capable of displaying very high mass transfer resistances but have no effect on heat transfer; the kinetics of evaporation were observed to follow those of pure water initially but then displayed relatively abrupt transitions to lower evaporation rates. A study of a similar nature was reported by Rubel (Reference 66) who described a mathematical model for the steady-state temperature of an evaporating water droplet with a "monolayer coating". Rubel's paper confirms the dramatic effect which surfactants have on the evaporation rates of water droplets; again a sudden discontinuity in evaporation rate was observed, resulting in an increase of droplet temperature corresponding to a reduction in the rate of rejection of latent heat. A more critical appraisal of these theoretical treatments is outwith the scope of the present report, however this subject may be of interest in future research on fire suppression, particularly the impact of surfactants and other fire-fighting additives on the evaporation efficiency of water. In

the meantime, the best way forward is to examine the published results of various large-scale fire suppression tests (see Section 7).

5.3.3 Heat transfer from solid surfaces to water droplets

In addition to absorbing heat from the fire gases or flames, water from fire-fighting sprays may gain heat through contact with a range of solid surfaces, including the burning (Class 'A') fuel, unburned fuel and various non-combustible surfaces (e.g. brick or metal structural elements). According to Bejan (Reference 58), four distinct regimes of boiling heat transfer can be identified for water at atmospheric pressure, depending upon the temperature of the solid surface with which it is in contact. In order of increasing excess surface temperature, these are: *natural convection boiling*, *nucleate boiling*, *transition boiling* and *film boiling*. The excess surface temperature is defined as the surface temperature minus the *saturation temperature* of liquid, and the latter is the temperature of the liquid-vapour interface at the local pressure. Since the objective in fire suppression is to continually reduce surface temperatures rather than increase them, it is logical to discuss these heat transfer mechanisms in reverse order.

According to Reference 58, film boiling of water occurs at surface excess temperatures greater than about 200 °C and is so-called because a continuous layer (or film) of water vapour is formed between the solid surface and the liquid water. Much of the literature relating to boiling heat transfer has its origins in the metallurgical processing industry where spray cooling is used extensively in the continuous casting of metals (References 67-72). Reiners *et al.* (Reference 67) reported a method for estimating the heat transfer coefficient pertaining to the "secondary cooling zone" (*i.e.* water spray cooling) of a steel casting process. The surface temperatures associated with this cooling zone were in the range 1400-800 °C and corresponded to the stable film boiling regime. It was found that the heat transfer coefficient remained constant ($\alpha \sim 140 \text{ W m}^{-2} \text{ K}^{-1}$) over the surface temperature range investigated ($\sim 830-950 \text{ °C}$), although locally high values of α ($\sim 2800 \text{ W m}^{-2} \text{ K}^{-1}$) were recorded when water-air nozzles were operated at high throughputs.

Ito *et al.* (Reference 68) performed an analytical study of the spray cooling of a hot surface and the associated film boiling heat transfer; these workers defined 'spray cooling' in the process industry as that originating from a single fluid nozzle, while mist (or fog) cooling was obtained by the use of twin-fluid nozzles where the mass flux of water was generally lower. The behaviour of spray droplets impinging onto horizontal heated surfaces was characterised in terms of the non-dimensional *Weber number*,

$$We = v(\rho d / \sigma)^{1/2} \quad (52)$$

which represents the ratio of the inertial force to the surface tension force. It was stated that for $We \leq 30$, a droplet will immediately rebound from the heated surface without disintegrating. Droplets in the range $30 \leq We \leq 80$ tend to spread radially over the surface, forming a thin vapour layer on the underside, before contacting with the hot surface and finally rebounding. However, for values of $We \geq 80$, an impinging droplet forms a thin spreading liquid film upon collision and subsequently disintegrates into smaller droplets. The model developed by Ito *et al.* included heat transfer by radiation,

convection and evaporation and took account of the transient reduction in droplet diameter. The model was compared with some empirical data obtained from experiments with various water spray nozzles operating at discharge rates in the range $0.03-0.17 \text{ l.m}^{-2}.\text{s}^{-1}$ and with volume mean drop diameters in the range $\sim 130-550$ microns; these experiments yielded total heat transfer rates in the film boiling régime of between $\sim 2.5 \times 10^4-1.5 \times 10^5 \text{ W.m}^{-2}$ at surface excess temperatures of $\sim 150-500 \text{ }^\circ\text{C}$. It was found that the analytical model gave predictions in good agreement with these data for drops of this size, with $10 \leq We \leq 120$, and impinging on heated surfaces with a temperature excess less than 500 K . Ohnishi *et al.* (Reference 69) described the performance of an experimental multi-nozzle spray apparatus designed to optimise the cooling of a steel specimen of dimensions $265 \times 265 \times 3 \text{ mm}$ thick. The nozzle separation from the surface was varied from $50-150 \text{ mm}$ and the water discharge flux was much higher than that reported in Reference 68, at between $1000-7000 \text{ l.m}^{-2}.\text{min}^{-1}$ ($17-117 \text{ l.m}^{-2}.\text{s}^{-1}$); water and specimen temperatures were in the range $7-30 \text{ }^\circ\text{C}$ and $500-800 \text{ }^\circ\text{C}$ respectively. Two correlations were determined for the variation of heat transfer coefficient with water flux,

$$\alpha \propto \dot{W}''^{0.51} \quad (53)$$

and

$$\alpha \propto \dot{W}''^{0.663} \quad (54)$$

where \dot{W}'' is the water flux; equations (53) and (54) were found to apply for $\dot{W}'' > 3000 \text{ l.m}^{-2}.\text{min}^{-1}$ and $\dot{W}'' < 2000 \text{ l.m}^{-2}.\text{min}^{-1}$ respectively. Irrespective of the applied water flux, it was found that the magnitude of α was inversely proportional to the specimen temperature; for a given value of the latter, higher values of α were obtained at higher \dot{W}'' . For $\dot{W}'' \sim 1000 \text{ l.m}^{-2}.\text{min}^{-1}$, surface temperatures of $800 \text{ }^\circ\text{C}$ and $500 \text{ }^\circ\text{C}$ yielded values for α of $\sim 1600 \text{ W.m}^{-2}.\text{K}^{-1}$ and $\sim 4600 \text{ W.m}^{-2}.\text{K}^{-1}$ respectively. At $\dot{W}'' \sim 5000 \text{ l.m}^{-2}.\text{min}^{-1}$ ($83 \text{ l.m}^{-2}.\text{s}^{-1}$) and the same surface temperatures, the corresponding α values were $\sim 3000 \text{ W.m}^{-2}.\text{K}^{-1}$ and $\sim 10000 \text{ W.m}^{-2}.\text{K}^{-1}$, respectively.

The advantages of using a fine water mist jet for cooling steel castings are discussed in Reference 70; these include a more uniform cooling action which reduces the risk of thermal shock and subsequent cracking of the steel. The "cooling capacity" of the mist jet was assessed by its ability to safely harden a crack-sensitive steel and no measurements of heat transfer coefficients were reported.

The application of twin-fluid water mist cooling in process metallurgy is discussed in greater depth in References 71 and 72. Prinz and Bamberger (Reference 71) made experimental temperature measurements of the surface temperatures of continuously cast copper and nickel samples subjected to cooling water spray densities of $0.34-2.72 \text{ l.m}^{-2}.\text{s}^{-1}$ and at air pressures between $2-4 \text{ bar}$ ($30-60 \text{ psig}$, $0.2-0.4 \text{ MPa}$); a bank of 48 specially constructed 90° full cone air mist nozzles were supplied by Spraying Systems Germany. Using the temperature data, the heat transfer coefficient was calculated, assuming that the overall heat loss was due to a combination of cooling mechanisms; these were identified as direct impingement of water on the surface, conduction through the vapour film, radiation and forced convection caused by the air in the two-phase mist. The experiments examined initial surface temperatures in the range $200-1000 \text{ }^\circ\text{C}$; in general for a given initial surface temperature, the heat transfer coefficient was found to

be proportional to the delivered water flux. For a given water flux, the heat transfer coefficient was found to decrease with increasing initial surface temperature. In the case of a nickel sample subjected to a spray of $0.68 \text{ l.m}^{-2} \text{ s}^{-1}$, α values of $\sim 3600 \text{ W m}^{-2} \text{ K}^{-1}$ and $\sim 350 \text{ W m}^{-2} \text{ K}^{-1}$, were obtained for initial temperatures of $200 \text{ }^\circ\text{C}$ and $1000 \text{ }^\circ\text{C}$ respectively. With an increased water flux $2.72 \text{ l.m}^{-2} \text{ s}^{-1}$, α values of $\sim 10000 \text{ W m}^{-2} \text{ K}^{-1}$ and $\sim 1000 \text{ W m}^{-2} \text{ K}^{-1}$ were measured at the same values of initial temperature, respectively. The heat transfer characteristics of water mist cooling were correlated by the expression,

$$\alpha_{\text{am}} = (10\sqrt{\dot{V}_{\text{ws}}} - 16\dot{V}_{\text{ws}}) \times \left[1.4(k\rho c)^{1/2} \exp\left(0.32 \frac{\theta_s - \theta_c}{\theta_b - \theta_c}\right) + \alpha_v \right] + \alpha_{\text{fc}} \quad (55)$$

and compared with the corresponding correlation for water spray cooling, obtained from a previous study,

$$\alpha_{\text{ws}} = 0.69 \log \frac{\dot{V}_{\text{ws}}}{0.0006} \times \left[1.4(k\rho c)^{1/2} \exp\left(0.32 \frac{\theta_s - \theta_c}{\theta_b - \theta_c}\right) + \alpha_v \right] + \alpha_{\text{rad}} \quad (56)$$

where α_{am} , α_{ws} are the heat transfer coefficient for air-mist and water spray respectively ($\text{W.m}^{-2} \text{K}^{-1}$) and α_{fc} , α_{rad} , α_v are the heat transfer coefficients for radiation plus forced convection, radiation only and film boiling (assumed to be $750 \text{ W m}^{-2} \text{K}^{-1}$). The temperatures of the hot surface, the cooling water and the evaporation of water are represented by $\theta_s, \theta_b, \theta_c$ ($^\circ\text{C}$) respectively and the water flux by \dot{V}_{ws} ($\text{m}^3 \text{m}^{-2} \text{s}^{-1}$). The product $k\rho c$ represents the *thermal inertia* of the material being cooled. A comparison of these two expressions for the same value of \dot{V}_{ws} showed that values of α_{am} were considerably greater than α_{ws} for all values of θ_s , although the difference decreased with increasing θ_s . It was argued that this difference could be attributed to the effect of the high air pressure on the droplets; smaller droplets moving with high momentum were better able to pass through the vapour barrier and reach the hot surface, thus increasing the rates of heat transfer. The additional contribution of forced convection from the air supply was considered to play a relatively minor role. At higher flow rates (above $\sim 3\text{--}4 \text{ l.m}^{-2} \text{s}^{-1}$), there was no significant difference in the heat transfer coefficients predicted from equations (55) and (56).

Mitsutsuka and Fukuda (Reference 72) also studied the cooling of hot steel ($\theta_s \sim 150\text{--}600 \text{ }^\circ\text{C}$) by twin-fluid water fog to ascertain whether the characteristically high values of α noted above were observed for lower levels of water flux. The experiments considered water fluxes in the range $2.2\text{--}390 \text{ l.m}^{-2} \text{min}^{-1}$ ($\sim 0.04\text{--}6.5 \text{ l.m}^{-2} \text{s}^{-1}$) and air or nitrogen flow rates from $14\text{--}160 \text{ m}^3 \text{m}^{-2} \text{min}^{-1}$; three nozzle variants were tested and separation of the nozzle from the hot surface was varied from $300\text{--}800 \text{ mm}$. The cooling temperature history of the hot sample (oriented either horizontally or vertically) was measured using thermocouples, and an effective heat transfer coefficient (including radiation) was calculated from these data. It was found that at low air velocities ($V_a < 5\text{--}10 \text{ m s}^{-1}$), the air flow only affected the quality of atomisation of the fog, at higher values of V_a however, the air flow was observed to influence both the atomisation and the resultant heat transfer. In the low air flow régime, it was found that the cooling capacity

of the fog was independent of the nozzle type and was a function of the water flux \dot{W}'' ($\text{l.m}^{-2}.\text{min}^{-1}$) only. The maximum and minimum values of heat transfer coefficient for the fog were found to lie in the temperature ranges 100-200 °C and 500-700 °C respectively. With $\dot{W}'' = 20 \text{ l.m}^{-2}.\text{min}^{-1}$ ($0.33 \text{ l.m}^{-2}.\text{s}^{-1}$), the corresponding maximum and minimum values of α were $\sim 2300\text{-}5800 \text{ W.m}^{-2}.\text{K}^{-1}$ and $\sim 350\text{-}580 \text{ W.m}^{-2}.\text{K}^{-1}$ respectively. For \dot{W}'' less than $50 \text{ l.m}^{-2}.\text{min}^{-1}$ ($0.83 \text{ l.m}^{-2}.\text{s}^{-1}$), the cooling capacity of the fog was found to be virtually identical to that of a water spray discharging an equal water flux. The effect of surface roughness was also investigated and it was found that during the fog cooling of a steel plate covered by a scale deposit, the value of α increased in proportion to the quantity of scale for small \dot{W}'' and surface temperatures over $\sim 200 \text{ }^\circ\text{C}$.

Ohkubo and Nishio (Reference 73) also examined the effects of surface roughness, or "wettability", on the heat transfer characteristics of mist cooling in steel production. Observations of the behaviour of droplets in contact with the hot steel surface were made by analysing video camera footage; in particular, estimates of the contact angle between the droplet and the surface were made to assess the wettability of the surface. The contact angle is the angle between the horizontal hot surface and the surface of the droplet where it meets the former, measured through the liquid; thus the more acute the angle, the greater is the wettability. The air-water mist was produced by a full-cone pneumatic atomising nozzle; the value of V_a was 20 m.s^{-1} (i.e. "high air flow" according to Reference 72) and \dot{W}'' was in the range $0.57\text{-}4.7 \text{ l.m}^{-2}.\text{s}^{-1}$. Aluminium test plates (15 mm diameter x 2 mm thick) with a range of surface finishes (e.g. machine-finished, acid-anodised etc.) were heated to 600 °C and mist-cooled to room temperature. The rate of heat loss (W.m^{-2}) was again inferred through the cooling temperature history but values of α were not calculated. At θ_s above $\sim 100 \text{ }^\circ\text{C}$, increased wettability was found to increase the minimum temperature associated with the onset of stable film boiling (also called the *Leidenfrost temperature*); in other words, the formation of a stable vapour layer on the surface was delayed with increasing wettability. Previous studies had shown a similar effect for steel coated with a thick oxide layer, which increased both the surface roughness and the wettability. Mitsutsuka and Fukuda (Reference 72) suggested that droplets could be trapped in areas of increased surface roughness where local heat transfer rates were high and violent evaporation was likely.

As discussed previously, when a hot surface ($\theta_s \sim 300+ \text{ }^\circ\text{C}$) is cooled by water, the initial cooling régime is known as stable film boiling, where an uninterrupted film of steam is generated between the solid and liquid phases. Heat continues to be lost from the surface, with a gradual reduction in heat flux until at some point the Leidenfrost temperature is reached, whereupon the steam film collapses, causing a sudden increase in the heat flux leaving the surface, accompanied by a sharp rise in the heat transfer coefficient (Reference 67). For water at 1 atmosphere, Bejan (Reference 58) estimated the Leidenfrost point to occur at an excess temperature of between 100-200 °C and a régime of *partial film boiling* (also called transition boiling) to exist in the range $\sim 30 \text{ }^\circ\text{C} < \theta_s < 200 \text{ }^\circ\text{C}$. Reiners *et al.* (Reference 67) have reported a fairly constant $\alpha \sim 500 \text{ W.m}^{-2}.\text{K}^{-1}$ during the stable film evaporation régime, rising to $\sim 8000 \text{ W.m}^{-2}.\text{K}^{-1}$ at the lower end of the transition boiling régime ($\sim 100+ \text{ }^\circ\text{C}$); the Leidenfrost point in this example was given as $\sim 350 \text{ }^\circ\text{C}$.

Makino and Michiyoshi (Reference 74) studied the behaviour of water droplets impacting on heated plates made of various metals, droplet sizes ranged from 2.54-4.5 mm with initial plate temperatures from 100-360 °C. Droplets were filmed using high-speed photography in order to determine the *waiting period* and the *contact period*, the former was defined as the time delay between first contact of the droplet and the initiation of bubbling while the latter corresponded to the time between first contact and the point where the droplet bounces or floats on a vapour (steam) layer. For a stainless steel plate and droplet diameter of 3.29 mm, it was found that the contact period decreased with increasing surface temperature, typical values were ~ 1 s at 150 °C decreasing to ~ 0.02 s at $\theta_s \sim 300+$ °C. For the same conditions a minimum evaporation time of ~ 0.1 s was observed at $\theta_s \sim 200$ °C. Some estimates of heat transfer rate during the contact period were also made and it was suggested that values up to, or exceeding $\sim 10^7$ W m⁻² could be attained.

Makino and Michiyoshi (Reference 75) extended their initial work by proposing a transient model of droplet heat transfer applicable to metal plates at initial temperatures ranging from 20-140 °C, the upper temperature limit was assumed to correspond to the Leidenfrost point. The theory was shown to be in good agreement with previous experimental data (e.g. Reference 74). Rymkiewicz and Zapalowicz (Reference 76) discussed the régimes of droplet evaporation on a heated surface and classified the behaviour of an impacting droplet in terms of three fundamental parameters: initial surface temperature, droplet diameter and droplet velocity. The initial surface temperatures of interest were much less than the lower limit of the transition boiling phase and were therefore well below the upper limit of *nucleate boiling* (Reference 58), the evaporation process was described with reference to the changing geometry of a single droplet. (The nucleate boiling régime is characterised by the generation of water vapour at a number of discrete locations on the solid-liquid interface, leading to the production of isolated bubbles which rise through the liquid phase and escape at the liquid-gas interface.)

Several papers have been published where the intention was to apply the above concepts to the problem of fire suppression of solid fuels (References 77-81). Trehan and Evans (Reference 77) noted that the solid fuels of interest in fire research were of low thermal conductivity and diffusivity (e.g. wood, cloth etc.). The application of water on such surfaces produces intense local cooling since heat conduction from adjacent areas of the solid is relatively slow. Consequently, it was suggested that the heat transfer in these cases was by droplet evaporation rather than by nucleate boiling or film boiling. Despite this observation, the initial investigations were performed using a heated aluminium (high thermal conductivity) block. The choice of material was motivated by the availability of published literature, such as reviewed above, and to reduce the complexity of the experimental procedure.

A comprehensive review of research on *dropwise evaporative cooling* conducted over the last decade has recently been published by di Marzo (Reference 81), the applications relevant to fire suppression were discussed with reference to the 'sparse spray cooling' of hot surfaces. The heat transfer régime of interest was identified as that associated with relatively low surface temperatures where nucleate boiling at the liquid-solid

interface is suppressed and evaporation at the liquid-vapour interface is the governing mechanism (as in Reference 76). The development of the sparse spray model was based initially on a simple one-dimensional model of heat conduction in a single droplet of liquid resting on a hot solid surface of high thermal conductivity (Reference 80); in this case the temperature of the solid-liquid interface may be assumed constant and uniform. Validation of the model was achieved by comparing calculated droplet evaporation times with those measured by experiment; these values were found to agree to within 10%. The heat flux distribution due to droplet evaporation was subsequently used as a boundary condition for the calculation of the transient cooling of the solid surface. Having confirmed the suitability of the simple conduction model for high thermal conductivity solids, the analysis was extended to the case of low thermal conductivity solids, known to be more representative of the fire suppression problem.

The transient evaporative cooling of a hot, low thermal conductivity solid was examined experimentally using a non-intrusive infrared thermographic technique; the material selected was *Macor*, a glass-like substance with a high emissivity. Initial surface temperatures were in the range 90-180 °C and water droplet volumes varied from 10-50 μl (\sim 2.7-4.6 mm diameter). The experimental data showed an intense local cooling effect, at first contact with the surface, which extended radially from the centre of the droplet and decayed with time until the surface regained its initial temperature. This behaviour is in marked contrast to the case of a high thermal conductivity solid where the surface temperature remains constant and therefore required a modification to the theoretical model in order to couple the behaviour of the solid and liquid phases. The new model was found to produce reasonable predictions for the transient surface temperature in the vicinity of a water droplet using the one-dimensional droplet heat conduction model.

The single droplet experiment was then further modified so that the source of heat was more akin to that in real fires, *i.e.* radiant heat received from above the solid surface; to this end, two conical radiant heaters were positioned symmetrically above the test surface. In this case radiant heat is received by the droplet at the liquid-vapour interface in addition to conducted heat at the liquid-solid interface; also the temperature in the solid decreases with depth, which is the reverse of the initial experiment where heat was supplied from below the solid by conduction. One effect of the new configuration was found to be a reduction in the surface tension of the droplet surface due to heat gained by radiation; this resulted in a more pronounced initial spreading of the droplet, *i.e.* an increase in 'wettability'. Another important difference is due to the reversal of the internal vertical temperature gradient within the solid and the reaction of the heat flux distribution to the deposition of a cool droplet on the upper surface. In the case where the solid is heated purely by conduction from below, the local cooling effect of the droplet results in a distortion of the isotherms leading to a convergence of the heat flux lines towards the droplet (Figure 19(a)). In contrast, when the maximum temperature is at the surface of the solid (due to radiative heating), the local cooling of the surface results in a divergence of the heat flux lines away from the droplet (Figure 19(b)).

It was concluded by di Marzo (Reference 81) that the contribution by conduction to droplet evaporation was much less for radiant heating than by conduction; the overall droplet vapourisation times were similar, but were achieved by a substantially different

mechanism. In order to incorporate these complex radiative effects into the theoretical model, a number of simplifying assumptions were made and these are described in Reference 81. Two versions of the complete model were developed, which differed only in their treatment of heat conduction within the liquid layer; each code included the effects of radiation and transient changes in the droplet geometry due to shrinkage of the wetted surface. Again the model was found to be in good agreement with the experimental measurements for this heating configuration.

Using the highly complex single droplet model, it was possible to simulate the cooling effect of a sparse spray by super-posing the effects of many individual droplets. In order to validate such calculations a further series of experiments were conducted where a monodisperse sparse spray ($d \sim 2.7$ mm) was directed at the solid *Macor* surface (exposed to radiant heating) and the transient thermal response was monitored. The duration of each experiment was approximately 15 minutes and the thermal and spatial resolutions obtained were reported as 0.77 °C and 70 microns respectively; the application rate of water was varied from 0.5 - 0.97 $\text{g}\cdot\text{m}^{-2}\cdot\text{s}^{-1}$ (~ 0.0005 - 0.001 $\text{l}\cdot\text{m}^{-2}\cdot\text{s}^{-1}$) and the initial temperature of the solid surface was between 131 - 162 °C. The results from the various experiments were normalised by plotting the parameter $(T - T_{\infty}) / (T_0 - T_{\infty})$ as a function of time, where T is the instantaneous mean temperature of the surface, T_0 is the initial temperature and T_{∞} is the final long-term mean temperature predicted by the model. The data were found to collapse onto a general exponential decay curve such that the surface cooling effect was independent of the water flux applied.

It was concluded that the thermal properties of the solid material played a far more significant role in determining the cooling history. It was further suggested that the overall response of solid surfaces to spray cooling could be estimated from a knowledge of the thermal diffusivity of the material ($\alpha = k/\rho c$) and the 'time constant'; the thermal penetration depth thus calculated (δ) was indicative of the droplet radius of influence on the solid surface. This work is very relevant to the fire suppression problem, although the experimental water fluxes were far lower than typical rates applied to fires; for example Rasbash (Reference 43) found critical flow rates for the extinguishment of liquid pool fires to be in the range ~ 0.5 - 2.0 $\text{g}\cdot\text{cm}^{-2}\cdot\text{min}^{-1}$ (~ 0.08 - 0.30 $\text{l}\cdot\text{m}^{-2}\cdot\text{s}^{-1}$). Also, it was noted in Section 2.1.1 that the surface temperatures of burning solids was of the order ~ 400 - 500 °C, which is considerably greater than the maximum surface temperature examined in Reference 81; di Marzo's experiments at the higher temperature indicated accelerated cooling due to nucleate boiling although this effect was omitted from the theoretical model. In practical situations where a char layer is formed, surface temperatures of ~ 1000 °C are possible and therefore there is scope to extend this type of model. Should this area form the subject of future research, di Marzo's (Reference 81) references provide a substantial bibliography.

5.3.4 Attenuation of thermal radiation by water droplets

Herterich (Reference 10) wrote that the ability of water to absorb radiant heat was well known and had been applied in fire-fighting for a long time; the technique had been routinely used to protect readily combustible materials from ignition and also to reduce

the effects of heat stress on fire-fighters. It was stated that a dense spray, comprising droplets of a small mean diameter would reflect a significant proportion of the incident thermal radiation. The absorption of radiant heat had been shown to increase with increasing water flow rate and with decreasing droplet diameter. The latter trend could not be relied upon indefinitely however, since smaller droplets evaporated at a faster rate. Rasbash (Reference 44) stated that heat transfer by radiation to the drops in fire-fighting sprays depended mainly on the temperature and emissivity of the flame, since the drops were generally large enough to absorb most of the incident radiation, rather than reflect or scatter it. Given that the emissivity of a flame depended on its thickness, Rasbash estimated that a ~ 1 m thick flame would radiate as a black body; for a representative flame temperature of $1000\text{ }^{\circ}\text{C}$ (1273 K), the corresponding heat transfer rate would be approximately 150 kW.m^{-2} . In comparison with the convective heat transfer rates calculated for water sprays ($\sim 1.7\text{-}2.5\text{ MW.m}^{-2}$, Section 5.3.2), the radiative transfer is negligible and Rasbash concluded that it was reasonable to ignore the latter's contribution to flame extinguishment.

More recently, a number of papers have been published which consider the interaction of thermal radiation with water sprays (References 82-86). Ravigururajan and Beltran (Reference 82) characterised the engineering aspects of water droplet attenuation of infrared radiation; the wavelengths of interest were in the range $\lambda \sim 0.6\text{-}25\text{ }\mu\text{m}$. A simple mathematical model was formulated to calculate the 'attenuation factor' and transmissivity for a monodisperse spherical particle distribution (water spray) interposed between a hypothetical flame source at 1273 K and a 3 m square aluminium target; the model also included a routine for calculating the transient heat-up of the target body. The attenuation was calculated for several discrete wavelengths of infrared radiation over a range of droplet sizes from $2\text{-}20\text{ }\mu\text{m}$ in diameter and over path lengths of 1.5 and 3 metres. The calculations also considered the effect of 'droplet loading' or mass concentration of the water spray on the transmission of radiation. It was found that the attenuation was strongly correlated with droplet radius; the peak attenuation was consistently achieved when the droplet radius was equal to the wavelength of the incident radiation. However for droplets of radius greater than $30\text{ }\mu\text{m}$, it was found that a fairly constant, though reduced, attenuation factor was predicted which was independent of the wavelength. In addition, the dominant mode of attenuation was found to be by scattering of the radiation rather than by absorption.

The 'porosity' of the spray was found to be critical in determining the associated transmissivity. For a given mass concentration, the number of droplets increases as the size decreases; hence a spray's transmissivity may be reduced by reducing its porosity through an increase in droplet concentration. An example calculation (for $\lambda = 2\text{ }\mu\text{m}$) showed that monodisperse sprays with $d = 2\text{ }\mu\text{m}$ and $10\text{ }\mu\text{m}$ exhibited very low transmissivities ($T_r \sim 0.1$) at low values of droplet loading ($< 10\text{ g.m}^{-3}$ or 0.01 l.m^{-3}), whereas large droplets ($d = 1000\text{ }\mu\text{m}$) formed a permeable medium ($T_r \sim 0.7$) even at a much higher mass concentration (50 g.m^{-3} or 0.05 l.m^{-3}); see Figure 20. It was concluded that the optimum spray comprised droplets of radius $2\text{ }\mu\text{m}$ and was efficient at blocking thermal radiation at very low mass concentrations; theoretically, larger sized droplets could achieve a similar performance but with much larger quantities of water.

Copalle *et al.* (Reference 83) also devised a simple theoretical model of thermal radiation attenuation by water sprays in order to assess the effectiveness of water curtains for fire protection during major hydrocarbon fires. Attenuation was assumed to be due to absorption and diffusion (scattering) by the water droplets and again it was noted that the latter would be the dominant mechanism. Assuming a fire to be represented by a black body at ~ 1300 K (whose maximum emission wavelength, $\lambda_{\max} = 1.93 \mu\text{m}$), it was noted that 95% of the total energy is then radiated in the wavelength interval between 1-10 μm ; the model was therefore solved by integrating over this entire 'thermal spectrum'. The attenuation factor was calculated for droplet diameters in the range 0.1-100 microns and for droplet loadings of 1, 10 and 100 $\text{g}\cdot\text{m}^{-3}$. The results of Ravigururajan and Beltran (Reference 82) were confirmed, *i.e.* the maximum blocking efficiency was afforded by drops whose diameter was of the order of the maximum emission wavelength of the source. In general, for a given drop diameter better attenuation was achieved with an increase in mass loading of the spray; for any given mass loading the 1 μm was the most effective, followed by the 10 μm , 0.1 μm and 100 μm sprays. Copalle *et al.* also cautioned that the 100 $\text{g}\cdot\text{m}^{-3}$ spray should be regarded as a practical upper limit of water loading, since above this level the water delivery would become more jet-like.

The paper by Buchlin and Pr etrel (Reference 84) describes the development of a more complex mathematical model of radiation attenuation by water curtains where the spray was considered to be a semi-transparent two-phase medium capable of scattering, absorbing and emitting thermal radiation; the effects of convective heat and mass transfer and change of phase (steam production) were also to be included. The various fundamental equations were described and it was asserted that the attenuation of thermal radiation was mainly controlled by the size and density of the droplets and the optical properties of the liquid. A preliminary parametric study was presented which further reinforced the conclusions of References 82 and 83. Although still in the development stage at the time of publication, the potential of the final 'engineering code' was demonstrated by an example calculation of the temperature field within a water curtain 0.4 m thick, characterised by a Rosin-Rammler mean droplet diameter of 85 μm and exposed to a black body heat source radiating at 650 K ($\lambda_{\max} \sim 4.5 \mu\text{m}$). The results were presented as a two-dimensional thermal contour plot and it was concluded that the 52% total attenuation was due mainly to absorption since the drops were not small enough to enhance the radiative backward scattering. An experimental facility, designed to provide validation data, was also briefly described.

Murrell *et al.* (Reference 85) described an experimental investigation of the radiation attenuation by four single-fluid water mist nozzles; three were of the full-cone type and one was of the hollow-cone design. Prior to testing, each nozzle was subjected to a drop size distribution analysis using the Fire Research Station's 'Phase Doppler Anemometer' (PDA) system (see also Section 5.5.12). The fairly simple experimental configuration comprised a 1 m square radiant panel (which approximated a black body source at 900 $^{\circ}\text{C}$), together with a heat flux meter at 4 m distance fixed at the same height as the centre of the panel. The mist nozzle under test was installed between these two points so as to ensure that no water reached either the radiant panel or the heat flux meter, in order to eliminate the possibility of heat transfer by impingement. During a

test each nozzle was operated at pressures from 1-8 bar (~ 15-120 psig) and the heat flux meter output was logged electronically. The four nozzles were categorised in terms of the flowrate (low-medium-high), droplet size (low-medium-high) and droplet velocity (low-medium-high) and graphs were presented showing the variation of % radiation attenuation versus operating pressure and water flowrate. For a given nozzle the radiation attenuation increased with increasing operating pressure and increasing water flowrate, an inter-comparison between nozzles proved very difficult although a tentative ranking order was suggested. It was also shown that attenuation increased with decreasing volume mean diameter (D_{v50}). The most effective attenuation was 35%, achieved with a nozzle discharging 7.5 l.min^{-1} and with $D_{v50} = 160 \text{ }\mu\text{m}$, designated a 'high flowrate, large droplet size, high-velocity' spray. The most efficient nozzle, in terms of the highest attenuation per unit flow (~ 15% at 1 l.min^{-1} and with $D_{v50} = 126 \text{ }\mu\text{m}$), was classified as a low flowrate, low droplet size, low velocity spray. It was concluded that optimal performance in terms of radiation attenuation would be obtained from nozzles with high flowrate, low droplet size and low velocity; an example of this performance was given (~ 31% attenuation at 3.25 l.min^{-1} and with $D_{v50} = 70 \text{ }\mu\text{m}$).

Log (Reference 86) described a method for calculating the attenuation potential of a 'real' (*i.e.* polydisperse) spray from a consideration of the idealised attenuation by monodisperse sprays of infrared wavelengths characteristic of luminous flames. Log argued that although radiant heat blocking had been suggested as an extinguishing mechanism relevant to water mists (Reference 24), in practice this suppression mode had been largely ignored in favour of convective heat absorption (flame cooling) and oxygen displacement (flame inerting). It was stressed that the continued development of a fire was linked with a critical level of radiant heat transfer from the flames to both burning and virgin fuel; therefore a reduction in the radiative flux from the flames to adjacent fuel surfaces would be expected to restrict the growth of a fire. Likewise, the blocking of cross-radiation between adjacent fuel elements burning at high temperatures would be expected to aid fire suppression. It was also noted that for some fuels, such as thermally thick slabs of wood, the existence of an external heat flux is essential for continued combustion given the internal conductive heat losses and the radiative losses associated with the high-temperature char layer. Log compared the attenuation potential of water sprays with that of water films of thickness between 0-2 mm for black body radiators at various temperatures. It was shown that a water film 0.1 mm thick transmitted only 15% of the incident heat flux whereas ~ 28% was passed when the same 'water load' was in the form of a 'Class 1 mist' (Reference 24), with $D_{v10} = 50 \text{ }\mu\text{m}$ and $D_{v90} = 100 \text{ }\mu\text{m}$. It was also suggested that a mist load of 100 g.m^{-3} with characteristics on the borderline between that of a 'Class 1' and 'Class 2' mist (Reference 24, Figure 10) could block ~ 60% of the radiation from a black body at $800 \text{ }^\circ\text{C}$ along a path length of 1 metre. It was concluded that some high-momentum mists may achieve practical water loadings in excess of the 100 g.m^{-3} figure and therefore radiant heat blocking could become a viable extinguishing mechanism even with reduced path lengths of ~ 0.3 m or so.

Reischl (Reference 87) discussed the radiation attenuation of fog streams in the context of the occupational health and safety of fire-fighters. It was noted that exposure to heat stress was often due to excessive levels of radiant heat, rather than the existence of high

local air temperatures and that a failure to distinguish between these two effects had led to 'misdirected efforts in heat stress control'. In particular, Reischl cited the development of excessively heavy insulative clothing which restricted natural ventilation and actually promoted the conditions leading to heat stress. Given the widely-acknowledged effectiveness of atmospheric water vapour in attenuating infrared radiation, it was argued that a quantitative study of 'fog stream shielding' would aid in the development of alternative approaches designed to minimise the exposure of fire-fighters to heat stress.

A series of field tests was described in Reference 87, where the object was to evaluate the radiation-blocking potential of three nozzles used by the Fire Service in the US. The test nozzles included a 1 inch model plus two 1½ inch models, all operated at 7 bar (100 psig) throughout the tests, but with different cone included angle settings; 30°, 60° and 90° variants were employed for the 1 inch nozzle tests, while only the 60° and 90° patterns were used for the 1½ inch nozzles. A liquid propane burner provided a constant high-intensity source of thermal radiation whose output was easily varied by adjusting the propane flow rate and the test nozzle was mounted horizontally at a distance of approximately 15 m from the flame. The nozzle support frame also carried a pressure gauge, water flowmeter and a radiometer mounted 450 mm above and 600 mm behind the nozzle tip, the radiometer position was chosen so as to correspond to the approximate location of a branch operator's head. Having selected a particular nozzle setting, the burner was ignited and allowed a pre-burn period of 15 seconds, thereafter the heat flux was recorded for a 30 second period first in the absence of water and then in the presence of the fog stream. Each series of measurements was repeated 3 times, resulting in a total of 138 data sets which were plotted as 'fog radiation' (*i.e.* fog-attenuated heat flux level in $W.m^{-2}$) against 'fire radiation' (*i.e.* heat flux level prior to water application, again in $W.m^{-2}$) for a given nozzle at each value of spray included angle. 'Best-fit' straight lines were fitted to the data, with the most effective radiation attenuation being produced by the fog streams associated with the lines of least slope, where the numerical value of the slope corresponded to the ratio of 'fog radiation'/'fire radiation'.

For all 3 test nozzles, radiation attenuation was found to increase with increasing values of spray included angle, although in the case of the two 1½ inch models the difference in performance between the 60° and 90° sprays was slight. The advantage of the wider (90°) spray is that effective shielding may be provided for two or three fire-fighters while narrower cone angles can provide protection for the branch operator only. The 1½ inch nozzles were found to yield a much better blocking performance (slope values between ~ 0.13-0.15) than the 1 inch unit (slope values between ~ 0.37-0.68), this was explained in terms of the increased flow rates of the former (~ 85-95 g.p.m) compared with the latter (~ 25 g.p.m) at 7 bar and probable differences in the drop size distribution. In all cases the shielding characteristics were found to be well described by the linear correlation and consequently it was suggested that the nozzle performance characteristics could be extrapolated beyond the maximum (unshielded) radiation intensity obtained during the tests (~ 3 $kW.m^{-2}$ at the nozzle position). A brief discussion of the health and safety implications was also presented and it was concluded that the reduction of thermal radiation by fog streams allows for a significant increase in exposure time for fire-fighters at the fireground. It was also suggested that the radiation

blocking effect of fog streams be incorporated into the design specifications for fire-fighters' protective clothing and that this would result in lighter, better ventilated and more effective clothing systems.

5.4 Concept of "optimum" droplet size

At this point it might be reasonably asked whether there exists an optimum droplet size for fire-fighting sprays. In attempting to answer this question, it is valuable to recall from Section 3 that the three major mechanisms for extinguishing a Class 'A' fire by water are: cooling of the flame, cooling of the fuel and inerting the atmosphere (oxygen displacement) by the production of water vapour. In addition, the mechanism of thermal radiation absorption may assist in fire suppression directly and the shielding properties are certainly useful in improving the comfort of fire-fighters (Section 5.3.4). If the process of fire suppression was known to be dominated by only one of these mechanisms, then it might be possible to stipulate an optimum drop size. For example, if flame cooling were the single most important factor, then a fine spray would be preferable, the large surface area:volume ratio promoting heat transfer and rapid evaporation (Section 5.3.2). On the other hand if cooling the fuel bed was seen as the preferred option, then a coarser spray would be better in order to ensure penetration of the droplets through the fire plume convection currents (Section 5.2.2); in this case it might also be necessary to provide a fine spray to protect fire-fighters from high levels of thermal radiation. For deep-seated glowing fires, Herterich (Reference 10) recommended the use of so-called 'hard jets', whose high kinetic energy provided a deeper penetration and good heat absorption following the atomisation produced on impact with the fuel bed (Section 4.1.1.2).

In practice however, it is not always apparent which fire suppression mechanism is the most important and it is likely that the relative importance of the various mechanisms will change during the fire-fighting operation (Section 6.1). Intuitively then, it would be surprising if a single drop size were found to be a 'cure-all' for the suppression and extinction of fire, given the complexities of fire dynamics and the physical and chemical interactions involved. In particular the geometry, temperatures and gas velocities involved will in general cover a wide range of scales and therefore it could be argued that the introduction of a range of drop sizes would be more effective in fire suppression. In Section 5.1.3 it was seen that monodisperse sprays are the exception in practice; practical spray populations comprise a range of droplet sizes although the distribution may be skewed by the appropriate selection of nozzle design.

Herterich (Reference 10) discussed the concept of an optimum droplet size for fire-fighting and arrived at a value of $d \sim 350 \mu\text{m}$. It was argued that the heat transfer number (α) for this droplet size was a maximum since the ratio of terminal velocity to droplet diameter was also maximised. The validity of this argument was questioned by Güttler (Reference 40) since the calculation did not take account of the numerical term in the corrected form of the droplet heat transfer equation (equation (48)). Güttler also pointed out that the emphasis should more correctly be placed on the total quantity of heat transferred to a given spray (*i.e.* W in equation (49)), rather than the heat transfer

potential of a single droplet, therefore there is a trade-off between maximising α and maximising the surface area to volume ratio of the spray (Section 5.1.3 and Figure 14). Again it must be remembered that this simplified argument is based on the case of monodisperse sprays, and applies to heat transfer by forced convection only (*i.e.* cooling of the flame or hot gases produced by the fire).

This case was also analysed by Grin and Sergeev (Reference 60) who developed a mathematical model of the heat transfer between a (monodisperse) spray and a propagating high-temperature flame caused by an explosion. Assuming a time of contact between the droplet cloud and the explosion flame to be 150 ms, a parametric study was performed to determine how the rate of cooling was affected by different diameters of droplet and the number of droplets per unit volume. Assuming a flame front temperature of 1273 K, an initial spray temperature of 293 K, and a flame extinction temperature of 775 K it was found that the optimum dispersed-water cloud had a density of 0.3 kg.m^{-3} and a droplet diameter of $75 \text{ }\mu\text{m}$. The rate of evaporation of the droplets depended on their size, the density of the dispersed cloud and its time of contact with the flame. These results were reported to be in good agreement with experimental data in which the water consumption for the extinction of an explosion flame was $0.25\text{-}0.4 \text{ kg.m}^{-3}$.

In the experiments reported by Rasbash in Reference 44, it was found that the penetration of the lower fraction of droplet sizes into the flames was extremely limited in some cases, thus restricting the cooling capacity of the spray to the upper $\sim 10\%$ of the flame height. In the case where the flame height was $\sim 1 \text{ m}$, and upward flame velocities were in the range $2\text{-}4 \text{ m.s}^{-1}$, it was found that 'only a very small fraction' of the sprays with mass median drop size less than $500 \text{ }\mu\text{m}$ could penetrate to the burning liquid. Consequently, the sprays were able to remove heat very effectively from the uppermost regions of the flame zone (comprised mainly of combustion products). However, heat removal from the base of the flame and from the fuel gases entering the combustion zone was limited and therefore flame extinguishment was not achieved.

Kaletka (Reference 88) derived computational data relating the rate of heat absorption (W m^{-3}) of a monodisperse spray to the initial droplet diameter (m) (Section 6.1.4). Strong 'peaks' were observed in the plots of rate of heat absorption against the initial droplet diameter; the heat abstraction rate was observed to fall away for diameters either larger or smaller than the critical diameter. Based on this study, Kaletka concluded that initial droplet sizes in the range $300\text{-}900 \text{ }\mu\text{m}$ produced the best extinguishing performance, but that the optimum diameter depended on the distance between the nozzle and the flame zone and the prevailing thermal environment (Section 6.1.4).

The problems associated with bringing water to the seat of the fire to promote cooling of the fuel were discussed in Section 5.2.2. Beyler (Reference 48) suggested that droplets smaller than $\sim 1 \text{ mm}$ would be ineffective in pre-wetting or extinguishing a fire larger than $\sim 250 \text{ kW}$, although droplets of diameter 2 mm and above were found to suffer little evaporation or deflection by the fire plume. Hence it was suggested that there may exist a critical heat release rate above which a given drop size would not contribute to fire extinguishment. Alpert (Reference 51) also discussed the critical drop size required to ensure penetration of the convection currents to the fuel surface and

proposed empirical correlations between this parameter and the heat release rate of the fire (equations (35) and (36)).

The interaction between water sprays and thermal radiation was discussed in Section 5.3.4. The strong correlation between droplet size and the wavelength of the radiation at minimum transmissivity has been confirmed by independent studies (References 82, 83). Ravigururajan and Beltran (Reference 82) identified the critical infrared wavelengths as the range $\lambda \sim 0.6\text{-}25 \mu\text{m}$ and radiant attenuation was found to be strongly correlated with droplet radius. Clearly, a spray whose characteristics are suited to plume penetration and fuel bed cooling (*i.e.* $d \sim 2 \text{ mm}$ and above) will not be compatible with the provision of optimum radiation attenuation.

Hayes (Reference 89) conducted a literature survey on the measurement of drop size and its impact on the extinguishment of confined and unconfined fires. The mechanisms of fire extinguishment and the techniques of fire-fighting were discussed; it was observed that different fire situations required different fire fighting tactics. In general however, the literature suggested that the primary strategy for extinguishing room fires should be to cool the fuel rather than smother the flame (by steam production); hence the ability of the spray droplets to penetrate to the fuel surface was of paramount importance. For intense fires in confined spaces, the initial strategy of directing the spray to the upper part of the space from a low level opening was advised. The use of this tactic assures that the maximum amount of water is converted to vapour; the accompanying absorption of heat coupled with the displacement of smoke produced better visibility and hence better accessibility to the seat of the fire. Since this type of fire is frequently under-ventilated when fire-fighting commences, the possibility of inducing a backdraught-like event by air entrainment was also stressed. The subject of optimum droplet size is discussed further in Sections 6 and 7 of this report.

5.5 Measurement of droplet size distribution in practice

5.5.1 General

Many diverse techniques for droplet size measurement have evolved over the years. In order to measure the droplet size distribution for a given spray, a technique must be selected which is best suited for the purpose. The optimum sizing technique for a given situation will depend on the nature of the spray itself and also the anticipated end use of the size data. The task of measuring the individual sizes of a large number of small and swiftly moving bodies is not trivial and modern optical techniques are almost exclusively used for the task. They have two main advantages over other, older methods (*e.g.* the collection of drops on slides or electrical techniques): they are non-intrusive and they allow measurements over very short and/or very sharply defined time intervals. Intrusive mechanical methods have also been developed and in some situations remain the only option.

Measuring the sizes of droplets and producing a frequency distribution is only useful if the sample size is large enough to ensure reliable results. If enough data are not available it may still be that the data acquired can be fitted to an appropriate model,

which will allow interpolation over a 'whole' distribution. At all stages, there must be enough information to be able to make informed comparisons between sprays. For example, two nozzles may each produce a spray which may be described as a '500 μm spray'. It can be assumed that it is highly unlikely that each droplet in the spray is exactly that size, so '500 μm ' must be some form of 'mean size', however, several different methods of calculating mean sizes are regularly used, depending on the application (Section 4.1.2.2). In addition, the width of the size distribution may be important, but is undefined in this example. Both nozzles may produce droplets with an arithmetic mean size of 500 μm , but one may produce droplets in the range 495-505 μm , and the other in the range 0-1000 μm , therefore the sprays may not be interchangeable for a given application.

5.5.2 Sample size and standard distributions

Any statistical sample becomes more reliable as the population sampled increases. The largest drops in most sprays will have diameters two orders of magnitude larger than the smallest drops, though they may be far fewer, so it is important that the population sampled is large enough to contain drops which represent all sizes present in the spray. Bowen and Davies (Reference 90) determined a relationship for the influence of sample size on the accuracy of drop size measurements, and this is reproduced in Figure 21. If there is good reason to believe that the distribution is a given shape, the collection of far fewer measurements may be justified and the data can be fitted to a standard distribution (or *model*). Ideally, this would permit interpolation and extrapolation from a relatively small sample. Many different distributions have been derived empirically, and have been found to work well if used in appropriate applications (Reference 91).

Arithmetic normal distributions occur if the measured value of some property of a system is determined by a large number of small effects. If a large number of measurements of the value are made and plotted as a frequency distribution, a bell-shaped curve results. This distribution is, perhaps surprisingly, relatively uncommon. One of the most commonly used distributions is the *log-normal distribution*, which is a *Gaussian* curve of frequency of occurrence of droplets of a given size range in a spray, on a logarithmic abscissa representing diameter. This has been found to work well for naturally-occurring sprays. Model-independent distributions are now increasingly used with the advent of automatic systems which can gather information from large samples. Models are still used where data gathering is labour-intensive and time-consuming: a drawback of many photographic techniques.

5.5.3 Spatial and temporal sampling

A droplet sizing method which counts and measures each drop is termed a 'temporal technique'. By contrast, a 'spatial technique' measures drops contained within a control volume over a short enough period for the contents of the volume to be constant within that time. Drop sizing techniques may fall into either or neither category - for example, a *Phase Doppler Anemometry* (PDA) system is a temporal technique, and *Interferometric Laser Imaging of Droplets* (I-LIDS) is a spatial technique, but a

Malvern Analyser takes data from the whole distribution over a finite time. It is important to make sure that 'raw' data from one type of device are not used for comparative studies with other techniques. Consider a nozzle producing droplets whose size distribution is to be measured; due to frictional forces, smaller drops will retard faster on leaving the nozzle than larger ones, so a high concentration of small drops will be found just downstream of the nozzle. A spatial sampling system will record a result skewed toward small droplet sizes, as it will record the sizes of the droplets which are in the region, rather than those which pass through the region to produce a fully developed spray. If all the drops were travelling at the same speed, there would be no spatial distribution of drops of different sizes, so spatial and temporal techniques would both return the same value (Reference 14).

5.5.4 Mechanical methods of drop size measurement

Perhaps the simplest mechanical method was developed by Wiesner (References 92, 93) at the end of the nineteenth century, to study raindrop size during a series of studies of weather in the Tropics. A piece of paper was stretched across a frame with water soluble dye dispersed across it in powder form. For a given paper, the surface area of the stain was found to be roughly proportional to the mass of the impinging drop, although for drops larger than 1 mm it is also a function of the terminal velocity (References 92, 94). Problems with this method include splattering drops and the non-circular stains produced by drops arriving at a non-perpendicular angle. To prevent the problems caused by splattering and spreading, later experiments employed fine mesh screens covered in soot, through which the drops fell, washing off the soot and producing marks very nearly proportional to drop diameter (Reference 95).

A more reliable method was devised by Bentley (Reference 96) and developed by Laws and Parsons (Reference 97) and Blanchard (Reference 98). A shallow tray was filled to a thickness of 2-3 cm with fine, uncompacted flour. The tray was exposed to rainfall for a time dependent on the rate of raindrop impacts. The resulting dough pellets were then left to dry until hard, and were then measured. In Reference 97, the dough pellets were baked and subsequently sieved. By counting the pellets and weighing the catch of each sieve, the mean mass of the pellets in a particular size group was found. Calibration was performed against pellets formed by droplets of known sizes, and it was found that drop size, D , (mm) was related to pellet mass, m , (mg) by $D = 1.29\sqrt[3]{m}$. Blanchard (Reference 98) used a deeper layer of flour with an irregular surface to prevent splattering and added a dye to make the pellets more visible.

A mechanical technique which is still used in laboratories today is that of droplet collection on slides (Reference 99). A layer of very fine grained material (such as soot or magnesium oxide) which will retain an impression by extremely small particles is deposited on a microscope slide. The slide is then exposed to the spray and examined, either using a travelling microscope or an image processing computer. The sizes of the impressions are converted to drop sizes by the use of a conversion factor; this method is good for drop sizes down to around 3 μm . Immersion sampling makes use of liquids which allow drops to enter and remain stable. In some investigations, cells filled with such liquids have been used to collect droplets, which, on entering the liquid, remain

intact and collect at the bottom of the cell. Problems are encountered with this technique when there is a large amount of spray, and particularly when the spray is coarse in nature. In these cases droplets may shatter on entering the collection medium, and may coalesce, returning an incorrect droplet size on measurement.

Cascade impactors (Reference 14) are based on the principle that large droplets with high momenta will hit obstacles placed in their path, whereas small droplets will conform to the flowfield around an obstacle more readily, and thus avoid it. Spray is channelled onto a slide through a nozzle. For given relative positions of the slide and the nozzle, increasing the slide area will lower the minimum size captured by the slide. Several impactors with different relative nozzle/slide sizes will allow different size ranges in the same spray to be measured, and the robustness of the systems allows them to be used under extreme conditions (e.g. on aeroplanes for sampling drop sizes in clouds). The molten wax technique (Reference 99) was used during the Second World War, to investigate the size of particles emitted by nozzles in aircraft engines. For certain temperatures, paraffin wax has similar characteristics to aviation fuel, so it could be ejected through the nozzles into a large cool vessel, where it solidified. Sieving would then reveal the drop size distribution. This will work with any liquid that can be frozen with sufficient speed, and it has been used in conjunction with photography for water shot into a liquid helium cooled vessel. Microphones have been carried aloft on balloons to measure cloud and rain droplet size (References 92, 100). As droplets hit membranes stretched across the microphones the sound was transmitted to a receiving station, at which the intensity of the sounds could be resolved into size distributions. Unfortunately, errors of 20% and larger were normal with this technique.

Electrical techniques (Reference 14) include measurements of the conductivity of a drop between two sharp needles, the cooling effect of a drop on a constant temperature hot-wire anemometer and the removal of charge from a charged wire. Because of the small physical size of the test region, and the tendency for drops to cling to wires and electrodes, they are limited in their applications to single droplet measurements, which in turn are only really useful for low flux rates. A recent development in this field is the *Electrical Low Pressure Impactor*, manufactured by Dekati of Finland. Particles entering the instrument pass through a diffusion charger and the electrical current carried by the charged particles into each impactor stage is measured in real time by a multi-channel electrometer, giving a real-time size distribution. However, this instrument is not suitable for measuring most sprays as the size range covered is very small: 30 nm to 10 μm .

5.5.5 Light scattering by water droplets: the basis of optical techniques

As mentioned previously, optical techniques are favoured over mechanical techniques, as they are non-intrusive of the system under investigation and are more able to return data from a clearly defined time interval. With the increasing availability of low-cost computing power and advanced signal processing techniques, there are now optical techniques which have the capacity to return size distributions in real time. When an optical system is used for the measurement of droplets in a gas, inferences are made about the size of the drop from the intensity, and in some systems the phase, of the light

scattered from it at different points in the far field. The theoretical basis for making such measurements comes from two approaches: *Mie Theory* and the *Theory of Geometrical Optics*.

In 1908, Gustav Mie (Reference 101) developed a set of equations which described the electromagnetic field within a sphere of uniform refractive index, when the sphere was illuminated by an electromagnetic wave of a given wavelength and polarisation. The work has been collected and given standard notation in books by Van de Hulst (Reference 102) and Kerker (Reference 103). The theory considers each element within the sphere to be a source of light, radiating into the far field. The contributions from all sources can then be summed to give an intensity of radiation of a known polarisation at a given point in the far field. The theory returns the amplitude of scattered light in terms of two functions, $S_1(D, m, \theta)$ and $S_2(D, m, \theta)$, which give the amplitude for incident polarisations perpendicular and parallel to the scattering plane respectively, where D is a non-dimensional size parameter, effectively drop diameter over fringe spacing for a sphere of diameter d , in light of wavelength λ , such that $D = \pi d / \lambda$; m is the relative refractive index and θ is the angle of incidence. Size and refractive index can be considered to be constants for a single droplet under most conditions, and angle of incidence can be treated alone as an independent variable. The intensity of the reflected and transmitted light is dictated by the angle of incidence and the polarisation of the light incident at each interface and is related to the square of the amplitude coefficient. The intensities for the two orthogonal incident polarisations are then:

$$i_1(\theta) = |S_1(\theta)|^2 \quad (57)$$

$$i_2(\theta) = |S_2(\theta)|^2 \quad (58)$$

The absolute intensity is the mean of these intensity values:

$$i(\theta) = \frac{i_1 + i_2}{2} \quad (59)$$

The approximation of a sphere of uniform refractive index can be reasonably applied to small water droplets in the absence of significant deforming aerodynamic forces. It has also been demonstrated that the number of terms needed to be computed in the series is proportional to the size parameter D , so the time taken to calculate a droplet diameter increases with the size of the droplet to be measured. This was once a serious drawback in the application of Mie theory, but the availability of relatively powerful desk-top computers is making Mie calculations possible for many applications. The restriction to a uniform field of light is a more serious constraint. Lasers produce very highly monochromatic light, so may seem to be ideal for Mie-based measurements. However, the intensity of light in a laser beam is not constant and a section through the beam reveals a Gaussian distribution of intensity.

In the *geometrical optics* approach, light scattered from a droplet is considered in terms of the superposition of reflected, refracted and diffracted light. Glantschnig and Chen

(Reference 104) used Geometrical Optics to derive $i_1(\theta)$ and $i_2(\theta)$ for the case of light scattered by a spherical water droplet, with a radius greater than the wavelength of the light used. Their specific objective was to study the feasibility of using Geometrical Optics as a mathematical basis for practical laser water droplet sizing. The functions are obtained in a closed form as functions of the scattering angle, θ , provided:

- Scattering is not to be considered beyond 170°
- Refractive index, n , is different from that of the surrounding medium ($2D(n-1) > 1$)
- The droplets are large: $D > 10$. In practice, this requires a drop diameter > 2 μm for visible wavelengths.
- Light is not scattered at the 'angle of rainbows' 128.7° & 137.5° for water/air

For scattering angles less than 30° - forward scattering - diffraction is the dominant means by which light is scattered. This region should be avoided since phase information cannot be extracted from diffracted light. As scattering angle increases, the intensity of scattered light from a given system of droplets diminishes, and so the signal to noise ratio decreases, but offsetting this, the maximum measurable concentration increases. The remaining scattering angles are dominated by one or two modes of reflection or refraction, as summarised in Table 7 (Reference 105).

Table 7
Scattering modes associated with various scattering angles

Scattering Angle	Important scattering modes
$\theta < 30^\circ$	Diffraction dominates
$30^\circ < \theta < 80^\circ$	Refraction dominates; some surface reflection
$80^\circ < \theta < 110^\circ$	Surface reflection dominates
$110^\circ < \theta < 130^\circ$	Two internal reflections
$130^\circ < \theta < 170^\circ$	One internal reflection

Geometrical Optics has the advantage that the behaviour of the scattered light can be readily visualised, and the accompanying calculations carry a modest cost in comparison with those for Mie Theory. More importantly, from a mathematical point of view, the Gaussian distribution of the intensity of the incident light beam can be included.

5.5.6 Optical droplet sizing techniques

There are many ways in which an ensemble of particles can be illuminated and the scattered light received and recorded. Each different method should be considered when choosing a technique for a programme of study. Techniques may be chosen for sensitivity or insensitivity to refractive index or shape, and can even be used in the case of amorphous and dark particles; for example, some intensity averaging and diffraction methods can be used for sizing coal dust and soot particles whereas systems reliant on refraction, such as the I-LIDS system, described later, cannot.

5.5.7 Limitations of optical systems

As with any piece of measuring equipment, it is crucial that optical drop sizing equipment is used under the conditions for which it was designed. Common problems have been listed by Yule (Reference 106) as:

Schlieren Effects Beam steering can occur due to gas temperature variations; this is particularly troublesome in the case of reactive flows.

High Droplet Concentrations High concentrations of particles can cause light to be multiply scattered, leading to larger scattering angles. This leads to a return of low values for diffraction techniques. In dense sprays, the sample volume of a system such as the PDA can be occupied by more than one droplet at a given instant. The instrument may then disregard this reading. As multiple occupancy is more likely to occur for small droplets, this phenomenon tends to skew the results toward larger drop sizes.

Deformation High relative gas-particle velocities can cause deformation of drops being measured. This can cause problems with bulk measurements; for example, the Malvern Analyser described later will return a distribution composed of the smallest dimensions of the droplets, and weight the data by using the total areas of the real particles.

Yule concluded by suggesting high speed imaging (either photography or holography) as the most promising way for droplet sizing technology to develop. However, these methods have their own attendant drawbacks, as will be shown.

5.5.8 Photography and holography

When considering optical systems for sizing water droplets, the most obvious technique to try would seem to be photography. If a photograph could be taken of the droplets in a spray, with a known magnification factor, it should be a trivial matter to measure the images of the droplets and produce a droplet size distribution. There are, however, problems with this technique.

Gathering clear images of droplets is not a simple task. As droplets in a spray move, it is desirable that the exposure time should be as short as possible, which may lead to problems with inadequate lighting. In dense sprays, it may be difficult to illuminate and photograph droplets in the core of the spray, which may exhibit a different size distribution from those on the periphery.

As has been discussed, for a droplet size distribution to be established reliably, it is desirable to measure as many droplets as possible. Measuring the sizes of individual droplets from photographic plates is extremely time-consuming and tedious for the analyst. There is a trade-off between having drops of sufficient size to reduce the errors in measurement and capturing a large number of droplets on a single frame. Using video techniques to produce a series of frames will resolve this problem provided that the droplet size distribution does not change with time. Overlapping images can also cause

problems if a group of small droplets are sufficiently close to appear as a single large drop, a phenomenon known as 'aliasing'.

Despite these problems, photographic droplet sizing has been attempted in a number of studies, with varying degrees of success. A few studies will be outlined here in order to demonstrate the situations under which it is best applied, and the ways in which some of the shortcomings of the technique have been overcome. The Fire Experimental Unit (FEU) attempted to photograph droplets within a spray during a study carried out in April 1985 (Reference 32). Conventional flash equipment was used to illuminate the spray and, although the flash was not fast enough to freeze the droplets in flight, results were sufficiently encouraging for a second series of tests to be carried out using a flash supplied by a specialist manufacturer of high speed photographic flashes. Although these tests were successful, they were not pursued further as the data collection was so laborious. At the time, there was no certainty of being able to contract this work out to an agency, or to automate the process. A second attempt was made in 1986, when the work was contracted out to Bete Fog Nozzle Inc., in the USA. This equipment gathered standard 625 line television pictures, from sprays illuminated with a high speed flash light source, and computer analysis was performed on the image to determine size data. A large number of tests were performed using this method, and the data were treated as being reliable. Further work on characterising sprinkler sprays using this equipment has been undertaken by the US Department of Commerce.

South Bank University have developed a photographic high-speed imaging laser technique, and have used it to provide data for their SPLASH model of sprinkler spray behaviour (Reference 107). This system uses an Oxford 10 W copper vapour laser to provide light pulses down to 10 ns. A Hadland Hyspeed H10/16 camera is used, synchronised to the laser pulses, to capture images on very fine-grained film. A special system of optics, called a Boroscope, is used to provide close-up images of the droplets. Three hundred drops were measured in each sample, to give an error of $\pm 20\%$ (Reference 90). Three methods of image analysis were used.

In the first technique tried, images were projected onto a screen, where they could be traced and the tracing measured. With the introduction of an image of a needle of known size, a magnification factor could be determined, and the real size of the droplets deduced from their apparent size. With the so-called Cortex IQ120 system, an operator searches each frame for droplets, and marks three points on the perimeter of the image. A best fitting circle is then calculated and the diameter of this best fitting circle is then recorded as the droplet diameter. Speed and trajectory of the droplets can also be deduced. Another system was semi-automatic. The Joyce Loebel 'Magiscan' was used, in which a computer scans a digitised image to look for structures, and records the diameters of structures with high circularity. Operator supervision is still required to prevent slowly moving drops from being counted twice, though this could largely be eliminated by taking measurements from frames spaced as far as possible apart in time. This system could not provide size and trajectory information.

More recent work has been carried out using a Drop Size Measuring System produced by Particle Measurement Systems Inc. (References 108, 109) which can measure drops ranging from 0.1 mm to 6.2 mm in size with a resolution of 0.1 mm. A He-Ne laser is

used to project a beam of light through the object plane of the optical system. The shadows behind the drops are projected onto a linear array of photodiodes. As drops pass through the laser beam, successive image slices are recorded; drop size corresponds to the width of the widest image slice. The droplet velocity can be calculated based on the droplet size and the droplet travelling time through the object plane of the probe.

Holography of sprays has been attempted, but for dense sprays the problems of analysing the holographic image become increasingly more difficult (Reference 110). One solution is to take holograms of very thin slices of the spray, but then it can be argued that holography has no significant advantage over photography.

5.5.9 Extinction systems

Extinction systems measure the amount of light absorbed and scattered by particles interrupting a light beam. Assuming the Bouguer-Lambert-Beer Law, intensity will decrease exponentially with the amount of material between the transmission and detection optics. This technique was used by Sapko *et al.* (Reference 111) to measure the diameter of water droplets in an experiment designed to quantify the amount of water and best size of droplet to arrest an explosion, or to inert an explosive mixture.

$$\frac{I}{I_0} = \exp\left(\frac{-3Kcl}{2\rho d}\right) \quad (60)$$

I/I_0 is the fraction of light transmitted, K is the extinction coefficient, c is droplet concentration, l is path length, ρ is particle density and d is particle surface mean diameter. This technique works best when it is reasonable to assume that the size distribution for a given droplet system is very narrow. Then, if droplet concentration is known, particle surface mean diameter will be calculable. This is quite a serious constraint, and the individual situation must be assessed carefully to see how closely it approaches this ideal.

5.5.10 Fraunhofer diffraction systems

Fraunhofer diffraction is the technique utilised in the widely-used Malvern Analyser, and has the advantage of not being sensitive to shape or refractive index. Systems based on this method work by measuring the modification in intensity across the width of an expanded beam caused by a cloud of particles (References 14, 112) (Figure 22). Each particle crossing the beam will contribute to an integral diffraction pattern, which is recorded by concentric rings of photo-detectors over a period of time. The particle size distribution is recovered by *de-convolution* techniques from the intensity pattern.

Commercial systems typically have a range of 1-1800 μm . Since they initially became available an important criticism, that they had little temporal resolution, has been overcome. Those available at the time of writing can return distributions every 5 ms, but have no spatial resolution. Particles moving at a high speed can also cause ambiguities.

As with many 'line-of-sight' methods, unreliable results can be given for high and extremely low concentrations. For the Malvern Analyser, the operating limits are for concentrations higher than 5% but less than 50%; correction tables are available for measurements outside these regions, but these are generally considered to be the limits of reliability. High particle concentrations cause multiple scattering of the laser light, which tends to skew the distribution towards lower droplet sizes.

5.5.11 Single particle sizers

Single particle counters (References 113-115) work by measuring the intensity of a scattered light source at an angle and integrating over several intensity lobes. These results in practice have been found to agree well with those obtained by electron microscopy. They tend to work best for opaque particles in very low concentrations.

5.5.12 Phase doppler anemometry

Phase Doppler Anemometry (PDA) is a development of Laser Doppler Velocimetry systems. In this technique (References 116-118), a laser beam is split into two beams which are made to cross in space to form a fringe pattern. A transparent droplet passing through this region will magnify the fringe pattern by acting as a lens, opaque droplets will perform the magnification by acting as a convex mirror. The degree of magnification is indicative of the size of the droplet. Measurement takes place in the region in which the two laser beams cross, a volume of typically $\sim 1\text{mm}^3$. Collection optics receive light from this measurement volume and focus it onto a spatial filter in the form of a vertical slit. Photo-detectors receive the light, and by calculating the phase difference between them, the apparent size of the fringe pattern can be determined, and the droplet size can be calculated.

A curve of phase difference between light received at two points in the far field against the Mie size parameter for light emitted from a point aperture will show small perturbations. These are due to interference between reflected and refracted components. If the same curve is considered with a finite aperture, a smoother curve is achieved, but in practice the perturbations set a lower limit on the size of particles that can be usefully measured: the spatial resolution of calculations must be better than $180^\circ/D$ to capture all details.

Three photo-detectors are used together to detect the fringes. Two would in fact be sufficient, as measurement of intensity with time at two points will give a value for the phase difference, from which the droplet size can be measured. However, a third is usually added, at an offset distance between the first two. This is partly to detect and reject signals from unwanted scattering modes - and sometimes a fourth detector is also used for this, however the main purpose of the third detector is to extend the sizing range, by overcoming the 360° ambiguity.

With only two detectors, the largest diameter measurable is limited by this ambiguity in which a phase difference of $2\pi + D$ may appear as a phase difference of D , producing an

ambiguity in drop size, and only spherical particles may be measured. To overcome this, a third detector is employed to give an independent check on the absolute phase difference between the other two. The equipment required to carry out this type of particle dynamics analysis is relatively expensive, because of the absolute accuracy needed in setting up both the transmission and collection optics, the high quality of the optical components, and the complexity of the data processing software needed to make full use of the data available from such a system. The only methods available that can be used in the same area of study as PDA are line of sight methods, but by the very nature of these processes, in which an integration is carried out along the beam, local variations in particle concentration along the length of the beam will not be recorded. A PDA system, because it is concerned only with the measuring volume, would detect these local variations. This spatial resolution of the spray particle concentration and size is the great advantage of PDA systems, but they also have the disadvantage of being unable to size and follow particles with low sphericity, or particles with high absorption and low reflectivity. PDA is unsuitable for measuring flows with very high droplet concentrations.

5.5.13 Interferometric laser imaging of droplets

Interferometric Laser Imaging of Droplets, or I-LIDS (Reference 119), is a process which enables droplet sizing of individual droplets, or groups of monodisperse droplets in a stream, retaining spatial information. In this system the droplets to be sized are illuminated by laser light and interference takes place between rays reflected off the surface of the droplet and those that are refracted after entering the droplet, to produce a fringe pattern (Figure 23). This can be most easily observed at an angle of 45° from the forward scattering direction, where, from Mie theory, there is a high intensity of scattered light.

To capture as much light as possible, a large aperture convex lens is used. If the lens is aligned with its central axis at 45° to the laser beam, scattered light from the droplets passing through the beam will be focused onto a point behind the lens. A sharp image can then be observed using either photographic techniques, or the eye if the power of the scattered laser light enables this to be done safely. The position of the camera is adjusted so that an out-of-focus image of the drop, composed of interference fringes, is seen. The extent of the image is determined by the aperture of the lens.

It can be shown that the refracted ray has a longer path length than the reflected rays, which produces a 'phase difference' between the rays, and interference fringes are formed when they are superposed at the observation medium. The number of fringes that can be counted in one disc is directly proportional to the size of the droplet, whose absolute value is calculable after ascertaining the magnification of the system. From Figure 23, the path difference, P_d , is given by:

$$P_d = d(ncos\beta - cos\alpha + \sin\theta) \quad (61)$$

where,

$$\tan \beta = \frac{\sin \theta}{n - \cos \theta} \quad (62)$$

and $\alpha = \theta + \beta$. We require $\Delta\theta$ to be the fringe angle for which $\Delta P_d = \lambda$

$$\Delta\theta = \frac{\lambda}{\left(\frac{dP_d}{d\theta}\right)} \quad (63)$$

As the fringe number is directly proportional to the droplet size, an I-LIDS system can also be calibrated by taking interference patterns from droplets of a known size, such as those from a *monodisperse* (or 'single-size') droplet generator, if independent confirmation of the size is possible.

Fringes from different droplets within the field of view are individually distinguishable provided the method used to record the interference pattern is fast enough to freeze a moving image. Also, if several droplets of roughly the same size pass through a small measuring zone in a given period, each droplet will contribute an identical fringe pattern, allowing confirmation of the narrow size spectrum and the size of the droplets. This technique was used recently in a study describing the evaporation and freezing of optically levitated droplets, and in a study of the mutual interaction between water droplets and methane-air burner flames (References 120, 121).

5.6 Summary

Various methods of spray production have been reviewed, most firefighting nozzles (branches) operate on the 'pressure atomising' principle and generate *polydisperse* sprays (*i.e.* sprays containing a wide range of droplet diameters). Gaseous, or twin-fluid nozzles have the ability to produce exceptionally small droplets, in some cases even down to 1 μm in diameter. For any nozzle design the liquid viscosity is the primary variable affecting the droplet size; a decrease in viscosity results in a more uniform spray of smaller droplets. The influence of nozzle pressure on droplet size has been widely debated; the weight of the evidence tends to suggest that, for a given nozzle, a minimum mean drop size (d_m) is produced at some value of pressure and any increase in pressure thereafter tends to increase d_m rather than reduce it further.

The penetration of a spray has been defined as 'the maximum distance it reaches when injected into stagnant air'. This value is governed by the relative magnitudes of the kinetic energy of the initial liquid jet and the degree of aerodynamic resistance offered by the surrounding atmosphere. It has been suggested that a single droplet has a 'stopping distance' which is an order of magnitude smaller than its parent spray and that compact narrow sprays possess better penetration characteristics than well-atomised sprays with wide cone angles. Again the influence of pressure is disputed and while some workers suggest a fall-off in penetration at elevated pressures, others have advocated the use of increasingly higher nozzle pressures (30 bar and above) as a means of increasing the

throw of fine sprays. On balance the latter view does appear to be questionable, however, empirical data in this area are sparse and particularly where high pressure sprays are concerned. A related topic is the degree of air entrainment to be expected in firefighting sprays; methods for estimating this effect range from a semi-empirical correlation to complex computational techniques. Again, this important area suffers from a lack of experimental data and this should be addressed in future. In addition, where computational studies have been performed, these have tended to focus on sprays discharging vertically downwards into buoyant fire plumes; this is because the models were originally developed as tools for optimising the design of sprinkler systems.

The thermodynamic properties of water (*i.e.* its heat capacity and latent heat of vapourisation) make it a uniquely suitable liquid extinguishing agent. The contributions of the various modes of heat transfer to the extinction process have been discussed by fire scientists and experimental and theoretical studies have been published. The heat transfer from hot gases to water droplets, which controls the overall cooling of the compartment atmosphere and any direct cooling of the flame zone, is usually modelled using well-established non-dimensional heat transfer correlations for forced convection around spherical bodies; in more advanced theoretical treatments, both the diameter and velocity of the droplet are time-dependent. Using these concepts it is possible to obtain approximations for the 'heat transfer capacity' (in $\text{W}\cdot\text{m}^{-3}$ or $\text{W}\cdot\text{m}^{-3}\cdot\text{K}^{-1}$ per unit volume of spray) of idealised monodisperse sprays travelling at a characteristic mean velocity; a little more effort is required for the practical case of polydisperse sprays.

Heat transfer by conduction from high temperature solid surfaces to water droplets is the primary mode of direct fuel cooling in Class 'A' fire suppression; this is also relevant to the indirect cooling of non-burning solid surfaces (*e.g.* compartment walls and ceiling). Experimental studies of the various cooling régimes have been reported by workers in the field of process metallurgy, specifically in the context of the forced cooling of steel castings by water sprays and mists. However, the results of these studies have little direct application to Class 'A' fire suppression because of important differences in the details of the heat transfer system. The most important difference is that metals possess a high thermal conductivity whereas typical Class 'A' fuels (*e.g.* wood) are of low thermal conductivity. In metallurgical applications therefore, it can be assumed that the surface temperature remains essentially constant during cooling but for low conductivity materials the impingement of water droplets produces intense localised cooling. Some efforts have been made to model the physics of spray cooling of low conductivity solids but this area of fire science is far from maturity.

The ability of water to absorb radiant heat has long been recognised and water sprays are routinely used for this purpose during firefighting to protect personnel and combustibles. A number of studies have been conducted in recent years in an effort to provide a more quantitative understanding of this phenomenon; it has been found that the absorption capacity of a given spray is strongly correlated with the droplet size and concentration. Although much of this work is experimentally-based, again there are mathematical models available which can provide estimates of the radiation-blocking performance of practical firefighting sprays (given the relevant input data on drop size distributions etc.).

The possible existence of an 'optimum droplet size' for firefighting has been considered by several authors, taking into account the thermodynamic properties just described and the need to project such sprays into hot, energetic, gaseous atmospheres. The problem is compounded by the need to cool not only the compartment gases, but moreover the hot fuel surfaces in order to achieve final extinguishment of Class 'A' materials. Fuel cooling is essential, but the contribution of gas phase cooling is also important, not least to ensure a tolerable environment in which firefighters can operate, in addition, where ventilation is restricted, extremely rapid initial flame knockdown is possible as a result of gas phase cooling and the subsequent formation of an inerting water vapour atmosphere. The optimum drop sizes for efficient gas phase cooling and radiation absorption are much smaller than that required to reach the solid fuel surface, since the latter must possess sufficient momentum to traverse the buoyant gases without being deflected. The 'optimum' drop sizes proposed in the literature fall in the wide range from 2 μm to 2 mm, for radiation attenuation to fuel bed cooling respectively. In practice it is usual to produce a wide range of drop sizes within polydisperse sprays and for firefighting this is probably helpful; some adjustment of spray characteristics at the nozzle is obviously advantageous however, given the foregoing discussion.

Many different droplet sizing techniques are available. It is imperative that one appropriate for the spray to be sized is selected. Users of particle sizing data must be aware of which measured quantity they are using, and must make sure that it is compatible with the application for which it is intended. Quoted droplet sizes are usually representative of a distribution: two sprays for which an identical mean size is quoted may be composed of different ranges of drop sizes. Each droplet sizing technique is subject to error, and the degree of error should be quantified, especially if comparisons are being made between results obtained using different techniques. If errors are not quantifiable then information should be included in the report of any adverse conditions under which the sample was taken.

6. PREDICTION OF SUPPRESSION & EXTINCTION USING MODELS

6.1 'Fundamental' theoretical models of the suppression/extinction process

6.1.1 General

The various mechanisms of suppression and extinction relevant to diffusion flame fires were discussed in a previous report (Reference 5). Section 3 of the present document cites the mechanisms most pertinent to Class 'A' fire suppression by water sprays as: fuel cooling, flame cooling, and flame inerting. In a discussion of water mist fire extinction mechanisms, Mawhinney (Reference 24) added to these the possibilities of thermal radiation attenuation, dilution of the flammable vapour/air mixture and chemical inhibition. The ability of water sprays to promote flame cooling, fuel cooling and the blocking of radiant heat were previously considered in Section 5.3. Some of the theoretical treatments of fire suppression and extinction described below also consider the additional mechanisms of flame inerting, dilution and chemical inhibition. Various types of "model" have been proposed ranging from fundamental theories which attempt to identify important physical or chemical processes to those which are designed to be of more direct practical application.

6.1.2 The firepoint equation - fuel surface cooling

Rasbash (Reference 122) defined the *firepoint* as the minimum temperature of a flammable liquid at which the application of a pilot source of ignition would result in sustained burning. The firepoint temperature is greater than the *flashpoint* for flammable liquids, which is the temperature at which a transient flash is obtained at a point away from the ignition source. In Reference 122, Rasbash extended the firepoint concept to the case of solid combustibles by including other criteria associated with a critical condition for piloted ignition, namely: a critical rate of convective heat transfer from the flame to the solid, a critical rate of emission of volatiles and a critical flame temperature. Early work on the extinction of liquid fires by water sprays indicated that for application rates less than 'critical' (*i.e.* the rate required for complete extinguishment of the fire), an intermediate steady burning régime was established with a corresponding fuel surface temperature somewhere between the firepoint and the free burning temperature. The heat balance equation for the steady, suppressed burning of solid combustibles in this régime may be written as,

$$S = (H_f - \lambda_f)\dot{m}'' + R_a - R_s \quad (64)$$

where S is the net sensible heat flux received by the fuel (W.m^{-2}), H_f is heat transferred to the fuel from the flame by convection per unit mass of fuel burned (J.kg^{-1}), λ_f is the heat required by the fuel for the production of unit mass of vapour (J.kg^{-1}) either by vapourisation or pyrolysis, \dot{m}'' is the burning rate of the fuel per unit area ($\text{kg.s}^{-1}.\text{m}^{-2}$), R_a is the heat flux transferred to the fuel by other routes such as radiation (W.m^{-2}) and R_s is the heat flux transferred from the fuel to the environment, particularly by re-radiation (W.m^{-2}). Critical conditions arise when the physical state of the system described by

equation (64) is just sufficient to sustain piloted ignition, or put another way, an established flame is on the point of extinction.

The critical condition is described by the modified version of equation (64), namely

$$S_c = (H_{fc} - \lambda_f) \dot{m}_c'' + R_a - R_s \quad (65)$$

where the subscript 'c' denotes a critical value of the parameter concerned. According to firepoint theory, the fire is extinguished if $H_f > H_{fc}$ or $\dot{m}'' < \dot{m}_c''$ where,

$$H_{fc} = \phi H \quad (66)$$

and

$$\dot{m}_c'' = f(h, B_c) = f\left(h, \frac{A}{H_{fc}}\right) \quad (67)$$

where ϕ is the maximum fraction of the heat of combustion of the volatiles which the flame reaction zone may lose to the fuel surface by convection without causing extinction of the flame (118). In equation (67), h represents the heat transfer coefficient ($\text{W.m}^{-2}\text{K}^{-1}$) and B_c is the value of Spalding's B -number (Reference 6) at critical conditions. The B -number,

$$B = \left(\frac{m_{oa} H / r + c(T_a - T_s)}{H_f} \right) \quad (68)$$

is the ratio of the factors which influence the burning rate (*i.e.* the sensible heat requirements) to the heat transferred to the fuel surface by convection per unit mass of fuel consumed. In equation (68), m_{oa} is the ambient mass fraction of oxygen, H is the heat of combustion of the volatiles (J.kg^{-1}), r is the stoichiometric ratio, c is the specific heat capacity of the gas ($\text{J.kg}^{-1}\text{K}^{-1}$) and T_a and T_s are the temperatures of the ambient atmosphere and the burning fuel surface respectively (K). The parameter A in equation (67) is then defined as the numerator of the B -number,

$$A = \frac{m_{oa} H}{r} + c(T_a - T_s) \quad (69)$$

where the first term is substantially larger than the second (Reference 122). Rasbash (Reference 122) also noted that,

$$f\left(h, \frac{A}{H_{fc}}\right) = \frac{h}{c} \ln\left(1 + \frac{A}{H_{fc}}\right) \quad (70)$$

which, in conjunction with equations (65) and (67) leads to the *firepoint equation*,

$$S_c = (\phi H - \lambda_f) \frac{h}{c} \ln \left(1 + \frac{A}{\phi H} \right) + R_a - R_s \quad (71)$$

where S_c is the critical value of net sensible heat flux (W.m^{-2}) required to be abstracted from the fuel to ensure extinguishment of the fire or to prevent piloted ignition. In the case where an extinguishing agent is used to cool the fuel surface (e.g. water in the form of a spray), Rasbash derived an expression for the critical flow rate (in $\text{kg.s}^{-1}.\text{m}^{-2}$) as S_c/λ_w where λ_w is the heat removing capacity of the agent per unit mass (J.kg^{-1}).

The significance of the various terms in equation (71) were also discussed in Reference 122 and the main points are now briefly summarised. It was suggested that the fraction ϕ may be associated with the critical flame temperature (T_c) and therefore to the kinetics of the combustion reaction, with ϕ being inversely proportional to T_c . In particular, the presence of inhibitors in the flame would lead to a reduced reaction rate and therefore to a decrease in ϕ and an increase in T_c . Rasbash also stressed the distinction between the heat of combustion H which appears in A (equation (69)) and the 'heat of combustion of the fuel'; the two are not equivalent, particularly when there is significant char production and if the volatiles are produced at high temperature. The importance of environmental factors and material properties on the parameters λ_f, h, R_a, R_s were highlighted by Rasbash and it was suggested that a rigorous implementation of the firepoint equation would require the inclusion of transient phenomena. Although it was conceded that there was 'a dearth of the necessary data' required for the general quantitative application of equation (71), particularly in relation to ϕ and λ_f , Rasbash did discuss some preliminary quantitative implications for fire extinguishment based on the firepoint analysis.

A value for ϕ of 0.23 was inferred from previous research on the combustion of kerosene, and a critical rate of water spray application of $100 \text{ g.m}^{-2}.\text{s}^{-1}$ was calculated for the extinction of kerosene pool fires by fuel cooling (assuming $\lambda_f = 200 \text{ J.g}^{-1}$). This compared well with the experimental data of Reference 43 where a minimum application rate of $80 \text{ g.m}^{-2}.\text{s}^{-1}$ was determined; it was suspected that the discrepancy was due to a dependency on the drop size distribution of the experimental sprays and the effect on λ_w . Earlier experimental investigations of the piloted ignition of wood found a critical decomposition rate of $\dot{m}_c'' \sim 5.1 \text{ g.m}^{-2}.\text{s}^{-1}$ which was fairly constant over a wide range of wood types; assuming $H = 17\,000 \text{ J.g}^{-1}$, Rasbash arrived at a value for ϕ of 0.27. Similar experiments on plastic materials gave values for \dot{m}_c'' of 3.0 and $4.5 \text{ g.m}^{-2}.\text{s}^{-1}$ for polymethylmethacrylate and polyoxymethylene respectively, yielding corresponding values for ϕ of 0.31 and 0.26 respectively. In general, values for ϕ were found to lie in the range 0.2-0.4 and it was suggested that a representative value of 0.3 be adopted for the combustion of ordinary organic materials burning in air at ambient temperatures. Larger values of ϕ indicate that a flame can withstand a higher degree of cooling without being extinguished; however the presence of steam will tend to reduce both the burning rate and the fraction ϕ returned to the fuel. It is therefore necessary to take account of the effect of the cooling water, through the production of steam, on the decomposition rate \dot{m}_c'' close to the firepoint. Although values of λ_f were proving somewhat intractable, Rasbash derived a value of 3000 J.g^{-1} ; it should be noted that this

is a factor of 15 times greater than the corresponding value for kerosene given earlier. This value was derived by assuming values of 0.27 and 4 kW.m⁻² for ϕ and R_c respectively in conjunction with the critical water application rate of 1.6 g.m⁻².s⁻¹ found from crib fire experiments performed by Bryan in 1945 (Reference 123). Overall it was concluded that the firepoint principle provided a simple approach to the problem of the extinction of fire, although problems such as the interdependence of the parameters and their time-dependent behaviour would require further consideration.

Beyler (Reference 124) extended the firepoint analysis to include both solid and gas phase effects, enabling extinction mechanisms other than surface cooling of the solid fuel to be modelled; the additional mechanisms included gas phase dilution, chemical inhibition of flame reactions and endothermic agent decomposition. The motivation for the study was to develop a unified framework for the inter-comparison of various extinguishing agents, the 'unified model' of fire suppression was expected to be of particular benefit in assessing the effectiveness of new agents proposed as replacements for 'environmentally objectionable suppression agents'. At the point of flame extinction by water application, Beyler expressed the firepoint equation as,

$$(\phi H - \lambda_r) \frac{h}{c} \ln \left(1 + \frac{Y_{O_2} H_R(O_2)}{\phi H} \right) + \dot{Q}_E'' - \dot{Q}_L'' - \dot{Q}_W'' = 0 \quad (72)$$

where Y_{O_2} is the oxygen mass fraction and $H_R(O_2)$ is the heat produced per unit mass of oxygen consumed in the combustion reaction (= 13 kJ.g⁻¹ for organic fuels). It can also be seen in equation (72) that the heat losses due to re-radiation (\dot{Q}_L'') have been separated from those due to the evaporation of water (\dot{Q}_W''). In order to simplify the application of the above expression, Beyler observed that most of the terms are material fire properties or may be assumed constant for a given fuel surface orientation. According to Beyler, for a particular material and fuel surface orientation H, λ_r, h, c and $H_R(O_2)$ may all be taken as constants.

Having defined the firepoint equation thus, Beyler described a conceptual procedure for evaluating the 'suppressibility of materials'. A data set is required from a series of experiments where material samples are exposed to various levels of constant external radiative heat flux while being subjected to a known application rate of water. For each value of radiant flux, a range of water application rates must be used in order to determine the minimum rate required for extinction, $\dot{m}_{c,w}''$. Having obtained these data, a plot of \dot{Q}_E'' as a function of $\dot{m}_{c,w}''$ can be constructed, as depicted in Figure 24. The straight lines which result from the plot have a slope of $c_w \lambda_w$, where c_w is the (non-dimensional) cooling efficiency of the water applied and λ_w is the latent heat of vapourisation of the water per unit mass (J.kg⁻¹). The parameter c_w is expected to depend on the degree of penetration achieved by the spray and will be approximately constant for a given experimental arrangement.

The heat lost in evaporating the water may be found using the expression,

$$\dot{Q}_W'' = c_w \dot{m}_{c,w}'' \lambda_w \quad (73)$$

and the x-axis intercept C is given by the expression,

$$C = \frac{(\phi H - \lambda_f) \frac{h}{c} \ln \left(1 + \frac{Y_{O_2} H_R(O_2)}{\phi H} \right) - \dot{Q}_L''}{c_w \lambda_w} \quad (74)$$

which is the water application rate required to extinguish the flame in the absence of an external radiative heat flux. The main features of the analysis may be illustrated with reference to the typical plots for 'material A' and 'material B' in Figure 24, where the former is characteristic of common thermoplastic materials (Reference 124). The intercept, C , is seen to be positive for material A which indicates that this material will continue to burn in the absence of external radiation and that a finite application rate of water is required to extinguish the flame. In contrast, material B exhibits a negative value of C , indicating that the material cannot burn without external heating. The minimum radiative flux required to sustain burning is equal to the y-axis intercept, given by $-C(c_w \lambda_w)$ (kW.m^{-2}). Beyler suggested that the best method for ranking the suppressibility of materials would be to compare values of C found by this method; the more negative the value of C , the better is the performance of the material in terms of its 'suppressibility'. It was also noted that the slope of the lines ($c_w \lambda_w$) is not material-dependent and that in principle, if c_w is known for a given experimental configuration, then experiments at only one value of \dot{Q}_E'' are required. The one caveat to this argument is that the chosen \dot{Q}_E'' value should be near the minimum at which burning can be achieved in order to minimise the extrapolation to $\dot{Q}_E'' = 0$. The form of equation (72) also suggests that extinguishability tests should not be performed at excessively high \dot{Q}_E'' since this term would then overshadow the material-dependent term. Taking this argument to the limit gives an approximation to equation (72) as $\dot{Q}_E'' - \dot{Q}_W'' = 0$ which implies that all materials would be 'equally suppressible' under these conditions; the main function of the water is the absorption of external radiation not the heat feedback from the flame itself (Reference 124).

Beyler also demonstrated how the firepoint principle could be further extended to model the efficiency of so-called 'flame extinguishing agents' such as diluents (e.g. nitrogen) and chemical agents such as Halons. Several important differences between the action of these agents and that of water were described; however, it was stressed that for water-based suppression of solid fuel fires, the dominant mechanism is fuel cooling rather than flame extinguishment. Reference 124 also includes suggestions for the development of a small-scale test methodology based on the unified suppression model, using either the FMRC Flammability Apparatus or the ISO Cone Calorimeter device. The interpretation of the test data for flame agents was shown to be far more difficult than for fuel surface agents such as water. Although the models performed well using existing data from the literature, a need was identified for further experimental work to fully validate the approach.

6.1.3 Thermal theory of solid fuel extinguishment - fuel surface cooling

Fuchs (Reference 125) also considered the process of fire extinguishment in terms of the removal of heat from a burning solid. Although the approach shared some similarities with the firepoint model described in Section 6.1.2, Fuchs employed a more analytical technique to model the transient, one-dimensional temperature field within an isotropic, semi-infinite solid (Figure 25). For this geometry, the three-dimensional Fourier differential heat conduction equation may be reduced to the form,

$$\frac{\delta T}{\delta t} = \frac{k}{\rho c} \frac{\delta^2 T}{\delta x^2} \quad (75)$$

where ρ and k are the density and thermal conductivity of the fuel, respectively and c is its specific heat capacity; in addition the mass loss per unit time, the flame temperature and the surface temperature are assumed to be constant. Under these conditions, the temperature field within the fuel, prior to the application of water, is given by the analytical solution to equation (75),

$$T(x, t) = T_{\infty} + (T_0 - T_{\infty}) \exp\left(-vx \frac{\rho c}{k}\right) \quad (76)$$

where T_{∞}, T_0 are the ambient and surface temperatures respectively (K) and v is the velocity of burning of the surface (*i.e.* the regression rate of the surface in the x -direction). During this initial period, the rate of heat released to the environment was assumed to be,

$$\dot{Q}_1 = \dot{m}H - \dot{Q}_f \quad (77)$$

where H is the heat of combustion of the volatiles and \dot{Q}_f is the rate of heat transfer from the flame back to the fuel surface (W); the similarity between this expression and the heat balance equation (64) is apparent. In order to achieve flame extinguishment, it was assumed that the surface temperature would have to be reduced below the 'ignition temperature' (T_z) by the removal of heat from the solid phase at a rate \dot{Q}_2 while at the same time also removing the heat produced by combustion, \dot{Q}_1 . A somewhat complex analytical expression for \dot{Q}_2 was obtained by solving the model for a zero temperature gradient fuel surface boundary condition.

A solution of the model for the case of fire extinguishment by water application was found by assuming the water to be 100% effective in abstracting the heat from both the flame (\dot{Q}_1) and the fuel bed (\dot{Q}_2); however, the detailed heat transfer mechanisms discussed in Section 5.3 were not considered. The thermal energy absorbed by evaporating 1 kg of water, initially at 20 °C, was taken to be 2592 kJ and the water requirement for fire extinguishment was given as,

$$m_w = m_{w_1} + m_{w_2} \quad (78)$$

where,

$$m_{w_1} = \frac{1}{2592} \int_{t=0}^{t=t_2} (\dot{Q}_1 + \dot{Q}_2) dt \quad (79)$$

and

$$m_{w_2} = \frac{1}{2592} \int_{t=t_2}^{t=t_e} \dot{Q}_2 dt \quad (80)$$

with t_2 being the time at which surface flaming ceases and t_e the time at which extinguishment is complete. During the first phase, the mass of water evaporated (m_{w_1}) both cools the fuel by heat transfer (\dot{Q}_2) and abstracts heat produced by combustion (\dot{Q}_1). In the second phase, the mass of water evaporated (m_{w_2}) reduces the surface temperature to below the ignition point. In order to test the model's predictions of the extinction of wood fires by water, some small scale experiments were performed to gather data on the combustion rate of the surface, ν , and the thermal diffusivity, $\alpha = k/\rho c$, in equation (76). From the results of 20 tests, a value for ν of 0.325 ± 0.02 mm.min⁻¹ was established, while it was found that the thermal diffusivity was strongly influenced by the degree of decomposition suffered by the wood during combustion. Values for α were found to increase typically from $\sim 2.86 \times 10^{-4}$ cm².s⁻¹ for wood to $\sim 5 \times 10^{-3}$ cm².s⁻¹ for charcoal. Using these variations in α , the temperature development in the wood was calculated from equation (76); it was found that, prior to the application of water, the temperature in the fuel increased with the degree of decomposition as a result of the increasing thermal diffusivity. Consequently, the 'heat current' required to be removed from the fuel bed (\dot{Q}_2) also increases with the burning time. Fuchs also noted that the time interval from the start of water application to the point where the fuel surface temperature drops below T_z is critical in determining the ultimate quantity of water required since the reaction heat (\dot{Q}_1) must be dissipated in addition to cooling the solid phase. The model indicated that the water requirement grows more or less linearly with the time taken to arrest the combustion reaction; hence the water requirement is also proportional to the duration of the fire. The practical significance of these two effects is that during the first phase of extinguishment, the flames must be knocked down as quickly as possible in order to halt the combustion reaction; this phase must then be followed by fuel cooling to prevent reignition.

Fuchs' model was also compared with the findings of earlier full-scale room fire tests where it had been established that an average of ~ 95 l of water was evaporated during the extinguishment of a typical furniture fire with water or foam; the volume of water vapourised was found to be independent of the method of application (different types of jet-pipe). Despite the variation in agent, delivery mechanisms and the resulting extinguishing times, the volume of water evaporated varied only slightly from the mean value of 95 litres; it was calculated that $\sim 38\%$ of the water was required to take up the heat of combustion with the remaining 62% being required to cool the fuel to below its ignition temperature, T_z . For a fuel surface area of ~ 40 m² the corresponding application rate was ~ 1.6 l.m⁻² until the fire was extinguished. Assuming a thermal diffusivity for wood of $\alpha = 20 \times 10^{-4}$ cm².s⁻¹, the mathematical model predicted an

application rate for fuel cooling of $\sim 1.5 \text{ l.m}^{-2}$ in the time range of 2 minutes, for a higher α of $5 \times 10^{-3} \text{ cm}^2 \text{ s}^{-1}$ (charcoal), the predicted application rate was higher, at $\sim 2.6 \text{ l.m}^{-2}$. Given that the furniture in the test room was about 40% consumed, Fuchs (Reference 125) supposed the experimental fuel characteristics during extinguishment to be close to those of charcoal. It was concluded that 'a good degree of concurrence' existed between the model predictions and the full-scale tests, even though the experiments employed different extinguishing agents and delivery rates.

6.1.4 Models of flame suppression and extinction - flame cooling, diluting and inerting

The theories described in Sections 6.1.2 and 6.1.3 are based solely on the physical mechanisms which induce cooling of the solid fuel phase in Class 'A' fires, however the importance of knocking down flames (gas phase combustion) during fire-fighting was also stressed in Section 6.1.3. The present Section describes some of the modelling work which has been carried out in this area.

In general, models of fire suppression based on flame cooling employ the heat transfer concepts described in Section 5.3.2. The particular model developed by Rasbash (Reference 44) is described in some detail in that Section and is typical of the approach adopted by other workers. Using this model, Rasbash was able to categorise the extinguishment effectiveness of water sprays in terms of two semi-empirical non-dimensional parameters: the 'spray heat transfer number' (N_H) and 'spray force number' (N_F), where,

$$N_H = \frac{XV}{\dot{m}H} \quad (81)$$

and

$$N_F = \sqrt{\frac{\rho_a v_a^2}{(\rho_a - \rho_f)gx}} \quad (82)$$

and X is the 'heat transfer capacity' of the spray (W.m^{-3}), defined by equation (51) in Section 5.3.2. Here, the variables V , \dot{m} , H represent the flame volume (m^3), the burning rate of the fire (kg.s^{-1}) and the heat of combustion of the fuel (J.kg^{-1}), in addition, g is the gravitational acceleration (m.s^{-2}), x is the flame height (m), ρ_a and ρ_f are the densities of the air and flame respectively (kg.m^{-3}) and v_a is the velocity of the entrained air current (m.s^{-1}).

The first of these parameters, N_H , represents the ratio of the rate of heat absorption by the spray to the rate of heat production by the fire while N_F is proportional to the square root of the ratio of the downward force of the water spray to the upward force of the flames. The analysis of experimental Class 'B' pool fire extinction data in terms of N_H and N_F showed that reliable extinction was achieved only when these parameters were greater than 0.4 and 0.7, respectively. From these results, Rasbash (Reference 44) concluded that the controlling influence of spray heat transfer in the extinction process

had been confirmed. It was also found that, in general, the extinction time decreased as both N_H and N_F were increased, although the influence of the latter was the greater. The reason why the extinction process depends so strongly on N_F is that this factor determines how well the spray can penetrate the flame, particularly to those regions of the flame in close proximity to the fuel surface. In the experiments reported in Reference 44, it was found that the penetration of the lower fraction of droplet sizes into the flames was extremely limited in some cases, thus restricting the cooling capacity of the spray to the upper $\sim 10\%$ of the flame height. In the case where $x \sim 1$ m, and upward flame velocities were in the range $2-4$ m.s⁻¹, it was found that 'only a very small fraction' of the sprays with mass median drop size less than 500 μm could penetrate to the burning liquid. Consequently, the sprays were able to abstract heat very effectively from the uppermost flame zone, comprised mainly of combustion products, but not from the base of the flame or from the fuel gases entering the combustion zone.

In considering the extrapolation of the above correlations to other fire suppression situations, Rasbash expressed some reservations concerning cases where the spray application was other than vertically downward onto the fire. Under these circumstances, it was suggested that the factor N_F should be replaced by a parameter which expressed more directly the ratio of the spray penetration into the flame and the characteristic flame dimension. Regarding the spray heat transfer number, N_H , it was stressed that this parameter was calculated in terms of the fire condition existing before the application of the spray. In reality, it is probable that additional air would be entrained by the water spray, which would tend to promote more intense combustion; thus the suppressive effect of the spray would tend to be decreased through the resultant reduction in N_H .

Kaletka (Reference 88) also developed a model of fire suppression by water sprays, based on the mechanisms of heat and mass transfer between the droplets and the gas phase. The contribution to fire suppression by oxygen displacement was considered to be of secondary importance and was not considered in the model formulation. In accordance with other workers, Kaletka noted that smaller droplets evaporate more easily and hence are advantageous in that they increase the theoretical heat absorption rate of the spray as it interacts with the flame zone or the fuel surface. In practice however, the effectiveness of fine sprays is reduced as they are liable either to be partially vapourised before reaching the flame or depleted by convective flows. Kaletka concluded therefore, that there exists a limiting degree of atomisation beyond which the firefighting effectiveness of a water spray is diminished; the theoretical model was used to determine the droplet diameters which would ensure the optimum extinguishing effectiveness of sprinkler systems.

Briefly, Kaletka's model divided the problem into two zones: the zone between the spray nozzle and the top of the flame zone and the 'flame zone', comprising the burning surface and the entire luminous combustion zone. The model was phrased in terms of the usual mass and energy balances and included expressions for the laminar or turbulent flow around a falling (spherical) droplet. Any heat absorbed by a droplet from the gas phase in the upper zone was not considered to contribute to the extinguishing effect of the spray; the latter was characterised by the rate of heat absorption from the seat of the fire. Kaletka presented some computational results of the rate of heat absorption (W.m^{-3})

against the initial droplet diameter (m) of the monodisperse spray, where the depth of the upper layer (H), temperature of the upper zone and the temperature of the flame zone were varied from 1-7 m, 373-493 K and 1273-1473 K respectively. For all values of H , the data showed a distinct maximum value (or 'peak') for rate of heat absorption associated with a particular 'critical' value of initial droplet diameter, the heat abstraction rate was observed to fall away for diameters either larger or smaller than the critical diameter. For given ambient and flame temperature values, the value of critical diameter was seen to decrease with decreasing 'path length' H , with a corresponding and significant increase in the rate of heat absorption. The effectiveness of a given droplet size was found to be better when the temperature of the upper zone was reduced and that of the flame zone was increased. Based on the study, Kaleta concluded that initial droplet sizes in the range 300-900 μm produced the best extinguishing performance, depending on path length and the prevailing thermal environment.

The distinction between premixed flames and diffusion flames was made in a previous FRDG report (Reference 5), where it was asserted that the fires of interest to the Fire Service comprise large-scale diffusion flames. The concept of the Damköhler number, \mathcal{D} in relation to the stability of diffusion flames was also introduced in Reference 5. The Damköhler number is defined as the non-dimensional ratio of a physical timescale to a chemical timescale,

$$\mathcal{D} = \frac{\tau_r}{\tau_c} \quad (83)$$

where τ_r is the 'residence time' of the fuel vapours in the reaction zone while τ_c is the chemical reaction time, *i.e.* the effective duration of the reaction at the temperature of the flame (Reference 6). The Damköhler number has been used by several workers to characterise the various régimes of combustion, and in particular to explain the discontinuous behaviour associated with the processes of ignition and extinction of flames (References 6, 126-129).

Fendell (Reference 126) described a mathematical model of 'stagnation point' diffusion flame combustion arising from the axisymmetric opposed flow of gaseous oxidiser and fuel streams, the circular flame sheet predicted to exist in the stagnation plane for this geometry is routinely studied experimentally using a 'counterflow diffusion flame burner' (described in Reference 5). Fendell modelled the gas-phase combustion reaction between initially unmixed reactants, assuming 'one-step' chemical kinetics (Reference 5) and inviscid, incompressible flow. The flow of fuel was assumed to originate from a solid or liquid reservoir, defined in the model as a 'wall' of constant temperature (equal to the boiling or sublimation temperature of the fuel). The model was phrased in terms of the usual conservation equations for fluid continua, *viz.* mass, momentum, species and energy. The effect of variations in Damköhler number on the flame character was investigated by solving the model over a wide range of \mathcal{D} solutions were expressed in terms of the radial and axial distributions of temperature and chemical species (fuel fraction and oxygen fraction).

The Damköhler number was defined as the ratio of the time taken for a fluid particle of reactant to traverse the combustion zone to the time for a reaction-inducing collision to occur. For small \mathcal{D} , the level of chemical activity is low and the solution corresponded to nearly 'chemically frozen flow'. For very large, but finite, \mathcal{D} a narrow region of very intense combustion was predicted with maximum temperatures slightly lower than the adiabatic flame temperature (Reference 6). At intermediate values of \mathcal{D} , Fendell (Reference 126) had to employ a numerical solution technique in order to circumvent certain 'intractable non-linearities' arising from the strong coupling between convection, diffusion and chemical reaction within the flow; numerical data for the acetone-air reaction were adopted during these simulations. The functional dependence of maximum temperature (T_{\max}) with \mathcal{D} is illustrated in Figure 26; although this figure is taken from Williams' later paper (Reference 127), the form of the plot is identical to that given by Fendell. According to Fendell, the middle branch (2nd branch in Figure 26) represents an inherently unstable physical state which is rarely observed; a system in this condition is expected to move rapidly towards either the weakly-burning state (1st branch) or the strongly-burning state (3rd branch). Both of the latter two states are stable and are normally observed. Ignition was defined as a sudden transition (or 'jump') from the weak branch to the strong branch; in this case the preferred state changes abruptly from negligible combustion to intense combustion as \mathcal{D} increases, for a system on the lower branch. Conversely, as \mathcal{D} decreases for a system on the upper branch, there is an increasing propensity for a sudden jump to the lower branch if the system is subjected to a large enough perturbation; this sudden transition to the weakly burning state is extinction.

Williams (Reference 127) proposed a unified model of fire suppression based on a consideration of the Damköhler number. Some potential advantages of this approach were anticipated, namely: the possibility of obtaining an improved insight into the suppression process and the potential identification of new fire suppression techniques. The Damköhler number in this instance (D) was defined as,

$$D = (l^2/\rho D) c_F^n c_O^m A \exp(-E/RT) \quad (84)$$

where l is a characteristic length scale (m), D is an appropriate diffusion coefficient ($\text{m}^2 \cdot \text{s}^{-1}$), c_F and c_O are the local concentrations of fuel and oxidiser respectively ($\text{kg} \cdot \text{m}^{-3}$), A is the pre-exponential constant ($(\text{kg} \cdot \text{m}^{-3})^{1-m-n} \cdot \text{s}^{-1}$), E is the activation energy ($\text{J} \cdot \text{kg}^{-1}$), R is the universal gas constant ($\text{J} \cdot \text{kg}^{-1} \cdot \text{K}^{-1}$) and T is the local temperature (K). Since equation (84) represents an approximation to a complex chemical kinetic scheme, the constants A , E , m and n must be determined empirically (Reference 127). Williams observed that the quantities c_F , c_O and T all vary substantially from point to point within a fire, which implies that D is also a variable. In order to make D a constant for a given fire, Williams suggested two alternative strategies. The first involved the evaluation of D at the centre of a flame, at a point of maximum temperature; the resulting constant was termed the 'flame-zone Damköhler number', D_s . The alternative, more practical, definition was termed the 'boundary Damköhler number' (D_b); here, values for T and c_F were evaluated for the gas at a point on the fuel surface while that for c_O was taken from the ambient air. Since the term E/RT is so large, it was shown that the two Damköhler numbers were related approximately by $D_b \sim D_s \exp(E/RT_s - E/RT_b)$.

The variation of the non-dimensional maximum temperature (T_{max}) as a function of D_a and D_b is shown in Figures 27 and 26 respectively. The general form of Figure 26 has been discussed previously, however Williams developed the argument relating to fire suppression beyond that initially suggested by Fendell (Reference 126). Williams stressed that it was important not only to extinguish the fire, but to ensure that it was not subsequently rekindled. With reference to Figure 26, if the value of D_b for a burning system is lowered below the extinction value (D_E), then the only physical state possible is a non-burning one on the 1st branch. From this condition however, if the value of D_b is raised above the critical value for ignition (D_I), then the only stable state corresponds to steady burning on the 3rd branch. In practice then, it is necessary to first reduce D_b below D_E and then prevent D_b from subsequently increasing above D_I , where reignition occurs. Williams stressed that the mode of action of the suppressant was crucially important in this respect, agents which removed the supply of fuel vapour during suppression automatically ensured that $D_b < D_I$. On the other hand, chemical agents were often very effective in initially reducing D_b below D_E but sometimes could not prevent reignition due to a subsequent increase in D_b above D_I . In order to provide a quantitative framework for the above discussion, Williams defined the critical Damköhler number corresponding to incipient flame extinction (D_E) as,

$$D_E = k \left[\frac{RcT_{af}^2}{EQ_F} \right]^3 \exp(E/RT_{af} - E/RT_b) \quad (85)$$

so that the critical inequality to be satisfied for flame extinction ($D_b < D_E$) becomes,

$$(l^2/\rho D) c_{Fb}^n c_{Ob}^m A \exp(-E/RT_{af}) < k \left[\frac{RcT_{af}^2}{EQ_F} \right]^3 \quad (86)$$

where c is the average specific heat capacity of the gas ($J.kg^{-1}.K^{-1}$), T_{af} is the absolute flame temperature in the limit of infinite Damköhler number (K), Q_F is the heat released in the gas-phase combustion reaction per unit mass of fuel consumed and k is a system-dependent constant whose value is typically $\sim 10^{-3}$ (Reference 127). A qualitative correspondence between equation (86) and the known mechanisms of fire extinguishment was described by Williams. Cooling a Class 'A' fuel reduces the flow of volatiles into the combustion zone and hence reduces c_{Fb} , while cooling of the fuel or the flame zone reduces T_{af} , which has a major effect on the exponential factor, $\exp(-E/RT_{af})$. Removing the oxidiser or reducing the concentration by inerting the atmosphere tends to reduce c_{Ob} and chemical inhibition slows down the chemical kinetics which is reflected in a reduction in A .

In the case of Class 'A' fire suppression by water application, Williams concluded that the most effective method of using water is to promote direct cooling of the solid fuel itself, which in addition to encouraging flame extinction also helps to prevent reignition. Rasbash's 'rules of thumb' extinction criteria of reducing the flame temperature below 1580 K, or extracting from the condensed fuel 2500 cal.g⁻¹ ($\sim 10.5 J.kg^{-1}$) of fuel gasified (Reference 43) were seen by Williams as approximations to equation (86). Williams concluded that the way water affects the parameters in equation (86) is complex and more thorough modelling studies were required to achieve a definitive understanding of the mechanism. It was also suggested that the validity of equation (86)

should be tested quantitatively by conducting experiments where fires were extinguished by different techniques. In a later review of flame extinction (Reference 128), Williams considered the fundamental criteria for the extinction of laminar diffusion flames by inert materials (e.g. water, carbon dioxide and nitrogen). This paper included a wide-ranging discussion of the factors affecting the Damköhler number at flame extinction for diffusion flames associated with 'condensed-phase' (*i.e.* solid and liquid) fuels. For a range of complex fuels, the adiabatic flame temperature at extinction was shown to lie in the range 1700-2300 K, significantly higher than the 1580 K limit proposed by Rasbash as a general extinction criterion (Reference 43). It was concluded that the 1580 K figure was conservative in that it is usually sufficiently low to assure extinction.

Corlett and Williams (Reference 130) described a modelling framework for direct suppression of open fires with the emphasis on water application as the primary means of suppression. The intention was to derive a quantitative measure of the deviation of a fire from its undisturbed history, as a function of the type and extent of suppressive action taken; suppression was defined by these workers as '...a reduction in the severity of an unwanted fire, eventually leading to its extinction in most cases...'. A 'horizontal coherent length of flaming', L , was introduced; successful suppression being viewed as a reduction in L below a critical value. After discussing the many inadequacies in the contemporary understanding of fire physics, a 'middle path' was chosen between a self-contained theoretical treatment and a wholly empirical model. The model was constructed around two key variables: the average value of flame-to-fuel energy feedback, q , and the volumetric evolution flux of gasified fuel, u . Only 'open fires' were considered, these being defined as situations where the combustion is sufficiently free of enclosure effects that oxygen starvation is impossible; the aerodynamic and heat transfer effects of walls or other obstacles were similarly excluded. Illustrative dimensions for L were given as a few millimetres for a burning match to ~ 2 m for an intensely burning bonfire and it was observed that all fires are coherent on some length scale L . Coherent flaming on a length scale L was said to occur '...if the visible and sensibly hot gas régime persistently extends throughout a volume whose horizontal dimensions are at least L ...'. From a consideration of the mass and energy balance above a condensed-phase fuel bed, a coherence criterion was expressed in terms of a critical Froude number, Fr^* ; the non-dimensional Froude number is conventionally used in the study of buoyant flows to express the ratio of inertial forces to gravitational forces. The mathematical descriptions of coherency, energy feedback and fuel bed response were combined to form a practical suppression criterion, based on the occurrence of a minimum mean 'flame' temperature,

$$T_f^* = T_\infty + \eta^*(T_e - T_\infty) \quad (87)$$

where T_e is the extinction temperature of the thin reaction zone (1580 K), T_∞ is the ambient air temperature (~ 293 K) and $\eta^* = 0.5$; thus $T_f^* \approx 940$ K. Although it was indicated that quantitative information could be obtained from the model on the basis of existing knowledge, Corlett and Williams (Reference 130) identified several areas where more detailed experimental measurements were desirable. Avenues for possible future investigation included: evaluating the effect of suppression on the radiant feedback to the fuel bed, determining the nature of the time-dependency of the fuel's response to

suppressant action and obtaining information on the 'unmixedness' within the turbulent diffusion flames.

Discussion of the above modelling strategies was reported by Levine (Reference 131) in the US; the discussion group involved researchers from the National Bureau of Standards' Centre for Fire Research (now NIST), Factory Mutual Research Corporation, the Naval Research Laboratory, NASA and the Federal Aviation Authority. Some existing theories were reviewed and the view was expressed that the various models had not yet reached a realistic, usable state, *i.e.* the technology was immature. It was also ventured that empirical fire extinguishment models might be more appropriate than a 'first-principles' theoretical approach, since the former was more able to incorporate the practical distribution of water resulting from the actions of a fire-fighter. Much of the work discussed in Reference 131 refers to experimental studies which are considered in more depth in Section 7 of the present report.

Recent investigations of fire suppression using mathematical models have favoured the 'first-principles' approach, and in particular have exploited 'Computational Fluid Dynamics' (CFD) techniques of the type employed to study the fire-plume interaction problem (Section 5.2.2, References 52-57). The National Fire Laboratory in Canada have used the CFD technique to simulate the suppression of enclosed liquid pool fires (References 132, 133). Hadjisophocleous *et al* described numerical simulations performed using the 'TASCflow' CFD code as a supplement to a series of full-scale tests on the suppression of heptane pool fires by water mist (Section 7). TASCflow is a general three-dimensional CFD code, capable of handling many types of laminar and turbulent flows; some advanced features include Lagrangian particle tracking, radiative heat transfer and the ability to simulate reacting combusting flows. In order to reproduce the behaviour of liquid pool fires, a number of improvements were added; these included the coupling of fuel evaporation rate to radiative heat feedback and the injection of 100 drops (of various diameters) of water per computational time step. The results confirmed the ability to predict the variation in water flux ($\text{kg.m}^{-2}.\text{s}^{-1}$) impinging on the compartment floor under non-fire conditions. The CFD predictions of temperature profile and of heat release rate were also found to be in reasonable agreement with the experimental findings; the heptane pool fire could not be extinguished by a single water mist nozzle because the strongly buoyant fire plume effectively prevented penetration of the spray to region near the fuel surface.

Mawhinney and Hadjisophocleous (Reference 133) discussed the emergence of an empirical understanding of how water mist systems work, or in some cases fail to work, based on a decade of intense research into fire suppression by fine water sprays. It was stated that the level of understanding was still below that required to enable water mist systems to be designed from 'first-principles'. A two-pronged approach was seen as the best way forward, specifically, a combination of full-scale testing and improved data analysis using CFD. The use of the latter was advocated because the fire suppression problem is multi-variant and non-linear in nature, involving complex relationships between the fuel, water spray, compartment geometry and the probability of extinguishment. It was envisaged that by including field modelling (CFD) as a diagnostic tool alongside full-scale testing, the ultimate goal of obtaining a first-

principles design methodology for water mist fire suppression systems (WMFSS) would be realised sooner.

6.2 Empirically-based models of compartment fires

6.2.1 Compartment fire models in the absence of fire suppression

Drysdale (Reference 6) noted that the early experimental work on compartment fires used wood cribs as the fuel bed, in order to achieve reproducible fire loads. However, the results from these tests inferred a strong dependence of burning rate upon the size and shape of the ventilation opening. This behaviour is not consistent with the observed fact that the burning rate in a confined situation is increased by radiative feedback from the surroundings. It was argued (Reference 6) that the burning of wooden cribs is a 'special case', where much of the burning surface is effectively shielded from the surroundings and the burning rate remains relatively unaffected by the local thermal environment. For 'real' fire loads, especially those involving non-cellulosic materials, there is no physical imperative for a strong coupling to exist between burning rate and the rate of air ingress. Drysdale (Reference 6) concluded that: *'Any realistic theoretical treatment of the post-flashover fire must consider rate of burning and rate of ventilation separately.'*

Friedman presented a review of compartment fire research in 1975 (Reference 134), describing work conducted on both the pre- and post-flashover phases. In the case of the pre-flashover fire, the scientific goals were considered to be the prediction of the critical conditions at incipient flashover and the time from ignition to this point. The major concern in post-flashover fires was the ability to predict the magnitude and duration of the thermal load imposed on the structure. Friedman discussed some criteria for defining the onset of flashover and various scaling strategies to enable the extrapolation of small scale test data. It was concluded that the flashover criteria were too simplistic to be generally applicable. Some scaling techniques used by Factory Mutual had achieved considerable success for certain geometries of enclosure, however the modelling of all fire phenomena simultaneously was deemed to be impractical. In order to model disparate combustible materials in enclosures, the use of the Spalding B -number was advocated as a scaling parameter (Reference 135); this was to ensure the correct scaling of energy release per unit mass of fuel, the latent heat of evaporation (or 'volatilisation') and the stoichiometric fuel-air ratio.

Bullen (Reference 136) and Bullen and Thomas (Reference 137) developed analyses based on the separation (or de-coupling) of burning rate and ventilation rate. In the former, a series of steady-state heat and mass balances were conducted for compartment fires containing Class 'B' fuels. It was shown that the thermal conductivity of the wall (k) and the area of the fuel bed (A_f) had the most significant effect on the burning rate, \dot{m} . Bullen and Thomas (Reference 137) burned small scale liquid and plastic fuel fires in a 2 x 1 x 1 metre compartment model with three different ventilation areas. It was confirmed that \dot{m} depends on the ventilation area and the exposed fuel surface area, with the burning rate approaching a constant ('open air') value as the ventilation area is

increased. A maximum value of \dot{m} was observed at some intermediate 'ventilation factor', $A_w H^{1/2}$, and the absolute value of this critical quantity was found to be proportional to the fuel area A_f . The importance of radiation as the dominant mode of heat transfer which determines \dot{m} was also confirmed by Bullen and Thomas (Reference 137) and it was shown that the extremely high rates of burning of some non-cellulosic fuels could lead to flashover with values of A_f only one-tenth of that required for wood.

Jones (Reference 138) reviewed different six state-of-the-art zone models of compartment fires in 1983 in an effort to define a framework for future research in this area. Only three of the six models incorporated a fire source sub-model for the prediction of flashover and multiple ignition problems, the other models required the user to input the burning rate as a function of time. While none of the models was entirely 'complete' in its formulation, all contained features which could potentially be exploited in a more general model. It was also concluded that all of the models suffered to some degree from weaknesses in their numerical schemes.

The post-flashover compartment fire model of Pettersson *et al.* (Reference 139) has been discussed in some depth by Drysdale (Reference 6). This theoretical model was developed as a design aid for assessing structural 'fire resistance requirements' and consequently assumes a time origin (t_0) corresponding to the inception of fully developed conditions; the thermal stresses on the structure during the pre-flashover phase are negligible in comparison, and are not considered in the model. The compartment is treated as a calorimeter (see Figure 28) in order to solve the heat balance equation.

$$\dot{q}_C = \dot{q}_L + \dot{q}_W + \dot{q}_R + \dot{q}_B \quad (88)$$

where,

- \dot{q}_C = rate of heat release due to combustion;
- \dot{q}_L = rate of heat loss due to replacement of hot gases by cold;
- \dot{q}_W = rate of heat loss through the walls, ceiling and floor;
- \dot{q}_R = rate of heat loss by radiation through the openings;
- \dot{q}_B = rate of heat storage in the gas volume (ignored).

Various simplifying assumptions are made within the model, including that of a uniform gas temperature within the compartment, T_g , which is then solved for using equation (88). The model also assumes that the fire is in the ventilation-controlled régime throughout, and that \dot{q}_C remains at a constant value until all the fuel is consumed. It is pointed out in Reference 6 that the former assumption will overestimate the burning rate if the fire is actually fuel-controlled. Although more sophisticated models have been developed which allow the user to specify the burning régime and details of the fuel disposition (References 140, 141), it was argued in Reference 6 that there may be a case for the use of simpler models, given the many assumptions and uncertainties associated with compartment fire models in general.

Pitts (Reference 142) has recently presented a review of compartment fire research in an attempt to characterise the formation mechanisms of carbon monoxide (CO) gas in enclosure fires; it was estimated that roughly two-thirds of all fire deaths could be attributed to the effects of CO. It was hoped that these recent data would lead ultimately to an improved understanding of CO formation, which would assist in the development of improved prediction techniques for existing life-safety hazard computer programs. A number of reduced-scale compartment fire tests were described which used fuels such as propane, hexane, natural gas, PMMA and wood as the fire source. The reduced-scale enclosure (RSE) developed by NIST was also described, together with some initial findings from experiments in this facility. Pitts analysed these experimental data, in conjunction with the results from chemical-kinetics calculations and field-modelling simulations of the compartment flow-field (using Harwell's *FLOW-3D* software), in an effort to produce a simple correlation between CO production and a single global parameter describing the compartment environment. The latter parameter was defined as the *Global Equivalence Ratio*, ϕ_g , of the upper stratified hot layer.

The 'GER' was defined as the ratio of the combustion product mass derived from the fuel to the mass introduced from entrained air, divided by the theoretical ratio required for complete combustion to the fully oxidised products CO₂ and H₂O (*i.e.* the *stoichiometric ratio*), therefore:

$$\phi_g = \frac{m_{\text{fuel}}/m_{\text{air}}}{(m_{\text{fuel}}/m_{\text{air}})_{\text{stoichiometric}}} \quad (89)$$

and was estimated by a variety of methods, depending on the experimental configuration (Reference 142). While some significant insights into the mechanisms of CO formation were obtained, the initial aim of the work was not realised since the validity of the ϕ_g correlation concept was restricted to highly idealised fire scenarios which were unrepresentative of real compartment fires. Some of the more important factors were identified as the mixing and chemical effects due to multiple and disparate fuel sources, hot layer temperatures in excess of 900 K (630 °C) and the likely direct introduction of air into this layer *via* various 'ventilation pathways'. It was concluded that additional understanding of very complicated processes (including the direct entrainment of air into the upper layer, and the high-temperature pyrolysis of wood and other polymeric materials) was required before accurate predictions of CO production could be made for the most relevant compartment fires.

6.2.2 Compartment fire models with fire suppression

The use of CFD techniques to model the effects of fire suppression has been mentioned previously in Sections 5.2.2 and 6.1.4; the models described therein are derived from a fundamental analysis of fluid dynamics and heat transfer. The present section considers models of compartment fire suppression which have a more empirical basis and are therefore more akin to those described in Section 6.2.1. Pietrzak described the development and use of a physically-based (heat and mass balance) computer code designed to simulate the manual suppression of post-flashover compartment fires and to

improve the performance of suppression systems used by fire-fighters (References 143-145). It was anticipated that the theoretical approach, in conjunction with some experimentation, would lead to a better understanding of the fire suppression phenomena than had been possible from numerous disparate empirical data gathered in the past. The so-called 'Fire Demand Model', or 'FD Model', focuses on the suppression of post-flashover charring and non-charring solid fuel fires in compartments, using portable hosereel systems.

Prior to the commencement of active fire suppression, the undisturbed compartment fire is modelled in the FD Model by the techniques described by Babrauskas and Williamson (References 140, 141). The FD Model contains many additions to the basic compartment fire simulation, including the ability to handle both charring and non-charring fuels, complex room geometry (including various wall materials), ventilation conditions and the effect of water application. A complete listing of the various input and output parameters for the FD Model is given by Pietrzak in Reference 143. The water spray is specified in terms of flow rate, pressure, volume mean diameter of drops, cone angle, 'sweep time' required for the stream to cover the compartment interior and the fuel area fraction accessible to water impact. The model assumes a suppression water inventory consisting of three components: (1) an amount which fails to penetrate the fire plume and is convected out of the compartment; (2) an amount which is vapourised in the compartment gases and (3); the remainder, which impacts on the fuel and other surfaces (walls, floor etc.) in liquid form.

In the FD Model, water droplets of a given initial size are assumed to fall at a characteristic terminal velocity and evaporate in a compartment of uniform temperature and uniform updraught velocity (v_c). For given compartment conditions there exist two critical droplet diameters: a lower value where the droplet terminal velocity is equal and opposite to v_c and an upper value where the droplet is just capable of reaching the floor before evaporation diminishes its size to that susceptible to convection by the updraught. Assuming a Rosin-Rammler drop size distribution (Section 5.1.3), the data for single droplets is extrapolated over the entire droplet population to produce an inventory of the water spray distribution as shown in Figure 29. The fraction of water vapourised is assumed to cool the gas phase and the fraction lost is discounted. The water fraction reaching the solid surfaces is re-distributed among the exposed areas, comprising the interior surfaces of the compartment and the fuel surfaces. The suppression effect on the fuel is treated differently depending on whether the combustion is charring or non-charring in nature (Reference 143).

Pietrzak (Reference 143) found that the results from the FD model compared well with the limited experimental data on the suppression of post-flashover fires with manually applied water sprays. The minimum application rate of water required for effective knockdown of the fire ($l \cdot min^{-1}$) was found to be strongly correlated with the volume-median drop size, values for the former of $34 l \cdot min^{-1}$ and $57 l \cdot min^{-1}$ were predicted for volume-median drop sizes of $300 \mu m$ and $700 \mu m$ respectively. An important point arising from the simulations is that the degree of control achieved by a given application rate is dependent upon the spray characteristics and on the fraction of the fuel area which can be reached by the water. Fire control can occur by two distinct mechanisms: direct cooling of the fuel or gaseous cooling of the compartment atmosphere. The

former requires larger drop sizes to facilitate penetration through the fire plume while evaporative cooling is most efficient with smaller drop sizes. In practice the model predicts a minimum application rate for fire control which is a function of the exposed fraction of fuel area and also of drop size. If the exposed fuel area is small, fire control can only be achieved by gaseous cooling and there exists an optimum drop size corresponding to a minimum application rate; the optimum range quoted in Reference 143 is 150-350 μm (Rosin-Rammler volume-median diameters). On the other hand, if the fuel surface is well exposed, the critical application rate for control is seen to decrease as the drop size increases; this is due to the lower evaporation and increased penetration and subsequent cooling achieved by larger water droplets.

It was concluded that for post-flashover compartment fires where gaseous cooling was decisive for fire control (*i.e.* where exposed fuel areas were low), the application rates for fire suppression could be optimised by careful selection of the drop size characteristics. It was recommended that future simulations using the FD Model should incorporate empirical drop size distribution data from real fire-fighting sprays in order to improve upon the Rosin-Rammler approximation. The need for additional experimental verification work was also stressed. A comparison of the FD Model with some more recent full-scale experiments on the manual suppression of compartment fires was described by Pietrzak in Reference 145. Although reasonable agreement was found between the theoretical and experimental temperature histories within the compartment, an extensive list of future improvements to the FD Model was suggested; the general areas considered were the 'burn' model, the water vapourisation model and the extinguishment model.

6.3 Summary

The theoretical models discussed here fall into two broad groups: those which attempt to describe the suppression and extinction problem in some 'local' sense (*e.g.* in the environs of the fuel surface and/or within the flame zone) and those which formulate the problem as part of a larger physical framework, typically a compartment containing a fire. Some interesting predictions have emerged, notably from Fuchs' analysis (Reference 125) where it was estimated that some 62% of the water applied to a room fire was required to cool the fuel below its characteristic ignition temperature. The fundamental modelling approaches described in References 126, 127 and 130 are elegant, but require some effort to apply to practical situations. Unfortunately, it is generally the case that such theoretical models have been subjected to insufficient independent scrutiny and furthermore have been used to solve only the particular problems devised by their originators. In the course of the present study it has not been possible to perform a critical appraisal of these modelling techniques. It would be of interest, at some future date, to compare the predictions from these models against some of the more recently-published experimental data on fire extinguishment. This would provide an independent assessment of the utility of the various modelling techniques and highlight any gaps in the experimental data which might be addressed in future studies.

7. LARGE SCALE AND SMALL SCALE SUPPRESSION TESTS

7.1 General

Fristrom (Reference 9) discussed the problems associated with the development of techniques for the evaluation of fire suppressants and their method of application. The problem is complicated because of the great diversity in the types of fire, extinguishing agents and techniques of application; these difficulties are compounded by the need to specify the condition and rate of application of the agent. The use of laboratory test methods is favoured for reasons of economy and the degree of control which may be exercised on the test conditions. However, the problems associated with scaling small-scale data to the full-scale situation are notorious, particularly in the case of combustion systems (References 146-148). Hirst (Reference 3) stated that 'a practical fire test is often the only convincing way of comparing the effectiveness of extinguishing agents...', and described the construction of the empirical curves shown in Figures 30 and 31. Figure 30 is obtained from the results of a series of tests where the extinguishment of a standard fire (e.g. a tray of flammable liquid or a wooden crib) is attempted by the application of an agent (e.g. water) at different rates; a plot of the extinguishment time against the application rate results in a curve of similar form to that shown in Figure 30. In tests such as this there exists a 'critical application rate', below which the fire cannot be extinguished; there is also a minimum time to extinguishment, which for an experienced fire-fighter can be quite reproducible (Reference 3). Using the data from Figure 30, the quantity of agent required for successful extinguishment can be calculated from the product of the extinguishment time and the application rate. A plot of quantity versus rate (or ' Q/R ') curve is shown in Figure 31. The critical rate for this plot has the same definition as before, but the 'optimum rate' and 'preferred rate' of agent application are also shown. The optimum rate corresponds to the case where fire extinguishment is achieved using the minimum total quantity of agent. The preferred rate corresponds to a somewhat higher rate used by fire-fighters in practice, in order to assure successful extinguishment. While the optimum rate is more economical, its proximity to the critical rate makes it less than the ideal choice in practical situations; although the preferred rate may be some 3-4 times greater than the critical rate and hence less economical than the optimum delivery rate, the time to extinguishment will be less (Figure 30).

Fristrom (Reference 9) wrote that it was customary in studies of fire extinguishment to express the application rate as a mass rate per unit area, for example $\text{kg.m}^{-2}.\text{s}^{-1}$ in the case of powder agents (or more usually in the case of water, $\text{l.m}^{-2}.\text{s}^{-1}$). It was pointed out that this practice tacitly assumes that the method of application, the agent's physical state and its degree of 'aggregation' are either standardised or unimportant and that the fire intensity is independent of the size. In practical situations none of these assumptions are strictly valid however, and the specification of droplet or particle size distributions and other relevant physical parameters of the extinguishant and its application are required. The additional problems of scaling laboratory and field experiments to larger fires has also been mentioned in the preceding paragraph. Notwithstanding these important issues, much may be learned from well designed experiments on fire

suppression and extinction; the following sections provide a review of the more notable studies.

7.2 Suppression tests on open fires

7.2.1 Fire suppression tests involving a range of fuel types

Herterich (Reference 10) reviewed much of the experimental data on fire suppression published up to 1960. Some early work (1933-36) was reported concerning the suppression of wood fires by the use of solid jets. The fuel was stacked as a 'heap' on a weighing platform and subjected to various water application rates. The success of the suppressive action was measured in terms of the magnitude of the 'fire residue', defined as the weight of fuel rescued from the fire. Two main points emerged from this study: firstly, the primary function of the water is to extract heat from the body of the fuel, therefore the water requirement depends on the 'heat content' of the fuel and not by the heat released in the products of combustion; secondly it was found that an increase in the pressure head of the jet did not increase the fire residue, contradicting the received wisdom regarding the superiority of so-called 'hard-jets'. In fact, it was found that 'soft sprays' were better absorbed by the wood charcoal. It was also found that for a burning rate of wood of 1 g.s^{-1} , corresponding to a heat release rate of $\sim 3 \text{ kcal.s}^{-1}$, the fire could be extinguished with a water application rate corresponding to an evaporative heat extraction rate of only $0.085 \text{ kcal.s}^{-1}$, which supported the proposed extinction mechanism (*i.e.* fuel cooling).

In the case of spray-jets, Herterich (Reference 10) noted that most of the early work had been performed using liquid fuels rather than Class 'A' materials. However, the laboratory study of fire extinguishment by water sprays conducted by National Board of Fire Underwriters in the US (Reference 149) included test fires of wood, in addition to petrol, kerosene and ethyl alcohol. The research objective was to determine experimentally, under controlled conditions, the mechanisms by which sprays of water droplets extinguish fires. Prior to the fire extinguishment tests, a total of 19 different nozzles were subjected to a quantitative performance appraisal; these included various simple orifice nozzles and an experimental impinging-jet impact nozzle. The droplet size distributions for each nozzle/operating pressure combination were tabulated on a frequency basis (showing the percentage of droplets occurring in a particular size band) and also on a cumulative basis (showing the maximum diameter of the droplets within the indicated percentage of the total). The 'mean diameter' of each spray was quoted in 6 different forms, including the arithmetic mean, surface area mean, volume mean and Sauter mean values; these correspond to D_{10} , D_{21} , D_{31} and D_{32} in Table 3 (page 15). The individual droplet sizes were measured using a conventional compound microscope fitted with an eyepiece micrometer, the water droplets having been captured previously in a viscous medium (either castor oil or a mineral oil-petrolatum mixture).

All of the extinguishment experiments were performed within a galvanised steel test chamber measuring $\sim 0.9 \times 0.9 \times 1.5 \text{ m}$ high (total volume $\sim 1.2 \text{ m}^3$). The base of the chamber remained sealed although the roof was removable; additional ventilation

openings (0.3 x 0.3 m) were provided in each of two opposing walls. Water sprays were applied to the fires either vertically, from a point ~ 3 m above the centre of the base of the chamber (with the roof removed) or horizontally through an opening in the side wall 250 mm above floor level. In the case of the wood fires, rectangular pieces of white pine wood (12 x 6 x 150 mm long) were used to construct cribs in the form of 150 mm cubes, with gaps of ~ 23 mm between the individual wooden strips. The water was applied either vertically from above the fuel or horizontally from one side and in each case a pre-burn period of 10 minutes was permitted before activation of the spray. During four of the former series of tests, the top of the chamber remained open and the side vents were shut but in one case the enclosure was completely removed. Only two tests were performed with the horizontally-applied spray and for these the top of the chamber was either open or provided with a vented cover and the side vents were closed.

During the wood fire tests, flaming combustion was extinguished rapidly by the water sprays, apart from the small flames which persisted in the interior of the cribs. Deep-seated glowing or smouldering combustion, particularly in the crib interiors, was not as readily extinguished by the sprays and flaming combustion recurred frequently within a few minutes after the spray was shut off. The degree of confinement was found to be an important factor and water sprays were more effective when the top of the chamber was covered; in these cases very little water was required to effect extinguishment. The fastest extinguishing times for both solid and liquid fuels were achieved using horizontally-applied sprays. For the petrol fires, droplets with mean diameters in the range 100-150 μm produced extinguishment when applied horizontally but failed to extinguish the fire when applied vertically downward; in the case of sprays comprising mean droplet diameters of the order 300 μm or more, there was a definite increase in the total amount of water required for extinguishment. Overall, the 'most suitable' droplet size was found to be between 300-400 μm , defined as the volumetric mean diameter (D_{30} in Table 3, page 15). In addition, the critical application rate to ensure extinguishment of the fire was found to be between 0.1-0.2 $\text{gal.ft}^2.\text{min}^{-1}$ (~ 4 $\text{l.m}^{-2}.\text{min}^{-1}$).

The work of Rasbash (References 43, 44, 150) on the suppression of liquid fires has been widely reported in texts dealing with the effectiveness of water sprays. In Reference 150, a range of impinging-jet sprays with different drop size distributions was used against 30 cm pan fires of alcohol, benzole, petrol, kerosene (firepoint ~ 60-68 °C), gas oil (firepoint ~ 104-115 °C) and transformer oil (firepoint ~ 175-180 °C). Five different sprays were employed, with volumetric mean diameters (D_{30}) in the range 157-250 μm , corresponding to Sauter mean diameters (D_{32} in Table 3, page 15) of 230-430 μm respectively. The pre-burn time for the liquids varied from 1 second to 8 minutes. It appeared that the finer sprays promoted the most rapid extinction on volatile fuel fires (alcohol, petrol, benzole) whereas the coarser sprays were better suited to extinguishing the less volatile fuels (gas oil, transformer oil). The experimental results were analysed by correlating the extinction time with properties of both the fires and the sprays. It was found that the extinction time was directly proportional to the droplet size of the spray but inversely proportional to the rate of water flow into the fire zone and also to the velocity of the air entrained by the spray. In other words, the most efficient sprays were those with the finest droplets, the highest rates of water flow and the highest velocities of entrained air. It proved difficult to extinguish the petrol and benzole fires when the

pre-burn time was short; this was attributed to the relatively thin vapour zone which existed between the fuel surface and the flame base prior to water application. A thin vapour layer, of the order of boundary layer thickness, was associated with very stable flat flames which were not easily extinguished. Where a relatively thick vapour layer formed however, instabilities were present in the flame and it was suggested that one beneficial effect of increased air entrainment was to hasten the disruption of the layer, thus promoting the observed rapid fire extinguishment.

In Reference 43, Rasbash discussed a series of experimental investigations on the extinction of fire; these were divided into two groups, according to whether the primary extinction mechanism was cooling of the fuel or cooling of the flame. It was noted that for experiments on room fire suppression, there remained some uncertainty as to the nature of the dominant extinction mechanism. For liquid fuels it was stated that the critical rate of heat transfer required for extinction of the fire by fuel cooling was controlled mainly by convection from the flame to the liquid rather than by radiation from the flame. In defining a critical application rate for the extinction of a wood fire, Rasbash cited the work of Bryan and Smith (Reference 151); this work was also summarised by Heskestad in Reference 152. The experiments involved a burning wood crib comprised of 51 mm square pieces of Corsican Pine (moisture content 12%) and with a total surface area of 80 ft² (7.2 m²). A single horizontal water spray impinged on the burning crib while it rotated about the vertical axis and the time to extinction was measured as a function of the application rate; in this manner the critical rate for extinguishment (\dot{m}''_{wc}) was determined to be 1.7 g.m⁻².s⁻¹ for a 38% pre-burn (*i.e.* water application commenced after the crib had lost 38% of its initial mass). The extinction mechanism in this case was by cooling of the wood, as in Reference 149. Heskestad (Reference 152) also presented data for the critical water application rate found from experiments on wooden cribs (References 153-155) and vertical wooden slabs (Reference 156).

Kida (Reference 153) applied a horizontal water spray manually to two sides of a burning wooden crib (Japanese Cedar, 12-15% moisture content) and determined $\dot{m}''_{wc} \sim 2.5 \text{ g.m}^{-2}.\text{s}^{-1}$ (0.15 l. m⁻².min⁻¹) Kung and Hill (Reference 154) studied wooden cribs of approximately zero water content and wooden pallets with moisture contents between 6-10%. The cribs were constructed from sticks of Eastern White Pine measuring 17 x 17 x 185 mm with 4 sticks per layer and a variable number of layers (6, 11, 16). The wooden pallets measured 1.22 m cubed and were of a similar wood. For the cribs the critical water application rate varied from 1.9-2.4 g.m⁻².s⁻¹ for pre-burn values of 5% and 20% respectively. For the fully-involved pallet fires a value for $\dot{m}''_{wc} \sim 2.5 \text{ g.m}^{-2}.\text{s}^{-1}$ was found to apply for both 10% and 20% pre-burns. Tamanini conducted fire suppression trials on wooden slabs (Reference 156) and cribs (Reference 155). The dimensions of the former were 191 x 279 mm with thicknesses of 6.4, 12.7 and 19.1 mm; a critical water rate of 1.3 g.m⁻².s⁻¹ was found to apply. The wooden cribs were constructed from sticks of thicknesses 10, 13 and 19 mm; values for \dot{m}''_{wc} of 1.5 and 3.0 g.m⁻².s⁻¹ were found to apply to 'loosely-packed' and 'densely-packed' cribs, respectively.

Stolp (Reference 157) discussed how the critical application rate appeared to vary greatly depending upon the scale of the fire, these data are reproduced in Table 8 below.

Table 8
Variation of critical application rate with fire surface area (adapted from Reference 157)

Fire surface area (m ²)	Critical rate of application for extinguishment (l.min ⁻¹)		
	UK	USA	Laboratory
10	600	360	60
100	~ 2000	~ 1700	180
1000	> 6000	~ 8000	~ 850

The discrepancies between the expected critical rates obtained from the extrapolation of laboratory data and those observed in practice are typically one order of magnitude, regardless of the size of fire. Stolp described a laboratory investigation designed to clarify some of the issues involved. Wooden cribs were burned on a rotating turntable attached to a balance and water was applied vertically downward onto the upper surface through a centrally-located nozzle. The crib dimensions were 0.2 x 0.2 x 0.2 m or 0.4 x 0.4 x 0.2 m, constructed of sticks which were 25 x 10 mm in cross-section. During these tests, a 35 kg crib with a surface area of 1 m² and burning at a constant rate between 5-6 kg.min⁻¹ was not extinguished by a water delivery rate of 0.85 l.min⁻¹.

Assuming a heat of combustion for the wood to be $\sim 19 \times 10^6 \text{ J.kg}^{-1}$ and the latent heat of evaporation of the water to be $2.5 \times 10^6 \text{ J.kg}^{-1}$, the vapourisation of water at this rate amounted to $\sim 2\%$ of the heat produced by the fire. It was stated that if water was applied at a rate sufficient to extract $\sim 9-10\%$ of the heat produced then the fire would be extinguished immediately). For free burning fires, the criterion for extinguishment was expressed as $\Delta R/\Delta W \sim 9-10$, where ΔR and ΔW are the heat release rate by the fire and its abstraction rate by the formation of water vapour respectively (measured in the same units). For confined crib fires where the ventilation was restricted, the ratio $\Delta R/\Delta W$ was reduced to $\sim 5-6$ implying an increased critical application rate. This latter observation was used to infer that fuel bed cooling is the dominant extinguishing mechanism. The logic here is that if a confined fire was extinguished by oxygen displacement through water vapour production, then it would be expected that the critical application rate might fall, the significant increase in the energy fraction required to be removed by the water confirms that fuel cooling is vital.

Takahashi (Reference 158) also investigated the critical water application rate for the extinction of small scale wooden crib fires and defined the 'fundamental condition for the total extinction' as *Reignition time \geq Time required for sweeping the entire fuel surface with water*. The test cribs were constructed of Japanese cedar ($\rho \sim 0.4-0.5 \text{ g.cm}^{-3}$) with a moisture content between 9-13%. The sticks were 3 cm square in cross-section by 21 cm in length and were arranged four per layer in eight tiers; the crib was supported on a load cell and the mass loss was monitored throughout the test. After ignition, the crib was allowed a variable pre-burn period and suppression commenced when the initial mass loss was either 20%, 40% or 60% of the initial mass. Water was then applied manually in a stream via a glass capillary and directed towards the interior

of the fuel array. Extinction was judged to have been achieved when all glowing of the charcoal had been eradicated. The critical application rate for extinguishment was found to lie in the range $1.2\text{-}3.8\text{ g.m}^{-2}\text{.s}^{-1}$, assuming an inner surface area of the crib (excluding the 'vertical side wall') of $\sim 0.5\text{ m}^2$; it was noted that these rates agreed well with those reported in Reference 152 (*i.e.* $1.3\text{-}3.0\text{ g.m}^{-2}\text{.s}^{-1}$). The actual value of critical application rate was found to vary with the amount of pre-burn and the method of application of the water; the rate increased in proportion to the degree of pre-burn and was lower when water was applied from the base of the crib upwards rather than from the top downwards. A simple model of the extinction process was also described, based on radiative heat transfer within the crib, which predicted a critical rate between $0.85\text{-}1.5\text{ g.m}^{-2}\text{.s}^{-1}$.

Scheffey and Williams (Reference 159) investigated the performance of low flow water hosereel systems, intended for use onboard ships where water delivery rates were limited. A preliminary assessment of the various hosereel pressure/flow characteristics was obtained through a series of extinguishment tests performed on various sizes of unconfined wooden cribs of types UL 10-A, 6-A and 3-A; the respective masses of the test cribs were nominally 187 kg, 96 kg and 57 kg and no attempt was made to control the moisture content of the wood. The hosereel consisted of a 15 m length of 1.9 cm diameter hard rubber hose fitted with a variable pattern nozzle delivering a nominal flow rate of 1.9 l.s^{-1} . The crib was mounted on four load cells and other instrumentation included standard video equipment, IR imaging and two radiometers.

After an initial pre-burn period of between 5-6 minutes, the firefighting attack was commenced by the branch operator, initially from a distance of 1.8 m and then freely from any position; the only restriction imposed was that water could not be applied to the rear vertical face of the crib. Extinguishment was deemed to have been achieved when visual inspection and IR imaging showed no flames or 'hot spots' respectively at any point in the crib. A total of 26 crib fire tests were performed and the average mass loss rates for the 10-A, 6-A and 3-A fires were $250\text{-}320\text{ g.s}^{-1}$, 158 g.s^{-1} and 94 g.s^{-1} respectively. The hosereel system performance was assessed from graphs of fire control time vs. nozzle pressure, radiation attenuation versus nozzle pressure and 'water density to control' (l.m^{-2}) vs. application rate ($\text{g.m}^{-2}\text{.s}^{-1}$). The application rates used during the tests varied widely, from $17\text{ g.m}^{-2}\text{.s}^{-1}$ (low flow, large crib) to $170\text{ g.m}^{-2}\text{.s}^{-1}$ (high flow, small crib). The water application density required to control the fires was found to be fairly constant, at $\sim 0.6\text{-}1.2\text{ l.m}^{-2}$, except in the case of the larger fires where the lowest application rates were used ($17\text{-}26\text{ g.m}^{-2}\text{.s}^{-1}$) or the nozzle was operated at $\sim 4.6\text{ m}$ from the fire ('stand-off' tactic); in these cases the range of application density required was higher, at $\sim 2.2\text{-}2.8\text{ l.m}^{-2}$. Overall, in terms of efficiency of water usage, a minimum nozzle pressure of $\sim 1.5\text{-}2\text{ bar}$ (20-30 psig) and corresponding flow rate of $\sim 45\text{-}60\text{ l.min}^{-1}$ were recommended. For a nozzle flow of $\sim 115\text{ l.min}^{-1}$, pressures below $\sim 1.5\text{ bar}$ were not recommended and delivery rates of $\sim 45\text{-}70\text{ l.min}^{-1}$ were provisionally recommended for fighting post-flashover compartment fires. Class 'A' compartment fire extinguishment trials were conducted in a subsequent phase of this investigation (see Section 7.3).

The effectiveness of low pressure 'water mist' nozzles in extinguishing Class 'A' test fires was investigated in References 34 and 160. The FEU tests described in Reference 34 comprised 13 fire tests, 7 of which involved heptane fires (of area 1.1 m^2) while the remaining 6 involved wooden cribs (size 27A to BS5423). Four water mist nozzles were tested on the Class 'A' fires, at operating pressures ranging from 7-250 bar and flow rates between $10\text{-}25 \text{ l.min}^{-1}$. In general the crib fires were slowly extinguished by all of the systems under test with times ranging from $\sim 2\text{-}5\frac{1}{2}$ minutes, the total volume of water required for extinguishment was generally between 44-67 litres (however in one case a total of 106 l was required). A comparison test was performed using a standard Fire Service hosereel operating at 100 l.min^{-1} and 20 bar; the fire was extinguished in 27 seconds using 45 l of water. The excessive extinguishment times produced by the mist nozzles were attributed to the low flow rates of the systems, although it was noted that the total water requirement was broadly similar to that of the hosereel branch.

Andrews (Reference 160) reported the results of some preliminary fire extinguishment tests carried out by the Fire Research Station using various low pressure mist nozzles and wooden crib fires. The crib consisted of 60 sticks, measuring $25 \times 25 \times 500 \text{ mm}$, arranged in 10 layers of 6 sticks; the overall dimensions of the array were $500 \times 500 \times 2500 \text{ mm}$ and the total mass was $\sim 10 \text{ kg}$. The fires were conducted beneath the hood of a 'Nordtest furniture calorimeter' so that the rate of heat release could be measured throughout the experiment; using this apparatus it was determined that the peak heat output of a crib fire was $\sim 350 \text{ kW}$, achieved at 3 minutes after ignition. Two different nozzle designs were tested: a rotary atomiser and a hydraulic spray head consisting of 7 individual hollow-cone nozzles. For tests with the former, a single spray head was used while for the latter an array of 12 nozzles was constructed. A total of 6 test configurations were employed, with nozzle pressure ranging from 2-9 bar and flowrates from $\sim 8\text{-}20 \text{ l.min}^{-1}$. None of the nozzles tested were able to extinguish the crib fire and this was attributed to the '... low mass flux of suitably sized droplets which were able to penetrate the fire plume.' It was suggested that the lack of confinement combined with the presence of the forced extraction system resulted in the very small water droplets and water vapour being removed from the combustion zone before they were able to exert their cooling and inerting effects, respectively, on the fire.

Bhagat (Reference 161) determined the critical water spray application rates for the extinguishment of 2.7 cm diameter charcoal cylinders burning in a vertical orientation from the top downwards. The initial effect of introducing fine uniformly distributed water drops into a pre-saturated air stream impinging on the burning upper surface was the removal of the surface ash layer and an increase in burning rate. Further increases in the water supply rate led to the quenching of the burning surface. It was suggested that the removal of ash by fine sprays could be of critical importance in practice, if water mist produced by fire-fighting nozzles were to enhance the burning rate of glowing charred furniture surfaces, thus increasing the radiative heat load in the room. Bhagat (Reference 161) concluded that future research should address the two important factors which govern the combustion characteristics of actual fires, namely: the radiation from other burning surfaces and the vitiation of the air available for combustion.

The extinguishment of plastic fires by water sprays has been investigated by Magee and Reitz (Reference 162), Takahashi (Reference 163) and Yang *et al.* (Reference 164).

Magee and Reitz performed extinguishment tests on four different plastics subjected to radiant heating. A uniform water spray was generated by a single nozzle in each case and the test geometry was either a vertical slab or a pool fire; the steady burning rates of the materials were measured as a function of the external radiant heat flux both with and without the water spray. The plastics used were polymethylmethacrylate (PMMA), polystyrene (PS), polyethylene (PE) and polyoxymethylene (POM); specimen dimensions were 178 x 356 x 50 mm (vertical slab) and 178 x 178 x 50 mm (horizontal pool). The droplet weight mean diameters for the two nozzles used were 1.3 mm (1300 μm) and 0.65 mm (650 μm); assuming the water to be of constant density these values are equivalent to volumetric mean diameters (D_{30}). In the absence of fire suppression, all the materials displayed a linear, monotonic increase in burning rate ($\text{g}\cdot\text{cm}^{-1}\cdot\text{s}^{-1}$) with increasing external radiant heat flux ($\text{cal}\cdot\text{cm}^{-1}\cdot\text{s}^{-1}$). If the rate of water spray application was insufficient to cause extinguishment, this trend was repeated, but at a reduced burning rate for a given external heat flux. Put another way, above a critical radiation level a given water flow rate was only able to suppress the fire while below this critical radiation level extinguishment occurred.

For each water application rate, curves of reduced burning rate and time to extinguishment were obtained; the time taken to extinguish the fire fell sharply as the external heat flux was decreased. A series of curves was constructed showing the critical external radiant flux as a function of the water application rate for the various plastics and configurations considered. For no external radiation, the critical water fluxes varied from 1.2 $\text{g}\cdot\text{m}^{-2}\cdot\text{s}^{-1}$ for horizontal PMMA to 4.4 $\text{g}\cdot\text{m}^{-2}\cdot\text{s}^{-1}$ for horizontal PE. When subjected to a radiant heat flux level of $\sim 0.2 \text{ cal}\cdot\text{cm}^{-1}\cdot\text{s}^{-1}$ ($\sim 8.4 \text{ kW}\cdot\text{m}^{-2}$), the critical water rates rose to $\sim 3.1 \text{ g}\cdot\text{m}^{-2}\cdot\text{s}^{-1}$ and $\sim 7.5 \text{ g}\cdot\text{m}^{-2}\cdot\text{s}^{-1}$ respectively. Using the radiant heat flux data from large scale rack storage fire tests, Magee and Reitz (Reference 162) extrapolated the data for polystyrene to predict the critical water application rate expected under realistic conditions; at radiant fluxes of $\sim 1.5 \text{ cal}\cdot\text{cm}^{-1}\cdot\text{s}^{-1}$ ($\sim 63 \text{ kW}\cdot\text{m}^{-2}$), the critical water delivery rate was 17.8 $\text{g}\cdot\text{m}^{-2}\cdot\text{s}^{-1}$, some 10% greater than the delivery of contemporary automatic sprinklers.

The particular problems associated with extinguishing plastics fires were also investigated by Takahashi (Reference 163), who stressed the importance of achieving early suppression. The study was specifically aimed at determining the burning behaviour, and suppressibility, of plastics arranged in three-dimensional structures rather than the simple slab/pool geometry examined by Magee and Reitz (Reference 162). To this end, rods of nine different plastics (15 mm in diameter by 330 mm in length) were used to construct three-dimensional cribs; the plastics used were: PVC (polyvinyl chloride), PU (polyurethane), PC (Polycarbonate), PF (phenol formaldehyde), PE (polyethylene), PMMA (polymethyl methacrylate), POM (polyoxymethylene), ABS (acrylonitrile-butadiene-styrene co-polymer) and PP (polypropylene). The rods were supported in 5 layers in a steel mesh frame with 6 rods per layer. Three foam plastics (PF, PS, PU), with and without flame retardants, were also tested as rectangular samples either singly (PU) or in small cribs (PF, PS). Following ignition of the test material a pre-burn delay of up to 5 minutes was allowed before application of water from a spray nozzle located 900 mm above the upper surface of the sample. Since the main aim of the research was to determine the suppression effectiveness of so-called 'wet water' (obtained by adding diluted foam agent to the water supply), a detailed discussion of

Takahashi's findings is deferred until Section 8 of the present report. Only the main conclusions regarding the effectiveness of plain water are considered here.

For the cribs made of plastic rods, a graph of extinction time against pre-burn time was plotted for a water delivery rate of $0.25 \text{ l.m}^{-2}.\text{s}^{-1}$ ($15 \text{ l.m}^{-2}.\text{min}^{-1}$), this showed clearly that the extinguishment time was proportional to the delay between ignition and the activation of the water spray for all the materials tested. For a given pre-burn time the extinction time was found to increase in the following order: PC, PF, PMMA, POM, PE, ABS, PP. For the foam plastics, unretarded PF was found to burn 'exactly like wood' and plain water easily extinguished the exposed surfaces, however the deep-seated flames persisted until the rate of water application was increased. A solid water stream proved more effective than a spray and this was attributed to the former's ability to penetrate deeper inside the densely-packed fuel array. In the case of the unretarded PS and PU foams, both plain and wet water proved ineffective, and were only able to extinguish the flames on the exposed surfaces while the combustion proceeded unabated deeper inside the fuel. In general it was found that there were large differences in the extinguishing behaviour of plastics fires due to their different chemical and physical properties; Takahashi's tentative ranking of the increasing difficulty of extinguishment placed a 'wood fire' between PMMA and POM. In general low water application rates were found only to 'agitate' the combustion and extinguishment was only possible above a certain critical rate. Unfortunately a ' Q/R ' curve of the form shown in Figure 31 was not given for these tests and the data were only presented for two fixed values of water application rate: $0.25 \text{ l.m}^{-2}.\text{s}^{-1}$ ($15 \text{ l.m}^{-2}.\text{min}^{-1}$) and $0.38 \text{ l.m}^{-2}.\text{s}^{-1}$ ($\sim 23 \text{ l.m}^{-2}.\text{min}^{-1}$). Takahashi's study is considered further in Section 8, where the advantages of using 'wet water' are addressed.

Yang *et al.* (Reference 164) reported experimental measurements of the extinguishment times of small samples ($50 \times 50 \times 20 \text{ mm}$) of PMMA, solid white pine and unretarded PS foam subjected to two different, low pressure, water sprays. The samples were burned either in a horizontal orientation or at a 45° inclination beneath a conical radiant heater capable of supplying a heat flux of up to $\sim 25 \text{ kW.m}^{-2}$ on the upper surface of the sample. After a preheating time of 1 minute the sample was ignited and following an additional 1 minute pre-burn interval the water spray was discharged vertically downward through the central aperture. The choice of spray nozzles used in the experiments was influenced by Mawhinney *et al.*'s proposed classification system for water mists (Reference 24, Figure 10); Yang *et al.* selected two average droplet sizes for their experiments, one of $\sim 200 \mu\text{m}$ and one in the range $400\text{-}1000 \mu\text{m}$. The former was supplied by two commercial 'micronozzle arrays' with orifice diameters of $52 \mu\text{m}$ and $62 \mu\text{m}$ and produced droplets with Sauter mean diameters (D_{32}) in the range $164\text{-}219 \mu\text{m}$ at flow rates of between $0.09\text{-}0.18 \text{ cm}^3.\text{s}^{-1}$ ($5.4\text{-}10.8 \times 10^{-3} \text{ l.min}^{-1}$). The larger droplets ($600 \mu\text{m} \pm 150 \mu\text{m}$) were produced by a Piezoelectric droplet generator; flow rates here were higher at $0.42\text{-}1.8 \text{ cm}^3.\text{s}^{-1}$ ($25\text{-}108 \times 10^{-3} \text{ l.min}^{-1}$). The experimental parameters under investigation were listed as: material type, water flow rate, level of external heat flux, nozzle size, sample orientation and separation distance between the nozzle and sample surface. Extinguishment was defined as the point when visible flaming above the sample surface disappeared. It was found that the extinguishment time generally decreased with increasing water application rate, approaching an asymptotic value at higher water flow rates. Also, for a given flow rate, the time to extinguishment was

found to decrease with decreasing mean droplet diameter. An analysis of the expected 'residence time' of the droplets in the flame zone suggested that water evaporation in the flame zone was negligible; hence fuel cooling rather than direct flame cooling appeared to be the primary extinction mechanism. However, it was stressed that the drop sizes produced by commercial, high pressure, water mist systems would be much smaller than those employed in the experimental study. This fact, and the increased nozzle-to-fuel distance, would tend to increase the residence times and hence the proportion of water evaporated in the fire plume. It was therefore concluded that in practice, the main suppression mechanism of water mist systems is likely to be flame cooling arising from the evaporation of the smaller droplet population. Given the importance of fuel cooling in Class 'A' fire extinguishment, it was recommended that future research should aim to characterise the nature of the spray near the fuel surface in order to better understand the complex heat transfer interactions occurring there.

In many of the experiments described thus far, the 'rate of burning' of the test fire is expressed simply in terms of its rate of mass loss (kg.s^{-1}). In recent years however, the technique known as 'oxygen consumption calorimetry' has become the method of choice for determining accurately the heat release rate (HRR) during reaction-to-fire experiments (Reference 165). The method relies upon the accurate determination of the amount of oxygen consumed during the combustion process and requires measurements of both the total flow rate and the oxygen concentration within the exhaust gases. In the normal application of the method to free burning materials, the presence of a small amount of water vapour in the exhaust gases, due to ambient moisture in the combustion air in addition to that produced by the combustion reaction, may be allowed for in the data reduction formulae; there is no requirement to measure explicitly the water vapour content of the exhaust gases. Dlugogorski *et al.* (Reference 166) considered the effect of large quantities of water vapour on the reduction of oxygen calorimetry data, in order to assess the suitability of the oxygen consumption technique to the study of fires under water suppression. These workers considered how the presence of significant concentrations of water vapour in the exhaust gases affects the derivation of the fundamental equations defining the HRR in terms of the oxygen concentration and other parameters. These equations were simplified, assuming certain limiting moisture levels in the exhaust gases, in order to determine when the explicit measurement of water vapour would become necessary during fire suppression tests.

In order to test the applicability of the various HRR equations derived, a series of large-scale open-space fire tests were conducted using the National Fire Laboratory (NFL) 'room calorimeter', a facility capable of accommodating test fires in the range 100-3000 kW (3 MW). A total of 12 open-space experiments were conducted, including both free-burning and suppression cases, using premixed and diffusive propane flames as well as diesel oil pool fires, over the HRR range 100-800 kW. A single-fluid water mist nozzle discharging 35.3 l.min^{-1} was located 1.5 m above the propane burner during the suppression tests; the orientation of the nozzle was initially upward to enhance water evaporation but avoid flame suppression, although later tests employed a downward-facing spray to achieve a level of suppression but not extinction. Dlugogorski *et al.* (Reference 166) reduced the gas analysis and exhaust flow rate data to derive HRR histories using the various equations derived earlier and compared the results critically. It was concluded that for open fires where the product gases contain ~ 7% or less water

vapour, the explicit measurement of water vapour is not required and simplified equations yield HRR values of acceptable accuracy. However, in the case of suppressed fires in test enclosures where moisture contents greater than 7% are likely, it was tentatively suggested that water vapour concentration should be included in the gas analysis and used in the more rigorous data reduction formulae.

7.2.2 Sprinkler suppression of warehouse fires

The extensive research by Factory Mutual Research Corporation (FMRC) in the area of sprinkler technology was discussed in Section 5.2.2, in the context of the spray/plume interaction. However, the FMRC work is also relevant to the present section since large scale suppression tests have been performed, and these test configurations were sufficiently unconfined to be classified as 'open fires'. The research has focused on the development of sprinkler systems which have a rapid response and high suppression capability, in an effort to limit the losses due to fires in high-rack storage areas and other 'high-challenge' situations. According to Przybyla and Ghandi (Reference 167), the motivation for this work was a shift in commercial packaging materials which was noted in the early 1980's. Researchers at FMRC noticed that plastic containers were replacing more traditional metal and glass packaging for some products, and it was anticipated that this would modify the fire protection requirement in warehouses. The interaction between the fire and the sprinkler system was subdivided into two domains, namely 'pre-actuation' and 'post-actuation'. In the former the goal is always to reduce the sprinkler response time to a minimum. Since this in turn relies on effective heat transfer from the fire plume to the sprinkler fuse, the FMRC tests have sought to determine the distribution of convective heat flux in the thermal plume above the storage-racks (see Section 5.2.2). Fire suppression can commence only after sprinkler actuation has occurred and thus the interaction between the fire and the water spray is associated with the post-actuation period. Despite being conducted under controlled conditions inside a building, the majority of the FMRC tests were essentially 'unconfined' during the early stages of the fire and therefore many features of the post-actuation phase are representative of fire suppression in the open.

The majority of the tests described by Przybyla and Ghandi (Reference 167) were performed using a standard packaging system, a flammable liquid within a plastic container inside a cardboard carton. A few additional tests were carried out using different configurations of commodities (a 'commodity' being the combination of product and associated packaging). One of the main problems in tests of this kind is to decide which storage configuration and packaging system to test, since the variations are many. The former was decided by assuming general purpose warehouse conditions and applying the relevant storage and protection requirements from the Codes of Practice (NFPA and others), while the latter was confined to the systems of direct interest.

Two types of cartons were tested, one made of standard commercially available cardboard and the other impregnated with flame-retardant solution. The number and size of plastic containers per carton was varied, as was the internal geometry of dividers and liners. The container capacity ranged from pints and quarts to half gallons and gallons with the container materials either high density polyethylene (HDPE) or a

composite of HDPE co-extruded with nylon (HDPE/N). Liquids used were Class IB heptane, isopropyl alcohol, Class IC xylene and Class II kerosene and mineral spirits. The cartons were stacked either 'straight' or 'interlocking'. In straight stacking, the cartons were simply placed directly above one another while interlocked stacking involved changing the orientation of the rectangular cartons in order to produce a staggered vertical joint; this arrangement was found to give additional stability to the pile during burning. The cartons were stacked in a single row across the width at the front of a wooden pallet, and were stacked until the pile was some 4 feet high (~ 1.2 m). The rear of the pallet was filled by a mock-up of a larger carton. One test investigated the response of free-standing 55-gallon HDPE/N drums (filled with water) to the ignition source in order to simulate a warehouse fire. For all the tests the ignition source consisted of a petrol-soaked cellulosic bundle.

During the tests, the combustion products were drawn through an exhaust hood and sampled for oxygen concentration; this enabled the heat release rate (HRR) to be calculated. The effect of sprinklers was simulated using a water spray device above the stack of cartons. The HRR during each test was used as input to a computer model of sprinkler response ('DETECT-QS', DETector ACTuation-QS) in order to determine when the water spray system should be activated manually. The results of the tests were tabulated to compare the fuel type, container and carton characteristics, peak HRR and whether or not fire control was achieved after actuation of the water spray. The two tests which used non-fire retardant cardboard resulted in rapid fire growth which exceeded 1000 kW (1 MW) in under four minutes and subsequent pool fires which the sprinkler system could not control. Conversely, some of the fire retardant carton tests produced fires which did not reach 1000 kW for over 20 minutes and in these cases fire control was achieved. Two directly comparable tests on one pint HDPE containers filled with kerosene illustrated well the advantages of fire retardant cartons. The standard carton led to a peak HRR of 1960 kW and a fire which could not be controlled by the sprinklers. The same test, but using fire retardant cartons gave a reduced maximum HRR of 1017 kW, and fire control was achieved with the water spray.

The results were analysed using the fire growth relationship,

$$\dot{Q} = at^2 \quad (90)$$

where \dot{Q} is the heat release rate (kW), a is the 'fire growth factor' (kW.s⁻²) and t is the time after ignition (s). The expression was modified slightly in order to take into account the test method. Since the water spray system was only active after the HRR exceeded 500 kW, analysis of the fire growth factor between HRR 500-1000 kW enabled an assessment of the propensity for fire spread. Hence, a was calculated as follows,

$$a = \frac{(\dot{Q}_2 - \dot{Q}_1)}{(t_2 - t_s)^2 - (t_1 - t_s)^2} \quad (91)$$

where $\dot{Q}_1 = 500$ kW, $\dot{Q}_2 = 1000$ kW, $t_1 =$ time when HRR reaches 500 kW, $t_2 =$ time when HRR reaches 1000 kW and $t_s =$ time when HRR exceeds ignition source HRR

This was the usual method of analysis, but for some experiments where the HRR did not reach 1000 kW, the value of a was calculated for \dot{Q} between 250-500 kW. On the basis of this analysis, the fire growth rate was ranked according to the resulting a value and the fire classes were defined as shown in Table 9 below,

Table 9
Classification of fire growth according to 'fire growth factor' (Reference 167)

Fire growth class	Fire growth factor, a
Ultra-fast	$a \geq 0.1876$
Fast	$0.1876 > a \geq 0.0469$
Medium	$0.0469 > a \geq 0.0117$
Slow	$0.0117 > a \geq 0.0029$
Very slow	$.0029 > a$

In the experiments, control of the fire by the sprinkler system was only guaranteed for the case of 'slow' fires. In 'fast' fires, control was never achieved, and of the two 'medium' fires tested, one was controlled and the other was not. The main conclusions of the work were firstly that the fire growth factor obtained from small scale testing may be used to classify the behaviour of the goods in a warehouse fire, secondly, good packaging design (*i.e.* use of flame-retardant materials) was found to be very effective in limiting the fire growth.

Lee's work with FMRC (Reference 168) was also concerned with the suppression of rack-storage fires, and in particular the aim was to gather data from corrugated fibre carton fires in order to compare the results with previous water sprinkler experiments where wood was burned in the form of cribs and pallets. The fuel array comprised FMRC's 'Standard Class II' commodity, a 1.07 x 1.07 x 1.07 m double tri-wall corrugated paper carton with a sheet metal liner supported on a wooden pallet. The outer carton had a mass of 19.5 kg while the inner and metal liner were of mass 18.6 kg and 23.1 kg respectively. Each carton was placed on a pallet and the stack configuration consisted of an arrangement of two pallets wide by two deep forming a square of four pallets in plan, inside a steel rack. The height of the stack during an experiment was either two, three or four tiers, giving overall heights of 3 m, 4.5 m and 6 m respectively.

A series of 32 rack-storage extinguishment experiments were conducted beneath a specially designed water spray applicator. Since the spray outlets were located very close to the upper fuel surface, it could be assumed that the sprays had 100% penetration and the effects of drop size and spray momentum were negligible. The device could be actuated at any stage of the fire development to deliver any required flow rate onto the fire. The instrumentation consisted of FMRC's 'Fire Products Collector', essentially a large-capacity calorimeter capable of monitoring fires of the order of megawatts (similar in principle to the NFL facility described in Reference 166). The Fire Products Collector enabled both the total HRR and the convective HRR to be monitored throughout the test, before and after actuation of the sprinkler system; an example of the graphical output (convective HRR versus time) for three different water flow rates is given in Reference 168. The parameters of interest in the study were the

height of the storage rack, the HRR history during the test and the water application rate.

The raw data were reduced by first defining E_w as the total heat energy released in the test during water application; thus E_w was calculated simply by integrating the HRR curve from the time of sprinkler actuation to the end of the test. The parameter M_{ext} was introduced, defined as E_w divided by the heat of combustion of the corrugated fibre; therefore M_{ext} was an estimate of the total mass of fuel consumed during water suppression. The effect of the sprinklers was non-dimensionalised by dividing M_{ext} by the total fuel mass available for combustion at the time of actuation ($M_{o,w}$). So, for example if $M_{ext}/M_{o,w}$ was found to be 0.5 (the maximum reported by Lee) then 50% of the available fuel had still been consumed even though sprinklers were in operation, but 50% had been 'saved' by the sprinkler system. This ratio expresses adequately the efficacy of the sprinkler system but another dimensionless parameter was needed in order to correlate the results meaningfully. The parameter selected was $M_w/M_{b,w}$ where M_w is the mass rate of water supply and $M_{b,w}$ is the mass rate of combustion at the point of sprinkler actuation (or fire brigade intervention in the context of the present study).

A log-log correlation plot of all the test data with $M_w/M_{b,w}$ as the x -value and $M_{ext}/M_{o,w}$ as the y -value confirmed the expected result that the higher the ratio of water supply to burning rate, the lower is the ratio of the consumed fuel to the available fuel for the remainder of the test. The best-fit straight line to the data was found to be:

$$M_{ext}/M_{o,w} = 0.35(M_w/M_{b,w})^{-1.55} \quad (92)$$

and it was noted that the numerical value of the exponent was identical to that obtained by other workers, but that the coefficient of proportionality was slightly different (values of 0.312 and 0.150 had been reported by Kung and Hill (Reference 154) during their experiments using wood cribs and pallets respectively).

Lee (Reference 168) concluded that the -1.55 power relationship adequately described the suppression efficiency of sprinklers for the case of loosely packed assemblies of fuel such as pallets, cribs and cartons. The variation in the coefficient of proportionality was seen as evidence that for the same value of $M_{ext}/M_{o,w}$ the water supply rate for the cartons is slightly greater than for wooden cribs while both cartons and cribs require substantially more water than wooden pallets. This was seen as a reasonable result since the flame spread on cardboard was observed to be much more rapid and more penetrative than the other materials. Finally, the empirical relationships were extrapolated back to the point where the lines intercepted the x -axis (*i.e.* at the y value $M_{ext}/M_{o,w}$ is unity). This point defines the situation where all the remaining fuel is consumed after the sprinklers have been actuated, and the corresponding x -value defines the critical water application rate below which all combustible mass is consumed.

Assuming that $M_{b,w}$ was equal to half the maximum burning rate for the stack, the critical values for wooden pallets, cribs and cardboard cartons were calculated as 1.9, 2.1 and 3.0 $\text{g.m}^{-2}.\text{s}^{-1}$ respectively. These values were found to be in good agreement with

previous work, and it was concluded that the critical water application is independent of the geometry and scale of the fuel array and mode of water application, but depends slightly on the HRR at the point of sprinkler actuation.

Kung *et al.* (Reference 169) described some of FMRC's work on the development of Early-Suppression Fast Response (ESFR) sprinkler systems specifically for high-rack storage applications; the objective was to improve upon the economic and operational deficiencies of conventional sprinklers. In economic terms, fire protection of warehouses with conventional ceiling sprinklers requires a high water demand and the capital cost of installation is therefore high. Realistic tests using existing systems have confirmed widespread fire damage extending beyond the original ignition area, coupled with water damage to goods unaffected by fire, the latter invariably occurs when a large number of sprinklers is activated. FMRC's objective was to develop a sprinkler which would detect and suppress a nascent fire, thus limiting the damage caused by both fire and water; an additional objective was to reduce the total number of sprinklers required for effective fire protection.

A series of tests was performed, which investigated the effects on suppression efficiency of fire location relative to the sprinklers, fire size at actuation, plume momentum flux, Required Delivery Density (RDD), spray distribution pattern and spray centre-core thrust force. (The term Required Delivery Density was introduced in Reference 168 to quantify the water flux necessary to ensure suppression of sprinklered high-rack storage fires in earlier FMRC tests). The general arrangement of the test facility was identical to that used in previous FMRC experiments (Reference 168) however in Reference 169 a 'standard plastic' commodity was used as the fuel. The pallet loads consisted of polystyrene cups in compartmented, single-wall corrugated paper cartons. Eight such cartons (0.53 x 0.53 x 0.51 m high) were placed on a wooden pallet, forming a stack two cartons wide by two deep and two high. Each of the cartons was internally subdivided into 125 compartments (*i.e.* 5 x 5 x 5) by 4 mm thick horizontal and vertical cardboard dividers, and each compartment contained a 473 ml polystyrene tub. The total mass of the polystyrene cups per pallet was 29.3 kg and the total mass of the empty carton with dividers was 21.8 kg (per pallet). The mass of the wood pallets ranged from 23.1 kg to 24.1 kg. A double-row steel rack was loaded two pallets wide by two deep, the height of the stack was four tiers for all the tests, with the ceiling clearance being 2.9 m from the top of the stack.

Ignition was established using the petrol-soaked cellu-cotton rolls described previously by Lee (Reference 168), lit by a propane torch. Four different prototype sprinkler heads were used, arranged on a grid 3.05 m x 3.05 m, and all sprinklers had a temperature rating of 73 °C. The location of the storage pile was varied from test to test, and three configurations were examined. The centre of the stack was located directly under a prototype sprinkler, centred below two sprinklers, or centred below four sprinklers. Therefore, a maximum of four sprinklers were installed during a single test. Thermocouples were installed at various points on the sprinkler grid, and brass disks were fitted at the active sprinkler points in order to simulate the thermal response of a fast-response sprinkler link. Prior to the tests, the sprinkler thrust force, spray flux and water distribution were measured for each configuration, under no-fire conditions. The experimental procedure for each of these is given in Reference 169. The fire size, as

indicated by the convective HRR, at sprinkler actuation was assumed to be critical in determining the success or failure of the suppression system. The results from Reference 168 were used to infer this value since it was assumed that the experiments in both cases were practically identical. The convective HRRs taken for the various test configurations are shown in Table 10 below.

Table 10
Convective heat release rate (HRR) values at sprinkler actuation for various
sprinkler/fuel array configurations (from Reference 169)

High-rack storage position relative to sprinklers	Convective HRR at sprinkler actuation (kW)
Centred below single sprinkler head	850 - 970
Centred below two sprinkler heads	1380 (1 test only)
Centred below four sprinkler heads	1150 - 1340

The inferred values of convective HRR were used to calculate the RDD and hence determine the water density required to suppress the fire. The HRR values also enabled fire plume characteristics, such as diameter and upward momentum flux, to be calculated. Interactions between sprinkler water spray and fire plumes were known to be critical in some instances and the sprinkler required sufficient force to penetrate the plume and deliver water to the fuel array. This condition was not achieved for one of the tests where the fuel array was centred directly under a single sprinkler head. The plume momentum flux was estimated at 0.98 N while the sprinkler core-thrust at the same location over the same area was only 0.44 N; fire suppression was not obtained for this test. It was noted that after sprinkler actuation, the fire plume was still visible at the top of the fuel array and the sprinkler spray appeared to be 'opened up' by the plume. Consequently, the water flux at the fuel surface during this particular test was expected to be significantly less than under no-fire conditions.

For the other three tests on this configuration, fire suppression was achieved as expected since the sprinkler momentum flux exceeded the plume momentum flux suggesting that water penetration would be effective. In addition, the water flux measured at the upper fuel surface of the stack under no-fire conditions exceeded the RDD water fluxes calculated by Lee (FMRC report) for a four-tier array of the Standard Plastic Commodity by at least 56% in all cases.

The nature of the fire plume/sprinkler spray interaction for the two-sprinkler and four-sprinkler configurations was somewhat different. In all these tests, the fire gases rose only through the centre flue of the stack at the time of the first sprinkler actuation. Interference between the water spray and the thermal plume was therefore not a significant problem and a high proportion of the water spray reached the top of the stack. The water flux at the top surface of the array was expected to be very close to the no-fire value. It was observed that with increasing ceiling clearance, the trajectories of individual drops become more vertical and consequently direct wetting of the sides of the fuel array was diminished. The main mode of fire suppression was therefore expected to be from direct wetting of the upper fuel surface. In practice however, it was

also observed that once the upper surface was saturated, water cascaded down the vertical surfaces of the centre flue and suppression was assisted in this manner.

Fire suppression was achieved in all cases, but the convective HRR of the fire necessary to activate the offset sprinklers was consistently greater than for the centrally-located sprinkler case. A larger fire (greater HRR) was necessary in order both to extend the plume sideways to the offset sprinklers and to maintain the plume temperature above the actuation temperature against increased heat losses to the surroundings. Kung *et al.* (Reference 169) concluded that for effective fire suppression by ESFR sprinklers it is essential that the centre-core thrust exceeds the upward plume momentum measured at the same point below the sprinkler head. Also the water spray flux which reaches the top of the fuel array must be at least equal to the RDD specified by Lee (Reference 168) for the commodity in question. Provided the first condition is met, it is probable that the water flux measured under no-fire conditions will be very close to the value delivered under fire conditions, provided this is not less than Lee's RDD then suppression is assured.

The current state-of-the-art regarding the choice of sprinklers is discussed in a recent paper which summarises FMRC's approach to fire protection in warehouses (Reference 170). It is emphasised that the protection design must be based on a sound knowledge of the storage hazard of the commodities, both present and future. The FMRC commodity classifications I, II, III and IV are explained (fire hazard increasing from I to IV) and examples of 'special hazards' (*i.e.* hazard potential greater than IV) are given. The classification system provides only a broad indication of how similar groups of commodities will behave and so FMRC are conducting ongoing commodity classification tests for clients using the Fire Products Collector facility. The heat release rates and products of combustion are measured, to provide an accurate assessment of the hazard. In practice the mode of storage (solid-piled, palletised or rack), height of storage, dimensions of storage rows, building height etc. all combine to influence the choice of the best fire protection for the warehouse concerned. Additional 'transient' factors (usually arising from poor storage practice) may also increase the fire hazard temporarily, and it was noted that the presence of shrink-wrap plastic on the outside of a commodity may prevent pre-wetting by sprinklers, reducing the effectiveness of standard sprinkler installations.

The sprinkler options for high-rack storage are given broadly as 'standard', 'in-rack', 'large-drop' or 'ESFR'. Standard sprinklers rely on their ability to pre-wet unburned combustibles in the vicinity of the fire and to cool adjacent areas of the building. Control of the fire is achieved as the original fuel is consumed and flame spread is limited due to the pre-wetting of nearby combustibles. The standard head was redesigned by FMRC in the 1950s in response to the increase in high-rack storage and the increased fire risk of commodities. The orifice diameter was increased from 12.7 mm (1/2 in.) to 13.5 mm (17/32 in.), thus increasing the discharge by about 40% for a given water pressure. The trend of increasing fire hazards in large warehouses continued, and often resulted in fires where conventional sprinklers installed in the ceiling alone were inadequate. This led to the next major improvement, sprinklers were installed within the rack structure in order to improve the penetration of water to the seat of the blaze.

The development of the large-drop sprinkler came about when it was noticed that standard sprinklers did not always manage to penetrate the strongly buoyant fire plume developed during warehouse fires. The orifice diameter in this type of sprinkler is 16.3 mm (0.64 in.) and an improved discharge pattern is employed enabling superior penetration of the up-draught. A graph comparing the standard and large-drop percentage penetration of spray as a function of water pressure shows an improvement at all pressures. The Early Suppression-Fast Response (ESFR) sprinkler head was originally designed in the US for residential applications in order to increase the time available for occupants to escape. FMRC adapted the fast-response technology to the warehouse environment; a more heat-sensitive fusible link combined with an orifice diameter of 17.8 mm (0.7 in.) and an improved discharge pattern resulted in a design which could suppress, not merely control, a fire.

7.3 Suppression tests on compartment fires

Although a review of the suppression of open fires is justified within the context of the present report, it is acknowledged that the main interest of the Fire Service is the suppression and extinction of confined fires, and in particular post-flashover compartment fires typically occurring in residential premises (Section 2.1.4). The present section is devoted to a review of published work in this important area.

Herterich (Reference 10) reviewed some of the early work on compartment fire suppression, mainly carried out in the UK in the late 1940s and early 1950s. Nash and Rasbash (Reference 171) investigated the extinguishment time for room fires using spray jets as a function of the water flow rate and the size of the room. The tests showed that a certain minimum water flow rate was required (expressed in $l \cdot \text{min}^{-1} \cdot \text{m}^{-3}$) in order to ensure successful extinguishment (see also Section 7.1); in the case of fires on flat fuel surfaces, the critical flow rate was expressed in $l \cdot \text{min}^{-1} \cdot \text{m}^{-2}$. The total quantity of water required was found to increase linearly with the room size and was strongly dependent on the rate of flow of the water. The extent of ventilation present also had a profound influence on the water consumption; the greater the ventilation area, the greater was the total quantity of water required for a given size of room. Reducing the available ventilation reduced the extinguishing time significantly; the enhanced fire suppression in this case is due to the large volume of water vapour produced which rapidly fills the room and 'smothers' the fire. The effectiveness of solid jets and spray-jets in combating compartment fire was also assessed in Reference 171. As a result of these investigations it was recommended that confined fires should initially be tackled with a mobile spray-jet at a 'sufficiently high' flow rate followed thereafter by a small solid water-jet to extinguish any remaining deep-seated pockets of fire. In the US, Layman (Reference 172) conducted a comprehensive series of internal fires which were extinguished with spray-jets. A large number of parameters were investigated, including: the rate of fire development, the number of hoses used and the rate of water application. In the particular case of spray-jets, Layman found that a low amount of water was required to effect extinguishment and this was often achieved in a surprisingly short time.

Thomas and Smart (Reference 173) reviewed work on compartment fire suppression prior to 1954 and concluded that the quantity of water required to achieve control was between 8-15 gallons per 1000 cubic feet of fire. Assuming British gallons, this converts to a metric equivalent of ~ 36-70 litres per 28 cubic metres or 1.3-2.5 l.m³. Two series of compartment fire suppression tests were also described in Reference 173: the first were conducted in a room measuring 8 x 8 x 8 ft (~ 14.5 m³) while the second employed a smaller 'model' room of volume 0.13 m³. The former series showed no significant difference in performance between water applied as a solid jet and that applied in the form of a spray, at a constant supply rate of ~ 2.2 gal.min⁻¹ (10 l.min⁻¹), extinguishment times were around 20-24 seconds and the total quantity of water required was between 0.6-1.0 gallons (2.7-4.5 litres). In the experiments at smaller scale, the rate of water application was varied, amongst other parameters, and it was found that the performance of jets and sprays was comparable only at low rates of flow (less than ~ 0.01 gal.min⁻¹ ft⁻³, or 1.6 l.min⁻¹ m³). At higher flow rates, the superiority of sprays was evident and the total quantity of water required for fire extinguishment was much lower than for solid jets. However, for both methods of application, there existed an optimum rate of application at which the fire suppression was most efficient in terms of total water usage, it was suggested that this optimum rate was not much greater than the critical rate (see Figure 31). The effect of ventilation was also examined and it was found that the quantity of water required to extinguish an enclosed fire increases with increasing ventilation. The displacement of oxygen by water vapour was identified as the critical mechanism in this respect and it was suggested that for levels of ventilation 'normally encountered in full-scale rooms...', the amount of water required was approximately equal to that required to replace the gaseous contents of the room by water vapour.

Some points relating to the use of water sprays in fighting domestic room fires were considered by Rasbash and Thomas in 1955 (Reference 174). The effect of droplet size on the extinguishment mechanism was discussed and it was noted that the most efficient gas-phase cooling (flame cooling) is achieved with smaller drops whereas, the efficiency in fuel cooling is less dependent on drop size provided the water is able to reach the burning surface. Consequently, the influence of drop size on fire extinguishment was expected to be greatest when the fire was unable to be extinguished by cooling the fuel, for example a fire involving a low firepoint liquid such as petrol. Tests at Birmingham (Section 4.1.2) on full-scale rooms (~ 43 m³) showed that the extinction of all large flames in a fully developed fire were extinguished with ~ 12 gallons (~ 55 l) of water either applied as a jet or spray. The observed superiority of sprays over jets was discussed, however it was concluded that this effect was only relevant at rates of flow which were too high to be used in practice. Since the required throw for water delivery was estimated to be ~ 20 ft (6 m), commensurate with the dimensions of a typical room, it was concluded that sprays operating at 100 psig (7 bar) were entirely adequate, even with cone angles of 30°; the corresponding flow rates were reported to be 20-30 gal.min⁻¹ (~ 90-140 l.min⁻¹). On the basis of this evidence, and the smaller effect on drop size of pressure above 7 bar (100 psig) (Section 5.1.2.1, Figure 15), it was considered that in general high pressure sprays offered no practical advantage over low pressure sprays (up to 7 bar) when tackling fires in enclosed spaces.

The 'Extinguishing Materials and Equipment Section' of the Joint Fire Research Organisation (JFRO) performed a series of tests in 1960 which were designed to provide a basis for the development of more efficient hosereel systems (References 12, 175). The effects of varying the rate of application, method of application (spray or jet) and nozzle pressure were studied during a series of 50 extinction trials against confined Class 'A' fires. The test enclosure comprised a well-ventilated brick building measuring ~ 4.3 x 4.3 m in plan and with a total volume of 49 m³; openings representing two windows (1.8 x 1.2 m) and a door (1.8 x 0.9 m) were included. The fire load (~590 MJ.m⁻²) was selected to yield a fully-developed blaze typical of the upper limit which could be reasonably tackled by hosereel systems of the time. The fuel consisted of a ~13 mm wooden floor plus simulated items of furniture made from 25 mm timber; two small trays of petrol were used as ignition sources, to promote rapid involvement of the entire contents and this was usually achieved within 3½ minutes.

Impinging jet-type spray nozzles were used, with a constant orifice size of ~1.6 mm producing a cone angle of 30°. The spray tests were conducted at a range of flow rates from 23-114 l.min⁻¹ and at nozzle pressures from ~ 5-35 bar (80-500 psig); the jet tests covered the same range of flow rates but with a constant nozzle pressure of ~ 5 bar (80 psig). In order to increase the rate of flow at a given spray nozzle pressure while maintaining the nozzle characteristics, more pairs of jets were added instead of increasing their size. All the nozzles were fitted to a trigger-operated gun-type branch, linked to an automatic recording system which accurately monitored the duration of each period when the branch valve was open; using these data and the flow rate the total water application during the test could be calculated. The 'mass median droplet size' (µm) was determined over the range of pressures and flowrates used during the spray tests (see Table 11 below); half of the mass of water discharged from the nozzle is in the form of droplets smaller than this value.

Table 11
Mass median drop size (microns) at a range of spray nozzle pressures
(adapted from Reference 175)

Rate of flow (l.min ⁻¹)	Nozzle pressures		
	5 bar (80 psig)	15 bar (225 psig)	35 bar (500 psig)
23	550	390	320
68	850	620	610
114	540	590	940

At lower rates of flow the droplet size decreased as the pressure increased, with the reduction being less marked at higher pressures. However at the highest flow rate the reverse was the case, contrary to expectations. Measurements of the water distribution within the sprays indicated that the proportion of water in the centre of the sprays tended to increase with both pressure and rate of flow, thus increasing the probability of droplet coalescence and offering an explanation for the observed behaviour.

Once the test room had been prepared as described, the petrol trays were ignited and the room was allowed to become fully involved. Two minutes after this 'flashover', water was applied continuously through the door of the room until the fire was 'controlled'.

Once the room had cleared of smoke, the branchman then extinguished any remaining pockets of flame using short bursts from the branch until complete extinguishment was achieved. The same operator was employed throughout the test series, in order to reduce the variation in application technique, however despite all efforts the variability of the results was still high. The average amount of water required to control the fire was ~32 litres, which was surprisingly small, although extreme variations of -50% to +400% were recorded in two tests. Likewise the total volume of water required to achieve complete extinction of the fire was on average ~77 litres, the corresponding extreme variations in this case were -70% to +250%.

A statistical analysis of the test data showed that for all practical purposes neither the pressure nor rate of flow had any significant effect on the total volume of water required to control or extinguish the fire. It was concluded that against this type of fire, increasing the flowrate would enable the fire to be controlled more rapidly without increasing the water demand, but that no saving in water could be gained by using pressures higher than normally available on hosereel systems. Some other practical observations were made by the branch operator during the tests: the gun proved difficult to manoeuvre at 35 bar (500 psig) and flowrates above 68 l min^{-1} , the protection offered by the spray made fire-fighting more comfortable than when using jets and the jet facilitated the extinction of deep-seated pockets of fire beneath collapsed furniture. It was concluded that an ideal hosereel branch would be trigger-operated, enable the fire to be controlled with a spray and allow final extinguishment using a jet.

Writing in 1962 (Reference 43), Rasbash stated that it was not clear whether confined solid fuel fires were better controlled by flame cooling (and subsequent inertion by water vapour) or by direct cooling of the fuel. However, it was argued that, in general, the best method of extinguishing a fire was the latter, it was also stated that in this case that the required rate of heat absorption from the fuel bed is generally far less than the rate of heat production by the fire itself. In this respect, it is also worth recalling Fuchs' account of the suppression water inventory from full-scale tests, where 38% of the water was required to suppress active combustion and the remaining 62% acted to cool the fuel below its ignition temperature (Section 6.1.3 and Reference 125). Regarding the amount of water required to effect successful fire extinguishment, Rasbash observed that experimental quantities for room fires were of the order of 10 gallons per 100 ft^2 of floor area ($\sim 5 \text{ l.m}^{-2}$). It was estimated that under operational conditions the practical application required was a factor of 100 times higher, it was concluded that either wastage or operational difficulties were the governing factors in the amount of water used and substantial research effort was justified in this area.

Salzberg *et al* (Reference 176) sought to quantify the amount of water required to extinguish typical room fires using a combination of laboratory and full-scale extinguishment tests. The laboratory configuration consisted of two rooms, each measuring $3.66 \times 3.66 \times 2.44 \text{ m}$ high (floor area 13.4 m^2) and connected by a 1 m wide corridor of length 3.66 m; in addition, each room had 2 window openings with dimensions $1.22 \times 1.53 \text{ m}$. The representative combustible contents of the rooms included wooden and upholstered furniture, books and clothing amounting to a fire load of $\sim 22 \text{ kg.m}^{-2}$. Experiments were performed on either one- or two-room fires using a single 25 mm 'booster line' fitted with a spray nozzle or a 38 mm hose line (again with a

spray nozzle); in all cases the nozzle pressure was maintained at 7 bar (100 psig). Fire suppression was commenced at 30-120 seconds after flashover in order to avoid undue damage to the test facility. In order to verify the laboratory results, experiments were also performed in actual structures to simulate fires in residential and commercial occupancies; each type of structure was furnished appropriately in order to provide realistic fire loads.

One early observation during the laboratory experiments was that the amount of water required for extinguishment and mopping-up operations varied greatly with the type of furnishings involved in the fire and also with the firefighting technique employed. The total water requirement was found to be particularly large when upholstered furniture was present. Consequently, the amount of water required to knock down or control the fires was quoted separately from that required for total extinguishment and mopping-up. The water application data reported were therefore those which were required to suppress all visible flaming and enable firefighters to remove the smouldering items from the room.

For the single room laboratory tests, an application rate of 25 l.min^{-1} (corresponding discharge density $\sim 1.9 \text{ l.min}^{-1}.\text{m}^{-2}$) was found to be the most efficient in terms of water usage, requiring a total of 9-30 litres to bring the fire under control. However, the increased control time and the high level of physical punishment suffered by the firefighters suggested that a higher application rate would be more appropriate. The use of a 68 l.min^{-1} delivery rate (discharge density $\sim 5 \text{ l.min}^{-1}.\text{m}^{-2}$) gave the best overall results in terms of efficiency (28-42 l total water consumption) and operational ease. Increasing the delivery rate still further, to 76 l.min^{-1} in the form of a straight stream proved ineffective, except when applied indirectly when a spray was produced upon impact with the ceiling; it was concluded that a 60° spray pattern gave the best overall performance. In the two room laboratory tests, an application rate of 68 l.min^{-1} (discharge density $\sim 2.2 \text{ l.min}^{-1}.\text{m}^{-2}$) yielded the minimum water requirement for fire control, but here again the heat stress on the firefighter was excessive. A higher delivery rate of 112 l.min^{-1} (discharge density $\sim 3.7 \text{ l.min}^{-1}.\text{m}^{-2}$) required between 120-243 litres to achieve control. Where an indirect attack was mounted, either from the corridor or through the window openings, knockdown was achieved with only 120-134 l of water; the larger water volumes required for a room-to-room attack (175-243 l) were attributed to the more punishing thermal environment inside the compartment which required the firefighters to cool the walls before advancing from one room to the next. The use of a 38 mm hose line providing a 232 l.min^{-1} spray application rate (discharge density $\sim 7.5 \text{ l.min}^{-1}.\text{m}^{-2}$) resulted in a significantly higher total water usage with no accompanying reduction in control time.

The water requirements for the tests performed in actual buildings (Reference 176) were found to be much greater than those obtained from similar laboratory tests. The amount of water required to achieve final extinguishment and mop-up of the building fires accounted for a much higher proportion of the total water volume than in the laboratory tests; this was attributed to the inexperience of the firefighters and the high proportion of upholstered furniture and clothing in the fire load. The use of the 25 mm hosereel with spray branch at 112 l.min^{-1} and delivery rates of $7.4 \text{ l.min}^{-1}.\text{m}^{-2}$ (one room with floor area

$\sim 15 \text{ m}^2$) and $3.5 \text{ l}\cdot\text{min}^{-1}\cdot\text{m}^{-2}$ (two rooms with floor area $\sim 32 \text{ m}^2$) was shown to be superior to the 38 mm hose line in terms of water usage.

Overall it was concluded that one- and two-room post-flashover compartment fires can be effectively suppressed by an indirect attack with a 25 mm hosereel and spray branch. For the single room fires, the mean total water requirement was estimated to be $\sim 57 \text{ l}$ for an application rate of $68 \text{ l}\cdot\text{min}^{-1}$. For the two room scenario, the corresponding figures were 182 l at $114 \text{ l}\cdot\text{min}^{-1}$, where an external attack is feasible for both rooms (or access to an interior connecting corridor is possible), or 300 l at $114 \text{ l}\cdot\text{min}^{-1}$ if a room-to-room sequential strategy is enforced. Control and extinguishment of one- and two-room residential building fires was expected to be achieved using total application densities of $\sim 4 \text{ l}\cdot\text{min}^{-1}\cdot\text{m}^{-2}$ and $\sim 6 \text{ l}\cdot\text{min}^{-1}\cdot\text{m}^{-2}$ respectively, at corresponding application rates of $\sim 76 \text{ l}\cdot\text{min}^{-1}$ and $\sim 114 \text{ l}\cdot\text{min}^{-1}$. The experiments in relatively small ($\sim 50\text{-}100 \text{ m}^2$) commercial-type occupancies indicated that typical post-flashover fires could be controlled using one or two 38 mm hose lines with spray branches at application densities of around $6.5 \text{ l}\cdot\text{m}^{-2}$ of the involved area.

Some of the research effort in sprinkler design has also added to the body of knowledge on compartment fire suppression (References 177, 178). Liu (Reference 177) reported a theoretical and experimental investigation into the effects of a corridor sprinkler system on the cooling and suppression of a fire in an adjacent compartment connected by an open doorway. A simplified one-dimensional mathematical model of spray cooling was developed to evaluate the reduction in corridor ceiling hot gas temperature by evaporative cooling. The model included the Ranz and Marshall heat transfer correlation (Reference 61, equation (46)) as well as a momentum model for predicting droplet trajectories; the reduction in droplet diameter due to evaporation was also included in the model.

Full-scale tests were carried out using a compartment of $2.44 \times 3.05 \text{ m}$ in plan connected to a 2.44 m wide corridor which was 6.1 m in length; the ceiling height for both the compartment and corridor was 2.44 m . The fire source was a hexane burner, located at floor level in the compartment and on the centreline of both the corridor and doorway, a single pendant sprinkler was located on this axis either at 1.22 m or 2.75 m from the compartment doorway. The fire heat release rates varied from $350\text{-}1050 \text{ kW}$ and water flow rates ranged from $10\text{-}35 \text{ US gal}\cdot\text{min}^{-1}$ ($\sim 38\text{-}132 \text{ l}\cdot\text{min}^{-1}$); three different sprinkler heads were tested ($\frac{1}{4}$ ", $\frac{3}{8}$ ", $\frac{1}{2}$ ") and the room-corridor environment was monitored by various instruments, including thermocouples and gas analysers. Some tests at $\frac{1}{4}$ scale were also conducted in order to extend the investigation economically; the fire source in these tests was either a natural gas burner or solid fuel (wood cribs and Plexiglas plates). It was concluded that the simplified one-dimensional analysis was sufficient to predict the net reduction in the corridor exit gas temperature and that at a given water flow rate, smaller droplet diameters were more effective in cooling the hot combustion products. It was also found that the water spray could initiate a recirculating flow at the doorway such that water vapour, fine droplets and combustion products were drawn back into the fire compartment; this back-flow was found to reduce the burning rate of the fuel and potentially even smother the fire, if the initial conditions favoured the production of a large volume of water vapour (*i.e.* high gas temperatures and hot surfaces).

You *et al.* (Reference 178) described a series of 25 tests where a single sprinkler was used to cool a fire compartment measuring 3.66 x 7.32 x 2.44 m (~ 65 m³); a single ventilation opening 1.22 x 2.44 m was also provided on one wall of the compartment. The fire source was an array of 4 heptane spray nozzles which developed total heat release rates ranging from ~ 130-500 kW; three different sprinkler nozzles were tested, having diameters of 6.9, 8.4 and 11.1 mm. A fire products collector (FPC) was positioned over the test room to extract and sample the combustion gases for CO, CO₂, O₂ and total hydrocarbons. Other measurements included: flow rate and temperature in the exhaust duct of the FPC, heat losses through the compartment walls and ceiling, radiative heat flux through the ventilation opening and gas temperatures within the enclosure. To aid the data analysis, an energy balance (in units of kW) was written for the room during a test,

$$\dot{Q}_a = \dot{Q}_{cool} + \dot{Q}_c + \dot{Q}_l \quad (93)$$

where \dot{Q}_a is the total heat release rate of the fire, \dot{Q}_{cool} is the heat absorption rate of the sprinkler spray, \dot{Q}_c is the convective heat loss rate through the room opening and \dot{Q}_l is the sum of heat loss rate to the walls and ceiling (\dot{Q}_w), the heat loss to the floor (\dot{Q}_f) and the radiative loss through the opening \dot{Q}_r . The total heat release rate was established from the FPC data by a carbon balance technique, a principle based on the mass conservation of elemental carbon involved in the combustion process. The convective heat release rate was calculated from the product of exhaust gas mass flow, excess temperature (above ambient) and the specific heat capacity at constant pressure.

The experimental data were presented in terms of the independent variable,

$$\Lambda = (AH^{1/2}\dot{Q}_l)^{-1/2} (\Delta\bar{P}W^3\bar{D}^{-2})^{1/3} \quad (\text{l.min}^{-1}.\text{kW}^{-1/2}.\text{m}^{-5/4}) \quad (94)$$

where A is the area of the opening (m²), H is the room height (m) and W is the sprinkler discharge rate (l.min⁻¹). The non-dimensional parameters $\Delta\bar{P}$ and \bar{D} correspond to the sprinkler operating pressure divided by 17.2 kPa (0.172 bar) and the sprinkler nozzle diameter divided by 0.0111 m respectively. The dependent variables selected for the correlations were the non-dimensional ratios \dot{Q}_{cool}/\dot{Q}_a and \dot{Q}_c/\dot{Q}_a , *i.e.* the fraction of the total heat release absorbed by spray cooling and removed by convective cooling of the room respectively. The data showed that \dot{Q}_{cool}/\dot{Q}_a increased rapidly with increasing Λ for values of Λ less than ~ 20; at higher Λ , the increase in \dot{Q}_{cool}/\dot{Q}_a was more moderate. The value of \dot{Q}_c/\dot{Q}_a was found to decrease with increasing Λ ; this was as expected since an increase in spray heat absorption would tend to reduce the amount of heat lost by convection through the opening. It was concluded that the correlation method was satisfactory and was more general than in previously published work since the effects of room geometry, opening size, sprinkler spray characteristics and fire size were all included.

Kokkala (Reference 179) reported the results of some 17 post-flashover fire extinguishment tests, performed in a compartment measuring 2.4 x 3.6 x 2.4 m high and incorporating a door opening of 0.8 x 2.0 m. The walls were constructed of 10 mm

thick particle board ($\rho = 720 \text{ kg m}^{-3}$) and the ceiling was either the same material or in some cases 10 mm thick porous fibre board, the floor was of concrete in all tests. The fire source consisted of a 20 kg wooden crib constructed from 12 layers of 38 x 41 x 500 mm pine sticks, located in the centre of the room. Two thermocouples were used to monitor the progress of the fire: one was located 100 mm below ceiling level at 0.7 m from the room centre towards the door and the other was in the plane of the door, located 100 mm below the top of the door opening. A wide-angle heat flux meter was sited 2 m outside the door, facing horizontally into the room, fire suppression commenced when this instrument recorded a heat flux of 20 kW m^{-2} (chosen to approximate post-flashover conditions and to standardise the test procedure). Water, Halon and 8 varieties of extinguishing powders were used in the studies but only the results of the 3 water tests are considered here.

A 7 mm spray-jet nozzle operating at $\sim 200 \text{ kPa}$ (2 bar) was used for all three tests, two as a jet (at flow rates of either 46 l min^{-1} or 17.8 l min^{-1}) and one as a spray, discharging at 46.7 l min^{-1} . At 46 l min^{-1} the direct jet required 10.7 l to put out the flames while the spray required only 7 l, however in both cases an additional 17 l of water was required to extinguish the glowing combustion. The direct jet discharging at 17.8 l min^{-1} was deemed to be very close to the critical rate required to extinguish the fire, this figure was also expressed as 7.5 g m^{-2} on the burning surface and its proximity to a theoretically-determined value of 7.8 g m^{-2} (Reference 180) was remarked upon. However, Kokkala also noted that in all three water experiments, the compartment floor was completely wetted, suggesting rather wasteful application.

Milke *et al.* (Reference 181) reported the results of a series of 5 experiments designed to investigate the effectiveness of a firefighting spray on a fully-developed compartment fire, the data were intended to be used to validate the 'Fire Demand Model' of compartment fire suppression (see Section 6.2.2). The compartment measured $2.44 \times 3.66 \times 2.44 \text{ m}$ high with one ventilation opening measuring $0.44 \times 1.51 \text{ m}$ high and the Class 'A' fuel load consisted of 7 white pine cribs, each 10 layers high and 3 sticks ($4 \times 4 \times 26 \text{ cm}$) per layer (total fuel surface area 7.59 m^2). Several sizes of 60° full cone nozzles were operated at pressures between 1.2-3.7 bar (17-54 psig) and flow rates between ~ 16 - 28 l min^{-1} , the corresponding range of application rate was 2.9 - $5.2 \times 10^{-2} \text{ l m}^{-2} \text{ s}^{-1}$ (based on the compartment floor area of 8.9 m^2). The suppression process was monitored by temperature, oxygen and mass loss measurements and the results were presented as variations in these quantities as a function of time. As the data were to be compared with the predictions of the FD Model at a later date, no detailed conclusions were reported in Reference 181.

Stroup and Evans (Reference 182) described the findings of a series of four full scale tests designed to measure the effect of manual fire suppression on post-flashover room fires through the application of water sprays. Once again the objective was to provide verification data for the 'FD Model' computer code (Section 6.2.2, References 143-145). A 'burn-room' measuring 2.44 m cubed was connected to a corridor measuring $2.44 \times 2.44 \times 12.8 \text{ m}$ in length and the fire source consisted of an array of nine wooden cribs ($0.6 \times 0.6 \times 0.3 \text{ m}$ high) arranged in three rows of three. Each crib was constructed of 48 sticks of Douglas Fir ($40 \times 40 \times 600 \text{ mm}$ long) arranged in 8 layers of 6 sticks and with an overall mass of $\sim 21.5 \text{ kg}$ and moisture content between 5-10%.

The burn room environment was monitored using thermocouple arrays and gas sampling was achieved *via* a tube located 900 mm below ceiling level towards a forward corner of the compartment. Peak heat release rates during the tests ranged from 1.8-2.6 MW and two different hose nozzles were employed during the tests, although both were operated at 584 kPa (~ 6 bar), with a cone angle of 60°. Flashover was generally reached 2 minutes after ignition and manual fire suppression commenced after a further 10 minutes had elapsed. The four combinations of nozzle flow rate ($\text{l}\cdot\text{min}^{-1}$) and volume median drop size (μm) were: 36.5/930, 36.5/930, 16.3/800 and 79.0/1040. It was found that the sprays delivering $36.5 \text{ l}\cdot\text{min}^{-1}$ were just able to control the fire, the $79 \text{ l}\cdot\text{min}^{-1}$ spray extinguished the fire easily and the $16.3 \text{ l}\cdot\text{min}^{-1}$ spray could not achieve fire extinguishment (indicating that for the specific test conditions, $16.3 \text{ l}\cdot\text{min}^{-1}$ is less than the critical application rate). A detailed comparison of the test data with the FD Model appeared in a separate report.

Fire extinguishment tests conducted in a full-scale simulated ship-board space using low flow rate hoses were discussed by Scheffey and Williams (Reference 183); these tests represented the second phase of the investigation described in Section 7.2.1 (Reference 159). The test compartment was approximately 4.3 x 2.3 x 2 m high and was made deliberately congested to prevent direct application of water to the seat of the Class 'A' fire (UL size 3A crib of mass ~ 57-68 kg). A total of 17 tests were carried out and variations included the degree of ventilation, the fuel mass and the opacity of the smoke (which was increased by adding tar-impregnated paper strips or rubber tyres to the fuel bed). Various firefighting tactics were also employed, including: direct (onto the fire) and indirect (cooling and 'steam smothering' of the entire compartment) spray application and continuous or pulsed spraying. The advantage of the latter was that steam burns to the firefighter could be avoided, since the production rate of water vapour clouds was more controllable and could therefore be more easily avoided by crouching at low level. The nozzle spray pattern was also varied: a wide angle fog was used for cooling and indirect firefighting while narrow angle fogs and straight streams were more effective for direct firefighting and breaking apart deep-seated smouldering materials.

To aid the analysis of the results, the test fires were classed as 'small', 'medium' or 'large'; the classification system was based primarily on the thermal environment within the compartment. For small fires the range of upper room gas temperatures was 250-380 °C and the chest height temperatures were 60-100 °C; here the pre-burn time was less than 1½ minutes. In the medium fires the corresponding temperature values were 375-575 °C and 120-195 °C respectively and the pre-burn period was between 3-8 minutes. Finally, for the large fires the maximum upper gas temperature was in excess of 500 °C and the chest height temperature was greater than 200 °C; the pre-burn time was from 8-15 minutes. The amount of water required for extinguishment was compared with the previous series of unconfined tests (Section 7.2.1, Reference 159) and the cessation of flaming as observed with the IR camera was adopted as the fire control criterion. It was found that the volume of water required to extinguish the enclosure fires was considerably greater than that required to extinguish similar fires under more 'controlled' conditions; between 15-50 times more water was used in extinguishing the compartment fires compared with the previous unconfined experiments. Specifically, for fires beyond the incipient level (small fires), the water

usage increased from ~ 7.6 l for the outdoor fires to between 113-378 l for similar enclosure fires. The efficiency of the low flow hosereel system (1.9 cm diameter hose delivering ~ 571 min⁻¹ at 1.7 bar) was found to be better than with higher flow hand lines (3.8 cm diameter hose delivering ~ 121-279 l.min⁻¹ at pressures between 3.8-4.1 bar). In addition, the 'short water burst' tactic was shown to be an effective procedure.

In the UK, the Fire Experimental Unit (FEU) of the Home Office Scientific Research and Development Branch (SRDB) have also investigated the suppression and extinction of compartment fires (Reference 32). The main purpose of the tests was to compare the effectiveness of 'high pressure fog' and 'low pressure spray' and in particular, to investigate claims that high pressure systems offered more rapid cooling through the production of finer sprays which were more easily evaporated in the fire compartment. The test compartment was ~ 4.3 m square in plan with an internal height of 2.7 m; the brick walls were ~ 0.3 m thick and the floor of the room was cast in concrete. Three of the four walls contained the following ventilation openings: a doorway 0.9 x 1.9 m high and two windows (1.8 x 1.2 m high) located centrally in the walls adjacent to the door at ~ 0.5 m below the ceiling. Three wooden cribs, conforming to BS 5423:1980 were arranged in the compartment to give a fire load of 500 kg; one crib (of length 2.7 m) was sited under each of the two windows and the third crib (3.4 m long) was located at the base of the back wall opposite the doorway. Instrumentation included thermocouples, radiometers, video cameras and a thermal imaging camera.

A total of 18 different types of hosereel gun were obtained for the trials, with operating pressures in the range 2-45 bar (~ 30-650 psig). Prior to the fire suppression tests the hosereel guns were subjected to mass distribution and drop size distribution tests in order to characterise the sprays produced. In order to standardise the application or 'sweep' of the spray during the suppression tests, by removing the human element, a remote fire-fighting rig was employed (described in detail in Reference 32). Each gun was fixed to the remotely-operated turntable and adjusted to give a spray cone angle of 26° at an operating pressure (4-35 bar) corresponding to a flow rate of 100 l.min⁻¹. Following ignition, the test cribs were allowed to burn for 8 minutes until steady-state conditions were attained with heat release rates of ~ 6 MW. At this point the spray gun was activated from its initial location at the centre of the doorway; the spray was continually swept from side to side in order to deliver water to the burning surfaces of all three cribs. After a further two minutes, the remote rig was advanced into the centre of the compartment; the sweep angle was then increased to ensure all the cribs were still being wetted by the sweeping action.

A total of 8 different hosereel systems were used for these trials and the general progression of fire suppression for the tests is illustrated in the temperature/time curve of Figure 32. During the first phase of suppression, a large volume of steam was generated which obscured the direct observation of the compartment interior; air temperatures in the doorway were observed to rise, on average, some 70° above the initial ambient level. This initial temperature rise was followed immediately by the most rapid cooling period where the compartment temperature was approximately halved over a 30 second interval. The test data indicated that after a period of 1 or 2 minutes, little or no further reduction in air temperature was obtained. The second phase of suppression shown in Figure 32 corresponds roughly to the period between a significant

fall in the cooling rate to the stage where the fire is 'stabilised' and considered to be 'under control'. No further progress was possible until the rig was moved further into the room, however the limitations of the fixed spray precluded final extinction to be achieved in any of the test fires. It is interesting to note that there is a good qualitative agreement between Figure 32 and some of Pietrzak's theoretical predictions reported in References 143-145.

On the basis of the trials, it was concluded that the way a hosereel is used to attack a fierce compartment fire is more important than any variations in the characteristic droplet size or velocity. It was found that the differences in mean droplet diameter for different sprays was not as great as was first expected; also all the droplet size data collected revealed a wide spectrum of droplet diameters. There appeared to be a broad trend for higher pressure guns to produce somewhat smaller mean droplet diameters. During 'phase 1' there was a trend for the finer sprays to induce more effective cooling of the air at the doorway due to their more rapid evaporation; however, the sudden exit of the expanding cloud of products and water vapour was seen as a potential threat to fire-fighters. In 'phase 2' of the suppression curve, fire suppression was generally better with lower velocity sprays; it was also concluded that sprays in the form of a solid, uniform cones were preferable. Also during 'phase 2', high pressure sprays offered potentially increased throw and possible increased flow rates. During 'phase 3', where persistent pockets of flame are to be extinguished from close range, droplet size variations are of little consequence and operator ability is paramount. Overall it was concluded that a versatile branch was important and that the spray should possess a solid and uniform cone. The effectiveness of good tactical firefighting was demonstrated, and higher pressure seemed to offer several benefits: increased flow at a given gun setting, increased throw and a finer spray (promoting more rapid room cooling).

7.4 Test data arising from WMFSS development

7.4.1 General

The burgeoning interest in 'Water Mist Fire Suppression Systems' (WMFSS) has already been discussed briefly in Section 4.1.3. Mawhinney (Reference 133) considered the current philosophy regarding the design of WMFSS as a fixed fire protection measure. The existing Draft Standards (References 22, 184) relating to the installation of such systems do not adopt a 'first-principles' approach because of the 'uncertainty about the ability to achieve a targeted performance under varying field conditions...' (Reference 133). Instead, current practice regarding the use of WMFSS is to accept (or reject) systems on a 'case-by-case' basis, relying on full-scale fire tests for the ultimate verification of performance. Thus the information contained in References 22 and 184 is more relevant to the design of such tests and does not provide any definitive performance criteria relating to commercially-available WMFSS nozzles. Therefore these Standards do not explicitly shed any light on how WMFSS sprays would be expected to interact with Class 'A' fires, although Reference 22 states that if Class 'A' fire extinguishment is required, then '... consideration shall be given to the potential for deep-seated fires as well as to the potential for smouldering fires'. The following section is comprised of reports of recent WMFSS trials, although the tests concentrate on Class 'B' fires, some of the observations are relevant to the present study of Class 'A' fire suppression.

7.4.2 Accounts of some notable WMFSS tests

7.4.2.1 *SINTEF experiments - Norway*

Wighus (Reference 185) reported reduced scale experiments on the effect of a water spray against a confined propane gas fire (~ 1 MW). The size of the model was 2.5 x 2.5 x 5 m (~ 30 m³) and represented a 1:4 scale offshore process module, with natural ventilation through openings at floor and ceiling level. The tests were intended to quantify the suppression effectiveness of various water sprays against enclosed hydrocarbon fires, in an effort to improve the design of active fire suppression systems and so move away from the traditional water deluge delivery standards based solely on industrial experience. The main mechanisms of fire suppression/extinction were given as: cooling of the flames to a temperature where the chemical reactions cannot be sustained, reduction of oxygen concentration to a level where combustion cannot be sustained, increasing the flow velocity to a level where the physical residence time of the fuel and oxygen in a combustible mixture is less than the time scale of the chemical reactions and adding components to the combustion zone which disrupt the chemical chain reactions by the substitution of competing endothermic reactions.

The most probable mechanisms applicable to water sprays are a combination of evaporative cooling (liquid water → water vapour) and subsequent depletion of the oxygen concentration by the steam produced. It was noted that the critical concentration for flame extinction in a well-stirred reactor is 30% (on a mole basis) but that the less efficiently-mixed case of a room fire would require a higher critical mole

fraction of steam to ensure extinction. Wighus (Reference 185) stressed the strong dependence of extinguishment effectiveness on water droplet diameter, previously observed by other workers (e.g. McCaffrey, Reference 45). Investigations conducted by Underwriter's Laboratories Inc. were cited (Reference 149), where a marked improvement in effectiveness was seen for water droplets $< 300 \mu\text{m}$ in small scale tests against gasoline fires (a 40% reduction in the required delivery density of water was observed when the mean droplet diameter was reduced from 300 to 125 μm). Smaller droplets are able to evaporate faster when exposed to hot gases and the 'residence time' of a spray droplet can be defined as the time from discharge until it impinges on a surface or is convected from the compartment. The residence time dictates how much heat can be absorbed from the fire environment. Very small droplets will tend to evaporate in the upper part of the room and most of the steam will be convected with the smoke through any exhaust opening. The rapid evaporation of the water leads to an increase in volume of the water by a factor of ~ 1000 and the ensuing increase in pressure may restrict the combustion air flowing into the enclosure. In addition, smoke and combustion products may be recirculated from the upper layers back down into the flame zone; a combination of these effects may lead to fire extinguishment by oxygen starvation.

Wighus (Reference 185) described the concept of the 'Spray Heat Absorption Ratio' (SHAR) which was used to assess the SINTEF test results. The analysis was based on measuring the various components of heat flux to the different parts of the room and its surroundings. The SHAR is defined by the heat balance equation,

$$\text{SHAR} = 1 - \left[(\dot{Q}_{\text{wall}} + \dot{Q}_{\text{ceiling}} + \dot{Q}_{\text{floor}} + \dot{Q}_{\text{vent}}) / \dot{Q} \right] \quad (95)$$

where the 'SHAR' is non-dimensional, \dot{Q} is the total heat release rate from fire (W), \dot{Q}_{wall} is the rate of heat absorption by walls, \dot{Q}_{ceiling} is the rate of heat absorption by ceiling, \dot{Q}_{floor} is the rate of heat absorption by floor and \dot{Q}_{vent} is the convection heat loss rate by ventilation. The thermal energy absorbed by the water was divided into four components: that required to heat the water from its supply temperature to 100°C; that required for phase change from liquid state to steam; that involved in superheating steam to the exhaust gas temperature and the energy required to heat "run off" water from the supply temperature to its final temperature. Experimental errors limited the accuracy of the SHAR calculation to $\pm 20\%$ (Reference 185).

The primary variables in the experiments were the nozzle type, the water pressure and the number (1 or 2) and location of the nozzles; the particular combination of these parameters determined the water application rate ($\text{l}\cdot\text{min}^{-1}\cdot\text{m}^{-2}$) and the mean droplet diameter (617-1569 μm). The propane line burner arrangement gave an initial heat output of $\sim 1 \text{ MW}$ at the start of the test and thereafter fell to 850-900 kW over a period of 15 minutes due to the pressure drop in the supply tank. The reaction of the fire to the application of the water spray was dependent upon the characteristics of the spray and two broad categories of behaviour were observed. The first few seconds of spray application were found to be critical in determining whether the outcome of the test was fire extinguishment or merely fire suppression (burning with a reduced heat release rate). The spray was initially observed to deflect the flames and a 'fight' ensued

between the flames and the spray, where the former became bluish and were replaced by steam. In some cases flaming was observed to persist in other parts of the enclosure, even at the high-level outlet only. If the spray was able to dislodge the flames from the burner base for longer than ~ 10 seconds, then total extinguishment was the most probable outcome. If this condition was not satisfied, flames were seen to re-enter the compartment and more or less stabilise, although they were subject to perturbations caused by the spray-induced air flows. The experimental programme was designed to find the limit for extinguishment for three different nozzles operating at a range of pressures (which produced different mean droplet diameters and corresponding delivery densities).

The results of the experiments showed that the SHAR value, initially zero (start of test, no water application), rose sharply to a peak upon activation of the nozzle and then fell to a lower value. It was determined that "instant extinction" was possible only if the SHAR value was greater than 0.6 in the early stages (*i.e.* that spray was absorbing 60% of the heat released by the fire). If instant extinguishment was not achieved, typical longer-term SHAR values of ~ 0.1-0.3 resulted in fire suppression only; in these cases the SHAR value had to be increased to > 0.7 to effect extinguishment in the longer term (by manually increasing the delivery pressure). A clear correlation was obtained between the SHAR value and nozzle pressure, higher pressure resulted in an increased delivery density and smaller mean droplet diameter. The heat transfer from the hot smoke to the water spray depends upon the temperature and velocity gradients between the droplets and the hot smoke and on the total surface area. For a constant water flow rate, the total surface area of the spray is directly proportional to the inverse of the droplet radius. Although it is true that smaller droplets evaporate faster than larger ones, the transport and residence time characteristics of the drops are also important. Wighus (Reference 185) inferred a 'critical droplet size' of 3000 μm (3 μm) from the SENTEF data, above this mean droplet diameter, the water application rate for extinguishment rose exponentially with increasing mean droplet diameter. A similar trend was noted in the (small-scale) Underwriter's Laboratories data, although the critical mean droplet diameter was ~ 300 μm , indicating a scale effect between the two sets of data.

A series of scaling criteria were presented by Wighus, based on Froude number similarity, as developed for the study of fire plume problems. The various scaling parameters were based on geometrical similarity, thermodynamic similarity and dynamic similarity principles as follows. The fire compartments must be geometrically similar, such that a length scale is defined as $L = l_m/l_p$. The fuel burning rate is scaled with $L^{3/2}$ so that $\dot{m}_f/L^{3/2} = \text{constant}$. Similarity between the thermal properties of the ceiling, walls and floor is preserved such that $k \cdot T_0 / (\delta \cdot L^{1/2}) = \text{constant}$, and $t_c \cdot L / (\rho \cdot C_p \cdot k \cdot T_0^2) = \text{constant}$. The flow pattern of the droplets leaving the nozzle is similar and the droplet velocity is scaled by $V_0/L^{1/2} = \text{constant}$. The droplet diameter is scaled by $d_m/L^{1/2} = \text{constant}$, and the water application rate is scaled by $\dot{m}_w/L^{3/2} = \text{constant}$.

It was cautioned that these relationships were solely theoretical and that experimental verification was still lacking, although there was some evidence to support their validity.

Using these criteria, Wighus derived 'full scale' predictions from the 30 m³ enclosure experiments assuming a prototype compartment with sides 4 times larger than the experimental case (*i.e.* an enclosure ~ 2000 m³). For a geometrically similar nozzle, the scaling predicts that:

- A fire of 32 MW ($\dot{m}_f = 0.7 \text{ kg.s}^{-1}$ propane) is extinguished by a water application rate of 2.7 l.min⁻¹.m⁻² with a full cone spray of mean droplet diameter 1200 μm; with a mean diameter of 2000 μm (2 mm), the required delivery rate is ~ 7 l.min⁻¹.m⁻²
- A water application rate of 10 l.min⁻¹.m⁻² (typical conventional deluge system) can extinguish a propane fire of 119 MW ($\dot{m}_f = 2.6 \text{ kg.s}^{-1}$) if the mean droplet diameter is 1200 μm.

Alternative methods of estimating the efficiency of water sprays and mists have been presented by other workers (*e.g.* in References 45 and 186). Carhart *et al.* (Reference 186) discussed the potential of water mist as a fire suppressant and showed by a simplistic calculation that one gram of water could, in theory at least, extinguish a flame volume of 50 litres by reducing its temperature from 2000 K to a limiting flame temperature of 1600 K. It was also suggested that the addition of 2.7 g of water per mole of hot gas would produce enough water vapour to reduce the oxygen concentration to ~ 18.3% and that this in turn would reduce the amount of water required to extinguish the remaining flame. McCaffrey (Reference 45) examined the mechanisms by which water sprays can effect the suppression and extinction of flames, including disruption of flame stability, interference with thermodynamic equilibrium (and therefore flame temperature) and momentum exchange between the water spray and the flame envelope. McCaffrey correlated his small-scale data using the concept of an "equivalent heat release rate", \dot{Q}_E , equal to the normal heat release rate of the flame, \dot{Q} , minus the calculated cooling effect of the water $\dot{Q}_{\text{H}_2\text{O}}$. Assuming an initial water temperature of 20°C, the latent and specific heat comprising $\dot{Q}_{\text{H}_2\text{O}}$ were defined as follows,

$$\begin{aligned} \text{liquid:} & \quad 0.0042 \text{ kW}/(\text{g.s}^{-1}.\text{K}) \times 80 \text{ K} \\ \text{vapourisation:} & \quad 2.26 \text{ kW}/(\text{g.s}^{-1}) \\ \text{steam:} & \quad 0.0024 \text{ kW}/(\text{g.s}^{-1}.\text{K}) \times (T_f - 373) \end{aligned}$$

or,

$$\dot{Q}_{\text{H}_2\text{O}} = [1.7 + 0.0024T_f(\text{K})]\dot{m}_{\text{H}_2\text{O}} \quad (96)$$

assuming a constant value for the specific heat capacity of steam C_p at 1150 K, a midrange value between that at boiling (0.0020 J.kg⁻¹.K⁻¹), a nominal maximum flame temperature of 2000 K (0.0028 J.kg⁻¹.K⁻¹) and $\dot{m}_{\text{H}_2\text{O}}$ measured in g.s⁻¹. It was noted that at a representative flame temperature of $T_f = 1500 \text{ K}$, the contribution to the total cooling capacity of 'liquid heating' plus 'vapourisation' is approximately equal to that of the 'steam heating' alone (see Figure 18); therefore the cooling capacity of a liquid water spray is double that of an equivalent mass flow of steam.

7.4.2.2 Ship protection

Turner (Reference 19) described the development of Marioff's Hi-Fog system and its marine applications in accommodation areas, engine rooms etc. and also some land-based uses. Two years of intensive development work, including over 400 actual fire tests, had resulted in the approval of the Hi-Fog system by European Authorities including the UK Department of Transport and systems had been installed in Europe and Scandinavia. Although the benefits of water mists had been recognised for some years, their use had been restricted to a very few practical applications such as chimney fire extinguishment. One of the main drawbacks was the lack of penetration of the fine droplets into the flue gases. Despite the extremely efficient cooling capacity compared with sprinklers, the low mass of the droplets made it impossible to penetrate the plume produced by even a moderate combustion source. The Marioff system overcomes this problem by using high pressure hydraulic technology to generate a fog which is propelled at a velocity high enough to penetrate even a post-flashover fire environment.

A number of tests were described by Turner (Reference 19), performed by SP, the Swedish National Testing & Research Institute in 1991/92 to investigate the system's performance against fires in cabins, large rooms and in public open spaces on board a passenger ship. The scenarios most relevant to the present study were designed to simulate fires in various machinery spaces. Marioff have designed a special system for these hazards, employing a low pressure water fog as a cooling and controlling mechanism and a high pressure fog for extinguishing. The operating sequence involves firstly a high pressure burst of fog ensures that the water achieves good penetration of the combustion zone and the subsequent continuation of the low pressure mist supplies continuous cooling to prevent reignition. The machinery space tests described in Reference 19 were as follows:

- *Prototype machinery space fire tests, Finland - July 1991*
A series of tests was carried out in a purpose built fire test engine room of 261 m³. Nine gas burners (~ 400 kW) were ignited to heat a steel plate simulating a split oil pipe or filter housing. When the temperature reached ~ 600 °C, an oil flow of 10 l min⁻¹ at 130 bar was sprayed over the hot plate to ignite the flow into the bilges. After a delay of several minutes the system was activated and in the 5 tests, extinguishment was attained in 6-35 s after activation and with a water demand of 6-34 litres.
- *Machinery space development trials, Sweden - April/June 1992*
A series of full scale tests were carried out in SP's fire hall within a compartment of dimensions 8 x 10 x 4.8 m high. The experiments were designed to evaluate the Hi-Fog's performance against pool and spray fires in a simulated ship's engine room. Fuel oil, diesel oil and lubrication oil pools fires of area 2-11 m² were set up, and spray fires and spray/pool combinations were also employed (using the same fuels). Approximately 150 different tests were conducted using the Hi-Fog high pressure system and a large number of system modifications and improvements were introduced. The tests showed that the system was able to extinguish large engine room fires with pool and spray fires combined with natural ventilation from open doors and hatches. Previous tests conducted by SP had shown that a water spray

with a $5 \text{ l} \cdot \text{min}^{-1} \cdot \text{m}^{-2}$ delivery rate (SOLAS Chapter II-2, Regulation 10) had a very limited extinguishing capacity compared with the Hi-Fog system.

- *Large engine room fire tests, Finland - November 1992*

Eight full-scale suppression experiments were carried in the large test hall belonging to the Fire Technology Laboratory at VTT. An engine mock-up, identical to that used in previous tests, was constructed in the test hall to simulate a large engine room and diesel oil was used as the fuel. The most intense fire constructed for the tests comprised four pool fires under the engine model plus one pool fire on top (total area 11 m^2) and a spray fire alongside. The maximum heat release rate was estimated to be $\sim 20 \text{ MW}$. The pre-burn time in all tests was around 2 minutes from the point of ignition, after which the Hi-Fog system was activated manually (with different water pressures used for different tests). The tests demonstrated the ability of the system to extinguish a 20 MW oil fire even in an unenclosed large space.

7.4.2.3 Telecommunications and utilities protection (live electrical equipment)

The use of water mist as a replacement for the 'total flooding' agent Halon 1301 has been discussed by Simpson and Smith (Reference 187) and by Mawhinney (Reference 188). In Reference 187 the point was made that while water is known to be a good Class 'A' and B fire suppressant, "...scepticism remains over its use in Class C applications due to its conductivity." Mawhinney (Reference 188) also raised the problem of possible corrosion of circuitry due to the increase in humidity. The feasibility study in Reference 187 was designed to assess the effectiveness of water mist in suppression a fire in telecommunications switch gear. The switch gear geometry was such that direct application of mist could be achieved from the top, bottom or side of the vertically-oriented void channels between the printed circuit boards. From a practical standpoint, total flooding ('room fogging') is undesirable because of the potential disruption to non fire affected equipment bays. The tests therefore, employed manifolds which allowed the nozzles to be sited between the rows of PCBs. It was found that twin-fluid nozzles performed equally as well as the single fluid types but the former's added complexity detracted from their suitability. Sprays with a narrow cone angle concentrated the water inside the bay and led to rapid extinguishment; also, coarse, low pressure sprays consumed more water and gave a longer extinguishment times than the high pressure single fluid or twin-fluid designs. The larger, lower velocity droplets produced by the coarse sprays were not able to negotiate obstacles or penetrate to the seat of combustion effectively. Experiments on energised equipment showed that water fog did not damage the electrical gear contained in the bay. The water fog activated the current trips (set at $\sim 10\text{-}100 \text{ mA}$) in each bay so the shock hazard associated with using water was low. The switch gear bays became fully operational after a 60 minute drying period.

7.4.2.4 Gas turbine enclosures

Wighus *et al.* (Reference 189) reported the results of a major research programme intended to assess the practicability of replacing Halon systems by water mist for the fire protection in turbine hoods on offshore platforms. The project was subdivided into 3 phases:

- Phase I involved tests in a 30 m³ test chamber designed to characterise the effect of different water spray nozzles against gas fires; these tests have been discussed in Section 7.4.2.1 of the present report (Reference 185). The main results of these tests were the identification of a suitable nozzle design and the most challenging fire scenarios.
- Phase II of the project was carried out in a full scale mock-up of a turbine hood with a model turbine inside. Attention was paid to retaining a realistic geometry, including obstacle and a representative ventilation system. The total volume of the turbine hood was ~ 70 m³. The Fine Water Spray system was used against various fires and the possibility of turbine damage from rapid cooling was investigated.
- Phase III employed the same turbine mock-up, but in an enclosure of ~ 140 m³, which simulated a room containing an emergency generator. Diesel pool- and spray-fires of various sizes were burned in different locations and the number and type of Fine Water Spray Nozzles was varied.

A full description of the turbine enclosure test series is included in Reference 189, for the sake of brevity, only the main conclusions are repeated below.

1. The Fine Water Spray system is very efficient in extinguishing large fires in enclosed spaces.
2. Ventilation-controlled fires are easily extinguished by the Fine Water Spray system.
3. Small fires are difficult to extinguish with the Fine Water Spray system, except when the spray directly hits the fire base.
4. Fires from fuel-soaked into insulation mats are the most difficult fires to extinguish permanently with the Fine Water Spray system. Reignition frequently occurs after some minutes, even if the original fire was extinguished by the first water spray.
5. The additive 'FIRESTOP 107' used in a 3% solution in the spray water prevented reignition of the insulation mats soaked in diesel oil when a sequence of 10 s shots of spray was applied. The sequence was: first shot (10 s duration), pause (60 s), second shot (10 s duration), followed by shots of 10 s duration repeated every 5 minutes until the steel temperature of the turbine was below the self-ignition temperature of diesel oil.
6. Insulation mats impregnated with 'FIRESTOP 102' were very difficult to ignite and reignition after an extinguished fire was not observed, even if the mats still contained

diesel oil. When ignited by a torch the diesel oil soaked insulation mats protected by 'FIRESTOP 102' burned at the edges only, in contrast to the unprotected mats which burned over their entire surface.

7. The Fine Water Spray system operates as a total flooding (inert) fire suppression system when the fire size is large compared with the room size.
8. The extinguishment mechanism of the Fine Water Spray system is a combination of inerting the combustion zone by water vapour and cooling of the reactants.
9. The Fine Water Spray system works in two distinct extinguishing modes, namely extinguishment of flames and inerting of the enclosure. The first requires a certain water application rate, directed at the base of the fire while the second mode requires a certain total amount of water applied into the enclosure, and the application rate then influences the time to extinguishment only.
10. When a small number of nozzles is installed in an enclosure, a sequence of 120 s water spray, pause of 120 s and then a second 120 s application of water spray is an efficient way of extinguishing small fires. This sequence is more efficient than one single spray of longer duration. When direct application to the base of the fire is not possible a spraying time of 20 s is more efficient in extinguishing the tested fires by the first spray than a 10 s spray.
11. The minimum amount of water required for rapid extinguishment of a large fire (2-3 diesel pool fires and a diesel spray fire) in a 70 m³ turbine hood is 4-5 litres. This amount corresponds to a specific water fraction of $m_{\text{water}} = 0.06-0.07 \text{ l.m}^{-3}$. A corresponding specific water fraction $m_{\text{water}} = 0.4-0.6 \text{ l.m}^{-3}$ is valid for small fires in large enclosures, where the spray from the nozzles does not cover the bases of all the fire sources. This proportion is valid for the actual turbine hood geometry and size, and for the Fine Water Spray nozzle jet at 10 l.min⁻¹ 90° only as it is not verified for any other conditions.
12. The pressure development in the turbine hood is characterised by a rapid drop immediately after introduction of the Fine Water Spray, and a stabilising about ambient pressure after a short period. The overpressure (~ 50 Pa or 0.5 mbar) in the turbine hood is induced by the fire itself, when the ventilation dampers are shut down. The possibility of the underpressure (occurs despite the expansion of mist to steam) (~ -250 to -350 Pa or -2.5 to -3.5 mbar) drawing in fresh combustion air was noted but not expanded upon.
13. The oxygen concentration in the turbine hood when a fire was self-extinguished was ~ 9%. Corresponding CO₂ concentration was 8% and CO was about 0.76% (7600 ppm). In the experiment where Fine Water Spray extinguished the fire, the minimum oxygen concentration was in the range from 12.5-18%. Corresponding maximum CO₂ concentration was in the range from 2-6% and CO concentration was in the range from 0.1-0.6% (1000-6000 ppm).

14. The conditions after extinguishment with the Fine Water Spray are much less hazardous for people than after a fire extinguished by oxygen starvation only. The concentration of oxygen and CO₂ are not critical for human exposure and the concentration of CO is well below critical values for 30 minutes in all experiments where the ventilation dampers were closed and the water spray activated shortly after ignition of the fire.
15. Many large fires would be self-extinguished through lack of oxygen in closed spaces, regardless of the fire fighting system. The positive effect of the Fine Water Spray system is that the burning time of the fire is reduced and the temperatures inside the enclosure are reduced to a level where the damage is small.
16. The inerting effect of water vapour decreases when the temperature is below the condensation point of water (100 °C). This means that the long-term inerting effect of the Fine Water Spray system is reduced both by leakages in the enclosure and by the condensation of water vapour.
17. The exit velocity of the water droplets is important regarding efficiency of the spray system. A high exit velocity combined with a Median Droplet Diameter of ~ 200 µm seems to be a near optimal combination for extinguishing hydrocarbon fires in enclosures with ceiling heights up to ~ 4 metres.

7.4.2.5 Gaseous combustion (explosions)

Smith (Reference 25) reported a series of explosion suppression trials carried out by Kidde International in a 6.2 m³ vessel of aspect ratio 2.6:1 against diesel spray explosions of defined severity. A number of aqueous solutions were examined as rapid discharge fine sprays and "critical concentrations" were established, defined as the lowest agent concentration per unit volume which enabled the test agent to suppress the diesel explosion. Of the additives tested, several were found to give a marked improvement in performance over plain water sprays and in doing so, to offer a capability greater than that of analogous Halon systems.

Jones and Nolan (Reference 13) reported that fine mists had been used successfully to arrest the propagation of flames in stoichiometric mixtures of methane and air. The experiments were performed at laboratory scale and at full-scale in a 100 m long tunnel of 2 m diameter and the methane flames were extinguished efficiently using fine, dense sprays with droplet diameters up to 100 µm. Other work quoted in Reference 13 had shown that a smaller quantity of water was required to inert a mixture prior to ignition than to quench a fully established flame propagating through an identical mixture. These tests were performed in a 1 m long perspex tube of 0.15 m i.d. and it was also found that less water was required when the spray mean diameter was reduced. Some tests using a mixture of steam and fine drops indicated that droplets with diameters < 10 µm behaved indistinguishably from the vapour. Studies of fine sprays used against hydrogen-air flames were reported Reference 13; mixtures of 6.1-6.8% hydrogen (by volume) in air were ignited in a closed vessel and then water sprays were applied at the rate of 3.8 l.min⁻¹. At a concentration of 0.0067 m³ of mist per cubic metre of protected space, the hydrogen-air flame was successfully quenched; a lower mist concentration allowed a

weakened flame to ignite but displayed some ability to cool the combustion. Computer simulations were quoted which had suggested that droplets of around 20 μm diameter should be capable of cooling a stoichiometric hydrogen-air flame significantly.

Grin and Sergeev (Reference 60) performed a computational simulation of the heat transfer between a water spray and high-temperature flame typical of a dust-gas-air explosion. Assuming a time of contact between the droplet cloud and the explosion flame to be 150 ms, a parametric study was performed to determine how the rate of cooling was affected by different diameters of droplet and the number of droplets per unit volume. Assuming a flame front temperature of 1273 K, an initial spray temperature of 293 K, and a flame cut-off temperature of 775 K it was found that the optimum dispersed-water cloud had a density of 0.3 kg.m^{-3} and a droplet diameter of 75 μm . The rate of evaporation of the droplets depended on their size, the density of the dispersed cloud and its time of contact with the flame. These results were reported to be in good agreement with experimental data in which the water consumption for the extinction of an explosion flame was $0.25\text{-}0.4 \text{ kg.m}^{-3}$.

Jones and Thomas (Reference 190) and van Wingerden (Reference 191) both reported that conventional water deluge systems have an initial acceleratory effect when applied to explosions, generating an increased overpressure compared with the 'unprotected' case. In the latter stages of combustion however, the sprays are observed to reduce the pressure generated. It was thought that the initial increase in combustion rate may be due to the enhanced mixing caused by spray-induced turbulence; it had been observed during some tests that a higher velocity spray nozzle produced a greater initial explosive overpressure. It was further suggested that the mitigation effect observed subsequently was due to a fine water mist being produced by droplet break-up of the 'parent spray' in the initial explosion (Reference 190). Once very small droplets are available, the usual very efficient mechanisms of heat removal and inertion can take place and suppress or even extinguish the combustion. It was also concluded that in the case of conventional deluge systems, very fast propagating flames ($200\text{-}400 \text{ m.s}^{-1}$) were more easily extinguished than slower ones as the latter could not generate the fragmentation processes required to produce the fine droplets required.

7.4.3 Design considerations for water mist fire suppression systems (WMFSS)

With the phaseout of Halons and the proliferation of commercial water mist systems, would-be users of the new technology require guidance as to the suitability of these systems for their particular application. Some attempts at providing this guidance have been made in References 192 and 193. Mawhinney (Reference 192) identified a considerable international interest in the development of engineering design criteria generated by two main expectations:

- It was anticipated that water mist systems would provide economic advantages due to the promise of a fast-acting, low water demand fire suppression system;

- Many fire safety specialists viewed the use of a fine mist as a potential replacement for gaseous fire suppressants, assuming that the mist will be drawn by convective air movements into all recesses of the protected space.

Mawhinney also referred to the extensive published work describing the successes of WMFSS technology and noted that despite these 'case studies', fundamental questions still remained regarding how to actually design such a system. Such questions included how to characterise the effectiveness of a 'fine spray', which systems are the most cost-effective and reliable, how are the spray characteristics related to the 'design fire' and the type of space involved, etc.? The situation regarding WMFSS design was compared with that of sprinkler design where well-established practices, built-up over a number of years (based on full-scale tests and backed up by years of fire loss data), allow the designer to tailor a sprinkler system to match the fuel type, heat release rate and geometry of the protected space. In the case of sprinklers these standardised procedures are valid for most commonly encountered situations and require expert modification only in a small number of cases; the design process is further aided by the availability of technical reference books and computerised design procedures. Such 'technical infrastructure' does not yet exist for WMFSS.

Mawhinney suggested an outline design procedure to indicate the nature of the problems to be solved at each stage and offering possible directions for resolving these problems. The general process suggested in Reference 192 is outlined here:

- *Define the fire scenario*

Fuel type - liquid pool/liquid jet/gas jet/electrical/Class 'A'

Fuel configuration - floor level pool /jet fire at floor, mid-height or ceiling height etc.

Compartment conditions - dimensions/open-closed/ventilation/shielded fire etc.

The fuel type determines the heat release rate and the potential duration of the fire. The fuel configuration determines how fast the fire grows and spreads, while the compartment conditions determine the intensity of radiation from the surroundings back to the fire, the velocity of the fire plume, the rate of deepening of the hot gas layer and the manner in which a fire suppressant can be distributed in space.

- *Define the fire safety objective*

Having identified the fire scenario, it is necessary for the designer to set realistic criteria by which to judge the WMFSS performance. For sprinkler systems two outcomes are possible, either it extinguishes the fire or limits the fire size, burning rate and room temperatures to minimise the potential for harm. Water mist systems provide additional possibilities, such as the attenuation of radiation (used in post-crash aircraft fire control), which may provide valuable additional escape time. If WMFSS is to replace a Halon system, then it is natural to compare the performance of the two, however it may be that the WMFSS does not completely extinguish the fire in contrast to the Halon performance. In this case there may exist various 'compensating factors' for WMFSS, such as a more rapid temperature reduction due its superior cooling effect, less restrictions on the level of compartment sealing design and more rapid re-entry to the space etc.

- *Characteristics of water mists for fire suppression*

To characterise a fine spray suitable for fire suppression, it is necessary to describe more than a single droplet diameter. At least two parameters are needed, one to describe a representative diameter and another to describe the range. Mawhinney suggested that a plot of cumulative percent volume versus diameter should be provided and noted that various empirical distribution functions were available to facilitate the input of drop size distribution data into CFD codes. In practice the droplets produced will vary greatly, for example the drop size distribution close to the nozzle will be much finer than at some distance away. Also the interaction between adjacent spray cones and obstructions results in agglomeration of drops so that the volumetric mean diameter (VMD) of the spray well inside the enclosure may be ~ 100% larger than at the nozzle. The range of drop sizes will also be expected to increase within the protected volume. The spray density is very important for fire suppression but Mawhinney noted that at present it is difficult to relate the 'actual delivered density' to the 'required delivered density' for a range of fire scenarios. The use of a global density defined as the mean density per unit volume in the protected space was considered to be only useful for basic comparisons due to the large difference in localised densities in practice. It was considered more important to understand and to have control over localised spray densities in relation to the fuel source than to quantify spray density broadly in average terms. The spray angle and spray momentum are the factors influencing nozzle spacing and the ability of the spray to fill the compartment in spite of obstructions. Mawhinney noted that sprays with high momentum interact turbulently with the flame and appear to improve extinguishment.

- *Spray flux required for extinguishment*

Mawhinney (Reference 192) reported that a great deal of work had been done over the past 40 years in an effort to answer the question of what minimum rate of application of spray is required to extinguish a fire. Various approaches were mentioned, including the determination of a critical ratio of spray volume to flame volume, where one hypothesis predicts extinguishment if the water mist occupies 10% of the flame volume. Wighus (Reference 193) estimated that the critical water application rate per unit flame volume was $\sim 0.5 \text{ l.m}^{-3}.\text{s}^{-1}$. Other criteria were also listed in Reference 192, including a critical reduction in radiant heat energy following the application of water mist and the critical water delivery to fuel evolution ratio (\dot{m}_w / \dot{m}_f).

Wighus' 'SHAR' or spray heat absorption ratio (Reference 185), introduced in Section 7.4.2.1, predicts pool fire extinction when the SHAR ~ 0.6 . Wighus (Reference 193) also gave approximate minimum water mist requirements for 'total flooding'. A 'large fire' in a 'small enclosure' was considered relatively easy to extinguish, particularly if the fire plume receives a 'direct hit' from the high-momentum mist spray, or if a large fire has had time to develop, resulting in heat-up of the compartment boundaries and a general decrease in ambient oxygen levels. As a result of the turbine enclosure fire suppression programme (Reference 189), Wighus (Reference 193) suggested that a large confined fire could be extinguished with a specific water fraction of 0.05-0.10 l.m^{-3} , and a small relatively unconfined fire would require approximately 0.42-0.66 l.m^{-3} for complete extinguishment.

Mawhinney's experiments at full-scale (Reference 192) also showed that it was easier to extinguish a large flaming fire than a small flaming fire. A 2 MW fire had reduced the compartment oxygen concentration to ~ 15% at the time of spray activation and extinguishment was thought to be due a combination of rapid cooling and steam production, the latter further reducing the already low oxygen concentration. A 600 kW fire in the same compartment proved more difficult to extinguish and the degree of obstruction within the compartment became significant. It was concluded that the relative importance of the extinguishment mechanisms changes with fire size. For a small fire, there is a greater need to make the spray interact with the visible flame whereas for a larger fire, steam displacement of oxygen reduces the need for direct spray-flame interaction.

Mawhinney (Reference 192) noted that the implication of allowing a fire to grow significantly before attacking it ran very much counter to conventional wisdom. It was thought that while the strategy might be acceptable in some cases, it was probably not acceptable for fire hazards currently protected by Halon systems and for which WMFSS was a potential replacement. It was considered more appropriate to design a suppression system with the intention of extinguishing the fire while small, implying that the nozzles would need to be located so as to maximise the probability of spray interaction with the flame. It was argued that strategic location of nozzles based on an analysis of potential fire hazards would be more effective than locating nozzles to provide uniform density throughout the compartment. Strategic placement of the nozzles brings the additional benefit of a finer spray (with higher momentum) than would be the case for mist descending from the ceiling. It was suggested that ceiling nozzles supplying a lower delivery density would have the additional benefit of extracting heat from the fire gases and preventing heat damage to other objects in the compartment.

- *Effect of obstructions on spray density*

Every surface engulfed in a cloud of spray will become coated with water and therefore extract water mass from the spray. Obstructions reduce the velocity and momentum of the spray and induce changes in direction; as a result, it is extremely important to take account of the effect of obstructions when designing WMFSS protection. It is often stated that water mists behave in the same manner as gaseous suppression agents and will move freely into all recesses of a compartment to the seat of the fire and then extinguish it. Smith (Reference 25) noted that most WMFSS produce droplets in the range 50-200 μm whereas it had been estimated that a droplet size of less than 20 μm was required for the spray to have true 'gas-like attributes'.

While Mawhinney (Reference 192) suggested that some mist usually was transported to all parts of the protected space, the crucial point was that the mass of water per unit volume of air was reduced every time an obstacle was traversed. It was emphasised that the success of a spray in extinguishing a flame appears to require that the spray has a degree of momentum to enable the droplets to penetrate the flame interior. Experiments were described where 0.5 m diameter pool fires were surrounded by a fine mist and continued to burn (the only momentum source was the buoyant fire plume in this case). The fire was apparently able to entrain sufficient

oxygen for combustion from the mist-filled atmosphere. Only when the mist was able to push itself into the flame core could the fire be extinguished. It is possible under some conditions that the presence of obstacles may improve the effectiveness of the mist by deflecting the spray into the flame region, but less favourable conditions will impair the spray's performance. Mawhinney (Reference 192) recommended adopting the conservative assumption that conditions will seldom be favourable and to compensate for obstructions by reducing nozzle spacings, increasing the initial spray momentum and to look for 'strategically favourable' nozzle locations. Although it is convenient to install ceiling mounted nozzles in all compartments (as in the case of sprinklers), it was strongly recommended that more detailed consideration should be given to the siting of water mist nozzles. Criteria for judging 'strategic location' include the projection capability of the nozzle, the spray angle and initial flux density and the geometry of obstructions. Nozzles may have to be mounted horizontally in some cases in order to maximise the coverage volume and to maintain the spray parallel to, rather than orthogonal to, cables trays and ducts etc. In large machinery spaces it becomes impractical to use nozzles with horizontal projection distances less than 3-4 metres because of the economic disadvantage of having to install too many nozzles.

- *Ventilation considerations*

Mawhinney (Reference 192) noted that where WMFSS are to be installed as a direct replacement for a Halon system, the compartment may be assumed to have no leaks, and in such cases the ventilation system will usually be designed to close automatically upon receipt of a detector signal. The potential advantage here is that the same extinction capability may be achieved at a lower spray density than would be required in an open, fully-ventilated compartment. One caveat for the installation of WMFSS in sealed compartments is that the twin-fluid variety of nozzle will quickly pressurise the compartment due to the substantial gas flow required for operation; such overpressures may have serious implications for subsequent smoke control in adjacent areas. One further effect is mentioned in (Reference 192), that of pressure fluctuations when the WMFSS is activated. It has been well documented by the Fire Service that windows may implode upon application of a water spray and Mawhinney cited observations in the literature that when a spray is injected directly into a flame or hot gas layer, the result is a sudden contraction and reduction in gas volume. The magnitude of the gas contraction is much greater than the expansion of steam as the droplets evaporate. It was observed that the magnitude of this implosion effect was greater for WMFSS than for sprinklers because the coarser droplet size of the latter does not promote the exceptionally rapid cooling typical of water mist droplets.

7.5 Summary

Many different techniques have been employed for the evaluation of fire suppressants and their method of application. The problem is complex, owing to the great diversity in fire types, extinguishing agents and the techniques of application; these difficulties are compounded by the need to specify the condition and rate of application of the agent. Laboratory tests are favoured for reasons of economy and the degree of control which may be exercised on the test conditions. However, the problems associated with extrapolating small-scale data to predict large-scale behaviour are well-known, particularly where combustion systems are concerned, and this recognition has provided the impetus for tests at more realistic scales. Fire suppression tests on confined and unconfined fires conducted at a range of scales have been described in this Section; the most important data from these tests are summarised in Tables A1 and A2 (Appendix 1).

Several important points emerge from reports of the various experimental studies:

- Fire suppression tests involving water are commonly discussed in terms of the 'application rate', measured in $\text{l}\cdot\text{min}^{-1}$ or $\text{l}\cdot\text{m}^{-2}\cdot\text{min}^{-1}$; a plot of extinguishment time versus application rate results in a characteristic curve (see Figure 30). In such tests, there exists a 'critical application rate' ($\dot{m}_{w,c}$), below which the fire cannot be extinguished. There is also a minimum time to extinguishment, which can be quite reproducible when the firefighter is familiar with the test conditions. The quantity of water required for successful extinguishment may be calculated from the product of the extinguishment time and the application rate. A plot of quantity versus rate (the ' Q/R ' curve) can then be constructed (see Figure 31);
- The critical rate (defined above), the 'optimum rate' and the 'preferred rate' of agent application may be plotted on a typical Q/R curve. The optimum rate corresponds to the case where fire extinguishment is achieved using the minimum total quantity of agent. The preferred rate corresponds to a somewhat higher rate used by fire-fighters in practice, in order to ensure successful extinguishment. While the optimum rate is more economical, its proximity to the critical rate makes it unsuitable in practice, although the preferred rate may be some 3-4 times greater than the critical rate and hence less economical than the optimum delivery rate, the time to extinguishment is reduced (Figure 30);
- The critical rate has been found to vary with the particular fire scenario, especially the fire development time (or 'pre-burn' period), degree of ventilation and method of water application. In general, the critical rate has been found to be higher with increasing pre-burn time and total area of ventilation openings (A_v) and lower when water is applied from the base of a fire upwards rather than *vice versa*;
- The total volume of water (l) required to extinguish a compartment fire may also be expressed 'per unit volume of flame' ($\text{l}\cdot\text{m}^{-3}$), per unit volume of enclosure ($\text{l}\cdot\text{m}^{-3}$) or per unit floor area ($\text{l}\cdot\text{m}^{-2}$). The total water volume required for Class 'A' fire extinguishment increases linearly with room size and depends also on Q ($\text{l}\cdot\text{min}^{-1}$) and A_v (m^2). Increasing the room ventilation increases the total water required for fire extinguishment, whereas reducing the ventilation decreases the extinguishment time significantly because the production of water vapour assists in smothering the fire;

- Values of the critical application rate (\dot{m}''_{wc}) determined in the laboratory are consistently some 10-100 times less than those required in practice. Expected critical rates in practice are typically one order of magnitude greater than laboratory determinations for unconfined fires and two orders of magnitude in confined cases. These disparities are usually attributed to wastage and/or operational difficulties, e.g. the need for firefighters to cool their environment;
- It has also been found that critical application rates are greater for wooden cribs in confined situations than for those in the open, which is taken as evidence that fuel cooling is the dominant extinguishment mechanism for Class 'A' fires. The argument runs that if fire suppression was aided by the production of by water vapour (inerting of the fire atmosphere) in the confined case, then the overall water demand should be reduced, not increased;
- Plastics fires have received relatively little attention in the literature. Preliminary work in this area suggests that \dot{m}''_{wc} values are generally higher than those typical of wood crib fires. It has also been found that the total water volume required for extinguishment and subsequent mopping-up varies with the type of furnishings involved and with the firefighting technique. The water requirement has been found to be particularly large where upholstered furniture is involved;
- The primary function of water in Class 'A' fire suppression is to remove heat from the body of the fuel and therefore the water requirement depends on the 'heat content' of the fuel rather than the instantaneous heat release rate (HRR) of the fire. In fact, the rate of heat absorption from the fuel bed required to achieve extinguishment is generally far less than the HRR of the fire itself. Higher values of critical water application rate (\dot{m}''_{wc}) have been observed for 'densely-packed' fuel beds than for 'loosely-packed' ones;
- Early UK tests (mid-50s) concluded that sprays were 'better' than jets only at very high rates of flow. Assuming a representative required throw of ~ 6 m in practice, sprays at 7 bar with 30° cone angles, delivering $90-140$ l.min⁻¹ were considered adequate. Also, statistical analyses of test data showed no effect of either pressure or flow rate on the total volume required to control or extinguish the fire. However, greater flowrates were found to promote more rapid fire control, but showed no saving in water usage at higher pressures;
- More recent US work on laboratory mock-ups of single and two-room compartments showed that a 60° , 68 l.min⁻¹ spray was superior to a 76 l.min⁻¹ solid jet in a single room (~ 33 m³) and required ~ 57 l of water to achieve control. In the two-room fire scenario, effective control required 182 l of water delivered at 114 l.min⁻¹. It was concluded that control and extinguishment of one- and two-room residential building fires would be expected to require application densities of ~ 4 l.min⁻¹.m⁻² and ~ 6 l.min⁻¹.m⁻² respectively, at corresponding application rates of approximately 76 l.min⁻¹ and 114 l.min⁻¹.
- The use of Water Mist Fire Suppression Systems (WMFSS) as replacements for fixed fire protection Halon systems has received much attention in recent years. Initial feasibility studies were largely concerned with confined Class 'B' and 'C' fire scenarios in the offshore and process industries. The mechanisms of extinguishment have been identified as flame cooling and atmospheric inerting by the production of

water vapour. These mechanisms have proved highly effective in the confined spaces and high thermal conductivity structures typical of these environments.

- The suppression efficiency of WMFSS is highly dependent on the characteristic droplet size of the mist, since smaller droplets evaporate more quickly and provide a more efficient heat sink, however the 'residence time' (within the flame zone) and transport properties of the droplets are also important. Experiments with confined gas burners have shown that 'instant extinction' is possible if the spray can absorb > 60% of the instantaneous HRR of the fire (as stated previously, this simplistic criterion does not apply to Class 'A' fires because of the overriding importance of heat absorption from the fuel bed and the tendency for such fires to 'burnback').
- Theoretically it has been calculated that a single gram of liquid water can extinguish a 50 l flame volume by reducing its temperature below a critical value (equivalent to an 'application rate' of 0.02 l.m^{-3}). Large-scale turbine hood enclosure fire experiments, involving diesel pool fires in a 70 m^3 enclosure, have shown that extinguishment can be achieved with a 'water fraction' of $\sim 0.07 \text{ l.m}^{-3}$. For small fires in large spaces, the corresponding figure is $\sim 0.5 \text{ l.m}^{-3}$, indicating the crucial role of confinement in these particular situations. Typical values for confined Class 'A' fires cover the range from $0.2\text{-}19 \text{ l.m}^{-3}$ (Table A2, Appendix 1), although most test data lie between the values of $\sim 0.2\text{-}2 \text{ l.m}^{-3}$.
- The spectacular efficiencies of WMFSS occur in tests where a large confined fire is allowed to develop, heating the surroundings and depleting the compartment oxygen concentration. The sudden introduction of a fine water mist promotes rapid cooling, and through the production of water vapour the combination of atmospheric cooling and inerting promotes extremely efficient extinguishment. The high thermal conductivity (metallic) compartment walls provide a continual flow of heat which maintains their high surface temperature and ensures that subsequent impinging droplets continue to be vapourised over a relatively long period. The latter effect is not observed with typical (low conductivity) residential building materials and therefore the evaporation of droplets in contact with the walls cannot continue indefinitely during the suppression of typical confined Class 'A' fires;
- Fire Experimental Unit (FEU) tests on unconfined Class 'A' crib fires have shown water mist nozzles (delivering between $10\text{-}25 \text{ l.min}^{-1}$ at pressures in the range 7-250 bar) to be inferior to a standard Fire Service hosereel operating at 20 bar and delivering $\sim 100 \text{ l.min}^{-1}$. The former nozzles took between 4 to 9 times longer to extinguish the fire. However, the total water required for extinguishment was found to be fairly constant (this would seem to support the heat absorption argument described above);
- It is commonly reported that spray-jets can effect extinguishment in compartment fires using a small total volume of water in a 'surprisingly' short time. Some estimates are given in Table A2, Appendix 1 (e.g. $1.3\text{-}2.5 \text{ l.m}^{-3}$), however there is also often extreme variance reported within test series. As a rule-of-thumb, it has been suggested that for levels of ventilation normally encountered in rooms, the amount of water required is approximately equal to that required to replace the gaseous contents of the room with water vapour. Assuming a room of 17 m^3 , and that 100% of the water applied is vapourised, with a consequent 1700-fold volume expansion, this

would require 10 litres of liquid water, or 0.6 l.m^{-3} . However, the inefficiencies in its application lead to the somewhat higher application rates quoted above;

- In the context of Fire Service operations, drop size is more relevant to the initial gas-phase cooling of the fire compartment (FEU 'Phase 1'). A smaller drop size promotes more efficient gas-phase cooling and therefore the influence of droplet size is greatest when the fire cannot be extinguished by fuel cooling (e.g. low firepoint liquids such as petrol). For Class 'A' fires, where solid-phase cooling is necessary, the efficiency of this process is expected to be less influenced by drop size, provided the water can reach the fuel surface. Recent work by the FEU, where high- and low-pressure hosereel systems (operating between 2-45 bar) were evaluated, has confirmed this hypothesis and it was concluded there that firefighting tactics are more decisive than any variations in characteristic droplet size or velocity;
- Some guidelines for firefighting tactics may be stated based on the foregoing discussion. Initial flame knockdown is achieved faster and with less water using a spray nozzle. However final extinction requires the same volume of additional water, regardless of the application method (jet/spray), provided the water reaches the fuel surface. Pulsed spray application in the early (room-cooling) phase reduces the possibility of 'steam burns' to the firefighter since the rate of production of clouds of water vapour is more predictable and therefore more easily avoided by crouching at low level. Wide-angle fog is recommended during this phase, followed by a narrow-angle fog or solid jet, particularly for fuel cooling of deep-seated Class 'A' materials which require adequate cooling to ensure final extinguishment (thus precluding 'burnback'), although gas-phase cooling and inerting of the fire atmosphere are beneficial to the firefighters' comfort and also contribute some suppressive effect. Based on small scale wooden crib fires, it has been postulated that the 'fundamental condition for total fire extinction' may be expressed as *reignition time* \geq *time required for sweeping the entire fuel surface with water*.

8. USE OF ADDITIVES FOR CLASS 'A' FIRE SUPPRESSION

8.1 General

Early accounts (*ca.* 1960) of the use of additives in fire-fighting water were given by Fristrom (Reference 9) and Herterich (Reference 10). Fristrom stated that two types of additives were being investigated in the 1960s, namely *viscosity modifiers* which decreased runoff by increasing the viscosity of fire-fighting water and *opacifiers* such as aluminium powder which formed a reflective barrier on top of the burning surface, thereby reducing radiant feedback to the fuel bed. Herterich (Reference 10) described the use of *viscosity modifiers*, *preservatives*, *corrosion inhibitors* and *antifreeze agents*.

Hirst (Reference 3) listed several areas where the properties of fire-fighting water may be improved by blending with suitable additives:

- *Wetting agents* improve the ability of water to penetrate into fibrous fuels such as a hay stack or a thatched roof. So-called 'wet-water' is also used against heather fires although the advantage gained is usually not significant (Reference 3);
- *Fire retardants* such as sodium ammonium phosphate do improve the effectiveness of fire-fighting water; portable extinguishers of this type are sometimes referred to as 'loaded stream' extinguishers. Since the improvement is not very great, the use of retardants is generally restricted to the suppression of forest fires where the water supply is limited;
- *Antifreeze agents* are used to maintain water in its liquid state during cold weather. The most frequently used agents are calcium chloride (CaCl_2) and magnesium chloride (MgCl_2) since the more effective alcohol-based agents are often precluded because of their own combustibility (Reference 10); in the case of CaCl_2 , a corrosion inhibitor may also be required. Hirst (Reference 3) noted that the addition of ~ 140 g CaCl_2 to a litre of water reduces the freezing temperature to -10 °C. The use of ethylene and propylene glycols was also mentioned in Reference 3, but it was stressed that these agents reduce the specific heat of water and are also flammable in high concentrations;
- *Thickeners* such as bentonite clay, sodium alginates and carboxymethyl cellulose have all been used to increase the viscosity of fire-fighting water. The friction losses in hoses is increased but the throw of the jet tends to be increased. The thickened water may be applied to exposed surfaces since it drains away only slowly and has proved effective against forest fires. The addition of $\sim 0.2\%$ additive can double the effectiveness of water in these cases (Reference 3);
- *Ablatives* may also be used to thicken the fire-fighting water. In this case a thick layer of gel is formed on an exposed surface and drainage is arrested, inhibiting ignition for a considerable period of time. However these gels have been found difficult to apply and less economical than thickened water;
- *Friction-reducing agents* such as polyethylene oxide polymer (POE) have been used to reduce the energy required for pumping water down small bore hoses and thus increase the height and throw of the resulting jet. Concentrations of POE as low as

0.003% have been found to reduce the pipe friction factor by ~ 70%; however these additives have proved more useful in the US since the convention in the UK is to employ a large-diameter hose to feed smaller nozzles;

- *Foam concentrates* comprise a range of standard film-forming agents designed to be mixed with water and applied in either aspirated (usually with air) or un-aspirated form.

8.2 Surface tension ('wettability') modifiers

The phenomenon of surface tension in a liquid arises because of the mutual attractions between the liquid molecules; such cohesive forces are exerted over a small, but finite, radius r . Thus, within the liquid body, a molecule is subjected to equal attractions in all directions while at the interface between the liquid and another medium (*e.g.* between water and air) the molecules at the surface experience a stronger attraction inwards from the surface. As a result, the surface tends to contract to the smallest possible area and mechanical work must be expended in order to form a free surface against these forces; this work is termed the *free surface energy*. If the liquid surface is assumed to be in tension in all directions, then the force required to maintain the straight edge of a plane liquid surface is σ (N.m^{-1}). Water in contact with air at room temperature has a value of $\sigma \sim 0.073 \text{ N.m}^{-1}$ (73 dyne.cm^{-1}) while most organic liquids have σ values in the range $0.020\text{-}0.030 \text{ N.m}^{-1}$ ($20\text{-}30 \text{ dyne.cm}^{-1}$); the liquid metal mercury has an exceedingly high value of $\sigma \sim 0.48 \text{ N.m}^{-1}$ (480 dyne.cm^{-1}) (Reference 194).

Herterich (Reference 10) observed that the surface tension of water is greater than for most other liquids and that this fact represented a technical disadvantage in terms of extinguishing effectiveness. Surface tension may be considered to be a measurement of the wetting capacity, or penetrative force, of a liquid, *i.e.* the lower the surface tension, the more quickly, or more deeply the liquid will penetrate into the fuel surface. The addition of so-called 'dousing agents' was advocated in Reference 10, in order to increase the penetration of fire-fighting water; this blend of water and dousing agent was referred to as 'dousing water'. Herterich advocated the use of dousing water for fires in brown coal dust or fibrous materials (hay, straw, cotton, jute etc.) to increase the rate of water penetration and therefore to achieve a greater effect at greater depths; the same qualities are required for tackling deep-seated Class 'A' fires. Aside from possessing good 'dousing' properties, it was recommended that such agents should possess low viscosity (in order to facilitate rapid mixing in the water-stream), be physiologically inert, be capable of being mixed with other solvent products (*e.g.* anti-freeze agents) and be non-corrosive (Reference 10). In addition, Herterich also recognised that the reduction of surface tension has implications for the production of spray-jets for fire-fighting, since the energy required to atomise a liquid is proportional to the magnitude of its surface tension (Section 5.1.1).

As an illustration of the effectiveness of typical dousing agents, Herterich quoted a reduction of 60% in the surface tension of water through the addition of 0.25% agent. Despite an ongoing debate regarding the most suitable test method for assessing the quality of such agents, initial studies (*ca.* 1960) had confirmed the ability of 'dousing water' to penetrate into a wide range of substrates at rates much higher than those

typically associated with plain water; in the particular case of raw cotton, a threefold increase in the depth of penetration was observed in the same period of application. Rosander and Giselsson (Reference 195) also stressed the importance of water penetration during the extinguishment of porous fuel beds. It was observed that a 50% reduction in the surface tension of plain water was possible through the addition of one gram of wetting agent per litre of water (*i.e.* ~ 0.1% solution by mass), it was also noted that any addition of wetting agent above this concentration was superfluous as subsequent reductions in σ were negligible. Rosander and Giselsson noted that by the judicious choice of wetting agent, the surface tension of plain water could be modified to be less than that of typical petro-chemical products. The significance of the latter is that a 'skin of water' can spread out on the surface of some hydrocarbon pool fires such as petrol, reducing or even totally arresting the flow of vapour and bringing about extinction of the flames by removing the fuel supply. Rosander and Giselsson referred to such additives as *film-forming foams*, known under the collective international designation AFFF ('A triple F') which is an abbreviation of *aqueous film forming foam*.

Geyler (Reference 196) discussed the results of a US research programme designed to establish the efficacy of AFFF agents against aircraft ground fires, where an increasing fire hazard was perceived due to the introduction of new types (and increased quantities) of aviation fuels. The research project included the assessment of fire suppression, fire containment and foam characteristics of two commercial AFFF agents and one protein foam and comprised both laboratory experiments and full-scale fire suppression tests in the field. The laboratory experiments included a range of standard tests intended to assess the stability (thermal and chemical), compatibility etc. of the AFFF and foam agents when mixed with each other, with certain dry-chemical powders and with typical Class B fuels; for the sake of brevity these results are not considered here.

The full-scale facility described in Reference 196 permitted fire suppression tests to be conducted on Class B pool fires ranging in diameter from 14-38 metres; the aviation fuels used were 'JP-4' (flashpoint ~ -1 °C⁴), 'JP-5' (flashpoint ~ 35 °C⁴) and 'Avgas' (flashpoint ~ -46 °C⁴) and instrumentation comprised radiometers and cameras located near the edge of the fuel reservoir. Following ignition of the fuel, a steady rise in radiation intensity was observed by the instruments until a maximum value was attained (typically ~ 30-50 kW.m⁻²); a pre-burn period of between 30-45 seconds was then allowed before the application of the extinguishing agent. The time from the initiation of fire suppression to the point where the radiometers recorded a heat flux level of approximately 2.3 kW.m⁻² was designated the 'fire control' time; the 'extinguishing time' was defined as the total elapsed time from the start of fire suppression until all flaming had ceased on the pool surface. Two different air-aspirating foam nozzles were used in the experiments: one single nozzle unit was capable of delivering ~ 950 l.min⁻¹ while a second 'composite' air-aspirating unit comprised two 1500 l.min⁻¹ foam nozzles plus two 1500 l.min⁻¹ water discharge nozzles. The single nozzle unit was capable of delivering the foam in various patterns ranging from a straight stream (~ 50 m throw and 5 m width) to a 'fully dispersed' pattern (~ 18 m throw and 14 m width). The

⁴Measured by closed cup method at sea level

performance of the composite nozzle ranged from a straight stream of ~ 38 m throw and 7 m width to a dispersed pattern of 26 m throw and 12 m width. The AFFF agents were designated 'A' and 'B' to preserve the anonymity of the manufacturer and were both used as a 6% solution by volume throughout the test programme.

The results of the full-scale tests were plotted in terms of the fire control and extinguishing times against the solution application rate, which was varied in the range 2-6 l.min⁻¹.m⁻², the application rate for a particular test was obtained by dividing the AFFF solution discharge rate by the plan area of the pool fire (~ 150-370 m²). In general, for the JP-4 and JP-5 fuels the trend was that the fire control and extinguishing times were reduced as the solution application rate was increased, although the JP-5 fires were found to be suppressed more rapidly using the type 'B' AFFF agent. The 'Avgas' fires were the most difficult to control using AFFF and it was noted that the fire control and extinguishment times were virtually independent of the solution application rate, indicating that the high evaporation rate of the fuel was the controlling factor in the suppression process⁵. It was also stressed that this anomalous behaviour was not unique to 'Avgas' compositions and it was therefore concluded that AFFF solution application rates should be determined experimentally for each fuel type expected to be met in practice.

A further series of tests was also conducted where the effectiveness of sprayed solutions of the two AFFF agents were assessed. Adjustable spray pattern water nozzles with discharge rates of ~ 950, 1500 and 3000 l.min⁻¹ were used to tackle JP-4 pool fires of ~ 740 m² area; the intention was to establish whether such a fire could be effectively controlled at application rates of ~ 1.3, 2 and 4 l.min⁻¹.m⁻². It was anticipated that the low surface tension of the AFFF solution combined with the strong shearing action developed at the liquid-air interface of the issuing stream would generate an effective firefighting foam. This proved to be the case with one exception and it was stressed that the suppression effectiveness was all the more remarkable since the 'foam expansion ratio' was less than 2:1 in all the tests; in addition the 'solution drainage time' was too rapid to be measured by standard foam tests. The performance of the sprayed AFFF solution was illustrated by an example: in the first test series, a 370 m² JP-4 pool fire was controlled in 34 s by AFFF foam applied at a rate of 4 l.min⁻¹.m², whereas in the latter tests control of a 740 m² JP-4 pool fire was achieved in 35 s with a 6% sprayed solution of AFFF discharged at the same rate. When the application rate was reduced to ~ 2 l.min⁻¹.m², the fire control times for the foam and the water solution were increased to 38 s and 51 s respectively.

The observed flame knockdown during the AFFF solution spray tests was 'visually more rapid than would have been anticipated on the basis of foam quality alone'. It was speculated that the reason for the effectiveness of the AFFF spray was due to the fine droplets produced during atomisation which promoted the pyrolysis of some of the fluorocarbon surfactants and liberated sufficient quantities of free radicals to effectively inhibit flame propagation by chemical means. In an effort to test this assumption, a control experiment was conducted using a pure water spray against a 370 m² JP-4 fire at an application rate of 2.64 l.min⁻¹.m²; in this case the water spray was unable to make

⁵ This is consistent with the very low flashpoint quoted previously

any significant progress in controlling or extinguishing the fire. The observed efficiency of the AFFF spray and the suggestion of chemical flame inhibition is of great interest to the present study; although Geyler's work concerned Class B fires, the same flame inhibition mechanisms would be expected to obtain in Class A situations. It is therefore to be regretted that Geyler's study did not include any quantitative measurements of the drop size distribution relevant to the AFFF spray trials.

Hems (Reference 197) also discussed the merits of AFFF, as an additive for water spray fire protection systems used in the chemical and petrochemical industries (*i.e.* Class 'B' fires) and identified five benefits.

- *Positive knock down.* AFFF will extinguish the fire whereas plain water will only achieve 'controlled burning',
- *Quicker knock down.* Even in cases where plain water would eventually achieve fire extinguishment, AFFF attains this goal faster;
- *Less water.* Due to the rapid knock down capacity of AFFF, the bulk of the water is required only for cooling,
- *Running fires.* The unique film-forming property of AFFF is able to seal the surface of a liquid fire and prevent a running fire;
- *Prevents re-ignition.* Even if the aqueous film is mechanically broken by falling debris or the like, it will automatically re-form and prevent flammable vapour forming.

It should be noted that AFFF is one of several foam additives originally developed for use against Class 'B' fires; other types such as 'AFFF-AR', 'FP' and 'FFFP' are discussed later in this Section. Also, despite the claims made for the performance of various additives, the results of independent tests have sometimes shown such advantages to be marginal or not proven; the Fire Experimental Unit in the UK have reported such findings in the past (see later in this Section).

In the particular case of the agents AFFF, FP and FFFP, Briggs and Abdo (Reference 198) reported a series of experiments designed to test whether the spreading of an aqueous film across the surface of typical hydrocarbon fuels provided a significant contribution to fire extinguishment. A 'spreading coefficient' was defined for each of the foam agents, which was related to the surface tension of the particular fuel (toluene, heptane or petrol); the associated surface and interfacial tension values were measured in the laboratory at ambient temperatures (~ 20 °C). It was noted that at the minimum surface temperatures of ~ 50 °C (burning petrol), the spreading coefficients would be close to zero; however, it was also remarked that the time-scales associated with practical firefighting would not normally be sufficient to allow the fuel-foam system to attain equilibrium. Extinguishment tests were carried out on fires of 0.25 m² area and these data indicated a marked variation in the extinguishing ability of the foams as a function of their spreading ability, in the case of toluene the extinguishing capacity was poor despite a relatively high spreading coefficient while the reverse was true for the heptane tests. Although the utility of film formation in firefighting was not questioned, it was suggested that a continued emphasis on this aspect of foams might give a misleading impression of their firefighting capability.

Takahashi's small-scale study of the suppression of plastics fires by plain water and 'wet water' (Reference 163) was described in Section 7.2.1, where the results of tests using plain water sprays were discussed. The experimental arrangement and a full list of the materials tested are described in Section 7.2.1. In brief, Takahashi measured the 'extinction properties' for 9 common plastic solids in the form of a crib and 4 others in the form of a solid slab. For the tests using 'wet water', the common foam agents 6% type 'Light Water' (3M trade name) and 6% type 'Synthetic Foam Agent (for methanol)' were diluted from 16- to 10 000-fold; e.g. in one case Takahashi stated that '*wet water was made by diluting 6% type 'Light Water' in 0.2% of the original liquid foam agent*'. Takahashi noted that these foam agents were a mixture of surfactants, however their exact chemical composition was unknown. The surface tension of the wet water solution and the 'adhered water density' were measured as a function of foam agent concentration prior to the suppression tests. The latter was measured by dipping small samples of plastic rod into the solution for 30 seconds, removing them and weighing the samples to deduce the mass of water adhered; it proved impractical to perform a similar measurement on burning samples of plastics. It was found that the adhesiveness of wet water on the plastics was approximately twice that of plain water, although still some 2-3 times lower than that for wood surfaces.

The extinguishment time was defined as the period between the start of water application and the point where no visible flame remained and the 'suppression time' was defined qualitatively as the interval between the start of water application to the point where flaming was limited to a small region a few centimetres in diameter on the underside of the fuel. The experimental results were discussed in terms of the 'effectiveness versus adhesiveness' and 'effectiveness versus concentration of wet water'. It was found that, in general, the increased adhesiveness of wet water was correlated with ease of extinction; in the particular case of polypropylene (crib fire), wet water produced extinguishment in under 2½ minutes whereas plain water was ineffective. A fairly linear relationship was apparent when adhesiveness (expressed in kg.m^{-2}) was plotted against 'extinction difficulty'; for the latter, the ranking of materials (in order of increasing difficulty) was PC, PU, PF, PMMA, ABS, PE, POM, PP (somewhat different from that obtained with plain water, see Section 7.2.1). Takahashi stated that although adhesiveness appeared to be a controlling factor in determining the ease of extinction, the reason was unknown.

Takahashi also plotted both extinction time (for the PP, PE and ABS fires) and surface tension against foam agent concentration (logarithmic scale) for both foam agents and showed that the extinguishing time curve was similar in form to the surface tension variation. The surface tension versus concentration curve exhibited two distinct linear régimes: at low concentrations ($\sim 10^{-3} \% - 10^{-1} \%$), σ was found to decrease with increasing agent concentration and above some critical point the value of σ remained constant at all higher concentrations. Takahashi described the transition point as the 'critical micelle concentration' (CMC), beyond which the constant values of σ for the Light Water and Synthetic Foam agents were $\sim 0.016 \text{ N.m}^{-1}$ (16 dyne.cm⁻¹) and $\sim 0.023 \text{ N.m}^{-1}$ (23 dyne.cm⁻¹) respectively. For both agents the extinction time t_e was found to reduce as the agent concentration was increased, reaching a 'saturation extinction time' beyond which further increases in concentration yielded a fairly constant value of t_e .

The value of the solution concentration corresponding to the saturation extinction time was found to depend on the type of plastic but was ~ 10 times greater than the CMC measured 'at normal temperatures' for both agents. Although it was noted that the CMC transition moves to a higher concentration at elevated temperatures, a definitive correlation between CMC and 'saturation extinction time' was not obtained by Takahashi. The *10-times-CMC* 'rule' was proposed as a tentative rule of thumb to determine the saturation of effectiveness for wetting agents although it was cautioned that the complex nature of fire extinguishment may also require the effect of variables such as the fuel type and array geometry to be taken into account. Notwithstanding these reservations, the performance of wet water was remarkable, even at low concentrations, at 0.01% concentration, t_e was reduced by 30-50% compared with plain water while at 1% concentration, t_e was reduced by a factor of between 10-20. It was concluded that although plain water could be used to extinguish most plastic fires, wet water was much more effective, even against 'difficult type plastics'. Fog spray was found to be more effective than a solid stream, except for foam plastics where the ability of the jet to force a high density of water into the interior of the fuel array was crucial.

In the UK, the Fire Experimental Unit (FEU) of the Home Office Fire Research and Development Group conducted a range of experiments at both small and large scales in order to assess the potential benefits of additives for hose reel systems used against Class 'A', Class 'B' and other 'non-standard' fuels (References 199, 200). All the Class 'A' tests employed wooden cribs designed to BS 5423; sizes 13A and 27A were used for the small scale tests and sizes 27A ($A_f \sim 24.3 \text{ m}^2$) and 34A ($A_f \sim 79.2 \text{ m}^2$) for the larger tests. The objectives of the initial small scale study were: to develop a small scale test method for future use, to refine the choice of additives for large scale testing and to provide data for correlation with the large scale experiments. The following additives, mixed with potable water at the concentrations indicated, were used during the series of small scale tests: Fluoroprotein (FP), 3%; Alcohol resistant FP (FP-AR), 3%; Film-forming Fluoroprotein foam (FFFP), 3%; Alcohol resistant FFFP (FFFP-AR), 3%; Aqueous film-forming foam (AFFF), 3%; Alcohol resistant AFFF (AFFF-AR), 3%; Synthetic (S), 3%; 'Wetwater' (Type 2 with foam trace), 1%; 'Halof foam', 15%; 'Fireout', 0.2%. Finally, potable water with no additives was also used, to provide a 'benchmark' against which the performance of the various agents could be judged. 'Halof foam' (trade name for an agent no longer in production) is a novel 'self-aspirating' firefighting foam, containing AFFF and two species of Halon with different boiling points; this chemical composition gives 'Halof foam' certain unique properties. The agent is applied un-aspirated using a conventional jet/spray branch. The initial vapourisation of the first Halon agent reduces the density of the stream while the second Halon is vapourised on contact with hot surfaces, producing an aspirated foam with an expansion ratio similar to that of conventional (LX) foams. Thus the initial application achieves a penetration similar to a conventional water spray but its effect is enhanced by the subsequent expansion.

A total of 34 small scale fire tests were performed, with size 27A cribs being used for 23 of the tests and size 13A being used in the other 11 experiments. The additive solution was pumped to the fire at 9 l.min^{-1} through a 36.6 m length of 19 mm hose, fitted with either an aspirating or a non-aspirating nozzle, the former was taken from a commercial foam extinguisher while the latter was a garden hose nozzle which gave a similar coarse

broken jet pattern. The temperature of the solution was monitored during the tests, as was the radiative heat flux from the crib fire. The ignition phase of each test consisted of a 2 minute pre-burn of heptane contained in trays beneath the crib, followed by a further 6 minute pre-burn period once the trays were removed; at this point each fire was hand-fought by a fire-fighter highly practised in the standard method of extinguishing crib fires. The assessment of extinguishing efficiency differed from that specified in BS 5423, *i.e.* it was judged on the basis of flame knockdown and control, rather than upon total extinguishment and a subsequent 3 minute dormant period.

On the basis of these tests, it was found that the larger size 27A cribs enabled a better comparison of the additive solutions than the smaller size 13A cribs. From the results of the 23 experiments using size 27A tests, the following conclusions were reached:

- Non-aspirated 'Halof foam' produced the shortest 'time to control', with a 46% improvement over pure water;
- 'Synthetic' proved to be the best of the non-aspirated conventional 'fire-fighting foam' additives, with a 42% improvement in control time over pure water;
- 'Synthetic' also proved to be the best of the aspirated conventional 'fire fighting foam' additives, with a 22% improvement in control time over pure water;
- Aspirated versions of additives (with the exception of AFFF-AR) showed an average 25% improvement in control time compared with non-aspirated versions;
- Non-aspirated AFFF produced a poor control time, which was only ~ 5% better than that of pure water.

In general, the results of the small scale fire tests showed large variations in the relative effectiveness of the additive solutions tested. In addition, since none of the additive solutions proved significantly less effective than pure water, all the agents tested at small scale were retained for the large scale tests.

The objectives of the large scale tests were twofold: to obtain Class 'A' fire suppression data from realistically-sized fires tackled using additive solutions applied by Fire Service equipment and to identify the most suitable additives for the control and extinction of Class 'A' fires. The range of additives and solution concentrations were identical to those used during the earlier small scale tests. The large scale fire configuration consisted of two size 27A cribs plus one size 34A crib arranged within the FEU 'Fire Test Room' as described in Section 7.3 of this report; therefore each test in the series was representative of a Class 'A' compartment fire with a fire load of 500 kg of wood. Instrumentation for the tests included video cameras, a thermal imaging camera, thermocouples and smoke density metering equipment etc. The test fires were tackled primarily using a remote firefighting rig (described in Section 7.3) which enabled the fire to be tackled initially from the doorway (at 8 minutes into the test) and then from the centre of the room (at 10 minutes into the test) in a standard manner. In some cases however, the fire was tackled by an experienced fire-fighter who was allowed to fight the fire from the doorway only, in a pre-determined sequence (Reference 199). Both methods of firefighting employed both aspirating and non-aspirating branchpipes, operating at a flowrate of 100 l.min^{-1} and with a 'spray' included cone angle of 26° ;

these parameters reflected typical hosereel system performance and were the same as those adopted in earlier FEU trials (Section 7.3).

The test data were presented in terms of the temperature histories at the compartment doorway and within the wooden cribs adjacent to the doorway and against the opposite wall of the compartment. The thermocouple positioned at approximately chest height near the doorway was intended to measure the temperatures likely to be experienced by a fire-fighter at this location. In general the air temperatures within the room after the 8 minute pre-burn period were in the range 540-624 °C and during the first 5 seconds of fire suppression activity, the doorway temperature rose to a peak of ~ 61 °C above this initial average temperature. Thereafter there was an immediate and rapid decline in air temperature to between 175-315 °C and after 8 minutes of fire-fighting the doorway air temperature had fallen to ~ 62-177 °C. The area under the time-temperature curves was used to quantify the percentage averaged temperature reduction of the air at the doorway over the first 30 seconds of fire-fighting, these data were then used to rank the cooling efficiency of each of the agents and hence determine which allowed the earliest entry of a fire-fighter into the compartment. The temperature histories of the cribs, as measured by groups of 4 or 5 thermocouples within the cribs, showed a non-uniform decay during the majority of tests; for example in both of the 'side cribs', the thermocouples nearest to the doorway exhibited the most rapid decay in temperature, typically dropping from ~ 800-100 °C during the first 10 seconds of fire-fighting. The central thermocouples showed a slower rate of cooling, generally falling to below ~ 200 °C within the first 3 minutes of fire-fighting; the rearmost thermocouples recorded the lowest rates of cooling and sometimes no cooling effect at all. The rearmost crib also displayed a non-uniform cooling history during the tests; however, it was found that graphs of the average crib temperature history could be used to represent the suppression of the crib fires. In addition, the area under the time-temperature curve was used to infer the mean temperature reduction of the test fire and to estimate the percentage averaged temperature reduction of the fire during the first 30 seconds and 6 minutes of fire-fighting activity.

The relative effectiveness of the various additives was discussed in terms of the FEU 'three-phase model' of compartment fire extinguishment, discussed in Section 7.3 and illustrated in Figure 32. The three distinct phases in this model are: cooling of the room prior to entry of the fire-fighter, controlling the fire and finally extinguishing any residual 'hot spots'. During the initial phase, with the branch operated in 'spray' mode, none of the additives showed a significant improvement over plain water in reducing the air temperature within the fire test room. In the second phase however, all of the additives were found to make a positive contribution in reducing the severity of the test fire, compared with plain water. Here, AFFF and Halofoam were the most effective, followed by FFFP, AFFF-AR and Synthetic; the AR versions of AFFF and FFFP were both inferior to their standard versions. In economic terms, it was concluded that the high cost of Halofoam would confine its use to 'special cases', it was also noted that Synthetic additive was around one-third of the price of the more sophisticated AFFF and FFFP products. During a brief comparison between aspirated and non-aspirated application of AFFF, there was found to be no significant difference in performance, also water was found to give a similar performance when used under the same conditions. It was concluded that although the best of the additives tested, AFFF, would reduce the

duration of the 'control phase' of fire-fighting, the overall saving in water and any reduction in fire damage would be small. Consequently, the decision on whether AFFF should be used for domestic fires would be necessarily based on operational considerations as to the merits of reducing the time to get a room fire under control (Reference 200).

The small-scale mechanics of water-surfactant solutions were investigated by Tinker *et al.* (Reference 201) and by Kudritskii *et al.* (Reference 202). Tinker *et al.* reported an experimental and theoretical study of the effect of surfactants on the 'dropwise evaporative cooling' of water sprays impinging on burning solids; this work was undertaken to extend the applicability of di Marzo's theoretical model, discussed in Section 5.3.3. The study considered the surfactant sodium dodecyl sulphate in the concentrations 0 ppm (pure water), 100 ppm and 1000 ppm. The measured rates of evaporation of a ~ 2 mm diameter droplet placed on a heated (80 °C) stainless steel plate were compared with those calculated by di Marzo's single droplet evaporation model; it should be stressed however that this surface temperature is much less than that typical of burning Class 'A' fuel surfaces (~ 400 °C). As the surfactant concentration was increased, the initial spreading of the droplet on the hot surface increased, due to the decreasing 'contact angle'; this effect was mentioned briefly in Section 5.3.3 of the present report. The increased 'wettability' of the water droplet was found to have a beneficial effect on the cooling effect since evaporation commenced at a faster rate. It was concluded that the presence of the surfactant enhances the heat transfer rate from a solid surface to the impinging water droplets and that this effect should be explored further in applications where 'intense cooling' is desirable with a limited water supply. The effect of dissolved gases on the rate of evaporative cooling was found to be much less significant under typical fire suppression conditions (*i.e.* large reductions in surface temperature together with initial surface temperatures close to the onset of nucleate boiling (Section 5.3.3)).

Kudritskii *et al.* (Reference 202) performed an experimental study of the adsorption of soluble surfactants and their influence on the evaporation of water drops over the temperature range 278-298 K (5-25 °C). Rates of evaporation and surface tension data were reported for confined water droplets of initial diameter ~ 720 µm, mixed at various concentrations (0.003-0.15%) with either potassium stearate or potassium palmitate. In all cases a 'saturated monolayer' was formed on the surface of the drop, which tended to inhibit subsequent evaporation. The formation of the monolayer was most rapid at higher initial concentrations of surfactant and for higher ambient temperatures. It was found that for concentrations above the 'critical micelle concentration' (CMC), a saturated monolayer formed very quickly, even before the beginning of droplet evaporation (*i.e.* < 60 s). For concentrations less than the CMC value, the droplet evaporation was initially identical to that observed for pure water; in these cases however, a saturated monolayer did eventually form, after a period of between 15 minutes to several hours (depending on the initial conditions).

The same behaviour was also found for the following surfactants: sodium stearate, lithium palmitate, and ammonium stearate, palmitate and laurate. It was therefore concluded that the evaporation retarding properties are common to all the alkali metal salts of the higher fatty acids; it was also verified that these properties were absent for

nonalkali metal salts. Kudritskii *et al.*'s data (Reference 202), although collected at temperatures far lower than typical fire atmospheres, may have some relevance to Geyler's (Reference 196) explanation for the efficacy of sprayed AFFF. Geyler suggested that the fine spray produced during atomisation of AFFF would tend to promote the pyrolysis of fluorocarbon surfactants, thus liberating sufficient quantities of free radicals to effectively inhibit flame propagation by chemical means. The possible existence of a saturated monolayer on the surface of droplets in this case would support Geyler's hypothesis and further study of the extinguishing mechanism relevant to AFFF sprays would be of interest.

8.3 Viscosity modifiers

The *viscosity* of a fluid (liquid or gas) is a measure of its resistance to flow, for example during the flow of water through fire-fighting hoses and nozzles etc. The magnitude of the viscous forces which resist the flow of one layer of fluid over another is found in practice to vary not only with the external conditions (*i.e.* the 'rate of shearing' of one fluid layer over another, equivalent to the 'velocity gradient' within the fluid) but also with the nature of the fluid itself. For example, some 'thick' (*i.e.* highly viscous) liquids such as tar and glycerine cannot be poured easily, whereas 'thin' liquids such as water and petrol are found to flow much more readily because of their lower viscosity. The majority of common fluids (including water) are so-called 'Newtonian fluids', where the 'coefficient of viscosity' or 'absolute viscosity' for laminar flow is a constant which is independent of the rate of shear but which may vary considerably with the temperature of the fluid. For these fluids then, the absolute viscosity is a constant for a given fluid at a particular temperature and is conventionally represented by η (Greek 'eta') and measured in Pa.s. Another form of viscosity, the 'kinematic viscosity' ($\nu = \eta/\rho$), is used routinely in hydraulic engineering applications; the kinematic viscosity is the ratio of viscous forces to inertial forces and has units of $\text{m}^2 \text{s}^{-1}$. For pure water at 20 °C and atmospheric pressure, $\eta \sim 10^{-3}$ Pa.s and $\nu \sim 10^{-6}$ $\text{m}^2 \text{s}^{-1}$ (Reference 194).

Early research on fire-fighting foams, conducted between 1947-57 at Syracuse University in the US, indicated that some of their most effective properties (such as blanketing ability and high viscosity) might be obtainable in water through the use of certain additives. Grove *et al.* (Reference 203) discussed the findings of a subsequent 4 year research programme (1957-61) designed to improve the fire-fighting characteristics of plain water by modifying its three perceived limitations: the low viscosity of water promotes rapid runoff from burning surfaces, the continued blanketing ability of water is limited and water has a relatively poor reflective capacity. The experimental procedure adopted by Grove *et al.* is familiar, *viz.* the additives were screened initially by laboratory testing and the more promising candidates were subsequently tested on small- and large-scale fires in a controlled environment.

Both the small- and large-scale tests were conducted within a galvanised sheet metal compartment ($\sim 3.9 \times 3.7 \times 3.7$ m), fitted with an observation window and an exhaust system. The fuel used was California clear pine, pre-soaked in kerosene for ~ 30 seconds. In the small-scale tests, 8 pieces of $\sim 25 \times 75 \times 250$ mm wood were arranged

in 2 tiers with a single 'Spraying Systems' nozzle located 1.8 m above the centre of the fuel bed; the flow rate for all these tests was $\sim 3.8 \text{ l.min}^{-1}$. Following ignition, a pre-burn period of 4 minutes was allowed before the start of fire extinguishment; thermocouple and radiometer data had previously indicated that the maximum fire intensity of most test fires occurred at 4 minutes after ignition. The larger-scale tests employed a 3-tier arrangement of 50 x 100 mm wood, where only the first tier was pre-soaked in kerosene. In this 'truncated pyramid' structure, the first (bottom) tier comprised 13 pieces each ~ 915 mm long spaced 25 mm apart, the second comprised 12 pieces each ~ 890 mm long and the top tier again comprised 12 pieces ~ 864 mm long. A total of 4 Spraying Systems nozzles were located ~ 0.4 m from the crib centreline and at a height of ~ 3.7 m above the fuel; the flow rate for all these tests was $\sim 13.7 \text{ l.min}^{-1}$, at 1.3 bar. Although the large-scale fires were known to attain maximum intensity at ~ 3 minutes after ignition, the pre-burn time before active fire suppression was deliberately varied in order to provide a rigorous test framework for the various additives; in addition a comprehensive control series of experiments was performed using plain water.

The viscosity additives investigated by Grove *et al.* included 'Monsato DX-840-91', bentonite clay 'Volclay', 'Dow ET-460-4', 'Dow ET-570' and carboxymethyl cellulose; the overall findings of the laboratory tests were that 'viscous water' produced a faster initial 'knockdown' of the fire, that the extinguishment time was drastically reduced and that there was much less likelihood of re-ignition occurring. Reductions in the overall consumption of water and water runoff were also reported. For the laboratory-scale fires, the optimum viscosity was reported to be between 10-15 centipoise (0.01-0.015 Pa.s), increasing to 50-300 cP (0.05-0.3 Pa.s) as the scale of the fire increases. The larger-scale experimental data exhibited a degree of scatter due to 'uncontrollable variables' such as the chemical and physical properties of the wood and problems associated with contriving a perfectly reproducible test fire. As an illustration of the rapid knockdown effect, Grove *et al.* cited a series of tests performed jointly by two fire departments in the US on a disused building which was ignited and allowed to become 'fully involved'; the details of the fuel load were not given. The fire was effectively knocked down in 15-20 seconds with viscous water applied at a rate of $\sim 110\text{-}150 \text{ l.min}^{-1}$; the demonstration was repeated successfully several times, while a plain water attack at $\sim 130 \text{ l.min}^{-1}$ could not make any progress at all against the fire.

Tables 12 and 13 (page 158) are reproduced from Grove *et al.* and illustrate the improved fire-fighting performance obtained with viscous water during large-scale trials. The data in Table 12 refer to field fire tests on cribs constructed from 50 x 100 mm timber and show a $\sim 40\%$ reduction in knockdown and a $\sim 52\%$ reduction in 'flame-out' time for viscous water (52 cP) over plain water. Even though only a 28% reduction in total extinguishment time was observed for 52 cP water over plain water, there was no rekindling or reignition. It was stressed that during final mop-up, the nozzle operator had to insert the nozzle into almost all the openings in the crib to ensure extinguishment; it was believed that this necessity of technique tended to obscure some of the effectiveness of the viscous water.

Table 12
Field fire tests, Norfolk Virginia (Reference 203)

Solution	Viscosity (centipoise)	'Knockdown' time (min)	Flame extinguishment time (min)	Total extinguishment time (min)
water	1	1.75	2.20	3.88
water	1	0.75	3.05	3.85
ET-570	19.5	0.70	1.55	2.55
ET-570	52	0.75	1.25	2.95

The data in Table 13 (below) were obtained from fire suppression tests performed in five purpose-built rooms measuring 2.4 x 2.4 x 2.4 m, constructed of timber, two were fabricated from old well-dried timber and three from newer timber which was not kiln-dried. Table 13 contains representative data from the tests conducted in the well-dried timber rooms; these data indicate an almost 50% reduction in knockdown time and flame extinguishment for 15.5 cP viscous water over plain water.

Table 13
Field fire tests, Onondaga County, New York (Reference 203)

	Water	Viscous water, Dow ET-570, 15.5cP
Pre-burn time (min)	3	3
Nozzle flow (l. min ⁻¹)	76	76
Knockdown time (min)		
Outside of building	1.75	0.9
Inside of building	2.75	1.4
Flame extinguishment (min)	5.5	3.0

Grove *et al.* (Reference 203) cited other anecdotal evidence supporting the use of viscous water, particularly against forest fires. A report by the US Department of Agriculture, Division of Forest Fire Research was quoted as saying: "*Viscous water reduced suppression time under many conditions and was outstanding in keeping fires from rekindling. The residual film of algin-thickened water seemed to be particularly effective in extinguishing usually difficult-to-extinguish fires in fuels such as sawdust...*" The use of carboxymethyl cellulose (CMC)-thickened water was advocated as a fire retardant to prevent the spread of forest fires: "*CMC retards the rekindling of a fire and it is possible to pre-lay a wet lane with much less chance of losing the fire than if plain water is used.*" Other experiments had shown that fires extinguished with viscous water were far less prone to reignition compared with fires extinguished with plain water; where reignition was observed with viscous water, its occurrence was delayed and much less severe. It was also evident that fires extinguished with plain water retained much more residual heat, a requirement for reignition, than those extinguished by viscous water. Both water consumption and water runoff were reported to be reduced in the case of viscous water. In the former, a reduction of between 30-

50% was stated to be common in the wide range of field fire tests conducted. A series of comparative, controlled tests were performed to measure the quantity of 'runoff' during fire extinguishment; for plain water applied at 13.6 l.min^{-1} , an average of $\sim 1.4 \text{ l.min}^{-1}$ runoff was recorded, for 'CMC' at 5.5 cP, the runoff was only $\sim 0.7 \text{ l.min}^{-1}$ and for ET-460-4 (5.5 cP viscous water) the runoff rate was less than 0.45 l.min^{-1} . Grove *et al.* stated that: "A corollary to the more effective use of viscous water is the reduced water damage to structures, contents, and adjoining facilities". Finally, given that satisfactory viscosity usually can be achieved with less than 0.2% of a chemical additive, Grove *et al.* estimated that the resulting costs "...would not be considered prohibitive under many conditions of fire-fighting and control."

Two practical issues were raised by Grove *et al.* (Reference 203): firstly regarding the shear stability of the thickened water solution and secondly concerning the character of the spray pattern produced by nozzles used in conjunction with viscous water. Measurements of viscosity on various thickened solutions over a period of mixing or recycling had shown that many agents were 'shear sensitive', resulting in a decrease in viscosity as a function of time; however the additive 'Dow ET-570' had proved to be less shear-sensitive during laboratory fire tests. It was stressed that in practice, special nozzles would be required in order to fully exploit the potential benefits of viscous water as changes in viscosity were known to affect the spray distribution pattern of a given nozzle; it was suggested for example, that the 'full cone' spray produced by a given nozzle used with plain water would very likely change to a 'hollow cone' pattern in the case of viscous water. A wide-ranging discussion of the effects of six commercially-formulated thickening agents on the droplet size distribution produced by a typical aerial crop spraying nozzle has been given by Bouse *et al.* (Reference 204); the rationale for increasing the liquid viscosity in this case was to reduce the amount of herbicide lost through 'spray drift' by increasing the volume mean diameter of the spray.

The overall conclusions of Grove *et al.* (Reference 203) concerning the use of viscous water for fire-fighting were that:

- Viscous water produces much more rapid initial control of Class 'A' fires;
- The rate of extinguishment of Class 'A' fires is more rapid with viscous water;
- The danger of reignition is markedly reduced when Class 'A' fires are extinguished with viscous water;
- A smaller amount of viscous water is required for extinguishment of Class 'A' fires;
- Reduced 'runoff' of viscous water gives better utilisation for fire control and minimises water damage;
- The logistics of chemical additives for fire-fighting is economical.

Reiner (Reference 205) described a series of room fire tests conducted at Karlsruhe University's 'Research Institute for Fire Protection Techniques' to investigate a range of fire-fighting additives, including 'Structurmaker', a viscosity modifier for water. On a microscopic scale, this additive was said to 'build huge water molecules' by increasing the forces of attraction between the existing molecules and thus form a 'three dimensional mesh' of 'tied water'. However, the magnitude of these internal forces

were such that only the viscosity was increased, while the thermal properties of the fluid remained unchanged, the viscosity of the ~ 0.5% wt. 'Structurmaker' solution used during the experiments was reported by Reiner to be ~ 18 mPa s (*i.e.* 18 cP). Two sizes of room were used for the tests, 12.8 m² x 2.2 m high and 21 m² x 2.5 m high but the format of the experiments was similar. In each case the room was filled with a representative fire load of typical house furnishings and ignited remotely. The gas temperatures and mass loss rate were monitored throughout the test and the fires were all manually extinguished by an experienced fire-fighter using a hand-held multi-purpose jet (DIN 14365: 100 l.min⁻¹ at 5 bar) after ~ 40% of the initial mass had been lost. The data in Tables 14 and 15 below show the relative effectiveness of plain water and viscous 'Structurmaker' water in the 12.8 m² and 21 m² compartments respectively.

Table 14

Viscous water fire extinguishment data for 12.8 m² room (Reference 205)

Extinguishing agent	Water	Water + 0.55% (by mass) 'Structurmaker'
Initial mass of furniture, (kg)	381	370
Burn period before start of suppression, (min)	21	18
Burning rate at start of suppression, (kg.min ⁻¹)	11.7	13.7
Extinguishment time, (min)	6.8	4.0
Amount of extinguishing agent, (l)	225	142
Amount of excess extinguishing agent, (l)	126	55
Amount vapourised, (l)	99	87
Amount of water flowed through, (l)	17.5	3.0

Table 15

Viscous water fire extinguishment data for 21 m² room (Reference 205)

Extinguishing agent	Water	Water + 0.5% (by mass) 'Structurmaker'
Compartment ceiling temperature, (°C)	1064	1028
Burning rate at start of suppression, (kg.min ⁻¹)	36.7	40.6
Mass loss at start of suppression, (%)	41.4	39.5
Extinguishment time, (min)	13.5	10.5
Amount of extinguishing agent, (l)	260	163
Amount of excess extinguishing agent, (l)	170	55
Amount vapourised, (l)	90	108

In the above tables, the 'amount of extinguishing agent' is simply the product of the nozzle flowrate and the application time while the 'amount of excess extinguishing agent' was derived from the sum of the overflow (collected by vessels beneath the test room) and the volume of liquid remaining on surfaces within the room itself; the 'amount vapourised' was taken to be the difference between these two figures. Reiner compared the performance of the viscous water with that of plain water in terms of the amount of extinguishing agent required and the volume of excess agent delivered during the tests. In the experiments reported in Table 14, the viscous water gave reductions of

37% and 56% in the two categories, respectively; the corresponding improvements for the tests in Table 15 are reductions of 37% and 68%, respectively. In both sets of tests there was no discernible difference in the behaviour of the fire-fighting jet but there was a pronounced increase in the period between 'suppression' and reignition of the flame; the latter observation is in accordance with Grove *et al.* (Reference 203). Reiner noted that this increase in 'service time' was produced during both the initial phase of fire-fighting and in 'supplementary extinguishing work'. The viscous water was also observed to adhere well to vertical surfaces although its presence on the floor increased the danger of sliding; Reiner cautioned that the latter problem would have to be considered during supplementary extinguishment operations.

The use of various chemicals, including thickening agents, to improve the properties of water used against forest fires has been discussed by Hardy *et al.* (Reference 206) and Guillaume (Reference 207). Hardy *et al.* (Reference 206) described a laboratory study of 7 chemical additive solutions intended for use as aerially-applied fire retardants rather than as fire suppressants. These chemicals were: algin-diammonium phosphate (algin-DAP), algin-calcium chloride (algin-gel), bentonite, sodium calcium borate ('Firebake'), sodium calcium borate ('Borate XPI-113'), ammonium sulphate-attapulgite clay ('Fire-Trol') and pectin-diammonium phosphate (pectin-DAP). In general however, the additive properties sought for such specialised applications are very different from those required for compartment fire suppression. In the case of viscosity modifiers, a large increase in thickness is desirable, at least initially, to ensure efficient aerial delivery of the agent by reducing airborne evaporation and 'spray drift'. Guillaume (Reference 207) discussed two forms of thickening systems: particulate and synthetic polymer agents. The former consist of small, particle-size, high surface area clays or silicas while the latter are commonly referred to as 'gum thickeners' (*e.g.* carboxymethyl cellulose, guar gum and 'derivatised guar'). The high apparent viscosity of the particulate systems is reduced drastically when shear is exerted however, and therefore these solutions become 'water-like' when subjected to discharge from an aircraft, free fall and ground impact. The synthetic polymer thickeners form a 'molecular network' within their solutions and exhibit much less shear-thinning. According to Guillaume, gum-thickened solution droplets of 5-10 mm in diameter are common, whereas clay-thickened and un-thickened solution droplets of 2-3 mm and 2-2.5 mm respectively are the most prevalent with drop altitudes in excess of 40 m.

The use of polyethylene oxide polymer (POE) as a drag-reducing agent in fire-fighting operations was discussed in References 208 and 209. Thorne (Reference 208) described the first demonstration of so-called 'slippery water' by the New York Fire Department, where a relatively concentrated (~ 1.5%) solution of POE was injected into the fire-fighting water at the pump outlet to produce a final concentration of 50 ppm (0.005%). The limitations of this system were listed as: a short storage life for the premixed solutions, the large bulk of premixed additive required (since 1 litre of 1.5% pre-mixed solution could treat only 300 litres of water) and its susceptibility to shear degradation. A 'more practicable' form of the additive was described, known as 'rapid water', where powdered PEO was introduced to the water supply as a suspension in a viscous (~ 6000 cP, or 6 Pa.s), water-soluble 'carrier' liquid; this system was effective at much lower solution concentrations and was claimed to be relatively immune to shear degradation.

Two series of experiments were conducted using 70 mm internal diameter non-percolating fire hose with both 'slippery water' (30 ppm solution) and commercially-available POE slurry ('rapid water') additives. A hose length of ~ 70 m was adopted for the first series of experiments while hose lengths up to 1100 m were used during the second test programme; the latter also investigated the effect of variations in hose diameter (from 19-89 mm), but these data were not reported by Thorne in Reference 208. The data from the 70 mm hose tests were presented in the form of graphs of friction factor versus Reynolds number and 'percent drag reduction' versus hose flow rate. The experimental work also featured an investigation of the effect of POE on the form of water jets produced from typical nozzles; in particular it was anticipated that the presence of drag-reducing agent would delay the onset of jet instability by reducing the level of internal turbulence in the water stream (Section 4.1.1.1). High-speed flash photography was used to record the streamwise disintegration of the water jet as it emerged from the nozzle and the resulting photographs were used to assess the level of coherence of the early stages of the jet.

As a result of these experiments, it was concluded that:

- Drag reduction of up to 60% can be achieved through the use of POE in appropriate concentrations in 70 mm UK fire hoses;
- Drag reduction is beneficial in fire-fighting where high pressure losses are encountered (e.g. during 'water relaying' and the operation of large-bore monitors fed by long hoses);
- The addition of POE to water has a noticeable effect on water jets but with the current (1975) design of UK Fire Service nozzles, the improvement in jet cohesion does not justify the use of such additives specifically for this purpose;
- There is a fall-off in the drag reduction effect in fire hoses at high Reynolds numbers which can be partially offset by increasing the concentration of the additive;
- A commercially-available formulation of POE in slurry form can be injected into the suction inlet of fire pumps with only a 5% loss in effect;
- The passage of water thus treated through a second relay pump reduces the subsequent drag reduction effect by about one quarter.

8.4 Chemical flame inhibitors for fire-fighting water

Writing in 1960, Guise (Reference 210) noted that the first addition of a true chemical extinguishment mechanism to plain water was in the 'loaded stream' solution; a solution of potassium carbonate in water, with other additives to reduce the freezing point to -40°C (used in hand and wheeled portable extinguishers). The loaded stream solution was found to be more effective than plain water on 'ordinary combustibles' such as wood, cloth or paper and in addition such extinguishers were also approved for flammable liquid fires where plain water proved ineffective (even when applied as a spray). Guise quoted earlier experimental results (ca. 1928) which indicated that water solutions of metallic salts based on elements in Group I of the Periodic Table (*i.e.* lithium, sodium, potassium, rubidium or caesium) were more effective as the atomic weights of the

cations (positive ions) increased. It was also found that alkali metal salts with anions (negative ions) containing oxygen and halogens were most effective; the extinguishment mechanisms was thought to be due to a 'negative catalytic' effect on the combustion reaction. Guise suggested that the effectiveness of such solutions was due to a 'chemical chain-breaking action'; the observed increase in effectiveness of a loaded stream on Class 'B' fires when applied as a spray was thought to support this view. A contemporary article by Friedman (Reference 211) also stressed the effectiveness of the alkali metal salts as flame inhibitors with the exception of lithium. In discussing the effectiveness of powdered chemical flame inhibitors some years later, Fristrom (Reference 9) again noted that the alkali metal salts were particularly effective and that their effectiveness increased with increasing atomic number (*e.g.* potassium bicarbonate is more effective than sodium bicarbonate which in turn is more effective than lithium bicarbonate).

A recurrent problem in the assessment of extinguishing agents is the frequent discrepancy between the suppression efficiencies achieved in the laboratory and those obtained during tests performed at more realistic scales. The studies performed by Kida (Reference 212) and Iya *et al.* (Reference 213) to investigate the suppression effectiveness of various metal salts are typical of laboratory-scale investigations. Iya *et al.* (Reference 213) measured the degree of inhibition of a premixed methane-air flame effected by sodium bicarbonate (NaHCO_3) and sodium tartrate ($\text{Na}_2\text{C}_4\text{H}_4\text{O}_6 \cdot 2\text{H}_2\text{O}$); the objective was to determine whether the inhibition was 'heterogeneous' (taking place on the surface of the salt particles) or 'homogeneous' (occurring in the gas phase due to the presence of vapourised inhibitor). The results indicated a strong correlation between the concentration of sodium evaporated and the degree of inhibition. Since the correlation proved to be independent both of the size of particle and the salt involved, it was concluded that the inhibition mechanism was very likely to be homogeneous in nature.

Kida (Reference 212) measured the extinguishment times for small pan fires exposed to sprayed water solutions of a variety of salts at different concentrations, including NH_4Cl (5%), Na_2CO_3 (5%), NaHCO_3 (5%), potassium citrate (5%), KHCO_3 (2.5, 5, 10, 20%), K_2CO_3 (2.5, 10, 20%), KI (5%), KCl (5%) and $\text{H}\cdot\text{COOK}$ (5%). The sprays were applied vertically downwards onto hexane pool fires 8 cm in diameter from a nozzle mounted 0.7 m above the level of the pan; when the nozzle was operated at a pressure of ~ 3.4 bar, the spray application rate was $16.2 \text{ l}\cdot\text{m}^{-2}\cdot\text{min}^{-1}$, although it is not clear from Reference 212 whether these were also the standard test conditions. For a given concentration of salt solution, the extinguishment test was repeated between 50-120 times 'under nominally identical conditions' in order that a statistical analysis of the process could be conducted. The average extinction time was found to vary between 15.3 seconds for plain water down to 3.3 seconds for 5% KCl solution. However, the measured extinction times showed considerable scatter and when plotted as a frequency distribution, the results were found to be 'positively skewed'. It was concluded that the mean extinction time was not sufficient to describe the extinguishment effectiveness of salt solutions and that an appreciation of the statistical features of the frequency distributions was necessary to understand the effect of salt additives in fire-fighting water.

In addition to the salts of the alkali metals, various other chemical additives have been found to increase the potency of fire-fighting water. Hardy *et al.* (Reference 206) noted that the use of 10% solutions of mono-ammonium phosphate had been found to extinguish 'from 50 to 80% more fire than an equal quantity of plain water'. Reiner (Reference 205) reported the results of fire extinguishment tests involving solutions of various chemical additives, including diammonium-phosphate, diammonium-sulphate, potassium-bicarbonate, sodium-bicarbonate and 'fluortensid', small-scale data were obtained using 6 kg wooden crib fires while larger-scale tests were conducted in a 12.8 m² compartment where ~ 380 kg of furniture was burned (as described in Section 8.3). In the small-scale tests, the performance of the various solutions was compared with that of plain water and the spray was applied after a pre-burn period had consumed 50% of the crib mass, the spray was applied until no flames were visible and the fire was considered to be extinguished when no reignition occurred after a period of two minutes. The test procedure for the compartment fires has previously been described in Section 8.3.

The results from these small- and large-scale tests are reproduced below in Tables 16 and 17, respectively, the format of the latter data is broadly similar to that of Table 14 in Section 8.3 (page 160).

Table 16
Quantities of loaded stream solutions (litres) required to extinguish 6 kg crib fires
(Reference 205)
[Mean requirement for plain water averaged over 25 tests = 2.79 l]

Extinguishing agent - % by mass	2.5%	5%	10%	15%	20%	27%
Diammonium-phosphate	2.2	1.45	1.55	1.54	0.93	2.0
Diammonium-sulphate	-	2.34	1.61	1.57	1.24	1.59
Potassium-bicarbonate	-	2.84	2.19	1.88	1.99	1.92
Sodium-bicarbonate	-	2.7	3.33	-	-	-
Fluortensid	-	2.18	-	-	-	-

Table 17
Loaded stream fire extinguishment data for 12.8 m² room (Reference 205)
[F5 = 5% by mass fluortensid; S10 = 10% by mass diammonium-sulphate; P5 = 5% by mass diammonium-phosphate; P20 = 20% by mass diammonium-phosphate]

Extinguishing agent	F5	S10	P5	P5	P20	water
Initial mass of furniture, (kg)	383	380	380	383	383	-
Burn period before start of suppression, (min)	25.3	23.6	21.5	25.7	19.3	-
Mass loss, (%)	40.6	40.4	41.1	40.0	40.0	-
Burning rate at start of suppression, (kg.min ⁻¹)	12.4	10.1	10.0	8.0	10.3	-
Extinguishment time, (min)	4.0	7.5	4.4	3.1	1.7	6.5
Amount of extinguishing agent, (l)	180	170	122	125	57	215
Amount of excess extinguishing agent, (l)	79	93	50	36	10	116
Amount vapourised, (l)	101	77	72	89	47	98

It can be seen from Table 16 (page 164) that in most of the small-scale tests there was a reduction in the water requirement for extinguishment and that there appear to be optimum concentrations of diammonium-phosphate, diammonium-sulphate and potassium-hydrogen-carbonate which correspond to a minimum water requirement. The maximum effectiveness was achieved with a 20% solution of diammonium-phosphate which resulted in a 67% decrease in the volume of water required for extinguishment. The data in Table 17 (page 164) confirm the superior effect of the 'P20' solution at large-scale, where a 73% decrease in extinguishing water was found for the compartment furniture fire. Reiner suggested that the increased efficiency at large-scale was due to the earlier application of the spray in this case, *i.e.* when the fuel load was 40% consumed; in the small scale tests the extinguishing streams were applied only when the cribs were 50% consumed and hence the fire was relatively better established. Table 17 also shows the decrease in extinguishment time for all additive solutions relative to the plain water stream, with the exception of the diammonium-sulphate solution. Reiner concluded that additives had been identified which 'allowed for an essential reduction in the amount of extinguishing agents needed for firefighting' and urged that further research should be conducted to establish that the various agents were environmentally benign.

Ryan *et al.* (Reference 214) described the experimental evaluation of additives on the extinguishment of coal fires comprised of 180 kg of Pittsburgh seam coal contained in underground test chambers. Three additive solutions and plain water were used to extinguish the fires; two of the additives were unspecified commercial agents (containing surfactants and other ingredients) and the third was a 20% by weight diammonium-phosphate (DAP) water solution. It was found that the 20% DAP solution required an average of 22 l to extinguish the fires while the other additive solutions required 30.6 and 30.3 l respectively; the volume of plain water required was 28 l. A statistical analysis of the extinguishment data, using the thermal energy of the coal bed to quantify the state of the fire at extinguishment, showed that the DAP solution was slightly more effective than plain water. The other two additive solutions were found to be statistically equivalent to plain water and therefore offered no practical advantage.

8.5 Class 'A' foam

In recent years some authorities have advocated the use of Class 'A' foam systems for fighting domestic compartment fires and claims have been made that this agent can yield a three to five times 'increase in effectiveness' when compared with plain water. Colletti (Reference 215) reported an extensive series of controlled, post-flashover, room-and-contents fires conducted in the US during 1992; the test programme, a major collaborative effort between the Fire Service and private industry, was seen as an important preliminary step towards quantifying the efficacy of Class 'A' foam in 'structure fire suppression'. The tests compared the rate of temperature reduction within identical test rooms during the application of plain water, Class 'A' foam solution (applied un-aspirated) and Class 'A' foam aspirated *via* a compressed air foam system (CAFS). Where used, the Class 'A' foam solution was always mixed to 0.5% concentration and in all cases (including plain water) the liquid agent was applied at ~ 76

1 min^{-1} , for the aspirated foam tests, the CAFS delivered an additional flow of compressed air at $\sim 20 \text{ ft}^3 \text{ min}^{-1}$ (20 cfm). The same branch operator was used in all tests to ensure a uniform attack, consisting of a 60-second indirect attack on the compartment ceiling followed by a 60-second direct attack on the room and contents; the dimensions of the compartment were approximately $3.3 \times 3 \times 2.4 \text{ m}$ high and the fuel loading was described as 'moderate'.

The temperature decay histories for the ceiling thermocouples were virtually identical for all three tests; this was not unexpected since the initial attack was directed at the ceiling and some impingement onto the thermocouples was also expected. However, the corresponding data for thermocouples at 1.2 m above floor level revealed significant variations in the cooling capacity of the various agents. Gas temperatures at this location were expected to be strongly correlated with the thermal stress and survivability of trapped occupants and firefighting personnel involved in rescue and suppression operations. The heat-absorbing capacity of the agent was characterised by the linear rate of cooling of the compartment gases from $538 \text{ }^\circ\text{C}$ ($1000 \text{ }^\circ\text{F}$) to $100 \text{ }^\circ\text{C}$ ($212 \text{ }^\circ\text{F}$); the values obtained for plain water, foam solution and aspirated foam were $-1.9 \text{ }^\circ\text{C.s}^{-1}$, $-4.2 \text{ }^\circ\text{C.s}^{-1}$ and $-11.4 \text{ }^\circ\text{C.s}^{-1}$ respectively. It was concluded that both the un-aspirated and aspirated foams promoted a faster rate of cooling within the compartment and consequently improved the thermal environment for both the occupants and firefighters alike. Based on these cooling rates it was determined that the foam solution was $\sim 110\%$ more effective than plain water while the aspirated system produced a 480% improvement; the total water supply required in each case was 280 l, 129 l and 49 l for plain water, foam solution and aspirated foam respectively.

As a result of the tests, number of advantages were perceived for the CAFS compared with a plain water strategy for post-flashover compartment fires:

- The firefighting crew consistently commented upon the 'outstanding visibility' since with very little smoke or steam was produced from the application of the compressed-air foam;
- The CAFS was seen as a way to increase the effectiveness of water in fighting compartment fires containing increasing quantities of 'rapidly burning synthetic furnishings' without incurring the logistical penalties involved in increasing plain water flowrates greatly above $\sim 350 \text{ l.min}^{-1}$;
- In particular, the tests indicated that a 100% increase in efficiency might be realisable in practice, and in this case a 450 l.min^{-1} foam application would be equivalent to a 900 l.min^{-1} plain water delivery. In fact the tests suggested that a $300\text{-}500\%$ increase in efficiency might be possible by the CAFS if 'applied correctly' in practice;
- Any increase in the effectiveness of compartment firefighting would lead to increased firefighter safety, improved operational efficiency and reduced property damage during structure fire operations;
- On the basis of these encouraging preliminary data, Colletti (Reference 215) urged that further 'full-scale, controlled laboratory comparative testing' of CAFS should be conducted by third-party agencies.

In the UK, the performance of a 'concept demonstration' CAFS unit was tested under non-fire conditions by the Home Office Fire Experimental Unit (Reference 216); test measurements included foam throw, expansion ratio, 25% drainage time and shear strength. A CAFS unit comprises essentially three elements, a water pump, a foam concentrate injector pump and an air compressor; commercial systems are available in a range of capacities but for the FEU tests the nominal performance data were $\sim 1000 \text{ l.min}^{-1}$ (at 10 bar), 9.8 l.min^{-1} (at up to 15 bar) and 90 cfm at 7 bar (and capable of operating at up to 15 bar) respectively. Initially, four foam concentrates were selected for the study: Fluoroprotein (3%), AFFF (1%), AFFF (3%) and FFFP-AR (3-6%). Three tests were performed for each solution, one where the CAFS produced low expansion (LX) foam (low air flow case), one where the CAFS produced medium expansion (MX) foam (high air flow rate) and a comparison test with an equivalent Fire Service LX primary aspirating branchpipe.

The expansion ratio of the foam was measured and gives a measure of the amount of air in a foam; low expansion foams fall in the range 1:1-20:1, medium in the range 20:1-200:1 and high expansion in the range 200:1-1000:1. For an expansion ratio of 10:1, a given volume of foam contains 90% air and 10% foam solution. The 25% 'drainage time' is the time taken for one quarter of a given mass of foam to return to foam solution; foam with low drainage times flow better whilst high values are associated with longer lasting foams. The 'shear strength' gives a measure of how well the foam has been 'worked' before application; water foams have low values (approaching zero) while stiff foams have higher values. Foams containing smaller and more uniform bubbles tend to be stiffer and hence have higher shear strengths.

In the event, practical difficulties with sample collection prevented an assessment of the MX foam quality produced by the CAFS and the relatively viscous FFFP-AR proved incompatible with the system as supplied. However, the LX foams produced by the CAFS achieved much greater heights (+17% to +192%) and throws (+14% to +63%) than were possible with the conventional primary aspirating branchpipe even though both nozzles were operated at an elevation of 40° to the horizontal. All three LX foams produced by the CAFS were found to have longer drainage times than those produced by the conventional nozzle, but the former also had lower expansion ratios; the latter was particularly unsatisfactory in the case of the 1% AFFF foam. The CAFS/LX foams produced with 3% AFFF and 3% Fluoroprotein were deemed to be of good quality. Despite the satisfactory performance with LX foams, it was felt that the system limitations, in terms of the maximum capacities of the air compressor and the water pump, reduced the versatility of the apparatus. It was suggested that a 'more balanced' system would comprise: the existing water pump (1000 l.min^{-1} at 10 bar), a larger concentrate injection pump (rated at $\sim 39 \text{ l.min}^{-1}$) and an air compressor rated at 200 cfm. It was stated that this configuration would be capable of generating LX foam at all expansion ratios up to 10:1 at several foam flow rates: 6% concentrate at 640 l.min^{-1} , 3% concentrate at 900 l.min^{-1} and 1% concentrate at 900 l.min^{-1} .

As an extension of the work described in References 199-200, the Home Office Fire Experimental Unit have recently completed an assessment of various Class 'A' water additives, based on an extensive series of large-scale (unconfined) fire suppression trials. The fire load comprised an array of 56 wooden pallets, arranged in a square of 4 stacks

of 14 pallets, ignited by a tray of heptane placed under each stack, the tests were performed under a large exhaust hood in the FEU 'Still Air Facility' at RAF Little Rissington. Following burnout of the heptane, which took approximately 2 minutes, the pallets were allowed to attain a steady burning rate (a nominal preburn period of ~ 5 minutes), prior to the commencement of firefighting.

During the initial test series, performed in 1995, a total of 13 Class 'A' additives were tested. In addition, plain water, AFFF and a synthetic detergent-based foam were used as comparison agents. The additive manufacturers claimed various advantages for their products, including increased penetration into the fuel bed and reduced burnback. For the tests, the additives were mixed according to the manufacturers' instructions and were applied to the test fire *via* a high pressure hosereel at 50 l.min⁻¹. Although it was recognised that this flowrate was lower than would be adopted in practice, it was selected in order to improve the inter-comparison between tests. The branch nozzle was adjustable between a jet setting and a fixed spray angle of 120°. An experienced local authority firefighter tackled the fire, using a jet for the first minute, in order to achieve initial knockdown. Following the jet attack, the branch was switched to spray mode and firefighting was continued until the firefighter considered that a consistent level of extinguishment had been achieved.

The relative effectiveness of each additive mixture was quantified with reference to the output from 4 fixed radiometers which were located normal to the centres of the sides of the fire load, attached to the supporting columns of the exhaust hood. The data were averaged and normalised relative to the peak radiative flux, which occurred just before firefighting commenced. Graphs of these data were analysed to assess the effectiveness of thermal energy removal, by calculating the area under the curves during the various phases of firefighting. It was found that most fire reduction occurred during the first 2 minutes of firefighting, and so the area under the graphs in this period was used as the primary measure of additive effectiveness. It was also found that the fire reduction during the first minute (jet attack) was considerably greater than in the second minute (spray attack). However, overall the data were inconclusive, partly because each additive had been tested only once, and it was therefore decided that further testing was required.

The second series of tests, conducted in 1996, was broadly similar to the first but was more strictly controlled. Specifically, all but one of the agents tested previously were tested at least twice (including water), the structure of the pallet stack was improved to prevent collapse and the moisture content of the wood was closely controlled. As a result of these measures, the range of maximum heat fluxes obtained during the 1996 tests was found to be 8.5-11 kW.m⁻², compared with the somewhat wider range of 12-22 kW.m⁻², obtained during the earlier tests. The test procedure was identical to that used previously, except that the hosereel branch was operated in spray mode throughout firefighting, and the initial jet attack was abandoned. The heat flux data from the radiometers were again used as the primary indicator of additive performance, and the period of most interest was increased to the first 4 minutes of fire suppression rather than the first 2 minutes in the earlier tests (due to the absence of jet attack).

The FEU are currently in the process of publishing detailed accounts of these tests, however the provisional conclusions are that none of the additives tested produced a significant improvement in firefighting performance when compared with water.

8.6 Summary

Many diverse additives have been proposed over the last three decades or so, with the aim of improving the effectiveness of firefighting water, by reducing the time taken to achieve flame extinction and reducing the total volume of water required. Much of the research effort on Class 'A' additives has focused on the use of surfactant chemicals such as AFFF, AFFF-AR, FP, FP-AR, FFFP, FFFP-AR etc. which were originally developed for Class 'B' fires and were intended to be applied as aspirated foams. However, because of the three-dimensional nature of typical Class 'A' fires, a greater degree of agent penetration is required initially and therefore additive streams are generally applied un-aspirated in these situations. The surface tension (σ) of these solutions is less than that of plain water and hence the 'wettability' of the solution is increased, this improves both the fuel-bed penetration and rate of heat extraction of the extinguishing water by conduction.

Reducing the magnitude of σ also reduces the energy required for spray atomisation by a given nozzle (alternatively, the character of the spray may be altered for a given nozzle when 'wet water' is substituted for plain water, all other things being equal). Large reductions in σ are possible with very low concentrations of agent (e.g. 50% reduction for ~ 0.1% solution by mass). In the case of film-forming foams (AFFFs), their values of σ are lower than typical petro-chemical products, however the relative contribution of the film-forming mechanism to fire extinction has been questioned by some authorities in the light of experimental data.

Thickening agents have been used to produce solutions of 'viscous water', which are reported to achieve faster knockdown, more rapid extinguishment and a reduced tendency to burnback; in addition, runoff and total water consumption were reduced. The literature contains much anecdotal evidence from forest fire operations where viscous water was seen to reduce the suppression time and prevent burnback. Also, fires extinguished with viscous water are expected to retain much less residual heat compared with fires extinguished by when plain water. It was also anticipated that the use of viscous water in compartment fire situations would reduce the water damage to structures, contents etc. Room and contents fire tests have confirmed a reduced tendency to runoff, with consequent reductions in time to extinguishment and total water consumption; a delayed burnback was also observed. An additional benefit of viscous water is its ability to adhere to vertical surfaces. Two practical limitations of viscous water were noted: first that during 'mop-up' operations, special effort must be made to reach deep-seated 'hot spots' and that some agents may be shear-sensitive so that the viscosity (η) of the solution decreases with recycling in pumps etc. Also, it seems that the effect of viscosity modifiers on σ and *vice-versa* is not well documented for common additives.

Chemical inhibitor additives work by interrupting the chemical chain reactions required to sustain combustion. e.g. potassium carbonate solution is known to be effective against Class 'A' materials, the alkali metal salts in general are more effective as the atomic number increases, therefore potassium bicarbonate is better than sodium bicarbonate, which is better than lithium bicarbonate. Remarkable (~ 70%) reductions in

the total extinguishing water requirement have been reported from recent room and contents burns, using a 20% by mass diammonium-hydrogen phosphate solution.

Class 'A' foam is a relatively recent development and recent US test experience of a CAFS (compressed air foam system) against post-flashover compartment fires has shown that an aspirated 0.5% solution can promote very rapid cooling of compartment gases, up to ~ 500% faster than plain water over the range ~ 540 °C to 100 °C and this required only 18% of the total plain water application to achieve this result. It should be noted however, that CAFS is just one particular method for producing an aspirated foam and it can be used in conjunction with any foaming agent. In the American tests, the relatively low steam and smoke production gave better visibility throughout the attack. It was also suggested that Class 'A' foam could provide a more efficient attack on high heat release rate synthetics in domestic fires without incurring the logistical problems associated with merely increasing plain water delivery rates beyond ~ 350 l.min⁻¹. Overall, it was concluded that this technology offered improved safety benefits for both firefighters and occupants, together with a reduction in property damage. In the UK, tests of this system have so far been limited to hydraulic performance evaluation and on the basis of these tests FEU have suggested some improvements to the CAFS system specifications to improve its versatility.

Regarding the influence of additives on droplet characteristics, all other things being equal, the droplet diameter will decrease as the liquid density (ρ) increases, as the surface tension (σ) decreases and to some extent also with increasing viscosity (η) of the sprayed liquid. Braidech and Neale (Reference 149) reported that for a range of 1-10 times the viscosity of water, no significant changes in droplet size will occur. Since surfactant agents ('wet water') act principally to reduce the surface tension of water, a 'reduction in the size of the droplets is to be anticipated where such treated water is dispersed as a spray'. Special consideration must be given to nozzles used in conjunction with viscous water as changes in η may affect the spray pattern significantly e.g. a full cone spray produced with plain water may be altered to a hollow cone spray if viscous water is used. Also if increased spray penetration is required then increasing η can produce larger drops possessing greater momentum.

Large scale tests of Class 'A' additives have almost exclusively employed wooden crib fires and it has been found that the larger crib fires give a better inter-comparison of agents than small fires. The effectiveness of Class 'A' additives against compartment fires was investigated by the FEU and the results were presented in terms of a 3-phase extinguishment model: initial room cooling, bringing the fire under control and final extinguishment of residual 'hot spots'. During phase 1, sprayed additives were found to be ineffective and no significant improvement was observed over plain water. During phase 2, all additives made a positive contribution in reducing fire severity compared with plain water, especially AFFF and 'Halofoam', with the former being much more economical. However, although the tests indicated that the duration of the 'control phase' would be reduced, the overall saving in water demand and fire damage was expected to be small. In the US, the use of sprayed AFFF has been found to be effective against large scale Class 'B' fires despite low expansion ratios (~ 2:1), and extremely rapid knockdown was reported. It was suggested that chemical inhibition mechanisms, particularly the evaporation of fluorocarbons, played a significant role in flame

knockdown. The FEU phase I observations however, are at variance with these reports of the efficacy of sprayed AFFF; it would be of interest to establish why these results differ. If a similarly enhanced knockdown could be achieved in Class 'A' compartment fires, this would be highly desirable. Although most of the FEU's Class 'A' suppression tests have employed Class 'B' additives, recent experiments have examined the effectiveness of special Class 'A' foam agents, at the time of writing this work is still ongoing.

Small scale tests of plastics fire suppression by 'wet water' have shown that increased adhesiveness is connected with ease of extinction and that wet water can be much more effective than plain water in many instances. Large scale plastics fires data have not been reported in the literature. Wet water applied as fog was found to be better than solid stream application except for foam plastics.

The use of additives has been investigated by groups concerned with the development of water mist systems as replacements for Halon systems, although much of these data remain confidential. Since much of the emphasis of these tests is on meeting industry standards as a prerequisite to commercial exploitation of systems, there is a lack of fundamental, systematic, basic research; the result is that although some additives appear to 'work', the exact mechanisms remain undetermined. Various additives have been tested in water mist systems, including salts and 'conventional foams'. It has been suggested (Reference 217) that water mists may optimise and combine the extinguishing effectiveness of both water and salts simultaneously if the rapidly evaporating droplets leave behind salt particles the size of which may be very small, again however, no systematic studies are available at present. Where foams have been used in mist systems, sometimes the water mist is lost completely, and the foam falls down as big 'flakes' (observed with low pressure systems), while in some cases the system works perfectly and the foam is well-distributed over the burning surfaces (this has been seen in both low and high pressure systems). In the case of foam-type additives the suppression efficiency appears to depend on how the mist is produced (high pressure, low pressure, twin fluid) but here again no systematic studies exist (Reference 217).

It has been suggested that additives may not find widespread acceptance in water mist systems because their possible environmental and/or health hazards and the importance of their long-term stability in storage tanks (Reference 217). While these factors are undoubtedly also of concern to the Fire Service, it seems likely that new additives will continue to appear and will require to be assessed. The wide range of test methods employed in the literature to some extent prevents direct comparisons of additive performance. Even in 1960, Heterich (Reference 10) noted the ongoing debate regarding the best test method for 'wetting agents' (or 'dousing agents'). Given the costs involved in large scale fire testing, it would be beneficial to develop a more standardised approach to compartment fire suppression experiments, preferable including a move away from the traditional wooden fires to incorporate more representative synthetic fuels. Such a development would permit a more rational assessment of additive performance. More immediately, serious consideration should be given to investigating the claims made for Class 'A' foam and viscous water against compartment fires, test data could be compared with the existing FEU database on compartment fire and large-scale pallet fire suppression with other additives.

9. DISCUSSION

Water has long been the first choice of agent for fighting Class 'A' fires, but the method of its application by the Fire Service, in developed countries at least, has developed much since the days of buckets and stirrup pumps. Modern UK fire appliances containing typically 1820 litres of water can attend typical residential or commercial compartment fires within minutes of receiving an alarm call and firefighters have the ability to deliver water at rates of up to $\sim 150 \text{ l.min}^{-1}$ in variable spray patterns using modern hosereel systems. It was noted in Section 5.3.1 that the thermal characteristics of water make it ideally suited as an extinguishing agent for most types of fire, whether it is used to extract heat directly from the flames or from the surface of the fuel; in addition, the production of water vapour in sufficient quantities may further contribute to fire extinguishment by inerting the surrounding atmosphere. In the case of fuels which liberate flammable vapours at or below ambient temperatures however, fuel cooling is not a viable extinguishing mechanism when water sprays are used and flame cooling and inerting are the only routes possible.

Many workers have concentrated their efforts on deriving quantities such as critical application rates ($\text{l.m}^{-2} \text{ min}^{-1}$), critical flow rates (l.min^{-1}) or total water volumes required to extinguish test fires in order to maximise the 'efficiency' of water usage. It has been found that the critical application rates for fire extinguishment obtained in the laboratory are much smaller (by one or two orders of magnitude) than those measured during full scale tests, particularly in compartments. The cause for this discrepancy has been sought for many years and the current view is that water intended for deposition on the fuel surface is 'wasted' by premature evaporation on contact with non-burning surfaces and with the hot gases in the compartment; in addition some very small water droplets will be convected out of the compartment before they have a chance to evaporate. It has also been remarked that the human element is responsible for some 'inefficiency' during manual firefighting since firefighters naturally employ indirect cooling of the compartment to ameliorate the punishing thermal environment.

The developments in the design of water mist systems has also been discussed in this report and in this respect there is an important distinction to be made between the compartment fires attended by the Fire Service and those for which fixed fire suppression installations are designed (or indeed those which are tackled either by the 'first-aid' use of hand-held extinguishers). Fixed fire suppression systems are designed to control and extinguish relatively small fires occurring in a known geometry, whereas the Fire Service are usually faced with large (post-flashover) compartment fires in unfamiliar surroundings and often with the added complication of removing trapped occupants from the scene. Under such circumstances it is debatable whether the most 'efficient' use of firefighting water is the highest priority. Despite the claims that water supplies are often limited, this is not usually so in the UK. It has been seen in the foregoing sections that typical compartment fires are extinguished using between 50-300 litres of water and typical fire appliances in the UK carry typically 1820 litres; so recourse to mains water is rare.

The data in Tables A1 and A2 (Appendix 1) are a distillation of many of the experimentally-based research papers which have been reviewed during the course of this project. The wide variation in critical application rates is readily apparent and it seems likely that water will continue to be 'wasted' by the Fire Service when attending real incidents. This is not to say that the application of water to a fire cannot be improved or its effectiveness in cooling burning surfaces increased. The former would benefit from a systematic study of the interaction between firefighting sprays and a compartment fire under realistic conditions; the present knowledge of spray/plume interaction is based almost exclusively on the vertical discharge of sprinkler sprays onto fuel arrays. Our understanding of the physical interaction between water sprays and low conductivity burning solids is also far from complete and again much of the existing knowledge is derived from an unsatisfactory analogy (the spray cooling of high thermal conductivity metals). It is also important that there is a coherency between Fire Service training and fire safety research; the latter can all too easily be seduced into searching for an ultimate target (such as a minimum water requirement) which may be realisable in the laboratory but which can never be approached remotely in practice.

In the majority of fire tests reviewed here, wooden cribs were used as the fuel source; they have the advantage that they are relatively cheap and 'repeatable' but they are not wholly representative of the solid fuels involved in many residential (or commercial) compartment fires, particularly where synthetic materials may be involved. Also, certain peculiarities of crib fires (*e.g.* internal cross-radiation effects between individual sticks) have resulted in suppression/extinction characteristics which are not generally representative of other fuel types. It would be sensible to investigate a wider range of fuels in future compartment fire tests.

Water mist systems are being developed as replacements for Halon fixed fire suppression systems. The 'optimum droplet size' debate in this case is governed by the perceived need to mimic the transport characteristics of Halon gas so that water droplets can fill a compartment and thus reach the fire in the absence of human intervention. However, the generation of very small water droplets is no guarantee of success in these systems either, due to physical differences between water and Halon gas, for example some of the water volume is lost by deposition on solid surfaces and may contribute nothing to the suppression process (particularly if the surface is cool initially). Those involved in testing water mist systems frequently report that although the fire can be 'controlled' and the rate of burning reduced, final extinguishment is not possible because the water droplets lack the necessary momentum to reach the fuel surface and lower its temperature sufficiently to stop the production of flammable vapours. On the other hand, water mist systems have also proven capable of achieving almost instantaneous extinguishment of certain fires, particularly Class 'B' or 'C' fires with a high degree of confinement; this rapid 'snuffing out' effect is due primarily to the inertion of the compartment atmosphere by the large volume of water vapour produced by heat transfer from the compartment gases and solid boundaries.

Regarding the heat transfer processes which control fire suppression and extinction, the thermodynamic interaction between water sprays and hot gases is well understood, the only question raised in this area by the current study is the importance of surfactants on the evaporation process. It has been suggested that the rapid flame knockdown

achieved with sprayed AFFF against Class 'B' test fires can only be explained by chemical flame inhibition arising from the preferential diffusion and evaporation of fluorocarbon species from finely divided sprays. Given the interest of FRDG and FEU in the effects of additives, this claim should be investigated further. The most significant gaps in our understanding of the extinction process appear to be in the conditions leading to final suppression and extinction (and the conditions which may lead to re-ignition). The formulation of an adequate description of this régime of the suppression/extinction process requires a detailed knowledge of the heat and mass transfer at the fuel surface, including the ability of water droplets to adhere to various burning materials, the dynamics of a spray impacting on a burning surface and the characteristics of the flow of heat from within the bulk of the fuel mass. The influence of additives such as thickeners and wetting agents should also be examined in this respect.

From an academic standpoint it would be of interest to rationalise some of the published experimental data and compare the predictions of some of the more empirically-based models reported in Section 6 of this report. This would provide an independent assessment of the utility of the models and allow for a more critical appraisal of the experimental data than has been possible within the present, necessarily broad, overview. An additional benefit of this activity is that gaps in the experimental data might emerge and this knowledge may improve the utility of future test programmes. Certainly the extrapolation of laboratory-scale fire suppression data to the practical situation of fighting a fully-developed post-flashover compartment fire containing diverse combustible materials must be carefully scrutinised. The problem with the semi-empirical models which have been reviewed here is that they have received only limited testing by the originator of the method and have often been compared with sparse laboratory-scale data. It would be sensible to put them to a more rigorous and independent test programme against a wider database.

10. CONCLUSIONS AND PROPOSALS FOR FUTURE WORK

The Fire Experimental Unit of the Home Office Fire Research and Development Group are seeking to produce a comprehensive description of the suppression and extinction of Class 'A' fires. As a result of the present literature review it seems that the current state-of-the-art is close to achieving this objective, but there remain certain gaps in the knowledge which need to be addressed by future research.

1. A comprehensive and wide-ranging review of the suppression and extinction of Class 'A' fires has been conducted. The review illustrates clearly the complex nature of the problem, due to variations in fuel type and geometry, compartment geometry and ventilation, spray characteristics and application method etc. It is proposed that this review be used as reference text to answer, as far as possible, the questions posed by the FRDG regarding the use of water sprays for the suppression of compartment fires.
2. The dominant mode of Class 'A' fire suppression has been identified as fuel cooling, although indirect cooling and inertion of the fire atmosphere may also play a role; the latter mechanisms are however more relevant to the initial knockdown of the fire than to its final extinguishment. There is general consensus in the literature that a Class 'A' fire cannot be finally extinguished until the fuel bed is cooled below some critical value, either expressed as a critical surface temperature or as a critical rate of heat flux to be abstracted.
3. Our present understanding of the processes involved during fuel cooling by water impingement is however, far from complete. This is particularly true for materials of low thermal conductivity, which are the most relevant to Class 'A' compartment fires. Although some progress has been made in recent years, much remains to be done particularly in the case of textiles and composite materials. Suppression may be obtained by the mechanisms of flame cooling and flame inertion, but unless the reservoir of thermal energy inside the solid fuel is dissipated, the threat of re-ignition remains. There is clearly scope for the experimental and/or theoretical investigation of this process for commonly-occurring Class 'A' fuels of low thermal diffusivity which are possibly composite in nature.
4. The critical application rate of water ($l.m^{-2}.min^{-1}$) required to secure the extinguishment of a Class 'A' fire has been shown to be a highly variable quantity, depending upon the parameters mentioned in 1. above.
5. Some objective 'consolidation' of the various stands of semi-empirical modelling is also indicated (together with some independent validation tests with more recent empirical data). It would be of interest to run the Fire Demand model for example, in order to simulate some of the most recent FEU experiments on the suppression of Class 'A' compartment fires. A qualitative agreement between the FEU 'three phase' model of extinguishment and some of the FD Model's output has already been observed (Section 7.2.2); by simulating the specific circumstances of the FEU high/low pressure hosereel tests (Reference 32), the three phase suppression/extinction description could be advanced in more quantitative terms. A particularly useful component of the output from the FD Model is an inventory of the suppression water applied, from which may be judged the efficiency of water application and the volume of water vapour generated etc.

6. Given that there is a sudden transition to extinction from flaming combustion (as illustrated in Figure 26), the problem would appear to be amenable to analysis by non-linear modelling techniques (*i.e.* 'catastrophe theory'), which are now routinely used in the study of various natural phenomena, including fire growth phenomena. Any future theoretical analysis of fire extinguishment should consider making use of this mathematical technique.
7. The interaction between water sprays and buoyant fire plumes has been widely studied, particularly in the case of sprays discharging vertically downwards (characteristic of sprinklers); there has also been some data gathered on drop size distributions from these sprinklers. Complex computer algorithms have been developed in order to track the progress of water droplets travelling in high temperature gaseous atmospheres and to estimate the magnitude of air entrainment into these sprays. At present however, there has been no comprehensive study of similar phenomena which occur during normal active fire-fighting operations where the initial droplet trajectories are typically horizontal, or very nearly so. The existing drop size distributions for jet-spray branches are sparse and have not been used to assess the ultimate fate of water droplets during fire-fighting in compartments.
8. There does not appear to be a consensus emerging from the literature on the benefits, or otherwise, of adopting high pressure (> 10 bar, ~ 150 psig) hosereel systems for tackling compartment fires. Some writers cite the advantages of finer sprays coupled with increased 'throws' but others remain sceptical. There would appear to be some scope for further investigation and clarification in this area.
9. Regarding the use of additives in firefighting water, two areas have been identified which might repay further study. Firstly the effectiveness of thickening additives has been reported independently by several authors; the reported benefits included reduced water runoff, reduced time to extinguishment and delayed burnback. The additive trials reported by the FEU to date have not investigated so-called 'viscous water' and it is recommended that future trials do include such agents. Secondly, the possibility that sprayed AFFF can produce chemical flame inhibition has been suggested to explain the rapid knockdown of certain Class 'B' fires in the US. Although FEU compartment fire tests have not confirmed this effect, it is suggested that further research in this area is warranted.
10. Finally, in the longer term, a natural extension of this work would be to consider the suppression and extinction of other classes of fire.

ACKNOWLEDGEMENTS

The authors gratefully acknowledge the sponsorship of the FRDG and the technical assistance of members of the FEU, particularly John Foster, Gary Pearson, Peter Snowden and Martin Fraser. Also thanks to John Brenton of the Edinburgh Fire Safety Engineering Group for the extract from his thesis on the subject of droplet size measurement and to FRS for permission to use photographs from the 'Front Room Fire' test. Finally, thanks to all those in the global 'fire safety community' who responded to our letters, e-mails and fax enquiries during the course of this project.

REFERENCES

1. *Classification of fires*, BS EN 2: 1992, British Standards Institution.
2. *Manual of Firemanship: Book I - Elements of Combustion and Extinction*, Home Office (Fire Department), HMSO, London, 1974.
3. Hirst, R. *Underdown's Practical Fire Precautions*, 3rd edition, Gower Publishing Co. Ltd., 1989.
4. Cox, G., ed. *Combustion Fundamentals of Fire*, Academic Press, 1995.
5. Grant, G. B. & Drysdale, D. D. A Review of the Extinction Mechanisms of Diffusion Flame Fires, Home Office Fire Research and Development Group, FRDG Publication No.6/96.
6. Drysdale, D. D. *An Introduction to Fire Dynamics*, John Wiley, 1985.
7. Williams, F. A. Mechanisms of Fire Spread, 16th Symp. (International) on Combustion, The Combustion Institute, Pittsburgh, pp.1281-1294, 1976.
8. *Manual of Firemanship-A Supplement: The Behaviour of Fire-Compartment Fires*, Home Office (Fire and Emergency Planning Department), HMSO, London, 1995.
9. Fristrom, R.M. Combustion Suppression, *Fire Research Abstracts and Reviews*, 9, pp.125-160, 1967.
10. Herterich, O. Water as an Extinguishing Agent, Application and Technology in the Field of Fire Protection, Library of the Science of Fire protection and Related Areas, The Dr. Alfred Hüthig Publishing Company, Heidelberg, 1960.
11. Clarke, S. H. 1961 Fire Research, *Fire Research Abstracts and Reviews*, 3, pp.67-75.
12. Hird, D., Pickard, R.W., Fittes, D.W. & Nash, P. The Use of High and Low Pressure Water Sprays Against Fully Developed Room Fires, F.R. Note No.388, Fire Research Station, Borehamwood, March 1959.
13. Jones, A. & Nolan, P.F., Discussions on the Use of Fine Water Sprays or Mists for Fire Suppression, *J. Loss Prev. Process Ind.*, 8(1), pp.17-22, 1995.
14. Lefebvre, A. H. *Atomization and Sprays*, Hemisphere Publishing, London, 1989.
15. Mugele, R. & Evans, H.D., Droplet Size Distributions in Sprays., *Ind. Eng. Chem.*, 43(6), pp.1317-1324, 1951.
16. Fraser, R. P. & Eisenklam, P. Liquid Atomization and the Drop Size of Sprays, *Trans. IChemE*, 34, pp.294-319, 1956.
17. Grimwood, P. T. *Fog Attack*, FMD International Publications Ltd., 1992.
18. *Proceedings of the First International Conference on Fire Suppression Research*, Stockholm and Borås, Sweden, May 5-8, 1992. Editors Sjölin, V., Evans, D. D. & Jason, N. H., Swedish Fire Protection Board, U.S. Department of Commerce, National Institute of Standards and Technology.

19. Turner, A.R.F. Water Mist in Marine Applications, *Water Mist Fire Suppression Workshop, March 1-2, 1993: Proceedings*, NISTIR 5207, National Institute of Standards and Technology, Gaithersburg, USA, June 1993.
20. Simpson, T. & Smith, D.P., A Fully Integrated Water Mist Fire Suppression System for Telecommunications and other Electronics Cabinets, *Water Mist Instead of Halon?: International Conference on Water Mist Fire Suppression Systems*, Borås, Sweden, November 4-5, 1993.
21. Back, G.G. Progress Report: Water Mist Fire Suppression System Technologies, *SFPE Bulletin - Fall 1995*, pp.11-18, 1995.
22. NFPA 750, Standard for the Installation of Water Mist Fire Suppression Systems, National Fire Protection Association, Quincy, MA, Draft, 5th May 1995.
23. Ramsden, N. Water mist - a status update, *Fire Prevention*, 287, March 1996, pp.16-20.
24. Mawhinney, J.R., Dlugogorski, B.Z. & Kim, A.K. A Closer Look at the Fire Extinguishing Properties of Water Mist, *Fire Safety Science - Proceedings of the Fourth International Symposium*, pp.47-60, 1995?
25. Smith, D.P. *Water Mist Fire Suppression Systems*, BFPSA Post Halon Era: One-Day Symposium Presented by The British Fire Protection Systems Association, Fire Research Station, 19th April 1994.
26. Hoare, E. R. The Development of Spraying Machines in this Country and Overseas and Methods of Assessing their Performance, *Journal of the Institution of British Agricultural Engineers*, No.4, Vol.X, Summer 1954, pp.3-23
27. Rimen, J. G. An Appraisal of Jet/Spray Branches; Part 1: Hydraulic Performance, Home Office SRDB, Publication 18/82.
28. Rimen, J. G. An Appraisal of Jet/Spray Branches; Part 2: Handling, Robustness and Maintenance, Home Office SRDB, Publication 66/83.
29. Rimen, J. G. An Appraisal of Jet/Spray Branches; Part 3: Summary and Guide to Parts 1 and 2, Home Office SRDB, Publication 67/83.
30. Rimen, J. G. An Appraisal of Jet/Spray Branches (Supplement to Research Report Number 22), Home Office SRDB, Research Report No. 28, 1986.
31. Theobald, C.R. The Design of a General Purpose Fire-Fighting Jet and Spray Branch, *Fire Safety Journal*, 7, 1984, pp.177-190.
32. Rimen, J.G. The Use of High Pressure and Low Pressure Pumps with Hosereel Systems, Home Office SRDB, Research Report No. 36, 1990.
33. Extinguishing Room Fires with High and Low Pressure Water Sprays: JFRO Tests, *Fire Protection Review*, May 1960, pp.358-360.
34. Johnson, B. F23.17 - Fire-fighting Sprays, Work Package 1: Report of Fire Tests carried out up until November 1994.
35. Johnson, B. F23.17 - Fire-fighting Sprays, Work Package 1: Report of Car Fire Tests carried out on 7 February 1995 using IFEX Water Gun and a Hosereel Branch.

36. Merrington, A.C. & Richardson, E.G. The Break-Up of Liquid Jets, *Proc. Phys. Soc. London*, 59(33), 1947, pp.1-13.
37. Hrubecky, H.F. Experiments in Liquid Atomisation by Air Streams, *J. Applied Physics*, 29(3), March 1958, pp.572-578.
38. Ranz, W.E. *On Sprays and Spraying: A Survey of Spray Technology for Research and Development Engineers - Part I*, Department of Engineering Research, The Pennsylvania State University, University Park, Pennsylvania, March 1956.
39. Euteneuer, G.A. 1957 Druckabhängigkeit von Wurfweite und Tropfengröße bei Sprühstrahlen, *VFDB-Z*, 6, pp.124-128.
40. Güttler, E. Normal Pressure v. High Pressure: A Comparison, Rosenbauer Fire Engineering Works, Linz, Austria, (date etc.?)
41. Thomas, P.H. & Smart, P.M.T. The Throw of Water Sprays, *JFRO Note No. 168*, May 1955.
42. Yule, A.J., Ereaut, P.R. & Ungut, A. Droplet Sizes and Velocities in Vaporising Sprays, *Combustion and Flame*, 54, pp.15-22, 1983.
43. Rasbash, D.J. The Extinction of Fires by Water Sprays, *Fire Research Abstracts and Reviews*, 4(1,2), pp.28-53, 1962.
44. Rasbash, D.J. Heat Transfer Between Water Sprays and Flames of Freely Burning Fires, *Proceedings of the Symposium on the Interaction between Fluids and Particles*, London, 20-22 June, 1962, pp.217-223.
45. McCaffrey, B.J., Jet Diffusion Flame Suppression Using Water Sprays - An Interim Report, *Comb. Sci. and Tech.*, 40, pp.107-136, 1984.
46. McQuaid, J. Examination of Entrained Air-Flow Rate Data for Large-Scale Water Spray Installations, Health and Safety Executive, Technical Paper 1, 1978.
47. McQuaid, J. The Design of Water-Spray Barriers for Chemical Plants, 2nd *International Loss Prevention Symposium*, Heidelberg September 6th-9th, Dechema Frankfurt, 1977.
48. Beyler, C.L. *The Interaction of Fire and Sprinklers*, Department of Fire Protection Engineering Report, University of Maryland, 1977.
49. Alpert, R.L. & Delichatsios, M.M. *Calculated Interaction of Water Droplet Sprays with Fire Plumes in Compartments*, National Bureau of Standards, NBS-GCR-86-520, 1986.
50. Heskestad, G. *Sprinkler/Hot Layer Interaction*, National Institute of Standards and Technology, NIST-GCR-91-590, 1991.
51. Alpert, R.L. Modeling of Sprinkler Spray Suppression of Fires, *Proc. 1st Int. Conf. on Fire Suppression Research*, Stockholm and Borås, Sweden, May 5-8, 1992. Editors Sjölin, V., Evans, D. D. & Jason, N. H., Swedish Fire Protection Board, U.S. Department of Commerce, National Institute of Standards and Technology, pp.245-260.

52. Jackman, L.A. and Nolan, P.F. Investigation into the Effect of Wind on Fire Protection Sprayers, using the Model SPLASH, *I. Chem. E. Symposium Series*, No.134, pp.415-440.
53. Jackman, L.A., Nolan, P.F., Gardiner, A.J. & Morgan, H.P. Mathematical Model of the Interaction of Sprinkler Spray Drops with Fire Gases, *Proc. 1st Int. Conf. on Fire Suppression Research*, Stockholm and Borås, Sweden, May 5-8, 1992. Editors Sjölin, V., Evans, D. D. & Jason, N. H., Swedish Fire Protection Board, U.S. Department of Commerce, National Institute of Standards and Technology, pp.209-227.
54. Hoffmann, N.A. & Galea, E.R. The Mathematical Modelling of Two-Phase Fire-Sprinkler Interaction, *Proc. 5th European Conf. On Mathematics in Industry*, Lahti, Finland, 1991, pp.249-253.
55. Hoffmann, N.A. & Galea, E.R. An extension of the fire-field modelling technique to include fire-sprinkler interaction - I: The mathematical basis, *Int. J. Heat Mass Transfer*, **36**(6), pp.1435-1444, 1993.
56. Hoffmann, N.A. & Galea, E.R. An extension of the fire-field modelling technique to include fire-sprinkler interaction - II: The simulations, *Int. J. Heat Mass Transfer*, **36**(6), pp.1445-1457, 1993.
57. Fthenakis, V.M., Schatz, K.W., Rohatgi, U.S. & Zakkay, V. Computation of Flow Fields Induced by Water Spraying of an Unconfined Gaseous Plume, *Trans. ASME - Journal of Fluids Engineering*, **115**, pp.742-750.
58. Bejan, A. *Heat Transfer*, John Wiley & Sons Inc., 1993
59. Coleman, E.H. The Cooling Effects of Water and Carbon Dioxide, Fire Offices' Committee, Fire Protection Association, Journal Reprint No.2, February 1949.
60. Grin, G.V. & Sergeev, V.S. Heat Transfer Between a High-Temperature Flame and Sprayed Water, *High Temperature - USSR*, **22**(4), pp.609-612, 1984.
61. Ranz, W.E. & Marshall, W.R. Evaporation from Drops, *Chem. Engng. Progr.*, **48**, 141-146; 173-180, 1952.
62. Kincaid, D.C. & Longley, T.S. A Water Droplet Evaporation and Temperature Model, *Transactions of the ASAE*, **32**(2), pp.457-463, 1989.
63. Kucherov, A.N. Régimes of Evaporation of a Drop of a Water Aerosol, *High Temperature - USSR*, **29**(1), pp.135-142, 1991.
64. Ferron, G.A. & Soderholm, S.C. Estimation of the Evaporation or Stabilisation Times of Water Droplets, *J. Aerosol Sci.*, **18**(6), pp.639-642, 1987.
65. Sadd, P.A., Lamb, J.A. & Clift, R. The Effect of Surfactants on Heat and Mass Transfer to Water Drops in Air, *Chemical Engineering Science*, **47**(17/18), pp.4415-4424, 1992.
66. Rubel, G.O. Steady-State Temperature of an Evaporating Water Droplet with a Monolayer Coating, *J. Appl. Phys.*, **67**(10), pp.6085-6087, 1990.
67. Reiners U., Jeschar, R., Scholz, R., Zebrowski, D. & Reichelt, W. A Measuring Method for Quick Determination of Local Heat Transfer Coefficients in Spray

- Water Cooling Within the Range of Stable Film Boiling, *Steel Research*, 56(5), pp.239-246, 1985.
68. Ito, T., Takata, Y. & Mousa, M.M. Studies on the Water Cooling of Hot Surfaces, *JSME Int. Jnl. Series II*, 35(4), pp 589-598, 1992.
 69. Ohnishi, A., Takashima, H. & Hakiri, M. Characteristics of Heat Transfer of Multi Water Spray Nozzle, *Transactions of the Iron and Steel Institute of Japan*, 27(12), 1987.
 70. Koria, S. & Datta, I. Studies on the Behaviour of Mist Jet and its Cooling Capacity of Hot Steel Surface, *Steel Research*, 63(1), pp 19-26, 1992.
 71. Prinz, B. & Bamberger, M. Determination of Heat Transfer Coefficient of Mist Air Sprays, *Materials Science and Technology*, 5(4), pp 389-393, 1989.
 72. Mitsutsuka, M. & Fukuda, K. Cooling Characteristics and Heat Transfer Coefficients during Fog Cooling of Hot Steel Plates, *Transactions of the Iron and Steel Institute of Japan*, 21(10), pp.689-698, 1981.
 73. Ohkubo, H. & Nishio, S. Study on Accurate Prediction of Heat Transfer Characteristics of Mist Cooling, *JSME Int. Jnl. Series II*, 33(2), pp.326-332, 1990.
 74. Makino, K. & Michiyoshi, I. The Behaviour of a Water Droplet on Heated Surfaces, *Int. J. Heat Mass Transfer*, 27(5), pp 781-791, 1984.
 75. Makino, K. & Michiyoshi, I. Discussions of Transient Heat Transfer to a Droplet on Heated Surfaces under Atmospheric Pressure, *Int. J. Heat Mass Transfer*, 30(9), pp.1895-1905, 1987.
 76. Rymkiewicz, J. & Zapalowicz, Z. Analysis of the Evaporation Process for Water Droplet on Flat Heated Surface, *Int. Comm. Heat Mass Transfer*, 20, pp 687-697, 1993.
 77. Trehan, A.K., di Marzo, M. & Evans, D.D. Transient Cooling of a Hot Surface by Droplet Evaporation, *Chemical and Physical Processes in Combustion: 1985 Fall Meeting. Eastern Section of the Combustion Institute*, Philadelphia, November 4-6, 1985.
 78. di Marzo, M. & Trehan, A.K. *Transient Cooling of a Hot Surface by Droplets Evaporation*, Mechanical Engineering Dept., University of Maryland, NBS Report NBS-GCR-86-516, July 1986.
 79. di Marzo, M. & Evans, D.D. *Evaporation of a Water Droplet Deposited on a Hot High Thermal Conductivity Solid Surface*, Mechanical Engineering Dept., University of Maryland, NBS Report NBIR 86-3384, August 1986.
 80. di Marzo, M. & Evans, D.D. Evaporation of a Water Droplet Deposited on a Hot High Thermal Conductivity Solid Surface, *Transactions of the ASME: Journal of Heat Transfer*, 111, pp 210-213, February 1989.
 81. di Marzo, M. Dropwise Evaporative Cooling, ATTI 13 Congresso Nazionale Sulla Trasmissione Del Calore, 13 Unione Itallana Di Thermofluidodinamica National Heat Transfer Conference, 22-23 Giugno 1995, Bologna, Italy.

82. Ravigururajan, T.S. & Beltran, M.R. A Model for Attenuation of Fire Radiation Through Water Droplets, *Fire Safety Journal*, **15**, pp.171-181, 1989.
83. Coppalle, A., Nedelka, D. & Bauer, B. Fire Protection: Water Curtains, *Fire Safety Journal*, **20**, pp.241-255, 1993.
84. Buchlin, J-M. & Prétrel, H. Atténuation de Sources Thermiques Radiatives par Rideaux d'Eau, *European Commission, Industrial Fires II: Workshop Proceedings*, 17-18 May 1994, Cadarache, France.
85. Murrell, J.V., Crowhurst, D. & Rock, P. Experimental Study of the Thermal Radiation Attenuation of Sprays from Selected Hydraulic Nozzles, *Halon Options Technical Working Conference: Proceedings*, 9-11 May 1995, Albuquerque, NM.
86. Log, T. Radiant Heat Attenuation in Fine Water Sprays, *Conference Proceedings: Interflam '96, Seventh International Fire Science and Engineering Conference*, 26-28 March, St. John's College, Cambridge, England, pp.425-434.
87. Reischl, U. Water Fog Stream Heat Radiation Attenuation, *Fire Technology*, **15**(4), pp.262-270, 1979.
88. Kaleta, A. Effect of Drop Size on Extinguishing Effectiveness of a Water Spray, *Archivum Combustionis*, **6**(3-4), 1986, pp.201-212.
89. Hayes, W.D. Jr. *Literature Survey on Drop Size Data, Measuring Equipment, and A Discussion of the Significance of Drop Size in Fire Extinguishment*, National Bureau of Standards, NBSIR 85-3100-1, 1985.
90. Bowen, I.G. & Davies, G.P. Report ICT28, Shell Research Ltd., London, 1951.
91. Allen T. *Particle Size Measurement*, Chapman and Hall, Fourth Edition, 1990.
92. Mason, B.J. *The Physics of Clouds*, Oxford at the Clarendon Press, 1957.
93. Wiesner, J. Beiträge zur Kenntnis des tropisches Regens, *Ber. Akad. Wiss, Wien*, **104**, p.1397, 1895.
94. Niederdorfer, E. Messungen der Größe der Regentropfen, *Met. Z.*, **49**, p.1, 1932.
95. Blanchard, D.C. *The Use of Sooted Screens for Determining Raindrop Size and Distribution*, G.E. Res. Lab., Project Cirrus, Occ. Rep. No.16, 1949.
96. Bentley, W.A. Studies of Raindrops and Raindrop Phenomena, *Mon. Wea. Rev.*, **32**, p.450, 1904.
97. Laws, J. O. & Parsons, D.A. The Relation of Raindrop Size to Intensity, *Trans. Amer.Geophys. Un.* **24**, p.452 1943.
98. Blanchard, D.C. The Distribution of Raindrops in Natural Rain, G.E. Res. Lab., Project Cirrus, Occ. Rep. No.15, 1949.
99. Gordon B. Water Spray Interaction with Air-Steam Mixtures, *Experimental Thermal and Fluid Science*, **4**, 698-713, 1991.
100. Schindelbauer, F. Versuch einer Registrierung der Tropfenzahl bei Regenfällen, *Met. Z.* **42**, **25**, p.428, 1925.
101. Mie, G. *Annalen der Physik* (4), **25**, p.377, 1908.

102. Van der Hulst, H.C. *Light Scattering by Small Particles*, Wiley, New York, 1957.
103. Kerker, M. *The Scattering of Light and other Electromagnetic Radiation*, Academic Press, New York (1969).
104. Glantschnig, W.J. & Chen, Sow-Hsin. Light Scattering from Water Droplets in the Geometrical Optics, *Applied Optics (USA)*, 20(14), 1981.
105. *Experimental and Computational Techniques For Dispersed Two-Phase Flow* Course Notes. Imperial College of Science Technology, and Medicine, London. 20th September 1990.
106. Yule A.J. Measurement Needs and Problems in Spray Technology, presented at UK Association of Laser Anemometry meeting *Laser Measurements for Spray Characterisation* at AEA Technology, Harwell, 20th January 1993.
107. Jackman L.A. Sprinkler Spray Interactions with Fire Gases, PhD thesis, South Bank University, 1992.
108. Tak-Sang Chan. Measurements of Water Density and Drop Size Distributions of Selected EFSR Sprinklers, *J. of Fire Prot. Engr.*, 6(2), 1994.
109. Yu H-Z. & Symonds A.P. *Sprinkler Drop-Size Measurements, Part I: An investigation of the FMRC PMS Drop-Size measuring System*, FMRC Technical Report, J.I. 0G1E7 RA, 1982.
110. Jones A.R., Sarjeant M., Davis C.R. & Denham R.O. Application of In-line Holography to Drop-Size Measurement in Dense Fuel Sprays, *Applied Optics* 17, 3, February I, 1978.
111. Sapko M.J., Furno A.L. & Kuchta J.M. *Quenching Methane-Air Ignitions with Water Sprays*, Report of Investigations: RI-8214 (U.S. Department of the Interior) 1977.
112. Dobbins, R.A. & Crocco, L. Measurement of Mean Particle Sizes of sprays from Diffractively Scattered Light, *AIAA J.*, 1(8), pp 1882-1886, 1963.
113. Pozhnarov, V.A. Measurement of Droplet Size Spectrum in Two-Phase Flows from Low-Angle Light Scattering. *Fluid Mechanics - Soviet Research* 4(5), September-October 1975.
114. Bachalo, W.D. & Hess, C.F. *Optical Diagnostics Techniques for Particulate and Turbulence Measurements in Combustion Research*, The Combustion Institute, Western States Section, 1980 Spring Meeting.
115. Hess, Cecil F. Non-Intrusive Optical Single-Particle Counter for Measuring the Size and Velocity of Droplets in a Spray. *Applied Optics*, 23(23), 1st December 1984.
116. Durst, F. & Umhauer H. Local Measurement of Particle Velocity, Size Distribution and Concentration with a Combined Laser Doppler Particle Sizing System. *Proceedings of the LDA-Symposium*. Copenhagen, 1975.
117. Yule, A.J., Chigier, N.A., Atakan S. & Ungut A., Particle Size and Velocity Measurement by Laser Anemometry. *J. Energy*, 1, pp.220-228, 1977.

118. Ungut, A.J., Yule, A.J., Taylor, D.S. & Chigier, N.A. Simultaneous Velocity and Particle Size Measurement in Two-Phase Flow by Laser Anemometry, *AIAA 16th Aerospace Sciences Meeting*. Paper 78-74, Huntsville, Alabama, 1978.
119. Ragucci R., Cavaliere, A. & Massoli P. Drop-sizing by Laser Light Scattering Exploiting Intensity Angular Oscillation in the Mie Régime, *Part. Part Syst. Charact.*, 7, pp.221-225, 1990.
120. Roth N., Anders K. & Frohn A. Determination of Size, Evaporation Rate and Freezing of Water Droplets Using Light Scattering and Radiation Pressure., *Part. Part. Syst. Charact.* 11, pp.207-211, 1994.
121. Brenton J.R. A Study of the Mutual Interaction Between Water Droplets and Burner Flames, M.Phil. Thesis, University of Wales, 1992.
122. Rasbash, D.J. Relevance of Firepoint Theory to the Assessment of Fire Behaviour of Combustible Materials, *International Symposium: Fire Safety of Combustible Materials, Edinburgh October 1975*, University of Edinburgh.
123. Bryan, J. *Engineering*, 159, p.457, 1945.
124. Beyler, C. A Unified Model of Fire Suppression, *Journal of Fire Protection Engineering*, 4(1), pp.5-16, 1992.
125. Fuchs, P. On the Extinguishing Effect of Various Extinguishing Agents and Extinguishing Methods with Different Fuels, *Fire Safety Journal*, 7(2), pp.165-175, 1984.
126. Fendell, F.E. Ignition and Extinction in Combustion of Initially Unmixed Reactants, *Journal of Fluid Mechanics*, 21(2), pp.281-303, 1965.
127. Williams, F.A. A Unified View of Fire Suppression, *Journal of Fire & Flammability*, 5, pp.54-63, 1974.
128. Williams, F.A. A Review of Flame Extinction, *Fire Safety Journal*, 3, pp.163-175, 1981.
129. Thorne, P.F. The Physics of Fire Extinguishment, *Physics in Technology*, 16(6), pp.263-268, 1985.
130. Corlett, R.C. & Williams, F.A. Modeling Direct Suppression of Open Fires, *Fire Research*, 1, pp.323-337, 1978/79.
131. Levine, R.S. Proceedings: Ad Hoc Mathematical Fire Modeling Working Group, *Fire Technology*, 20(2), pp.47-63, 1984.
132. Hadjisophocleous, G., Kim, A. & Knill, K. Modelling of a Fine Waterspray Nozzle and Liquid Pool Fire Suppression, *Proceedings: International Conference on Fire Research and Engineering*, 10-15 September 1995, Orlando, Florida, pp.389-394.
133. Mawhinney, J. & Hadjisophocleous, G. The Role of Fire Dynamics in Design of Water Mist Fire Suppression Systems, *Proceedings: Interflam 96 - Seventh International Fire Science and Engineering Conference*, 26-28 March 1996, St. John's College, Cambridge, England, pp.415-424.

134. Friedman, R. Behaviour of Fires in Compartments, *International Symposium: Fire Safety of Combustible Materials*, University of Edinburgh, October 1975, pp.100-113.
135. Friedman, R. Aerothermodynamics and Modelling Techniques for Prediction of Plastic Burning Rates, *Journal of Fire and Flammability*, 2, pp.240-256, 1971.
136. Bullen, M. L. A Combined Overall and Surface Energy Balance for Fully Developed Ventilation Controlled Liquid Fuel Fires in Compartments, *Fire Research*, 1, 171-185, 1975.
137. Bullen, M. L. & Thomas, P. H. Compartment Fires with Non-Cellulosic Fuels, *17th Symposium (International) on Combustion*, The Combustion Institute, Pittsburgh, pp.1139-1148, 1979.
138. Jones, W. W. A Review of Compartment Fire Models, NBSIR 83-2684, National Bureau of Standards, Washington, DC, April 1983.
139. Pettersson, O., Magnusson, S. E. & Thor, J. Fire Engineering Design of Structures, Swedish Institute of Steel Construction, Publication 50, 1976.
140. Babrauskas, V. & Williamson, R. B. Post-flashover Compartment Fires: Basis of a Theoretical Model, *Fire and Materials*, 2, pp.39-53, 1978.
141. Babrauskas, V. & Williamson, R. B. Post-flashover Compartment Fires: Application of a Theoretical Model, *Fire and Materials*, 3, pp.1-7, 1979.
142. Pitts, W. M. The Global Equivalence Ratio Concept and the Formation of Mechanisms of Carbon Monoxide in Enclosure Fires, *Prog. Energy Combust. Sci.*, 21, pp.197-237, 1995.
143. Pietrzak, L.M. & Johanson, G.A. Directions for Improving Manual Fire Suppression Using a Physically Based Computer Simulation, *Fire Technology*, 22(3), pp.184-209, 1986.
144. Pietrzak, L.M. & Dale, J.J. User's Guide for the Fire Demand Model, Mission Research Corporation, MRC-R-1364 Final, Grant No. NIST 6ONANBODI050, April 1992.
145. Pietrzak, L.M. Recent Research and Future Requirements for Modelling Fire Suppression Effectiveness, *Proc. 1st Int. Conf. on Fire Suppression Research*, Stockholm and Borås, Sweden, May 5-8, 1992. Editors Sjölin, V., Evans, D. D. & Jason, N. H., Swedish Fire Protection Board, U.S. Department of Commerce, National Institute of Standards and Technology, pp.261-281.
146. Williams, F.A. Scaling Mass Fires, *Fire Research Abstracts and Reviews*, 11, pp.1-22, 1969.
147. Spalding, D.B. The Art of Partial Modeling, *Ninth Symposium (International) on Combustion*, pp.833-843, Academic Press, New York, 1963.
148. Quintiere, J.G. Scaling Applications in Fire Research, *Fire Safety Journal*, 15, pp.3-29, 1989.

149. Braidech, M.M., Neale, J.A., Matson, A.F. & Dufour, R.E. *The Mechanism of Extinguishment of Fire by Finely Divided Water*, Research Report No.10, National Board of Fire Underwriters, New York, 1955.
150. Rasbash, D.J., Rogowski, Z.W. & Stark, G.W.V. Mechanisms of Extinction of Liquid Fires with Water Sprays, *Combustion and Flame*, 4, pp.223-234, 1960.
151. Bryan, J. & Smith, D.N. The Effect of Chemicals in Water Solutions on Fire Extinction, *Engineering*, 159, p.457, 1945.
152. Heskestad, G. The Role of Water in Suppression of Fire: A Review, *Journal of Fire and Flammability*, 11, pp.254-262, 1980.
153. Kida, H. Extinction of Fires of Small Wooden Crib with Sprays of Water and Some Solutions, Report of Fire Research Institute of Japan, No.36, 1973.
154. Kung, H.C. & Hill, J.P. Extinction of Wood Crib and Pallet Fires, *Combustion and Flame*, 24, pp.305-317, 1975.
155. Tamanini, F. A Study of the Extinguishment of Vertical Wooden Slabs in Self-Sustained Burning by Water Application, *Combustion Science and Technology*, 14, pp.1-15, 1976.
156. Tamanini, F. The Application of Water Sprays to the Extinguishment of Crib Fires, *Combustion Science and Technology*, 14, pp.17-23, 1976.
157. Stolp, M. The Extinction of Small Wood Crib Fires by Water, 5th International Fire Protection Seminar, Karlsruhe, 22-24 September 1976, pp.127-141.
158. Takahashi, S. Experiments and Theory in the Extinction of a Wood Crib, *Fire Safety Science - Proceedings of the First International Symposium*, 1985, pp.1197-1206.
159. Scheffey, J.L. & Williams, F.W. The Extinguishment of Fires Using Low Flow Water Hose Streams-Part I, *Fire Technology*, 27(2), pp.128-144, May 1991.
160. Andrews, S.P. *Fire Extinguishing with Water Sprays: Preliminary Tests*, Building Research Establishment Note N162/92, August 1992.
161. Bhagat, P.M. Extinguishment of Burning Wood Charcoal Surfaces, *Fire Safety Journal*, 3(1), pp.47-53, 1980.
162. Magee, R.S. & Reitz, R.D. Extinguishment of Radiation Augmented Plastic Fires by Water Sprays, *Fifteenth Symposium (International) on Combustion*, The Combustion Institute, Pittsburgh, pp.337-347, 1975.
163. Takahashi, S. Extinguishment of Plastics Fires with Plain Water and Wet Water, *Fire Safety Journal*, 22(2), pp.169-179, 1994.
164. Yang, J.C., Boyer, C.I. & Grosshandler, W.L. *Minimum Mass Flux Requirements to Suppress Burning Surfaces with Water Sprays*, NISTIR 5795, Building and Fire Research Laboratory, National Institute of Standards and Technology, April 1996.
165. ISO 5660, Fire Tests - Reaction to Fire - Rate of Heat Release from Building Products, International Standards Organisation, Geneva, Switzerland, 1991.
166. Dlugogorski, B., Mawhinney, J.R. & Duc, V.H. The Measurement of Heat Release Rates by Oxygen Consumption Calorimetry in Fires Under Suppression,

- Fire Safety Science - Proceedings of the Fourth International Symposium, Ottawa, Ontario, 13-17 June 1994, pp.877-888.
167. Przybyla, L. & Ghandi, P. The Results are in on Flammable Liquids in Plastic Containers. *Fire Journal*, 84, 3, May/June 1990, pp.38-39, 41-43.
 168. Lee, J.L. Extinguishment of Rack Storage Fires of Corrugated Cartons Using Water, *Fire Safety Science - Proceedings of the First International Symposium*, 1985, pp.1177-1186.
 169. Kung, H.C., You, H.Z., Brown, W.R. & Vincent, B.G. Four-Tier Array Rack Storage Fire Tests with Fast Response Prototype Sprinklers, *Fire Safety Science - Proceedings of the Second International Symposium*, 1988, pp.633-642.
 170. Which Sprinkler Will Best Protect Your Warehouse? *Record*, March/April 1991.
 171. Nash, P. & Rasbash, D.J. The Use of Water to Extinguish Fire, *The Institution of Fire Engineers Annual Report*, pp.93-116, 1955.
 172. Layman, L. *Attacking and Extinguishing Interior Fires*, Boston, 1952.
 173. Thomas, P.H. & Smart, P.M.T. The Extinction of Fires in Enclosed Spaces, F.R. Note No. 86/1954, Fire Research Station, Borehamwood.
 174. Rasbash, D.J. & Thomas, P.H. Water Sprays for Fires in Rooms, Joint Fire Research Organisation - Draft for Discussion at Meeting on 14th February 1955, Fire Research Station, Borehamwood.
 175. Extinguishing Room Fires with High and Low Pressure Water Sprays: JFRO Tests, *Fire Protection Review*, pp.358-360, May 1960.
 176. Salzberg, F., Vodvarka, F.J. & Maatman, G.L. Minimum Water Requirements for Suppression of Room Fires, *Fire Technology*, 6(1), pp.22-28, 1970.
 177. Liu, S.T. Analytical and Experimental Study of Evaporative Cooling and Room Fire Suppression by Corridor Sprinkler System, NBSIR 77-1287, Center for Fire Research, National Bureau of Standards, October 1977.
 178. You, H.Z., Kung, H.C. & Han, Z. Spray Cooling in Room Fires, *Twenty-First Symposium (International) on Combustion*, The Combustion Institute, Pittsburgh, pp.129-136, 1986.
 179. Kokkala, M.A. Extinguishment of Compartment Fires using Portable Chemical Extinguishers and Water, *Fire Safety Journal*, 11(3), pp.201-209, 1986.
 180. Takahashi, S. A Theoretical Study on the Requirements of Water Application for a Compartment Fire Extinction, *Bull. Japanese Assoc. Fire Sci. Eng.*, 34, pp.1-5, (in Japanese, abstract in English), 1984.
 181. Milke, J., Evans, D. & Hayes, W.Jr. *Water Spray Suppression of Fully-Developed Wood Crib Fires in a Compartment*, NBSIR 88-3745, National Bureau of Standards, June 1988.
 182. Stroup, D.W. & Evans, D.D. Suppression of Post-Flashover Compartment Fires Using Manually Applied Water Sprays, NISTIR 4625, Building and Fire Research Laboratory, National Institute of Standards and Technology, July 1991.

183. Scheffey, J.L. & Williams, F.W. The Extinguishment of Fires Using Low Flow Water Hose Streams-Part II, *Fire Technology*, 27(4), pp.291-320, November 1991.
184. Alternative Arrangements for Halon Fire-Extinguishing Systems in Machinery Spaces and Pump Rooms, International Maritime Organization, MSC/Circ.668, 30th December 1994.
185. Wighus, R., *Active Fire Protection-Extinguishment of Enclosed Gas Fires with Water Sprays*, SINTEF Report No. STF25 A91028, June 1991.
186. Carhart, H.W., Sheinson, R.S., Tatem, P.A. & Lugar, J.R. Fire Suppression Research in the U.S. Navy, *Proc. 1st Int. Conf. on Fire Suppression Research*, Stockholm and Borås, Sweden, May 5-8, 1992. Editors Sjölin, V., Evans, D. D. & Jason, N. H., Swedish Fire Protection Board, U.S. Department of Commerce, National Institute of Standards and Technology, pp.337-357.
187. Simpson, T.; Smith, D.P., *A Fully Integrated Water Mist Fire Suppression System for Telecommunications and other Electronics Cabinets*, Water Mist Instead of Halon?: International Conference on Water Mist Fire Suppression Systems, Borås, Sweden, November 4-5, 1993.
188. Mawhinney, J.R. Water-Mist Fire Suppression Systems for the Telecommunication and Utility Industries, *Fire Research News*, National Fire Laboratory, National Research Council Canada, Fall 1994.
189. Wighus, R., Aune, P., Drangsholt, G. & Stensaas, J.P. *Full Scale Water Mist Experiments*, Water Mist Instead of Halon?: International Conference on Water Mist Fire Suppression Systems, Borås, Sweden, November 4-5, 1993.
190. Jones, A. & Thomas, G.O. The Action of Water Sprays on Fires and Explosions: A Review of Experimental Work, *Trans. IChemE.*, 71(B), pp.41-49, 1993.
191. van Wingerden, C.J.M. Water Sprays for Mitigation of Gaseous Explosions in Offshore Modules, *EuropEx Newsletter*, Edition 24, pp.4-7, 10-11, March 1994.
192. Mawhinney, J.R., Engineering Criteria for Water Mist Fire Suppression Systems, *Water Mist Fire Suppression Workshop, March 1-2, 1993: Proceedings*, NISTIR 5207, National Institute of Standards and Technology, Gaithersburg, USA, June 1993.
193. Wighus, R., Engineering Relations for Water Mist Fire Suppression Systems, *Proceedings of the 1995 Halon options Technical Working Conference*, Albuquerque, New Mexico, May 1995.
194. Massey, B.S. *Mechanics of Fluids*, 4th edition, Van Nostrand Reinhold, 1979.
195. Rosander, M. & Giselsson, K. Making the Best Use of Water for Extinguishing Purposes, *FIRE*, October 1984, pp.43-46.
196. Geyler, G.B. Firefighting Effectiveness of Aqueous-Film-Forming-Foam (AFFF) Agents, Technical Report ASD-TR-73-13, National Aviation Facilities Experimental Center Atlantic City, New Jersey, April 1973.
197. Hems, P. The Increasing Use of Water Spray Systems, *Fire Surveyor*, August 1979, pp.21-27.

198. Biiggs, A.A. & Abdo, B. Spreading of AFFFs and Fire Extinction, PD 15/88, Fire Research Station, 1988.
199. Johnson, B.P. Additives for Hosereel Systems: Trials of Foam on Wooden Crib Fires, FRDG Publication No. 3/91, 1991.
200. Johnson, B.P. Additives for Hosereel Systems Summary Report, FRDG Research Report No. 46, 1992.
201. Tinker, S., di Marzo, M., Tartarini, P., Chandra, S. & Quiao, Y.M. Dropwise Evaporative Cooling: Effect of Dissolved Gases and Effect of Surfactants, *Proceedings: International Conference on Fire Research and Engineering*, 10-15 September 1995, Orlando, Florida, USA.
202. Kudritskii, S.B., Chaichuk, S.A. & Dmitrieva, E.M. A Study of the Adsorption of Soluble Surfactants and their Influence on the Evaporation of Water Drops, *Colloid Journal USSR*, 43(4), 1981, pp.625-630.
203. Grove, C.S., Jr., Grove, S.T. & Aidun, A.R. Improving the Effectiveness of Water for Fire Fighting, *Fire Research Abstracts and Reviews*, 4(1-2), 1962, pp.54-66.
204. Bouse, L.F., Carlton, J.B. & Jank, P.C. Effect of Water Soluble Polymers on Spray Droplet Size, *Trans. of the ASAE*, 31(6), 1988, pp.1633-1641, 1648.
205. Reiner, J. New Additives to Extinguishing Water for Fire Fighting, *New Technology to Reduce Fire Losses and Costs*, Luxembourg, 1986, Editors: Grayson, S.J. & Smith, Chap. 35, pp.280-287.
206. Hardy, C.E., Rothermel, R.C. & Davis, J.B. *Evaluation of Forest Fire Retardants: A Test of Chemicals on Laboratory Fires*, Research Paper 64, Intermountain Forest and Range Experiment Station, Forest Service, US Dept. of Agriculture, Ogden, Utah, 1962.
207. Guillaume, C.A. The Use of Chemicals in Forest Fire Suppression, *Forest Fire Prevention and Control*, Warsaw, 1982, Editor: Vannad, T., Chap. 27, pp.159-163.
208. Thorne, P.F. *Drag Reduction in Fire-Fighting*, Building Research Establishment Current Paper, CP 70/75, 1975.
209. Thorne, P.F. & Jordan, K. *Preliminary Experiments on the Use of Water Additives for Friction Reduction in Fire Hoses*, Fire Research Note No.959, Fire Research Station, February 1973.
210. Guise, A.B. The Chemical Aspects of Fire Extinguishment, *Quarterly of the National Fire Protection Association*, 53, pp.330-336, 1961.
211. Friedman, R. Survey of Chemical Inhibition in Flames, *Fire Research Abstracts and Reviews*, 3, pp.128-132, 1961.
212. Kida, H. Some Statistical Features on Extinction of Small Diffusion Flame of Burning Liquid with Sprays of Several Salt Solutions, *Bulletin of the Fire Prevention Society of Japan*, 18(2), pp.1-8, 1969.

213. Iya, K.S., Wollowitz, S. & Kaskan, W.E. The Mechanism of Flame Inhibition by Sodium Salts, *Fifteenth Symposium (International) on Combustion*, The Combustion Institute, Pittsburgh, pp.329-336, 1975.
214. Ryan, M.W., Smith, A.C. & Lazzara, C.P. A Method to Evaluate the Effectiveness of Coal Fire Extinguishing Agents, *New Technology in Mine Health & Safety*, Phoenix, Arizona, 1992, Editor: Khair, A.W., pp.105-114.
215. Colletti, D.J. Quantifying the Effects of Class 'A' Foam in Structure Firefighting: The Salem Tests, *Fire Engineering*, February 1993, pp.41-44.
216. Thomas, M.D. A Brief Assessment of a Compressed Air Foam System, Home Office Fire Research and Development Group, FRDG Publication No. 1/94, 1994.
217. Tuomisaari, M. Private communication, VTT Building Technology, Finland, October 1996.

LIST OF SYMBOLS

a	fire growth factor (kW s^{-2})
a, b	numerical indices used in general equation for mean drop diameter (-)
A	area (m^2)
	numerator in Spalding's B -number (J kg^{-1})
A_f	plan area of fire (m^2)
A_v	area of ventilation openings in fire compartment (m^2)
B	Spalding's B -number for mass transfer (-)
c	concentration (spray or gas) (kg m^{-3})
c, C_p	specific heat capacity (at constant pressure) ($\text{J kg}^{-1} \text{K}^{-1}$)
C_D	drag coefficient (spray) (-)
C_{Ds}	drag coefficient (single droplet) (-)
d, D	diameter (mm, cm or m)
D	mass diffusivity of water vapour in air ($\text{m}^2 \text{s}^{-1}$)
D, \emptyset	Damköhler number τ_r/τ_c (-)
d_M	main drop size (μm)
E	total heat energy released (J)
	activation energy (J kg^{-1})
Fr	Froude number v^2/gd (-)
g	gravitational acceleration (m s^{-2})
h_a, H	static pressure head (metres water gauge)
H_f	heat transferred by convection from flame to fuel per unit mass of fuel consumed (firepoint equation) (J kg^{-1})
$H_R(\text{O}_2)$	heat produced by combustion per unit mass of oxygen consumed ($\sim 13 \text{ kJ g}^{-1}$ for organic fuels)
I	external heat flux (kW m^{-2})
i, I	intensity of light beam (lux)
k	thermal conductivity ($\text{W m}^{-1} \text{K}^{-1}$)
K	extinction coefficient (-)
l, L	length (m)
L_v	latent heat of evaporation ('heat of gasification' for solid fuels) (kJ g^{-1})
m	relative refractive index (-)
m, M	mass (kg)
\dot{m}	mass burning rate (g s^{-1} , kg min^{-1} etc.)
	mass flow rate in nozzles (kg s^{-1})
\dot{m}''	mass burning rate per unit area ($\text{g m}^{-2} \text{s}^{-1}$, $\text{kg m}^{-2} \text{s}^{-1}$)
\dot{M}	vertical thrust of water spray/fire plume (N)
n	refractive index (-)
N	non-dimensional parameter relating to spray/plume interaction (-)
N_i	number of drops of a given diameter, l
Nu	Nusselt number $\alpha d/k$ (-)
O	total surface area of water spray per unit volume (m^{-1})
p	pressure (bar, Pa)
P_A	aerodynamic (externally-induced) pressure (Pa)
P_d	path difference (m)
P_c	penetration ratio (sprinkler/plume interaction) (-)

P_i	droplet internal pressure (Pa)
P_σ	droplet pressure due to surface tension (Pa)
ΔP	differential pressure (Pa)
Pe	Péclet number vd/α (-)
Pr	Prandtl number $C_p \eta/k$ (-)
\dot{Q}	volume flow rate (l.min^{-1} , Imperial gal.h^{-1})
\dot{Q}	heat release rate (kW)
\dot{Q}''	rate of transfer of thermal energy per unit area (kW.m^{-2})
r, R	radius (m)
r	stoichiometric ratio (-)
R	universal gas constant ($\text{J.kg}^{-1}.\text{K}^{-1}$)
R_a	heat flux received by fuel in addition to convection (firepoint equation) (W.m^{-2})
R_s	heat flux lost to the environment in firepoint equation (W.m^{-2})
R_w	burning rate of wood (linear rate of char production) (mm.min^{-1})
Re	Reynolds number $\rho vd/\eta$ (-)
V	volume (m^3)
ΔR	heat release rate (W)
S	net sensible heat received by fuel per unit surface area (firepoint equation) (W.m^{-2})
	rotation speed (r.p.m.)
S_{tot}	total spray surface area (mm^2)
S_1, S_2	amplitude of scattered light for optical drop sizing ($\text{lux}^{1/2}$)
Sc	Schmidt number v/D (-)
t	time (s)
T	absolute temperature (K)
	spray film thickness (m)
T_r	transmissivity of infrared radiation (-)
ΔT	differential absolute temperature (K)
v, V	velocity (m.s^{-1} , mm.min^{-1} etc.)
V_{tot}	total spray volume (mm^3)
\dot{V}''	water flux ($\text{m}^3.\text{m}^{-2}.\text{s}^{-1}$)
w	average throw of jet/spray (m)
W	volumetric heat transmission of water spray ($\text{W.m}^{-3}.\text{K}^{-1}$)
\dot{W}''	water flux ($\text{l.m}^{-2}.\text{min}^{-1}$ or $\text{l.m}^{-2}.\text{s}^{-1}$)
ΔW	rate of heat abstraction by water application (W)
We	Weber number $\rho atv^2/\sigma$ (-)
x	throw distance of jet/spray (m)
x_1, x_2 etc.	non-dimensional 'controlling parameters' in spray/plume interaction (-)
X	heat transfer capacity of water spray (W.m^{-3})
Y_{O_2}	oxygen mass fraction (-)
Z	non-dimensional jet break-up parameter (-)

Greek symbols

α	heat transfer coefficient ($\text{W.m}^{-2}\text{K}^{-1}$) thermal diffusivity ($\text{m}^2.\text{s}^{-1}$, $\text{cm}^2.\text{s}^{-1}$)
δ	depth of thermal penetration (m) wall thickness (m)
η	absolute (or dynamic) viscosity (N.s.m^{-2} or Pa.s)
θ	interception angle of impinging jet nozzles ($^\circ$) included angle of spray ($^\circ$) half-angle of sprinkler spray envelope ($^\circ$) temperature ($^\circ\text{C}$)
κ	thermal diffusivity of air ($\text{m}^2.\text{s}^{-1}$)
λ	wavelength of infrared radiation (μm)
λ_f	heat required by fuel to produce unit mass of vapour (firepoint equation) (J.kg^{-1})
λ_w	heat-removing capacity of suppression agent in firepoint theory (J.kg^{-1})
ν	kinematic viscosity of jet at exit ($\text{m}^2.\text{s}^{-1}$)
ρ	density (kg.m^{-3})
σ	surface tension (N.m^{-1} or dynes.cm^{-1})
τ	time (s)
ϕ	volume fraction (-) critical fraction of heat lost to fuel surface in firepoint equation (-) equivalence ratio (-)

Subscripts

a, A	ambient, aerodynamic, air
am	air mist
an	annular
B	accumulated
b	boiling
C	combustion
c	critical, convective, cooling, chemical
d	diameter
E	external
e	extinguishment, extinction
f, F	fire, flame, fuel, force
fc	forced convection
G	gain
g	gas, global
H	heat transfer
hp	high pressure
I	internal
inj	injected
L	liquid, loss
M	main

m	mean, model
max	maximum value
mp	normal pressure
o	initial value, orifice, oxygen
p	plume, prototype
R	radiation
r	residence
rad	radiation
s	spray, surface
ss	steady-state value
tot	total
v	ventilation, vapourisation, evaporation, film boiling
v50	50% volume mean diameter etc.
W	water, window opening (compartment fire)
ws	water spray
z	ignition
∞	ambient value

Superscripts

•	non-dimensional variable
---	--------------------------



Figure 1. *The Front Room Fire*
(© Crown copyright, courtesy of BRE)

Time from ignition = 30 s



Figure 2. *The Front Room Fire*
(© Crown copyright, courtesy of BRE)

Time from ignition = 1 min 15 s



Figure 3. *The Front Room Fire*
(© Crown copyright, courtesy of BRE)

Time from ignition = 2 min 15 s



Figure 4. *The Front Room Fire*
(© Crown copyright, courtesy of BRE)

Time from ignition = 3 min. 0 s



Figure 5. *The Front Room Fire*
(© Crown copyright, courtesy of BRE)

Time from ignition = 3 min. 15 s



Figure 6. *The Front Room Fire*
(© Crown copyright, courtesy of BRE)

Time from ignition = 3 min. 20 s
(onset of *Flashover*)

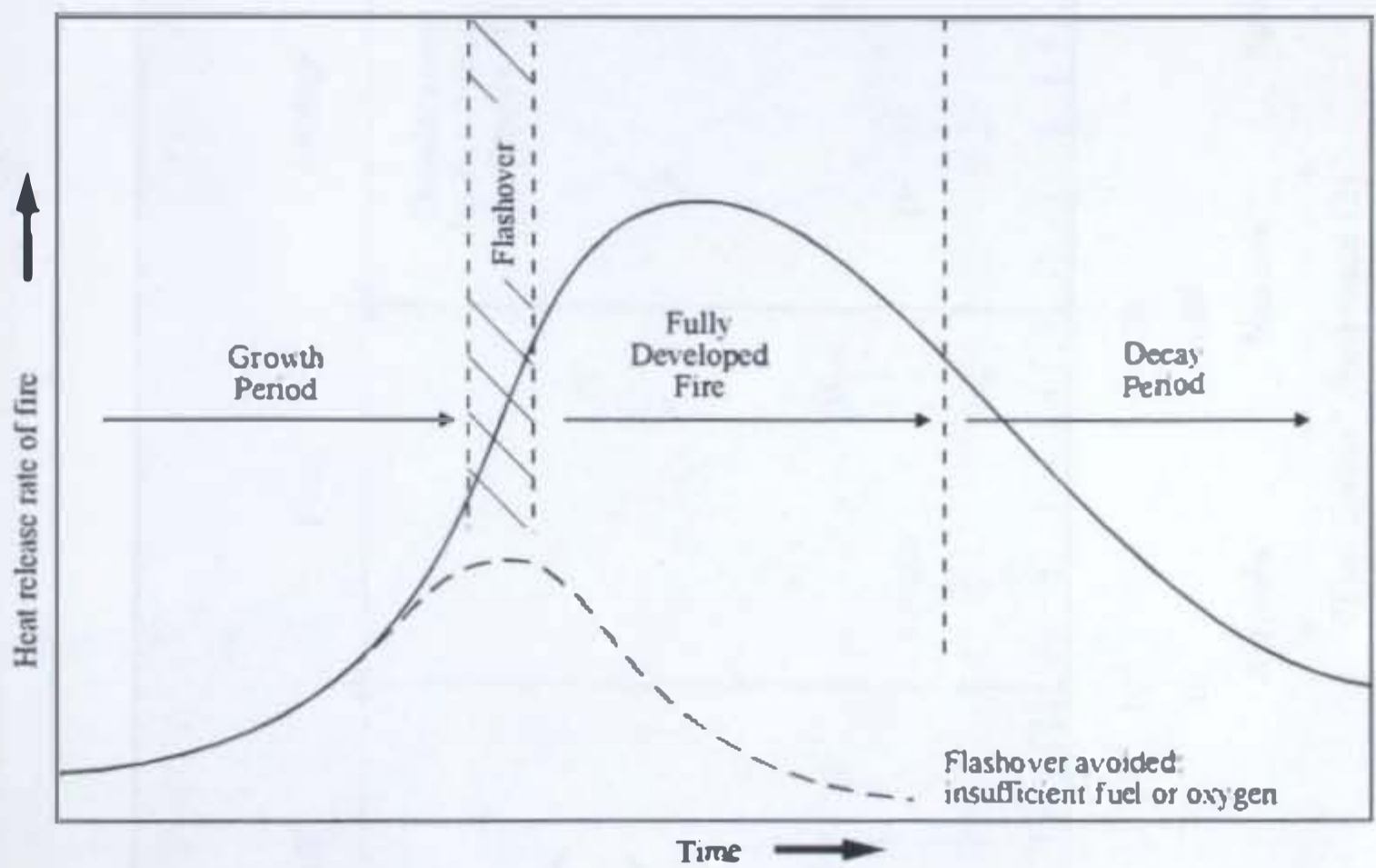

Figure 7. Schematic of compartment fire growth history (after Reference 6)

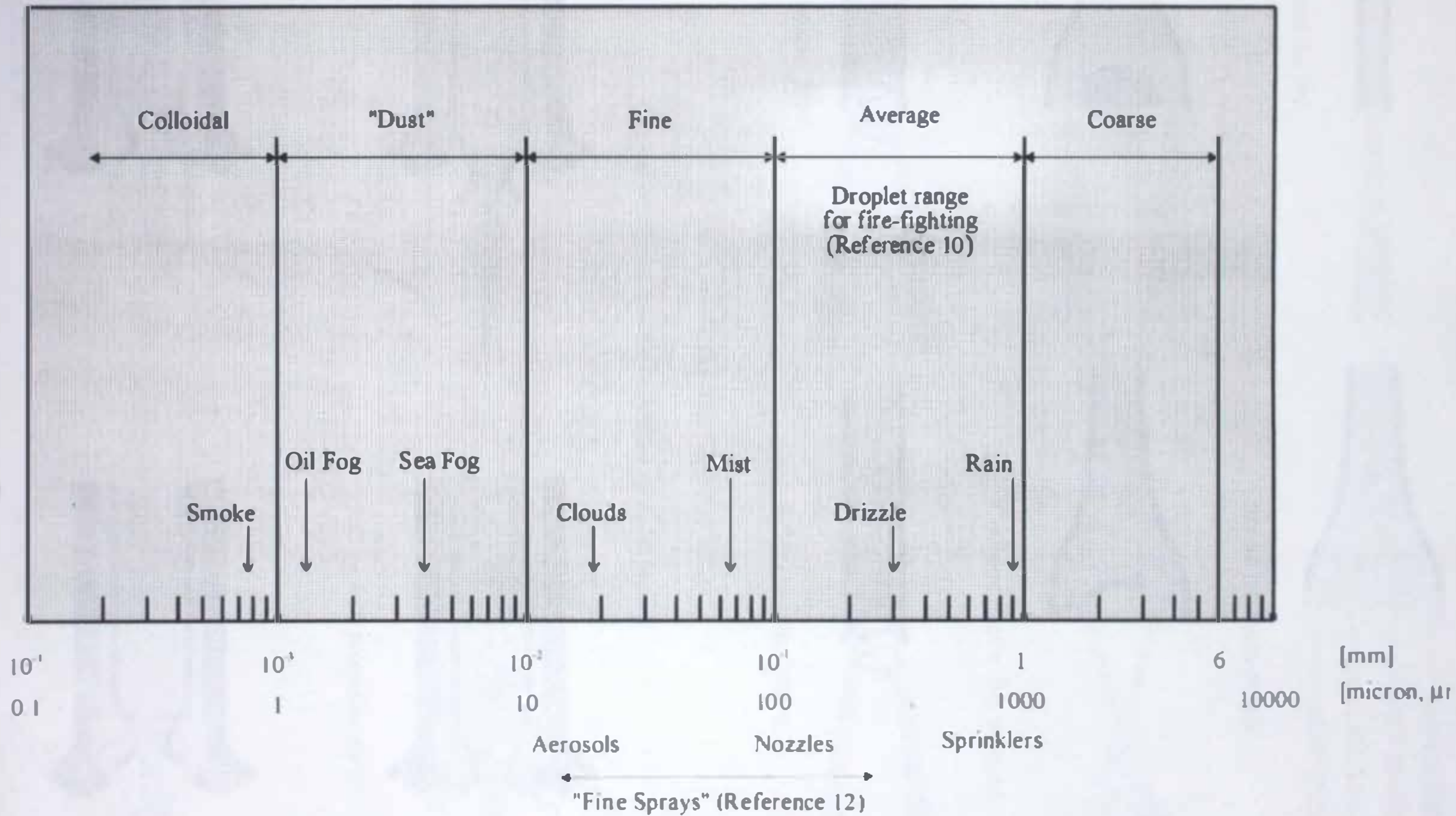
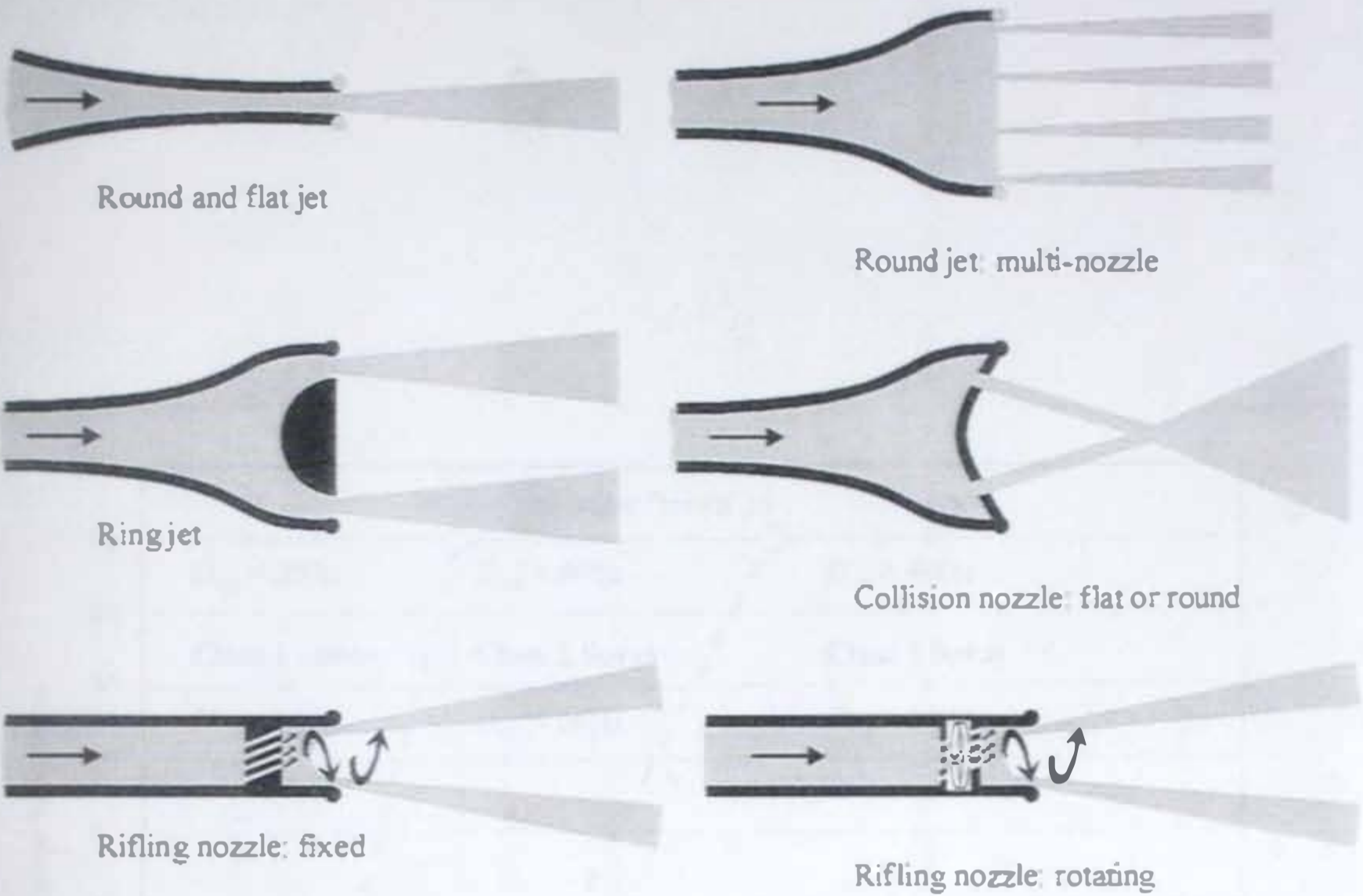

Figure 8. Spectrum of droplet diameters (adapted from References 10, 13 & 14)



Typical configurations for combined spray/jet branch

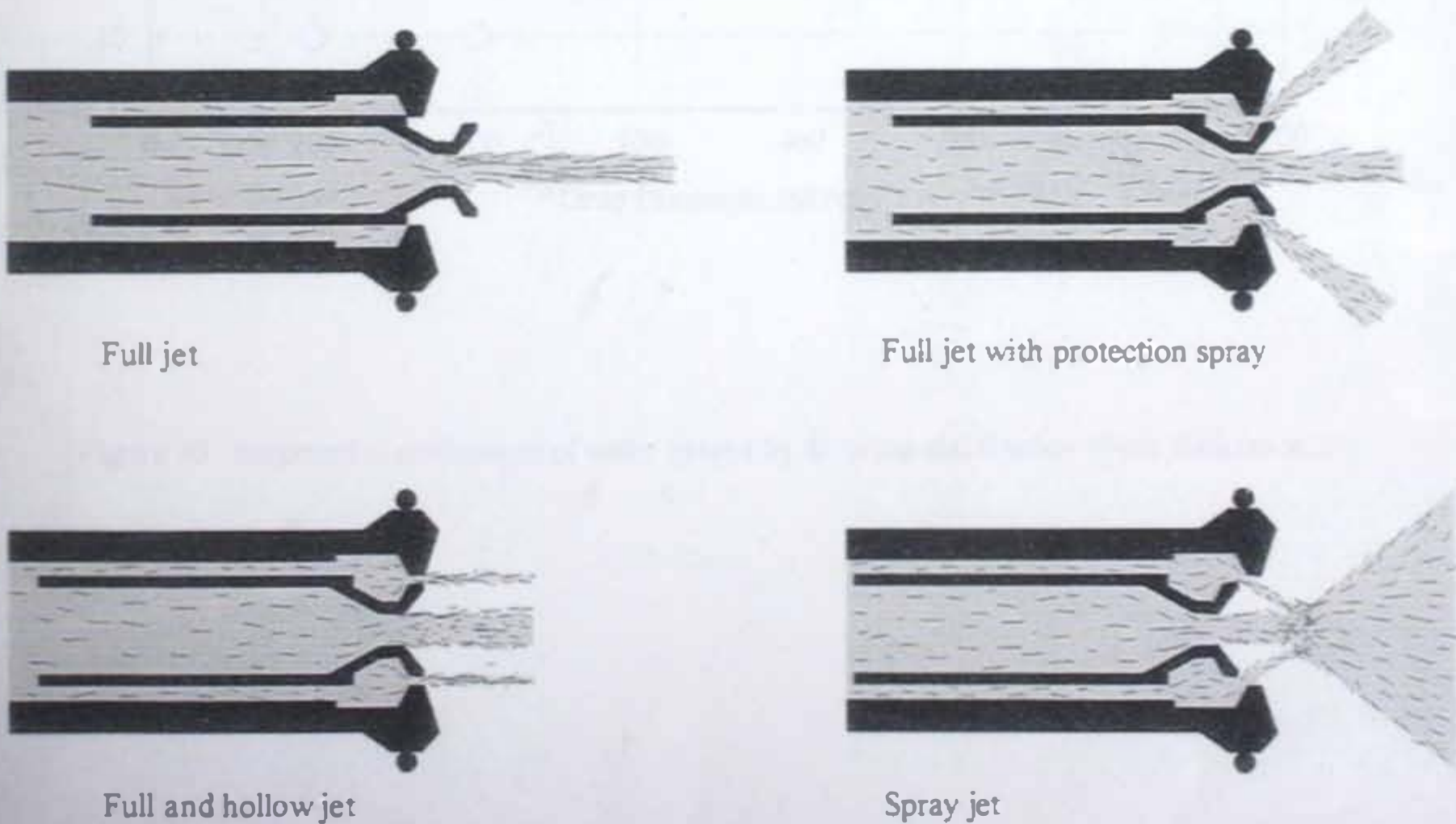

Figure 9. Schematic illustration of fire-fighting nozzles (adapted from Reference 10)

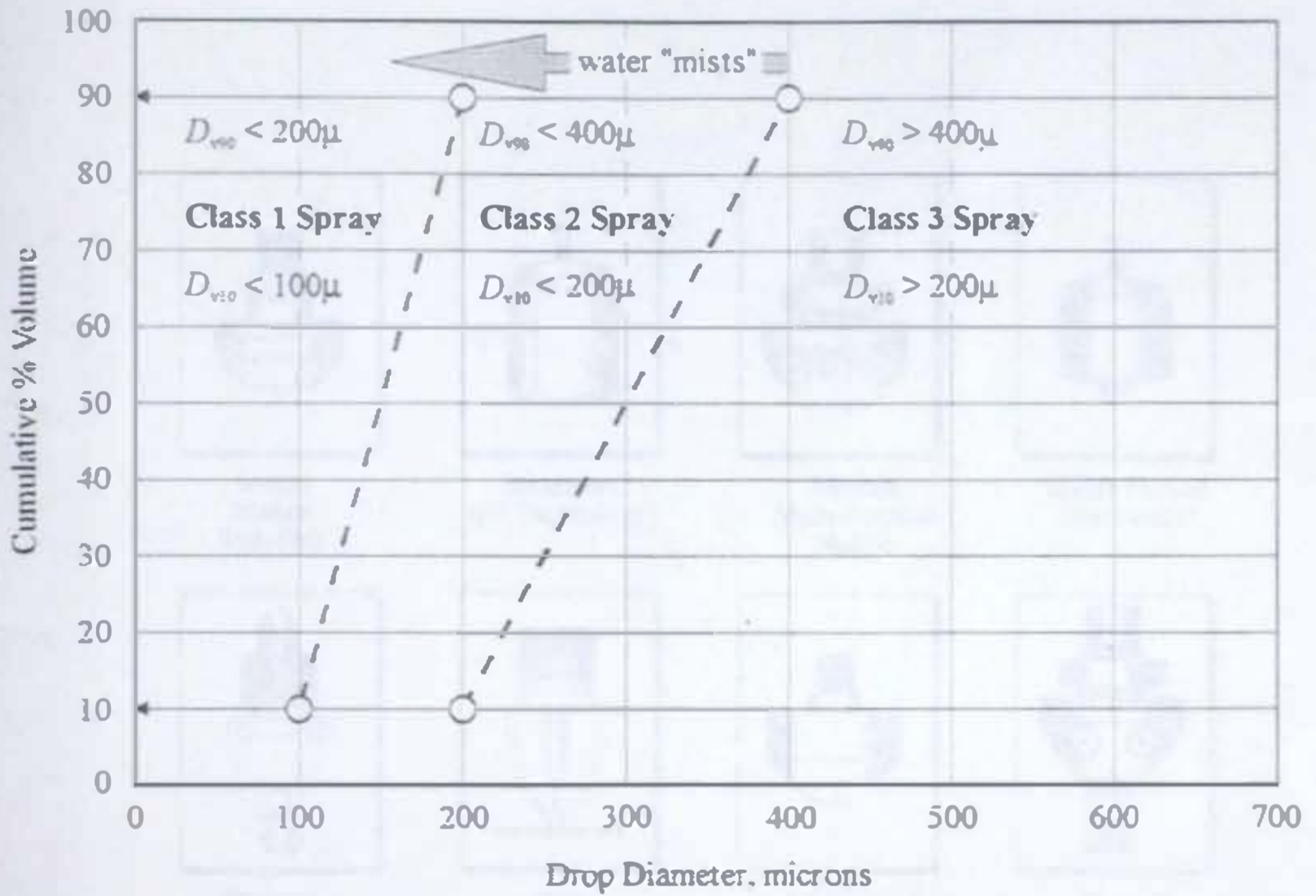

Figure 10. Proposed classification of water sprays by droplet size distribution (from Reference 24)

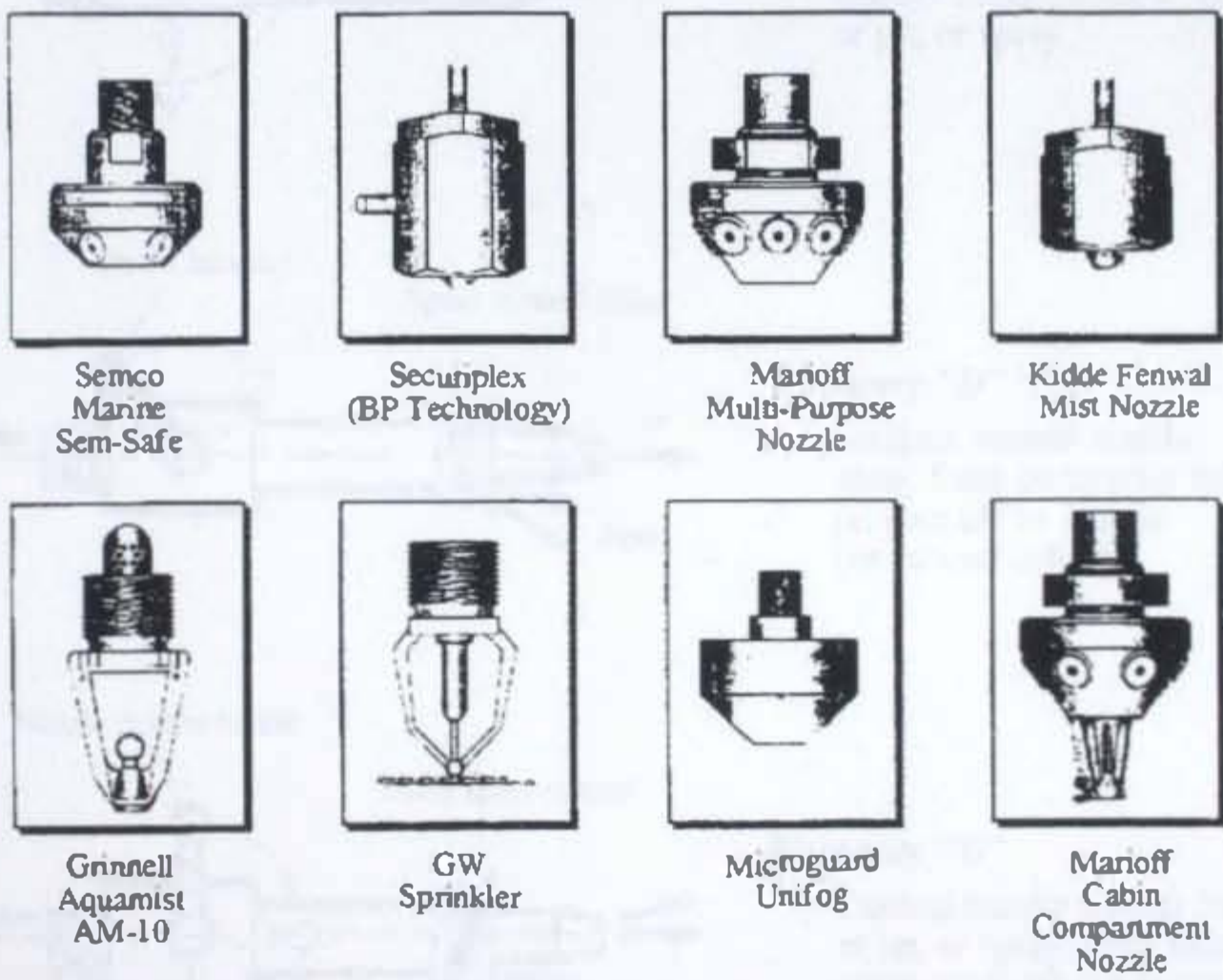
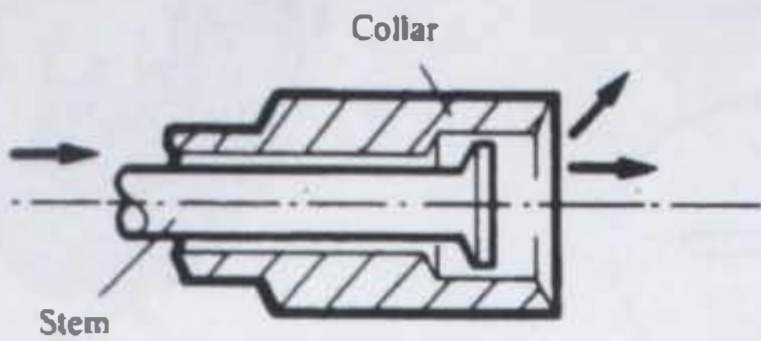

Figure 11. Various commercial water mist nozzles (from Reference 21)



Diffuser:

Collar back - spray
Collar forward - jet

Category "A"

Shut with collar in extreme forward position

Category "B"

Shut by on/off control upstream

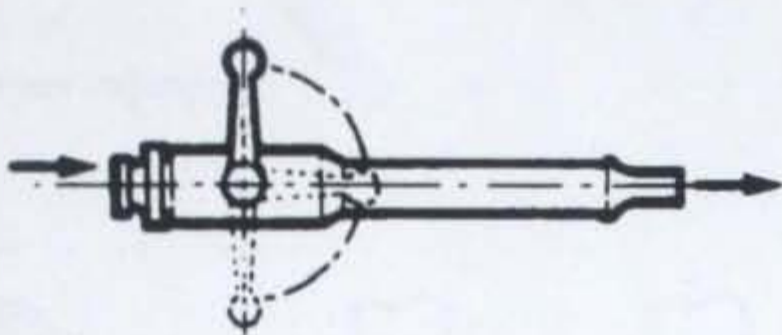

Category "C"

Single nozzle - control handle selects "off", or jet, or spray

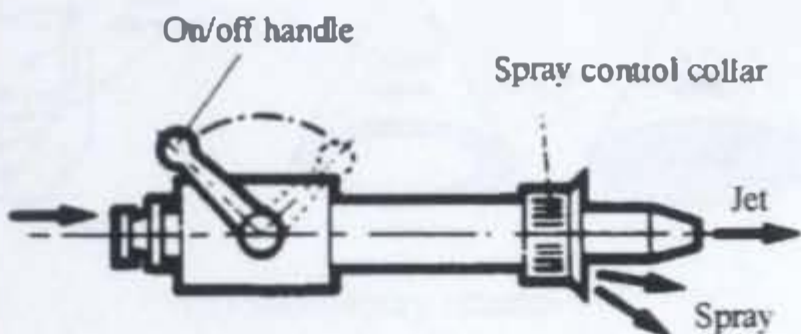

Category "D"

Jet from central nozzle, spray from concentric collar, jet shut off by handle (or second collar)

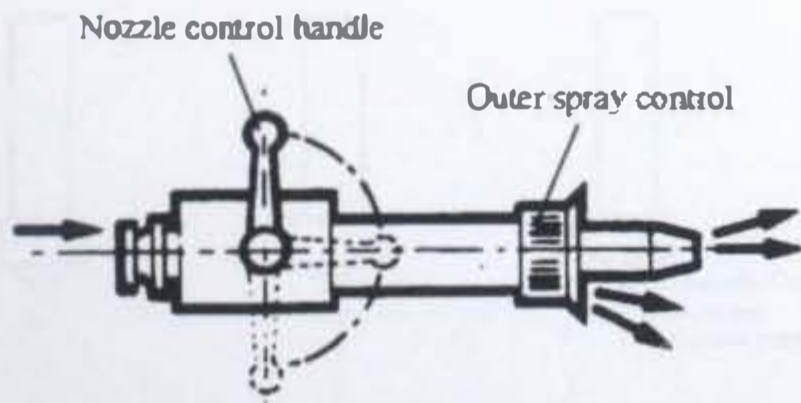

Category "E"

Control handle selects "off", or jet, or spray, from central nozzle, concentric collar adjusts and shuts off additional spray

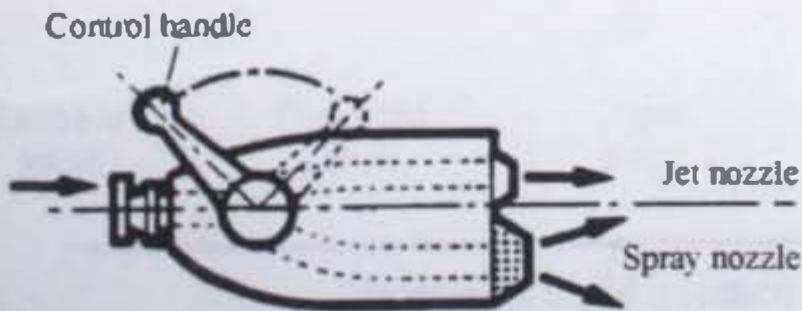

Category "F"

Control handle selects "off", or jet, or spray

Figure 12. Basic categories of fire-fighting branches (adapted from Reference 27)

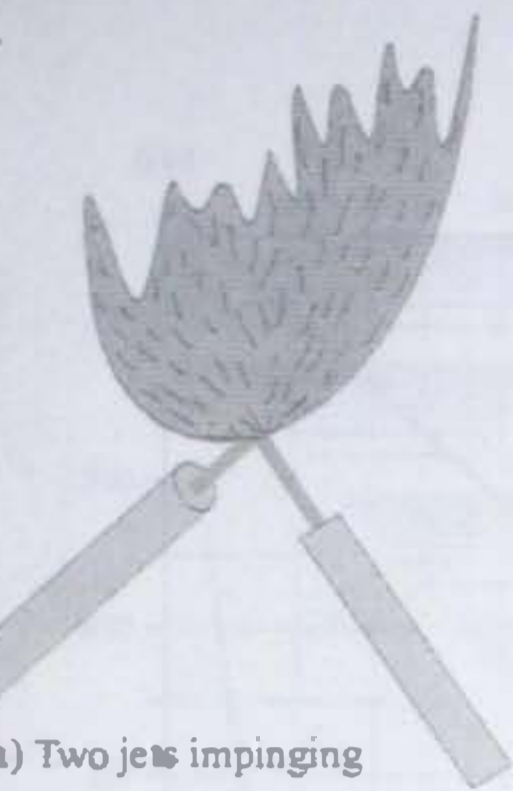

(a) Two jets impinging

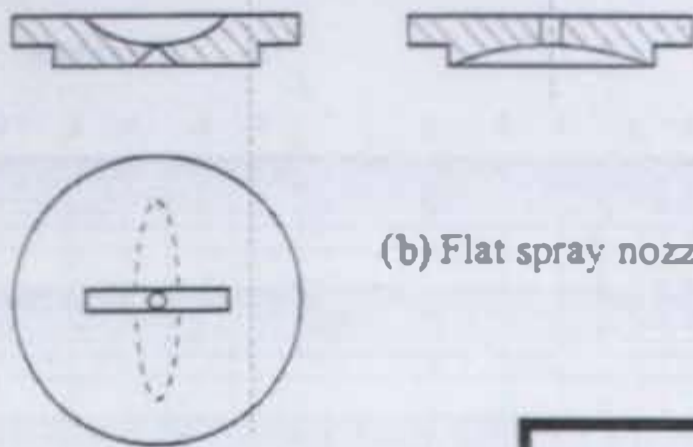

(b) Flat spray nozzle

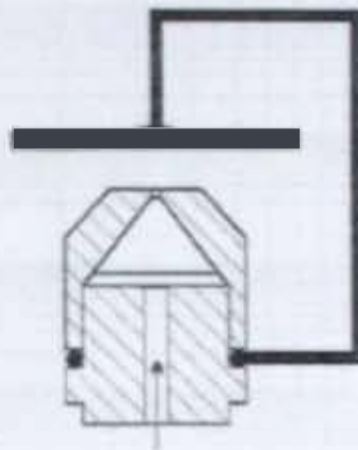

(c) Impact nozzle

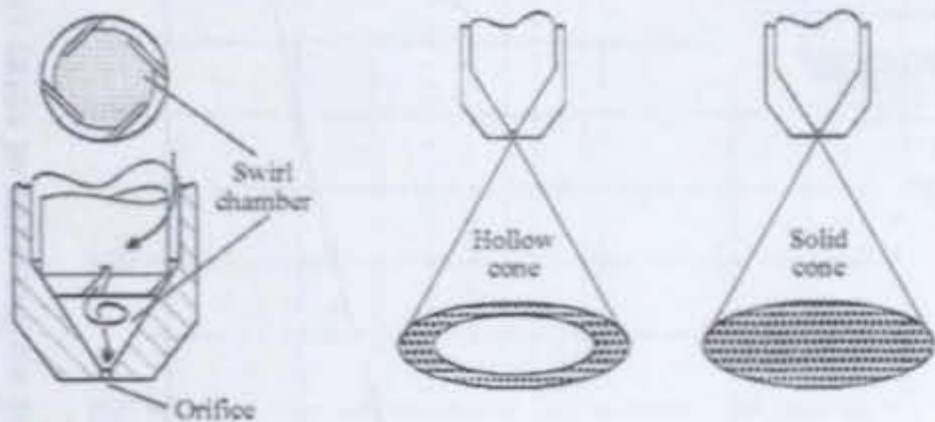

(d) Swirl spray nozzle

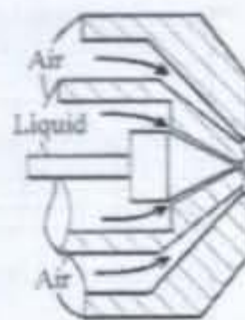

(f) Twin fluid atomiser nozzle

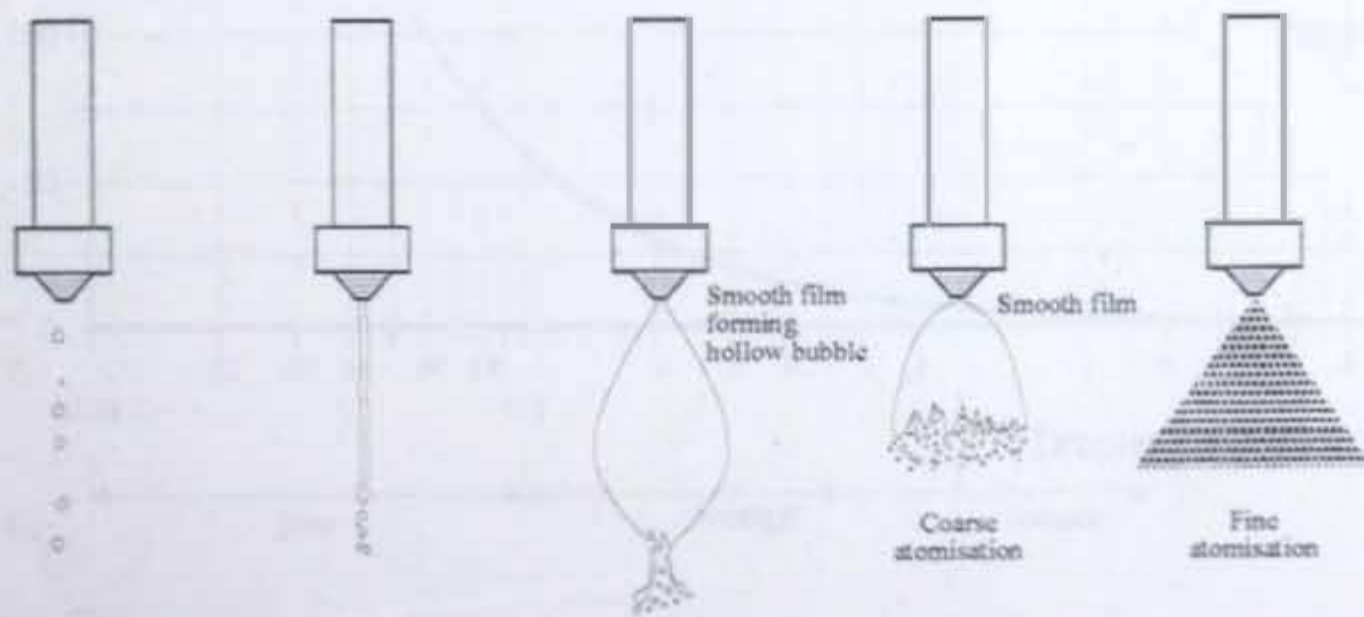

Dribble stage

Distorted pencil

Onion stage

Tulip stage

Fully-developed spray

Increasing liquid injection pressure

(e) Stages of spray development with increasing injection pressure (after Reference 14)

Figure 13. Principal techniques of water atomisation by nozzles

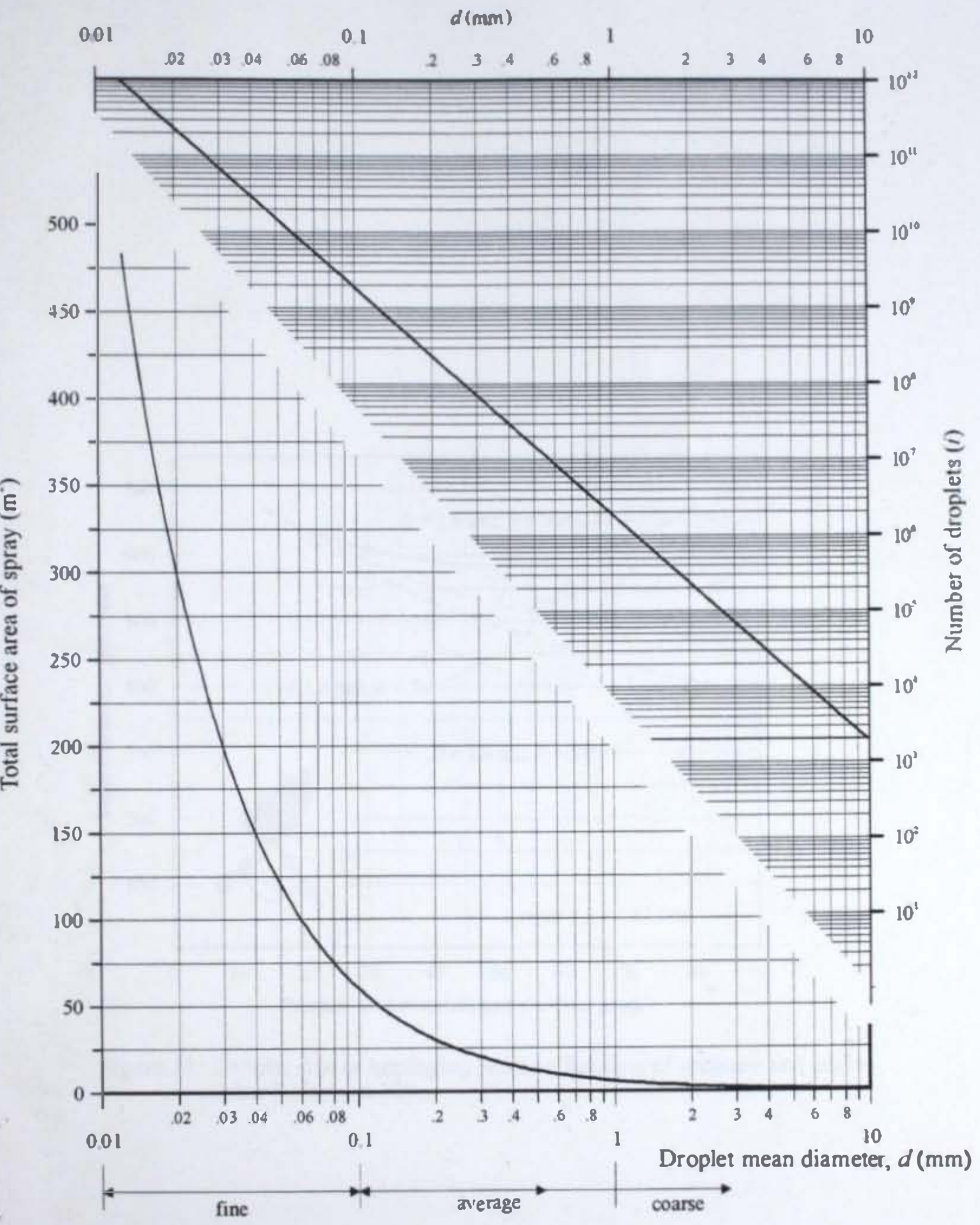

Figure 14. Number of droplets and total surface area produced by one litre of water, as monodisperse sprays with various mean droplet diameters, d .

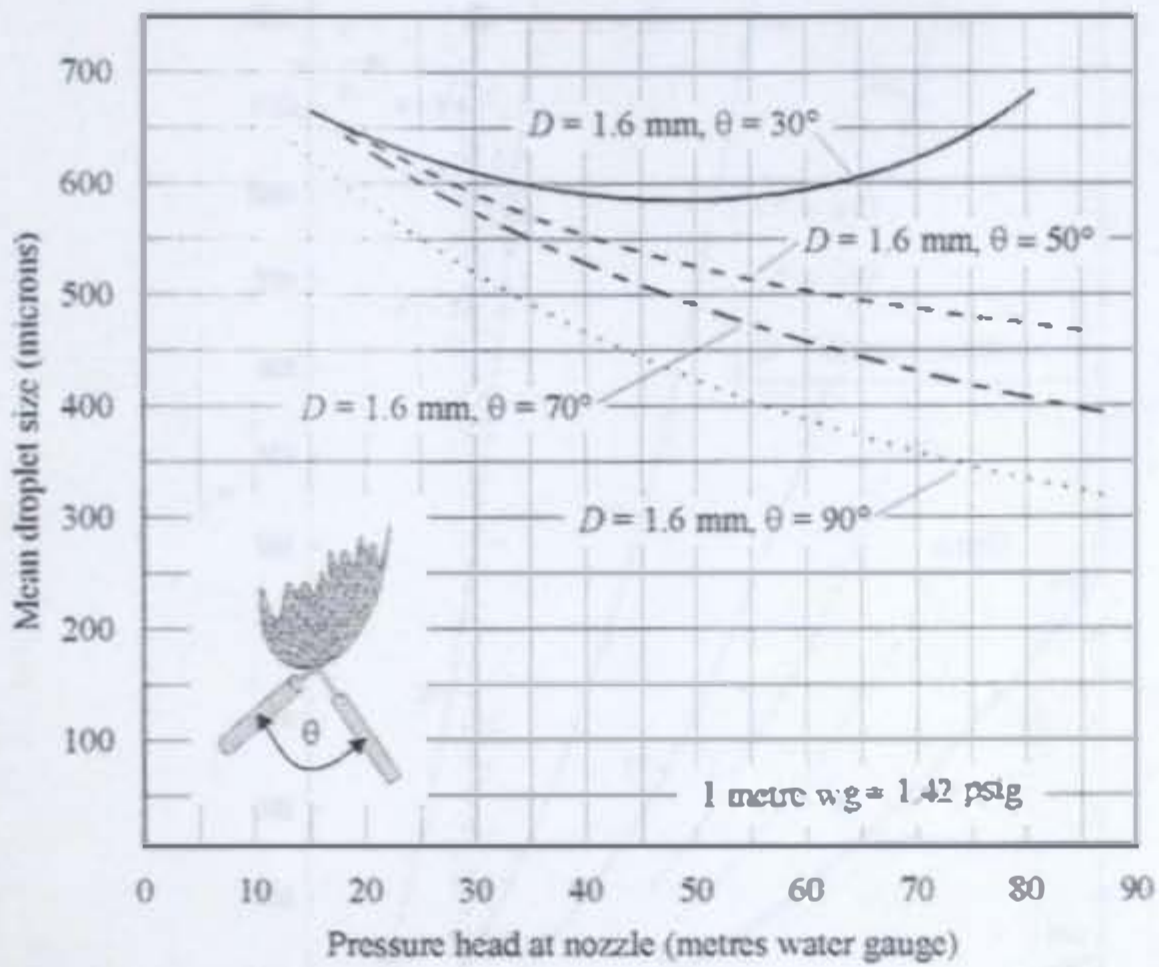

Figure 15. Droplet size of impinging jets as a function of pressure and angle (after Reference 10)

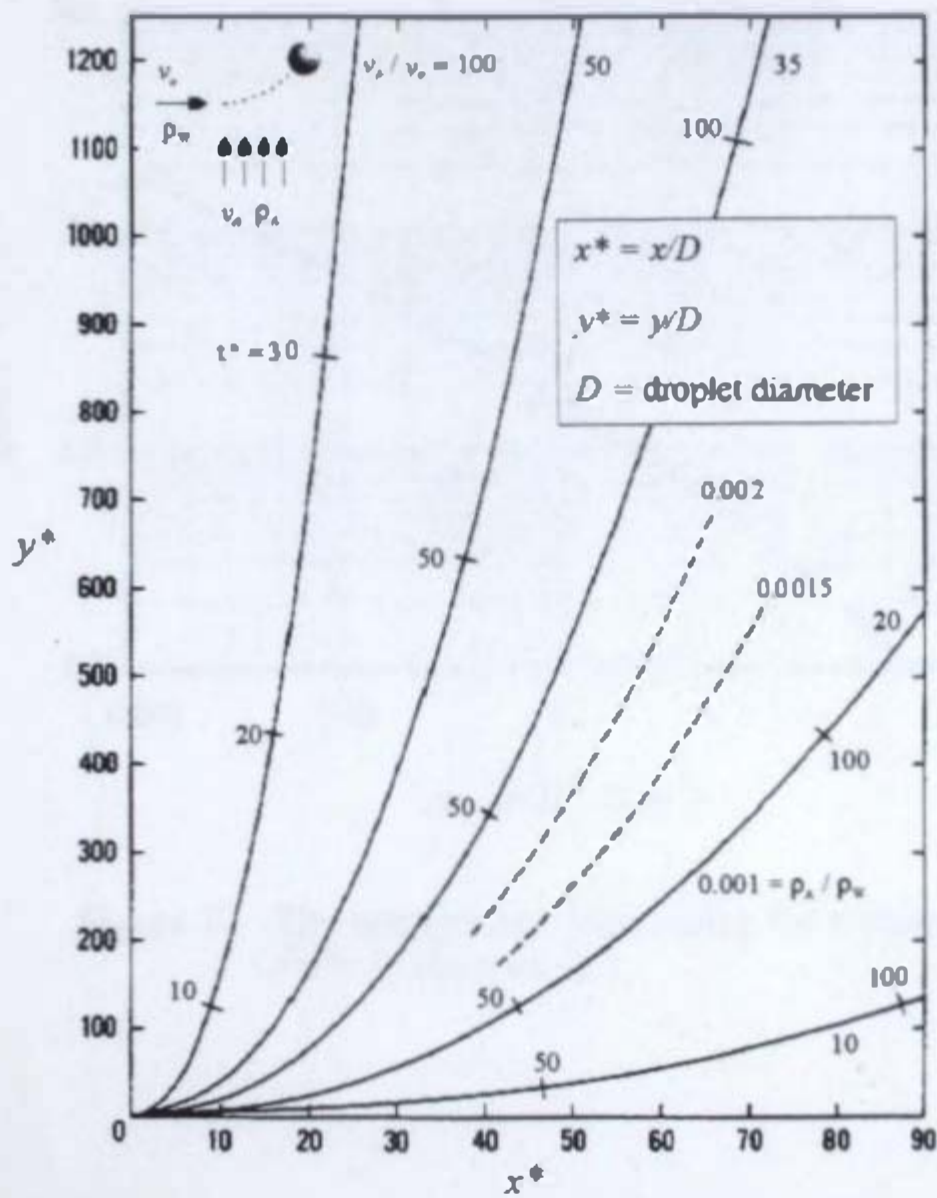

Figure 16. McCaffrey's 'first stage' (momentum conservation) model of water droplet-flame interaction (from Reference 45)

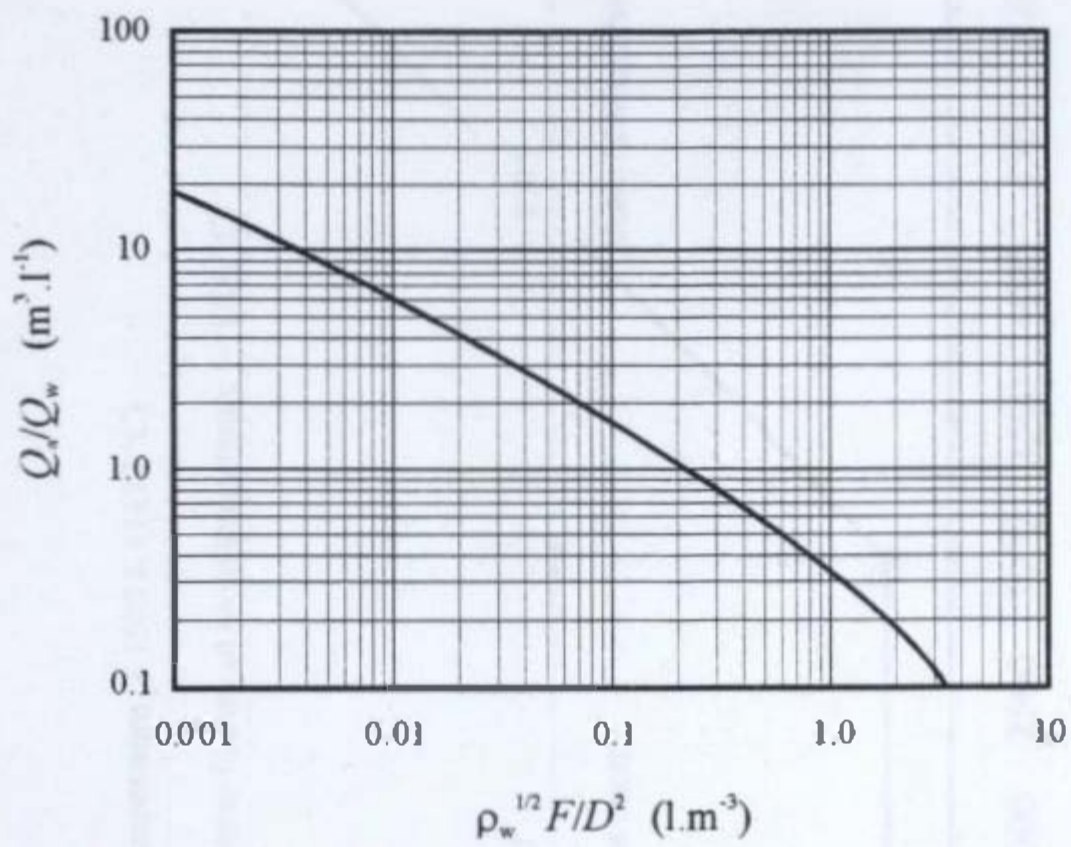

Figure 17. The entrainment relationship for a water spray (after Reference 46)

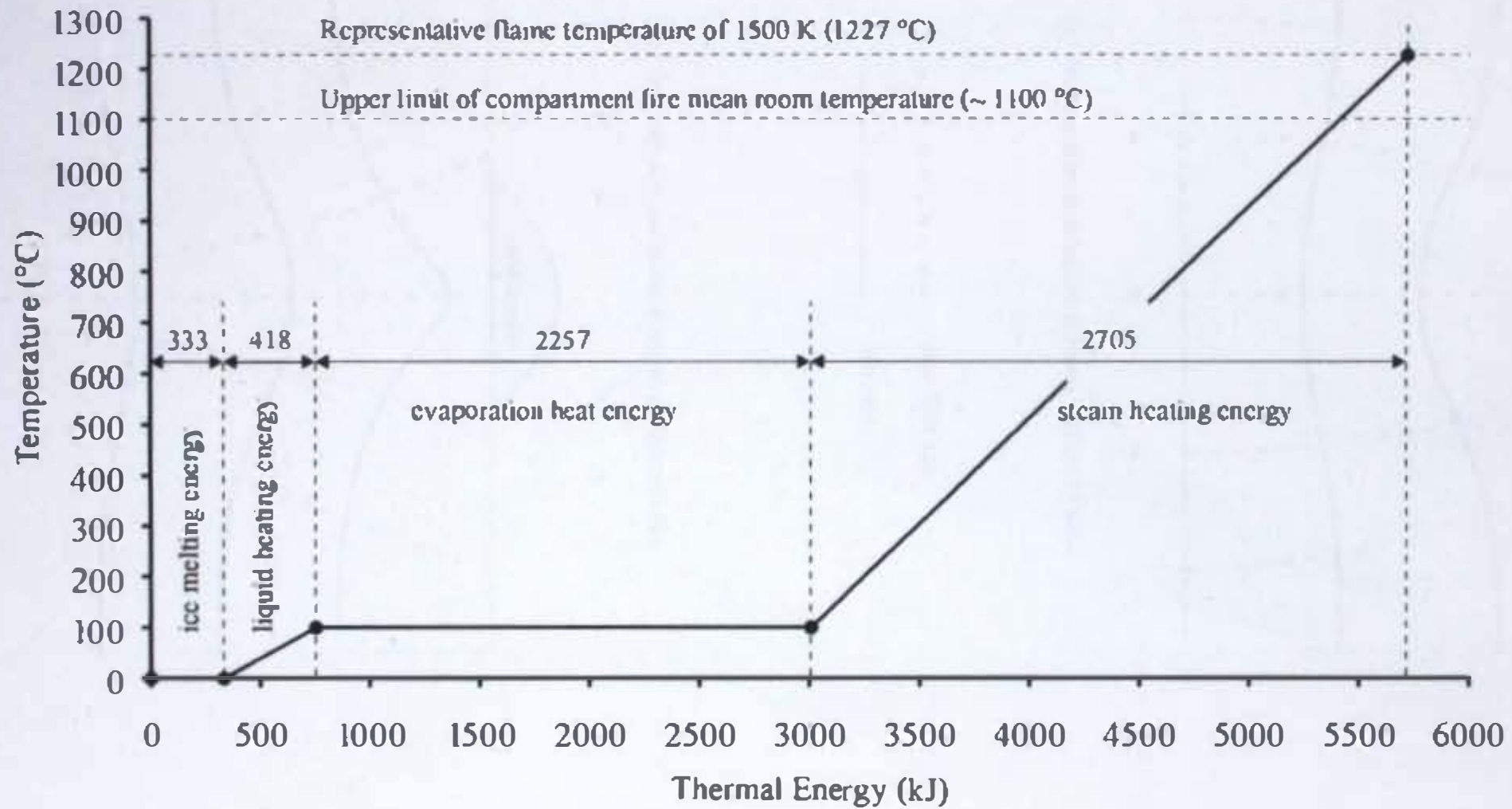
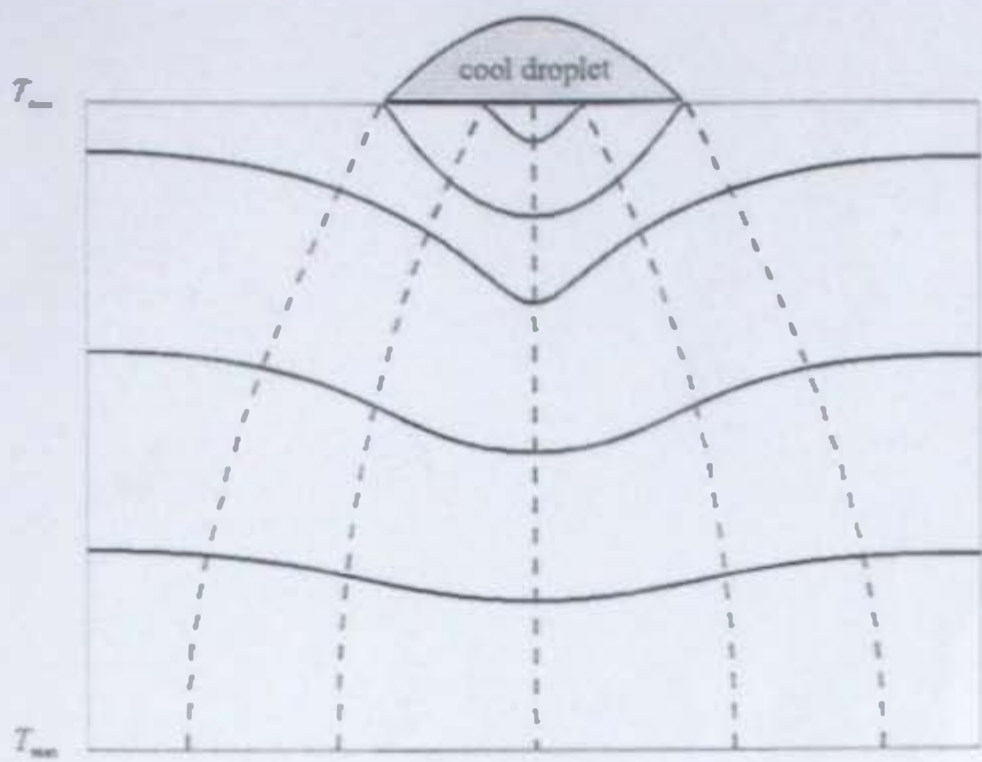
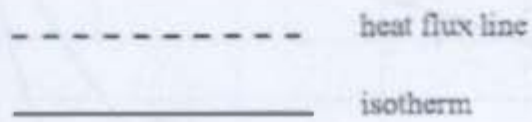

Figure 18. Thermal energy requirement for heating and phase changes of 1 litre (1 kg) of water



(a) heat input by conduction at lower surface of solid



(b) heat input by radiation at upper surface of solid

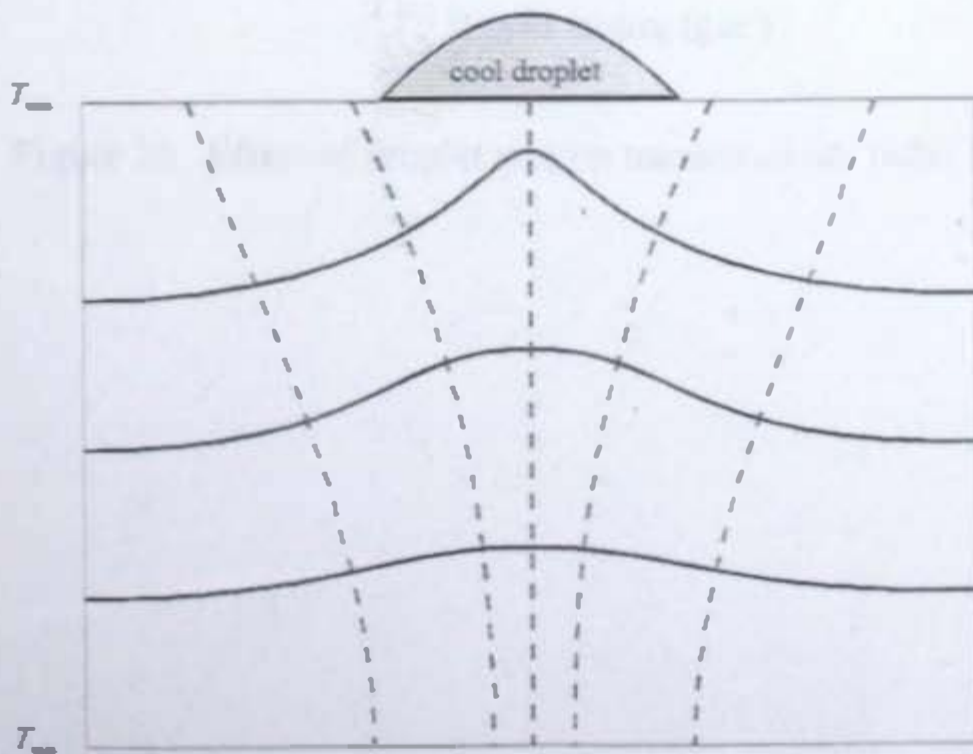

19. Schematic heat transfer during surface cooling showing convergence (a) and divergence (b) of heat flux lines at droplet impact site

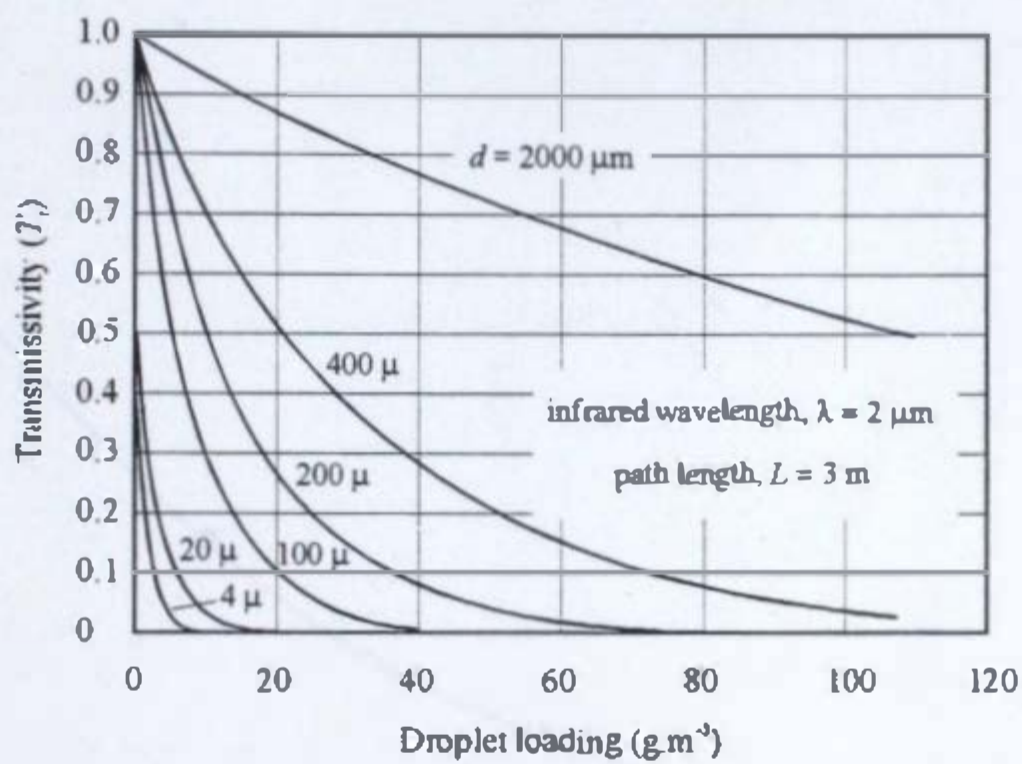

Figure 20. Effect of droplet size on transmissivity (after Reference 72)

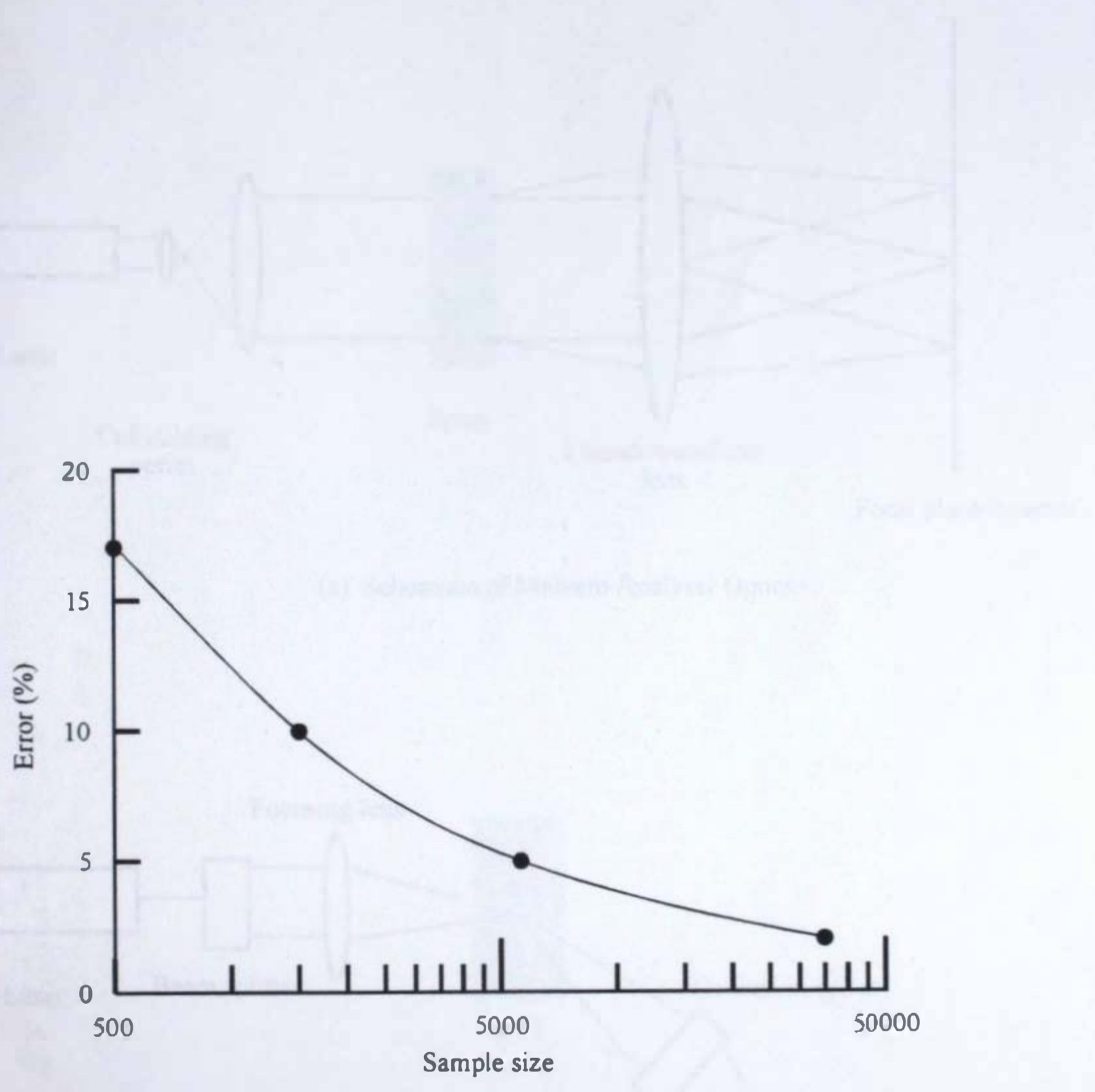
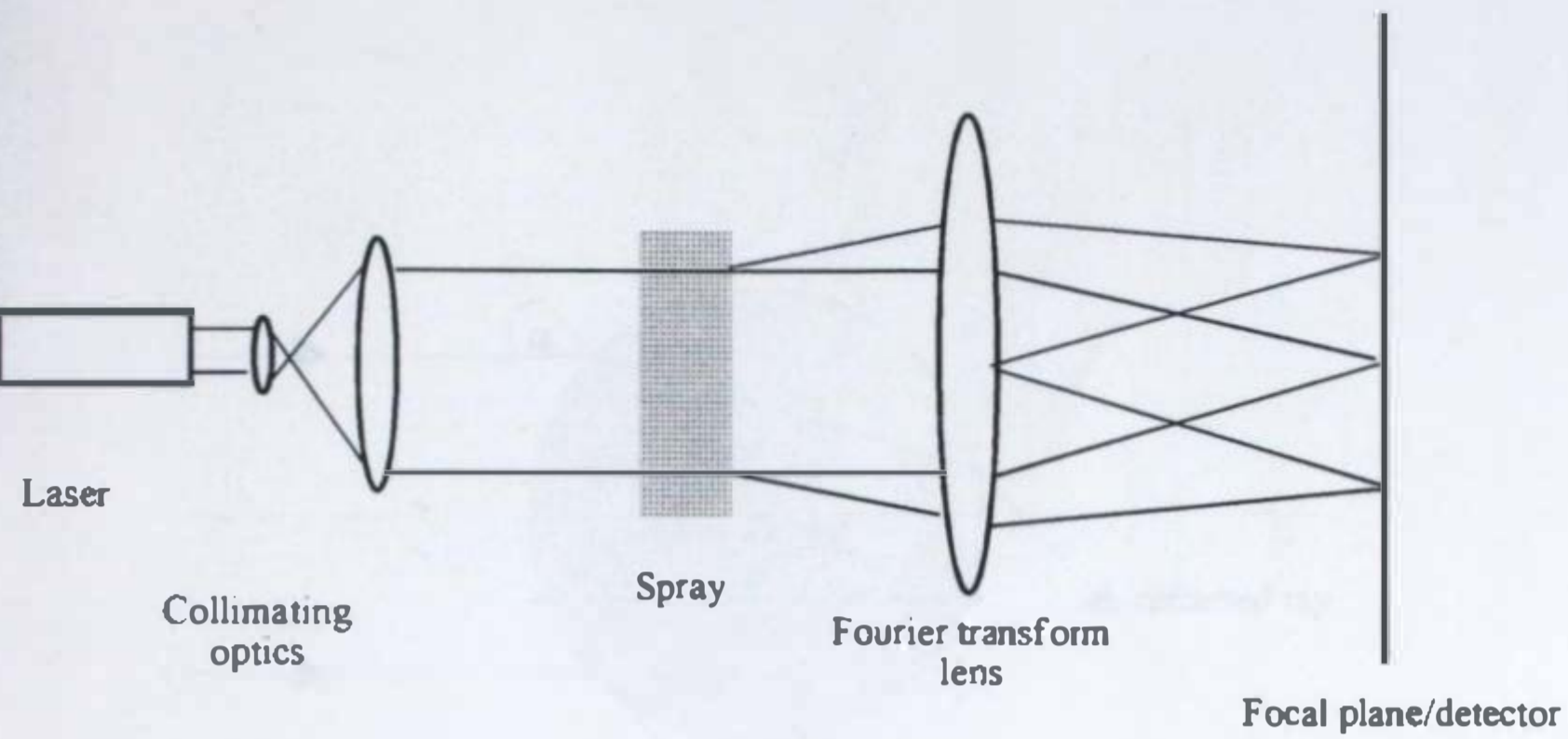
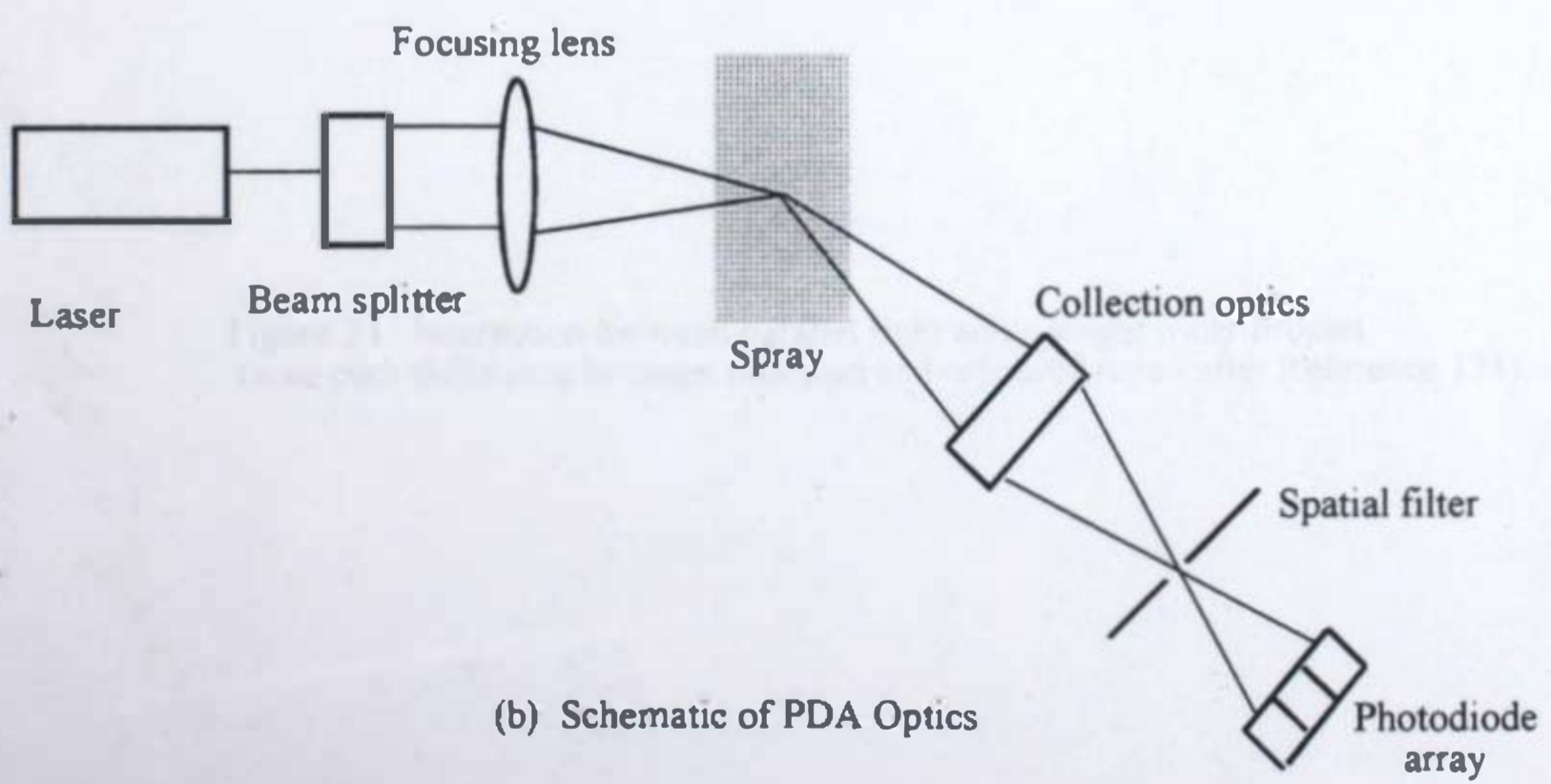

Figure 21 Accuracy of mean diameter as a function of sample size (after Reference 90)



(a) Schematic of Malvern Analyser Optics



(b) Schematic of PDA Optics

Figure 22. Schematics of Malvern (a) and PDA (b) optical layout (after Reference 121)

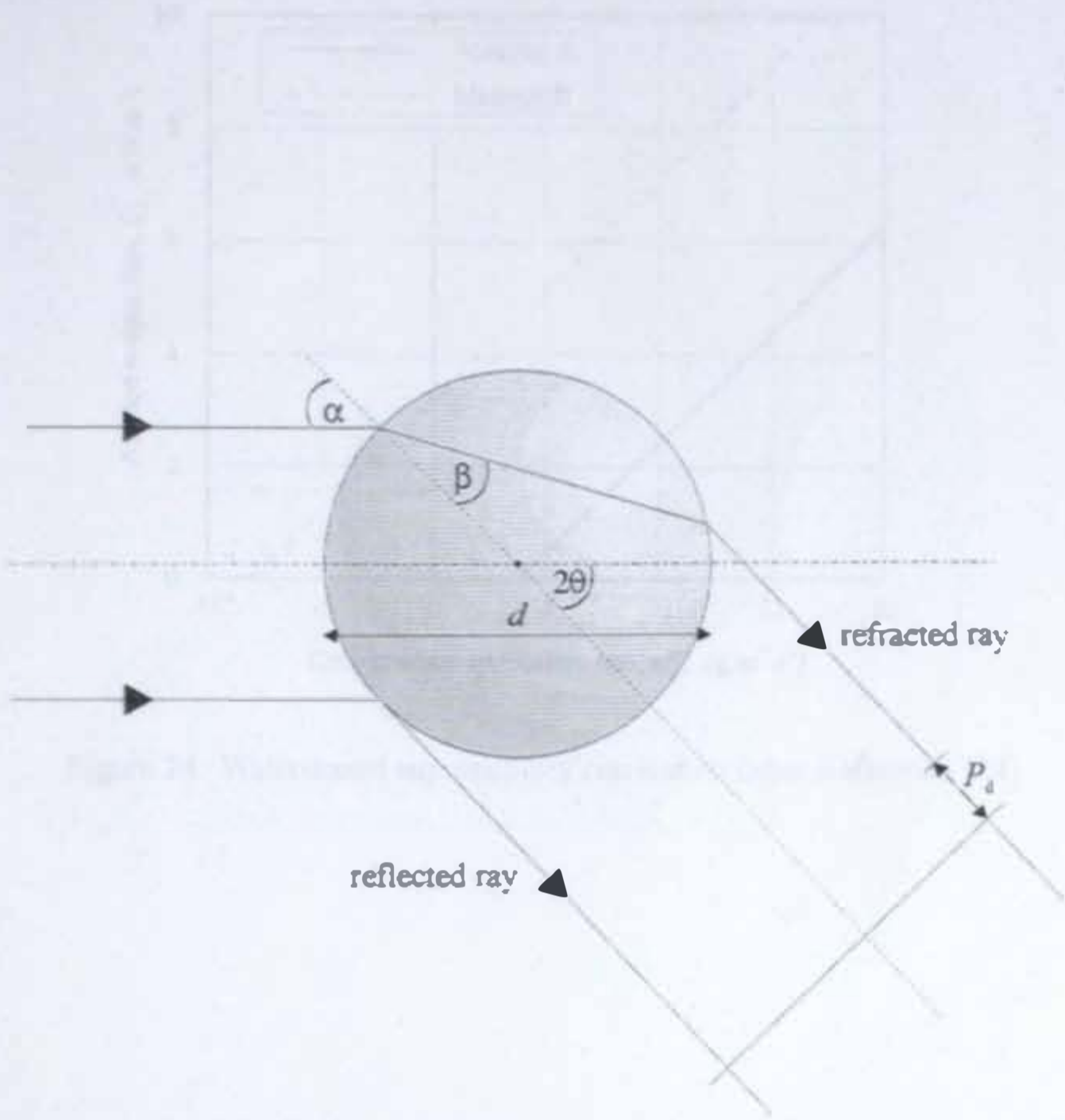

Figure 23 Interaction between parallel light and a single water droplet (note path difference between reflected and refracted rays - after Reference 121)

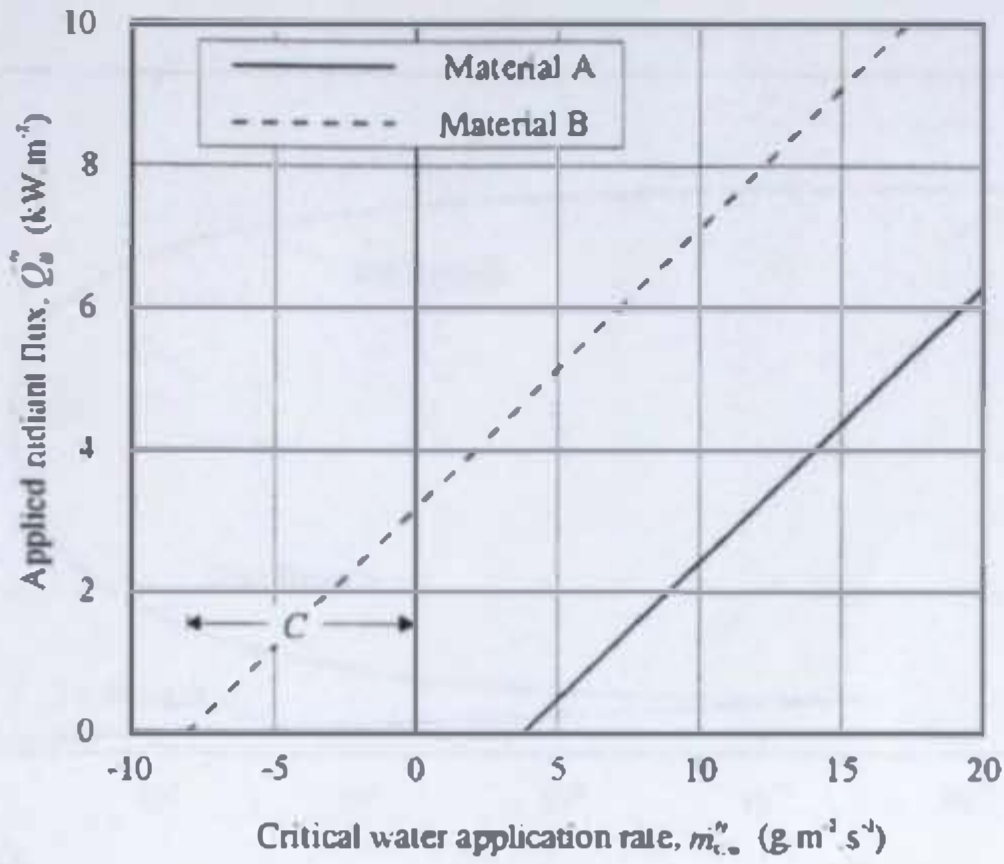

Figure 24. Water-based suppressibility correlation (after Reference 124)

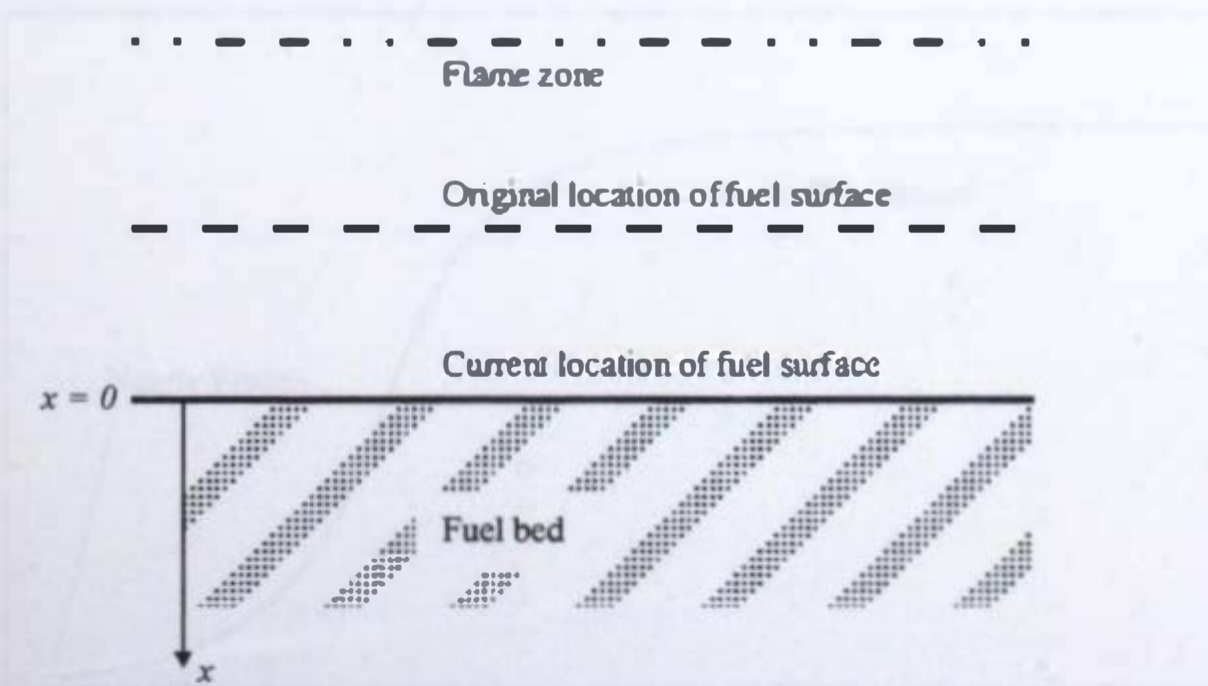

Figure 25. Thermal model of combustion process (after Reference 125)

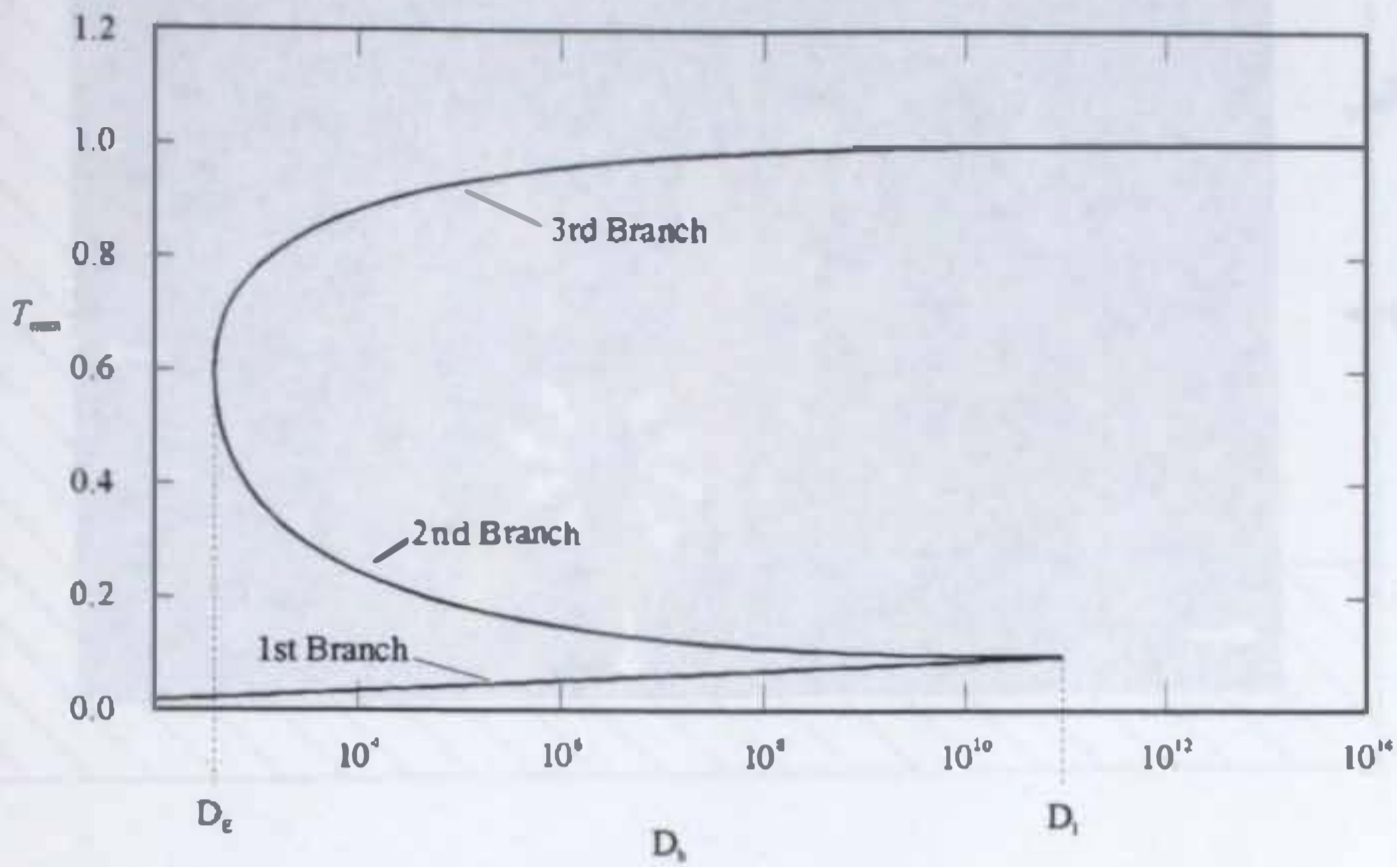

Figure 26. Variation of non-dimensional maximum temperature with 'boundary Damköhler number' (after Reference 127)

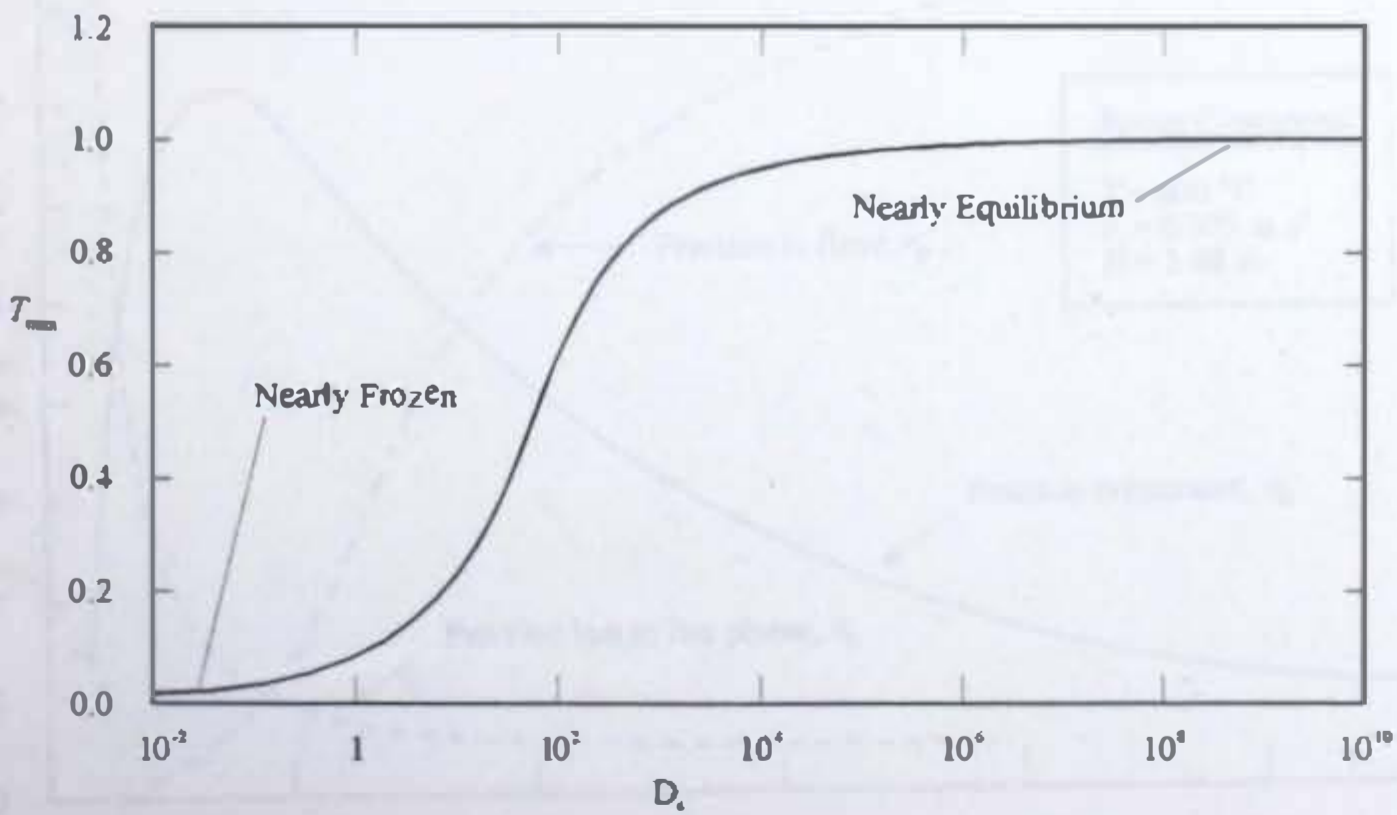

Figure 27. Variation of non-dimensional maximum temperature with 'flame zone Damköhler number' (after Reference 127)

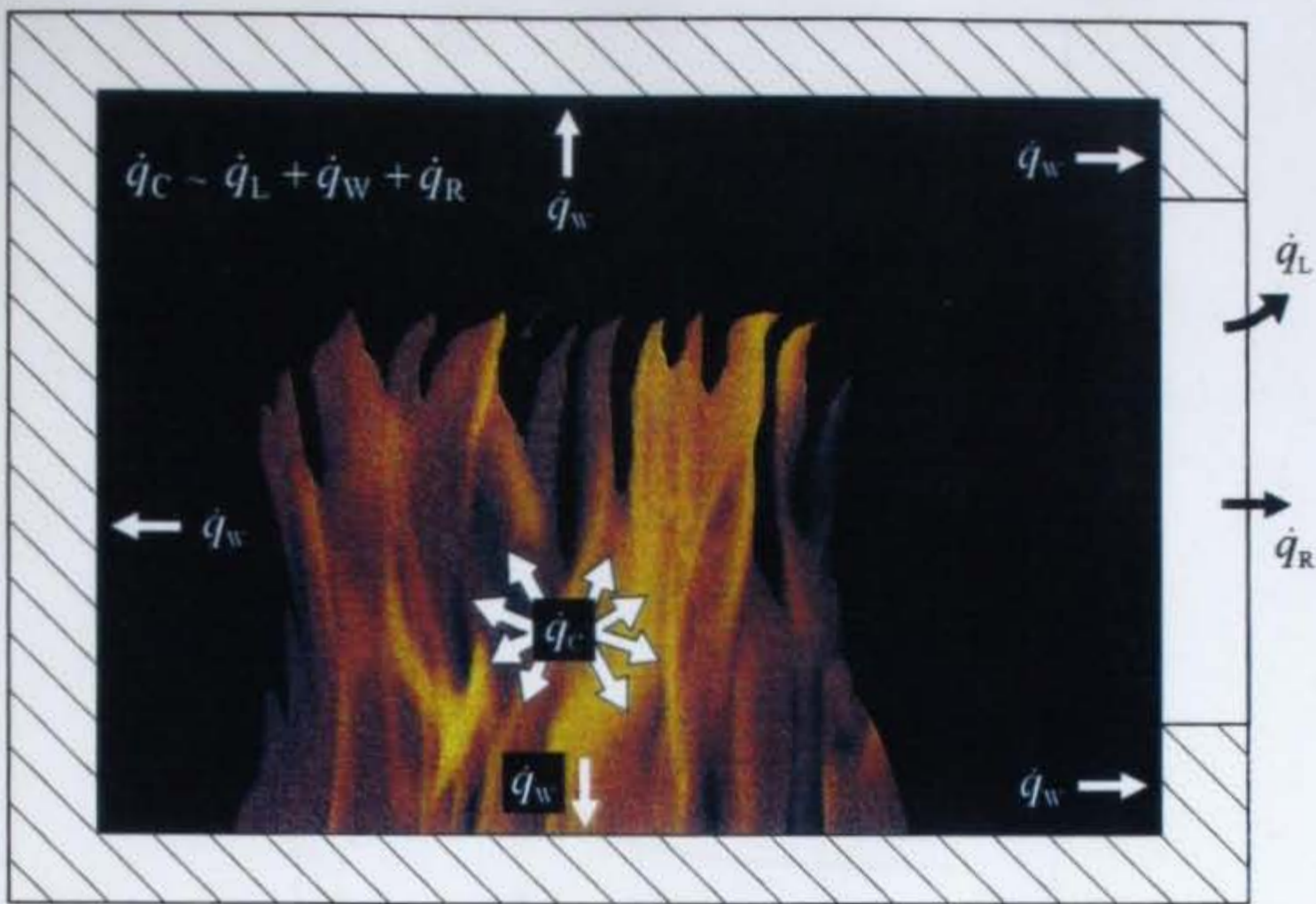

Figure 28 Heat losses during a fully-developed compartment fire (after Reference 139)

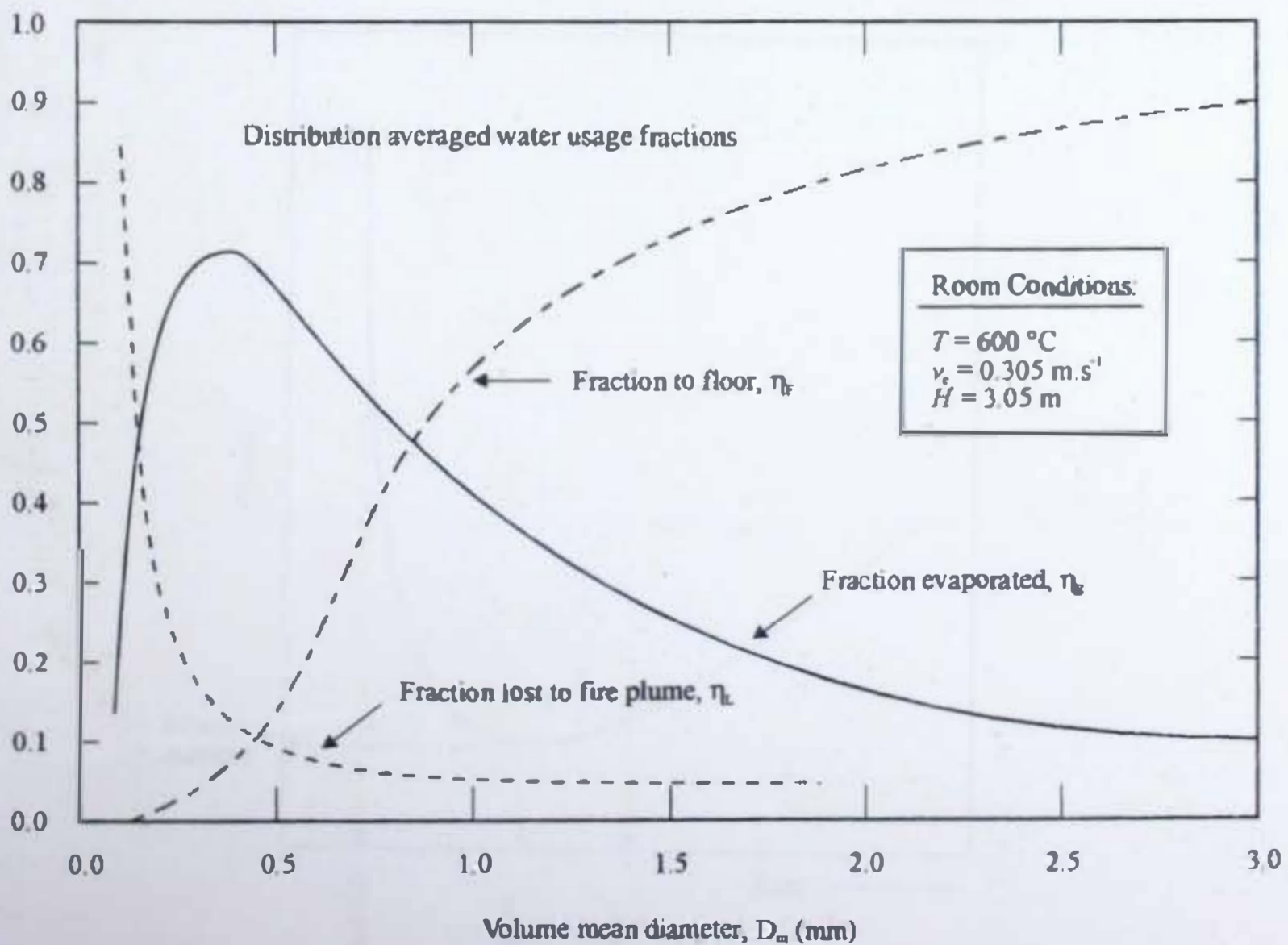

Figure 29 'Fire Demand Model' suppression water inventory (after Reference 143)

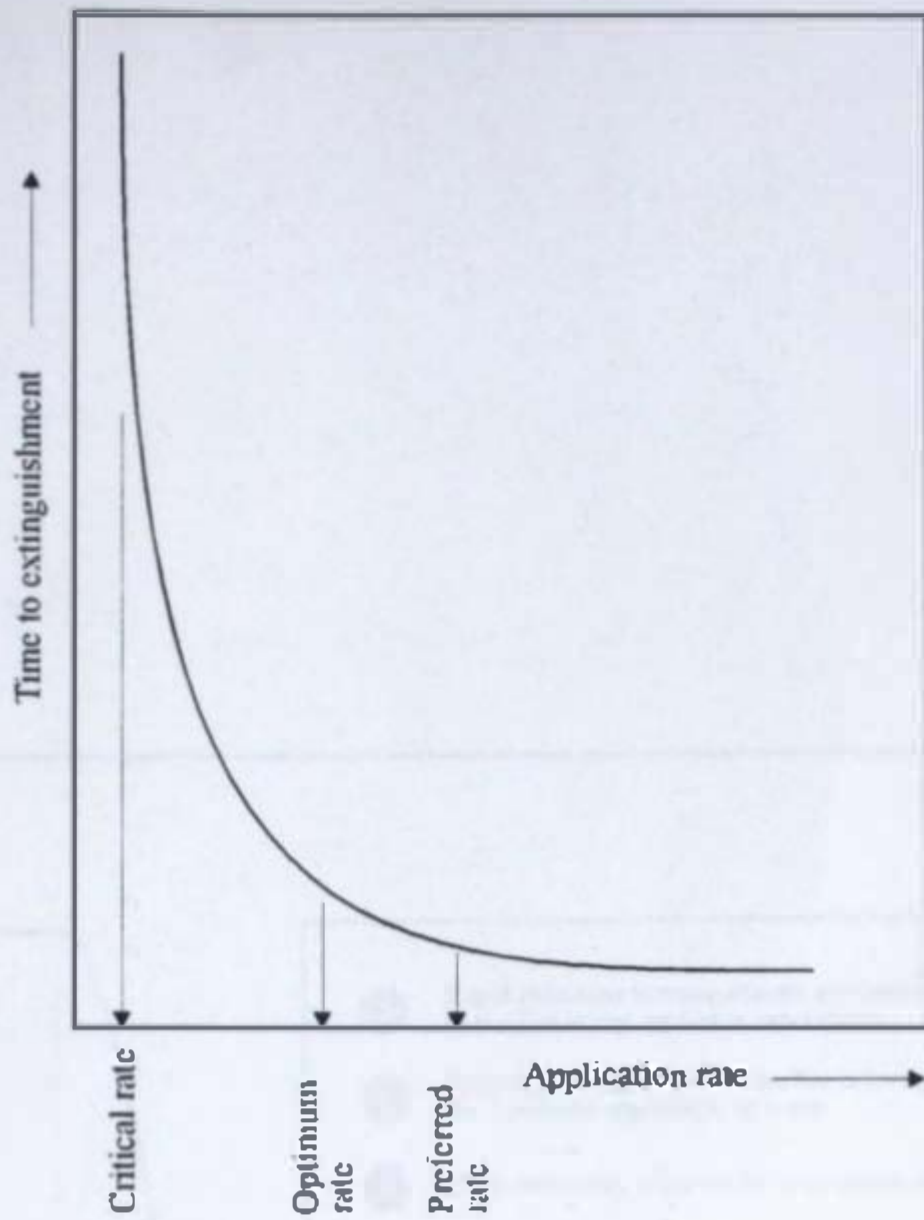

Figure 30. Time to extinguish a fire vs. agent application rate (after Reference 3)

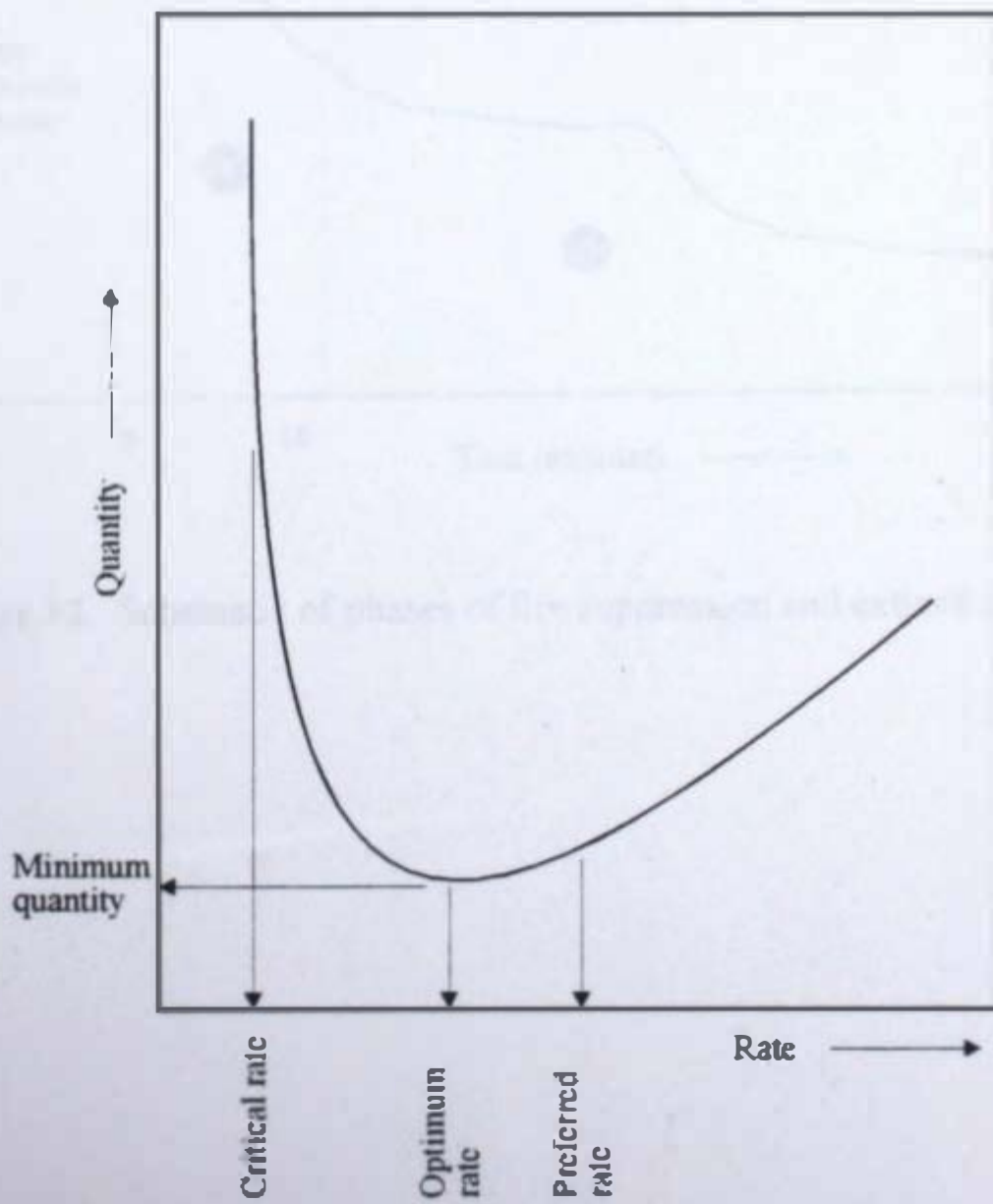

Figure 31. Suppression agent quantity/rate curve (after Reference 3)

APPENDIX I

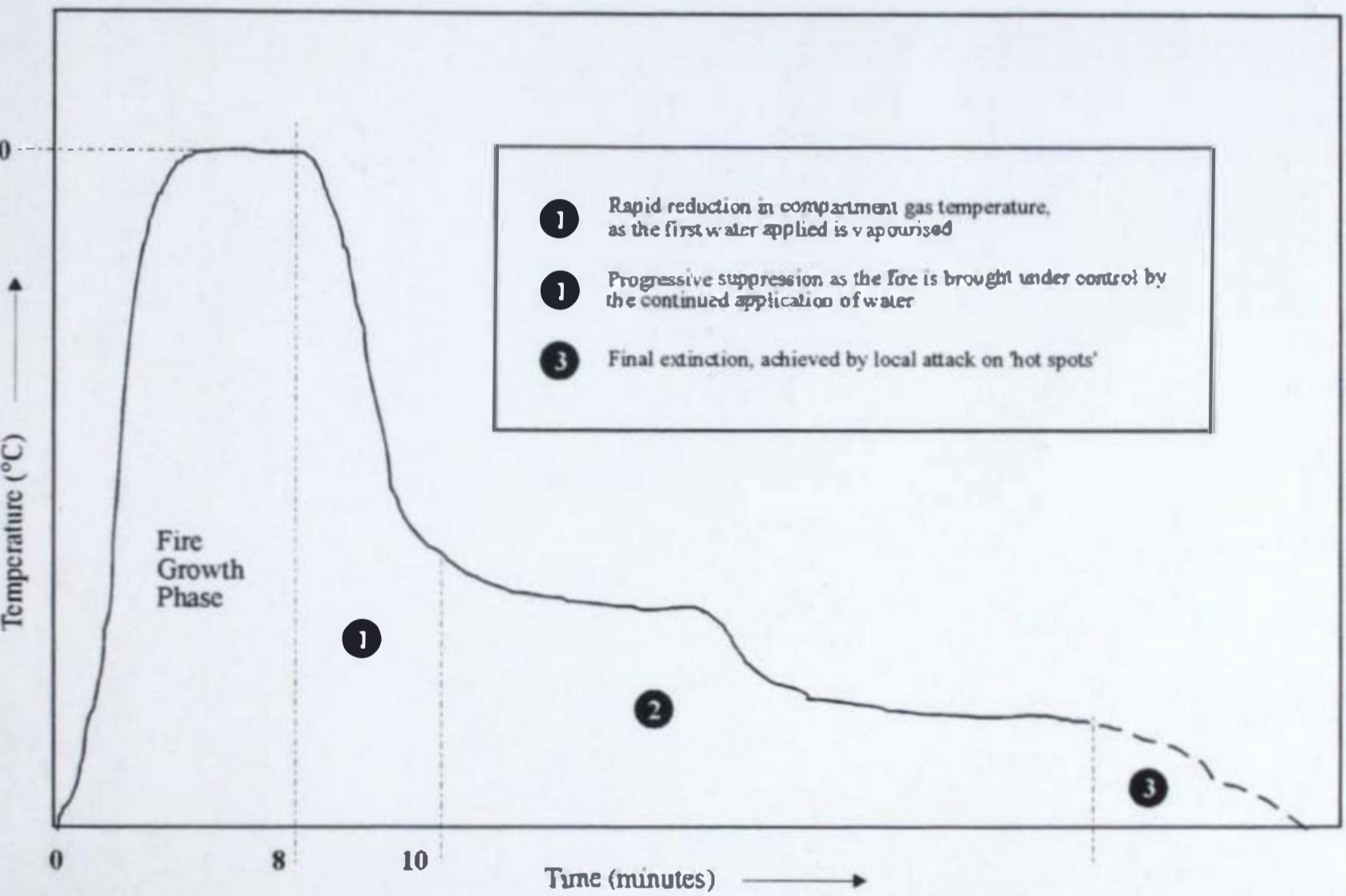

Figure 32. Schematic of phases of fire suppression and extinction (after Reference 32)

APPENDIX 1

Year	Project Name	Location	Start Date	End Date	Status	Notes
1980
1981
1982
1983
1984
1985
1986
1987
1988
1989
1990
1991
1992
1993
1994
1995
1996
1997
1998
1999
2000
2001
2002
2003
2004
2005
2006
2007
2008
2009
2010
2011
2012
2013
2014
2015
2016
2017
2018
2019
2020
2021
2022

Table A1. Summary of experimental data on water suppression and extinction of open fires

Ref. (date)	Fuel & geometry	Pre-burn period	Spray type	Flow rate (l.min ⁻¹)	Application density (l.m ⁻² .min ⁻¹)	Total water (l)	Notes
150 (1960)	Class B pool fires (0.3 m): alcohol, benzole, petrol, kerosene	0.02-8 min	Vertically downwards 157 < D ₃₀ < 250 μm 230 < D ₃₂ < 430 μm	-	0.16-0.4	-	Most efficient sprays were those with fine droplets, high rates of water flow & high velocities of entrained air
151 (1945)	Rotating cribs of Corsican pine (51 mm square sticks, A _f ~ 7.2 m ²)	38% of initial fuel mass	Single horizontal water spray	-	$\dot{m}''_{wc} \sim 0.1$	-	Extinguishment by fuel cooling
153 (1973)	Japanese cedar wood crib	-	Horizontal spray, applied manually to 2 sides of crib	-	$\dot{m}''_{wc} \sim 0.15$	-	-
154 (1975)	Eastern white pine cribs (~ 0.2 m cubed) and pallets (~ 1.2 m cubed)	cribs: 5-20% of initial mass	Vertically downwards	~ 0.05-0.4	cribs: $\dot{m}''_{wc} \sim 0.11 - 0.14$ (5% & 20% pre-burns respectively)	-	Simple empirical correlation was established to relate fuel consumed during suppression to application rate and pre-burn mass loss
		pallets: 10-20% of initial fuel mass	"	"	pallets: $\dot{m}''_{wc} \sim 0.15$ (all pre-burn values)	-	
155 (1976)	Sugar pine cribs	10-30% of initial fuel mass	4 horizontal nozzles	-	$\dot{m}''_{wc} \sim 0.09$ ('loose' cribs) $\dot{m}''_{wc} \sim 0.18$ ('dense' cribs)	-	-
158 (1985)	Japanese cedar cribs	20, 40 or 60% of initial fuel mass	Manual application of water stream	-	$\dot{m}''_{wc} \sim 0.07-0.23$	-	\dot{m}''_{wc} was reduced with shorter pre-burn time and application from bottom to top of crib
156 (1976)	Sugar pine vertical slabs	30-60% of initial fuel mass	2 horizontal nozzles	-	$\dot{m}''_{wc} \sim 0.11$	-	-

Table A1. (continued)

Ref. (date)	Fuel & geometry	Pre-burn period	Spray type	Flow rate (l.min ⁻¹)	Application density (l.m ⁻² . min ⁻¹)	Total water (l)	Notes
159 (1991)	UL standard wood cribs; 3-A: 57 kg 6-A: 96 kg 10-A: 187 kg	5-6 min	Manual attack with hosereel/ spray " "	32-103 " "	3.2-10.2 1.9-6.3 1-3.2	6-10 13-16 22-90	For 'large' fires, $\dot{m}''_{wc} \sim 1.7 \text{ l.m}^{-2}.\text{min}^{-1}$
34 (1994)	BS 5423:27A wood crib, $A_f \sim 24.3 \text{ m}^2$	8 min	Manual attack with hosereel/ spray	100	4.1	45	extinguished in 27 s
160 (1992)	10 kg wood crib (0.5 x 0.5 x 2.5m)	3	12 water mist nozzles	8-20	-	-	Fires not extinguished
161 (1980)	2.7 cm diameter charcoal cylinders	-	60-120 μm spray droplets	-	$\dot{m}''_{wc} \sim 0.6-1.2$	-	Enhanced burning observed due to dislocation of ash by mist impingement
162 (1975)	Various plastics: as vertical slabs (178 x 356 x 50 mm) and pool fires (178 x 178 x 50 mm)	-	Horizontal & vertical (downward facing) nozzles for slab & pool fires respectively	-	$\dot{m}''_{wc} \sim 0.07-0.26$; for $\dot{Q}'' = 0$ $\dot{m}''_{wc} \sim 0.19-0.45$; for $\dot{Q}'' = 8.4 \text{ kW.m}^{-2}$	-	$\dot{m}''_{wc} \sim 1.07 \text{ l.m}^{-2}.\text{min}^{-1}$ for polystyrene (PS) data extrapolated to $\dot{Q}'' \sim 63 \text{ kW.m}^{-2}$
163 (1994)	Plastic cribs (made from rods 15 mm diameter x 330 long) and foam plastic slabs	0-5 min	Vertically downward spray	-	15-23	-	Extinguishment time \propto pre-burn time; 'wet water' yielded more rapid extinction
164 (1996)	Slabs (50 x 50 x 20 mm) of PMMA, PS & white pine	1 min pre-heat & 1 min pre-burn	Vertically downward spray; either $d_m \sim 200 \mu\text{m}$ or $400 \mu\text{m} < d_m < 1000 \mu\text{m}$	0.005-0.01	-	-	Extinguishment time decreased with higher flow rate, approaching an asymptotic limit
168 (1985)	3-6 m high stacks of wooden pallets, cribs & cardboard cartons	-	Sprinkler heads discharging vertically downwards	-	$\dot{m}''_{wc} \sim 0.11$ (pallets), 0.13 (cribs) & 0.18 (cardboard boxes)	-	See also equation (92) in Section 7.2.2

Table A2. Summary of experimental data on water suppression and extinction of compartment fires

Ref. (date)	Fuel & geometry	Room volume (m ³)	Pre-burn period	Spray type	Flow rate (l.min ⁻¹)	Application density (l.m ⁻² .min ⁻¹)	Total water (l)	Notes
149 (1955)	150 mm cubed white pine cribs	1.2	10 min	horizontal & vertically downwards	-	$\dot{m}''_{wc} \sim 4$	-	optimum drop size, $D_{50} \sim 300-400 \mu\text{m}$ fastest extinguishment with horizontal sprays & sealed compartment deep-seated fires not well extinguished by sprays-frequent burnback
157 (1976)	rotating 35 kg wood crib ($A_f \sim 1 \text{ m}^2$), $\dot{m}_f \sim 5-6 \text{ kg.min}^{-1}$	0.13	-	vertically downward	0.85	0.85	-	Heat production reduced by 15-18%, but fire not extinguished.
173 (1954)	compartment with fibreboard walls & ceiling	15	2-4 min	spray & solid jet	10	$\sim 0.67 \text{ l.min}^{-1}.\text{m}^{-2}$	2.7-4.5	Extinguishment time $\sim 20-24 \text{ sec}$, for sprays & solid jets
173 (1954)	model room with fibreboard walls & ceiling	0.13	1.5-2 min	spray & solid jet	variable	$\sim 4-17 \text{ l.min}^{-1}.\text{m}^{-2}$	-	Sprays more efficient than jets at all application rates $> 1.6 \text{ l.min}^{-1}.\text{m}^{-2}$; 0.8-1.6 l.m ⁻² total water delivery advised for typical room fires
174 (1955)	ventilated room containing furniture	43	-	spray & solid jet	~ 180	$4.2 \text{ l.min}^{-1}.\text{m}^{-2}$	55	Extinction water demand $\sim 1.3 \text{ l.m}^{-2}$

Table A2. (continued)

Ref. (date)	Fuel & geometry	Room volume (m ³)	Pre-burn period	Spray type	Flow rate (l.min ⁻¹)	Application density (l.m ⁻² . min ⁻¹)	Total water (l)	Notes
175 (1960)	590 MJ.m ⁻² wood fire-load: vented room, $A \sim 19 \text{ m}^2$, A_v $\sim 6 \text{ m}^2$	49	$\sim 5 \text{ min}$	solid jets & impinging jet sprays with 30° cone angle	23-114	$\sim 1.2-6$ (based on floor area) or $0.5-2.3 \text{ l.min}^{-1}.\text{m}^{-2}$	77 (4 l.m ⁻²)	0.65 l.m ⁻³ total water required for fire control (32 l) & 1.6 l.m ⁻³ for extinction
176 (1970)	1 or 2 test rooms (3.66 x 3.66 x 2.44 m high), $A_v \sim 4 \text{ m}^2$; Class 'A' fire-load \sim 22 kg.m ⁻²	33 1 room	$\sim 2-3 \text{ min}$	25 mm hosereel/spray	25-76 (1 room)	$\dot{m}''_{wc} \sim 1.9$ ~ 5	9-30 28-42	Maximum efficiency (0.3-0.9 l.m ⁻³) Recommended rate (0.8-1.3 l.m ⁻³)
					68-112 (2 rooms)	$\dot{m}''_{wc} \sim 2.2$ ~ 3.7	- 120-243	Maximum efficiency Recommended rate (1.6-3.2 l.m ⁻³)
					38 mm hose-line/spray	232 (2 rooms)	~ 7.5	much higher
176 (1970)	commercial occupancy	50-100	-	38 mm hose-line/spray	-	-	-	control achieved at rates of $\sim 6.5 \text{ l.m}^{-2}$
179 (1986)	20 kg wood crib in particle board compartment $\sim 2.4 \times$ $3.6 \times 2.4 \text{ m}$ high, A_v $\sim 1.6 \text{ m}^2$	~ 21	$\sim 5-7 \text{ min}$	jet nozzle (2 bar)	46	-	10.7	additional 17 l needed to extinguish embers
				spray nozzle (2 bar)	46	-	7	flame-out
				jet nozzle (2 bar)	17.8	close to critical rate of $\sim 7.8 \times 10^{-3} \text{ l.m}^{-2}$	-	flame-out
182 (1991)	wooden crib fires; total mass $\sim 194 \text{ kg}$, $A_f \sim 39.2 \text{ m}^2$ $\dot{Q}_{max} \sim 1.8-2.6 \text{ MW}$	15	$\sim 12 \text{ min}$	various sprays with 60° cone angles	16.3	0.42	-	No extinguishment
					36.5	0.93 ($\sim \dot{m}''_{wc}$)	-	Fire just controlled
					79	2.0	-	Fire extinguished easily

Table A2. (continued)

Ref. (date)	Fuel & geometry	Room volume (m ³)	Pre-burn period	Spray type	Flow rate (l.min ⁻¹)	Application density (l.m ⁻² . min ⁻¹)	Total water (l)	Notes
183 (1991)	UL standard 3-A wood crib: 57-68 kg, within 4.3 x 2.3 x 2 m high room	198	< 1.5 min ('small' fire)	19 mm hosereel/vari-nozzle	568	-	48	Water volume for extinguishment found to be 15-50 times greater than similar-sized (UL 3-A crib) unconfined fires (Reference 176)
			3-8 min ('medium' fire)	"	"	76-227		
			8-15 min ('large' fire)	"	"	151-379		
32 (1990)	2 no. 27A cribs plus 1 no. 34A crib to BS542: $A_r \sim 128 \text{ m}^2$, mass $\sim 500 \text{ kg}$, $A_v \sim 6 \text{ m}^2$	50	8 min ($\dot{Q} \sim 6 \text{ MW}$)	various hosereel systems with cone angles of 26° mounted on remote firefighting rig; one test used manual operation of the branch as a control experiment	100	~ 0.78	~ 250	Fire was extinguished in $\sim 2\frac{1}{2}$ minutes by an experienced firefighter; final extinction was not possible using only the remote rig
189 (1993)	diesel pool & diesel spray fires	70	-	fine water spray nozzle with 90° cone angle	10	-	4-5	$m_w \sim 0.06-0.071 \text{ m}^{-3}$ for 'large fires'; $m_w \sim 0.4-0.61 \text{ m}^{-3}$ for 'small fires'