

INTERACTIONS BETWEEN PEPTIDES AND MONOAMINES
IN THE CONTROL OF THE RELEASE OF HORMONES
FROM THE ADENOHYPHYSIS

BY

AVRIL M. HORN

Thesis submitted for the Degree of Doctor of Philosophy

University of Edinburgh
January 1984.



This thesis is dedicated to my parents

I declare that the studies presented in this thesis are the result of my own independent investigation with the exception of

- i) the initial radioimmunoassays for vasopressin and oxytocin which were carried out in collaboration with Dr. I.C.A.F. Robinson (National Institute for Medical Research, London).
- ii) implantation of electrodes and intracerebroventricular cannulae for the studies described in Chapter 8 which were carried out by Dr. G. Fink, who also carried out the procedure of adrenalectomy for the same studies.
- iii) the radioimmunoassay for oestradiol-17 β in Chapter 6 which was carried out by Mr. H. Dick, and the radioimmunoassay for TSH in Chapter 7 which was carried out by Mr. W. J. Sheward.

This work has not been and is not being concurrently submitted for candidature for any other degree.

Alice M. Horn

Candidate

George Fink
13/1/84

Supervisor

Some of the results presented in this thesis have been published as follows:

D.K. Sarkar, Avril Horn, R.C. Dow, A.C. Cuello and G. Fink (1981).

Uptake and electrically-induced release of ^3H -dopamine by stalk median eminence in vitro

Procs. of the Endocrine Society, 63rd Ann. Meeting,
June 17-19, Cincinnati, U.S.A.

G.W. Arbuthnott, A. Horn and V. Kapoor (1982).

Comparison of dopamine overflow from stimulated slices of the neostriatum and median eminence 'in vitro'.

British Journal of Pharmacology 77, p.360 Proceedings Supplement.

G. Fink, A.M. Horn and I.C.A.F. Robinson (1983).

Vasopressin and oxytocin in hypophysial portal blood.

Journal of Physiology, in press. Proceedings of the Physiological Society, September, 1983.

ABBREVIATIONS

ADR	adrenaline
AH	anterior hypothalamic area
ARC	arcuate nucleus
CRF	corticotrophin releasing factor
CRH	corticotrophin releasing hormone
DA	dopamine
DOPAC	dihydroxyphenylacetic acid
DR	dorsal raphe nucleus
EL	external layer
5-HT	5-hydroxytryptamine (serotonin)
5-HTP	5-hydroxytryptophan
5-HIAA	5-hydroxyindoleacetic acid
i.c.v.	intracerebroventricular
i.p.	intraperitoneal
i.v.	intravenous
KH	Krebs-Heinsleit buffer
MBH	medial basal hypothalamic area
ME	median eminence
MPOA	medial preoptic area
MR	medial raphe nucleus
NA	noradrenaline
OB	oestradiol benzoate
OE	oestradiol-17 β
OT	oxytocin
OVLT	organum vasculosum lamina terminalis
OVX	ovariectomized
P	progesterone
PCPA	parachlorophenylalanine
PD	pars distalis
PH	posterior hypothalamic area
PI	pars intermedia
PIF	prolactin inhibitory factor
PN	pars nervosa
POA	preoptic area
PRF	prolactin releasing factor
PVN	paraventricular nucleus
R	raphe nuclei

S.C.
SCN
SOHT
SON

subcutaneous
suprachiasmatic nucleus
supraopticohypophysial tract
supraoptic nucleus

TIDA

tuberoinfundibular dopaminergic

VP

vasopressin

ACKNOWLEDGEMENTS

I would like to thank the SERC for providing personal support, Professor B.L. Ginsborg for the opportunity to study in the Department of Pharmacology, and Dr. George Fink and the MRC for the opportunity to carry out these studies in the MRC Brain Metabolism Unit within the Department of Pharmacology. Special thanks go to Dr. Fink, my supervisor, to whom I am indebted for expert advice, and unflinching encouragement throughout the course of this project. Thanks also go to Dr. Brian Tiplady of Astra Pharmaceuticals for useful discussion, for supplies of alaproclate and zimelidine and for some very pleasant lunches.

Much valuable and helpful technical assistance, particularly concerned with radioimmunoassays was given at various times by Mrs. Roberta Rosie, Mrs. Graciela Sanchez-Watts and Mr. John Sheward. The assay for oestradiol-17 β in Chapter 6 was carried out by Mr. Heinz Dick. Dr. A. Watts gave much appreciated help in the use of the HPLC-LCED system. The anti-TRH serum used in the studies in Chapter 7 was kindly provided by Dr. H. Fraser of the MRC Reproductive Biology Unit, Edinburgh. Thanks go to Dr. Iain Robinson and his technical staff at the National Institute for Medical Research, for carrying out the initial radioimmunoassays for vasopressin and oxytocin and later for the provision of laboratory space to carry out these assays during a few enjoyable visits to London.

Many thanks also go to Mrs. Jean Hunter and her staff for their excellent care of the animals used in these studies and for a useful education in the handling of small animals.

Heartfelt thanks are given to Norma Brearley, Jo Donnelly and Celia Leitch for their expert typing of this thesis.

I should like to express my gratitude to all members of the MRC Brain Metabolism Unit for their help during the course of these studies and for making the time spent there so enjoyable.

Finally, special thanks go to Kevin, my sister Fiona, my brother Wylie and my parents for their support, particularly during the last stages of this thesis; for keeping everything in perspective, love and thanks to them and to my Cardiff family.

There is no subject so old that something
new cannot be said about it.

Dostoevsky

'A Diary of a Writer"

1876

ABSTRACT OF THESIS

Interactions between various hypothalamic peptides and monoamines in the control of the release of luteinizing hormone (LH) and prolactin (PRL) have been investigated in the rat. Attention was focussed on serotonin (5-HT), dopamine (DA), thyrotropin-releasing hormone (TRH), vasopressin (VP) and oxytocin (OT).

The release of ^3H -DA from the median eminence (ME) in vitro was studied with a view towards developing this system to investigate interactions between monoaminergic transmitters and hypothalamic peptides. Electrical stimulation released ^3H -DA from the ME in a Na^+ and Ca^{2+} dependent manner, and neither basal nor stimulated release was changed significantly during different phases of the oestrous cycle, or by DA agonists or antagonists, luteinizing hormone releasing hormone (LHRH), TRH or PRL. Nomifensine, a DA uptake blocker, caused a significant increase in the electrically-stimulated but not basal release of ^3H -DA. It did not prove possible to adapt this system for the investigation of 5-HT function and so all further studies were carried out in vivo.

The 5-HT reuptake blockers, alaproclate and zimelidine, were investigated to determine their effects on the steroid-induced surges of LH and PRL in the pro-oestrous female rat and in a number of experimental models. Alaproclate, but not zimelidine, caused changes in the peripheral concentrations of LH and PRL, and the direction of change was dependent upon the steroid status of the animal. These changes may have been due to changes in central 5-HT transmission since there was a significant decrease in the ratio of 5-hydroxyindoleacetic acid (5-HIAA) to 5-HT in the posterior hypothalamus and raphe nuclei in those animal models which had shown changes in LH and PRL. The spontaneous, pro-oestrous PRL surge was abolished by injection of the 5-HT synthesis inhibitor, parachlorophenylalanine (PCPA), and was delayed but not abolished by the injection of a specific antiserum to TRH, a putative PRL-releasing factor. The action of PCPA was possibly due to a reduction in the plasma concentration of oestradiol-17 β .

Vasopressin and oxytocin were present in hypophysial portal plasma at concentrations significantly higher (~ 20-50 fold) than those in peripheral plasma. In Brattleboro rats, VP was undetectable in both portal and peripheral plasma. Several experiments showed that VP and OT in portal blood was derived from nerve terminals in the ME. However, hypothalamic stimulation with a stimulus that significantly increased the release of LHRH did not increase the release of VP and OT which was also unaffected by alaproclate, PCPA or experimental manipulation of the plasma glucocorticoid concentrations. A likely explanation for this result is that under the experimental conditions used here, the release of VP and OT is at a maximum and, therefore, cannot be increased further.

CONTENTS

	Page
Abbreviations	v
Acknowledgements	vii
Abstract of Thesis	x
Chapter 1 <u>Introduction</u>	1
1.1 Development of the neurohumoral hypothesis	
1.2 The releasing factor concept	
1.3 Neuroanatomical considerations	
1.4 Control of the release of luteinizing hormone	
1.5 Control of the release of prolactin	
Chapter 2 <u>Materials and Methods</u>	42
2.1 Animals	
2.2 Surgical and experimental procedures	
2.3 Radioimmunoassay	
2.4 High pressure liquid chromatography	
Chapter 3 <u>The Release of ^3H-Dopamine from the Median Eminence 'in vitro'</u>	65
3.1 Introduction	
3.2 Materials and Methods	
3.3 Results	
3.4 Discussion	
Chapter 4 <u>The Effects of Inhibition of Uptake of Serotonin on the Concentration of Luteinizing Hormone and Prolactin in Plasma in Various Animal Models</u>	84
4.1 Introduction	
4.2 Materials and Methods	
4.3 Results	
4.4 Discussion	

	Page
Chapter 5 <u>The Effects of Inhibition of the Uptake of Serotonin on the Concentration of Serotonin and 5-Hydroxyindole Acetic Acid in the Brains of Various Animal Models</u>	106
5.1 Introduction	
5.2 Materials and Methods	
5.3 Results	
5.4 Discussion	
Chapter 6 <u>The Effects of Inhibition of the Synthesis of Serotonin on the Concentration of Luteinizing Hormone and Prolactin in Plasma in the Pro-oestrous Rat</u>	119
6.1 Introduction	
6.2 Materials and Methods	
6.3 Results	
6.4 Discussion	
Chapter 7 <u>The Effects of an Injection of Anti-TRH Serum on the Concentration of Prolactin in Plasma in the Pro-oestrous Rat</u>	125
7.1 Introduction	
7.2 Materials and Methods	
7.3 Results	
7.4 Discussion	
Chapter 8 <u>Vasopressin and Oxytocin in Hypophysial Portal Blood</u>	134
8.1 Introduction	
8.2 Materials and Methods	
8.3 Results	
8.4 Discussion	
Chapter 9 <u>Summary</u>	154
Bibliography	161
Appendices	

CHAPTER 1

Introduction

INTRODUCTION

It has been known for many years that reproductive function can be modified by exteroceptive factors such as light, temperature and tactile stimuli (Marshall, 1936, 1942). Since these factors exert their actions through the nervous system, a functional link between the nervous and endocrine systems has been proposed to be involved in the control of reproductive function. The pituitary gland has been shown to be essential for reproductive function since reflex ovulation in the rabbit was inhibited after removal of the pituitary gland (Fee and Parkes, 1929) and in the rat, mammary involution occurred after removal of the gland (Jacobsohn and Westmann, 1946). In addition, extracts of anterior pituitary gland (PD)* stimulated ovulation in rabbits (Bellerby, 1929a, b). It had been demonstrated that the reflex ovulation occurring in rabbits in response to coitus involved both neural (Marshall and Verney, 1936) and humoral factors (Friedman, 1929) but the connection between the two types of stimuli was unknown. These and many other studies (Harris, 1948, 1955) led to the concept of the existence of a neural link between the pituitary gland and the central nervous system (CNS) controlling the release of hormones from the gland. The nature of this link became an area of intensive study and eventually the neurohumoral hypothesis was proposed.

*The definition of pituitary structure used in this thesis is that proposed by Wislocki and King (1936) of anterior pituitary gland = pars distalis (PD), and posterior pituitary gland = pars nervosa (PN) and pars intermedia (PI).

1.1 Development of the neurohumoural hypothesis

It had been demonstrated many times that the posterior lobe of the pituitary gland was densely innervated (Cajal, 1894; Fisher, Ingram and Ranson, 1938) and that from its embryological origins the pars nervosa (PN) could be classified as a neural structure. However, the existence of a prominent innervation of the anterior lobe of the pituitary gland was in dispute (Harris, 1948) and although the anterior lobe is in close proximity to the posterior lobe, its embryological origins are from non-neural tissue (Hanström, 1966). There were reports of sympathetic and parasympathetic innervation of the anterior lobe (Dandy, 1913; Pines, 1925; Chorobski and Penfield, 1932; Cobb and Finesinger, 1932; Hair, 1938; Zacharias, 1941) but experiments designed to determine the role of these systems in the control of reproductive function yielded negative results. Rabbits still exhibited reflex ovulation in response to coitus after sympathectomy (Haterius, 1933a; Brooks, 1935) and stimulation of the cervical sympathetic nerves failed to produce ovulation in the same species (Haterius, 1933b; Friedgood and Cannon, 1936; Markee, Sawyer and Hollinshead, 1946). Similar results were obtained after destruction of the presumed parasympathetic innervation of the PD (Hair and Mezen, 1939; Vogt, 1942). Later work demonstrated that 'nerve fibres' in the PD revealed by histological staining were probably reticular fibres (Wingstrand, 1951) and Rasmussen (1938) and Green (1951) concluded that the PD was either not innervated or innervated so sparsely as to make it very unlikely that nerve fibres were the major secretory route for active substances to pass from the CNS to

the PD.

Despite these observations, there were still indications of a neural link between the CNS and the activity of the PD. Ovulation could be induced in the rabbit and in the rat by the application of an electrical stimulus to the head (Harris, 1936; Marshall and Verney, 1936) an effect later localized to the hypothalamus (Harris, 1937; Haterius and Derbyshire, 1937). There was some dispute concerning the effect of electrical stimulation of the pituitary gland. Although direct electrical stimulation of the PD could induce ovulation in the anaesthetized rabbit (Harris, 1937; Markee et al., 1946), remote control stimulation of the PD in the conscious rabbit had no effect on ovulation (Harris, 1948). The differences between these results could have been due to differences in magnitude of the applied stimuli, since the stimuli applied in the earlier studies were likely to be much greater than those applied in the later study of Harris (1948). There is also a possibility, however remote, that the gross stimulation (Harris, 1937; Markee et al., 1946) led to changes in the electrical excitability of the cells of the PD (Poulsen and Williams, 1976; Taraskevich and Douglas, 1977) and consequently to changes in hormone release.

Due to the relative paucity of nerve fibres in the PD, a few authors had tentatively suggested the existence of a humoral link between the PD and the hypothalamus that might be important in the control of the activity of the PD (Friedgood, 1936; Harris, 1937; Hinsey, 1937; Brooks, 1938; Taubenhaus and Soskin, 1941). The necessary anatomical connection for a direct humoral link between the hypothalamus and the pituitary gland was first described by Popa

and Fielding (1930, 1933) and confirmed by Wislocki and King (1936). Although both groups of investigators described a system of portal vessels in the pituitary stalk, consisting of a large number of fine vessels in the hypothalamus that united into large trunks in the pituitary stalk before breaking up into a second set of capillaries in the pituitary gland, they differed in their interpretations of the direction of blood flow within the vessels. While Popa and Fielding (1930, 1933) believed that the direction of flow was probably from the pituitary gland towards the hypothalamus, Wislocki and King (1936) thought that blood flowed in the opposite direction, from hypothalamus to pituitary gland. This difference of interpretation persisted until flow through these vessels was observed in the living animal. Blood flow in this system in the anaesthetized toad was demonstrated to be from the hypothalamus to the pituitary gland (Houssay, Biasotti and Sammartino, 1935). These observations were later confirmed in the rat (Green and Harris, 1949). Despite these findings, there continue to be disputes concerning the direction of blood flow in these hypophysial portal vessels. There have been many claims of evidence consistent with the existence of flow of blood from the anterior pituitary gland to the hypothalamus (Török, 1962; Ambach, Palkovits and Szentagothai 1976; Oliver, Mical and Porter, 1977; Bergland and Page, 1978) perhaps by way of the posterior pituitary gland (Bergland and Page, 1979). However, a recent study of blood flow in the ME and pituitary gland in the anaesthetized pig demonstrated that there was no evidence for blood flow from the pituitary gland to the ME although there was evidence for intra-pituitary blood flow from the

PN to the PD (Page, 1983).

Experiments designed to sever any link, whether humoral or neural, between the pituitary gland and the hypothalamus yielded contradictory results concerning the degree of control exerted by the hypothalamus over the activity of the PD (Richter, 1933; Dempsey and Uotila, 1940; Dempsey and Searles, 1943; Jacobsohn and Westmann, 1945). Although this may have been due to incomplete sectioning of the pituitary stalk, allowing the persistent expression of a neural or a humoral control, the inconsistencies were probably due to differing degrees of regeneration of the hypophysial portal vessels after stalk section (Harris, 1950, 1955; Harris and Jacobsohn, 1952; Nikitovitch-Winer and Everett, 1958) leading to differing degrees of reconnection of the hypothalamus and the pituitary gland. Difficulties of interpretation in these experiments also arose due to the probable release of hormones from the degenerating gland which undergoes necrosis after stalk section (Daniel and Pritchard, 1956). This phenomenon is well-documented for hormones of the PN: after stalk section or lesion of the supraopticohypophysial tract (SOHT) (Chapter 8), urine output occurs in three different phases, a rapid increase for 1-2 days followed by a decrease for the next few days and then a permanent phase of polyuria after 5-8 days (Fisher et al., 1938); the phase of decreased urine production does not occur if the PN is removed at the time of cutting the pituitary stalk (O'Connor, 1952).

Transplantation of endocrine organs is a classical procedure in the study of endocrine function which revealed much information concerning the mechanisms of control of these organs (e.g. Marshall

and Jolly, 1907; Manley and Marine, 1916; Moore, 1926; Wyman and Tum Suden, 1937). This was also to prove true of studies on the mechanisms of control of the transplanted pituitary gland.

Although the vascular link to the PD from the hypothalamus had been demonstrated to be important for the maintenance of functional activity of the PD, it was not until studies were carried out on the transplanted pituitary gland that the importance of the physical contact between the pituitary gland and the hypothalamus was realized. When the PD was transplanted to other areas in hypophysectomized animals, such as into the ocular chamber (Westmann and Jacobsohn, 1940), under the kidney capsule (Nikitovitch-Winer and Everett, 1958) or below the temporal lobe (Harris and Jacobsohn, 1952), although the tissue was well vascularized, there was almost no resumption of functional activity of the PD. However, Everett (1954) found a marked luteotrophic response in the ovaries of hypophysectomized animals implanted with PD tissue under the kidney capsule. This was the first demonstration that the 'luteotrophic factor' of the PD, now recognized as prolactin, was secreted at a greater rate after removal of the PD from the influence of the hypothalamus. The lack of complete functional activity of the transplanted pituitary glands in spite of good vascularization was in marked contrast to the maintenance of activity observed in studies concerning the transplantation of peripheral endocrine organs (Marshall and Jolly, 1907; Manley and Marine, 1916; Moore, 1926; Wyman and Tum Suden, 1937). Full functional activity of the PD only returned when pituitary tissue was transplanted immediately below the cut pituitary stalk of hypophysectomized animals, where it

could become vascularized by the hypophysial portal vessels of the ME (Harris and Jacobsohn, 1952). These observations indicated therefore that it was the vascular link between the hypothalamus and the pituitary gland that was of critical importance in the control of the functional activity of the gland. The importance of the vascular link was confirmed by Benoit and Assenmacher (1953) in their studies on birds. The PD and PN of the pituitary gland in birds are separated by a thick connective septum, which enables sectioning of either the nerve fibres or of the hypophysial portal vessels in the pituitary stalk, a procedure not possible in most mammals due to the close anatomical association of these structures. Benoit and Assenmacher (1953) demonstrated that reproductive function was maintained after sectioning of the nerve fibres of the pituitary stalk but not after sectioning of the hypophysial portal vessels, and they therefore concluded that the vascular link was of vital importance in the control of PD function.

Once the neurohumoural hypothesis of control of the function of the PD had been established there still remained the question as to the mechanism of control. Early ideas such as control being exerted by means of nervous regulation to change blood flow to the PD or by some 'filtering' mechanism for hormones from peripheral endocrine organs, leading to differences in feedback and so to differences in the release of PD hormones, received little support. The currently accepted view of the means of regulation of anterior pituitary function is embodied in the releasing-factor concept.

1.2. The releasing factor concept

The releasing factor concept has been reviewed in detail (e.g.

Harris, 1955, 1972; Schally, Arimura and Kastin, 1973; Fink, 1976). Empirical studies into the nature of the humoral substances that might act as releasing-factors investigated those substances that were known to act as transmitter agents in the peripheral nervous system. The demonstration by Taubenhaus and Soskin (1941) that pseudopregnancy could be induced in rats by application of a mixture of acetylcholine (ACh) and prostygmine suggested that there was perhaps an acetylcholine-like humoral transmission between the hypothalamus and the pituitary gland. However, later work by Feldberg and Vogt (1954) showed that there was very little choline-acetyltransferase activity in an area of brain containing the ME and so rendered the idea of an ACh-link unlikely. Markee, Sawyer and Hollinshead (1948) reported that an injection of adrenaline (ADR) into the pituitary gland could stimulate ovulation in the rabbit and that the reflex ovulation that occurs in this species after coitus could be blocked by the administration of a sympatholytic drug within one minute of copulation. These results received support from the demonstration of the presence of high concentrations of NA and ADR in the hypothalamus (Vogt, 1954). However, these results were criticized because of the high concentrations of ADR that were required to be effective (Harris, 1955), the possible non-specific actions of the sympatholytic drugs used (Nickerson, 1949), and the fact that studies by Donovan and Harris (1956) suggested that the ovulation induced by the injection of ADR into the pituitary gland could have been due to the low pH of the injection fluid rather than the ADR. More recent data has demonstrated that a direct action of these

neurotransmitter agents on anterior pituitary function is unlikely in the majority of cases (Weiner and Ganong, 1978; Kordon Enjalbert, Hery, Joseph-Bravo, Rotsztejn, and Ruberg, 1980; Meites and Sonntag, 1981) and that the action is of an indirect nature through the releasing hormones of the hypothalamus.

The observation that ACTH and vasopressin (VP) are frequently released together after physiological stimuli suggested that neurohypophysial hormones might be involved in the release of ACTH, and by extension in the release of other anterior pituitary hormones (McCann and Brobeck, 1954; Mirsky, Stein and Paulisch, 1954). However, studies by other workers demonstrated the presence of a releasing factor for ACTH in hypothalamic extracts and extracts of PN, that was not VP or oxytocin (OT), and that was active both in vivo and in vitro (Guillemin and Rosenberg, 1955; Saffran, Schally and Benfrey, 1955; Guillemin, Dear, Nicholas and Lipscomb, 1959; Schally and Guillemin, 1959) (see Chapter 8 for a detailed discussion of the status of VP as a CRF). With the realization that there was a distinct CRF present in hypothalamic tissue which did not appear to be related to known neural transmitters or neurohypophysial hormones, it was logical to search for other hypothalamic factors, similarly unrelated to known substances, that might regulate the secretion of PD hormones.

A broad review of the control of the release of hormones from the PD by releasing factors is beyond the scope of this thesis and therefore details are only discussed for LH and PRL. Several recent reviews have been published concerning the control of hormones of the PD by releasing factors (McCann, 1980, 1982; Vale, Rivier and

Brown, 1980; Meites and Sonntag, 1981; Yasuda, Greer and Aizawa, 1982).

1.2.1 Luteinizing hormone-releasing hormone

Luteinizing hormone-releasing activity was demonstrated in ME/hypothalamic extracts by a number of workers in the early sixties using various in vivo methods. Ovulation in the rabbit and in the pentobarbital-blocked rat could be stimulated by intrapituitary injections of ME extracts (Nikitovitch-Winer, 1962; Campbell, Feuer and Harris, 1964). Injections of extracts from other brain areas or of a number of other active substances were ineffective. Injections of the extract were ineffective when injected into other areas of the pituitary gland. McCann, Taleisnik and Friedman (1960) demonstrated the LH-releasing activity of a hypothalamic extract, using the ovarian ascorbic acid depletion bioassay method of Parlow (1958). Subsequently it was shown that the extract could stimulate the release of LH from pituitary glands incubated in vitro (Schally and Bowers, 1964). If this factor with LH-releasing activity was active in vivo it was presumed that it must be released into the hypophysial portal vessels and so capable of being measured in portal blood. This was demonstrated initially by bioassay (Fink, Nallar and Worthington, 1967; Fink and Harris, 1970) and later by radioimmunoassay (Fink and Jamieson, 1976; Eskay, Mical and Porter, 1977). Although LH-releasing activity in hypothalamic tissue had been demonstrated in 1960, it was a decade before the releasing factor was isolated and characterized from porcine and ovine hypothalami (Matsuo, Baba, Nair, Arimura and Schally, 1971; Burgus, Butcher, Amoss, Ling, Monabian, Rivier,

Fellows, Blackwell, Vale and Guillemin, 1972). The synthetic decapeptide LHRH (pyro) Glu-His-Trp-Ser-Tyr-Gly-Leu-Arg-Pro-Gly-NH₂ stimulates LH and FSH release both in vitro and in vivo.

1.2.2 Prolactin-inhibiting factors and prolactin-releasing factors.

Unlike LH, the control of the release of PRL from the PD in the mammal is predominantly inhibitory (Everett, 1954; McCann, Dhariwal and Porter, 1968; Meites and Nicoll, 1966). The secretion of PRL from the PD in vitro (Meites, Kahn and Nicoll, 1967) is increased compared with secretion in vivo whereas secretion of other hormones is decreased, similarly when the PD is transplanted to sites distant from the ME, PRL secretion increases (Everett, 1954; McNeilly, Sharpe, Davidson and Fraser, 1978). The first observations of the presence of prolactin-inhibitory factor (PIF) activity in hypothalamic extracts were made in in vitro systems (Talwalker, Ratner and Meites, 1963; Kragt and Meites, 1967). The identity of PIF has been difficult to elucidate since it did not have the properties of a peptide, unlike other identified releasing factors (McCann and Porter, 1969). A role for the catecholamines in the regulation of the release of PRL was suggested by Kanematsu, Hilliard and Sawyer (1963) when they observed the induction of pseudopregnancy in rabbits after the administration of reserpine. However, it was not until the anatomical observations of Hökfelt and Fuxe (1967), showing DA-containing nerve terminals in the ME adjacent to the portal blood vessels, that a direct action of the monoamines on the release of PRL from the PD could be proposed. Further evidence for a possible direct action came from the demonstration by Van Maanen and Smelik (1968) of the induction of

pseudopregnancy in the rat after local depletion of monoamines in the ME. Direct inhibition of the release of PRL by DA in vitro was demonstrated a few years later (Birge, Jacobs, Hammer and Daughaday, 1970; MacLeod, Fontham and Lehmyer, 1970) and a significant proportion of PIF activity in hypothalamic extracts was identified as DA (Shaar and Clemens, 1974). It has now been shown that the concentration of DA in hypophysial portal blood is sufficient to inhibit the release of PRL from the PD in vivo (Ben-Jonathan, Oliver, Weiner, Mical and Porter, 1977; Gibbs and Neill, 1978; Plotsky, Gibbs and Neill, 1978). However, unlike the relative certainty concerning the role of LHRH, there is growing scepticism as to the identity of DA as the sole PIF (Leong, Frawley and Neill, 1983). Additional PIFs have been proposed such as GABA (Schally, Redding, Arimura, Dupont and Linthicum, 1977; Enjalbert, Ruberg, Arancibia, Fiore, Priam and Kordon, 1979; Racagni, Apud, Locatelli, Cocchi, Nistico, di Giorgio and Muller, 1979), catecholoestrogens (Linton, White, de Tineo and Jeffcoate, 1981) and histidyl-proline-diketopiperazine (a metabolite of TRH, itself proposed as a prolactin-releasing factor (PRF) (Tashjian, Barowsky and Jensen, 1971; Enjalbert, Ruberg, Arancibia, Priam and Kordon, 1979).

That PRL may also be under a degree of stimulatory control is suggested by a number of observations. Abrupt increases in PRL secretion are known to follow ether stimuli, anaesthesia or suckling (Terkel, Blake and Sawyer, 1972) which cannot be solely accounted for by decreased DA transmission (Plotsky and Neill, 1982). Extracts of hypothalamus induced lactation in oestrogen-primed rats

(Meites, Talwalker and Nicoll, 1960) and injections of sodium pentobarbital only raised plasma PRL for 30 min, after which PRL was depressed, implying initial blockade of an inhibitory control and subsequent blockade of a stimulatory control (Wuttke and Meites, 1970). Prolactin releasing activity has also been identified in hypothalamic extracts tested in vitro (Nicoll, Fiordino, McKenney and Parsons, 1970; Arimura and Schally, 1977). The identity of a possible PRF is far from being elucidated with numerous substances being put forward for this role. In a recent review, Leong et al (1983) listed at least sixteen substances that have been reported to exhibit PRF activity, of which 5-HT (Wehrenberg, Nicol, Frantz and Ferin, 1980) TRH (Tashjian et al., 1971) LHRH (Denef, 1981) VP (Shin, 1982) OT (Forsling, Reinhard and Himmler, 1974; Lumpkin, Samson and McCann, 1983) and oestradiol (Zyzek, Dufy-Barbe, Dufy and Vincent, 1981) are of particular relevance to this thesis.

1.3 Neuroanatomical considerations

There is a vast amount of confusing evidence concerning the role of the hypothalamus in the control of the release of LH and PRL (Fink and Geffen, 1978; Weiner and Ganong, 1978; Barraclough and Wise, 1982). Before discussion of the aspects of this control as relevant to this thesis, a brief outline will be given of the neural pathways involved in the studies reported here.

As discussed in section 1.2.2, numerous substances have been proposed as PIFs and PRFs but the delineation of their distribution within the CNS is outwith the scope of this thesis. Therefore, only the distribution of those substances investigated in this thesis as possible PRFs and PIFs is considered.

1.3.1 Serotonin

The distribution of 5-HT in the CNS, and particularly in the hypothalamus, has been extensively studied by Descarries and Beaudet (1978) and by Parent, Descarries and Beaudet (1981) using autoradiographic techniques and by Steinbusch (1981) and Steinbusch and Nieuwenhuys (1981) using immunohistochemical techniques. The advantages and disadvantages of both detection techniques have been reviewed by Consolazione and Cuello (1982).

Most of the 5-HT in the brain originates from cell bodies in the raphe nuclei of the midbrain (Parent et al., 1981; Steinbusch, 1981). Projections from these nuclei extend widely throughout the brain and there is a dense 5-HT innervation within the hypothalamus (Descarries and Beaudet, 1978, Kent and Sladek, 1978). The concentration of 5-HT is highest in the arcuate (ARC) and suprachiasmatic nuclei (SCN) although all nuclei in the hypothalamus appear to contain some 5-HT (Saavedra, Palkovits, Brownstein and Axelrod, 1974). Recent work by Van de Kar and Lorens (1979) has suggested that the hypothalamus may be differentially innervated from the raphe nuclei, with the medial raphe (MR) nucleus supplying the anterior hypothalamus (AH) and the medial preoptic area (MPOA), and both the MR and dorsal raphe (DR) nuclei supplying the antero-lateral hypothalamus and the ARC. There is evidence for the existence of an intrahypothalamic 5-HT system since 20-30% of the total content of 5-HT was still present in the hypothalamus after electrolytic lesions of the DR nuclei and after deafferentation of the medio-basal hypothalamus (MBH) (Palkovits, Saavedra, Jacobowitz, Kizer, Zaborsky and Brownstein, 1977; Palkovits, Brownstein, Kizer,

Saavedra and Kopin, 1979). Cell bodies containing 5-HT have been demonstrated in hypothalamic nuclei by autoradiographic (Beaudet and Descarries, 1979) but not by immunohistochemical techniques (Steinbusch, 1981; Consolazione and Cuello, 1982).

Serotonin-containing fibres and terminals are present in the ME (Baumgarten and Lachenmayer, 1974; Calas, Alonso, Arnould and Vincent, 1974), and although it has been stated that there are no 5-HT-containing fibres in the PD (Steinbusch and Nieuwenhuys, 1982), a brief report by Westlund and Childs (1982) of the results of an immunocytochemical study, claims to demonstrate the presence of fine, varicose fibres containing 5-HT that extend over the surface of the PD and penetrate the first 2-3 layers of cells. However, the authors state that the origin of these proposed fibres is unknown, and the fact that the reaction product for 5-HT is situated alongside the blood vessels of the PD may cast some doubt as to a possible central neural origin of the 5-HT.

1.3.2 Dopamine

The detailed anatomy of the DA systems of the brain has been reviewed by Moore and Bloom (1978) and, therefore, only those areas of DA innervation directly relevant to this thesis will be discussed. Two hypothalamic systems are of relevance, the tuberohypophysial system and the incertohypothalamic system.

The cell bodies of the tuberohypophysial system are located in the ARC and periventricular areas of the hypothalamus (Björklund, Falck, Nobin and Stenevi, 1973) and projections pass ventrally to terminate in the PN (Smith and Fink, 1972), the PI (Björklund, Moore, Nobin and Stenevi, 1973) and the ME and pituitary stalk

(Björklund, Falck et al., 1973).

The cell bodies of the incertohypothalamic system are located in the posterior hypothalamus and zona incerta and in the periventricular nucleus (Lindvall, Björklund, Moore and Stenevi, 1974; Björklund, Lindvall and Nobin, 1975). This system supplies its surrounding areas with a network of short, diffuse fibres (Björklund et al., 1975).

1.3.3 Noradrenaline

The cell bodies of the NA systems in the brain are situated, like those of the 5-HT systems, in the brain stem (Moore and Bloom, 1979). The hypothalamus receives a rich, though diffuse NA innervation with the highest concentrations of NA being present in the retrochiasmatic area and the paraventricular (PVN) and dorsomedial nuclei. The majority of the hypothalamic nuclei receive innervation from NA cell bodies in the lateral tegmentum (Lindvall and Björklund, 1978). Exceptions to this are the supra-optic (SON), the dorsomedial, the PVN and the periventricular nuclei, which also receive projections from the locus coeruleus (Jones and Moore, 1977). The ME also contains some NA terminals from projections outwith the MBH, as shown by the presence of dopamine- β -hydroxylase in the ME (Fuxe et al., 1978) and its dramatic reduction after deafferentation of the MBH (Palkovits, 1979).

1.3.4 Luteinizing hormone-releasing hormone

There is a dense plexus of LHRH terminals in the external layer of the ME, particularly in the lateral regions (Selmanoff, 1981). There is also a significant LHRH terminal field in the organum

vasculosum lamina terminalis (OVLT) (Fuxe et al., 1978). A recent report has demonstrated the presence of widely-dispersed LHRH fibres in the rat CNS (Witkin, Paden and Silverman, 1982). It has proved difficult to determine the location of LHRH-containing cell bodies in the rat CNS, although several studies have now demonstrated the presence of these cell bodies within the MPOA and the SCN (Barry, Dubois and Poulain, 1973; Sétáló, Vigh, Schally, Arimura and Flerko, 1976; Kawano and Daikoku, 1981). The presence of LHRH-containing cell bodies within the MBH remains controversial although, as for 5-HT, the demonstration that 20-30% of the total LHRH content is still present in the MBH after deafferentation, indicates that there may be some intrinsic hypothalamic LHRH neurons. Although the majority of investigators have not been able to demonstrate LHRH-containing cell bodies in the MBH, a recent report (Kelly, Ronnekleiv and Eskay, 1982) demonstrated the presence of LHRH-containing cell bodies in the MBH and particularly in the ARC.

The LHRH terminals in the EL of the ME appear to be from cell bodies in the AH but projections to the lateral and medial regions of the ME follow different courses. The lateral regions of the ME receive projections from the septal and lateral POA which run laterally and then converge onto the ME. The medial region of the ME receives projections from the SCN and from near the optic chiasm which run ventrally and caudally before reaching the ME (Kawano and Daikoku, 1979; Réthelyi, Vigh, Sétáló, Merchenthaler, Flerko and Petrusz, 1981).

1.3.5 Thyrotrophin-releasing hormone

Thyrotrophin-releasing hormone has been implicated in the control of PRL secretion (Chapter 7) and, therefore, a brief outline of its distribution is given here.

Thyrotrophin-releasing hormone is widely distributed in the CNS (Brownstein, Palkovits, Saavedra, Bassiri and Utiger, 1974; Winokur and Utiger, 1974; Hökfelt, Fuxe, Johansson, Jeffcoate and White, 1975) but little is known of TRH pathways in the brain. The presence of TRH has been demonstrated in the hypothalamus in the dorsomedial and ventromedial areas and in the perifornical area. The external layer of the ME also exhibits a significant amount of TRH (Fuxe et al., 1978; Renaud, 1981). In common with LHRH and 5-HT, although the TRH content of the MBH was decreased after deafferentation (Palkovits, 1979) the concentration remaining was high enough to allow the proposal of the existence of an intrahypothalamic TRH system. Recently, cell bodies containing TRH have been demonstrated in the PVN (Jackson, 1983).

1.3.6 Vasopressin and oxytocin

A detailed description of the distribution and function of VP and OT in the PN system, consisting of the magnocellular neurons of the SON and PVN, their axons in the SOHT and their terminals in the PN (Scharrer and Scharrer, 1954; Sloper, 1966; Lederis, 1974) are not directly relevant to the studies reported in this thesis and attention will be focussed on the system of VP and OT with terminals in the EL of the ME (Silverman and Zimmerman, 1983).

The existence of a projection to the EL of the ME from the PVN and/or SON has been proposed for some years on the basis of the

results of Gomori staining. Gomori-positive material was described in the EL of the ME in a number of vertebrates, including the rat (Dierickx and Van den Abeele, 1959; Oksche, Laws, Kamemoto and Farner, 1959; Rinne, 1960) and this material seemed to subserve different functions from the hormones of the PN, since it was unaffected by experimental manipulations that caused changes in the Gomori-positive material of the PN. However, extracts of ME shared many of the physiological characteristics of extracts of PN (Ishii, Hirano and Kobayashi, 1962). It was thought that the material might be involved in the release of ACTH since the size of neurosecretory granules within Gomori-positive fibres in the EL of the ME was increased after adrenalectomy (Wittkowski and Bock, 1972) and the increase could be inhibited by the administration of glucocorticoids (Brinkmann and Bock, 1973). It was subsequently demonstrated using immunohistochemical techniques that the neurosecretory material was composed of VP and OT and associated neurophysins (Zimmermann, Hsu, Robinson, Carmel, Frantz and Tannenbaum, 1973; Dierickx, Vandesande and De Mey, 1976). Lesion studies and the application of retrograde tracers to the ME have demonstrated that the cells of origin of this system differ from those of the PN system and that they are located in the PVN rather than in the SON (Vandesande, Dierickx and De Mey, 1977; Wiegand and Price, 1980). There is electrophysiological evidence that suggests that some cell bodies in the PVN may send axon branches to both the PN and the EL of the ME (Pittman, Blume and Renaud, 1978).

The PVN is a complex nucleus composed of distinct magnocellular and parvocellular divisions. The magnocellular components form

three dense clusters of neurons, termed the anterior, medial and posterior divisions, which are embedded in a matrix of five parvocellular divisions, the periventricular, anterior, medial, dorsal and lateral parts (Fig. 1-1). These divisions give rise to a number of different efferent projections (Fig. 1-1) (Swanson and Sawchenko, 1983). The projection to the EL of the ME arises from the periventricular, medial and anterior parts of the parvocellular division of the PVN, areas that have few projections to the PN (Wiegand and Price, 1980; Swanson and Sawchenko, 1983).

Vasopressin and oxytocin are not uniformly distributed in the PVN: OT-containing cells are found mainly in the anterior and medial magnocellular divisions of the nucleus, whereas VP-containing cells are found mainly in the dorsal and lateral parts of the posterior magnocellular division (Swanson and Sawchenko, 1983).

The relationship of the VP and OT system in the EL of the ME to other VP and OT-containing neurons in the CNS is described in detail by Silverman and Zimmerman (1983) and Swanson and Sawchenko (1983).

1.3.7 Possible structural interactions between the dopaminergic and luteinizing hormone-releasing hormone systems

The close anatomical relationship of many identified nerve terminals, particularly in the ME, has led to suggestions that monoamines and peptides may interact by way of axo-axonic or axo-dendritic contacts. Terminals containing LHRH and DA are in close proximity in the ME (Kizer, Arimura, Schally and Brownstein, 1975; Ajika, 1979; Selmanoff, 1981) and it has been claimed that these terminals are in direct contact with each other (Ajika, 1979). However, there is no ultrastructural evidence for the

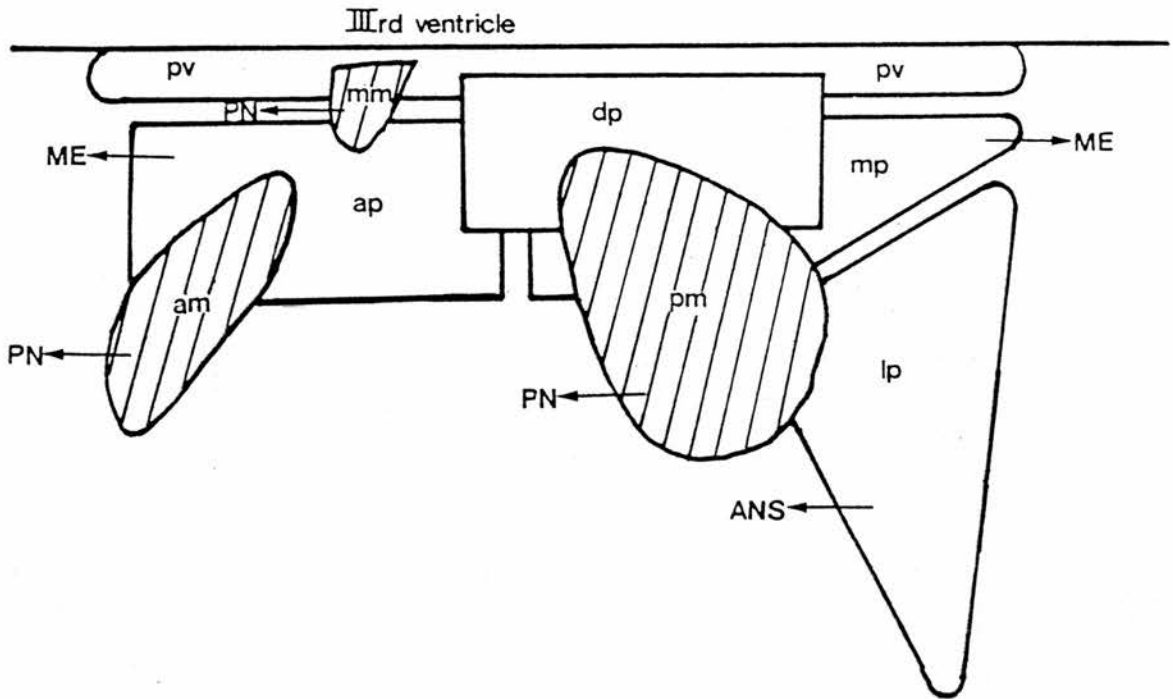

FIGURE 1-1 Diagrammatic representation of the major subdivisions and projections of the paraventricular nucleus (hatched areas = magnocellular parts), pv = periventricular part, ap = anterior parvocellular part, dp = dorsal parvocellular part, mp = medial parvocellular part, lp = lateral parvocellular part, am = anterior magnocellular part, mm = medial magnocellular part, pm = posterior magnocellular part.
 PN = projection to pars nervosa
 ME = projection to median eminence
 ANS = projection to autonomic nervous system.

From Swanson and Sawchenko (1983).

existence of axo-axonic synapses in the ME of the rat. (The only published report of the presence of axo-axonic synapses in the ME is concerned with the turtle (Tsuneki, 1976)). The density of LHRH terminals is highest in the lateral regions of the ME (Selmanoff, 1981) and the concentration of DA seems to be higher in the lateral than in the medial region of the ME (Löfström, Jonsson and Fuxe, 1976). However, a recent report (Reymond, Speciale and Porter, 1983) suggests that this may not be a significant correlation since the concentration of DA in hypophysial portal vessels in the lateral region of the pituitary stalk was lower than the concentration in hypophysial portal blood in the medial region of the pituitary stalk.

1.4 Control of the release of luteinizing hormone

The secretion of LH from the PD is directly controlled by the release of LHRH from the hypothalamus. The release of LHRH is itself controlled by monoaminergic systems in the CNS whose activity is modified by gonadal steroids. These various aspects of the control of the release of LH have been extensively reviewed: LHRH involvement by Fink (1979a), McCann (1982), and Sarkar (1983); monoaminergic involvement by Fink and Geffen (1978), Weiner and Ganong (1978), Krulich (1979), Sawyer (1979), Kordon et al., (1980), Barraclough and Wise (1982), Meites and Sonntag (1982); steroid modulation by McCann (1974), Fink (1979a, b) and Goodman and Knobil (1980). As shown by the number of recent reviews cited, this is an enormous field of research and, therefore, only those aspects of control directly relevant to the studies reported in this thesis will be discussed.

While acknowledging that the degree of control at each of these

levels may differ between species, particularly in the primate (Knobil, 1974; Goodman and Knobil, 1980), the examples cited are concerned primarily with studies in the rat.

1.4.1 Dopaminergic involvement in the release of luteinizing hormone

Current evidence for a role of DA in the control of LH release is confusing and conflicting due to the presence of multiple DA pathways and receptors that may be involved in the basal and phasic release of LH (1.3.2.; Sarkar and Fink, 1981).

Much work has been published by Fuxe and his co-workers (e.g. Hökfelt and Fuxe, 1972) on immunohistochemical observations of changes in activity of DA neurons during different endocrine states. They claim the existence of an inhibitory DA system modifying the release of LH. However, as with all histochemical observations it is difficult to correlate observed changes with peripheral events since so many other parameters may be changing besides those that are of immediate interest. For example, the correlation claimed by Fuxe et al. (1976) between the increased DA turnover and the inhibition of LH release after oestradiol treatment of castrated animals may well be invalid since the oestradiol treatment also induces changes in PRL release that may cause changes in DA turnover (Gudelsky, Simpkins, Mueller, Meites and Moore, 1976).

These interpretations are also not in agreement with a suggestion in the literature that steroid treatment may change the DA influence on LH from an inhibition to a stimulation (Weiner and Ganong, 1978). It has been shown that apomorphine causes a decrease in the release of LH in ovariectomized rats (Beck and Wuttke, 1977) whereas, DA causes an increase in the release of LH in

ovariectomized rats that have been treated with oestrogen and progesterone (Vijayan and McCann, 1978). However, these results may also indicate that in addition, DA has different effects at different sites since an i.p. injection of apomorphine caused a decrease in the release of LH in the ovariectomized rat (Beck and Wuttke, 1977) but an i.c.v. injection of apomorphine had no effect (Vijayan and McCann, 1978).

There are 3 possible sites of action at which DA may affect the release of LH: either directly at the gonadotrophs of the PD, or through interactions with LHRH terminals in the ME (1.3.6), or through neurons in the hypothalamus. Schneider and McCann (1969) were unable to show that DA released LH directly from the PD but it has been reported that DA can cause an increase in the release of LHRH from hypothalamic/ME tissue in vitro (Schneider and McCann, 1969; Bennett, Edwardson, Holland, Jeffcoate and White, 1975) in particular from the rostral palisade region of the ME (Rotsztejn, Charli, Pattou and Kordon, 1977), an area that receives a dense LHRH-innervation (1.3.4). Dopamine can both stimulate and inhibit neurons in the hypothalamus (Moss, Kelly and Riskind, 1975).

1.4.2 Serotonergic involvement in the release of luteinizing hormone

The role of 5-HT in the control of the release of LH from the PD is equally as controversial as the role of DA. Indeed, the difficulty of assigning a role to 5-HT in this system is compounded by the involvement of this transmitter in the maintenance of many hormonal circadian rhythms (Moore, 1978; Kordon, Héry, Szafaraczyk Ixart and Assenmacher, 1980). The function of 5-HT appears to be essentially permissive or 'neuromodulatory' and therefore its

effects are dependent on the overall hormonal and metabolic status of the animal.

As for DA, the effect of 5-HT on the release of LH appears to be inhibitory in the ovariectomized animal but stimulatory in the presence of gonadal steroids, particularly progesterone (Walker, 1983; Walker and Wilson, 1983). An i.c.v. injection of 5-HT caused a decrease in LH release in the ovariectomized rat (Schneider and McCann, 1970) but blockade of 5-HT synthesis inhibited the LH surge in the pro-oestrous rat (Coen and Mackinnon, 1980) and in the ovariectomized rat treated with oestrogen and progesterone (Héry, Laplante and Kordon, 1976).

It has recently been suggested that these similar results seen after either an augmentation or a depletion of 5-HT in the CNS may be due to a disruption of the circadian rhythm of 5-HT activity present in the brain (Héry, Rouer and Glowinski, 1972; Hiller and Redfern, 1976; Meyer and Quay, 1976; Héry, Faudon, Dusticier and Héry, 1982). Walker (1983), has proposed that "if drugs abolish the rhythm (of 5-HT) and thus the facilitatory signal (for LH release) then it becomes physiologically irrelevant whether the compounds stimulate or retard 5-HT synthesis"; that is, it is the abolition of rhythmic changes in the activity of 5-HT systems that is important and not whether there is an increase or decrease in the absolute concentration of 5-HT.

The possible sites of action of 5-HT to alter the release of LH from the PD are discussed in detail in section 4.1.1.

1.4.3 Noradrenergic involvement

There is general agreement that NA stimulates the release of LH

under many conditions (Fink and Geffen, 1978; Weiner and Ganong, 1978; Barraclough and Wise, 1982). The contribution of ADR to the control of the release of LH is as yet, undefined; however, ADR and phenylethanolamine N-methyl transferase are present in the hypothalamus (Moore and Bloom, 1979) and ADR has been found in hypophysial portal blood at concentrations higher than those present in peripheral blood (Johnston, Gibbs and Negro-Vilar, 1983). Adrenaline has been reported to be involved in the LH surge of the ovariectomized rat treated with oestrogen (Coen, Coombs, Wilson, Clement and Mackinnon, 1983).

1.4.4 The role of gonadal steroids in the control of the release of luteinizing hormone.

The negative feedback effects of gonadal steroids have been reviewed in detail by McCann (1974). Positive feedback effects of gonadal steroids have been considered in depth by Fink (1979a,b). Possible sites of action of gonadal steroids within the CNS have been reviewed by Goodman and Knobil (1981).

The release of LH under basal and 'surge' conditions is controlled by two different systems. Deafferentation of the MBH leads to a loss of ovulation without any marked disruption of follicular development (Halasz, 1969) indicating that the 'tonic' release of LH is controlled from within the MBH while the LH surge is generated by systems outwith the MBH. Attention has focussed on the POA and SCN, both of which contain LHRH cell bodies (1.3.4). Early studies in the rat demonstrated that stimulation of the POA could cause ovulation (e.g. Everett, 1965) and an increase in the release of LH (e.g. Cramer and Barraclough, 1971). There is now

general agreement that the neural signal for the release of LHRH in the rat is generated in the POA (e.g. Fink, 1979a; Goodman and Knobil, 1981). It is generally presumed that the POA-LHRH neurons act by way of their projections to the ME. However, studies which showed that lesions of the OVLT blocked the LH surge in ovariectomized rats treated with oestrogen and progesterone, make it impossible to exclude the physiological significance for the LH surge of the POA projections to the OVLT (Samson and McCann, 1976; Wiegand, Terasawa and Bridson, 1978). In the rhesus monkey the relative importance of the POA and the SCN for the generation of the LH surge is still a matter of debate (Norman, Resko and Spies, 1976; Plant, Moosy, Hess, Nakai, McCormack and Knobil, 1979).

In addition to disagreement over the importance of various neural structures in the generation of the surge of LH, the sites at which gonadal steroids exert their feedback effects is also a matter of dispute.

Since Bogdanove (1963) conclusively demonstrated that oestrogen had a direct effect in the pituitary gland to prevent the appearance of castration cells in the pituitaries of castrates (which are caused by increased synthesis and release of gonadotrophins) argument has continued regarding the relative importance of the hypothalamus compared with the pituitary gland as a site for the feedback actions, whether stimulatory or inhibitory, of gonadal steroids on the release of LH.

The inhibitory effect of oestrogen on the basal release of LH is probably exerted both at the pituitary (Bogdanove, Nolin and Campbell, 1975) and at the hypothalamic levels since the

concentration of LHRH in hypophysial portal plasma is increased after ovariectomy (Sarkar and Fink, 1980). The site of the inhibitory action of progesterone on the tonic release of LH has received little attention although a site within the MBH may be important, since progesterone still exerted an inhibitory feedback after deafferentation of the MBH (Blake, 1977).

A dual level of control is also apparent for the stimulatory effects of oestrogen on the release of LH. Oestrogen increases the responsiveness of the pituitary gland to LHRH (Henderson, Baker and Fink, 1977a) and facilitates the self-priming effect of LHRH (Aiyer, Chiappa and Fink, 1974). In addition, oestrogen caused an increase in the amount of LHRH released into hypophysial portal blood following electrical stimulation of the POA (Sherwood, Chiappa and Fink, 1976) and an increase in the concentration of LHRH in hypophysial portal blood in the ovariectomized rat (Sarkar and Fink, 1979). The stimulatory effects of progesterone on the release of LH are thought to be restricted to the pituitary gland.

Progesterone treatment of the ovariectomized rat, primed with oestrogen, causes an increase in the responsiveness of the pituitary gland to LHRH (Aiyer and Fink, 1974) but does not cause an increase in the release of LHRH (Sarkar and Fink, 1979). However, there is increasing evidence that progesterone may also have stimulatory effects in the hypothalamus. Levine and Ramirez (1980) have demonstrated that progesterone administration to ovariectomized rats, primed with oestrogen, caused an increase in the release of LHRH from the ME in vivo in rats bearing a push-pull cannula in the ME. This study can be subjected to a number of criticisms.

Firstly, the tip of the push-pull cannula was situated in the third ventricle and not directly in the ME and, therefore, LHRH could have been released into the CSF of the ventricle from sources other than the hypothalamus, such as the OVLT. Secondly, the lower limit of sensitivity of the LHRH RIA used was 0.8pg/tube and it was claimed that the significant increases of LHRH were from 1.0pg/ml to 3.0pg/ml. While this may be claimed to be an increase of over 100% in the amount of LHRH released, as these values are so close to the lower limit of sensitivity of the RIA, the results must be interpreted with a great deal of caution. A more recent report by Drouva, Laplante and Kordon (1983) has demonstrated that progesterone treatment in vivo of ovariectomized rats primed with oestrogen can enhance the K^+ -induced release of LHRH from MBH tissue from these animals in vitro.

There is evidence that progesterone acting in the hypothalamus may inhibit the stimulatory action of oestrogen under some circumstances (Banks and Freeman, 1980). Progesterone can decrease the release of LHRH induced by treatment of ovariectomized rats with oestradiol benzoate (OB)(Sarkar and Fink, 1979) and can reduce the LHRH output in response to stimulation of the POA (Sherwood et al., 1976). These results are consistent with the observation that progesterone tends to inhibit the firing of hypothalamic neurons (Moss, 1976).

To summarize, oestrogen appears to both directly stimulate and inhibit the release of LH from the PD although there must be additional actions in the CNS to account for the release of LH during the LH surge. Similarly, progesterone also appears to have

both stimulatory and inhibitory actions on the PD and may also have mixed actions in the hypothalamus.

1.4.4.1 The pro-oestrous female

The spontaneous surge of LH occurring on the afternoon of pro-oestrus in the female rat, is dependent upon the increased secretion of oestrogen by the ovary (Ferin, Tempone, Zimmering and Van de Wiele, 1969). The increased concentration of oestrogen permits the expression of a neural signal for the release of LH (Everett and Sawyer, 1950) in the form of an increased release of LHRH from the hypothalamus. The responsiveness of the pituitary gland to LHRH, increased due to the action of oestrogen, is further increased by the self-priming effect of LHRH. The increasing peripheral concentration of LH causes increased secretion of ovarian progesterone, which causes further increases in responsiveness to LHRH. This amplifying cascade of events leads to the massive LH surge (Fink, 1979a, b). Termination of the surge is probably due to a decrease in the concentration of LHRH in hypophysial portal plasma (Blake, 1977) which may be due to an inhibitory effect of progesterone (Freeman, Dupke and Croteau, 1976; Rahe, Owens, Newton, Fleeger and Harms, 1979; Drouva et al., 1983).

The different roles of gonadal steroids in the control of LH release have been determined by studies on ovariectomized rats treated with various combinations of steroids at different times after ovariectomy (Fink, 1979b).

1.4.4.2 The short-term ovariectomized rat treated with oestrogen and progesterone.

In this model, designed to mimic the changes occurring in

steroid concentrations in the intact animal, rats are ovariectomized and given an injection of OB on dioestrus followed by an injection of progesterone (P) on the next day, presumptive pro-oestrus (Kalra, Fawcett, Krulich and McCann, 1973; Mann and Barraclough, 1973; Aiyer and Fink, 1974; Tapper, Grieg and Brown-Grant, 1974). There is a surge of LH in peripheral plasma approximately 5h after the injection of P. It has been shown that the injection of OB in this model caused the concentration of LHRH in hypophysial portal plasma to increase above concentrations seen at dioestrus (Sarkar and Fink, 1979). However, although the subsequent injection of P caused an increase in the pituitary responsiveness to LHRH and a surge of LH (Fink and Henderson, 1977) P had either no or an inhibitory effect (depending on dose) on the stimulatory effect of OB on the release of LHRH (Sarkar and Fink, 1979). These apparently contradictory effects of P are consistent with a proposed stimulatory site of action of the steroid at the pituitary gland (Martin, Tyrey, Everett and Fellows, 1974; Fink and Henderson, 1977) and an inhibitory site of action within the CNS, either at the hypothalamus or POA (Schuiling, van Dieten and van Rees, 1974; McLean, Chang and Nikitovitch-Winer, 1975; Blake, 1977).

1.4.4.3 The long-term ovariectomized rat treated with oestrogen and progesterone

The concentration of LH in peripheral plasma in the long-term ovariectomized rat is increased due to the removal of the negative feedback effects of gonadal steroids (McCann, 1974). This increase is inhibited by the administration of oestrogen (Blake, Norman and Sawyer, 1974) but an LH surge can be induced by an injection of P

72h after an injection of OB (Caligaris, Astrada and Taleisnik, 1968; Brown-Grant, 1974). Contrary to expectation, Sarkar and Fink (1980) were not able to demonstrate an increase in the release of LHRH into hypophysial portal blood in this model. Although a blocking effect of anaesthesia and surgical trauma might be involved, it is conceivable that the surge of LH in this model is due primarily to a massive increase in pituitary responsiveness (approximately three times greater than that seen at 1700h on pro-oestrus (Aiyer, Sood and Brown-Grant, 1976; Sarkar and Fink, 1980). Although LHRH release does not need to be increased, some LHRH release is required for the occurrence of the LH surge since the stimulatory effect of P is blocked by an injection of sodium pentobarbitone (Brown-Grant, 1974) or by administration of an anti-LHRH serum (Lu and Yen, 1980).

1.4.4.4 The long-term ovariectomized rat exposed to a constantly elevated concentration of oestrogen.

Continuous exposure of long-term ovariectomized rats to elevated peripheral concentrations of oestrogen results in a diurnal rhythm of LH, with a peak in the late afternoon in rats maintained under a summer lighting schedule (Caligaris, Astrada and Taleisnik, 1971; Henderson, Baker and Fink, 1977b). The afternoon surge of LH would appear to be generated by increases both in the secretion of LHRH (Sarkar and Fink, 1980) and in pituitary responsiveness (Henderson et al., 1977a).

1.4.5 Interactions between gonadal steroids and monoamine systems involved in the release of luteinizing hormone.

Numerous aspects of the interactions occurring between gonadal

steroids and the transmitter systems involved in the release of LH have been reviewed by McEwen (1979) and McEwen and Parsons (1982). Steroids may affect the activity of monoamine systems either by changes in the electrical activity of neurons, or changes in the turnover of monoamines, perhaps as a result of changes in enzyme activity, or by changes in number or affinity of neurotransmitter receptors. Many examples of each of these effects are cited by McEwen and Parsons (1982). Of particular relevance to this thesis are reports of i) changes in the turnover of DA after oestrogen or after oestrogen and P treatment (Eikenburg, Ravitz, Gudelsky and Moore, 1977; Löfström, Eneroth, Gustafsson and Skett, 1977; Rance, Wise and Barraclough, 1981; Rance, Wise, Selmanoff and Barraclough, 1981) and of the turnover of 5-HT after oestrogen and P treatment (Ladisch, 1974; Everitt, Fuxe, Hökfelt and Jonsson, 1975) and ii) a reported biphasic effect of oestrogen on 5-HT receptors, with oestrogen causing an acute decrease in the number of 5-HT receptors, followed by an increase in receptor number 48-72h later (Biegnon and McEwen, 1982).

Many experimental changes in transmitter function reported to be due to oestrogen, may be changes secondary to an increase in the release of hormones from the PD, for example, oestrogen causes the release of PRL from the PD (Chen and Meites, 1970; Haug and Gautvik, 1976) and there are well-documented effects of PRL on the turnover of DA (see 3.1 and 3.4).

1.5 Control of the release of prolactin

The physiological conditions under which PRL is released have been reviewed by Meites, Lu, Wuttke, Welsch, Nagasawa and Quadri

(1972) and by Neill (1974). This discussion is concerned with the control mechanisms for PRL release.

The release of PRL in the mammal is under the inhibitory influence of the hypothalamus (1.2.2). For many years, it was assumed that changes in PRL secretion could be accounted for solely by changes in PIF activity, mediated by feedback effects of PRL itself. In the absence of the production of any obvious target-tissue hormones, the degree of control was thought to be much less complex than that of other hormones of the PD, for example, of LH. However, a recent review by Leong et al. (1983) demonstrates that this view has been too simple and that, in addition to control of PRL secretion through changes in PIF activity, recognition must be made of the contribution of PRFs and of PRL responsiveness factors controlling the responsiveness of the PD to PRFs and PIFs.

1.5.1 Inhibitory control of the release of prolactin

Since the statement of Meites et al. in 1972 that "the direct effects of catecholamines (dopamine) on pituitary prolactin release observed in vitro are mainly of pharmacological significance" it is now recognised that these effects are indeed of physiological significance and that DA is one of the major PIFs secreted by the mammalian hypothalamus. The large body of work in support of this fact has been reviewed by MacLeod (1976), Ben-Jonathan (1980) and Neill (1980). Briefly, DA is found in hypophysial portal plasma (Plotsky, Gibbs and Neill, 1980) at concentrations greater than in peripheral plasma, that are high enough to inhibit the release of PRL (Gibbs and Neill, 1978). The release of PRL is inhibited by a direct action of DA (Shaar and Clemens, 1974; Takahara, Arimura and

Schally, 1974) on DA receptors on the pituitary lactotrophs (Goldsmith, Cronin and Weiner, 1979).

However, it seems increasingly likely that hypothalamic DA is not the sole physiological PIF. For example, the concentration of PRL in peripheral plasma in male rats is low (Neill, 1972) but the responsiveness of pituitary cells from male rats to DA is lower than in cells from female rats (Leong et al., 1983) and the concentration of DA in hypophysial portal plasma is lower in male than in female rats (Gudelsky and Porter, 1981). Therefore, it would appear that the existence of an additional PIF must be invoked, since PRL release is low but the DA system is not particularly active. Possible PIFs have been discussed in 1.2.2.

Ben-Jonathan (1980) proposed that DA may be the sole PIF but that in addition to DA released by the hypothalamus some DA may reach the PD from extrahypothalamic sources. In particular, it was suggested that DA may be released from the PN into the portal vessels, a suggestion that is supported by observations of blood flow from the PN to the PD (Bergland and Page, 1979) and of the presence of a rich network of capillaries between the two lobes (Page, 1983). The concentration of DA in the PN is similar to that in the hypothalamus (Saavedra, Palkovits, Kizer, Brownstein and Zivin, 1975), and the release of PRL was inhibited by an acidic extract of the PN (Hoefer, Arbogast and Ben-Jonathan, 1979). Removal of the PN has been demonstrated to cause an increase in the concentration of PRL in peripheral plasma (Oliver, Mical and Porter, 1977) but this increase has since been found to be transient (Froehlich and Ben-Jonathan, 1983).

1.5.2 The role of serotonin in the release of prolactin

The prevailing view in the literature is that 5-HT stimulates the phasic release of PRL and may also stimulate tonic release (Weiner and Ganong, 1978; Krulich, 1979; Kordon et al., 1981; Meites and Sonntag, 1981).

The concentration of PRL in peripheral plasma is increased after a systemic injection of 5-HTP, the immediate precursor of 5-HT (Lu and Meites, 1973; Chen and Meites, 1975) an effect which is potentiated by administration of an inhibitor of 5-HT reuptake (Krulich, 1975; Clemens, Cerimele and Sawyer, 1977). Blockade of 5-HT synthesis causes an inhibition of steroid-induced or suckling-induced surges of PRL (Caligaris and Taleisnik, 1974; Kordon, Blake, Terkel and Sawyer, 1974) an effect which could be overcome by treatment with 5-HTP (Kordon et al., 1974).

Serotonin does not appear to have a direct effect on the pituitary gland to release PRL (Birge, Jacobs, Hammer and Daughaday, 1970) but has its action at the level of the hypothalamus. There are two possible mechanisms by which 5-HT could cause an increase in the release of PRL, i) by inhibiting the secretion of a PIF, or ii) by stimulating the release of a PRF. There is little evidence that interactions between DA and 5-HT contribute to an increase in the release of PRL (Krulich, Coppings, Giachetti, McCann and Mayfield, 1980; Pilotte and Porter, 1981), however, since DA is probably not the only PIF, there is a possibility of interaction with other as yet unidentified PIFs. It seems more likely that 5-HT stimulates the release of a PRF (Clemens, Roush and Fuller, 1978; Garthwaite and Hagen, 1979) that may be VIP (Garthwaite,

Martinson and Hagen, 1983; Shimatsu, Kato, Matsushita, Katakami, Ohta, Yanaihara and Imura, 1983).

Pharmacological evidence presented as indicating a stimulatory effect of 5-HT on the release of PRL must be interpreted with some care, since many of the drugs used in pharmacological studies of the role of 5-HT have mixed actions (Douglas, 1975). For example, the effect of methysergide to decrease the release of PRL has been variously ascribed to its 5-HT antagonist properties (Gallo, Rabin and Moberg, 1975), its DA antagonist properties (Lamberts and MacLeod, 1978) and to its DA agonist properties (Krush et al., 1980).

As with LH, the involvement of 5-HT in the phasic release of PRL is difficult to assess due to its important role in the maintenance of neural rhythms (1.4.2). It must be borne in mind that a facilitatory effect of 5-HT on rhythmic hormonal surges does not necessarily preclude inhibitory effects of the transmitter on minute-to-minute release of hormones.

1.5.3 The role of noradrenaline in the release of prolactin

There is some dispute concerning the effect of NA on the release of PRL (Fink and Geffen, 1978; Weiner and Ganong, 1978).

Noradrenaline may be involved in the release of PRL induced by oestrogen (Subramanian and Gala, 1976; Carr, Conway and Voogt, 1977; Langelier and McCann, 1977) but does not seem to be involved in basal PRL secretion (Weiner, 1975). As discussed in 1.4.3, effects assumed to be due to NA activity might also be mediated by ADR, but any involvement of ADR in the release of PRL does not appear to have been investigated.

1.5.4 The role of gonadal steroids in the release of prolactin

The role of gonadal steroids in the release of PRL appears to differ from their role in the release of LH. Whereas gonadal steroids essentially modulate the release of LH as induced by LHRH their role in the release of PRL is more direct. Oestrogen directly stimulates the release of PRL from the PD (Chen and Meites, 1970) but probably also causes changes in responsiveness of pituitary lactotrophs to PIFs and PRFs (Raymond, Beaulieu, Labrie and Boissier, 1978). Progesterone alone seems to have no direct effect on the release of PRL (Nicoll and Meites, 1964) but can partially counteract the stimulatory effect of oestrogen (Chen and Meites, 1970).

1.5.4.1 The release of prolactin in the pro-oestrous rat

At approximately the same time as the LH surge on the afternoon of pro-oestrus there is a massive surge of PRL (Niswender, Chen, Midgley, Meites and Ellis, 1969; Amenomori, Chen and Meites, 1970). The increase in the release of PRL is dependent upon the increasing plasma concentration of oestrogen since administration of an anti-LH serum on dioestrus or of an anti-oestrogen serum on pro-oestrus abolished the surge of PRL (Neill, Freeman and Tillson, 1971; Freeman, Reichert and Neill, 1972) and both of these inhibitory effects could be overcome by the administration of exogenous oestrogen.

In addition to the direct effect of oestrogen to release PRL from the PD (Chen and Meites, 1970) there are also changes in the PRL responsiveness of the PD that may be mediated by oestrogen. De Léan, Garon, Kelly and Labrie (1977) reported that the amount of PRL

released in response to TRH was much higher at pro-oestrus than at other stages of the oestrous cycle but that the increased responsiveness was not due to a self-priming effect of TRH, a proposed PRF. Pickering and Fink (1977) have also reported that a self-priming effect of a PRF was not present since repeated exposure of pituitary glands in short-term incubation to a hypothalamic extract had no effect on the PRL response. Further work has demonstrated a complex series of interactions between oestrogen and proposed PIFs and PRFs to increase the secretion of PRL by the PD: pre-incubation with oestrogen of pituitary cells in culture caused a decreased responsiveness to DA in addition to an increased responsiveness to TRH (Raymond et al., 1978). Low concentrations of TRH in combination with oestrogen pre-treatment caused a significant increase in the release of PRL in the presence of inhibitory concentrations of DA. Thyrotrophin-releasing hormone alone caused no stimulated release of PRL in the presence of DA. However, it has also been demonstrated that there are interactions between DA and TRH to alter PRL responsiveness in the absence of oestrogen; a brief decrease in the concentration of DA before the addition of TRH causes a greater stimulation of PRL release than the sum of each treatment applied alone (Fagin and Neill, 1981). A detailed discussion of the role of TRH as a PRF is given in Chapter 7.

The surge of PRL occurring on the afternoon of pro-oestrus is often regarded as a singular phenomenon occurring on only one day of the oestrous cycle, but there is ample evidence to suggest that as for the LH surge, the PRL surge is due to an amplification by

oestrogen of a circadian rhythm generated by a daily neural signal. There is a diurnal release of PRL in male rats (Dunn, Arimura and Scheving, 1972; Mattheij and Swarts, 1978) and in intact and ovariectomized female rats (Koch, Chow and Meites, 1971; Lawson and Gala, 1974) and a pro-oestrous-like surge of PRL can be induced in ovariectomized rats by injection of OB or OB followed by P (Caligaris, Astrada and Taleisnik, 1974). The pro-oestrous PRL surge can be blocked by sodium pentobarbital (Wuttke and Meites, 1970) and nicotine (Blake, Norman, Scaramuzzi and Sawyer, 1973) demonstrating that a neural signal is required for manifestation of the surge. The neural signal may be generated in the anterior hypothalamus since the oestrogen-induced PRL surge in the ovariectomized rat was blocked by a retrochiasmatic cut (Neill, 1972; Caligaris and Taleisnik, 1977). Dunn, Johnson, Castro and Swenson (1980) have demonstrated a loss of PRL surges in pro-oestrous rats after placement of a lesion in the SCN, an area thought to be important in the maintenance of many other circadian rhythms (Brown-Grant and Raisman, 1977; Szafarczyk et al., 1979).

Although the surges of LH and PRL occur at approximately the same time during the oestrous cycle, there are differences in the neural mechanisms involved. Exposure to constant light blocks the oestrogen-induced surge of LH in the ovariectomized rat but the surge of PRL although diminished, is still present (Mann, Cost, Jacobson and Macfarland, 1977; Pieper and Gala, 1979) and the dose of oestrogen required to induce a surge of PRL in the ovariectomized rat is much lower than that required to induce a surge of LH (Caligaris et al., 1971; Caligaris et al., 1974).

1.5.4.2 The release of prolactin in various endocrine models

Although it is known that surges of PRL can be induced by steroid treatment of ovariectomized rats, in which the concentration of PRL in peripheral plasma is decreased due to the loss of stimulatory effects of oestrogen, the mechanisms by which steroids induce this surge have been less widely investigated than those which induce the LH surge. Almost nothing is known of the sites at which steroids act to induce the PRL surge although both central and pituitary sites are likely to be involved (1.5.3.1). There is some suggestion that oestrogen may act at a site in the AH to induce a PRL surge but that progesterone has an action outwith this area (Kawakami and Arita, 1981). In the majority of cases, the two models most frequently studied, the long-term ovariectomized rat treated with oestrogen and progesterone or exposed to a continuously elevated concentration of oestrogen, have been used as tools to investigate neurotransmitter involvement in the release of PRL, with little investigation being carried out as to the mechanisms of generation of the PRL surge.

1.5.4.3. Neurohypophysial hormones and the release of prolactin

The observation by Benson and Folley (1956) that injections of OT, like PRL, could retard mammary involution in postpartum lactating rats after the removal of a litter, led them to suggest that OT might be capable of causing the release of PRL. However, the mechanisms by which this effect is induced by the two hormones differ markedly (Meites and Nicoll, 1966) and therefore the idea received little support.

More recent work has shown that VP and OT can stimulate the

release of PRL from the PD (Forsling, Reinhard and Himmler 1974; Vaughan, Blask and Johnson, 1979; Shin, 1982; Lumpkin, Samson and McCann, 1983) although there have also been some negative reports (Hoefler et al., 1979; Ben-Jonathan, 1980). (A detailed discussion of the possible role of VP as a CRF is given in Chapter 8).

1.6 Aims of this thesis

The main hypothesis tested in this thesis was that central 5-HT systems affect the release of certain pituitary and hypothalamic hormones. An in vitro preparation was first investigated with the intention of developing a method for investigating 5-HT uptake and release by ME slices. However, while the system yielded data on the uptake and release of DA, it proved difficult to adapt the system for 5-HT. Therefore, attention was focussed on in vivo studies. The 5-HT systems were manipulated by the use of the 5-HT reuptake blockers, alaproclate and zimelidine, and an inhibitor of 5-HT synthesis, parachlorophenylalanine. The pituitary hormones studied were LH and PRL and their release was examined under 'physiological' conditions as well as in several well-defined animal preparations designed to investigate the effect of different steroid hormone regimes on the function of the hypothalamic-pituitary-LH and -PRL systems. Vasopressin and oxytocin were the hypothalamic hormones studied, not with respect to their release from the PN, but rather with respect to their release into hypophysial portal blood. The release of the two peptides was studied under 'basal' conditions in normal and Brattleboro rats and also after manipulations of adrenal steroids.

CHAPTER 2

Materials and Methods

2.1 ANIMALS

Animals used in these studies were adult male and female Wistar cobs (caesarean-originated barrier-sustained) supplied by Charles River UK Ltd. (Margate, Kent), and male homozygous and heterozygous Brattleboro rats obtained from Charing Cross Hospital Medical School. Animals were housed in groups of four (unless they were cannulated intra-atrially, when they were housed singly) under controlled lighting (lights on 0500-1900h) and temperature (22°C). Access to food (Diet 41B; Oxoid, Basingstoke) and tap water was freely available. All animals that had been subjected to surgery and maintained for more than 48 hours had access to drinking water which was supplemented with aureomycin (50mg/litre) (chlortetracycline hydrochloride; Cynamid G.B. Ltd., Gosport). Long-term adrenalectomized animals received 0.9% saline supplemented with glucose (250mg/litre) and aureomycin instead of tap water.

2.2 SURGICAL AND EXPERIMENTAL PROCEDURES

2.2.1 Anaesthetics

Four anaesthetics were used:-

- i) Anaesthetic ether - purchased from Macfarlane Smith Ltd., Edinburgh. Anaesthesia was induced by placing the animal in a sealed box containing a cotton wool pad saturated with ether. Time to anaesthesia was usually less than 2 minutes.
- ii) Ethyl carbamate - (Urethane; BDH, Poole). A 10% w/v in 0.9% saline solution was used at a dose of 10ml/kg body weight (b.w.) and injected intraperitoneally (i.p.)
- iii) Halothane - (Fluothane; ICI Pharmaceuticals, Cheshire). Animals were placed in a sealed box through which a 5% halothane/air

mixture was circulated by a vaporizer. After induction, anaesthesia was maintained with a 1.5% halothane/air mixture administered through a face mask.

iv) Avertin - (tribromoethanol; Winthrop, Surrey). Stored as 1 gm/ml stock in amylene hydrate, was prepared for injection by dilution in absolute ethanol (1:4) and then diluted with saline (1:10), and administered i.p. at a dose of 0.25 gm/kg b.w.

2.2.2 Steroids for Injection

Dexamethasone (9 α -fluoro-16 α -methyl prednisolone; Sigma, Poole, Dorset) was stored as a stock solution of 0.9 mg/ml in ethanol and diluted 1:10 with 0.9% saline before i.p. injection.

Oestradiol benzoate (OB) and progesterone (P) (Paines and Byrne Ltd., Greenford, Middlesex) were supplied in ethyl oleate and diluted to working concentrations with arachis oil (Hopkins and Williams, Romford, Essex). Steroids were injected subcutaneously (s.c.) while the animals were lightly restrained.

2.2.3 Drugs Acting on Serotonergic Systems

Parachlorophenylalanine and 5-hydroxytryptophan (PCPA and 5-HTP; Sigma, Poole, Dorset) and 2-(4-chlorophenyl)-1,1 dimethylethyl 2-aminopropionate, (alaproclate) and (z)-1-(4-bromophenyl)-1-(3-pyridyl)-3-dimethylaminopropene dihydrochloride hydrate, (zimelidine) (Astra Pharmaceuticals, Södertälje, Sweden) were dissolved in 0.9% saline immediately before use and administered intravenously (i.v.) or i.p. (See appendix I for chemical structures of alaproclate and zimelidine).

2.2.4 Median Eminence Dissection

Rats were decapitated and brains removed and placed ventral side

uppermost on an ice-cold microscope slide. A few drops of ice-cold Krebs-Heinsleit (K-H) buffer (see appendix II) were placed on the median eminence-pituitary stalk region and all further dissection carried out under a binocular operating microscope (Zeiss, Switzerland) according to the method of Cuello, Horn, Mackay and Iversen (1973). The cut pituitary stalk was held with fine forceps and the borders of the median eminence (ME) (defined by the presence of capillary loops) cut to a depth of 0.2-0.3mm with iridectomy scissors. Tissue weight was 0.2-0.3mg. Dissected ME tissue was floated free of the forceps in 1ml of ice-cold K-H buffer.

2.2.5 Hypothalamus and Raphe Dissection

Rats were decapitated and brains rapidly removed and placed on ice, ventral side uppermost. Before dissection of the hypothalamus, the optic nerves were grasped with fine forceps and removed at the level of the optic chiasm. A block of tissue about 2mm deep, extending rostro-caudally from the pre-optic area to just caudal to the mammillary bodies and laterally 1mm on either side of the ME, was dissected out. The block was cut at the optic chiasm into two pieces, designated posterior and anterior hypothalamus and weighing 16-20mg and 5-8mg, respectively.

The brain was further sectioned between the cerebellum and the superior colliculus, leaving a block of tissue containing the raphe nuclei. Tissue in this block lying 1.0mm laterally to the aqueduct was retained as a representative sample of raphe nuclei. Tissue weights were 15-20mg.

2.2.6 Pro-oestrous Animals

Animals in pro-oestrous were defined as those with a vaginal

smear showing a large majority of nucleated epithelial cells. Only animals showing at least two consecutive, regular 4 day oestrous cycles were used. Oestrous cycles were determined by inspection of daily vaginal smears obtained by lavage between 0900-1100h and a regular pattern was defined as:

metoestrus - smear shows a mixture of cells, predominantly leucocytes with a few epithelial and cornified cells.

dioestrus - smear shows only leucocytes

pro-oestrus - smear shows clumps of nucleated epithelial cells (clumps visible to the naked eye).

oestrus - smear shows cornified epithelial cells.

2.2.7 Ovariectomy

Bilateral ovariectomy was carried out on dioestrus between 0630-0900h under ether or halothane anaesthesia. The posterior flank was shaved and a small (1.5cm) incision made in the skin and abdominal wall. The ovary and distal end of the uterus were drawn out of the wound and the ovary and oviduct excised. A silk ligature was tied round the end of the uterus to prevent haemorrhage as these animals were also implanted with an intra-atrial cannula containing heparin during the same operative period. Incisions in the abdominal wall and skin were sutured and animals left to recover for 24h before use.

Long-term Ovariectomy

Bilateral ovariectomy was carried out as for short-term ovariectomy with the exception of the ligaturing of the excised end of the uterus.

2.2.8 Adrenalectomy

Animals were adrenalectomized in 2 stages; the second adrenal gland was removed 7 days after removal of the first gland. This was found to give a better survival rate than immediate bilateral adrenalectomy.

On day 1 animals were anaesthetized with Avertin and an incision made along the right costal margin. The right kidney was exposed and the adrenal gland excized. Any bleeding was stopped by gentle pressure with a piece of cotton wool and once bleeding had ceased the incision was sutured. On day 8, animals were again anaesthetized and the left adrenal removed as for the right adrenal, noting hypertrophy of the more recently removed gland. The incision was sutured and animals left to recover for the requisite post-operative period.

Some groups of animals were sham-adrenalectomized, during which incisions were made along the costal margins and were then sutured.

2.2.9 Blood Sampling from Conscious Animals

Sequential blood samples were withdrawn from conscious animals by means of a cannula implanted long-term into the right atrium.

The cannulae consisted of an i.v. portion of Silastic^R tubing (0.5mm i.d., 0.93mm o.d. Dow-Corning cat. no. 602-135; Macarthy's Surgical Ltd., Dagenham, Essex) (3.2cm for 200-250g rat) connected to a piece of Tygon tubing (0.5mm i.d. 2.25mm o.d.; Technicon Inst. Co. Ltd., Basingstoke, Hampshire) by a connecting pin (0.6cm long) made from a 23 gauge stainless steel needle. Heparinized saline (250 IU/ml) was introduced into the cannula immediately before use with a 1ml syringe attached to the Tygon tubing.

Animals were anaesthetized with Halothane and placed in a supine position. A longitudinal incision, approximately 2.0cm long was made over the right external jugular vein, about 1.0cm above the clavicle. Tissue was gently retracted to reveal the underlying vein. Three silk ligatures were placed underneath the vein and the most anterior tied immediately. Gentle traction was applied to this ligature and a small incision made in the external surface of the vein, above the level of the 2 posterior ligatures, with iridectomy scissors. The i.v. portion of the cannula was then introduced into the vein and the 2 posterior ligatures tied firmly round the connecting pin. The anterior ligature was tied round the Tygon tubing to hold the cannula in close contact with the vein. After checking the patency of the cannula, the 1ml syringe was removed and replaced with a stainless steel dental plug. A small ventral incision was made between the scapulae and the cannula brought out through this with the aid of a stainless steel trochar. After suturing the ventral incision, the patency of the cannula was again checked, the Tygon tubing was trimmed to a length of 4cm and the dental plug was replaced. Animals were kept in individual cages until used.

Blood samples were taken using an extension cannula, consisting of a length of Tygon tubing (30-35cm) filled with heparinized saline with a 1ml syringe at one end and a connecting pin at the other.

The dental plug was removed from the indwelling cannula and the extension cannula attached with the connecting pin. Heparinized saline remaining in the indwelling cannula was withdrawn into the 1ml syringe. When blood appeared within 1cm of the syringe needle,

the syringe was replaced with an empty heparinized syringe and blood was withdrawn. Blood volume was maintained by replacing blood withdrawn with 0.9% saline of equal volume.

When blood samples were taken frequently, the cannula extension was left in place and the free end brought through onto the roof of the cage, allowing the animal to move freely. When less frequent sampling was required, the cannula extension was removed after each sample and was replaced by the dental plug.

2.2.10 Treatment of Blood Samples

Blood was collected with heparinized syringes into small plastic tubes (LP2; Luckham Ltd., Sussex) kept on ice. Samples were centrifuged at 2500g for 15 min at 4°C and plasma removed with a Pasteur pipette into plastic storage tubes (PT-0944; Luckham Ltd, Sussex) kept at -25°C until assayed.

2.2.11 Long-term Electrode Implantation and Electrical Stimulation

Electrodes were made and implanted according to the method of Jamieson and Fink (1976), using co-ordinates described by de Groot (1959) (for details see particular experiments).

A 13mm piece of platinum wire (0.125mm diameter) was insulated with glass tubing to within 0.3mm of the tip and soldered to a length of copper wire. The whole assembly was mounted in a Teflon jig and fixed in place with acrylic cement (Simplex; Dental Fillings Ltd., London). Both single and bipolar electrodes were used: bipolar electrode tips were separated by 1.0mm for stimulation of the paraventricular nucleus (PVN) and suprachiasmatic nucleus (SCN).

Male animals (180-200g) were anaesthetized with Avertin and placed in a stereotactic frame in which the incisor bar was 5mm

higher than the ear bars. A midline incision was made in the scalp and the cranial periosteum removed to reveal the frontal and parietal bones. Using a bench dental drill (John Quayle Dental Manufacturing Co. Ltd., Sussex) a hole was drilled in the frontal bones, taking care to avoid damage to the superior sagittal sinus. Bone fragments were removed to reveal the dura mater. Bleeding was controlled with gentle pressure on cotton wool saturated with 0.9% saline. Three screws (diameter 3mm) were inserted into the skull near the margins of the drilled hole. Electrodes were implanted with the aid of a triplanar micromanipulator at co-ordinates appropriate for each experiment. The electrode assembly was secured to the skull using dental cement and the scalp was sutured.

Animals were used 7-10 days after implantation. Electrical stimuli were applied using a constant current generator (Digitimer-Neurolog; Welwyn Garden City) based on parameters used by Jamieson and Fink (1976). The parameters of the stimulus, which consisted of accurately balanced biphasic square waves, were, frequency 50Hz, pulse width 1 msec and amplitude of 1mA, in trains of 30 sec on and 30 sec off. Stimuli were monitored on a calibrated oscilloscope and applied for a period of 30 minutes.

At the end of each experiment, animals were decapitated and the heads placed in 10% phosphate-buffered formalin for at least 7 days. Dental cement was dissolved with chloroform and the screws and electrode assembly gently removed. The brain was then removed from the skull and stored in 10% formalin. Serial 40 μ m frozen sections of the brain were prepared and stained with luxol fast blue and cresyl violet for microscopic assessment of the position of the

electrode tracks.

2.2.12 Electrothermal Lesions

Electrothermal lesions were made using an a.c. current of 3-5mA at a frequency of 100KHz for 15 sec with a lesion maker (Grass; West Germany). Animals were anaesthetized with Avertin and prepared as for long-term electrode implantation (2.2.11).

A unipolar glass-insulated platinum electrode was lowered to the required co-ordinates (see particular experiments for details) and an indifferent electrode inserted into the rectum and a lesion made as stated above. The scalp was sutured and animals left to recover for 7-10 days before use.

2.2.13 Intracerebroventricular Cannulation and Collection of Cerebrospinal Fluid

Intracerebroventricular (i.c.v.) cannulae consisted of a 27 gauge needle (11.5mm long) fixed in a metal block, with patency maintained by a wire stilet protruding 0.3mm below the tip of the needle.

Animals were anaesthetized with Avertin and prepared as for electrode implantation substituting the i.c.v. cannula for the electrode. Co-ordinates for implantation into the third ventricle were, lateral 0.0 mm, anterior +5.8 mm and ventral +2.0 mm according to de Groot (1959). The cannula was secured to the skull using dental cement, the scalp sutured and a perspex cap screwed over the top of the cannula and stilet. Animals were left to recover for 7-10 days before CSF was sampled.

On the day of sampling, animals were anaesthetized with urethane and placed on an operating board. The protective perspex cap was

removed and the top of the cannula and stilet visualized under a binocular dissecting microscope. When the stilet was removed, CSF welled-up spontaneously to the top of the cannula. A piece of Silastic^R tubing was attached and CSF flowed passively from the cannula into the tubing. Occasionally, gentle suction was applied with a 1ml syringe to enhance flow. Collection continued for 1h. Samples were stored at -25°C until assayed.

2.2.14 Collection of Pituitary Stalk Blood

Hypophysial portal blood was collected according to the method of Worthington, (1966) as used in this laboratory by Fink and Jamieson, (1974) with a few minor modifications.

The animal was anaesthetized with urethane and immobilized supine on an operating board. General anaesthesia was supplemented with xylocaine (1%) (Astra Pharmaceuticals; Sweden) injected into the skin and muscle of the lower jaw. A midline incision was made in the skin of the lower jaw, extending caudally from the lower lip for 3-4cm. Skin and subcutaneous tissue were gently retracted to expose the muscles overlying the trachea. A 1cm longitudinal midline incision was made in these to expose the trachea. A silk thread was passed beneath the trachea and a small transverse incision (rostral to the thread) was made allowing the insertion of a 1.5cm piece of polythene tubing rostral to the bronchi. The tubing was then secured with the thread. Gentle traction was applied to the tongue by means of a long silk Guy suture passed through the tip. Ligatures were placed round each mandibular ramus, taking care to avoid damage to the tongue. Traction was applied to the jaw with these ligatures and the lower jaw and floor of the



mouth divided with a midline incision. The incision was extended through the muscles of the floor of the mouth parallel to each side of the mandible, and the fauces were cut, resulting in mobilization of the tongue. Using the Guy suture already in place, the tongue was gently retracted to reveal the soft palate and epiglottis, and fixed over the chest under gentle traction. Haemorrhage was controlled with sterilised cellulose gauze (Ethicon; Edinburgh). All further manipulations were performed under a binocular operating microscope.

The soft palate was incised longitudinally along the midline with an iris electrocautery from the posterior edge of the hard palate to 1mm anterior to the epiglottis, and laterally to the pterygoid processes of the sphenoid bone, (in preparations involving removal of the pituitary gland, the incision was extended caudally to the epiglottis). This incision exposed the mucosa overlying the basosphenoid which was then removed with cotton wool.

Using a dental drill, a hole was drilled in the outer table of the basosphenoid bone from the occipito-sphenoid suture to the basosphenoido-presphenoid suture anteriorly. Throughout the drilling procedure, the hole formed was packed with bone wax, particularly in the area of the transverse venous sinus. The exposed inner table was then gently eburnated until it yielded to gentle pressure from either a drill or a pair of fine forceps. The thin layer of bone remaining was removed with a pair of watchmaker forceps, revealing the dura mater overlying the ME and pituitary gland. A piece of razor blade held in a pin chuck was used to make a "V"-shaped cut in the dura. The base of the "V" was over the

pituitary gland and the apex was just rostral to the portal vessels. Cerebrospinal fluid appearing at this stage was removed with a small piece of cotton wool. The flap of cut dura (with cut arachnoid attached) was retracted caudally, thus exposing the median eminence and pituitary gland.

Animals which were to be sampled with the pituitary gland in situ were then injected with 2500IU heparin into the external jugular vein. Using iridectomy scissors the pituitary stalk was cut transversely at its junction with the pituitary gland. Blood was allowed to flow into the drilled trough and collected using a glass Pasteur pipette; fluid collected during the first 5 minutes after cutting was discarded to allow removal of any tissue debris, bone wax or cotton wool fibres. Collection was continued into ice-cooled plastic tubes.

The procedure differed slightly in animals used with the pituitary gland removed. After exposure of the ME and pituitary gland, the pituitary stalk was cut and the pituitary gland was removed by suction. Suction was maintained for a few minutes to reduce haemorrhage and prevent formation of a blood clot. After haemorrhage into the pituitary fossa had ceased (about 5 min), 2500 IU of heparin were injected into the external jugular vein. To recommence bleeding from the pituitary stalk, the free end of the stalk was either gently massaged with watchmakers forceps or the stalk was again cut close to the site of the initial transection. Blood was collected as in animals with the pituitary gland in situ, discarding fluid collected during the first 5 min and taking great care not to touch the pituitary fossa. Peripheral blood samples

were routinely taken from the external jugular vein at the beginning and end of the procedure. Plasma was stored at -25°C until assayed.

2.2.15 Median Eminence Stimulation

Animals were prepared as for collection of pituitary stalk blood until the ME and pituitary gland had been exposed. A unipolar electrode (2.2.11) was then lowered into position on the ME with the aid of a dissecting microscope and a micromanipulator. The electrode was placed on the ME over the long portal vessels, about 1mm rostral to their junction with the pituitary gland. (In those experiments involving animals with the pituitary gland removed, the electrode was positioned before the removal of the gland.) The portal vessels were cut and blood collection carried out as before. Electrical stimulation was applied only during the second half-hour collection of blood, using parameters described in section 2.2.13.

2.3 RADIOIMMUNOASSAY

The principle of radioimmunoassay (RIA) is the competition between labelled and unlabelled antigen for a limited number of molecules of specific antibody. The amount of labelled antigen that is bound to antibody decreases as the concentration of unlabelled antigen is increased, and by comparing the degree of inhibition with the inhibition produced by a set of known standards, an estimate of the unknown concentration of antigen can be made.

Numerous reviews on the subject of RIA have been published (Midgeley, Niswender and Rebar, 1969; Kirkham and Hunter, 1971; Rodbard, 1971; Abraham, 1974; Ekins, 1974; Yalow, 1980), therefore only the methods used in this thesis to measure hormones in rat plasma will be discussed.

Rat-prolactin (PRL), ovine-luteinizing hormone (LH), rat thyroid stimulating hormone (TSH) and rat luteinizing hormone releasing hormone (LHRH) were labelled with ^{125}I (Na^{125}I ; Amersham International, Bucks.) using modifications of the chloramine-T method of Greenwood, Hunter and Glover (1963). 'Free' hormone was separated from antibody-bound ('bound') hormone by the double antibody technique of Utiger, Parker and Daughaday (1962).

Oestradiol- 17β was measured in rat plasma using an RIA modified from that used by Dick, Culbert, Wells, Gilbert and Davidson (1978). Samples were incubated with ^3H -oestradiol and 'free' hormone separated from 'bound' hormone using dextran coated charcoal.

Oxytocin was measured in rat plasma using a modification of the method described by Robinson (1980). Oxytocin was iodinated using the iodogen procedure as described by Salacinski, Hope, McLean, Clement-Jones, Sykes, Price and Lowry (1979). Free hormone was separated from bound hormone by the addition of absolute ethanol.

Vasopressin in rat plasma was measured using an antiserum raised by Mohring and Mohring (1975) and described by North, La Rochelle, Haldar, Sawyer and Valtin (1978), using the same assay conditions as for OT.

The assays of VP and OT were carried out in the laboratories of Dr. I.C.A.F. Robinson, (Department of Endocrine Physiology, National Institute for Medical Research, Mill Hill, London).

The inter-assay and intra-assay variability for each hormone were monitored by including a 'high pool' sample and a 'low pool' sample in duplicate within each assay, and repeating estimations of these same samples in successive assays. Assay quality was also

monitored by recording 'total counts' (total labelled hormone), and 'blanks' (no specific antibody) and 'total bound' (no unlabelled hormone) as a percentage of the total counts. The equivalent concentrations of the 20%, 50% and 80% B/Bo* were also recorded for each assay.

Standards were assayed in triplicate and samples in duplicate for all assays except OT and VP where standards were assayed in duplicate and samples were assayed singly.

Details of stock solutions used and methods for radioisotope labelling for all hormones studied are given in Appendices III-VI.

All samples and standards were aliquoted into LP3 tubes (Luckham Ltd., Dagenham, Essex) using Gilson pipettman automatic pipettes (Scotlab Instrument Sales Ltd.; Carlisle, Scotland). All assay reagents were dispensed using a Micromedic 25006 automatic dispenser (Micromedic-Systems; Horsham, PA, U.S.A.).

The 'bound' hormone was counted using an automatic Gamma Counter (Berthold Mag 310; Scotlab Instrument Sales Ltd., Carlisle, Scotland) and the concentration of hormones was obtained by linear regression of the standard curves of logit B/Bo on the ordinate against log concentration on the abscissa, $(B/Bo = \text{counts per minute (cpm) of standard or sample} - \text{background cpm} / \text{cpm of total bound} - \text{background cpm})$, $\text{logit } B/Bo = \ln (B/Bo / (1 - B/Bo))$. The lower limit of sensitivity of the assay was determined as being the $\text{cpm} - 2 \times \text{standard deviation of the total bound tubes}$ (Rodbard, 1971).

2.3.1 Radioimmunoassay of prolactin

The concentration of PRL in rat plasma samples was measured using double antibody RIA kits supplied by the National Institute of

*
B = cpm of standard or sample — background cpm
Bo = cpm of total bound — background cpm

Arthritis, Diabetes, Digestive and Kidney Diseases (NIADDK; Baltimore, U.S.A.). The assay has been described by Pickering (1978) and is briefly outlined in Appendix (III). Reference standards were prepared from rat-PRL-RP-1 (NIADDK) (range 0.5-64 ng/ml) and rat-PRL-I-S (NIADDK) was used for iodination. The hormone-specific antibody was anti-rat-PRL-55 (NIADDK) used at a final dilution of 1:20,000. After incubation of ^{125}I -PRL with anti-PRL serum and samples/standards, the 'bound' hormone was separated from the 'free' hormone using anti-rabbit gamma globulin (ARGG) supplied by the Scottish Antibody Production Unit (SAPU) (Law Hospital, Carlisle, Lanarkshire), at a final dilution of 1:100.

A representative standard curve and quality control data for the assay are shown in Figures 2-1 and 2-2, respectively. Using a high and a low pool sample, the inter- and intra-assay coefficients of variation were found to be 10% and 7% respectively. The lower limits of sensitivity ranged from 20-27ng/ml for 20 μ l samples of plasma.

2.3.2 Radioimmunoassay of luteinizing hormone

The ovine-ovine RIA developed by Niswender, Midgley, Monroe and Reichert (1968) was used to measure the concentration of LH in rat plasma. The protocol used in this thesis has been described by Aiyer (1974) and Aiyer and Fink (1974) and is outlined in Appendix (III). Ovine-LH (LER-1056-C2) provided by Dr. L.E. Reichert Jr. (NIADDK) was used for iodination and ovine-LH (NIH-LH-S18) was used to prepare the standards (range 0.25-16ng/ml). The specific antibody, antiovine-LH (GDN 15) was provided by Dr. G.D. Niswender (NIADDK) and was used at a final

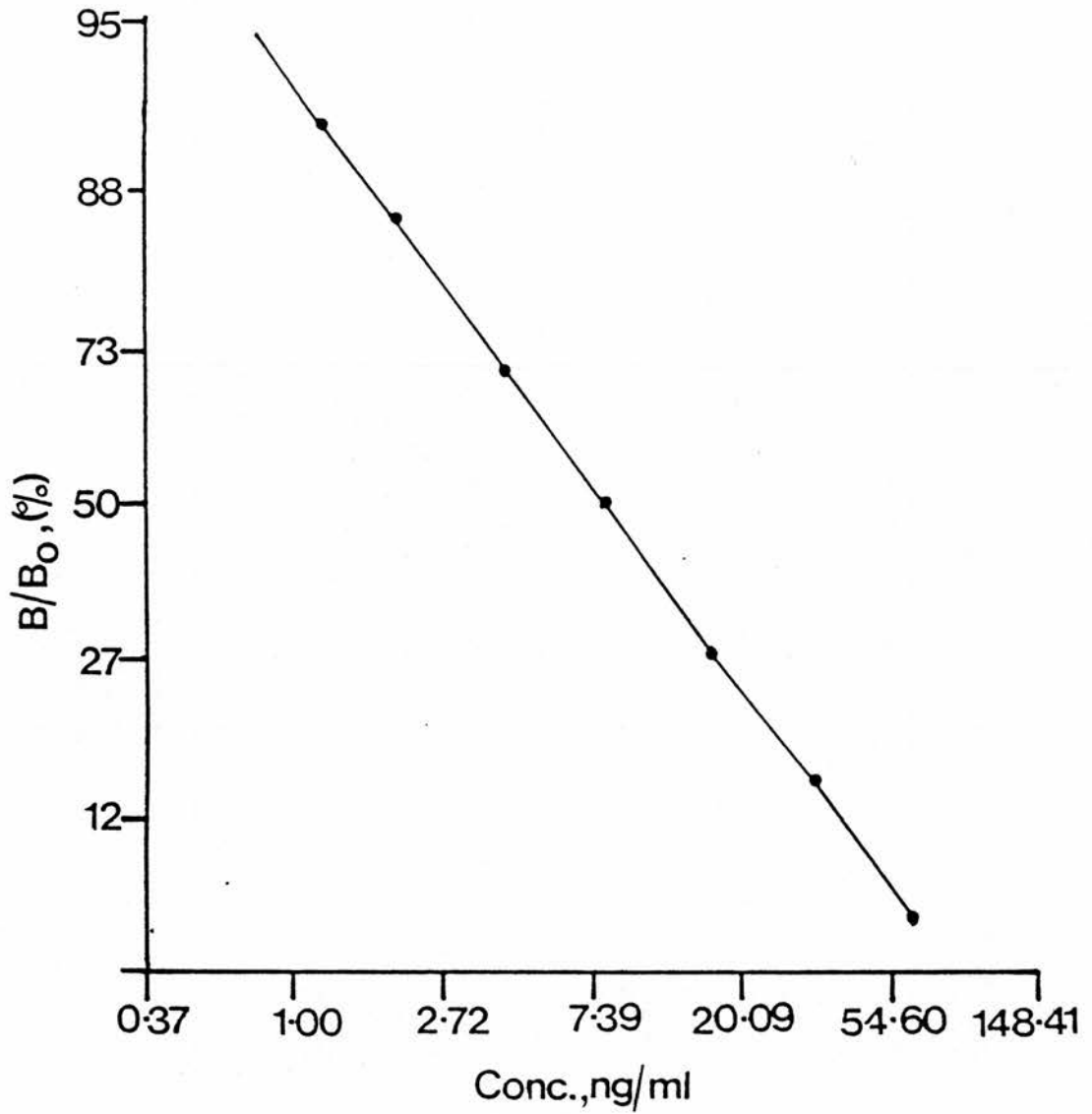

FIGURE 2-1 Standard curve of a representative assay for prolactin (PRL). Each point represents the mean of three replicates.

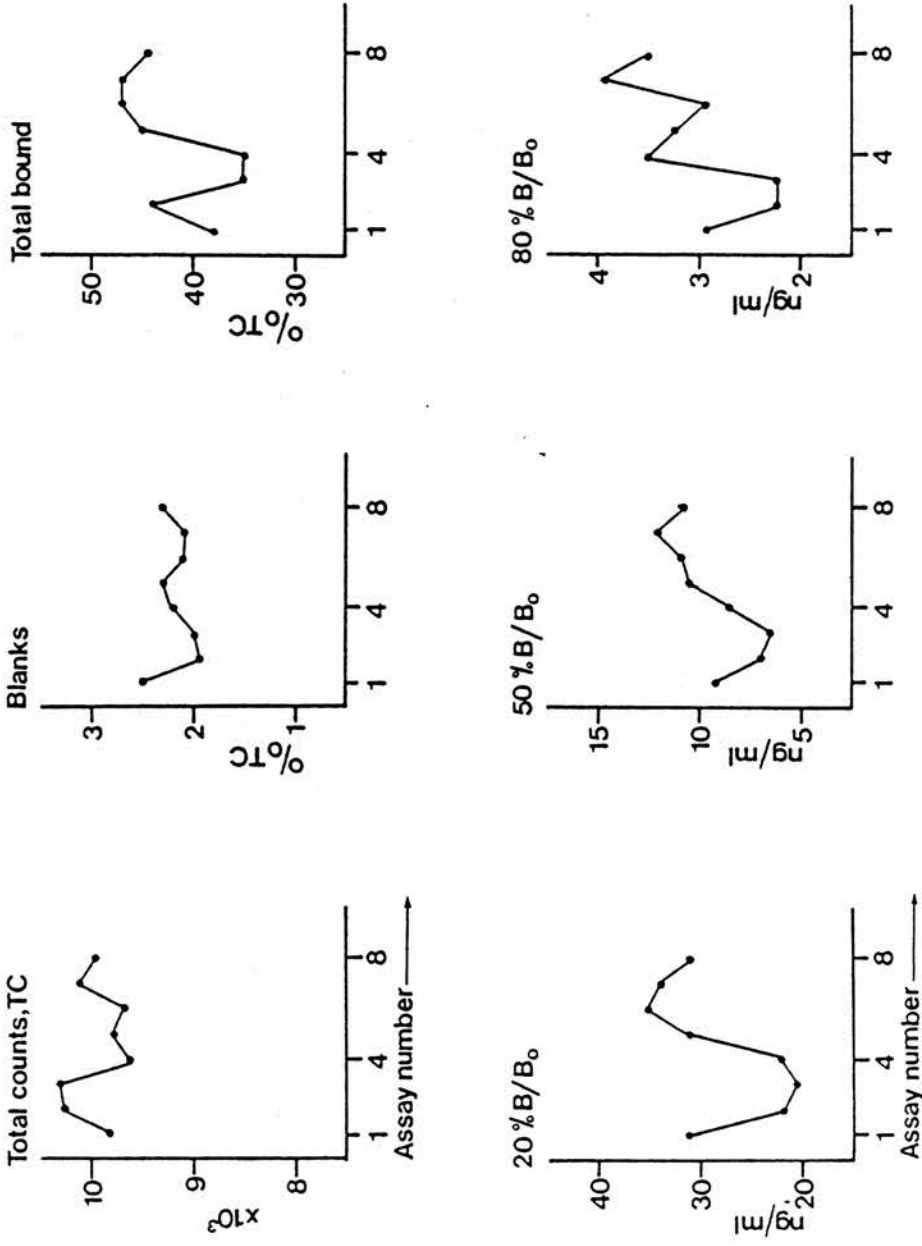

FIGURE 2-2 Quality control data for eight prolactin (PRL) assays.

dilution of 1:240,000. After incubation of ^{125}I LH with anti-LH serum and samples/standards, the 'bound' hormone was separated from the 'free' hormone using ARGG (SAPU) at a final dilution of 1:100.

A representative standard curve and quality control data for the assay are shown in Figure 2-3 and Figure 2-4, respectively. The inter- and intra-assay coefficients of variation were 10% and 9% respectively. The lower limits of sensitivity ranged from 1.0-1.5ng/ml for 20 μ l samples of plasma.

2.3.3 Radioimmunoassay of luteinizing hormone releasing hormone

The concentration of LHRH in rat hypophysial plasma was measured using the double-antibody RIA developed by Nett, Akbar, Niswender, Hedlund and White (1973). The protocol used in this thesis has been described by Jamieson (1974), Fink and Jamieson (1976) and Chiappa (1976) and is outlined in Appendix (IV). Synthetic LHRH (ICI Pharmaceuticals, Macclesfield) was used both to prepare standards (7.8-500pg/ml) and for iodination. The specific antibody (R-42-anti-GnRH) was provided by Dr. G.D. Niswender (NIADDK) and was used at a final dilution of 1:32,000. The antibody recognized the whole LHRH molecule and did not cross-react with LHRH analogues or fragments (Nett et al, 1973) or various pituitary hormones and peptides (Nett et al, 1973; Chiappa, 1976; Jamieson and Fink, 1976). After incubation of ^{125}I LHRH with anti-LHRH serum and samples/standards, the 'bound' hormone was separated from the 'free' hormone using ARGG (SAPU) at a final dilution of 1:100.

Since only one LHRH RIA was carried out, the standard curve is shown in Figure 2-5. In this case, intra-assay variation only was determined and found to be 10%. The lower limits of sensitivity

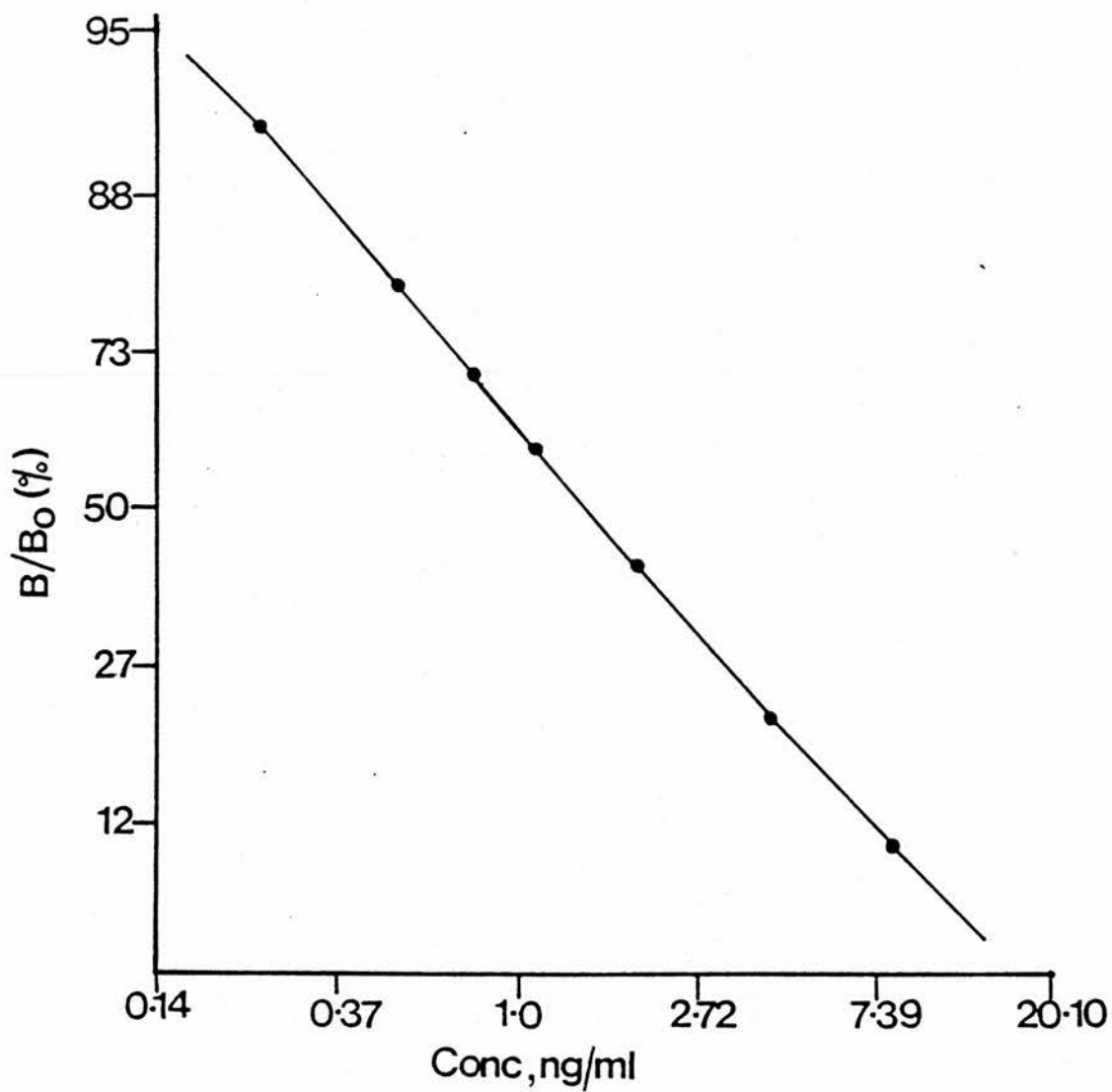

FIGURE 2-3 Standard curve of a representative assay for luteinizing hormone (LH). Each point represents the mean of three replicates.

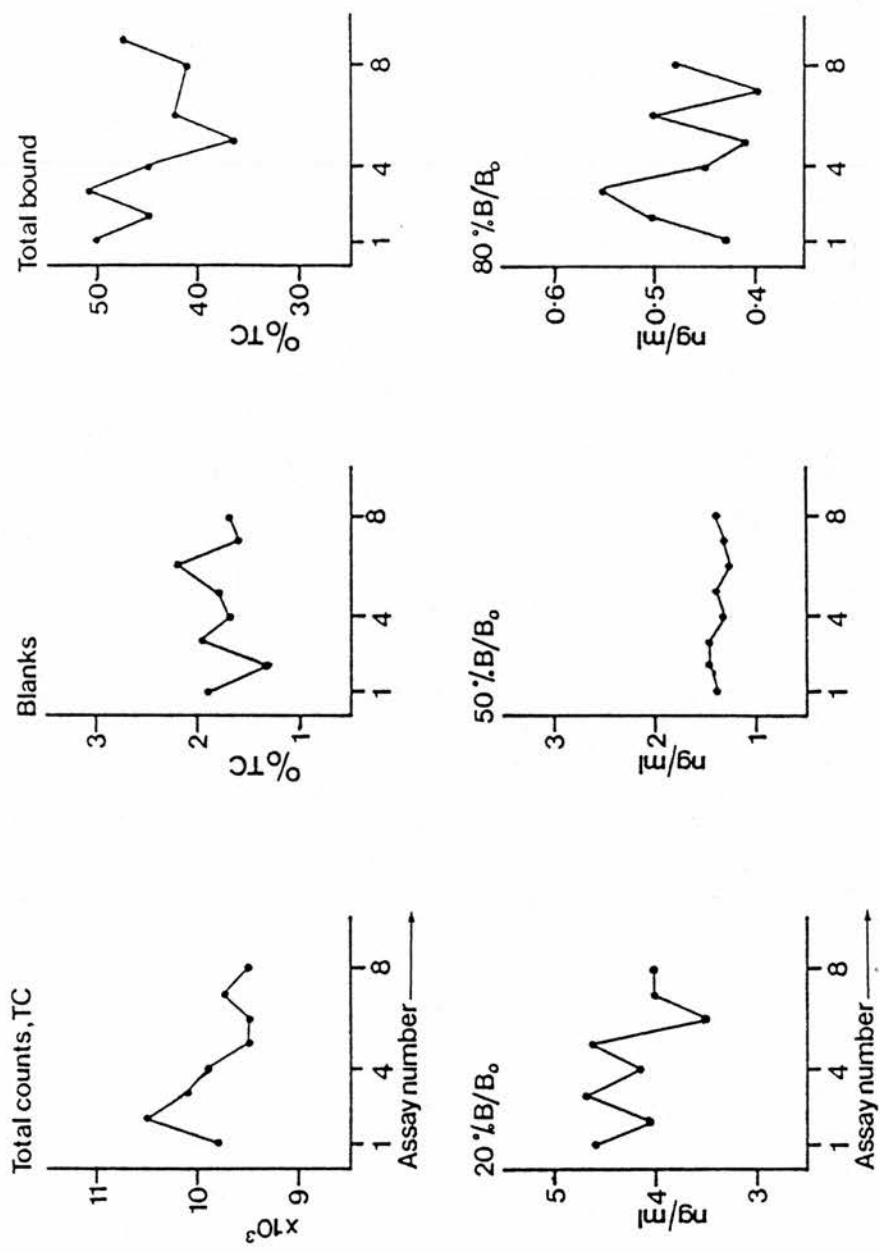

FIGURE 2-4 Quality control data for eight luteinizing hormone (LH) assays.

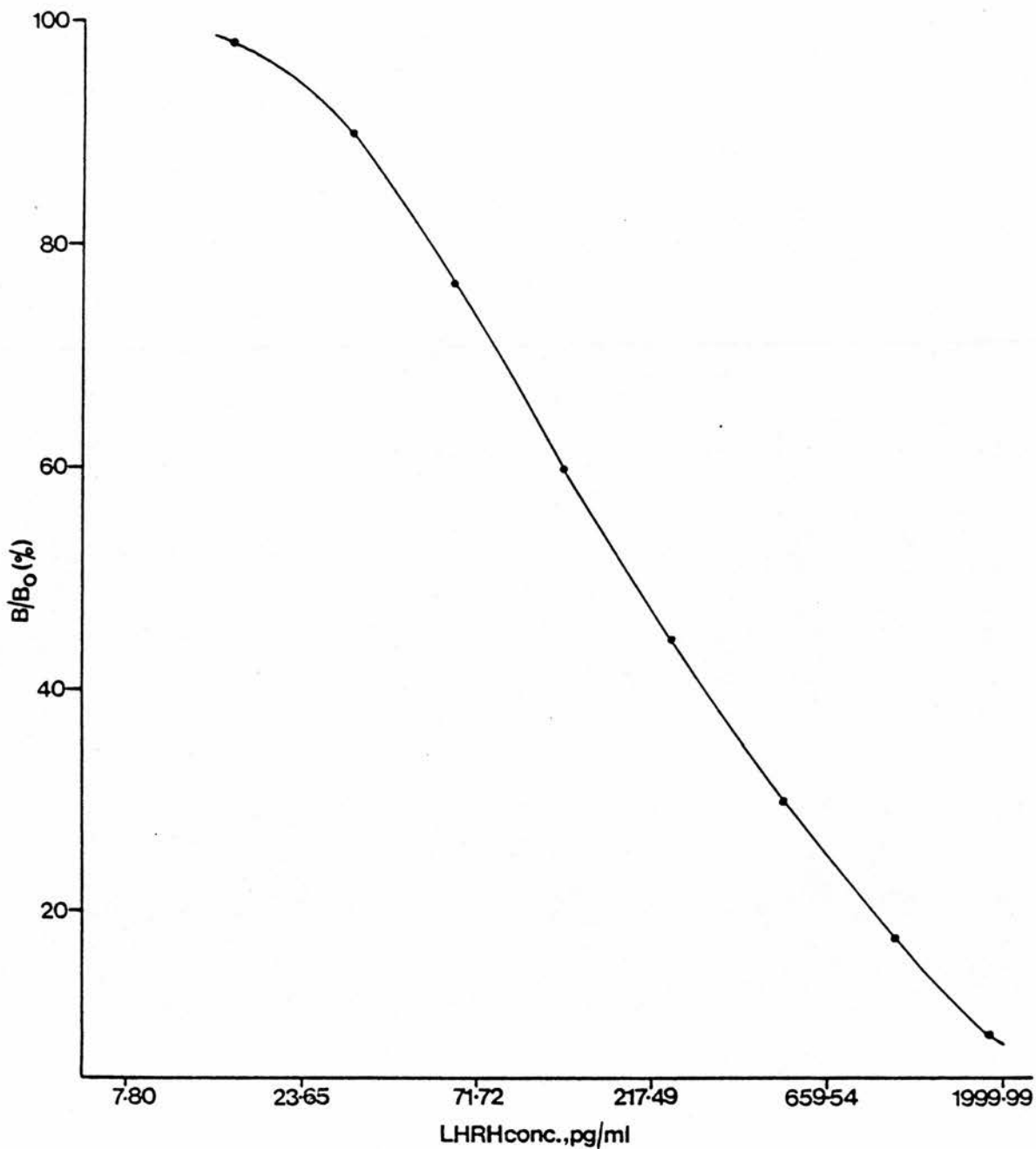

FIGURE 2-5 Standard curve of the assay for luteinizing hormone-releasing-hormone (LHRH). Each point represents the mean of three replicates.

ranged from 10-12pg/ml for 100 μ l samples of hypophysial portal plasma.

2.3.4 Radioimmunoassay of oxytocin

The RIA developed by Robinson (1980) was used to measure the concentration of OT in rat plasma. This assay has been described in detail by Robinson (1980) and the protocol used in this thesis is outlined in Appendix (V). Reference standards (range 1-250pg) were prepared from the IVth International Standard for oxytocin (National Institute for Biological Standards and Controls: Hampstead, England) (NIBSC) and OT (440 IU/mg) (a gift from Dr. H. Vilhardt, Ferring AB, Malmo, Sweden) was used for iodination. The specific antibody, R₃ was raised in rabbits, against OT conjugated with porcine thyroglobulin, by Dr. I.C.A.F. Robinson (full details in Robinson, 1980) and was used at a final dilution of 1:225,000. The antibody showed < 0.004% cross reactivity with arginine-VP. After incubation of ¹²⁵I OT with anti-OT serum and samples/standards, the 'bound' hormone was separated from the 'free' hormone by the rapid addition of absolute ethanol.

A representative standard curve is shown in Figure 2-6. The inter- and intra-assay coefficients of variation were 7% and 12% respectively. The lower limit of sensitivity ranged from 2-5pg/tube for 50 μ l samples of plasma.

2.3.5 Radioimmunoassay of vasopressin

The concentration of VP in rat plasma was measured using an assay described in detail by Mohring and Mohring (1975) and North et al (1978). The protocol used in this thesis is outlined in Appendix (V). Dilutions of the 1st International Standard for VP

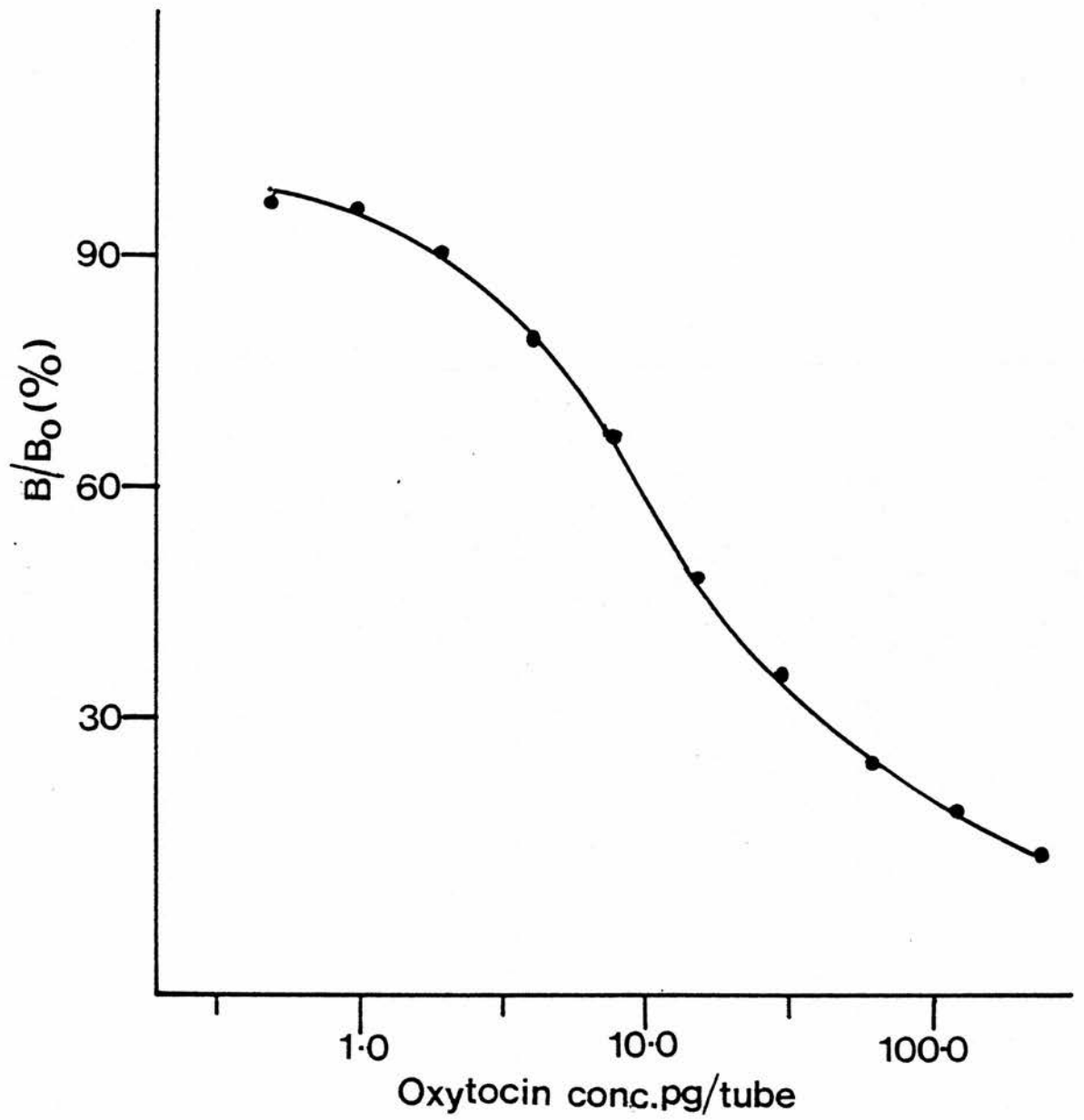

FIGURE 2-6 Standard curve of a representative assay for oxytocin. Each point represents the mean of duplicates.

(NIBSC) were used as working standards (range 1-250pg) and synthetic VP (400IU/mg) (Batch no. 770110, Ferring; Sweden) was used for iodination. The specific antibody, Erwin 74 was raised in rabbits to arginine-VP conjugated with porcine gamma globulin and donated by Dr. J. Mohring (Mohring and Mohring, 1975). Used at a final dilution of 1:5,000, it showed < 0.01% cross reactivity with OT. After incubation of ^{125}I VP with anti-VP serum and standards/samples, the 'bound' hormone was separated from the 'free' hormone by the rapid addition of absolute ethanol. A representative standard curve is shown in Figure 2-7. The inter- and intra-assay coefficients of variation were 6% and 12% respectively and the lower limit of sensitivity ranged from 1-3pg/tube for 25 μ l samples of plasma.

2.4 HIGH PRESSURE LIQUID CHROMATOGRAPHY

2.4.1 Introduction

High pressure liquid chromatography (HPLC) with electrochemical detection (LCED) was used to measure the concentrations of catecholamines and indoleamines in brain extracts. This technique is highly selective and sensitive and is more rapid and inexpensive than the previously used radioenzymatic method (Coyle and Henry, 1973; Saavedra, Brownstein and Axelrod, 1973), and it also allows simultaneous measurement of several amines and their metabolites with minimal sample preparation. The detailed theory of electrochemical reactions and continuous flow voltammetry have been described by Adams (1969) and Weber and Purdy (1978). Therefore, only the principles relevant to the measurement of catechol- and indoleamines in this thesis are described.

The basis of HPLC-LCED is the ability of compounds, after having

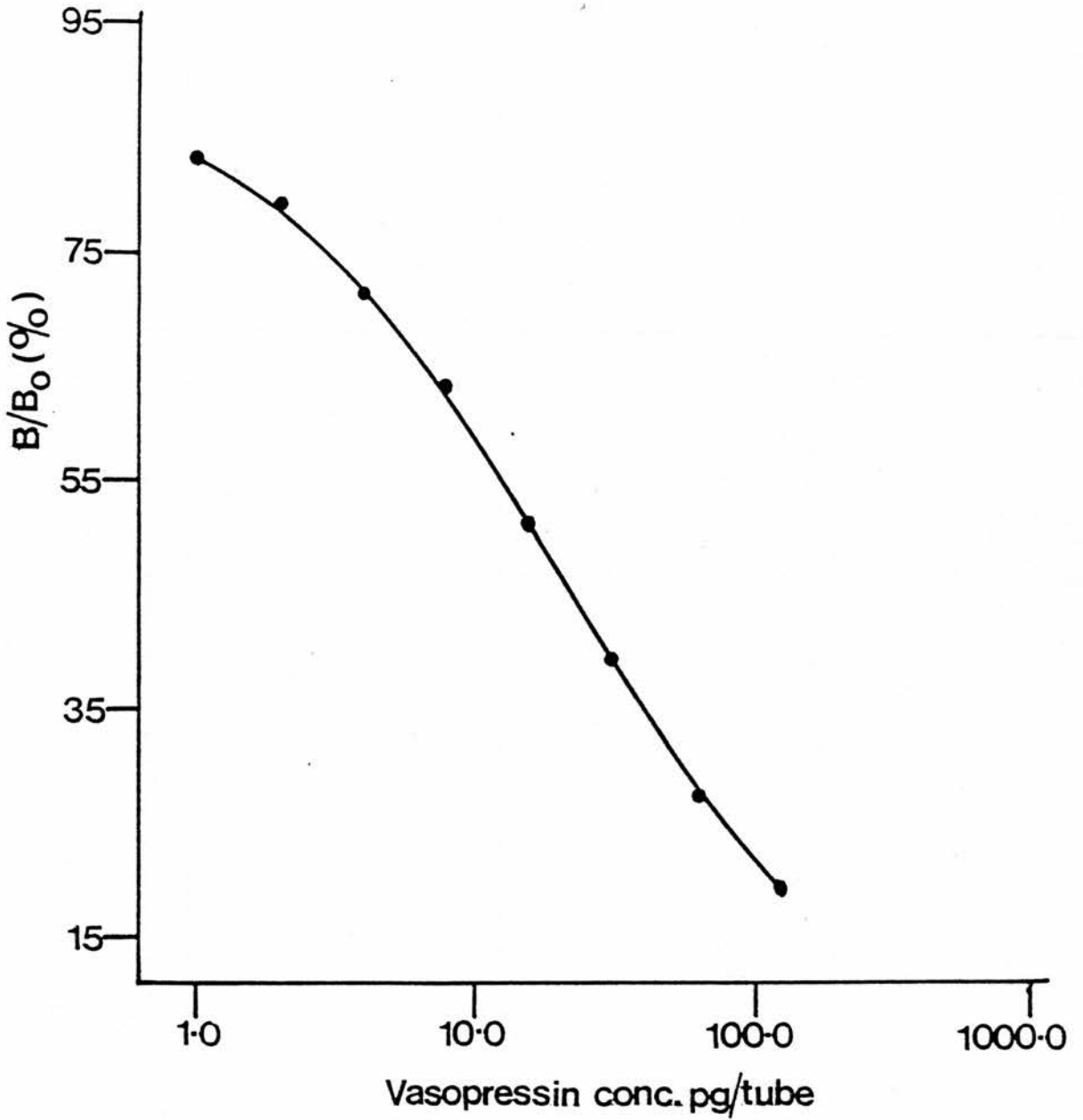

FIGURE 2-7 Standard curve of a representative assay for vasopressin. Each point represents the mean of duplicates.

been separated on a chromatographic column, to undergo redox reactions in such a way as to accommodate either loss or gain of one or more electrons within certain limits of electrical potential. These limits are fixed by the composition of the electrolyte solution in which the compound is dispersed and the material of which the detector electrode is composed. Almost all catechol- and indoleamines are oxidised between the potential limits of +0.5 and +0.7 volts (with reference to an Ag/AgCl reference electrode). Typical oxidative reactions for a catecholamine and an indoleamine are shown in Figure 2-8. Electrons are lost to the detector electrode and the current which is derived is proportional to the concentration of the amine present in the sample. This generated current is then converted to a proportional voltage and displayed on a suitable recorder.

2.4.2 Materials and Methods

2.4.2.1 Instrumentation

The system used in these studies is shown schematically in Figure 2-9. All equipment was purchased from Scotlab Instrument Sales Ltd. unless otherwise stated.

The mobile phase (2.4.2.2) was pumped through the system at a rate of 1ml/min using an Altex 110A pump. Standards and samples were loaded onto the columns through a Rheodyne 7125 injection valve, fitted with a 20 μ l injection loop, using an SGE 25 μ l syringe. The main analytical column was protected from deterioration by first passing samples through a pre-column consisting of a 10cm x 0.4cm stainless steel tube packed with either Ultrasphere ODS (column purchased pre-packed) or Spherisorb 5 μ m ODS

a)

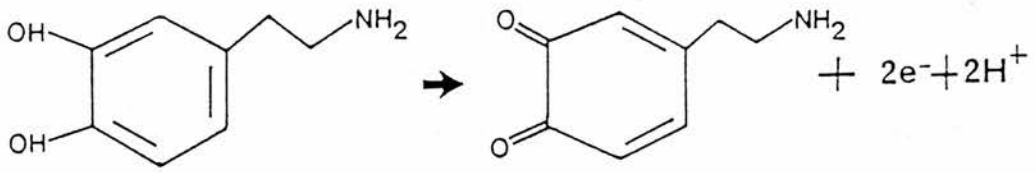

b)

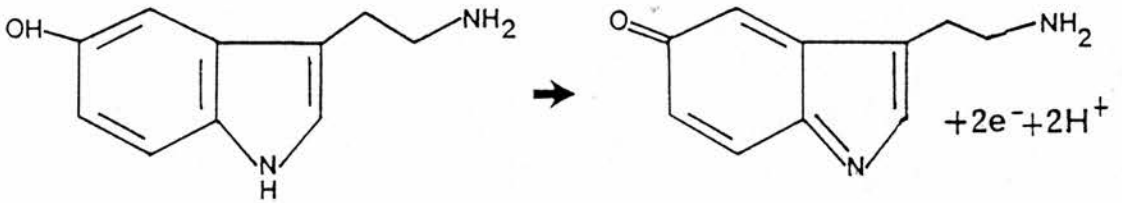

FIGURE 2-8 Oxidative reactions for a) a catecholamine and b) an indolamine.

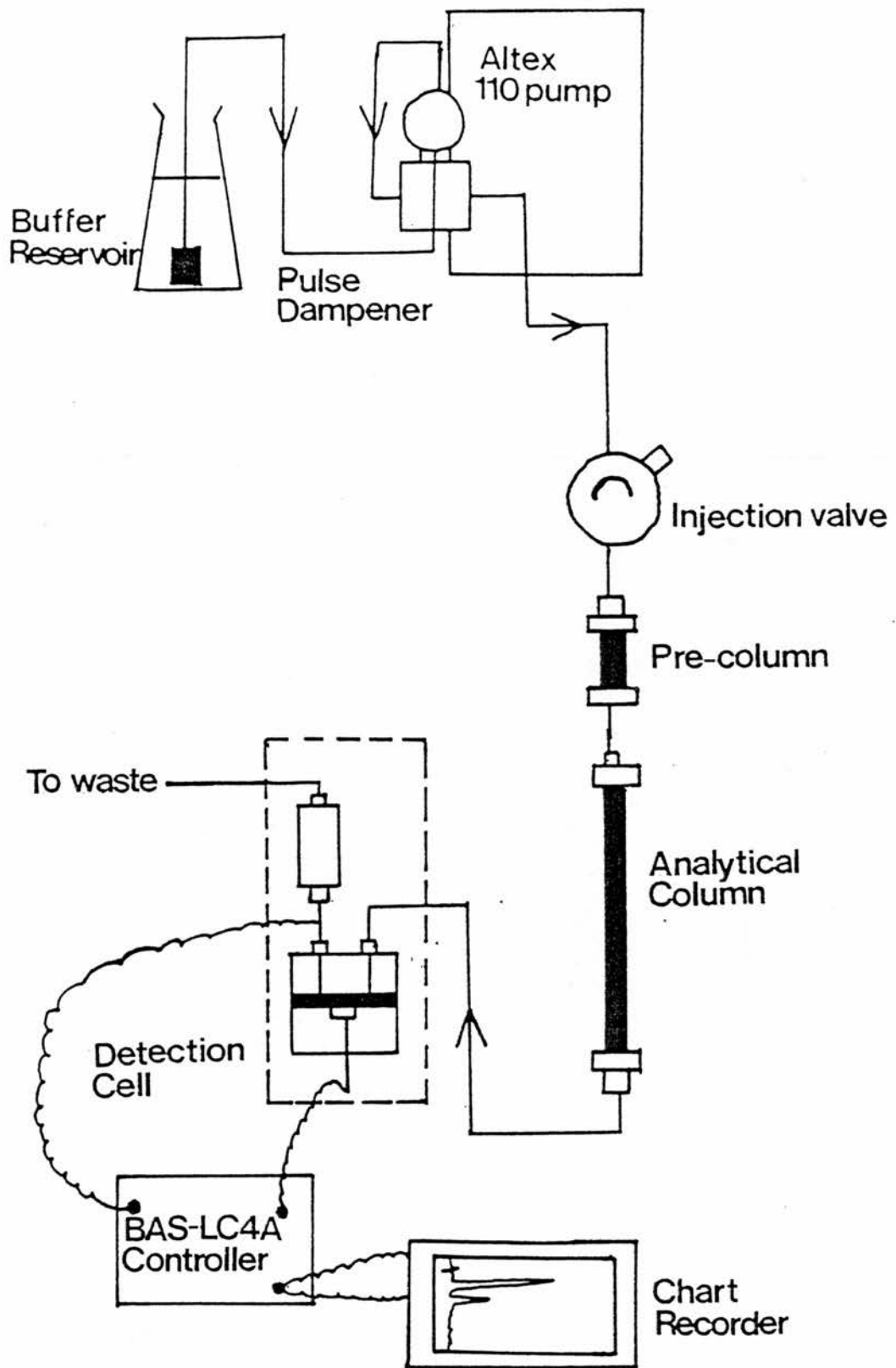

FIGURE 2-9 Diagrammatic representation of the HPLC-LCED system.

(column packed in the laboratory with a Magnus slurry packer at a pressure of 4000psi). (These 2 different types of pre-column were interchanged freely as no difference was found in their performance.) The analytical column consisted of a 25cm x 0.46cm stainless steel tube, purchased pre-packed with Ultrasphere ODS (5 μ m silica particles coated with hydrocarbon chains, 18 CH₂ groups in length). Compounds were detected by a Bioanalytical System (BAS Inc., Indiana, U.S.A.) LC-17 glassy carbon transducer cell (Fig. 2-10). The cell consisted of a plexiglass block divided in half by a 0.2mm polytetrafluoroethylene (teflon) gasket. A flow cell with a volume of < 1 μ l, containing the glassy carbon working electrode, was formed by a slit (1.6cm x 0.5cm) cut in the gasket. A potential of + 0.7 volt was maintained across the cell (with reference to an Ag/AgCl reference electrode) by a BAS-LC4A controller which also amplified and converted the signal from the working electrode to a voltage for display on a Tarkan 600 chart recorder set at a range of 1 volt for a full-scale chart deflection.

2.4.2.2 Mobile phase

An aqueous mobile phase (buffer) was used, consisting of 0.1 M sodium acetate, 0.1M citric acid, 5% (v/v) methanol, 2% (v/v) tetrahydrofuran (THF) and 100mg/l sodium octanesulphonic acid (Mayer and Shoup, 1983), brought to pH 4.9-5.1 with sodium hydroxide. Distilled, deionized water and Analar grade reagents were used at all times.

Buffer without THF was filtered under pressure through a 0.22 μ m millipore filter and then degassed for 10 min. Tetrahydrofuran was added and the buffer and THF very gently mixed taking care not

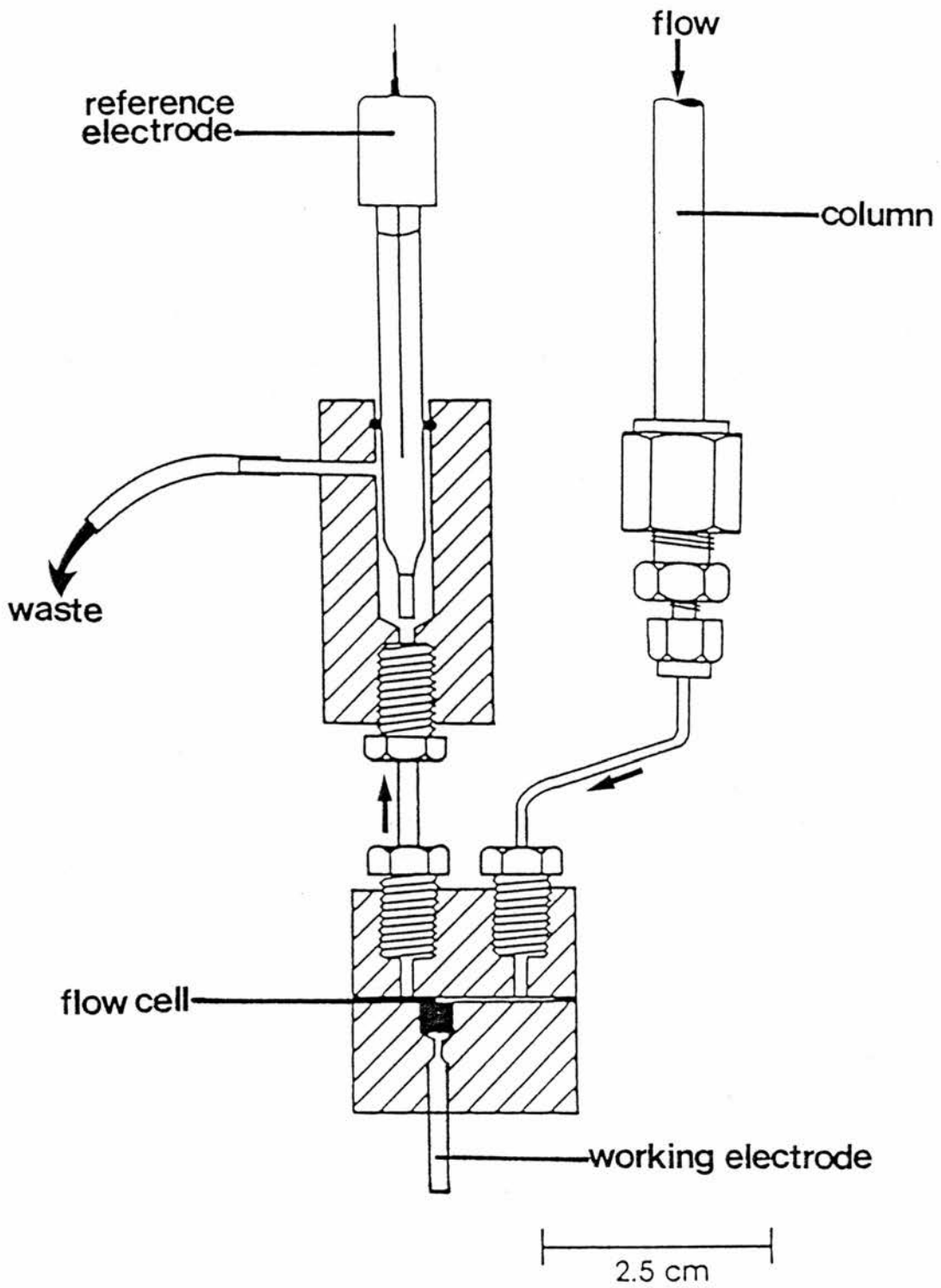

FIGURE 2-10 Cross-sectional diagram of the BAS LC-17 transducer cell.

to introduce any air into the mixture.

2.4.2.3 Standards

Stock solutions (100 μ g free base/ml) of noradrenaline hydrochloride (NA), dopamine hydrochloride (DA), dihydroxyphenyl acetic acid (DOPAC), 5-hydroxytryptamine creatinine sulphate (5-HT), 5-hydroxyindoleacetic acid (5-HIAA) and of internal standard, n-acetyldopamine hydrochloride (n-acDA), were prepared in 10^{-4} M cysteine and diluted daily before use in 0.2M perchloric acid (HClO_4). Stock solutions were stable for up to 6 weeks when stored in the dark at 4°C. The range of concentrations used routinely was 50pg, 100pg, 200pg and 2ng per 20 μ l injection but standard curves were linear over the range of 20pg to 2ng (see Fig. 2-11). An internal standard of 1ng/20 μ l of n-acDA was included in both the sample homogenization buffer and in the standard solutions. Typical chromatograms for 2 different concentrations of standards are shown in Figure 2-12.

The lower limit of sensitivity of this procedure was defined as three times baseline 'noise' and was between 15-20pg per 20 μ l injection for all compounds studied.

2.4.2.4 Extraction and preparation of samples

The amines present in brain samples were extracted by homogenization of tissue in 0.2M HClO_4 containing 10^{-4} M cysteine as antioxidant, and 1ng/20 μ l of internal standard. Homogenized tissue was centrifuged at 1000 x g for 5 min and the supernatant then filtered through a 0.2 μ m regenerated cellulose filter using a BAS MF1 centrifugal microfilter. The filtered supernatant was then kept on ice until injected directly into the

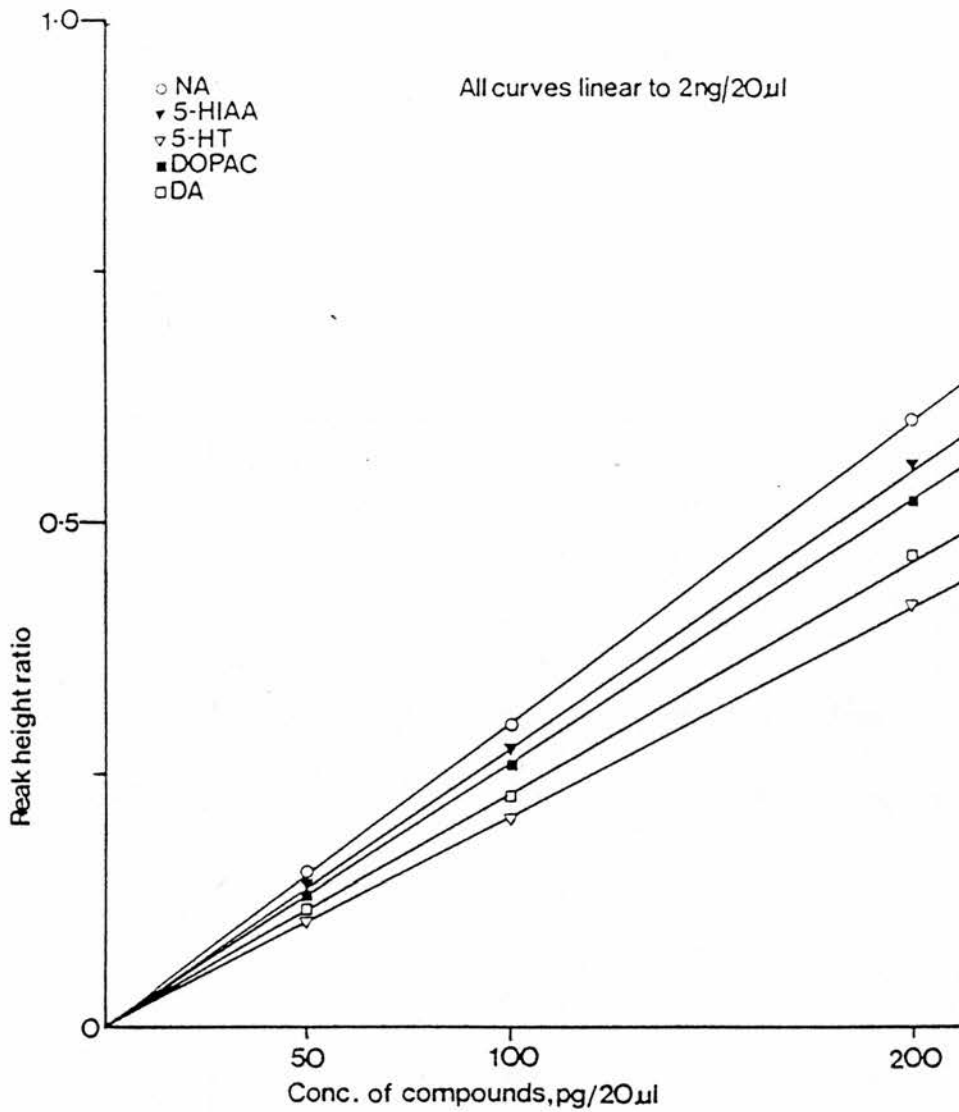

FIGURE 2-11 Standard curves for noradrenaline (NA), dopamine (DA), dihydroxyphenylacetic acid (DOPAC), 5-hydroxytryptamine (5-HT) and 5-hydroxyindoleacetic acid (5-HIAA) using peak height ratios=

$$\frac{\text{Peak height of standard ('x' ng/20}\mu\text{l)}}{\text{Peak height of internal standards (1ng/20}\mu\text{l)}}$$

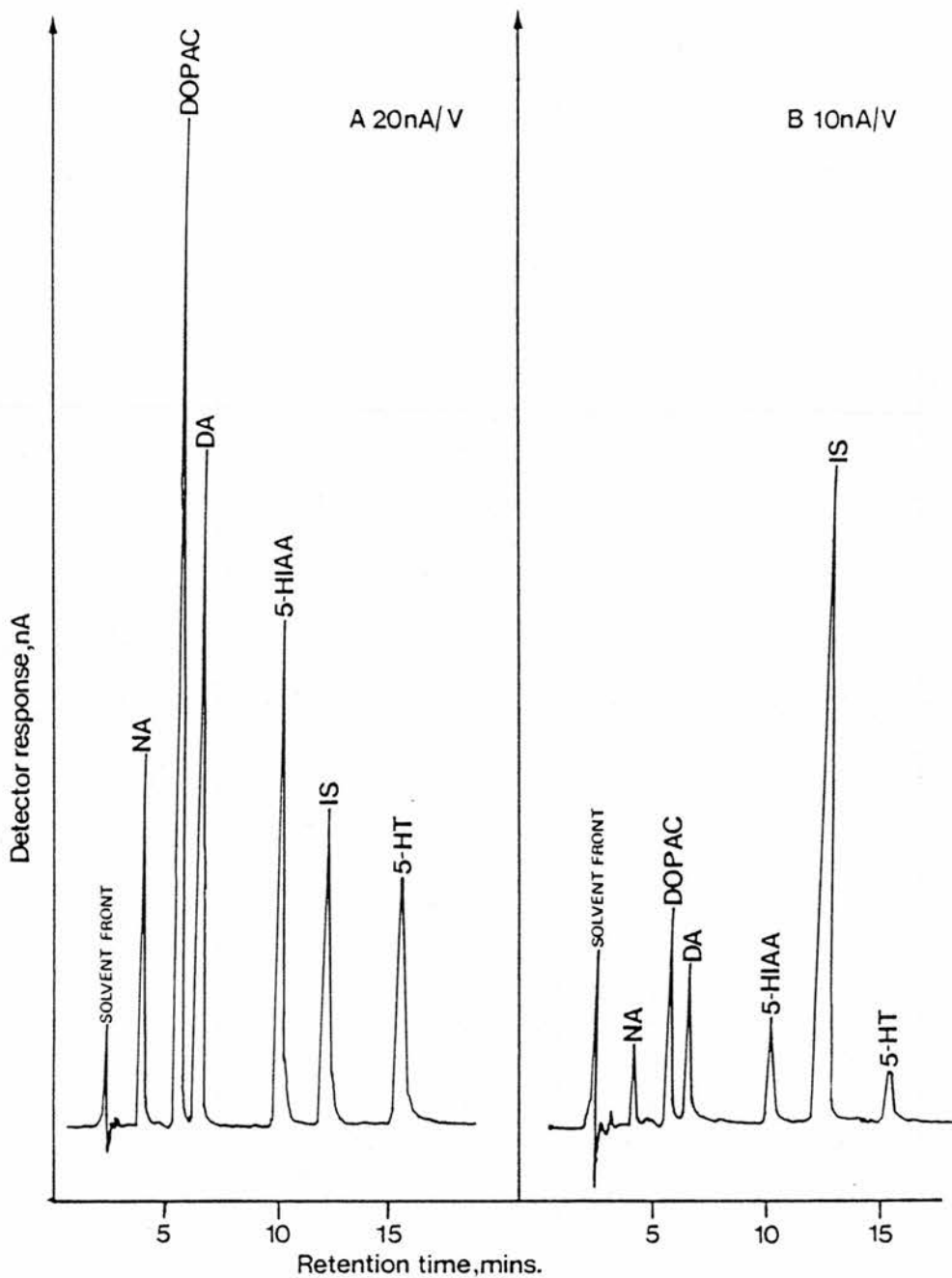

FIGURE 2-12 Representative chromatograms for a) 2ng/20 μ l and b) 200pg/20 μ l of noradrenaline (NA) dopamine (DA), dihydroxyphenyl acetic acid (DOPAC), 5-hydroxytryptamine (5-HT) and 5-hydroxyindoleacetic acid (5-HIAA) with the addition of 1ng/20 μ l of n-acetyldopamine (IS - internal standard) to each injection.

HPLC-LCED system.

2.4.2.5 Calculation of results

Peak heights were measured from a point on the baseline from which a perpendicular (relative to the direction of movement of the recorder paper) could be drawn to the maximum point of the peak.

Since the same mass of internal standard (1ng/20 μ l) had been added to all standards and samples, the peak height ratio (PHR) relative to the internal standard, for each concentration of standard, was calculated, i.e.

Peak height of standard ('x' ng/20 μ l)/Peak height of internal standard (1ng/20 μ l)

Peak height ratios relative to an internal standard allowed for correction of recovery and injection volume variation without further calculation. A standard curve was constructed for each compound using PHR against concentration. Typical examples are shown in Figure 2-11. The mass of each different compound in each sample was determined by linear regression from the relevant standard curve using the PHR of each compound relative to the internal standard in that sample.

CHAPTER 3

The Release of ^3H -Dopamine from the Median Eminence
'in vitro'

3.1 INTRODUCTION

The secretion of hormones by the anterior pituitary gland is largely controlled by hypothalamic releasing- and release-inhibiting factors (Harris, 1955; Sawyer, 1959). Much attention has focussed on the modulation of the release of PRL, which in the mammal appears to be primarily under inhibitory control (Everett, 1954; Meites et al., 1972; Bishop, Krulich, Fawcett and McCann, 1971). The identity of the prolactin-inhibitory factor (PIF) has been sought for a number of years and the most likely candidate proposed, so far, is DA (Macleod, 1976). Dramatic decreases in the secretion of PRL are seen both in vivo and in vitro after treatment with DA (Macleod, 1969; Birge et al., 1970; Blake, 1973; Mueller, Simpkins, Meites and Moore, 1976) and there is anatomical and neuroendocrine evidence to support the role of DA as a PIF under some circumstances (Leong et al., 1983).

It has been demonstrated (Hökfelt and Fuxe, 1967; Smith and Fink, 1972) that fluorescence associated with DA terminals is present in the ME adjacent to the hypophysial portal vasculature and to other nerve terminals, the probable sites of hypophysiotrophic hormone storage (Barnea, Ben-Jonathan, Colston, Johnston and Porter, 1976). This has been confirmed by electron microscopy (Cuello and Iversen, 1973) and by radioenzymatic assay in combination with RIA (Selmanoff, 1981). The cell bodies of these tuberoinfundibular DA (TIDA) neurons are located mainly in the arcuate nucleus, with some fibres arising in the periventricular area and the paraventricular nucleus (Moore and Bloom, 1978; Renaud, 1981). There is some dispute regarding possible sites of origin in the ventromedial

nucleus and the preoptic area, as although projections from these areas to the ME have been identified by retrograde tracing studies they have not been shown to contain DA (Wiegand and Price, 1980). All of the areas mentioned above have been shown to be involved in the control of the release of anterior pituitary hormones (Joseph and Knigge, 1978). Consistent with the view that DA is a PIF are observations of changes in DA turnover that are associated with changes in PRL concentration. The turnover of DA in TIDA neurons is increased when plasma PRL concentrations are high (Hökfelt and Fuxe, 1972; Gudelsky et al., 1976; Eikenburg et al., 1977) and treatment of animals with exogenous PRL results in increased DA turnover in TIDA neurons (Annunziato and Moore, 1978). However, data from turnover studies must be interpreted carefully due to several assumptions which have to be made and which may not be valid (Weiner, 1974), such as the existence of a direct relationship between turnover and neuronal release of DA. The latter assumption has been shown not to be valid for the method of measuring turnover by estimating the conversion of ^3H -tyrosine to ^3H -DA (Roth, Walters and Aghajanian, 1974). Further evidence that DA may function physiologically as a PIF comes from measurements of DA in hypophysial portal blood (Ben-Jonathan et al., 1977; Reymond et al., 1983) and detection of specific DA receptors on cells from the anterior pituitary gland (Goldsmith et al., 1979). The concentration of DA in hypophysial portal plasma is sufficient to inhibit PRL secretion in vivo (Gibbs and Neill, 1978) and the DA receptors of the anterior pituitary exhibit supersensitivity after withdrawal of hypothalamic hypophysiotrophic factors by destruction

of the medial basal hypothalamus (MBH) (Cheung and Weiner, 1976).

The TIDA neuronal system appears to differ markedly from another well-characterized central dopaminergic neuronal pathway, the striato-nigral system (Annunziato, 1979). The well-documented negative feedback effect of DA agonists on DA synthesis (Carlsson, 1975) appears to be absent in the TIDA neuron (Meltzer, Simonovic, Fang, Piyakalamala and Young, 1978) and there are significant differences in the kinetics of DA uptake and release in the two systems (Demarest and Moore, 1979; Annunziato, Cerrito and Raiteri, 1980).

Much information concerning DA function in other brain areas has been discovered using synaptosomal and brain slice preparations in vitro (Snyder and Coyle, 1969; Bogdanski and Tissari, 1976; Starke, Reinmann, Zumstein and Hertting, 1978; Aceves and Cuello, 1981). The TIDA system has not been extensively studied in vitro and there are only a few reports of work on either ME synaptosomes or slices of MBH (Annunziato et al., 1981; Foreman and Porter, 1981). The MBH is a complex structure (Björklund, Falck et al., 1973; Kavanagh and Weisz, 1973) and the release of DA seen in vitro (Perkins and Westfall, 1978; Foreman and Porter, 1980) is likely to be due to the summation of stimulatory and inhibitory influences present in the slice. The ME is a much simpler structure containing mainly axons and terminals (Scott, Krobisch-Dudley, Gibbs and Brown, 1972), therefore, interpretation of neurotransmitter release from a ME slice should be simpler than interpretation of release from a MBH slice.

Recently, it has been demonstrated that it is possible to

electrically-induce the release of neurotransmitters from very small pieces of brain tissue in vitro (Aceves and Cuello, 1981). This technique was used in the studies reported here, to investigate the release of ^3H -DA from slices of rat ME in vitro. After initial studies had been completed, further experiments were carried out to determine:

- (i) whether ^3H -DA release was altered under different physiological conditions
- (ii) if ^3H -DA release was affected by DA agents
- (iii) whether there was any evidence for the presence of a pre-synaptic DA receptor on the terminals of TIDA neurons.

3.2 MATERIALS AND METHODS

3.2.1 Animals

Animals used in these studies were male Wistar cobs, (200-350g) and female Wistar cobs (200-250g) that had exhibited two consecutive 4 day oestrous cycles. Dissection of the ME was carried out as described in section 2.2.5.

3.2.2 Buffers and compounds

Krebs-Heinsleit buffer (Appendix II) containing $0.27 \times 10^{-8}\text{M}$ EDTA and $1.3 \times 10^{-8}\text{M}$ ascorbic acid was freshly made up before each superfusion. Luteinizing hormone-releasing hormone, TRH and PRL were dissolved in distilled water and stored frozen at -20°C in aliquots of 10mg/ml. Aliquots were thawed immediately before use and then added to the K-H buffer. Peptides were protected from degradation by the addition of $5 \times 10^{-5}\text{M}$ bacitracin (Sigma) to the K-H buffer. Nomifensine, apomorphine, haloperidol, chlorpromazine and domperidone were dissolved in distilled water containing 10^{-6}M

ascorbic acid as antioxidant and stored in the dark at 4°C until added to the K-H buffer. Stock solutions of drugs were not retained for longer than 8h during any experiment. Drugs and peptides were added to superfusion buffer after the initial control stimuli and before the test stimuli.

3.2.3 Accumulation of ^3H -dopamine

Six ME at a time were placed in 1ml of oxygenated K-H buffer at 37°C and preincubated for 5 min. Three ME were then removed from this storage buffer and placed in another 1ml of buffer containing various concentrations of ^3H -DA and incubated for a further 5 min. In those experiments designed to study the rate of ^3H -DA uptake, tissue was incubated under similar conditions for varying lengths of time. Uptake was terminated by removing the tissue from the incubation tube and plunging it into 1ml of ice-cold buffer. Tissue was rinsed by transfer into another 1ml ice-cold buffer and then removed and homogenized in 1.0ml of 0.1N HCl. A 250 μ l aliquot was taken and mixed with 10ml of scintillation fluid (NE260, Nuclear Enterprises Ltd.) in a plastic scintillation vial, and radioactivity determined by liquid scintillation counting.

Vials were placed in the scintillation counter (Nuclear Chicago, Mark II Liquid Scintillation System) to cool for 1h before counting. Counting efficiency was 37%.

3.2.4 Release of ^3H -dopamine

Median eminence tissue was incubated for 20 min with $0.5 \times 10^{-6}\text{M}$ ^3H -DA in a final volume of 1ml of oxygenated K-H buffer at 37°C. Tissue was then placed in a small perspex chamber (3 ME per chamber) in the superfusion apparatus (Fig. 3-1). Oxygenated

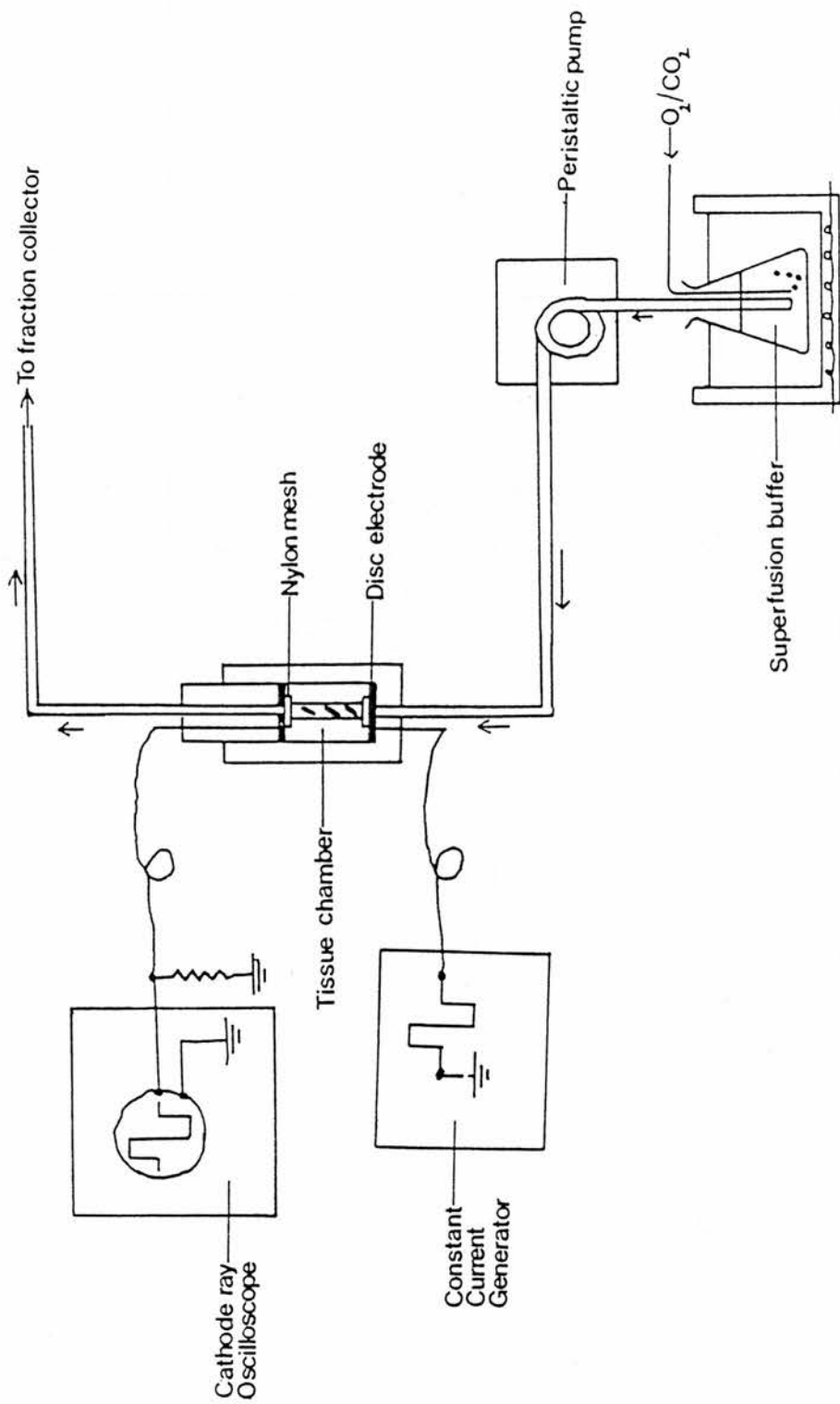

FIGURE 3-1 Schematic representation of the superfusion system used to study the release of 3H -dopamine (3H -DA) from median eminence tissue in vitro

K-H buffer at 37°C was passed through the system at a rate of 500 μ l/min using a peristaltic pump. A 40 min wash-out period was allowed to remove non-specific binding of ^3H -DA to the tissue after which 1ml fractions were collected on ice for another 40-60 min.

Electrical field stimulation consisting of a train of accurately-balanced biphasic square waves was applied using a constant current generator (Neurolog system; Digitimer, Welwyn Garden City). The stimuli were monitored with a calibrated oscilloscope. Electrodes were silver plates embedded in perspex plugs, linked to the stimulator by connecting clips attached to the steel superfusion inlet and outflow (Fig. 3-1).

At the end of the superfusion, 250 μ l aliquots from each collected fraction were taken and mixed with 10ml of scintillation fluid and counted as before. Tissue was removed from the superfusion chambers and homogenized in 1ml of 0.1N HCl and a 250 μ l aliquot counted as before for determination of the amount of radioactivity left in the tissue.

Results were expressed as a fractional rate constant for basal release and as a relative fractional rate constant (RFRC) for stimulated release, defined as,

fractional rate constant for ^3H -DA release during stimulation
(2 fractions)

fractional rate constant for ^3H -DA release immediately before stimulation + fractional rate constant for ^3H -DA release immediately after stimulation

3.2.5 Statistics

Data are presented as mean \pm S.E.M. Significance of difference between two means was determined by Students t-test. The significance of differences between more than two means was determined by analysis of variance and Duncan's multiple range test.

3.3 RESULTS

3.3.1 Accumulation of ^3H -dopamine $0.5 \times 10^{-6} \text{M}$

When ME tissue was incubated with ^3H -DA there was an accumulation of radioactivity in the tissue. The accumulation was rapid and time-dependent (Fig. 3-2) and could be inhibited by incubation at 4°C (62% inhibition) or in the presence of 10^{-4}M ouabain (65% inhibition) (Fig. 3-2).

The specificity of uptake of the ^3H -DA was tested by incubating the tissue with various concentrations (10^{-8}M - 10^{-4}M) of unlabelled DA. Dopamine caused a dose-dependent inhibition of ^3H -DA accumulation in the tissue with an IC_{50} of $0.5 \times 10^{-6}\text{M}$, (Fig 3-3).

Accumulation could also be inhibited by nomifensine, a specific DA uptake inhibitor, in a dose-dependent manner.(Fig. 3-4).

3.3.2 Spontaneous release of ^3H -dopamine

Spontaneous ^3H -DA release decreased from an initially very high to a low basal rate (rate constant = $2-4 \times 10^{-3}, \text{min}^{-1}$) after 40 min (Fig. 3-5) Spontaneous release was higher in Ca^{2+} -free and lower in Na^{+} -free buffer than in normal buffer (Fig. 3-5).

Footnote

Median eminence tissue was examined histologically for the presence of cell bodies. Haematoxylin and eosin staining revealed no evidence for the presence of cell bodies.

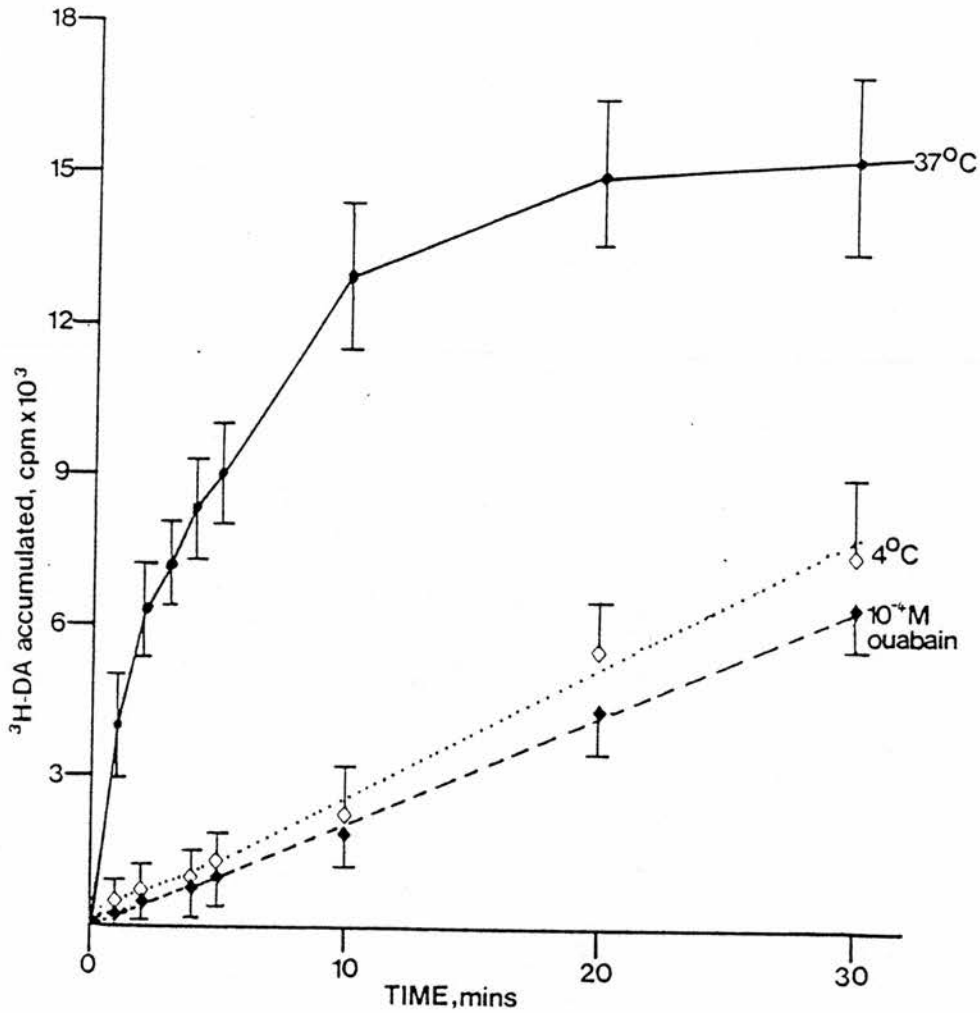

FIGURE 3-2 Accumulation of ³H-dopamine (³H-DA) in median eminence tissue after incubation with $0.5 \times 10^{-6}M$ ³H-DA for different periods of time at 37°C, at 4°C or in the presence of $10^{-4}M$ ouabain in incubation medium. Each point represents the mean \pm S.E.M. for 6 experiments.

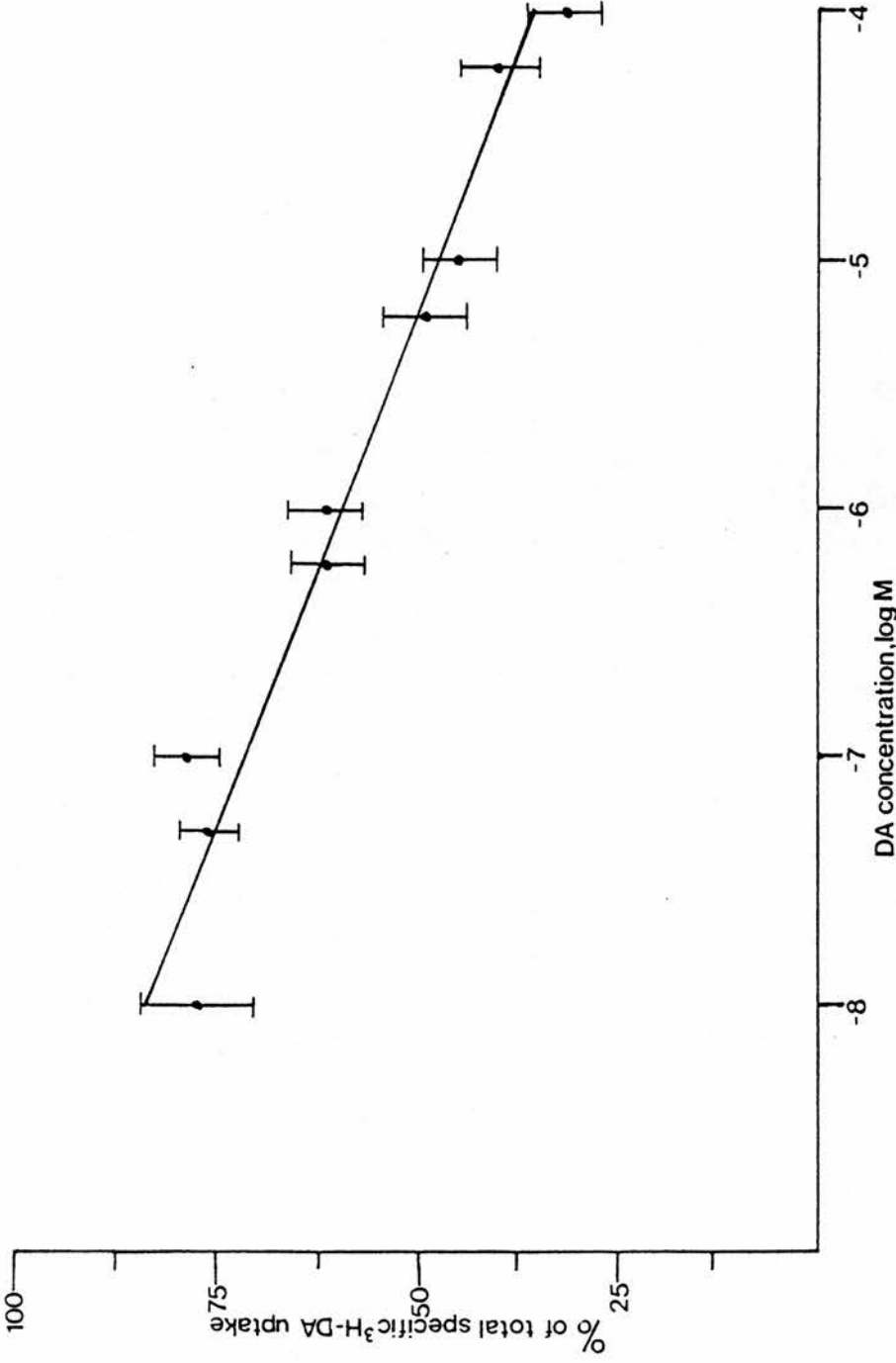

FIGURE 3-3 Inhibition of specific ³H-dopamine (³H-DA) uptake into median eminence tissue by increasing concentrations of DA added to incubation medium. Each point represents the mean \pm S.E.M. for 6 experiments.

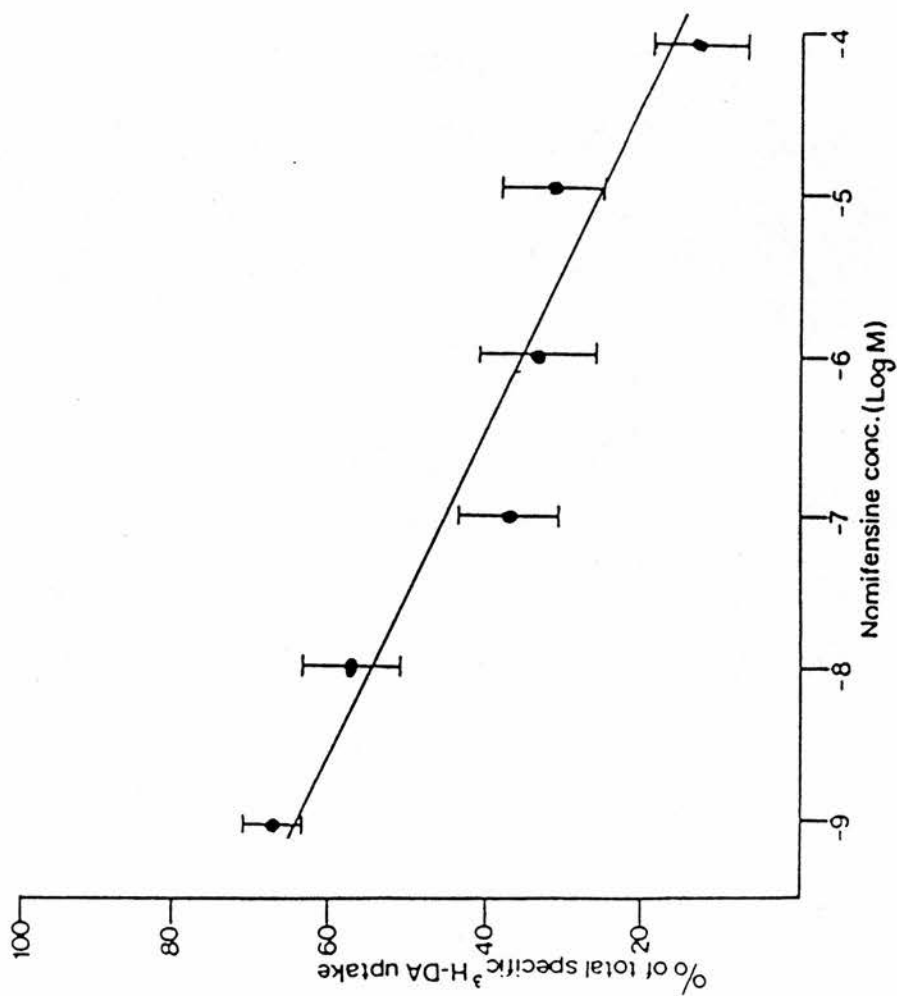

FIGURE 3-4 Inhibition of specific ³H-dopamine (³H-DA) uptake into median eminence tissue by increasing concentrations of nomifensine added to incubation medium. Each point represents the mean \pm S.E.M. for 4 experiments.

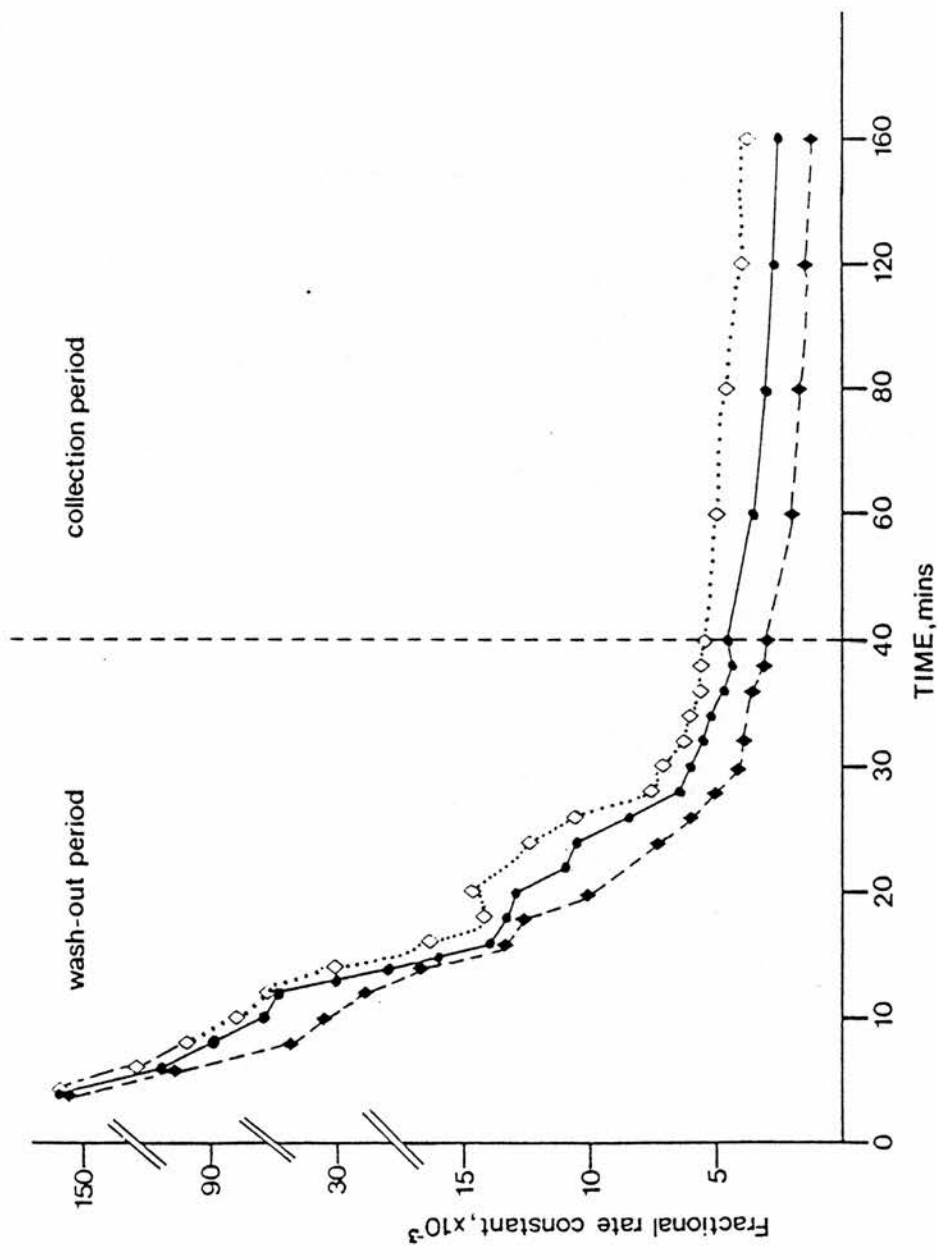

FIGURE 3-5 Spontaneous release of pre-accumulated ³H-dopamine (³H-DA) from median eminence ●, in normal Krebs-Heinsleit (KH) superfusion buffer, ◇ Ca²⁺-free KH superfusion buffer, and ◆ Na⁺-free KH superfusion buffer. Release is expressed as a fractional rate constant.

3.3.3 Electrically stimulated release of ^3H -dopamine

Release of ^3H -DA was raised significantly above basal rates by applying an electrical stimulus. The increase in the rate of ^3H -DA release was dependent on the amplitude (Fig. 3-6) frequency (Fig. 3-8) and duration (Fig. 3-7) of the stimulus. Electrically induced ^3H -DA release was abolished in Ca^{2+} -free buffer and greatly reduced in Na^+ -free buffer (Fig. 3-9)

From these initial studies a submaximal stimulus of 6mA at 50 Hz applied for 15 sec ^(Fig. 3-9a) was chosen for all subsequent experiments.

3.3.4 Effect of dopaminergic agents on the release of ^3H -dopamine

Dopaminergic agents (3.2.2) were added to the superfusion buffer and the effect on spontaneous and electrically-induced release tested. None of the agonists or antagonists tested had any significant effect on spontaneous or induced release (Table 3-1 and Fig. 3-10).

Nomifensine, a dopamine reuptake blocker, had no effect on the basal release of ^3H -DA but caused a significant increase in the electrically-induced release (Table 3-1 and Fig. 3-10). This effect was still seen in the presence of apomorphine even although apomorphine itself had no effect (Fig. 3-10).

3.3.5 The release of ^3H -dopamine throughout the oestrous cycle

Figure 3-11 and Table 3-2 show that there were no significant differences between either electrically-induced or basal ^3H -DA release during the different stages of the oestrous cycle, and that this release was also unaffected by the presence of TRH.

3.3.6 Effect of peptides on the release of ^3H -dopamine

Figure 3-12 and Table 3-3 show that none of the three peptides

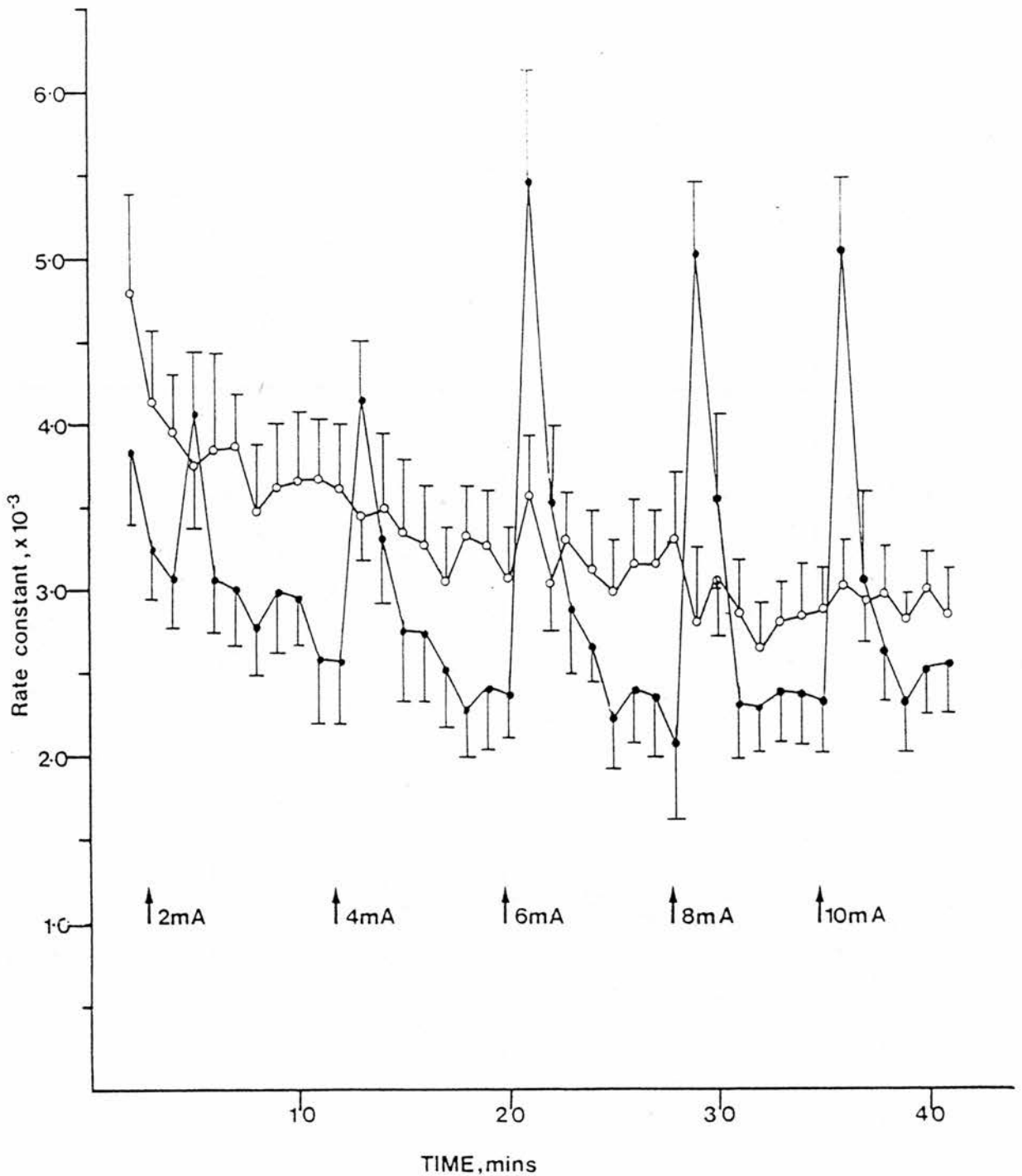

FIGURE 3-6 Electrically-stimulated release of 3H -dopamine (3H -DA) from superfused slices of median eminence: the effect of increasing the amplitude of the applied stimulus.

Tissue was pre-incubated with $0.5 \times 10^{-6}M$ 3H -DA for 20 min. After 40 min wash-out period, tissue was stimulated at 10min interval with biphasic square waves, pulse width 2ms, duration 15s, frequency 50Hz and increasing pulse amplitude.

●, normal K-H superfusion buffer
 ○, Ca^{2+} -free K-H superfusion buffer.

Each point represents the mean \pm S.E.M. for 6 experiments.

Release is expressed as a fractional rate constant

FIGURE 3-7 Electrically-stimulated release of ^3H -dopamine (^3H -DA) from superfused slices of median eminence: the effect of increasing the duration of the applied stimulus.

Tissue was pre-incubated with $0.5 \times 10^{-6}\text{M}$ ^3H -DA for 20 min. After a 40 min wash-out period, tissue was stimulated at 10 min intervals with biphasic square waves, pulse width 2ms, amplitude 6mA, frequency 50Hz and increasing duration of the applied stimulus.

●, normal K-H superfusion buffer
○, Ca^{2+} -free K-H superfusion buffer

Each point represents the mean \pm S.E.M. for 6 experiments.

Release is expressed as a fractional rate constant

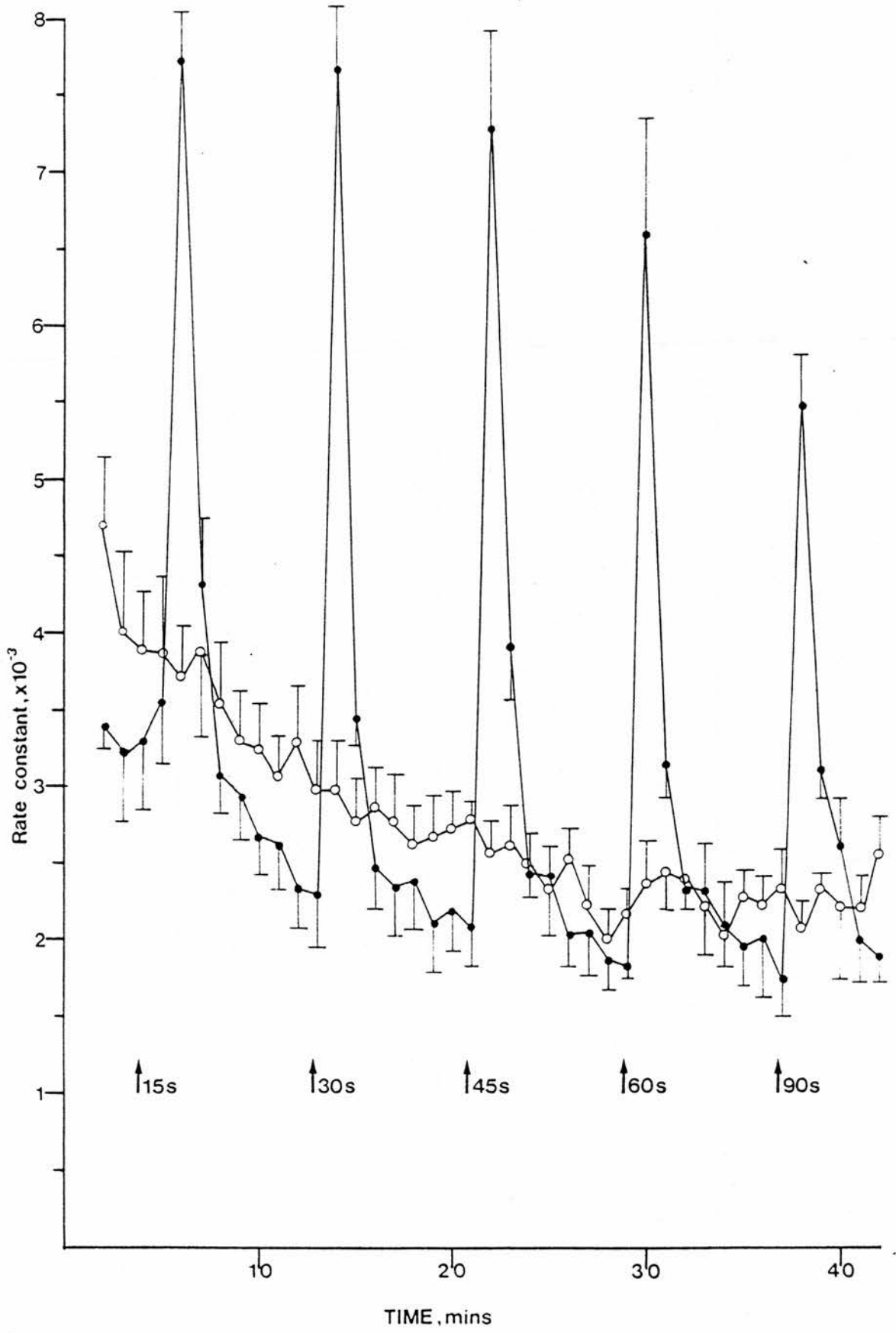

FIGURE 3-8 Electrically-stimulated release of ^3H -dopamine (^3H -DA) from superfused slices of median eminence: the effect of increasing the frequency of the applied stimulus.

Tissue was pre-incubated with $0.5 \times 10^{-6}\text{M}$ with ^3H -DA for 20min. After a 40min wash-out period, tissue was stimulated at 10 min intervals with biphasic square waves, pulse width 2ms, amplitude 6mA, duration 15s and increasing frequency of the applied stimulus.

●, normal K-H superfusion buffer

○, Ca^{2+} -free K-H superfusion buffer

Each point represents the mean \pm S.E.M. for 6 experiments.

Release is expressed as a fractional rate constant.

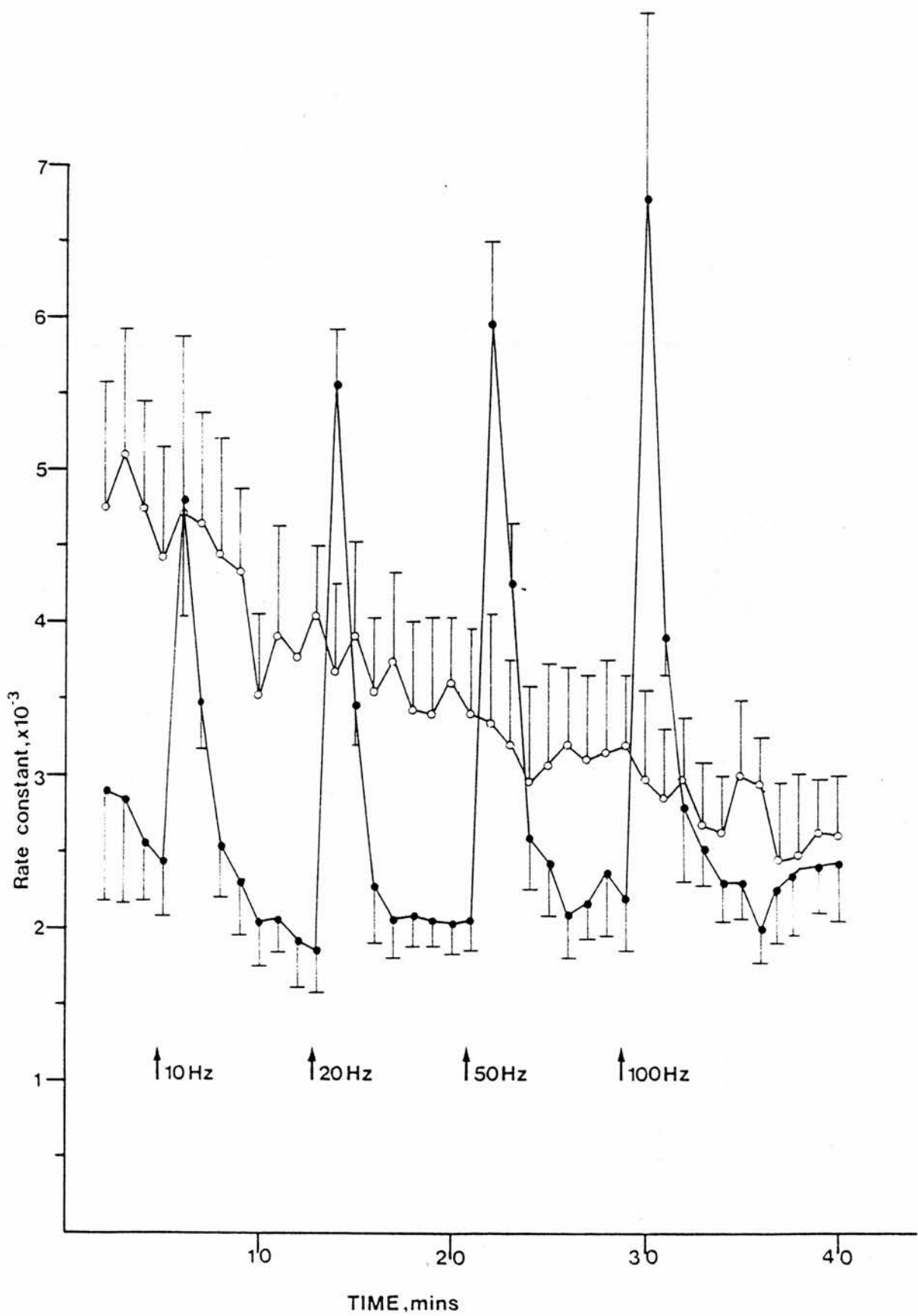

FIGURE 3-9 The relative fractional rate constants (RFRC) for the electrically-stimulated release of ^3H -dopamine (^3H -DA) from superfused slices of median eminence: the effect of increasing amplitude, frequency and duration of the applied stimulus (Data derived from Figs. 3-6, 3-7 and 3-8). RFRC =
$$\frac{\text{fractional rate constant for } ^3\text{H-DA release during stimulation (2 fractions)}}{\text{fractional rate constant for } ^3\text{H-DA release immediately before stimulation} + \text{fractional rate constant for } ^3\text{H-DA release immediately after stimulation.}}$$

Mean \pm S.E.M. of 6 experiments.

normal K-H superfusion buffer

Ca^{2+} -free K-H superfusion buffer

Na^{+} -free superfusion buffer.

(Electrical stimuli of increasing duration (Fig. 3-9a) were applied at a frequency of 50Hz and amplitude of 6mA).

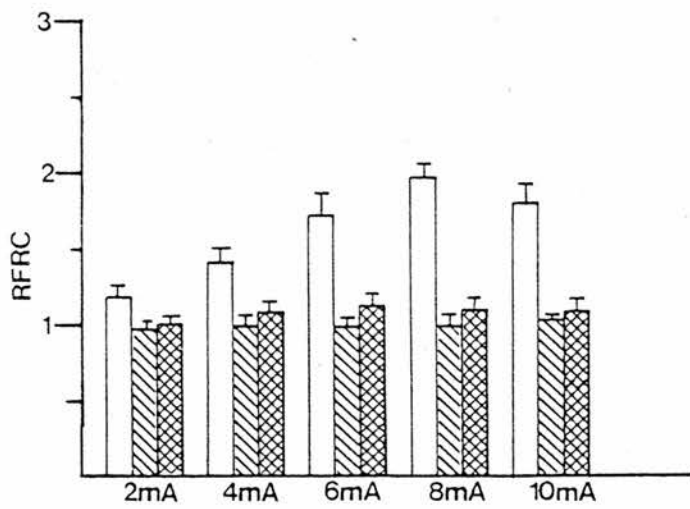
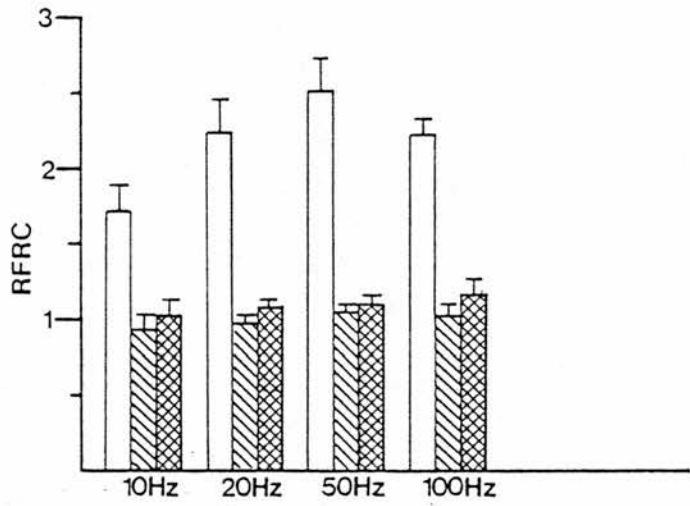
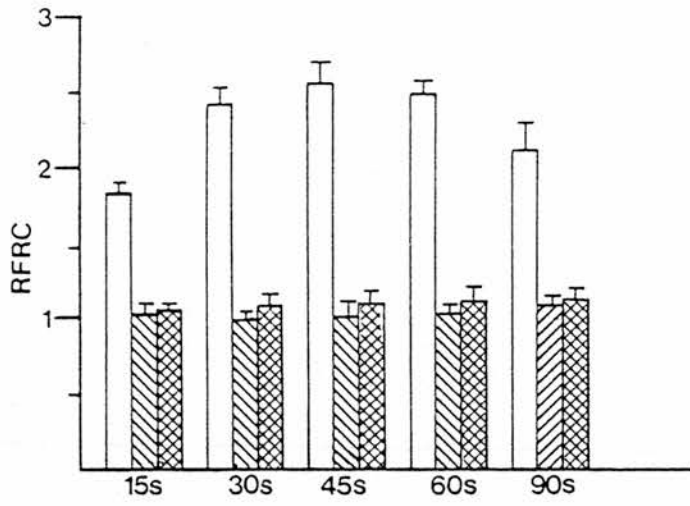

TABLE 3-1

The mean (\pm S.E.M.) basal release of ^3H -dopamine (^3H -DA) (fractional rate constant $\times 10^{-3}$) from median eminence tissue superfused with various dopaminergic drugs. Initial basal release is the fractional rate constant of ^3H -DA release at the end of the initial 40 min wash-out period. Final basal release is the fractional rate constant for ^3H -DA release after the additional 40 min superfusion in the presence of dopaminergic drugs.

Group	n	Initial basal release (pre-drug)	Final basal release (post-drug)
No drug	8	4.60 \pm 0.54	2.05 \pm 0.27
Dopamine 10^{-6}M	5	5.84 \pm 1.46	4.24 \pm 1.45
Apomorphine 10^{-5}M	4	2.35 \pm 0.27	1.57 \pm 0.07
Chlorpromazine 10^{-5}M	6	2.75 \pm 0.36	1.56 \pm 0.13
Haloperidol 10^{-5}M	5	5.68 \pm 0.60	2.48 \pm 0.35
Domperidone 10^{-5}M	5	4.30 \pm 0.19	2.78 \pm 0.19
Nomifensine 10^{-5}M	6	3.06 \pm 0.40	1.51 \pm 0.18

Drugs were tested at a range of concentrations from 10^{-9} - 10^{-3}M . Since there were no significant effects of any of the drugs at any concentration, only one representative concentration of each drug is shown.

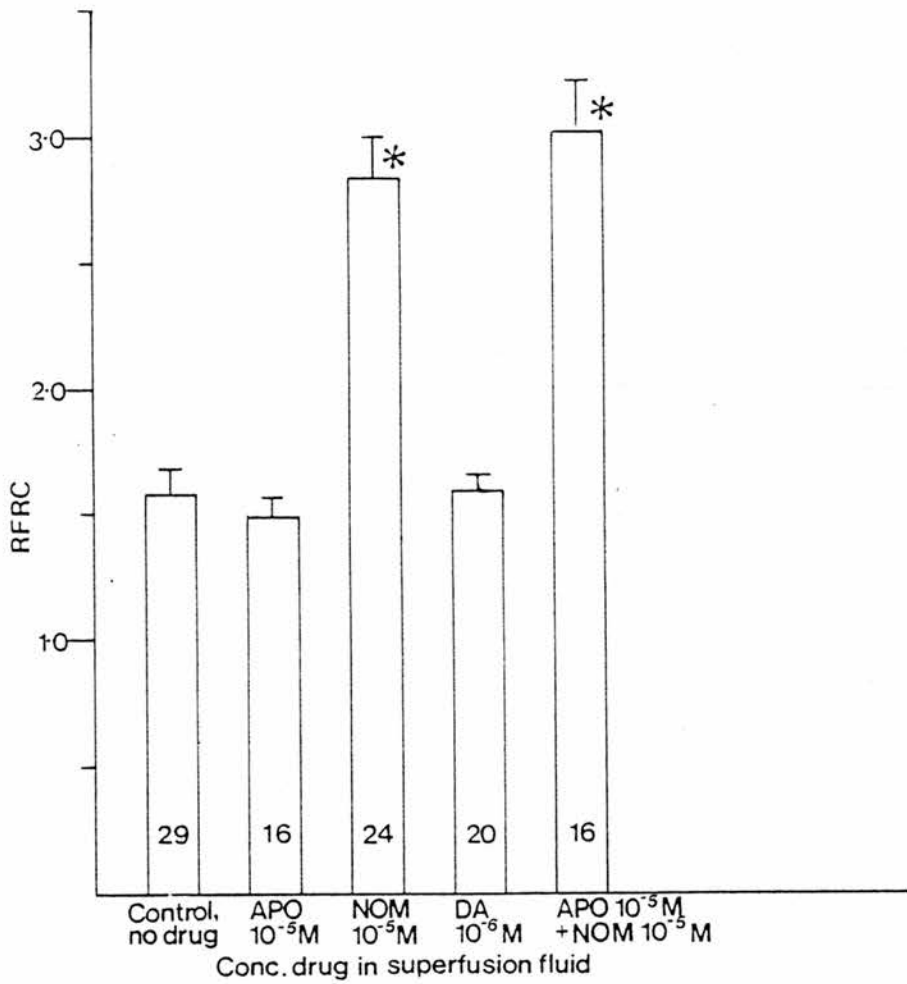

FIGURE 3-10 The effects of dopamine (DA), apomorphine (APO) and nomifensine (NOM) on the electrically-stimulated release of ^3H -dopamine (^3H -DA) from superfused slices of median eminence. Data, expressed as mean \pm S.E.M. of relative fractional rate constant (RFRC). After pre-incubation with ^3H -DA, $0.5 \times 10^{-6}\text{M}$, tissue was superfused with K-H buffer containing dopaminergic drugs, and electrical stimulation applied every 10 min, (number of stimulated periods shown within each column). * $p < 0.01$; level of significance of difference between electrically-stimulated release of ^3H -DA in the absence of drugs compared with ^3H -DA release in the presence of NOM.

TABLE 3-2

The mean (\pm S.E.M.) basal release of ^3H -dopamine (^3H -DA) (fractional rate constant $\times 10^{-3}$) from median eminence tissue removed from rats at different stages of the oestrous cycle. Initial basal release is the fractional rate constant of ^3H -DA release at the end of the initial 40 min wash-out period. Final basal release is the fractional rate constant for ^3H -DA release after the additional 40 min superfusion period.

Group	n	Initial basal release	Final basal release
Males	6	2.49 \pm 0.56	0.88 \pm 0.15
Dioestrus	6	2.60 \pm 0.14	1.22 \pm 0.06
Pro-oestrus (pm)	5	3.74 \pm 0.29	1.69 \pm 0.16
Oestrus	5	3.00 \pm 0.46	1.24 \pm 0.17
Pro-oestrus (am) + TRH 10^{-8}M	5	3.04 \pm 0.28	1.34 \pm 0.13
Pro-oestrus (pm) + TRH 10^{-8}M	5	2.07 \pm 0.36	0.96 \pm 0.15

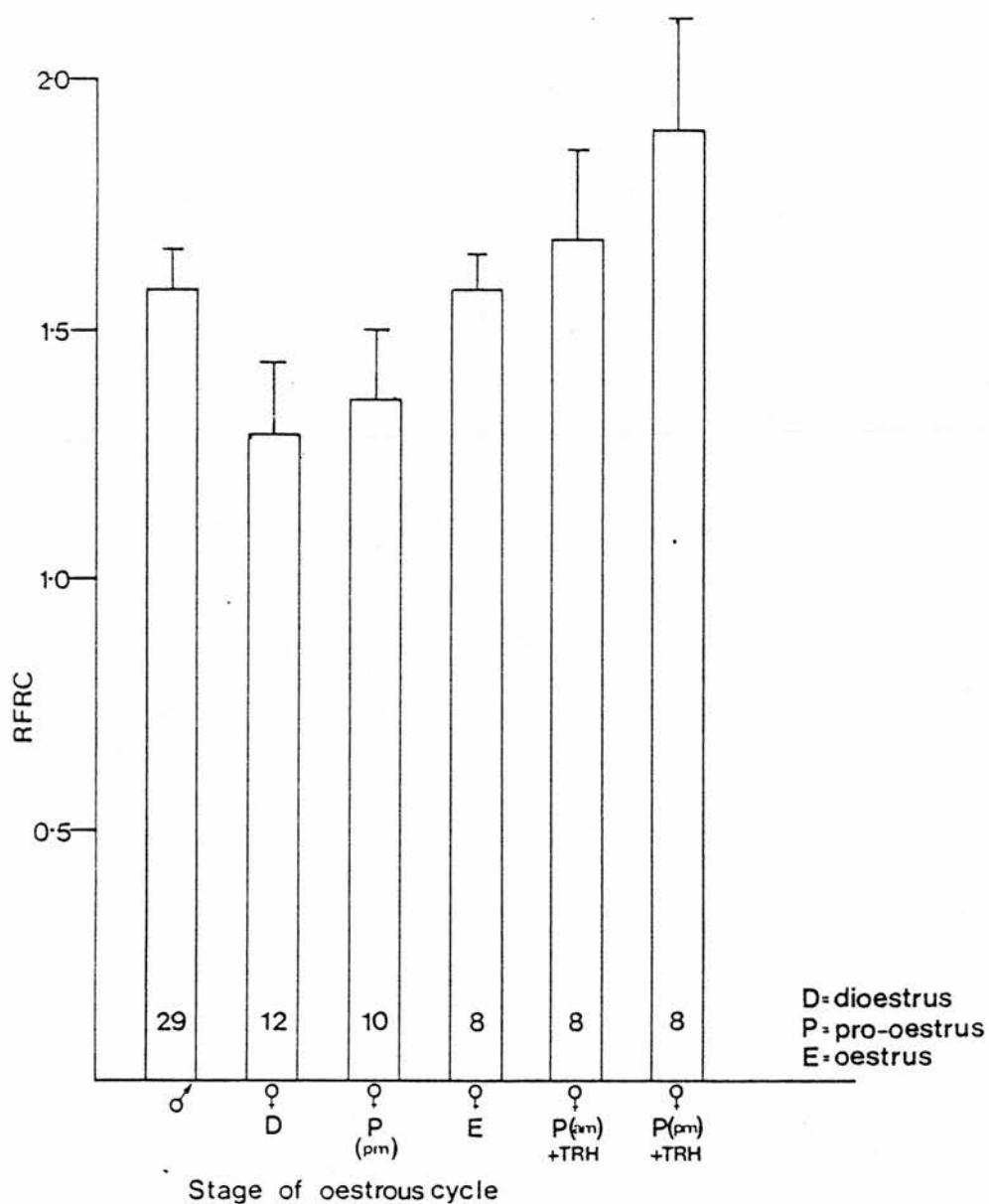

FIGURE 3-11 The electrically-stimulated release of ^3H -dopamine (^3H -DA) from slices of median eminence throughout the oestrus cycle. After pre-incubation with ^3H -DA, $0.5 \times 10^{-6}\text{M}$, tissue was superfused with K-H buffer and electrical stimulation applied every 10 min. Data expressed as mean \pm S.E.M. of relative fractional rate constant (RFRC), (number of stimulated periods shown within each column).

TABLE 3-3

The mean (\pm S.E.M.) basal release of ^3H -dopamine (^3H -DA) (fractional rate constant $\times 10^{-3}$) from median eminence tissue superfused with prolactin (PRL), luteinizing hormone-releasing hormone (LHRH) or thyrotrophin-releasing hormone (TRH). Initial basal release is the fractional rate constant of ^3H -DA release at the end of the initial 40 min wash-out period. Final basal release is the fractional rate constant for ^3H -DA release after the additional 40 min superfusion in the presence of PRL, LHRH or TRH.

Group	n	Initial basal release (pre-peptide)	Final basal release (post-peptide)
No peptide	8	4.60 \pm 0.54	2.05 \pm 0.27
PRL 10^{-8}M	8	2.96 \pm 0.29	2.45 \pm 0.36
PRL 10^{-7}M	6	3.56 \pm 0.49	1.52 \pm 0.09
LHRH 10^{-9}M	6	3.99 \pm 0.77	1.52 \pm 0.32
LHRH 10^{-8}M	5	2.94 \pm 0.29	1.43 \pm 0.29
LHRH 10^{-7}M	8	4.66 \pm 0.57	1.72 \pm 0.16
TRH 10^{-9}M	4	3.57 \pm 0.54	1.73 \pm 0.18
TRH 10^{-8}M	5	4.74 \pm 1.28	1.89 \pm 0.54
TRH 10^{-7}M	7	3.31 \pm 0.31	1.42 \pm 0.15

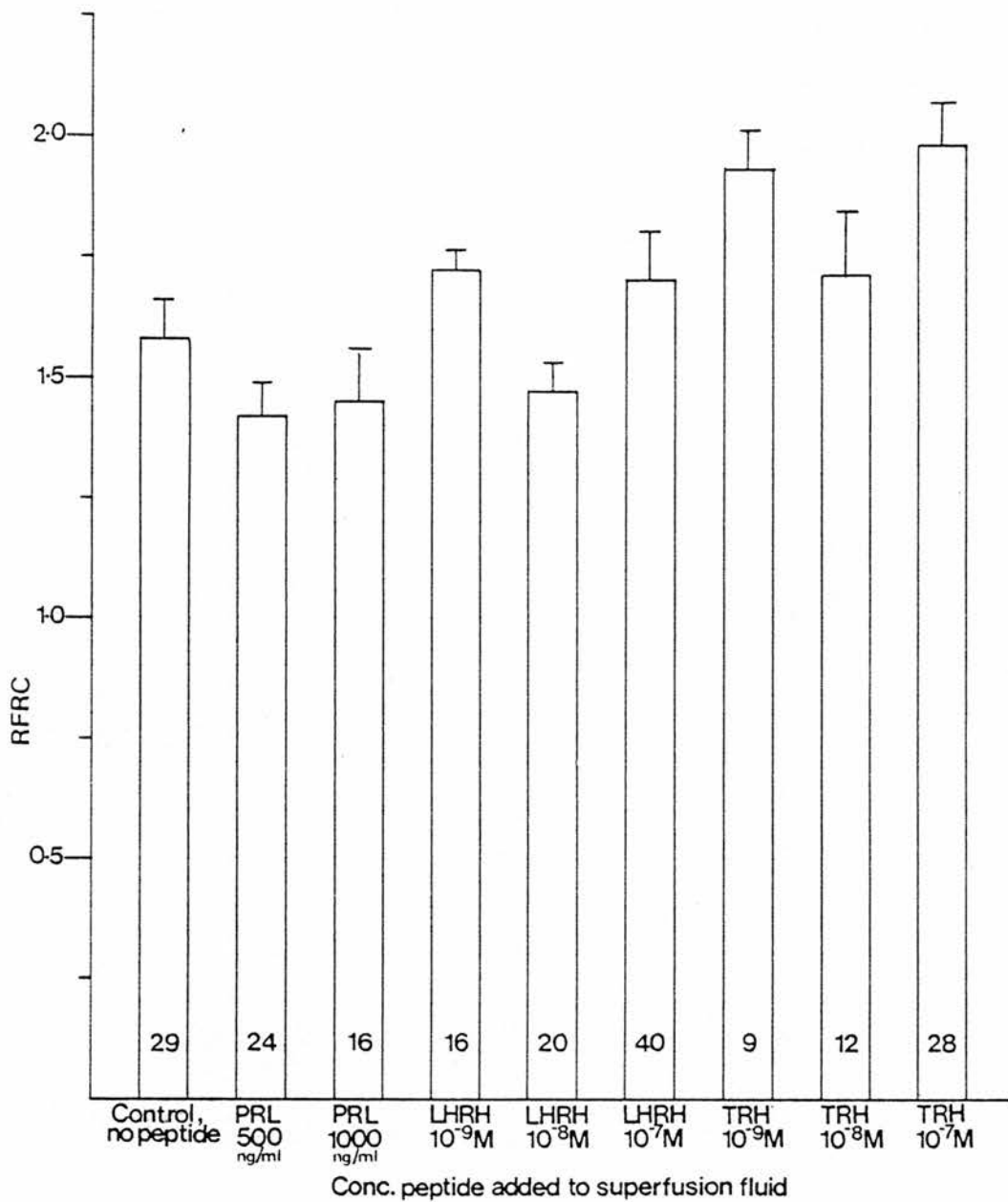

FIGURE 3-12 The effects of various peptides on the electrically-stimulated release of ³H-dopamine (³H-DA) from superfused slices of median eminence. Data expressed as mean ± S.E.M. of relative fractional rate constant (RFRC). After pre-incubation with ³H-DA, 0.5 × 10⁻⁶M, tissue was superfused with K-H buffer containing peptides and bacitracin (peptidase inhibitor) and electrical stimulation applied every 10 min, (number of stimulated periods shown within each column).

tested, LHRH, TRH and PRL had any effect on the electrically-induced or the basal release of $^3\text{H-DA}$.

3.4 DISCUSSION

The studies reported here show that the ME, a tissue containing primarily nerve axons and terminals (Scott et al., 1972; Björklund, Falck et al., 1973) can take-up and release exogenous $^3\text{H-DA}$ under in vitro conditions. While there are several reports in the literature of $^3\text{H-DA}$ uptake into and release from MBH slices and ME synaptosomes in vitro (Perkins and Westfall, 1978; Annunziato et al., 1981), the release has generally been induced by a medium containing a high concentration of K^+ . These studies report the release of $^3\text{H-DA}$ from the ME caused by the application of an electrical stimulus.

The uptake of $^3\text{H-DA}$ was temperature, Na^+ - and Ca^{2+} -dependent, indicating that the site of uptake was likely to be neuronal (Orrego, 1979), and displayed characteristics similar to neurotransmitter uptake in other CNS regions in vitro (Bogdanski, Blaszkowski and Tissari, 1970; Baldessarini and Vogt, 1971; Geffen, Jessell, Cuello and Iversen, 1976; Aceves and Cuello, 1981). When incubations were carried out in the presence of exogenous DA, uptake of $^3\text{H-DA}$ was inhibited (Fig. 3-3). The IC_{50} for inhibition of $^3\text{H-DA}$ uptake by DA, $0.5 \pm 0.2 \times 10^{-6}\text{M}$, is in good agreement with the reported K_D for $^3\text{H-DA}$ uptake into ME synaptosomes ($1.8 \pm 0.9 \times 10^{-6}\text{M}$) (Annunziato et al., 1980) and ME homogenates ($1.5 \pm 0.2 \times 10^{-6}\text{M}$) (Demarest and Moore, 1979). Uptake of $^3\text{H-DA}$ was also significantly inhibited in the presence

of nomifensine, a specific DA uptake blocker (Hunt, Kennengiesser and Raynaud, 1974). These data indicate that the uptake of $^3\text{H-DA}$ into the ME is a specific process but is of low affinity unlike the uptake of $^3\text{H-DA}$ into striatal and cortical DA terminals which is a high-affinity process (Snyder and Coyle, 1969). This conclusion is supported by measurements of low concentrations of DOPAC in fluid from superfused ME stimulated with high K^+ , relative to concentrations of DOPAC in fluid from superfused and stimulated striatal tissue (Kapoor, 1982) which was interpreted as lack of uptake and subsequent degradation by MAO. The incubation medium used in the present studies did not include any inhibitors of catecholamine uptake into noradrenergic terminals as have been used in other studies (e.g. Annunziato et al., 1981), since it has been shown that 78% of total $^3\text{H-DA}$ taken up by a ME homogenate is taken up specifically into DA terminals (Demarest and Moore, 1979).

Median eminence tissue pre-incubated with $^3\text{H-DA}$ showed a spontaneous release of $^3\text{H-DA}$ consisting of an initial high rate of release rapidly decreasing to a much slower sustained rate of release (Fig. 3-5). The initial phase of the spontaneous release is thought to represent release of extraneuronal $^3\text{H-DA}$ present in the ME tissue whereas the following slower phase is thought to represent release from intraneuronal stores (Orrego, Jankelevich, Ceruti and Ferrera, 1974). The slower phase of spontaneous release of $^3\text{H-DA}$ was increased in Ca^{2+} -free medium and slightly decreased in Na^+ -free medium (Fig. 3-5). The increase in spontaneous release of $^3\text{H-DA}$ observed in Ca^{2+} -free medium could be due to an increase in intraneuronal Na^+ (Keeseey, Wallgren and McIlwain,

1975), which occurs when cells are placed in a Ca^{2+} -free environment, and this increase in Na^+ concentration subsequently causing increased release of transmitter (Schultz and Curran, 1970). The decrease in spontaneous release of ^3H -DA observed in Na^+ -free medium is more difficult to explain since, in a Na^+ -free medium, the ratio of intra- and extracellular Na^+ concentrations is reversed, and an outward downhill gradient across the nerve membrane is formed; according to the Na^+ -gradient hypothesis (Crane, 1965), this should facilitate the release of a neurotransmitter whose uptake depends on the normal Na^+ gradient. In contrast to the present data on ^3H -DA release from ME slices, ^3H -DA release from ME synaptosomes was increased in Na^+ -free medium, (Annunziato et al., 1981). This difference between the slice and synaptosome preparations may indicate that the spontaneous release of ^3H -DA from ME slices in vitro is not a carrier-mediated process but rather that the release is due to non-specific changes in membrane permeability under in vitro conditions. Further evidence for this possibility is the observation that nomifensine (10^{-5} M) did not modify the spontaneous release of ^3H -DA from ME slices in vitro in the present studies, or ^3H -DA release from ME synaptosomes (Annunziato et al., 1981), suggesting again that this spontaneous release is not a carrier-mediated process.

It has been shown on numerous occasions that brain slices in vitro can release endogenous and exogenous neurotransmitter in response to electrical stimulation (Orrego et al., 1974; Saldate and Orrego, 1975; Saldate and Orrego, 1977; Potaschner, 1978;

Starke et al., 1978; Szerb, 1979; Arbilla, Kamal and Langer, 1980). Using a technique described by Aceves and Cuello (1981) the studies reported in this chapter show that it was possible to elicit the release of previously accumulated $^3\text{H-DA}$ from ME slices in vitro by the application of an electrical stimulus (Fig. 3-6,7,8). This evoked release was Na^+ - and Ca^{2+} - dependent, important criteria to be fulfilled before classifying such depolarization-induced release as being from nerve terminals (see Orrego, 1979). The release of $^3\text{H-DA}$ increased proportionally in response to increasing amplitude or frequency of the stimulus (Fig. 3-7,8) up to an amplitude of 10mA and a frequency of 100Hz. Stimuli which were above 12mA or 100Hz caused a massive release of $^3\text{H-DA}$, which was probably due to the high current intensities displacing $^3\text{H-DA}$ from sites other than those operating during the action potential. This has been observed to occur in slices of neocortex in vitro where low stimulation intensities caused release of a neurotransmitter and high stimulation intensities caused a much greater release of the neurotransmitter accompanied by the release of a non-transmitter amino acid (Orrego et al., 1974).

Nomifensine, a compound proposed as a DA uptake blocker, caused a significant increase in the release of $^3\text{H-DA}$ caused by electrical stimulation (Fig. 3-10). It has been proposed that the apparent reuptake blocking action of nomifensine on DA is in fact due to a DA-releasing action of this compound (Baumann and Maitre, 1976). This is not supported by the present studies, as nomifensine had no effect on the spontaneous, unstimulated release of $^3\text{H-DA}$ (Table 3-1). These effects of nomifensine were also present during

K^+ stimulation of endogenous DA release from ME slices (Kapoor, 1982). The study of Kapoor (1982) also found that the concentration of DOPAC in superfusion fluid from ME slices in vitro was very low compared with the concentration in fluid from superfused striatal slices. This again suggests the absence of a high-affinity DA uptake mechanism in ME tissue.

Since the electrically-stimulated release of 3H -DA from ME slices in vitro showed characteristics comparable to neuronal release of neurotransmitters in vitro and since the release was reproducible, it was decided that this was a suitable model for investigation of TIDA function and further studies were carried out.

There is much evidence for the involvement of DA in the release of LH and PRL from the anterior pituitary gland during the oestrous cycle particularly during pro-oestrus, but, whereas there is some evidence for a decrease in the action of DA to inhibit the release of PRL during the pro-oestrous PRL surge, the question as to whether DA stimulates or inhibits the pro-oestrous surge of LH is still controversial (Fink and Geffen, 1978; Weiner and Ganong, 1978; Barraclough and Wise, 1982; 1.4.1). Measurements of steady-state DA concentrations in the ME during the oestrous cycle have yielded little information, with some groups claiming increased DA concentration (Crowley, Donohue and Jacobowitz, 1978) and others claiming that DA concentrations do not change (Selmanoff, Pramik-Holdway and Weiner, 1976; Demarest, Johnston and Moore, 1981). However, it has been argued that measurement of steady-state concentrations of neurotransmitters gives no information on the activity of the neuronal system (Weiner, 1974) and that before any

indication can be obtained as to neuronal function, turnover of neurotransmitter and not steady-state concentration must be measured. It has been shown histochemically (Ahren, Fuxe, Hamberger and Hökfelt, 1971; Löfström, 1977) and radioenzymatically (Demarest et al., 1981, Rance et al., 1981b) that the turnover of DA in TIDA neurons is decreased on the afternoon of pro-oestrus. In support of these studies, there have been reports of decreased concentrations of DA in hypophysial portal blood on the afternoon of pro-oestrus (Ben-Jonathan et al., 1977) and of changes in tyrosine-hydroxylase (the rate-limiting enzyme in DA synthesis) activity during the oestrous cycle (Carr and Vogt, 1980).

In the present studies no change was found in the spontaneous or the electrically-induced release of ^3H -DA from the ME in vitro at any stage of the oestrous cycle (Table 3-3 and Fig. 3-11). This result was unexpected, but could perhaps be due to the specific activity of the ^3H -DA released by the ME being too low to allow detection of the small changes that might be expected to occur in the activity of the TIDA neurons. It could also be argued that the ^3H -DA taken up and released by the ME in vitro does not mix with the endogenous DA pool and so may not be under the same control. This hypothesis is supported by the results of Kapoor (1982) who found that endogenous DA released from the ME in vitro was almost undetectable, using an LCED system with a detection sensitivity of 50pg. These results appear to contradict those of Ben-Jonathan et al. (1977) and Raymond et al. (1983) who found high concentrations of DA in hypophysial portal blood in vivo, presumably released from terminals of TIDA neurons. However, it may be that DA

was arriving in portal blood from a source other than the TIDA terminals (Ben-Jonathan, 1980) or that TIDA function was disrupted by the anaesthesia and surgical preparation of the animals used in the studies of Ben-Jonathan et al. (1977) and Reymond et al. (1983).

Changes in DA turnover in response to dopaminergic drugs have been reported in other central dopaminergic systems both in vivo (DiChiara, Porceddu, Vargui, Argiolas and Gessa, 1976) and in vitro (Farnebo and Hamberger, 1971; Westfall, Benson, Giorguieff and Glowinski, 1976). These changes have been claimed to be mediated in part by a specific pre-synaptic dopaminergic 'autoreceptor' (Nowycky and Roth, 1978; Kebabian and Calne, 1981). Studies on DA turnover in TIDA neurons in vivo (Gudelsky and Moore, 1977; Demarest and Moore, 1979) and on ^3H -DA release from ME synaptosomes in vitro (Annunziato et al., 1981) have shown that these 'autoreceptors' do not appear to be present on the terminals of TIDA neurons. The results of the present studies are consistent with this view as there was no change in either the spontaneous or the electrically-induced release of ^3H -DA from ME slices in vitro when either DA or DA agents were added to the superfusion medium (Table 3-1 and Fig. 3-10). It seems unlikely that there would be 'autoreceptors' present on the terminals of TIDA neurons since they do not abut onto a classical post-synaptic neuron and form a synapse, but rather they presumably release their transmitter into the hypophysial portal blood, which carries it to act some distance away, in the anterior pituitary gland.

Although DA synthesis and release in TIDA neurons do not appear to be regulated by autoreceptors or by a neuronal feedback loop,

there is evidence for some feedback control by PRL. Animals implanted with PRL-secreting tumours or given exogenous PRL show increased DA turnover in TIDA neurons (Olson, Fuxe and Hökfelt, 1972; Gudelsky et al., 1976; Höhn and Wuttke, 1978; Perkins, Westfall, Paul, Macleod and Rogol, 1979) and PRL injected into the lateral ventricle also causes increased DA turnover in these neurons (Annunziato and Moore, 1978).

In experiments designed to investigate the possible roles of oestrogen and haloperidol in TIDA neuronal regulation, it was discovered that the stimulatory effects of these agents on DA turnover were secondary to the increases in plasma PRL concentrations caused by these agents since they were ineffective in hypophysectomized animals (Eikenburg et al., 1977; Moore and Demarest, 1982).

Prolactin has also been shown to release both endogenous and ^3H -DA from pieces of MBH in vitro (Perkins and Westfall, 1978; Foreman and Porter, 1981).

In the present studies PRL was found to have no effect on either the spontaneous or the electrically-induced release of ^3H -DA from the ME in vitro. This was unexpected, as two other studies had shown that DA could be released from the MBH in response to PRL (Perkins and Westfall, 1978; Foreman and Porter, 1981). However, Kapoor (1982) did not find any significant effect of PRL on the release of endogenous DA from the ME in vitro. It may be that the increase in DA turnover caused by PRL is exerted through the cell bodies of TIDA neurons in the arcuate nucleus rather than at the nerve terminals. This is supported by reports that PRL can change

the electrical activity in some hypothalamic neurons (Clemens, Gallo, Whitmayer and Sawyer, 1971; Yamada, 1975) and that PRL in CSF can change DA turnover in TIDA neurons (Annunziato and Moore, 1978). However, the lack of effect may also be due to the brief duration of exposure of the tissue in the ME slice to PRL. The PRL effect on DA turnover has been reported to have a latency of at least 4h in vivo and to be dependent on de novo protein synthesis (Johnston, Demarest and Moore, 1980).

The terminals of the TIDA system in the ME are found in close association with terminals containing TRH (Kizer, Palkovits, Tappaz, Kebabian and Brownstein, 1976; Agnati, Fuxe, Hökfelt, Goldstein and Jeffcoate, 1977) and those containing LHRH (Ajika, 1979; Selmanoff, 1981). There is evidence that in some systems in the CNS putative amine and peptide neurotransmitters may co-exist in the same neuron (Burnstock, 1975; Chan-Palay, Jonsson and Palay, 1978; Hökfelt, Ljungdahl, Steinbusch, Verhofstad, Nilsson, Brodin, Pernow and Goldstein, 1978), however it has been demonstrated that in the ME, DA, LHRH and TRH are present in different terminals (Kizer, Arimura, Schally and Brownstein, 1975). The interactions of central monoamines and neuropeptides are likely to be very complex, whether substances are present in the same terminal or not. An example of this is shown in work by Rotzstejn, Drouva, Pattou and Kordon, (1978) who reported that DA could induce the release of LHRH from MBH tissue in vitro and that this DA-stimulated release, but not basal release, was inhibited by met-enkephalin. Other reports show the possibility of complex interactions between NA and somatostatin (SS) and between melatonin, LHRH and DA. Göthert (1980) reported

that SS inhibited the release of ^3H -NA from hypothalamic slices in vitro and Epelbaum, Tapia-Arancibia and Kordon, (1981) subsequently showed that NA could stimulate SS release from slices of POA but not from MBH in vitro; melatonin has been reported to stimulate LHRH release (Richardson, Prasad and Hollander, 1982) and inhibit ^3H -DA release (Zisapel, Egozi and Laudon, 1983) from the MBH in vitro. While there are well-documented effects of DA on the release of both LHRH and TRH (Maeda and Frohman, 1980; Negro-Vilar, 1982), there are very few observations on reciprocal interactions between LHRH or TRH on the release of DA. These interactions might be expected on consideration of the anatomical data discussed previously. There is evidence that TRH can stimulate release of ^3H -DA from bovine retina (Reading, 1983) and from rat nucleus accumbens (Kerwin and Pycocock, 1979) in vitro, and a brief report (Bennett, Marsden, Metcalf, Sharp and Tulloch, 1981) stated that endogenous DA could be released from rat hypothalamus, nucleus accumbens and septum by incubation with a long-acting TRH analogue, CG5309 (orotyl-histidyl-prolyl-amide). There are no reports of LHRH affecting DA release.

In the present studies it was found that the addition of LHRH or TRH to the superfusion medium had no effect on the spontaneous or on the electrically-induced release of ^3H -DA from ME slices in vitro. This lack of effect may again be due to the fact that the ME slice contains only axons and terminals and these peptides, if they have any effect on TIDA function may do so at the level of the cell body in the arcuate nucleus. However, it has been reported that TI cell bodies in the arcuate nucleus are unresponsive to

microiontophoretically applied LHRH and TRH (Moss et al., 1975; Moss, 1977) in contrast to the inhibitory and stimulatory action of these peptides on electrophysiological activity in other regions of the CNS (Dyer and Dyball, 1974; Renaud, Martin and Brazeau, 1975).

In summary, although the ME has been shown to take-up and release $^3\text{H-DA}$ in vitro its usefulness as a model to study function in the TIDA neuron seems limited. These limitations are perhaps reflected in the paucity of literature concerning catecholamine release from the ME in contrast to the increasing body of literature dealing with the release of peptides from this tissue (e.g. Rotsztein et al., 1977; Bény and Baertschi, 1981; Negro-Vilar, 1982).

It had been hoped that this in vitro system could be adapted to investigate the uptake and release of 5-HT in the ME. However, this proved difficult and attention was focussed on in vivo studies.

CHAPTER 4

The Effects of Inhibition of Uptake of Serotonin
on the Concentration of Luteinizing Hormone and
Prolactin in Plasma in Various Animal Models

4.1 INTRODUCTION

The role of 5-HT in the control of the release of LH and PRL from the anterior pituitary gland has long been controversial (Weiner and Ganong, 1978; Krulich, 1979; Meites and Sonntag, 1981). The release of LH has been reported to be inhibited in castrated male and ovariectomized female rats after peripheral or i.c.v. injection of 5-HT (Kamberi, Mical and Porter, 1970; Schneider and McCann, 1970; Pilotte and Porter, 1979) and both spontaneous ovulation and that induced by pregnant mare serum gonadotrophin (PMSG) have been reported to be blocked after peripheral injection of 5-HT (O'Steen, 1965; Kordon and Glowinski, 1972; Labhetswar, 1972; Wilson and MacDonald, 1974). However, these findings conflict with those of the numerous reports showing an inhibition of LH release after injection of either a 5-HT synthesis inhibitor or a 5-HT neurotoxin in both pro-oestrous rats and ovariectomized rats treated with exogenous steroids (Héry et al., 1976; Wuttke, Hancke, Höhn and Baumgarten, 1978; Coen and Mackinnon, 1980; Chen, Sylvester, Heiri and Meites, 1981).

In contrast to the confusion in the literature concerning the effect of 5-HT on LH release, there appears to be general agreement that 5-HT stimulates the release of PRL under most circumstances. The concentration of PRL in peripheral plasma is increased after peripheral or i.c.v. injection of 5-HT or a 5-HT depletor (Kamberi, Mical and Porter, 1971; Caligaris and Taleisnik, 1974; Becu and Libertun, 1982; Van de Kar and Bethea, 1982) and also after injection of 5-HTP (the immediate precursor of 5-HT) in combination with a 5-HT reuptake blocker (Krulich, 1975; Clemens et al., 1977).

Although there appear to be no reports of an inhibitory influence of 5-HT on PRL release, there have been a few studies which have found no change in the concentration of PRL in peripheral plasma after experimental manipulations designed to alter 5-HT transmission (Gallo et al., 1975; Krulich et al., 1980).

Much of the dispute concerning the effect of 5-HT on the release of LH and PRL arises from the multiplicity of experimental animal models studied. Although there is a naturally occurring model suitable for the study of the release of LH and PRL and their possible 5-HT components, namely the cyclic release of LH and PRL during the oestrous cycle of the female rat (Butcher, Collins and Fugo, 1974), most investigators have examined the role of 5-HT in the release of LH and PRL using the ovariectomized female rat treated with various combinations of exogenous steroids. The models that have been used most commonly to study possible involvement of 5-HT have been i) the long-term ovariectomized rat, injected with a priming dose of oestrogen followed at least 72h later by an injection of progesterone (Caligaris, Astrada and Taleisnik, 1968; Caligaris and Taleisnik, 1974) and ii) the long-term ovariectomized rat exposed to a continuously elevated concentration of oestrogen achieved by either daily injections of high doses of OB (Caligaris et al., 1971), injection of a long-acting preparation of oestrogen (Subramanian and Gala, 1976) or implantation of a silicone elastomer capsule containing crystalline OE (Legan, Coon and Karsch, 1975; Henderson et al., 1977b). The first model shows an increase in the concentration of both LH and PRL in peripheral plasma, beginning 4-5h after the injection of progesterone and persisting

for a few hours, before returning to baseline values. The second model shows a circadian rhythm of LH and PRL with increases in hormone concentration in peripheral plasma every day during the late afternoon. It has been proposed (Legan et al., 1975; Freeman et al., 1976; Brown-Grant, 1977) that the mechanisms involved in the massive release of hormones in these models, and specifically that of LH, may be similar to those that subserve the surges of LH and PRL that occur spontaneously on the afternoon of pro-oestrus. However, this may not be strictly correct since, for example, while the spontaneous surge of LH depends upon an increased release of LHRH into hypophysial portal blood and an increase in the responsiveness of the pituitary gland to LHRH, the LH surge in animals treated with oestrogen followed by progesterone may be due mainly to a massive increase in responsiveness to LHRH (Sarkar and Fink, 1980).

The aim of the present study was to investigate the role of 5-HT in the release of LH and PRL in a range of animal models, using two drugs, alaproclate and zimelidine, developed by Astra Pharmaceuticals, and shown to be potent inhibitors of 5-HT reuptake in vitro (Astra, unpublished data; Ross, Ögren and Renyi, 1976). In preliminary studies alaproclate and zimelidine have been tested, by Astra, for their effects on endocrine function in the male rat. Alaproclate, injected i.p. at doses ranging from 3-30mg/kg, caused increases in plasma LH and PRL at doses of 10-30mg/kg, and an increase in plasma corticosterone at a dose of 30mg/kg. Zimelidine, tested at a similar range of doses, caused a small increase in plasma PRL and had no significant effect on plasma LH. Unlike

alaproclate, zimelidine caused a decrease in plasma corticosterone.

Theoretically an inhibitor of the uptake of 5-HT could affect the release of LH and PRL by a number of different routes, for instance:

- i) by altering the release of releasing factors or release-inhibiting factors
- ii) by altering the responsiveness of the pituitary gland to releasing factors or release-inhibiting factors
- iii) by increasing the concentration of 5-HT in the immediate vicinity of the anterior pituitary gland and so changing the magnitude of a possible direct action of 5-HT on the gland
- iv) by an effect on the ovary, either directly or indirectly, to alter peripheral concentrations of steroid hormones.

There is evidence for the involvement of 5-HT in all of these possible mechanisms of action.

4.1.1 Involvement of serotonin in the release of luteinizing hormone

It has been reported that incubation of hypothalamic tissue with 5-HT in vitro causes an inhibition of LH-releasing activity (Moszkowska, 1965) and of LHRH release (Charli, Rotsztejn, Pattou and Kordon, 1978). An increase in LHRH immunoreactivity in rat brain after an i.c.v. injection of 5-HT has also been interpreted as indicating an inhibitory action of 5-HT on the release of LHRH (Leonardelli, Dubois and Poulain, 1974). Other workers have failed to demonstrate any effect of 5-HT on the release of LHRH from hypothalamic synaptosomes (Bennett et al., 1975) or on the release of LH from the medial basal hypothalamus/anterior pituitary complex in vitro (Schneider and McCann, 1969).

The change in pituitary responsiveness to LHRH leading to increased LH release is a complex phenomenon involving a direct effect of oestrogen and a 'priming' effect of LHRH on the gonadotrophs of the anterior pituitary gland (Aiyer and Fink, 1974; Aiyer et al., 1974). There has been an interaction proposed for 5-HT in the release of LH caused by LHRH. Martin, Engel and Klein (1977) showed that 5-HT could cause a 40% decrease in the concentration of LH released from neonatal rat pituitary glands in response to LHRH in vitro. However, this effect was not specific for 5-HT, since melatonin caused a 100% suppression of the release of LH in response to LHRH stimulation.

An unconfirmed report by Kamberi et al. (1970) claimed that 5-HT injected into a hypophysial portal vessel had no effect on peripheral LH concentration, but that an i.c.v. injection of 5-HT caused an inhibition of the release of LH, and concluded that 5-HT did not have a direct effect on the pituitary gland to affect LH release but did so instead by inhibiting the release of LHRH. Schneider and McCann (1969) and Birge et al. (1970) found that 5-HT had no effect on the release of LH from isolated pituitary glands in vitro.

Both 5-HT and PCPA, an inhibitor of 5-HT synthesis, have been shown to disrupt ovarian function and cause an inhibition of ovulation by way of a decrease in peripheral steroid concentrations (Wilson and Macdonald, 1974; Al Satli and Aron, 1981) caused by vasoconstriction in the ovary (Wilson and Macdonald, 1974). Although this may occur in the intact pro-oestrous animal it is unlikely to be an important factor in the proposed studies since the

effects of alaproclate in the male rat were of short duration, and a change in peripheral steroid concentrations in the female rat is unlikely to occur during this short period. Obviously, this effect does not have to be considered when dealing with the experimental models involving ovariectomized animals.

4.1.2 Involvement of serotonin in the release of prolactin

Although there is general agreement in the literature that 5-HT stimulates the release of PRL, there is some dispute as to whether this is due to the stimulation of the release of a PRF or to the inhibition of the release of a PIF. There is evidence that 5-HT can stimulate the release of an unspecified PRF (Clemens et al., 1978; Garthwaite and Hagen, 1979) and the release of TRH and VIP, both proposed as possible PRFs, is stimulated by 5-HT (Chen and Ramirez, 1981; Shimatsu, Kato, Matsushita, Katakami, Yanaihara and Imura, 1982; Shimatsu et al., 1983). Dopamine, generally, but not universally accepted as the major physiological PIF (Weiner and Ganong, 1978; Leong et al., 1983), is decreased in portal plasma after an i.c.v. injection of 5-HT (Pilotte and Porter, 1981) and PRL in peripheral plasma is increased. However, although this result indicates that 5-HT can inhibit the release of a presumed PIF, there seems to be the additional involvement of a PRF since an intra-atrial infusion of DA to give concentrations of DA equivalent to those normally present in hypophysial portal plasma did not prevent the 5-HT stimulated increase in the concentration of PRL in peripheral plasma.

The mechanisms involved in the increase in PRL responsiveness of the anterior pituitary gland are unknown. There does not appear to

be a self-priming effect of a PRF, by analogy with LHRH, since repeated administration of hypothalamic extracts to anterior pituitary glands in short-term incubation in vitro did not increase PRL responsiveness (Pickering and Fink, 1979). Although there are suggestions of interactions between DA, oestrogen and a PRF to increase PRL responsiveness (Leong et al., 1983), there has so far been no suggestion of a comparable interaction involving 5-HT.

Results from in vitro studies concerning a direct action of 5-HT on the anterior pituitary gland have mainly been negative (Lamberts and MacLeod, 1978; Delitala, Yeo, Stubbs, Jones and Besser, 1980) but a very brief report by Fang (1976) claimed a stimulatory effect of 5-HT on PRL release from anterior pituitary cells. The latter report, must however, be accepted with caution, since the author also claimed that 5-HIAA was more effective than 5-HT in the system studied. It would seem unlikely that a neurotransmitter metabolite would be more effective than the neurotransmitter itself on the release of a hormone. A possible direct effect of 5-HT on the release of PRL from the anterior pituitary gland has been shown in vivo. Wehrenberg et al. (1980) found that 5-HT caused an increase in the concentration of PRL in peripheral plasma in the stalk-sectioned monkey and very recently Stobie and Shin (1983) demonstrated that 5-HT could cause the release of PRL from an ectopic pituitary gland implanted under the kidney capsule. It has been suggested that the failure of 5-HT to cause any increase in PRL secretion in vitro may be due to the presence of a very high release of PRL upon which it is not possible to superimpose any further stimulation. However in the in vivo studies quoted above (Wehrenberg

et al. 1980; Stobie and Shin 1983), PRL release was high and yet 5-HT caused further stimulation of release. An unconfirmed report by Kamberi et al. (1971) stated that 5-HT injected directly into a hypophysial portal vessel in an intact animal, had no effect on peripheral PRL concentrations.

It has been claimed that 5-HT does not cross the blood-brain barrier (Axelrod and Iscoe, 1963) and so studies showing an increase in PRL concentrations in peripheral plasma after a systemic injection of 5-HT (Lawson and Gala, 1975; Gala, Subramanian, Peters and Pieper, 1977; Stevens and Lawson, 1977) could be interpreted as a direct action of 5-HT acting directly on the anterior pituitary gland. However, it does appear that 5-HT can cross the blood-brain barrier (Bulat and Supek, 1968) and so these results must be interpreted with care.

As was discussed for 5-HT and LH release, although steroids do alter the release of PRL in response to 5-HT (Caligaris and Taleisnik, 1974) it is unlikely that an alteration of steroid concentrations caused by the vasoconstrictor action of 5-HT in the ovary (Wilson and Macdonald, 1974) would be of significance in the proposed studies.

4.1.3 Possible sites of action of serotonin

There is a large body of indirect evidence which is consistent with an involvement of 5-HT in the release of LH and PRL from the anterior pituitary gland. The uptake of 5-HT in hypothalamic slices is significantly increased on the afternoon of pro-oestrus (Meyer and Quay, 1976) and the number of 5-HT receptors in the basal forebrain is decreased at a similar time (Biegnon, Bercovitz and

Samuel, 1980). Recently it has been shown that tryptophan hydroxylase activity in the dorsal raphe nuclei was decreased after castration of adult male rats (Long and Youngblood, 1983). The ME contains 5-HT (Baumgarten and Lachenmayer, 1974; Calas et al., 1974) and in vitro can synthesize and release 5-HT (Hamon, Javoy, Kordon and Glowinski, 1974). The anterior pituitary gland has been shown to exhibit 5-HT immunofluorescence (Dahlström and Fuxe, 1966) and 5-HT has also been detected in pituitary tissue by a radioenzymatic assay (Saavedra, Palkovits, Kizer, Brownstein and Zivin, 1975). Cells of the anterior pituitary have the capacity to take up 5-HT (Nunez, Gershon and Silverman 1981; Johns, Azmitia and Krieger 1982) and 5-HIAA has been reported to be present at a higher concentration in hypophysial portal plasma than in peripheral plasma (Johnston et al., 1983).

4.1.4 Proposed experimental studies

In addition to studies on the pro-oestrous rat and the two experimental models described previously, studies were carried out on the short-term ovariectomized rat treated with OB and P (Mann and Barraclough, 1973; Fink and Henderson, 1977a,b) and the long-term ovariectomized rat injected with OB followed by another injection of OB 72h later (Brown-Grant, 1974). Very few studies have been carried out on possible 5-HT involvement in the release of LH and PRL in the short-term ovariectomized steroid-primed rat although this is perhaps the model that most closely mimics the changes in peripheral steroid concentration that occur in the intact animal (Mann and Barraclough, 1973; Aiyer and Fink, 1974; Tapper, Grieg and Brown-Grant, 1974; Sarkar and Fink, 1979). Studies were

carried out on the long-term ovariectomized rat treated with 2 injections of OB 72h apart, because although there is an increase in the release of LH and PRL after the second injection of OB, the LH response has been reported to be of a smaller magnitude (Tapper et al., 1974; Brown-Grant, 1974) and to involve different mechanisms (Dyer and Mansfield, 1983) than the LH surges seen in long-term ovariectomized animals, induced by an injection of OB followed by P. The release of PRL in this model in response to a second injection of either OB or P was also studied since this was not measured in the studies of Tapper et al. (1974) or Brown-Grant (1974).

4.2 MATERIALS AND METHODS

4.2.1 Animals

Animals used in this series of experiments were female Wistar cobs (180-250g) maintained as described in section 2.1. Five experimental models were studied,

- i) the pro-oestrous rat (pro-oestrus was determined as in section 2.2.7).
- ii) the short-term OVX female rat (2.2.9), injected with OB on the day of OVX, dioestrus (day 1), and with P on the day of presumptive pro-oestrus (day 2) (Model 1).
- iii) the long-term OVX female rat (2.2.9), injected with OB on day 1 and 72h later with P (day 4) (Model 2).
- iv) the long-term OVX female rat (2.2.9), injected with two injections of OB, one on day 1 and the next 72h later on day 4 (Model 3).
- v) the long-term OVX female rat (2.2.9) injected with daily injections of OB for 4 days (Model 4).

4.2.2 Steroid treatments

Both steroids were kept as stock solutions in arachis oil, OB at 100 μ g/ml and P at 10mg/ml and were injected s.c. (2.2.2.) into the nape of the neck. Various combinations of surgery and steroid treatment were studied;

- i) Short term OVX rats were ovariectomized between 0630-0900h of dioestrus (experimental day 1) and injected at 1200h with 20 μ g OB. The next day (day 2), presumptive pro-oestrus, the animals were injected at 1200h with 2mg P.
- ii) Long term OVX rats were injected with 20 μ g OB at 1200h of experimental day 1 and 72h later, (experimental day 4) either with 2mg P, or 20 μ g OB.
- iii) Long term OVX rats were injected daily with 20 μ g OB at 1200h for 4 days.

4.2.3 Intra-atrial cannulation

Animals were cannulated (2.2.11) under halothane anaesthesia between 0630-0900h either on day 1 of the experiment, (OVX animals), or between 0630-0900h on the morning of pro-oestrus, and then caged individually for the duration of the experiment.

4.2.4 Drug treatments and blood sampling

Alaproclate and zimelidine (2.2.3) were dissolved in 0.9% saline immediately before use, and injected i.v. in a volume of 0.4-0.6ml over a period of 2 min at doses and times stated in each experiment. Control animals were injected with i.v. 0.4-0.6ml saline.

Blood samples, 0.3ml, were taken using heparinized syringes at times stated in each experiment and the plasma volume was maintained

by replacing the withdrawn blood by an equal volume of 0.9% saline. Samples were kept on ice until centrifuged at 2500g for 20 mins at 4°C. Plasma was removed and stored at -25°C until assayed for LH and PRL.

4.2.5 Measurement of luteinizing hormone and prolactin

Concentrations of LH and PRL were measured using specific RIAs (2.3).

4.2.6 Statistics

All data are presented as mean \pm S.E.M. The significance of the difference between two means was analysed using Students t-test. The significance of differences between more than two means was determined by analysis of variance and Duncan's multiple range test.

4.3 RESULTS

4.3.1 The effect of different doses and times of administration of alaproclate on plasma luteinizing hormone and prolactin concentrations in the pro-oestrous female rat

The i.v. injection of alaproclate at dosages of either 3mg/kg or 10mg/kg at 1500h, had no effect on the plasma concentrations of either LH or PRL in the pro-oestrous rat, but injection of 30mg alaproclate/kg at this time caused a significant ($p < 0.01$), though transient, decrease in PRL concentration 30 minutes after administration (Table 4-1 and Fig. 4-1). The concentration of LH was unaffected by any dose of alaproclate (Table 4-2 and Fig. 4-2).

When 30mg alaproclate/kg was injected i.v. into pro-oestrous female rats at 1000h there was no significant difference between control and treated animals in either the morning low plasma concentrations of PRL or in the higher (surge) afternoon

TABLE 4-1

Mean (\pm S.E.M.) concentrations of prolactin (ng/ml) in peripheral plasma from pro-oestrous female rats at various times after i.v. injection of different doses of alaproclate (Alap.) at 1500h. Blood samples were removed from conscious animals by way of an intra-atrial cannula inserted between 0630-0800h on the morning of pro-oestrus.

		1000	1500	1530	1600	1700	1800
<u>Group</u>	<u>n</u>						
Saline	6	22 \pm 5	864 \pm 85	922 \pm 96	858 \pm 126	814 \pm 170	831 \pm 167
Alap. 3mg/kg	6	29 \pm 8	1003 \pm 147	915 \pm 104	1456 \pm 200	1297 \pm 138	852 \pm 97
Alap. 10mg/kg	6	30 \pm 4	984 \pm 115	805 \pm 98	801 \pm 111	968 \pm 98	905 \pm 93
Alap. 30mg/kg	6	43 \pm 11	959 \pm 103	389 \pm 60**	769 \pm 123	743 \pm 115	693 \pm 108

**p < 0.01; level of significance of difference between animals injected with alaproclate at 1500h compared with animals injected with saline at 1500h.

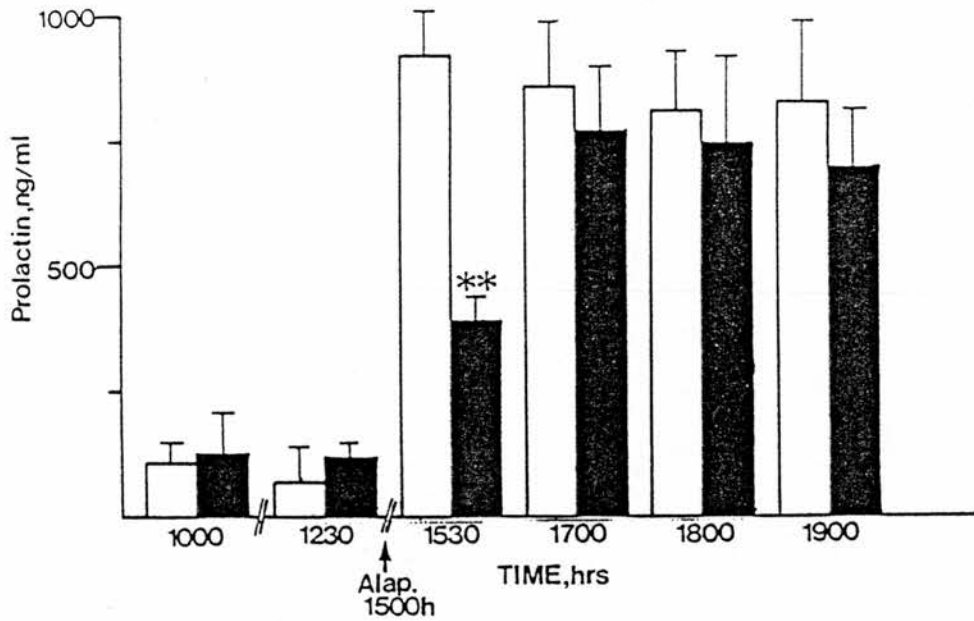

FIGURE 4-1 Mean (\pm S.E.M.) concentrations of prolactin in peripheral plasma from pro-oestrous female rats at various times after an i.v. injection of 30mg alaproclate/kg at 1500h. Blood samples were removed from conscious animals by way of an intra-atrial cannula inserted between 0630-0830h on the morning of pro-oestrus.

Open bar = control group, injected with saline (n = 6)
 Closed bar = experimental group, injected with alaproclate (n = 6)

**p < 0.01; level of significance of difference between animals injected with alaproclate at 1500h compared with animals injected with saline at 1500h.

TABLE 4-2

Mean (\pm S.E.M.) concentrations of luteinizing hormone (ng/ml) in peripheral plasma from pro-oestrous female rats at various times after i.v. injection of different doses of alaproclate (Alap.) at 1500h. Blood samples were removed from conscious animals by way of an intra-atrial cannula inserted between 0630-0800h on the morning of pro-oestrus.

Time (h)	1000	1500	1530	1600	1700	1800	
<u>Group</u>	n						
Saline	6	<1.0	<1.0	<1.0	18.2 \pm 4.6	20.4 \pm 6.5	13.1 \pm 3.0
Alap. 3mg/kg	6	<1.0	<1.0	<1.0	16.4 \pm 3.9	25.3 \pm 5.4	18.6 \pm 7.5
Alap. 10mg/kg	6	<1.0	<1.0	<1.0	19.4 \pm 7.2	30.1 \pm 4.7	23.1 \pm 7.2
Alap. 30mg/kg	6	<1.0	<1.0	<1.0	20.1 \pm 4.3	24.5 \pm 6.3	20.2 \pm 5.3

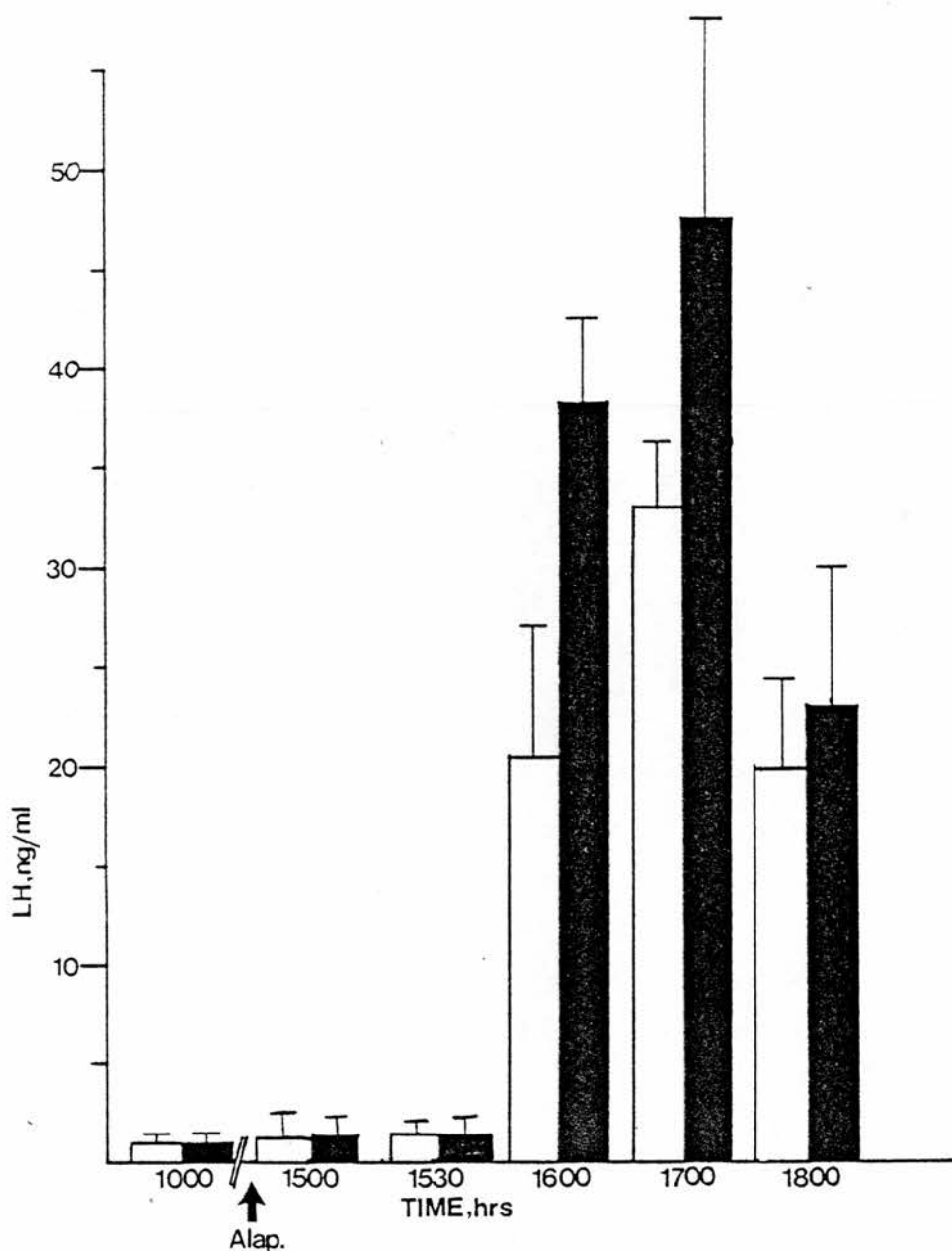

FIGURE 4-2 Mean (\pm S.E.M.) concentrations of luteinizing hormone (LH) in peripheral plasma from pro-oestrous female rats at various times after an i.v. injection of 30mg alaproclate/kg at 1500h. Blood samples were removed from conscious animals by way of an intra-atrial cannula inserted between 0630-0830h on the morning of pro-oestrus.
 Open bar = control group, injected with saline (n = 6)
 Closed bar = experimental group, injected with alaproclate (n = 6)

concentrations (Table 4-3). There were also no significant differences in the morning or afternoon plasma LH concentrations between control and treated animals (Table 4-4).

From these two studies it was decided that a dose of alaproclate of 30mg/kg given at 1500h would be used in all other experiments.

4.3.2 The effect of alaproclate on plasma luteinizing hormone and prolactin concentrations in the short-term ovariectomized rat treated with oestradiol benzoate and progesterone (Model 1)

In short term OVX rats treated with OB followed by P, alaproclate, injected i.v. at a dose of 30mg/kg at 1500h on experimental day 2 caused a significant decrease ($p < 0.01$) in the concentration of plasma PRL 30 min later (Fig. 4-3). Figure 4-3 also shows that this difference between the control and experimental animals although much smaller, was still significant ($p < 0.05$) at 1600h. The plasma concentrations of PRL in treated animals had returned to control values by 1700h and there was no significant difference between the maximum observed plasma concentrations of PRL.

The plasma concentration of LH at 1530h in alaproclate treated animals was not significantly different from that in control animals at 1530h (Fig. 4-4) but was significantly ($p < 0.01$) decreased compared with that in control animals at 1600h. The decrease was not sustained and there was no significant difference between the maximum observed plasma concentrations of LH.

4.3.3 The effect of alaproclate on luteinizing hormone and prolactin concentrations in the long-term ovariectomized rat treated with oestradiol benzoate and progesterone (Model 2).

When alaproclate (30 mg/kg at 1500h on experimental day 4) was

TABLE 4-3

Mean (\pm S.E.M.) concentrations of prolactin (ng/ml) in peripheral plasma from pro-oestrous female rats at various times after an i.v. injection of 30mg alaproclate/kg at 1000h or 1500h on pro-oestrus. Blood samples were removed from conscious animals by way of an intra-atrial cannula inserted between 0630-0800h on the morning of pro-oestrus.

	1000	1030	1230	1530	1700	1800	1900	
<u>Group</u>	<u>n</u>							
Saline	6	19 \pm 7	22 \pm 6	67 \pm 19	922 \pm 96	858 \pm 126	814 \pm 170	831 \pm 167
Alap. 1000h	6	38 \pm 14	54 \pm 27	166 \pm 46	806 \pm 146	876 \pm 124	917 \pm 124	848 \pm 135
Alap. 1500h	6	25 \pm 6	-	118 \pm 45	389 \pm 60**	769 \pm 123	743 \pm 115	693 \pm 108

** p < 0.01; level of significance of difference between animals injected with alaproclate at 1500h compared with animals injected with saline at 1500h.

TABLE 4-4

Mean (\pm S.E.M.) concentrations of luteinizing hormone (ng/ml) in peripheral plasma from pro-oestrous female rats at various times after i.v. injection of 30mg alaproclate/kg at 1000h or 1500h on pro-oestrus. Blood samples were removed from conscious animals by way of an intra-atrial cannula inserted between 0630-0800h on the morning of pro-oestrus.

Time (h)	1000	1030	1230	1530	1700	1800	1900
<u>Group</u>							
n							
Controls	6	< 1.0	< 1.0	< 1.0	20.4 \pm 6.5	13.1 \pm 3.0	9.8 \pm 4.3
Alap. 1000h	6	< 1.0	< 1.0	< 1.0	22.5 \pm 8.1	20.3 \pm 7.8	15.6 \pm 5.9
Alap. 1500h	6	< 1.0	< 1.0	< 1.0	38.2 \pm 4.7	37.4 \pm 10.0	23.1 \pm 7.2

FIGURE 4-3 Mean (\pm S.E.M.) concentrations of prolactin in peripheral plasma at various times after an i.v. injection of 30mg alaproclate/kg at 1500h into short-term ovariectomized rats treated with oestradiol benzoate (OB) and progesterone (P). Animals were injected s.c. with 20 μ g OB at 1200h on the day of ovariectomy (dioestrus) and with 2mg P 24h later (presumptive pro-oestrus). Alaproclate was injected at 1500h on presumptive pro-oestrus. Blood samples were removed from conscious animals by way of an intra-atrial cannula inserted at the time of ovariectomy (0630-0900h on dioestrus).

Open bar = control group, injected with saline (n = 6)
Closed bar = experimental group, injected with alaproclate (n = 6)

*p < 0.05, **p < 0.01; levels of significance of difference between animals injected with alaproclate at 1500h compared with animals injected with saline at 1500h.

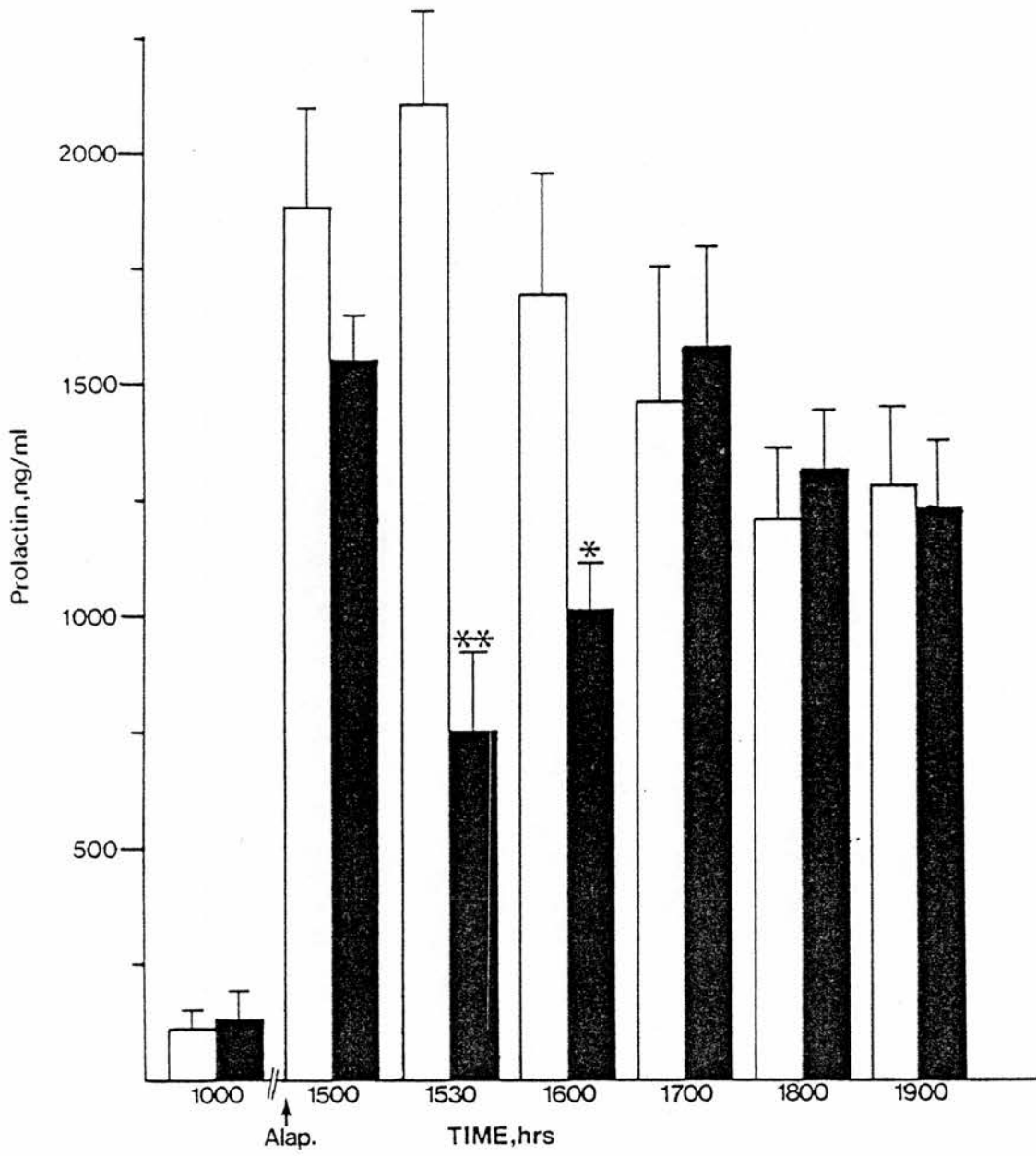
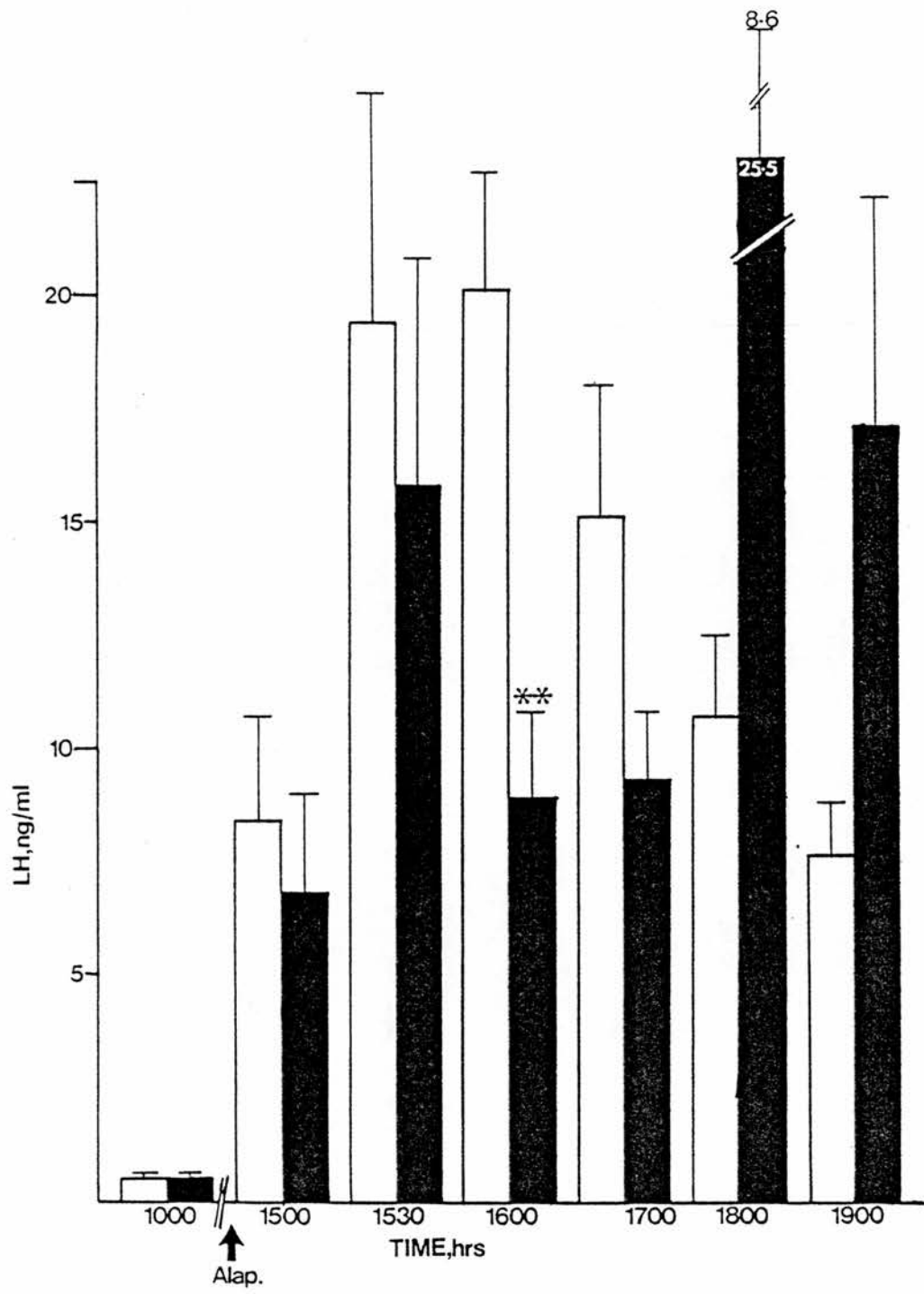

FIGURE 4-4 Mean (\pm S.E.M.) concentrations of luteinizing hormone (LH) in peripheral plasma at various times after an i.v. injection of 30mg alaproclate/kg at 1500h into short-term ovariectomized rats treated with oestradiol benzoate (OB) and progesterone (P). Animals were injected s.c. with 20 μ g OB at 1200h on the day of ovariectomy and with 2mg P 24h later (presumptive pro-oestrus). Alaproclate was injected at 1500h on presumptive pro-oestrus. Blood samples were removed from conscious animals by way of an intra-atrial cannula inserted at the time of ovariectomy (0630-0900h on dioestrus).

Open bar = control group, injected with saline (n = 6)

Closed bar = experimental group, injected with alaproclate (n = 6)

**p < 0.01; level of significance of difference between animals injected with alaproclate at 1500h compared with animals injected with saline at 1500h.



administered i.v. to long-term ovariectomized rats treated with OB plus P, there were significant increases ($p < 0.01$) in plasma PRL concentrations at 1700h and 1800h (Fig. 4-5). There was no significant difference in the maximum observed PRL plasma concentration between control and treated groups.

Alaproclate injection caused significant decreases ($p < 0.01$ and < 0.05 , respectively) in plasma LH concentrations in this model at 1600h and 1700h (Fig. 4-6). In this case there was also a significant difference ($p < 0.01$) in the maximum concentration of plasma LH measured.

4.3.4 The effect of alaproclate on plasma luteinizing hormone and prolactin concentrations in the long-term ovariectomized female rat treated with oestradiol benzoate (Model 3).

In long term OVX rats treated with OB and injected i.v. with 30 mg alaproclate/kg at 1500h on experimental day 4, there was a significant ($p < 0.02$) decrease in the plasma concentration of PRL 30 min after injection, (Fig. 4-7). The decrease was not sustained and there was no significant difference between the maximum observed PRL concentrations.

There were no significant differences in either the plasma LH concentrations compared with the control animals or in the maximum observed plasma concentration of LH (Fig. 4-8).

4.3.5 The effect of alaproclate on plasma luteinizing hormone and prolactin concentrations in long-term ovariectomized rats injected with multiple doses of oestradiol benzoate (Model 4)

When 30mg alaproclate/kg was injected i.v. at 1500h into long-term OVX rats that had been injected with daily doses of 20 μ g

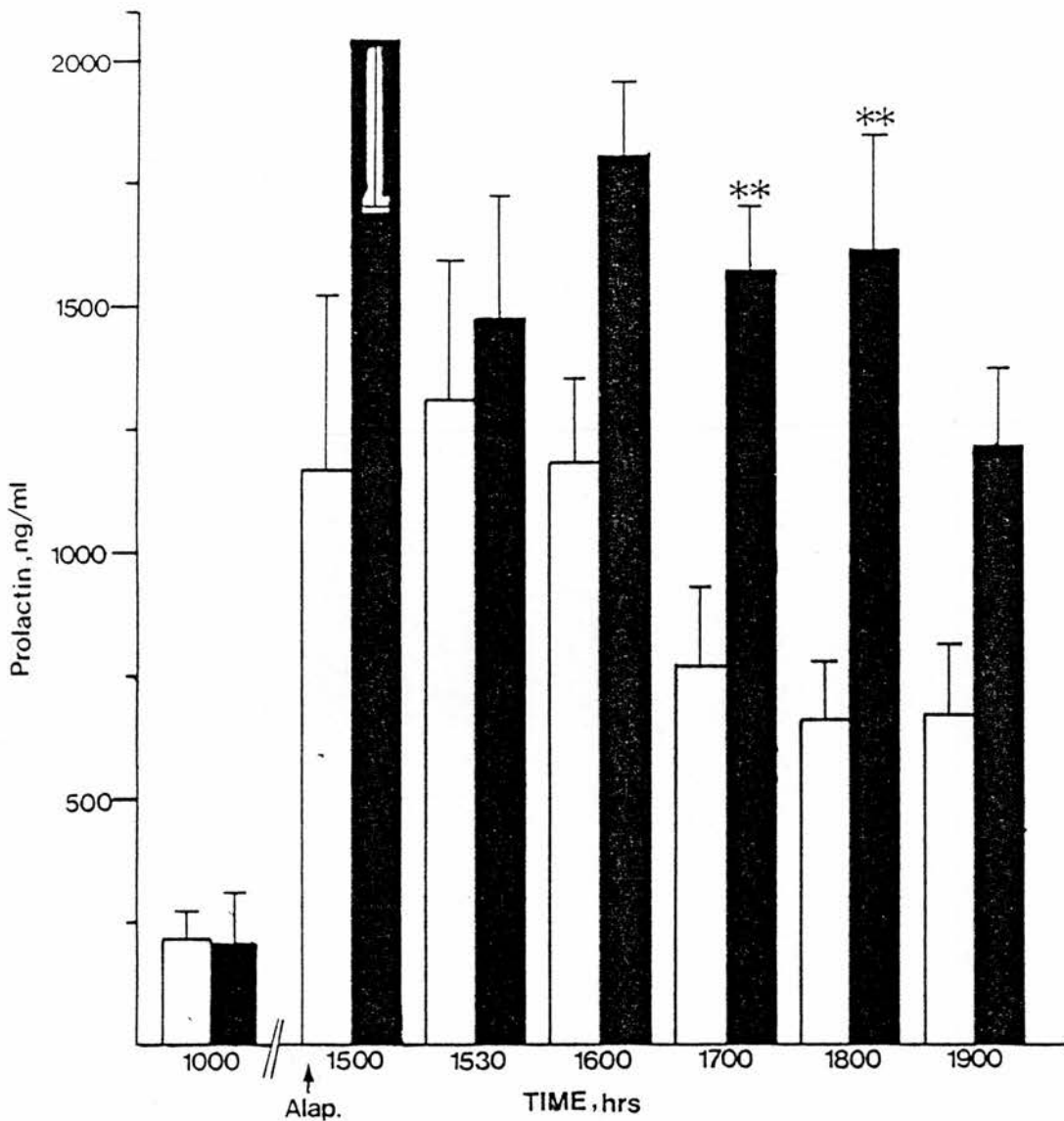

FIGURE 4-5 Mean (\pm S.E.M.) concentrations of prolactin in peripheral plasma at various times after an i.v. injection of 30mg alaproclate/kg at 1500h into long-term ovariectomized (OVX) rats treated with oestradiol benzoate (OB) and progesterone (P). Long-term OVX animals were injected s.c. with 20 μ g OB at 1200h on experimental day 1 and 72h later (experimental day 4) with 2mg P. Alaproclate was injected at 1500h on experimental day 4. Blood samples were removed from conscious animals by way of an intra-atrial cannula inserted between 0900h - 1200h on experimental day 1. Open bar = control group, injected with saline (n = 6) Closed bar = experimental group, injected with alaproclate (n = 6). **p < 0.01; level of significance of difference between animals injected with alaproclate at 1500h compared with animals injected with saline at 1500h.

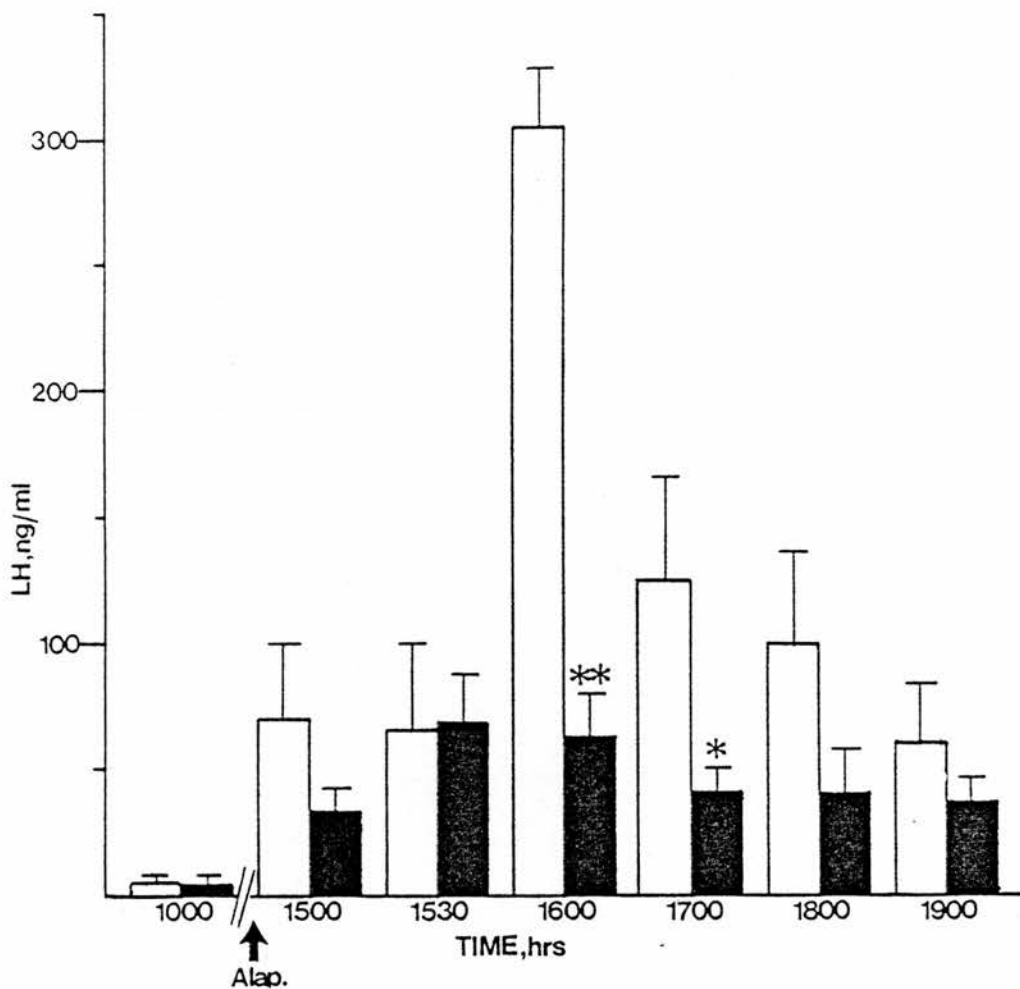

FIGURE 4-6 Mean (\pm S.E.M.) concentrations of luteinizing hormone (LH) in peripheral plasma at various times after an i.v. injection of 30mg alaproclate/kg at 1500h into long-term ovariectomized (OVX) rats treated with oestradiol benzoate (OB) and progesterone (P). Long-term OVX animals were injected s.c. with 20 μ g OB at 1200h on experimental day 1 and 72h later (experimental day 4) with 2mg P. Alaproclate was injected at 1500h on experimental day 4. Blood samples were removed from conscious animals by way of an intra-atrial cannula inserted between 0900h - 1200h on experimental day 1. Open bar = control group, injected with saline (n = 6) Closed bar = experimental group, injected with alaproclate (n = 6). *p < 0.05, **p < 0.01; levels of significance of difference between animals injected with alaproclate at 1500h compared with animals injected with saline at 1500h.

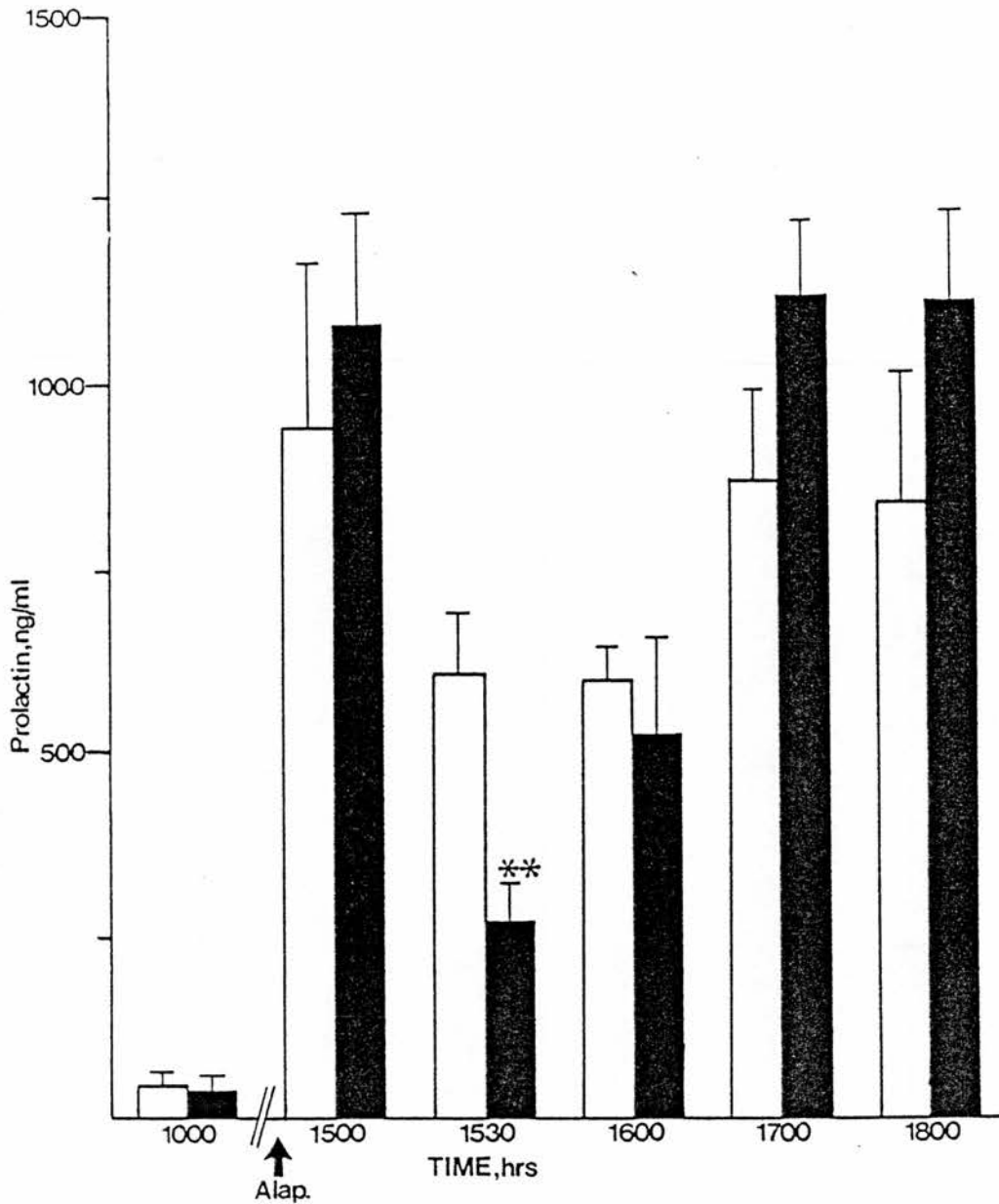

FIGURE 4-7 Mean (\pm S.E.M.) concentrations of prolactin in peripheral plasma at various times after an i.v. injection of 30mg alaproclate/kg at 1500h into long-term ovariectomized (OVX) rats treated with oestradiol benzoate (OB) followed by another injection of OB. Long-term OVX animals were injected s.c. with 20 μ g OB at 1200h on experimental day 1 and 72h later (experimental day 4) with another 20 μ g OB. Alaproclate was injected at 1500h on experimental day 4. Blood samples were removed from conscious animals by way of an intra-atrial cannula inserted between 0900h - 1200h on experimental day 1.

Open bar = control group, injected with saline (n = 6)
 Closed bar = experimental group, injected with alaproclate (n = 6).

FIGURE 4-8 Mean (\pm S.E.M.) concentrations of luteinizing hormone (LH) in peripheral plasma at various times after an i.v. injection of 30mg alaproclate/kg at 1500h into long-term ovariectomized (OVX) rats treated with oestradiol benzoate (OB) followed by another injection of OB. Long-term OVX animals were injected s.c. with 20 μ g OB at 1200h on experimental day 1 and 72h later (experimental day 4) with another 20 μ g OB. Alaproclate was injected at 1500h on experimental day 4. Blood samples were removed from conscious animals by way of an intra-atrial cannula inserted between 0900h - 1200h on experimental day 1.

Open bar = control group, injected with saline (n = 6)
Closed bar = experimental group, injected with alaproclate (n = 6).

*p < 0.02; level of significance of difference between animals injected with alaproclate at 1500h compared with animals injected with saline at 1500h.

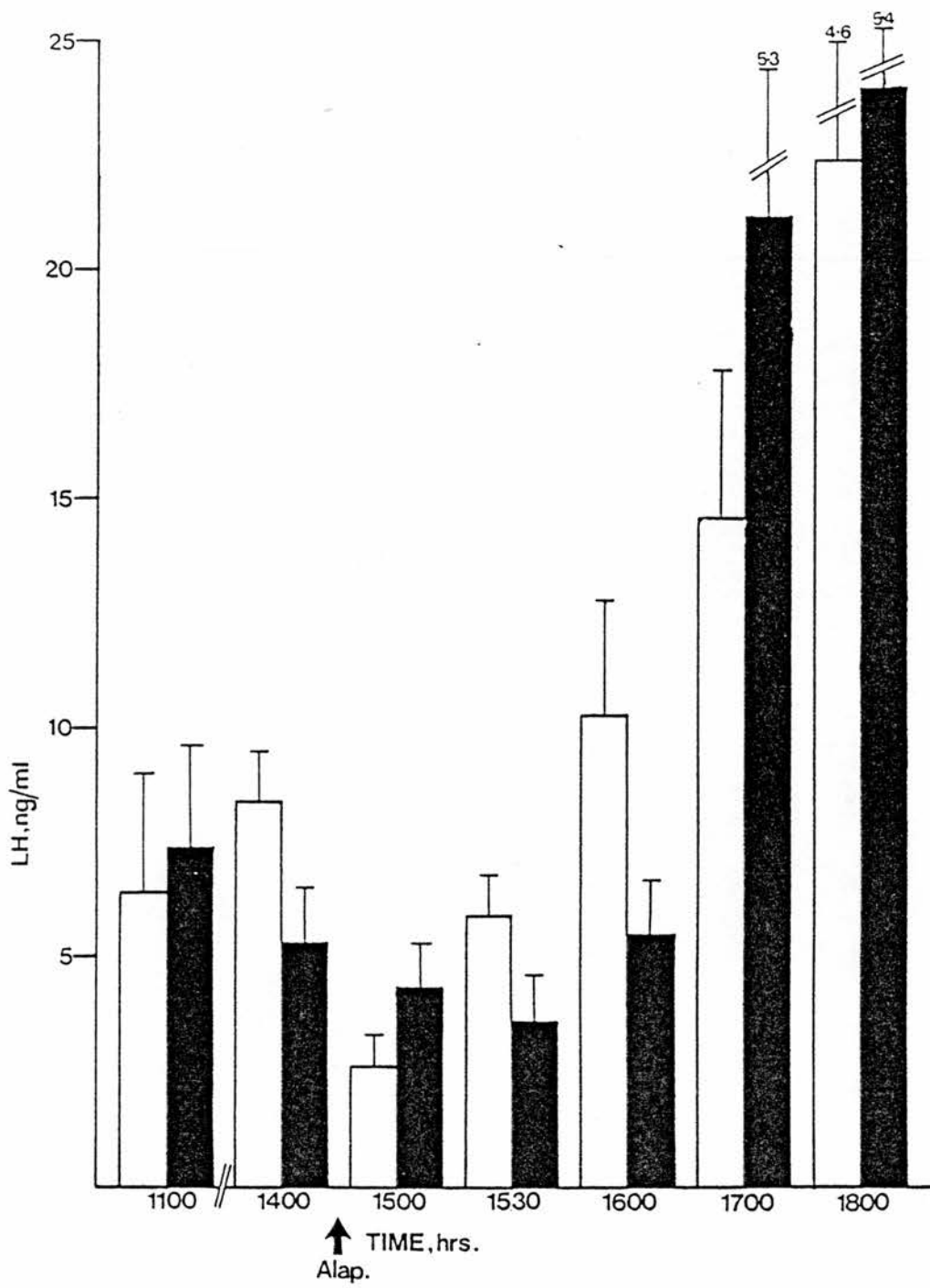

of OB for 4 days, there was a persistent significant decrease ($p < 0.01$) in the concentration of PRL in plasma compared with concentrations in rats that had been injected with saline at 1500h (Fig. 4-9). There was no significant difference in the concentration of LH in plasma from rats that had been injected with alaproclate compared with animals that had been injected with saline (Fig. 4-10).

4.3.6 Effect of zimelidine on plasma luteinizing hormone and prolactin concentrations in the pro-oestrous rat and in models 1 and 2

Zimelidine, injected i.v. at a dose of 20mg/kg at 1500h did not cause any significant changes in the plasma concentrations of either LH or PRL in either the pro-oestrous rat or experimental models 1 and 2 (Figs. 4-11 to 4-16). There was a trend towards a decreased plasma PRL concentration in model 2 after zimelidine treatment (Fig. 4-15), but this was not significant.

4.4 DISCUSSION

The question as to whether 5-HT has a physiological role in the control of the release of LH and PRL from the anterior pituitary gland remains unanswered despite many years of intensive study (Weiner and Ganong, 1978). Difficulties in interpretation of results have arisen due to the large number of different animal models studied (Fink, 1979), wide variation in the doses of 5-HT and its precursors administered and the use of drugs which were thought to act specifically on 5-HT systems but which on further study have been found to have mixed actions (Douglas, 1975; Lamberts and Macleod, 1978; Krulich, McCann and Mayfield, 1981).

FIGURE 4-9 Mean (\pm S.E.M.) concentrations of prolactin in peripheral plasma at various times after an i.v. injection of 30mg alaproclate/kg at 1500h, into long-term ovariectomized (OVX) rats treated with multiple injections of oestradiol benzoate (OB). Long-term OVX animals were injected daily with 20 μ g OB s.c. at 1200h for 4 days. Alaproclate was injected at 1500h on the 4th day of injection of OB. Blood samples were removed from conscious animals by way of an intra-atrial cannula inserted between 0900-1200h on the first day of OB treatment.

Open bar = control group, animals injected with saline (n = 6)

Closed bar = experimental group, animals injected with alaproclate (n = 6)

*p < 0.05, **p < 0.01; levels of significance of difference between animals injected with alaproclate at 1500h compared with animals injected with saline at 1500h.

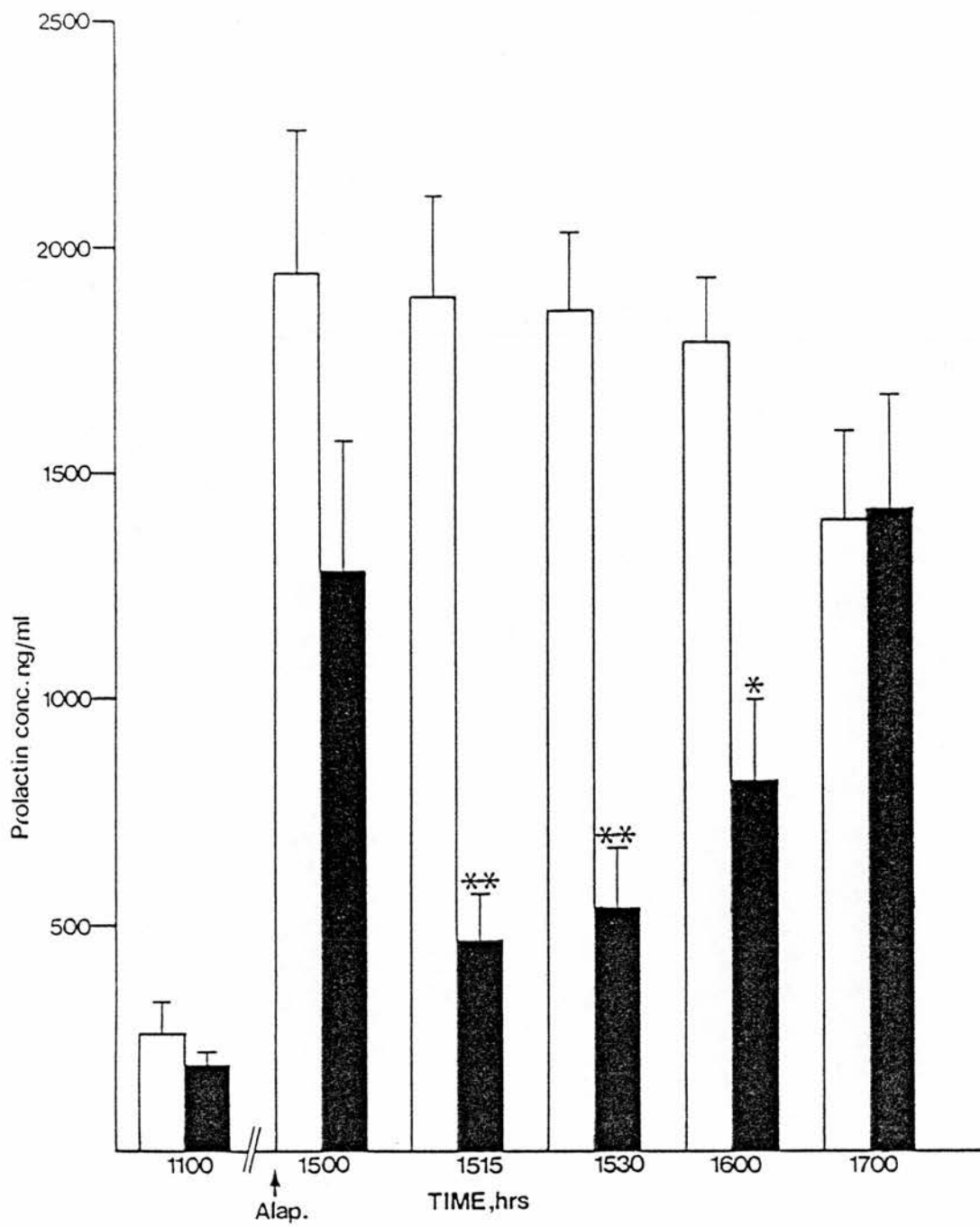

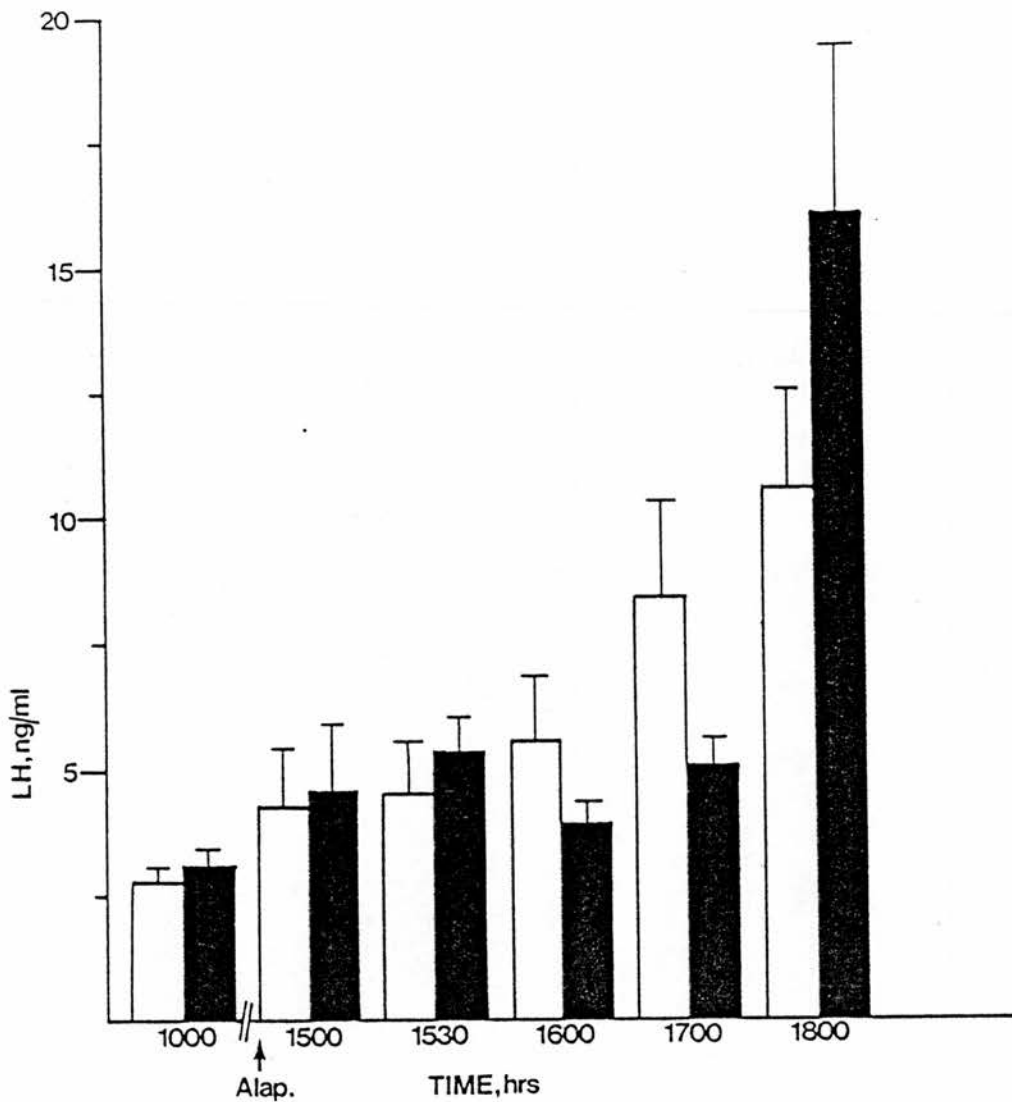

FIGURE 4-10 Mean (\pm S.E.M.) concentrations of luteinizing hormone (LH) in peripheral plasma at various times after an i.v. injection of 30mg alaproclate/kg at 1500h, into long-term ovariectomized (OVX) rats treated with multiple injections of oestradiol benzoate (OB). Long-term OVX animals were injected daily with 20 μ g OB s.c. at 1200h for 4 days. Alaproclate was injected at 1500h on the 4th day of injection of OB. Blood samples were removed from conscious animals by way of an intra-atrial cannula inserted between 0900-1200h on the first day of OB treatment. Open bar = control group, animals injected with saline (n = 6)
 Closed bar = experimental group, animals injected with alaproclate (n = 6)

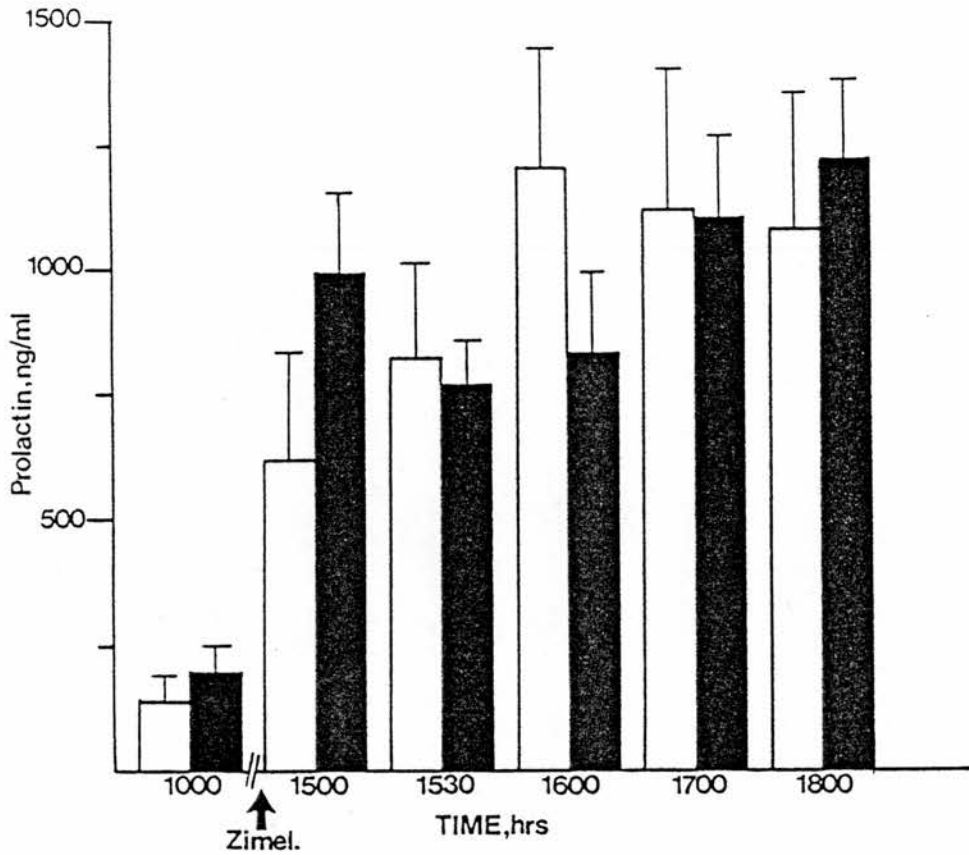

FIGURE 4-11 Mean (\pm S.E.M.) concentrations of prolactin in peripheral plasma from pro-oestrous female rats at various times after an i.v. injection of 20mg zimelidine/kg at 1500h. Blood samples were removed from conscious animals by way of an intra-atrial cannula inserted between 0630-0830h on the morning of pro-oestrus.
 Open bar = control group, injected with saline (n = 6)
 Closed bar = experimental group, injected with zimelidine (n = 6)

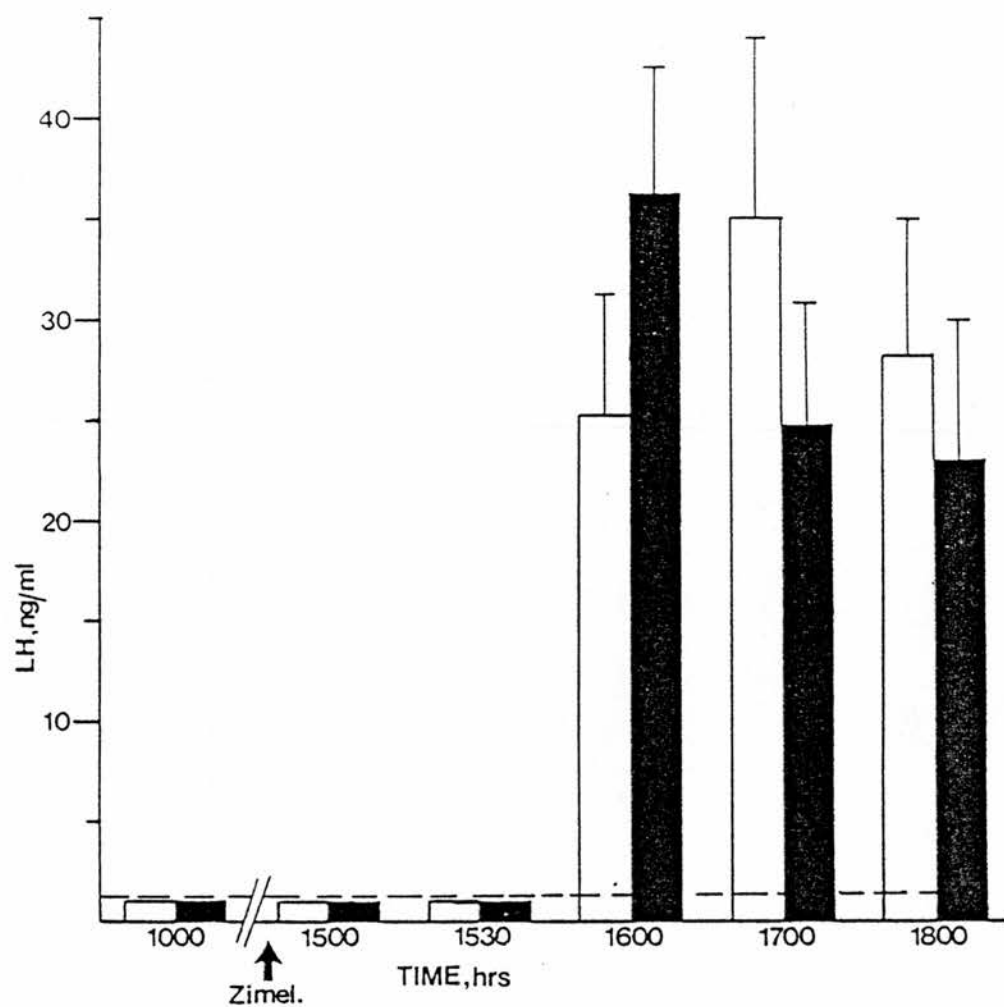

FIGURE 4-12 Mean (\pm S.E.M.) concentrations of luteinizing hormone (LH) in peripheral plasma from pro-oestrous female rats at various times after an i.v. injection of 20mg zimelidine/kg at 1500h. Blood samples were removed from conscious animals by way of an intra-atrial cannula inserted between 0630-0830h on the morning of pro-oestrus.
 Open bar = control group, injected with saline (n = 6)
 Closed bar = experimental group, injected with zimelidine (n = 6)

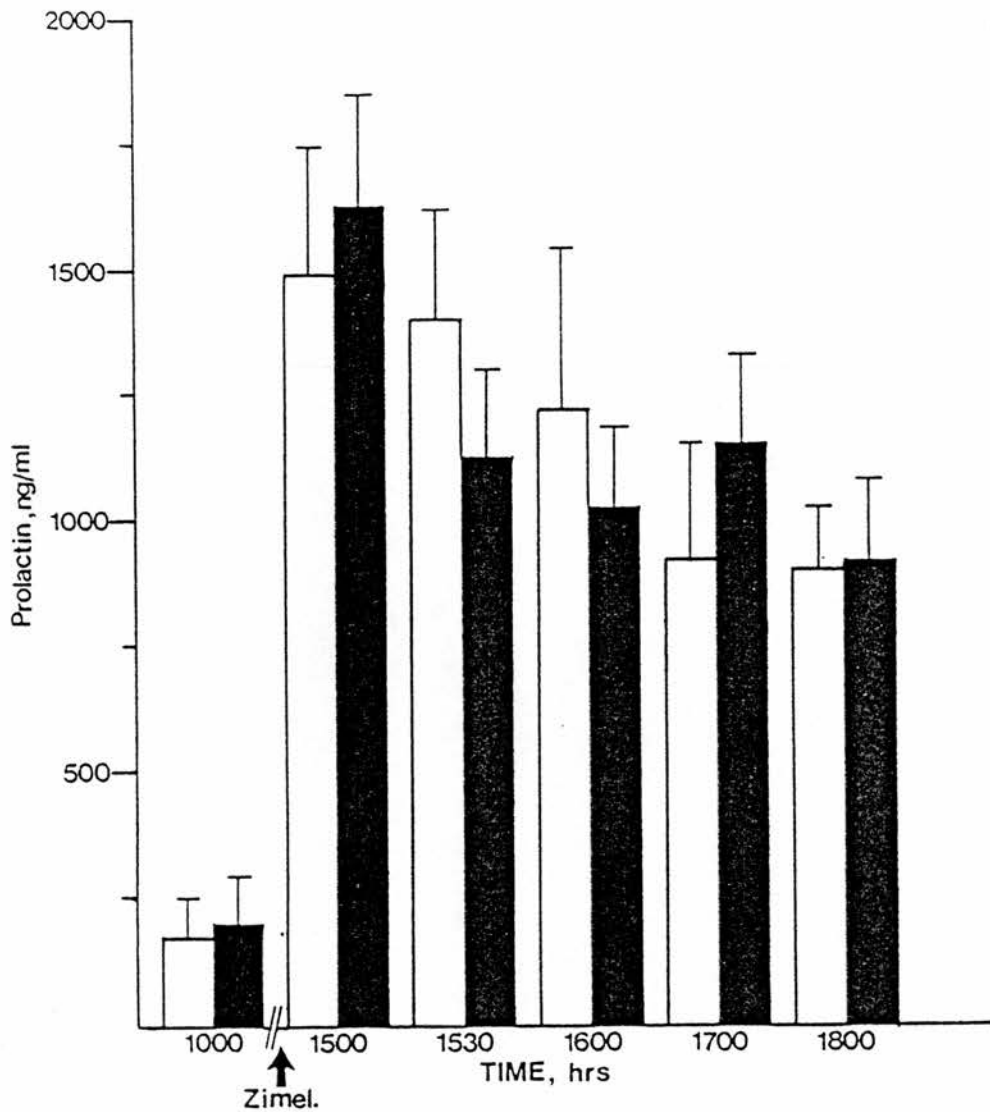

FIGURE 4-13 Mean (\pm S.E.M.) concentrations of prolactin in peripheral plasma at various times after an i.v. injection of 20mg zimelidine/kg at 1500h into short-term ovariectomized rats treated with oestradiol benzoate (OB) and progesterone (P). Animals were injected s.c. with 20 μ g OB at 1200h on the day of ovariectomy (dioestrus) and with 2mg P 24h later (presumptive pro-oestrus). Zimelidine was injected at 1500h on presumptive pro-oestrus. Blood samples were removed from conscious animals by way of an intra-atrial cannula inserted at the time of ovariectomy (0630-0900h on dioestrus).
 Open bar = control group, injected with saline (n = 6)
 Closed bar = experimental group, injected with zimelidine (n = 6)

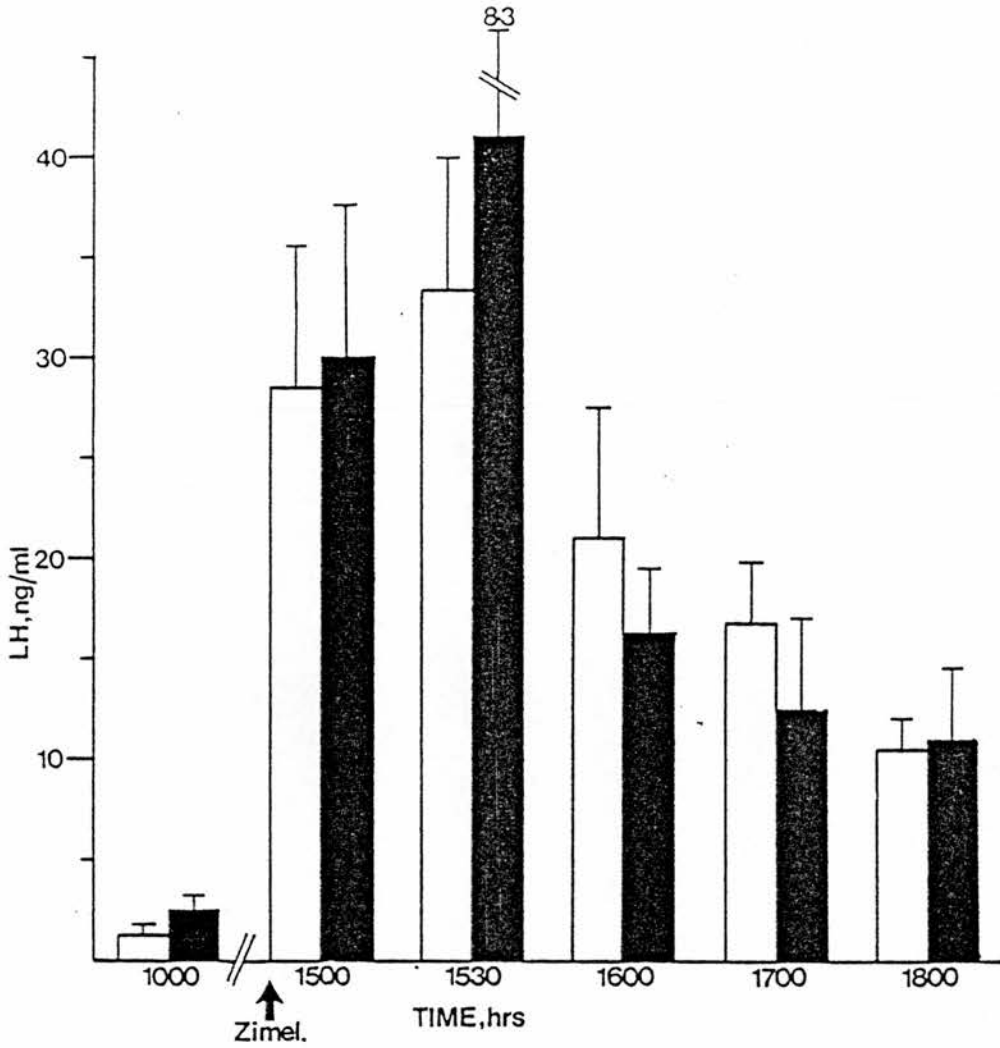
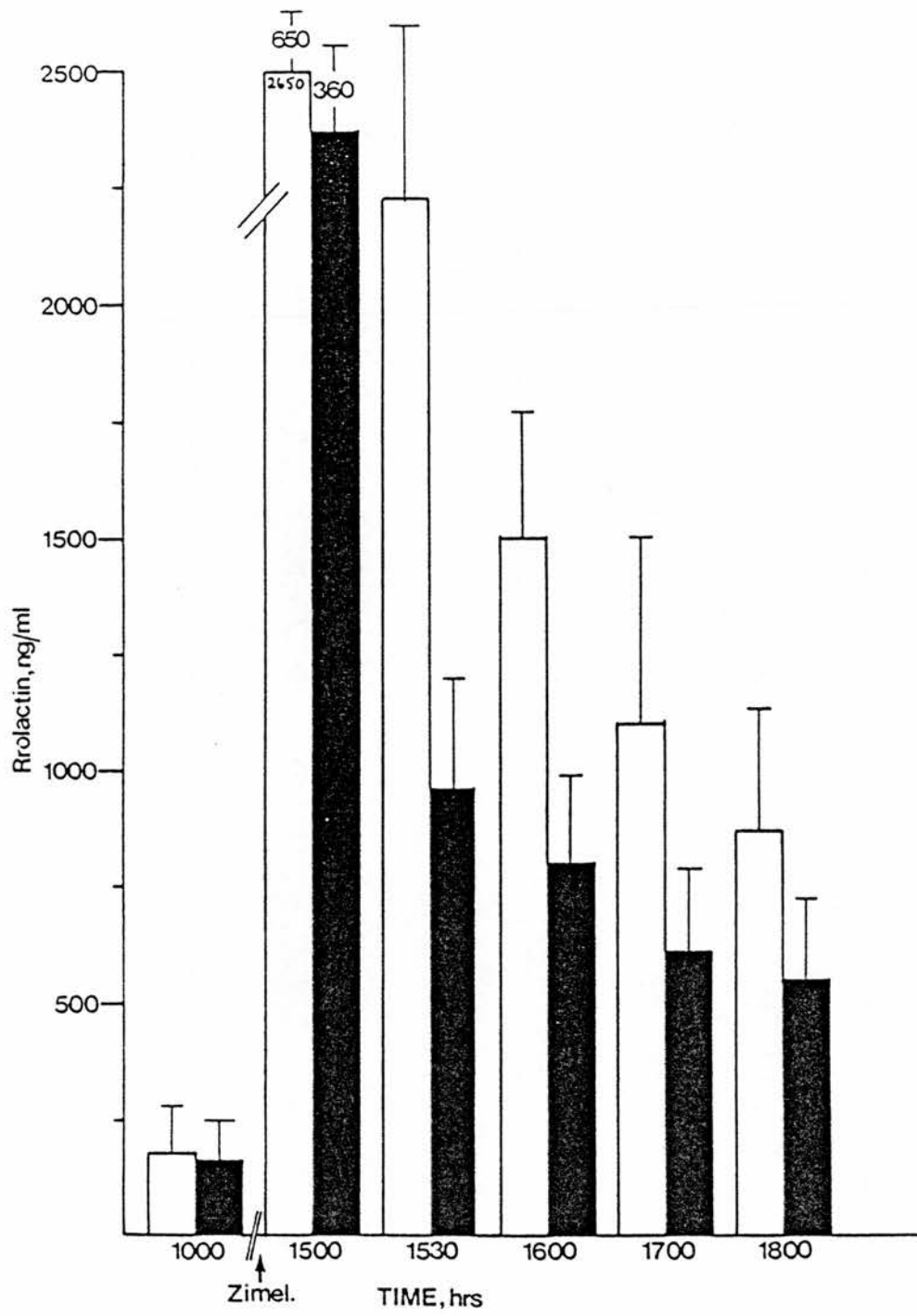

FIGURE 4-14 Mean (\pm S.E.M.) concentrations of luteinizing hormone (LH) in peripheral plasma at various times after an i.v. injection of 20mg zimelidine/kg at 1500h into short-term ovariectomized rats treated with oestradiol benzoate (OB) and progesterone (P). Animals were injected s.c. with 20 μ g OB at 1200h on the day of ovariectomy (dioestrus) and with 2mg P 24h later (presumptive pro-oestrus). Zimelidine was injected at 1500h on presumptive pro-oestrus. Blood samples were removed from conscious animals by way of an intra-atrial cannula inserted at the time of ovariectomy (0630-0900h on dioestrus).
 Open bar = control group, injected with saline (n = 6)
 Closed bar = experimental group, injected with zimelidine (n = 6)

FIGURE 4-15 Mean (\pm S.E.M.) concentrations of prolactin in peripheral plasma at various times after an i.v. injection of 20mg zimelidine/kg at 1500h into long-term ovariectomized (OVX) rats treated with oestradiol benzoate (OB) and progesterone (P). Long-term OVX animals were injected s.c. with 20 μ g OB at 1200h on experimental day 1 and 72h later (experimental day 4) with 2mg P. Zimelidine was injected at 1500h on experimental day 4. Blood samples were removed from conscious animals by way of an intra-atrial cannula inserted between 0900h - 1200h on experimental day 1. Open bar = control group, injected with saline (n = 6) Closed bar = experimental group, injected with zimelidine (n = 6).



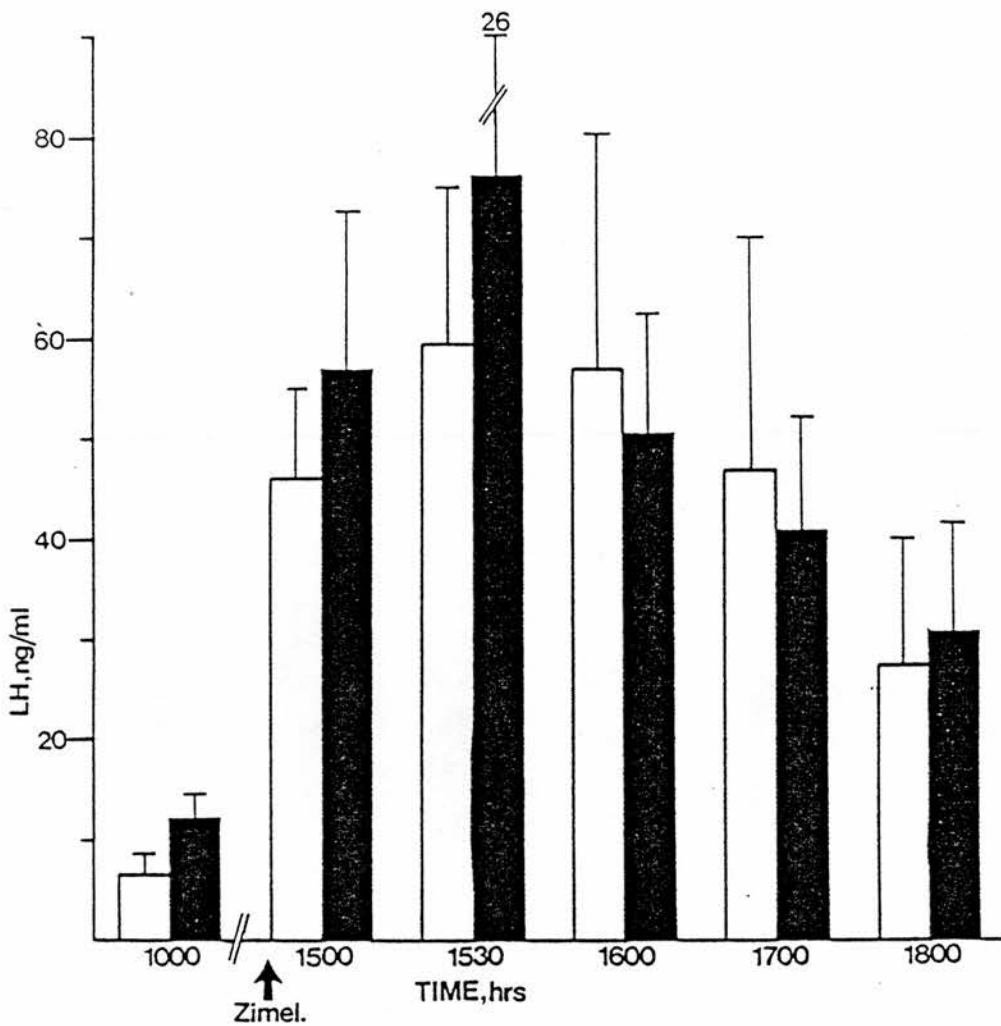

FIGURE 4-16 Mean (\pm S.E.M.) concentrations of luteinizing hormone (LH) in peripheral plasma at various times after an i.v. injection of 20mg zimelidine/kg at 1500h into long-term ovariectomized (OVX) rats treated with oestradiol benzoate (OB) and progesterone (P). Long-term OVX animals were injected s.c. with 20 μ g OB at 1200h on experimental day 1 and 72h later (experimental day 4) with 2mg P. Zimelidine was injected at 1500h on experimental day 4. Blood samples were removed from conscious animals by way of an intra-atrial cannula inserted between 0900h - 1200h on experimental day 1. Open bar = control group, injected with saline (n = 6) Closed bar = experimental group, injected with zimelidine (n = 6).

The present studies investigated the effect of two reportedly specific inhibitors of 5-HT uptake, alaproclate and zimelidine (Ross and Renyi, 1975a,b; Ross et al., 1976) on the concentrations of LH and PRL in peripheral plasma in a number of different animal models. It is known, particularly for LH, that the mechanisms governing the concentrations of both of these hormones in peripheral plasma are likely to differ in different experimental models (Brown-Grant 1977; Henderson et al., 1977b; Fink, 1979b) and, therefore, it was of interest to determine the effect of one experimental manipulation, namely injection with an inhibitor of 5-HT uptake, on LH and PRL in a variety of animal models. It was found that alaproclate, but not zimelidine, caused short-term changes in the concentrations of both hormones, and that the changes whether an increase or a decrease, were dependent upon the steroid status of the animal (Figs. 4-1 to 4-16).

The supposition that alaproclate and zimelidine are selective inhibitors of the uptake of 5-HT was based on studies carried out by Astra in a number of in vivo and in vitro systems. Slices of hypothalamus removed from animals that had been injected in vivo with alaproclate or zimelidine, had a significantly lower accumulation of ^3H -5-HT in vitro than slices of hypothalamus from saline-injected control animals, and both drugs when added to incubation media in vitro caused a significant decrease in ^3H -5-HT uptake into hypothalamic slices from untreated animals (Ross and Renyi, 1975a,b). The effects of the two drugs on endocrine systems have not been extensively studied. Male rats, injected i.p. with doses of alaproclate ranging from 3-30mg/kg, showed increased

concentrations of LH, PRL and corticosterone in peripheral plasma 2h after injection (Astra, unpublished data). Similar effects were seen after an injection of 10mg zimelidine/kg, although the increases were apparent at 30 min after the injection (Fuxe, Ögren, Everitt, Agnati, Eneroth, Gustafsson, Jonsson, Skett and Holm, 1977).

The animal models chosen for study in the present series of experiments all show prominent surges of LH and PRL in peripheral plasma as a consequence of increased peripheral concentrations of oestrogen and/or progesterone (Fink, 1979a, b). The increases in the plasma concentrations of LH are due to changes in the release of LHRH and in pituitary responsiveness to LHRH (Aiyer, Fink and Greig, 1974; Aiyer et al., 1974; Aiyer et al., 1976; Sarkar, Chiappa, Fink and Sherwood, 1976; Fink and Henderson, 1977a; Fink, 1979; Sarkar and Fink, 1979). Although the PRL surge also involves changes in the secretion of releasing and/or release-inhibiting factors and changes in pituitary responsiveness to PRFs and PIFs (Leong et al., 1983), the relative contribution of each of these components is uncertain.

4.4.1 Changes in luteinizing hormone and prolactin caused by inhibition of serotonin uptake

The initial experiments carried out on the intact pro-oestrous rat indicated that the release of PRL could be inhibited by a high dose of alaproclate (30mg/kg) injected at 1500h (a time near to the initiation of the spontaneous surges of LH and PRL in the animals used in these studies), but not at 1000h (a time proposed as a 'critical period' for the activation of the release of LH; Coen and Mackinnon, 1979), and that the release of LH was unaffected by an

injection at either 1000h or 1500h (Tables 4-1 to 4-4). These results suggest that 5-HT is not involved in the spontaneous pro-oestrous LH surge although there may be some involvement in the release of PRL.

There was a significant decrease in the concentration of LH in peripheral plasma after an i.v. injection of 30mg alaproclate/kg, in model 1 (short-term OVX rat injected with OB and P), model 2 (long-term OVX rat injected with OB and P) and in model 4 (long-term OVX rat injected daily with OB), although the decrease seen in model 4 was of a shorter duration than the decreases seen in models 1 and 2. It has been argued that the steroid status of model 1 mimics the changes in steroid concentration occurring on dioestrus and pro-oestrus and that similar mechanisms are involved in the generation of the LH surge in these two systems (Fink, 1979a,b). The results presented here are not consistent with this view, at least with respect to ^{alaproclate and it's possible} involvement with 5-HT, since alaproclate caused a decrease in the concentration of LH in peripheral plasma in model 1 (Fig. 4-4) but had no effect on the plasma LH concentration in the pro-oestrous animal.

It has been proposed that the mechanisms involved in the generation of the LH surge in models 2 and 3 are only quantitatively and not qualitatively different (Brown-Grant, 1974). The results of the present studies indicate that this may not be so since alaproclate caused a decrease in the concentration of LH in peripheral plasma only in model 2 (OB + P) and not in model 3 (OB + OB). A possible explanation for these differences may be the finding of Franks, McElhone, Young, Kraulis and Ruf (1980) that the

stimulatory effect of progesterone on LH in model 2 requires activity of 5-HT systems. Unfortunately, these workers did not investigate whether this was also true of the stimulatory effect of a second injection of oestrogen in model 3. On the basis of differences in the times at which stimulatory effects on LH can be induced by OB and P in long-term ovariectomized rats, Dyer and Mansfield (1983) have also postulated that the release of LH in these two models is indeed controlled by different mechanisms.

Injection of alaproclate in model 4 had no effect on the concentrations of LH in peripheral plasma (Fig. 4-10). It has been claimed that 5-HT is stimulatory to LH in this model (Héry et al., 1976) but this conclusion has been reached after interpretation of results from experiments involving the injection of PCPA. This drug has recently been shown to have mixed actions in vivo (Coen et al., 1983) that may include the inhibition of the synthesis of adrenaline, and it has been shown that this transmitter may be involved in the generation of the LH surge, in addition to 5-HT (Coen et al., 1983). This statement may be countered by the observation that an injection of 5-HTP can restore the LH surge (Héry et al., 1976; Coen and Mackinnon, 1979). However it has been shown that catecholamine-containing terminals can take up 5-HTP (Lichtensteiger, Muntzner and Langemann, 1967) and that 5-HTP can displace catecholamines from nerve terminals (Ng, Chase, Colburn and Copin 1972) and therefore, the restorative effects of exogenous 5-HTP, like the inhibitory effects of PCPA may not be specific for 5-HT containing neurons.

It is not possible to determine from the results of the present

studies whether the uptake blocker is acting at the hypothalamic or at the pituitary level since there was a decrease in LH concentration in peripheral plasma in models which are thought to involve different mechanisms to generate the LH surge . For example, there was a decrease in the concentration of LH in peripheral plasma in model 1 in which the LH surge is generated by increases in both the release of LHRH and in pituitary responsiveness, but there was also a decrease in model 2, in which the LH surge is due primarily to an increase in pituitary responsiveness (Fink, 1979b).

Although the results of the present studies tend to suggest that the involvement of 5-HT in the generation of the LH surge is of a minor degree, this conclusion must be reached tentatively since it has been found in previous studies that uptake blockers when injected alone have very little effect on LH release (Ruszas, Limonta and Martini, 1982) and require additional injection of 5-HTP before any effects are seen.

4.4.2 Changes in prolactin caused by inhibition of serotonin uptake

The surge of PRL occurring in these models has not been as intensively studied as the surge of LH, and where it has been examined, most workers have examined models 2 and 4. Results of the majority of reported studies are consistent with 5-HT stimulating the release of PRL (Weiner and Ganong, 1978). Injection of 30mg alaproclate/kg caused a short-term decrease in the concentration of PRL in peripheral plasma in all models studied except model 2 where PRL concentrations were sustained above those in animals injected with saline throughout the period of the experiment (Fig. 4-5). The

latter result could be interpreted to mean that 5-HT stimulates PRL release. However, on the assumption that the uptake blocker was causing an increased stimulation by 5-HT of post-synaptic neurons (Fuller, Perry and Molloy, 1974), the other results of the present studies indicate that 5-HT may be inhibiting the release of PRL. Although this is in direct opposition to the prevailing view in the literature, it would appear that previous studies should be re-examined, particularly as discussed previously, those involving the use of PCPA and 5-HTP or 5-HT (Caligaris and Taleisnik, 1974; Lawson and Gala, 1975).

Zimelidine, injected at a dose equipotent to alaproclate, did not cause any significant changes in the concentrations of LH and PRL in peripheral plasma in any of the animal models studied. This was unexpected as zimelidine, and particularly its active metabolite norzimelidine, has been found to be a more potent inhibitor of 5-HT uptake in vitro than alaproclate (Fuxe et al., 1977). However, there are indications that the potency of alaproclate ^{in some systems} may have been underestimated, since it has been shown to be more potent than zimelidine in behavioural studies (Fuxe et al., 1977). More recently, it has been reported that zimelidine had no effect on endocrine function in man (Sylvlahti, Nagy and Van Praag, 1979; Kletzky, St.Michel, Maschak and Coleman, 1983). Another possibility may be that zimelidine is not as specific as has been thought (Harms, 1983) and that the drug may have mixed actions on other systems, particularly noradrenergic and cholinergic (Astra, unpublished data), which may be in direct opposition to effects

caused by inhibition of 5-HT uptake, causing no net changes to be observed in vivo.

The results of the studies reported here, cannot be interpreted fully without some knowledge as to the concentrations of 5-HT and 5-HIAA in the brain after the injection of the uptake blocker. There is the possibility of both increased and decreased 5-HT transmission occurring after injection of such a drug (Fuller et al., 1974) and the next chapter details the changes in the concentrations of 5-HT and 5-HIAA in the brains of a few of these animal models after injection of alaproclate, in an attempt to correlate these with the observed changes in hormone concentration in peripheral plasma.

CHAPTER 5

The Effects of Inhibition of the Uptake of Serotonin
on the Concentration of Serotonin and 5-Hydroxy^yindole Acetic Acid
in the Brains of Various Animal Models

5.1 INTRODUCTION

The studies presented in Chapter 4 indicate that there may be some involvement of 5-HT in the release of LH and PRL from the anterior pituitary gland, and that the degree of involvement may depend upon the steroid status of the animal. As was stated in Chapter 4, it is difficult to interpret the results of the studies reported therein without some knowledge of the degree of possible changes in 5-HT function that could be induced by the steroid treatments or any changes that may occur subsequent to the injection of an inhibitor of 5-HT uptake.

Although studies concerning direct effects of steroids on 5-HT metabolism in vivo have yielded conflicting results (Munaro, 1978; Crowley, O'Donohue, Muth and Jacobowitz, 1979; Cone, Davis and Goy, 1981; Di Paolo, Daigle, Picard and Barden, 1983) there is suggestive evidence from in vivo and in vitro studies that there are interactions between ovarian steroids and 5-HT systems in the brain. The uptake of 5-HT in brain is increased at times coincident with the surge of LH on the afternoon of pro-oestrus (Quay, 1968; Héry et al., 1972) and this effect has been localized to the hypothalamus, particularly to the SCN (Meyer and Quay, 1976; Héry et al., 1982; Héry, Dusticier and Calas, 1982), a site in which there is a high density of 5-HT containing terminals (Saavedra et al., 1974; Descarries and Beaudet, 1978; Steinbusch, 1981) and which is thought to be important in the maintenance of circadian rhythms (Moore, 1978). The decrease in the number of 5-HT receptors in the basal forebrain on the afternoon of pro-oestrus (Biegnon et al., 1980) may depend upon an increased peripheral concentration of

oestrogen (Biegon and McEwen, 1982). Studies in vitro have shown that the accumulation of ^3H -5-HT into hypothalamic slices can be inhibited by incubation with physiologically relevant concentrations of oestrogen and progesterone (Endersby and Wilson, 1974).

The experiments reported in this chapter were therefore carried out to determine a) whether the different steroid status' of the animal models studied induced any significant changes in the concentration of 5-HT and its major metabolite, 5-HIAA, in brain, and b) whether the different animal models showed any differences in the concentrations of 5-HT and 5-HIAA in brain after injection of a 5-HT reuptake blocker at times during which changes in the concentrations of LH and PRL in peripheral plasma had been observed (Chapter 4).

Three types of animal model were studied in this series of experiments; the pro-oestrous female rat, model 1 (see Chapter 4) and model 2 (see Chapter 4). These three models were chosen since there is increasing evidence for an interaction between 5-HT and progesterone in the control of neuroendocrine function (Munaro, 1978; Franks et al., 1980; Walker, 1983; Walker and Wilson, 1983) whereas evidence for a possible interaction between oestrogen and 5-HT is as yet less convincing (Crowley et al., 1979; Cone et al., 1981).

The concentrations of 5-HT and 5-HIAA were measured simultaneously in tissue from 5-HT terminal areas, AH and PH, (Steinbusch, 1981) and an area containing 5-HT cell-bodies, R, (Steinbusch, 1981) using an HPLC-LCED system described in detail in section 2.4. The HPLC-LCED system used allowed the simultaneous

determination of the concentrations of NA, DA and DOPAC in the same samples and these are also reported.

5.2 MATERIALS AND METHODS

5.2.1 Animals and drugs

Animals used in this series of experiments were male and female Wistar cobs (180-250g) maintained as described in section 2.1. The experimental models studied are described in detail in section 4.1.2 and were:

- i) the male rat
- ii) the pro-oestrous female rat
- iii) the short term OVX female rat (2.2.9) treated with OB and P (Model 1)
- iv) the long term OVX female rat (2.2.9) treated with OB and P (Model 2)

Animals were cannulated (2.2.11) either on day 1 of the experiment (male animals and ovariectomized animals) or on the morning of pro-oestrus, and then caged individually for the duration of the experiment.

Alaproclate and zimelidine were dissolved in 0.9% saline immediately before use and injected i.v. as described in section 4.2.4. Parachlorophenylalanine was dissolved in 0.9% saline, neutralized with 5M Na_2HPO_4 , and injected i.p. in a volume of 0.4ml of buffered saline. Control animals were injected i.v. with 0.4ml buffered saline or 0.4ml 0.9% saline at times appropriate for each experiment.

5.2.2 Detection of monoamines and their metabolites

Animals were killed 30 min after injection of alaproclate or

zimidine, and brains rapidly removed and placed on ice. Anterior hypothalamus (AH) (3.10 ± 0.15 mg), ⁽ⁿ⁼²⁰⁾ posterior hypothalamus (PH) (17.70 ± 0.28 mg) and raphe nuclei (R) (17.24 ± 0.43 mg) were dissected out (2.2.5) and homogenized in 75 μ l, 150 μ l and 150 μ l of homogenization buffer (2.4.2.4) respectively. After the homogenates had been centrifuged and filtered (2.4.2.4), supernatants were kept on ice until injected into the HPLC-LCED system.

The concentrations of catechol- and indoleamines and their metabolites in the supernatants were measured using the HPLC-LCED system described in detail in section 2.4.

5.2.3 Statistics

All data are presented as mean \pm S.E.M. The significance of the difference between two means was measured using Students t-test. The significance of differences between more than two means was determined by analysis of variance and Duncan's multiple range test.

5.3 RESULTS

5.3.1 The concentrations of catecholamines and indoleamines and their metabolites in the brain of the male rat after an injection of alaproclate

When male rats were injected i.v. at 1100h with 30mg alaproclate/kg and killed 30 min later, the concentration of 5-HT was slightly increased and the concentration of 5-HIAA was slightly decreased in the three areas of brain studied (Table 5-1) but these differences were not significant when compared with control rats which had been injected i.v. with saline. The ratio of 5-HIAA/5-HT concentration was significantly decreased ($p < 0.05$) in all three areas when compared with control values (Table 5-1).

TABLE 5-1

Mean (\pm S.E.M.) concentrations (ng/mg wet wt) of serotonin (5-HT), 5-hydroxyindoleacetic acid (5-HIAA) and the 5-HIAA/5-HT ratio in anterior hypothalamus (AH), posterior hypothalamus (PH) and raphe (R) in male rats injected i.p. with saline (Sal.) or parachlorophenylalanine (PCPA) and 72h later injected i.v. with saline or alaproclate (Alap.). Animals were cannulated between 0630-0900h on the morning of the day of the i.v. injection and were killed 30 min after the i.v. injection of saline or Alap. (n = 3). (N.D. = undetectable at a lower limit of sensitivity of 15pg).

Treatment	Area	5-HT	5-HIAA	5-HIAA/5-HT
Sal. + Sal.	AH	1.18 \pm 0.24	0.33 \pm 0.03	0.30 \pm 0.04
Sal. + Alap.	AH	1.56 \pm 0.26	0.24 \pm 0.014	0.16 \pm 0.02*
Sal. + Sal.	PH	1.42 \pm 0.18	0.29 \pm 0.05	0.20 \pm 0.01
Sal. + Alap.	PH	1.43 \pm 0.03	0.20 \pm 0.017	0.14 \pm 0.01*
Sal. + Sal.	R	1.95, 1.44	0.88, 0.65	0.31, 0.33
Sal. + Alap.	R	2.60 \pm 0.12	0.64 \pm 0.04	0.26 \pm 0.01*
PCPA + Sal.	AH	N.D.**	N.D.**	-
PCPA + Alap.	AH	N.D.**	N.D.**	-
PCPA + Sal.	PH	0.14 \pm 0.01**	0.08 \pm 0.01**	0.44 \pm 0.20
PCPA + Alap.	PH	0.17 \pm 0.01**	0.06 \pm 0.01	0.48 \pm 0.20
PCPA + Sal.	R	0.39 \pm 0.02**	0.27 \pm 0.04**	0.69 \pm 0.10**
PCPA + Alap.	R	0.38 \pm 0.07**	0.27 \pm 0.02**	0.71 \pm 0.15**

* p < 0.05; level of significance of difference between animals injected with saline and then 72h later with alaproclate compared with animals injected with saline and then 72h later with another injection of saline.

**p < 0.01; level of significance of difference between animals injected 72h previously with saline compared with animals injected 72h previously with PCPA.

There were no significant differences between control animals and animals injected with alaproclate in the concentrations of NA, DA or DOPAC in any of the three areas (Table 5-2).

5.3.2 Depletion of 5-HT and 5-HIAA in the brain of the male rat after an injection of parachlorophenylalanine and the effect of a subsequent injection of alaproclate

When male rats were killed 72h after an i.p. injection of 300mg PCPA/kg there was a total depletion of 5-HT and 5-HIAA in the AH and marked reductions in the concentrations of both compounds in PH and R when compared with control rats (Table 5-1) which had been injected with buffered saline 72h previously. There was no significant difference between control animals and animals that had been injected with PCPA in the 5-HIAA/5-HT ratios in PH (Table 5-1), but there was a significant increase ($p < 0.01$) in R.

Table 5-1 shows that when male rats injected 72h previously with PCPA, were injected i.v. at 1100h (30 min before killing) with 30mg alaproclate/kg there were no significant differences in either 5-HT or 5-HIAA concentrations in PH or R compared with control animals that had been injected with PCPA and saline. There were also no significant differences in the 5-HIAA/5-HT ratios in PH or R in animals that had been injected with PCPA and alaproclate compared with the ratios either in animals that had been injected with PCPA and saline or animals that had been injected with saline alone (Table 5-1).

The concentrations of NA, DA and DOPAC in any of the three areas were not significantly different in any of the four groups of animals (Table 5-2).

TABLE 5-2

Mean (\pm S.E.M.) concentrations (ng/mg wet wt) of noradrenaline (NA), dopamine (DA) and dihydroxyphenylacetic acid (DOPAC) in anterior hypothalamus (AH), posterior hypothalamus (PH) and raphe (R) in male rats injected i.p. with either saline (Sal.) or parachlorophenylalanine (PCPA) and then 72h later injected i.v. with either saline or alaproclate (Alap.). Animals were implanted with an intra-atrial cannula on the morning of the day of the injection with alaproclate. Animals were decapitated 30 min after the injection of alaproclate. (N.D. = undetectable at a lower limit of sensitivity of 15pg).

Treatment	Brain Area	NA	DA	DOPAC
Sal. + Sal.	AH	1.53 \pm 0.10	0.42 \pm 0.03	N.D.
Sal. + Alap.	AH	1.47 \pm 0.20	0.46 \pm 0.03	N.D.
Sal. + Sal.	PH	1.89 \pm 0.08	0.74 \pm 0.05	N.D.
Sal. + Alap.	PH	1.94 \pm 0.04	0.65 \pm 0.03	N.D.
Sal. + Sal.	R	0.74 \pm 0.10	0.78 \pm 0.07	0.16 \pm 0.03
Sal. + Alap.	R	0.63 \pm 0.06	0.69 \pm 0.09	0.16 \pm 0.05
PCPA + Sal.	AH	1.60 \pm 0.13	0.53 \pm 0.05	N.D.
PCPA + Alap.	AH	1.66 \pm 0.08	0.51 \pm 0.06	N.D.
PCPA + Sal.	PH	2.34 \pm 0.13	0.87 \pm 0.04	N.D.
PCPA + Alap.	PH	2.63 \pm 0.22	0.78 \pm 0.02	N.D.
PCPA + Sal.	R	0.80 \pm 0.03	0.80 \pm 0.06	0.15 \pm 0.005
PCPA + Alap.	R	0.72 \pm 0.02	0.78 \pm 0.04	0.16 \pm 0.03

5.3.3 The effect of alaproclate on the concentrations of catecholamines and indoleamines and their metabolites in the brains of various animal models

i) The pro-oestrous female rat

An i.v. injection of 30mg alaproclate/kg at 1500h on the afternoon of pro-oestrus caused a small increase in the mean concentration of 5-HT in PH and R, a small decrease in ^{mean} 5-HT concentration in AH and a small decrease in the concentration of 5-HIAA in all three areas 30 min later (Table 5-3). These differences were not significant when compared with control animals in pro-oestrus that had been injected with saline. The 5-HIAA/5-HT ratio was significantly decreased ($p < 0.01$) compared with control animals in PH and R (Table 5-3).

There were no significant differences in the concentrations of NA, DA or DOPAC in any of the three areas (Table 5-4) between control animals and animals that had been injected with alaproclate.

ii) The short term ovariectomized female rat treated with oestradiol benzoate and progesterone (model 1)

Table 5-5 shows that when short term ovariectomized female rats (model 1) treated with OB and P were injected i.v. with 30mg alaproclate/kg at 1500h on experimental day 2, the concentration of 5-HT was slightly decreased in AH and slightly increased in PH and R, and the concentration of 5-HIAA was slightly decreased in all three areas, but these differences were not significant when compared with the values in rats that had been injected i.v. with saline. There were significant decreases ($p < 0.01$) in the 5-HIAA/5-HT ratios in PH and R in animals injected with alaproclate

TABLE 5-3

Mean (\pm S.E.M.) concentrations (ng/mg wet wt) of serotonin (5-HT) and 5-hydroxyindoleacetic acid (5-HIAA), and ratio of 5-HIAA/5-HT in anterior hypothalamus (AH), posterior hypothalamus (PH) and raphe (R), 30 min after an i.v. injection of 30mg alaproclate/kg (Alap.) or saline at 1500h on the afternoon of pro-oestrus (n = 9). Alaproclate was injected i.v. into conscious animals by way of an intra-atrial cannula inserted between 0630-0830h on the morning of pro-oestrus and animals were decapitated 30 min after injection of alaproclate.

Treatment	Brain Area	5-HT	5-HIAA	5-HIAA/5-HT
Saline	AH	1.77 \pm 0.22	0.45 \pm 0.04	0.27 \pm 0.02
Alap.	AH	1.64 \pm 0.44	0.38 \pm 0.04	0.23 \pm 0.02
Saline	PH	1.64 \pm 0.09	0.29 \pm 0.02	0.18 \pm 0.01
Alap.	PH	1.79 \pm 0.18	0.24 \pm 0.03	0.13 \pm 0.01**
Saline	R	2.26 \pm 0.11	0.73 \pm 0.04	0.30 \pm 0.01
Alap.	R	2.48 \pm 0.13	0.64 \pm 0.06	0.25 \pm 0.01**

** p < 0.01; level of significance of difference between animals injected with alaproclate at 1500h compared with animals injected with saline at 1500h.

TABLE 5-4

Mean (\pm S.E.M.) concentrations (ng/mg wet wt) of noradrenaline (NA), dihydroxyphenylacetic acid (DOPAC) and dopamine (DA) in anterior hypothalamus (AH), posterior hypothalamus (PH) and raphe (R) 30 min after an i.v. injection of 30mg alaproclate/kg (Alap.) or saline at 1500h on the afternoon of pro-oestrus.

Alaproclate was injected i.v. into conscious animals by way of an intra-atrial cannula inserted between 0630-0830h on the morning of pro-oestrus and animals were decapitated 30 min after the injection of alaproclate (n = 9). (N.D. - not detectable at lower limit of sensitivity = 15pg).

Treatment	Brain Area	NA	DA	DOPAC
Saline	AH	2.62 \pm 0.31	0.56 \pm 0.09	N.D.
Alap.	AH	2.13 \pm 0.22	0.54 \pm 0.07	N.D.
Saline	PH	2.22 \pm 0.19	0.71 \pm 0.04	0.09 \pm 0.01
Alap.	PH	2.37 \pm 0.13	0.67 \pm 0.03	0.07 \pm 0.01
Saline	R	0.77 \pm 0.04	0.64 \pm 0.04	0.14 \pm 0.01
Alap.	R	0.74 \pm 0.07	0.56 \pm 0.03	0.16 \pm 0.01

TABLE 5-5

Mean (\pm S.E.M.) concentrations (ng/mg wet wt.) of serotonin (5-HT) and 5-hydroxyindoleacetic acid (5-HIAA), and the ratio of 5-HIAA/5-HT in anterior hypothalamus (AH), posterior hypothalamus (PH) and raphe (R), 30 min after an i.v. injection of 30mg alaproclate/kg (Alap.) or saline into short-term ovariectomized rats treated with oestradiol benzoate (OB) and progesterone (P) (n = 9). Animals were ovariectomized between 0630-0830h on dioestrus (day 1), injected s.c. with 20 μ g OB at 1200h on day 1 and with 2mg P at 1200h on day 2 (presumptive pro-oestrus). Alaproclate was injected i.v. into conscious animals at 1500h on day 2 by way of an intra-atrial cannula inserted on day 1, and animals were decapitated 30 min after the injection of alaproclate.

Treatment	Brain Area	5-HT	5-HIAA	5HIAA/5-HT
Saline	AH	1.86 \pm 0.36	0.45 \pm 0.09	0.27 \pm 0.03
Alap.	AH	1.70 \pm 0.12	0.42 \pm 0.04	0.22 \pm 0.02
Saline	PH	1.68 \pm 0.12	0.33 \pm 0.04	0.20 \pm 0.01
Alap.	PH	1.86 \pm 0.03	0.26 \pm 0.007	0.14 \pm 0.005**
Saline	R	2.46 \pm 0.30	0.90 \pm 0.12	0.37 \pm 0.02
Alap.	R	2.50 \pm 0.10	0.82 \pm 0.15	0.28 \pm 0.01**

** p < 0.01; level of significance of difference between animals injected with alaproclate at 1500h compared with animals injected with saline at 1500h.

TABLE 5-6

Mean (\pm S.E.M.) concentrations (ng/mg wet wt) of noradrenaline (NA), dopamine (DA) and dihydroxyphenyl acetic acid (DOPAC) in anterior hypothalamus (AH), posterior hypothalamus (PH) and raphe (R) 30 min after an i.v. injection of 30mg alaproclate/kg (Alap.) or saline into short-term ovariectomized rats treated with oestradiol benzoate (OB) and progesterone (P) (n = 9). Animals were ovariectomized between 0630-0830h on dioestrus (day 1), and injected s.c. with 20 μ g OB at 1200h on day 1 and with 2mg P at 1200h on day 2 (presumptive pro-oestrus). Alaproclate was injected i.v. into conscious animals at 1500h on day 2 by way of an intra-atrial cannula inserted on day 1, and animals were decapitated 30 min after the injection of alaproclate. (N.D. - not detectable at lower limit of sensitivity = 15pg).

Treatment	Brain Area	NA	DA	DOPAC
Saline	AH	1.61 \pm 0.22	0.37 \pm 0.06	N.D.
Alap.	AH	1.69 \pm 0.13	0.32 \pm 0.02	N.D.
Saline	PH	1.92 \pm 0.13	0.61 \pm 0.04	N.D.
Alap.	PH	1.80 \pm 0.11	0.61 \pm 0.08	N.D.
Saline	R	0.62 \pm 0.02	0.59 \pm 0.03	0.13 \pm 0.01
Alap.	R	0.55 \pm 0.02	0.55 \pm 0.03	0.16 \pm 0.02

when compared with control animals (Table 5-5). Noradrenaline, DA and DOPAC concentrations in any of the three areas were not significantly different between control animals and animals that had been injected with alaproclate (Table 5-6).

iii) The long term ovariectomized female rat treated with oestradiol benzoate and progesterone (model 2)

When long term ovariectomized rats treated with OB and P were injected i.v. with 30mg alaproclate/kg at 1500h on experimental day 4, there were small increases in 5-HT concentration in all three areas studied and a small increase in AH and small decreases in PH and R in 5-HIAA concentration (Table 5-7), but these changes were not significant when compared with control rats. The 5-HIAA/5-HT ratio was significantly decreased ($p < 0.01$) in the \mathcal{R} (Table 5-7).

There were no significant differences in NA, DA or DOPAC concentrations in any of the three areas between control animals and animals that had been injected with alaproclate (Table 5-8).

5.3.4 The effect of zimelidine on the concentrations of catecholamines and indoleamines and their metabolites in the brain of the long term ovariectomized female rat treated with oestradiol benzoate and progesterone (model 2)

Table 5-9 shows that an i.v. injection of 20mg zimelidine/kg at 1500h on experimental day 4 into long term ovariectomized rats treated with OB and P caused small increases in 5-HT concentrations and small decreases in 5-HIAA concentrations in all three areas studied, but that these differences were not significant when compared with control animals. There was no significant difference in the 5-HIAA/5-HT ratio in any of the three areas when animals

TABLE 5-7

Mean (\pm S.E.M.) concentrations (ng/mg wet wt) of serotonin (5-HT) and 5-hydroxyindoleacetic acid (5-HIAA), and the ratio of 5-HIAA/5-HT in anterior hypothalamus (AH), posterior hypothalamus (PH) and raphe (R) 30 min after an i.v. injection of 30mg alaproclate/kg (Alap.) or saline into long-term ovariectomized rats treated with oestradiol benzoate (OB) and progesterone (P) (n = 9). Long-term ovariectomized animals were injected s.c. with 20 μ g OB at 1200h on day 1 and with 2mg P 72h later on day 4. Alaproclate was injected i.v. into conscious animals by way of an intra-atrial cannula, inserted on day 1, and animals were decapitated 30 min after the injection of alaproclate.

Treatment	Brain Area	5-HT	5-HIAA	5-HIAA/5-HT
Saline	AH	1.37 \pm 0.13	0.38 \pm 0.04	0.31 \pm 0.03
Alap.	AH	1.90 \pm 0.28	0.44 \pm 0.08	0.23 \pm 0.02
Saline	PH	1.84 \pm 0.12	0.27 \pm 0.018	0.15 \pm 0.01
Alap.	PH	1.97 \pm 0.16	0.25 \pm 0.015	0.13 \pm 0.006
Saline	R	2.61 \pm 0.22	0.78 \pm 0.06	0.30 \pm 0.017
Alap.	R	2.52 \pm 0.20	0.60 \pm 0.05	0.24 \pm 0.007**

** p < 0.01; level of significance of difference between animals injected with alaproclate at 1500h compared with animals injected with saline at 1500h.

TABLE 5-8

Mean (\pm S.E.M.) concentrations (ng/mg wet wt) of noradrenaline (NA), dopamine (DA) and dihydroxyphenylacetic acid (DOPAC) in anterior hypothalamus (AH), posterior hypothalamus (PH) and raphe (R) 30 min after an i.v. injection of 30mg alaproclate/kg (Alap.) or saline into long-term ovariectomized rats treated with oestradiol benzoate (OB) and progesterone (P) (n = 9). Long-term ovariectomized animals were injected s.c. with 20 μ g OB at 1200h on day 1 and with 2mg P 72h later on day 4. Alaproclate was injected i.v. into conscious animals by way of an intra-atrial cannula, inserted on day 1, and animals were decapitated 30 min after the injection of alaproclate. (N.D. - not detectable at a lower limit of sensitivity = 15pg).

Treatment	Brain Area	NA	DA	DOPAC
Saline	AH	1.92 \pm 0.12	0.37 \pm 0.05	N.D.
Alap.	AH	1.89 \pm 0.24	0.51 \pm 0.07	N.D.
Saline	PH	1.97 \pm 0.19	0.73 \pm 0.04	N.D.
Alap.	PH	2.03 \pm 0.20	0.78 \pm 0.06	N.D.
Saline	R	0.62 \pm 0.05	0.65 \pm 0.03	0.11 \pm 0.009
Alap.	R	0.53 \pm 0.05	0.60 \pm 0.015	0.11 \pm 0.01

TABLE 5-9

Mean (\pm S.E.M.) concentrations (ng/mg wet wt) of serotonin (5-HT) and 5-hydroxyindoleacetic acid (5-HIAA) and the ratio of 5-HIAA/5-HT in anterior hypothalamus (AH), posterior hypothalamus (PH) and raphe (R) 30 min after an i.v. injection of 20mg zimelidine/kg (Zimel.) or saline into long-term ovariectomized rats treated with oestradiol benzoate (OB) and progesterone (P) (n = 9). Long-term ovariectomized animals were injected s.c. with 20 μ g OB at 1200h on day 1 and with 2mg P 72h later on day 4. Zimelidine was injected i.v. into conscious animals by way of an intra-atrial cannula, inserted on day 1, and animals were decapitated 30 min after the injection of zimelidine.

Treatment	Brain Area	5-HT	5-HIAA	5-HIAA/5-HT
Saline	AH	0.99 \pm 0.20	0.58 \pm 0.06	0.61 \pm 0.08
Zimel.	AH	1.05 \pm 0.24	0.51 \pm 0.08	0.57 \pm 0.07
Saline	PH	1.62 \pm 0.07	0.57 \pm 0.05	0.35 \pm 0.02
Zimel.	PH	1.70 \pm 0.35	0.47 \pm 0.05	0.31 \pm 0.01
Saline	R	1.92 \pm 0.12	1.09 \pm 0.10	0.58 \pm 0.06
Zimel.	R	2.11 \pm 0.20	0.92 \pm 0.08	0.44 \pm 0.04

TABLE 5-10

Mean (\pm S.E.M.) concentrations (ng/mg wet wt) of noradrenaline (NA), dopamine (DA) and dihydroxyphenylacetic acid (DOPAC) in anterior hypothalamus (AH), posterior hypothalamus (PH) and raphe (R) 30 min after an i.v. injection of 20mg zimelidine/kg (Zimel.) or saline into long-term ovariectomized rats treated with oestradiol benzoate (OB) and progesterone (P) (n = 9). Long-term ovariectomized animals were injected s.c. with 20 μ g OB at 1200h on day 1 and with 2mg P 72h later on day 4. Zimelidine was injected i.v. into conscious animals by way of an intra-atrial cannula, inserted on day 1, and animals were decapitated 30 min after the injection of zimelidine.

Treatment	Brain Area	NA	DA	DOPAC
Saline	AH	2.68 \pm 0.21	0.41 \pm 0.11	0.08 \pm 0.009
Zimel.	AH	2.31 \pm 0.22	0.44 \pm 0.09	0.09 \pm 0.004
Saline	PH	1.83 \pm 0.16	0.59 \pm 0.03	0.06 \pm 0.007
Zimel.	PH	1.84 \pm 0.15	0.65 \pm 0.05	0.08 \pm 0.008
Saline	R	0.69 \pm 0.06	0.64 \pm 0.10	0.10 \pm 0.01
Zimel.	R	0.72 \pm 0.06	0.61 \pm 0.09	0.11 \pm 0.01

injected with zimelidine were compared with control animals (Table 5-9).

The concentrations of NA, DA and DOPAC in any of the three areas were not significantly different in animals injected with zimelidine when compared with control animals (Table 5-10).

5.4 DISCUSSION

The results of the present studies showed that 30 min after the injection of an inhibitor of 5-HT uptake there were small but significant decreases in the 5-HIAA/5-HT ratio in various regions of the brain in the pro-oestrous animal, in animal model 1 and in animal model 2 (Tables 5-3, 5-5 and 5-7). The greatest changes in the concentration of LH and PRL in peripheral plasma had been seen, in most cases, 30 min after the injection (see Chapter 4).

The concentration of 5-HT measured in the three areas of brain in the present studies was comparable to that reported by Crowley et al. (1979), Cone et al. (1981) and Di Paolo et al. (1983). The concentration of 5-HIAA measured in the present studies was lower than that reported by Di Paolo et al. (1983). This difference is not due to differences in the detection systems, since both studies used HPLC-LCED, but is likely to be due to differences in dissection. Microdissection of hypothalamic and raphe nuclei, as used by Di Paolo et al. (1983), is a more precise technique than the gross dissection carried out in the present studies, since any 'dilution' of 5-HT and its metabolites by areas of brain devoid of 5-HT is avoided. In the studies cited (Crowley et al., 1979; Cone et al., 1981; Di Paolo et al., 1983), the concentration of 5-HT and 5-HIAA was much higher in brain areas containing raphe nuclei than

in hypothalamic areas and this was confirmed in the present experiments.

Although there were also significant differences between AH, PH and R in the concentrations of NA, DA and DOPAC (Tables 5-4, 5-6 and 5-8) there did not appear to be any significant differences between the three different models in the concentrations of these neurotransmitters in the three areas studied. This is perhaps not surprising since it has frequently been argued that a static measurement of neurotransmitter concentration gives very little indication concerning its functional activity or the control of its metabolism (Weiner, 1974).

It has been reported that, after blockade of 5-HT uptake in vivo, the concentration of 5-HIAA is decreased (Fuller et al., 1974; Hyttel, 1977) and this was confirmed in the experiments reported here (Tables 5-3, 5-5 and 5-7). In contrast to reports stating that there is no change in the concentration of 5-HT until some time after the injection of a reuptake blocker (Fuller et al., 1974), there was a trend towards an increase in the concentration of 5-HT in the present studies. This observation is, however, in agreement with a report by Halaris, Lovell and Freedman, (1973) which showed an increase in the concentration of 5-HT 1h after injection of an inhibitor of 5-HT uptake, followed some hours later by a decrease. Unfortunately, it was not possible to study the effect of alaproclate on the concentration of 5-HT in brain at later periods after the injection.

The changes in the concentrations of 5-HIAA and 5-HT, although not significant by themselves, accounted for significant decreases

in the ratio of 5-HIAA/5-HT. This decrease would be expected after the inhibition of 5-HT reuptake in vivo since 5-HIAA is formed intraneuronally from 5-HT which has been released and taken back up into the pre-synaptic neuron (Reinhard and Wurtman, 1977) and therefore if reuptake is blocked, the concentrations of 5-HIAA and 5-HT would fall and rise respectively and this would be reflected in a decreased 5-HIAA/5-HT ratio. It cannot be concluded from the present results whether the net change in the ratio of 5-HIAA/5-HT is due solely to the inhibition of 5-HT reuptake since there are other compensatory mechanisms which may come into effect after the inhibition of reuptake that may also cause changes in this ratio (Tozer, Neff and Brodie, 1966). There is unlikely to have been any alteration in the synthesis of 5-HT over the short time-period of the experiment through changes in tryptophan hydroxylase, since this enzyme has been shown to have a relatively long half-life (Meeks and Nett, 1972), and to be resistant to short-term changes (Kizer, Palkovits, Zivin, Brownstein, Saavedra and Kopin, 1974; Palkovits et al., 1976). There is however a possibility that a block of reuptake could have caused a decrease in neuronal firing (Sheard, Zolovick and Aghajanian, 1972; Clemens et al., 1977) by a direct pre-synaptic effect of 5-HT (Göthert and Weinheimer, 1979) and hence a decrease in the release of 5-HT and a consequential decrease in the concentration of 5-HIAA. This idea is supported by the observation that in the studies reported here, there were no significant changes in the ratio of 5-HIAA/5-HT in the anterior hypothalamic area ^{in female rats} where it has been reported that there were no changes in neuronal firing rate after injection of an inhibitor of

5-HT uptake (Clemens et al., 1977) but there were significant changes in R, where there were also changes in firing rate (Clemens et al., 1977). However, there was no significant change in the concentration of 5-HT in either of these areas. The observed decreases in the 5-HIAA/5-HT ratio could also result from an inhibition of MAO, but this is uncertain under the present circumstances as alaproclate has not been reported to inhibit MAO.

As has already been stated, there were no significant differences in the concentrations of 5-HT or 5-HIAA in the three brain regions in any of the animal models, but there were differences between the models in the areas in which there was a significant change in the ratio of 5-HIAA/5-HT (Tables 5-1-10). The most obvious difference between the three models is the absence of any change in the ratio of 5-HIAA/5-HT in the PH in model 2. ^(Table 5-7) Since this was the only model not to show a decrease in the concentration of PRL in peripheral plasma after alaproclate (Tables 5-1-10 and Fig. 4-7) and to show in fact a PRL surge sustained above the values seen in control animals, this may be a significant correlation. It is difficult to explain why there was no change seen in the ratio of 5-HIAA/5-HT in the PH in model 2 after alaproclate. If there had been no change in the 5-HIAA/5-HT ratio in R and no changes in PRL, it could be suggested that this model is resistant to alaproclate. However, PRL was raised significantly in this model at 1700h and 1800h which suggests that the neurons in this area show a delayed response to alaproclate by way of a decrease in turnover so causing the increase in PRL seen at later stages. Obviously this suggestion requires verification by measuring the ratio of 5-HIAA/5-HT at these

later times.

The AH region of the present study contains the SCN, an area of brain that has been postulated to be important in the control of the rhythmic release of LH and PRL (Dunn et al., 1980; Héry et al., 1982) and to be modulated by input from the raphe nuclei (Van de Kar and Lorens, 1979; Van de Kar and Bethea, 1982). The fact that there was no change in the 5-HIAA/5-HT ratio in AH in any ^{Female} model after alaproclate at a time at which there were changes in both PH and R suggests that neurons in this area may respond differently to alaproclate. It has recently been proposed (Long, Youngblood and Kizer, 1983) that there are regional differences in the response of 5-HT neurons in the rat CNS to drugs affecting 5-HT function.

Since the changes seen in these models were so small, the question was posed as to whether the effects of an inhibitor of 5-HT reuptake could not be better distinguished against a much smaller functional pool of 5-HT. To answer this question, male rats were first injected with PCPA, and 72h later with alaproclate. Surprisingly, while alaproclate caused small decreases in the ratio of 5-HIAA/5-HT in the normal male rat (Table 5-1), in the male rat injected with PCPA and in which the concentrations of 5-HT and 5-HIAA were severely depleted, there was no change in the ratio of 5-HIAA/5-HT (Table 5-1). This may indicate that the 'functional pool' of 5-HT (Shields and Eccleston, 1973; Morot-Gaundry, Bourgoïn and Hamon, 1981) in the animal treated with PCPA is so severely depleted that 5-HT is released at such a slow rate that any effect of a reuptake blocker is not seen.

Zimelidine, that had no effect on LH and PRL in any of the animal models tested (Chapter 4) also had no effect on the concentrations of 5-HT or 5-HIAA or the ratio of 5-HIAA/5-HT in the three brain regions in model 2. These two results suggest that although zimelidine is a potent inhibitor of the uptake of 5-HT in vitro (Ross et al., 1976) it may require prolonged exposure before any effects are observed in vivo.

The results presented in this chapter and in Chapter 4 are consistent with a possible involvement of 5-HT in the release of LH and PRL as induced by steroid hormones but do not show clearly the degree or direction of this involvement. This is also true of the published work in this area, where much confusion has been generated, particularly by the use of drugs whose specificity of action can be questioned. Indeed, Krulich et al. (1981) reached the conclusion that "because of the dual nature of the PRL-inhibiting mechanism of methysergide and metergoline (two supposed blockers of 5-HT receptors), combined possibly with other actions, the serotonin receptor blockers have limited value in studies concerning the role of the central serotonergic system in the regulation of PRL secretion". This claim is probably also applicable to many other drugs used in the study of 5-HT function and so results of pharmacological studies must be accepted with some caution.

Due to uncertainty regarding the effect of alaproclate on systems other than 5-HT, it must be emphasised that the results reported in Chapters 4 and 5 may be due to other actions of alaproclate on neurotransmitter systems which were not measured.

CHAPTER 6

The Effects of Inhibition of the Synthesis of Serotonin
on the Concentration of Luteinizing Hormone and Prolactin
in Plasma in the Pro-oestrous Rat

6.1 INTRODUCTION

The injection of animals with PCPA, an inhibitor of tryptophan hydroxylase (Koe and Weissman, 1966) has been reported to block the LH surge and ovulation in the pro-oestrous rat and the LH surge in the long-term ovariectomized rat treated with exogenous steroids (Héry et al., 1976; Coen and Mackinnon, 1979, 1980), supposedly by way of its action to deplete 5-HT in the brain (Miller and Cox, 1970; Sloviter, Drust and Connor, 1978). However, other treatments designed to deplete 5-HT in the brain, such as i.c.v. injections of serotonin neurotoxins had no effect on the pre-ovulatory surges of LH and PRL (Wuttke et al., 1978). Paradoxically it has also been reported that increased peripheral concentrations of 5-HT, achieved by injections of either 5-HT or 5-HTP, can block ovulation, but this has been stated to be due to a peripheral vasoconstrictor action of 5-HT leading to decreased release of ovarian steroids (Wilson and Macdonald, 1974). Recent work has implied that PCPA may have mixed actions in vivo and that any effects of the drug may be due either to unspecified actions on the ovary (Al Satli and Aron, 1981) or to disruption of central or peripheral adrenergic activity (Coen et al., 1983).

In contrast to the number of studies concerned with the investigation of a possible 5-HT component of the pro-oestrous surge of LH, there is a lack of information concerning the possible involvement of this system in the surge of PRL on pro-oestrus. In particular, the effect of PCPA on this surge does not appear to have been investigated. Complementing the studies in Chapter 4 using 5-HT uptake blockers, the present study set out to determine whether

the inhibition of the LH surge seen after treatment with PCPA (Coen and Mackinnon, 1980) was accompanied by an inhibition of the PRL surge and if there was any inhibition, whether this could be due to a peripheral action of PCPA resulting in an altered secretion of oestradiol-17 β by the ovary.

6.2 MATERIALS AND METHODS

6.2.1 Animals

All animals used in this study were female Wistar cobs (180-200g) maintained as in section 2.1.

Animals were cannulated (2.2.11) under halothane anaesthesia between 0630-0900h on the morning of pro-oestrus. After recovery, animals were caged singly for the duration of the experiment.

Parachlorophenylalanine was dissolved in 0.9% saline and brought to pH 6.0 by the addition of 5M Na₂HPO₄. It was administered at a dose of 200mg/kg in 0.4ml buffered saline s.c. at 1200h on dioestrus. Control animals were injected with 0.4ml of buffered saline s.c. at 1200h of dioestrus.

Blood samples were taken as described in section 2.2.11 at times stated in each experiment.

6.2.2 Luteinizing hormone, prolactin and oestradiol-17 β measurements

Oestradiol-17 β was measured by RIA (2.3) in plasma remaining from samples after LH and PRL had been assayed. Due to the small amount of plasma left after assay for LH and PRL, all the plasma remaining in a set of samples from each animal was pooled into one aliquot and OE measured in this aliquot.

6.3 RESULTS

6.3.1 The effect of parachlorophenylalanine on prolactin concentration in peripheral plasma in the pro-oestrous female rat

Figure 6-1 shows that treatment with 200mg PCPA/kg at 1200h on dioestrus markedly reduced ($p < 0.001$) the height of the afternoon surge of PRL in the plasma of a group of pro-oestrous rats compared with that in a control group of pro-oestrous rats injected with saline. Another group of pro-oestrous rats, although also similarly treated with 200mg PCPA/kg showed surges of plasma PRL that were not significantly different from those in the control rats (Fig. 6-1).

There was no significant difference in the morning concentration of PRL in plasma in any of the three groups.

6.3.2 The effect of parachlorophenylalanine on luteinizing hormone concentration in peripheral plasma in the pro-oestrous female rat

Figure 6-2 shows that the LH surge was blocked completely in the PCPA-treated animals that had shown reduced surges of plasma PRL. Plasma LH concentrations were also markedly reduced compared with control animals in those PCPA-treated animals that had shown normal surges of plasma PRL (Fig. 6-2).

6.3.3 The effect of parachlorophenylalanine on oestradiol-17 β concentration in peripheral plasma in the pro-oestrous female rat

On the basis of whether or not animals treated with PCPA showed surge of PRL, the animals were divided into three groups. In the PCPA-treated animals not showing a PRL surge,

FIGURE 6-1 Mean (\pm S.E.M.) concentrations (ng/ml) of prolactin in peripheral plasma during the afternoon of pro-oestrus from female rats injected s.c. with either saline or 200mg parachlorophenylalanine (PCPA)/kg at 1200h on dioestrus. Blood samples were withdrawn from an intra-atrial cannula inserted between 0630-0830h on the morning of pro-oestrus.

Open bar = animals injected with saline at 1200h on dioestrus, and with peripheral oestradiol-17 β (OE) concentration > 60pg/ml plasma (n = 9).

Hatched bar = animals injected with PCPA at 1200h on dioestrus, and with peripheral OE concentration > 30pg/ml plasma but < 60pg/ml plasma (n = 4).

Cross-hatched bar = animals injected with PCPA at 1200h on dioestrus and with peripheral OE concentration < 30pg/ml plasma (n = 6).

**p < 0.01; level of significance of difference between animals injected with PCPA at 1200h on dioestrus and with peripheral OE concentration < 30pg/ml plasma compared both with animals injected with saline (OE concentration > 60pg/ml plasma) and with animals injected with PCPA (OE concentration > 30pg/ml plasma but < 60pg/ml plasma).

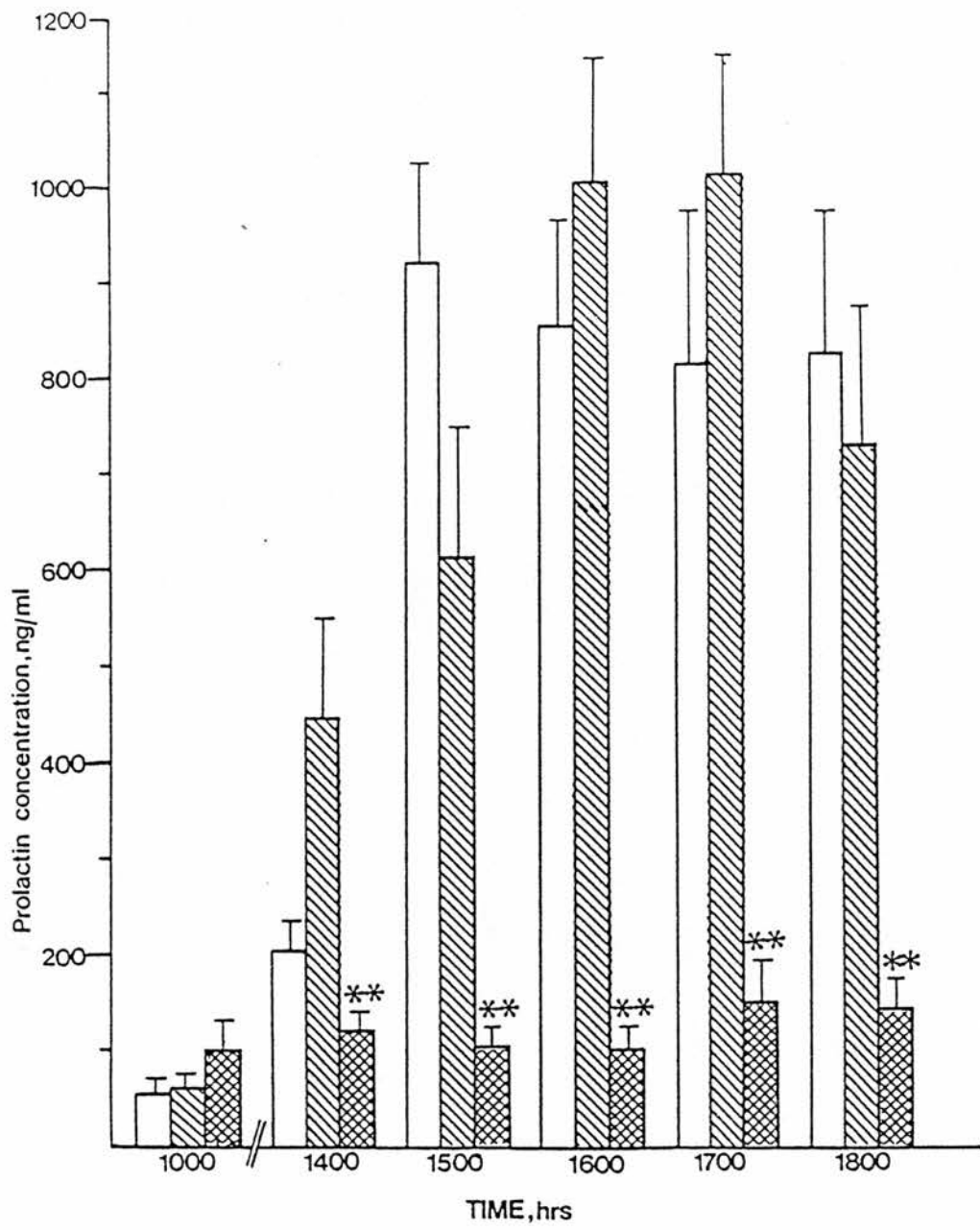

FIGURE 6-2 Mean (\pm S.E.M.) concentrations (ng/ml) of luteinizing hormone (LH) in peripheral plasma during the afternoon of pro-oestrus from female rats injected s.c. with either saline or 200mg parachlorophenylalanine (PCPA)/kg at 1200h on dioestrus. Blood samples were withdrawn from an intra-atrial cannula inserted between 0630-0830h on the morning of pro-oestrus.

Open bar = animals injected with saline at 1200h on dioestrus, and with peripheral oestradiol-17 β (OE) concentration > 60pg/ml plasma (n = 9).

Hatched bar = animals injected with PCPA at 1200h on dioestrus, and with peripheral OE concentration > 30pg/ml plasma but < 60pg/ml plasma (n = 4).

Cross-hatched bar = animals injected with PCPA at 1200h on dioestrus and with peripheral OE concentration < 30pg/ml plasma (n = 6) lower limit of sensitivity of LH radioimmunoassay.

**p < 0.01; level of significance of difference between animals injected with PCPA at 1200h on dioestrus and with peripheral OE concentration < 30pg/ml plasma compared both with animals injected with saline (OE concentration > 60pg/ml plasma) and with animals injected with PCPA (OE concentration > 30pg/ml plasma but < 60pg/ml plasma).

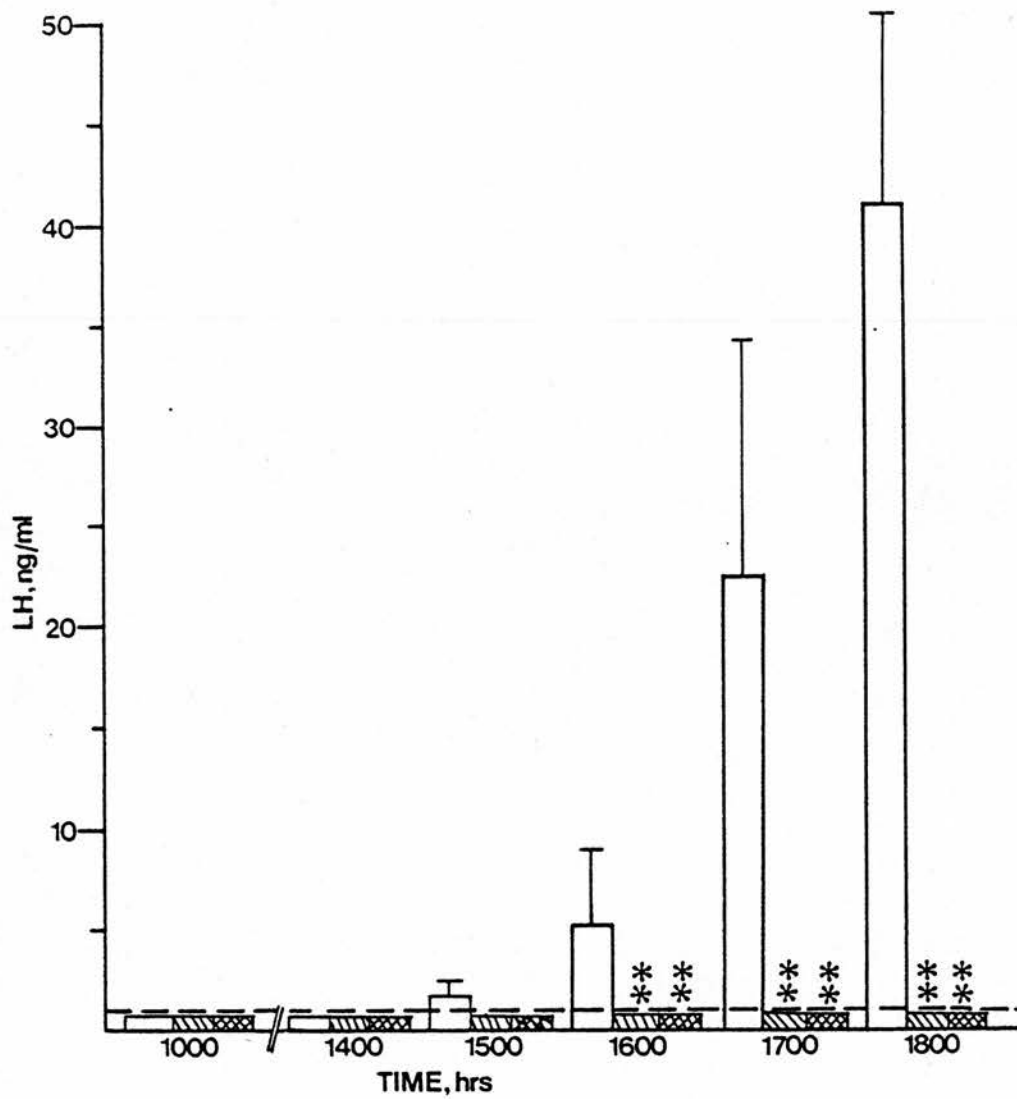

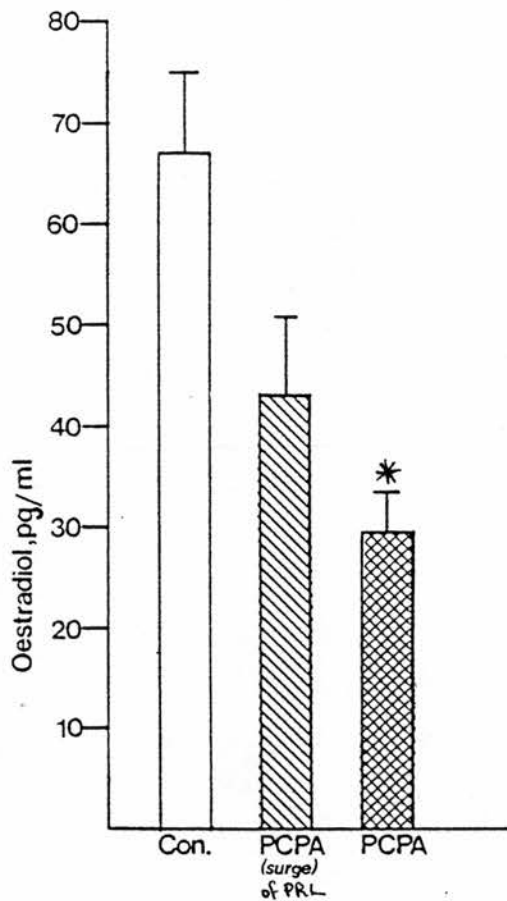

FIGURE 6-3 Mean (\pm S.E.M.) concentrations (pg/ml) of oestradiol-17 β (OE) in peripheral plasma on the afternoon of pro-oestrus from female rats injected s.c. with 200mg parachlorophenylalanine (PCPA)/kg at 1200h on dioestrus. Plasma remaining in samples after measurement of luteinizing hormone and prolactin was pooled and OE measured in these pooled aliquots for each animal.

Open bar = animals injected s.c. with saline at 1200h on dioestrus and showing surges of both LH and PRL (n = 9).

Hatched bar = animals injected s.c. with PCPA at 1200h on dioestrus and in which the LH surge but not the PRL surge was abolished (n = 4).

Cross-Hatched bar = animals injected s.c. with PCPA at 1200h on dioestrus and in which both the LH and PRL surges were abolished (n = 6).

*p < 0.02; level of significance of difference between animals injected with PCPA at 1200h on dioestrus and in which the LH and PRL surges were abolished compared with animals injected with saline.

the OE values were significantly lower ($p < 0.02$) than those in control animals. Plasma concentrations of OE in PCPA-treated animals which did show a PRL surge fell in between the values of the control group and the values in the PCPA-treated animals that did not show a PRL surge. There was a significant correlation ($r = 0.70$, $p < 0.01$) between the peak concentration of PRL and the concentration of OE in peripheral plasma (Figs. 6-1 and 6-3).

6.4 DISCUSSION

In the present study, and in agreement with other workers (Coen and Mackinnon, 1980) it was found that an s.c. injection of PCPA (Koe and Weissman, 1966) caused a complete abolition of the pre-ovulatory surge of LH in the pro-oestrous female rat (Fig. 6-2). In addition to this finding, it was also discovered that the pre-ovulatory surge of PRL was inhibited, but not in all animals injected with PCPA (Fig. 6-1). Subsequent analysis of the concentration of OE in peripheral plasma revealed that the concentrations of OE in animals in which the surge of PRL was abolished by PCPA, were significantly lower (Fig. 6-3) than those in animals injected with buffered saline which showed a marked surge of PRL.

This study reveals two new findings. Firstly, the pre-ovulatory surge of PRL in peripheral plasma, like the pre-ovulatory LH surge can be abolished by a s.c. injection of PCPA. It cannot be stated from the present studies whether this is due solely to a depletion of 5-HT in the brain since the concentration of 5-HT in brain after the PCPA injection was not measured in this study. However, there was likely to have been a significant reduction (Chapter 5). There

was a significant decrease in the concentration of OE in peripheral plasma from animals in which the PRL surge was absent, which may have been due to peripheral effects of PCPA, and this indirect effect may have resulted in the abolition of the surges of both LH and PRL. It has been claimed that the effects of PCPA on the ovary that lead to decreased peripheral concentrations of OE can be avoided by administering the drug s.c. rather than i.p. (Coen and Mackinnon, 1980), but the present study shows that these effects are still present after an s.c. injection. It has been found that rats exhibit massive abdominal lesions^{*} after both i.p. and s.c. injections of PCPA (Watts, A.G. personal communication).

The concentration of P in peripheral plasma was not measured in the present study, but it is likely that this was affected by the injection of PCPA since some animals that had been injected with PCPA but were not included in the hormonal study, showed vaginal indications of pseudopregnancy after the injection of PCPA, indicating that a disruption of ovarian activity had occurred. It has been reported that PCPA can induce pseudopregnancy (Gonzalez-Baron, Jimenez-Vargas and Marco, 1975), and in the study of Coen and Mackinnon (1980) one animal that had been injected i.p. with PCPA on dioestrus showed an increased peripheral concentration of P 12h later, consistent with the induction of pseudopregnancy.

The second main finding of this study was the presence of a difference in the threshold of the peripheral concentration of OE required for expression of the surges of LH and PRL in the intact pro-oestrous animal. In animals in which the concentration of OE in peripheral plasma was < 30pg/ml both the LH and the PRL surges

*The gut wall of these animals showed gross oedema and haemorrhage.

were abolished. However, in animals in which the concentration of OE was > 35pg/ml, but < 60pg/ml only the LH and not the PRL surge was abolished. Animals injected with buffered saline had OE concentrations > 60pg/ml and exhibited surges of both LH and PRL. Although it has been reported in the ovariectomized animal that there is a threshold concentration of OE which must be reached before LH secretion is increased (Henderson et al., 1977a; Krey and Parsons, 1982), and that this threshold may be higher than that required for the induction of the release of PRL (Caligaris et al., 1971; Caligaris et al., 1974) there does not appear to be any indication in the literature that this is also true of the intact pro-oestrous animal.

The present results indicate that PCPA has severe effects on peripheral organs, and the results of these effects may be misinterpreted as being due to an inhibition of 5-HT transmission in the CNS. As has been discussed previously, the drastic and mixed actions of this compound (Coen et al., 1983) indicate that experimental studies involving its use should be interpreted with caution.

CHAPTER 7

The Effects of an Injection of Anti-TRH Serum on the Concentration
of Prolactin in Plasma in the Pro-oestrous Rat

7.1 INTRODUCTION

The release of PRL from the anterior pituitary gland is thought to be controlled by many different factors under different physiological conditions (MacLeod, 1976; Vale et al., 1980; Leong et al., 1983). A bewildering array of substances have been reported to cause release of PRL from the anterior pituitary gland by a direct action on the gland itself, including TRH (Tashjian et al., 1971), 5-HT (Wehrenberg et al., 1980), oestradiol (Zyzek et al., 1981), LHRH (Denef, 1981), VP (Shin, 1982), somatostatin (Vale et al., 1974) vasoactive intestinal polypeptide (Ruberg, Rotsztein, Arancibia, Besson and Enjalbert, 1978) and numerous other neuropeptides and neurotransmitters (Lien, Fenichel, Garsky, Sarantakis and Grant, 1976; Grandison and Guidotti, 1977; Vijayan and McCann, 1979; Malarkey, O'Dorisio, Kennedy and Cataland, 1981).

Thyrotrophin-releasing hormone, besides its role in the regulation of TSH secretion, has been shown to release PRL from the anterior pituitary gland in a number of species (Jacobs, Snyder, Wilber, Utiger, Utiger and Daughaday, 1971; Fell, Findlay, Cumming and Goding, 1973; Kelly, Bedirian, Baker and Friesen, 1973) under circumstances in which TSH release is unchanged (Gautvik, Tashjian, Kourides, Weintraub, Graeber, Maloof, Suzuki, Zuckerman, 1974) but its role in PRL secretion in the rat is controversial. While there is some evidence for the involvement of TRH in the suckling-induced rise in plasma PRL in the rat (Blake, 1974; de Greef and Visser, 1981; Fink, Koch and Ben Aroya, 1983) its role in the release of PRL under other conditions is not clear. It has been reported that TRH can release PRL in a number of experimental models (Mueller,

Chen and Meites, 1973; D'Angelo, Wall, Bowers and Rosa, 1975; Lawson, Gala, Chin and Haislender, 1980) and that the concentration of TRH in hypophysial plasma is increased on the afternoon of pro-oestrus (Fink et al., 1983), a time at which the concentration of PRL, but not of TSH, in peripheral plasma is increased (Smith, Freeman and Neill, 1975; Fukuda, Greer, Roberts, Allen, Critchlow and Wilson, 1975). It has been claimed that differences in the response of TSH and PRL to TRH may be due to differences in the responsiveness of mammotrophs and thyrotrophs (DeLéan et al., 1977; Leong et al., 1983). However, the changes in pituitary responsiveness to TRH do not appear to be mediated by TRH itself (De Léan et al., 1977; Pickering and Fink, 1979). Thyrotrophin releasing hormone can release PRL from rat pituitary tumour cells in vitro (Tashjian et al., 1971) but appears to have rather a minor effect on PRL release from normal rat pituitary cells both in vitro and in vivo (Lu, Shaar, Kortright and Meites, 1972; Vale, Blackwell, Grant and Guillemin, 1973; Hill-Samli and MacLeod, 1974; Rivier and Vale, 1974).

In the study reported here, the technique of passive immunization (injection of an animal with antiserum, raised in another species, against an antigen from the antiserum recipient) has been used to investigate the involvement of TRH in the PRL surge occurring on the afternoon of pro-oestrus in the female rat. This technique has been used to identify the main physiological action of various hormones including those released by the hypothalamus (Shani, Goldhaber and Sulman, 1975; Arimura, Smith and Schally, 1976; McCormack, Plant, Hess and Knobil, 1977; Robinson and

Parsons, 1981) but experiments designed using this technique to elucidate the involvement of TRH in the release of PRL into plasma have yielded contradictory results (Koch, Goldhaber, Fireman, Zor, Shani and Tal, 1977; Harris, Christianson, Smith, Fang, Braverman and Vagenakis, 1978).

7.2 MATERIALS AND METHODS

7.2.1 Animals

Animals used in these studies were female Wistar cobs, (200-300g) maintained as described in section 2.11. Only those animals that had shown at least 2 consecutive 4 day oestrous cycles were used. Animals were cannulated (2.2.11) under halothane anaesthesia between 0630-0830h on the morning of pro-oestrus, and, after recovery, were placed in individual cages for the duration of the experiment.

Experimental animals were injected i.p. with 1ml of undiluted anti-TRH serum at 1300h. Control animals were injected with 1ml of undiluted normal sheep serum (NSS) i.p. at 1300h.

Anti-TRH serum (donated by Dr. H. Fraser, MRC Reproductive Biology Unit; Edinburgh) was raised by immunizing sheep with TRH conjugated with BSA. Sheep were injected at 4 s.c. sites with 1ml of a solution containing 6mg TRH/BSA conjugate in 10ml of saline, emulsified in 16ml Freund's complete adjuvant. Booster injections were given at 3-monthly intervals (Fraser and McNeilly, 1982). The particular antiserum used in these experiments showed a sensitivity of 0.3pg/tube when used in an RIA for TRH. Specificity of the antiserum is shown in Table 7-1.

TABLE 7-1

Cross reactivity of thyrotrophin-releasing hormone (TRH) and its analogues with anti-TRH serum used in these studies.

Structure	Relative activity (%)
p-Glu-His-ProNH ₂ (TRH)	100
p-Glu-Phe-ProNH ₂	100
p-Glu-Met-ProNH ₂	1.4
p-Glu-Lys-ProNH ₂	12.5
p-Glu-Lys(BOC)-ProNH ₂	0.26
p-Glu-His-Pro-OH	< 0.005
p-Glu-Leu-Pro-OH	< 0.005
p-Glu-Ala-Pro-OH	< 0.005
p-Glu-His-Pro-propylamide	0.03
p-Glu-His-TrpNH ₂	0.05
p-Glu-His-Gly	< 0.005
H. His-ProNH ₂	0.004
Glu(BOS)-His-ProNH ₂	0.96
3Met-His-ProNH ₂	< 0.005
LHRH	< 0.005
Oxytocin	< 0.005
CRF	< 0.005
Substance P	< 0.005
β-endorphin	< 0.005

Reprinted by kind permission of Dr. H. Fraser, MRC Reproductive Biology Unit, Edinburgh.

7.2.2 Collection of blood samples and assaying of hormones

Blood samples, (0.4ml), were taken (2.2.11) using heparinized syringes, 3h and 5 min before administration of sera, and every hour after administration of sera, until 1900h. Plasma volume was maintained by replacing the volume of blood removed with an equal volume of heparinized (100IU/ml) 0.9% saline solution after each sampling.

Samples were kept on ice until centrifuged at 2500g for 20 min at 4°C. Plasma was removed and stored at -25°C until assayed for PRL, LH and thyroid stimulating hormone (TSH).

Due to the small amount of plasma left after assay for LH and PRL, TSH estimates were carried out on pooled plasma samples, designated as:

- i) Pre-treatment - plasma obtained before administration of sera:
1000h and 1255h samples pooled.
- ii) Post-treatment(1) - plasma obtained after administration of
sera: 1400h, 1500h and 1600h samples
pooled.
- iii) Post-treatment (2) - plasma obtained after administration of
sera: 1700h, 1800h and 1900h samples
pooled.

PRL, LH and TSH concentrations were all determined by double-antibody radioimmunoassay (RIA) as described in Chapter 2

7.2.3 Statistics

Concentrations of PRL, LH and TSH were expressed as mean \pm SEM. Student's t-test was used to determine significance of difference between two means. In cases where the values for LH and PRL

concentrations were below the lower limit of detection of the RIA, a value equal to the lower limit of detection of the assay was assigned and the difference between groups determined by non-parametric statistics, using either the Mann-Whitney or Kruskal Wallis tests.

7.3 RESULTS

7.3.1 Effect of anti-TRH serum on plasma concentrations of prolactin in the pro-oestrous female rat.

Administration of 1ml of anti-TRH serum at 1300h to pro-oestrous female rats caused a delay in the onset of the PRL surge. The concentrations of PRL in plasma from animals injected with anti-TRH serum at 1300h were significantly lower at 1400h and 1500h ($p < 0.01$ and $p < 0.05$, respectively) than those in pro-oestrous animals injected with 1.0ml NSS (Fig. 7-1). There was no difference in the maximum concentration of PRL.

7.3.2 Effect of anti-TRH serum on plasma concentrations of luteinizing hormone in the pro-oestrous female rat

There were no significant differences in plasma LH concentrations between the two groups of animals at any time nor was there any significant difference between the maximum concentration of plasma LH or the time at which the maximum concentration was reached (Fig. 7-2).

7.3.3 Effect of anti-TRH serum on plasma concentrations of thyroid stimulating hormone in the pro-oestrous female rat

In animals injected with anti-TRH serum, plasma TSH concentrations were significantly decreased at 1400-1600h and at 1700-1900h compared with the concentrations before the anti-TRH

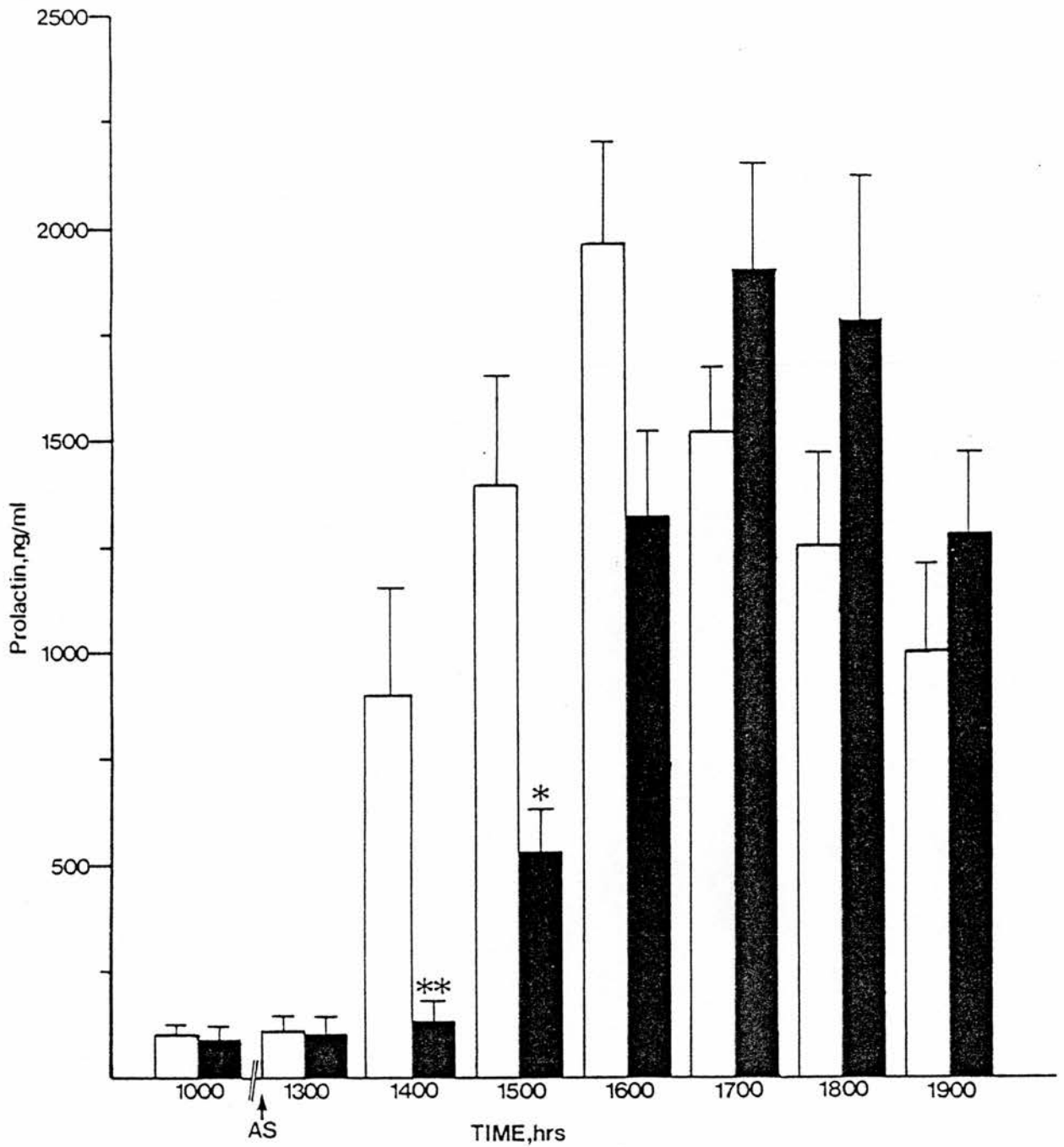

FIGURE 7-1 Mean (\pm S.E.M.) concentrations (ng/ml) of prolactin in peripheral plasma during the afternoon of pro-oestrus from animals injected i.p. either with normal sheep serum (NSS) or anti-TRH serum at 1300h on pro-oestrus. Blood samples were removed by way of an intra-atrial cannula inserted between 0630-0830h on the morning of pro-oestrus.
 Open bar = animals injected i.p. with NSS (n = 6)
 Closed bar = animals injected i.p. with anti-TRH serum (n = 6)
 (AS = antiserum)
 *p < 0.05, **p < 0.01; level of significance of difference between animals injected with anti-TRH serum at 1300h compared with animals injected with NSS at 1300h.

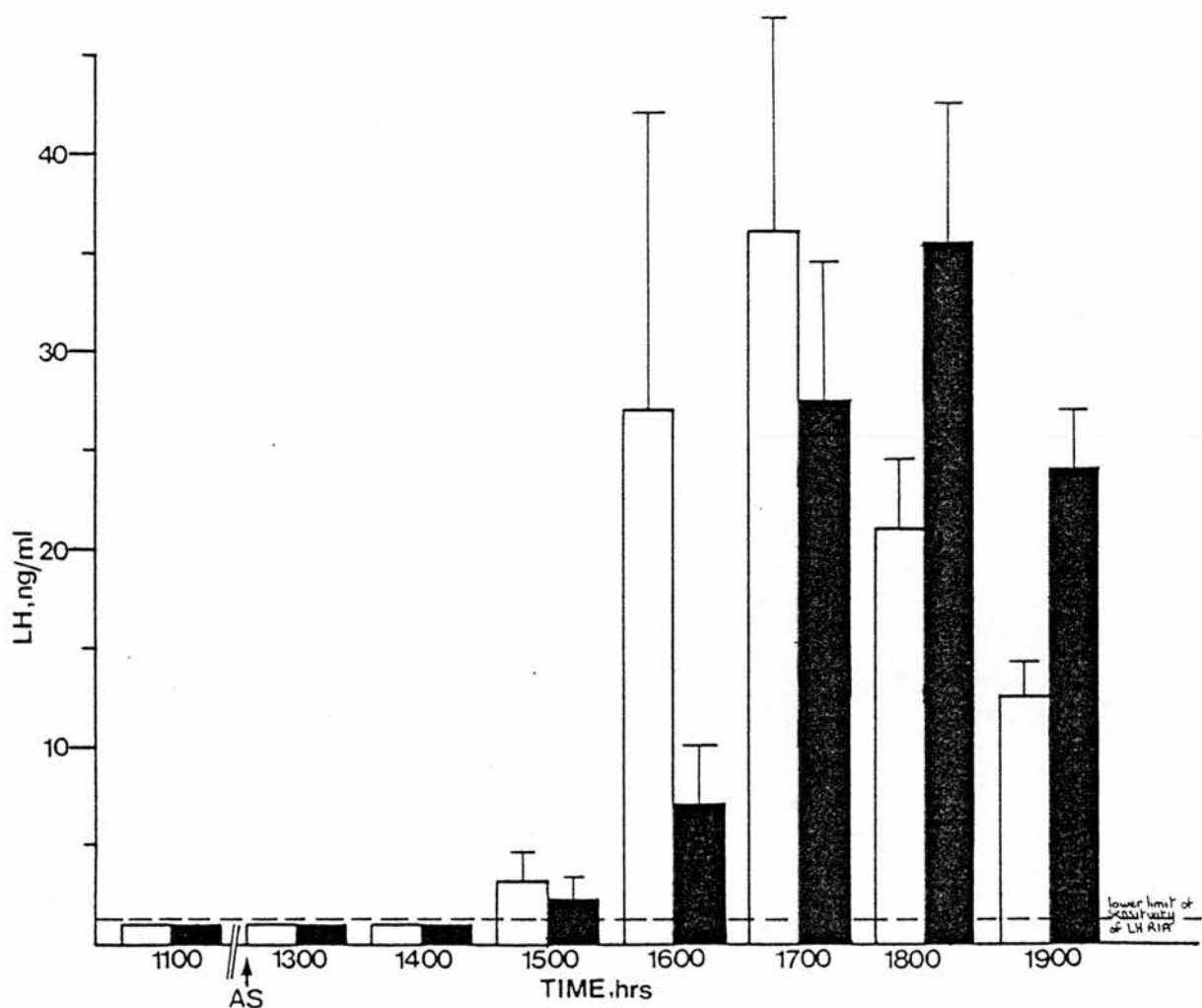

FIGURE 7-2 Mean (\pm S.E.M.) concentrations (ng/ml) of luteinizing hormone (LH) in peripheral plasma during the afternoon of pro-oestrus from animals injected i.p. either with normal sheep serum (NSS) or anti-TRH serum at 1300h on pro-oestrus. Blood samples were removed by way of an intra-atrial cannula inserted between 0630-0830h on the morning of pro-oestrus.
 Open bar = animals injected i.p. with NSS (n = 6)
 Closed bar = animals injected i.p. with anti-TRH serum (n = 6)
 (AS = antiserum)

serum was injected, and the concentrations in the plasma of animals treated with NSS (Table 7-2).

Plasma concentrations of TSH in the afternoon in animals injected with NSS were not significantly different from the values in the morning (Table 7-2).

7.4 DISCUSSION

There is considerable evidence that TRH, in addition to its role in mediating the neural control of TSH, can release PRL from the anterior pituitary gland. The results of the present study showed that an i.p. injection of anti-TRH serum at 1300h caused a delay in the onset of the PRL surge in a group of pro-oestrous rats compared with the time of onset in a group of rats injected with NSS (Fig. 7-1). The delay was manifested as a significant decrease ($p < 0.01$) in the plasma PRL concentration at 1400h and 1500h in the animals injected with anti-TRH serum compared with those injected with NSS. By 1600h, the plasma concentration of PRL in the animals injected with anti-TRH serum had reached the same value as those injected with NSS, and this was probably not due to degradation of the antiserum as the half-life in plasma is approximately 10 days. ^(Fraser and McNeilly, 1982)
Other studies carried out on concentrations of TSH and PRL in plasma after passive-immunization have yielded conflicting results. Koch et al. (1977), reported a decrease in the concentrations of both TSH and PRL at 1500h in plasma from pro-oestrous animals that had been injected i.p. with 1.0ml of an anti-TRH serum. However, in a more complete study, Harris et al. (1978), found a decrease in plasma TSH concentration, without any accompanying change in plasma PRL concentration, at 1300h, 1500h and 1700h on pro-oestrus after an

TABLE 7-2

Mean (\pm S.E.M.) concentration^(ng/ml) of thyroid stimulating hormone (TSH) after i.p. injection of normal sheep serum (NSS) or anti-TRH serum

	(n)	Pre-treatment	Post-treatment(1)	Post-treatment(2)
Anti-TRH serum	(6)	1.08 \pm 0.13(A)	0.59 \pm 0.15(B)	0.53 \pm 0.09(C)
NSS	(4)	0.91 \pm 0.30(D)	1.46 \pm 0.15(E)	1.07 \pm 0.08(F)

(A) vs (B), $0.025 < p < 0.0125$, Student's t-test

(A) vs (C), " " " "

(B) vs (E), $0.005 < p < 0.0025$ " "

(C) vs (F), $0.0025 < p < 0.0005$ " "

Pre-treatment = plasma obtained before administration of sera:
1000h and 1255h samples pooled.

Post-treatment (1) = plasma obtained after administration of sera:
1400h, 1500h and 1600h samples pooled.

Post-treatment (2) = plasma obtained after administration of sera:
1700h, 1800h and 1900h samples pooled.

i.v. injection of 0.1ml of an anti-TRH serum at 1230h. The discrepancy between the results of the present study and those of Harris et al. (1978) could be due to a number of factors. The most obvious are differences between the two antisera used. Harris et al. (1978) used a much smaller volume of antiserum (0.1ml, against 1.0ml used in the present study) which when used in a RIA had a lower limit of detection of 2pg (Vagenakis, Roti, Mannix and Braverman, 1975). The antiserum used in the study reported here showed a lower limit of detection of 0.3pg when used in a RIA (Fraser and McNeilly, 1982). The smaller volume of antiserum of lower affinity may not have been sufficient to remove all of the TRH present in hypophysial portal blood (Wilber and Porter, 1970; Eskay, Oliver, Ben-Jonathan and Porter, 1978; Fink et al., 1983) allowing enough TRH to reach the lactotrophs of the anterior pituitary gland and cause release of PRL. It is also possible that any changes occurring in PRL concentrations in plasma after the injection of anti-TRH serum in the study of Harris et al. (1978) were not seen due to infrequent sampling of blood. Prolactin secretion has been shown to be pulsatile (Leighton, McNeilly and Chard, 1976; Saunders, Terry, Audet, Brazeau and Martin, 1976; Shin and Reifel, 1981) and any short-term changes occurring in plasma PRL concentration after the suppression of releasing or release-inhibiting factors may be masked by this pulsatile release and so, not be apparent during infrequent blood sampling.

Plasma TSH concentrations were significantly lower after an injection of anti-TRH serum than after an injection of NSS and remained low after PRL concentrations had returned to the control

range (Table 7-2). This agrees with the studies of Koch et al. (1977) and Harris et al. (1978) and confirms the role of TRH in the neural control of TSH secretion (Reichlin, Martin, Mitnick, Boshans, Grimm, Bollinger, Gordon and Malacara, 1972). However, TSH release was not completely suppressed as shown by the fact that the concentration of TSH in plasma after the injection of anti-TRH serum was still 40% of the value of the concentration of TSH in plasma from animals injected with NSS. This is in agreement with the previous studies of Koch et al. (1977) and Harris et al. (1978) who both found that the plasma TSH concentration in animals injected with immune serum was approximately 40% of that in animals injected with non-immune serum. The incomplete suppression of TSH release may again have been due to insufficient antiserum being present to neutralize all of the TRH in hypophysial portal blood. In the present studies, it was not possible to inject animals with more than 1ml of either anti-TRH serum or NSS due to a severe anaphylactic response of the animals to larger volumes of sera.

The fact that plasma TSH concentrations remained low after PRL concentrations had returned to control values further suggests a dissociation between TRH-stimulated TSH release and TRH-stimulated PRL release on the afternoon of pro-oestrus. This is in contrast to a suggestion by Brown-Grant, Dutton and ter Haar (1977) that increases in the plasma concentrations of both PRL and TSH (not seen in the present study) on the afternoon of pro-oestrus are mediated by TRH.

There was no significant difference in the concentration of LH in plasma at any time between animals injected with anti-TRH serum

and those injected with non-immune serum, indicating that the decreases in the concentrations of TSH and PRL in plasma were not due to a non-specific action of the anti-TRH serum on the release of hormones from the anterior pituitary gland. These results indicate that the involvement of TRH in the pro-oestrous PRL surge is probably of importance only at the beginning of the surge and is transient and rapidly overtaken by other factors (Valverde, Chieffo and Reichlin, 1972; Blake, 1974; Grosvenor and Mena, 1980; de Greef and Visser, 1981). Fraser and McNeilly (1982) have shown that major physiological changes in PRL release can still occur when TRH is inhibited long-term even although responses to some stimuli such as heat stress, suckling or injection of TRH, which generally cause significant increases in plasma PRL concentrations, are blunted. Fink, Fraser and Sheward (1983) have also recently shown that electrically-stimulated release of PRL cannot be inhibited by an injection of anti-TRH serum. Therefore, in summary, the role of TRH in PRL secretion, which may be important during suckling, is not so during the PRL surge of the pro-oestrous female rat.

CHAPTER 8

Vasopressin and Oxytocin in Hypophysial Portal Blood

8.1 INTRODUCTION

There are an increasing number of substances thought to be involved in the regulation of the release of hormones from the anterior pituitary gland (Weiner and Ganong, 1978; McCann, 1980; Vale et al., 1980). Vasopressin and oxytocin, for many years thought to be exclusively located in the posterior pituitary gland (Lederis, 1974) and concerned primarily with osmoregulation (Moses and Miller, 1974) and milk ejection (Tindal, 1974) respectively, have recently been discovered in a fibre system terminating in the EL of the ME (Zimmerman, Stillman, Recht, Antunes and Carmel, 1977) and have been implicated in the control of ACTH release (Burlet, Chateau and Czernichow, 1978; Bény and Baertschi, 1980; Gillies and Lowry, 1979, 1982) and PRL release (Vaughan et al., 1979; Salisbury, Kreig and Seibel, 1980; Shin, 1982). This fibre system has been identified immunohistochemically in numerous species including amphibia, birds, and mammals (Parry and Livett, 1973; Silverman, 1976; Dierickx and Vandesande, 1977; Zimmerman et al., 1977) and using Gomori staining has been identified in birds (Oksche, Kirscht, Hartwig, Oemke and Farner, 1974). The VP component, but not the OT component is absent in the homozygous Brattleboro rat (Vandesande and Dierickx, 1976) genetically deficient in VP (Valtin, Sawyer and Sokol, 1965).

It has been reported that VP can be released from the isolated ME in vitro (Bény and Baertschi, 1981) at concentrations higher than would be expected if all the VP measured was being released from cut axons of the SOHT (Lésnik, Guzek and Traczyk, 1969) and there are a few reports showing the presence of high concentrations of VP in

hypophysial portal plasma from both rats and monkeys (Zimmerman, Carmel, Husain, Ferin, Tannenbaum, Frantz and Robinson, 1973; Oliver et al., 1976; Recht, Hoffman, Haldar, Silverman and Zimmerman, 1981). However, the high concentrations of VP in hypophysial portal plasma may be derived, in addition to the proposed VP-containing terminals in the EL of the ME, from a number of other areas; for example, from the PN, and carried to the portal vessels by backflow of blood (Oliver et al., 1976; Page and Bergland, 1977), from cut axons of the SOHT (Lésnik et al., 1969) or from CSF (Dogterom, van Wimersma Griedanus and de Wied, 1978).

There are no reports of the VP or OT in the ME system being involved in either osmoregulation or milk-ejection but there is evidence that VP has a functional role in the release of ACTH from the anterior pituitary gland (Gillies and Lowry, 1982). Vasopressin has been shown to alter the release of ACTH both in vivo and in vitro (Hedge, Yates, Marcus and Yates, 1966; Portanova and Sayers, 1973; Lutz-Bucher, Koch and Mialhe, 1977; Aizawa, Yasuda, Greer and Sawyer, 1982) but this appears to be due to a synergistic action with corticotrophin-releasing hormone (CRH) (Vale, Speiss, Rivier and Rivier, 1981; Gillies and Lowry 1982; Gillies, Linton and Lowry, 1982; Yasuda et al., 1982) since CRH activity is still present in the hypothalamus and ME of the homozygous Brattleboro rat, in which VP is absent (Pearlmutter, Dokas, Kong, Miller and Saffran, 1980; Buckingham, 1981; Pearlmutter, Dokas, Loeser, Kong, Saffran and Simmons, 1982).

An isolated report by Shin (1982) claimed that VP could also release PRL from the anterior pituitary gland in vitro by a direct

action on the lactotrophs.

There have, as yet, been no reports of the presence of OT in hypophysial portal blood but there is increasing speculation as to a functional role for OT, or fragments of OT, in the release of hormones from both the intermediate and anterior lobes of the pituitary gland. Two different fragments of OT have been isolated from hypothalamic tissue and have been proposed as a melanocyte-stimulating hormone (MSH) inhibitory factor (NH₂-Gly-Leu-Pro) (Kastin, Viosca and Schally, 1974; Kastin, Schally and Kostrzewa, 1980) and as an MSH releasing factor (SH-Cys-Tyr-Ile-Gln-Asn-OH) (Celis, Taleisnik and Walter, 1971) and OT itself has been shown to cause release of PRL both in vivo and in vitro (Forsling et al., 1974; Vaughan et al., 1979; Lumpkin et al., 1983).

The studies presented in this chapter were designed to investigate:

- i) whether VP and OT could be measured in pituitary stalk plasma
- ii) the possible sources of these peptides in pituitary stalk plasma
- iii) whether the increased VP immunoreactivity seen after adrenalectomy was reflected in increased release of VP into pituitary stalk plasma.

8.2 MATERIALS AND METHODS

8.2.1 Animals and surgery

Animals used in this series of experiments, unless otherwise stated, were male Wistar cob rats (200-300g). In some experiments the animals used were male heterozygous and homozygous Brattleboro

rats (200-250g) maintained as described in section 2.1. Homozygous and heterozygous Brattleboro rats were caged singly in metabolic cages to allow measurement of urine output. A homozygous Brattleboro rat was defined as an animal which passed urine equal to or greater than 75% of body weight (150ml for a 200g rat) during a 24h collection period. Brattleboro rats passing less than this volume during the 24h collection period were designated heterozygous. These definitions were tested at the end of the experiment when the pituitary gland was removed and assayed for VP and OT.

Adrenalectomy, collection of peripheral blood, collection of hypophysial portal blood and CSF, electrothermal lesioning, and electrical stimulation of the hypothalamus and ME were all carried out under urethane anaesthesia as described in Chapter 2.

Hypophysial portal blood was collected (2.2.16) during two consecutive periods of 30 min each and electrical stimulation, when applied, was applied during the second 30 min period.

Electrothermal lesions (2.2.14) of the SOHT were made using co-ordinates, lateral 0.0mm, anterior + 6.0mm, ventral + 1.2mm, described by de Groot (1959). The correct placement of the lesion was determined by monitoring urine output of lesioned animals in the first few post-operative days. Only those animals which continued to show an increase in urine output 5 days after placement of the lesion were used. Animals in which lesion placement was correct (verified histologically) showed a typical phasic pattern of urine output consisting of an initial increase (days 1-2 post-lesioning)

followed by a decrease (days 2-3) and a subsequent sustained increase (days 4-12) (Table 8-1). The position and extent of lesions were checked histologically and a representative lesion is shown in Figure 8-1. Bipolar electrodes were implanted long-term (2.2.13) into the PVN and SCN and unipolar electrodes were implanted long-term into the SON. Co-ordinates for implantation used for rats weighing 200g (based on de Groot, 1959) were

Hypothalamic area	Lateral	Anterior	Ventral
PVN	0.0mm	+6.3mm	+3.4mm
SCN	0.0mm	+7.4mm	+1.6mm
SON	+2.0mm	+7.0mm	+2.3mm

Lateral co-ordinates given for PVN and SCN indicate the position of the exact mid-point between the 2 electrode tips of the bipolar electrode assembly (electrodes were 1mm apart).

8.2.2 Drugs used and measurement of peptides

Alaproclate and zimelidine were dissolved in 0.9% saline immediately before use. Parachlorophenylalanine was dissolved in 0.9% buffered saline before use. Dexamethasone stock solution (2.2.2) was diluted in 0.9% saline immediately before use. All drugs were injected i.p. at times stated in results.

Vasopressin, OT and LHRH in peripheral and hypophysial portal plasma and VP and OT in the pituitary gland of Brattleboro rats were measured by specific RIAs described in section 2.4.

8.2.3 Statistics

All data are presented as mean \pm S.E.M. The significance of the difference between two means was measured using Student's t-test. The significance of difference between more than two means was

TABLE 8-1

Urine output (ml/24h) in male rats after placement of an electrothermal lesion in the supraopticohypophysial tract. Lesions were placed on day 0.

Animal	Day 1	Day 2	Day 3	Day 4	Day 5	Day 6	Day 7
1	13	2	5	70	120	105	95
2	41	15	14	32	36	60	70
3	31	14	10	24	35	46	54
4	24	9	12	16	35	42	61
5	40	35	20	36	46	50	58
6	16	9	6	16	33	53	60

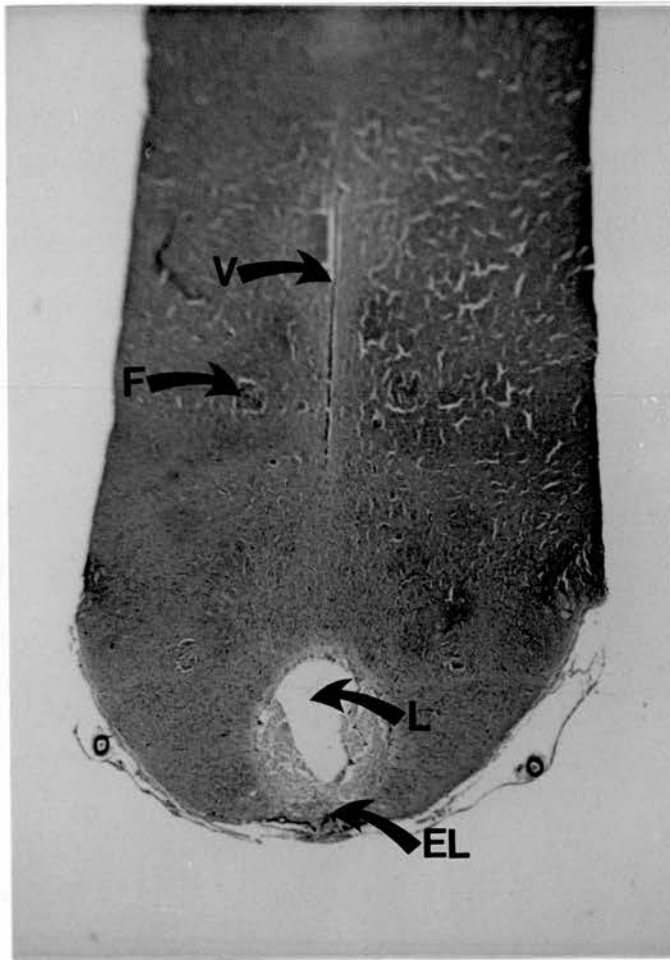

FIGURE 8-1 Representative photomicrograph of a lesion in the supraopticohypophysial tract.
EL = intact external layer of median eminence
L = lesion
V = third ventricle
F = fornix

measured by analysis of variance and Duncan's multiple range test.

8.3 RESULTS

8.3.1 Vasopressin and oxytocin in peripheral and hypophysial portal plasma

The concentrations of OT and VP in hypophysial portal plasma were significantly greater ($p < 0.001$) than the concentrations in peripheral plasma (Fig. 8-2). When the pituitary gland was removed at the time of pituitary stalk section, and hypophysial portal blood collected as before, there were no significant differences in the concentrations of either peptide in either peripheral or hypophysial portal plasma compared with the concentrations in plasma from animals sampled with the pituitary gland in situ (Figs. 8-3 and 8-4).

8.3.2 The effect of a lesion in the supraopticohypophysial tract on vasopressin and oxytocin concentrations in hypophysial portal and peripheral plasma

Hypophysial portal blood was sampled from animals 8-10 days after placement of a lesion in the SOHT. There were significant increases ($p < 0.01$) in the concentrations of both VP and OT in hypophysial portal plasma from animals that had a lesion in the SOHT compared with concentrations in hypophysial portal plasma from unlesioned animals (Figs. 8-3 and 8-4). There were no significant differences in the concentrations of either VP or OT in peripheral plasma from lesioned animals when compared with peripheral plasma concentrations from unlesioned animals.

8.3.3 Vasopressin and oxytocin in peripheral and hypophysial portal plasma from heterozygous and homozygous Brattleboro rats

The concentration of VP in peripheral plasma from heterozygous

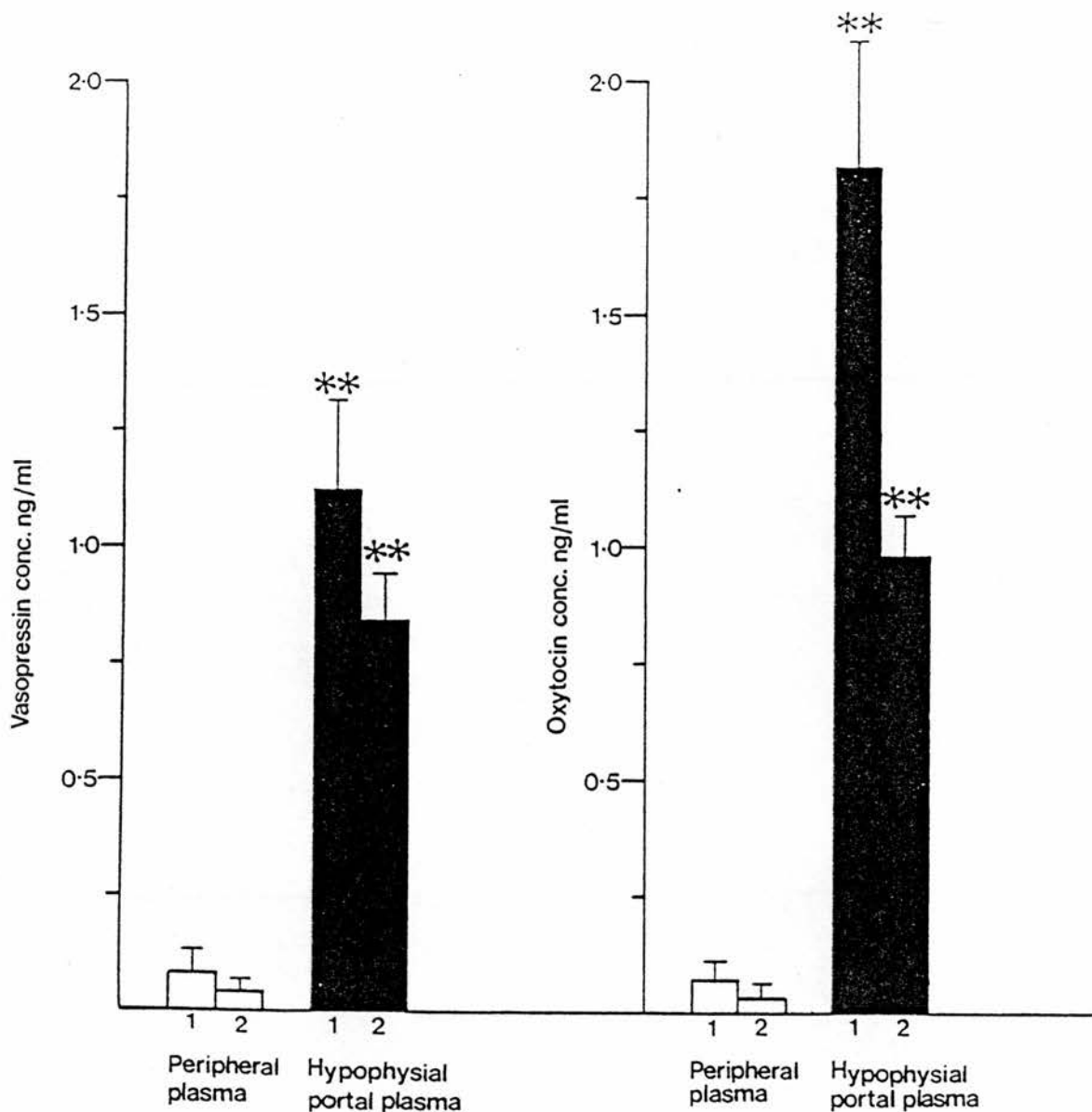

FIGURE 8-2 Mean (\pm S.E.M.) concentrations (ng/ml) of vasopressin (VP) and oxytocin (OT) in peripheral plasma (open bar, $n = 9$) and hypophysial portal plasma (closed bar, $n = 9$) from male rats.

Peripheral blood samples were removed from anaesthetized animals from the external jugular vein after exposure but before cutting of pituitary stalk (1), and, (2) after the completion of the collection of hypophysial portal blood.

Hypophysial portal blood was collected during 2 half-hour periods (1 and 2).

*** $p < 0.001$; level of significance of difference between the concentration of VP and OT in hypophysial portal plasma compared with the concentration of VP and OT in peripheral plasma.

FIGURE 8-3 Mean (\pm S.E.M.) concentrations (ng/ml) of vasopressin (VP) in hypophysial portal plasma and peripheral plasma from intact male rats (pituitary in situ), male rats with the pituitary gland removed at the time of stalk section (pituitary removed) or with a lesion placed in the supraopticohypophysial tract 7-8 days before sampling of blood (SOHT lesion), (n = 8 in each group). Peripheral blood samples were removed from anaesthetized animals from the external jugular vein after exposure but before cutting of pituitary stalk (1) and (2) after the completion of the collection of hypophysial portal blood.

Hypophysial portal blood was collected during 2 half-hour periods (1 and 2).

*p < 0.01; level of significance of difference between the concentration of VP in hypophysial portal plasma from animals with a lesion in the SOHT compared with the concentration of VP in hypophysial portal plasma from intact animals.

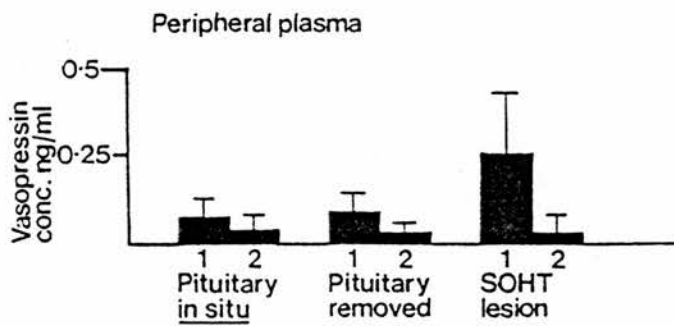
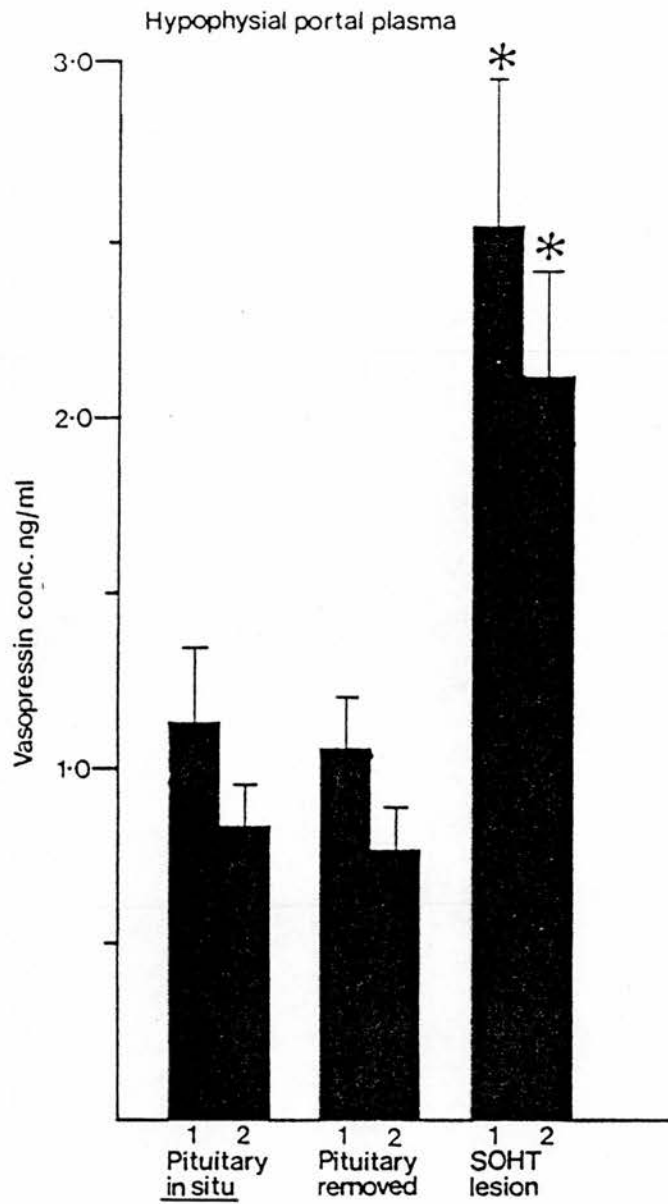
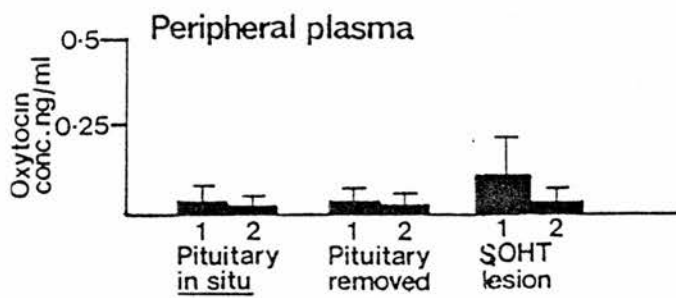
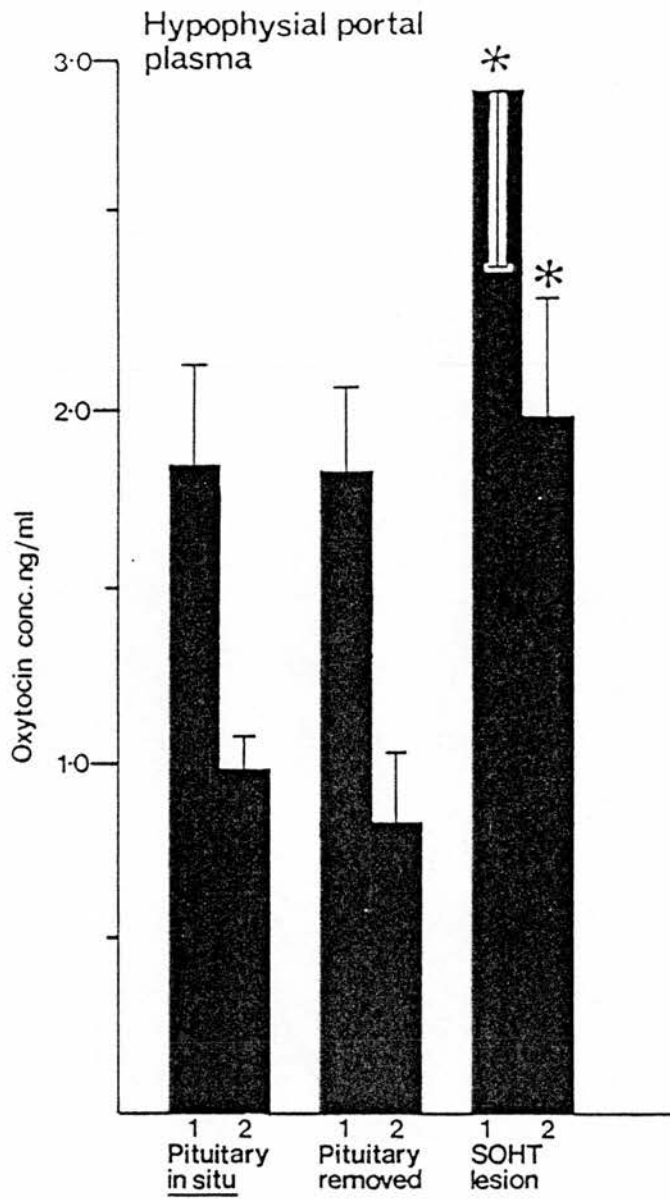

FIGURE 8-4 Mean (\pm S.E.M.) concentrations (ng/ml) oxytocin (OT) in hypophysial portal plasma and peripheral plasma from intact male rats (pituitary in situ), male rats with the pituitary gland removed at the time of stalk section (pituitary removed) or with a lesion placed in the supraopticohypophysial tract 7-8 days before sampling of blood (SOHT lesion), (n = 8 in each group). Peripheral blood samples were removed from anaesthetized animals from the external jugular vein after exposure but before cutting of pituitary stalk (1) and (2) after the completion of the collection of hypophysial portal blood. Hypophysial portal blood was collected during 2 half-hour periods (1 and 2). *p < 0.01; level of significance of difference between the concentration of OT in hypophysial portal plasma from animals with a lesion in the SOHT compared with the concentration of VP in hypophysial portal plasma from intact animals.



and homozygous Brattleboro rats was undetectable (Fig. 8-5). The concentration of VP in hypophysial portal plasma from heterozygous Brattleboro rats collected during the first 30 min collection period was slightly but not significantly lower than that in Wistar rats (Fig. 8-5). Vasopressin was undetectable in hypophysial portal plasma from homozygous Brattleboro rats (Fig. 8-5).

There were no ~~detectable~~ differences between Wistar and heterozygous and homozygous Brattleboro rats in the concentration of OT in peripheral plasma but there was a significant increase ($p < 0.01$) in the concentration of OT in hypophysial portal plasma from both heterozygous and homozygous Brattleboro rats compared with the concentration in hypophysial portal plasma from Wistar rats (Fig. 8-6).

8.3.4 Vasopressin and oxytocin concentrations in cerebrospinal fluid

Cerebrospinal fluid was removed from ^{Wistar} animals that had been implanted 10 days previously with a cannula in the third cerebral ventricle. Concentrations of VP were lower than those in hypophysial portal blood, and ranged from $< 0.02 - 0.5 \text{ ng/ml}$ (mean \pm S.E.M. = 0.24 ± 0.10 , $n = 8$). On the basis of the concentrations of OT, the rats could be divided into two groups, those with high concentrations of OT, mean $\pm 1.33 \text{ ng/ml}$ ($n=4$), and those with low concentrations of OT, mean = $0.04 \pm 0.01 \text{ ng/ml}$ ($n = 4$). There was no correlation between VP and OT concentrations in CSF.

8.3.5 The effect of electrical stimulation of the hypothalamus and median eminence on the concentrations of vasopressin and oxytocin in peripheral and hypophysial portal plasma

To determine the effects of ME stimulation on the release of VP

FIGURE 8-5 Mean (\pm S.E.M.) concentrations (ng/ml) of vasopressin (VP) in peripheral plasma and hypophysial portal plasma from Wistar male rats (Wistar), heterozygous Brattleboro rats (Hetero. Bratt'b's) and homozygous Brattleboro rats (Homo. Bratt'b's) (n = 6, in each group). (N.D. = not detectable at a lower limit of assay sensitivity of 1pg/tube).

Peripheral blood samples were removed from anaesthetized animals from the external jugular vein after exposure but before cutting of pituitary stalk (1), and, (2) after the completion of the collection of hypophysial portal blood.

Hypophysial portal blood was collected during 2 half-hour periods (1 and 2).

*p < 0.01; level of significance of difference between the concentration of VP in hypophysial portal plasma from heterozygous and homozygous Brattleboro rats compared with the concentration of VP in hypophysial portal plasma from Wistar rats.

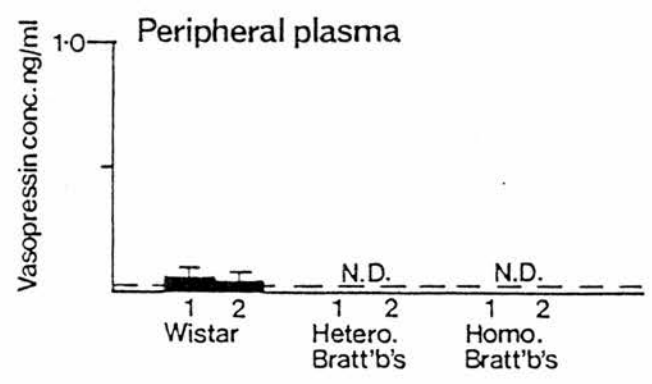
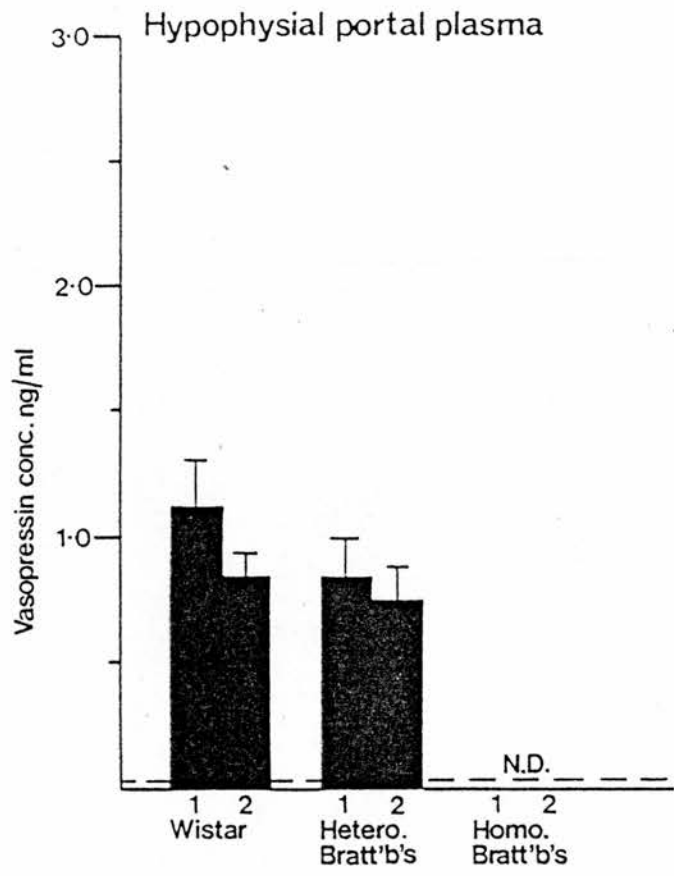
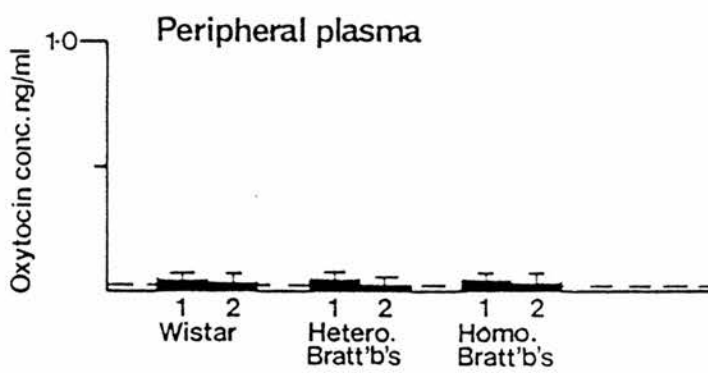
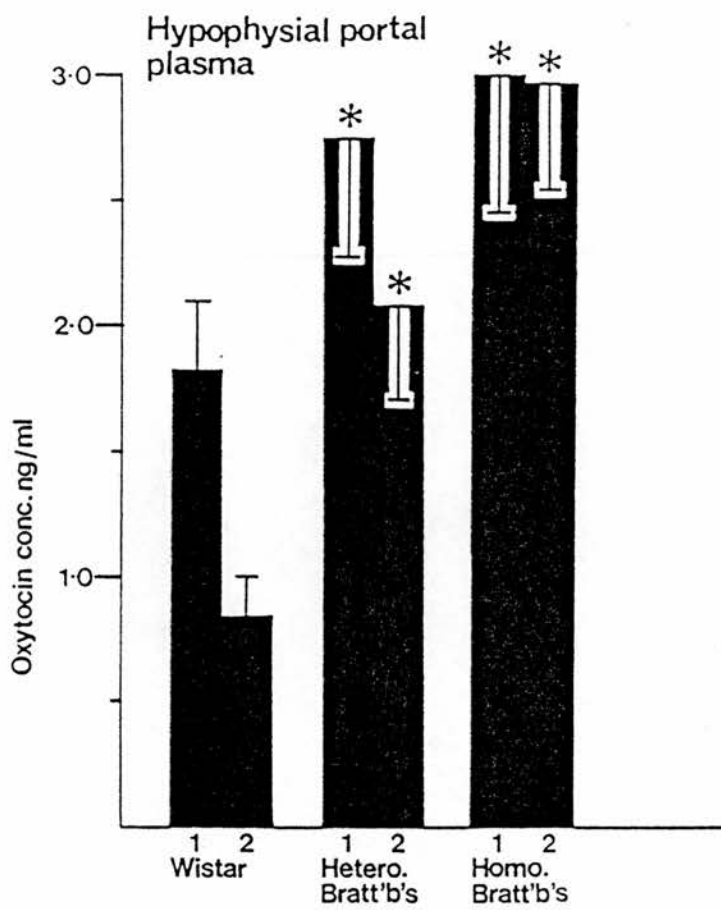

FIGURE 8-6 Mean (\pm S.E.M.) concentrations (ng/ml) of oxytocin (OT) in peripheral plasma and hypophysial portal plasma from Wistar male rats (Wistar), heterozygous Brattleboro rats (Hetero. Bratt'b's) and homozygous Brattleboro rats (Homo. Bratt'b's) (n = 6, in each group). Peripheral blood samples were removed from anaesthetized animals from the external jugular vein after exposure but before cutting of pituitary stalk (1), and, (2) after the completion of the collection of hypophysial portal blood. Hypophysial portal blood was collected during 2 half-hour periods (1 and 2). *p < 0.01; level of significance of difference between the concentration of OT in hypophysial portal plasma from heterozygous and homozygous Brattleboro rats compared with the concentration of OT in hypophysial portal plasma from Wistar rats.



and OT into peripheral blood, the ME and pituitary stalk were exposed but the stalk was not cut. A unipolar electrode was placed onto the ME and a stimulus applied. The stimulus consisted of accurately balanced biphasic rectangular waves, 1mA peak-peak, 1m sec duration at 50Hz, applied in trains of 30 sec on and 30 sec off for 30 min. Peripheral blood samples were removed from the external jugular vein at 15 and 30 min during application of the stimulus. Figures 8-7 and 8-8 show that ME stimulation was accompanied by significant increases ($p < 0.01$) in the concentrations of VP and OT in peripheral plasma. Application of the same stimulus to the ME during the second 30 min collection of portal blood from animals in which the pituitary stalk had been cut produced no significant change in the concentrations of VP and OT compared either with the concentrations in hypophysial portal plasma collected from the same animals during the first 'pre-stimulation' 30 min collection period or with concentrations in hypophysial portal plasma from control animals that were not electrically stimulated, (Table 8-2). This stimulus did however cause increased release of LHRH into hypophysial portal plasma in another group of animals (Table 8-3). In another group of animals, however, the same electrical stimulus applied to the ME in trains of 10 sec on and 110 sec off, for 30 min had no effect on the concentration of either VP or OT in either peripheral or hypophysial portal plasma (Table 8-2).

Electrical stimulation of the PVN, SCN or SON with the same stimulus used for stimulating the ME and intact pituitary stalk, had no effect on the concentrations of either peptide in hypophysial

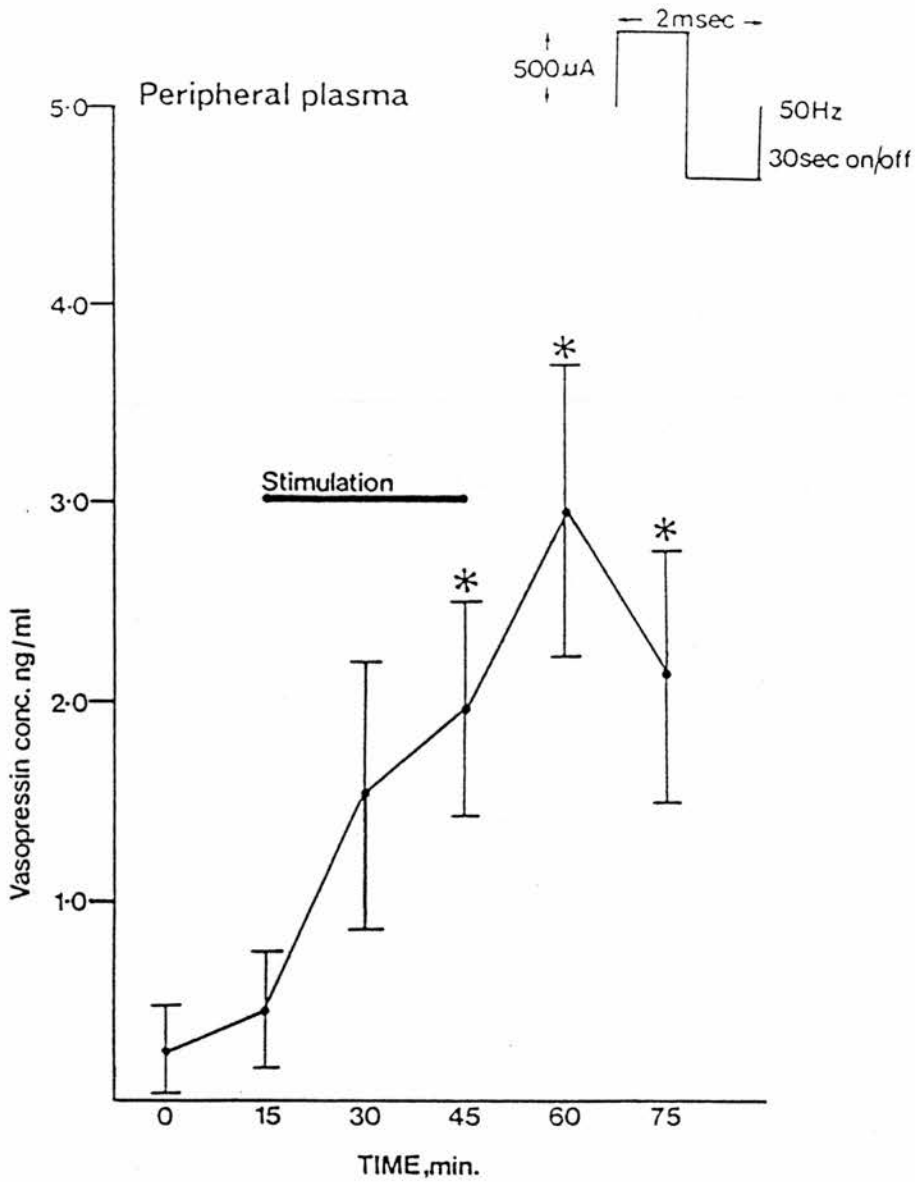

FIGURE 8-7 Mean (\pm S.E.M.) concentrations of vasopressin (VP) in peripheral plasma from intact male rats after electrical stimulation of the posterior pituitary gland by way of a unipolar electrode on the median eminence ($n = 6$). Blood samples were removed from the external jugular vein at 15 min intervals before, during and after the period of stimulation (shown by the black bar). Stimulation parameters are shown in the upper right of the figure.

* $p < 0.01$; level of significance of difference between concentrations of VP in peripheral plasma during and after stimulation compared with concentrations present before stimulation.

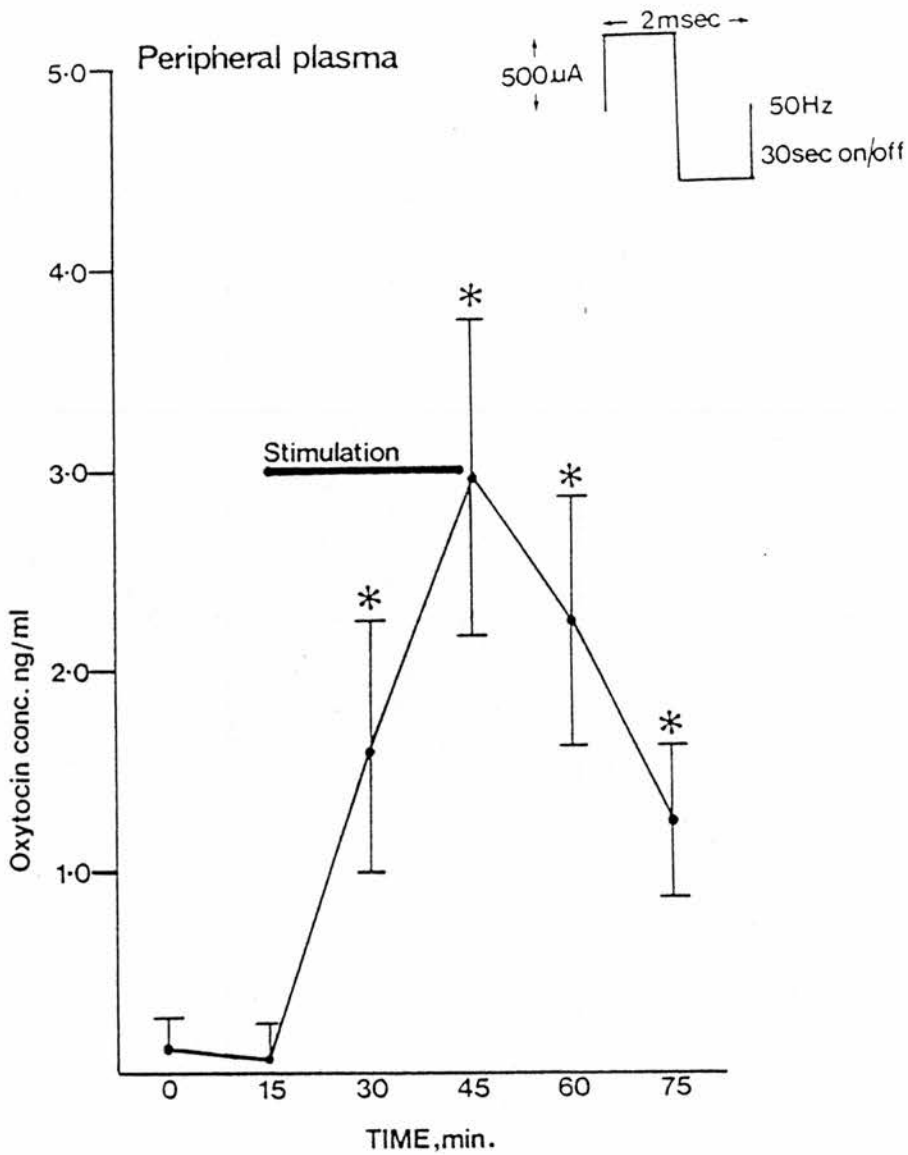

FIGURE 8-8 Mean (\pm S.E.M.) concentrations of oxytocin (OT) in peripheral plasma from intact male rats after electrical stimulation of the posterior pituitary gland by way of a unipolar electrode on the median eminence ($n = 6$). Blood samples were removed from the external jugular vein at 15 min intervals before, during and after the period of stimulation (shown by the black bar). Stimulation parameters are shown in the upper right of the figure.
 * $p < 0.01$; level of significance of difference between concentrations of OT in peripheral plasma during and after stimulation compared with concentrations present before stimulation.

TABLE 8-2

Vasopressin (VP) and oxytocin (OT) concentrations (ng/ml) (mean \pm S.E.M.) in hypophysial portal plasma from male rats after electrical stimulation of the hypothalamus and median eminence

Stimulated area	n	Vasopressin		Oxytocin	
		Portal (1)	Portal (2)	Portal (1)	Portal (2)
Controls (no stimulation)	6	1.12 \pm 0.19	0.60 \pm 0.16	1.82 \pm 0.27	0.94 \pm 0.13
Median eminence (a)	8	1.61 \pm 0.51	1.05 \pm 0.30	1.54 \pm 0.21	1.26 \pm 0.38
Median eminence (b)	8	1.94 \pm 0.55	1.02 \pm 0.36	1.99 \pm 0.34	1.04 \pm 0.26
Supraoptic nucleus (SON)	6	1.72 \pm 0.55	0.95 \pm 0.45	2.20 \pm 0.51	1.25 \pm 0.32
Suprachiasmatic nucleus (SCN)	6	1.91 \pm 0.30	0.91 \pm 0.23	1.95 \pm 0.32	1.25 \pm 0.35
Paraventricular nucleus (PVN)	8	0.32 \pm 0.16*	0.20 \pm 0.04*	0.41 \pm 0.19*	0.13 \pm 0.05*

Portal (1) = concentration of peptide in hypophysial portal plasma collected during first 30 min, without electrical stimulation

Portal (2) = concentration of peptide in hypophysial portal plasma collected during second 30 min with electrical stimulation

(a) = stimulation at 30 sec on/30 sec off

(b) = stimulation at 10 sec on/110 sec off

*p < 0.01; level of significance of difference between concentrations of VP and OT in hypophysial portal plasma from animals implanted long-term with an electrode in the PVN compared with concentrations in hypophysial portal plasma from control, unstimulated animals or in any other stimulated group.

Concentrations of VP and OT in peripheral plasma were all < 0.02ng/ml in samples taken both before and after cutting of the pituitary stalk.

TABLE 8-3

The concentration (pg/ml) and content (pg/30 min) of luteinizing hormone-releasing hormone (LHRH) in hypophysial portal plasma from male rats after electrical stimulation of the median eminence during the second half-hour collection of hypophysial portal blood (Portal 2).

Animal	LHRH content		LHRH concentration	
	Portal (1)	Portal (2)	Portal (1)	Portal (2)
1	30	276	301	1840
2	35	106	468	708
3	272	466	906	465
4	95	255	315	424
5	81	244	266	417
	99 ± 49	269 ± 57*	451 ± 119	771 ± 272*

*p < 0.05; level of significance of difference between the concentration or content of LHRH present in hypophysial portal plasma before stimulation of the median eminence (Portal 1) compared with the concentration or content of LHRH present after stimulation of the median eminence (Portal 2).

portal plasma or peripheral plasma compared with concentrations before the start of the stimulation (Table 8-2).

There were significant decreases, ($p < 0.01$) compared with control animals, in the concentrations of both peptides in hypophysial portal plasma collected during both 'stimulated' and 'unstimulated' collection periods from animals implanted long term with electrodes in PVN (Table 8-2).

8.3.6 The effect of adrenalectomy on the concentrations of vasopressin and oxytocin in peripheral and hypophysial portal plasma.

When hypophysial portal blood was collected from animals that had been bilaterally adrenalectomized either 3, 7 or 10 days previously, there were no differences in the concentrations of either VP or OT in hypophysial portal plasma or peripheral plasma when compared with the concentrations in hypophysial portal plasma or peripheral plasma from animals that had undergone sham-adrenalectomy 7 days previously (Table 8-4). Injection of animals that had been adrenalectomized 7 days previously with 0.5mg dexamethasone/kg 1h before the start of the collection of hypophysial portal blood had no effect on the concentration of either peptide in hypophysial portal plasma or peripheral plasma when compared either with plasma concentrations from animals that had been adrenalectomized 7d previously and injected with injection vehicle, or with sham-adrenalectomized animals.

8.3.7 Serotonergic involvement in the release of vasopressin and oxytocin into hypophysial portal blood

Injection of 200mg PCPA/kg i.p. 72h before the start of the

TABLE 8-4

Vasopressin (VP) and oxytocin (OT) concentrations (ng/ml) in hypophysial portal plasma from male rats at various times after bilateral adrenalectomy (ADX).

Group	n	Vasopressin		Oxytocin	
		Portal (1)	Portal (2)	Portal (1)	Portal (2)
Sham ADX	8	1.44 ± 0.37	1.69 ± 0.35	4.02 ± 0.62	3.84 ± 0.51
3d post-ADX	14	2.48 ± 0.62	2.10 ± 0.46	3.58 ± 0.60	2.78 ± 0.44
7d post-ADX	17	2.52 ± 0.42	2.35 ± 0.27	3.88 ± 0.44	3.16 ± 0.49
10d post-ADX	12	1.31 ± 0.39	1.36 ± 0.31	3.18 ± 0.52	2.33 ± 0.69
*7d post-ADX + 0.5mg dexameth/kg	14	1.78 ± 0.47	2.19 ± 0.50	3.22 ± 0.46	3.56 ± 0.43

Portal (1) = concentration of peptide in hypophysial portal plasma collected during first 30 min.

Portal (2) = concentration of peptide in hypophysial portal plasma collected during second 30 min.

*Dexamethasone was injected i.p. 1h before the start of the collection of hypophysial portal blood.

Concentrations of VP and OT in peripheral plasma were all < 0.02ng/ml in samples taken both before and after cutting of the pituitary stalk.

experiment had no significant effect on either the OT or VP concentrations in either peripheral or hypophysial portal plasma compared with the plasma concentrations in control animals (Table 8-5). Zimelidine and alaproclate, injected i.p. at doses of 20mg/kg and 30mg/kg, respectively, 1h before the start of the collection of hypophysial portal blood, had no significant effect on either VP or OT concentrations in either peripheral or hypophysial portal plasma (Table 8-5).

8.4 DISCUSSION

The results reported in this chapter show the presence of high concentrations of both VP and OT in pituitary stalk plasma. There have so far been no reports concerning the presence of OT in hypophysial portal plasma and only a few reports concerning the presence of VP. Early work, using a relatively insensitive bioassay for VP (Dékanski, 1952) claimed that there was no VP activity detectable in hypophysial portal blood (Rumfeld and Porter, 1959; Fink, Smith and Tibballs, 1971). However, with the development of sensitive RIAs for VP, high concentrations of VP have been found in hypophysial portal plasma from monkeys (Zimmerman et al., 1973) and rats (Oliver et al., 1977; Recht et al., 1981). It has been argued that the high concentrations of VP seen in hypophysial portal plasma are due either to the presence of VP in blood arising from backflow from the posterior pituitary gland to the hypophysial portal vessels (Bergland and Page, 1977; Oliver et al., 1977) or to the presence of VP in CSF (Dogterom et al., 1977) or to the leakage of VP from cut axons of the SOHT (Lésnik et al., 1969). It is unlikely that a significant amount of either VP or OT is arising in hypophysial

TABLE 8-5

Vasopressin (VP) and oxytocin (OT) concentrations (ng/ml) in hypophysial portal plasma from male rats from animals injected i.p. with drugs altering serotonergic function.

Drug injected	n	Vasopressin		Oxytocin	
		Portal (1)	Portal (2)	Portal (1)	Portal (2)
Controls (saline)	6	1.12 ± 0.19	0.60 ± 0.10	1.82 ± 0.27	0.94 ± 0.13
Alaproclate 30 mg/kg	7	2.12 ± 0.54	1.33 ± 0.38	2.43 ± 0.30	1.89 ± 0.46
Zimelidine 20 mg/kg	7	2.59 ± 0.48	1.59 ± 0.36	2.34 ± 0.35	1.48 ± 0.35
PCPA 200 mg/kg	13	2.15 ± 0.32	1.16 ± 0.22	2.17 ± 0.36	0.87 ± 0.20

Portal (1) = concentration of peptide in hypophysial portal plasma collected during first 30 min

Portal (2) = concentration of peptide in hypophysial portal plasma collected during second 30 min

Alaproclate and zimelidine were injected 1h before the start of the collection of hypophysial portal blood. Parachlorophenylalanine (PCPA) was injected 72h before the start of the collection of hypophysial portal blood. Concentrations of VP and OT in peripheral plasma were all < 0.02ng/ml in samples taken both before and after cutting of the pituitary stalk.

portal plasma due to backflow of blood from the posterior pituitary gland, since the present studies showed that there was no significant change in the concentration of either peptide in hypophysial portal plasma from animals in which the pituitary gland had been removed at the time of pituitary stalk section compared with concentrations in hypophysial portal plasma from animals with the pituitary gland left in situ (Figs. 8-3 and 8-4). These results agree with those of Recht et al. (1981) who also found no significant change in the concentration of VP in hypophysial portal plasma after removal of the posterior pituitary gland compared with concentrations present when the gland was left in situ. However, the results found here do not agree with those of Oliver et al. (1977) who found significant decreases in the concentrations of a number of anterior and posterior pituitary hormones, including VP, in hypophysial portal plasma after removal of the pituitary gland, and concluded that all of the VP in hypophysial portal plasma originated from the posterior pituitary gland. The vasculature that was originally proposed to be involved in the backflow of blood from the pituitary gland to the hypophysial portal vessels (Bergland and Page, 1978) has recently been shown to be part of a different system which does not after all flow from the posterior pituitary gland to the hypophysial portal vessels in the ME (Page, 1983). The differences between the studies of Oliver et al (1977) and those of Recht et al. (1981) and the present studies cannot be attributed to differences in the method of collection of hypophysial portal blood or to the method used for determination of VP concentrations since both Oliver et al. (1977) and Recht et al. (1981) used the portal

vessel cannulation method of Porter and Smith (1967) and all three studies measured the concentration of VP by RIA.

There is evidence for the presence of VP and OT in CSF (Robinson and Zimmerman, 1973; Dogterom et al. 1978; Jackson, 1980) and in the tanycytes lining the floor of the third ventricle (Robinson and Zimmerman, 1973), but concentrations found in CSF in the present studies are similar to those in peripheral plasma (20-50pg/ml) and so are not high enough to be contributing significantly to the concentrations seen in hypophysial portal plasma.

The outflow of VP from cut axons of the SOHT has been estimated to be 80pg/h (Lésnik et al., 1969) and this is clearly not sufficient to account for the measurement of approximately 1.25ng VP/h in hypophysial portal plasma. It also seems unlikely that axons of the SOHT contribute significantly to the high concentrations of VP and OT in hypophysial portal blood since, after lesioning of these axons, there is a significant increase in the concentrations of VP and OT in hypophysial portal plasma compared with concentrations in hypophysial portal plasma from unlesioned animals (Figs. 8-3 and 8-4). The increased concentrations could be due to a build-up of both peptides behind the lesion (Moll, 1957; Beck and Daniel, 1961) which are released upon subsequent section of the pituitary stalk (histological examination of the brains of these animals showed some intact perikarya in the SON and PVN and a lesion in the internal layer of the ME). Another possible explanation for the increased concentrations could be the presence of axon branches from axons in the SOHT, terminating in the EL of the ME, and containing increased concentrations of peptides after lesioning of

the main axon. There is electrophysiological (Blume, Pittman and Renaud, 1978; Pittman, Blume and Renaud, 1978; Hatton, Ho and Mason, 1983) and neuroanatomical (Hayward, 1974; Lu Qui and Fox, 1976; Sofroniew and Glasmann, 1981) evidence for the existence of axon collaterals on neurons of the SON, but so far evidence is sparse for these collaterals being present at distances of more than a few hundred microns outside the nucleus (Hayward, 1974; Lu Qui and Fox, 1976). Even if these collaterals did not show 'classical' terminals in the EL of the ME there is evidence for the presence of varicosities, usually associated with neurotransmitter release, in axons of both the peripheral (Richardson, 1958; Burnstock and Holman, 1961) and central (Andèn, Dahlström, Fuxe, Larsson, Olson and Ungerstedt, 1969) nervous systems which may also be present in this VP and OT containing system. Evidence against the VP and OT containing fibres in the EL of the ME arising from the same neurons in the SON as those projecting to the neurohypophysial system comes from anatomical studies. Wiegand and Price (1980) and Swanson, Sawchenko, Wiegand and Price, (1980) have shown differences in both the size and distribution of the VP and OT containing cells that project to the EL of the ME compared with those that project to the posterior pituitary gland. In addition to these differences, the neurosecretory granules in the terminals on the portal vessels are smaller (100nm) than those found in the posterior pituitary gland (120-180nm) (Silverman and Zimmerman, 1975). These differences would indicate that the neurons of these two systems are different and that the ME system is not composed solely of axon collaterals from the neurons of the SOHT.

The destruction of the internal layer of the ME by the SOHT lesion probably causes changes in many other peptide and neurotransmitter systems present in this area. In an immunohistochemical study by Seybold, Elde and Hökfelt (1981) it was shown that VP immunoreactivity in the EL of the ME was depleted 24h after an injection of reserpine. This result was interpreted as indicating the presence of a tonic inhibitory catecholamine system involved in the control of the release of VP in the EL of the ME, and it is possible that the destruction of this, or some other neuroactive system, by the SOHT lesion, is causing the observed increased release of VP and OT into hypophysial portal blood.

It has been reported that the vasopressinergic component of the VP and OT system in the ME is absent in the homozygous Brattleboro rat, genetically deficient in VP (Sokol, Zimmerman, Sawyer and Robinson, 1976; Vandesande and Dierickx, 1977). This was confirmed in the present studies where VP was undetectable in hypophysial portal plasma from homozygous Brattleboro rats and slightly but not significantly lower in hypophysial portal plasma from heterozygous Brattleboro rats compared with concentrations in hypophysial portal plasma from Wistar rats (Fig. 8-5). The concentration of OT was significantly higher in hypophysial portal plasma from both heterozygous and homozygous Brattleboro rats compared with concentrations in hypophysial portal plasma from Wistar rats (Fig. 8-6). This may have been due to the chronic dehydration of the Brattleboro rats, which has been shown to cause increased concentration of OT in peripheral plasma when compared with Long-Evans rats (Valtin et al., 1965; Dogterom et al., 1978).

However, the present studies did not show any differences in the concentration of OT in peripheral plasma from either Wistar or Brattleboro rats (Fig. 8-6) and others (Balment, Brimble and Forsling 1980) have found no differences between rats of the Long-Evans and Brattleboro strains.

The involvement of VP in the hypothalamo-hypophysial-adrenal axis has long been controversial (Martini, 1964) with claims for VP being an ACTH inhibitory factor (Itoh and Arimura, 1954) an ACTH releasing factor (McCann, 1957) or having no effect on ACTH release (Barondes, Johnson and Field, 1961). More recently, the discovery of a 41-residue peptide with potent CRF-activity (Vale et al, 1981) has shown that while VP may not be the CRH it has synergistic properties with CRH (Gillies et al, 1982) and in some cases is as potent (on an equimolar basis) as CRH (Rivier and Vale, 1983), to a degree sufficient to allow it to be called a corticotrophin-releasing factor (CRF). Vasopressin immunoreactivity in the EL of the ME has been reported to increase after adrenalectomy (Zimmerman et al., 1977; Burlet et al., 1978) but not after dehydration (Seybold et al., 1981). Oxytocin immunoreactivity does not change after adrenalectomy or dehydration (Zimmerman et al., 1977; Seybold et al. 1981). There was no change in the concentration of either VP or OT in hypophysial portal plasma from animals which had been bilaterally adrenalectomized 3, 7 or 10 days previously compared with concentrations in hypophysial portal plasma from sham-adrenalectomized animals (Table 8-4). Treatment of adrenalectomized animals with dexamethasone, which has been reported to inhibit the increase in VP-immunoreactivity (Stillman,Recht,

Rosario, Seif, Robinson and Zimmerman, 1977; Silverman, Hoffman, Gadde, Krey and Zimmerman, 1981) had no effect on either VP or OT concentrations in hypophysial portal plasma (Table 8-4). It may be that the increased VP immunoreactivity seen in the EL of the ME after adrenalectomy is due to decreased release of VP from these terminals rather than to increased synthesis. This is supported by the present studies which showed no change in the concentration of VP and OT in hypophysial portal plasma from adrenalectomized animals. However, it has been reported that there is an increase in the incorporation of ³H-cytidine into RNA in neurons of the PVN (Silverman, Gadde and Zimmerman, 1980), and in the production of a VP precursor (Russell, Brownstein and Gainer, 1980) after adrenalectomy, which is consistent with adrenalectomy causing increased synthesis of VP.

There have been claims that OT may also function as a CRF, with reports of a CRF extracted from the hypothalamus of Brattleboro rats being identified as OT (Bény and Baertschi, 1981) and OT concentrations in peripheral plasma being increased after stress (Lang, Heil, Granten, Hermann, Unger and Rascher, 1983). However, there was no significant change in the concentrations of OT in hypophysial portal plasma from adrenalectomized animals (Table 8-4) in the present study.

High densities of VP and OT immunoreactivity have been shown to be present in PVN, SCN and SON and in scattered fibres throughout the brain (Sofroniew and Weindl, 1981). Most evidence indicates that the VP and OT system of the ME arises from the PVN (Parry and Livett, 1973; Vandesande et al., 1977; Zimmerman et al., 1977;

Swanson and Sawchenko, 1983). However, when an electrical stimulus, that had already been shown to cause release of VP and OT into peripheral plasma (Figs. 8-7 and 8-8) and also to be effective in releasing LHRH into hypophysial portal blood (Table 8-3), was applied to any of these three areas there was no change in the concentrations of VP and OT in hypophysial portal plasma (Table 8-2). The stimulus was also ineffective when applied directly to the ME (Table 8-2). The decrease in the concentration of both peptides in hypophysial portal plasma from animals implanted with an electrode in the PVN was not due to lesioning of this nucleus itself. However, histological examination of the brains of these animals revealed damage to an area approximately 200 μ m anterior to the PVN. This may represent an important area of afferent input to the nucleus (Swanson and Sawchenko, 1983), lesioning of which causes decreased neuronal activity and so, decreased peptide release. Note, however, that electrical stimulation still caused no change in these lower concentrations (Table 8-2). The lack of effect of electrical stimulation on the release of these peptides into hypophysial portal blood is puzzling since the stimulus used has been shown both in the present and previous studies to cause release of other peptides into hypophysial portal blood (Fink and Jamieson, 1976; Sherwood, Chiappa, Sarkar and Fink, 1980; Millar, Sheward, Wegener and Fink, 1983; Sheward, Benoit and Fink, 1984). There are several possible explanations for the lack of effect of hypothalamic stimulation on VP and OT release. First, the frequency of the stimulation pulses may have been too high, but this frequency caused a significant release of VP

and OT in intact animals (Figs. 8-7 and 8-8) and a similar frequency was found to cause milk ejection in the rabbit (Harris, Manabe and Ruf, 1969). Secondly, the neurons may have been fatigued by the frequency of stimulation or the length of the trains of pulses (Boer, Cransberg and Dogterom, 1980; Bicknell and Leng, 1981) but again, Figures 8-7 and 8-8 make this seem unlikely. The third, and most likely explanation, is that exposure and subsequent cutting of the pituitary stalk somehow leads to maximum activity of the VP and OT neurons so that release of the peptides cannot be further increased by electrical stimulation.

Although there is evidence for the involvement of Ach, DA and NA in the release of VP and OT from terminals in the posterior pituitary gland (Bhargava, Kulshrestha and Srivastava, 1972; Bridges, Hillhouse and Jones, 1976; Hoffman, Phillips and Schmid, 1977; Moos and Richard, 1979; Sladek and Joynt, 1979; Kimura, Share, Wang and Crofton, 1981), the neurotransmitters involved in the control of the VP and OT system of the ME have yet to be elucidated. Those that have been studied have been concerned with the possible adrenocorticotrophic function of this system. There is a large body of evidence concerning the involvement of 5-HT in the hypothalamo-pituitary-adrenal axis (Fuller, 1981). Serotonin has been shown to cause release of ACTH from the pituitary gland (Bruni, Hawkins and Yen, 1982; Spinedi and Negro-Vilar, 1983) and of a CRF from the hypothalamus (Jones, Gillham and Hillhouse, 1977; Buckingham and Hodges, 1979; Fehm, Voigt, Lang and Pfeiffer, 1980; Holmes, Dorenzo, Beckford, Gillham and Jones, 1982) and there is evidence that adrenocortical hormones can alter tryptophan

hydroxylase activity (Azmitia and McEwen, 1974) and change the firing rate of 5-HT containing neurons (Foote, Liels, Martz and Gordon, 1972). Vasopressin can also change the release and synthesis of 5-HT in hippocampal slices (Auerbach and Lipton, 1982). However, 5-HT has been reported to have no effect on electrical activity of the PVN (Moss, Urban and Cross, 1972), although there is evidence for serotonergic input into this nucleus (Kent and Sladek, 1978).

The studies reported in this chapter show that injection of animals with either a 5-HT synthesis inhibitor or with a 5-HT reuptake blocker, treatments designed to decrease and increase, respectively, 5-HT concentrations at synapses, had no effect on the concentrations of VP or OT in hypophysial portal plasma (Table 8-5). However, although 5-HT may not be involved in the release of VP and OT from ME terminals, there is evidence for an interaction between VP and 5-HT to affect ACTH release from the anterior pituitary gland. Spinedi and Negro-Vilar (1983) recently reported a synergistic effect of 5-HT both with synthetic VP and with an ME extract to increase ACTH release from pituitary cells in vitro. That this may occur in vivo is given support by recent work by Johnston et al. (1983) who found significantly higher concentrations of 5-HIAA in hypophysial portal plasma than in peripheral plasma.

The studies reported here are consistent with the existence of a separate VP and OT containing fibre system, terminating on the EL of the ME. In addition to the long proposed involvement of VP in ACTH release (Hedge et al., 1966; Gillies and Lowry, 1982; Rivier and Vale, 1983) there is increasing evidence for the involvement of both

peptides in the release of other anterior pituitary hormones such as PRL (Salisbury et al., 1980; Shin, 1982; Lumpkin et al., 1983) and LH (Cheesman, Osland and Forsham, 1977; Salisbury et al., 1980). Evidence is also accumulating for the involvement of both of these peptides in many other functions such as memory (de Wied, 1977; de Wied and Versteeg, 1979) and maternal behaviour (Pedersen and Prange, 1979) and it has been shown that both peptides can affect neuronal firing (Morris, Salt, Sofroniew, 1980) and neurotransmitter metabolism (Tanaka, de Kloet, de Wied and Versteeg, 1977; Auerbach and Lipton, 1982).

Further studies, particularly concerning electrical stimulation of areas thought to contain the cell bodies of this fibre system, are needed before the physiological significance of this system can be ascertained.

CHAPTER 9

Summary

9. SUMMARY

The studies in this thesis were carried out to investigate possible interactions between hormones, hypothalamic peptides and monoamines in the hypothalamic-PD system.

The release of $^3\text{H-DA}$ from the superfused ME in vitro was investigated and studies carried out to determine whether this was a suitable system for the investigation of TIDA function. The uptake of DA into the ME was determined to be of low affinity and to be inhibited by the DA uptake blocker, nomifensine. After an initial wash-out period, the release of previously accumulated $^3\text{H-DA}$ from the ME reached a steady baseline upon which it was possible to superimpose an electrically-stimulated release. The electrically-stimulated release was dependent on both Na^+ and Ca^{2+} , indicating that release was probably from neurons. Nomifensine caused a significant increase in the electrically-stimulated release of $^3\text{H-DA}$ but had no effect on the basal release. This result suggests that the DA uptake system in the ME, although of low affinity, may be important during times of increased TIDA activity. There was no difference in either the basal or the electrically-stimulated release of $^3\text{H-DA}$ at any stage throughout the oestrous cycle nor was there any difference in the release when LHRH, TRH or PRL were added to the superfusion buffer. To determine whether there was any evidence for the presence of presynaptic DA receptors on the terminals of the TIDA neurons in the ME, the release of $^3\text{H-DA}$ was measured after the addition of various DA agonists and antagonists to the superfusion buffer. None of the drugs tested caused any changes in the basal or in the electrically-stimulated

release of ^3H -DA suggesting that there are unlikely to be any presynaptic DA receptors on the terminals of the TIDA neurons.

It had been hoped that this in vitro system could be adapted to investigate the uptake and release of 5-HT in the ME. However, this proved difficult and attention was focussed on in vivo studies. The involvement of 5-HT in the control of the release of LH and PRL into peripheral blood was studied using two 5-HT reuptake blockers, alaproclate and zimelidine, in a number of different animal models in which the release of LH and PRL induced by gonadal steroids are thought to be controlled by different mechanisms. The models studied were:

- i) the pro-oestrous female rat
- ii) the short-term OVX rat treated with OB followed by P (model 1)
- iii) the long-term OVX rat treated with OB followed by P (model 2)
- iv) the long-term OVX rat treated with OB followed by OB (model 3)
- v) the long-term OVX rat exposed to a continuously elevated concentration of OB (model 4).

Injection of 30mg alaproclate/kg at 1500h caused a short-term significant decrease in the concentration of PRL in the pro-oestrous rat and in models 1, 3 and 4. In model 2, after a similar injection of alaproclate, the plasma PRL concentration was sustained when the concentration of PRL in animals injected with saline had decreased. Alaproclate had no effect on the concentration of LH in peripheral plasma in the pro-oestrous rat or in models 3 and 4 but did cause a significant decrease in the concentration of LH in models 1 and 2 when compared with control animals injected with saline. Zimelidine had no effect on either LH or PRL in any of the models tested.

are consistent with the hypothesis
These results \wedge that the blockade of 5-HT uptake affects the release of LH and PRL in several types of endocrine preparations and that the direction of change is dependent upon the steroid environment of the preparation. The lack of effect of zimelidine may be due to the mixed actions of this compound (Harms, 1983) that may cause changes in the activity of systems other than 5-HT: these changes may be in direct opposition to those induced by alterations in 5-HT activity and hence lead to no net effect on hormone release.

To determine whether the hormonal changes were due to changes in 5-HT activity, the concentration of 5-HT and its major metabolite, 5-HIAA, were measured in three areas of the brain (AH, PH and R) in some of these animal models at the time of maximal changes in hormone concentration. The three models studied, the pro-oestrous rat and models 1 and 2, were chosen because there is more convincing evidence for interactions between 5-HT systems and progesterone than there is for interactions between 5-HT systems and oestrogen. There were no changes in the concentration of either 5-HT or 5-HIAA or in the 5-HIAA/5-HT ratio in the AH in any of the three models after an injection of alaproclate. There were small but not significant increases in the concentration of 5-HT and decreases in the concentration of 5-HIAA in PH and R in the pro-oestrous rat and in model 1, which accounted for significant decreases in the 5-HIAA/5-HT ratio. Model 2 only showed changes in 5-HT, 5-HIAA and in the 5-HIAA/5-HT ratio in R. It was proposed that the changes in 5-HT and 5-HIAA caused by the reuptake blocker might be more easily seen if they were superimposed upon a smaller functional pool of 5-HT. However, in male animals treated with a

5-HT synthesis inhibitor and in which the concentrations of 5-HT and 5-HIAA were markedly reduced, there were no significant differences in the concentration of 5-HT or 5-HIAA, or in the 5-HIAA/5-HT ratio. While this may indicate that the 'functional pool' of 5-HT in animals treated with a synthesis inhibitor is so severely depleted that 5-HT is released at such a low rate that the effect of a reuptake blocker is not seen, there is also the possibility that the reuptake blocker may only be effective on the release of newly-synthesized 5-HT and may have no effect on the release of previously-synthesized and stored transmitter.

The studies carried out in Chapter 6 were designed to determine whether the PRL surge that accompanies the LH surge on the afternoon of pro-oestrus is inhibited by treatment of animals with an inhibitor of 5-HT synthesis, and if so, whether this could be due to a peripheral action of the inhibitor on the ovary. The LH surge was abolished in all animals treated with the synthesis inhibitor but although the PRL surge was also abolished after treatment with the synthesis inhibitor in most animals, a few animals still exhibited normal PRL surges despite the treatment. Subsequent measurement of the peripheral plasma concentration of OE revealed that the effect of the synthesis inhibitor to block the surges of LH and PRL was probably due to an action on the ovary since OE concentrations were decreased in the treated group of animals. The treated group of animals could be divided into two groups: firstly, animals in which both the LH and PRL surges had been abolished and in which the plasma OE concentration was <30pg/ml and secondly, animals in which the LH but not the PRL surge had been abolished and in which the

plasma OE concentration was $>30\text{pg/ml}$ but $<60\text{pg/ml}$. (There are also likely to have been changes in the peripheral concentration of progesterone, although this was not measured, since certain animals treated with the synthesis inhibitor but not included in the hormonal study showed vaginal indications of pseudopregnancy.) This study revealed the existence of a possible difference in the peripheral threshold concentration of OE required to induce the LH and PRL surges. This hypothesis requires further investigation using OVX animals treated with different doses of oestrogen and progesterone before it can be more than a tentative proposal.

The release of PRL during the afternoon of pro-oestrus is dependent upon a complex series of interactions between gonadal steroids, PIFs and PRFs. The contribution of a proposed PRF, TRH, to the pro-oestrous PRL surge was studied in Chapter 7. Injection of female rats with a specific anti-TRH serum at 1300h on the afternoon of pro-oestrus caused a delay in the onset of the PRL surge but had no effect on the maximum concentration of PRL in peripheral plasma. This result suggests that if TRH has a functional role in the control of the pro-oestrous surge of PRL, it is unlikely to be of major importance and is probably transient.

In common with TRH, originally proposed solely as a releasing factor for TSH but subsequently ascribed additional actions, other hypothalamic peptides originally proposed as having only one action have been suggested to have many other effects. Vasopressin and oxytocin were studied in this thesis with respect to their release into hypophysial portal blood and possible function as releasing factors, rather than with respect to their more classical actions in

the PN. The two peptides were present in hypophysial portal blood at concentrations significantly higher than those in peripheral blood. The source of the two peptides was probably specific VP- and OT- containing terminals in the EL of the ME since neither the PN, axons of the SOHT or CSF contributed significantly to the concentrations present in hypophysial portal blood. Vasopressin was undetectable in hypophysial portal blood from the homozygous Brattleboro rat, genetically deficient in VP, but OT was significantly higher in hypophysial portal plasma from both heterozygous and homozygous Brattleboro rats compared with concentrations in Wistar rats. Electrical stimulation of the ME or of areas known to contain VP and OT cell bodies (PVN, SON and SCN) failed to cause any change in the concentrations of the two peptides in hypophysial portal blood. It has been proposed that the VP in the EL of the ME may act as a CRF. This proposal was examined by measuring the concentrations of VP and OT in hypophysial portal blood at various times after adrenalectomy. However, there was no change in the concentration of either of the two peptides at 3, 7 or 10 days after adrenalectomy. As suggested in Chapter 8, the lack of effect of electrical stimulation and of adrenalectomy on the concentrations of VP and OT in hypophysial portal blood suggests that the surgical procedure of exposure and subsequent cutting of the pituitary stalk may lead to trauma and non-specific damage to the VP- and OT- containing terminals in the EL of the ME, causing them to release the two peptides at a maximal rate upon which it is not possible to superimpose any further increase in release.

This thesis serves to demonstrate the increasing complexity of

the control of the release of LH and PRL by hypothalamic peptides and monoamines at both the hypothalamic and pituitary level. The differences between the effects of 5-HT uptake blockers in the various systems studied in this thesis makes it almost impossible to present one unifying hypothesis concerning interactions between 5-HT and peptides in the control of the release of LH and PRL from the PD. This applies equally to the monoamines, NA, DA and ADR. Further work on interactions between aminergic and peptidergic neurons in the hypothalamus and ME is confounded by the biological complexities of the interactions and the fact that there are few, if any, drugs (none in the case of 5-HT) which have only one specific action.

BIBLIOGRAPHY

- ABRAHAM, G.E. (1974). Radioimmunoassay of steroids in biological materials. *Acta. Endocrinol. (Supp.)* 183, 7-42.
- ACEVES, J. and CUELLO, A.C. (1981). Dopamine release induced by electrical stimulation of microdissected caudate-putamen and substantia nigra of the rat brain. *Neuroscience* 6, 2069-2075.
- ACHILLI, G., PEREGO, C., PONZIO, F. and ALGERI, S. (1983). Simultaneous determination of DA, NA, 5-HT and their metabolites in several rat brain areas by HPLC with electrochemical detection. *Res. Commun. Chem. Pathol. Pharmacol.* 40, 67-72.
- ADAMS, K. (1969). "Electrochemistry of Solid Electrodes". Marcel Dekker: New York.
- AGNATI, L., FUXE, K., HÖKFELT, T., GOLDSTEIN, M. and JEFFCOATE, S.L. (1977). A method to measure the distribution pattern of specific nerve terminals in sampled regions. Studies of tyrosine hydroxylase, LHRH, TRH and GIH immunofluorescence. *J. Histochem. Cytochem.* 25, 1222-1236.
- AHRÉN, K., FUXE, K., HAMBERGER, L. and HÖKFELT, T. (1971). Turnover changes in the tuberoinfundibular dopamine neurons during the ovarian cycle of the rat. *Endocrinology* 88, 1415-1424.
- AIYER, M.S. (1974). Changes in the sensitivity of the anterior pituitary gland to gonadotrophin-releasing factors during the oestrous cycle of the rat. D. Phil thesis, Oxford Univ.
- AIYER, M.S., CHIAPPA, S.A. and FINK, G. (1974). A priming effect of luteinizing hormone releasing factor on the anterior pituitary gland in the female rat. *J. Endocrinol.* 62, 573-588.
- AIYER, M.S. and FINK, G. (1974). The role of sex steroid hormones in modulating the responsiveness of the anterior pituitary to luteinizing hormone releasing factor in the female rat. *J. Endocrinol.* 62, 553-572.
- AIYER, M.S., FINK, G. and GREIG, F. (1974). Changes in the sensitivity of the pituitary gland to luteinizing hormone releasing factor (LRF) during the oestrous cycle of the rat. *J. Endocrinol.* 60, 47-64.
- AIYER, M.S., SOOD, M.C. and BROWN-GRANT, K. (1976). Pituitary response to exogenous luteinizing hormone releasing factor in the female rat. *J. Endocrinol.* 69, 255-262.
- AIZAWA, T., YASUDA, N., GREER, M.A. and SAWYER, W.H. (1982). In vivo adrenocorticotropin-releasing activity of neurohypophyseal hormones and their analogs. *Endocrinology* 110, 98-104.

- AJIKA, K. (1979). Simultaneous localization of LHRH and catecholamines in rat hypothalamus and median eminence. *J. Anat.* 128, 331-347.
- AL SATLI, M. and ARON, C.L. (1981). Role played by serotonin in the control of oestrus receptivity, ovarian activity and ovulation in the cyclic female rat. *Psychoneuroendocrinology* 6, 121-129.
- AMEMOMORI Y., CHEN, C.L. and MEITES, J. (1970). Serum prolactin levels in rats during different reproductive states. *Endocrinology*, 86, 505-510.
- ANDÈN, N.E., DAHLSTRÖM, A., FUXE, K., LARSSON, K., OLSON, L. and UNGERSTEDT, U. (1966). Ascending monoamine neurons to the telencephalon and diencephalon. *Acta. Physiol. Scand.* 67, 313-326.
- ANNUNZIATO, L. (1979). Regulation of the tuberoinfundibular and nigrostriatal systems (evidence for different kinds of dopaminergic neurons in the brain). *Neuroendocrinology* 29, 66-76.
- ANNUNZIATO, L., CERRITO, F. and RAITERI, M. (1981). Characteristics of dopamine release from isolated nerve endings of the tuberoinfundibular neurones. *Neuropharmacology* 20, 727-731.
- ANNUNZIATO, L., LEBLANC, P. KORDON, C. and WEINER, R.I. (1980). Differences in the kinetics of dopamine uptake in synaptosome preparations of the median eminence relative to other dopaminergically innervated brain regions. *Neuroendocrinology* 31, 316-310.
- ANNUNZIATO, L. and MOORE, K.E. (1978). Prolactin in CSF selectively increases dopamine turnover in the median eminence. *Life Sci.* 22, 2037-2042.
- ARBILLA, S., KAMAL, L.A. and LANGER, S.Z. (1980). Presynaptic dopamine receptors modulate electrical stimulation but not amphetamine-evoked release of ³H-dopamine from the rabbit caudate nucleus. *Br. J. Pharmacol.* 70, 45P-46P.
- ARIMURA, A. and SCHALLY, A.V. (1977). Prolactin release inhibiting and stimulating factors in the hypothalamus. In "Hypothalamic Peptide Hormones and Pituitary Regulation". Ed. Porter J.C. Raven Press: New York; p.237-252.
- ARIMURA, A., SMITH, W.D. and SCHALLY, A.V. (1976). Blockade of the stress-induced decrease in blood GH by anti-somatostatin serum in rats. *Endocrinology* 98, 540-543.
- AUERBACH, S. and LIPTON, P. (1982). Vasopressin augments depolarization-induced release and synthesis of serotonin in hippocampal slices. *J. Neurosci.* 2, 477-482.

- AXELROD, J. and ISCOE, J.K. (1963). The uptake and binding of circulating serotonin and the effect of drugs. *J. Pharmacol. Exp. Ther.* 141, 161-165.
- AZMITIA, E.C. and MCEWEN, B.S. (1974). Adrenal cortical influence on rat brain tryptophan hydroxylase activity. *Brain Res.* 78, 291-302.
- BALDESSARINI, R.J. and VOGT, M. (1971). Uptake and release of norepinephrine by rat brain tissue fractions prepared by ultrafiltration. *J. Neurochem.* 18, 951-962.
- BALMENT, R.J., BRIMBLE, M.J. and FORSLING, M.L. (1980). Release of oxytocin induced by salt loading and its influence on renal excretion in the male rat. *J. Physiol.* 308, 439-449.
- BANKS, J.A. and FREEMAN, M.E. (1980). Inhibition of the daily LH release mechanism by progesterone acting at the hypothalamus. *Biol. Reprod.* 22, 217-222.
- BARNEA, A., BEN-JONATHAN, N., COLSTON, C., JOHNSTON, J.M. and PORTER, J.C. (1975). Differential sub-cellular compartmentalization of thyrotropin releasing hormone (TRH) and luteinizing hormone releasing hormone (LRH) in hypothalamic tissue. *Proc. Natl. Acad. Sci. USA*, 72, 3153-3157.
- BARONDES, S.H., JOHNSON, P. and FIELD, J.B. (1961). Stimulation of anterior pituitary and cerebral glucose oxidation by neurohumoral agents. *Endocrinology* 69, 809-818.
- BARRACLOUGH, C.A. and WISE, P.M. (1982). The role of catecholamines in the regulation of pituitary luteinizing hormone and follicle-stimulating hormone secretion. *Endocr. Rev.* 3, 91-119.
- BARRY, J., DUBOIS, M.P. and POULAIN, P. (1973). LRF producing cells of the mammalian hypothalamus; a fluorescent antibody study. *Z. Zellforsch.* 146, 351-366.
- BAUMANN, P.A. and MAITRE, L. (1976). Is drug inhibition of dopamine uptake a misinterpretation of in vitro experiments?. *Nature* 264, 789-790.
- BAUMGARTEN, H.G. and LACHENMAYER, L. (1974). Indoleamine-containing nerve terminals in the rat median eminence. *Z. Zellforsch.* 147, 285-292.
- BEAUDET, A. and DESCARRIES, L. (1979). Radioautographic characterization of a serotonin accumulating nerve cell group in adult rat hypothalamus. *Brain Res.* 160, 231-243.
- BECK, E. and DANIEL, P.M. (1961). Degeneration and regeneration in the hypothalamus. In: "Cytology of Nervous Tissue" proceedings, Anatomical Society. Taylor and Francis: London; p. 60-63.

- BECK, W. and WUTTKE, W. (1977). Densitization of the dopaminergic inhibition of pituitary luteinizing hormone release by prolactin in ovariectomized rats. *J. Endocrinol.* 74, 67-74.
- BECU, D. and LIBERTUN, C. (1982). Comparative maturation of the regulation of prolactin and thyrotropin by serotonin and thyrotropin-releasing hormone in male and female rats. *Endocrinology* 110, 1879-1884.
- BELLERBY, C.W. (1929a). The physiological properties of anterior lobe pituitary extract in relation to the ovary. *J. Physiol.* 67, 32P-33P.
- BELLERBY, C.W. (1929b). The relation of the anterior lobe of the pituitary to ovulation. *J. Physiol.* 67, 33P-34P.
- BEN-JONATHAN, N. (1980). Catecholamines and pituitary prolactin release. *J. Reprod. Fertil.* 58, 501-512.
- BEN-JONATHAN, N., OLIVER, C., WEINER, H.J., MICAL, R.S. and PORTER, J.C. (1977). Dopamine in hypophysial portal plasma of the rat during the estrous cycle and throughout pregnancy. *Endocrinology*, 100, 452-458.
- BENNETT, G.W., EDWARDSON, J.A., HOLLAND, D.T., JEFFCOATE, S.L. and WHITE, N. (1975). Release of immunoreactive luteinizing hormone releasing hormone and thyrotrophin-releasing hormone from hypothalamic synaptosomes. *Nature* 257, 323-325.
- BENNETT, G.W., MARSDEN, C.A., METCALF, G., SHARP, T. and TULLOCH, I.F. (1981). Analogues of thyrotrophin releasing hormone (TRH) stimulate *in vitro* release of endogenous dopamine from rat brain regions. *Br. J. Pharmacol.* 74, 227-228.
- BENOIT J. and ASSENMACHER I. (1953). Rapport entre la stimulation sexuelle prehypophysaire et la neurosecretion chez l'oiseau. *Archs. Anat. Microsc. Morph. Exp.* 42, 334-386.
- BÉNY, J.L. and BAERTSCHI, A.J. (1980). Oxytocin: major corticotropin-releasing factor secreted from diabetes insipidus rat posterior pituitary *in vitro*. *Neuroendocrinology* 31, 261-264.
- BÉNY, J.L. and BAERTSCHI, A.J. (1981). Release of vasopressin from the microdissected median eminence of the rat. *Brain Res.* 206, 469-473.
- BERGLAND, R.M. and PAGE, R.B. (1978). Can the pituitary secrete directly to the brain? (affirmative anatomical evidence). *Endocrinology* 102, 1325-1338.
- BHARGAVA, K.P., KULSHRESTHA, V.K. and SRIVASTAVA, V.P. (1972). Central cholinergic and adrenergic mechanisms in the release of anti-diuretic hormone. *Br. J. Pharmacol.* 44, 617-627.

- BICKNELL, R.J. and LENG, G. (1981). Relative efficiency of neural firing patterns for vasopressin release in vitro. *Neuroendocrinology*, 33, 295-299.
- BIEGON, A., BERCOVITZ, H. and SAMUEL, D. (1980). Serotonin receptor concentration during the oestrus cycle of the rat. *Brain Res.* 187, 221-225.
- BIEGON, A., FISCHETTE, C.T., RAINBOW, T.C. and MCEWEN, B.S. (1982). Serotonin receptor modulation by oestrogen in discrete brain nuclei. *Neuroendocrinology* 35, 287-291.
- BIEGON, A. and MCEWEN, B.S. (1982). Modulation by estradiol of serotonin receptors in brain. *J. Neurosci.* 2, 199-205.
- BIRGE, C.A., JACOBS, L.S., HAMMER, C.T. and DAUGHADAY, W.H. (1970). Catecholamine inhibition of prolactin secretion by isolated adenohypophyses. *Endocrinology* 86, 120-130.
- BISHOP, W., KRULICH, L. FAWCETT, C.P. and MCCANN, S.M. (1971). The effect of median eminence (ME) lesions on plasma levels of FSH, LH and prolactin in the rat. *Proc. Soc. Exp. Biol. Med.* 136, 925-927.
- BISSONETTE, T.H. (1932). Modifications of mammalian sexual cycles; reactions of ferrets (*Putorius vulgaris*) of both sexes to electric light added after dark in November and December. *Proc. R. Soc. Lond. (Biol)* 110, 322-336.
- BJÖRKLUND, A., FALCK, B., NOBIN, A. and STENEVI, U. (1973). Organization of the dopamine and noradrenaline innervations of the median eminence-pituitary region in the rat. In "Neurosecretion - The Final Neuroendocrine Pathway". Ed. Knowles F. and Vollrath P. Springer: New York; p.209-222.
- BJÖRKLUND A., LINDVALL, O. and NOBIN, A. (1975). Evidence of an incerto-hypothalamic dopamine neurone system in the rat. *Brain Res.* 89, 29-42.
- BJÖRKLUND A., MOORE, R.Y., NOBIN, A. and STENEVI, U. (1973). The organization of tubero-hypophyseal and reticulo-infundibular catecholamine neuron system in the rat brain. *Brain Res.* 51, 171-191.
- BLAKE, C.A. (1974). Stimulation of pituitary prolactin and TSH release in lactating and proestrous rats. *Endocrinology* 94, 503-508.
- BLAKE, C.A. (1977). A medial basal hypothalamic site of synergistic action of estrogen and progesterone on the inhibition of pituitary luteinizing hormone release. *Endocrinology* 101, 1130-1134.

- BLAKE, C.A., NORMAN, R.L. and SAWYER, C.H. (1974). Localization of the inhibitory actions of estrogen and nicotine on release of luteinizing hormone in rats. *Neuroendocrinology* 16, 22-35.
- BLAKE, C.A., NORMAN, R.L., SCARAMUZZI, R.T. and SAWYER, C.H. (1973). Inhibition of the proestrus surge of prolactin in the rat by nicotine. *Endocrinology*, 92, 1334-1338.
- BLUME, H.W., PITTMAN, Q.J., RENAUD, L.P. (1978). Electrophysiological indications of a 'vasopressinergic' innervation of the median eminence. *Brain Res.* 155, 153-158.
- BOER, K., CRANSBERG, K. AND DOGTEROM, J. (1980). Effect of low-frequency stimulation of the pituitary stalk on neurohypophysial hormone release in vivo. *Neuroendocrinology* 30, 313-318.
- BOGDANOVA, E.M. (1963). Direct gonad-pituitary feedback: analysis of the effects of intracranial estrogenic depots on gonadotrophin secretion. *Endocrinology*, 73, 696-712.
- BOGDANOVA, E.M., NOLIN, T.H. and CAMPBELL, G.T. (1975). Qualitative and quantitative gonad-pituitary feedback. *Recent Prog. Horm. Res.* 31, 567-619.
- BOGDANSKI, D.F., BLASZKOWSKI, T.P. and TISSARI, A.H. (1970). Mechanism of biogenic amine storage and transport IV Relationship between K^+ and Na^+ requirement for transport and storage of 5-hydroxytryptamine and norepinephrine in synaptosomes. *Biochim. Biophys. Acta.* 211, 521-532.
- BOGDANSKI, D.F. and TISSARI, A. (1976). Sodium dependent uptake and storage of amines in synaptosomes. *Pharmacologist.* 9, 250-253.
- BRIDGES, T.E., HILLHOUSE, E.W. and JONES, M.T. (1976). The effect of dopamine on neurohypophysial hormone release in vivo and from the rat neural lobe and hypophysis in vitro. *J. Physiol.* 260, 647-666.
- BRINKMANN H. and BOCK, R. (1973). Influence of various corticoids on the augmentation of "Gomori-positive" granules in the median eminence of the rat following adrenalectomy. *N.S. Arch. Pharmacol.* 280, 49-62.
- BROOKS, C.McC. (1935). Studies on the neural basis of ovulation in the rabbit. *Am. J. Physiol.* 113, 18-19.
- BROWN-GRANT, K. (1974). Steroid hormone administration and gonadotrophin secretion in the gonadectomized rat. *J.Endocrinol.* 62, 319-332.
- BROWN-GRANT, K. (1977). Physiological aspects of steroid hormone gonadotropin interrelationships. In: *International Review of Physiology, Reproductive Physiology II*, Vol 13. Ed. Greep, R.O., University Park Press: Baltimore; p. 57-83.

- BROWN-GRANT, K., DUTTON, A. and TER HAAR, M.B. (1977). Variations in plasma thyrotropin concentration during the rat oestrous cycle. *J. Endocrinol.* 72, 33P.
- BROWN-GRANT, K. and RAISMAN, G. (1977). Abnormalities in reproductive function associated with the destruction of the suprachiasmatic nuclei in female rats. *Proc. R. Soc. Lond (Biol)*, 198, 279-296.
- BRUNI, J.F., HAWKINS, R.L. and YEN, S.S.C. (1982). Serotonergic mechanism of the control of β -endorphin and ACTH release in male rats. *Life Sci.* 30, 1247-1254.
- BROWNSTEIN, M.J., PALKOVITS, M., SAAVEDRA, J.M., BASSIRI, R. and UTIGER, R.D. (1974). Thyrotropin-releasing hormone in specific nuclei of rat brain. *Science*, 185, 267-279.
- BUCKINGHAM, J.C. (1981). The influence of vasopressin on hypothalamic corticotrophin releasing activity in rats with inherited diabetes insipidus. *J. Physiol.* 312, 9-16.
- BUCKINGHAM, J.C. and HODGES, J.R. (1979). Hypothalamic receptors influencing the secretion of corticotrophin releasing hormone in the rat. *J. Physiol* 290, 421-431.
- BULAT, M. and SUPEK, Z. (1968). Passage of 5-hydroxytryptamine through the blood brain barrier, its metabolism in the brain and elimination of 5-hydroxyindoleacetic acid from the brain tissue. *J. Neurochem.* 15, 383-389.
- BURGUS, R., BUTCHER, M., AMOSS, M., LING, N., MONAHAN, M., RIVIER, J. FELLOWS, R., BLACKWELL, R., VALE, W. and GUILLEMIN, R. (1972). Primary structure of the hypothalamic luteinizing hormone-releasing factor (LRF) of ovine origin. *Proc. Natl. Acad. Sci. USA* 69, 278-282.
- BURLET, A., CHATEAU, M. and CZERNICHOW, P. (1979). Infundibular localization of vasopressin, oxytocin and neurophysins in the rat; its relationships with corticotrope function. *Brain Res.* 168, 275-286.
- BURNSTOCK, G. (1976). Do some nerve cells release more than one transmitter?. *Neuroscience* 1, 239-248.
- BURNSTOCK, G. and HOLMAN, M.E. (1961). The transmission of excitation from autonomic nerve to smooth muscle. *J. Physiol.* 155, 115-133.
- BUTCHER, A.L., COLLINS, W.E. and FUGO, N.W. (1974). Plasma concentration of LH, FSH, prolactin, progesterone and estradiol-17 β throughout the 4-day oestrous cycle of the rat. *Endocrinology* 94, 1704-1708.

- CAJAL, S.R., (1894). Algunas contribuciones al conocimiento del cerebro, III Hypophysis. In: An. Soc. Esp. Hist. Nat. 2 a series t3, cited from "Histologie du systeme nerveux de l'Homme et de Vertebres". S.R.Cajal, French translation, Paris 1911. editeur A. Maloine.
- CALAS, A., ALONSO G., ARNAULD, E. and VINCENT, J.D. (1974). Demonstration of indoleaminergic fibres in the median eminence of the duck, rat and monkey. *Nature* 250, 241-243.
- CALIGARIS, L., ASTRADA, J.J. and TALEISNIK, S. (1968). Stimulating and inhibiting effects of progesterone on the release of luteinizing hormone. *Acta Endocrinol.* 59, 177-185.
- CALIGARIS, L., ASTRADA, J.J. and TALEISNIK, S. (1971). Release of luteinizing hormone induced by estrogen injection into ovariectomized rats. *Endocrinology*, 88, 810-815.
- CALIGARIS L., ASTRADA, J.J. and TALEISNIK, S. (1974). Oestrogen and progesterone influence on the release of prolactin in ovariectomized rats. *J. Endocrinol.* 60, 205-215.
- CALIGARIS, L. and TALEISNIK, S. (1974). Involvement of neurones containing 5-hydroxytryptamine in the mechanism of prolactin release induced by oestrogen. *J. Endocrinol.* 62, 25-33.
- CALIGARIS L. and TALEISNIK, S. (1977). Further evidence on the role of the hypothalamic afferents on the estrogen-induced prolactin release. *Neuroendocrinology* 23, 323-329.
- CAMPBELL, H.J., FEUER, G. and HARRIS, G.W. (1964). The effect of intra-pituitary infusion of median eminence and other brain extracts on anterior pituitary gonadotrophic secretion. *J. Physiol.* 170, 474-486.
- CARLSSON, A. (1975). Receptor-mediated control of dopamine metabolism. In: "Pre- and postsynaptic receptors". Eds. Usdin, E. and Bunney, W.E. Jr. Marcel Dekker: New York; p. 49-66.
- CARR, L.A., CONWAY, P.M. and VOOGT, J.L. (1977). Role of norepinephrine in the release of prolactin induced by suckling and oestrogen. *Brain Res.* 133, 305-314.
- CARR, L.A. and VOGT, J.L. (1980). Catecholamine synthesizing enzymes in the hypothalamus during the oestrus cycle. *Brain Res.* 196, 437-445.
- CELIS, M.E., TALEISNIK, S. and WALTER, R. (1971). Release of pituitary melanocyte-stimulating hormone by the oxytocin fragment H-Cys-Tyr-Ile-Gln-Asn-OH. *Biochem. Biophys. Res. Comm.* 45, 564-569.

- CHAN-PALAY, V., JONSSON, G. and PALAY, S.L. (1978). On the coexistence of serotonin and substance P in neurons of the rat's central nervous system. Proc. Natl. Acad. Sci. USA 75, 1582-1586.
- CHARLI, J.L., ROTSZTEJN, W.H., PATTOU, E. and KORDON, C. (1978). Effect of neurotransmitters on *in vitro* release of luteinizing-hormone-releasing-hormone from the mediobasal hypothalamus of male rats. Neurosci. Lett. 10, 159-163.
- CHEESMAN, D.W., OSLAND, R.B. and FORSHAM, P.H. (1977). Effects of 8-arginine vasotocin on plasma prolactin and follicle-stimulating hormone surges in the proestrous rat. Proc. Soc. Exp. Biol. Med. 156, 369-372.
- CHEESMAN, D.W., OSLAND, R.B. and FORSHAM, P.H. (1977). Suppression of the pre-ovulatory surge of luteinizing hormone and subsequent ovulation in the rat by arginine vasotocin. Endocrinology 101, 1194-1202.
- CHEN, C.L. and MEITES, J. (1970). Effects of estrogen and progesterone on serum and pituitary prolactin levels in ovariectomized rat. Endocrinology 86, 503-505.
- CHEN, Y.F. and RAMIREZ, V.D. (1981). Serotonin stimulates thyrotropin-releasing hormone release from superfused rat hypothalami. Endocrinology 108, 2359-2366.
- CHEN, H.T., SYLVESTER, P.W., HEIRI, T. and MEITES, J. (1981). Potentiation of luteinizing hormone release by serotonin agonists in ovariectomized steroid-primed rats. Endocrinology 108, 948-952.
- CHEUNG, C.Y. and WEINER, R.I. (1976). Supersensitivity of pituitary dopamine receptors involved in the inhibition of prolactin secretion following destruction of the medial basal hypothalamus. Endocrinology 99, 914-916.
- CHIAPPA, S.A. (1976). Measurement of gonadotrophin and corticotrophin releasing activity of pituitary stalk blood and brain extracts under various physiological and experimental conditions. D. Phil. Thesis: Oxford Univ.
- CHOROBSKI, J. and PENFIELD, W. (1932). Cerebral vasodilator nerves and their pathway from the medulla oblongata. Arch. Neurol. Psychiat. 28, 1257-1289.
- CLARK, R.H. and BAKER, B.L. (1964). Circadian periodicity in the concentration of prolactin in the rat hypophysis. Science 143, 375-376.
- CLEMENS, J.A., GALLO, R.V., WHITMOYER, D.I. and SAWYER, C.H. (1971). Prolactin responsive neurons in the rabbit hypothalamus. Brain Res. 25, 371-379.

- CLEMENS, J.A., ROUSH, M.E. and FULLER, W. (1978). Evidence that serotonin neurons stimulate secretion of prolactin releasing factor. *Life Sci.* 22, 2209-2214.
- CLEMENS, J.A., SAWYER, B.D. and CERIMELE, B. (1977). Further evidence that serotonin is a neurotransmitter involved in the control of prolactin secretion. *Endocrinology* 100, 692-698.
- COBB, S. and FINESINGER, J.E. (1932). Cerebral circulation: XIX The vagal pathway of the vasodilator impulses. *Arch. Neurol. Psychiat.* 28, 1243-1256.
- COEN, C.W., COOMBS, M.C., WILSON, P.M.J., CLEMENT, E.M. and MACKINNON, P.C.B. (1983). Possible resolution of a paradox concerning the use of p-chlorophenylalanine and 5-hydroxytryptophan: evidence for a mode of action involving adrenaline in manipulating the surge of luteinizing hormone in rats. *Neuroscience* 8, 593-608.
- COEN, C.W., FRANKLIN, M., LAYNES, R.W. and MACKINNON, P.C.B. (1980). Effects of manipulating serotonin on the incidence of ovulation in the rat. *J. Endocrinol.* 87, 195-201.
- COEN, C.W. and MACKINNON, P.C.B. (1979). Serotonin involvement in the control of phasic release^{of LH} in the rat: evidence for a critical period. *J. Endocrinol.* 82, 105-113.
- CONE, R.I., DAVIS, G.A. and GOY, R.W. (1981). Effects of ovarian steroids on serotonin metabolism within grossly dissected and microdissected brain regions of the ovariectomized rat. *Brain Res. Bull.* 7, 639-644.
- CONSOLAZIONE A. and CUELLO, A.C. (1982). CNS serotonin pathways. In: "Biology of serotonergic transmission". Ed. Osborne N.N., Wiley: New York; p.29-61.
- COYLE, J.T. and HENRY, D. (1973). Catecholamines in fetal and newborn rat brain. *J. Neurochem.* 21, 61-67.
- CRAMER, O.M. and BARRACLOUGH, C.A. (1971). Effect of electrical stimulation of the preoptic area on plasma LH concentrations in proestrous rats. *Endocrinology* 88, 1175-1183.
- CRANE, R.K. (1965). Na⁺-dependent transport in the intestine and other animal tissues. *Fed. Proc.* 24, 1000-1006.
- CROWLEY, W.R., O'DONOHUE, T.L. and JACO BOWITZ, D.M. (1978). Changes in catecholamine content in discrete brain nuclei during the oestrus cycle of the rat. *Brain Res.* 147, 315-326.
- CROWLEY, W.R., O'DONOHUE, T., MUTH, E.A. and JACOBOWITZ, D.M. (1979). Effects of ovarian hormones on levels of luteinizing hormone in plasma and on serotonin concentrations in discrete brain nuclei. *Brain Res. Bull.* 4, 571-574.

- CUELLO, A.C. (1979). The radioenzymatic assay of catecholamines. In: "The Neurobiology of Dopamine" Eds. Horn, A.S., Westerink, B. and Korf, J., Academic Press: London; p.77-88.
- CUELLO, A.C., HORN, A.S. MACKAY, A.V.P. and IVERSEN, L.L. (1973). Catecholamines in the median eminence: new evidence for a major noradrenergic input. *Nature* 243, 465-467.
- CUELLO, A.C. and IVERSEN, L.L. (1973). Localization of tritiated dopamine in the median eminence of the rat hypothalamus by electron microscope autoradiography. *Brain Res.* 63, 474-478.
- DAHLSTRÖM, A. and FUXE, K. (1966). Monoamines and the pituitary gland. *Acta. Endocrinol.* 51, 301-314.
- DANDY, W.E. (1913). The nerve supply to the pituitary body. *Am. J. Anat.* 15, 333-343.
- D'ANGELO, S.A., WALL, N.R., BOWERS, C.Y. and ROSA, C.G. (1975). Effects of acute and chronic administration of TRH on TSH and prolactin secretion in normal and hypothyroid rats. *Neuroendocrinology* 18, 161-175.
- DANIEL, P.M. and PRICHARD, M.M.L. (1956). Anterior pituitary necrosis. Infarction of the pars distalis produced experimentally in the rat. *Q. J. Exp. Physiol.* 41, 215-229.
- DE GREEF, W.J. and VISSER, T.J. (1981). Evidence for the involvement of hypothalamic dopamine and thyrotropin-releasing hormone in suckling-induced release of prolactin. *J. Endocrinol.* 91, 213-223.
- DE GROOT, J. (1959). The rat forebrain in stereotaxic co-ordinates. *Trans. R. Neth. Acad. Sci.* 52, 1-40.
- DÉKANSKI, J. (1952). The quantitative assay of vasopressin. *Br. J. Pharmac. Chemother.* 7, 567-572.
- DE LÉAN, A., GARON, M., KELLY, P.A. and LABRIE, F. (1977). Changes of pituitary thyrotropin releasing hormone (TRH) receptor level and prolactin response to TRH during the rat estrous cycle. *Endocrinology* 100, 1505-1510.
- DELITALA, G., YEO, T., STUBBS, W.A., JONES, A. and BESSER, G.M. (1980). Effect of serotonin on prolactin secretion *in vitro*. In: "Long Term Effects of Neuroleptics" Eds. Costa, E. and Greengard, P. *Adv. Biochem. Psychopharm.* 24, Raven Press: New York; p. 443-444.
- DEMAREST, K.T., JOHNSTON, C.A. and MOORE, K.E. (1981). Biochemical indices of catecholaminergic neuronal activity in the median eminence during the estrous cycle of the rat. *Neuroendocrinology* 32, 24-27.

- DEMAREST, K.T. and MOORE, K.E. (1979). Lack of a high affinity transport system for dopamine in the median eminence and posterior pituitary. *Brain Res.* 171, 545-551.
- DEMPSEY, E.W. and SEARLES, H.F. (1943). Environmental modification of certain endocrine phenomena. *Endocrinology* 32, 119-128.
- DEMPSEY, E.W. and UOTILA, V.V. (1940). The effect of pituitary stalk section upon reproductive phenomena in the female rat. *Endocrinology* 27, 573-589.
- DENEFF, C. (1981). LHRH stimulates prolactin release from rat pituitary lactotrophs co-cultured with a highly purified population of gonadotrophs. *Ann. Endocrinol. (Paris)* 42, 65-66.
- DESCARRIES, L. and BEAUDET, A. (1978). L'innervation a serotonine de l'hypothalamus chez le rat adulte. In: *Biologie Cellulaire des Processus Neurosecretoires Hypothalamiques. Colloques Internationaux du C.N.R.S.* 880, Ed. Vincent J.D. and Kordon C. p.135-153.
- DE WIED, D. (1977). Peptides and behavior: a review. *Life Sci.* 20, 195-204.
- DE WIED, D. and VERSTEEG, D.H. (1979). Neurohypophyseal principles and memory. *Fed. Proc.* 38, 2348-2354.
- DI CHIARA, G., PORCEDDU, M.L., VARGUI, L., ARGIOLAS, A. and GESSA, G.L. (1976). Evidence for dopamine receptors mediating sedation in the mouse brain. *Nature* 264, 564-567.
- DICK, H.R., CULBERT, J., WELLS, J.W., GILBERT, A.B. and DAVIDSON, M.F. (1978). Steroid hormones in the postovulatory follicle of the domestic fowl (*Gallus domesticus*). *J. Reprod. Fert.* 53, 103-107.
- DIERICKX, K. and VAN DEN ABEELE, A. (1959). On the relations between the hypothalamus and the anterior pituitary in *Rana temporaria*. *Z.Zellforsch.* 51, 78-87.
- DIERICKX, K., VANDESANDE, F. and DE MEY, J. (1976). Identification in the external region of the rat median eminence of separate neurophysin-vasopressin and neurophysin-oxytocin containing nerve fibres. *Cell Tissue Res.* 168, 141-151.
- DIERICKX, F. and VANDESANDE, F. (1977). Immunocytochemical demonstration, in the external region of the amphibian median eminence, of separate vasotocinergic and mesotocinergic nerve fibres. *Cell Tiss. Res.* 177, 47-56.
- DI PAOLO, T., DAIGLE, M., PICARD, V. and BARDEN, N. (1983). Effect of acute and chronic 17β -estradiol treatment on serotonin and 5-hydroxyindole acetic acid content of discrete brain nuclei of ovariectomized rat. *Exp. Brain Res.* 51, 73-76.

- DOGTEROM, J., VAN WIMERSMA GRIEDANUS, Tj.B., and DE WIED, D. (1978). Vasopressin in cerebrospinal fluid and plasma of man, dog and rat. *Am. J. Physiol.* 234, E463-E467.
- DONOVAN, B.T. and HARRIS, G.W. (1956). Adrenergic agents and the release of gonadotrophic hormone in the rabbit. *J. Physiol* 132, 577-585.
- DOUGLAS, W.W. (1975). Histamine and 5-hydroxytryptamine (serotonin) and their antagonists. In: "The Pharmacological Basis of Therapeutics". Eds. Goodman, L.S. and Gilman, A. MacMillan: New York; p. 609-646.
- DROUVA, S.V., LAPLANTE, E. and KORDON, C. (1983). Effects of ovarian steroids on *in vitro* release of LHRH from mediobasal hypothalamus. *Neuroendocrinology* 37, 336-341.
- DUNCAN, D.B. (1955). Multiple range and multiple F tests. *Biometrics* 11, 1-42.
- DUNN, J.D., ARIMURA, A. and SCHEVING, L.E. (1972). Effect of stress on circadian periodicity in serum LH and prolactin concentration. *Endocrinology* 90, 29-33.
- DUNN, J.D., JOHNSON, D.C., CASTRO, A.J. and SWENSON, R. (1980). Twenty-four hour pattern of prolactin levels in female rats subjected to transection of the mesencephalic raphe or ablation of the suprachiasmatic nuclei. *Neuroendocrinology* 31, 85-91.
- DYER, R.J. and DYBALL, R.E.J. (1974). Evidence for a direct effect of LRF and TRF on single unit activity in the rostral hypothalamus. *Nature* 252, 486-488.
- DYER, R.G. and MANSFIELD, S. (1983). Evidence that different mechanisms probably mediate the LH surges induced by progesterone and oestrogen in the rat. *J. Physiol.* 343, 123P.
- EIKENBURG, D.C., RAVITZ, A.J., GUDELSKY, G.A. and MOORE, K.E. (1977). Effects of estrogen on prolactin and tuberoinfundibular dopaminergic neurons. *J. Neural Transm.* 40, 235-244.
- EKINS, R.P. (1974). Basic principles and theory. *Brit. Med. Bull.* 30, 3-11.
- ENDERSBY, C.A. and WILSON, C.A. (1974). The effect of ovarian steroids on the accumulation of ³H-labelled monoamines by hypothalamic tissue *in vitro*. *Brain Res.* 73, 321-331.
- ENJALBERT, A., RUBERG, M., ARANCIBIA S., FIORE, L. PRIAM, M. and KORDON, C. (1979). Independent inhibition of prolactin secretion by dopamine and γ -aminobutyric acid *in vitro*. *Endocrinology* 105, 823-826.

- ENJALBERT, A., RUBERG, M., ARANCIBIA, S., PRIAM, M. and KORDON, C. (1979). Inhibition of in vitro prolactin secretion by histidyl-proline-diketopiperazine, a degradation product of TRH. Nature 280, 595-597.
- EPELBAUM, J., TAPIA-ARANCIBIA, L. and KORDON, C. (1981). Noradrenaline stimulates somatostatin release from incubated slices of the amygdala and the hypothalamic preoptic area. Brain Res. 215, 393-397.
- ESKAY, R.L., MICAL, R.S. and PORTER, J.C. (1977). Relationship between luteinizing hormone releasing hormone concentration in hypophysial portal blood and luteinizing hormone release in intact, castrated and electrochemically-stimulated rats. Endocrinology 100, 263-270.
- ESKAY, R.L., OLIVER, C., BEN-JONATHAN, N. and PORTER, J.C. (1978). Hypothalamic hormones in portal and systemic blood. In: "Hypothalamic Hormones: Chemistry, Physiology and Clinical Uses". Eds. Motta, M., Martini, L. and Crosignani, P.G. Academic Press: New York; p. 139-160.
- EVERETT, J.W. (1954). Luteotrophic function of autografts of the rat hypophysis. Endocrinology 54, 685-690.
- EVERETT, J.W. (1964). Central neural control of reproductive functions of the adenohypophysis. Physiol. Rev. 44, 373-431.
- EVERETT, J.W. (1965). Ovulation in rats from preoptic stimulation through platinum electrodes. Importance of duration and spread of stimulus. Endocrinology 76, 1195-1201.
- EVERETT, J.W. and QUINN, D.L. (1966). Differential hypothalamic mechanisms inciting ovulation and pseudopregnancy in the rat. Endocrinology 78, 141-150.
- **
- EVERITT, B.J., FUXE, K., HÖKFELT, T. and JONSSON, G. (1975). Role of monoamines in the control of hormones of sexual receptivity in the female rat. J.Comp.Physiol.Psychol. 89, 556-572.
- FAGIN, K.D. and NEILL, J.D. (1981). The effect of dopamine on thyrotropin-releasing hormone-induced prolactin secretion in vitro. Endocrinology 109, 1835-1840.
- FANG, V.S. (1976). Effects of dopamine and serotonin on prolactin release from rat pituitary cells. Fed. Proc. 35 305 (Abst.)
- FARNEBO, L-O and HAMBERGER, B. (1971). Drug-induced changes in the release of ³H-monoamines from field stimulated rat brain slices. Acta. Physiol Scand. (Suppl.) 371, 35-44.
- FEE, A.R. and PARKES, A.S. (1929). Studies on ovulation I. The relation of the anterior pituitary body to ovulation in the rabbit. J.Physiol. 67, 383-388.

** EVERETT, J.W. and SAWYER, C.H. (1950) A 24hr periodicity in the 'LH-release apparatus' of female rats disclosed by barbiturate sedation. Endocrinology 47 198-218.

- FEHM, H.L., VOIGT, K.H., LANG, R.E. and PFEIFFER, E.F. (1980). Effect of neurotransmitters on the release of corticotropin releasing hormone (CRH) by rat hypothalamic tissue in vitro. *Exp. Brain Res.* 39, 229-234.
- FELDBERG, W. and VOGT, M. (1948). Acetylcholine synthesis in different regions of the central nervous system. *J.Physiol.* 107, 372-381.
- FELL, L.R., FINDLAY, J., CUMMING, I.A. and GODING, J.R. (1973). Effect of synthetic TRF on prolactin release in the sheep. *Endocrinology* 93, 487-491.
- FERIN, M., TEMPONE, A., ZIMMERING, P.E. and VAN DE WIELE, R.L. (1969). Effect of antibodies to 17 β -estradiol and progesterone on the estrous cycle of the rat. *Endocrinology* 85, 1070-1078.
- FINK, G. (1976). The development of the releasing factor concept. *Clin.Endocrinol.* 5, 245s-260s.
- FINK, G. (1979a). Neuroendocrine control of gonadotrophin secretion. *Brit. Med. Bull.* 35, 155-160.
- FINK, G. (1979b). Feedback actions of target hormones on hypothalamus and pituitary with special reference to gonadal steroids. *Ann. Rev. Physiol.* 41, 571-585.
- FINK, G.F., FRASER, H.M. and SHEWARD, J.W. (1983). Effect of passive immunisation with anti-TRH serum on electrically stimulated release of prolactin and TSH in the male rat. *J. Physiol.* (in press).
- FINK, G. and GEFFEN, L.B. (1978). The hypothalamo-hypophysial system: model for central peptidergic and monoaminergic transmission. In: *International Review of Physiology Neurophysiology III Volume 17*. Ed. Porter, R. University Park Press: Baltimore; p.1-48.
- FINK, G. and HARRIS, G.W. (1970). The luteinizing hormone releasing activity of extracts of blood from the hypophysial portal vessels of rats. *J. Physiol.* 208, 221-241.
- FINK, G. and HENDERSON, S.R. (1977a). Steroids and pituitary responsiveness in female, androgenized female and male rats. *J.Endocrinol.* 73, 157-164.
- FINK, G. and HENDERSON, S.R. (1977b). Site of modulatory action of oestrogen and progesterone on gonadotrophin response to luteinizing hormone releasing factor. *J. Endocrinol.* 73, 165-170.
- FINK, G. and JAMIESON, M.G. (1976). Immunoreactive luteinizing hormone releasing factor in rat pituitary stalk blood: effects of electrical stimulation of the medial preoptic area. *J. Endocrinol.* 68, 71-87.

- FINK, G., KOCH, Y. and BEN AROYA, N. (1983). TRH in hypophysial portal blood: characteristics of release and relationship to thyrotropin and prolactin secretion. In: "Thyrotropin-Releasing Hormone". Eds. Griffiths, E.C. and Bennet, G.W. Raven Press: New York; p. 127-143.
- FINK, G., NALLAR, R. and WORTHINGTON, W.C.Jr. (1967). The demonstration of luteinizing hormone releasing factor in hypophysial portal blood of pro-oestrous and hypophysectomized rats. *J.Physiol.* 191, 407-416.
- FINK, G., SMITH, J.R. and TIBBALLS, J. (1971). Corticotropin releasing factor in hypophyseal portal blood of rats. *Nature* 230, 467-468.
- FISHER, C., INGRAM, W.R. and RANSON, S.W. (1938). "Diabetes Insipidus and the neuro-hormonal control of water balance". Edward Bros. Inc; Ann Arbor., Michigan.
- FOOTE, W.E., LIELS, J.F., MARTZ, R.L. and GORDON, M.W. (1972). Effect of hydrocortisone on single unit activity in midbrain raphe. *Brain Res.* 41, 242-244.
- FOREMAN, M.M. and PORTER, J.C. (1981). Prolactin augmentation of dopamine and norepinephrine release from superfused medial basal hypothalamic fragments. *Endocrinology* 108, 800-804.
- FORSLING, M.L., REINHARD, V. and HIMMLER, V. (1974). Neurohypophyseal hormones and prolactin release. *J.Endocrinol.* 63, 579-580.
- FRANKS, S., MCELHONE, J., YOUNG, S.N., KRAULIS, I., RUF, K.B. (1980). Factors determining the diurnal variation in progesterone-induced gonadotropin release in the ovariectomized rat. *Endocrinology* 107, 353-358.
- FRASER, H.M. and MCNEILLY, A.S. (1982). Effect of chronic immunoneutralization of thyrotrophin-releasing hormone on the hypothalamic-pituitary-thyroid axis, prolactin and reproductive function in the ewe. *Endocrinology* 111, 1964-1973.
- FREEMAN, M.C., DUPKE, K.C. and CROTEAU, C.H. (1976). Extinction of the estrogen-induced daily signal for LH release in the rat: a role for the proestrous surge of progesterone. *Endocrinology*, 99, 223-229.
- FREEMAN, M.E., REICHERT, L.E.Jr. and NEILL, J.D. (1972). Regulation of the proestrous surge of prolactin secretion by gonadotropins and oestrogen in the rat. *Endocrinology* 90, 232-238.

- FRIEDGOOD, H.B. (1936). Studies on the sympathetic nervous control of the anterior hypophysis with special reference to a neuro-humoral mechanism. Symp. on Endocr. Glands. Harvard Tercent Celebration. Cited by Friedgood, H.B. in Textbook of Endocrinology, Ed. Williams, R.H. Saunders: Philadelphia; p. 644.
- FRIEDMAN, M.H. (1929). The mechanism of ovulation in the rabbit. I. The demonstration of a humoral mechanism - ovulation in transplanted ovaries. *Am.J.Physiol.* 89, 438-442.
- FROELICH, J.C. and BEN-JONATHAN N. (1983). Effect of posterior pituitary lobectomy on PRL, LH and FSH secretion during the estrous cycle in the rat. *Endocrine Soc. Abs., 65th Annual Meeting. Abs.* 339, p.165.
- FUKUDA, H., GREER, M.A., ROBERTS, L., ALLEN, C.F., CRITCHLOW, V. and WILSON, H. (1975). Nyctohemeral and sex-related variations in plasma thyrotropin, thyroxine and triiodothyronine. *Endocrinology* 97, 1424-1431.
- FULLER, R.W. (1981). Serotonergic stimulation of pituitary-adrenocortical function in rats. *Neuroendocrinology* 32, 118-127.
- FULLER, R.W., PERRY, K.W. and MOLLOY, B.B. (1974). Effect of an uptake inhibitor on serotonin metabolism in rat brain: studies with 3-(p-trifluoromethylphenoxy)-N-methyl-3-phenylpropylamine (Lilly 110140). *Life Sci.* 15, 1161-1171.
- FUXE, K., HÖKFELT, T., LÖFSTRÖM, A., JOHANSSON, O., AGNATI, L., EVERITT, B., GOLDSTEIN M., JEFFCOATE, S., WHITE, N., ENEROTH, P., GUSTAFSON, J.A. and SKETT, P. (1976). On the role of neurotransmitters and hypothalamic hormones and their interactions in hypothalamic and extrahypothalamic control of pituitary function and sexual behaviour. In: "Subcellular Mechanisms in Reproductive Neuroendocrinology". Eds. Naftolin, F., Ryan, K.J. and Davies, J. Elsevier: Amsterdam; p.193-246.
- FUXE, K., ÖGREN, S-O, EVERITT, B.J., AGNATI, L.F., ENEROTH, P. GUSTAFSSON, J-A, JONSSON, G., SKETT, P. and HOLM, A.C. (1977). The effect of antidepressant drugs of the imipramine type on various monoamine systems and their relation to changes in behaviour and neuroendocrine function. In: "Depressive Disorders" Symposia Medica Hoechst 13, p. 67-94.
- GALA, R.R. and REECE, R.P. (1964). Influence of estrogen on anterior pituitary lactogen production in vitro. *Proc. Soc. Exp. Biol. Med.* 115, 1030-1032.
- GALA, R.R., SUBRAMANIAN, M.G., PETERS, J.A. and PIEPER, D.R. (1977). The effects of serotonergic and adrenergic receptor antagonists on prolactin release in the monkey. *Life Sci.* 20, 631-638.

- GALLO, R.V., RABII, J. and MOBERG, G.P. (1975). Effect of methysergide, a blocker of serotonin receptors, on plasma prolactin levels in lactating and ovariectomized rats. *Endocrinology*, 97, 1096-1105.
- GARTHWAITE, T.L. and HAGEN, T.C. (1979). Evidence that serotonin stimulates a prolactin releasing factor in the rat. *Neuroendocrinology*, 29, 215-220.
- GARTHWAITE, T.L., MARTINSON, D.R. and HAGEN, T.C. (1983). Evidence that vasoactive intestinal peptide (VIP) is the hypothalamic prolactin releasing factor (PRF) which modulates serotonin (5HT) induced prolactin (PRL) secretion. *Endocrine Soc. Abs. 65th Annual Meeting*. San Antonio, Texas.
- GAUTVIK, K.M., TASHJIAN, A.H. Jr., KOURIDES, I.A., WEINTRAUB, B.D. GRAEBER, C.T., MALOOF, F., SUZUKI, K. and ZUCKERMAN, J.E. (1974). Thyrotropin-releasing hormone is not the sole physiologic mediator of prolactin release during suckling. *N. Engl. J. Med.* 209, 1162-1165.
- GEFFEN, L.B., JESSELL, T.M., CUELLO, A.C. and IVERSEN, L.L. (1976). Release of dopamine from dendrites in rat substantia nigra. *Nature* 260, 258-260.
- GIBBS, D.M., and NEILL, J.D. (1978). Dopamine levels in hypophysial stalk blood are sufficient to inhibit prolactin secretion in vivo. *Endocrinology* 102, 1895-1900.
- GILLIES, G.E., LINTON, A.E. and LOWRY, P.J. (1982). Corticotropin releasing activity of the new CRF is potentiated several times by vasopressin. *Nature* 299, 355-357.
- GILLIES, G.E. and LOWRY, P.J. Corticotropin releasing factor may be modulated vasopressin. *Nature* 278, 463-464.
- GILLIES, G.E. and LOWRY, P.J. (1982). Corticotropin-releasing hormone and its vasopressin component. In: "Frontiers in Neuroendocrinology" Vol. 7. Eds. Ganong, W.F. and Martini, L. Raven Press: New York; p. 45-75.
- GOLDSMITH, P.C., CRONIN, M.J. and WEINER, R.I. (1979). Dopamine receptor sites in the anterior pituitary. *J. Histochem. Cytochem.* 27, 1205-1207.
- GONZALEZ-BARON, S., JIMENEZ-VARGAS, J. and MARCO, J. (1975). Efecto de la p-chlorofenilalanina sobre la reproduccion en la rata. Cited by Coen, C.W., Franklin, M., Laynes, R.W. and MacKinnon, P.C.B. (1980). *Revista Espanola de Fisiologia* 31, 63-68.
- GOODMAN, R.L. and KNOBIL, E. (1981). The sites of action of ovarian steroids in the regulation of LH secretion. *Neuroendocrinology*, 32, 57-63.

- GÖTHERT, M. (1980). Somatostatin selectively inhibits noradrenaline release from hypothalamic neurones. *Nature* 288, 86-88.
- GÖTHERT, M. and WEINHEIMER, G. (1979). Extracellular 5-hydroxytryptamine inhibits 5-hydroxytryptamine release from rat brain cortex slices. *N.S. Arch. Pharm.* 310, 93-96.
- GRANDISON, L. and GUIDOTTI, A. (1977). Regulation of prolactin release by endogenous opiates. *Nature* 270, 357-359.
- GREEN, J.D. (1951). The comparative anatomy of the hypophysis, with special reference to its blood supply and innervation. *Am. J. Anat.* 88, 225-312.
- GREEN, J.D. and HARRIS, G.W. (1949). Observation of the hypophysiportal vessels of the living rat. *J. Physiol.* 108, 359-361.
- GREENWOOD, F.C., HUNTER, W.M. and GLOVER, J.S. (1963). The preparation of ¹³¹I-labelled growth hormone of high specific radioactivity. *Biochem. J.* 89, 114-123.
- GROSVENOR, C.E. and MENA, F. (1980). Evidence that thyrotropin-releasing hormone and a hypothalamic prolactin-releasing factor may function in the release of prolactin in the lactating rat. *Endocrinology* 107, 863-868.
- GUDELSKY, G.A. and MOORE, K.E. (1977). A comparison of the effects of haloperidol on dopamine turnover in the striatum, olfactory tubercle and median eminence. *J. Pharm. Exp. Ther.* 202, 149-156.
- GUDELSKY, G.A. and PORTER, J.C. (1981). Sex-related difference in the release of dopamine into hypophysial portal blood. *Endocrinology*, 109, 1394-1398.
- GUDELSKY, G.A., SIMPKINS, J., MUELLER, G.P., MEITES, J. and MOORE, K.E. (1976). Selective actions of prolactin on catecholamine turnover in the hypothalamus and on serum LH and FSH. *Neuroendocrinology* 22, 206-215.
- GUILLEMIN, R., DEAR, W.E., NICHOLAS, B. Jr., and LIPSCOMB, H.S. (1959). ACTH releasing activity *in vivo* of a CRF preparation and lysine vasopressin. *Proc. Soc. Exp. Biol. Med.* 101, 107-111.
- GUILLEMIN, R. and ROSENBERG, B. (1955). Humoral hypothalamic control of anterior pituitary; a study with combined tissue cultures. *Endocrinology*, 57, 599-607.
- HAIR, G.W. (1938). The nerve supply of the hypophysis of the cat. *Anat.Rec.* 71, 141-160.
- HAIR, G.W. and MEZEN, F. (1939). A study of the functional innervation of the hypophysis. *Endocrinology*, 25, 965-969.

HALARIS, A.E., LOVELL, R.A. and FREEDMAN, D.X. (1973). Effect of chlorimipramine on the metabolism of 5-hydroxytryptamine in the rat brain. *Biochem. Pharmacol.* 22, 2200-2202.

HALASZ, B. (1969). The endocrine effects of isolation of the hypothalamus from the rest of the brain. In: *Frontiers in Neuroendocrinology*. Eds. Ganong W.F. and Martini L. Raven Press: New York; p.307-342.

HAMON, M., JAVOY, F., KORDON, C. and GLOWINSKI, J. (1970). Synthesis and release of serotonin in the median eminence of the rat. *Life Sci.* 9, 167-173.

HANSTRÖM, B. (1966). Gross anatomy of the hypophysis in mammals. In: *"The Pituitary Gland"*, Vol 1. Eds. Harris, G.W. and Donovan, B.T., p. 1-57.

HARMS, H.H. (1983). The antidepressant agents desipramine, fluoxetine, fluvoxamine and norzimelidine inhibit uptake of ³H-noradrenaline and ³H-5-hydroxytryptamine in slices of human and rat cortical tissue. *Brain Res.* 275, 99-105.

HARRIS, A.R., CHRISTIANSON, C., SMITH, D., FANG, S.L. BRAVERMAN, L.E. and VAGENAKIS, A.G. (1978). The physiological role of thyroid-releasing hormone in the regulation of thyroid-stimulating hormone and prolactin secretion in the rat. *J. Clin. Invest.* 61, 441-448.

HARRIS, G.W. (1936). The induction of pseudopregnancy in the rabbit by electrical stimulation through the head. *J. Physiol.* 88, 361-367.

HARRIS, G.W. (1937). The induction of ovulation in the rabbit by electrical stimulation of the hypothalamo-hypophysial mechanism. *Proc. R. Soc. Lond. (Biol)* 122, 374-394.

HARRIS, G.W. (1948a). Electrical stimulation of the hypothalamus and the mechanism of neural control of the adenohypophysis. *J. Physiol.* 107, 418-429.

HARRIS, G.W. (1948b). Neural control of the pituitary gland. *Physiol. Rev.* 28, 139-179.

HARRIS, G.W. (1950). Oestrous rhythm, pseudopregnancy and the pituitary stalk in the rat. *J. Physiol.* 111, 347-360.

HARRIS, G.W. (1955). "Neural control of the pituitary gland". Edward Arnold: London.

**

HARRIS, G.W. and JACOBSON, D. (1952). Functional grafts of the anterior pituitary gland. *Proc. R. Soc. Lond. (Biol)* 139, 263-276.

HARRIS, G.W. (1971) *Humours and hormones*. *J. Endocrinol.* 53 ii-xxiii.

- HARRIS, G.W., MANABE, Y. and RUF, K.B. (1969). A study of parameters of electrical stimulation of unmyelinated fibres in pituitary stalk. *J. Physiol.* 203, 67-81.
- HATERIUS, H.O. (1933a). Partial sympathectomy and induction of pseudopregnancy. *Am. J. Physiol.* 103, 97-103.
- HATERIUS, H.O. (1933b). The genital-pituitary pathway. Non-effect of stimulation of superior cervical sympathetic ganglia. *Proc. Soc. Exp. Biol. Med.* 31, 1112-1113.
- HATERIUS, H.O. and DERBYSHIRE, A.J.Jr. (1937). Ovulation in the rabbit following upon stimulation of the hypothalamus. *Am. J. Physiol.* 119, 329-330.
- HATTON, G.I., HO, Y.W., and MASON, W.T. (1983). Rat supraoptic (s.o.n.) neurones have axon collaterals: anatomical and electrophysiological evidence. *J. Physiol.* 343, 39P.
- HAUG, E. and GAUTVIK, K.M. (1976). Effects of sex steroids on prolactin secreting rat pituitary cells in culture. *Endocrinology* 99, 1482-1489.
- HAYWARD, J.N. (1974). Physiological and morphological identification of hypothalamic magnocellular neuroendocrine cells in goldfish preoptic nucleus. *J. Physiol.* 239, 103-124.
- HAYWARD, J.N. (1977). Functional and morphological aspects of hypothalamic neurons. *Physiol. Rev.* 57, 574-658.
- HEDGE, G.A., YATES, M.B., MARCUS, R. and YATES, F.E. (1966). Site of action of vasopressin in causing corticotropin release. *Endocrinology* 79, 328-340.
- HENDERSON, S.R., BAKER, C. and FINK, G. (1977a). Oestradiol-17 β and pituitary responsiveness to luteinizing hormone releasing factor in the rat: a study using rectangular pulses of oestradiol-17 β monitored by non-chromatographic radioimmunoassay. *J. Endocrinol.* 73, 441-455.
- HENDERSON, S.R., BAKER, C. and FINK, G. (1977b). Effect of oestradiol-17 β exposure on the spontaneous secretion of gonadotrophins in chronically gonadectomized rats. *J. Endocrinol.* 73, 455-462.
- HÉRY, M., DUSTICIER, G. and CALAS, A. (1982). Application of the 2-deoxy-(1-¹⁴C) glucose method to the study of suprachiasmatic nucleus activity and functions: phasic luteinizing hormone secretion and serotonin innervation. *Exp. Brain Res.* 47, 465-468.
- HÉRY, M., FAUDON, M. DUSTICIER, G. and HÉRY, F. (1982). Daily variations in serotonin metabolism in the suprachiasmatic nucleus of the rat: influence of oestradiol impregnation. *J. Endocrinol.* 94, 157-166.

- HÉRY, M., LAPLANTE E. and KORDON, C. (1976). Participation of serotonin in the phasic release of LH I. Evidence from pharmacological experiments. *Endocrinology* 99, 496-503.
- HÉRY, F., ROUER, E., and GLOWINSKI, J. (1972). Daily variations of serotonin metabolism in the rat brain. *Brain Res.* 43, 445-465.
- HILLER, J.G. and REDFERN, P.H. (1976). Twenty-four hour rhythms in serum and brain indoleamine concentrations: tryptophan-5-hydroxylase and monoamine oxidase activity in the rat. *Int. J. Chronobiol.* 4, 197-210.
- HILL-SAMLI, M. and MACLEOD, R.M. (1974). Interaction of thyrotropin-releasing hormone and dopamine on the release of prolactin from the rat anterior pituitary in vitro. *Endocrinology* 95, 1189-1192.
- HINSEY, J.C. (1937). The relation of the nervous system to ovulation and other phenomena of the female reproductive tract. *Cold.Spr. Harb.Sym.Quant.Biol.* 5, 269-279.
- HOEFER, M.T., ARBOGAST, L.A. and BEN-JONATHAN, N. (1979). Modulation of prolactin secretion in vitro by dopamine, TRH and hypothalamic and posterior pituitary extracts. *Endocrinology*, 104, (Suppl.) Abs. 871
- HOFFMAN, W.E., PHILLIPS, M.I. and SCHMID, P. (1977). The role of catecholamines in central antidiuretic and pressor mechanisms. *Neuropharmacology* 16, 563-569.
- HOHN, K.G. and WUTTKE, W.O. (1978). Changes in catecholamine turnover in the anterior part of the mediobasal hypothalamus and the medial preoptic area in response to hyperprolactinaemia in ovariectomized rats. *Brain Res.* 156, 241-252.
- HÖKFELT, T., ELDE, R., FUXE, K., JOHANSSON, O., LJÜNGDAHL, A., GOLDSTEIN, M., LUFT, R., EFENDIC, S., NILSSON, G., TERENIUS, L., GANTEN, D., JEFFCOATE, S.L., REHFELD, J., SAID, S., PEREZ DE LA MORA, M., POSSANI, L., TAPIA, R., TERAN, L., and PALACIOS, R. (1978). Aminergic and peptidergic pathways in the nervous system with special reference to the hypothalamus. In: *The Hypothalamus* (A.R.N.M.D. 56) Eds. Reichlin, S., Baldessarini, R.J. and Martin, J.B. Raven Press: New York; p.69-135..
- HÖKFELT, T. and FUXE, K. (1967). The possible ultrastructural identification of tuberoinfundibular dopamine-containing nerve endings in the median eminence of the rat. *Brain Res.* 5, 121-123.
- HÖKFELT, T. and FUXE, K. (1972). Effects of prolactin and ergot alkaloids on tubero-infundibular dopamine (DA) neurons. *Neuroendocrinology*, 9, 100-115.

- HÖKFELT, T., FUXE, K., JOHANSSON, O., JEFFCOATE, S. and WHITE, N. (1975). Thyrotropin releasing hormone (TRH) in the central nervous system as revealed with immunohistochemistry. *Eur. J. Pharmacol.* 34, 389-392.
- HÖKFELT, T., LJÜNGDAHL, A., STEINBUSCH, H., VERHOFSTAD, A., NILSSON, G., BRODIN, E., PERNOW, B. and GOLDSTEIN, M. (1978). Immunohistochemical evidence of substance P-like immunoreactivity in some 5-hydroxytryptamine-containing neurons in the rat central nervous system. *Neuroscience* 3, 517-538.
- HOLMES, M.C., DIRENZO, G., BECKFORD, U., GILHAM, B. and JONES, M.T. (1982). Role of serotonin in the control of secretion of corticotropin releasing factor. *J. Endocrinol.* 93, 151-160.
- HOUSSAY, B-A., BIASOTTI, A. and SAMMARTINO, R. (1935). Modifications fonctionelles de l'hypophyse apres les lesions infundibulo tuberiennes chez le crapaud. *Compt. Rend. Soc. Biol.* 120, 725-727.
- HUNT, P., KENNENGEISSER, M.H. and RAYNAUD, J.P. (1974). Nomifensine: A new potent inhibitor of dopamine uptake into synaptosomes from rat brain corpus striatum. *J. Pharm. Pharmacol.* 26, 370-371.
- HYTTEL, J. (1977). Effect of selective 5-HT reuptake inhibitor-LU 10-171- on rat brain 5-HT turnover. *Acta. Pharmacol. Toxicol.* 40, 439-446.
- ISHII, S., HIRANO, T. and KOBAYASHI, H. (1962). Neurohypophyseal hormones in the avian median eminence and pars nervosa. *Gen. Comp. Endocrinol.* 2, 433-440.
- ITOH, S. and ARIMURA, A. (1954). Effect of posterior pituitary hormone on the release of adrenocorticotrophic hormone. *Nature* 174, 37.
- JACKSON, I.M.D. (1980). Significance and function of neuropeptides in cerebrospinal fluid. In: "Neurobiology of Cerebrospinal Fluid". Ed. Wood, J.H. Plenum Press: New York; p. 625-650.
- JACKSON, I.M.D. (1983). Thyrotropin-releasing hormone (TRH): distribution in mammalian species and its functional significance. In: "Thyrotropin-Releasing Hormone" Eds. Griffiths, E.C. and Bennett, G.W. Raven Press: New York; p. 3-18.
- JACOBS, L.S., SNYDER, P.J., WILBER, W.F., UTIGER, J.F., UTIGER, R.D. and DAUGHADAY, W.H. (1971). Increased serum prolactin after administration of synthetic thyrotrophin releasing hormone in man. *J. Clin. Endocrinol. Metab.* 33, 996-999.
- JACOBSON, D. and WESTMAN, A. (1945). On the structure and function of the mammary glands after hypophysectomy and transection of the hypophyseal stalk in rats. *Acta. Physiol. Scand.* 9, 284-295.

- JAMIESON, M.G. (1974). Some aspects of the hypothalamic control of pituitary gonadotrophin secretion. D. Phil. Thesis: Oxford Univ.
- JAMIESON, M.G. and FINK, G. (1976). Parameters of electrical stimulation of the medial preoptic area for release of gonadotrophins in male rats. *J. Endocrinol.* 68, 57-70.
- JOHNS, M.A., AZMITIA, E.C. and KRIEGER, D.T. (1982). Specific *in vitro* uptake of serotonin by cells in the anterior pituitary of the rat. *Endocrinology* 110, 754-760.
- JOHNSTON, C.A., DEMAREST, K.T. and MOORE, K.E. (1980). Cycloheximide disrupts the prolactin-mediated stimulation of dopamine synthesis in tubero-infundibular neurons. *Brain Res.* 195, 236-240.
- JOHNSTON, C.A., GIBBS, D.A. and NEGRO-VILAR, A. (1983). High concentrations of epinephrine derived from a central source and of 5-hydroxyindole-3-acetic acid in hypophysial portal plasma. *Endocrinology* 113, 819-821.
- JONES, B.E. and MOORE, R.Y. (1977). Ascending projections of the locus coeruleus in the rat. II Autoradiographic study. *Brain Res.* 127, 23-53.
- JONES, M.T., GILLHAM, B. and HILLHOUSE, E.W. (1977). The nature of corticotropin releasing factor from rat hypothalamus *in vitro*. *Fed. Proc.* 36, 2104-2109.
- JOSEPH, S.A. and KNIGGE, K.M. (1978). The endocrine hypothalamus: recent anatomical studies. In: "The Hypothalamus" Eds. Reichlin, S., Baldessarini, R.J. and Martin, J.B. Raven Press: New York; p. 15-47.
- KALRA, P.S., FAWCETT, C.P., KRULICH, L. and McCANN, S.M. (1973). The effects of gonadal steroids on plasma gonadotropins and prolactin in the rat. *Endocrinology*, 92, 1256-1268.
- KAMBERI, I.A., MICAL, R.S. and PORTER, J.C. (1970). Effect of anterior pituitary perfusion and intra-ventricular injection of catecholamines and indoleamines on LH release. *Endocrinology* 87, 1-12.
- KAMBERI, I.A., MICAL, R.S. and PORTER, J.C. (1971). Effects of melatonin and serotonin on the release of FSH and prolactin. *Endocrinology* 88, 1288-1293.
- KANEMATSU, S., HILLIARD, J. and SAWYER, C.H. (1963). Effect of reserpine on pituitary prolactin content and its hypothalamic site of action in the rabbit. *Acta Endocrinol.* 44, 467-474.
- KAPOOR, V. (1982). The role of presynaptic receptors in the control of neurotransmitter release. Ph.D. Thesis, Univ. of Edinburgh.

- KASTIN, A.J., SCHALLY, A.V. and KOSTRZEWA, R.M. (1980). Possible aminergic mediation of MSH release and of the CNS effects of MSH and MIF-1. *Fed. Proc.* 39, 2931-2936.
- KASTIN, A.J., VIOSCA, S. and SCHALLY, A.V. (1974). Regulation of melanocyte-stimulating hormone release. In: *Handbook of Physiology*, Vol. 4, Sect. VII Endocrinology. Eds. Knobil, E. and Sawyer, W.H. *Am. Physiol. Soc.* p. 551-562.
- KAVANAGH, J. and WEISZ, J. (1973). Localization of dopamine and norepinephrine in the medial basal hypothalamus of the rat. *Neuroendocrinology* 13, 201-212.
- KAWAKAMI, M. and ARITA, J. (1981). Effects of lesions in the medial basal part of the suprachiasmatic area on prolactin and gonadotropin surges induced by estrogen and progesterone treatment in ovariectomized rats. *Neuroendocrinology*, 32, 242-247.
- KAWANO, H. and DAIKOKU, S. (1981). Immunohistochemical demonstration of LHRH neurons and their pathways in the rat hypothalamus. *Neuroendocrinology*, 32, 179-186.
- KEBABIAN, J.W. and CALNE, B.D. (1979). Multiple receptors for dopamine. *Nature* 277, 93-96.
- KEESEY, J.C., WALLGREN, H. and MCILWAIN, H. (1965). The sodium, potassium and chloride of cerebral tissues: maintenance, change on stimulation and subsequent recovery. *Biochem. J.* 95, 289-300.
- KELLY, M.J., RONNEKLEIV, O.K. and ESKAY, R.L. (1982). Immunocytochemical localization of luteinizing hormone-releasing hormone in neurons in the medial basal hypothalamus of the female rat. *Exp. Brain Res.* 48, 97-106.
- KELLY, P.A., BEDIRIAN, K.M., BAKER, R.D. and FRIESEN, H.G. (1973). Effect of synthetic TRH on serum prolactin, TSH and milk production in the cow. *Endocrinology* 92, 1289-1293.
- KENT, D.L. and SLADEK, J.R. (1978). Histochemical, pharmacological and microspectrofluorimetric analysis of new sites of serotonin localisation in the rat hypothalamus. *J.Comp.Neurol.* 180, 221-236.
- KERWIN, R.W. and PYCOCK, C.J. (1979). Thyrotrophin releasing hormone stimulates release of ³H-dopamine from slices of rat nucleus accumbens *in vitro*. *Br. J. Pharmac.* 67. 323-325.
- KIMURA, T., SHARE, L., WANG, B.C. and CROFTON, J.T. (1981). The role of central adrenoceptors in the control of vasopressin release and blood pressure. *Endocrinology* 108, 1829-1836.
- KIRKHAM, K.E. and HUNTER, W. (1971). *Radioimmunoassay methods*. Churchill Livingstone, London.

- KIZER, J.S., ARIMURA, A., SCHALLY, A.V. and BROWNSTEIN, M.J. (1975). Absence of luteinizing hormone-releasing hormone (LH-RH) from catecholaminergic neurons. *Endocrinology* 96, 523-525.
- KIZER, J.S., PALKOVITS, M., TAPPAZ, M., KEBABIAN, J. and BROWNSTEIN, M.J. (1976). Distribution of releasing factors, biogenic amines, and related enzymes in the bovine median eminence. *Endocrinology* 98, 685-695.
- KIZER, J.S., PALKOVITS, M., ZIVIN, J., BROWNSTEIN, M. SAAVEDRA, J.M. and KOPIN, I.J. (1974). The effect of endocrinological manipulations on tyrosine hydroxylase and dopamine- β -hydroxylase activities in individual hypothalamic nuclei of the adult male rat. *Endocrinology* 95, 799-812.
- KLETZKY, O.A., ST. MICHEL, P., MASHCHAK, C.A. and COLEMAN, B.S. (1983). Lack of effect of fluvoxamine, a new serotonin reuptake inhibitor, on hypothalamic-pituitary function. *Curr. Therapeut. Res.* 33, 394-400.
- KNOBIL, E. (1974). On the control of gonadotropin secretion in the rhesus monkey. *Recent. Prog. Horm. Res.* 30. 1-36.
- KOCH, Y., CHOW, Y.F. and MEITES, J. (1971). Metabolic clearance and secretion rates of prolactin in the rat. *Endocrinology*, 89, 1303-1308.
- KOCH, Y., GOLDBERGER, G., FIREMAN, I., ZOR, U., SHANI, J. and TAL, E. (1977). Suppression of prolactin and thyrotropin secretion in the rat by antiserum to thyrotropin-releasing hormone. *Endocrinology* 100, 1476-1478.
- KOE, K.B. and WEISSMAN, A. (1966). p-chlorophenylalanine: a specific depletor of brain serotonin. *J. Pharmacol. Exp. Ther.* 154, 499-516.
- KORDON, C., BLAKE, C.A., TERKEL, J. and SAWYER, C.H. (1974). Participation of serotonin-containing neurons in the suckling-induced rise in plasma prolactin levels in lactating rats. *Neuroendocrinology*, 13. 213-223.
- KORDON, C., ENJALBERT, A., HÉRY, M., JOSEPH-BRAVO, P.I., ROTSZTEJN, W. and RUBERG, M. (1980). Role of neurotransmitters in the control of adenohypophyseal secretion. In: "Handbook of the Hypothalamus" Vol. 2. Eds. Morgane, P.J. and Panksepp, J. Marcel Dekker: New York; p. 253-306.
- KORDON, C. and GLOWINSKI, J. (1972). Role of hypothalamic monoaminergic neurones in the gonadotrophin release-regulating mechanisms. *Neuropharmacology* 11, 153-162.

- KORDON, C., HÉRY, M., SZAFARCZYK, A., IXART, G. and ASSENMACHER, I. (1981). Serotonin and the regulation of pituitary hormone secretion and of neuroendocrine rhythms. *J.Physiol.(Paris)* 77, 489-496.
- KRAGT, C.L. and MEITES, J. (1967). Dose-response relationships between hypothalamic PIF and prolactin release by rat pituitary tissue in vitro. *Endocrinology*, 80, 1170-1173.
- KREY, L.C. and PARSONS, B. (1982). Characterization of stimuli sufficient to initiate cyclic luteinizing hormone release in acutely ovariectomized rats. *Neuroendocrinology* 34, 315-322.
- KRIEG, R.J. and SAWYER, C.H. (1976). Effects of intraventricular catecholamines on luteinizing hormone release in ovariectomized steroid-primed rats. *Endocrinology* 99, 411-419.
- KRULICH, L. (1975). The effect of a serotonin uptake inhibitor (Lilly 110140) on the secretion of prolactin in the rat. *Life Sci.*, 17, 1141-1144.
- KRULICH, L. (1979). Central neurotransmitters and the secretion of prolactin, GH, LH and TSH. *Ann.Rev. Physiol.* 41, 603-615.
- KRULICH, L., COPPINGS, R.J., GIACHETTI, A., MCCANN, S.M. and MAYFIELD, M.A. (1980). Lack of evidence that the central serotonergic system plays a role in the activation of prolactin secretion following inhibition of dopamine synthesis or blockade of dopamine receptors in the male rat. *Neuroendocrinology*, 30, 133-138.
- KRULICH, L., MCCANN, S.M. and MAYFIELD, M.A. (1981). On the mode of the prolactin release-inhibiting action of the serotonin receptor blockers metergoline, methysergide and cyproheptadine. *Endocrinology* 108, 1115-1124.
- LABHETSWAR, A.P. (1972). Role of monoamines in ovulation: evidence for a serotonergic pathway for inhibition of spontaneous ovulation. *J. Endocrinol.* 54, 269-275.
- LADISCH (1974). Effect of progesterone on regional 5-hydroxytryptamine metabolism in the rat brain. *Neuropharmacol.* 13, 877-883.
- LAMBERTS, S.W.J. and MACLEOD, R.M. (1978). The interaction of the serotonergic and dopaminergic systems on prolactin secretion in the rat. *Endocrinology* 103, 287-295.
- LAMBERTS, S.W.J. and MACLEOD, R.M. (1979). Metergoline and other peripheral serotonin antagonists inhibit prolactin secretion through mechanisms unrelated to serotonin. *Proc. Soc. Exp. Biol. Med.* 162, 75-79.

- LANG, R.E., HEIL, J.W.E., GANTEN, D., HERMANN, K., UNGER, T. and RASCHER, W. (1983). Oxytocin unlike vasopressin is a stress hormone in the rat. *Neuroendocrinology* 37, 314-316.
- LANGELIER, P. and MCCANN, S.M. (1977). The effects of interruption of the ventral noradrenergic pathway on the proestrous discharge of prolactin in the rat. *Proc. Soc. Exp. Biol. Med.* 154, 553-557.
- LAWSON, D.M. and GALA, R.R. (1974). The influence of surgery, time of day, blood volume reduction and anesthetics on plasma prolactin in ovariectomized rats. *J. Endocrinol.* 62, 75-83.
- LAWSON, D.M. and GALA, R.R. (1975). The influence of adrenergic, dopaminergic, cholinergic and serotonergic drugs on plasma prolactin levels in ovariectomized estrogen-treated rats. *Endocrinology* 96, 313-318.
- LAWSON, D.M., GALA, R.R., CHIN, M.L. and HAISLENDER, D.H. (1980). Size heterogeneity of plasma prolactin in the rat: TRH and serotonin-induced changes. *Life. Sci.* 27, 1147-1151.
- LEDERIS, K. (1974). Neurosecretion and the functional structure of the neurohypophysis. In: *Handbook of Physiology, Section 7, Endocrinology Vol IV. The Pituitary Gland, part 1.* Eds. Knobil, E. and Sawyer, W.H. *Am. Phys. Soc.* p. 81-102.
- LEGAN, S., COON, G.A. and KARSCH, F.J. (1975). Role of oestrogen as initiator of daily LH surges in the ovariectomized rat. *Endocrinology* 96, 50-56.
- LEIGHTON, P.C., MCNEILLY, A.S. and CHARD, T. (1976). Short-term variation in blood levels of prolactin in women. *J. Endocrinol.* 68, 177-178.
- LEONARDELLI, J., DUBOIS, P. and POULAIN, P. (1974). Effect of exogenous serotonin on LH-RH secreting neurons in guinea-pig hypothalamus as revealed by immunofluorescence. *Neuroendocrinology* 15, 69-72.
- LEONG, D.A., FRAWLEY, S. and NEILL, J.D. (1983). Neuroendocrine control of prolactin secretion. *Ann. Rev. Physiol.* 45, 109-127.
- LÉSNIK, H., GUZEK, J.W. and TRACZYK, W.Z. (1969). The release of antidiuretic hormone from the pituitary stalk after intravenous calcium chloride or magnesium chloride infusion in rats. *J. Endocrinol.* 45, 83-90.
- LEVINE, J.E. and RAMIREZ, V.D. (1980). *In vivo* release of luteinizing hormone-releasing hormone estimated with push-pull cannulae from the mediobasal hypothalamus of ovariectomised steroid-primed rats. *Endocrinology* 107, 1782-1790.

- LICHTENSTEIGER, W., MUNTZNER, U. and LANGEMANN, H. (1967). Uptake of 5-hydroxytryptamine and 5-hydroxytryptophan by neurons of the central nervous system normally containing catecholamines. *J. Neurochem.* 14, 489-497.
- LIEN, E.L., FENICHEL, R.L. GARSKY, V., SARANTAKIS, D. and GRANT, N.H. (1976). Enkephalin-stimulated prolactin release. *Life Sci.* 19, 837-840.
- LINDVALL, O., BJÖRKLUND, A., MOORE, R.Y. and STENEVI, V. (1974). Mesencephalic dopamine neurons projecting to neocortex. *Brain Res.* 81, 325-331.
- LINDVALL, O. and BJÖRKLUND, A. (1978). Organization of catecholamine neurons in the rat central nervous system. In: "Handbook of Psychopharmacology". Ed. Iversen L., Iversen, S., Snyder S.H. Plenum Press: New York; p.139-231.
- LINTON, E.A., WHITE, N., LIRA DE TINEO, O. and JEFFCOATE, S.L. (1981). 2-Hydroxyoestradiol inhibits prolactin release from the superfused rat pituitary gland. *J.Endocrinol.* 90, 315-322.
- LÖFSTRÖM, A. (1977). Catecholamine turnover alterations in discrete areas of the median eminence of 4- and 5-day cyclic rat. *Brain Res.* 120, 113-131.
- LÖFSTRÖM A., ENEROTH, P., GUSTAFSSON, J-A. and SKETT, P. (1977). Effects of estradiol benzoate on catecholamine levels and turnover in discrete areas of the median eminence and the limbic forebrain, and on serum luteinizing hormone, follicle stimulating hormone and prolactin concentrations in the ovariectomized female rat. *Endocrinology*, 101, 1559-1569.
- LÖFSTRÖM, A., JONNISON, G. AND FUXE, K. (1976). Microfluorimetric quantitation of catecholamine fluorescence in rat median eminence. I Aspects of the distribution of dopamine and noradrenaline nerve terminals. *J. Histochem. Cytochem.* 24, 415-429.
- LONG, J.B., YOUNGBLOOD, W.W. and KIZER, J.S. (1983). Effects of castration and adrenalectomy on *in vitro* rates of tryptophan hydroxylation and levels of serotonin in microdissected brain nuclei of adult male rats. *Brain Res.* 277, 289-297.
- LONG, J.B., YOUNGBLOOD, W.Y. and KIZER, J.S. (1983). Regional differences in the response of serotonergic neurons in rat CNS to drugs. *Eur. J. Pharmacol.* 88, 89-97.
- LU, K-H. and MEITES, J. (1973). Effects of serotonin precursors and melatonin on serum prolactin release in rats. *Endocrinology* 93, 152-155.

- LU, K-H, SHAAR, C.J., KORTRIGHT, K.H. and MEITES, J. (1972). Effects of synthetic TRH on in vitro and in vivo prolactin release in the rat. *Endocrinology* 91, 1540-1545.
- LU, K-H. and YEN, S.S.C. (1980). The effect of an antiserum to luteinizing hormone-releasing hormone on the progesterone-induced luteinizing hormone surge in ovariectomized, estrogen-primed rats. *Endocrinology* 106, 867-870.
- LU QUI, J.J. and FOX, C.A. (1976). The supraoptic nucleus and the supraoptico-hypophysial tract in the monkey. *J. Comp. Neurol.* 168, 7-40.
- LUMPKIN, M.D., SAMSON, W.K. and MCCANN, S.M. (1983). Hypothalamic and pituitary sites of action of oxytocin to alter prolactin secretion in the rat. *Endocrinology*, 112, 1711-1717.
- LUTZ-BUCHER, B., KOCH, B. and MIALHE, C. (1977). Comparative in vitro studies on corticotropin releasing activity of vasopressin and hypothalamic median eminence extract. *Neuroendocrinology* 23, 181-192.
- MCCANN, S.M. (1957). The ACTH-releasing activity of the posterior lobe of the pituitary in vivo. *Endocrinology* 60, 664-676.
- MCCANN, S.M. (1974). Regulation of secretion of follicle-stimulating hormone and luteinizing hormone. In: *Handbook of Physiology* Sec. 7. Vol.IV pt. 2. Ed. Knobil, E. and Sawyer, W.H., Am. Physiol. Soc. p. 489-517.
- MCCANN, S.M. (1982). Physiology and pharmacology of LHRH and somatostatin. *Ann. Rev. Pharmacol. Toxicol.* 22, 491-515.
- MCCANN, S.M. and BROBECK, J.R. (1954). Evidence for a role of the supraopticohypophyseal system in regulation of adrenocorticotrophin secretion. *Proc. Soc. Exp. Biol. Med.* 87, 318-324.
- MCCANN, S.M., DHARIWAL, A.P.S. and PORTER, J.C. (1968). Regulation of the adenohypophysis. *Ann. Rev. Physiol.* 30, 589-640.
- MCCANN, S.M. and PORTER, J.C. (1969). Hypothalamic pituitary stimulating and inhibiting hormones. *Physiol. Rev.* 49, 240-284.
- MCCANN, S.M., TALEISNIK, S. and FRIEDMAN, S.M. (1960). LH-releasing activity in hypothalamic extracts. *Proc. Soc. Exp. Biol. Med.* 104, 432-434.
- MCCORMACK, J.T., PLANT, T.M., HESS, D.L. and KNOBIL, E. (1977). The effect of luteinizing hormone releasing hormone (LHRH) antiserum administration on gonadotropin secretion in the rhesus monkey. *Endocrinology* 100, 663-667.

- MCEWEN, B.S. (1979). Steroid hormone interactions with the brain: cellular and molecular aspects. In: Reviews of Neuroscience Vol.4 p. 1-30.
- MCEWEN, B.S. and PARSONS, B. (1982). Gonadal steroid action on the brain: neurochemistry and neuropharmacology. Ann. Rev. Pharmacol. Toxicol. 22, 555-598.
- MCLEAN, B.K., CHANG, N. and NIKITOVICH-WINER, M.B. (1975). Ovarian steroids directly alter luteinizing hormone (LH) release by pituitary homografts. Endocrinology 96, 196-201.
- MACLEOD, R.M. (1969). Influence of norepinephrine and catecholamine-depleting agents on the synthesis and release of prolactin and growth hormone. Endocrinology 85, 916-923.
- MACLEOD, R.M. (1976). Regulation of prolactin secretion. In: Frontiers in Neuroendocrinology Vol. 4. Eds. Ganong, W.F. and Martini, L. Raven Press: New York; p.169-194.
- MACLEOD, R.M., FONTHAM, E.H., and LEHMEYER, J.E. (1970). Prolactin and growth hormone production as influenced by catecholamines and agents that affect brain catecholamines. Neuroendocrinology, 6, 283-294.
- MCNEILLY, A.S., SHARPE, R.M., DAVIDSON, D.W. and FRASER, H.M. (1978). Inhibition of gonadotrophin secretion by induced hyperprolactinaemia in the male rat. J. Endocrinol. 79, 59-68.
- MAEDA, K. and FROHMAN, L.A. (1980). Release of somatostatin and thyrotropin-releasing hormone from rat hypothalamic fragments in vitro. Endocrinology 106, 1837-1842.
- MALARKEY, W.B., O'DORISIO, T.M., KENNEDY, M. and CATALAND, S. (1981). The influence of vasoactive intestinal polypeptide and cholecystokinin on prolactin release in rat and human monolayer cultures. Life Sci. 28, 2489-2495.
- MANLEY, O.T. and MARINE, D. (1916). The transplantation of ductless glands with reference to permanence and function. J.A.M.A. 67, 260-262.
- MANN, D.R. and BARRACLOUGH, C.A. (1973). Role of estrogen and progesterone in facilitating LH release in 4-day cyclic rats. Endocrinology, 93, 694-699.
- MANN, D.R., COST, M.G., JACOBSON, D.C. and MACFARLAND, L.A. (1977). Adrenal gland rhythmicity and pituitary regulation of adrenal steroid secretion. Proc. Soc. Exp. Biol. Med. 156, 441-445.
- MARKEE, J.E., SAWYER, C.H. and HOLLINSHEAD, W.H. (1948). Adrenergic control of the release of luteinizing hormone from the hypophysis of the rabbit. Recent Prog. Horm. Res. 2, 117-131.

- MARSHALL, F.H.A. (1936). Sexual periodicity and the causes which determine it. The Croonian Lecture. Philos. Trans. Roy Soc. B., 226, 423-456.
- MARSHALL, F.H.A. (1942). Exteroceptive factors in sexual periodicity. Biol. Rev. 17, 68-90.
- MARSHALL, F.H.A. and JOLLY, W.A. (1907). Results of removal and transplantation of ovaries. Trans. Roy. Soc. Edin. 45, 589-599.
- MARSHALL, F.H.A. and VERNEY, E.B. (1936). The occurrence of ovulation and pseudopregnancy in the rabbit as a result of central nervous stimulation. J. Physiol. 86, 327-336.
- MARTIN, J.E., ENGEL, J.N. and KLEIN, D.C. (1977). Inhibition of the in vitro pituitary response to luteinizing hormone-releasing hormone by melatonin, serotonin and 5-methoxytryptamine. Endocrinology 100, 675-680.
- MARTIN, J.E., TYREY, L., EVERETT, J.W. and FELLOWS, R.E. (1974). Estrogen and progesterone modulation of the pituitary response to LRF in the rat. Endocrinology, 95, 1664-1673.
- MARTINI, L. (1966). Neurohypophysis and anterior pituitary activity. In: "The Pituitary Gland" Vol. 3, Eds. Harris, G.W. and Donovan, B.T. Univ. California Press: Berkeley; p. 535-577.
- MATSUO, H., BABA, Y., NAIR, R., ARIMURA, A. and SCHALLY, A.V. (1971). Structure of the porcine LH- and FSH-releasing hormone. Biochem. Biophys. Res. Comm., 43, 1334-1339.
- MATTHEIJ, J.A.M. and SWARTS, J.J.M. (1978). Circadian variations in the plasma concentration of prolactin in the adult male rat. J. Endocrinol. 79, 85-89.
- MAYER, G.S. and SHOUP, R.E. (1983). Simultaneous multiple electrode liquid chromatographic/electrochemistry assay for catecholamines, indoleamines and metabolites in brain tissue. J. Chromatogr. 255, 533-544.
- MEEK, J.L. and NEFF, N.H. (1972). Tryptophan 5-hydroxylase: approximation of half-life and rate of axonal transport. J. Neurochem. 19, 1519-1526.
- MEFFORD, I.N. (1981). Application of high performance liquid chromatography with electrochemical detection to neurochemical analysis: measurement of catecholamines, serotonin and metabolites in rat brain. J. Neurosci. Methods 3, 207-227.
- MEFFORD, I.N. and BARCHAS, J.D. (1980). Determination of tryptophan and metabolites in rat brain and pineal tissue by reverse-phase high-performance liquid chromatography with electrochemical detection. J. Chromat. 181, 187-193.

- MEITES, J., KAHN, R.H. and NICOLL, C.S. (1967). Prolactin production by rat pituitary in vitro. *Endocrinology*, 81, 826-834.
- MEITES, J., LU, K.H., WUTTKE, W., WELSCH, C.W., NAGASAWA, H. and QUADRI, S.K. (1972). Recent studies on functions and control of prolactin secretion in rats. *Recent Prog. Horm. Res.* 28, 471-516.
- MEITES, J. and NICOLL, C.S. (1966). Adenohypophysis: Prolactin. *Ann. Rev. Physiol.* 28, 57-88.
- MEITES, J. and SONNTAG, W.E. (1981). Hypothalamic hypophysiotropic hormones and neurotransmitter regulation: current views. *Ann. Rev. Pharmacol. Toxicol.* 21, 295-322.
- MEITES, J., TALWALKER, P.K. and NICOLL, C.S. (1960). Inhibition of lactation in rats with hypothalamic or cerebral tissue. *Proc. Soc. Exp. Biol. Med.* 103, 298-302.
- MELTZER, H.Y., SIMONOVIC, M., FANG, V., PIYAKALAMALA, S. and YOUNG, M. (1978). A comparison of the effects of anti-psychotic drugs on pituitary, striatal and limbic system post-synaptic dopamine receptors. *Life Sci.* 23, 605-610.
- MEYER, D.C. and QUAY, W.B. (1976). Hypothalamic and suprachiasmatic uptake of serotonin in vitro: twenty-four-hour changes in male and proestrous female rats. *Endocrinology* 98, 1160-1165.
- MIDGELEY, A.R. Jr., NISWENDER, G.D. and REBAR, R.W. (1969). Principles for the assessment of the reliability of radioimmunoassay methods (precision, accuracy, sensitivity, specificity). *Acta. Endocrinol. (Suppl.) (Copenh.)* 142, 163-180.
- MILLAR, R.P., SHEWARD, W.J., WEGENER, I. and FINK, G. (1983). Somatostatin-28 is an hormonally active peptide secreted into hypophysial portal blood. *Brain Res.* 260, 334-337.
- MILLER, F.P. and COX, R.H. Jr. (1970). Comparative effects of p-chlorophenylalanine, p-chloramphetamine and p-chloro-N-methylamphetamine on rat brain norepinephrine, serotonin and 5-hydroxyindole acetic acid. *Biochem. Pharmac.* 19, 435-442.
- MIRSKY, A., STEIN, M. and PAULISCH, G. (1954). The secretion of an antidiuretic substance into the circulation of adrenalectomized and hypophysectomized rats exposed to noxious stimuli. *Endocrinology* 55, 28-29.
- MOHRING, B. and MOHRING, J. (1975). Plasma ADH in Long-Evans rats and in Long-Evans rats heterozygous and homozygous for hypothalamic diabetes insipidus. *Life Sci.* 17, 1307-1314.
- MOLL, J. (1957). Regeneration of the supraoptico-hypophysial and paraventriculohypophysial tracts in the hypophysectomized rat. *Z. Zellforsch.* 46, 686-709.

- MOORE, C.R. (1926). On the properties of the gonads as controllers of somatic and psychical characteristics. *Am. J. Anat.* 37, 351-416.
- MOORE, K.E. and DEMAREST, K.T. (1982). Tuberoinfundibular and tuberohypophyseal dopaminergic neurons. In: "Frontiers in Neuroendocrinology", Vol 9. Eds. Ganong, W.F. and Martini, L. Raven Press: New York; p. 161-190.
- MOORE, R.Y. (1978). Central neural control of circadian rhythms. In: *Frontiers in Neuroendocrinology* Vol. 5. Ed. Ganong, W.F. and Martini, L. Raven Press: New York; p. 185-206.
- MOORE, R.Y. and BLOOM, F.E. (1978). Central catecholamine neuron systems: anatomy and physiology of the dopamine systems. *Ann. Rev. Neurosci.* 1, 129-169.
- MOORE, R.Y. and BLOOM, F.E. (1979). Central catecholamine neuron systems: anatomy and physiology of the epinephrine and norepinephrine systems. *Ann. Rev. Neurosci.* 2, 113-168.
- MOOS, F. and RICHARD, P. (1979). Effects of dopaminergic antagonists and agonists on oxytocin release induced by various stimuli. *Neuroendocrinology* 28, 138-144.
- MOROT-GAUNDRY, Y., BOURGOIN, S. and HAMON, M. (1981). Kinetic characteristics of newly synthesized ³H-5-HT in the brain of control and reserpinized mice: Evidence for the heterogeneous distribution of 5-HT in serotonergic neurons. *N.S. Arch. Pharm.* 316, 311-316.
- MORRIS, R., SALT, T.E., SOFRONIEW, M.V. and HILL, R.G. (1980). Actions of microiontophoretically applied oxytocin and immunohistochemical localization of oxytocin, vasopressin and neurophysins in the rat caudal medulla. *Neurosci. Lett.* 18, 163-168.
- MOSES, A.M. and MILLER, M. (1974). Osmotic influences on the release of vasopressin. In: *Handbook of Physiology, Section 7 Endocrinology, Vol. IV The Pituitary Gland, part 1*, Eds. Knobil, E. and Sawyer, W.H. *Ann. Phys. Soc.* p. 225-242.
- MOSS, R.L. (1977). Role of hypophysiotropic neurohormones in mediating neural and behavioral events. *Fed. Proc.* 36, 1978-1983.
- MOSS, R.L., KELLY, M.J. and RISKIND, P. (1975). Tuberoinfundibular neurons: dopaminergic and norepinephrinergic sensitivity. *Brain Res.* 89, 265-277.
- MOSS, R.L., URBAN, I. and CROSS, B.A. (1972). Microelectrophoresis of cholinergic and aminergic drugs on paraventricular neurons. *Am. J. Physiol.* 223, 310-318.

- MOSZKOWSKA, A. (1965). Contribution a l'etude du mecanisme de l'antagonisme epiphyso-hypophysaire. *Prog. Brain Res.* 10, 564-575.
- MUELLER, G.P., CHEN, H.J. and MEITES, J. (1973). *In vivo* stimulation of prolactin release in the rat by synthetic TRH. *Proc. Soc. Exp. Biol. Med.* 144, 613-615.
- MUELLER, G.P., SIMPKINS, J., MEITES, J. and MOORE, K.E. (1976). Differential effects of dopamine agonists and haloperidol on release of prolactin, thyroid stimulating hormone, growth hormone and luteinizing hormone in rats. *Neuroendocrinology* 20, 121-135.
- MUNARO, N.I. (1978). The effect of ovarian steroids on hypothalamic 5-hydroxytryptamine neuronal activity. *Neuroendocrinology* 26, 270-276.
- NEGRO-VILAR, A. (1982). The median eminence as a model to study presynaptic regulation of neural peptide release. *Peptides* 3, 305-310.
- NEILL, J.D. (1970). Effects of stress on serum prolactin and luteinizing hormone levels during the estrous cycle of the rat. *Endocrinology*, 87, 1192-1197.
- NEILL, J.D. (1972). Sexual differences in the hypothalamic regulation of prolactin secretion. *Endocrinology* 90, 1154-1159.
- NEILL, J.D. (1980). Neuroendocrine regulation of prolactin secretion. In: *Frontiers in Neuroendocrinology* 8, Eds. Martini, L. and Ganong, W.F. Raven Press: New York; p.125-155.
- NEILL, J.D., FREEMAN, M.E. and TILLSON, S.A. (1971). Control of the proestrous surge of prolactin and luteinizing hormone secretion by oestrogens in the rat. *Endocrinology* 89, 1448-1453.
- NETT, T.M., AKBAR, A.M., NISWENDER, G.D., HEDLUND, M.T. and WHITE, W.F. (1973). A radioimmunoassay for gonadotropin releasing hormone (GnRH) in serum. *J. Clin. Endocrinol. Metab.* 36, 880-885.
- NG, L.K.Y., CHASE, T.N., COLBURN, R.W. and KOPIN, J.J. (1972). Release of ³H-dopamine by L-5-hydroxytryptophan. *Brain Res.* 45, 499-505.
- NICKERSON, M. (1949). Interpretation of experimental results obtained with dibenamine. *Endocrinology* 44, 287-288.
- NICOLL, C.S., FIORDINO, R.P., MCKENEE, C.T. and PARSONS, J.A. (1970). Assay of hypothalamic factors which regulate prolactin secretion. In: *"Hypophysiotropic Hormones of the Hypothalamus: Assay and Chemistry"*. Ed. Meites J. Williams and Wilkins: Baltimore; p. 115-150.

- NICOLL, C.S. and MEITES, J. (1964). Prolactin secretion in vitro: effects of gonadal and adrenal cortical steroids. Proc. Soc. Exp. Biol. Med. 117, 579-583.
- NIKITOVITCH-WINER, M.B. (1962). Induction of ovulation in rats by direct intrapituitary infusion of median eminence extracts. Endocrinology 70, 350-358.
- NIKITOVICH-WINER, M.B. and EVERETT, J.W. (1958). Functional restitution of pituitary grafts re-transplanted from kidney to median eminence. Endocrinology 63, 916-930.
- NISWENDER, G.D., CHEN, C.L., MIDGLEY, A.R.Jr., MEITES J. and ELLIS, S. (1969). Radioimmunoassay for rat prolactin. Proc. Soc. Exp. Biol. Med. 130, 793-797.
- NISWENDER, G.D., MIDGELEY, A.R. Jr., MONROE, S.E. and REICHERT, L.G. Jr. (1968). Radioimmunoassay for rat luteinizing hormone with anti-ovine-LH serum and ovine LH ¹³¹I. Proc. Soc. Exp. Biol. Med. 128, 807-811.
- NORMAN, R.L., RESKO, J.A., SPIES, H.G. (1976). The anterior hypothalamus: how it affects gonadotropin secretion in the rhesus monkey. Endocrinology 99, 59-71.
- NORTH, W.G., LA ROCHELLE, F.T., HALDAR, Y., SAWYER, W.M. and VALTIN, H. (1978). Characterization of an antiserum used in a radioimmunoassay for arginine-vasopressin: implications for reference standards. Endocrinology 103, 1976-1984.
- NOWKCKY, M.C. and ROTH, R.H. (1978). Dopaminergic neurons: role of presynaptic receptors in the regulation of transmitter biosynthesis. Prog. Neuropsychopharmacol. 2, 139-160.
- NUNEZ, E.A., GERSHON, M.D. and SILVERMAN, A.J. (1981). Specific uptake of serotonin by gonadotrophs of the bat pituitary: confirmation by a combined technique of radioautography and immunocytochemistry. Anat. Rec. 199, 185A.
- O'CONNOR, W.J. (1952). The normal interphase in the polyuria which follows section of the supraoptico-hypophysial tracts in the dog. Q.J. Exp. Physiol. 37, 1-10.
- OKSCHE, A., KIRSCHT, H., HARTWIG, H.G., OEMKE, H.J. and FARNER, J.S. (1974). Secretory parvocellular neurons in rostral hypothalamus and tuberal complex of passer domesticus. Cell Tissue Res. 149, 363-370.
- OKSCHE, A., LAWS, D.F., KAMEMOTO, F.I. and FARNER, D.S. (1959). The hypothalamo-hypophysial neuro secretory system of the white-crowned sparrow Zonotrichia leucophrys Gambelii. Z.Zellforsch 51, 1-42.

- OLIVER, C., MICAL, R.S. and PORTER, J.C. (1977). Hypothalamic-pituitary vasculature: evidence for retrograde blood flow in pituitary stalk. *Endocrinology* 101, 598-604.
- OLSON, L., FUXE, K. and HÖKFELT, T. (1972). The effect of pituitary transplants on the tuberoinfundibular dopamine neurons in various endocrine states. *Acta. Endocrinol. (Copenh.)* 71, 233-244.
- ORREGO, F. (1979). Criteria for the identification of central neurotransmitters, and their application to studies with some nerve tissue preparations *in vitro*. *Neuroscience* 4, 1037-1057.
- ORREGO, F., JANKELEVICH, J., CERUTI, L. and FERRERA, E. (1974). Differential effects of electrical stimulation on release of ³H-noradrenaline and ¹⁴C- α -aminoisobutyrate from brain slices. *Nature* 251, 55-57.
- O'STEEN, W.K. (1965). Suppression of ovarian activity in immature rats by serotonin. *Endocrinology* 77, 937-939.
- PAGE, R.B. (1983). Directional pituitary blood flow: a microcinematographic study. *Endocrinology* 112, 157-165.
- PAGE, R.B. and BERGLAND, R.M. (1977). The neurohypophyseal capillary bed. *Am. J. Anat.* 148, 345-351.
- PALKOVITS, M. (1979). Effects of surgical deafferentation on the transmitter and hormone content of the hypothalamus. *Neuroendocrinology*, 29, 140-148.
- PALKOVITS, M., BROWNSTEIN, M., KIZER, J.S., SAAVEDRA, J.M. and KOPIN, J. (1976). Effect of stress on serotonin concentration and tryptophan hydroxylase activity of brain nuclei. *Neuroendocrinology* 22, 298-304.
- PALKOVITS, M., SAAVEDRA, J.M., JACOBOWITZ, D.M., KIZER, J.S., ZABORSKY, L. and BROWNSTEIN, M.J. (1977). Serotonergic innervation of the forebrain: effect of lesions on serotonin and tryptophan hydroxylase levels. *Brain Res.* 130, 121-134.
- PARENT, A., DESCARRIES, L. and BEAUDET, A. (1981). Organization of ascending serotonin systems in the adult rat brain. A radioautographic study after intraventricular administration of [³H]5-hydroxytryptamine. *Neuroscience*, 6, 115-138.
- PARLOW, A.F. (1958). A rapid bioassay method for LH and factors stimulating LH secretion. *Fed. Proc.* 17, 402.
- PARRY, H.B. and LIVETT, B.G. (1973). A new hypothalamic pathway to the median eminence containing neurophysin and its hypertrophy in sheep with natural scrapie. *Nature* 242, 63-65.

- PARSONS, B., RAINBOW, T.C., PFAFF, D.W. and McEWEN, B.S. (1981). Oestradiol, sexual receptivity and cytosol progesterin receptors in rat hypothalamus. *Nature* 292, 58-59.
- PEARLMUTTER, A.F., DOKAS, L., KONG, A., MILLER, R. and SAFFRAN, M. (1980). Is corticotropin releasing factor modulated vasopressin? *Nature* 283, 697-698.
- PEARLMUTTER, A.F., DOKAS, L.A., LOESER, B., KONG, A., SAFFRAN, M. and SIMMONS, W. (1982). Properties of CRF from normal and Brattleboro rat median eminence. *Neuroendocrinology* 34, 99-103.
- PEDERSEN, C.A. and PRANGE, A.J. (1979). Induction of maternal behavior in virgin rats after intracerebroventricular administration of oxytocin. *Proc. Natl. Acad. Sci. USA* 76, 6661-6665.
- PERKINS, N.A. and WESTFALL, T.C. (1978). The effect of prolactin on dopamine release from rat striatum and medial basal hypothalamus. *Neuroscience* 3, 59-63.
- PERKINS, N.A., WESTFALL, T.C., PAUL, C.V., MACLEOD, R. and ROGOL, A.D. (1979). Effect of prolactin on dopamine synthesis in medial basal hypothalamus, evidence for a short loop feedback. *Brain Res.* 160, 431-444.
- PFAFF, D.W. (1983). Impact of estrogens on hypothalamic nerve cells: Ultrastructural, chemical and electrical effects. *Recent Prog. Horm. Res.* 39, 127-175.
- PICKERING, A.J.M.C. (1978). Aspects of the mechanism of action of the gonadotrophin releasing hormone. D. Phil. Thesis: Oxford Univ.
- PICKERING, A.J. and FINK, G. (1979). Do hypothalamic regulatory factors other than luteinizing hormone releasing factor exert a priming effect?. *J. Endocrinol.* 81, 235-238.
- PIEPER, D.R. and GALA, R.R. (1979). The effect of light on the prolactin surges of pseudopregnant and ovariectomized, estrogenized rats. *Biol. Reprod.* 20, 727-732.
- PILOTTE, N.S. and PORTER, J.C. (1979). Circulating luteinizing hormone and prolactin concentrations in intact or castrated male rats treated with 5-hydroxytryptamine. *Endocrinology* 105, 875-878.
- PILOTTE, N.S. and PORTER, J.C. (1981). Dopamine in hypophysial portal plasma and prolactin in systemic plasma of rats treated with 5-hydroxytryptamine. *Endocrinology* 108, 2137-2141.
- PINES, I.L. (1925). Uber die Innervation der Hypophysis Cerebri. *Z. Ges. Neurol. Psychiat.* 100, 123-138.

- PITTMAN, Q.J., BLUME, H.W. and RENAUD, L.P. (1978). Electrophysiological indications that individual hypothalamic neurones innervate both median eminence and neurohypophysis. *Brain Res.* 157, 364-368.
- PLANT, T.M., MOOSY, J., HESS, D.L., NAKAI, Y., MCCORMACK, J.T. and KNOBIL, E. (1979). Further studies on the effects of lesions in the rostral hypothalamus on gonadotropin secretion in the female rhesus monkey (*Macaca mulatta*). *Endocrinology* 105, 465-473.
- PLOTSKY, P.M. and NEILL, J.D. (1982). Interactions of dopamine and thyrotropin releasing hormone (TRH) in the regulation of prolactin release in lactating rats. *Endocrinology* 111, 168-173.
- PLOTSKY, P.M., GIBBS, D.M. and NEILL, J.D. (1980). Liquid chromatographic-electrochemical measurement of dopamine in hypophysial stalk blood of rats. *Endocrinology* 102, 1887-1894.
- POPA, G. and FIELDING, V. (1930). A portal circulation from the pituitary to the hypothalamic region. *J.Anat.* 65, 88-91.
- POPA, G.T. and FIELDING, V. (1933). Hypophysio-portal vessels and their colloid accompaniment. *J. Anat.* 67, 227-232.
- PORTANOVA, R. and SAYERS, G. (1973). Isolated pituitary cells: CRF-like activity of neurohypophyseal and related peptides. *Proc. Soc. Exp. Biol. Med.* 143, 661-666.
- PORTER, J.C. and SMITH, K.R. (1967). Collection of hypophysial stalk blood in rats. *Endocrinology* 81, 1182-1185.
- POTASCHNER, S.J. (1978). Effects of tetrodotoxin, calcium and magnesium on the release of amino acids from slices of guinea-pig cerebral cortex. *J. Neurochem.* 31, 187-195.
- POULSEN, J.H. and WILLIAMS, J.A. (1976). Spontaneous, repetitive hyperpolarisations from cells in the rat adenohypophysis. *Nature* 263, 156-158.
- QUAY, W.B. (1968). Differences in circadian rhythms in 5-hydroxytryptamine according to brain region. *Am. J. Physiol.* 215, 1448-1453.
- RACAGNI, G., APUD, J.A., LOCATELLI, V., COCCHI, D., NISTICO, G., di GIORGIO, R.M. and MULLER, E.E. (1979). GABA of CNS origin in the rat anterior pituitary inhibits prolactin secretion. *Nature*, 281, 575-578.
- RAHE, C.H., OWENS, R.E., NEWTON, H.J., FLEEGER, J.L. and HARMS, P.G. (1979). Dependence of the pattern of circulating luteinizing hormone (LH) upon the stage of the estrous cycle. *Fed. Proc.* 38, 981.

- RANCE, N., WISE, P.M., and BARRACLOUGH, C.A. (1981a). Negative feedback effect of progesterone correlated with changes in hypothalamic norepinephrine and dopamine turnover rates, median eminence luteinizing hormone-releasing hormone, and peripheral plasma gonadotropin. *Endocrinology* 108, 2194-2199.
- RANCE, N., WISE, P.M., SELMANOFF, M.K. and BARRACLOUGH, C.A. (1981b). Catecholamine turnover rates in discrete hypothalamic areas and associated changes in median eminence luteinizing hormone-releasing hormone and serum gonadotropins on proestrus and diestrus. *Endocrinology* 108, 1795-1801.
- RASMUSSEN, A.T. (1938). Innervation of the hypophysis. *Endocrinology* 23, 263-278.
- RAYMOND, V., BEAULIEU, M. LABRIE, F., and BOISSIER, J. (1978). Potent antidopaminergic activity of estradiol at the pituitary level on prolactin release. *Science*, 200, 1173-1175.
- READING, H.W. (1983). Dopaminergic receptors in bovine retina and their interaction with thyrotropin-releasing hormone. *J. Neurochem.* 41, 1587-1595.
- RECHT, L.D., HOFFMAN, D.L., HALDAR, J., SILVERMAN, A-J. and ZIMMERMAN, E.A. (1981). Vasopressin concentrations in hypophysial portal plasma; insignificant reduction following removal of the posterior pituitary gland. *Neuroendocrinology* 33, 88-90.
- REICHLIN, S., MARTIN, J.B., MITNICK, M.A., BOSHANS, R.L., GRIMM, Y. BOLLINGER, J., GORDON, J. and MALACARA, J. (1972). The hypothalamus in pituitary-thyroid regulation. *Recent Prog. Horm. Res.* 28, 229-286.
- REINHARD, J.F. Jr. and WURTMAN, R.J. (1977). Relation between 5-HIAA levels and the release of serotonin into brain synapses. *Life Sci.* 21, 1741-1746.
- RENAUD, L.P. (1981). A neurophysiological approach to the identification connections and pharmacology of the hypothalamic tuberoinfundibular system. *Neuroendocrinology* 33, 186-191.
- RENAUD, L.P., MARTIN, J.B. and BRAZEAU, P. (1975). Depressant action of TRH, LH-RH and somatostatin on activity of central neurons. *Nature* 255, 233-235.
- RÉTHÉLYI, M., VÍGH, J., SÉTÁLO, G., MERCHENTHALER, I., FLERKO, B. and PETRUSZ, P. (1981). The luteinizing hormone-releasing hormone-containing pathways and their co-termination with tanycyte processes in and around the median eminence and in the pituitary stalk of the rat. *Acta. Morph. Acad. Sci. Hung.* 29, 259-283.

- REYMOND, M.J., SPECIALE, S.G. and PORTER, J.C. (1983). Dopamine in plasma of lateral and medial hypophysial portal vessels: evidence for regional variation in the release of hypothalamic dopamine into hypophysial portal blood. *Endocrinology* 112, 1958-1963.
- RICHARDSON, K.C. (1958). Electronmicroscopic observations on Auerbach's plexus in the rabbit, with special reference to the problem of smooth muscle innervation. *Am. J. Anat.* 103, 99-136.
- RICHARDSON, S.B., PRASAD, J.A. and HOLLANDER, C.S. (1982). Acetylcholine, melatonin and potassium depolarization stimulate release of luteinizing hormone releasing hormone from rat hypothalamus in vitro. *Proc. Natl. Acad. Sci. USA* 79, 2686-2689.
- RICHTER, C.P. (1933). Cyclical phenomena produced in rats by section of the pituitary stalk and their possible relation to pseudopregnancy. *Am. J. Physiol.* 106, 80-90.
- RINNE, U.K. (1960). Neurosecretory material around the neurohypophyseal portal vessels in the median eminence of the rat. *Acta. Endocrinol.* 57, 1-108.
- RIVIER, C. and VALE, W. (1974). In vivo stimulation of prolactin secretion in the rat by thyrotropin releasing factor, related peptides and hypothalamic extracts. *Endocrinology* 95, 978-983.
- RIVIER, C. and VALE, W. (1983). Interaction of corticotropin-releasing factor and arginine vasopressin on adrenocorticotropin secretion in vivo. *Endocrinology* 113, 939-942.
- ROBINSON, A.G. and ZIMMERMAN, E.A. (1973). Cerebrospinal fluid and ependymal neurophysins. *J. Clin. Invest.* 52, 1260-1267.
- ROBINSON, I.C.A.F. (1980). The development and evaluation of a sensitive and specific radioimmunoassay for oxytocin in unextracted plasma. *J. Immunoassay* 1, 323-347.
- ROBINSON, I.C.A.F. and PARSONS, J.A. (1981). Suckling in the guinea-pig: the effects of passive immunisation with an antiserum to oxytocin. *J. Endocrinol.* 90, 237-244.
- RODBARD, D. (1971). Statistical aspects of radioimmunoassays. In: "Principles of Competitive Protein-Binding Assays", Eds. Odell, W.D. and Daughaday, W.H. Lippencott: Philadelphia; p. 204-253.
- ROSS, S.B., ÖGREN, S.O. and RENYI, A.L. (1976). (Z)-dimethylamino-1-(4-bromophenyl)-1-(3-pyridyl) propene (H102/09), a new selective inhibitor of the neuronal 5-hydroxytryptamine uptake. *Acta. Pharmacol. Toxicol. (Copenh.)* 39, 152-166.

- ROSS, S.B. and RENYI, A.L. (1975a). Tricyclic antidepressant agents I Comparison of the inhibition of the uptake of ^3H -noradrenaline and ^{14}C -5-hydroxytryptamine in slices and crude synaptosome preparations of the midbrain-hypothalamus region of the rat brain. *Acta. Pharmacol. Toxicol. (Copenh.)* 36, 382-394.
- ROSS, S.B. and RENYI, A.L. (1975b). Tricyclic antidepressant agents II Effect of oral administration on the uptake of ^3H -noradrenaline and ^{14}C -5-hydroxytryptamine in slices of the midbrain-hypothalamus region of the rat brain. *Acta. Pharmacol. Toxicol. (Copenh.)* 36, 395-408.
- ROTH, R.H., WALTERS, J.R. and AGHAJANIAN, G.K. (1974). Effect of impulse flow on the release and synthesis of dopamine in the rat striatum. *Biochem. Pharmacol. Suppl.* 1, 457-464.
- ROTSZTEJN, W.H., CHARLI, J.L., PATTOU, E. and KORDON, C. (1977). Stimulation by dopamine of luteinizing hormone-releasing hormone (LHRH) release from mediobasal hypothalamus in male rats. *Endocrinology*, 101, 1475-1483.
- ROTSZTEJN, W.H., DROUVA, S.V., PATTOU, E. and KORDON, C. (1978). Met-enkephalin inhibits *in vitro* dopamine-induced LHRH release from mediobasal hypothalamus of male rats. *Nature* 274, 281-282.
- RUBERG, M., ROTSZTEJN, W.H., ARANCIBIA, S., BESSON, J. and ENJALBERT, A. (1978). Stimulation of prolactin release by vasoactive intestinal polypeptide (VIP). *Eur. J. Pharmacol.* 51, 19-20.
- RUMSFELD, H.W. and PORTER, J.C. (1959). Investigation of the release of ACTH. *Endocrinology* 64, 942-947.
- RUSSELL, J.T., BROWNSTEIN, M.J. and GAINER, H. (1980). ^{35}S -cysteine labelled peptides transported to the neurohypophysis of adrenalectomized, lactating and Brattleboro rats. *Brain Res.* 201, 227-234.
- RUZSAS, C., LIMONTA, P. and MARTINI, L. (1982). Role of serotonergic neurones in the control of gonadotrophin and prolactin secretion in the rat. *J. Endocrinol.* 94, 83-89.
- SAAVEDRA, J.M., BROWNSTEIN, M. and AXELROD, J. (1973). A specific and sensitive enzymatic-isotopic microassay for serotonin in tissues. *J. Pharmacol. Exp. Ther.* 186, 508-515.
- SAAVEDRA, J.M., PALKOVITS, M., BROWNSTEIN, M.J. and AXELROD, J. (1974). Serotonin distribution in the nuclei of the rat hypothalamus and preoptic area. *Brain Res.* 77, 157-165.

- SAAVEDRA, J.M., PALKOVITS, M., KIZER, J.S., BROWNSTEIN, M. and ZIVIN, A.J. (1975). Distribution of biogenic amines and related enzymes in the rat pituitary gland. *J. Neurochem.* 25, 257-260.
- SAFFRAN, M., SCHALLY, A.V. and BENFREY, B.G. (1955). Stimulation of the release of corticotrophin from the adenohypophysis by a neurohypophysial factor. *Endocrinology* 57, 439-444.
- SALACINSKI, P., HOPE, J., MCLEAN, C., CLEMENT-JONES, V., SYKES, J., PRICE, J. and LOWRY, P.J. (1979). A new simple method which allows theoretical incorporation of radio-iodine into proteins and peptides without damage. *J. Endocrinol.* 81, 131P.
- SALDATE, M.C. and ORREGO, F. (1975). Electrically-induced release of (³H)-5-hydroxytryptamine from neocortical slices *in vitro*: influence of calcium but not of lithium ions. *Brain Res.* 99, 184-188.
- SALDATE, M.C. and ORREGO, F. (1977). Electrically-induced release of ³H-dopamine from slices obtained from different rat brain cortex regions. Evidence for a widespread dopaminergic innervation of the neocortex. *Brain Res.* 130, 483-494.
- SALISBURY, R.L., KREIG, R.J. and SEIKEL, H.R. (1980). Effects of arginine vasotocin, oxytocin and arginine vasopressin on steroid-induced surges of luteinizing hormone and prolactin in ovariectomized rats. *Acta. Endocrinol.* 94, 166-173.
- SAMSON, W.K. and MCCANN, S.M. (1976). Effects of lesions in the organum vasculosum lamina terminalis on the hypothalamic distribution of luteinizing hormone-releasing hormone and gonadotropin secretion in the ovariectomized rat. *Endocrinology*, 105, 939-946.
- SARKAR, D.K. (1983). Does LHRH meet the criteria for a hypothalamic releasing factor? *Psychoneuroendocrinology*, 8, 259-275.
- SARKAR, D.K., CHIAPPA, S.A., FINK, G. and SHERWOOD, N.M. (1976). Gonadotropin-releasing hormone surge in pro-oestrous rats. *Nature* 264, 461-463.
- SARKAR, D.K. and FINK, G. (1979). Effects of gonadal steroids on output of luteinizing hormone releasing factor into pituitary stalk blood in the female rat. *J. Endocrinol.* 80, 303-313.
- SARKAR, D.K. and FINK, G. (1980). Luteinizing hormone releasing factor in pituitary stalk plasma from long-term ovariectomized rats: effects of steroids. *J. Endocrinol.* 86, 511-584.
- SARKAR, D.K. and FINK, G. (1981). Gonadotropin releasing hormone surge: possible modulation through postsynaptic α -adrenoreceptors and two distinct dopamine receptors. *Endocrinology* 108, 862-867.

- SAUNDERS, A., TERRY, L.C., AUDET, J., BRAZEAU, P. and MARTIN, J.B. (1976). Dynamic studies of growth hormone and prolactin secretion in the female rat. *Neuroendocrinology* 21, 193-203.
- SAWYER, C.H. (1959). Nervous control of ovulation. In: "Recent Progress in the Endocrinology of Reproduction", Ed. Lloyd, C.W. Academic Press: New York; p. 1-18.
- SAWYER, C.H. (1979). Brain amines and pituitary gonadotrophin secretion. *Can. J. Physiol. Pharmacol.* 57, 667-680.
- SAWYER, C.H., MARKEE, J.E. and HOLLINSHEAD, W.H. (1947). Inhibition of ovulation in the rabbit by the adrenergic-blocking agent dibenamine. *Endocrinology* 41, 395-402.
- SCHALLY, A.V., ARIMURA, A. and KASTIN, A.J. (1973). Hypothalamic regulatory hormones. *Science* 179, 341-350.
- SCHALLY, A.V. and BOWERS, C.Y. (1964). *In vitro* and *in vivo* stimulation of the release of luteinizing hormone. *Endocrinology* 75, 608-614.
- SCHALLY, A.V. and GUILLEMIN, R. (1959). Concentration of corticotrophin releasing factor by chromatography on carboxymethyl-cellulose. *Proc. Soc. Exp. Biol. Med.* 100, 138-139.
- SCHALLY, A.V., REDDING, T.W., ARIMURA, A., DUPONT, A. and LINTHICUM, G.L. (1977). Isolation of gamma-aminobutyric acid from pig hypothalamus and demonstration of its prolactin release-inhibiting (PIF) activity *in vivo* and *in vitro*. *Endocrinology* 100, 681-691.
- SCHARRER, E. and SCHARRER, B. (1954). Hormones produced in neurosecretory cells. *Recent Prog. Horm. Res.* 10, 183-240.
- SCHNEIDER, H.P.G. and MCCANN, S.M. (1969). Possible role of dopamine as transmitter to promote discharge of LH-releasing factor. *Endocrinology* 85, 121-132.
- SCHNEIDER, H.P.G. and MCCANN, S.M. (1970). Mono- and indoleamines and control of LH secretion. *Endocrinology* 86, 1127-1133.
- SCHUILING, G.A., VAN DIETEN, J.A.M.J. and VAN REES, G.P. (1974). Induction and inhibition of ovulation in the rat by intracerebral progesterone implants. *Neuroendocrinology* 15, 38-50.
- SCHULTZ, S.G. and CURRAN, P.F. (1970). Coupled transport of sodium and organic solutes. *Physiol. Rev.* 50, 637-718.
- SCOTT, D.E., KROBISCH-DUDLEY, G., GIBBS, F.P. and BROWN, G.M. (1972). The mammalian median eminence. In: "Brain-Endocrine Interaction. Median Eminence: Structure and Function", Eds. Knigge, K.M., Scott, D.E. and Weindl, A. Karger: Basel; p. 35-49.

- SELMANOFF, M. (1981). The lateral and medial median eminence: Distribution of dopamine, norepinephrine and luteinizing hormone releasing hormone and the effect of prolactin on catecholamine turnover. *Endocrinology* 108, 1716-1722.
- SELMANOFF, M.K., PRAMIK-HOLDWAY, M.J. and WEINER, R.I. (1976). Concentrations of dopamine and norepinephrine in discrete hypothalamic nuclei during the rat oestrous cycle. *Endocrinology* 99, 326-329.
- SETALO, G., VIGH, S., SCHALLY, A.V., ARIMURA, A. and FLERKO, B. (1976). Immunohistological study of the origin of LH-RH-containing nerve fibres of the rat hypothalamus. *Brain Res.* 103, 597-602.
- SEYBOLD, B., ELDE, R. and HÖKFELT, T. (1981). Terminals of reserpine-sensitive vasopressin-neurophysin neurons in the external layer of the rat median eminence. *Endocrinology* 108, 1803-1809.
- SHAAR, C.J. and CLEMENS, J.A. (1974). The role of catecholamines in the release of anterior pituitary prolactin in vitro. *Endocrinology* 95, 1202-1212.
- SHANI (MISHKINSKY) J., GOLDBERGER, G. and SULMAN, G. (1975). Effect of antiserum to rat prolactin on milk yield and food intake in the rat. *J. Reprod. Fertil.* 43, 571-573.
- SHEARD, M.H., ZOLOVICK, A. and AGHAJANIAN, G.K. (1972). Raphe neurons: effect of tricyclic antidepressant drugs. *Brain Res.* 43, 690-694.
- SHERWOOD, N.M., CHIAPPA, S.A. and FINK, G. (1976). Immunoreactive luteinizing hormone releasing factor in pituitary stalk blood from female rats: sex steroid modulation of response to electrical stimulation of preoptic area or median eminence. *J. Endocrinol.* 70, 501-511.
- SHERWOOD, N.M., CHIAPPA, S.A., SARKAR, D.K. and FINK, G. (1980). Gonadotropin-releasing hormone (GnRH) in pituitary stalk blood from proestrous rats: effects of anaesthetics and relationship between stored and released GnRH and luteinizing hormone. *Endocrinology* 107, 1410-1417.
- SHEWARD, W.J., BENOIT, R. and FINK, G. (1984). Somatostatin-28(1-12)-like immunoreactive substance is secreted into hypophysial portal blood in the rat. *Neuroendocrinology* 38, 88-90.
- SHIELDS, P.J. AND ECCLESTON, D. (1973). Evidence for the synthesis and storage of 5-hydroxytryptamine in two separate pools in the brain. *J. Neurochem.* 20, 881-888.

- SHIMATSU, A., KATO, Y., MATSUSHITA, N., KATAKAMI, H., OHTA, H., YANAIHARA, N. and IMURA, H. (1983). Serotonin stimulates vasoactive intestinal polypeptide release from rat hypothalamus in vitro. Brain Res. 264, 148-151.
- SHIMATSU, A., KATO, Y., MATSUSHITA, N., KATAKAMI, H., YANAIHARA, N. and IMURA, H. Stimulation by serotonin of vasoactive intestinal polypeptide release into rat hypophysial portal blood. Endocrinology 111, 338-340.
- SHIN, S.H. (1982). VP has a direct effect on PRL release in male rats. Neuroendocrinology 34, 55-58.
- SHIN, S.H. and REIFEL, C.W. (1981). Adenohypophysis has an inherent property for pulsatile prolactin secretion. Neuroendocrinology 32, 139-144.
- SILVERMAN, A-J. Ultrastructural studies on the localization of neurohypophyseal hormones and their carrier proteins. J. Histochem. Cytochem. 24, 816-827.
- SILVERMAN, A-J., GADDE, C.A. and ZIMMERMAN, E.A. (1980). Effects of adrenalectomy on the incorporation of ³H-cytidine in neurophysin and vasopressin-containing neurons of the rat hypothalamus. Neuroendocrinology 30, 285-290.
- SILVERMAN, A-J., HOFFMAN, D., GADDE, C.A., KREY, L.C. and ZIMMERMAN, E.A. Adrenal steroid inhibition of the vasopressin-neurophysin neurosecretory system to the median eminence of the rat. Neuroendocrinology 32, 129-133.
- SILVERMAN, A-J. and ZIMMERMANN, E.A. (1975). Ultrastructural localization of neurophysin and vasopressin in the median eminence and posterior pituitary of the guinea-pig. Cell Tissue Res. 159, 291-301.
- SILVERMAN, A-J. and ZIMMERMAN, E.A. (1983). Magnocellular neurosecretory system. Ann. Rev. Neurosci. 6, 357-380.
- SLADEK, C.D. and JOYNT, R.J. (1979). Characterization of cholinergic control of vasopressin release by organ cultured rat hypothalamo-neurohypophyseal system. Endocrinology 104, 659-663.
- SLOPER, J.C. (1966). The experimental and cytopathological investigation of neurosecretion in the hypothalamus and pituitary. In: "The Pituitary Gland" Vol. 3 Eds. Harris, G.W. and Donovan, B.T. Univ. California Press: Berkeley; p.131-180.
- SLOVITER, R.S., DRUST, E.G. and CONNOR, J.D. (1978). Serotonin agonist actions of p-chlorophenylalanine. Neuropharmacology 17, 1029-1033.

- SMITH, G.C. and FINK, G. (1972). Experimental studies on the origin of monoamine-containing fibres in the hypothalamo-hypophysial complex of the rat. *Brain Res.* 43, 37-51.
- SMITH, M.S., FREEMAN, M.E. and NEILL, J.D. (1975). The control of progesterone secretion during the oestrous cycle and early pseudopregnancy in the rat: Prolactin, gonadotropin and steroid levels associated with rescue of the corpus luteum of pseudopregnancy. *Endocrinology* 96, 219-226.
- SMITH, P.E. (1932). The secretory capacity of the anterior hypophysis as evidenced by the effect of partial hypophysectomies in rats. *Anat. Rec.*, 52, 191-208.
- SNYDER, S.H. and COYLE, J.T. (1969). Regional difference in ³H-norepinephrine and ³H-dopamine uptake into rat brain homogenates. *J. Pharmacol. Exp. Ther.* 165, 78-86.
- SOFRONIEW, M.V. and GLASMANN, W. (1981). Golgi-like immunoperoxidase staining of hypothalamic magnocellular neurons that contain vasopressin, oxytocin or neurophysin in the rat. *Neuroscience* 6, 619-643.
- SOFRONIEW, M.V. and WEINDL, A. (1981). CNS distribution of VP, OT and neurophysins. In: "Endogenous Peptides and Learning and Memory Processes", Eds. Martinez, J.L., Jenson, R.A., Messing, R.B., Rigter, H. and McGaugh, J.L. Academic Press: London; p. 327-369.
- SOKOL, H.W., ZIMMERMAN, E.A., SAWYER, W.H. and ROBINSON, A.G. (1976). The hypothalamo-neurohypophysial system of the rat. Localization and quantification of neurophysin by light microscopic immunocytochemistry in normal rat and in Brattleboro rats deficient in vasopressin and a neurophysin. *Endocrinology* 98, 1176-1188.
- SPINEDI, E. and NEGRO-VILAR, A. (1983). Serotonin and adrenocorticotropin (ACTH) release: direct effects at the anterior pituitary level and potentiation of arginine-vasopressin induced ACTH release. *Endocrinology* 112, 1217-1223.
- STARKE, K., REINMANN, W., ZUMSTEIN, A. and HERTTING, G. (1978). Effect of dopamine receptor agonists and antagonists on release of dopamine in the rabbit caudate nucleus in vitro. *N.S. Arch. Pharmacol.* 305, 27-36.
- STEINBUSCH, H.W.M. (1981). Distribution of serotonin-immunoreactivity in the central nervous system of the rat; cell bodies and terminals. *Neuroscience* 6, 557-618.
- STEINBUSCH, H.W.M. and NIEUWENHUYS, R. (1981). Localization of serotonin-like immunoreactivity in the central nervous system and pituitary of the rat, with special reference to the innervation of the hypothalamus. *Adv. Expl. Med. Biol.* 133,

- STEVENS, R.W. and LAWSON, D. M. (1977). The influence of estrogen on plasma prolactin levels induced by thyrotropin releasing hormone (TRH), clonidine and serotonin in ovariectomized rats. *Life Sci.* 20, 261-266.
- STILLMAN, M.A., RECHT, L.D., ROSARIO, S.L., SEIF, S.M., ROBINSON, A.G. and ZIMMERMAN, E.A. (1977). The effects of adrenalectomy and glucocorticoid replacement on vasopressin and vasopressin-neurophysin in the zona externa of the median eminence of the rat. *Endocrinology* 101, 42-49.
- STOBIE, K.M. and SHIN, S.H. (1983). Serotonin stimulates prolactin secretion in the hypophysectomized, adeno-hypophyseal grafted rat. *Acta. Endocrinol.* 102, 511-516.
- SUBRAMANIAN, M.G. and GALA, R.R. (1976). The influence of cholinergic, adrenergic and serotonergic drugs on the afternoon surge of plasma prolactin in ovariectomized, estrogen-treated rats. *Endocrinology* 98, 842-848.
- SWANSON, L.W. and SAWCHENKO, P.E. (1983). Hypothalamic integration: organization of the paraventricular and supraoptic nuclei. *Ann. Rev. Neurosci.* 6, 269-324.
- SWANSON, L.W., SAWCHENKO, P.E., WIEGAND, S.J. and PRICE, J.L. (1980). Separate neurons in the paraventricular nucleus project to the median eminence and to the medulla or spinal cord. *Brain Res.* 198, 190-195.
- SYVALAHTI, E., NAGY, A., and VAN PRAAG, H.M. (1979). Effects of zimelidine, a selective 5-HT uptake inhibitor on serum prolactin levels in man. *Psychopharmacology* 64, 251-253.
- SZAFARACZYK, A., IXART, G., MALAVAL, F., NOUGIER-SOULE, J. and ASSENMACHER, I. (1979). Effects of lesions of the supra-chiasmatic nuclei and of p-chlorophenylalanine on the circadian rhythms of adrenocorticotrophic hormone and corticosterone in the plasma, and on locomotor activity of rats. *J. Endocrinol.* 83, 1-16.
- SZERB, J.C. (1979). Relationship between Ca^{2+} -dependent and independent release of 3H -GABA evoked by high K^+ , veratridine or electrical stimulation from rat cortical slices. *J. Neurochem.* 32, 1565-1573.
- TAKAHARA, J., ARIMURA, A. and SCHALLY, A.V. (1974). Suppression of prolactin release by a purified porcine PIF preparation and catecholamines infused into a rat hypophysial portal vessel. *Endocrinology* 95, 462-465.
- TALWALKER, P.K., RATNER, A. and MEITES, J. (1963). *In vitro* inhibition of pituitary prolactin synthesis and release by hypothalamic extracts. *Am. J. Physiol.* 205, 213-218.

- TANAKA, M., DE KLOET, E.R., DE WIED, D. and VERSTEEG, D.H. (1977). Arginine-8-vasopressin affects catecholamine metabolism in specific brain nuclei. *Life Sci.* 20, 1799-1808.
- TAPPER, C.M., GREIG, F. and BROWN-GRANT, K. (1974). Effects of steroid hormones on gonadotrophin secretion in female rats after ovariectomy during the oestrous cycle. *J. Endocrinol.* 62, 511-525.
- TARASKEVICH, P.S. and DOUGLAS, W.W. (1977). Action potentials occur in cells of the normal anterior pituitary gland and are stimulated by the hypophysiotropic peptide thyrotropin-releasing hormone. *Proc. Natl. Acad. Sci. USA* 74, 4064-4067.
- TASHJIAN, A.H. Jr., BAROWSKY, N.J. and JENSEN, D.K. (1971). Thyrotropin releasing hormone: direct evidence for stimulation of prolactin production by pituitary cells in culture. *Biochem. Biophys. Res. Commun.* 43, 516-523.
- TAUBENHAUS, M. and SOSKIN, S. (1941). Release of luteinising hormone from anterior hypophysis by an acetylcholine-like substance from the hypothalamic region. *Endocrinology* 29, 958-964.
- TERKEL, J., BLAKE, C.A. and SAWYER, C.H. (1972). Serum prolactin levels in lactating rats after suckling or exposure to ether. *Endocrinology* 91, 49-53.
- TINDAL, J.S. (1974). Stimuli that cause the release of oxytocin. In: *Handbook of Physiology, Section 7, Endocrinology Vol. IV, The Pituitary Gland, part 1.* Eds. Knobil, E. and Sawyer, W.H. *Am. Phys. Soc.* p. 257-267.
- TÖRÖK, B. (1962). Neue Angaben zum Blutkreislauf der Hypophyse. *Verh. 1. Eur. Anatomen-Kongr. Strasbourg, 1960.* *Anat. Anz.* 622-629.
- TOZER, T.N., NEFF, N.H. and BRODIE, B.B. (1966). Application of steady state kinetics to the synthesis rate and turnover time of serotonin in the brain of normal and reserpine-treated rats. *J. Pharmacol. Exp. Ther.* 153, 177-182.
- TSUNEKI, N. (1976). Neurosecretory axo-axonal synapses in the median eminence of the turtle *Geoclemys reevesii*. *Neuroendocrinology* 20, 59-62.
- UTIGER, R.D., PARKER, M.L. AND DAUGHADAY, W.H. (1962). Studies on human growth hormone I A radioimmunoassay for human growth hormone. *J. Clin. Invest.* 41, 254-261.
- VAGENAKIS, A.G., ROTI, E., MANNIX, J. and BRAVERMAN, L.E. (1975). Problems in the measurement of urinary TRH. *J. Clin Endocrinol. Metab.* 41, 801-804.

- VALE, W., BLACKWELL, R., GRANT, G. and GUILLEMIN, R. (1973). TRF and thyroid hormones on prolactin secretion by rat anterior pituitary cells in vitro. *Endocrinology* 93, 26-33.
- VALE, W., RIVIER, C., BRAZEAU, P. and GUILLEMIN, R. (1974). Effects of somatostatin on the secretion of thyrotropin and prolactin. *Endocrinology* 95, 968-977.
- VALE, W., RIVIER, C. and BROWN, M. (1980). Physiology and pharmacology of hypothalamic regulatory peptides. In: "Handbook of the Hypothalamus" Vol 2, Eds. Morgane, P.J. and Panksepp, J. Marcel Dekker: New York; p. 165-252.
- VALE, W., SPEISS, J., RIVIER, C. and RIVIER, J. (1981). Characteristics of a 41-residue ovine hypothalamic peptide that stimulates secretion of corticotrophin and β -endorphin. *Science* 213, 1394-1397.
- VALTIN, H.W., SAWYER, H. and SOKOL, H.W. (1965). Neurohypophysial principles in rats homozygous and heterozygous for hypothalamic diabetes insipidus. *Endocrinology* 77, 701-706.
- VALVERDE R.C., CHIEFFO, V. and REICHLIN, S. (1972). Prolactin-releasing factor in porcine and rat hypothalamic tissue. *Endocrinology* 91, 982-993.
- VAN DE KAR, L.D. and BETHEA, C.L. (1982). Pharmacological evidence that serotonergic stimulation of prolactin secretion is mediated via the dorsal raphe nucleus. *Neuroendocrinology* 35, 225-230.
- VAN DE KAR, L.D. and LORENS, S.A. (1979). Differential serotonergic innervation of individual hypothalamic nuclei and other forebrain regions by the dorsal and median midbrain raphe nuclei. *Brain Res.*, 162, 45-54.
- VANDESANDE, F. and DIERICKX, K. (1976). Immunocytochemical demonstration of the inability of the homozygous Brattleboro rat to synthesize vasopressin and vasopressin-associated neurophysin. *Cell Tissue Res.* 165, 307-316.
- VANDESANDE F., DIERICKX, K. and DE MEY, J. (1977). The origin of the vasopressinergic and oxytocinergic fibers of the external region of the median eminence of the rat hypophysis. *Cell Tissue Res.*, 180, 443-452.
- VAN MAANEN, J.H. and SMELIK, P.G. (1968). Induction of pseudo-pregnancy in rats following local depletion of monoamines in the median eminence of the hypothalamus. *Neuroendocrinology* 3, 177-186.

- VAUGHAN, M.H., BLASK, D.E. and JOHNSON, L.Y. (1979). Effect of subcutaneous injections of melatonin, arginine vasotocin and related peptides on pituitary and plasma levels of luteinizing hormone, follicle stimulating hormone and prolactin in castrated male rats. *Endocrinology* 104, 212-217.
- VIJAYAN, E. and McCANN, S.M. (1978). Re-evaluation of the role of catecholamines in control of gonadotropin and prolactin release. *Neuroendocrinology* 25, 150-165.
- VIJAYAN, E. and MCCANN, S.M. (1979). *In vivo* and *in vitro* effects of substance P and neurotensin on gonadotrophin and prolactin release. *Endocrinology* 105, 64-68.
- VOGT, M. (1942). Ovulation in the rabbit after destruction of the greater superficial petrosal nerves. *J. Physiol.* 100, 410-416.
- VOGT, M. (1954). The concentration of sympathin in different parts of the central nervous system under normal conditions and after the administration of drugs. *J. Physiol.* 123, 451-481.
- WALKER, R.F. (1983). Quantitative and temporal aspects of serotonin's facilitatory action on phasic secretion of luteinizing hormone in female rats. *Neuroendocrinology* 36, 468-474.
- WALKER, R.W. and WILSON, C.A. (1983). Changes in hypothalamic serotonin associated with amplification of LH surges by progesterone in rats. *Neuroendocrinology* 37, 200-205.
- WEBER, S.G. and PURDY, W.C. (1978). The behaviour of an electrochemical detector used in liquid chromatography and continuous flow voltammetry. Part I Mass transport limited current. *Anal. Chim. Acta.* 100, 531-544.
- WEHRENBURG, W.B., MCNICOL, D., FRANTZ, A.G. and FERIN, M. (1980). The effects of serotonin on prolactin and growth hormone concentrations in normal and pituitary stalk-sectioned monkeys. *Endocrinology* 107, 1747-1750.
- WEINER, N. (1974). A critical assessment of methods for the determination of monoamine synthesis turnover rates *in vivo*. In: "Neuropsychopharmacology of Monoamines and their Regulatory Enzymes". Ed. Usdin, E. Raven Press: New York; p. 141-159.
- WEINER, R.I. (1975). Role of brain catecholamines in the control of LH and prolactin secretion. In: "Hypothalamic Hormones". Eds. Motta, M., Crosignani, P.G. and Martini L. Academic Press: London; p.249-253.
- WEINER, R.I. and GANONG, W.E. (1978). Role of brain monoamines and histamine in regulation of anterior pituitary secretion. *Physiol. Rev.* 58, 905-976.

- WESTFALL, T.C., BENSON, M.J., GIORGUEFF, M.F. and GLOWINSKI, J. (1976). The role of pre-synaptic receptors in the release and synthesis of ^3H -dopamine by slices of rat striatum. *N.S. Arch. Pathol. Pharmacol.* 292, 279-287.
- WESTLUND, K.N. and CHILDS, G.V. (1982). Localization of serotonin fibres in the rat adenohypophysis. *Endocrinology* 111, 1761-1763.
- WIEGAND, S.J. and PRICE, J.L. (1980). Cells of origin of the afferent fibres to the median eminence in the rat. *J. Comp. Neurol.* 192, 1-19.
- WIEGAND, S.J., TERASAWA, E. and BRIDSON, W.E. (1978). Persistent estrus and blockade of progesterone-induced LH release follows lesions which do not damage the suprachiasmatic nucleus. *Endocrinology* 102, 1645-1648.
- WILBER, J.F. and PORTER, J.C. (1970). Thyrotropin and growth hormone releasing activity in hypophysial portal blood. *Endocrinology* 87, 807-811.
- WILSON, C.A. and MCDONALD, P.G. (1974). Inhibitory effect of serotonin on ovulation in adult rats. *J. Endocrinol.* 60, 253-260.
- WINGSTRAND, K.G. (1951). The structure and development of the avian pituitary. Sweden: C.W.K. Gleerup, Lund.
- WINOKUR, A. and UTIGER, R.D. (1974). Thyrotropin-releasing hormone: regional distribution in rat brain. *Science* 185, 265-267.
- WISLOCKI, G.B. and KING, L.S. (1936). The permeability of the hypophysis and hypothalamus to vital dyes with the study of the hypophyseal vascular supply. *Am. J. Anat.* 58, 421-472.
- WITKIN, J.W., PADEN, C.M. and SILVERMAN, A-J. (1982). The luteinizing hormone-releasing hormone (LHRH) systems in the rat brain. *Neuroendocrinology* 35, 429-438.
- WITTKOWSKI, W. and BOCK, R. (1972). Electron microscopical studies of the median eminence following interference with the feedback system, anterior pituitary-adrenal cortex. In: "Brain-Endocrine Interaction, Median Eminence: Structure and Function". Eds. Knigge, K.M., Scott, D.E. and Weindl, A. Karger: Basel; p. 171-180.
- WUTTKE, W., GELATO, M. and MEITES, J. (1971). Mechanisms of pentobarbital action on prolactin release. *Endocrinology* 89, 1191-1194.
- WUTTKE, W., HANCKE, J.L., JOHN, K.G. and BAUMGARTEN, H.G. (1978). Effect of intraventricular injection of 5,7-dihydroxytryptamine on serum gonadotropins and prolactin. *Ann. N.Y. Acad. Sci.* 305, 423-436.

- WUTTKE, W. and MEITES, J. (1970). Effects of ether and pentobarbital on serum prolactin and LH levels in proestrous rats. *Proc. Soc. Exp. Biol. Med.* 135, 648-652.
- WYMAN, L.C. and TUM SUDEN, C. (1937). Factors determining and limiting the growth of transplanted suprarenal cortical tissue. *Endocrinology* 21, 523-528.
- YALOW, R.S. (1980). Radioimmunoassay. *Ann. Rev. Biophys. Bioeng.* 9, 327-345.
- YAMADA, Y. (1975). Effects of iontophoretically-applied prolactin on unit activity of the rat brain. *Neuroendocrinology* 18, 263-271.
- YASUDA, N., GREER, M.A. and AIZAWA, T. (1982). Corticotropin-releasing factor. *Endocr. Rev.* 3, 123-140.
- ZACHARIAS, L.R. (1941). Further studies in naso-genital relationship. Anatomical studies of the peri-hypophyseal region in the rat. *J. Comp. Neurol.* 74, 421-445.
- ZIMMERMAN, E.A., CARMEL, P.W., HUSAIN, P.K., FERUN, M., TANNENBAUM, M. FRANTZ, A.G. and ROBINSON, A.G. (1973). Vasopressin and neurophysin: high concentration in monkey hypophyseal portal blood. *Science* 182, 925-927.
- ZIMMERMAN, E.A., HSU, K.C., ROBINSON, A.G., CARMEL, P.W., FRANTZ, A.G. AND TANNENBAUM, M. (1973). Studies of neurophysin secreting neurones with immunoperoxidase techniques employing antibody to bovine neurophysin I. Light microscopic findings in monkey and bovine tissues. *Endocrinology*, 92, 931-940.
- ZIMMERMAN, E.A., STILLMAN, M.A., RECHT, L.D., ANTUNES, J.L. and CARMEL, P.W. (1977). Vasopressin and corticotropin-releasing factor: an axonal pathway to portal capillaries in the zona externa of the median eminence containing vasopressin and its interaction with adrenal corticoids. *Ann. N.Y. Acad. Sci.* 297, 405-417.
- ZISAPEL, N., EGOZI, Y. and LAUDON, M. (1983). Inhibition by melatonin of dopamine release from rat hypothalamus *in vitro*: variations with sex and the estrous cycle. *Neuroendocrinology*, 37, 41-47.
- ZYZEK, E., DUFY-BARBE, L., DUFYM B. and VINCENT, J.D. (1981). Short-term effect of estrogen on release of prolactin by pituitary cells in culture. *Biochem. Biophys. Res. Commun.* 102, 1151-1157.

Appendix I Chemical structures of alaproclate and zimelidine

Alaproclate

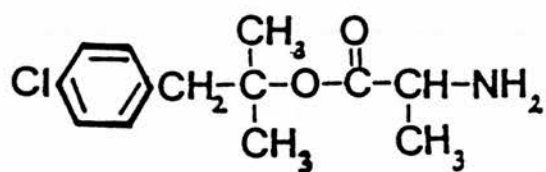

Zimelidine

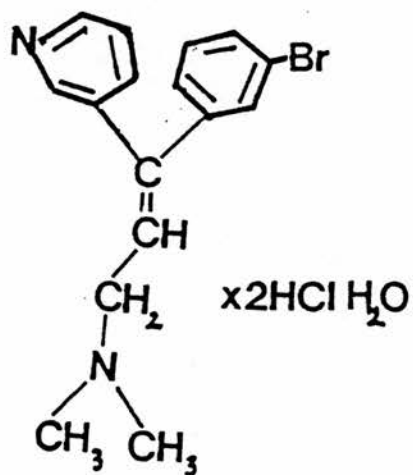

Appendix II Composition of Krebs-Heinsleit (K-H) buffer

<u>Substance</u>	<u>Weight, g/litre</u>	<u>Final Concentration</u>
Gelatine	0.100	0.1% w/v
NaCl	8.080	134mM
NaHCO ₃	2.100	25mM
KCl	0.372	5mM
CaCl ₂	0.220	2mM
KH ₂ PO ₄	0.170	1.25mM
MgSO ₄	0.098	1mM
Ascorbic acid	0.030	130 μ M
EDTA	0.010	27 μ M

Buffer saturated with 95% O₂/5% CO₂

pH = 7.4

In Na⁺-free buffer, NaHCO₃ and NaCl are replaced with 50mM Tris (hydroxymethyl) amino-methane hydrochloride buffer (pH 7.4) and 0.25M isotonic sucrose, respectively.

In Ca²⁺-free buffer, CaCl₂ is replaced with 5mM ethyleneglycol-bis-(β -amino-ethyl ether) - N.N-tetra-acetic acid (EGTA).

Appendix III Radioimmunoassays for prolactin (PRL) and luteinizing hormone (LH): based on the methods of Greenwood et al (1963); Niswender et al (1968)

III.1 Stock solutions

0.01M phosphate buffered saline (PBS):

8.17g NaCl

0.10g Na methiolate

0.25g $\text{NaH}_2\text{PO}_4 \cdot 2\text{H}_2\text{O}$

1.193g Na_2HPO_4 (anhydrous)

per litre distilled H_2O , pH to 7.6

Antiserum (AS) buffer

500ml 0.01M PBS

9.306g EDTA (ethylenediamine tetra-acetic acid disodium salt)

1.7ml normal rabbit serum (NRS)

pH to 7.6

Assay buffer (0.01M PBS/1% BSA)

1000ml 0.01M PBS

10g bovine serum albumin (BSA)

0.01M Borate buffer (for PRL iodination)

0.618g boric acid

0.1g Na methiolate

11.8ml 0.1M NaOH (4g/100ml distilled H_2O)

per litre distilled H_2O , pH to 8.6

0.05M Phosphate buffer (PB)

12.5g $\text{NaH}_2\text{PO}_4 \cdot 2\text{H}_2\text{O}$

59.65g Na_2HPO_4 (anhydrous)

per litre distilled H_2O

Rinse for PRL iodination:

0.1g KI

0.8g sucrose

per 10ml distilled H_2O

0.01M PBS/5% egg white

5g egg albumin

per 100ml 0.01M PBS, centrifuged at 2000 x g for 5 min before use

0.01M PBS/4.5% human albumin

4.5g human albumin
per 100ml 0.01M PBS

0.01M NaHCO₃
1.14g NaHCO₃
per 100ml distilled H₂O

III.2 Iodination

a) Materials

Columns	For LH - 12 x 1cm Biogel P60, coated with 1.5 ml 0.01M PBS/5% egg white, eluted with 0.01M PBS/1% BSA. For PRL - 25 x 1cm Sephadex G50, coated with 200µl human albumin, eluted with 0.01M borate buffer.
Hormones	Ovine-LH (LER-1056-C2; NIADDK) - 500µg/ml 0.01M PBS; 20µl aliquots stored at -40°C. Rat-PRL (rat-PRL-I-S; NIADDK) - 100µg/400µl 0.01M NaHCO ₃ ; 20µl aliquots stored at -40°C.
Na ¹²⁵ I	1mCi in 10µl for each assay.
Chloramine T	For LH: 5.0mg/ml 0.01M PBS; 10µl used. For PRL: 1.0mg/ml 0.05M PB; 15µl used. Made up fresh before use.
Sodium metabisulphite (Na ₂ S ₂ O ₅)	For LH: 5.0mg/ml 0.01M PBS; 25µl used. For PRL: 2.4mg/ml 0.05M PB; 50µl used. Made up fresh before use.

b) Protocol:

i) Defrost hormone aliquot.

- ii) Add 1mCi Na¹²⁵I and mix gently.
- iii) Add Chloramine T and mix gently.
- iv) Reaction times: LH iodination = 2 min.
PRL iodination = 20 sec.
- v) Add Na₂S₂O₅ solution and mix gently.
- vi) Transfer to column: PRL - after transfer of reaction mixture onto the column, rinse reaction vial with 2 x 100μl of rinse solution and transfer these onto the column; elute with 0.1M borate buffer. LH - elute with 0.01M PBS.
- vii) Collect fractions: for LH collect 0.5 ml fractions into tubes containing 0.5ml 0.01M PBS/5% egg white; for PRL, collect 0.5ml fractions into 0.5ml PBS/1% BSA.
- viii) Estimate radioactivity in fractions; retain fractions with peaks of radioactivity.

N.B. LH iodination: two peaks of radioactivity found to elute; ¹²⁵I labelled hormone eluted in the first peak and free ¹²⁵I in the second. ¹²⁵I-ovine- LH could be used for up to 10 days without further purification. It could still be used for up to another 14 days following re-chromatography on another Biogel P60 column.

PRL iodination: two peaks of radioactivity found to elute; ¹²⁵I labelled hormone eluted in the first peak and free ¹²⁵I in the second. ¹²⁵I-PRL was routinely only used in the RIA on the day of iodination.

III.3 Standards

Ovine LH (NIH-LH-S18; NIADDK) - 0.25, 0.5, 0.75, 1.2, 2.0, 4.0, 8.0 and 16.0ng/ml 0.01M PBS/1% BSA; 200μl aliquots stored at -40°C.

Rat PRL (rat-PRL-RP-1; NIADDK) - 0.5, 1.2, 2.0, 4.0, 8.0, 16.0, 32.0 and 64.0ng/ml 0.01M PBS/1% BSA; 200μl aliquots stored at -40°C.

III.4 Assay protocol

All incubations at 4°C.

Day	LH	PRL
1	200 μ l standards/samples 200 μ l 0.01M PBS/1% BSA 200 μ l antiserum diluted in AS buffer	200 μ l standards/samples 200 μ l 0.01M PBS/1% BSA 200 μ l antiserum diluted in AS buffer
2	200 μ l 125 I-ovine-LH (~ 10,000 cpm) diluted in 0.01M PBS/1% BSA)	200 μ l 125 I-rat-PRL (~ 10,000 cpm) diluted in 0.01 M PBS/1% BSA
3	--	--
4	200 μ l ARGG diluted in 0.01M PBS	200 μ l ARGG diluted in 0.01M PBS
5	Centrifuge tubes for 30 min at 2000 x g at 4°C; aspirate supernatant and count pellet.	Centrifuge tubes for 45 min at 2000 x g at 4°C aspirate supernatant and count pellet.

Appendix IV Radioimmunoassay for luteinizing hormone releasing hormone (LHRH): based on the methods of Nett et al (1973); Pickering (1978)

IV.1 Stock Solutions

0.01M PBS see Appendix III.1
Antiserum buffer see Appendix III.1
Assay buffer (0.01 M PBS/ 0.1% gelatine)
 1g gelatine
 dissolved by heating in 0.01M PBS, made up to 1 litre

IV.2 Iodination

a) Materials:

Column 20 x 0.75cm Sephadex G25 coated with 0.01M
 PBS/1% gelatine
Hormone Synthetic LHRH (ICI Pharmaceuticals Ltd.,
 Macclesfield) - 1mg/10ml 0.01M PBS; diluted
 to 2 μ g/20 μ l in distilled H₂O, stored at
 -40°C.
Na¹²⁵I 1mCi in 10 μ l
Chloramine T 2mg/ml 0.01M PBS; 20 μ l used
 made up fresh before use
Na₂S₂O₅ 2mg/ml 0.01M PBS; 20 μ l used
 made up fresh before use

b) Protocol

- i) Defrost LHRH aliquot.
- ii) Add 1mCi ¹²⁵I and mix gently.
- iii) Add Chloramine T and mix gently.
- iv) Reaction time = 15 sec
- v) Add Na₂S₂O₅ and mix gently.
- vi) Transfer to column: elute with 0.01M PBS/0.1% gelatine

vii) Collect fractions - collect first 10ml fraction as a pool, then 1ml fractions until total volume eluted is 22ml.

viii) Estimate radioactivity in fractions; retain fractions with peaks of radioactivity.

N.B. Two peaks of radioactivity found to elute; free ^{125}I eluted in the first 11-14 ml and ^{125}I -LHRH eluted in the 15-19 ml fractions. The labelled hormone could be used for up to 10 weeks without further purification.

IV.3 Standards

Synthetic LHRH (ICI Pharmaceuticals Ltd., Macclesfield) -
7.8, 15.5, 31.0, 62.0, 125.0, 250.0, 500.0pg/ml 0.01M
PBS/0.1% gelatine; 200 μ l aliquots stored at -40°C .

IV.4 Assay protocol

Day 1 200 μ l standards/samples
 200 μ l assay buffer
 200 μ l antiserum diluted in AS buffer
 200 μ l ^{125}I -LHRH (~ 5,000 cpm) diluted in assay
 buffer
Day 2 200 μ l ARGG diluted in 0.01M PBS
Day 3 1ml 0.01M PBS, then centrifuge at 2000 x g for 45
 min at 4°C ; aspirate supernatant and count
 pellet.

Appendix V Radioimmunoassays for vasopressin (VP) and oxytocin (OT): based on the method of Robinson (1980)

V.1 Stock solutions

0.1M Tris buffer

12.114g tris-(hydroxy-methyl)-methylamine per litre distilled H₂O, adjusted to pH 7.4 with 5M HCl.

Assay buffer (0.1M Tris buffer/3% BSA)

1000ml 0.1M Tris buffer

3g BSA

0.2M Phosphate buffer (PB)

50g NaH₂PO₄·2H₂O

238.6g Na₂HPO₄ (anhydrous) per litre distilled H₂O

V.2 Iodination

a) Materials:

Columns For both VP and OT - 20 x 1cm Sephadex A-25, eluted with 0.1M Tris/3% BSA

Hormones Oxytocin (440IU/mg; Dr. H. Vilhardt, Ferring, Sweden) - 250µg/ml 0.2M PB; 20µl aliquots stored at -20°C.

Vasopressin (400IU/mg; Batch no. 770110; Ferring Sweden) - 250µg/ml 0.2M PB buffer; 20µl aliquots stored at -20°C.

Na¹²⁵ 1mCi in 10µl for each assay

Iodogen 2.5µg, deposited in a small glass tube.

b) Protocol:

- i) Defrost hormone aliquot.
- ii) Add hormone and Na¹²⁵I in 100µl PB to tube containing iodogen.
- iii) Reaction time = 20 min.
- iv) Transfer to column, elute with assay buffer.

- v) Collect fractions - iodinated peptide appears as a single broad peak. This peak is rechromatographed on a smaller column (1 x 10cm, Sephadex A-25) under the same conditions and the fractions tested for binding to excess antibody.
- vi) Fraction showing the best immunoreactivity is divided into 1 μ Ci aliquots and stored at -20°C.

V.3 Standards

Oxytocin (IVth International Standard for OT; NIBSC) 1.0, 2.0, 4.0, 8.0, 16.0, 32.0, 64.0, 128.0, 256.0pg/tube. Made up immediately before use by doubling dilutions in cleared dog plasma from a stock solution of 5ng/ml assay buffer, stored at -20°C.

Vasopressin (Ist International Standard for VP; NIBSC) 1.0, 2.0, 4.0, 8.0, 16.0, 32.0, 64.0, 128.0, 256.0pg/tube. Made up immediately before use by doubling dilutions in cleared dog plasma from a stock solution of 5ng/ml assay buffer, stored at -20°C.

V.4 Assay protocol

All incubations at 4°C.

Day	VP	OT
1	25 μ l standards/samples 275 μ l assay buffer containing ¹²⁵ I-VP (~ 3,000 cpm) and specific anti-VP-serum, 1: 5,000	50 μ l standards/samples 250 μ l assay buffer containing ¹²⁵ I-OT (~ 3,000 cpm) and specific anti-OT- serum, 1: 225,000.
2	---	---
3	---	---
4	900 μ l absolute alcohol Centrifuge at 3000 x g for 10 min at 4°C. Aspirate supernatant and count pellet.	900 μ l absolute alcohol Centrifuge at 3000 x g for 10 min at 4°C. Aspirate supernatant and count pellet.

Appendix VI Radioimmunoassay for oestradiol-17 β , based on the method of Dick et al. (1978)

VI.1 Recovery solution

500 cpm $^3\text{H-OE}$ blown to dryness, taken up in 50 μl assay buffer (0.01M PBS/1% gelatine) and added to each 0.5ml plasma sample.

VI.2 Sample extraction

0.5ml plasma + 2 x 5ml diethyl ether/petroleum ether at 50°C. Ether extracts combined, blown to dryness and taken up in 300 μl 0.01M PBS/1% gelatine. 2 x 100 μl aliquots taken for assay.

50 μl counted for % recovery.

VI.3 Standards

4.5, 9.0, 18.0, 36.0, 72.0, 144.0pg OE/tube.

VI.4 Assay protocol

100 μl standard/sample

100 μl 0.01M PBS/1% gelatine

500 μl antiserum (1:300,000) in 0.01M PBS/1% gelatine

100 μl - 5000 cpm $^3\text{H-OE}$

Mixed and incubated at 4°C for 24h

500 μl dextran coated charcoal solution

Incubated for 15 min on ice.

Centrifuge at 2000 x g for 30 min at 4°C.

500 μl of supernatant removed for counting.