

GENERATION OF REACTIVE INTERMEDIATES
FROM THE THERMOLYSIS OF FUROXANS
AND RELATED HETEROCYCLES

by

WILLIAM ROBERTSON MITCHELL, B.Sc.

Thesis presented for the degree

of

DOCTOR of PHILOSOPHY

University of Edinburgh



September 1981

*To my wife LINDA
and our daughter FIONA
and my parents*

DECLARATION

I declare that this thesis is my own composition, that the work of which it is a record has been carried out by myself, and that it has not been submitted in any previous application for a Higher Degree.

The thesis describes results of research carried out in the Department of Chemistry, University of Edinburgh, under the supervision of Dr. R.M. Paton since the 1st October 1976, the date of my admission as a research student.

The following courses were attended during the three years of my research:

Five lectures by Dr. D. Leaver on "Organic Sulphur Compounds in General Synthesis" (1 unit);

Five lectures by Dr. I. Gosney on "Strategy of Organic Syntheses" (1 unit);

Four lectures by Professor J.H. Knox and Drs. Pryde and Done on "High Performance Liquid Chromatography" (1 unit);

Four lectures by Mr. D.H. Desty on "The Encouragement and Exploitation of Inventiveness in the Oil Industry" (1 unit);

Five lectures by Dr. J.T. Sharp on "Frontier Orbitals in Chemistry" (1 unit);

Five lectures by the Staff of the Research Department, ICI Organics Division, Blackley - "Chemistry at its most colourful" (1 unit);

Three years at Laboratory 29 group seminars in Edinburgh University Chemistry Department (3 units);

ACKNOWLEDGEMENTS

I should like to express my gratitude to Dr. R.M. Paton for both suggesting the topic of my research and for his guidance and encouragement throughout the course of the work.

Thanks and appreciation are also due to staff members in the Chemistry Department of Edinburgh University and to Mrs. J. Gorrie for her skill and patience in typing the manuscript.

Finally I would like to thank the Science Research Council for the award of a Studentship for the period during which this research was carried out.

ABSTRACT

The thermal decomposition of furoxans has been investigated using Flash Vacuum Pyrolysis (FVP) apparatus and technique. It has been established that the decomposition proceeds via a retro-1,3-dipolar cycloaddition to give nitrile oxides ($\text{RC}\equiv\overset{\ddagger}{\text{N}}-\bar{\text{O}}$). The above technique has enabled the isolation of reactive nitrile oxides in solution where previously their intermediacy in the decomposition of furoxans had been demonstrated by i.r. spectroscopy and by the isolation of the appropriate 1,3-dipolar cycloadduct formed from reaction of the nitrile oxide with a suitable dipolarophile. In addition the synthetic utility of furoxans as a source of nitrile oxides has been greatly extended. Indeed, for acetonitrile oxide and propionitrile oxide FVP of the corresponding furoxans is probably the method of choice.

An investigation into the thermal decomposition of furazans has been carried out and it has been demonstrated, as was the case with furoxans, that the thermolytic ring opening to nitrile oxides is a general reaction for furazans. Nitrile oxides and nitriles are formed in high yield both in solution and in the vapour phase. In addition thermolysis of unsymmetrically disubstituted furazans suggests that the fragmentation of the oxadiazole ring takes place in favour of the more stable nitrile oxide.

The thermal decomposition of three related heterocycles were also investigated. FVP of diphenyl-1,2,4-oxadiazole

established that the compound was extremely stable with no evidence to support a retro-1,3-dipolar cycloaddition to nitrile oxide and nitrile. Similarly 2[H]-1,2,3-triazole-1-oxides also exhibited considerable thermal stability and unlike the isoelectronic furoxans there was no evidence to support the intermediacy of nitrile oxides during their decomposition. An examination into the thermolysis of 1,4,2,5-dioxadiazines revealed that, unlike the isomeric furoxans, nitrile oxides were not formed on pyrolysis. Rather the decomposition was complex giving rise to many decomposition products. These products have been rationalised by a mechanism in which initial fragmentation of the heterocyclic ring gives rise to the corresponding nitrile and nitroso-carbonyl compound (R.CO.NO).

Preliminary reports on some aspects of this work have been published:-

"Isolation of Nitrile Oxides from the Thermal Fragmentation of Furazan-N-oxides", W.R. Mitchell and R.M. Paton, Tet.Letts., 1979, 2433.

"Generation of Isocyanates from the Flash Vacuum Pyrolysis of Furazan-N-oxides", W.R. Mitchell and R.M. Paton, Chem.Ind. (London), 1980, 655.

CONTENTS

	<u>PAGE NO.</u>
<u>INTRODUCTION</u>	
1. NITRILE OXIDES	1
2. FUROXANS	46
3. FURAZANS	65
4. FLASH VACUUM PYROLYSIS	75
 <u>EXPERIMENTAL</u>	
SYMBOLS AND ABBREVIATIONS	88
INSTRUMENTATION	89
SOLVENTS AND REAGENTS	93
1. PREPARATION OF FUROXANS	94
2. PREPARATION OF FURAZANS	97
3. PREPARATION OF 3,6-DISUBSTITUTED- 1,4,2,5-DIOXADIAZINES	106
4. PREPARATION OF 2[H]-1,2,3-TRIAZOLE- 1-OXIDES	107
5. PREPARATION OF 4,5-DIMETHYL-2-PHENYL- 1,2,3-TRIAZOLE	110
6. PREPARATION OF AUTHENTIC ADDUCTS	110
7. FLASH VACUUM PYROLYSIS (FVP) - APPARATUS AND GENERAL METHOD	116
8. FVP OF 3,4-DISUBSTITUTED FUROXANS - GENERATION OF NITRILE OXIDES	118
9. SPECTROSCOPIC EXAMINATION OF ALIPHATIC NITRILE OXIDES	133
10. DIMERISATION OF ACETONITRILE OXIDE TO 3,4-DIMETHYLFUROXAN	133

11.	THERMOLYSES OF 3,4-DISUBSTITUTED FURAZANS	137
12.	SYNTHESIS AND THERMOLYSIS OF 3,5-DIPHENYL- 1,2,4-OXADIAZOLE	144
13.	THERMOLYSIS OF 2[H]-1,2,3-TRIAZOLE-1-OXIDES	148
14.	FVP of 3,6-DIARYL-1,4,2,5-DIOXADIAZINES	151

DISCUSSION

1.	FLASH VACUUM PYROLYSIS OF FUROXANS	159
2.	THERMOLYSIS OF OXADIAZOLES	179
3.	THERMOLYSIS OF 2,4,5-TRISUBSTITUTED- 1,2,3-TRIAZOLE-1-OXIDES	196
4.	FLASH VACUUM PYROLYSIS OF 3,6-DIARYL- 1,4,2,5-DIOXADIAZINES	204

REFERENCES

INTRODUCTION

	<u>PAGE No.</u>
1. NITRILE OXIDES	1
1.1 Historical Background	1
1.2 Spectroscopic Properties	6
1.3 Preparation of Nitrile Oxides	7
1.3.1 Dehydrogenation of Aldoximes	7
1.3.2 Dehydrochlorination of Hydroximoyl Chlorides	11
1.3.3 Nitrile Oxides from Primary Nitroalkanes	15
1.3.4 Nitrile Oxides from 1,3,2,4-Dioxathiazole- 2-Oxides	17
1.3.5 Nitrile Oxides from the Potassium Salts of Dinitroalkanes	20
1.3.6 Nitrile Oxides from Furazans and Furoxans	21
1.4 Reactions of Nitrile Oxides	22
1.4.1 Isomerisation to Isocyanates	22
1.4.2 Dimerisation of Nitrile Oxides	28
1.4.3 1,3-Dipolar Cycloadditions Reactions of Nitrile Oxides	34
1.4.4 1,3-Dipolar Additions of Nitrile Oxides	46
2 FUROXANS	46
2.1 Structure of Furoxans	47
2.2 Preparation of Furoxans	52
2.2.1 Dimerisation of Nitrile Oxides	52
2.2.2 Dehydrogenation of Glyoximes	52
2.2.3 Dehydration of Pseudonitrisites	54
2.2.4 Furoxans from 1,2-Dinitroalkenes	56
2.3 Thermal Stability of Furoxans	58

3.	FURAZANS	65
3.1	Preparation of Furazans	65
3.1.1	Dehydration of Glyoximes	66
3.1.2	Deoxygenation of Furoxans	67
3.2	Thermal and Photolytic Stability of the Furazan Ring	68
4.	FLASH VACUUM PYROLYSIS	75
4.1	Apparatus and Technique	75
4.2	Applications of Flash Vacuum Pyrolysis	78

1. NITRILE OXIDES

1.1 Historical Background

Nitrile oxides are compounds containing the fulmido group - CNO. In general this functional group is bound directly to the carbon atom of the organic moiety of the molecule, the parent of the family, formonitrile oxide (fulminic acid), is the exception. As a consequence of the hydrogen atom bound directly to the functional group, the chemistry of formonitrile oxide differs in many ways from that of its higher homologues and as a result will not be discussed other than in the history of the nitrile oxides.

The history of the nitrile oxides starts at the beginning of the 19th century with Howard,¹ who in 1800 attempted to synthesize hydrochloric acid from the reaction of ethanol, nitric acid and mercury. Instead of mercuric chloride he obtained, unknown to him, mercuric fulminate which on subsequent heating to liberate the expected hydrochloric acid detonated violently. This was the "spark" which prompted further investigations by many eminent chemists, including Gay Lussac,² Liebig,² and Kékulé,³ throughout the 19th century and the first half of the 20th century, into the identification and structure elucidation of formonitrile oxide. The carbonyl oxime structure (1a) suggested by Nef⁴ in 1894, which with

the small refinement added much later of including the dipolar contribution (1b)⁵ to take account of the growing understanding of chemical bonding was accepted until the 1960's.

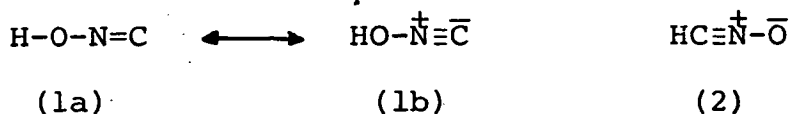

Ley⁶ had proposed the dipolar structure (2) in 1899, but this was not generally accepted as it did not appear to account for the formation of (3) on treatment with hydrogen halides (HX). At the time these were only explicable in terms of 1,1-addition to the divalent carbon.

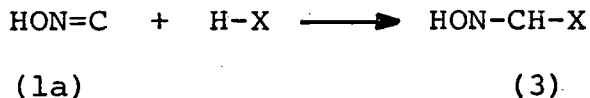

Although not widely accepted, at the time, structure (2) gained support from the experimental studies of Quilico and co-workers⁷ and from theoretical studies of Pauling⁸ who calculated the potential energies for all the possible structures and concluded that (2) was favoured over (1).

Finally, in 1961 Huisgen removed the last obstacle to the acceptance of (2), namely the aforementioned addition reactions, with his concept of 1,3-dipolar

reactivity of nitrile oxides.⁹ This gave rise to the resonance hybrid (2a) which readily explained the above addition reaction.

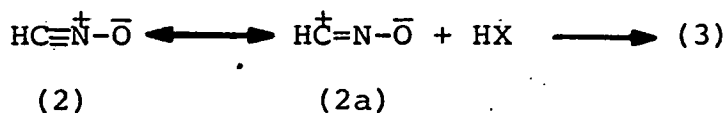

Final proof came in 1965 when Beck recorded the infrared spectrum of gaseous fulminic acid¹⁰ and found it only consistent with structure (2).

The history of the higher homologues of formonitrile oxide is much shorter. Before the first member of the series was ever prepared it had been postulated in 1886¹¹ that the formation of phenyl isocyanate (6) from the attempted distillation of 3,4-diphenylfuroxan (4) occurred via a nitrile oxide intermediate (Scheme 1).

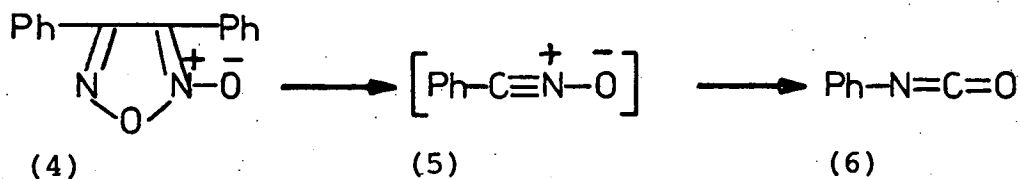

Scheme 1

However, benzonitrile oxide (5) was not identified until 1894 when Werner¹² while attempting to synthesize α -nitrobenzaloxime (7) from benzaloxime via the reaction of silver nitrite with benzohydroximoyl chloride (8) actually prepared (4) (Scheme 2).

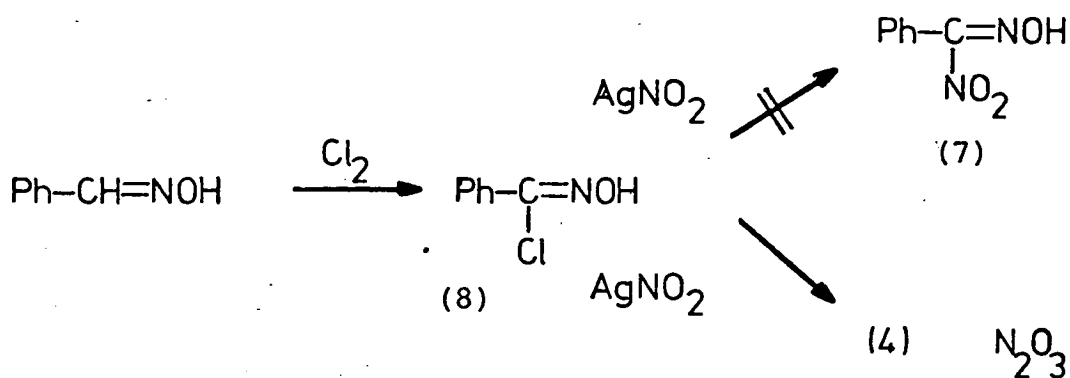

Scheme 2

He demonstrated that in the presence of weak bases (8) gave an unstable oil which solidified to give the furoxan to which he assigned the dioxadiazine structure (9).

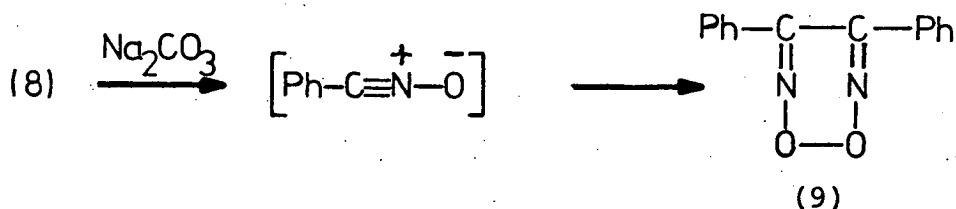

Werner did not attempt to purify or analyse this oil but deduced its structure from its hydrolysis products; with acid, hydroxylamine and benzoic acid were formed, whereas the action of alkali produced benzohydroxamic acid.

Benzonitrile oxide was obtained pure for the first time by Wieland in 1907¹³ using Werner's procedure.

He also determined its molecular weight and established some of its addition reactions. Initially, the structure of the nitrile oxides was represented by the cyclic structure (10)¹⁴ but optical data¹⁵ and energy level calculations later indicated that the linear structure (11) was preferred.

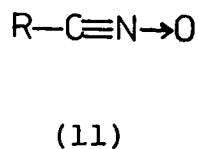
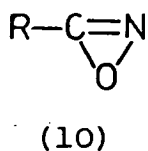

A further refinement was provided by Huisgen who suggested that the structure was best represented as a resonance hybrid of structures (12a-e).^{9,15}

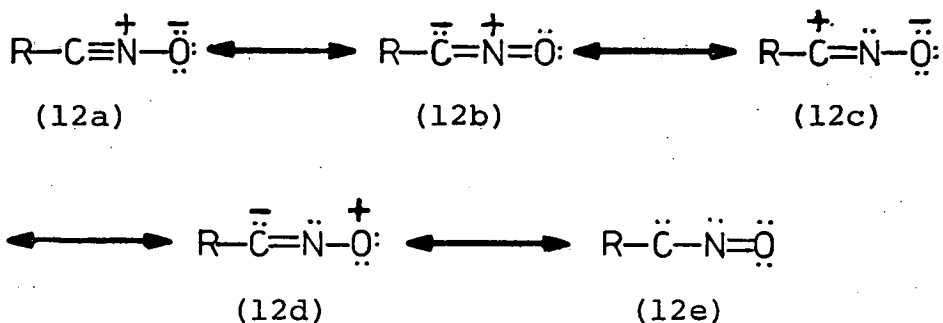

Among these mesomeric structures, the octet formulae (12a) and (12b) presumably represent the electronic distribution in the ground state, where (12c) expresses best most reactions of nitrile oxides, especially 1,3-dipolar additions.

Over the whole series the stability of the nitrile oxides varies greatly. All simple aliphatic and most aromatic nitrile oxides are only permanently stable at temperatures far below 0°C. They are energy rich compounds and as a result should be considered explosive.¹⁶ However, the main difficulties in handling nitrile oxides are not caused by their explosiveness but by their rapid spontaneous dimerisation to furoxans. The stability of

nitrile oxides can be influenced by both steric and electronic factors. However, the influence electronic factors have on the stability of aromatic nitrile oxides is variable and very weak¹⁷ and may be overshadowed by steric effects. On the other hand a very pronounced effect can be achieved by steric hinderance. Substitution of aromatic nitrile oxides in the ortho positions with bulky substituents inhibits the dimerisation to furoxans.¹⁸ For example, 2,4,6-trimethylbenzonitrile oxide is stable indefinitely at ambient temperatures, attempts to force its dimerisation to the corresponding furoxan by heating it above its melting point or by refluxing in a high-boiling solvent results in a clean rearrangement to the isomeric 2,4,6-trimethylphenyl isocyanate. Despite its stability towards dimerisation it will undergo 1,3-dipolar cycloadditions with several dipolarophiles.¹⁸ In similar fashion di-t-butylacetonitrile oxide ((t-C₄H₉)₂CHCNO)^{+ -} is indefinitely stable at 25°C and rearranges to the corresponding isocyanate on heating at 125-130°C for five hours.¹⁹

1.2 Spectroscopic Properties

Although nitrile oxides have been studied by many techniques,²⁰ the most widely applicable method has been i.r. spectroscopy. Almost all isolated oxides have been characterised by their i.r. spectra. Indeed, for many of the less stable nitrile oxides it has been the sole means of identification of the nitrile oxide intermediate.²¹ Both aliphatic and aromatic nitrile oxides are characterised by two strong absorption bands at ca. 2300 cm⁻¹ (C≡N stretch)

and at ca. 1370 cm^{-1} (-N=O stretch). The band at 2300 cm^{-1} is well suited for the identification of monomeric nitrile oxides; the corresponding nitriles absorb strongly in the same region, but usually ca. 70 cm^{-1} lower. The intensity of the nitrile oxide band is also normally stronger and broader than the corresponding nitrile. The isomeric isocyanates also absorb in this region but they lack the band at 1370 cm^{-1} .

1.3 Preparation of Nitrile Oxides

The most common routes to both aliphatic and aromatic nitrile oxides start from the corresponding aldoxime. The aldoxime can in many instances be converted directly to the nitrile oxide by oxidation with hypohalites or more commonly via chlorination to the corresponding hydroximoyl chlorides and subsequent dehydrochlorination by the action of base.

1.3.1 Dehydrogenation of Aldoximes

Aliphatic and aromatic aldoximes can usually be dehydrogenated to the nitrile oxide by the action of potassium ferricyanide or sodium hypohalites in alkaline solution.^{18,19,22}



The reagent of choice is an alkaline solution of sodium hypobromite with the oxidation proceeding in high yield at ca. 0°C. In contrast, the reaction of sodium hypochlorite, first studied by Ponzio in 1906,²³ usually yields only a small amount of the nitrile oxide plus a dimeric compound derived from the abstraction of one hydrogen atom per molecule. The exact structure of the dimer is still unknown but it is believed to be either an oxime anhydride N-oxide (13)^{24(a)} or an aldazine bis-N-oxide (14)^{24(b)}.

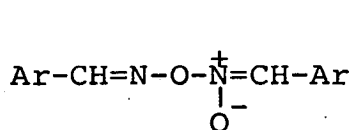

(13)

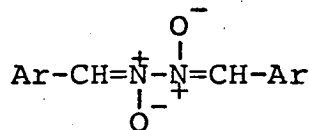

(14)

Although oxidation of the aldoxime by hypobromite is an extremely useful route to nitrile oxides it is restricted to those aldoximes which are stable to the oxidising agent and have no alkali-labile functional groups. A milder and more selective dehydrogenation can be achieved with N-bromosuccinamide in the presence of alkali alkoxides or tertiary bases.²⁵ This modification is probably the most generally applicable route for the synthesis of nitrile oxides enabling heterocyclic amino, substituted aromatic and polyfunctional nitrile oxides to

be synthesised. Direct oxidation is particularly useful where the nitrile oxides cannot be prepared by the older route from the hydroximoyl chloride because of side reactions during chlorination of the oxime. Aldoximes can also be dehydrogenated with lead tetra-acetate,²⁶ the reaction products being dependent upon the stereochemical conformation of the aldoxime and the temperature at which the reaction occurs. At low temperature (-78°C), all syn-aldoximes behave similarly and give nitrile oxides in high yield. In contrast, reaction above -78°C and with anti-aldoximes at all temperatures gives rise to various products; the main products from reaction with aliphatic aldoximes are nitrosoacetate dimers (15) and acetylhydroxamates (17). It would appear that (15) is in equilibrium with the gem-nitrosoacetate monomers (16) which rearrange easily to (17); Scheme 3.

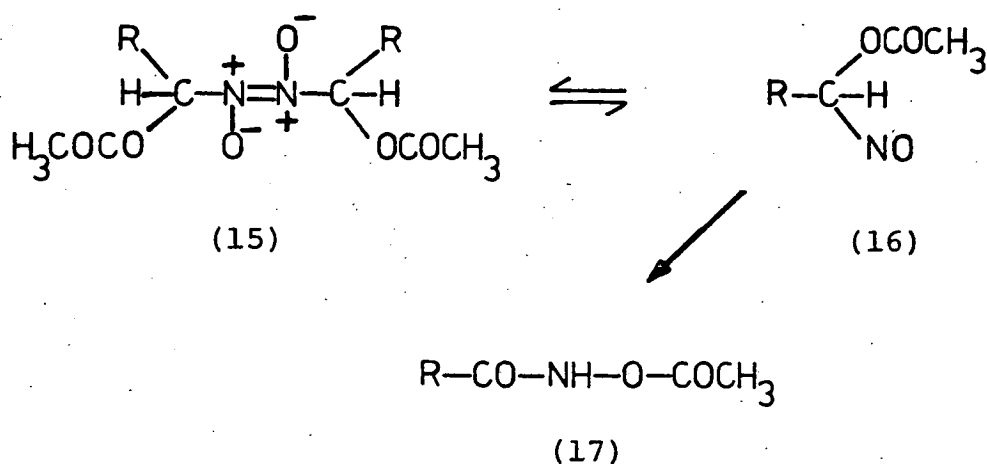

Scheme 3

The mechanistic proposals for these reactions are built around the presence of iminoxy radicals and nitrile oxide intermediates in the system. The mechanism put forward by Just and Dahl²⁶ is outlined in Scheme 4.

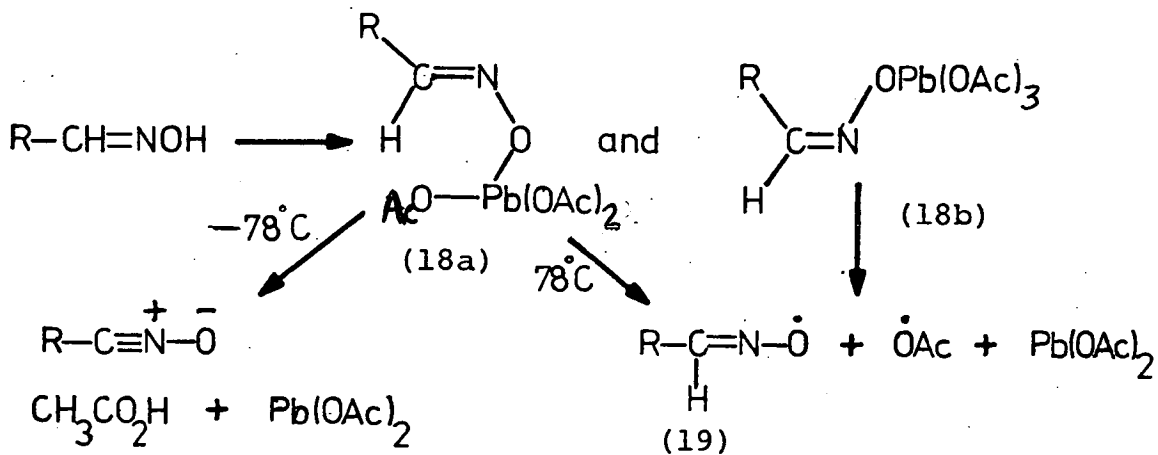

Scheme 4

Their postulate invokes the formation of the organo lead species (18a, 18b); the syn-isomer (18a) of which could readily give a nitrile oxide. As the temperature is raised, free iminoxy radicals (19) could be formed along with acetoxy radicals, and combinations of these could yield the products isolated. However, the experimental evidence is not conclusive and an alternative mechanism involving a cationic intermediate has been suggested.²⁷

The conditions employed to synthesize nitrile oxides are so mild that aromatic and aliphatic aldoximes containing functional groups which would not normally permit the use of more conventional methods,¹⁸ can be converted to nitrile oxides. The main limitations of the reaction are the stereochemical requirement that only syn-aldoximes can be used, and the reactivity towards lead tetra-acetate exhibited by certain functional groups containing labile hydrogen atoms.

1.3.2 Dehydrochlorination of Hydroximoyl Chlorides

Dehydrochlorination of hydroximoyl chlorides is the oldest known route to nitrile oxides and was utilised by Wieland in 1907 for the original preparation of benzo- nitrile oxide.¹³ Typically, hydroximoyl chlorides are prepared from the corresponding aldoxime by direct chlorination or by the action of nitrosyl chloride.²⁸ Direct chlorination is usually carried out in an inert solvent at low temperature (< 0°C) and many aromatic and aliphatic hydroximoyl chlorides are prepared by this method. The reaction proceeds via the geminal chloro- nitroso compound (20) or its dimer (21) which rearranges to the desired product on warming to room temperature,²⁹ as outlined in Scheme 5.

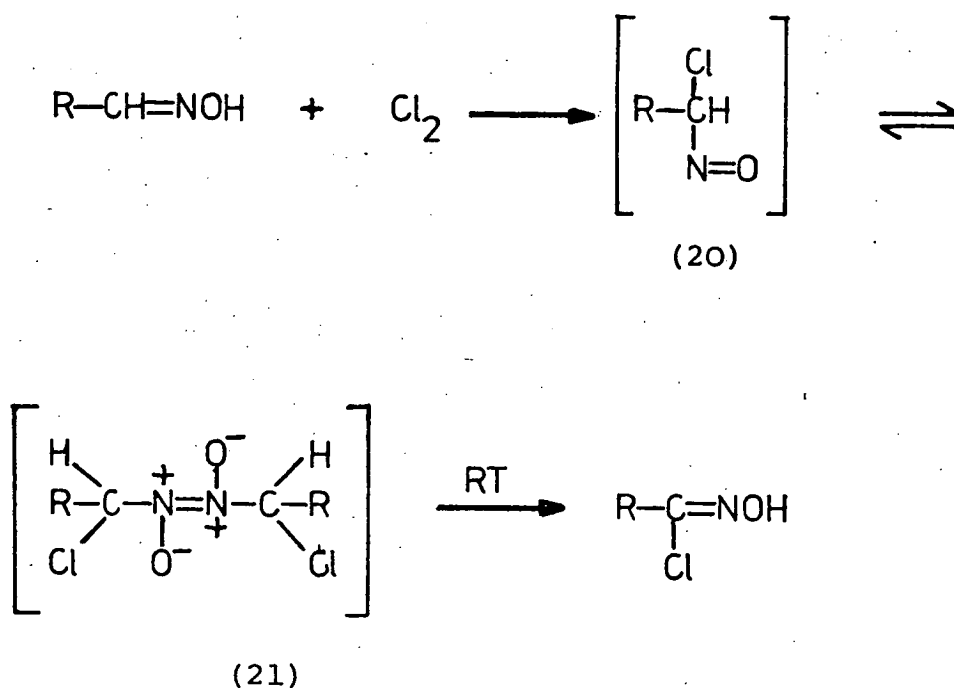

Scheme 5

The major disadvantage of this synthetic route is often the formation of products from unwanted side reactions. For example, direct chlorination of thiophene-2-carbaldehyde (22) gives 5-chlorothiophene-2-carbohydroximoyl chloride (23). However, by employing nitrosyl chloride as the chlorinating agent this problem is avoided and thiophene-2-carbohydroximoyl chloride (24) is produced in excellent yield.³⁰

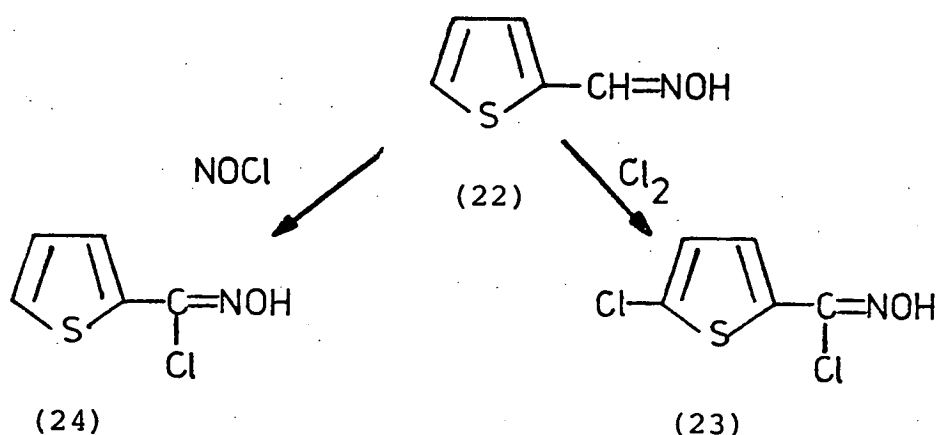

Despite this refinement the main limitation of the method remains the chlorination of the aldoximes. Unsaturated aldoximes add chlorine across the double bond²¹ and in addition many substituted aromatic aldoximes undergo electrophilic aromatic substitution producing inseparable mixtures of hydroximoyl chlorides.¹⁸ This property has been utilised in the synthesis of stable nitrile oxides. By using three moles of chlorine 2,4,6-trimethylbenzaldehyde (25) is cleanly converted into 3,5-dichloro-2,4,6-trimethylbenzohydroximoyl chloride (26) which may be converted to the corresponding nitrile oxide (27) by treatment with base.³¹

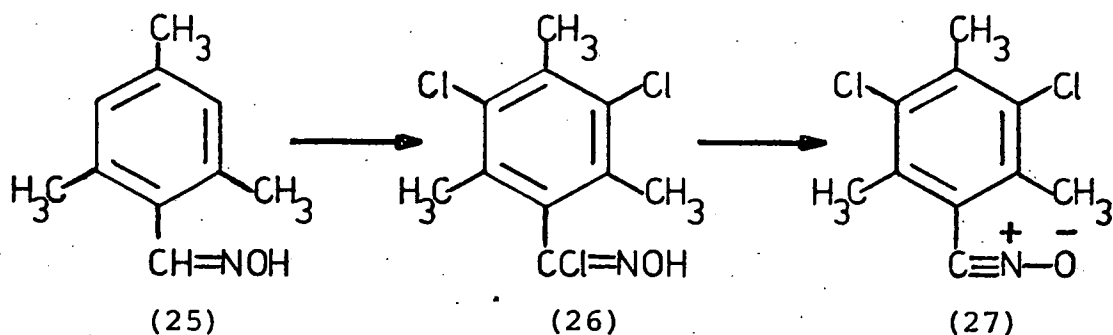

Despite the difficulty in preparing some hydroximoyl chlorides it is still an extremely important route to nitrile oxides. In particular it permits the preparation of nitrile oxides at low temperature and in situ in the presence of the dipolarophile, thus enabling a facile synthesis of many cycloadducts.³²

It is also claimed that nitrile oxides can be generated from the thermal dehydrochlorination of hydroximoyl chlorides.²⁰ When the hydroximoyl chloride is refluxed in an inert solvent, (e.g. toluene), in the presence of a dipolarophile the same cycloadduct as that prepared from the action of base, is isolated. However, Sasaki and Yoshioko³³ have suggested that the hydroximoyl chloride undergoes a 1,3-dipolar cycloaddition directly and that nitrile oxides take no part in the reaction. They also claim that the cycloadducts are formed in much higher yields than when prepared by the action of base on the hydroximoyl chloride. For example, as illustrated in Scheme 6, refluxing furanocarbohydroximoyl chloride (28) in toluene in the presence of phenylacetylene gave the expected isoxazole (29) in 64% yield whereas reaction of (28) with triethylamine in the presence of

phenylacetylene yields only the corresponding furoxan (30).

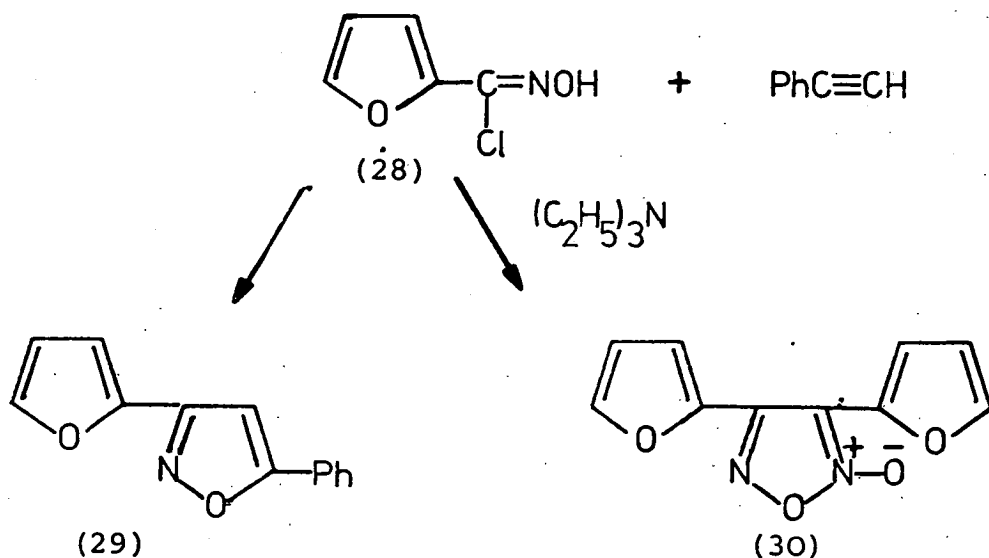

Scheme 6

They proposed that the reaction proceeded via a complex (31) formed directly from the hydroximoyl chloride and the dipolarophile to give the cycloadduct as outlined in Scheme 7.

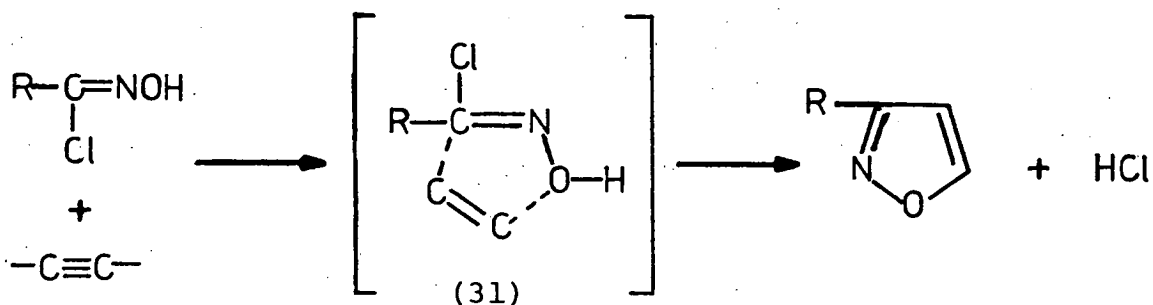

Scheme 7

In support of this hypothesis only starting material was recovered when 5-nitrofurhydroximoyl chloride was heated in toluene in the presence of ethanol. Under these conditions any nitrile oxide (32) formed would have undergone a 1,3-addition to yield ethyl-5-nitrofuranohydroxamic acid³⁴ (33).

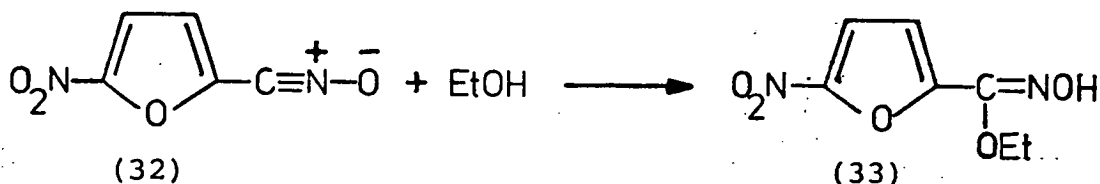

Moreover, the only isolated products from the pyrolysis of benzohydroximoyl chloride (8) were phenyl isocyanate and *o*-benzoylbenzohydroximoyl chloride.³⁵ Chiang suggested, since no furoxan was isolated, that the intermediacy of benzonitrile oxide was excluded.

1.3.3 Nitrile Oxides from Primary Nitroalkanes

Primary nitroalkanes can be converted into the corresponding nitrile oxides by three different methods.

Reaction of nitroalkanes with hydrogen chloride under anhydrous conditions yields hydroximoyl chlorides, which readily lose HCl to give nitrile oxides,³⁶ as discussed in the preceding section 1.3.2. However, hydroximoyl chlorides are generally more accessible by the routes discussed above and as a consequence this route offers no advantage. Reaction of primary nitroalkanes with

nitrous acid yields the corresponding nitrolic acids,^{24a} which on gentle heating eliminate nitrous acid to give nitrile oxides. Although several nitrile oxides have been obtained by this route the reaction has not been fully investigated.

More recently it has been established that nitrile oxides can be prepared directly from primary nitroalkanes.³⁷ This is achieved by dehydration of the nitroalkane with phenyl isocyanate in the presence of catalytic amounts of triethylamine.

The direct dehydration proceeds well with several primary nitroalkanes and is particularly useful in the lower aliphatic series as the primary nitroalkanes are often more easily accessible than the corresponding hydroximoyl chlorides. The mechanism proposed by Mukaiyama and Hoshino³⁷ is outlined in Scheme 8.

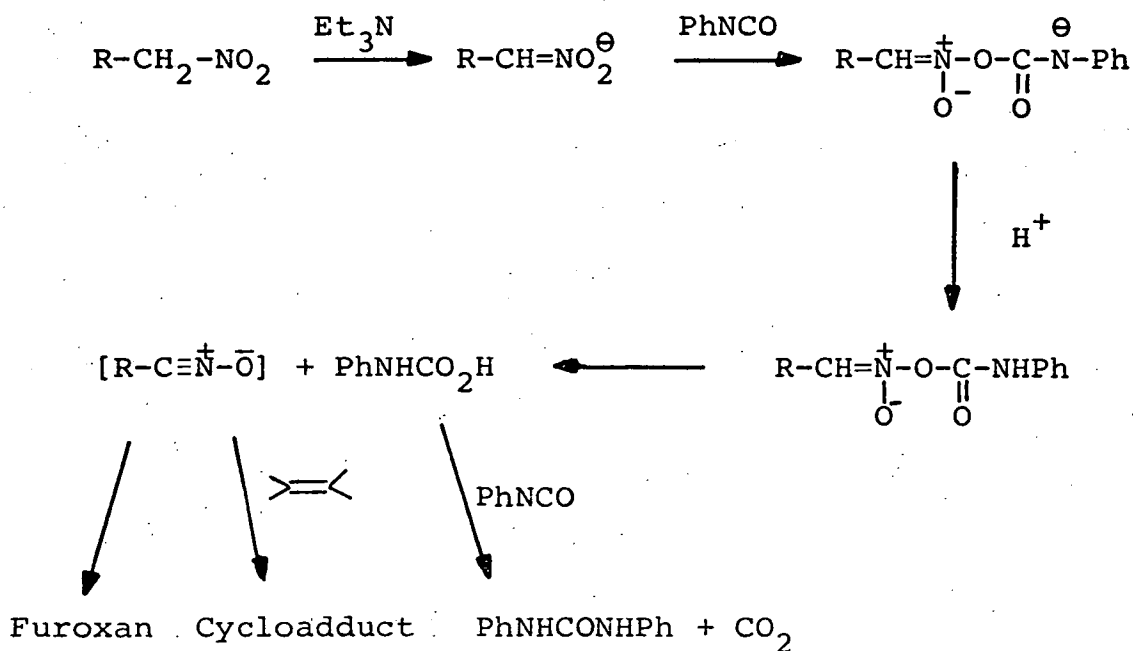

Scheme 8

Although the method is widely used, nitrile oxides have never been isolated during the course of the reaction. Rather, the existence of the nitrile oxide is established by isolation of the furoxan dimer or by the formation of the 1,3-dipolar cycloadduct.

The three methods described above, namely the dehydration of aldoximes, dehydrochlorination of hydroximoyl chlorides and dehydration of primary nitroalkanes are the most commonly used and the most synthetically useful preparations of nitrile oxides. However, recent investigations by several groups of workers has given rise to some novel and interesting routes to nitrile oxides.⁴¹⁻⁴⁴

1.3.4 Nitrile Oxides from 1,3,2,4-Dioxathiazole-2-Oxides

Although it has been known since 1906 that the reaction between a hydroxamic acid and thionyl chloride gave rise to the corresponding isocyanate³⁸ it is only recently that it was established that it occurred via 1,3,2,4-dioxathiazole-2-oxide (34) intermediates³⁹

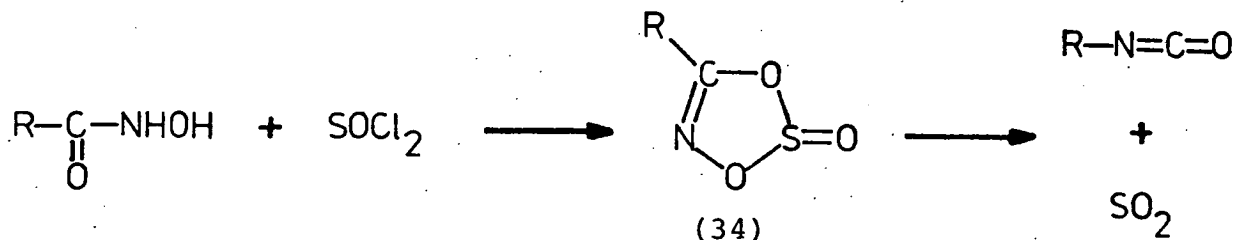

Since their isolation the thermal decomposition of (34) has attracted considerable attention,^{39,40,41} but at present the exact nature of the mechanism remains unresolved. Scheme 9 illustrates the three possible mechanisms:- (a) decomposition to the acyl nitrene (35) with subsequent rearrangement, (b) a concerted process and (c) decomposition via the nitrile oxide followed by rearrangement.

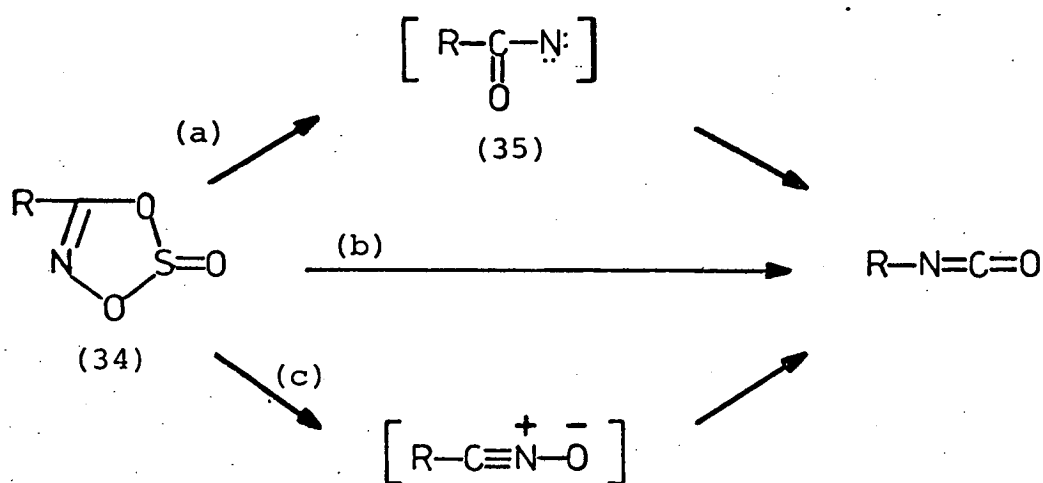

Scheme 9

Recent studies have given some insight into the mode of decomposition.

It is known that the analogous 1,3,4-dioxazole-2-oxides (36) decompose through an acyl nitrene intermediate (35), path (a). Thermolysis of (36) in the presence of dimethyl sulphoxide (DMSO) results in the isolation of the N-acylsulphoximine adduct (37), derived from (35), and N,N'-diphenylurea (38) derived from the isocyanate.³⁹ However,

attempts to isolate the N-acylsulphoximine adduct from the thermolysis of (34) in the presence of DMSO failed.³⁹ The only isolated product was the isocyanate derived urea (38), Scheme 10.

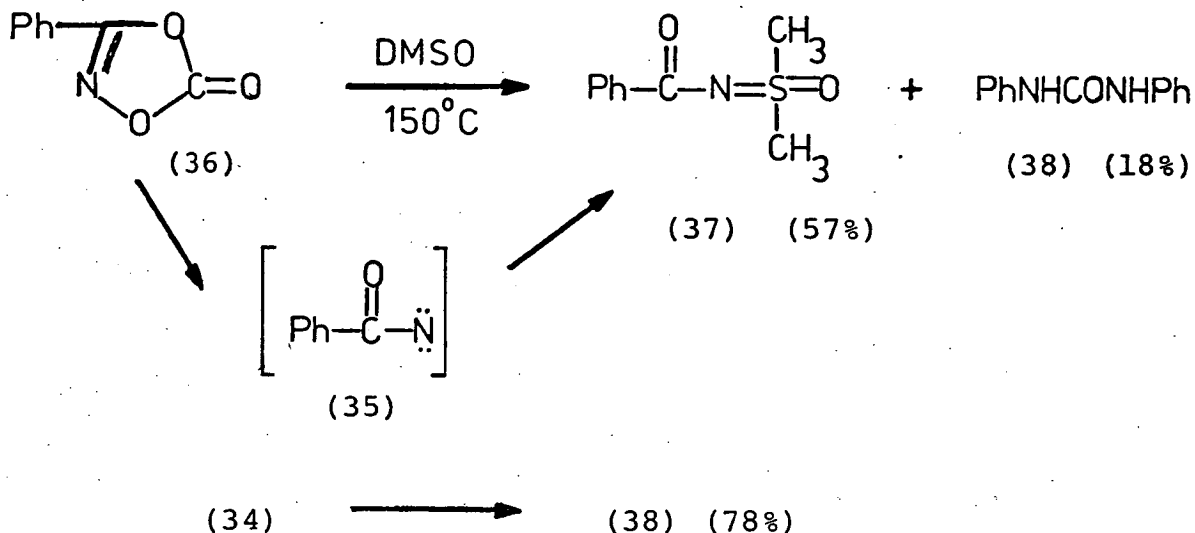

Scheme 10

A positive indication as to the mode of decomposition of (34) was obtained by Franz and Pearl in 1976.⁴¹ They found that thermolysis of (34) in the presence of highly reactive dipolarophiles, such as dimethyl acetylenedicarboxylate (DMAD) and norbornene, produced mixtures of the corresponding isocyanates and the corresponding 2-isoxazole (39) and 2-isoxazoline (40) respectively. The isolation of the 1,3-dipolar cycloadducts is consistent with the formation of nitrile oxide intermediates. As a result of these observations they proposed the decomposition mechanism outlined in Scheme 11.

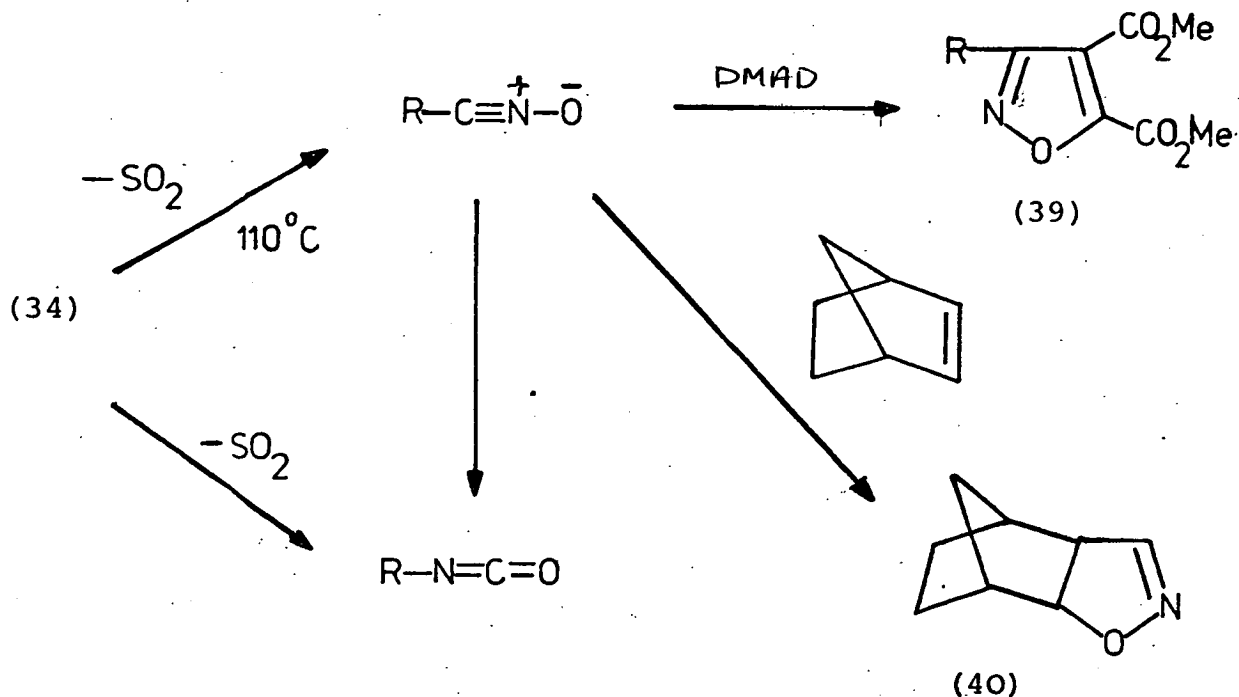

Scheme 11

1.3.5 Nitrile Oxides from the Potassium Salts of Dinitroalkanes

The thermal decomposition of the potassium salts of dinitroalkanes in polar solvents such as dimethylformamide (DMF) and DMSO at $80^\circ C$ gives rise to carboxylic acids (>75%) and potassium nitrite. However, in the presence of a suitable dipolarophile under the same conditions an isoxazoline and potassium nitrite are formed. It has been proposed that the reaction proceeds via a nitrile oxide intermediate as outlined in Scheme 12.⁴²

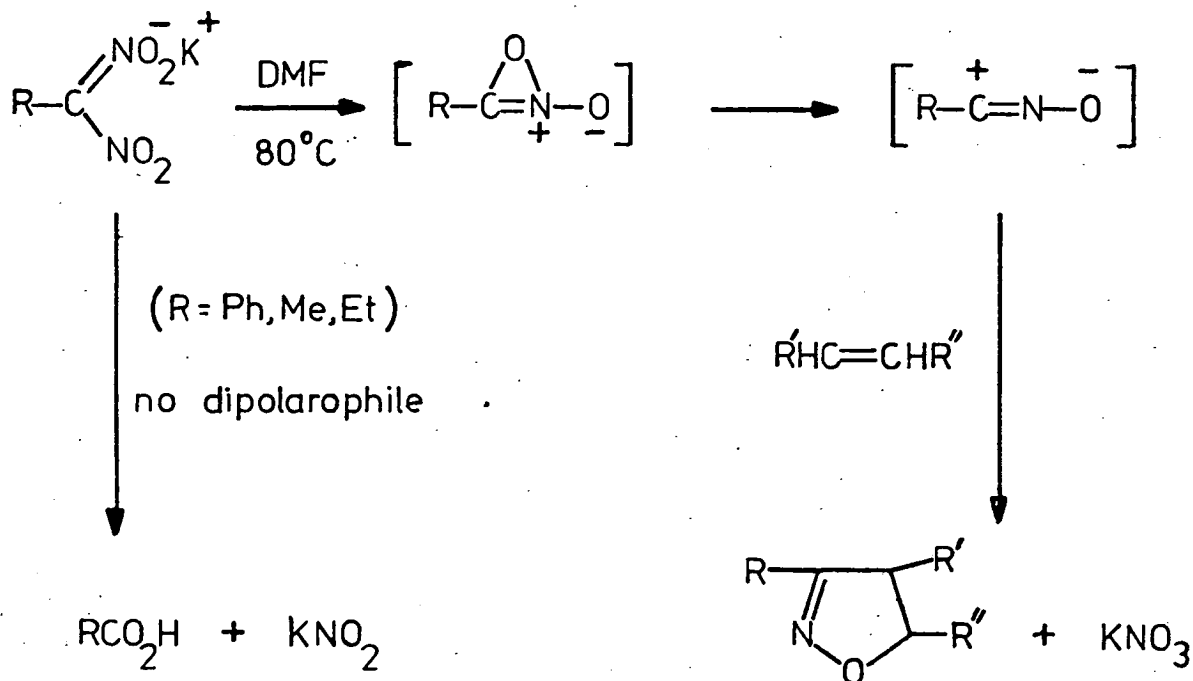

Scheme 12

Although the reaction appears to be quite general and several isoxazolines have been prepared, this route offers no advantage over the more conventional routes described earlier.

1.3.6 Nitrile Oxides from Furazans and Furoxans

It has recently been established that nitrile oxides can be generated from the fragmentation of both disubstituted furazans (41)⁴³ and furoxans (42).⁴⁴ A detailed account of these reactions will be presented later.

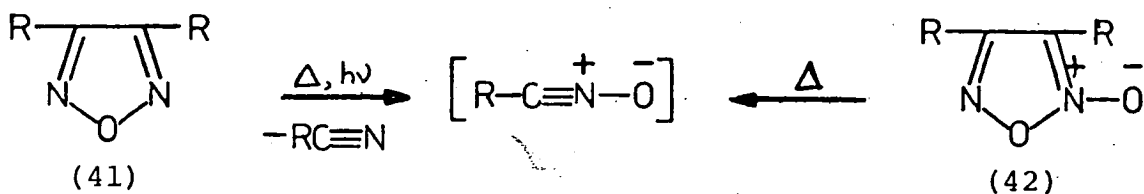

1.4 Reactions of Nitrile Oxides

An authoritative review on the reactions of nitrile oxides is given by Grundmann and Grünanger in their book, 'The Nitrile Oxides'.²⁰ Although extensive, with many applications, the reactions of nitrile oxides fall into four main categories:-

1. Isomerisation to Isocyanates.
2. Dimerisation.
3. 1,3-Dipolar Cycloadditions.
4. 1,3-Dipolar Additions.

1.4.1 Isomerisation to Isocyanates

When a nitrile oxide is heated above its limits of thermal stability two competing reactions occur:

(a) dimerisation to the furoxan; (b) rearrangement to the isocyanate.

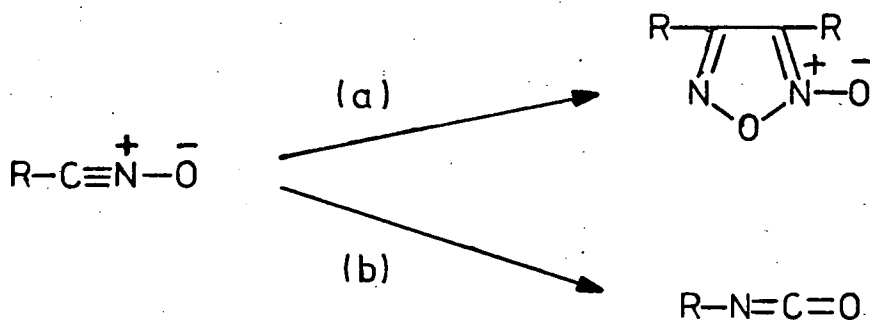

The behaviour of aromatic nitrile oxides of moderate stability strongly suggests quite different activation energies for both reactions. For example, benzonitrile

oxide gives diphenylfuroxan almost quantitatively at room temperature whereas rapid heating in xylene to 110°C results in 10% conversion to the isocyanate while the rest dimerises to the furoxan.^{45,46} In contrast, when path (a) is blocked by steric hindrance around the fulmido group, nitrile oxides follow path (b) to isocyanates with excellent to quantitative yield. For example, 2,4,6-trimethylbenzotrile oxide is indefinitely stable at room temperature, while attempts to force its dimerisation only results in a clean rearrangement to the corresponding isocyanate with no furoxan formation.^{18,19}

The mechanism of the thermal isomerisation of nitrile oxides to isocyanates has been investigated, in depth, by Grundmann et al.^{46,47} who established that the isomerisation occurs via an intramolecular concerted mechanism. The evidence for such a mechanism is two-fold. The rearrangement of (-)-2-methyl-2-phenyl-butyronitrile oxide (43) and endo-2-methyl-2-norbornyl-2-nitrile oxide (44) demonstrated that the isomerisation occurs with complete retention of optical asymmetry and stereochemical configuration as illustrated in Scheme 13.

Additional evidence in support of an intramolecular, rather than an intermolecular, mechanism came from the rearrangement of *p*-deuteriobenzotrile oxide (45) in the presence of [α -¹³C]benzotrile oxide⁴⁶ (46) (Scheme 14).

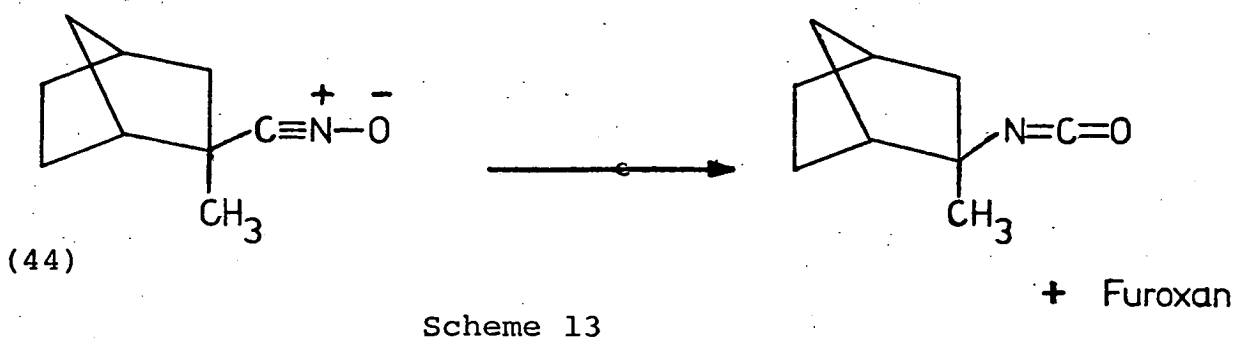
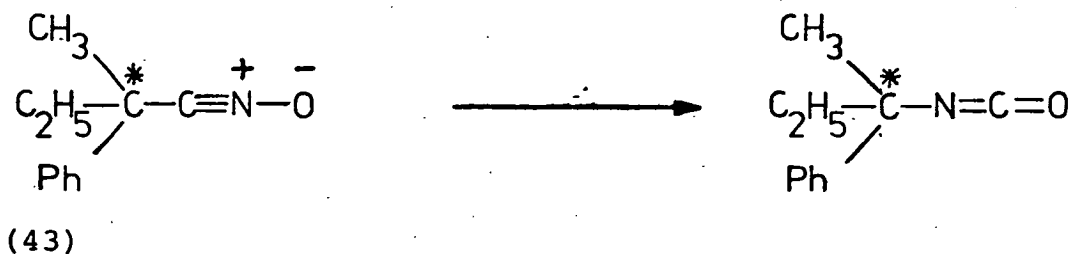

The phenyl isocyanate thus formed was isolated as the unsymmetrical urea by reaction with *o*-toluidine.

Analysis by mass spectrometry established that only the singly labelled products (47) and (48) were present.

As the two nitrile oxides (45) and (46) would be expected to isomerise at very similar rates the absence of the urea (49) from the reaction of *p*-deuterio- $[\alpha\text{-}^{13}\text{C}]$ phenyl isocyanate and *o*-toluidine strongly supports the intramolecular mechanism.

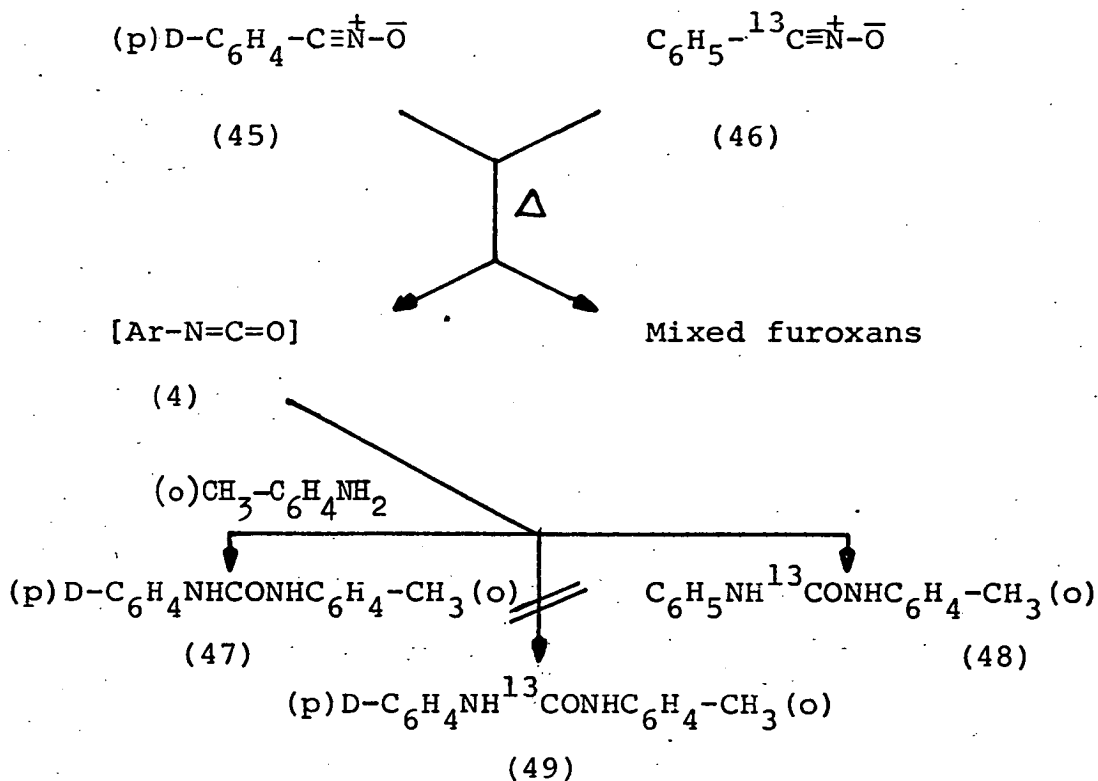

Scheme 14

Having demonstrated experimentally that the isomerisation occurs by an intramolecular mechanism Grundmann et al. considered the reaction paths illustrated in Scheme 15.

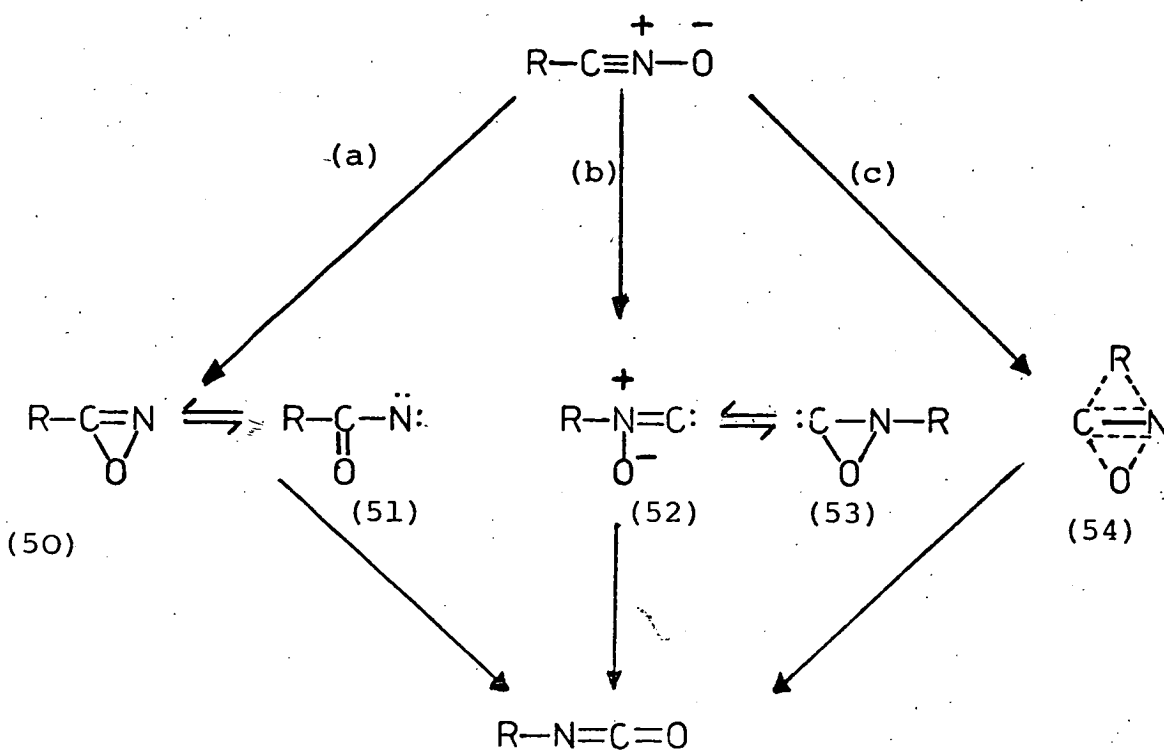

Scheme 15

Path (a) via an oxazirine (50) and an acyl nitrene (51) was eliminated as attempts to trap the acyl nitrene with cyclohexene to give the corresponding acylaziridine failed. In addition, ultra-violet (u.v.) and i.r. spectroscopy failed to produce evidence for the transient existence of the oxazirine.²⁰ Similarly, path (b) was considered unlikely as no adducts were observed from the expected carbene type addition of the nitrene-carbene (52) or the oxaziridine-carbene (53) intermediates across the double bond of cyclohexene.⁴⁷ Therefore, path (c) which proceeds via the activated complex (54), in which bond breaking and bond making are essentially synchronous,⁴⁷ is considered to be the mechanism which best satisfies the experimental data.

Nitrile oxides also isomerise to isocyanates on photolysis. The mechanism of the photochemical isomerisation of nitrile oxides to isocyanates differs from that described above for the thermal isomerisation in that the products derived from acyl nitrene intermediates (path (a), Scheme 15) have been isolated. Photolysis of 2,4,6-trimethylbenzotrile oxide (55) in pentane gave a five membered lactam (56) and the symmetrical urea (57). Irradiation in methanol gave equimolar amounts of (56) and the methyl carbamate (58),⁴⁸ Scheme 16.

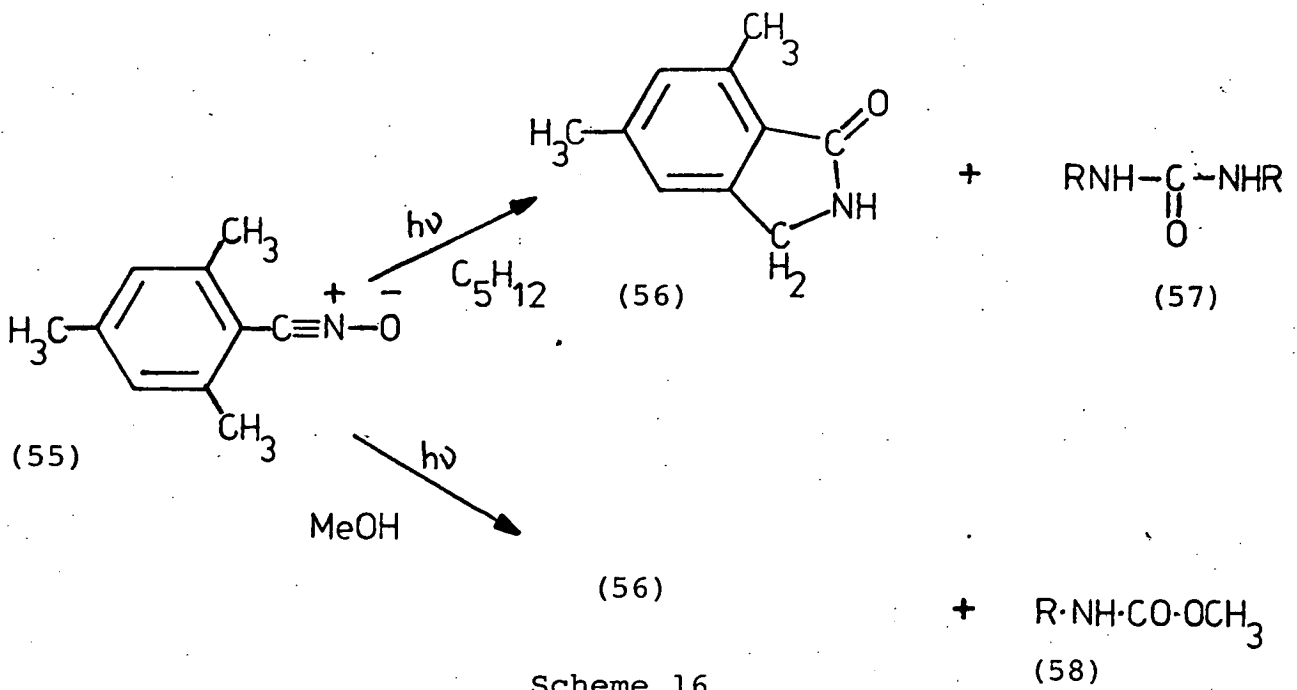

Scheme 16

In addition, photolysis of *o*-methyl podocaronitrile oxide (59) in pentane and methanol gave the lactam (60).⁴⁸

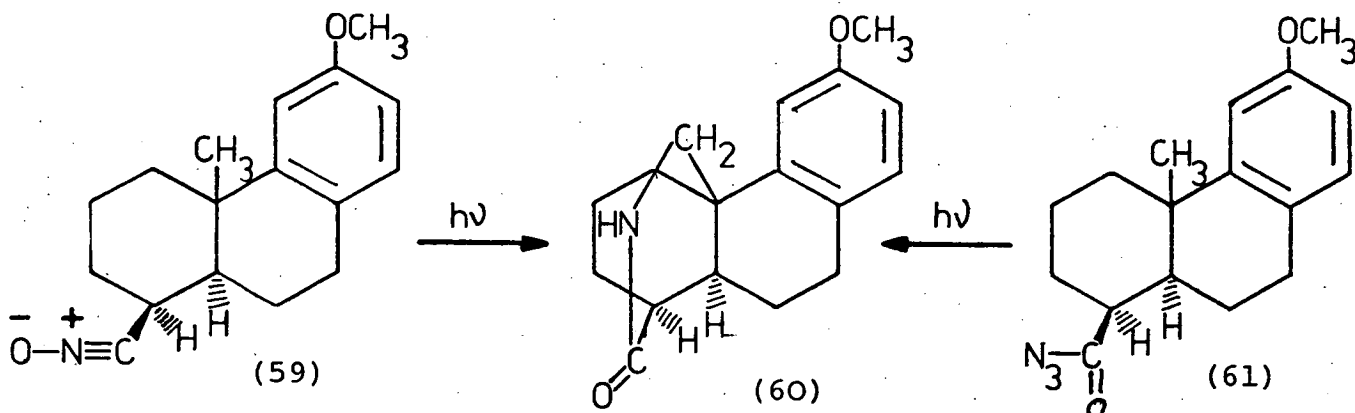

These results have been rationalised in terms of the pathway illustrated in scheme 17.

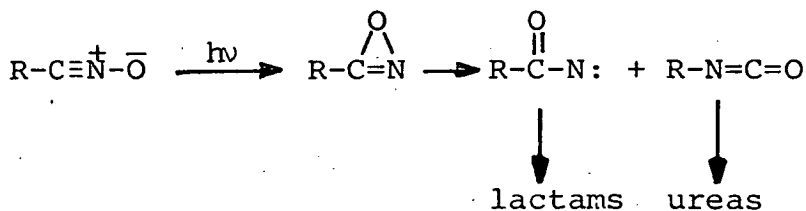

Scheme 17

Confirmation that the acyl nitrene is the intermediate giving rise to the lactams came from the synthesis of (60) from the photolysis of the corresponding acyl azide (61), a known nitrene precursor.⁴⁹

1.4.2 Dimerisation of Nitrile Oxides

The most commonly observed reaction of nitrile oxides is dimerisation to furoxans. This reaction occurs at ambient temperature for all but the most sterically hindered nitrile oxides; 2,4,6-trimethylbenzonitrile oxide (55) for example, is indefinitely stable at room temperature. In general the rate of dimerisation is dependent on the nature of the nitrile oxide. At room temperature the lower aliphatic nitrile oxides dimerise instantaneously whereas the half-life of most aromatic nitrile oxides is of the order of hours to days. Although dimerisation to furoxans was one of the first observed reactions of nitrile oxides little attention was paid to the reaction mechanism. Detailed examination of this topic began in the 1960's and resulted in two alternative mechanisms being proposed.

It has been demonstrated for several aromatic nitrile oxides that the dimerisation proceeds with clean second order kinetics.⁵⁰ Further, Dondoni's study into this reaction can be summarised as follows; (1) the reaction rate is increased by electron-withdrawing groups in the phenyl ring and decreased by electron-releasing groups ($m\text{-Cl} > p\text{-Cl} > \text{H} > p\text{-CH}_3 > p\text{-OCH}_3$), the effect being small with a Hammett ρ -value of +0.86; (2) the reaction rate is largely unaffected by the polarity or solvating

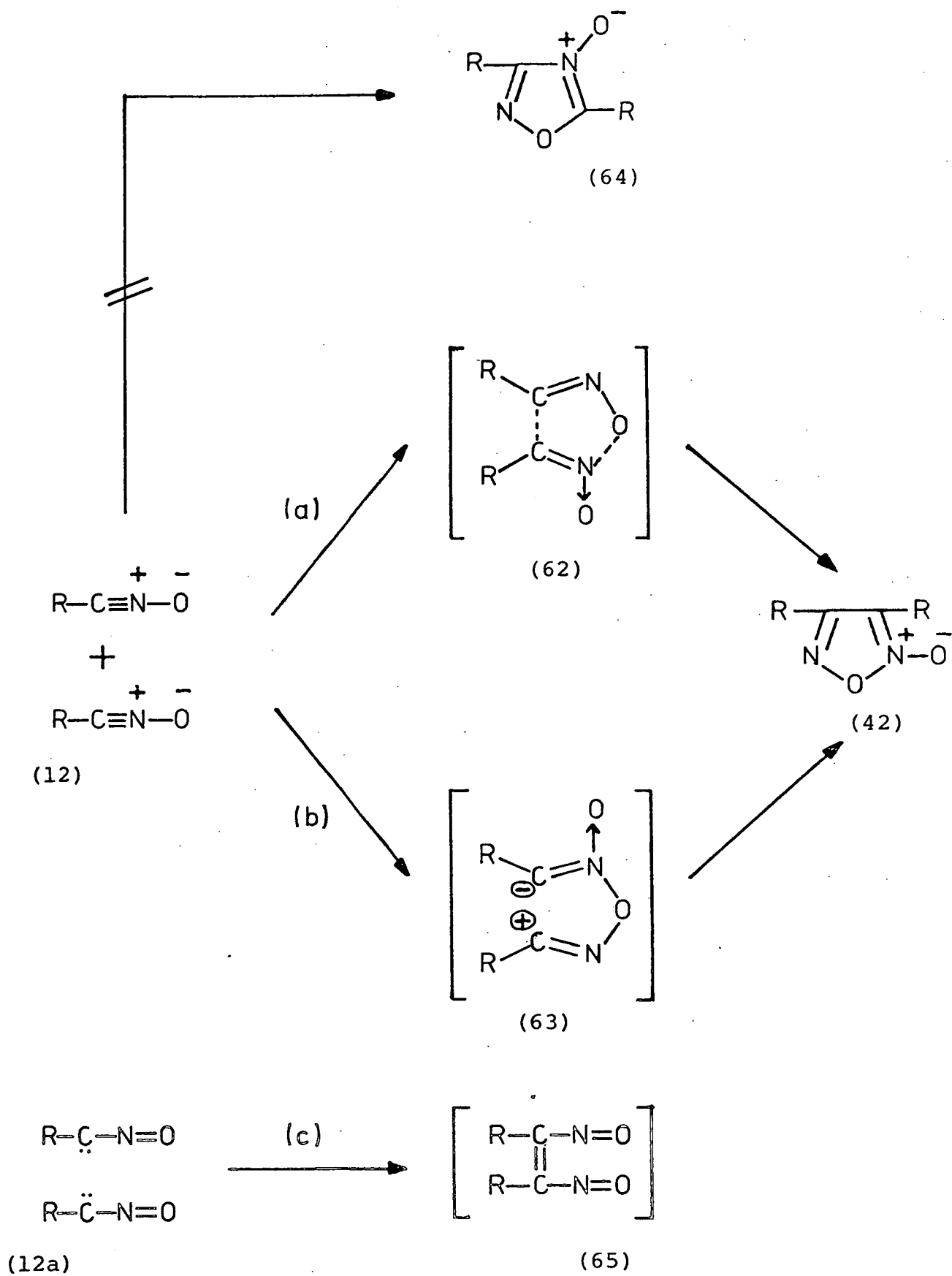

Scheme 18

power of the solvent; (3) the dimerisation is characterized by a large negative value (ca. 20 e.u.) for the activation entropy, which is substantially unmodified by change of solvent; (4) the addition of tertiary amines does not influence the rate. The overall features of the kinetics parallel those for 1,3-dipolar cycloaddition reactions,¹⁵ the general mechanism of which has been established as a one-step concerted formation of two new bonds. Therefore, the dimerisation to furoxan has been postulated⁵⁰ as a 1,3-dipolar cycloaddition where, because of the non-synchronous formation of σ -bonds, a partially polarised transition state (62) is involved, (route (a) in Scheme 18). On the other hand, a zwitterionic intermediate (63) (route (b)) is considered far less probable because of the negligible effect increasing the solvent polarity has on the reaction rate.

However Huisgen considered that this concerted mechanism contravened the principle of maximum gain in σ -bond energy,¹⁵ most generally found valid in all the other types of 1,3-dipolar cycloadditions. Huisgen's principle states that, "the driving force behind the 1,3-dipolar addition is the stronger, the more the loss of π -bond energy in the reactants is overcompensated by the energy of the two new σ -bonds. A part of this σ -bond energy contributes to the transition state of the concerted cycloaddition".¹⁵ To satisfy this principle, the dimerisation should lead, not to the furoxan (42), but to the isomeric 1,2,4-oxadiazole-4-oxide (64).

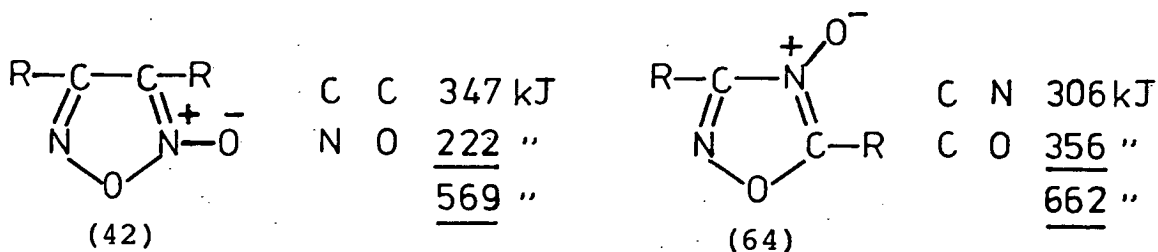

However, although 1,2,4-oxadiazole-4-oxides are accessible by various routes, some starting with nitrile oxides,⁵⁹ they have only been observed as products of the spontaneous dimerisation of nitrile oxides in one instance: namely 4-chlorobenzonitrile oxide and even in this case the furoxan is the major product.⁵¹

It has been suggested⁵² that the formation of the furoxan might occur in a two step reaction via a 1,2-dinitrosoethylene intermediate (65) which would then immediately stabilize itself by regrouping electrons to form the furoxan (path (c), scheme 18). This hypothesis is supported by the fact that the interconversions of asymmetric furoxans occurs via an analogous transient 1,2-dinitroso intermediate.^{52,53,54} However, there is no definitive evidence to support the existence of such an intermediate in the acyclic case.

The exact nature of the mechanism is still unproven. However, despite the fact that it contravenes the principle of maximum gain in σ -bond energy, a true 1,3-dipolar cycloaddition seems the most probable mechanism. This

proposal is supported by perturbation theory⁵⁵ which states that cycloaddition reactions take place in the direction which allows the maximum overlap of the frontier molecular orbitals. As illustrated for acetonitrile oxide frontier orbitals ψ_2 and ψ_3 (Fig. 1), interactions (a) and (b) for which the greatest overlaps are between C-C and N-O respectively, favour the formation of the furoxan.⁵⁶

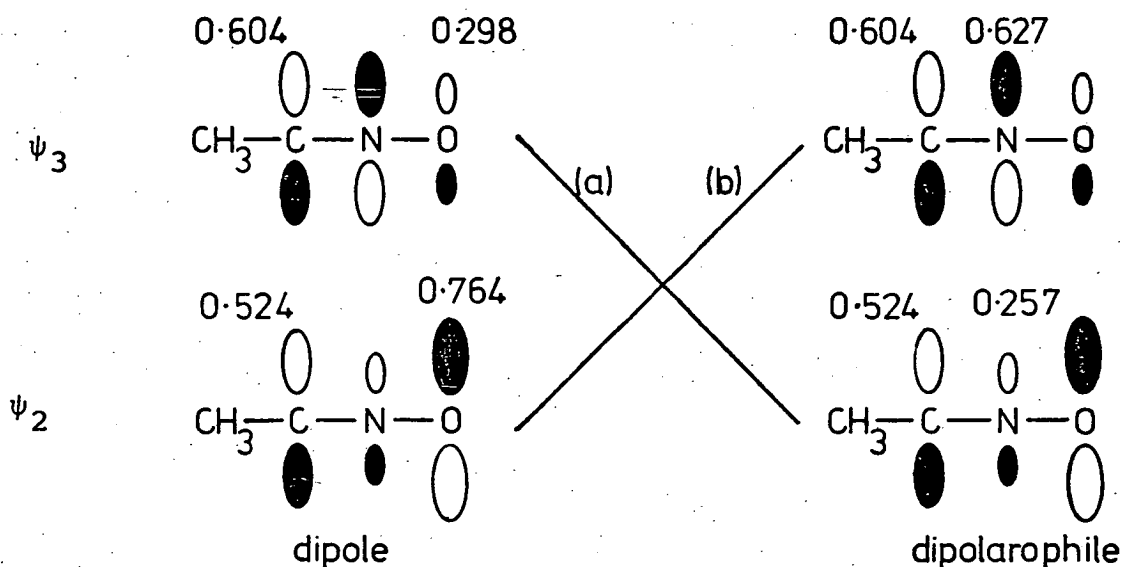
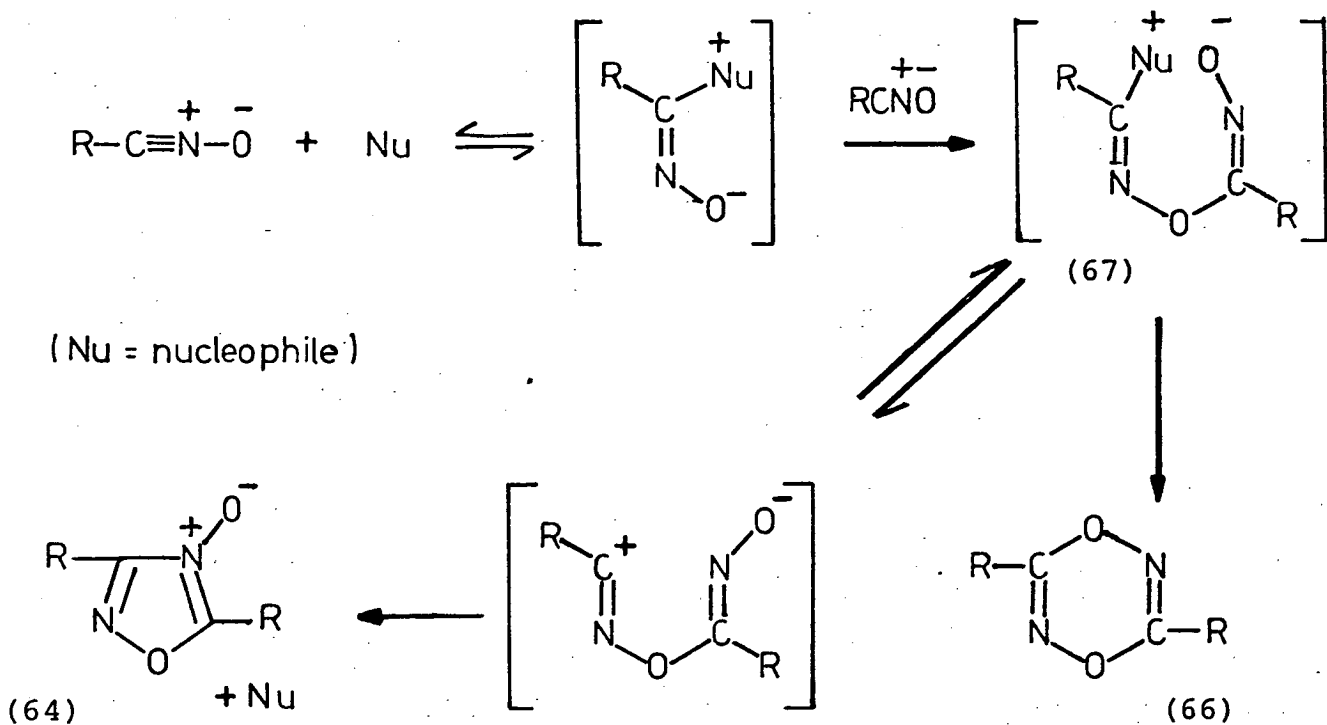

Figure 1

In addition to furoxans, nitrile oxides under the influence of acids and bases form other dimers. In the presence of pyridine in ethanol or with boron trifluoride in benzene, aromatic nitrile oxides form 3,6-diaryl-1,4,2,5-dioxadiazines (66).^{57,58} In contrast, in the presence of trimethylamine in ethanol 3,5-diaryl-1,2,4-oxadiazole-4-oxides (64) are the main products.⁵⁹ The fact that the formation of a particular isomer is dependent on the nucleophile employed as a catalyst led De Sarlo⁵⁹ to propose the general mechanism outlined in Scheme 19.



Scheme 19

This mechanism is supported by kinetic measurements which show that both the catalysed dimerisations of aromatic nitrile oxides are, under certain circumstances, second order; the second order rate constant for the dimerisation to (64) is ca. 10^4 times slower than that for dimerisation to (66).

Moreover, molecular models suggest that dioxadiazines (66) are formed when the nucleophile does not hinder the approach of the charged oxygen atom to the carbon atom adjacent to the positive pole. In contrast the formation of the other isomer (64) would be favoured when the above pathway is sterically hindered. Therefore, in the presence of trimethylamine the approach of the charged oxygen atom would be sterically hindered favouring the formation of (64).

In addition to dimers, oligomers and polymers have also been obtained as the products from the reaction of nitrile oxides and nucleophiles. In particular acetonitrile oxide (69) gives rise to several different polymers depending on the reaction conditions;⁶⁰ increasing both the acetonitrile oxide and nucleophile concentration results in an increase in the yield of polymers. De Sarlo et al. have rationalised these observations in terms of the mechanism illustrated in Scheme 20.⁶⁰

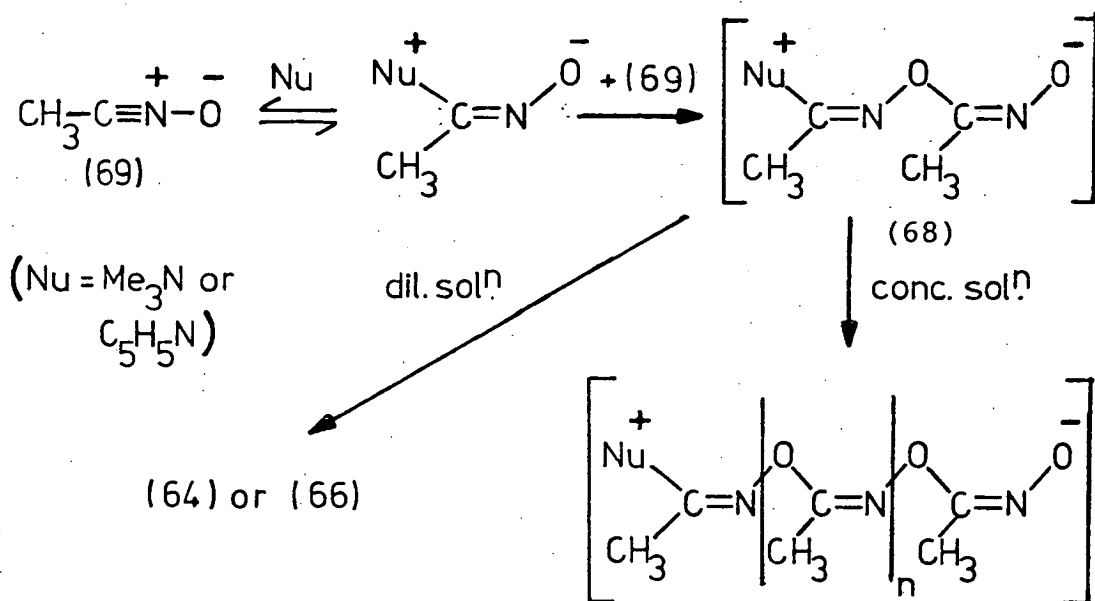

Scheme 20

The key feature of the mechanism is that, in concentrated solution, addition of another molecule of acetonitrile oxide to (68) occurs faster than rearrangement to (64) or (66).

1.4.3 1,3-Dipolar Cycloaddition Reactions of Nitrile Oxides

A 1,3-dipolar cycloaddition is that reaction which occurs between a 1,3-dipole, in this instance a nitrile oxide ($\text{RC}\equiv\text{N}^+\text{O}^-$), and a multiple bond system, the dipolarophile ($\text{d}=\text{e}$), to give a five membered cyclic compound. Intuitively, there are three conceivable mechanisms by which this reaction can take place; as one concerted step (path (a)) or in two stages via a dipolar intermediate (path (b)) or a diradical intermediate (path (c)). The three possibilities are illustrated in Scheme 21.

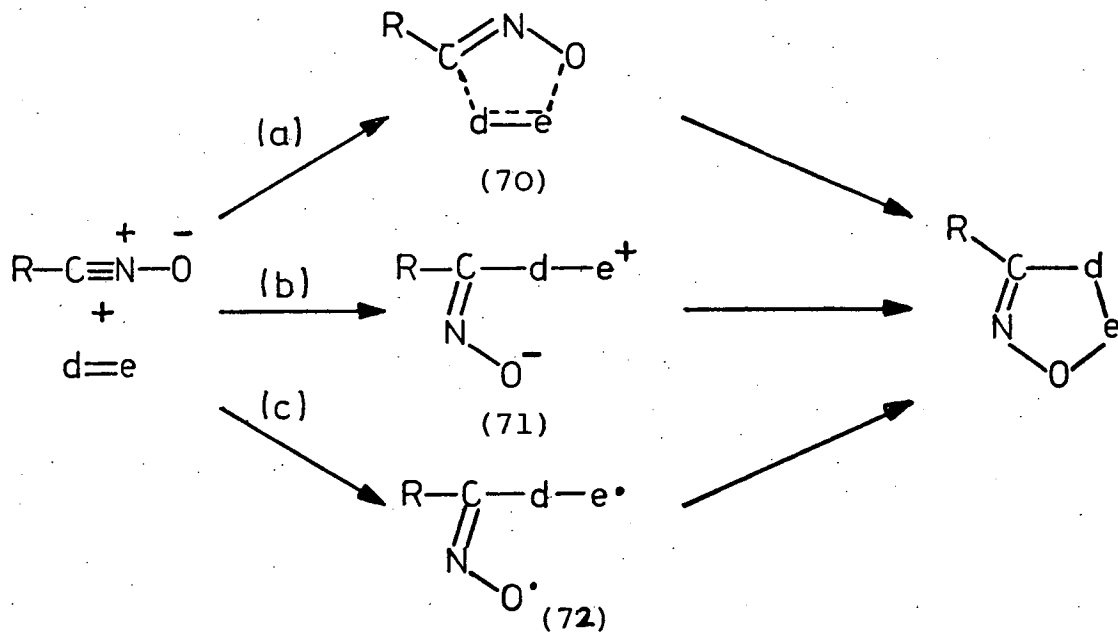

Scheme 21

Of the three possible mechanisms the weight of experimental evidence supports a one step concerted process (path(a)).¹⁵ In all cases the reactions proceed with complete stereospecificity, the configuration of the reactants being retained in the product. This would only be conceivable in a two step process

if rotation above the single bond d-e in the dipolar (71) or diradical (72) intermediates is much slower than ring closure. Kinetic studies have shown that the reaction rate obeys a second order rate law which is first order in both reactants, is only moderately influenced by solvent polarity, and is increased by both electron releasing and electron withdrawing substituents on the dipolarophile. The reaction is also characterised by a large negative activation entropy (20-30 e.u.), a fact which is indicative of a highly ordered transition state.⁵⁶ Although the above experimental evidence was considered compatible only with a concerted mechanism,¹⁵ the simple "polarised transition state" failed to explain certain characteristics of the reactivity and regioselectivity of the cycloadditions. These anomalies led Firestone⁶¹ to propose a two-step mechanism via a diradical intermediate (72). However, with the application of Frontier Molecular Orbital Theory to the system, Huigen⁶² has refuted Firestone's proposal in favour of the concerted process. The successful application of molecular orbital theory to 1,3-dipolar cycloadditions requires a knowledge of the energy values of the frontier molecular orbitals [highest occupied (HOMO) and lowest unoccupied (LUMO)], their coefficients and symmetry properties. It is then possible, by using this

information as input, to apply a general perturbation treatment to 1,3-dipolar cycloaddition reactivity, regioselectivity and periselectivity.⁶³⁻⁶⁶

Although the energy values and the coefficients of the frontier molecular orbitals (FMO) have been calculated by a number of different methods, they are not readily available from experimental data.⁶³ However, in a few cases the energy of the LUMO has been derived from the electron affinity whose negative value is taken and the HOMO energy has been calculated from photoelectron spectroscopy. According to Koopman's Theorem,⁶⁶ the first vertical ionization potential is the negative value of the orbital energy. Thus by a combination of theoretical calculations and the available experimental data, Houk et al.⁶³ have estimated FMO energies for many 1,3-dipoles. These estimates were made for the parent systems and take no account of the effect of substitution in the dipole. However, because of the lack of experimental data for 1,3-dipoles the effect substituents exert on FMO energies and coefficients are more readily seen for alkenes since much more experimental data is available from which to make reliable estimates.⁶³ The FMO energies and coefficients of substituted alkenes relative to those of the parent, ethylene are summarised in Fig. 2.⁵⁶ Clearly, from Fig. 2, the introduction of an electron-donating group (\bar{X} ,R) in ethylene raised the energy levels of both HOMO and LUMO, the HOMO being destabilised to a greater extent. An electron-withdrawing substituent (Z), which is simultaneously

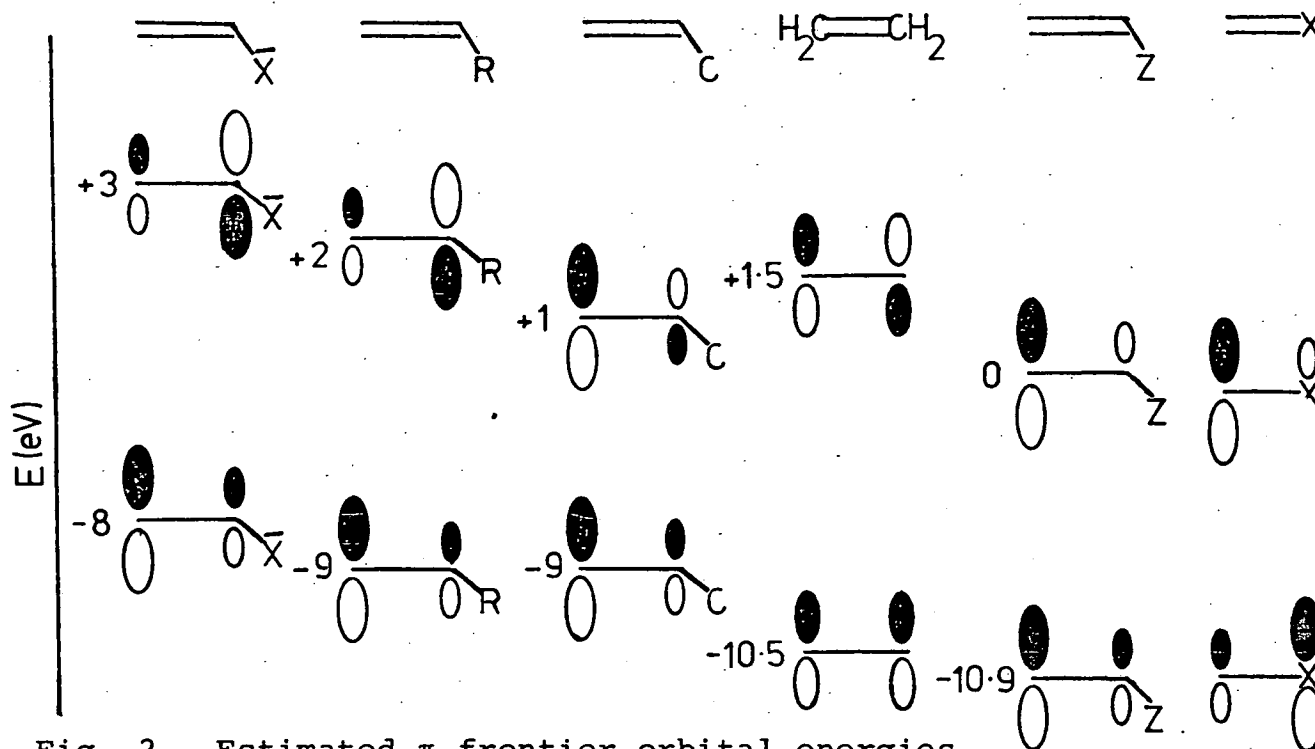

Fig. 2. Estimated π frontier orbital energies and coefficients for dipolarophiles

conjugating, lowers both HOMO and LUMO energies the effect on the LUMO being the greater. Conjugating substituents (C) compress the frontier orbital separation by raising the HOMO and lowering the LUMO. Electron donating groups give rise to a larger β -coefficient in the HOMO, whereas the ratio of coefficients is reversed in the LUMO ($\alpha > \beta$), as would be expected on inductive grounds. Not surprisingly electron-withdrawing groups if they interact only inductively (e.g. CCl_3) have exactly the opposite effect from that of donor groups. Conjugating groups and electron-withdrawing groups which are also conjugating give rise to larger coefficients in the β than in the α position in both the HOMO and LUMO. Finally, the coefficients of polysubstituted dipolarophiles represent the sum of the individual effects of the substituents.

For 1,3-dipoles it was assumed that similar substituents have comparable effects on both the dipolarophile and the 1,3-dipole enabling the effect of substitution to be

Having gained some knowledge of the energies and coefficients of the FMO's of 1,3-dipoles and dipolarophiles it is now possible to rationalise the various phenomena associated with 1,3-dipolar cycloadditions using perturbation theory.^{56,63-68} Second order MO perturbation theory provides equation 1.⁶⁶ This equation was derived from the more general expression, proposed by Salem,⁶⁹ for the energy gain in bond formation between centres a and c of the 1,3-dipole ($a \equiv b^+ - c^-$) and centres d and e of the dipolarophile ($d=e$) when they approach each other.

$$\Delta E = \frac{(C_a C'_d \gamma_{ad} + C_c C'_e \gamma_{ce})^2}{E_{\psi_2} - E_{\psi_B}} + \frac{(C'_a C_d \gamma_{ad} + C'_c C_e \gamma_{ce})^2}{E_{\psi_A} - E_{\psi_3}} \quad (1)$$

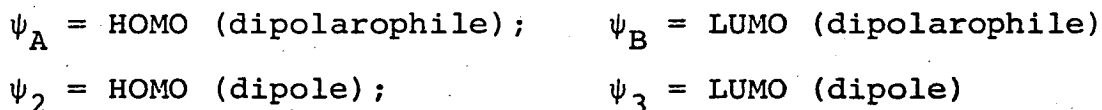

Equation (1) considers the energy change occurring when the frontier orbitals of the 1,3-dipole and the dipolarophile are interacting. E represents orbital energy, C and C' are atomic orbital coefficients within the molecular orbitals of the HOMO's and LUMO's respectively. The resonance integral γ is a function of the distance between the reacting centres. It can be easily deduced from equation (1) that the stabilisation energy, ΔE , is

inversely proportional to the orbital energy differences of the interacting frontier orbitals. Consequently only the HOMO and LUMO of the dipole and dipolarophile need be taken into account.

Sustmann^{65,66} divided 1,3-dipolar cycloadditions into three types (Fig. 3) depending on the relative energies of the 1,3-dipole and the dipolarophile FMO's.

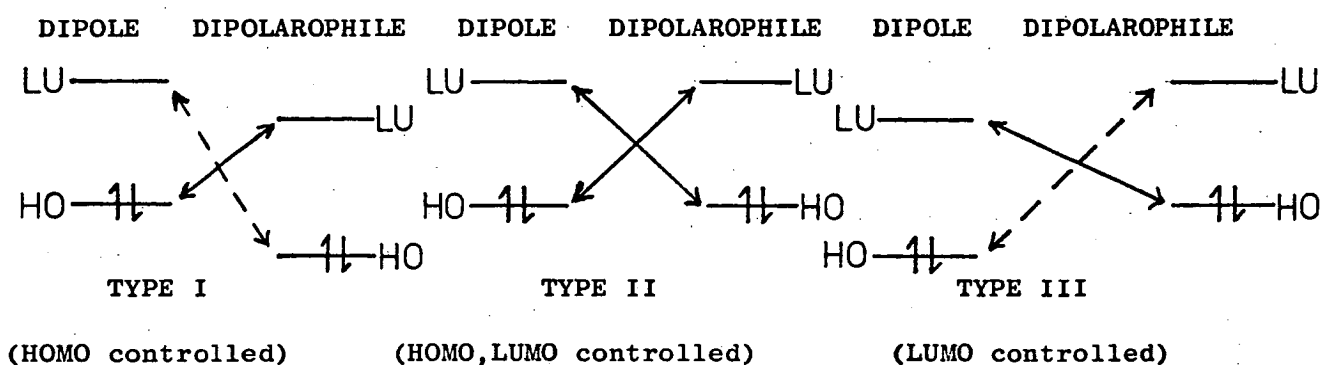

Fig. 3. Classification of 1,3-dipolar cycloadditions

Qualitatively, substituents which raise the dipole HOMO energy (R, \bar{X} , C) or lower the dipolarophile LUMO energy (C, Z) enhance HOMO-controlled (TYPE I) and retard LUMO-controlled (TYPE III) reactions. Conversely, substituents which lower the dipole LUMO energy (C, Z) or raise the dipolarophile HOMO energy (R, \bar{X} , C) will enhance LUMO-controlled and retard HOMO-controlled reactions. HOMO, LUMO-controlled (TYPE II) reactions will be accelerated by an increase in either of the dipole-dipolarophile frontier orbital interactions.

The phenomenon of orientation in 1,3-dipolar cycloadditions has represented an intricate problem for a long time. In recent years, perturbation theory provided a complete rationalisation of regioselectivity of several 1,3-dipole

cycloadditions.⁶³⁻⁶⁸ According to Fukui,⁷⁰ reactions take place in the direction which allows maximum frontier orbital overlap.



Fig. 4. Regioisomeric transition states

Therefore orientation (a), Fig. 4, is more stabilised than (b) and in the transition state (a) there is unequal bond formation. As a rule, the favoured regioisomer is the one formed through that transition state in which atoms with largest orbital coefficients overlap (Equation 1). Thus, from a consideration of the magnitudes of the coefficients of the dipole and dipolarophile it is possible to predict the regioisomer expected from HOMO- and LUMO-controlled cycloadditions, Fig. 5.

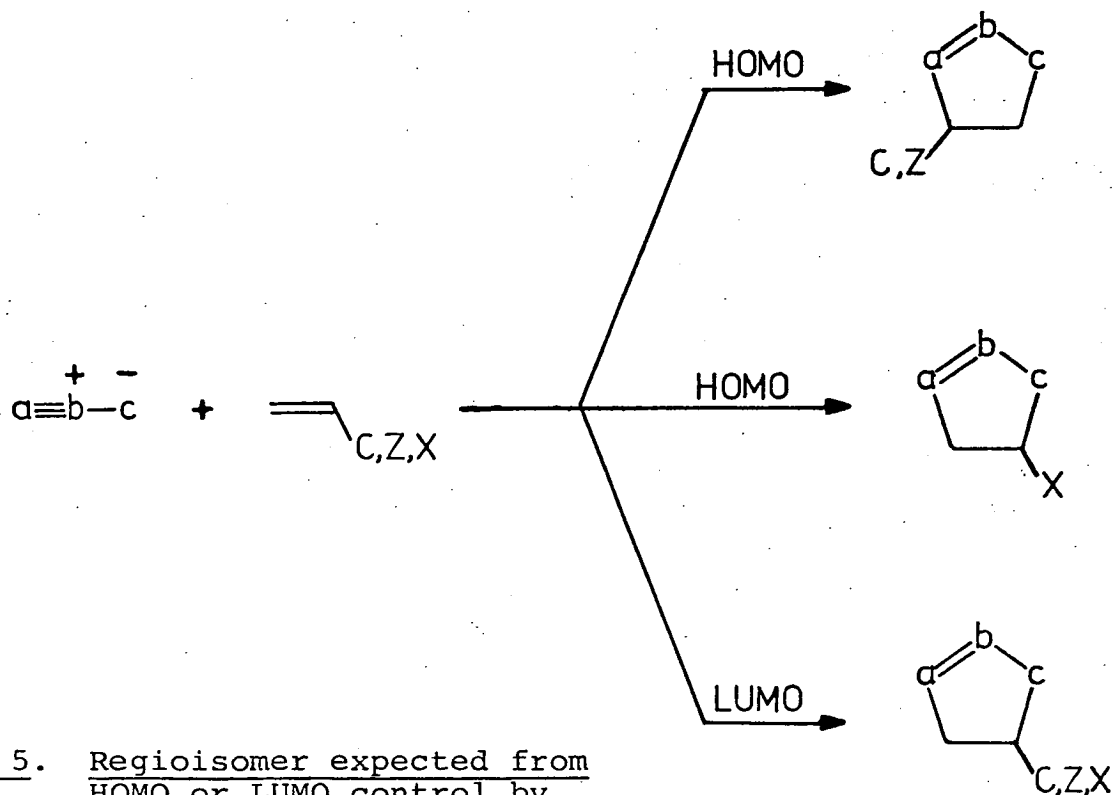

Fig. 5. Regioisomer expected from HOMO or LUMO control by the dipole

The above argument works well in most instances although it is an oversimplification failing to take account of possible complications produced by electrostatic or closed-shell repulsions and, in some cases, the reversal of terminal coefficients magnitudes by substitution.

Nitrile oxide cycloaddition reactions with substituted olefins are accelerated by both electron withdrawing and electron donating substituents.^{71,72} A plot of the logarithmic rate constants against the ionization potentials of the substituted olefins results in a U-shaped plot as illustrated in Fig. 6.

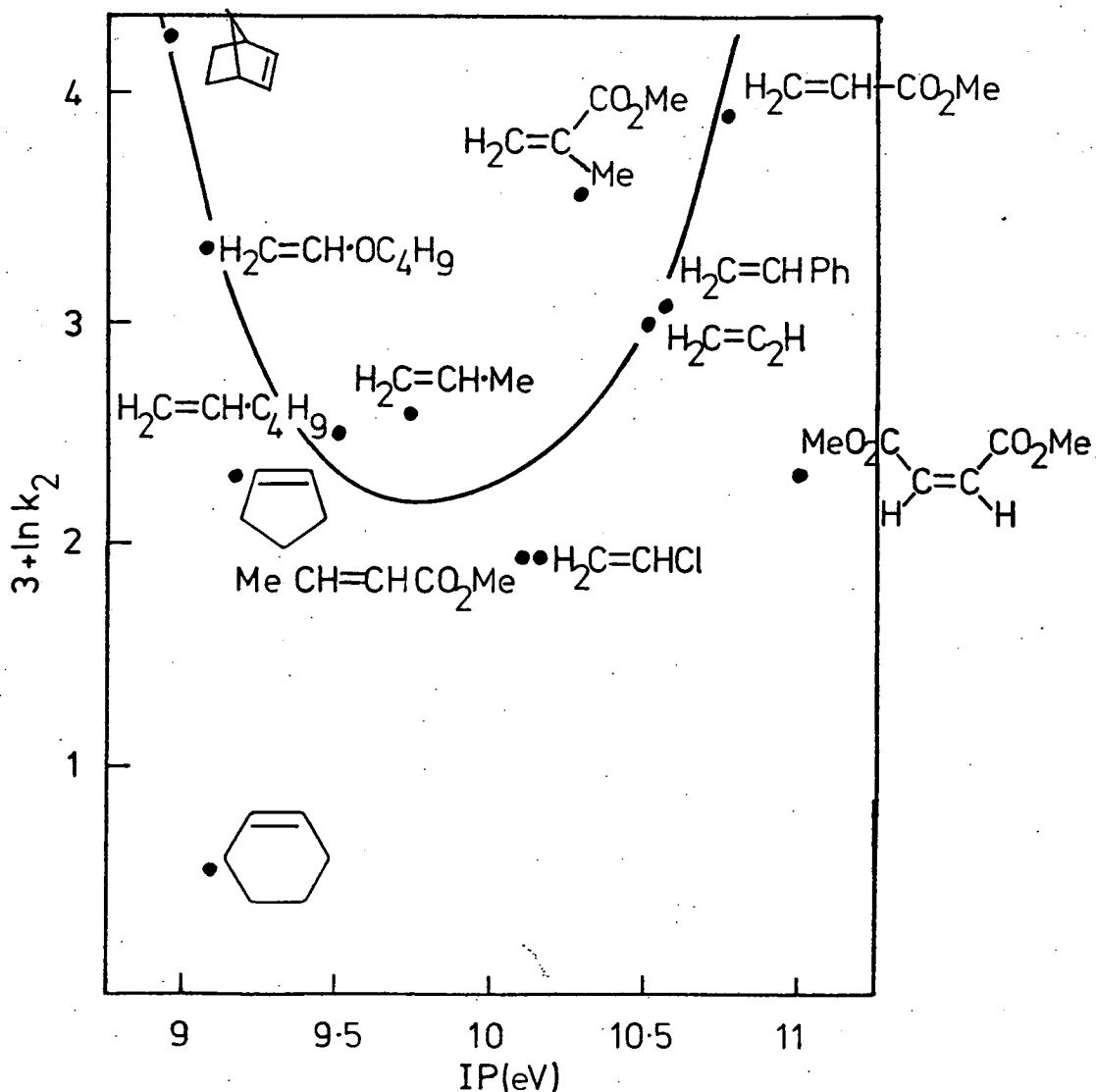

Fig. 6

This phenomenon, which is general for all 1,3-dipoles, can, by considering the relative energies of the FMO's of benzonitrile oxide and the substituted olefins, be rationalised by perturbation theory,^{57,64} Fig. 7

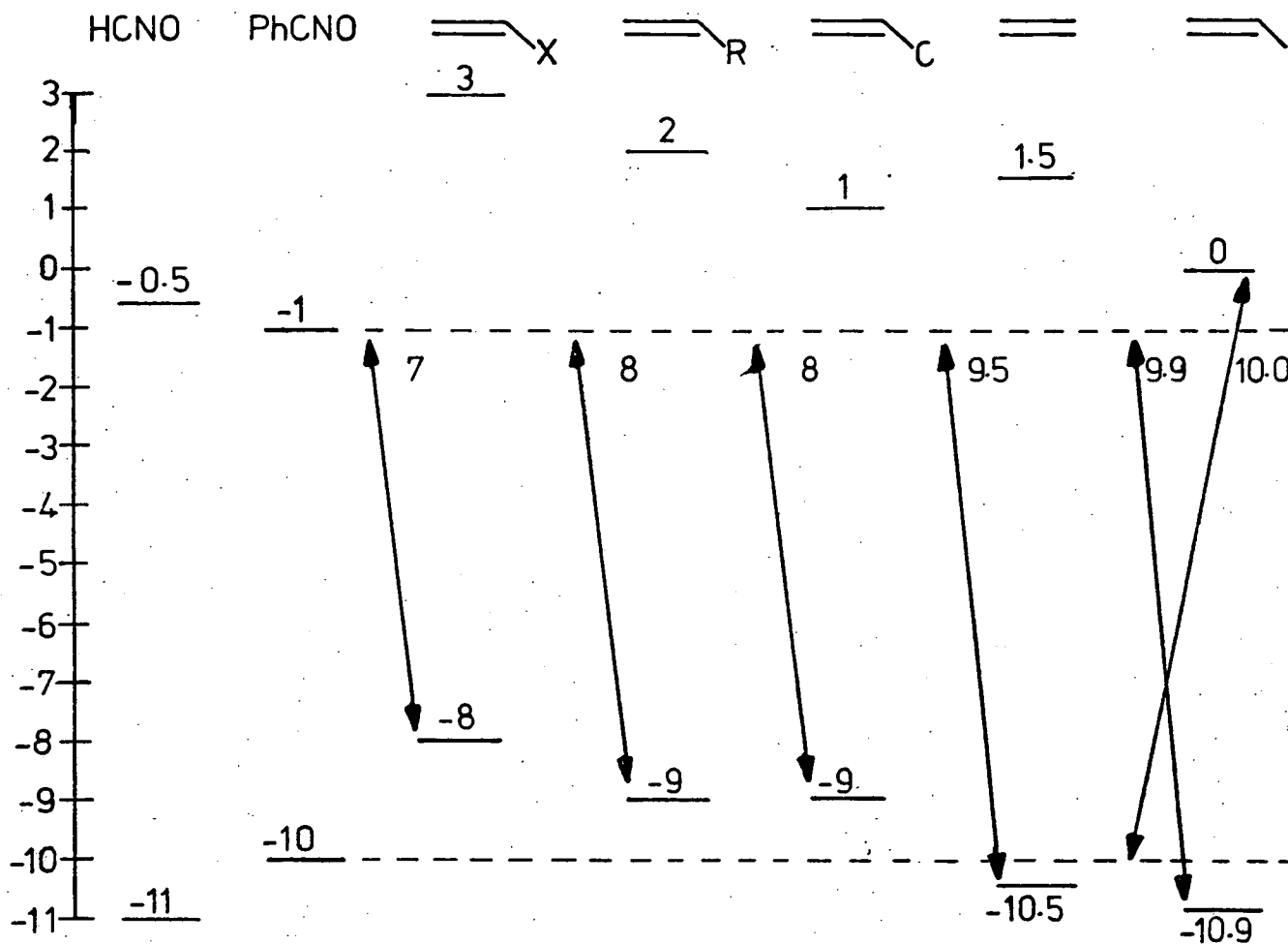

Fig. 7. FMO energies for nitrile oxides and dipolarophiles

It is clear from Fig. 7 that nitrile oxide 1,3-dipolar cycloadditions with olefins are, according to Sustmann's classification,^{65,66} Type III, LUMO-dipole controlled cycloadditions. Therefore, the rate acceleration observed with electron rich olefins is

readily accounted for by the dipolarophile HOMO being raised in energy resulting in increased FMO overlap. The rate increase observed with electron deficient dipolarophiles is due, in part, to the influence of both HOMO and LUMO interactions i.e. a Type II cycloaddition. These arguments have also been applied to explain the difference in reactivity between two substituted benzonitrile oxides.⁷³ In accord with the electrophilic nature of the nitrile oxide, 4-nitrobenzonitrile oxide reacts about ten times faster than 4-methoxybenzonitrile oxide over a range of dipolarophiles.⁷³ This is compatible with the dominant interaction of the 1,3-dipole LUMO with the olefin HOMO: the nitro group should lower the LUMO energy of the nitrile oxide and increase the interaction of this orbital with the olefin HOMO, accelerating the reaction.

Several substituent effects, inexplicable using a partial charge or polarisation model,¹⁵ have been rationalised using perturbation theory.^{56,62,64} For example, when electron donating and withdrawing substituents are attached to the different ethylene carbons (e.g. $\text{CH}_3\text{-CH=CH-CO}_2\text{CH}_3$) the expected increase in reactivity was not observed. This observation can be rationalised by perturbation theory as the methyl group would raise and the acetyl group lower the orbital energies. Therefore, as a consequence of the opposing substituent effects the

net result would be negligible leading to an unreactive dipolarophile.

Perturbation theory is a useful tool in predicting and explaining the relative reactivity for many dipolarophiles. However, if taken in isolation, it can be misleading. For example, it predicts that the reactivity of norbornene, cyclopentene and cyclohexene would be approximately equal but due to ring strain, the observed order of reactivity is norbornene >> cyclopentene >> cyclohexene,⁷¹ Fig. 6.

In addition to affecting the rate of reaction, the nature of the dipolarophile determines, to a large extent, the regioselectivity of the reaction. For example, the 5-substituted isomer is formed exclusively from the reaction of benzonitrile oxide (5) with vinyl ethers⁷¹ and enamines.⁷⁴ On the other hand, reaction of (5) with acrylic esters⁷⁴ yields both the 4- and the 5-substituted isomers, Scheme 22.

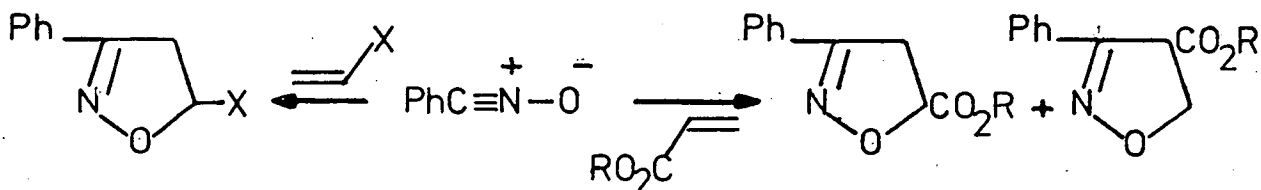

Scheme 22

This type of behaviour has been rationalised by considering the FMO's (Fig. 8) and applying perturbation theory.

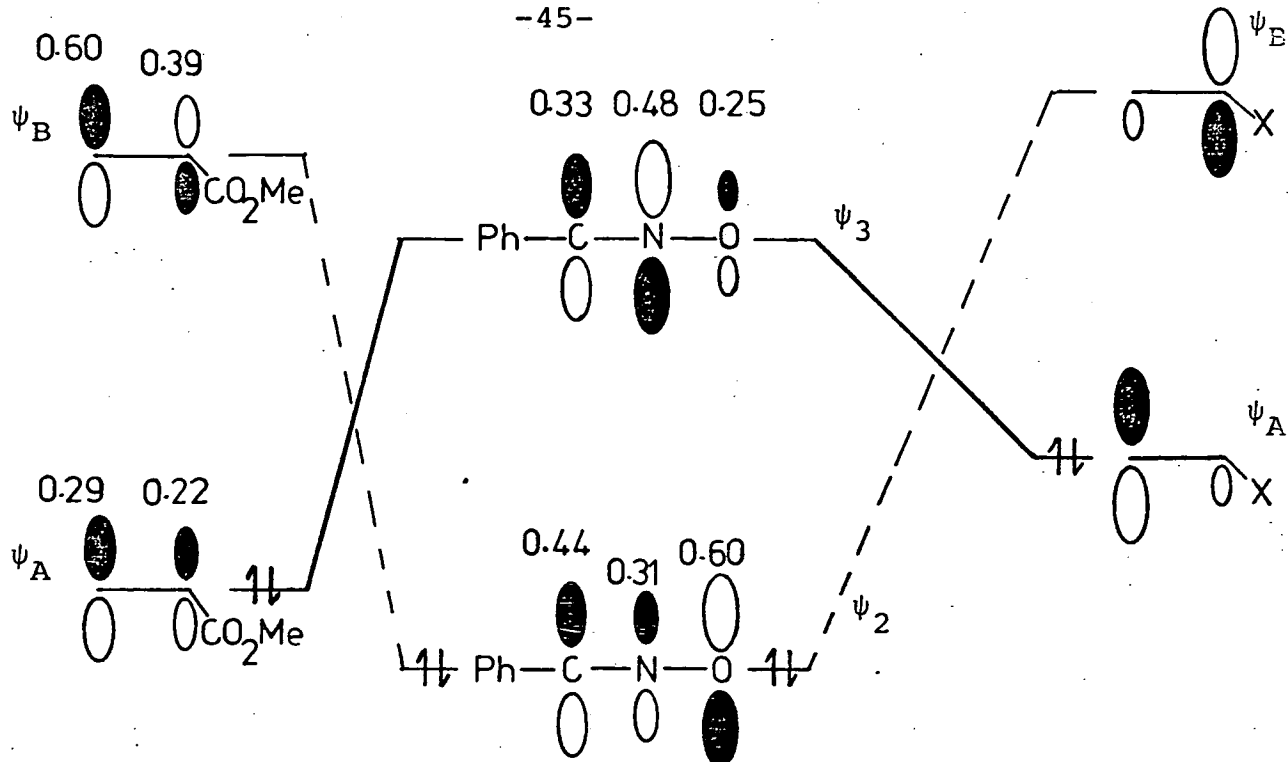

Fig. 8. HOMO and LUMO orbitals of methyl acrylate, benzonitrile oxide and electron rich dipolarophiles

For electron-rich dipolarophiles, Type III reactions, the LUMO (dipole)-HOMO (dipolarophile) interaction is dominant and overlap of the largest coefficients results in the formation of the 5-substituted isomer. For methyl acrylate the LUMO (dipole)-HOMO (dipolarophile) is also the dominant interaction with overlap of the largest coefficients yielding the 5-substituted isomer. However, in the dipolarophile HOMO the magnitude of the coefficients are very similar and the formation of a small amount of the 4-substituted product is not surprising. Further, the HOMO (dipole)-LUMO (dipolarophile) interaction is similar in magnitude to the LUMO (dipole)-HOMO (dipolarophile) and it also favours formation of the 4-substituted isomer.

The formation of regioisomers have been found in many nitrile oxide cycloadditions with various asymmetrically 1,2-disubstituted ethylenes⁵⁶ and acetylenes.⁷⁴

Nitrile oxide 1,3-dipolar cycloadditions are extremely important reactions which occur with a whole variety of dipolarophiles.²⁰ They are of considerable synthetic importance providing a facile synthesis of many different five membered heterocycles. These and many other aspects of nitrile oxide 1,3-dipolar cycloaddition reactions have been discussed in depth.^{15,20}

1.4.4 1,3-Addition Reactions of Nitrile Oxides

In addition to 1,3-dipolar cycloaddition reactions, nitrile oxides react readily with nucleophiles to yield open chain 1,3-addition products. The reaction, which is general for a whole range of nucleophiles, is characterised by nucleophilic attack on the electrophilic carbon of the nitrile oxide.

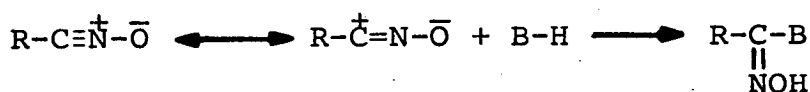

The chemistry and scope of these important reactions has been reviewed by Grundmann and Grünanger.²⁰

2.

FUROXANS

Furoxans can be divided into two classes, benzofuroxans where the heterocyclic ring is fused to a six-membered aromatic ring and acyclic furoxans which are typically 3,4-disubstituted. Although closely related their chemistry

differs due to the influence of the aromatic ring in the benzofuroxans. Therefore, because it is the acyclic furoxans that are of particular interest in the present investigation, the chemistry of benzofuroxans will not be discussed other than in general terms as the need arises. Their chemistry is adequately covered in a review by Boulton and Ghosh and the references therein.⁷⁵

2.1 Structure of Furoxans

Furoxans have been known since 1858 when Kekulé unknowingly synthesised dibromofuroxan from the reaction of bromine and mercuric fulminate.³ Since that time until the 1960's a large part of the literature relating to furoxans has been concerned with the elucidation of their structure, the problem having been reviewed by several workers.⁷⁵⁻⁷⁸ In 1886, following studies with β -naphthaquinone dioxime, Koreff⁷⁹ proposed a six-membered peroxide structure, the dioxadiazine (9).

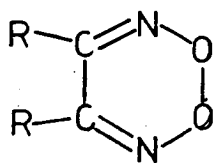

(9)

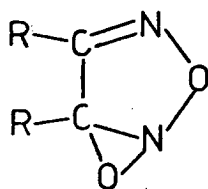

(73)

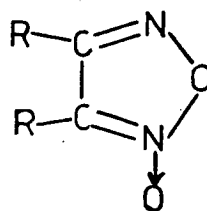

(42)

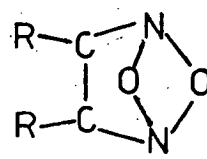

(74)

For a long time structure (9) was assumed to be correct. However, Wieland showed that these compounds do not have the properties ordinarily possessed by peroxides. They are not strong oxidising agents, and the $C_2N_2O_2$ moiety is stable. Furthermore he demonstrated that the furoxan could, in many instances, be reduced to the furazan by heating with phosphorous pentachloride at high temperatures, a conversion which had previously been effected in isolated cases using reducing agents. On the basis of these facts, Wieland concluded that the additional oxygen atom was extra-annular with respect to the furazan ring, and that the properties were best represented by the alternative formulas (73) and (42).^{80,81} Due to the difficulty in observing the isomers predicted by the unsymmetrical structures (42) and (73) these structures were abandoned in favour of the symmetrical structure (74).⁸² In addition, hypochlorite oxidation (a general method for obtaining benzofuroxans from *o*-nitroanilines) of 3-amino-4-nitrotoluene (75) and 4-amino-3-nitrotoluene (76) led to the same methylbenzofuroxan (77).⁸³

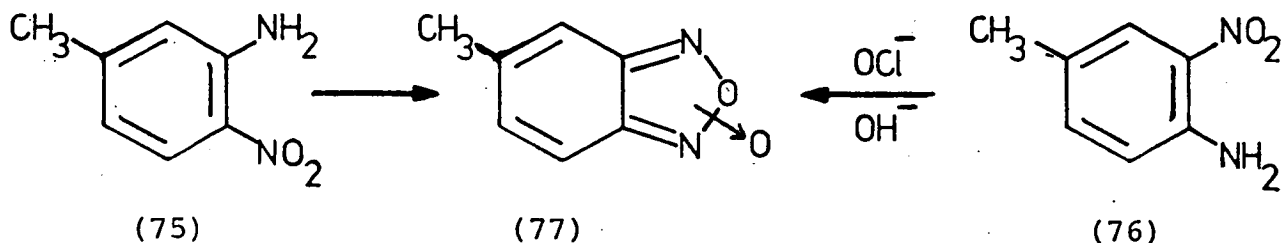

However, in 1925, Meisenheimer et al., demonstrated for the first time, the existence of isomers in the furoxan series.⁸⁴ In work corroborated by Kinney in 1929,⁸⁵ they isolated the two isomers of 4-methoxyphenyl-phenylfuroxan (78) and (79)

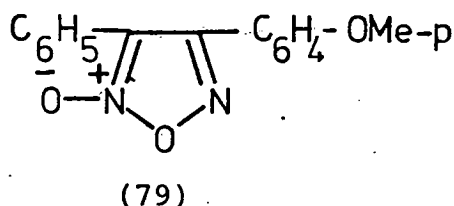
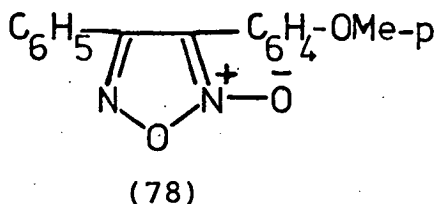

thus indicating the unsymmetrical nature of the furoxan. Following studies on the bromination of benzofuroxan and benzofurazan Hammick et al.⁸⁶ supported the unsymmetrical furoxan structure (42). He also suggested that a rapid interconversion of unstable into stable isomers, probably via the dinitroso structure (80) could be the reason for the formation of single compounds when pairs of isomers were to be expected.

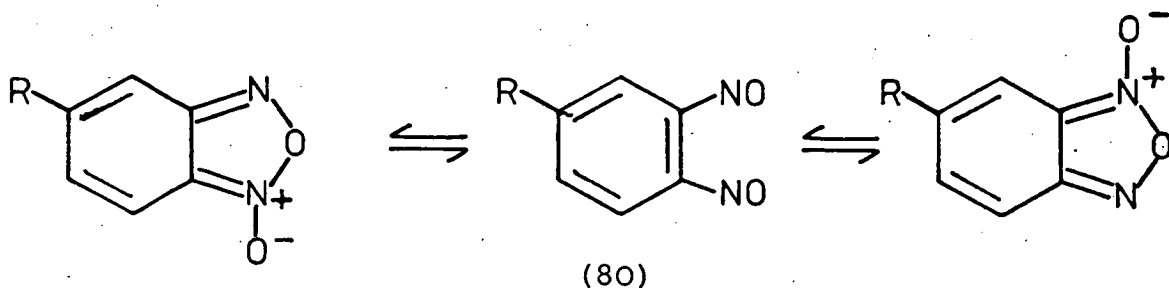

The present-day picture of the gross features of the furoxan structure differs slightly from that of Hammick in that both isomers of the tautomeric system are known to be present in solutions of most benzo-furoxans. The unsymmetrical structure for acyclic furoxans has been demonstrated, as above, by the preparation of individual isomers. The dinitroso intermediate derived from the acyclic furoxan is much less stable than the corresponding intermediate in the benzofuroxan series because there is no extra benzene resonance to be gained on ring opening. However at high temperatures spontaneous ring opening can occur, resulting in the interconversion of isomer pairs.⁸⁷

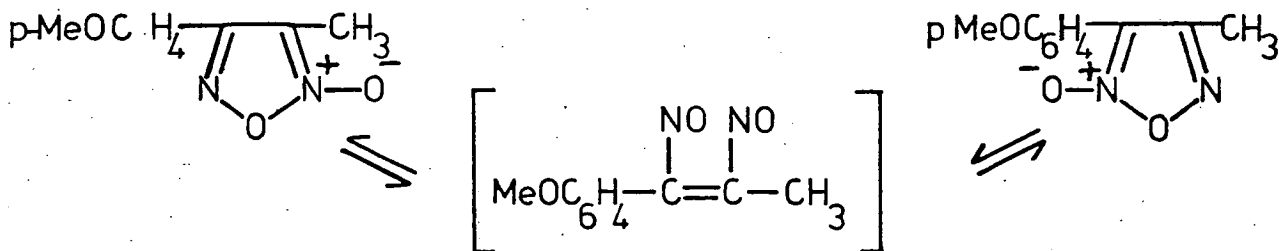

Suschitzky et al.⁵⁴ clearly demonstrated that the tautomerism actually occurred through the o-dinitroso compound (80) and not via some other intermediate when he successfully trapped (81), Scheme 23, from the reaction of benzofuroxan and p-anisylazide.

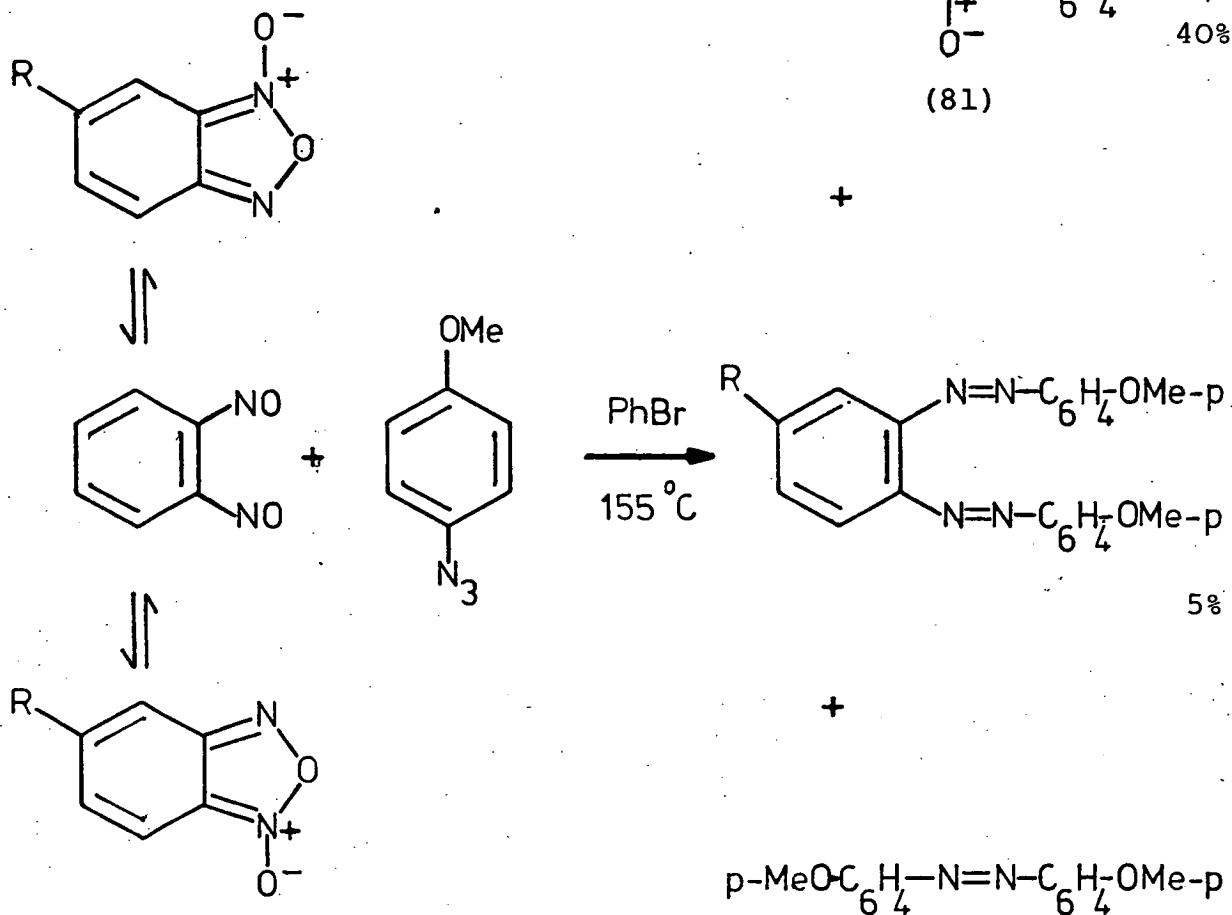

Scheme 23

Previously, the intermediacy of the *o*-dinitroso compound had been predicted from a consideration of thermodynamic parameters provided by kinetic measurements⁸⁸ and arguments based on bond energy considerations.⁵³

The first evidence for the unsymmetrical structure for the benzofuroxan molecule and for the tautomerism was provided in 1961 using proton n.m.r. spectroscopy.⁷⁵ Finally, the furoxan structure (42) was established unequivocally by X-ray crystallography of 5-chloro- and 5-bromobenzofuroxans⁷⁵ and the X-ray structure determination of 4-bromophenyl-methyl furoxan.⁸⁹



2.2 Preparation of Furoxans

2.2.1 Dimerisation of Nitrile Oxides

Of the variety of methods by which furoxans can be prepared,⁹⁰ the dimerisation of nitrile oxides is amongst the most important. In neutral solution nitrile oxides yield, almost exclusively, furoxans. In fact the detection of a furoxan is taken, in many cases, as an indication that nitrile oxides have been generated during the course of the reaction. There exists a large number of different routes to nitrile oxides, and consequently furoxans, and these have been adequately described in section 1.

The limitation of the dimerisation of nitrile oxides lies in the fact that, preparatively, only symmetrically disubstituted furoxans can be readily prepared. Further it is not possible to prepare sterically hindered and bicyclic furoxans.

2.2.2 Dehydrogenation of Glyoximes

The oxidation of glyoximes is one of the oldest and best established routes to furoxans. It was first utilised by Koreff in 1886 when he prepared 1,2-naphtho-furoxan by the hypochlorite oxidation of 1,2-naphthoquinone dioxime.⁷⁹ Since that time many oxidising agents have been employed, some more successfully than others. For example, 3,4-diphenylfuroxan is formed when diphenylglyoxime is treated with alkaline ferricyanide,⁷⁹ chlorine in ethanol or benzene,⁹¹ alkaline hypochlorite,⁹² or dinitrogen trioxide.⁹³

In fact, oxidation of the glyoxime provides a most versatile route to furoxans which are not readily accessible by other means. For many years it was the method of choice for the preparation of dimethylfuroxan, the glyoxime being oxidised by dinitrogen tetroxide.⁹¹ The advantage over other routes available at the time was the ease of preparation of dimethylglyoxime. At the present time oxidation of glyoximes is still an extremely important route to dialkylfuroxans⁹⁴ although dehydration of nitroethane by phenyl isocyanate is probably the preferred method for dimethylfuroxan.³⁷

The versatility of the route lies in the ease of preparation of cyclic and unsymmetrical glyoximes. Direct oximation of the 1,2-diketone using hydroxylamine is an extremely facile method of synthesis. If, on the other hand the diketone is not readily available, the glyoxime can be obtained by a number of methods. Two of the more interesting and novel routes involve nitrosation of ketones⁹⁴ and the formation of silyl ethers from ketones or aldehydes.⁹⁵ For example, the nitrosation of ketones (82) with alkyl nitrites yields the 1,2-diketone monoxime (83) which on subsequent reaction with hydroxylamine gives the glyoximes (84),

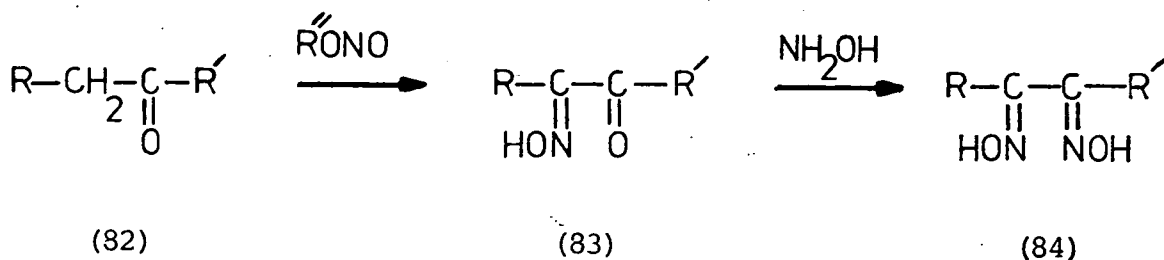

This method has been used with considerable success in the synthesis of unsymmetrical dialkylfuroxans where the intermediate compounds from other routes are not readily available.

Reaction of ketones and aldehydes with trimethylsilyl chloride in the presence of triethylamine in DMF yields trimethylsilylenol ethers (85).⁹⁶ On reaction with nitrosyl chloride (85) gives the corresponding 1,2-diketone monoxime, which on addition of hydroxylamine yields the glyoxime (84), Scheme 24.

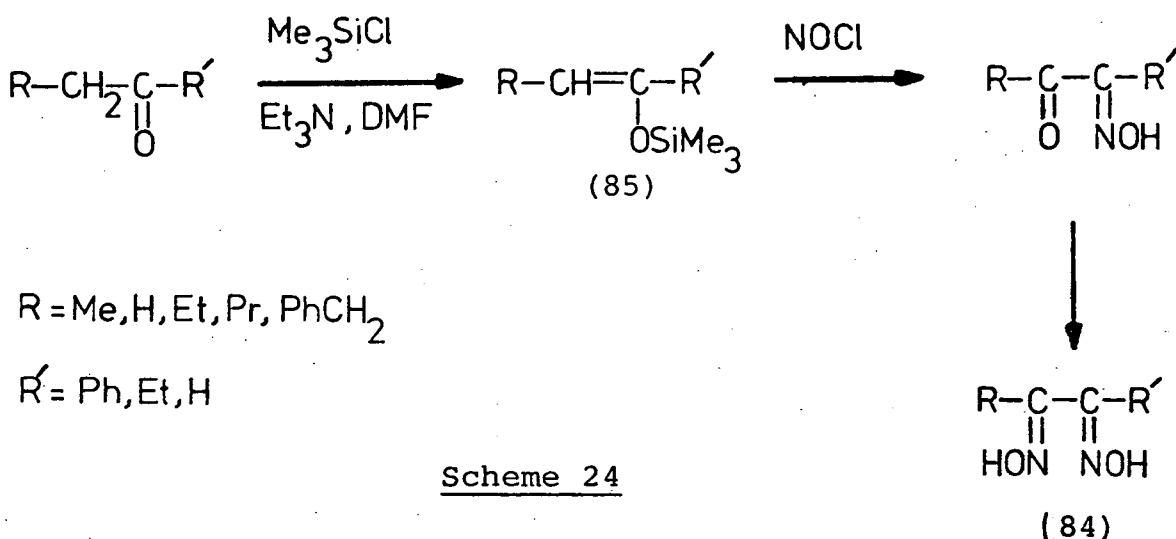

This is a novel and interesting route utilising both ketones and aldehydes and would appear to have fairly wide application.

2.2.3 Dehydration of Pseudonitrosites

Olefins react with dinitrogen trioxide to form pseudonitrosites (86). The pseudonitrosite is then easily converted to the corresponding nitro-oxime (87) by heating in a polar solvent. Subsequent dehydration affords furoxans in high yields⁹⁷ (70-90%), Scheme 25.

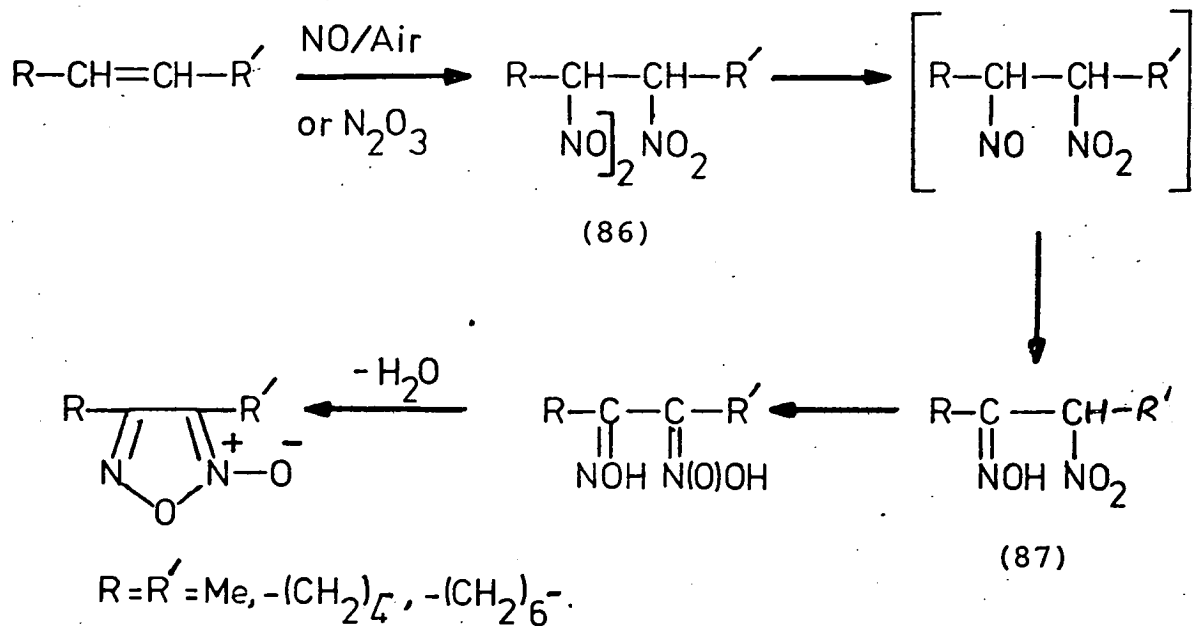

Scheme 25

The method has been successfully applied to the conversion of strained cycloalkenes into the corresponding bicyclic furoxans. For example, both norbornene and dicyclopentadiene have been successfully transformed into the corresponding furoxans,⁹⁸ (88) and (89) respectively, Scheme 26.

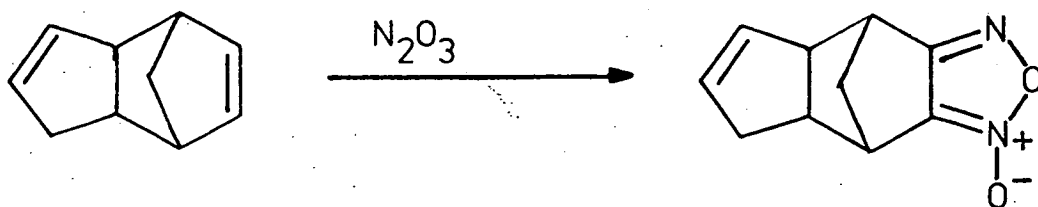
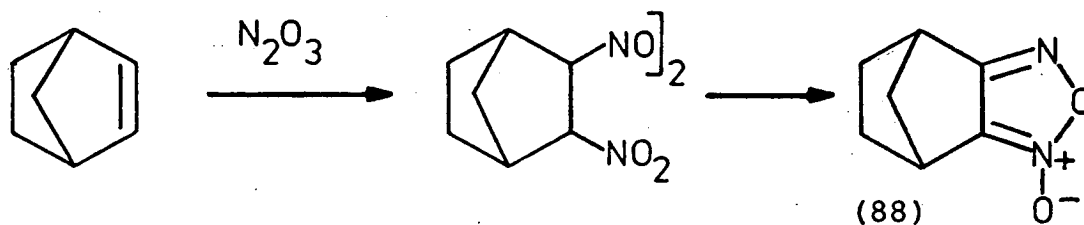

Scheme 26

(89)

2.2.4 Furoxans from 1,2-Dinitroalkenes

1,2-Dinitroalkenes, the products from the reaction of 1-chloro-1-nitroalkanes and sodium hydroxide,⁹⁹ possess an electron deficient double bond which is vulnerable to nucleophilic attack. Prior to 1957 it had been shown that these compounds react quite readily with amines to form β -aminonitroalkenes.¹⁰⁰ In 1957, Emmons and Freemann discovered that 1,2-dinitroalkenes also react readily with sodium azide yielding furoxans, presumably formed by the decomposition of the azido nitroalkene intermediate (90)¹⁰¹ as illustrated in scheme 27.

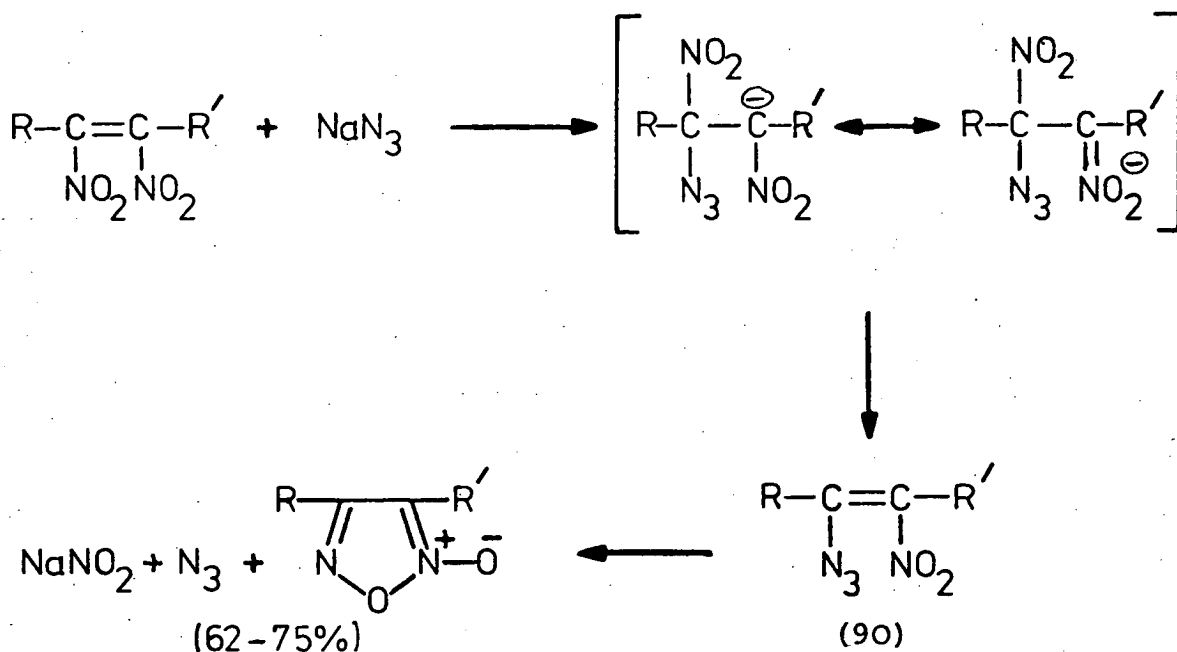

Scheme 27

The reaction takes place at ambient temperatures and would appear to provide a general route to dialkyl furoxans, the limiting factor is the preparation of the 1,2-dinitroalkene.

It was also established that 3,4-diphenylfuroxan was the product of the reaction of cis-1,2 dinitrostilbene, formed by the reaction of N_2O_4 with tolane,¹⁰² and sodium azide.

The process is reminiscent of the formation of benzo-furoxans from the decomposition of o-nitrophenyl azides.⁷⁵

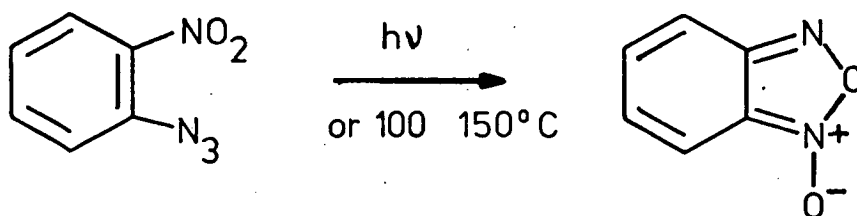

However, it is interesting to note that the aliphatic nitro azides cannot be isolated, the formation of the furoxan taking place at room temperature. Presumably, the higher temperatures are required for the formation of benzo-furoxan to overcome the loss of aromaticity present in the o-nitrophenyl azide.

An interesting reaction, directly analogous to the above, was discovered in 1958 by Stevens and Emmons while studying the reaction of dinitrogen tetroxide and iodine with olefins and acetylenes.¹⁰³ Reaction of diphenyl acetylene with N_2O_4 and I_2 gave trans- α -nitro- α' -iodostilbene which, as above, has an electron deficient double bond. Not surprisingly, subsequent reaction with sodium azide yielded 3,4-diphenylfuroxan.

2.3 Thermal Stability of Furoxans

Despite early reports that phenyl isocyanate was formed during an attempted distillation of 3,4-diphenylfuroxan,^{11,104} furoxans have generally been considered as the stable products from the dimerisation of nitrile oxides.²⁰ It was postulated that formation of the isocyanate involved dissociation of the heterocyclic ring to two nitrile oxide fragments, followed by the well established nitrile oxide/isocyanate rearrangement,¹¹ Scheme 1. This hypothesis found support with the observations that strained furoxans and furoxans with bulky substituents decompose at moderate temperatures to give, in the presence of suitable dipolarophiles, nitrile oxide cycloadducts.^{105,106} For example, in 1972 Boulton *et al* isolated the 1,3-dipolar cycloadducts (91) and (92) from the thermolysis of 4,5,6,7-tetrahydro-4,8,8-trimethyl-4,7-methanobenzofuroxan (93) and 4,4a,6,7,7a,8-hexahydro-4,8-methano-5H-indeno[5,6-c]furoxan (94) in phenylacetylene,¹⁰⁵ Scheme 28.

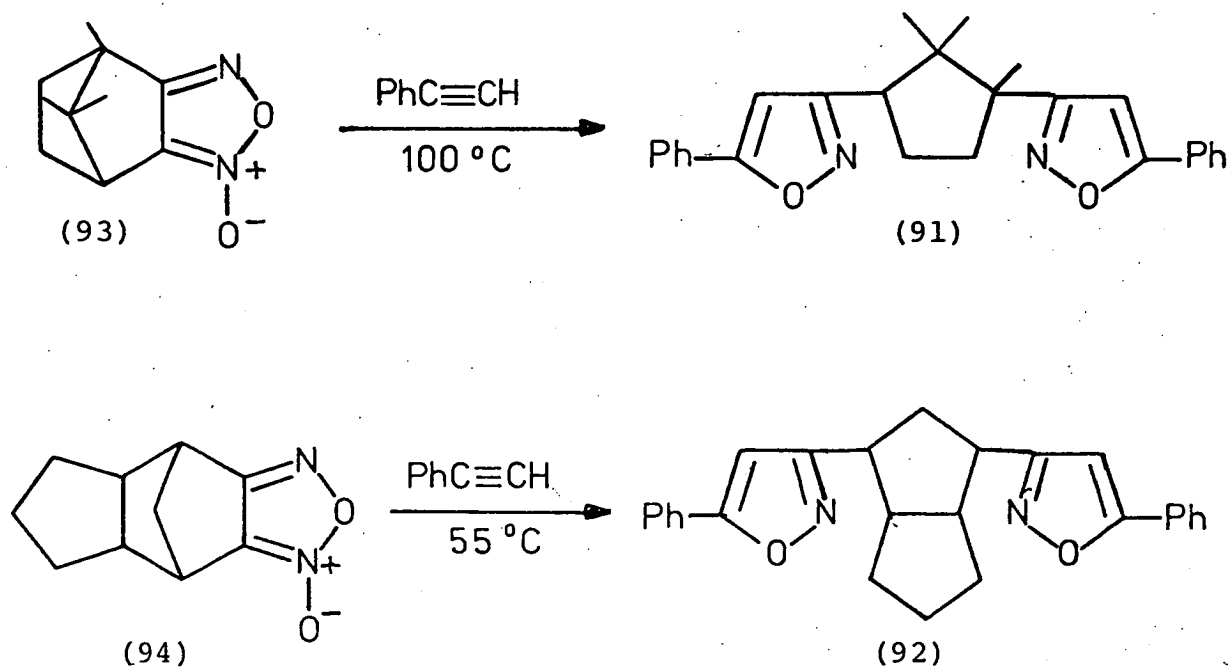

Scheme 28

In 1976, Crosby and Paton¹⁰⁷ established that the thermolytic ring opening did not depend upon special structural features such as bulky substituents or high ring strain, but is a general reaction under more forcing conditions. When 3,4-diphenyl- and 3,4-dimethylfuroxan were heated at reflux in 1-dodecanol phenyl and methyl isocyanate were trapped as their carbamates in yields of 81 and 20% respectively. Moreover, when diphenylfuroxan was heated for 2h in 1-tetradecene and then cooled 5-dodecyl-3-phenyl-2-isoxazoline (82%) was isolated, indicating that the 1,3-cycloaddition reaction is faster than isomerisation to the isocyanate. In addition, thermolysis of decamethylenefuroxan (95) in the presence of 1-tetradecene and decanonitrile afforded the cycloadducts (96) and (97) respectively. Thermolysis in decanol resulted in the isolation of (98) formed directly from reaction of the di-isocyanate (99) and decanol, Scheme 29.¹⁰⁷

Thus it was established that the ring opening of furoxans is a general reaction with a threshold temperature that is dependent on the substituents or ring strain. It has also been demonstrated that bicyclic furoxans might find use both as sources of bis-nitrile oxides suitable for applications such as the formation of polymer cross-links of high thermal stability,¹⁰⁸ and as intermediates in a phosgene-free route to di-isocyanates from commercially available cycloalkenes.¹⁰⁹ However, the synthetic utility of the reaction as a route to di-isocyanates was restricted

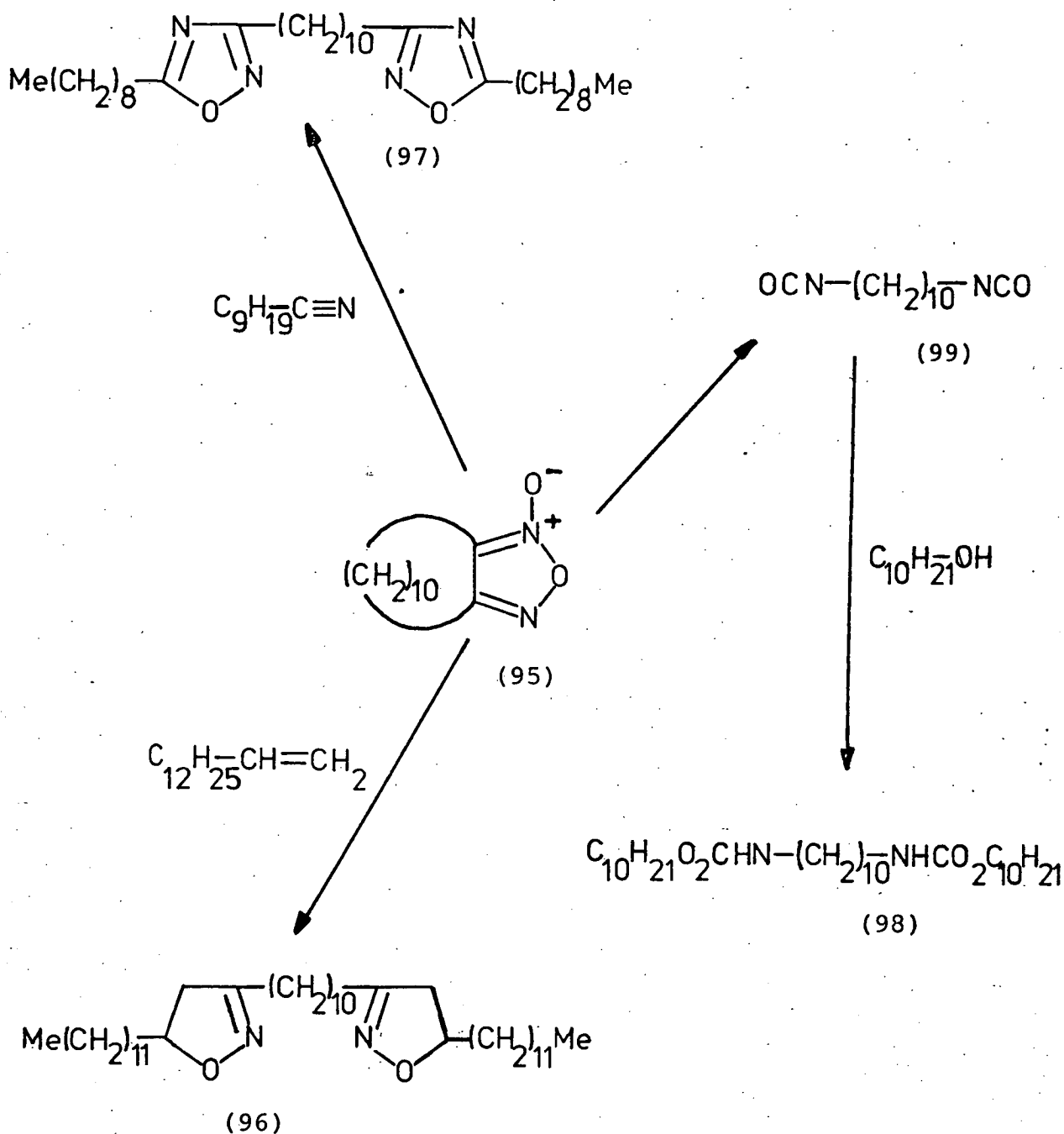

Scheme 29

to those bicyclic furoxans, such as decamethylenefuroxan, which decompose at temperatures ($>150^\circ\text{C}$) which the nitrile oxide to isocyanate rearrangement takes place rapidly.

In 1978, Crosby and Paton⁹⁸ reported that by inclusion of sulphur dioxide in the reaction medium the previously unattainable conversion of strained furoxans of the norbornane series (100) into the corresponding di-isocyanates (102) is realised, Scheme 30.

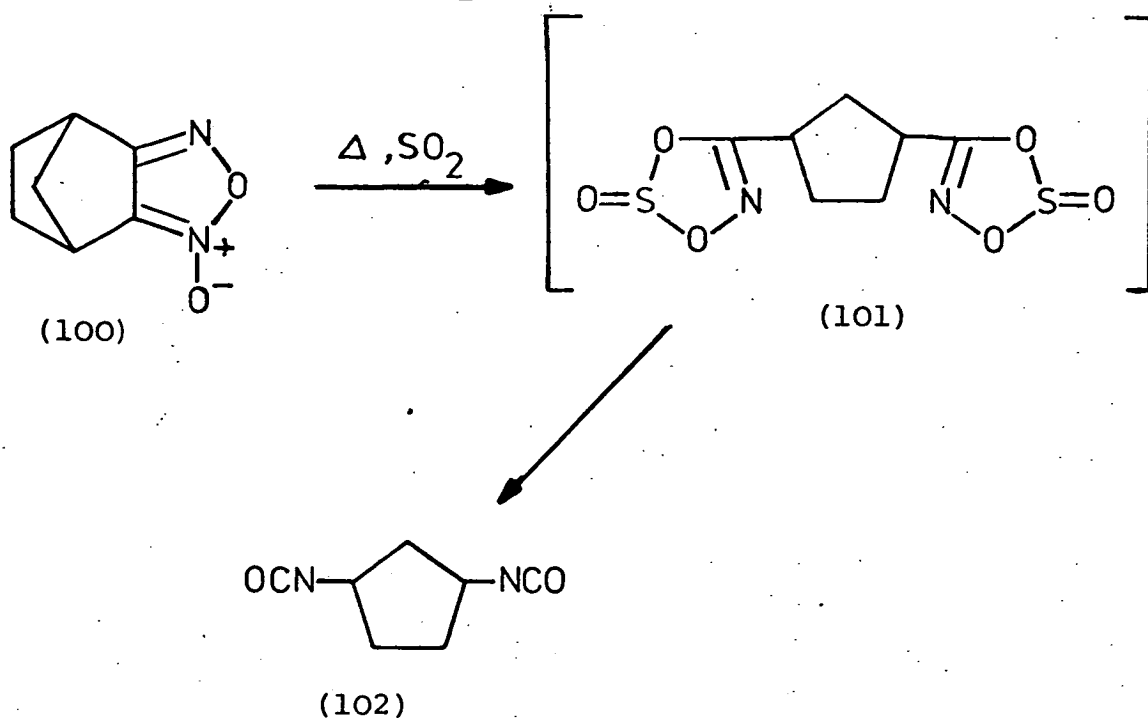

Scheme 30

The fact that no isocyanate was detected during the thermolysis of (100) in the absence of sulphur dioxide and that the only product isolated was an amorphous white solid, believed on the basis of its i.r. spectrum to be polymeric furoxan, confirmed the essential role of sulphur dioxide in the conversion of furoxans to isocyanates.

Although the exact nature of the reaction mechanism is unclear, chemical and spectroscopic evidence⁹⁸ has suggested the intermediacy of bis-1,3,2,4-dioxathiazole-2-oxides (101). Previously it had been demonstrated that the dioxathiazole-2-oxides, which are readily prepared by the reaction of nitrile oxides and sulphur dioxide, decompose on heating to yield the corresponding isocyanate and sulphur dioxide⁴⁰ (section 1.3.4). The dubiety surrounding the reaction mechanism arises from the observation

that, in reactions of strained furoxans with dipolarophiles to give bis-adducts, the rate of disappearance of the furoxan is dependent on the dipolarophile used.^{98,110} For example, the pseudo-first-order rate constant for the disappearance of (100) in mesitylene in the presence of sulphur dioxide was found to be 169 times greater than that for the thermolysis in the absence of sulphur dioxide. In general the rate of disappearance of the furoxan increased as the dipolarophile reactivity increased (norbornene > cycloheptene > 1-methylcyclohexene).¹¹⁰

These observations can be rationalised in two ways; either there is direct interaction between the furoxan and the dipolarophile or alternatively there is an equilibrium between the furoxan and the bis-nitrile oxide as illustrated in Scheme 31.

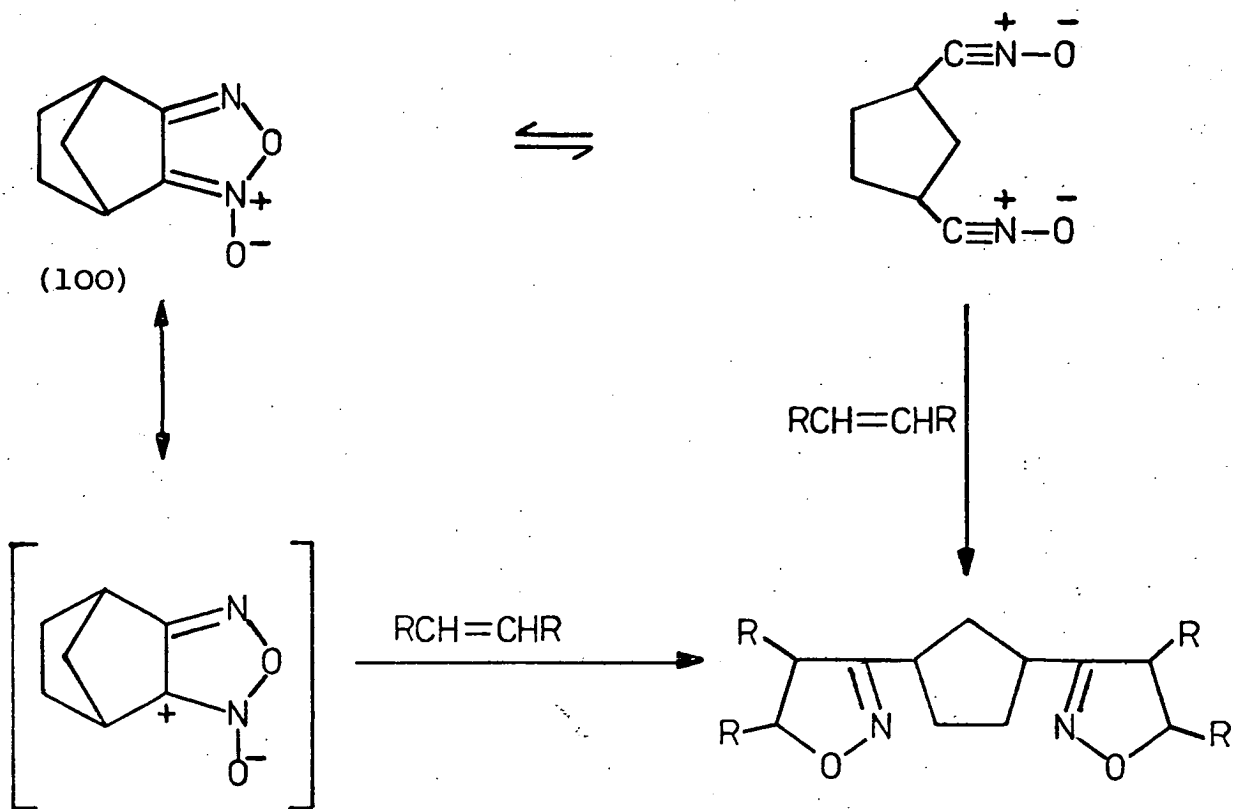

Scheme 31

The evidence supporting the direct interaction of the furoxan with the dipolarophile came from a study on 3,4-dibenzoylfuroxan (103).¹¹¹ When (103) was refluxed in xylene with phenylacetylene, styrene or stilbene, the expected cycloadducts formed by 1,3-dipolar cycloaddition of phenylglyoxalonitrile oxide ($\text{Ph}\cdot\text{CO}\cdot\text{C}\equiv\text{N}^+\text{O}^-$) with the above dipolarophiles were not detected. Instead, the cycloadduct (104) formed via a nitron addition to the dipolarophile was formed. The proposed mechanism for phenylacetylene is that illustrated in Scheme 32.

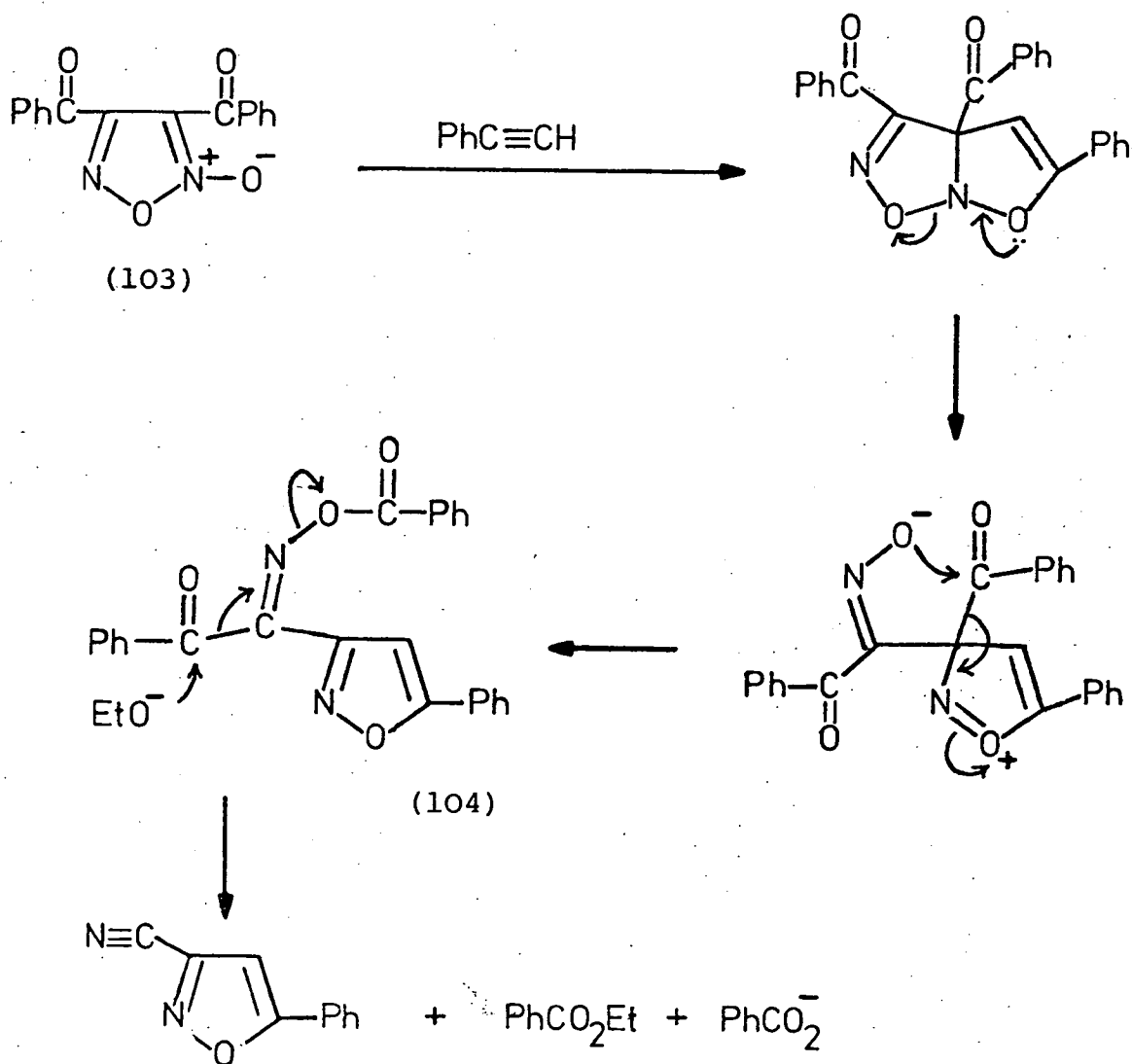

Scheme 32

The direct interaction of the furoxan with a dipolarophile in a nitrene 1,3-dipolar cycloaddition is analogous to the iso-electronic imidazole-N-oxides. Reaction of 1-methylbenzimidazole-3-oxide (105) with dimethyl acetylenedicarboxylate (DMAD) or methyl propiolate gave methyl methoxyallyl- or methyl formyl(1-methyl-2-benzimidazolyl) acetate¹¹² (107a or 107b respectively). As shown in Scheme 33 the formation of (107a) and (107b) has been rationalised by initial 1,3-dipolar cycloaddition to form the isoxozaline intermediate (106) which then rearranges to form the products.

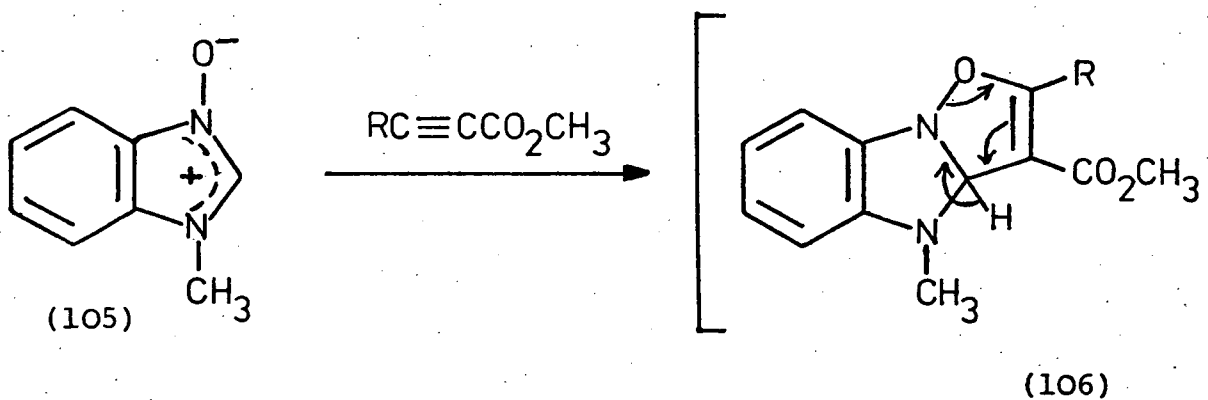

(a), $R = CO_2CH_3$

(b), $R = H$

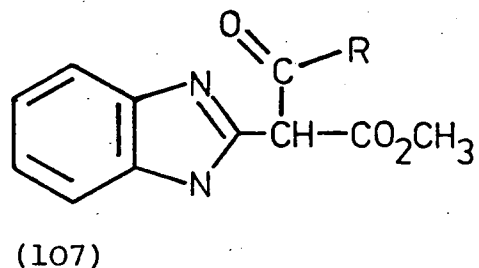

Scheme 33

Similarly, Simmonds et al.¹¹³ claim to have isolated the nitrono cycloadduct (109) from the reaction of 4,5-dimethyl-2,2-diphenylimidazole-1-oxide (108) with DMAD.

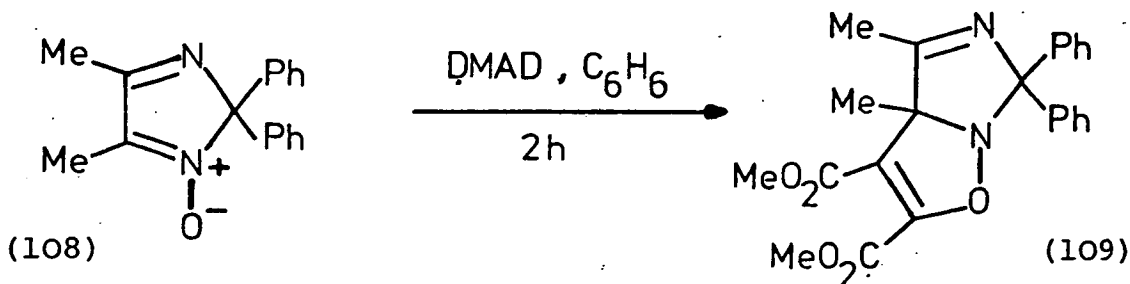

3.

FURAZANS

Furazans (1,2,5-oxadiazoles) have long been regarded as the stable products from the dehydration of glyoximes. Their chemistry which dates from before 1900 is well documented and has been reviewed on more than one occasion.^{77,78,114} In the present context only those areas of particular interest, such as their synthesis and ring fragmentations will be dealt with in depth.

3.1 Preparation of Furazans

Although there are many synthetic routes to furazans by far the most important are the dehydration of glyoximes and the deoxygenation of furoxans.

3.1.1 Dehydration of Glyoximes

The success of this route lies in the ease of preparation of both cyclic and unsymmetrical glyoximes; a point already covered in section 2.2.2. Dehydration of the glyoxime occurs with many dehydrating agents including concentrated sulphuric acid,¹¹⁵ succinic anhydride,¹¹⁶ urea solutions and thionyl chloride.¹¹⁸ For example, 3,4-dimethylfuran (111) has been synthesised from dimethylglyoxime (110) using succinic anhydride.¹¹⁶

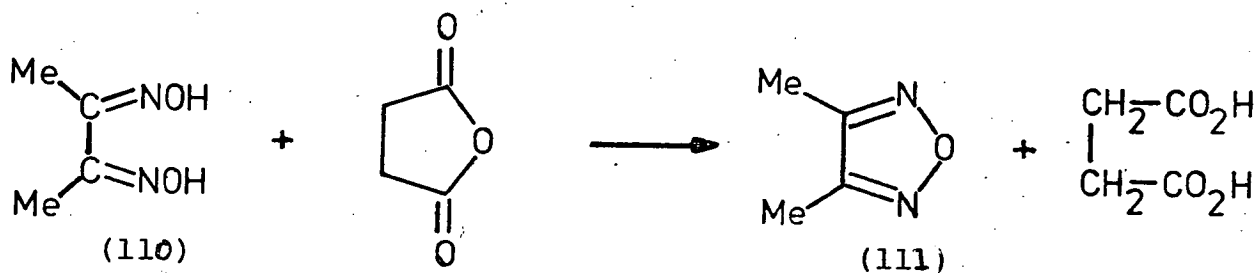

The route has been successfully applied to the synthesis of strained furazans. Indeed, Boulton and Mathur achieved the first synthesis of a furazan fused to a five membered ring when they prepared acenaphtho [1,2-c]furazan (112) from the corresponding glyoxime.¹¹⁹ Dehydration of the glyoxime was effected by thionyl chloride in methylene chloride, a modification of the method of Tokura *et al.*¹¹⁸ who synthesised 3,4-tetra-methylenefurazan (113). They synthesised the furazan while investigating the direction of the Beckmann rearrangement. Contrary to their expectations, the rearrangement did not occur and instead of isolating the

1,2,4-oxadiazole the furazan was formed. This was in contrast to the behaviour of benzil dioxime with thionyl chloride which resulted in the formation of 3,5-diphenyl-1,2,4-oxadiazole quantitatively.

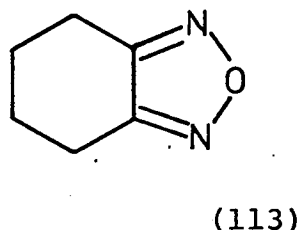
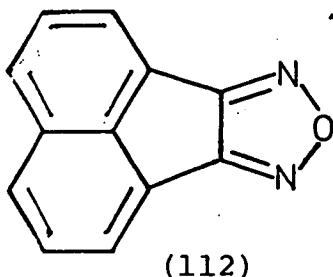

The difference in reactivity was rationalised by Tokura *et al.* who postulated that benzil dioxime has a planar structure which would favour a Beckmann rearrangement to the 1,2,4-oxadiazole. On the other hand cyclohexane-1,2-dione dioxime would be expected to undergo dehydration to the furazan since it is sterically more constrained than benzil dioxime. In addition the formation of the intermediate cation might be stabilised by the presence of a participating phenyl group.

3.1.2 Deoxygenation of Furoxans

The importance of this route lies in the fact that furoxans are available from various starting materials and that reduction to the furazan can be effected in extremely high yields. Several reagents have been utilized; sodium carbonate followed by acid;⁷⁷ zinc/acetic acid;⁷⁷ phosphorous pentachloride or stannous chloride in acetic acid;⁷⁷ trialkyl and triarylphosphines and phosphites.^{120,121} Perhaps the most widely used is that

first utilized by Mukaiyama and co-workers¹²⁰ who heated 3,4-diphenylfuroxan with triethylphosphite at 160-170°C, under nitrogen for 5 h, to give 3,4-diphenylfurazan (93%) and triethylphosphate (94%).

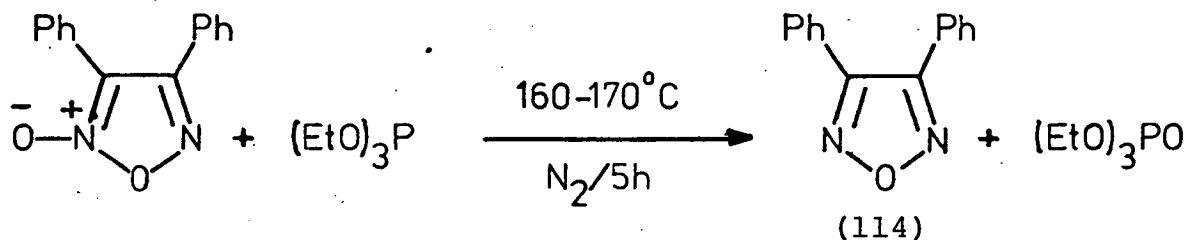

Under more forcing conditions (270°C) with triphenyl phosphite benzonitrile is formed.¹²²

3.2 Thermal and Photolytic Stability of the Furazan Ring

The earliest reports indicating instability of the furazan ring were in 1888 when it was noted that rapid heating of 3,4-diphenylfurazan resulted in the formation of benzonitrile and phenyl isocyanate,^{123,124} Scheme 34.

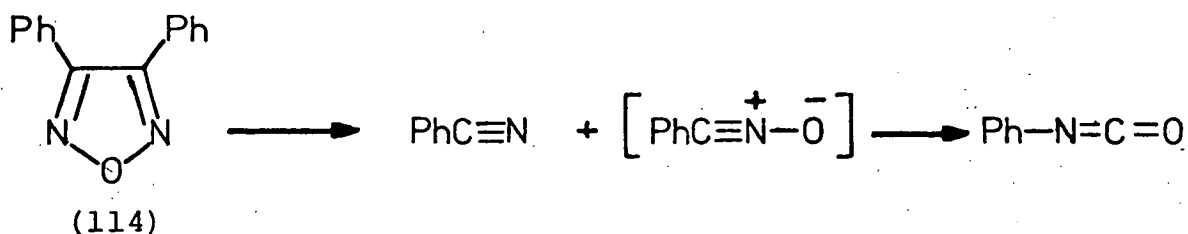

Scheme 34

Despite this early observation suggesting the intermediacy of benzonitrile oxide no further work on the ring opening of furazans was carried out until 1968 when Cantrell and Haller investigated the photolytic decomposition

of 3,4-diphenyl- and 3,4-dimethylfuranan.¹²⁵ They discovered that irradiation of (114) in ether resulted in the formation of benzonitrile (82%) and phenyl isocyanate (48%). Irradiation of (111) gave acetonitrile (41%) and an intractable tar. However, irradiation in the presence of cyclopentene resulted in the isolation of the corresponding methyl-isoxazoline (115) (23%) and established the intermediacy of the nitrile oxide as illustrated in Scheme 35.

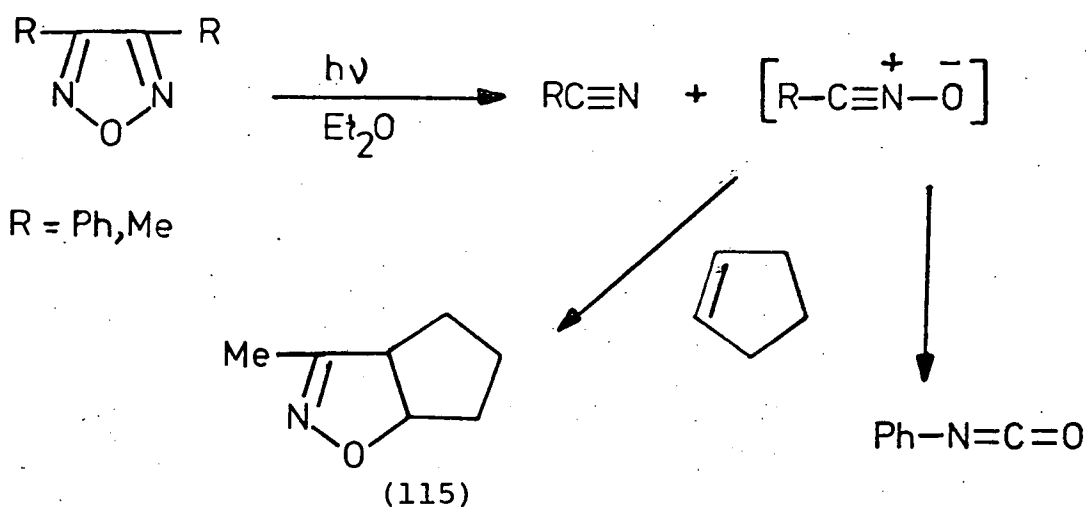

Scheme 35

When the photolysis of (114) was carried out in the presence of cyclopentene, no isoxazoline was detected. Cantrell and Haller suggested that the failure to trap benzonitrile oxide by 1,3-dipolar cycloaddition to cyclopentene might be due to the nitrile oxide to isocyanate rearrangement for benzonitrile oxide being faster than the ground state 1,3-dipolar cycloaddition. The alternative proposal that an excited benzonitrile oxide fragment rearranges directly to phenyl isocyanate is militated

against by the failure to observe methyl isocyanate or related by-products in the photolysis of (111).

Confirmation of the intermediacy of benzonitrile oxide was achieved by the isolation of diphenylfuroxan and diphenyl-1,2,4-oxadiazole from the products of the irradiation of (111) in benzene.⁴³

In contrast to monocyclic furazans, photolysis of a polycyclic furazans, such as benzo-(116), naphtho- and phenanthro-furazans led to complex product mixtures derived, it was assumed, from a reactive intermediate (117) possessing a nitrile oxide group.¹²⁶ In order to obtain a clean reaction the photolysis was carried out in the presence of a reagent capable of reducing the nitrile oxide to the corresponding nitrile. Under these conditions the photoreaction of (116) afforded cis-cis-1,4-dicyanobuta-1,3-diene (118) in 80% yield accompanied by lesser amounts of the other isomers, Scheme 36.¹²⁶

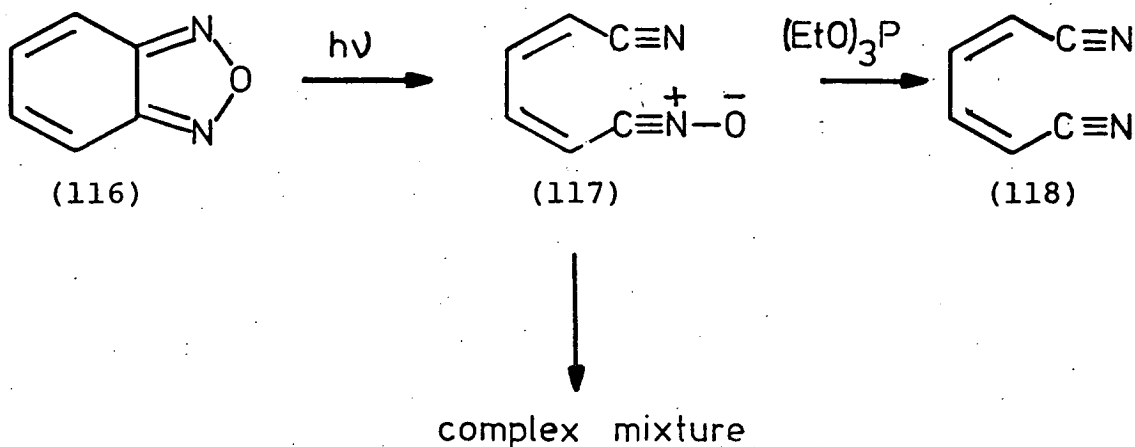

Scheme 36

The photolysis of (116) in benzene gave a complex mixture of products including an azepide (119) derived presumably from an acyl nitrene intermediate (120).¹²⁷

In methanol, as is the case with 3,4-diphenylfurazan, the corresponding *N*-substituted carbamate (121) was isolated.¹²⁷

Acyl nitrene derived products have been isolated during the photochemical ^{rearrangement} of nitrile oxides to isocyanates.⁴⁸ Consequently, Schmid and his co-workers rationalised their results by the mechanism shown in Scheme 37.

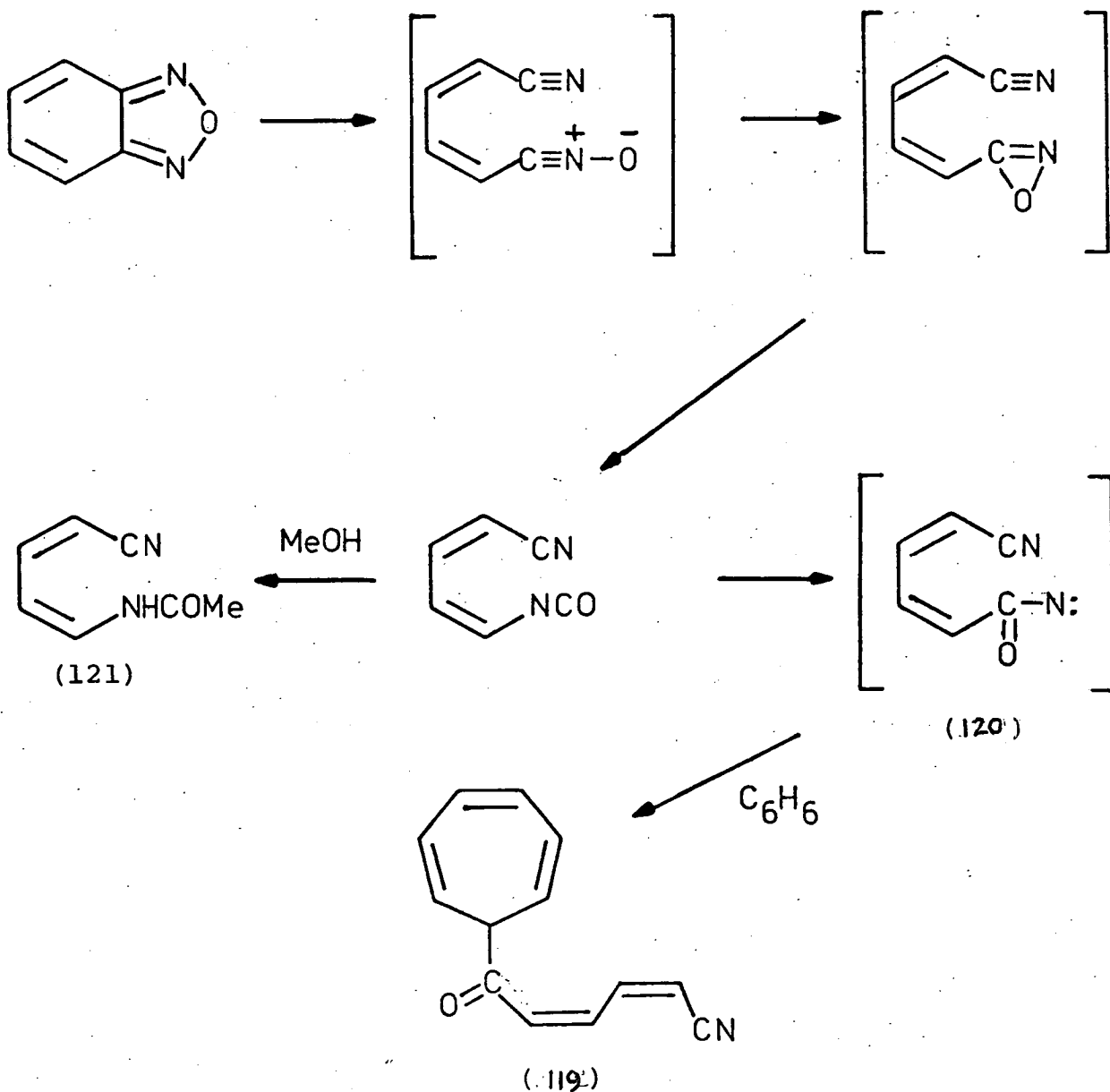

Scheme 37

The isolation of a nitrile oxide intermediate in the photolysis of a bicyclic furazan was elegantly demonstrated by the photolysis of (116) in the presence of DMAD. The nitrile oxide reacted with the DMAD to produce various geometrical isomers of dimethyl 3-(4-cyanobuta-1,3-dienyl)isoxazole-4,5-dicarboxylate (122),¹²⁸ Scheme 38.

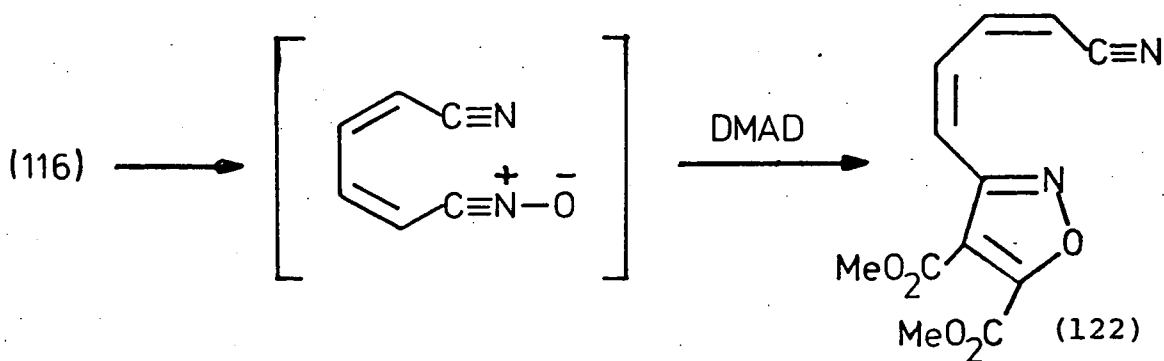

Scheme 38

In contrast to the detailed examination of the photolytic decomposition the thermolysis of furazans has received little attention. The first reported case of a furazan thermally fragmenting to give a nitrile oxide intermediate was that of acenaphtho[1,2-c]furazan (123), reported by Boulton and Mathur in 1973.¹¹⁹ They found that the furazan, which they had synthesised from the dioxime, slowly decomposed on warming. By following the decomposition of (123) by i.r., at 72°C in toluene, the appearance of two bands at 2285 (CNO) and 2210 (CN) cm⁻¹ were observed. Thermolysis of the furazan in phenylacetylene resulted in the isolation of 3-(8-cyano-1-naphthyl)-

5-phenylisoxazole (125). The isolation of the nitrile oxide 1,3-dipolar cycloadduct in conjunction with the i.r. observations established the intermediacy of the dinitrile monoxide (124), Scheme 39.

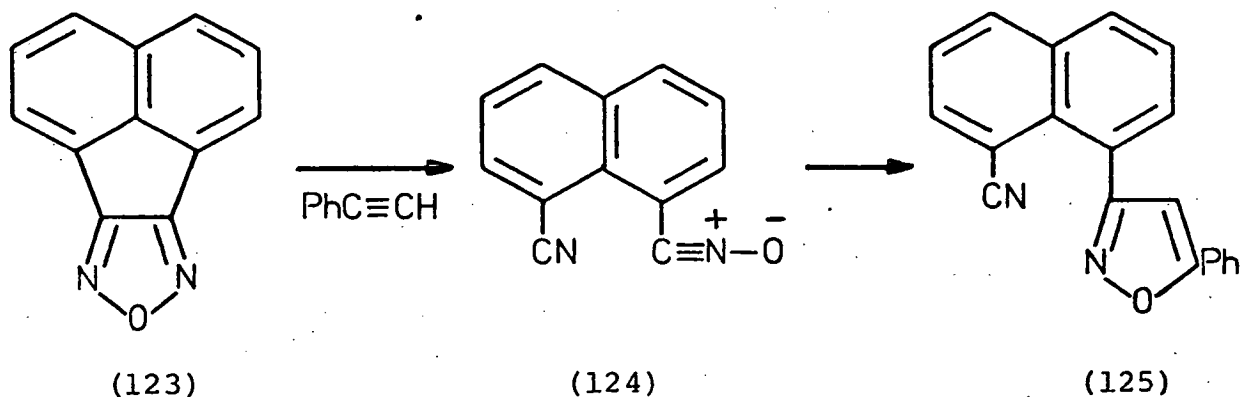

Scheme 39

At the outset of the present investigation acenaphtho [1,2-c]furan (123) was the only reported case where the oxadiazole ring cleaved thermally to give a nitrile oxide intermediate which could be trapped by a dipolarophile and isolated as the 1,3-dipolar cycloadduct. Since then the thermolysis has been extended to other furazans which are fused to five-membered rings.^{110,129}

Thermolysis of 3,4-trimethylene-(126a) and 6-methyl-3,4-trimethylenefuran (126b) in the presence of sulphur dioxide or a suitable dipolarophile resulted in the isolation of the corresponding isocyanate (128) or 1,3-dipolar cycloadduct (129) derived from the dinitrile monoxide intermediate (127) as illustrated in Scheme 40.¹¹⁰

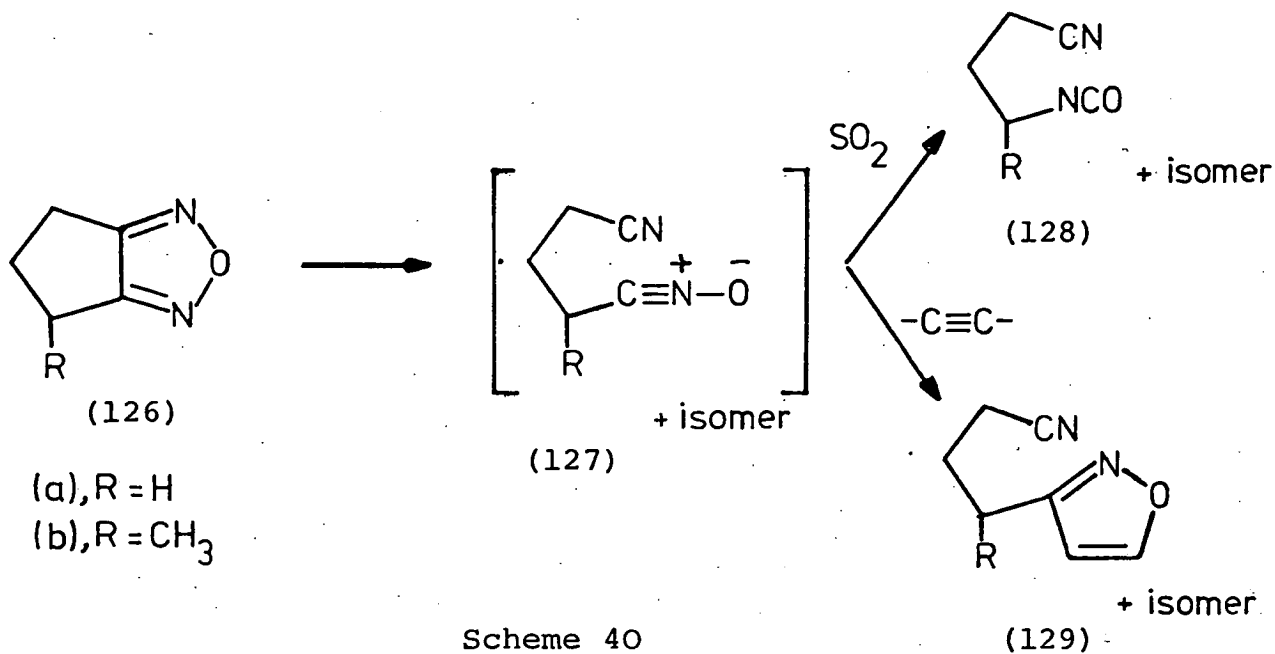

While studying the reactions of 4,6-diphenyl-thieno[3,4-c]furazan (130) with *N*-phenylmaleimide (131) Tsuge *et al.*¹²⁹ discovered that thermolysis of the cycloadduct (132), formed across the thiocarbonyl ylide of (130), resulted in the formation of a dinitrile monoxide intermediate (133). When the thermolysis was carried out in the presence of a suitable dipolarophile, (131), DMAD or methylpropiolate, (133) was trapped as the corresponding 1,3-dipolar cyclo-adducts (134) as shown in Scheme 41.

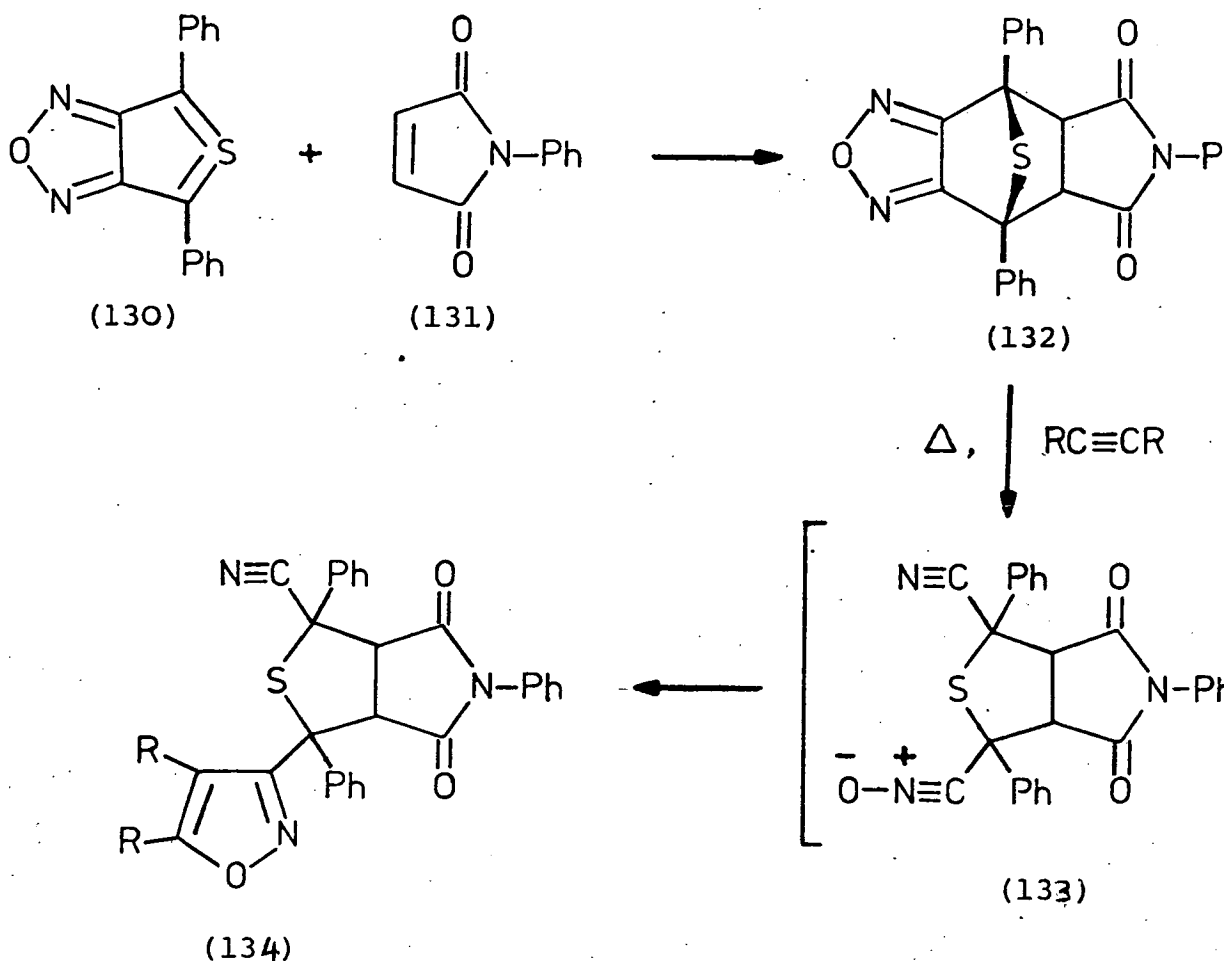

Scheme 41

4.

FLASH VACUUM PYROLYSIS

4.1 Apparatus and Technique

Flash vacuum pyrolysis (FVP) is a form of gas-phase thermolysis which is particularly suitable for the production and isolation of unstable reaction products. Although the technique had been applied in a few isolated cases, it is only recently that the potential of the method has been recognised and utilised in a systematic fashion.

FVP is governed by three important principles:-

- 1) The contact time, the time the substance to be pyrolysed remains in the hot zone is very short, typically between 10^{-3} and 10^{-1} s.
- 2) The steady-state concentration of reactants and consequently products in the reaction (hot) zone is kept to a minimum.
- 3) Immediately after passage through the hot zone the pyrolysate is cooled to very low temperature (e.g. -196°C) and thus protected from modification by subsequent reaction.

The short contact times and the low steady-state concentrations are achieved by arranging that the substance to be pyrolysed flows through a heated tube and is condensed in a cold trap as soon as it leaves the hot zone. Typically, the necessary flows can be achieved in two ways:- a vacuum is used, the substance being distilled into the reactor, or alternatively the compound to be pyrolysed is carried into the reactor in a stream of inert gas.

In line with the three basic principles the FVP apparatus must in principle consist of three components:- an inlet system, pyrolysis tube, and lastly a condensation region. The actual design of the apparatus is dependent, to some extent, on the particular problem in question. However, if the thermolysis products are relatively stable a simple apparatus in which the heating jacket is outside the vacuum system can be employed, thus facilitating simple construction and easy cleaning. Such a system is illustrated in Figure 9.

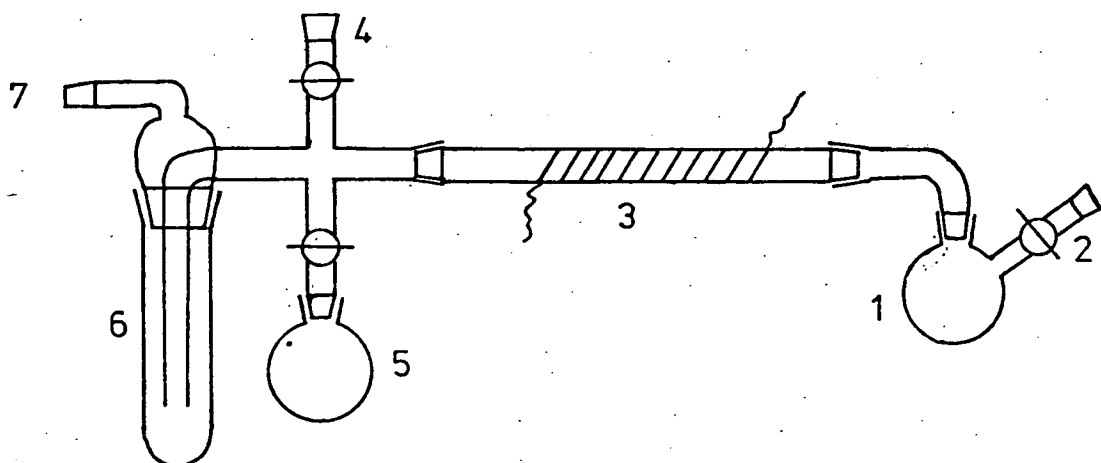

Fig. 9. 1, substance inlet vessel; 2, inert-gas inlet,
3, electrically heated quartz tube; 4, to
manometer; 5, solvent supply inlet; 6, cold trap;
7, to pump.

Many variations of this basic design have been successfully employed.¹³⁰ The contact time can be extended as desired by the addition of quartz wool or other filling material into the pyrolysis tube.

The main disadvantage of such an apparatus is the large distance between the hot zone and the cold trap making it unsuitable for the isolation of very reactive species e.g. radicals. Consequently a modified version has been designed¹³¹ in which the pyrolysis tube is heated within the vacuum system. This enables the distance between the hot zone and the cold trap to be very much reduced and allows the isolation of short lived reactive intermediates.¹³² A consequence of the short

contact times is that higher temperatures are generally required in FVP than in thermolyses effected in solution. For example whereas 1,2,3-benzothiadiazole in solution is completely cleaved at 200°C with evolution of N₂,¹³³ FVP with a contact time of 10⁻³ s required a temperature of 850°C for quantitative fission.¹³⁴ Use of these higher temperatures has led to the occasional contention¹³⁵ that FVP conditions are extremely severe. This has been shown not to be the case by the fact that an attempted distillation of phenyl azide at atmospheric pressure results in an explosion; whereas the azide is recovered largely unchanged after "pyrolysis" at 300°C and 10⁻² mm.¹³⁵

4.2 Applications of Flash Vacuum Pyrolysis

The applicability of the method to the preparation of reactive intermediates and thermally unstable products has been widely demonstrated.^{135,136} For example, the preparative advantage of FVP is clearly demonstrated by the thermolysis of 1,2,3-thiadiazoles (135). Flash thermolysis of (135) at 550°C leads directly to thioketenes (136)¹³⁶ a class of compounds that was, with few exceptions, previously unknown. Thermolysis in solution leads to secondary products derived from reactions of the thioketenes,¹³⁶ Scheme 42.

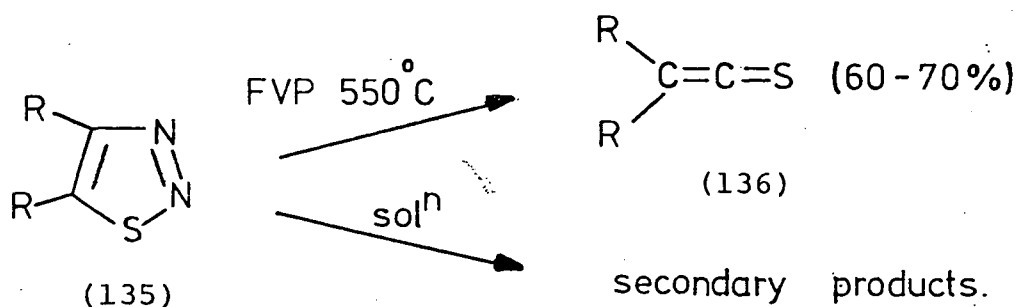

Scheme 42

Of particular interest, in the present context, are those examples where FVP of heterocycles yield 1,3-dipolar species.

Thermolysis and photolysis of 2,5-diaryltetrazoles is known to represent a facile route to nitrile imines.^{15,56} In 1976, Reichen¹³⁷ in a search for new heterocyclic precursors to nitrile imines discovered that FVP of disubstituted-1,3,4-oxadiazole-5-ones (137) at 450°C gave substituted indazoles (140). He postulated that the thermolysis proceeded with initial elimination of carbon dioxide to give the nitrile imine (138) which under the conditions used underwent an intramolecular electrophilic substitution, via the carbene resonance form of the nitrile imine (139), to give the indazole, Scheme 43.

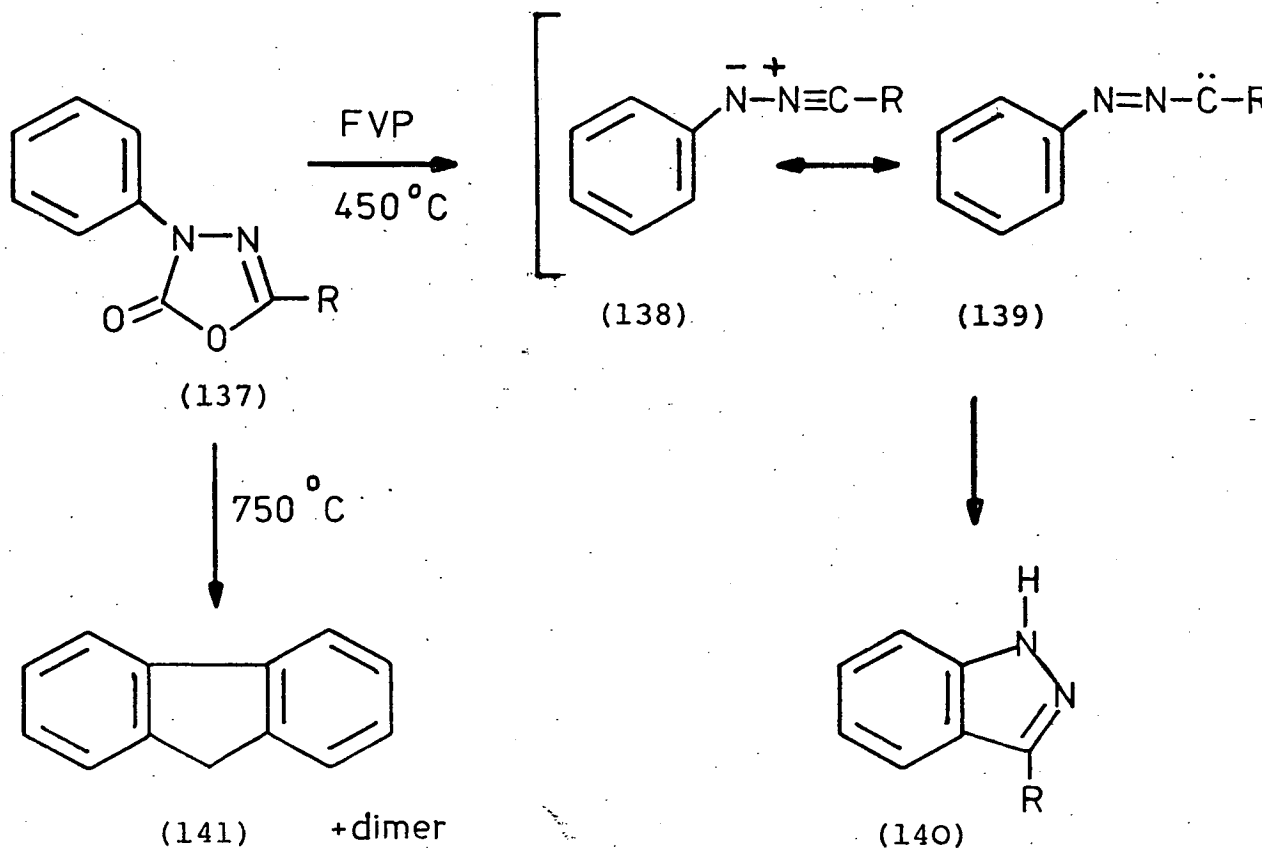

Scheme 43

At higher temperatures (750°C) nitrogen is also eliminated to give carbene derived products such as fluorene (141). It is interesting to note that under photolytic conditions the nitrile imine derived from (137) is trapped as a 1,3-dipolar cycloadduct (142) with acrylonitrile.^{137,138}

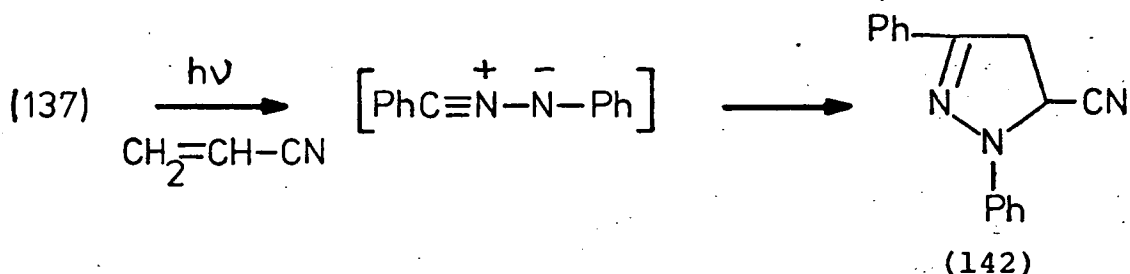

The only reported instance of a nitrile oxide being formed during the FVP of a heterocyclic compound is the somewhat surprising case of the FVP of a 2-isoxazoline (143).¹³⁹ 2-Isioxazolines, which are readily prepared by reaction of nitrile oxides with alkenes, are usually considered to be thermally stable compounds. However, under the conditions of FVP at 600-650°C, (143) gives a quantitative yield of 2,4,6-trimethylbenzonitrile oxide (144).

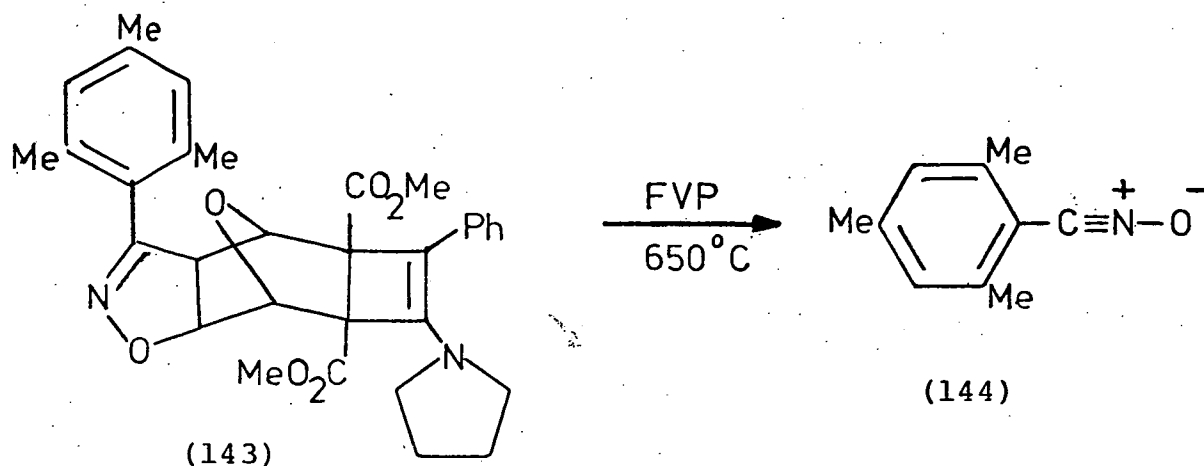

This is the only reported example and as such the thermolysis cannot be regarded as general for 2-isoxazolines.

EXPERIMENTAL

	<u>Page No.</u>
SYMBOLS AND ABBREVIATIONS	88
INSTRUMENTATION	89
SOLVENTS AND REAGENTS	93
1. PREPARATION OF FUROXANS	94
1.1 3,4-Diphenylfuroxan	94
1.2 3,4-Bis(4-methoxyphenyl) furoxan	94
1.3 3,4-Bis(4-methylphenyl) furoxan	95
1.4 3,4-Bis(4-chlorophenyl) furoxan	96
1.5 3,4-Dimethylfuroxan	96
1.6 3,4-Diethylfuroxan	97
2. PREPARATION OF FURAZANS	97
2.1 3,4-Tetramethylenefurazan	97
2.2 3,4-Dimethylfurazan	98
2.3 3,4-Bis(4-methoxyphenyl) furazan	98
2.4 3,4-Bis(4-methylphenyl) furazan	98
2.5 3,4-Diphenylfurazan	99
2.6 3,4-Decamethylenefurazan	99
2.7 3-Methyl-4-phenylfurazan	100
2.8 3-(4-Chlorophenyl)-4-phenylfurazan	101
2.9 3-(4-Methoxyphenyl)-4-phenylfurazan	103
2.10 Attempted Preparation of 3,4-Diphenylfurazan	104
3. PREPARATION OF 3,6-DISUBSTITUTED-1,4,2,5-DIOXADIAZINES	106
3.1 3,6-Diphenyl-1,4,2,5-dioxadiazine	106
3.2 3,6-(4-Methylphenyl)-1,4,2,5-dioxadiazine	107

4.	PREPARATION OF 2[H]-1,2,3- TRIAZOLE-1-OXIDES	107
4.1	2,4,5-Triphenyl-1,2,3-triazole- 1-oxide	107
4.2	4,5-Dimethyl-2-phenyl-1,2,3- triazole-1-oxide	109
5.	PREPARATION OF 4,5-DIMETHYL-2- PHENYL-1,2,3-TRIAZOLE	110
6.	PREPARATION OF AUTHENTIC ADDUCTS	110
6.1	2-Isoxazolines	110
6.1.1	5-Butyl-3-(4-methoxyphenyl)-2- isoxazoline	111
6.1.2	5-Dodecyl-3-(4-methoxyphenyl)- 2-isoxazoline	111
6.1.3	5-Dodecyl-3-phenyl-2-isoxazoline	112
6.1.4	3-(4-Chlorophenyl)-5-dodecyl-2- isoxazoline	112
6.1.5	trans-4,5-Dicarbethoxy-3-phenyl-2- isoxazoline	112
6.2	Urethanes, Ureas and Thioureas	113
6.2.1	Ethyl phenylaminoformate	113
6.2.2	<u>N</u> -Butyl- <u>N'</u> -phenylurea	113
6.2.3	<u>N,N'</u> -Diphenylthiourea	114
6.2.4	<u>N</u> -Benzoyl- <u>O</u> -methyl hydroxylamine	114
6.2.5	Methyl phenylaminoformate	115
7.	FLASH VACUUM PYROLYSIS (FVP) - APPARATUS AND GENERAL METHOD	116
8.	FVP OF 3,4-DISUBSTITUTED FUOXANS - GENERATION OF NITRILE OXIDES	118
8.1	Preparation of 2-Isoxazolines from the Cycloaddition of Nitrile Oxides to Alkenes.	118

	<u>Page No.</u>	
8.1.1	trans-4,5-Dicarbethoxy-3-phenyl-2-isoxazoline	118
8.1.2	5-Butyl-3-phenyl-2-isoxazoline	119
8.1.3	5-Butyl-3-(4-methoxyphenyl)-2-isoxazoline	119
8.1.4	5-Dodecyl-3-(4-methylphenyl)-2-isoxazoline	120
8.1.5	5-Butyl-3-(4-chlorophenyl)-2-isoxazoline	120
8.1.6	5-Butyl-3-methyl-2-isoxazoline	121
8.1.7	5-Butyl-3-ethyl-2-isoxazoline	121
8.2	Preparation of Isocyanates via the Reaction of Nitrile Oxides with Sulphur Dioxide	125
8.2.1	Phenyl isocyanate	126
8.2.2	4-Methylphenyl isocyanate	126
8.2.3	4-Methoxyphenyl isocyanate	127
8.2.4	Butyl isocyanate	128
8.2.5	Methyl isocyanate	128
8.2.6	Isolation of Acetohydroxamic Acid from the Hydrolysis of 5-Methyl-1,3,2,4-dioxathiazole-2-oxide	129
8.3	Generation of Phenyl Isocyanate from the FVP of 3,4-Diphenylfuroxan in the Absence of Sulphur Dioxide	130
8.3.1	FVP of Diphenylfuroxan at 550°C	130
8.3.2	FVP of Diphenylfuroxan at 700°C	130
8.3.3	FVP of Diphenylfuroxan at 800°C	131
8.4	Preparation of Phenyl Isothiocyanate via the Reaction of Benzonitrile Oxide with <u>N,N</u> -Dimethylthioformamide	131
9.	SPECTROSCOPIC EXAMINATION OF ALIPHATIC NITRILE OXIDES	133
9.1	Acetonitrile oxide	133
9.2	Propionitrile oxide	133

		<u>Page No.</u>
10.	DIMERISATION OF ACETONITRILE OXIDE TO 3,4-DIMETHYLFUROXAN	133
11.	THERMOLYSES OF 3,4-DISUBSTITUTED FURAZANS	137
11.1	Preparation of Nitriles and 2- Isoxazolines for the FVP of 3,4-Disubstituted Furazans	137
11.1.1	5-Butyl-3-Phenyl-2-isoxazoline	137
11.1.2	5-Butyl-3-(4-methoxyphenyl)-2- isoxazoline	138
11.1.3	5-Butyl-3-(4-methylphenyl)-2- isoxazoline	138
11.1.4	5-Butyl-3-methyl-2-isoxazoline	139
11.1.5	4-Cyanobutyl isocyanate	140
11.2	FVP of Unsymmetrical 3,4-Disub- stituted Furazans	140
11.2.1	FVP of 3-Methyl-4-phenylfurazan at 650°C	140
11.2.2	FVP of 3-(4-Chlorophenyl)-4- phenylfurazan at 600°C	141
11.2.3	FVP of 3-(4-Methoxyphenyl)-4- phenylfurazan at 600°C	141
11.3	Liquid Phase Thermolysis of Furazans	141
11.3.1	Thermolysis of 3,5-Diphenylfurazan in 1-Tetradecene	141
11.3.2	Thermolysis of 3,5-Tetramethylene- furazan in 4-Methoxybenzotrile	142
11.3.3	Thermolysis of 3,4-Decamethylene- furazan in 4-Methoxybenzotrile	143
12.	SYNTHESIS AND THERMOLYSIS OF 3,5-DIPHENYL- 1,2,4-OXADIAZOLE	144
12.1	Preparation of 3,5-Diphenyl-1,2,4- oxadiazole	144
12.2	Thermolysis 3,5-Diphenyl-1,2,4-oxadiazole in 1-Tetradecene	145
12.3	FVP of 3,5-Diphenyl-1,2,4-oxadiazole at 500°C onto 1-Tetradecene	145
12.4	FVP of 3,5-Diphenyl-1,2,4-oxadiazole at 600°C onto 1-Hexene	145

		<u>Page No.</u>
12.5	FVP of 3,5-Diphenyl-1,2,4-oxadiazole at 700°C onto 1-Hexene	146
12.6	FVP of 3,5-Diphenyl-1,2,4-oxadiazole at 800°C onto Methanol	147
13.	THERMOLYSIS OF 2[H]-1,2,3-TRIAZOLE-1-OXIDES	148
13.1	2,4,5-Triphenyl-1,2,3-triazole-1-oxide	148
13.1.1	Thermolysis in Toluene in the Presence of Diethyl Acetylene-dicarboxylate	148
13.1.2	Thermolysis in Xylene in the presence of Diethyl Fumarate	148
13.1.3	Thermolysis in 4-Methoxybenzotrile	148
13.1.4	FVP at 650°C	149
13.2	4,5-Dimethyl-1,2,3-triazole-1-oxide	149
13.2.1	Thermolysis in Benzene in the Presence of Diethyl Fumarate	149
13.2.2	FVP at 650°C	150
14.	FVP OF 3,6-DIARYL-1,4,2,5-DIOXADIAZINES	151
14.1	FVP of 3,6-Diphenyl-1,4,2,5-dioxadiazine at 600°C onto 1-Hexene	151
14.2	FVP of 3,6-Diphenyl-1,4,2,5-dioxadiazine at 600°C onto Thebaine	151
14.3	FVP of 3,6-Diphenyl-1,4,2,5-dioxadiazine at 600°C onto Benzene	152
14.4	FVP of 3,6-Diphenyl-1,4,2,5-dioxadiazine at 600°C onto Chloroform	153
14.5	FVP of 3,6-Diphenyl-1,4,2,5-dioxadiazine at 600°C onto benzene-d	153
14.6	FVP of 3,6-Diphenyl-1,4,2,5-dioxadiazine at 550°C onto Chloroform Examination of the Reaction Mixture by E.S.R. Spectroscopy	154
14.7	FVP of 3,6-Diphenyl-1,4,2,5-dioxadiazine at 400°C onto Chloroform	155

		<u>Page No.</u>
14.8	FVP of 3,6-Diphenyl-1,4,2,5-dioxadiazine at 800°C onto Chloroform	156
14.9	FVP of 3,6-Bis(4-methylphenyl)-1,4,2,5-dioxadiazine at 600°C onto Chloroform	156
14.10	FVP of 3,6-Diphenyl- and 3,6-Bis(4-methylphenyl)-1,4,2,5-dioxadiazines at 800°C onto Chloroform	157

SYMBOLS AND ABBREVIATIONS

b.p.	boiling point
m.p.	melting point
g.l.c.	gas liquid chromatography
t.l.c.	thin-layer chromatography
h.p.l.c.	high performance liquid chromatography
i.r.	infra-red
n.m.r.	nuclear magnetic resonance
e.s.r.	electron spin resonance
m.s.	mass spectrometry
m/e	mass/charge ratio
M ⁺	parent ion
q	quaternary

INSTRUMENTATION

Melting Points. Melting points of compounds were determined using a Kofler hot-stage apparatus and an Electrothermal apparatus.

Nuclear Magnetic Resonance Spectroscopy

(a) ^1H n.m.r. Routine spectra were recorded on a Varian EM360 spectrometer which operated at a frequency of 60 MHz. 100 MHz spectra were obtained using a Varian HA-100 spectrometer operated by Mr. J. Millar. 360 MHz spectra were recorded by Dr. I.H. Sadler using a Bruker WH 360 spectrometer. Chemical shifts (δ_{H}) were measured in parts per million relative to tetramethylsilane (TMS) as standard ($\delta = 0.0$).

(b) ^{13}C n.m.r. Spectra were generally recorded on a Varian CFT 20 spectrometer operated by J. Millar, and in a few cases, on a Varian XL-100 spectrometer operated by Dr. A. Boyd. Chemical shifts (δ_{C}) were measured in p.p.m. relative to TMS ($\delta = 0.0$).

Infra-red Spectroscopy

I.R. spectra were recorded on a Perkin-Elmer 157G Grating Spectrophotometer, liquid samples being examined as thin films and solid samples as nujol mulls (unless otherwise stated) or in solution.

Elemental Analysis

Microanalyses were carried out on a Perkin-Elmer Elemental Analyser 240 by Mr. J. Grunbaum.

Mass Spectroscopy

Mass spectra and exact masses were obtained on an AEI MS-902 double focussing mass spectrometer operated by Mr. D. Thomas. Reaction mixtures were analysed using a V.G. Micromass 12, single focussing mass spectrometer/gas chromatograph, using helium as the carrier gas. The instrument was operated by Miss O.F. Johnson.

Gas Liquid Chromatography

For analytical and quantitative g.l.c. investigations, Pye 104 and Perkin-Elmer F11 chromatographs, with flame ionisation detectors were used. Quantitative measurements were made following the technique of Hibbert¹⁴⁰ after calibration of the instrument with known mixtures of authentic samples and internal standards. All authentic samples and internal standards were purified before use. The carrier gas was nitrogen, the flow rates being as recommended by the manufacturers. The following stationary phases, supported on chromasorb G were employed; silicone grease (SE30) and (OV-1) and neopentylglycolsuccinate (NPGS).

High Performance Liquid Chromatography

Analytical and qualitative h.p.l.c. investigations were carried out using polished stainless steel columns (16 cm x 0.5 cm i.d.) packed with, (a) 5 micron Spherisorb silica, (b) 5 micron Spherisorb Alumina and (c) 5 micron octadecyl silicate (ODS-Hypersil) supplied by Shandon-Southern Ltd. These columns were then coupled to either a Cecil Instruments CE 12 U.V. monitor or a Chromatronix (3100) mixed wavelength detector. Quantitative measurements were made following the same procedure used for g.l.c. All authentic samples and internal standards were purified before use. Both straight phase and reverse phase h.p.l.c. were employed.

Straight Phase:- Alumina and silica columns were deactivated by pumping diethyl ether containing a known percentage of water through the columns. The alumina column was 25% H₂O saturated and the silica column 50% H₂O saturated.

All solvents used were mixtures of methylene chloride and hexane both of which required purification. Methylene chloride was purified by washing with 5% sodium carbonate, followed by water, dried over anhydrous calcium chloride, fractionated, and stored over molecular sieve (40 Å). To remove the U.V. absorbing impurities, the hexane was passed down an activated silica column. The desired h.p.l.c. solvent was made by mixing the desired percentages of methylene chloride and hexane. A portion of the resulting

solution was then stirred with distilled water for 12 h to 'water saturate' it. Depending on the column a given percentage was then added to the dry solvent to give 25% or 50% water saturated solvents which when degassed were ready for use.

Reverse Phase:- Solvents were prepared by simply mixing analar methanol and distilled water. The solvent was then refluxed for 1 h to ensure efficient degassing.

Column Chromatography

The alumina used for column chromatography was Laporte Industries Ltd., activated aluminium oxide, type H, (Brockmann activity = 1). This was deactivated by the addition of 5 wt % water (Brockmann activity = 2) before use.

Thin Layer Chromatography

Chromatograms were developed on 0.3 mm layers of alumina (Merck, Aluminium Oxide G) or silica gel (Merck, Silica Gel G) containing Woelm fluorescent green indicator (0.5%). Components of the chromatogram were detected by their quenching of fluorescence under U.V. light, or by their absorption of iodine.

Electron Spin Resonance Spectroscopy

The e.s.r. spectra were recorded on a Decca XI spectrometer, in conjunction with a Newport Instruments 8 inch magnet system, using 100 KHz modulation and an X-band Klystron. Spectral simulations were carried out using a modified version of Programme QCPE 83 obtained from Quantum Chemistry Program Exchange, Indiana University.

Measurements of splitting constants and g values were made by comparison with a saturated sodium carbonate solution of Fremy's salt (potassium nitrosodisulphonate) for which $a_N = 1.3091 \pm 0.0004 \text{ mT}^{141}$ and $g = 2.00550 \pm 0.00005^{142}$.

SOLVENTS AND REAGENTS

Diethyl ether was stored over sodium wire. Toluene and xylene were distilled and stored over sodium wire. Triethylamine was redistilled and stored over sodium hydroxide pellets. Aniline was refluxed with zinc dust for 1 h, distilled and stored in the dark under nitrogen. Pyridine was refluxed with potassium hydroxide for 30 min, distilled and stored over potassium hydroxide. 1-Hexene was redistilled and stored over molecular sieve. Triethyl phosphite was allowed to stand over sodium wire for 24 h, distilled and stored over molecular sieve.

Nitrosyl chloride was prepared by the method of Morton and Wilcox¹⁴³ by the action of hydrochloric acid on sodium nitrite. The gas was passed through towers containing sodium nitrite, potassium chloride and calcium chloride before being dissolved as a 30% w/v solution in ether and stored at -15°C .

1. PREPARATION OF FUROXANS

1.1 3,4-Diphenylfuroxan was prepared from diphenylglyoxime after the method of Boyer.¹⁴⁴ Diphenylglyoxime (10.0 g, 41.7 mmol) was dissolved in 4% aqueous sodium hydroxide (275 ml). Sodium hypochlorite (ca. 20 g) as a 10% w/v solution in water was added slowly and the furoxan precipitated from solution. The furoxan was extracted with methylene chloride, dried over calcium chloride, filtered and the solvent evaporated to leave a yellowish solid. Recrystallisation from ethanol gave 3,4-diphenylfuroxan (7.4 g, 75%) as white needles, m.p. 115-117°C (lit.,⁸¹ 117°C); ν_{\max} (nujol) 1595 cm^{-1} (C=N).

1.2 3,4-Bis(4-methoxyphenyl)furoxan was prepared from 4-methoxybenzaldehyde via the oxime and hydroximoyl chloride. 4-Methoxybenzaldoxime was prepared from the bisulphite addition compound after the method described by Vogel.¹⁴⁵ The oxime (88% yield) was collected as a white powder. Absence of a C=O absorption (1800-1600 cm^{-1}) indicated complete conversion to the oxime.

4-Methoxybenzohydroximoyl chloride was prepared by a similar method to that described by Kinney.¹⁴⁶ 4-Methoxybenzaldoxime (23.0 g, 0.15 mol) was dissolved in sodium dried ether (200 ml) and the solution cooled to -10°C. Nitrosyl chloride (20.0 g, 0.31 mol) as a 20% w/v solution in dry ether was added slowly. The reaction mixture was stirred at 0°C for 30 min and then for 1 h at room temperature. The solvent was evaporated and the product (15.0 g, 61%),

a yellow oil, was dissolved in chloroform and precipitated with petrol to yield 4-methoxybenzohydroximoyl chloride as a white solid, m.p. 89-90°C (lit.,¹⁴⁶ 88-89°C).

3,4-Bis(4-methoxyphenyl)furoxan. 4-Methoxybenzohydroximoyl chloride (4.0 g, 24.8 mmol) in ether (200 ml) was stirred vigorously with a saturated solution of sodium carbonate (excess) for 36 h. The ether layer was separated and the aqueous layer extracted with ether (2 x 50 ml), the combined extracts being dried over calcium chloride. The ether solution was filtered and the solvent evaporated to leave the product (3.0 g, 81%), a yellow solid, which was recrystallised as white needles from ethanol, m.p. 111°C (lit.,¹⁴⁶ 112°C); ν_{\max} (nujol) 1590 cm^{-1} (C=N).

1.3 3,4-Bis(4-methylphenyl)furoxan was prepared in similar fashion from 4-methylbenzaldoxime via the hydroximoyl chloride. 4-Methylbenzohydroximoyl chloride was prepared by the action of nitrosyl chloride on the oxime, as above. The product (62%) was isolated as white crystals from a chloroform/pentane mixture, m.p. 68-69°C (lit.,²⁸ 69-70°C).

3,4-Bis(4-methylphenyl)furoxan was formed from the reaction of 4-methylbenzohydroximoyl chloride with excess saturated sodium carbonate at ambient temperature after 15 h. The product (70%) was isolated as white needles from methanol, m.p. 141-143°C (lit.,²⁸ 143-145°C); ν_{\max} (nujol) 1590 cm^{-1} (C=N); δH (CDCl_3); 2.38 (3H, s, CH_3), 2.39 (3H, s, CH_3) and 7.1-7.5 (8H, AB, ArH).

1.4 3,4-Bis(4-chlorophenyl)furoxan

4-Chlorobenzohydroximoyl chloride was prepared by the above method; the product (77%) was isolated as white needles from chloroform/pet-ether (40-60), m.p. 78-81°C (lit.,⁵¹ 82-83°C).

3,4-Bis(4-chlorophenyl)furoxan. 4-Chlorobenzohydroximoyl chloride (3.0 g, 0.016 mol) was dissolved in sodium dried ether (30 ml). The resulting solution was cooled to -10°C and triethylamine (1.6 g, 0.016 mol) added. The reaction mixture was stirred for 12 h and the triethylamine hydrochloride removed by filtration. The ether was evaporated to leave the product (2.1 g, 88%); a white solid, which was recrystallised from ethanol to give white needles, m.p. 145-146°C (lit.,⁵¹ 145°C); ν_{\max} (nujol) 1590 cm^{-1} (C=N).

1.5 3,4-Dimethylfuroxan was prepared by an analogous method to that described by Mukaiyama.³⁷ To an ice cooled solution of phenyl isocyanate (70.0 g, 0.59 mol) and nitroethane (22.0 g, 0.29 mol) in sodium dried toluene (400 ml) triethylamine (10 drops) was added. The reaction mixture was stirred under dry nitrogen for 2h, refluxed for 2h and allowed to stand for 12 h. The diphenylurea (35 g) formed in the reaction was separated by filtration and the toluene was evaporated from the filtrate to leave a red oil. Distillation afforded a yellow oil, 3,4-dimethylfuroxan (10.0 g, 68%), b.p. 68°C/0.4 mmHg (lit.,³⁷ 107-108°C/ 5 mmHg); ν_{\max} (liquid) 1610 cm^{-1} (C=N); $\delta\text{H}(\text{CDCl}_3)$: 2.21 (3H, s, CH₃), 2.40 (3H, s, CH₃).

1.6 3,4-Diethylfuroxan was prepared by the above method from 1-nitropropane. Distillation gave the product, a yellow oil (40% yield), b.p. 60°C/0.3 mmHg (lit.¹⁰¹ 66-67°C/0.1 mmHg); ν_{\max} (liquid) 1600 cm^{-1} (C=N); $\delta\text{H}(\text{CDCl}_3)$: 0.90-1.20 (6H, d of t, J 7.5 Hz, 2 x CH₃), 2.62 (2H, sextet, J 7.5 Hz, 2 x CH₂).

2. PREPARATION OF FURAZANS

The furazans synthesised were prepared via one of the following two methods.

1) Dehydration of the glyoxime with thionyl chloride after the method of Boulton.¹¹⁹

2) Deoxygenation of the furoxan with triethylphosphite after the method of Mukaiyama.¹²⁰

In addition to the usual analytical evidence, confirmation of the structure of the furazans was established by ¹³C n.m.r. spectroscopy (Table 1).

2.1 3,4-Tetramethylenefurazan was prepared from the glyoxime via method (1). Cyclohexane-1,2-dione dioxime (5.0 g, 0.04 mol) was suspended in dry methylene chloride (50 ml). Thionyl chloride (4.2 g, 0.04 mol) was added and the mixture stirred for 24 h. The reaction mixture was then poured onto crushed ice and extracted with methylene chloride, dried over magnesium sulphate, and the solvent removed to leave a red oil. The red oil was applied to an alumina column and elution with methylene chloride gave 3,4-tetramethylenefurazan (2.28 g, 53%)

which was collected as platelets from n-pentane, m.p. 18-19°C (lit.⁹⁷ 20.5°C); ν_{\max} (liquid) 1588 cm^{-1} (C=N); m/e (%) 124 (86, M^+), 107 (36), 97 (39), 94 (46), 70 (64), 67 (96), 41 (100).

2.2 3,4-Dimethylfuran was prepared from dimethylglyoxime as above. The product was collected as a colourless oil (52%), b.p. 56°C/18 mmHg (lit.,¹¹⁶ 154-159°C/760 mmHg); ν_{\max} (liquid) 1590 cm^{-1} (C=N); m/e 98 (M^+), 57 ($\text{M}^+ - \text{CH}_3\text{CNO}$).

2.3 3,4-Bis(4-methoxyphenyl)furan was prepared from the furoxan via method (2). A mixture of 3,4-bis(4-methoxyphenyl)furoxan (1.2 g 3.82 mmol) and triethyl phosphite (10 ml) was heated at 160-170°C under nitrogen for 12 h. The excess triethyl phosphite and the triethyl phosphate formed in the reaction were removed by vacuum distillation to leave a white solid. The furan (1.0 g, 93%) was isolated as white crystals from ethanol, m.p. 125-127°C (Found: C, 67.9; H, 4.9; N, 9.9. $\text{C}_{16}\text{H}_{14}\text{N}_2\text{O}_3$ requires C, 68.1; H, 5.0; N, 9.9%); ν_{\max} (nujol) 1612 cm^{-1} (C=N); δH (CDCl_3): 3.81 (6H, s, OCH_3); 6.80-7.60 (8H, AB, ArH); m/e (%) 283 (20), 282 (100, M^+), 252 (40), 149 (55, $\text{CH}_3\text{OC}_6\text{H}_4\text{CNO}$), 126 (17), 119 (15), 106 (10).

2.4 3,4-Bis(4-methylphenyl)furan was prepared via method (2). A mixture of 3,4-bis(4-methylphenyl)furoxan

(2.0 g, 7.5 mmol) and triethyl phosphite were refluxed under nitrogen for 12 h. The excess triethyl phosphite and triethyl phosphate formed in the reaction were removed by vacuum distillation to leave a white solid. The furazan (1.1 g, 60%) was isolated as white crystals from ethanol, m.p. 92-94°C (Found: C, 76.85; H, 5.7; N, 11.2).

$C_{16}H_{14}N_2O$ requires C, 76.8; H, 5.6; N, 11.2%; m/e (%) 250 (100, M^+), 220 (74). 133 (89, MeC_6H_4CNO), 103 (46), 77 (31); $\delta H(CHCl_3)$: 2.38 (6H, s, CH_3); 7.08-7.55 (8H, AB, ArH).

2.5 3,4-Diphenylfurazan was prepared via method (2). The product (90%) was isolated as white platelets from methanol, m.p. 95-97°C (lit.,¹²³ 98°C).

2.6 3,4-Decamethylenefurazan was prepared via method (2). After refluxing for 12 h, the solution was cooled and poured onto crushed ice, a few drops of 2M hydrochloric acid added and the mixture was allowed to stand for 12 h. The reaction mixture was extracted with petrol (40-60), dried over anhydrous magnesium sulphate and the solvent evaporated to leave a colourless oil. The oil was applied to an alumina column, which on elution with petrol, afforded a white solid. T.l.c. (Al_2O_3 ; pentane) of the white solid showed it to consist of two components. Distillation of the solid under vacuum gave the product (79% yield), a white solid, m.p. 43-44°C; (Found: C, 69.2; H, 9.9; N, 13.2). $C_{12}H_{20}N_2O$ requires C, 69.2; H, 9.6; N, 13.4%.

2.7 3-Methyl-4-phenylfuran

3-Methyl-4-phenylfuran was synthesised from phenylacetone via methylphenylglyoxime with subsequent dehydration to the furoxans and deoxygenation to the furazan.

Methylphenylglyoxime. . α -Acetylbenzaldoxime (Ph.C(NOH).

CO.CH₃, 23.0 g, 0.14 mol), prepared from phenylacetone and amyl nitrite,⁹⁴ was dissolved in a solution of sodium

hydroxide (11.2 g, 0.28 mol) in water (100 ml). Hydroxylamine hydrochloride (20.0 g, 0.29 mol) was added slowly.

The mixture was heated on a steam bath for 1 h and allowed to stand for 3 h. The product (15.6 g, 63%), which precipitated out of solution, was isolated as a white powder from ethanol, m.p. 236-239°C (lit.,¹⁴⁷ 238-239°C). Absence of a C=O absorption (1800-1600 cm⁻¹) indicated complete conversion to the dioxime.

Methylphenylfuroxans were prepared from methylphenylglyoxime after the method of Ponzio.¹⁴⁷ The product, an isomeric mixture, was isolated as a yellow solid (94%). 3-Methyl-4-phenylfuroxan (41%) was collected as white crystals from ethanol, m.p. 91-92°C (lit.,¹⁴⁷ 96°C); δ H(CDCl₃): 2.31 (3H, s, CH₃); 7.40-7.60 (5H, m, ArH); δ C(CDCl₃): 8.8 (-CH₃); 111.8, 126.3, 127.0, 128.9 (Aromatic C); 130.7, 156.6 (furoxan ring C).

3-Methyl-4-phenylfuran was prepared from 3-methyl-4-phenylfuroxan via method (2), the reaction mixture being refluxed under nitrogen for 24 h. The crude product was purified by column chromatography (alumina, pet.-ether (40-60)) and by vacuum distillation. The product was

isolated as a colourless oil (94%), b.p. $65^{\circ}\text{C}/0.1\text{ mmHg}$ (lit.,¹⁴⁸ $145^{\circ}\text{C}/16\text{ mmHg}$); ν_{max} (liquid) 1590 cm^{-1} (C=N); $\delta\text{H}(\text{CDCl}_3)$: 2.43 (3H, s, $-\text{CH}_3$); 7.32-7.73 (5H, m, ArH).

3-(4-Chlorophenyl)-4-phenylfuran and 3-(4-methoxyphenyl)-4-phenylfuran were synthesised from the acid chlorides via the Friedel-Crafts acylation and subsequent conversion of the ketone to the dioxime. The dioxime was dehydrogenated and the resulting furoxan deoxygenated to yield the furazan.

2.8 3-(4-Chlorophenyl)-4-phenylfuran

4-Chlorophenylacetyl chloride. A mixture of 4-chlorophenylacetic acid (34.0 g, 0.20 mol) and thionyl chloride (150 ml) was heated at reflux (77°C) for 1 h. The excess thionyl chloride was removed by evaporation under reduced pressure to leave the product, a red oil, (34.0 g, 90%), ν_{max} (liquid) ca. 1800 cm^{-1} (C=O acid chloride). Complete conversion to the acid chloride was indicated by the absence of the carboxylic acid carbonyl peak at 1700 cm^{-1} .

4-Chlorobenzyl phenyl ketone was prepared from 4-chlorophenylacetyl chloride and benzene via the Friedel-Crafts acylation after the method of Vogel.¹⁴⁵ The product (90%) was collected as white platelets from ethanol, m.p. $139-140^{\circ}\text{C}$ (lit.,¹⁴⁹ 133°C); ν_{max} (nujol) 1682 cm^{-1} (C=O).

4-Chloro-benzil-7-oxime. Sodium (1.0 g, 43.3 mmol) was added to absolute ethanol (500 ml). The solution was cooled to -10°C and 4-chlorobenzyl phenyl ketone (10.0 g, 43.3 mmol) was slowly added, the temperature of the solution was maintained at 0°C . Amyl nitrite (5.1 g, 43.4 mmol) was added over a period of $1\frac{1}{2}$ h and the mixture allowed to stand

for 2 days. The solvent was evaporated under reduced pressure and the residue dissolved in water (250 ml), acidified with 2M hydrochloric acid and the resulting precipitate collected by filtration. The brown solid was taken up in diethyl ether and precipitated with pet.-ether (40-60) to give the monoxime (6.0 g, 53%). The oxime was isolated as a white powder by recrystallisation from an ethanol/water mixture (2:1), ν_{\max} 1642 (C=O); 3390 cm^{-1} (O-H); m/e 261,259 (M^+).

4-Chlorobenzil dioxime. 4-Chlorobenzil-7-oxime (4.0 g, 0.016 mol) was dissolved in a solution of sodium hydroxide (2.0 g, 0.05 mol) in water (150 ml). Hydroxylamine hydrochloride (2.2 g, 0.032 mol) was added and the reaction mixture was heated on a steam bath for 1 h and allowed to stand for 60 h. A white solid, which had precipitated out of solution, was collected by filtration, the filtrate concentrated, cooled and a second batch of solid collected. The identity of the product (3.5 g, 82%) was confirmed by i.r. and m.s. ν_{\max} (nujol) 3250 cm^{-1} (OH); no C=O absorption 1600-1800 cm^{-1} . m/e 276,274 (M^+).

Mixture of (4-chlorophenyl)-phenylfuroxans. 4-Chlorobenzil dioxime (2.0 g, 7.29 mmol) was dissolved in a solution of sodium hydroxide (1.0 g, 25 mmol) in water (50 mls). The solution was cooled to -10°C and toluene (20 ml) added. Sodium hypochlorite (ca. 5 g) as a 10% w/v solution in water was added dropwise and the reaction mixture stirred overnight. The organic layer was separated, dried over calcium chloride, filtered and the solvent removed to leave

the product (1.8 g, 91%), which was isolated as yellow crystals by recrystallisation from a methanol/water mixture. On examination of the product by h.p.l.c. on a silica column (20% H₂O saturated) eluting with 20% methylene chloride/80% n-hexane (20% H₂O saturated) two peaks, attributable to the isomeric furoxans were observed, ν_{\max} (nujol) 1595 cm⁻¹ (C=N); m/e 274, 272 (M⁺).

3-(4-Chlorophenyl)-4-phenylfuran was prepared via method (2), the reaction mixture being refluxed, under nitrogen, for 12 h. The isomeric mixture of furoxans (1.5 g, 5.51 mmol) gave the product (1.3 g, 92%) as white needles m.p. 94-96°C from an ethanol/water mixture (92% recovery); (Found: C, 65.7; H, 3.6; N, 11.0 C₁₄H₉ClN₂O₂ requires C, 65.5; H, 3.5; N, 10.9%); ν_{\max} (nujol) 1600 cm⁻¹ (C=N); m/e (%) 258 (14, M+2), 256 (100, M⁺), 226 (60), 153 (18, Cl.C₆H₄CNO), 123 (11), 118 (11), 89 (20), 63 (10).

2.9 3-(4-Methoxyphenyl)-4-phenylfuran

4-Methoxyphenyl benzyl ketone was prepared from anisole and phenylacetyl chloride via the Friedel-Crafts acylation after the method of Vogel.¹⁴⁵ The product (68%) was isolated as white platelets from ethanol, m.p. 73-74°C (lit.,¹⁵⁰ 76°C); ν_{\max} (nujol) 1679 cm⁻¹ (C=O).

4'-Methoxy-benzil-7-oxime was prepared by the action of amyl nitrite on 4-methoxyphenyl benzyl ketone by the method outlined above. The identity of the monoxime (99%) was confirmed by i.r. and m.s.; ν_{\max} (nujol) 1690 (C=O), 3225 cm⁻¹ (O-H); m/e 255 (M⁺).

4-Methoxybenzil dioxime was prepared by a similar method to that for 4-chlorobenzil dioxime. The product (72%) was collected as a white powder. The dioxime was identified from its infra-red and mass spectra; ν_{\max} (nujol) 3260 cm^{-1} (OH); no C=O absorption at 1690 cm^{-1} ; m/e 270 (M^+).

The isomeric mixture of (4-methoxyphenyl)-phenylfuroxans were prepared by a similar method to that used for the (4-chlorophenyl)-phenylfuroxans. The product (89%) was isolated as white crystals from a methanol/water mixture. On examination of the product by h.p.l.c. (Silica column, 20% CH_2Cl_2 /80% C_6H_{14} (20% H_2O saturated)) two peaks attributable to the furoxans were observed; ν_{\max} (nujol) 1585 cm^{-1} (C=N); m/e 268 (M^+), 208 ($\text{CH}_3\text{O.C}_6\text{H}_4\text{C.CC}_6\text{H}_5$).

3-(4-Methoxyphenyl)-4-phenylfurazan was prepared via method 2, the reaction mixture being refluxed for 12 h. The product (90%) was collected as white crystals from ethanol, m.p. $78-79^\circ\text{C}$ (lit.,⁸⁴ 80°C); $\delta\text{H}(\text{CDCl}_3)$: 3.81 (3H, s, OCH_3); 6.80-7.65 (9H, m, ArH); m/e 252 (M^+), 222, 149 (M^+ , $\text{CH}_3\text{O-C}_6\text{H}_4\text{-CNO}$).

2.10. Attempted Preparation of 3,4-Diphenylfurazan via Method (1)

Diphenylglyoxime (5.0 g, 0.02 mol) was suspended in dry methylene chloride (30 ml). Thionyl chloride (2.4 g, 0.02 mol) was added slowly and the mixture stirred, at room temperature, for 24 h. The reaction mixture was poured onto crushed ice and extracted with methylene chloride.

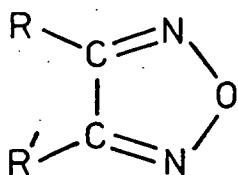
Table 1. ^{13}C NMR of 3,4-Disubstituted Furazans

R, R'	Oxadiazole Ring Carbons	R, R'
R=R'=C ₆ H ₅	153.1	125.9; 128.9; 130.4.
R=R'=pCH ₃ O.C ₆ H ₄	152.45	55.1(OCH ₃); 114.2; 117.9; 130.05; 161.0
R=R'=pCH ₃ .C ₆ H ₄	152.8	21.2(CH ₃); 122.8; 128.5; 129.4; 140.4
R=C ₆ H ₅	152.6(C ₃)	55.2(OCH ₃); 114.3; 117.7; 125.9; 128.7;
R'=pCH ₃ O.C ₆ H ₄	152.8(C ₄)	129.1; 129.6; 130.1; 161.15
R=C ₆ H ₅	152.0(C ₃)	124.2; 125.4; 128.7; 129.15; 130.0;
R'=pCl-C ₆ H ₄	152.8(C ₄)	130.5; 136.7;
R=C ₆ H ₅	149.4(C ₃)	9.4(CH ₃); 125.9; 127.8; 128.9; 130.2.
R'=CH ₃	153.6(C ₄)	
R=R'=CH ₃	151.65	8.0
-(CH ₂) ₄ -	151.65	20.25; 22.25.
-(CH ₂) ₁₀ -	154.7	20.1; 23.3; 24.7; 25.3; 26.9.

On evaporation of the solvent a yellow solid was collected; this was purified by column chromatography (Al_2O_3 ; ether: petrol (1:10)). 3,5-Diphenyl-1,2,4-oxadiazole (3.8 g, 85%) was isolated as white needles from ethanol, m.p. $97-98^\circ\text{C}$ (lit.,¹⁶⁵ 108°C); δC (CDCl_3): 175.6, 168.9 (q, oxadiazole ring C); 132.6, 131.1, 129.0, 128.8, 128.1, 127.5 (aromatic CH); 127.0, 124.3 (q, aromatic C); m/e 222 (M^+ , 119 (M^+ , PhCNO^+)).

3. PREPARATION OF 1,4,2,5-DIOXADIAZINES

3,6-Diphenyl, and 3,6-bis(4-methylphenyl)-1,4,2,5-dioxadiazines were synthesised using a similar method to that described by De Sarlo.⁵⁷

3.1 3,6-Diphenyl-1,4,2,5-dioxadiazine

Benzohydroximoyl chloride (5.0 g, 0.032 mol) was dissolved in sodium dried ether (100 ml) and the solution cooled by placing the flask in a bowl of crushed CO_2 . A solution of triethylamine (3.25 g 0.032 mol) in ether (50 ml) was added slowly. Triethylamine hydrochloride precipitated almost immediately and was removed by filtration, care being taken to keep the filtrate cold. The ether was then removed under reduced pressure, keeping the flask cold, to leave a white solid, benzonitrile oxide. ν_{max} (ethanol) 2270 cm^{-1} ($-\text{C}\equiv\text{N}^+-\text{O}^-$).²¹ The benzonitrile oxide was dissolved in cold ethanol (200 ml) and an ethanolic solution of pyridine (14.0 g in 100 ml) was added. The solution, which

turned yellow, was stirred for 2 h and allowed to stand overnight. The volume of the solution was reduced and the resulting precipitate collected by filtration.

Recrystallisation from ethanol afforded 3,6-diphenyl-1,4,2,5-dioxadiazine (3.1 g, 81%) as white needles, m.p. 98-100°C (decomp.) (lit.,⁵⁷ 100-101°C, decomp.);

ν_{\max} (nujol): 1338 (C-O-N.as.); 1615 cm^{-1} (C=N);

$\delta\text{C}(\text{CDCl}_3)$: 125.5, 127.1, 128.6, 132.6 (Aromatic C);

162.4 (dioxadiazine ring C); m/e 238 (M^+), 105, 103 (PhCN).

The absence of diphenylfuroxan was confirmed by h.p.l.c.

(alumina column, 20% CH_2Cl_2 /80% C_6H_{14} (25% H_2O saturated)).

3.2 3,6-Bis(4-Methylphenyl)-1,4,2,5-dioxadiazine

3,6-Bis(4-methylphenyl)-1,4,2,5-dioxadiazine was prepared in like manner from 4-methylbenzohydroximoyl chloride in 68% yield, m.p. 167-168°C (decomp) (lit.,⁵⁷ 167-168°C (decomp)); ν_{\max} (nujol) 1340 (C-O-N as), 1610 cm^{-1} (C=N); $\delta\text{C}(\text{CDCl}_3)$: 21.5 (CH_3); 122.7 (q); 127.1, 129.3, 143.25 (q aromatic C); 162.7 (dioxadiazine ring C). The absence of the furoxan was established by h.p.l.c., as above.

4. PREPARATION OF 2[H]-1,2,3-TRIAZOLE-1-OXIDES

4.1 2,4,5-Triphenyl-1,2,3-triazole-1-oxide

α -Benzilmonoxime was prepared from benzil after the method described by Vogel.¹⁴⁵ The product (81%) was isolated as a white powder, m.p. 130-132°C (lit.,¹⁵¹ 137°C); ν_{\max} (nujol) 1650 (C=O); 3390 (OH) cm^{-1} ; m/e 225 (M^+).

Benzil monoxime phenylhydrazone was prepared by a similar method to that described by Geigy.¹⁵² Phenylhydrazine (3.8 g, 0.035 mol) in ethanol (25 ml) was added dropwise to a solution of α -benzil monoxime (8.0 g; 0.035 mol) in ethanol (50 ml) over a period of 15 min. The reaction mixture was acidified with a 50:50 acetic acid/water mixture (20 ml), stirred at 50°C for 2 h and left to stand overnight. The solvent was removed to leave a red gum which after successive triturations with petrol (60-80) gave the product (61%), a yellowish solid, m.p. 168-170°C (lit.,¹⁵¹ 173-174°C). The oxime-hydrazone was confirmed by the absence of a C=O absorption in the i.r., and by m.s., m/e 315 (M^+).

2,4,5-Triphenyl-1,2,3-triazole-1-oxide was prepared after the method of Geigy.¹⁵² To a solution of benzil monoxime phenylhydrazone (5.0 g, 0.016 mol) in pyridine (100 ml), copper sulphate (10 g, 0.040 mol) in water (70 ml) was added over 1 h. The reaction mixture was refluxed for 1½ h, cooled, and poured over crushed ice; the resulting solid was extracted with toluene and dried over calcium chloride. The calcium chloride was filtered off and the toluene evaporated to leave the product (2.2 g, 44%) which was dissolved in ethanol and refluxed with charcoal for ½ h and finally recrystallised from ethanol, m.p. 167°C (lit.,¹⁵³ 169°C); ν_{\max} (nujol) 1590 cm^{-1} (C=N) (Found: C, 76.5; H, 4.9; N, 13.3. $\text{C}_{20}\text{H}_{15}\text{N}_3\text{O}$ requires C, 76.7; H, 4.8; N, 13.4%).

(Note: In repeated preparations of the above compound the 'red gum' formed in the preparation of benzilmonooxime phenyl hydrazone was used without further purification.)

4.2 4,5-Dimethyl-2-phenyl-1,2,3-triazole-1-oxide

Diacetyl monoxime phenylhydrazone was prepared from diacetyl monoxime by the above method; the product (84%) was isolated as yellow platelets, from ethanol, m.p. 154-156°C (lit.,¹⁵⁴ 158°C). Absence of C=O absorption in the i.r. confirmed complete conversion to the hydrazone. 4,5-Dimethyl-2-phenyl-1,2,3-triazole-1-oxide was prepared after the method of Geigy.¹⁵² To a solution of diacetyl monoxime phenylhydrazone (9.6 g, 0.050 mol) in pyridine (150 ml), copper sulphate (25 g, 0.10 mol) in water (250 mls) was added over 1½ h. The reaction mixture was refluxed for 1½ h, cooled and poured over ice. The resulting solid was extracted with methylene chloride, washed with water and dried over calcium chloride. The methylene chloride was evaporated and the resulting red solid was applied to an alumina column, which on elution with methylene chloride gave the product (6.7 g, 71%) as a yellow solid. The product was dissolved in ethanol, refluxed with decolourising charcoal and finally recrystallised from ethanol as white needles, m.p. 87-89°C (lit.,¹⁵⁵ 92-93°C), ν_{\max} (nujol) 1595 (C=N) cm^{-1} ; $\delta\text{C}(\text{CDCl}_3)$: 7.6, 11.65, (2 x CH_3); 122.6, 124.5 (q); 128.4, 129.0 (aromatic C's); 135.5 (q); 141.3(q). (Triazole-1-oxide ring C's); m/e 189 (M^+); strong peaks at 173 (M^+ , triazole) and 132 (M^+ , CH_3CNNPh).

5. PREPARATION OF 4,5-DIMETHYL-2-PHENYL-1,2,3-TRIAZOLE

4,5-Dimethyl-2-phenyl-1,2,3-triazole-1-oxide (20 g, 10.58 mmol) and triethyl phosphite (10 ml) were refluxed under dry nitrogen. The deoxygenation was monitored by h.p.l.c. (ODS silica column; methanol/water (70:30)) and the reaction stopped after 9 h when nearly all the triazole-N-oxide had been consumed. The excess triethyl phosphite was removed by vacuum distillation and the residue poured over crushed ice. A few drops of dilute hydrochloric acid were added and the ice allowed to melt. The mixture was extracted with ether and dried over anhydrous calcium chloride. A yellow oil was isolated, after removal of the solvent, and was purified by column chromatography (Al_2O_3 ; CH_2Cl_2) and vacuum distillation ($75^\circ\text{C}/0.01$ mmHg) to yield a white solid, 4,5-dimethyl-2-phenyl-1,2,3-triazole (77%) m.p. $33-35^\circ\text{C}$ (lit., ¹⁵⁵ $34-35^\circ\text{C}$). $\delta\text{H}(\text{CDCl}_3)$: 2.25 (6H, s, 2CH_3); 7.15-7.95 (5H, m, ArH); $\delta\text{C}(\text{CDCl}_3)$: 9.7 (2CH_3); 117.8, 126.2, 128.9, 139.7 (ArC); 143.5 (triazole ring C); m/e 173 (M^+), other peaks at m/e 182 and 91.

6. PREPARATION OF AUTHENTIC ADDUCTS

6.1 2-Isoxazolines

The isoxazolines were prepared from the cycloaddition of the corresponding alkenes to the nitrile oxide generated in situ from the corresponding hydroximoyl chloride, either by treatment with bases at or below room temperature, or by

thermal dehydrochlorination. In addition to the usual analytical evidence the structure of the 2-isoxazolines was confirmed by ^1H and ^{13}C n.m.r. (Tables 2 and 3).

6.1.1 5-Butyl-3-(4-methoxyphenyl)-2-isoxazoline

4-Methoxybenzohydroximoyl chloride (2.0 g, 10.78 mmol) and 1-hexene were dissolved in sodium dried xylene (70 ml) and the reaction mixture heated to reflux (140°C). After 48 h evolution of the hydrogen chloride had ceased and the solvent was evaporated to leave the product (2.4 g, 95%), a brown solid, which was dissolved in chloroform and refluxed with decolourising charcoal for 0.5 h. The chloroform was evaporated under reduced pressure and 5-butyl-3-(4-methoxyphenyl)-2-isoxazoline was isolated as white platelets, m.p. $82-84^\circ\text{C}$, from ethanol/water (70:30) (71% recovered). (Found: C, 71.9; H, 8.3; N, 6.0.

$\text{C}_{14}\text{H}_{19}\text{NO}_2$ requires C, 72.1; H, 8.2; N, 6.0%). ν_{max} (nujol) 1598, 1610 cm^{-1} ; m/e (%) 234 (15), 233 (87, M^+), 177 (12), 176 (100), 148 (12), 147 (11), 134 (12), 133 (19), 121 (31), 92 (12), 76 (19).

6.1.2 5-Dodecyl-3-(4-methoxyphenyl)-2-isoxazoline

4-Methoxybenzohydroximoyl chloride (0.70 g, 3.77 mmol) was dissolved in a solution of 1-tetradecene (2.0 g, 10.20 mmol) in sodium dried ether at -15°C . Triethylamine (0.41 g, 3.77 mmol) was added and the reaction mixture stirred for 24 h. The triethylamine hydrochloride, formed during the reaction, was filtered off and the ether evaporated to leave a viscous oil. The oil was applied to an alumina column which on elution with petrol gave the unreacted tetradecene and the

product (0.82 g, 63%), a white solid. 5-Dodecyl-3-(4-methoxy-phenyl)-2-isoxazoline was isolated as white platelets, m.p. 97-98°C, from ethanol water (70:30) (63% recovered). (Found: C, 76.6; H, 9.8; N, 4.0. $C_{22}H_{35}NO_2$ requires C, 76.5; H, 10.15; N, 4.1%).

6.1.3 5-Dodecyl-3-phenyl-2-isoxazoline was prepared by the above method. The triethylamine hydrochloride was extracted with water, and ether layer being dried over calcium chloride. The drying agent was filtered off and the ether evaporated to leave the product (89% yield), which was isolated as white platelets from ethanol, m.p. 69-71°C (lit.,¹⁰⁷ 69-70°C).

6.1.4 3-(4-Chlorophenyl)-5-dodecyl-2-isoxazoline was prepared by the above method. The product was applied to an alumina column which, on elution with petrol, gave the excess unreacted tetradecene and the product (78%), a white solid. 3-(4-Chlorophenyl)-5-dodecyl-2-isoxazoline was recrystallised from ethanol and isolated as a white powder, m.p. 87°C (Found: C, 71.9; H, 9.4; N, 3.9. $C_{21}H_{32}ClNO$ requires C, 72.1; H, 9.2; N, 4.0%).

6.1.5 trans-4,5-Dicarbethoxy-3-phenyl-2-isoxazoline was prepared by the above method. The triethylamine hydrochloride was extracted with water and the ether layer dried over calcium chloride. The drying agent was removed by filtration and the ether evaporated to leave a yellow oil. The product (90%)

was purified by vacuum distillation, b.p. 130°C/0.1 mmHg (lit.,⁴² 158-160°C/0.2 mmHg); ν_{\max} (liquid) 1595 (C=N); 1740 (C=O) cm^{-1} .

6.2 Urethanes, Ureas and Thioureas

The authentic urethanes, ureas and thioureas prepared from the reaction of the corresponding isocyanate or isothiocyanate with alcohols or amine respectively.

6.2.1 Ethyl phenylaminoformate was prepared from the reaction of phenyl isocyanate and ethanol by a similar method to that described by Hofmann.¹⁵⁶ The product (98% yield), which was collected as a white solid, was purified by distillation under vacuum, b.p. 75°C/0.1 mmHg (lit.¹⁵⁷ 152°C/14 mmHg); m.p. 51-53°C (lit.,¹⁵⁷ 53°C).

6.2.2 N-Butyl-N'-phenylurea was prepared from butyl isocyanate and aniline after the method of Boehmer.¹⁵⁸ The product (96%) was collected as white needles from ethanol, m.p. 128-129°C (lit.,¹⁵⁸ 130°C); ν_{\max} (nujol) 1654 (C=O), 3380 (N-H) cm^{-1} ; $\delta\text{H}(\text{CDCl}_3)$: 0.75-1.51 (7H, m, Alkyl H); 3.08 (2H, q, J_{NH} ca. 6Hz, J_{CH} ca. 5Hz, CH_2); 6.50 (1H, t, J ca 6Hz, NH); 6.72-7.34 (5H, m, ArH); 8.31 (1H, s, NH); $\delta\text{C}(\text{CDCl}_3)$: 13.7 (CH_3); 19.6, 32.0, 38.8 (3 x CH_2); 117.65, 120.9, 128.65, 140.7 (ArC); 155.3 (C=O).

6.2.3 N,N'-Diphenylthiourea was prepared from phenyl isothiocyanate and aniline. Phenyl isothiocyanate (1.1 g, 8.15 mmol) was dissolved in dry ether (25 ml). An ethereal solution (25 ml) of freshly distilled aniline (1.5 g, 16.3 mmol) was added and the reaction mixture stirred for 12 h. The product (18 g, 97%) which precipitated out of solution was filtered off and recrystallised from ethanol, m.p. 154-156°C (lit.,¹⁵⁹ 153°C); ν_{\max} (nujol) 1348, 1380, 1550, 1605, 3210 (N-H) cm^{-1} ; m/e 228 (M^+).

6.2.4 N-Benzoyl-O-methylhydroxylamine

Potassium benzohydroxamate (21.7 g, 0.12 mol), methyl iodide (21.3 g, 0.15 mol) and anhydrous sodium carbonate (6 g) were dissolved in a methanol/water (3:2) solution (500 ml) and the reaction mixture stirred, at room temperature, for 64 h. After evaporation of the methanol the residue was acidified with 12M hydrochloric acid. The aqueous solution was then extracted with chloroform and the extracts washed with a 10% w/v solution of sodium bicarbonate. The product was then extracted with 6M sodium hydroxide (any dialkyl benzohydroxamate formed in the reaction remains in the chloroform). The combined sodium hydroxide extracts were acidified with 12M hydrochloric acid and the aqueous extracted with chloroform, dried over calcium chloride, filtered and the solvent evaporated to leave a yellow oil. N-Benzoyl-O-methylhydroxylamine (5.5 g, 30%) was purified by column

chromatography (Al_2O_3 ; ether) and vacuum distillation (b.p. $105^\circ\text{C}/0.1$ mmHg). $\delta\text{H}(\text{CDCl}_3)$: 3.70 (3H, s, CH_3); 7.15-7.80 (5H, m, ArH); 11.20 (1H, s, NH); $\delta\text{C}(\text{CDCl}_3)$: 63.8 (CH_3O); 127.0, 128.2, (C_6H_5); 166.1 (C=O); m/e (%) 151 (M^+ , 68), 105 (PhCO, 100), 77 (80), 51 (28).

6.2.5 Methyl phenylaminoformate was prepared by a similar method to that described by Hoffmann.¹⁶⁰ A few drops of triethylamine were added to a solution of phenyl isocyanate (5.0 g, 0.04 mol) in dry methanol (25 ml) and the solution stirred for 12 h. The excess methanol was evaporated and the residue distilled, in vacuo, ($80^\circ\text{C}/0.05$ mmHg) to give the product (6.0 g, 95%), a white solid, m.p. $45-47^\circ\text{C}$ (lit.,¹⁶⁰ 47°C).

7. FLASH VACUUM PYROLYSIS (FVP) - APPARATUS AND GENERAL METHOD

The furnace consisted of a horizontal silica tube (36 cm by 2 cm i.d.) with B24 sockets at each end. The central region was packed with 6 cm lengths of silica tube (7 mm o.d., 5 mm i.d.) and the whole was heated by a Stanton Redcroft Horizontal Furnace, No. 810 (Range 0-1600°C), which gave a uniform hot zone in excess of 35% of the overall length. Temperatures were calibrated against a Pt/Pt-13%Rh thermocouple situated in the central zone. Samples were volatilised into the furnace from one of two inlet systems:- (1) a horizontal quartz test tube (B24 cone, 2 cm o.d. by 10 cm) which was heated by a Büchi Kugelrohr oven; (2) a horizontal quartz tube (B24 cone, 2 cm o.d. by 10 cm) with a side arm (overall length 5 cm to a B10 cone) to which volatile samples could be attached and frozen until the furnace had reached the desired temperature. The exit from the furnace was usually lagged with aluminium foil to reduce heat loss and premature condensation of relatively involatile products. Pyrolysis products were condensed in a liquid nitrogen trap, and the pressure recorded by an Edwards Speedivac gauge, model B4, (range $1-10^{-3}$ mmHg). The vacuum source consisted of an Edwards Speedivac rotary vacuum pump (ED100). Fig. 10 gives a schematic representation of the apparatus used.

Fig. 10 FVP Apparatus used in Pyrolysis Experiments

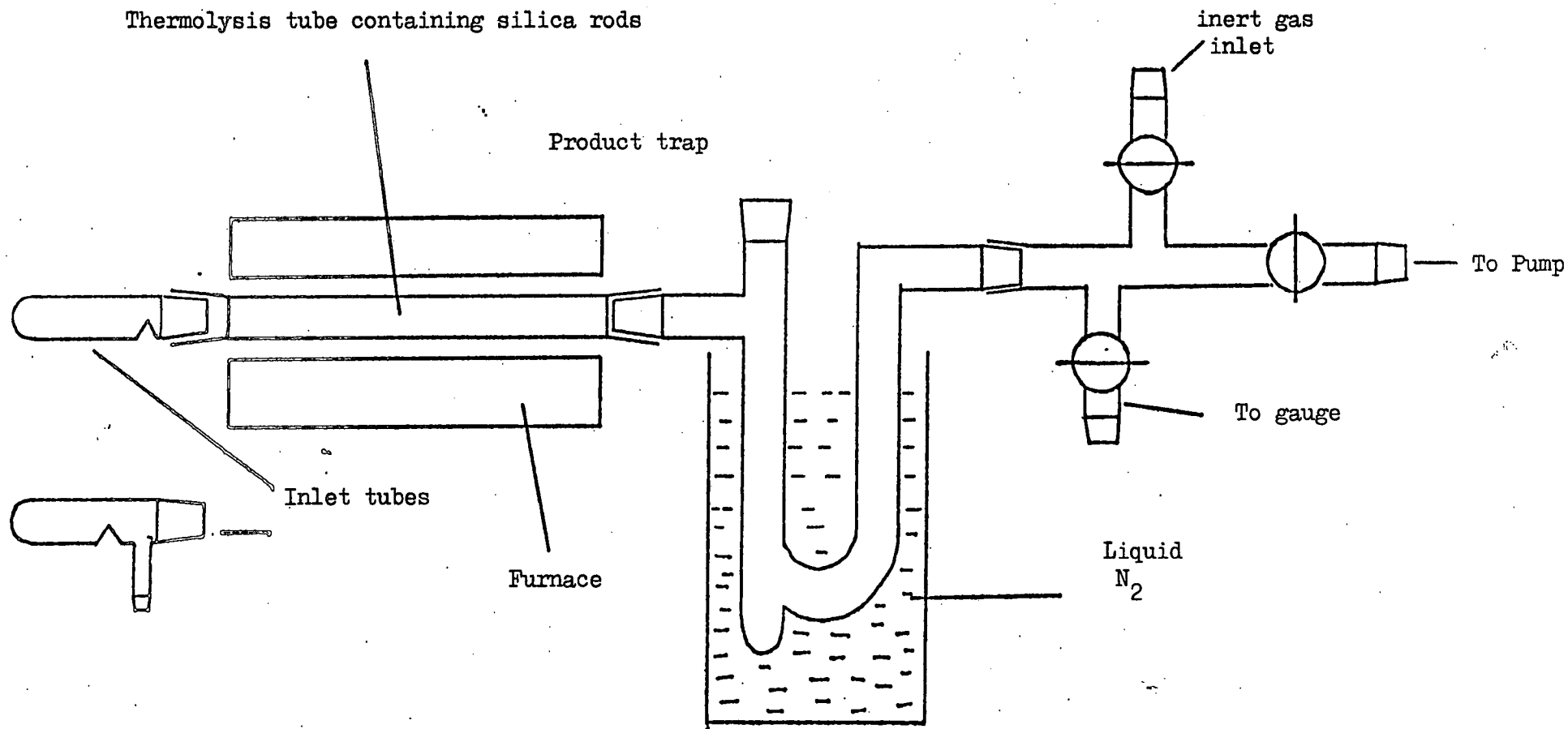

All compounds were pyrolysed onto a co-reactant or an inert solvent. In most cases, where the co-reactant or solvent was low boiling ($< 110^{\circ}\text{C}$) it was distilled directly into the cold trap at room temperature by simply applying the vacuum. If on the other hand the co-reactant was relatively high boiling it was distilled from the inlet system containing the side arm, through the furnace which was at a temperature of 100°C , into the cold trap. Care was taken to exclude moisture from the system by purging the apparatus with dry nitrogen and by use of co-reactants and solvents which had previously been distilled and dried. The material to be pyrolysed was then distilled into the furnace and the pyrolysate trapped onto a layer of co-reactant and solvent; a further layer of co-reactant and solvent was distilled into the trap to form a "sandwich". Finally, the reaction was allowed to warm to room temperature, under dry nitrogen.

8. FLASH VACUUM PYROLYSIS (FVP) of 3,4-DISUBSTITUTED FUROXANS - GENERATION OF NITRILE OXIDES

The furoxans were pyrolysed at various temperatures (450-800°C), the products of the pyrolysis being condensed into a cold trap (-196°C), which contained either an inert solvent or a co-reactant which, on subsequent warming to room temperature, would undergo a 1,3-dipolar cycloaddition with any nitrile oxide formed during the pyrolysis.

8.1 Preparation of 2-Isioxazolines from the Cycloaddition of Nitrile Oxides to Alkenes

8.1.1 trans-4,5-Dicarbethoxy-3-phenyl-2-isioxazoline

3,4-Diphenylfuroxan (0.5 g, 2.10 mmol) was sublimed (120°C/10⁻³ mmHg) and the vapour pyrolysed at 450°C. The pyrolysate condensed into a cold trap (-196°C) containing diethyl fumarate (0.8 g, 4.65 mmol) in toluene (5 ml). The reaction mixture was allowed to warm to room temperature and the resulting solution examined by i.r.; benzonitrile oxide was identified by the characteristic $\text{-C}\equiv\overset{+}{\text{N}}\text{-}\overset{-}{\text{O}}$ absorption at $\nu_{\text{max}} = 2281 \text{ cm}^{-1}$ and its subsequent disappearance was monitored by i.r. The toluene was evaporated and t.l.c. investigation of the residue showed the isioxazoline to be the sole product. trans-4,5-Dicarbethoxy-3-phenyl-2-isioxazoline (1.0 g, 3.44 mmol, 82%) was isolated as a colourless liquid b.p. 132°C/0.1 mm Hg (lit.⁴² 158-160°C/0.2 mmHg) on distillation of the residue.

ν_{\max} (liquid) 1595, 1740 cm^{-1} . I.r. and ^{13}C n.m.r. spectra were indistinguishable from those of the authentic isoxazoline.

8.1.2 5-Butyl-3-phenyl-2-isoxazoline

3,4-Diphenylfuroxan (0.5 g, 2.10 mmol) was sublimed and the vapour pyrolysed at $550^{\circ}\text{C}/\sim 10^{-3}$ mmHg. The pyrolysate condensed into a cold trap (-196°C) containing 1-hexene (2.0g, 23.8 mmol) in dry ether. After warming to room temperature the solvent and unreacted 1-hexene were evaporated to leave the product (0.83 g, 4.09 mmol, 97%), which was isolated as white platelets from ethanol, m.p. $40-41^{\circ}\text{C}$ (lit.¹⁶¹ 41°C); (Found: C, 76.7; H, 8.4; N, 6.7. $\text{C}_{13}\text{H}_{17}\text{NO}$ requires C, 76.85; H, 8.4; N, 6.9%). ^1H and ^{13}C n.m.r. data in Tables 2 and 3.

8.1.3 5-Butyl-3-(4-methoxyphenyl)-2-isoxazoline

3,4-Bis(4-methoxyphenyl)furoxan (0.3 g, 1.01 mmol) was pyrolysed at $500^{\circ}\text{C}/\sim 10^{-3}$ mmHg. The pyrolysate condensed onto 1-hexene (2 g, 23.8 mmol). The product (0.35 g, 1.50 mmol, 75%) was isolated as white platelets from ethanol/water mixture, m.p. 85°C (m.p. of authentic material prepared in 6.1.1 ($82-84^{\circ}\text{C}$)). Its i.r., ^1H and ^{13}C n.m.r. spectra were indistinguishable from those of the authentic isoxazoline.

8.1.4 5-Dodecyl-3-(4-methylphenyl)-2-isoxazoline

3,4-Bis(4-methylphenyl)furoxan (0.2 g, 0.75 mmol) was sublimed ($110^{\circ}\text{C}/10^{-3}$ mmHg) and the vapour pyrolysed at 500°C . The pyrolysate condensed into a cold trap containing 1-tetradecene (1.5 g, 0.75 mmol) in ether (5 ml). After warming to room temperature the reaction mixture was examined by t.l.c. (Al_2O_3 ; pet. ether (40-60)); this demonstrated that only two components were present, unreacted 1-tetradecene and the desired isoxazoline. The ether was removed, the residue triturated with pentane and the product (0.38, 1.16 mmol, 77%) was collected, and recrystallised from methanol, m.p. $75-77^{\circ}\text{C}$ (lit., 110 $75-77^{\circ}\text{C}$) (found: C, 80.1; H, 10.8; N, 4.1. $\text{C}_{22}\text{H}_{35}\text{NO}$ requires C, 80.2; H, 10.6; N, 4.3%). I.r. and ^1H n.m.r. spectra were indistinguishable from those of authentic 5-dodecyl-3-(4-methylphenyl)-2-isoxazoline.

8.1.5 5-Butyl-3-(4-chlorophenyl)-2-isoxazoline

3,4-Bis(4-chlorophenyl)furoxan (0.30 g, 0.98 mmol) was pyrolysed at $600^{\circ}\text{C}/\sim 10^{-3}$ mmHg, the pyrolysate being condensed onto 1-hexene (10 fold excess) in the cold trap. The reaction mixture, on examination by hplc using a silica column (20% H_2O saturated) eluting with 20% methylene chloride/80% n-hexane (20% H_2O saturated), was found to contain a trace of unreacted furoxan and the product. The solvent was evaporated and the crude product applied to a silica column which, on elution with methylene chloride,

gave the product (0.42 g, 1.76 mmol, 90%) a white solid.

5-Butyl-3-(4-chlorophenyl)-2-isoxazoline was isolated as white needles, m.p. 73-74°C from a methanol/water mixture. (Found: C, 65.5; H, 6.8; N, 5.8. $C_{13}H_{16}ClNO$ requires C, 65.7; H, 6.7; N, 5.9%).

8.1.6 5-Butyl-3-methyl-2-isoxazoline

3,4-Dimethylfuroxan (0.3 g, 2.63 mmol) was pyrolysed at 600°C, the pyrolysate being condensed onto 1-hexene (4.4 g, 52.6 mmol). T.l.c. analysis (Al_2O_3 ; ether/petrol, 1:1) of the reaction mixture indicated that the furoxan had been consumed and a product formed. The solvent was evaporated and the resulting oil applied to an alumina column which, on elution with ether/petrol (1:1), gave the product (0.58 g, 4.16 mmol, 79%) a yellow oil. 5-Butyl-3-methyl-2-isoxazoline was distilled under vacuum, b.p. 40°C/0.02 mmHg. (Found: M^+ , m/e 141.114942 $C_8H_{15}NO$ requires m/e 141.115358); m/e (%) 141 (30, M^+), 85 (14), 84 (100), 57 (23), 56 (94), 55 (23), 42 (16), 41 (32).

8.1.7 5-Butyl-3-ethyl-2-isoxazoline

3,4-Diethylfuroxan (0.4 g, 2.80 mmol) was pyrolysed at 650°C, the pyrolysate being trapped onto 1-hexene (10 fold excess). After warming to room temperature the excess 1-hexene was evaporated to leave a yellow liquid which on vacuum distillation yielded the product (0.83 g, 5.38 mmol, 96%) b.p. 45°C/0.01 mmHg. (Found: M^+ , 155.131481, $C_9H_{17}NO$ requires 155.131007); m/e (%) 155 (20, M^+), 98 (38), 71 (15), 70 (100), 46 (14), 41 (32), 40 (24).

Table 2. ¹H NMR of 2-Isoxazolines

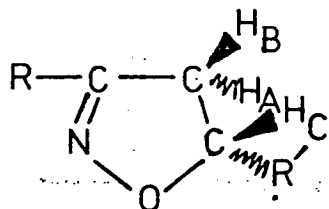

R	R'	
C ₆ H ₅	C ₄ H ₉	0.8-1.9 (9H, m, alkyl H); 2.93 (1H, q, J _{AB} 16.5Hz, J _{AC} 8.5Hz, H _A); 3.38 (1H, q, J _{AB} 16.5Hz, J _{BC} 10.5Hz, H _B); 4.5-4.8 (1H, m, H _C); 7.2-7.7 (5H, m, ArH).
4-CH ₃ OC ₆ H ₄	C ₄ H ₉	0.8-1.9 (9H, m, alkyl H); 2.90 (1H, q, J _{AB} 16Hz, J _{AC} 8Hz, H _A); 3.35 (1H, q, J _{AB} 16Hz, J _{BC} 10Hz, H _B); 3.80 (3H, s, OMe); 4.5-4.8 (1H, m, H _C); 6.89 (2H, d, J10Hz, ArH); 7.60 (2H, d, J10Hz, ArH).
4CH ₃ C ₆ H ₄	C ₄ H ₉	0.55-1.8 (9H, m, alkyl H); 2.33 (3H, s, Me); 2.78 (1H, q, J _{AB} 16Hz, J _{AC} 8Hz, H _A); 3.24 (1H, q, J _{AB} 16Hz, J _{BC} 10Hz, H _B); 4.4-4.7 (1H, m, H _C); 7.08 (2H, d, J8Hz, ArH); 7.42 (2H, d, J8Hz, ArH).
4ClC ₆ H ₄	C ₄ H ₉	0.8-1.9 (9H, m, alkyl H); 2.88 (1H, q, J _{AB} 16Hz, J _{AC} 8Hz, H _A); 3.33 (1H, q, J _{AB} 16Hz, J _{BC} 10Hz, H _B); 4.6-4.9 (1H, m, H _C); 7.32 (2H, d, J8Hz, ArH); 7.58 (2H, d, J8Hz, ArH).
4CH ₃ O.C ₆ H ₄	C ₁₂ H ₂₅	0.8-1.8 (25H, m, alkyl H); 2.88 (1H, q, J _{AB} 16Hz, J _{AC} 8Hz, H _A); 3.35 (1H, q, J _{AB} 16Hz, J _{BC} 10Hz, H _B); 3.80 (3H, s, OMe); 4.5-4.8 (1H, m, H _C); 6.89 (2H, d, J10Hz, ArH); 7.60 (2H, d, J10Hz, ArH).

Table 2. (contd.)

R	R'	
4Cl-C ₆ H ₄	C ₁₂ H ₂₅	0.8-1.9 (25H, m, alkyl H); 2.88 (1H, q, J _{AB} 16Hz, J _{AC} 8Hz, H _A); 3.33 (1H, q, J _{AB} 16Hz, J _{BC} 10Hz, H _B); 4.6-4.9 (1H, m, Hc); 7.32 (2H, d, J8Hz, ArH); 7.58 (2H, d, J8Hz, ArH).
CH ₃	C ₄ H ₉	0.88 (3H, t, J7Hz, CH ₃); 1.28-1.66 (6H, m, Alkyl-CH ₂); 1.96 (3H, t, J 0.98Hz, CH ₃); 2.52 (1H, d of q, J _{AB} 16.8Hz, J _{AC} 8.2Hz, J _{A-CH₃} 0.98Hz, H _A); 2.94 (1H, d of q, J _{AB} 16.8Hz, J _{BC} 10.2Hz, J _{B-CH₃} 0.98 Hz, H _B); 4.46-4.54 (1H, m, Hc)
C ₂ H ₅	C ₄ H ₉	0.8-1.8 (9H, m, alkyl H); 1.14 (3H, t, J8Hz, CH ₃); 2.33 (2H, q, J8Hz, CH ₂); 2.54 (1H, q, J _{AB} 16Hz, J _{AC} 8Hz, H _A); 2.98 (1H, q, J _{BC} 10Hz, H _B); 4.3-4.65 (1H, m, Hc).

Table 3. ^{13}C NMR of 2-Isoxazolines

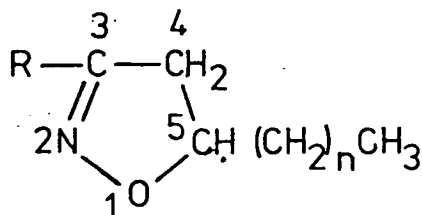

R	C ₃	C ₄	C ₅	R	-(CH ₂) _n CH ₃
C ₆ H ₅ , n=3	156.1	39.7	81.2	126.3; 128.4; 129.6	13.7; 22.3; 27.4; 34.8
4-CH ₃ O-C ₆ H ₄ n=3	155.8	40.0	81.0	55.1(OCH ₃); 113.8; 122.3 127.85; 160.7	13.8; 22.3; 27.5; 34.8
4-CH ₃ -C ₆ H ₄ (n=3)	156.2	39.9	81.15	21.2(CH ₃); 126.4; 127.0; 129.2; 139.9	13.8; 22.4; 27.5; 34.9
4-Cl-C ₆ H ₄ n=3	155.3	39.6	81.7	128.8; 128.35; 127.6; 135.6	13.8; 22.4; 27.5; 34.85
4-CH ₃ O-C ₆ H ₄ (n=11)	155.8	40.1	81.1	55.2(OCH ₃); 113.9; 122.5; 127.9; 160.8	13.9; 22.5; 25.45; 29.2; 29.4; 29.5; 31.8; 35.2
4-Cl-C ₆ H ₄ n=11	155.3	39.7	81.7	127.7; 128.4; 128.8; 135.7	14.0; 22.55; 25.4; 29.25; 29.4; 29.5; 31.8; 35.2
CH ₃ , n=3	154.8	43.4	80.0	12.9	13.6; 22.2; 27.4; 34.6
C ₂ H ₅ , n=3	159.5	41.6	79.8	11.0; 2.1	13.6; 22.2; 27.4; 34.85

8.2 Preparation of Isocyanates via the Reaction of Nitrile Oxides with Sulphur Dioxide

The technique made use of the known conversion of furoxans into the corresponding isocyanates via the cycloaddition of the nitrile oxide, generated from the FVP of the furoxan, to sulphur dioxide to form 5-substituted-1,3,2,4-dioxathiazole-2-oxides which on heating decompose to yield the desired isocyanate and sulphur dioxide.

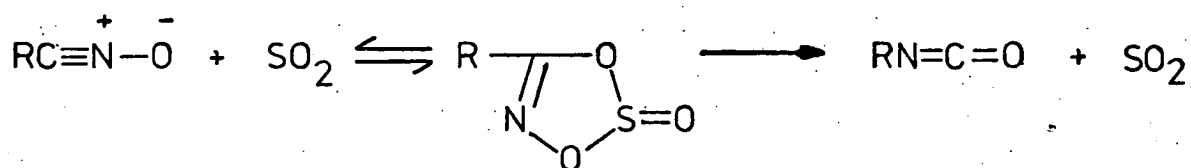

General method: Sulphur dioxide was dried by passing the gas through a calcium chloride drying tower. The dry sulphur dioxide was dissolved in sodium dried toluene (ca. 5 ml) and the mixture co-distilled into a cold trap (-196°C). The furoxan was then pyrolysed ($500\text{--}650^\circ\text{C}$ at 10^{-3} mmHg) and the pyrolysate condensed in the cold trap. A further layer of dry sulphur dioxide was condensed into the trap, to form a "sandwich", and the reaction mixture allowed to warm to room temperature. Dry toluene (ca. 50 ml) was added and the reaction mixture refluxed for 1-2 h. Any remaining sulphur dioxide was then removed by passing dry nitrogen through the solution and the presence of the isocyanate was established by g.l.c. and/or reaction of the isocyanate with aniline or ethanol to form the urea or urethane respectively.

8.2.1 Phenyl Isocyanate

3,4-Diphenylfuroxan (0.33 g; 1.39 mmol) was sublimed and the vapour pyrolysed at 500°C, the pyrolysate being trapped onto sulphur dioxide. G.l.c. analysis (10% SE 30, 110°C) on 1/10th reaction mixture, using freshly distilled nitrobenzene as internal standard, indicated the presence of phenyl isocyanate (2.59 mmol, 93%). Dry ethanol (10 ml) and triethylamine (5 drops) were added to the remainder of the reaction mixture and the solution was stirred for 24 h. The excess ethanol and the solvent were evaporated and the residue distilled under vacuum to give the product, ethyl phenylaminoformate (0.34 g, 2.09 mmol, 75%) m.p. 42-44°C (lit.¹⁵⁷ 53°C). The i.r. spectrum was identical with that of authentic ethyl phenylaminoformate and its purity was confirmed by t.l.c.

8.2.2 (4-Methylphenyl)isocyanate

3,4-Bis(4-methylphenyl)furoxan (0.50 g, 1.86 mmol) was pyrolysed at 500°C ca 10^{-3} mmHg, the pyrolysate being trapped onto dry sulphur dioxide. After refluxing in toluene the presence of the isocyanate was established by i.r., ν_{max} (toluene) 2250 cm^{-1} (N=C=O). G.l.c. analysis (10% SE 30, 150°C) on 1/10th reaction mixture, using freshly distilled ethyl benzoate as internal standard indicated the presence of 4-methylphenyl isocyanate (2.83 mmol, 76%).

Freshly distilled aniline (excess) was added to the remainder of the reaction mixture and the solution left for 12 h.

N-(4-methylphenyl)-N'-phenyl urea (0.54 g, 2.64 mmol, 71%) which precipitated from the reaction mixture, was filtered off and recrystallised from ethanol, m.p. 221-222°C (lit.,¹⁵⁷ 226°C). (Found: C, 74.2; H, 6.2; N, 12.2. $C_{14}H_{14}N_2O$ requires C, 74.3; H, 6.2; N, 12.4%); m/e 226 (M^+).

8.2.3 (4-Methoxyphenyl)isocyanate

3,4-Bis(4-methoxyphenyl)furoxan (0.20 g, 0.67 mmol) was pyrolysed at 500°C/10⁻³ mmHg the pyrolysate being trapped onto dry sulphur dioxide. After warming to room temperature the reaction mixture was examined by i.r. ν_{max} (toluene): 2460, 1300, 1125 (SO_2);¹¹⁰ 2265 (C=N of isocyanate); 1243 (characteristic absorption (1240-1260 cm^{-1}) for 5-substituted-1,3,2,4-dioxathiazole-2-oxides)¹³⁸ cm^{-1} . The solution was heated to reflux and the decomposition of 5-(4-methoxyphenyl)-1,3,2,4-dioxathiazole-2-oxide was monitored by i.r. The intensity of the absorption at 2265 cm^{-1} increased and that at 1243 cm^{-1} decreased, indicating decomposition of the dioxathiazole-2-oxide with loss of sulphur dioxide and rearrangement to (4-methoxyphenyl)isocyanate. After the reaction had been refluxed for 12 h, freshly distilled aniline was added and the solution stirred for 24 h. The solvent was evaporated under reduced pressure and the residue recrystallised from an ethanol/water mixture to give N-(4-methoxyphenyl)-N'-phenyl urea (0.31 g, 1.27 mmol, 95%) m.p. 186-188°C (lit.,¹⁶² 186-190°C).

8.2.4 Butyl isocyanate

3,4-Dibutylfuroxan (0.30 g, 1.52 mmol) was pyrolysed at $600^{\circ}\text{C}/10^{-3}$ mmHg the pyrolysate being trapped onto dry sulphur dioxide. H.p.l.c. analysis of the reaction mixture (Al_2O_3 ; 35% CH_2Cl_2 / 65% hexane (25% H_2O saturated)) showed that all the furoxan had been consumed. The solution was then heated to reflux for 3 h and on cooling the presence of butyl isocyanate was established by i.r. [ν_{max} (toluene) 2260 cm^{-1}]. Aniline was added to the reaction mixture and the solution stirred for 12 h. The toluene was evaporated and sodium dried ether added to precipitate the product (0.31 g, 1.85 mmol, 61%). The product was dissolved in chloroform and refluxed with decolourising charcoal for 30 min, hot filtered and recrystallised from chloroform/pentane. N-butyl-N'-phenyl urea was collected as white needles, m.p. $128\text{-}129^{\circ}\text{C}$ (lit.,¹⁵⁸ 130°C). A mixed m.p. with authentic N-butyl-N'-phenyl urea was determined: m.p. $128\text{-}129^{\circ}\text{C}$. The i.r. spectrum of the product was identical with that of an authentic sample.

8.2.5 Methyl isocyanate

3,4-Dimethylfuroxan (0.65 g, 5.70 mmol) was pyrolysed at 550°C , the pyrolysate being trapped onto dry sulphur dioxide. After refluxing the reaction mixture for 3 h freshly distilled aniline (4 ml) was added and the solution refluxed for 10 minutes. N-methyl-N'-phenyl urea (0.93, 6.16 mmol, 54%) precipitated from the solution on cooling and was isolated as white platelets from ethanol,

m.p. 149-150°C (lit.,¹⁶³ 151-152°C). (Found: C, 64.2; H, 6.7; N, 18.6. $C_8H_{10}N_2O$ requires C, 64.0; H, 6.7; N, 18.7%); ν_{\max} (nujol): 1650, 1700 (C=O); 3309, 3360 (N-H) cm^{-1} .

The toluene was evaporated from the filtrate and the residue distilled under vacuum to give a yellow liquid (40°C/0.05 mmHg). H.p.l.c. analysis (Al_2O_3 (25% H_2O saturated); 25% CH_2Cl_2 /75% hexane (25% H_2O sat.)) of the distillate (1.12 g) using 3,4-diphenylfuroxan as internal standard indicated the presence of 3,4-dimethylfuroxan (0.85 mmol, 15%). Therefore, the yield of N-methyl-N'-phenyl urea, based on the amount of furoxan consumed during the course of the reaction is 74 mol %. In a parallel experiment the presence of methyl isocyanate was established by i.r. ν_{\max} (toluene) 2270 cm^{-1} .

8.2.6 Isolation of Acetohydroxamic Acid from the Hydrolysis of 5-Methyl-1,3,2,4-dioxathiazole-2-oxide

3,4-Dimethylfuroxan (1.0 g, 8.77 mmol) was pyrolysed at 550°C, the pyrolysate being trapped onto sulphur dioxide. Ether was added and the reaction mixture shaken vigorously. A few drops of the reaction mixture were applied to a piece of filter paper saturated with aqueous ferric chloride. An intense purple colour formed indicating the presence of the hydroxamic acid. The solvent was then evaporated to dryness and the resulting yellow oil triturated with pentane to give acetohydroxamic acid (0.80 g, 10.7 mmol, 61%) m.p. 89-91°C (lit.,¹⁶⁴ 89-92°C).

8.3 Generation of Phenyl Isocyanate from the FVP of 3,4-Diphenylfuroxan in the Absence of Sulphur Dioxide

8.3.1 FVP of 3,4-Diphenylfuroxan at 550°C

3,4-Diphenylfuroxan (0.30 g, 1.26 mmol) was pyrolysed in the usual manner, the pyrolysate being trapped onto 1-hexene (ca. 2 g). Examination of the reaction mixture by g.l.c. (10% SE 30, 100-230°C) indicated that less than 0.05 mmol phenyl isocyanate was formed during the pyrolysis. The solvent was evaporated to leave as the major product 5-butyl-3-phenyl-2-isoxazoline (0.5 g, 2.47 mmol, 98%) which was isolated as white platelets from ethanol, m.p. and mixed m.p. 40-41°C. The purity of the isoxazoline was confirmed by peak enhancement on h.p.l.c. (Al₂O₃, 25% H₂O saturated; 25% CH₂Cl₂/75% Hexane (25% H₂O saturated)).

8.3.2 FVP of 3,4-Diphenylfuroxan at 700°C

3,4-Diphenylfuroxan (0.30 g, 1.26 mmol) was pyrolysed in the usual manner, the pyrolysate being condensed onto 1-hexene (ca. 2.0 g). G.l.c. analysis (10% SE 30, 100°C) of the reaction mixture, using standard solutions of authentic phenyl isocyanate to calibrate the column, indicated the presence of phenyl isocyanate (0.11 mmol, 4%) G.l.c. analysis using diphenyl ether as internal standard demonstrated the presence of 5-butyl-3-phenyl-2-isoxazoline (2.4 mmol, 95%). On work up the isoxazoline was isolated as white platelets from ethanol, m.p. and mixed m.p. 41-42°C.

8.3.3 FVP of 3,4-Diphenylfuroxan at 800°C

The furoxan (0.31 g, 1.31 mmol) was pyrolysed as above. However, at this temperature the pyrolysis proceeded with considerable charring. G.l.c. analysis (10% SE 30, 100-230°C) using diphenyl ether as internal standard indicated the presence of phenyl isocyanate (0.97 mmol, 37%) and 5-butyl-3-phenyl-2-isoxazoline (0.71 mmol, 27%).

8.4 Preparation of Phenyl Isothiocyanate via the Reaction of Benzonitrile Oxide with N,N-Dimethylthioformamide

3. 3,4-Diphenylfuroxan (0.4 g, 1.69 mmol) was sublimed and the vapour pyrolysed at 550°C at 10^{-3} mmHg, the pyrolysate being trapped onto N,N-dimethylthioformamide (1.5 g, 1.69 mmol) in dry ether (ca 2 ml). The solution was allowed to warm to room temperature and after standing for 3 h the reaction mixture was examined by i.r. The i.r. spectrum clearly demonstrated the presence of phenyl isothiocyanate (2050 cm^{-1}) and the co-product N,N-dimethylformamide (1685 cm^{-1} (C=O)). Freshly distilled aniline was added and the reaction mixture stirred for 24 h; the disappearance of the isothiocyanate was monitored by i.r. spectroscopy. N,N'-Diphenylthiourea (0.38 g, 1.66 mmol, 49%) precipitated from the solution and was isolated as white platelets from an ethanol/water mixture, m.p. 152°C (lit.,¹⁶⁴ 153°C). The i.r. spectrum was indistinguishable from that of authentic N,N'-diphenylthiourea.

Table 4. ^{13}C , ^1H n.m.r. and i.r. spectra of Acetonitrile oxide and Dimethylfuroxan

	^{13}C n.m.r. (ppm)	^1H n.m.r. (ppm)	I.r. (cm^{-1})
$\begin{array}{c} 2 \quad 1 \\ \text{CH}_3 - \text{CH} = \text{N}^+ - \text{O}^- \end{array}$	0.8 (C_2); 35.6 (t, $J_{\text{CN}} \sim 48 \text{ Hz}$, C_1)	2.26 (C_2)	2280 ($-\text{C}=\text{N}$) 1300 ($\text{N}=\text{O}$)
$\begin{array}{c} 4 \quad 3 \quad 2 \quad 1 \\ \text{CH}_3 \quad \quad \quad \text{CH}_3 \\ \diagdown \quad \diagup \\ \text{N} \quad \quad \quad \text{N}^+ - \text{O}^- \\ \diagup \quad \diagdown \\ \text{O} \end{array}$	6.9 (C_4); 10.5 (C_1) 112.7 (C_3); 154.4 (C_2)	2.21 (C_4) 2.40 (C_1)	1615 ($\text{C}=\text{N}$)

Table 5. Summary of the main features of the ^{13}C and ^1H n.m.r. spectra of Propionitrile Oxide and Diethylfuroxan

	^{13}C n.m.r. (ppm)	^1H n.m.r. (ppm)
$\begin{array}{c} 3 \quad 2 \quad 1 \\ \text{CH}_3 \text{CH}_2 \text{C} = \text{N}^+ - \text{O}^- \end{array}$	11.0 (C_2, C_3); 39.1 (t, $J_{\text{CN}} \sim 42 \text{ Hz}$, C_1)	1.30 (3H, t, J 7.5 Hz, C_3) 2.61 (2H, q, J 7.5 Hz, C_2)
$\begin{array}{c} 6 \quad 5 \quad 4 \quad 3 \quad 2 \quad 1 \\ \text{CH}_3 \text{CH}_2 - \text{C} - \text{C} - \text{CH}_2 \text{CH}_3 \\ \diagdown \quad \diagup \\ \text{N} \quad \quad \quad \text{N}^+ - \text{O}^- \\ \diagup \quad \diagdown \\ \text{O} \end{array}$	9.5 (C_6); 10.6 (C_1); 15.7 (C_5); 19.0 (C_2); 116.5 (C_4); 158.5 (C_3)	1.18 (3H, t, J 7.5 Hz, C_6) 1.30 (3H, t, J 7.5 Hz, C_1) 2.55 (2H, q, J 7.5 Hz, C_5) 2.71 (2H, q, J 7.5 Hz, C_2)

9. SPECTROSCOPIC EXAMINATION OF ALIPHATIC NITRILE OXIDES

9.1 Acetonitrile oxide is conveniently prepared by FVP of dimethylfuroxan. 3,4-Dimethylfuroxan (0.5 g, 4.4 mmol) was pyrolysed at 600°C, the pyrolysate being condensed onto deuteriochloroform (ca. 2 ml) at -196°C. A second layer of deuteriochloroform was distilled into the trap to form a "sandwich". After warming to -78°C (carbon dioxide/acetone slush bath), under dry nitrogen, the resulting solution of acetonitrile oxide was transferred to several n.m.r. tubes. These tubes were then stored at -78°C and the ^1H and ^{13}C n.m.r. and i.r. spectra recorded. The spectroscopic data of acetonitrile oxide along with that of dimethylfuroxan is summarised in Table 4.

9.2 Similarly propionitrile oxide is readily prepared by FVP of 3,4-diethylfuroxan at 600°C. The ^1H and ^{13}C n.m.r. data for propionitrile oxide and 3,4-diethylfuroxan are summarised in Table 5.

10. DIMERISATION OF ACETONITRILE OXIDE TO 3,4-DIMETHYLFUROXAN

Acetonitrile oxide solutions, in CDCl_3 , were prepared by the FVP of dimethylfuroxan, as above. It was observed, by both i.r. and ^1H n.m.r. that the dimerisation took several hours to reach completion. More specifically, the dimerisation was followed by monitoring the disappearance of the $\nu_{\text{C}\equiv\text{N}}$ adsorption band (2280 cm^{-1}) of the nitrile oxide, and the appearance of the $\nu_{\text{C}=\text{N}}$ adsorption (1615 cm^{-1}) of the furoxan (Fig. 11). Using ^1H n.m.r. the dimerisation was monitored by replacement of the n.m.r. signal at δ 2.26 by two singlets at δ 2.21 and δ 2.40. On the addition of 1,4-dioxan, as an internal

Fig. 11 Disappearance of Acetonitrile oxide (2280 cm^{-1}) and appearance of Dimethylfuroxan (1615 cm^{-1})

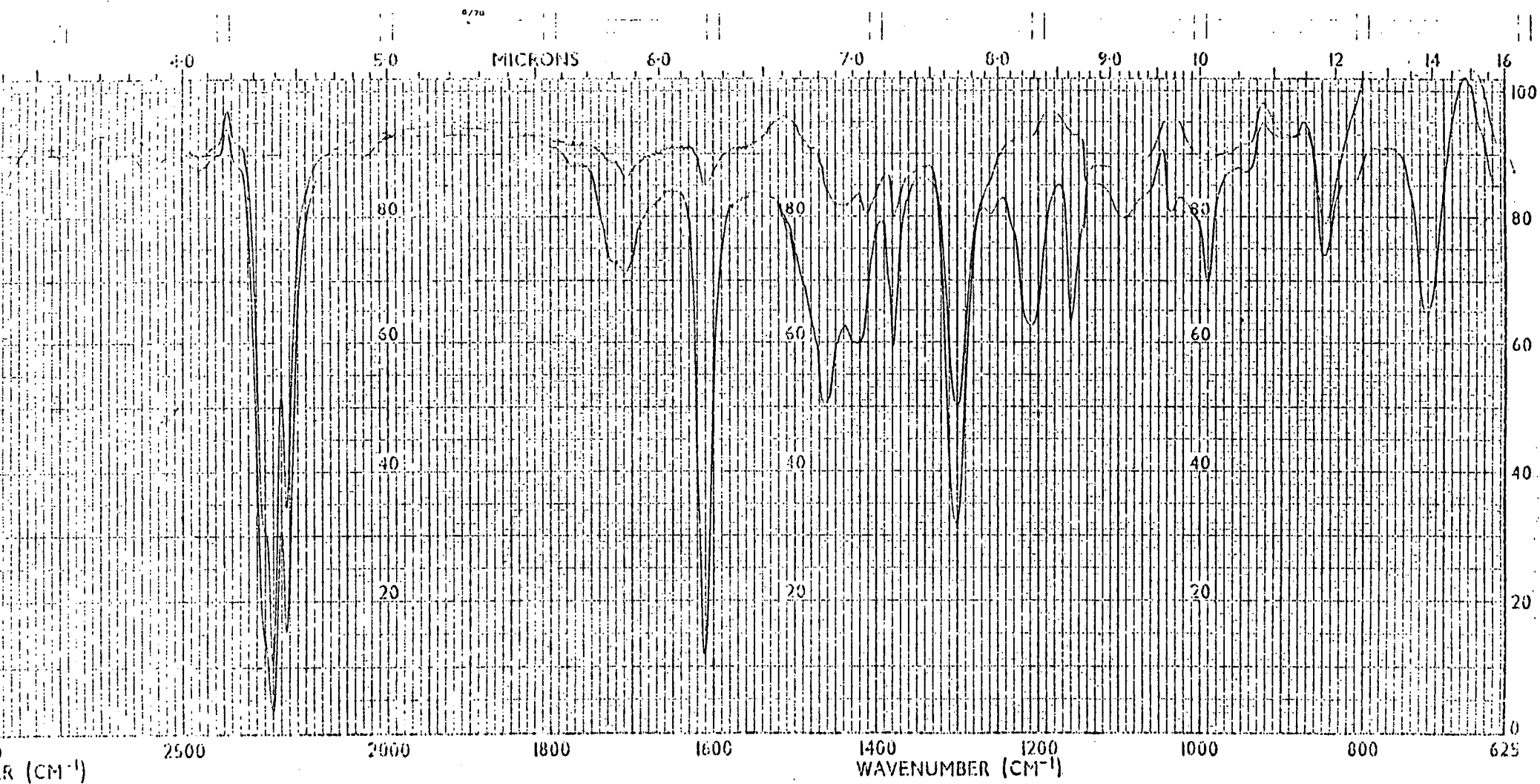

standard, to an n.m.r. tube containing acetonitrile oxide, it was possible to demonstrate that the dimerisation followed the expected second order kinetics.⁵⁰ Excellent linearity when the reciprocal of the integral for dimethylfuroxan was plotted against time.

Determination of the Second Order Rate Constant for the Dimerisation of Acetonitrile Oxide to Dimethylfuroxan at 23°C

The determination of the second order rate constant was carried out using ^1H n.m.r. spectroscopy. A 100 MHz spectrometer using a sweep width of 250 Hz, was used. It was decided to monitor the appearance of the furoxan rather than the disappearance of the nitrile oxide as the integral of the singlet at 2.40 δ (furoxan) could be measured more accurately than the singlet at 2.26 δ (nitrile oxide). 1,4-Dioxan (singlet, 3.75 δ) was used as an internal standard.

Determination of the Number of Moles of Dimethylfuroxan in Solution

Dioxan ($10.0 \pm 0.2 \mu\text{l}$) was added to each of seven n.m.r. tubes and varying amounts of dimethylfuroxan added. The volume of each tube was made up to $0.50 \pm 0.005 \text{ ml}$. A plot of the ratio of furoxan to dioxan integrals versus the number of moles of furoxan, for each tube, gave a straight line. Therefore, assuming the dioxan concentration to be constant, for a given ratio of furoxan:dioxan, the number of moles of dimethylfuroxan in solution at any time during the course of the dimerisation, could be determined.

Table 6. Moles of 3,4 Dimethylfuroxan formed in Dimerisation of Acetonitrile Oxide

Temperature/ $^{\circ}\text{C}$: 23 ± 0.5

F_{∞} = 3.48×10^{-4} mol

The experimental results are summarised in Table 6.

time/min	$\frac{\text{Furoxan}}{\text{Dioxan}}$	Moles of Furoxan ($\times 10^{-4}$)	$F_{\infty} - F$ ($\times 10^{-4}$)	$\frac{1}{F_{\infty} - F}$ ($\times 10^4$)
0	0.348	1.13	2.35	0.43
5	0.398	1.29	2.19	0.46
10	0.428	1.39	2.09	0.48
15	0.485	1.57	1.91	0.52
20	0.473	1.53	1.95	0.51
25	0.517	1.67	1.81	0.55
30	0.538	1.74	1.74	0.58
35	0.619	2.00	1.48	0.68
40	0.619	2.00	1.48	0.68
45	0.637	2.15	1.33	0.75
50	0.678	2.20	1.28	0.78
55	0.688	2.23	1.25	0.80

Fig.12

Plot of $1/[\text{Dimethylfuroxan}]$ vs time; determination of 2nd Order rate constant for rate of dimerisation of Acetonitrile Oxide to Dimethylfuroxan

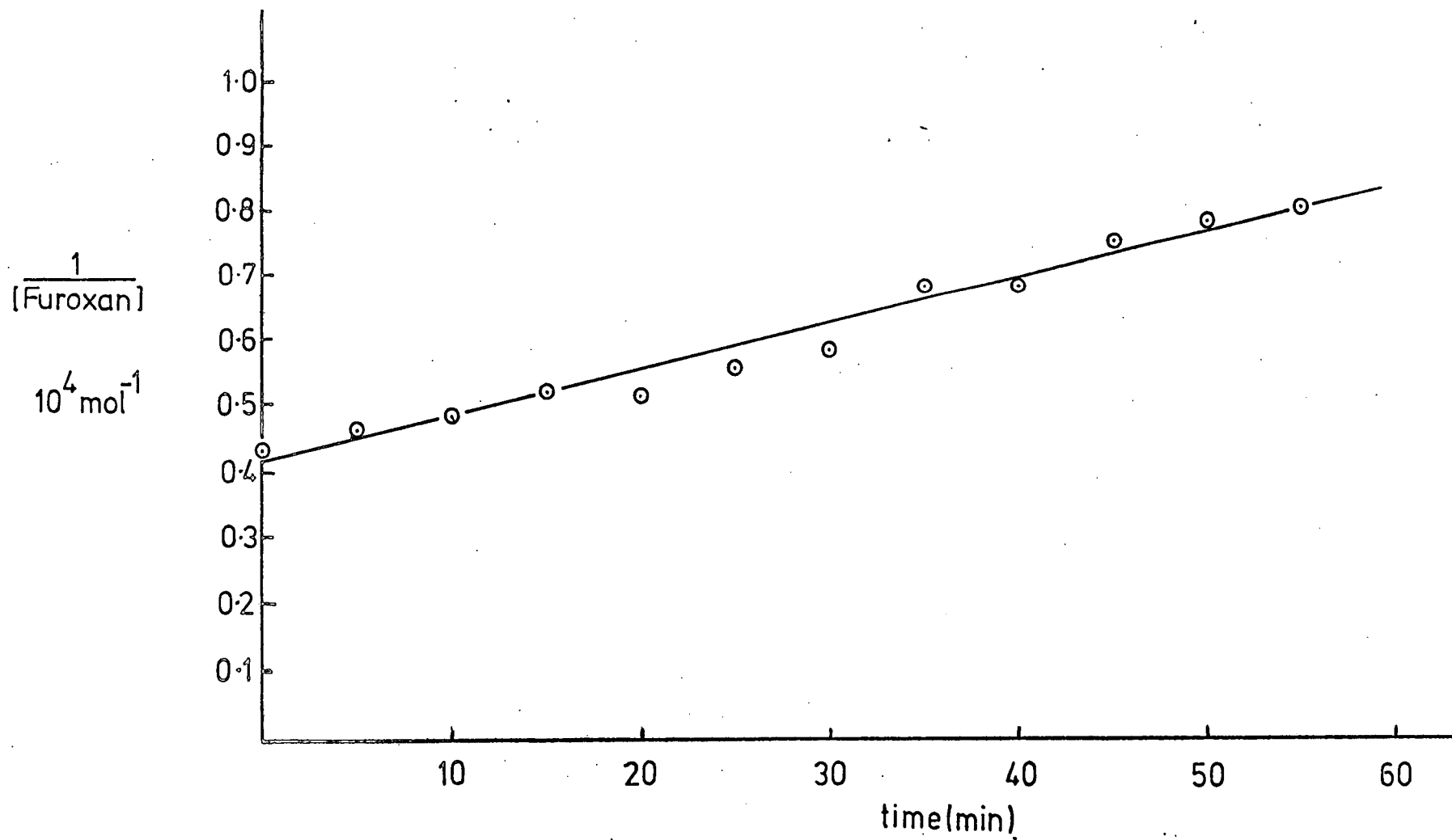

A solution of acetonitrile oxide (CDCl_3) was prepared from the FVP of dimethylfuroxan (0.5 g, 4.39 mmol) at 650°C as above, the solution being stored at -78°C . Dioxan (10.0 μl) was added to an n.m.r. tube, 0.50 ml of the acetonitrile oxide solution added and the ^1H n.m.r. spectrum recorded at -40°C . The initial concentration of dimethylfuroxan was then determined by measuring the ratio of the integrals and reading the number of moles from the calibration curve. The reaction was initiated by raising the temperature of the probe to 23°C . A thermocouple, inserted into the probe, monitored the temperature throughout the course of the reaction. The integral of the spectrum was plotted every 5 min (± 5 s), the ratios of the integrals measured and hence the number of moles of furoxan in solution determined. (Table 6) After 55 min. the experiment was terminated and the tube allowed to stand for two days at room temperature. The final concentration of furoxan (F_∞) was then determined.

A plot of $\frac{1}{F_\infty - F}$ vs. time gave a straight line (Fig. 12). The gradient was determined by the least squares method, $m = 71.4 \pm 2.3 \text{ mol}^{-1} \text{ min}^{-1}$. Consequently, the second order rate constant, k_2 , is

$$\underline{k_2 = 5.95 \pm 0.2 \times 10^{-4} \text{ mol}^{-1} \text{ dm}^3 \text{ s}^{-1}}$$

A repeat experiment gave

$$\underline{k_2 = 6.19 \pm 0.2 \times 10^{-4} \text{ mol}^{-1} \text{ dm}^3 \text{ s}^{-1}}$$

Mean value for k_2 at 23°C

$$= \underline{6.1 \pm 0.2 \times 10^{-4} \text{ mol}^{-1} \text{ dm}^3 \text{ s}^{-1}}$$

11. FVP of 3,4-DISUBSTITUTED FURAZANS

The furazans were pyrolysed at various temperatures (550-650°C), the pyrolysate being condensed into a cold trap (-196°C) containing a dipolarophile, usually 1-hexene, which would undergo a 1,3-dipolar cycloaddition with any nitrile oxide formed during the pyrolysis. The general method employed was that described for the FVP of the Furoxans.

11.1 Preparation of Nitriles and 2-Isoxazolines from the FVP of 3,4-Disubstituted Furazans

11.1.1 5-Butyl-3-phenyl-2-isoxazoline

3,4-Diphenylfuran (0.4 g, 1.8 mmol) was pyrolysed at 600°C, the pyrolysate being trapped onto 1-hexene (4.0 g, excess). H.p.l.c. examination (Al_2O_3 ; 35% CH_2Cl_2 /65% hexane (25% H_2O saturated)) of the reaction mixture clearly demonstrated the presence of 5-butyl-3-phenyl-2-isoxazoline. The excess hexene was evaporated and the residue distilled under vacuum to give a colourless liquid, benzonitrile (0.17 g, 1.65 mmol, 92%) b.p. 40°/0.05 mmHg (lit.,¹⁵⁷ 191°C). The i.r. spectrum was indistinguishable from that of authentic benzonitrile. Sublimation of the residue (75°/0.05 mmHg) gave 5-butyl-3-phenyl-2-isoxazoline, (0.35 g, 1.73 mmol, 96%) m.p. and mixed m.p. 40-41°C (lit.,¹⁶¹ 41°C). The proton n.m.r.

spectrum was indistinguishable from that of authentic isoxazoline.

11.1.2 5-Butyl-3-(4-methoxyphenyl)-2-isoxazoline

3,4-Bis(4-methoxyphenyl)furazan (0.3 g, 1.10 mmol) was pyrolysed at 550°C, the pyrolysate being trapped onto 1-hexene (5 ml). After warming to ambient temperature the excess hexene was evaporated and the residue distilled under vacuum (95°C at 0.06 mmHg) to yield a white solid, 4-methoxybenzotrile (0.14 g, 1.06 mmol, 96%) m.p. and mixed m.p. 60-61°C (lit.,¹⁵⁷ 60-61°C). The purity of the product was confirmed by t.l.c. (Al₂O₃; ether/petrol (1:1)) and i.r. spectroscopy. 5-Butyl-3-(4-methoxyphenyl)-2-isoxazoline (0.23 g, 1.02 mmol, 93%) was separated from the residue by column chromatography (Al₂O₃; ether/petrol (1:1)) and finally purified by recrystallisation from a chloroform/pentane mixture, m.p. and mixed m.p. 84-85°C. Both ¹H n.m.r. and i.r. spectra were indistinguishable from those of authentic isoxazoline prepared from 4-methoxybenzohydroximoyl chloride.

11.1.3 5-Butyl-3-(4-methylphenyl)-2-isoxazoline

3,4-Bis(4-methylphenyl)furazan (0.3 g, 1.20 mmol) was pyrolysed at 600°C, the pyrolysate being trapped onto 1-hexene (5 ml). After warming to room temperature the excess hexene was evaporated and the residue distilled under vacuum. 4-Methylbenzotrile (0.13 g, 1.11 mmol, 93%) was collected as a white solid, m.p. 26-27°C (lit.,¹⁵⁷ 26-28°C).

The i.r. spectra of the product and of authentic 4-methylbenzotrile were indistinguishable. 5-Butyl-3-(4-methylphenyl)-2-isoxazoline (0.26 g, 1.15 mmol, 96%) was separated, from the residue by column chromatography (Al_2O_3 ; ether/petrol (1:1)) and was collected as white platelets from *n*-pentane (60% recovery), m.p. 42-44°C. (Found: C, 77.3; H, 8.7; N, 6.4. $\text{C}_{14}\text{H}_{19}\text{NO}$ required C, 77.4; H, 8.8; N, 6.45%); m/e (%) 217 (55, M^+), 161 (14), 160 (100), 132 (34), 105 (14), 92 (32), 65 (11). ^1H and ^{13}C n.m.r. are tabulated in tables 2 and 3 respectively.

11.1.4 5-Butyl-3-methyl-2-isoxazoline

3,4-Dimethylfurazan (0.50 g, 5.12 mmol) was pyrolysed at 600°C, the products being trapped onto 1-hexene (6 ml). G.l.c. analysis (15% PEG, 90°C), on 1/10th reaction mixture, using freshly distilled propionitrile as internal standard indicated the presence of acetonitrile (3.79 mmol, 74%). The excess hexene was evaporated from the remainder of the reaction mixture and the residue distilled under vacuum to yield unreacted dimethylfurazan (0.09 g, 0.92 mmol, 18%) and 5-butyl-3-methyl-2-isoxazoline (0.43 g, 3.38 mmol, 66%), (62°C/0.05 mm). The identity of the dimethylfurazan was confirmed by t.l.c. and i.r., the spectrum being indistinguishable from that of an authentic sample. The purity of the isoxazoline was established by ^1H n.m.r. and ^{13}C n.m.r., both spectra being indistinguishable with those of authentic isoxazoline. The revised yields of the products, based on the amount of furazan consumed during the reaction are Acetonitrile (4.66 mmol, 91%) and 5-Butyl-3-methyl-2-isoxazoline (4.15 mmol, 81%).

11.1.5 4-Cyanobutyl isocyanate

3,4-Tetramethylenefurazan (0.53 g, 4.3 mmol) was pyrolysed at 650°C at 10^{-3} mmHg, the pyrolysate being trapped onto dry sulphur dioxide. Dry toluene was added to the pyrolysate and the reaction mixture allowed to warm to room temperature. After refluxing, under nitrogen, for 3h the solution was concentrated and the presence of 4-cyanobutyl isocyanate was established by i.r. spectroscopy [ν_{\max} (toluene) 2160 cm^{-1} (C≡N), 2265 cm^{-1} (N=C=O)]. Freshly distilled aniline was added and the reaction mixture heated at reflux for 30 min. The solvent was evaporated to leave a dark brown solid which was dissolved in toluene and refluxed with activated charcoal for 1 h. The charcoal was removed by filtration and N-(4-cyanobutyl)-N'-phenylurea was recrystallised from toluene (0.45 g, 2.06 mmol, 45%), m.p. 130-132°C. (Found: M^+ 217.122252, $\text{C}_{12}\text{H}_{15}\text{N}_3\text{O}$ requires 217.121505); m/e 217 (35, M^+), 119 (32), 94 (28), 93 (100).

11.2 FVP of Unsymmetrical 3,4-Disubstituted Furazans

11.2.1 FVP of 3-Methyl-4-phenylfurazan at 650°C

3-Methyl-4-phenylfurazan (0.43 g, 2.68 mmol) was pyrolysed at 650°C, the products being trapped onto 1-hexene. G.l.c. analysis (10% SE 30, 130-210°C) using 4-methylbenzotrile and diphenylether as internal standards gave benzotrile (0.94 mmol, 35%), 5-butyl-3-methyl-2-isoxazoline (0.94 mmol, 35%) and 5-butyl-3-phenyl-2-isoxazoline 1.17 mmol, 65%). Acetonitrile was not detected under the g.l.c. conditions used.

11.2.2 FVP of 3-(4-Chlorophenyl)-4-phenylfuran at 600°C

3-(4-Chlorophenyl)-4-phenylfuran (0.21 g, 0.84 mmol) was pyrolysed at 600°C and the products condensed onto 1-hexene. G.l.c. analysis (10% SE 30, 150-210°C) using diphenyl ether as internal standard gave benzonitrile (0.41 mmol, 49%), 4-chlorobenzonitrile (0.43 mmol, 51%), 5-butyl-3-phenyl-2-isoxazoline (0.39 mmol, 47%) and 5-butyl-3-(4-chlorophenyl)-2-isoxazoline (0.39 mmol, 47%).

11.2.3 FVP of 3-(4-Methoxyphenyl)-4-phenylfuran at 600°C

3-(4-Methoxyphenyl)-4-phenylfuran (0.22 g, 0.88 mmol) was pyrolysed at 600°C, the products being condensed onto 1-hexene. G.l.c. analysis (10% SE 30, 150-210°C) using diphenyl ether as internal standard gave benzonitrile (0.46 mmol, 52%), 4-methoxybenzonitrile (0.38 mmol, 43%), 5-butyl-3-phenyl-2-isoxazoline (0.35 mmol, 40%) and 5-butyl-3-(4-methoxyphenyl)-2-isoxazoline (0.41 mmol, 47%).

11.3 Liquid Phase Thermolysis of Furazans

11.3.1 Thermolysis of 3,4-Diphenylfuran in 1-Tetradecene

3,4-Diphenylfuran (0.2 g, 0.90 mmol), and 1-tetradecene (15 ml) were heated to reflux (251°C), under dry nitrogen, in the presence of *o*-terphenyl (37 mg) as internal standard. The reaction mixture was sampled at regular intervals and monitored by h.p.l.c. (Al₂O₃; 20% CH₂Cl₂/80% hexane (25% H₂O sat.)). It was evident from the h.p.l.c. analysis that the benzonitrile formed

during the thermolysis, presumably due to its volatility, was lost from the solution. Also, from a comparison of the ratios of furazan: o-terphenyl: isoxazoline it became clear that after 6 h the isoxazoline began to decompose. Therefore, the thermolysis was terminated and the excess tetradecene removed by vacuum distillation (95°C/0.5 mmHg). T.l.c. investigation (Al₂O₃; Petrol) showed the residue to consist of unreacted furazan and a second component (Rf 0.2). This material was isolated by column chromatography (Al₂O₃; petrol) and was identified as 5-dodecyl-3-phenyl-2-isoxazoline. Recrystallisation from ethanol afforded white platelets, (0.21 g, 0.68 mmol, 75%) m.p. and mixed m.p. 69-70°C (lit.,¹⁰⁷ 69-70°C).

H.p.l.c. analysis of the reaction mixture of a repeated experiment, under the same conditions, gave 5-dodecyl-3-phenyl-2-isoxazoline (0.75 mmol, 83%) and unreacted diphenyl furazan (0.14 mmol, 15%).

11.3.2 Thermolysis of 3,4-Tetramethylenefurazan in 4-Methoxybenzonitrile

3,4-Tetramethylenefurazan (0.30 g, 2.34 mmol) and 4-methoxybenzonitrile (1.50 g, 11.28 mmol) were heated to reflux (240°C), under dry nitrogen, for 2 h. Examination of the reaction mixture by t.l.c. (silica; toluene) indicated that the furazan had been consumed. Distillation of the reaction mixture, under vacuum, removed the excess 4-methoxybenzonitrile and column chromatography (silica; methylene chloride) of the black residue afforded a yellow solid which was refluxed in ethanol with activated charcoal for 30 min. After removal of the charcoal by filtration and evaporation

of the solvent, 5-(4-methoxyphenyl)-3-(4-cyanobutyl)-1,2,4-oxadiazole (0.43 g, 1.68 mmol, 72%) was isolated as a white solid. Recrystallisation from a chloroform/pentane mixture afforded white needles, m.p. 65-67°C.

(Found: C, 65.4; H, 5.95; N, 16.3. $C_{14}H_{15}N_3O_2$ requires C, 65.4; H, 5.8; N, 16.3%); $\delta H(CDCl_3)$: 1.60-2.20 (4H, m, alkyl H); 2.42 (2H, t, $J \sim 6$ Hz, CH_2); 2.84 (2H, t, $J \sim 6$ Hz, CH_2); 3.87 (3H, s, OCH_3); 6.91-8.08 (4H, AB, ArH); $\delta C(CDCl_3)$: 16.7, 24.6, 25.0, 25.7 (4 CH_2); 55.3 (CH_3O); 114.4, 129.8 (2 aromatic CH); 116.6 (q, CN); 119.1, 163.0 (q, 2 aromatic C); 169.95, 175.3 (q, oxadiazole ring C); m/e (%): 257 (50), 228 (10), 217 (9), 203 (14), 190 (58), 135 (100), 133 (30).

11.3.3 Thermolysis of 3,4-Decamethylenefurazan in 4-Methoxybenzonitrile

3,4-Decamethylenefurazan (0.21 g, 0.94 mmol) and 4-methoxybenzonitrile (1.0 g, 9.26 mmol) were heated to reflux (240°C), under dry nitrogen, for 3 h. T.l.c. examination (silica/methylene chloride) indicated that the furazan had been consumed. The excess 4-methoxybenzonitrile was removed by vacuum distillation and the black residue applied to a column (silica/methylene chloride). 3-(10-cyano-decyl)-5-(4-methoxyphenyl)-1,2,4-oxadiazole (0.21 g, 0.63 mmol, 67%) was isolated as a white solid. Recrystallisation from an ether/petrol solution gave white platelets, m.p. 74-75°C (Found: C, 70.5; H, 8.0; N, 12.2. $C_{20}H_{27}N_3O_2$ requires C, 70.4; H, 7.9; N, 12.3%); $\delta H(CDCl_3)$: 1.20-2.00 (16H, m, 8 CH_2); 2.28 (2H, t, J 6Hz, CH_2); 2.78 (2H, t, J 6Hz, CH_2);

3.85 (3H, s, CH₃O); 6.86 - 8.14 (4H, AB, ArH); δ C(CDCl₃); 16.9, 25.2, 26.0, 26.9, 28.5, 28.95, 29.04 (10CH₂); 55.30 (CH₃O); 114.3, 129.8 (Aromatic CH); 116.8 (CN), 119.6, 162.9 (q, Aromatic C); 171.0 (q, oxadiazole ring C); m/e (%); 341 (20), 301 (17), 287 (5), 273 (7), 259 (7), 245 (13), 232 (9), 217 (8), 203 (37), 191 (16), 190 (97), 136 (21), 135 (100), 134 (16), 133 (16), 113 (15), 99 (57), 97 (36), 92 (15).

12. SYNTHESIS AND THERMOLYSIS OF 3,5-DIPHENYL-1,2,4-OXADIAZOLE

12.1 Preparation of 3,5-Diphenyl-1,2,4-oxadiazole

Benzohydroximoyl chloride (2.5 g, 16.1 mmol) and benzonitrile (2.0 g, 19.4 mmol) were dissolved in sodium dried toluene (30 ml) and the solution heated to reflux until the evolution of hydrogen chloride ceased (43 h). The toluene was evaporated to leave a brown solid, which after successive recrystallisations from methanol gave 3,5-diphenyl-1,2,4-oxadiazole (2.1 g, 58%) m.p. 110-112°C (Lit.,¹⁶⁵ 108°C); δ C(CDCl₃): 175.1, 169.0 (q, oxadiazole ring C); 132.7, 131.1, 129.1, 128.8, 128.2, 127.5 (aromatic CH); 127.1, 124.4 (q, aromatic C); m/e, 222 (M⁺), 119 (M⁺, PhCNO⁺).

12.2 Thermolysis of 3,5-Diphenyl-1,2,4-oxadiazole in
1-Tetradecene

A solution of 3,5-diphenyl-1,2,4-oxadiazole (0.5 g, 2.25 mmol) and 1-tetradecene (15 ml) were refluxed (251°C) for a total of 12 h. T.l.c. investigation (Al_2O_3 ; ether:petrol (1:10)) established that no benzonitrile or 5-dodecyl-3-phenyl-2-isoxazoline were present in the reaction mixture. The only identifiable component was that corresponding to unreacted starting material.

12.3 FVP of 3,5-Diphenyl-1,2,4-oxadiazole at 500°C onto
1-Tetradecene

3,5-Diphenyl-1,2,4-oxadiazole (0.50 g, 2.25 mmol) was pyrolysed at 500°C in the above manner, the products being trapped onto 1-tetradecene. H.p.l.c. analysis (Al_2O_3 ; 25% CH_2Cl_2 /75% hexane (25% H_2O saturated) established the presence of starting material and the absence of 5-dodecyl-3-phenyl-2-isoxazoline.

12.4 FVP of 3,5-Diphenyl-1,2,4-oxadiazole at 600°C
onto 1-Hexene

3,5-Diphenyl-1,2,4-oxadiazole (0.7 g, 3.15 mmol) was pyrolysed as above, the products being trapped onto 1-hexene. H.p.l.c. analysis indicated that the reaction mixture consisted of only one component, namely the starting material. The 1-hexene was evaporated to leave 3,5-diphenyl-1,2,4-oxadiazole (0.6 g, 3.06 mmol), m.p. and mixed m.p. 107-108°C (lit.,¹⁶⁵ 108°C). The i.r. spectrum was indistinguishable from that of authentic oxadiazole.

12.5 FVP of 3,5-Diphenyl-1,2,4-oxadiazole at 700°C
onto 1-Hexene

The oxadiazole (0.65 g, 2.93 mmol) was pyrolysed at 700°C and the products trapped onto 1-hexene. The pyrolysis proceeded with some charring. Evaporation of the solvent gave a yellow solid. T.l.c. examination (Al₂O₃; ether:petrol, 1:10) indicated that the solid comprised four components. The solid was applied to an alumina column and elution with ether:petrol (1:10) yielded a white solid (1). Further elution with methylene chloride gave solids (2) and (3); finally elution with methanol afforded solid (4). T.l.c. established that solid (1) was the starting material (0.35 g, 54% recovered), its identification being confirmed by i.r. spectroscopy and by mixed m.p. 107-108°C (lit.,¹⁶⁵ 108°C). Solid (2) was recrystallised from ether/pentane (8 mg), m.p. 140-142°C, m/e 433, 415, 414, 239, 194, 105, 93, 77. Solid (3) was also recrystallised from ether/pentane (10 mg), m.p. 155-158°C. (Found: M⁺ 197.083163, C₁₃H₁₁NO requires 197.084059); m/e (%) 197 (56, M⁺), 105 (100), 77 (44); ν_{\max} 3430 (N-H), 1675 cm⁻¹ (C=O). Finally solid (4) was recrystallised from ether/pentane solution (13 mg), m.p. 115-117°C. (Found: M⁺ 240.088763, C₁₄H₁₂N₂O₂ requires 240.089872); m/e (%) 240 (80, M⁺), 119 (100), 105 (75), 93 (35), 77 (45); ν_{\max} 3418, 3530 (N-H), 1675 cm⁻¹ (C=O). It was also established that 5-butyl-3-phenyl-2-isoxazoline was not formed during the reaction.

12.6 FVP of 3,5-Diphenyl-1,2,4-oxadiazole at 800°C
onto Methanol

The oxadiazole (0.5 g, 2.25 mmol) was pyrolysed at 800°C, the pyrolysate being trapped onto dry methanol in order to trap any acyl nitrene reactive intermediate which might have been formed during the pyrolysis. The thermolysis proceeded with extensive charring. H.p.l.c. analysis (column: ODS/TMS; Solvent: MeOH/H₂O, 70:30) indicated a complex product mixture comprising approximately ten components and that all the starting material had been consumed. By using authentic methyl phenylaminoformate (C₆H₅NHCO₂CH₃) and N-Benzoyl-O-methyl hydroxylamine (C₆H₅.CO.NH.CO.CH₃), the expected products from reaction of methanol with phenyl isocyanate and benzoyl nitrene respectively, it was established that the phenyl isocyanate derived product was present in the complex reaction mixture. There was no evidence to support the formation of the acyl nitrene derived product. G.l.c. examination (10% SE30, 170°C) indicated the presence of at least six different components. G.l.c./m.s. analysis (10% SE30, 170°C) demonstrated that the main components had mass spectra consistent with the following assignments: benzonitrile (m/e 103, M⁺), methyl phenylaminoformate (m/e 151, 106, 92) and biphenyl (m/e 154). The absence of any N-benzoyl-O-methyl hydroxylamine was confirmed by examination of the authentic material under the same g.l.c./m.s. conditions.

13 THERMOLYSIS OF 2,4,5-TRISUBSTITUTED-1,2,3-
TRIAZOLE-1-OXIDES

13.1 2,4,5-Triphenyl-1,2,3-triazole-1-oxide

13.1.1 Thermolysis in Toluene in the presence of Diethyl
acetylenedicarboxylate

2,4,5-Triphenyl-1,2,3-triazole-1-oxide
(0.5 g, 1.60 mmol) and diethyl acetylenedicarboxylate
(0.3 g, 1.77 mmol) were dissolved in sodium dried toluene
(50 ml) and the solution refluxed (110°C) for 4 h. T.l.c.
examination (Al₂O₃; ether/petrol, 2:3) of the reaction
mixture clearly indicated that only the starting materials
were present.

13.1.2 Thermolysis in Xylene in the presence of Diethyl
Fumarate

2,4,5-Triphenyl-1,2,3-triazole-1-oxide
(0.5 g, 1.60 mmol) and diethyl fumarate (0.6 g, 3.20 mmol)
were dissolved in sodium dried xylene (20 ml). The reaction
mixture was refluxed for six days after which time t.l.c.
analysis clearly demonstrated that the starting material was
still present and that there was no 4,5-dicarbethoxy-3-phenyl-
2-isoxazoline present in the reaction mixture.

13.1.3 Thermolysis in 4-Methoxybenzotrile

2,4,5-Triphenyl-1,2,3-triazole-1-oxide (0.8 g,
2.56 mmol) and 4-methoxybenzotrile (3.5 g, 26.32 mmol) were
refluxed under dry nitrogen for 60 h.

T.l.c. examination (Al₂O₃; toluene) of the black reaction

mixture established that the only identifiable components to be the starting material. The excess 4-methoxybenzotrile was removed by distillation and the residue applied to an alumina column which on elution with methylene chloride gave 2,4,5-triphenyl-1,2,3-triazole-1-oxide (0.61 g, 76% recovered). Recrystallisation from ethanol gave yellow crystals, m.p. 167-168°C (lit.,¹⁵³ 169°C). Elution of the alumina column with methanol gave an intractible black tar.

13.1.4. FVP of 2,4,5-Triphenyl-1,2,3-triazole-1-oxide at 650°C

2,4,5-Triphenyl-1,2,3-triazole-1-oxide (0.5 g, 1.60 mmol) was pyrolysed in the above manner, the pyrolysate being condensed onto diethyl fumarate (3.0 g) in sodium dried toluene (5 ml). On warming, the solution was examined by i.r. spectroscopy to determine whether or not any nitrile oxide had been produced during the pyrolysis. There was no significant absorption around 2330 cm^{-1} which is the characteristic region for the $\text{C}\equiv\text{N}^+\text{O}^-$ stretch of the nitrile oxide. The toluene and excess diethyl fumarate were removed by vacuum distillation and t.l.c. examination of the residue and proton n.m.r. indicated that there was no 4,5-dicarbethoxy-3-phenyl-2-isoxazoline present.

13.2 4,5-Dimethyl-2-phenyl-1,2,3-triazole-1-oxide

13.2.1 Thermolysis in Benzene in the presence of Diethyl Fumarate

4,5-Dimethyl-2-phenyl-1,2,3-triazole-1-oxide (0.50 g, 2.60 mmol) and diethylfumarate (0.45 g, 2.60 mmol)

were heated at 80°C in sodium dried benzene. The reaction was monitored by t.l.c. (Al₂O₃; CH₂Cl₂) and after 24 h it was apparent that the only identifiable components in the reaction mixture were the starting materials, thus indicating no reaction had taken place.

13.2.2 FVP of 4,5-Dimethyl-2-phenyl-1,2,3-triazole-1-oxide at 650°C

4,5-Dimethyl-2-phenyl-1,2,3-triazole-1-oxide (0.25 g, 1.32 mmol) was pyrolysed at 650°C, the pyrolysate being condensed onto 1-hexene (5 ml). After warming to room temperature the excess 1-hexene was evaporated to leave a brown oil. T.l.c. examination (Al₂O₃; ether/petrol, 1:1) indicated that the oil consisted of five components, one of which was the starting material. Comparison of the R_f values with that of authentic 5-butyl-3-methyl-isoxazoline established that there was no isoxazoline present. The brown oil was applied to an alumina column which on elution with ether/pentane (1:1) yielded a brown solid (85 mg). Recrystallisation from aqueous methanol yielded white platelets, m.p. 138-139°C, the purity of which was confirmed by t.l.c. δH(CDCl₃); 2.21 (3H, s, CH₃); 3.10 (2H, s, CH₂); 7.21-8.05 (5H, m, ArH); δC(CDCl₃); 9.8 (CH₃); 24.1 (CH₂); 118.1, 126.5, 129.1, 139.8 (Aromatic C); 143.5, 146.5 (triazole ring C); (Found: M⁺, m/e 344.174454 C₂₀H₂₀N₆ requires 344.174936); m/e (%) 345 (18, M+1), 344 (83, M⁺), 185 (16), 173 (15), 172 (100), 91 (27), 77 (18).

14 FVP OF 3,5-DIARYL-1,4,2,5-DIOXADIAZINES

14.1 FVP of 3,6-Diphenyl-1,4,2,5-dioxadiazine at 600°C onto 1-Hexene.

3,6-Diphenyl-1,4,2,5-dioxadiazine (0.30 g, 1.26 mmol) was pyrolysed at 600°C, the pyrolysate being condensed into a trap containing 1-hexene (5 ml). The pyrolysis proceeded with considerable charring and a blue/green colour developed in the trap. As the reaction mixture warmed to room temperature the green colour disappeared and a black solution remained. G.l.c. analysis (10% SE 30, 130-230°C) of the reaction mixture established the presence of benzonitrile and the absence of 5-butyl-3-phenyl-2-isoxazoline. The benzonitrile (0.12 g, 1.165 mmol) was removed by distillation and t.l.c. examination (Al₂O₃; pet-ether (40-60)) of the residue (0.10 g) showed it consisted of at least six different components. The absence of 5-butyl-3-phenyl-2-isoxazoline was confirmed by t.l.c. and ¹H n.m.r. spectroscopy of the residue.

14.2 FVP of 3,6-Diphenyl-1,4,2,5-dioxadiazine at 600°C onto Thebaine.

3,6-Diphenyl-1,4,2,5-dioxadiazine (0.30 g, 1.26 mmol) was pyrolysed at 600°C, the pyrolysate being condensed into a trap containing a chloroform solution of thebaine (0.8 g, 2.58 mmol). After warming to room temperature the reaction mixture was examined by h.p.l.c. and proton n.m.r. spectroscopy. H.p.l.c. analysis (ODS silica; CH₃OH/H₂O, 70:30) of the complex

reaction mixture, established, by peak enhancement with authentic materials, the presence of benzonitrile and benzoic anhydride and the absence of the cycloadduct from the Diels-Alder cycloaddition of nitrosocarbonyl benzene and thebaine. Comparison of the ^1H n.m.r. spectra of thebaine, authentic cycloadduct and the reaction mixture confirmed the absence of the cycloadduct.

Samples of thebaine and authentic cycloadduct were kindly supplied by Prof. G.W. Kirby (University of Glasgow).

14.3 FVP of 3,6-Diphenyl-1,4,2,5-dioxadiazine at 600°C
onto Benzene

3,6-Diphenyl-1,4,2,5-dioxadiazine (0.5 g, 2.10 mmol) was pyrolysed at 600°C, the pyrolysate being condensed onto sodium dried benzene (5 ml). After warming to room temperature the reaction mixture was analysed by h.p.l.c. and g.l.c. H.p.l.c. analysis (ODS silica; $\text{CH}_3\text{OH}/\text{H}_2\text{O}$, 70:30) established the presence of benzonitrile, benzophenone, benzil, benzoic anhydride and biphenyl in the reaction mixture. G.l.c./m.s. analysis (2½% OV-1, 150°C) showed the main components of the reaction mixture to be benzonitrile (m/e 103), biphenyl (m/e 154), benzophenone (m/e, 182, 105, 77) and benzil (m/e 210, 105, 77). G.l.c./m.s. analysis of authentic samples of the above compounds confirmed their identification.

14.4 FVP of 3,6-Diphenyl-1,4,2,5-dioxadiazine at 600°C onto Chloroform

3,6-Diphenyl-1,4,2,5-dioxadiazine (0.87 g, 3.65 mmol) was pyrolysed at 600°C, the products being trapped onto dry chloroform (7 ml). H.p.l.c., g.l.c. and g.l.c./m.s. analysis of the reaction mixture, as above, gave the following range of identified products:- benzonitrile, biphenyl, benzophenone, benzoic anhydride, benzene and phenyl benzoate.

In a repeated experiment, gaseous products were trapped in a glass ampule as the reaction mixture warmed to room temperature. M.s. analysis of these gaseous products indicated that both carbon dioxide and nitrous oxide were present. M/e 44 (M^+), m/e 30 (main fragment peak). High resolution m.s. of the parent ion showed that it was in fact a doublet in the ratio, CO₂ (lower mass): N₂O (higher mass) 1:2. Quantitative g.l.c. analysis (2½% OV-1, 75 → 175°C) using ethyl benzoate as internal standard gave benzonitrile (2.63 mmol), benzophenone (0.16 mmol), biphenyl (0.12 mmol), benzil (0.045 mmol) and phenyl benzoate (0.020 mmol).

14.5 FVP of 3,6-Diphenyl-1,4,2,5-dioxadiazine at 600°C onto Benzene-d⁶

3,6-Diphenyl-1,4,2,5-dioxadiazine (0.4 g, 1.68 mmol) was pyrolysed at 600°C, the products being condensed onto dry deuterobenzene (4 ml). As the reaction mixture warmed up gaseous products, as before, were trapped in a glass ampule. M.s. analysis gave, m/e 44 (m^+), m/e 30 (fragment peak). Exact mass determination of the

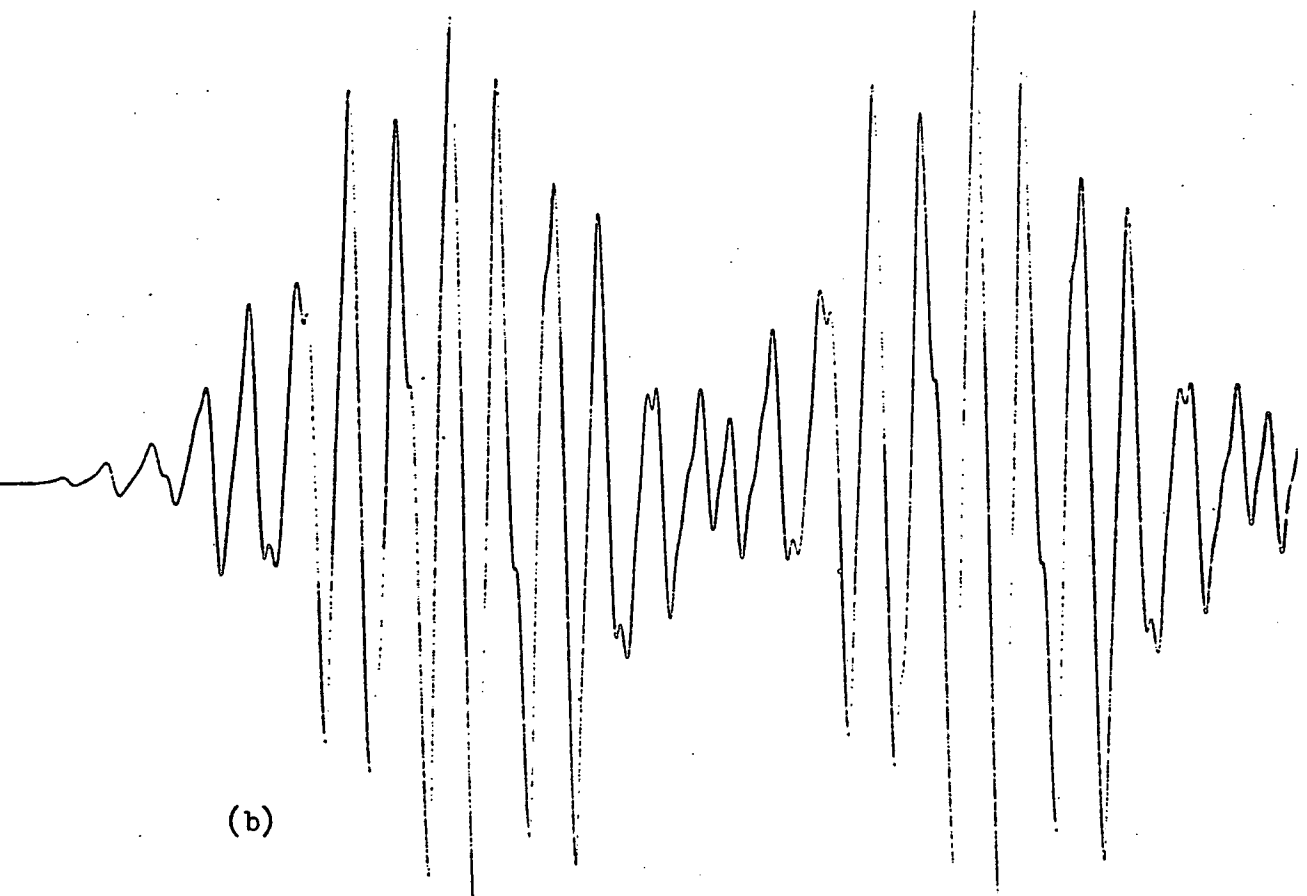
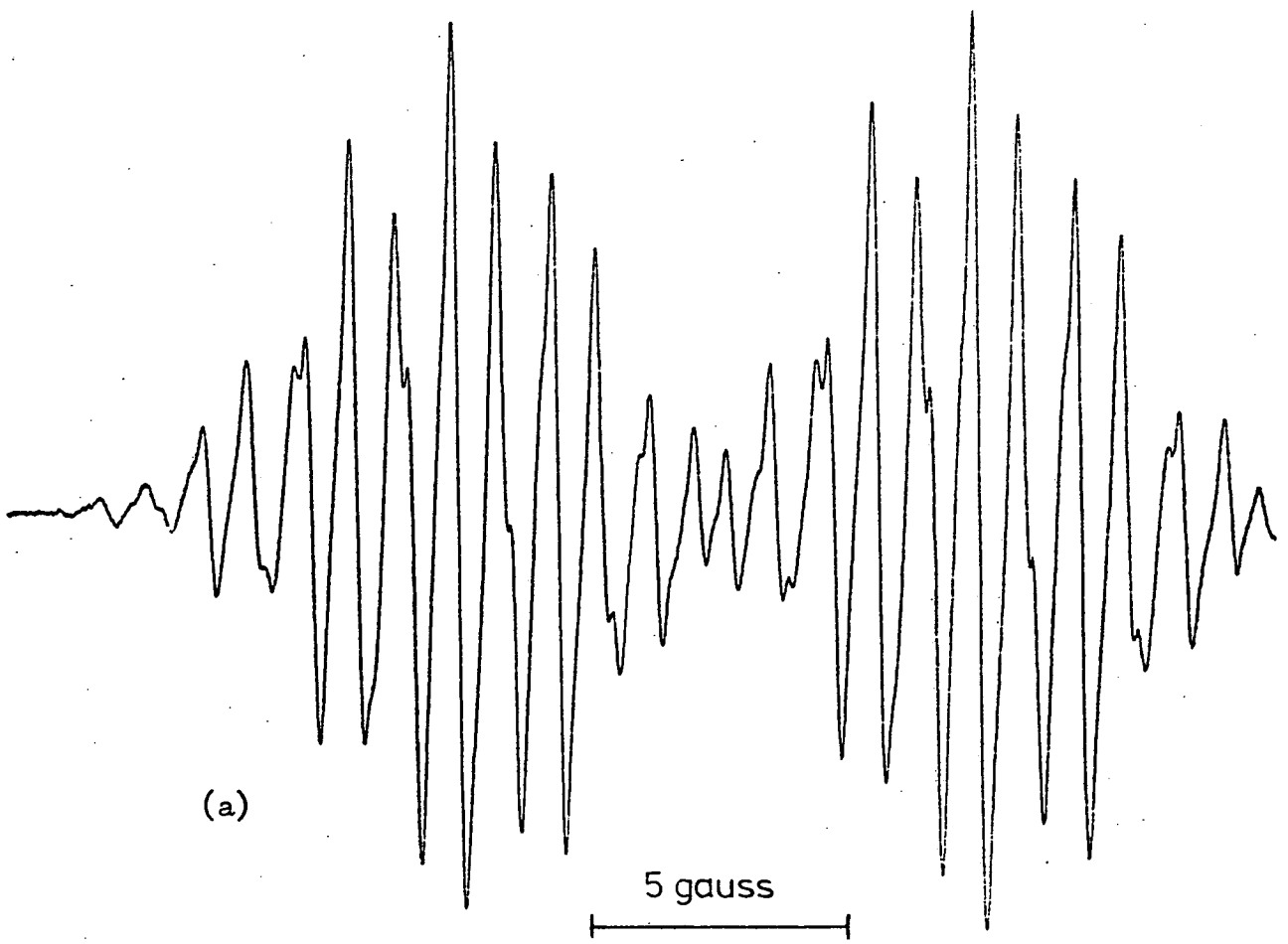

Fig. 13 (a) Part of e.s.r. spectrum of Diphenylnitroxide;
(b) Computer simulation.

parent ion gave M^+ , m/e 43.989837 and m/e 44.001062.

(CO_2 requires m/e 43.989828, N_2O requires m/e 44.001062).

G.l.c./m.s. analysis (2½% OV-1, 70-200°C) established that there was no incorporation of the solvent in the formation of the following products:- biphenyl (m/e 154), benzophenone (m/e 182, 105, 77) and benzil (m/e 210, 105, 77).

14.6 FVP of 3,6-Diphenyl-1,4,2,5-dioxadiazine at 550°C onto Chloroform.

Examination of the Reaction Mixture by E.S.R.

Spectroscopy

3,6-Diphenyl-1,4,2,5-dioxadiazine (0.28 g, 1.18 mmol) was pyrolysed at 550°C, the products being condensed onto dry chloroform (2 ml). The pyrolysis, as usual, proceeded with considerable charring and the formation of a bright green colour in the trap. The contents of the trap were warmed to -78°C by removing the liquid nitrogen trap and replacing it with an acetone/ CO_2 slush bath. The reaction mixture was then transferred, using a Pasteur pipette, to two e.s.r. tubes (3-5 mm. i.d.) which were then stored at -196°C under vacuum. After degassing the solution, the e.s.r. spectrum was recorded at -70°C. A strong signal, which was stable for several hours at -70°C, was observed immediately. The spectrum was recorded at 15°C (Fig. 13) and analysis with the aid of computer simulation indicated coupling of the unpaired electron to

one nitrogen nucleus ($a_N = 10.40$ gauss) and ten protons with hyperfine splitting constants 2.02 gauss (6 ortho/para H) and 0.88 gauss (4 meta H). Comparison of these values and that of the g-factor (2.0055 ± 0.00005 gauss) with those of authentic diphenyl nitroxide (Ph_2NO)¹⁶⁶ allows the signal to be assigned, unequivocally, to diphenyl nitroxide.

In a parallel experiment where 3,6-bis(4-methylphenyl)-1,4,2,5-dioxadiazine was pyrolysed at 550°C and the reaction mixture examined by e.s.r. at -70°C a broad triplet (1:1:1) with a_N ca 10 gauss was observed. This is consistent with the species being ditolyl nitroxide but not sufficient to be diagnostic.

14.7 FVP of 3,5-Diphenyl-1,4,2,5-dioxadiazine at 400°C onto Chloroform

3,6-Diphenyl-1,4,2,5-dioxadiazine (0.32 g, 1.35 mmol) was pyrolysed at 400°C, the pyrolysate being condensed onto dry chloroform. H.p.l.c. analysis (ODS silica; $\text{CH}_3\text{OH}/\text{H}_2\text{O}$, 70:30) of the complex reaction mixture established the presence of benzonitrile, nitrosobenzene, benzophenone, benzoic anhydride, and biphenyl. G.l.c. and g.l.c./m.s. analysis ($2\frac{1}{2}$ OV-1, 48°-200°C) established the presence of benzene (m/e 78), diphenylamine (m/e 169) and phenyl benzoate (m/e 198, 105, 77) and confirmed the presence of benzonitrile (m/e 103), nitrosobenzene (m/e 107, 77), biphenyl (m/e 154), benzophenone (m/e 182, 105, 77) and

benzil (m/e 210, 105, 77). The ratio of the products formed are presented in table 7.

14.8 FVP of 3,6-Diphenyl-1,4,2,5-dioxadiazine at 800°C

3,6-Diphenyl-1,4,2,5-dioxadiazine (0.30 g, 1.26 mmol) was pyrolysed at 800°C, the products being condensed onto dry chloroform. The pyrolysis proceeded with extensive charring and there was no green colour in the trap. G.l.c./m.s. analysis (2½% OV-1, 52-200°C) established the presence of benzene (m/e 78), benzonitrile (103), biphenyl (m/e 154), diphenylamine (m/e 169) and benzophenone (m/e 182, 105, 77). It was clear from the above analysis that there was no nitrosobenzene, phenyl benzoate or benzil present in the reaction mixture.

The ratio of the products formed in the reaction are summarised in table 7.

14.9 FVP of 3,6-Bis(4-methylphenyl)-1,4,2,5-dioxadiazine at 600°C onto Chloroform

3,6-Bis(4-methylphenyl)-1,4,2,5-dioxadiazine (0.20 g, 0.76 mmol) was pyrolysed at 600°C, the pyrolytate being trapped onto dry chloroform. G.l.c. analysis (2½% OV-1, 60 → 100°C) of the complex reaction mixture established the presence of, toluene, toluonitrile, 4,4'-dimethyl benzophenone, 4,4'-dimethyl biphenyl.

G.l.c./m.s. analysis (2½% OV-1, 50-210°C) showed the main components of the reaction mixture to have m.s. consistent with the following assignments:- toluene (m/e 92, 81); 4-methyl nitrosobenzene (m/e 121, 91, 65); toluonitrile (m/e 117); 4,4'-dimethyl biphenyl (m/e 182); ditolylamine (m/e 198, 184, 91); 4,4'-dimethylbenzophenone (m/e 210, 119, 91); 4-methylphenyl-4'-methyl benzoate (m/e 226, 119, 91). The identity of toluene and 4,4'-dimethyl biphenyl were confirmed by comparison of the m.s. of authentic samples under the same conditions. The ratio of products is summarised in table 7.

14.10 FVP of 3,6-Diphenyl- and 3,6-Bis(4-methylphenyl)-1,4,2,5-dioxadiazines at 800°C

3,6-Diphenyl-1,4,2,5-dioxadiazine (0.30 g, 1.26 mmol) and 3,6-bis(4-methylphenyl)-1,4,2,5-dioxadiazine (0.38 g, 1.41 mmol) were co-distilled and the vapour pyrolysed at 800°C, the pyrolysate being condensed onto dry chloroform. G.l.c. analysis (2½ OV-1, 65-185°C) established the presence of benzene, toluene, benzonitrile, toluonitrile, 4-methyl biphenyl and 4-methylbenzophenone. G.l.c./m.s. analysis of the appropriate portion of the complex reaction mixture established the presence of vapour phase cross-over products. Biphenyl (m/e 154), 4-methyl biphenyl (m/e 168), 4,4'-dimethyl biphenyl (m/e 182) and 4-methyl benzophenone.

Table 7. Ratio^(d) of Products from the FVP of
3,6-Diphenyl- and 3,6-Bis(4-methylphenyl)-
1,4,2,5-dioxadiazines

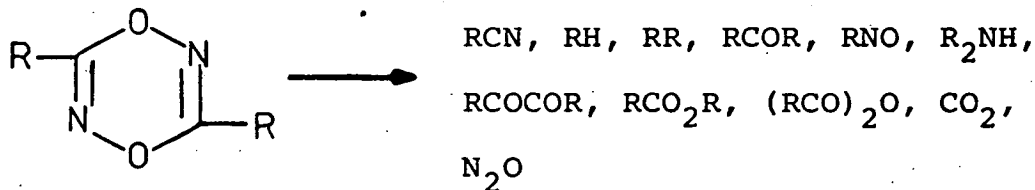

R	Oven temp/ ^o C	RCN	RH	RNO	RR	RCOR	R ₂ NH	RCOCOR	RCO ₂ R
Ph	400	100	12	23	5	15 ^b		5	10
Ph	600	100	- ^a	5.5	8	12 ^b		3	1.5
Ph	800	100	16	0	14	13 ⁶		0	0
4-CH ₃ C ₆ H ₄	600	100	15	3	6	7	3		10 ^c

- a. Benzene not looked for in this experiment
- b. Benzophenone and diphenylamine could not be separated under the g.l.c. conditions used.
- c. 4,4'-dimethyl benzil and 4-methylphenyl-4'-methyl benzoate were not completely resolved under the g.l.c. conditions.
- d. G.l.c. integral ratios assuming benzonitrile equals 100.

DISCUSSION

PAGE No.

1.	FLASH VACUUM PYROLYSIS OF FUROXANS	159
1.1	Isolation of Nitrile Oxides from FVP of Furoxans	159
1.2	Generation of Isocyanates from the FVP of Furoxans	169
2.	THERMOLYSIS OF OXADIAZOLES	179
2.1	Isolation of Nitrile Oxides and Nitriles from the Thermolysis of Furazans	179
2.2	Thermolysis of 3,5-Diphenyl-1,2,4-oxadiazole	190
3.	THERMOLYSIS OF 2,4,5-TRISUBSTITUTED-1,2,3-TRIAZOLE-1-OXIDES	196
4.	FLASH VACUUM PYROLYSIS OF 3,6-DIARYL-1,4,2,5-DIOXADIAZINES	204

1. FLASH VACUUM PYROLYSIS OF FUROXANS

1.1 Isolation of Nitrile Oxides from the FVP of Furoxans

Since the earliest reports that phenyl isocyanate had been formed during an attempted distillation of 3,4-diphenylfuroxan^{11,104} it has been postulated that the reaction involves dissociation of the furoxan to two nitrile oxide fragments, followed by the established rearrangement to phenyl isocyanate, Scheme 44. If this is the case then it might be expected that thermolysis of the furoxan in the presence of suitable dipolarophiles would lead to the formation of 1,3-dipolar cycloadducts from the nitrile oxide fragments and the dipolarophile.

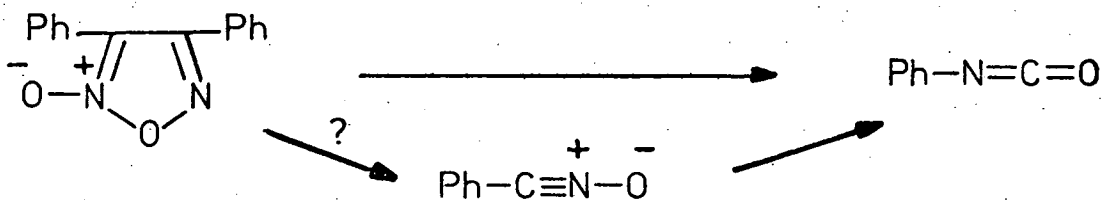

Scheme 44

The isolation of such cycloadducts was first reported in 1972^{105,106} when it was observed that strained furoxans and furoxans with bulky substituents decomposed at moderate temperatures, in the presence of suitable dipolarophiles, to give 1,3-dipolar cycloadducts. However, more recently it has been reported¹⁰⁷ that the thermolytic ring opening does not depend upon special structural features but is a general reaction which takes place under more forcing conditions. It has been established that the thermolysis

3,4-disubstituted furoxans (42) in the presence of alkenes at temperatures in excess of 200°C results in the formation of isoxazolines¹⁰⁷ (145). As above, the process was assumed to involve a 1,3-dipolar cycloaddition between the alkene and the two nitrile oxide fragments (12) resulting from the thermal cleavage of the oxadiazole ring [Path A], thus reversing the established nitrile oxide to furoxan dimerisation.²⁰ However, nitrile oxides were not detected during the course of the reaction and the possibility of the isoxazoline being formed by direct interaction between the alkene and the furoxan could not be ruled out. Cycloaddition of the alkene to the furoxan itself via a nitron-like cycloaddition and subsequent collapse of the intermediate adduct (146) would also lead to the observed products [Path B]. The two modes of reaction are illustrated in Scheme 45.

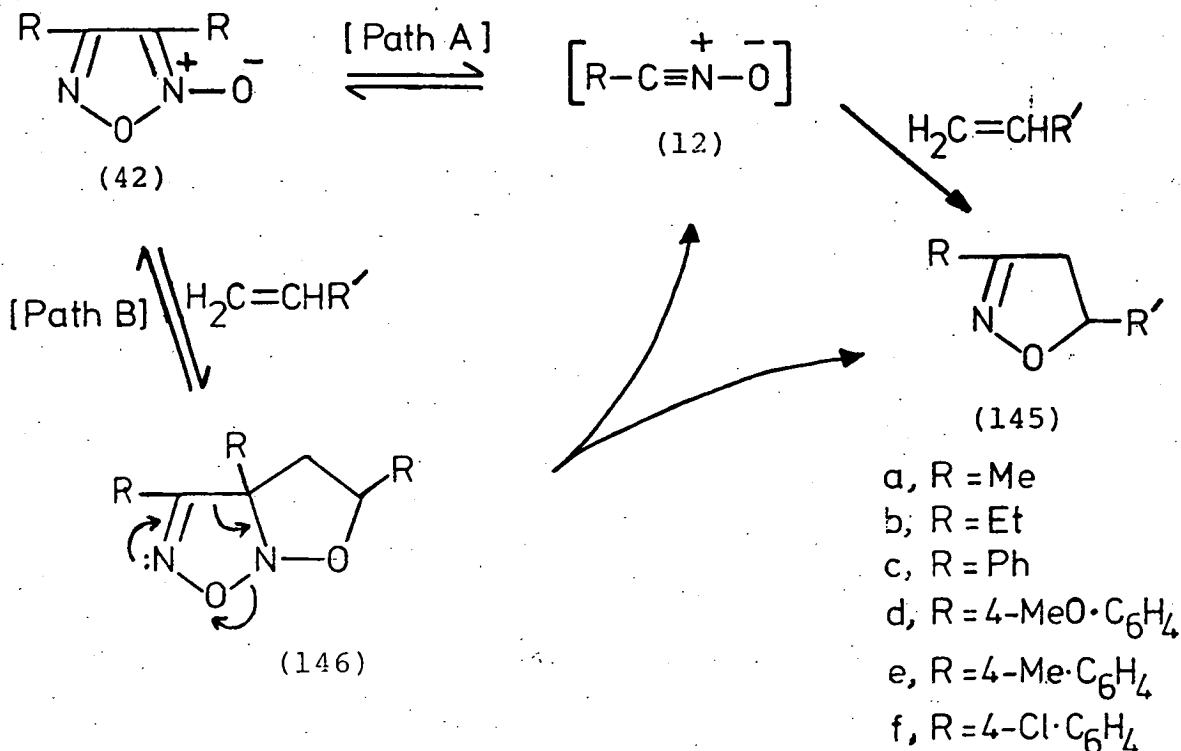

Although nitrile oxides were not detected under these conditions ($>200^{\circ}\text{C}$) there is some spectroscopic evidence¹⁰⁶ to support decomposition via nitrile oxide intermediates at lower temperatures. While studying the reactions of adamantane-1-carbonitrile oxide (147) Dondoni and his co-workers discovered that prolonged heating of di[1-adamantyl]furoxan in carbon tetrachloride resulted in a retrocycloaddition to (147) and 1-adamantyl isocyanate.¹⁰⁶ The identity of (147) was established by i.r. spectroscopic analysis of the decomposition solution; after 40 h two overlapping bands at 2286 and 2255 cm^{-1} were clearly defined; the latter was assigned to the nitrile oxide after comparison with the i.r. spectrum of authentic (147) prepared independently from the corresponding aldoxime. In addition 3-[1-adamantyl]-5-phenyl-2-isoxazoline (72%) was isolated when the thermolysis was carried out in the presence of styrene. However, there is also some evidence in support of [path B] in Scheme 45. Thermolysis of 3,4-dibenzoylfuroxan (103), page 63 in the presence of phenylacetylene resulted in products formed by direct interaction of the dipolarophile with the furoxan¹¹¹ (Scheme 32); behaviour which is directly analogous to the imidazole-N-oxides¹¹² (148).

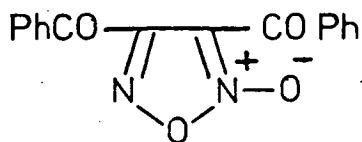

(103)

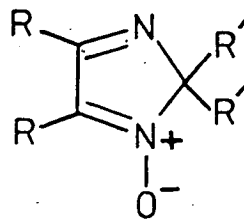

(148)

The failure to detect nitrile oxides during the thermolysis of furoxans under the more forcing conditions (e.g. $> 200^{\circ}\text{C}$)¹⁰⁷ can be attributed to the fact that under these conditions the nitrile oxide isocyanate rearrangement and their cycloaddition reactions with alkenes are extremely rapid.²⁰ Furthermore, because of the high temperatures required to effect the decomposition of all but the most strained bicyclic furoxans and furoxans with bulky substituents, their thermolysis provides only a very limited source of nitrile oxide derived products. Ideally the decomposition temperature of the furoxan should be less than its boiling point. For example, when 3,4-diphenyl (42c) - and 3,4-dimethylfuroxan (42a) were heated under reflux in 1-dodecanol (b.p. 257°C) phenyl and methyl isocyanate were trapped as their carbamates in yields of 81 and 20% respectively. The low yield of carbamate derived from the methyl isocyanate can be attributed, in part, to the volatility of the furoxan (b.p. $107^{\circ}\text{C}/5\text{ mmHg}$).³⁷ The range of isocyanate traps and dipolarophiles is very much restricted by temperature; firstly the boiling point must be less than the decomposition temperature of the furoxan and secondly the dipolarophile must be thermally stable at these temperatures and must give rise to thermally stable cyclo-adducts.

Therefore the widespread use of furoxans as a source of nitrile oxides is seriously limited by these constraints.

The objectives of the present investigation were to expand the synthetic usefulness of the decomposition and to isolate and identify the previously unattainable nitrile oxide intermediates. To achieve these ends the thermolysis of furoxans was investigated using conventional Flash Vacuum Pyrolysis (FVP) apparatus (Fig. 10, page 117) and technique.

The use of this gas phase thermolytic technique has enabled the isolation and identification of the nitrile oxide fragments. For example, FVP of diphenylfuroxan (42c) at 450°C and 10^{-3} mmHg resulted in a clean fragmentation of the oxadiazole ring to yield benzonitrile oxide (12c) which was isolated in a cold trap at -196°C. The identity of the benzonitrile oxide was established by the characteristic absorption at 2281 cm^{-1} in the i.r. spectrum and by comparison of the spectrum with that of authentic material prepared by base treatment of benzohydroximoyl chloride. Further confirmation of the identity of the product was obtained by treating it with excess diethyl fumarate and isolating the cycloadduct, 4,5-dicarbethoxy-3-phenyl-2-isoxazoline (85%) (150), as illustrated in Scheme 46.

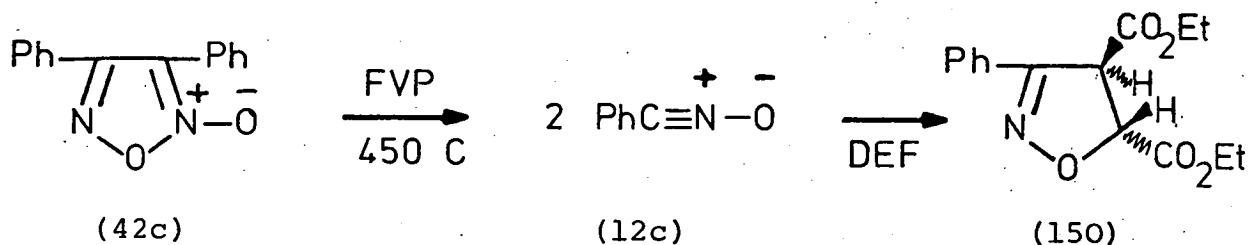

Scheme 46

Fig. 14

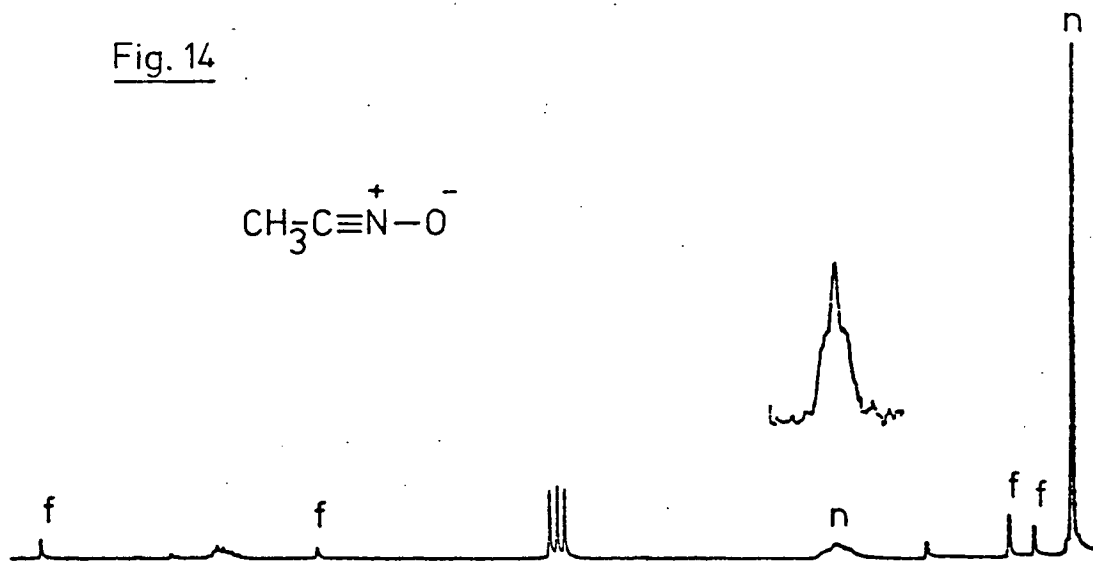

Fig. 15

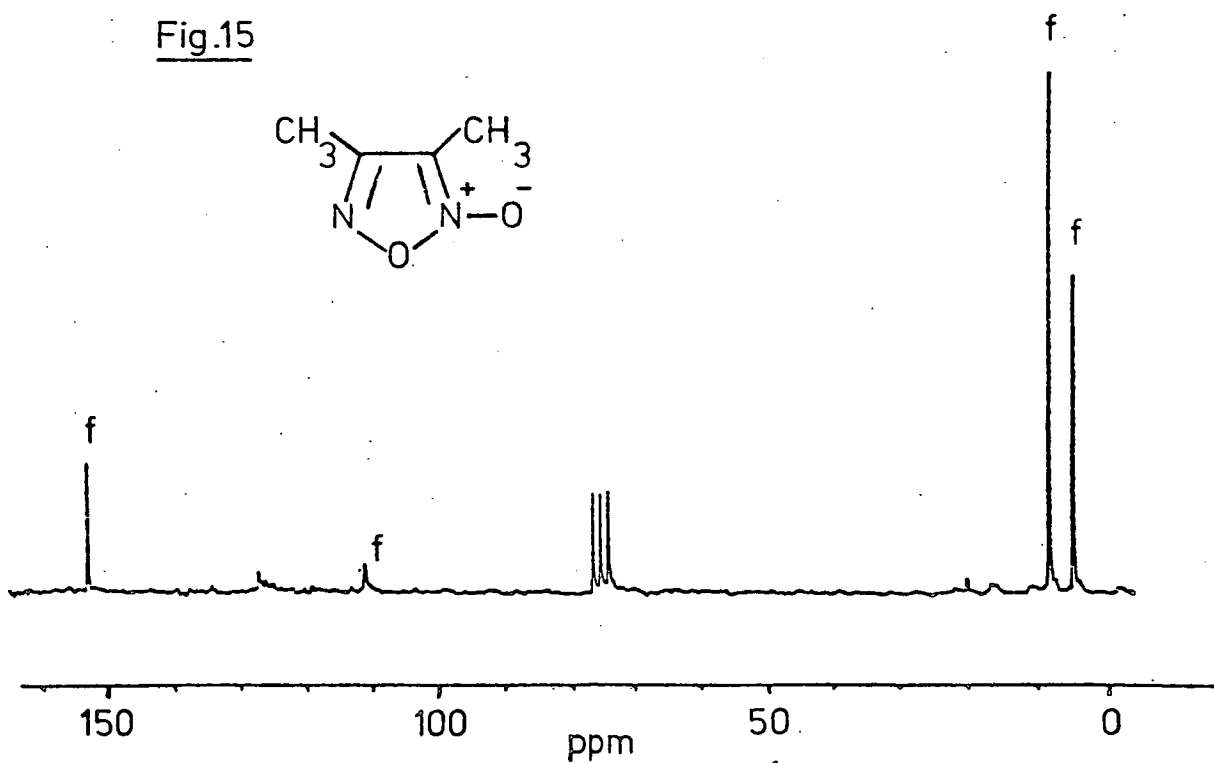

Fig. 14 ^{13}C n.m.r. of acetonitrile oxide (CDCl_3 , -51°C) formed by FVP of dimethylfuroxan

Fig. 15 ^{13}C n.m.r. spectrum of Reaction mixture after 3 days at room temperature, indicating formation of dimethylfuroxan

While the conventional methods, dehydrogenation of aldoximes^{18,19,22} and dehydrochlorination of hydroximoyl chlorides,^{13,28} are satisfactory for the preparation of aromatic nitrile oxides having long lifetimes, they prove cumbersome for the isolation of the short-lived aliphatic counterparts, which undergo rapid dimerisation to the corresponding furoxan.²⁰ Thus acetonitrile oxide (12a) is reported to exist for less than 1 minute at 18°C,²⁰ although De Sarlo et al⁶⁰ have suggested that the low stability refers to the pure substance above its m.p. Nevertheless, because of its reactivity and its tedious preparation from the hydroximoyl chloride, (12a) has received little attention.^{20,167} In contrast FVP (600°C, 10⁻³ mmHg) of dimethylfuroxan provides a straightforward means of generating the nitrile oxide, thus permitting detailed examination of its properties. Having generated the reactive intermediate it was conveniently stored at -78°C (CO₂/Acetone slush bath) for several days after which there was no observable change in the n.m.r. spectrum. Therefore, under these conditions recombination back to the furoxan is prevented. By using this technique solutions of (12a) and propionitrile oxide (12b) in CDCl₃ were prepared and their n.m.r. spectra recorded.

The ¹³C n.m.r. spectrum (CDCl₃, -51°C) of (12a) comprises the two lines marked 'n' in Fig. 14. The larger peak at 0.8 ppm is attributed to the methyl carbon, while the broad signal centred at 35.6 ppm, which is partially resolved into a triplet due to coupling with the ¹⁴N nucleus, is assigned

to the carbon of the nitrile oxide group.¹⁶⁸ Some contamination by (12a), either resulting from incomplete fragmentation or due to partial dimerisation of the nitrile oxide,²⁰ is indicated by the presence of the four lines marked "f", this assignment being made by comparison with the spectrum obtained from authentic furoxan.

The poor resolution of the fulmido carbon resonance is most probably due to ¹⁴N nuclear quadrupole relaxation which is known to cause extensive line broadening.¹⁶⁸ The chemical shift and the one bond ¹³C-¹⁴N coupling constant of 48 ± 2 Hz are consistent with those for the only previous reported case, namely the stable 2,4,6-trimethylbenzonitrile oxide, of 36.6 ppm and 52 ± 2 Hz.¹⁶⁸ Similarly the ¹³C n.m.r. spectrum (CDCl₃, -51°C) of (12b) exhibits a broad, partially resolved triplet at 39.1 ppm with a ¹³C-¹⁴N coupling constant of 42 ± 2 Hz.

On allowing the solutions of (12a) and (12b) to warm to, and remain at, room temperature for approximately 3 days, the lines attributed to (12a) and (12b) disappeared, while those due to (42a) and (42b) increased in intensity, as is illustrated in Fig. 15 for (12a), consistent with the expected recombination to the furoxan. Similarly, the dimerisation to furoxan was also monitored by ¹H n.m.r. The spectrum of (12a) at -40°C consists of three lines, the outside two at 2.21 and 2.40 δ being due to (42a) while the third line at 2.26 δ is assigned

Fig. 16 Dimerisation of Acetonitrile oxide followed
by H n.m.r.

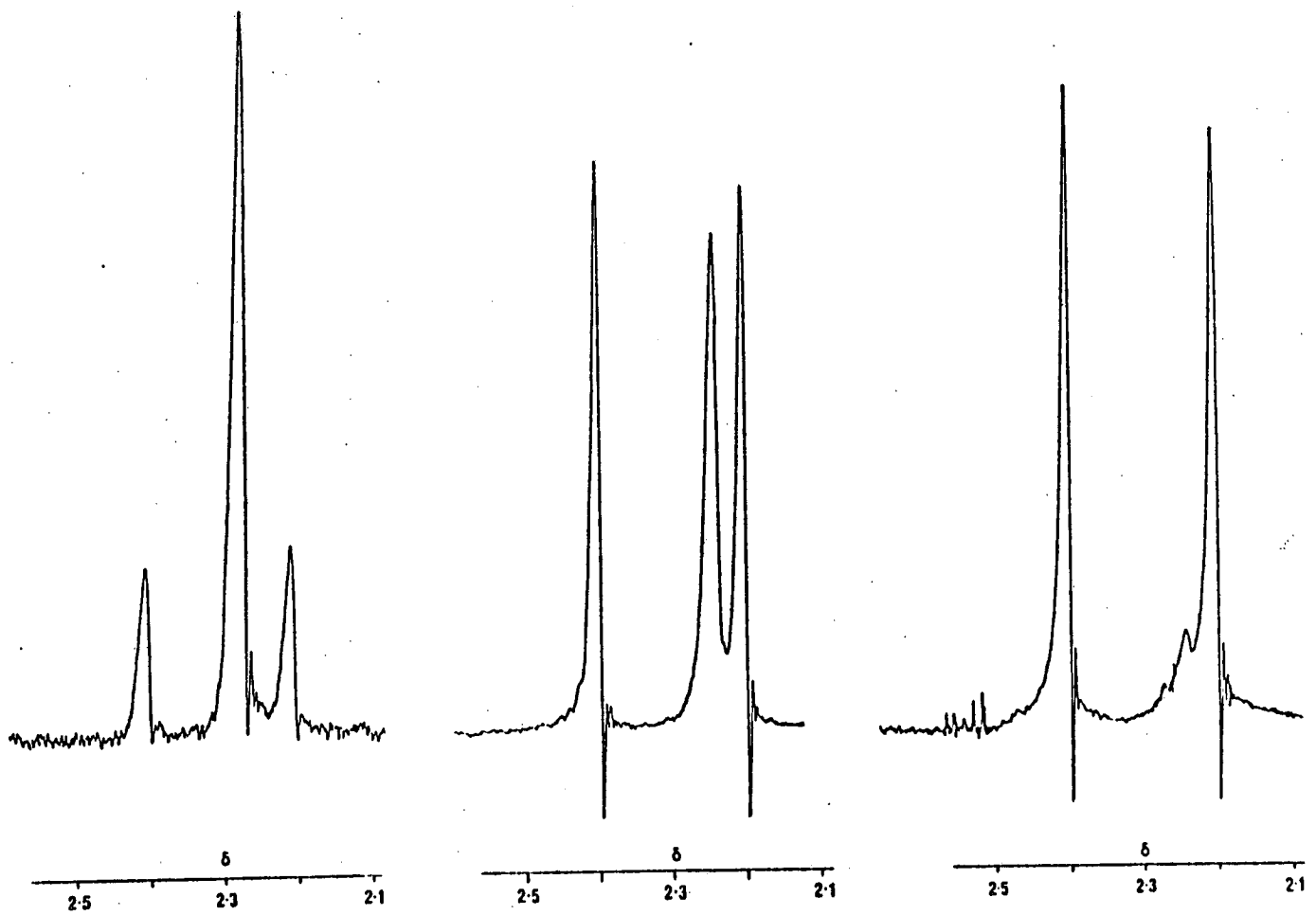

to (12a)⁶⁰. On warming to room temperature the signal due to (42a) increased at the expense of that due to (12a), the process being complete after approximately 3 days. The ¹³C and ¹H n.m.r. data for (12a) and (12b) are recorded in Tables 4 and 5 respectively.

In addition to allowing the spectroscopic examination of these short lived aliphatic nitrile oxides, the FVP technique also enables the kinetics of the dimerisation to the furoxan to be examined in more detail. For example, by following the dimerisation of (12a) in CDCl₃ by ¹H n.m.r. (Fig. 16) the rates of disappearance of (12a) and the formation of (42a) showed the expected second order kinetics. The use of 1,4-dioxan as an internal standard enabled the rate constant to be determined. At 23°C the second order rate constant for the dimerisation of acetonitrile oxide to dimethylfuroxan in CDCl₃ is $6.1 \pm 0.2 \times 10^{-4} \text{ mol}^{-1} \text{ dm}^3 \text{ s}^{-1}$. This value compares with that reported for the dimerisation of 4-chlorobenzonitrile oxide (12f) in CHCl₃ at 25°C, $1.77 \times 10^{-4} \text{ mol}^{-1} \text{ dm}^3 \text{ s}^{-1}$.⁵⁰

That the rate constant for the dimerisation of (12a) is greater than that for (12f) under similar conditions was to be expected. Rather in the light of the original reports²⁰ as to the stability of (12a), it is perhaps surprising that they are so similar. These findings tend to confirm the view suggested by De Sarlo et al.⁶⁰ that the reported short lifetime of (12a) refers not to its solutions but to the pure substance above its m.p. In dilute solution have a second order rate law for a bimolecular process, therefore the greater the concentration the greater the rate.

In addition to the advantages outlined above with respect to the isolation and spectroscopic examination of short lived aliphatic nitrile oxides, application of FVP greatly enhances the synthetic utility of furoxans as nitrile oxide sources. For example, the synthetic route from furoxans to isoxazolines is greatly extended by the removal of the necessity for the alkenes to boil at $>200^{\circ}\text{C}$ ¹⁰⁷ if the reaction is to be carried out at atmospheric pressure. Furthermore, the yields of the cycloadducts are increased and there is a reduction of the amount of tarry by-products which were a feature of the original furoxan based route, and which may be attributed to the limited thermal stability of both alkenes and the isoxazoline products.¹⁰⁷ The isoxazolines prepared by the FVP technique are listed in Table 8, together with the reaction conditions used.

The unequivocal identification of the isoxazolines was achieved, in most cases, by mixed m.p. and by comparison of their ^1H and ^{13}C n.m.r. spectra (Tables 2 & 3) with those of authentic adducts prepared from the reaction of the alkene with the corresponding hydroximoyl chlorides.

The ^1H n.m.r. of 5-butyl-3-methyl-2-isoxazoline (151) is particularly interesting because in addition to the usual splitting pattern for the isoxazoline ring hydrogens, characteristic of an ABX system, there is long range coupling between the 3-methyl group and the methylene group at the 4-position of the ring. This is illustrated in the 360 MHz

TABLE 8

2-Isloxazolines (145) produced by reaction of alkenes with nitrile oxides (12) produced via FVP of furoxans (42)

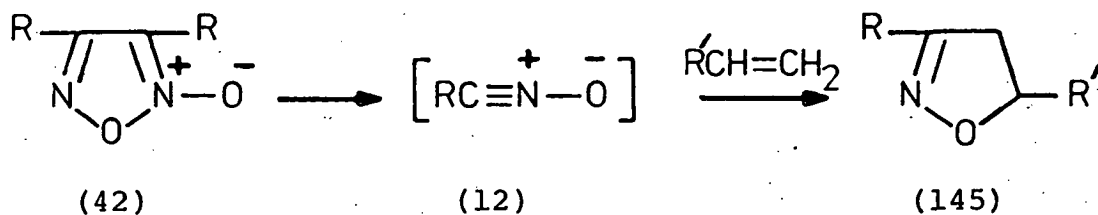

R	R'	FVP (a) oven temp. ($^{\circ}C$)	mol % yield (b)
C_6H_5	C_4H_9	550	97
4- $CH_3OC_6H_4$	C_4H_9	500	75
4- ClC_6H_4	C_4H_9	600	90
4- $CH_3C_6H_4$	$C_{12}H_{25}$	500	86
CH_3	C_4H_9	600	75
C_2H_5	C_4H_9	650	95

(a) 10^{-3} mmHg;

(b) isolated yields

Fig. 17 360 MHz ¹H.n.m.r. spectrum of 5-Butyl-3-methyl-2-isoxazoline

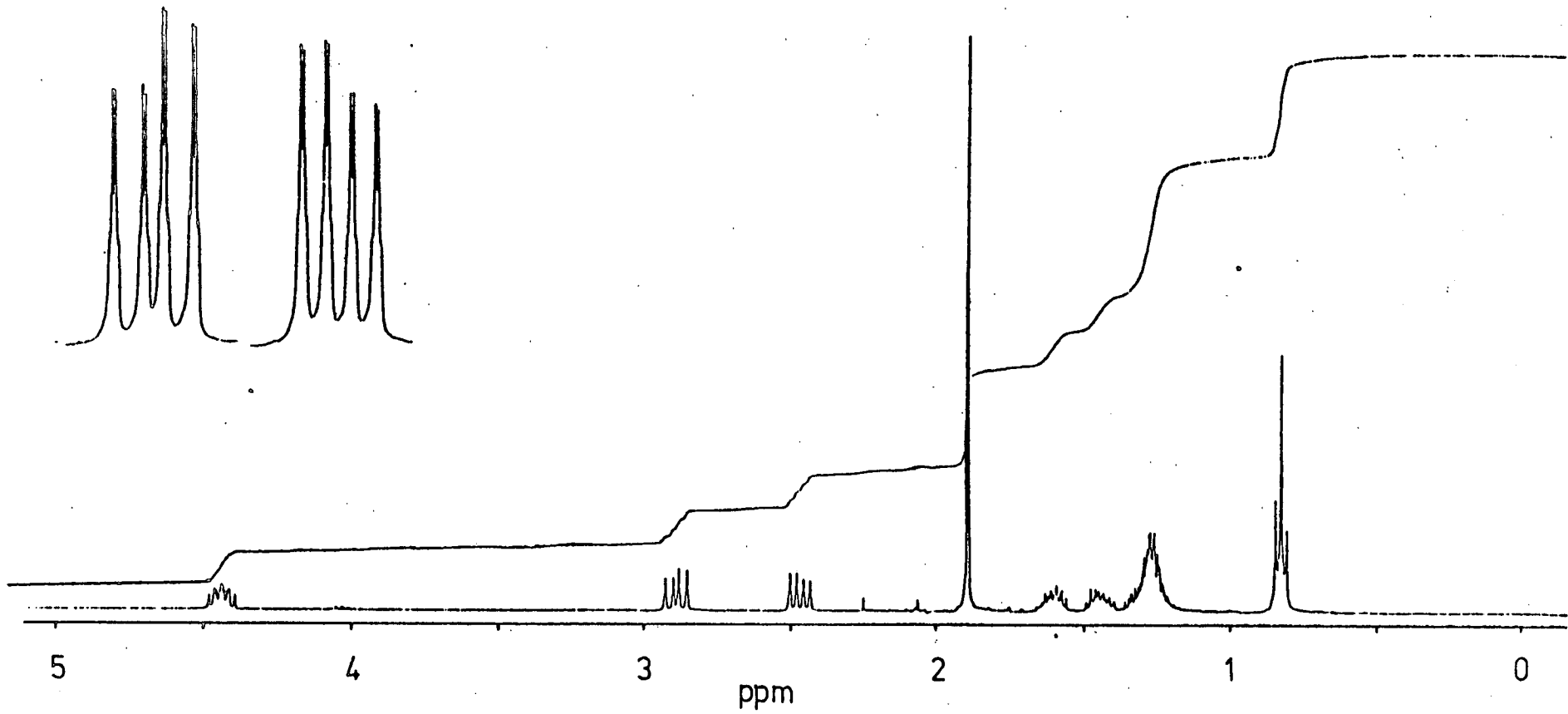

spectrum of (151) shown in Fig. 17. The coupling constants are illustrated and summarised below:-

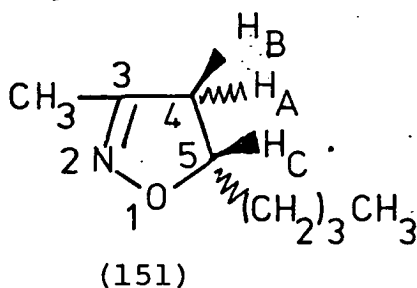

J_{AB}	16.8 Hz
J_{AC}	8.2 Hz
J_{BC}	10.2 Hz
J_{4,CH_3}	0.98 Hz

The assignment and magnitude of the coupling constants, J_{AB} , J_{AC} and J_{BC} , are in close agreement with those reported by Huisgen *et al*¹⁶⁹ for several closely related isoxazolines. More recently a long range coupling such as the one described above has been observed for several related 3-methyl-5-(1-substituted pyrrolyl)-2-isoxazolines¹⁷⁰ (152) prepared from the 1,3-dipolar cycloaddition of acetonitrile oxide, prepared *in situ* from nitroethane, with 1-substituted vinylpyrroles, Scheme 47.

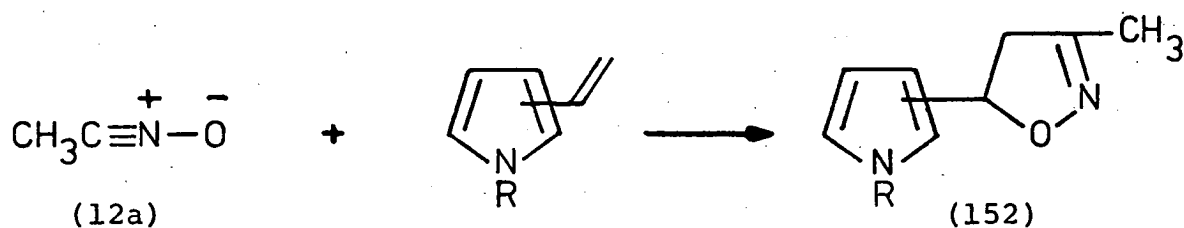

Scheme 47

1.2 Generation of Isocyanates from the FVP of Furoxans

It has been known since the very early attempts to distil diphenylfuroxan (42c),^{11,104} and from the more recent work of Crosby and Paton *et al*,¹⁰⁷ that phenyl isocyanate (153c) is formed during the thermolysis of (42c). Consequently it might have been expected that some (153c)

be formed under the FVP conditions. To establish whether or not this is the case (42c) was pyrolysed at different temperatures, the products being condensed onto 1-hexene. Examination of the anhydrous product mixture by g.l.c. established that, along with the isoxazoline, formed from the cycloaddition of benzonitrile oxide and 1-hexene, (153c) was present. The product yields are summarised in Table 9.

TABLE 9

Phenyl isocyanate (153c) and 5-butyl-3-phenyl-2-
isoxazoline (154) formed via the FVP of 3,4-
diphenylfuroxan

FVP oven temp. °C	(153c) mol %	(154) mol %
550	2	98
700	4	95
800	37	27

The yield of phenyl isocyanate indicates the fraction of the initially formed benzonitrile oxide which undergoes rearrangement, in the gas-phase, to the isocyanate. Not surprisingly, the concentration of (153c) increases as the FVP oven temperature increases. However, even at 800°C where the isocyanate is the major product the actual yield is still relatively poor, offering no advantage over the

conventional solution thermolysis of (42c) which results in 42% yield¹⁰⁷ of (153c).

Although, from the above results, it would appear that isocyanates cannot be obtained in good yield from the FVP of furoxans directly, they can be readily prepared by catalysed isomerisation of the nitrile oxides thus formed. The method employed was that first reported by Burk and Carlos⁴⁰ and involves the reaction of sulphur dioxide with nitrile oxides to yield 1,3,2,4-dioxathiazole-2-oxide cycloadducts and the latter's ready thermolysis to isocyanate and sulphur dioxide. For example, terephthalonitrile dioxide (155) reacts with liquid sulphur dioxide to give the bis-dioxathiazole-2-oxide (156) in 85% yield. Subsequent heating in an inert solvent at about 100-130°C gave *p*-phenylenediisocyanate (157) and sulphur dioxide quantitatively⁴⁰ as illustrated in Scheme 48.

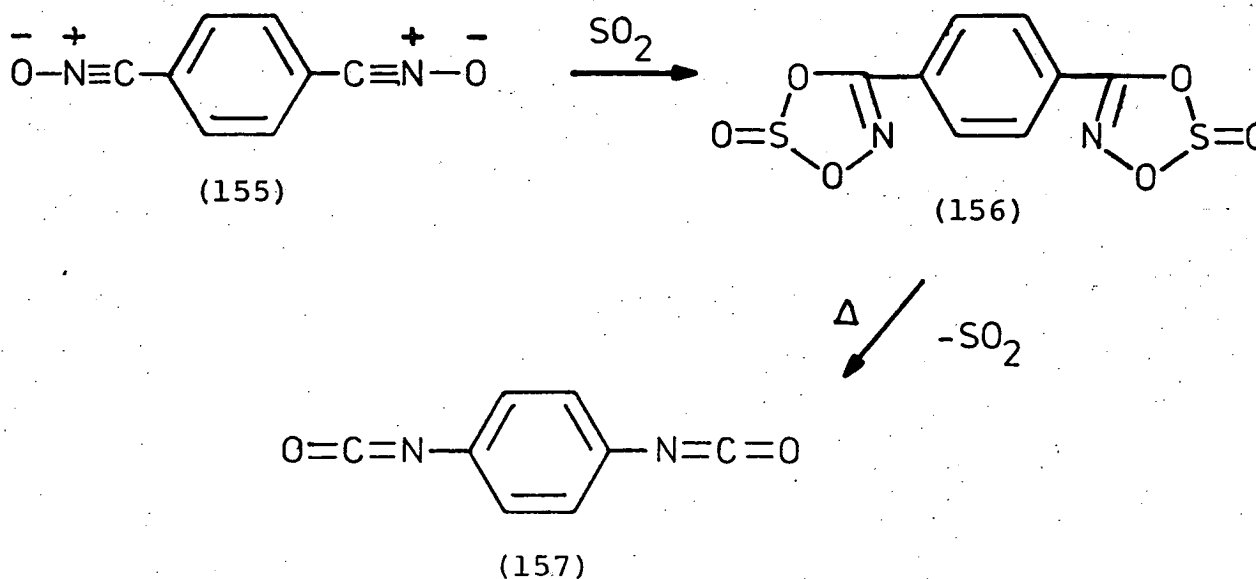

Scheme 48

The inclusion of sulphur dioxide has been successfully applied to the generation of isocyanates from the solution thermolysis of furoxans.⁹⁸ Pyrolysis of strained furoxans of the norbornane series resulted in the fragmentation of the oxadiazole ring, the isolated products being di-isocyanates (158) when the reactions were carried out in the presence of sulphur dioxide, while in its absence strained polymeric furoxans (159) were formed,⁹⁸ Scheme 49.

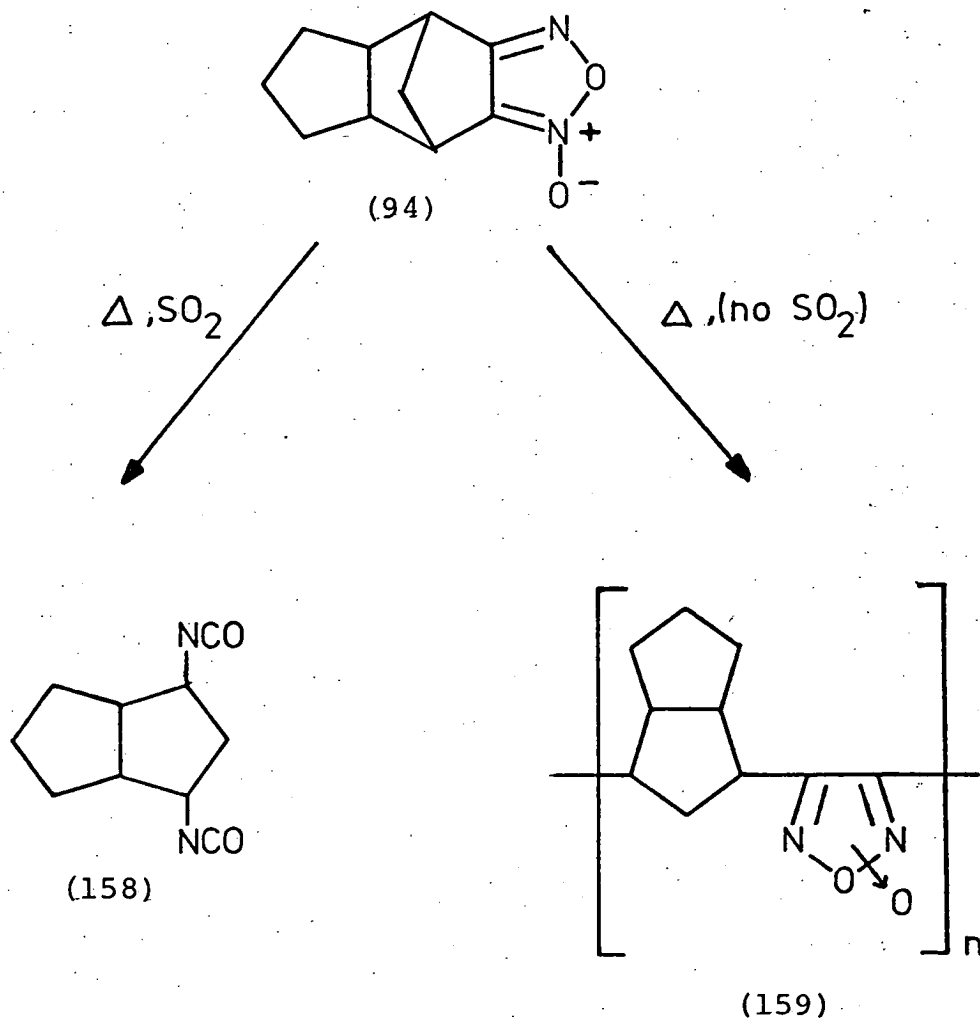

Scheme 49

In the present investigation the furoxans were subjected to FVP and the products collected in a cold trap (-196°C) containing excess sulphur dioxide. Dry toluene was added and the resulting solution heated under reflux for 1 h. After removal of the sulphur dioxide from the solution with a stream of dry nitrogen, the presence of the isocyanate was established by i.r. spectroscopy (ν_{max} ca 2260 cm^{-1} , $-\text{NCO}$), g.l.c. and by reaction with ethanol or aniline to yield the corresponding urethane or urea respectively. The isocyanates prepared by this technique are listed in Table 10, together with the reaction conditions used.

TABLE 10

Isocyanates prepared by the FVP of 3,4-disubstituted furoxans via the reaction of sulphur dioxide with the nitrile oxides thus formed

R	FVP oven temp. $^{\circ}\text{C}$	RNCO mol %	RNHCONHC ₆ H ₅ mol %	RNHCO ₂ Et mol %
C ₆ H ₅	500	93		75
4-CH ₃ C ₆ H ₄	500	76	71	
4-CH ₃ OC ₆ H ₄	500		95	
C ₄ H ₉	600		61	
CH ₃	550		74	

The formation of the isocyanates (153) may be rationalised in terms of initial cleavage of the furoxan (42) under the FVP

conditions to its two nitrile oxide fragments (12), followed by sulphur dioxide-mediated isomerisation of (12) to (153) via the 1,3,2,4-dioxathiazole-2-oxide (34) as illustrated in Scheme 50.

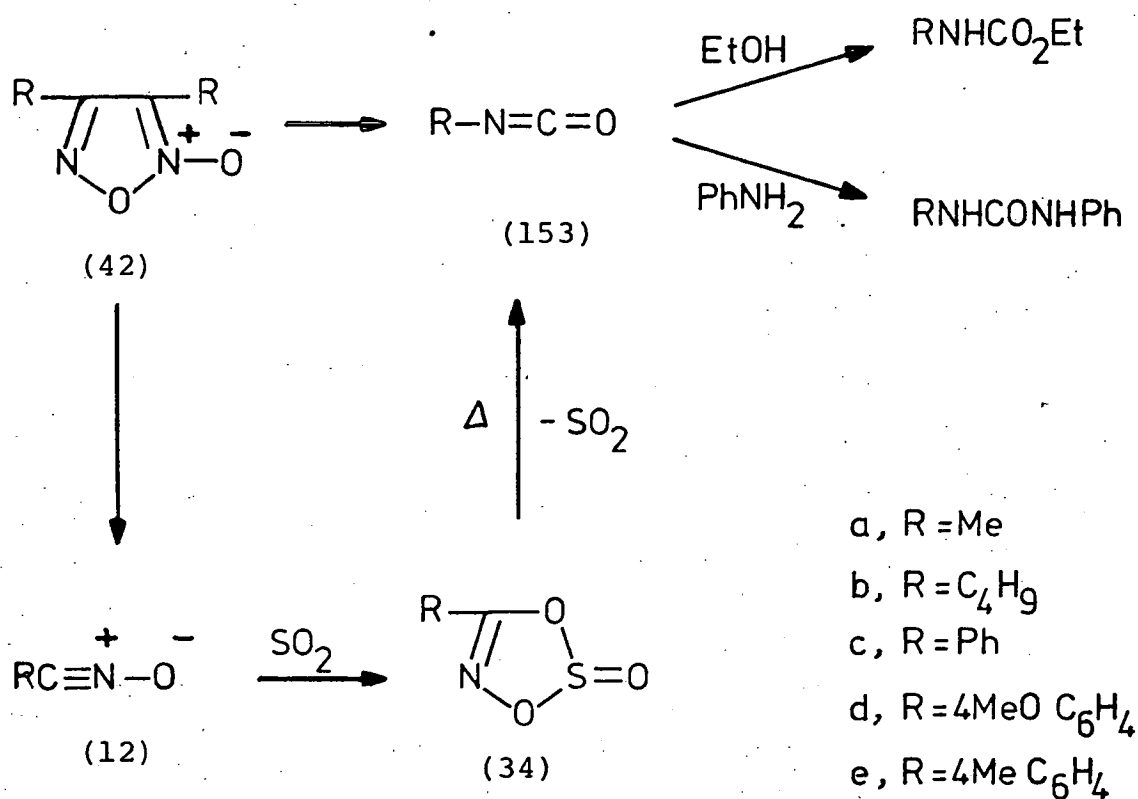

Scheme 50

The intermediacy of the dioxathiazole-2-oxide (34) and in particular compound (34a) was indicated by the characteristic⁴⁰ i.r. absorption at 1240 cm⁻¹, and demonstrated by treatment of the pyrolysate solution with water and isolation of the corresponding hydroxamic acid (CH₃CONHOH).

From the fact that isocyanates are formed in high yields from the decomposition of the dioxathiazole-2-oxides⁴⁰ (Table 10), and from the work of Franz and Pearl⁴¹ who demonstrated unequivocally that thermolysis in the presence of DMAD resulted in nitrile oxide cycloadducts in addition to the corresponding isocyanates, the following observations can be made as to the reaction pathway. For example, thermolysis of (34c) at 110°C in the presence of DMAD produced phenyl isocyanate (55%) and 4,5-dicarbomethoxy-3-phenylisoxazole (160)⁴¹ (39%). In contrast, in the present investigation, thermolysis in the absence of DMAD resulted in a very high yield of phenyl isocyanate (93%). In addition, at 110°C the rate of dimerisation of benzonitrile oxide to diphenylfuroxan is faster than the rate of isomerisation to phenyl isocyanate. For example when benzonitrile oxide is heated rapidly in xylene to 110°C there is approximately a 10% conversion to phenyl isocyanate while the rest dimerises to diphenylfuroxan.⁴⁶ However, under these conditions where the furoxan would be stable, no furoxan is detected. Therefore it seems probable that the decomposition mechanism involves both an isocyanate forming pathway (path a), involving a concerted fragmentation, and a separate reversible step to give sulphur dioxide and the nitrile oxide (path b) which in the presence of a dipolarophile (DMAD) is trapped as the 1,3-dipolar cycloadduct, Scheme 51. Initial cleavage to acyl nitrene and its subsequent rearrangement is improbable as attempts to trap the acyl nitrene have so far proved unsuccessful.³⁹

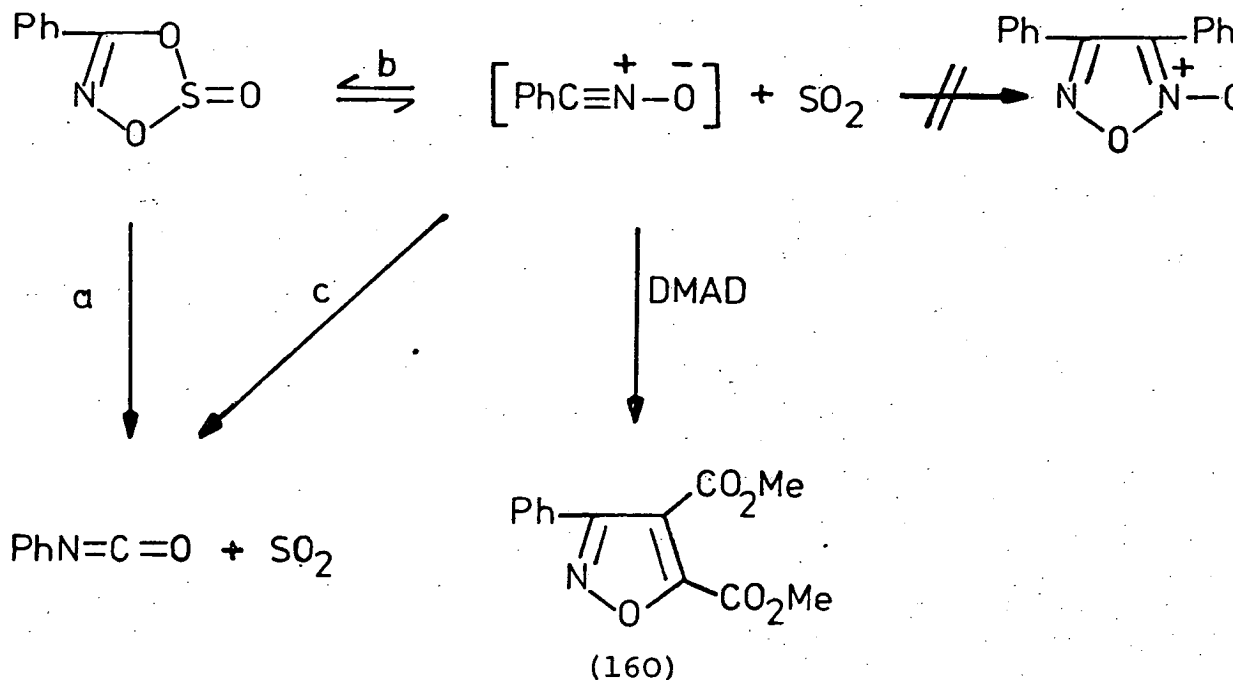

Scheme 51

Evidence for or against such a proposal could be obtained by preparing the dioxathiazole-2-oxide from the nitrile oxide, readily generated by FVP of the furoxan, and doubly labelled ^{18}O sulphur dioxide. If on subsequent thermolysis all the isocyanate contained the ^{18}O -label then the concerted mechanism is strongly supported and the nitrile oxide rearrangement route eliminated (path c).

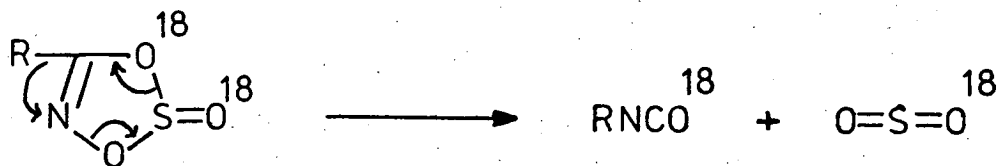

The results in Table 10 demonstrate the power of the FVP technique when applied to furoxans. Prior to the use of FVP, the synthetic utility of the fragmentation, as previously stated had been restricted by the high temperatures demanded limited the use of co-reactants such as alcohols, and lead to extensive by-product formation resulting from the decomposition of the

isocyanates and their urethane adducts. The method is particularly valuable for the generation of methyl isocyanate (153a) from dimethylfuroxan, which is readily available from 2-butene and dinitrogen trioxide,⁹⁷ and for which straightforward thermolysis in the liquid phase is ineffective; only traces of methyl isocyanate are formed from dimethylfuroxan at its boiling point.⁷⁷ This route to methyl isocyanate offers an alternative to the conventional routes which involve phosgenation of methylamine.

In addition to the synthesis of isocyanates the technique has also been successfully applied for the preparation of phenyl isothiocyanate. Nitrile oxides react readily with several thiocarbonyl derivatives to give the corresponding 1,4,2-oxathiazole cycloadducts. Subsequent thermolysis of the oxathiazole results in the formation of the isothiocyanate and the oxygen analogue of the thiocarbonyl derivative employed.¹⁷¹ Moreover if the reaction takes place with a thioamide the 5-amino-1,4,2-oxathiazoles, thus formed, are unstable and the corresponding amides and isothiocyanates are directly obtained.

Thus, FVP of diphenylfuroxan at 550°C onto N,N-dimethylthioformamide resulted in a 1,3-dipolar cycloaddition of benzonitrile oxide across the thiocarbonyl bond to give the cycloadduct (161). On warming to ambient temperature (161) decomposed to yield phenyl isothiocyanate (49%), and N,N-dimethylformamide, Scheme 52.

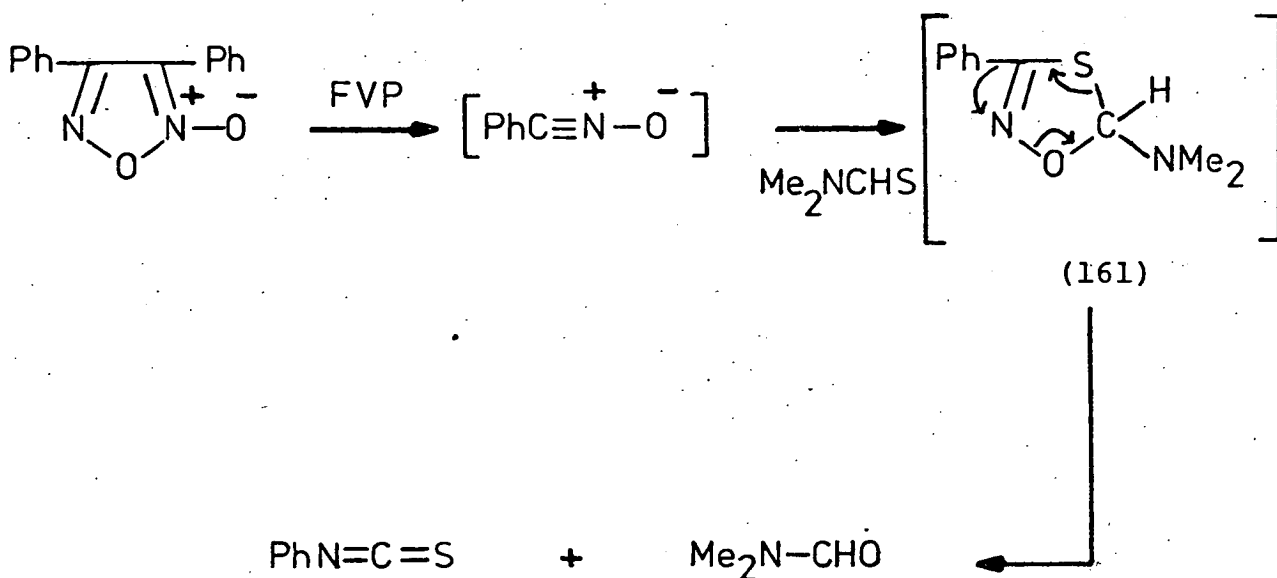

Scheme 52

In conclusion, the generation of nitrile oxides from the thermal fragmentation of furoxans represents an example of a retro 1,3-dipolar cycloaddition.¹⁷² Moreover, the FVP technique gives the resultant nitrile oxides in excellent yield and has enabled the more reactive aliphatic nitrile oxides to be examined spectroscopically. In addition the synthetic utility of furoxans as a source of nitrile oxides has been greatly extended by the removal of the aforementioned temperature constraints. Indeed, for acetonitrile oxide and propionitrile oxide FVP of the corresponding furoxans is probably the method of choice, the nitrile oxides being readily obtained from stable precursors. The one limitation of the FVP technique would be the low reactivity of some dipolarophiles such that the predominant reaction of the nitrile oxides in these cases would be dimerisation to the furoxan and not the desired 1,3-dipolar cycloaddition with the dipolarophile. In these instances generation in situ in the presence of excess dipolarophile would remain the method of choice.

2. THERMOLYSIS OF OXADIAZOLES

2.1 Isolation of Nitrile Oxides and Nitriles from the Thermolysis of Furazans

The furazans under investigation were synthesised from either the corresponding glyoximes by direct dehydration, using thionyl chloride, after the method of Boulton¹¹⁹ or by deoxygenation of the corresponding furoxans, with triethyl phosphite, after the method of Mukaiyama,¹²⁰ Scheme 53.

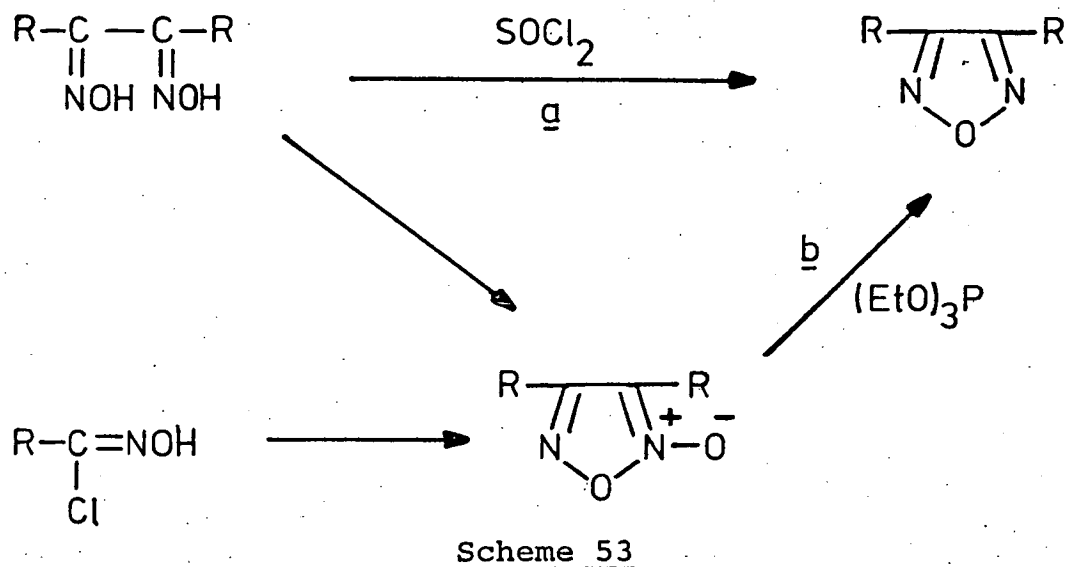

Of the two synthetic routes deoxygenation of the furoxan, route b, is a general method for the preparation of furazans whereas direct dehydration of the glyoxime with thionyl chloride, route a, is restricted to those glyoximes which do not readily undergo a Beckmann rearrangement to the 1,2,4-oxadiazole. In the present context route a was used successfully for the synthesis of 3,4-tetramethylene- and

3,4-dimethylfuran. In contrast, an attempt to prepare 3,4-diphenylfuran via route a resulted, not in the formation of the furazan but in the formation of 3,5-diphenyl-1,2,4-oxadiazole (85%). This behaviour was first observed by Tokura et al during a study of the reaction of cyclohexane-1,2-dioxime with thionyl chloride in liquid sulphur dioxide.¹¹⁸

If the furoxan is readily available, as it was in the present investigation, route b is the method of choice the deoxygenation occurring in excellent yield (usually >90%) whereas route a normally only gives ca 50% yield of the furazan.

Despite the early reports that rapid heating of diphenylfuran resulted in the formation of benzonitrile and phenyl isocyanate,^{123,124} and the hypothesis that, like diphenylfuroxan,^{11,104} the decomposition proceeds via benzonitrile oxide, the thermal decomposition of furazans has not been investigated in any depth.

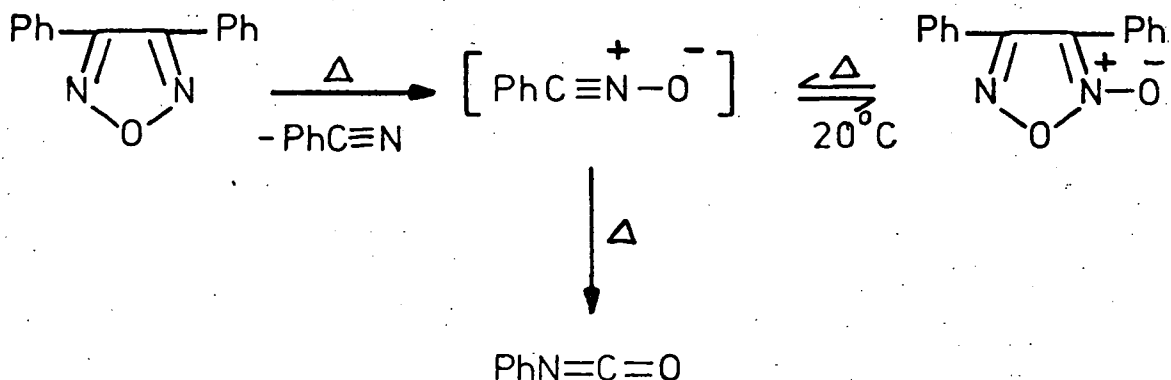

In contrast, the photolytic decomposition has received considerable attention^{43,125-128} and it has been established that photolysis of the furazan generally leads to nitrile oxide derived products and the corresponding nitrile. Prior to 1979, the only reported instance of a furazan thermally decomposing to a nitrile oxide was the case of the strained, bicyclic acenaphtho[1,2-c]furazan¹¹⁹ (123). The intermediacy of the nitrile oxide was established by i.r. spectroscopy and the isolation of the 1,3-dipolar cycloadduct (124) with phenylacetylene, Scheme 39, page 73. More recently the thermolytic ring opening to nitrile oxides and nitriles has been extended to include other strained bicyclic furazans.^{110,129} Paton et al have demonstrated that in the presence of a suitable dipolarophile or sulphur dioxide thermolysis of 3,4-trimethylenefurazans (126) results in the formation of the corresponding 1,3-dipolar cycloadduct (129) or 3-cyanopropyl isocyanate (128) respectively,¹¹⁰ Scheme 40, page 74.

In similar fashion Tsuge et al¹²⁹ have demonstrated the thermolytic ring opening of 4,6-diphenylthieno[3,4-c]furazan (130) to nitrile/nitrile oxide intermediates, Scheme 41, page 75.

One of the objectives of the present research was to determine whether or not the thermolytic ring opening to nitrile oxides and nitriles is a general reaction for furazans and not one dependent on special structural features such as ring strain.

To establish whether or not this is the case the thermolysis of 3,4-diphenyl-3,4-tetramethylene- and 3,4-decamethylenefurazan were carried out in a large excess of a suitable dipolarophile. In a similar experiment to that carried out with diphenylfuroxan by Paton and Crosby,¹⁰⁷ diphenylfurazan was heated under reflux for 6 h at 245°C in 1-tetradecene. The thermolysis afforded 5-dodecyl-3-phenyl-2-isoxazoline (162) (83%) and unreacted diphenylfurazan (15%). Due to its volatility (b.p. 191°C) only traces of benzonitrile were detected.

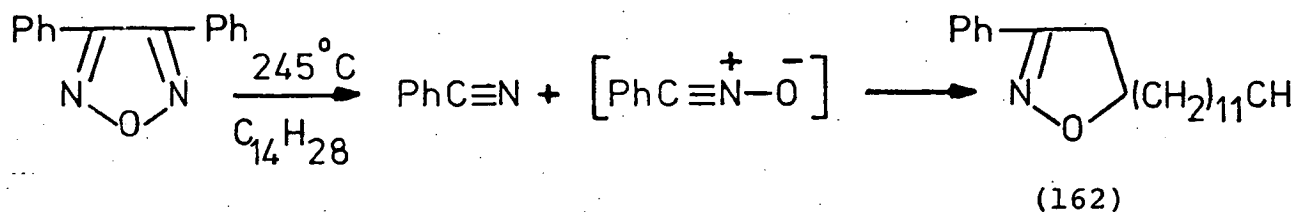

Although no benzonitrile oxide was detected during the thermolysis, the isolation of the 1,3-dipolar cycloadduct is proof of the intermediacy of the nitrile oxide. Unlike the furoxans there is less likelihood of the dipolarophile and the furazan interacting directly as no nitron-like behaviour is possible. This particular experiment gives some indication as to the relative stability of furazans and furoxans. Under identical conditions diphenylfuroxan was consumed after 2 h¹⁰⁷ whereas after 6 h not all the diphenylfurazan had decomposed. It would appear that furazans have greater thermal stability than the corresponding furoxans.

Bicyclic furoxans, both strained and unstrained, ring open on heating to bis-nitrile oxides which can be readily trapped as their 1,3-dipolar cycloadducts.^{105,107} In contrast, as illustrated above, only furazans fused to a five-membered ring have been shown to fragment to the analogous nitrile oxide intermediate,^{110,119,129} which in turn can be readily trapped by suitable dipolarophiles. Moreover, during their investigation into the reaction of cyclohexane-1,2-dioxime Tokura et al¹¹⁸ found that the 3,4-tetramethylenefurazan (113), formed from the dioxime and thionyl chloride in liquid sulphur dioxide, was extremely stable. (113) resisted hydrolysis on refluxing with concentrated hydrochloric and sulphuric acids for 5 and 7 h respectively and with aqueous 25% sodium hydroxide for 6.5 h. This high stability suggests that the thermal decomposition is not a general reaction but only takes place when other factors such as ring strain are present. 3,4-Tetramethylene- (163a) and 3,4-decamethylenefurazan (163b) were heated in refluxing 4-methoxybenzotrile (240°C) for 2 and 3 h respectively. On cooling, the corresponding 1,2,4-oxadiazoles (164) were isolated in 72 and 67% respectively, Scheme 54.

Whereas disubstituted furazans produce monofunctional nitrile oxides and nitriles, the bicyclic analogues such as (163), which are conveniently prepared from the furoxans which, in turn, is prepared from the appropriate cycloalkene after the method of Klamman,⁹⁷ (Introduction p. 54) give rise to a series of ω -cyanoalkyl-nitrile oxides which are not readily available by other routes.

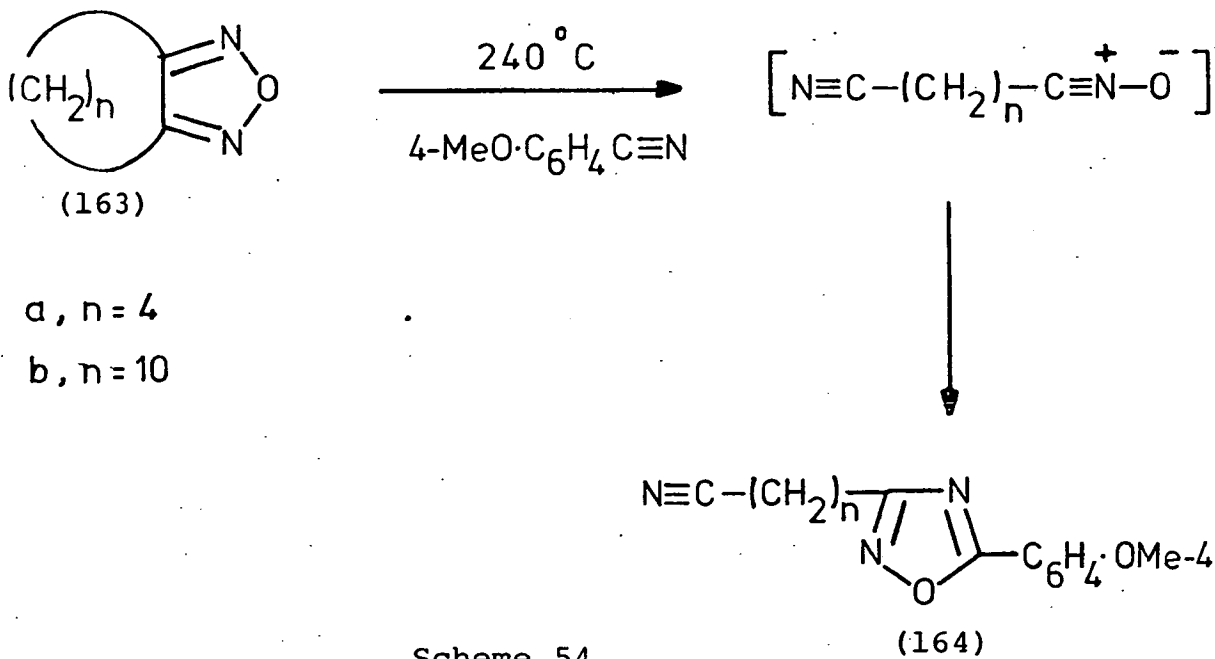

The above results demonstrate that, as was found to be the case with furoxans, the thermolytic ring opening to nitrile oxides does not depend on special structural features such as ring strain but is a general reaction for furazans which takes place under more forcing conditions.

Following the high yield of (162) and the failure to quantify the benzonitrile formed during the thermolysis of diphenylfurazan in 1-tetradecane, it was decided to study the thermal decomposition using FVP. If successful the FVP technique would offer the same advantages as those outlined for furoxans in 1.1. Several 3,4-disubstituted furazans were investigated and the results summarised in Table 11, together with the reaction conditions employed.

TABLE 11

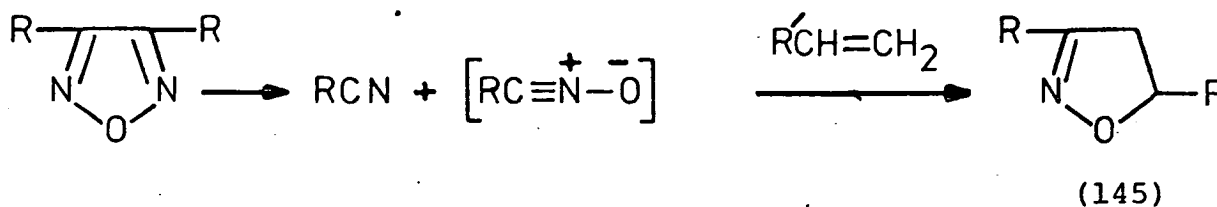
2-Isoxazolines and Nitriles from the FVP of Furazans

R	R'	FVP (a) oven temp °C	RC≡N mol %	(145) mol %
C ₆ H ₅	C ₄ H ₉	600	92	96
4-MeOC ₆ H ₄	C ₄ H ₉	550	96	93
4-MeC ₆ H ₄	C ₄ H ₉	600	93	96
Me	C ₄ H ₉	600	91 (b)	81

(a) 10⁻³ mmHg

(b) g.l.c. yield

The results in Table 11 clearly demonstrate that FVP of 3,4-disubstituted furazans represents a valuable technique for the generation of nitrile oxides and nitriles. The advantages of FVP over solution thermolysis are similar to those outlined for the thermolysis of furoxans. Namely, the removal of the constraint that the decomposition temperature of the furazan must be less than its boiling point for high

conversion to the nitrile oxide and nitrile. It is highly probable that solution thermolysis of dimethylfuran, at atmospheric pressure, would be inefficient due to the volatility of the furazan (b.p. 154-159°C)¹¹⁶. By allowing the use of volatile dipolarophiles, such as 1-hexene, FVP widens the synthetic application of the fragmentation. It also enables the relatively volatile nitriles to be isolated.

An isolated experiment worthy of note is the FVP of 3,4-tetramethylenefurazan (113) at 600°C onto sulphur dioxide. In like manner to the furoxans subsequent refluxing of the reaction mixture in toluene resulted in the formation of ω-cyanobutyl isocyanate (165) which was isolated as the urea (166) (48%) with aniline, Scheme 55.

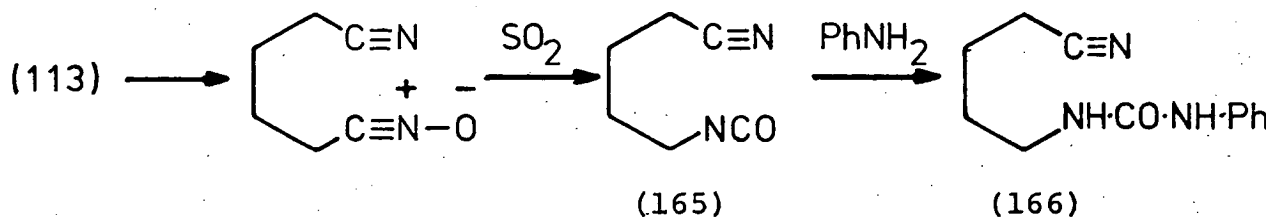

Scheme 55

Having established that the thermolytic ring opening to nitrile oxides and nitriles is a general reaction for furazans the question of how the oxadiazole ring fragments arises. In an attempt to answer this problem three asymmetrically disubstituted furazans, 3-methyl-4-phenyl- (167a), 3-(4-chlorophenyl)-4-phenyl- (167b) and 3-(4-methoxyphenyl)-4-phenyl- (167c) were investigated. These furazans were all prepared via the same synthetic pathway, Scheme 56, the key

feature of which was the nitrosation of the intermediate ketone (168) with amyl nitrite⁹⁴ to ultimately give the dioxime which which was then dehydrogenated to the isomeric furoxans which in turn were deoxygenated with triethylphosphite to the furazan. (167a) was prepared from the commercially available phenylacetone while (167b) and (167c) were prepared from 4-chlorophenylacetic acid and phenylacetic acid respectively.

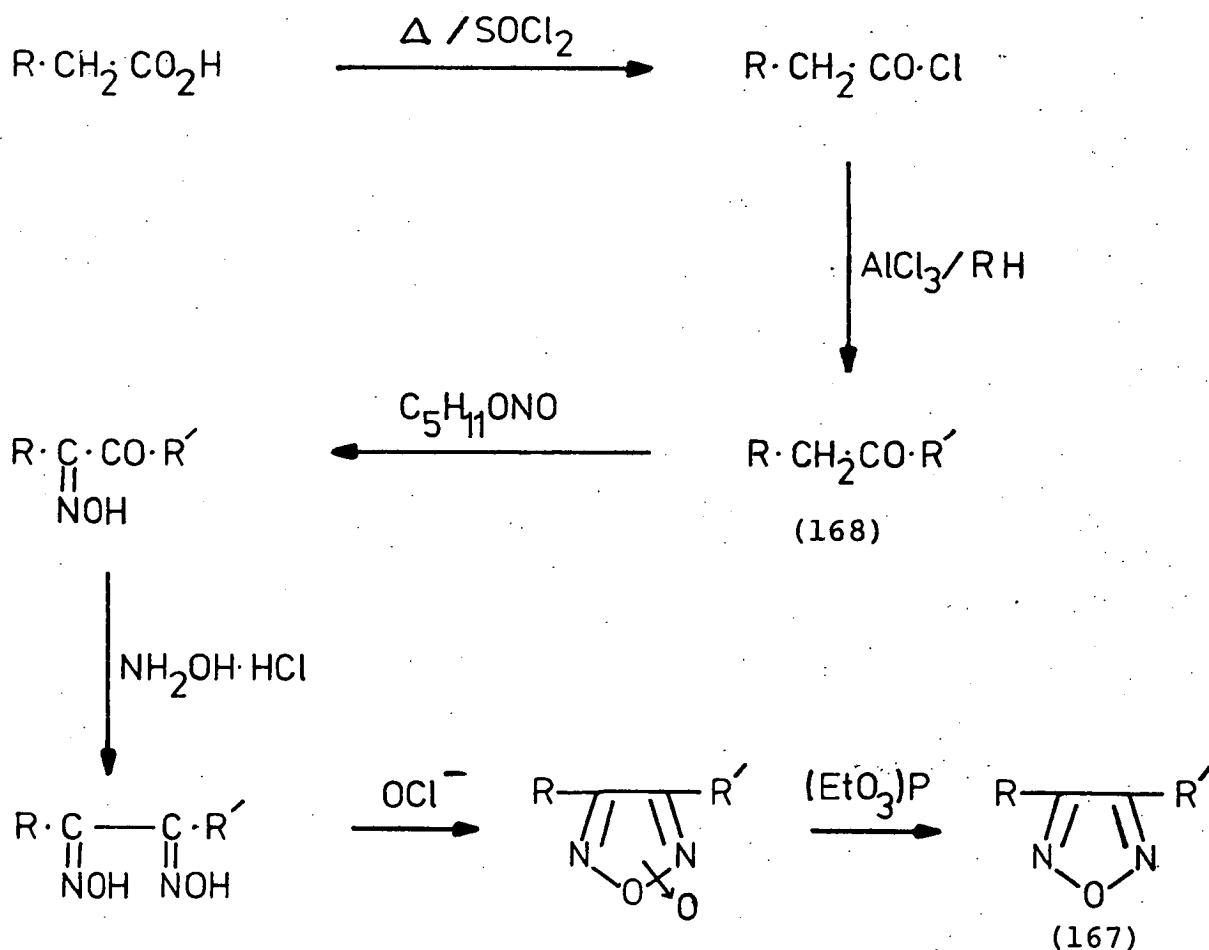

a : R = Ph, R' = Me

b : R = 4-ClC₆H₄, R' = Ph

c : R = Ph, R' = 4-MeOC₆H₄

Scheme 56

The unsymmetrical furazans were then pyrolysed at 600-650°C, the products being condensed onto 1-hexene and the reaction mixtures analysed by g.l.c. (10% SE-30). The results are summarised in Table 12, along with the pyrolysis conditions.

TABLE 12
Nitriles and 2-Isoxazolines from the FVP of
Unsymmetrical Furazans

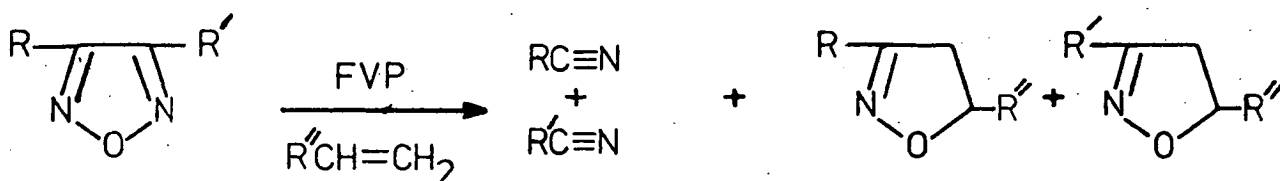

R	R'	R''	Oven temp/°C	RC≡N %	R'C≡N %	R-Isox %	R'-Isox %
Ph	CH ₃	C ₄ H ₉	650	35	-	65	35
4-ClC ₆ H ₄	Ph	C ₄ H ₉	600	51	49	47	47
Ph	4-MeOC ₆ H ₄	C ₄ H ₉	600	52	43	40	47

These results, although not conclusive, suggest that the fragmentation of the oxadiazole ring takes place in favour of the more stable nitrile oxide. In this instance if the rate of dimerisation of the nitrile oxide to the furoxan is taken as a measure of the stability of the nitrile oxide then, according

to Dondoni et al,¹⁰⁶ the stability of substituted benzonitrile oxides increases $m\text{-Cl} < p\text{-Cl} < \text{H} < p\text{Me} < p\text{MeO}$. Furthermore, it is quite clear that acetonitrile oxide is the least stable of the possible nitrile oxides under consideration. The above results can be rationalised by considering that in the transition state (169), for the fragmentation, there are developing partial charges.

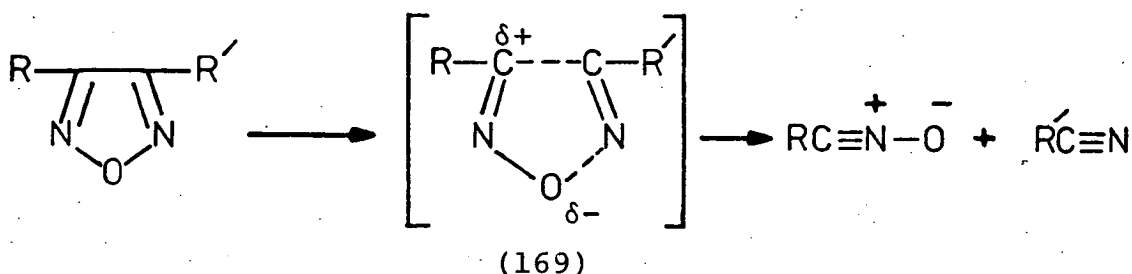

Therefore, if R is more electron donating than R' the developing positive charge will be stabilised and $\text{R}-\text{C}\equiv\text{N}^+-\text{O}^-$ will be favoured over $\text{R}'\text{C}\equiv\text{N}^+-\text{O}^-$. This would appear to be the case for (167a) and (167c) where benzonitrile oxide and 4-methoxybenzonitrile oxide are formed preferentially. For (167b) it would appear that there is little difference in the stability of the two possible nitrile oxides which are produced on thermolysis.

The evidence in support of this hypothesis is tentative and further work, on a greater number of asymmetrically disubstituted furazans, would have to be carried out to establish its validity.

2.2 Thermolysis of 3,5-Diphenyl-1,2,4-oxadiazole

Prior to the present investigation the thermolysis of 3,5-disubstituted-1,2,4-oxadiazoles had only been briefly investigated.^{173,174} Since the early work of Tiemann and Krüger,¹⁷⁵ who found that 3,5-diphenyl-1,2,4-oxadiazole (170) could be distilled without decomposition at normal pressure (b.p. 296°C), 3,5-diaryl-1,2,4-oxadiazoles have been renowned for their stability and unreactiveness. However, as was found later with the isomeric furazan,^{123,124} rapid heating of (170) resulted in partial decomposition to phenyl isocyanate and benzonitrile.¹⁶⁵

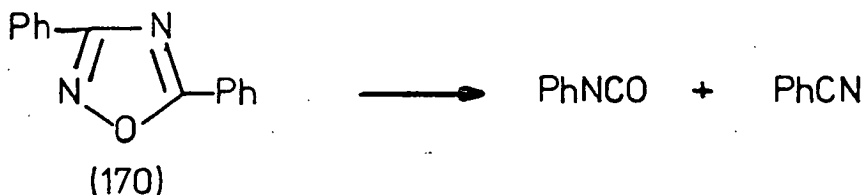

As illustrated in Scheme 57, there are three possible decomposition pathways; (a) a retro-1,3-dipolar cycloaddition to nitrile oxide and nitrile; (b) a concerted decomposition to isocyanate and nitrile; (c) fragmentation to acyl nitrene and nitrile.

Cotter and Knight¹⁷³ examined the thermal decomposition of (170) at 340°C in a sealed glass ampoule evacuated to a residual pressure of 10^{-4} torr. G.l.c. analysis of the product mixture revealed, as above, that the only products were phenyl isocyanate and benzonitrile along with undecomposed (170). Mass-spectrometric examination identified carbon dioxide and diphenylcarbodiimide, derived from phenyl isocyanate,¹⁷⁶ amongst the products. These observations led Cotter and Knight¹⁷³ to propose that the decomposition occurred through a concerted mechanism, path (b) Scheme 57.

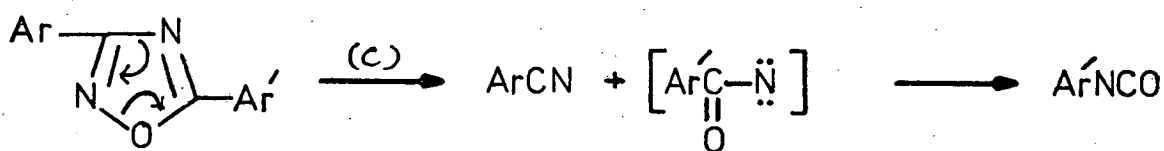
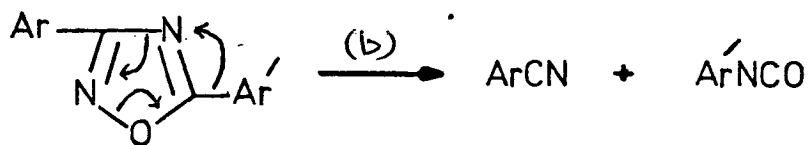
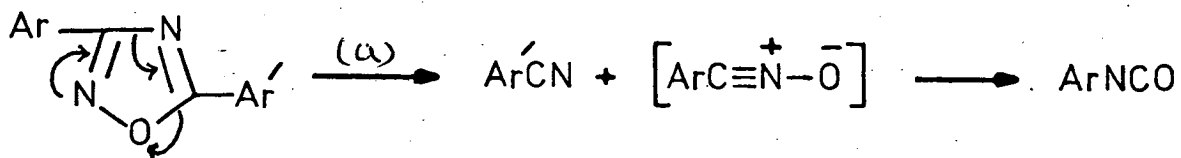

Scheme 57

In contrast, the work carried out by Ainsworth¹⁷⁴ militates against a concerted mechanism in favour of a retro-1, 3-dipolar cycloaddition to nitrile and nitrile oxide, path (a) Scheme 57. Experimentally, he found that thermolysis of the unsymmetrically disubstituted oxadiazoles, 3-(4-chlorophenyl)-5-phenyl- (171a) and 3-(4-chlorophenyl)-5-(4-methoxyphenyl)-1,2,4-oxadiazole (171b) resulted in the formation of 4-chlorophenyl isocyanate and benzonitrile and 4-methoxybenzonitrile respectively, Scheme 58.

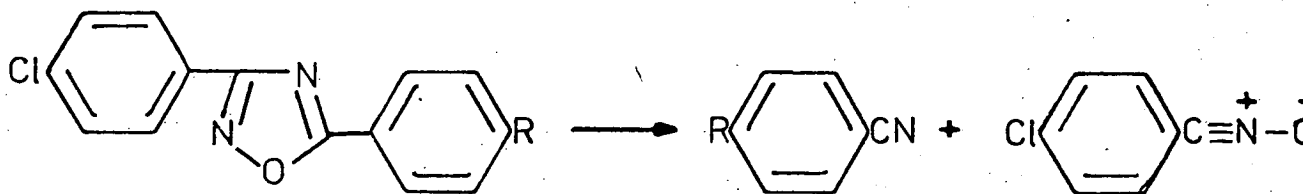

(171)

a, R = H

b, R = OMe

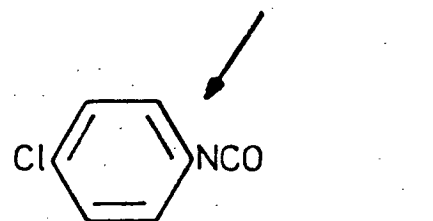

More recently mass-spectrometric examination of unsymmetrically disubstituted 1,2,4-oxadiazoles has added weight to the decomposition occurring via a retro-1,3-dipolar cycloaddition to nitrile oxide and nitrile.¹⁷⁷ Selva et al have studied the m.s. decomposition of 3,5-diaryl-1,2,4-oxadiazoles in some detail and have claimed that their results are only consistent with the fragmentation taking place via a retro-1,3-dipolar cycloaddition to nitrile oxide and nitrile. In particular they refute the concerted mechanism proposed by Cotter and Knight. Mass spectral investigation of (172a) gives the main fragment $[C_7H_5NO]^+$; m/e 119, and m.s. of 3-phenyl-5-(4-d₁-phenyl)-1,2,4-oxadiazole (172b) gives the same fragment without deuterium incorporation.

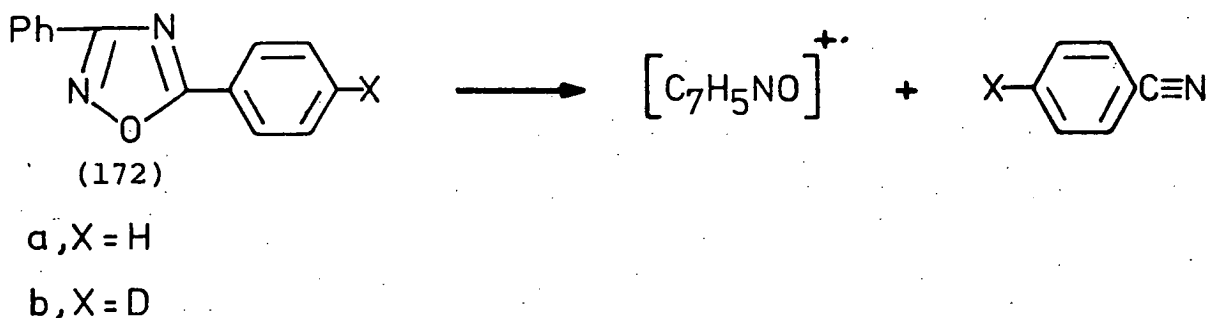

This result unequivocally indicates the $[C_7H_5NO]^+$ does not contain the 5-phenyl ring and definitely rules out the concerted mechanism, under the m.s. conditions. Confirmatory evidence for the intermediacy of benzonitrile oxide was acquired by m.s. investigation of authentic phenyl isocyanate and benzonitrile oxide. It was established that the fragmentation pattern from (170) was only consistent with the molecule ion $[C_7H_5NO]^+$ being the nitrile oxide and not the isocyanate.¹⁷⁷

The photolytic decomposition of 1,2,4-oxadiazoles has only been briefly investigated, the photolysis of (170) giving rise, not to phenyl isocyanate and benzonitrile the thermolytic decomposition products, but to N-benzoylbenzamide presumably formed by initial cleavage of the weak 1,2 N-O bond.¹⁷⁸

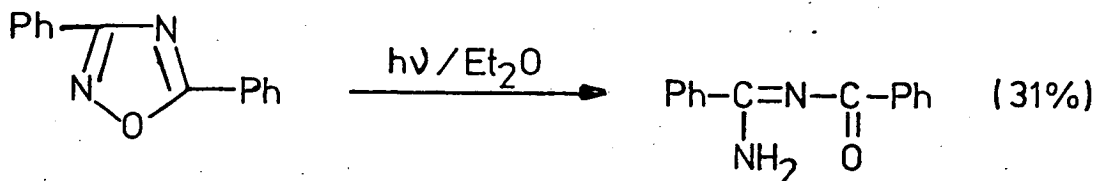

It was hoped that by using the FVP technique, successfully applied to furoxans and furazans, it might prove possible to isolate the nitrile oxide, if formed, and therefore confirm that the thermal decomposition, in line with the m.s. decomposition, does in fact occur via a retro-1,3-dipolar cycloaddition.

To achieve these ends the thermal decomposition of (170), prepared from both diphenylglyoxime and from the thermolysis of benzohydroximoyl chloride in toluene in the presence of benzonitrile, was examined. The recovery of the starting material from thermolysis of (170) in 1-tetradecene at 251°C and the failure to detect any isoxazoline cycloadduct confirmed the greater stability of (170) with respect to the isomeric diphenylfurazan (114) and the corresponding furoxan (4).

Thermolysis of (114) and (4) in 1-tetradecane gave 5-dodecyl-3-phenyl-2-isoxazoline (162) in 81 and 82 mol % respectively. Similarly, FVP of (170) at 500° and 600°C onto 1-tetradecane and 1-hexene resulted in a 97% recovery of the oxadiazole. At higher temperatures the oxadiazole showed some signs of decomposition, but even at 700°C 54% was recovered unchanged and no isoxazoline was detected. In addition to the recovered starting material traces of three solids were isolated but unfortunately they could not be identified unambiguously. Solid (a) gave no distinct parent ion peak in the m.s. and had a m.p. of 140-142°C. On the basis of an exact mass determination on the parent ion, m/e 197, solid (b) was assigned the molecular formula $C_{13}H_{11}NO$. Furthermore from the m.s. fragmentation pattern, i.r. spectrum and m.p. 155-158°C, solid (b) was tentatively identified as benzoylaniline (lit.¹⁵⁷ m.p. 163°C). Similarly, from the m.s. solid (c) was assigned the molecular formula $C_{14}H_{12}N_2O_2$. The possible formation of benzoylaniline as one of the products from the pyrolysis of (170) suggested that benzoyl nitrene might be present during the decomposition. In an attempt to trap any benzoyl nitrene that might be present (170) was pyrolysed at 800°C. The thermolysis proceeded with extensive charring and the products were condensed onto methanol. G.l.c./m.s. analysis of the product mixture established the presence of methyl phenylaminoformate (173), derived from the reaction of phenyl isocyanate and methanol. There was no evidence for N-benzoyl-O-methyl hydroxylamine (174), the expected product from the reaction of benzoyl nitrene and methanol, Scheme 59.

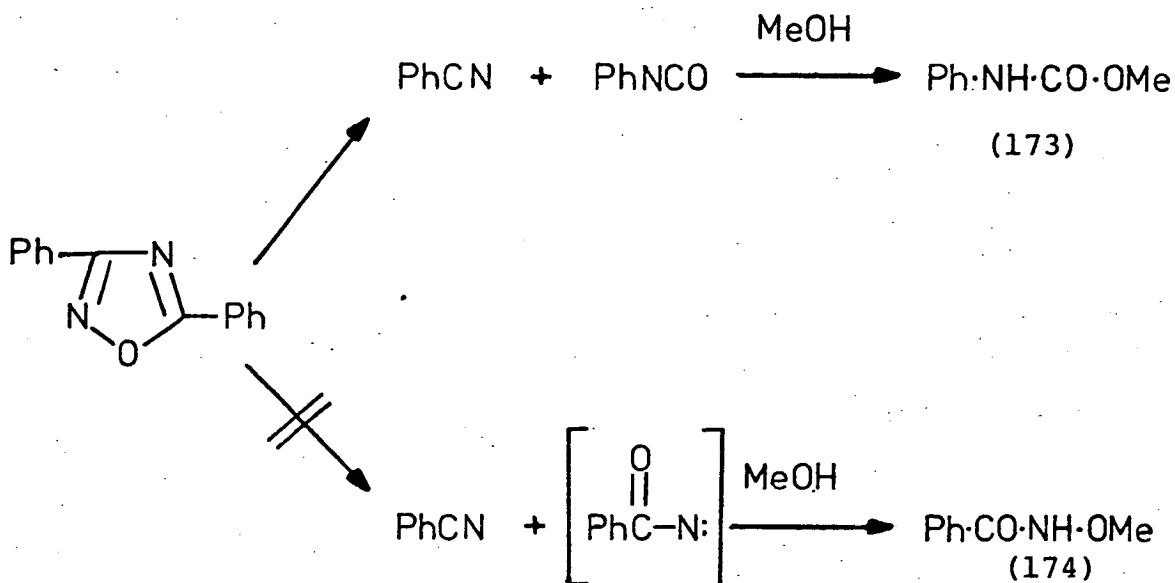

Scheme 59

Although not definitive the above experiments do give some insight into the mode of fragmentation of (170). It would appear that, under the FVP conditions, the thermal decomposition, unlike fragmentation in the mass spectrometer, does not proceed via a retro-1,3-dipolar cycloaddition. If any benzonitrile oxide had been formed under these conditions it would, by analogy with the FVP of diphenylfuroxan at 700°C, have been trapped by the dipolarophile in the cold trap.

However, it has not proved possible to distinguish between the concerted decomposition and fragmentation to benzoyl nitrene. The possible presence of benzoylaniline from pyrolysis of (170) at 700°C suggests the intermediacy of benzoyl nitrene but failure to trap it with methanol and the isolation of methyl phenylaminoformate argues, at first sight, against the intermediacy of the nitrene. However, if formed the

nitrene could have undergone further reaction, perhaps rearrangement to the isocyanate, before reaching the cold trap. Therefore to distinguish between the remaining two alternative modes of decomposition for (170) an alternative FVP apparatus in which the distance between hot zone and oven is very much reduced enabling short lived reactive intermediates to be isolated might be required.

In summary, it is quite clear that 3,5-diphenyl-1,2,4-oxadiazole is much more stable than the isomeric 3,4-diphenyl-furazan and on thermal decomposition under more severe conditions, does not appear to undergo a retro-1,3-dipolar cycloaddition to benzonitrile oxide and benzonitrile.

3. THERMOLYSIS OF 2,4,5-TRISUBSTITUTED-1,2,3-TRIAZOLE-1-OXIDES.

The thermal decomposition of 2,4,5-trisubstituted-1,2,3-triazole-1-oxides was investigated because they are a class of heterocyclic compounds closely related to furoxans. Like the analogous imidazole-N-oxides they are related to furoxans and represent the third member of the group.

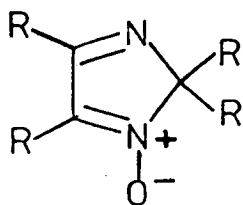

Imidazole-1-oxide

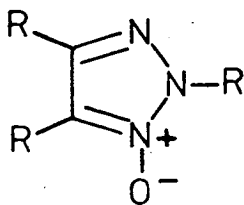

Triazole-1-oxide

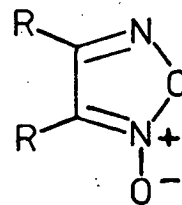

Furoxan

It is known¹⁰⁵⁻¹⁰⁷ and has already been demonstrated that furoxans decompose thermally to give nitrile oxides. Furthermore, in some instances the decomposition in solution is accelerated by the presence of certain dipolarophiles.¹¹⁰ Although not the only rationale, this behaviour can be explained by direct interaction of the dipolarophile with the furoxan in a nitrene 1,3-dipolar cycloaddition, Scheme 45 page 160. An example of such behaviour is the thermolysis of dibenzoylfuroxan (103) in the presence phenylacetylene,¹¹¹ the products being derived, not from the 1,3-dipolar cycloaddition of phenylglyoxalonitrile ($\text{Ph}\cdot\text{CO}\cdot\text{C}\equiv\text{N}^+\text{O}^-$); but from direct interaction of the dipolarophile with the furoxan, Scheme 32, page 63. Moreover, imidazole-N-oxides have been shown to react as nitrenes with suitable dipolarophiles¹¹² and in the case of 2,2-diphenyl-4,5-dimethyl-2H-imidazole-N-oxide (108) the nitrene cycloadduct (109) has been isolated from thermolysis in benzene in the presence of DMAD.¹¹³

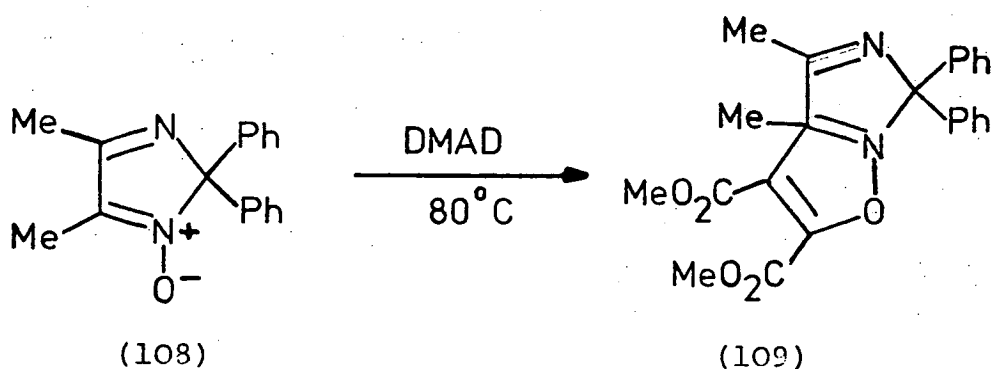

The corresponding process for 2[H]-1,2,3-triazole-1-oxides would lead to the cycloadduct (175), while thermal fragmentation analogous to that observed for furoxans would result in the formation of nitrile imines and nitrile oxides, as illustrated in Scheme 60.

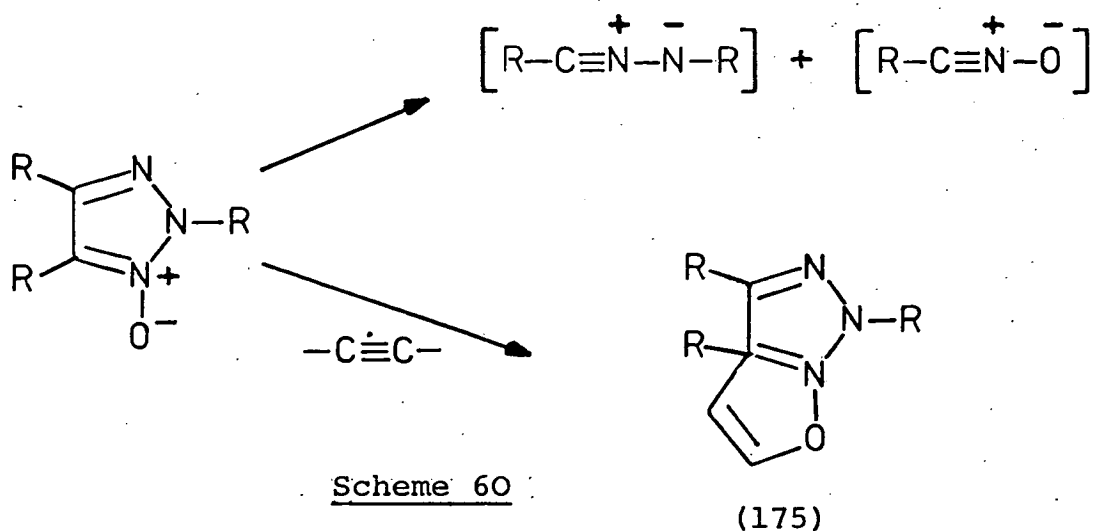

To establish whether or not the triazole-1-oxides behave in the above manner the thermolysis of 2,4,5-triphenyl- (176a) and 4,5-dimethyl-2-phenyl-1,2,3-triazole-1-oxide (176b) were investigated. They were synthesised from benzil and diacetyl monoxime respectively via the corresponding monoxime phenyl-hydrazone which on oxidation with aqueous copper sulphate and pyridine, after the method of Geigy,¹⁵² gave the triazole-1-oxides as illustrated in Scheme 61.

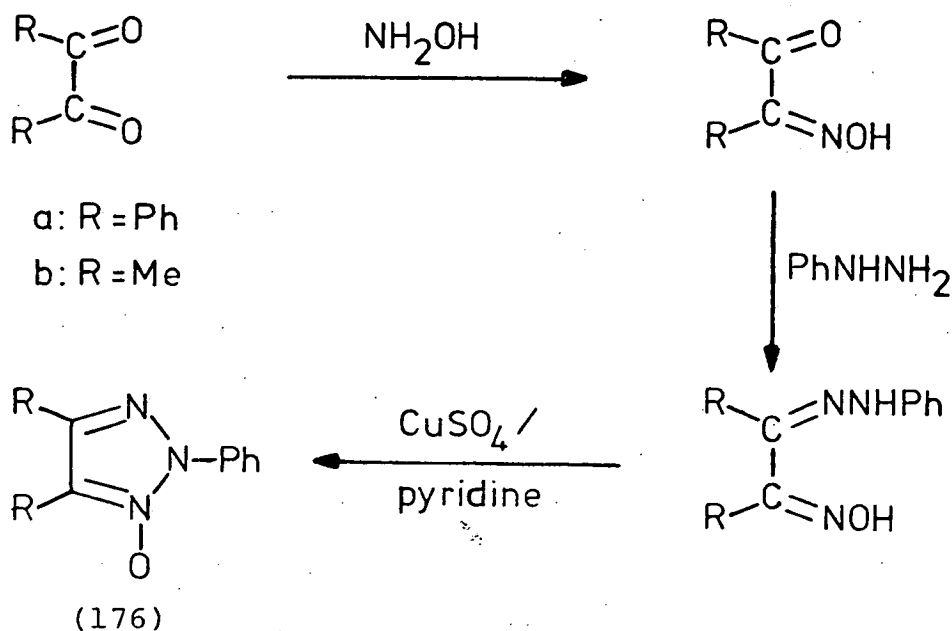

Scheme 61

In contrast to the isoelectronic furoxans all attempts to isolate any nitrile oxide derived product from (176a) were singularly unsuccessful. In fact, (176a) proved to be very stable with no observable reaction taking place after refluxing in toluene for 4 days and xylene for 6 days in the presence of DEAD and DEF. Furthermore it was recovered unchanged after FVP at 650°C. The only sign of decomposition was after refluxing in 4-methoxybenzonitrile for 60 h at 240°C. Even in this case no product was isolated, the starting material was recovered (76%) along with an intractable black tar. It is unlikely that the decomposition gave rise to benzonitrile oxide as the 1,2,4-oxadiazole which would have been formed is stable at this temperature.

Following the work of Simmonds et al¹¹³ who isolated the nitrono cycloadduct (109) from the analogous imidazole-N-oxide, (108) was refluxed in benzene, in the presence of DEF, for 24 h. However, after this time there was no evidence to support the formation of the corresponding cycloadduct (177), only starting material being detected by t.l.c.

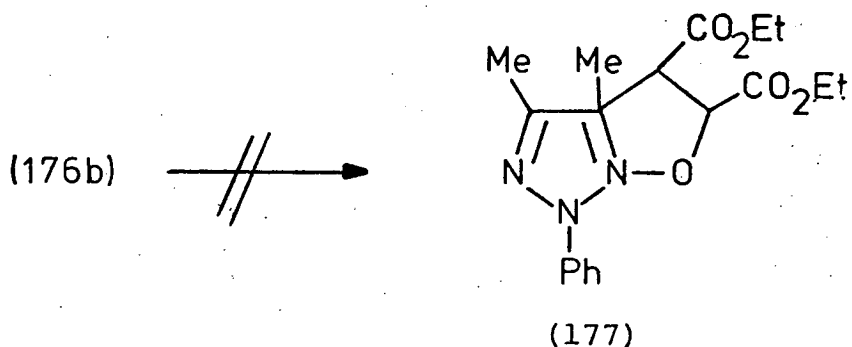

The only decomposition product isolated from this brief investigation into the thermolysis of 2[H]-1,2,3-triazole-1-oxides was from the FVP of (176b) at 650°C. The pyrolysis products were condensed onto 1-hexene to trap any acetonitrile oxide and C-methyl-N-phenylnitrile imine which might have been generated under the pyrolysis conditions. However, t.l.c. analysis of the product mixture indicated that 5-butyl-3-methyl-2-isoxazoline was not present. Rather, in addition to unaltered starting material a dimeric species, to which structure (178) was assigned, was isolated (37.4%).

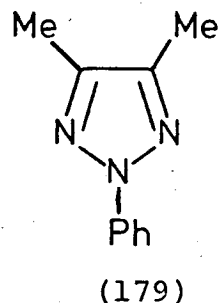
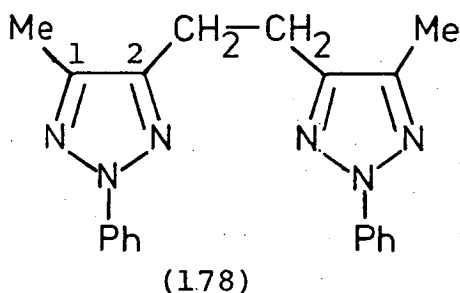

The evidence in support of structure (178) came, primarily, from m.s. and n.m.r. spectrometry. The m.s. gave a molecular ion m/e 344, the exact mass indicating a molecular formula $C_{20}H_{20}N_6$, and a main fragment ion at m/e 172, $[C_{10}H_{10}N_3]^+$ suggesting the dimeric nature of the compound. A comparison of the 1H and ^{13}C n.m.r. spectra with those of 4,5-dimethyl-2-phenyl-1,2,3-triazole (179), prepared by triethylphosphite deoxygenation of the triazole-1-oxide (Table 13), established structure (178).

TABLE 13

	(178)		(179)	
	^1H nmr (δ)	^{13}C nmr (δ)	^1H nmr (δ)	^{13}C nmr (δ)
CH_3^-	2.21	9.97	2.25	9.8
C_1	-	143.5	-	143.5
C_2	-	146.5	-	-
CH_2^-	3.10	24.1	-	-
Ph-	7.21-8.05	118.1, 126.5	7.15-7.95	117.8, 126.2
		129.1, 139.8		128.9, 139.7

Having proposed the symmetrical structure (178) for the isolated product from the FVP of (176b) the question of how it is formed arises. As little is known about the thermal decomposition of 2[H]-1,2,3-triazole-1-oxides any mechanistic proposal must be based on the established chemistry of related species.

During their investigations into the reactions of the closely related 1-phenylimino-2,4,5-triphenyl-1,2,3-triazoles (180) Sukumaran et al.¹⁷⁹ found that not only could (180) be successfully trapped with dipolarophiles such as DMAD and DEF, but on photolysis or thermolysis (180) eliminated phenylnitrene to give the corresponding triazole (181), Scheme 62.

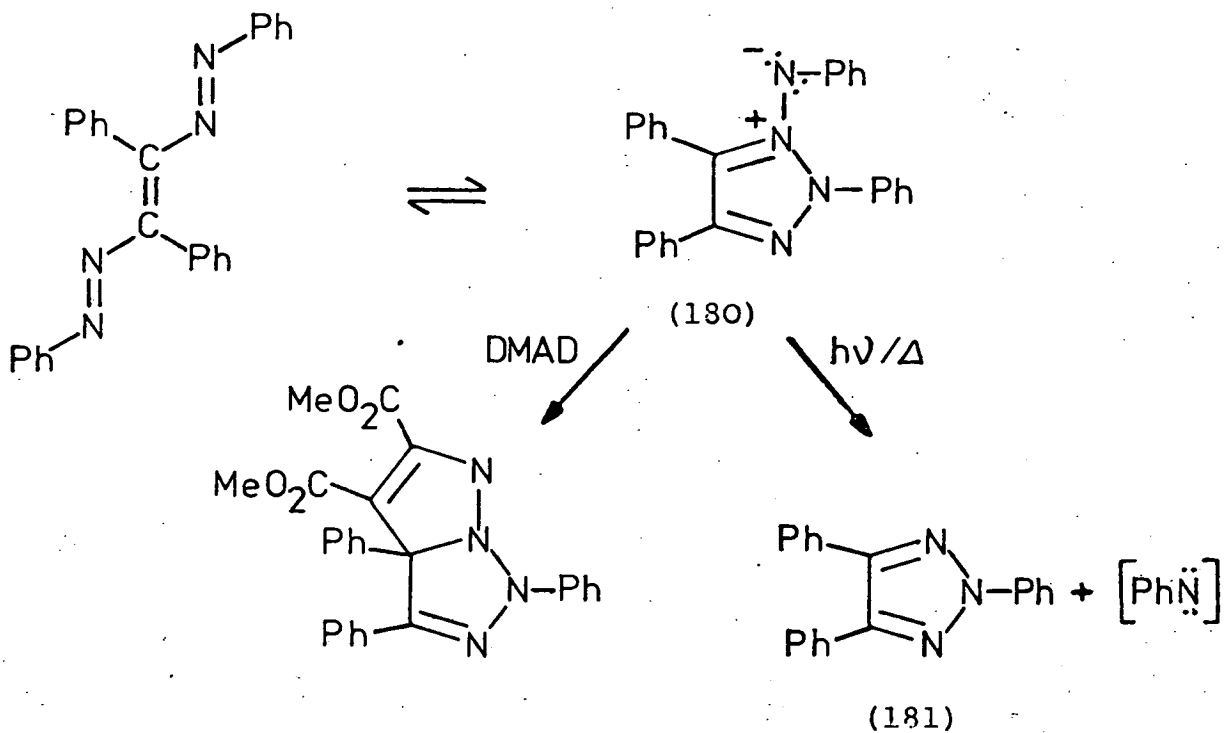

Scheme 62

Attempts to trap the eliminated phenylnitrene during the thermolysis of (180) proved unsuccessful. In contrast photolysis of (180) in cyclohexene resulted in the isolation of N-phenylcyclohexylamine, the product from phenylnitrene insertion into the C-H bond.¹⁸⁰ Photolysis of (182) results not only in the formation of the corresponding triazole but also in the hydrogen abstraction product (183).

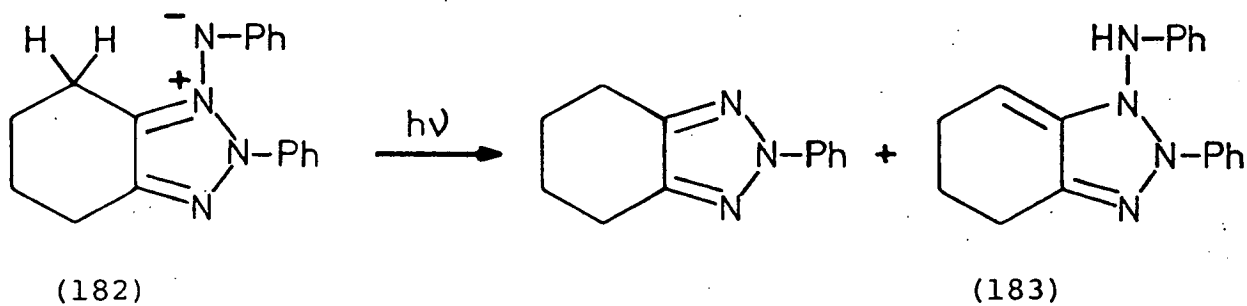

With this background information it is now possible to postulate a mechanism, Scheme 63, for the formation of the deoxygenated dimer (178) from the FVP of (176b).

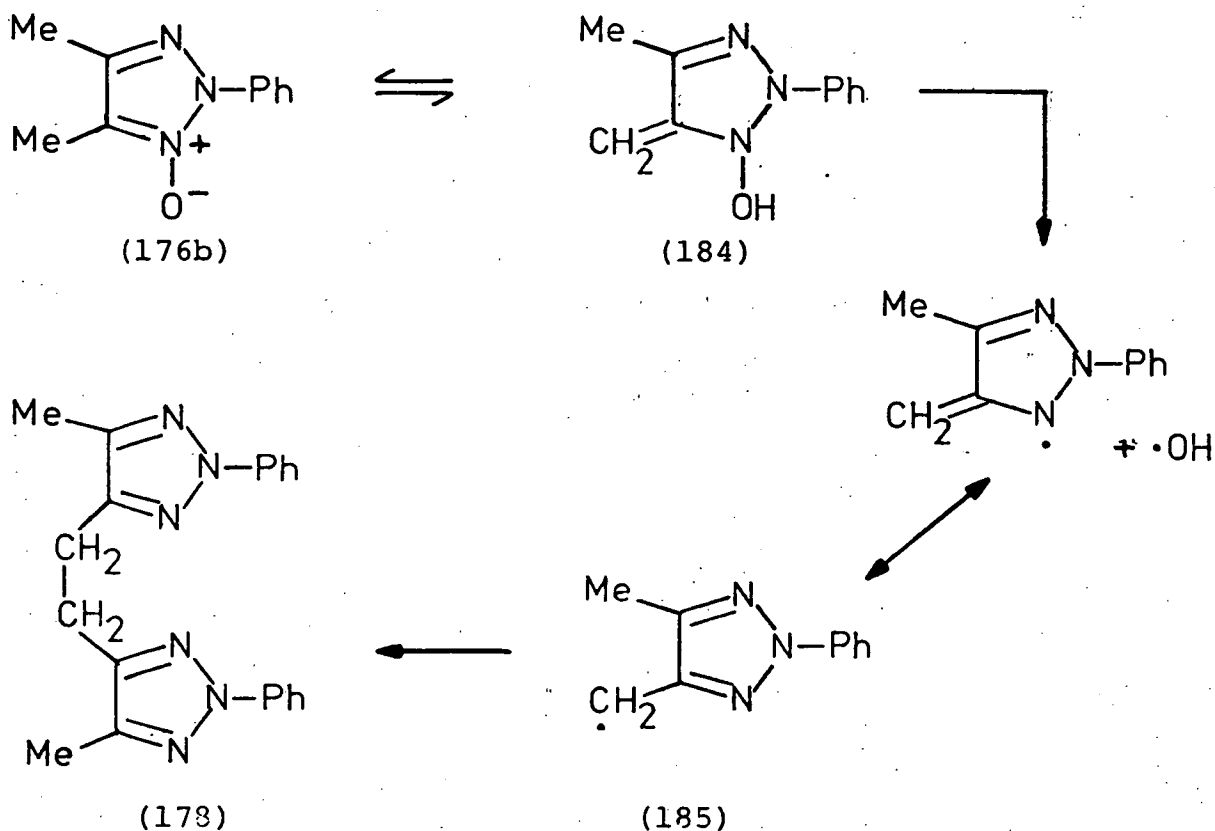

Scheme 63

The first step in the mechanism has a direct analogy as described above in the formation of (183) from photolysis of (182). Under the FVP conditions it is conceivable that (184) would lose the hydroxyl radical to form the resonance-stabilised radical (185) which undergoes dimerisation to (178). The dimerisation of (185) is directly analogous to the dimerisation of benzyl radicals to give bibenzyl.^{181a}

Furthermore, as is demonstrated in the FVP of 3,6-diphenyl-1,4,2,5-dioxadiazine (Section 4) phenyl radicals and benzoyl radicals dimerise under the FVP conditions, in the gas phase, to give biphenyl and benzil respectively.

Therefore, unlike the isoelectronic furoxans and imidazole-N-oxides, 2[H]-1,2,3-triazole-1-oxides do not exhibit any 1,3-dipolar reactivity. Rather they exhibit considerable stability. In the case of (176b), FVP results not in fragmentation of the heterocyclic ring but in the formation of the deoxygenated dimer (178) presumably formed by radical coupling in the gas phase.

4. FLASH VACUUM PYROLYSIS OF 3,6-DIARYL-1,4,2,5-DIOXADIAZINES

In the presence of pyridine or boron trifluoride aryl nitrile oxides dimerise to give 3,6-diaryl-1,4,2,5-dioxadiazines.^{57,58}

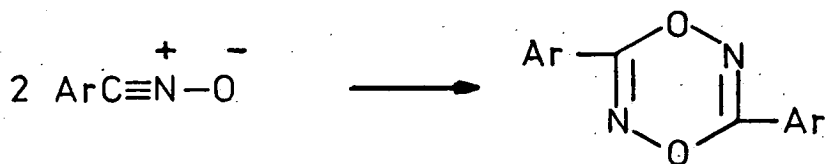

The thermal decomposition of these compounds has not been investigated in any depth; the only reported example being that of 3,6-(2,4,6-trimethylphenyl)-1,4,2,5-dioxadiazine (186).⁴⁷ During their investigations into the mechanism of the thermal isomerisation of nitrile oxides to isocyanates Grundmann et al. heated (186) in xylene. The only products

isolated were the corresponding nitrile (27%) and 2,4,6-trimethylbenzoic acid (3%).⁴⁷ No attempt was made to rationalise the formation of such decomposition products.

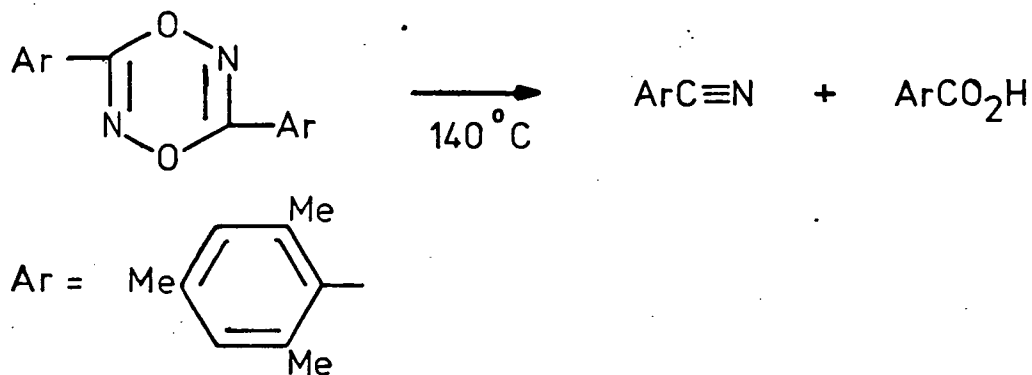

Intuitively, as illustrated in Scheme 64, there are four possible decomposition pathways:- path (a), fragmentation of the heterocyclic ring to nitrile oxides; path (b) ring opening to nitrosocarbonyl compounds and the corresponding nitrile; path (c), fragmentation to acyl nitrenes; path (d), a concerted decomposition which would result in the formation of isocyanates. In an attempt to determine the mode of fragmentation which actually occurs the thermal decomposition of 3,6-diphenyl- (187) and 3,6-bis(4-methylphenyl)-1,4,2,5-dioxadiazine (188) were investigated using conventional FVP apparatus and technique.

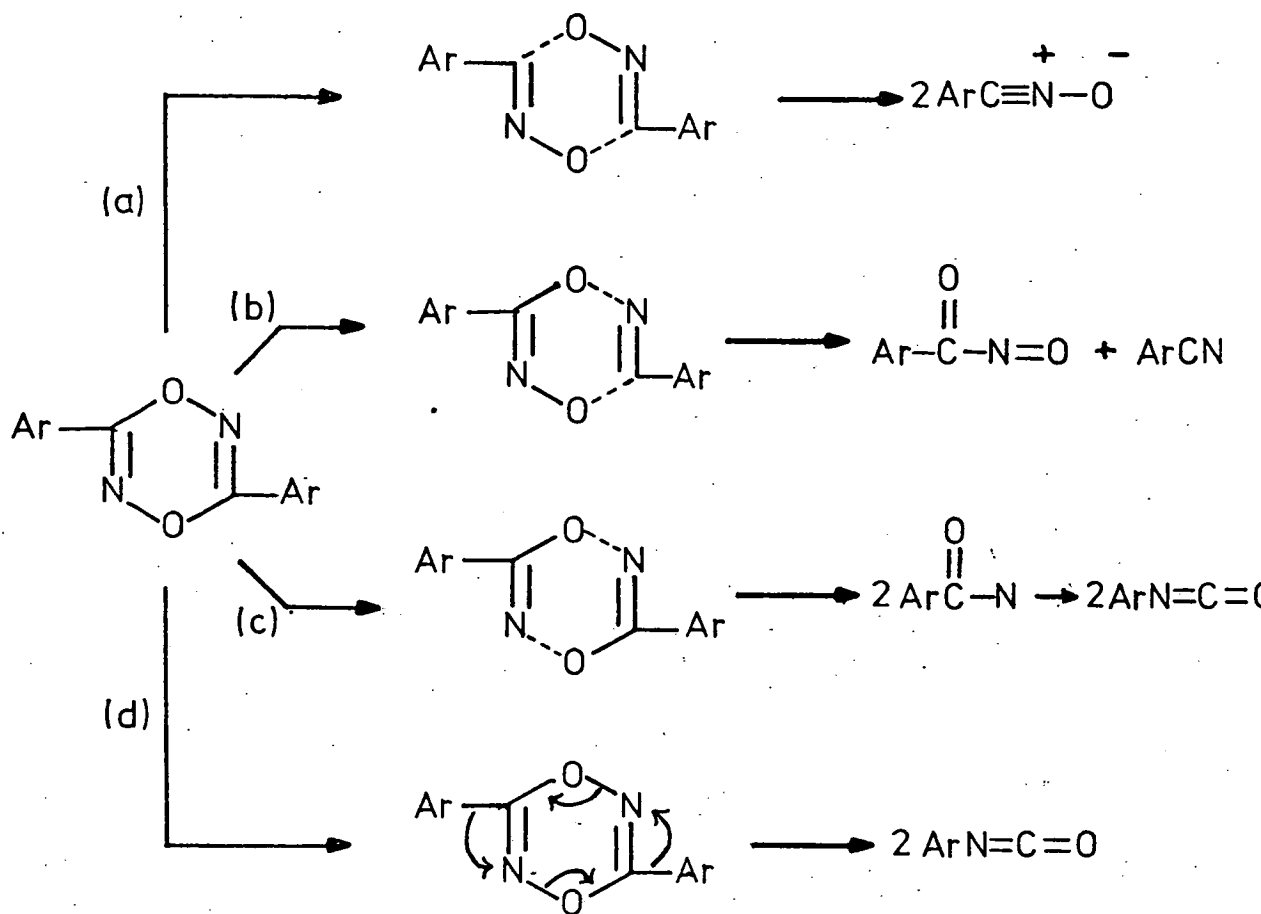

Scheme 64

To establish whether or not nitrile oxides are formed on thermolysis of dioxadiazines, (187) was subjected to FVP at 600°C and the pyrolysate condensed onto 1-hexene. By analogy, FVP of diphenylfuroxan under similar conditions resulted in the isolation of 5-butyl-3-phenyl-2-isoxazoline (154) in greater than 90%, (Table 8, page 168). Therefore, the formation of benzonitrile oxide, during the pyrolysis of (187), should be indicated by the formation of (154) in the presence of 1-hexene. However, g.l.c., t.l.c. and ^1H n.m.r. of the product mixture failed to detect any

of this isoxazoline, the only product isolated being benzonitrile (0.94 mol per mol of (187)) with the remainder a black residue comprising at least six components. The failure to detect any 5-butyl-3-phenyl-2-isoxazoline eliminates path (a), decomposition to benzonitrile oxide.

The second pathway involves ring opening to nitroso-carbonylbenzene (189, R = Ph) and benzonitrile; the isolation of benzonitrile in the above experiment suggests that path (b) is a distinct possibility. Nitrosocarbonylalkanes and -arenes (189) have previously been proposed as transient intermediates in the oxidative cleavage of hydroxamic acids (190)¹⁸²⁻¹⁸⁴ and the pyrolysis of alkyl nitrites in the presence of aldehydes.¹⁸⁵ However, prior to 1973 there was no direct evidence for the existence of species (189), the reaction products being typically, acyl derivatives of various nucleophiles present in the reaction mixtures (Scheme 65).

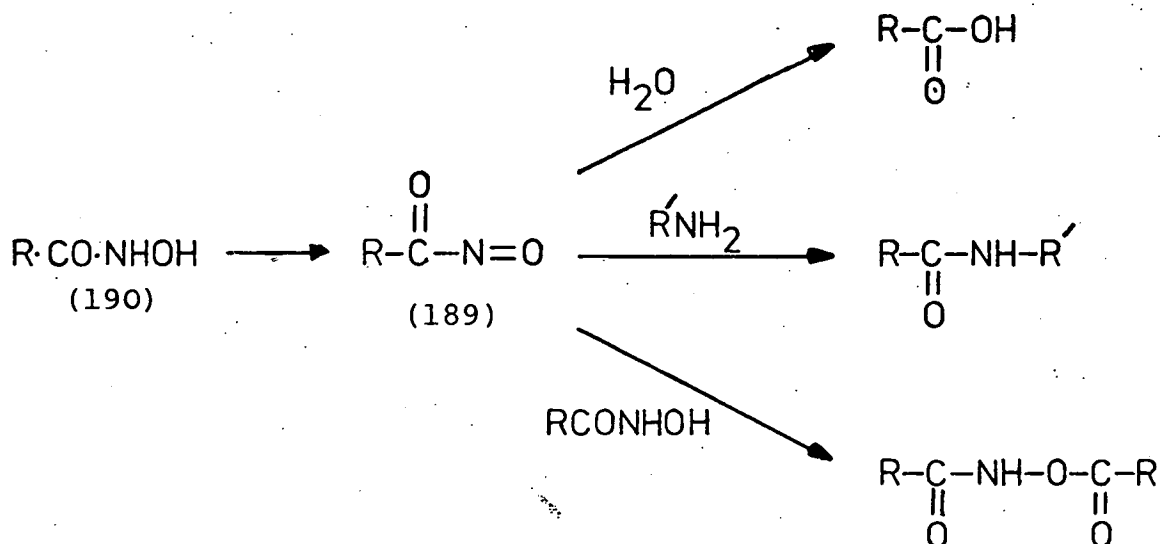

Scheme 65

In 1973 Kirby et al., having previously trapped the closely related nitrosyl cyanide ($\text{N}\equiv\text{C}-\text{N}=\text{O}$) via its Diels-Alder reaction with thebaine (191),¹⁸⁶ successfully trapped (189) as the Diels-Alder cycloadduct (192) during the periodate oxidation of benzohydroxamic acid in the presence of thebaine,¹⁸⁷ Scheme 66.

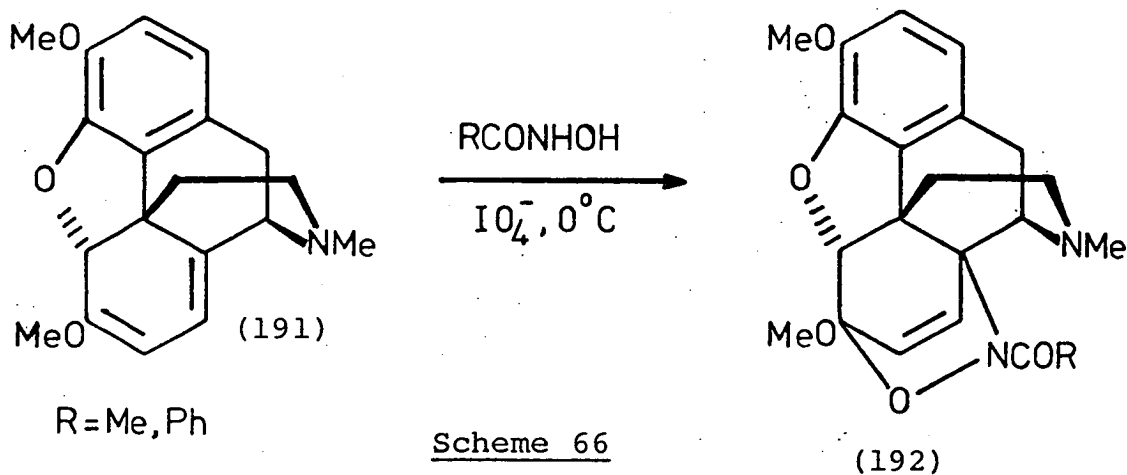

Therefore (187) was pyrolysed at 600°C and the products condensed onto a chloroform solution of thebaine. However examination of the product mixture by h.p.l.c. and ^1H n.m.r. spectroscopy, failed to detect any of the Diels-Alder cycloadduct (192, R=Ph). The only products identified were benzonitrile and benzoic anhydride. The identification of these products is consistent with decomposition via path (b), Scheme 64, to give nitrosocarbonylbenzene; benzoic anhydride having been isolated by Kirby during his studies into the chemistry of nitrosocarbonyl compounds.¹⁸⁸ It would appear that, under the FVP conditions employed, if nitrosocarbonylbenzene had been formed, on fragmentation of the heterocyclic ring, then secondary reactions, perhaps in the gas phase, had taken place in preference to cycloaddition with thebaine in the cold trap.

If decomposition of the dioxadiazine occurred through path (c), Scheme 64, then the resultant benzoyl nitrene would be expected to react with benzene to give either the corresponding N-benzoyl azepine or benzoyl aniline¹⁸⁹ as illustrated in Scheme 67.

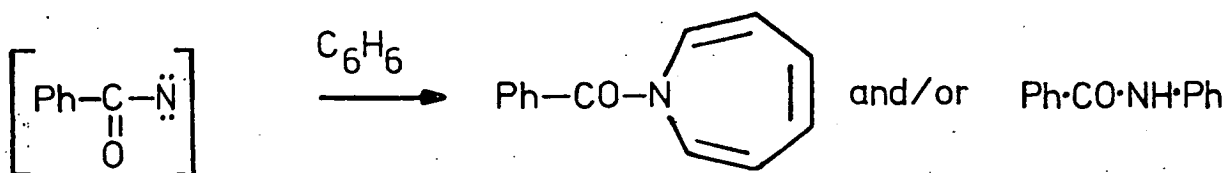

Scheme 67

However no evidence was found to support fragmentation via benzoyl nitrene. Rather pyrolysis of (187) onto benzene resulted in the positive identification of biphenyl, benzonitrile, benzophenone benzil and benzoic anhydride. The presence of biphenyl, benzil and benzophenone strongly suggests the intermediacy of phenyl and benzoyl radicals in the decomposition. If present in solution phenyl radicals would readily undergo homolytic aromatic substitution with aromatic substrates. For example, the main products from the thermolysis of dibenzoyl peroxide at high dilution in benzene, at 80°C, are carbon dioxide (1.77 mol/mol of peroxide) and biphenyl (0.36 mol/mol of peroxide).¹⁹⁰ To examine whether or not the biphenyl and benzophenone formed in the above decomposition were a result of the reaction of phenyl and benzoyl radicals with the solvent, (187) was pyrolysed at

600°C and the pyrolysate condensed onto deuterobenzene-d⁶. G.l.c./m.s. examination of the product mixture indicated that the biaryl product was C₁₂H₁₀ with C₁₂H₅D₅ not detected. Similarly, the benzophenone had molecular formula C₁₃H₁₀O with C₁₃H₅D₅O not detected thereby establishing unequivocally that there was no solvent incorporation in the formation of biphenyl and benzophenone. This indicates that these products were formed in the gas phase. In addition, the identification of benzil amongst the products suggests the gas phase dimerisation of benzoyl radicals.

Corroboration of these gas phase reactions was provided by the co-pyrolysis of (187) and (188) at 800°C. In addition to the products derived from the decomposition of each dioxadiazine, g.l.c./m.s. established the presence of 4-methylbiphenyl and 4-methylbenzophenone, the gas phase cross-over products, Scheme 68.

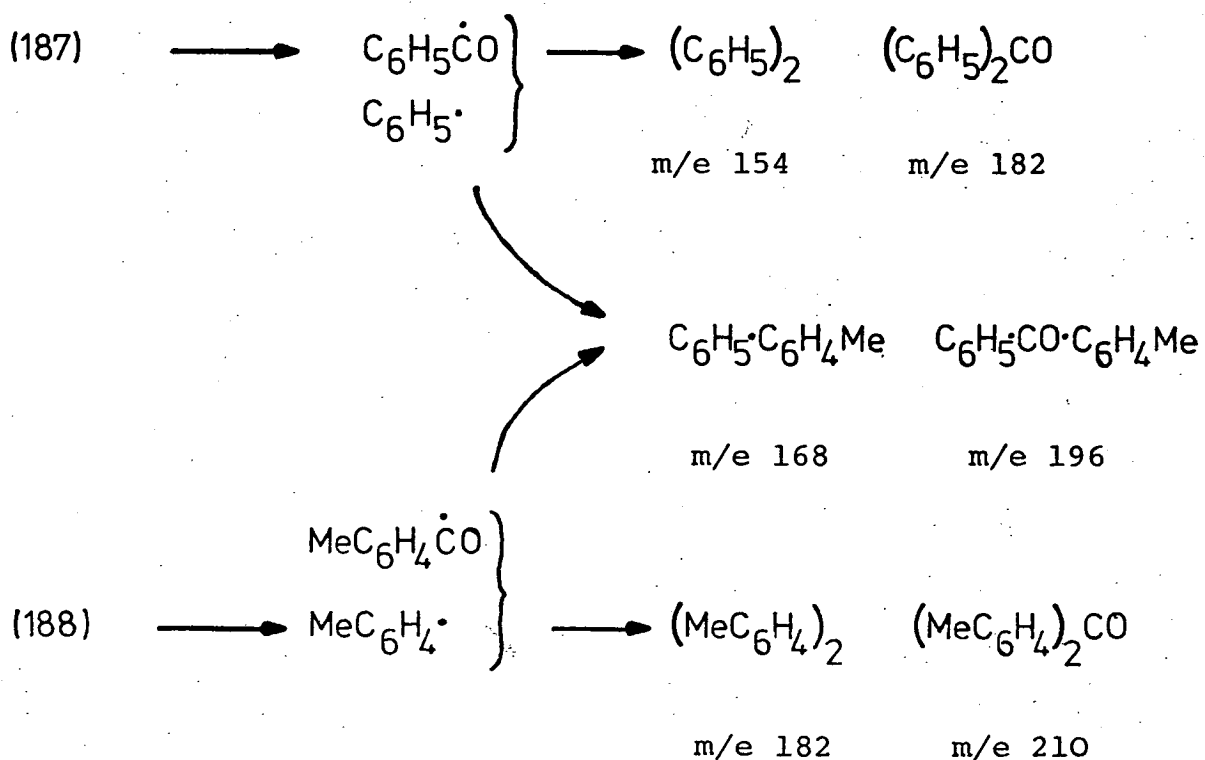

Scheme 68

Further confirmation that some of the decomposition products were formed independently of the solvent employed in the cold trap came from the pyrolysis of (187) at 600°C onto chloroform. All of the products previously found when the pyrolysate was condensed onto benzene, namely, benzonitrile, benzophenone, benzil, benzoic anhydride and biphenyl were identified. In addition benzene and phenyl benzoate were detected by g.l.c./m.s. A quantitative analysis by g.l.c. (2½% OV-1, 70-200°C) using ethyl benzoate as internal standard gave benzonitrile (0.72 mol per mol of dioxadiazine), biphenyl (0.032 mol per mol), benzophenone (0.043 mol per mol), phenyl benzoate (0.006 mol per mol) and benzil (0.012 mol per mol). These products account for 46% of the phenyl groups derived from diphenyldioxadiazine. In addition to the above products it was observed that as the contents of the cold trap warmed to ambient temperature gases were liberated. Mass spectral investigation established that the gas comprised two components both having a parent ion, m/e 44. High resolution m.s. confirmed their identity as carbon dioxide and nitrous oxide.

The detection of nitrous oxide and benzoic anhydride amongst the decomposition products points to path (b), Scheme 64, as being the most probable mode of fragmentation of the dioxadiazine. Kirby et al.¹⁸⁸ while investigating the reactions of nitrosocarbonyl compounds discovered that the cycloadduct (193), formed by the reaction of nitrosocarbonylbenzene and dimethylantracene decomposed in benzene

at 80°C to give benzoic anhydride (73%) with the evolution of nitrous oxide, Scheme 69.

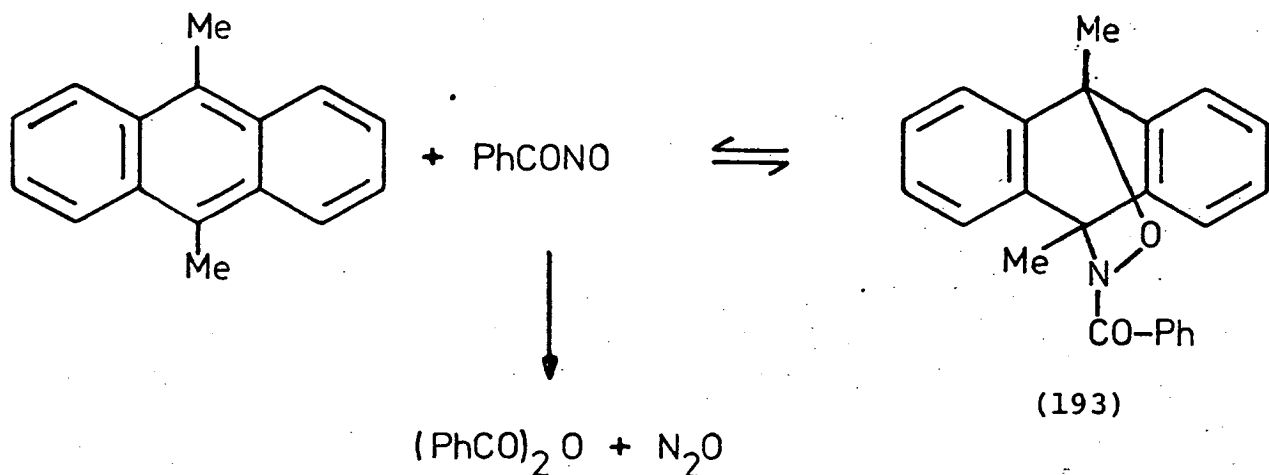

Scheme 69

Although no mechanism was proposed for the formation of these products Kirby¹⁸⁸ suggested that it might involve dimerisation of nitrosocarbonylbenzene as the first step.

Having established the presence of phenyl and benzoyl radicals in the gas phase during the pyrolysis of (187) the question of whether or not there are any radical species in solution arises. If the decomposition of (187) proceeds via nitrosocarbonylbenzene (189, R=Ph) then it is possible that radicals derived from (189) might be present. It has recently been demonstrated that nitrosocarbonyl compounds can act as radical traps for nucleophilic radicals to give nitroxides.¹⁹¹ For example, thermolysis of N-acyloxyamides (194) in benzene with lead tetraacetate at 70°C gave an e.s.r. signal which was attributed to the acyloxy amidyl structure (195). On addition of acetic acid spectra of acyl secondary alkyl nitroxides (196), $a_N = 7.1$, $a_H^{CH} = 1.2G$, were produced. The formation of (196) was rationalised by

the following reaction sequence, Scheme 70, where nitroso-carbonylbenzene (189) acts as a radical trap.

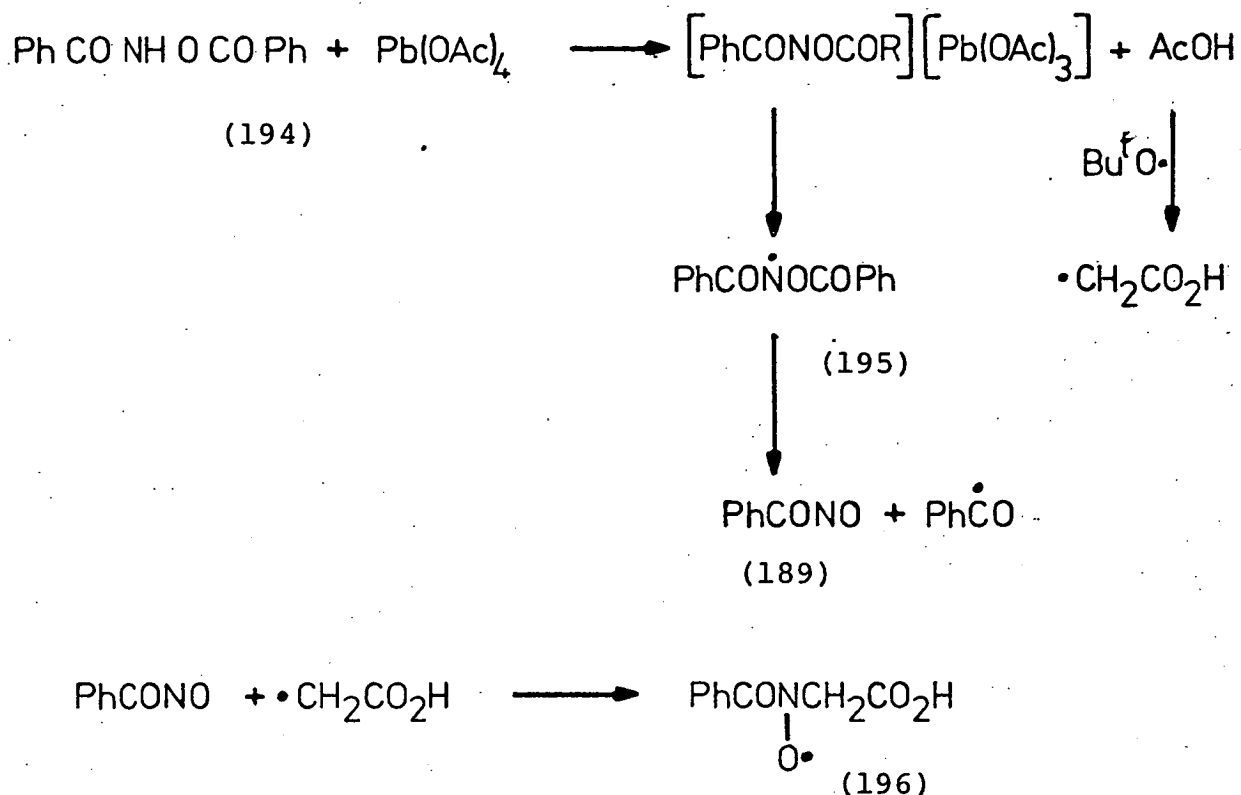

Scheme 70

Therefore, (187) was pyrolysed onto chloroform and the product mixture examined by e.s.r. spectroscopy. At -70°C , a strong signal was observed immediately. The spectrum was recorded at 15°C and analysis with the aid of computer simulation indicated coupling of the unpaired electron to one nitrogen nucleus ($a_N = 10.40$ gauss) and ten protons with hyperfine splitting constants 2.02 gauss (6 ortho/para H) and 0.88 gauss (4 meta H). Comparison of these values and that of the g -factor (2.0055 ± 0.0005) with those of authentic

diphenylnitroxide¹⁶⁶ allows the radical to be identified, unequivocally, as diphenylnitroxide. In a parallel experiment where (188) was pyrolysed at 550°C a broad triplet (1:1:1) with $a_N \sim 10$ gauss was observed in the e.s.r. spectrum. This is consistent with the radical species being ditolylnitroxide but not sufficient to be diagnostic.

Having established the presence of diphenylnitroxide in the reaction mixture its decomposition products, diphenylamine and the corresponding quinonimine-N-oxide (197),¹⁹² were also expected to be present in the product mixture.

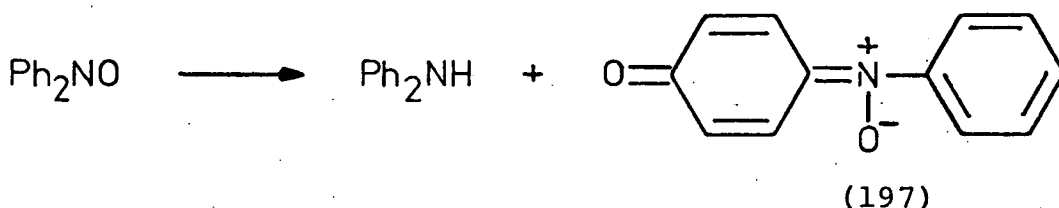

G.l.c./m.s. analysis of the product mixture from the FVP of (187) at 400°C onto chloroform established the presence of diphenylamine and nitrosobenzene amongst the decomposition products. The positive identification of nitrosobenzene gives some indication as to the source of diphenylnitroxide. It has been widely demonstrated, particularly during photolysis, that nitrosocompounds act as spin traps for short lived radicals to form nitroxides.¹⁶⁶ In this instance it is likely that nitrosobenzene reacts with phenyl radicals, formed in the

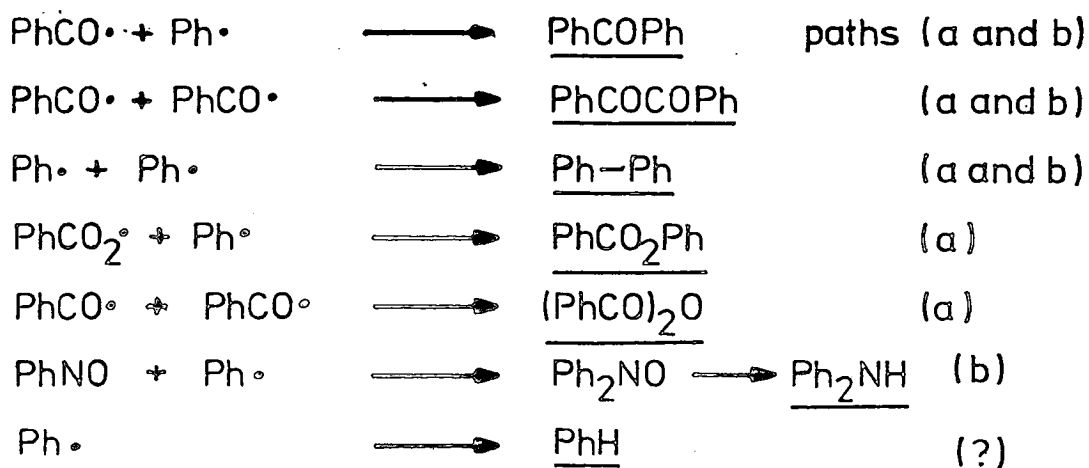
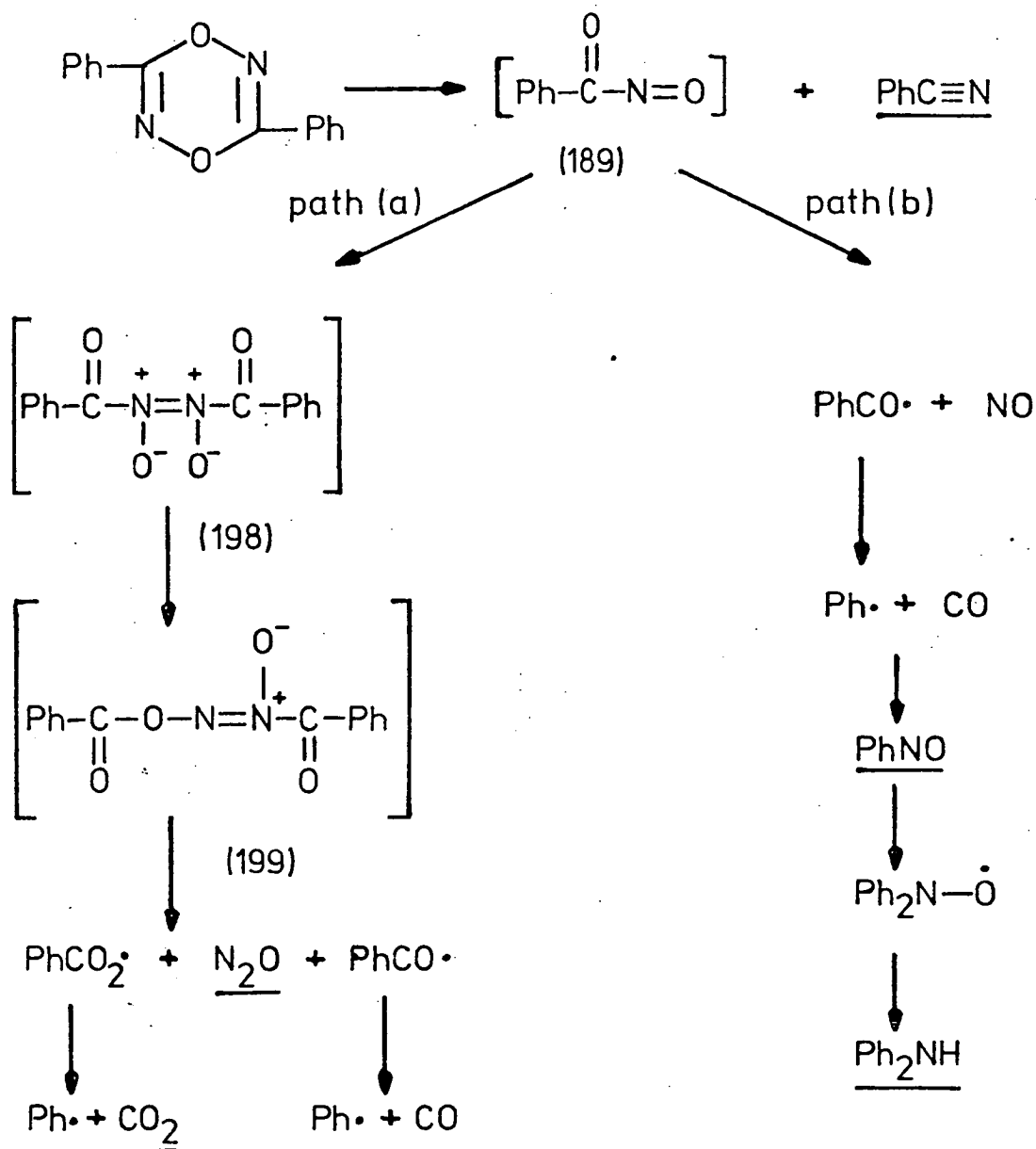

decomposition, to form diphenylnitroxide which on warming decomposes to diphenylamine.

The general nature of the decomposition was partly established by FVP of (188) at 600°C onto chloroform. G.l.c./m.s. analysis of the product mixture clearly identified toluene, toluonitrile, 4-methylnitrosobenzene, 4,4'-dimethyl biphenyl, ditolylamine, 4,4'-dimethyl benzophenone and 4-methylphenyl-4'-methyl benzoate.

The change in the ratios of the products formed, relative to the nitrile, with temperature was established by a series of experiments in which the pyrolysis temperature was increased from 400-800°C. The results and products formed are summarised in Table 7.

Although not detected during the pyrolyses of (187) the identification of nitrous oxide, carbon dioxide and benzoic anhydride, amongst the decomposition products, strongly suggests the intermediacy of nitrosocarbonylbenzene (189), path (b), Scheme 64. Once formed it is proposed that (189) could undergo further reactions by the two alternative pathways illustrated in Scheme 71: (a) dimerisation to the nitroso dimer (198) or (b) fragmentation to benzoyl radicals and nitric oxide.

Support for the proposed mechanism is provided by the work of Kirby and others. As previously stated Kirby et al¹⁸⁸ found while investigating the chemistry of nitrosocarbonyl compounds, that thermolysis of the corresponding dimethyl-

anthracene cycloadduct (193) gave benzoic anhydride (73%) and nitrous oxide. Moreover Grundmann isolated 2,4,6-trimethylbenzonitrile and 2,4,6-trimethylbenzoic acid (3%) from the thermolysis of (186).⁴⁷ The formation of nitrous oxide is consistent with initial dimerisation of nitrosocarbonylbenzene to the dinitroso intermediate (198), which then undergoes rearrangement to (199). The failure of Kirby to detect carbon dioxide from the subsequent fragmentation of (199) may be explained by the operation of an additional pathway in solution. It is conceivable that (199) may collapse in a solvent cage to form benzoic anhydride and nitrous oxide as illustrated in Scheme 72.

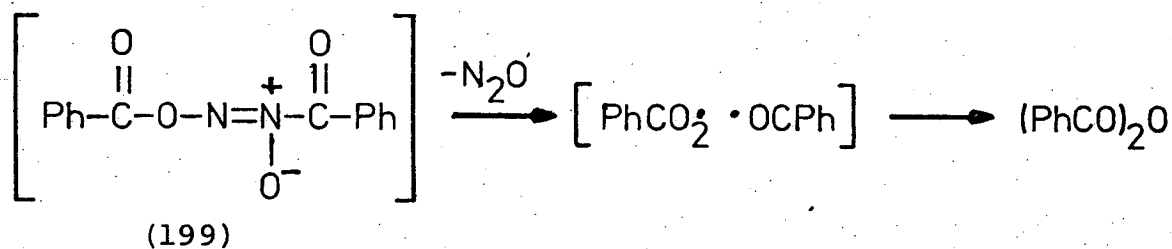

Scheme 72

In this instance, in the gas phase, the likelihood of two molecules coming in contact with each other is reduced. Furthermore under these conditions decomposition of (199) would not be expected to give benzoic anhydride to such an extent as the probability of benzoyl and benzoyloxy fragments recombining would be very much reduced. Rather products derived from their reactions are isolated.

Such differences in the products formed in solution and the gas phase have been observed in the thermolysis of diacetyl peroxide (200).¹⁹³ In the gas phase, (200) dissociates directly to methyl radicals which recombine to form ethane, and carbon dioxide. On the other hand, in solution it dissociates to form two acetate radicals which are held in close proximity to each other by a solvent cage in which the two acetate radicals react to give methyl acetate and carbon dioxide, Scheme 73.

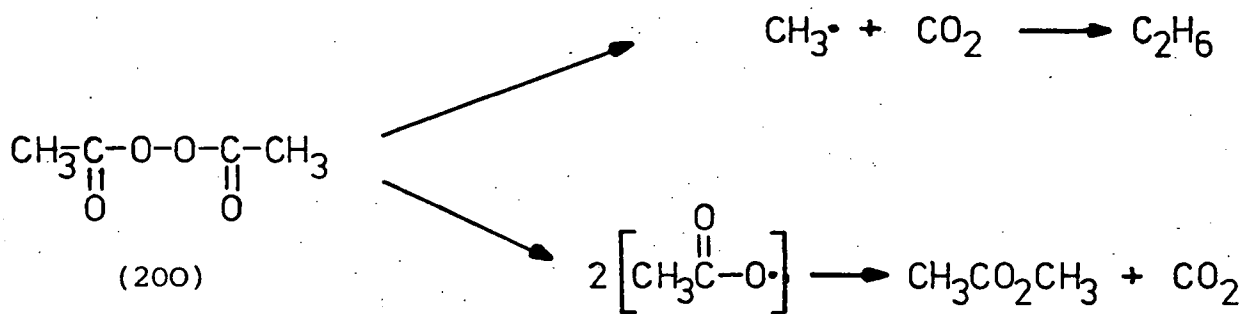

Scheme 73

Although Scheme 73 is an oversimplification much more ethane is formed in the gas phase as would be expected as the result of a combination of free, noncaged methyl radicals and, in agreement with this, ethane is almost eliminated if iodine vapour is present to trap free methyl radicals. Practically no methyl acetate is formed in the gas phase suggesting its formation is a result of cage reactions or of non-radical processes.¹⁹⁴

Returning to the case in hand the formation of all the observed products with the exception of nitrosobenzene and diphenylamine can be rationalised via path (a) in Scheme 71. Benzoyloxy radicals generated from the thermolysis of dibenzoyl peroxide readily decarboxylate to form phenyl radicals and carbon dioxide as the isolation of biphenyl and carbon dioxide amongst the decomposition products readily demonstrates.^{181b} Thus the benzoyloxy radical formed from the decomposition of (199) gives rise to phenyl radicals and carbon dioxide. Moreover, the benzoyl radical may be expected to eliminate carbon monoxide to yield phenyl radicals. The formation of biphenyl, benzophenone, benzil, phenyl benzoate and benzoic anhydride are readily explicable from the decomposition of (199). Although yields are not available for the various products at different pyrolysis temperatures, Table 7 gives the product distribution, relative to $RC\equiv N$, over the temperature range 400-800°C. Experimentally, the concentration of biphenyl increases with increasing pyrolysis temperature whereas the relative concentrations of benzil and phenyl benzoate decrease with increasing temperature and neither is detected amongst the products when the pyrolysis temperature is 800°C. These trends are consistent with the products being derived from the gas phase reactions of benzoyloxy and benzoyl radicals. The increase in the biphenyl concentration presumably arises from the greater proportion of benzoyloxy and benzoyl radicals which fragment, at the higher temperature, to form phenyl radicals. The formation of

Table 7. Ratio (d) of Products from the FVP of 3,6-Diphenyl- and 3,6-Bis(4-methylphenyl)-1,4,2,5-dioxadiazines

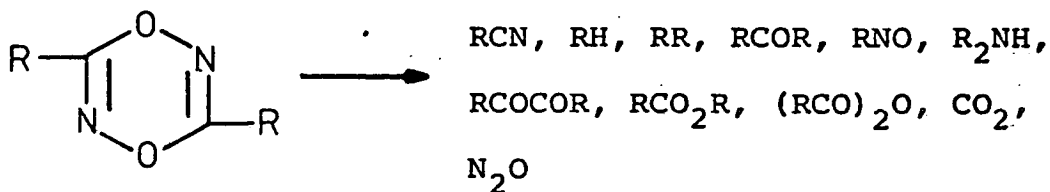

R	Oven temp/°C	RCN	RH	RNO	RR	RCOR	R ₂ NH	RCOCOR	RCO ₂ R
Ph	400	100	12	23	5	15 ^b		5	10
Ph	600	100	- ^a	5.5	8	12 ^b		3	1.5
Ph	800	100	16	0	14	13 ⁶		0	0
4-CH ₃ C ₆ H ₄	600	100	15	3	6	7	3		10 ^c

- a. Benzene not looked for in this experiment
- b. Benzophenone and diphenylamine could not be separated under the g.l.c. conditions used.
- c. 4,4'-dimethyl benzil and 4-methylphenyl-4'-methyl benzoate were not completely resolved under the g.l.c. conditions.
- d. G.l.c. integral ratios assuming benzonitrile equals 100.

benzene during the pyrolysis poses a mechanistic problem as there are no readily available hydrogen atoms which could be easily abstracted by phenyl radicals. That benzene is formed in the gas phase was demonstrated by the failure to detect C_6H_5 C_6D_5 when (187) was pyrolysed and the products condensed onto benzene- d^6 . In addition absence of hexachloroethane amongst the decomposition products after FVP of (187) onto chloroform supported the fact that there are no phenyl radicals in solution. How it is formed is unclear but there is a precedent for its formation as the products of the decomposition of pure dibenzoyl peroxide includes a small amount of benzene in addition to biphenyl, phenyl benzoate and carbon dioxide.¹⁹⁵

On the other hand the detection of nitrosobenzene and diphenylamine amongst the products cannot be rationalised by the above mechanism. Rather it is proposed that an alternative mechanism, path (b), Scheme 71, whereby nitroso-carbonylbenzene does not dimerise but fragments to give benzoyl radicals and nitric oxide. Subsequent reaction of the nitric oxide with phenyl radicals, formed by the elimination of carbon dioxide or carbon monoxide from benzoyloxy or benzoyl radicals respectively, yields nitrosobenzene. The nitrosobenzene thus formed would then react with phenyl radicals to form diphenyl nitroxide which in turn gives diphenylamine. The relative concentration of nitrosobenzene decreases with increasing pyrolysis temperature, a phenomenon which may be explicable in terms of the availability of phenyl radicals.

At a temperature of 400°C the relative yields of benzil and phenyl benzoate are at a maximum while biphenyl is at a minimum over the temperature range investigated. This suggests that a greater proportion of benzoyloxy and benzoyl radicals undergo coupling reactions at the lower temperature rather than fragment to phenyl radicals and, as a consequence, the concentration of phenyl radicals is reduced. Therefore, there are fewer phenyl radical nitrosobenzene reactions to give diphenyl nitroxide and as a result the overall concentration of nitrosobenzene is increased. Alternatively, as the pyrolysis temperature increases the tendency for nitrosobenzene to fragment to phenyl radicals and nitric oxide may increase.

In conclusion, it has been established that the thermal decomposition of 3,6-diaryl-1,4,2,5-dioxadiazines does not give rise to nitrile oxide derived products. Rather the thermolysis under FVP conditions is complex giving rise to a variety of products most of which are derived from free radical reactions in the gas phase. These reactions and the products isolated are consistent with initial fragmentation of the dioxadiazine ring to the corresponding nitrile and nitrosocarbonyl reactive intermediate as outlined in the decomposition mechanism proposed in Scheme 71.

REFERENCES

1. E. Howard, Phil.Trans.Roy.Soc.London, 1800, 204.
2. J. Liebig and J.L. Gay-Lussac, Ann.Chim.Phys., 1824, 25, 285.
3. A. Kekulé, Ann.Chem., 1858, 105, 281.
4. J.U. Nef, Ann.Chem., 1894, 280, 291.
5. H. Lindemann and L. Wiegrebe, Chem.Ber., 1930, 63, 1650.
6. H. Ley and M. Kissel, Chem.Ber., 1899, 32, 1357.
7. A. Quilico and G. Sperain, Gazz.Chim.Ital., 1946, 76, 148.
8. L. Pauling and S.B. Hendricks, J.Amer.Chem.Soc., 1926, 48, 641.
9. R. Huisgen, Proc.Chem.Soc., 1961, 357.
10. W. Beck, E. Schuierer and K. Fedl, Angew.Chem.Int.Ed., 1965, 4, 698.
11. S. Gabriel and M. Koppe, Chem.Ber., 1886, 19, 1145.
12. A. Werner and H. Buss, Chem.Ber., 1894, 27, 2197.
13. H. Wieland, Chem.Ber., 1907, 40, 1667.
14. K. Auwers, Chem.Ber., 1928, 61, 1041.
15. R. Huisgen, Angew.Chem.Int.Ed., 1963, 2, 565, 633.
16. C. Grundmann, V. Mini, J.M. Dean and H.D. Frommeld, Ann.Chem., 1965, 687, 191.
17. P. Beltrame, A. Comotti and C. Veglio, J.C.S.Chem.Comm., 1967, 996.
18. C. Grundmann and J.M. Dean, J.Org.Chem., 1965, 30, 2809.

19. C. Grundmann and S.K. Datta, J.Org.Chem., 1969, 34, 2016.
20. C. Grundmann and P. Grünanger, The Nitrile Oxides, Springer-Verlag, New York, 1971.
21. R.H. Wiley and B.J. Wakefield, J.Org.Chem., 1960, 25, 546.
22. C. Grundmann and R. Richter, J.Org.Chem., 1967, 32, 2308.
23. G. Ponzio and G. Busti, Gazz.Chim.Ital., 1906, 36, 338.
- 24(a). H. Wieland and L. Semper, Chem.Ber., 1906, 39, 2522;
(b) L. Horner, L. Hockenberger and W. Kirmse, Chem.Ber., 1961, 94, 290.
25. C. Grundmann and R. Richter, J.Org.Chem., 1968, 33, 476.
26. G. Just and K. Dahl, Tetrahedron, 1968, 24, 5251.
27. H. Kropf and R. Lambeck, Ann.Chem., 1966, 700, 18.
28. H. Rheinboldt, M. Dewald, F. Jansen and O. Schmitz-Dumont, Ann.Chem., 1927, 451, 161.
29. G. Casnati and A. Ricca, Tet.Letts., 1967, 327.
30. H. Iwakura, K. Uno, S. Shiraishi and T. Hongu, Bull.C.S.Japan, 1968, 41, 2954.
31. P. Beltrame, C. Veglio and M. Simonetta, J.Chem.Soc.(B), 1967, 867.
32. R. Huisgen and W. Mack, Tet.Letts., 1961, 583.
33. T. Sasaki and T. Yoshioko, Bull.Chem.Soc.Japan, 1967, 40, 2604.
34. C. Grundmann and H.D. Frommeld, J.Org.Chem., 1966, 31, 157.

35. Y. Hui Chiang, J.Org.Chem., 1971, 36, 2155.
36. W. Steinkopf and B. Jürgens, J.Prakt.Chem., 1911,
[2] 84, 686.
37. T. Mukaiyama and T. Hoshino, J.Amer.Chem.Soc.,
1960, 82, 5339.
38. M.R. Marquis, Compt.Rend., 1906, 143, 1163.
39. J. Sauer and K. Mayer, Tet.Letts., 1968, 319.
40. E.H. Burk and D.D. Carlos, J.Heterocyclic Chem.,
1970, 7, 177.
41. J.E. Franz and H.K. Pearl, J.Org.Chem., 1976, 41,
1296.
42. A. Rahman and L.B. Clapp, J.Org.Chem., 1967, 41, 122.
43. T. Mukai, T. Oine and A. Matsubara, Bull.Chem.Soc.Japan,
1969, 42, 581.
44. A. Rahman and A.J. Boulton, J.C.S.Chem.Comm., 1968, 73.
45. H. Wieland, Chem.Ber., 1909, 42, 803, 4207.
46. C. Grundmann and P. Kochs, Angew.Chem.Int.Ed., 1970,
9, 635.
47. C. Grundmann, P. Kochs and J.R. Boal, Ann.Chem.,
1972, 761, 162.
48. G. Just and W. Zehetner, Tet.Letts., 1967, 3389.
49. J.W. Apsimon and O.E. Edwards, Can.J.Chem., 1962,
40, 896.
50. G. Barbaro, A. Battaglia and A. Dondoni, J.Chem.Soc.(B),
1970, 588.
51. A.J. Boulton, P. Hadjimihalakis, A.R. Katritzky and
A. Majid Hamid, J.Chem.Soc.(C), 1969, 1901.

52. P. Diehl, H.A. Christ and F.B. Mallory, Helv.Chim.Acta, 1962, 45, 504.
53. F.B. Mallory and A. Cammarata, J.Amer.Chem.Soc., 1966, 88, 61.
54. Bulacinski, E.F.V. Scriven and H. Suschitzky, Tet.Letts., 1975, 3577.
55. K. Fukui, Accounts Chem.Res., 1971, 4, 57.
56. G. Bianchi, C. De Micheli and R. Gandolfi, 'The Chemistry of Double-bonded Functional Groups', Part 1, S. Patai, Ed., Interscience, London, 1977, 369 and references therein.
57. F. De Sarlo, J.C.S. Perkin I, 1974, 1951.
58. S. Morrochi, A. Ricca, A. Selva and A. Zanarotti, Gazz.Chim.Ital., 1969, 99, 165.
59. F. De Sarlo and A. Guarna, J.C.S. Perkin I, 1976, 1825.
60. A. Brandi, F. De Sarlo and A. Guarna, J.C.S. Perkin I, 1976, 1827.
61. R.A. Firestone, Tetrahedron, 1977, 33, 3009 and references therein.
62. R. Huisgen, J.Org.Chem., 1976, 41, 403 and references therein.
63. K.N. Houk, J. Sims, R.E. Duke, Jr., R.W. Strozier and J.K. George, J.Amer.Chem.Soc., 1973, 95, 7287.
64. K.N. Houk, J.Sims, C.R. Watts and L.J. Luskus, J.Amer.Chem.Soc., 1973, 95, 7301.
65. R. Sustmann, Tet.Letts., 1971, 2717.

66. R. Sustmann and H. Trill, Angew.Chem.Int.Ed.,
1972, 11, 838.
67. W.C. Herndon, J.Amer.Chem.Soc., 1971, 93, 125.
68. W.C. Herndon, Chem.Rev., 1972, 72, 157.
69. L. Salem, ibid., 1968, 90, 543 and 553.
70. K. Fukui, Accounts Chem.Res., 1972, 4, 57.
71. K. Bast, M. Christl, R. Huisgen, W. Mack and
R. Sustmann, Chem.Ber., 1973, 106,
3258.
72. A. Dondoni and G. Barbaro, J.C.S. Perkin II,
1973, 1769.
73. A. Battaglia, S.M. Shaw, C.-S. Hsue and
K.N. Houk, J.Org.Chem., 1979,
44, 2800.
74. M. Christl and R. Huisgen, Tet.Letts., 1968, 5209.
75. A.J. Boulton and P.B. Ghosh, "Advances in Heterocyclic
Chemistry" 1969, 10, 1.
76. J.V.R. Kaufmann and J.P. Picard, Chem.Rev., 1959,
59, 429.
77. L.C. Behr, "Chemistry of Heterocyclic Compounds"
(ed. A. Weissberger), 1962, 17, 295.
78. J.H. Boyer, "Heterocyclic Compounds" (ed. R.C.
Elderfield), 1961, 7, 462.
79. R. Koreff, Chem.Ber., 1886, 19, 176.
80. H. Wieland, Ann.Chem., 1903, 329, 225.

81. H. Wieland and L. Semper, ibid., 1908, 358, 36.
82. A.G. Green and F.M. Rowe, J.Chem.Soc., 1913, 103, 897.
83. M.O. Forster and M.F. Barker, J.Chem.Soc., 1913, 103,
1918.
84. J. Meisenheimer, H. Lange and W. Lamparter,
Ann.Chem., 1925, 444, 94.
85. C.R. Kinney, J.Amer.Chem.Soc., 1929, 59, 1592.
86. D.L. Hammick, W.A.M. Edwardes and E.R. Steiner,
J.Chem.Soc., 1931, 3308.
87. G. Ponzio, Gazz.Chim.Ital., 1929, 59, 713.
88. F.B. Mallory, S.L. Manatt and C.S. Wood, J.Amer.Chem.Soc.,
1965, 87, 5433.
89. M. Calleri and G. Ferraris, Tet.Letts., 1967, 4549.
90. L.I. Smith, Chem.Rev., 1938, 125, 501.
91. J.H. Boyer and U. Toggweiler, J.Amer.Chem.Soc.,
1957, 79, 895.
92. G. Ponzio, Gazz.Chim.Ital., 1906, 36, 103.
93. E. Beckmann, Chem.Ber., 1889, 22, 1501 and 1588.
94. Yu. N. Matyushin, V.I. Pepekin, A.D. Nikolaeva,
N.M. Lyapin, L.V. Nikolaeva, A.V. Artyushin
and A. Ya. Apin, Izvestiya Akademii Nauk.
SSSR, 1973, 842. - Chem.Abs., 79, 42422.
95. J.K. Rasmussen and A. Hassner, J.Org.Chem., 1974,
39, 2558.
96. H.O. House, L.J. Czuba, M. Gall and H.D. Olmstead,
J.Org.Chem., 1969, 34, 2324.
97. D. Klamman, W. Koser, P. Weyerstahl and M. Fligge,
Chem.Ber., 1965, 98, 1831.

98. J.F. Barnes, R.M. Paton, P.L. Ashcroft, R. Bradbury, J. Crosby, C.J. Joyce, D.R. Holmes and J.A. Milner, J.C.S.Chem.Comm., 1978, 113.
99. E.M. Nygaard and T.T. Noland, US 2396282 - Chem.Abs., 1946, 40, 3126.
100. L.B. Clapp, J.F. Brown and L. Zefitel, J.Org.Chem., 1950, 15, 1043.
101. W.D. Emmons and J.P. Freeman, J.Org.Chem., 1957, 22, 456.
102. J. Schmidt, Chem.Ber., 1901, 34, 619; H. Wieland and E. Bhumick, Ann.Chem., 1921, 424, 100.
103. T.E. Stevens and W.D. Emmons, J.Amer.Chem.Soc., 1959, 80, 338.
104. K. Auwers and V. Meyer, Chem.Ber., 1889, 22, 705.
105. J. Ackrell, M. Altaf-ur-Rahman, A.J. Boulton and R.C. Brown, J.C.S.Perkin I, 1972, 1587.
106. A. Dondoni, G. Barbaro, A. Battaglia and P. Giorgiani, J.Org.Chem., 1972, 37, 3196.
107. J.A. Chapman, J. Crosby, C.A. Cummings, R.A.C. Rennie and R.M. Paton, J.C.S.Chem.Comm., 1976, 240.
108. West German Patent, 2,336,403 (Chem.Abs. 1974, 81, P49257a).
109. West German Patent, 2,422,764 (Chem.Abs. 1975, 82, P141047a).
110. J.F. Barnes, J. Crosby and R.M. Paton, unpublished observations.
111. M. Altaf-ur-Rahman, A.J. Boulton and D. Middleton, Tet.Letts., 1972, 3469.

112. S. Takahashi and H. Kanō, Tet.Letts., 1963, 1687.
113. R.G. Simmonds, B.A.J. Clark and T.J. Evans,
J.C.S.Perkin I, 1975, 1803.
114. K.L. Stuart, Heterocycles, 1975, 3, 651.
115. L. Avagadro, Gazz.Chim.Ital., 1924, 54, 549.
116. L.C. Behr and J.T. Brent, Org.Synth., 1954, 34, 40.
117. C.V. Banks and C.I. Adams, J.Org.Chem., 1956, 21, 185.
118. N. Tokura, R. Tada and K. Yokoyama, Bull.Chem.Soc.Jap.,
1961, 34, 270.
119. A.J. Boulton and S.S. Mathur, J.Org.Chem., 1973, 38.
1054.
120. T. Mukaiyama, H. Nambu and M. Okamoto, J.Org.Chem.,
1962, 27, 3651.
121. C. Grundmann, Chem.Ber., 1964, 97, 575 (CA 60, 9267e).
122. S.M. Katzman and J. Moffat, J.Org.Chem., 1972, 37, 1842.
123. K. Auwers and V. Meyer, Chem.Ber., 1888, 21, 784.
124. F.D. Dodge, Ann.Chem., 1890, 264, 178.
125. T.S. Cantrell and W.S. Haller, J.C.S.Chem.Comm.
1968, 977.
126. T. Mukai and M. Nitta, J.C.S.Chem.Comm., 1970, 1192.
127. M. Georgarakis, J.H. Rosenkranz and H. Schmid,
Helv.Chim.Acta, 1971, 54, 819.
128. I. Yarari, S. Esfandiari, A.J. Mostashari and P.W.
Hunter, J.Org.Chem., 1975, 40, 2880.
129. (a) O. Tsuge, T. Takata and M. Noguchi, Heterocycles,
1977, 6, 1173; (b) O. Tsuge and T. Takata,
Chem.Lett., 1979, 1029; (c) O. Tsuge and
T. Takata, Heterocycles, 1980, 14, 423;
(d) O. Tsuge and T. Takata, J.Org.Chem.,
1980, 45. 2956.

130. (a) D.J. Anderson, D.C. Horwell, E. Stanton, T.L. Gilchrist and C.W. Rees, J.C.S. Perkin I, 1972, 1317; (b) J.A. Oliver and P.A. Ongley, Chem. Ind. (London), 1965, 1024; (c) R.F.C. Brown, R.K. Solly, Aust. J. Chem., 1966, 19, 1045.
131. G. Seybold and U. Jersak, Chem. Ber., 1977, 110, 1239.
132. E. Hedaya and D. McNeil, J. Amer. Chem. Soc., 1967, 89, 4213.
133. R. Huisgen and V. Weberndörfer, Experientia, 1961, 17, 566. (Chem. Abs. 1962, 57, 11189h).
134. G. Seybold and C. Heibl, Chem. Ber., 1977, 110, 1229.
135. C. Wentrup, Chimia, 1977, 31, 258. (Chem. Abs. 1977, 87, 133218V).
136. G. Seybold, Angew. Chem. Int. Ed., 1977, 16, 365 and references therein.
137. W. Reichen, Helv. Chim. Acta, 1976, 59, 1636.
138. J. Sauer and K. Mayer, Tet. Letts., 1968, 325.
139. D.N. Reinhoudt and C.G. Kouwenhoven, Rec. Trav. Chim., Pays-Bas, 1976, 95, 67.
140. P.G. Hibbert, Ph.D. Thesis, London, 1963.
141. R.J. Faber and G.K. Fraenkel, J. Chem. Phys., 1967, 47, 2462.
142. J.Q. Adams and J.R. Jones, J. Chem. Phys., 1963, 39, 1904.
143. J.R. Morton and H.W. Wilcox, Inorg. Synthesis, 1953, 4, 48.
144. J.H. Bcyer, R.F. Reinisch, M.J. Danzig, G.A. Stoner and F. Sahher, J. Amer. Chem. Soc., 1955, 77, 5688.

145. A.I. Vogel, 'Practical Organic Chemistry',
Longmans, Green and Co., London,
3rd Edition 1956.
146. C.R. Kinney, E.W. Smith, B.L. Woolley and A.R. Willey,
J.Amer.Chem.Soc., 1933, 55, 3418.
147. G. Ponzio, Chem.Ber., 1928, 61, 1320.
148. E. Borello and M. Milone, Gazz.Chim.Ital., 1951,
81, 368.
149. P. Petrenko-Krischenko, Chem.Ber., 1892, 25.
2240.
150. E. Ney, Chem.Ber., 1888, 21, 2450.
151. K. Auwers and M. Siegfeld, Chem.Ber., 1896,
26, 792.
152. J.R. Geigy, French Patent 1,559,131. (Chem.Abs.,
1969, 71, 12445;).
153. G. Ponzio, Gazz.Chim.Ital., 1900, 30II, 463.
154. H.V. Peckmann and K. Wehsarg, Chem.Ber., 1888, 21.
2997.
155. G. Ponzio, Gazz.Chim.Ital., 1898, 28, 176.
156. A.W. Hoffmann, Chem.Ber., 1870, 3, 654.
157. "Dictionary of Organic Compounds", Eyre and Spottiswoode
(Pub.) Ltd., E. and F.N. Spon Ltd., London,
1965.
158. J.H. Boehmer, Rec.Trav.Chim.Pays-Bas, 1936, 55, 386.
159. B. Pawlewski, Chem.Ber., 1904, 37, 158.
160. A.W. Hoffmann, Chem.Ber., 1870, 3, 653.

161. G. Bianchi and P. Grünanger, Tetrahedron, 1965,
21, 817.
162. L. Conrad, Helv.Chim.Acta, 1938, 21, 1127.
163. O. Degner and H.V. Pechman, Chem.Ber., 1897,
30, 650.
164. C. DeWitt Hurd and P.B. Cochran, J.Amer.Chem.Soc.,
1923, 45, 515.
165. O. Schulz, Chem.Ber., 1885, 18, 1081.
166. A.R. Forrester, J.M. Hay and R.H. Thomson, Organic
Chemistry of Stable Free Radicals,
Academic Press, London and New York, 1968.
167. G. Zinner and H. Gunther, Angew.Chem.Int.Ed., 1964,
3, 383.
168. M. Christl, J.P. Warren, B.L. Hawkins and J.D. Roberts,
J.Amer.Chem.Soc., 1973, 95, 4392.
169. R. Sustmann, R. Huisgen and H. Huber, Chem.Ber.,
1967, 100, 1802.
170. R.A. Jones and M.T.P. Marriott, Heterocycles,
1980, 14, 185.
171. R. Huisgen, W. Mack and E. Anneser, Angew.Chem.,
1961, 73, 656.
172. G. Bianchi, C. De Micheli and R. Gandolfi, Angew.
Chem.Int.Ed., 1979, 18, 721.
173. J.L. Cotter and G.J. Knight, J.C.S.Chem.Comm.,
1966, 336.
174. C. Ainsworth, J.Heterocyclic Chem., 1966, 3, 470.

175. F. Tiemann and P. Krüger, Chem.Ber., 1884, 17, 1685.
176. R. Stolle, Chem.Ber., 1908, 41, 1125.
177. A. Selva, L.F. Zerilli, B. Cavalleri and G.G. Gallo, Org. Mass Spectrometry, 1972, 6, 1347;
ibid., 1974, 9, 558.
178. H. Newman, Tet.Letts., 1968, 2417, 2421.
179. (a) C.S. Angadiyavar, K.B. Sukumaran and M.V. George, Tet.Letts., 1971, 633. (b) K.B. Sukumaran, S. Satish and M.V. George, Tetrahedron, 1974, 445.
180. C. Wintner, Tet.Letts., 1970, 2275.
181. (a) G.H. Williams, 'Homolytic Aromatic Substitution,' Pergamon Press, London, 1960, p.63, 94;
(b) p.35.
182. B. Sklarz and A.F. Al-Sayyab, J.Chem.Soc., 1964, 1318.
183. J.E. Rowe and A.D. Ward, Aust.J.Chem., 1968, 21, 2761.
184. U. Lerch and J.E. Moffat, J.Org.Chem., 1971, 36, 3391.
185. A.L.J. Beckwith and G.W. Evans, J.Chem.Soc., 1962, 130.
186. (a) P. Horsewood and G.W. Kirby, J.C.S.Chem.Comm., 1971, 1139. (b) R. Dickinson, G.W. Kirby, J.G. Sweeney and J.K. Tyler, ibid., 1973, 241.
187. G.W. Kirby and J.G. Sweeney, J.C.S.Chem.Comm., 1973, 704.
188. G.W. Kirby, Chem.Soc.Reviews, 1977, 6, 1.
189. T.L. Gilchrist and C.W. Rees, 'Carbenes, nitrenes and arynes', Nelson, London, 1969.
190. D.H. Hey, M.J. Perkins and G.H. Williams, J.Chem.Soc., 1964, 3412.

191. A.R. Forrester, J. Henderson, E.M. Johansson and
R.H. Thomson, Tet.Letts., 1978, S139.
192. H. Wieland and K. Roth, Chem.Ber., 1920, 53, 210.
193. L. Herk, M. Field and M. Szwarc, J.Amer.Chem.Soc.,
1961, 83, 2998.
194. W.A. Pryor, 'Free Radicals', McGraw-Hill, 1960,
p.87-91.
195. H. Erlenmeyer and W. Schoenaur, Helv.Chim.Acta,
1936, 19, 338.

APPENDIX

ISOLATION OF NITRILE OXIDES FROM THE THERMAL FRAGMENTATION OF FURAZAN N-OXIDES

William R. Mitchell and R. Michael Paton*

Department of Chemistry, University of Edinburgh, West Mains Road, Edinburgh EH9 3JJ.

Summary: Flash vacuum pyrolysis of furoxans generates nitrile oxides, which have been reacted with alkenes to yield 2-isoxazolines, and have been examined by ^1H and ^{13}C nmr spectroscopy.

It has recently been established¹ that the thermolysis of 3,4-disubstituted furazan N-oxides (furoxans, **1**) in the presence of alkenes at temperatures in excess of 200°C results in the formation of isoxazolines (**2**). The process was assumed to involve a 1,3-dipolar cycloaddition reaction between the alkene and the two nitrile oxide fragments (**3**) resulting from the thermal cleavage of the oxadiazole ring [Path A], thus reversing the established nitrile oxide to furoxan dimerisation.^{2a} However, nitrile oxides were not detected during the course of the reaction³ and the possibility of **2** being formed by direct interaction between the alkene and the furoxan could not therefore be ruled out; for nitrene-like cycloaddition⁴ of the furoxan itself to the alkene and subsequent collapse of the intermediate adduct (**4**) would also lead to the observed products [Path B].

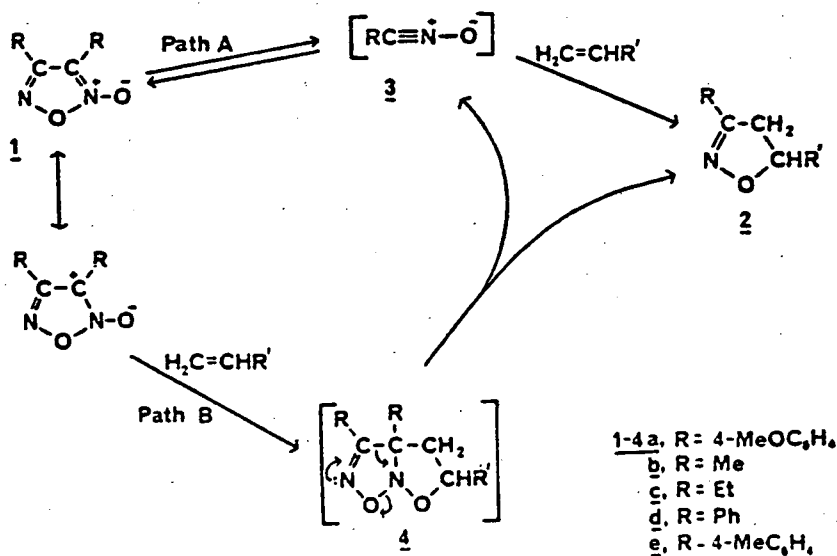

We have now found that, using conventional Flash Vacuum Pyrolysis (FVP) apparatus and technique,⁵ it is possible to isolate and identify the nitrile oxide fragments. For example, FVP (500°C, 10⁻³ mmHg) of dianisylfuroxan (1a) yielded anisonitrile oxide (2a), the ir and ¹H nmr spectra of which were indistinguishable from those of the authentic material generated by base treatment of the corresponding hydroxamic acid chloride.^{2c} Further confirmation of the identity of the product was obtained by treating it with excess hex-1-ene and isolating the isoxazoline cycloadduct (2a, R' = Bu, 75%).

While the conventional methods^{2d} are satisfactory for the preparation of aromatic nitrile oxides having long lifetimes, they prove cumbersome for the isolation of the short-lived aliphatic counterparts, which undergo rapid dimerisation to the corresponding furoxan.^{2a} Thus acetonitrile oxide (3b) is reported^{2e} to exist for less than 1 min at 18°C and has consequently received little attention.⁶ In contrast we find that FVP (600°C, 10⁻³ mmHg) of dimethylfuroxan (1b) provides a straightforward means of generating acetonitrile oxide, thus permitting detailed examination of its properties. Recombination of the nitrile oxide fragments back to the furoxan is prevented by maintaining the FVP cold trap temperature at <-40°C. By this technique solutions of 3b in CDCl₃ were prepared and its nmr spectra recorded. The ¹³C nmr spectrum (CDCl₃, -51°C) comprises the two lines marked 'n' in Fig. 1. The larger peak at 0.8 ppm is attributed to the methyl carbon, while the broad signal centred at 35.6 ppm, which is partially resolved into a triplet due to coupling with the ¹⁴N nucleus, is assigned to the carbon of the nitrile oxide group.⁷ Some contamination by 1b, either resulting from incomplete fragmentation or due to partial dimerisation of the nitrile oxide,^{2a} is indicated by the presence of the four lines marked 'f', this assignment being made by comparison with the spectrum obtained for the authentic material. On allowing the solution to warm to and remain at room temperature for 3 days, the lines attributed to 3b disappeared, while those due to 1b increased in intensity (Fig. 2), consistent with the expected recombination of 3b to 1b. This process may also be monitored by ¹H nmr. The spectrum at -40°C consists of three lines, the outside two at 2.21 and 2.40δ being due to 1b while the third line at 2.26δ is assigned to 3b.^{6b} On warming to 26°C the signal due to 1b increased at the expense of that due to 3b, the process being complete after ca 3 days.⁸

In addition to allowing spectroscopic examination of the short lived nitrile oxides, the FVP technique also broadens the scope of the synthetic route from furoxans to isoxazolines. For the range of usable alkenes is greatly extended by the removal of the necessity for them to boil at >200°C.⁹ Furthermore, the yields of the cycloadducts are increased by the reduction of the amount of tarry byproducts which were a feature of the original furoxan based route,¹ and which may be attributed to the limited thermal stability

of both the alkenes and the isoxazoline products. The isoxazolines produced by the FVP technique are listed in the Table, together with the reaction conditions used.

While these FVP results do not necessarily preclude direct reaction between the alkene and the furoxan in solution, they demonstrate both a novel means of isolating and studying even the most reactive nitrile oxides, and a more generally applicable route from furoxans to isoxazolines.

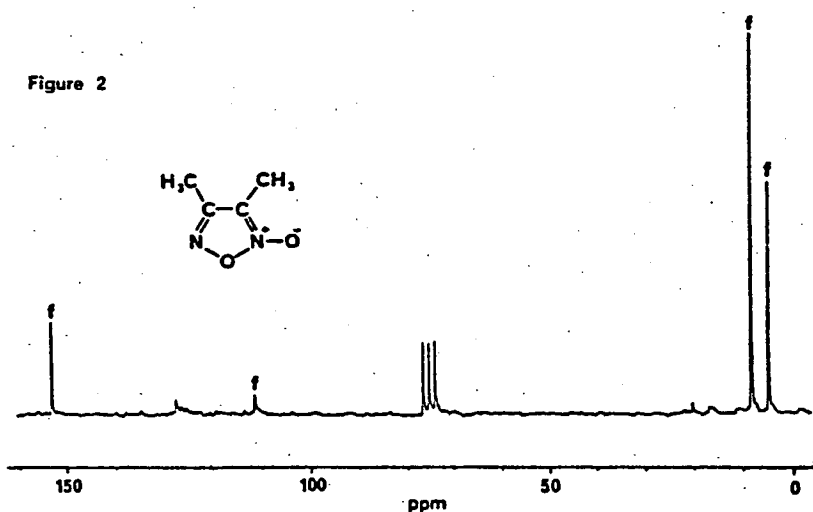
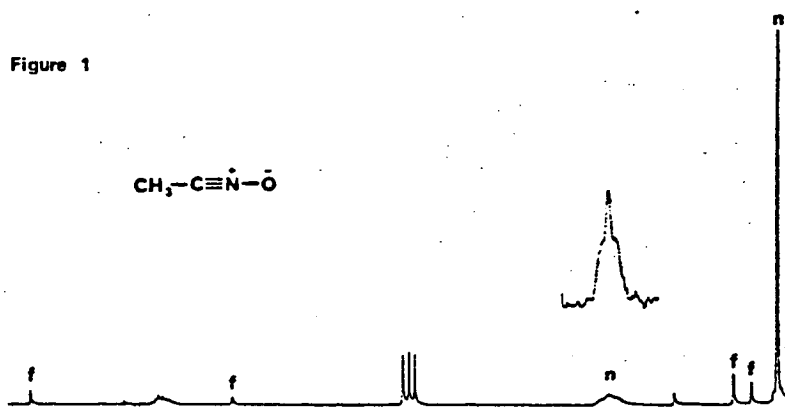

Figure 1. ¹³C nmr spectrum (CDCl₃, -51 °C) of solution resulting from FVP of dimethylfuroxan (1b), showing signal due to acetonitrile oxide (3b, lines marked "n") with contamination by 1b (lines marked "f").

Figure 2. ¹³C nmr spectrum of reaction mixture after 3 days at room temperature, indicating increased concentration of 1b and absence of 3b.

TABLE

Isoxazolines(2) produced by reaction of alkenes ($\text{CH}_2=\text{CHR}'$) with nitrile oxides (RCNO , 3) produced via FVP fragmentation of furoxans (1).

R	R'	FVP ^(a) oven temp (°C)	% Yield
4-MeOC ₆ H ₄	Bu	500	75
Me	Bu	600	79
Et	Bu	650	95
Ph	Bu	550	97
4-MeC ₆ H ₄	C ₁₂ H ₂₅	500	86

(a) Pressure ca 10^{-3} mmHg.

Acknowledgement. - We thank the S.R. C. for financial support.

References and Footnotes

1. J. A. Chapman, J. Crosby, C. A. Cummings, R. A. C. Rennie, and R. M. Paton, J. C. S. Chem. Comm., 240 (1976) and references therein.
2. C. Grundmann and P. Grünanger, 'The Nitrile Oxides,' Springer-Verlag, West Berlin and Heidelberg, (1971); (a) pp. 75-81; (b) pp. 62-67 and 96-111; (c) p. 55; (d) Chapter 3; (e) p. 16.
3. At temperatures in excess of 200°C the rearrangement of nitrile oxides to isocyanates and their cycloaddition reactions with alkenes are rapid; see Ref. 2b.
4. Nitrene-like character of furoxans has been invoked to explain the reactions of dibenzoylfuroxan with phenylacetylene, styrene and stilbene:
M. Altaf-ur-Rahman, A. J. Boulton and D. Middleton, Tetrahedron Lett., 3469 (1972).
5. See for example: G. Seybold, Angew. Chem. Int. Edn., 16, 365 (1977).
6. (a) G. Zinner and H. Gunther, Angew. Chem. Int. Edn., 3, 383 (1964).
(b) A. Brandi, F. De Sarlo and A. Guana, J. C. S. Perkin I, 1827 (1976).
7. M. Christl, J. P. Warren, B. L. Hawkins and J. D. Roberts, J. Am. Chem. Soc., 95, 4392 (1973).
8. The rates of disappearance of 3b and formation of 1b showed the expected second order kinetics; W. R. Mitchell and R. M. Paton, unpublished observations.
9. In the original furoxan to isoxazoline route¹ all the furoxans required >200°C for fragmentation to occur and the reactions were performed at atmospheric pressure.

(Received in UK 19 April 1979)

Generation of isocyanates from the flash vacuum pyrolysis of furazan *N*-oxides

William R Mitchell and R Michael Paton

Chemistry Department, University of Edinburgh, West Mains Road, Edinburgh, EH9 3JJ

It has been established¹ that isocyanates (I) are formed by the thermolysis of furazan *N*-oxides (furoxans, II), but the synthetic utility of the reaction has been restricted² by the high temperatures (>200°C) usually required. Thus phenyl isocyanate (Ia) may be obtained¹ in moderate yield (42 per cent) by heating 3,4-diphenylfuroxan (IIa) at ca 250°C, but only traces of methyl isocyanate (Ib) are formed¹ from (IIb) at its boiling point. Now it is reported that, using the flash vacuum pyrolysis (FVP) technique, both dialkyl and diaryl-furoxans may be converted into their respective isocyanates in good yield.

Compound (IIa) (330mg, 139mmol) was subjected to FVP (500°C, 10⁻³mm Hg) and the products were collected in a cold trap (-193°C) containing excess of sulphur dioxide (ca 3g). Dry toluene (50cm³) was added and the resulting mixture was heated under reflux for 1h. After removal of the sulphur dioxide from the solution with a stream of dry nitrogen, the presence of compound (Ia) was established by g.l.c. (93 per cent) and by reaction with ethanol to yield the

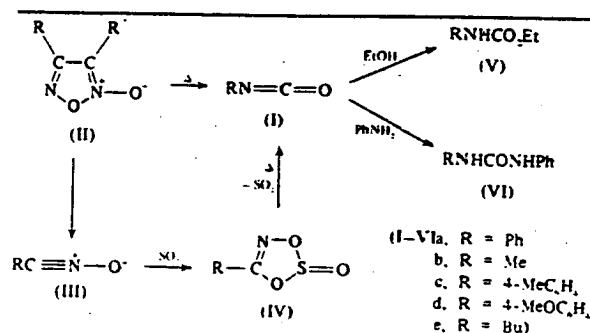

urethane (Va) (75 per cent). In like manner FVP of compounds (IIc) and (IId) gave (Ic) and (Id) which with aniline afforded the urea adducts (VIc) (71 per cent) and (VIId) (95 per cent).

The method is particularly valuable for the generation of methyl isocyanate (Ib) from 3,4-dimethylfuroxan, which is

readily available* from but-2-ene and N_2O_5 , and for which straightforward thermolysis in the liquid phase is ineffective. FVP (550°C) of compound (IIb) and treatment with sulphur dioxide gave compound (Ib) and with aniline its urea adduct (VIb) (74 per cent). Similarly compound (IIe) (600°C) afforded (VIe) (61 per cent).

The formation of the isocyanates may be rationalised in terms of initial cleavage of the furoxan under the FVP conditions to its two nitrile oxide fragments (III),³ followed by sulphur dioxide-mediated isomerisation of (III) to (I) via the 1,3,2,4-dioxathiazole 2-oxide (IV).⁶ Such a conversion of nitrile oxides into isocyanates, by the 1,3-dipolar cyclo-addition of the nitrile oxide to sulphur dioxide yielding (IV) and its subsequent thermal fragmentation, was first reported by Burk and Carlos,⁷ and has recently been exploited further^{8,9} for the preparation of both mono- and di-isocyanates.

By avoiding the temperature limitations of the previous method, the FVP technique provides a more effective means of converting furoxans into isocyanates.

Received 11 February 1980

References

- 1 Chapman, J. A., Crosby, J., Cummings, C. A., Rennie, R. A. C. & Paton, R. M., *J. Chem. Soc. Chem. Commun.*, 1976, 240 and references therein
- 2 The high temperatures required limit the use of coreactants (e.g. alcohols and phenols) and lead to extensive by-product formation resulting from the decomposition of the isocyanates (and their urethane adducts)
- 3 Behr, L. C., in 'The chemistry of heterocyclic compounds,' Vol. 17, Wiley, R. H. (ed.), New York and London: Interscience: 1962, p 298
- 4 Klamann, D., Koser, W., Weyerstahl, P. & Fligge, M., *Chem. Ber.*, 1965, 98, 1831
- 5 FVP of compound (IIa) in the absence of sulphur dioxide results in the formation of III a (97 per cent); Mitchell, W. R. & Paton, R. M., *Tetrahedron Lett.*, 1979, 2443
- 6 The presence of compound (IVb) was indicated by the characteristic infrared absorption at 1240cm^{-1} , and demonstrated by treatment of the solution with water and isolation of the corresponding hydroxamic acid (MeCONHOH)
- 7 Burk, E. H. & Carlos, D. D., *J. Heterocyclic Chem.*, 1970, 7, 177
- 8 Barnes, J. F., Paton, R. M., Ashcroft, P. L., Bradbury, R., Crosby, J., Holmes, D. R. & Milner, J. A., *J. Chem. Soc. Chem. Commun.*, 1978, 113
- 9 Trickes, G. & Meier, H., *Angew. Chem. Int. Edn*, 1977, 16, 555