

# The role of the hippocampus in event memory in the rat

*Ms Rosamund Fay Langston*



Doctor of Philosophy  
Biomedical Sciences  
School of Medicine and Veterinary Medicine  
University of Edinburgh

2007

## Abstract

This thesis aims to examine the role of the hippocampus in declarative memory through the development of animal behavioural models of episodic memory for laboratory rats. Episodic memory- memory for unique events or episodes- is part of the declarative memory system thought to be mediated by the medial temporal lobe area of the brain in humans. One commonly used test of episodic memory in human subjects is paired associate learning. The first part of this thesis describes the adaptation of this human test for use with laboratory rats. Using their natural foraging tendency, rats were trained to search for different flavours of food at different locations within a large enclosure. When cued with a piece of food of a particular flavour in a separate box, rats learned to return to the place where that flavour of food had previously been found. This paradigm was used to investigate the role of the hippocampus in paired-associate learning using temporary pharmacological inactivation and permanent neurotoxic lesion techniques. The hippocampus has also been strongly implicated in spatial navigation, learning and memory in rats and humans. In the experiments described previously, attempts were therefore made to demonstrate that the results were not confounded by a simple deficit in spatial navigation.

An alternative approach to studying episodic memory in the laboratory rat is to use the criteria established by Tulving in 1972 to describe episodic memory. He stated that episodic memory should encompass the memory for an event and the spatiotemporal context in which it occurred, i.e. the "what", "where" and "when" of an event. He later updated these criteria to include demonstration of autonoetic consciousness- most easily described as a sense of self awareness. Since this is difficult or impossible to demonstrate in animals, the term "episodic-like" memory was coined (Clayton & Dickinson 1998) to describe the flexible use of information about the spatiotemporal aspects of an event by non-human species. Since it has been difficult to demonstrate the use of time (when) in rats (Bird et al; 2003, Babb & Crystal 2006a), Eacott & Norman (2004) suggested that the "when" component could be replaced by context; i.e. another element specific to a particular event that they labelled "which". The next part of this thesis describes the use of the task published by Eacott & Norman to test episodic-like memory in the laboratory rat. Using the innate spontaneous behaviour of rats to explore novel aspects of their environment, they were exposed to multiple unique events. These consisted of various three-dimensional objects being presented in different locations within different contexts. Their memory for manipulations of the environment was then tested by presenting them with an event in which one combination of object, location and context was different from combinations which had previously been encountered. Due to their tendency to explore

novel aspects of their environment, normal rats spent the majority of their time exploring the object that was in a novel location relative to the context in which it was presented. This successfully demonstrated integrated memory for what, where and which- similar to that previously defined by Tulving. The rats also showed that they could use this information flexibly because every trial involved unique combinations of objects, locations and contexts so there was no inadvertent semantic rule-learning involved. Permanent neurotoxic lesions of the hippocampus were used to determine the extent to which this structure is involved in memory for the what, where and which of an event.

The experimental results presented in this thesis demonstrate an indisputable role for the hippocampus in a variety of tasks designed to parallel episodic memory in humans. The next steps in this line of research should involve characterisation of the roles of the various subregions of the hippocampus in episodic-like and paired associate memory.

## Acknowledgements

Firstly, thanks to my parents who have supported my perpetual student habit- without them my Neuroscience career would never have got off the ground! I am eternally grateful.

To everyone in the Appleton Tower/1 George Square lab- I can never thank you all enough. You have all contributed to moulding me into the kind of researcher I am today. Obsessive, paranoid... only joking! I can't possibly name everyone but those of you who I have worked most closely with deserve special mentions. Firstly Mark Day, who gave me my first experience of life in the lab with endless hours of mice in the water-maze. I took my first steps into research with him as my guide, and then (by leaving for the States!) he taught me how to work independently (and, incidentally, introduced me to my future husband!) Steve Martin was always there in times of experimental crisis (or beer) and I certainly could not have survived without the technical rescue services of Patrick Spooner either. Jane Tulloch always knew how to solve any problems I had in the lab and has always been on hand for histology, tea, yoga sessions and the occasional glass of wine when necessary. It has been an absolute pleasure to work with Dorothy Tse- she is one of the most organised and hardworking people I know, but still always has time to leave you a note just to ask how your day was, usually accompanied by some kind of exotic confectionery type gift! I am so glad that Ingrid Bethus and Iain Wilson came to join the Edinburgh lab after spending a wonderful and exhausting week with them both on the FENS Winter School in Kitzbuehel. I have also been lucky enough to supervise countless wonderful undergraduate and Masters students- Steven Huang, Rowland Sil-lito and Cassie Hosburn to name my "favourites"- with never a bad experience- although perhaps the accidental decapitation of one of my rats by an undergrad (who shall remain nameless) whilst I was on holiday could be classed as the exception to an otherwise clean slate! Matthijs van der Meer was the perfect office mate and everyday companion for our short writing-up period in the Forrest Hill Informatics Office (which I should thank Mark van Rossum for). He provided port, cheese and excellent company throughout and will be a friend for life. I'm sure if everyone had a Matt, writing up would be a much more enjoyable experience.

Of course, my biggest debt is to my fantastic and much-loved supervisors Emma Wood and Richard Morris, who I will always be grateful to. They have allowed me to spread my wings in the lab and elsewhere, supporting me in my enthusiasm to attend as many conferences and talk to as many researchers as possible, but always there to bring me sensibly back down to earth before I get over-ambitious. I could not have wished for a better start to my career and I hope that I can make them proud in the future.

## **Declaration**

I declare that this thesis was composed by myself, that the work contained herein is my own except where explicitly stated otherwise in the text, and that this work has not been submitted for any other degree or professional qualification except as specified.

*(Ms Rosamund Fay Langston)*

To Jamie Ainge, with whom I shall elope to Trondheim very shortly to begin a beautiful  
new life!

# Table of Contents

<b>1</b>	<b>Introduction</b>	<b>1</b>
1.1	Different types of memory processing . . . . .	2
1.1.1	Declarative memory: the semantic vs. episodic distinction . . . . .	2
1.1.2	The Serial Parallel Independent model of declarative memory . . . . .	3
1.1.3	The Automaticity of Encoding Theory . . . . .	4
1.1.4	Declarative memory: the recollection vs. familiarity distinction . . . . .	4
1.1.5	Declarative memory: distinctions intertwined . . . . .	5
1.1.6	What constitutes an episodic memory, and is it uniquely human? . . . . .	6
1.2	Curriculum Vitae of the hippocampus in research . . . . .	8
1.2.1	Discovery of a valuable research tool . . . . .	8
1.2.2	Hypothesised functional roles of the hippocampus . . . . .	9
1.2.3	The hippocampus in episodic memory . . . . .	11
1.3	Studies of memory dysfunction in animals . . . . .	13
1.4	Paired Associate Learning . . . . .	16
1.5	The What, Where and When of Episodic Memory . . . . .	18
1.6	Why is When So Important? . . . . .	28
1.7	The What, Where and Which of Episodic-Like Memory . . . . .	31
1.8	The Rat Hippocampus . . . . .	35
1.9	Aims of this thesis . . . . .	37
<b>2</b>	<b>Glutamate receptor mediated retrieval of paired associate learning</b>	<b>39</b>
2.1	Introduction . . . . .	40
2.2	Materials & Methods . . . . .	43
2.2.1	Subjects . . . . .	43
2.2.2	Surgery . . . . .	43
2.2.3	Apparatus . . . . .	45
2.2.4	Behavioural Testing . . . . .	46
2.2.5	Histological Procedures . . . . .	53

2.3	Results . . . . .	54
2.3.1	Electrophysiology . . . . .	54
2.3.2	Behavioural Results . . . . .	54
2.3.3	Cannula placement . . . . .	63
2.4	Conclusions and Discussion . . . . .	64
<b>3</b>	<b>Semantic schema and paired associate memory consolidation</b>	<b>68</b>
3.1	Introduction . . . . .	69
3.2	Materials and Methods . . . . .	73
3.2.1	Subjects . . . . .	73
3.2.2	Apparatus . . . . .	73
3.2.3	Surgery . . . . .	74
3.2.4	Perfusion, Histology and Lesion Analysis . . . . .	74
3.2.5	Behavioural Testing . . . . .	76
3.2.6	Non-rewarded probe tests . . . . .	77
3.2.7	Performance measures . . . . .	77
3.3	Results . . . . .	83
3.3.1	Experiment 1 . . . . .	83
3.3.2	Experiment 2 . . . . .	85
3.3.3	Histology . . . . .	92
3.4	Conclusions and Discussion . . . . .	95
<b>4</b>	<b>Integrated memory for objects, places and contexts in the rat</b>	<b>100</b>
4.1	Introduction . . . . .	101
4.2	Materials & Methods . . . . .	105
4.2.1	Subjects . . . . .	105
4.2.2	Surgery . . . . .	105
4.2.3	Apparatus . . . . .	107
4.2.4	Behavioural Testing . . . . .	108
4.2.5	Data Collection & Analysis . . . . .	116
4.2.6	Histological Procedures . . . . .	117
4.3	Results . . . . .	118
4.3.1	Behavioural Data . . . . .	118
4.3.2	Histology Data . . . . .	125
4.4	Conclusions and Discussion . . . . .	127
<b>5</b>	<b>Manipulations of object location parameters: effects of hippocampus lesions</b>	<b>130</b>
5.1	Introduction . . . . .	131



5.2	Materials & Methods . . . . .	137
5.2.1	Subjects . . . . .	137
5.2.2	Surgery . . . . .	137
5.2.3	Apparatus . . . . .	137
5.2.4	Behavioural Testing . . . . .	137
5.2.5	Data collection and analysis . . . . .	140
5.2.6	Histological analysis . . . . .	140
5.3	Results . . . . .	141
5.3.1	Behavioural Data . . . . .	141
5.4	Conclusions and Discussion . . . . .	145
<b>6</b>	<b>Concluding Remarks</b>	<b>147</b>
6.1	Concluding Remarks . . . . .	148
6.1.1	Glutamate receptor mediated retrieval of paired associate learning	148
6.1.2	Semantic schema and paired associate memory consolidation . . .	150
6.1.3	Integrated memory for objects, places and contexts in the rat and the extent of involvement of the hippocampus in spatial location parameters . . . . .	153
6.2	Future Plans . . . . .	156
	<b>Bibliography</b>	<b>159</b>

# **Chapter 1**

## **Introduction**

## 1.1 Different types of memory processing

Memory has over the course of history been primarily studied due to its absence, being defined by the lack of abilities in humans who have lost it. As early as 1881, the French philosopher/psychologist Ribot suggested that memory loss may be a symptom of progressive brain disease, even suggesting that it might be caused by alterations in neurons. It has long been known that memory is not a unitary process: division of memory on the basis of habits vs. explicit memory expressed through language was made as long ago as 1890 (James 1890). Division of memory based on its temporal characteristics was only officially recorded just over 50 years ago. Waugh and Norman (1965) made the first segregation of memory into primary (short term) memory and secondary (long term) memory. Primary memory as defined in 1965 is now more intuitively labelled as working memory (Baddeley and Hitch 1974) and involves the temporary storage, rehearsal and manipulation of information over short time scales (seconds to minutes). An example of a very simple working memory test still used in humans is simply to repeat a list of digits immediately after studying them, without referring back to the original study material (Miller 1956), a test that was devised as a measure of “information processing capacity” long before the term working memory was introduced. Long term (secondary) memory involves both procedural (skill learning) and declarative (fact learning) aspects of memory (James’ (1890) habits vs. explicit memory). Procedural memory can be most easily exemplified by the ability to carry out a motor or perceptual task such as riding a bicycle or mirror reading. These tasks can be performed implicitly with ease once the appropriate skill has been learned over repeated sessions, but may not necessarily be easy to describe explicitly. Declarative memory, in contrast, encompasses the ability to explicitly communicate facts about the world and descriptions of our own personal experiences, usually via the medium of language in humans. Declarative memory is the type of memory that will be discussed and explored experimentally in this thesis.

### 1.1.1 Declarative memory: the semantic vs. episodic distinction

Declarative memory may be subdivided into knowledge of facts, such as “Porridge is normally eaten for breakfast” and “Prince Charles plays polo at Cirencester Park”, which are known as semantic memories. This type of knowledge is explicit and can be easily communicated to others but it does not necessarily include any contextual features that specify the occasion during which the fact was learned. You need not remember the time and place of the first experience you had of eating porridge in order to declare that it is normally eaten for breakfast. Similarly, exposure to newspaper articles, television and

conversations with others may have instilled in you the fact that Prince Charles plays polo at Cirencester Park, and if asked how you know this fact, your probable answer would be “I just know it”. Over the course of everyday life you will have been exposed to facts like these on multiple occasions and will have learned them without necessarily having a conscious memory for when or how this learning occurred. Memory for specific events (including their temporal and spatial parameters), such as “When did I last eat porridge for breakfast?” or “Which team won when I went to watch Prince Charles play polo at Cirencester Park?” is known as episodic memory. These are unique personal events that have only occurred once and therefore have not had the repeated exposures required in order to be established as learned facts. In order to answer the questions above, it is essential to remember the event itself and have a conscious awareness of it before extracting the necessary details. This distinction between semantic and episodic memory was made known by Endel Tulving (1972) although it was based on previous ideas from many sources that had simply been ignored up until this point. These putative memory systems are not completely separate- this is a matter of common sense since semantic facts about the world must be learned over various unique occasions which have specific episodic features. However these episodic features need not necessarily be encoded or stored in order to extract semantic factual information from the occasions.

### **1.1.2 The Serial Parallel Independent model of declarative memory**

Tulving (2001) was also the proponent of the serial parallel independent (SPI) model of declarative memory, which is designed to deal with the independent processes of encoding, storage and later retrieval which underlie any long-term memory. In this model, different features of declarative memory are arranged hierarchically, meaning that the most basic prerequisite of an explicit memory- the perceptual features allowing identification of the content the memory (e.g. “this looks like porridge”)- are at the bottom of the hierarchy. Semantic features or learned facts related to the memory (e.g. “porridge is normally eaten for breakfast”) are next and at the top of the hierarchy is the episodic component of the memory- the features that make the memory unique in aspects of time, space and context of the event being encoded (e.g. “I remember the last time I ate porridge for breakfast. It was at my Aunt’s farm last summer and we made it with fresh milk from the cows”). Encoding is believed to be serial (S), meaning that in order to encode the episodic (unique spatiotemporal) features of a event, semantic facts and perceptual observations about the things in the memory must also be included as prerequisites. Likewise, in order to encode the semantic knowledge from an event, the perceptual features must be processed. Perceptual features about an event can be stored alone as a purely percep-

tual memory. Storage is parallel (P), so all the 3 features of the declarative memory can be consolidated simultaneously. Retrieval can take place via independent (I) processes which permits that the retrieval of a memory can use processes associated with any of the three levels of memory for which details were provided at encoding.

### **1.1.3 The Automaticity of Encoding Theory**

A previous but related theory- the automaticity of encoding theory of Morris and Frey (1997)- predicts that in an intact brain, all the feature levels (perceptual, semantic and episodic) are by default encoded at the time of an event. This process is important because events or episodes may only occur once, and may be unanticipated, so this theory gives a chance for all the necessary information to be encoded at the time of experiencing an event. Retrieval may therefore flexibly use any of the 3 types of memory, depending on the complexity required by the demands of the retrieval task or the available neural mechanisms at retrieval. Thus an independent retrieval process enables the use of episodic memory to retrieve perceptual or semantic details of an event provided the relevant neural mechanisms are intact. If however experimental manipulations have blocked the use of the putative episodic memory system at any stage during memory processing, semantic or perceptual details may be retrieved but are not sufficient to reconstruct the full episodic content of the memory.

### **1.1.4 Declarative memory: the recollection vs. familiarity distinction**

Another related dissociation within declarative memory is the distinction between familiarity and recall based retrieval judgements, described by Tulving (1993) as the difference in humans between “knowing” as opposed to “remembering”. This is well established in humans through the use of language to ask subjects whether they remember the specifics of the encoding event and this is how they are making a retrieval decision, or whether the retrieval decision is based on a feeling of familiarity with the retrieval stimulus. This can be exemplified by being asked whether you recognise a photograph of Cirencester Park (is it a familiar stimulus?). A positive answer may simply be given on the basis of a “feeling of familiarity” with the stimulus, i.e. the place on the photograph looks familiar. However your answer may also be based on a memory for a specific event or episode, for example you recognise the photograph of Cirencester Park because whilst studying the photo you are recalling the occasion when you went there to watch Prince Charles playing polo. This type of judgement, based on recognising the stimulus along with recollection of other (incidental) contextual details about the occasion on which it

was previously seen are usually given a much higher confidence rating and are more accurate relative to familiarity judgements when human subjects are asked to rate how sure they are that the given stimulus has been seen before (Dewhurst and Hitch 1999). Receiver operating characteristics (ROCs) have been used to study the contributions of recollection and familiarity to declarative memory retrieval in humans for a number of years (Yonelinas 1994). The proportion of correct responses to a question or task, for example "have you seen this item before" are plotted against the false positive responses (identifying an item as previously seen when it is actually novel) based on the confidence level reported for each judgement ("how sure are you on a scale of (e.g.) 1-5?"). The shape of the graph in healthy human subjects produces an asymmetric result across confidence levels that cannot be explained by one memory process alone and resulted in the popular dual process model of declarative memory retrieval: contributions from both recollection and familiarity (Yonelinas 2001). Recollection and familiarity are not thought to be necessarily exclusive- declarative memory judgements can be made using a combination of both.

### **1.1.5 Declarative memory: distinctions intertwined**

As can be inferred from the previous paragraphs, for a memory to be classed as episodic, it must be retrieved by a process consisting at least partly of recollection (remembering or even mentally reexperiencing the event itself). Simply having a feeling of familiarity about an event ("knowing" that it happened) does not fit the criterion for episodic memory. It is not possible just by recognising something as familiar to extract any of the necessary details about it which are integral to a context-rich episodic memory as defined by Tulving (2001). Semantic memory can of course be "remembered" using an episodic strategy of travelling back in one's mind to a specific event and recalling the semantic details, as well as just "known" by a feeling of familiarity with the stimulus. Both of the above statements are predictable by Tulving's SPI model, Frey and Morris' automaticity of encoding theory and Yonelinas' dual process model of declarative memory retrieval. There was a period during the 1980s in which Tulving's divisions of declarative memory into episodic and semantic or recollective and familiarity components was challenged (Roediger et al. 1989; Humphreys et al. 1989), particularly with the criticism that experimental data was simply being interpreted in the light of these useful definitions rather than experiments being designed to test the validity of the data (McKoon et al. 1986). However, experimental evidence to support Tulving's division of declarative memory has continued to accumulate, for example through functional magnetic resonance imaging studies (Eldridge et al. 2000), event related potential recordings (Düzel et al. 1997)

and further work using ROC analyses (Yonelinas and Levy 2002) and his definitions are still generally accepted today (Agrest 2001).

### **1.1.6 What constitutes an episodic memory, and is it uniquely human?**

Tulving (2001) has a basic belief that episodic memory is a uniquely human attribute and cannot be possessed by animals, and he has updated his original opinions on the criteria for classification of episodic memory regularly since his original definition (Tulving 1972), with it becoming more and more complex each time (Tulving 1983; Tulving 1993; Tulving 2001) thereby raising the bar for the expectations of the qualities that should be possessed by a species in order to conclude that it has episodic memory.

In his 1972 landmark paper, Tulving described episodic memory as memory for events and their unique spatiotemporal aspects. This can be more simply interpreted as remembering the what, where and when of an event and has been demonstrated, although only relatively recently and not frequently, in animals (Clayton and Dickinson 1998; Babb and Crystal 2006; Eacott and Norman 2004a; Eacott et al. 2005; Kart-Teke et al. 2006; Good et al. 2007). The content of these papers will be discussed later.

In 1983, Tulving updated his definition to add in the requirement for autothetic consciousness. This may be termed self-awareness and permits the realisation that you yourself have experienced an event and that this event occurred in the past (a sense of subjective time). In humans, self-awareness is only evident from the age of 3 or 4 years in children (Perner and Ruffman 1995; Suddendorf and Corballis 1997). This has been the biggest stumbling block in animal research: self-awareness has been demonstrated in chimpanzees (Gallup 1970; Hirata 2007) and in fact its development somewhat mirrors that of humans (Povinelli et al. 1993) but it has not been successfully shown in any other non-human species. Showing self awareness does not automatically imply that the animal in which it is shown uses it for episodic memory, and the previous demonstrations have all involved extended training periods in order for the animals to “learn” self awareness- it may not be implicit. There has followed fierce debate between psychologists and neuroethologists as to whether animals can ever truly possess episodic memory since, without the aid of language, it is incredibly difficult to know whether an animal is consciously experiencing an event and can later demonstrate recall of that experience (Suddendorf and Corballis 1997; Griffiths et al. 1999; Clayton et al. 2001; Morris 2001; Clayton et al. 2003; Suddendorf and Busby 2003b; Clayton et al. 2003; Suddendorf and Busby 2003a; Dere et al. 2006).

In 1993, Tulving discussed the concept that there may be different kinds of conscious

awareness that accompany episodic vs. semantic memories in humans, these being the qualities of conscious memory for the rich contextual details of events (episodic recall) vs. a feeling of familiarity with them (semantic knowledge). Although humans can simply be asked whether or not they “just know” or actually recall a memory, assessment of this property is not so easy in animals. The most common approach to this problem in animal research is to design tasks that we believe cannot be solved by familiarity and must be solved by recollection (Day et al. 2003; Bird et al. 2003; Eacott et al. 2005; Babb and Crystal 2006) but laboratory rats in particular have a huge capacity for solving tasks based on familiarity judgements, even in cases in which humans would be expected to primarily employ a recollective strategy (Bunge et al. 2004; Clark and Martin 2005; Eichenbaum et al. 2007). Recently it has been shown using ROC analysis (Yonelinas 2001) that odour recognition memory in the rat shows a similar dual process pattern of recollection and familiarity to that of human declarative memory. Fortin et al. (2004) very cleverly used manipulations of task difficulty and reward size to bias the rats’ choices therefore creating the equivalent of different confidence levels reported in human tasks, which are necessary to analyse the receiver operating characteristics. This novel approach shows the first evidence that putative declarative memory in laboratory animals may have the same characteristics of combined recollection and familiarity as in humans. This finding is of critical importance in proving that it is possible to test a system analogous to human episodic memory under controlled conditions in laboratory rodents: suitable criteria for exploring the neural mechanisms underlying the phenomenon of episodic memory.

In 2001 Tulving added yet more dimensions to his criteria for assessment of episodic memory, one of which was the flexible use of information. This was related to the progress in research of modelling episodic memory in animals. This new criterion demands that rather than always demonstrate a fixed behaviour prompted by fixed knowledge, subjects should be able to make a response to demonstrate memory that is not directly related to the expected response to the stimuli. This can be easily demonstrated in humans by the use of language to describe a memory, rather than its physical demonstration. An animal, in contrast, is forced in the absence of language to demonstrate some kind of conditioned response to a stimulus rather than being able to describe it abstractly. It appears that Tulving’s aim with this latest criterion was to escape the “stimulus-response” nature of animal memory tests, since in humans displaying memory by thought or speech does not necessarily lead to action. With the lack of language in non-human species however he only succeeded in alienating the animal kingdom from the possibility of possessing episodic memory. The other suggestion made in 2001 which he claimed would make a convincing argument that animals could possess episodic memory was that a characteristic of human episodic memory is forward planning. This is an-



other demonstration of auto-noetic consciousness or self awareness, but this time based on knowing what may happen in the future and taking steps- based not on current stimuli but on future anticipated needs- to prepare oneself for this future. Tulving suggested that since humans spend a very large proportion of their time on behaviours that are oriented towards responding to future stimuli, a demonstration of this in animals would imply the possession of a human-like episodic memory system. Forward planning behaviour which is not dependent on current stimuli has been shown in scrub jays (Raby et al. 2007; Correia et al. 2007), apes (Mulcahy and Call 2006) and squirrel monkeys (McKenzie et al. 2004) but the same experiments have failed in rats (Naqshbandi and Roberts 2006).

There is much debate in the literature with regard to how many of Tulving's criteria are necessary to demonstrate a capacity for episodic memory and how many are purely human qualities which may enhance the description of episodic memory in our own species, but may not necessarily be prerequisites for the memory of unique events in other species. Evidence that some non-human species can display self-awareness and future planning provides support for neuroethologists who aim to show that animals can possess episodic memory and that it is not just a uniquely human quality. However the question of whether or not animals possess episodic memory is a different question that that which is being asked by this thesis. The aim of the thesis is to explore ways in which aspects of human episodic memory can be modelled in animals in order to explore its underlying neurobiological mechanisms and their possible roles in health and disease.

## **1.2 Curriculum Vitae of the hippocampus in research**

### **1.2.1 Discovery of a valuable research tool**

The hippocampus is currently at the centre of research interest in a wide variety of disciplines, from psychologists interested in its role in learning and memory to clinicians studying its pathology in Alzheimer's disease. It also has a more generic role as a research tool, in that many methodological developments and new hypotheses about general brain function have been made using its anatomical and physiological properties. The 1960s and 1970s were a particularly important time for these methodological developments: intracellular activity was first recorded, pyramidal cells were recorded extracellularly in behaving rats, the method of *in vitro* hippocampal slice recording was developed and long term potentiation was first described. Other methodological developments at this time that would prove very important in defining the role of the hippocampus in memory later included the introduction of computerized recognition mem-

ory tasks for non-human primates and the invention of the Morris watermaze, for the examination of spatial navigation and memory in laboratory rodents.

### 1.2.2 Hypothesised functional roles of the hippocampus

Until the middle of the 20th century, the functional role of the hippocampus had for many years been assumed to be as part of the olfactory system. This may have been based on observations that animals with a strong reliance on their sense of odour had large hippocampi as well as olfactory areas. More substantive evidence for this theory is thought to have arisen from clinical observations of epilepsy patients. It was reported during the 1940s that epileptic seizures originated in the hippocampus and in some case studies that their onset was preempted by patients experiencing subjective olfactory sensations (Penfield and Jasper 1954), therefore linking the hippocampus to the sense of olfaction. This is still a well known but little understood phenomenon today, characterised by a patient always being aware of a particular smell (e.g. roses) which reliably indicates the rapid onset of a seizure (Slater 2001).

An alternative theory of hippocampal function that abounded during the 20th century was that the hippocampus was an anatomical substrate of emotion, first formally proposed by Papez (1937). This provided a popular alternative to the theory of an olfactory role for the hippocampus, particularly following the discovery of Allen (1940). Allen developed a task to test conditioned reflexes in the dog using an olfactory discrimination procedure and found that ablation of the hippocampus (and much more besides!) did not affect conditioning based on odour discriminations. Papez's theory was that the hippocampus acted to integrate multiple types of sensory information in order to produce an appropriate emotional response to the current environment. This was followed up by experimental evidence from Kluver and Bucy (1939) who showed that complete removal of the temporal lobe in monkeys led to visual agnosia and a complete lack of fear. These symptoms were attributed to the hippocampus- even though it is now known that they were probably caused by loss of the amygdala and its connections to the visual cortex- and the now well-known effects of memory loss with medial temporal lobe removal were not even noticed, let alone investigated. However Kluver and Bucy had a strong influence on the field at the time and there were, relatively recently, still proponents of their original theory (Gray 1983; Gray 1988).

The role of the human hippocampus in memory was eventually brought to light (it may even be said accidentally) in a key publication by Scoville and Milner (1957). It involved the case of patient H.M. who had received bilateral surgical removal of parts of the medial

temporal lobe (including the hippocampus) in a radical and rather experimental attempt to cure his epilepsy in 1953. This radical surgery was being tested primarily to treat psychosis: removal of the ventral part of the frontal lobe had shown to be of some therapeutic effect in this condition and due to the known connectivity between the posterior part of the frontal lobes and the medial temporal lobes, it had been decided that additional removal of medial temporal tissue could be of further benefit to psychotic patients. Patient H.M. was not psychotic but severely epileptic, and his frequent seizures had been unresponsive to all available medications and left him completely incapacitated. The focus of H.M.'s seizures was widespread (in most cases electro-encephalographic recordings could identify the locus of seizure activity) and so removal of the specific brain area responsible for the electrical hyperactivity was not possible. However since in many cases the hippocampus was the main focus of seizure activity, and medial temporal lobectomy in psychotic patients had not led to the induction of seizures, it was hypothesised that medial temporal lobectomy in H.M. would at least not worsen the epilepsy. After the surgery, the frequency of H.M.'s seizures was indeed decreased dramatically, but with additional devastating consequences: a loss of memory. This was first reported by Scoville (1954) and then, in the landmark paper of Scoville and Milner (1957), the extent of this memory deficit was systematically examined in H.M. and nine other patients who had received similar surgeries for psychosis. H.M.'s lesion was estimated to have affected the anterior two thirds of his hippocampus bilaterally, plus the amygdaloid complex and the uncus (part of the olfactory cortex). Functional magnetic resonance imaging later revealed that in fact only the anterior 50% of the hippocampal complex (hippocampus + subiculum) was damaged, but the remaining hippocampal tissue would have been completely deafferented due to the complete removal of the entorhinal cortex, making it potentially useless (Corkin et al. 1997). Memory was tested using the Wechsler Memory Scale, which tests various categories of memory including personal (episodic) knowledge, general (semantic) knowledge, logical memory, verbal and visual paired associate learning, configural memory and memory span both verbal and visual. This memory scale was used alongside the Wechsler Adult Intelligence Scale, with the important measure being the difference between the scores of an individual on the intelligence scale and the memory scale, which indicates a dissociation between memory and intelligence rather than an overall deficit in mental capacity, which could feasibly be concluded with less sensitive tests. The patients studied were categorised according to their memory deficits into 3 groups: severe deficits, moderate deficits and no deficits. H.M. was categorized as having severe memory deficits, which included very poor scores on recall of stories (verbal) and drawings (visuomotor), very poor associative learning performance (visual and verbal paired associate learning and recall) and it was observed that each

time a new test was begun, H.M. could no longer remember completing the previous one. His intelligence score was unchanged since before the surgery, and he appeared to show normal perception and reasoning ability. His family reported his behaviour as being completely normal apart from the obvious memory deficit. Of the two other patients categorized to have severe memory deficits, one had a lobectomy of approximately the same size and location as H.M. and the other had a smaller medial temporal lobectomy but this was accompanied by additional removal of tissue from the frontal cortices. Patients categorized as having moderate memory deficits typically had smaller amounts of brain tissue from the same areas as H.M. removed. Interestingly, the two patients in the group characterised by no memory deficits after the surgery provided very interesting evidence that has been verified in many human (Bechara et al. 1995; Scoville and Milner 2000; Williams et al. 2001; Hanlon et al. 2003; Somerville et al. 2006; Cipolotti and Bird 2006; Buchanan et al. 2006) and animal (Olton et al. 1982; Kesner and Hardy 1983; Ridley and Baker 1991; McDonald and White 1993; Kesner and Williams 1995; Warburton et al. 2000) studies since. The first received bilateral removal of the amygdaloid complex and the uncus, but the hippocampus was not targeted. The second received the same sized and located lesion as H.M. but only unilaterally, leaving one complete medial temporal lobe and one damaged. Both of these patients produced memory scale scores consistent with their intelligence scores, both of which were completely normal. The patients in this group helped to verify that H.M.'s memory deficit was due to damage suffered by the hippocampus, and not to the amygdala or uncus, and that bilateral damage was necessary to see these devastating effects on declarative memory.

### **1.2.3 The hippocampus in episodic memory**

Further testing of H.M. revealed that he showed a complete loss of the ability to form new episodic memories for events (anterograde amnesia). He also showed no episodic memory for the 19 months prior to the surgery (retrograde amnesia) and an impairment in some episodic memories for up to 3 years before the surgery. This was in contrast to the fact that he would frequently talk about events from his childhood. This apparently graded retrograde amnesia, with memories from the more recent past being more affected than those from the remote past, shaped a popular idea of a temporary role of the hippocampus for memory storage (Marr 1971; Alvarez and Squire 1994; Morris 2006). However over the last 50 years, the differentiation of semantic and episodic memory has been refined, H.M.'s capacity for these types of memory has been examined more closely, and it is now doubted that he has any episodic memory at all (Corkin 2002). It is possible that all the memories he has previously described from childhood which appeared to

show spared remote episodic memory have actually been based on multiple combined representations of personal semantic knowledge, which would have been repeatedly experienced. It is very difficult in fact to investigate episodic memory in humans (as autobiographical reports of previous life experiences). Personal semantic memory is likely to consist of memories for things that have been experienced over and over again, either actions that are carried out regularly or facts that are told repeatedly. Personal episodic memories which last for a long time are likely to consist of things that happened which, although they only actually occurred once, were out of the ordinary- different from the normal semantic routine. This in turn means that even if you do not remember them very clearly, they will likely have been repeated to you over and over again by friends or family members, purely because they are perceived as novel or interesting things that have happened. This implies that many episodic memories, even the most convincing examples provided by H.M., are likely to have been semanticized by repeated "story-telling" from other people and that they may be retrieved in a semantic way that may not require the hippocampus. The current information about H.M. suggests that he has no episodic memory, but his semantic memory prior to his medial temporal lobectomy is intact. This distinction between memory systems supports Tulving's previous classifications of declarative memory (Tulving 1972; Tulving 1983; Tulving 2001) and also provides support for the Nadel and Moscovitch (1997) multiple trace theory of memory, in which certain types of memory (in this case episodic memory) are stored in the cortex but an index is kept in the hippocampus in order to direct retrieval to the correct cortical memory traces. This therefore requires that the hippocampus (or at least the part containing the relevant index) must always be intact in order to retrieve the episodic memory. Thus, the relative sparing of semantic memory retrieval relative to episodic memory retrieval in amnesic patients such as H.M. is explained by the fact that semantic memories are (or have been) frequently experienced in unique events (episodes), each of which are encoded by the hippocampus. Each episode in which the semantic memory is experienced creates a new index entry in the hippocampus, so for any semantic memory there are more indices distributed around the hippocampus (via which the memory can be retrieved) than there are for each episodic memory. After hippocampal damage there is therefore more chance of any remaining hippocampal tissue containing an index to a given semantic memory than there is of it containing an index to a given episodic memory (Moscovitch et al. 2005). This is in contrast to the earlier thoughts of Marr (1971) whose standard consolidation theory suggests that after a certain period of time, all memories which required the hippocampus for their encoding will cease to rely on it for retrieval of those memories, as they have become completely "copied" over to the cortex. Perhaps elements of the multiple trace theory contribute to a valid hypothesis

for episodic memory, which it appears may always require the hippocampus for encoding, storage and retrieval, whilst the standard theory of consolidation that hypothesises a time-dependent role for the hippocampus in memory is relevant to semantic memory, which may require the hippocampus for normal learning but not necessarily for later retrieval.

Vargha-Khadem et al. (1997) subsequently showed more clear cut evidence for the role of the hippocampus in episodic but not semantic learning, and the recollective but not familiarity aspects of memory in a study of 3 patients who had developed amnesia as a result of brain injury during early childhood and whose functional magnetic resonance imaging profiles showed bilateral damage relatively restricted to the hippocampus. These patients had normal intelligence levels, performed well at school and acquired normal levels of semantic knowledge as demonstrated by their capacity to communicate good general knowledge. However in all 3 cases their episodic memory for unique day to day events was completely absent and they could not provide recollective details about the contexts or episodes in which they had learned any semantic facts. It is not yet clear whether or not these patients' ability to acquire new semantic information at a relatively normal rate is due to some kind of compensatory strategies employed at an early age whilst their memory systems were still developing, which rescued their capacity for semantic learning but were unable to compensate for the lack of a hippocampus for episodic memory processing.

Cases of adult onset amnesia are relatively rare (Agrest 2001) particularly those that can be confirmed to have damage limited to the hippocampus. More recent data from adult onset amnesia patients has not clarified the situation in terms of whether anterograde amnesia for semantic memory or semantic and episodic memory is affected by hippocampal damage, and whether the hippocampus has a temporary or permanent role in retrograde memory for events (Bayley et al. 2003; Bayley and Squire 2005; Steinvorth et al. 2005). The case remains clear however from most of the human data that there is support for a semantic-episodic and recollection-familiarity distinction in human declarative memory and that episodic memory and the recollective component of declarative memory are mediated by the hippocampus in humans (Vargha-Khadem et al. 2001).

### **1.3 Studies of memory dysfunction in animals**

One of the first animal models of memory dysfunction was complete medial temporal lobe lesion in monkeys (Mishkin 1978), aiming to target the same brain areas (hippocampal formation and amygdaloid complex) that were thought to have been lesioned by

H.M.'s operation (Scoville and Milner 1957). Monkeys with these lesions were tested on a delayed non-match to sample (DNMTS) task commonly employed with non-human primates. The task involved the presentation of a sample stimulus, either on a computer screen or in the form of a 3D object. After a short delay, 2 stimuli were presented concurrently, one of which was identical to the sample stimulus and one of which was novel to the monkey. The monkey would be rewarded with an edible prize for selecting (pointing to on a screen or picking up) the novel stimulus that had not been presented during the sample. Monkeys with combined lesions of the hippocampus and amygdala were severely impaired on this task, which led to the idea that the DNMTS task was a good model of the type of memory in which H.M. showed impairments. The fact that some monkeys in this study also received lesions of either the hippocampus or the amygdala alone- lesions which had no effect on the DNMTS task- suggests in the light of more current work that this task was not a good episodic memory test, but the available data of the time did not conflict with the finding of Mishkin (1978). Although one of the other patients in the study of Scoville and Milner (1957) had bilateral amygdala lesions and showed no memory impairments, there had not been any evidence that bilateral damage limited to the hippocampus had any effect on memory. Since H.M. had a lesion of the amygdaloid and hippocampal systems, it was an informed conclusion at the time that damage to both of these structures was necessary to see memory impairments and that the two systems were interlinked in terms of H.M.'s memory deficit.

It was not until some years later that further experiments showed that the lesion technique that had been used to produce the combined hippocampal and amygdaloid lesion in the monkeys had actually resulted in the ablation of most of the rhinal cortices as well (Murray and Mishkin 1986). Subsequent experiments removing the rhinal cortices without hippocampal and amygdaloid ablation showed that in fact it was the perirhinal cortex in monkeys (Meunier et al. 1993) and rats (Otto and Eichenbaum 1992) that was the crucial area for task performance in the DNMTS task and that both monkeys (Nemanic et al. 2004) and rats (Steckler et al. 1998; Mumby 2001) were capable of performing the task if lesions were restricted to the hippocampus- or even hippocampus and amygdala (Murray and Mishkin 1998)- and did not damage the parahippocampal (rhinal) cortices.

Already, new tasks were being designed to better test the concept of episodic memory. Gaffan (1991) and Tulving (1993) believed that a vital component of episodic memory in humans was the organization of spatial stimuli in a scene. This was envisaged as a critical part of episodic memory because each unique event will occur with a different configuration of stimuli present in space and remembering components of each scene could help to differentiate episodic memories which are similar in many other ways. The

elegant example Gaffan used to describe this theory in his 1991 review was that of giving a lecture in which you fielded questions at the end. If a colleague inquired about what questions were asked after the lecture, in order to answer you would be likely to retrieve the information (which is of an entirely non-spatial nature) by using a recall process that reconstructs the whole scene in the lecture hall as you previously viewed it, including the positions in the audience of the people who asked you the questions. Thus Gaffan's scene memory became the next example of a putative episodic memory task (Gaffan 1994). He described data in his 1991 paper showing that monkeys with transection of the fornix were impaired at recognising naturalistic complex visual scenes that they had experienced before surgery and were also much slower than controls at learning to recognise new scenes after the surgery. Subsequent data showed that in more controlled conditions it was the associations of objects with positions in their environment that was affected by the transection of the fornix, rather than discriminating objects alone as in the traditional DNMTS task (Gaffan and Harrison 1989). This deficit has also been shown in rats with lesions of the hippocampus (Save et al. 1992; Mumby et al. 2002) and humans with damage similar to that of H.M. (Milner et al. 1997; Stepankova et al. 2004). The scene memory tasks designed by Gaffan were also much more similar to tasks commonly used to test episodic memory in humans, which used paired associate learning (forming associations between 2 stimuli) to test episodic memory. The association of objects with visual scenes was thought to mimic this kind of learning.

While Gaffan's scene memory task is much more representative of human episodic memory tests than its predecessor the DNMTS task, there is still another aspect of paired associate tests in humans that neither task exploits, and this is the use of forced recollection rather than familiarity based processes. In the scene memory task, monkeys (or rats) would be rewarded for choosing a scene that was familiar and/or had been designated as a positive (rewarded) stimulus over choosing a novel or negative (non-rewarded) stimulus. Animals are able to learn over a long training period to discriminate scenes that are rewarded compared to those that are not- a process that is most likely consolidated into semantic memory- and could use a familiarity judgement to decide whether a scene presented is completely novel or not. Thus, although this task is hippocampal dependent, there is no evidence that animals are using recollection to solve it. The recruitment of the hippocampus may arise due to the spatial nature of the task (Olton and Papas 1979; Morris et al. 1982) - an alternative account of hippocampal function in animals - rather than any episodic or recollective requirements. The importance of this was brought to light by data suggesting that humans solve many recognition memory tasks using an additional recollection strategy rather than familiarity alone (Yonelinas 1994) and that the recollection component of the memory is the part that recruits the hippocampus (Ran-



ganath et al. 2004; Yonelinas et al. 2005; Aggleton and Brown 2006), which has also been shown more recently to be the case in rats (Fortin et al. 2004; Eacott et al. 2005). This recollective property of certain memory tasks in humans is independent of whether or not the tasks have any spatial elements (Cave and Squire 1991; Burgess et al. 2002; Corkin 2002). These data indicate that if we are to test episodic memory thoroughly, we need to create tasks in animals which require that they use recollection rather than being able to rely on familiarity, and ideally tasks that do not involve a spatial or navigational element in order to eradicate this as a confound.

## **1.4 Paired Associate Learning**

Paired-associate learning is a frequently used tool in the examination of episodic memory in humans (Tulving 1983) where lists of abstract stimuli (often pairs of random words that would not normally be linked via semantic knowledge) are studied by a subject who is later asked to recall one stimulus of a pair when presented with just the other stimulus alone (a verbal or written response is usually required). This type of task is known as paired associate recall, since only one half of the pair of stimuli is available at the test phase and the task cannot therefore be solved by a recognition judgement (see Figure 1.1).

### Paired associate learning in humans

Human subjects are required to study lists of abstract word pairs, with no semantic relationship, as a sensitive test for specific episodic memory impairments.

Only one half of the original stimulus pair is available at the test, necessitating cued recall rather than simply recognition of the stimulus pair. This test is carried out using verbal or written memory in humans .

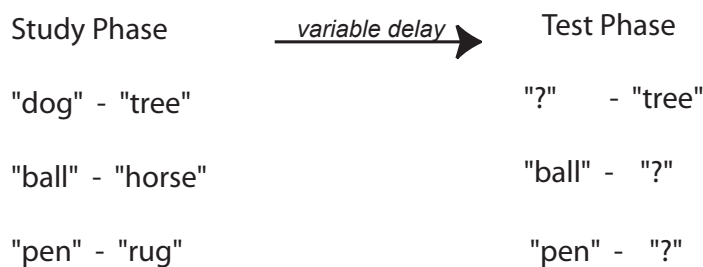

**Figure 1.1:** Paired associate recall tested in humans.

Paired associate recall in humans has proved to be a very sensitive test of episodic memory in humans, perhaps because it encourages that a recollection process be used in order to solve the task, while at the same time using trial-unique lists of words, which incorporates the episodic factor. Episodic memory impairment as tested by paired associate learning has been proved useful as a tool to detect early symptoms of Alzheimer's Disease (AD) (Swainson et al. 2001), specific to early onset AD type dementia (Lee et al. 2003). Paired associate recall is also indisputably severely impaired in human subjects with medial temporal lobe damage including damage to the hippocampus (Vargha-Khadem et al. 1997; Spiers et al. 2001). Functional imaging studies in intact, healthy human subjects have reported activation of the hippocampus specifically during paired associate recall tasks (Eldridge et al. 2000; Burgess et al. 2002). Creation of an animal analogue of paired associate recall tasks will therefore be an invaluable link to understanding the neurobiology of human episodic memory in health and disease, and will be reported in the first two experimental chapters of this thesis.

## 1.5 The What, Where and When of Episodic Memory

An alternative approach to studying models of episodic memory, to be described in the second two experimental chapters of this thesis, is that of designing novel behavioural tasks for rats based on elements of the literary definition of episodic memory. Episodic memory was seminally described by Endel Tulving (Tulving 1972) as memory for the spatiotemporal aspects of unique events. This can be simplified as the event (“what”), “where” it took place and “when” it happened. These 3 pieces of information- the what, where and when of an event- are what Tulving considered to be the foundation of episodic or event memory and this view was widely adopted.

Clayton and Dickinson’s landmark paper (Clayton and Dickinson 1998) demonstrating that scrub jays could remember the “what, where and when” of an event provided the first evidence of something resembling episodic memory in a non-human species. Clayton and Dickinson coined the term “episodic-like” memory to describe the behaviour shown by their scrub jays and this term is now in general use to describe demonstrations of Tulving’s original (1972) definition of episodic memory in non-human species whilst appreciating that autonoetic consciousness, as demanded by his 1983 definition, cannot as yet be irrevocably demonstrated in animals.

Clayton & Dickinson’s experiment utilised the natural behaviour of scrub jays to store or “cache” food, for retrieval at a later date (Shettleworth 1995). Birds were given access to food (e.g. wax worms) which they were allowed to cache in one side of an ice cube tray. The wells of the ice cube tray were filled with sand in which the birds could bury the food (see Figure ?? on page ??). 120 hours later the birds were given access to a second type of food (e.g. peanuts) and allowed to cache these in the other side of the ice cube tray (the first side that the birds had cached in 120h previously was now covered and inaccessible). After this second caching event, there was a delay of 4 hours before the retrieval phase. Over just 2 or 3 training trials the birds learned the rule that if a long period of time had passed since caching (124h) their favourite food - the wax worms - would have decayed and no longer be suitable for consumption, so they should recover peanuts from the appropriate wells in the ice cube tray where they had stored them 4h ago and disregard the locations where they had stored the wax worms 124h ago. If presented with the foods for caching in the opposite order - peanuts first 120h before the retrieval phase then wax worms just 4h before the retrieval phase - the birds learned that the wax worms would still be fresh and since this was their favourite foodstuff, they would preferentially search in the locations where they had cached the wax worms 4h ago. In a series of critical probe tests the ice cube tray in which a bird had cached peanuts and wax worms would

be emptied of food and sand and refilled with only fresh sand containing no food at all and therefore no odour to guide the birds to where they had stored the different types of food. In these tests, the birds' memory for what food they had stored where and when could be assessed by observing in which wells of the ice cube tray a bird directed its first and subsequent searches for food. As predicted, birds directed their searches preferentially to the locations where they had cached wax worms after a 4h delay, but after a 124h delay they searched more in the locations where they had cached peanuts. The birds successfully showed memory for what foods they had stored where, and how long ago (when) and their behaviour was not guided by the odour of the foods. The criteria for episodic memory as defined by Tulving also include the fact that an event must be unique, since repetition of the same event would constitute something more like semantic fact learning. In the experiments of Clayton and Dickinson, the ice cube trays that the scrub jays stored food in were made unique on each trial, so no two trials were ever the same for a given bird. This was done by attaching the ice cube tray to a wooden board on which stood a 3D Duplo (children's building brick) model. Each ice cube tray was attached to a board with a different 3D model. Birds could use the visuospatial features of the model to locate which wells of the ice cube tray they had stored particular foods in. However this information could only be used for one trial (2 caching sessions and a retrieval phase) as on the next trial the birds would be presented with a new tray and 3D visuospatial model that they had never previously encountered. This ensured that each trial was indeed a unique event, although there is no evidence presented in this paper to show that the birds actually encoded the visuospatial cues during caching or that they used them to locate the correct wells from which to retrieve the food. This could be investigated in a variety of ways: for example by removing the 3D visuospatial Duplo model at caching, retrieval or both phases; or by presenting a different ice cube tray with a different model at retrieval to the one presented at caching. To show that the birds in this experiment were not just searching at the most familiar cache sites (e.g. those used 4h ago rather than 124h ago) and may simply have forgotten the caching event from 124h ago, a second control group of birds (the "Replenish" group) was employed. This group of birds never experienced degradation of the wax worms, their favourite food, so regardless of the delay between caching and retrieval, they would always preferentially search for food in the sites where they had previously stored the wax worms and did not search for the peanuts. This piece of data provides crucial evidence that the birds could remember what food they had stored and where, even at the 124h delay. This shows that the birds in the original "Degrade" group; who experienced the decay of the wax worms they had stored 124h before retrieval; were not just choosing the most familiar cache sites because they had forgotten where the 124h old cache sites were located or the memory

trace was weaker, since the birds in the “Replenish” group (who never experienced the decay of the wax worms) could accurately locate the 124h old cache sites when they contained their preferred food (wax worms).

A number of further studies by the same group carried out after this 1998 paper was published provided further and more convincing evidence for the existence of episodic-like memory in scrub jays. Clayton and Dickinson showed that their scrub jays could learn to use time intervals that were not necessarily based on circadian interval timing (in the original 1998 experiment the scrub jays had to distinguish between 124h and 4h which could be easily deduced from whether a night period had passed or not), use more than two time intervals to judge whether different foods had decayed or not and also infer whether or not a food would have decayed at a previously untrained time interval, using knowledge from their previous experience of decay times (Clayton and Dickinson 1999, unpublished observations in Clayton et al. 2001). They also showed that the memories for what, where and when were integrated (Clayton et al. 2001) and that they could be used flexibly in situations other than those previously trained (Clayton et al. 2003). Much of this further evidence is summarised in two review articles (Clayton et al. 2001; Clayton et al. 2003) with the conclusion that animals may in fact possess at least some features of episodic memory which are therefore not unique to humans.

The episodic-like food caching task described above was the first task to begin to fulfill Tulving’s criteria for episodic memory in a non-human animal, however the scrub jay is used primarily to study convergent evolution and little is known about the functional anatomy of this species. Since the amount of available techniques and knowledge of functional neuroanatomy is so extensive with regard to more common laboratory species such as rodents and primates, it seems a sensible progression would be to adapt Clayton and Dickinson’s insightful task to suit these alternative species. It must be borne in mind however that this task was designed from a neuroethological perspective in order to be particularly relevant to the natural behaviours of the species for which it was designed (in this case, the scrub jay). This must be taken into account when trying to adapt this task for other species, as we are unlikely to be able to evoke such sophisticated behaviour in other animals unless, like Clayton and Dickinson, we are asking the right questions (Mackintosh 1983; Real 1993; Healy and Braithwaite 2000).

Bird et al. (2003) attempted to directly replicate Clayton and Dickinson’s scrub jay experiment in the common laboratory rat (Norway rat, *Rattus Norvegicus*) using a similar food caching paradigm on an 8-arm radial maze (Olton and Samuelson 1976). Although this species does not generally show caching behaviours in the wild except in the case of lactating females (Whishaw 2005), the phenomenon of food storing has been demonstrated

in the Norway rat in the laboratory (Wolfe 1939). Further studies showed that manipulating the size and supply of food items and also the availability of sheltered spaces for eating can encourage temporary food hoarding behaviour in the Norway rat (Whishaw and Oddie 1989). In this extended and complex series of experiments by Bird et al. (2003), many aspects of food preferences and food hoarding were explored. Rats learned to carry 4 pieces of food (cheese or pretzels) down experimenter-chosen arms of an 8-arm radial maze (this was a measure designed to prevent rats choosing preferred arms down which to carry food based on a series of body turns or other non-spatial strategies, see Olton and Samuelson (1976)). They very quickly developed a preference for returning accurately to arms in which they had stored food compared to arms where they had not in a later retrieval phase of delays from 1 min to 24h. Rats also showed a strong preference for cheese over pretzels in the home cage and on the maze and returned preferentially to maze arms in which they had previously stored cheese rather than those in which they had stored pretzels. This showed evidence that the rats could remember “what” food type they had stored and “where” they had stored it (i.e. in which arms of the maze).

In an attempt to teach rats to use a temporal rule to determine which arms of the maze to enter, and therefore completing the “what-where-when” triad demonstrated by Clayton and Dickinson in their scrub jay experiments, rats were split into 2 groups to learn about the degradation of specific food types. They had already demonstrated knowledge of what food types they had stored and where they had stored them by preferentially locating cheese first then pretzels later whilst avoiding arms in which neither food had been stored (see Hulse and O’Leary (1982) for earlier evidence of similar behaviour in rats). The next stage was to attempt to teach one group of rats - the 25h degrade group - that their preferred food - cheese - would have degraded after a 25h delay since storage, so they should choose to retrieve pretzels when returned to the maze. The 25h degrade group were also tested separately at a delay of 1h between storage and retrieval in which they could successfully retrieve cheese which would not have decayed during this short period. The second group of rats - the 1h degrade group - were supposed to learn a different rule. In their case, their preferred food - cheese - would have degraded at an interval of only 1h after storage, so if allowed to retrieve food 1h after storage they should choose to retrieve pretzels. If, however, they were returned to the maze to retrieve food at a 25h delay since storage, they could now retrieve cheese as it would not be decayed or inedible. Cheese was degraded and made unpalatable by soaking in a quinine solution. Unfortunately neither group of rats demonstrated that they had learned to use the temporal information about how long ago they had stored food to decide which arms to enter and search for food in in the retrieval phase. All rats in both conditions continued to search for cheese rather than pretzels, even after repeated presentations of degraded

cheese (the inedibility of which was proven by the rats' refusal to eat this cheese). The ethological validity of the 1h degrade group seems questionable however, since if rats have any intrinsic knowledge or can remember anything about the food decay process, this rule would be nonsensical- how can a food which was decayed beyond palatability after just 1h be perfectly edible after 25h? It may have been more valuable to imitate Clayton and Dickinson's scrub jay model more closely and have a "replenish" group of rats who never experienced the decay of any food. In this way their performance and pattern of behaviour could have been compared to the rats who experienced the degradation of cheese to see if there were any other quantitative or qualitative behavioural variables which may have cast light on the reason why the rats in the degrade group did not learn the degrade rule.

There are many possible explanations as to why the rats in this series of experiments could not learn to use a temporal rule in order to direct their food searches. One of the most simple reasons could be that the cheese was much too salient relative to pretzels and was so strongly preferred by the rats that they may have taken an incredibly long time (if at all) to inhibit their tendency to search for it as a priority. Perhaps the use of another food which was more preferable than pretzels, i.e. somewhere on the scale of preference between pretzels and cheese, could have been used. On the other hand, if rats do not have an intrinsic reason to learn about the rate at which different foodstuffs degrade (perhaps due to the fact that this species does not cache food in the wild for retrieval at a later date) then there is in fact no need to have a preferred and non-preferred food in the context of the experiment by Bird et al. The experiment could have been carried out just as effectively with 2 foods highly favoured by the rats, for example cheese and chocolate, and if the incentive value of both these foods was very high it may have stimulated some differential search activity in the retrieval tests. The idea that the degradation times of different foods may not be an inbuilt mechanism which rats utilise in the wild is supported by a comparison of this experiment with that of Clayton and Dickinson. In the latter, scrub jays learned very quickly (within 2-3 trials) which foods would degrade at which time intervals and ethological evidence supports that this is a skill that they do indeed use in the wild. The rats in Bird et al's experiment however showed no learning about which food would degrade even after 40 trials, suggesting that this may not be an ethologically valid paradigm for use with laboratory rats.

There is evidence in the literature that rats do in fact have some knowledge of time (reviewed in Gallistel 1990) and temporal order, so it seems unlikely that a complete lack of a sense of time is the reason for the failure of the rats in the experiment by Bird et al to show use of a temporal rule. Meck et al. (1984) showed that rats could discriminate

between and respond differentially to auditory stimuli with durations of 2 or 8 seconds, remember the stimulus length over a 5s retention interval before being allowed to respond and also transfer this judgement of stimulus length to the visual modality with ease. However there is a lack of convincing evidence that rats can keep track of exact time over longer intervals.

Babb & Crystal (2005;2006) succeeded in designing a task for rats which involved the animals remembering which arms of a radial maze contained certain types of food, and to use a time interval (long or short) to choose which arms to return to (memories for what, where and when) although the evidence that these 3 components are integrated at any one time is lacking. In Babb and Crystal (2005), rats were trained to sample 4 arms of a radial maze, 3 of which contained standard rat chow and 1 of which contained their preferred chocolate flavoured chow. After a 30 minute delay, rats were exposed to the radial maze again with all 8 arms open and were trained to visit the 4 arms that had not contained food during the sampling phase (a simple DNMTS rule). After a 4 hour delay, rats were trained to return to the arm that had contained chocolate food in the sampling phase to receive a chocolate reward, along with any of the other 4 arms not open in the sampling phase, which were also rewarded but only with standard rat chow. The measure of whether or not the rats remembered what food was found when and where was based on how many of their initial 4 arm choices in the test phase were directed towards the maze arm that contained the chocolate food. The result was that after the 30 minute delay, rats chose the chocolate arm as one of their first 4 choices approximately 20% of the time ("chance" level), whereas after the 4 hour delay (when the chocolate arm had been replenished), rats chose it as one of their first 4 choices approximately 50% of the time. These results appear promising, but the large number of training sessions required to acquire the task (approximately 80), alongside the fact that the training had to be very methodical (teaching the rats what to do at the 30 minute delay first, then introducing the 4 hour delay, then intermixing trials) in addition to the fact that the rats were very well trained on the layout of the radial maze (having been trained on it for a different experiment beforehand) are all facts that imply that some kind of long-term semantic rule-learning was occurring, rather than trial-unique episodic-like memories for the task. In the experiments of Clayton and Dickinson (1998), the birds tested required barely any training to acquire the temporal rules, suggesting that the use of this kind of temporal memory was easier or more natural for them. Also, the performance of the rats on the task of Babb and Crystal (2005) was not very convincing: considering that these rats had spent weeks (or even months) learning that the chocolate arm should be revisited after the long retention interval, choosing the chocolate arm as one of their first 4 choices only 50% of the time seems a very low level of performance.



The authors attempted to show that the memory for what (chocolate food), where (chocolate arm) and when (long delay) was not an effect of matching or non-matching to sample rules by incorporating three testing days in which chocolate exposure after sampling was associated with lithium chloride, which induces nausea, producing a conditioned taste aversion. Rats were then tested after the long delay in which they previously showed repeated visits to the chocolate arm. After lithium chloride treatment, rats decreased their number of visits to the chocolate arm, which indicates superficially that they remembered where the chocolate arm was and actively avoided it. However, the criterion for ending the test phase in the lithium chloride condition was altered, in that rather than collecting pellets from the 4 correct arms before termination of the trial, the rats now simply had to visit 4 locations and may not have eaten any pellets during the test phase. Also, the proportion of correct choices in the test phase after lithium chloride decreased by approximately the same amount as the proportion of visits to the chocolate arm, which may indicate a general decrease in accuracy or motivation to eat after the lithium chloride treatment, or some other non-specific side-effect of the treatment. The authors tested the efficiency of their protocol to induce taste aversion in naïve rats, who showed a dramatic decrease in choosing chocolate food over standard chow when chocolate food had been paired with lithium chloride. This is in contrast to the much smaller decrease seen in rats choosing the chocolate arm in the radial maze after lithium chloride treatment, which implies that perhaps the memory for where the chocolate food was was not very well intact. Interestingly, the rats undergoing treatment with lithium chloride showed no aversion to eating the chocolate pellets when they encountered these pellets in the sample phases during the taste aversion testing days. This is unusual as conditioned taste aversion usually produces a very strong and long-lasting memory (Morrison and Collyer 1974), although the relevance of this observation to the experimental results is not clear.

In a later paper, Babb and Crystal (2006) used a slightly different paradigm in order to provide more convincing evidence that the rats actually remembered the specific locations of the flavoured foods in the radial arm maze. In this study, 2 of the 4 available arms in the sample phase contained 2 different flavoured foods, both of which were preferred by the rats to the standard rat chow available in the other 2 arms. In the test phase, both of these preferred flavours were replenished after a long but not a short delay. Rats preference for one or the other flavoured foods was then biased by feeding them to satiation with food of one flavour. Results showed that after the long delay, rats showed a decrease in the number of entries to both of the arms that contained flavoured foods relative to normal training performance, although the food flavour that had been satiated did show a barely significantly lower number of entries than the one that had not. Biasing the ani-

mals' preferences by treating them with lithium chloride to produce a conditioned taste aversion to one of the flavours did show a convincing differentiation between choices of the arm associated with the conditioned flavour relative to the non-conditioned flavour, thus demonstrating that the animals did remember what food was at what location. This was a much stronger result than that seen in the previous paper (Babb and Crystal 2005) but there was a small change in protocol that actually makes the standard task on which the rats were trained rather less convincing than in the original paper. In the 2006 version, the arms rewarded after the short retention phase were the ones not available in the sample phase, so again requiring a simple DNMTS rule to solve them. However in the test phase after the long retention interval, the arms that were rewarded were the 2 flavoured arms, and the other 2 standard arms were not rewarded. The 4 arms not presented in the sample phase were also rewarded in this test phase, but a simple DNMTS rule after a short delay and the opposite rule after a long delay would mean that these 4 sample arms would not be entered after a long delay. If rats used a matching to sample rule on the long delay trials, they would choose to enter the 2 flavoured rewarded arms that they experienced during the sample phase, along with the 2 arms that had contained standard chow in the sample phase. It is not necessary to learn which arms are replenished to learn this rule. The measure used to judge whether a rat was correct was whether it entered one of the flavoured arms during one of its first 4 choices. Since there were only 4 arms that had been available on the sample trial, and using a simple match to sample rule after a long delay, rats would always have entered one of the correct arms within the first 4 choices, especially since they had been trained from the start of the experiment not to re-enter an already visited arm within a single session on the maze. This experiment again shows evidence that the rats remember when and where in the standard training, and that they remember what and where during the conditions where they are biased against one food flavour. However, since during the bias testing, only the long delay is used, there is no evidence for integration of the temporal rule in the conditioned taste aversion condition. An elegant way to address this would be to train the rats to choose one flavour at each time delay and then bias them against each flavour to see the effects at both delays.

The task of Babb and Crystal (2005) has been replicated since (Naqshbandi et al. 2007), but although all the elements required for an episodic-like memory task are present, the large amounts of training required imply that the task involves a substantial amount of semantic rule learning, which takes away from its value as an episodic memory test. There is also a lack of convincing evidence that the 3 elements of the task - the what, where and when - are truly integrated at any single time point in the task.

An easier way to examine temporal memory in rats may be to look at their memory for

temporal sequences - orders of events - or their knowledge of how long ago a previous event occurred based on the relative familiarity (upon re-presentation) of the associated stimuli. These methods have been successfully used in a radial arm maze task (Kesner and Novak 1982; Chiba et al. 1997), examining the ability of rats to return to arms in the same order that they originally visited them or to discriminate between a more or less recently visited arm in a forced choice paradigm.

The spontaneous novelty exploration paradigm has also been successfully used to examine temporal order memory in rats. In its basic form it is often referred to more simply as "object recognition". This paradigm is based on the innate capacity of rats to display preferential exploration of novel aspects of their environment over familiar aspects. This phenomenon was probably first observed by Pavlov (1927) in dogs. Whilst involved in conditional learning experiments, Pavlov observed that if a novel or unexpected stimulus occurred, his dogs would redirect their attention to this stimulus, although this was a completely unconditioned response. The detection of and response to novel stimuli was investigated further in the laboratory rat (Berlyne 1950) and has been carefully assessed (Renner and Seltzer 1991; Mumby 1995) and systematically reviewed (Berlyne 1966; Mumby 2001). Ennaceur and Delacour (1988) published a landmark paper describing a carefully controlled laboratory paradigm which could be used to quantify rats' behavioural responses to novelty. This involved familiarising rats with a testing box, then placing 2 identical copies of a 3D object into the box for the rat to explore during a habituation session (lasting a predetermined amount of time, commonly 2-5 mins). After a retention interval (of between 1min and 24h) the rat would be returned to the testing box and presented with 2 more 3D objects. One of these would be another identical copy of the object presented in the habituation session and the other a completely new object that the rat had not encountered before. Memory for the previously encountered (familiar) object was quantified by measurement of the amount of time the rats spent exploring the new object compared to the familiar one. This task can also easily be extended to include other factors as well as the identity of the object. Rats can detect and will preferentially explore spatial changes such as a familiar object moving to a novel position, or familiar objects whose locations have been swapped (Save et al. 1992; Ennaceur and Aggleton 1994; Ennaceur et al. 1997; Dix and Aggleton 1999; Mumby et al. 2002; Eacott and Norman 2004a; Kart-Teke et al. 2006; Barker et al. 2007; Good et al. 2007). They are also able to detect novel combinations of objects and contexts, e.g. a familiar object which is then encountered in a different context from that which it was originally presented will be re-explored (Dix and Aggleton 1999; Mumby et al. 2002; Norman and Eacott 2005). (Context in this paradigm can be various features of the environment, such as colour, texture, shape or spatial cues/location). It has also now been shown that rats will pref-

erentially explore an object which was presented longer ago in time over a more recently presented object (Mitchell and Laiacona 1998; Kart-Teke et al. 2006; Barker et al. 2007; Good et al. 2007) which provides another possible way of approaching the study of time and temporal order in rats.

Episodic-like memory task design from Kart-Teke et al. (2006)

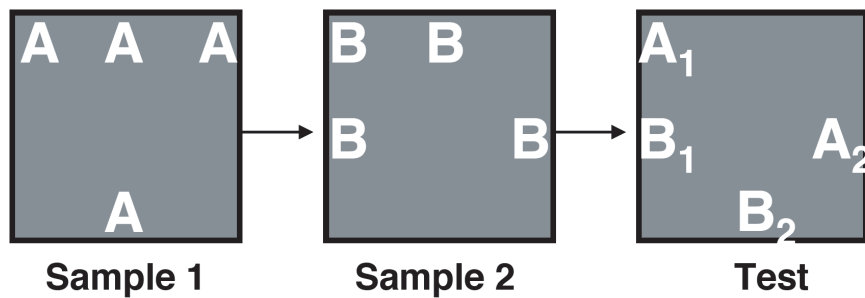

**Figure 1.2:** Task design from Kart-Teke et al. (2006)

Recently Kart-Teke et al. (2006) made use of a combination of these novel exploration paradigms to attempt to create a new model of episodic-like memory in the laboratory rat involving memory for objects, their locations and the order in which they were presented (see Figure 1.2). Rats were familiarised with a square testing box before the testing began. They were then presented with 4 identical copies of an object in 4 different spatial locations within the testing box (the first exposure phase). The rats were allowed to explore these 4 objects for 5 mins before being removed from the testing box. 50 mins later, rats were replaced in the testing box for a second exposure phase in which they were presented with another 4 identical but new objects in new places which they were again allowed to explore for 5 mins. After another retention delay of 50 mins, the rats were replaced in the testing box for the memory retrieval phase. As shown in Figure 1.2, 2 copies of each of the objects from the exposure phases were present in this phase. All 4 objects (A<sub>1</sub>, B<sub>1</sub>, A<sub>2</sub> & B<sub>2</sub>) were placed in locations in which objects had been previously encountered in the exposure phases, but one of the two objects from each exposure phase was displaced during the test phase (A<sub>2</sub> & B<sub>2</sub>) while the other two objects (A<sub>1</sub> & B<sub>1</sub>) remained in their previously experienced locations. The prediction made by the authors was that the displaced objects (A<sub>2</sub> & B<sub>2</sub>) would be explored more than the stationary objects (A<sub>1</sub> & B<sub>1</sub>) demonstrating memory for what and where; and that the least recent (110 min old) objects (A<sub>1</sub> & A<sub>2</sub>) would be explored more than the more recent (55 min old) objects (B<sub>1</sub> & B<sub>2</sub>) demonstrating memory for what and when. These predictions were partially

upheld in that the more recent displaced object (B2) was explored more than the more recent stationary object (B1) demonstrating memory for what and where. Also, the less recent stationary object (A1) was explored more than the more recent stationary object (B1) indicating memory for what and where. It was shown that this result was not due to less exploration of the objects in the second exposure phase and therefore a weaker memory trace for these objects. Unfortunately the rats showed a preference for the less recent stationary object (A1) over the less recent displaced object (A2) which was not predicted. There is a possibility that this was due to the object A2 being located in a position which had been explored more recently (in the second exposure phase), albeit containing a different object, which would imply that the temporal order of the locations used in this task were of more salience to the rats than the identity of the objects. This hypothesis would be consistent with the result that the more recent displaced object (B2) was explored more than the recent stationary object (B1) since B2 was placed in a location which had been encountered less recently than the location of B1, irrelevant of object identity. To fulfil the criterion for demonstrating episodic-like memory, the experiment should show evidence for integration of all three features- what, where and when- which I believe it fails to do. The object A2, which was less recently experienced and displaced, should most importantly have been explored the most by the rats, followed by either A1 or B2, depending on the salience of the temporal vs. spatial elements of this particular task. The object B1, which had been seen recently and had not been displaced, should have been explored least by the rats. A slightly stronger case for the integration of these 3 aspects of episodic-like memory has been shown recently, with the exploratory behaviour of the rats showing a pattern of results more similar to those predicted by the above hypothesis (Good et al. 2007). This experiment also showed that the task was dependent on the presence of an intact hippocampus, however the hippocampus lesions also produced an impairment in the spatial part of the task alone, suggesting that the “what, where, when” impairment may just be secondary to a purely spatial deficit.

The details of the experiments from this section illustrate the difficulties of combining the basic requirements- memory for what, where and when- into a task suitable for laboratory rats in which the results are easily interpretable and the hippocampus does not become involved due to the purely spatial nature of the task.

## 1.6 Why is When So Important?

Tulving’s original (1972) definition of episodic memory concentrated on the 3 key elements of what, where and when; but assessing the ability of animals to keep track of time

over experimentally viable delays has proved to be difficult, with an additional lack of evidence that animals use anything other than relative familiarity to judge how long ago an event occurred, outside the realm of a few seconds. I believe showing that animals do have a knowledge of exactly when events occurred in the past will remain virtually impossible without the aid of language. To address this point, Eacott and Norman (2004b) suggested that memory for the exact time of an event- the when- may not be critical for the demonstration of episodic or episodic-like memory in humans or animals. Clayton et al. (2003) however state that the temporal component of an episodic memory is the most important of the 3 key elements described by Tulving. Their reasoning for this is simple: that every episodic memory must have its own unique time, since no 2 episodes can be personally experienced by an individual at exactly the same time. It is easy to assume that their argument makes sense- it is obvious that 2 separate events or episodes experienced by the same individual cannot have an identical temporal element. However since this is true by definition, then it is also possible to make the opposite argument. Since any given episode cannot possibly have happened simultaneously with another, it seems that it may be unnecessary to explicitly encode an exact temporal marker for each one. There may be more value in remembering other more salient and diverse contextual features of the event in question in order to aid discrimination of the event from other similar ones. Although it is commonly assumed that part of the episodic memory phenomenon in humans includes knowledge of the specific time of past events, this may not necessarily be true. Friedman (1993) reviewed evidence from many human studies, both in the laboratory and out, concluding that in fact there does not seem to be one single temporal code in human memory which naturally stores events and their associated details chronologically. There have been many theories about how people encode time and subsequently recall the time of past events. Friedman (1993) divided these theories into 3 basic categories: distance theories, location theories and theories of the relative time of occurrence of an event.

The first type- distance theories- are based on processing which calculates the amount of actual time that has elapsed since an event occurred (Hinrichs and Buschke 1968; Anisfeld and Knapp 1968; Glenberg et al. 1983; Brown et al. 1985). This is to say, for example, that you know you had a particular meal exactly 11 months ago because you have an intrinsic mechanism which has been altering the memory since it occurred, and can be correlated with the amount of time that has passed since encoding. This may be based on the memory strength (Hinrichs and Buschke 1968; Anisfeld and Knapp 1968), the number of details that can be remembered about an event (Brown et al. 1985), or the amount

of contextual overlap between the past event and the present time<sup>1</sup> (Glenberg et al. 1983).

The second type- location theories- are based on information provided at the time of the event and are not reliant on the knowledge of the passage of time (Yntema 1963; Glenberg and Swanson 1986; Brown et al. 1985; Friedman and Wilkins 1985). Some uphold the belief that every event is assigned a “time tag” at encoding, which is unchanged by the passage of time or by future events and from which the temporal value can simply be retrieved at any point (Yntema 1963; Glenberg and Swanson 1986), i.e. the particular meal you ate was encoded with its own unique time stamp at the time you ate it. The reconstructive view (Brown et al. 1985; Friedman and Wilkins 1985)(sometimes called the contextual association model) theorises that many contextual elements are encoded at the time of the event (both internal and external) and that these are combined with a subjects knowledge of time (on a factual and personal experience level) to determine the actual time at which an event occurred, e.g. the meal you ate was a dinner, which from your factual knowledge of the world’s eating patterns you can deduce would most likely have occurred in the evening). The important factor in this model is that no specific time tag need be assigned upon encoding- other contextual features are enough to enable a calculation of the temporal context of an event when retrieval necessitates this and therefore memories need not be stored in any kind of chronological order.

The third and final type of theories are those based on the relative times of occurrence of events (Hintzman et al. 1975; Tzeng et al. 1979; Lewandowsky and Murdock 1989). Lewandowsky and Murdock (1989) proposed a very simple theory based on the pairwise association of events- one event is associated with its predecessor and then subsequently the next event that occurs. This could be interpreted in various ways- e.g. the meal that you ate at a restaurant could be associated with the last time that you ate at a restaurant, or the last time that you ate dinner or even the last time you ate anything at all. It could alternatively work on a different scale based on time in hours or even minutes and seconds- a chronological, scalar system rather than associating events in similar categories. Hintzman et al. (1975) and Tzeng et al. (1979) are both proponents of the order code theory, the last one that will be discussed here. They also demand no specific time tag to be attached to an event upon its occurrence, only that multiple contextual elements are encoded. According to this theory however, not only are contextual features allocated to an event at the time it occurred, but extra information can be added to memories of the event even after it has been stored. This means that if another event occurs that is similar or relevant to the original event of, for example, eating that meal at a restaurant (perhaps

---

<sup>1</sup>This assumes that certain contextual elements of an event will be more likely to be similar at the time of retrieval if the event was more recent and that the degree of contextual overlap provides some kind of scale from which a temporal value can be read off.

reading a review of that same restaurant some time later), these two events will become linked, even though they did not occur consecutively in time.

Friedman (1993) provides a thorough investigation of these theories of temporal memory and the methods used to investigate them in human studies. Many differences between the findings from these studies are confounded by the methods used for testing—the experiments are subjective and designed specifically to test the desired hypothesis, therefore subtle manipulations could easily lead to very different conclusions. In spite of these confounds, the majority of support from Friedman's review is in favour of those theories which are not in fact based on the time-stamping of an event at the time it occurs, or even the knowledge of the passing of time since an event. Theories that support the encoding (and possible updating) of contextual (but not necessarily temporal) information at the time an event actually occurs, followed at the time of retrieval by integration of episodic contextual memories and semantic knowledge to invoke an accurate memory for the time of a past event are the ones least criticised in this review.

## 1.7 The What, Where and Which of Episodic-Like Memory

The information provided previously (Section 1.6) provides a convincing body of evidence that the actual time at which an event occurs may not be directly encoded, stored or retrieved. If this is the case in human episodic memory, then surely it is a huge expectation to assume that animals should be able to demonstrate this type of knowledge when we ourselves cannot? Eacott and Norman (2004b) therefore suggested that the temporal element of an event can be replaced by a different occasion setting characteristic. In this way, the temporal or “when” element of an event is replaced by a different contextual element that the authors call “which”. So, now we have a new episodic-like memory triad consisting of the what, where and which of a unique event. In the example of eating dinner at a restaurant, you may remember “what” the occasion was, “where” the restaurant was and; rather than the exact date and time that you were there (“when”); in this example you may be more likely to remember what the weather was like, or who you were with: both could be examples of “which” - another occasion specifying element of the event that helps you to identify it as unique.

Eacott and Norman (2004b) designed an elegant task to show that rats could in fact display memory for “what, where and which”. In this task, rats were exposed to different 3D objects (what) in different locations (where) in different testing boxes (which). As in Kart-Teke et al. (2006), this task required no training as it relied upon the spontaneous behaviour of rats to explore novel features which are introduced to an otherwise familiar



environment<sup>2</sup>.

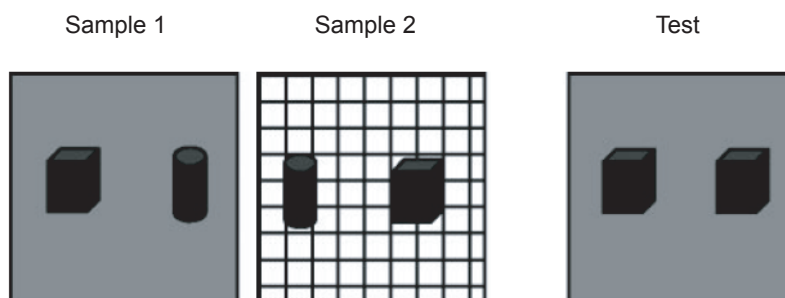

**Figure 1.3:** Schematic representation of Eacott and Norman's what-where-which task.

In the task designed by Eacott and Norman (2004b), naïve rats were habituated to a square testing box which could be configured as either of two different contexts by replacing the floor and walls with alternative colours and textures. In the context 1 condition, the testing box had a matt black painted wooden base and matt white painted wooden walls. In the context 2 condition, these were replaced with natural wooden walls and an insert of plastic coated white wire mesh was laid on the floor of the box. Rats were allowed to explore and habituate to these context configurations of the testing box before the start of the experiment proper. Testing on the what, where and which task consisted of the following (see Figure 1.3). For the first sample event, a rat was placed into the testing box which contained 2 different objects (e.g. rectangle on the left, cylinder on the right) at locations equidistant from the side walls of the box, with the box configured as (e.g.) context 1. The rat was allowed to explore the objects until it had accumulated 15 seconds of exploration time at each object, within a time window of between 2 and 5 mins<sup>3</sup>. The rat was then removed from the box and placed in a separate holding cage for a 2 min retention delay. The rat was then placed back into the testing box, which was now

<sup>2</sup>This is an important feature of this task: the idea of replacing the temporal or “when” aspect of the episodic-like memory triad with a different contextual element in this task came from earlier studies by D. Gaffan and colleagues. Gaffan proposed that his experiments on monkeys and rats which involved discrimination of objects and their locations in background scenes provided a model of episodic memory in animals. This was based on the fact that various components of the putative hippocampus related memory system were shown to be involved (using lesion studies) in these types of tasks. The contextual element in these tasks was defined by the background scene. However, these tasks are typically learned over many trials, which detracts from their episodic-like nature and suggests a role for semantic rule learning. The task designed by Eacott and Norman (2004b) on the other hand requires no training and is acquired with ease by intact rats.

<sup>3</sup>Exploration was defined as: “the rats nose being within 1cm of and oriented toward the object, sniffing at, or otherwise closely attending to the object” (Eacott and Norman 2004b).

configured as (e.g.) context 2, for the second sample event. Copies of the same 2 objects were located in the box in the same positions as the previous sample event, but the object identity at each location was reversed (e.g. cylinder on the left, rectangle on the right). The rat was allowed to explore as in the first sample event and was then removed to the holding cage for a variable retention delay (2,5,10,15,30,60 or 120 mins). After the retention delay the rat was returned to the testing box for a 3 min test session. The box was configured as (e.g.) context 1 and contained 2 identical copies of one of the previously experienced objects, e.g. the rectangle. At this point, the rat has seen the rectangle in both the left and the right locations. It has also seen the rectangle in context 1 and context 2. However, the rat has not previously seen the rectangle in the right location in context 1. Therefore, by combining information about the objects and their previous locations and contexts, the rat should be able to detect that the copy of the rectangle on the right is in fact in a novel location for the current context, context 1<sup>4</sup>. To demonstrate this knowledge, the rat should preferentially explore the rectangle on the right over the rectangle on the left, as it is in a novel configuration of location and context. Intact rats show robust preferences for this novel configuration of object, location and context (what, where and which) at short retention delays of up to 15 mins, and still show some residual level of performance at 30 and 60 min delays, although this is abolished by imposing a 120 min delay. Each trial was conducted with entirely new objects, making the task trial-unique, an important requirement of episodic (-like) memory. The authors also tested rats with pretraining permanent lesions of the postrhinal or perirhinal (parahippocampal) cortices, or of the fornix (fibre bundles providing input to and output from the hippocampus and its numerous connected structures (see 1.8) on the exact same task but using only the 2 min and 5 min retention delays. Only rats with fornix lesions were impaired at detecting the novel what-where-which configuration, exploring both objects equally during the 3 min test phase.

These rats were also tested on a control task involving objects and locations, with no intentional contextual processing required. This was in order to establish that the impairment seen in the fornix lesioned rats was not simply due to an inability to process location (where) or object-in-location (what-where) information. This control task consisted of the following: a rat was placed into the testing box (e.g. context 1, see Figure 1.3) and allowed to explore 2 different objects (e.g. cube on the left and cylinder on the right). The criteria for exploration were identical to those described previously in the sample and test events. After this single sample event, the rat spent the retention interval (2 min or 5 min) in the holding cage before being returned to the box for the test event. In the test event, the context of the box was the same as in the sample event (e.g. context 1). 2 identical copies

---

<sup>4</sup>although I'm not sure that I would be able to do the same with no training!

of 1 of the objects from the sample event were now present in the box (e.g. cube on the right and the left), and the rat was allowed to explore them for 3 mins. In this situation, the rat has seen the cube on the left in the previous sample event, so the novel configuration of object and location is the copy of the cube on the right in this example. There is no contextual element involved in this task, as both the sample and the test events take place in the same context. All rats (regardless of surgical manipulation) showed a preference for the copy of the cube that was on the right, demonstrating that they could recognise the novel configuration of object with location (what-where). This result showed that the impairment seen in the rats with fornix lesions on the what-where-which task described previously was not due to an inability to process what-where information alone.

There remains the possibility that the deficit seen in the fornix lesioned rats was due to an inability to process context (which), or object-in-context (what-which) information. In a subsequent paper (Norman and Eacott 2005), the authors demonstrate (in the same rats) that an object-in-context task reveals some deficits in the fornix lesioned rats at recognising a novel configuration of object and context (what-which). This control task consisted of the following: a rat was placed into the testing box (e.g. context 1) where it was allowed to investigate 2 identical copies of an object (e.g. cylinder in both the left and right locations). The criteria for exploration in this task were that the rat had to spend 30 secs in total exploring either or both of the objects within a time window of between 2 and 5 mins. The reason for the slight change in criteria from 15 secs at each object to 30 secs at either/both objects was due to the fact that processing of the locations of the objects was not necessary for this task, so exploring one object to establish an association of object identity with context was sufficient. After a 2 min delay (spent in the holding cage) the rat was replaced in the testing box for the second sample event. The testing box was configured as the opposite context to that seen previously in the first sample event (e.g. context 2). It contained 2 identical copies of another object (e.g. cubes in both the left and right locations). After this second sample event there was a retention delay of either 2 or 5 mins (as in the previous 2 tasks) before the rat was replaced in the box for the test event, again lasting 3 mins. The testing box was configured as (e.g.) context 1 and contained 1 copy of each of the objects from the previous 2 sample events (e.g. cylinder on the left and cube on the right, although the relative locations of the 2 objects were not important in this task). In this situation the rat has seen both of the objects before, but has only seen the cylinder in context 1 and the cube in context 2. Since the testing box is now configured as context 1, the novel configuration of object and context is the cube on the right in this example. There is no location (where) element involved in this task as both objects appear in both locations, only the identity of the object is context-specific (what-which). In this what-which task, fornix lesioned rats showed a mild impairment which could

have contributed to their performance deficit in the what-where-which task. However the difference in severity of the deficit between the 2 tasks makes it seem unlikely that the deficit seen in the fornix lesioned rats in the what-where-which task is entirely due to the contribution of the fornix to context processing as seen in the what-which task.

The spontaneous memory for what, where and which provides a useful and flexible task to measure these elements of episodic memory. It seems that removing the temporal context of an event from the criteria for episodic memory and replacing it with another similar contextual feature makes it much more amenable to study elements of episodic memory in the laboratory rat. The spontaneous and unrewarded nature of the task removes the confounds of semantic rule learning, and the evidence in the previous sections regarding humans processing of time makes this a valid model of Tulving's original (1972) definition of episodic memory with which to start to unravel its neurobiological mechanisms.

## 1.8 The Rat Hippocampus

The hippocampus has remained very similar throughout evolution between humans, primates and rodents so is an ideal candidate for attempting to study types of memory that may be analogous between these species (Amaral and Witter 1989). The rat hippocampus is a large and prominent structure that resides in the medial temporal lobe of the brain. It is a central hub which is connected with many cortical and subcortical structures, receiving input of multiple modalities from different sensory cortices whilst also being influenced by brainstem, thalamic and other limbic structures, making it a good candidate for being involved in processes which involve many different types of stimuli such as episodic memory. The intrinsic anatomy of the rat hippocampus was first explored and comprehensively defined at the beginning of the 20th C by Cajal Ramon y Cajal (1911), however the constant introduction of new techniques means that the structure and function of the hippocampus and its surrounding parahippocampal areas is still progressing, and technical advances such as 3D reconstruction of brain manipulations (see Figure 3.8 on page 93) mean that the hippocampus can be visualised more clearly than ever before (Amaral and Witter 1989). The following section will discuss solely the rat hippocampus and associated areas and will use terminology specifically relevant to the rat brain unless otherwise stated.

It is possible to separate the hippocampus from the surrounding allocortex partly by its 3-layered laminar structure and also by the unidirectionality of its neuronal connections, both of which are properties which make it unique from neocortical areas which typi-

cally have 4 or more laminar layers and within which reciprocal connections dominate. The hippocampus consists of the dentate gyrus (DG) area which contains mostly granule cells, basket cells and a polymorphic area near the border with the cornu ammonis (CA) areas. Pyramidal cells are the primary construct of the hippocampus' CA areas 1-4. There are two main pathways connecting the hippocampus to cortical and other subcortical brain regions. The first, known as the perforant path, is the major input route of sensory information. This information arrives via the perirhinal and entorhinal cortices from a wide variety of multimodal sensory cortical areas, with a particularly strong input from the primary olfactory cortex. The second pathway is via the fornix- a bundle of axons providing reciprocal communication between the hippocampus and many subcortical structures e.g. the amygdala, various thalamic nuclei and the hypothalamus. Within the hippocampus, there are a number of pathways along which information can travel, the most well known being the unidirectional trisynaptic circuit. Perforant path inputs from the entorhinal cortex synapse with the pyramidal cells of CA3 directly and also indirectly via the dentate gyrus granule cells (the mossy fibre pathway). The CA3 region has many autoassociative projections back to other CA3 cells and also outputs to CA1 (via the Schaffer collateral pathway) and commissurally to the contralateral CA1 and CA3 regions. The output from the CA1 region then travels back to the entorhinal cortex (directly or via the subiculum) to complete the circuit loop. The subiculum then provides the main hippocampal output to subcortical structures.

There is some controversy surrounding the subiculum, less well studied than the hippocampus until recent years but sometimes included under the umbrella term "hippocampal formation". Others however class the subiculum and its associated cortical areas into the "subicular complex" (O'Mara 2006; O'Mara 2005) The cortical areas associated with the subiculum are known as the pre- and para- subiculum (although the dorsal presubiculum is also sometimes given the name "postsubiculum"). These are of neocortical structure, very similar to the entorhinal cortex, whereas the subiculum itself has 3 laminar layers, much like the hippocampus. However, the subiculum has mainly reciprocal connections (although also a few unidirectional ones); and is also the origin of the bidirectional fornix, the main input and output pathway of the hippocampus. The subiculum receives inputs from mostly the same sources that the hippocampus proper does, and sends many projections to cortical and subcortical regions, most prominently the retrosplenial, perirhinal and postrhinal cortices and the septum but also the nucleus accumbens, mammillary nuclei and various hypothalamic regions. One very important consideration of the function of the subiculum is that it has a separate pathway connecting it to the entorhinal cortex which does not travel via CA1. In light of the role of the entorhinal cortex in spatial navigation (Steffenach et al. 2005), this pathway could be very

important, highlighting the often overlooked possibility of a major role for the subiculum in spatial learning and memory. The reason for this discussion of the subiculum is that often researchers who use manipulations such as permanent lesions of the hippocampus automatically include the subiculum in the ablated area (as part of the “hippocampal formation”). Another common finding is that fornix lesions are used to infer the role of the hippocampus, but since the fornix provides an extrahippocampal route between the subiculum and entorhinal cortex, this type of lesion also affects communication between these 2 structures as well as between the hippocampus and other brain areas. Considering the connectivity between the entorhinal cortex and subiculum independent of the hippocampus, inclusion of the subiculum in such manipulations could hugely amplify the damage caused by a smaller manipulation confined to the DG and CA fields alone. Complete inclusion of the subiculum in a hippocampus lesion has been shown to attenuate performance in a hippocampal sensitive memory task more than with a lesion of strictly the hippocampus alone (Morris et al. 1990a). To address the concerns raised above, the term hippocampus as used in the context of this thesis will be defined as the dentate gyrus and the CA fields only. All references to the subiculum or parahippocampal cortices will be made separately and clearly.

## 1.9 Aims of this thesis

This thesis aims to develop and improve new and existing models of testing declarative memory in the laboratory rat. This problem can be approached in two alternative ways.

1. The first is to take tasks known to specifically and sensitively test episodic memory in humans, and adapt these so that they are suitable for use in the laboratory rat. One must take a great degree of care in the experimental design, to try and ensure that not only are the demands being placed on the animal as similar as possible to those being placed on the human in the analogous test, but also that the rats are solving the test in the same way as humans do, using the equivalent memory system. This may be difficult to deduce while animals are performing the task, but careful consideration of the analysis afterwards must be used to try to qualify whether and how the laboratory rat solves a human test of episodic memory. This is a high risk approach, since it is difficult to predict whether animals will be able to acquire tasks designed for humans, and even if they do, whether the kind of memory processes they are using are analogous to human episodic memory.

2. The second is to examine elements of episodic memory based on the theoretical criteria for this type of memory in humans. This involves examining different subsets of

the characteristics of episodic memory in humans by designing tasks to test these characteristics in animals. One of the advantages of this method is that it avoids the main caveat of the previous method of approach: that is, one is not tricked into thinking that animals have episodic memory because they can solve a task that utilises (but not necessarily requires) episodic memory in humans. This second approach involves using the types of tasks already known to be of use in the laboratory rodent, but adapting these in order to incorporate the subset of episodic memory characteristics one wishes to test. This approach is less likely to produce a satisfactory complete model of episodic memory, unless all the theoretical criteria are incorporated. However, it will still provide very useful tasks in order to explore the neurobiological bases of elements of episodic memory within a framework of behavioural tasks of which we already have prior knowledge.

The follow-up approach, which will be applied to both of the above methods, is to focus on a brain structure that has been implicated in clinical studies to be of importance to episodic memory capabilities in humans. In this case, the hippocampus is the chosen area of study as it is the pre-eminent candidate as a substrate of episodic memory. Although it has been shown many times that the hippocampus has a fundamental role in spatial memory in laboratory rodents (and this may or may not be an indication that we have been testing episodic memory in animals for some time now), humans with amnesic syndromes involving hippocampal damage and episodic memory effects are impaired on a wide range of episodic memory tests, many of which do not have any spatial or navigational components. Thus, this thesis aims to investigate the role of the hippocampus in episodic-like memory in the laboratory rat independent of its role in spatial memory. It should be noted that "independent of" does not imply that there is no spatial element, just that this will be controlled for to show that the characteristics of episodic memory more typical to humans may also depend on the same neural structures in the rat. This should lead to informative models of the neurobiological basis of episodic memory in the laboratory rat.

## **Chapter 2**

# **Glutamate receptor mediated retrieval of paired associate learning**



## 2.1 Introduction

Day et al. (2003) developed an animal analogue of the human paired associate word-list task for the laboratory rat. This allows testing retrieval of one stimulus when a rat is presented with the other half of the stimulus pair, as with the word pairs presented in the human version of this test. Since it is immediately more taxing to try and extract this information from laboratory rodents without the benefits of language, the task was designed to maximise ethological relevance to the rat, in order to maximise the amount of naturally occurring behaviours and therefore validity of the data collected (Clark et al. 2005). There have been a number of previous paired associate tasks designed for rats, but most can be easily solved by recognition - pairs of stimuli are presented simultaneously, rather than one stimulus being used to prompt recall of the other (Cho and Kesner 1995)- or are trained over repeated presentations (Bunsey and Eichenbaum 1993; Kesner et al. 2005), making them less like tests of episodic memory in humans and more semantic in nature. The new protocol developed for rats by Day et al. (2003) consists of the animals learning, on a trial-unique basis, pairs of associations between particular flavours of food and the specific locations in which these food flavours are found in an arena. Rats were trained on a trial-unique basis- as in the human paired associate word-list task- with unique pairs of flavour-location associations experienced on each training session. The measure of memory recall for the paired associates is tested by giving rats a retrieval "cue"- a small piece of food, the flavour of which has been previously associated with a specific location in the arena during a single experience. If the cue flavour evokes a memory of the previous experience of eating that particular food, rats should be able to retrieve the memory of the location in which the food was eaten (the second, absent stimulus of the paired associate) and then return to this location when given access to the arena.

To investigate the role of the hippocampus in this rat version of a human episodic memory test, Day et al. (2003) examined the effects of temporary inactivation of this region at different time points during the task. Selective antagonists 6-cyano-7- nitroquinoxaline (CNQX, an antagonist of AMPA receptors) and D(2)-2-amino-5-phosphonopentanoic acid (D-AP5, an antagonist of NMDA (N-methyl-D-aspartate) receptors) were infused into the dorsal hippocampus of rats prior to either encoding or retrieval of trial-unique flavour-location paired associates. The temporal control enabled by the use of reversible pharmacological manipulations allowed examination of the retrieval process of flavour-location paired associate learning separately from that of encoding. AMPA receptors are thought to be primarily involved in fast synaptic transmission in the hippocampus whereas NMDA receptors are thought to play a significant role in synaptic plasticity

(Bashir et al. 1991; Asztly and Gustafsson 1996; Zorumski et al. 1996; Sprengel 2006). Day et al. (2003) showed that the blockade of dorsal hippocampal AMPA receptors by CNQX- effectively inactivating the dorsal hippocampus- blocked both encoding and retrieval of trial-unique flavour-location paired associates. Inactivation of NMDA receptors in the dorsal hippocampus impaired solely those parts of the task involving synaptic plasticity, namely encoding and storage of the memory trace and did not affect retrieval of paired-associates which had previously been encoded and stored during periods of normal hippocampal NMDA receptor activity.

A common caveat arising in many paired associate tasks for rats (and one that was faced in the experiments by Day et al. (2003)) is that if a spatial element is included as part of a paired associate, the task is likely to be dependent on the hippocampus due to the role of this structure in spatial navigation (O'Keefe and Nadel 1978; Gilbert and Kesner 2002). Non-spatial paired-associates however are often unaffected by damage to the hippocampus (Whishaw and Tomie 1991; Jarrard 1993; Li et al. 1999; Wood et al. 2004) although none of these tasks used a trial-unique forced recall paradigm. Although the novel flavour-location paired associate task presented here does have a spatial element, this series of experiments aimed to show that it was the recall of flavour-location paired associates on a trial unique basis, rather than spatial navigation, which was affected by the experimental manipulations performed.

The following chapter also examines another element of the paired associate learning task of Day et al. (2003), that being the possible differential interpretation of the main measures used to analyse performance of rats in this task.

The main measure used by Day et al. (2003) to examine performance in the critical non-rewarded probe tests was the measure of the time rats spent digging at the correct (cued) and incorrect sand-well locations during non-rewarded probe tests where no food reward was present in any of the sand-wells. This can be used as a raw time (in seconds) which can be highly variable between individual rats but is very useful to assess any unwanted sensorimotor or motivation deficits that may be caused by drug infusions, as it is a good measure of overall activity of the rats. The main use of the measure however was to convert it to a % correct dig time. This was done by dividing the amount of time spent digging in the correct sand-well by the total amount of time spent digging in all sand-wells for each rat. This provided a standardised number, removing the actual raw dig time variable which could differ greatly between rats and trials. This measure of persistence of digging is particularly useful (and was used as the primary measure) in non-rewarded probe tests where no food was present in the sand-wells but rats would persist in digging even after the normal time it would have taken them to retrieve the

food reward had it been present, showing their certainty of being at the correct sand-well location. It was previously assumed that this dig time measure was an equivalent performance measure to using the “all or nothing” measure of whether or not rats made their first dig in the correct sand-well (% correct first choice). The drawback to the % correct first choice measure however is that because it is an “all or nothing” response (i.e. did the rat dig in the correct location first: yes or no?) it has a very large amount of variance attached when averaging across the group of rats and gives less quantifiable information so was used less frequently. However, in the following chapter a possible alternative explanation of the performance measures is investigated. This is based on the idea that the first choice of sand-well made by a rat may be the most accurate measure of cued recall based on retrieval of memory during or immediately after the processing of the flavour cue, and the possibility that the amount of time spent digging at a given sand-well could be a reflection of recognition of the location upon arrival, but not prior recall. The relationship between these two performance measures will be discussed in this chapter.

These data are published as part of Day et al. (2003), a manuscript of which is provided in Appendix 1.

## 2.2 Materials & Methods

### 2.2.1 Subjects

A total of 16 male Lister Hooded rats (Charles River, UK) were used in this experiment, aged 9 weeks and weighing around 250g upon arrival. 12 rats initially underwent surgery aged 10 weeks (275-300g) for the implantation of cannulae (see Section 2.2.2) but behaviourally were procedurally naïve at the start of testing. The remaining 4 rats were used for the acute electrophysiology experiment which was carried out when the rats were approximately 14-16 weeks old, weighing 400-450g. All rats were housed individually in cages with opaque white plastic bases measuring 25 x 40 x 10 cm (width x length x height). Metal mesh lids 15 cm high were placed on top of the plastic cages providing a total cage height of 25cm. Rats were kept on a 12 hour light/dark cycle (lights on at 8am, off at 8pm) with all experimental procedures carried out in the light phase. The 4 rats used in the acute electrophysiology experiment had unrestricted access to food and water at all times. The 12 rats used in the behavioural experiment had unrestricted access to water throughout the experiment and to food prior to surgery and during a 7 day postoperative recovery period. During behavioural testing, rats were fed standard laboratory diet (RM1, SDS, UK) according to individual feeding regimes to maintain each rat at a minimum of 85% of its free-feeding bodyweight (bodyweights were recorded at least once per week). Compliance was ensured with national (Animals [Scientific Procedures] Act of 1986) and international (European Communities Council Directive of 24 November 1986 [86/609/EEC]) legislation governing the maintenance of laboratory animals and their use in scientific experiments. All efforts were made to minimize the number of rats used and their suffering.

### 2.2.2 Surgery

#### Cannula Implantation

Rats were anaesthetised with intraperitoneal injections of tribromoethanol (Avertin, 10ml/kg) and positioned in a stereotaxic frame. The top surface of the rats head was shaved and cleaned with ethanol and the skin was retracted to expose the skull. Holes were drilled and small stainless steel jewellers screws inserted at 5 points in the skull in slightly varying dorsoventral planes in order to provide anchorage for the cannulae. Small holes were then drilled above the cannula target sites (AP -4.5mm, ML +/- 3.0mm) and dura was pierced at these sites. 26 Ga stainless steel guide cannulae were lowered simulta-

neously through the bilateral target holes and positioned in the dorsal hippocampus at a depth of 2.5mm ventral to dura. Dental cement was then sculpted around the guide cannulae, covering the screws and the bases of the cannulae and creating a “cap” over the exposed skull. Solid stainless steel (“dummy”) cannulae were inserted into the implanted guide cannulae to prevent entry of infection or blockage. These dummy cannulae extended ventrally to a depth of 3mm from dura (i.e. 0.5 mm deeper than the guide cannulae) to make them the same length as the injection cannulae that would be used later to infuse drugs, and were also the of the same diameter as the injection cannulae. This design aimed to minimise tissue damage occurring at the time of infusions, when the injection cannulae were inserted into the hippocampus. By having a constant cannula track made by the dummy injector all the way down to the injection site, we hoped to avoid any non-specific effects accompanying the drug infusions due to simultaneous trauma to previously intact hippocampal tissue (J.M.Inglis, Personal Communication). Analgesia was administered by subcutaneous injection of Small Animal Rimadyl (0.1ml/kg body-weight) in 1ml sterile saline at the end of the surgical procedure and rats were placed in clean cages on a heated surface until they recovered from the anaesthetic. All rats were given a recovery period of at least 7 days to allow them to regain their presurgery weights before food restriction and behavioural testing commenced.

### **Electrophysiology**

Dentate gyrus field excitatory post-synaptic potentials (fEPSPs) were recorded in 4 intact anaesthetised rats in order to test the effects of CNQX on fast synaptic transmission in the dorsal hippocampus. This was a precautionary measure to test that the batch of the drug used in this experiment had the same effect as the batch used in the preceding experiment (Day et al. 2003). Rats were anaesthetised by intraperitoneal injection of Urethane (1.5g/kg bodyweight), positioned in a stereotaxic frame and the skin cut and retracted to expose the skull. Holes were drilled in one side of the skull for a unilateral injection cannula (AP -4.5mm, ML -3.0mm), a stimulating electrode (located in the perforant path input to the dentate gyrus at AP -7.5 mm, ML -4.0mm), a recording electrode (located in the hilus of the dentate gyrus at AP -3.5 mm, ML -2.0 mm) and the earth wire of the recording electrode (small hole anterior to Bregma: location varied). No screws or cement were needed for anchorage during these acute electrophysiological experiments as the cannula and electrodes remained suspended from the stereotaxic arms, which were fixed to the frame throughout the procedure. An anal temperature probe was inserted in to the rat which controlled the amount of heat provided by a heated pad on which the rat rested throughout the procedure, in order to maintain a stable body temperature of 35°C

- 37°C. The bipolar stimulating electrode was lowered first to a depth of 1.5mm, followed by the monopolar recording electrode (to the same depth). The stimulating electrode was then lowered in 0.1mm intervals every 2 mins until an fEPSP was evoked (biphasic stimulation was delivered at 100 $\mu$ A, 0.1Hz with a pulse half-width of 0.1 secs). Next, the recording electrode was lowered very slowly (0.1mm every 10 mins) until a maximal fEPSP (with a population spike slope of at least 2mV/ms, amplified at 100 x) was established. The population spike slope was measured as this gives an accurate indication of AMPA receptor mediated fast synaptic transmission in the hippocampus (S.J.Martin, Personal Communication). Slope measurements were taken automatically every 10 secs, over a 0.6ms period between 2.2ms and 2.8 ms after stimulation. The fEPSP was monitored until it had been stable for at least 20 mins, then recorded as a measure of baseline (100%) activity for another 30 mins before the drug infusion. Just before the infusion, the injection cannula was lowered to a depth of 3mm ventral to dura. This was done just before the infusion to prevent the injection cannula becoming blocked over the course of establishing a satisfactory fEPSP. Occasionally, the insertion of the injection cannula caused some disruption to the fEPSP but if this happened, the infusion was postponed until the fEPSP slope returned to baseline level. A total volume of 1 $\mu$ l of either artificial cerebrospinal fluid (aCSF) or CNQX (3mM, Tocris, UK) was then infused from an infusion pump into the dorsal hippocampus at a speed of 0.33 $\mu$ l/min. This concentration and amount was selected based on previous literature (Davis et al. 1992; Bianchin et al. 1993; Izquierdo et al. 1993) in order to achieve a similar time course of action for CNQX and D-2-amino-5-phosphonopentanoate (D-AP5) which were used in parallel during the preceding experiment (Day et al. 2003). After infusion of the drug, the fEPSP was monitored and recorded until it returned to baseline (approximately 90 mins after infusion).

### 2.2.3 Apparatus

The 'event arena' in which rats were trained to find flavoured food was made of plexiglass and placed in a laboratory room containing a number of prominent and distinctive cues which were visible through the transparent arena walls. The arena measured 1.6m x 1.6m and the opaque white floor contained a 7 x 7 grid of 49 circular holes (6cm diameter) at 20 cm spacing, covered by plastic lids. Two distinctive landmarks (a glued stack of golf balls and a painted wooden pyramid) were placed in 2 locations: row 4, column 2 (R4/C2) and (R4/C6). Access to the arenas was from any of four transparent plexiglass start boxes (25 cm x 25 cm x 25 cm) that were placed centrally in each wall with remotely controlled sliding doors. The entire floor (including inside the start boxes) was covered in a layer of wood shavings of the same type found inside the rats' home cages to make the

apparatus more inviting than the bright and reflective white plexiglass surface. This layer of wood shavings was also very useful as it could be redistributed around the arena after each trial to disperse the previous odour trails left by each rat more easily than by washing the arena floor after each trial. This was one of many precautionary measures taken to avoid the rats being distracted by or basing their search strategies on odour trails left by themselves or conspecifics (Wallace et al. 2002). Plastic sand-wells could be inserted into the holes in the floor of the arena and food rewards could be placed inside them. These food rewards were 1g spherical pellets manufactured to order in various flavours (all with equal nutritional value) by Bioserv, New Jersey, USA. The sand-wells were 2cm deep and could be filled with a mixture of 90g sand plus ground-up food (25g/2.5kg sand) which included all the flavours used in the experiment. When food reward was made available in a sand-well, 1 pellet rested on the bottom of the sand-well under the sand. The sand and ground-up food mixture was renewed every 2/3 days to ensure that every sand-well had the same odour. These measures were designed to ensure that when the rats entered the arena, their search for food reward would be guided only by memory for the flavor location association and not by any odours emanating from the sand-well containing the food. Lighting in the room was maintained at a constant level of illumination by wall mounted halogen lamps. Rats were observed during testing by means of video cameras connected to video recorders and computers. Software written in LabView was used to track the rats' movements and record multiple behavioural parameters.

## **2.2.4 Behavioural Testing**

### **Habituation**

On the first day of exposure to the arena, each rat was first given 5 minutes in one of the start boxes (counterbalanced across the group of rats). The start box door was then opened and rats had access to the arena to explore the whole area for a further 5 mins, although most rats remained in the start box. Those who explored it did so largely around the perimeter (thigmotaxic behaviour). Thereafter only the central sand-well (R4/C4) was opened and a non-flavoured ("control") 1 gm food pellet was placed on the surface of the sand. Providing food at this well encouraged the rats to approach the centre of the arena. Over days 2-5, a 1g control pellet was repeatedly available but systematically lowered deeper and deeper until the rats were digging the full depth of the sand-well to retrieve it. Rats quickly became accustomed to returning to the central sand-well to retrieve food and decreased their thigmotaxic behaviour. Over a further 5 days, different sand-wells were made available and baited with food during the habituation sessions to

encourage the rats to adopt a more diverse search strategy and to teach them that food could be found at various points around the arena. It was observed that the rats rarely ate the 1g food pellet at or near the sand-well from which they retrieved it. Some rats ate near one of the intra-arena landmarks (see Section 2.2.3 on page 45) but most returned to the start box (the start box door always remained open throughout the habituation session). At the end of habituation (10 days), notes were made of where each rat tended to eat so that this information could be taken into consideration when assigning rats to experimental groups. After this initial habituation phase rats were trained on two trial-unique flavour-location paired associates each day for 6 days so that their prior experience was the same as that of the rats in the first experiment reported in Day et al. (2003).

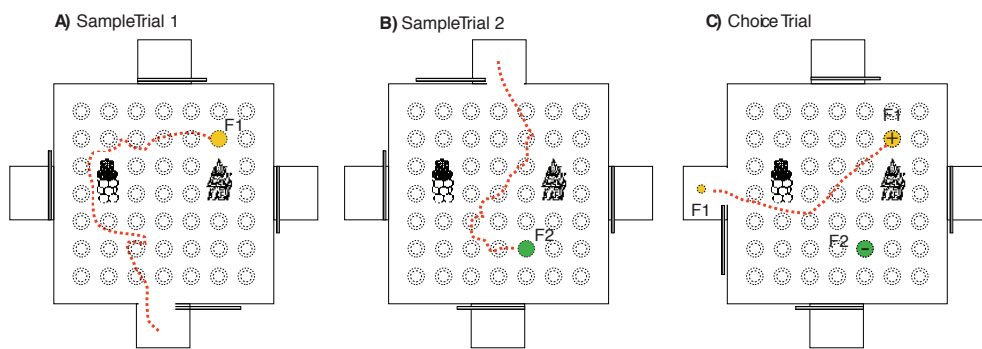

**Figure 2.1:** Schematic representation of the event arena: The 4 start boxes with sliding doors from which trials were begun are shown on each of the 4 sides of the square arena. Coloured circles indicate locations where specific flavours of food (F1 or F2) were available in the sample trials. In Panel C, only one of the 2 coloured sand-wells contained a 1g food reward (marked with "+"). The rewarded sand-well is the one at which the rat previously found food F1 in sample trial 1 (Panel A). The 0.5g half-pellet of food (indicated as a small yellow circle in the west start box in Panel C) acted as a cue for the rat to return to the location at which that particular food flavour had previously been found. The location not cued in the choice trial contained no food reward (marked with "-"). Black dashed circles indicate the other possible sand-well locations where food could be made available, which were closed and inaccessible on these particular trials. The red dashed lines indicate an example of the path of a rat during its search for the available sand-well during the sample trials (Panels A & B) and its return to a previously sampled location in the choice trial (Panel C).



### Main training

The aim of the main training procedure in this experiment was to familiarise rats with 2 flavour-location pairs that were to be presented repeatedly and remain constant throughout the experiment with the aim that they would become consolidated (stored) outwith the hippocampus. The next step would be to test whether these repeatedly presented paired associates were susceptible to disruption by dorsal hippocampus inactivation before retrieval.

On each testing day, a rat would experience two sample trials and a choice trial. (See Figure 2.1 on the preceding page for an example of the trials carried out on a testing day.) A sample trial began after the rat had been placed in one of the start boxes (e.g. south) and remained there for 30 secs, at which point the door was remotely opened allowing access to the arena. Rats were required to locate the one available sand-well and then to dig through the sand in order to retrieve the 1g flavoured food pellet (e.g. vanilla flavour (F1) at location R2/C6 (L1)) that was buried beneath the sand. After retrieving and consuming the food pellet- either in the arena or back in the start box- (rats were free to choose), the rat was returned to its home cage out of sight of the arena for a short (2 min) intertrial interval. During this interval the used sandwell was removed, excess sand disposed of and the wood shavings redistributed around the arena. The arena was then reconfigured for the second sample trial (e.g. grape flavour (F2) at location R6/C5 (L2)). The rat would be placed in a different start box (e.g. north) for the second sample trial and now had the opportunity to find a second flavour of food (grape) at a new location (R6/C5) and eat it. After the second sample trial the rat was again replaced in its home cage while the experimenter reconfigured the arena for the choice trial. A retention interval of 5 min between the end of the second sample trial and the start of the choice trial was used in the main training procedure. In the choice trial, the rat was placed into a third start box (e.g. west) and given a "cue"- a 0.5g piece of food of one of the two flavours previously experienced in the sample trials (e.g. vanilla)- and allowed to eat it in the start box. 30 secs after the rat had finished eating the food, the start box door was opened and the rat was released into the arena. There were now 2 available (open) sandwells, each previously associated with a different flavour of food during the sample trials. The aim was for the rat to use the flavour provided in the start box as a cue to return to where that food flavour had been previously experienced. Further food reward could be found only in the location where the specific cue flavour had been experienced during the previous (sample) trials that day. Since the rat was, in this example, given a piece of vanilla food (F1) in the start box it should return to the location where vanilla food was provided in the sample trial, e.g. L1, location R2/C6 to find a 1g vanilla food reward.

Rats were allowed to remain in the arena for a maximum of 10 mins to locate, retrieve and consume the food reward on each of the sample and choice trials. After this time had elapsed, a trial was terminated if the rat had failed to find the food reward or return to the start box. The experimenter would enter the arena and, in the case of food retrieval failure, manually excavate the food pellet from the appropriate sand-well so it sat on the surface of the sand, then guide the rat to the correct location. If the rat had retrieved and consumed the food but had not returned to the start box, it was lifted from the arena by the experimenter and replaced in the home cage.

Over the next 8 weeks, two flavour-location pairs consisting of apple (at location R1/C6) and brandy (at location R7/C6) were repeatedly presented either as a whole trial (e.g. sample 1 = apple at R1/C6, sample 2 = brandy at R7/C6) or in combination with a trial-unique flavour (e.g. sample 1 = apple at R1/C6, sample 2 = bacon at R3/C4) using the procedure described above.

24 different flavours of food were manufactured by Bioserv for use in the event arena and there were 49 possible sand-well locations. This meant that if required, 2 different flavours could be used each day for 12 days. If flavours were then re-used, there were still 48 possible new locations for each to be provided in, so a flavour never needed to be re-used in the same location in the experience of any individual rat. The trials across rats and across days were carefully counterbalanced to control for flavour or location preference and primacy or recency effects. In addition to redistributing the wood shavings around the arena to prevent rats tracking previous odour trails, the sequence of start boxes used was also counterbalanced across the group of rats on any given day.

Week 1			Week 2			
Day	Sample 1	Sample 2	Choice	Sample 1	Sample 2	Choice
Mon	Trial-unique	Trial-unique	Unique S1	Repeat-trial	Repeat-trial	Repeated S2
Tues	Repeat-trial	Repeat-trial	Repeated S1	Trial-unique	Trial-unique	Unique S2
Weds	Trial-unique	Repeat-trial	Repeated S2	Trial-unique	Repeat-trial	Unique S1
Thurs	Repeat-trial	Trial-unique	Unique S2	Trial-unique	Repeat-trial	Repeated S2
Fri	Repeat-trial	Trial-unique	Repeated S1	Repeat-trial	Trial-unique	Unique S2

**Figure 2.2:** Example of a 2-week training timetable for an individual rat during training of the two repeated flavour-location pairs. The two repeated pairs were presented either together as sample 1 and sample 2 on the same day, or individually but accompanied by a trial-unique flavour-location presented during one of the sample phases. Some days consisted of standard trial-unique flavour-location pairs during both sample phases, as in the original training. The days on which these trial types occurred were varied across rats and across the 8 week training period for each rat.

In any of these sessions, the cue flavour presented at the start of the choice trial could be either the repeatedly presented flavour or the trial-unique flavour: see Figure 2.2. This was so that the rats could learn to discriminate the apple and brandy flavours and their distinct locations, and also that they could learn to respond appropriately to either a repeat-trial or a trial-unique flavour cue, without showing an intrinsic preference for the more novel (trial-unique) or more familiar (repeated) flavour-location pair. In choice trials during this experiment (excluding the first 6 pretraining days) there was always a choice of 4 sand-wells open: the correct (cued) location, the non-cued but previously sampled location (both of these could be either trial-unique or repeat-trial locations), a trial-unique “distraction” sand-well at a novel location and finally a repeated “distraction” sand-well at location R3/C3 which was always available but never rewarded. The

different distraction sand-wells acted as controls to check that rats were discriminating between rewarded and non-rewarded locations as well as unique vs. repeated locations in the “mixed” choice trials (i.e. the choice trials which had been preceded by one repeat flavour sample trial and one unique flavour sample trial). During the last 2 weeks of training (weeks 6-8), 6 trials were performed with the retention interval between the second sample trial and the choice trial increased to 20 mins. This was in preparation for the drug infusions, when this longer retention interval would be necessary in order to allow time for the drug to take effect between the second sample and choice trials and therefore to be active during retrieval (Day et al. 2003).

### **Data collection**

During the trials, a number of behavioural measures were recorded including:

**“Making a choice”:** defined as the rat placing its paws on or initiating digging in a sand-well. Stopping at and sniffing sand-wells was not classed as making a choice.

**First choice measure:** whether the rat dug first in the correct sand-well location.

**Dig time measure:** how long the rat spent digging in each sand-well.

**Latency to retrieval:** how long it took the rat from leaving the start box to retrieving the food reward.

The performance measures were observed and recorded by the experimenter via a video monitor with the assistance of LabView software written by P.A. Spooner. This software had a timer which could be programmed to respond when the computer cursor was held over a particular sand-well and the left mouse button held down. This recorded the location and duration of each digging event that was observed by the experimenter.

**Non-Rewarded Probe Testing and Drug Infusions** Infusions of CNQX or aCSF were given 15 mins before the choice trial (immediately after completion of the second sample trial) to see if the blockade of dorsal hippocampal activity by CNQX would disrupt the retrieval of the repeat-trial flavour-location pairs that had been trained over the previous 8 weeks. Non-rewarded probe tests with and without drug infusions were carried out over the 3 weeks following the initial 9 weeks of main training. The first 2 weeks consisted

entirely of mixed trials (sessions in which one of the sample trials used a trial-unique flavour and the other used a repeated-trial flavour, e.g. see Weds, Thurs or Fri sessions in Figure 2.2 on page 50) interspersed with standard training days. During the final week, additional non-rewarded probe tests were carried out to confirm that the rats could discriminate between the 2 repeated-trial flavours when presented in a single session in the drug infusion condition, since the all the probe test sessions had been mixed trials and the rats may simply have been using a sense of familiarity to search for food at the one overtrained previously rewarded location that was present.

In a non-rewarded probe test, the sample trials were identical to those described previously (see Figure 2.1A & B), but in the choice trials no food reward was provided. The amount of time the rats spent digging in each sand-well during the first 60 seconds of the probe test was recorded and a % dig time was calculated based on the amount of time a given rat spent digging at each sand-well as a proportion of the total amount of time spent digging, with chance level being 25% (100%/4 sand-wells). At the end of the 60 secs the experimenter entered the testing room and dropped a 1g reward pellet of the appropriate flavour into the sand-well at the cued location in order to minimise extinction of the learned behaviour through lack of reinforcement. The rat was allowed to retrieve and eat this food pellet, then the trial was complete.

The actual procedure for the drug infusion involved lightly restraining the rat in the hand of the experimenter whilst the dummy cannulae were unscrewed and removed from the guide cannulae<sup>1</sup>. The injection cannulae were then inserted and the rat was placed in large bucket where it was free to move around whilst the infusion took place<sup>2</sup>. After the injection cannulae had been in place for 1 min, the infusion pump was started and the 3 min infusion of the appropriate drug began. The injection cannulae were left in place for 1 min after the end of the infusion, then the rat was removed from the bowl and again lightly restrained in the hand of the experimenter whilst the injection cannulae were removed and the dummy cannulae screwed back in. The rat was then placed into the home cage until the choice trial was scheduled to begin (15 mins after cessation of the infusion).

---

<sup>1</sup>the rats had been habituated to the process of removal and insertion of cannulae throughout the experiment since surgery, so this part of the procedure was not thought to cause them any distress.

<sup>2</sup>the injection cannulae were connected to the infusion pump via a pivot arm which rotated when the rat moved around so as to avoid twisting and blocking the rubber tubing through which the drug flowed.

### **2.2.5 Histological Procedures**

At the end of behavioural testing and acute electrophysiological experiments, all animals were terminally anaesthetised with an overdose of sodium pentobarbitol (1ml/1.4kg bodyweight) and then perfused intracardially with 0.9% saline followed by 4% formalin. The brains were removed and stored in 4% formalin for a minimum of 24 hours before coronal 30 $\mu$ m sections were cut on a cryostat with every fifth section recovered throughout the hippocampus. The sections were mounted on gelatine coated slides, stained with 0.1% cresyl violet acetate and coverslipped using DPX. Each brain was examined under a microscope to check that the cannulae had been positioned correctly in the dorsal hippocampus.

## 2.3 Results

### 2.3.1 Electrophysiology

Figure 2.3 on the next page shows examples of field potential recordings. CNQX produced maximal neural inactivation in the dorsal hippocampus approximately 15 mins after infusion (indicated by a steep decline in fEPSP slope) which lasted for 60 mins, with the fEPSP slowly returning to baseline (100%, as before the infusion) over a further 30 mins. Infusion of aCSF had no effect on the fEPSP (slope remained at 100% baseline level). These results showed that the infusion protocol was successful in blocking fast synaptic transmission mediated by AMPA receptors in the dorsal hippocampus. The time taken for activity in dorsal hippocampus to be maximally reduced was 15 mins, and this effect lasted for 90 mins. This result was identical to that seen by Day et al. (2003), so this new batch of CNQX was approved for use in this experiment. The result necessitated that the retention interval between the second sample trial and the choice trial be a minimum of 20 mins to accommodate the CNQX infusion time (5 mins) and the delayed effect of the drug (15 mins) in order to ensure maximal reduction of AMPA mediated fast synaptic transmission in the dorsal hippocampus during the choice trial, as in Day et al. (2003).

### 2.3.2 Behavioural Results

#### General Observations

A short video clip of a rat performing a demonstration sample and choice trial is available on a CD as Appendix 3. In this video footage the wood shavings have been removed from the arena in order to aid visibility of the 49 possible sand-well locations more clearly.

Typically, the rats left the start box and kept their heads near the floor of the arena during sample trials, displaying small lateral head movements reflecting their search for the single sand-well that was open. When a rat found the available sand-well, it would dig through the sand very efficiently in order to retrieve the 1g pellet of flavoured food that was buried beneath the sand. Rats would then either return to the start box, move to a favoured location elsewhere in the arena or, in rarer cases, stay at the sand-well to consume the food. After eating, rats generally returned to the start box relatively directly (although some proceeded to explore the rest of the arena before returning) and the door was closed. The performance measures used (first choice of sand-well, digging time in each sand-well and latency to retrieve the food reward) were recorded by the

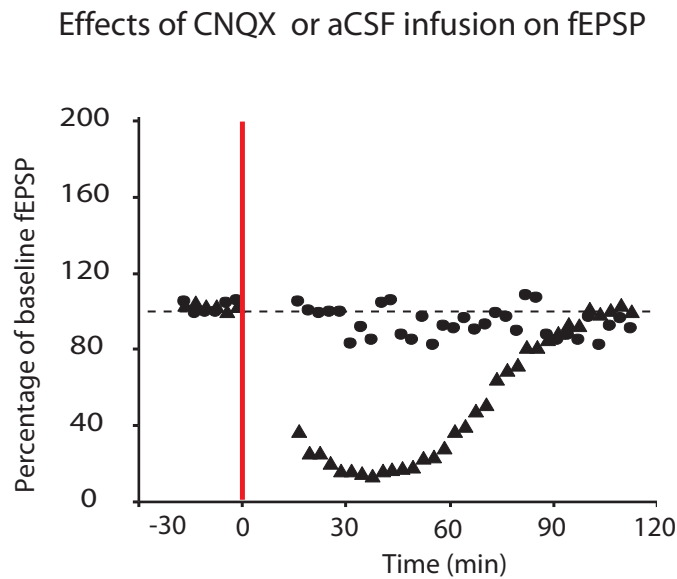

**Figure 2.3:** Examples of fEPSP recordings in the dentate gyrus of anaesthetised rats: The percentage of baseline fEPSP (y axis) was calculated from the slope of the population spike at maximal amplitude (defined as 100%) recorded at regular intervals (each symbol- circle or triangle- indicates a fEPSP response from which the slope was calculated and expressed as a % of maximum slope value at regular time points (x axis). Reduction of AMPA receptor mediated fast synaptic transmission in the dorsal hippocampus can be seen after CNQX infusion (infusion indicated by red bar). Triangles represent fEPSP slope values substantially reduced by AMPA receptor blockade. After 60 mins, activity began to recover (increase in fEPSP slope) and by 90 mins it had returned to baseline (100%). Circles represent slope values measured after aCSF infusion, which had no effect on dorsal hippocampal fast synaptic transmission (fEPSP slope value remains at 100% of baseline value for 120 mins after aCSF infusion).

experimenter. Digging behaviour was surprisingly easy to recognise from observing the video monitor: in the case of just sniffing at a sand-well, rats would barely pause at the location and would remain in a typical ambulatory posture. The initiation of digging typically involved the rat “gathering its haunches” underneath itself to grip the edge of the sand-well or anchor itself to the floor with its hind legs whilst most of its head and front legs would disappear inside the sand-well! On the rare occasion that there was any ambiguity about whether or not a rat had actually initiated digging at a sand-well, the experimenter would check the ambiguous location for traces of sand that would be dispersed around the sand-well if digging had occurred.

#### **Differential performance over training when cued by trial-unique vs. repeat-trial flavours**

Over the first 6 weeks of training on the 2 repeat-trial flavour-location paired associates, first choice performance and dig times in each of the 4 available sand-wells were examined both on trials in which the correct sand-well location was cued by one of the repeat



trial flavours and trials in which the correct sand-well location was cued by a trial-unique flavour (see Figure 2.4).

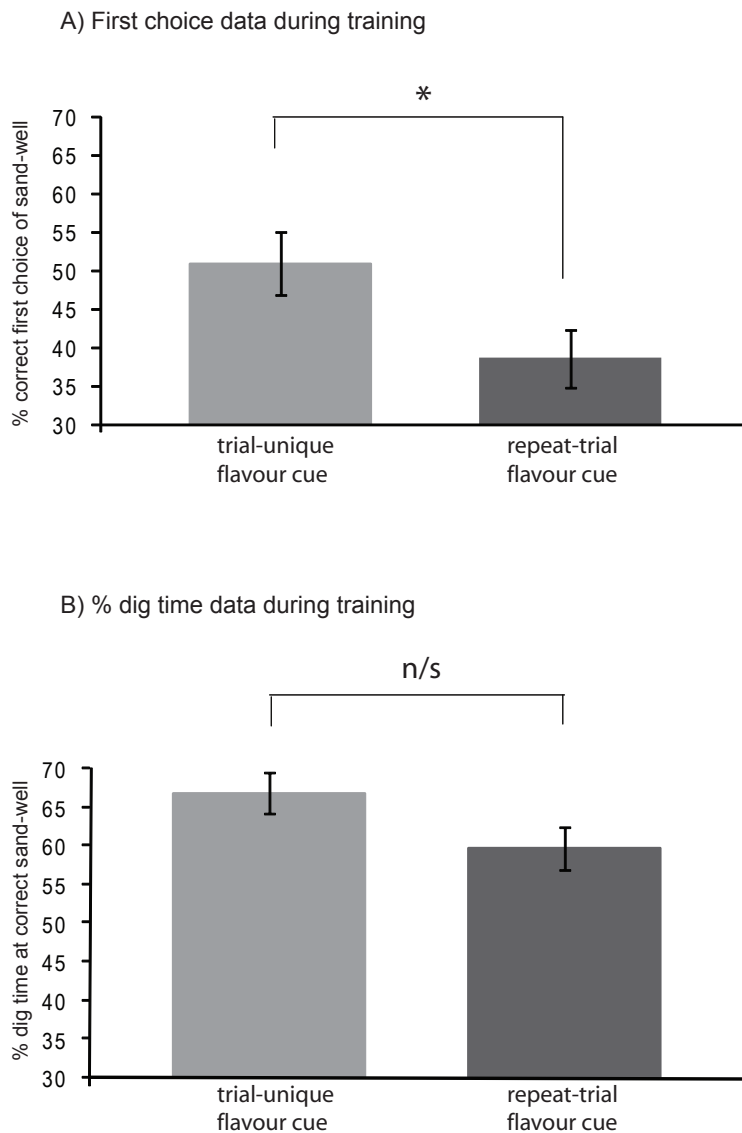

**Figure 2.4:** Differential choice accuracy on trial-unique and repeat-trial tests: Panel A shows the measure of % correct first choice of sand-well: rats were significantly less accurate in choice trials in which they were cued with a repeat-trial flavour compared to choice trials in which they were cue with a trial-unique flavour. Panel B shows the measure of % dig time in the cued sand-well on trial-unique and repeat-trial choice trials, which was not different between trial types.

Interestingly, rats were significantly less accurate in their choice of which sand-well to dig in first when they were cued with a repeat trial flavour than with a trial unique flavour (see Figure 2.4A). This effect was not seen in the % of their total dig time that the rats spent searching at the correct sand-well. A repeated measures ANOVA on % correct first choice

of sand-well with trial type (trial-unique or repeat-trial) and training day as within-subjects factors showed a significant main effect of trial type ( $F_{(1,14)} = 6.06; p = 0.03$ ) but no effect of training day or interaction between factors (both  $p > 0.1$ ). The same analysis of % dig time in the cued sand-well showed no significant effects (all  $p > 0.05$ ). (The lack of effect of training day is not surprising considering that the rats had already undergone pretraining for 6 days on the trial-unique task reported in (Day et al. 2003)). Food was present in the sand-wells throughout the training period, so it would not be expected that the actual time in seconds spent digging in the correct sand-well in order to retrieve it would differ between the trial types. However, the % time rats spent digging in correct and incorrect sand wells is interesting in this situation: the data show that on both trial types the rats spent equal percentages of their time digging in the correct sand-wells. This, by default, means that rats also spent the same % of their time digging in the incorrect sand-wells. If the rats were simply worse at the repeat-trial task in general, the data should indicate that they spent a smaller percentage of their time searching for food at the correct location during the repeat-trial tests compared to the trial-unique tests. This is not the case- what the data imply is that in the repeat-trial tests, rats were initiating digging in incorrect sand-wells significantly more often than in the trial-unique tests but were not persistent in their searches at these incorrect locations, quickly moving on to the next sand-well. The average latency to retrieval, i.e. how long rats took to retrieve the food pellet from the correct sand-well after leaving the start box, although not significant, did support the above proposal. On trials where a trial-unique sand well was cued, rats took an average latency of  $29.73 \pm 3.23$  seconds to retrieve the food pellet whereas on trials where a repeat-trial sand-well was cued, rats took an average of  $34.68 \pm 2.70$  seconds. Although not significantly different ( $p > 0.05$ ), this slight trend over multiple training sessions indicates that the rats may have been using a more indirect route to reach the correct sand-well on trials cued with repeat-trial flavours.

### **Rats under the influence of CNQX can still navigate to a familiar location**

The retrieval of repeat-trial paired associates as assessed by % dig time at the correct sand-well which had been experienced over at least 20 presentations each as assessed by % dig time at the correct sand-well was not affected by intrahippocampal infusion of CNQX 15 mins before the choice trial. Performance measured by the % time spent digging in the cued sand-well over 60 sec non-rewarded probe tests was indistinguishable between the CNQX infusion, aCSF infusion and no drug conditions (see Figure 2.5D). Over the 2-week probe test period, each rat completed 3 repeat-trial probe tests in total, with 1 in each drug condition (CNQX, aCSF or no drug). Repeated measures ANOVA

showed that rats dug differentially at the 4 sand-wells (main effect of sand-well:  $p < 0.001$ ) but that CNQX did not disrupt performance: rats under the influence of CNQX were indistinguishable from aCSF and control rats (no effect of drug or drug x sand-well interaction: both  $p > 0.1$ ). % dig times at the correct cued repeat-trial sand-well were significantly greater than chance (one-sample t-test with data for 3 groups combined:  $p < .005$ ). % dig times at the never-rewarded repeat-trial location and the average of the random novel locations were significantly below chance (one-sample t-tests with data for 3 groups combined in each case:  $p < 0.005$  and  $p < 0.05$  respectively). Actual time that the rats spent digging in each condition was also analysed to check for any nonspecific sensorimotor impairments the drug treatment may have induced. CNQX infusions did not affect the total amount of time in seconds that rats spent digging during the 60 second probe tests (Repeated measures ANOVA: CNQX =  $23.3 \pm 2.0$ , aCSF =  $22.1 \pm 1.2$ , no drug =  $26.6 \pm 2.2$  secs,  $F_{(2,16)} = 1.48$ ;  $p = 0.27$ ). Analysis of the % correct first choice of sand-well (see Figure 2.5E) using a repeated measures ANOVA with the drug treatments during the probe tests (CNQX, aCSF or no drug) as within subjects factors showed no significant effect of drug treatment on % correct first choice of sand-well ( $F_{(2,22)} = 0.762$ ;  $p = 0.478$ ). This indicated that CNQX had no effect on the first choice measure, although the graph in Figure 2.5 Panel E gives the impression that there is a trend towards worse first choice performance in CNQX-treated rats. Planned post-hoc comparisons (pairwise, Bonferroni corrected) however revealed that CNQX-treated rats were not different from either aCSF-treated rats ( $P = 1.000$ ) or rats in the no drug condition ( $P = 0.573$ ). One-sample t-tests against the chance level of 25% revealed that rats in neither the CNQX or aCSF conditions performed above chance levels on the % correct first choice measure in this series of probe tests ( $t_{(11)} = 0.586$ ;  $p = 0.570$  and  $t_{(11)} = 1.658$ ;  $p = 0.125$  respectively) The results from the no drug condition showed that the % correct first choice measure did reach levels significantly above chance ( $t_{(11)} = 2.242$ ;  $p = 0.047$ ).

These results showed that rats with the dorsal hippocampus inactivated by CNQX are still able to navigate successfully in the event arena in response to a flavour cue. These data helped to alleviate the concerns raised in Experiment 1 about the ability of rats under the influence of CNQX to display any spatial memory or navigational skills. It also provides evidence that CNQX infusions did not cause nonspecific sensorimotor deficits. The data from the % correct first choice measure in this series of probe tests (1 for each drug condition) is difficult to interpret as the amount of variability on just one "all-or-nothing" response per probe test is huge. It was not possible to see any clear differential effects of CNQX depending on which performance measure was used, and the main statistical test (repeated measures ANOVA on % correct first choice with drug condition as within subjects factor) suggests the conclusion that the effect of CNQX on % correct first

choice of sand-well is no different from its effects on % dig time in the correct sand-well. If the first choice measure were to be interpreted as a measure of cued recall, it would be pertinent to suggest that, at least in the drug infusion conditions, the rats were not solving the task using a recall strategy, but perhaps a sense of relative familiarity with the location of the repeat-trial sand-well compared to the trial-unique one. However from a single “all-or-nothing” response in each drug condition it is not possible to make any strong conclusions.

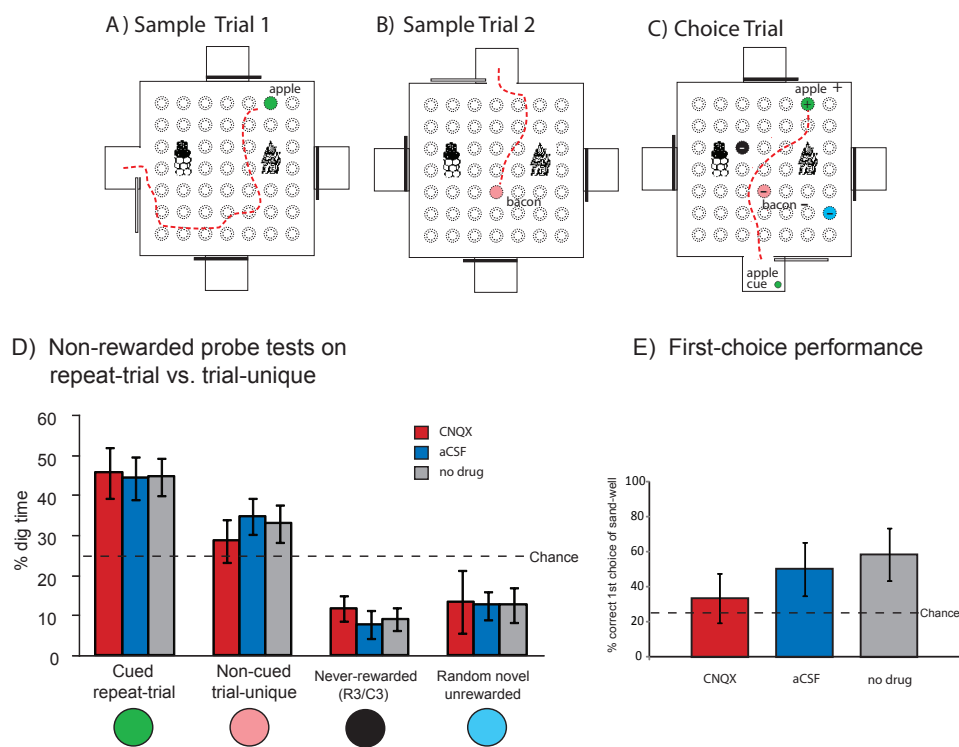
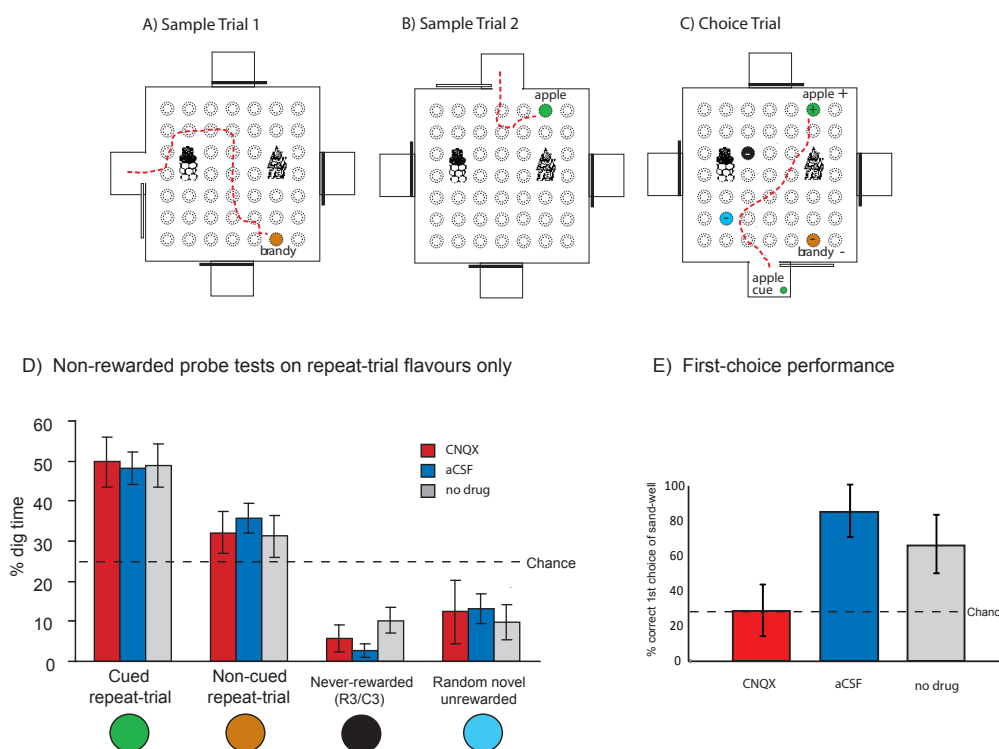

**Figure 2.5:** Repeat-trial paired associates are not affected by CNQX infusion: navigation is intact: A representative layout from a mixed repeat-trial and trial-unique non-rewarded probe test is shown in A, B & C. Rats had to choose between 4 sand-wells: the cued repeat-trial location (e.g. apple at R1/C6, coloured green), a non-cued single-trial location (e.g. bacon at R5/C4, coloured pink), the repeat-trial never-rewarded location (coloured black at R3/C3) and a random novel location (coloured blue at R6/C7). Panel D shows that rats dug differentially at the 4 sand-wells but that CNQX did not disrupt performance. Rats under the influence of CNQX were indistinguishable from aCSF and control rats. Panel E shows the % correct first choice of sand-well by rats in each of the probe test conditions shown in Panel D.

### Rats can choose between 2 repeat-trial locations after CNQX infusion: cued retrieval is intact

Extra probe tests were carried out which tested the retrieval of the 2 repeat-trial paired

associates against each other. The previous probe tests carried out in rats treated with CNQX in this experiment all comprised of mixed trial types (see Figure 2.5A, B & C and Weds, Thurs or Fri sessions in Figure 2.2 on page 50) where it was theoretically possible that the rats could just be returning to the one repeat-trial rewarded location that was available during each non-rewarded choice trial, using a sense of relative familiarity of the sand-wells but without using the flavour cue. In the extra probe tests there were still 4 sand-wells available in the choice trial: the never-rewarded sand-well at location R3/C3, a random novel sand-well at a different location on each trial which were the same as in the mixed trial probe tests reported in the previous section. However the other 2 available sand-wells were the repeat trial apple and brandy sand-wells at locations R1/C6 and R7/C6 respectively. In this probe test condition, rats sampled one of the repeat-trial flavours in sample trial 1 (e.g. apple at R1/C6), the other in sample trial 2 (e.g. brandy at R7/C6) and then had to choose between these 2 repeat-trial locations depending on whether they received an apple or brandy recall cue in the start box prior to the choice trial (see Figure 2.6 A, B & C and Tues sessions in Figure 2.2 on page 50). A repeated measures ANOVA showed that rats dug differentially at the 4 sand-wells (main effect of sand-well,  $p < 0.001$ ) but that CNQX did not disrupt performance: rats under the influence of CNQX were again indistinguishable from aCSF and control rats (no effect of drug,  $p > 0.1$ ). Rats with the dorsal hippocampus inactivated with CNQX performed significantly above chance on these probe tests (see 2.6D) and were indistinguishable from control rats (aCSF or no infusion) demonstrating that they could remember both the repeat-trial locations and the specific food flavours associated with them and return to the appropriate one when cued with a repeat-trial flavour. Further one-sample t-tests showed that % dig time at the cued repeat-trial sand-well was significantly greater than chance ( $< 0.003$ ), % dig times at the never-rewarded repeat-trial location and the random novel location (trial-unique) were both significantly below chance ( $p < 0.005$  and  $p < 0.05$  respectively) and % dig time at the non-cued repeat trial sand-well did not differ from chance ( $p > 0.05$ ) CNQX infusions did not affect the total amount of time in seconds that rats spent digging during the 60 second probe tests (Repeated measures ANOVA: CNQX =  $22.4 \pm 2.3$ , aCSF =  $21.5 \pm 1.4$ , no drug =  $26.6 \pm 2.8$  secs,  $F_{(2,16)} = 1.47$ ;  $p = 0.26$ ).



**Figure 2.6:** Rats can choose between 2 repeat-trial locations after CNQX infusion: cued retrieval is intact: A representative layout from a repeat-trial probe test is shown in A, B & C. Rats had to again choose between 4 sand-wells in the probe test, but in these purely repeat-trial cued probe tests, both repeat-trial locations were available (e.g. apple at R1/C6, coloured green, and brandy at R7/C6, coloured brown) so rats had to choose between them based on the flavour cue. The repeat-trial never-rewarded location (coloured black at R3/C3) and a random novel location (coloured blue at R6/C2) were also available during the choice trial. Panel D shows that rats dug differentially at the 4 sand-wells but that CNQX did not disrupt performance: rats under the influence of CNQX were again indistinguishable from aCSF and control rats. Panel E shows the % correct first choice of sand-well by rats in each of the probe test conditions shown in Panel D.

Analysis of the % correct first choice of sand-well (see Figure 2.6E) using a repeated measures ANOVA with the drug treatments during the probe tests (CNQX, aCSF or no drug) as within subjects factors showed a just significant effect of drug treatment on % correct first choice of sand-well ( $F_{(2,22)} = 3.348; p = 0.05$ ). Planned post-hoc comparisons (pairwise, Bonferroni corrected) revealed that CNQX-treated rats performed differently to aCSF-treated rats ( $P = 0.021$ ) but not differently to rats in the no drug condition ( $P = 0.312$ ). Performance in the aCSF and no drug conditions were not different ( $P = 1.000$ ). Further one-sample t-tests against the chance level of 25% revealed that rats in the aCSF and no drug conditions performed above chance levels on the % correct first choice measure in

this series of probe tests ( $t_{(11)} = 3.830; p = 0.003$  and  $t_{(11)} = 2.242; p = 0.047$  respectively) but that rats in the CNQX condition performed at chance levels ( $t_{(11)} = 0.001; p = 1.000$ ). The data from the % correct first choice measure in this series of probe tests (1 for each drug condition) suggests that CNQX may have a differential effect on the performance measures of % correct dig time and % correct first choice. Figure 2.6E shows a stronger but similar pattern to that in Figure 2.5E, and the results of the main statistical analysis just reached significance for a differential effects of the drug conditions upon the % correct first choice measure. If the first choice measure were to be interpreted as a measure of cued recall in this semantic probe test situation, it could be suggested that the rats could not solve this task using a relative familiarity recognition strategy, since both repeat-trial sand-wells were equally familiar. Using a recall strategy, measured by correct first choice of sand-well, rats performed significantly better than chance in the no drug or aCSF conditions but at chance level when the hippocampus was inactivated in the CNQX condition. Thus, the differential analysis of these two behavioural measures provides a possible means to dissociate the putative use of recognition from recall.

Overall, the results from this experiment allow us to conclude that rats are not “lost in space” (Day et al. 2003) under the influence of CNQX. They are able to navigate to a familiar location in the event arena during dorsal hippocampal inactivation. Not only that, but they can differentially navigate to two locations based on the individual food flavours associated with each of those locations. In conclusion, if rats are repeatedly exposed to flavour-location paired associates over an extended training period (2 months) then it is possible for them to retrieve the memory for a particular location when cued with a particular food flavour, independent of fast synaptic transmission in the dorsal hippocampus. We cannot clearly conclude in which situations rats may be using a sense of recall (as measured by first choice of sand-well) or a sense of recognition or familiarity (as measured by the dig time at the correct sand-well- a measure of persistence) to guide their behaviour. Although the task developed by Day et al. (2003) clearly provides conditions in which cued recall can be used to accurately solve the task (and indeed is probably a necessity), it is not clear what behavioural measures best represent the strategies used by the rats in a given test situation.

### 2.3.3 Cannula placement

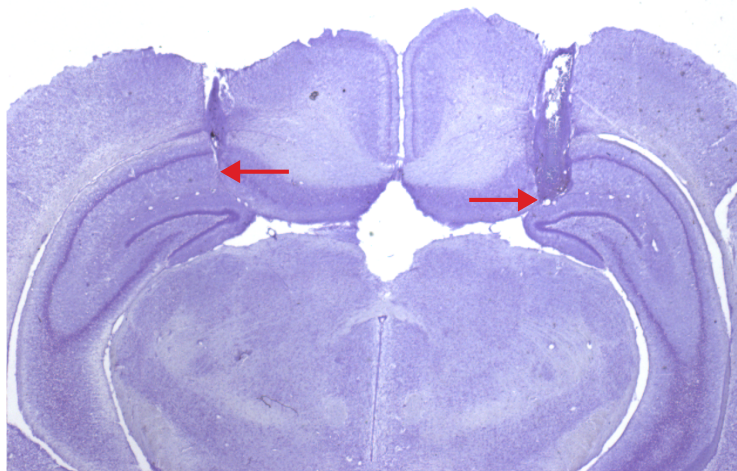

**Figure 2.7:** Cannula placement in the dorsal hippocampus: Coronal section at AP -4.5mm from Bregma. Red arrows indicate the depth of the cannulae in each hemisphere.

A typical coronal section at approximately 4.5mm posterior to Bregma and stained with cresyl violet is shown in Figure 2.7. All cannulae in the experimental rats were correctly placed in the target site (dorsal hippocampus) so no rats were excluded from the study on histological grounds. All the brains from the experimental rats were sectioned and examined for accuracy of cannula placement after behavioural testing was finished. The section photographed in the figure is from rat D0704 who participated in this behavioural experiment and is a typical example of the appearance of the brains after chronic cannula implantation and multiple drug infusions.



## 2.4 Conclusions and Discussion

Day et al. (2003) previously showed that rats can learn a trial-unique flavour-location paired associate task and perform above chance in a cued recall test scheduled after a short retention delay of up to 20 mins. Encoding of the trial-unique paired associates depends on NMDA receptor activation in the dorsal hippocampus, but retrieval is NMDA receptor independent. Retrieval of a trial-unique paired associate also requires AMPA receptor activation in the dorsal hippocampus. Encoding may also depend on intact AMPA receptor mediated fast synaptic transmission, but this was not definitively shown.

The experiments described in the previous chapter build on the data from Day et al. (2003). Extended training of 2 concurrent paired associates over 8 weeks was carried out using an identical daily protocol to that of Day et al. (2003), but with 2 particular paired associates appearing repeatedly amidst other trial-unique pairs. This repeated training of 2 paired associates resulted in their memory traces becoming independent of AMPA receptor-mediated transmission in the dorsal hippocampus- rats could navigate to either of these 2 cued locations under the influence of CNQX. This has two important implications: the first is that the retrieval of flavour-location paired associates can become independent of the hippocampus- presumably consolidated in higher neocortical structures- if presented repeatedly. The second is that navigation to these repeatedly trained locations when cued with the appropriate food flavour is intact and thus hippocampal inactivation with CNQX does not render rats "lost in space" (Day et al. 2003).

Bast et al. (2005) recently investigated the effects of CNQX and AP5 on trial-unique spatial memory in the event arena, finding similar effects of CNQX and AP5 on trial-unique spatial memory as Day et al. (2003) did on trial-unique flavour-location paired associate memory. Bast et al. (2005) suggest that the dependence of trial-unique spatial memory retrieval on AMPA receptor mediated dorsal hippocampal activity could contribute to the effects of CNQX on trial-unique flavour-location paired associate memory. This is possible, however a few points should be noted. Firstly, trial-unique spatial memory as shown by Bast et al. (2005) took much longer to decay than trial-unique paired associate memory shown by Day et al. (2003). The longest memory retention interval tested in Bast et al. (2005) was 6 hours and rats still showed a significant preference for digging at the rewarded sand-well 6 hours after finding food in it. Day et al. (2003) showed that memory for trial-unique flavour-place associations had decayed to chance levels by a 90 minute retention interval. This infers that trial-unique spatial memory (using a simple match-to-place rule) has different characteristics to cued recall of trial-unique flavour-location paired associates in the event arena.

In the series of experiments presented in this chapter, rats learned repeat-trial flavour-location paired associates and were successfully cued to a repeat-trial location during dorsal hippocampal inactivation. The graph that shows this result (Figure 2.5 on page 59) also shows that while dig time in the non-cued trial-unique sand-well location was at 25%, dig time at the random novel (trial-unique) sand-well was significantly below this. This additional information infers that there may be some residual memory for one-trial location information even after CNQX infusion in paired associate paradigm. If there was no memory at all for having visited the trial-unique sand-well on the probe test, the amount of time spent digging in it should be equal to that spent digging in the random novel location which had never been experienced prior to the probe trial. This is further evidence to suggest that impairment in retrieval of trial-unique flavour-location paired associates is not just secondary to a deficit in trial-unique spatial memory.

Although the confounding effects of spatial memory and its dependence on the rodent hippocampus were controlled for as thoroughly as possible in this series of experiments, it would be very interesting to examine the effects of hippocampal inactivation on a similar cued recall task in which neither of the elements were of a spatial nature. Heron-Maxwell (2002) attempted to develop a task involving the pairing of food flavours with different odours of sand in which the foods were hidden. This was based on the large and flexible capacity of rats for learning about odours without necessarily requiring the role of the hippocampus (Dudchenko et al. 2000). However, this task was unsuccessful, most likely due interference caused by the overlap both behaviourally and anatomically between the olfactory and gustatory systems (Schneider and Pinnow 1994; Mediavilla et al. 1998; Fu et al. 2004; Dardou et al. 2006). Langston and Wood (2004) developed a task in which food flavours were used as one stimulus in a paired associate, as in Day et al. (2003) but instead of being cued to a location by a food flavour, rats were cued to choose from a variety of textured substances and dig through these to find food reward, i.e. the location element of the task was replaced by textured digging substrates (Birrell and Brown 2000). Each textured substrate (e.g. sand, woodchip, gravel) was paired with a different food flavour. Rats were required to dig through a particular substrate when cued by a particular food flavour, with the bowls containing the digging substrates being in locations that changed between trials and therefore were not relevant to successful task performance. This paradigm therefore eliminates the spatial element of the paired associate task (or at least the relevance of the spatial element), but performance levels on the task (based on accuracy in choice of the correct substrate in response to the flavour cue) could not be achieved or maintained at a consistently high enough level to warrant attempts at determining the role of the hippocampus in this task (see Appendix 4 for the poster presentation of this work from SFN 2004).

Another subtle yet very interesting finding from further analysis of these data is that whilst rats were being trained on both repeated-trial and trial-unique flavour-location paired associates concurrently, their accuracy at choosing a location cued with a repeated-trial flavour was significantly lower than when cued with a trial-unique flavour that had only been experienced once before. However on an alternative performance measure- the % of time rats spent digging in the cued (correct) location, these two types of trial did not differ (see Figure 2.4). This implies that the rats made very brief visits to non-cued sand-wells in the repeat-trial condition much more frequently than in the trial-unique condition. However the % time rats spent digging in the cued sand-well in each condition did not differ, indicating that when the rats had located the cued sand-well in the repeat-trial condition, they persisted in digging there just as much as in the trial-unique condition. Thus, it is an impairment in initial choice accuracy that is seen in the repeat-trial condition, not in memory for the cued location as measured by persistence in searching there. It may be possible that this subtle difference, which is seen only in the comparison of different performance measures, may reflect the difference in familiarity and recall, which can be conceived in human terms as being analogous to “remembering” vs. “knowing” where the cued sand-well is located. This is a distinction seen readily in human studies of declarative memory (Yonelinas 1994; Knowlton and Squire 1995; Duezel et al. 1997; Woodruff et al. 2006) and more recently interpreted from rodent studies in the laboratory (Fortin et al. 2004; Eacott et al. 2005). Analysis of the % correct first choice data from the two different types of probe tests (repeated-flavour probe during mixed trial sessions and repeated-flavour probe during repeated trial only sessions) in each of the three drug conditions (CNQX, aCSF and no drug) hinted at an effect of drug condition on the first choice performance (recall accuracy measure) resulting in an impairment of the putative recall measure with CNQX treatment; although this was not consistently statistically significant; in the CNQX condition. As described above, CNQX had no effect on the % dig time that rats spent at the correct sand-well location during the repeated-trial probe tests, in contrast to the results found in the first experiment of Day et al. (2003) in which the retrieval of trial-unique flavour location paired associates was blocked by CNQX.

The results from this chapter, regarded in combination with the previous results from Day et al. (2003) suggest a dissociation of hippocampal involvement in episodic-like (trial-unique) and semantic-like (repeated-trial) memory but also possibly another differential role for the hippocampus in recollection vs familiarity as mechanisms of memory retrieval, both of which are popular hypotheses in human literature on amnesics with hippocampal pathology ((Baddeley et al. 2001), (King et al. 2004)). Although the measures used to assess task performance have resulted in the idea that recollection and familiarity may be dissociable, the event arena flavour-location paired associate task as

it is currently designed does not address this issue explicitly, as separate behavioural responses are not demanded based on whether the rat is using recall or recognition memory. The task does however elegantly separate the idea of episodic-like and semantic-like memory in the laboratory rat within the same behavioural task.

Thus, the event arena offers a valid test of associative cued recall in animals. The protocol could make it valuable as an animal analogue of a diagnostic test for mild Alzheimers disease and to analyse further the neural mechanisms of episodic-like memory.

## **Chapter 3**

# **Semantic schema and paired associate memory consolidation**

### 3.1 Introduction

The series of experiments in Day et al. (2003) established a novel protocol for examining paired associate learning- a commonly used episodic memory test in humans- in the laboratory rat. Rats could learn flavour-location paired associates on a trial-unique (episodic-like) basis and retrieval of these paired associates, perhaps by a cued recall mechanism, was dependent on a functioning (dorsal) hippocampus. The previous chapter of this thesis described that repeat-trial (semantic-like) paired associates could also be learned using the same protocol and these were insensitive to hippocampal inactivation at retrieval based on the measure of persistence of rats to dig in the correct sand-well on non-rewarded probe tests.

Tse (2005) described the training of rats on a concurrent set of 6 repeat-trial flavour-location paired associates in the event arena apparatus with the aim of observing a gradual, semantic-like learning process and hopefully a longer-lasting memory trace than that found with the protocol used by Day et al. (2003). This was to allow further dissociation of the mechanisms of encoding, storage and retrieval of declarative memory, and perhaps offer the opportunity to “boost” episodic memory by providing rats with a relevant semantic-like framework within which to encode new information, as has been shown very recently in a human case of developmental hippocampal pathology (Brandt et al. 2006). This idea is based on the classical psychological concept of mental schemas in human memory organisation (Eldridge et al. 1994) whereby information is more readily learned and remembered if it can be assimilated into a pre-existing framework of relevant semantic knowledge. Training of rats to asymptotic performance on a repeated set of 6 flavour-location pairs may result in the creation of a mental schema, if such a thing exists in rats, in the form of a “flavour map”. The mental schema concept implies that if the relevant schema (i.e. the appropriate flavour map) is activated, we should see some evidence of facilitation of new learning within the context of the schema. This could be displayed in a number of ways, but the experiments in Tse and Langston et al (2007) and this chapter were designed primarily to examine the possibility of extending the length of the memory (Tuckey and Brewer 2003) for newly learned trial-unique paired associates in order to allow manipulation of the hippocampus during different memory processing stages after learning.

In the first experiment of Tse (2005), rats showed gradual learning of a flavour map consisting of 6 concurrently trained flavour-location associations and, once performing at apparently asymptotic levels (after 13 training sessions given on alternate days), showed correct retrieval of the associated location when cued with its corresponding flavour at a

memory delay of 24 hours after the previous training trial as assessed by the % time spent digging at the correct (cued) location in a non-rewarded probe test. Once the flavour map was acquired rats showed rapid learning of new flavour-location pairs with just a single exposure to them- these pairs were analogous to the trial-unique paired associates that rats in Day et al. (2003) learned from the outset of training. Memory for the newly acquired paired associates was intact after a 24 hour delay, so this memory was much longer lasting than in Day et al. (2003), where trial-unique paired associates were forgotten after less than 90 mins. This implies that the training of 6 concurrent flavour-location pairs, perhaps resulting in the formation of a putative flavour map schema, had boosted the strength of the memory trace formed after experiencing flavour-location pairs for just one trial.

In a further experiment, lesions of the entire hippocampus made 48 hours after exposure to novel trial-unique flavour-location paired associates and paired associates from the original flavour map resulted in no deficits in memory of the original flavour map or of the novel trial-unique flavour-location pairs in non-rewarded probe tests scheduled 2 weeks later after recovery from surgery. Since the standard model of memory transfer or consolidation from the hippocampus to neocortical sites of long-term storage would predict a much longer time scale, stretching in humans to decades for this process to occur following the encoding of new information (Squire and Alvarez 1995), these new data support the schema hypothesis which would predict accelerated or facilitated processing of memory for episodic-like unique information if this information was associated with a previously learned schema (Eldridge et al. 1994). In a later experiment not reported in this chapter, Tse and Langston et al (2007) showed that the schema or map of flavours with their associated locations was essential to the facilitation of the memory for trial-unique flavour location pairs: by training some rats on the previously described flavour map and others on a purely spatial schema in which food flavours were not always rewarded at the same locations throughout training. Rats trained on inconsistent pairs of flavours and locations could not remember a trial-unique novel pair after a 24 hour delay whereas rats trained on a standard flavour map could. This data adds support to the hypothesis that the presence of the activated learned flavour map schema of 6 consistent paired associates was instrumental in the improved memory performance on tests of the trial-unique flavour-location pairs.

Tse and Langston et al (2007) showed that after lesions of the hippocampus, rats could not learn any new flavour-location pairs either within the original flavour map on a trial-unique basis or in a completely new context when trained repeatedly on a new set of six concurrent flavour-location pairs, whereas control rats were unimpaired on all of the

above. Schema learning in this task was also highly context specific (Hirsh 1974)- no evidence of a learning set was shown by experienced control rats when trained on a new schema- they take the same amount of time to learn it as they did the original schema. This supports the standard theory of hippocampal function in memory to the extent that the hippocampus is still necessary for the encoding of declarative memories, but may have a temporary role in their consolidation and/or retrieval and this data provide new evidence that this time period can in fact be much shorter than traditionally thought (less than 48 hours). It is also possible that the learning of a flavour map of multiple flavour-location paired associates is not necessarily always dependent on the hippocampus: the previously described experiments involved the removal of the hippocampus after a flavour map had already been learned. Rats were presented with new flavour-location pairs after the removal of the hippocampus and did not show memory for them, but it is likely that they would fail at this point due to the neurobiological pathways which were used to learn the original task (likely involving the hippocampus) having been disrupted by the lesion and no compensatory mechanism or strategy having taken over. It is possible (although unlikely) that over the relatively prolonged training period for the learning of a flavour map (13 sessions on alternate days, with each of the 6 flavour-location pairs being experienced once during each session) rats could develop a hippocampus-independent strategy for learning it. This could be based on perhaps 24 individual stimulus-response rules (4 responses for each of 6 flavours- one response for each possible start position from which the rat would have to travel to the appropriate location). To test this theory of an alternative hippocampus-independent learning strategy, the first experiment in this chapter reports rats that were given complete lesions of the hippocampus before training, at which point they had no experience of the event arena apparatus or indeed of any behavioural testing which may have artificially prompted the use of a hippocampus-dependent learning strategy. This experiment aimed to test whether the role of the hippocampus was truly critical to the learning of a flavour map. This investigation was partly fuelled by human literature which suggests that some patients with relatively selective lesions to the hippocampus can still encode new semantic (factual) information learned over a prolonged time period (Mishkin et al. 1997). It is not yet known whether it is truly the case that the hippocampus is not required for forming new semantic memories or whether, in patients where this appears to be the case, there are actually residual portions of hippocampal tissue performing a semantic learning and memory function.

Another separate possible interpretation from the data presented so far is that the hippocampus has no function in the consolidation or retrieval of episodic-like or trial-unique information when a semantic-like schema is already present (presumably in neocortex),



and that its only critical role is during encoding. The second experiment in this chapter aimed to examine further the possible time-dependent role of the hippocampus in the processing of novel episodic-like memory in the presence of a semantic-like schema more closely. Rats learned a flavour map and were then given lesions of the whole hippocampus either 48 hours after the encoding of novel flavour-location associations, as previously described in Tse (2005) or 3 hours after to see if the hippocampus was involved in consolidation of the memory during a shorter time period (less than 48 hours) after experiencing a novel flavour-location pair or if in fact it was never necessary for this encoding in the presence of an activated learned flavour map schema.

This chapter also introduces a new behavioural measure (Tse and Langston et al 2007) for assessing the performance of rats in this task which provides more flexible and meaningful information per trial about the accuracy of the choice of sand-well, possibly reflecting a more robust measure of recall than that used in Day et al. (2003). This measure was the number of errors made (i.e. the number of incorrect sand-wells rats dug in) before choosing the correct sand-well (primary error measure: chance = 2.5 errors with 6 sand-wells present). This was also converted to a performance index ( $100 - 100 * (\text{errors} / 5)$ ) presented as a %. This new measure still aims to represent recall accuracy, as it is based on which order sand-wells were dug in regardless of how long the rats persisted in digging at them, but it gives more information per trial than the previous measure used in Day et al. (2003), as the number of wrong choices, rather than just whether or not the rat made the correct choice, are taken into account. Due to the suggestive results from the previous chapter which hinted that the measures of correct first choice of sand-well and % dig time in the correct sand-well may not be equivalent and may even reflect different types of memory processing, we aimed to characterise more accurately the data on choice of sand-wells as a putative measure of cued recall.

The data from Tse (2005), alongside the data from this chapter, have recently been published as a Research Article in Science Magazine (Tse and Langston et al 2007) which is included as Appendix 2.

## 3.2 Materials and Methods

### 3.2.1 Subjects

The subjects were adult male Lister-hooded rats (Charles River, UK), aged 8-10 weeks at the start of experimentation and weighing 200-250g. They were housed in groups of 3/4 rats in cages with opaque white plastic bases measuring 35 x 50 x 15 cm (width x length x height) fitted with wire mesh lids (15 cm high) bringing the total height of each cage to approximately 30 cm. They had free access to water at all times and were maintained at at least 85% of their free-feeding weight throughout behavioural testing. For a 12 day recovery period after lesions of the hippocampus rats were given unrestricted access to food. Experiment 1 was conducted on a 12 hr (on)/12 hr (off) light cycle, with training during the light phase (8am-8pm). Experiment 2 was conducted using a reverse day/night cycle of the same length, with training during the night phase (8am-8pm). A total of 32 rats were used (Experiment 1:  $n = 12$ ; Experiment 2:  $n = 20$ ). All procedures were compliant with the national Animals [Scientific Procedures] Act of 1986 and international European Communities Council Directive of 24 November 1986 [86/609/EEC] legislation governing the maintenance of laboratory animals and their use in scientific experiments. All efforts were made to minimize the number of rats used and their suffering.

### 3.2.2 Apparatus

A full description of the event arena in which rats were trained to find flavoured food is provided in Section 2.2.3 so this section will just describe the differences in the apparatus between the previous chapter and this one. The 4 start boxes were covered with black paper to make them dark inside to encourage the rats to return to them and treat them as a "home base". The sand-wells were 4cm deep with a removable metal mesh grid fixed half way down. The area above the grid was filled with a mixture of 90g sand plus ground-up food (25g per 2.5kg sand) which included all the flavours used in the experiments. When food reward was made available in a sand-well, 3 pellets (0.5g each) of the appropriate flavor rested on the upper surface of the metal grid under the sand layer. The sand and food mixture was renewed every 2/3 days. The area below the grid was filled with a mixture of food pellets which also included all the flavours being used during the experiments. Flavoured food was made available to the animals in a small plastic bowl in the start-boxes (as a cue to determine which flavour they should search for in the sand-wells of the arena) and in addition, each start-box contained water for drinking. A photograph of the arena configured for the experiments in this chapter is

provided in Figure 3.1 on page 76.

### 3.2.3 Surgery

Complete hippocampus lesions (HPC lesions) were made bilaterally by stereotaxic injection of ibotenic acid throughout the entire hippocampus, including dentate gyrus and CA fields. Sham operated control rats (sham controls) received anaesthetic, surgery including removal of a large section of the skull and piercing of the dura, but no injections. Anaesthetised control rats (Experiment 2 only) were anaesthetised for the same time period as rats receiving complete hippocampus lesions, but did not undergo any invasive procedures. The number of surgeries was: Experiment 1: HPC  $n = 6$ , Sham  $n = 6$ ; Experiment 2, HPC  $n = 12$ , Sham  $n = 8$ . The actual surgical procedure was as described previously in 4.2.2 on page 105. Thirteen (Experiment 1) or fifteen (Experiment 2) injections of ibotenic acid were made into each hippocampus at different rostrocaudal and dorsoventral levels: the co-ordinates were modified for Experiment 2 to account for the larger size of the rats at the time of surgery due to the length of time they had been undergoing training (see Table 3.1 on the next page). Each rat received 0.03ml carprofen analgesia (Small Animal Rimadyl, Pfizer, UK) in 5ml saline subcutaneously at the end of the procedure. Analgesia was also administered in oral form in the rats' water supply. This analgesic solution was freely available to all rats from 24 hours pre-surgery until 96 hours post-surgery. Food restriction began 12 days into the post-operative recovery period, and behavioral testing recommenced after 14 days.

### 3.2.4 Perfusion, Histology and Lesion Analysis

All rats were terminally anaesthetised with 1.4 ml/kg sodium pentobarbital then perfused intracardially with 0.9% saline followed by 4% formalin. The brains were removed and stored in 4% formalin for a minimum of 24 hours, then placed into cuboid moulds filled with fresh egg yolk and incubated at 37°C in a shallow 4% formalin bath for a further 24 hours. The egg coating solidified around the brains in a cube shape which was designed to provide extra support for the lesioned brains while they were being sectioned, because they become very fragile after losing the large central portion comprising the hippocampus. The brains with the egg-yolk coating were then removed from the plastic moulds and placed back into jars of 4% formalin for a further 48 hours. Coronal 30 $\mu$ M sections were cut using a cryostat with one in every five sections recovered for histological analysis. These sections were mounted on slides, stained with cresyl violet and cover slipped using DPX. The extent of the lesions was assessed by calculating the

**A** Complete hippocampus lesion co-ordinates for Experiment 1  
Mean weight of subjects = 289g

AP	ML	DV	uL ibotenic acid (10mg/ml)
-2.4	+/- 1.0	-3.0	0.05
-3.0	+/- 3.0	-2.7	0.10
	+/- 1.4	-2.1	0.05
		-2.9	0.05
-4.0	+/- 3.7	-2.7	0.10
	+/- 2.6	-1.8	0.05
		-2.8	0.05
-4.3	+/- 4.0	-7.0	0.05
-4.9	+/- 3.9	-3.5	0.05
		-7.0	0.10
-5.9	+/- 5.1	-4.5	0.08
		-5.3	0.08
	+/- 4.3	-3.9	0.10

**B** Complete hippocampus lesion co-ordinates for Experiment 2  
Mean weight of subjects = 460g

AP	ML	DV	uL ibotenic acid (10mg/ml)
-2.4	+/- 1.0	-3.0	0.05
-3.0	+/- 3.0	-2.7	0.10
	+/- 1.4	-2.1	0.05
		-2.9	0.05
-4.0	+/- 3.7	-2.7	0.10
	+/- 2.6	-1.8	0.05
		-2.8	0.05
-4.3	+/- 4.0	-7.0	0.05
-5.0	+/- 3.0	-3.0	0.10
	+/- 3.9	-7.0	0.10
	+/- 5.4	-5.1	0.10
-6.1	+/- 3.9	-3.6	0.05
		-7.0	0.05
	+/- 5.0	-4.5	0.05
-6.6	+/- 4.6	-4.6	0.05

**Table 3.1:** Complete hippocampus lesion co-ordinates

volume of hippocampus spared in each of the brains (DG and CA fields). Each coronal section was placed under a Makroscope and the image transferred to a computer using a camera. The images could then be opened in Leica QWin software and the calibrated area measurement tool in the program allowed calculation of the amount of hippocampus tissue remaining in each brain section, with the program recording the size of the area in mm<sup>2</sup>. The brain sections from control rats were measured in this way to give a standardised value (i.e. an intact hippocampus with no lesion, 100%). The sum of all the areas of hippocampal sparing in each of the lesioned rats (i.e. the overall volume of sparing) was then compared with the average value for all control rats to calculate a % sparing of hippocampus tissue.

### 3.2.5 Behavioural Testing

The key difference between this series of experiments and those described in the previous chapter is that in this protocol rats were trained on 6 flavour-location paired associates concurrently, which remained constant each day- a flavour map (see Figure 3.1).

A) Photograph of the event arena configured as a flavour map

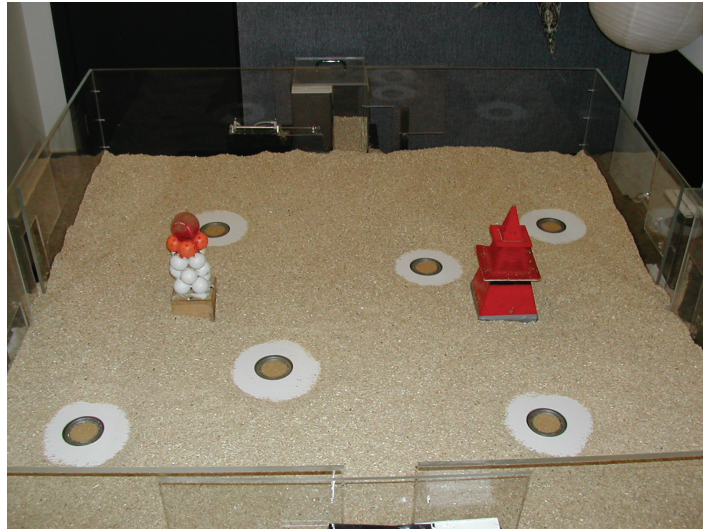

B) Schematic of the flavour-location paired associates depicted above

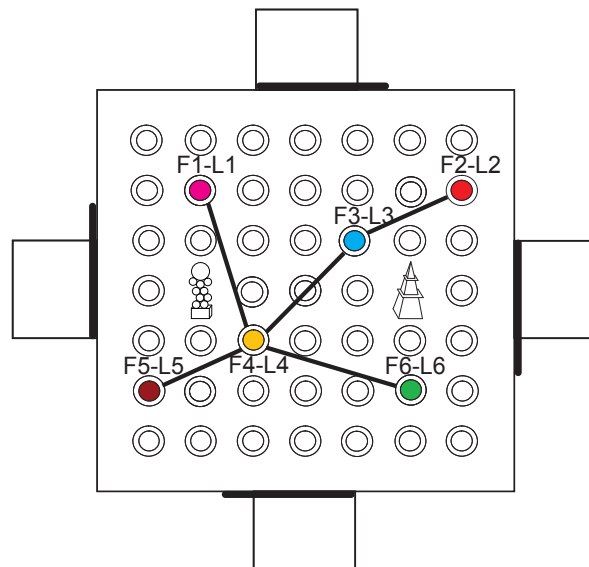

**Figure 3.1:** Photographic (A) and schematic (B) representation of the original flavour map used to train rats initially. F1-L1 = Rum at R2/C2, F2-L2 = strawberry at R2/C7, F3-L3 = ginger at R3/C5, F4-L4 = banana at R5/C3, F5-L5 = very berry at R6/C1 and F6-L6 = bacon at R6/C6.

Habituation is described in the sections below referring to each of the individual experi-

ments. Each training session consisted of one trial on each of the 6 flavour-location pairs in a pseudo-randomised order of presentation, and training sessions were scheduled at 24 or 48 hour intervals. On each trial, a rat was placed into one of the start boxes and given a 0.5g cue pellet of one of the 6 flavours. 30 secs after eating the food, the start box door was opened and the rat released into the arena. All of the 6 sand-wells that were to be associated with the 6 flavours were open and available for digging, but only the one associated with the cued flavour given in the start box contained food reward. (Rats had no prior training on which location was associated with which food flavour before the first trial.) The rewarded sand-well contained three 0.5g food pellets on each trial and rats were always allowed to return twice to the correct sand-well after they had initially located it, to retrieve all 3 pellets of food. After the rat returned to the start box with the third food pellet, the start box door was closed. When the rat had finished eating the final pellet, it was replaced in home cage. The following 5 trials- one trial on each of the remaining flavour-location pairs- occurred at approximately 60 min inter-trial intervals. To prevent the rats using olfactory traces from a previous rat to locate the reward, the sand used in the wells in different locations was mixed between each trial and the sawdust surrounding each sand-well distributed around the arena between trials. None of these manipulations affect performance. The experimenter conducting the behavioral training (IB/RFL/DT) was blind to which rats had hippocampus lesions and which were sham controls. The different timetables and training protocols are described below for each experiment.

### 3.2.6 Non-rewarded probe tests

During these tests, scheduled regularly throughout the 4 experiments, all six sand-wells were open and the rats could dig in any of them, but none contained food reward. The rats were cued with a single flavor as usual, and then allowed into the arena for a total of 120 secs, with memory performance measured as preferential digging at the cued location. These probe tests served as a control for odour confounds- the lack of food in the sand-wells precluded any specific olfactory guidance to the correct location.

### 3.2.7 Performance measures

During each trial several parameters were measured:

**Number of errors** The number of incorrect sand-wells rats dug in before choosing the correct sand-well (primary error measure: chance = 2.5 errors; conversion to a Perfor-

mance Index =  $100 - 100 * (\text{errors} / 5)$ ).

**latency to dig** Latency to dig at the correct well from leaving the start box in seconds.

**% dig times** The time spent digging in seconds at each of 6 sand-wells, calculated as the proportion of time spent at cued and non-cued locations.

The experimenters recorded a 'choice' only when a rat placed its front paw on or into a sand-well. Rats running past or sniffing around a sand-well were not considered as making a choice. In rare cases, it was difficult to tell from the video monitors whether or not the rats had made a choice as defined here. In this situation, when an experimenter entered the room at the end of a trial, they could check carefully if there were any traces of digging (i.e. whether the sand had been displaced around an ambiguous sand-well) and could also review the video footage from any trial, although this was not usually necessary.

### Experiment 1

The aim of this experiment was to establish whether the concurrent learning of 6 flavour-location paired associates requires the integrity of the hippocampus. Rats were given either complete hippocampus lesions ( $n = 6$ ) or sham surgeries ( $n = 6$ ) upon arrival, before any experience of the event arena.

**Habituation** 12 days after recovery from surgery, rats were habituated to the event arena and trained to search and dig for control (non-flavoured) food pellets in the sand-wells as in the previous chapter. In this series of experiments there were always 3 0.5g (half) pellets available in a rewarded sand-well. Rats learned to carry the 0.5 gm pellets to the start box, and eat them there before returning to retrieve further pellets. Habituation consisted of a series of stages across days, allowing exploration of the arena and its cues, experience of each of the 4 start-boxes, digging for food in various sand-well locations, and carrying pellets to the start boxes. By the end of habituation, all rats were running quickly into the arena, collecting food and returning to the start boxes to eat each pellet. There were 6 habituation sessions, shown at the beginning of the timeline of the full experiment in Figure 3.2 on the next page.

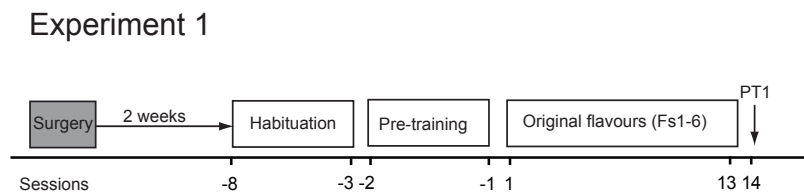

**Figure 3.2:** Timeline of sessions in Experiment 1

**Training of paired-associates** The key feature of the protocol was the training of multiple flavour-place paired associates simultaneously. During 2 pretraining sessions rats received 3 trials per session, in which 3 of the 6 flavors were used each day. After these 2 pretraining sessions, all 6 flavours were trained, each flavour for 1 trial/session throughout the 13 sessions of acquisition (see Figure 3.2) with Flavour 1 (F1) at Location 1 (L1) (Rum), F2/L2 (Strawberry), F3/L3 (Ginger), F4/L4 (Banana), F5/L5 (Very Berry) and F6/L6 (Bacon). On any trial, all 6 sand-wells were available, but only the sand-well in the location associated with the cued food flavour contained the food rewards. The rats were run on alternate days in 2 groups of 6 rats each (3 lesioned and 3 control rats in each group) with each group receiving 3 training sessions per week. The various possible sequences of different flavored pellets across 6 trials within a session were carefully counterbalanced across rats and sessions. In addition, half the rats were cued from one start box (e.g. South) while the other half were cued from a different start box (e.g. North) for all of their trials within a session. The start locations were then pseudo-randomly assigned (N, S, E or W) across training sessions. On day 14, a non-rewarded probe test was scheduled.

## Experiment 2

The main aim of this experiment was to examine the time course over which 2 trial-unique flavour-location paired associates become independent of the hippocampus. Intervals of 3 hours and 48 hours (the latter interval was used in Tse and Langston et al (2007), by which time trial-unique paired associates did become hippocampus independent, see Introduction) were used between the encoding experience of a novel, trial-unique flavour-location paired-associate and hippocampus lesion surgery. The (rather complex) experimental design is shown in Figure 3.3 on the next page. This experiment



used a reverse day-night cycle with all testing during the night phase in order to minimize the likelihood of sleep episodes between the end of the novel paired-associate encoding experience and the time of lesion for the rats in the 3 hour interval group.

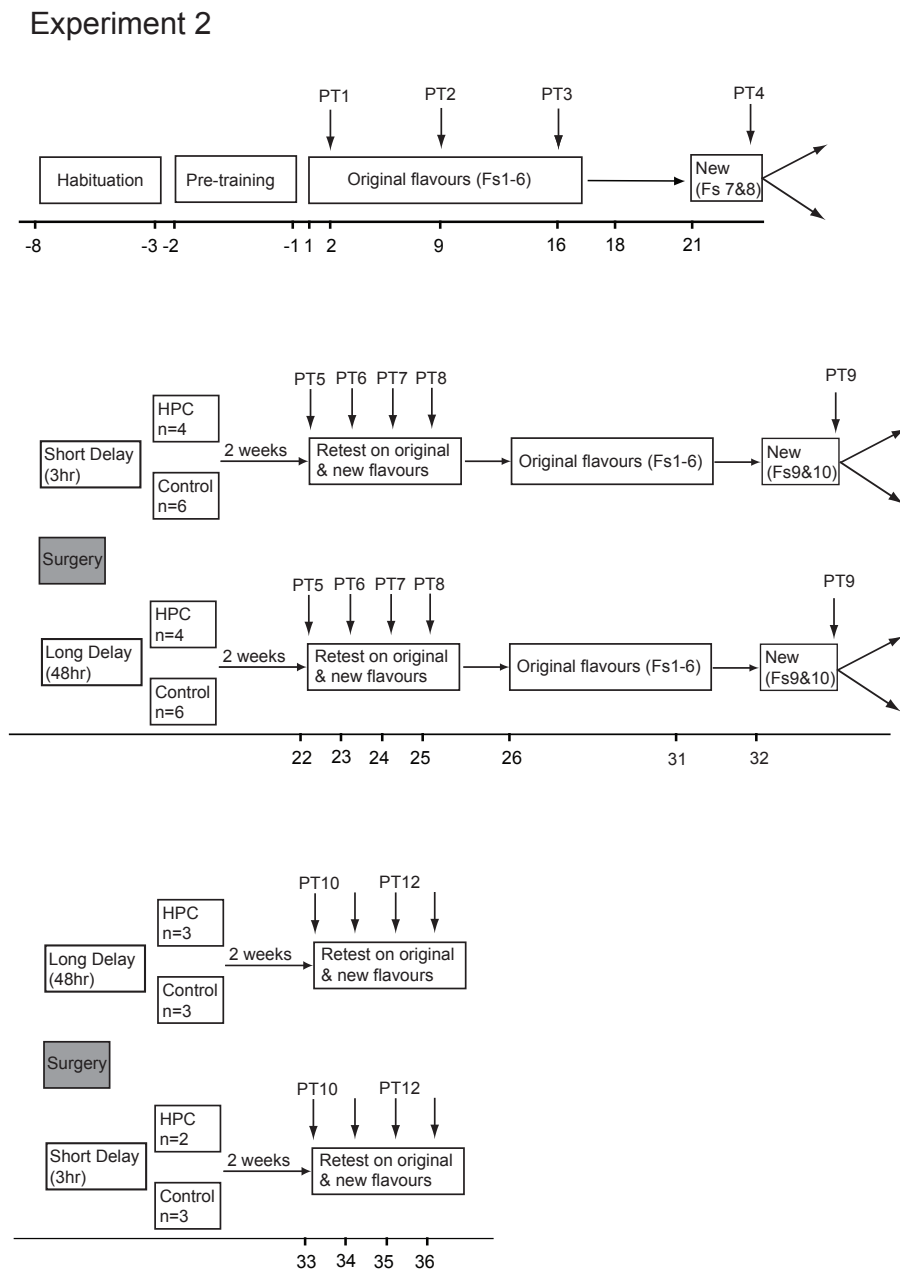

**Figure 3.3:** Timeline of sessions in Experiment 2

20 intact rats were habituated as described for Experiment 1 (with the exception that

no surgery took place before the start of the experiment), then trained on the same set of 6 flavour-location paired associates in the same geometric arrangement as used in Experiment 1 (see Figure 3.1 on page 76). They were subjected to non-rewarded probe tests on Sessions 2, 9 & 16. After 4 more standard training sessions, the sand-wells for F1-L1 (rum at R2/C2) and F6-L6 (bacon at R6/C6) were replaced by two new novel flavours, F7-L7 (marshmallow at R1/C2) and F8-L8 (apple at R7/C6) on Session 21. Rats were trained for 6 trials in a single session with the 2 novel flavours introduced in the 4th (either F7-L7 or F8-L8) and 5th (vice versa) trials of the session. 1 hour after the last training trial (trial 6, an original flavour map trial), a probe test (PT4) was given for the novel flavour-location paired associate experienced on the 4th trial (this was F7-L7 for half of the rats and F8-L8 for the other half, and the probe trial was 3 hours after the rats had first experienced the flavour being tested).

One hour after the end of the probe test, half of the rats ( $n = 10$ ) were anaesthetised and underwent either complete hippocampus lesion surgery ( $n = 4$ ) or served as anaesthetised controls ( $n = 6$ ). These rats therefore received surgery (or anaesthetic only) exactly 3 hours after they had experienced their first novel flavour-location pair on trial 5. The other half of the rats ( $n = 10$ ) received hippocampus lesions ( $n = 4$ ) or anaesthetic only ( $n = 6$ ) 48 hours after trial 5<sup>1</sup>.

Post-operative non-rewarded probe tests were scheduled (PTs 5-8, Sessions 22-25) to test memory for the original and newly trained flavour-location paired associates. For the subset of rats which had received complete hippocampus lesions during this first surgery session ( $n = 8$ ), this was the end of the experiment<sup>2</sup>.

The 12 rats that had served as anaesthetized controls continued training on the remaining 4 original flavour-location pairs (Fs 2-5) plus the recently learned trial-unique flavour-location pairs (Fs 7 & 8) for a further 6 sessions (Sessions 26-31). They then experienced 2 more new trial-unique flavour-location paired associates: F9-L9 (anise at R2/C3) and F10-L10 (butter at R6/C5), at adjacent but distinct locations to F7-L7 and F8-L8 which were removed. The rats were trained for 6 trials in one session (Session 32), with Fs 9 & 10 experienced in the 4th and 5th trials and a probe test (PT9) scheduled 1 hour after the

---

<sup>1</sup>This complex experimental design with very specific demands for surgery time meant that from the start of the experiment, training was staggered so that the new flavour and surgery sessions occurred on different actual days: the amount of surgery space and surgeons (just me!) meant that this was the only feasible way to run the experiment. Assignment to surgery groups was initially done using % dig time performance on the final probe test of the original flavour map, before the introduction of the new flavours (PT3, Session 16) so that the average performance of rats in each surgery group was matched. It was then adjusted if necessary by monitoring the performance of rats on the 1 hour probe test for the novel, trial-unique pairs (PT4, Session 21) as they completed this test.

<sup>2</sup>these rats were not sacrificed at this point, but remained on food deprivation and housed with their companions so as not to disrupt the other rats' social situation.

last training trial and 3 hours after the new flavour-location pair was experienced in trial 4.

The 12 rats were then divided again into 2 further groups with a 3 hour ( $n = 6$ ) or a 48 hour ( $n = 6$ ) interval between the first experience of the novel flavour-location paired associates (Fs 9 or 10, trial 5) and the surgery, as described previously. In the 3 hour interval group, 2 rats received hippocampus lesions (1 rat died 2 hours after surgery) and 3 rats received sham surgeries. In the 48 hour interval group, 3 rats received hippocampus lesions and 3 received sham surgeries.

After a 14-day recovery period, a series of non-rewarded probe tests was scheduled (PTs 10-13, Sessions 33-36) to test the original and new flavours as had been done after the first surgery session. After these probe tests all the rats were sacrificed.

This partially within-subjects design meant that data could be acquired in 2 different conditions from the 12 rats that underwent anaesthetic only and no lesion during the first surgery epoch after Session 21 (PT4). Thus, from a starting group of 20 rats, the final group sizes which were made up partially from within subjects data and partially from between subjects data were comprised of data from 6 rats in the 3 hour lesion group (short delay lesion, SDL); 7 rats in the 48 hour delay lesion group (long delay lesion, LDL) and 9 rats in each of the control groups (3 anaesthetised controls and 6 sham lesioned controls in each of the short and long delay control groups (SDC and LDC respectively)). Group was treated as between subjects factor for the purposes of statistical analysis.

### 3.3 Results

#### 3.3.1 Experiment 1

##### Learning a map of 6 flavour-location paired associates requires the hippocampus

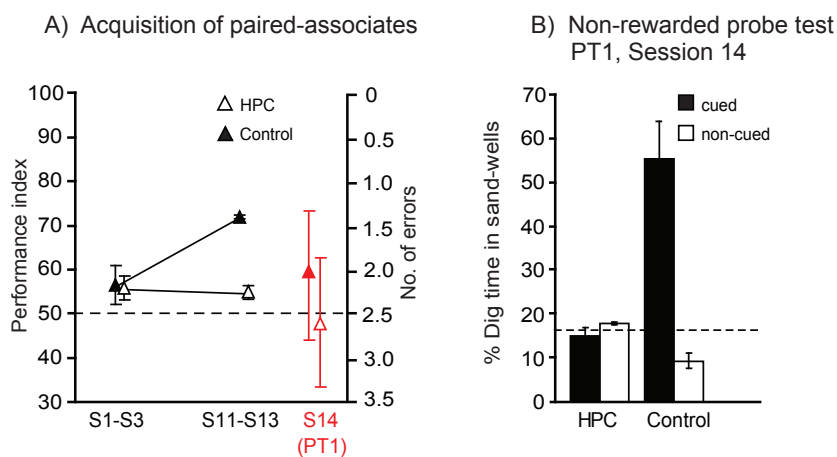

**Figure 3.4:** Effects of pretraining lesions of the hippocampus on acquisition of the task: Acquisition of a flavour map depends on the integrity of the hippocampus. Panel A shows that the performance index improved for the sham control group but not the hippocampus-lesioned (HPC) rats over the 13 sessions of training. Panel B shows preferential digging at the cued sand-well during a non-rewarded probe test (PT1) by sham but not HPC rats. The white bars represent an average of the total time spent digging in the 5 non-cued sand-well locations. Dashed line = chance level, 16.7%.

Rats in this experiment received either sham operations or complete hippocampus lesions before the start of training. The lesions successfully targeted the hippocampus with minimal damage to other structures. The average amount of spared hippocampus tissue in the lesion group ( $n = 6$ ) in this experiment was  $9.67 \pm 6.94\%$ . More details about the histological results are available at the end of this chapter. During the first few days of training, rats were procedurally inexperienced and had also not yet learned to go to the correct sand-well in response to the flavour cue, so trials could take up to 10 minutes per rat. Over the course of training it was observed that trials became quicker in both groups of rats, reaching an asymptote of 3–4 min per trial. The 12 rats were run on alternate days in 2 groups of 6 rats each (3 lesioned and 3 control rats in each group) with each group receiving 3 training sessions per week. As all 6 rats were run consecutively, the intertrial interval for an individual rat between successive flavour-place pairings was around 1 hour,

resulting in a total daily session time of up to 6 hours. This intertrial interval was kept constant throughout the experiments described in this chapter. The rats visited and sometimes dug at incorrect sand-wells before they found the correct one (see Appendix 5 for a video clip of a rat performing a choice trial). Typically, the animals would retrieve the first of three buried food pellets, return to the start box to eat it, and then run back to the correct sand-well to collect the second and third pellets. The choice accuracy (measured by number of errors) improved only for the sham operated rats (sham) as they learned to associate a specific flavour cue with a specific sand-well location (see Figure 3.4A). After 13 sessions of training, sham lesioned rats (sham) were making fewer approaches to incorrect sand-wells before digging in the correct well, whereas the hippocampal lesioned rats (HPC) did not improve. ANOVA showed a Group (HPC vs. sham)  $\times$  Session (1-13) interaction,  $F_{(1,10)} = 9.42; p < 0.025$ . A single non-rewarded probe trial was then scheduled (Session 14) which started with the provision of one cue flavour in the start-box. An independent samples t-test showed that the sham rats spent significantly more time digging at the cued location than the HPC rats ( $t_{(10)} = 5.25; p < 0.001$ ). One sample t-tests against chance (16.7%) showed that sham rats dug at the cued sand-well significantly more than expected by chance ( $p < 0.005$ ) but HPC rats did not ( $p > 0.05$ ). These data are shown in Figure 3.4B. Interestingly, analysis of the performance index as measured by the number of errors made on this probe trial (see Figure 3.4A) showed that the sham rats performed no differently to the HPC lesioned rats on this measure (independent samples t-test,  $p > 0.10$ ) and that neither group performed significantly above chance (one-sample t-tests, both ( $p > 0.05$ )). This was unexpected considering the significant increase in performance index/number of errors made over the course of the thirteen training sessions to levels well above chance by the sham rats. This measure was examined further during the next experiment.

We can conclude that this is a hippocampal-dependent paired-associate task in which rats learn to retrieve the memory for the spatial location of a specific flavour of food when cued with that particular flavour of food. Rats with the whole hippocampus removed by excitotoxic lesion prior to training failed to acquire the task and their performance remained at chance levels. Rats with sham lesions appeared to learn the task over thirteen training sessions based on the number of errors made (number of incorrect sand-wells dug in before digging in the correct one) but their performance dropped based on this measure during a non-rewarded probe test with no food present in any of the sand-wells. The levels of performance based on % of time spent digging in the correct sand-well during the probe test however reflected the acquisition data over sessions 1-13 in that the sham rats but not the hippocampus lesioned rats spent significantly more time searching for the food reward at the correct sand-well. The unexpected difference between results

assumed from the different performance measures will be discussed later.

### **3.3.2 Experiment 2**

It may be helpful to refer back to the complex partial within-subjects design presented in Figure 3.3 on page 80 in order to interpret the results of this experiment. The reversed day-night cycle in this experiment did not appear to affect the rats' performance relative to that seen in Tse and Langston et al (2007) Experiment 2, based on the performance index during the first 13 acquisition sessions and the % correct dig time in Probe Test 3 which can be seen in Tse and Langston et al (2007) Figure 2A&B.

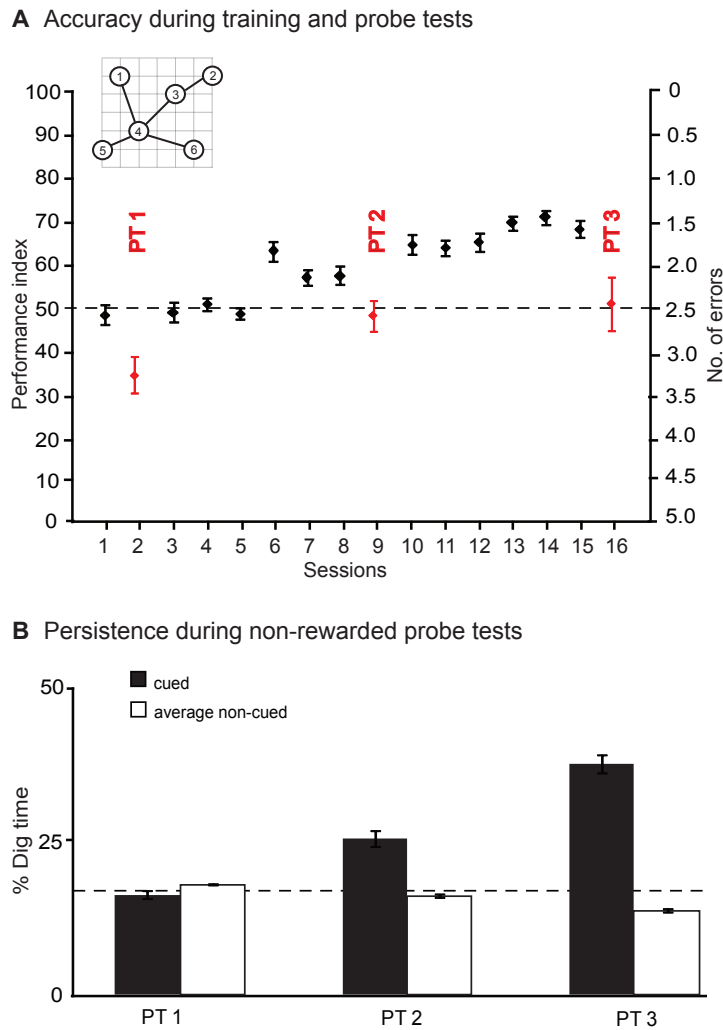

**Figure 3.5:** Acquisition of 6 concurrently trained paired associates as assessed by performance index and dig time. Panel A shows the performance index over 13 acquisition sessions interspersed with 3 non-rewarded probe tests (shown in red). Chance performance level (50% or 2.5 errors) is shown by the dashed line. The schematic in the top left corner shows the layout of the 6 flavours of the original flavour map. Panel B shows the % time spent digging in the correct (cued) vs. incorrect (average of 5 non-cued) sand-wells over 3 probe tests scheduled on Sessions 2, 9 and 16 of training. Chance level (16.7%) is shown by the dashed line.

The acquisition of the flavour map by the 20 unoperated rats over Sessions 1-16 of training is shown in Figure 3.5A. Performance on standard training sessions indicated that rats were improving over days. A repeated measures ANOVA with performance index over sessions as the within subjects factor showed a significant main effect of session ( $F_{(12,228)} = 21.537; p < 0.001$ ). Non-rewarded probe tests (PT1, 2 and 3) scheduled on sessions 2, 9 and 16 were assessed by the % time rats spent digging in the correct

(cued) sand-well during the 60 second test. A repeated measures ANOVA with % correct dig time over the 3 probe test sessions showed a significant main effect of probe test ( $F_{(2,38)} = 86.390; p < 0.001$ ). Bonferroni corrected paired t-tests on % dig time in correct (cued) vs incorrect (non-cued) sand-wells on each probe test showed that rats dug preferentially in the correct sand-well on PT2 and PT3 (both  $p < 0.001$ ). Further one-sample t-tests showed that % dig time in the correct sand-well was significantly greater than chance on PT2 and PT3 (both  $p < 0.001$ ) whereas the % dig time in the incorrect sand-well in these probes was significantly lower than chance (both  $p < 0.001$ ).

Although the acquisition of the task on standard training sessions as measured by the performance index indicated learning over days, as did the % correct dig time in probe tests PT1-3, the performance index on the probe test sessions was much lower than that on standard sessions and showed no improvement over the 3 probe test sessions. Repeated measures ANOVA on the dig time data across the 3 probe tests showed no main effect of session ( $F_{(2,38)} = 0.558; p = 0.557$ ). This discrepancy between the standard and probe test sessions using the same measure was similar to that seen in Experiment 1 and in the probe tests for the new flavours (F7-F10) in this experiment (see next paragraph). Thus, the combined results from both experiments suggest that rats may have been using a subtly different strategy to solve the task when there was food present in the sand-wells compared to when there was not. This caveat of the performance index measure is discussed in the conclusion to this chapter in relation to its possible explanation when both experiments 1 and 2 are taken into consideration. The remaining results in this chapter are based on the interpretation of the % correct dig time measure as the performance index based on number of errors remained at chance levels in all further probe tests independent of new vs. old flavour, lesion vs. control and short vs. long delay.



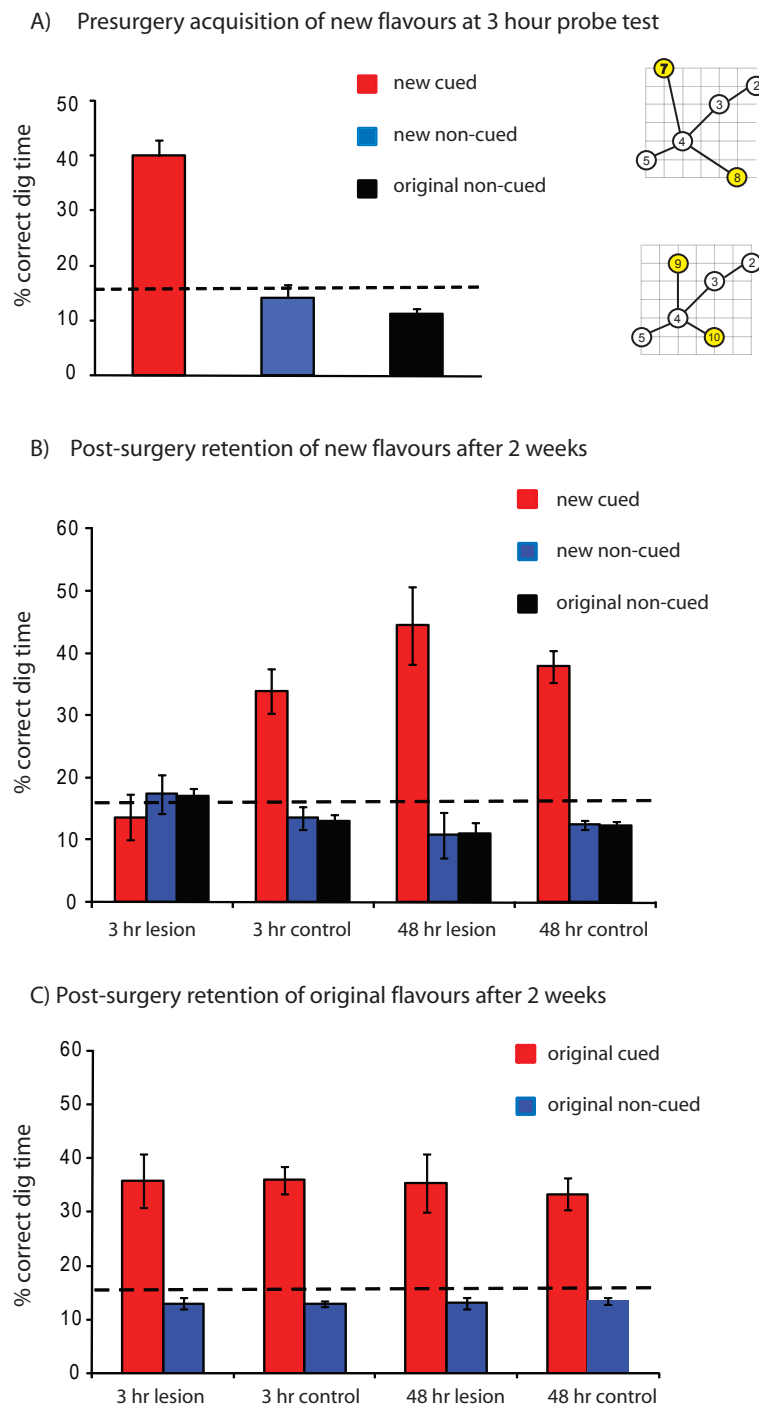

**Figure 3.6:** Presurgery acquisition and post-surgery retention of new and old flavours. Panel A shows the % correct dig time performance on new flavours first experienced 3 hours ago, averaged across flavours 7 & 8 (surgery epoch 1) and flavours 9 & 10 (surgery epoch 2). 2 new flavours were experienced in the pre-surgery session but only one (new cued) was tested 3 hours later. The inset schematics show the relative locations of the 2 new flavours introduced before surgery epoch 1 and surgery epoch 2. Panel B shows the % time spent digging in the correct (cued) vs. incorrect (1 new non-cued plus average of 4 original non-cued) sand-wells when rats were tested 2 weeks after surgery on the flavours learned in just one session either 3 hours or 48 hours prior to surgery. Panel C shows the % time spent digging in the correct (original cued) vs. incorrect (average of 5 original non-cued) sand-wells when the same rats were tested 2 weeks after surgery on the original flavour map. Chance level (16.7%) is shown by the dashed line in all 3 panels. Labels on the y axis show delay and lesion group.

Figure 3.6A shows the performance as measured by % dig time in the correct sand-well of rats in the probe tests prior to each surgery epoch in which 2 new flavour-location paired associates were introduced. This data is combined from probe tests PT4 (session 21) and PT9 (session 32). PT 4 was scheduled 3 hours after trial 4 of session 21, in which one of the new flavours (F7 or F8, counterbalanced across rats relative to their anticipated surgery group) was introduced for the first time. (The second new flavour was introduced in trial 5 of session 21 and surgery was scheduled 3 or 48 hours after it). PT 9 was scheduled 3 hours after trial 4 of session 32, in which one of the second set of new flavours (F9 or F10, counterbalanced across rats relative to their surgery group) was introduced for the first time. (The second new flavour was introduced in trial 5 of session 32 and surgery was scheduled 3 or 48 hours after it). The probe tests for the presurgery acquisition of new flavours in this experiment were scheduled 3 hours after the rats had experienced the new flavours (rather than 24 hours in Tse and Langston et al (2007) experiment 2) in order to have the opportunity to test all the rats for acquisition of one of the new flavours before they underwent surgery. No previous data was available to confirm that the retrieval of the newly experienced paired associates would be successful at a 3 hour delay, but the results of the 3 hour probe tests for the new flavours in this experiment showed results (based on % correct dig time) that were comparable to those obtained at a 24 hour delay in Figure 2 of Tse and Langston et al (2007). The probe tests were carried out at this time delay for rats in the 48 hour surgery groups as well as those in the 3 hour lesion groups in order to standardise this factor and eliminate it as a variable. A repeated measures ANOVA with sand-well (correct new cued, incorrect new non-cued and incorrect original non-cued) showed a significant effect of sand-well and pairwise Bonferroni corrected comparisons showed that % correct dig time in the correct (new cued) sand-well was significantly different from % correct dig time in the non-cued sand-wells (all  $p < 0.001$ ). A one-sample t-test against chance (16.67%) showed that the % correct dig time was significantly higher ( $t_{(19)} = 10.317; p < 0.001$ ). The performance index based on the number of errors before rats dug in the correct sand-well in this probe test was  $37.78 \pm 8.63\%$ , not significantly different from chance ( $t_{(19)} = 1.488; p = 0.153$ ).

Based on the % dig time in the correct (new cued) sand-well on the presurgery probe test of new flavours, all rats successfully acquired a memory for the new flavour-location pairs after one trial which was expressed 3 hours after this initial acquisition.

Rats in this experiment received either sham operations or complete hippocampus lesions over 2 separate surgery epochs after Sessions 21 & 32, as described previously. The lesions successfully targeted the hippocampus with minimal damage to other structures. More details about the histological results are available at the end of this chapter.

Rats in the 3 hour group received surgery exactly 1 hour after completion of the probe for the trial 4 new flavour-location pair, which was exactly 3 hours after trial 5 - the novel flavour that they would be tested on postoperatively. Assignment of rats to groups was initially made by matching % correct dig time performance on probe test PT3 (acquisition of original flavour map) between the anticipated surgery groups. Data from PT4 and PT9 (one-trial acquisition of the new flavours) was also incorporated as it was collected and group assignment adjustments made accordingly. Thus, the eventual surgery groups presented in Figure 3.6B&C are based on presurgery performance balanced between groups as accurately as possible on PT 3, 4 and 9. The data presented in Figure 3.6B are an average of the probe tests PT6, PT8, PT10 and PT12 (all new flavour probe tests after both surgery epochs) and the data presented in Figure 3.6C are an average of the probe tests PT5, PT7, PT11 and PT13 (all old flavour probe tests after both surgery epochs). It may be helpful to refer to Figure 3.3 for the timeline showing the sessions on which these probe tests took place.

Figure 3.6B shows post-operative performance based on % correct dig time for the new flavours experienced for just one trial either 3 hours or 48 hours prior to surgery. Figure 3.6C shows the same data for the original flavour map learned over the 13 original training sessions. These data reveal a time-dependent role for the hippocampus in memory for novel flavour-location pairs in the presence of a putative activated schema in the form of a flavour map. Hippocampus lesions given 3 hours after experiencing a novel flavour-location pair abolish memory for this pair 2 weeks later, whereas anaesthetic or sham control surgery at the same time point have no effect. Hippocampus lesions given 48 hours after experiencing a novel flavour-location pair have no effect on the retrieval of this memory 2 weeks later, as do anaesthetic or sham lesion procedures. This latter part of the data replicates that found in experiment 2 of Tse and Langston et al (2007). The data in Figure 3.6B&C were analysed by multivariate ANOVA on the % dig time in the correct (cued) sand-well with delay (3 or 48 hours) and lesion group (HPC or control) as between-subjects factors and probe test type (new or original flavours) as the within-subjects factor. This revealed a 3-way interaction between delay, lesion group and trial type ( $F_{(1,27)} = 5.766; p = 0.023$ ). Further testing by univariate ANOVA on % correct dig time in the new flavours condition (Figure 3.6B) revealed a significant group effect ( $F_{(3,27)} = 12.076; p < 0.001$ ) on dig time in the correct sand-well when cued with a new flavour experienced only once. Bonferroni corrected pairwise comparisons of this effect showed that the 3hour hippocampus lesion group were significantly different from the other 3 groups (all  $p < 0.003$ ) while the other 3 groups (3 hour control, 48 hour lesion and 48 hour control) were not different from each other (all  $p = 1.000$ ). The same analysis on the original flavours condition (Figure 3.6C) showed no effect of group

( $F_{(3,27)} = 0.130$ ;  $p = 0.941$ ). Finally, a paired t-test on the data from the 3 hour lesion group comparing % correct dig time performance in the new flavour condition and the original flavour condition showed a significant difference in performance dependent on flavour condition ( $t_{(6)} = 4.491$ ;  $p = 0.004$ ). This comparison in the 3 hour control, 48 hour lesion and 48 hour control groups revealed no significant effects (all  $p > 0.100$ ).

Post-operative testing therefore revealed a time dependent role for the hippocampus in memory for flavour-location paired associates experienced in only 1 trial before surgery (see Figure 3.7). Removal of the hippocampus 3 hours after experiencing a novel flavour-location paired associate impaired retrieval of the location associated with the food flavour after a 14 day retention interval (recovery from surgery necessitates this interval). However the results of experiment 2 of Tse and Langston et al (2007) were also replicated within this experiment, showing that if the hippocampus is removed 48 hours after experiencing a novel flavour-location paired associate, retrieval of the location when cued with the food flavour is not impaired 14 days later. Hippocampus lesions did not have any effect on memory for an original set of 6 concurrently learned flavour-location paired associates (a flavour map) learned over an extended training period. The time dependence of the hippocampus is summarised in Figure 3.7).

Time-dependent involvement of the hippocampus in flavour-location consolidation

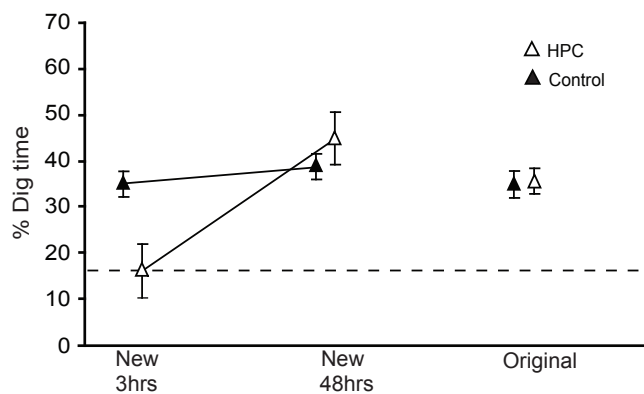

**Figure 3.7:** Time-dependent hippocampal role in consolidation of flavour-location pairs: Novel flavour-location pairs are consolidated outside the hippocampus after 48 hours but not after 3 hours.

### 3.3.3 Histology

All rats in both experiments successfully received large lesions of the target hippocampal area with minimal damage to other structures. Slightly different co-ordinates were used in Experiment 2 compared to Experiment 1 to account for the different ages of the rats used in each study, whose brain sizes were likely to be quite different (M.P. Witter, Personal Communication). These co-ordinates are presented in the Methods section.

Region	Exp 1	Exp 2 3hr delay	Exp 2 48hr delay
Dorsal %	13.14 +/- 6.94	9.24 +/- 3.52	4.20 +/- 1.84
Ventral %	6.23 +/- 2.73	28.88 +/- 4.53	20.70 +/- 3.81
Mean Total %	9.67 +/- 4.41	19.09 +/- 2.80	12.48 +/- 1.36

**Table 3.2:** % hippocampus spared in each experiment.

Table 3.2 shows the % spared hippocampal tissue relative to sham controls (100% hippocampus spared) in each experiment. The lesion extent varied slightly across experiments ranging from 9.67% spared tissue through to 19.09% but these are large lesions by established standards. Qualitative analysis showed that the hippocampus lesions were specific to the target area, producing maximal damage to the hippocampus whilst avoiding damage to entorhinal, perirhinal, postrhinal and retrosplenial cortices. There was some minor damage to the overlying parietal cortex in the lesioned rats which can be most clearly visualised in the 3D reconstruction image.

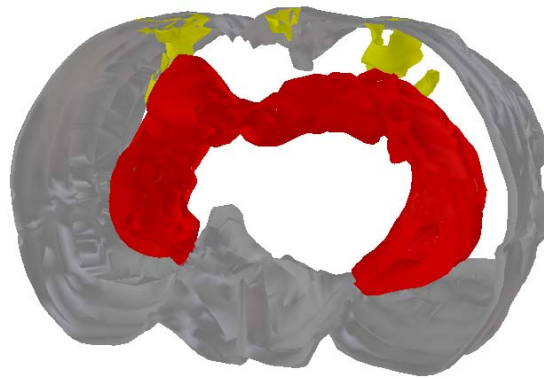

**Figure 3.8:** Three dimensional reconstruction of a complete hippocampus lesion. Red = lesioned hippocampus, yellow = damage to overlying parietal cortex, grey = outline of coronal section. This was reconstructed from a brain cut into 30 $\mu$ m sections with one in every 3 recovered, so coronal sections at intervals of 90 $\mu$ m.

Presubiculum and parasubiculum were generally intact, however in the larger hippocampus lesions there was some damage to a small portion of the subiculum both dorsally and ventrally. To assess any effects of this damage, Pearson correlations were carried out where relevant to see if there was any correlation between the subicular damage (lesion size) and behavioral performance (% dig time at the correct sand-well). These correlations were carried out for postoperative probe tests PT5 - PT8 and PT10 - PT13 (Experiment 2). No significant correlation was found between lesion size and behavioral performance (all  $p > 0.05$ , 2-tailed). Representative photomicrographs of a sham operated and a lesioned brain are taken from 2 rats who underwent surgery at the same time as the other 20 rats in Experiment 2, but was sacrificed after 14 days- the critical point at which postoperative probe tests were taking place for the experimental rats- to verify the extent of the lesion at that point in time.

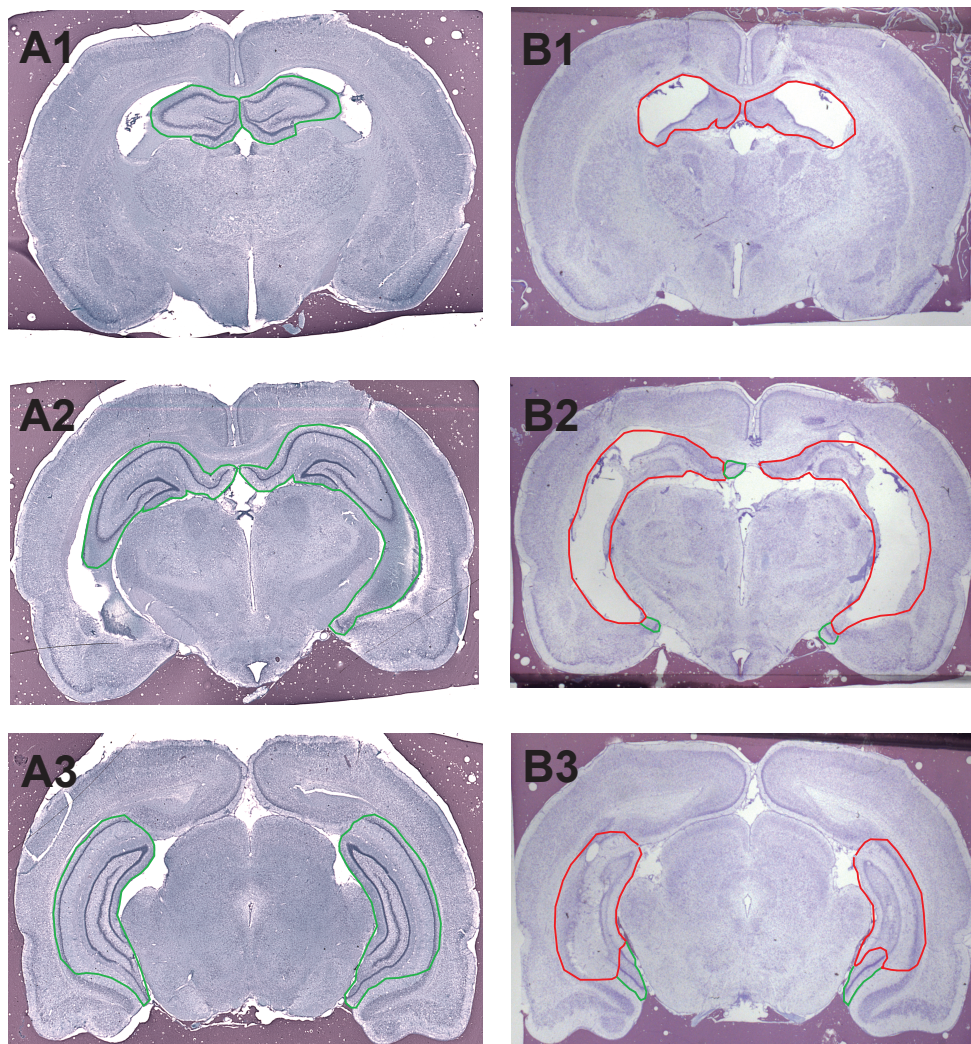

**Figure 3.9:** Photomicrographs of a complete hippocampus lesion and a sham operated brain. These sections are taken at the following approximate distances from Bregma: AP - 2.8 (A1 & B1), AP - 4.5 (A2 & B2) and AP - 6.0 (A3 & B3). The green lines represent the target hippocampal area (intact) in a sham lesioned brain (A1 - A3) and any sparing in the complete hippocampus lesion (B1 - B3). The lesioned area is shown in red.

### 3.4 Conclusions and Discussion

The first experiment in this chapter showed that the learning of a flavour map of six flavour-location paired associates, perhaps forming a putative mental schema, is critically dependent on the hippocampus. After 13 training sessions (at which point the data from the experiments presented here and those in Tse (2005) and Tse and Langston et al (2007) would suggest that control rats reach asymptotic performance on this task) rats with pretraining excitotoxic lesions of the whole hippocampus showed no learning of the flavour map assessed by either % dig time in the correct sand-well or performance index based on the number of errors made (incorrect digs) before digging in the correct sand-well (although the caveats associated with the use of the measure of performance index are discussed later). These data support the findings from Tse and Langston et al (2007) in which it was found that rats with hippocampus lesions given after training on one flavour map failed to encode any new information incorporated into that map or presented in a completely new flavour map context after the lesion. It was necessary to confirm however that it was not possible for naïve rats with the hippocampus removed prior to training to develop a hippocampus-independent strategy for learning the task in order to be certain that the acquisition of a flavour map is truly a hippocampus dependent task. The results of Experiment 1 confirmed this hypothesis, showing that there did not appear to be any alternative neurobiological mechanisms in the absence of the hippocampus that could instigate initial learning of the flavour map.

The second experiment in this chapter showed that memory for trial-unique flavour-location paired associates encoded as part of an active flavour map schema became independent of the hippocampus somewhere between 3 and 48 hours following encoding. Rats with complete lesions of the hippocampus given 48 hours after encoding of new flavour-location associates in just one trial showed retrieval of this memory 2 weeks later at levels indistinguishable from controls based on % dig time at the correct sand-well location (as shown in Tse and Langston et al (2007)). Rats with complete lesions of the hippocampus given 3 hours after encoding of new trial-unique paired associates were impaired relative to controls, and in fact performed at chance levels, in a retrieval test 2 weeks later.

The time course of a memory becoming hippocampus dependent (somewhere between 3 and 48 hours) was greatly accelerated compared to standard views on consolidation, which would predict a time course of weeks (e.g. multiple trace theory Moscovitch et al. (2005)) for a memory to become consolidated into long term storage. It would be interesting to see how the retention of this schema based learning of 6 flavour-location paired



associates now correlates with the 2 repeat-trial paired associates learned by rats in Day et al. (2003): does the repeated training of 2 pairs constitute a schema? Would repeat-trial learning of 2 paired associates have produced a long-lasting memory had we tested it at different delays, and would it have facilitated the learning of or memory for the concurrently trained trial-unique flavour-location pairs?

We were concerned that the non-specific side effects of administration of a long epoch of anaesthetic so soon after the encoding of a sensitive trial-unique memory event would disrupt memory in the sham control group, so each rat that received a lesion at the 3 hour delay was partnered by a sham anaesthetised control whose onset and duration of anaesthesia were identical. The anaesthetised controls however retrieved memories of both the trial-unique and original schema paired associates successfully after the 14 day postoperative recovery period (see Figure 3.6 on page 88, proving that we were really seeing specific effects of the role of the hippocampus in the rapid processing of a trial-unique paired associate memory in the context of a pretrained schema.

These experiments support the predictions of the basic theory behind the work of Day et al. (2003) and also provided additional support for the Tulving's SPI model of declarative memory- that successful episodic memory is partly dependent on the prior presence of perceptual and semantic knowledge associated with the same memory. They also suggest that animals- as well as humans- may be able to form some kind of mental schema. This seems to be learned gradually- perhaps in the form of semantic facts about where certain food flavours can be found- but then enables the rapid encoding and storage of trial-unique episodic-like information. Thus, this task provides a successful dissociation of semantic-like vs. episodic-like memory and provides evidence that animals as well as humans may be able to form mental schema which facilitate the encoding of new information. The schema appears to be highly specific- a map of food flavours and locations- as Tse and Langston et al (2007) showed that simply having an activated spatial representation of the flavour map sand-well locations without a consistent map of which flavours were available in which locations was not sufficient to facilitate the long-lasting memory of trial-unique paired associates.

An interesting (although not desirable!) finding from this experiment was that the measure of performance index based on the number of errors rats made before digging in the correct sand-well was inconsistent between standard training and non-rewarded probe tests in both experiments, and did not accurately reflect the results based on % dig time in sand-wells. Figure 3.5 on page 86 showed the performance index on thirteen standard training sessions interspersed on sessions 2, 9 and 16 with non-rewarded probe tests. It appears from the training data that performance index increases gradually across

days in line with the data from the interspersed probe tests (which were included in this experiment to check the acquisition process based on the data from experiment 1, in which the one final probe test (PT1) at the end of training (Session 14) indicated learning had occurred in the control group, based on the % dig time in the correct sand-well but not based on the highly variable performance index in this probe test (see Figure 3.4 on page 83). However when the performance index on the interspersed probe test sessions was examined, it revealed no increase across the training sessions and remained at chance throughout, in contrast to the high performance with very little daily variance in the standard sessions. The % correct dig times in the three interspersed probe test sessions showed a significant gradual increase over the sessions, resulting in better than chance performance on PT 2 and PT3, scheduled on sessions 9 and 16 respectively, which also indicated that the rats were learning the flavour map (see Figure 3.6 on page 88). The immediately obvious conclusion from this differential performance on the standard vs. the probe trials is that the rats can smell the food reward when it is present in the sand-wells on standard trials and this is how they make their judgement of which sand-well to dig in first. On non-rewarded probe tests, no food is present in the sand-wells until the 60 second probe is complete so this strategy would not be available to the rats upon entering the arena. However the problem is in fact more complicated than that for at least 2 reasons. Firstly, if the rats' performance was based solely on the odour of the food emanating from the correct sand-well, their probe test performance when no food is present in the sand-wells would be expected to be at chance and show no improvement over training. This is not the case- rats dig preferentially at the correct sand-well during non-rewarded probe tests PT2 onwards, even though no food is present in any sand-wells during these trials. Secondly, if the rats' performance were based solely on being able to smell the food reward during the standard training sessions before they had even arrived at the sand-well, it would be expected that rats with complete hippocampus lesions would also be able to use this strategy, as there is no evidence that a lesion of the hippocampus affects the rats' sense of smell, and it has further been shown that hippocampus lesions do not affect rats' ability to form and remember odour-reward associations, even on a trial-unique basis (Wood et al. 2004).

I hypothesise that rats do in fact use cued recall to solve this flavour map task, perhaps in combination with recognition, but that we have not yet found the correct way to measure this behaviour. It is feasible that rats may recall the location of the food with which they are cued in the start box at the beginning of each trial. Upon visiting the (correctly recalled) sand-well, the smell of the food reward emanating from it confirms their choice so they go ahead and dig in it. On the interspersed probe tests, which occur at a much lower frequency than standard training sessions, rats may approach the correct sand-

well after successful recall of the location of the cue flavour but upon arrival may be confused by the lack of the food odour emanating from the sand-well and consequently leave without digging to investigate the other sand-wells, resulting in their first dig being made relatively randomly after the discovery that none of the sand-wells visited contain food. After failing to discover food reward in any of the other sand-wells sampled, a recognition memory process may be called upon which would result in the cued sand-well location eventually being recognised and the majority of the dig time during the probe test then being spent there. This seems to be the only reasonable explanation for the dissociation of performance index between standard and probe test sessions. The hypothesised role of food odour in the task is surprising, as the precautions taken to prevent this happening (all flavours of food mixed with the digging sand, the new design of sand-well described in the introduction of this chapter with food pellets hidden below a mesh grid as a masking odour) were improved relative to the Day et al. (2003) study, in which unwanted odour cues did not seem to be a problem affecting performance. However this could be explained by the fact that in the experiments described in this chapter, 3 food pellets were always available in the correct sand-well, and this may emanate a stronger and more distinctive odour than that of the single pellet of food used in Day et al. (2003).

Although the discrepancy found when considering the performance index and the possible role of unwanted food odours described in this chapter was unexpected and disappointing considering the extra procedural precautions taken and the introduction of what was expected to be a better indicator of recall accuracy in the task, the main results based on the % dig time at the correct sand-well; that the hippocampus is necessary to acquire a flavour map but has a time limited (3-48 hour) role in its storage and retrieval; remained a very exciting new finding. Unfortunately the dissociation between the putative memory processes of recognition and recall which were tentatively suggested in the previous chapter could not be examined further in this protocol due to lack of a reliable measure of putative memory recall. A better measure of cued recall in this task and perhaps in the task described in the previous chapter and in Day et al. (2003) may be to examine the first sand-well approached, instead of or in combination with the first sand-well dug in. This would require careful planning as to how close a rat should be to a sand-well before it is classed as an "approach" and also careful analysis of the distance between the start box and the first sand-well approached to check that the first approach measure is not based on the closest sand-well to an individual rats' start box location. Currently, Patrick Spooner at the University of Edinburgh is working on incorporating into the current event arena software a program designed to track the rats movements within the arena, which could be programmed to register a response when a rat came within a cer-

tain distance of any sand-well, designated by the experimenters. Careful adjustment of this parameter could reveal an accurate measure of cued recall in this paradigm. Patrick Spooner is also working on an automated mechanism through which food pellets would be delivered to the rewarded sand-well only after the rat had begun to dig there, or persisted in digging there for a predetermined length of time. This may eradicate the need for changing the measure used to evaluate putative recall as the absence of food on any session (standard or probe test) would discourage the use of odour cues to confirm the first choice of sand-well, if this was indeed what rats in this experiment were using.

In summary, this paradigm is a robust and useful method for comparing semantic-like vs. episodic-like memory using a paired associate learning paradigm, which is known to utilise cued recall in humans and may or may not do so in rats. The task as it stands cannot be used to reliably dissociate the putative mechanisms of recall vs. recognition memory. We have demonstrated that the task is completely dependent on the hippocampus for acquisition and that the hippocampus has a time limited role in the storage and/or retrieval of trail-unique paired associate memory which may be facilitated by the presence of an activate flavour map, or mental schema.

## **Chapter 4**

# **Integrated memory for objects, places and contexts in the rat**

## 4.1 Introduction

As described in Section 1.7 on page 31, (Eacott and Norman 2004b) recently published an elegant paper which used the natural propensity of rats to explore novel aspects of their environment to demonstrate trial-unique integrated memory for object, locations and contexts. The integration of these 3 things- object, location and context- provides an alternative to the original “episodic memory triad” (Tulving 1972) of what, where and when by replacing the temporal element- “when”- with another factor unique to an event, such as the context in which it occurs- “which”. In Section 1.6 on page 28 I have discussed the relative merits of this approach and why the demonstration of “when” may not necessarily be vital to an episodic-like memory task in rats.

The task published by Eacott and Norman (2004b) has already been described in detail in Section 1.7 on page 31. The authors showed that rats with lesions of the fornix could not recognise an object (what) that was presented in a novel configuration of location (where) and context (which). Importantly, the fornix was not necessary to recognise configurations of just object and location (what-where), so the memory deficit seen in the integrated what-where-which task was not secondary to a more basic impairment in processing object-location information. There was however a mild impairment in rats with fornix lesions on memory for configurations of objects and contexts, published separately (Norman and Eacott 2005). Although this deficit was not as severe as that seen in the integrated what-where-which task, it is possible it may have contributed to this finding.

Lesions of the fornix are often reported as being equivalent to lesions of the hippocampus, but these 2 manipulations are not necessarily comparable. They produce different behavioural symptoms, both specifically in memory tasks and secondarily in locomotor function (Cassel et al. 1998; Coutureau et al. 2000; Galani et al. 2002). These differential effects are probably due in part to the different techniques used to produce the lesions- electrolytic or radiofrequency lesions are commonly used to produce fornix lesions, whereas Jarrard (1989) developed a technique in rats using ibotenic acid to produce neuroexcitotoxic lesions of the hippocampus. In these lesions, associated fibre bundles (e.g. the fornix) are mostly spared<sup>1</sup> by the nature of the agent injected since it acts specifically upon glutamatergic receptors in the hippocampus, causing cell death by overactivity in excitatory pyramidal cells (Wree and Erselius 1991). There are also anatomical considerations: not only does lesioning the fornix disconnect the hippocampus from cortical and subcortical input and output structures, but it also disconnects other (although more minor) pathways whose fibres did not necessarily synapse at the hippocampus it-

---

<sup>1</sup>although see Erselius and Wree (1991) in which the authors suggest that some myelinated axons undergo demyelination in the vicinity of the ibotenic acid injection

self (Deller et al. 1996), such as some connections between the entorhinal cortex and subiculum, both of which have been implicated in memory processes (Morris et al. 1990a; Hebert and Dash 2002; Jarrard et al. 2004; Steffenach et al. 2005).

The human hippocampus is thought to be involved in episodic memory (as previously discussed in the main introductory section) and in recent functional imaging studies, its role in the successful retrieval of contextual features of an event and associations between these features is thought to be of particular importance (Burgess et al. 2001; Davachi and Wagner 2002; Davachi et al. 2003; Dobbins et al. 2003). This has also recently been demonstrated in rats (Kennedy and Shapiro 2004). We decided to replicate the innovative task designed by Eacott and Norman (2004b) to study the specific role of the hippocampus itself in the retrieval of memory for what-where-which associations. This was done using selective ibotenic acid lesions of the hippocampus after (Jarrard 1989).

In addition to replicating the studies of Eacott and Norman (2004b) and Norman and Eacott (2005), we tested the effects of complete hippocampus lesions on the standard spontaneous novel object recognition paradigm (Ennaceur and Delacour 1988) since there is still some debate about the role of the hippocampus in this task (Mumby 2001; Broadbent et al. 2004; Ainge et al. 2006). The concept spontaneous novel object recognition is central to the procedural demands of this task, so we wished to establish that- under the specific conditions of our paradigm- the basic process of memory for a previously encountered object (measured by preference for a novel object over the familiar one) was not affected by complete lesions of the hippocampus.

A) what-where (object-location) task

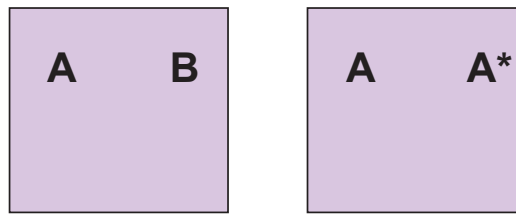

B) what-which (object-context) task

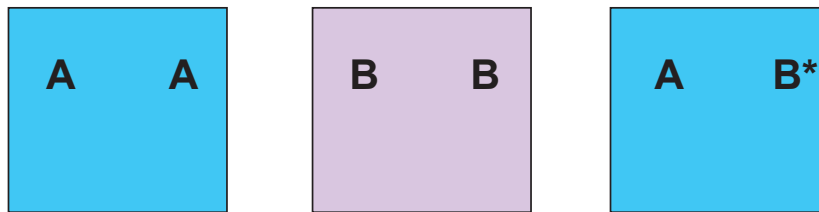

C) what-where-which (integrated object-location-context task)

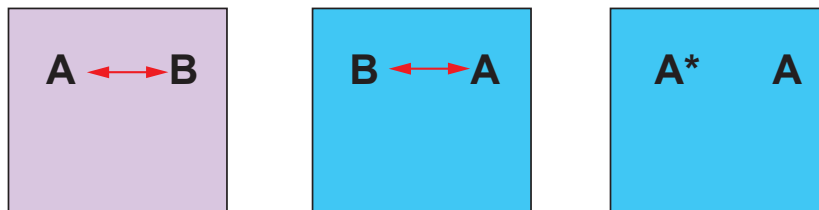

**Figure 4.1:** Possible interference due to overlap of stimuli: It is possible that hippocampal-dependent interference could affect the integrated what-where-which task (Panel C) due to the object swap (indicated by red arrows) that occurs between events 1 & 2. This swap creates a higher level of stimulus overlap between the events preceding the memory test (right column) in the integrated task than in the other 2 tasks (Panels A & B) which rats with lesions of the hippocampus may be more susceptible to. The letters A & B within the coloured boxes represent schematically the identities of 2 different objects and their relative locations within in the different tasks. The different colours of the boxes represent the different contexts that each event occurred in, although an understanding of this is not necessary for this point- the interference that may occur is proposed to be purely related to the objects and their locations.

Another concern (A.D. Redish & B. Poucet, Personal Communications) was that the integrated what-where-which task as designed by Eacott and Norman (2004b) has one procedural factor that differs from its pairwise control tasks of testing what-where and what-which memory separately, which is illustrated in Figure 4.1. The red arrows in Panel C show the element which is unique to the procedure of the integrated what-where-which task: between event 1 and event 2 (1st and 2nd column), the positions of object A and object B are swapped. In both of the control tasks depicted above it (Panels A and B), an object location swap never actually occurs, although objects do appear in novel locations



or contexts. In order to perform the integrated what-where-which task (and recognise that the object marked with an asterisk is in a novel configuration of location and context therefore, rats need to be able to encode that 2 objects have swapped locations. Although it has recently been shown that rats with dorsal hippocampus lesions can detect that 2 objects have swapped within a configuration of 4 objects (Goodrich-Hunsaker et al. 2005), here we only present 2 swapped objects (Figure 4.1C), meaning that there are no “control” non-swapped objects: all what-where features are equally manipulated. It is possible that these overlapping what-where features of event 1 and event 2 mean that rats with lesions of the hippocampus are impaired at recognising the object swap between events 1 and 2 (O’Reilly and Rudy 2001; Sanderson et al. 2006). This in turn could contribute to or even cause the deficit in memory test on the integrated what-where-which task. This was a subtle caveat that I did not consider at the outset of the experiment. However, it was investigated at the end of behavioural testing using the object-swap task paradigm described in Section 4.2 on the following page.

In summary, the series of experiments presented in this chapter aimed to replicate and extend analysis of the episodic-like what-where-which integrated memory task designed by (Eacott and Norman 2004b) and investigate the role of the hippocampus in this task.

## 4.2 Materials & Methods

### 4.2.1 Subjects

A total of 22 male Lister Hooded rats (Charles River, UK) were used in the two experiments. None of the 22 rats had experience of the testing apparatus before surgery; however the 12 rats used in the first replication of this experiment had been previously tested in this apparatus on another object exploration task. The 10 rats used in the second replication were given extensive habituation to compensate for being procedurally naïve. There was no difference between the results obtained from the two replications of the experiment so all data were pooled unless stated otherwise. Rats were aged 8-10 weeks at the start of experimentation and weighed 200-250g. They were housed in groups of 2-4 rats in cages with opaque white plastic bases measuring 35 x 50 x 15 cm (width x length x height) fitted with wire mesh lids (15 cm high) bringing the total height of each cage to approximately 30 cm. Rats were kept on a 12 hour light/dark cycle (lights on at 8am, off at 8pm). All rats had unrestricted access to water throughout the experiment and were fed approximately 30g of standard laboratory diet (RM1, SDS, UK) per rat per day so as to maintain a minimum of 85% of their free-feeding bodyweight (individual bodyweights were recorded at least once per week). Compliance was ensured with national (Animals [Scientific Procedures] Act, 1986) and international (European Communities Council Directive of 24 November 1986 [86/609/EEC]) legislation governing the maintenance of laboratory animals and their use in scientific experiments. All efforts were made to minimize the number of rats used and their suffering.

### 4.2.2 Surgery

The rats were pseudo-randomly assigned to one of two groups: a complete hippocampus lesion group which were given bilateral excitotoxic lesions of the entire hippocampus including dentate gyrus and CA fields ( $n = 5$  per replication) and a sham control group that received no lesions ( $n = 7$  in the first replication and  $n = 5$  in the second replication). The assignment to surgery groups ensured that each cage group contained a mixture of lesioned and control rats and the surgery groups were also matched for variations in individual rat weights. Lesions were made with ibotenic acid hydrate (Biotechnology, CA); dissolved in phosphate buffered saline (pH 7.4) at 10mg/ml, following the protocol of Jarrard (1989). Anaesthesia was induced and maintained using Halothane (Merial Animal Health, UK) and rats were positioned in a stereotaxic frame (Kopf, CA). Bilateral craniotomy was carried out at the target site to expose the dura above the hippocampus.

Thirteen injections of ibotenic acid were made into each hemisphere via a bevelled 1 $\mu$ l syringe (SGE, UK) attached to the frame by a stereotaxic arm (Kopf, CA). Ibotenic acid was injected manually at a rate of 0.1 $\mu$ l/min, beginning 30 seconds after the syringe was lowered. The syringe was raised slowly 60 seconds after the injection. A total of 0.91 $\mu$ l per hemisphere was injected. The co-ordinates were modified from Jarrard (1989) according to de Hoz et al. (2003).

Complete hippocampus lesion co-ordinates  
Mean weight of subjects = 281g

AP	ML	DV	uL ibotenic acid (10mg/ml)
-2.4	+/- 1.0	-3.0	0.05
-3.0	+/- 3.0	-2.7	0.10
	+/- 1.4	-2.1	0.05
		-2.9	0.05
-4.0	+/- 3.7	-2.7	0.10
	+/- 2.6	-1.8	0.05
		-2.8	0.05
-4.3	+/- 4.0	-7.0	0.05
-4.9	+/- 3.9	-3.5	0.05
		-7.0	0.10
-5.9	+/- 5.1	-4.5	0.08
		-5.3	0.08
	+/- 4.3	-3.9	0.10

**Table 4.1:** Complete Hippocampus Lesion Co-Ordinates

Sham lesions were carried out in the same way, but the injections were substituted with piercing of the dura with a 23G needle to simulate the mechanical damage caused by syringe entry. After completion of the ibotenic acid injections (or piercing of dura for sham control rats), gelatine sponge (Johnson & Johnson, UK) was placed over areas where bone had been removed and a subcuticular stitching technique used to close the skin over the top of the skull. Rats were placed back in their group cages immediately after surgery. Analgesia was administered in oral form (Large Animal Rimadyl, Pfizer, UK) at 2ml/l in the rats' water supply. This analgesic solution was freely available to all rats from 24 hours pre-surgery until 48 hours post-surgery. Rats were also administered with extra analgesic via intraperitoneal injection (0.05ml/kg Small Animal Rimadyl in 2ml sterile saline) at the end of surgery. This was because the lesioned rats were sometimes reluctant to drink or eat for up to 24 hours after surgery and would therefore not receive the benefits of the oral analgesic. Behavioural testing commenced after a 14 day postopera-

tive recovery period, allowing ample time for all rats to regain their presurgery weights before food restriction recommenced.

### 4.2.3 Apparatus

Figure 4.2 shows the layout of the experimental room. All testing was carried out in this room in a circular box, 76cm diameter with 40cm side walls. The circular floor section and the walls were interchangeable in order to create two different contexts. Context 1 consisted of a wooden floor painted with gloss black paint and walls covered in brown wood-effect sticky-backed plastic. Context 2 consisted of a white plastic floor insert (also 76cm diameter, 3mm thick) with holes (2cm diameter) drilled at various points across its surface so the original black wooden floor of context 1 was still visible through these holes. The walls of context 2 were covered in white wood-effect sticky-backed plastic. Each of the floor sections had 2 pieces of Dual-Lock (3M, UK) reusable adhesive attached at the 2 locations in which objects were always presented (marked with x in figure 4.2). These locations were approximately 10cm from the box wall, at the north-east and south-east points and were the only locations on the arena in which objects appeared. The circular testing boxes were placed on the floor of the room within a square curtained enclosure of dimensions 100cm x 100cm x 200cm. The enclosure had black cotton curtains on three of its four sides (north, west and south) on which were hung 2 large 3D visual cues. These cues were positioned with their bases at the top of the 40cm side walls, approximately above the locations of the objects to be explored. A yellow plastic curtain was hung on the east side. The square enclosure was in a constant position in the room relative to external cues (i.e. experimenter, computer, home cage) and the wall and floor pieces of the circular testing box were always placed inside the square enclosure at the same location and with the same orientation (shown by an arrow in figure 4.2). The apparatus was lit by a single, centrally placed overhead fluorescent light. Objects for exploration were collected from a variety of sources but had to fulfil the criteria of being easily cleaned, made from non-porous materials and either heavy enough that the rats could not push them over or having a suitable base where a reusable adhesive strip could be attached. Object dimensions ranged from 8 x 8 x 3cm to 21 x 17 x 13cm. Pilot exploration data was analysed (data not shown) in order to pair objects with others which rats tended to explore for similar amounts of time with the aim of pairing objects that were of equivalent "interest" to the rats.

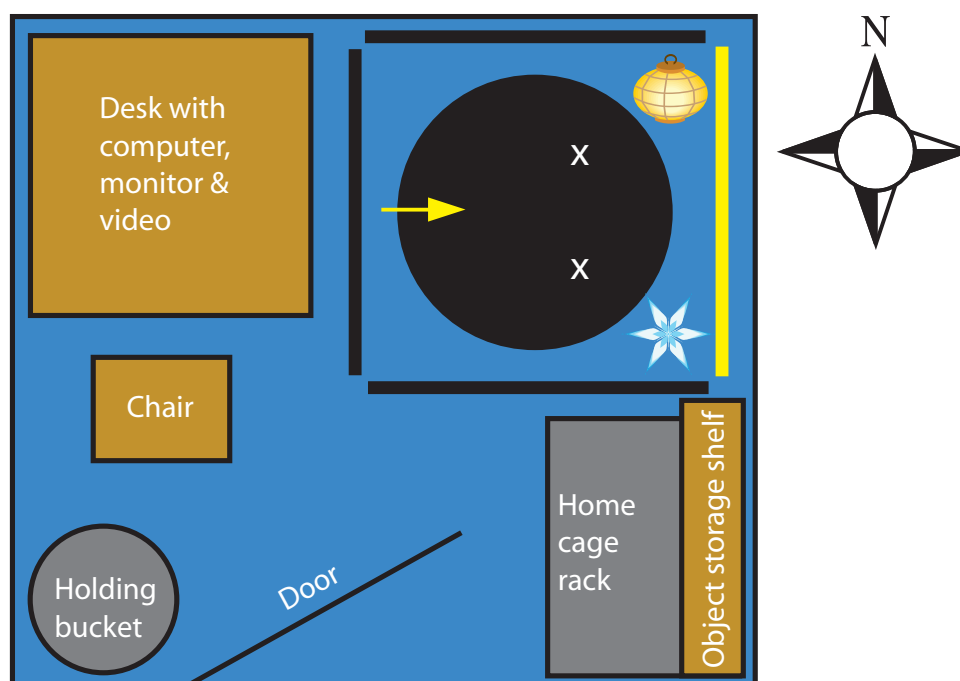

**Figure 4.2:** Schematic of Testing Room: This shows the layout of the experimental room and the objects it contained, all in their actual positions/orientations relative to the compass shown at the top right. The 3 black and 1 yellow line represent curtains hanging around the black circular testing box from a height of 200cm (see main text). The positions of the cues are shown as the light shade and star-shaped images. The crosses mark the positions of the objects in the arena and the arrow represents the location and orientation from which rats entered the arena.

#### 4.2.4 Behavioural Testing

All behavioural testing was carried out in the light phase (8am-8pm), 6-7 days per week. A home cage (containing 2-4 rats) was brought in to the testing room and stored on a metal rack near to the testing apparatus (see Figure 4.2).

##### 4.2.4.1 Habituation

Initial daily habituation sessions were carried out before behavioural testing commenced to familiarise the rats with the contexts, the locations in which objects could be presented and also the presentation of random junk objects in the testing box.

**Day 1** Rats experienced a 30 minute session in one context in cage mate groups (2-4 rats). Half of the rats experienced context 1 and the other half experienced context 2. There were no objects present in the testing box. Following the session in the testing box,

the rats were placed in the holding bucket (which would be used to house them during intervals between sampling and test events when testing commenced) for 30 mins.

**Day 2** Rats experienced a 30 minute session in cage mate groups in the opposite context to Day 1. There were no objects present in the testing box. Following the session in the testing box, the rats were placed in the holding bucket for 30 mins.

**Day 3** Rats experienced a 10 minute session in the same context as Day 2, but this time individually. No objects were present in the testing box. Each rat was placed in the holding bucket individually for 10 mins after the session in the testing box.

**Day 4** Rats experienced another individual 10 minute session in the opposite context to Day 3. No objects were present in the testing box. Each rat was placed in the holding bucket individually for 10 mins after the session in the testing box.

**Days 5 - 8** These sessions were identical to sessions 3 and 4 except that 2 objects were present (different objects for each session) in the testing box in the 2 locations marked with x in figure 4.2. These 4 days ensured that rats were familiar with the locations in which objects would appear, and that the identity of these objects changed daily. The 2 locations in which rats experienced objects were kept constant throughout testing. The objects were various shapes and sizes (within the dimensions listed in Section 4.2.3) and constructed from a variety of materials. These random junk objects were only presented once for any given rat during habituation and did not appear at any later stage of testing. The rats experienced the contexts over Days 5 - 8 in the same order, for a given rat, as they were experienced over Days 1 - 4.

The purpose of these habituation sessions was to familiarise the rats with the contextual configurations of the box, the type of objects that would be placed in the box during testing and the locations in which these objects would be placed. The rats always entered the testing box from the west, facing the west wall during the habituation, as would happen during testing.

**Novel Object Recognition** 3 days after the end of habituation, rats were tested for their recognition of novel objects. The novel object recognition task (Figure 4.3A) was really an extension of the habituation process. The purpose of this task was to ensure that the

rats were encoding the identities of the objects and could recognise that an object was familiar (previously seen) and therefore aim exploratory behaviour at the novel object<sup>2</sup>.

---

<sup>2</sup>In the integrated object, place and context task and its 2 control tasks (Figure 4.3B,C&D) there was no actual novel object recognition involved in the test event as the rats were always presented with familiar objects in different configurations based on location and/or context. However the novel object recognition task provided a way of testing that the rats were encoding the identity of the objects, as they would need to use this information about the identity of familiar objects in the test event of the other tasks. The data from the novel object recognition task was analysed to check that rats were performing this task and encoding the identities of the objects before proceeding with the other 3 tasks.

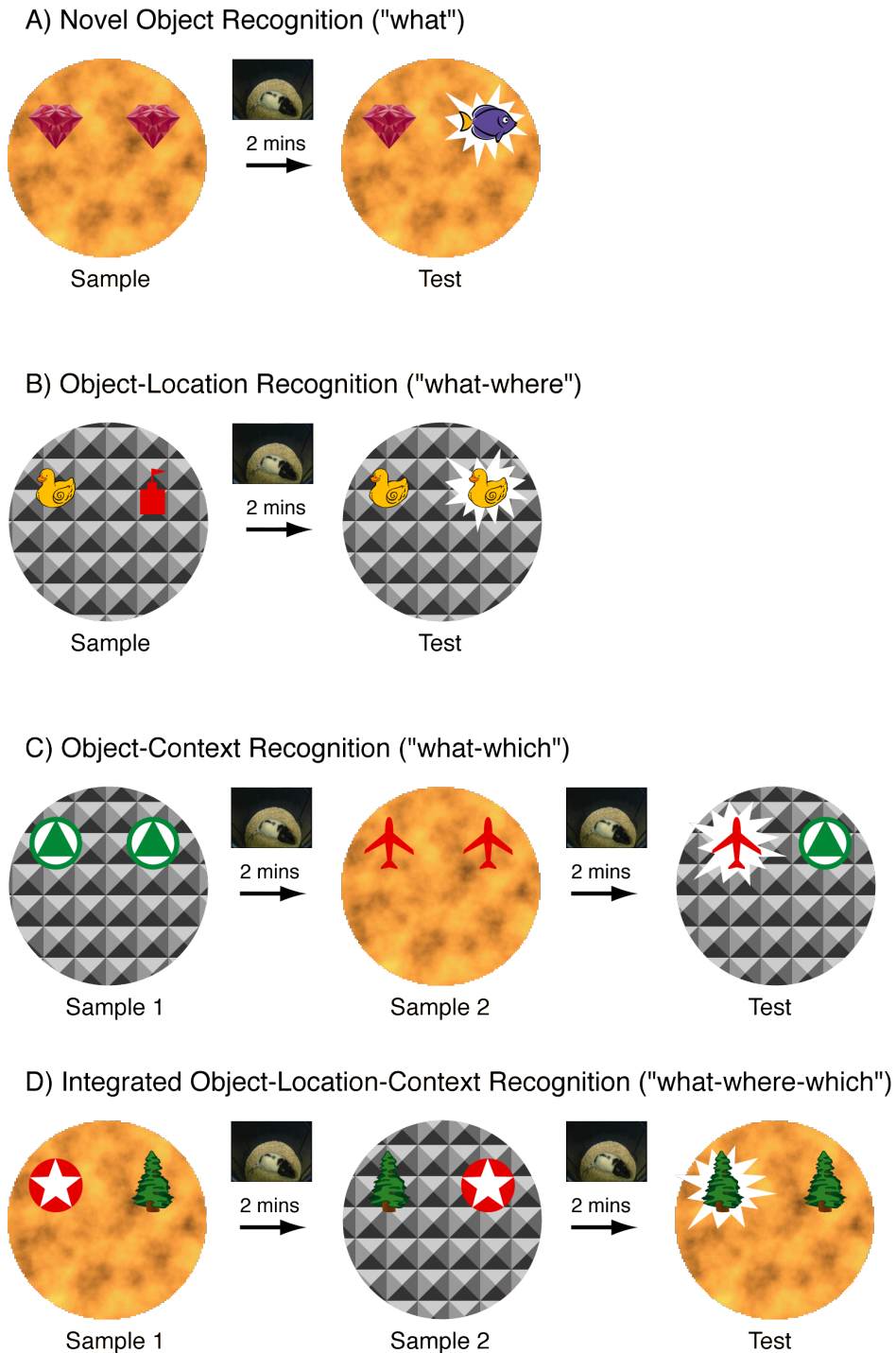

**Figure 4.3:** Schematic showing the different tasks, including the object recognition habituation task (A) used in this chapter. For ease of viewing the orientation of the testing box schematics has been rotated 90° from Figure 4.2. The novel object (or novel configuration of object with location/context) is highlighted in white in the test event schematics.

On a given trial, the rat to be tested was removed from the home cage and placed in an opaque holding bucket (approx. 25cm diameter, containing standard bedding ma-



terial 2cm deep) on a stool next to the testing apparatus. The objects to be used were cleaned with baby wipes (Tushies, UK) and attached at the appropriate locations (see x in figure 4.2 on page 108 in the testing box configured as either context 1 or context 2 (counterbalanced across rats). The rat was placed into the box from the west side, facing the wall for the sample event. The sample event consisted of the rat being allowed to explore the 2 identical objects in the testing box until it had accumulated at least 15 seconds of exploration at each object within a time of 2-5 minutes. Exploration was defined as the rat being within 2cm of an object, directing its nose at the object and being involved in active exploration such as sniffing or whisking. Sitting on or next to an object without any signs of active exploration was not included. After reaching the time and exploration criteria (at least 2 minutes in the box and 15 secs of exploration at each object) the rat was removed from the box at the same point from which it entered. During an interval of 2 mins the rat was returned to the holding bucket while the experimenter prepared the box for the next part of the trial. The floor and wall of the box were removed, cleaned and replaced in the same context configuration as the sample event. New copies of objects were cleaned and attached in the box. For the test event one object copy had the same identity as the objects seen in the sample event while the other object was completely novel (highlighted in figure 4.3A). A test event was carried out using exactly the same procedure as the sample phase except that the event lasted 3 mins and all data were recorded, regardless of how much exploration time the rat accumulated. The trial was then complete, and the rat was returned to the home cage. The next trial was given either 24 or 48 hours later. Each rat underwent 4 trials of novel object recognition testing, with 2 trials taking place in context 1 and 2 trials taking place in context 2. In 2 trials (one in each context) the novel object was presented on the left and in the other 2 it was presented on the right.

**Object In Location Testing (what-where)** The procedure for the rats in the object in location task was identical to that used in the novel object recognition task, but the configuration of the testing box was manipulated as can be seen in figure 4.3B. During the sample event, 2 different objects were present in the testing box. During the test event, which occurred in the same context as the sample event (as in the novel object recognition task), a further 2 copies of one of the objects presented in the sample event were present. Thus, one of the objects was presented in the same location as it had been in the sample event, whereas the other was in a location which had been previously occupied by a different object (highlighted in figure 4.3B). In this situation, both the object and the 2 locations were familiar to the rat, but the novel aspect of the test event was the mismatch between the identity and location of one of the objects relative to the sample event, i.e. a novel object location configuration. Each rat underwent 4 trials of object in location testing, with 2

trials taking place in context 1 and 2 trials taking place in context 2. In 2 trials (one in each context) the novel object was presented on the left and in the other 2 it was presented on the right.

**Object In Context Testing (what-which)** The procedure for the rats in the object in context task was identical to that used in the novel object recognition task, but the configuration of the testing box was manipulated as can be seen in figure 4.3C, and there were also 2 sample events followed by a test event. During the first sample event (Sample 1), 2 identical copies of an object were present in the testing box, which was configured as either context 1 or context 2. After Sample 1, there was a 2 minute interval during which the rat was placed in the holding bucket and the testing box was cleaned and reconfigured as the opposite context to Sample 1. During Sample 2, 2 identical copies of a second different object were present. After Sample 2, there was a 2 minute delay during which the rat was again placed in the holding bucket and the testing box was cleaned and either reconfigured as the context used in Sample 1 (as in figure 4.3C, which happened on 2 of 4 trials) or replaced in the same context configuration as in Sample 2 (which happened on the other 2 of 4 trials). During the test event, one copy of the object from Sample 1 and 1 copy of the object from Sample 2 were present. Thus, one of the objects was presented in the same context as it had been in the sample event in which it appeared, whereas the other was in the context in which it had not been previously experienced (highlighted in figure 4.3C). In this situation, both objects and the context at the test event were familiar, but the novel aspect of the test event was the mismatch between the identity and background context of one of the objects relative to the sample events, i.e. a novel object in context configuration. Each rat underwent 4 trials of object in context testing. 2 trials used context 1 in Sample 1, and 2 trials used context 2 in Sample 1 (and the opposite context was always used in Sample 2 relative to Sample 1). 2 trials used the context from Sample 1 in the test event, and the other 2 used the context from Sample 2 in the test event. This was to counterbalance for the effects of primacy or recency of the objects or contexts. In one of the test events in each context, the novel object in context configuration was presented on the left (as highlighted in figure 4.3C) and in the other test event in the same context, the novel object in context configuration was presented on the right.

**Integrated Object, Location and Context Testing (what-where-which)** The procedure for the rats in the object, location and context task was identical to that used in the object in context task, but the configuration of objects in the testing box was manipulated in a slightly different way, as can be seen in figure 4.3D. During the first sample event (Sample 1), 2 different objects were present in the testing box, e.g. object A on the left and object B

on the right), and the box was configured as either context 1 or context 2. After Sample 1, there was a 2 minute interval during which the rat was placed in the holding bucket and the testing box was cleaned and reconfigured as the opposite context to Sample 1. During Sample 2, 2 more identical copies of the same objects from Sample 1 were present, but their locations were swapped relative to Sample 1 e.g. object B on the left and object A on the right, and they appeared in the opposite context to Sample 1. After Sample 2, there was a 2 minute delay during which the rat was again placed in the holding bucket and the testing box was cleaned and either reconfigured as the context used in Sample 1 (as in figure 4.3D, which happened on 2 of 4 trials) or replaced in the same context configuration as in Sample 2 (which happened in the other 2 of 4 trials). During the test event, 2 identical copies of 1 of the objects from the sample events were present. Thus, one of the object copies was presented in the same location and context configuration as it had been in one of the sample events (e.g. the copy of object A on the right, which had previously appeared in context 1 on the right), whereas the other copy was in a location and context configuration in which it had not been previously experienced (e.g. the copy of object A on the left, highlighted in figure 4.3C, which had appeared in context 1 previously, but on the right and had appeared on the left but in context 2). In this situation, both the objects, locations and context in the test event were familiar, but the novel aspect of the test event was the mismatch between the identity of the objects and the locations relative to the background context in which they appeared, i.e. one object was in a novel object-location-context configuration. Each rat underwent 4 trials of integrated object, location and context testing. 2 trials used context 1 in Sample 1, and 2 trials used context 2 in Sample 1 (and the opposite context was always used in Sample 2 relative to Sample 1). 2 trials used the context from Sample 1 in the test event, and the other 2 used the context from Sample 2 in the test event. This was to counterbalance for the effects of primacy or recency of the objects or contexts. In one of the test events in each context, the novel object-location-context configuration was presented on the left (as highlighted in figure 4.3D) and in the other test event in the same context, the novel object-location-context configuration was presented on the right.

**Object Swap Task** To control for the possible effects of interference described in the Introduction (Section 4.1), a separate control task was run which was designed to test whether the rats with hippocampus lesions were able to recognise that 2 objects had swapped places: the only part of the integrated object, location and context task which was not included in either of the control tasks seen in Figure 4.3B&C. It was therefore important to test that the small procedural difference in the design of the integrated object, location and context task was not the reason for the deficit seen in the rats with

hippocampus lesions.

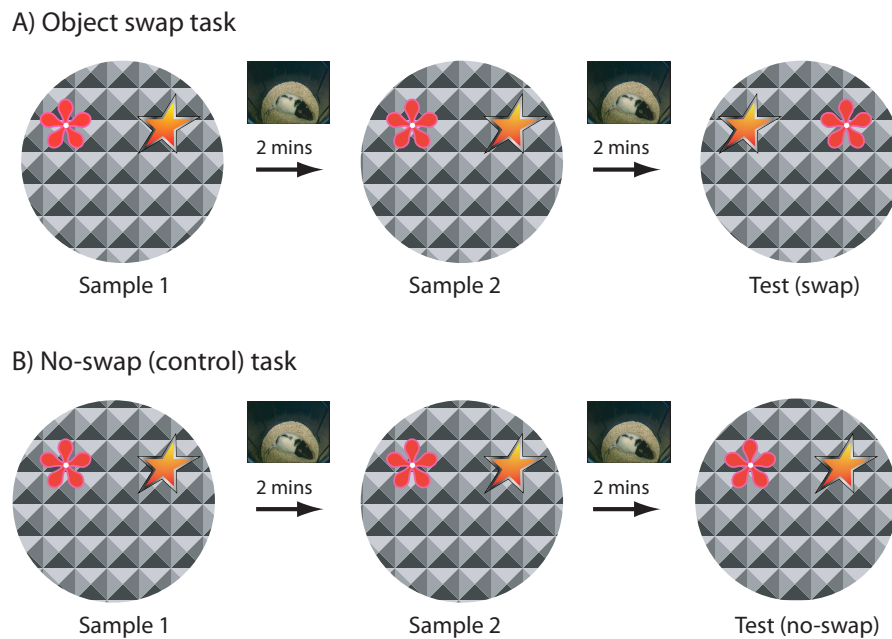

**Figure 4.4:** This Figure shows the object swap and no-swap (control) tasks which were performed to check that rats with lesions of the hippocampus could detect a simple object swap, which was an integral part of the object, location and context task (see Figure 4.3D).

In this task (see Figure 4.4), the procedure was very similar to that used in the integrated object, location and context task. There were 2 sample events and a test: each lasted 2 minutes and was separated by a 2 minute retention delay. Copies of 2 different objects were presented in the first sample event, followed by copies of the same 2 objects in the same locations in the second sample event. The 2 sample events were identical and occurred in the same context configuration of the test box. These 2 identical events were to measure the habituation of the rats to the configuration of objects. The test event consisted of either a situation in which the copies of the 2 objects had swapped positions (object swap task, Figure 4.4A) OR a third presentation of the same configuration of objects from the sample events (no-swap (control) task, Figure 4.4B). Each rat completed 4 trials of the swap and 4 trials of the no-swap condition, 2 in each context configuration. Each swap trial had a partner no-swap trial in which the same objects were used, but these sessions were separated by a 2 week gap. Only the 10 rats from the second replication of the object, location and context experiments were subjected to this extra control task.

#### 4.2.5 Data Collection & Analysis

An overhead black and white camera (Panasonic, UK) tracked the movement of the rat around the arena. This picture was fed into a TV monitor on the desk of the experimenter. A computer ran an in-house timing program (National Instruments, LabView) whereby depression of a key on the computer keyboard would activate a timer. This was done manually by the experimenter who observed the behaviour of the rat via the TV monitor and recorded the amount of time the rat was engaged in exploration. The experimenter was blind as to whether a particular rat belonged to the control or hippocampus lesion group at the time of testing. Key presses activated timers which differentially timed exploration at the 2 objects. This data was saved as a comma separated values file for each event that a rat experienced which could then be opened and the exploration times analysed in Microsoft Excel. Statistics were then run in SPSS and a random selection checked by hand. Greenhouse-Geisser corrections for sphericity were used when necessary and the Bonferroni correction for multiple comparisons was applied when a main effect or interaction was found from an ANOVA and simple effects were analysed (Hinton (1999), Howell (1997)). All t-tests are 2-tailed.

All raw data from sample and test events were recorded as times in seconds that rats spent exploring the novel and familiar objects configurations. The raw times were then converted into an exploration ratio for each rat on each trial using the following formula:

$$\frac{\text{time at novel} - \text{time at familiar}}{\text{time at novel} + \text{time at familiar}} \quad (4.1)$$

This calculation took into consideration the amount of time a rat spent exploring in total during the test event of a trial, regardless of which object it was exploring and was used so as to be comparable with Eacott and Norman (2004b). A value of zero indicated no preference for either object configuration, with a positive value indicating preferential exploration of the novel object configuration and a negative value indicating preferential exploration of the familiar object configuration. The exploration times in the sample phase were carefully controlled by the use of the criteria mentioned previously whereby there was a minimum and maximum time limit imposed on the rats' total time in the arena and a minimum amount of exploration that must be attained within this time window. If these criteria were not reached during the sample event(s) the data for the relevant rat for that entire trial (sample and test events) was excluded from further analysis. This was a rare occurrence and if it did happen, the rat was retested at a later date on the same trial but using different objects. The test events involved 3 minutes in the testing box with all exploration recorded and the theoretical criterion for inclusion of a trial

based on the test event performance was that there should be a minimum of 10 seconds of exploration in total. If this criterion was not reached, the data for that rat on that trial would be excluded from further analysis; however this situation never arose<sup>3</sup>.

#### 4.2.6 Histological Procedures

At the end of testing all animals were terminally anaesthetised with sodium pentobarbital (Euthatal, Merial Animal Health, UK) and then perfused intracardially with 0.9% saline followed by 4% formalin. The brains were removed and stored in formalin for a minimum of 24 hours. The brains were then trimmed to remove unwanted tissue and maximise fixation and placed into cuboid plastic moulds filled with fresh egg yolk which were incubated at 37°C for a further 24 hours in a shallow formalin bath. The egg coating solidified around the brains in a cube shape which was designed to provide extra support for the lesioned brains while they were being sectioned, because they become very fragile after losing the large central portion comprising the hippocampus. The egg embedded brains were then removed from the moulds and placed back into jars of 4% formalin at room temperature for a further 48 hours. Coronal 30µm sections were cut on a cryostat with every fifth section recovered for histological analysis. These recovered sections were mounted on gelatine coated slides, stained with 0.1% cresyl violet acetate and coverslipped using DPX. The extent of the lesions was then assessed by examining each section under a microscope (Wild M420, Switzerland) and transferring each image to a computer using a video camera (Leica) mounted on the microscope. The images could then be opened in the Leica QWin program and the area measurement tool allowed us to outline the area of any remaining hippocampus (CA field, dentate gyrus) and recorded the size of these areas in mm<sup>2</sup> for each section. This allowed us to calculate a total "volume" of hippocampal tissue remaining in each of the 22 brains. An average of the hippocampus volume in each of the 12 sham operated control brains was used as a value for 100% sparing of the hippocampus (i.e. intact hippocampus with no lesion) and any remaining hippocampal tissue in the lesioned brains was calculated as a percentage of this value .

---

<sup>3</sup>Data from swap vs. no-swap task was analysed in a slightly different way: see Section 4.3.1. The minimum of 15 seconds cumulative exploration applied only to the first of the 3 sessions. The theoretical criterion of at least 10 seconds total exploration in the test was revoked for this task due to the unknown effects that the 2 sample events (effectively habituation session to the object configurations) may have on the rats behaviour in a third no-swap test. It seemed possible that after 2 events of exploring the same objects in the same locations, that the rats may not explore them at all in a third no-swap session.

## 4.3 Results

### 4.3.1 Behavioural Data

#### 4.3.1.1 The hippocampus is not necessary for recognition of a novel object

The results of the novel object recognition task were analysed after the initial 4 trials to check that the rats were encoding the identity of the objects they were exploring, as discussed in Section 4.2.4. A value for the discrimination index during the test event was calculated for each trial completed by each rat on the novel object recognition task and then averaged across the 4 trials for each rat, then across the group (HPC lesion or sham control). A comparison of the discrimination ratio between the two groups by univariate ANOVA did not find any differences in performance between the control and hippocampus lesion groups on the novel object recognition task ( $F_{(1,20)} = 0.396; p = 0.536$ , see figure 4.5A). Further one-sample t-tests (2-tailed) against chance showed that both the control ( $t_{(11)} = 6.663; p < 0.001$ ) and hippocampus lesion ( $t_{(9)} = 10.302; p < 0.001$ ) groups were exploring the novel object significantly more than expected by chance.

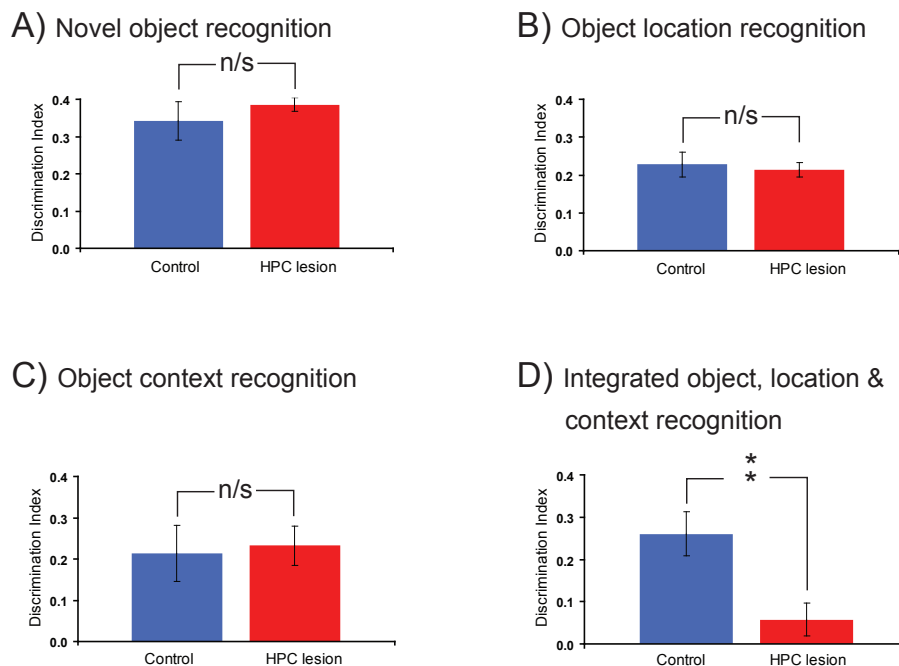

**Figure 4.5:** This Figure shows the performance (as measured by the discrimination index) of the 2 groups of rats in the different tasks.

#### 4.3.1.2 The hippocampus is necessary for integrated what-where-which memory but not for what-where or what-which memory

Rats with complete hippocampus lesions were impaired on the integrated object-location-context task but not the object in location or object in context tasks. A repeated measures ANOVA was performed on the discrimination index measure with Group (hippocampus lesion vs. control) as the between subjects factor and Task as the within subjects factor, with 3 levels for the 3 tasks (object in location, object in context and integrated object-location-context recognition tasks respectively). This showed that there was no main effect of Task ( $F_{(2,40)} = 1.606; p = 0.213$  or Group ( $F_{(1,20)} = 1.871; p = 0.187$ ) but a significant Task x Group interaction was found ( $F_{(2,40)} = 4.412; p = 0.019$ ). Corrected pairwise comparisons showed that the control rats performed equally well on all 3 tasks (all 3 comparisons  $p = 1.000$ ) but rats with hippocampus lesions showed impaired performance on the integrated object-location-context task relative to the object in location task ( $p = 0.010$ ) and the object in context task ( $p = 0.043$ ). (The 2 control tasks- object in location and object in context- were not significantly different ( $p = 1.000$ ).) Further corrected pairwise comparisons showed that the rats with hippocampus lesions differed from the control rats only on their performance in the integrated object-location-context task, where they were significantly impaired ( $p = 0.007$ ), but not the object in location or object in context tasks ( $p = 0.637$  &  $p = 0.838$  respectively).

One-sample t-tests against chance showed that the control rats were exploring the novel integrated object-location-context configuration significantly more than expected by chance ( $t_{(11)} = 4.935; p < 0.001$ ) but the rats with hippocampus lesions were performing at chance level ( $t_{(9)} = 1.514; p = 0.164$ ). One-sample t-tests performed on the object in location and object in context control tasks showed that both groups were performing significantly better than expected by chance on both of these control tasks (all 4 comparisons,  $p < 0.001$ ). These results show that rats with hippocampus lesions are impaired only on their ability to recognise an integrated novel configuration of object, location and context; not combinations of object in location or object in context alone.

#### 4.3.1.3 Additional measures of exploratory behaviour

Alternative measures of the rats' behaviour were also analysed to see whether the difference in discrimination index found between the 2 groups in the integrated object-location-context task could be due to differences in overall exploratory behaviour caused by the hippocampus lesion surgery.



**Total exploration time during the test event.** The first measure to be tested was the total amount of time in seconds that the rats spent exploring in the test event of each task. A repeated measures ANOVA was performed on this measure with Group as the between subjects factor and Task as the within subjects factor. This revealed a main effect of Task ( $F_{(1,327,26,538)} = 5.158; p = 0.023$ ), but showed no Task x Group interaction ( $F_{(1,327,26,538)} = 0.875; p = 0.388$ ) and no main effect of Group ( $F_{(1,20)} = 3.232; p = 0.087$ ). This analysis showed that the difference in performance between the lesion and control groups on the integrated what-where-which task cannot be explained by differential total exploration differences between groups. Corrected pairwise comparisons did not reveal any significant differences in total exploration time between any of the tasks for the lesion group (all comparisons  $p > 0.468$ ). The only significant comparison to result from this analysis was that the total exploration time in the test event differed between the object location and the object context tasks in the control group only ( $78.29 \pm 5.78$  vs.  $61.76 \pm 3.85$  seconds;  $p = 0.001$ ). This finding does not explain the specific impairment shown in the lesion group in the integrated what-where-which task.

**Number of visits made to the objects during the test event.** The number of visits that the rats made to the objects during the test event was also analysed. The number of visits corresponding to the novel vs. the familiar object configuration in each task was analysed first and neither group showed any significant differences on this measure in any of the tasks (all  $p > 0.243$ ) so this analysis is based on the total number of visits (to either object) made during the test event. A repeated measures ANOVA with Group as the between subjects factor and Task as the within subjects factor revealed an interesting result- there was a significant main effect of Group ( $F_{(1,20)} = 18.506; p < 0.001$ ) but no main effect of Task ( $F_{(2,40)} = 0.820; p = 0.447$ ) or Task x Group interaction ( $F_{(2,40)} = 1.112; p = 0.339$ ). Simple effects of Group revealed that the lesion group made more visits to the objects than the control group in both the object location and object context control tasks ( $p = 0.004$  &  $p < 0.001$  respectively). However in the integrated object, location and context task the difference in visits to the objects did not reach significance between the lesion and control groups ( $p = 0.084$ , see Figure 4.6A). It is, however, difficult to speculate whether this could be the cause of the impairment or an effect of it.

**Analysis of the sample events** To further investigate the possibility that the impairment seen in the integrated object, location and context task may be due to differential exploratory behaviour between the lesioned and control rats, the exploration data from the sample events in each task was also analysed. Although the exploration in the sample events was controlled, with the criteria being that rats must accumulate 15 seconds of

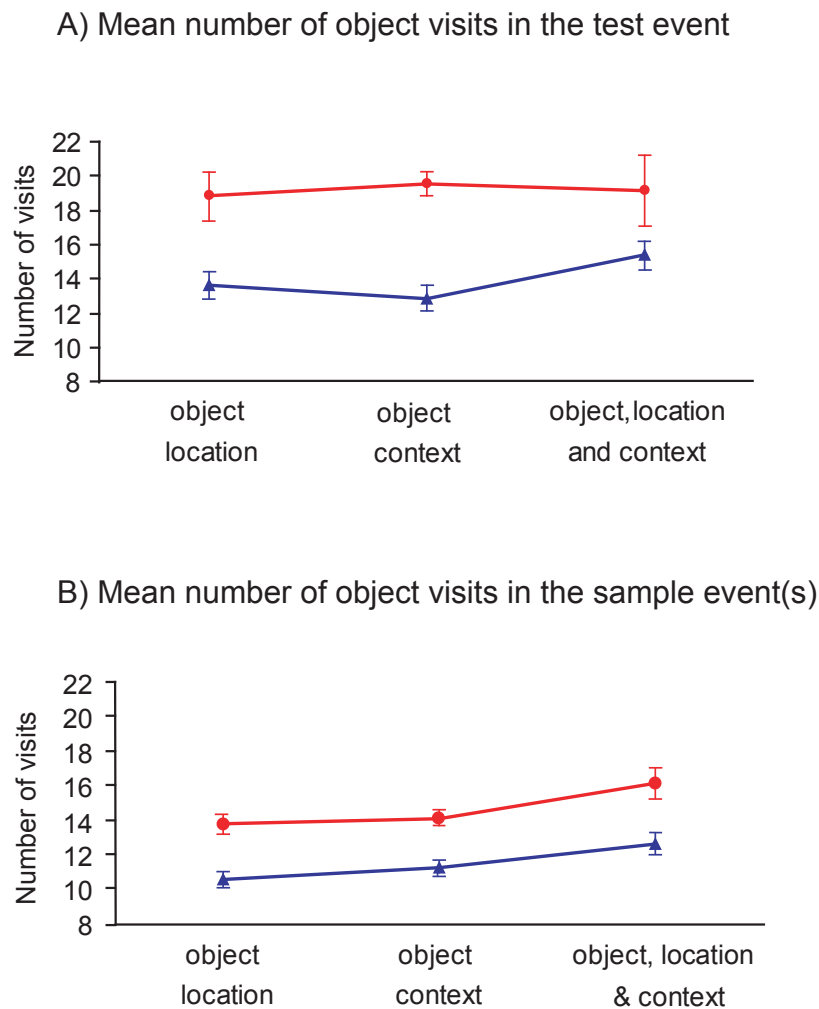

**Figure 4.6:** This Figure shows the mean number of visits each group made on average to the objects during the test events (A) and sample events (B).

exploration time at each object within a time frame of a minimum of 2 minutes and a maximum of 5 minutes, there was still room for variability. Therefore, analysis of the sample event data aimed to test for differences in the total amount of time the rats spent exploring, the trial length (i.e. how long it took the rats to accumulate this total exploration time) and the number of visits that the rats made to the objects.

**Total exploration time during the sample events.** The amount of exploration in each sample event in the object context and integrated tasks was analysed previously to check for differences in exploration between the first and second sample event. Both tasks and both groups showed no significant difference on this measure (all  $p = 1.000$ ) so the following

analysis is based on the mean amount of time taken to achieve the required exploration time in the tasks with 2 sample events. A repeated measures ANOVA was first performed on the total amount of time in seconds that the rats spent exploring during the sample events, with Group as the between subjects factor and Task as the within subjects factor. This showed a highly significant main effect of Task ( $F_{(2,40)} = 22.476; p < 0.001$ ) but no main effect of Group ( $F_{(1,20)} = 0.002; p = 0.964$ ) and no Task  $\times$  Group interaction ( $F_{(2,40)} = 0.224; p = 0.801$ ). Corrected pairwise comparisons showed significant differences in sample event exploration time between the object location control task and the other 2 tasks (object context task: lesions  $p = 0.011$ , controls  $p = 0.001$ ; integrated task: lesions  $p = 0.003$ , controls  $p = 0.002$ ) however these differences do not show a pattern consistent with a specific impairment in the lesioned rats in the integrated object-location-context task. The amount of exploration in each sample event in the object context and integrated tasks was analysed previously to check for differences in exploration between the first and second sample event. Both tasks and both groups showed no significant difference on this measure (all  $p = 1.000$ ) so the analysis above is based on the mean amount of time taken to achieve the required exploration time in the tasks with 2 sample events..

**Length of sample events.** All rats were required to spend between 2 and 5 minutes in the testing box during the sample events (depending on how long it took them to accumulate 15 seconds of exploration time at each object). The lengths of each sample event in the object context and integrated tasks were analysed previously to check for differences in exploration between the first and second sample event. Both tasks and both groups showed no significant difference on this measure (all  $p = 1.000$ ) so the analysis above is based on the mean amount of time taken to achieve the required exploration time in the tasks with 2 sample events. A repeated measures ANOVA was performed on the length of the sample events, with Group as the between subjects factor and Task as the between subjects factor. There was no main effect of Task ( $F_{(2,40)} = 0.367; p = 0.695$ ) or of Group ( $F_{(1,20)} = 1.919; p = 0.181$ ) and no Task  $\times$  Group interaction ( $F_{(2,40)} = 0.149; p = 0.862$ ). This showed that there were no obvious differences in the length of time taken to accumulate the required amount of object exploration in the sample events.

**Number of visits made to objects during the sample events.** The final parameter to be investigated was the number of visits that the rats made to the objects during the sample events. This was the only other behavioural measure in the test event analysis to show a pattern of differences between the control and lesion groups that correlates in any way with the lesion group performance deficit seen in the integrated object, location and context task. The number of object visits made in each sample event in the object context

and integrated tasks were analysed previously to check for differences in number of visits between the first and second sample event. Both tasks and both groups showed no significant difference on this measure (all  $p > 0.339$ ) so the analysis above is based on the mean number of visits made to the objects in each sample event in the object context and integrated task. A repeated measures ANOVA was performed on this measure with Task as the within subjects factor and Group as the between subjects factor. This revealed a main effect of Task ( $F_{(1.485,29.696)} = 8.442; p = 0.003$ ) and a main effect of Group ( $F_{(1,20)} = 67.37; p < 0.001$ ) but no Task x Group interaction ( $F_{(1.485,29.696)} = 0.196; p = 0.757$ ). Simple effects of Task and Group revealed that neither the lesion or control group showed significant differences in the number of visits they made to objects between the tasks (all  $p > 0.075$ ) but the lesion group again made consistently more visits to the objects than the control group showing a similar pattern to that seen in the equivalent measure in the test event (all  $p < 0.003$ , see Figure 4.6B.<sup>4</sup>

#### **Rats with hippocampus lesions can detect a simple object swap**

Results from the object swap task show that animals with lesions of the hippocampus can recognise that 2 objects have swapped places. This is a vital part of successfully performing the object in location part of the integrated object-location-context task (see Figure 4.3 on page 111), due to the slight change in procedure from the object location control task presented previously in Section 4.2.4. One rat from the control group was removed from further analysis because of failure to accumulate the minimum amount of exploration time in the first event of any of the trials, which leaves groups of  $n=4$  control rats and  $n=5$  rats with hippocampus lesions. Initially, the mean total exploration time in each of the sessions for the swap and no-swap tasks was analysed. A repeated measures ANOVA was performed across all the sessions with Session as the within subjects factor and Group as the between subjects factor. This revealed a main effect of Session ( $F_{(5,35)} = 26.826; p < 0.001$ ) and no main effect of Group ( $F_{(1,7)} = 1.993; p = 0.207$ ) or Session x Group interaction ( $F_{(5,35)} = 1.706; p = 0.159$ ). Corrected pairwise comparisons showed that there was no difference in exploration time between the first exposure to the objects (all  $p > 0.093$ ) and the second exposure to the objects (all  $p > 0.112$ ) on the object swap vs. the no-swap task condition. All rats however showed differential exploration in the third session, depending on whether the condition was swap or no-swap (all  $p < 0.027$ ). This gives a good indication that both groups of rats were exploring the displaced objects

---

<sup>4</sup>the number of object visits made in each sample event in the object context and integrated tasks were analysed previously to check for differences in number of visits between the first and second sample event. Both tasks and both groups showed no significant difference on this measure (all  $p > 0.339$ ) so the analysis above is based on the mean number of visits made to the objects in each sample event in the object context and integrated task.

in the swap condition more than the stationary objects in the no-swap condition (lesions  $52.92 \pm 3.13$  vs.  $26.73 \pm 3.76$ ; controls  $47.49 \pm 7.01$  vs.  $18.77 \pm 7.48$  respectively).

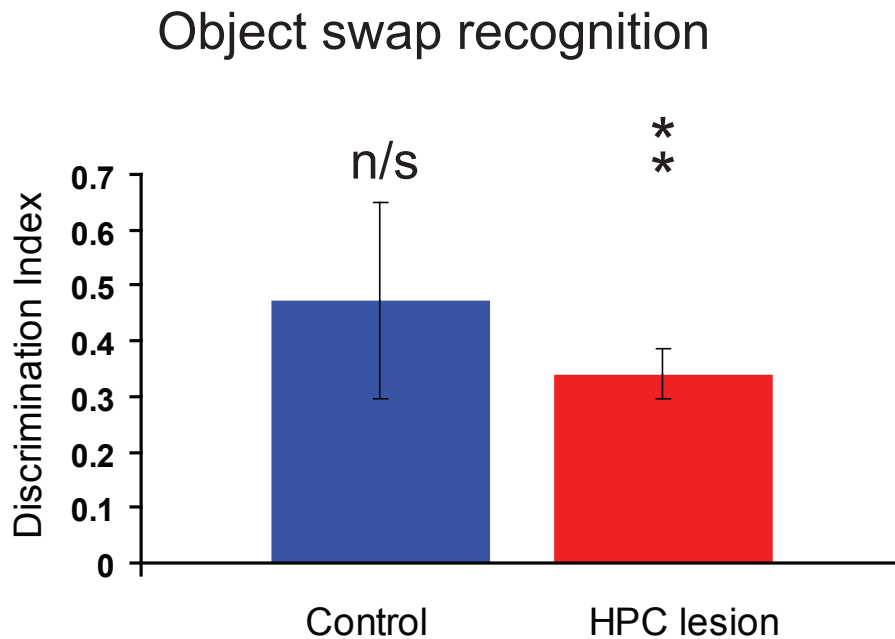

**Figure 4.7:** This Figure shows the performance (as measured by discrimination index values) of the 2 groups of rats on the object swap task. The discrimination index was calculated using the test event of the swap task as the novel exploration value and the test event of the no-swap (control) task as the familiar exploration value.

In this situation the mean total exploration time in the third event of the object swap task (where the swap manipulation occurred) was used as the novel value and the mean total exploration time in the third event of the control no-swap task (where no manipulation of the objects took place) was used as the familiar value in order to calculate the discrimination index. There was no difference between the discrimination indices of the groups when tested with a univariate ANOVA ( $F_{(1,8)} = 0.653$ ;  $p = 0.446$ ). The discrimination index of the hippocampus lesion group was significantly above chance ( $t_{(4)} = 7.625$ ;  $p = 0.002$ ) but the same index for the control rats actually failed to reach significance due to a high level of variability ( $t_{(3)} = 2.670$ ;  $p = 0.076$ ). Although the variability in the results from the 4 control rats in this task meant that they were not statistically performing above chance, the important result is that the rats with hippocampus lesions could recognise that 2 objects had swapped locations. Data from the object swap task show that the impairment seen in the integrated object-location-context task in the previous section is not due to a hippocampus-dependent interference effect. The swapping of objects between 2 locations between the first and second sample events of the integrated object-location-context task is not dependent on the hippocampus and therefore a failure

to recognise this swap is not the cause of the impairment seen in the lesion group.

### 4.3.2 Histology Data

L hemisphere	R hemisphere	Total sparing
3.50% +/- 1.63%	10.16% +/-2.27	6.83% +/- 1.95

N.B: All spared tissue was in the ventral hippocampi

**Table 4.2:** This Table shows the % tissue sparing in rats with hippocampus lesions relative to sham operated controls.

At the end of testing, the brains from all the rats were processed as described in Section 4.2.6. Both lesion and sham rats suffered a small amount of damage to the overlying parietal cortex from needle insertion. Damage to the pre- and post-subiculum, entorhinal and perirhinal cortices and the majority of subicular cells was successfully avoided in the lesion group. Table 4.2 shows the size of the hippocampus lesions in numerical form, where the figures for tissue spared in the hippocampus (DG, CA1-4) are calculated as a percentage of the mean volume of hippocampus tissue in the average of the sham operated control rats (100%). Figure 4.8 shows an example of a hippocampus lesion typical of that produced in a 250-300g bodyweight Lister hooded rat with 10mg/ml ibotenic acid using the coordinates in Table 4.1 where the brain has been processed as described previously in Section 4.2.6. Note the loss of supportive/connective tissue in the area surrounding the lesion, in contrast to the lesion histology presented in Chapter 2. This difference is due to the different amounts of time that the rats remained alive after the lesion. In Chapter 2, the histology example shows a brain from a rat which underwent surgery at the same time as the rats used in the behavioural experiment but was sacrificed 2 weeks post-surgery instead of undergoing behavioural testing. This was to illustrate the state of the brain at the critical behavioural testing point. The brain shown in Figure 4.8 is from a rat who participated in the reported behavioural experiment and previous experiments in the same room (as described in Section 4.2.1) so was sacrificed almost 12 months after receiving the lesion surgery. This longer time scale results in the

death of the structural tissue surrounding the cell layers (DG, CA1-4; the target of the lesion) which makes the lesion site appear as “holes” in the coronal section (Jarrard 1989). This phenomenon has the added effect of making the brains very difficult to section as they have lost a large amount of central tissue in both the antero-posterior and dorso-ventral planes, leaving the cortical layers prone to tearing and distortion, which can be seen in Figure 4.8. As mentioned in Section 4.2.6, the egg embedding process is used to provide the fragile lesioned brains with additional support in order to retain their shape and attempt to minimise cortical disruption during histological processing.

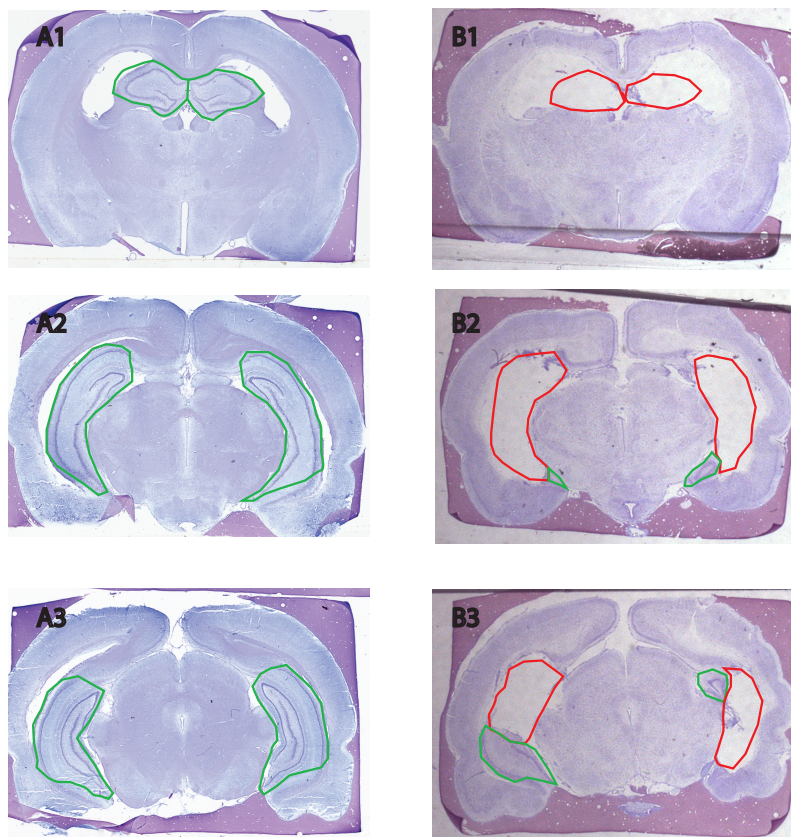

**Figure 4.8:** Photomicrographs of cresyl violet stained coronal sections of the hippocampus in a sham operated brain (rat D6412, A1-3) and a representative complete hippocampus lesion (D6418, B1-3). Approximate anteroposterior distances from Bregma: A1 & B1 = -2.6mm; A2 & B2 = -5.0mm; A3 & B3 = -6.0mm.

## 4.4 Conclusions and Discussion

The integrated what-where-which experiment designed by Eacott and Norman (2004b) was successfully replicated with very similar levels of performance shown in the control rats between the published results and my own. Rats with hippocampus lesions showed a deficit in memory for trial-unique object-location-context (what-where-which) configurations at a retention delay of 2 mins whilst performing at a level indistinguishable from controls on a variety of other control tasks. Specifically, rats with large complete lesions of the hippocampus showed no impairments in memory for novel objects, trial-unique object-location configurations, trial-unique object-context configurations and discrimination of an object-location swap. These tasks provided a complete set of controls for all the procedural and associative elements of the integrated what-where-which task, therefore confirming that the impairment seen in rats with hippocampus lesions was not due to secondary effects of procedural difficulty, or lack of memory for the location or context elements of the task either alone or in pairs.

There appears to be something specific to the integration of the 3 aspects of the task- object, location and context information- that necessitates the involvement of the hippocampus. Eacott and Norman (2004b) published this experiment as a model of episodic-like memory in the rat and my recent results provide further strength to this argument. It is unlikely that the hippocampus becomes necessary for the integrated task simply due to the increased number of stimuli involved, since rats can show learning and retention of multiple stimuli, and even pairs of stimuli, in different modalities independent of the hippocampus (Gaffan and Eacott 1997; McDonald et al. 1997; Dudchenko et al. 2000). It also seems unlikely that this task can easily be solved by relative familiarity alone since the memory test involves presentation of 3 familiar stimuli (object, place and context are all familiar) and even the pairwise configurations of object with context and object with location are familiar. This brings us to the remaining possibility, which is that memories for each object- and the contexts and locations each one appears in over the 2 sample events- are stored as scene memories (Gaffan 1991), and these memories are compared with the current scene to “spot the difference” and recognise which object now appears in a novel scene, or which part of the scene is novel with respect to the object in it. However in monkeys (Gaffan 1994) and humans (Boyce et al. 1989; King et al. 2004; Hollingworth 2006) there is evidence that this type of memory may in fact be a valid test of episodic memory involving the hippocampus so the argument has come full circle. Although this paradigm does not force the use of recall by design, it is possible that the 3 different types of stimuli that need to be integrated- what, where and which- necessitate the formation of an episodic-like representation of an event, which may then require the contribution



of recollection at the point of memory retrieval: the task may be too complex to be solved by familiarity (recognition) alone, or recall may perhaps be the most efficient strategy. The latter seems less likely, since rats with hippocampus lesions perform at chance levels on this task; not just showing an impairment relative to controls; which is what would be expected if familiarity and recollection were both involved. The striking difference in performance between rats with hippocampus lesions and control rats posits the possible (and desirable!) explanation that the integrated task may indeed be a model of episodic-like memory recall and therefore perhaps involve the putative recollection circuitry suggested by Aggleton and Brown (1999).

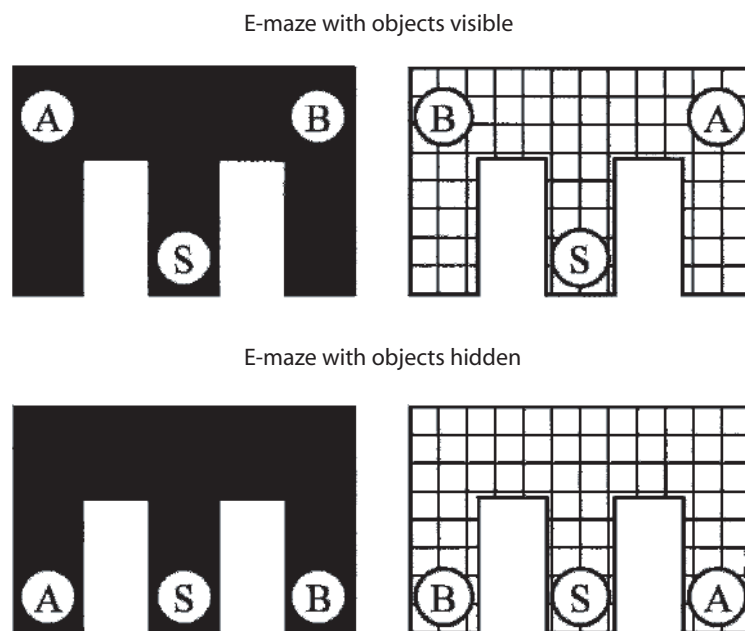

**Figure 4.9:** Schematic representation of the Emaze apparatus used in the recall version of Eacott and Norman's original what-where-which task.

Eacott et al. (2005) have now developed a version of their original what-where-which task that involves an element of forced recollection in order to solve it (see Figure 4.9). This has been achieved by the use of an E-shaped maze which can- like the arena used in their 2004 experiments- be configured as either of 2 contexts. Objects (A and B) may be present in locations where they are visible to the animal while it is still in the start area (S), making the task very similar to that used previously, or the objects may be hidden from view. In order to induce a preference for one of the objects without presenting the rats with the complete object-place-context configuration (in which they may be able to

recognise the novel combination of what, where and which using a simple familiarity recognition process), rats are habituated to one of the objects seen in the sample phases over a short retention delay. Their natural novelty seeking behaviour means that when they are replaced into the Emaze, they will search for the object that they have not just been habituated to. To approach this object successfully when the Emaze is in the “objects hidden” configuration (bottom panel of Figure 4.9), the rats must remember the location (where) of the object (what) in the particular context (which). The overall concept of the experiment is the same as the “familiarity” version described in this chapter, but the subtle change in apparatus and protocol has allowed Eacott et al to truly examine recall—a combination of the aims of the first and second parts of this thesis! A minor drawback of this task is the difficulty in testing the control conditions of object-place and object-context recognition. It is of course not simple to carry out the object-context recognition version of the task using hidden objects, as there is then automatically a spatial element involved, but it would be very interesting to know whether the recall of the location alone (or left/right turn required to reach it) would involve the hippocampus. Although a large body of previous literature would assume the answer would be positive, more recent evidence from work by Eacott et al and myself and colleagues would suggest that allocentric spatial recall or egocentric encoding (both strategies that would be valid to solve this task) may in some conditions become independent of the hippocampus.

In summary, we have successfully replicated the task of Eacott and Norman (2004b) and shown therefore that this is a robust protocol replicable between laboratories. The task has many features that make it comparable to episodic memory in humans, including that it is acquired over a single experience without the requirement for training which may give rise to semantic rule learning. The use of contextual elements of an event or episode as an alternative to strictly temporally mediated control of episodic memory has been justified in the introduction to this thesis, making the paradigm designed by Eacott and Norman (2004b) a valid and useful laboratory task to study the neurobiology of elements of episodic-like memory in the rat.

## **Chapter 5**

# **Manipulations of object location parameters: effects of hippocampus lesions**

## 5.1 Introduction

The previous experiment clearly revealed a role for the rat hippocampus in memory for integrated object, location and context information but raised ambiguities regarding the current body of literature on object recognition. The object location recognition and object context recognition “control” tasks described in the previous chapter (see Panels A&B, Figure 4.3 on page 111) are not dependent on the integrity of the hippocampus. This result is crucial to the observations made about the specific role of the hippocampus in the integration of the object, location and context information in the experiment since a deficit on either of the control tasks induced by the hippocampus lesion would imply that the deficit seen in the integrated task was probably due to impaired processing of one of its elements (e.g. impaired location or context information processing). Deficits in novel object recognition due to removal of the hippocampus would not necessarily be expected at the short memory retention period (2 mins) used in the previous experiment (Clark et al. 2000; Ainge et al. 2006; Save et al. 1992). The role of the hippocampus in object location and object context processing however could easily be implicated from the literature which contains both direct and indirect evidence. The huge body of evidence implicating the rodent hippocampus in spatial navigation and contextual processing (Morris et al. 1982; Stubbley-Weatherly et al. 1996; Selden et al. 1991; Kim and Fanselow 1992) easily leads to the conclusion that processing the location of an object or the context in which it appears in variations on the novel object recognition paradigm (Ennaceur and Delacour 1988) also depends on the hippocampus. Mumby et al. (2002) showed that object recognition was intact in rats with complete excitotoxic lesions of the hippocampus at a retention delay of five minutes, while memory for the location or context in which an object had appeared was absent in these rats. Similarly, Save et al. (1992) showed that rats with electrolytic dorsal hippocampus lesions failed to recognise objects that had changed location within an environment after a three minute retention delay, although these rats could also recognise a completely novel object without any impairment. Examination of these papers revealed procedural differences in the way the experiments were conducted compared to the procedures used in my task and Eacott and Norman (2004b) which will be examined in this section of the thesis as a possible cause for the contrasting results seen.

Given the indisputable evidence for the role of the rodent hippocampus in spatial navigation, the results from the object location test described in the previous chapter may seem surprising. However it should be noted that in the way the experiment was run, there should have been no requirement for the rats to have a representation of allocentric space in order to discriminate the novel object location configuration. The rats were

always placed into the testing box at the same point, facing in the same direction and the objects were always fixed at the same two locations within the box. There were also large three dimensional cues attached to the curtains surrounding the box, and two of these hung approximately above the positions of the two objects. All these measures were designed to do exactly what the data show: to make it possible for rats with lesions of the hippocampus to perform the control tasks by simplifying them as much as possible so that what we were examining in the integrated object, location and context task was purely the rats ability to integrate the three elements of the task. This is not to say of course that the rats did not have an allocentric representation of space in the testing apparatus, just that it should not have been essential, thus rendering it possible for rats with hippocampus lesions, who would be expected to lack the ability to form an allocentric representation, to detect the novel object location configuration using information relative to themselves (egocentric) rather than an allocentric representation of the environment. Since all the rats received their surgical procedures before having any experience of the testing environment, evidence from the literature would strongly suggest that the rats who had their hippocampi removed during surgery would never have formed an allocentric representation of it (Morris et al. 1990b). The rats in the control group who received sham surgeries should have been able to form an allocentric representation of the testing environment as their hippocampi were intact throughout, but the task would not have forced them to form or indeed use such a representation.

In the object location task used by Mumby et al. (2002) the displacement of one of two identical copies of an object was to a location in the testing arena in which there had never previously been an object, i.e. a completely novel location (shown in Panel A of Figure 5.2 on page 138). In contrast, Figure 4.3 on page 111 shows the way the object location task was run in my experiment: there are no novel locations involved, but one of the object locations was filled by an object which was neither itself novel nor in a novel location, but in a configuration of object identity and location that was novel. A slightly different caveat appears in the task used by Save et al. (1992), shown in Panel B of Figure 5.2 on page 138. In this paper the authors use a configuration of 5 objects whose locations are manipulated and rats are tested on their recognition of these manipulations after a three minute retention delay. In the crucial testing phase, three of the five objects are displaced but of these three, two of them swap locations with each other (a topological change) while a third is moved to a location in the environment where an object has never previously been encountered (a metric change), as in Mumby et al. (2002). The analysis by Save et al. (1992) however does not take into account the type of displacement applied to an object, but groups exploration data for all 3 of the displaced objects together. Recent data suggest that detecting topological versus metric manipulations of objects in

an environment may in fact be dependent on different brain regions (Goodrich-Hunsaker et al. 2005). This paper shows evidence that excitotoxic dorsal hippocampus lesions impair rats' recognition of a metric change in the relationship between two objects in their environment (i.e. that two objects have been moved further apart or closer together on a horizontal plane perpendicular to the rat) but have no effect on their ability to detect a topological change (i.e. that two out of four objects in a square arrangement have had their locations swapped, see Figure 5.1 on the next page).

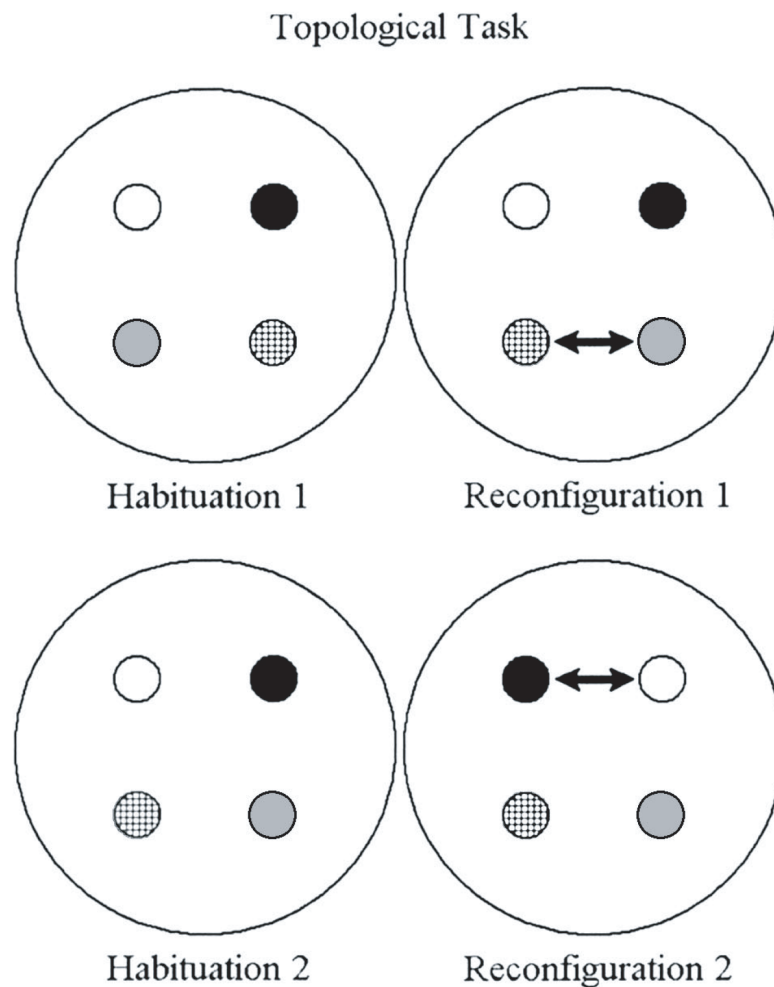

**Figure 5.1:** Schematic of the topological object swap task used by Goodrich-Hunsaker et al. (2005). Black arrows indicate which of the 4 objects (represented by circles) have had their locations swapped. Note that no novel locations are introduced- objects are simply swapped between familiar locations, which is what is meant by “topological” in object recognition terms. Rats with lesions of the dorsal hippocampus could recognise that 2 objects had swapped positions and explored them preferentially over the 2 stationary objects.

In the first experiment therefore, all the rats from the two replications of the experiment described in the previous chapter were tested on an object location task which involved moving one of two objects to a completely novel location in the test box to see if an intact hippocampus was required under these conditions to perform the task. Another caveat was that in Save et al. (1992), there was a configuration of 5 objects which the rats had to

explore, so as well as the fact that one object was moved to a completely novel location, another reason for the involvement of the hippocampus in the task may have been the task complexity due to the increased numbers of stimuli that had to be encoded. In my version of the object location task there were only two objects involved, but it is possible that having a larger number of stimuli (or a more complex configuration of stimuli) to remember may necessitate the recruitment of the hippocampus, although evidence for this in rats is ambiguous (Kesner et al. 1988; Steele and Rawlins 1993; Dudchenko et al. 2000). To investigate this more fully, the object location task was again repeated using a subset of rats (from the second replication of the experiment described in the previous chapter) with a configuration of 4 objects, where two of the objects from diagonally opposite corner positions swapped location in the test. This was an attempt to see if the effect of the hippocampus lesions seen in Save et al. (1992) would be revealed if the number of stimuli in the object-location task was increased. After closer investigation into the methods used in Save et al. (1992) and Mumby et al. (2002), it was revealed through personal communications with the authors of these two papers that there may be a further critical factor which may have affected whether or not the hippocampus was necessary for rats to perform the object location tasks. Throughout my experiment in the previous chapter, I consistently placed the rats into the testing box at the same location (west) and facing the same direction (the west wall) at the start of every session; sample and test. Although this information was not published in the papers (Mumby et al. 2002; Save et al. 1992), previous literature from watermaze experiments (Morris et al. 1982; Eichenbaum et al. 1990; Compton et al. 1997) led me to think that this could have been a very important procedural aspect of the object location tasks. However in Save et al. (1992) the rats were placed into the testing box at an arbitrarily chosen location each time they entered it. In Mumby et al. (2002) the rats were placed into the testing box equidistant from the two objects but due to the nature of the task, in that one of the objects would move to a novel location within the box for the test, this location was not fixed relative to the environment, only relative to the objects. After receiving this information from the authors I decided to also check if this could contribute to whether or not an object location task required the hippocampus. Using the same rats that had just completed the 4-object location task, I then reverted to the 2-object location task but while the rats entered the testing box at the usual west location at the start of the sample event, they were then placed into the box at either the north or south locations at the start of the test to force them to utilise allocentric information to recognise the novel object location configuration.

These manipulations aimed to investigate the possible reasons for the discrepancies between the results seen previously in the object location recognition literature and the object location task of Eacott and Norman (2004b) which I successfully replicated in the



previous chapter.

## 5.2 Materials & Methods

### 5.2.1 Subjects

The subjects used in the first experiment (novel location recognition) included all 22 rats from both replications of the object, location and context tasks described in Section 4.2.1 on page 105 ( $n = 12$  controls,  $n = 10$  hippocampus lesions). The second and third experiments (4-object location task and “allocentric” 2-object location task) used only the rats from the second replication of the object, location and context task ( $n = 5$  controls,  $n = 5$  hippocampus lesions).

### 5.2.2 Surgery

Surgical procedures for these rats are described in Section 4.2.2 on page 105.

### 5.2.3 Apparatus

Apparatus for the experiments described in this chapter is as described previously in Section 4.2.3 on page 107<sup>1</sup>.

### 5.2.4 Behavioural Testing

#### Novel location recognition

This experiment was carried out in 2 replications which involved the 12 rats and the 10 rats from the first and second replications of the object, location and context tasks described in Section 4.2.1 respectively. A schematic example of a trial from this task is shown in Figure 5.2C. The task comprised two events: 1 sample event and 1 test and the procedure was the same as for the object location task described in Section 4.2.4 on page 108. During the sample event, the rats explored 2 identical objects, following the same criteria defined previously (Section 4.2.4)<sup>2</sup>. The test event consisted of 3 minutes of exploration of 2 further copies of the 2 identical objects from the sample event, but one

---

<sup>1</sup>the 4-object location task involved the positioning of two extra objects in the testing box: these were positioned in the north-west and south-west locations.

<sup>2</sup>The retention delay between this sample event and the test event was 5 minutes for the rats in the first replication, in order to allow direct comparison with Mumby et al. (2002). In the second replication, a retention delay of 2 mins was used to compare with the Eacott and Norman (2004b) object location task. There was no significant difference between the data collected from each replication so they were pooled for analysis.

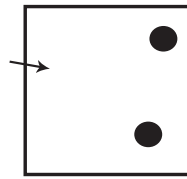
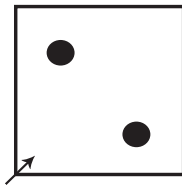
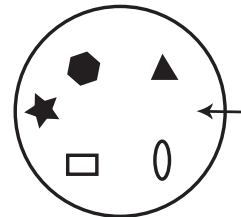
A) Novel location recognition task of Mumby *et al.* (2002)B) Object location recognition task of Save *et al.* (1992)

C) Novel location recognition task

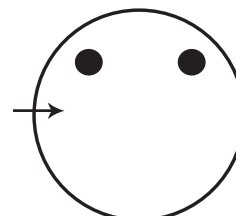
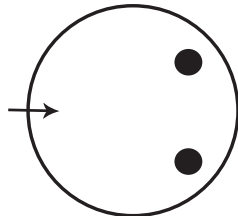

D) 4-object location recognition task

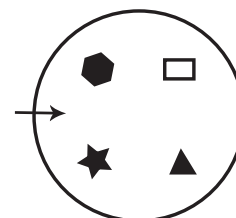
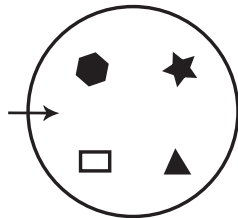

E) "Allocentric" object location recognition task

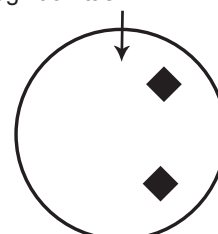
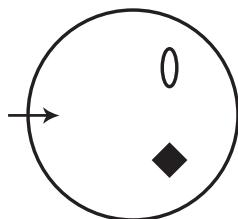

**Figure 5.2:** This Figure shows examples of trials from the tasks used by Mumby *et al.* (A), Save *et al.* (B) and my variations of them (C,D&E). The entry points of the rats into the arena are marked by black arrows and are relative to the compass shown at the top right. The sample events are represented in the left column and the tests in the right column.

of the copies was displaced from the usual north-east or south-east locations to a novel location in which the rats had never previously seen any object. Each rat completed 4 trials on this task: 2 in each context configuration. 2 trials involved the displacement of the

north-east object, and 2 trials the south-east object. On each of the 4 trials, a different and therefore completely novel location was chosen to move the displaced object to. This was to test whether the introduction of a familiar object to a novel location in the environment would require the hippocampus for recognition.

#### 4-object location recognition

This experiment was carried out using only the 10 rats from the second replication of the object, location and context tasks described in Section 4.2.1. This 4-object location task also involved one sample event and one test. A schematic example of a trial from this task is shown in Figure 5.2D. In the sample event, rats entered the arena from the west, facing the west wall (as in all previous experiments) but they were now faced with 4 objects, 2 in the usual north-east and south-east locations and an additional 2 in the equivalent north-west and south-west locations<sup>3</sup>. Each of the 4 objects was different. The length of the sample event was increased to 5 minutes as standard and the amount of exploration time the rats had to accumulate at each object was reduced to 10 seconds due to the increased number of stimuli that the rats were expected to investigate. A total of 10 rats were involved in this experiment and each completed 4 trials; 2 in each context configuration. 2 trials (one in each context) involved the swapping of the objects in the north-east and south-west locations and the other 2 involved the swapping of the objects in the north-west and south-east locations<sup>4</sup>. On any trial where a rat did not achieve the target of 10 seconds of cumulative exploration of each of the 4 objects, the data for that trial was not included in further analysis<sup>5</sup>. The retention delay was 2 minutes long and the rats spent it in the opaque holding bucket as described in Section 4.2.4. In the test, copies of the same 4 objects as in the sample event were presented, but 2 objects from diagonally opposite locations (e.g. north-east and south-west) were swapped. Instead of the rat looking at 2 identical objects in the test (as was the case in the object location task described previously (see Figure 4.3 on page 111 Panel B)), there were now the same 4 objects as in the sample event, but 2 of them had swapped locations. This was to test the hypothesis that the low

<sup>3</sup>The rats were habituated to the 2 additional locations in 2 10-minute habituation sessions before testing on this task began. These involved free exploration of 4 random junk objects that would not be presented again during testing, with one session held in each context configuration of the testing box.

<sup>4</sup>It should be noted that each object location swap involved one object from one of the original (north-east or south-east) locations and one object from the more recently introduced (north-west or south-west) locations. This was done intentionally with the aim of counterbalancing for any effect of the object locations being new or old, since in any trial the pair of displaced objects consisted of one from a newer and one from an older location.

<sup>5</sup>This situation occurred in 5/40 trials, 4 of those trials were due to 3 control rats and the other was due to a lesioned rat. In each case, only 1 object of the 4 presented was not explored for the minimum time of 10 seconds. The locations of the objects which failed to reach the exploration criteria were the recently introduced locations (north-west and south-west) 3 times, and the older (original) locations (north-east and south-east) twice.

number of stimuli in the Eacott and Norman (2004b) object location task may have been the reason that this task was not dependent on the hippocampus in neither their nor my replications of it.

### **“Allocentric” object location recognition**

After the discovery via personal communication with the authors that in both of their published experiments (Save et al. (1992); Mumby et al. (2002)) the rats had entered the test boxes from a variety of starting positions, I decided to impose this condition on the original object location task described in Section 4.2.4 (see Figure 4.3, Panel B). This experiment was carried out using the same rats as the 4-object location recognition task described above and the procedure was identical to that described for the object location task in 4.2.4 apart from the one critical condition: at the start of the test, the rats were placed into the box from a different entry point. A schematic example of a trial from this task is shown in Figure 5.2E. All rats completed 4 trials, 1 trial in each context entering from the north on the test, 1 trial in each context entering from the south on the test. The rest of the test phase was identical to that described previously in Section 4.2.4. On any trial where a rat did not reach the criterion level for exploration in the sample event (i.e. 15 seconds cumulative exploration at each object), the data from that trial was excluded from further analysis<sup>6</sup>. This manipulation aimed to see if the rats were able to flexibly use information about the features of their environment to recognise which object was in a different location to where it had been in the sample event, without relying on the information about the locations of the objects relative to the rats themselves.

### **5.2.5 Data collection and analysis**

All data collection and analysis was identical to that described in Section 4.2.5<sup>7</sup>.

### **5.2.6 Histological analysis**

All histological analysis was carried out as described in Section 4.2.6.

---

<sup>6</sup>This situation occurred in 2/40 trials: one failure to achieve criterion was due to a control rat and the other was due to a rat with a hippocampus lesion.

<sup>7</sup>where 4 objects were used instead of 2, the mean exploration time for the two swapped objects was analysed relative to the mean exploration time for the 2 stationary objects.

## 5.3 Results

### 5.3.1 Behavioural Data

#### Novel location recognition

A univariate ANOVA was performed on the discrimination index data with Replication and Group as the between subjects factors. This showed no main effect of Replication ( $F_{(1,18)} = 0.122; p = 0.731$ ) or Group ( $F_{(1,18)} = 2.803; p = 0.109$ ) and no Replication  $\times$  Group interaction ( $F_{(1,18)} = 0.080; p = 0.780$ ). Performance (as measure by discrimination index) was therefore not dependent on retention delay length (2 vs. 5 minutes) or surgery group (hippocampus lesion vs. control). Further one-sample t-tests against chance showed that both the control ( $t_{(11)} = 7.642; p < 0.001$ ) and hippocampus lesion groups ( $t_{(9)} = 3.324; p = 0.009$ ) were exploring the object in the novel location significantly more than expected by chance (see Figure 5.3A).

#### 4-object location recognition

This experiment was done with only a small subsection of the rats ( $n=5$  hippocampus lesion group,  $n=5$  control group) from the second replication of the experiments described in chapter 4. There was only a single replication, consisting of each rat completing 4 trials. Since there were 2 displaced objects and 2 stationary objects in the test, data from each displaced object was combined to give a single value for average exploration time for displaced objects and the same was done for the stationary objects. The discrimination index for each trial for each rat was then calculated using these average times. A univariate ANOVA was performed on the discrimination index data with Group as the between subjects factor. This showed no main effect of Group ( $F_{(1,8)} = 0.503; p = 0.498$ ). Unfortunately, further one-sample t-tests against chance showed that neither the control ( $t_{(4)} = 1.722; p = 0.160$ ) or hippocampus lesion groups ( $t_{(4)} = 2.129; p < 0.001$ ) were performing above chance (see Figure 5.3B). This is not very surprising considering the small group sizes but does mean that these results are difficult to interpret. If we assume that neither the control rats nor those with hippocampus lesions can perform the task at all, then there is no useful interpretation of the results. However, if we consider that none of the statistics show any indication of a difference in performance between the 2 groups, however low that performance may be, then we could intimate that the hippocampus is not likely to be required to perform the task, since rats with hippocampus lesions are certainly performing no worse than control rats. However it remains somewhat ambigu-

ous whether there is any hippocampus-dependent effect of increasing the numbers of stimulus objects.

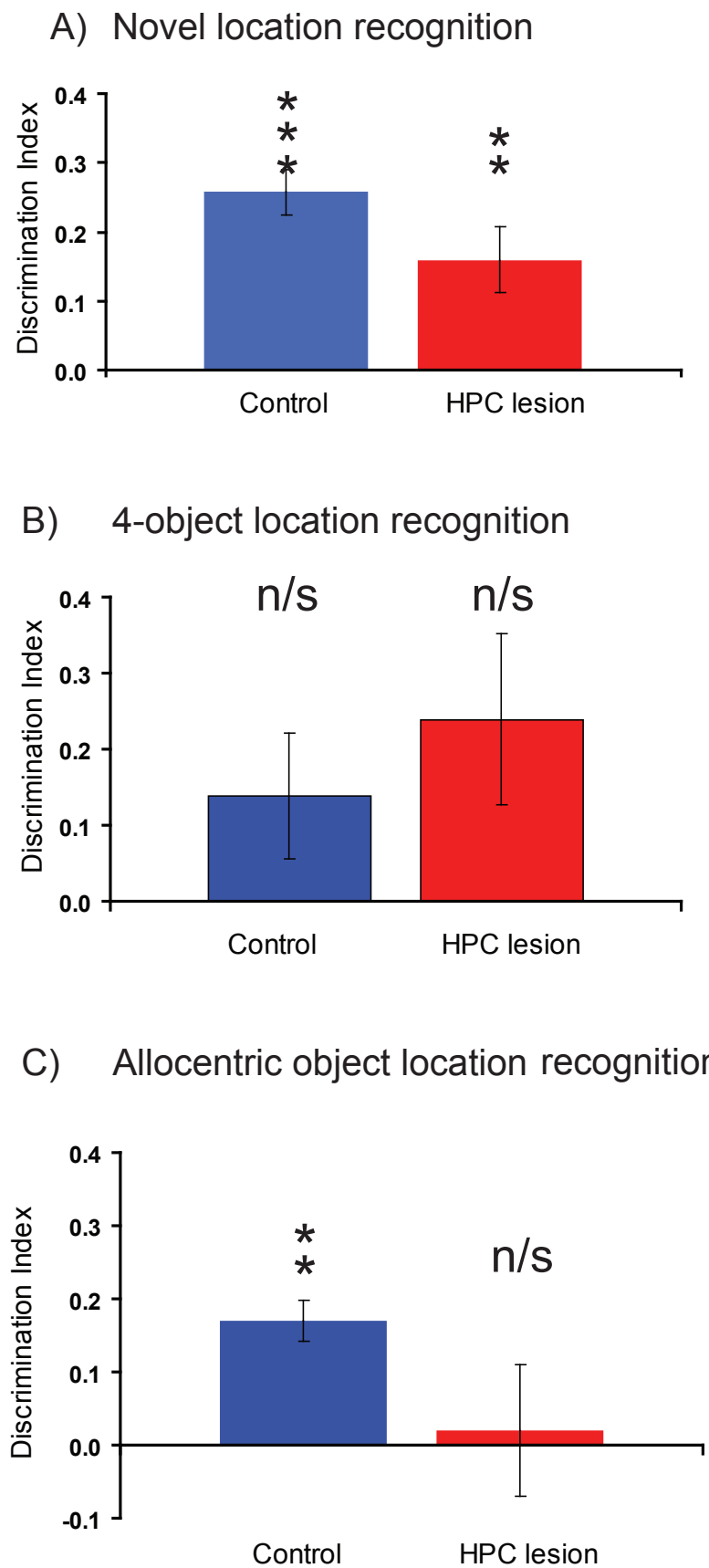

**Figure 5.3:** This Figure shows the performance (as measured by discrimination index) for each group of rats on the different object location tasks discussed in this chapter.



**“Allocentric” object location recognition**

This experiment was also done with only a small subsection of the rats ( $n=5$  hippocampus lesions,  $n=5$  controls) from the second replication of the experiments described in Chapter 4. There was again only a single replication, consisting of each rat completing 4 trials. The discrimination index values for the 10 rats in this experiment were compared to the discrimination index values for the same 10 rats in the standard object location task reported in Section 4.3.1 (also see Figure 4.3 on page 111B). A repeated measures ANOVA was performed on the discrimination index with Group as the between subjects factor and Task as the within subjects factor. This showed no main effect of Task ( $F_{(1,8)} = 4.777; p = 0.060$ ) or Group ( $F_{(1,8)} = 3.102; p = 0.116$ ) and no Task x Group interaction ( $F_{(1,8)} = 0.821; p = 0.391$ ). One-sample t-tests showed that the control rats were in fact performing highly significantly above chance ( $t_{(4)} = 5.783; p = 0.004$ ) whereas the rats with hippocampus lesions were performing at chance level ( $t_{(4)} = 0.220; p = 0.837$ ) (see Figure 5.3C). The fact that there was no difference revealed between the control and hippocampus lesion groups in the overall ANOVA means that these results are difficult to interpret. This task does however give the strongest hint of an impairment in rats with hippocampus lesions out of the 3 manipulations of spatial location tested in this chapter.

## 5.4 Conclusions and Discussion

The experiments in this chapter were designed to investigate some of the discrepancies found between my results in the replication of Eacott and Norman (2004b) task and previous data from object recognition studies. The control tasks complementary to the integrated what-where-which task described in the previous chapter provided vital evidence that hippocampal involvement was indeed specific to the integrated task. However, in doing so, they were in conflict with previous similar studies (Save et al. 1992; Mumby et al. 2002), which had been a common theme of “interested criticism” at conference presentations of this task and is still not entirely resolved.

There were a number of differences between the previously published and accepted data on object-location and object-context recognition and my results. However, data from this chapter suggests a role for a subtle but very important procedural difference in how the tasks were run, which was not specified in the comparison papers and only discovered after personal communication with the authors (Poucet, B. and Mumby, D.G. , Personal Communication). This difference was based on the fact that in the 2 previously published papers, rats were placed into the testing box from different starting locations (as in a standard water maze navigation task, Morris et al. (1982)) and were therefore forced to use allocentric strategies to recognise the relative locations of objects in these tasks. Since rats in both previous studies received lesions of the hippocampus before the onset of behavioural testing, it is very unlikely that they could form representations of the object locations based on an allocentric “map” of the environment and were probably relying on egocentric strategies (e.g. path integration (Alyan and McNaughton 1999) or viewpoint-specific spatial representations (McNaughton et al. 1996)). In Save et al. (1992), rats were placed into the testing box from pseudorandomised start locations which differed on each trial, as in a standard hippocampal-dependent water maze navigation task, Morris et al. (1982) making it difficult or impossible to represent the locations of the objects using an egocentric approach. In Mumby et al. (2002), rats were always placed into the arena equidistant from the 2 objects it was to explore. This may sound similar to the procedure used in my experiment. However, consider the fact that the task in this paper used a variation of the object location task in which one of two identical objects was moved to a novel location (see Figure 5.2 on page 138). If the rat is placed into the testing box equidistant from the 2 objects in their new configuration, from a path integration or viewpoint-specific strategy, there is likely to be very little apparent difference in the relative locations of the 2 objects, producing an apparent deficit in memory for the locations of the objects in rats with hippocampus lesions. In the integrated what-where-which paradigm I reported in the previous chapter, all the separate elements of the tasks could

be solved using egocentric processing strategies. The only task in this chapter in which I saw any impairment in the performance of rats with complete hippocampus lesions on object-location memory was when I forced the use of allocentric strategies by using the same method as Save et al. (1992). Unfortunately this evidence is not conclusive, as the results lack statistical significance for a difference between hippocampus lesioned and control rats on the “allocentric” task (see Figure 5.3 on page 143)<sup>8</sup>.

---

<sup>8</sup>The results of this task were presented as a poster at SFN 2006 in Atlanta. The poster (Appendix 6) also shows the results of attempts to clarify the differences in object-context memory found between my data and that of Mumby et al. (2002). Although rats achieved variable performance levels in the various versions of the object-context task that were performed, there was no indication in any of the tasks that rats with hippocampus lesions were impaired in memory for object-context associations relative to controls. The results of those studies are not included here. The probable cause of the discrepancy with Mumby et al. (2002) is suspected to be the lesion protocol and results, but this is still being investigated.

## **Chapter 6**

# **Concluding Remarks**

## 6.1 Concluding Remarks

This thesis has attempted to examine the role of the hippocampus in models of human episodic memory tests and models of the theoretical elements of episodic memory in the rat.

### 6.1.1 Glutamate receptor mediated retrieval of paired associate learning

This chapter describes experiments attempting to directly convert a sensitive human episodic task into a paradigm suitable for laboratory rats. Day et al. (2003) successfully modelled paired associate learning in a rat analogue of human paired associate learning whereby rats forage for food in an open field arena and encode the locations of specific food flavours. When cued with a food flavour, rats are then able to retrieve the memory for the location in which that flavour was previously found and return to it. This is designed to be analogous to human paired associate learning of lists of paired words and recalling one half of a previously experienced word pair when prompted or cued with the other half. Rats can learn these flavour-location paired associates on a trial-unique or a repeat trial basis. Trial-unique paired associates are sensitive to inactivation of the dorsal hippocampus at retrieval, whereas paired associates trained repeatedly over a number of weeks become independent of dorsal hippocampal activity at retrieval.

Despite data from (Bast et al. 2005) showing that hippocampal inactivation prior to retrieval also impairs trial-unique spatial memory (without the food flavour component to make it a paired associate memory), the data presented in Chapter 2 give a convincing demonstration that in our paradigm we are not simply affecting the ability of rats to navigate around their environment during hippocampal activations, but specifically affecting their ability to retrieve episodic-like paired associates that have only been encoded on a trial-unique basis. The crucial experiment to show this was the demonstration that if flavour-location paired associates are repeatedly experienced over a period of weeks, rats with the dorsal hippocampus inactivated by CNQX can still retrieve these semantic-like overtrained pairs.

A crucial additional analysis of the data revealed interesting yet subtle findings regarding the putative memory processes that the rats may have been using to solve the paired associate task. A differential result on two measures used to examine the initial accuracy and further persistence of the rats when they made their choices of which location to dig at in response to a particular food flavour showed that on semantic-like (repeat trial) tests, the rats were less accurate in their first choice of sand-well to dig at than on episodic-like

(trial unique) tests. This implied that there was a dissociation between the memory processes used to retrieve the paired associates dependent on the testing condition. There was no procedural difference between the way that the repeat-trial and trial-unique tests were carried out. This difference in the accuracy between semantic-like and episodic-like paired associates could reflect the difference seen in human studies between remembering and knowing- the familiarity vs. recollection distinction. It is well characterised in humans that declarative memory is a dual process relying on both recollection and familiarity, whereby semantic memories can be retrieved using either process (although in the healthy brain both usually contribute) and episodic memory is dependent on recollection (Duezal et al. 1997; Yonelinas 2001; Woodruff et al. 2006). This dual process model of memory has also been recently analysed in rats (Fortin et al. 2004), showing that they too use a combination of familiarity and recollection to solve recognition tasks. This data suggest that it is possible that in the paired associate learning task presented here there is a distinction between the two processes. Whereas humans tend to use recollection to retrieve memories even when a task does not demand it, animals (particularly laboratory rats (Aggleton and Brown 1999; Eichenbaum et al. 2007)) are particularly adept at using familiarity to solve problems unless recollection is a task demand, so perhaps in the case of semantic-like overlearned paired associates when recollection may not be necessary, it contributes to a lesser extent, but in the case of trial-unique episodic-like paired associates it is necessary to perform the task. Recollection judgements in humans are correlated with better accuracy performance on paired associate tasks, so perhaps this can explain why the forced recollection component of the first choice of sand-well on a trial-unique paired associate test provides a more accurate level of performance.

However, data from the non-rewarded probe tests in these experiments showed a suggestion (although not significant) that putative recall accuracy (as measured by first choice of sand-well) was very poor when rats underwent inactivation of the dorsal hippocampus, regardless of whether the test was episodic-like or semantic like. This was in contrast to the persistence measure (putative familiarity) based on how long the rats spent digging at the correct sand-well which was intact for the semantic-like paired associates but fell to chance when the dorsal hippocampus was inactivated during episodic-like paired associate retrieval. This suggests that inactivation of the dorsal hippocampus contributed differentially to the putative memory processes of recollection and familiarity. Although upon initial analysis it was assumed that the repeat trial semantic-like paired associates were unaffected by the hippocampal inactivation, closer analysis of the data hints that perhaps the first choice accuracy - the possible recollection measure - was affected, even though when rats reached the correct location of the repeat-trial food flavour, they could recognise it using familiarity and still perform well on the % dig time in the correct sand-

well over the probe test. This would agree with data from human studies (Duezel et al. 2001; Vargha-Khadem et al. 2001; Aggleton et al. 2005) and recent rat studies (Fortin et al. 2004; Eacott et al. 2005) suggesting a role for the hippocampus in recollective but not familiarity based declarative memory (Aggleton and Brown 1999).

This additional analysis does not detract from the main results of Day et al. (2003) in that dorsal hippocampal activation does specifically affect the retrieval of trial-unique episodic-like flavour-location paired associates, but adds a new possible double dissociation of the role of the hippocampus in episodic-like vs. semantic-like and recollective vs. familiarity processing in the rodent brain.

### **6.1.2 Semantic schema and paired associate memory consolidation**

Overtraining flavour-location paired associates to create a mental schema rendered them insensitive to hippocampus damage and also accelerated the consolidation of trial-unique paired associates when learned alongside them. This theory was based on human data which is almost a matter of common sense, but had not been investigated previously in animal tests. The theory is that having an activated mental schema of relevant knowledge prior to a novel encoding event will boost encoding and therefore subsequent recall of the novel event. This has recently been shown to be of particular relevance in the human amnesia literature (Brandt et al. 2006) where a famous developmental amnesic, Jon, who has bilateral hippocampal damage, is actually able to perform retrieval of some episodic-like information if he is carefully trained on a relevant semantic schema in which to incorporate that information beforehand. The experiments in Chapter 3 showed that in the presence of a putative semantic schema of food flavour and location paired associates, consolidation of novel associates was much more rapid than predicted by standard consolidation theory (Moscovitch et al. 2005).

Since publication of this data (Tse and Langston et al 2007) there has been a commentary from Rudy and Sutherland (In press at *Neurobiology of Learning and Memory*) suggesting that the apparently rapid systems consolidation seen of the paired associates into a putative neocortical schema is in fact cellular consolidation. They suggest that in fact the putative schema means that the task is not dependent on the hippocampus at all by the time rats encode novel flavour-location paired associates. They suggest that the time dependent effect whereby novel paired associates incorporated into the schema 3 hours prior to removal of the hippocampus are not successfully retrieved whereas those incorporated 48 hours prior to the removal of the hippocampus are is due to a disruption of cellular consolidation. The theory behind this is that the excitotoxic hippocampus lesion

given 3 hours after the encoding of the novel paired associates results in hyperactivity of hippocampal-cortical connections, which result in disruption of the cortical networks that would be processing the new information over the first few hours after encoding.

Regarding criticisms of the lesion technique; using very small volumes of ibotenic acid injected at multiple sites within the hippocampus following the protocol of Jarrard (1989) would not be expected to produce such a huge range of undesirable side effects as suggested by Rudy and Sutherland. Whilst seizure-like spiking activity is present locally and cortically for 2-3 hours after large injections of ibotenic acid (at 5-20 times the doses used in Tse et al. 2007) no spiking was seen in neocortex when recordings were made up to 12 hours after the procedure used in the current study (see Jarrard 1989). Moser et. al. (1995) showed that small focal injections of ibotenic acid into ventral hippocampus had no effects on recordings made from dorsal hippocampus for up to 9 hours post-injection and that acetyl cholinesterase staining showed no degradation of extrinsic connections to residual hippocampal tissue, emphasizing the focal and axon-sparing properties of ibotenic acid lesions when carried out according to the protocol of Jarrard (1989). Rudy and Sutherland's concern regarding "excessive release of transmitters into terminal fields of hippocampal outputs" (McClelland et. al. 1995) is based on data using kainic acid injections (Jacobson et. al. 1997). Kainic acid is one of the most potent amino acid excitotoxins (Cooper et. al. 1996) and is known to be a powerful convulsant even at doses which cause limited local neuronal damage (French et. al. 1982) and it is thought that propagation of this seizure activity (which is not commonly seen with ibotenic acid, particularly at the doses used in Tse et. al. (2007)) is the cause of unintentional remote damage to many other brain areas including subiculum, amygdala, thalamic nuclei, and piriform, entorhinal and other cortical areas (Ben-Ari et. al. 1980; Jarrard & Meldrum 1993). Intentional injection or incidental diffusion of ibotenic acid into the subiculum or ventricles (usually caused by large injection volumes) is a frequently seen "side-effect" of lesioning the rat hippocampus (Lobaugh et. al. 1995; Jarrard 2001). This can lead to degeneration in a wide range of areas including fimbria-fornix axons; subicular targets including deep layers of the entorhinal cortex; nucleus accumbens, septum, hypothalamus and cingulate cortex. Fink-Heimer silver staining has shown that degeneration in perforant path axons may still be occurring 12-14 weeks after injection of ibotenic acid into the subiculum (Jarrard, 1989). Differential behavioural results are also found between lesions restricted to the hippocampus and those that include or separately target the subiculum (Morris et. al. 1990; Bolhuis et. al. 1994). In contrast, focal injections restricted to the hippocampus do not cause damage to nearby fibers of passage (Guldin & Markowitsch 1982; Jonsson 1983; Kohler & Schwarcz 1983; Jarrard 1989) or more remote hippocampal target areas (Jarrard 1989; Galani et. al. 2002). As stated by Rudy and Sutherland, it has been shown



by Glenn et. al. (2005) that neurotoxic lesions of the perirhinal cortex result in alterations of c-fos expression in other cortical areas and in the dentate gyrus. Albasser et. al. (2007) showed a similar change in c-fos expression in the retrosplenial cortex following ibotenic acid lesions of the hippocampus. Both of these studies use c-fos- a marker of neuronal activation - but neither gives any clues as to the consequences or whether this is change in activation pattern reflects any dysfunction. Albasser et. al. (2007) in fact analyzed numbers of cells expressing the specific neuronal marker Neu-N and their characteristics in areas showing altered c-fos activation patterns, and found them to be completely normal with no differences between lesioned and control animals at 2-3 months post-surgery. This indicates, and it is even stated in the paper, that these IEG changes reveal no evidence of covert pathology or proof of any dysfunction in the affected cells, even 3 months after the lesion.

The argument of Rudy and Sutherland that the task is dependent only upon the neocortex and that cellular consolidation is resulting in amnesia for paired associates experienced just 3 hours prior to the hippocampus lesion does not stand based on technical considerations of the lesion technique employed. More behavioural data from Tse and Langston et al (2007) also suggest that their theory that the task has simply become dependent on the neocortex (or always was) is incorrect. Rats with lesions of the hippocampus fail to encode any new information either within the context of the intact schema or in an entirely new context. This implies that the new flavour location pairs were dependent on the hippocampus 3 hours after encoding and that there was a rapid gradient of systems consolidation between 3 hours and 48 hours after learning. This conclusion is in accordance with the original theory that the presence of an active relevant semantic schema boosts episodic-like memory performance in a rat model as well as in humans.

These data confirm the validity of paired associate testing in the event arena as a valid model of a sensitive episodic memory test in humans. However there are also lessons to be learned, as discussed at the end of Chapter 3, in that rats are certainly not always solving tasks in the hypothesised or expected way, and as well as trying to design tasks that encourage a certain type of memory processing, the measures used to assess the animals' performance must adhere to very strict criteria. This was a failure of the experiments presented in this chapter. Even though the measures and the technical advances in the testing equipment used were designed to represent an improvement from the experiments in Chapter 2, they also had some adverse effects that were entirely unpredictable. Unfortunately these meant that the subtle yet exciting distinction between putative recollection and familiarity discussed in regard to the experiments in Chapter 2 could not be followed up in Chapter 3 due to the rats potentially adopting new strategies to solve

the tasks.

Nevertheless, these data confirm in addition to those in Chapter 2 that paired associate learning in the event arena is a valuable tool to model different aspects of human episodic memory testing, and it is a future aim to learn how to measure and define the strategies used by the animals to solve the tasks, in order to further elucidate the neurobiological mechanisms of episodic memory models in the rat.

### **6.1.3 Integrated memory for objects, places and contexts in the rat and the extent of involvement of the hippocampus in spatial location parameters**

Using the original definition of episodic memory (Tulving 1972), which has been designated the term episodic-like memory for its use in animal studies (Clayton and Dickinson 1998), an integrated what-where-which experiment designed by Eacott and Norman (2004b) was successfully replicated with very similar levels of performance shown in the control rats between the published results and my own. Rats with hippocampus lesions showed a deficit in memory for trial-unique object-location-context (what-where-which) configurations whilst performing at a level indistinguishable from controls on a variety of other control tasks. These tasks provided a complete set of controls for all the procedural and associative elements of the integrated what-where-which task, therefore confirming that the impairment seen in rats with hippocampus lesions was not due to secondary effects of procedural difficulty, or lack of memory for the location or context elements of the task either alone or in pairs.

Eacott and Norman (2004b) published this experiment as a model of episodic-like memory in the rat and my recent results provide further strength to this argument. It is unlikely that the hippocampus becomes necessary for the integrated task simply due to the increased number of stimuli involved, since rats can show learning and retention of multiple stimuli, and even pairs of stimuli, in different modalities independent of the hippocampus (Gaffan and Eacott 1997; McDonald et al. 1997; Dudchenko et al. 2000). It also seems unlikely that this task can easily be solved by relative familiarity alone since the memory test involves presentation of 3 familiar stimuli (object, place and context are all familiar) and even the pairwise configurations of object with context and object with location are familiar. Although this paradigm does not force the use of recall by design, it is possible that the 3 different types of stimuli that need to be integrated- what, where and which- necessitate the formation of an episodic-like representation of an event, which may then require the contribution of recollection at the point of memory retrieval: the task may be too complex to be solved by familiarity (recognition) alone, or recall may

perhaps be the most efficient strategy. The latter seems less likely, since rats with hippocampus lesions perform at chance levels on this task; not just showing an impairment relative to controls; which is what would be expected if familiarity and recollection were both involved. The striking difference in performance between rats with hippocampus lesions and control rats posits the possible explanation that the integrated task may indeed be a model of episodic-like memory recall and therefore perhaps involve the putative recollection circuitry suggested by Aggleton and Brown (1999).

The contributions of the hippocampus to object-location memory was also examined in Chapter 5, due to the unexpected results that the hippocampus was not necessary for the object-location recognition part of the integrated object, place and context task. Even though the object-location part of the task was simplified as much as possible to discourage the attempted use of unnecessary allocentric spatial strategies, the results still received a lot of criticism when presented at conferences. It was accepted that there was certainly no problem with the hippocampus lesions, which are large by established standards, so the different protocols used to test object-location memory were tested, to see if the "expected" deficit in the hippocampus lesioned rats would be found. A hint at the explanation was found, in that rats with hippocampus lesions did not perform significantly above chance when tested using a forced allocentric strategy to discriminate between the relative locations of 2 objects. This was the expected result, which suggested that the lack of an impairment in object-location memory in the integrated object, place and context task was simply a result of making the task very easy to solve using an egocentric strategy which did not appear to rely on the hippocampus (achieved by always placing the rat into the arena at the same point facing in the same direction, and placing large prominent cues near the test objects, so it was expected that the rat could use its own sense of self motion and egocentric space to determine whether or not objects had moved relative to itself). Unfortunately this theory was only tested on a very small group of rats, so the results did not quite reach statistical significance, but the experiment is currently being replicated in order to confirm that there is differential involvement of the hippocampus depending on the procedural methods used to run object-location tests.

Another interesting additional piece of data analysis currently under way is the re-analysis of the sample phases of the integrated object, place and context task and the object, context and place control tasks. The idea behind this is that it may be possible to gain an insight as to whether or not it is an encoding deficit in the hippocampus lesioned rats that leads to their failure on the integrated task. The hypothesis is that a change in either object, place or context or any of these combinations between sample phase 1 and sample phase 2 should provoke some increased level of exploration when compared to nothing

changing between these two phases. The data is being analysed with the possibility in mind that if the change in baseline exploration when objects and contexts are changed is greater than that when only one or the other is changed, this would imply that the change in both object and context has been encoded, as additive or integrative information. If rats with hippocampus lesions than demonstrate that they also encode this integrated change with a higher change in level of exploration than an individual change in object or context, and this exploration change is comparable to that seen in control rats, then it can be interpreted as the hippocampus lesioned rats having no deficit in encoding, and that the deficit must be in consolidation or retrieval of the memory. Of course, if the rats do show an "encoding" deficit, there is no extra information about storage or retrieval to be gained from this method. However as an initial attempt, it may allow an insight into the separate mechanism of encoding without the use of more rats and reduces the memory processes that would need to be investigated in a pharmacological study. Although the process of extracting this data for equivalent objects and time periods is tedious, it may help to reduce animal use in experimentation in this particular ongoing project.

In summary, the task of Eacott and Norman (2004b) has been successfully replicated, showing that this is a robust protocol replicable between laboratories. The task has many features that make it comparable to episodic memory in humans, including that it is acquired over a single experience without the requirement for training which may give rise to semantic rule learning. The use of contextual elements of an event or episode as an alternative to strictly temporally mediated control of episodic memory has been justified in the introduction to this thesis, making the paradigm designed by Eacott and Norman (2004b) a valid and useful laboratory task to study the neurobiology of elements of episodic-like memory in the rat.

Although none of these tasks could be described as the perfect test of episodic(-like) memory in laboratory rats, and they certainly do not answer the neuroethologist's question of whether or not episodic memory is a uniquely human trait, we have demonstrated that flexible use of these protocols can provide insight into the neurobiological processing underlying elements of declarative memory as defined in humans.

## 6.2 Future Plans

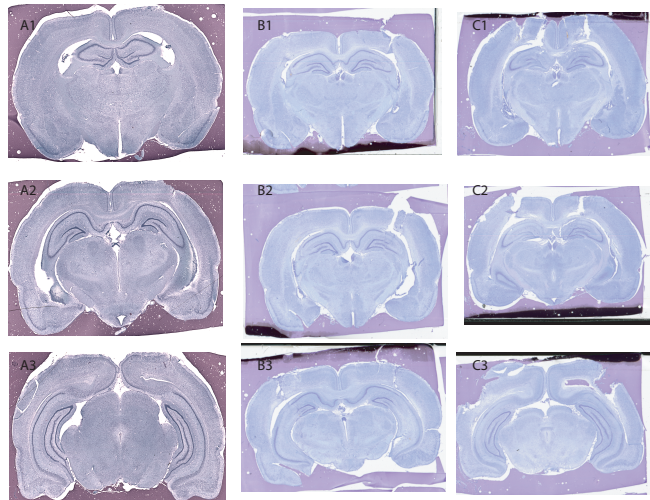

**Figure 6.1:** Preliminary histological analysis of subregion-specific CA1 and CA3 lesions is promising, although these sections are only stained with cresyl violet acetate to visualise the Nissl bodies of living cells. More complex histological and electrophysiological analysis is necessary to examine whether remaining tissue is still functional and also the possibility of more widespread damage due to the overexcitability caused by the ibotenic acid action in these subregional networks, particularly since a number of animals have suffered severe seizure activity after the CA1 manipulation in particular. A1-3 show sections from a control brain, B1-3 show sections from a CA3 lesioned brain and C1-3 show a CA1 lesioned brain, all represented from anterior to posterior down the columns from 1-3.

Further experiments are currently under way to examine the role of the CA1 and CA3 subregions of the hippocampus, which may have important but differential roles in episodic-like memory. These areas have been under scrutiny recently, disrupting the traditional idea that the hippocampal trisynaptic circuit acts as a unidirectional, serial pathway. Computational (Rolls and Kesner 2006; Hasselmo 2005), lesion (Kesner et al. 2005; Gilbert and Kesner 2003; Hunsaker et al. 2006; Hunsaker et al. 2007), electrophysiological (Brun et al. 2002; Leutgeb et al. 2004; Mizumori et al. 1999), pharmacological (Daumas et al. 2005) and genetic studies (Nakazawa et al. 2002; Nakazawa et al. 2003) indicate that CA3 appears to play an important role in one-trial memory, however almost all of the experiments that have made this conclusion have used tasks involving allocentric space or navigational requirements. Evidence points to CA1 involvement when information must be remembered over a temporal delay (Hunsaker et al. 2006), or consolidated (Daumas et al. 2005). However an additional caveat of most of these studies is that the manipu-

lation of the hippocampal subregions are not complete, usually only affecting the dorsal part of the CA1, CA3 or dentate gyrus network. My current aim is to produce selective axon-sparing lesions (using ibotenic acid) of the entire subregions CA1 or CA3, including the ventral parts, in order to fully test the role of each subregional network in episodic-like memory in a variety of behavioural tasks including the ones described in this thesis.

Appendix 1

# Bibliography

- Aggleton, J., S. Vann, C. Denby, S. Dix, A. Mayes, and A. Roberts, N. and Yonelinas (2005). Sparing of the familiarity component of recognition memory in a patient with hippocampal pathology. *Neuropsychologia* 43(12), 1810–1823.
- Aggleton, J. P. and M. W. Brown (1999). Episodic memory, amnesia, and the hippocampal-anterior thalamic axis. *Behav Brain Sci* 22(3), 425–44; discussion 444–89.
- Aggleton, J. P. and M. W. Brown (2006). Interleaving brain systems for episodic and recognition memory. *Trends Cogn Sci* 10(10), 455–463.
- Agrest, M. (2001, Dec). [classification of memory systems: a revision]. *Vertex* 12(46), 261–267.
- Ainge, J., C. Heron-Maxwell, P. Theofilas, P. Wright, L. de Hoz, and E. Wood (2006). The role of the hippocampus in object recognition in rats: Examination of the influence of task parameters and lesion size. *Behavioural Brain Research* 167(1), 183–195.
- Allen, W. (1940). Effect of ablating the frontal lobes, hippocampi and occipito-parietotemporal lobes on positive and negative olfactory conditioned reflexes. *American Journal of Physiology* 132, 81–91.
- Alvarez, P. and L. Squire (1994). Memory consolidation and the medial temporal lobe: a simple network model. *Proc. Natl. Acad. Sci. U. S. A.* 91(15), 7041–7045.
- Alyan, S. and B. L. McNaughton (1999). Hippocampectomized rats are capable of homing by path integration. *Behav Neurosci* 113(1), 19–31.
- Amaral, D. G. and M. P. Witter (1989). The three dimensional organization of the hippocampal formation: a review of anatomical data. *Neuroscience* 31, 571–591.
- Anisfeld, M. and M. Knapp (1968). Association, synonymity, and directionality in false recognition. *Journal of Experimental Psychology* 77(2), 171–179.
- Asztly, F. and B. Gustafsson (1996). Ionotropic glutamate receptors. their possible role in the expression of hippocampal synaptic plasticity. *Mol Neurobiol* 12(1), 1–11.
- Babb, S. and J. Crystal (2005). Discrimination of what, when and where: Implications for episodic-like memory in rats. *Learning and Motivation* 36, 177–189.
- Babb, S. and J. Crystal (2006). Episodic-like memory in the rat. *Current Biology* 16(13), 1317–1321.
- Baddeley, A. and G. Hitch (1974). *Working memory*, Chapter 8, pp. 47–89. New York: Academic Press.
- Baddeley, A., F. Vargha-Khadem, and M. Mishkin (2001, Apr). Preserved recognition in a case of developmental amnesia: implications for the acquisition of semantic memory? *J Cogn Neurosci* 13(3), 357–369.
- Barker, G. R. I., F. Bird, V. Alexander, and E. C. Warburton (2007, Mar). Recognition memory for objects, place, and temporal order: a disconnection analysis of the role of the medial prefrontal cortex and perirhinal cortex. *J Neurosci* 27(11), 2948–2957.



- Bashir, Z. I., S. Alford, S. N. Davies, A. D. Randall, and G. L. Collingridge (1991). Long-term potentiation of NMDA receptor-mediated synaptic transmission in the hippocampus. *Nature* 349(6305), 156–158.
- Bast, T., B. M. da Silva, and R. G. M. Morris (2005). Distinct contributions of hippocampal NMDA and AMPA receptors to encoding and retrieval of one-trial place memory. *J Neurosci* 25(25), 5845–5856.
- Bayley, P. and L. Squire (2005). Failure to acquire new semantic knowledge in patients with large medial temporal lobe lesions. *Hippocampus* 15(2), 273–280.
- Bayley, P. J., R. O. Hopkins, and L. R. Squire (2003, Apr). Successful recollection of remote autobiographical memories by amnesic patients with medial temporal lobe lesions. *Neuron* 38(1), 135–144.
- Bechara, A., D. Tranel, H. Damasio, R. Adolphs, C. Rockland, and A. R. Damasio (1995, Aug). Double dissociation of conditioning and declarative knowledge relative to the amygdala and hippocampus in humans. *Science* 269(5227), 1115–1118.
- Berlyne, D. (1950). Unknown. *British Journal of Psychology* 41, 68.
- Berlyne, D. E. (1966). Curiosity and exploration. *Science* 153(731), 25–33.
- Bianchin, M., R. Walz, A. C. Ruschel, M. S. Zanatta, R. C. D. Silva, M. Bueno e Silva, N. Paczko, J. H. Medina, and I. Izquierdo (1993). Memory expression is blocked by the infusion of CNQX into the hippocampus and/or the amygdala up to 20 days after training. *Behav Neural Biol* 59(2), 83–86.
- Bird, L., W. Roberts, B. Abroms, K. Kit, and C. Crupi (2003). Spatial memory for food hidden by rats (*rattus norvegicus*) on the radial maze: Studies of memory for where, what, and when. *J. Comp. Psychol.* 117, 176–187.
- Birrell, J. M. and V. J. Brown (2000). Medial frontal cortex mediates perceptual attentional set shifting in the rat. *J Neurosci* 20(11), 4320–4324.
- Boyce, S. J., A. Pollatsek, and K. Rayner (1989). Effect of background information on object identification. *J Exp Psychol Hum Percept Perform* 15(3), 556–566.
- Brandt, K. R., J. M. Gardiner, F. Vargha-Khadem, A. D. Baddeley, and M. Mishkin (2006). Using semantic memory to boost 'episodic' recall in a case of developmental amnesia. *Neuroreport* 17(10), 1057–1060.
- Broadbent, N., L. Squire, and R. Clark (2004). Spatial memory, recognition memory, and the hippocampus. *Proceedings of the National Academy of Sciences USA* 101(40), 14515–14520.
- Brown, N., L. Rips, and S. Shevell (1985). The subjective dates of natural events in very-long-term memory. *Cognitive Psychology* 17(2), 139–177.
- Brun, V. H., M. K. Otnass, S. Molden, H.-A. Steffenach, M. P. Witter, M.-B. Moser, and E. I. Moser (2002, Jun). Place cells and place recognition maintained by direct entorhinal-hippocampal circuitry. *Science* 296(5576), 2243–2246.
- Buchanan, T. W., D. Tranel, and R. Adolphs (2006, Jan). Memories for emotional autobiographical events following unilateral damage to medial temporal lobe. *Brain* 129(Pt 1), 115–127.
- Bunge, S. A., B. Burrows, and A. D. Wagner (2004). Prefrontal and hippocampal contributions to visual associative recognition: interactions between cognitive control and episodic retrieval. *Brain Cogn* 56(2), 141–152.
- Bunsey, M. and H. Eichenbaum (1993). Critical role of the parahippocampal region for paired-associate learning in rats. *Behav Neurosci* 107(5), 740–747.
- Burgess, N., S. Becker, J. King, and J. O'Keefe (2001). Memory for events and their spatial context: Models and experiments. *Philosophical Transactions of the Royal Society of London Series B Biological Sciences* 356, 1493–1503.

- Burgess, N., E. A. Maguire, and J. O'Keefe (2002). The human hippocampus and spatial and episodic memory. *Neuron* 35(4), 625–641.
- Cassel, J. C., S. Cassel, R. Galani, C. Kelche, B. Will, and L. Jarrard (1998). Fimbria-fornix vs selective hippocampal lesions in rats: effects on locomotor activity and spatial learning and memory. *Neurobiol Learn Mem* 69(1), 22–45.
- Cave, C. and L. Squire (1991). Equivalent impairment of spatial and nonspatial memory following damage to the human hippocampus. *Hippocampus* 1(3), 329–340.
- Chiba, A., R. Kesner, and C. Gibson (1997). Memory for temporal order of new and familiar spatial location sequences: role of the medial prefrontal cortex. *Learning and Memory* 4, 311–317.
- Cho, Y. H. and R. P. Kesner (1995). Relational object association learning in rats with hippocampal lesions. *Behav Brain Res* 67(1), 91–98.
- Cipolotti, L. and C. M. Bird (2006, Dec). Amnesia and the hippocampus. *Curr Opin Neurol* 19(6), 593–598.
- Clark, R., N. Broadbent, and L. Squire (2005). Hippocampus and remote spatial memory in rats. *Hippocampus* 15(2), 260–272.
- Clark, R. and S. Martin (2005). Interrogating rodents regarding their object and spatial memory. *Current Opinion in Neurobiology* 15(5), 593–598.
- Clark, R., S. Zola, and L. Squire (2000). Impaired recognition memory in rats after damage to the hippocampus. *Journal of Neuroscience* 20(23), 8853–8860.
- Clayton, N., D. Griffiths, N. Emery, and A. Dickinson (2001). Elements of episodic-like memory in animals. *Philosophical Transactions of the Royal Society of London Series B* 356, 1483–1491.
- Clayton, N. S., T. J. Bussey, and A. Dickinson (2003). Can animals recall the past and plan for the future? *Nature Reviews Neuroscience* 4, 685–691.
- Clayton, N. S., T. J. Bussey, N. Emery, and A. Dickinson (2003). Prometheus to proust: the case for behavioural criteria for mental time travel. *Trends in Cognitive Sciences* 7(10), 436–437.
- Clayton, N. S. and A. Dickinson (1998). Episodic-like memory during cache recovery by scrub-jays. *Nature* 395, 272–278.
- Clayton, N. S. and A. Dickinson (1999). Scrub jays (*aphelocoma coerulescens*) remember the relative time of caching as well as the location and content of their caches. *Journal of Comparative Psychology* 113, 403–416.
- Clayton, N. S., K. S. Yu, and A. Dickinson (2001). Scrub-jays (*aphelocoma coerulescens*) form integrated memories of the multiple features of caching episodes. *Journal of Experimental Psychology: Animal Behavior Processes* 27, 17–29.
- Clayton, N. S., K. S. Yu, and A. Dickinson (2003). Interacting cache memories: evidence of flexible memory use by scrub jays. *Journal of Experimental Psychology: Animal Behavior Processes* 29, 14–22.
- Compton, D., H. Griffith, W. McDaniel, R. Foster, and B. Davis (1997). The flexible use of multiple cue relationships in spatial navigation: a comparison of water maze performance following hippocampal, medial septal, prefrontal cortex, or posterior parietal cortex lesions. *Neurobiology of Learning and Memory* 68(2), 117–132.
- Corkin, S. (2002, Feb). What's new with the amnesic patient h.m.? *Nat Rev Neurosci* 3(2), 153–160.
- Corkin, S., D. G. Amaral, R. G. Gonzalez, K. A. Johnson, and B. T. Hyman (1997, May). H. m.'s medial temporal lobe lesion: findings from magnetic resonance imaging. *J Neurosci* 17(10), 3964–3979.
- Correia, S. P. C., A. Dickinson, and N. S. Clayton (2007, May). Western scrub-jays

- anticipate future needs independently of their current motivational state. *Curr Biol* 17(10), 856–861.
- Coutureau, E., R. Galani, L. E. Jarrard, and J. C. Cassel (2000). Selective lesions of the entorhinal cortex, the hippocampus, or the fimbria-fornix in rats: a comparison of effects on spontaneous and amphetamine-induced locomotion. *Exp Brain Res* 131(3), 381–392.
- Dardou, D., F. Datiche, and M. Cattarelli (2006). Fos and egr1 expression in the rat brain in response to olfactory cue after taste-potentiated odor aversion retrieval. *Learn Mem* 13(2), 150–160.
- Daumas, S., H. Halley, B. Francs, and J.-M. Lassalle (2005). Encoding, consolidation, and retrieval of contextual memory: differential involvement of dorsal ca3 and ca1 hippocampal subregions. *Learn Mem* 12(4), 375–382.
- Davachi, L., J. P. Mitchell, and A. D. Wagner (2003). Multiple routes to memory: distinct medial temporal lobe processes build item and source memories. *Proc Natl Acad Sci U S A* 100(4), 2157–2162.
- Davachi, L. and A. D. Wagner (2002). Hippocampal contributions to episodic encoding: insights from relational and item-based learning. *J Neurophysiol* 88(2), 982–990.
- Davis, S., S. P. Butcher, and R. G. Morris (1992). The NMDA receptor antagonist D-2-amino-5-phosphonopentanoate (D-AP5) impairs spatial learning and LTP in vivo at intracerebral concentrations comparable to those that block LTP in vitro. *J Neurosci* 12(1), 21–34.
- Day, M., R. Langston, and R. Morris (2003). Glutamate-receptor-mediated encoding and retrieval of paired-associate learning. *Nature* 424(6945), 205–209.
- de Hoz, L., J. Knox, and R. Morris (2003). Longitudinal axis of the hippocampus: Both septal and temporal poles of the hippocampus support water maze spatial learning depending on the training protocol. *Hippocampus* 13(5), 587–603.
- Deller, T., G. Adelmann, R. Nitsch, and M. Frotscher (1996). The alvear pathway of the rat hippocampus. *Cell Tissue Res* 286(3), 293–303.
- Dere, E., E. Kart-Teke, J. Huston, and M. De Souza Silva (2006). The case for episodic memory in animals. *Neuroscience and Biobehavioral Reviews* 30(8), 1206–1224.
- Dewhurst, S. and G. Hitch (1999). Cognitive effort and recollective experience in recognition memory. *Memory* 7(2), 129–146.
- Dix, S. and J. Aggleton (1999). Extending the spontaneous preference test of recognition: evidence of object-location and object-context recognition. *Behavioral Brain Research* 99(2), 191–200.
- Dobbins, I. G., H. J. Rice, A. D. Wagner, and D. L. Schacter (2003). Memory orientation and success: separable neurocognitive components underlying episodic recognition. *Neuropsychologia* 41(3), 318–333.
- Dudchenko, P. A., E. R. Wood, and H. Eichenbaum (2000). Neurotoxic hippocampal lesions have no effect on odor span and little effect on odor recognition memory but produce significant impairments on spatial span, recognition, and alternation. *J Neurosci* 20(8), 2964–2977.
- Duezel, E., F. Vargha-Khadem, H. J. Heinze, and M. Mishkin (2001). Brain activity evidence for recognition without recollection after early hippocampal damage. *Proc Natl Acad Sci U S A* 98(14), 8101–8106.
- Duezel, E., A. P. Yonelinas, G. R. Mangun, H. J. Heinze, and E. Tulving (1997). Event-related brain potential correlates of two states of conscious awareness in memory. *Proc Natl Acad Sci U S A* 94(11), 5973–5978.
- Eacott, M., A. Easton, and A. Zinkivskay (2005). Recollection in an episodic-like mem-

- ory task in the rat. *Learning and Memory* 12(3), 221–223.
- Eacott, M. and G. Norman (2004a). Integrated memory for object, place, and context in rats: a possible model of episodic-like memory? *Journal of Neuroscience* 24(8), 1948–1953.
- Eacott, M. and G. Norman (2004b). Integrated memory for object, place, and context in rats: a possible model of episodic-like memory? *Journal of Neuroscience* 24(8), 1948–1953.
- Eichenbaum, H., C. Stewart, and R. Morris (1990). Hippocampal representation in place learning. *Journal of Neuroscience* 10(11), 3531–3542.
- Eichenbaum, H., A. P. Yonelinas, and C. Ranganath (2007). The medial temporal lobe and recognition memory. *Annu Rev Neurosci* 30, 123–152.
- Eldridge, L. L., B. J. Knowlton, C. S. Furmanski, S. Y. Bookheimer, and S. A. Engel (2000). Remembering episodes: a selective role for the hippocampus during retrieval. *Nat Neurosci* 3(11), 1149–1152.
- Eldridge, M. A., P. J. Barnard, and D. A. Bekerian (1994). Autobiographical memory and daily schemas at work. *Memory* 2(1), 51–74.
- Ennaceur, A. and J. Aggleton (1994). Spontaneous recognition of object configurations in rats: effects of fornix lesions. *Experimental Brain Research* 100(1), 85–92.
- Ennaceur, A. and J. Delacour (1988). A new one-trial test for neurobiological studies of memory in rats. 1: Behavioral data. *Behavioral Brain Research* 31(1), 47–59.
- Ennaceur, A., N. Neave, and J. Aggleton (1997). Spontaneous object recognition and object location memory in rats: the effects of lesions in the cingulate cortices, the medial prefrontal cortex, the cingulum bundle and the fornix. *Experimental Brain Research* 113(3), 509–519.
- Erselius, R. T. and A. Wree (1991). Ultrastructure of axons in stereotaxically placed ibotenic acid-induced lesions of the hippocampus in the adult rat. Evidence for demyelination and degeneration of dispersed axons of passage. *J Hirnforsch* 32(2), 139–148.
- Fortin, N., S. Wright, and H. Eichenbaum (2004). Recollection-like memory retrieval in rats is dependent on the hippocampus. *Nature* 431, 188–191.
- Friedman, W. (1993). Memory for the time of past events. *Psychological Bulletin* 113(1), 44–66.
- Friedman, W. and A. Wilkins (1985). Scale effects in memory for the time of events. *Memory and Cognition* 13(2), 168–175.
- Fu, W., T. Sugai, H. Yoshimura, and N. Onoda (2004). Convergence of olfactory and gustatory connections onto the endopiriform nucleus in the rat. *Neuroscience* 126(4), 1033–1041.
- Gaffan, D. (1991). Spatial organization of episodic memory. *Hippocampus* 1(3), 262–264.
- Gaffan, D. (1994). Scene-specific memory for objects: a model of episodic memory impairment in monkeys with fornix transection. *Journal of Cognitive Neuroscience* 6, 305–320.
- Gaffan, D. and S. Harrison (1989). Place memory and scene memory: effects of fornix transection in the monkey. *Exp Brain Res* 74(1), 202–212.
- Gaffan, E. and M. Eacott (1997). Spatial memory impairment in rats with fornix transection is not accompanied by a simple encoding deficit for directions of objects in visual space. *Behavioral Neuroscience* 111(5), 937–954.
- Galani, R., S. Obis, E. Coutureau, L. Jarrard, and J.-C. Cassel (2002). A comparison of the effects of fimbria-fornix, hippocampal, or entorhinal cortex lesions on spatial reference and working memory in rats: short versus long postsurgical recovery

- period. *Neurobiol Learn Mem* 77(1), 1–16.
- Gallistel, R. (1990). *The Organization of Learning*. MIT Press.
- Gallup, G. J. (1970). Chimpanzees: Self-recognition. *Science* 167(3914), 86–97.
- Gilbert, P. E. and R. P. Kesner (2002). Role of the rodent hippocampus in paired-associate learning involving associations between a stimulus and a spatial location. *Behav Neurosci* 116(1), 63–71.
- Gilbert, P. E. and R. P. Kesner (2003). Localization of function within the dorsal hippocampus: the role of the CA3 subregion in paired-associate learning. *Behav Neurosci* 117(6), 1385–1394.
- Glenberg, A. and N. Swanson (1986). A temporal distinctiveness theory of recency and modality effects. *Journal of Experimental Psychology: Learning, Memory and Cognition* 12(1), 3–15.
- Glenberg, A. M., M. M. Bradley, T. A. Kraus, and G. J. Renzaglia (1983). Studies of the long-term recency effect: Support for the contextually guided retrieval hypothesis. *Journal of Experimental Psychology: Learning, Memory, and Cognition* 9, 231–255.
- Good, M. A., P. Barnes, V. Staal, A. McGregor, and R. C. Honey (2007, Feb). Context-but not familiarity-dependent forms of object recognition are impaired following excitotoxic hippocampal lesions in rats. *Behav Neurosci* 121(1), 218–223.
- Goodrich-Hunsaker, N., M. Hunsaker, and R. Kesner (2005). Dissociating the role of the parietal cortex and dorsal hippocampus for spatial information processing. *Behavioral Neuroscience* 119(5), 1307–1315.
- Gray, J. (1983). A theory of anxiety: the role of the limbic system. *Encephale* 9(4 suppl 2), 161B–166B.
- Gray, J. (1988). Behavioural and neural-system analyses of the actions of anxiolytic drugs. *Pharmacol Biochem Behav* 29(4), 767–769.
- Griffiths, D. P., A. Dickinson, and N. S. Clayton (1999). Declarative and episodic memory: What can animals remember about their past? *Trends in Cognitive Sciences* 3, 7480.
- Hanlon, F. M., M. P. Weisend, M. Huang, R. R. Lee, S. N. Moses, K. M. Paulson, R. J. Thoma, G. A. Miller, and J. M. Caive (2003, Oct). A non-invasive method for observing hippocampal function. *Neuroreport* 14(15), 1957–1960.
- Hasselmo, M. E. (2005, Feb). The role of hippocampal regions ca3 and ca1 in matching entorhinal input with retrieval of associations between objects and context: theoretical comment on lee et al. (2005). *Behav Neurosci* 119(1), 342–345.
- Healy, S. and V. Braithwaite (2000). Cognitive ecology: a field of substance? *Trends in Ecology and Evolution* 15(1), 22–26.
- Hebert, A. E. and P. K. Dash (2002). Extracellular signal-regulated kinase activity in the entorhinal cortex is necessary for long-term spatial memory. *Learn Mem* 9(4), 156–166.
- Heron-Maxwell, C. (2002). The role of the hippocampus in object recognition memory and episodic-like memory in the rat: Investigating hippocampal function at the systems level using behavioural and electrophysiological single-unit recording techniques. Master's thesis, School of Biological Sciences, University of Edinburgh.
- Hinrichs, J. and H. Buschke (1968). Judgment of recency under steady-state conditions. *Journal of Experimental Psychology* 78(4), 574–579.
- Hinton, P. (1999). *Statistics Explained: A Guide For Social Science Students*. Routledge.
- Hintzman, D. L., J. J. Summers, and R. A. Block (1975). Spacing judgments as an index of study-phase retrieval. *Journal of Experimental Psychology: Human Learning and Memory* 1, 31–40.

- Hirata, S. (2007). A note on the responses of chimpanzees (pan troglodytes) to live self-images on television monitors. *Behav Processes* 75(1), 85–90.
- Hirsh, R. (1974). The hippocampus and contextual retrieval of information from memory: a theory. *Behav Biol* 12(4), 421–444.
- Hollingworth, A. (2006). Scene and position specificity in visual memory for objects. *J Exp Psychol Learn Mem Cogn* 32(1), 58–69.
- Howell, D. (1997). *Statistical Methods for Psychology (4th Edition)*. Wadsworth Publishing Company.
- Hulse, S. H. and D. K. O'Leary (1982). Serial pattern learning: Teaching an alphabet to rats. *Journal of Experimental Psychology: Animal Behavior Processes* 8(3), 260–273.
- Humphreys, M., I. Bain, and R. Pike (1989). Different ways to cue a coherent memory system: a theory for episodic, semantic and procedural tasks. *Psychological Review* 96, 208–233.
- Hunsaker, M. R., K. D. Allan, and R. P. Kesner (2007, Apr). Role of dca3 efferents via the fimbria in the acquisition of a delay nonmatch to place task. *Hippocampus* 17(6), 494–502.
- Hunsaker, M. R., J. A. Thorup, T. Welch, and R. P. Kesner (2006). The role of CA3 and CA1 in the acquisition of an object-trace-place paired-associate task. *Behav Neurosci* 120(6), 1252–1256.
- Izquierdo, I., M. Bianchin, M. B. Silva, M. S. Zanatta, R. Walz, A. C. Ruschel, R. C. D. Silva, N. Paczko, and J. H. Medina (1993). CNQX infused into rat hippocampus or amygdala disrupts the expression of memory of two different tasks. *Behav Neural Biol* 59(1), 1–4.
- James, W. (1890). *Principles of psychology*. New York: Holt.
- Jarrard, L. (1989). On the use of ibotenic acid to lesion selectively different components of the hippocampal formation. *Journal of Neuroscience Methods* 29(3), 251–259.
- Jarrard, L. E. (1993). On the role of the hippocampus in learning and memory in the rat. *Behav Neural Biol* 60(1), 9–26.
- Jarrard, L. E., T. L. Davidson, and B. Bowring (2004). Functional differentiation within the medial temporal lobe in the rat. *Hippocampus* 14(4), 434–449.
- Kart-Teke, E., M. De Souza Silva, J. Huston, and E. Dere (2006). Wistar rats show episodic-like memory for unique experiences. *Neurobiology of Learning and Memory* 85(2), 173–182.
- Kennedy, P. J. and M. L. Shapiro (2004). Retrieving memories via internal context requires the hippocampus. *J Neurosci* 24(31), 6979–6985.
- Kesner, R. P., K. Crutcher, and D. R. Beers (1988). Serial position curves for item (spatial location) information: role of the dorsal hippocampal formation and medial septum. *Brain Res* 454(1-2), 219–226.
- Kesner, R. P. and J. D. Hardy (1983, May). Long-term memory for contextual attributes: dissociation of amygdala and hippocampus. *Behav Brain Res* 8(2), 139–149.
- Kesner, R. P., M. R. Hunsaker, and P. E. Gilbert (2005). The role of CA1 in the acquisition of an object-trace-odor paired associate task. *Behav Neurosci* 119(3), 781–786.
- Kesner, R. P. and J. M. Novak (1982). Serial position curve in rats: role of the dorsal hippocampus. *Science* 218(4568), 173–175.
- Kesner, R. P. and J. M. Williams (1995, Nov). Memory for magnitude of reinforcement: dissociation between the amygdala and hippocampus. *Neurobiol Learn Mem* 64(3), 237–244.
- Kim, J. J. and M. S. Fanselow (1992). Modality-specific retrograde amnesia of fear. *Science* 256(5057), 675–677.

- King, J. A., I. Trinkler, T. Hartley, F. Vargha-Khadem, and N. Burgess (2004). The hippocampal role in spatial memory and the familiarity–recollection distinction: a case study. *Neuropsychology* 18(3), 405–417.
- Knowlton, B. and L. Squire (1995). Remembering and knowing: two different expressions of declarative memory. *Journal of Experimental Psychology: Learning, Memory and Cognition* 21(3), 699–710.
- Langston, R. and E. Wood (2004). Development of a non-spatial paired associate task to investigate elements of episodic-like memory in the rat. SFN Abstracts 205.4.
- Lee, A. C. H., S. Rahman, J. R. Hodges, B. J. Sahakian, and K. S. Graham (2003). Associative and recognition memory for novel objects in dementia: implications for diagnosis. *Eur J Neurosci* 18(6), 1660–1670.
- Leutgeb, S., J. K. Leutgeb, A. Treves, M.-B. Moser, and E. I. Moser (2004, Aug). Distinct ensemble codes in hippocampal areas ca3 and ca1. *Science* 305(5688), 1295–1298.
- Lewandowsky, S. and J. Murdock, B. B. (1989). Memory for serial order. *Psychological Review* 96, 25–57.
- Li, H., K. Matsumoto, and H. Watanabe (1999). Different effects of unilateral and bilateral hippocampal lesions in rats on the performance of radial maze and odor-paired associate tasks. *Brain Res Bull* 48(1), 113–119.
- Mackintosh, N. J. (1983). *Conditioning and associative learning*. Oxford: Clarendon Press.
- Marr, D. (1971, Jul). Simple memory: a theory for archicortex. *Philos Trans R Soc Lond B Biol Sci* 262(841), 23–81.
- McDonald, R. J., R. A. Murphy, F. A. Guarraci, J. R. Gortler, N. M. White, and A. G. Baker (1997). Systematic comparison of the effects of hippocampal and fornix-fimbria lesions on acquisition of three configural discriminations. *Hippocampus* 7(4), 371–388.
- McDonald, R. J. and N. M. White (1993, Feb). A triple dissociation of memory systems: hippocampus, amygdala, and dorsal striatum. *Behav Neurosci* 107(1), 3–22.
- McKenzie, T., T. Cherman, L. R. Bird, M. Naqshbandi, and W. A. Roberts (2004, Nov). Can squirrel monkeys (*saimiri sciureus*) plan for the future? studies of temporal myopia in food choice. *Learn Behav* 32(4), 377–390.
- McKoon, G., R. Ratcliff, and G. Dell (1986). A critical evaluation of the semantic-episodic distinction. *Journal of experimental psychology* 12(2), 295–306.
- McNaughton, B. L., C. A. Barnes, J. L. Gerrard, K. Gothard, M. W. Jung, J. J. Knierim, H. Kudrimoti, Y. Qin, W. E. Skaggs, M. Suster, and K. L. Weaver (1996). Deciphering the hippocampal polyglot: the hippocampus as a path integration system. *J Exp Biol* 199(Pt 1), 173–185.
- Meck, W., R. Church, and D. Olton (1984). Hippocampus, time, and memory. *Behavioral Neuroscience* 98(1), 3–22.
- Mediavilla, C., F. Molina, and A. Puerto (1998). Bilateral lesions in the cerebellar interpositus-dentate region impair taste aversion learning in rats. *Physiol Behav* 65(1), 25–33.
- Meunier, M., J. Bachevalier, M. Mishkin, and E. A. Murray (1993, Dec). Effects on visual recognition of combined and separate ablations of the entorhinal and perirhinal cortex in rhesus monkeys. *J Neurosci* 13(12), 5418–5432.
- Miller, G. (1956). The magical number seven, plus or minus two: Some limits on our capacity for processing information. *The Psychological Review* 63, 81–97.
- Milner, B., I. Johnsrude, and J. Crane (1997, Oct). Right medial temporal-lobe contribution to object-location memory. *Philos Trans R Soc Lond B Biol Sci* 352(1360), 1469–1474.

- Mishkin, M. (1978, May). Memory in monkeys severely impaired by combined but not by separate removal of amygdala and hippocampus. *Nature* 273(5660), 297–298.
- Mishkin, M., W. A. Suzuki, D. G. Gadian, and F. Vargha-Khadem (1997). Hierarchical organization of cognitive memory. *Philos Trans R Soc Lond B Biol Sci* 352(1360), 1461–1467.
- Mitchell, J. and J. Laiacina (1998). The medial frontal cortex and temporal memory: tests using spontaneous exploratory behaviour in the rat. *Behavioural Brain Research* 97, 107113.
- Mizumori, S. J., K. E. Ragozzino, B. G. Cooper, and S. Leutgeb (1999). Hippocampal representational organization and spatial context. *Hippocampus* 9(4), 444–451.
- Morris, R. (2001). Episodic-like memory in animals: psychological criteria, neural mechanisms and the value of episodic-like tasks to investigate animal models of neurodegenerative disease. *Philosophical Transactions of the Royal Society of London Series B: Biological Sciences* 356(1413), 1453–1465.
- Morris, R., P. Garrud, J. Rawlins, and J. O'Keefe (1982). Place navigation impaired in rats with hippocampal lesions. *Nature* 297(5868), 681–683.
- Morris, R., F. Schenk, F. Tweedie, and L. Jarrard (1990a). Ibotenate lesions of hippocampus and/or subiculum: Dissociating components of allocentric spatial learning. *European Journal of Neuroscience* 2(12), 1016–1028.
- Morris, R. G. and U. Frey (1997). Hippocampal synaptic plasticity: role in spatial learning or the automatic recording of attended experience? *Philos Trans R Soc Lond B Biol Sci* 352(1360), 1489–1503.
- Morris, R. G. M. (2006). Elements of a neurobiological theory of hippocampal function: the role of synaptic plasticity, synaptic tagging and schemas. *Eur J Neurosci* 23(11), 2829–2846.
- Morris, R. G. M., F. Schenk, F. Tweedie, and L. E. Jarrard (1990b). Ibotenate lesions of hippocampus and/or subiculum: Dissociating components of allocentric spatial learning. *Eur J Neurosci* 2(12), 1016–1028.
- Morrison, G. and R. Collyer (1974). Taste-mediated conditioned aversion to an exteroceptive stimulus following licl poisoning. *J Comp Physiol Psychol.* 86(1), 51–55.
- Moscovitch, M., R. S. Rosenbaum, A. Gilboa, D. R. Addis, R. Westmacott, C. Grady, M. P. McAndrews, B. Levine, S. Black, G. Winocur, and L. Nadel (2005). Functional neuroanatomy of remote episodic, semantic and spatial memory: a unified account based on multiple trace theory. *J Anat* 207(1), 35–66.
- Mulcahy, N. J. and J. Call (2006, May). Apes save tools for future use. *Science* 312(5776), 1038–1040.
- Mumby, D. (1995). Assessing working memory for objects in rats: no one said it was easy. *Neuroreport* 6(15), 1960–1962.
- Mumby, D., S. Gaskin, M. Glenn, T. Schramek, and H. Lehmann (2002). Hippocampal damage and exploratory preferences in rats: memory for objects, places, and contexts. *Learning and Memory* 9(2), 49–57.
- Mumby, D. G. (2001). Perspectives on object-recognition memory following hippocampal damage: lessons from studies in rats. *Behav Brain Res* 127(1-2), 159–181.
- Murray, E. A. and M. Mishkin (1986, Jul). Visual recognition in monkeys following rhinal cortical ablations combined with either amygdalectomy or hippocampectomy. *J Neurosci* 6(7), 1991–2003.
- Murray, E. A. and M. Mishkin (1998, Aug). Object recognition and location memory in monkeys with excitotoxic lesions of the amygdala and hippocampus. *J Neurosci* 18(16), 6568–6582.



- Nadel, L. and M. Moscovitch (1997, Apr). Memory consolidation, retrograde amnesia and the hippocampal complex. *Curr Opin Neurobiol* 7(2), 217–227.
- Nakazawa, K., M. C. Quirk, R. A. Chitwood, M. Watanabe, M. F. Yeckel, L. D. Sun, A. Kato, C. A. Carr, D. Johnston, M. A. Wilson, and S. Tonegawa (2002, Jul). Requirement for hippocampal ca3 nmda receptors in associative memory recall. *Science* 297(5579), 211–218.
- Nakazawa, K., L. D. Sun, M. C. Quirk, L. Rondi-Reig, M. A. Wilson, and S. Tonegawa (2003, Apr). Hippocampal ca3 nmda receptors are crucial for memory acquisition of one-time experience. *Neuron* 38(2), 305–315.
- Naqshbandi, M., M. C. Feeney, T. L. B. McKenzie, and W. A. Roberts (2007, Feb). Testing for episodic-like memory in rats in the absence of time of day cues: replication of babb and crystal. *Behav Processes* 74(2), 217–225.
- Naqshbandi, M. and W. A. Roberts (2006, Nov). Anticipation of future events in squirrel monkeys (*saimiri sciureus*) and rats (*rattus norvegicus*): tests of the bischof-kohler hypothesis. *J Comp Psychol* 120(4), 345–357.
- Nemanic, S., M. C. Alvarado, and J. Bachevalier (2004, Feb). The hippocampal/parahippocampal regions and recognition memory: insights from visual paired comparison versus object-delayed nonmatching in monkeys. *J Neurosci* 24(8), 2013–2026.
- Norman, G. and M. Eacott (2005). Dissociable effects of lesions to the perirhinal cortex and the postrhinal cortex on memory for context and objects in rats. *Behavioral Neuroscience* 119(2), 557–566.
- O'Keefe, J. and L. Nadel (1978). *The hippocampus as a Cognitive Map*. Oxford University Press.
- Olton, D. and B. Papas (1979). Spatial memory and hippocampal function. *Neuropsychologia* 17(6), 669–682.
- Olton, D. and R. Samuelson (1976). Remembrance of places passed: Spatial memory in rats. *Journal of Experimental Psychology: Animal Behavior Processes* 2, 97–116.
- Olton, D., J. Walker, and W. W.A. (1982). A disconnection analysis of hippocampal function. *Brain Research* 233(2), 241–253.
- O'Mara, S. (2005, Sep). The subiculum: what it does, what it might do, and what neuroanatomy has yet to tell us. *J Anat* 207(3), 271–282.
- O'Mara, S. (2006, Nov). Controlling hippocampal output: the central role of subiculum in hippocampal information processing. *Behav Brain Res* 174(2), 304–312.
- O'Reilly, R. C. and J. W. Rudy (2001). Conjunctive representations in learning and memory: principles of cortical and hippocampal function. *Psychol Rev* 108(2), 311–345.
- Otto, T. and H. Eichenbaum (1992, Oct). Complementary roles of the orbital prefrontal cortex and the perirhinal-entorhinal cortices in an odor-guided delayed-nonmatching-to-sample task. *Behav Neurosci* 106(5), 762–775.
- Papez, J. (1937). A proposed mechanism of emotion. *Archives of Neurology and Psychiatry* 38, 725–743.
- Pavlov, I. (1927). *Conditioned Reflexes*. Oxford University Press.
- Penfield, W. and H. H. Jasper (1954). *Epilepsy and the functional anatomy of the human brain*. Boston, Little & Brown.
- Perner, J. and T. Ruffman (1995). Episodic memory and autonoetic consciousness: Developmental evidence and a theory of childhood amnesia. *Journal of Experimental Child Psychology* 59(3), 516–548.
- Povinelli, D., A. Rulf, K. Landau, and D. Bierschwale (1993). Self-recognition in chim-

- panzees (pan troglodytes): distribution, ontogeny, and patterns of emergence. *J Comp Psychol* 107(4), 347–372.
- Raby, C. R., D. M. Alexis, A. Dickinson, and N. S. Clayton (2007, Feb). Planning for the future by western scrub-jays. *Nature* 445(7130), 919–921.
- Ramon y Cajal, S. (1911). *Histologie du Systeme Nerveux de l'Homme et des Vertebres*. Maloine.
- Ranganath, C., A. P. Yonelinas, M. X. Cohen, C. J. Dy, S. M. Tom, and M. D'Esposito (2004). Dissociable correlates of recollection and familiarity within the medial temporal lobes. *Neuropsychologia* 42(1), 2–13.
- Real, L. (1993). Toward a cognitive ecology. *Trends in Ecology and Evolution* 8, 413–417.
- Renner, M. and C. Seltzer (1991). Molar characteristics of exploratory and investigatory behavior in the rat (*rattus norvegicus*). *Journal Comparative Psychology* 105(4), 326–339.
- Ridley, R. M. and H. F. Baker (1991). A critical evaluation of monkey models of amnesia and dementia. *Brain Res Brain Res Rev* 16(1), 15–37.
- Roediger, H., M. Weldon, and B. Challis (1989). Explaining dissociations between implicit and explicit measures of retention: a processing account. In H. Roediger and F. Craik (Eds.), *Varieties of memory and consciousness: essays in honour of Endel Tulving*. Erlbaum & Hillsdale.
- Rolls, E. T. and R. P. Kesner (2006, May). A computational theory of hippocampal function, and empirical tests of the theory. *Prog Neurobiol* 79(1), 1–48.
- Sanderson, D. J., J. M. Pearce, R. J. Kyd, and J. P. Aggleton (2006). The importance of the rat hippocampus for learning the structure of visual arrays. *Eur J Neurosci* 24(6), 1781–1788.
- Save, E., B. Poucet, N. Foreman, and M.-C. Buhot (1992). Object exploration and reactions to spatial and nonspatial changes in hooded rats following damage to parietal cortex or hippocampal formation. *Behavioral Neuroscience* 106(3), 447–456.
- Schneider, K. and M. Pinnow (1994). Olfactory and gustatory stimuli in food-aversion learning of rats. *J Gen Psychol* 121(2), 169–183.
- Scoville, W. (1954). The limbic lobe in man. *Journal of Neurosurgery* 11, 64–66.
- Scoville, W. B. and B. Milner (1957). Loss of recent memory after bilateral hippocampal lesions. *J Neurol Neurosurg Psychiatry* 20(1), 11–21.
- Scoville, W. B. and B. Milner (2000). Loss of recent memory after bilateral hippocampal lesions. 1957. *J Neuropsychiatry Clin Neurosci* 12(1), 103–113.
- Selden, N. R., B. J. Everitt, L. E. Jarrard, and T. W. Robbins (1991). Complementary roles for the amygdala and hippocampus in aversive conditioning to explicit and contextual cues. *Neuroscience* 42(2), 335–350.
- Shettleworth, S. J. (1995). *Comparative studies of memory in food storing birds: From the field to the Skinner box*. Dordrecht: Kluwer Academic Press.
- Slater, L. (2001). *Spasm*. Methuen.
- Somerville, L. H., G. S. Wig, P. J. Whalen, and W. M. Kelley (2006, Aug). Dissociable medial temporal lobe contributions to social memory. *J Cogn Neurosci* 18(8), 1253–1265.
- Spiers, H. J., N. Burgess, E. A. Maguire, S. A. Baxendale, T. Hartley, P. J. Thompson, and J. O'Keefe (2001). Unilateral temporal lobectomy patients show lateralized topographical and episodic memory deficits in a virtual town. *Brain* 124(Pt 12), 2476–2489.
- Sprengel, R. (2006). Role of AMPA receptors in synaptic plasticity. *Cell Tissue Res* 326(2), 447–455.

- Squire, L. R. and P. Alvarez (1995, Apr). Retrograde amnesia and memory consolidation: a neurobiological perspective. *Curr Opin Neurobiol* 5(2), 169–177.
- Steckler, T., W. H. Drinkenburg, A. Sahgal, and J. P. Aggleton (1998, Feb). Recognition memory in rats—i. concepts and classification. *Prog Neurobiol* 54(3), 289–311.
- Steele, K. and J. N. Rawlins (1993). The effects of hippocampectomy on performance by rats of a running recognition task using long lists of non-spatial items. *Behav Brain Res* 54(1), 1–10.
- Steffenach, H.-A., M. Witter, M.-B. Moser, and E. I. Moser (2005). Spatial memory in the rat requires the dorsolateral band of the entorhinal cortex. *Neuron* 45(2), 301–313.
- Steinvorth, S., B. Levine, and S. Corkin (2005). Medial temporal lobe structures are needed to re-experience remote autobiographical memories: evidence from h.m. and w.r. *Neuropsychologia* 43(4), 479–496.
- Stepankova, K., A. A. Fenton, E. Pastalkova, M. Kalina, and V. D. Bohbot (2004). Object-location memory impairment in patients with thermal lesions to the right or left hippocampus. *Neuropsychologia* 42(8), 1017–1028.
- Stubley-Weatherly, L., J. W. Harding, and J. W. Wright (1996). Effects of discrete kainic acid-induced hippocampal lesions on spatial and contextual learning and memory in rats. *Brain Res* 716(1-2), 29–38.
- Suddendorf, T. and J. Busby (2003a). Like it or not? the mental time travel debate: Reply to clayton et al. *Trends in Cognitive Sciences* 7(10), 437–438.
- Suddendorf, T. and J. Busby (2003b). Mental time travel in animals? *Trends in Cognitive Sciences* 7(9), 391–396.
- Suddendorf, T. and M. Corballis (1997). Mental time travel and the evolution of the human mind. *Genet. Soc. Gen. Psychol. Monogr.* 123(2), 133–67.
- Swainson, R., J. R. Hodges, C. J. Galton, J. Semple, A. Michael, B. D. Dunn, J. L. Iddon, T. W. Robbins, and B. J. Sahakian (2001). Early detection and differential diagnosis of alzheimer's disease and depression with neuropsychological tasks. *Dement Geriatr Cogn Disord* 12(4), 265–280.
- Tse, D. (2005). Flavour maps: paired associate learning in an event arena as an animal model of associative recall. Master's thesis, University of Edinburgh.
- Tse, D. and R. F. Langston et al (2007, Apr). Schemas and memory consolidation. *Science* 316(5821), 76–82.
- Tuckey, M. R. and N. Brewer (2003). The influence of schemas, stimulus ambiguity, and interview schedule on eyewitness memory over time. *J Exp Psychol Appl* 9(2), 101–118.
- Tulving, E. (1972). *Organization of memory*. New York: Academic Press.
- Tulving, E. (1983). *Elements of Episodic Memory*. Oxford: Clarendon Press.
- Tulving, E. (1993). What is episodic memory? *Current Directions in Psychological Science* 2(3), 67–70.
- Tulving, E. (2001). Episodic memory and common sense: how far apart? *Philos Trans R Soc Lond B Biol Sci* 356(1413), 1505–1515.
- Tzeng, O. J. L., A. T. Lee, and C. D. Wetzel (1979). Temporal coding in verbal information processing. *Journal of Experimental Psychology: Human Learning and Memory* 5, 52–64.
- Vargha-Khadem, F., D. G. Gadian, and M. Mishkin (2001, Sep). Dissociations in cognitive memory: the syndrome of developmental amnesia. *Philos Trans R Soc Lond B Biol Sci* 356(1413), 1435–1440.
- Vargha-Khadem, F., D. G. Gadian, K. E. Watkins, A. Connelly, W. V. Paesschen, and M. Mishkin (1997). Differential effects of early hippocampal pathology on episodic

- and semantic memory. *Science* 277(5324), 376–380.
- Wallace, D., B. Gorny, and I. Wishaw (2002). Rats can track odors, other rats, and themselves: implications for the study of spatial behavior. *Behavioral Brain Research* 131(1-2), 185–92.
- Warburton, E. C., A. L. Baird, A. Morgan, J. L. Muir, and J. P. Aggleton (2000, May). Disconnecting hippocampal projections to the anterior thalamus produces deficits on tests of spatial memory in rats. *Eur J Neurosci* 12(5), 1714–1726.
- Waugh, N. and D. Norman (1965). Primary memory. *Psychological Review* 72, 89–104.
- Wishaw, I. (2005). *The behavior of the laboratory rat: A handbook with tests.*, Chapter 20, pp. 217–226. Oxford University Press.
- Wishaw, I. and S. Oddie (1989). Qualitative and quantitative analyses of hoarding in medial frontal cortex rats using a new behavioral paradigm. *Behavioral Brain Research* 33(3), 255–266.
- Wishaw, I. Q. and J. A. Tomie (1991). Acquisition and retention by hippocampal rats of simple, conditional, and configural tasks using tactile and olfactory cues: implications for hippocampal function. *Behav Neurosci* 105(6), 787–797.
- Williams, L. M., M. L. Phillips, M. J. Brammer, D. Skerrett, J. Lagopoulos, C. Rennie, H. Bahramali, G. Olivieri, A. S. David, A. Peduto, and E. Gordon (2001, Nov). Arousal dissociates amygdala and hippocampal fear responses: evidence from simultaneous fmri and skin conductance recording. *Neuroimage* 14(5), 1070–1079.
- Wolfe, J. (1939). An exploratory study of food-storing in rats. *Journal of Comparative Psychology* 28, 97–108.
- Wood, E. R., K. M. Agster, and H. Eichenbaum (2004). One-trial odor-reward association: a form of event memory not dependent on hippocampal function. *Behav Neurosci* 118(3), 526–539.
- Woodruff, C. C., H. R. Hayama, and M. D. Rugg (2006). Electrophysiological dissociation of the neural correlates of recollection and familiarity. *Brain Res* 1100(1), 125–135.
- Wree, A. and R. T. Erselius (1991). Differential vulnerability of neurons toward local injection of ibotenic acid in the hippocampus of the adult rat. an electron microscopic study. *J Hirnforsch* 32(2), 185–193.
- Yntema, D. (1963). Keeping track of several things at once. *Human Factors* 5, 7–17.
- Yonelinas, A. P. (1994). Receiver-operating characteristics in recognition memory: evidence for a dual-process model. *J Exp Psychol Learn Mem Cogn* 20(6), 1341–1354.
- Yonelinas, A. P. (2001). Components of episodic memory: the contribution of recollection and familiarity. *Philos Trans R Soc Lond B Biol Sci* 356(1413), 1363–1374.
- Yonelinas, A. P. and B. J. Levy (2002). Dissociating familiarity from recollection in human recognition memory: different rates of forgetting over short retention intervals. *Psychon Bull Rev* 9(3), 575–582.
- Yonelinas, A. P., L. J. Otten, K. N. Shaw, and M. D. Rugg (2005). Separating the brain regions involved in recollection and familiarity in recognition memory. *J Neurosci* 25(11), 3002–3008.
- Zorumski, C. F., S. Mennerick, and J. Que (1996). Modulation of excitatory synaptic transmission by low concentrations of glutamate in cultured rat hippocampal neurons. *J Physiol* 494 ( Pt 2), 465–477.