

THE CONSERVATION CHALLENGES OF REGENERATING AN URBAN INDUSTRIAL ZONE:
EXPLORING THE DESIGN OPTIONS

A Design Project submitted for

MSc in Architectural Conservation,
University of Edinburgh

by N.S. Kartalou – student no. s1257511

First Reader: Ruxandra-Iulia Stoica

SCOTTISH CENTRE FOR CONSERVATION STUDIES
EDINBURGH SCHOOL OF ARCHITECTURE AND LANDSCAPE ARCHITECTURE
EDINBURGH COLLEGE OF ART
UNIVERSITY OF EDINBURGH
2012-13

Contents

List of Abbreviations

List of Illustrations

Abstract

Acknowledgments

I. INTRODUCTION 13

Aims and objectives of the study

II. SHRUB PLACE LANE, LEITH 17

1. Location & Context 17

2. History 19

3. Industrial Heritage 20

III. ANALYSIS 23

1. Identification of the Current Condition 23

• Shrub Place 23

• Surrounding Area 27

2. Analysis of Shrub Place 30

• Historical Development (1850-2013) 30

• Geometry of the Site & Connection with the Surrounding Area 33

3. First Results 37

4. Developing Shrub Place Lane 37

• Previous Proposals 37

• Development Objectives 41

5. Evaluation of Findings 41

• Conclusions From the Analysis of the Area 42

• Conservation Principles 43

• Successful Regenerations 44

IV. DESIGN PROPOSAL 47

1. Vision 47

• Character of Shrub Place 47

• Design Principles 48

2. Masterplan 49

• Steps 1-6 49

V. CONCLUSION 59

Bibliography

List of Abbreviations

AUTH	Aristotle University of Thessaloniki
BR	Buildings at Risk
CEC	City of Edinburgh Council
CECI	Centro de Estudos Avançados da Coservação Integrada
CUP	Cambridge University Press
HS	Historic Scotland
PBSOS	Planning and Building Standards Online Services
RCAHMS	Royal Commission on the Ancient and Historical Monuments of Scotland
TCA	Technopolis City of Athens
TICCIH	The International Committee for the Conservation of the Industrial Heritage

List of Illustrations

Figure 1	Location of Shrub Place	17
Figure 2	Diagram showing site's connection with the city centre	17
Figure 3	Conservation Area of Leith	18
Figure 4	View of Tramway Workshops	18
Figure 5	View of the old depot from northwest	18
Figure 6	View of the interior of Body Shop from northeast	19
Figure 7	Timeline of Shrub Place	19
Figure 8	Current map	23
Figure 9	Panoramic views to southeast	24
Figure 10	Panoramic views to northwest	24
Figure 11	Diagram showing the access to the site	24
Figure 12	Diagram showing the connection with the railway	24
Figure 13	Historic map of 1940	25
Figure 14	Historic map of 1960	25
Figure 15	View of the damage	25
Figure 16	View of remaining walls	26
Figure 17	View of Leith Walk from the interior	26
Figure 18	View of Masonic Social Club	26
Figure 19	Map showing the built fabric	27
Figure 20	View of northeast area	27
Figure 21	View of colony houses & remaining walls	28
Figure 22	View of the site from Leith Walk	28
Figure 23	View of the site from Mc Donald Road	28
Figure 24	Map with the functions in the area	29
Figure 25	Map showing the public space of the neighborhood	29
Figure 26	Skyline diagram	29
Figure 27	Historic map of 1850	30
Figure 28	Historic map of 1890	30
Figure 29	Historic map of 1910	30
Figure 30	Historic map of 1940	31
Figure 31	Historic map of 1960	31
Figure 32	Historic map of 1990	31
Figure 33	Historic map of 2008	31
Figure 34	Current map of 2013	31
Figure 35	Overlay of historic maps	32
Figure 36	Current condition diagram with traces of the old structures	33

Figure 37	Diagrams showing the orientation of the plots in 2008	35
Figure 38	Diagrams showing the orientation of the plots in 2013	35
Figure 39	Diagrams showing site's interaction with the area	36
Figure 40	3D model of the volumes in the area	36
Figure 41	Proposed demolition plan from BL Developments	38
Figure 42	Proposed site layout plan from BL Developments	38
Figure 43	Proposed elevation for the new buildings from BL Developments	39
Figure 44	Proposed section for the listed building from BL Developments	39
Figure 45	Proposed site layout plan from Frasers Hamilton	40
Figure 46	Proposed section from northwest from Frasers Hamilton	40
Figure 47	View of Technopolis Gazi, Athens	44
Figure 48	View of G-Mex Centre, Manchester	44
Figure 49	Sketch showing the new principles	48
Figure 50	Sketch showing the new principles	48
Figure 51	Sketch showing the new principles	48
Figure 52	Sketch showing the new principles	49
Figure 53	Sketch showing the new principles	49
Figure 54	Sketch showing the new principles	50
Figure 55	Sketch showing the new principles	50
Figure 56	Sketch showing the new principles	51
Figure 57	Sketch showing the new principles	51
Figure 58	3D model showing the new structures	52
Figure 59	Sketch showing the new principles	53
Figure 60	Sketch showing the new principles	53
Figure 61	Sketch showing the new principles	53
Figure 62	Sketch showing the new principles	54
Figure 63	Sketch showing the new principles	55
Figure 64	Sketch showing the new principles	55
Figure 65	Sketch showing the new principles	56
Figure 66	Sketch showing the new principles	56
Figure 67	Proposed view of the entrance, 3D model	57
Figure 68	Proposed site layout, 3D model	57
Figure 69	Proposed view of the site, 3D model	58
Figure 70	Proposed view of the site, 3D model	58

Abstract

This document is a design project study which concerns the regeneration of an urban industrial zone. In particular it focuses on the conservation challenges that arise from the new development of Shrub Place Lane, where the traces from the past meet the new design options. As this study is guided by design methods, it is accompanied by a considerable number of illustrations while each part of the research constitutes a step for the final proposal. Due to the size of the area of focus and its component structures, the following study can be characterized as an urban conservation project and includes different phases of research. The new planning methods are formed through a detailed analysis of the site, based on cartographic sources, including previous case studies for its development and examples of regenerations in Europe that succeeded to conserve the original character of deserted places. This regeneration is guided strictly by conservation principles, in order to achieve a successful assimilation of the site into the urban fabric and propose an appropriate masterplan for its future development.

Acknowledgments

I would like to thank my supervisor Dr. Ruxandra-Iulia Stoica for her guidance through the project and her support. I would also like to thank the director of MSc Architectural Conservation, Pr. Miles Glendinning for his guidance at the beginning of my research.

Image Credits

Historic images and maps included in this report have been taken from various organizations as listed below. Some of them have been reproduced by the author. Diagrams not listed are made by the author.

Ordnance Survey Maps	25, 30, 31
CANMORE by RCAHMS	18, 19
City of Edinburgh Council	18, 38, 39, 40,
Google Maps	1, 2,
Technopolis Gazi	44
Central Manchester	44

I. INTRODUCTION

I. INTRODUCTION

This study focuses on the exploration of conservation initiatives for the regeneration of an old industrial zone in Edinburgh. The choice of this particular subject lies principally on the old character of the site in combination with its location. Edinburgh has only a few industrial monuments, the majority of them are on the outskirts of the city. Shrub Place, an old tram depot located in Leith, which today consists of two listed buildings and a chimney, is an exemption to this 'rule'. It represents a great example of industrial architecture and consequently a piece of cultural heritage for the city of Edinburgh. In a constantly evolving world, Shrub Place remains stagnant, threatened from abandonment and time. Its future development constitutes a matter of high importance for the neighborhood, not only for the integration of the zone into the urban fabric but also for the revival of the area. An approach of urban regeneration can be extremely demanding, as the new design, which will bring new principles in the area, is obligated to respect the historic fabric and coexist with the urban environment. It is a design challenge that aims to emerge the past into the present through conservation principles, a fact that introduces Shrub Place as a very tempting case study.

In order to accomplish a successful regeneration for this abandoned manufacturing area, which is the main aim of this study, the project will follow a specific methodology of research, composed by different phases of analysis, which are required to proceed before the masterplan. More particular, the design investigation of cartographical and historical sources and the detailed analysis of the geometry of the site through diagrams, maps and 3D models will be the key for the identification of the area and the introduction to the new design principles. Moreover, the previous proposals for the development of Shrub Place will be mentioned while citing their strengths and weaknesses, for the better understanding of the needs of the area. Last but not least, examples of regenerations of abandoned industrial zones, which achieved to incorporate harmoniously with the urban fabric using conservation principles, are also required, in order to serve as guides for the new proposal. All of the above actions will serve as exploring mechanisms, producing a realistic development for this deserted industrial zone.

The first chapter concerns the introduction of Shrub Place; with references to its historical background and its development through the past years, including details about the location of the site and its relationship with the existing built fabric. This section will define the area of focus, with the intention of establishing the values of industrial heritage.

The second chapter, which constitutes the biggest part of the study, will focus on the analysis of the physical, functional, and theoretical interpretation of industrial heritage. This chapter will be divided by the following sections:

- The identification of the current condition of the area of focus will be first presented, illustrated by maps, images and sketches, in order to observe how the area functions and connects with the neighborhood of Pilrig. With the intention of examining the site's interaction with the built fabric and its connection with the cityscape, the recognition of Shrub Place's geometry composition is the next step of the analysis. In addition to this, the historic development of the area will follow, including maps with the changes of the urban pattern. The above investigation will guide the configuration of the first design principles, as the geometrical findings of the area can structure the new pattern for the masterplan.
- After evaluating the first results, it is fundamental to identify the values and the needs of the area. This can be accomplished through references to the previous proposals for the development of Shrub Place, which will illustrate the demands of the neighborhood. The combination of this data will determine the character of the site and will introduce the importance of conservation need.
- Shortly before the introduction of the design proposal, the conservation methods of industrial heritage should be understood. In order to propose a future development for this old manufacturing area, the fundamental principles of urban conservation should be mentioned. This will be achieved by using noticeable examples of successful regenerations; to demonstrate the feasibility of this project.

The design proposal constitutes the last part of this study and it is based on the evaluation of the previous chapter's findings. It will present the masterplan for the development of Shrub Place, including detailed drawings of the new pattern and the new built fabric, guided by design principles.

Finally, the conclusion will comprise the results of the analysis in combination with the recommendations for the future regeneration of the site. As the object of this study is to extend the understanding of urban conservation, this chapter will present the findings of the analysis and will indicate the strengths of the project.

II. SHRUB PLACE LANE, LEITH

II. SHRUB PLACE LANE, LEITH

This chapter introduces the area of focus and its history while referring to the value of industrial heritage. Historical research of a zone such Shrub Place will reveal the character of the place and will give context for a better evaluation. The question of authenticity follows in the next chapter. The answer lies on one hand in the historical development of the area and on the other hand in the area's function.

1. Location and Context

This project focuses on Shrub Place Lane, an old industrial legacy at the northern side of Leith. The site borders Leith Walk, the major street to Leith, which connects this neighborhood with the centre of Edinburgh.¹ (Fig 1) It is only one mile away from the city centre and 1.5 miles away from the port of Leith. (Fig 2) Shrub Place is not included in the Conservation Area of Leith;² however, the existing buildings which are parts of the old workshops are listed as Category B.³ (Figs 3, 4) Those two buildings, a chimney and some walls of previous structures constitute the remains of another era, when the site was functioning as a tram depot.⁴ As an old manufacturing area, on the one hand the site retains its previous image due to the presence of these original structures, but on the other it suffers from the absence of the industrial use. Shrubhill Tramway Workshops, the only original parts of the depot, are now at risk due to the abandonment of the site.

¹CEC, *Leith Conservation Area Chapter Appraisal* (Edinburgh: CEC, 2002), 5

²Idem

³"Shrubhill Tramworks Workshop to NW, Shrub Place, Leith", BR (by HS, 2013), http://www.buildingsatrisk.org.uk/search/planning_authority/186/p/3/event_id/917195/building_name/, Accessed February, 2013

⁴Idem

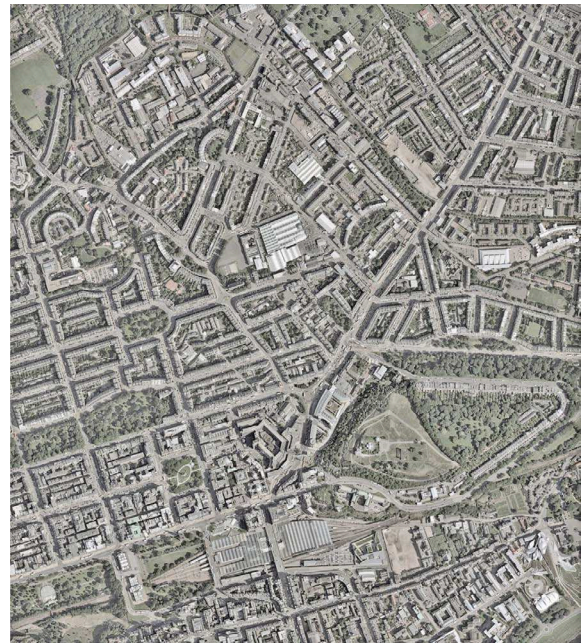

Figure 1: Location of Shrub Place by Google Maps

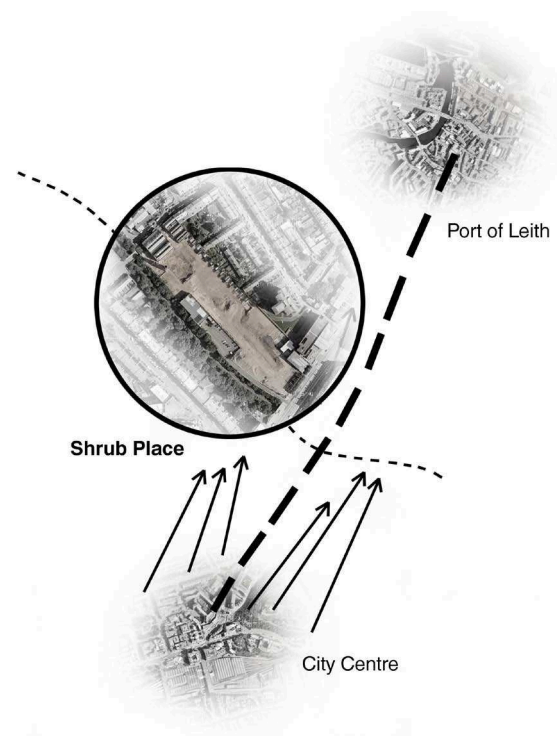

Figure 2: Connection with the city centre made by the author



Figure 3: Leith Conservation Area map from CEC



Figure 4: View of Tramway Workshops, Image taken by the author



Figure 5: View of the old depot from northwest, Image from CANMORE

2. History

The sites history begins back in 16th century, according to historical references, which cite Shrub Place as a possible site of public executions. The image of the neighborhood changed completely during the 17th century, where the area served as a quarry for mortar sand. In 1800, a small country house with gardens was constructed and named Shrub House. The industrial character of the site appeared for first time at the end of 17th century, probably around 1877, when the construction of the stables and workshops for the Edinburgh's Street Tramways began. In 1898, new decorated brick buildings were constructed in order to function as power stations and workshops, on account of the replacement of horse-drawn trams by the new cable tram system⁵. (Figs 5, 6)



Figure 6: View of the interior of Body Shop from northeast, Image from CANMORE

	Timeline	
	1500-1600	Possible site of public executions
	1700	Area serving as a quarry for mortar sand
	1800	Construction of Shrub House
	1877	Construction of stables and workshops for the Edinburgh's Street Tramways
	1898	Replacement of horse-drawn trams from the new cable tram system and construction of new brick buildings
	1956	Edinburgh's tram system was decommissioned
	1960	Demolition of the south part of the site, including Shrub House New post-modern buildings serving for the accommodation of EastLothian Transport
	1999	Shrubhill Tramway Workshops to NW and NE were listed grade B
	2002	Submission of the first proposal for the development of the area from Jenkins & Marr Architects and Chartered Town Planners
	2005	Second proposal for the development of the area from BL Developments Ltd
	2008	Demolition of the biggest part of the depot
	2013	Proposal for the development of the site from Frasers Hamilton Ltd

Figure 7: Timeline of Shrub Place, made by the author

⁵ "Edinburgh, Leith Walk, Shrub Place Lane, Shrubhill Tramway Workshops And Power Station", CANMORE (by RCAHMS, 2011), <http://canmore.rcahms.gov.uk/en/event/577227/>, Accessed June, 2013

In the years following the Second World War, the character of Shrub Place begun to alter. In 1956, Edinburgh's tram system was decommissioned; an action which led to the demolition of the south part of the site, including Shrub House in 1960. New buildings for the accommodation of East Lothian Transport were constructed, influenced by the post-war architecture of that time⁶. In 1999, two buildings in the site were registered as Category B of listed: Shrubhill Tramway Workshops.⁷

In the late 20th century, after workshops relocation in Annandale Street, a few hundred metres west of Shrub Place, the depot changed ownership.⁸ Different proposals for the development of the site have been submitted during the past years, cited by chronological order below:

- 2002 by Jenkins & Marr Architects and Chartered Town Planners⁹
- 2005 by BL Developments Ltd¹⁰
- 2013 by Frasers Hamilton Ltd¹¹

The above cases will be examined in the next chapter, including references to the proposed developments and accompanied by illustrations. At this point, it is worth mentioning that the biggest part of Shrub Place was demolished in 2008,¹² after the approval of BL Developments proposal.¹³

3. Industrial Heritage

“Industrial heritage consists of the remains of industrial culture which are of historical, technological, social, architectural or scientific value.”¹⁴ The site of focus includes all these values, due to its historic fabric, its historical background and its technological progress during the past years. However, its manufacturing character tends to disappear because of the economic and social revolution of the present age. The following chapter will justify the reasons why Shrub Place Lane is a prominent example of industrial heritage and will define why its preservation is necessary.

⁶Idem

⁷Leith Walk, Shrub Place, Shrubhill Tramway Workshops And Power Stations, HS 2013, http://hsewsf.sedsh.gov.uk/hslive/hsstart?P_HB- NUM=45956, Accessed August, 2013

⁸Interview with Philip Myerscough, Managing Director of BL Developments, February 22, 2013

⁹CEC, PBSOS Application Number: 02/04593/FUL, Accessed March, 2013

¹⁰CEC, PBSOS Application Number: 05/03128/FUL, Accessed February, 2013

¹¹CEC, PBSOS Application Number: 13/01070/FUL, Accessed, April, 2013

¹²Interview with Will Garrett, Development Planning Group Leader, CEC, June 28, 2013

¹³CEC, PBSOS Application Number: 05/03128/FUL, Accessed February, 2013

¹⁴TICCIH Congress in Russia, *The Nizhny Tagil Charter For The Industrial Heritage*, July 2003

III. ANALYSIS

This chapter covers the primary part of the project, including the different steps of the identification of Shrub Place with references to the values of industrial heritage. With an intention to regenerate the site through conservation appraisals, this section focuses on the analysis of the area, the historical changes of its urban fabric and the principles that the site creates by itself for its future development. These findings will constitute the catalyst factor, which in combination with the values of industrial culture, will guide the project to its final purpose: the regeneration of Shrub Place.

At first, the identification of the area will indicate both the most important elements to be preserved as well as how the site interacts with the neighborhood. Therefore, the historic development will illustrate how the urban pattern has changed and how authentic Shrub Place remains, after the alterations that have taken place in the site during the passing years. In addition, the previous proposals for the development of the area will indicate different perspectives of the needs of the site and consequently the demands of Pilrig. Finally, a global presentation of the findings, which can be combined with conservation principles of industrial heritage through successful examples of regeneration, will guide the new masterplan that follows in the next chapter.

1. Identification of the Current Condition

• Shrub Place

Built Fabric

The built fabric of Shrub Place covers less than the 10% of the total area. (Fig 8) The two listed buildings with the chimney at the north part of the site constitute the oldest part of the depot. Operating as power stations and workshops for the repair of trams from the late 19th century, retain their strong industrial character. Some walls that were retained after the demolition of 2008, parts of the original brick structures from 1898, remain like ghosts from the past, diametrically opposed to the west and east side of the area. At the west side of this zone, a post-war concrete structure, adjusted to the original walls, cannot stay unnoticed. It forms the only building which is still in use and hosts the Edinburgh Masonic Social Club. (Figs 9, 10) Today the area is abandoned, buildings' category of risk is high and its connection with the cityscape does not exist.

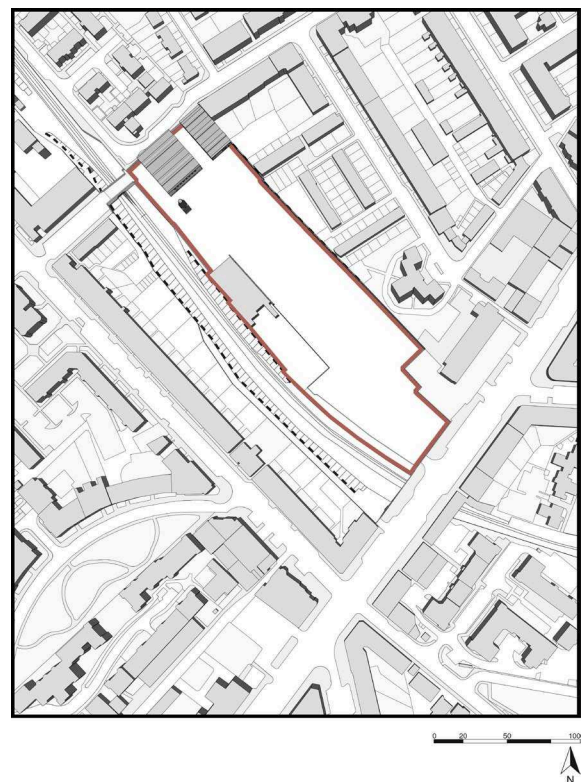

Figure 8: View of the interior of Body Shop from northeast, made by the author



Figure 9: Panoramic view to southeast, *by the author*



Figure 10: Panoramic view to northwest, *by the author*

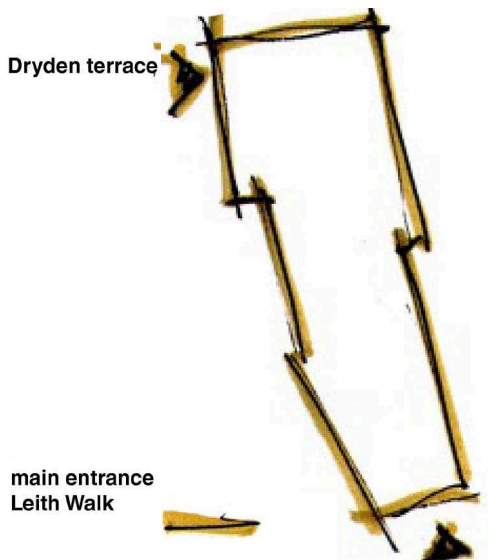

Figure 11: Access to the site, *made by the author*

Access to the site

The morphology of the site, as it is indicated on the plan, is very strict. Its width is almost twelve times its length, creating an oblong shape, neither accessible from the west nor the east side of the area. The main entrance to the area seems to be from Leith Walk, which is temporary closed, as railing installation covers the elevation. The site is also accessible from Dryden Terrace, through McDonald road, a secondary entrance which leads directly to the listed buildings through a bridge above the rails. (Fig 11)

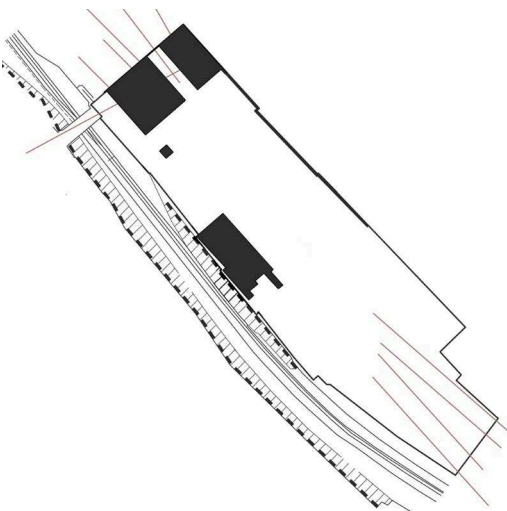
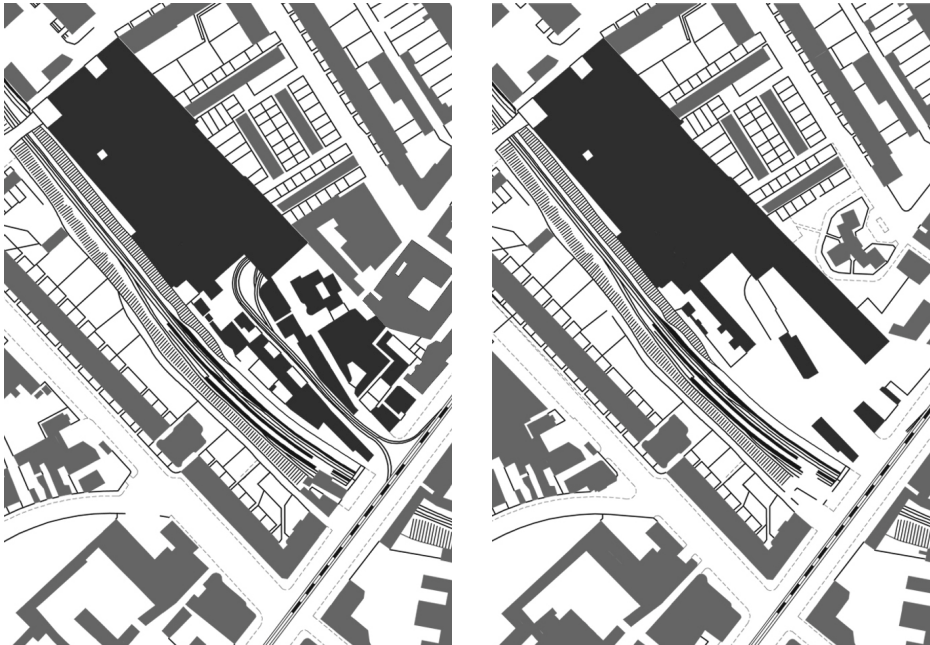

Figure 12: Connection with the railway, *made by the author*

Connection with the railway

The tramlines adjacent to Shrub Place on the west side of the area form another element of the character of the area. Connected through a basement level in the buildings, the rails of the old tramway system remain. (Fig 12) It is very clear from the drawings that the rails are cutting off any possible connection of the site with the western part of the area. In this part, it is worth mentioning that the lines used to be connected with the site through Leith Walk as well, but this image changed com-

pletely after the first demolition around 1960. (Figs 13, 14)



Figures 13 &14: Historic maps form 1940 & 1960, made by the author

Panoramic view from the interior of the site

Observing the morphology of the area in the midst of the plot, a visitor can discover the views in every direction, since the land is flat. The following panoramas illustrate the first impression of the area nowadays.

• Listed buildings

Signs of abandonment and vandalism are coming up to surface while observing the condition of the industrial heritage of the site. The demolition of the parts of the depot, which were adjoined to listed buildings, left its traces, causing damages to the masonry while leading to deterioration. (Fig 15)

• Remaining walls

On the east side of Shrub Place, some parts of demolished buildings still exist. There are only walls, extending till the midway of the site and cutting off the connection with the colony houses at the east part of the area. About 11 metres high, same as the listed building's on the east side of the site of focus, those walls are the physical memory of the original image of this industrial legacy. (Fig 16)

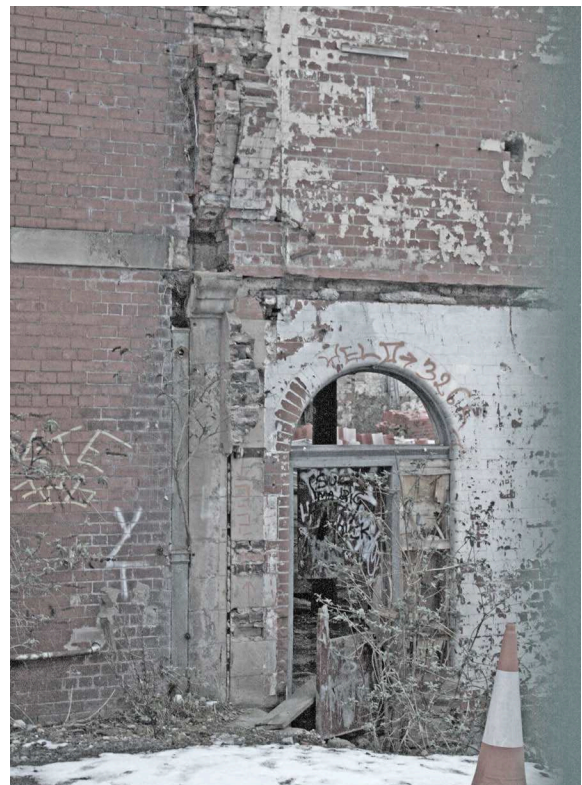

Figure 15: View of the damage, made by the author

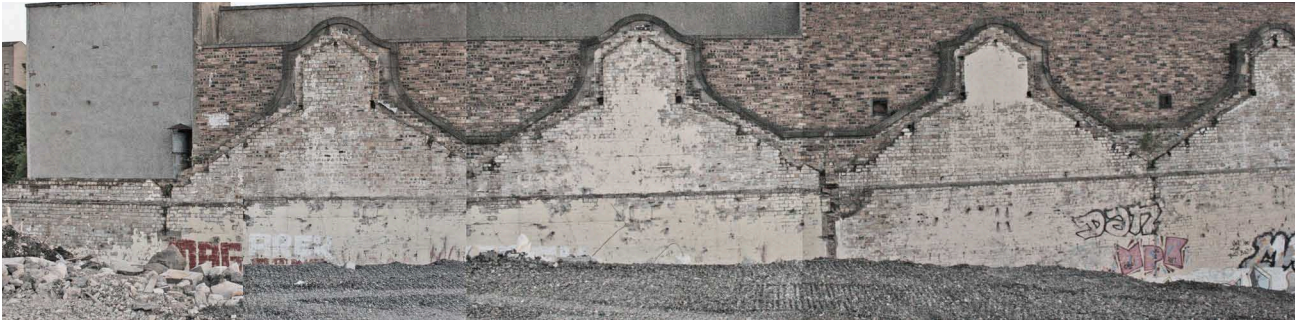

Figure 16: View of remaining walls, *by the author*



Figure 17: View of Leith Walk, *by the author*

- **View of Leith Walk from the interior**

Leith Walk constitutes the most central street of Leith. It connects different neighborhoods and the most important, is the main route which guide to the city centre. (Fig 17)

- **Masonic Social Club, Remaining walls**

The Masonic Social Club is located on the west side of the site, adjoined with the walls from the demolished workshops. As it was built during the post war period, its architecture represents an era which opposites to the industrial character of Shrub Place. However, the walls on that side retain their manufacturing character; and constitute references to the original built form of the depot. (Fig 18)



Figure 18: View of Masonic Social Club, *by Google Maps*

- **Surrounding Area**

Built fabric

This map illustrates the built fabric in the area. It is important to observe how much of the area is structured and how much is free-standing. This particular drawing will help to calculate how much space needs to be covered in the site, in order to achieve continuity of the urban environment in the proposed masterplan. (Fig 19)

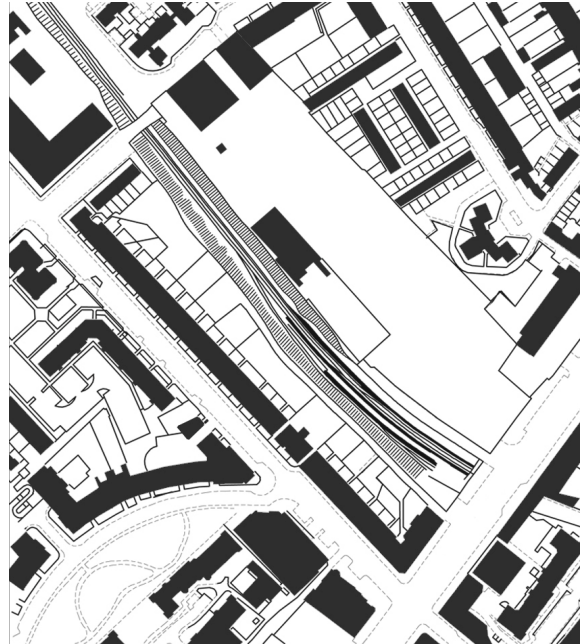

Figure 19: Built fabric, *made by the author*

Panoramic views to the site

- **Northeast area**

The northern part of the area was built in the late 20th century. Those new housing buildings follow the geometry of Shrub Place, as the rails continue to the north side of the area. (Fig 20)

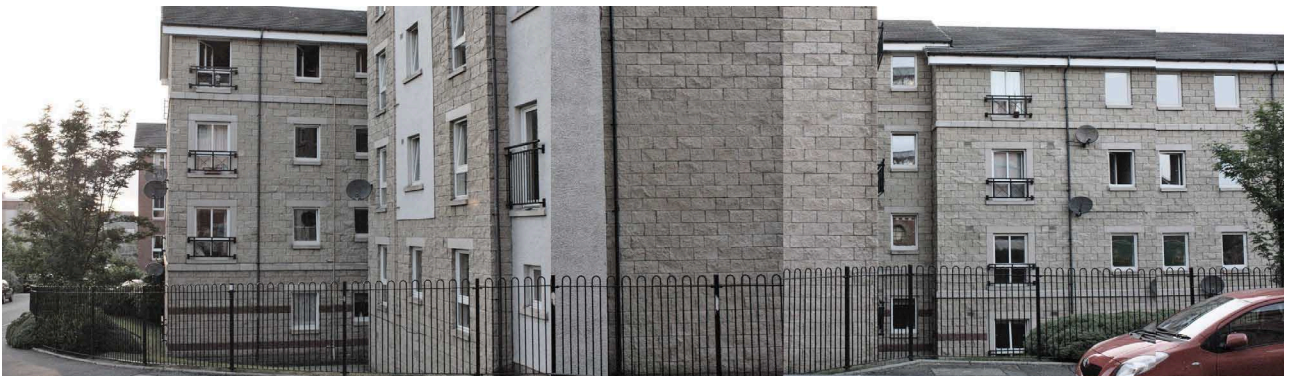

Figure 20: View of northeast area, *by the author*

- **Colony houses**

Those colony houses were built by workers, when Shrub House was the only building of the site of focus and the area was surrounded by fields.¹⁵ As the oldest part of the neighborhood, it engraved the plot lines for the new built fabric on the east side of Leith. (Fig 21)

¹⁵CEC, Leith Conservation Area Chapter Appraisal (Edinburgh: CEC, 2002), 5



Figure 21: View of colony houses and remaining walls, *by the author*

• Leith Walk

Leith Walk was formed in the earlier 17th century and became the main route to the city centre.¹⁶ Bilateral of the street the neighborhoods of Leith were structured. (Fig 22)

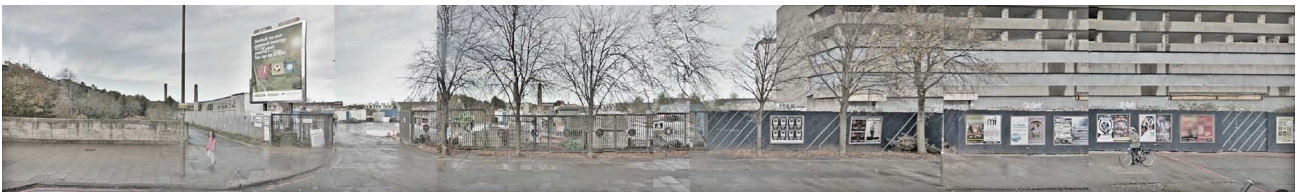

Figure 22: View of the site from Leith Walk, *by Google Maps*

• McDonald Road

McDonald Road was formed in the beginning of the 20th century, when the construction of the buildings block on the east side of Shrub Place begun. A strict block of houses covers the east side of the road, obscuring every visual connection with Shrub Place. (Fig 23)



Figure 23: View of the site from McDonald Road, *by the author*

¹⁶ CEC, *Leith Conservation Area Chapter Appraisal* (Edinburgh: CEC, 2002), 5

Functions in the area

This map illustrates the functions in the area. An observation to be made is that the buildings in Leith Walk accommodate mixed uses on ground floor level and residences on the levels above, in contrast to McDonald Road and Dryden Street, where the buildings are entirely residential.

(Fig 24)

Circulation map

Shrub Place is close to transport links as it is adjacent to Leith Walk. A bus stop just in front of the main entrance facilitates the access to Shrub Place and connects directly the area to the city centre. McDonald Road has also transport links, as it leads to the northeast side of the city.

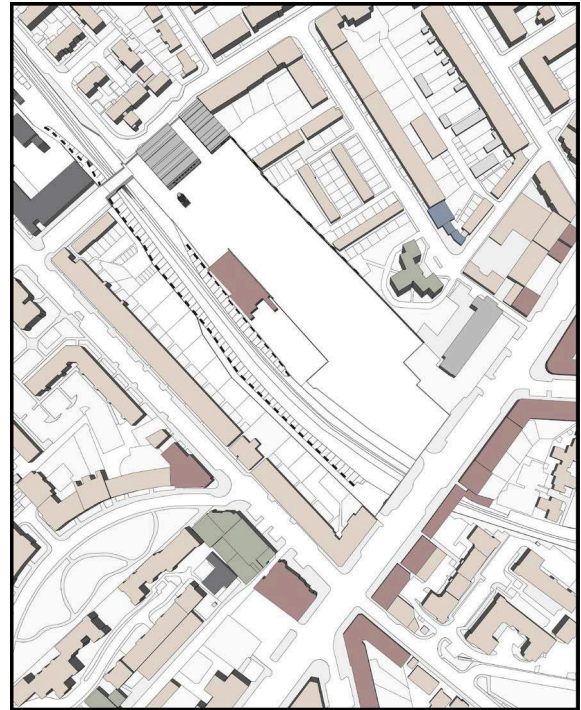

Figure 24: Map with the functions in the area, by the author

Public & Green spaces in the neighborhood

While observing the spaces where the neighborhood breaths, it is worth to mention that the built environment does not overshadow the landscape. A lot of green spaces are formed, including Pilrig and St. Marks Park on the north and east side of Leith, integrating harmoniously with the built environment. (Fig 25)

Skyline

These diagrams illustrate the heights of buildings in the surrounding area. This analysis of the skyline can establish the new principles for the height limitations of the new structures at the following masterplan. (Fig 26)

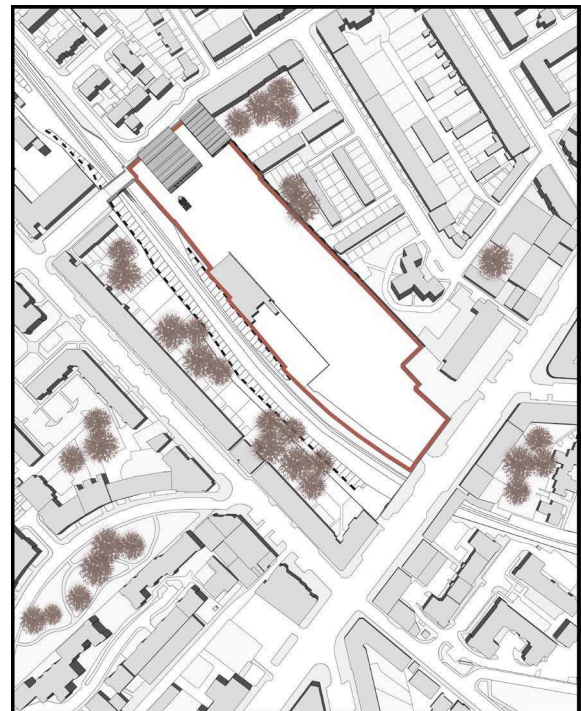

Figure 25: Map showing the public space in the neighborhood, by the author

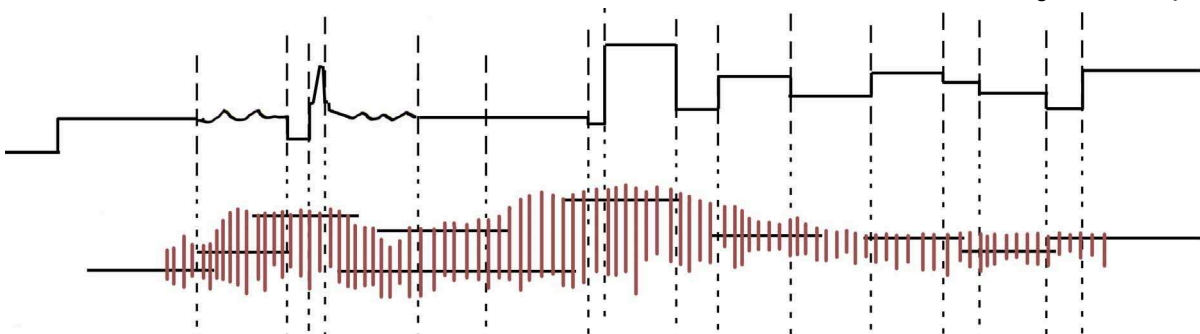

Figure 26: Skyline diagram, by the author

2. Analysis of Shrub Place

- **Historical Development (1850-2013)**

Historic analysis of the development of the area

In order to have a complete image of the area and its development through the past, it is necessary to illustrate the changes of the urban pattern in time. The results of the following historic analysis will support the better understanding of the area and can guide the future masterplan. The changes of Shrub Place from 1850 to 2013 are shown below through the following map analysis. In 1850, it is obvious that the area was mostly covered by crofts, probably for agriculture. Shrub House was the only built structure in the area, surrounded by its gardens. (Fig 27)

In 1877, the development of the site began, after the construction of stables and workshops and completed in 1898 with the final construction of the depot. (Fig 28) Observing the changes of the urban pattern, it is worth mentioning that in 1910 more buildings were added to serve as workshops in the depot, while the western part of the neighborhood began to form. (Fig 29) In the following maps it can be seen that the image of the industrial area has not changed significantly for almost 50 years, until 1960, when the first demolitions occurred, including Shrub House. (Fig 30)

As the new transport system replaced trams, the railway on the south side of the area was completely demolished. During the same period the reconstruction of the surrounding area took place, including enormous post war housing blocks on the east side. (Fig 31) In the following years, just up to 1990, Shrub Place has not changed much, except from the later additions in the south part.



Figure 27: Map of 1850, by the author

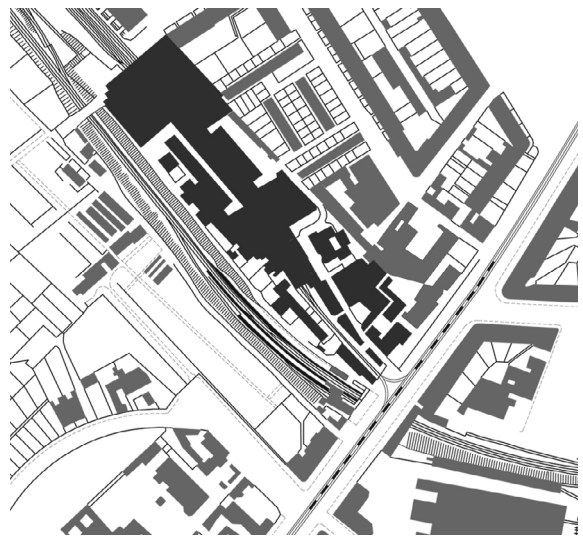

Figure 28: Map of 1890, by the author



Figure 29: Map of 1910, by the author

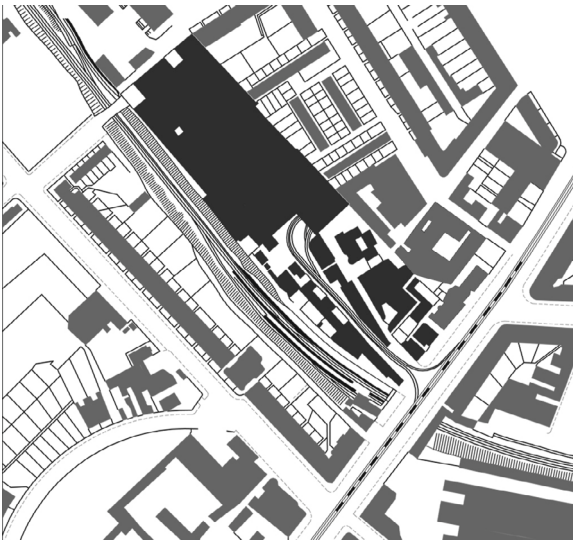

Figure 30: Map of 1940, by the author

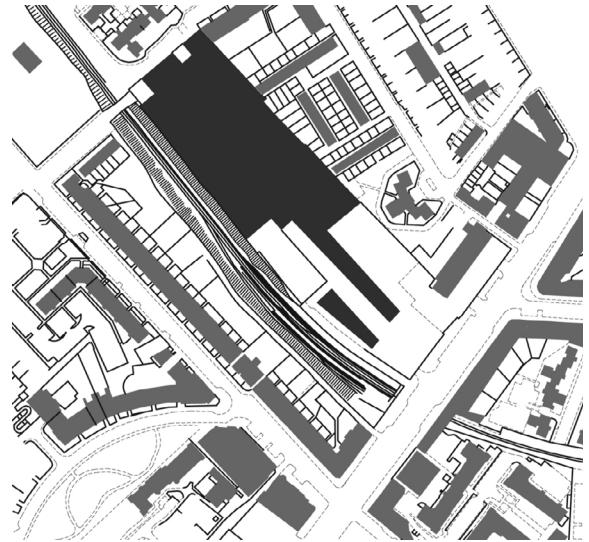

Figure 33: Map of 2008, by the author

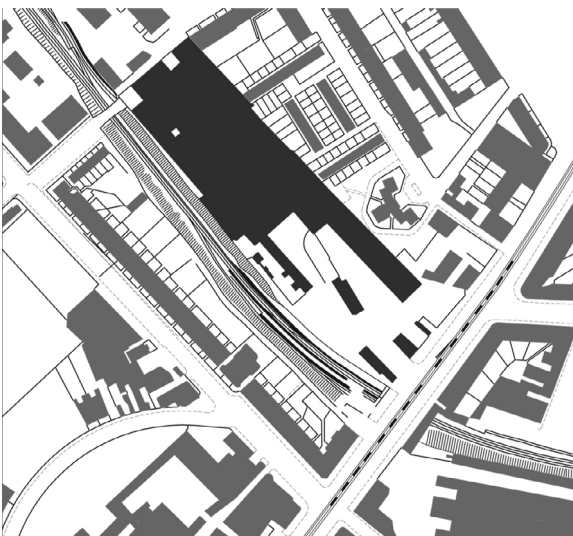

Figure 31: Map of 1960, by the author

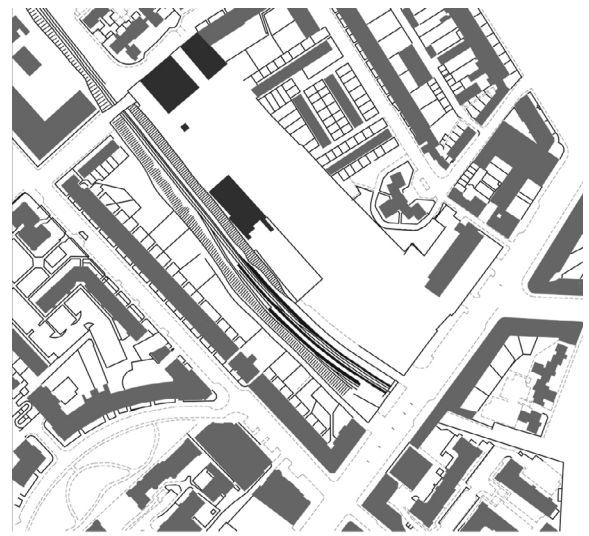

Figure 34: Current map of 2013 by the author

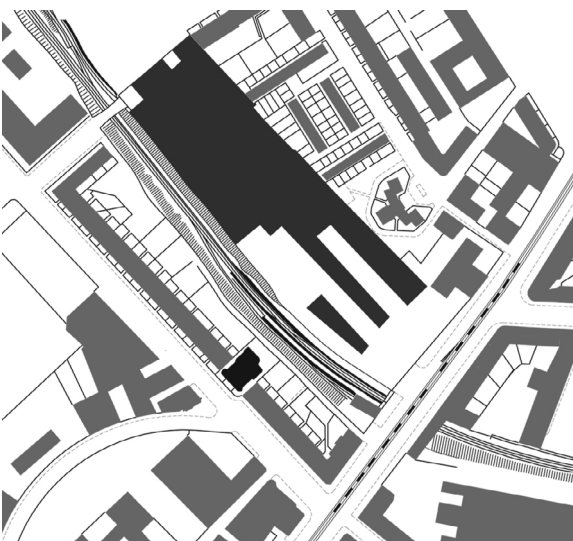

Figure 32: Map of 1990, by the author

Some buildings of the surrounding area have been altered too. (Fig 32) The biggest part of the built fabric in the site was demolished in 2008,¹⁷ under the proposal of BL Developments Ltd for a future development of Shrub Place.¹⁸ In the map from 2008 it can be seen how the surrounding area was formed during the 21st century. (Fig 33) The site has been abandoned since the late 20th century and its current condition is illustrated in the 2013 map. (Fig 34)

¹⁷ Interview with Will Garrett, Development Planning Group Leader, CEC, June 28, 2013

¹⁸ CEC, PBSOS Application Number: 05/03128/FUL, Accessed February, 2013

Map overlay with changes

To show how the area's pattern was developed from 1850 till today, the following drawing illustrates all the changes that occurred in the site. By overlaying the above maps, a gathering of the traces of previous structures can be achieved while representing the progress of Shrub Place during the past decades. (Fig 35)

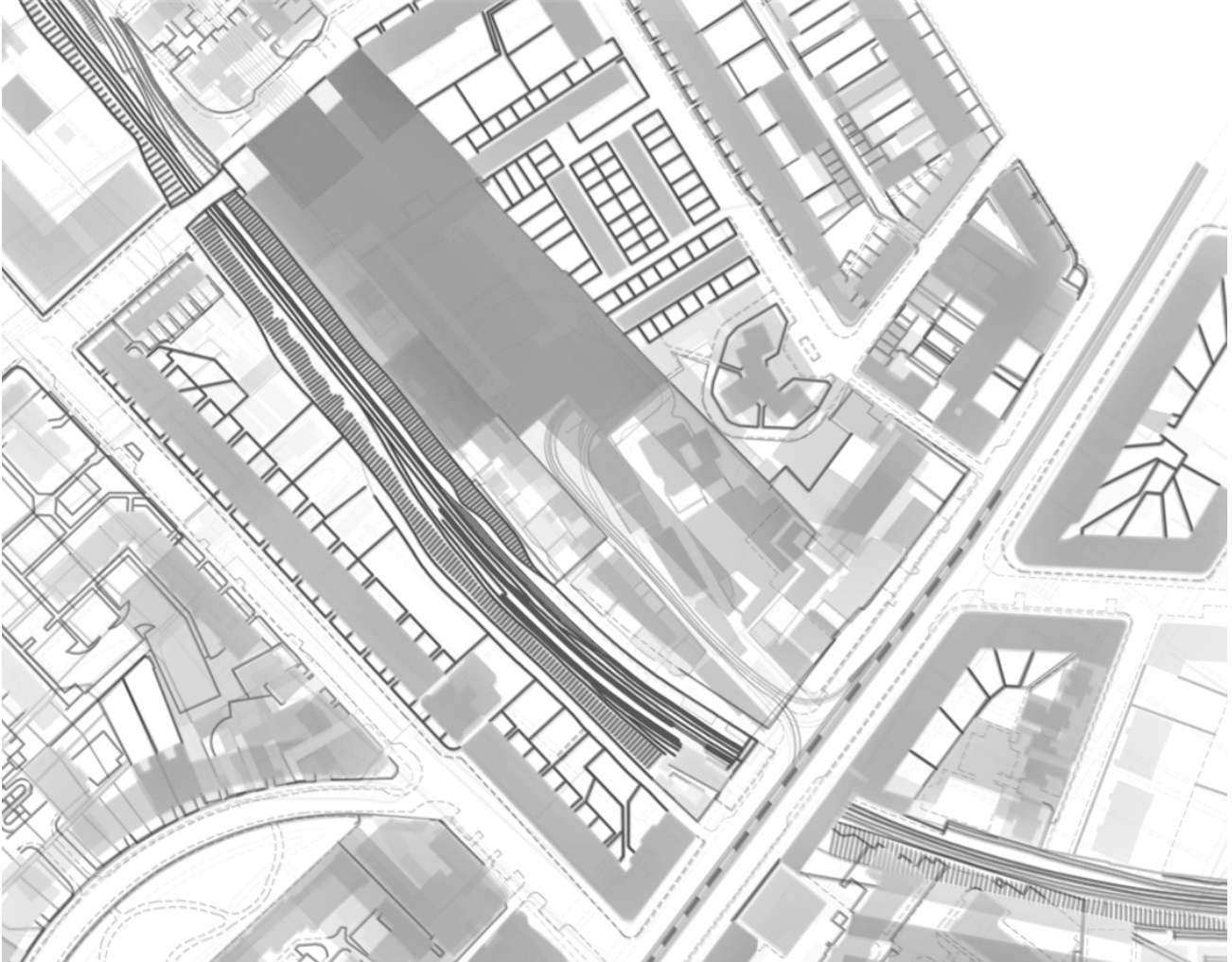

Figure 35: Overlay of historic maps, *by the author*

Traces of ghosts from the demolished original structures

The last part of the historical analysis is formed by a drawing that represents the current condition of the area, including the remains of the old workshops, from its first development to present. As it is displayed above, the whole area was serving as a depot, a fact that makes very clear its industrial character and its authentic function.

(Fig 36)



Figure 36: Traces of the old structures, *by the author*

- **Geometry of the Site & Connection with the Surrounding Area**

In order to fully analyze the characteristics of the area and observe its geometry, there are some specific steps that should be followed. It is important to understand in depth how a site functions, especially when it is surrounded by a complete and well-functioned built environment. This is a challenge of regeneration through urban conservation. As the previous analysis has shown, the area was formed very early and has kept strict rules in its previous developments. This can be concluded from the previous overlay, where the old plot lines meet the new ones. Now that the biggest part of the site of focus is unstructured, the question for its development can be answered by its relationship with the neighborhood, its visual connections and its integration with the urban fabric. In order for the master-plan to complete this challenge and to obtain the desired results, the following diagrams illustrate the visual connection of the site with the urban fabric.

Diagrams with the orientation of the site before and after the demolition of the depot

Both diagrams illustrate how the site integrates with the neighborhood. The left one represents the interaction into the urban fabric in 2008 and the right one in the present. The selection of those particular dates lies on the dramatic change of the image of the depot, after the demolition of the workshops. The first step shows the orientation of Shrub Place's buildings while the second one represents the orientation of neighborhood's fabric. The third one is a combination of all the orientations. (Figs 37, 38)

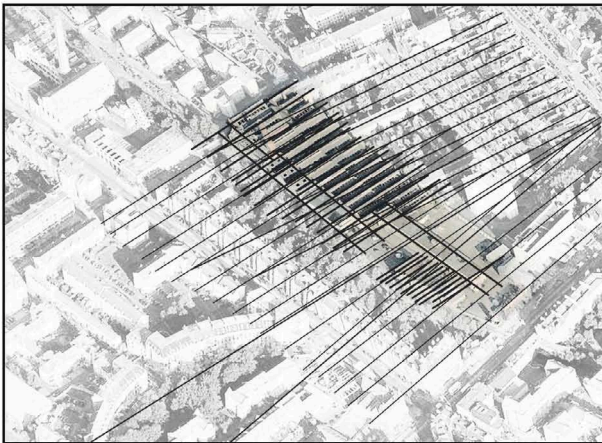
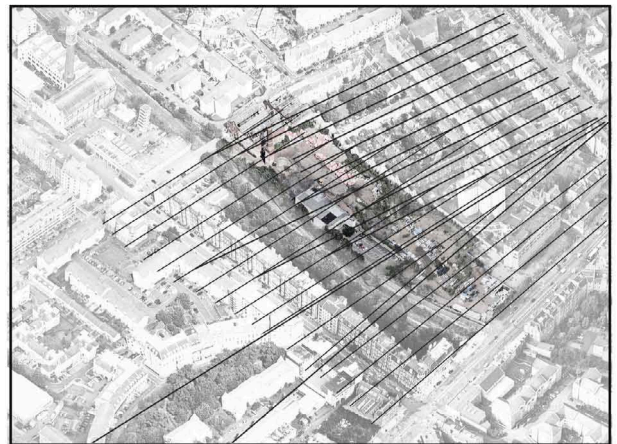
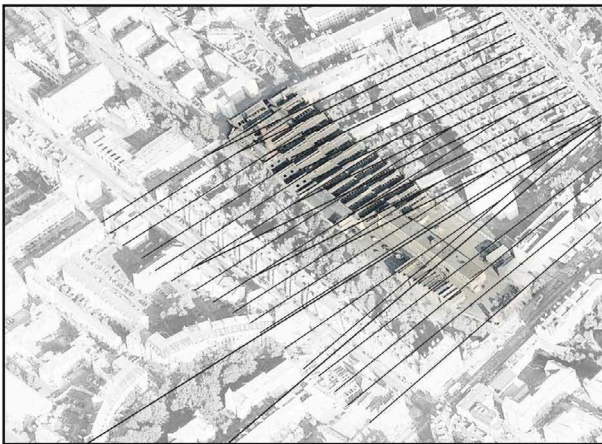
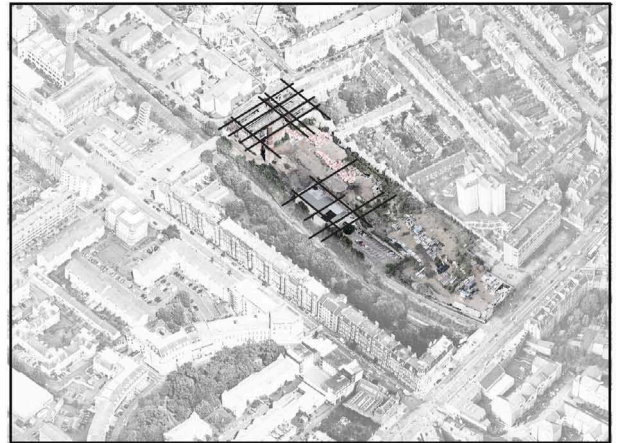
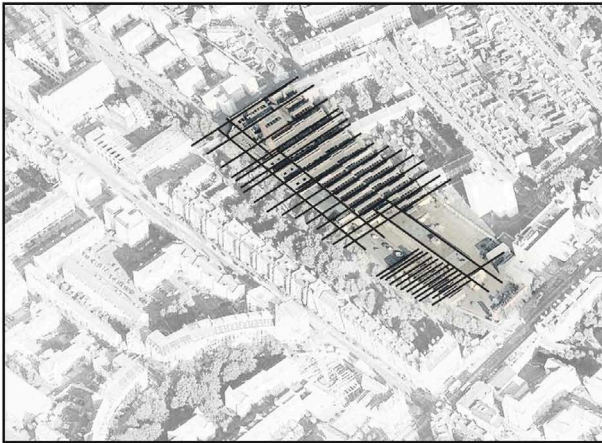
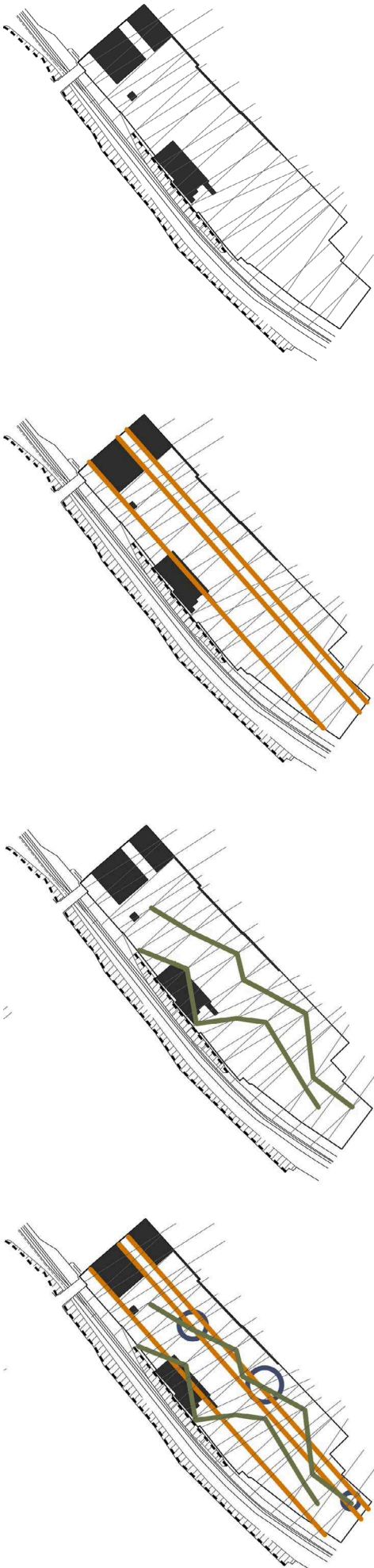

Figure 37: Orientation of the plots, 2008, *by the author*

Figure 38: Orientation of the plots, 2013, *by the author*

How the site interacts with the surrounding area

The following diagrams attempt to represent the extension of urban pattern's coordinates in the area of focus. The geometry of the site is very distinct now, as the analysis of the orientation shows clearly the connection of Shrub Place with the urban fabric. At this point, it is extremely important to observe the geometry of the neighborhood as the plot lines, which interact with the site's geometry, will form the basic guidelines for the new design. (Fig 39)



Buildings as volumes in the area

In order to perceive a complete image of the area it is fundamental to investigate the cityscape. A representation of the volumes in the area could be extremely helpful for the better understanding of the space and for the observation of city views from different perspectives. (Fig 40)

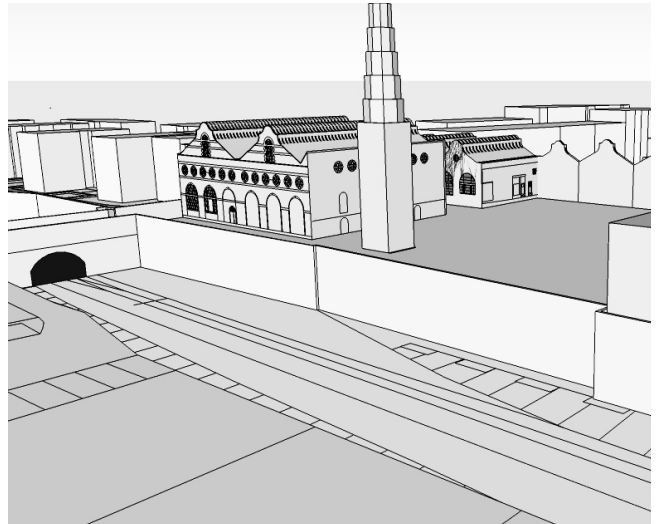

Figure 40: 3D model of the area, by the author

Figure 39: Site's interaction with the area, by the author

2. First Results

The above analysis has been held for the site of focus with the intention to identify the style of the area. Shrub Place forms a very introverted zone with a strong industrial character, isolated from the neighborhood. Its geographical boundaries represent an ensemble that changed through time, maintained through its function, as history has shown. This old manufacturing area has been threatened from the past alterations due to the vertiginous progress of technology; a fact that leads to the confusion of its integrity. Its authenticity could be characterized as a controversial issue; the image of the site has been virtually destroyed after the demolition of its biggest part and the removal of its machinery. Shrub Place remains authentic in a level of process but not in individual steps. Moreover, the function of the site, which introduced the industrial character of the area, did not change through the years, but only in the level of progress, where buses replaced cable trams that in turn have replaced horse trams. However, every single step of this process occurred in different ways, cutting out the continuity of the built fabric, because every change carried the principles of its own era. As an example of industrial legacy, Shrub Place needs to preserve its functional integrity to a maximum level while assimilating with the surrounding area.

3. Developing Shrub Place Lane

At this point of the study it is necessary to make a short reference to the previous proposals for the development of the site. After evaluating the first findings of the analysis it is important to examine the different perspectives of those studies in order to perceive the area's demands and include them in the new design proposal. However, it is important to take into consideration that those proposals aim to develop the site without preserving the character of the area to the maximum level. This can be an opportunity to compare the findings of the previous analysis with the following cases, in order to propose a masterplan which focuses on the regeneration of Shrub Place through conservation principles.

- **Previous proposals**

- **Jenkins & Marr Architects and Chartered Town Planners**

The first proposal for the development of Shrub Place was submitted in 2002, from Jenkins & Marr Architects and was refused from the City Council. It concerns a new urban village. Car parking, open spaces and roads are provided to this mixed use development which includes residential and commercial uses. Unfortunately there is no relevant documentation in the planning portal and therefore no possibility for comments.¹⁹

¹⁹ CEC, PBSOS Application Number: 02/04593/FUL, Accessed March, 2013

▪ **BL Developments Ltd**

In 2005, BL Developments submitted a full planning application including the proposal for demolition of some parts of the workshops and a masterplan for the development of Shrub Place site. The first part of the application, which concerned the demolition of the bus depot, was granted by the City Council.

(Fig 41)



Figure 41: Proposed demolition plan, by BL Developments, by CEC

The proposed masterplan was mainly focused on the regeneration of the area, providing a mixed use development. Specifically, converting the listed buildings into residential units and the construction of a new building to accommodate the Masonic Social Club were suggested. New building blocks were recommended for the rest of the area while housing and retail were the first priority of the development.

(Fig 42) The application was granted, but only the first part was carried out in 2008, because Historic Scotland objected to the new design proposal; due to the architectural significance of industrial buildings.²⁰



Figure 42: Proposed site layout plan, by BL Developments, by CEC

²⁰ CEC, PBSOS Application Number: 05/03128/FUL, Accessed February, 2013

Although, the planning application included many details about the proposed masterplan, the development did not take into consideration either the historic fabric or the existing urban pattern, which is clearly shown on the one hand from the demolition of the walls of previous structures and on the other hand from the orientation of the new pattern. As it is illustrated in the proposed elevation of the suggested building blocks, the new structures overshadow the listed buildings, as the new volume's height is clearly over 25 meters. (Fig 43) In addition to that, the complexity of the façade includes so many details and different elements which contradict to the industrial character of Shrub Place.



Figure 43: Proposed elevation, by BL Developments, by CEC

Lastly, the conversion of listed buildings into residential units does not seem appropriate, not only because of the new function, which is completely different from the old one, but also because of the proposed interior design intervention. (Fig 44)

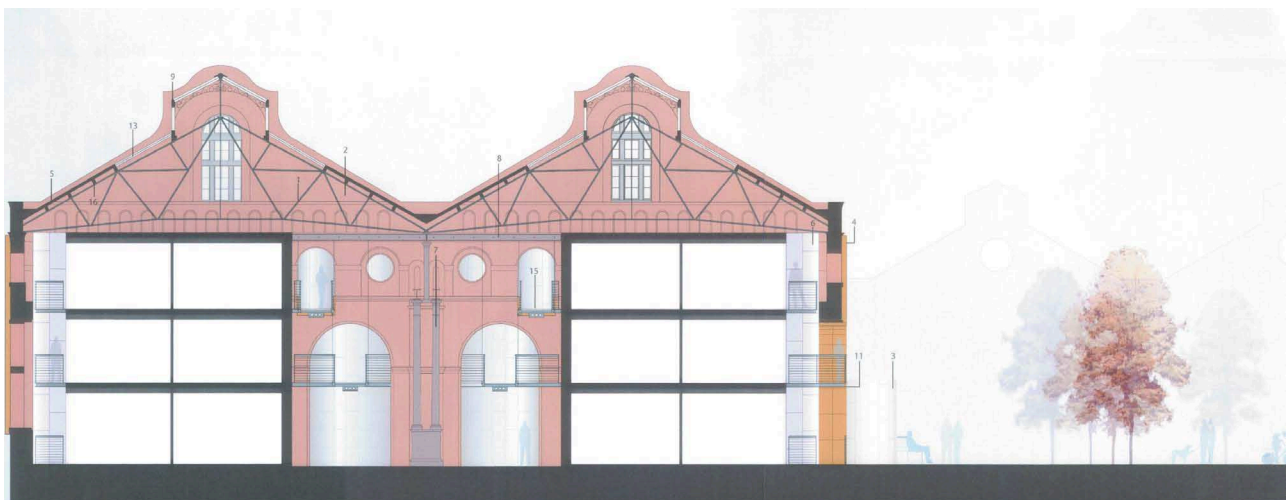

Figure 44: Proposed section for listed buildings, by BL Developments, by CEC

▪ **Frasers Hamilton Ltd**

The last case was submitted in April of 2013 and was prepared by 'EMA Architecture & Design'. It proposes the same development scenario as the previous one but it is guided by different design principles. This masterplan seems to focus more on the geometry of the area, as the new design is influenced by the existing coordinates of the site. Colony houses lower in height than listed buildings follow the motif of the old ones at the east side of the neighborhood, while landscape design and parking spaces are also included in the masterplan.²¹ (Fig 45) However, the new structures located on the south side of the area, which are not continuing the pattern of the site, seem to have the same height as the listed buildings. As a result, the proposed design in its total 'breaks' the visual connection with the cityscape and leads to a discontinuity of the built fabric. (Fig 46)

Complementary to this case follows another one, which includes the listed building consent. Submitted from the same applicant and prepared by the same architecture firm, paradoxically proposes the conversion of listed buildings into residential units, in the same way as the case of 2005 did.²² In addition to this, the suggestion to reduce the height of the existing cable walls does not show any intention to preserve the pieces of industrial heritage. In both cases, the consideration still is pending.^{23,24}



Figure 45: Proposed site layout plan by Frasers Hamilton, by CEC



Figure 46: Proposed section from northwest by Frasers Hamilton, by CEC

²¹ CEC, PBSOS Application Number: 13/01070/FUL, Accessed, April, 2013

²² CEC, PBSOS Application Number: 13/01071/LBC, Accessed, April, 2013

²³ Idem

²⁴ CEC, PBSOS Application Number: 13/01070/FUL, Accessed, April, 2013

- **Development objectives**

The following development objectives will be formed through the combination of data from the previous analysis. In particular, the area's identity brings into the light all the elements of the site which constitute the industrial heritage and need to be preserved. In addition, the previous proposals for development of the site emerge the needs of the area, as all of the above cases suggested the same model of functions. In order to ensure a stable future community for Shrub Place, it is important to establish some rules which subsequently will associate with the conservation principles.

- Edinburgh's city needs housing. Shrub Place, due to its central location is suitable to accommodate residential units.²⁵ The previous cases have clearly shown that the site demands housing. However, the industrial heritage of the site still remains through the presence of the old workshops and forms a very strong element for its future function.
- A revival of a wide area such Shrub Place demands primarily an introduction to its close environment. Located only one mile away from the city centre and adjacent to Leith Walk, the site is encircled by commercial uses. As the regeneration of an abandoned area requires its assimilation with the existing neighborhood, retail could be an acceptable function for the connection with the surrounding zone.
- At the northeast side of Leith, a lot of workshops are located constituting a part of Edinburgh's industry. An expansion of this function to the site can be a possible option, which could achieve a connection with its old manufacturing use.

4. Evaluation of Findings

²⁵ Interview with Will Garrett, Development Planning Group Leader, CEC, June 28, 2013

- **Conclusions from the Analysis of the Area**

In this section it is important to refer to the findings of the previous analysis and the conservation principles in order to proceed to a masterplan. The analysis of the area has presented the current condition of the site and acknowledged elements from the past that form its industrial character. Due to its history and its geographic location, the site of focus can function as an ensemble. This fact indicates that the site does not integrate with the urban fabric and it can be characterized as an independent and separate zone. However, this zone cannot remain abandoned and detached from the city any longer. Leith Walk is one of the most central streets in Edinburgh and the site is adjacent to it. The regeneration of the area demands its incorporation with the urban fabric and this could be achieved only through conservation principles in order to preserve the industrial heritage that remains. The following appraisals will indicate the steps that the masterplan will have to include:

- Shrub Place is a deserted manufacturing area, which needs to be preserved. The only way to achieve it is through a future development, in order to bring life back into the site and connect it with the urban environment.
- The site of focus is an independent zone which used to function independently from the rest of the neighborhood. Due to its introvert character, Shrub Place has to remain autonomous, with the intention to retain its previous image. This 'close' element could be preserved through the introduction of new functions in the area.
- In order to assimilate with the urban pattern, the new design will have to respect and follow the coordinates of the built structures. The continuity of the pattern could be achieved through this integration.
- Although the biggest part of the depot was demolished, traces that indicate its old presence survive in some parts of the site. The new design should take into account the ghosts of the past and use them as guidelines, as their presence is part of the industrial heritage.
- The abandonment of Shrub Place during the past years led to the disrespect of the remaining pieces of industrial heritage. The listed buildings were deteriorating due to the absence of function and vandalized due to the isolation of the zone from the surrounding area. Thus, the new development will have to include the restoration of the built fabric and ensure its preservation through time. In addition to this, the future revival is obligated to coexist with the continuous evolution of progress while conserving the values of industrial culture.

- **Conservation Principles**

The industrial culture is part of the heritage and its value is significant not only for historical reasons but also for its unity. The unity of the ensemble lies within the image of the total and not of the individual. When an ensemble breaks into pieces and some of its parts are lost, its unity needs to be preserved through the traces of the figures that survived. It is important to examine if those parts that have been detached from the fabric were monuments. If not, a possible reconstruction based on traces of the previous structures will achieve a reformation of the space without being degraded.²⁶ The purpose of a restoration in this scale is the reformation of the site data where the additions will have to be recognizable and different to the level of structure but not to the level of form.²⁷ Where new functions appear in the area, in order to preserve the unity and ensure the continuation of their existence, the monuments, which compose the ensemble, have to accommodate, if not relevant to the previous ones, the uses that have to respect and emerge their historical character.²⁸

In terms of industrial preservation, those principles remain the same, while the maintenance of industrial heritage is significant in terms of social values. With a manufacturing legacy such as Shrub Place, the functional integrity needs to be preserved to the maximum level. With the intention to assimilate the remaining parts of this site at risk to the surrounding area, guidelines for the new design proposal should be established and followed.²⁹

²⁶ G.P. Karadedos, Προστασία μνημείων και συνόλων, Τεύχος 2 (Conservation of monuments and ensembles, Vol. 2) (Thessaloniki: AUTH, 1991-92), 65

²⁷ Idem, 56

²⁸ Idem, 38

²⁹ TICCIH Congress in Russia, *The Nizhny Tagil Charter For The Industrial Heritage*, July 2003

- **Successful Regenerations**

A remarkable example of regeneration through conservation principles is Technopolis Gazi, in Greece. An old industrial zone very close to the centre of Athens built in 1857 and served as a factory for coal and gas production until 1984. The scale of the site is smaller than Shrub Place but it is a successful example of regeneration. After its restoration and development to a cultural hub in 1999, the surrounding area was upgraded and the old industrial character of the site emerged.³⁰ (Fig 47) The success of this regeneration lies in the adaption of the site to the new uses which ensured its conservation. The original fabric was preserved and highlighted, with new materials, compatible to the original ones. Interventions were done to the minimum level, while emphasizing the integrity of the ensemble. Lastly, this industrial monument was adapted to the urban environment through conservation principles and represents a previous era in the present.

Another example worth mentioning is the G-Mex Centre, in Manchester, England. (Fig 48) The old Manchester Central railway station, listed as Grade II, was converted to an exhibition centre from 1978 to 1983.^{31,32} This Victorian masterpiece is a landmark in the centre of the city, proving an urban renaissance through new functions can be achieved.³³

Both examples accomplished their original purpose: the regeneration through conservation principles, guided by the needs and policies of their cities. These regenerations can be examples for the master-plan which follows at the next chapter.



Figure 47: View of Technopolis Gazi, Athens, by TCA

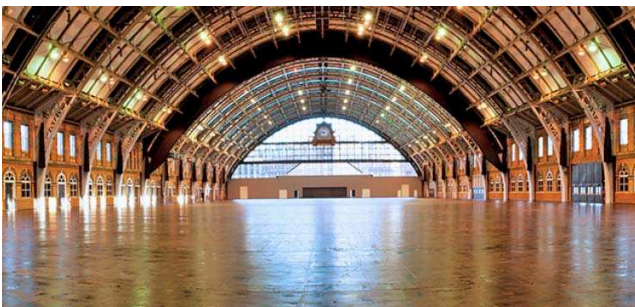

Figure 48: View of G-Mex Centre, Manchester, by Manchester Central

³⁰ TCA, Industrial Gas Museum, Technopolis - Gazi SA, <http://www.technopolis-athens.com/web/guest/museum/home>, Accessed May, 2013

³¹ Manchester Central, <http://www.manchestercentral.co.uk/>, Accessed August, 2013

³² *Conservation – Led Regeneration: The Work of English Heritage* (London: English Heritage, 1998), 5

³³ *Idem*

IV. DESIGN PROPOSAL

IV. DESIGN PROPOSAL

Conserve the historic urban fabric and reinforce the existing context

The previous analysis has shown that the geometry of the area constitutes the most significant part of the identity of Shrub Place. In order to proceed with a masterplan which will inevitably affect the urban environment through additions, it seems crucial to establish some principals. These fundamental principals will form the guidelines for the masterplan, which has to support and respect the character of the site and interact harmoniously with the geometry of the area. On the one hand, the character of the old depot can be preserved through the new functions that the site will accommodate and on the other hand, the geometry of the area can be reinforced through the new design which will be integrated in the existing urban fabric.

1. **Vision**

- **Character of Shrub Place**

Shrub Place served as a tram depot for about 100 years. This industrial function established the character of the site which remains through today due to the existing listed buildings and walls. These elements, in combination with the geometry of the site and its built fabric, make a very clear zone that forms an ensemble which has to function separately from the rest of the area. In order to preserve the industrial image of the site, it is crucial to include in the masterplan functions relative to industry. However, the site functions as an interstitial space between the residential area of Pilrig and for that reason its viability through the day is required. The regeneration of this zone must take into consideration the relation of the previous industrial function with the current residential use of the surrounding neighborhood. An approach of development in a central area as Shrub Place through an effort to restore the past use must be translated into the current needs of the city. In order for this attempt to succeed, a new model of manufacture use in combination with residential units is recommended for the masterplan. This can establish both the preservation of the industrial character and also the integration with the current functions of the area, especially with the north part of Leith that is composed of workshops for craftsmen. Furthermore, this mixed development can be accomplished with the introduction of more functions in the site. A small market and an exhibition related to the history of the place can be included in the masterplan too, which is intended to highlight the architectural significance of the listed buildings and achieve complexity in the area. (Fig 49)

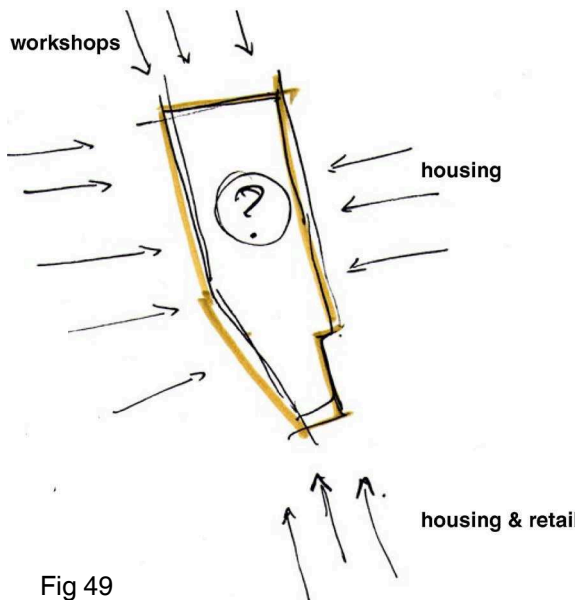

Fig 49

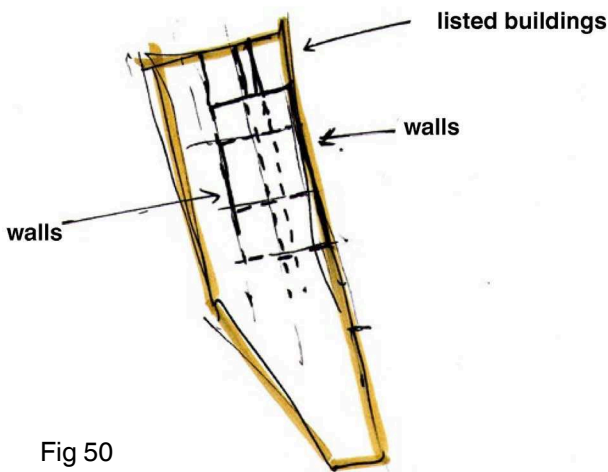

Fig 50

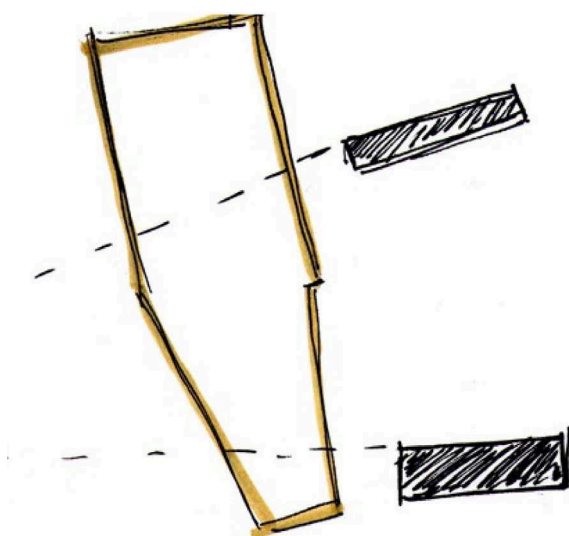

Fig 51

Figures 49, 50, 51: Visual sketches, made by the author

• Design Principles

Shrub Place covers a total area of 2 ha. Apart from the unlisted building, which is separated from the old industrial zone, the listed buildings and the remaining walls of the demolished workshops cover the 8.15 per cent of the total area. This is a very important factor for the conception of the new design, considering that the new tracings must integrate with the existing pattern. Thus, the continuity of the urban fabric will be achieved and the new build forms will be included harmoniously into the cityscape. Considering the previous layers in the site which have been demolished during the past years, urban memory can be reinforced by the reinstatement of the tracings through a new design based on the existing pattern. The remaining walls, ghosts from the old depot, will outline the basic guide for this regeneration and create new build forms similar to the old ones but different to the level of function and materials. (Fig 50)

With a view to include the abandoned area to the current built environment and accomplish a seamless integration of the past and the present, the new design is obligated to follow the orientation of the plots of the surrounding area. The coordinates from the buildings which were built almost the same time as the depot, will lead the way for the new planning. (Fig 51)

Last but not least, it is extremely important that the new built forms have to be structured in a sensitive way in order to support the listed buildings and not to overshadow them. Lower volumes are most appropriate for the new design including materials friendly and similar to the existing built fabric.

2. Masterplan

Restoring and reusing Shrub Place demands awareness of architectural design and conservation appraisals. The following masterplan is an attempt of regeneration, based on urban conservation principles and guided by the analysis of the area described in the previous chapter. The intention of the new design is to propose a new viable model of neighborhood within the framework of cultural heritage. The following drawings illustrate step by step a logical sequence of the design procedure which will conclude to the final proposal for the development of Shrub Place.

▪ Step 1: Existing built fabric and connection with the new architectural forms

A controversial issue in this study can be the building that accommodates the Masonic Club. Not only does the architecture of this building have no significant or aesthetic value but its structural form and use are not connected with the character of the site. As for the fact that the building is not listed, a possible demolition can be considered favorably and the quality of the replacement building will have to be appropriate for the new design. However, assuming that the building can function separately from the rest of the area and its use is not suitable for the proposed development, there is no need to intrude and modify the existing built form. Therefore, the Masonic Club will not be included in the masterplan, due to its function and its lack of architectural value. (Fig 52)

The two listed buildings and the chimney structure are the only complete volumes in the area. Their presence indicates-in all its magnificence-the industrial character of the old tram depot. These significant structures, which covered the biggest part of the depot in a repetitive motif, form the basic tracing of the area. In addition to that, the remaining walls, which paradoxically were maintained after the demolition, are references from the past and complete-in a theoretical way-the previous image of the workshops.

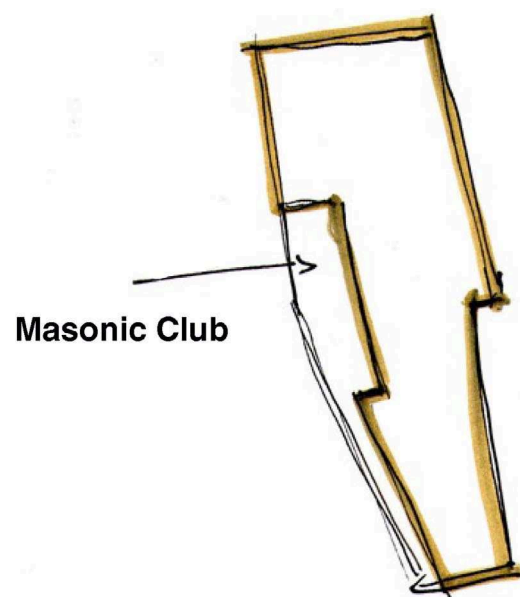

Fig 52

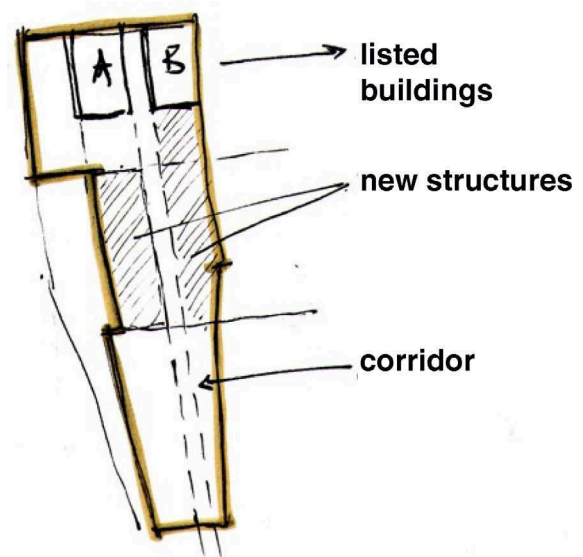

Fig 53

Figures 52, 53: Visual sketches, made by the author

In order to highlight the industrial architecture of the depot, these walls can be guides for new buildings, which can be constructed in a contemporary way based on the original industrial design. New materials should be provided for the modern structures to avoid an imitation, but relative to the authentic fabric for a successful incorporation. The corridor between the two listed buildings can be extended to separate the new ones too, composing an element of division but also a passage through the site. In order to retain this passage and conserve in the same time the original image of the depot, a visual separation with the aid of an arcade seems necessary. This action will provide visual and structural unity in the area and will also reinforce the revival of the previous structures. In this way, a restoration of the original design is achieved, in parallel with the integration of the new planning principles. (Fig 54)

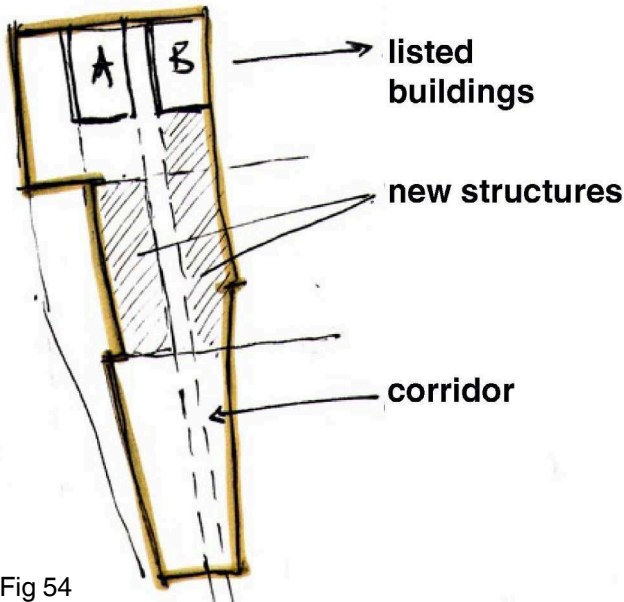

Fig 54

▪ **Step 2: Integration of the surrounding area and connection with the new design**

As mentioned above, the existing geometry of the site forms an ensemble that is extremely introverted in relation to the surrounding areas pattern. The intention of this masterplan is to 'break' this strict form and to 'bring' the neighborhood in the site. This can be translated architecturally with the extension of the urban pattern in the site of focus. A new orientation which arises from the visual expansion of the oldest buildings of the area can be used as guideline for the new design. Colony houses and Shrubhill House on the east part of the area form those buildings that represent the orientation of the pattern, not only for the area but also for the new design tracings.

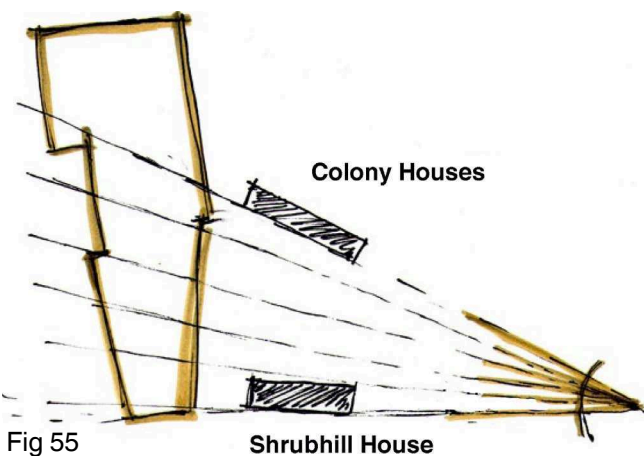

Fig 55

Figures 54, 55: Visual sketches, made by the author

In order to include this new geometry in the site, first, a calculation of the dimensions is required. The intersection of those lines forms an angle that can be copied in the site. The equally divided coordinates that appear from the point of intersection form the rest of the tracings in the site. This step introduces the new design of the masterplan and guides the new architectural structures of the site. (Fig 55)

▪ Step 3: Structure of new buildings

From the previous orientation analysis, the new design guidelines were formed for the creation of the new built structures. In order to form structures that can follow the new geometry of the site but also respect the existing, a new building motif is suggested for the masterplan. The most appropriate model for this step can be based on the geometry of the smallest listed, that its pattern is constantly repeated in the area. Having one third of the width of the building as a guide, the new structure can be adapted to the same dimension. (Fig 56) Following the orientation of the surrounding areas plots, the new volumes with the width of the existing fabric will be created and interact harmoniously with the cityscape. In addition to that, the buildings will be separated in both sides of the visual corridor that listed buildings form. Two buildings on the east side are recommended and five on the west, with equal space between them for the formation of their yards. (Fig 57)

New volumes must not surpass the height of listed buildings. It is required that the new buildings, which are modern structures in an already built environment, will adjust to the skyline without overshadowing the existing fabric. The higher volumes must have maximum height of 8 metres, the same

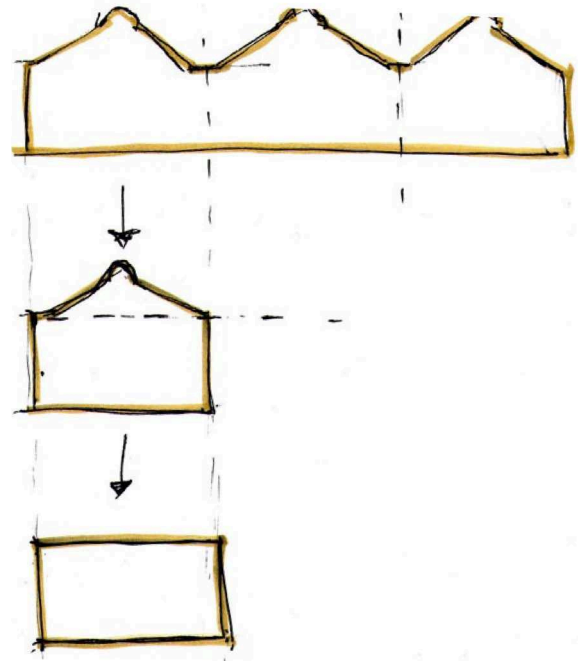

Fig 56

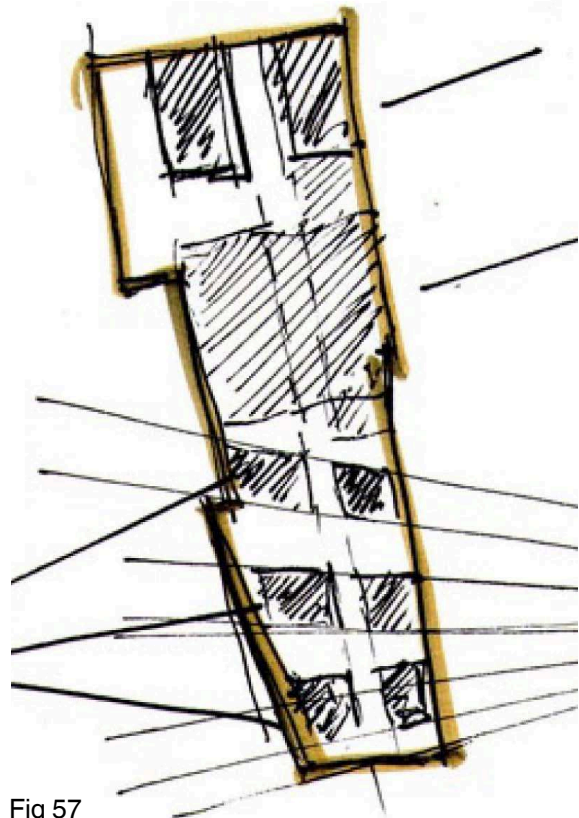
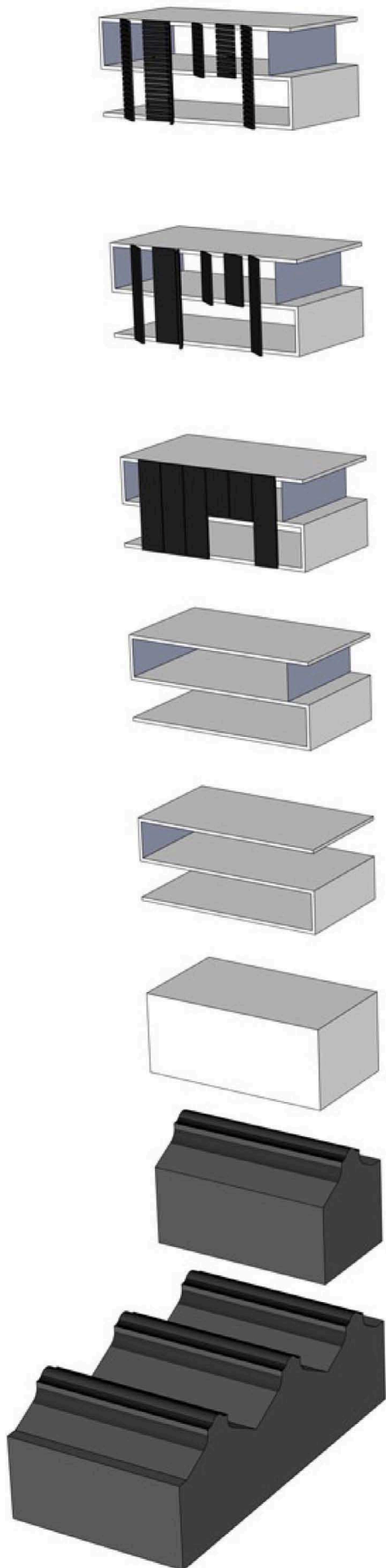

Fig 57

Figures 56, 57: Visual sketches, made by the author



as the listed building without its roof. The levels will follow a descending sequence as approaching Leith Walk, like the original buildings have already engraved, with the intention to create a visual connection with the cityscape. (Fig 58) In addition, the first building that a person meets while entering the regenerated zone from Leith Walk, has a portico which extends to the boundary of the site. This architectural element was added in order to signal the main entrance of the site and separate it from the entrance of Masonic Club, which is only few metres long. (Fig 59)

The new design must represent its own era, but it must also coexist with respect to the existing fabric. This can be accomplished through the differentiation of the shape and the materials of the new buildings. Minimal structures, different in a shape from the existing buildings, can emphasize the new addition in the site. Materials such as brick, steel, timber and glass, which were used for the construction of the original depot, can support the effort of the new designs incorporation into the area.

▪ Step 4: Functions in the area

Particular attention was given in the previous chapter to the preservation of the old industrial character of the zone. First, it is required to separate the uses in the area, in order to create a logical sequence of functions in the site and to avoid overload a part of the site with the same use. The following diagram represents how the new functions can be spread into the area and how their connection is accomplished, through passages or public spaces.

(Fig 60)

Figure 58: 3D model showing the volumes, *made by the author*

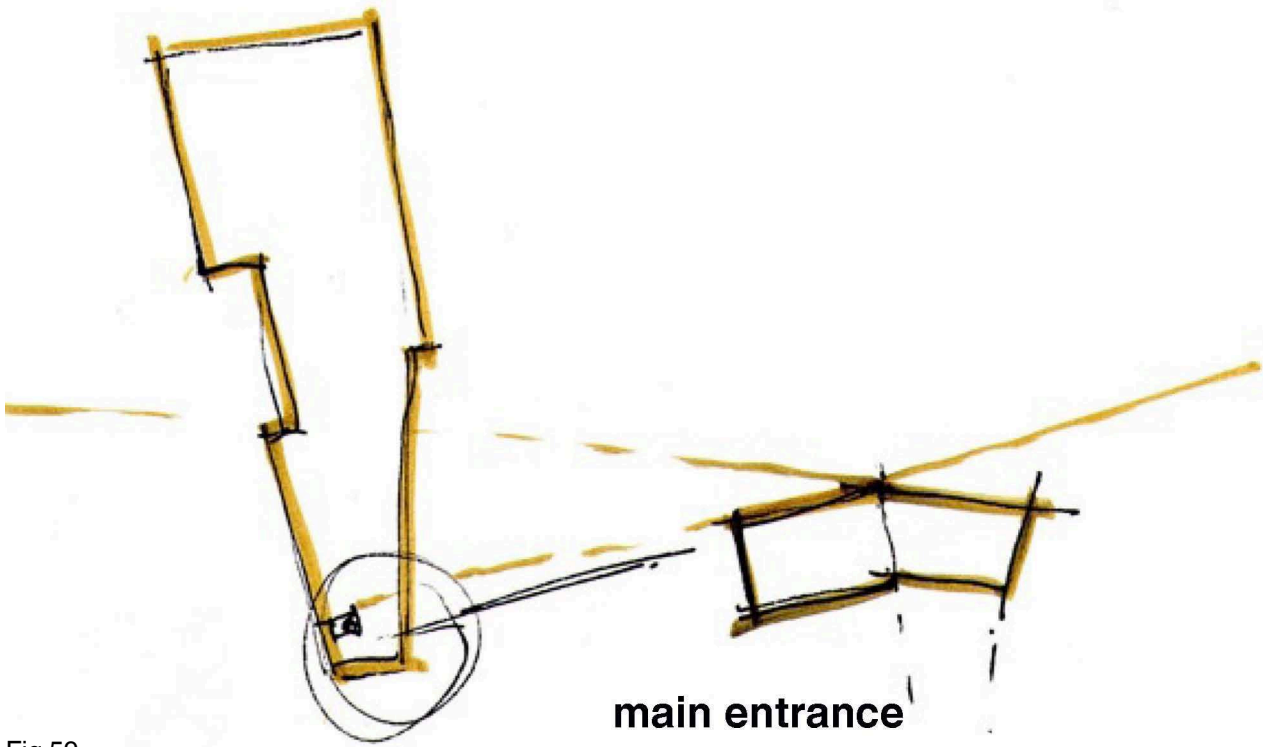

Fig 59

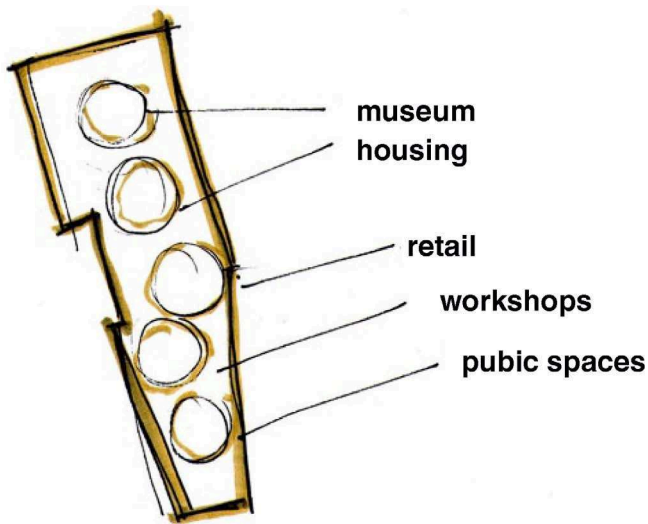

Fig 60

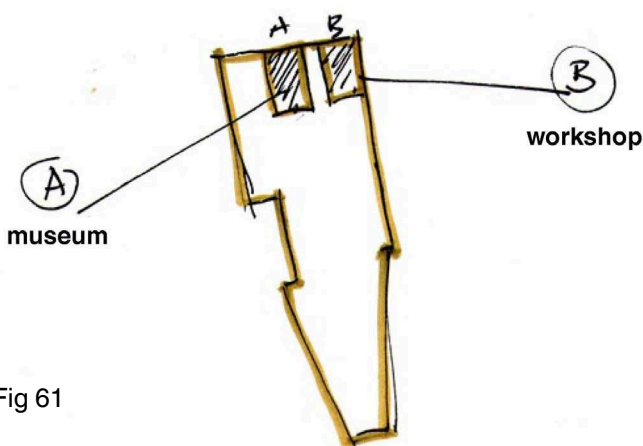

Fig 61

main entrance

Given that each function must be translated differently in the new architectural design, an attempt of separation of functions follows. Listed buildings must preserve to a maximum level their history and their original function. Therefore, under the principles stated above, the most suitable uses for those structures can be translated as either museum to the highlight of the cultural heritage or as workshops for the conservation of the depots original use. The connection of the western building with the basement level, which communicates directly with the rails, constitutes a strong argument for its future use. Its enormous size can accommodate old tram machinery in both levels, achieving an architectural renaissance that will emerge the industrial image of the area in all its glory. For example, the eastern listed building can serve as a workshop for temporary use, accommodating university events or performances. (Fig 61)

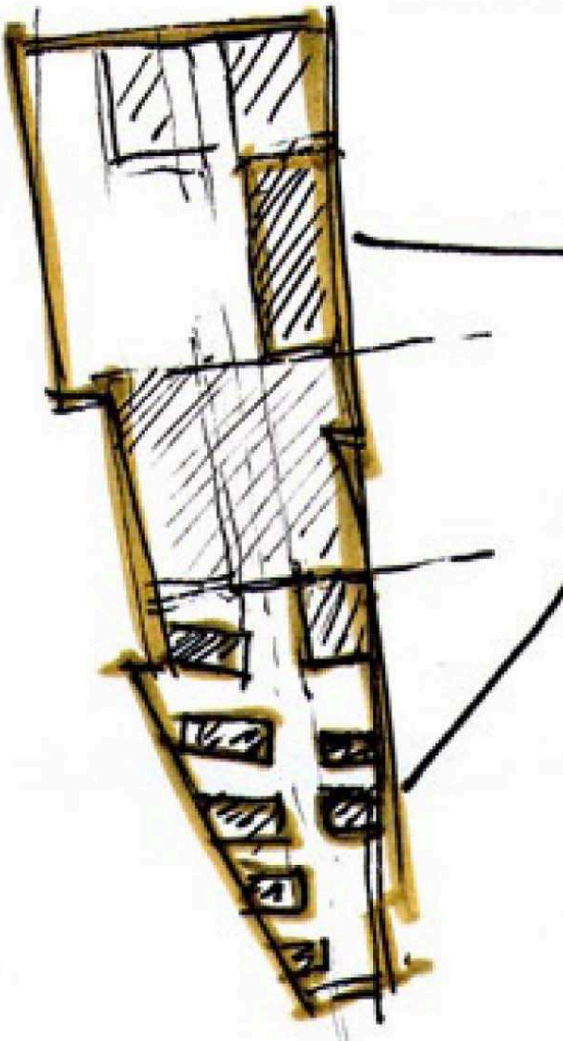

Figure 62: Visual sketch, *made by the author*

New buildings, both those which are similar to the listed ones and those which are completely new, can accommodate manufacture uses and housing. Spreading the different uses all the way through the site to achieve multiplicity, it is fundamental to consider how these functions interact with each other and how viable this model can be in the proposed development. It is a given that a site like Shrub Place, which includes functions such as museum and market, will constitute a magnet for attracting visitors. In addition, it is mandatory to ensure that the area will be safe twenty-four hours per day, without the fear of abandonment that can increase criminality, especially during the night. The only function that can succeed to offer safety during the whole day is residence; therefore it is crucial to be spread through the entire area. However, residential units cannot be accessible to anyone, but only to the residents, so they have to be placed in an upper level. This action will introduce to an alternative model of housing, which can include workshops and residences in the same building; a revival of the old residential model, where craftsmen or merchants used to have their workshops or shops in the ground floor of their properties. (Fig 62)

▪ Step 5: Public Space and Open Market

From the analysis of the surrounding area it can be seen that the neighborhood does not need extra green space. However, the masterplan must include a small percentage of public space, with small zones of green, to allow the site to breathe. Due to the sites geometry-the width is extremely small compared to its length-the public space must extend vertically. The walkway that has been created from the listed buildings penetrates the site and ends to the main entrance of Leith Walk, forming a

public space of 0.25 ha. Trees, lights and benches can form the elements to accompany this route till its final destination: the original structures of the old depot.

Approaching the listed buildings through the passage, an area of 0.2 ha remains unstructured in order to serve as the 'yard' of Shrub Place. Just above the biggest building's basement, this area may compose a space for exterior exhibition, a space of cultural memories and images. An intervention to this part of the area can connect the basement level with the public space through a visual connection. From the western listed building to the chimney and the start of the passage, the ground can be excavated and replaced with glass tiles, without destroying or affecting the existing fabric. This alteration can guide to an actual representation of the old image of the building and can include parts of trams or machines that used to be present in previous years. A new design for this public space is required, generated from the existing geometry of the site. Trees and flower beds are the most appropriate tools for the configuration of this space. (Fig 63)

In the heart of Shrub Place, the new buildings with the arcade would be the most appropriate to accommodate functions that can attract visitors. On the west side, the new buildings can serve as multi-purpose venues, including café, pub exhibitions and spaces for festival events. Due to their structure, with no openings diametrically and no possibility of lightening, except from the roof, those volumes constitute the most appropriate place for the retail uses of the area, interacting in the same time with the market beside. On the east side, the semi open space, which is formed by a glass roof, creates the perfect atmosphere for an open mar-

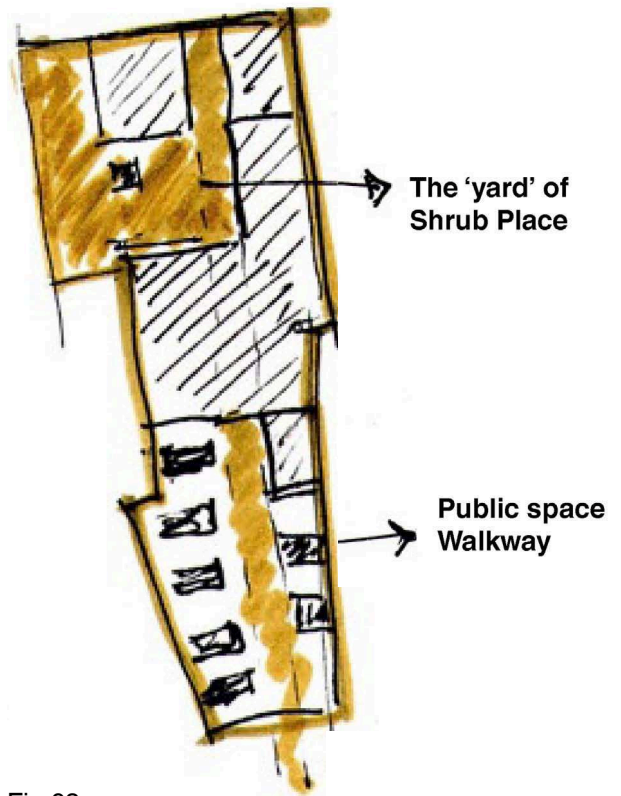

Fig 63

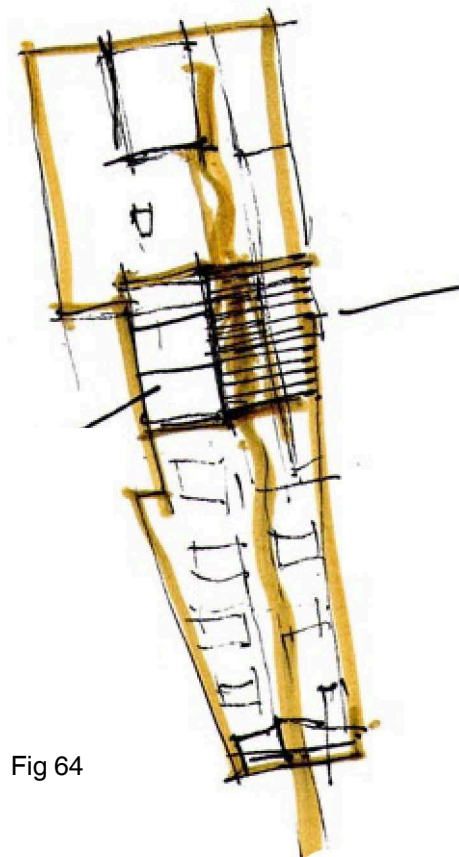

Fig 64

Figures 62, 63: Visual sketches, made by the author



Fig 65

ket. A market protected from rain and wind due to its location, adaptable to a variety of products, from vegetables to second hand items. (Fig 64)

▪ **Step 6: Accessibility**

The access to Shrub Place can be accomplished from two different entrances. The basic one and also the most central, is from Leith Walk. A visitor can pass through the walkway and end to the listed buildings, following a very specific walkway in the regenerated zone. The secondary entrance of the site is reached from Dryden Terrace, at the northern part of the area and leads directly to the listed buildings. The new design does not include space for vehicles, neither parking spaces nor pathways for cars. However, the site is accessible by car, in situations of emergency or supplies. (Fig 65)

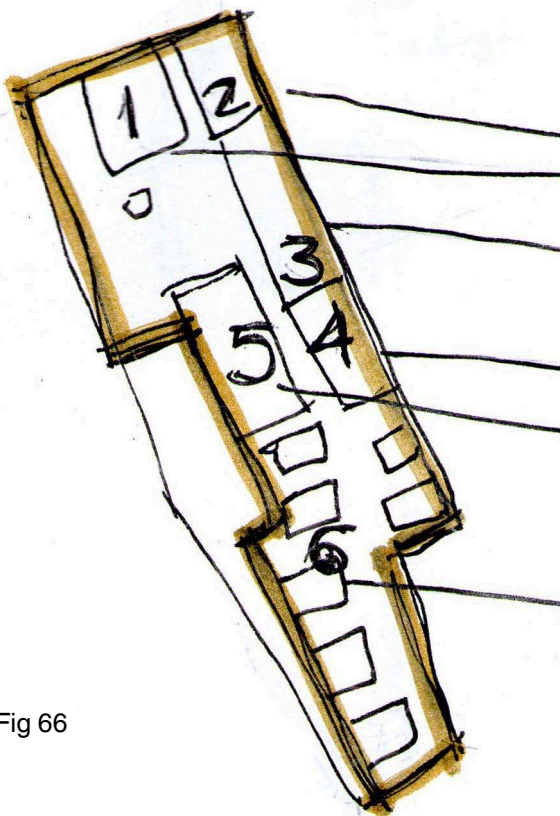

Fig 66

- 1 — workshop
- 2 — museum
- 3 — workshops & housing
- 4 — market
- 5 — multi-purpose venues
- 6 — workshops & housing

Figures 65, 66: Visual sketches, made by the author

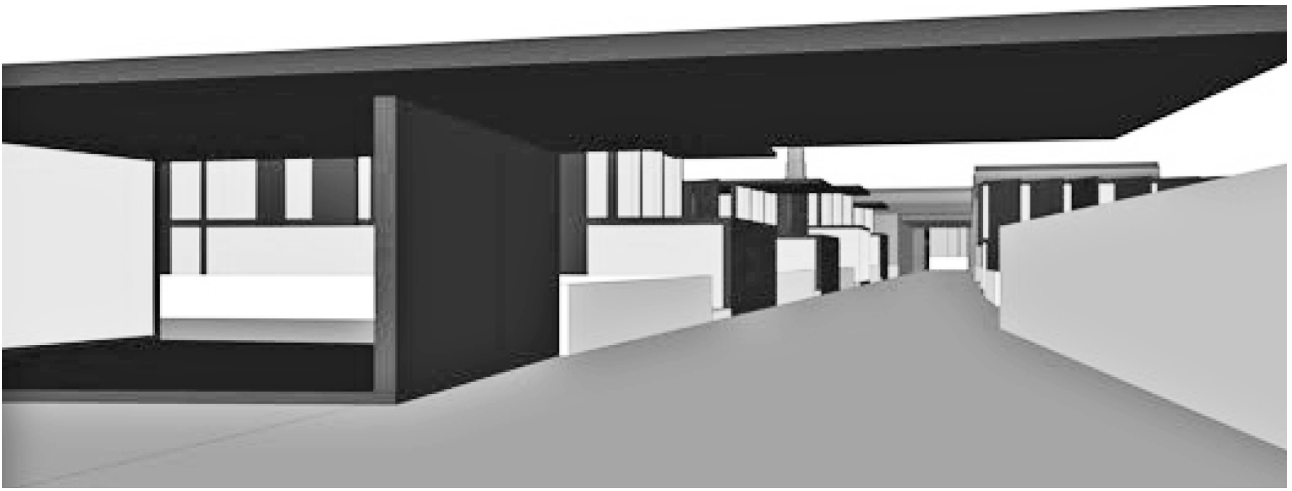

Figure 67: Proposed view of the entrance, *made by the author*

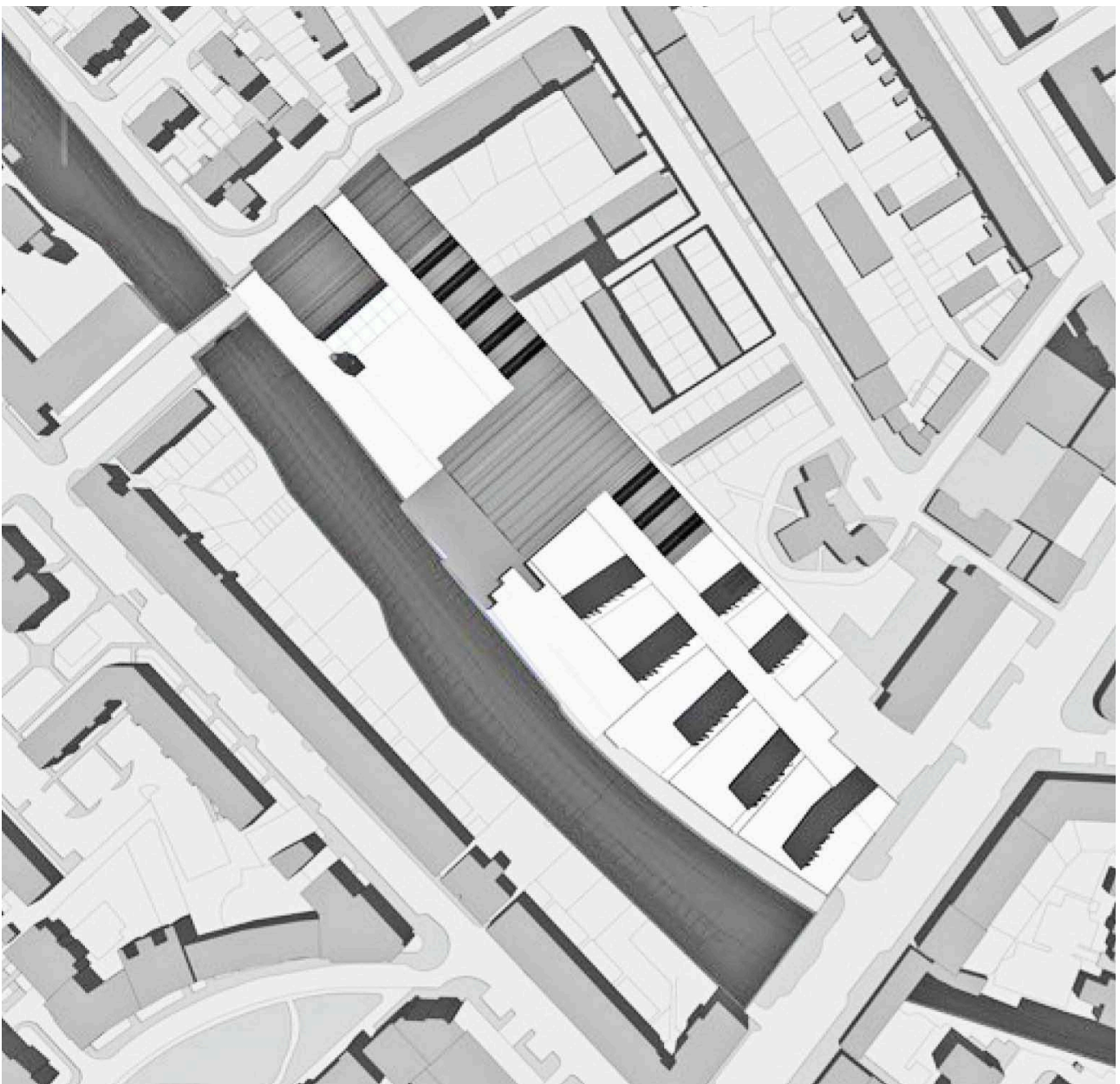

Figure 68: Proposed site layout, *made by the author*

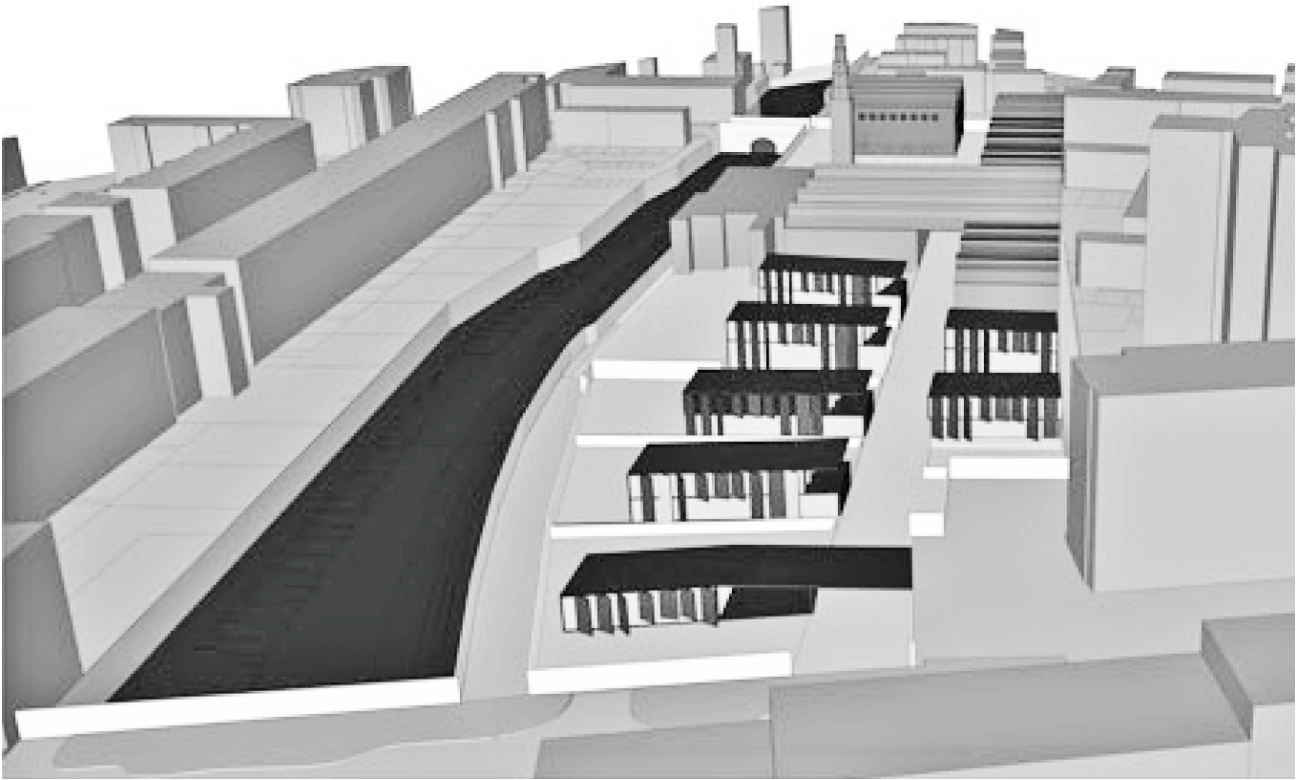

Figure 69: Proposed view of the site, *made by the author*

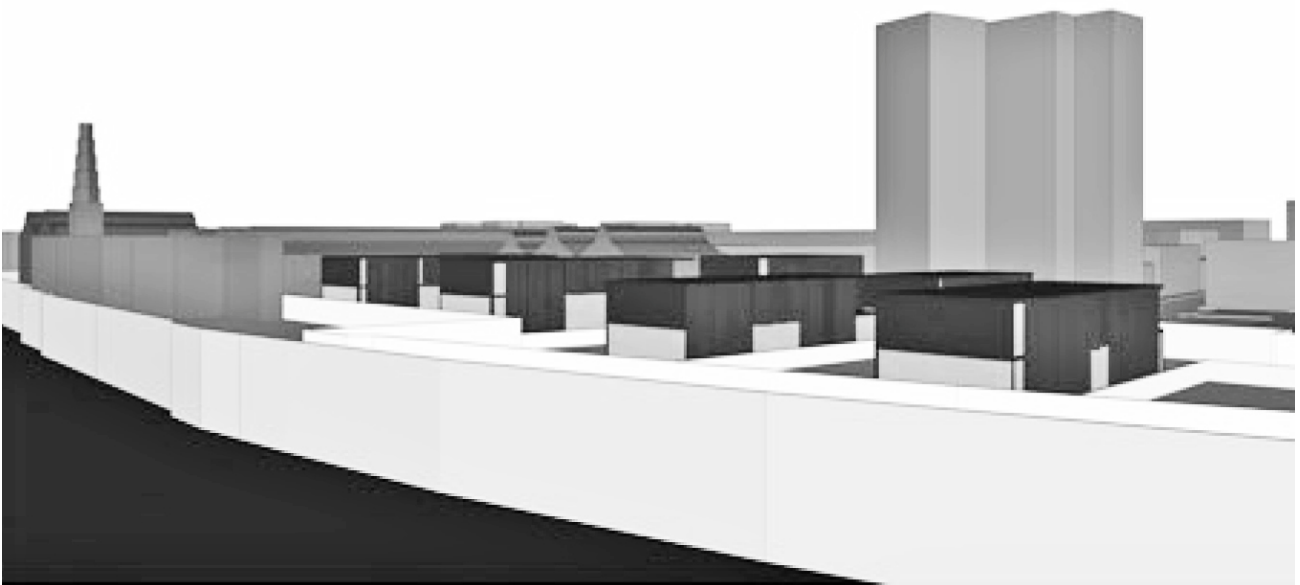

Figure 70: Proposed view of the site, *made by the author*

V. CONCLUSION

V. CONCLUSION

Industry is a function related directly to technology and constitutes an immutable factor of progress. Manufacturing areas with special heritage values are part of a city's structure and reveal the history of the urban fabric. As an area related to industry, not only because of the existence of industrial architecture, but also because of the presence of urban memory, Shrub Place constitutes a cultural monument for the city of Edinburgh and its regeneration should be achieved through the combination of conservation and development.

The main purpose of this study was the regeneration of Shrub Place Lane through conservation principles. The proposed masterplan for the development of this urban industrial zone was produced by the evaluation of area's identity in combination with the importance of industrial heritage. The new design was an attempt to integrate the site integration into the urban fabric, a connection that has lost more than 50 years.

The proposed development was a combination of the analysis findings. Each step, accompanied by appropriate illustrations, followed a logical sequence with the intention to conclude to a successful regeneration of Shrub Place.

- The location of the site and its history introduced Shrub Place while presenting its historical background. Those elements defined the character of the site and indicated its cultural significance through the values of the industrial heritage.
- The in-situ investigation led to the identification of the area, while its geometry, its current condition and its connection with the surrounding area illustrated its relation with the urban fabric and the cityscape.
- The developments shown on the historic maps revealed the traces of the past, while the analysis of the geometry of the area, through the orientation diagrams, explained how the site interacts with the urban environment and Shrub Place's authenticity.
- The past proposals concerning the development of the area from different perspectives presented the needs of the area and formed the new development objectives which were included in the masterplan.
- The conservation principles for industrial and cultural heritage defined the rules for future modifications, including references to successful examples of regenerations served as catalysts and set the guidelines for the masterplan's process.

During this period of time, the area suffers from abandonment and its built fabric is in danger. The inner city's pressure demands the assimilation of the area to the urban environment. The masterplan focused on that need and takes into consideration the character of the area and its function as an ensemble. Specifically, the new uses respect the previous industrial image, while being compatible with the original function.³⁴ Supplementary functions have also been included to the masterplan, in order to serve as connections with the neighborhood for its harmonious integration with the area. The preservation of industrial architecture that emerges from the presence of these listed buildings, the chimney structure and the walls of the demolished workshops, are also included in the masterplan. The interventions proposed through the new design have a minimal impact to the existing structures and respect the original fabric, following the urban pattern and geometry of the area. In addition, the reconstruction of the previous structures through new materials can be beneficial for the integrity of the site and reveal memories and images of the old depot.³⁵

“Human beings change the land around them in a way and on a scale matched, for the most part, by no other animal. The land around us is a reflection of both our practical and technological capacities and also of our culture and society – of our very needs, our hopes, our preoccupations and dreams.”³⁶

Shrub Place, as an example of this evolutionary process, obtained its identity by social and economical factors which defined its integrity through time. This old zone consists of urban memories and remains of industrial culture and constitutes a monument; an ensemble. A city needs to be treated as a living body which demands careful treatment when it is threatened.³⁷ Abandoned places, ghosts from the past, are desperately demanding concern while being at risk. Shrub Place Lane is one of them.

³⁴ TICCIH Congress in Russia, *The Nizhny Tagil Charter For The Industrial Heritage*, July 2003

³⁵ Idem

³⁶ J.E. Malpas, *Place and Experience, A Philosophical Topography* (Cambridge: CUP, 1999), 1 as quoted by Rebecca Madgin, *Heritage, Culture and Conservation: Managing the Urban Renaissance* (Saarbrücken: VDV Verlag Dr. Müller, 2009), 1

³⁷ Michel Bonnette, *Urban Conservation and Sustainable Development, A Theoretical Framework*, CECI, 2nd International Seminar (Recife Pernambuco, Brazil: CECI, 1999), 13

Bibliography

Buildings at Risk. "Shrubhill Tramworks Workshop to NW, Shrub Place, Leith" (by Historic Scotland, 2013). Accessed February, 2013. http://www.buildingsatrisk.org.uk/search/planning_authority/186/p/3/event_id/917195/building_name/.

CANMORE by Royal Commission on the Ancient and Historical Monuments of Scotland, 2011. "Edinburgh, Leith Walk, Shrub Place Lane, Shrubhill Tramway Workshops And Power Station". Accessed June, 2013. <http://canmore.rcahms.gov.uk/en/event/577227/>.

Centro de Estudos Avançados da Coservação Integrada, 2nd International Seminar. *Urban Conservation and Sustainable Development, A Theoretical Framework*. Recife Pernambuco, Brazil: CECI, 1999.

City of Edinburgh Council. *Leith Conservation Area Chapter Appraisal*. Edinburgh: City of Edinburgh Council, 2002.

City of Edinburgh Council. "Planning and Building Standards Online Services". Application Number: 02/04593/FUL. Accessed March, 2013. <https://citydev-portal.edinburgh.gov.uk/idoxpa-web/simpleSearchResults.do?action=firstPage>.

City of Edinburgh Council. "Planning and Building Standards Online Services". Application Number: 05/03128/FUL. Accessed February, 2013. <https://citydev-portal.edinburgh.gov.uk/idoxpa-web/applicationDetails.do?activeTab=summary&keyVal=IMV10LEWF1000>.

City of Edinburgh Council. "Planning and Building Standards Online Services". Application Number: 13/01070/FUL. Accessed April, 2013. <https://citydev-portal.edinburgh.gov.uk/idoxpa-web/simpleSearchResults.do?action=firstPage>.

City of Edinburgh Council. "Planning and Building Standards Online Services". Application Number: 13/01071/FUL. Accessed April, 2013. <https://citydev-portal.edinburgh.gov.uk/idoxpa-web/simpleSearchResults.do?action=firstPage>.

English Heritage. *Conservation–Led Regeneration: The Work of English Heritage*. London: English Heritage, 1998.

Historic Scotland, 2013. "Leith Walk, Shrub Place, Shrubhill Tramway Workshops And Power Stations". Accessed August, 2013. http://hsewsf.sedsh.gov.uk/hslive/hsstart?P_HBNUM=45956.

Karadedos, G.P. Προστασία μνημείων και συνόλων, Τεύχος 2 (Conservation of monuments and ensembles, Vol. 2). Thessaloniki: AUTH, 1991-92.

Lavas, G. P. Προστασία μνημείων και συνόλων, Τεύχος 1 (Conservation of monuments and ensembles, Vol. 1). Thessaloniki: AUTH, 1991-92.

Madgin, Rebecca. *Heritage, Culture and Conservation: Managing the Urban Renaissance*. Saarbrücken: VDV Verlag Dr. Müller, 2009.

Malpas, J.E. *Place and Experience, A Philosophical Topography*. Cambridge: Cambridge University Press, 1999.

Manchester Central. Accessed August, 2013. <http://www.manchestercentral.co.uk/>.

Reference Services, Central Office of Information, HMSO. *Aspects of Britain: Urban Regeneration*. London: HMSO, 1995.

Technopolis City of Athens. "Industrial Gas Museum, Technopolis-Gazi SA". Accessed May, 2013. <http://www.technopolis-athens.com/web/guest/museum/home>.

The International Committee for the Conservation of the Industrial Heritage. *The Nizhny Tagil Charter For The Industrial Heritage*. TICCIH Congress in Russia, July 2003.

