

J Portacal

WAVE ENERGY

The Department of Energy's

R&D PROGRAMME 1974-1983

126

J 22 May 04
from British Library Copy

ET

126

BRITISH LIBRARY
20 JUL 1985
3816.47

dupe

Wave Energy

The Department of Energy's R&D Programme 1974-1983

March 1985

ETSU

for the Department of Energy



49883265

for RMS
use only

Return Date:

-8 JUN 04 40061

Request Ref. No.

RO20166 S LOAN SE

If no other library indicated please return loan to:-
The British Library Document Supply Centre, Boston Spa,
Wetherby, West Yorkshire, LS23 7BQ

Wave Energy

The Department of Energy's R&D Programme 1974-1983

Prepared by:

P G Davies (Editor)

M S Cloke

K A Major

D I Page

R J Taylor

March 1985

Contents

	Foreword	v
	Summary	vii
1	Introduction	1
2	Historical Background to the UK Programme	5
3	Sea Waves as a Source of Power	11
4	Principles of Wave Energy Converters	21
5	Device Designs	27
6	Wave Energy Converter Structures	49
7	Mooring and Anchoring	55
8	Power Conversion and Transmission	63
9	Availability and Maintenance	73
10	Mean Annual Output of a Wave Power Station	79
11	The Cost of Energy from a Wave Power Station	87
12	The Economics of Wave Energy	99
13	Impacts on Man and the Environment	101
14	Programme Achievements and Prospects for the Future	105
15	International Wave Energy Research	107
 Appendices		
A1	Management of the Wave Energy Programme	111
A2	Principal Contractors in the Department of Energy Wave Energy Programme	113
A3	Industrial Involvement in Wave Energy Research	115
A4	A Selection of General Publications on Wave Energy	117
A5	Glossary of Terms	119

Foreword

This Report marks the completion of that phase of the Department of Energy's R&D Programme in which the Energy Technology Support Unit was charged with assessing the contribution that wave energy could make to energy supplies in the United Kingdom. At the beginning of the programme, in 1974, waves were seen as a very substantial source of energy, but there were large gaps in understanding how to exploit this resource. There were uncertainties about the nature of waves and of the principles of extracting energy from them, experimental methods were not well developed, and the practical problems of building a useful energy converter were poorly understood.

These problems were tackled in two main ways: original design concepts were developed by means of experimental work and design studies; at the same time, programmes of supporting work of value to all devices were carried out, for instance, on the wave climate, mooring, materials, etc. The teams engaged on this work were from University, Industry and Government research laboratories, supported, when appropriate, by engineering contractors and consultants.

The whole programme cost approximately £15M, and it is impossible in this short report to convey the high quality of the work carried out if only because of the sheer quantity of information produced. As a result of this programme, there has been an immense increase in the understanding of all aspects of wave energy technology, which is a tribute to the dedication and skill of the scientists and engineers involved.

It is sad that, at the end of the programme, wave energy is left as one of the less-promising renewable energy resources.

I would like to express my thanks to the former Manager of the Programme, Mr. C.O.J. Grove-Palmer, and to the present Manager, Mr. P.G. Davies, for their dedicated work. I would also like to thank Mr. Davies, Mr. M. Cloke, Mr. K.A. Major, Dr. D.I. Page and Dr. R.J. Taylor for their work in preparing the Report, and the past and present members of the Wave Energy Steering Committee for their advice and time freely given over the years. Thanks are also due to the many Department officials – especially the four Chief Scientists – who have been associated with the programme, with a particular mention for the present Departmental Programme Director, Mr. W. Macpherson, who has helped with the preparation of this report. Finally, it is worth repeating that the Programme was made and sustained by the enthusiasm and skill of the scientists and engineers in the UK Wave Energy Community, and this has been particularly evident to those of us who have been privileged to be close to the programme and aware of the quality and ingenuity of their work.

P Iredale
Chairman
Wave Energy Steering Committee

Summary

Introduction

The intensive phase of the Department of Energy's wave energy research and development programme ran from 1974 to 1983 and cost approximately £15M. The basic objectives of the programme were to establish the feasibility of extracting energy from ocean waves and to estimate the cost of this energy, if used on a large-scale to supply UK needs.

Programme Content

In order to meet these objectives, a comprehensive programme of work was carried out in the following main areas:

Wave Data

Work on collecting and analysing wave data has advanced our knowledge of the wave climate considerably. The variable nature of wave energy is now better understood and the size of the resource is more firmly established.

Conversion Principles

The most suitable form of energy to which wave energy can be converted is electricity. At present, the most cost-effective type of converter is likely to use wave motion to generate an air flow to drive turbines.

Device Designs

Over three hundred ideas for capturing wave energy were examined. The most attractive concepts were tested at small scale in wave tanks, and three were tested in sea conditions at one-tenth scale. Eight devices were taken to the stage where reference designs for a 2GW power station located off NW Scotland were produced and costed. This required the development of design codes for structures and a study of materials and construction techniques, and a great deal is now known about the sheer scale of the operations involved in building such stations.

Mooring and Anchoring

Although mooring and anchoring technology has made advances in recent years, certain unique requirements of mooring systems for wave energy converters required special approaches. Significant progress was made on the design of 'compliant' mooring systems.

Power Conversion and Transmission

The particular problems of aggregating power from thousands of individual generating sets and delivering it via a single transmission line to the Grid were studied in depth and suitable systems were designed.

Availability and Maintenance

The economics of wave energy are heavily dependent upon the availability of devices and the cost of maintaining them. Mainly through the development of computer modelling techniques, the level and type of maintenance and repair resources required by wave power stations were determined.

Size of the Resource

When the wave energy programme began, estimates suggested the potential resource around the UK coast was enormous. It is now evident from wave measurements and calculations which take account of geographical limitations and the overall conversion efficiency of the assessed wave energy stations that the technically achievable UK resource does not exceed 6 GW mean annual power. This is equivalent to approximately 50 TWh of energy per annum or 20 Mtce per annum representing about 6% of the total current primary demand for energy in the UK. This achievable resource will probably be further limited in practice by environmental and economic constraints.

Cost of Wave Energy

The cost of energy produced by the various devices was assessed by Consultants using cost data from the 2GW reference designs. The assessment concluded that there was only a low probability of any design achieving an energy cost below 8p/kWh (in May 1982 money values).

Economics of Wave Energy

In January 1982, ETSU produced its 'Strategic Review of the Renewable Technologies' which made an economic analysis of all renewables including wave energy. It concluded that the overall economic prospects for wave energy looked poor when compared with other electricity-producing renewable energy technologies. An up-dated analysis in 1984 confirmed this conclusion.

In the light of the Strategic Review, the Advisory Council for Research and Development for Fuel and Power (ACORD) concluded in March 1982 that large scale prototype work was not justified and that the programme should be reduced. The Department of Energy decided therefore to fund a small research programme to see if progress could be made which might justify larger-scale work in later years. Research work continues to be funded at the Universities of Edinburgh, Belfast and Lancaster and SEA Ltd. at Coventry.

The Way Forward

The work carried out in the programme has indicated that constructing and maintaining wave power stations necessary for large-scale exploitation of the resource would present formidable tasks. The diffuse nature of the energy and its remoteness from industrial centres and consumers are major factors contributing to the unattractiveness of large-scale wave energy relative to other energy sources, renewable and conventional. Smaller scale wave energy might, however, have a brighter future in remote locations where the competition comes from expensive fuels such as diesel.

The Department is currently supporting work by SEA Ltd. directed towards a small-scale version of the CLAM device. In addition, the Department of Trade and Industry has supported a feasibility study of a small-scale demonstration of the NEL Breakwater device. These and developments overseas will be studied carefully; any re-assessment of the application of wave energy on a large scale must await the demonstration of its viability at these smaller scales.

1

Introduction

1.1 Wave energy is created when winds caused by solar energy interact with the surfaces of the oceans. The largest concentration of wave energy on earth is between latitudes 40° and 60° in both the northern and southern hemispheres where the winds blow strongest. Because wave energy increases with the distance, or 'fetch', over which winds interact with the ocean, the UK, at the eastern end of long fetches across the Atlantic and in the 50° latitudes, has a potentially large wave energy resource.

1.2 Numerous ideas for converting wave energy to a more suitable form of energy have been proposed in the past but none was sufficiently attractive to warrant development to the exploitation stage as long as fossil fuels remained cheap and plentiful. Within the last decade, however, the realisation that the era of cheap energy might be over has given fresh impetus to the study of renewable sources of energy, especially wave energy.

1.3 From a situation in the early 1970s of very limited knowledge of wave energy conversion and crude estimates of what appeared to be a vast energy resource, a research and development programme, largely funded by the Department of Energy, has advanced wave energy knowledge considerably. Very much more quantitative information is now available and many uncertainties have been eliminated or reduced. Unfortunately it has been shown that wave energy is, at present, not economically attractive for large-scale power generation when compared with conventional and other renewable energy sources.

1.4 The UK has always had more wave data available than most other places in the world but even so it is difficult to make a definitive estimate of the size of the resource. By analysing existing data and gathering new data from possible wave power station sites, it has been possible to show that, in principle, wave energy might make a significant contribution to UK energy needs. Chapter 3 explains the way in which the resource has been calculated and Chapter 4 discusses the principles by which it might be converted to useful energy.

1.5 Wave energy would most conveniently be converted to and distributed as electricity. The programme therefore set out to study concepts of devices which could form a wave power station and supply electricity in bulk to the UK Grid. Preliminary study of such devices led through a number of stages including small-scale model testing and large-scale sea trials to full-scale designs. In the latter stages of the programme, estimates of the cost of energy produced from waves were made by costing large-scale power stations designed by each device team. The common requirement for these 'reference' designs was that the station should be capable of delivering 2GW for 5% of the year and be located off South Uist in the outer Hebrides. By choosing this size, advantage could be taken of economies of scale even though 2GW is not necessarily the optimum rating for a wave power station. The costs quoted in this report are from the 1983 assessment report produced by the Department's Consultants, Rendel, Palmer & Tritton. Chapter 5 describes the most promising devices, the generating costs of which were assessed.

1.6 The wave energy programme also studied many of the problems common to all wave energy devices including:

- Structure design (Chapter 6)
- Mooring and anchoring (Chapter 7)
- Power conversion and transmission to shore (Chapter 8)
- Availability and maintenance (Chapter 9)
- Design of a 2GW power station (Chapter 10)
- Environmental effects (Chapter 13).

1.7 The methodology used for deriving energy costs is described in Chapter 11 and the economic analysis of these costs in the context of the 'Strategic Review of the Renewable Energy Technologies'* is discussed in Chapter 12. The Review concluded in 1982 that large-scale wave energy appeared to be economically unattractive when compared with competing technologies. It was on the basis of this conclusion that the Advisory Council on Research and Development for Fuel and Power (ACORD) made its recommendation that no new development work on wave energy should be supported, and that the work done in the programme should be published.

1.8 This report therefore marks the completion of the major phase of the Department of Energy's wave energy research programme. Research on wave energy did not, however, cease in 1982 – the Department decided that a small programme should continue with the objective of establishing the likely minimum cost for generating electricity from wave energy from the best of the current types of devices and any new devices that may emerge.

1.9 The report is almost entirely based on the R&D programme funded by the Department of Energy which dominated UK wave energy research. Two other organisations, the Science and Engineering Research Council and the Central Electricity Generating Board, also funded much smaller programmes and will continue to do so. Liaison between the separate programmes was very good and there was a constant interchange of views and results between them.

1.10 The prices and costs quoted in this report are in terms of the value of money in May 1982, except where otherwise stated.

*Strategic Review of the Renewable Energy Technologies – An Economic Assessment (2 vols. 1982) ETSU Report R13 (HMSO, London)

no

v of

or

rel

kn

e

all

s

d

su

Fig. 2.1 Annual expenditure on wave energy research (not adjusted for inflation)

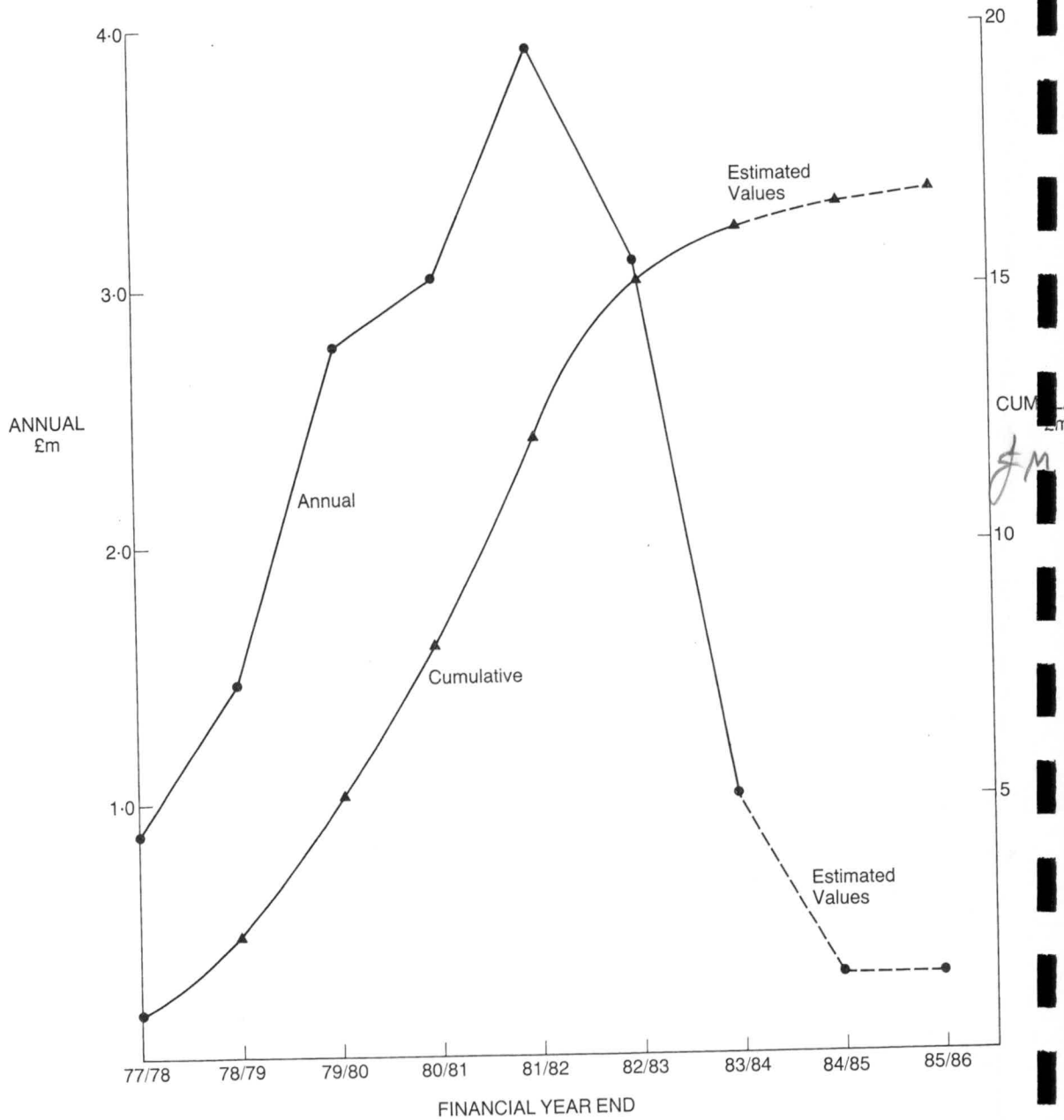

2

Historical Background to the UK Programme

2.1 Interest in wave energy increased significantly in the UK in 1974 with the publication of a report entitled 'Energy Conservation' by the Central Policy Review Staff. This report started from the recognition of the vulnerability of the UK's energy-intensive economy to disruptions in supply such as those illustrated vividly by the Middle East crisis of that time. It identified the Government's responsibility to ensure that as wide a range as possible of energy options should be assessed to ensure security of energy supplies in the long term. It reviewed the possibility of developing new contributions to electricity supply from inexhaustible sources of energy and highlighted wave energy as being an apparently enormous resource. Its main recommendation was that the first stage of a full technical and economic appraisal should be put in hand.

2.2 The Department of Energy's wave energy R&D programme began in February 1974 with a preliminary study to assess the large-scale generation of electricity from waves, undertaken by the National Engineering Laboratory (NEL). Research at Edinburgh University, which later played a significant part in the Department's programme, actually began in the winter of 1973.

2.3 In 1976 the Department announced the start of a more detailed study with the dual aims of establishing the feasibility of extracting energy from ocean waves and estimating the cost of further development. The Energy Technology Support Unit (ETSU) based at Harwell was asked to formulate and manage the Department's programme. The philosophy adopted was that of supporting experimental teams, each dedicated to the development of a concept, with freedom to optimise the design of an actual device which used the concept. The Wave Energy Steering Committee (WESC) was set up to advise on the technical content of the programme.

2.4 Within a year, progress had been sufficiently encouraging for the programme to be expanded and by 1978 it covered three areas of work:

- examination of new ideas for wave energy devices
- specialist studies related to marine structures, materials, moorings, transmission systems, wave climate and other 'generic' topics
- one-tenth scale model tests of devices in the open sea.

Scale models of a number of devices were being tested in a specially constructed wave tank at Edinburgh University.

2.5 Four widely differing concepts were assessed in order to establish the feasibility of each and its potential for future development:

- the DUCK (invented by Stephen Salter; developed at the University of Edinburgh)
- the RAFT (Sir Christopher Cockerell; Wavepower Ltd.)
- the RECTIFIER (Robert Russell; Hydraulics Research Station, Wallingford)
- the OSCILLATING WATER COLUMN (NEL and Vickers Ltd.).

Fig. 2.2 Funding allocation

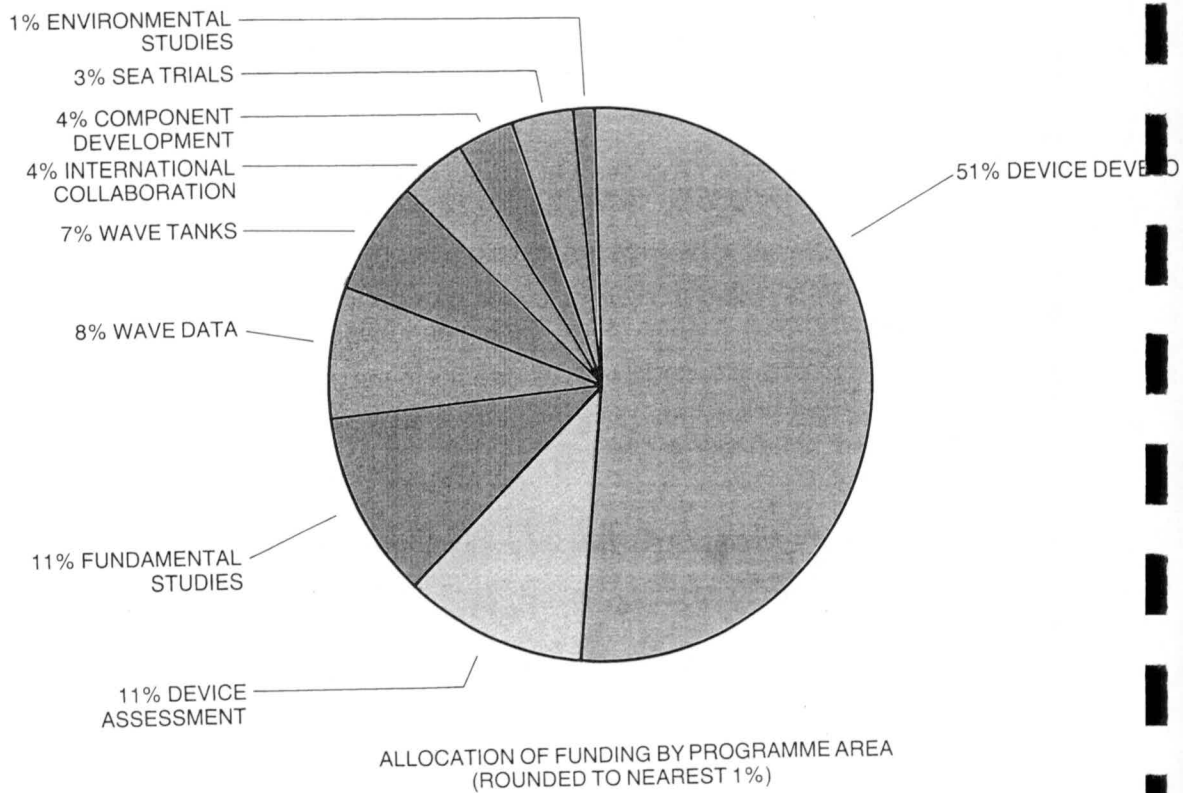
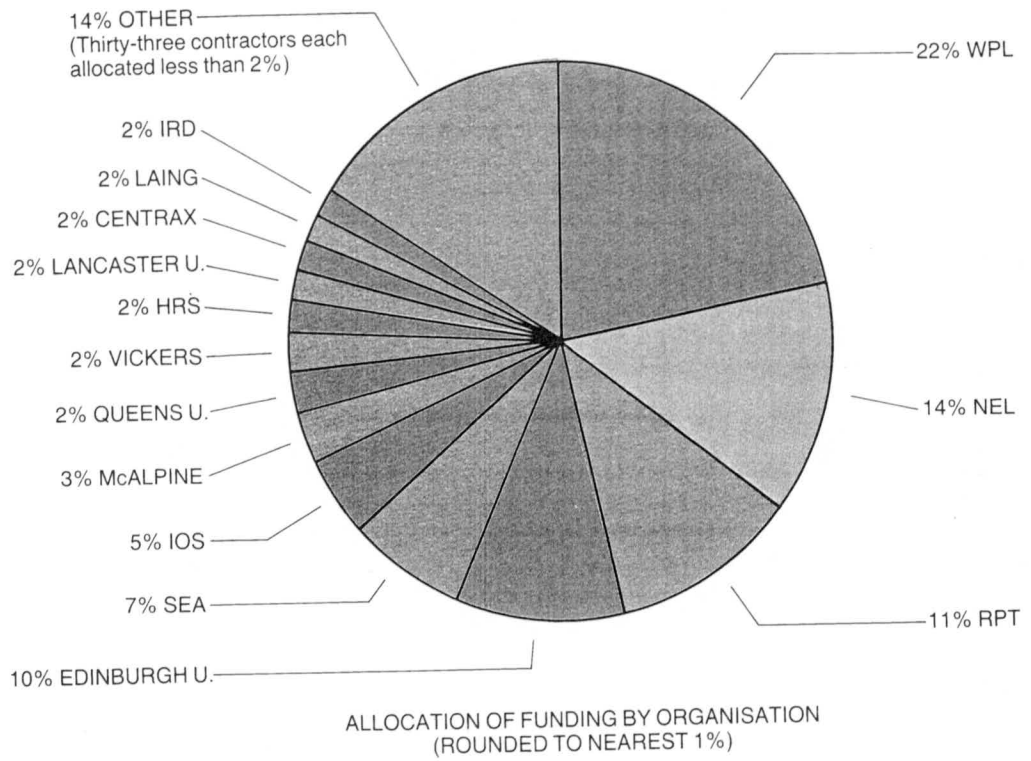

By late 1978, one-tenth scale models of the DUCK and RAFT devices were being tested at Loch Ness by Sea Energy Associates (SEA) Ltd and in the Solent by Wavepower Ltd respectively, whilst smaller scale models of the other two were being tested in wave tanks.

2.6 In order to ensure that device teams were working to a common basis they were asked to optimise their respective devices to meet the criterion of a 2 GW wave power station off South Uist in the Hebrides and to estimate the cost of electricity generated by such a station. The Consultants, Rendel, Palmer & Tritton (RPT), assessed the resulting station designs (which became known as the 'reference designs') and costed, in pence per kilowatt hour (p/kWh), the energy they would produce. These costs, presented at the Heathrow Wave Energy Conference in November 1978, were disappointingly high, particularly for the RECTIFIER. A new device, the FLEXIBLE BAG, appeared to have the lowest predicted costs of any device assessed. One major outcome of the Heathrow Conference was the identification of the high cost centres which had to be tackled to improve the economics of wave energy.

2.7 By the time the second Workshop was held (at Maidenhead in December 1979), new concepts which showed prospects for cost reduction had swelled the list of devices being studied in depth to:

- four variations of the OSCILLATING WATER COLUMN
- the RECTIFIER
- the FLEXIBLE BAG (Michael French; University of Lancaster)
- the RAFT
- the CLAM (Norman Bellamy; Lanchester Polytechnic and Sea Energy Associates)
- The TRIPLATE (Francis Farley; Royal Military College of Science)
- the CYLINDER (David Evans; University of Bristol)
- the DUCK.

In addition, many other concepts were assessed by a Technical Advisory Group of WESC. Revised costings showed that in many cases the cost of power in p/kWh had been reduced by as much as a factor of three, but the range of 6 to 12p/kWh, was still too high to make wave energy economically attractive compared with other sources of energy.

2.8 In March 1980, ACORD recommended that the number of devices being studied in the programme should be reduced. As a result, work was concentrated on the CYLINDER, the FLEXIBLE BAG, and the OSCILLATING WATER COLUMN. The RECTIFIER, the TRIPLATE and the RAFT were abandoned and only limited funding was made available for the DUCK and CLAM teams.

2.9 In January 1982, ETSU produced its 'Strategic Review of the Renewable Technologies'. This concluded that 'wave power is likely to be economic only in those futures more favourable to renewable energy technologies' and 'Although wave power could just be economically acceptable at the bottom of its estimated cost range . . . other electricity generating sources . . . are consistently more attractive when analysed under the same circumstances.'

Fig. 2.3 Wave energy programme calendar

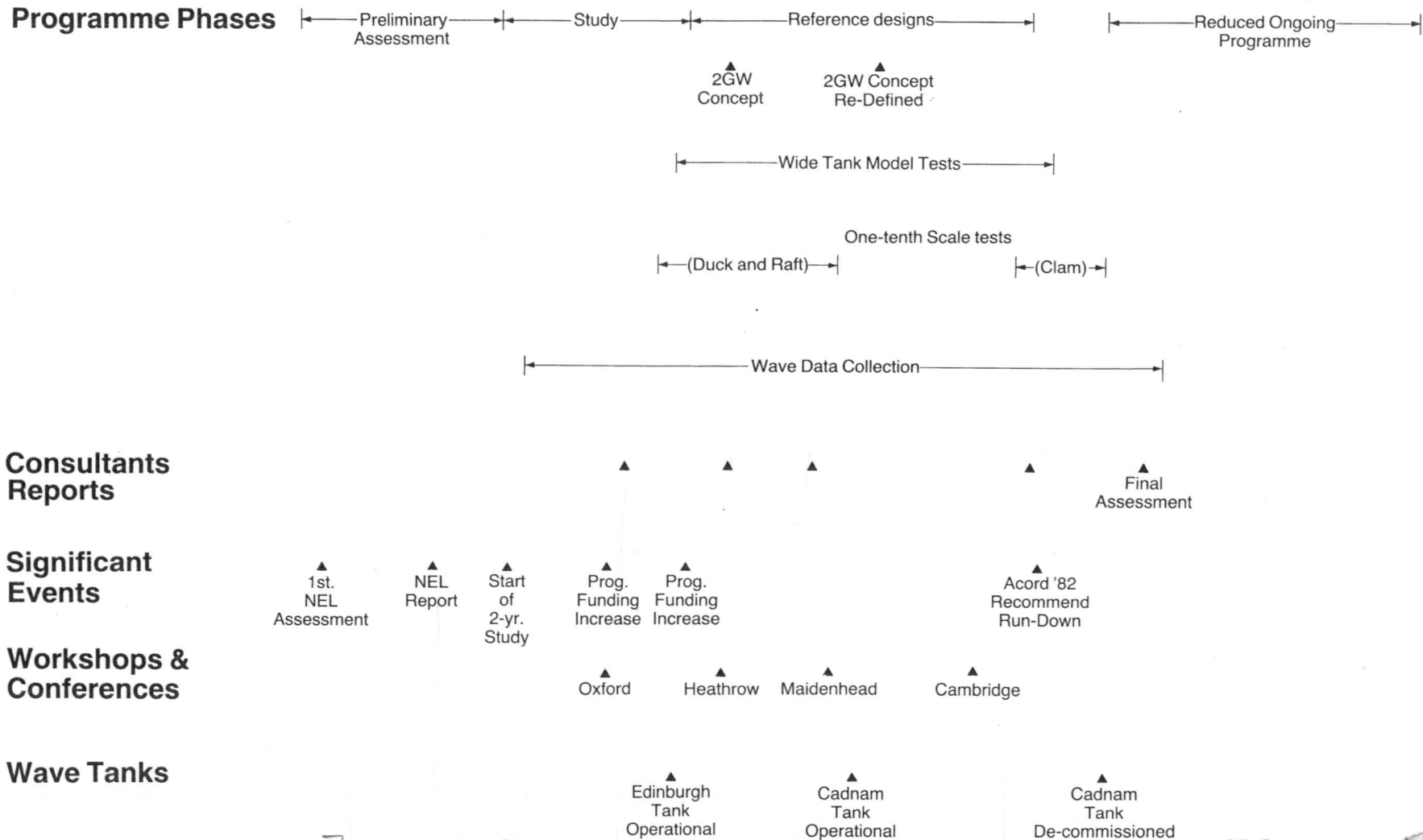

74 75 76 77 78 79 80 81 82 83 84 85 86

2.10 When it reviewed renewable energy technologies in March 1982, ACORD recommended, in the light of the Strategic Review, that 'no new development work . . . should be supported . . .' and the results of the wave energy programme 'should be prepared for publication by the Department'. This recommendation was broadly accepted by the Department of Energy and UK wave energy R&D has been reduced to a small ongoing programme at the Universities of Edinburgh, Belfast and Lancaster, and SEA Ltd. at Coventry.

2.11 The wave energy programme ran for some nine years and cost over £15M. Fig 2.1 shows the programme expenditure over this period. Fig. 2.2 shows how the funding was allocated by organisation and by technical area. Fig. 2.3 records the calendar of events during the programme.

2.12 The funding allocation in Fig. 2.2 refers only to those funds provided by the Department of Energy and does not include the contributions of a number of the industrial partners of device teams. Industrial involvement in the programme is listed in Appendix 3.

Fig. 3.1 An idealised wave

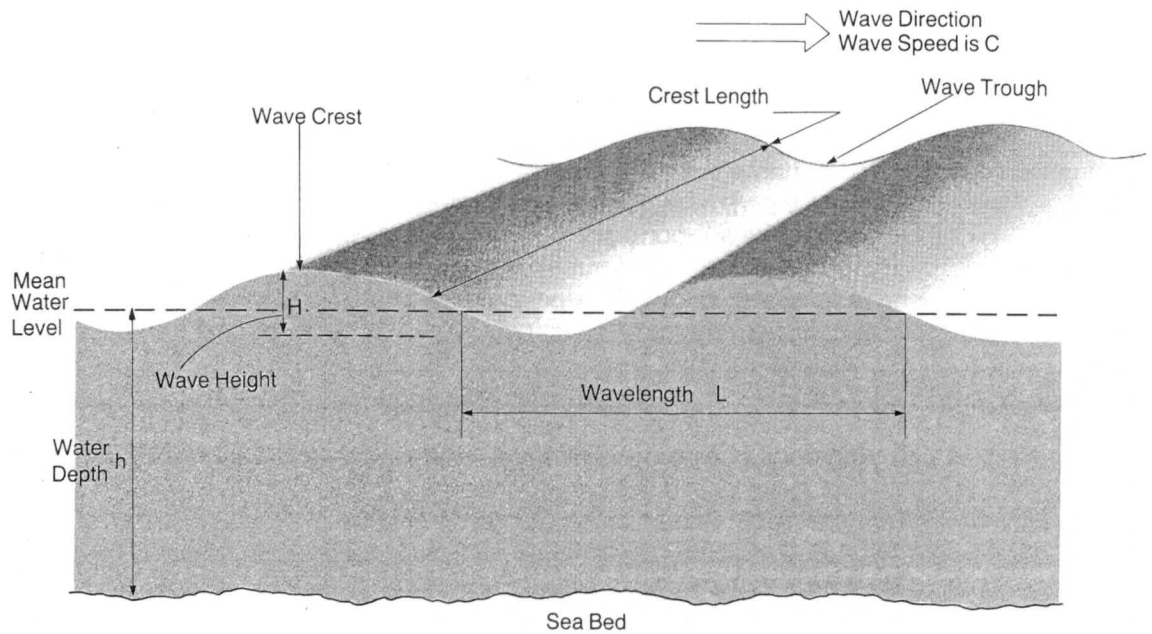

Some Useful Equations

Wave period $T = L/C$

In deep water $L = gT^2/2\pi$
 $C = gT/2\pi$

In shallow water $L^2 \approx ghT^2$
 $C^2 \approx gh$

Some Wave Dimensions

- Typical waves off South Uist have wavelengths in the range 50–250 m and wave heights in the range 1–6 m.
- A wave of wavelength 150 m, period 10 seconds and height 3 m would have a power of 50 kW/m.

Fig. 3.2 Particle orbits for different water depths

(i) Deep Water
Depth, $h > L/4$

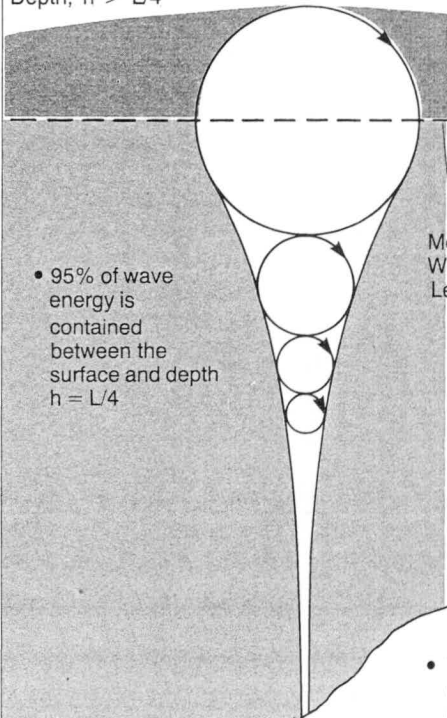

(ii) Shallow Water
Depth, $h < L/4$

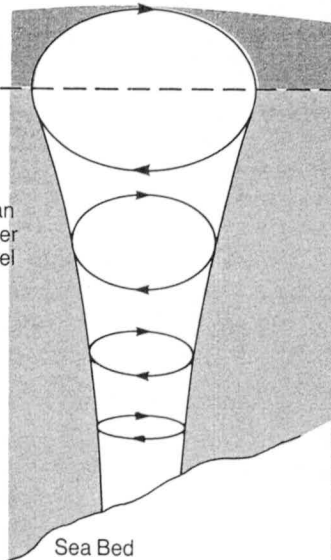

- Water particles move in almost circular orbits which become elliptical as the wave progresses into shallow water.

Fig. 3.3 Wave approaching a beach

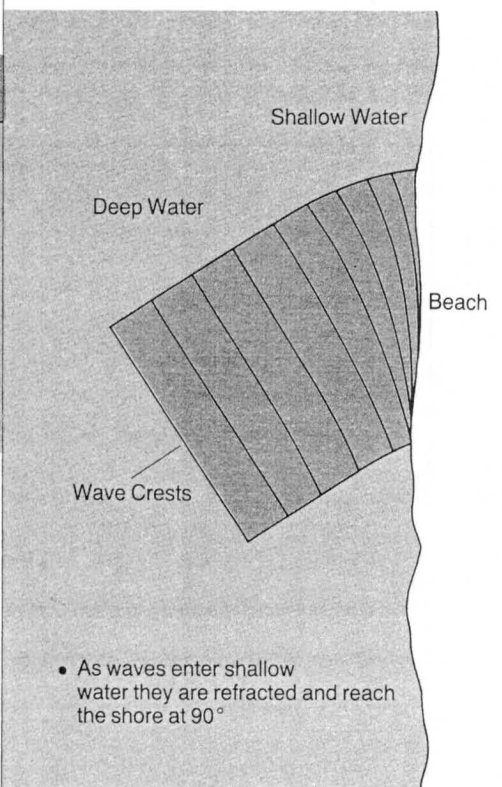

- As waves enter shallow water they are refracted and reach the shore at 90°

3

Sea Waves as a Source of Power

The Nature of Waves

3.1 Waves at sea are caused primarily by the interaction of winds with the sea surface. They represent a transfer of energy from the wind to the sea and the energy in a wave is a function of the amount of water displaced from the mean sea level. The energy transferred depends on the wind speed, the distance over which it interacts with the water and the duration of time for which it blows. Prevailing westerly winds blowing for long distances over the Atlantic Ocean can generate waves tens of metres high with over a hundred metres between crests and many tonnes of water displaced in each wave.

3.2 Individual waves (Fig. 3.1) can be characterised by their height H ; distance between crests (wavelength) L ; time between successive crests (period) T ; and speed, C . A real sea is made up of many individual waves of different H , L , T , and C , some of which may be generated by local winds and some of which may have travelled a long distance.

3.3 Waves travel with velocities which depend on their wavelengths – the longer the wavelength, the faster a wave travels – and in a real sea longer wavelength components move to the front. This effect is seen in hurricane areas where long waves generally travel faster than the storm generating them and a hurricane is often preceded by heavy surf on beaches.

3.4 Waves once formed will continue to travel in the direction of their formation after the wind dies down and even in a glassy calm the sea can be observed heaving in a long swell, probably caused by a storm which may have occurred days before and hundreds of kilometres distant. In deep water, waves lose energy mainly by interacting with the atmosphere but long smooth swells can persist for hundreds of kilometres; shorter, steeper seas rapidly die out.

3.5 Although a wave travels rapidly in a direction at right angles to the wave front, the water itself undergoes oscillatory motion (Fig. 3.2), progressing only slowly in the direction of the waves. The water particles actually travel in closed orbits which in deep water are circular. Near the surface the diameter of this circle is roughly equal to the vertical distance between crest and trough but it decreases rapidly with depth; in shallow water the orbits become elliptical.

Description of Sea-states

3.6 In a mixed sea, many wave heights and lengths occur simultaneously and the waves may travel in different directions. Such a sea can only be properly described statistically, and it is usual to use the root mean square elevation of the water level for this purpose. A traditional definition closer to the intuitive idea of wave height is, however, that of 'significant wave height' (H_s) which is the average height of the highest one-third of the waves. In describing the wave period statistically, 'significant period' (T_z) is used. This is the average time interval between successive crossings of the mean water level in an upward direction. Both H_s and T_z are calculated from measurements obtained from a buoy which follows the rising and falling of the waves and records the elevation of the sea surface over

Fig. 3.4 The representation of wave data

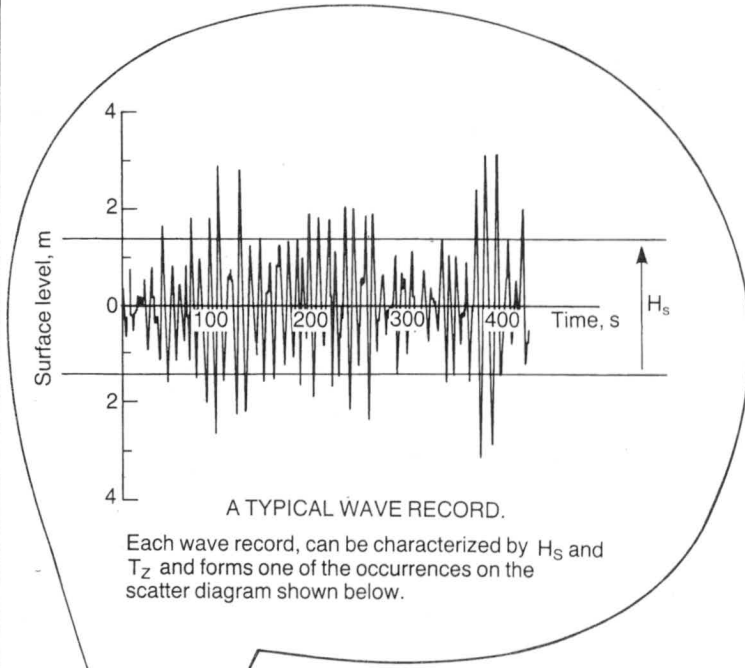

- Real seas are a mixture of waves of various heights, periods, wavelengths and directions.
- The usual form that wave data take is a record of the height of the water surface as a function of time at a fixed position in space.
- Wave records are characterized by two 'average' parameters called significant wave height H_s (m) and period T_z (secs)
- H_s is defined by $H_s = 4\sigma$ where σ is the root mean square water elevation.
- T_z is defined by
$$T_z = \frac{D}{n_z}$$
 where n_z is the number of times the water surface moves through its mean level in an upward direction in a record of duration D .
- An approximate relationship for determining the power in kW per metre of wave front is
$$P \approx 0.55H_s^2 \cdot T_z$$

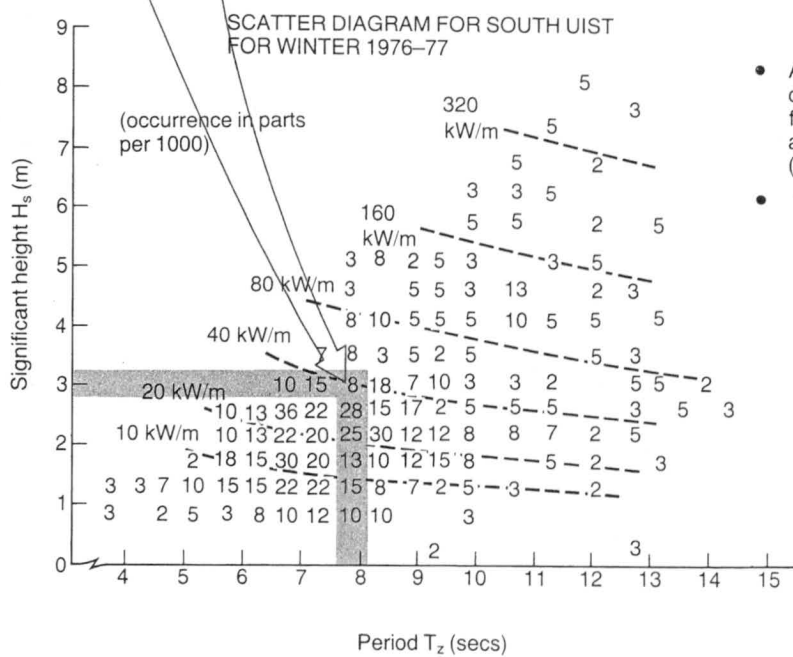

- Another representation of wave-data is a scatter diagram. The numbers on the graph represent the fractional occurrences of each significant wave height and period throughout the winter months (December-February).
- The broken lines show constant power levels.

a period of time. Fig. 3.4 shows a time record of wave heights and illustrates the large spread in heights and periods over a short space of time. Annual data for any particular site are summarised on a 'scatter diagram' which for any combination of H_s and T_z shows the number of times it has occurred during the year. The data generated from buoys are also often presented to show the seasonal variation in power and the number of days in a year a particular power level is exceeded. Fig. 3.5 shows the location of wave data buoys around the UK coast.

3.7 Wave directions are usually summarized in 'directional roses' of lines drawn through a point on a map to show the directions from which waves arrive at that point (Fig. 3.6). The length of a line in a given direction is proportional to the total energy arriving from that direction. Directionality is of great importance for wave energy conversion because devices cannot usually extract energy equally efficiently in all directions. Precise directional measurements are difficult and reliable data are available for a few sites only. Theoretical calculations have been carried out, estimating the sea state from the measured meteorological conditions, using a model developed by the Meteorological Office and have been validated by the limited measurements available from wave energy buoys.

Power in the Waves

3.8 The power in a wave is a function of the rate at which its energy is transferred across a one metre line at right angles to the wave direction and it is expressed in units of kilowatts per metre of wave front. When, in a practical situation, it is necessary to estimate the total power crossing a line along which a device may be positioned, the direction of the wave must be taken into account, and the power crossing a one metre plane in the sea is usually less than that estimated from measurements made by a buoy which accepts energy from all directions. It is customary to talk in terms of the mean annual power in the waves (Chapter 10).

3.9 The power in a wave train remains relatively constant in deep water with small losses arising from the viscosity of the water and interaction with the atmosphere. In water shallower than about half a wavelength, the oscillating motion of water particles near the bottom becomes appreciable and there are energy losses due to friction with the sea-bed.

3.10 As well as causing losses, a shelving sea-bed causes a reduction in wave speed and may also cause a change of wave direction if the wave fronts approach the sea-bed slope obliquely. This latter effect, illustrated in Fig. 3.3, occurs as the wave front is progressively slowed down, swinging it more parallel to the beach – a phenomenon readily observed in nature. If the sea-bed contours are irregular, focussing or de-focussing of waves can occur.

3.11 The power at any specific coastal site may also be reduced by the presence of land masses which prevent waves from particular directions reaching the site.

Wave Measurements

3.12 The prevailing south-westerly winds over the British Isles associated with the long fetches across the Atlantic Ocean mean that the most vigorous wave climates are to the west of the British Isles, namely SW England, W. Ireland and NW Scotland.

Fig. 3.5 Locations around UK where wave data have been recorded

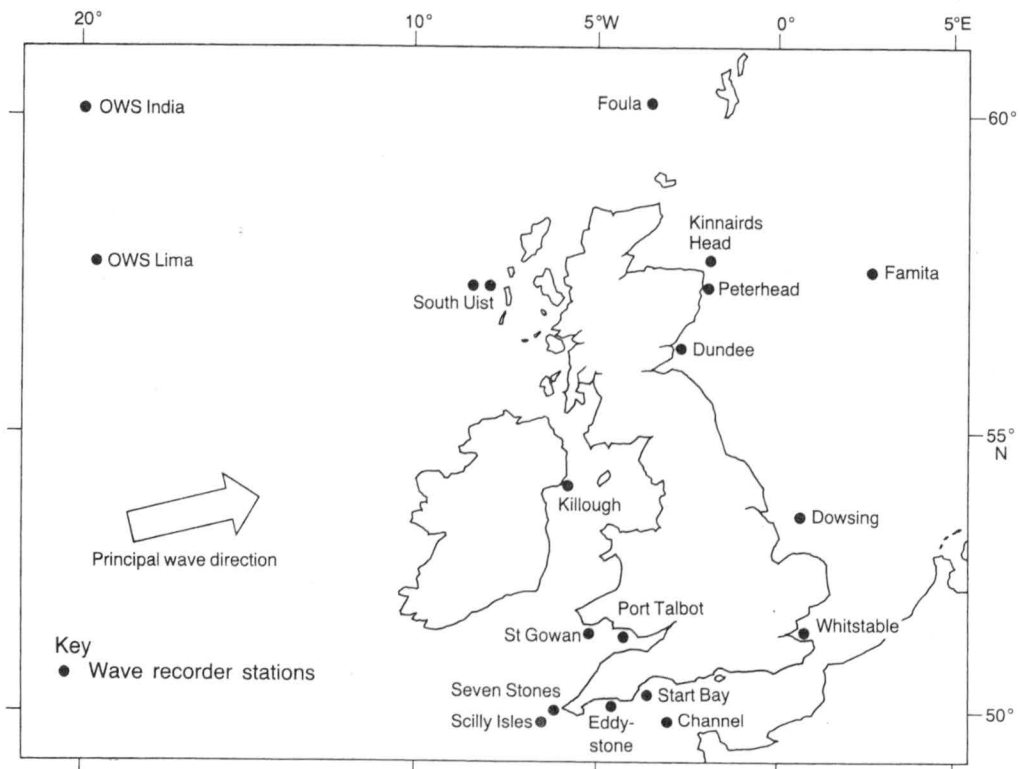

Notes:

- The prevailing winds and waves approach the UK shores from a Westerly direction
- Owing to the shielding effect of Ireland the most favourable UK wave power locations are to be found off the NW coast of Scotland and the SW coast of England.
- The Hebrides have been chosen as the reference location for the purposes of costing a 2 GW wave power station.
- The Institute of Oceanographic Sciences is responsible for the operation of the wave recorder stations shown above. Not all of these stations are operating at present.

3.13 The first reliable wave energy measurements were made before the Department of Energy's R&D programme at Ocean Weather Ship Station 'India' in the NE Atlantic some 710 km west of the Hebrides and the mean annual power density at this location was estimated as 70-90 kW/m. Wave-recording buoys have subsequently been deployed at a number of sites around the coast and Fig. 3.5 shows the location of those buoys for which the Institute of Oceanographic Sciences (IOS) is responsible.

3.14 The Department of Energy wave programme has used the data from IOS buoys but has also funded the collection of data off South Uist, the most likely site for a wave power station. Data from a buoy in 42 metres water depth have provided the reference wave climate for the testing of wave energy devices. The emphasis in the programme has been on the determination of wave spectra in order to provide data for designing devices. In this particular area significant gains in knowledge have been made.

3.15 Two additional buoys have been used in several locations and water depths off South Uist to obtain data on the change in power density between offshore and inshore sites. The reduction of the power density inshore depends on local sea bed conditions and coastal topography, thus the measured values are site-specific.

3.16 Practically all wave measurements to date are of the total power arriving at a buoy from all directions. In estimating the resource it is necessary to take account of the directional properties of waves to allow for the fact that wave energy converters would normally be deployed in lines and could not absorb energy equally from all directions. This directionality effect reduces the amount of power arriving at a line (e.g. a depth contour), by a 'directionality factor'.

3.17 At present only limited measurements are available and so the Meteorological Office wind-wave forecasting model has been used to derive directional spectra at grid points around the UK coast; these spectra are used to calculate wave power and directions. At the reference site, in a water depth of 42m, the mean annual power has been calculated as 48 kW/m with a directionality factor of 0.85. This means that 85% of the power measured by a buoy would be available to a line of devices at this depth. Fig. 3.6 indicates the variation in power and directionality off SW England and NW Scotland, the areas of greatest power concentration.

3.18 Large variations in power are possible and although the mean annual power off South Uist is 48kW/m, power levels can exceed 1000 kW/m in storm conditions. There is also a seasonal variation of power and at South Uist the ratio of mean power in the winter to that in summer is 3.6 (Fig. 3.7).

Estimation of the Resource

3.19 An important aim of the programme has been to establish the likely contribution that wave energy might make to future UK energy supplies. The *total potential resource*, irrespective of physical and economic constraints, can be calculated but this resource is not achievable in practice. Not all sea areas off the UK are available or suitable for siting wave power stations. Taking this into account enables an estimate to be made of the *available resource*. The *achievable resource* is a still lower figure which takes account of the practical performance of wave power stations and operational considerations such as availability and transmission efficiency. It is the achievable resource which is used in estimates of the possible wave energy contribution to UK power generation.

Fig. 3.6 The variation of wave power with location around the UK coast

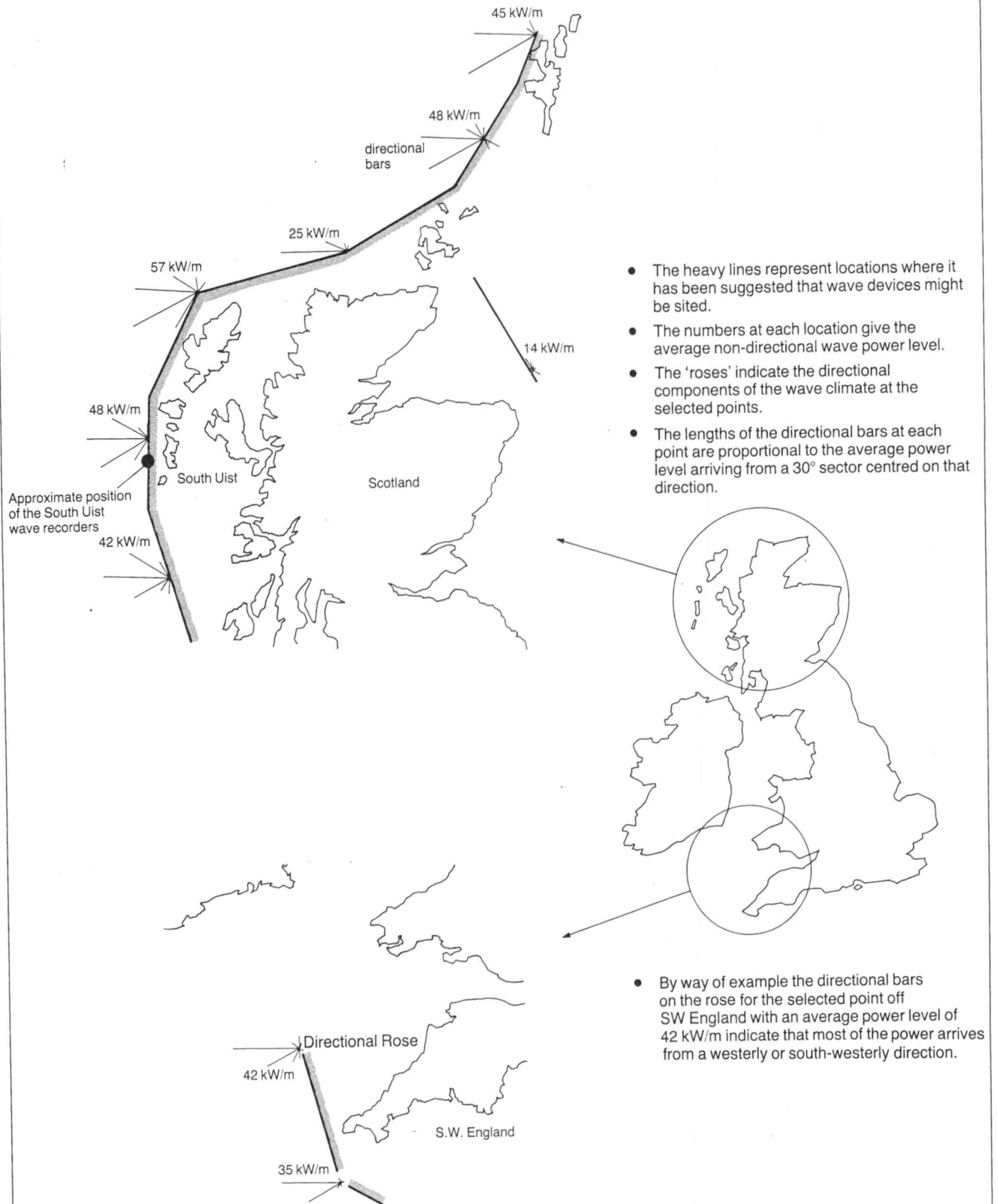

Total Potential Resource

3.20 The total potential UK resource is defined as the total power crossing a deep water contour around the UK, along which a single line of devices might be deployed.

3.21 Earliest estimates of this resource were 120 GW, obtained by extrapolating the 70-90 kW/m mean annual power at OWS 'India' to the UK Atlantic coastline but this estimate was reduced to 48 GW on the basis of 48 kW/m and 1000 km of coastline. Later, more realistic estimates, which took into account wave directions and used the Meteorological Office Model and some measurements, arrived at a total UK resource of about 36 GW.

Available Resource

3.22 Not all the UK sea space is suitable for locating wave power stations and the preferred areas are those areas around N and NW Scotland and SW England shown in Fig. 3.6, where power densities are high. The available resource from deep water in these areas is about 27 GW.

3.23 The available resource reduces with water depth for reasons stated earlier and if wave power stations were to be located in water depths of less than about 80m, the potential resource would be lower.

Achievable Resource

3.24 The overall conversion efficiency of wave energy stations (defined later in Chapter 10) would be such that at most about 20% of the available resource could be delivered to the Grid. Thus the achievable UK resource is around 6 GW mean annual power which is equivalent to approximately 50 TWh of energy per annum or 20 Mtce per annum. This resource may not actually be achievable in practice due to environmental constraints.

3.25 The reasons why the achievable resource is so much lower than the first estimates made from OWS 'India' data are shown in diagrammatic form in Fig. 3.8.

Fig. 3.7 The seasonal variation of the resource

The seasonal variation of the weather affects the amount of wave energy available. During the winter when the seas are high, a wave power station will operate at maximum power thus replacing conventional generating capacity, with consequent fuel savings. Conversely, in calm summer weather there will be no output from the station and conventional plant must operate to make up the deficiency.

In assessing the achievable wave energy resource, we must take account of this variation. The data used are summarised pictorially below and are derived from analysis of wave data supplied by IOS and the conversion characteristic of a typical wave energy device.

The following instances exemplify the variation in wave energy during the year. Approximately 70% (i.e. 2.7 TWh) of all the energy would be supplied by the system during October to March and it would operate at full power for 9% of this time. In the calmer summer months of May to August, only about 10% (i.e. 0.4 TWh) of the annual energy is generated. However, there is very little operation at full power during this summer period and for about two thirds of the time there is no output at all.

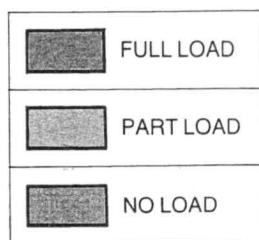

The area of each pie is proportional to the seasonal power output.

Part load operation includes all power output levels between full load and no load. In general the load duration curve is fairly linear over this range.

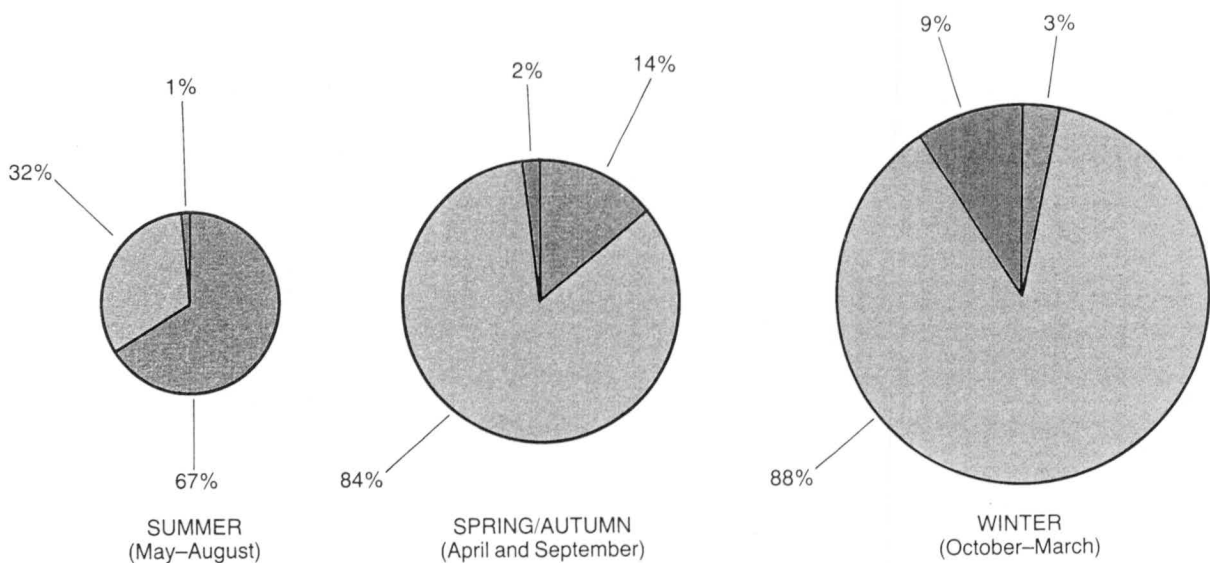
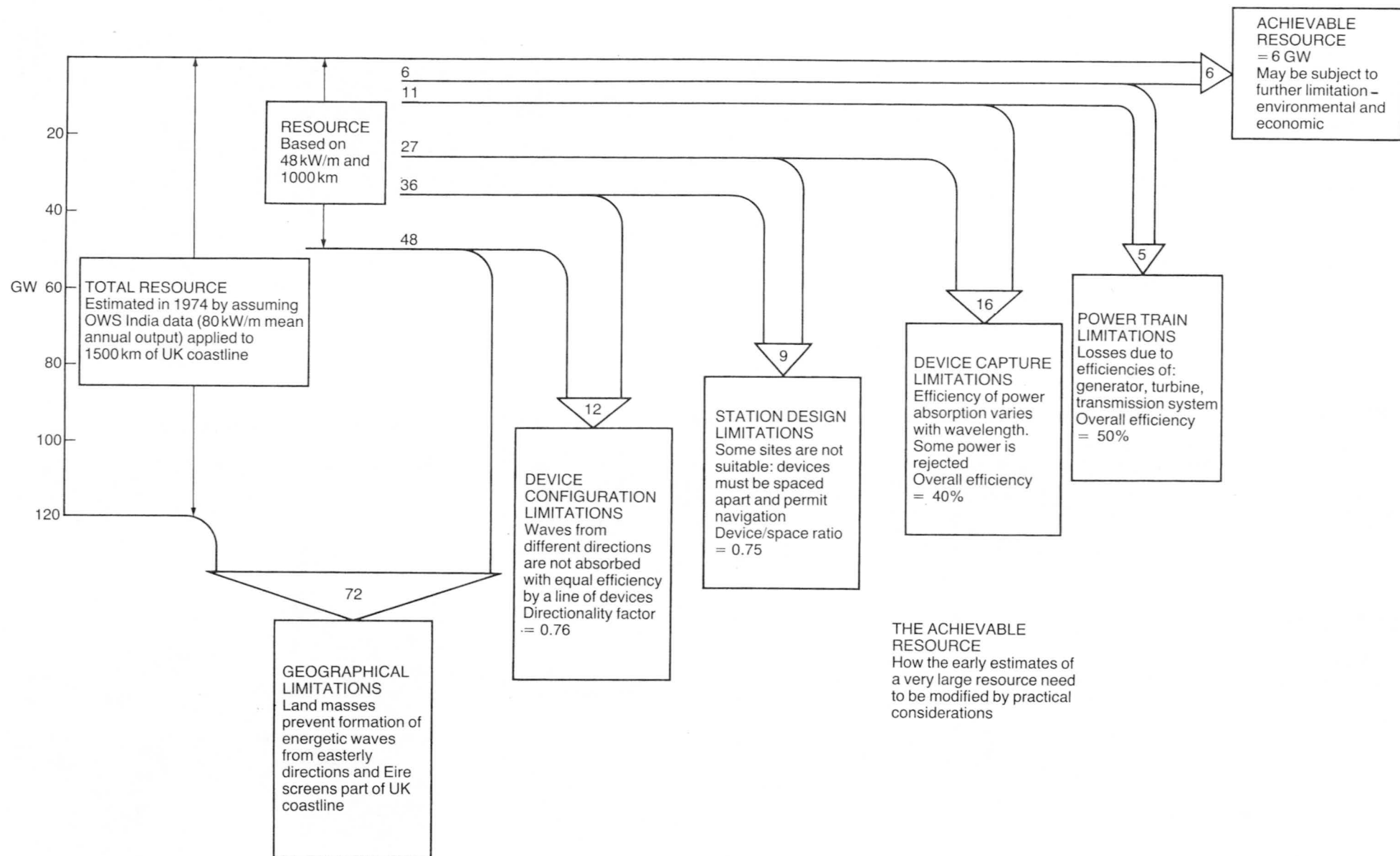

Fig. 3.8 The achievable resource



4

Principles of Wave Energy Converters

Introduction

4.1 The basic requirement of a wave energy converter is that it should extract energy from the sea and convert it into an alternative form – usually fluid pressure or mechanical motion. This is done at the 'primary interface' where the converter reacts to the motions of the sea to produce useful energy. The conversion of this energy to electricity is a particularly difficult problem because the low frequency of the waves (around 0.1 Hz) must be 'geared up' to the mains frequency of 50 Hz. This problem is considered in Chapter 8.

Simple Device Concepts

4.2 There are several ways that converters can interact with the sea. Some simple concepts are shown in Fig. 4.1 and include:

- tethered buoyant structures at or near the surface of the sea which would, if unrestrained, perform circular orbits
- hinged structures which follow the contours of waves
- structures in which wave pressure pumps air enclosed by a flexible element
- structures with an enclosed column of water acting as a piston to pump air. (These structures can float or be fixed at, or below, the sea surface).

Frame of Reference

4.3 In interfacing with the waves, any converter must be constrained so that wave forces are resisted; this gives rise to the concept of a 'frame of reference' against which the converter reacts.

4.4 A frame of reference can be achieved in a number of ways, for example by:

- using the sea-bed for fixing or mooring
- mounting several converters on a common frame or spine so that relative motion is obtained between them
- using the inertial force due to the gyroscopic action of a flywheel
- relying on the mass and inertia of the device.

Coupling to a suitable frame of reference is a major problem in the design of wave energy converters.

Device Orientation

4.5 When several converters are mounted on a spine, the obvious way to orientate the spine is normal to the principal wave direction so that the maximum available energy in the sea is intercepted. This orientation is defined as the 'terminator' mode because energy is absorbed by terminating the waves. In this mode the device intercepts energy in a wavefront which has a length equal to the length of the converter (or group of converters) and it is said to have a 'capture ratio' of unity.

Fig. 4.1 Simple device concepts

(A) Tethered Buoyant Structures

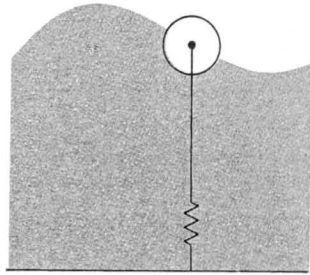

- Horizontal motion of the body is unrestrained
- Its rise and fall is restrained by the mooring
- Energy extracted from pump in mooring

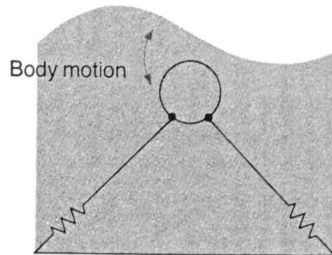

- Body describes circular orbits
- Energy extracted from pump in mooring

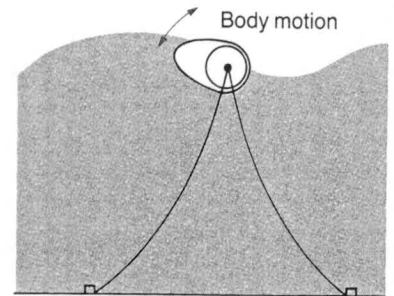

- Outer section nods up and down
- Energy extracted from relative motion

(B) Hinged Wave Contour Structure

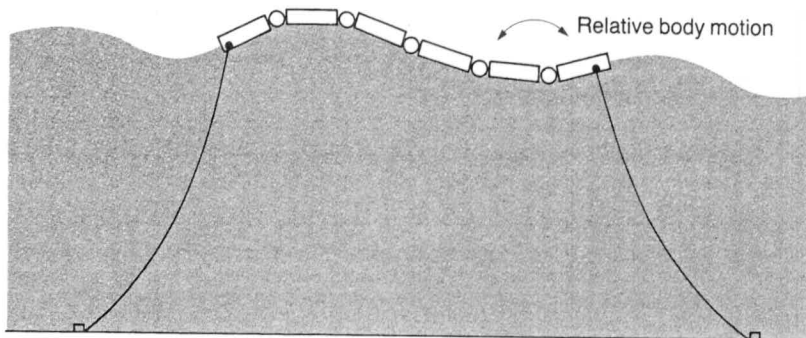

- Hinged structure follows wave contours
- Energy extracted from the relative motion of adjacent sections.

(C) Structure With Flexible Element

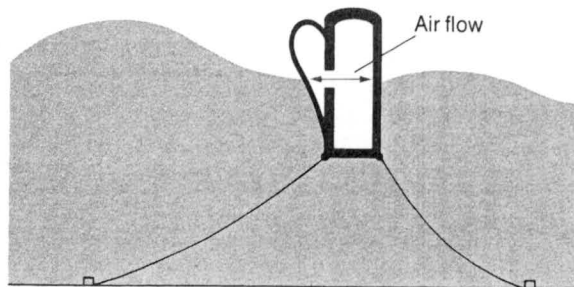

- Flexible element is displaced under wave pressure
- Energy extracted from air flow

(D) Structure With Enclosed Water Column

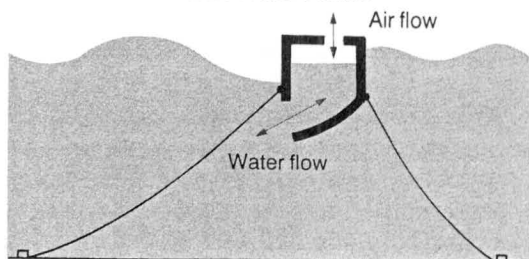

- Column of water rises and falls.
- Energy extracted from air flow

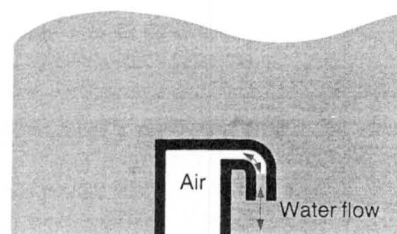

- Wave pressure causes oscillatory motion in trapped water column
- Energy extracted from air flow

4.6 When a converter in the terminator mode is constrained in heavy seas, considerable wave forces are exerted on its structure. One way to reduce these forces would be to re-orientate the converter parallel to the principal wave direction so that a much smaller length of wave front would then be incident upon it and it would ride the waves rather like a ship does. In this orientation, energy capture could be expected to be much reduced but, in practice, as energy is extracted from the sea at the head of the spine, the wave front diffracts into the sides of the spine and energy is progressively absorbed there. This orientation is known as the 'attenuator' mode (see Fig. 4.2).

4.7 Converters can be mounted on both sides of a spine in the attenuator mode, giving a theoretical doubling in the energy output.

4.8 The disadvantage of the attenuator compared with the terminator is that idealised analysis shows the capture ratio of an attenuator of a given length to be only 62% of that of a terminator of the same length.

4.9 Interaction between converters mounted on a common frame of reference has led to the conclusion that the optimum orientation may be between the two extremes depending on the characteristics of the converter.

Size of Devices

4.10 The dimensions of a converter depend on the sea-state in which it is planned to operate. The designer usually attempts to get the system resonant with the wave components carrying the most power by arranging that the natural oscillating periods of the converter match the periods of the most powerful waves; this is a complex problem.

4.11 A simple way of calculating the approximate dimensions of a converter is to consider the volume of moving water in a typical wave and realise that for maximum energy absorption an equivalent volume must be swept within or by the converter. For a typical sea off Western Scotland, where the power-carrying components are waves with heights around 3m and wavelengths around 100m, the calculation of the swept volume gives linear dimensions for a converter of about 10m. This large size for a single converter reflects the diffuseness of the power in the sea; large structures are necessary to intercept appreciable amounts of power.

4.12 In the case of devices comprising several converters mounted on a frame of reference in the form of a rigid floating spine, the minimum length of the spine is determined by the need to ensure that the spine would always straddle at least two wave crests, thus reducing pitching motion. The maximum length is determined by the strength of the spine structure and, in general, is limited to about twice the wavelength. A spine length would therefore typically be 200m and this would allow approximately 10 converters to be mounted on it to form a single device.

Arrays

4.13 Many hundreds of devices would need to be deployed if appreciable quantities of electricity were to be generated. The problems of collecting and transmitting power mean the devices should be geographically close together.

Fig. 4.2 Device configuration

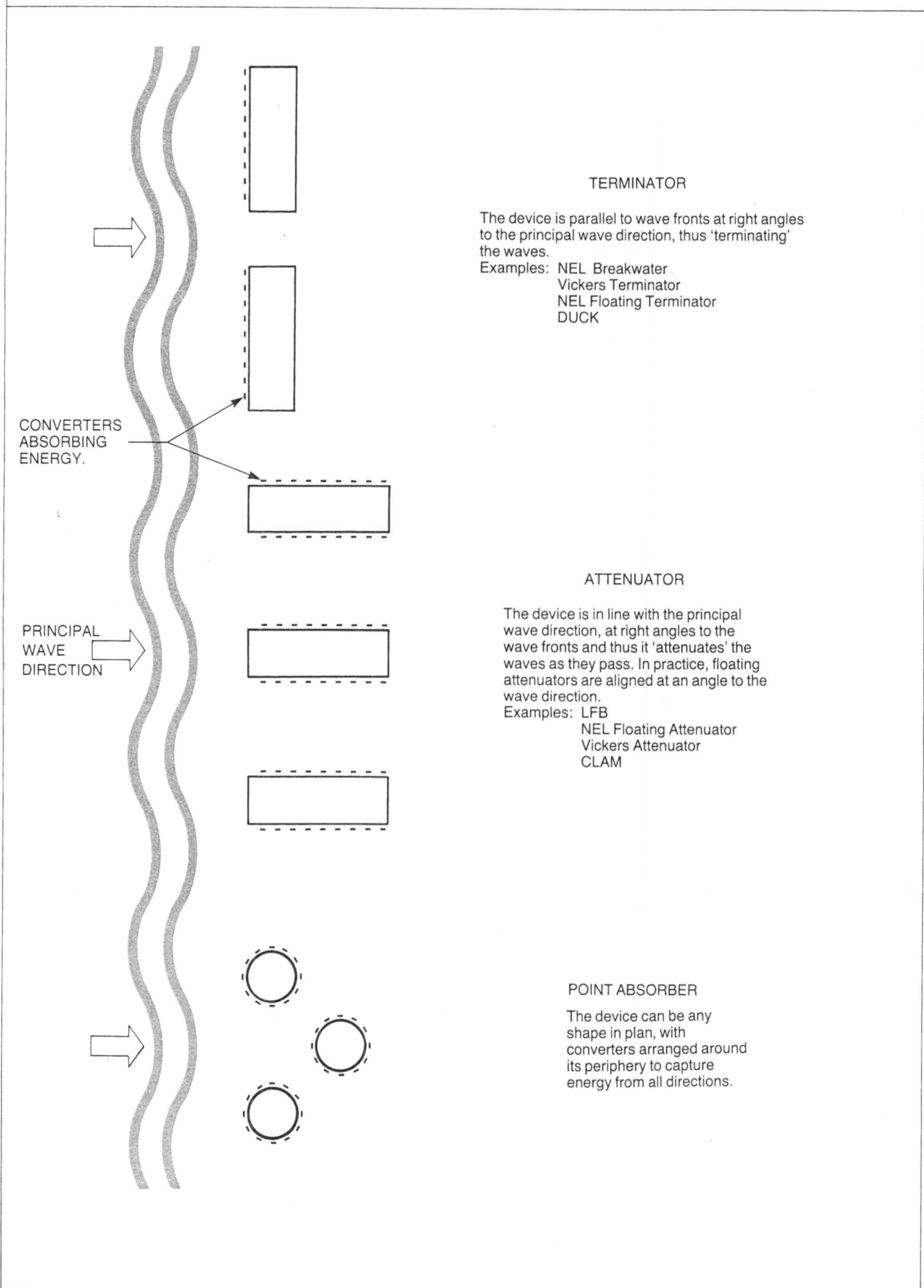

TERMINATOR

The device is parallel to wave fronts at right angles to the principal wave direction, thus 'terminating' the waves.

Examples: NEL Breakwater
Vickers Terminator
NEL Floating Terminator
DUCK

CONVERTERS
ABSORBING
ENERGY.

ATTENUATOR

The device is in line with the principal wave direction, at right angles to the wave fronts and thus it 'attenuates' the waves as they pass. In practice, floating attenuators are aligned at an angle to the wave direction.

Examples: LFB
NEL Floating Attenuator
Vickers Attenuator
CLAM

PRINCIPAL
WAVE
DIRECTION

POINT ABSORBER

The device can be any shape in plan, with converters arranged around its periphery to capture energy from all directions.

4.14 Several problems would arise, however, if the devices were arranged in rows or too closely together:

- shadowing by devices in the front rows would cut off most of the incident energy from those in the rear unless there were a considerable fetch between rows
- reflection of waves by a device could affect the power available at adjacent devices, often adversely
- the response of each device would be dependent on the incident direction of the waves and even if large gaps were left in each row to allow sufficient power to reach devices in the rear, changes in the sea's directionality could result in loss of efficiency.

4.15 Because each of these problems would cause loss of energy, the most efficient array of devices in a wave power station would be a single row.

Size of Arrays

4.16 A wave power station of 2 GW installed capacity could be expected to deliver a mean annual power of approximately 400 MW and it is possible to calculate the size of the array required for this.

4.17 If a single converter approximately 10m wide was deployed off the West Coast of Scotland, it would intercept just over 400 kW mean annual power. Conversion inefficiencies and losses would reduce the delivered electrical power to about 100 kW. Therefore to achieve an average total output of 400 MW, 4000 converters would be required.

4.18 Assuming a device to comprise 10 converters on a spine of 200m length, then 400 devices would be required. If these devices were moored 50m apart in the terminator mode, the wave power station would be at least 100km long. Allowance for shipping lanes and unsuitable anchorage sites could make this much longer.

Point Absorbers

4.19 The point absorber is a special category of device which is neither a terminator nor an attenuator. Its linear dimensions are small compared with those of the waves and although it is capable of capturing energy equally from all directions, its size prevents it from capturing the energy in large waves. Research at Queen's University, Belfast originally began with point absorbers in the form of buoys but the Belfast Device in the final assessment is not a point absorber because its oscillating water columns only face forward.

Fig. 5.1 Device designs

The matrix below indicates the aspects of design of the various devices which were examined. Of necessity there is some duplication but the wide ranging nature of the investigation is clear

DESIGN ASPECT		DEVICE	Bristol Cylinder	SEA Clam	Edinburgh Duck	Lancaster Flexible Bag	NEL OWC (floating terminator)	NEL OWC (bottom standing terminator)	Vickers OWC (bottom standing terminator)	Vickers OWC (bottom standing attenuator)	Belfast OWC
Frame of Reference	a Spine			•	•	•					
	b Structure Inertia						•				
	c Sea bed		•					•	•	•	•
	d Gyro				•						
Interface	a None at all						•	•	•	•	•
	b Flexible Material			•		•					
	c Rigid		•		•						
Power Take off	a Pneumatic			•		•	•	•	•	•	•
	b Hydraulic		•		•						
Mooring and Anchoring	a Conventional Moorings			•	•	•	•				
	b Controlled Damping		•			•					
	c Tension Leg		•								
	d Rock Anchor		•				•	•	•	•	•
	e Conventional Anchor			•	•	•					
Transmission	a Electrical – fixed		•					•	•	•	•
	b Electrical – flexible			•	•	•	•				
	c Hydraulic – fixed		•								
	d Hydraulic – flexible		•								
Hydrodynamic Configurations	a Point Absorber										φ
	b Attenuator					•				•	
	c Terminator		•	•	•		•	•	•		
	d Surface Piercing			•	•	•	•	•			•
	e Submerged		•						•	•	

φ In its present form this device is not a true point absorber

5

Device Designs

5.1 Since the start of the UK wave energy programme in 1974, more than three hundred device ideas have been evaluated. Of these, twelve have received substantial financial support, but of these twelve only nine are included in this report. It was considered unlikely that further detailed study would reduce the costs of three of the designs which were not funded after March 1980 and are not reviewed in this report. The three are the RAFT, the RECTIFIER and the TRIPLATE. The following pages contain details of the nine devices which have been reported on in 1983.

5.2 The research programme had to tackle a very broad range of topics and some twenty-three design aspects in six main problem areas were studied, if appropriate, for each device concept. Fig. 5.1 illustrates the wide-ranging scope of the programme.

5.3 Model devices at scales ranging from one-hundredth to one-sixtieth were tested in the wide wave tanks at Edinburgh University and Wavepower Ltd., Cadnam, Southampton. These tanks were capable of modelling real mixed seas on the basis of selected data extracted from measurements made by the Waverider buoys off the NW coast of Scotland. Some testing was carried out at one-tenth scale on the RAFT in the Solent, and on the CLAM and an early version of the DUCK in Loch Ness. In this way a limited understanding of the scaling laws involved has been developed.

5.4 Evaluation of the various concepts was based upon reference designs produced by the Development Teams using the results of model tests and theoretical investigations. Each device team was given freedom to optimise its device as it wished, choosing appropriate technology.

5.5 The wave energy Consultants, Rendel, Palmer & Tritton, were given the task of assessing the engineering viability and power outputs of the reference designs and of estimating for each one the costs of generating electricity for use in the Grid. To ensure that reference designs were assessed to a common basis they were required to be based on a wave power station located off South Uist, capable of delivering at least 2GW for 5% of the year. Such a station would deliver a mean annual output of around 400 MW to shore. The data quoted in the following pages are intended to give an impression of the size of devices and of a 2GW station. Cost data are presented in Chapter 11.

5.6 Inset in each of the illustrations of the reference designs in the following pages is a representation in black of the device against the outline of Tower Bridge, London in order to give some idea of the size of devices.

Fig. 5.2 Bristol Cylinder

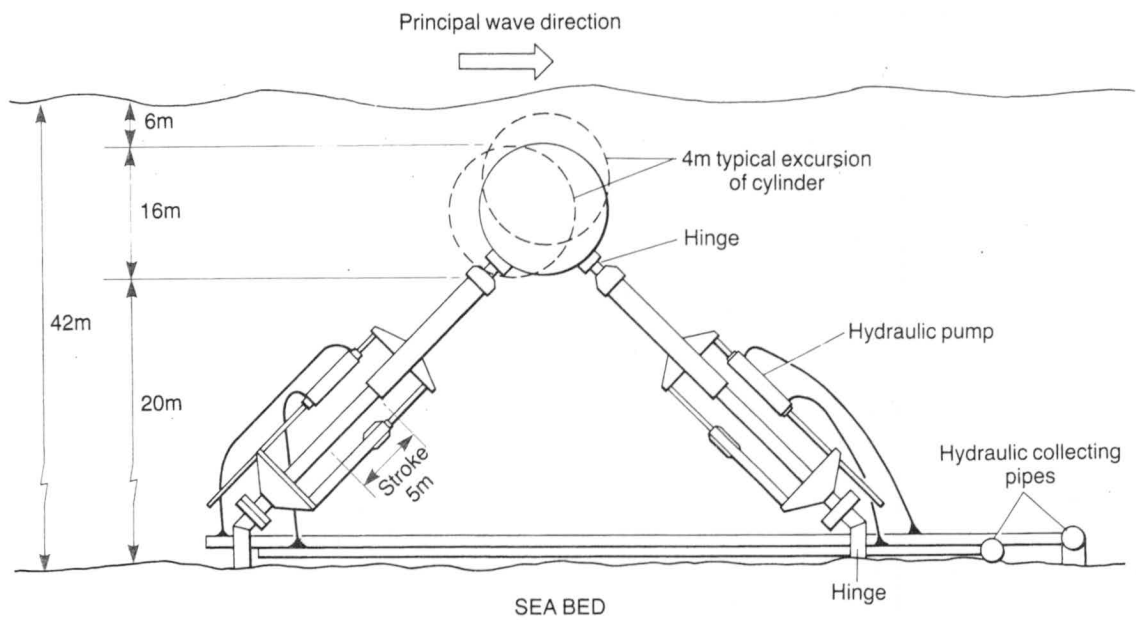

DEVICE SILHOUETTE WITH TOWER BRIDGE FOR COMPARISON

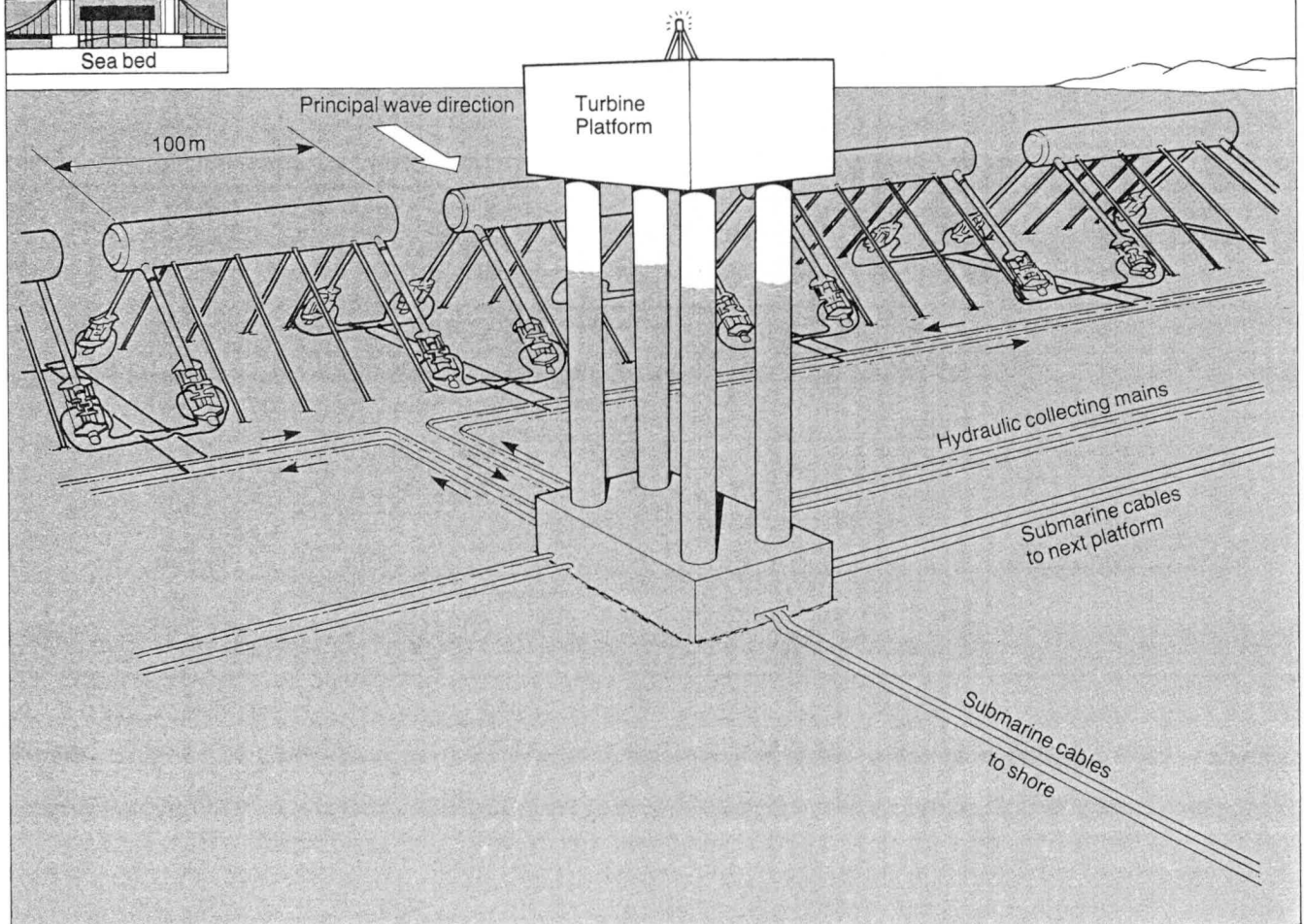

BRISTOL CYLINDER

5.7 The Cylinder is based upon ideas proposed by Dr. David Evans of Bristol University. If a submerged cylinder is moored just below the sea surface with its axis held parallel to the wave fronts, the axis will be caused to move on a circular path when a wave passes over it. If the movement of the mooring rods is suitably damped, the energy in small amplitude waves can be extracted. Theoretically, the device could extract 100% of the energy from normally incident waves at the design frequency.

5.8 A device based upon these ideas was investigated by a team combining theoretical input from members of Bristol University and engineering from Sir Robert McAlpine & Sons Ltd. The structure would be a simple buoyant cylinder with a power take-off forming part of the mooring and the sea bed acting as its frame of reference. The present design is based upon a high pressure sea-water power take-off, with the output from a group of wave energy converters being transmitted by subsea pipelines to Pelton wheel turbo-generators mounted on platforms above sea level. A 2GW station would require 3 turbo-generators on each of six platforms. Although operating subsurface reduces wave forces on the device it introduces maintenance difficulties.

5.9 The Bristol Cylinder has been tested at approximately one-hundredth scale in the Cadnam wave tank with a variety of mooring arrangements. The power take-off systems were simulated using small electric motors as tachometers on each rode.

5.10 Reference Design Parameters

Dimensions:	Cylinder diameter 16m length 100m weight 17,000 tonnes
Rating:	7.6 MW
Water depth:	42m
Installation:	8 mooring rodes (plus 4 hydraulic power take-offs)

2GW station

Number of devices:	384
Approximate overall length:	50 km
Distance offshore:	12-20 km
Load factor:	14%
Mean annual power delivered to shore:	410 MW

Fig. 5.3 SEA Clam

The moving wave collapses the bag. This is then reflat as the wave falls. Air is pumped through the turbine on both strokes.

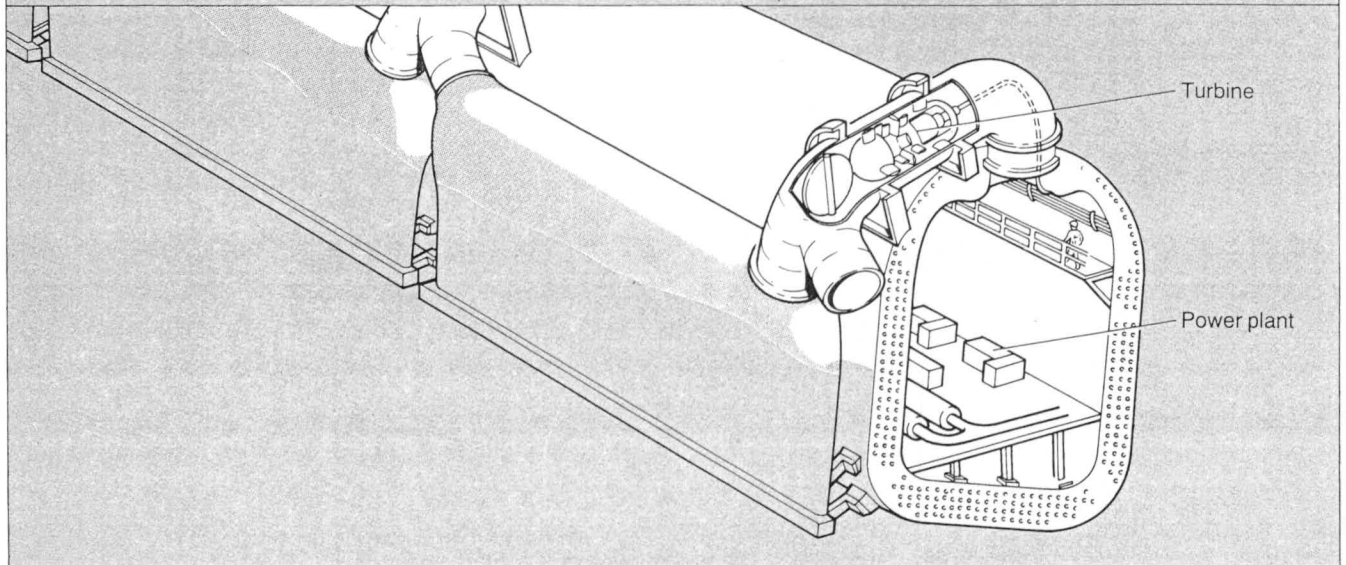
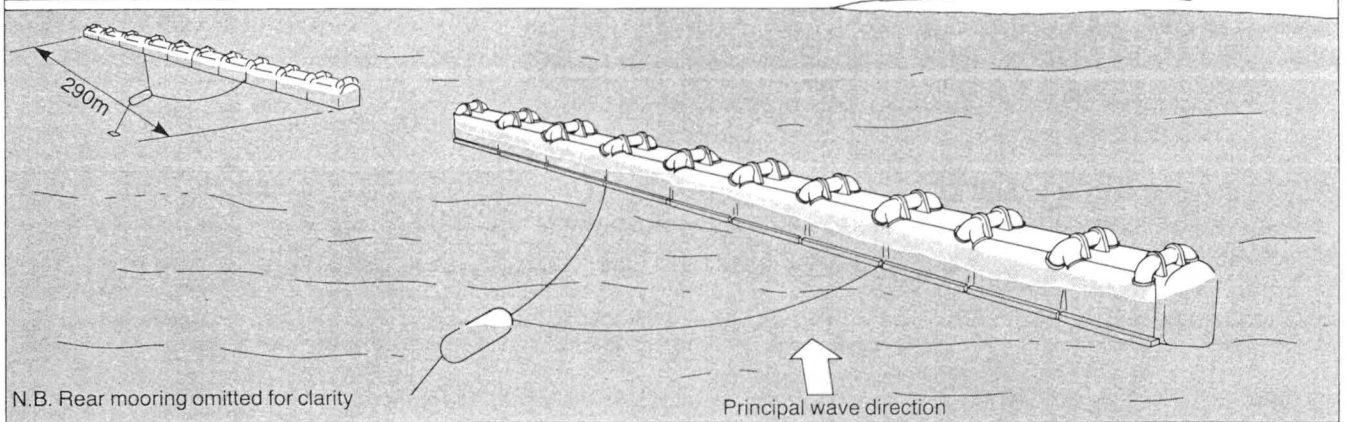
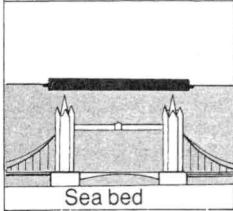
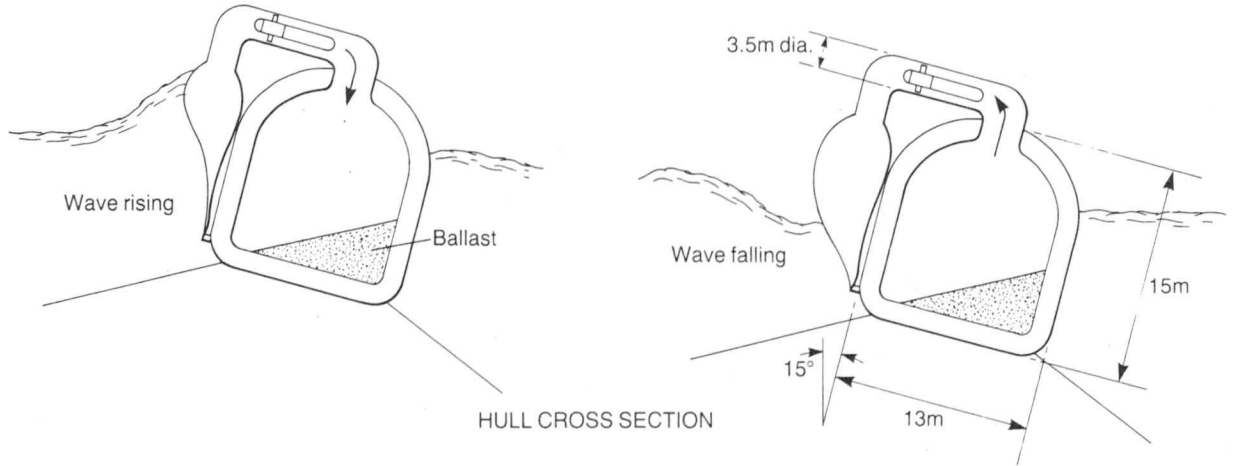

CLAM

5.11 The Clam device, developed by Sea Energy Associates, is based upon the ideas of Dr. Norman Bellamy of Coventry (Lanchester) Polytechnic. The device would consist of a floating concrete spine with flexible bags attached to one side, moored at approximately 55° to the incident wave direction. The action of approaching waves would force the air from the bags through turbines in a duct into the hollow spine in a closed system. Not all bags would be deflated at the same time and the air in the spine would reflate bags when a wave crest had passed. The turbines would be of the Wells self-rectifying type which rotates in the same direction irrespective of the direction of the air flow.

5.12 The Clam in its present form has been tested at one-sixtieth scale in the Cadnam wave tank and in Draycote reservoir near Coventry and at one-tenth scale in Loch Ness. The power take-off systems have been simulated using orifice plates of special design.

5.13 Reference Design Parameters

Dimensions:	Spine length	290m
	beam	13m
	depth	15m
	weight	45,000 tonnes
	Bag dimensions	25m x 13m
Rating:	10 MW	
Water depth:	80-100m	
Installation:	Compliant moorings	
2GW station		
Number of devices:	250	
Approximate overall length:	100 km	
Distance offshore:	26 km	
Load factor:	17%	
Mean annual power delivered to shore:	430 MW	

Fig. 5.4 Edinburgh Duck

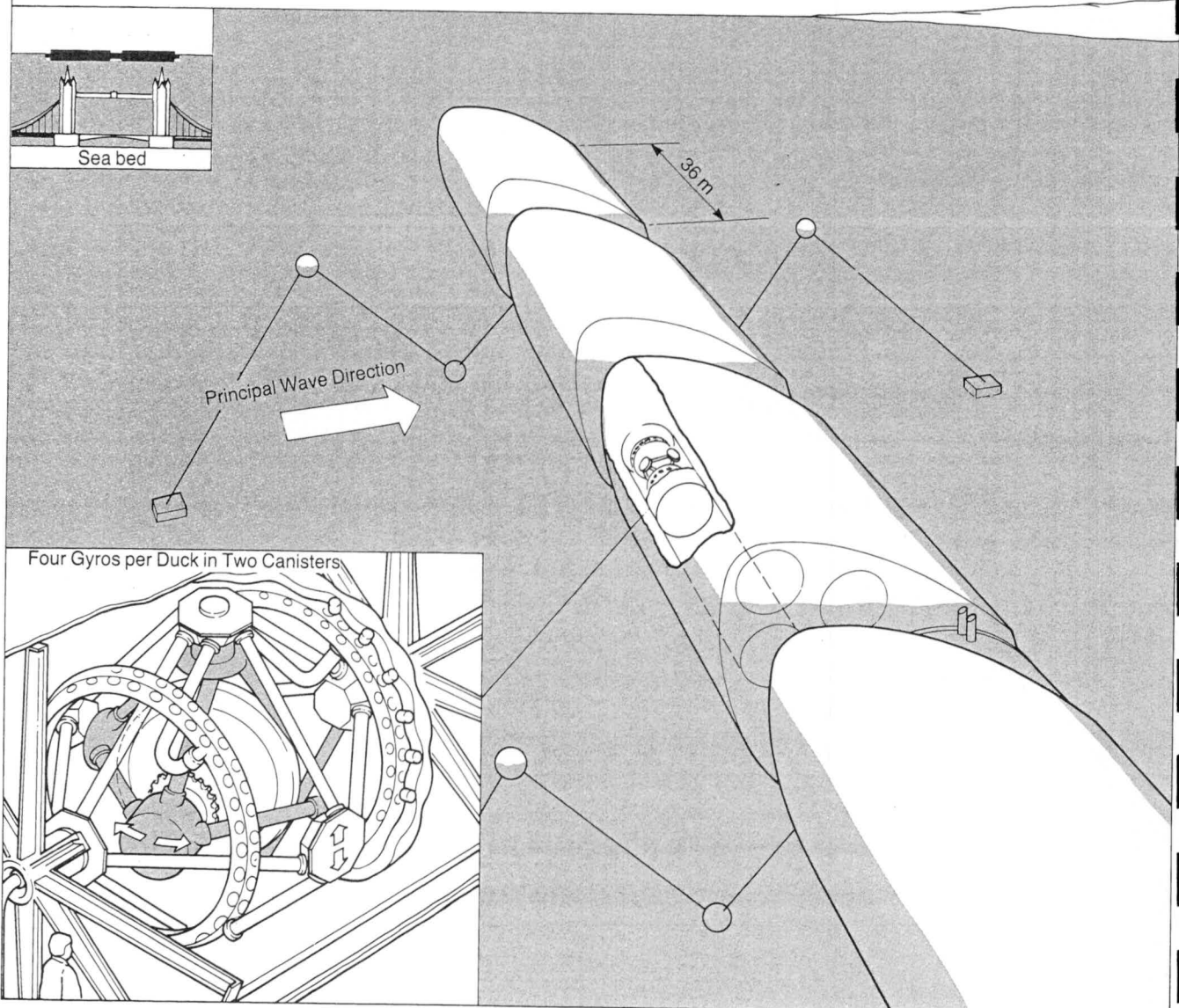
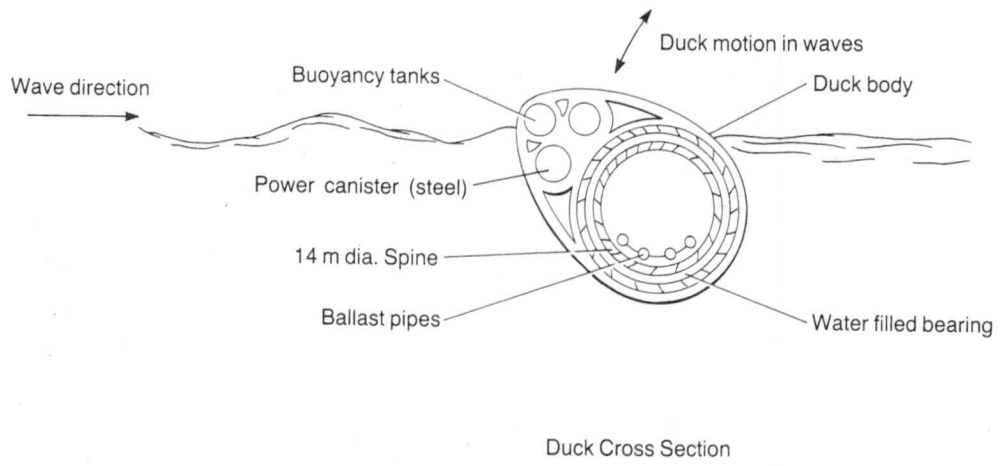

DUCK

5.14 The Duck is based upon the ideas proposed by Mr. Stephen Salter, Edinburgh University; engineering studies have been undertaken by John Laing Ltd. Ducks would be mounted on a long cylindrical spine, about which they could rotate, moored in the terminator mode.

5.15 The original Duck concept was based on the extraction of power by mechanical or hydraulic means from the relative motion between the spine and Duck. The present design uses the precession of gyroscopes mounted in the nose of the oscillating Duck to drive a high pressure hydraulic system.

5.16 The latest design for the device has Ducks mounted in pairs on a section of articulated spine. The spine joint consists of hydraulic rams which are controlled so that the flexing of the spine is regulated within certain limits which allow optimum power extraction.

5.17 The Duck has been extensively tested at one-hundredth scale in the wide wave tank at Edinburgh University and an early version at one-tenth scale in Loch Ness. The power take-off system has been examined using an electronic analogue model for the one-hundredth scale tests.

5.18 Reference Design Parameters

Dimensions:	Duck body length	38m
	diameter	14m
	width	22m
	weight	10,600 tonnes
	Spine diameter	14m
	length (2 ducks)	91.5m
Rating:	2.25 MW	
Water depth:	80-100 m	
Installation:	Compliant moorings	
2GW station		
Number of devices:	896	
Approximate overall length:	40 km	
Distance offshore:	35 km	

The potential power capture capabilities of the Duck are believed to be the highest of the devices assessed. The Consultants were, however, not able to estimate its load factor or mean annual output because of difficulties in resolving the question of the availability of the design presented for assessment. The 'special case' of Duck energy costs is dealt with in Chapter 11.

Fig. 5.5 Lancaster Flexible Bag

HP Valves open when wave is rising
LP Valves open when wave is falling

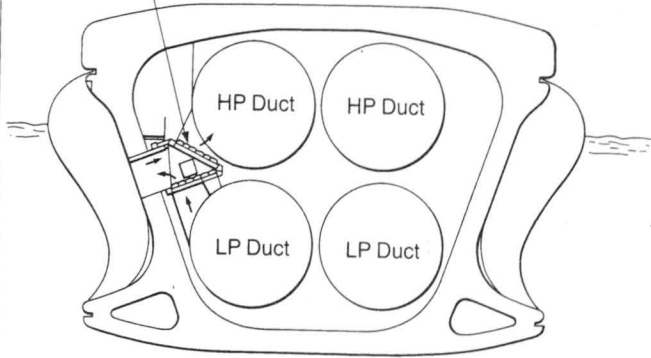

Wave rising

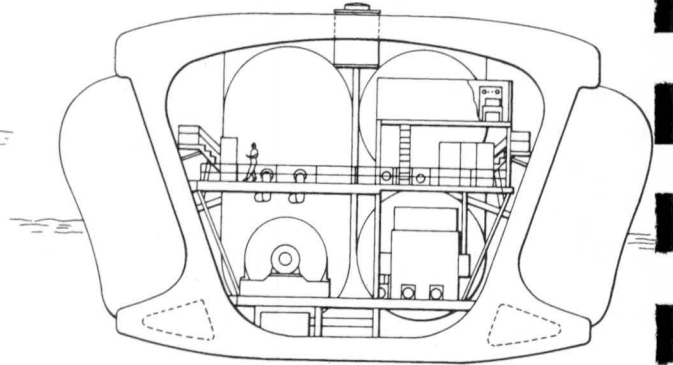

Wave falling

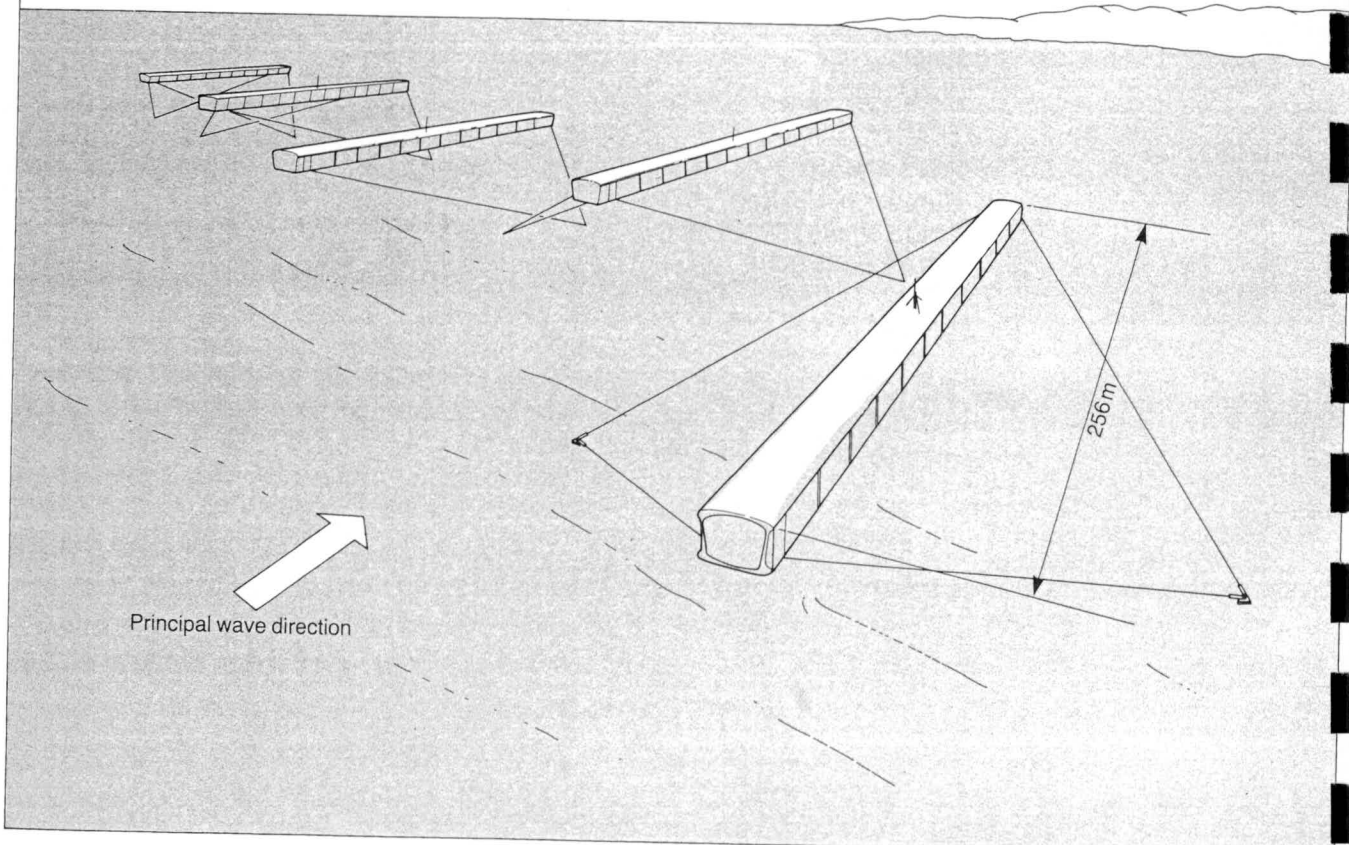
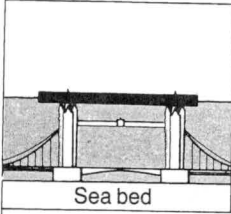

LANCASTER FLEXIBLE BAG

5.19 The Lancaster Flexible Bag (LFB) device is based upon ideas proposed by Prof. Michael French, Lancaster University, and further developed by Wavepower Ltd., Cadnam, near Southampton.

5.20 Air-filled flexible bags divided into cells would be mounted on both sides of a long narrow-beamed hull. The hull would contain high and low pressure air ducts, running fore and aft, connected through air turbines. The device would be moored bow-on to the incident wave direction, in the attenuator mode. Passing waves would compress the flexible bags, displacing air through the high pressure duct to the air turbine. In wave troughs the bags would be refilled by air from the low pressure ducts. Air within the closed system would be held at a slightly positive pressure to ensure proper bag function. Two turbines would be installed, each fed by air from one side of the device.

5.21 The Flexible Bag has been tested at one-hundredth scale in the Cadnam wave tank with various mooring systems. The bag materials were carefully constructed to give close-to-scale stiffness. Turbine damping and air compressibility (such as would occur at full scale) were simulated externally by the use of compression chambers.

5.22 Reference Design Parameters

Dimensions:	length	256m
	beam	22m
	depth	15m
	weight	59,000 tonnes
	bags	20m x 10m
Rating:	8 MW	
Water depth:	60-80 m	
Installation:	Compliant tube moorings	
2GW station		
Number of devices:	380	
Approximate overall length:	130 km	
Distance offshore:	22 km	
Load factor:	9%	
Mean annual power delivered to shore:	282 MW	

OSCILLATING WATER COLUMN (OWC)

5.23 The OWC devices are based upon the principle of a box mounted vertically in the water, open at the bottom and with an orifice in the top. The incident waves cause the water level in the box to rise and fall, thereby forcing air contained in the box through the orifice to drive a turbine. Such devices can be floating or bottom mounted, on the surface or submerged.

5.24 Each of these geometrical arrangements presents different engineering and operational problems. In order to establish which form of OWC was likely to be the most cost effective, six variations were investigated:

- floating attenuator (NEL)
- floating terminator (NEL)
- bottom-standing terminator (Breakwater) (NEL)
- submerged terminator (Vickers)
- submerged attenuator (Vickers)
- Belfast device (Queen's University, Belfast).

A 125 kW version of an OWC was built and tested in the IEA Kaimeai experiment (Chapter 15).

5.25 Vickers Ltd. have consistently adopted the view that the reduction of wave loading achieved by submerging the device would be a large enough advantage to overcome the disadvantages of piling and access for maintenance. They originally favoured a point absorber in the form of a cylindrical duct but this developed into a linear version with both attenuator and terminator configurations.

5.26 Of the three variations of the OWC studied by NEL, the floating attenuator was abandoned before this last costing exercise as it was clear that it could never match the economic performance of the other two, largely because of its low capture efficiency and consequently large number of devices needed to form a station.

5.27 NEL have now concentrated their efforts on the Breakwater, undertaking only a limited costing of the floating terminator. The Breakwater is being considered for deployment as a 4 MW module off the island of Lewis with funding for a feasibility study provided by the Department of Trade and Industry, Roxburgh & Partners and a number of industrial interests including the North of Scotland Hydro-Electric Board (NSHEB).

Fig. 5.6 NEL OWC (floating terminator)

1. Air direction when water column is rising
2. Air direction when water column is falling

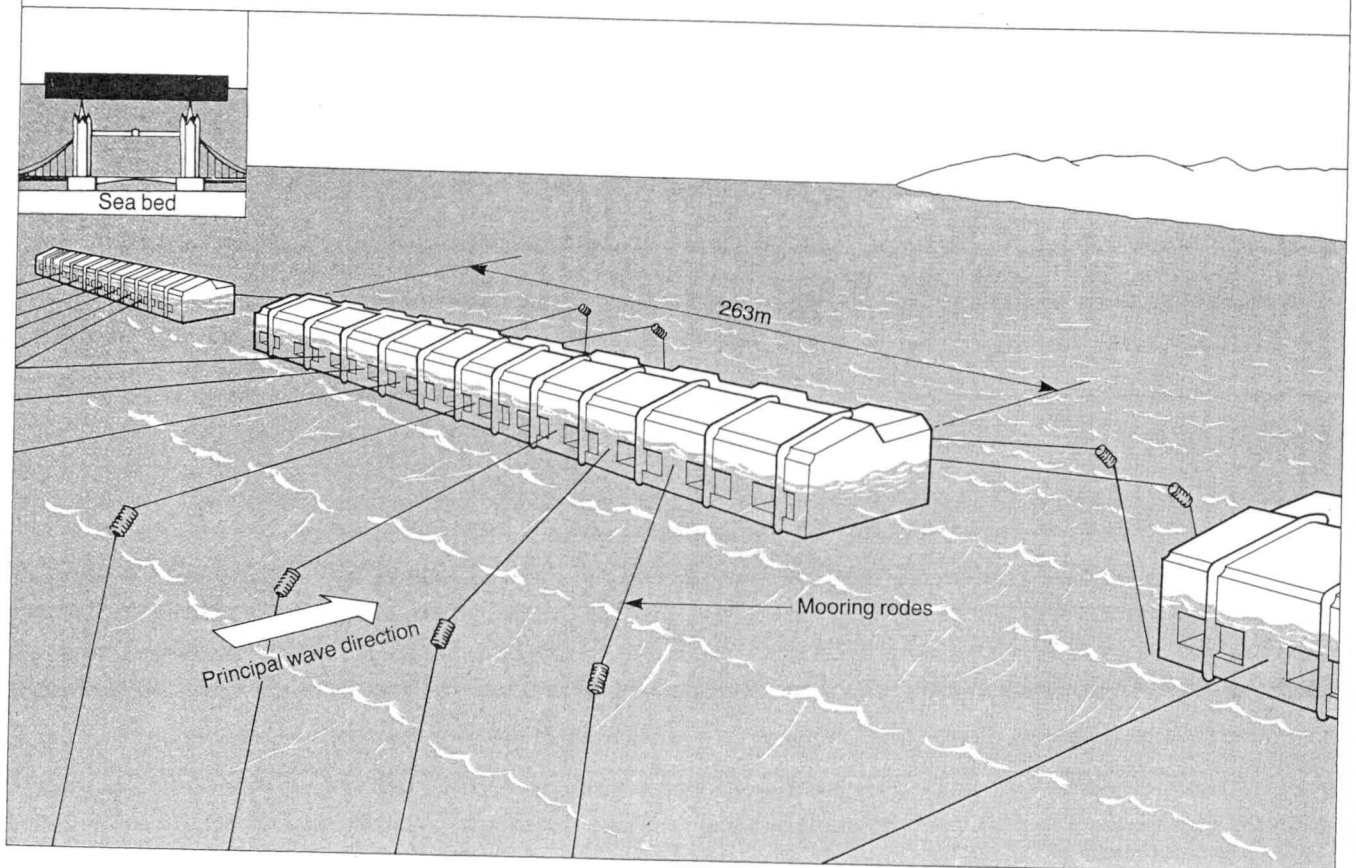
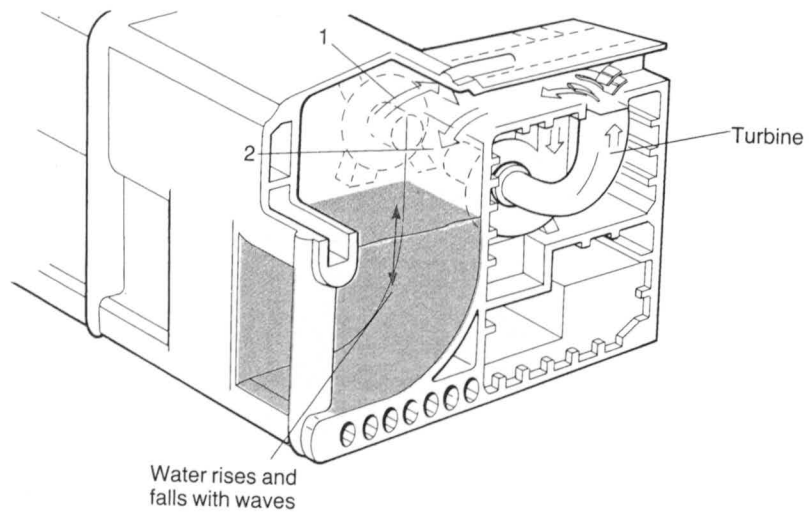

OSCILLATING WATER COLUMN NEL Floating Terminator

5.28 The National Engineering Laboratory team has considered several variations of the OWC concept of which the Floating Terminator was the first. The rectified air supply for the turbines would be open to atmosphere and there is no recirculation. The costs associated with the massive floating structure combined with difficulties arising from the operation and maintenance of such a large moored device led the team to consider alternative designs. Only a limited costing exercise was carried out on this device.

5.29 Reference Design Parameters

Dimensions:	length	263m
	width	28m
	depth	19m
	weight	120,000 tonnes
Rating:	14.4 MW	
Water depth:	100 m	
Installation:	Conventional moorings	
2GW station		
Number of devices:	220	
Approximate overall length:	80 km	
Distance offshore:	30 km	
Load factor:	15%	
Mean annual power delivered to shore:	400 MW	

Fig. 5.7 NEL OWC (bottom standing terminator)

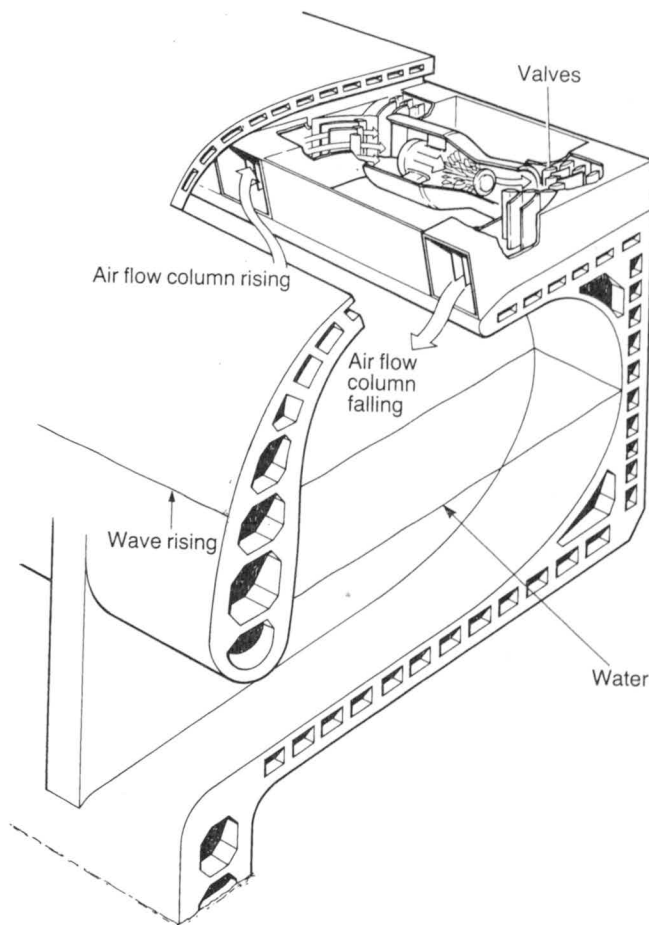

AIR FLOW RECTIFICATION SYSTEM

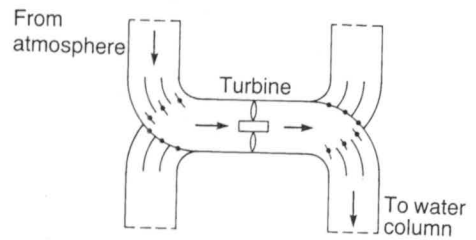

a) Suction stroke

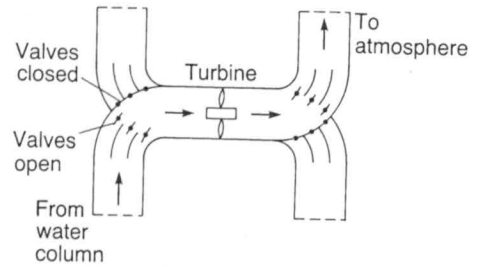

b) Pressure stroke

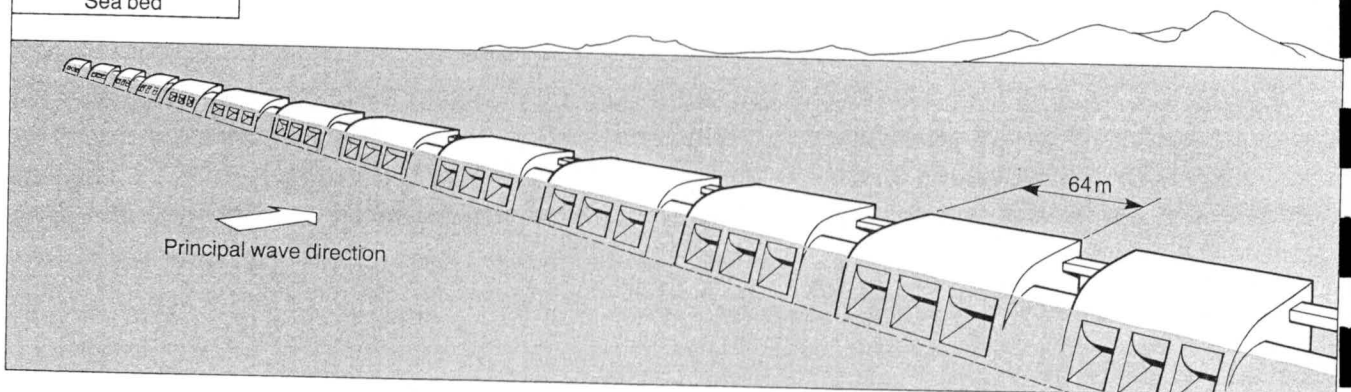
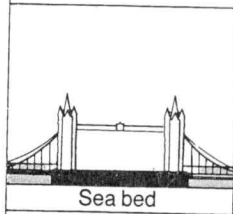

OSCILLATING WATER COLUMN NEL Breakwater (Bottom Standing Terminator)

5.30 The National Engineering Laboratory team's research into the OWC has culminated in the Breakwater design. In the development of this design they have been supported by consulting engineers Roxburgh & Partners. The Breakwater would be a simple concrete structure mounted on the sea-bed, close to the shore. Although the gross energy in the waves inshore is much less than in deep water, the choice of a bottom mounted device leads to a higher conversion efficiency and a cheaper structure. In this design the air supply to the turbines would be open to atmosphere with no recirculation. As in other NEL devices, each column would drive a separate turbine with a rectified air flow.

5.31 The present design concept has not been tested in either the Edinburgh or the Cadnam wave tank but experimental data from tests in the wave tank at NEL are available. Extensive computer simulations of the device hydrodynamics and power take-off systems were completed during 1982.

5.32 Reference Design Parameters

Dimensions:	length	64m
	width	32m
	height	34m
	weight	22,500 tonnes
Rating:	4.7 MW	
Water depth:	21m	
Installation:	Bottom standing	
2GW station		
Number of devices:	640	
Approximate overall length:	40 km	
Distance offshore:	6 km	
Load factor:	12%	
Mean annual power delivered to shore:	370 MW	

Fig. 5.8 Vickers OWC (terminator)

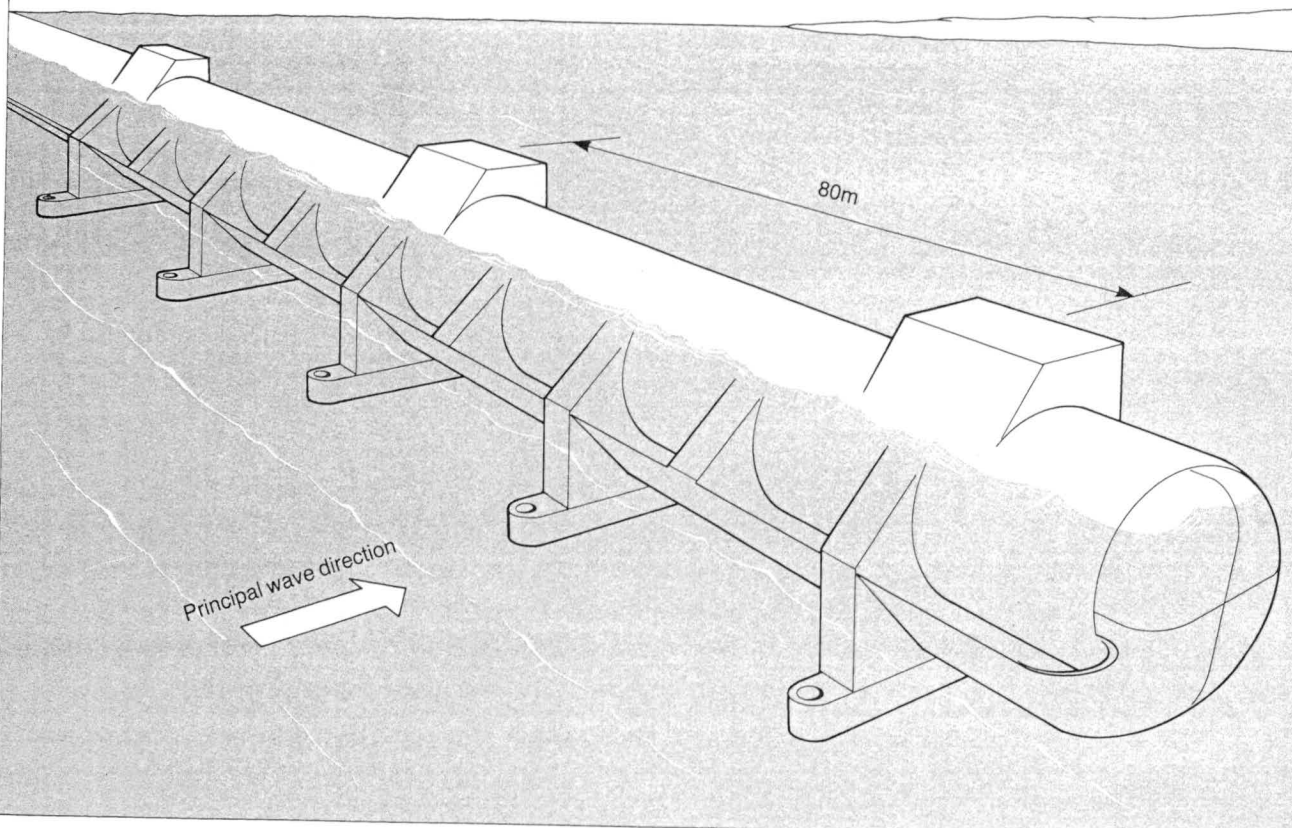
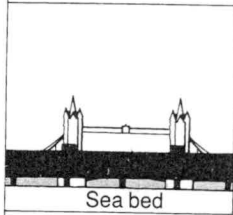
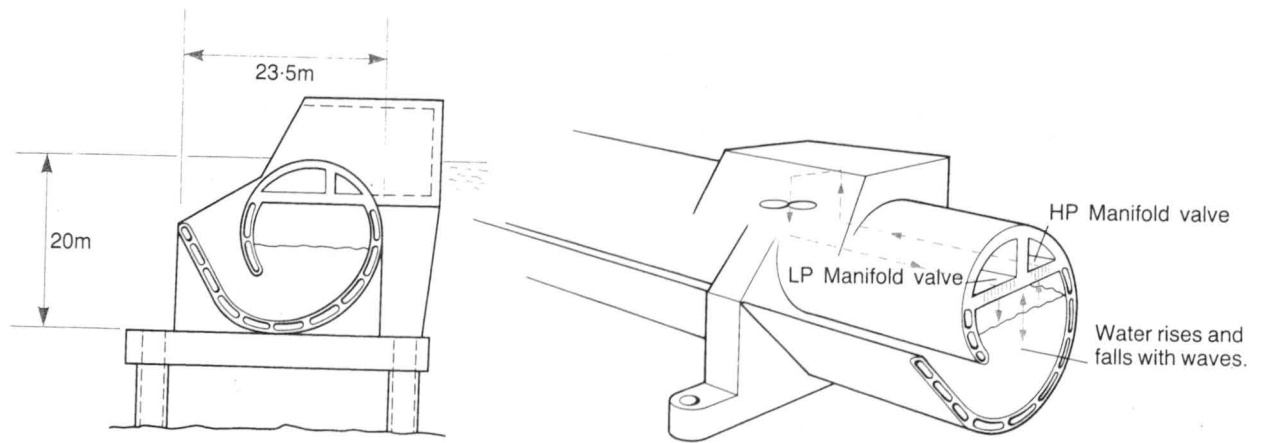

OSCILLATING WATER COLUMN Vickers Terminator

5.33 The development team at Vickers Engineering concentrated upon designs for the OWC which are totally submerged. Air supply to the turbines would therefore be totally enclosed and circulate from high pressure to low pressure ducts using rectifying valves to ensure correct directional air flow. The terminator design shown would be bottom mounted on 2m diameter piles. In order to obtain optimum performance, the structure carrying the manifolds would just break the water surface.

5.34 Complete models of this design have been tested in the Cadnam tank at one-hundredth scale and a 6-cell model fitted with a large air reservoir to simulate the out-of-phase effects of other cells was tested at one-sixty-seventh scale. The power take-off systems were simulated using orifice plates. Mathematical modelling techniques were used to relate these test results to device design.

5.35 Reference Design Parameters

Dimensions:	length	80m
	width	23.5m
	height	27m
	weight	23,000 tonnes
Rating:	3 MW	
Water depth:	25m	
Installation:	Piled to seabed	

2GW station

Number of devices:	700
Approximate overall length:	60 km
Distance offshore:	7.5 km
Load factor:	20%
Mean annual power delivered to shore:	430 MW

Fig. 5.9 Vickers OWC (attenuator)

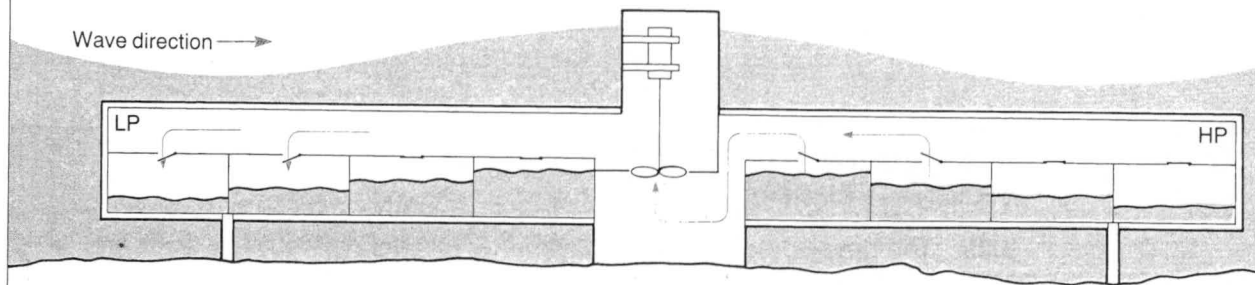

Diagrammatic representation of operation cycle

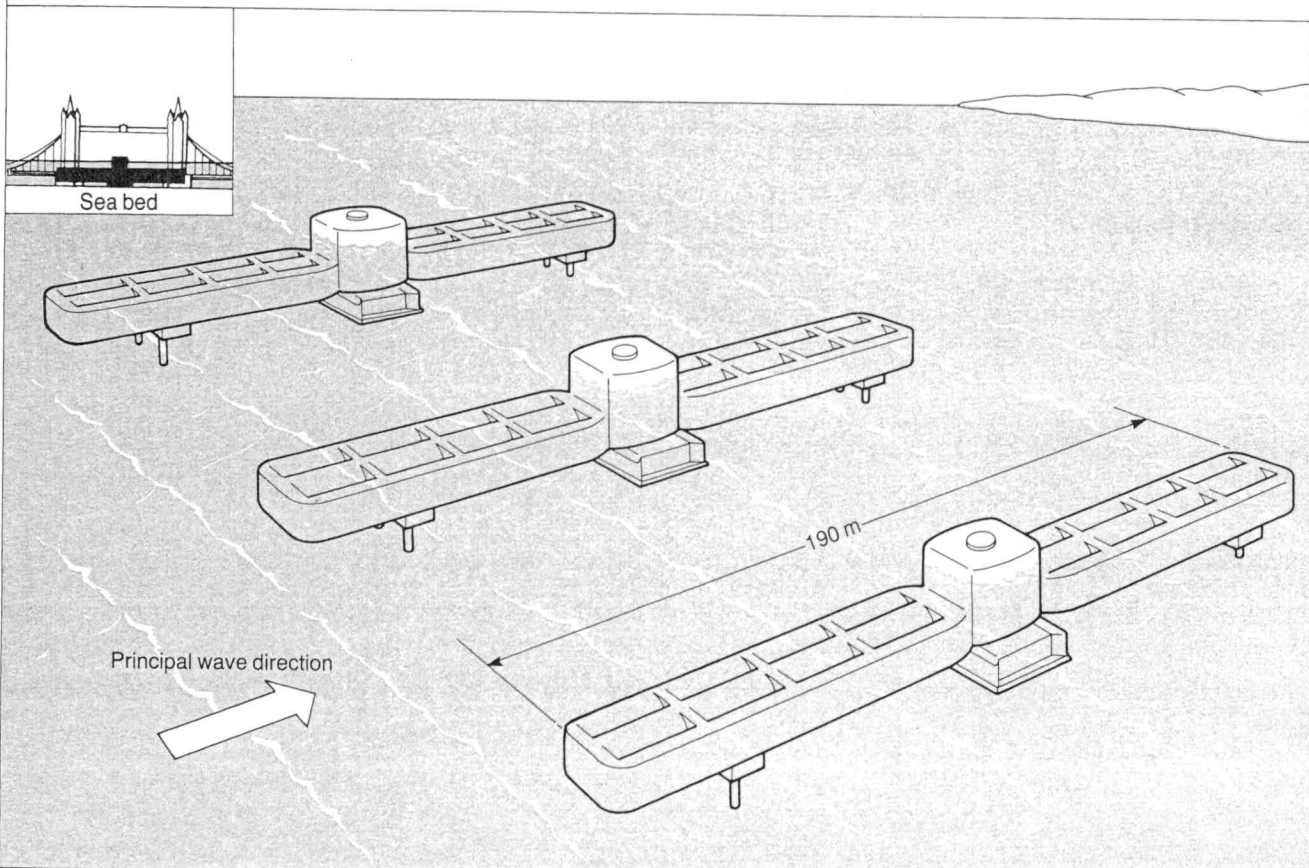
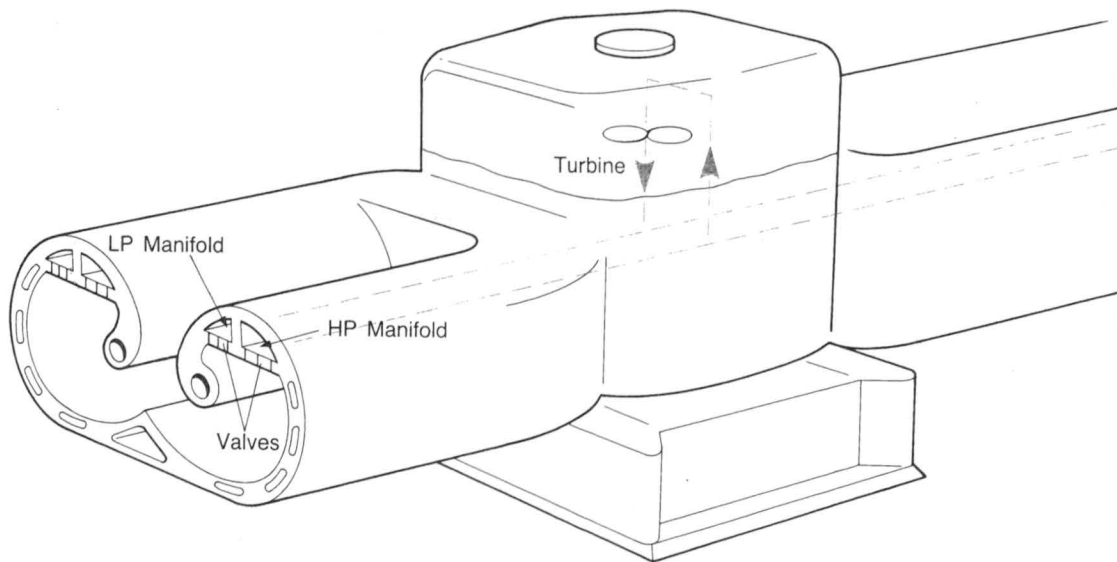

OSCILLATING WATER COLUMN Vickers Attenuator

5.36 This design is essentially a variation of the Vickers submerged terminator. In the attenuator, submerged columns would be linked to high pressure and low pressure ducts so that air passing through the turbines would be totally recirculated. The air flow direction would be corrected by rectifying valves in the turbine manifold. The turbines would be mounted in surface-piercing towers at the centre of each device. As the wave passes above and along the device, air pressure would increase or decrease in successive cells, causing air to circulate through the ducts.

5.37 As with the Vickers terminator, models of the device have been tested in the Cadnam wave tank at one-hundredth and at one-sixty-seventh scale.

5.38 Reference Design Parameters

Dimensions:	length	190m
	width	19.5m
	height	10m
	weight	28,000 tonnes
Rating:	4 MW	
Water depth:	25m	
Installation:	Piled to seabed	
2GW station		
Number of devices:	560	
Approximate overall length:	75 km	
Distance offshore:	7.5 km	
Load factor:	20%	
Mean annual power delivered to shore:	430 MW	

Fig. 5.10 Belfast OWC

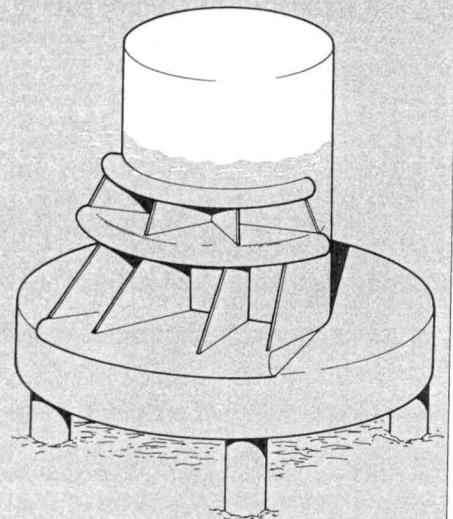
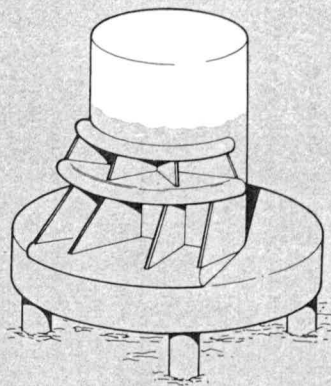
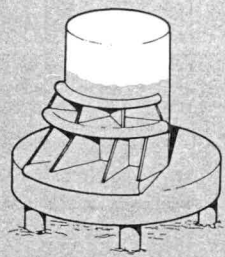
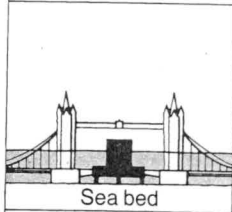
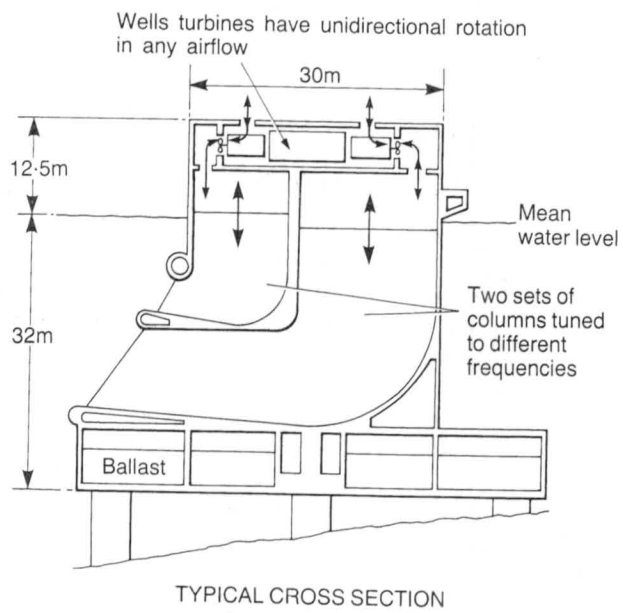

Principal wave direction

Oscillating Water Column Device

5.39 The team at Queen's University, Belfast, led by Prof. Adrian Long concentrated upon developing the OWC as a point absorber to be used as part of an array. Early ideas of a free-floating symmetrical buoy were abandoned in favour of a bottom mounted arrangement of multiple 'J' shaped columns to accept waves from any direction. The current design, which is no longer a point absorber, would have columns facing over 180° at two discrete water depths. Each column would drive a Wells turbine, rotating in one direction irrespective of the direction of the air flow, with no rectifying valves.

5.40 Development of this device concept was funded between 1980 and 1982. Development of the 'J' shaped columns has been supported by exhaustive tank tests and theoretical studies. The present device design has not, however, been tank tested and the estimated performance has been based on experiments which show that there is no interaction between adjacent columns in one module.

5.41 Reference Design Parameters

Dimensions:	seabed diameter	64m
	surface diameter	30m
	height	51m
	weight	25,000 tonnes
Rating:	4.8 MW	
Water depth:	34m	
Installation:	Bottom standing	
2GW station		
Number of devices:	600	
Approximate overall length:	50 km	
Distance offshore:	5-10 km	
Load factor:	12%	
Mean annual power delivered to shore:	350 MW	

Fig. 6.1 Cross-sections of device structures

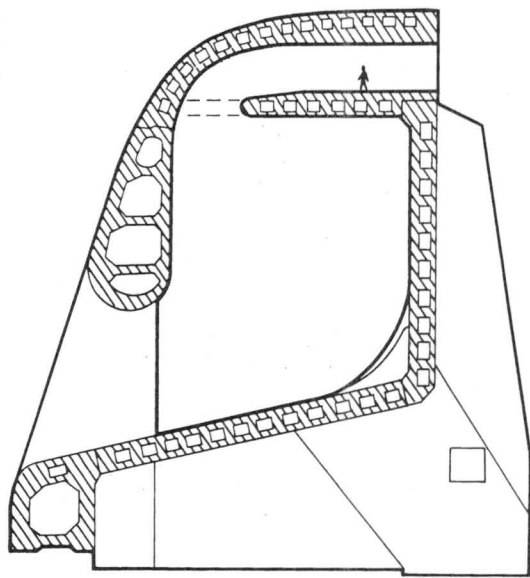

NEL Breakwater

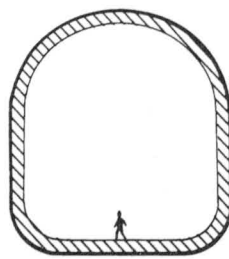

SEA-Clam

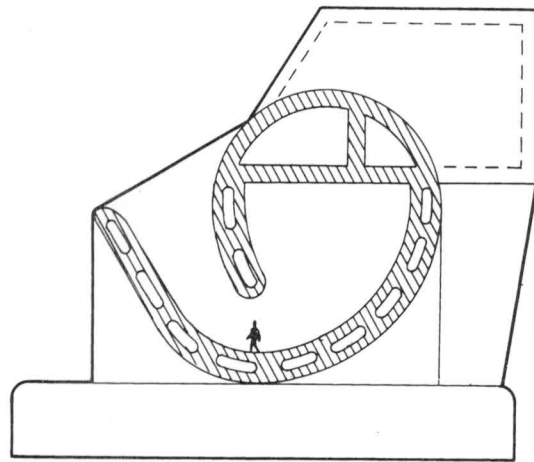

Vickers Terminator

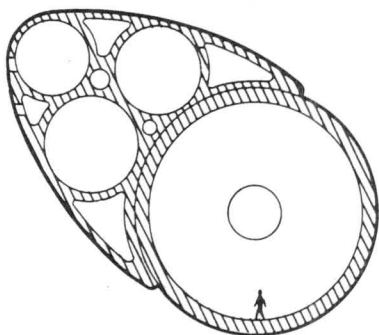

Edinburgh Duck

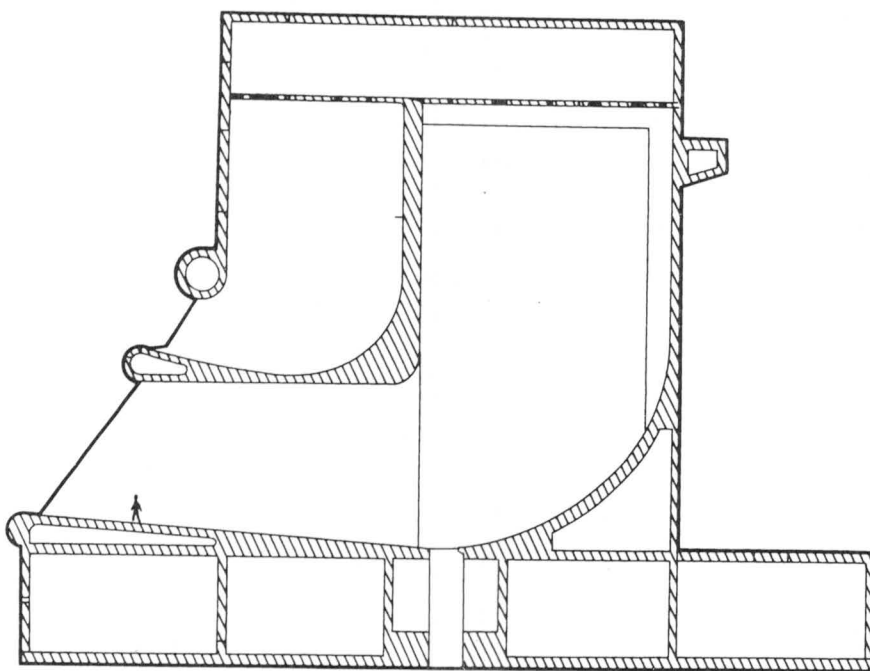

Belfast Device

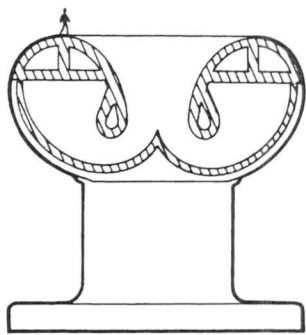

Vickers Attenuator

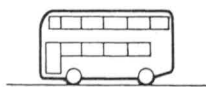

Double-decker bus
to same scale

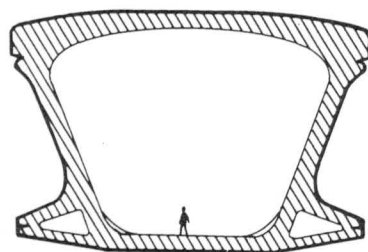

Lancaster Flexible Bag

6

Wave Energy Converter Structures

Introduction

6.1 In almost all cases the structure is the largest single cost centre of a device and it would contribute some 30-40% to the capital cost of a wave power station. It has been shown in Chapter 4 that a device would be necessarily large – a fact determined by the volume of water in the most powerful waves – and it is the sheer size of devices which makes structure costs high. Fig. 6.1 gives an indication of structure sizes by comparing their cross-sections with a double decker bus.

Functions of the Structure

6.2 The structure would have a number of functions to perform, usually simultaneously. These would include providing buoyancy and inertia, resisting wave and other loads, enclosing converter chambers and acting as the working interface with the waves.

6.3 Pneumatic device structures would need to contain large reservoirs or a series of air chambers, wholly or partly submerged, with surfaces subjected to hydrostatic pressure. If the structure was bottom-mounted the structure would either need to be sufficiently massive to resist floating or require expensive ground anchorage.

6.4 Floating structures designed to span wave crests would function as heavily loaded beams, with bending forces alternating between tension and compression. Structures of floating devices which would rely on inertia as the reference frame would also need to be massive.

6.5 In most cases the structure would be the working interface with the waves and it would need to provide the right interface shape. In the case of the DUCK the shape of the overall structure is critical and it must also be massive enough to be neutrally buoyant despite numerous internal voids. The working chambers of Oscillating Water Columns are critically dependent upon shape.

Loads on a Wave Energy Structure

6.6 The structure would need to withstand a wide variety of loads which could be broadly grouped into the following categories:

- Static (gravity) loads:* structure mass; fixed equipment; ballast; stored liquids; buoyancy in calm seas.
- Dynamic loads:*
 - environmental (from waves, currents, wind, ice etc.);
 - operational (from hydrostatic pressures, moving machinery, helicopters and service vessels etc.);
 - temporary (from installation, towing launching etc.).
- Deformation loads:* pre-stress; shrinkage and expansion; creep; temperature variations.

Fig. 6.2 Typical mass production system

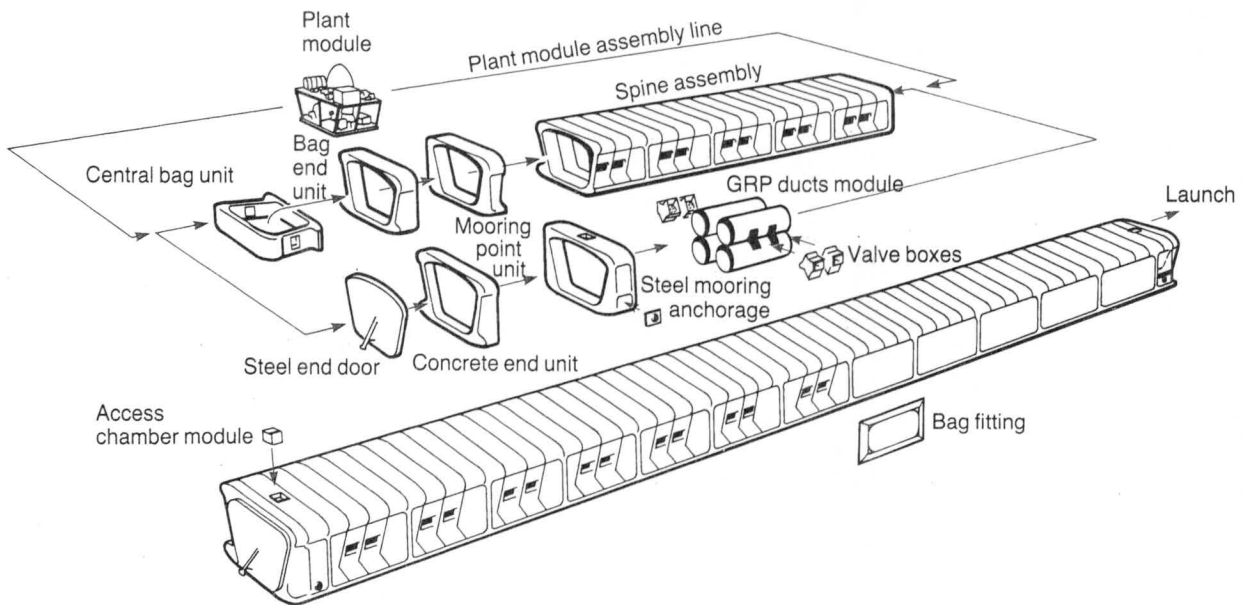
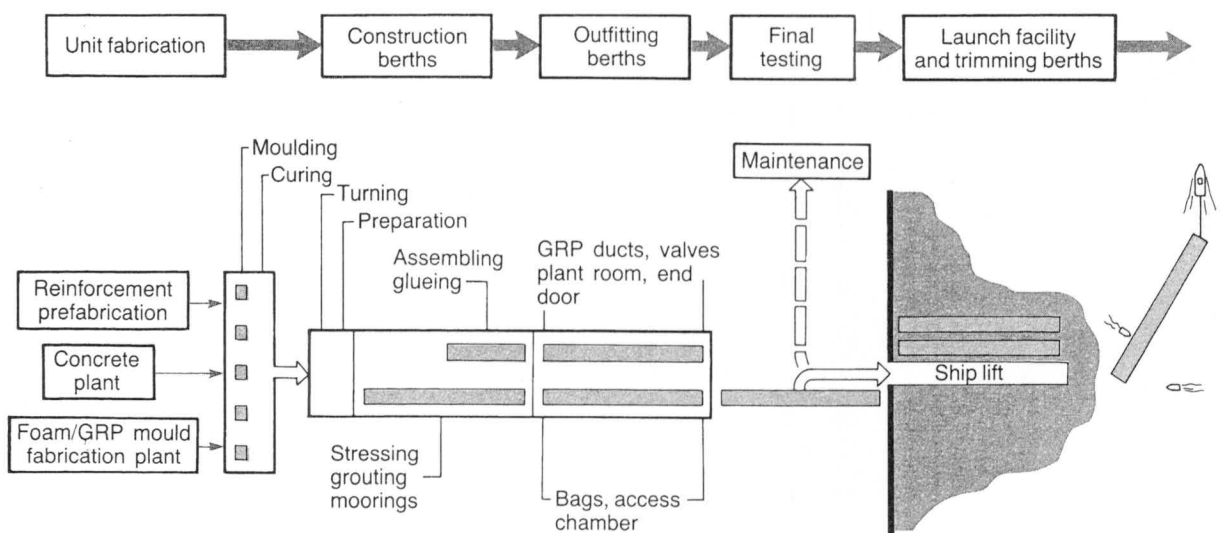

Fig. 6.3 Operations in typical construction facility



6.7 Design loads are governed by the need for the structure to survive in seas which could have maximum or storm energy levels much greater than the seas they would normally work in.

Loading Conditions

6.8 Different loading conditions would arise from combinations of various loads and must be taken into account in designing the structure. Operational loading would involve both extreme environmental loads and the lifetime spectrum of loading arising from the wave climate. Extreme loading would occur during normal device operation in extreme environmental conditions which, for the purpose of design, are defined as conditions with a return period of one hundred years. Temporary loading conditions, involving a combination of maximum imposed loads and extreme environmental conditions, would arise during construction, tow-out and installation, and when the power take-off is shut down, or when the structure has been damaged. Of these conditions the least well known is probably extreme loading – because of a lack of data on extreme waves.

Fatigue

6.9 Wave energy devices would be exposed throughout their lives to cyclic stress reversals which could lead to fatigue cracking and potential failure. The fatigue life of the main structure and the lives of the main components subjected to stress reversals must be designed to be longer than the desired life of the device. During a 20-year life, normal low-frequency wave action would result in approximately 10^8 cycles of stress reversals. In addition to this, loads resulting from slamming and breaking waves could cause transient vibrations in the structure, thereby increasing the number of reversals considerably and adding to the risk of fatigue failure.

Corrosion

6.10 Sea water produces serious corrosion effects in the 'splash zone' where surfaces are exposed intermittently to water and oxygen. These effects are an important consideration in the design of structures which must achieve long operating lives with the minimum of maintenance.

Stability

6.11 Floating wave energy devices would need to possess adequate stability to withstand overturning forces while being subjected to extreme motions. Calculations of device stability would need to take into account the possibility of accidental damage and the design would have to ensure that stability would be maintained after sea-water ingress.

Choice of Materials for Structures

6.12 Concrete is so suitable for meeting each of the requirements listed above that no really serious alternative to it has been considered for the large devices. It is by far the easiest and cheapest material for producing structures with high loading over large surface areas, it provides mass relatively cheaply and it can be

formed in complicated sections with a consistent quality. Its low tensile strength is overcome by the use of reinforcement or by prestressing, whilst its compressive strength is high enough to result in very economical compression sections.

6.13 Some devices would use steel for large components and there is confidence that adequate fatigue and corrosion lives could be achieved for them. It is worth noting, however, that some early device designs which proposed steel as the structure material ended up using large quantities of concrete as ballast – another reason why concrete became the preferred material.

Structure Design

6.14 Although steel ships and (to a lesser extent) concrete structures similar in size to wave energy devices have been designed and built, the guidance notes and codes in existence have proved to have limited applicability to device design. Guidance notes specifically for use in designing wave energy structures were produced during the programme by Lloyds Register of Shipping. The parts of existing codes incorporated in these notes were largely concerned with the choice of materials and construction techniques.

6.15 The lack of existing design data is not surprising when contrasting the use of concrete in wave energy with the use of steel in ships and offshore structures. Ships are required to propel their mass through the water so the emphasis is on low weight – the opposite to wave energy. Offshore structures are designed to be as transparent as possible to waves but wave energy devices must interact with the waves and present large surfaces to them.

6.16 Much of the limited data available for designing concrete structures has come from the Department of Energy's 'Concrete in the Oceans' programme, particularly data on the fatigue properties of concrete in a marine environment. Equivalent data for steel has come from the UK Offshore Steels Research Programme.

Construction

6.17 Construction of the modules forming a 2GW wave energy station would require mass production techniques on a scale not previously known in the concrete industry. A typical station might involve several hundred units each weighing in excess of 20,000 tonnes representing a total weight of around 15 million tonnes. To achieve a ten-year construction programme, production rates of around 75-100 units per annum would be required. The sheer scale of this operation can be gauged from the fact that concrete production for a single wave energy station would represent around 5% of the total annual concrete production in the UK.

6.18 Several different construction techniques have been proposed by the design teams but the most common is the assembly and post-tensioning of a number of cast sections. Exceptions to this are the CLAM which would have a spine cast as a single unit and post-tensioned, and the Belfast device which would be constructed in a similar manner to offshore concrete oil production platforms.

6.19 The construction facility required to assemble a 2GW wave energy station would contribute between 5 and 10% to the cost of energy produced. More than one such facility would be desirable for reasons of easier labour supply and less impact of works on the surrounding area. Having more than one site would, however, reduce the benefits of large scale production and increase capital investment in such items as casting plant and lifting equipment.

6.20 A typical construction site might cover an area of 120 hectares and would comprise:

- a concrete casting factory capable of producing pre-cast units at a production rate around 1.5 million tonnes per annum
- an assembly area in which to produce device structures by assembling pre-cast units or by employing other techniques
- a device assembly area for installation of mechanical and electrical equipment in the structure
- a device launching area either in the form of a slipway or a ship lift
- adequate mechanical handling equipment for moving pre-cast units, sub assemblies and complete devices which might weigh hundreds, thousands, and tens of thousands of tonnes, respectively
- facilities for retrieval of devices for overhaul or repair.

Figs. 6.2 and 6.3 illustrate the kind of facilities and production flow which could be needed for device production.

Structure Costs

6.21 Throughout the wave energy programme, efforts have been directed towards the reduction of the cost of energy from waves by concentrating on cost centres. From a study of the structure cost centre of each of the devices assessed, which includes the construction facility, it has become clear that there is probably less scope for reduction in this area than others. One reason for this is that it is the nature of the waves which determines the size of structures and the wave climate is not going to change to allow scaling down. Another reason is that the design and construction of devices would be relatively conventional and assessed costs carry less uncertainties than those in cost centres involving development. The fact that the structure cost centre represents such a high proportion of the costs of a wave power station means that it would have a strong influence on the minimum cost of wave energy.

Fig. 7.1 Tube spring mooring

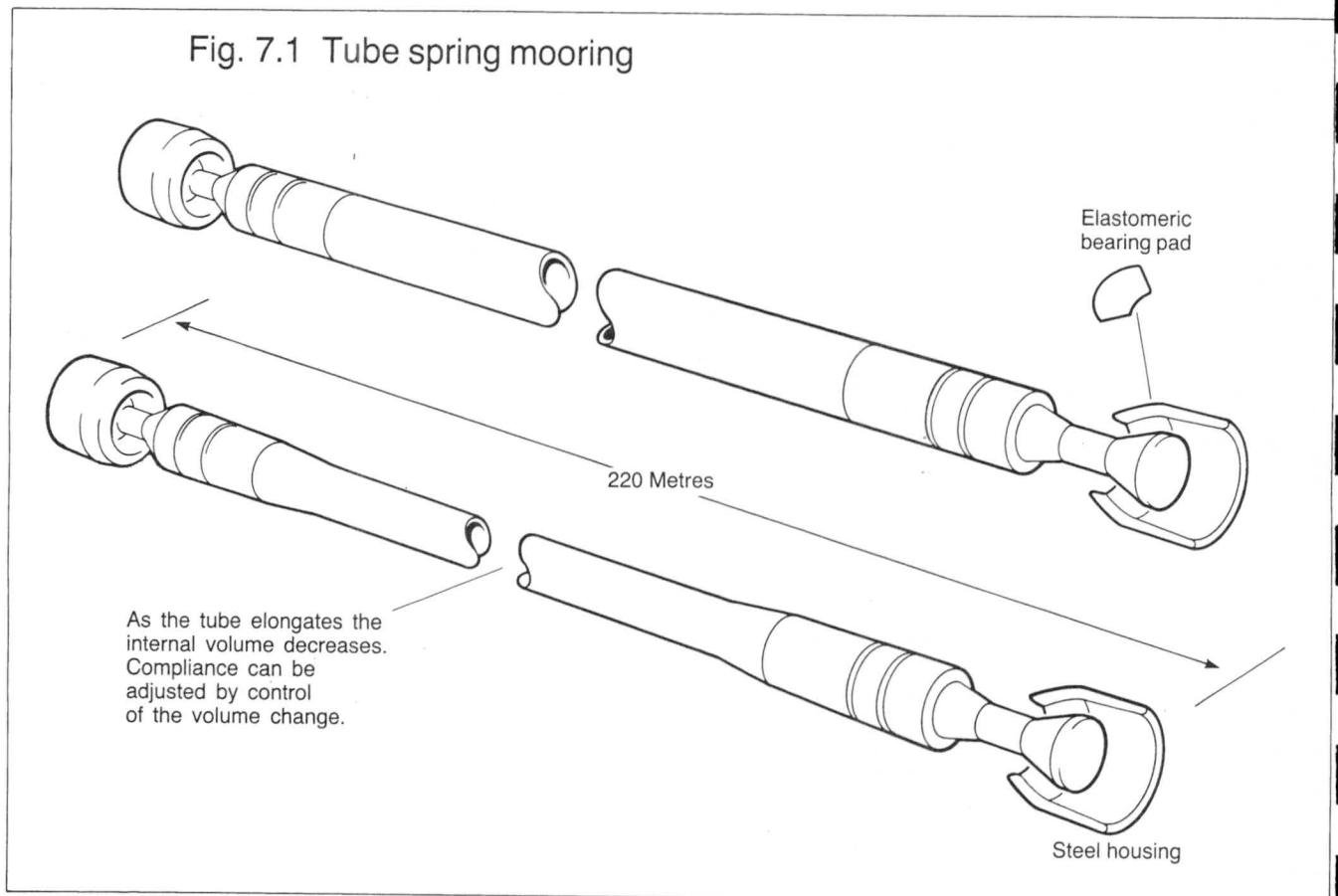
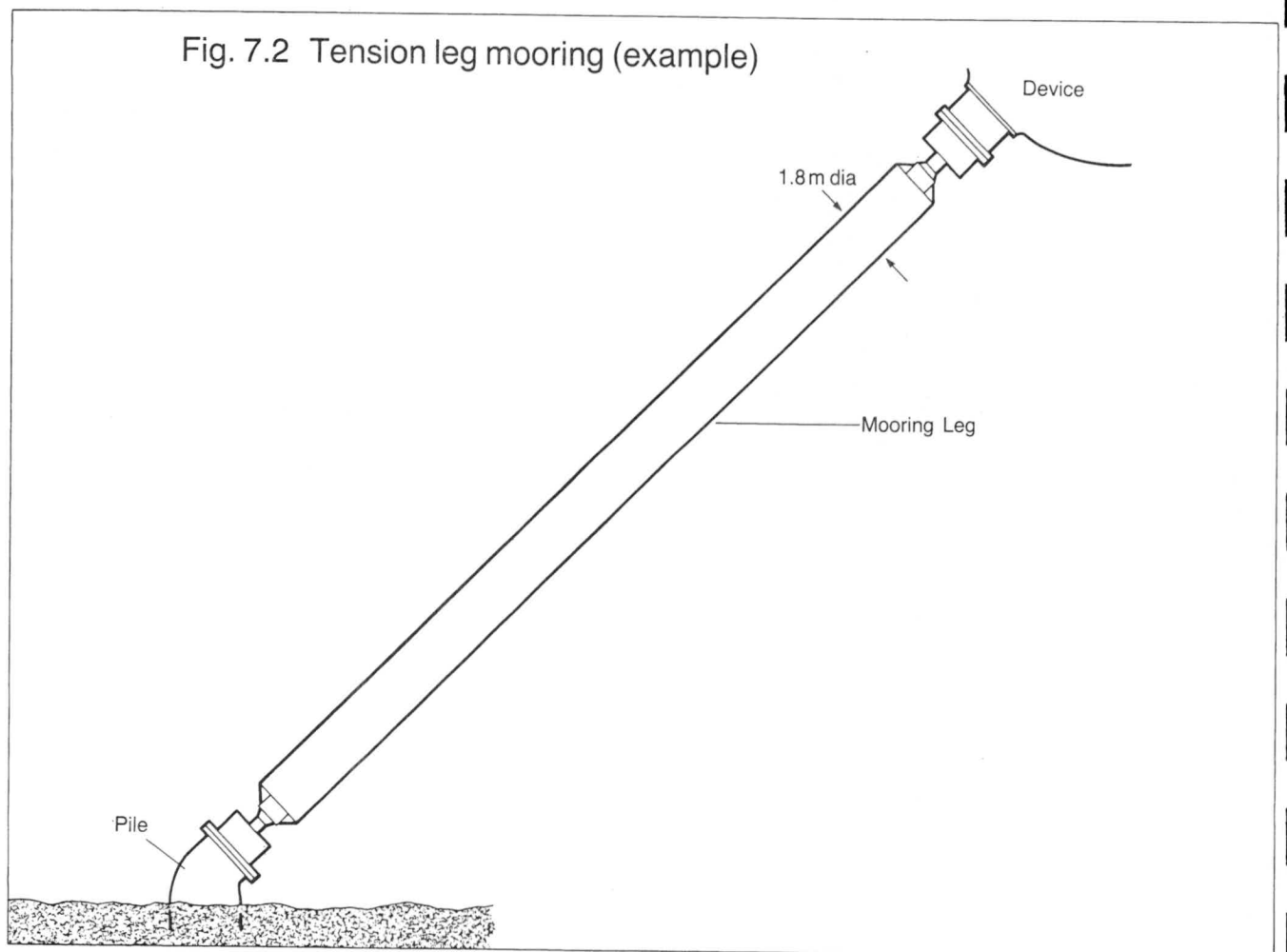

Fig. 7.2 Tension leg mooring (example)



7

Mooring and Anchoring

Introduction

7.1 The ultimate safety and survivability of a wave energy device would depend upon the integrity of either the mooring system, if the device were floating, or the method of sea-bed attachment if the device were bottom-standing.

7.2 Mooring principles have remained substantially unchanged for hundreds of years. Even though in the last decade or two the offshore oil industry has created the need for improved mooring systems with greater efficiency, durability and holding power, the technology of mooring has changed very little. The traditional chain and anchor remains the most effective mooring system for ships despite the dramatic increase in their sizes.

Design Considerations

7.3 Among the factors which must be taken into account in considering wave energy mooring systems and which make them unlike those used at present are:

- the location of the wave power station off the West Coast of Scotland in the North Atlantic, generally in water depths up to 100 metres
- the large number of structures required to be installed and the ability to spread the cost of expensive specialist equipment over the whole system.
- the permanence of the moorings, demanding reliability of a much higher order than previously achieved
- the sea-bed at the station sites – hard rock with little or no silt or sediment over it.

7.4 It was recognised from the outset of the wave energy programme that because of these factors, current mooring technology would be inadequate and it would, therefore, require extrapolation of current designs or a completely new approach.

7.5 The principal design requirements for a wave energy mooring are:

- an operational life of 30 years
- a capability of holding devices on station in the worst environmental conditions (defined as the 100 year return wave, estimated to have a maximum height of 32 metres in water depths greater than 40 metres off South Uist)
- a capability of maintaining devices in the optimum orientation for energy capture and in the best position relative to other devices to minimise the collision risk in the event of mooring failure
- a level of security such that installation, inspection and maintenance of the moorings would be possible without significantly reducing the safety of the device.

Fig. 7.3 Multipoint mooring (example)

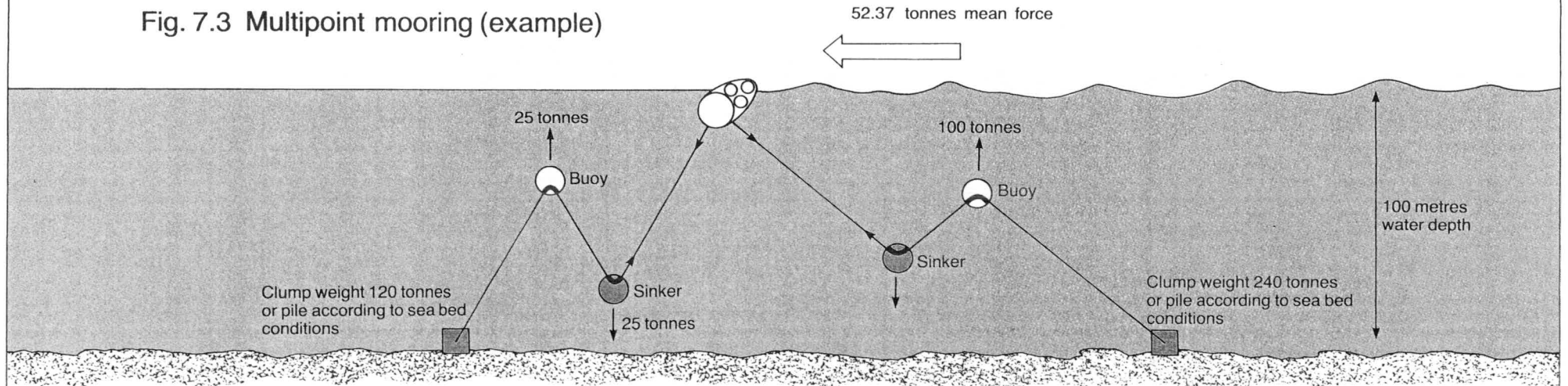

ELEVATION OF SINGLE MOORING LINE

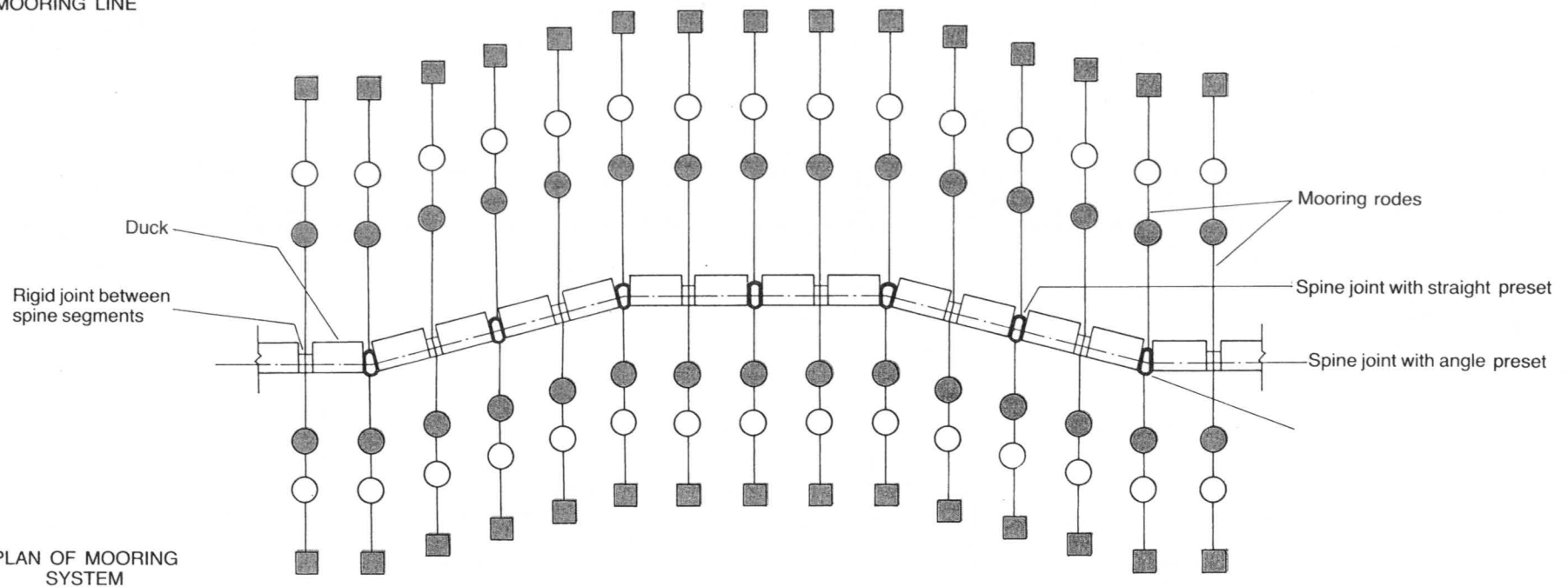

7.6 Contemporary mooring systems do not have the high reliability necessary to ensure continuity of electricity generation by devices, nor have they been used in such a hostile climate. It is only on relatively small devices, such as navigation buoys and lightships, that a degree of permanence has been achieved. Even so, the life of such moorings is still appreciably less than the required life of a wave power station and permanence is achieved only by frequent maintenance and replacement.

7.7 The total mooring force on a wave energy device could be in the range of 500-1500 tonnes – comparable with the force on a large semi-submersible drilling rig. However, unlike the rig which weighs anchor and moves off-station to ride out storms, the wave energy device must remain on-station and survive the worst storms. Considerable effort, including theoretical studies, one-hundredth scale tank testing, one-tenth scale sea testing and the fatigue testing of man-made fibre moorings, has been directed towards design solutions which minimise the mooring problem.

Compliance

7.8 One critical characteristic of a mooring line is its stiffness or compliance. In general, the use of a compliant mooring system would reduce the peak mooring force but result in considerable device movement. Use of a stiff mooring line would restrict device movement – desirable where devices need to be moored in close proximity and the limited flexibility of electrical power cables has also to be accommodated – but this would result in higher peak mooring forces. In engineering terms, neither of these two extremes would be acceptable.

7.9 Conventional anchor and chain mooring systems for ships exhibit insufficient compliance for wave energy purposes but it can be introduced by using buoys and sinkers. Another solution, developed specifically within the wave energy programme, would be the use of a tube spring mooring.

7.10 The tube spring (Fig. 7.1) is an internally-pressurised rubber tube reinforced with opposed spiral cords, the geometry of which can be selected to provide a considerable reduction in the internal volume of the tube when it is stretched. The spring rate of the tube can thus be controlled by varying the internal gas pressure, its total stiffness being a function of the gas pressure and cord geometry. It is believed that the tube spring concept offers excellent fatigue characteristics combined with high compliance and an operational life of 25 years.

Types of Mooring

7.11 Very different approaches have been adopted by the various mooring designers for the devices studied, since the performance of moorings would have to be compatible with the device operation. The different types of designs fall into three broad categories:

- tension leg
- multi-point
- single point.

Fig. 7.4 Single point mooring (example)

- ① Deadweight anchors.
- ② Polyester parafil rodes
- ③ Leading buoy
- ④ Rear buoys
- ⑤ Rear sinkers

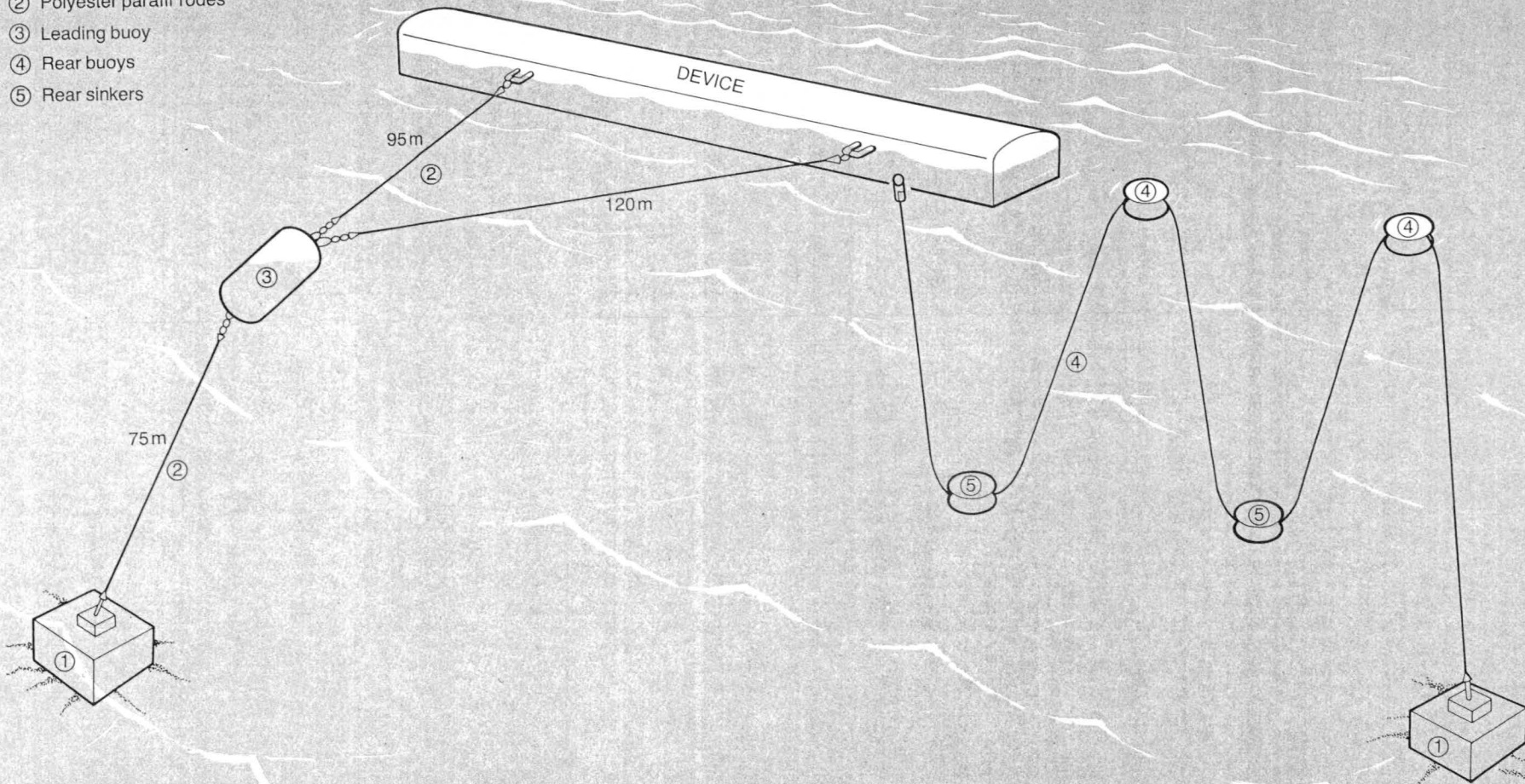

7.12 Tension leg mooring is a relatively recent development which is based upon the simple concept of using a taut mooring line or rope to connect the moored structure to a heavy weight on the sea-bed. The mooring line (or rode as it is usually termed) is maintained under tension at all times by the buoyancy of the tethered vessel, with the object of maintaining it in a relatively fixed position. In practical systems the heavy weight on the sea-bed is replaced by a fixed tethering point which permits some angular motion of the rode. Two devices, the CYLINDER and the LFB, would utilise tension leg moorings (Fig. 7.2).

7.13 Multi-point systems, as their name implies, would employ redundancy in the number of rodes used to moor a structure. For example, the NEL floating terminator OWC would have 11 rodes, any four of which would be capable of holding the device on-station. The DUCK would also employ a multi-point mooring system with one rode per 46 metres of spine (Fig. 7.3).

7.14 A single-point mooring would allow a wave energy device a greater degree of freedom to orientate itself to the predominant wave direction. The CLAM would utilise this type of mooring with a 'V' yoke arrangement to control device excursions (Fig. 7.4).

7.15 Devices located in shallower waters (for example the NEL Breakwater) would not require the use of mooring rodes and the structure would be attached directly to the sea-bed. This type of installation would require some degree of sea-bed levelling and preparation before installation, possibly involving rock cutting and dredging. The Belfast and Vickers devices would also be sea-bed mounted but piled 'legs' in their design would ease the problem of site preparation.

Anchors

7.16 The sea-bed conditions at the location determine the type of anchor which can be used in the mooring system. Only two types of anchor have been used or are possible on hard rock:

- drilled pile rock anchors
- dead-weight anchors.

7.17 Piled anchors may comprise single or multiple piles grouted, usually vertically, in the sea-bed and placed by drilling or driving. The most widely used technique for establishing piled anchors in the offshore oil industry is drilling.

7.18 Present-day drilling operations have been considerably streamlined by using semi-submersible drilling rigs, large enough to allow simultaneous drilling and placing of large diameter piles. Although operations of this nature are expensive, some of the mooring solutions suggested above are only possible with the horizontal and vertical restraint offered by piles, especially those systems where high mooring forces would be encountered.

Fig. 7.5 Properties of moorings for wave energy converters

<i>Material</i>	<i>Corrosion resistance</i>	<i>Fatigue life</i>	<i>Abrasion resistance</i>	<i>Susceptibility to marine fouling</i>	<i>Handleability</i>	<i>Termination</i>	<i>Compliance</i>	<i>Special features</i>	<i>Usage in similar applications</i>
Chain	Poor	Unknown	Poor	Average	Difficult	Various	Catenary limited	—	Widely used
Wire/rope	Poor/good	Unknown	Good	Average	Good	Socket or eye splice	Catenary limited	—	Widely used
Nylon	Excellent	Unknown	Very poor	High	Relatively light	Eye splice	Very elastic	—	None
Polyester	Excellent	Unknown	Very poor	High	Relatively light	Eye splice	Very elastic	—	None
Polypropylene	Excellent	Unknown	Very poor	High	Relatively light	Eye splice	Moderately elastic	Buoyant	None
Parafil	Excellent	Good on limited data	Poor	Low	Relatively light and good	Patented metal termination	Slightly elastic	Buoyant	Very little

7.19 A dead-weight anchor is simply a heavy weight resting on the sea-bed, resisting lift by its weight and lateral displacement by frictional resistance with the sea-bed. Dead-weight anchors come in a variety of shapes and sizes and concrete or steel blocks, chain, scrap metal or practically any high-density material can be used. Very large dead-weight anchors are usually partitioned reinforced concrete or steel boxes constructed on shore, towed into position by tugs and positioned on the sea-bed by crane barges before being filled with dense material.

7.20 Dead-weight anchors in the form of concrete clumps have been chosen for both the CLAM and the DUCK. In the case of the CLAM, a novel method of creating a clump anchor at a precise location is proposed. This would involve filling a large reinforced rubber bag in-situ on the sea-bed with concrete pumped from a surface vessel. It is claimed that because the bag moulds into the sea-bed topography, much higher friction can be achieved.

Costs of Moorings

7.21 In general, the cost of mooring and anchoring, or the provision of sea-bed attachment, together with the cost of the initial device installation would be a significant fraction of the overall capital costs. It could range from 10 – 15% for floating devices, and could be as high as 30% for devices fixed to the sea-bed. The latter systems would be virtually maintenance free whereas moorings require periodic inspection and replacement, thereby incurring an operational cost penalty.

Properties of Moorings

7.22 Fig 7.5 lists some of the properties of materials considered for wave energy devices.

Fig. 8.1 One example of the variation of power plant cost with plant rating

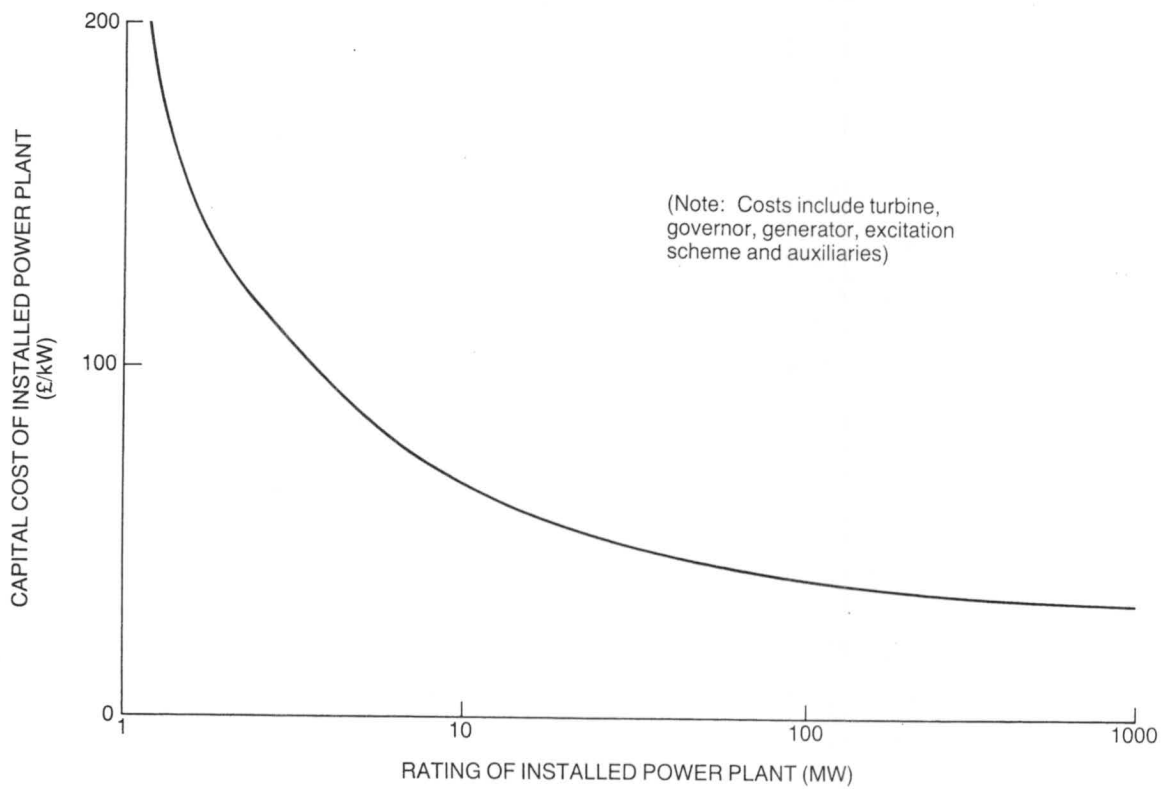

- The cost of power plant in terms of £/kW of installed capacity varies with the plant rating.
- The graph illustrates the variation of cost with plant rating for one particular item, namely hydro turbo-generator units.
- The shape of the above curve applies to many items of power plant and, in general, it is more economic to install high plant ratings.
- The present trend in conventional power systems is towards plant ratings of the order of 500–660 MW.
- Typical wave power plant, with a rating of 1–5 MW, is likely to be relatively more expensive than equivalent modern CEGB plant.

8

Power Conversion and Transmission

Introduction

8.1 In order to be of practical use, wave energy captured by devices must be converted to a form of energy suitable for transmission to consumers. Schemes considered included conversion to chemical energy (battery storage or hydrogen production) and thermal energy (hot water) but conversion to electricity is the most attractive. It is not, however, an easy process because of two characteristic features of the sea, namely the low, variable frequency of the waves and the diffused nature of the energy they contain.

Power Conversion

8.2 The low energy density in waves means that the power conversion equipment of even the largest individual device would have a rating of less than 10MW and a more typical rating would be 1MW. This is in marked contrast to modern power stations where the trend is for fewer, but larger, generating units. A conventional 2GW power station contains three or four large generating sets whereas a similar wave power station might contain 1000-2000 sets.

8.3 The requirement for a large number of small generators does not pose any significant technical problems but it can give rise to both capital and operating cost penalties. The operating cost implications are discussed in Chapter 11 and the effect of plant rating on the capital cost of power plant (in £/kW) is illustrated in Fig. 8.1. The cost curve is for one particular item of plant, namely the turbine-generator unit of the CYLINDER, but the costs of other power plant such as synchronous generators, transformers and reactors follow a similar trend. By way of example, the cost curve indicates that the cost of one 10 MW turbine-generator would be almost half the cost of an equivalent arrangement comprising five 2MW units.

8.4 Most of the technical problems relating to power conversion are associated with the primary interface of the device. Here the power plant has to meet two, sometimes conflicting, requirements:

- to provide the correct loading at the primary interface in order to enhance the device response, and hence power capture, over a wide range of sea conditions
- to convert the captured power to electricity as efficiently as possible.

8.5 Conventional electrical generators normally operate at a high, constant rotational speed producing power at the Grid frequency of 50Hz whereas the motion at the primary interface of a wave energy converter would be variable and only of the order of 0.1 Hz. Thus the power conversion system would need to combine an element of stepping up the frequency with power smoothing in order to provide a satisfactory link between the sea and the Grid.

8.6 The power conversion problem is common to all devices and can be tackled in a variety of ways which can be classified under three main headings:

- pneumatic systems
- hydraulic systems
- mechanical systems.

Fig. 8.2 Classification of the various pneumatic systems utilised by wave power devices

WAVE POWER DEVICE	PNEUMATIC SYSTEM CHARACTERISTICS					
	OPEN CIRCUIT	CLOSED CIRCUIT	RECTIFYING VALVES	SELF-RECTIFYING TURBINE	MANIFOLD	FLEXIBLE ELEMENT
NEL OWC's	•		•			
VICKERS OWC's		•	•		•	
LANCASTER FLEXIBLE BAG		•	•		•	•
SEA CLAM		•		•	• ¹	•
BELFAST OWC	•			•		

Notes: 1 The Clam has individual bag and turbine units feeding into a low pressure manifold.

In principle, any system could be used with any device concept, but in practice some devices would be most suited to one particular power conversion arrangement.

Pneumatic Systems

8.7 In a converter using a pneumatic power conversion system, the motion of the primary interface would be used to pump an air volume, producing a variable, oscillating air flow at the converter outlet. The air circuit may be open, drawing in from and exhausting to the atmosphere, or closed with a number of converters connected to a manifold. In both cases the low velocity air flow would be forced through a convergent duct to produce a high velocity air flow which could drive a turbine-generator.

8.8 The variable oscillating air flow presents a problem to the turbine designer because a turbine is most efficient when operating in a steady air flow with a constant rotational speed. In order to maximise power conversion a turbine in a wave energy device must be operated at the highest possible efficiency at all times and if the air flow is variable its rotational speed would therefore vary.

8.9 If a conventional air turbine was used to drive the electrical generator, the oscillating air flow would have to be rectified to give a unidirectional flow through the turbine. This could be done by the use of valves, either actuated by the air flow itself (passive valves) or actuated independently (active valves). In theory the latter arrangement could also be used to control the movement of the water column in an OWC chamber in order to enhance the energy capture of such devices – a technique termed 'phase control'.

8.10 The need for rectification valves could be eliminated by using a turbine which rotates in the same direction, irrespective of the direction of the air flow through it. The Wells turbine has such a characteristic and is also a high rotational speed machine, making it suitable for direct coupling to standard electrical generators. It is, however, not as efficient as more conventional turbines.

8.11 Closed-circuit pneumatic systems would generally employ a flexible element, such as a bag, as the primary interface. The air enclosed by the bags would circulate within the device using high and low pressure ducts coupled by a turbine. The aggregation of air flows from individual converters feeding a common manifold would provide a degree of power smoothing at the turbine which would ease the problems of turbine control.

8.12 The use of a closed-circuit system would allow the air within the device to be shielded from the hostile offshore environment, but the use of a manifold would prevent individual control of the converters in a device, thus reducing the efficiency of energy capture. The problem could be partly overcome by providing each converter with a turbine feeding a single low pressure manifold. The Wells turbine is particularly suitable for this arrangement.

Fig 8.3 Power collection and transmission

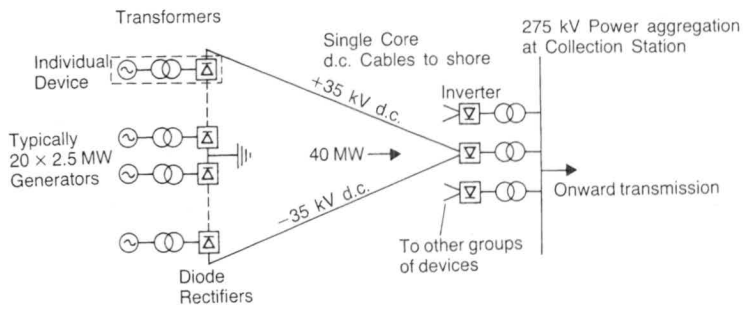

(i) Schematic diagram of the power collection arrangement for a group of devices

- There are a number of ways in which the electricity produced by devices can be transmitted to shore. One method which is applicable to most devices is shown opposite.
- a.c. power is generated on board individual devices at a variable frequency and converted to direct current by an on-board rectifier.
- Adjacent devices are interconnected on either side by single core flexible d.c. cables.
- The number of devices which can be interconnected in this manner depends upon the power transmission capacity of the flexible cable.
- In the present studies the cable is assumed to be capable of carrying 600 amps at a voltage of 35 kV.

(ii) Schematic arrangement of a 2 GW wave power station

- Devices are interconnected to form 40 MW power groups with flexible d.c. cables of positive and negative polarity respectively, running from the two ends of each such group to the seabed.
- The medium voltage d.c. cables from a number of power groups would be brought ashore at a common point where the outputs would be aggregated and the voltage raised to a level suitable for long distance transmission.
- The proposed method of aggregation involves connecting the power output from each device group to an a.c. busbar via an inverter.

(iii) Schematic diagram of the interconnection of a 2 GW wave power station with the Grid.

- One of the most favourable locations for a wave power station is to the west of the Uist islands.
- One disadvantage of this location and most other locations off the NW coast of Scotland is they are remote from the Grid.
- Overland transmission distances up to 300 km are necessary to reach major Grid interconnection points.
- Large scale implementation of wave power would also involve some strengthening of the Grid.
- The overall cost of power collection and transmission can be as high as 1-2 p/kWh.

8.13 Several wave power concepts utilise pneumatic systems. A classification of the main characteristics of the pneumatic system of each device is shown in Fig. 8.2.

Hydraulic Systems

8.14 The simplest method employing liquid as the moving fluid in a turbine uses the difference in head between the crest and trough of the waves. The average head is less than 5 metres – somewhat lower than normally encountered in water turbines – consequently the turbines would be slow speed, large diameter, expensive machines. For this and other reasons, low head devices such as the RECTIFIER would not be cost-effective.

8.15 Sea water could be pumped by the mechanical motion of devices, thus allowing a choice of operating pressures and the use of manifolding similar to the pneumatic arrangement above. A very high pressure system using submarine pipes could aggregate power from a large array of devices efficiently. It would, however, present materials problems and involve the centralised siting of turbines on a platform adjacent to the array although it would avoid the pollution problems which might arise if oil were the hydraulic fluid. The CYLINDER utilises this arrangement.

8.16 Mechanical motion could also be used to pump oil rather than sea water. In such a system, a pump would be connected hydraulically to a motor which would, in turn, drive a generator. This versatile arrangement would allow several possible control alternatives and the incorporation of some short-term energy storage in parallel with the prime mover. Energy storage could either be in the form of conventional hydraulic accumulators, or as in the case of the DUCK, kinetic energy in a flywheel.

Direct Mechanical Coupling

8.17 Direct mechanical coupling between the primary interface of a device and the power plant would be possible using one or more of several options including cranks, gears, cams, belts and friction drives. Whilst in theory it is possible to transmit the required torque levels with these options, they would be susceptible to wear caused by the onerous duty cycle imposed by wave motions. As a consequence these options have not been pursued in recent years and devices have developed either pneumatic or hydraulic alternatives.

Power Collection and Transmission

8.18 If power smoothing were introduced into the energy conversion chain it would limit the number and size of the power peaks to be handled by the electrical generator. This has cost advantages and allows the possibility of controlling the generator to permit constant frequency (synchronous) operation with conventional electrical coupling to the Grid. In the majority of wave energy systems, however, it would be more cost-effective to allow the generator to operate at variable frequency with an intermediate conversion stage provided to allow connection with the Grid.

8.19 The most convenient buffer between the Grid and the variable frequency generated by a device would be a rectification/inversion arrangement. Such an arrangement would rectify the variable frequency AC to DC and then invert it back

Fig. 8.4 Power conversion, collection and transmission costs for a 2 GW wave power installation

COST ITEM	COST RANGE £M	COMMENTS
1. M & E PLANT	630-1125	Mainly conventional equipment operated with an unconventional duty cycle in a marine environment.
2. POWER COLLECTION AND TRANSMISSION TO THE HEBRIDES	210-630	The lower end of the cost range is associated with an a.c. synchronous system utilising flexible 132kV cables. The upper end of the cost range is the medium voltage d.c. system employing rectification/inversion.
3. POWER AGGREGATION ON THE HEBRIDES	50-585	This cost is mainly a function of the length of the 2GW wave power station. Part of this cost would not apply to some wave power locations.
4. SUBMARINE CABLE LINK FROM THE HEBRIDES TO SKYE	190	Common to all device designs. Development team's costs for this item are in the range £35M-£235M. The wave energy Consultants have adopted costs comparable with other recent studies. (e.g. Offshore wind energy). This cost is particular to the Hebrides location.
5. POWER TRANSMISSION FROM SKYE TO THE GRID AT CRAIGROYSTON	130	Costed by Kennedy & Donkin Ltd. Much of this cost is location dependent.
6. GRID REINFORCEMENT	Nil-700	Dependent upon location and the amount of wave power already connected to the Grid.
7. TOTAL POWER CONVERSION COLLECTION AND TRANSMISSION COSTS	1390-3330	This represents approximately 3-7 p/kWh.

(Total costs are totals for the different device types and are not the simple addition of the individual cost items).

to AC in synchronism with the Grid. Where the individual outputs from a number of devices need to be connected to the Grid, it would be possible to aggregate them after the rectification stage by connecting them in series via flexible DC cables. The number of devices in a group which could be interconnected in this manner is limited by the maximum power transmission capacity of the pair of flexible cables to the shore – assumed in the present study to be about 40 MW. Once ashore the outputs of a number of groups would be connected via inverters to a conventional AC switching station for onward transmission to the Grid. A 2GW station could require 100 DC cables with a total length of 2500 km to transmit power to shore. Fig 8.3 illustrates the stages of power collection and transmission for a typical wave power station.

Grid Strengthening

8.20 The major wave energy locations are off the NW coast of Scotland and the SW coast of England. In both these areas the potential wave energy resource is greater than the power which the Grid could accept without some reinforcement. This is particularly true for NW Scotland where the peak winter resource of about 12 GW is greater than the present installed capacity of the NSHEB. It therefore seems certain that the cost of wave energy will need to include a cost component relating to Grid reinforcement if wave power stations are deployed on a large scale.

8.21 Estimating this cost component is very difficult because it would depend upon both the development of the Grid up to the time of the introduction of GW-sized wave power stations and the scale of their installation. Long-term Grid reinforcement costs could be decreased by installing sufficient transmission capacity at the outset to cope with the anticipated scale of wave power station deployment. In the shorter term this would increase energy costs because of under-utilisation of this capacity.

The Costs Associated with Power Conversion and Transmission

8.22 Power conversion and transmission costs of the 2GW reference designs can be attributed to six main areas, namely:

- mechanical and electrical (M&E) power conversion plant
- power collection and transmission from the station to South Uist
- aggregation of power on South Uist
- bulk transmission of power from South Uist to Skye
- bulk transmission of power from Skye to the Grid at Craigroyston (50 km NW of Glasgow)
- any necessary Grid reinforcement.

8.23 Of these, the first three are a function of the device concept and are relatively insensitive to the geographical location of the wave power station (except for its distance from shore). Conversely, the last three are independent of device considerations, but are dependent upon the power station's geographical siting.

8.24 The cost ranges for the various device concepts in the reference location off South Uist are shown in Fig. 8.4. In general, costs of the other major wave energy location, off the SW coast of England, would be similar with the following exceptions:

- the costs of power aggregation in readiness for onward bulk transmission to the Grid (Item 3 in the table) would be towards the low end of the cost range because it would take place on the mainland rather than on islands
- the 400kV submarine cable link would not be required
- Grid interconnection costs (Item 5 in the table) would be considerably lower in the South West.

8.25 As is seen in Fig. 8.4, the costs associated with the power conversion, collection and transmission aspects of wave energy would be considerable and even at the low end of the cost range, would represent almost 3p/kWh in terms of the unit cost of landed energy. Furthermore, it is difficult to see how this cost might be reduced since it is mainly a function of the diffuseness and remoteness of the wave energy resource rather than any particular technological limitation imposed by the power collection system. The inherently low load factor of wave energy power stations would also contribute to transmission costs because transmission lines would need to be capable of carrying much more than the mean annual power.

Fig. 9.1 Maintenance activities

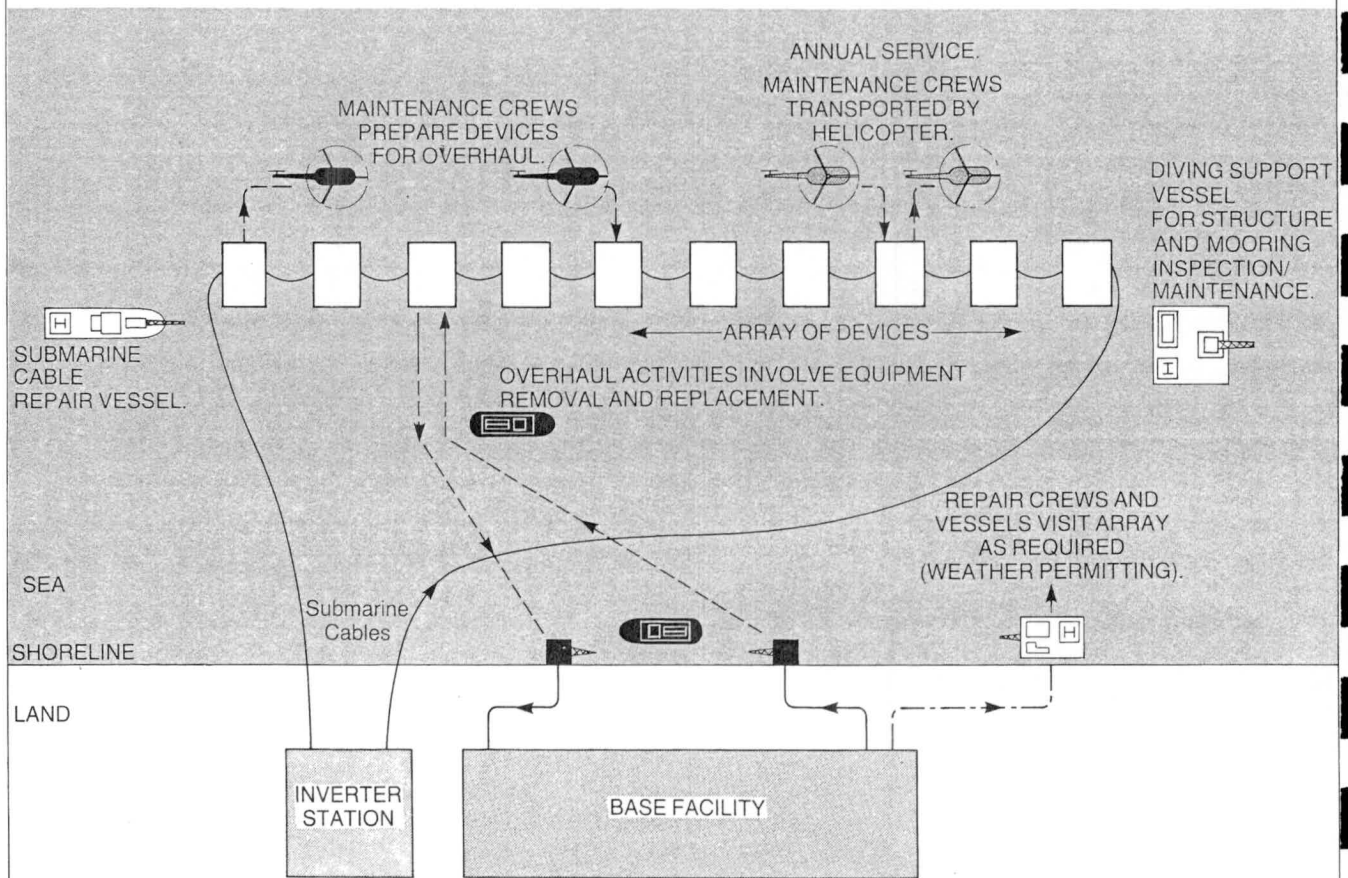

- The maintenance activities include:
 - Annual service and five-yearly overhaul of onboard equipment.
 - Inspection and maintenance of device structure and mooring arrangement.
 - Repair of on board equipment
 - Repair/replacement of submarine cables and moorings.
- Typical resources might be:
 - 500–1000 maintenance personnel
 - 32 vessels (including crane ships, support vessels, diving support vessels, cable ships, survey ships, submersibles and tugs.)
 - 6 Helicopters
- The annual work load might include:
 - Service: 300 devices
 - Overhaul: 60 devices
 - Replace: 50 moorings
 - Repair: 500 onboard items, 10 cable faults, 5 mooring failures.

Note: All numbers relate to a 2 GW power station.

9

Availability and Maintenance

Introduction

9.1 In any conventional power station the failure or malfunction of its component parts incurs a cost penalty associated with the necessary repair activity. This cost penalty has two components:

- the cost of the actual repair (men, spares etc.)
- the loss of revenue (i.e. energy) during the period that the station operates at reduced output.

9.2 In a wave energy station, carrying out repairs would be made more difficult by two features not normally found in conventional stations:

- the station would consist of a large number of relatively small generator sets, widely distributed geographically
- access to the station would be limited by the weather because of its offshore, exposed location.

Availability

9.3 If a repair were delayed by the weather, the proportion of the year during which the station functions normally would be reduced. This proportion, formally termed the 'availability', is usually expressed as a percentage. For wave energy, however, this would not be a very useful measure because of the seasonal nature of the resource. The failure of components in the winter would be potentially more serious, in terms of lost energy, than in the summer. Thus in a wave energy station the term availability must be redefined as the annual energy delivered to the Grid (after allowance for component failure and seasonal effects) expressed as a percentage of the potential output of the station, assuming perfect operation.

Maintenance Considerations

9.4 High availability can be achieved only by reliable operation of the station or by having sufficient maintenance resources to be able to respond quickly to any failure, and hence minimise the amount of time plant is out of action. The maintenance resources consisting of men, ships and base facilities would have to cope with both the preventive activities such as inspection, servicing and overhaul, and with the unscheduled repair activities. (Fig. 9.1).

9.5 The cost of maintenance could be minimised by organising the teams to carry out preventive maintenance during the calm summer months, leaving the same teams free to do unscheduled repairs in the winter when more failures could be expected. The aim would be to keep a constant, but minimum, level of manpower employed throughout the year. In practice, however, there would always have to be some resources dedicated to repair activities throughout the year.

Fig. 9.2 Some maintenance cost sensitivities for a 2 GW wave power station

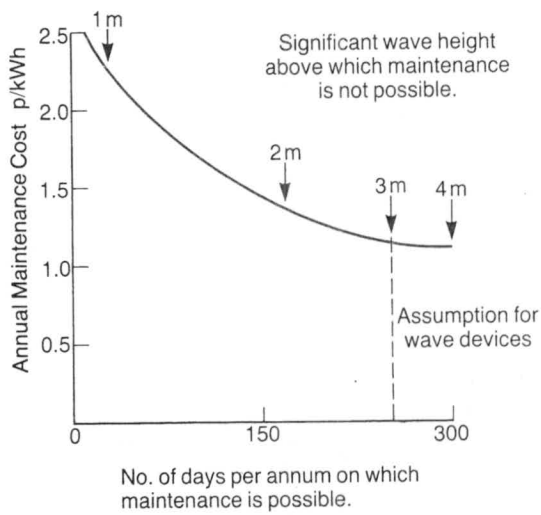

- The number of days during which maintenance operations can occur is limited by the weather.
- The most important weather factor is the state of the sea as defined by the significant wave height.
- Wave power studies assume that maintenance operations can take place in seas up to $H_s = 3$ m.
- If the maintenance activities require calmer sea conditions (i.e. $H_s < 3$ m) the cost of maintenance increases.
- There is little potential cost gain in attempting to carry out maintenance activities in heavier sea conditions (i.e. $H_s > 3$ m).

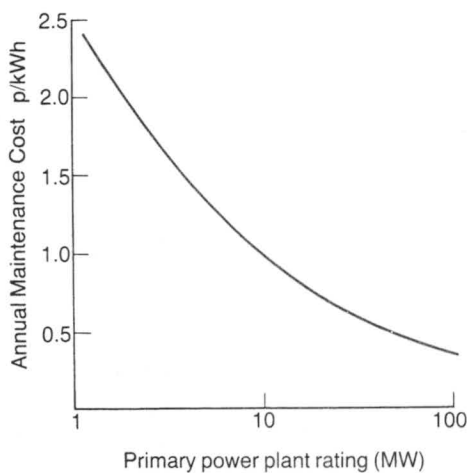

- Wave power stations contain a large number of power plant units with ratings typically in the range 1–5 MW.
- Maintenance costs are a function of the number of units comprising a system.
- A significant maintenance cost reduction can be achieved for wave power stations containing fewer power plant units (with higher plant ratings).

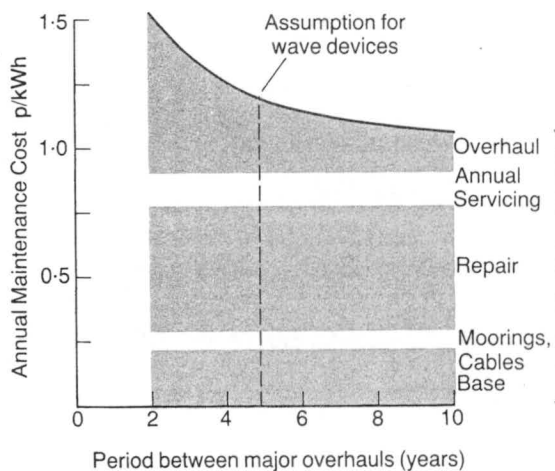

- The number of power plant units overhauled each year depends upon the total number of units and the period between overhauls.
 - The period between overhauls for conventional power plant is 3 years.
 - The assumption for wave power systems is overhaul at 5 yearly intervals.
 - Overall maintenance costs are not particularly sensitive to the overhaul assumption because overhaul represents only 25–30% of the maintenance budget.
- Breakdown of the Maintenance Costs.

9.6 Maintenance costs would depend upon a number of factors and studies suggest the most important of these would be:

- whether a device is bottom standing or floating
- the maximum wave height at which access to a device would be possible
- the frequency with which overhauls must be carried out
- the number of devices in a 2GW station.

The sensitivity of the cost of maintenance to some of these factors is shown in Fig. 9.2 for a generalised OWC device.

9.7 Costs have been estimated for several devices and in general have been found to be in the range £40-£90M for a 2GW wave power station which represents 1-2p/kWh on the cost of energy. These figures include an allowance for the cost of:

- spares
- the shore base facility
- repairs to the submarine cable installation
- inspection of the device structures and foundations.

9.8 For simplicity, the results, as presented in Fig. 9.2, relate to one assumption for the required level of repair resources. It is these resources which would determine the availability of the station and they are optimised by considering the cost-effective availability target.

Availability Considerations

9.9 A station which operates without repair resources would commence operation with 100% availability. Thereafter, availability would fall with time as plant either broke down or its performance deteriorated. The rate of fall would be determined by the failure rate of the components in the system and the severity of each failure, since not every component failure would cause loss of output. With a no-repair policy the average availability over the life of a station would be likely to be low and yet the saving in the overall cost of maintenance would be minimal because a large proportion of the cost would be unavoidable. Resources would be needed for scheduled activities, such as statutory inspection or service, and there would need to be support facilities, such as an on-shore base, irrespective of the repair philosophy adopted.

9.10 A computer simulation model was used to estimate the availability of wave energy stations. The model simulated the failure and repair processes of a 2GW station and included allowances for the time to gain access to a device, the number of devices waiting in the 'repair queue' for resources to become available and the efficiency of utilising weather windows. In the model, devices were represented by a small number of major sub-systems, each of which had an estimated failure rate. By way of example it is possible to characterise the CLAM as four major sub-systems, namely the bag-driven pneumatic circuit, the turbine-generator, on-board power collection system, and the auxiliary systems (low voltage supplies, generator cooling etc.)

Fig. 9.3 Some availability considerations for wave power station

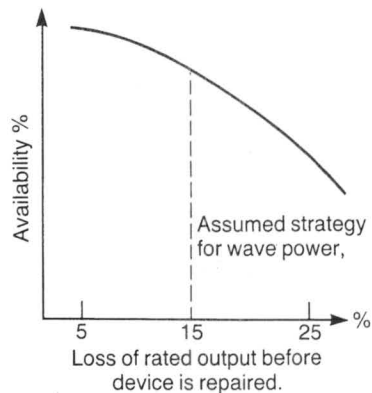
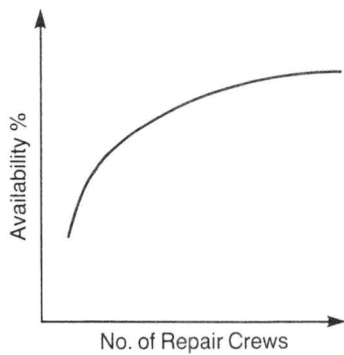
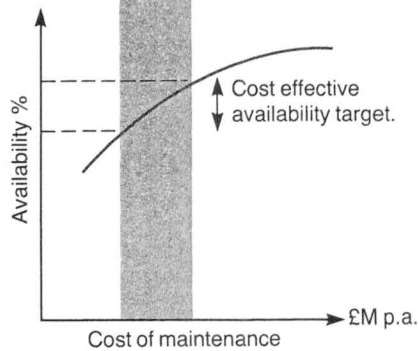
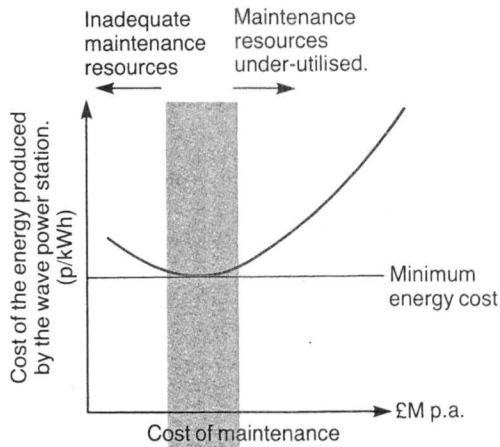

- The cost of energy produced by a wave power station is a function of the level of resources allocated to maintenance activities.
- With inadequate resources the system output falls below the optimum level with a corresponding increase in the cost of delivered energy.
- As maintenance resources are increased the output of the power station rises as it is kept in a better state of repair. Under these circumstances the cost of the energy produced decreases until the increase in the maintenance cost is greater than the value of the increased availability.
- At this point the introduction of further maintenance resources only tends to increase the cost of the energy produced by the power station.

- The purpose of the availability studies is to provide the data to enable the cost effective level of maintenance resources to be determined.
- The primary data describe the relationship between availability and cost of maintenance.
- This curve is derived from consideration of several interactive parameters including the repair resources, the maintenance philosophy, the utilisation of weather windows and the sea conditions during which repair activities are possible.

- Availability is a function of the number of crews allocated to repair activities. In this context the term repair crew includes all the resources necessary for a repair operation (i.e. manpower, vessels, spares etc.)

- It may not be economical for the repair crews to respond immediately to failures which only cause a small loss of power output.
- The level of performance degradation at which the repair crews respond is part of the maintenance strategy.
- During the present studies the sensitivity analysis has indicated that repairs should be carried out during the first available weather window after the output capacity falls by 15% of the rated value.

9.11 Data for the performance of the sub-systems were synthesised from the reliability data for the individual components of each particular sub-system. In some instances, especially where the use of novel components is proposed, failure rates for individual items cannot be estimated with any great accuracy. Fortunately, the overall reliability performance of the sub-systems, which could comprise up to thirty items of equipment, is not usually sensitive to any one item.

9.12 Some of the factors considered in the availability studies are shown in Fig. 9.3. In general, the cost-effective availabilities of the device systems included in the study were estimated to be in the range 70-90%. The upper end of the range tended to be associated with bottom-standing devices which would have easy access for repairs. The lower end of the range was associated with devices where at-sea repair would be difficult or the number of devices comprising a 2GW power station was relatively high.

9.13 The team developing the DUCK device proposed a novel approach to availability involving the design and development of components which could achieve maintenance-free, reliable operation over the entire 25 year design life of a station. This design approach yields very low availability estimates even when assessed by the Consultants on the basis of the best reliabilities achieved by present-day equipment. For this reason, the estimates for the availability and cost of repair components of the maintenance costs of the DUCK have not been included in the latest assessment.

9.14 A further consideration for floating devices is whether the major on-board systems or components could be repaired at sea. The need to tow a complete device back to base for repair would significantly reduce availability unless provision is made for spare devices with which the faulty device could be exchanged. The cost of spare devices must be included in the compromise between a high availability and a low maintenance cost.

9.15 The main points arising from this study of maintenance and availability are:

- a fixed device would be expected to have a higher availability than an equivalent floating device because maintenance crews could gain access to it and work in it in weather too severe for access to floating devices
- a floating device which could not be repaired at sea is likely to be at a considerable disadvantage in terms of availability unless provision for sufficient spare devices is made
- the present studies suggest that availability levels in the range 70-90% might be achieved with an annual maintenance cost equivalent to 1-2p/kWh.

Fig. 10.1 Summary of power chain characteristics

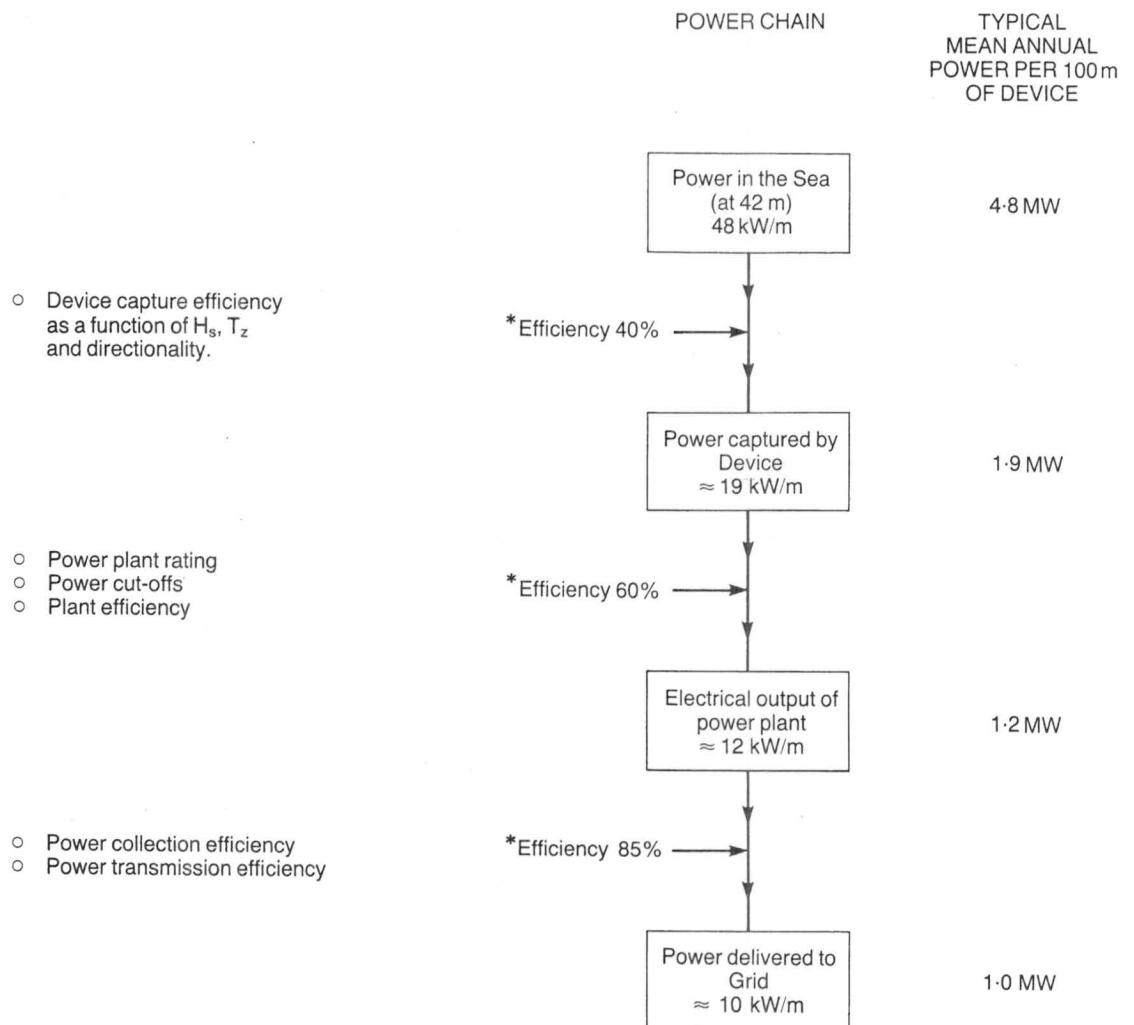

Some useful definitions

Overall System Efficiency = $\frac{\text{Power to Grid}}{\text{Power in Sea}} \times 100\% \approx 20\%$
Load Factor = $\frac{\text{Power to Grid}}{\text{Power plant rating}} \times 100\% \approx 10\text{--}20\%$

*These are averaged annual efficiency figures

10

Mean Annual Output of a Wave Power Station

Introduction

10.1 Wave energy devices could not capture and deliver to the Grid all of the power available to them in the sea. At each step in the power chain, from the interaction of the devices with the waves to the final connection of the on-land transmission line to the Grid, power losses would occur.

10.2 Studies to date have shown that the overall efficiency of wave power stations would be low and could be expected to be around 20%. This is not surprising in view of the nature of the sea and the conflicting constraints it would place upon the operation of devices, thus limiting their efficiency. For most of the year they would be required to be effective power extractors over a wide range of wave heights and frequencies, yet during heavy sea conditions they would need to avoid efficient power capture in order to survive.

10.3 The factors which would influence the overall efficiency of the station power chain are shown schematically in Fig. 10.1 and include:

- the capture efficiency of the device
- the rating of the power plant
- the efficiency and operating characteristics of the plant
- the efficiency and operating characteristics of the power collection and transmission system.

The Calculation of the Mean Annual Output of a Wave Power Station

10.4 A rigorous calculation of the mean annual output of a station would involve the summation of the energy captured from each wave by each device during the course of the year. However, since a station would see approximately three million waves per year, some method of averaging by grouping together waves with common characteristics must be employed. This is done by selecting a number of sea state spectra which are representative of the annual wave climate. The annual power output is estimated by summing the delivered power for each spectrum, suitably weighted to take into account the occurrence of each spectrum during the year.

10.5 Such a procedure involves the use of average values for both the power level in each spectrum, defined by the significant wave height, and the steady state performance of the power chain. This neglects the transient fluctuations in power level seen by the power chain and tends to overestimate the overall plant efficiency. The error is not large because both the inertia and the short term overload rating of the power plant allow a proportion of the power peaks to be handled, provided the mean power level is below the plant rating. Nevertheless, it is necessary to apply a correction factor to the steady state calculation in order to obtain a more accurate estimate of the mean annual power output and this generally results in a reduction of 5-10%.

Fig. 10.2 Scatter diagram showing the range of sea states over which devices would work with reasonable efficiency

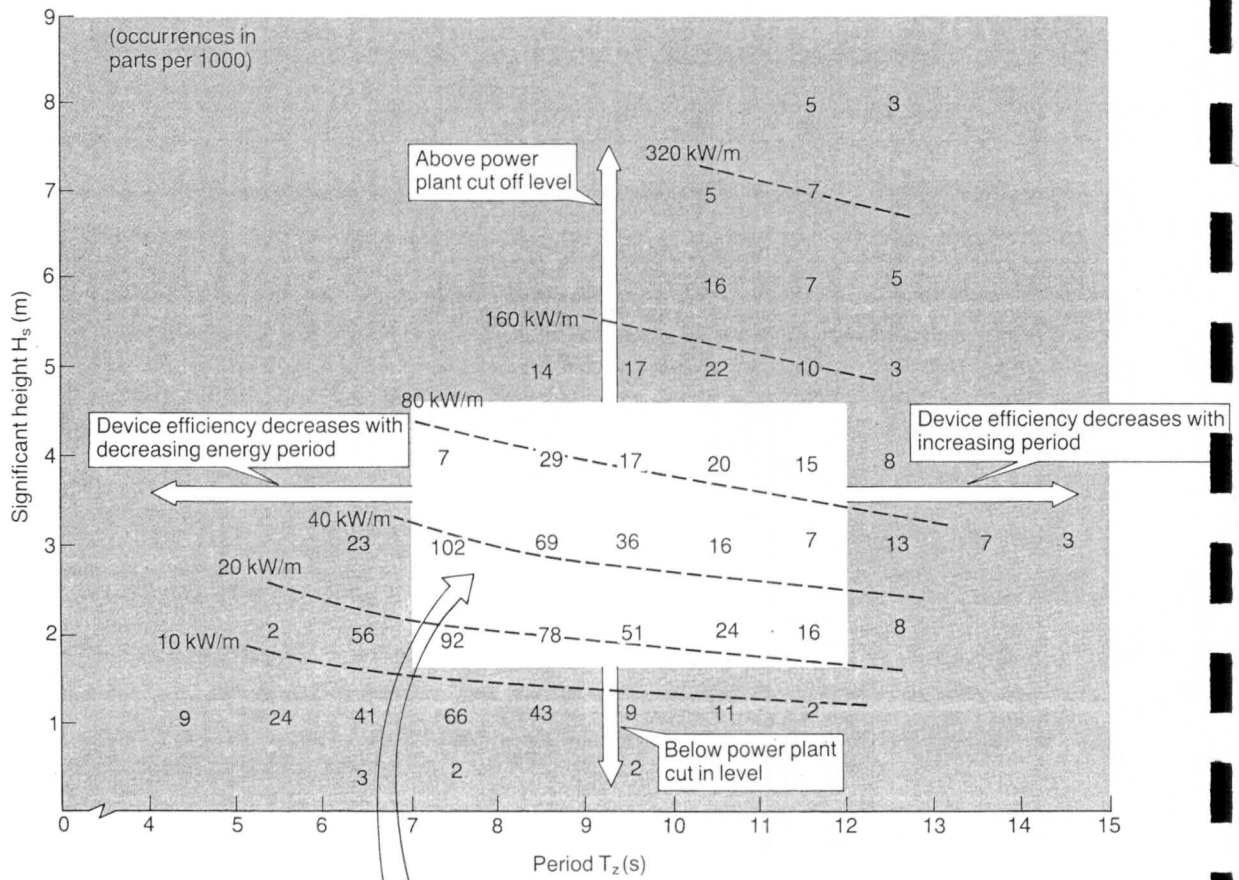

The performance of a wave energy device is limited to a region of the scatter diagram defined by the frequency response of the device and the operating range of the power plant.

Device Capture Efficiency

10.6 The first step in the power chain is the interaction of a device with waves. The capture efficiency of a device is a function of wave period and is a maximum at a period determined mainly by the dimensions of the primary interface of the device. This is one reason why most devices would be of a similar size.

10.7 All devices face the same design problem of ensuring that peak capture efficiency would occur at a period close to the predominant wave period. Even so, much of the power available in the sea would not be captured because device performance would begin to deteriorate at wave periods outside the range 7-12 seconds. In effect, the outer left and right hand areas of the scatter diagram, (Fig. 10.2), are not available to the devices.

10.8 The capture efficiency of devices is also a function of wave height. In order to survive the excessive power levels present during storm conditions, devices would be designed to operate with reduced capture efficiency at wave heights above 4-5 m (about 160-250 kW/m). This means that the upper portion of the scatter diagram (Fig. 10.2) is not accessible to devices. It would be difficult to improve the overall capture efficiency of a device above about 40% even though individual waves with particular periods and heights could be captured with an efficiency approaching 100%.

The Power Plant

10.9 The power captured by a device would vary both seasonally and on a wave-to-wave basis. Under these circumstances the power plant would be under-utilised if it was rated at the maximum power capture level of the device. Plant would therefore be rated lower than the capture capability of the device and incorporate a power limiting arrangement to prevent overloads on those occasions when an individual wave exceeded the plant rating.

10.10 In sea states with low incident powers, the power plant would be required to operate well below its design rating and its efficiency would be low. Furthermore, there is a minimum power level which must be achieved to overcome the fixed losses in the system. Thus most devices would be likely to have a cut-in power level around 10 kW/m below which it is not productive to operate the system. For this reason, wave energy systems could be inactive for up to two-thirds of the summer period (May-August).

10.11 The rating of the power plant is therefore a compromise whereby the plant could handle a reasonable proportion of the power available in winter and yet retain a reasonable efficiency during part-load operation for most of the year. This problem is common to all devices and further reduces the proportion of the scatter diagram which is accessible to them (Fig. 10.2).

10.12 Studies of a number of device concepts suggest that the overall power plant efficiency, with its optimum rating, would be about 60%. To achieve this figure it would be necessary to rate the plant at 2-3 times the average power level captured by the device.

Fig. 10.3 The mean annual output and load factor of the various wave energy devices shown in histogram form

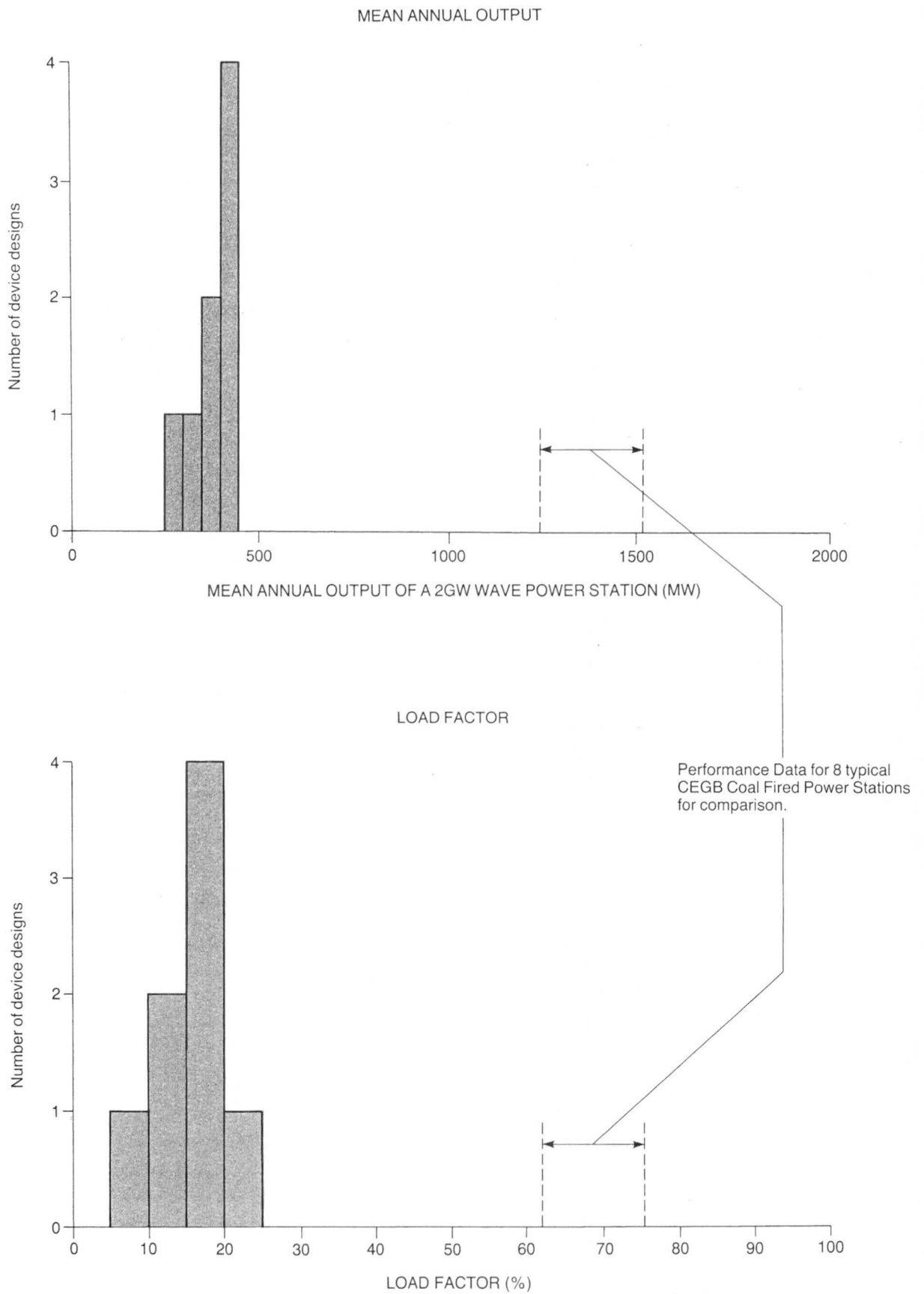

Power Collection and Transmission

10.13 The final stage of the power chain includes:

- the aggregation of power from groups of devices
- transmission of the aggregated power to shore
- the on-shore aggregation of power for bulk transmission to the Grid
- overland transmission of power to the Grid.

10.14 The estimated annual efficiency of this final stage of the power chain is 85%. This figure is a little lower than that of conventional power systems, but the seasonal nature of the wave resource means that the transmission system would operate at part-load for longer periods than a conventional system.

Overall Station Efficiency

10.15 The efficiencies of the three stages of the power chain, namely device capture (about 40%), the power plant (about 60%) and power collection and transmission (about 85%) are discussed above. The overall efficiency of a wave power station from the sea to the Grid is simply the product of these three efficiencies and could be expected to be of the order of 20%.

Definition of a 2GW Power Station

10.16 The seasonal nature of wave power means that a wave power station would operate at its nominal power rating for only a small fraction of the year. For the purposes of the present costing exercise, a 2GW wave power station has been defined as one which could deliver 2GW for 5% of the year. The figure of 5% would be readily achievable within the average annual sea climate and avoids the unrealistic situation where a 2GW wave power station is so rated that it could only deliver a momentary peak of 2GW.

10.17 With this definition, a 2GW wave power station would be capable of delivering greater than 2GW for short periods. In the present studies, stations have plant ratings in the range 2.1-2.9GW depending upon the particular device performance characteristic.

Mean Annual Output of a 2GW Wave Power Station

10.18 Estimates of the mean annual output of the wave power stations under consideration range from 280-430MW and this is shown in Fig. 10.3. The most likely value in this range is approximately 425MW and this represents 3.7 TWh of energy per annum or about 1.5 Mtce per annum.

Load Factor

10.19 When comparing the performance of different devices or device systems in different wave climates, the mean annual power output is not a very convenient measure because, whilst it takes into account the availability, it does not take into account the utilisation of the costly power plant. A more useful measure, which includes both factors, is the load factor or the mean annual power output expressed as a percentage of the power plant rating. Studies show that the load factor of a wave power station would generally be in the range 10-20% (Fig. 10.3). By comparison, the load factor of a conventional power system is of the order of 65%.

10.20 The load factor of a wave energy system could be increased by decreasing the power plant rating below the optimum for maximum power extraction. This would allow the power plant to operate for a greater proportion of the year, which could be of benefit in some applications, but the mean annual power would be greatly reduced with only a marginal saving in the capital cost of the system. Thus an improvement in load factor could be achieved only at the expense of an increase in the unit cost of the landed energy.

Summary

10.21 Studies of the reference designs produced during the programme concluded that the performance of a wave power station would be characterised by:

- a low overall power conversion efficiency of about 20%
- a mean annual power output which would be a small fraction of the power plant rating, generally in the range 10-20%.

Fig. 11.1 The costing detail for the various 2 GW wave power stations

COST ITEM	BRISTOL CYLINDER	SEA CLAM	EDINBURGH DUCK	LANCASTER FLEXIBLE BAG	NEL BREAKWATER	NEL FLOATING TERMINATOR	BELFAST OWC	VICKERS TERMINATOR	VICKERS ATTENUATOR
CONSTRUCTION (INC. FACILITIES)	£M 825	£M 1430	£M 1580	£M 3120	£M 1640	£M 1900	£M 2190	£M 1910	£M 1955
MAIN POWER UNIT AND ANCILLARIES	630	825	810	1105	950	1125	740	770	770
INSTALLATION AND/OR MOORING	1555	260	205	750	890	690	800	1035	775
POWER COLLECTION AND TRANSMISSION	920	1015	580	1530	860	965	870	800	800
TOTAL CAPITAL COST	3930	3530	3175	6505	4340	4680	4600	4515	4300
ANNUAL OPERATIONS & MAINTENANCE COST	92	67	—	50	47	57	58	41	41

- Costs are those presented by RPT in the 1983 Assessment report and are undiscounted, May 1982 values.
- Only the mode value of the cost ranges is shown.
- Uncertainty is indicated as an 'average' for all devices. Individual devices can vary considerably.
- The Annual Operations & Maintenance costs do not include the cost of spare plant and scheduled replacement items.
- It has not been possible to cost the annual operations and maintenance cost for the Duck.
- The Power Collection and Transmission costs include £130M for the cost of interconnection between Skye and the Grid at Craigoyston.

11

The Cost of Energy from a Wave Power Station

Introduction

11.1 Throughout the programme the likely cost of electrical energy generated by devices has been assessed by the Consultants – in later stages using reference designs of a 2GW wave power station. Although the cost of energy could be measured in a number of ways, the unit selected in the cost assessment was pence per kilowatt-hour of energy delivered. This cost was used as a measure of the progress made by the various teams towards their final objective of producing energy at a competitive price.

Calculating the Cost of Wave Energy

11.2 The simplest way of calculating the cost of wave energy is to divide the total cost of a wave power station (capital and interest cost plus the costs of operating and maintaining it) by the energy the station delivers to the Grid.

11.3 In practice, the calculation is rather more complicated than this because it is necessary to take into account the fact that it would take a long time to build a station and it could begin to operate before it was actually complete. Calculations of cost and energy are therefore discounted back to an initial or base year with a discount rate chosen to relate to the rate of interest possible from alternative uses of the capital employed. Discounting these calculations enables the preference for benefits now or later to be quantified.

11.4 Care must be taken when attempting to compare the costs of the energy from a wave power station, as calculated above, with the costs from other renewable or conventional sources of energy. This comparison is best made by comparing benefit to cost ratios of each energy source and this is discussed in Chapter 12 – The Economics of Wave Energy.

The Capital Cost of a Wave Power Station

11.5 The construction, assembly and installation of a wave power station, together with the necessary electrical interconnection with the Grid, would be a considerable undertaking and require the total investment of several billion pounds. The power station would, however, be made up from self-contained groups of devices, which would allow the building of the station in stages and provision of energy to the Grid before the construction was fully complete.

11.6 For costing purposes a wave power station is divided into a number of 'cost centres':

- device structure
- mechanical and electrical (M&E) plant
- installation and mooring
- power collection and transmission.

Fig. 11.2 Assessed cost of energy (example)

COST RATES

- Structure
- M & E
- Installation
- Maintenance

Discounted cash flow

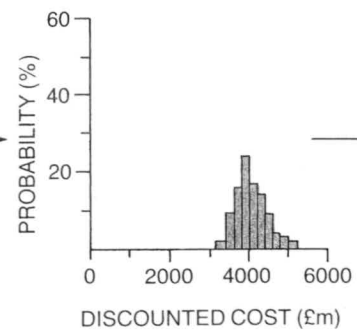

NPV of expenditure

TIMING

- When money spent
- When electricity delivered

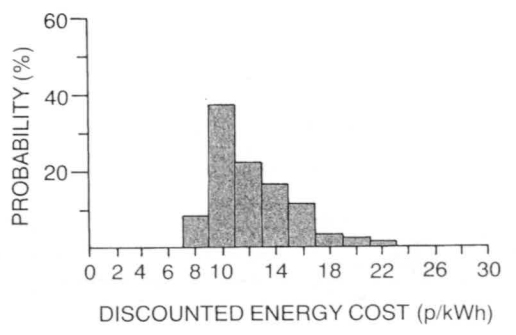

p/kWh

PERFORMANCE

- Energy capture
- Conversion efficiency
- Availability factor

Electrical energy to Skye

Discounted energy

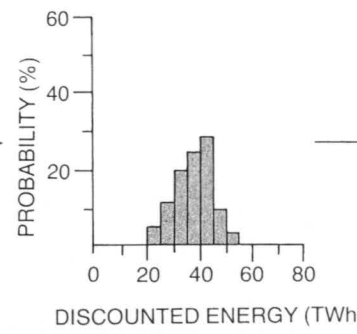

NPV of electrical energy

11.7 Some elements of a wave power station are difficult to cost and considerable uncertainty has to be attached to the final cost estimates. In order to allow for these uncertainties, the estimates for each element of the cost centres have been allocated tolerances leading to a probability distribution for the overall cost. In choosing these tolerances, considerable care has been taken to ensure that the necessary engineering judgements have been made in a consistent fashion.

11.8 Fig. 11.1 shows the breakdown of capital costs for the wave energy devices assessed in the 1983 report, presented as the mode values of the Consultants' undiscounted cost ranges. They are in general based on an engineering approach which relied where possible upon established technology, nevertheless there are significant uncertainties in all the values, largely due to the lack of detail design.

Device Structure

11.9 The device structure would contribute about 30-40% to the total capital cost of a station and in general there was good agreement in this area between the Consultants and the device teams. Consequently the uncertainty associated with this cost item is low. The cost estimates have allowed for the vast size of the scheme and some economies of scale which are believed to be achievable include:

- savings in overheads (11%)
- savings from large scale, long-term buying of materials (10%)
- savings from a reduction in labour needs due to wide and efficient use of construction plant (40%).

11.10 Structure costs range from those for the CYLINDER which is a relatively simple concrete cylinder, to the LFB which is a complex assembly of pre-formed modules.

Mechanical and Electrical Plant

11.11 The mechanical and electrical components of a wave power station could together account for about 20% of the total costs. Most of the items in this cost centre would be conventional components, albeit used in a unusual environment or subjected to an abnormal duty cycle; the uncertainty in their costs is therefore low. Some of the components would, however, be novel, for example self-rectifying air turbines and some of the hydraulic equipment proposed for the DUCK, and the costs of these items have been given fairly wide tolerances.

11.12 It is in this area that some of the largest differences between the cost estimates of the development teams and Consultants lie. Fortunately, the novel items usually represent a small fraction of the total cost centre so the differences have little effect on final energy costs. It is difficult to assess the cost of development of a novel item and then to estimate its unit cost when produced in the hundreds or thousands needed for a wave station. In many cases no detailed designs are available and estimates necessarily require wide tolerances.

Fig. 11.3 An example of cost and energy profiles for a 2 GW scheme

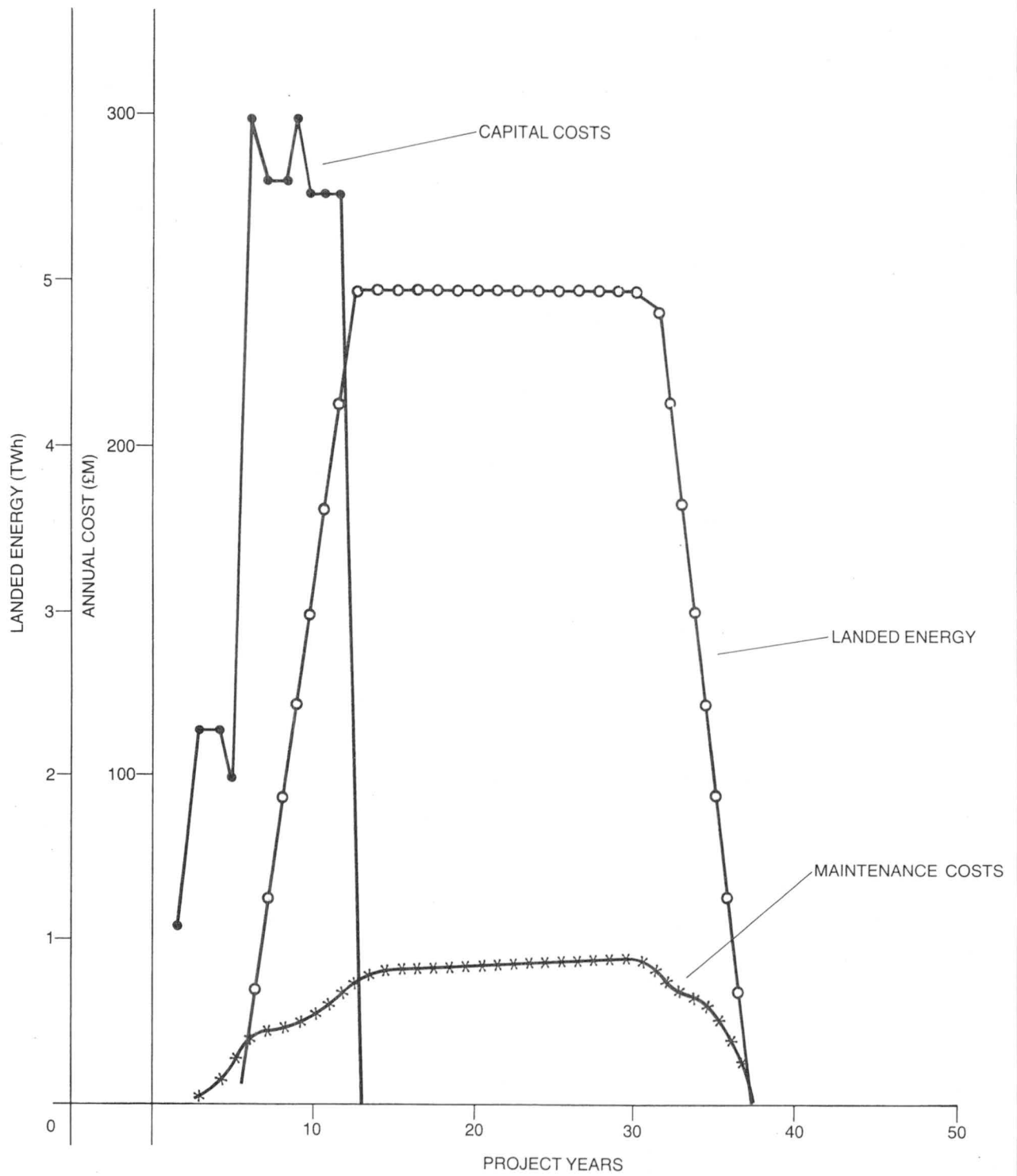

11.13 Mechanical and electrical costs fall into a relatively narrow band at the low cost end of which is the CYLINDER with relatively few items of plant on central platforms. At the high cost end are floating devices which would require many units of low rating.

Installation and Mooring

11.14 Installation and mooring costs are very device-specific because of the different concepts involved. Expressed as a percentage of the capital cost of the station, they would be lower than 10% in the case of the compliantly moored deep water devices, around 20% for the conventionally moored devices, and over 40% for the CYLINDER in which the power take-off costs are included with the moorings. The uncertainties associated with installation and mooring costs are less than in other cost centres, mainly because experience gained in recent years in adverse environmental conditions such as the North Sea has been used in extrapolating costs.

Power Collection and Transmission

11.15 The cost of collecting power from all the devices in a station and transmitting it to the Grid is broadly similar for each of the devices and would represent approximately 20% of the capital cost of the station. No allowance has been made in these costs for Grid strengthening (see Chapter 8) which would not be needed for a single 2GW station. Despite the relatively conventional technology and the data available on laying long cables off-shore, it has proved difficult to reconcile development teams' and Consultants' views on costs in this area. The sensitivities of final energy costs to cable-laying costs are, however, such that the disagreement has no material effect on the cost-of-energy calculations.

Operation and Maintenance Costs

11.16 In general, operation and maintenance aspects of wave power stations received less attention from development teams than the design and performance of devices. A general study was therefore undertaken to determine the appropriate maintenance philosophy for a wave power station, the level of resources required and the costs of those resources. The sensitivity of the cost of energy to such things as availability of devices, significant wave heights in which maintenance could be undertaken and provision of spare devices was determined. Experience gained from offshore oil and gas operations in difficult environmental conditions was used in these studies.

11.17 A major uncertainty in this area is the accessibility of the wave power station because of limited 'weather windows'. It has, for example, been assumed that maintenance could be carried out on a device in a significant wave height of three metres. If access could be gained only in calmer sea states, the number of days available for maintenance in a year would be much reduced and costs would rise significantly. Certain maintenance operations require prolonged periods of calm weather which could not be forecast with accuracy. The maintenance costs calculated have been based on the need to keep wave power station availability up to around 70-90%, or generally better than coal-fired, on-land generating systems.

Fig. 11.4 Wave energy cost breakdown

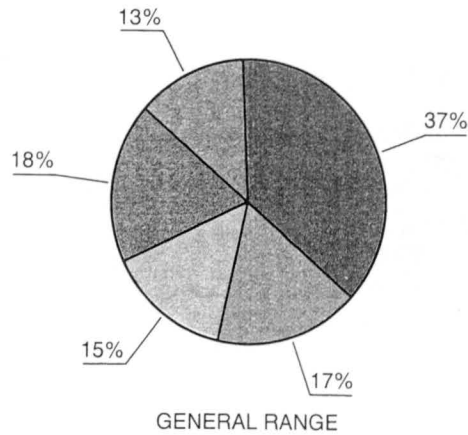
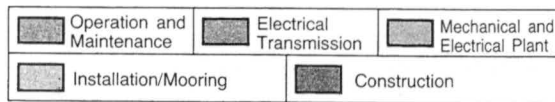

The cost breakdowns for most of the devices assessed by the Consultants fall into the general range illustrated by the pie-chart above. The predominant cost is that of construction which is due to the massive structures needed.

Examples of cost breakdowns of devices which did not fit into the general range are shown below. The LFB costs are dominated by the construction costs of a particularly massive, complex spine; the CLAM has relatively low mooring costs. The CYLINDER has very high mooring costs because these include a portion of the power take-off costs and its maintenance costs reflect the cost of underwater maintenance.

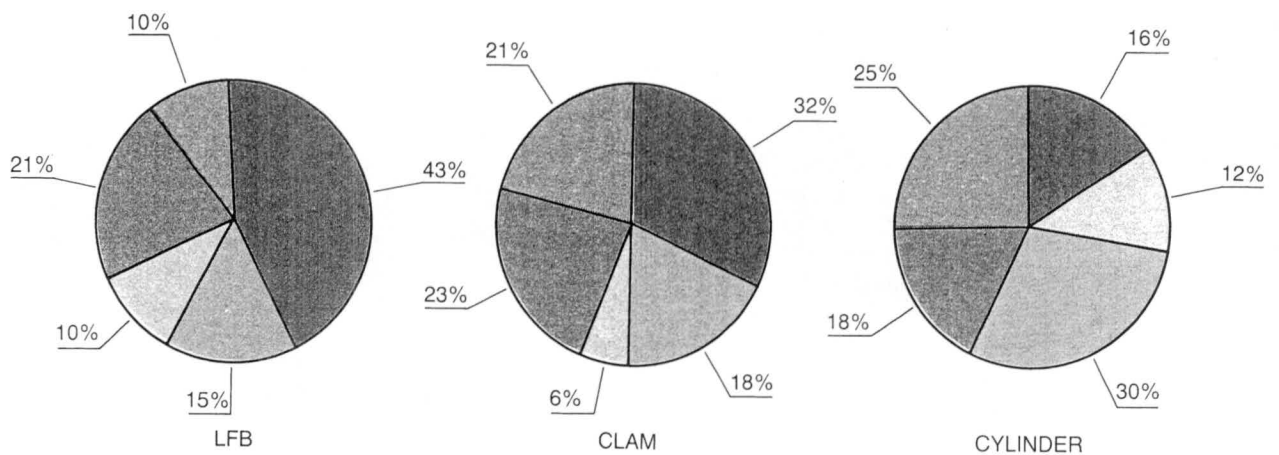

Energy from a 2GW Station

11.18 For reasons discussed earlier in this report it would not be possible for a 2GW station to deliver 2GW of power to the Grid the whole year round. It is customary to talk of the power output of a wave energy station in terms of its mean annual power output, or that power which, on average, it could deliver for 8,760 hours a year. This is calculated by taking into account the efficiencies of the system and the availability of the station, this latter taking into account maintenance and reliability. Typically, a 2GW wave power station would have a mean annual power output of approximately 425 MW representing 3.7 TWh of energy per year, or approximately 1.5 Mtce per year.

11.19 The calculation of the energy produced by a wave station represents the most uncertain factor in the cost equations. It relies upon an accurate determination of the energy produced by each of the thousands of converters in the station. The uncertainties lie in the fact that with the exception of the CLAM, the RAFT and an early design of the DUCK, none of the devices has been tested at scales larger than one-fiftieth or one-hundredth and calculations of their energy output depend on extrapolation from these small scales to full scale with numerous compensating factors applied.

11.20 In the early days of the programme, there was uncertainty about the number, frequency and height of waves which would be encountered by a station and different results were obtained by teams which used different assumptions. This source of uncertainty was eliminated with the building of two wide wave tanks capable of generating predetermined wave spectra in which different devices could be tested to consistent standards.

11.21 At the scales at which devices were tested, many parameters which can be neglected at full scale become significant, for example, parameters associated with surface tension, skin friction and air compressibility. It is also difficult to manufacture model components, particularly flexible elements, which correctly model characteristics such as stiffness and inertia. Correction factors must therefore be applied to allow for such scaling errors and these may typically be as high as 20%, causing much debate between the development teams and the Consultants.

11.22 Although it may be said that the cost differences tended to arise because of the natural optimism of development teams, there are many instances where the Consultants' costs have proved to be lower than the device teams. In general, agreement between the two parties has been encouragingly good, considering the uncertainties involved.

The Consultants' Cost Model

11.23 Fig. 11.2 shows a schematic diagram of the form of the model used by the Consultants to calculate the cost of energy produced by each device. Although the calculation of energy is basically straightforward, the value of the model lies in its application of tolerances to uncertain numbers and the consideration of probabilities that costs would fall within the tolerances assumed. It is now possible to give ranges of energy costs and also to determine the effect on overall costs of significant changes in any of the cost centres. The model is also sufficiently flexible to be able to apply different probability distributions to costs for different devices if, for example, costs of one are far better known than for another. As well as allowing for tolerances and distributions because of uncertainties in design, a contingency has been added as is the practice in the engineering industry.

Fig. 11.5 The probability distribution of the cost of energy

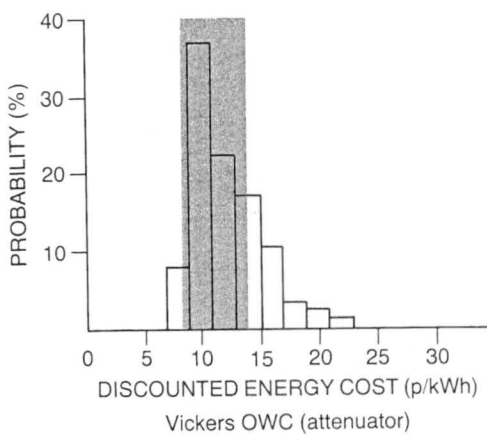
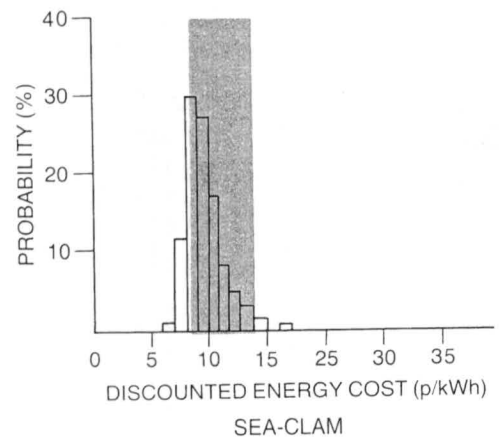
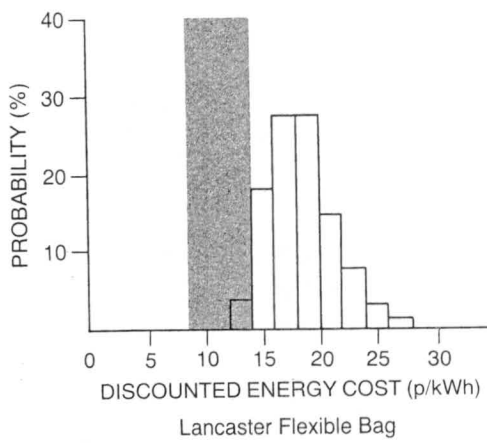
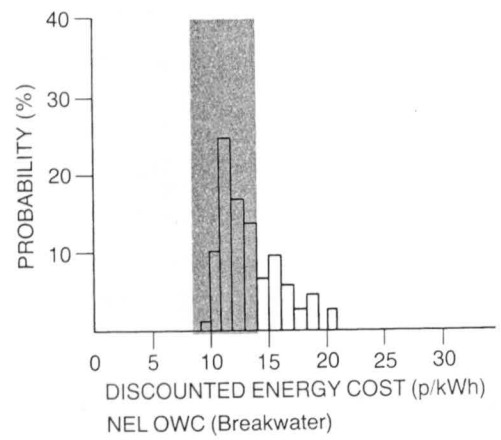
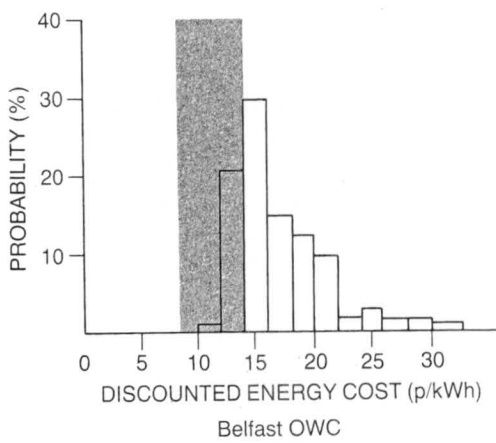
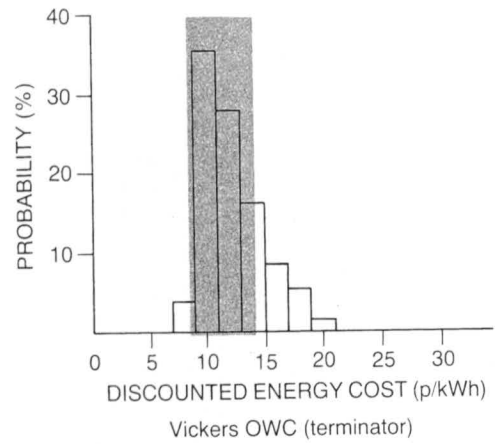
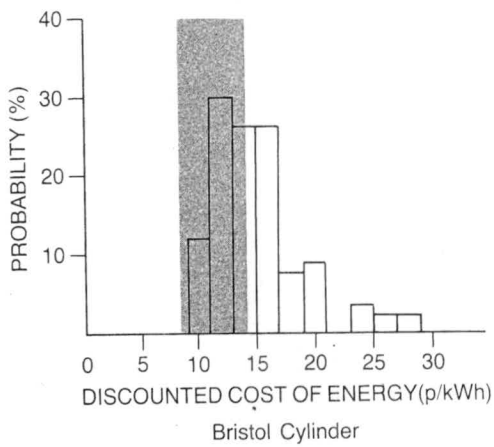

The shaded bands cover the range 8 to 14 p/kWh. It will be seen that there is a small probability of any design achieving an energy cost below this range.

11.24 Fig. 11.3 shows a typical cost/power profile for a 2GW wave energy station, revealing the expected build-up of capital costs, maintenance costs and the amount of energy landed. Fig. 11.4 shows how the major cost elements of a wave power station contribute to the cost of energy.

Results of the Cost Assessment

11.25 Most of the devices subjected to the Consultants' assessment would produce energy at an estimated cost in the range of 8-14p/kWh. The probability distributions for each device are shown in Fig. 11.5.

11.26 Scope for reduction in these energy costs is limited by cost centres which are common to all devices. The greatest scope would appear to be in improving converter efficiency to extract more energy from the waves but reduction of structure – and hence capital – cost would also have a very significant effect.

The 'Special Case' of the DUCK

11.27 Most of the devices subjected to a cost-of-energy assessment exhibit sufficient similarities for the general approach described to be valid. There are similarities between, for example, the LFB and the CLAM and the OWC's are a family of devices. The DUCK, however, is sufficiently different from the other devices to be treated as a special case.

11.28 The DUCK was conceived in accordance with one important principle – to maximise energy capture from a given sea, regardless, initially, of other considerations such as optimisation of output. In following this philosophy the team took the hydrodynamically elegant concept of the nodding duck and added hydraulic power take-off with its inherently high volumetric energy density, gyroscopic frames of reference which incorporated energy storage, vacuum technology to reduce losses and a sophisticated monitoring and control system to implement control strategies capable of improving capture. The penalty in following this approach is the costly development needed to achieve practical designs.

11.29 The result is a sophisticated concept which, if successfully developed, offers a potential performance well in excess of that of other devices. It is, however, the antithesis of the rugged, current-technology approach favoured by many, particularly those who saw early sea-trials as important. The DUCK can only be considered as a second generation wave energy device with no guarantee of successful development and with questions to be asked of its capacity for sustained operation in an offshore environment.

11.30 The Consultants were unable to derive a cost of energy for the DUCK because their assessment concluded that its availability was unacceptably low. More recent work undertaken by ETSU has allowed the DUCK to be subjected to a cost-of-energy assessment consistent with the other devices, using the availability model. This work made the assumption that a development programme would be successful in solving the engineering problems which prevented the Consultants from carrying out their assessment.

11.31 With the DUCK represented as four sub-systems, the model was able to calculate the maintenance resources necessary to achieve sensible availabilities. Using this data, together with the Consultants' capital and output figures, the cost of energy from the DUCK might possibly be 5p/kWh. This figure must be treated with a great deal of caution. Not only has a successful development programme been assumed, but the capital and maintenance costs have not been re-appraised. Furthermore, current work in ETSU on parametric costing suggests that the capital costs derived in 1983 for all wave energy devices were optimistic. The uncertainties surrounding this latest assessment and the assumptions made in it lead to the conclusion that the economic attractiveness of wave energy is not at this stage mis-represented by the Consultants' figures of 8-14p/kWh.

Fig 12.1 Costs of electricity generation in year 2010

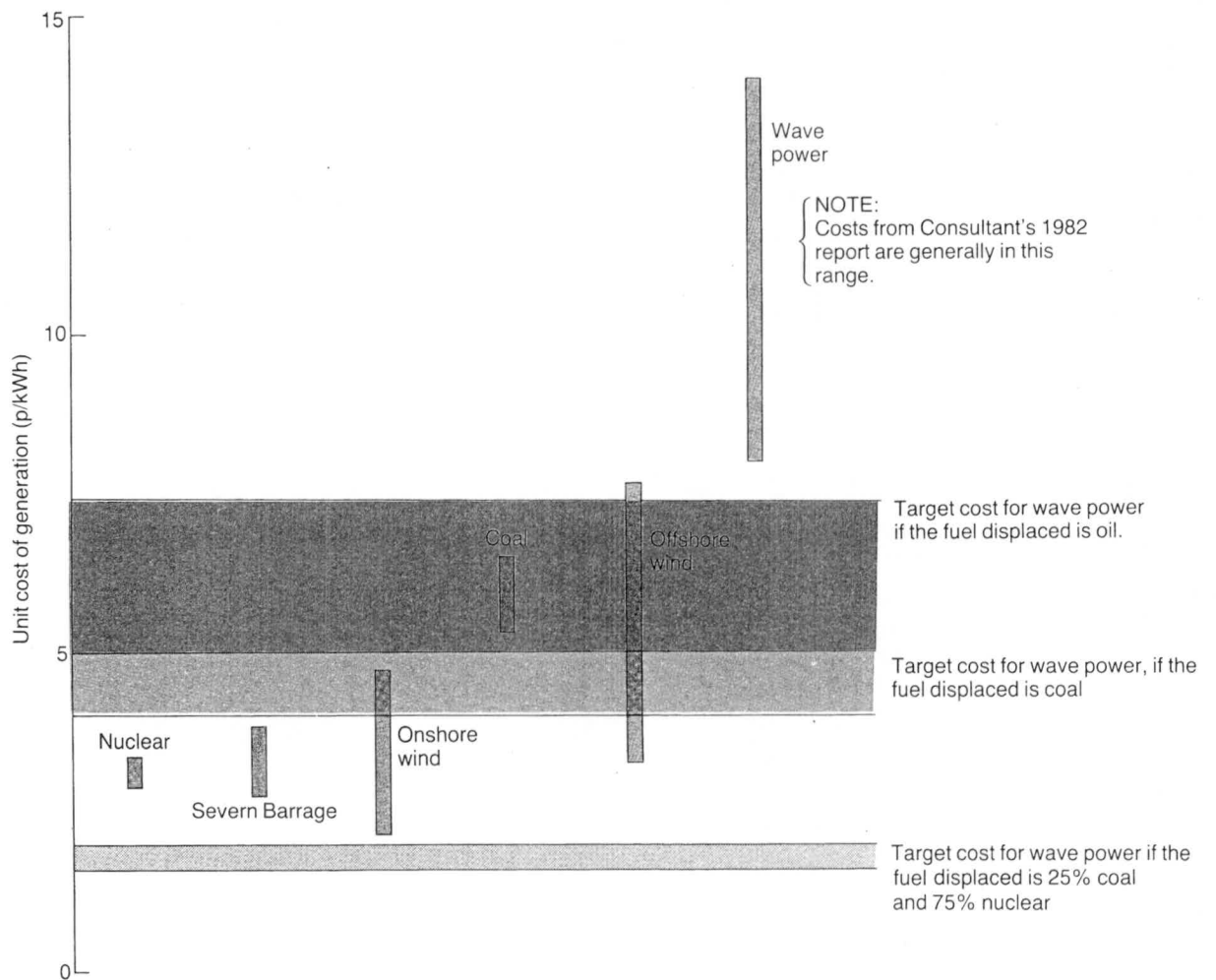

Notes:

- All costs are shown in May, 1982 money values.
- All cost data except those for wave power are taken from the Strategic Review of the Renewable Energy Technologies
- The fuel prices used to derive the target costs are those in Scenario IIM for the year 2010. Scenario IIM represents the mid-range assumptions for nuclear growth, demand growth and fuel cost rise.
- The wave power cost range includes the estimated cost of most of the devices assessed to date. Some devices have been excluded because their estimated cost of power is believed to be either too high to warrant further development or they cannot be assessed on the basis of current technology.

12

The Economics of Wave Energy

Introduction

12.1 One of the main factors which determine whether wave energy would be exploited is its economic attractiveness relative to other sources of energy, both renewable and non-renewable. A thorough examination of the economics of all the renewable energy technologies was undertaken by ETSU in 1982 and published as the 'Strategic Review of the Renewable Energy Technologies'.

12.2 The conclusions reached by the Strategic Review that wave energy is at present economically unattractive on a large scale has been confirmed and indeed strengthened both by the most recent Consultants' cost assessment and by further economic analysis.* Because the Strategic Review and the later work dealt with the subject so thoroughly, this report gives only a summary of the findings.

A Simplified Economic Analysis

12.3 A first indication of wave energy economics can be obtained by considering whether savings in fuel made by using wave energy exceed the cost of a wave power station. Fig. 12.1 compares the currently-assessed wave energy costs of 8-14p/kWh with crude values of fuel savings from other sources of energy. This figure clearly suggests that, on this basis, wave energy is not at present economically attractive even when compared with other electricity-producing renewable energy sources – a conclusion that the more detailed investigation using models of the electricity supply system and scenarios of the future energy scene confirms.

12.4 The Strategic Review derived ratios of the discounted benefits to discounted total costs for wave energy in various scenarios of the future energy scene in the UK. The benefits arise from the value of the energy generated and the costs are those of building and operating the station.

12.5 The nine scenarios chosen covered high, medium and low fuel price rises and demand growth and high, medium and low rates of installing nuclear power. For each of these scenarios, the benefit/cost ratio of wave energy was calculated using typical data on wave power station performance derived from the programme. The economics of wave energy are most attractive in scenarios which combine a high rate of rise in fossil fuel prices with a low rate of installation of nuclear plant.

12.6 In the latest economic assessment, the Strategic Review methodology was again adopted but the currently-assessed wave energy costs of 8-14p/kWh were used. In none of the scenarios considered did wave energy benefit/cost ratios reach unity, and only in the most favourable case did the ratio reach 0.9 (and then only at the lowest energy cost figure of 8p/kWh). In the scenarios used by the CEGB, wave energy is even less attractive than in the Strategic Review.

*'The Economic Analysis of Wave Energy' H. G. Tolland and J. F. Walker. Paper presented at Alternative Energy Systems Conference, Coventry, September 1984

12.7 Benefit/cost ratios can be used not only to judge the economic acceptability of an investment but also to rank investment options. Wave energy fails to pass the first test with currently available designs and it is ranked last when compared with other renewable and conventional sources of electrical energy. Furthermore, if investment in the competing renewable energy technologies takes place, the economic benefit of wave energy decreases, making it even less attractive.

Sensitivity Analysis

12.8 The latest economic analysis involved exploring various options including longer station life, higher load factors and changes in discount rate, but the overall economic picture did not change sufficiently to improve the economic prospects of wave energy.

Small-scale Wave Energy

12.9 The economic examination of wave energy discussed above was carried out in the context of renewable energies being used to supply energy on a large scale to the Grid. On a smaller scale, for example on small islands, the economics may be much more attractive when the normal electricity supply is derived from diesel-driven generators.

Prospects for the Improvement of Wave Energy Economics

12.10 A significant reduction in the cost of wave energy must be achieved if it is to become economically more attractive. Such a reduction can only be achieved by reducing the cost of stations, by increasing the efficiency of energy capture, or both.

12.11 Prospects for reducing costs, which are essentially capital and maintenance costs, do not appear good. Capital costs of all the devices assessed are dominated by the costs of the large number of massive structures needed and the M&E plant costs have the economic disadvantage associated with turbine generator units with small ratings. The scale of wave power stations and their locations – remote from industrial centres and consumers – causes transmission and maintenance costs to be relatively high.

12.12 On the other side of the equation, significant improvements in energy capture must be achieved to reduce energy costs. Although techniques such as 'harbour walls' have been shown to increase capture, they are usually associated with increased capital costs. Devices can already be designed for 100% energy extraction at resonance but the variability of waves on an individual and seasonal basis will always tend to keep energy extraction efficiencies low.

13

Impacts on Man and the Environment

Introduction

13.1 When considering the possible impacts of wave power stations on man and the environment it is important to bear in mind that a typical 2GW station would extend over some 100 km and comprise several hundred separate devices. Any environmental effects from such a station might therefore be felt over a wide area.

Characteristics of Devices

13.2 Among the characteristics of wave stations which may have environmental implications are:

- the areas of sheltered water they would create
- the noise they would make
- the attraction they would have for fish, seabirds, seals and seaweed
- the effects they would have on tidal currents.

The sheer scale of activity involved in building a station would have environmental implications around the construction sites.

Coastal Effects

13.3 A wave power station would modify the local wave climate. Floating devices with low freeboard well out to sea would probably have little or no effect on the coastline but a station of bottom mounted devices might. A decrease in the wave energy incident upon shores and shallow sub-tidal areas could result in changes in the density and species of organisms they support. Along the west coast of Uist the shore is predominantly an extensive shell-sand beach and any decrease in wave activity and wave steepness could deposit more sand on these beaches if sufficient sediment is available.

Effects on Fish and Fishing

13.4 The areas around UK coasts most suitable for locating wave power stations tend to overlap the areas which produce the largest catches of fish such as herring. Modification of drift currents might alter the survival of herring larvae, though on the basis of present limited knowledge this appears unlikely. Herring spawn on the gravel areas of the seabed off the Hebrides and major disturbance or removal of the gravel for construction purposes appears inadvisable.

13.5 The Hebrides are also important for salmon and it has been suggested that a wave power station could affect their navigation. The devices might also create a favourable environment for large colonies of predatory birds, which might feed on the young salmon (smolts) and of seals which might feed on the adult fish. These possible effects are largely conjecture at present and further investigation might well determine they need not be considered.

Navigation of Ships

13.6 Wave energy devices would present a hazard to shipping because of their low freeboard which would render them relatively invisible either by sight or by radar. The devices would need to be properly marked and navigation channels left in device arrays. Most of the shipping off NW Scotland is concerned with fishing but clearways for oil tankers to and from Sullom Voe would need to be provided if stations were located off Orkney. Additional complexities would arise in other areas, for example, internationally agreed clearways for shipping would need to be taken into account for wave power stations around the Isles of Scilly.

13.7 Wave energy devices drifting as a result of mooring failure would also present a navigation hazard, not only to ships but to coasts and harbours to landward of a station. Studies carried out on loss rates and mooring failures show that a number of devices might suffer mooring failures in a year. Repair resources would need to be deployed sufficiently rapidly to retrieve them before they reached land.

Economic and Social Development of Communities

13.8 Introducing the industrial infrastructure associated with wave energy would be a formidable task but could contribute to a reversal of the present trend in the Outer Hebrides towards a declining population and high unemployment. While construction of the devices may take place elsewhere because of the high tonnages involved, supply and probably much of the maintenance would be from relatively local bases. Major work would require deep well-sheltered water which could be found in a Scottish sea-loch.

Visual Amenity

13.9 The land-based collection and switching stations and the transmission lines could give rise to serious visual amenity problems. Power would need to be carried across Skye and over the mainland to either Craighoyston or Blairgowrie. This would involve crossing areas of outstanding natural beauty and the choice of the 300km route would require great care. Grid reinforcement to Glasgow and on to the English Midlands would also be required for larger installations.

13.10 The choice of transmission route is likely to prove difficult and may be crucial to the acceptability of wave energy.

Risks to Personnel

13.11 Although wave energy stations would be unmanned during normal operation, personnel would be required for installation, maintenance and repair tasks, all of which would be hazardous. However, it is not expected that fatality rates would be any worse than those already experienced in existing fields such as shipping operations and offshore oil and gas operations. The actual jobs would be particularly attractive, involving long journeys to the station by helicopter or ship and cramped working conditions, exacerbated in the case of floating devices by their pitching and rolling.

Environmental Impact

13.12 The environmental studies carried out did little more than identify potential problems and make some preliminary assessments, concentrating on locations off the Outer Hebrides. Areas studied included effects on nature conservation, fish, navigation, the social/economic development of communities and visual amenity. The conclusion reached was that the exploitation of wave energy may not be environmentally benign.

14

Programme Achievements and Prospects for the Future

- 14.1** The programme set out to determine whether it was feasible to extract energy from ocean waves and to estimate what this would cost if wave energy were used on a large scale to supply UK needs. The designs of wave power stations produced during the programme showed that such stations could be feasible but the estimated costs of energy from them were too high in comparison with other energy sources to justify proceeding to the demonstration stage.
- 14.2** Work on collecting and analysing wave data advanced our knowledge of the wave climate considerably but highlighted one of the main draw-backs of wave energy – the variability of the energy in the waves. The programme explored various concepts for converting wave energy and was able to eliminate many types which for various reasons were economically unattractive.
- 14.3** The study of deployment of large power stations off NW Scotland produced reference designs which were sufficiently detailed to carry out an evaluation of their costs. This exercise also revealed the sheer scale of the operations which would be involved in building such stations.
- 14.4** Much was learned about the problems of installing and mooring floating and fixed devices. Significant results were obtained from tests of compliant moorings designed to withstand wave forces while ensuring the survival of a device.
- 14.5** The unique features of wave power stations with hundreds of devices strung over tens of kilometres presented electrical engineers with unusual design problems. Systems were designed to collect power from thousands of individual generating sets with aggregation to a single transmission line to the Grid.
- 14.6** Computer modelling techniques proved to be the most suitable way of determining the maintenance philosophies and costs associated with a wave power station. Much is now known about the level and type of maintenance and repair resources which would be needed to support such a station.
- 14.7** Materials research carried out in the programme and research results from other programmes suggest that there are no insurmountable materials problems associated with wave power stations.
- 14.8** The programme relied upon model testing to confirm experimental work and sophisticated techniques were developed for processing large amounts of experimental data and for compensating for scaling effects.
- 14.9** Despite the attractions of a renewable energy resource, wave energy may not be environmentally benign and the areas where investigations will need to be carried out before considering deployment of wave power stations were identified.
- 14.10** A thorough economic analysis against various scenarios of the future determined the relative attractiveness of large-scale wave energy compared with other sources, renewable and conventional. It was this analysis which provided the data on which the decision to reduce wave energy research was made.

14.11 The programme was notable for the formation of development teams based on research bodies, such as universities, closely integrated with industrial partners who provided the engineering expertise needed to take theoretical concepts to the design stage.

14.12 "Spin-off" from wave energy research includes:

- tube springs, which show promise in providing controlled mooring loads
- Wells turbines which are being built under licence in Japan for use in navigation buoys
- energy storage flywheels for electrical distribution systems and vehicles (particularly in mines)
- hydraulic drive systems, applicable to wind turbines.

Prospects for the Future

14.13 Wave energy R&D continued to be funded beyond 1982 by the Department of Energy but at a more modest level. The objectives of the reduced programme were to establish the likely minimum cost of generating electricity from the best of the current types of device, and any new devices which emerged during the programme.

14.14 Theoretical aspects of wave energy continue to be researched at the University of Edinburgh and The Queen's University of Belfast. Edinburgh are using the wide wave tank to study the behaviour of various types of spines, the effects of extreme waves and mooring forces; Belfast continue to develop the Wells turbine. Other theoretical studies outside the Department's programme, funded by CEGB and SERC, are available to cross-fertilise research. The Department of Trade and Industry has provided funds for further study of a modular version of the NEL Breakwater.

14.15 Development of a one-third scale, 1000kW CLAM at Lanchester Polytechnic, jointly funded with SEA, has provided a measure of progress of designs towards minimum cost, albeit at small-scale. The CLAM team had access to the results of the theoretical studies to aid them in their design.

14.16 Prospects for wave energy as a large-scale supplier of power to the Grid are at present poor due to its economic performance when compared with other energy sources, renewable and conventional. This situation is unlikely to change as long as fossil fuels and more economic renewable energy sources are available. The diffuseness of wave energy, its distance from consumers and the sheer scale of the engineering problems needed to capture it will not change significantly, at least in the foreseeable future.

14.17 Prospects for wave energy on a small scale appear brighter because it will then be in competition with expensive fuels such as diesel, although it will also face competition from wind energy. The most promising way ahead is to prove the feasibility of small devices to generate electricity reliably and cheaply before re-considering the use of wave energy on a large scale. Progress with the smaller CLAM and the modular Breakwater will be watched with interest as this will be a pointer to the future of wave energy.

15

International Wave Energy Research

Introduction

15.1 The UK is not the only nation to have carried out a research programme into wave energy, however it is probably true to say that the UK programme has been the most comprehensive in terms of the scope of the research and the knowledge gained of large scale generation of electrical power from waves. The absence of wave energy research elsewhere in the world was a major factor in the decision to create a UK programme.

15.2 The UK as a world leader in this area of research has been kept informed of progress in other nation's research programmes and through the auspices of the International Energy Agency has been, and will continue to be, involved in international co-operation. This chapter summarises the progress made by those nations who have undertaken wave energy research on a significant scale.

Japan

15.3 If there is a pioneer in wave energy exploitation, it must be the Japanese Commander Yoshio Masuda. As early as 1947 he built and patented a wave powered navigation buoy and hundreds of this type of buoy are now deployed around the coast of Japan. Commander Masuda remains in the forefront of Japanese wave energy research.

15.4 The main Japanese effort in wave energy research has been directed towards large scale at-sea testing of oscillating water columns on a floating barge. The experiment, called the Kaimei experiment after the name of the barge, is the only research programme on wave energy which was carried out under the auspices of IEA. In addition to Japan, the UK, Canada, Ireland and the United States participated in the experiment.

15.5 The 800 tonne, 80 metre barge was moored in the Sea of Japan and carried eight oscillating water column experiments each intended to generate about 125 kW. The main objectives of the experiment were to:

- obtain wave and wind statistics
- analyse the effect of wind and wave on the barge and on its wave energy absorption characteristics
- evaluate the conversion process from wave energy to electrical energy
- determine the feasibility of supplying electricity to the shore
- determine scale effects between tank testing and the full scale test.

One of the experiments used an air turbine designed and constructed by a UK company, Centrax Ltd.

15.6 Although the Kaimei experiment provided the programme with open sea experience at a scale considerably larger than the tests in the Solent and Loch Ness, overall it proved to be of more limited value than expected since the severe motion of the barge, caused by its relatively short length, reduced the efficiency of absorption of the wave energy. The overall efficiency of energy conversion in terms of the electrical output obtained from the wave fronts was approximately 4% when the significant wave height was 3 metres.

15.7 A second sea trial of the Kaimei barge is planned by Japan with assistance from Ireland and the USA. Associated with this and still under IEA auspices, will be an agreement to exchange wave and R&D data arising from national programmes in which the three nations above will be joined by Norway, Sweden, and the UK.

15.8 The main contact with Japan has been through the Japan Marine Science and Technology Centre (JAMSTEC) who have been responsible for the Kaimei work. Other Japanese research has been carried out into a version of the fixed breakwater OWC which might be suitable for supplying power to many of the 500 small populated islands off Japan – at present supplied by diesel. This work has been based on an OWC design which can be fixed in cliff faces and a 40 kW prototype has been tested. The Japanese have maintained an interest in the Wells turbine being developed by Queen's University, Belfast and two private Japanese firms have negotiated licences for the manufacture of such turbines for use in navigation buoys and prototype devices.

Norway

15.9 Initial phases of Norwegian wave energy research paralleled the work in the UK. In 1978 research was being carried out into two completely different concepts:

- a point absorber buoy
- wave focussing.

15.10 The Budal and Falnes buoy, named after its inventors, was essentially a surface-following buoy, moored to the sea bed. Although the development of this buoy has now ceased, it was notable for the phase control system which it utilised to maximise energy extraction. This system controlled the motion of the buoy relative to the phases of the waves thus keeping it in resonance with the waves – a condition in which maximum energy is extracted. Results of this work could be applicable to other wave energy devices.

15.11 The wave focussing concept utilised submerged plates designed to focus waves rather as light waves are in an optical lens. The focussing effect results in higher amplitude waves from which energy can be extracted. The development of this concept continues with a private concern. One interesting off-shoot of this work has been the study of coastal areas where wave focussing occurs naturally because of sea bottom contours.

15.12 Norwegian research is now largely concentrated on an OWC which has industrial backing from Kvaerner Brug. Although similar in concept to the NEL device in the UK, it has refinements including 'harbour walls' projecting towards the oncoming waves which improve the device's efficiency by inducing resonance in the waves at the mouth of the converter. Kvaerner's work on OWCs will continue with the building of a large-scale prototype in a cliff face, initially to prove the concept but eventually to generate power.

Sweden

15.13 Sweden has had a relatively modest wave energy research programme since 1976. Device development has been largely confined to a study of a buoy which is claimed to have a broad bandwidth which allows it to capture energy across a wider spectrum than usual.

15.14 The Swedish company Swedyards remains interested in developing wave energy and is studying a simple buoy system which uses a power take-off rather similar to the tube spring developed in the UK programme. Full scale tests of this buoy began in 1983 and it is intended that a version suitable for export should be developed.

15.15 Because the potential contribution from wave energy to the energy demand in Sweden is likely to be small (1-2TWh/year) Swedish interest in wave energy will be largely confined to observing the international scene and collecting wave data from Swedish waters.

Other IEA Participants

15.16 Of the remaining participants in the original phase of the Kaimei experiment, Canada, the USA and Ireland continue to research wave energy but at very low levels. Canada is restricting its activities to wave data collection. America has dropped wave energy from its national ocean research programmes and is not continuing with its earlier work on turbines, although industrial interest in novel wave energy devices continues. Ireland is continuing to collect data on wave climates off its West coast where power levels appear to be even higher than off NW Scotland. One interesting practical application of wave energy is a natural OWC formed by a cave under a lighthouse in SW Ireland which appears to have potential for generating a significant amount of power.

Mauritius

15.17 One novel application of wave energy which is worthy of mention in a review of international work is the Mauritius scheme. In this scheme a natural reef off the island of Mauritius is well placed to form a foundation for a breakwater. Waves overtopping the specially-shaped breakwater would gradually fill the lagoon behind it and create a head above mean water level which could be used to drive low head turbines. Although this principle is similar to the rectifier rejected early in the UK programme, the natural reef reduces the capital cost of the scheme so significantly that energy costs become economically attractive. The scheme has been researched under the auspices of the Crown Agents but it is not yet known whether it will proceed. Mauritius may be unique in having a suitable reef in the right place, but there might be other Pacific Islands which could use this principle; it is not applicable to UK waters.

A1

Management of the Wave Energy Programme

POLICY Wave energy is one of the renewable energy programme areas (the others are solar, biofuels, geothermal, wind and tide) which form part of the Department of Energy's R&D programme. Policy matters concerning the objectives of these R&D programmes and the allocation of funds to them are decided by the Chief Scientist, his Programme Director and other officials in Energy Technology Division (ENT) in the Department, with advice from a number of Committees.

MANAGEMENT Management of the wave energy programme was carried out by a small team of engineers and scientists at the Energy Technology Support Unit at Harwell under a Programme Manager; most of the contracts for research were placed by Harwell Contracts Branch. ETSU recruited proposals and selected contractors to undertake a programme of research aimed at meeting the Department's objectives.

STEERING COMMITTEE The Wave Energy Steering Committee (WESC) was formed in 1975 with the terms of reference:

- to draw up and agree a national programme of work for the study of wave energy
- to advise on the implementation and management of that programme
- to advise on the technical briefing of UK delegates to international meetings on wave energy
- to report to the Chief Scientist, Department of Energy on matters relating to wave energy.

Members of this Committee were drawn from industry, academic institutions, consultants, officials and ETSU.

WESC was able to draw on detailed technical advice from Technical Advisory Groups of specialists in six areas:

- New Concepts and Devices
- Wave Data
- Structures and Fluid Loading
- Mooring and Anchoring
- Generation and Transmission
- Environmental Impact.

Members of WESC in 1983 were:

Dr P Iredale	Harwell (Chairman)
Mr A M Adye	Science and Engineering Research Council
Mr P J Clark	Rendel, Palmer and Tritton
Dr D Fairmaner	Department of Energy
Dr R A Goodman	Lloyds Register
Mr G A Goodwin	Department of Energy
Mr P G Davies	ETSU (Programme Manager)
Mr R Hancock	Department of Industry
Dr G Long	ETSU
Mr R C H Russell	Consultant (lately of HRS Wallingford)
Dr R G S Skipper	Department of Energy
Mr J Syrett	CEGB
Mr D S Townend	Consultant (lately of BP)
Mr A T L Murray	NSHEB

OTHER COMMITTEES From time to time the Department of Energy consulted its Energy Research and Development Committee (ERDC) in its advisory role on the management of individual programmes.

The Chief Scientist obtained advice and guidance from the Advisory Council on Research and Development for Fuel and Power on the objectives of his research and development programme.

A2

Principal Contractors in the Department of Energy Wave Energy Programme

University of Aberdeen
Advanced Production Systems
A & P Appledore Ltd.
Atkins R & D
Avon Rubber
University of Belfast
Bertlin & Partners
University of Bristol
British Ship Research Association
Central Electricity Generating Board (CEGB)
Centrax Ltd.
Commercial Hydraulics Ltd.
Crown Agents
Easams Ltd.
University of Edinburgh
Foster Wheeler Offshore Ltd.
GEC Energy Systems Ltd.
Gifford & Partners
Harwell Laboratory
Hydraulics Research Station (HRS)
Institute of Oceanographic Sciences (IOS)
International Research & Development (IRD)
Kennedy & Donkin
John Laing Ltd.
University of Lancaster
Lloyds Register of Shipping
London Offshore Consultants
Lucas
Marex
Sir Robert McAlpine & Sons Ltd.
Merz & McLellan
The Meteorological Office
National Engineering Laboratory (NEL)
National Maritime Institute (NMI)
Nature Conservancy Council
The P E Consulting Group
Pirelli Cables
Rendel, Palmer & Tritton (RPT)
Roxburgh & Partners
Royal Military College of Science
Scottish Marine Biological Association
Sea Energy Associates (SEA) Ltd.
Sunderland Polytechnic
Taylor Woodrow Construction Ltd.
Vickers Engineering Ltd.
Wavepower Ltd.
Wimpey Laboratories Ltd.
Wolfson Microelectronics Institute
YARD

A3

Industrial Involvement in Wave Energy Research

In the case of all devices finally assessed, the device development team comprised a research organisation with industrial partners, and these are listed below:

Research Organisation

The Queen's University
of Belfast

Coventry (Lanchester)
Polytechnic

NEL

Vickers (Design and Projects) Ltd.

Bristol University

Edinburgh University

Lancaster University

Industrial Partners

Taylor Woodrow Construction
Davidson & Co.
Kirk McClure & Morton

Sea Energy Associates Ltd.

Roxburgh & Partners

Vickers Engineering Ltd.

Sir Robert McAlpine & Sons Ltd.

John Laing plc

Wavepower Ltd.

A4

A Selection of General Publications on Wave Energy

INTERNATIONAL SYMPOSIA PROCEEDINGS:

1st on Wave and Tidal Energy, Canterbury (BHRA, Bedford 1978)
ISBN 0-906085-00-4

2nd on Wave and Tidal Energy, Cambridge (BHRA, Bedford 1981)
ISBN 0-906085-43-8

1st on Wave Energy Utilisation, (Chalmers University, Gothenburg 1979)

2nd on Wave Energy Utilisation, Trondheim (Tapir, Trondheim 1982)
ISBN 82-519-0478-1

Hydrodynamics in Ocean Engineering, Trondheim (Tapir, Trondheim 1981)

CONFERENCE PROCEEDINGS:

Wave Energy Conference, Heathrow, London (ETSU, Harwell 1978)
ISBN-0-70-580751-7

Workshop, Maidenhead (ETSU, Harwell 1979)

IEE 2nd on Future Energy Concepts, Conference Pub. No.171
(IEE, London 1979)

IEE 3rd on Future Energy Concepts, Conference Pub. No.192
(IEE, London 1981)

BOOKS:

'Ocean Wave Energy Conversion', M.E. McCormick (Wiley, 1981)
ISBN-0-471-08543-X

'Power from Sea Waves', Ed. B.M. Count (Academic Press, London 1980).
ISBN 0-12-193550-7

'Energy From The Waves', D. Ross (Pergamon 1979). ISBN 008-023-2728

'Wave Energy - A Design Challenge', R. Shaw (Ellis Horwood, 1982)
ISBN 0-85312-382-9

MISCELLANEOUS:

'Wave Energy - Energy Paper No.42', Ed. J.K. Dawson. (HMSO, London 1979).

'The Developments of Wave Power', J.M. Leishman & G. Scobie
(NEL Report No. EAU M25 1976).

'Strategic Review of the Renewable Energy Technologies'.
ETSU Report R13 (HMSO, London 1982).

Glossary of Terms

Achievable Resource The power which could be delivered to the Grid from wave power stations at practical locations around the UK coast.

ACORD Advisory Council on Research and Development in the Fuel and Power Industries. It advises the Chief Scientist of the Department of Energy on his R & D policy.

Array The configuration of devices which form a wave power station.

Attenuator A wave device which is aligned with the principal wave direction, and which is at right angles to the wave fronts (Fig. 4.2).

Availability Usually the proportion of a year that a generating station is capable of operation. It is redefined for wave energy as the annual energy delivered to the Grid expressed as a percentage of the potential output of the station assuming perfect operation.

Available Resource The energy in the waves at sites around the UK where the energy density is high.

Benefit/Cost Ratio The ratio of the benefits obtained from a wave power station in terms of the value of the fuel saved to the cost of building and operating the station.

Breakwater Device A fixed bottom-standing terminator.

Bristol Cylinder The device proposed by Dr. D. Evans at Bristol University and developed by Sir Robert McAlpine & Sons Ltd.

Cadnam Tank The wide wave tank built by Wavepower Ltd at Cadnam, Southampton.

Capture Ratio The ratio of power intercepted by a device to the power in a wave front equal to the principal dimension of the device (length of terminator or attenuator, diameter of point absorbers). This is normally unity in the case of a terminator, less than unity for attenuators but greater than unity for point absorbers.

Clam The device developed by Coventry (Lanchester) Polytechnic and Sea Energy Associates Ltd.

Cockerell Raft The device invented by Sir Christopher Cockerell and developed by Wavepower Ltd.

Compliant A term applied to moorings and spines which allow movement of devices to reduce wave forces.

Consultants Rendel Palmer & Tritton, the Consultants to ETSU and WESC who undertook cost and other assessments throughout the programme.

Converter A single unit converting wave energy to some other form of energy. A number of converters assembled together form a device.

Cylinder See Bristol Cylinder.

Device An assembly of converters in a single structure.

Directional Rose A means of displaying the relative power in waves from directions around the compass (Fig. 3.6).

Directionality The factor used in calculating the amount of wave energy captured by a converter to allow for the fact that waves arrive at a converter from various directions with different amounts of energy.

Duck The device based on the ideas of Mr Stephen Salter and developed by Edinburgh University and John Laing Ltd.

ETSU The Energy Technology Support Unit, Harwell.

Fetch The uninterrupted distance over which winds interact with the sea to produce waves.

Frame of Reference The inertial system against which a device reacts when resisting wave forces (e.g. the seabed or mooring).

Gigawatt (GW) 10^9 watts; one thousand megawatts; one million kilowatts.

Grid Reinforcement Upgrading of present transmission lines which cannot necessarily handle power levels generated by wave power stations.

Grid The UK electricity distribution network.

GW See Gigawatt

Head A difference in water height, usually referring to the difference between wave crest and trough.

Interface A boundary across which energy has to be transferred, (e.g. the wave/air surface in an OWC).

IOS The Institute of Oceanographic Sciences (National Environmental Research Council.)

'J' Tube The oscillating water column on a Belfast Device, so called because of its physical shape.

Kilowatts/Metre (kW/m) The unit used to measure power in waves. It is the power flowing across a one metre line on the sea.

- Lancaster Flexible Bag (LFB)** The device based on the ideas of Professor Michael French, and developed by Lancaster University and Wavepower Ltd.
- LFB** See Lancaster Flexible Bag.
- Load Factor** The mean annual power output of a wave power station expressed as a percentage of the installed capacity.
- Mean Annual Output** The output of a wave power station averaged over a whole year.
- Megawatt (MW)** One million watts or one thousand kilowatts.
- Mtce** Millions of tonnes of coal equivalent to electricity, assuming a thermal efficiency of a coal-fired power station to be 35%.
- MW** See Megawatt.
- M & E** Mechanical and Electrical.
- NEL** National Engineering Laboratory, East Kilbride.
- NPV** Nett Present Value
- NSHEB** North of Scotland Hydro-Electric Board.
- Ocean Weather Station (OWS) 'India'** The Ocean Weather Ship stationed at 59N, 19W which provided early data on wave energy in the Atlantic.
- Oscillating Water Column (OWC)** A hollow chamber, open to the waves, in which water is forced to oscillate in sympathy with waves.
- OWC** See Oscillating Water Column.
- OWS** See Ocean Weather Station.
- Phase Control** Use of the power conversion system to control the resonant frequency of a device.
- Point Absorber** A device of small linear dimensions relative to the sea wavelengths (eg. a buoy); these devices are usually capable of collecting wave energy equally from any direction (see Fig. 4.2).
- Power Smoothing** The reduction of large power excursions in order to produce a smoother mean output. This can be achieved by energy storage, cutting-off peaks or machinery inertia.
- Power Chain** That part of the system from the prime-mover (e.g. turbine) to the point at which power enters the Grid.
- p/kWh** Pence per kilowatt-hour; the unit of energy cost used in this report and device assessment.
- Raft** See Cockerell Raft.

- Rectifier** The device developed at the Hydraulics Research Station, Wallingford by Mr Robert Russell.
- Rectification/Inversion** The process whereby variable-frequency AC is rectified to DC and then inverted back to mains frequency (50 Hz) AC.
- Resource** The energy available in waves.
- Rode** A single element in the mooring system of a device
- Root Mean Square** A statistical value of a fluctuating quantity very useful in measurement of waves and electrical current
- RPT** Rendel Palmer & Tritton – see Consultants.
- Running Cost** The costs of running a wave power station including maintenance and repair costs.
- Scatter Diagram** A diagram plotting occurrences of wave height and frequency. The nature of the waves results in a "scatter" of the occurrences (see Fig. 3.4)
- Significant Wave Height** The average height of the highest one-third of waves
- Significant Period** The average time between successive crossings of the mean sea level in the upward direction.
- South Uist** An island in the outer Hebrides.
- Spine** The long floating structure on which converters are mounted.
- Synchronous** In synchronism with the UK electricity mains frequency of 50 Hz
- Terminator** A wave device which is aligned parallel to wave fronts and which is at right-angles to the principal wave direction (see Fig. 4.2).
- Triplate** A device invented and developed by Dr Francis Farley of the Royal Military College of Science, Shrivenham.
- Tube Spring** A flexible tube which provides compliance in a mooring system by stretching. (See Fig. 7.1).
- Wave Tank** A large tank, with the means of generating wave patterns representing scaled real seas, in which device models are tested.
- Wavelength** The distance between the crests of successive waves.
- Wells Turbine** An air turbine, invented by Prof. Wells of Belfast University, with the characteristic of rotation in the same direction irrespective of the direction of air flow through it.
- WESC** Wave Energy Steering Committee.

20

Available from
HER MAJESTY'S STATIONERY OFFICE

49 High Holborn, London WC1V 6H
P.O.Box 569, London SE1 9N
(Trade and London area mail orders)
13a Castle Street, Edinburgh EH2 3A
41 The Hayes, Cardiff CF1 1JW
Brazennose Street, Manchester M60 8AA
Southey House, Wine Street, Bristol BS1 2B
285 Broad Street, Birmingham B1 2H
80 Chichester Street, Belfast BT1 4JL
or any bookseller

PRICE £8 n

Printed in England

ISBN 0-7058-127