

Cyclotomic Matrices and Graphs

Graeme Taylor

Doctor of Philosophy
University of Edinburgh
2010

Abstract

We generalise the study of cyclotomic matrices - those with all eigenvalues in the interval $[-2, 2]$ - from symmetric rational integer matrices to Hermitian matrices with entries from rings of integers of imaginary quadratic fields. As in the rational integer case, a corresponding graph-like structure is defined.

We introduce the notion of ‘4-cyclotomic’ matrices and graphs, prove that they are necessarily maximal cyclotomic, and classify all such objects up to equivalence. Six rings $\mathcal{O}_{\mathbb{Q}(\sqrt{d})}$ for $d = -1, -2, -3, -7, -11, -15$ give rise to examples not found in the rational-integer case; in four ($d = -1, -2, -3, -7$) we recover infinite families as well as sporadic cases.

For $d = -15, -11, -7, -2$, we demonstrate that a maximal cyclotomic graph is necessarily 4-cyclotomic and thus the presented classification determines all cyclotomic matrices/graphs for those fields. For the same values of d we then identify the minimal noncyclotomic graphs and determine their Mahler measures; no such graph has Mahler measure less than 1.35 unless it admits a rational-integer representative.

Acknowledgements

Firstly, I would like to thank my supervisor Chris Smyth for his insight, guidance and support throughout my studies. I would also like to thank James McKee for many helpful contributions, particularly the Gram vector approach adopted in Chapter 5.

Thanks are also due to the EPSRC, the Maxwell Institute for Mathematical Sciences, the University of Edinburgh School of Mathematics and the ECDF. I am grateful to all involved for making this work possible financially and practically.

I would also like to thank the many organisations which have offered travel funding or speaking opportunities. I have found conference attendance and the resulting sharing of ideas an invaluable part of the research process - and caught the travel bug along the way!

On a more personal note, I have no doubt that I will look back at my time in Edinburgh as some of the best years of my life, due to the friends (local and otherwise) who helped make them so enjoyable. Thanks especially to Julia: I could not have got this far without you. I also thank my family for their love and patience.

This work has made use of the resources provided by the Edinburgh Compute and Data Facility (ECDF). (<http://www.ecdf.ed.ac.uk/>). The ECDF is partially supported by the eDIKT initiative (<http://www.edikt.org.uk>).

Declaration

I declare that this thesis was composed by myself and that the work contained therein is my own, except where explicitly stated otherwise in the text.

(Graeme Taylor)

Contents

Abstract	ii
Acknowledgements	iii
Declaration	iv
1 Introduction	1
1.1 Overview	1
1.2 Mahler Measure and Lehmer's Problem	1
1.3 Integer Symmetric Matrices and Charged Signed Graphs	2
1.4 Maximal Connected Cyclotomic Charged Signed Graphs	4
1.5 Maximal Cyclotomic Graphs	6
1.6 Minimal Noncyclotomic Integer Symmetric Matrices	7
1.7 Motivation and Results	9
2 Cyclotomic Matrices and Graphs over Imaginary Quadratic Fields	11
2.1 Overview	11
2.2 Entries of Cyclotomic Matrices over Imaginary Quadratic Fields	11
2.3 Cyclotomic Graphs Over Imaginary Quadratic Fields	14
2.4 Equivalence and Switching	15
2.5 Weighted Degree	16
2.6 Existence of Infinite Families	21
2.6.1 Graphs of the Form \mathcal{T}_{2k}	23
2.6.2 Graphs of the Form \mathcal{T}_{2k}^4	27
2.6.3 Graphs of the Form $\mathcal{C}_{2k}^{2\pm}$	30
2.6.4 Graphs of the Form $\mathcal{C}_{2k}^{+\pm}$	32
3 4-cyclotomic Graphs I- Reduction to Infinite Families	35
3.1 Overview	35
3.2 Growing Algorithms	35
3.2.1 Cyclotomic Additions	35

3.2.2	Refinements	37
3.3	Graphs With Weight 3 Edges	43
3.4	Graphs With All Edges Weight 1	44
3.4.1	Preliminaries	44
3.4.2	Uncharged Triangles	45
3.4.3	Uncharged-Triangle Free Graphs	47
3.4.4	Sporadic Forms With More Than Eight Vertices	49
3.4.5	Uncharged Cyclotomic Graphs With All Edges of Weight 1	51
3.4.6	Charged Cyclotomic Graphs With All Edges Weight 1	53
3.5	Uncharged Graphs With Weight 2 Edges	54
3.5.1	Reduction to Isolated $\mathcal{L}_2, \mathcal{L}_2$ Paths	55
3.5.2	Isolated Weight 2 Pairs	56
3.6	Charged Graphs With Weight 2 Edges	62
3.6.1	Reduction to Isolated $\mathcal{L}_2, \mathcal{L}_2$ Paths	62
3.6.2	Isolated Weight 2 Pairs	64
3.7	Conclusions	68
4	4-Cyclotomic Graphs II- Classification up to Equivalence	69
4.1	Overview	69
4.2	Graphs of Form \mathcal{T}_{2k}	69
4.2.1	Proof of Corollary 4.2.2 for Sufficiently-large Graphs	69
4.2.2	Proof of Theorem 4.2.1	72
4.3	Graphs of Form $\mathcal{C}_{2k}^{+\pm}$	77
4.4	Graphs of form \mathcal{T}_{2k}^4	81
4.5	Graphs of Form $\mathcal{C}_{2k}^{2\pm}$	83
4.6	Sporadic Forms	85
4.7	Conclusions	97
5	Maximal Cyclotomic Graphs are 4-Cyclotomic	99
5.1	Overview	99
5.2	Preliminaries	99
5.3	Charged Signed Graphs	100
5.3.1	Constructing Cyclotomic Supermatrices With Gram Vectors	100
5.3.2	Excluded Subgraphs	101
5.3.3	Charged Signed Graphs With Weight 3 Vertices	103
5.3.4	Charged Signed Graphs With Weight 2 Vertices	115
5.3.5	Charged Signed Graphs With Weight 1 Vertices	129
5.4	\mathcal{L} -Graphs With Edges Of Weight 3 Or 4	131

5.5	\mathcal{L} -Graphs Over $\mathcal{O}_{\mathbb{Q}(\sqrt{-2})}, \mathcal{O}_{\mathbb{Q}(\sqrt{-7})}$	131
5.5.1	Constructing Cyclotomic Supermatrices With Gram Vectors	132
5.5.2	Excluded Subgraphs	132
5.5.3	\mathcal{L} -Graphs With Weight 3 Vertices	134
5.5.4	\mathcal{L} -Graphs With Weight 2 Vertices	138
5.5.5	\mathcal{L} -Graphs With Weight 1 Vertices	150
5.6	Conclusions	151
6	Minimal Noncyclotomics	153
6.1	Overview	153
6.2	Minimal Noncyclotomic R -Matrices With Large Norm Entries	153
6.2.1	R -Matrices with Entries On Diagonal of Large Modulus	153
6.2.2	R -Matrices with Entries Off Diagonal of Large Norm	154
6.2.3	\mathcal{L} -Graphs with Vertices of Charge ± 2	154
6.2.4	\mathcal{L} -Graphs with Weight 4 Edges	154
6.2.5	\mathcal{L} -Graphs with Weight 3 Edges	155
6.3	Minimal Noncyclotomic \mathcal{L} -Graphs Over $\mathcal{O}_{\mathbb{Q}(\sqrt{-2})}, \mathcal{O}_{\mathbb{Q}(\sqrt{-7})}$ With Weight 2 Edges	156
6.3.1	Excluded Subgraphs	156
6.3.2	Small Minimal Noncyclotomic Graphs	159
6.3.3	Large Minimal Noncyclotomic \mathcal{L} -Graphs	176
6.3.4	Supersporadics	176
6.3.5	Non-Supersporadics	178
6.4	Summary	186
6.4.1	$d \leq -17$ or $d \in \{-5, -6, -10, -13, -14\}$	186
6.4.2	$d = -15$	187
6.4.3	$d = -11$	187
6.4.4	$d = -7$	188
6.4.5	$d = -2$	188
7	Curiosities	190
7.1	Overview	190
7.2	3-cyclotomic Matrices and Graphs	190
7.3	Connected Sums of Graphs	193
	Bibliography	196
A	Implementation	199
A.1	Initialisation and Basic Procedures	199
A.1.1	Field Setup	199

A.1.2	Testing Cyclotomicity	201
A.2	Testing Equivalence	202
A.2.1	Support Functions	202
A.2.2	Equivalence Testing	203
A.3	Column sets	205
A.4	Growing Algorithms For Cyclotomics and 4-Cyclotomics	208
A.5	Mahler Measure and Minimal Noncyclotomics	214
A.6	Growing Algorithms For Minimal Noncyclotomics	216

List of Figures

1.1	The 14-vertex sporadic maximal connected cyclotomic signed graph S_{14}	5
1.2	The 16-vertex sporadic maximal connected cyclotomic signed graph S_{16}	5
1.3	The family T_{2k} of $2k$ -vertex maximal connected cyclotomic toral tessellations. . .	5
1.4	The three sporadic maximal connected cyclotomic charged signed graphs S_7, S_8, S'_8 . . .	6
1.5	The families of $2k$ -vertex maximal connected cyclotomic cylindrical tessellations C_{2k}^{++} and C_{2k}^{+-} , for $k \geq 2$	6
1.6	The maximal connected cyclotomic graphs $\tilde{E}_6, \tilde{E}_7, \tilde{E}_8, \tilde{A}_n, \tilde{D}_n$	6
1.7	Charged signed graphs with Mahler measure λ_0	7
2.1	The 2-vertex sporadic maximal connected cyclotomic \mathcal{L} -graph S_2	17
2.2	The 2-vertex sporadic maximal connected cyclotomic \mathcal{L} -graph S_2^*	18
2.3	The family T'_{2k} of $2k$ -vertex maximal connected cyclotomic \mathcal{L} -graphs.	26
2.4	The family T_{2k}^4 of $2k$ -vertex maximal connected cyclotomic \mathcal{L} -graphs.	30
2.5	The family $T_{2k}^{4'}$ of $2k$ -vertex maximal connected cyclotomic \mathcal{L} -graphs.	30
2.6	The family C_{2k}^{2+} of $2k + 1$ -vertex maximal connected cyclotomic \mathcal{L} -graphs.	32
4.1	The 2-vertex sporadic maximal connected cyclotomic charged \mathcal{L} -graph S'_2	85
4.2	The 4-vertex sporadic maximal connected cyclotomic charged \mathcal{L} -graph S_4	85
4.3	The 4-vertex sporadic maximal connected cyclotomic \mathcal{L} -graph S'_4	85
4.4	The 4-vertex sporadic maximal connected cyclotomic \mathcal{L} -graph S_4^*	86
4.5	The 4-vertex sporadic maximal connected cyclotomic charged \mathcal{L} -graph S_4^\dagger	86
4.6	The 5-vertex sporadic maximal connected cyclotomic charged \mathcal{L} -graph S_5	87
4.7	The 6-vertex sporadic maximal connected cyclotomic charged \mathcal{L} -graph S_6	87
4.8	The 6-vertex sporadic maximal connected cyclotomic charged \mathcal{L} -graph S'_6	88
4.9	The 6-vertex sporadic maximal connected cyclotomic \mathcal{L} -graph S_6^\dagger	89
4.10	The 8-vertex sporadic maximal connected cyclotomic \mathcal{L} -graph S_8^*	91
4.11	The 8-vertex sporadic maximal connected cyclotomic \mathcal{L} -graph S_8^\dagger	93
4.12	The 8-vertex sporadic maximal connected cyclotomic \mathcal{L} -graph S_8^\ddagger	94
4.13	The 10-vertex sporadic maximal connected cyclotomic \mathcal{L} -graph S_{10}	95
4.14	The 12-vertex sporadic maximal connected cyclotomic \mathcal{L} -graph S_{12}	96

7.1	The 3-cyclotomic charged signed graphs.	191
7.2	The 3-cyclotomic \mathcal{L} -graphs for $d = -1$	191
7.3	The 3-cyclotomic \mathcal{L} -graphs for $d = -2$	192
7.4	The 3-cyclotomic \mathcal{L} -graphs for $d = -3$	192
7.5	The 3-cyclotomic \mathcal{L} -graphs for $d = -7$	193
7.6	The 3-cyclotomic \mathcal{L} -graph for $d = -11$	193

Chapter 1

Introduction

1.1 Overview

The Mahler measure is a height function on polynomials which is conjectured to be bounded away from 1 for noncyclotomic \mathbb{Z} -polynomials. In this Chapter we summarise some of the partial answers to this question, which has become known as Lehmer's problem. In particular, we describe recent work which verified the conjecture for polynomials arising in a natural way from integer symmetric matrices. A key component of this approach was the classification of such matrices with all eigenvalues in $[-2, 2]$. This thesis generalises both this classification problem and Lehmer's problem to matrices with entries from rings of integers of imaginary quadratic fields and their associated polynomials.

1.2 Mahler Measure and Lehmer's Problem

Let $P(z) = a_d z^d + \cdots + a_0 = a_d \prod_{i=1}^d (z - \alpha_i) \in \mathbb{C}[z]$ be a non-constant polynomial.

Definition 1.2.1. The *Mahler Measure* $M(P)$ is given by

$$M(P) := |a_d| \prod_{i=1}^d \max(1, |\alpha_i|) = |a_d| \prod_{|\alpha_i| > 1} |\alpha_i| \quad (1.1)$$

(In [13] Mahler studied an equivalent formulation,

$$M(P) := \exp \left(\int_0^1 \log |P(e^{2\pi i t})| dt \right),$$

from which the name arises; the version given in (1.1) is from Lehmer's earlier paper [12].)

Clearly for $P(z) \in \mathbb{C}[z]$ $M(P)$ may take any value $\geq |a_d|$; thus for a monic P , $M(P) \in [1, \infty)$. This therefore holds for $P(z) \in \mathbb{Z}[z]$, but here much more can be said.

The cyclotomic polynomials¹ have Mahler measure 1, so the lower bound is attainable over monic polynomials from $\mathbb{Z}[z]$. By a result of Kronecker [11] we have essentially the converse: $M(P) = 1$ only if $\pm P$ is the product of a cyclotomic polynomial and a power of z .

For a monic integer polynomial with $M(P) > 1$, Lehmer asked (in [12]) whether $M(P)$ could be arbitrarily close to 1. This is now known as *Lehmer's Problem*; the negative result - that there is some $\lambda > 1$ such that $M(P) > 1 \Rightarrow M(P) \geq \lambda$ - is sometimes referred to as *Lehmer's Conjecture*.

Lehmer exhibited the polynomial

$$z^{10} + z^9 - z^7 - z^6 - z^5 - z^4 - z^3 + z + 1$$

with Mahler measure $\lambda_0 = 1.176280818$ in his 1933 paper; no smaller examples have been found since. Further, Lehmer's Conjecture has been proven for various classes of polynomials; for a survey see Smyth [19]. In particular, in [14], [15] McKee and Smyth considered polynomials arising from integer symmetric matrices, and it is these results which motivate the extensions presented in this thesis. We thus summarise their results in the following sections.

1.3 Integer Symmetric Matrices and Charged Signed Graphs

For a monic polynomial $g \in \mathbb{Z}[x]$ of degree n , define its *associated reciprocal polynomial* to be

$$z^n g(z + 1/z)$$

which is a monic reciprocal polynomial of degree $2n$. For A an n -by- n symmetric matrix with entries from \mathbb{Z} , denote by $R_A(z)$ the associated reciprocal polynomial of its characteristic polynomial $\chi_A(x) = \det(xI - A)$. Further, we define $M(A)$, *the Mahler measure of A* , to be $M(R_A(z))$.

If g has all roots real and in $[-2, 2]$, then the roots of its associated reciprocal polynomial are all of modulus 1 and hence (by Kronecker) it is a cyclotomic polynomial. For A an integer symmetric matrix, all roots of $\chi_A(x)$ are real algebraic integers, and thus $R_A(z)$ is cyclotomic if A has spectral radius at most 2. Such an A is described as a cyclotomic matrix; the Mahler measure of A is 1 precisely when A is a cyclotomic matrix.

If A is a block diagonal matrix, then its list of eigenvalues is the union of the lists of the eigenvalues of the blocks. If there is a reordering of the rows (and columns) of A such that

¹For convenience, we will use 'cyclotomic' to refer to any polynomial for which all roots are roots of unity, rather than just the irreducible polynomials Φ_n .

it has block diagonal form with more than one block, then A will be called *decomposable*; if there is no such reordering, A is called *indecomposable*. Clearly any decomposable cyclotomic matrix decomposes into cyclotomic blocks, so to classify all cyclotomic matrices it is sufficient to identify the indecomposable ones.

The following result is of central importance to this effort:

Theorem 1.3.1 (Cauchy Interlacing Theorem). *Let A be a Hermitian $n \times n$ matrix with eigenvalues $\lambda_1 \leq \lambda_2 \leq \dots \leq \lambda_n$.*

Let B be obtained from A by deleting row i and column i from A .

Then the eigenvalues $\mu_1 \leq \dots \leq \mu_{n-1}$ of B interlace with those of A : that is,

$$\lambda_1 \leq \mu_1 \leq \lambda_2 \leq \mu_2 \leq \dots \leq \lambda_{n-1} \leq \mu_{n-1} \leq \lambda_n.$$

(This is Théorème I of Cauchy’s curiously titled paper [4] from 1829. For a modern reference in English see Theorem 4.3.8 of [9], which provides a proof by the Courant-Fischer min-max theorem (*Id.* Theorem 4.2.11); a very short proof by reduction to interlacing of polynomials is given in Fisk [7].)

Thus if A is cyclotomic, so is any B obtained by successively deleting a series of rows and corresponding columns from A . We describe such a B as being *contained* in A . If an indecomposable cyclotomic matrix A is not contained in a strictly larger indecomposable cyclotomic matrix, then we call A *maximal*; it thus suffices to classify all maximal indecomposable cyclotomic matrices.

Finally, an equivalence relation on cyclotomic matrices can be defined as follows. Let $O_n(\mathbb{Z})$ denote the orthogonal group of $n \times n$ signed permutation matrices. Conjugation of a cyclotomic matrix by a matrix from this group gives another matrix with the same eigenvalues, which is thus also cyclotomic. Cyclotomic matrices A, A' related in this way are described as *strongly equivalent*; indecomposable cyclotomic matrices A and A' are then considered equivalent if A' is strongly equivalent to either A or $-A$.

The following (Lemma 6 of [14]) is an easy consequence of Theorem 1.3.1:

Lemma 1.3.2. *Apart from matrices equivalent to either (2) or $\begin{pmatrix} 0 & 2 \\ 2 & 0 \end{pmatrix}$, any indecomposable cyclotomic matrix has all entries from the set $\{0, 1, -1\}$.*

This motivates the following generalisations of the adjacency matrix of a graph. If M is an $n \times n$ matrix with diagonal entries all zero and off-diagonal elements from $\{0, 1, -1\}$ then M describes an n -vertex *signed* graph (as in [3], [21]), whereby a non-zero (i, j) th entry indicates an edge between vertices i and j with a ‘sign’ of -1 or 1 . For a general $\{0, 1, -1\}$ matrix we extend this to *charged signed graphs*, interpreting a non-zero diagonal entry as a ‘charge’ on the corresponding vertex.

A charged signed graph G is therefore described as cyclotomic if its adjacency matrix A is cyclotomic; the Mahler measure of G is that of A (i.e., of $R_A(z)$), and graphs G, G' are (strongly) equivalent if and only if their adjacency matrices A, A' are. A charged signed graph G is connected if and only if its adjacency matrix is indecomposable. If a cyclotomic matrix A' is contained in A then its corresponding charged signed graph G' is an induced subgraph of G corresponding to A' ; thus a maximal cyclotomic charged signed graph is not an induced subgraph of any strictly larger connected cyclotomic charged signed graph.

The equivalence relation on cyclotomic matrices has the following graphical interpretation. $O_n(\mathbb{Z})$ is generated by diagonal matrices of the form $\text{diag}(1, 1, \dots, 1, -1, 1, \dots, 1)$ and permutation matrices. Conjugation by the former has the effect of negating the signs of all edges incident at some vertex v ; following [3] this is described as *switching at v* . Conjugation by a permutation matrix merely permutes vertex labels and so up to equivalence we may ignore vertex labellings: strong equivalence classes are therefore determined only by switching operations on unlabelled graphs. Equivalence of charged signed graphs is then generated by switching and the operation of negating all edge signs and vertex charges of a connected component.

For conciseness, we indicate edge signs visually, with a sign of 1 given by an unbroken line --- and a sign of -1 given by a dotted line Vertices with charge 0 (neutral), 1 (positive) and -1 (negative) will be drawn as \bullet , \oplus and \ominus respectively.

By Lemma 1.3.2 we thus have that (with the exception of (2) or $\begin{pmatrix} 0 & 2 \\ 2 & 0 \end{pmatrix}$ and their equivalents) any maximal indecomposable cyclotomic integer symmetric matrix is the adjacency matrix of a maximal connected cyclotomic charged signed graph.

1.4 Maximal Connected Cyclotomic Charged Signed Graphs

A complete classification of cyclotomic matrices/graphs over \mathbb{Z} is therefore given via the following main results of [14]:

Theorem 1.4.1. *Every maximal connected cyclotomic signed graph is equivalent to one of the following:*

- (i) *The 14-vertex signed graph S_{14} shown in Fig. 1.1;*
- (ii) *The 16-vertex signed graph S_{16} shown in Fig. 1.2;*
- (iii) *For some $k = 3, 4, \dots$, the $2k$ -vertex toral tessellation T_{2k} shown in Fig. 1.3.*

Further, every connected cyclotomic signed graph is contained in a maximal one.

Theorem 1.4.2. *Every maximal connected cyclotomic charged signed graph not included in Theorem 1.4.1 is equivalent to one of the following:*

- (i) One of the three sporadic charged signed graphs S_7, S_8, S'_8 shown in Fig. 1.4;
- (ii) For some $k = 2, 3, 4, \dots$, one of the two $2k$ -vertex cylindrical tessellations C_{2k}^{++}, C_{2k}^{+-} shown in Fig. 1.5.

Further, every connected cyclotomic charged signed graph is contained in a maximal one.

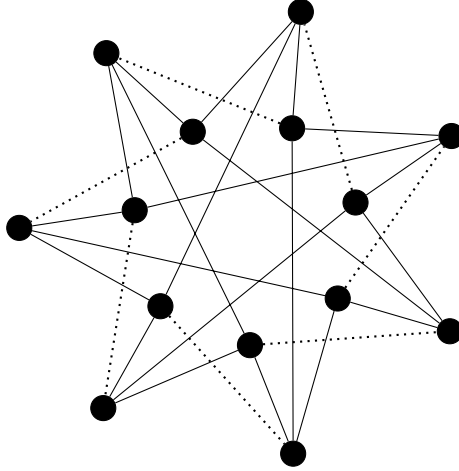

Figure 1.1: The 14-vertex sporadic maximal connected cyclotomic signed graph S_{14} .

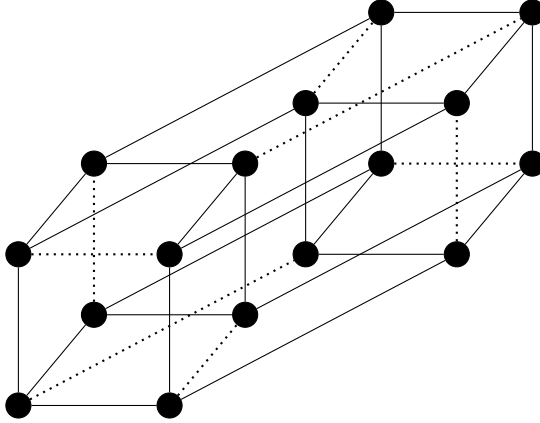

Figure 1.2: The 16-vertex sporadic maximal connected cyclotomic signed graph S_{16} .

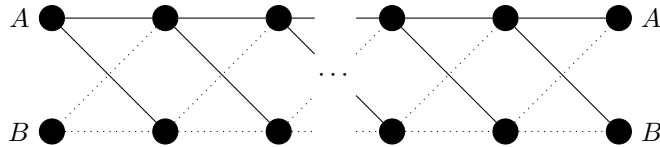

Figure 1.3: The family T_{2k} of $2k$ -vertex maximal connected cyclotomic toral tessellations. (Where $k \geq 3$, and the two copies of vertices A and B should be identified.)

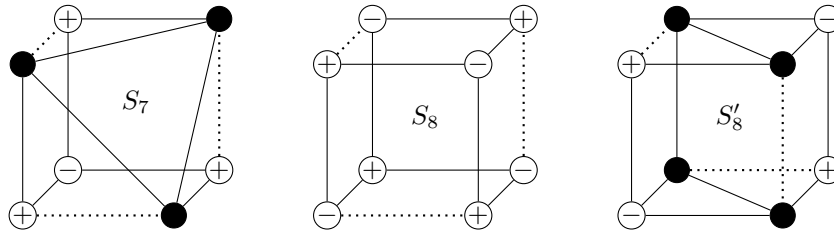

Figure 1.4: The three sporadic maximal connected cyclotomic charged signed graphs S_7, S_8, S'_8 .

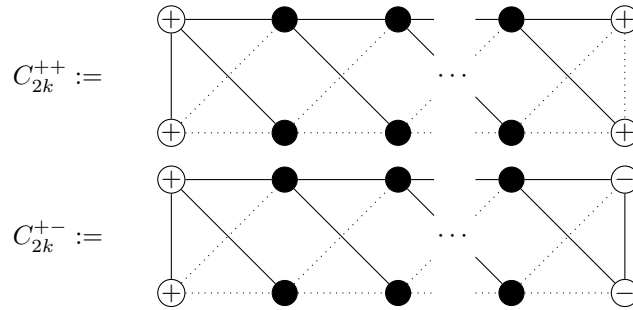

Figure 1.5: The families of $2k$ -vertex maximal connected cyclotomic cylindrical tessellations C_{2k}^{++} and C_{2k}^{+-} , for $k \geq 2$.

1.5 Maximal Cyclotomic Graphs

Since any graph is a charged signed graph, it is natural to ask which are the connected cyclotomic graphs (corresponding to the indecomposable symmetric $\{0, 1\}$ -matrices with zero diagonal). This earlier result of Smith [18] is given as Lemma 2.2 in [16] as follows:

Theorem 1.5.1. *The connected cyclotomic graphs are precisely the induced subgraphs of the graphs $\tilde{E}_6, \tilde{E}_7, \tilde{E}_8$ and those of the $(n + 1)$ -vertex graphs \tilde{A}_n ($n \geq 2$), \tilde{D}_n , ($n \geq 4$) as in Fig. 1.6.*

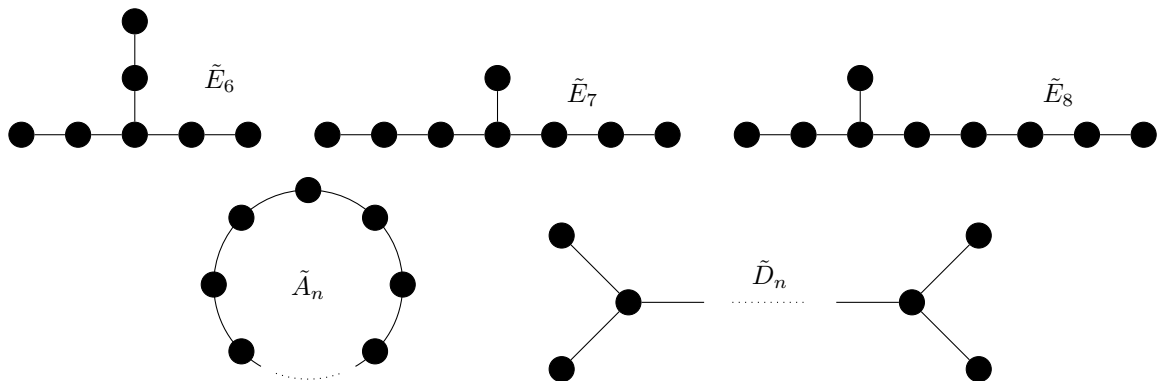

Figure 1.6: The maximal connected cyclotomic graphs $\tilde{E}_6, \tilde{E}_7, \tilde{E}_8, \tilde{A}_n, \tilde{D}_n$. (The number of vertices is one more than the subscript; $n \geq 2$ for \tilde{A}_n and $n \geq 4$ for \tilde{D}_n .)

The cyclotomic graphs $\tilde{E}_6, \tilde{E}_7, \tilde{E}_8, \tilde{A}_n, \tilde{D}_n$ are thus maximal in the sense that they are not contained in any strictly larger connected cyclotomic graph. They are however nonmaximal as charged signed graphs ($\tilde{E}_6, \tilde{E}_7, \tilde{E}_8$ are equivalent to subgraphs contained in S_{16} , whilst each $\tilde{A}_{n-1}, \tilde{D}_n$ is contained in the corresponding T_{2n} .)

1.6 Minimal Noncyclotomic Integer Symmetric Matrices

Definition 1.6.1. A symmetric $n \times n$ matrix is *minimal noncyclotomic* if it is noncyclotomic and every $(n - 1) \times (n - 1)$ submatrix is cyclotomic.

We note that every minimal noncyclotomic integer symmetric matrix is necessarily indecomposable.

In [15] McKee and Smyth prove that $M(A) \geq \lambda_0$ for all minimal noncyclotomic integer symmetric matrices and that this bound is best possible since the charged signed graphs given in Fig. 1.7 are minimal noncyclotomic with Mahler measure λ_0 .

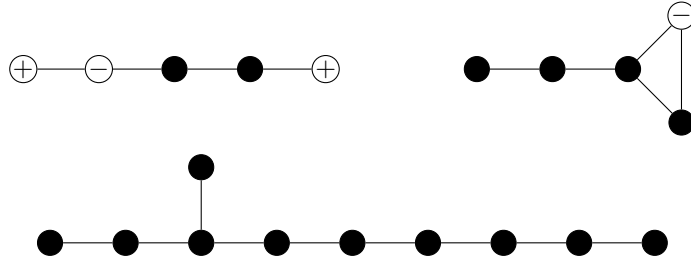

Figure 1.7: Charged signed graphs with Mahler measure λ_0 .

An immediate consequence of Theorem 1.3.1 is that if an integer symmetric matrix B is contained in a larger A , then $M(B) \leq M(A)$. Therefore if A is a noncyclotomic integer symmetric matrix, then there exists a minimal noncyclotomic integer symmetric matrix A' with $M(A) \geq M(A')$. Thus [15] settles Lehmer's problem for integer symmetric matrices:

Theorem 1.6.2. ([15] Corollary 2) *If A is an integer symmetric matrix, then the Mahler measure of A is either 1 or at least λ_0 . Further, if A is indecomposable and has Mahler measure equal to λ_0 then it is equivalent to the adjacency matrix of one of the charged signed graphs given in Fig. 1.7.*

For an algebraic integer α with minimal polynomial P_α , define the Mahler measure of α to be $M(\alpha) := M(P_\alpha)$. We say α is *reciprocal* if P_α is; equivalently, α is conjugate to α^{-1} . Breusch [2] proved that if α is nonreciprocal then

$$M(\alpha) \geq M\left(z^3 - z^2 - \frac{1}{4}\right) = 1.17965\dots > \lambda_0$$

with Smyth showing further in [20]

$$M(\alpha) \geq M(z^3 - z - 1) = \theta_0 = 1.3247\dots$$

Let \mathcal{P} be the set of nonreciprocal monic polynomials with integer coefficients. If $P \in \mathcal{P}$ then it has a root α such that α^{-1} is not a root of P ; α is therefore a nonreciprocal algebraic integer with P_α dividing P . As the Mahler measure is multiplicative and at least 1 for each factor of P , we have

$$M(P) \geq M(P_\alpha) = M(\alpha) \geq \theta_0$$

That is, Lehmer's conjecture holds for $P \in \mathcal{P}$ as for any such P , $M(P) \geq \theta_0 > \lambda_0$; we note that no greater lower bound than θ_0 is possible for such P since $z^3 - z - 1 \in \mathcal{P}$ and has Mahler measure θ_0 .

Thus Theorem 1.6.2 would resolve the general version of Lehmer's problem if for any reciprocal monic P with integer coefficients there exists an integer symmetric matrix A such that

$$M(P) = M(A). \tag{1.2}$$

Clearly (1.2) would hold if it could be shown that for every monic reciprocal $P \in \mathbb{Z}[z]$ there existed an integer symmetric matrix A with

$$P = R_A(z). \tag{1.3}$$

However, there are simple counterexamples to (1.3). For instance, suppose $x^2 - 3$ were the characteristic polynomial of a matrix

$$A = \begin{pmatrix} a & b \\ b & c \end{pmatrix}.$$

Then A has eigenvalues

$$\lambda_{\pm} = \frac{(a+c) \pm \sqrt{(a-c)^2 + 4b^2}}{2} = \pm\sqrt{3}$$

but there are no $a, b, c \in \mathbb{Z}$ satisfying these equations². Thus by taking the associated reciprocal polynomial $z^4 - z^2 + 1$ of $x^2 - 3$ there exists a monic reciprocal polynomial $P \in \mathbb{Z}[z]$ for which there can be no integer symmetric matrix A satisfying (1.3).

(We note in passing that if minimal polynomials rather than characteristic polynomials of integer symmetric matrices are considered, then more can be achieved. In [6] Estes and Guralnick

²Note that the requirement that A be symmetric is a crucial obstruction since for any monic $P \in \mathbb{Z}$ the companion matrix $C(P)$ satisfies $\chi_{C(P)} = P$.

demonstrated that if $f \in \mathbb{Z}[x]$ is a monic, separable, degree $n \leq 4$ polynomial with all real roots, then f is the minimal polynomial of a $(2n) \times (2n)$ integer symmetric matrix.³ They thus conjectured that for such f of any degree there is an integer symmetric matrix with f as minimal polynomial. In [5] Dobrowolski proves that this is not so, even with the relaxation of the dimension condition: there are infinitely many algebraic integers whose minimal polynomial is not the minimal polynomial of an integer symmetric matrix.)

In [15] it is shown that if an integer symmetric matrix A is noncyclotomic with $M(A) < 1.3$, then $M(A)$ is one of sixteen given values. By comparison with the tables of small Salem numbers ([1], [17]), noncyclotomic counterexamples to not just (1.3) but (1.2) are found: the polynomial $z^{14} - z^{12} + z^7 - z^2 + 1$ has $M(P) = 1.20261\dots$, but this is not one of the possible $M(A) < 1.3$ for A an integer symmetric matrix.

1.7 Motivation and Results

Lehmer’s problem therefore remains open for reciprocal polynomials due to these ‘missing’ Mahler measures. An obvious approach is to extend the study of integer symmetric matrices / charged signed graphs to broader classes of combinatorial objects, in the hope of recovering generalisations of Theorem 1.6.2 and thus further evidence for Lehmer’s conjecture.

In this thesis we consider cyclotomicity in the context of imaginary quadratic fields $K = \mathbb{Q}(\sqrt{d})$ for squarefree $d < 0$. The objects of interest are Hermitian matrices A with entries from the ring of integers $R = \mathcal{O}_K$; we consider d negative rather than positive to ensure $R_A(z) \in \mathbb{Z}[z]^4$.

In Chapter 2 we find that there are finitely many $d < 0$ yielding cyclotomic matrices inequivalent to any \mathbb{Z} -matrix and that there are finite sets \mathcal{L} such that all examples are \mathcal{L} -matrices. We introduce a corresponding graph-like structure, charged \mathcal{L} -graphs, which serve as the main tool in proofs. We define 4-cyclotomic \mathcal{L} -matrices and graphs, demonstrate that they are maximal, and identify new infinite families with this property.

In Chapter 3 we exploit interlacing to provide algorithms to ‘grow’ cyclotomic and 4-cyclotomic \mathcal{L} -matrices. For each $d < 0$, this leads to a classification of all connected 4-cyclotomic \mathcal{L} -graphs up to ‘form’ (that is, specifying the underlying weighted graph).

In Chapter 4 we refine this to a classification up to equivalence: for each $d < 0$ any connected 4-cyclotomic graph is shown to be equivalent to a member of one of the infinite families identified in Chapter 2 or one of finitely many given sporadic examples.

In Chapter 5 we show for all $d < 0 \notin \{-1, -3\}$ that a maximal connected cyclotomic \mathcal{L} -graph is 4-cyclotomic and thus the earlier classification determines all cyclotomic \mathcal{L} -matrices. This

³In Chapter 7 we provide a simple construction of $\{0, 1, -1\}$ -matrices with minimal polynomial $x^2 - n$.

⁴ $\chi_A(x) \in R[x]$ for any ring R , and $\chi_A(x) \in \mathbb{R}[x]$ if A is Hermitian; for $d < 0$ $R \cap \mathbb{R} = \mathbb{Z}$, but for $d > 0$ this is not the case.

also gives an alternative proof of Theorems 1.4.1, 1.4.2 to that of [14].

In Chapter 6 we find for all $d < 0 \notin \{-1, -3\}$ a classification of the minimal noncyclotomic matrices, proving Lehmer's Conjecture for such d .

In Chapter 7 we classify for all $d < 0$ the maximal connected cyclotomic \mathcal{L} -graphs with eigenvalues $\pm\sqrt{3}$ - in each case, a finite set - and deduce a construction of \mathcal{L} -matrices with minimal polynomial $x^2 - n$ for each $n \in \mathbb{Z}$.

Chapter 2

Cyclotomic Matrices and Graphs over Imaginary Quadratic Fields

2.1 Overview

In this Chapter we generalise the study of cyclotomic matrices from symmetric \mathbb{Z} -matrices to Hermitian R -matrices, where $R = \mathcal{O}_{\mathbb{Q}(\sqrt{d})}$ for some $d < 0$, determining the values of d for which new cyclotomic examples can arise. We identify finite sets \mathcal{L} such that any cyclotomic R -matrix is an \mathcal{L} -matrix and define a corresponding graph-like structure. The weighted degree of each vertex is shown to be bounded for cyclotomic graphs. We then introduce the notion of 4-cyclotomic graphs, prove that any such graph is maximal cyclotomic, and use this to demonstrate the existence of new infinite families of maximal connected cyclotomic \mathcal{L} -graphs.

2.2 Entries of Cyclotomic Matrices over Imaginary Quadratic Fields

We assume throughout that $d < 0$ and squarefree. Then (e.g., by [8] II(1.31)-(1.33)) we have that

$$R := \mathcal{O}_{\mathbb{Q}(\sqrt{d})} = \begin{cases} \mathbb{Z}[\frac{1+\sqrt{d}}{2}] & d \equiv 1 \pmod{4} \\ \mathbb{Z}[\sqrt{d}] & d \equiv 2, 3 \pmod{4} \end{cases}$$

Remark 2.2.1. If $x = a + b\sqrt{d} \in R$ then $x\bar{x} = a^2 - db^2 = \text{Norm}(x) \in \mathbb{N} \cup \{0\}$.

We note the following obvious sufficient condition for a matrix to be non-cyclotomic:

Lemma 2.2.2. *Let A be an $n \times n$ Hermitian matrix. If either $\chi_A(2) < 0$ or $(-1)^n \chi_A(-2) < 0$, then A is not cyclotomic.*

We now consider the possible entries from R of a cyclotomic matrix.

Lemma 2.2.3. *Let M be an $n \times n$ Hermitian matrix with all entries from R . If M is cyclotomic, then for all $1 \leq i \leq n$,*

$$M_{i,i} \in \{0, \pm 1, \pm 2\}$$

and if $n \geq 2$ and M is indecomposable, then $M_{i,i} \in \{0, \pm 1\}$.

Proof. $M_{i,i} = d_i$ is an entry on the diagonal of M and thus real. By interlacing, the 1×1 matrix (d_i) is cyclotomic, so $|d_i| \leq 2$. If M is an indecomposable cyclotomic matrix with $M_{i,i} = 2$ for some i , then it is either the matrix (2) or it induces a cyclotomic submatrix

$$M' := \begin{pmatrix} 2 & x \\ \bar{x} & d_j \end{pmatrix}$$

for some x, d_j . By indecomposability, there is such a matrix with $x \neq 0$. But then $\chi_{M'}(2) = -x\bar{x} < 0$ by Remark 2.2.1, which contradicts Lemma 2.2.2; the proof for $M_{i,i} = -2$ is equivalent. \square

Lemma 2.2.4. *Let M be an $n \times n$ Hermitian matrix with all entries from R . If M is cyclotomic, then for all i, j ,*

$$|M_{i,j} \overline{M_{i,j}}| \leq 4.$$

Proof. By Lemma 2.2.3, the result holds for $i = j$ and thus for $n = 1$. For $i \neq j$ and $n \geq 2$ we consider the entry $M_{i,j} = x$. By interlacing, the 2×2 matrix

$$M' := \begin{pmatrix} c_{ii} & x \\ \bar{x} & c_{jj} \end{pmatrix}$$

is cyclotomic, and by Lemma 2.2.3 $c_{ii}, c_{jj} \in \{0, \pm 1\}$. M' has eigenvalues

$$t_{\pm} = \frac{(c_{ii} + c_{jj}) \pm \sqrt{4x\bar{x} + (c_{ii} - c_{jj})^2}}{2}$$

and so for $\max(|t_+|, |t_-|) \leq 2$ we require $|x\bar{x}| \leq 4$. \square

Definition 2.2.5. For $n \geq 1$, define

$$\mathcal{L}_n = \{x \in R \mid x\bar{x} = n\}.$$

Remark 2.2.6. By Remark 2.2.1, for any $x \in R$ either $x = 0$ or $x \in \mathcal{L}_n$ for some $n \in \mathbb{N}$. We set

$$\mathcal{L} := \{0\} \cup \mathcal{L}_1 \cup \mathcal{L}_2 \cup \mathcal{L}_3 \cup \mathcal{L}_4$$

and describe a Hermitian matrix with all entries from this set as an \mathcal{L} -matrix. Then by Lemma 2.2.4 if M is a cyclotomic Hermitian matrix with all entries from R , then M is a cyclotomic \mathcal{L} -matrix.

Theorem 2.2.7. Let M be a Hermitian cyclotomic \mathcal{L} -matrix with entries from $\mathcal{O}_{\mathbb{Q}(\sqrt{d})}$ for some $d < 0$. If

$$d \notin \{-1, -2, -3, -7, -11, -15\}$$

then M is a rational integer symmetric cyclotomic matrix.

Proof. Let x be an entry of M . If $d \equiv 1 \pmod{4}$ then $x = a + b\frac{1+\sqrt{d}}{2}$ for some $a, b \in \mathbb{Z}$; if x is not a rational integer then $b \neq 0$ and

$$x\bar{x} = (a + b/2)^2 + b^2|d|/4 \geq b^2|d|/4$$

By Lemma 2.2.4 this is impossible for $|d| > 16$, which we have for any $d \equiv 1 \pmod{4} \notin \{-3, -7, -11, -15\}$.

If instead $d \equiv 2, 3 \pmod{4}$ then x is of the form $a + b\sqrt{d}$ for some $a, b \in \mathbb{Z}$. By Lemma 2.2.4 $a^2 + b^2|d| \leq 4$; thus if $d \notin \{-1, -2\}$ then $b = 0$ and $x \in \mathbb{Z}$. \square

Since the Interlacing Theorem applies for Hermitian matrices, we inherit the notion of maximal indecomposable cyclotomic \mathcal{L} -matrices from the integer symmetric case, and as before need only classify such matrices to determine all possible cyclotomic \mathcal{L} -matrices.

Cyclotomic Matrices Over $\mathcal{O}_{\mathbb{Q}(\sqrt{-1})}$

For $d = -1$ we have

$$\mathcal{L}_1 = \{\pm 1, \pm i\}, \mathcal{L}_2 = \{\pm 1 \pm i\}, \mathcal{L}_3 = \emptyset, \mathcal{L}_4 = \{\pm 2, \pm 2i\}$$

Cyclotomic Matrices Over $\mathcal{O}_{\mathbb{Q}(\sqrt{-2})}$

For $d = -2$ we have

$$\mathcal{L}_1 = \{\pm 1\}, \mathcal{L}_2 = \{\pm\sqrt{-2}\}, \mathcal{L}_3 = \{\pm 1 \pm \sqrt{-2}\}, \mathcal{L}_4 = \{\pm 2\}$$

Cyclotomic Matrices Over $\mathcal{O}_{\mathbb{Q}(\sqrt{-3})}$

For $d = -3$ we have

$$\mathcal{L}_1 = \left\{ \pm 1, \pm \frac{1}{2} \pm \frac{\sqrt{-3}}{2} \right\}, \mathcal{L}_2 = \emptyset, \mathcal{L}_3 = \left\{ \pm \frac{3}{2} \pm \frac{\sqrt{-3}}{2}, \pm \sqrt{-3} \right\}, \mathcal{L}_4 = \{ \pm 2, \pm 1 \pm \sqrt{-3} \}$$

Cyclotomic Matrices Over $\mathcal{O}_{\mathbb{Q}(\sqrt{-7})}$

For $d = -7$ we have

$$\mathcal{L}_1 = \{ \pm 1 \}, \mathcal{L}_2 = \left\{ \pm \frac{1}{2} \pm \frac{\sqrt{-7}}{2} \right\}, \mathcal{L}_3 = \emptyset, \mathcal{L}_4 = \left\{ \pm 2, \pm \frac{3}{2} \pm \frac{\sqrt{-7}}{2} \right\}$$

Cyclotomic Matrices Over $\mathcal{O}_{\mathbb{Q}(\sqrt{-11})}$

For $d = -11$ we have

$$\mathcal{L}_1 = \{ \pm 1 \}, \mathcal{L}_2 = \emptyset, \mathcal{L}_3 = \left\{ \pm \frac{1}{2} \pm \frac{\sqrt{-11}}{2} \right\}, \mathcal{L}_4 = \{ \pm 2 \}$$

Cyclotomic Matrices Over $\mathcal{O}_{\mathbb{Q}(\sqrt{-15})}$

For $d = -15$ we have

$$\mathcal{L}_1 = \{ \pm 1 \}, \mathcal{L}_2 = \emptyset, \mathcal{L}_3 = \emptyset, \mathcal{L}_4 = \left\{ \pm 2, \pm \frac{1}{2} \pm \frac{\sqrt{-15}}{2} \right\}$$

Cyclotomic Matrices Over $\mathcal{O}_{\mathbb{Q}(\sqrt{d})}$, all other $d < 0$

By Theorem 2.2.7, we have only rational integer entries, and by Lemma 2.2.4 any such non-zero entry must be in one of

$$\mathcal{L}_1 = \{ \pm 1 \}, \mathcal{L}_2 = \emptyset, \mathcal{L}_3 = \emptyset, \mathcal{L}_4 = \{ \pm 2 \}$$

2.3 Cyclotomic Graphs Over Imaginary Quadratic Fields

In Section 1.3 symmetric $\{-1, 0, 1\}$ matrices are identified with *charged, signed graphs*: an $n \times n$ matrix corresponds to an n -vertex graph, with a non-zero (i, j) th entry denoting an edge with a ‘sign’ of -1 or 1 between vertices i and j ; and a non-zero (i, i) th entry indicating a ‘charge’ on the i th vertex.

We may generalise this for Hermitian \mathcal{L} -matrices to *charged \mathcal{L} -graphs*: for $n \geq 2$ we can (by Lemma 2.2.3) interpret diagonal entries as charges in the usual way; for $i < j$ a non-zero (i, j) th

entry $x \in \mathcal{L}$ corresponds to an edge with label x between vertices i and j .

Definition 2.3.1. For an edge with label x we define its *weight* to be the norm of x (so a *weight n edge* is one with a label from \mathcal{L}_n).

We will often specify graphs up to the weight of their edges, indicated as follows:

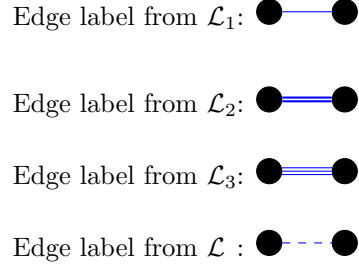

For convenience, we further distinguish known edges of norm 1: in all fields, $\bullet\text{---}\bullet$ and $\bullet\cdots\bullet$ denote $1, -1$ respectively; in $\mathcal{O}_{\mathbb{Q}(i)}$ $\bullet\text{---}\bullet$ and $\bullet\cdots\bullet$ denote $i, -i$ respectively; and in $\mathcal{O}_{\mathbb{Q}(\sqrt{-3})}$ we have $\bullet\text{---}\bullet, \bullet\cdots\bullet, \bullet\text{---}\bullet$ and $\bullet\cdots\bullet$ for $\omega, -\omega, \bar{\omega}$ and $-\bar{\omega}$ respectively.

An uncharged ('neutral') vertex is indicated by \bullet ; a vertex with charge $+1$ by \oplus and a vertex with charge -1 by \ominus . If the vertex is of unknown charge $c \in \{0, 1, -1\}$ then we denote it by \otimes ; a vertex known to be charged but of unknown polarity is denoted \oplus .

We specify the *form* of a charged \mathcal{L} - graph by indicating the possible charges of each vertex and the possible label sets \mathcal{L}_i containing each edge label. The corresponding Hermitian \mathcal{L} -matrix is therefore determined up to the possible norms of its entries.

2.4 Equivalence and Switching

As in Section 1.3, let $O_n(\mathbb{Z})$ denote the orthogonal group of $n \times n$ *signed permutation matrices*, and for $d \neq -1, -3$ define two cyclotomic \mathcal{L} -matrices m_1, m_2 to be *strongly equivalent* if $m_1 = X m_2 X^{-1}$ for some $X \in O_n(\mathbb{Z})$. For $d = -1, -3$ we generalise this notion to $U_n(R)$ the group of $n \times n$ unitary matrices generated by permutations and diagonal matrices of the form $\text{diag}(1, 1, \dots, \lambda, 1, \dots, 1)$ for $\lambda \in \mathcal{L}_1$ (describing a matrix generated by such a diagonal matrix with $\lambda \neq \pm 1$ as a *complex switching matrix*).

We describe two indecomposable cyclotomic matrices A, A' as merely *equivalent* if A' is strongly equivalent to any of $A, -A, \bar{A}, -\bar{A}$. This equivalence relation then extends easily to decomposable cyclotomic matrices, and as before it is therefore sufficient to classify all maximal indecomposable cyclotomic matrices up to equivalence.

The notions of strong equivalence and equivalence then apply to charged \mathcal{L} -graphs by considering their corresponding \mathcal{L} -matrices.

Conjugation by a diagonal matrix $\text{diag}(1, 1, \dots, -1, 1, \dots, 1)$ corresponds to reversing the signs of all edges incident at some vertex v ; this was described as *switching at v* . For $d = -1, -3$ we need also consider *complex switching at v* corresponding to conjugation by a diagonal matrix $\text{diag}(1, 1, \dots, \lambda, 1, \dots, 1)$ with $\lambda \neq \pm 1$. Considered as edges e_{ij} from v_i to v_j , this has the effect of multiplying the labels of all edges incident at v_i by λ ; due to the labelling convention this will give new edge labels $\bar{\lambda}e_{ji}$ for any $j < i$ and λe_{ij} for any $j > i$.

Conjugation by a permutation matrix permutes vertex numberings; up to form, we may thus ignore such numberings, but for $d = -1, -3$ equivalent matrices may have graphs with visually distinct edge labels and thus a numbering should be fixed before determining classes. Equivalence of graphs is generated by the operations of: permutation; (complex) switching; negating all edge labels and vertex charges in a component; and taking the complex conjugate of all edge labels in a component.

Remark 2.4.1. *There is thus a single class of maximal indecomposable cyclotomic matrices with a diagonal entry not in $\{0, 1, -1\}$, with representative*

$$(2).$$

2.5 Weighted Degree

Definition 2.5.1. For a vertex v we define its *weighted degree* as the sum of the weights of the edges incident at v , plus 1 if v has a charge of ± 1 .

Theorem 2.5.2. *If v is a vertex in a cyclotomic graph over $R = \mathcal{O}_{\mathbb{Q}(\sqrt{d})}$ for some $d < 0$, then v has weighted degree at most 4.*

We first prove the following special case:

Lemma 2.5.3. *For $R = \mathcal{O}_{\mathbb{Q}(\sqrt{d})}$, $d < 0$ The only connected cyclotomic matrices containing an entry of weight 4 are of the form \mathcal{S}_2 :*

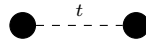

for some $t \in \mathcal{L}_4$.

Proof. For each ring (and its corresponding label set \mathcal{L}) we consider all matrices of the form

$$\begin{pmatrix} x & t & a \\ \bar{t} & y & b \\ \bar{a} & \bar{b} & z \end{pmatrix}$$

for charges $x, y, z \in \{0, -1, 1\}$ and edge labels $t \in \mathcal{L}_4$, $a, b \in \mathcal{L}$.

Testing, we find that such matrices are cyclotomic if and only if $x = y = a = b = 0$; that is, a cyclotomic matrix of the form

$$\begin{pmatrix} x & t \\ \bar{t} & y \end{pmatrix}$$

has $x = y = 0$ and admits no indecomposable cyclotomic supermatrix; thus it is maximal. Since any indecomposable maximal cyclotomic matrix M with a weight 4 entry induces such a submatrix, M must be a 2×2 matrix of this form. \square

Remark 2.5.4. For all rings $R = \mathcal{O}_{\mathbb{Q}(\sqrt{d})}$, we have a class of maximal cyclotomic matrices with representative

$$\begin{pmatrix} 0 & 2 \\ 2 & 0 \end{pmatrix}$$

and corresponding \mathcal{L} -graph as given in Fig. 2.1. For $d = -1, -2, -3, -11$ this is the only class of maximal cyclotomic matrices with a weight 4 entry.

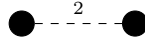

Figure 2.1: The 2-vertex sporadic maximal connected cyclotomic \mathcal{L} -graph S_2 .

Remark 2.5.5. For $d = -7$ we have an additional class with representative

$$\begin{pmatrix} 0 & \frac{3}{2} + \frac{\sqrt{-7}}{2} \\ \frac{3}{2} - \frac{\sqrt{-7}}{2} & 0 \end{pmatrix}$$

and corresponding \mathcal{L} -graph as given in Fig. 2.2.

Remark 2.5.6. For $d = -15$, we have an additional class with representative

$$\begin{pmatrix} 0 & \frac{1}{2} + \frac{\sqrt{-15}}{2} \\ \frac{1}{2} - \frac{\sqrt{-15}}{2} & 0 \end{pmatrix}$$

and corresponding \mathcal{L} -graph as given in Fig. 2.2.

As $\mathcal{L}_1 \cup \mathcal{L}_2 \cup \mathcal{L}_3 = \{1, -1\}$ for $d = -15$ this is the only class of maximal cyclotomic \mathcal{L} -matrices with a non-rational integer entry.

Remark 2.5.7. We are thus able to exclude edge labels of weight 4 (and hence $d = -15$) from now on - that is, we will consider $\mathcal{L} = \mathcal{L}_1 \cup \mathcal{L}_2 \cup \mathcal{L}_3 \cup \{0\}$ - significantly reducing the combinatorial complexity of proofs.

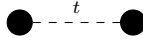
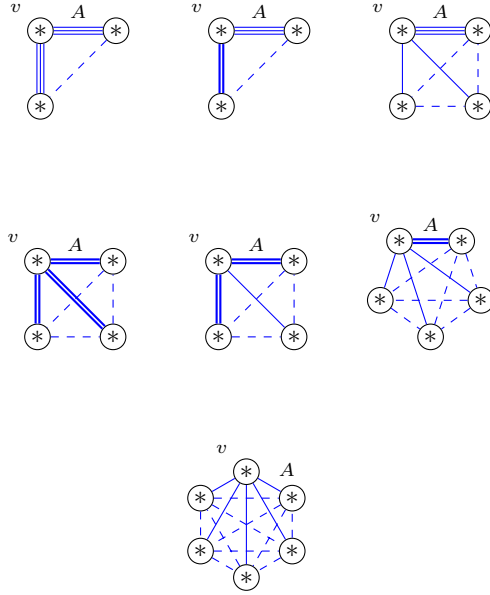

Figure 2.2: The 2-vertex sporadic maximal connected cyclotomic \mathcal{L} -graph S_2^* .
 (Where $t = \frac{3}{2} + \frac{\sqrt{-7}}{2}, \frac{1}{2} + \frac{\sqrt{-15}}{2}$ for $d = -7, -15$ respectively.)

Subject to this restriction, we may resume the proof of Theorem 2.5.2.

Let v be a vertex with weighted degree greater than four and let A be an edge incident at v with the greatest weight amongst such edges. Depending on the weight of A , a subgraph of the following form is necessarily induced on v and some of its neighbours:



We will demonstrate that no matrix corresponding to such a graph is cyclotomic.

Remark 2.5.8. Fixing a numbering, let \mathbf{M} be the set of matrices corresponding to a graph specified up to form. Then there are sets $L_{i,j} \subseteq \mathcal{L}$ such that for each $M \in \mathbf{M}$, $M_{i,j} \in L_{i,j}$. For $n \times n$ Hermitian matrices of a given form, determining which are cyclotomic naïvely requires $\prod_{i=1}^n \prod_{j=i}^n |L_{i,j}|$ matrices to be tested; this rapidly becomes unfeasible.

However, by interlacing we may eliminate unsuitable entries $M_{i,j}$ column by column: if M is an $n \times n$ cyclotomic matrix, then so is the $(n - 1) \times (n - 1)$ matrix with entries

$$\begin{pmatrix} M_{1,1} & \cdots & M_{1,n-1} \\ \vdots & \ddots & \vdots \\ M_{n-1,1} & \cdots & M_{n-1,n-1} \end{pmatrix}$$

Thus if for a list of candidate entries $m_{i,j}$ the matrix

$$\begin{pmatrix} m_{1,1} & \cdots & m_{1,n-1} \\ \vdots & \ddots & \vdots \\ m_{n-1,1} & \cdots & m_{n-1,n-1} \end{pmatrix}$$

is not cyclotomic, then we may discard any superlist

$$\begin{pmatrix} m_{1,1} & \cdots & m_{1,n-1} & M_{1,n} \\ \vdots & \ddots & \vdots & \vdots \\ m_{n-1,1} & \cdots & m_{n-1,n-1} & M_{n-1,n} \\ M_{n,1} & \cdots & M_{n,n-1} & M_{n,n} \end{pmatrix}$$

since, regardless of the choice of each $M_{i,j} \in L_{i,j}$, the $n \times n$ matrix obtained cannot be cyclotomic. In this way, we may first restrict testing to a submatrix of practical size (typically 4×4), then iteratively determine suitable entries for successive columns.

Lemma 2.5.9. (A weight 3) There are no cyclotomic graphs of form

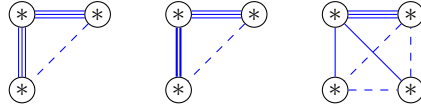

Proof. Fixing a numbering, we consider for the first two graphs the general matrix representative:

$$\begin{pmatrix} x & A & \alpha \\ \bar{A} & y & a \\ \bar{\alpha} & \bar{a} & z \end{pmatrix}$$

for charges $x, y, z \in \{0, -1, 1\}$ and edge labels $A \in \mathcal{L}_3, \alpha \in \mathcal{L}_2 \cup \mathcal{L}_3, a \in \mathcal{L}$. Testing, we find that no such matrix is cyclotomic.

For the final graph we again fix a numbering and consider general matrix representative:

$$\begin{pmatrix} x & A & \alpha_1 & \alpha_2 \\ \bar{A} & y & a_1 & a_2 \\ \bar{\alpha}_1 & \bar{a}_1 & z & a_3 \\ \bar{a}_2 & \bar{a}_2 & \bar{a}_3 & w \end{pmatrix}$$

for charges $x, y, z, w \in \{0, -1, 1\}$ and edge labels $A \in \mathcal{L}_3, \alpha_i \in \mathcal{L}_1, a_i \in \mathcal{L}$. By (complex) switching, if such a matrix is cyclotomic then there is such a matrix with $\alpha_1 = \alpha_2 = 1$; testing confirms there are none. \square

Lemma 2.5.10. (*A weight 2*) *There are no cyclotomic graphs of form*

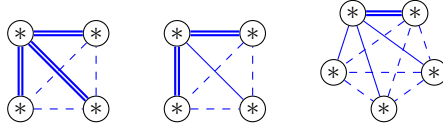

Proof. Fixing a numbering, we consider for the first two graphs the general matrix representative:

$$\begin{pmatrix} x & A & \alpha & B \\ \bar{A} & y & a_1 & a_2 \\ \bar{\alpha} & \bar{a}_1 & z & a_3 \\ \bar{B} & \bar{a}_2 & \bar{a}_3 & w \end{pmatrix}$$

for charges $x, y, z, w \in \{0, -1, 1\}$ and edge labels $A, B \in \mathcal{L}_2, \alpha \in \mathcal{L}_1 \cup \mathcal{L}_2, a_i \in \mathcal{L}$. Testing, we find that no such matrix is cyclotomic.

For the final graph we again fix a numbering and consider general matrix representative:

$$\begin{pmatrix} x & A & \alpha_1 & \alpha_2 & \alpha_3 \\ \bar{A} & y & a_1 & a_2 & a_3 \\ \bar{\alpha}_1 & \bar{a}_1 & z & a_4 & a_5 \\ \bar{\alpha}_2 & \bar{a}_2 & \bar{a}_4 & w & a_6 \\ \bar{\alpha}_3 & \bar{a}_3 & \bar{a}_5 & \bar{a}_6 & v \end{pmatrix}$$

for charges $x, y, z, w, v \in \{0, -1, 1\}$ and edge labels $A \in \mathcal{L}_2, \alpha_i \in \mathcal{L}_1, a_i \in \mathcal{L}$. By (complex) switching, if such a matrix is cyclotomic then there is such a matrix with $\alpha_1 = \alpha_2 = \alpha_3 = 1$. By Lemma 2.5.9 we can discard choices of the a_i that yield a vertex with both an edge label of weight 3 and a total weighted degree of greater than four. We then proceed as described in Remark 2.5.8, starting with the induced 4×4 matrices, and find that none of the possible 5×5 matrices of this form are cyclotomic. \square

Lemma 2.5.11. (*A weight 1*) *There are no cyclotomic graphs of the form*

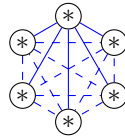

Proof. Fixing a numbering, such a graph admits a matrix representation

$$\begin{pmatrix} x & \alpha_1 & \alpha_2 & \alpha_3 & \alpha_4 & \alpha_5 \\ \overline{\alpha_1} & y & a_1 & a_2 & a_3 & a_4 \\ \overline{\alpha_2} & \overline{a_1} & z & a_5 & a_6 & a_7 \\ \overline{\alpha_3} & \overline{a_2} & \overline{a_5} & w & a_8 & a_9 \\ \overline{\alpha_4} & \overline{a_3} & \overline{a_6} & \overline{a_8} & v & a_{10} \\ \overline{\alpha_5} & \overline{a_4} & \overline{a_7} & \overline{a_9} & \overline{a_{10}} & u \end{pmatrix}$$

for charges $x, y, z, w, v, u \in \{0, -1, 1\}$ and edge labels $\alpha_i \in \mathcal{L}_1, a_i \in \mathcal{L}$. By (complex) switching, if such a matrix is cyclotomic then there is such a matrix with $\alpha_i = 1$ for each i . By Lemma 2.5.9 we can discard choices of the a_i that yield a vertex with both an edge label of weight 3 and a total weighted degree of greater than four; and similarly by Lemma 2.5.10 a_i yielding vertices with both an edge label of weight 2 and a total weighted degree greater than four.

Working subject to these restrictions, we proceed as in Remark 2.5.8, starting with the induced 4×4 matrices, and find that no choice of weights and edge labels ultimately yields a cyclotomic 6×6 matrix of this form. \square

Remark 2.5.12. *Lemmata 2.5.3, 2.5.9, 2.5.10, 2.5.11 prove Theorem 2.5.2.*

2.6 Existence of Infinite Families

In the rest of this chapter, we present proofs of the existence of infinite families of maximal cyclotomic graphs.

Definition 2.6.1. If a connected cyclotomic \mathcal{L} -graph G has all vertices of weighted degree 4, then we describe G (or its corresponding indecomposable \mathcal{L} -matrix) as 4-cyclotomic.

Remark 2.6.2. *By Geršgorin's Circle Theorem¹, if G is any \mathcal{L} -graph with all vertices of weighted degree 4, then every eigenvalue of G is in $[-4, 4]$ at worst.*

Proposition 2.6.3. *If G is a 4-cyclotomic \mathcal{L} -graph over $R = \mathcal{O}_{\mathbb{Q}(\sqrt{d})}$ for some $d < 0$ with all vertices of weighted degree 4, then G is maximal.*

Proof. Any connected supergraph of G would have a vertex of weighted degree greater than 4 and thus (by Theorem 2.5.2) be non-cyclotomic. \square

Lemma 2.6.4. *If an indecomposable Hermitian \mathcal{L} -matrix M satisfies $M^2 = 4I$, then M is 4-cyclotomic and hence a maximal indecomposable cyclotomic matrix.*

¹See e.g., [10] Section 19.7 Theorem 1

Proof. If $M^2 = 4I$ then

$$(M + \lambda I)(M - \lambda I) = (4 - \lambda^2)I$$

So if $\lambda \notin \{-2, 2\}$, $M - \lambda I$ is nonsingular; thus the only possible eigenvalues of M are $\pm 2 \in [-2, 2]$. Hence M is cyclotomic. Further, $(M^2)_{i,i} = 4$ for all i , but this is precisely the weighted degree of vertex i in the \mathcal{L} -graph G of M , so M is 4-cyclotomic. \square

Remark 2.6.5. *By Theorems 1.4.1, 1.4.2 we have the converse for integer symmetric cyclotomic matrices- each maximal indecomposable example M satisfies $M^2 = 4I$, so (by Lemma 2.6.4) we have that over \mathbb{Z} a cyclotomic matrix is maximal indecomposable if and only if it is 4-cyclotomic.*

Remark 2.6.6. *Motivated by this observation, we will classify all 4-cyclotomic \mathcal{L} -graphs over $R = \mathcal{O}_{\mathbb{Q}(\sqrt{d})}$ for each $d < 0$ in the following two chapters.*

Lemma 2.6.7. *Let M be a cyclotomic \mathcal{L} -matrix with corresponding \mathcal{L} -graph G . For fixed vertices $i \neq j$, label each common neighbour l with $M_{i,l}M_{l,j}$. If vertex i is charged and a neighbour of vertex j , label it with $M_{i,i}M_{i,j}$; if vertex j is charged and a neighbour of vertex i , label it with $M_{i,j}M_{j,j}$. Then $(M^2)_{i,j}$ is the sum of these vertex labels.*

Proof. Let M be an $n \times n$ matrix. Then the entry $(M^2)_{i,j}$ is given by

$$(M^2)_{i,j} = \sum_{l=1}^n M_{i,l}M_{l,j} \tag{2.1}$$

For each $l \notin \{i, j\}$, if vertex i is not a neighbour of vertex l then $M_{i,l} = 0$, and if vertex l is not a neighbour of vertex j then $M_{l,j} = 0$. Thus the summand $M_{i,l}M_{l,j}$ is zero whenever vertex l is not a common neighbour of vertices i and j .

For $l = i$ (or $l = j$) the summand $M_{i,i}M_{i,j}$ ($M_{i,j}M_{j,j}$) is zero unless vertices i and j are adjacent so that $M_{i,j} \neq 0$, and vertex i (j) is charged so that $M_{i,i} \neq 0$ ($M_{j,j} \neq 0$).

By construction, the list of vertex labels is therefore the non-zero summands in (2.1), so their sum is $(M^2)_{i,j}$. \square

Corollary 2.6.8. *Let M be a cyclotomic \mathcal{L} -matrix. If vertices $i \neq j$ in the corresponding \mathcal{L} -graph have no common neighbours and are uncharged, then $(M^2)_{i,j} = (M^2)_{j,i} = 0$.*

Corollary 2.6.9. *Let M be a cyclotomic \mathcal{L} -matrix. If vertices $i \neq j$ in the corresponding \mathcal{L} -graph have no common neighbours and are non-adjacent, then $(M^2)_{i,j} = (M^2)_{j,i} = 0$.*

2.6.1 Graphs of the Form \mathcal{T}_{2k} .

Definition 2.6.10. For $k \geq 3$, define the $2k$ -vertex graphs of form \mathcal{T}_{2k} by:

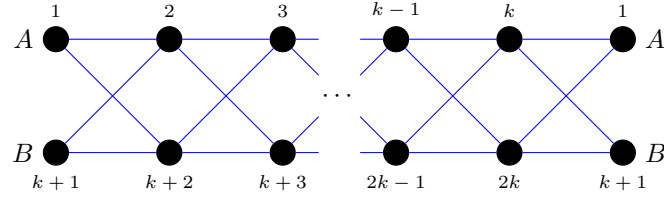

Theorem 2.6.11. Let a be an algebraic integer satisfying $a\bar{a} = 1$. Then for $k \geq 3$ the $2k$ -vertex graph G of form \mathcal{T}_{2k} with edge labels

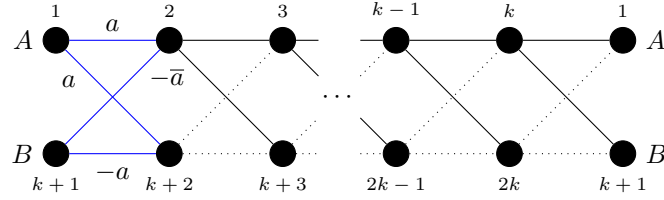

is cyclotomic.

Proof. For $k = 3, 4$ the result can easily be verified directly using Lemma 2.6.4 with matrices:

$$\begin{pmatrix} 0 & a & 1 & 0 & a & -1 \\ \bar{a} & 0 & 1 & -\bar{a} & 0 & 1 \\ 1 & 1 & 0 & 1 & -1 & 0 \\ 0 & -a & 1 & 0 & -a & -1 \\ \bar{a} & 0 & -1 & -\bar{a} & 0 & -1 \\ -1 & 1 & 0 & -1 & -1 & 0 \end{pmatrix}$$

$$\begin{pmatrix} 0 & a & 0 & 1 & 0 & a & 0 & -1 \\ \bar{a} & 0 & 1 & 0 & -\bar{a} & 0 & 1 & 0 \\ 0 & 1 & 0 & 1 & 0 & -1 & 0 & 1 \\ 1 & 0 & 1 & 0 & 1 & 0 & -1 & 0 \\ 0 & -a & 0 & 1 & 0 & -a & 0 & -1 \\ \bar{a} & 0 & -1 & 0 & -\bar{a} & 0 & -1 & 0 \\ 0 & 1 & 0 & -1 & 0 & -1 & 0 & -1 \\ -1 & 0 & 1 & 0 & -1 & 0 & -1 & 0 \end{pmatrix}$$

By Lemma 2.6.4 it suffices to show that $(M^2)_{i,j} = 4\delta_{ij}$ for all $1 \leq i, j \leq 2k$.

If $i = j$, then by inspection vertex i has weighted degree 4 as required.

So we seek to show that $(M^2)_{i,j} = 0$ for all $i \neq j$. By Corollary 2.6.8 this holds immediately for vertex pairs i, j with no common neighbours and if true for $(M^2)_{i,j}$ is also true for $(M^2)_{j,i}$. Thus we need only consider $1 \leq i < j \leq 2k$ such that vertices i, j have common neighbours.

For $k \geq 5$, the only possible induced subgraphs on i, j and their common neighbours are the following, shown with the neighbours labelled as in Lemma 2.6.7:

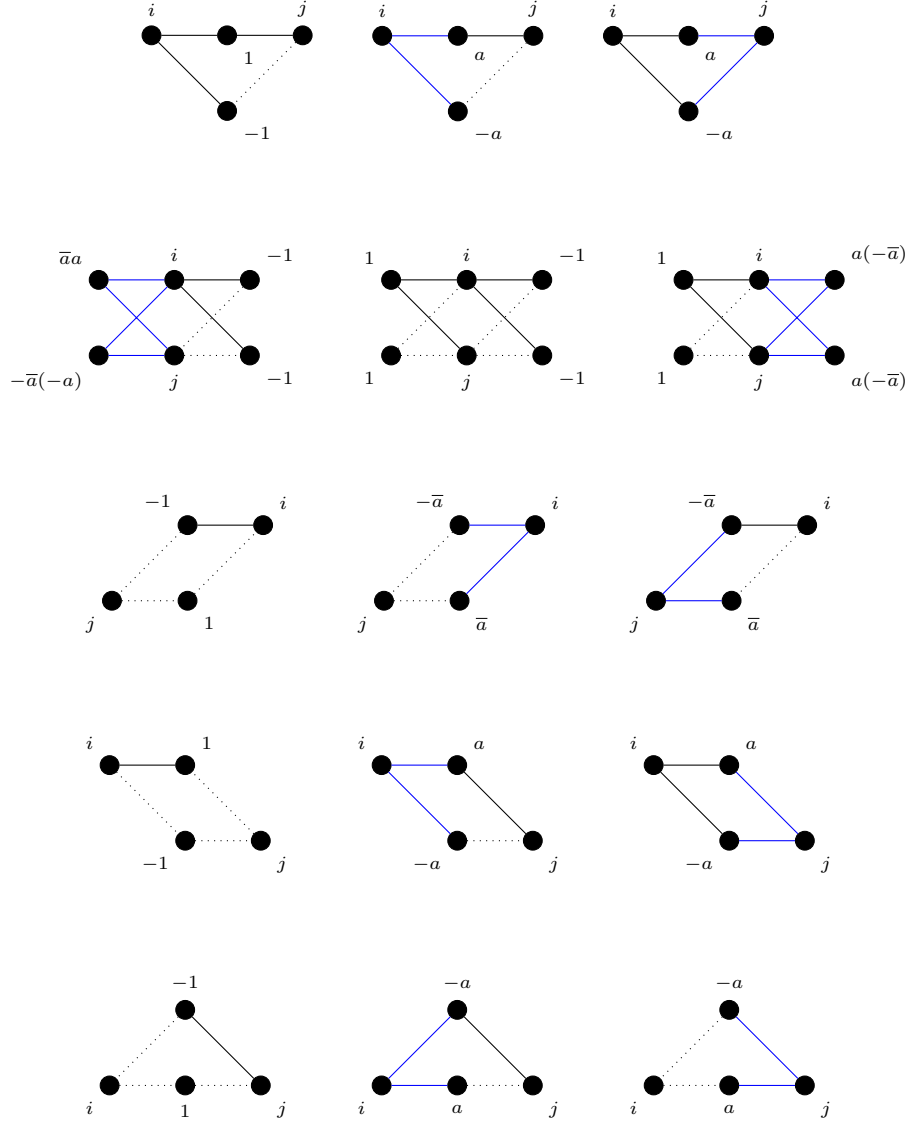

In all cases, the sum of the labels is zero, confirming that $(M^2)_{i,j} = 0$ for all $i \neq j$. So $(M^2)_{i,j} = 4\delta_{ij} \forall 1 \leq i \leq j \leq 2k$ as required.

□

Corollary 2.6.12. *By setting $a = 1$ we recover (for $k \geq 3$) the infinite family of maximal*

cyclotomic graphs T_{2k} as given in Fig. 1.3:

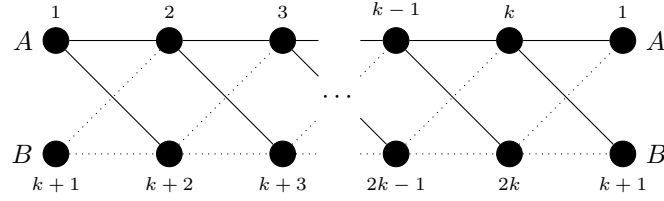

Corollary 2.6.13. *By setting $a = i$ we recover (for $k \geq 3$) an infinite family of maximal cyclotomic graphs T'_{2k} with entries from $\mathcal{O}_{\mathbb{Q}(i)}$:*

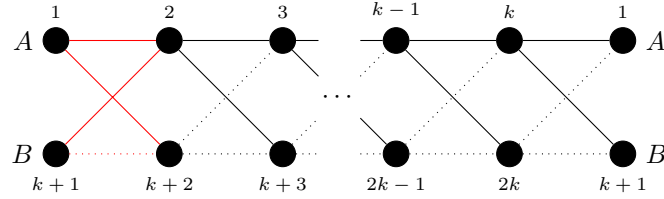

Corollary 2.6.14. *By setting $a = \omega = \frac{1}{2} + \frac{\sqrt{-3}}{2}$ we recover (for $k \geq 3$) an infinite family of maximal cyclotomic graphs T'_{2k} with entries from $\mathcal{O}_{\mathbb{Q}(\sqrt{-3})}$:*

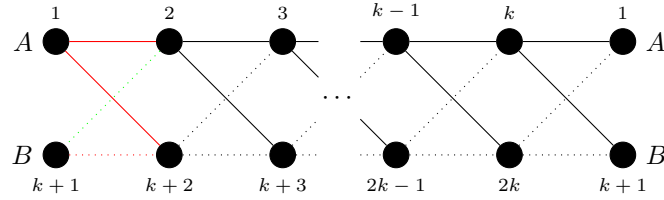

Remark 2.6.15. *The conditions in Theorem 2.6.11 are sufficiently general that we may obtain cyclotomic graphs in many more rings of integers. For example, if $\zeta = e^{i\theta}$ is a primitive n^{th} root of unity then it is an algebraic integer satisfying $\zeta\bar{\zeta} = 1$ and thus gives a cyclotomic graph over $\mathcal{O}_{\mathbb{Q}(\zeta)}$.*

Theorem 2.6.16. *The graphs T'_{2k} given in Corollaries 2.6.13 and 2.6.14 are inequivalent to the graph T_{2k} ; that is, the rings $\mathcal{O}_{\mathbb{Q}(i)}$, $\mathcal{O}_{\mathbb{Q}(\sqrt{-3})}$ admit more than one class of cyclotomic graphs of form T_{2k} .*

Proof. We will demonstrate that T'_{2k} is not equivalent to *any* graph with all edge labels rational integers.

Lemma 2.6.17. *The product of edge labels in a cycle is preserved by complex switching.*

Proof. Let S be an arbitrary complex switching matrix; in fact, all that is necessary is that S be diagonal, which such a matrix is. Let vertices v_1, \dots, v_n be a cycle s.t. each edge label $e_{i,j}$

joins v_i to v_j for $j = i + 1 \pmod n$. Let $e'_{i,j}$ be the edge label obtained after switching by S ; then $e'_{i,j} = S_{ii}e_{i,j}(S_{jj})^{-1}$ and so

$$\prod_{i=1}^n e'_{i,j} = \prod_{i=1}^n S_{ii} \prod_{j=1}^n (S_{jj})^{-1} \prod_{i=1}^n e_{ij} = \prod_{i=1}^n e_{ij}$$

since $j = i + 1 \pmod n$. □

Let T'_{2k} , with matrix representative M' , be as given in Corollary 2.6.13 or 2.6.14, so $a = i$ or $a = \omega$ respectively. Consider the subgraph induced on vertices $1, \dots, k$: this is a k -cycle with a single edge label a joining vertices $1, 2$; each other edge has label 1 and joins vertices $l, l + 1 \pmod k$ for $2 \leq l \leq k$. Thus the product of the edge labels is $a \notin \mathbb{Z}$, and by Lemma 2.6.17 this is invariant under switching.

Now let G be any graph equivalent to T'_{2k} , and M_G any matrix representative of G . Then there exists a permutation matrix P and a complex switching matrix S such that

$$M_G = \pm PSM'S^{-1}P^{-1} = \pm PMP^{-1}$$

for some M . By the above M must have at least one entry not from $\{-1, 1\}$, corresponding to an edge label between some pair of vertices $1 \leq i, j \leq k$ - if not, then all such labels are rational integers and cannot have product a . But then, since permutation does not alter the set of entries of a matrix, M_G has at least one non-rational integer entry also. Thus G has at least one non-rational integer edge label and therefore cannot be T_{2k} . □

Thus for $d = -1, -3$ we have a new infinite family of 4-cyclotomic graphs as in Fig. 2.3.

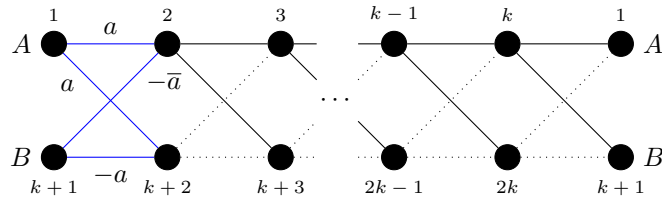
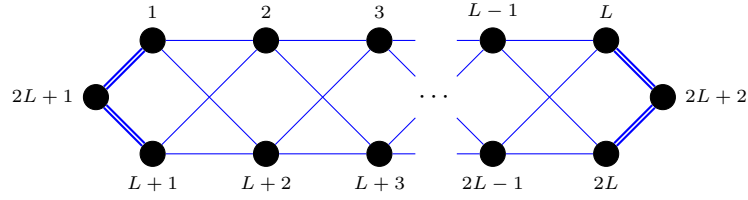

Figure 2.3: The family T'_{2k} of $2k$ -vertex maximal connected cyclotomic \mathcal{L} -graphs. (Where $k \geq 3$, $a = i$ or ω for $d = -1, -3$ respectively, and the two copies of vertices A and B should be identified)

2.6.2 Graphs of the Form \mathcal{T}_{2k}^4

Definition 2.6.18. For $k = L + 1 \geq 3$ define the $2k$ -vertex form \mathcal{T}_{2k}^4 by



Theorem 2.6.19. Let A, B be algebraic integers satisfying $A\bar{A} = 2 = B\bar{B}$. Then for $k = L + 1 \geq 3$ the $2k$ -vertex graph G of form \mathcal{T}_{2k}^4 with charges and edge labels

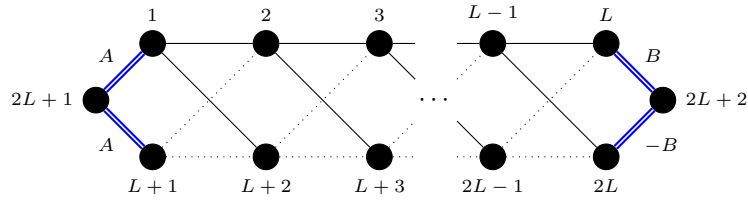

is cyclotomic.

Proof. For $k = 3, 4$ the result can easily be verified using Lemma 2.6.4 and the matrices

$$\begin{pmatrix} 0 & 1 & 0 & 1 & A & 0 \\ 1 & 0 & -1 & 0 & 0 & B \\ 0 & -1 & 0 & -1 & A & 0 \\ 1 & 0 & -1 & 0 & 0 & -B \\ \bar{A} & 0 & \bar{A} & 0 & 0 & 0 \\ 0 & \bar{B} & 0 & -\bar{B} & 0 & 0 \end{pmatrix}$$

$$\begin{pmatrix} 0 & 1 & 0 & 0 & 1 & 0 & A & 0 \\ 1 & 0 & 1 & -1 & 0 & 1 & 0 & 0 \\ 0 & 1 & 0 & 0 & -1 & 0 & 0 & B \\ 0 & -1 & 0 & 0 & -1 & 0 & A & 0 \\ 1 & 0 & -1 & -1 & 0 & -1 & 0 & 0 \\ 0 & 1 & 0 & 0 & -1 & 0 & 0 & -B \\ \bar{A} & 0 & 0 & \bar{A} & 0 & 0 & 0 & 0 \\ 0 & 0 & \bar{B} & 0 & 0 & -\bar{B} & 0 & 0 \end{pmatrix}$$

By Lemma 2.6.4 it suffices to show for the remaining cases $k \geq 5$ that $(M^2)_{i,j} = 4\delta_{ij}$ for all $1 \leq i, j \leq 2k$.

If $i = j$, then by inspection vertex i has weighted degree 4 as required.

So we seek to show that $(M^2)_{i,j} = 0$ for all $i \neq j$. By Corollary 2.6.8 this holds immediately for vertex pairs i, j with no common neighbours, and if true for $(M^2)_{i,j}$ also holds for $(M^2)_{j,i}$. Thus we need only consider $1 \leq i < j \leq 2k$ such that vertices i, j have common neighbours.

For $k \geq 5$, the only possible induced subgraphs on i, j and their common neighbours are the following, shown with the neighbours labelled as in Lemma 2.6.7:

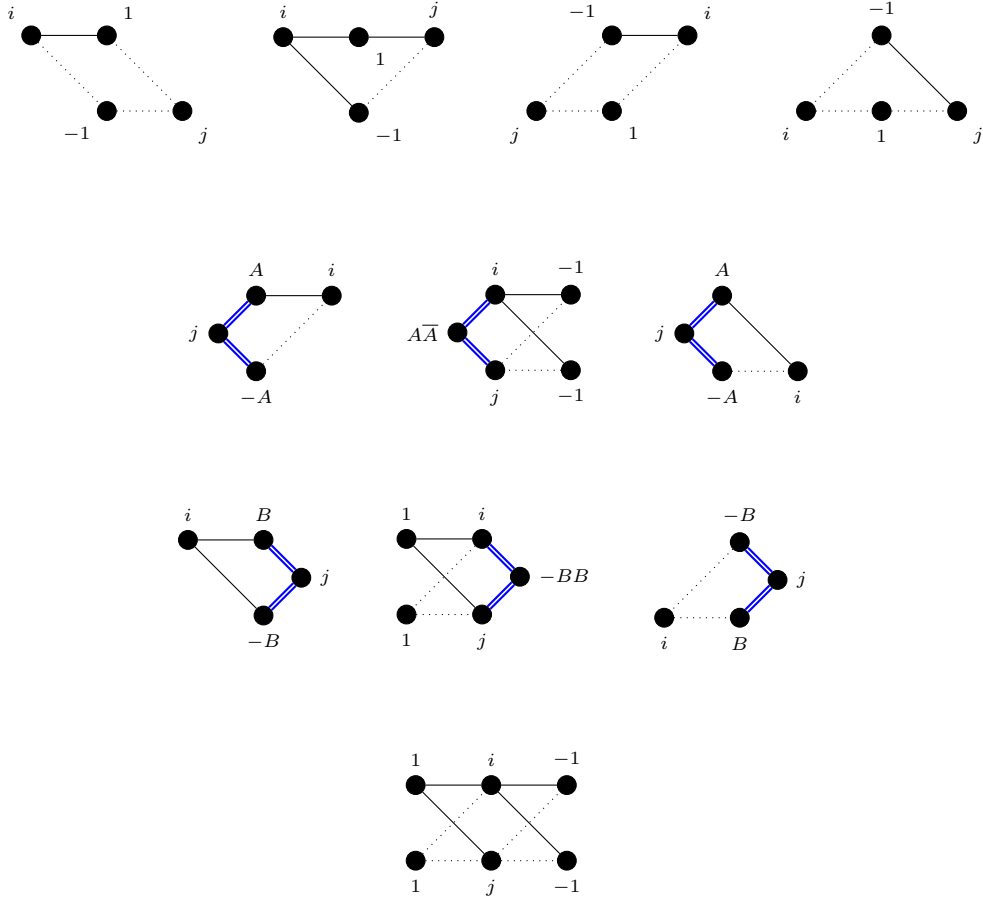

In all cases, the sum of the labels is zero, confirming that $(M^2)_{i,j} = 0$ for all $i \neq j$. So $(M^2)_{i,j} = 4\delta_{ij} \forall 1 \leq i \leq j \leq 2k$ as required. □

Corollary 2.6.20. *By setting $A = B = \frac{1}{2} + \frac{\sqrt{-7}}{2}$, $A = B = \sqrt{-2}$ or $A = B = 1 + i$ in Theorem 2.6.19 we recover infinite families of maximal cyclotomic graphs T_{2k}^4 (for $k \geq 3$) with entries from $\mathcal{O}_{\mathbb{Q}(\sqrt{-7})}$, $\mathcal{O}_{\mathbb{Q}(\sqrt{-2})}$ and $\mathcal{O}_{\mathbb{Q}(i)}$ respectively; clearly, these are not equivalent to any rational integer cyclotomic graph.*

Corollary 2.6.21. *For $d = -7$, set $A = \omega = \frac{1}{2} + \frac{\sqrt{-7}}{2}$ and $B = \bar{\omega}$ in Theorem 2.6.19 to recover an infinite family of maximal cyclotomic graphs $T_{2k}^{4'}$ for $k \geq 3$.*

Theorem 2.6.22. For $d = -7$, the graphs T_{2k}^4 given in Corollary 2.6.21 are inequivalent to the graphs T_{2k}^4 given in Corollary 2.6.20.

Proof. Let M, M' be the matrix representatives of T_{2k}^4, T_{2k}^4 respectively. If M is strongly equivalent to M' then there exists a permutation matrix P and a switching matrix S such that

$$M = PSM'S^{-1}P^{-1}$$

where $S = S^{-1} = \text{diag}(s_1, \dots, s_{2k})$ for $s_i \in \mathcal{L}_1 = \{\pm 1\}$; and there exists $\sigma \in \mathbb{S}_{2k}$ such that for matrices X, Y , if $X = PYP^{-1}$ then $X_{i,j} = Y_{\sigma(i),\sigma(j)}$.

Thus in general $M_{i,j} = s_{\sigma(i)}s_{\sigma(j)}M'_{\sigma(i),\sigma(j)} = \pm M'_{\sigma(i),\sigma(j)}$. Since $\omega = M_{1,2L+1} = M_{L+1,2L+1} = M_{L,2L+2} = -M_{2L,2L+2}$, considering the entries $\pm\omega$ in M' we therefore require that the sets

$$\begin{aligned} & \{M'_{\sigma(1),\sigma(2L+1)}, M'_{\sigma(L+1),\sigma(2L+1)}, M'_{\sigma(L),\sigma(2L+2)}, M'_{\sigma(2L),\sigma(2L+2)}\} \\ & \{M'_{1,2L+1}, M'_{L+1,2L+1}, M'_{2L+2,L}, M'_{2L+2,2L}\} \end{aligned}$$

be equal, which is impossible since it implies

$$\{\sigma(2L+1), \sigma(2L+2)\} = \{2L+1, L, 2L\}$$

For $-M$ strongly equivalent to M' we obtain the same condition, whilst for $\pm\overline{M}$ strongly equivalent to M' we would require equality of the sets

$$\begin{aligned} & \{M'_{\sigma(1),\sigma(2L+1)}, M'_{\sigma(L+1),\sigma(2L+1)}, M'_{\sigma(L),\sigma(2L+2)}, M'_{\sigma(2L),\sigma(2L+2)}\} \\ & \{M'_{L,2L+2}, M'_{2L,2L+2}, M'_{2L+1,1}, M'_{2L+1,L+1}\} \end{aligned}$$

which is also impossible.

So M, M' are necessarily inequivalent. □

Thus for $d = -1, -2, -7$ we have a new infinite family of 4-cyclotomic graphs as in Fig. 2.4 and for $d = -7$ we additionally have the distinct family given in Fig. 2.5.

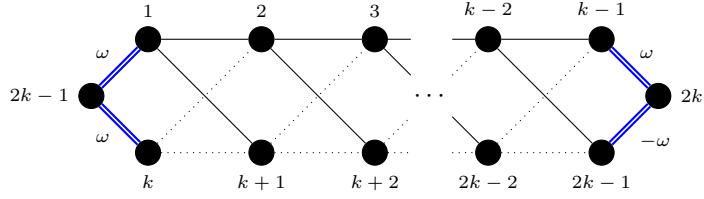

Figure 2.4: The family T_{2k}^4 of $2k$ -vertex maximal connected cyclotomic \mathcal{L} -graphs. (Where $k \geq 3$ and $\omega = 1 + i, \sqrt{-2}, \frac{1}{2} + \frac{\sqrt{-7}}{2}$ for $d = -1, -2, -7$ respectively.)

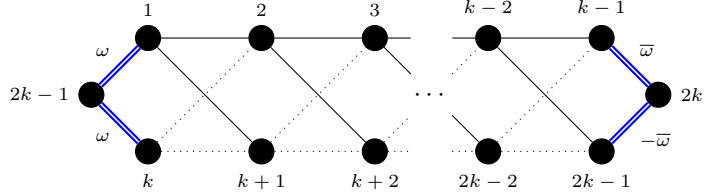
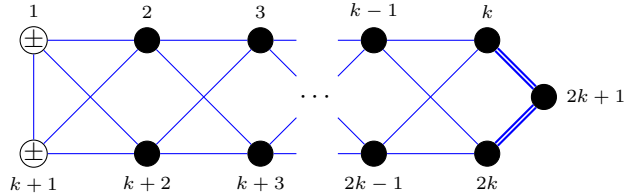

Figure 2.5: The family $T_{2k}^{4'}$ of $2k$ -vertex maximal connected cyclotomic \mathcal{L} -graphs. (Where $k \geq 3$ and $\omega = \frac{1}{2} + \frac{\sqrt{-7}}{2}$.)

Remark 2.6.23. The conditions in Theorem 2.6.19 are sufficiently general that we may obtain cyclotomic graphs in other rings of integers. For example, by setting $A = B = \sqrt{2}$ we are able to exhibit an infinite family of real symmetric matrices with all entries algebraic integers from $\mathcal{O}_{\mathbb{Q}(\sqrt{2})}$ and all eigenvalues ± 2 ; whilst by taking A, B from different quadratic fields we can construct cyclotomic matrices from rings of integers of fields of necessarily higher degree, such as taking $A = \frac{1}{2} + \frac{\sqrt{-7}}{2}, B = 1 + i$ to obtain a cyclotomic matrix from $\mathcal{O}_{\mathbb{Q}(\sqrt{-7}, i)}$.

2.6.3 Graphs of the Form $\mathcal{C}_{2k}^{2\pm}$

Definition 2.6.24. For $k \geq 1$ define the $2k + 1$ -vertex form $\mathcal{C}_{2k}^{2\pm}$ by



Theorem 2.6.25. Let A be an algebraic integer satisfying $A\bar{A} = 2$. Then for $k \geq 2$ the

$2k + 1$ -vertex graph G of form $C_{2k}^{2\pm}$ with charges and edge labels

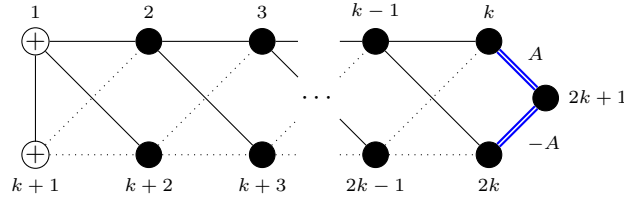

is cyclotomic.

Proof. For $k = 2$ the result can easily be verified using Lemma 2.6.4 and the matrix

$$\begin{pmatrix} 1 & 1 & 1 & 1 & 0 \\ 1 & 0 & -1 & 0 & A \\ 1 & -1 & 1 & -1 & 0 \\ 1 & 0 & -1 & 0 & -A \\ 0 & \bar{A} & 0 & -\bar{A} & 0 \end{pmatrix}$$

By Lemma 2.6.4 it suffices to show for the remaining cases $k \geq 3$ that $(M^2)_{i,j} = 4\delta_{ij}$ for all $1 \leq i, j \leq 2k$.

If $i = j$, then by inspection vertex i has weighted degree 4 as required.

So we seek to show that $(M^2)_{i,j} = 0$ for all $i \neq j$. By Corollary 2.6.8 this holds immediately for vertex pairs i, j with no common neighbours, and if true for $(M^2)_{i,j}$ also holds for $(M^2)_{j,i}$. Thus we need only consider $1 \leq i < j \leq 2k$ such that vertices i, j have common neighbours.

For $k \geq 2$, the only possible induced subgraphs on i, j and their common neighbours are the following, shown with the neighbours labelled as in Lemma 2.6.7:

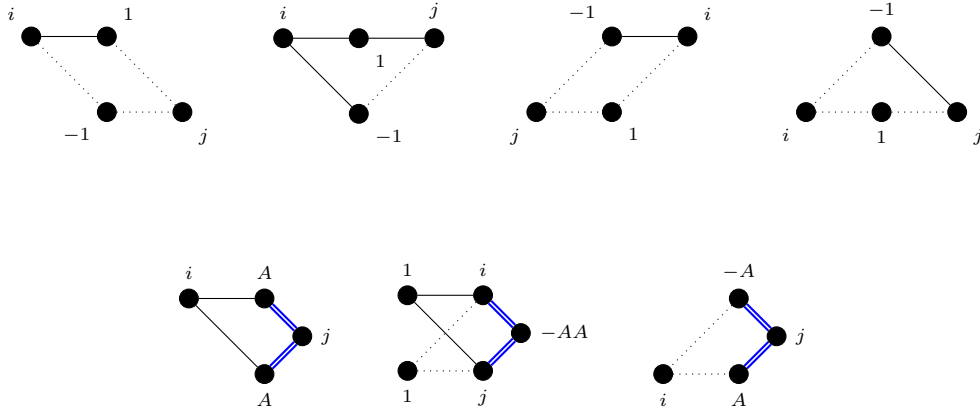

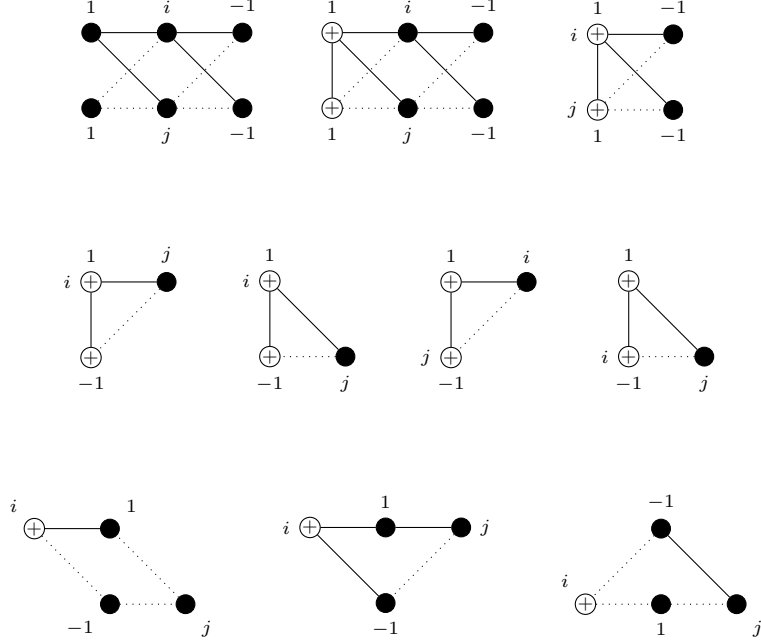

In all cases, the sum of the labels is zero, confirming that $(M^2)_{i,j} = 0$ for all $i \neq j$. So $(M^2)_{i,j} = 4\delta_{ij} \forall 1 \leq i \leq j \leq 2k$ as required. \square

Corollary 2.6.26. *By setting $A = \frac{1}{2} + \frac{\sqrt{-7}}{2}$, $A = \sqrt{-2}$ or $A = 1 + i$ in Theorem 2.6.25 we recover infinite families of maximal cyclotomic graphs C_{2k}^{2+} (see Fig. 2.6) with entries from $\mathcal{O}_{\mathbb{Q}(\sqrt{-7})}$, $\mathcal{O}_{\mathbb{Q}(\sqrt{-2})}$ and $\mathcal{O}_{\mathbb{Q}(i)}$ respectively; clearly, these are not equivalent to any rational integer cyclotomic graph.*

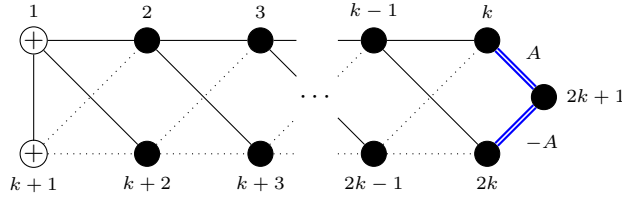
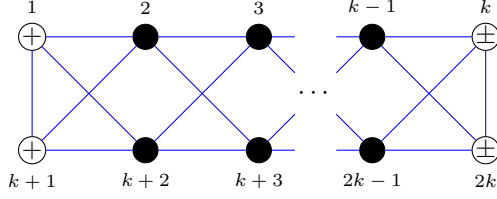

Figure 2.6: The family C_{2k}^{2+} of $2k + 1$ -vertex maximal connected cyclotomic \mathcal{L} -graphs. (Where $k \geq 1$ and $A = 1 + i, \sqrt{-2}, \frac{1}{2} + \frac{\sqrt{-7}}{2}$ for $d = -1, -2, -7$ respectively.)

Remark 2.6.27. *Theorem 2.6.25 is also sufficiently general to provide results in other rings of integers: for example, by setting $A = \sqrt{2}$ we are able to exhibit an infinite family of real, symmetric matrices with all entries algebraic integers from $\mathcal{O}_{\mathbb{Q}(\sqrt{2})}$ and all eigenvalues ± 2 .*

2.6.4 Graphs of the Form $C_{2k}^{+\pm}$.

Definition 2.6.28. For $k \geq 2$ define the $2k$ -vertex form $C_{2k}^{+\pm}$ by



Theorem 2.6.29. For $k \geq 2$ the $2k$ -vertex graphs C_{2k}^{++}, C_{2k}^{+-} of form $C_{2k}^{+\pm}$ with charges and edge labels as in Fig. 1.5

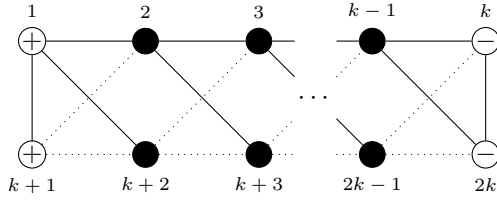
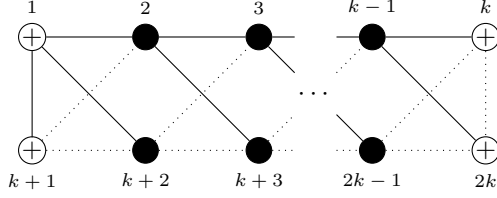

are (for $R = \mathcal{O}_{\mathbb{Q}(\sqrt{d})}, d < 0$) maximal cyclotomic.

Proof. For $k = 2, 3$ the result can easily be verified using Lemma 2.6.4 and the matrices

$$\begin{pmatrix} 1 & 1 & 1 & 1 \\ 1 & 1 & -1 & -1 \\ 1 & -1 & 1 & -1 \\ 1 & -1 & -1 & 1 \end{pmatrix} \quad \begin{pmatrix} 1 & 1 & 1 & 1 \\ 1 & -1 & -1 & -1 \\ 1 & -1 & 1 & -1 \\ 1 & -1 & -1 & -1 \end{pmatrix}$$

$$\begin{pmatrix} 1 & 1 & 0 & 1 & 1 & 0 \\ 1 & 0 & 1 & -1 & 0 & 1 \\ 0 & 1 & 1 & 0 & -1 & -1 \\ 1 & -1 & 0 & 1 & -1 & 0 \\ 1 & 0 & -1 & -1 & 0 & -1 \\ 0 & 1 & -1 & 0 & -1 & 1 \end{pmatrix} \quad \begin{pmatrix} 1 & 1 & 0 & 1 & 1 & 0 \\ 1 & 0 & 1 & -1 & 0 & 1 \\ 0 & 1 & -1 & 0 & -1 & 1 \\ 1 & -1 & 0 & 1 & -1 & 0 \\ 1 & 0 & -1 & -1 & 0 & -1 \\ 0 & 1 & 1 & 0 & -1 & -1 \end{pmatrix}$$

By Lemma 2.6.4 it suffices to show for the remaining cases $k \geq 4$ that $(M^2)_{i,j} = 4\delta_{ij}$ for all $1 \leq i, j \leq 2k$.

If $i = j$, then by inspection vertex i has weighted degree 4 as required.

So we seek to show that $(M^2)_{i,j} = 0$ for all $i \neq j$. By Corollary 2.6.8 this holds immediately for vertex pairs i, j with no common neighbours, and if true for $(M^2)_{i,j}$ also holds for $(M^2)_{j,i}$. Thus we need only consider $1 \leq i < j \leq 2k$ such that vertices i, j have common neighbours.

For $k \geq 4$, the only possible induced subgraphs on i, j and their common neighbours are the following, shown with the neighbours labelled as in Lemma 2.6.7:

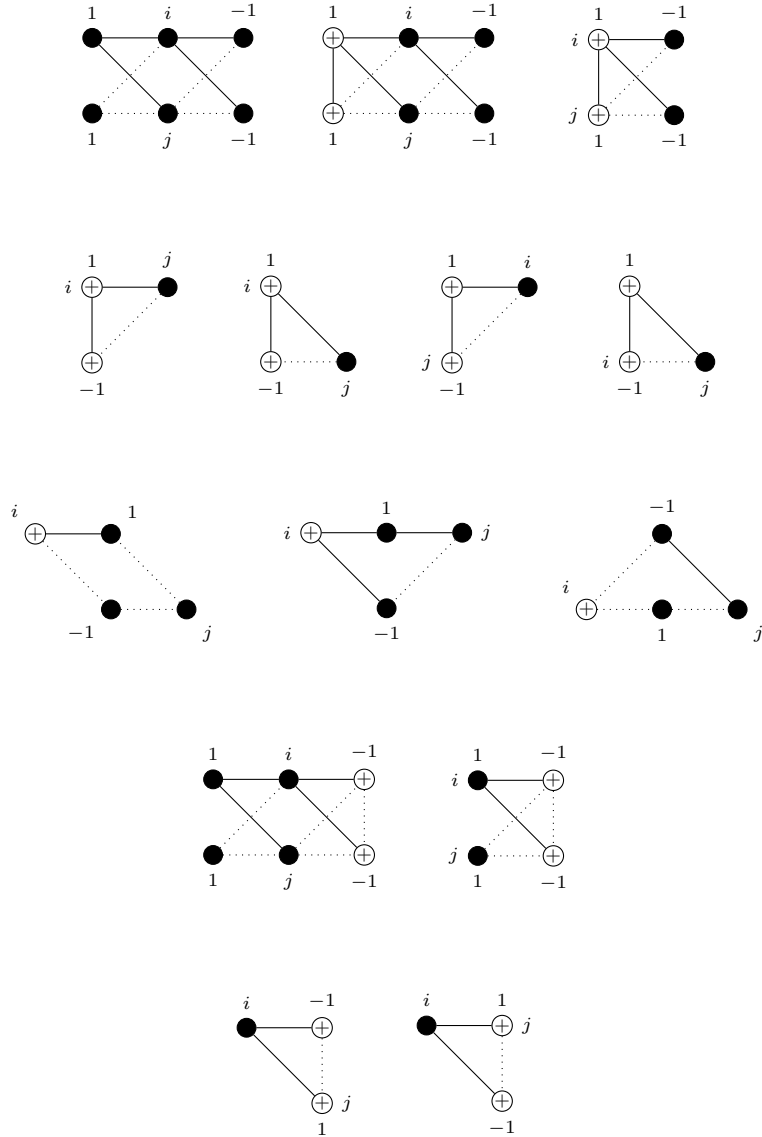

In all cases, the sum of the labels is zero, confirming that $(M^2)_{i,j} = 0$ for all $i \neq j$. So $(M^2)_{i,j} = 4\delta_{ij} \forall 1 \leq i \leq j \leq 2k$ as required. \square

Chapter 3

4-cyclotomic Graphs I- Reduction to Infinite Families

3.1 Overview

In this Chapter, we will prove the following *classification up to form*:

Theorem 3.1.1. *Let G be a connected 4-cyclotomic \mathcal{L} -graph with entries from $\mathcal{O}_{\mathbb{Q}(\sqrt{-d})}$ for some $d < 0$. Then, with only finitely many exceptions, G is of the form \mathcal{T}_{2k} , $\mathcal{C}_{2k}^{+\pm}$, \mathcal{T}_{2k}^4 or $\mathcal{C}_{2k}^{2\pm}$.*

Further, we identify the form of the exceptions.

3.2 Growing Algorithms

Algorithms are presented here as pseudocode to illustrate the key ideas; for implementation specifics and further optimisations, see Appendix A.

3.2.1 Cyclotomic Additions

Given a maximal cyclotomic graph G and an induced subgraph G' , we clearly may recover G from G' by reintroducing the ‘missing’ vertices one at a time, giving a sequence of cyclotomic supergraphs of G' contained in G .

Thus, given a seed n -vertex cyclotomic graph G' , we may recover *all* cyclotomic $n + 1$ -vertex graphs inducing G' as a subgraph by considering all possible additions of a new vertex to G . If an addition yields a connected cyclotomic graph we describe it as a *cyclotomic addition*,

otherwise as a *noncyclotomic addition*; a graph that admits no cyclotomic addition is clearly maximal.

Iterating this process allows us to generate sets of successively larger cyclotomic graphs with G' as an induced subgraph. Given a set S_k of k -vertex graphs with this property, applying this growing procedure produces two sets: M_k , the set of elements of S_k which admit no cyclotomic addition; and S_{k+1} , the set of $(k+1)$ -vertex cyclotomic supergraphs of the elements of S_k .

The entries (if any) of M_k are all the maximal k -vertex graphs inducing G' as a subgraph; any maximal cyclotomic graph with $n > k$ vertices inducing G' as a subgraph necessarily induces some $g \in S_{k+1}$ as a subgraph. Thus if $S_n = \emptyset$ for some n , then the set of maximal cyclotomic graphs inducing G' as a subgraph is finite, namely

$$\bigcup_{k=|G'|}^n M_k.$$

Naïvely, this gives a procedure for determining *all* maximal cyclotomic graphs up to a given vertex count: Take as seed set S_2 the graphs of the form

$$\textcircled{*} \overset{t}{-} \textcircled{*}$$

for $t \in \mathcal{L} \setminus \{0\}$, and iteratively find maximal supergraphs by repeated rounds of testing for cyclotomic additions. However, since (with possible vertex charges $0, 1, -1$) each round requires testing $3(|\mathcal{L}|^k - 1)|S_k|$ graphs for cyclotomicity, this rapidly becomes impractical - and the existence of infinite families of cyclotomic graphs proves it can never terminate with a complete classification. Nonetheless, with refinement such growing techniques allow us to characterise various special cases and provide the foundations for the general proof.

We now formalise some of these ideas in terms of matrix representatives of cyclotomic graphs.

Definition 3.2.1. For $k \in \mathbb{N}$ and a label set \mathcal{L} , define the *naïve column set* $C_k(\mathcal{L})$ as the set of all k -tuples $c = (c_1, \dots, c_k) \in \mathcal{L}^k$ such that at least one $c_i \neq 0$ (i.e, $c \neq \mathbf{0}$).

Definition 3.2.2. For a $k \times k$ matrix representative m of a k -vertex cyclotomic \mathcal{L} -graph, a label set \mathcal{L} and a charge set X , let the *naïve cyclotomic addition set of m* be the set of $(k+1) \times (k+1)$ matrices

$$\text{super}(m, \mathcal{L}, X) := \left\{ m_{c,x} = \begin{pmatrix} m & c \\ \bar{c} & x \end{pmatrix} \mid c \in C_k(\mathcal{L}), x \in X, m_{c,x} \text{ is cyclotomic} \right\}.$$

Proposition 3.2.3. *If G is a $(k+1)$ -vertex cyclotomic \mathcal{L} -graph obtained from a k -vertex \mathcal{L} -graph G' by a cyclotomic addition, and m' is a matrix representative of G' , then there is a matrix representative of G in $\text{super}(m', \mathcal{L}, \{0, 1, -1\})$.*

Definition 3.2.4. Let S_k be a set of $k \times k$ cyclotomic matrices m_i . For a label set \mathcal{L} and charge set X we define a *round of naïve growing* as the direct determination of sets

$$S_{k+1} = \bigcup_{m_i \in S_k} \text{super}(m_i, \mathcal{L}, X)$$

and

$$M_k = \{m_i \in S_k \mid \text{super}(m_i, \mathcal{L}, X) = \emptyset\}.$$

Proposition 3.2.5. Let G be an n -vertex cyclotomic \mathcal{L} -graph inducing a k -vertex cyclotomic subgraph G' with matrix representative M' . Let S_n be the set obtained after $n - k$ rounds of naïve growing of any set S_k containing M' , with $X = \{0, 1, -1\}$. Then there is a matrix representative of G in S_n .

Proposition 3.2.6. Let G' be a k -vertex cyclotomic \mathcal{L} -graph with matrix representative M' . If G is a maximal n -vertex cyclotomic graph inducing G' as a subgraph, then there is a matrix representative of G in the set M_n found by $n - k + 1$ rounds of naïve growing of seed set $S_k = \{M'\}$ with $X = \{0, 1, -1\}$.

3.2.2 Refinements

Bounded Weight Growing

From Theorem 2.5.2 we have that any vertex in a cyclotomic graph has weighted degree at most four. Note that if $m_{c,x}$ is obtained by an addition to a matrix m then it is the matrix representative of a graph with a vertex of weighted degree $w = |x| + \sum c_i \bar{c}_i$; for this to be a cyclotomic addition we therefore require $w \leq 4$.

This allows us to refine our choice of potential addition columns to the following:

Definition 3.2.7. For $k \in \mathbb{N}$, bound $b \in \mathbb{N}$ and label set \mathcal{L} , define the *bounded weight column set* $C_k^b(\mathcal{L})$ as the set of all k -tuples $(c_1, \dots, c_k) \in C_k(\mathcal{L})$ such that

$$\sum_1^k c_i \bar{c}_i \leq b$$

This gives rise to a corresponding growing procedure:

Definition 3.2.8. For a $k \times k$ matrix representative m of a k -vertex cyclotomic \mathcal{L} -graph, a label set \mathcal{L} , a bound $b \in \mathbb{N}$ and a charge set X , let the *bounded weight cyclotomic addition set* of m be the set of $(k + 1) \times (k + 1)$ matrices

$$\text{super}_b(m, \mathcal{L}, X) := \left\{ m_{c,x} = \begin{pmatrix} m & c \\ \bar{c} & x \end{pmatrix} \mid c \in C_k^b, x \in X, m_{c,x} \text{ is cyclotomic} \right\}$$

Definition 3.2.9. Let S_k be a set of $k \times k$ cyclotomic matrices m_i . For a label set \mathcal{L} and charge set X We define a *round of bounded weight growing* as the determination of sets

$$S_{k+1} = \bigcup_{m_i \in S_k} \text{super}_4(m_i, \mathcal{L}, X)$$

and

$$M_k = \{m_i \in S_k \mid \text{super}_4(m_i, \mathcal{L}, X) = \emptyset\}.$$

Proposition 3.2.10. For a given \mathcal{L}, X the sets S_{k+1}, M_k obtained after a round of naïve growing or a round of bounded weight growing are equal.

Proof. Note that for all m ,

$$\begin{aligned} \text{super}(m, \mathcal{L}, X) &= \text{super}_4(m, \mathcal{L}, X) \cup \{m_{c,x} \mid c \in C_k(\mathcal{L}) \setminus C_k^4(\mathcal{L}), m_{c,x} \text{ cyclotomic}\} \\ &= \text{super}_4(m, \mathcal{L}, X) \cup \emptyset = \text{super}_4(m, \mathcal{L}, X) \end{aligned}$$

since if $c \in C_k(\mathcal{L}) \setminus C_k^4(\mathcal{L})$ then $m_{c,x}$ corresponds to a graph with a $(k+1)$ st vertex of weighted degree greater than four which, by Theorem 2.5.2, is not cyclotomic. \square

Equivalent Growing

Consider a $k \times k$ cyclotomic matrix m and a vector $c \in C_k$. If the $(k+1) \times (k+1)$ matrix $m_{c,x}$ is cyclotomic for some c, x , then, by (complex) switching at the new vertex, so are the matrices $m_{\lambda c, x}$ for any $\lambda \in \mathcal{L}_1$, and they are equivalent to $m_{c,x}$.

We may thus restrict our attention to the *reduced column set* $C_{k'}(\mathcal{L}) := C_k(\mathcal{L}) / \sim$, where $c = (c_1, \dots, c_k) \equiv c'$ if and only if $c' = (\lambda c_1, \dots, \lambda c_k)$ for some $\lambda \in \mathcal{L}_1$; this gives a *reduced cyclotomic addition set*, $\text{super}'(m, \mathcal{L}, X)$.

Combining with the observations in Section 3.2.2, this gives

Definition 3.2.11. For $k \in \mathbb{N}$, bound $b \in \mathbb{N}$ and label set \mathcal{L} , define the *reduced bounded weight column set* $C_{k'}^b(\mathcal{L})$ as the set of all k -tuples $(c_1, \dots, c_k) \in C_{k'}(\mathcal{L})$ such that

$$\sum_1^k c_i \bar{c}_i \leq b$$

(equivalently, $C_{k'}^b(\mathcal{L}) = C_k^b(\mathcal{L}) / \sim$.)

Definition 3.2.12. For a $k \times k$ matrix representative m of a k -vertex cyclotomic graph, a label set \mathcal{L} and a charge set X , let the *reduced bounded weight cyclotomic addition set of m* be the

set of $(k + 1) \times (k + 1)$ matrices

$$\text{super}'_b(m, \mathcal{L}, X) := \left\{ m_{c,x} = \begin{pmatrix} m & c \\ \bar{c} & x \end{pmatrix} \mid c \in C_{k'}^b, x \in X, m_{c,x} \text{ is cyclotomic} \right\}$$

Definition 3.2.13. Let S_k be a set of $k \times k$ cyclotomic matrices m_i . For a label set \mathcal{L} and charge set X we define a *round of reduced bounded weight growing* as the determination of sets

$$S_{k+1} = \bigcup_{m_i \in S_k} \text{super}'_4(m_i, \mathcal{L}, X)$$

and

$$M_k = \{m_i \in S_k \mid \text{super}'_4(m_i, \mathcal{L}, X) = \emptyset\}.$$

If cyclotomic matrices m_1, m_2 are equivalent, then for fixed \mathcal{L}, X, b any $m'_1 \in \text{super}'_b(m_1, \mathcal{L}, X)$ is equivalent to some $m'_2 \in \text{super}'_b(m_2, \mathcal{L}, X)$. Where practical we may therefore reduce each S_k modulo equivalence between rounds. We have thus arrived at the following:

Theorem 3.2.14. *Let G be an n -vertex cyclotomic graph with matrix representative M . Let G' be a k -vertex cyclotomic graph equivalent to an induced subgraph of G and with matrix representative M' . Then G is equivalent to a graph with a matrix representative in the set S_n obtained after $n - k$ rounds of reduced bounded weight growing from seed set $S_k = \{G'\}$.*

Definition 3.2.15. (The **equivgrow** algorithm) Let S_k be a seed set of $k \times k$ cyclotomic matrices, \mathcal{L} a label set and X a charge set. Let $C_{k'}^4(\mathcal{L})$ be the reduced bounded weight column set as in Definition 3.2.11 with $b = 4$. Then the following algorithm performs a *round of reduced bounded weight growing* as described in Definition 3.2.13:

Algorithm 1: equivgrow

Input: $S_k, X, C_{k'}^4(\mathcal{L})$
Output: S_{k+1}, M_k corresponding to reduced bounded weight growing

$S_{k+1} = \emptyset$
 $M_k = \emptyset$

for $m \in S_k$ **do**
 $S_m = \emptyset$
 for $x \in X$ **do**
 for $c \in C_{k'}^4(\mathcal{L})$ **do**
 $m_{c,x} = \begin{pmatrix} m & c \\ \bar{c} & x \end{pmatrix}$
 if $m_{c,x}$ *is cyclotomic* **then**
 $S_m = S_m \cup \{m_{c,x}\}$
 if $S_m = \emptyset$ **then**
 $M_k = M_k \cup \{m\};$ // Found a maximal example
 else
 $S_{k+1} = S_{k+1} \cup S_m$
return S_{k+1}, M_k

By using the reduced bounded weight column set $C_{k'}^4(\mathcal{L})$ in **equivgrow** we avoid extending any of the seed matrices by a $(k+1)$ st vertex of weight greater than four. However, for $m \in S_k$, $x \in X$, $c \in C_{k'}^4(\mathcal{L})$ it is still possible for the weight of another vertex in the graph of $m_{c,x}$ to have weight greater than four; such an extension can also be rejected as necessarily noncyclotomic. Thus for small sets of large seed matrices it can prove computationally advantageous to preselect the suitable entries of $C_{k'}^4(\mathcal{L})$.

To this end, we define the i th *row weight* of a $k \times k$ \mathcal{L} -matrix M to be

$$\text{RowWeight}(M)_i := \sum_{j=1}^k M_{i,j} \overline{M_{i,j}}$$

i.e., $\text{RowWeight}(M)$ is the list of weighted degrees of vertices in the corresponding \mathcal{L} -graph.

Then we have the following variant of **equivgrow**:

Algorithm 2: bounded **equivgrow**

Input: $S_k, X, C_{k'}^4(\mathcal{L})$

Output: S_{k+1}, M_k corresponding to reduced bounded weight growing

$S_{k+1} = \emptyset$

$M_k = \emptyset$

for $m \in S_k$ **do**

$S_m = \emptyset$

$C_m = C_{k'}^4(\mathcal{L})$

for l from 1 to k **do**

$rowWeights_l = \sum_{i=1}^k m_{l,i} \overline{m_{l,i}}$

for $c \in C_m$ **do**

$newWeights_l = rowWeights_l + Norm(c_l)$

if $\max(newWeights) > 4$ **then** $C_m = C_m - \{c\}$

for $x \in X$ **do**

for $c \in C_m$ **do**

$m_{c,x} = \begin{pmatrix} m & c \\ \bar{c} & x \end{pmatrix}$

if $m_{c,x}$ is cyclotomic **then**

$S_m = S_m \cup \{m_{c,x}\}$

if $S_m = \emptyset$ **then**

$M_k = M_k \cup \{m\};$

 // Found a maximal example

else

$S_{k+1} = S_{k+1} \cup S_m$

return S_{k+1}, M_k

Saturating Growing

So far we have considered algorithms to find (up to equivalence) all n -vertex cyclotomic graphs with a specified induced subgraph. However, if we restrict our attention to 4-cyclotomic graphs, then further improvements are possible.

Given a maximal cyclotomic graph G and an induced subgraph G' , define the *saturation* of a vertex v of G' to be the number of its neighbours in G that are also present in G' . If all such neighbours are present, then v is described as *saturated*; otherwise, *unsaturated*. For a fixed numbering of the vertices, describe a cyclotomic addition as *saturating* if it strictly increases the saturation of the first unsaturated vertex.

Clearly, any G can be recovered from one of its induced subgraphs by a sequence of saturating cyclotomic additions. Given a matrix representative m' of a cyclotomic graph G' with the first r vertices saturated, we thus need only consider growing by columns c such that $c_1 = \dots = c_r = 0$ and $c_{r+1} \neq 0$. In general, we do not necessarily know if a vertex is saturated (weighted degree

4 is sufficient but potentially not necessary). If G is 4-cyclotomic, however, then a vertex of G' is saturated if and only if it has weighted degree 4.

Definition 3.2.16. The **satgrow** algorithm

Let S_k be a seed set of $k \times k$ cyclotomic matrices, \mathcal{L} a label set and X a charge set. Let C be the reduced bounded weight cyclotomic addition set $C_{k'}^4(\mathcal{L})$ (as in Definition 3.2.11 with $b = 4$). Then the following algorithm performs a *round of saturating growing*:

Algorithm 3: satgrow

Input: S_k, X, C

Output: S_{k+1}, M_k corresponding to saturating growing

$S_{k+1} = \emptyset$

$M_k = \emptyset$

for $m \in S_k$ **do**

$S_m = \emptyset$

$r = 1$

while $\text{RowWeight}(m)_r = 4$ and $r \leq k$ **do** $r=r+1$

 // r now stores the index of the first unsaturated vertex, or $k+1$ if

 all saturated

if $r = k+1$ **then**

$M_k = M_k \cup \{m\};$ // Found a maximal example

else

for $x \in X$ **do**

for $c \in C$ **do**

if ($r = 1$ and $c_1 \neq 0$) or ($r \geq 2$ and $c_1 = \dots = c_{r-1} = 0$ and $c_r \neq 0$) **then**

 // c a saturating addition; see if it gives a cyclotomic

 matrix

$$m_{c,x} = \begin{pmatrix} m & c \\ \bar{c} & x \end{pmatrix}$$

if $m_{c,x}$ is cyclotomic **then** $S_m = S_m \cup \{m_{c,x}\}$

if $S_m = \emptyset$ **then**

 // Found an m with vertex of weighted degree < 4 but no

 saturating additions^a

$M_k = M_k \cup \{m\}$

else

$S_{k+1} = S_{k+1} \cup S_m$

return S_{k+1}, M_k

^aWe guard against this possibility, but in practice found it never to occur for any seed graph tested.

We thus have the following result:

Theorem 3.2.17. *Let G be an n -vertex connected 4-cyclotomic graph inducing a k -vertex*

subgraph G' equivalent to a graph G'' . Let M_n be the set of maximal matrices obtained by $n - k + 1$ rounds of saturating growing from seed set $S_k = \{G''\}$. Then G is equivalent to some graph with a matrix representative $M \in M_n$.

Saturated extensions

Definition 3.2.18. If we have a cyclotomic \mathcal{L} -graph G on vertices $v_1 \dots v_k$, we will describe the extension of G by vertices $x_1 \dots x_n$ and corresponding edges as a *saturating extension* if all vertices $v_1 \dots v_k$ then have weighted degree four; the x_i needn't also be saturated.

Trivially, any subgraph G' of a 4-cyclotomic \mathcal{L} -graph G can be grown to G by a saturating extension- simply reintroduce all missing vertices and edges. We thus describe a saturating extension by $x_1 \dots x_n$ as *minimal* if omitting any one of the x_i and its corresponding edges gives a non-saturating extension (that is, each x_i is necessary to saturate some v_j). Note that a minimal saturating extension corresponds to some sequence of saturating additions.

Proposition 3.2.19. *Any 4-cyclotomic \mathcal{L} -graph G can be grown from any of its induced subgraphs by a sequence of minimal saturating extensions.*

Proof. Reintroduce the neighbours of all unsaturated vertices, either recovering the maximal \mathcal{L} -graph G or a strictly larger subgraph of G with unsaturated vertices only amongst those just added. Repeat this process until G is recovered, which must occur after a finite number of saturating extensions. \square

3.3 Graphs With Weight 3 Edges

For $d = -2, -3$ or -11 , let G be a maximal connected cyclotomic \mathcal{L} -graph with a weight 3 edge label. For $d = -2$ or -11 , we have (by negating and/or conjugating if necessary) that G is equivalent to such a graph with an edge label of $\alpha = 1 + \sqrt{-2}$ or $\alpha = \frac{1}{2} + \frac{\sqrt{-11}}{2}$ respectively; whilst for $d = -3$ we have that G is strongly equivalent to a graph with an edge label of $\alpha = \frac{3}{2} + \frac{\sqrt{-3}}{2}$ by complex switching.

We may thus take as seed set S_2 the cyclotomic matrices of the form

$$\begin{pmatrix} x_1 & \alpha \\ \bar{\alpha} & x_2 \end{pmatrix}$$

for $x_1, x_2 \in \{0, 1, -1\}$, and iterate the **equivgrow** algorithm to recover representatives of the maximal n -vertex connected cyclotomic \mathcal{L} -graphs inducing a $\overset{\alpha}{\textcircled{=}} \textcircled{=}$ subgraph: if G has n vertices, then $G \sim H$ for some H with representative in M_n . For each ring, this process terminates after three rounds ($S_5 = \emptyset$; i.e., for all $m \in S_4$, $m \in M_4$), giving the following result:

Proposition 3.3.1. *There are only finitely many maximal cyclotomic \mathcal{L} -graphs with a weight 3 edge label. Up to form, they are:*

Lines of Form \mathcal{S}'_2



Squares of Form \mathcal{S}'_4

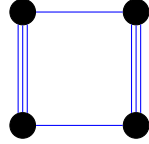

with cyclotomic examples of each in the three rings $\mathcal{O}_{\mathbb{Q}(\sqrt{d})}$ for $d = -2, -3, -11$.

Remark 3.3.2. *For $d = -11$, these are the only maximal classes with a non-rational integer entry.*

Remark 3.3.3. *For $d = -3$, this reduces the classification of maximal connected cyclotomic \mathcal{L} -graphs to those with all edges of weight 1.*

3.4 Graphs With All Edges Weight 1

3.4.1 Preliminaries

Note that it suffices to consider $d = -1$ and $d = -3$ only, since, for any other $\mathcal{O}_{\mathbb{Q}(\sqrt{d})}$ with $d < 0$ (or simply \mathbb{Z}), if G is an \mathcal{L} -graph with all edge labels of weight 1 then it has all edge labels from $\mathcal{L}_1 = \{1, -1\}$ and thus is also a cyclotomic graph with all edge labels of weight 1 over $\mathcal{O}_{\mathbb{Q}(i)}$. To that end, we make the following useful definitions and establish some preliminary results.

Definition 3.4.1. We describe any $2k$ -vertex graph of the form

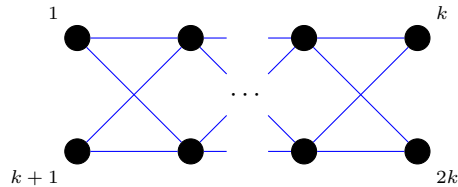

as a *cylinder of length k* .

Definition 3.4.2. We describe any $2k$ -vertex graph of the form

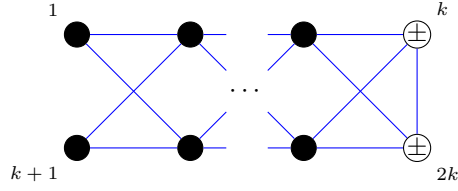

as a *stem of length k*.

Lemma 3.4.3. *There are no cyclotomic \mathcal{L} -graphs of the form*

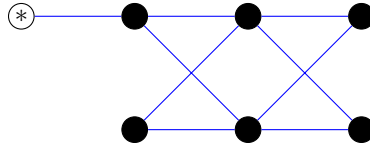

Proof. For each of $d = -1, -3$, we find up to equivalence the possible uncharged cyclotomic graphs of the form

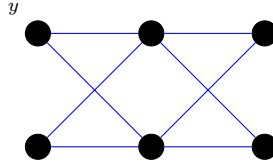

However, no addition to such a graph formed by adjoining a new vertex x (of any charge) to only vertex y is cyclotomic, thus there can be no cyclotomic graphs of the form described in the Lemma. □

3.4.2 Uncharged Triangles

In order to exclude them from future arguments, we first determine the 4-cyclotomic \mathcal{L} -graphs which induce an uncharged triangle:

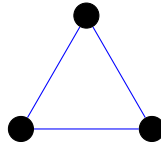

We consider both charged and uncharged \mathcal{L} -graphs, and thus repeatedly apply **satgrow** with the cyclotomic triangles as seed set S_3 , taking $\mathcal{L} = \mathcal{L}_1 \cup \{0\}$, $X = \{0, 1, -1\}$ and reducing intermediate stages by complex switching where feasible.

For $d = -3$, this process terminates at 7 vertices, having yielded the following maximal forms:

5-vertex maximal form \mathcal{S}_5

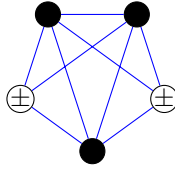

6-vertex maximal forms

\mathcal{T}_6 form

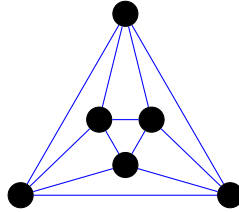

2 charge form \mathcal{S}'_6

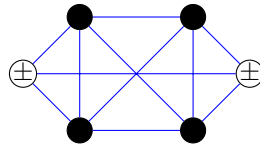

7-vertex maximal form \mathcal{S}_7

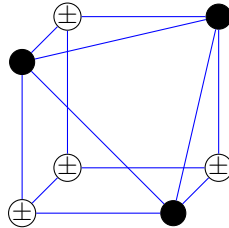

For $d = -1$, this process terminates at 8 vertices, having yielded the maximal forms $\mathcal{T}_6, \mathcal{S}_7$ as above and an 8 vertex form:

8-vertex maximal form \mathcal{S}_8^\dagger

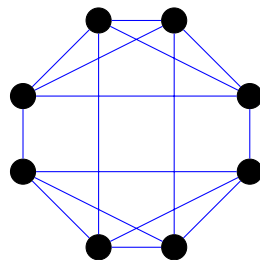

These computations imply the following result:

Proposition 3.4.4. *If G is a 4-cyclotomic \mathcal{L} -graph with at least 8 vertices not of the form \mathcal{S}_8^\dagger , then G does not contain as a subgraph an uncharged cycle of the form . That is, G is uncharged-triangle free.*

3.4.3 Uncharged-Triangle Free Graphs

We now repeatedly apply the **satgrow** algorithm to the most general subgraph $\textcircled{*} \text{---} \textcircled{*}$, again with $\mathcal{L} = \mathcal{L}_1 \cup \{0\}$, $X = \{0, 1, -1\}$. After each round we may discard any graph containing an uncharged triangle (since by Proposition 3.4.4 we know all possible maximal supergraphs), and can reduce modulo complex switching whilst feasible. In this way we generate representatives of all possible 4-cyclotomic \mathcal{L} -graphs of 8 or less vertices, and a set of nonmaximal 8-vertex cyclotomic \mathcal{L} -graphs $G_8 := \mathcal{S}_8 \setminus M_8$ such that if G is a connected 4-cyclotomic uncharged-triangle free \mathcal{L} -graph (not necessarily itself uncharged) then G induces as a subgraph some $g_8 \in G_8$. Thus if the forms of all possible 4-cyclotomic supergraphs of the elements of G_8 can be determined, then this completes the classification of all 4-cyclotomic \mathcal{L} -graphs up to form.

4-Cyclotomic Graphs Of At Most Eight Vertices

We obtain the following maximal forms:

4-vertex maximal form $\mathcal{C}_4^{+\pm}$

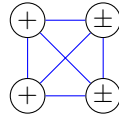

6-vertex maximal forms

6 charge form \mathcal{S}_6 ($d = -3$ only)

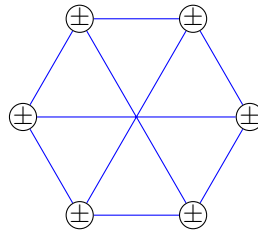

$\mathcal{C}_6^{+\pm}$ form

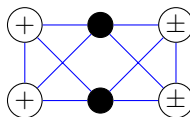

8-vertex maximal forms

\mathcal{S}_8 form

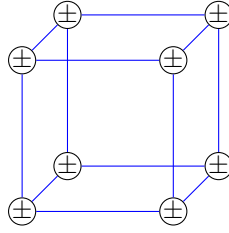

\mathcal{S}'_8 form

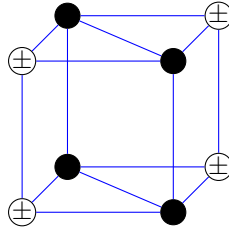

Plus the uncharged form \mathcal{T}_8 and charged form $\mathcal{C}_8^{+\pm}$.

Combining these results with Proposition 3.4.4, we conclude the following:

Proposition 3.4.5. *If G is a connected 4-cyclotomic \mathcal{L} -graph of at most 8 vertices, with all edges of weight 1, then G is of the form $\mathcal{C}_4^{+\pm}, \mathcal{S}_5, \mathcal{T}_6, \mathcal{S}_6, \mathcal{S}'_6, \mathcal{C}_6^{+\pm}, \mathcal{S}_7, \mathcal{T}_8, \mathcal{S}_8, \mathcal{S}'_8, \mathcal{S}_8^\dagger$ or $\mathcal{C}_8^{+\pm}$.*

Nonmaximal 8-Vertex Cyclotomic Forms

In addition to the maximal forms described above, we recover the set G_8 . If $g \in G_8$ then g is either a *cylinder of length 4*, *stem of length 4* or one of the forms $\mathcal{S}_{8A}, \mathcal{S}_{8B}$ or \mathcal{S}_{8C} given below.

Form \mathcal{S}_{8A}

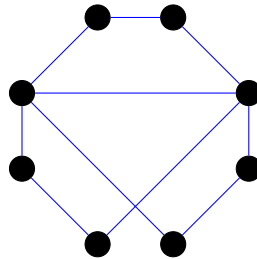

Form S_{8B} ($d = -3$ only)

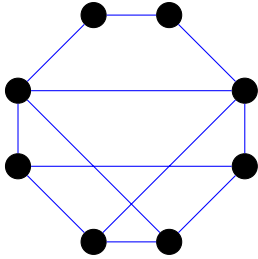

Form S_{8C} ($d = -3$ only)

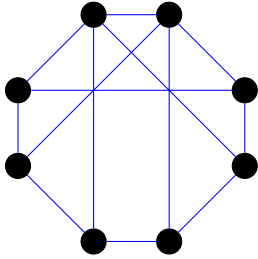

3.4.4 Sporadic Forms With More Than Eight Vertices

We define the following maximal forms

10-vertex form S_{10} ($d = -3$ only)

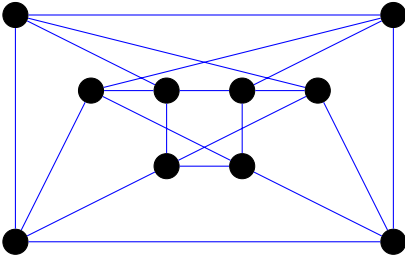

12-vertex form S_{12} ($d = -3$ only)

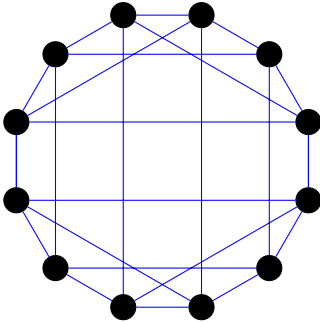

14-vertex form \mathcal{S}_{14}

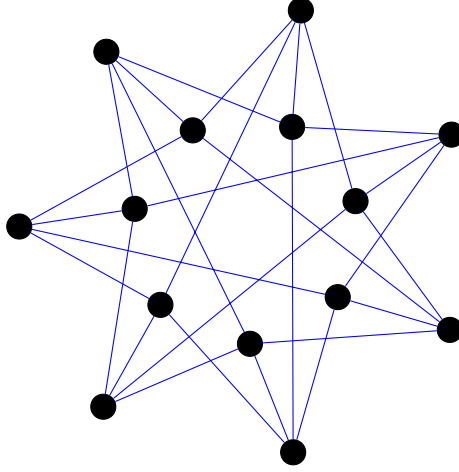

16-vertex form \mathcal{S}_{16}

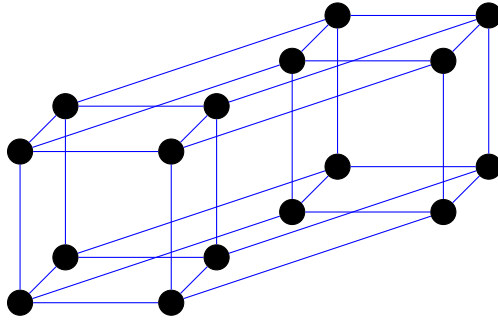

Then the following hold:

Lemma 3.4.6. *The only 4-cyclotomic \mathcal{L} -graphs to induce a subgraph of the form \mathcal{S}_{8A} are of the form $\mathcal{S}_{12}, \mathcal{S}_{14}$ or \mathcal{S}_{16} .*

Proof. Repeated application of **satgrow** to the representatives of graphs of form \mathcal{S}_{8A} in G_8 terminates at 16 vertices, with all maximal examples being of the claimed forms. \square

Lemma 3.4.7. *The only 4-cyclotomic \mathcal{L} -graphs to induce a subgraph of the form \mathcal{S}_{8B} are of the form \mathcal{S}_{12} .*

Proof. Repeated application of **satgrow** to the representatives of graphs of form \mathcal{S}_{8B} in G_8 terminates at 12 vertices, with all maximal examples being of the claimed form. \square

Lemma 3.4.8. *The only 4-cyclotomic \mathcal{L} -graphs to induce a subgraph of the form \mathcal{S}_{8C} are of the form \mathcal{S}_{10} .*

Proof. Repeated application of **satgrow** to the representatives of graphs of form \mathcal{S}_{8C} in G_8 terminates at 10 vertices, with all maximal examples being of the claimed form. \square

3.4.5 Uncharged Cyclotomic Graphs With All Edges of Weight 1

Theorem 3.4.9 (Uncharged Graphs). *If G is an uncharged 4-cyclotomic \mathcal{L} -graph with all edges of weight 1, then G is of one of the forms $\mathcal{S}_8^\dagger, \mathcal{S}_{10}, \mathcal{S}_{12}, \mathcal{S}_{14}, \mathcal{S}_{16}$; or of form T_{2k} for some $k \geq 3$.*

Proof of Theorem 3.4.9

If G has 8 or less vertices and is uncharged then, by Proposition 3.4.5 we have that G is of the form $\mathcal{S}_8^\dagger, T_6$ or T_8 , which is consistent with the above Theorem. Else G has 9 or more vertices, and must have as an induced subgraph some $g \in G_8$. Since G is uncharged, this means it is a 4-cyclotomic supergraph of a cylinder of length 4 or of a graph of the form S_{8A}, S_{8B} or S_{8C} . By the previous Section, if G induces a subgraph of the form S_{8A}, S_{8B} or S_{8C} then it is $\mathcal{S}_{10}, \mathcal{S}_{12}, \mathcal{S}_{14}$ or \mathcal{S}_{16} . Otherwise, G has a cylinder of length 4 as an induced subgraph and the following suffices to complete the proof:

Theorem 3.4.10. *If all edge labels are restricted to \mathcal{L}_1 , then the only minimal saturating extensions of a cylinder of length $k \geq 4$ are maximal graphs of the form $\mathcal{T}_{2(k+1)}$ or $\mathcal{T}_{2(k+2)}$, or a nonmaximal cylinder of length $k + 2$.*

There is necessarily a sequence of minimal saturating extensions that grow any remaining 4-cyclotomic G from a cylinder of length 4; inductively, G can therefore only be of the form \mathcal{T}_{2m} for some $m \geq 5$; conversely, for any $m \geq 5$ we can obtain \mathcal{T}_{2m} in this way (and we already have $\mathcal{T}_6, \mathcal{T}_8$).

Proof of Theorem 3.4.10

We consider minimal saturating extensions by a set of vertices $X = \{x_1, \dots, x_i\}$. We first note the following generalisation of Lemma 3.4.3:

Lemma 3.4.11. *If C is a cylinder of length $k \geq 4$ and x is an element of a saturating set such that x is attached to one of the vertices $1, k + 1$ then x is also attached to the other; and the same for vertices $k, 2k$.*

Proof. If x were attached to one of vertex $1, k + 1$ but not the other, then the subgraph induced on $x, 1, 2, 3, k + 1, k + 2, k + 3$ would violate Lemma 3.4.3. Similarly for the subgraph on $x, k, k - 1, k - 2, 2k, 2k - 1, 2k - 2$ were x to be attached to only one of $k, 2k$. \square

Minimal Saturating extensions of length- k cylinders Let C be a cylinder of length $k \geq 4$ with unsaturated vertices $1, k + 1, k, 2k$ as in Definition 3.4.1. We consider minimal saturating extensions of C . By minimality, we require each of the saturating vertices x_j to be attached to at least one of the unsaturated vertices. By Lemma 3.4.11, an element of the

saturating set must therefore be attached to at least 2 vertices. Since there are 4 unsaturated vertices of capacity 2 each this means there are at most 4 saturating vertices. To ensure all existing vertices $1, \dots, 2k$ are saturated, we require at least 2 new vertices, so $2 \leq i \leq 4$.

W.l.o.g., we may assume that x_1 and x_2 are attached to vertex 1, and thus by Lemma 3.4.11 to $k+1$. Either x_1 is additionally attached to k and thus $2k$, or it is not. If it is, then necessarily so is x_2 , else as $k \neq 2$ the induced subgraph on $k, x_1, 1, 2, x_2, k+1, k+2$ would be

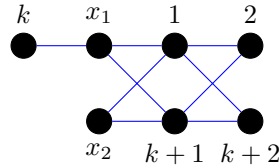

which contradicts Lemma 3.4.3. Further, if x_2 but not x_1 were connected to k and hence $2k$ we would induce a subgraph

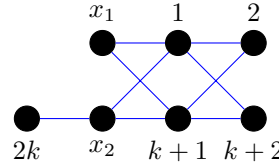

again in violation of the lemma. So x_1 is a common neighbour of all four of $1, k+1, k, 2k$ if and only if x_2 is.

If they are, we obtain a maximal graph of form $\mathcal{T}_{2(k+1)}$

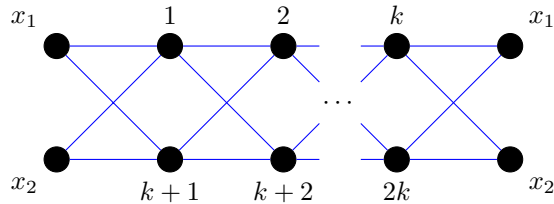

If not, then we require an additional 2 vertices x_3, x_4 to saturate vertex k , and by Lemma 3.4.11 these are also neighbours of $2k$. This gives us the most general form:

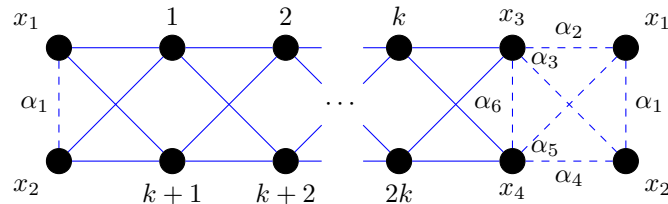

where the $\alpha_i \in \mathcal{L}_1 \cup \{0\}$. Since the graph is uncharged and has at least 12 vertices, by Proposition

3.4.4 $\alpha_1 = \alpha_6 = 0$.

Now if $\alpha_2 \in \mathcal{L}_1$ we have $\alpha_3 \in \mathcal{L}_1$ else we induce a subgraph

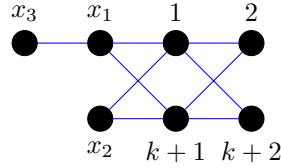

which contradicts Lemma 3.4.3. By the same Lemma we also have the converse, so $\alpha_2 \in \mathcal{L}_1$ if and only if $\alpha_3 \in \mathcal{L}_1$. But then by consideration of the appropriate 7-vertex subgraphs we find $\alpha_2 \in \mathcal{L}_1$ if and only if $\alpha_3 \in \mathcal{L}_1$ if and only if $\alpha_5 \in \mathcal{L}_1$ if and only if $\alpha_4 \in \mathcal{L}_1$. So the possible cyclotomic graphs are determined by the norm of α_2 .

If $\alpha_2 \in \mathcal{L}_1$ then so are $\alpha_3, \alpha_4, \alpha_5$ and we have as general form a maximal $\mathcal{T}_{2(k+2)}$:

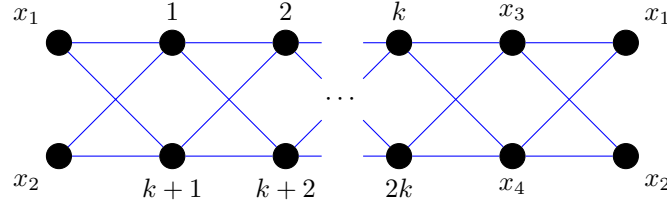

Else, $\alpha_2 = \alpha_3 = \alpha_4 = \alpha_5 = 0$ and we have as general form a nonmaximal cylinder of length $k+2$:

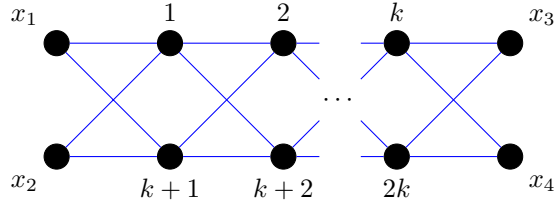

as claimed.

3.4.6 Charged Cyclotomic Graphs With All Edges Weight 1

Theorem 3.4.12 (Charged Graphs). *If G is a charged 4-cyclotomic \mathcal{L} -graph with all edges of norm 1, then G is of one of the forms $\mathcal{S}_5, \mathcal{S}'_6, \mathcal{S}_6, \mathcal{S}_7, \mathcal{S}_8, \mathcal{S}'_8$, or the form $\mathcal{C}_{2k}^{+\pm}$ for some $k \geq 2$.*

Proof of Theorem 3.4.12

If G has 8 or less vertices and is charged then, by Proposition 3.4.5, we have that G is of the form $\mathcal{C}_4^{+\pm}, \mathcal{S}_5, \mathcal{C}_6^{+\pm}, \mathcal{S}'_6, \mathcal{S}_6, \mathcal{S}_7, \mathcal{S}_8, \mathcal{S}'_8$ or $\mathcal{C}_8^{+\pm}$, which is consistent with the above Theorem. Else G has 9 or more vertices and must have as an induced charged subgraph some $g \in \mathcal{G}_8$. But

then g is necessarily a stem of length 4, so the following Theorem suffices to prove Theorem 3.4.12.

Theorem 3.4.13. *Given a stem of length $k \geq 4$, the only minimal saturating extensions, subject to the constraint that all edge labels be from \mathcal{L}_1 , are nonmaximal stems of length $k + 1$ or maximal graphs of the form $\mathcal{C}_{2(k+1)}^{+\pm}$.*

Proof. Let $X = \{x_1, \dots, x_i\}$ be the saturating set. By saturation, minimality and the requirement that all edges labels have weight 1, we have $i = 2, 3$ or 4, since the unsaturated vertices $1, k + 1$ have a capacity of two.

If $i = 3, 4$ then there is necessarily an x_j attached to 1 but not $k + 1$. W.l.o.g., let that vertex be x_1 . Then the subgraph induced on $x_1, 1, 2, 3, k + 1, k + 2, k + 3$ would contradict Lemma 3.4.3 if cyclotomic. Hence there can be no minimal saturating extension by 3 or 4 vertices.

If $i = 2$ then for saturation both x_1 and x_2 are attached to each of $1, k + 1$, with general graph

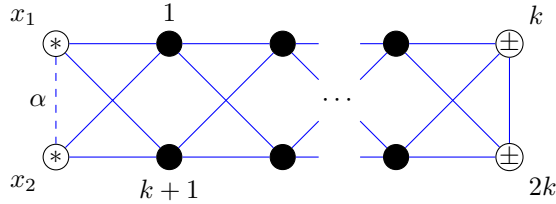

Suppose at least one of x_1, x_2 charged. Testing of the possible 6-vertex graphs induced on $x_1, x_2, 1, 2, k + 1, k + 2$ confirms that the only cyclotomic examples arise from $\alpha \in \mathcal{L}_1$ with both x_1, x_2 charged; this gives a maximal graph of form $\mathcal{C}_{2(k+1)}^{+\pm}$ as required.

Otherwise, they are both uncharged and unsaturated, so (as $k \geq 4$), the subgraph induced on $x_1, x_2, 1, 2, 3, k + 1, k + 2, k + 3$ is a nonmaximal (hence not \mathcal{S}_8^\dagger) connected subgraph with eight vertices and all edge labels of weight 1. So Proposition 3.4.4 applies and we can conclude that this subgraph is triangle free, so $\alpha = 0$ and we have a stem of length $k + 1$ as required. \square

3.5 Uncharged Graphs With Weight 2 Edges

We return our attention to the cases where $\mathcal{L}_2 \neq \emptyset$, namely $d = -1, -2$ or -7 , and consider graphs with edge labels from $\mathcal{L} = \mathcal{L}_1 \cup \mathcal{L}_2 \cup \{0\}$. For now, we consider only uncharged graphs, but naturally require at least one label from \mathcal{L}_2 .

Theorem 3.5.1. *If G is an uncharged 4-cyclotomic graph with a weight 2 edge then, with only finitely many exceptions, G is of the form \mathcal{T}_{2k}^4 for some $k \geq 2$.*

3.5.1 Reduction to Isolated $\mathcal{L}_2, \mathcal{L}_2$ Paths

$\mathcal{L}_1, \mathcal{L}_2, \mathcal{L}_1$ Paths

Lemma 3.5.2. For $d = -1, -7$, there are no cyclotomic 3-vertex \mathcal{L} -graphs consisting of a  cycle. For $d = -2$, by *equivgrow* (with charge set $\{0, 1, -1\}$ for future convenience) the only maximal \mathcal{L} -graphs to induce such a cycle are of the form \mathcal{S}_4^* :

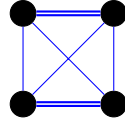

Lemma 3.5.3. By application of *equivgrow* (with charge set $\{0, 1, -1\}$ for future convenience) to seed graphs of the form

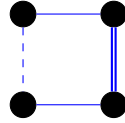

the only maximal cyclotomic connected \mathcal{L} -graphs inducing a non-cyclic uncharged $\mathcal{L}_1, \mathcal{L}_2, \mathcal{L}_1$ subpath are of the following forms:

6 vertex form \mathcal{S}_6^\dagger ($d = -7$ only)

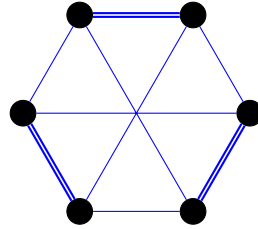

8 vertex form \mathcal{S}_8^\ddagger ($d = -1$ only)

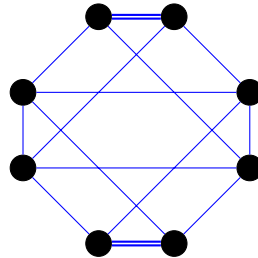

8 vertex form \mathcal{S}_8^* (all d)

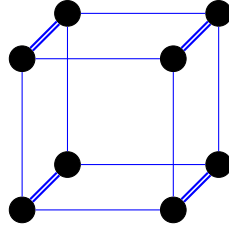

$\mathcal{L}_2, \mathcal{L}_2, \mathcal{L}_2$ Subpaths

Lemma 3.5.4. *Testing shows that for each d , no $\bullet \text{---} \bullet \text{---} \bullet$ cycle is cyclotomic, and that the only connected maximal cyclotomic \mathcal{L} -graphs to contain a $\mathcal{L}_2, \mathcal{L}_2, \mathcal{L}_2$ path are of the form \mathcal{T}_4^4 :*

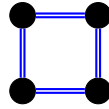

$\mathcal{L}_1, \mathcal{L}_2, \mathcal{L}_2$ Paths

Lemma 3.5.5. *For each d , none of the possible cycles $\bullet \text{---} \bullet \text{---} \bullet$ are cyclotomic.*

Thus if an edge of weight 2 is present, it must be contained in an $\mathcal{L}_2, \mathcal{L}_2, \mathcal{L}_2, \mathcal{L}_2$ cycle as in Lemma 3.5.4; as part of a six- or eight-vertex graph as in Lemma 3.5.3; or else a $\mathcal{L}_1, \mathcal{L}_2, \mathcal{L}_2, \mathcal{L}_1$ path. That is, if any other connected maximal cyclotomic \mathcal{L} -graph contains weight 2 edges then they arise as isolated pairs.

3.5.2 Isolated Weight 2 Pairs

Uncharged Graphs With $\mathcal{L}_2, \mathcal{L}_2$ Paths: Theorem

Proposition 3.5.6 (Base Step). *Given the graph $\bullet \text{---} \bullet \text{---} \bullet$, the only possible minimal saturating extensions are maximal graphs of the form*

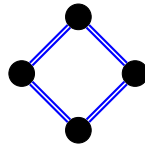

or nonmaximal chains of length one:

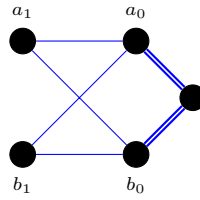

Theorem 3.5.7 (Inductive Step). *Given a chain of length k :*

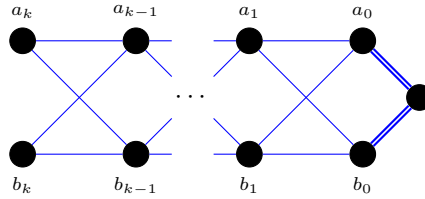

the only possible minimal saturating extensions are a nonmaximal chain of length $k + 1$ of the form:

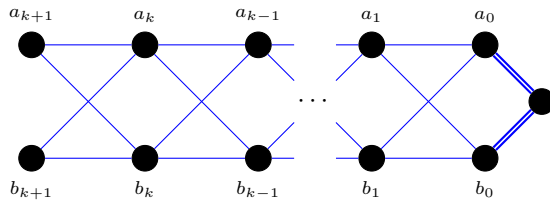

or maximal graphs of the form

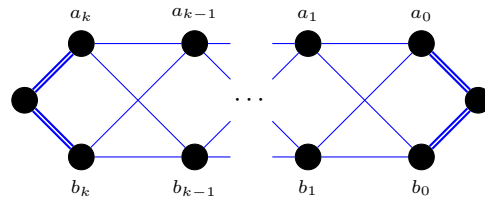

Uncharged Graphs With $\mathcal{L}_2, \mathcal{L}_2$ Paths: Proofs

Lemma 3.5.8. *If a non-saturated weight 1 connected subgraph of a 4-cyclotomic \mathcal{L} -graph contains at least eight vertices, then it is triangle-free.*

Proof. By Section 3.4.2, if a connected \mathcal{L} -graph contains only weight 1 edges and features an $\mathcal{L}_1, \mathcal{L}_1, \mathcal{L}_1$ cycle, then it is an induced subgraph of one of the maximal forms $\mathcal{S}_5, T_6, \mathcal{S}_7, \mathcal{S}_8^\dagger$. If it has at least eight vertices yet is unsaturated, then this is clearly impossible. \square

Lemma 3.5.9. *The \mathcal{L} -graph H*

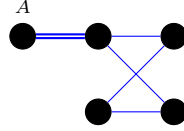

cannot be an induced subgraph of a 4-cyclotomic \mathcal{L} -graph G whose weight 2 edges arise as isolated pairs.

Proof. Vertex A has weighted degree 2 in H , so must have at least one neighbour B in G attached by some edge with label α . Then the subgraph induced on $H \cup \{B\}$ is of the form

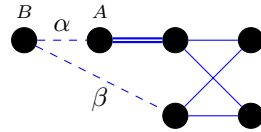

If α were in \mathcal{L}_1 then we would have

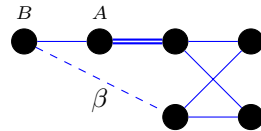

but the upper path is forbidden since weight 2 edges are assumed to occur in pairs. So $\alpha \in \mathcal{L}_2$, giving

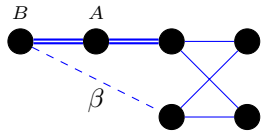

But then to prevent an $\mathcal{L}_2, \mathcal{L}_2, \mathcal{L}_2$ path, we require $\beta \notin \mathcal{L}_2$. However, for each d testing of the possible graphs with $\alpha \in \mathcal{L}_2, \beta \in \mathcal{L}_1 \cup \{0\}$ shows that none are cyclotomic.

Thus G necessarily induces a noncyclotomic subgraph if it induces a subgraph H . □

Proof of Proposition 3.5.6 We consider minimal saturating extensions of the graph

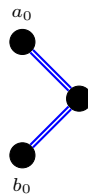

in terms of the size of the extension set $x_1 \dots x_n$. Since the weighted degrees of a_0, b_0 are two, we require between one and four new vertices. If we adjoin a weight 2 edge to either of a_0 or b_0 , then by Lemma 3.5.4 we are in the $n = 1$ case and must form a square as claimed in the base step; and conversely this is the only possible saturation when $n = 1$. So we may assume that $n \geq 2$ and that only weight 1 edges are adjoined.

For the $n = 2$ case we wish to saturate a_0, b_0 by new vertices x_1, x_2 . Hence x_1, x_2 must be neighbours of each of a_0, b_0 . The general form of the graph is then

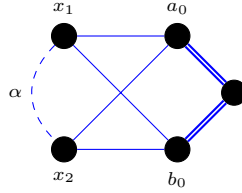

but we require $\alpha \notin \mathcal{L}_2$ to prevent an isolated weight 2 edge, and (for each d) testing of the remaining possibilities confirms that the general form can only be cyclotomic if $\alpha = 0$ (no edge). Thus we have the chain of length 1 as desired.

For the remaining cases, we note the following result:

Lemma 3.5.10. *There are no cyclotomic \mathcal{L} -graphs of the form*

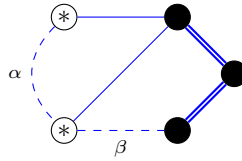

for $\alpha \in \mathcal{L}, \beta \in \mathcal{L}_1 \cup \{0\}$.

Thus no cyclotomic \mathcal{L} -graph has such a graph as an induced subgraph.

For the $n = 3$ case there is by saturation necessarily a common neighbour of a_0, b_0 amongst the x_i (call it x_2) and by minimality this is their only common neighbour amongst the x_i . Thus the general extension is:

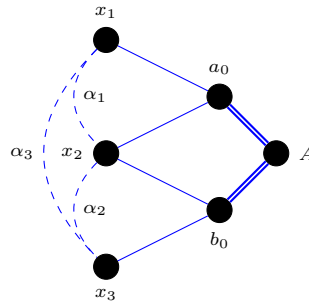

For the $n = 4$ case there is by minimality no common neighbour amongst the x_i of a_0 and b_0 .

Thus the general extension is

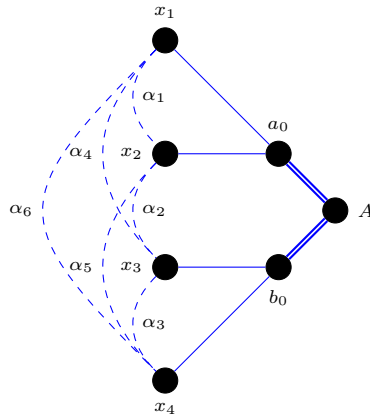

but in each case, were such an extension cyclotomic it would induce a cyclotomic subgraph on x_1, x_2, a_0, b_0, A in contradiction with Lemma 3.5.10. Thus there are no minimal saturating extensions by three or four vertices of an $\mathcal{L}_2, \mathcal{L}_2$ pair, and so the base step holds.

Proof of Theorem 3.5.7 We first seek to reject minimal saturating extensions of length k chains by three or four vertices. General graphs are:

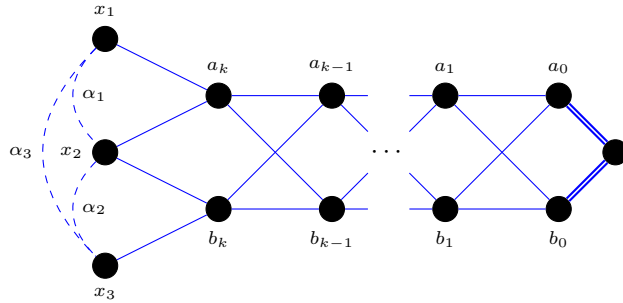

and

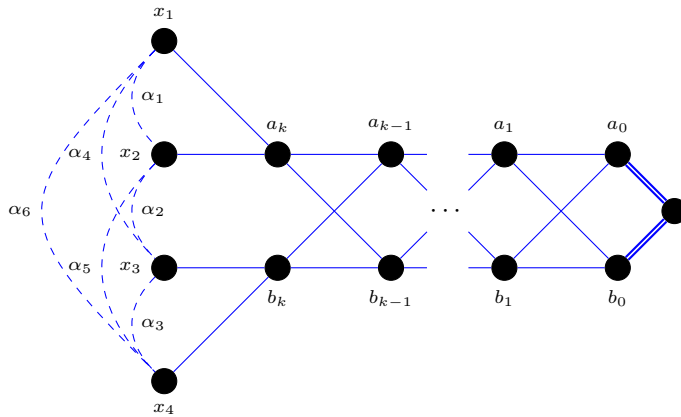

For $k = 1$ we verify directly the following result:

Lemma 3.5.11. *There are no cyclotomic graphs of the form*

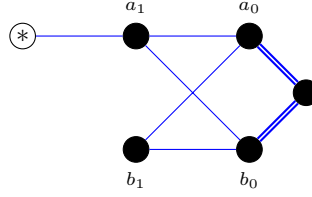

If $k = 1$ the above general forms would induce such a subgraph on x_1, a_1, a_0, b_1, b_0 ; thus they are not possible saturating extensions.

Otherwise we have $k \geq 2$ and can appeal to Lemma 3.4.3:

If there were cyclotomic minimal saturating extensions by three or four vertices of a chain of length $k \geq 2$, then they would induce cyclotomic subgraphs on vertices $x_1, a_k, a_{k-1}, a_{k-2}, b_k, b_{k-1}, b_{k-2}$ in contradiction with Lemma 3.4.3; thus such extensions are not possible.

This leaves only saturating extensions by one or two vertices. If a single vertex is to saturate both a_k, b_k , then necessarily each must be attached to it by a weight 2 edge, giving the claimed maximal graph.

Finally, for an extension by 2 vertices Lemma 3.5.9 and minimality ensures we cannot attach a weight 2 edge to either a_k or b_k . Hence for saturation each is attached to both of the two new vertices, with the general graph being

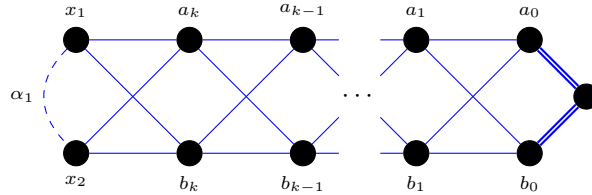

But to prevent an isolated weight 2 edge we have $\alpha_1 \notin \mathcal{L}_2$. During the proof of the base step we verified that for $k = 0$, such a graph can be cyclotomic only if $\alpha_1 = 0$. If $k \geq 2$ then the induced weight 1 subgraph on $x_1, x_2, a_k, a_{k-1}, a_{k-2}, b_k, b_{k-1}, b_{k-2}$ is a nonmaximal connected eight-vertex subgraph and thus triangle free by Lemma 3.5.8, forcing $\alpha_1 = 0$. Finally, if $k = 1$, we have the graph

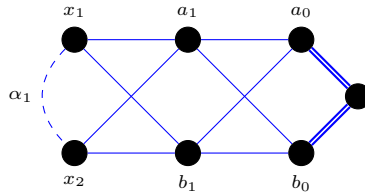

If $\alpha_1 \neq 0$ then w.l.o.g. we may assume $\alpha_1 = 1$ and consider the induced subgraph on

$x_1, x_2, a_1, b_1, a_0, b_0$. Testing confirms that of the possible such graphs, none are cyclotomic and thus for the supergraph to be cyclotomic, we must have $\alpha_1 = 0$.

Thus for all k , a minimal saturating extension by 2 vertices can only be cyclotomic if $\alpha_1 = 0$; that is, the only such extension is a chain of length $k + 1$ as claimed. This completes the proof of the inductive step, and thus of Theorem 3.5.1.

3.6 Charged Graphs With Weight 2 Edges

This leaves one possible case: charged graphs with weight 2 edges. In this Section, we will prove the following:

Theorem 3.6.1. *If G is a 4-cyclotomic \mathcal{L} -graph with at least one charged vertex and at least one edge of weight 2 then, with finitely many exceptions, G is of the form $\mathcal{C}_{2k}^{2\pm}$ for some $k \geq 2$.*

3.6.1 Reduction to Isolated $\mathcal{L}_2, \mathcal{L}_2$ Paths

Here we demonstrate that, except for finitely many examples, if a graph features both charged vertices and weight 2 edges, then those edges occur in isolated pairs.

Charged Vertices With Weight 2 Edges

$\oplus\mathcal{L}_2\otimes$ **Paths** By initial testing then **satgrow**, we obtain classes of 3-vertex 4-cyclotomic \mathcal{L} -graphs with general form $\mathcal{C}_2^{2\pm}$:

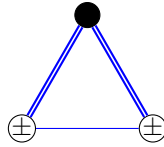

and of 4-vertex \mathcal{L} -graphs with general form \mathcal{S}_4 :

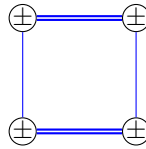

as the only possible connected 4-cyclotomic forms containing a $\oplus\mathcal{L}_2\otimes$ subgraph.

Isolated Charges

By the previous result, we may assume that in a graph featuring both charged nodes and weight 2 edges, these features are isolated.

$\mathcal{L}_1, \mathcal{L}_2, \mathcal{L}_1$ **cycles** Since we are excluding the possibility of $\oplus\mathcal{L}_2\otimes$ subpaths, the only possible cycles of the form $\circledast \text{---} \circledast \text{---} \circledast$ are uncharged cycles of the form $\bullet \text{---} \bullet \text{---} \bullet$ or charged cycles of the form $\oplus \text{---} \bullet \text{---} \bullet$. By Lemma 3.5.2 we may exclude the former; for $d = -2, -7$ the latter is never cyclotomic.

For $d = -1$, there are cyclotomic examples: **satgrow** terminates with maximal squares of the form S_4^\dagger

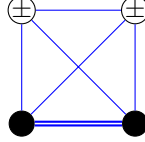

$\mathcal{L}_1, \mathcal{L}_2, \mathcal{L}_1$ **paths** Excluding $\oplus\mathcal{L}_2\otimes$ subgraphs, the general charged non-cyclic $\mathcal{L}_1, \mathcal{L}_2, \mathcal{L}_1$ path is given by $\oplus \text{---} \bullet \text{---} \bullet \text{---} \circledast$, contained in some \mathcal{L} -graph of form

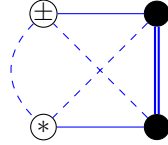

However, the only cyclotomic examples of such an \mathcal{L} -graph are of the maximal form S_4^\dagger as above.

Thus if a 4-cyclotomic \mathcal{L} -graph contains both charges and a non-cyclic $\mathcal{L}_1, \mathcal{L}_2, \mathcal{L}_1$ path, then the 4 vertices in the path are uncharged. However, for each d applying **satgrow** to representatives of all 4-vertex cyclotomic graphs with such a path terminates at 8 vertices, with only the uncharged graphs described in Section 3.5.1.

$\mathcal{L}_2, \mathcal{L}_2, \mathcal{L}_2$ **paths** We now consider paths of more than 2 consecutive weight 2 edges. By $\oplus\mathcal{L}_2\otimes$ avoidance and the prior result that no $\bullet \text{---} \bullet \text{---} \bullet$ cycle is cyclotomic, the simplest such path is $\bullet \text{---} \bullet \text{---} \bullet \text{---} \bullet$. However, by Lemma 3.5.4 the only cyclotomic examples are contained in maximal uncharged squares, so there are no charged 4-cyclotomic graphs containing an $\mathcal{L}_2, \mathcal{L}_2, \mathcal{L}_2$ path. Hence they can contain no longer such path, so if any weight 2 edge occurs, then it does so as part of an isolated $\bullet \text{---} \bullet \text{---} \bullet$ pair.

3.6.2 Isolated Weight 2 Pairs

Charged Graphs With $\mathcal{L}_2, \mathcal{L}_2$ Paths: Theorem

Proposition 3.6.2 (Base Case). *Given the graph , the only possible minimal saturating extensions including at least one charged vertex are maximal graphs of the form $\mathcal{C}_4^{2\pm}$:*

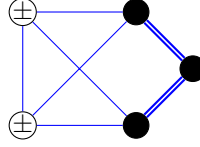

Theorem 3.6.3 (General Case). *Given a chain of length $k \geq 1$:*

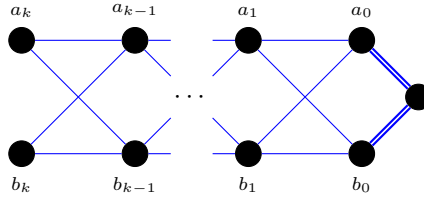

the only possible minimal saturating extensions including at least one charged vertex are maximal graphs of the form $\mathcal{C}_{2(k+2)}^{2\pm}$:

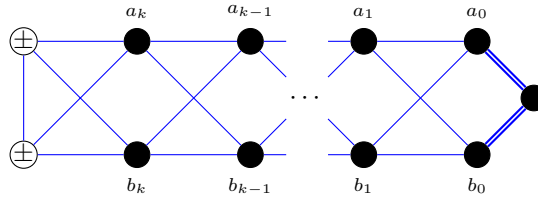

By the earlier Proposition 3.5.6 and Theorem 3.5.7 on minimal saturating extensions of chains of length k , these suffice to complete the proof of Theorem 3.6.1 as follows. There must be a weight 2 edge which, excluding the maximal forms of the previous section, means that there must be a  subgraph. From this, the maximal graph can be grown by minimal saturating extensions. If that extension involves a charge, then we terminate as in the base case with a graph of form $\mathcal{C}_4^{2\pm}$. If it does not, then it is an uncharged minimal saturating extension and must (by Proposition 3.5.6) give a chain of length 1.

Given a chain of length k , its minimal saturating extension either includes a charged vertex or it does not. If it does, then we terminate with the desired maximal charged graph. If it does not, then it is an uncharged minimal saturating extension-this (by Theorem 3.5.7) gives either a chain of length $k + 1$ or an uncharged maximal graph of form \mathcal{T}_{2k}^4 . Since we desire a charged vertex, we cannot have the latter, so we must obtain the chain of length $k + 1$.

Thus, inductively, all charged 4-cyclotomic \mathcal{L} -graphs not of the form \mathcal{S}_4 or \mathcal{S}_4^\dagger are of the claimed form $\mathcal{C}_{2k}^{2\pm}$ for some k .

Charged Graphs With $\mathcal{L}_2, \mathcal{L}_2$ Paths: Proofs

Proof of Proposition 3.6.2 As before, we consider minimal saturating extensions of the graph

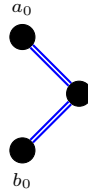

in terms of the size of the extension set $x_1 \dots x_n$.

Note that we cannot adjoin a vertex by an edge from \mathcal{L}_2 as this creates a $\mathcal{L}_2, \mathcal{L}_2, \mathcal{L}_2$ path, which is excluded (as it forces the uncharged maximal square T_4^4). Thus the $n = 1$ case is impossible as it cannot saturate either of a_0, b_0 , and in the remaining cases we need only consider vertices attached by weight 1 edges.

In the $n = 2$ case we seek to saturate a_0, b_0 by adjoining common neighbours x_1, x_2 , at least one of which is charged: w.l.o.g. x_1 . This gives the general graph

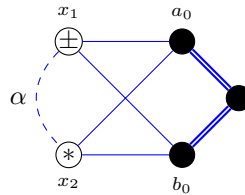

where by $\oplus\mathcal{L}_2\otimes$ avoidance $\alpha \notin \mathcal{L}_2$. Testing then confirms that such a graph is cyclotomic only if $\alpha \in \mathcal{L}_1, x_2 = \pm 1$, that is, of the claimed maximal form $\mathcal{C}_4^{2\pm}$.

For the $n = 3$ case there is by saturation necessarily a common neighbour of a_0, b_0 amongst the x_i (call it x_2) and by minimality this is their only common neighbour amongst the x_i . Thus the general extension is:

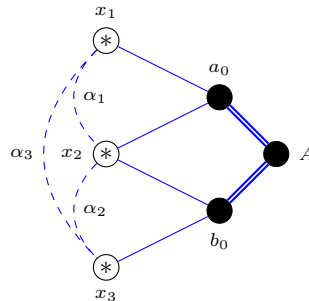

where $x_i \in \{0, 1, -1\}$ not all zero, $\alpha_i \in \mathcal{L}$. Since $\mathcal{L}_1, \mathcal{L}_2, \mathcal{L}_1$ cycles have been excluded, $\alpha_1, \alpha_2 \notin \mathcal{L}_2$ and since $\mathcal{L}_1, \mathcal{L}_2, \mathcal{L}_1$ paths have been excluded, nor is α_3 . But then if any such \mathcal{L} -graph were cyclotomic, it would induce a cyclotomic \mathcal{L} -graph on A, a_0, b_0, x_1, x_2 , which contradicts Lemma 3.5.10 (with $\alpha = \alpha_1, \beta \in \mathcal{L}_1$). Thus there can be no such extension.

For the $n = 4$ case there is by minimality no common neighbour amongst the x_i of a_0 and b_0 . Thus the general extension is

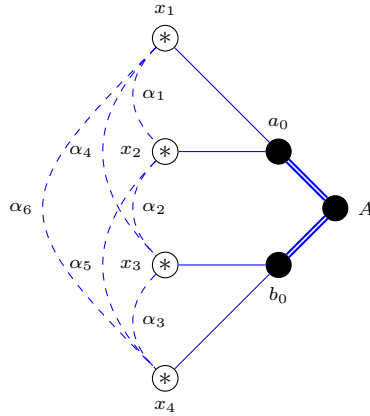

where $x_i \in \{0, 1, -1\}$ not all zero, $\alpha_i \in \mathcal{L}$. Since $\mathcal{L}_1, \mathcal{L}_2, \mathcal{L}_1$ cycles have been excluded, $\alpha_1, \alpha_3 \notin \mathcal{L}_2$ and since $\mathcal{L}_1, \mathcal{L}_2, \mathcal{L}_1$ paths have been excluded, nor are the remaining α_i . Again, if such an \mathcal{L} -graph were cyclotomic, then Lemma 3.5.10 would be contradicted by the subgraph induced on A, a_0, b_0, x_1, x_2 (where $\alpha = \alpha_1, \beta = 0$). Thus a minimal saturating extension by four vertices is not possible.

As a minimal saturating extension of the vertices a_0, b_0 cannot involve more than four new vertices, this completes the proof of the base case.

Proof of Theorem 3.6.3 Lemmata 3.4.3 and 3.5.11 allow us to reject minimal saturating extensions of length k chains by three or four vertices. Recall from Lemma 3.5.9 that the subgraph

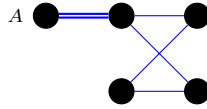

is excluded from a 4-cyclotomic \mathcal{L} -graph with all weight 2 edges in isolated pairs, since vertex A is unsaturated yet there cannot be another edge incident at it. Since we have also excluded $\oplus \mathcal{L}_2 \otimes$ paths, the subgraph with A charged is also forbidden. Thus no minimal saturating extension by more than one vertex of a length k chain can have a weight 2 edge adjoined to

either a_k or b_k . This gives general graphs for the three and four vertex extensions as follows:

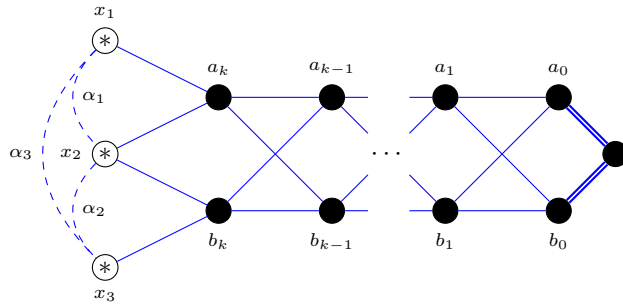

and

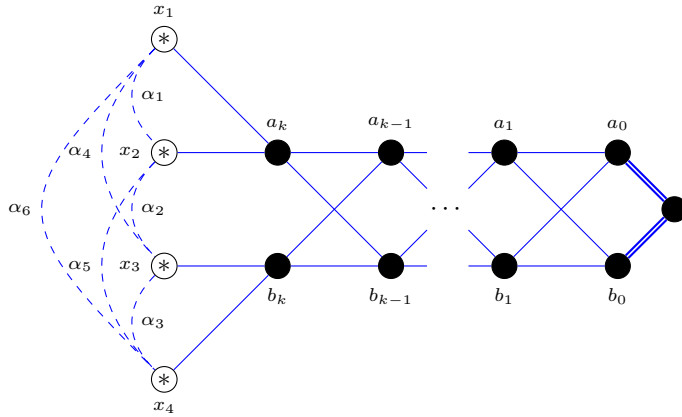

For $k = 1$ we again note that the above general forms would induce a cyclotomic subgraph on x_1, a_1, a_0, b_1, b_0 if they were cyclotomic, contradicting Lemma 3.5.11. Therefore there are no such saturating extensions. Otherwise $k \geq 2$ and a cyclotomic graph of any of the above forms would induce a cyclotomic subgraph on $x_1, a_k, a_{k-1}, a_{k-2}, b_k, b_{k-1}, b_{k-2}$ in contradiction with Lemma 3.4.3. Thus minimal saturating extensions of chains of length k by three or four vertices (not all uncharged) cannot occur.

The $n = 1$ case is also clearly invalid: we require x_1 to be charged, but then as $\oplus \mathcal{L}_2$ paths have been excluded it cannot saturate either a_k or b_k .

Finally, for an extension by 2 vertices a_k, b_k are necessarily (by Lemma 3.5.9 and saturation) attached to each of the two new vertices by weight 1 edges, with the general graph (assuming w.l.o.g. x_1 charged) being

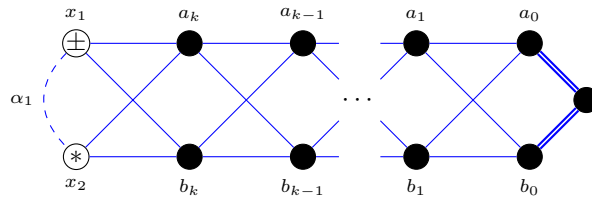

Testing of the possible 6-vertex graphs induced on $x_1, x_2, a_k, a_{k-1}, b_k, b_{k-1}$ confirms that the only cyclotomic examples arise from $\alpha_1 \in \mathcal{L}_1$ with both x_1, x_2 charged; this gives a maximal graph of form $\mathcal{C}_{2(k+2)}^{2\pm}$ as required.

3.7 Conclusions

In this Chapter, we have shown:

Theorem 3.7.1. *Let G be a 4-cyclotomic \mathcal{L} -graph with all edge labels of weight at most 3 and charges from $\{0, 1, -1\}$. Then G is of one of the following forms:*

- $\mathcal{S}'_2, \mathcal{S}_4, \mathcal{S}'_4, \mathcal{S}_4^*, \mathcal{S}_4^\dagger, \mathcal{S}_5, \mathcal{S}_6, \mathcal{S}'_6, \mathcal{S}_7, \mathcal{S}_8, \mathcal{S}'_8, \mathcal{S}_8^*, \mathcal{S}_8^\dagger, \mathcal{S}_8^\ddagger, \mathcal{S}_{10}, \mathcal{S}_{12}, \mathcal{S}_{14}$, or \mathcal{S}_{16} ;
- \mathcal{T}_{2k} for $k \geq 3$;
- $\mathcal{C}_{2k}^{+\pm}$ for $k \geq 2$;
- \mathcal{T}_{2k}^4 for $k \geq 2$;
- or $\mathcal{C}_{2k}^{2\pm}$ for $k \geq 1$.

Recall from Chapter 2 that if G is a 4-cyclotomic \mathcal{L} -graph with entries from $\mathcal{O}_{\mathbb{Q}(\sqrt{-d})}$ for some $d < 0$ then: all charges are from $\{0, 1, -1\}$ unless G is in the class (2) (Lemma 2.2.3); all edge labels in G have weight at most 4 (from Theorem 2.5.2); and if G has an edge label of weight 4 then it is in the class \mathcal{S}_2 .

Combined with Theorem 3.7.1, we have thus classified all 4-cyclotomic \mathcal{L} -graphs over $\mathcal{O}_{\mathbb{Q}(\sqrt{-d})}$, $d < 0$ up to form; and as a corollary Theorem 3.1.1 holds.

Chapter 4

4-Cyclotomic Graphs II- Classification up to Equivalence

4.1 Overview

In this Chapter, we classify all 4-cyclotomic \mathcal{L} -graphs over $\mathcal{O}_{\mathbb{Q}(\sqrt{d})}$, $d < 0$ (and thus implicitly over \mathbb{Z}) up to equivalence.

4.2 Graphs of Form \mathcal{T}_{2k}

We will prove the following:

Theorem 4.2.1. *Let G be a $2k$ -vertex maximal cyclotomic \mathcal{L} -graph of the form \mathcal{T}_{2k} , $k \geq 3$. Then G is equivalent to either the signed graph T_{2k} shown in Fig. 1.3; or, for $d = -1$ or $d = -3$, the \mathcal{L} -graph T'_{2k} as defined in Corollary 2.6.13 or 2.6.14 respectively.*

Corollary 4.2.2. *Let R be \mathbb{Z} or $\mathcal{O}_{\mathbb{Q}(\sqrt{-d})}$ for $d < 0, d \neq -1, -3$. Then if G is a cyclotomic \mathcal{L} -graph of form \mathcal{T}_{2k} with all entries from R , then G is equivalent to the signed graph T_{2k} .*

4.2.1 Proof of Corollary 4.2.2 for Sufficiently-large Graphs

It is useful to first prove the following:

Lemma 4.2.3. *If g is a cyclotomic $2m$ -vertex cylinder of length $m \geq 4$ with all edge labels ± 1*

then g is equivalent to the signed graph

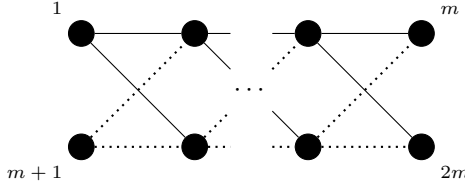

Proof. First consider $m = 4$. Then by switching we may ensure that at least one edge at each vertex has the ‘correct’ label. Fixing the top and bottom m -vertex paths in this way, we obtain general graph \mathcal{G}_4

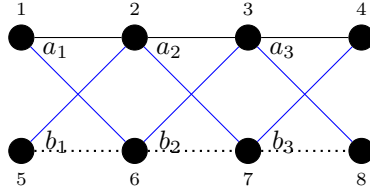

where the edge labels $a_i, b_i \in \mathcal{L}_1$ are free, subject to the constraint that g - and hence, having only applied switching, \mathcal{G}_4 - is cyclotomic. However, testing confirms that the only such signed graphs satisfy either $a_i = 1, b_i = -1$ or $a_i = -1, b_i = 1$. Both cases are precisely the desired form; the former being as numbered in the Lemma and the latter being its mirror image (that is, reversing the left-right numbering of the vertices recovers the illustrated graph). Thus the Lemma holds for $m = 4$. Inductively, suppose the result holds for some m . Then for $m + 1$ we may assume that the first $2m$ vertices have the appropriate edge labels, and by switching fix one edge label at each of the two new vertices x_1, x_2 . The subgraph induced on vertices $m - 2, m - 1, m, 2m - 2, 2m - 1, 2m, x_1, x_2$ is then

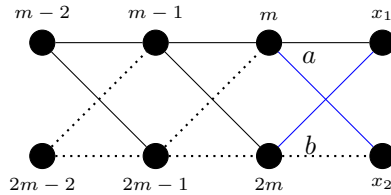

but this is cyclotomic if and only if $a = 1, b = -1$; that is, if the cylinder of length $m + 1$ is also of the desired form.

Hence for any $m \geq 4$ any cyclotomic cylinder of length m is equivalent to the cylinder given in the Lemma. \square

This gives us the following special case of Theorem 4.2.1:

Theorem 4.2.4. *Let G be a $2k$ -vertex maximal cyclotomic signed graph of the form \mathcal{T}_{2k} , $k \geq 5$ with all edge labels ± 1 . Then G is equivalent to the signed graph T_{2k} .*

Proof. We can confirm the case $k = 5$ of theorem 4.2.4 immediately. If G is a cyclotomic \mathcal{L} -graph with all edgel labels ± 1 of form \mathcal{T}_{10} then, using Lemma 4.2.3 and switching at A, B , it is equivalent to one with edge labels as follows:

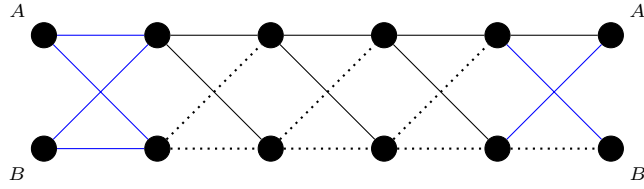

This gives 64 possible signed graphs, but only one is cyclotomic, that with the desired labelling:

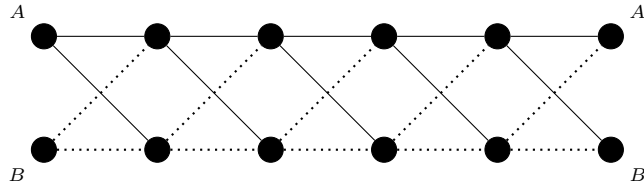

Thus, any cyclotomic signed graph of the form \mathcal{T}_{10} is equivalent to T_{10} as claimed.

Else, $k \geq 6$ and G contains a cylinder of length $m = k - 1 \geq 5$ which by Lemma 4.2.3 is of the required form. Let the remaining two vertices be A, B and consider the subgraph induced on vertices $1, 2, m - 1, m, m + 1, m + 2, 2m - 1, 2m, A, B$ which, fixing an edge at each of A, B by switching, is:

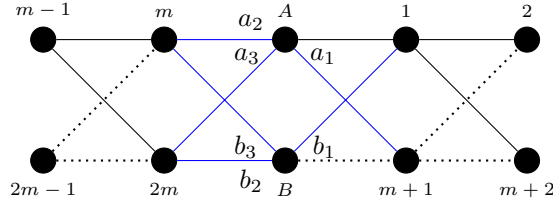

(Note that this is a cylinder rather than a torus since $m \geq 5$ as $k \geq 6$; that is, vertex $m - 1$ is neither vertex 2 nor a neighbour, and similarly for the other unsaturated vertices.)

As before, the edges a_i, b_i are constrained only by the requirement of cyclotomicity. There are then only two valid assignments: $a_1 = a_2 = b_3 = 1, a_3 = b_2 = b_1 = -1$ and $a_1 = a_3 = b_2 = 1, a_2 = b_1 = b_3 = -1$, both of which correspond to the desired representative (redraw with the positions of $m, 2m$ swapped to see that the latter is also T_{2k}). \square

Remark 4.2.5. Corollary 4.2.2 thus holds for $k \geq 5$, since for any such R we have that $\mathcal{L}_1 = \{1, -1\}$. To complete the proof we need only confirm the cases $k = 3, 4$; these will be obtained as special cases of Theorem 4.2.1 in the following section.

4.2.2 Proof of Theorem 4.2.1

We now return to general \mathcal{L} -graphs of the form \mathcal{T}_{2k} ; thus for $d = -1, -3$ we have the possibility of weight 1 edge labels other than ± 1 .

Graphs of Form \mathcal{T}_6 or \mathcal{T}_8 ($k \leq 4$)

\mathcal{T}_6 We consider the general \mathcal{L} -graph of form \mathcal{T}_6 , fixing a numbering as follows:

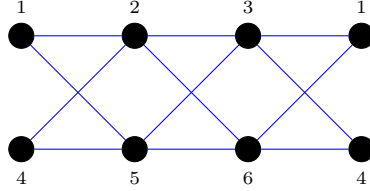

Then by switching at 1 to fix the edge 1 – 2, at 3 to fix the edge 2 – 3, at 4 to fix the edge 4 – 5 and 6 to fix the edge 5 – 6 we have that any cyclotomic \mathcal{L} -graph of form \mathcal{T}_6 is equivalent to one of the form

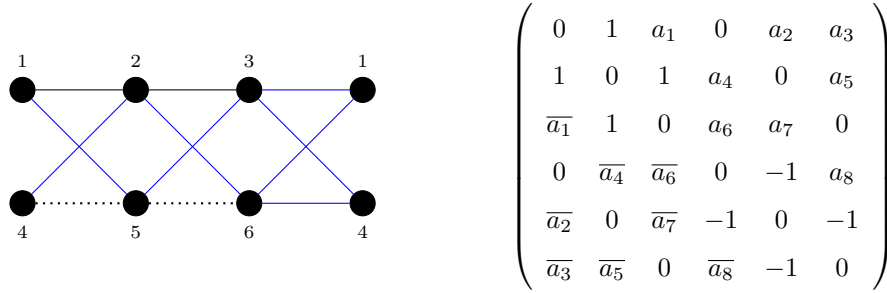

for some $a_1, \dots, a_8 \in \mathcal{L}_1$.

For $d = -1$, there are 65,536 possible \mathcal{L} -graphs. Testing (via the process described in Remark 2.5.8) allows us to recover the 16 cyclotomic examples. Up to equivalence, we find that there are two classes with representatives:

$$\begin{pmatrix} 0 & 1 & 1 & 0 & 1 & -1 \\ 1 & 0 & 1 & -1 & 0 & 1 \\ 1 & 1 & 0 & 1 & -1 & 0 \\ 0 & -1 & 1 & 0 & -1 & -1 \\ 1 & 0 & -1 & -1 & 0 & -1 \\ -1 & 1 & 0 & -1 & -1 & 0 \end{pmatrix} \text{ and } \begin{pmatrix} 0 & i & 1 & 0 & i & -1 \\ -i & 0 & 1 & i & 0 & 1 \\ 1 & 1 & 0 & 1 & -1 & 0 \\ 0 & -i & 1 & 0 & -i & -1 \\ -i & 0 & -1 & i & 0 & -1 \\ -1 & 1 & 0 & -1 & -1 & 0 \end{pmatrix}$$

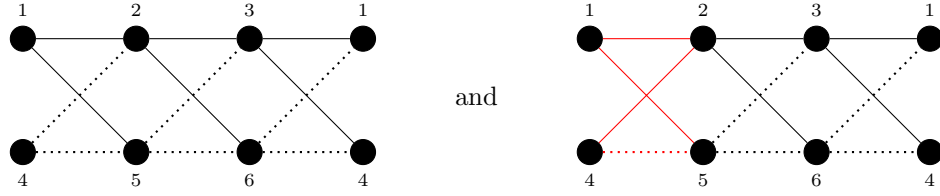

but these are precisely the signed graph T_6 and \mathcal{L} -graph T'_6 as required.

For $d = -3$, the proof is the same; again, we obtain two distinct equivalence classes, with representatives T_6 and T'_6 .

For any other $d < 0$ (or $R = \mathbb{Z}$) we have that $\mathcal{L}_1 = \{1, -1\} \subset \{1, -1, i, -i\}$; so if G is a cyclotomic signed graph of form \mathcal{T}_6 then by the result for $d = -1$ it must be equivalent to T_6 or T'_6 . But it was shown earlier that no \mathcal{L} -graph equivalent to T'_6 has all edge labels rational integers, so G cannot be equivalent to T'_6 . Thus it is equivalent to T_6 .

\mathcal{T}_8 If G is a cyclotomic \mathcal{L} -graph of form \mathcal{T}_8 then, by switching, it is equivalent to an \mathcal{L} -graph G' with labels

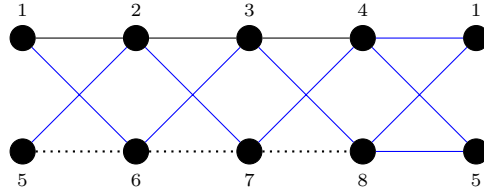

We consider the induced subgraph on vertices $1, \dots, 6$:

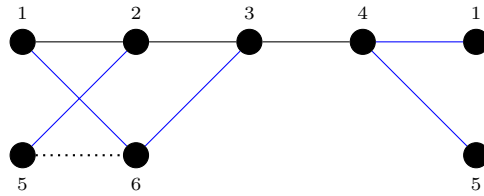

If G' is cyclotomic, then this subgraph is cyclotomic. For $d = -1$, we have 1024 possible edge labellings, of which 96 yield a cyclotomic \mathcal{L} -graph, from one of two equivalence classes. Let S_1, S_2 be representatives of those classes. Then G' and hence G is equivalent to either a 4-cyclotomic supergraph of S_1 or of S_2 . By applying **satgrow** (with weight 1 edge labels and neutral vertices only) we can generate representatives of all classes of such supergraphs, then discard those not of form \mathcal{T}_8 to recover representatives of the possible equivalence classes for G . Doing so, we find two classes. For one, no switching produces a representative with all edge labels from $\{1, -1\}$, whilst the other admits such a representation. Thus there is only one class

of cyclotomic signed graphs of form \mathcal{T}_8 , and since T_8 is such a graph, it suffices as representative:

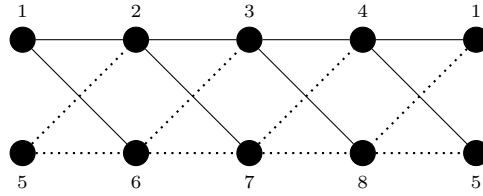

The \mathcal{L} -graph T'_8 is also cyclotomic, but no switching of it produces an \mathcal{L} -graph with all edge labels in $\{1, -1\}$. Thus it cannot be equivalent to T_8 , so serves as a representative of the other class:

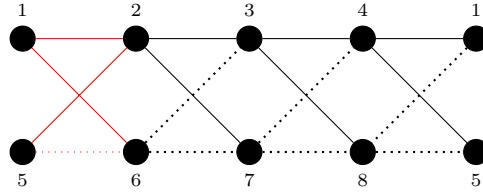

That is, the case $k = 4$ of Theorem 4.2.1 holds for $d = -1$. An identical proof establishes the result for $d = -3$ also; for any other $d < 0$ (or $R = \mathbb{Z}$) the result for $d = -1$ implies that any graph of form \mathcal{T}_8 with all edge labels ± 1 is equivalent to T_8 as claimed.

Remark 4.2.6. *These results for $k = 3, 4$, combined with Theorem 4.2.4, complete the proof of Corollary 4.2.2.*

Graphs of Form T_{2k} , $k \geq 5$

We generalise Lemma 4.2.3:

Lemma 4.2.7. *If g is a cyclotomic $2m$ -vertex cylinder of length $m \geq 4$ with all edge labels from \mathcal{L}_1 then g is equivalent to the graph*

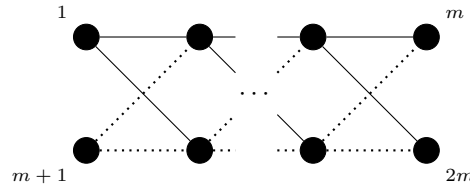

Proof. First consider $m = 4$. Then by (complex) switching we may ensure that at least one edge at each vertex is of the appropriate label. Fixing the top and bottom m -vertex paths in

this way, we obtain general graph \mathcal{G}_4

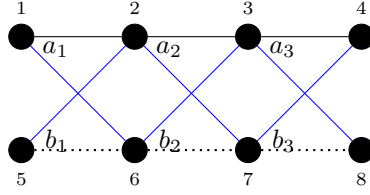

where the edges a_i, b_i are free, subject to the constraint that g and hence (having only applied switching) \mathcal{G}_4 is cyclotomic.

For $d = -1$, testing confirms that the only such \mathcal{L} -graphs satisfy $a_1 = a_2 = a_3 = -b_1 = -b_2 = -b_3$ with $a_1 \in \mathcal{L}_1$. The cases $a_1 = 1, a_1 = -1$ thus give a signed graph, which by Lemma 4.2.3 is of the desired form. The cases $a_1 = i, a_1 = -i$ are equivalent by complex conjugation. We thus need only consider the case $a_1 = i$:

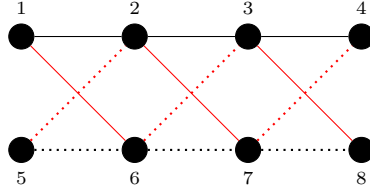

However, by complex switching at vertices 1, 2, 3, 4 in that order, we can replace all $\{\pm i\}$ edge labels with ones from $\{\pm 1\}$ (without introducing any more from $\{\pm i\}$ in the process). But then we have a cylinder with all edge labels ± 1 , so Lemma 4.2.3 applies and we have the desired form. Thus the Lemma holds for $m = 4$ and $d = -1$.

Similarly for $d = -3$, we have that \mathcal{G}_4 is cyclotomic if and only if $a_1 = a_2 = a_3 = -b_1 = -b_2 = -b_3$. For each choice of $a_1 \in \mathcal{L}_1$, there is a complex switching that gives a signed graph; by Lemma 4.2.3 this, and hence any g via \mathcal{G}_4 , is equivalent to the desired form. Thus the Lemma holds for $m = 4$ and $d = -3$ also.

Inductively, suppose the result holds for some m . Then for $m + 1$ we may assume that the subgraph on the first $2m$ vertices is ‘correct’, and by complex switching fix one edge at each of the two new vertices x_1, x_2 . The subgraph induced on vertices $m - 2, m - 1, m, 2m - 2, 2m - 1, 2m, x_1, x_2$ is then:

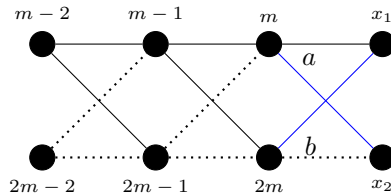

with $a, b \in \mathcal{L}_1$. But for each of $d = -1, -3$ this is cyclotomic if and only if $a = 1, b = -1$; that

is, if the cylinder of length $m + 1$ is of the desired form.

Hence for any $m \geq 4$ any cyclotomic cylinder of length m is equivalent to the cylinder given in the statement of the Lemma. \square

We can now complete the proof of Theorem 4.2.1.

Graphs of Form T_{10} The case $k = 5$ of Theorem 4.2.1 is then immediate. If G is a cyclotomic \mathcal{L} -graph of form T_{10} then, using Lemma 4.2.7 and switching at A, B , it is equivalent to one with edge labels as follows:

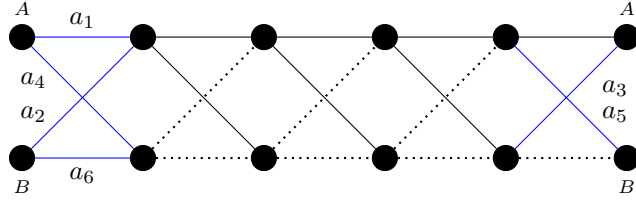

for $a_1, \dots, a_6 \in \mathcal{L}_1$.

For $d = -1$, this gives 4096 possible \mathcal{L} -graphs, with the only cyclotomic examples being:

- $a_1 = i, a_2 = i, a_3 = -1, a_4 = i, a_5 = 1, a_6 = -i$: the \mathcal{L} -graph T'_{10}
- $a_1 = -i, a_2 = -i, a_3 = -1, a_4 = -i, a_5 = 1, a_6 = i$: the conjugate of T'_{10} (hence, equivalent)
- $a_1 = 1, a_2 = 1, a_3 = -1, a_4 = -1, a_5 = 1, a_6 = -1$: the signed graph T_{10}
- $a_1 = -1, a_2 = -1, a_3 = -1, a_4 = 1, a_5 = 1, a_6 = 1$: a signed graph, hence equivalent to T_{10} by Theorem 4.2.4.

For $d = -3$ this gives 46,656 possible graphs, with the only cyclotomic examples being:

- $a_1 = 1, a_2 = 1, a_3 = -1, a_4 = -1, a_5 = 1, a_6 = -1$: the signed graph T_{10}
- $a_1 = -1, a_2 = -1, a_3 = -1, a_4 = 1, a_5 = 1, a_6 = 1$: a signed graph, hence equivalent to T_{10} by Theorem 4.2.4.
- $a_1 = \omega, a_2 = \omega, a_3 = -1, a_4 = -\bar{\omega}, a_5 = 1, a_6 = -\omega$: the \mathcal{L} -graph T'_{10}
- $a_1 = \bar{\omega}, a_2 = \bar{\omega}, a_3 = -1, a_4 = -\omega, a_5 = 1, a_6 = -\bar{\omega}$: the conjugate of T'_{10} (hence, equivalent)
- $a_1 = -\omega, a_2 = -\omega, a_3 = -1, a_4 = \bar{\omega}, a_5 = 1, a_6 = \omega$: equivalent to T'_{10} by permuting vertices 1,6.

- $a_1 = -\bar{\omega}, a_2 = -\bar{\omega}, a_3 = -1, a_4 = \omega, a_5 = 1, a_6 = \bar{\omega}$: the conjugate of the above (hence, equivalent to T'_{10})

Thus, the case $k = 5$ of Theorem 4.2.1 holds.

$k \geq 6$ If $k \geq 6$ then G contains a cylinder of length $m = k - 1 \geq 5$ which by Lemma 4.2.7 is of the required form. Let the remaining two vertices be A, B and consider the subgraph induced on vertices $1, 2, m - 1, m, m + 1, m + 2, 2m - 1, 2m, A, B$ which, fixing an edge at each of A, B by switching, is:

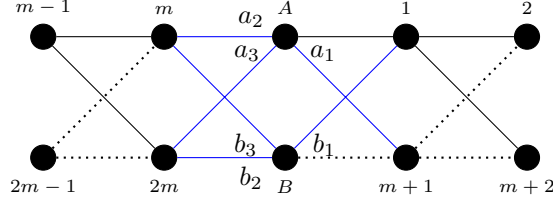

(Note that this is a cylinder rather than a torus since $m \geq 5$ as $k \geq 6$; that is, vertex $m - 1$ is neither vertex 2 nor a neighbour, and similarly for the other unsaturated vertices.)

As before, the edges $a_k, b_k \in \mathcal{L}_1$ are constrained only by the requirement of cyclotomicity. In addition to the two labellings as in the proof for Theorem 4.2.4 - which correspond to T_{2k} - for $d = -1, -3$ there are further choices which yield a cyclotomic \mathcal{L} -graph.

For $d = -1$ we have $a_1 = 1, a_2 = i, a_3 = i, b_1 = -1, b_2 = -i, b_3 = i$ - corresponding to T'_{2k} ; and $a_1 = 1, a_2 = -i, a_3 = -i, b_1 = -1, b_2 = i, b_3 = -i$ - the complex conjugate of (and thus equivalent to) T'_{2k} .

For $d = -3$ we have case A : $a_1 = 1, a_2 = \omega, a_3 = -\bar{\omega}, b_1 = -1, b_2 = -\omega, b_3 = \omega$ and its conjugate; plus case B : $a_1 = 1, a_2 = -\omega, a_3 = \bar{\omega}, b_1 = -1, b_2 = \omega, b_3 = -\omega$. Numbered as in Corollary 2.6.14, case A is T'_{2k} , whilst case B is the graph obtained by permuting vertices $1, k + 1$ in T'_{2k} and thus is equivalent.

This completes the proof of Theorem 4.2.1.

4.3 Graphs of Form $\mathcal{C}_{2k}^{+\pm}$

We will prove the following result:

Theorem 4.3.1. For $R = \mathbb{Z}$ or $R = \mathcal{O}_{\mathbb{Q}(\sqrt{d})}, d < 0$, if G is a $2k$ -vertex cyclotomic \mathcal{L} -graph of the form $\mathcal{C}_{2k}^{+\pm}$ for $k \geq 2$ then G is equivalent to one of the charged signed graphs $\mathcal{C}_{2k}^{++}, \mathcal{C}_{2k}^{+-}$ shown in Fig. 1.5.

It suffices to prove the result for $d = -1, -3$. We first verify some simple cases, then use the results of the previous section to prove the general case.

$$k \leq 5$$

$$k = 2$$

We have as general graph the charged square

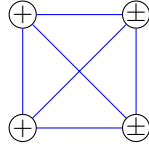

For both $d = -1, -3$, it is easy to determine the cyclotomic examples and reduce them modulo equivalence; as claimed, there are two distinct classes with representatives C_4^{++} and C_4^{+-} :

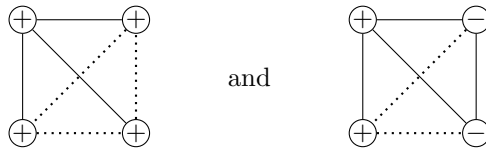

$$k = 3$$

We note the following:

Lemma 4.3.2. *A charged \mathcal{L} -graph of the form*

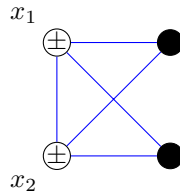

is cyclotomic only if $x_1 = x_2$ (that is, the two charged vertices have the same charge).

Thus if G is a cyclotomic \mathcal{L} -graph of the form

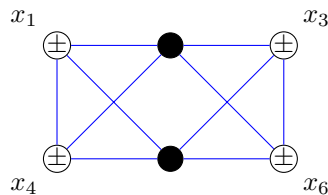

then $x_1 = x_4$ and $x_3 = x_6$; negating if necessary, G is equivalent to such an \mathcal{L} -graph with $x_1 = x_4 = 1$. Further, by (complex) switching G is then equivalent to an \mathcal{L} -graph with fixed

edge labels and charges:

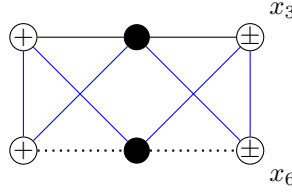

Of the possible edge labellings for each choice of $x_3 = x_6$, those which yield cyclotomic graphs split into two equivalence classes with representatives C_6^{++}, C_6^{+-} . Thus any \mathcal{L} -graph of form $C_6^{+\pm}$ is equivalent to one of these charged signed graphs, as required.

$k = 4$

We note the following condition, which holds by direct testing:

Lemma 4.3.3. *If F is a cyclotomic \mathcal{L} -graph of the form*

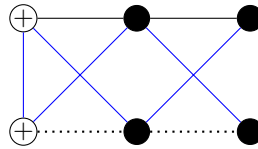

then, by (complex) switching, F is equivalent to the charged signed graph

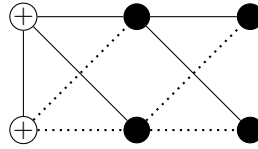

Let G be a cyclotomic \mathcal{L} -graph of the form $C_8^{+\pm}$. Negating if necessary, then by (complex) switching, G is equivalent to one with edges and charges fixed as follows:

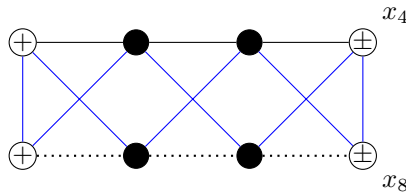

with $x_4 = x_8$ by Lemma 4.3.2.

By Lemma 4.3.3 then (complex) switching at vertices 4 and 8 we thus have that G is equivalent

to an \mathcal{L} -graph with labels:

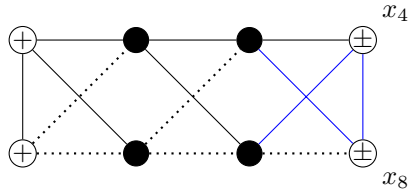

But for each choice of $x_4 = x_8$ only one such \mathcal{L} -graph is cyclotomic, corresponding to the two classes C_8^{++}, C_8^{+-} as required.

$k = 5$

Negating if necessary, then applying Lemma 4.3.3 and switching at the remaining four vertices, an \mathcal{L} -graph of form C_{10}^{+-} is equivalent to one with charges and edge labels as follows:

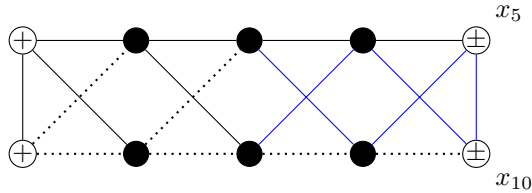

with $x_5 = x_{10}$ by Lemma 4.3.2. However, for each choice of those charges, just one combination of edge labels gives a cyclotomic \mathcal{L} -graph, corresponding to the two classes C_{10}^{++}, C_{10}^{+-} . So G is an element of one of those equivalence classes, as required.

$k \geq 6$

To complete the proof of Theorem 4.3.1, it therefore suffices to confirm the following:

Theorem 4.3.4. *If G is a $2k$ -vertex cyclotomic \mathcal{L} -graph of the form $C_{2k}^{+\pm}$ for $k \geq 6$ then G is equivalent to one of the charged signed graphs C_{2k}^{++}, C_{2k}^{+-} .*

Proof. From Lemma 4.3.2, if G is an \mathcal{L} -graph of form

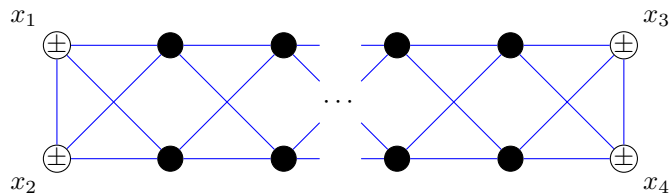

then (negating if necessary) G is equivalent to such an \mathcal{L} -graph with $x_1 = x_2 = 1$ and either $x_3 = x_4 = 1$ or $x_3 = x_4 = -1$.

Having so arranged, we may apply Lemma 4.2.7 to the middle $2k - 4$ vertices to obtain the desired edge labels, and apply (complex) switching at the charged vertices to ensure the top and bottom k -vertex paths are ‘correct’. This then leaves undetermined edges at the charged vertices only, with the cyclotomicity condition completing the proof: at the left edge we have

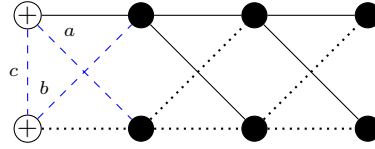

which is cyclotomic if and only if $a = c = 1, b = -1$ as desired; whilst at the right edge we have

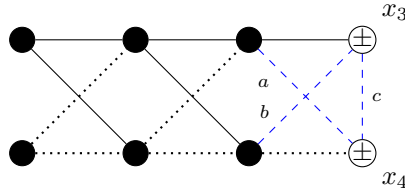

which is cyclotomic if and only if $x_3 = x_4 = a = 1, b = c = -1$ (giving C_{2k}^{+++}) or $x_3 = x_4 = b = -1, a = c = 1$ (giving C_{2k}^{+-}). \square

4.4 Graphs of form \mathcal{T}_{2k}^4

We note the following useful computational results:

Lemma 4.4.1. *If G is cyclotomic and induces a subgraph of the form*

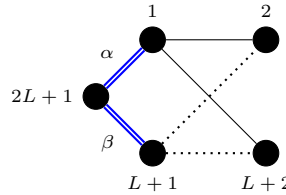

then $\alpha = \beta \in \mathcal{L}_2$.

Lemma 4.4.2. *If G is cyclotomic and induces a subgraph of the form*

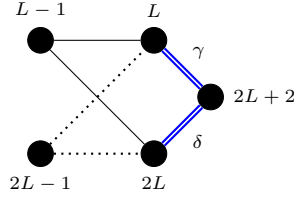

then $\gamma = -\delta \in \mathcal{L}_2$.

Theorem 4.4.3. *If G is a cyclotomic \mathcal{L} -graph of form T_{2k}^4 then it is equivalent to the \mathcal{L} -graph T_{2k}^4 given in Corollary 2.6.20 or ($d = -7$ only) $T_{2k}^{4'}$ given in Corollary 2.6.21.*

Proof. For $k \geq 5$ the result is immediate: for the vertex numbering given in Definition 2.6.18, vertices $1, \dots, 2L$ are a cylinder of length at least 4, so by Lemma 4.2.7 G is equivalent to an \mathcal{L} -graph of form

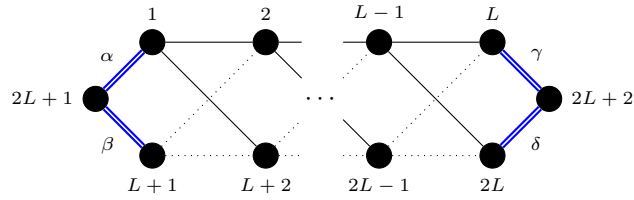

for some $\alpha, \beta, \gamma, \delta \in \mathcal{L}_2$. Then by Lemmata 4.4.1, 4.4.2 we have that $\alpha = \beta$ and $\gamma = -\delta$. For $d = -1$, complex switching at vertices $2L+1, 2L+2$ ensures $\alpha = \gamma = 1 + i$, giving the \mathcal{L} -graph T_{2k}^4 . For $d = -2$, $\mathcal{L}_2 = \{\pm\sqrt{-2}\}$ so by switching at $2L+1, 2L+2$ we can ensure that $\alpha = \gamma = \sqrt{-2}$, giving the \mathcal{L} -graph T_{2k}^4 . For $d = -7$, by negation and/or conjugation G is equivalent to an \mathcal{L} -graph with $\alpha = \omega = \frac{1}{2} + \frac{\sqrt{-7}}{2}$, and by switching at vertex $2L+2$ we can ensure $\gamma = \omega$ - giving T_{2k}^4 - or that $\gamma = \bar{\omega}$, giving $T_{2k}^{4'}$.

For $k = 2$, we have the degenerate case of squares

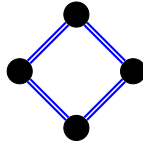

for which we can test equivalence directly; all cyclotomic examples are equivalent to T_4^4 or (for $d = -7$ only) $T_4^{4'}$, where the latter is inequivalent to the former.

For $k = 3$, by negation and/or conjugation we can fix $\alpha = 1 + i, \sqrt{-2}$ or $\omega = \frac{1}{2} + \frac{\sqrt{-7}}{2}$ for

$d = -1, -2, -7$ respectively, then by (complex) switching G is equivalent to an \mathcal{L} -graph of form

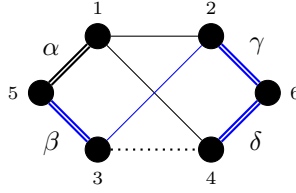

for some $\beta, \gamma, \delta \in \mathcal{L}_2$; testing confirms that all cyclotomic examples are equivalent to T_6^4 or (for $d = -7$) $T_6^{4'}$.

For $k = 4$, by negation and/or conjugation we can fix $\alpha = 1 + i, \sqrt{-2}$ or $\omega = \frac{1}{2} + \frac{\sqrt{-7}}{2}$ for $d = -1, -2, -7$ respectively, then by (complex) switching G is equivalent to an \mathcal{L} -graph of form

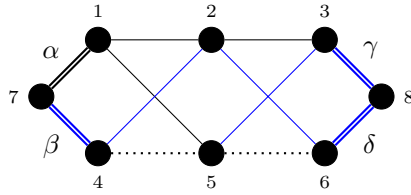

for some $\beta, \gamma, \delta \in \mathcal{L}_2$; testing confirms that all cyclotomic examples are equivalent to T_8^4 or (for $d = -7$) $T_8^{4'}$. □

4.5 Graphs of Form $\mathcal{C}_{2k}^{2\pm}$

Theorem 4.5.1. *If G is a cyclotomic charged \mathcal{L} -graph of form $\mathcal{C}_{2k}^{2\pm}$ then it is equivalent to the charged \mathcal{L} -graph \mathcal{C}_{2k}^{2+} defined in Corollary 2.6.26.*

Proof. For $k \geq 5$, the result is immediate. By Lemma 4.3.2 we have that the charges on vertices $1, k + 1$ are equal; negating if necessary G is equivalent to an \mathcal{L} -graph with both charges $+1$. Then vertices $2, \dots, k, k + 2, \dots, 2k$ are a cylinder of length at least 4, so by Lemma 4.2.7 and switching at $1, k + 1$ G is equivalent to an \mathcal{L} -graph with edges specified as follows:

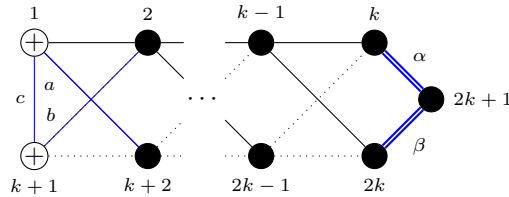

for some $a, b, c \in \mathcal{L}_1, \alpha, \beta \in \mathcal{L}_2$. But, as in the proof of Theorem 4.3.4, the subgraph induced on vertices $1, 2, 3, 4, k + 1, k + 2, k + 3, k + 4$ is cyclotomic if and only if $a = c = -b = 1$. By

complex conjugation and/or switching at $2k + 1$, we can ensure $\alpha = 1 + i, \sqrt{-2}$ or $\frac{1}{2} + \frac{\sqrt{-7}}{2}$ for $d = -1, -2, -7$ respectively; by Lemma 4.4.2, $\beta = -\alpha$. Thus we recover the charged \mathcal{L} -graph C_{2k}^{2+} as claimed.

If $k = 3$ then, by Lemma 4.3.2, negating if necessary, then switching, then conjugating/switching to fix α we have that G is equivalent to an \mathcal{L} -graph with edge labels and charges:

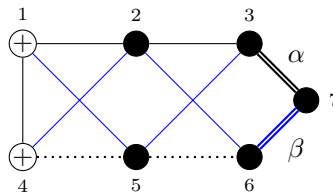

Only one such \mathcal{L} -graph is cyclotomic, C_6^{2+} .

Similarly, if $k = 4$ we have that G is equivalent to some \mathcal{L} -graph with edge labels and charges

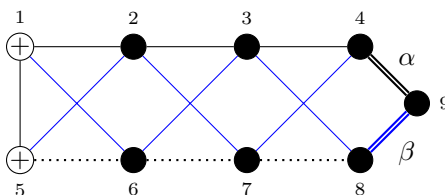

but the only cyclotomic example for fixed α is C_8^{2+} .

For $k = 2$ we have G equivalent to some \mathcal{L} -graph with edge labels and charges

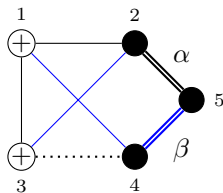

but the only cyclotomic example for fixed α is C_4^{2+} .

Finally, for $k = 1$ we have that G is equivalent to some \mathcal{L} -graph with edge labels and charges

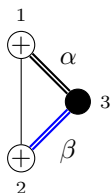

but the only cyclotomic example for fixed α is C_2^{2+} .

4.6 Sporadic Forms

2-vertex maximal forms

The maximal form \mathcal{S}_2 was classified up to equivalence in Remarks 2.5.4, 2.5.5, 2.5.6: there is a single class as in Fig. 2.1 for $d = -1, -2, -3, 11$, and two distinct classes as in Figures 2.1 and 2.2 for $d = -7, -15$.

For $d = -2, -3, -11$, any cyclotomic \mathcal{L} -graph of form \mathcal{S}'_2 is equivalent to the example given in Fig. 4.1.

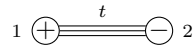

Figure 4.1: The 2-vertex sporadic maximal connected cyclotomic charged \mathcal{L} -graph \mathcal{S}'_2 . (Where $t = 1 + \sqrt{-2}, \frac{3}{2} + \frac{\sqrt{-3}}{2}, \frac{1}{2} + \frac{\sqrt{-11}}{2}$ for $d = -2, -3, -11$ respectively.)

4-vertex maximal forms

For $d = -1, -2, -7$ any cyclotomic \mathcal{L} -graph of the form \mathcal{S}_4 is equivalent to the example given in Fig. 4.2.

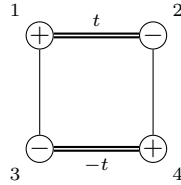

Figure 4.2: The 4-vertex sporadic maximal connected cyclotomic charged \mathcal{L} -graph \mathcal{S}_4 . (Where $t = 1 + i, \sqrt{-2}, \frac{1}{2} + \frac{\sqrt{-7}}{2}$ for $d = -1, -2, -7$ respectively.)

For $d = -2, -3, -11$ any cyclotomic \mathcal{L} -graph of the form \mathcal{S}'_4 is equivalent to the example given in Fig. 4.3.

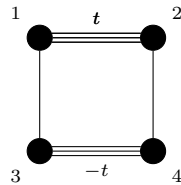

Figure 4.3: The 4-vertex sporadic maximal connected cyclotomic \mathcal{L} -graph \mathcal{S}'_4 . (Where $t = 1 + \sqrt{-2}, \frac{3}{2} + \frac{\sqrt{-3}}{2}, \frac{1}{2} + \frac{\sqrt{-11}}{2}$ for $d = -2, -3, -11$ respectively.)

For $d = -2$ any cyclotomic \mathcal{L} -graph of the form \mathcal{S}_4^* is equivalent to the example given in Fig. 4.4.

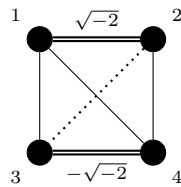

Figure 4.4: The 4-vertex sporadic maximal connected cyclotomic \mathcal{L} -graph \mathcal{S}_4^* .

For $d = -1$ any cyclotomic \mathcal{L} -graph of the form \mathcal{S}_4^\dagger is equivalent to the example given in Fig. 4.5.

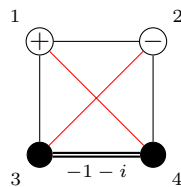
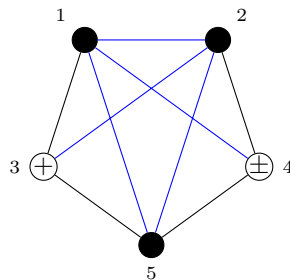

Figure 4.5: The 4-vertex sporadic maximal connected cyclotomic charged \mathcal{L} -graph \mathcal{S}_4^\dagger .

5-vertex maximal forms

For $d = -3$, if G is an \mathcal{L} -graph of form \mathcal{S}_5 then, negating to ensure a positive charge and by (complex) switching as necessary, G is equivalent to an \mathcal{L} -graph of form



but testing confirms there are only two cyclotomic matrices corresponding to this form, and they are conjugates and thus equivalent. So any cyclotomic \mathcal{L} -graph of form \mathcal{S}_5 is equivalent to the example given in Fig. 4.6.

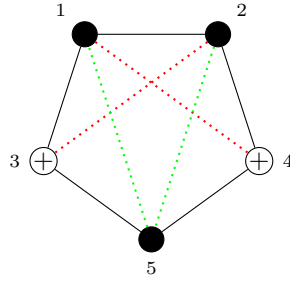
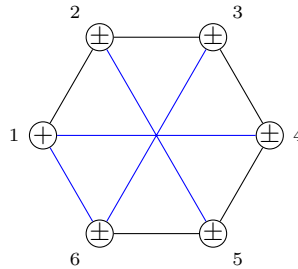

Figure 4.6: The 5-vertex sporadic maximal connected cyclotomic charged \mathcal{L} -graph S_5 .

6-vertex maximal forms

For $d = -3$, if G is an \mathcal{L} -graph of form \mathcal{S}_6 , then, negating to ensure a positive charge and by (complex) switching as necessary, G is equivalent to an \mathcal{L} -graph of form



but testing confirms there are only two cyclotomic matrices corresponding to this form, and they are conjugates and thus equivalent. So any cyclotomic \mathcal{L} -graph of form \mathcal{S}_6 is equivalent to the example given in Fig. 4.7.

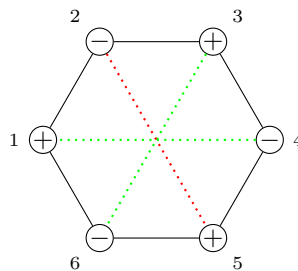
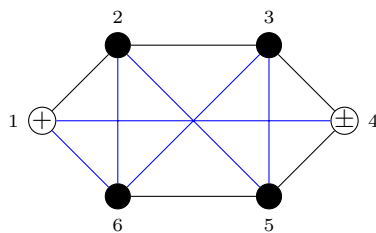

Figure 4.7: The 6-vertex sporadic maximal connected cyclotomic charged \mathcal{L} -graph S_6 .

For $d = -3$, if G is an \mathcal{L} -graph of form \mathcal{S}'_6 , then, negating to ensure a positive charge and by

(complex) switching as necessary, G is equivalent to an \mathcal{L} -graph of form



but testing confirms there are only two cyclotomic matrices corresponding to this form, and they are conjugates and thus equivalent. So any cyclotomic \mathcal{L} -graph of form \mathcal{S}'_6 is equivalent to the example given in Fig. 4.8.

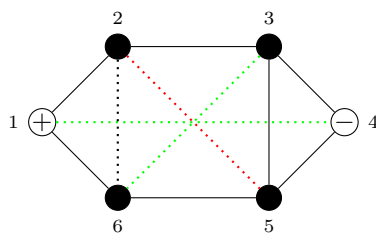
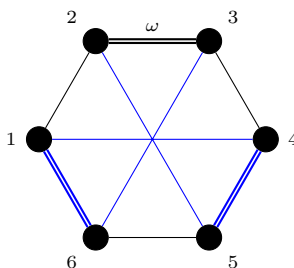

Figure 4.8: The 6-vertex sporadic maximal connected cyclotomic charged \mathcal{L} -graph \mathcal{S}'_6 .

For $d = -7$, if G is an \mathcal{L} -graph of form \mathcal{S}'_6 then, negating and/or conjugating to fix a weight 2 edge then by switching if necessary, G is equivalent to an \mathcal{L} -graph of form



where $\omega = \frac{1}{2} + \frac{\sqrt{-7}}{2}$.

Testing confirms that only two such \mathcal{L} -graphs are cyclotomic and they are strongly equivalent by switching. So any cyclotomic \mathcal{L} -graph of form \mathcal{S}'_6 is equivalent to the example given in Fig. 4.9.

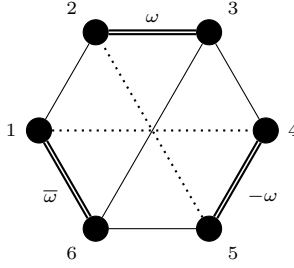
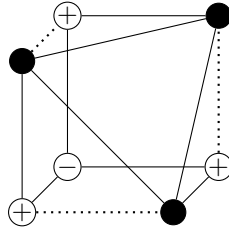

Figure 4.9: The 6-vertex sporadic maximal connected cyclotomic \mathcal{L} -graph \mathcal{S}_6^\dagger .
(where $\omega = \frac{1}{2} + \frac{\sqrt{-7}}{2}$.)

7-vertex maximal forms

The only sporadic 7-vertex maximal form is \mathcal{S}_7 , with cyclotomic examples for all d . However, since all edges have weight 1, it suffices to prove that there is only a single class of this form for each of $d = -1, -3$. For a given numbering, fixing some edge labels by (complex) switching, and proceeding as in Remark 2.5.8, we find for both (and thus all) d that any \mathcal{L} -graph of form \mathcal{S}_7 is equivalent to the charged signed graph given in Fig. 1.4:



8-vertex maximal forms

Graphs of form \mathcal{S}_8

As for \mathcal{S}_7 , it suffices to confirm for $d = -1, -3$ that there is only one class of \mathcal{L} -graphs of form \mathcal{S}_8 . If G is such an \mathcal{L} -graph, then negating to fix a charge then (complex) switching as necessary, G is equivalent to an \mathcal{L} -graph of form

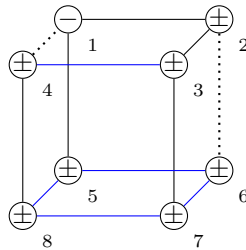

Consider the subgraph induced on vertices $1, \dots, 6$. Testing for each $d = -1, -3$ confirms that

all cyclotomic examples are equivalent; a representative is the charged signed graph H :

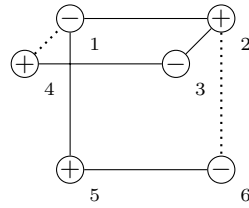

Thus G is equivalent to a cyclotomic \mathcal{L} -graph inducing H as subgraph on vertices $1, \dots, 6$; proceeding as in Remark 2.5.8 and fixing an edge label at each of vertices $7, 8$ by (complex) switching as specified, we find that G is necessarily equivalent to the representative given in Fig. 1.4:

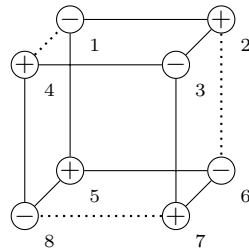

Graphs of form \mathcal{S}'_8

Again, it suffices to confirm for $d = -1, -3$ that there is only one class of \mathcal{L} -graphs of form \mathcal{S}'_8 . If G is such an \mathcal{L} -graph, then negating to fix a charge then (complex) switching as necessary, G is equivalent to an \mathcal{L} -graph of form

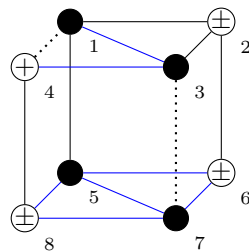

Consider the subgraph induced on vertices $1, \dots, 6$. Testing for each $d = -1, -3$ confirms that all cyclotomic examples are equivalent; a representative is the charged signed graph H :

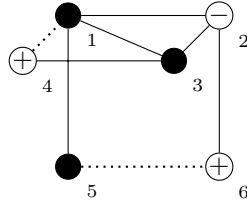

Thus G is equivalent to a cyclotomic \mathcal{L} -graph inducing H as subgraph on vertices $1, \dots, 6$; proceeding as in Remark 2.5.8 and fixing an edge label at each of vertices 7,8 by (complex) switching as specified, we find that G is necessarily equivalent to the representative given in Fig. 1.4:

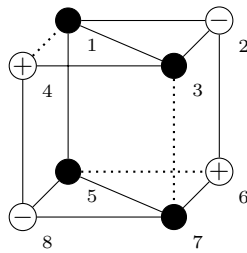

Graphs of form \mathcal{S}_8^*

For $d = -1, -2, -7$, we note that the \mathcal{L} -graph in Figure 4.10 is cyclotomic and of form \mathcal{S}_8^* .

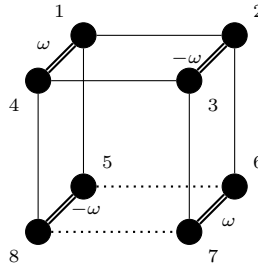
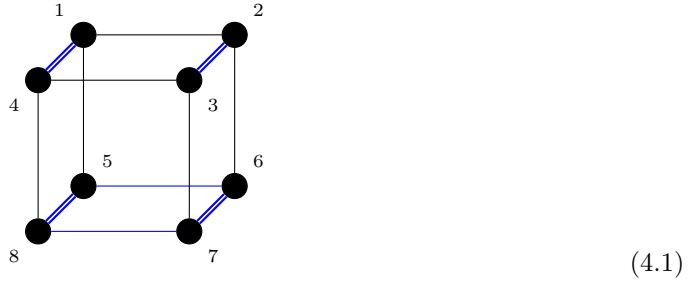

Figure 4.10: The 8-vertex sporadic maximal connected cyclotomic \mathcal{L} -graph \mathcal{S}_8^*

$$(\omega = 1 + 1, \sqrt{-2}, \frac{1}{2} + \frac{\sqrt{-7}}{2} \text{ for } d = -1, -2, -7 \text{ respectively.})$$

If G is an \mathcal{L} -graph of form \mathcal{S}_8^* then, by (complex) switching, G is equivalent to an \mathcal{L} -graph of form



For $d = -2$ we verify directly that, after the switching required to obtain edges labels as in (4.1), any cyclotomic G of form S_8^* is equivalent to one of two possible \mathcal{L} -graphs, but they are conjugate and thus equivalent. Hence there is only a single equivalence class, with the \mathcal{L} -graph given in Fig. 4.10 thus serving as a representative.

For $d = -1$, consider the subgraph of G induced on vertices $1, \dots, 6$ (as labelled in (4.1)). Testing confirms that four choices of edge labels yield a cyclotomic \mathcal{L} -graph; and that these four are strongly equivalent by (complex) switching: in particular, all four are strongly equivalent to the \mathcal{L} -graph H :

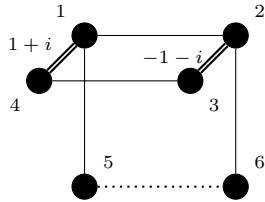

Thus any cyclotomic G is equivalent to a cyclotomic \mathcal{L} -graph inducing H as subgraph on vertices $1, \dots, 6$; testing confirms that (up to equivalence, fixing edges at vertices $7, 8$ as in (4.1) by switching) there is only one such \mathcal{L} -graph. Thus the example given in Fig. 4.10 serves as representative for any cyclotomic \mathcal{L} -graph of form S_8^* for $d = -1$.

Similarly, for $d = -7$ we find that by conjugation and/or switching any cyclotomic G of form S_8^* is equivalent to a cyclotomic \mathcal{L} -graph with subgraph H :

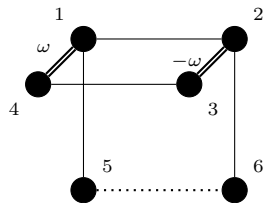

where $\omega = \frac{1}{2} + \frac{\sqrt{-7}}{2}$, but then testing confirms that such a G is equivalent to the \mathcal{L} -graph given in Fig. 4.10.

Graphs of form \mathcal{S}_8^\dagger

We need consider only $d = -1$. If G is of form \mathcal{S}_8^\dagger , then by (complex) switching it is equivalent to an \mathcal{L} -graph of form

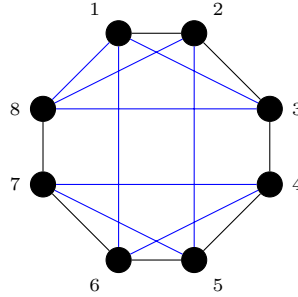

There are only two cyclotomic possibilities for the subgraph induced on vertices $1, \dots, 6$; proceeding as in Remark 2.5.8 we recover two possible cyclotomic \mathcal{L} -graphs of the above form, and they are conjugates and thus equivalent. Any cyclotomic \mathcal{L} -graph of form \mathcal{S}_8^\dagger is therefore equivalent to any other, such as the example given in Fig. 4.11.

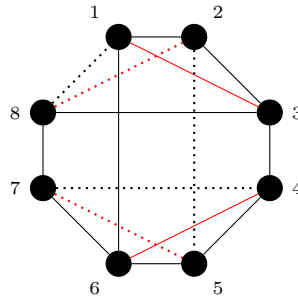
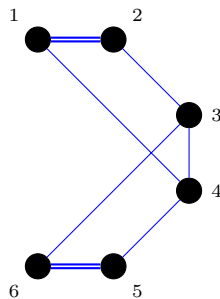

Figure 4.11: The 8-vertex sporadic maximal connected cyclotomic \mathcal{L} -graph \mathcal{S}_8^\dagger .

Graphs of form \mathcal{S}_8^\ddagger

We need consider only $d = -1$. If G is of form \mathcal{S}_8^\ddagger , then it induces a subgraph of form



but all cyclotomic examples lie in a single equivalence class. Let H' be a representative of that class. As in Theorem 3.2.14, we may thus generate representatives of the possible equivalence

classes for a cyclotomic G of form S_8^\dagger from H' . This yields a single class, with a representative given in Fig. 4.12.

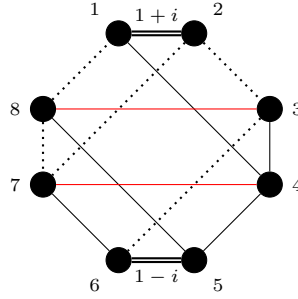
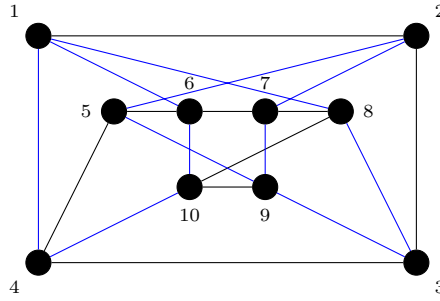

Figure 4.12: The 8-vertex sporadic maximal connected cyclotomic \mathcal{L} -graph S_8^\dagger .

10-vertex maximal forms

We have for $d = -3$ only the sporadic form S_{10} ; by (complex) switching any cyclotomic \mathcal{L} -graph G of this form is equivalent to one with specified edge labels



For the subgraph H induced on vertices $1, \dots, 7$ only two choices of edge labels give cyclotomic \mathcal{L} -graphs H_1, H_2 . Thus G is equivalent to an \mathcal{L} -graph of the above form inducing either H_1 or H_2 as subgraph; applying the growing procedure described in Remark 2.5.8 we can find representatives of all possible such \mathcal{L} -graphs. However, for each of H_1, H_2 only one such representative is found and further they are conjugates of each other. So there is only a single class of cyclotomic \mathcal{L} -graphs of the form S_{10} inducing H_1 or H_2 and G is necessarily in this class; a representative is given in Fig. 4.13.

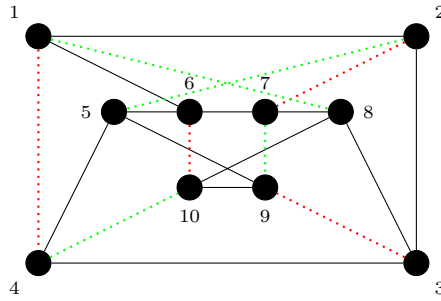
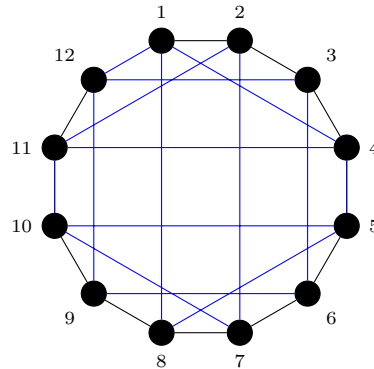

Figure 4.13: The 10-vertex sporadic maximal connected cyclotomic \mathcal{L} -graph S_{10} .

12-vertex maximal forms

We have for $d = -3$ only the sporadic form S_{12} ; by (complex) switching any cyclotomic \mathcal{L} -graph G of this form is equivalent to one with specified edge labels



Starting from the cyclotomic induced subgraphs on vertices $1, \dots, 6$ we apply the growing procedure from Remark 2.5.8 to find possible classes for G ; only two 12-vertex \mathcal{L} -graphs of the above form are obtained, and as they are conjugate, there is only a single equivalence class. Thus any cyclotomic \mathcal{L} -graph of form S_{12} is equivalent to any other, such as the example given in Fig. 4.14.

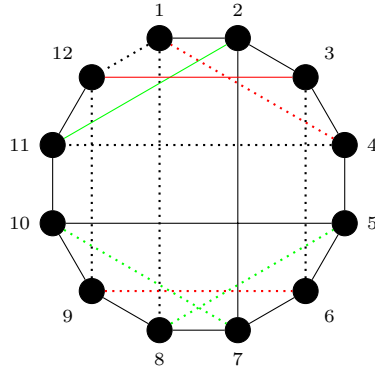
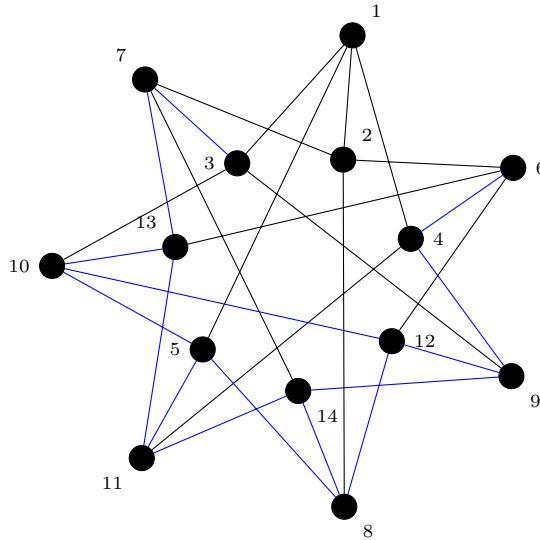

Figure 4.14: The 12-vertex sporadic maximal connected cyclotomic \mathcal{L} -graph S_{12} .

14-vertex maximal forms

The only sporadic 14-vertex maximal form is S_{14} , with cyclotomic examples for all d . However, since all edges have weight 1, it suffices to prove that there is only a single class of this form for each of $d = -1, -3$. By (complex) switching, any G of this form is equivalent to an \mathcal{L} -graph of form



Note that the subgraph induced on vertices $1, \dots, 6$ has only one unspecified edge; for each of $d = -1, -3$ only a single choice yields a cyclotomic \mathcal{L} -graph H . Using this as a seed graph, we proceed as in Remark 2.5.8 to determine the remaining edge labels vertex by vertex; at each stage, we recover only 1 cyclotomic example, terminating with a single class of cyclotomic \mathcal{L} -graphs of the form S_{14} inducing H . Thus any cyclotomic \mathcal{L} -graph of form S_{14} is equivalent to any other, such as the signed graph given in Fig. 1.1.

- (iv) The 8-vertex \mathcal{L} -graph S_8^* shown in Fig. 4.10;
- (v) The 8-vertex \mathcal{L} -graph S_8^\dagger shown in Fig. 4.11;
- (vi) The 8-vertex \mathcal{L} -graph S_8^\ddagger shown in Fig. 4.12;
- (vii) For some $k = 3, 4, \dots$, the $2k$ -vertex \mathcal{L} -graph T'_{2k} shown in Fig. 2.3;
- (viii) For some $k = 2, 3, 4, \dots$, the $2k$ -vertex \mathcal{L} -graph T_{2k}^4 shown in Fig. 2.4;
- (ix) For some $k = 1, 2, 3, \dots$, the $2k + 1$ -vertex \mathcal{L} -graph C_{2k}^{2+} shown in Fig. 2.6.

Theorem 4.7.3. ($d = -3$) Every connected 4-cyclotomic \mathcal{L} -graph for $R = \mathcal{O}_{\mathbb{Q}(\sqrt{-3})}$ not included in Theorems 1.4.1, 1.4.2 is equivalent to one of the following:

- (i) The 2-vertex \mathcal{L} -graph S_2 shown in Fig. 2.1;
- (ii) The 2-vertex \mathcal{L} -graph S'_2 shown in Fig. 4.1;
- (iii) The 4-vertex \mathcal{L} -graph S'_4 shown in Fig. 4.3;
- (iv) The 5-vertex \mathcal{L} -graph S_5 shown in Fig. 4.6;
- (v) The 6-vertex \mathcal{L} -graph S_6 shown in Fig. 4.7;
- (vi) The 6-vertex \mathcal{L} -graph S'_6 shown in Fig. 4.8;
- (vii) The 10-vertex \mathcal{L} -graph S_{10} shown in Fig. 4.13;
- (viii) The 12-vertex \mathcal{L} -graph S_{12} shown in Fig. 4.14;
- (ix) For some $k = 3, 4, \dots$, the $2k$ -vertex \mathcal{L} -graph T'_{2k} shown in Fig. 2.3.

Chapter 5

Maximal Cyclotomic Graphs are 4-Cyclotomic

5.1 Overview

In this Chapter we first prove that a charged signed graph is maximal only if every vertex has weighted degree four: thus the maximal connected charged signed graphs are the 4-cyclotomic charged signed graphs. Combined with the results of the previous Chapters, this gives a new proof of Theorems 1.4.1, 1.4.2 of [14]. We are able to extend this to \mathcal{L} -graphs in the case $\mathcal{L}_1 = \{\pm 1\}$, and thus for $d = -2, -7, -11, -15$ are able to classify all maximal connected cyclotomic \mathcal{L} -graphs.

5.2 Preliminaries

For vectors $x = (x_1, \dots, x_n), y = (y_1, \dots, y_n) \in \mathbb{C}^n$ we take as standard inner product

$$\langle x, y \rangle = xy^* = \sum_{i=1}^n x_i \overline{y_i}.$$

For $x, y \in \mathbb{R}^n$, this gives the standard dot product $x \cdot y$.

Definition 5.2.1. For an $n \times n$ Hermitian matrix A we describe a set $W = \{w_1, \dots, w_n\}$ as a *set of Gram vectors* for A if $\langle w_i, w_j \rangle = A_{ij}$ for all $1 \leq i, j \leq n$.

Lemma 5.2.2. (*Special case of [9] Thm. 7.2.6*) Let A be a positive semidefinite Hermitian matrix. Then there exists a positive semidefinite Hermitian matrix B such that $B^2 = A$.

Proof. A can be unitarily diagonalised as $A = U\Lambda U^*$ with $\Lambda = \text{diag}(\lambda_1, \dots, \lambda_n)$ and all $\lambda_i \geq 0$. Define $\sqrt{\Lambda} = \text{diag}(\sqrt{\lambda_1}, \dots, \sqrt{\lambda_n})$, taking the unique nonnegative square root in each case. Then $B = U\sqrt{\Lambda}U^*$ is Hermitian, positive semidefinite, and satisfies $B^2 = A$. \square

Proposition 5.2.3. *Let A be an $n \times n$ positive semidefinite integer symmetric matrix. Then there exists a set of real Gram vectors for A (that is, $W = \{w_1, \dots, w_n\}$ with each $w_i \in \mathbb{R}^n$ such that $A_{ij} = w_i \cdot w_j$).*

Proof. Since A is real symmetric it can be diagonalised by orthogonal matrices, so the matrix B given in Lemma 5.2.2 is a real symmetric matrix. Let W be the set of rows of B ; then $B_{ij}^2 = w_i \cdot w_j$. But by the Lemma $B_{ij}^2 = A_{ij}$, so W is a set of Gram vectors for A . \square

Proposition 5.2.4. *Let A be an $n \times n$ positive semidefinite Hermitian R -matrix. Then there exists a set of Gram vectors for A .*

Proof. By Lemma 5.2.2, let B be a Hermitian matrix satisfying $B^2 = A$. Take W to be the set of rows of B . But then as B is Hermitian we have for the inner product as defined above that $\langle w_i, w_j \rangle = B_{ij}^2 = A_{ij}$ as required. \square

5.3 Charged Signed Graphs

We will demonstrate the following:

Theorem 5.3.1. *Let G be a cyclotomic charged signed graph with a vertex of weighted degree 1, 2 or 3. Then G is nonmaximal.*

Thus, a cyclotomic charged signed graph is maximal only if all vertices have weighted degree 4. In Proposition 2.6.3 it was shown that this condition is also sufficient for maximality over (for instance) $R = \mathcal{O}_{\mathbb{Q}(i)}$ and thus over \mathbb{Z} ; so we have

Corollary 5.3.2. *A cyclotomic charged signed graph is maximal if and only if it is 4-cyclotomic.*

5.3.1 Constructing Cyclotomic Supermatrices With Gram Vectors

Let M be a matrix representative of a connected cyclotomic charged signed graph G . Then both $A = M + 2I$ and $B = (-M) + 2I$ are positive semidefinite. Hence (by Proposition 5.2.3) there exist sets of real Gram vectors W and W' for A and B respectively, whereby $A_{ij} = w_i \cdot w_j$ and $B_{ij} = w'_i \cdot w'_j$. We then have:

- For all $i \neq j$, $w_i \cdot w_j$ and $w'_i \cdot w'_j$ are in $\{0, 1, -1\}$, with $w_i \cdot w_j = -w'_i \cdot w'_j$; $w_i \cdot w_j$ gives the label of the edge between vertices i, j (0 if no edge).

- For all $w \in W$ and $w' \in W'$, $w \cdot w$ and $w' \cdot w'$ are in $\{1, 2, 3\}$; $w_i \cdot w_i - 2$ gives the charge on vertex i .
- For all i , $w'_i \cdot w'_i = 4 - w_i \cdot w_i$.

Theorem 5.3.3. *Let M be a matrix representative of a cyclotomic charged signed graph G . Fix a vertex labelling then determine Gram vectors W, W' as above. If there exist vectors x, x' with the following properties:*

- $x \cdot x \in \{1, 2, 3\}$
- For all $w_i \in W$, $x \cdot w_i \in \{0, 1, -1\}$
- There exists $w_i \in W$ such that $x \cdot w_i \neq 0$
- $x' \cdot x' = 4 - x \cdot x$
- For all i , $x' \cdot w'_i = -x \cdot w_i$

then define A^* to be the matrix determined by the set of Gram vectors $W \cup \{x\}$. $M^* = A - 2I$ is then a matrix representative of a cyclotomic, connected, charged signed graph G^* inducing G as a proper subgraph, so G is nonmaximal.

Proof. By construction A^* is symmetric and positive semidefinite. Thus M^* has all eigenvalues in $[-2, \infty)$. By the first two conditions on w , M^* has all entries in $\{0, 1, -1\}$ so describes a charged signed graph G^* and by choice of Gram vectors this is an extension of G by a single vertex. By the third condition G^* is connected so G is a proper subgraph of G^* ; G is therefore nonmaximal provided G^* is cyclotomic.

Consider B^* the Gram matrix corresponding to vectors $W' \cup \{x'\}$; by the properties of W, W' and the final two conditions, B^* is precisely the matrix $(-M^*) + 2I$. As B^* is positive semidefinite, $-M^*$ has all eigenvalues in $[-2, \infty)$. Hence M^* has all eigenvalues in $(-\infty, 2]$; combined with the earlier bound this ensures all eigenvalues of M^* are in $[-2, 2]$ and G^* is thus cyclotomic. \square

5.3.2 Excluded Subgraphs

For various cyclotomic charged signed graphs H we note that if G is cyclotomic but not 4-cyclotomic and induces H as a subgraph, then G is not maximal. This holds when such an H is contained in only finitely many cyclotomic charged signed graphs, and each of these is contained in a maximal 4-cyclotomic example; G is necessarily also a proper subgraph of one of those maximal examples.

For instance, let G contain a singly-charged weight 1 triangle H ; w.l.o.g. H is

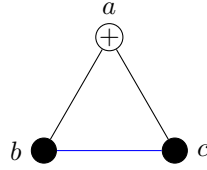

but such an H is cyclotomic if and only if $e_{bc} = -1$. Then by bounded **equivgrow** the only cyclotomic charged signed graphs to induce H as a subgraph are (up to equivalence) S_7, S'_8 , or appropriate subgraphs. Thus if G is cyclotomic and induces H as a subgraph but is not 4-cyclotomic, then it is not equivalent to either S_7 or S'_8 and hence is equivalent to a proper subgraph of one of them. Therefore G is nonmaximal.

By the same procedure (determination by **equivgrow**, with label set and charge set both $\{0, 1, -1\}$, of a finite set of cyclotomic charged signed supergraphs all contained in 4-cyclotomic examples) we thus have the following:

Lemma 5.3.4. *A cyclotomic charged signed graph G with not all vertices weight 4 is nonmaximal if it induces a subgraph of any of the following forms (where cyclotomic):*

(a) *Uncharged triangles*

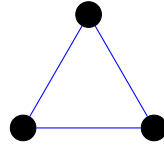

(G contained in cyclotomic charged signed graph equivalent to T_6 or S_7)

(b) *Single-charged triangles*

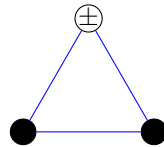

(G contained in cyclotomic charged signed graph equivalent to S_7 or S'_8)

(c) *Triple-charged triangles*

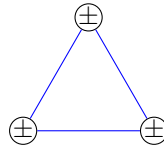

(G contained in cyclotomic charged signed graph equivalent to C_4^{++} or C_4^{+-})

(d) Double-charged paths of form



(G contained in cyclotomic charged signed graph equivalent to C_8^{++} or C_8^{+-})

(e) Triple-charged 3-paths of form

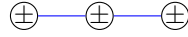

(G contained in cyclotomic charged signed graph equivalent to S_7 or S_8)

(f) Double-charged 3-paths of form

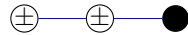

(G contained in cyclotomic charged signed graph equivalent to S_7 or S'_8)

Or of form



(G contained in cyclotomic charged signed graph equivalent to C_6^{++} , C_6^{+-} , S_7 or S'_8)

(g) Uncharged 5-cycles

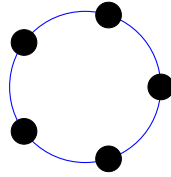

(G contained in cyclotomic signed graph equivalent to T_{10})

5.3.3 Charged Signed Graphs With Weight 3 Vertices

Let G be a cyclotomic charged signed graph with a vertex v of weight 3. We seek to show that G is nonmaximal; we consider separately the cases v charged and v uncharged.

v **charged**

W.l.o.g., v has a positive charge and neighbours a, b . Then one of the following holds:

- (i) Both a, b charged;
- (ii) Only one of a, b charged;
- (iii) Neither charged.

In case (i), if $e_{ab} \neq 0$ then G induces a triple-charged triangle on vertices v, a, b and thus is nonmaximal by Lemma 5.3.4 (c). Otherwise v, a, b is a triple-charged 3-path in G , which is therefore nonmaximal by part (e) of the same Lemma.

In case (ii), if $e_{ab} = 0$ then the subgraph on vertices v, a, b is a double-charged 3-path and thus renders G nonmaximal by Lemma 5.3.4 (f). Otherwise, the subgraph on v, a, b is a double-charged triangle, but up to equivalence the only cyclotomic example is



In case (iii) if $e_{ab} \neq 0$ then G induces a single-charged triangle on vertices v, a, b and thus is nonmaximal by Lemma 5.3.4 (b). Otherwise, up to equivalence the subgraph on vertices v, a, b is



G is thus equivalent to a graph G' inducing one of I or II as a subgraph, and if G' is nonmaximal then so is G . In each case we will demonstrate the existence of a cyclotomic supergraph of G' (and hence G) by exhibiting suitable Gram vectors x, x' as in Theorem 5.3.3.

Subgraph I Let W be the set of Gram vectors for $A = M + 2I$ where M is a matrix representative of a cyclotomic G' inducing I as a subgraph. By identifying vertex i with its Gram vector w_i , we note the following conditions on W :

$$w_v \cdot w_v = w_a \cdot w_a = 3; w_b \cdot w_b = 2$$

$$w_v \cdot w_a = w_v \cdot w_b = 1; w_a \cdot w_b = -1$$

Consider $x = w_v - w_a - w_b$. Then the following hold:

$$\begin{aligned} x \cdot w_a &= 1 - 3 - -1 = -1 \\ x \cdot w_b &= 1 - -1 - 2 = 0 \\ x \cdot w_v &= 3 - 1 - 1 = 1 \\ x \cdot x &= 1 - -1 - 0 = 2 \end{aligned}$$

Further, if $w_i \in W \setminus \{w_v, w_a, w_b\}$ then by assumption $w_v \cdot w_i = 0$ and so

$$x \cdot w_i = -(w_a \cdot w_i + w_b \cdot w_i)$$

For any corresponding vertex $i \notin \{v, a, b\}$ the subgraph H induced on vertices v, a, b, i is necessarily cyclotomic; H is of form

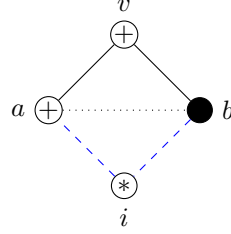

(5.3)

but testing confirms cyclotomic examples occur only when $w_a \cdot w_i + w_b \cdot w_i \in \{0, 1, -1\}$ and so $x \cdot w_i \in \{0, 1, -1\}$ for all such i .

Thus $x \cdot x \in \{1, 2, 3\}$ and $x \cdot w_i \in \{0, 1, -1\}$ for all $w_i \in W$. Further, $x \cdot w_v \neq 0$, so all conditions on x required by the Theorem are satisfied.

With the same vertex labelling we now consider W' the Gram vectors of $B = (-M) + 2I$, for which the following hold:

$$w'_v \cdot w'_v = w'_a \cdot w'_a = 1; w'_b \cdot w'_b = 2$$

$$w'_v \cdot w'_a = w'_v \cdot w'_b = -1; w'_a \cdot w'_b = 1$$

Setting $x' = -w'_a - w'_b - 3w'_v$ we then have

$$\begin{aligned} x' \cdot w'_a &= -(1) - (1) - 3(-1) &= 1 &= -x \cdot w_a \\ x' \cdot w'_b &= -(1) - (2) - 3(-1) &= 0 &= -x \cdot w_b \\ x' \cdot w'_v &= -(-1) - (-1) - 3(1) &= -1 &= -x \cdot w_v \\ x' \cdot x' &= -(1) - (0) - 3(-1) &= 2 &= 4 - x \cdot x \end{aligned}$$

Finally, if $w'_i \in W' \setminus \{w'_v, w'_a, w'_b\}$ then by assumption $w'_v \cdot w'_i = 0$ and hence

$$x' \cdot w'_i = -w'_a \cdot w'_i - w'_b \cdot w'_i = w_a \cdot w_i + w_b \cdot w_i = -x \cdot w_i$$

Therefore by Theorem 5.3.3, G' is nonmaximal; thus G is nonmaximal if it induces a subgraph equivalent to I .

Subgraph II (This case is analogous to graphs with subgraph I , again taking $x = w_v - w_a - w_b$ and $x' = -w'_a - w'_b - 3w'_v$)

Let W be the set of Gram vectors for $A = M + 2I$ where M is a matrix representative of a cyclotomic G' inducing II as a subgraph. By identifying vertex i with its Gram vector w_i , we note the following conditions on W :

$$w_v \cdot w_v = 3; w_a \cdot w_a = w_b \cdot w_b = 2$$

$$w_v \cdot w_a = w_v \cdot w_b = 1; w_a \cdot w_b = 0$$

Consider $x = w_v - w_a - w_b$. Then the following hold:

$$x \cdot w_a = 1 - 2 - 0 = -1$$

$$x \cdot w_b = 1 - 0 - 2 = -1$$

$$x \cdot w_v = 3 - 1 - 1 = 1$$

$$x \cdot w = 1 - -1 - -1 = 3$$

Further, if $w_i \in W \setminus \{w_v, w_a, w_b\}$ then by assumption $w_v \cdot w_i = 0$ and so

$$x \cdot w_i = -(w_a \cdot w_i + w_b \cdot w_i)$$

For any corresponding vertex $i \notin \{v, a, b\}$ the subgraph H induced on vertices v, a, b, i is necessarily cyclotomic; H is of form

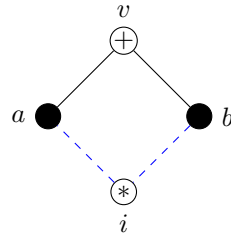

(5.4)

but testing confirms cyclotomic examples occur only when $w_a \cdot w_i + w_b \cdot w_i \in \{0, 1, -1\}$ and so $x \cdot w_i \in \{0, 1, -1\}$ for all such i .

Thus $x \cdot x \in \{1, 2, 3\}$ and $x \cdot w_i \in \{0, 1, -1\}$ for all $w_i \in W$. Further, $x \cdot w_v \neq 0$, so all conditions on x required by the Theorem are satisfied.

With the same vertex labelling we now consider W' the Gram vectors of $B = (-M) + 2I$, for which the following hold:

$$w'_v \cdot w'_v = 1; w'_a \cdot w'_a = w'_b \cdot w'_b = 2$$

$$w'_v \cdot w'_a = w'_v \cdot w'_b = -1; w'_a \cdot w'_b = 0$$

Setting $x' = -w'_a - w'_b - 3w'_v$ we then have

$$\begin{aligned} x' \cdot w'_a &= -(2) - (0) - 3(-1) = 1 = -x \cdot w_a \\ x' \cdot w'_b &= -(0) - (2) - 3(-1) = 1 = -x \cdot w_b \\ x' \cdot w'_v &= -(-1) - (-1) - 3(1) = -1 = -x \cdot w_v \\ x' \cdot w' &= -(1) - (1) - 3(-1) = 1 = 4 - x \cdot x \end{aligned}$$

Finally, if $w'_i \in W' \setminus \{w'_v, w'_a, w'_b\}$ then by assumption $w'_v \cdot w'_i = 0$ and hence

$$x' \cdot w'_i = -w'_a \cdot w'_i - w'_b \cdot w'_i = w_a \cdot w_i + w_b \cdot w_i = -x \cdot w_i$$

Therefore by Theorem 5.3.3, G' is nonmaximal; thus G is nonmaximal if it induces a subgraph equivalent to II . This completes the proof that a cyclotomic graph G with a charged vertex of weight 3 is nonmaximal.

v uncharged

All neighbours of v charged Up to equivalence, G induces a subgraph on v and its neighbours a, b, c of the following form:

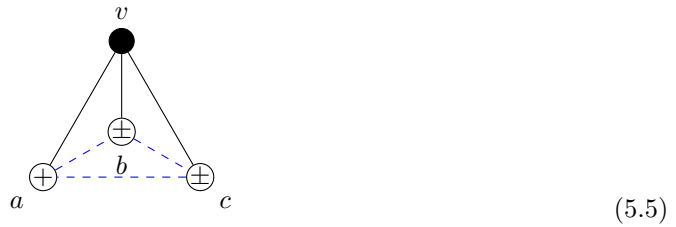

but the only cyclotomic examples are

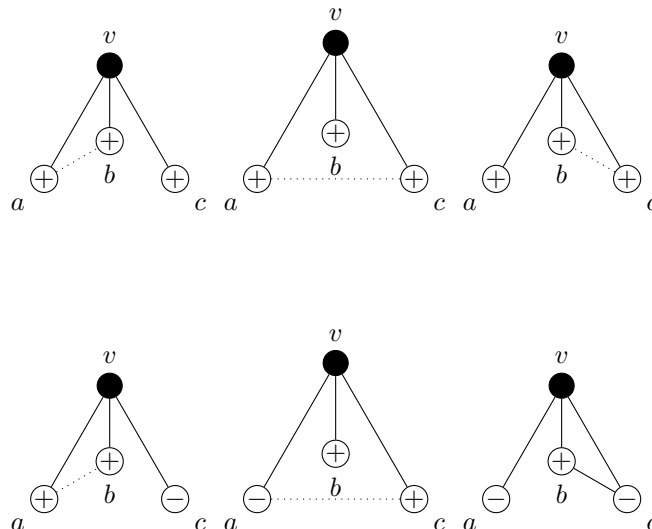

each of which induces a double-charged 3-path; thus G is equivalent to a nonmaximal graph by Lemma 5.3.4 (f).

Two neighbours of v charged Up to equivalence, G induces a subgraph on v and its neighbours a, b, c of the form

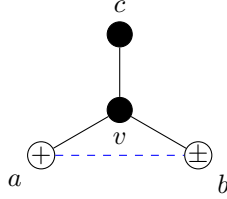

where, having chosen a, b to be charged, the possibility of e_{ac} or e_{bc} being nonzero is excluded by Lemma 5.3.4 (b).

There are two cyclotomic examples: the first is

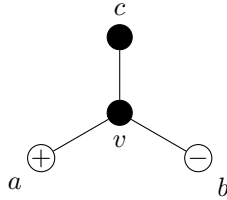

which can be excluded by part (f) of Lemma 5.3.4; the second is

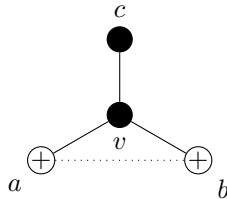

(5.6)

for which we consider the two possibilities: a has a neighbour in G , or it doesn't.

If not, then let W be the set of Gram vectors for $A = M + 2I$ where M is a matrix representative of G with the subgraph on v, a, b, c as above. By identifying vertex i with its Gram vector w_i , we note the following conditions on W :

$$w_a \cdot w_a = w_b \cdot w_b = 3; w_v \cdot w_v = w_c \cdot w_c = 2$$

$$w_v \cdot w_a = w_v \cdot w_b = w_v \cdot w_c = 1; w_a \cdot w_b = -1$$

Consider $x = w_a + w_b - w_v$. Then the following hold:

$$\begin{aligned}
x \cdot w_a &= 3 + (-1) - (1) = 1 \\
x \cdot w_b &= (-1) + 3 - (1) = 1 \\
x \cdot w_c &= 0 + 0 - (1) = -1 \\
x \cdot w_v &= 1 + 1 - 2 = 0 \\
x \cdot x &= 1 + 1 - 0 = 2
\end{aligned}$$

Further, if $w_i \in W \setminus \{w_v, w_a, w_b, w_c\}$ then by assumption $w_v \cdot w_i = w_a \cdot w_i = 0$ and so

$$x \cdot w_i = w_b \cdot w_i \in \{0, 1, -1\}$$

Thus $x \cdot w \in \{1, 2, 3\}$ and $x \cdot w_i \in \{0, 1, -1\}$ for all $w_i \in W$. Further, $x \cdot w_a \neq 0$, so all conditions on x required by the Theorem are satisfied.

With the same vertex labelling we now consider W' the Gram vectors of $B = (-M) + 2I$, for which the following hold:

$$w'_a \cdot w'_a = w'_b \cdot w'_b = 1; w'_v \cdot w'_v = w'_c \cdot w'_c = 2$$

$$w'_v \cdot w'_a = w'_v \cdot w'_b = w'_v \cdot w'_c - 1; w'_a \cdot w'_b = 1$$

Setting $x' = -3w'_a + w'_b - w'_v$ we then have

$$\begin{aligned}
x' \cdot w'_a &= -3(1) + 1 - (-1) = -1 = -x \cdot w_a \\
x' \cdot w'_b &= -3(1) + 1 - (-1) = -1 = -x \cdot w_b \\
x' \cdot w'_c &= -3(0) + 0 - (-1) = 1 = -x \cdot w_c \\
x' \cdot w'_v &= -3(-1) + (-1) - (2) = 0 = -x \cdot w_v \\
x' \cdot x' &= -3(-1) + (-1) - (0) = 2 = 4 - x \cdot x
\end{aligned}$$

Finally, if $w'_i \in W' \setminus \{w'_v, w'_a, w'_b, w'_c\}$ then by assumption $w'_v \cdot w'_i = w'_a \cdot w'_i = 0$ and hence

$$x' \cdot w'_i = w'_b \cdot w'_i = -w_b \cdot w_i = -x \cdot w_i$$

Therefore by Theorem 5.3.3, G is nonmaximal if a has no other neighbours.

This leaves the case in which a has a neighbour $d \neq v, b$; up to equivalence the subgraph induced

on vertices v, a, b, c, d is then of the form



for which the only cyclotomic example is



Therefore, let W be the set of Gram vectors for $A = M + 2I$ where M is a matrix representative of G with such an induced subgraph. By identifying vertex i with its Gram vector w_i , we note the following conditions on W :

$$w_a \cdot w_a = w_b \cdot w_b = 3; w_v \cdot w_v = w_c \cdot w_c = w_d \cdot w_d = 2$$

$$w_v \cdot w_a = w_v \cdot w_b = w_v \cdot w_c = w_a \cdot w_d = w_b \cdot w_d = 1; w_a \cdot w_b = w_c \cdot w_d = -1$$

Consider $x = w_a + w_b - w_c - 2w_d$. Then the following hold:

$$\begin{aligned} x \cdot w_a &= 3 + -1 - 0 - 2(1) &= 0 \\ x \cdot w_b &= -1 + 3 - 0 - 2(1) &= 0 \\ x \cdot w_c &= 0 + 0 - 2 - 2(-1) &= 0 \\ x \cdot w_d &= 1 + 1 - (-1) - 2(2) &= -1 \\ x \cdot w_v &= 1 + 1 - 1 - 2(0) &= 1 \\ x \cdot w &= 0 + 0 - 0 - 2(-1) &= 2 \end{aligned}$$

Further, if $w_i \in W \setminus \{w_v, w_a, w_b, w_c, w_d\}$ then by assumption $w_v \cdot w_i = 0$ and also, as vertices a, b have weighted degree 4, $w_a \cdot w_i = w_b \cdot w_i = 0$. Thus

$$x \cdot w_i = -w_c \cdot w_i - w_d \cdot w_i$$

and the subgraph on v, a, b, c, d, i is of form

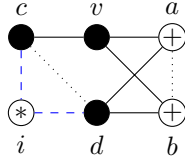

(5.9)

which is cyclotomic only if $-w_c \cdot w_i - w_d \cdot w_i \in \{0, 1, -1\}$.

Thus $x \cdot x \in \{1, 2, 3\}$ and $x \cdot w_i \in \{0, 1, -1\}$ for all $w_i \in W$. Further, $x \cdot w_v \neq 0$, so all conditions on x required by the Theorem are satisfied.

With the same vertex labelling we now consider W' the Gram vectors of $B = (-M) + 2I$, for which the following hold:

$$w'_a \cdot w'_a = w'_b \cdot w'_b = 1; w'_v \cdot w'_v = w'_c \cdot w'_c = w'_d \cdot w'_d = 2$$

$$w'_v \cdot w'_a = w'_v \cdot w'_b = w'_v \cdot w'_c = w'_a \cdot w'_d = w'_b \cdot w'_d = -1; w'_a \cdot w'_b = w'_c \cdot w'_d = 1$$

Setting $x' = -4w'_a - w'_c - w'_d - 3w'_v$ we then have

$$\begin{aligned} x' \cdot w'_a &= -4(1) - (0) - (-1) - 3(-1) = 0 = -x \cdot w_a \\ x' \cdot w'_b &= -4(1) - (0) - (-1) - 3(-1) = 0 = -x \cdot w_b \\ x' \cdot w'_c &= -4(0) - (2) - (1) - 3(-1) = 0 = -x \cdot w_c \\ x' \cdot w'_d &= -4(-1) - (1) - (2) - 3(0) = 1 = -x \cdot w_d \\ x' \cdot w'_v &= -4(-1) - (-1) - (0) - 3(2) = -1 = -x \cdot w_v \\ x' \cdot x' &= -4(0) - (0) - (1) - 3(-1) = 2 = 4 - x \cdot x \end{aligned}$$

Further, if $w'_i \in W' \setminus \{w'_v, w'_a, w'_b, w'_c, w'_d\}$ then by assumption $w'_v \cdot w'_i = 0$ and further as vertices a, b have weighted degree 4, $w'_a \cdot w'_i = w'_b \cdot w'_i = 0$. Thus

$$x' \cdot w'_i = -w'_c \cdot w'_i - w'_d \cdot w'_i = w_c \cdot w_i + w_d \cdot w_i = -x \cdot w_i$$

Therefore by Theorem 5.3.3, G is nonmaximal if a has another neighbour. This completes the proof in the case of v having two charged neighbours.

One neighbour of v charged Using Lemma 5.3.4 (a) and (b), the subgraph on vertex v and its neighbours a, b, c is necessarily triangle free, and up to equivalence is therefore



Let W be the set of Gram vectors for $A = M + 2I$ where M is a matrix representative of G with the subgraph on v, a, b, c as above. By identifying vertex i with its Gram vector w_i , we note the following conditions on W :

$$w_a \cdot w_a = 3; w_v \cdot w_v = w_b \cdot w_b = w_c \cdot w_c = 2$$

$$w_v \cdot w_a = w_v \cdot w_b = w_v \cdot w_c = 1$$

Setting $x = 2w_v - w_a - w_b - w_c$ we then have

$$\begin{aligned} x \cdot w_a &= 2(1) - 3 - 0 - 0 &= -1 \\ x \cdot w_b &= 2(1) - 0 - 2 - 0 &= 0 \\ x \cdot w_c &= 2(1) - 0 - 0 - 2 &= 0 \\ x \cdot w_v &= 2(2) - 1 - 1 - 1 &= 1 \\ x \cdot x &= 2(1) - (-1) - 0 - 0 &= 3 \end{aligned}$$

Further, if $w_i \in W \setminus \{w_v, w_a, w_b, w_c\}$ then by assumption $w_v \cdot w_i = 0$, so

$$x \cdot w_i = -(w_a \cdot w_i + w_b \cdot w_i + w_c \cdot w_i)$$

and the subgraph induced on v, a, b, c, i is of form



which is cyclotomic only if $w_a \cdot w_i + w_b \cdot w_i + w_c \cdot w_i \in \{0, 1, -1\}$.

Thus $x \cdot x \in \{1, 2, 3\}$ and $x \cdot w_i \in \{0, 1, -1\}$ for all $w_i \in W$. Further, $x \cdot w_v \neq 0$, so all conditions on x required by the Theorem are satisfied.

With the same vertex labelling we now consider W' the Gram vectors of $B = (-M) + 2I$, for

which the following hold:

$$w_a \cdot w_a = 1; w_v \cdot w_v = w_b \cdot w_b = w_c \cdot w_c = 2$$

$$w_v \cdot w_a = w_v \cdot w_b = w_v \cdot w_c = -1$$

Setting $x' = -w'_a - w'_b - w'_c - 2w'_v$ we then have

$$\begin{aligned} x' \cdot w'_a &= -(1) - (0) - (0) - 2(-1) &= 1 &= -x \cdot w_a \\ x' \cdot w'_b &= -(0) - (2) - (0) - 2(-1) &= 0 &= -x \cdot w_b \\ x' \cdot w'_c &= -(0) - (0) - (2) - 2(-1) &= 0 &= -x \cdot w_c \\ x' \cdot w'_v &= -(-1) - (-1) - (-1) - 2(2) &= -1 &= -x \cdot w_v \\ x' \cdot x' &= -(1) - (0) - (0) - 2(-1) &= 1 &= 4 - x \cdot x \end{aligned}$$

Further, if $w'_i \in W' \setminus \{w'_v, w'_a, w'_b, w'_c\}$ then by assumption $w'_v \cdot w'_i = 0$ and so

$$x' \cdot w'_i = -w'_a \cdot w'_i - w'_b \cdot w'_i - w'_c \cdot w'_i = w_a \cdot w_i + w_b \cdot w_i + w_c \cdot w_i = -x \cdot w_i$$

Therefore by Theorem 5.3.3, G is nonmaximal if it contains an uncharged weight-3 vertex with a single charged neighbour.

All neighbours of v uncharged (*This case is analogous to the previous, with the same choice of x, x' now yielding a cyclotomic extension by an uncharged vertex*)

Using Lemma 5.3.4 (a), the subgraph on vertex v and its neighbours a, b, c is necessarily triangle-free and up to equivalence is therefore

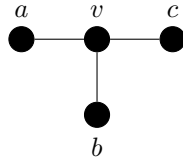

(5.12)

Let W be the set of Gram vectors for $A = M + 2I$ where M is a matrix representative of G with the subgraph on v, a, b, c as above. By identifying vertex i with its Gram vector w_i , we note the following conditions on W :

$$w_a \cdot w_a = w_b \cdot w_b = w_c \cdot w_c = w_v \cdot w_v = 2$$

$$w_v \cdot w_a = w_v \cdot w_b = w_v \cdot w_c = 1$$

Setting $x = 2w_v - w_a - w_b - w_c$ we then have

$$\begin{aligned}
x \cdot w_a &= 2(1) - 2 - 0 - 0 &= 0 \\
x \cdot w_b &= 2(1) - 0 - 2 - 0 &= 0 \\
x \cdot w_c &= 2(1) - 0 - 0 - 2 &= 0 \\
x \cdot w_v &= 2(2) - 1 - 1 - 1 &= 1 \\
x \cdot x &= 2(1) - (0) - 0 - 0 &= 2
\end{aligned}$$

Further, if $w_i \in W \setminus \{w_v, w_a, w_b, w_c\}$ then by assumption $w_v \cdot w_i = 0$ and so

$$x \cdot w_i = -(w_a \cdot w_i + w_b \cdot w_i + w_c \cdot w_i)$$

and the subgraph induced on v, a, b, c, i is of form

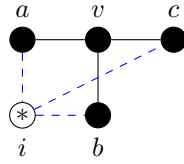

(5.13)

which is cyclotomic only if $w_a \cdot w_i + w_b \cdot w_i + w_c \cdot w_i \in \{0, 1, -1\}$.

Thus $x \cdot x \in \{1, 2, 3\}$ and $x \cdot w_i \in \{0, 1, -1\}$ for all $w_i \in W$. Further, $x \cdot w_v \neq 0$, so all conditions on x required by the Theorem are satisfied.

With the same vertex labelling we now consider W' the Gram vectors of $B = (-M) + 2I$, for which the following hold:

$$w_a \cdot w_a = w_b \cdot w_b = w_c \cdot w_c = w_v \cdot w_v = 2$$

$$w_v \cdot w_a = w_v \cdot w_b = w_v \cdot w_c = -1$$

Setting $x' = -w'_a - w'_b - w'_c - 2w'_v$ we then have

$$\begin{aligned}
x' \cdot w'_a &= -(2) - (0) - (0) - 2(-1) &= 0 &= -x \cdot w_a \\
x' \cdot w'_b &= -(0) - (2) - (0) - 2(-1) &= 0 &= -x \cdot w_b \\
x' \cdot w'_c &= -(0) - (0) - (2) - 2(-1) &= 0 &= -x \cdot w_c \\
x' \cdot w'_v &= -(-1) - (-1) - (-1) - 2(2) &= -1 &= -x \cdot w_v \\
x' \cdot x' &= -(0) - (0) - (0) - 2(-1) &= 2 &= 4 - x \cdot x
\end{aligned}$$

Further, if $w'_i \in W' \setminus \{w'_v, w'_a, w'_b, w'_c\}$ then by assumption $w'_v \cdot w'_i = 0$, thus

$$x' \cdot w'_i = -w'_a \cdot w'_i - w'_b \cdot w'_i - w'_c \cdot w'_i = w_a \cdot w_i + w_b \cdot w_i + w_c \cdot w_i = -x \cdot w_i$$

Therefore by Theorem 5.3.3, G is nonmaximal if it contains an uncharged vertex of weighted degree 3 with uncharged neighbours. This completes the proof for v uncharged, and thus for v of weighted degree 3.

5.3.4 Charged Signed Graphs With Weight 2 Vertices

Let G be a cyclotomic charged signed graph with a vertex of weighted degree 2. We seek to show that G is nonmaximal.

We may assume by the previous section that G has no vertices of weighted degree 3, so all vertices of G have weighted degree 1, 2 or 4. If there are no vertices of weighted degree 4, then G is a chordless path or cycle and is clearly nonmaximal by embedding in an appropriate T_{2k} or $C_{2k}^{+\pm}$. We therefore need only consider graphs G containing a weight 2 vertex v with a neighbour w of weight 4 (since a weight 1 vertex clearly cannot neighbour both a weight 2 vertex and a weight 4 vertex). This gives rise to the following cases:

- (i) Both v, w charged;
- (ii) v charged, w uncharged;
- (iii) v uncharged, w charged;
- (iv) Neither charged.

In case (i), there necessarily exist neighbours a, b of w but not of v , and up to equivalence the subgraph of G on vertices v, w, a, b is therefore of the form



but the only cyclotomic examples are

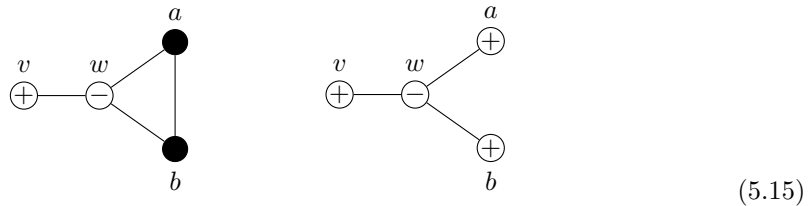

which can be excluded by Lemma 5.3.4 (b) and (e) respectively.

In case (ii), there necessarily exist neighbours a, b, c of w but not of v , and up to equivalence the subgraph of G on vertices v, w, a, b, c is therefore of the form

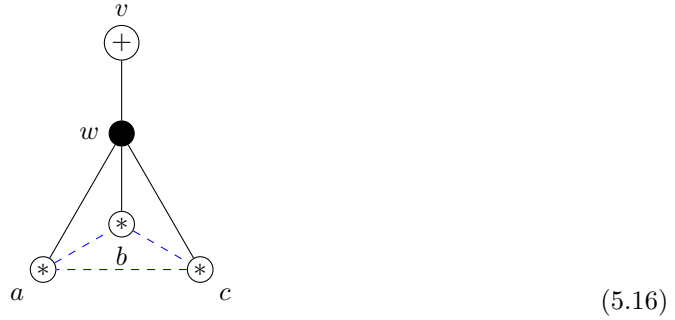

But there is no choice of charges on vertices a, b, c and edge labels $e_{ab}, e_{ac}, e_{bc} \in \{0, 1, -1\}$ for which such a graph is cyclotomic, so this case is excluded by the cyclotomicity of G .

In case (iii), there necessarily exists a neighbour u of v . If u does not neighbour w , then w has two other neighbours a, b and - up to equivalence - the subgraph of G on vertices u, v, w, a, b is of the form

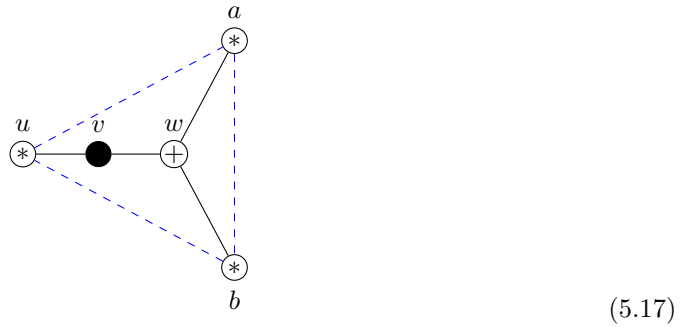

But there is no choice of charges on vertices u, a, b and edge labels $e_{au}, e_{bu}, e_{ab} \in \{0, 1, -1\}$ for which such a graph is cyclotomic, so this case is excluded by the cyclotomicity of G . Vertex u is therefore a neighbour of w , which has one other neighbour a , and up to equivalence the subgraph of G on vertices u, v, w, a is of the form

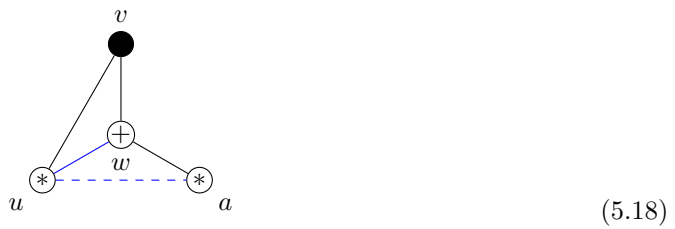

but the only cyclotomic examples are

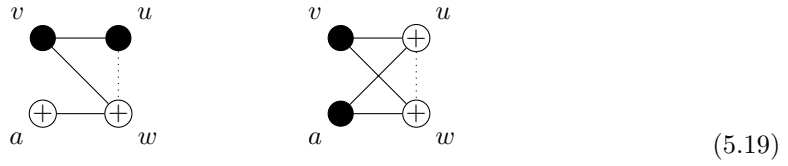

The first of these is excluded by Lemma 5.3.4 (b). For the second, we deduce that u, v, w, a are the only vertices of G : any other vertex could not be a neighbour of v by assumption of weighted degree 2; nor of u or w since these have weight 4. So for G to be any larger a would necessarily have a neighbour a' , inducing (up to equivalence) a subgraph of G of the form

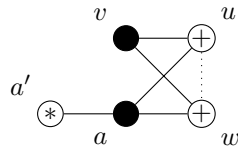

but no such graph is cyclotomic. The 4-vertex graph G is then clearly not maximal by embedding into (for example) an appropriate graph of form \mathcal{C}_6^{++} .

This completes the proof of nonmaximality of G when at least one of v or w is charged.

Neither v, w charged

There is necessarily a neighbour u of v ; by Lemma 5.3.4 (a) and (b) this cannot be a neighbour of w . Thus w also has neighbours a, b, c ; up to equivalence the subgraph of G on vertices u, v, w, a, b, c is therefore of the form

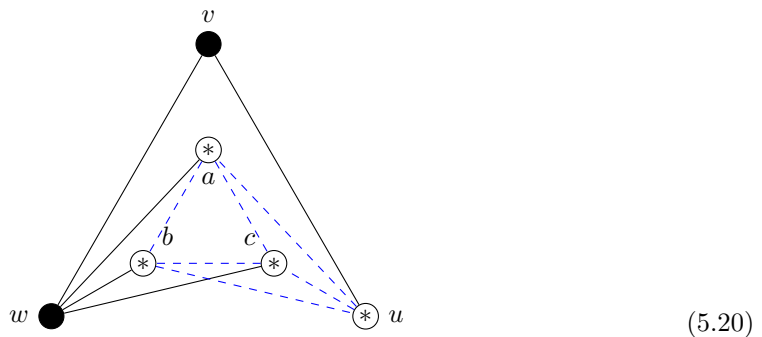

We may reduce the number of cases to be considered by further fixing the first charge (by negation) and the identity of the charged vertices (by permutation of a, b, c), which leads to the following possibilities (where x_i denotes the charge on vertex i):

- (I) u charged, a, b, c uncharged. W.l.o.g. $x_u = 1, x_a = x_b = x_c = 0$;

- (II) u charged, a, b, c charged. W.l.o.g. $x_u = 1, x_a, x_b, x_c \in \{1, -1\}$;
- (III) u charged, two of a, b, c charged. W.l.o.g. $x_u = 1, x_a, x_b \in \{1, -1\}, x_c = 0$;
- (IV) u charged, one of a, b, c charged. W.l.o.g. $x_u = 1, x_a \in \{1, -1\}, x_b = x_c = 0$;
- (V) u uncharged, a, b, c uncharged. W.l.o.g. $x_u = x_a = x_b = x_c = 0$;
- (VI) u uncharged, a, b, c charged. W.l.o.g. $x_u = 0, x_a = 1, x_b, x_c \in \{1, -1\}$;
- (VII) u uncharged, two of a, b, c charged. W.l.o.g. $x_a = 1, x_b \in \{1, -1\}, x_u = x_c = 0$;
- (VIII) u uncharged, one of a, b, c charged. W.l.o.g. $x_a = 1, x_u = x_b = x_c = 0$.

Cases (II), (IV), (VI), (VIII) can immediately be discarded since no choice of undetermined edge labels and charges yields a cyclotomic graph on u, v, w, a, b, c which contradicts the cyclotomicity of G . Case (III) can also be ruled out, as the only cyclotomic examples are

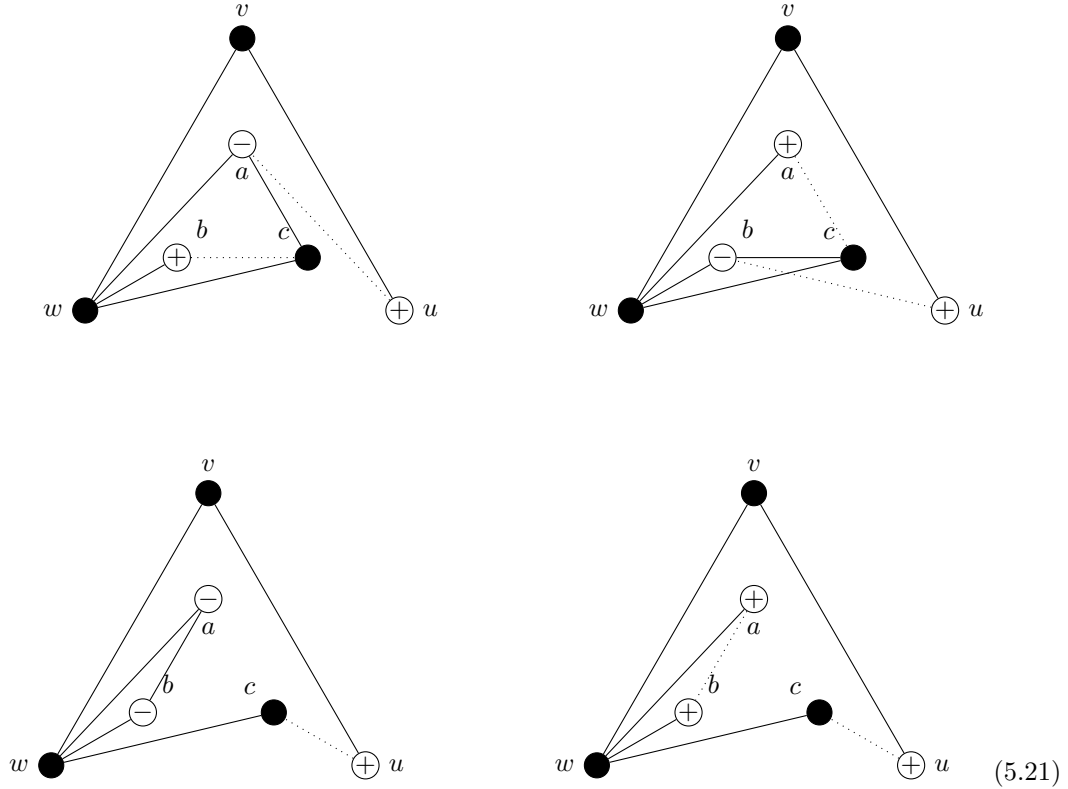

but the first two are excluded by Lemma 5.3.4 (b) (e.g., vertices w, b, c) whilst the second two are excluded by part (d) of the same (using vertices u, v, w, b).

We now dispense with the remaining cases by Gram vector constructions.

(I) Up to permutation of a, b, c the only cyclotomic example occurs when $e_{au} = -1$ and all other undetermined edge labels are zero. Redrawing, this gives



Let W be the set of Gram vectors for $A = M + 2I$ where M is a matrix representative of G with the subgraph on u, v, w, a, b, c as above. By identifying vertex i with its Gram vector w_i , we note the following conditions on W :

$$w_u \cdot w_u = 3; w_v \cdot w_v = w_w \cdot w_w = w_a \cdot w_a = w_b \cdot w_b = w_c \cdot w_c = 2$$

$$w_w \cdot w_a = w_w \cdot w_b = w_w \cdot w_c = w_u \cdot w_v = w_v \cdot w_w = 1; w_u \cdot w_a = -1$$

Let i be any other vertex of G . Then by assumption $w_v \cdot w_i = 0$, and as vertex w has weighted degree four $w_w \cdot w_i = 0$ by cycлотomicity of G . The most general subgraph on u, v, w, a, b, c, i is therefore



but testing all possible combinations of edge labels and charges shows that this is cycлотomic only if

$$w_a \cdot w_i = w_u \cdot w_i = 0$$

which matches our expectation that any further neighbour of u or a would be a neighbour of v .

Setting $x = w_v + w_a - w_w$ we then have

$$\begin{aligned} x \cdot w_u &= 1 - 1 - 0 = 0 \\ x \cdot w_v &= 2 + 0 - 1 = 1 \\ x \cdot w_w &= 1 + 1 - 2 = 0 \\ x \cdot w_a &= 0 + 2 - 1 = 1 \\ x \cdot w_b &= 0 + 0 - 1 = -1 \\ x \cdot w_c &= 0 + 0 - 1 = -1 \\ x \cdot x &= 1 + 1 - 0 = 2 \end{aligned}$$

Further, if $w_i \in W \setminus \{w_u, w_v, w_w, w_a, w_b, w_c\}$ then by the previous observation

$$x \cdot w_i = w_v \cdot w_i + w_a \cdot w_i - w_w \cdot w_i = 0$$

So $x \cdot x \in \{1, 2, 3\}$ and $x \cdot w_i \in \{0, 1, -1\}$ for all $w_i \in W$. Further, $x \cdot w_v \neq 0$, so all conditions

on x required by the Theorem are satisfied.

With the same vertex labelling we now consider W' the Gram vectors of $B = (-M) + 2I$, for which the following hold:

$$w'_u \cdot w'_u = 1; w'_v \cdot w'_v = w'_w \cdot w'_w = w'_a \cdot w'_a = w'_b \cdot w'_b = w'_c \cdot w'_c = 2$$

$$w'_w \cdot w'_a = w'_w \cdot w'_b = w'_w \cdot w'_c = w'_u \cdot w'_v = w'_v \cdot w'_w = -1; w'_u \cdot w'_a = 1$$

and for any other $w'_i \in W'$,

$$w'_a \cdot w'_i = w'_u \cdot w'_i = w'_v \cdot w'_i = w'_w \cdot w'_i = 0$$

Setting $x' = -2w'_u - 2w'_v - w'_w$ we then have

$$\begin{aligned} x' \cdot w'_u &= -2(1) - 2(-1) - (0) = 0 = -x \cdot w_u \\ x' \cdot w'_v &= -2(-1) - 2(2) - (-1) = -1 = -x \cdot w_v \\ x' \cdot w'_w &= -2(0) - 2(-1) - (2) = 0 = -x \cdot w_w \\ x' \cdot w'_a &= -2(1) - 2(0) - (-1) = -1 = -x \cdot w_a \\ x' \cdot w'_b &= -2(0) - 2(0) - (-1) = 1 = -x \cdot w_b \\ x' \cdot w'_c &= -2(0) - 2(0) - (-1) = 1 = -x \cdot w_c \\ x' \cdot x' &= -2(0) - 2(-1) - (0) = 2 = 4 - x \cdot x \end{aligned}$$

Further, if $w'_i \in W' \setminus \{w'_u, w'_v, w'_w, w'_a, w'_b, w'_c\}$ then

$$x' \cdot w'_i = -2w'_u \cdot w'_i - 2w'_v \cdot w'_i - w'_w \cdot w'_i = 0 = -x \cdot w_i$$

Therefore by Theorem 5.3.3, G is nonmaximal if case (I) holds.

(V) We note the following useful result:

Lemma 5.3.5. *If a cyclotomic charged signed graph G induces a subgraph equivalent to*

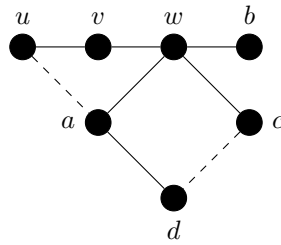

where v has weight 2 in G and no vertices of G have weight 3, then G is equivalent to a nonmaximal subgraph of S_{16} .

Proof. Since a has weight 3, there must exist a neighbour e of a in G ; testing confirms that the subgraph on u, v, w, b, c, d, e must then be

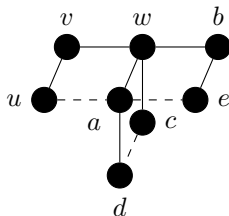

If this is all of G then we are done, since this is equivalent to a subgraph of S_{16} . Otherwise, one of u, c, d, b or e must have a neighbour in G , and by the assumption on weight 3 vertices it must then have two. We will illustrate the argument in the case of u having neighbours; the other possibilities hold in the same way.

Introducing neighbours x, y of u , fixing $e_{ux} = e_{uy} = 1$ by switching and testing subgraphs, we find that one of x, y neighbours e and the other neighbours d , and the graph obtained is a subgraph of S_{16} ; w.l.o.g. we may take x a neighbour of d . Now d and e have weight 3, so they must have neighbours in G ; testing confirms that the only possibility is that they share a mutual neighbour z . The graph obtained is again a proper subgraph of S_{16} , and no vertices have weight 3; if this is all of G then we are done. Otherwise our existing 11 vertex graph can be grown into G by **equivgrow** subject to the constraint that no vertex added can be a neighbour of v . This process terminates with at most 14 vertices, and each graph obtained can be embedded in a graph of form S_{16} , so the result holds. \square

In case (V) for cyclotomicity the subgraph on u, v, w, a, b, c is necessarily equivalent to one of

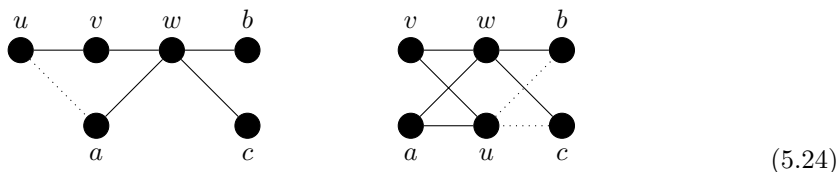

depending on whether u and w share one or three of a, b, c as mutual neighbours (no cyclotomic examples arise otherwise). If this is all of G then we are done, since each can be embedded into a graph of form \mathcal{T}_{2k} . Otherwise, there exists a neighbour d in G of at least one of u, a, b, c . Considering the subgraphs on u, v, w, a, b, c, d we have, up to equivalence, the following possi-

bilities:

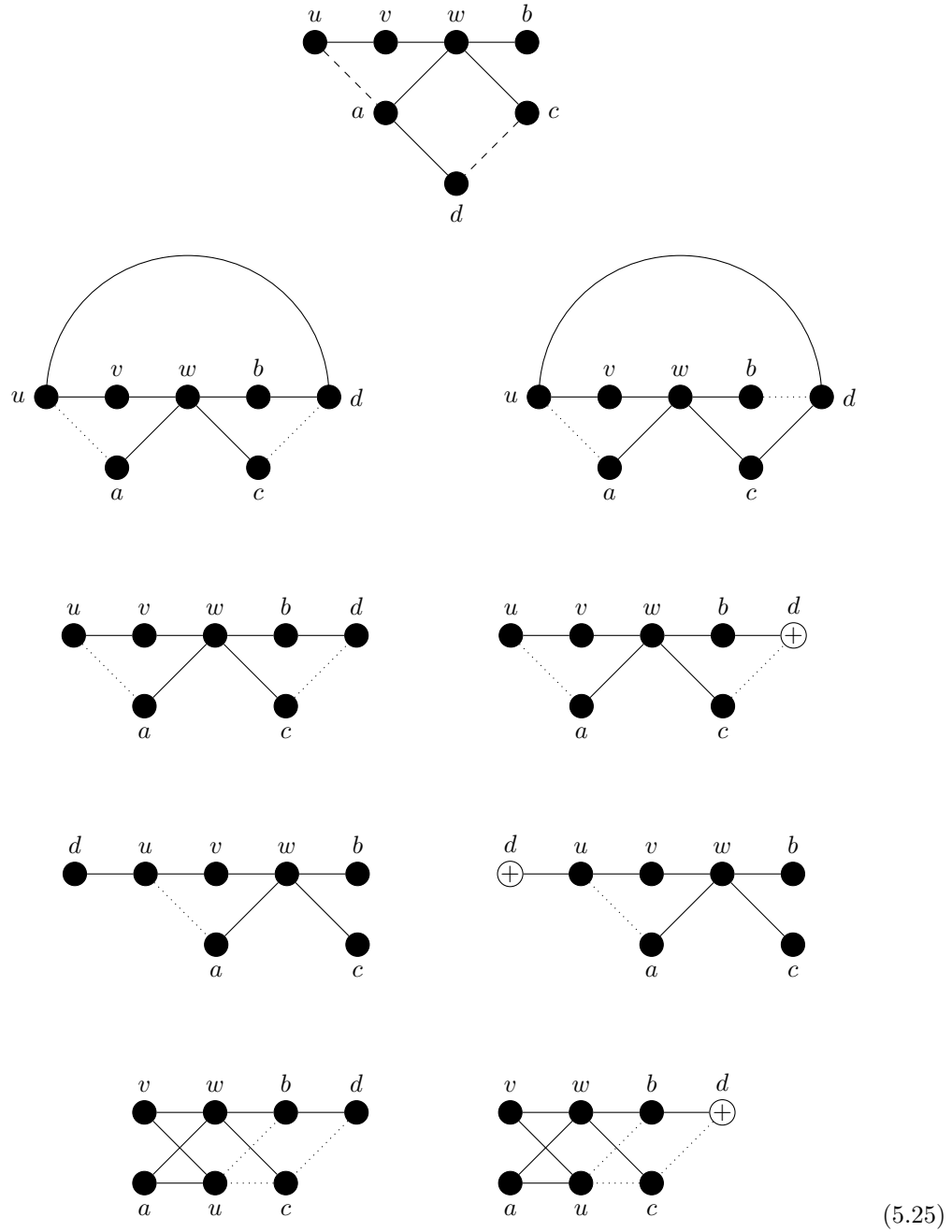

The first example is precisely the subgraph excluded by Lemma 5.3.5, whilst the second two force G to be a nonmaximal subgraph of some \mathcal{T}_{10} by Lemma 5.3.4 (g). For the others we proceed by Gram vector construction in accordance with Theorem 5.3.3.

Let W be the set of Gram vectors for $A = M + 2I$ where M is a matrix representative of G with subgraph on u, v, w, a, b, c, d one of the graphs

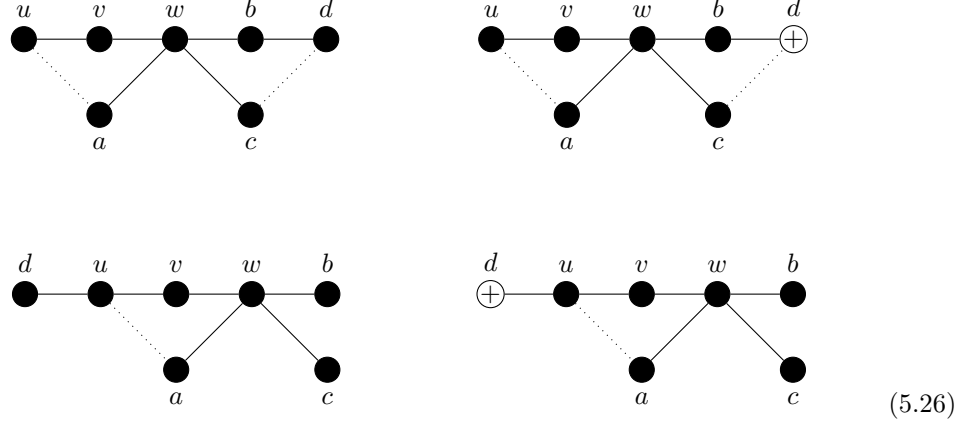

By identifying vertex i with its Gram vector w_i , we note the following conditions on W :

$$w_u \cdot w_u = w_v \cdot w_v = w_w \cdot w_w = w_a \cdot w_a = w_b \cdot w_b = w_c \cdot w_c = 2; w_d \cdot w_d \in \{2, 3\}$$

$$w_u \cdot w_v = w_v \cdot w_w = w_w \cdot w_b = w_w \cdot w_a = w_w \cdot w_c = 1$$

$$w_u \cdot w_a = -1$$

$$w_u \cdot w_d \in \{0, 1\}, w_b \cdot w_d \in \{0, 1\}, w_c \cdot w_d \in \{-1, 0\}$$

Setting $x = w_v - w_w + w_a$ we then have

$$\begin{aligned} x \cdot w_v &= 2 - 1 + 0 &= 1 \\ x \cdot w_a &= 0 - 1 + 2 &= 1 \\ x \cdot w_b &= 0 - 1 + 0 &= -1 \\ x \cdot w_c &= 0 - 1 + 0 &= -1 \\ x \cdot w_u &= 1 - 0 + (-1) &= 0 \\ x \cdot w_w &= 1 - 2 + 1 &= 0 \\ x \cdot w_d &= 0 - 0 + 0 &= 0 \\ x \cdot x &= 1 - 0 + 1 &= 2 \end{aligned}$$

Remark 5.3.6. *Let i be any other vertex of G . We find that if $w_a \cdot w_i \neq 0$ then G necessarily induces a subgraph on u, v, w, a, b, c, i which can be excluded by Lemma 5.3.5.*

Thus we may assume $w_a \cdot w_i = 0$ and, as vertex w has weight 4, $w_w \cdot w_i = 0$. As $w_v \cdot w_i = 0$ by assumption, we conclude that $x \cdot w_i = 0$ for all $w_i \in W \setminus \{w_a, w_b, w_c, w_d, w_u, w_v, w_w\}$. So $x \cdot x \in \{1, 2, 3\}$ and $x \cdot w_i \in \{0, 1, -1\}$ for all $w_i \in W$. Further, $x \cdot w_v \neq 0$, so all conditions on x required by the Theorem are satisfied.

With the same vertex labelling we now consider W' the Gram vectors of $B = (-M) + 2I$, for

which the following hold:

$$w'_u \cdot w'_u = w'_v \cdot w'_v = w'_w \cdot w'_w = w'_a \cdot w'_a = w'_b \cdot w'_b = w'_c \cdot w'_c = 2; w'_d \cdot w'_d \in \{1, 2\}$$

$$w'_u \cdot w'_v = w'_v \cdot w'_w = w'_w \cdot w'_b = w'_b \cdot w'_d = w'_w \cdot w'_a = w'_w \cdot w'_c = -1$$

$$w'_u \cdot w'_a = w'_c \cdot w'_d = 1$$

Setting $x' = -w'_v - w'_w - w'_a$ we then have

$$\begin{aligned} x' \cdot w'_v &= -(2) - (-1) - (0) &= -1 &= -x \cdot w_v \\ x' \cdot w'_a &= -(0) - (-1) - (2) &= -1 &= -x \cdot w_a \\ x' \cdot w'_b &= -(0) - (-1) - (0) &= 1 &= -x \cdot w_b \\ x' \cdot w'_c &= -(0) - (-1) - (0) &= 1 &= -x \cdot w_c \\ x' \cdot w'_u &= -(-1) - (0) - (1) &= 0 &= -x \cdot w_u \\ x' \cdot w'_w &= -(-1) - (2) - (-1) &= 0 &= -x \cdot w_w \\ x' \cdot w'_d &= -(0) - (0) - (0) &= 0 &= -x \cdot w_d \\ x' \cdot x' &= -(-1) - (0) - (-1) &= 2 &= 4 - x \cdot x \end{aligned}$$

Further, if $w'_i \in W' \setminus \{w'_u, w'_v, w'_w, w'_a, w'_b, w'_c, w'_d\}$ then by Remark 5.3.6

$$x' \cdot w'_i = -w'_v \cdot w'_i - w'_w \cdot w'_i - w'_a \cdot w'_i = -w'_a \cdot w'_i = 0 = -x \cdot w_i$$

Thus all conditions of the Theorem are satisfied for these graphs.

Alternatively let W be the set of Gram vectors for $A = M + 2I$ where M is a matrix representative of G with the subgraph on u, v, w, a, b, c, d one of the remaining graphs

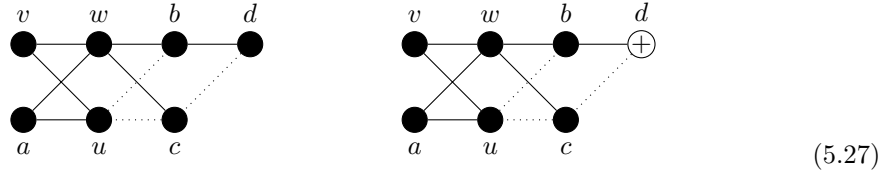

By identifying vertex i with its Gram vector w_i , we note the following conditions on W :

$$w_u \cdot w_u = w_v \cdot w_v = w_w \cdot w_w = w_a \cdot w_a = w_b \cdot w_b = w_c \cdot w_c = 2; w_d \cdot w_d \in \{2, 3\}$$

$$w_u \cdot w_v = w_v \cdot w_w = w_w \cdot w_b = w_w \cdot w_a = w_w \cdot w_c = w_a \cdot w_u = w_b \cdot w_d = 1$$

$$w_u \cdot w_b = w_u \cdot w_c = w_c \cdot w_d = -1$$

Let w_α be a vector with the properties that $w_\alpha \cdot w_i = 0$ for all $w_i \in W$ and $w_\alpha \cdot w_\alpha = 1$. Then

setting $x = -\frac{1}{2}w_a + \frac{1}{2}w_v + w_\alpha$ we have

$$\begin{aligned}
x \cdot w_v &= -\frac{1}{2}(0) + \frac{1}{2}(2) + 0 &= 1 \\
x \cdot w_a &= -\frac{1}{2}(2) + \frac{1}{2}(0) + 0 &= -1 \\
x \cdot w_w &= -\frac{1}{2}(1) + \frac{1}{2}(1) + 0 &= 0 \\
x \cdot w_u &= -\frac{1}{2}(1) + \frac{1}{2}(1) + 0 &= 0 \\
x \cdot w_b &= -\frac{1}{2}(0) + \frac{1}{2}(0) + 0 &= 0 \\
x \cdot w_c &= -\frac{1}{2}(0) + \frac{1}{2}(0) + 0 &= 0 \\
x \cdot w_d &= -\frac{1}{2}(0) + \frac{1}{2}(0) + 0 &= 0 \\
x \cdot x &= -\frac{1}{2}(-1) + \frac{1}{2}(1) + w_\alpha \cdot w_\alpha &= 2
\end{aligned}$$

Remark 5.3.7. *By testing possible subgraphs on u, v, w, a, b, c, d, i for cycлотomicity we find that for any $w_i \in W \setminus \{w_u, w_v, w_w, w_a, w_b, w_c, w_d\}$ $w_a \cdot w_i = 0$.*

Thus $x \cdot w_i = 0$ for any such w_i also. So $x \cdot x \in \{1, 2, 3\}$ and $x \cdot w_i \in \{0, 1, -1\}$ for all $w_i \in W$. Further, $x \cdot w_v \neq 0$, so all conditions on x required by the Theorem are satisfied.

With the same vertex labelling we now consider W' the Gram vectors of $B = (-M) + 2I$, for which the following hold:

$$w_u \cdot w_u = w_v \cdot w_v = w_w \cdot w_w = w_a \cdot w_a = w_b \cdot w_b = w_c \cdot w_c = 2; w_d \cdot w_d \in \{1, 2\}$$

$$w_u \cdot w_v = w_v \cdot w_w = w_w \cdot w_b = w_w \cdot w_a = w_w \cdot w_c = w_a \cdot w_u = w_b \cdot w_d = -1$$

$$w_u \cdot w_b = w_u \cdot w_c = w_c \cdot w_d = 1$$

Let w'_α be a vector with the properties that $w'_\alpha \cdot w'_i = 0$ for all $w'_i \in W'$ and $w'_\alpha \cdot w'_\alpha = 1$. Then setting $x' = -\frac{1}{2}w'_v + \frac{1}{2}w'_a + w'_\alpha$ we have

$$\begin{aligned}
x' \cdot w'_v &= -\frac{1}{2}(2) + \frac{1}{2}(0) + 0 &= -1 &= -x \cdot w_v \\
x' \cdot w'_a &= -\frac{1}{2}(0) + \frac{1}{2}(2) + 0 &= 1 &= -x \cdot w_a \\
x' \cdot w'_w &= -\frac{1}{2}(-1) + \frac{1}{2}(-1) + 0 &= 0 &= -x \cdot w_w \\
x' \cdot w'_u &= -\frac{1}{2}(-1) + \frac{1}{2}(-1) + 0 &= 0 &= -x \cdot w_u \\
x' \cdot w'_b &= -\frac{1}{2}(0) + \frac{1}{2}(0) + 0 &= 0 &= -x \cdot w_b \\
x' \cdot w'_c &= -\frac{1}{2}(0) + \frac{1}{2}(0) + 0 &= 0 &= -x \cdot w_c \\
x' \cdot w'_d &= -\frac{1}{2}(0) + \frac{1}{2}(0) + 0 &= 0 &= -x \cdot w_d \\
x' \cdot x' &= -\frac{1}{2}(-1) + \frac{1}{2}(1) + w'_\alpha \cdot w'_\alpha &= 2 &= 4 - x \cdot x
\end{aligned}$$

Further, if $w'_i \in W' \setminus \{w'_u, w'_v, w'_w, w'_a, w'_b, w'_c, w'_d\}$ then by Remark 5.3.7

$$x' \cdot w'_i = \frac{1}{2}w'_a \cdot w'_i = 0 = -x \cdot w_i$$

Thus all conditions of the Theorem are satisfied for these graphs.

Therefore by Theorem 5.3.3, G is nonmaximal if case (V) holds.

(VII) We recover three possible cyclotomic graphs on u, v, w, a, b, c :

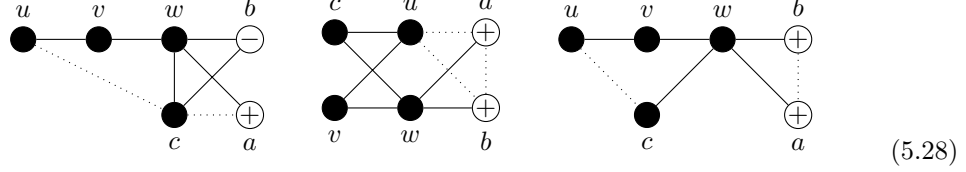

The first is excluded by Lemma 5.3.4 (b) (e.g., vertices w, a, c .) The remaining two we eliminate by Gram vector constructions as in Theorem 5.3.3.

Let W be the set of Gram vectors for $A = M + 2I$ where M is a matrix representative of G with subgraph on u, v, w, a, b, c



By identifying vertex i with its Gram vector w_i , we note the following conditions on W :

$$w_u \cdot w_u = w_v \cdot w_v = w_w \cdot w_w = w_c \cdot w_c = 2; w_a \cdot w_a = w_b \cdot w_b = 3$$

$$w_u \cdot w_v = w_v \cdot w_w = w_w \cdot w_b = w_w \cdot w_a = w_w \cdot w_c = w_c \cdot w_u = 1$$

$$w_u \cdot w_a = w_u \cdot w_b = w_a \cdot w_b = -1$$

Let w_α be a vector with the properties that $w_\alpha \cdot w_i = 0$ for all $w_i \in W$ and $w_\alpha \cdot w_\alpha = 1$. Then setting $x = w_v - \frac{1}{2}w_u - \frac{1}{2}w_w + w_\alpha$ we have

$$\begin{aligned} x \cdot w_v &= 2 - \frac{1}{2}(1) - \frac{1}{2}(1) + 0 &= 1 \\ x \cdot w_c &= 0 - \frac{1}{2}(1) - \frac{1}{2}(1) + 0 &= -1 \\ x \cdot w_u &= 1 - \frac{1}{2}(2) - \frac{1}{2}(0) + 0 &= 0 \\ x \cdot w_w &= 1 - \frac{1}{2}(0) - \frac{1}{2}(2) + 0 &= 0 \\ x \cdot w_a &= 0 - \frac{1}{2}(-1) - \frac{1}{2}(1) + 0 &= 0 \\ x \cdot w_b &= 0 - \frac{1}{2}(-1) - \frac{1}{2}(1) + 0 &= 0 \\ x \cdot x &= 1 - \frac{1}{2}(0) - \frac{1}{2}(0) + w_\alpha \cdot w_\alpha &= 2 \end{aligned}$$

As w and u have weighted degree 4, they have no further neighbours in G and thus for $w_i \in$

$W \setminus \{w_u, w_v, w_w, w_a, w_b, w_c\}$,

$$x \cdot w_i = w_v \cdot w_i - \frac{1}{2}w_u \cdot w_i - \frac{1}{2}w_w \cdot w_i + w_\alpha \cdot w_i = 0$$

So $x \cdot x \in \{1, 2, 3\}$ and $x \cdot w_i \in \{0, 1, -1\}$ for all $w_i \in W$. Further, $x \cdot w_v \neq 0$, so all conditions on x required by the Theorem are satisfied.

With the same vertex labelling we now consider W' the Gram vectors of $B = (-M) + 2I$, for which the following hold:

$$w_u \cdot w_u = w_v \cdot w_v = w_w \cdot w_w = w_c \cdot w_c = 2; w_a \cdot w_a = w_b \cdot w_b = 1$$

$$w_u \cdot w_v = w_v \cdot w_w = w_w \cdot w_b = w_w \cdot w_a = w_w \cdot w_c = w_c \cdot w_u = -1$$

$$w_u \cdot w_a = w_u \cdot w_b = w_a \cdot w_b = 1$$

Let w'_α be a vector with the properties that $w'_\alpha \cdot w'_i = 0$ for all $w'_i \in W'$ and $w'_\alpha \cdot w'_\alpha = 1$. Then setting $x' = -w'_u - w'_v + w'_a + w'_\alpha$ we have

$$\begin{aligned} x' \cdot w'_v &= -(-1) - (2) + (0) + 0 &= -1 &= -x \cdot w_v \\ x' \cdot w'_c &= -(-1) - (0) + (0) + 0 &= 1 &= -x \cdot w_v \\ x' \cdot w'_u &= -(2) - (-1) + (1) + 0 &= 0 &= -x \cdot w_u \\ x' \cdot w'_w &= -(0) - (-1) + (-1) + 0 &= 0 &= -x \cdot w_w \\ x' \cdot w'_a &= -(1) - (0) + (1) + 0 &= 0 &= -x \cdot w_a \\ x' \cdot w'_b &= -(1) - (0) + (1) + 0 &= 0 &= -x \cdot w_b \\ x' \cdot x' &= -(0) - (-1) + (0) + w'_\alpha \cdot w'_\alpha &= 2 &= 4 - x \cdot x \end{aligned}$$

Further, if $w'_i \in W' \setminus \{w'_u, w'_v, w'_w, w'_a, w'_b, w'_c\}$ then by the earlier observation

$$x' \cdot w'_i = 0 = -x \cdot w_i$$

Thus all conditions of the Theorem are satisfied for this graph.

Finally, let W be the set of Gram vectors for $A = M + 2I$ where M is a matrix representative of G with subgraph on u, v, w, a, b, c

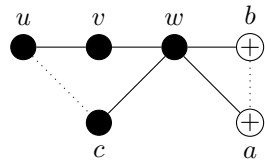

(5.30)

By identifying vertex i with its Gram vector w_i , we note the following conditions on W :

$$w_u \cdot w_u = w_v \cdot w_v = w_w \cdot w_w = w_c \cdot w_c = 2; w_a \cdot w_a = w_b \cdot w_b = 3$$

$$w_u \cdot w_v = w_v \cdot w_w = w_w \cdot w_b = w_w \cdot w_a = w_w \cdot w_c = 1$$

$$w_u \cdot w_c = w_a \cdot w_b = -1$$

Setting $x = w_a + w_b - w_w$ we have

$$x \cdot w_u = 0 + 0 - (0) = 0$$

$$x \cdot w_v = 0 + 0 - (1) = -1$$

$$x \cdot w_c = 0 + 0 - (1) = -1$$

$$x \cdot w_w = 1 + 1 - (2) = 0$$

$$x \cdot w_a = 3 + -1 - (1) = 1$$

$$x \cdot w_b = -1 + 3 - (1) = 1$$

$$x \cdot x = 1 + 1 - (0) = 2$$

Now if $w_i \in W \setminus \{w_u, w_v, w_w, w_a, w_b, w_c\}$, then as w can have no further neighbours in G , $x \cdot w_i = w_a \cdot w_i + w_b \cdot w_i$. But by considering the general subgraph on u, v, w, a, b, i :

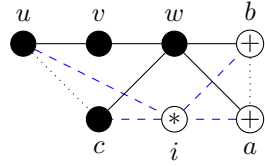

(5.31)

we find (by cyclocticity of G) that $w_a \cdot w_i = w_b \cdot w_i = 0$, and thus $x \cdot w_i = 0$ also.

With the same vertex labelling we now consider W' the Gram vectors of $B = (-M) + 2I$, for which the following hold:

$$w_u \cdot w_u = w_v \cdot w_v = w_w \cdot w_w = w_c \cdot w_c = 2; w_a \cdot w_a = w_b \cdot w_b = 1$$

$$w_u \cdot w_v = w_v \cdot w_w = w_w \cdot w_b = w_w \cdot w_a = w_w \cdot w_c = -1$$

$$w_u \cdot w_c = w_a \cdot w_b = 1$$

Setting $x' = -w'_w - 2w'_a$, we have

$$\begin{aligned}
 x' \cdot w'_u &= -(0) - 2(0) = 0 = -x \cdot w_u \\
 x' \cdot w'_v &= -(-1) - 2(0) = 1 = -x \cdot w_v \\
 x' \cdot w'_c &= -(-1) - 2(0) = 1 = -x \cdot w_c \\
 x' \cdot w'_w &= -(2) - 2(-1) = 0 = -x \cdot w_w \\
 x' \cdot w'_a &= -(-1) - 2(1) = -1 = -x \cdot w_a \\
 x' \cdot w'_b &= -(-1) - 2(1) = -1 = -x \cdot w_b \\
 x' \cdot x' &= -(0) - 2(-1) = 2 = 4 - x \cdot x
 \end{aligned}$$

and as for $w'_i \in W' \setminus \{w'_u, w'_v, w'_w, w'_a, w'_b, w'_c\}$ $w'_w \cdot w'_i = w'_a \cdot w_i = 0$ by earlier observations, we have $x' \cdot w'_i = 0 = -x \cdot w_i$ also. Thus all conditions of the Theorem are satisfied for this graph.

This completes the proof of nonmaximality for case (VII), and thus for all graphs containing uncharged neighbouring vertices v, w of weight 2,4 respectively. Hence any cyclotomic graph with a vertex of weighted degree 2 is nonmaximal.

5.3.5 Charged Signed Graphs With Weight 1 Vertices

Let G be a cyclotomic charged signed graph with a vertex v of weighted degree 1. By the previous two sections, we may assume that all vertices of G have weight 1 or 4, and thus that v has a neighbour w of weight 4 (else we have the trivially nonmaximal 1-vertex charged graph or 2-vertex uncharged graph).

If w were charged, then it would necessarily have two neighbours a, b , and (up to equivalence) G would induce a cyclotomic subgraph of the form



but no such graph is cyclotomic. Hence w is uncharged and must have three neighbours a, b, c . Up to equivalence, G therefore contains a cyclotomic subgraph of the form

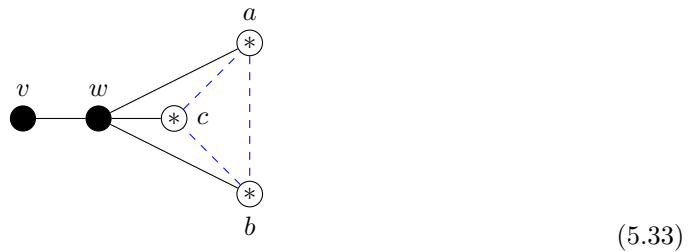

Up to equivalence - in particular, by permuting a, b, c to fix the identity of charged vertices - there are only three cyclotomic possibilities:

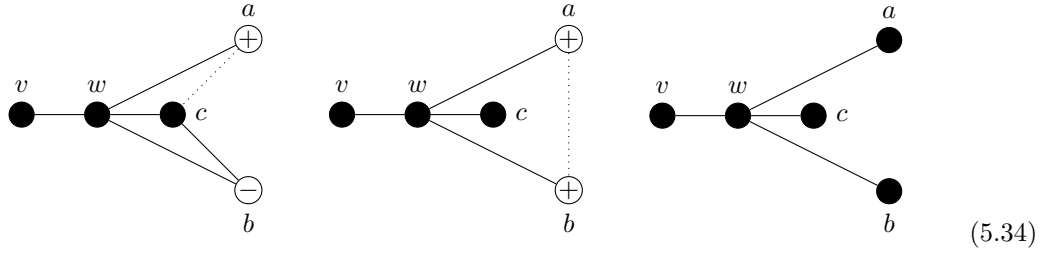

The first is excluded by Lemma 5.3.4 (b). For the second, we note that there must exist some neighbour d in G of a since otherwise it would have weighted degree 3. Since d cannot be a neighbour of v (by assumption) or w (as that vertex has weight 4) we obtain as general subgraph on v, w, a, b, c, d :



but no such graph is cyclotomic, so the second case is excluded. In the remaining case, at least one of a, b, c has a neighbour else G is the five vertex graph on v, w, a, b, c which is trivially nonmaximal. W.l.o.g., let a have a neighbour in G ; by assumption a must be weight 4 and thus have three neighbours x, y, z . We first establish the possible subgraphs on v, w, a, b, c, x, y : up to equivalence this must be of form

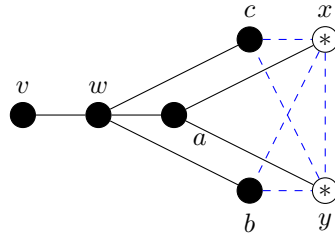

Up to equivalence there are three cyclotomic examples:

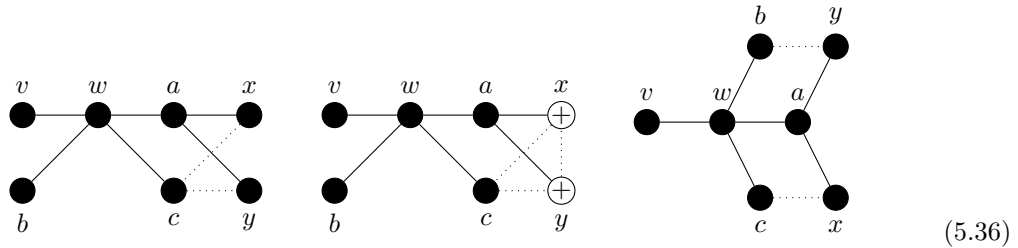

but testing confirms that for all three it is impossible to construct a cyclotomic supergraph

with a neighbour z of a in which v has weight 1. Thus the final case is also excluded, and we conclude that a graph with a weight 1 vertex is nonmaximal.

This completes the proof of Theorem 5.3.1.

5.4 \mathcal{L} -Graphs With Edges Of Weight 3 Or 4

By Theorem 2.5.3, if G is a maximal connected cyclotomic \mathcal{L} -graph over $\mathcal{O}_{\mathbb{Q}(\sqrt{d})}$ for $d < 0$ with an edge label of weight 4, then G is of form \mathcal{S}_2 and hence 4-cyclotomic.

By Proposition 3.3.1 there are only finitely many maximal connected cyclotomic \mathcal{L} -graphs with a weight 3 edge, and each is 4-cyclotomic.

Thus we have

Theorem 5.4.1. *If G is a maximal connected cyclotomic \mathcal{L} -graph over $\mathcal{O}_{\mathbb{Q}(\sqrt{-15})}$, then G is 4-cyclotomic.*

Proof. If G has an edge of weight 4 then it is 4-cyclotomic by Theorem 2.5.3. But if not, then G has all edge labels from \mathbb{Z} and by Corollary 5.3.2 is 4-cyclotomic. \square

Theorem 5.4.2. *If G is a maximal connected cyclotomic \mathcal{L} -graph over $\mathcal{O}_{\mathbb{Q}(\sqrt{-11})}$, then G is 4-cyclotomic.*

Proof. If G has an edge of weight 4 then it is 4-cyclotomic by Theorem 2.5.3. If it has an edge of weight 3 then it is 4-cyclotomic by Proposition 3.3.1. Otherwise, G has all edge labels from \mathbb{Z} and by Corollary 5.3.2 is 4-cyclotomic. \square

5.5 \mathcal{L} -Graphs Over $\mathcal{O}_{\mathbb{Q}(\sqrt{-2})}$, $\mathcal{O}_{\mathbb{Q}(\sqrt{-7})}$

In this section we generalise Theorem 5.3.1 as follows:

Theorem 5.5.1. *Let G be a cyclotomic \mathcal{L} -graph with edge labels from $\mathcal{O}_{\mathbb{Q}(\sqrt{-2})}$ or $\mathcal{O}_{\mathbb{Q}(\sqrt{-7})}$. If G has a vertex of weighted degree 1, 2 or 3, then G is nonmaximal.*

By the previous section, we may assume that G has all edge labels from $\mathcal{L} = \mathcal{L}_1 \cup \mathcal{L}_2 \cup \{0\}$. Since for $d = -2, -7$ $\mathcal{L}_1 = \{1, -1\}$, Theorem 5.3.1 ensures the result holds if G has no edge labels from \mathcal{L}_2 . Thus we may assume that G has at least one edge of weight 2.

5.5.1 Constructing Cyclotomic Supermatrices With Gram Vectors

Let M be a matrix representative of a connected cyclotomic \mathcal{L} -graph G . Then both $A = M + 2I$ and $B = (-M) + 2I$ are positive semidefinite. Hence (by Proposition 5.2.4) for a given ordering on the vertices there exist sets of Gram vectors W and W' for A and B respectively, whereby $A_{ij} = \langle w_i, w_j \rangle$ and $B_{ij} = \langle w'_i, w'_j \rangle$. We then have:

- For all $i \neq j$, $\langle w_i, w_j \rangle$ and $\langle w'_i, w'_j \rangle$ are in \mathcal{L} , with $\langle w_i, w_j \rangle = -\langle w'_i, w'_j \rangle$.
- $\langle w_i, w_j \rangle$ gives the label e_{ij} of the edge from vertex i to j (0 if no edge); so $\langle w_j, w_i \rangle = e_{ji} = \overline{e_{ij}}$ as required.
- For all $w \in W$ and $w' \in W'$, $\langle w, w \rangle$ and $\langle w', w' \rangle$ are in $\{1, 2, 3\}$; $\langle w_i, w_i \rangle - 2$ gives the charge on vertex i .
- For all i , $\langle w'_i, w'_i \rangle = 4 - \langle w_i, w_i \rangle$.

Thus Theorem 5.3.3 generalises to Hermitian matrices as follows:

Theorem 5.5.2. *Let M be a matrix representative of a cyclotomic \mathcal{L} -graph G . Fix an ordered vertex labelling then determine Gram vectors W, W' as above. If there exist vectors x, x' with the following properties:*

- $\langle x, x \rangle \in \{1, 2, 3\}$
- For all $w_i \in W$, $\langle x, w_i \rangle \in \mathcal{L}$
- There exists $w_i \in W$ such that $\langle x, w_i \rangle \neq 0$
- $\langle x', x' \rangle = 4 - \langle x, x \rangle$
- For all i , $\langle x', w'_i \rangle = -\langle x, w_i \rangle$

then define A^* to be the matrix determined by the set of Gram vectors $W \cup \{x\}$. $M^* = A - 2I$ is then a matrix representative of a cyclotomic \mathcal{L} -graph G^* inducing G as a proper subgraph, so G is nonmaximal.

5.5.2 Excluded Subgraphs

Let G be a cyclotomic \mathcal{L} -graph with edge labels from $\mathcal{L} = \mathcal{L}_1 \cup \mathcal{L}_2 \cup \{0\}$.

Proposition 5.5.3. *If a non 4-cyclotomic \mathcal{L} -graph G induces a subgraph of any of the forms described in Lemma 5.3.4, then G is nonmaximal.*

Proof. As in the proof of Lemma 5.3.4 we confirm that any such G is contained in one of a finite set of maximal cyclotomic supergraphs of the induced subgraph H ; for this we use bounded **equivgrow** with label set $\mathcal{L} = \mathcal{L}_1 \cup \mathcal{L}_2 \cup \{0\}$ instead of $\{0, 1, -1\}$. \square

We also identify the following excluded subgraphs with an edge of weight 2:

Lemma 5.5.4. *A cyclotomic \mathcal{L} -graph G with not all vertices weight 4 is nonmaximal if it induces a subgraph of any of the following forms (where cyclotomic):*

(A) *Vertex with a charge and a weight 2 edge*



(G contained in cyclotomic \mathcal{L} -graph of form $C_2^{2\pm}$ or S_4)

(B) $\mathcal{L}_1, \mathcal{L}_2, \mathcal{L}_1$ Cycles

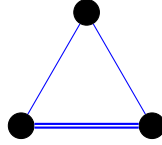

(G noncyclotomic for $d = -7$, contained in cyclotomic \mathcal{L} -graph of form S_4^* for $d = -2$)

(C) $\mathcal{L}_1, \mathcal{L}_2, \mathcal{L}_1$ Subpaths

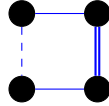

(G contained in cyclotomic \mathcal{L} -graph of form S_8^* or, if $d = -7$, S_6^\dagger)

(D) $\mathcal{L}_2, \mathcal{L}_2, \mathcal{L}_2$ Cycles

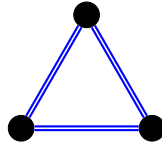

(G noncyclotomic)

(E) $\mathcal{L}_2, \mathcal{L}_2, \mathcal{L}_2$ Subpaths

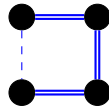

(G contained in cyclotomic \mathcal{L} -graph of form T_4^A)

(F) $\mathcal{L}_1, \mathcal{L}_2, \mathcal{L}_2$ Cycles

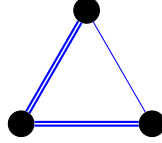

(G noncyclotomic)

(G) Charged $\mathcal{L}_1, \mathcal{L}_2, \mathcal{L}_1$ Cycles

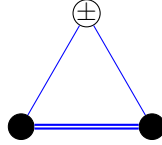

(G noncyclotomic)

(H) $\mathcal{L}_2, \mathcal{L}_1$ charged path of form



(G contained in cyclotomic \mathcal{L} -graph of form $\mathcal{C}_4^{2\pm}$)

(I) $\mathcal{L}_2, \mathcal{L}_1, \mathcal{L}_1$ charged path of form



(G contained in cyclotomic \mathcal{L} -graph of form $\mathcal{C}_6^{2\pm}$)

Proof. (A) holds by **equivgrow** with charge set $\{0, 1, -1\}$, label set \mathcal{L} ; (B) and (C) are the content of Lemmata 3.5.2 and 3.5.3 respectively; (D) and (E) are Lemma 3.5.4; (F) is Lemma 3.5.5; (G) is by direct testing; (H),(I) hold by **equivgrow** with charge set $\{0, 1, -1\}$, label set \mathcal{L} . □

5.5.3 \mathcal{L} -Graphs With Weight 3 Vertices

Let G be a cyclotomic \mathcal{L} -graph with a vertex v of weighted degree 3. As before, we seek to show that G is nonmaximal and consider the cases of v charged and uncharged separately.

v charged

W.l.o.g., v has positive charge. Then by Lemma 5.5.4 (A), there cannot be a weight 2 edge from v to any other vertex of G . Thus v has two neighbours a, b and one of the following holds:

- (i) Both a, b charged;
- (ii) Only one of a, b charged;

(iii) Neither charged.

In case (i), if $e_{ab} \in \mathcal{L}_2$ then G is nonmaximal by Lemma 5.5.4 (A), whilst if $e_{ab} \in \mathcal{L}_1$ then G is nonmaximal by Lemma 5.3.4 (c). Thus $e_{ab} = 0$, but then as before G is nonmaximal by Lemma 5.3.4 (e).

In case (ii) if $e_{ab} \in \mathcal{L}_2$ then G is nonmaximal by Lemma 5.5.4 (A), and if $e_{ab} = 0$ then G is nonmaximal by Lemma 5.3.4 (f). So the subgraph on v, a, b is, up to equivalence, the graph I given in (5.1).

For case (iii), we first note that $e_{ab} \notin \mathcal{L}_2$ by Lemma 5.5.4 (G); further if $e_{ab} \in \mathcal{L}_1$ then G is nonmaximal by Lemma 5.3.4 (b). So $e_{ab} = 0$ and the subgraph on v, a, b is, up to equivalence, the graph II given in (5.2).

G is thus equivalent to a graph G' inducing one of I or II as a subgraph, and if G' is nonmaximal then so is G . We thus verify the nonmaximality of G' by confirming the Gram vectors identified in the rational-integer case are still suitable when G' has edge labels from \mathcal{L} . This can only fail if the existence of weight 2 edges in G causes $\langle x, w_i \rangle \notin \mathcal{L}$ for some $w_i \in W \setminus \{v, a, b\}$.

For I and $x = w_v - w_a - w_b$ the subgraph on v, a, b, i is as given in (5.3), with the possibility of $e_{ai}, e_{bi} \in \mathcal{L}_2$. Fixing an ordering $v < a < b < i$, testing confirms that cyclotomic examples arise only if $\langle x, w_i \rangle = -\langle w_a, w_i \rangle - \langle w_b, w_i \rangle \in \mathcal{L}$ as required for Theorem 5.5.2.

For II and $x = w_v - w_a - w_b$ the subgraph on v, a, b, i is as given in (5.4), with the possibility of $e_{ai}, e_{bi} \in \mathcal{L}_2$. Fixing an ordering $v < a < b < i$, testing confirms that cyclotomic examples arise only if $\langle x, w_i \rangle = -\langle w_a, w_i \rangle - \langle w_b, w_i \rangle \in \mathcal{L}$ as required for Theorem 5.5.2.

As the vectors x' identified satisfy the conditions of Theorem 5.3.3 w.r.t. the given x , they are also suitable for Theorem 5.5.2. Hence a cyclotomic graph G with a charged vertex v of weight 3 is nonmaximal.

v uncharged

We now have two possibilities: v has two neighbours (with $e_{va} \in \mathcal{L}_2$ for some a) or v has three neighbours.

v has two neighbours Up to equivalence, G induces a subgraph H on v and its neighbours a, b of form

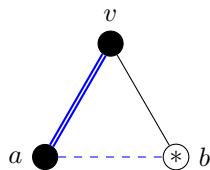

as a is necessarily uncharged by Lemma 5.5.4 (A). If $e_{ab} \in \mathcal{L}_1$ then (if b uncharged) G is nonmaximal by 5.5.4 (B) or (if b charged) noncyclotomic by part (G) of the same Lemma. If $e_{ab} \in \mathcal{L}_2$ then b is uncharged by (A), but then G is noncyclotomic by (F).

Thus we conclude that $e_{ab} = 0$. If b is charged we have a $\mathcal{L}_2, \mathcal{L}_1$ charged path, and G is nonmaximal by 5.5.4 (H). Therefore b is uncharged and, fixing a vertex ordering such that $v < a < b$, we have that (up to equivalence) H is

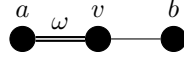

where $\omega = \sqrt{-2}$ or $\frac{1}{2} + \frac{\sqrt{-7}}{2}$ for $d = -2, -7$ respectively and edge labels indicate e_{ij} for $i < j$ (so here $e_{va} = \omega$).

Let W be the set of Gram vectors for $A = M + 2I$ where M is a matrix representative of G with subgraph on v, a, b as above. Identifying vertex i with its Gram vector w_i , the following conditions on W hold:

$$\langle w_v, w_v \rangle = \langle w_a, w_a \rangle = \langle w_b, w_b \rangle = 2$$

$$\langle w_v, w_a \rangle = \omega, \langle w_v, w_b \rangle = 1$$

Setting $x = 2w_v - \omega w_a - w_b$ we have

$$\begin{aligned} \langle x, w_v \rangle &= 2 \langle w_v, w_v \rangle - \omega \langle w_a, w_v \rangle - \langle w_b, w_v \rangle = 2(2) - \omega(\bar{\omega}) - 1 = 4 - 2 - 1 = 1 \\ \langle x, w_a \rangle &= 2 \langle w_v, w_a \rangle - \omega \langle w_a, w_a \rangle - \langle w_b, w_a \rangle = 2(\omega) - \omega(2) - 0 = 2\omega - 2\omega = 0 \\ \langle x, w_b \rangle &= 2 \langle w_v, w_b \rangle - \omega \langle w_a, w_b \rangle - \langle w_b, w_b \rangle = 2(1) - \omega(0) - 2 = 2 - 2 = 0 \\ \langle x, x \rangle &= 2 \langle w_v, x \rangle - \omega \langle w_a, x \rangle - \langle w_b, x \rangle = 2(1) - \omega(0) - 0 = 2 = 2 \end{aligned}$$

Further, for any $w_i \in W \setminus \{w_v, w_a, w_b\}$ $\langle w_v, w_i \rangle = 0$ by assumption so

$$\langle x, w_i \rangle = -\omega \langle w_a, w_i \rangle - \langle w_b, w_i \rangle$$

but (fixing $v < a < b < i$) testing confirms that the subgraph induced on v, a, b, i

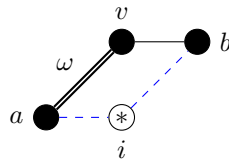

is cyclotomic only if $-\omega \langle w_a, w_i \rangle - \langle w_b, w_i \rangle \in \mathcal{L}$; thus $\langle x, w_i \rangle \in \mathcal{L}$ for all $w_i \in W$, $\langle x, x \rangle \in \{1, 2, 3\}$ and $\langle x, w_v \rangle \neq 0$. So all conditions on x required by Theorem 5.5.2 hold.

With the same vertex labelling and ordering we now consider W' the Gram vectors of $B =$

$(-M) + 2I$, for which the following hold:

$$\langle w'_v, w'_v \rangle = \langle w'_a, w'_a \rangle = \langle w'_b, w'_b \rangle = 2$$

$$\langle w'_v, w'_a \rangle = -\omega, \langle w'_v, w'_b \rangle = -1$$

Setting $x' = -2w'_v - \omega w'_a - w'_b$ we have

$$\begin{aligned} \langle x', w'_v \rangle &= -2(2) - \omega(\overline{-\omega}) - (-1) = -1 = -\langle x, w_v \rangle \\ \langle x', w'_a \rangle &= -2(-\omega) - \omega(2) - 0 = 0 = -\langle x, w_a \rangle \\ \langle x', w'_b \rangle &= -2(-1) - \omega(0) - 2 = 0 = -\langle x, w_b \rangle \\ \langle x', x' \rangle &= -2(-1) - \omega(0) - 0 = 2 = 4 - \langle x, x \rangle \end{aligned}$$

and for $w'_i \in W' \setminus \{w'_v, w'_a, w'_b\}$,

$$\langle x, w'_i \rangle = -\omega \langle w'_a, w'_i \rangle - \langle w'_b, w'_i \rangle = \omega \langle w_a, w_i \rangle + \langle w_b, w_i \rangle = -\langle x, w_i \rangle$$

so by Theorem 5.5.2 G is nonmaximal.

v has three neighbours, all charged Up to equivalence, G induces a subgraph H on v and its neighbours a, b, c of the form given in (5.5), but by Lemma 5.5.4 (A) the free edges e_{ab}, e_{ac}, e_{bc} cannot be in \mathcal{L}_2 . Thus H necessarily induces a double-charged 3-path and G is therefore nonmaximal by Lemma 5.3.4 (f) as before.

v has three neighbours, two charged Again, Lemma 5.5.4 (A) ensures $e_{ab}, e_{ac}, e_{bc} \notin \mathcal{L}_2$ so the subgraph H on v, a, b, c is (up to equivalence) as given in (5.6). In the case where a has no further neighbours, the vectors $x = w_a + w_b - w_v, x' = -3w'_a + w'_b - w'_v$ also satisfy all the requirements of Theorem 5.5.2, as $\langle x, w_i \rangle = \langle w_b, w_i \rangle \in \mathcal{L}$ with $\langle x, w_i \rangle = \langle x', w'_i \rangle$ for all vertices $i \neq v, a, b, c$.

If a has a neighbour d then, as before, the subgraph on v, a, b, c, d is (up to equivalence) of form H given in (5.7), as $e_{ad} \in \mathcal{L}_1$ by Lemma 5.5.4 (A). But then, as before, the only possibility is that H is the charged signed graph (5.8) since no choice of e_{bd} or e_{cd} from \mathcal{L}_2 gives a cyclotomic \mathcal{L} -graph. Further, for any i the subgraph on v, a, b, c, d, i remains of form (5.9), which is cyclotomic only if $-\langle w_c, w_i \rangle - \langle w_d, w_i \rangle \in \mathcal{L}$. So the vectors $x = w_a + w_b - w_c - 2w_d, x' = -4w'_a - w'_c - w'_d - 3w'_v$ are again suitable for Theorem 5.5.2, since $\langle x, w_i \rangle = -\langle x', w'_i \rangle \in \mathcal{L}$.

So G is nonmaximal.

v has three neighbours, one charged Up to equivalence, the subgraph H on v and its neighbours a, b, c is of form

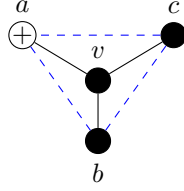

but $e_{ab}, e_{ac} \notin \mathcal{L}_2$ by Lemma 5.5.4 (A) and $e_{bc} \notin \mathcal{L}_2$ by part (B) of the same; further $e_{ab}, e_{ac} \notin \mathcal{L}_1$ by Lemma 5.3.4 (b) and $e_{bc} \notin \mathcal{L}_1$ by part (a) of the same. So $e_{ab} = e_{ac} = e_{bc} = 0$ and thus we have that H is (5.10) as before.

Hence for any other vertex i the subgraph on v, a, b, c, i is (5.11), which (fixing an ordering) is cyclotomic only if $\langle w_a, w_i \rangle + \langle w_b, w_i \rangle + \langle w_c, w_i \rangle \in \mathcal{L}$. Thus the vectors $x = 2w_v - w_a - w_b - w_c$, $x' = -w'_a - w'_b - w'_c - 2w'_v$ are again suitable for Theorem 5.5.2, since $\langle x, w_i \rangle = -\langle x', w'_i \rangle \in \mathcal{L}$. So G is nonmaximal.

v has three uncharged neighbours Up to equivalence, the subgraph H on v and its neighbours a, b, c is of form

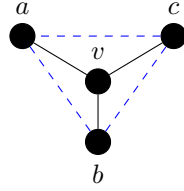

but $e_{ab}, e_{ac}, e_{bc} \notin \mathcal{L}_2$ by Lemma 5.5.4 (B) and $e_{ab}, e_{ac}, e_{bc} \notin \mathcal{L}_1$ by Lemma 5.3.4 (a). So $e_{ab} = e_{ac} = e_{bc} = 0$ and thus we have that H is (5.12) as before.

Hence for any other vertex i the subgraph on v, a, b, c, i is (5.13), which (fixing an ordering) is cyclotomic only if $\langle w_a, w_i \rangle + \langle w_b, w_i \rangle + \langle w_c, w_i \rangle \in \mathcal{L}$. Thus the vectors $x = 2w_v - w_a - w_b - w_c$, $x' = -w'_a - w'_b - w'_c - 2w'_v$ are again suitable for Theorem 5.5.2, since $\langle x, w_i \rangle = -\langle x', w'_i \rangle \in \mathcal{L}$. So G is nonmaximal.

This completes the proof of nonmaximality for a cyclotomic graph with a vertex of weighted degree 3.

5.5.4 \mathcal{L} -Graphs With Weight 2 Vertices

Let G be a cyclotomic \mathcal{L} -graph with a vertex of weighted degree 2. We seek to show that G is nonmaximal.

We may assume by the previous section that G has no vertices of weight 3. If all vertices have

weight 1 or 2 then G is a nonmaximal chordless path or cycle as before, or the trivial graph



which is clearly nonmaximal.

We therefore need only consider \mathcal{L} -graphs G containing a weight 2 vertex v with a weight 4 neighbour w , in one of the following combinations:

- (i) Both v, w charged;
- (ii) v charged, w uncharged;
- (iii) v uncharged, w charged;
- (iv) Neither charged.

v or w charged

In case (i), by Lemma 5.5.4 (A) w necessarily has two neighbours a, b which do not neighbour v , and so up to equivalence the subgraph H of G on vertices v, w, a, b is as in (5.14). If either of a, b is charged then $e_{ab} \notin \mathcal{L}_2$ by Lemma 5.5.4 (A), but if neither is charged then the possibility of $e_{ab} \in \mathcal{L}_2$ can be excluded by part (G) of the same. Thus H is (up to equivalence) one of the graphs given in (5.15), so G is nonmaximal by Lemma 5.3.4 as before.

In case (ii) we confirm that there are no cyclotomic graphs of form (5.16). However, as w is uncharged and of weight 4, it may instead have only two neighbours a, b with the subgraph H induced on v, w, a, b being (up to equivalence) of form

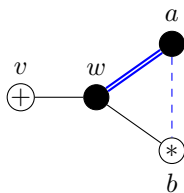

where a is necessarily uncharged by Lemma 5.5.4 (A). But then H induces a $\mathcal{L}_2, \mathcal{L}_1$ charged path on v, w, a and so G is nonmaximal by part (H) of the same Lemma.

In case (iii), w necessarily has two neighbours by Lemma 5.5.4 (A). Further, there exists u a neighbour of v with $e_{uv} \in \mathcal{L}_1$ (since v has weighted degree 2). If u does not neighbour w , then the subgraph on u, v, w, a, b is as in (5.17), of which there are still no cyclotomic examples.

So u neighbours w and, by Lemma 5.5.4 (A), $e_{uw} \in \mathcal{L}_1$. So the subgraph induced on u, v, w, a is as in (5.18), with the only cyclotomic examples being (5.19). The first is excluded by Lemma

5.3.4 (b) as before, whilst for the second we note that the cyclotomic \mathcal{L} -graph of form

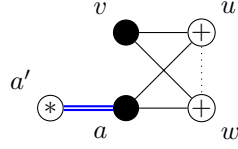

is excluded by Lemma 5.5.4 (A),(H) and that $e_{aa'} \notin \mathcal{L}_1$ by noncyclotomicity. So G is precisely the nonmaximal charged signed graph on u, v, w, a as before.

Neither v, w charged

$e_{vw} \in \mathcal{L}_2$ For \mathcal{L} -graphs we now have the possibility of $e_{vw} \in \mathcal{L}_2$. If so, then the subgraph H on v, w and their neighbours is (up to equivalence) of one of the forms

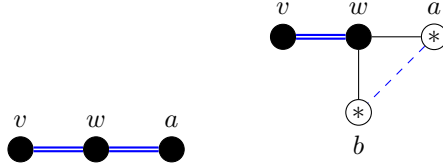

For the first we note that w has weighted degree 4 and v is assumed to have no further neighbours, so if G has any other vertices then at least one, b , is a neighbour of a . But then the subgraph on v, w, a, b is of form

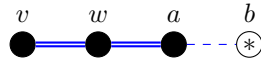

for which there are no cyclotomic examples with $e_{ab} \neq 0$. So v, w, a is the entirety of G , which is then trivially nonmaximal.

In the second case G is nonmaximal by Lemma 5.5.4 (H) if either a or b is charged, but if neither is charged then $e_{ab} \notin \mathcal{L}_2$ by part (B) of the same and $e_{ab} \notin \mathcal{L}_1$ by Lemma 5.3.4 (a). Hence we may assume $e_{ab} = 0$ and that a, b are uncharged; fixing an ordering $v < w < a < b$ we have that H is, up to equivalence,

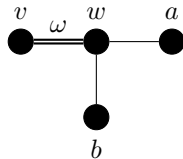

where $\omega = \sqrt{-2}$ or $\frac{1}{2} + \frac{\sqrt{-7}}{2}$ for $d = -2, -7$ respectively.

Let W be the set of Gram vectors for $A = M + 2I$ where M is a matrix representative of G

with subgraph on v, w, a, b as above. Identifying vertex i with its Gram vector w_i , the following conditions on W hold:

$$\langle w_v, w_v \rangle = \langle w_w, w_w \rangle = \langle w_a, w_a \rangle = \langle w_b, w_b \rangle = 2$$

$$\langle w_v, w_w \rangle = \omega, \langle w_w, w_a \rangle = \langle w_w, w_b \rangle = 1$$

Setting $x = w_w - w_a - w_b$ we have

$$\begin{aligned} \langle x, w_v \rangle &= \langle w_w, w_v \rangle - \langle w_a, w_v \rangle - \langle w_b, w_v \rangle &= \bar{\omega} - (0) - (0) &= \bar{\omega} \\ \langle x, w_w \rangle &= \langle w_w, w_w \rangle - \langle w_a, w_w \rangle - \langle w_b, w_w \rangle &= 2 - (1) - (1) &= 0 \\ \langle x, w_a \rangle &= \langle w_w, w_a \rangle - \langle w_a, w_a \rangle - \langle w_b, w_a \rangle &= 1 - (2) - (0) &= -1 \\ \langle x, w_b \rangle &= \langle w_w, w_b \rangle - \langle w_a, w_b \rangle - \langle w_b, w_b \rangle &= 1 - (0) - (2) &= -1 \\ \langle x, x \rangle &= \langle w_w, x \rangle - \langle w_a, x \rangle - \langle w_b, x \rangle &= 0 - (-1) - (-1) &= 2 \end{aligned}$$

Further, for any $w_i \in W \setminus \{w_v, w_w, w_a, w_b\}$, $\langle w_w, w_i \rangle = 0$ since w has weighted degree 4, so

$$\langle x, w_i \rangle = -\langle w_a, w_i \rangle - \langle w_b, w_i \rangle$$

but (fixing an ordering) testing confirms that for any vertex i , the subgraph induced on v, w, a, b, i

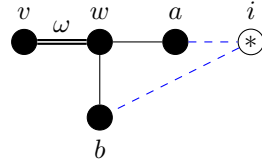

is cyclotomic only if $\langle w_a, w_i \rangle = -\langle w_b, w_i \rangle$ and so $\langle x, w_i \rangle = 0$ for all such w_i . Hence all conditions on x required by Theorem 5.5.2 are satisfied.

With the same vertex labelling and ordering we now consider W' the Gram vectors of $B = (-M) + 2I$, for which the following hold:

$$\langle w'_v, w'_v \rangle = \langle w'_w, w'_w \rangle = \langle w'_a, w'_a \rangle = \langle w'_b, w'_b \rangle = 2$$

$$\langle w'_v, w'_w \rangle = -\omega, \langle w'_w, w'_a \rangle = \langle w'_w, w'_b \rangle = -1$$

Setting $x' = w'_w + w'_a + w'_b$ we have

$$\begin{aligned}
 \langle x', w'_v \rangle &= \overline{-\omega} + (0) + (0) = \overline{-\omega} = -\langle x, w_v \rangle \\
 \langle x', w'_w \rangle &= 2 + (-1) + (-1) = 0 = -\langle x, w_w \rangle \\
 \langle x', w'_a \rangle &= -1 + (2) + (0) = 1 = -\langle x, w_a \rangle \\
 \langle x', w'_b \rangle &= -1 + (0) + (2) = 1 = -\langle x, w_b \rangle \\
 \langle x', x' \rangle &= 0 + (1) + (1) = 2 = 4 - \langle x, x \rangle
 \end{aligned}$$

and for $w'_i \in W' \setminus \{w'_v, w'_w, w'_a, w'_b\}$,

$$\langle x', w'_i \rangle = \langle w'_a, w'_i \rangle + \langle w'_b, w'_i \rangle = -(\langle w_a, w_i \rangle + \langle w_b, w_i \rangle) = -(0) = -\langle x, w_i \rangle$$

Thus G is nonmaximal by Theorem 5.5.2. This completes the proof for $e_{vw} \in \mathcal{L}_2$.

$e_{vw} \in \mathcal{L}_1$ Otherwise, v has a neighbour u : if u were charged then $e_{uw} \notin \mathcal{L}_2$ by Lemma 5.5.4 (A) and $e_{uw} \notin \mathcal{L}_1$ by Lemma 5.3.4 (b); whereas if u were uncharged then $e_{uw} \notin \mathcal{L}_2$ by Lemma 5.5.4 (B) and $e_{uw} \notin \mathcal{L}_1$ by Lemma 5.3.4 (a). So we may assume $e_{uw} = 0$.

w has two neighbours If w has only two neighbours a, b , then (up to equivalence, and fixing $u < v < w < a < b$) the subgraph H on u, v, w, a, b is of form

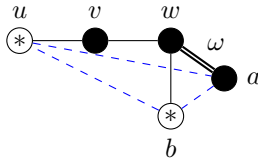

(where a is uncharged by Lemma 5.5.4 (A))

For cycлотomicity, H is then one of the following:

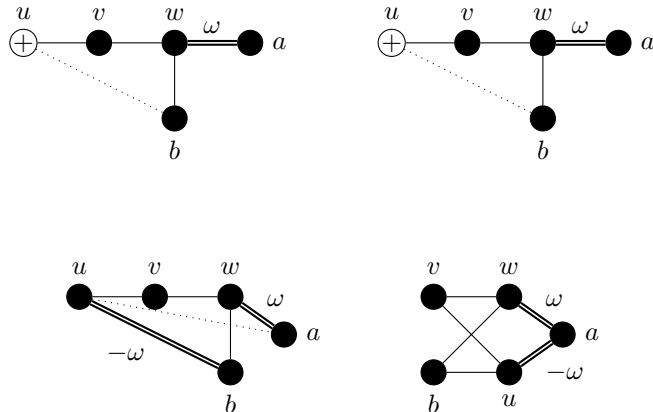

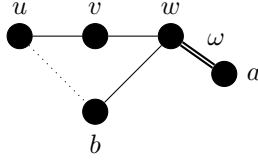

(5.37)

The first two are excluded by Lemma 5.5.4 (I) and the third by (C) of the same. For the fourth, testing shows that for cyclotomicity any neighbour of b is also a neighbour of v , so (as u, a, w have weighted degree 4 and v is assumed to have no further neighbours) H is G which is clearly nonmaximal by embedding in, for example, a graph of form \mathcal{T}_6^4 . So we are left with only the fifth case.

Let W be the set of Gram vectors for $A = M + 2I$ where M is a matrix representative of G with subgraph on u, v, w, a, b as in (5.37). Identifying vertex i with its Gram vector w_i , the following conditions on W hold:

$$\langle w_u, w_u \rangle = \langle w_v, w_v \rangle = \langle w_w, w_w \rangle = \langle w_a, w_a \rangle = \langle w_b, w_b \rangle = 2$$

$$\langle w_w, w_a \rangle = \omega, \langle w_w, w_v \rangle = \langle w_w, w_b \rangle = 1$$

$$\langle w_u, w_v \rangle = 1, \langle w_u, w_b \rangle = -1$$

Setting $x = w_w - w_v - w_b$ we have

$$\langle x, w_u \rangle = \langle w_w, w_u \rangle - \langle w_v, w_u \rangle - \langle w_b, w_u \rangle = 0 - (1) - (-1) = 0$$

$$\langle x, w_v \rangle = \langle w_w, w_v \rangle - \langle w_v, w_v \rangle - \langle w_b, w_v \rangle = 1 - (2) - (0) = -1$$

$$\langle x, w_w \rangle = \langle w_w, w_w \rangle - \langle w_v, w_w \rangle - \langle w_b, w_w \rangle = 2 - (1) - (1) = 0$$

$$\langle x, w_a \rangle = \langle w_w, w_a \rangle - \langle w_v, w_a \rangle - \langle w_b, w_a \rangle = \omega - (0) - (0) = \omega$$

$$\langle x, w_b \rangle = \langle w_w, w_b \rangle - \langle w_v, w_b \rangle - \langle w_b, w_b \rangle = 1 - (0) - (2) = -1$$

$$\langle x, x \rangle = \langle w_w, x \rangle - \langle w_v, x \rangle - \langle w_b, x \rangle = 0 - (-1) - (-1) = 2$$

Let i be any other vertex in G . Then the general subgraph on u, v, w, a, b, i is

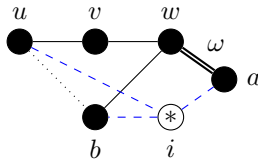

which is cyclotomic only if $\langle w_b, w_i \rangle = \langle w_a, w_i \rangle = 0$ or $\langle w_b, w_i \rangle \in \mathcal{L}_2, \langle w_a, w_i \rangle \in \mathcal{L}_1$; but the latter case can be excluded by Lemma 5.5.4 (C). So we may assume that $\langle w_b, w_i \rangle = 0$, and since $\langle w_v, w_i \rangle = 0$ by assumption and $\langle w_w, w_i \rangle = 0$ by weight of w , we conclude that for all

$$w_i \in W \setminus \{w_u, w_v, w_w, w_a, w_b\}$$

$$\langle x, w_i \rangle = 0$$

and as $\langle x, w_v \rangle \neq 0$, the conditions on x in Theorem 5.5.2 are satisfied.

With the same vertex labelling and ordering we now consider W' the Gram vectors of $B = (-M) + 2I$, for which the following hold:

$$\langle w'_u, w'_u \rangle = \langle w'_v, w'_v \rangle = \langle w'_w, w'_w \rangle = \langle w'_a, w'_a \rangle = \langle w'_b, w'_b \rangle = 2$$

$$\langle w'_w, w'_a \rangle = -\omega, \langle w'_w, w'_v \rangle = \langle w'_w, w'_b \rangle = -1$$

$$\langle w'_u, w'_v \rangle = -1, \langle w'_u, w'_b \rangle = 1$$

Setting $x' = w'_v + w'_w + w'_b$ we have

$$\begin{aligned} \langle x', w'_u \rangle &= \langle w'_v, w'_u \rangle + \langle w'_w, w'_u \rangle + \langle w'_b, w'_u \rangle &= -1 + 0 + 1 &= 0 &= -\langle x, w_u \rangle \\ \langle x', w'_v \rangle &= \langle w'_v, w'_v \rangle + \langle w'_w, w'_v \rangle + \langle w'_b, w'_v \rangle &= 2 + -1 + 0 &= 1 &= -\langle x, w_v \rangle \\ \langle x', w'_w \rangle &= \langle w'_v, w'_w \rangle + \langle w'_w, w'_w \rangle + \langle w'_b, w'_w \rangle &= -1 + 2 + -1 &= 0 &= -\langle x, w_w \rangle \\ \langle x', w'_a \rangle &= \langle w'_v, w'_a \rangle + \langle w'_w, w'_a \rangle + \langle w'_b, w'_a \rangle &= 0 + -\omega + 0 &= -\omega &= -\langle x, w_a \rangle \\ \langle x', w'_b \rangle &= \langle w'_v, w'_b \rangle + \langle w'_w, w'_b \rangle + \langle w'_b, w'_b \rangle &= 0 + -1 + 2 &= 1 &= -\langle x, w_b \rangle \\ \langle x', x' \rangle &= \langle w'_v, x' \rangle + \langle w'_w, x' \rangle + \langle w'_b, x' \rangle &= 1 + 0 + 1 &= 2 &= 4 - \langle x, x \rangle \end{aligned}$$

and for any $w'_i \in W' \setminus \{w'_u, w'_v, w'_w, w'_a, w'_b\}$,

$$\langle x', w'_i \rangle = \langle w'_b, w'_i \rangle = -\langle w_b, w_i \rangle = 0 = -\langle x, w_i \rangle$$

so G is nonmaximal by Theorem 5.5.2.

w has three neighbours As in the charged signed graph case the subgraph H induced on u, v, w, a, b, c is, up to equivalence, of form (5.20) and we consider the possible charges on u, a, b, c as enumerated in cases (I) through (VIII).

In case (II) H is necessarily a charged signed graph since no undetermined edge can be in \mathcal{L}_2 by Lemma 5.5.4 (A). Thus case (II) is again excluded since there were no cyclotomic examples.

In case (IV) the only possibility for H to have an edge label from \mathcal{L}_2 is if $e_{bc} \in \mathcal{L}_2$, but then G is nonmaximal by Lemma 5.5.4 (B). Thus H is a charged signed graph, but there were no cyclotomic examples of this form, so case (IV) is excluded.

In case (VI) H is necessarily a charged signed graph since no undetermined edge can be in \mathcal{L}_2 by Lemma 5.5.4 (A). Thus case (VI) is again excluded since there were no cyclotomic examples.

In case (VIII) $e_{au}, e_{ab}, e_{ac} \notin \mathcal{L}_2$ by Lemma 5.5.4 (A) and $e_{bc} \notin \mathcal{L}_2$ by part (B). Testing the

remaining possible combinations of edge labels confirms that there are no cyclotomic examples, so case (VIII) is excluded.

In case (III) H is necessarily a charged signed graph since no undetermined edge can be in \mathcal{L}_2 by Lemma 5.5.4 (A). Thus we have one of the graphs (5.21), all of which continue to be excluded by Lemma 5.3.4.

In case (I) $e_{au}, e_{bu}, e_{cu} \notin \mathcal{L}_2$ by Lemma 5.5.4 (A) and $e_{ab}, e_{ac}, e_{bc} \notin \mathcal{L}_2$ by Lemma 5.5.4 (B) from considering the triangle with w and two such vertices. Thus H is necessarily a charged signed graph and so up to equivalence is as given in (5.22). But then for any

$$w_i \in W \setminus \{w_u, w_v, w_w, w_a, w_b, w_c\}$$

the subgraph (5.23) induced on u, v, w, a, b, c, i is cyclotomic only if

$$\langle w_a, w_i \rangle = \langle w_b, w_i \rangle = 0$$

so the original vectors $x = w_v + w_a - w_w$, $x' = -2w'_u - 2w'_v - w'_w$ suffice for proving nonmaximality of G by Theorem 5.5.2.

Thus we are left with the cases (V) and (VII), which admit new cyclotomic examples over \mathcal{L} . We seek Gram vectors for supergraphs in accordance with Theorem 5.5.2, as well as to confirm the existing constructions for G with a charged signed subgraph H remain suitable.

(V)

Remark 5.5.5. *Lemma 5.3.5 generalises to \mathcal{L} -graphs.*

Proof. By **equivgrow** it is impossible to extend the 8-vertex graph given in Lemma 5.3.5 to a 9-vertex graph G' containing a weight 2 edge; thus any neighbour of u, b, c, d or e is attached by weight 1 edges, and if any of those vertices has a third neighbour it also has a fourth. So we proceed as in the proof of Lemma 5.3.5: first introducing a pair of neighbours of a candidate unsaturated vertex in the subgraph; further introducing neighbours of any weight 3 vertex produced; then using bounded **equivgrow** now with label set \mathcal{L} instead of $\{0, 1, -1\}$. For each vertex, we generate only a finite set of candidates for G , each equivalent to a subgraph of S_{16} as required. \square

For case (V) we note that $e_{ab}, e_{ac}, e_{bc} \notin \mathcal{L}_2$ by Lemma 5.5.4 (B); testing the remaining possibilities confirms that, up to equivalence, H is one of the graphs given in (5.24), depending on whether v and w share one or three of a, b, c as neighbours. As before, if H is G then we are done, since then it is nonmaximal by embedding into some \mathcal{T}_{2k} . Otherwise, there exists some neighbour d of at least one of u, a, b, c ; the subgraph H' on u, v, w, a, b, c, d is then (up to equivalence)

one of the nine charged signed graphs identified in (5.25) or (fixing $u < v < w < a < b < c < d$)

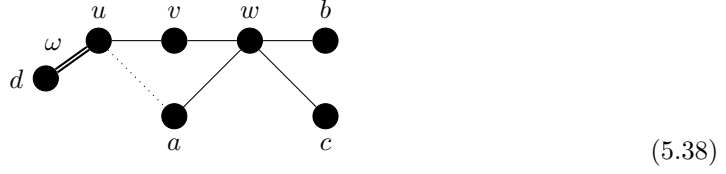

or

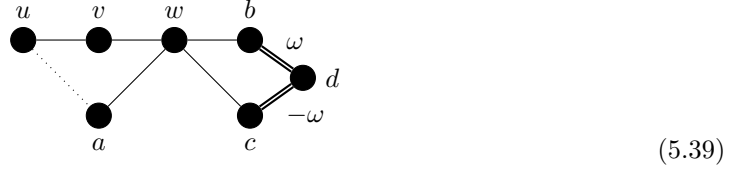

The first three graphs given in (5.26) can be excluded by Remark 5.5.5 and Lemma 5.3.4 (f).

For the four \mathcal{L} -graphs (5.26) we note that Remark 5.3.6 generalises to \mathcal{L} -graphs, so $\langle w_a, w_i \rangle = 0$ for all $w_i \in W \setminus \{w_u, w_v, w_w, w_a, w_b, w_c, w_d\}$, and hence the Gram vectors $x = w_v - w_w + w_a$, $x' = -w'_v - w'_w - w'_a$ remain suitable for Theorem 5.5.2 since

$$\langle x, w_i \rangle = \langle w_a, w_i \rangle = 0 = \langle w'_a, w'_i \rangle = -\langle x', w'_i \rangle$$

Similarly, for the remaining two charged signed graphs (5.27) we confirm that Remark 5.3.7 generalises to \mathcal{L} -graphs, so the Gram vectors $x = -\frac{1}{2}w_a + \frac{1}{2}w_v + w_\alpha$, $x = \frac{1}{2}w_a - \frac{1}{2}w_v + w_\alpha$ remain suitable for Theorem 5.5.2 since

$$\langle x, w_i \rangle = \langle w_a, w_i \rangle = 0 = \langle w'_a, w'_i \rangle = -\langle x', w'_i \rangle$$

for any $w_i \in W \setminus \{w_u, w_v, w_w, w_a, w_b, w_c, w_d\}$.

Let W be the set of Gram vectors for $A = M + 2I$ where M is a matrix representative of G with subgraph on u, v, w, a, b, c, d as in (5.38). Identifying vertex i with its Gram vector w_i , the following conditions on W hold:

$$\langle w_u, w_u \rangle = \langle w_v, w_v \rangle = \langle w_w, w_w \rangle = \langle w_a, w_a \rangle = \langle w_b, w_b \rangle = \langle w_c, w_c \rangle = \langle w_d, w_d \rangle = 2$$

$$\langle w_u, w_v \rangle = \langle w_v, w_w \rangle = \langle w_w, w_a \rangle = \langle w_w, w_b \rangle = \langle w_w, w_c \rangle = -1$$

$$\langle w_u, w_d \rangle = -\omega, \langle w_u, w_a \rangle = 1$$

Setting $x = w_v - w_u - w_a$ we have

$$\begin{aligned}
\langle x, w_u \rangle &= \langle w_v, w_u \rangle - \langle w_u, w_u \rangle - \langle w_a, w_u \rangle = 1 - (2) - (-1) = 0 \\
\langle x, w_v \rangle &= \langle w_v, w_v \rangle - \langle w_u, w_v \rangle - \langle w_a, w_v \rangle = 2 - (1) - (0) = 1 \\
\langle x, w_w \rangle &= \langle w_v, w_w \rangle - \langle w_u, w_w \rangle - \langle w_a, w_w \rangle = 1 - (0) - (1) = 0 \\
\langle x, w_a \rangle &= \langle w_v, w_a \rangle - \langle w_u, w_a \rangle - \langle w_a, w_a \rangle = 0 - (-1) - (2) = -1 \\
\langle x, w_b \rangle &= \langle w_v, w_b \rangle - \langle w_u, w_b \rangle - \langle w_a, w_b \rangle = 0 - (0) - (0) = 0 \\
\langle x, w_c \rangle &= \langle w_v, w_c \rangle - \langle w_u, w_c \rangle - \langle w_a, w_c \rangle = 0 - (0) - (0) = 0 \\
\langle x, w_d \rangle &= \langle w_v, w_d \rangle - \langle w_u, w_d \rangle - \langle w_a, w_d \rangle = 0 - (\omega) - (0) = -\omega \\
\langle x, x \rangle &= \langle w_v, x \rangle - \langle w_u, x \rangle - \langle w_a, x \rangle = 1 - (0) - (-1) = 2
\end{aligned}$$

Further, for any other vertex i of G the subgraph induced on u, v, w, a, b, c, d, i is cyclotomic only if $\langle w_a, w_i \rangle = 0$, hence for any such i

$$\langle x, w_i \rangle = \langle w_v, w_i \rangle - \langle w_u, w_i \rangle - \langle w_a, w_i \rangle = 0 - 0 - 0 = 0$$

since u has weighted degree 4 and v is assumed to have no other neighbours. Since additionally $\langle x, w_v \rangle \neq 0$, all conditions on x in Theorem 5.5.2 are satisfied.

With the same vertex labelling and ordering we now consider W' the Gram vectors of $B = (-M) + 2I$, for which the following hold:

$$\begin{aligned}
\langle w'_u, w'_u \rangle &= \langle w'_v, w'_v \rangle = \langle w'_w, w'_w \rangle = \langle w'_a, w'_a \rangle = \langle w'_b, w'_b \rangle = \langle w'_c, w'_c \rangle = \langle w'_d, w'_d \rangle = 2 \\
\langle w'_u, w'_v \rangle &= \langle w'_v, w'_w \rangle = \langle w'_w, w'_a \rangle = \langle w'_w, w'_b \rangle = \langle w'_w, w'_c \rangle = 1 \\
\langle w'_u, w'_d \rangle &= \omega, \langle w'_u, w'_a \rangle = -1
\end{aligned}$$

Setting $x' = w'_a - w'_u - w'_v$ we have

$$\begin{aligned}
\langle x', w'_u \rangle &= \langle w'_a, w'_u \rangle - \langle w'_u, w'_u \rangle - \langle w'_v, w'_u \rangle = 1 - (2) - (-1) = 0 = -\langle x, w_u \rangle \\
\langle x', w'_v \rangle &= \langle w'_a, w'_v \rangle - \langle w'_u, w'_v \rangle - \langle w'_v, w'_v \rangle = 0 - (-1) - (2) = -1 = -\langle x, w_v \rangle \\
\langle x', w'_w \rangle &= \langle w'_a, w'_w \rangle - \langle w'_u, w'_w \rangle - \langle w'_v, w'_w \rangle = -1 - (0) - (-1) = 0 = -\langle x, w_w \rangle \\
\langle x', w'_a \rangle &= \langle w'_a, w'_a \rangle - \langle w'_u, w'_a \rangle - \langle w'_v, w'_a \rangle = 2 - (1) - (0) = 1 = -\langle x, w_a \rangle \\
\langle x', w'_b \rangle &= \langle w'_a, w'_b \rangle - \langle w'_u, w'_b \rangle - \langle w'_v, w'_b \rangle = 0 - (0) - (0) = 0 = -\langle x, w_b \rangle \\
\langle x', w'_c \rangle &= \langle w'_a, w'_c \rangle - \langle w'_u, w'_c \rangle - \langle w'_v, w'_c \rangle = 0 - (0) - (0) = 0 = -\langle x, w_c \rangle \\
\langle x', w'_d \rangle &= \langle w'_a, w'_d \rangle - \langle w'_u, w'_d \rangle - \langle w'_v, w'_d \rangle = 0 - (-\omega) - (0) = \omega = -\langle x, w_d \rangle \\
\langle x', x' \rangle &= \langle w'_a, x' \rangle - \langle w'_u, x' \rangle - \langle w'_v, x' \rangle = 1 - (0) - (-1) = 2 = 4 - \langle x, x \rangle
\end{aligned}$$

and for any other $w'_i \in W' \setminus \{w'_u, w'_v, w'_w, w'_a, w'_b, w'_c, w'_d\}$,

$$\langle x', w'_i \rangle = \langle w'_a, w'_i \rangle - \langle w'_u, w'_i \rangle - \langle w'_v, w'_i \rangle = 0 - 0 - 0 = 0 = -\langle x, w_i \rangle$$

so G is nonmaximal by Theorem 5.5.2.

Finally, let W be the set of Gram vectors for $A = M + 2I$ where M is a matrix representative of G with subgraph on u, v, w, a, b, c, d as in (5.39). Identifying vertex i with its Gram vector w_i , the following conditions on W hold:

$$\langle w_u, w_u \rangle = \langle w_v, w_v \rangle = \langle w_w, w_w \rangle = \langle w_a, w_a \rangle = \langle w_b, w_b \rangle = \langle w_c, w_c \rangle = \langle w_d, w_d \rangle = 2$$

$$\langle w_u, w_v \rangle = \langle w_v, w_w \rangle = \langle w_w, w_a \rangle = \langle w_w, w_b \rangle = \langle w_w, w_c \rangle = 1$$

$$\langle w_b, w_d \rangle = \omega, \langle w_c, w_d \rangle = -\omega, \langle w_u, w_a \rangle = -1$$

Setting $x = w_w - w_v - w_a$ we have

$$\begin{aligned} \langle x, w_u \rangle &= \langle w_w, w_u \rangle - \langle w_v, w_u \rangle - \langle w_a, w_u \rangle = 0 - (1) - (-1) = 0 \\ \langle x, w_v \rangle &= \langle w_w, w_v \rangle - \langle w_v, w_v \rangle - \langle w_a, w_v \rangle = 1 - (2) - (0) = -1 \\ \langle x, w_w \rangle &= \langle w_w, w_w \rangle - \langle w_v, w_w \rangle - \langle w_a, w_w \rangle = 2 - (1) - (1) = 0 \\ \langle x, w_a \rangle &= \langle w_w, w_a \rangle - \langle w_v, w_a \rangle - \langle w_a, w_a \rangle = 1 - (0) - (2) = -1 \\ \langle x, w_b \rangle &= \langle w_w, w_b \rangle - \langle w_v, w_b \rangle - \langle w_a, w_b \rangle = 1 - (0) - (0) = 1 \\ \langle x, w_c \rangle &= \langle w_w, w_c \rangle - \langle w_v, w_c \rangle - \langle w_a, w_c \rangle = 1 - (0) - (0) = 1 \\ \langle x, w_d \rangle &= \langle w_w, w_d \rangle - \langle w_v, w_d \rangle - \langle w_a, w_d \rangle = 0 - (0) - (0) = 0 \\ \langle x, x \rangle &= \langle w_w, x \rangle - \langle w_v, x \rangle - \langle w_a, x \rangle = 0 - (-1) - (-1) = 2 \end{aligned}$$

Further, for any other vertex i of G the subgraph induced on u, v, w, a, b, c, d, i is cyclotomic only if $\langle w_a, w_i \rangle = 0$, hence for any such i

$$\langle x, w_i \rangle = \langle w_w, w_i \rangle - \langle w_v, w_i \rangle - \langle w_a, w_i \rangle = 0 - 0 - 0 = 0$$

since w has weighted degree 4 and v is assumed to have no other neighbours. Since additionally $\langle x, w_v \rangle \neq 0$, all conditions on x in Theorem 5.5.2 are satisfied. With the same vertex labelling and ordering we now consider W' the Gram vectors of $B = (-M) + 2I$, for which the following hold:

$$\langle w'_u, w'_u \rangle = \langle w'_v, w'_v \rangle = \langle w'_w, w'_w \rangle = \langle w'_a, w'_a \rangle = \langle w'_b, w'_b \rangle = \langle w'_c, w'_c \rangle = \langle w'_d, w'_d \rangle = 2$$

$$\langle w'_u, w'_v \rangle = \langle w'_v, w'_w \rangle = \langle w'_w, w'_a \rangle = \langle w'_w, w'_b \rangle = \langle w'_w, w'_c \rangle = -1$$

$$\langle w_b, w_d \rangle = -\omega, \langle w_c, w_d \rangle = \omega, \langle w_u, w_a \rangle = 1$$

Setting $x' = w'_v + w'_w + w'_a$ we have

$$\begin{aligned}
\langle x', w'_u \rangle &= \langle w'_v, w'_u \rangle + \langle w'_w, w'_u \rangle + \langle w'_a, w'_u \rangle &= -1 + 0 + 1 &= 0 &= -\langle x, w_u \rangle \\
\langle x', w'_v \rangle &= \langle w'_v, w'_v \rangle + \langle w'_w, w'_v \rangle + \langle w'_a, w'_v \rangle &= 2 + (-1) + 0 &= 1 &= -\langle x, w_v \rangle \\
\langle x', w'_w \rangle &= \langle w'_v, w'_w \rangle + \langle w'_w, w'_w \rangle + \langle w'_a, w'_w \rangle &= (-1) + 2 + (-1) &= 0 &= -\langle x, w_w \rangle \\
\langle x', w'_a \rangle &= \langle w'_v, w'_a \rangle + \langle w'_w, w'_a \rangle + \langle w'_a, w'_a \rangle &= 0 + (-1) + 2 &= 1 &= -\langle x, w_a \rangle \\
\langle x', w'_b \rangle &= \langle w'_v, w'_b \rangle + \langle w'_w, w'_b \rangle + \langle w'_a, w'_b \rangle &= 0 + (-1) + 0 &= -1 &= -\langle x, w_b \rangle \\
\langle x', w'_c \rangle &= \langle w'_v, w'_c \rangle + \langle w'_w, w'_c \rangle + \langle w'_a, w'_c \rangle &= 0 + (-1) + 0 &= -1 &= -\langle x, w_c \rangle \\
\langle x', w'_d \rangle &= \langle w'_v, w'_d \rangle + \langle w'_w, w'_d \rangle + \langle w'_a, w'_d \rangle &= 0 + 0 + 0 &= 0 &= -\langle x, w_d \rangle \\
\langle x', x' \rangle &= \langle w'_v, x' \rangle + \langle w'_w, x' \rangle + \langle w'_a, x' \rangle &= 1 + 0 + 1 &= 2 &= 4 - \langle x, x \rangle
\end{aligned}$$

and for any other $w'_i \in W' \setminus \{w'_u, w'_v, w'_w, w'_a, w'_b, w'_c, w'_d\}$,

$$\langle x', w'_i \rangle = \langle w'_v, w'_i \rangle + \langle w'_w, w'_i \rangle + \langle w'_a, w'_i \rangle = 0 + 0 + 0 = 0 = -\langle x, w_i \rangle$$

so G is nonmaximal by Theorem 5.5.2.

This completes case (V).

(VII) Since $e_{ab}, e_{ac}, e_{bc}, e_{au}, e_{bu} \notin \mathcal{L}_2$ by Lemma 5.5.4 (A) and $e_{cu} \notin \mathcal{L}_2$ by part (C) of the same, subgraph H is necessarily a charged signed graph and thus (up to equivalence) one of the graphs (5.28). The first is excluded by Lemma 5.3.4 (b) as before.

For the second charged signed graph (5.29) we note that the vectors $x = w_v - \frac{1}{2}w_u - \frac{1}{2}w_w + w_a$, $x' = -w'_u - w'_v + w'_a + w'_a$ also satisfy the conditions of Theorem 5.5.2, since for any $w_i \in W \setminus \{w_u, w_v, w_w, w_a, w_b, w_c\}$ we have

$$\langle w_u, w_i \rangle = \langle w_v, w_i \rangle = \langle w_w, w_i \rangle = \langle w_a, w_i \rangle = \langle w_b, w_i \rangle = 0$$

by weighted degree considerations, so

$$\langle x, w_i \rangle = 0 = -\langle x', w_i \rangle$$

for all such w_i .

Finally, for the third charged signed graph (5.30) we confirm that the \mathcal{L} -graph (5.31) is cyclo-tomic only if $\langle w_a, w_i \rangle = \langle w_b, w_i \rangle = 0$. So the vectors $x = w_a + w_b - w_w$, $x' = -w'_w - 2w'_a$ satisfy

$$\langle x, w_i \rangle = 0 = -\langle x', w_i \rangle$$

for any $w_i \in W \setminus \{w_u, w_v, w_w, w_a, w_b, w_c\}$ and thus the conditions of Theorem 5.5.2 hold.

This completes case (VII), and thus the proof for graphs with a weight 2 vertex.

5.5.5 \mathcal{L} -Graphs With Weight 1 Vertices

Let G be a cyclotomic \mathcal{L} -graph with a vertex v of weight 1. By the previous two sections, we may assume that all vertices of G have weight 1 or 4, and thus that v has a neighbour w of weight 4 (else we have the trivially nonmaximal 1 vertex charged graph or 2 vertex uncharged graph).

If w were charged, then by Lemma 5.5.4 (A) it must have neighbours a, b with $e_{wa}, w_{wb} \in \mathcal{L}_1$. Then, up to equivalence, G induces a subgraph of form (5.32), but over \mathcal{L} no such graph is cyclotomic.

Thus w is uncharged and has either two or three neighbours in addition to v . If there are only two, a, b , then - fixing an ordering $v < w < a < b$ - the subgraph H induced on these four vertices is (up to equivalence)

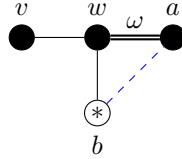

since a is uncharged by Lemma 5.5.4 (A). But then the only cyclotomic example is

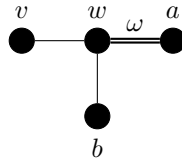

If H is all of G then we are done, since G is then clearly nonmaximal by embedding in, for example, a graph of form \mathcal{T}_6^4 . But if not then there exists a vertex c of G neighbouring at least one of a, b but not v ; the only such graph is (up to equivalence)

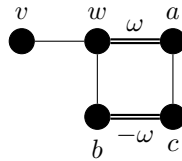

which is excluded by Lemma 5.5.4 (C).

So w has three neighbours a, b, c with the subgraph on v, w, a, b, c being (up to equivalence) as in (5.33). However, over \mathcal{L} we have only the charged signed graphs (5.34). The first is excluded by Lemma 5.3.4 (b) as before, whilst for the second we note that there are no cyclotomic \mathcal{L} -graphs of form (5.35) either, so again G is H and hence excluded by the assumption of no weight 3

vertices. In the third case we note that a has at least 2 neighbours x, y giving a graph of form

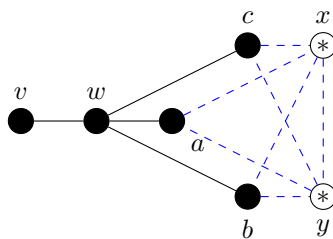

but (considering $e_{ax} \in \mathcal{L}_1, e_{ax} \in \mathcal{L}_2$ in turn) the only cyclotomic examples are the charged signed graphs (5.36). In each of these a has weighted degree 3, but no cyclotomic supergraph introduces a fourth neighbour z without violating the assumption that v has weight 1. Thus the final case is excluded, and the proof is complete for \mathcal{L} -graphs with weight 1 vertices.

This completes the proof of Theorem 5.5.1.

5.6 Conclusions

From Theorems 5.4.1, 5.4 and 5.5.1 we have that for $d \in \{-2, -7, -11, -15\}$ any maximal connected cyclotomic \mathcal{L} -graph is a connected 4-cyclotomic \mathcal{L} -graph. Thus, combined with the results of Chapters 3 and 4, we have a complete classification of maximal connected cyclotomic \mathcal{L} -graphs for such d (and hence cyclotomic \mathcal{L} -matrices).

Theorem 5.6.1. ($d = -2$) *Every maximal connected cyclotomic \mathcal{L} -graph for $R = \mathcal{O}_{\mathbb{Q}(\sqrt{-2})}$ not included in Theorems 1.4.1, 1.4.2 is equivalent to one of the following:*

- (i) *The 2-vertex \mathcal{L} -graph S_2 shown in Fig. 2.1;*
- (ii) *The 2-vertex \mathcal{L} -graph S'_2 shown in Fig. 4.1;*
- (iii) *The 4-vertex \mathcal{L} -graph S_4 shown in Fig. 4.2;*
- (iv) *The 4-vertex \mathcal{L} -graph S'_4 shown in Fig. 4.3;*
- (v) *The 4-vertex \mathcal{L} -graph S_4^* shown in Fig. 4.4;*
- (vi) *The 8-vertex \mathcal{L} -graph S_8^* shown in Fig. 4.10;*
- (vii) *For some $k = 2, 3, 4, \dots$, the $2k$ -vertex \mathcal{L} -graph T_{2k}^4 shown in Fig. 2.4;*
- (viii) *For some $k = 1, 2, 3, \dots$, the $2k + 1$ -vertex \mathcal{L} -graph C_{2k}^{2+} shown in Fig. 2.6.*

Theorem 5.6.2. ($d = -7$) *Every maximal connected cyclotomic \mathcal{L} -graph for $R = \mathcal{O}_{\mathbb{Q}(\sqrt{-7})}$ not included in Theorems 1.4.1, 1.4.2 is equivalent to one of the following:*

- (i) The 2-vertex \mathcal{L} -graph S_2 shown in Fig. 2.1;
- (ii) The 2-vertex \mathcal{L} -graph S_2^* shown in Fig. 2.2;
- (iii) The 2-vertex \mathcal{L} -graph S_2' shown in Fig. 4.1;
- (iv) The 4-vertex \mathcal{L} -graph S_4 shown in Fig. 4.2;
- (v) The 6-vertex \mathcal{L} -graph S_6^\dagger shown in Fig. 4.9;
- (vi) The 8-vertex \mathcal{L} -graph S_8^* shown in Fig. 4.10;
- (vii) For some $k = 2, 3, 4, \dots$, the $2k$ -vertex \mathcal{L} -graph T_{2k}^A shown in Fig. 2.4;
- (viii) For some $k = 2, 3, 4, \dots$, the $2k$ -vertex \mathcal{L} -graph $T_{2k}^{A'}$ shown in Fig. 2.5;
- (ix) For some $k = 1, 2, 3, \dots$, the $2k + 1$ -vertex \mathcal{L} -graph C_{2k}^{2+} shown in Fig. 2.6.

Theorem 5.6.3. ($d = -11$) Every maximal connected cyclotomic \mathcal{L} -graph for $R = \mathcal{O}_{\mathbb{Q}(\sqrt{-11})}$ not included in Theorems 1.4.1, 1.4.2 is equivalent to one of the following:

- (i) The 2-vertex \mathcal{L} -graph S_2 shown in Fig. 2.1;
- (ii) The 4-vertex \mathcal{L} -graph S_4' shown in Fig. 4.3.

Theorem 5.6.4. ($d = -15$) Every maximal connected cyclotomic \mathcal{L} -graph for $R = \mathcal{O}_{\mathbb{Q}(\sqrt{-15})}$ not included in Theorems 1.4.1, 1.4.2 is equivalent to one of the following:

- (i) The 2-vertex \mathcal{L} -graph S_2 shown in Fig. 2.1;
- (ii) The 2-vertex \mathcal{L} -graph S_2^* shown in Fig. 2.2.

Remark 5.6.5. Theorems 5.3.1, 3.7.1 and the results of Chapter 4 also provide an alternative proof of Theorems 1.4.1, 1.4.2.

Chapter 6

Minimal Noncyclotomics

6.1 Overview

For $R = \mathcal{O}_{\mathbb{Q}(\sqrt{d})}$, $d < 0, \neq -1, -3$, squarefree we prove Lehmer's Conjecture for R -matrices: if A is such a matrix, then $M(A) = 1$ or $M(A) \geq \lambda_0$. We reduce to adjacency matrices of \mathcal{L} -graphs, then identify the minimal noncyclotomic \mathcal{L} -graphs not equivalent to any minimal noncyclotomic charged signed graph given in [15]. As in the rational integer case, to do so we prove that there can be no minimal noncyclotomic examples with more than ten vertices and determine the remaining small examples and their Mahler measures.

6.2 Minimal Noncyclotomic R -Matrices With Large Norm Entries

6.2.1 R -Matrices with Entries On Diagonal of Large Modulus

As in [15], we note that for any $n \in \mathbb{N}$ such that $n \geq 2$, The matrix

$$(n)$$

is minimal noncyclotomic with Mahler measure $(n + \sqrt{n^2 - 4})/2 \geq 2.618$; and no larger indecomposable noncyclotomic matrix can contain such a charge and still be minimal. Thus we may restrict our attention to matrices with entries on the diagonal from $\{0, \pm 1, \pm 2\}$.

6.2.2 R -Matrices with Entries Off Diagonal of Large Norm

Let a be an algebraic integer satisfying $a\bar{a} = n \geq 5$. If M is a minimal noncyclotomic R -matrix with a as an off-diagonal entry, then by Interlacing it is necessarily of the form

$$\begin{pmatrix} x & a \\ \bar{a} & y \end{pmatrix}$$

where we may assume that $x, y \in \{0, \pm 1, \pm 2\}$ by the above. By computing eigenvalues of M then roots of the associated polynomial in terms of n for each choice x, y , we note the Mahler measure is increasing in n and find the possible values for $n = 5$. In this way we observe that there are infinite families of minimal noncyclotomic R -matrices of form

$$\begin{pmatrix} x & a \\ \bar{a} & y \end{pmatrix} x \in \{0, 1, 2\}, y \in \{0, \pm 1 \pm 2\}, a\bar{a} \geq 5$$

with Mahler measure at least 2.36.

We may thus exclude off-diagonal entries of norm greater than four from future consideration. That is, we need only consider \mathcal{L} -matrices or their corresponding \mathcal{L} -graphs.

6.2.3 \mathcal{L} -Graphs with Vertices of Charge ± 2

Since the matrix

$$(2)$$

is maximal cyclotomic, any extension is noncyclotomic, and thus can only be minimal if it equivalent to one of the form

$$\begin{pmatrix} 2 & x \\ \bar{x} & y \end{pmatrix}$$

Testing each choice of $y \in \{0, \pm 1, \pm 2\}$ and $n = x\bar{x} \in \{1, 2, 3, 4\}$ we find that any matrix of this form has Mahler measure at least 1.722 (attainable with $n = 1, y = -1$, so an integer symmetric matrix example exists).

Thus we may restrict our attention to \mathcal{L} -graphs with charges from $\{0, \pm 1\}$.

6.2.4 \mathcal{L} -Graphs with Weight 4 Edges

For t a weight 4 edge, an \mathcal{L} -graph with a $\oplus \overset{t}{\text{---}} \oplus^*$ subgraph is necessarily noncyclotomic, so the minimal noncyclotomics with such a feature are (up to equivalence)

$$\oplus \overset{t}{\text{---}} \bullet \quad \oplus \overset{t}{\text{---}} \oplus \quad \oplus \overset{t}{\text{---}} \ominus$$

where $t = 2, \frac{3}{2} + \frac{\sqrt{-7}}{2}$ or $\frac{1}{2} + \frac{\sqrt{-15}}{2}$ as appropriate; the first has Mahler measure $2.081\dots$, the others $2.618\dots$

As the only connected cyclotomic \mathcal{L} -graphs to feature a weight 4 edge are of the form \mathcal{S}_2 , any minimal noncyclotomic \mathcal{L} -graph containing such an edge between uncharged vertices must be equivalent to one of the form

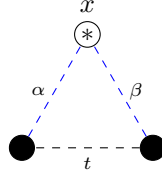

with $t = 2, \frac{3}{2} + \frac{\sqrt{-7}}{2}$ or $\frac{1}{2} + \frac{\sqrt{-15}}{2}$, $x \in \{0, \pm 1\}$ and $(\alpha, \beta) \in C_{2'}(\mathcal{L})$.

Testing for each d we find that the Mahler measure of an \mathcal{L} -graph of the above form is greater than 2.08, with a charged signed graph example being

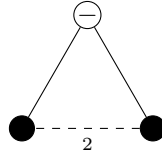

We may thus exclude weight 4 edges from future consideration, and assume $\mathcal{L} = \mathcal{L}_3 \cup \mathcal{L}_2 \cup \mathcal{L}_1 \cup \{0\}$ for the rest of the Chapter.

6.2.5 \mathcal{L} -Graphs with Weight 3 Edges

For $d = -2, -3$ or -11 , any cyclotomic \mathcal{L} -graph containing a weight 3 edge is equivalent to an \mathcal{L} -graph of form $\mathcal{S}'_2, \mathcal{S}'_4$ or an induced subgraph of such an \mathcal{L} -graph.

If G is a minimal noncyclotomic \mathcal{L} -graph containing an \mathcal{L} -graph of form \mathcal{S}'_2 it is necessarily equivalent to one of the form

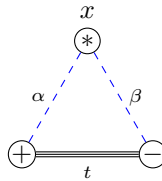

with $t = 1 + \sqrt{-2}, \frac{3}{2} + \frac{\sqrt{-3}}{2}$ or $\frac{1}{2} + \frac{\sqrt{-11}}{2}$, $x \in \{0, \pm 1\}$ and $(\alpha, \beta) \in C_{2'}(\mathcal{L})$.

Testing for each suitable d we find that the smallest Mahler measure of an \mathcal{L} -graph of the above form is ≈ 2.52 , with a representative \mathcal{L} -graph being

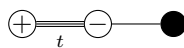

Otherwise, G must induce a subgraph equivalent to one of the \mathcal{S}'_4 representative

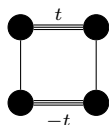

where $t = 1 + \sqrt{-2}$, $\frac{3}{2} + \frac{\sqrt{-3}}{2}$ or $\frac{1}{2} + \frac{\sqrt{-11}}{2}$ as appropriate.

By constructing all noncyclotomic 5-vertex supergraphs of this \mathcal{L} -graph - subject to the earlier constraints on relevant edge labels (those from $\mathcal{L}_1 \cup \mathcal{L}_2 \cup \mathcal{L}_3 \cup \{0\}$) and charges ($0, \pm 1$ only) - we may find a representative of any such G by generating successively smaller subgraphs, discarding cyclotomic or disconnected examples and noting minimal noncyclotomics as they occur.

In this way, we find classes of 4,3 and 2-vertex minimal noncyclotomics for each d ; in all three cases the smallest Mahler measure observed is ≈ 1.56 , with an example being the \mathcal{L} -graph

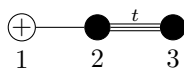

We may thus exclude weight 3 edges from future consideration, and assume $\mathcal{L} = \mathcal{L}_2 \cup \mathcal{L}_1 \cup \{0\}$ for the rest of the Chapter. For $d < 0, \notin \{-1, -2, -3, -7\}$, squarefree this gives $\mathcal{L} = \{-1, 0, 1\}$ and so the results of Sections 6.2.1 - 6.2.5 plus those of [15] give a complete classification of minimal noncyclotomics over such $\mathcal{O}_{\mathbb{Q}(\sqrt{d})}$.

6.3 Minimal Noncyclotomic \mathcal{L} -Graphs Over $\mathcal{O}_{\mathbb{Q}(\sqrt{-2})}, \mathcal{O}_{\mathbb{Q}(\sqrt{-7})}$ With Weight 2 Edges

6.3.1 Excluded Subgraphs

We first note the following results, which will be of use for the subsequent sections.

Lemma 6.3.1. *If G is a connected \mathcal{L} -graph with six or more vertices and contains a weight 2 edge adjacent to a charged vertex (that is, induces some $\oplus \text{---} *$ subgraph H), then G cannot be cyclotomic or minimal noncyclotomic.*

Proof. By Section 3.6.1 the only connected cyclotomic \mathcal{L} -graphs to induce such a subgraph H have at most four vertices, so G is necessarily noncyclotomic. Let G have vertices v_1, \dots, v_n , $n \geq 6$, such that H is the subgraph induced on vertices v_1, v_2 . Then it suffices to show that G induces a connected proper subgraph G' with at least five vertices including v_1, v_2 , since G' is

then also noncyclotomic by Section 3.6.1 and so G cannot be minimal.

If $G - \{v_n\}$ is connected, then clearly we are done. If not, then $G - \{v_n\}$ has connected components X_1, \dots, X_k , $k \geq 2$, and for each l there is some $x_l \in X_l$ a neighbour of v_n . W.l.o.g, let $v_1, v_2 \in X_1$ and $1 \leq |X_2| \leq \dots \leq |X_k|$.

If $|X_1| \geq 4$ then the subgraph induced on $X_1 \cup \{v_n\}$ is connected, contains at least five vertices including v_1, v_2 and is a proper subgraph of G since it contains none of the vertices in X_2 , so we are done.

If $|X_1| = 3$ then the subgraph induced on $X_1 \cup \{v, x_2\}$ is connected and contains precisely five vertices including v_1, v_2 .

If $|X_1| = 2$ and additionally $|X_2| = 1$ then $G - \{x_2\}$ is a connected $(n - 1)$ -vertex subgraph of G containing v_1, v_2 as desired. Else $2 \leq |X_2|$ and there exists $x'_2 \in X_2$ a neighbour of x_2 ; the subgraph induced on $X_1 \cup \{v, x_2, x'_2\}$ is hence connected, has five vertices, and contains v_1, v_2 . \square

Lemma 6.3.2. *If G is a connected \mathcal{L} -graph with six or more vertices that induces a subgraph H of form*

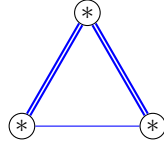

then G cannot be cyclotomic or minimal noncyclotomic.

Proof. If any of the vertices of H are charged then Lemma 6.3.1 applies. Otherwise, H is noncyclotomic by Lemma 3.5.5 and thus $G \neq H$ is noncyclotomic yet not minimally so. \square

Lemma 6.3.3. *If G is a connected \mathcal{L} -graph with six or more vertices that induces a subgraph H of form*

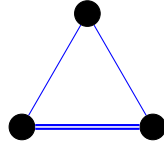

then G cannot be cyclotomic or minimal noncyclotomic.

Proof. For $d = -1, -7$ the subgraph H is necessarily noncyclotomic, so $G \neq H$ is noncyclotomic but not minimally so. For $d = -2$, let the vertices of H be v_1, v_2, v_3 . Then by connectedness of G , there exists a vertex v_4 which is a neighbour of at least one of v_1, v_2, v_3 . If the graph induced on $H \cup \{v_4\}$ is noncyclotomic, then we are done; else there exists a vertex v_5 a neighbour of at least one of v_1, \dots, v_4 so the subgraph induced on v_1, \dots, v_5 is a connected proper 5-vertex

subgraph of G containing H . But by the results of Section 3.5.1 it cannot be cyclotomic, so G is noncyclotomic but cannot be minimally so. \square

Lemma 6.3.4. *If G is a connected \mathcal{L} -graph with ten or more vertices that induces a subgraph H of form*

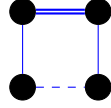

then G cannot be cyclotomic or minimal noncyclotomic.

Proof. Let G have $n \geq 10$ vertices, and let the vertices of H be v_1, v_2, v_3, v_4 . By the results of Section 3.5.1, the largest connected cyclotomic graph to induce a subgraph of form H has eight vertices. Thus for both noncyclotomicity and nonminimality it suffices to show that G induces a connected subgraph with at least nine vertices including v_1, v_2, v_3, v_4 . However, there must exist a sequence of vertices v_5, \dots, v_9 such that for each $i \geq 5$, v_i is a neighbour of at least one of v_1, \dots, v_{i-1} : if for a given i no such v_i could be found then v_1, \dots, v_{i-1} would be a connected component of G yet not all of G , contradicting connectedness. But then the subgraph induced on v_1, \dots, v_9 has the desired properties. \square

Lemma 6.3.5. *For $d = -2, -7$, If G is a connected \mathcal{L} -graph with nine or more vertices that induces a subgraph H of form*

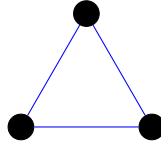

then G cannot be cyclotomic or minimal noncyclotomic.

Proof. By Theorems 5.6.1 and Theorem 5.6.2 the only maximal cyclotomic \mathcal{L} -graphs to induce such an H are equivalent to either \mathcal{T}_6 or \mathcal{S}_7 . Thus for both noncyclotomicity and nonminimality of an n -vertex \mathcal{L} -graph G it suffices to show that it induces a connected proper subgraph with at least eight vertices including the vertices v_1, v_2, v_3 of H . However, there must exist a sequence of vertices v_4, \dots, v_8 such that for each $i \geq 4$, v_i is a neighbour of at least one of v_1, \dots, v_{i-1} : if for a given i no such v_i could be found then v_1, \dots, v_{i-1} would be a connected component of G yet not all of G , contradicting connectedness. But then the subgraph induced on v_1, \dots, v_8 has the desired properties. \square

Lemma 6.3.6. *By Theorem 2.5.2, any vertex in a cyclotomic \mathcal{L} -graph has weighted degree at most four. Thus any minimal noncyclotomic \mathcal{L} -graph with seven or more vertices also has all vertices of weighted degree at most four.*

Lemma 6.3.7. *There are no cyclotomic \mathcal{L} -graphs of the form*

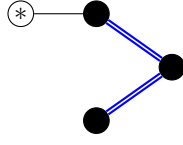

Corollary 6.3.8. *For $n \geq 5$, If vertices i, j of an n -vertex \mathcal{L} -graph G share a common neighbour k such that $e_{i,k}, e_{j,k} \in \mathcal{L}_2$, then i, j must have the same set of neighbours for G to be minimal noncyclotomic.*

6.3.2 Small Minimal Noncyclotomic Graphs

In this Section we determine all remaining minimal noncyclotomic \mathcal{L} -graphs for $d = -2, -7$ with at least one weight 2 edge label and at most ten vertices. Such an \mathcal{L} -graph G necessarily induces as a subgraph some cyclotomic \mathcal{L} -graph H of form $\textcircled{*} \text{---} \textcircled{*}$. By negating, taking complex conjugates and/or switching, we may assume that H is one of the following:

$$H_1 := \textcircled{+} \text{---}^{\omega} \textcircled{+} \quad H_2 := \textcircled{+} \text{---}^{\omega} \textcircled{-} \quad H_3 := \bullet \text{---}^{\omega} \bullet \quad H_4 := \textcircled{+} \text{---}^{\omega} \bullet$$

where $\omega = \sqrt{-2}$ or $\frac{1}{2} + \frac{\sqrt{-7}}{2}$ for $d = -2, -7$ respectively. We note immediately that the \mathcal{L} -graph H_1 is noncyclotomic (with Mahler measure 1.883...) and clearly minimal.

Let G have vertices x_1, \dots, x_n ; by the above, we may assume that the subgraph induced on vertices x_1, x_2 is from the seed set $\{H_2, H_3, H_4\}$. Further, by minimality the subgraph induced on x_1, \dots, x_{n-1} is cyclotomic. A representative of G can therefore be found by a series of $n - 3$ cyclotomic additions to one of the seeds, followed by a noncyclotomic addition. Thus, representatives of *all* minimal noncyclotomic \mathcal{L} -graphs up to a given number of vertices can be found by repeated application of the following growing algorithm:

Definition 6.3.9. The **mncyc** algorithm

Let S_k be a seed set of $k \times k$ cyclotomic matrices. Let C be a suitable column set and X a suitable charge set. Then the following algorithm performs a *round of cyclotomic/minimal noncyclotomic growing*:

Algorithm 4: mncyc

Input: S_k, X, C

Output: Sets $S_{k+1}, MNCYC_{k+1}$ of cyclotomic, minimal noncyclotomic supermatrices

$S_{k+1} = \emptyset$

$MNCYC_{k+1} = \emptyset$

for $m \in S_k$ **do**

$S_m = \emptyset$

$MNCYC_m = \emptyset$

for $x \in X$ **do**

for $c \in C$ **do**

$$m_{c,x} = \begin{pmatrix} m & c \\ \bar{c} & x \end{pmatrix}$$

if $m_{c,x}$ *is cyclotomic* **then**

$$S_m = S_m \cup \{m_{c,x}\}$$

else

if $m_{c,x}$ *is minimal noncyclotomic* **then**

$$MNCYC_m = MNCYC_m \cup \{m_{c,x}\}$$

$$S_{k+1} = S_{k+1} \cup S_m$$

$$MNCYC_{k+1} = MNCYC_{k+1} \cup MNCYC_m$$

return $S_{k+1}, MNCYC_{k+1}$

Recall from Definition 3.2.1 the naïve column set $C_k(\mathcal{L})$ of nonzero vectors from \mathcal{L}^k , where here we may take $\mathcal{L} = \mathcal{L}_1 \cup \mathcal{L}_2 \cup \{0\}$.

Then, for $C = C_k(\mathcal{L})$ and $X = \{0, \pm 1\}$, starting **mncyc** with $S_2 = \{H_2, H_3, H_4\}$, then using each S_{k+1} as the input for the next round for $m - 2$ iterations will recover successive sets $MNCYC_3, \dots, MNCYC_m$ such that for any $n \leq m$ -vertex minimal noncyclotomic G containing a weight 2 edge, there is a representative of G in $MNCYC_n$.

However, as in Section 3.2.2, if the matrix $m_{c,x}$ is cyclotomic or minimal noncyclotomic for some c , then, by (complex) switching at the new vertex, so are the matrices $m_{\lambda c,x}$ for any $\lambda \in \mathcal{L}_1$, and they are equivalent to $m_{c,x}$. In each round, we may thus avoid redundant supermatrices by restricting our attention to the following:

Definition 6.3.10. Recall from Section 3.2.2 the *reduced naïve column set* $C_k'(\mathcal{L}) := C_k(\mathcal{L}) / \sim$, where

$$c = (c_1, \dots, c_k) \equiv c' \text{ if and only if } c' = (\lambda c_1, \dots, \lambda c_k) \text{ for some } \lambda \in \mathcal{L}_1$$

For a $k \times k$ matrix representative m of a k -vertex cyclotomic graph, let the *reduced naïve*

cyclotomic addition set of m be the set of $(k + 1) \times (k + 1)$ matrices

$$\text{super}'(m, \mathcal{L}, X) := \left\{ m_{c,x} = \begin{pmatrix} m & c \\ \bar{c} & x \end{pmatrix} \mid c \in C_{k'}(\mathcal{L}), x \in X, m_{c,x} \text{ cyclotomic} \right\}$$

With $C = C_{k'}(\mathcal{L})$ and a charge set X , the set S_{k+1} produced by **mncyc** is thus

$$\bigcup_{m \in S_k} \text{super}'(m, \mathcal{L}, X)$$

For small n , it is also possible to directly test matrices in the supersets for equivalence. Between rounds we may reduce sets $S_k, MNCYC_k$ in this way since if m_1, m_2 are strongly equivalent then any $m'_1 \in \text{super}'(m_1, \mathcal{L}, X)$ is equivalent to some $m'_2 \in \text{super}'(m_2, \mathcal{L}, X)$. However, the size of column sets grows exponentially, and since for an $n \times n$ noncyclotomic matrix testing minimality requires checking up to $n(n-1) \times (n-1)$ matrices for cyclotomicity, it rapidly becomes computationally infeasible. We thus seek to further optimise the search by excluding addition columns that cannot yield either a cyclotomic or minimal noncyclotomic supermatrix of a given seed matrix; thus saving the time required for their construction and testing. For later rounds, we may achieve this by using the results of Section 6.3.1 and a refinement of the growing algorithm:

Corollary 6.3.11. *For $k \geq 6$, the following modification of **mncyc** does not alter its output, but reduces computation time by preemptively discarding columns which (by Theorem 2.5.2 and Lemma 6.3.6) cannot yield supermatrices in S_{k+1} or $MNCYC_{k+1}$:*

Algorithm 5: bounded mncyc

Input: S_k, X, C **Output:** Sets $S_{k+1}, MNCYC_{k+1}$ of cyclotomic, minimal noncyclotomic supermatrices $S_{k+1} = \emptyset$ $MNCYC_{k+1} = \emptyset$ **for** $m \in S_k$ **do** $S_m = \emptyset$ $MNCYC_m = \emptyset$ $C_m = C$ **for** l from 1 to k **do** $rowWeights_l = \sum_{i=1}^k m_{l,i} \overline{m_{l,i}}$ **for** $c \in C$ **do** $newWeights_l = rowWeights_l + Norm(c_l)$ **if** $\max(newWeights) > 4$ **then** $C_m = C_m - \{c\}$ **for** $x \in X$ **do****for** $c \in C_m$ **do**

$$m_{c,x} = \begin{pmatrix} m & c \\ \bar{c} & x \end{pmatrix}$$

if $m_{c,x}$ is cyclotomic **then** $S_m = S_m \cup \{m_{c,x}\}$ **else****if** $m_{c,x}$ is minimal noncyclotomic **then** $MNCYC_m = MNCYC_m \cup \{m_{c,x}\}$ $S_{k+1} = S_{k+1} \cup S_m$ $MNCYC_{k+1} = MNCYC_{k+1} \cup MNCYC_m$ **return** $S_{k+1}, MNCYC_{k+1}$

The search

We therefore proceed as follows for the eight rounds necessary to generate representatives of all minimal noncyclotomic \mathcal{L} -graphs of ten or less vertices containing a weight 2 edge:

$n = 3$ We grow the seed set $\{H_2, H_3, H_4\}$ with reduced column set $C_{2'}(\mathcal{L})$ and charge set $\{0, \pm 1\}$. This yields 13 (13) 3-vertex cyclotomics, and 80 (161) minimal noncyclotomics for $d = -2$ ($d = -7$). We reduce these modulo equivalence (by brute force comparison of signed permutations) to 6 cyclotomics (both d) and 34 (67) minimal noncyclotomics for $d = -2$ ($d = -7$).

$n = 4$ We grow the sets S_3 with reduced column set $C_{3'}(\mathcal{L})$ and charge set $\{0, \pm 1\}$. This yields 16 (20) 4-vertex cyclotomics, and 129 (131) minimal noncyclotomics for $d = -2$ ($d = -7$). We

reduce these modulo equivalence (by brute force) to 12 (15) cyclotomics and 51 (61) minimal noncyclotomics for $d = -2$ ($d = -7$).

$n = 5$ We grow the sets S_4 with reduced column set $C_{4'}(\mathcal{L})$ and charge set $\{0, \pm 1\}$. This yields 36 (47) 5-vertex cyclotomics, and 48 (108) minimal noncyclotomics for $d = -2$ ($d = -7$). We reduce these modulo equivalence (by brute force) to 14 (17) cyclotomics, 14 (25) minimal noncyclotomics.

$n = 6$ From now on, we may apply Lemma 6.3.1. Thus we generate S_6 , $MNCYC_6$ from S_5 by two runs of **mncyc**- one uncharged only with $C = C_{5'}(\mathcal{L})$ and $X = \{0\}$, the other necessarily charged with $C = C_{5'}(\mathcal{L}_1 \cup \{0\})$, $X = \{\pm 1\}$ (that is, excluding addition vectors with entries from \mathcal{L}_2 , since for such a v $m_{v, \pm 1}$ is not in S_6 or $MNCYC_6$). In this way we obtain 54 (64) 6-vertex cyclotomics and 30 (40) minimal noncyclotomics for $d = -2$ ($d = -7$). Brute force reduction is no longer feasible, but by manipulation of graphical representatives we reduce the set of minimal noncyclotomics to 12 (17).

$n = 7$ As Lemmata 6.3.1 and 6.3.6 both now apply, we generate S_7 and $MNCYC_7$ from S_6 by **mncyc** with $C = C_{6'}^4(\mathcal{L})$, $X = \{0\}$ and $C = C_{6'}^3(\mathcal{L}_1 \cup \{0\})$, $X = \{\pm 1\}$. This ensures that the vertex x being added has weighted degree at most four, and that there is not a weight 2 edge incident at x if it is charged. We may also use bounded **mncyc** as described in Corollary 6.3.11. For both d we obtain only three minimal noncyclotomics, which are easily seen to be equivalent.

$n = 8$ Using Lemmata 6.3.1, 6.3.6 and Corollary 6.3.11, we generate S_8 and $MNCYC_8$ from S_7 by runs of bounded **mncyc** with $C = C_{7'}^4(\mathcal{L})$, $X = \{0\}$ and $C = C_{7'}^3(\mathcal{L}_1 \cup \{0\})$, $X = \{\pm 1\}$. For both d we obtain only three minimal noncyclotomics, which are easily seen to be equivalent.

$n = 9$ Using Lemmata 6.3.1, 6.3.6 and Corollary 6.3.11, we generate S_9 and $MNCYC_9$ from S_8 by runs of bounded **mncyc** with $C = C_{8'}^4(\mathcal{L})$, $X = \{0\}$ and $C = C_{8'}^3(\mathcal{L}_1 \cup \{0\})$, $X = \{\pm 1\}$. For both d we obtain only three minimal noncyclotomics, which are easily seen to be equivalent.

$n = 10$ For $d = -2$, using Lemmata 6.3.1, 6.3.6 and Corollary 6.3.11, we generate S_{10} and $MNCYC_{10}$ from S_9 by runs of bounded **mncyc** with $C = C_{9'}^4(\mathcal{L}_1 \cup \mathcal{L}_2 \cup \{0\})$, $X = \{0\}$ and $C = C_{9'}^3(\mathcal{L}_1 \cup \{0\})$, $X = \{\pm 1\}$.

For $d = -7$, we run bounded **mncyc** with $C = C_{9'}^3(\mathcal{L}_1 \cup \{0\})$, $X = \{\pm 1\}$; $C = C_{9'}^4(\mathcal{L}_1 \cup \{0\})$, $X = \{0\}$; and $C = C_{9'}^4(\mathcal{L}_2 \cup \{0\})$, $X = \{0\}$. By Lemmata 6.3.1, 6.3.6 and Corollary 6.3.11 this covers all potential cyclotomic additions from $C = C_{9'}^4(\mathcal{L})$, $X = \{0, \pm 1\}$ with the exception of vectors from $C = C_{9'}^4(\mathcal{L})$ containing entries from both \mathcal{L}_1 and \mathcal{L}_2 .

Let c be such a vector and consider a seed matrix $m \in S_9$; we wish to determine whether $m_{c,x}$ can be cyclotomic/minimal noncyclotomic. By Lemma 6.3.1 we need only consider $x = 0$. Let $c_i \in \mathcal{L}_2$ and $c_j, c_{j'} \in \mathcal{L}_1$ (if c has weight 3, take $j' = j$). Then if $\exists k$ such that $m_{i,k} \in \mathcal{L}_1$ then $m_{c,x}$ is noncyclotomic but not minimal by Lemma 6.3.3 (if $k = j$ or $k = j'$) or by Lemma 6.3.4 if $k \neq j, j'$. If there is no such k then by connectedness of m there exists k such that $m_{i,k} \in \mathcal{L}_2$. Now by Corollary 6.3.8 $m_{c,x}$ is noncyclotomic but not minimal if either $m_{k,j} = 0$ or $m_{k,j'} = 0$. This leaves only a few cases, which (after further discarding m, c pairs that would violate Lemma 6.3.6) we test for membership of $S_{10}, MNCYC_{10}$.

For each d we obtain only three minimal noncyclotomics, which are easily seen to be equivalent.

Representatives and Least Mahler Measures

Throughout, let $\omega = \sqrt{-2}$ or $\omega = \frac{1}{2} + \frac{\sqrt{-7}}{2}$ for $d = -2, -7$ respectively.

$n = 3, d = -2$ We have 34 classes, with Mahler measure at least 1.401... and representatives

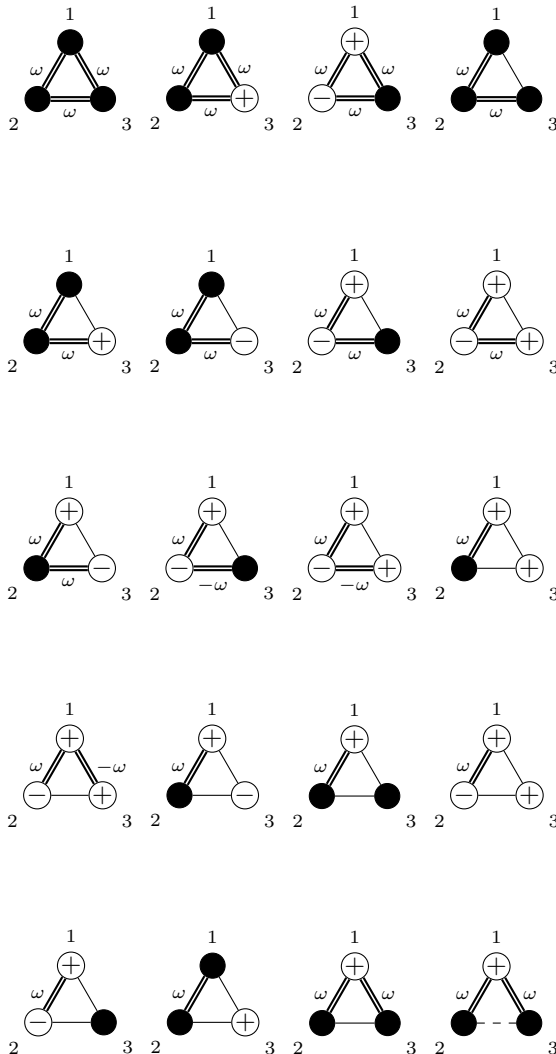

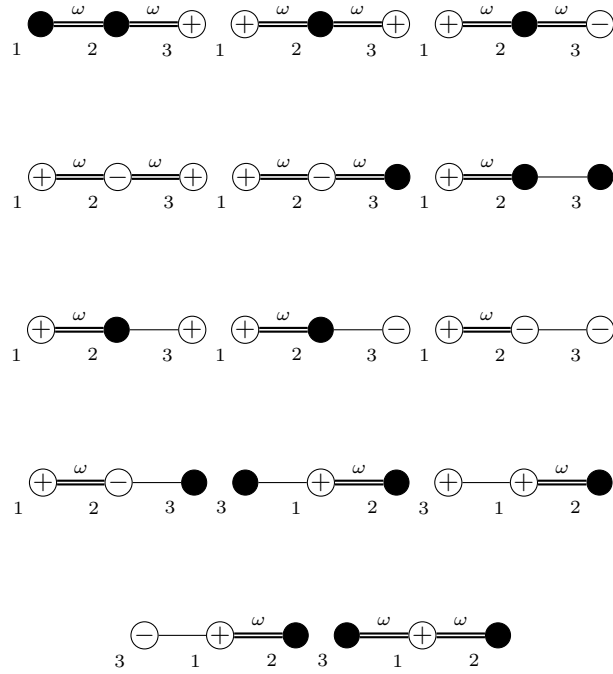

$n = 3, d = -7$ We have 67 classes, with Mahler measure at least 1.401... and representatives

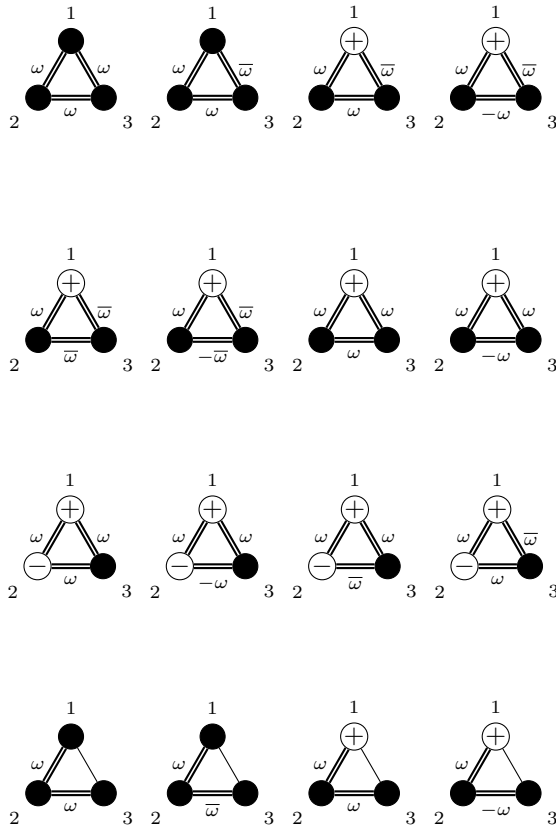

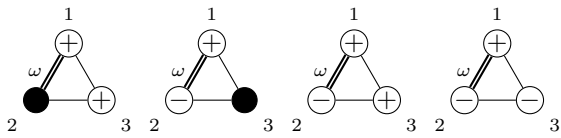
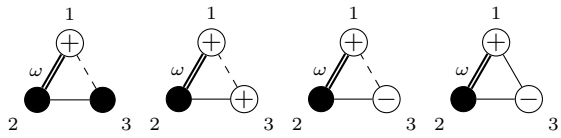
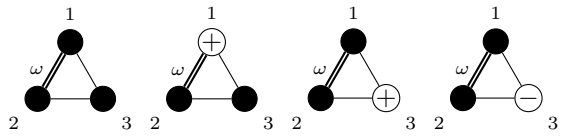
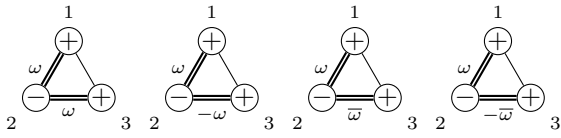
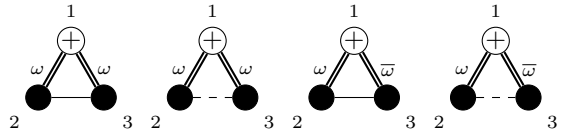
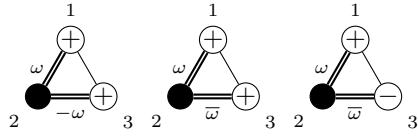
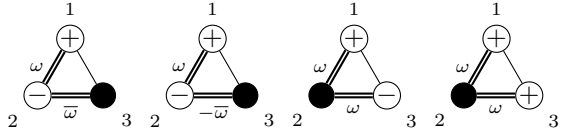
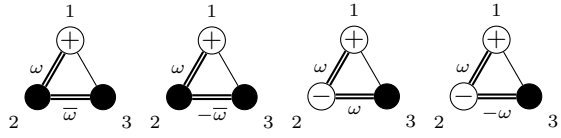

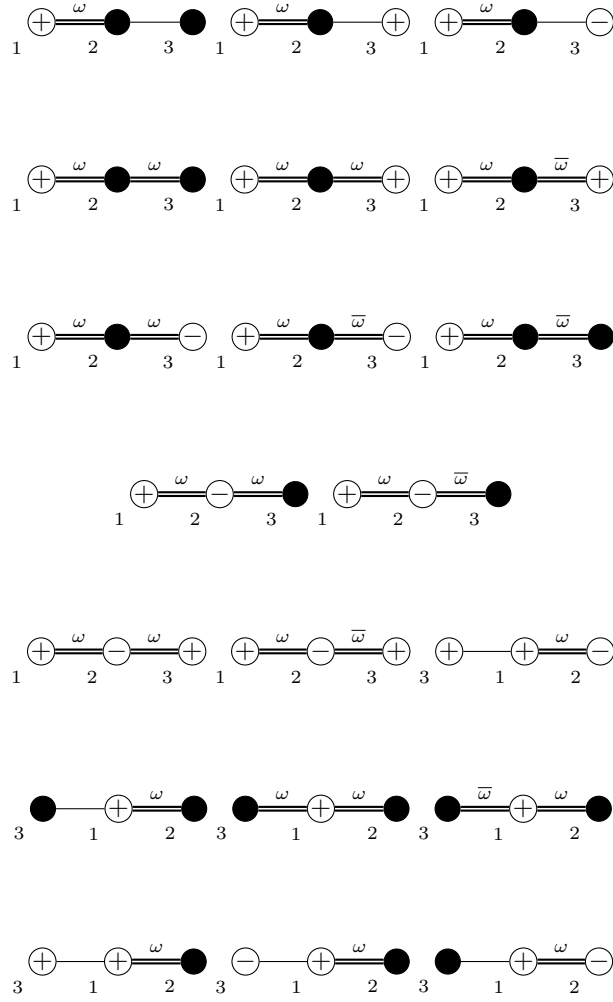

$n = 4, d = -2$ We have 51 classes, with Mahler measure at least 1.401... and representatives

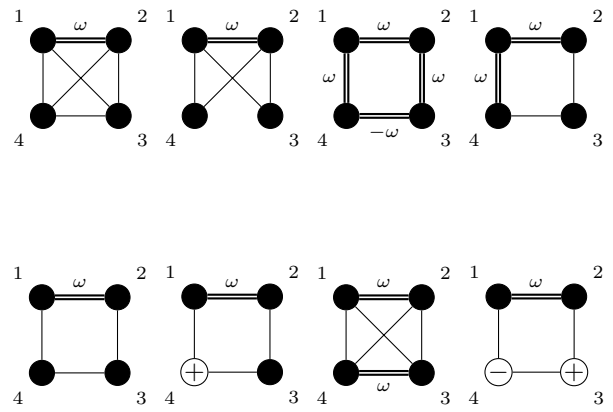

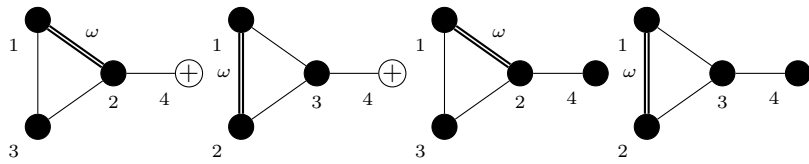
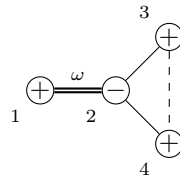
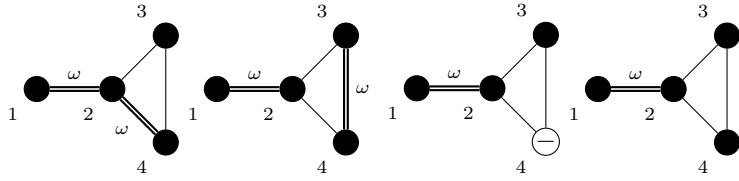
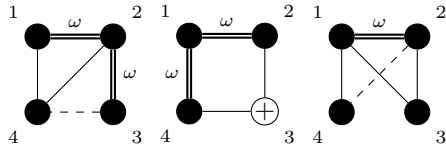
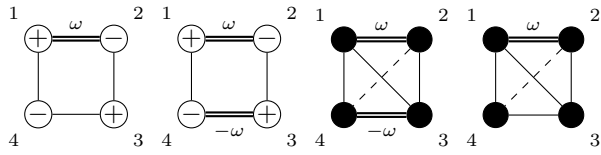
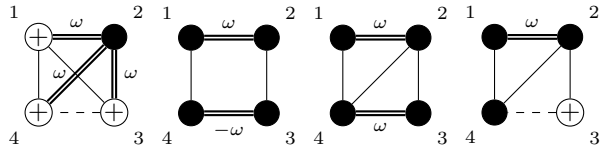
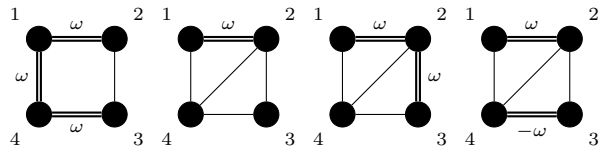

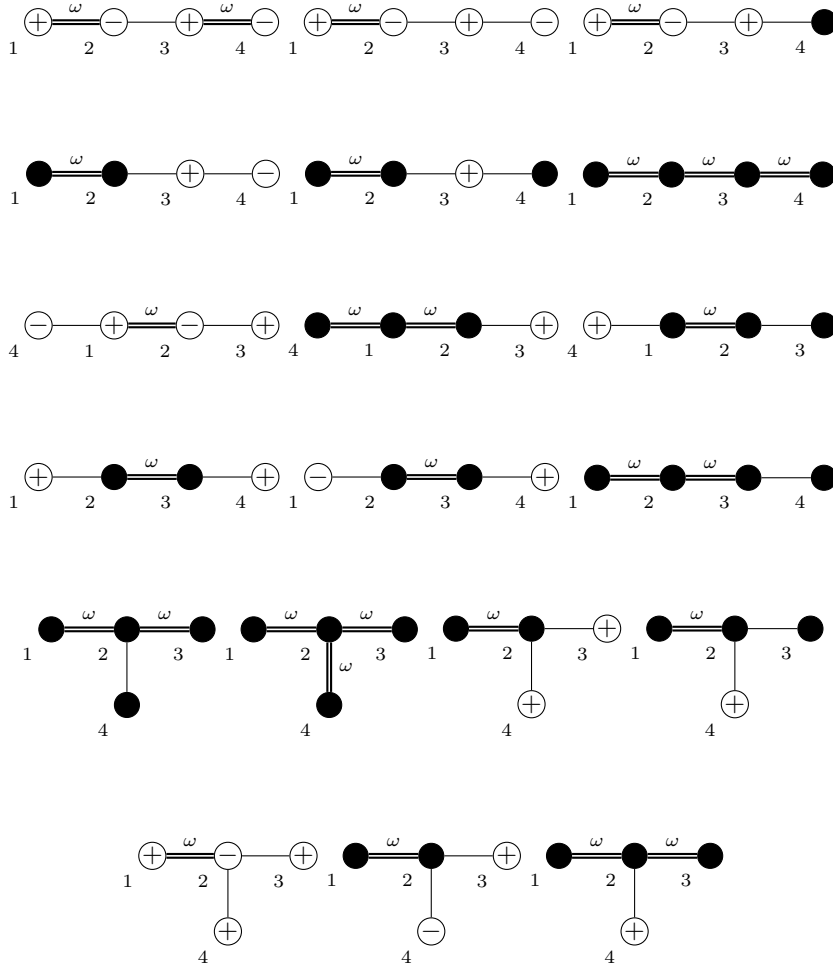

$n = 4, d = -7$ We have 61 classes, with Mahler measure at least 1.401... and representatives

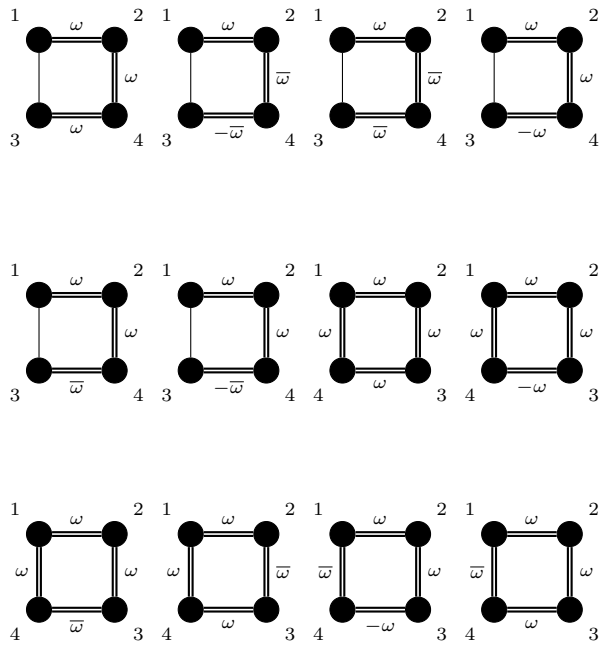

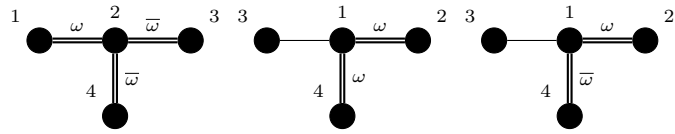
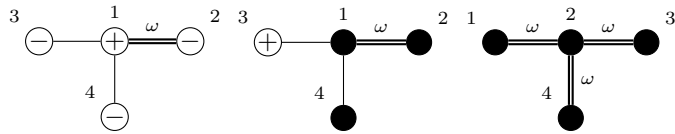
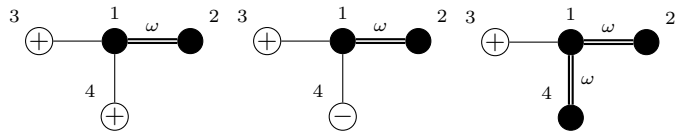
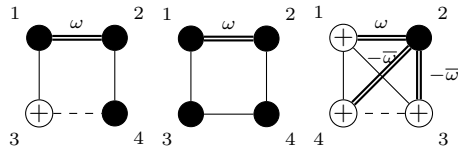
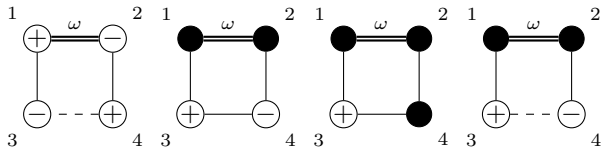
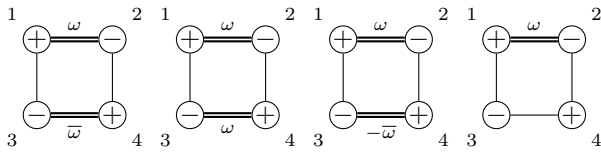
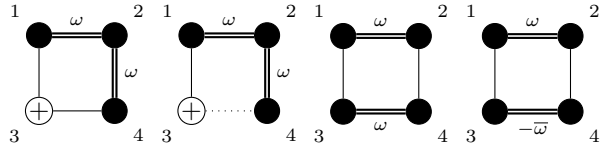
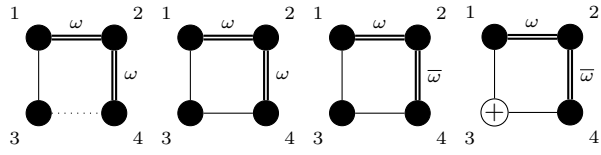

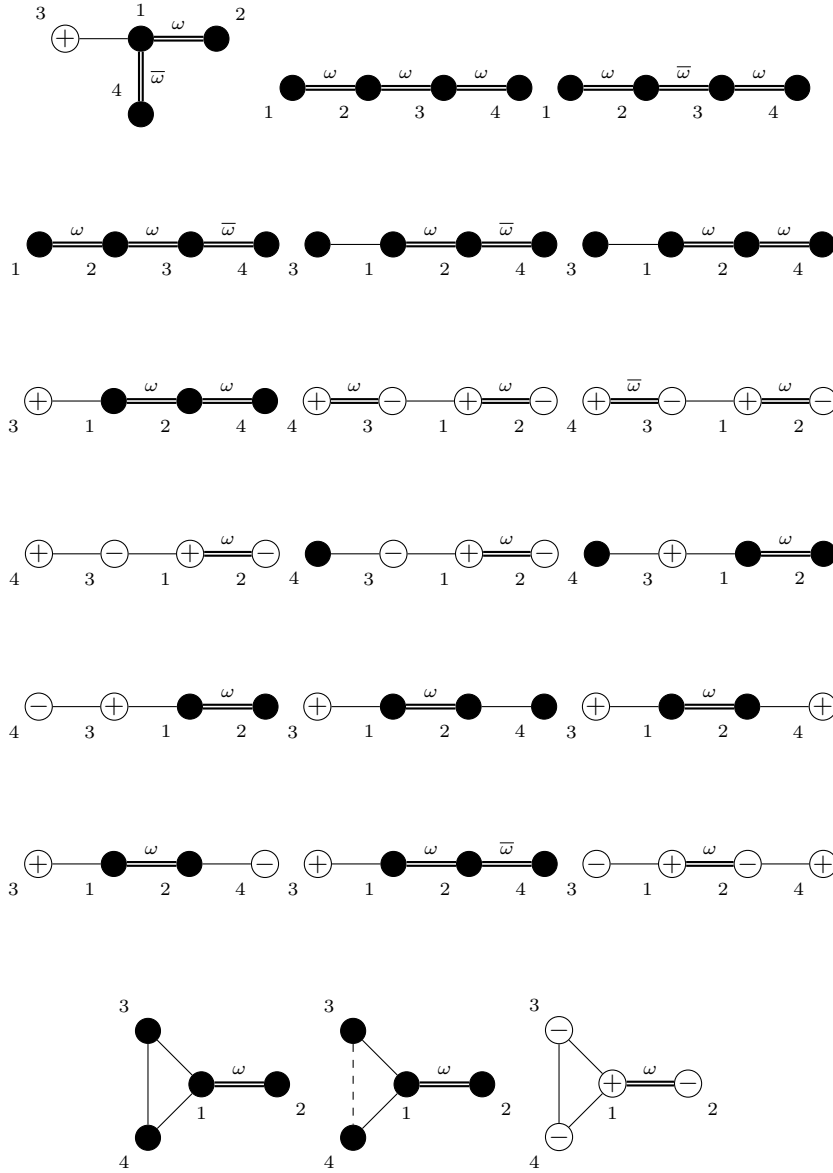

$n = 5, d = -2$ We have 14 classes, with Mahler measure at least 1.351... and representatives

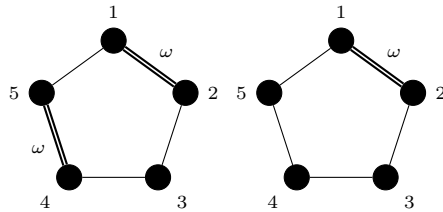

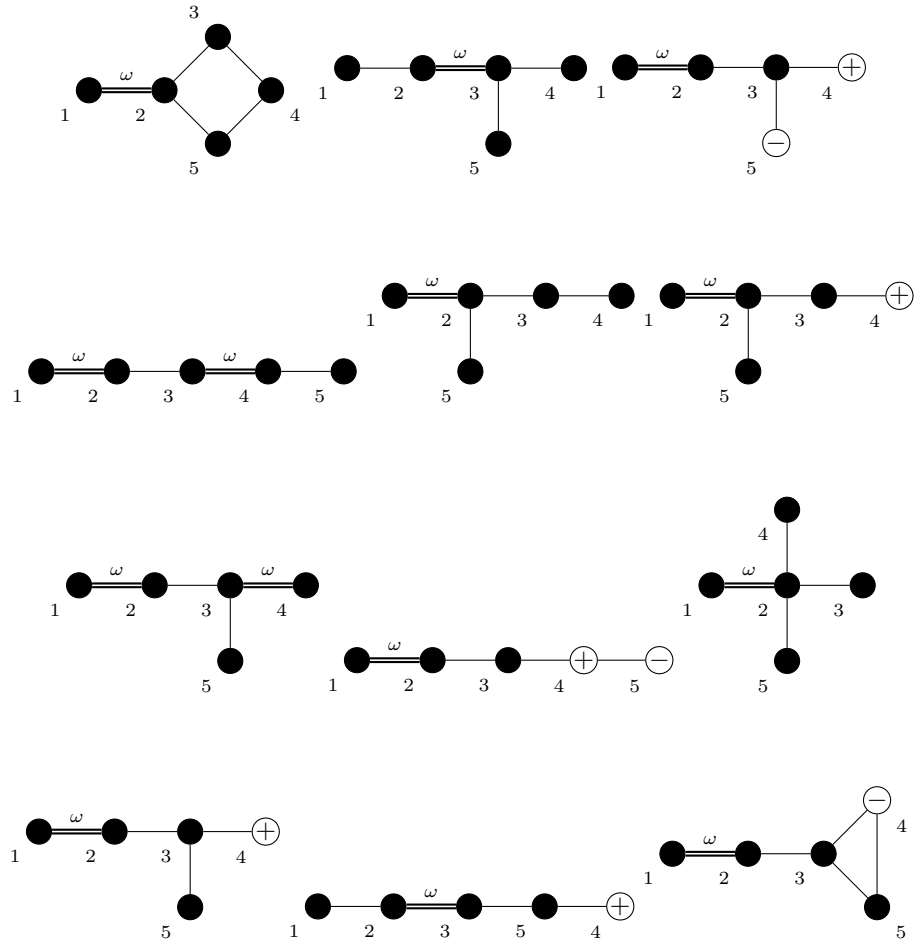

$n = 5, d = -7$ We have 25 classes, with Mahler measure at least 1.351... and representatives

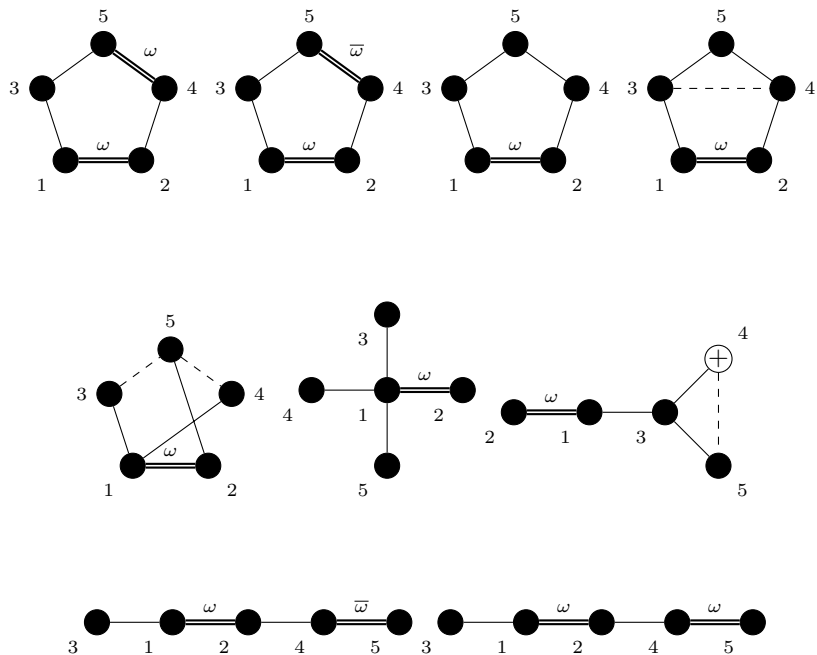

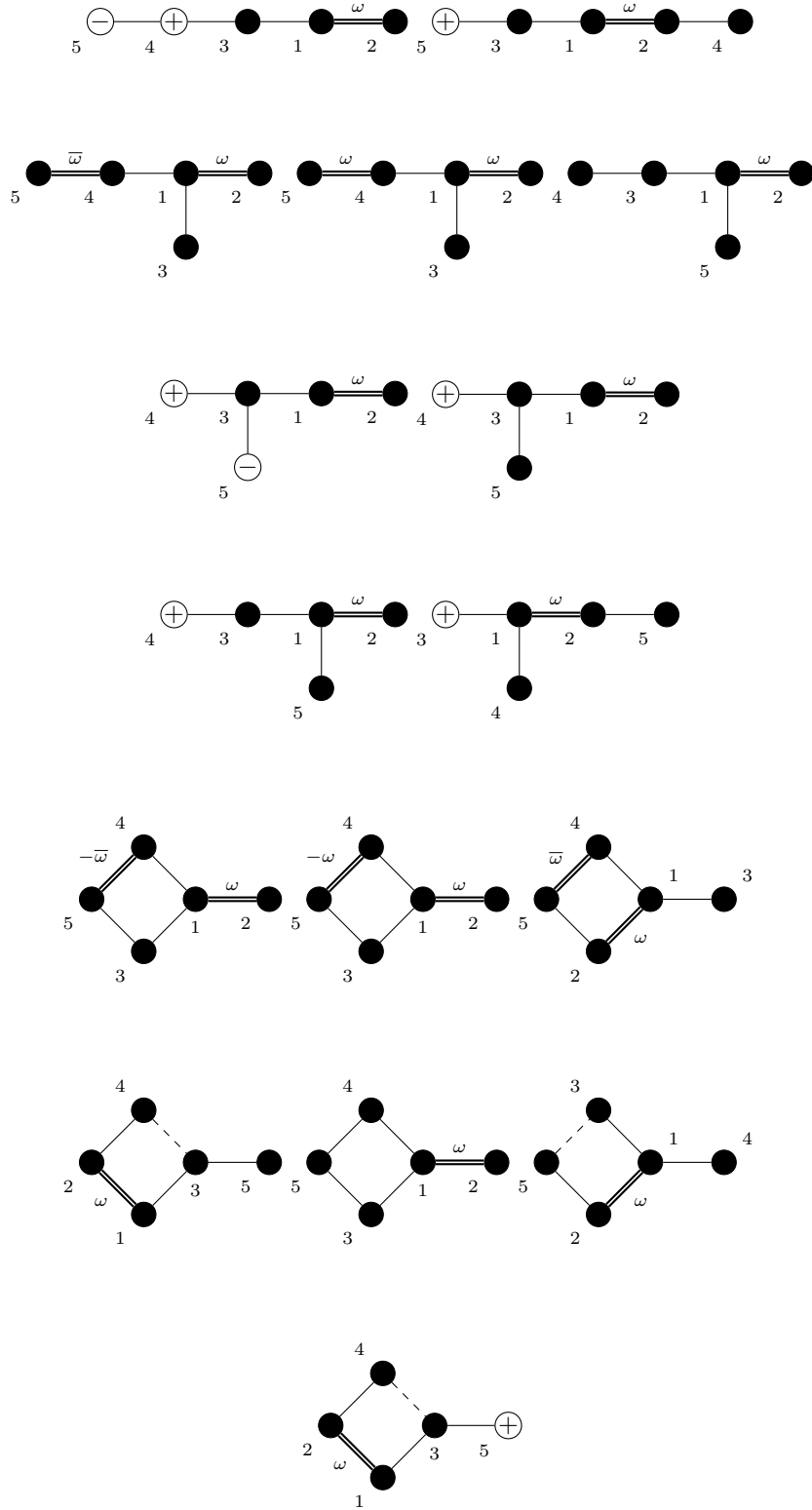

$n = 6, d = -2$ We have 12 classes, with Mahler measure at least 1.401... and representatives



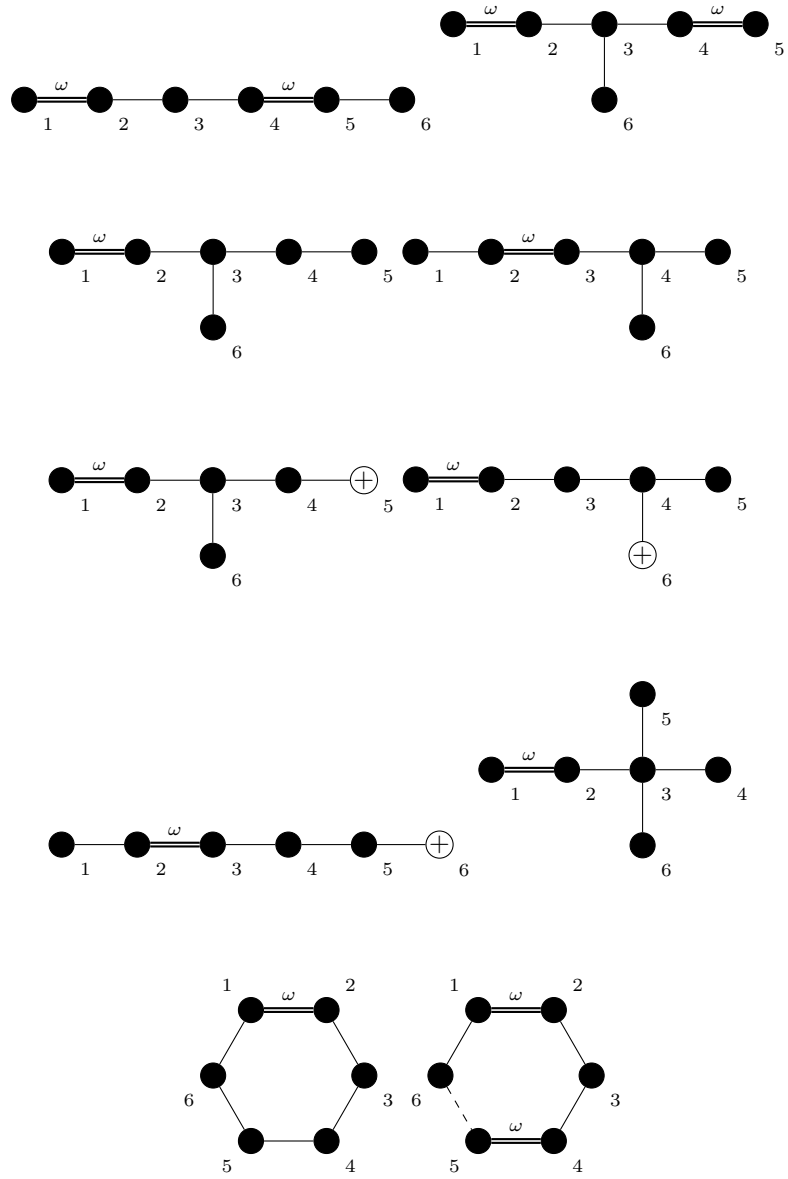

$n = 6, d = -7$ We have 17 classes, with Mahler measure at least 1.401... and representatives

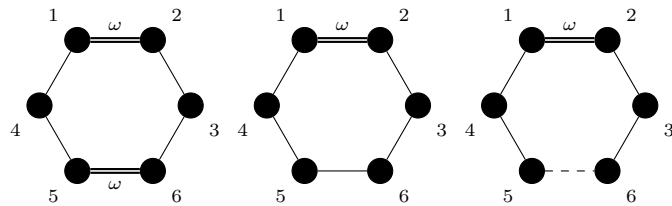

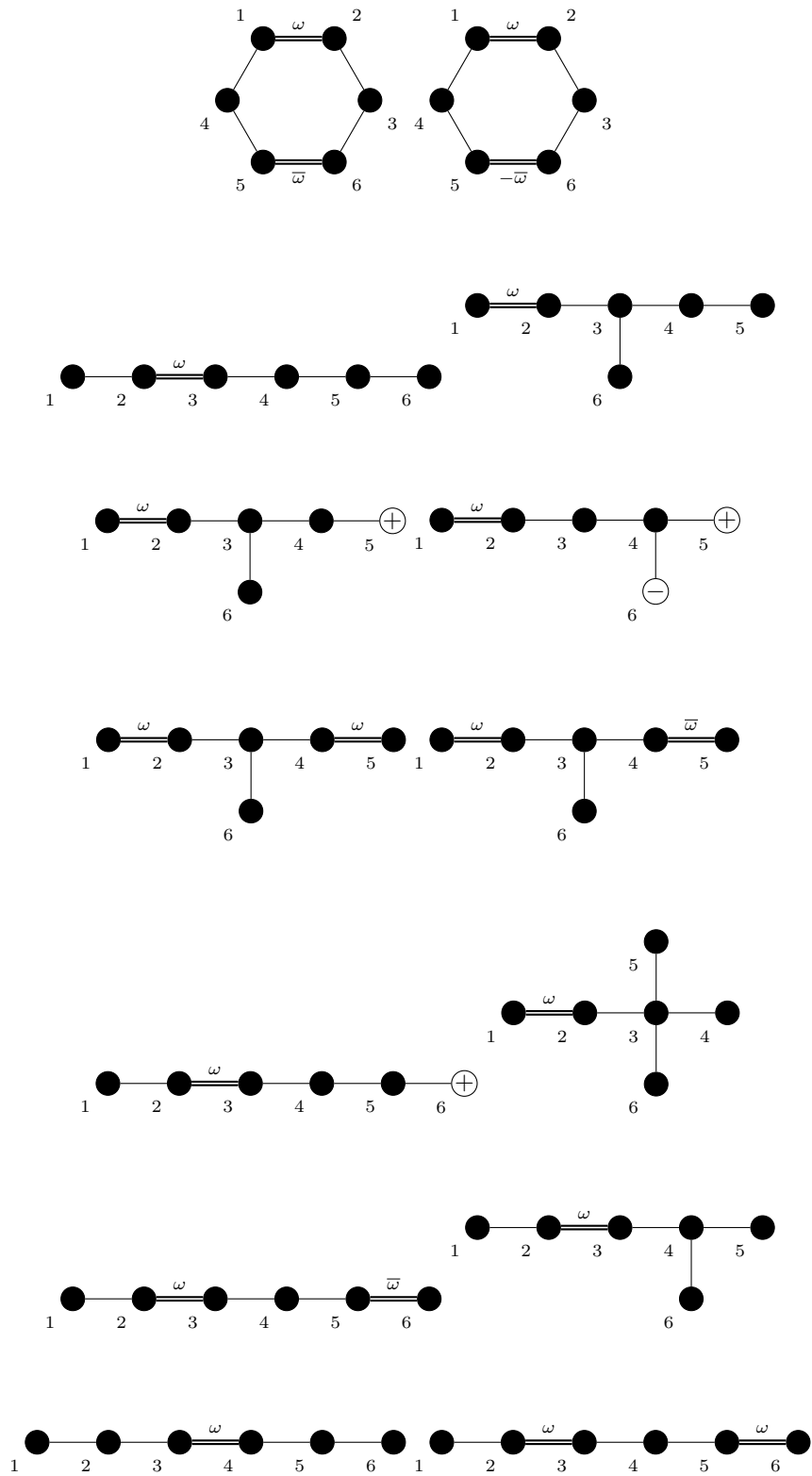

$7 \leq n \leq 10$ For each such n there is only a single minimal noncyclotomic class, with representative G_n (where $\omega = \sqrt{-2}, \frac{1}{2} + \frac{\sqrt{-7}}{2}$ for $d = -2, -7$ respectively):

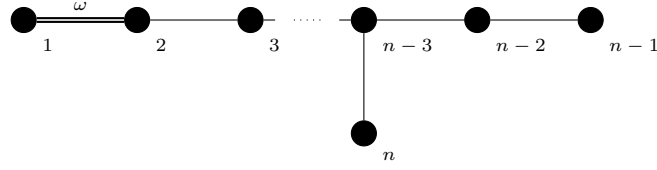

and Mahler measures $1.506\dots, 1.458\dots, 1.425\dots, 1.401\dots$ for $n = 7, 8, 9, 10$ respectively.

We note that the \mathcal{L} -graph G_n for $n \geq 11$ is not minimal noncyclotomic, since the induced subgraph H_{n-1} on vertices $2, \dots, n$ is not cyclotomic. However, for $n \geq 11$ we may obtain an \mathcal{L} -graph with Mahler measure smaller than the value $1.401\dots$ observed for $n = 10$ but, as H_{n-1} is a noncyclotomic signed graph it has Mahler measure at least λ_0 and thus so does G_n by Interlacing.

6.3.3 Large Minimal Noncyclotomic \mathcal{L} -Graphs

We will prove that the results of the previous Section provide a complete classification of the minimal noncyclotomics for $d = -2, -7$, by showing the following:

Theorem 6.3.12. *For $d = -2, -7$, Let G be a connected \mathcal{L} -graph including at least one edge label from \mathcal{L}_2 . If G has eleven or more vertices, then it is not minimal noncyclotomic.*

6.3.4 Supersporadics

For $d = -2, -7$, let \mathcal{S}_d be the set of representatives of the sporadic 4-cyclotomic graphs with edges of weight at most 2 over $\mathcal{O}_{\mathbb{Q}(\sqrt{d})}$. So (from Theorem 5.6.1)

$$\mathcal{S}_{-2} = \{S_4, S_4^*, S_7, S_8, S_8', S_8^*, S_{14}, S_{16}\}$$

and (from Theorem 5.6.2)

$$\mathcal{S}_{-7} = \{S_4, S_6^\dagger, S_7, S_8, S_8', S_8^*, S_{14}, S_{16}\}$$

Definition 6.3.13. For $d = -2, -7$ we describe a minimal noncyclotomic \mathcal{L} -graph with n -vertices as *supersporadic* if it has a connected subgraph with $n - 1$ vertices that is equivalent to a subgraph H of some $G \in \mathcal{S}_d$.

The set of supersporadic minimal noncyclotomic \mathcal{L} -graphs is finite, and could (in principle) be computed from the set of all subgraphs of each $G \in \mathcal{S}_d$ by considering all possible single-vertex

additions to each such subgraph. Supersporadic minimal noncyclotomic charged signed graphs have been classified in [15], so we need only identify \mathcal{L} -graphs with at least one edge label from \mathcal{L}_2 . As such, by the results of the previous Section, we need only consider graphs with at least 11 vertices. Thus we seek connected minimal noncyclotomic \mathcal{L} -graphs G obtained by the noncyclotomic addition of a vertex x to a k -vertex subgraph H of S_{14} or S_{16} , for $k \geq 10$. As G therefore has $k+1 \geq 11$ vertices, Lemma 6.3.6 applies, so (determining G up to equivalence) the addition column c may be assumed to be from $C_{k'}^A(\mathcal{L})$. Since all the H are cyclotomic signed graphs, the addition vector c necessarily contains an entry from \mathcal{L}_2 , and so by Lemma 6.3.1 x (and hence the whole of G) is uncharged.

Lemma 6.3.14. *Let $c \in C_{k'}^A(\mathcal{L})$ with $c_i \in \mathcal{L}_2$ for some i . Let m be a representative of a connected $n \geq 10$ -vertex subgraph H of S_{14} or S_{16} . If $c \notin C_{k'}^A(\mathcal{L}_2 \cup \{0\})$ then the \mathcal{L} -graph G with representative $m_{c,0}$ cannot be minimal noncyclotomic.*

Proof. Let j be any neighbour of vertex i in H ; by connectedness, there is at least one, and $e_{i,j} \in \mathcal{L}_1$ since H is a signed graph. Now suppose there exists l such that $c_l \in \mathcal{L}_1$. If $l = j$ then the subgraph on vertices x, i, j ensures the nonminimality of G by Lemma 6.3.3. Otherwise, the subpath on vertices l, x, i, j ensures the non-minimality of G by Lemma 6.3.4. \square

Lemma 6.3.15. *For $k \geq 10$, let H be a disconnected k -vertex subgraph of S_{14} or S_{16} with matrix representative m such that no connected component of H consists of a single vertex. If G is the graph of $m_{c,0}$ for any $c \in C_{k'}^A(\mathcal{L})$ such that at least one entry of c has weight 2, then G is not minimal noncyclotomic.*

Proof. We may assume that G is connected, else it cannot be minimal noncyclotomic. Let i be such that $c_i \in \mathcal{L}_2$. H contains at least two distinct connected components X_1, X_2 ; w.l.o.g let $i \in X_1$. For connectedness, the vertex x added must have neighbours in both X_1, X_2 : pick any $j \in X_2$ such that $c_j \neq 0$, plus a neighbour $l \in X_1$ of i . If $c_j \in \mathcal{L}_1$ then the subgraph on vertices l, i, x, j contains a $\mathcal{L}_1, \mathcal{L}_2, \mathcal{L}_1$ path; as G has at least 11 vertices it cannot be minimal noncyclotomic by Lemma 6.3.4. If instead $c_j \in \mathcal{L}_2$, then vertices i, j both have x as a neighbour yet l is not a neighbour of j , so by Corollary 6.3.8 G is not minimal noncyclotomic. \square

Thus for each $10 \leq k \leq 16$ we determine seed sets S_k of representatives of the k -vertex subgraphs of S_{14} and S_{16} and partition each into two subsets: connected and disconnected. By Lemma 6.3.15, we may discard any disconnected seed that does not have at least one vertex which is its own connected component. For the connected seeds, by Lemma 6.3.14 we use **mncyc** with $C = C_{k'}^A(\mathcal{L}_2 \cup \{0\})$, $X = \{0\}$, whilst for the remaining disconnected seeds we take $C = C_{k'}^A(\mathcal{L})$, $X = \{0\}$, with the restriction that at least one entry of each $c \in C$ is of weight 2. In both cases, we may apply bounded **mncyc** as described in Corollary 6.3.11. For each m we may further discard any addition column c that induces a triangle in the graph G of $m_{c,0}$: such

a triangle will be uncharged and contain at most two weight 2 edges, so by Lemma 6.3.3, 6.3.2 or 6.3.5 G cannot be minimal noncyclotomic.

Subject to these conditions, for each seed set the bounded **mncyc** process yields no minimal noncyclotomic \mathcal{L} -graphs. In [15] it is shown that a minimal noncyclotomic charged signed graph has at most ten vertices. Thus:

Proposition 6.3.16. *For $d = -2, -7$, a supersporadic minimal noncyclotomic \mathcal{L} -graph has at most ten vertices.*

6.3.5 Non-Supersporadics

Let G be an n -vertex minimal noncyclotomic \mathcal{L} -graph with a weight 2 edge. If $n \leq 10$, then G has already been classified. Otherwise $n \geq 11$ and each of the $(n - 1)$ -vertex subgraphs G'_i of G must be cyclotomic. By the previous Section G cannot then be supersporadic so the G'_i (and hence their subgraphs) are equivalent to subgraphs of some $\mathcal{T}_{2k}, \mathcal{C}_{2k}^{+\pm}, \mathcal{C}_{2k}^{2\pm}$ or \mathcal{T}_{2k}^4 . The following result thus completes the proof of Theorem 6.3.12:

Proposition 6.3.17. *Let G be an $(n \geq 11)$ -vertex connected \mathcal{L} -graph such that every proper connected subgraph of G is equivalent to a subgraph of some $\mathcal{T}_{2k}, \mathcal{C}_{2k}^{+\pm}, \mathcal{C}_{2k}^{2+}$ or \mathcal{T}_{2k}^4 . Then G is also equivalent to a subgraph of some $\mathcal{T}_{2k}, \mathcal{C}_{2k}^{+\pm}, \mathcal{C}_{2k}^{2+}$ or \mathcal{T}_{2k}^4 .*

From [15], this result holds for any connected charged signed graph G and so we may assume that G contains a weight 2 edge.

Profiles

The following definitions and notation are essentially as in [15] Section 4.1.

Definition 6.3.18. An uncharged \mathcal{L} -graph *has a profile* if its vertex set can be partitioned into a sequence of $k \geq 3$ subsets V_1, \dots, V_k so that either

- two vertices are adjacent if and only if for some i one belongs to V_i and the other to V_{i+1} ;

or

- two vertices are adjacent if and only if for some i one belongs to V_i and the other to V_{i+1} or one belongs to V_k and the other to V_1 (in this case, the profile is described as *cycling*).

The V_i are described as the *columns* of the profile; we will be interested only in profiles where each column contains at most two vertices. For a vertex v in a 2-vertex column, the other vertex in that column will be denoted \bar{v} , the *conjugate* of v .

For charged graphs, we extend the definition by introducing the requirement that each column contains only neutral vertices or only charged vertices all of the same charge, but relaxing the adjacency rule such that xy is an edge in G if and only if *either* x and y are in adjacent columns *or* are charged vertices in the same column.

Definition 6.3.19. If G has a profile, then we define the *rank* to be the number of columns in this profile.

Definition 6.3.20. For an \mathcal{L} -graph G we describe a path or cycle P as *chordless* if it has the property that if two vertices of P are adjacent in G then they are also adjacent in P . Then the *path rank* of G is the maximum number of vertices taken over all chordless paths and chordless cycles of G .

Proposition 6.3.21. *The $2k$ -vertex graph T_{2k} has a cycling profile of rank k :*

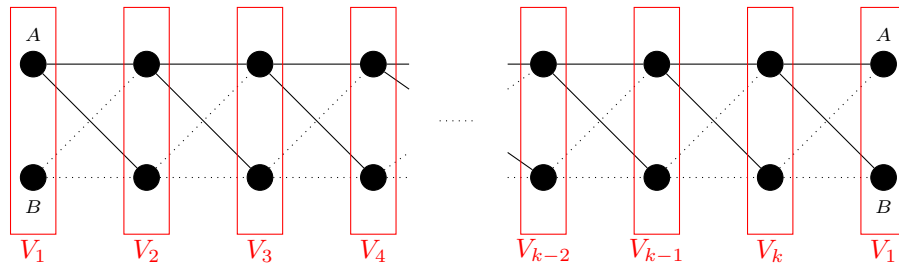

Proposition 6.3.22. *The $2k$ -vertex graph C_{2k}^{++} has a profile of rank k :*

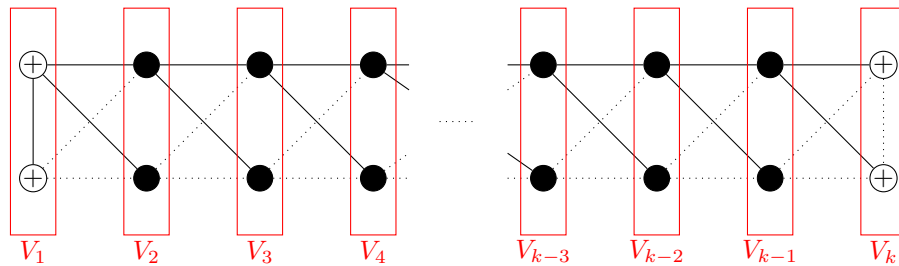

as does C_{2k}^{+-} .

Proposition 6.3.23. *The $2k$ -vertex graphs $T_{2k}^A, T_{2k}^{A'}$ (with A, B as in Corollaries 2.6.20, 2.6.21) have a profile of rank $k + 1$:*

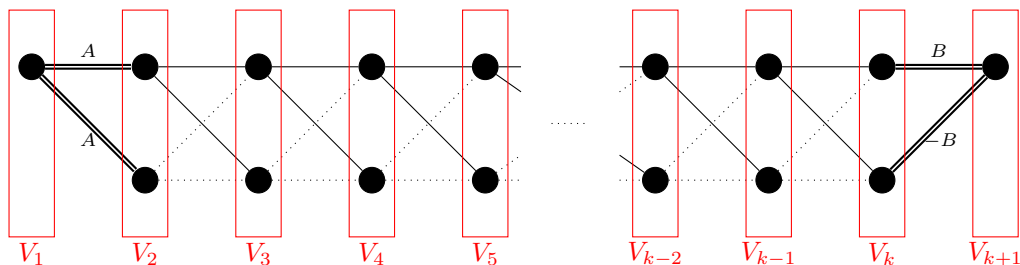

Proposition 6.3.24. *The $2k+1$ -vertex graph C_{2k}^{2+} (with A as in Corollary 2.6.26) has a profile of rank $k+1$:*

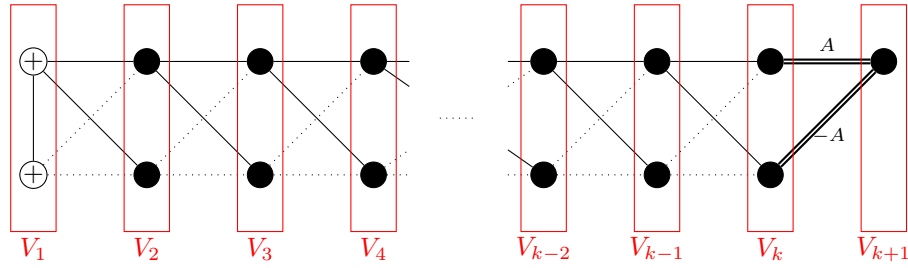

Lemma 6.3.25. *Let G be equivalent to a connected subgraph of one of T_{2k} , $C_{2k}^{+\pm}$, C_{2k}^{2+} , T_{2k}^4 or $T_{2k}^{4'}$. If G has path rank at least 5 then this equals its profile rank, and its columns are uniquely determined. Moreover, their order is determined up to reversal or cycling.*

For G equivalent to a connected subgraph of T_{2k} , C_{2k}^{++} or C_{2k}^{+-} , this is the content of Lemma 6 in [15]; we note the remark there that the result is best possible, in the sense that it is false if ‘5’ is replaced with ‘4’ (as the example of T_8 shows). The proof carries over immediately to the remaining cases C_{2k}^{2+} and T_{2k}^4 , but we include it here for completeness.

Proof. Let P be a chordless path or cycle with the maximal number of vertices r . As $r \geq 5$ no two of these vertices are in the same column. Each column of G contains exactly one vertex in P , so the profile rank equals the path rank. Each column in the profile of P inherited from that of G contains only a single vertex; we may recover the profile of G by adding the vertices of $G - P$ to those columns. Because $r \geq 5$ there is only one valid column for each such vertex, determined by its neighbours in G . The last sentence is clear. \square

Subgraph Conditions

As drawn in Propositions 6.3.21-6.3.5, any induced 4-cycle in a subgraph of rank at least 5 must be one of the following:

Hourglass 4-cycles Underlying graph of form

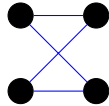

Parallelogram 4-cycles Underlying graph of one of the forms

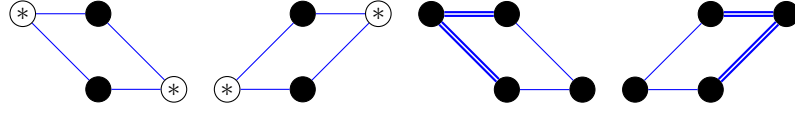

Triangular 4-cycles Underlying graph of one of the forms

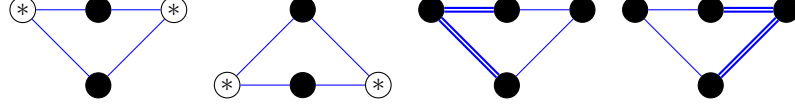

Further, choosing a numbering on the \mathcal{L} -graphs $T_{2k}^4, T_{2k}^{4'}$ and C_{2k}^{2+} as in Corollaries 2.6.20, 2.6.21, 2.6.26 fixes their weight 2 edge labels. For $d = -2$, we define an edge to be *positive* if it has label $+1$ or $\omega = \sqrt{-2}$; otherwise (label from $\{-1, -\sqrt{-2}\}$) we call it *negative*. For $d = -7$, we define an edge to be *positive* if it has label from $\{+1, \omega = \frac{1}{2} + \frac{\sqrt{-7}}{2}, \bar{\omega}\}$ or *negative* if it has label from $\{-1, -\omega, -\bar{\omega}\}$.

Proposition 6.3.26. (i) *Let H be a signed graph of rank at least 5 that has, for some k , an underlying graph of the same form as a subgraph of T_{2k} , as drawn in Proposition 6.3.21. Then H is equivalent to a subgraph G of T_{2k} if and only if*

- *The hourglass 4-cycles all have an even number of positive edges;*
- *The parallelogram 4-cycles all have an odd number of positive edges;*
- *The triangular 4-cycles all have an odd number of positive edges.*

(ii) *Let H be a charged signed graph of rank at least 5 that has, for some k , the same underlying graph as a subgraph of C_{2k}^{++} or C_{2k}^{+-} , drawn as in Proposition 6.3.22. Then H is equivalent to a subgraph G of C_{2k}^{++} or C_{2k}^{+-} if and only if*

- *The hourglass 4-cycles all have an even number of positive edges;*
- *The parallelogram 4-cycles all have an off number of positive edges;*
- *The triangular 4-cycles all have an odd number of positive edges;*
- *The triangles containing two charged vertices in the subgraph have the property that if the charges are positive (respectively negative) then the triangle has an even number of positive (resp. negative) edges.*

(iii) *Let H be an uncharged \mathcal{L} -graph of rank at least 5 that has, for some k , an underlying graph of the same form as a subgraph of T_{2k}^4 or $T_{2k}^{4'}$, as drawn in Proposition 6.3.23 with numbering*

as in Corollary 2.6.20/2.6.21. Then H is equivalent to a subgraph G of T_{2k}^4 or $T_{2k}^{4'}$ if and only if

- The hourglass 4-cycles all have an even number of positive edges;
- The parallelogram 4-cycles all have an odd number of positive edges;
- The triangular 4-cycles all have an odd number of positive edges.

(iv) Let H be a charged \mathcal{L} -graph of rank at least 5 that has, for some k , an underlying graph of the same form as a subgraph of C_{2k}^{2+} or C_{2k}^{2-} , as drawn in Proposition 6.3.5 with numbering as in Corollary 2.6.26. Then H is equivalent to a subgraph G of C_{2k}^{2+} if and only if

- The hourglass 4-cycles all have an even number of positive edges;
- The parallelogram 4-cycles all have an odd number of positive edges;
- The triangular 4-cycles all have an odd number of positive edges;
- The triangles containing two charged vertices in the subgraph have the property that if the charges are positive (respectively negative) then the triangle has an even number of positive (resp. negative) edges.

Proof. We note that (i) and (ii) hold by Proposition 7 of [15]; we will adopt the same techniques to prove (iii) and (iv).

We first show that the conditions given in Proposition 6.3.26 are necessary. Since H has rank at least 5, by Lemma 6.3.25 the columns of its profile are uniquely determined. Thus by our standard drawings in Propositions 6.3.21-6.3.5 each 4-cycle of H is either

- an hourglass

or

- a parallelogram 4-cycle or triangular 4-cycle. (Interchanging the position of conjugate vertices in the drawing may cause parallelograms to become triangular, and vice versa).

Since each 4-cycle is even length and contains zero or two edges of weight 2, the equivalence relation operations (permutation, switching, conjugation) will preserve the parity of the number of positive edges in each cycle, proving necessity. We now assume that the given conditions hold, and prove that they are sufficient: that our given subgraph is equivalent to a subgraph of $T_{2k}, C_{2k}^{+\pm}, C_{2k}^{2+}, T_{2k}^4$ or $T_{2k}^{4'}$. To do this, we need to embed an \mathcal{L} -graph equivalent to H into one of $T_{2k}, C_{2k}^{+\pm}, C_{2k}^{2+}, T_{2k}^4$ or $T_{2k}^{4'}$ so that the resultant embedding G inherits its edge and vertex signs from the \mathcal{L} -graph it is embedded into. Cases (i) and (ii) hold by Proposition 7 of [15]; for (iii) and (iv) we may assume that H contains at least one edge of weight 2 else the conditions for that result are met with H equivalent to a subgraph of T_{2k}, C_{2k}^{++} or C_{2k}^{+-} .

- (iii) Given that H contains a weight 2 edge it cannot be equivalent to a subgraph of T_{2k}, C_{2k}^{++} or C_{2k}^{+-} , and as it is uncharged we therefore seek to embed an equivalent of H in T_{2k}^4 (or $T_{2k}^{4'}$ for $d = -7$).

Let P be a maximum-length chordless path or cycle in H ; since no chordless cycle in the underlying graph of T_{2k}^4 or $T_{2k}^{4'}$ has length greater than 4 but H has rank at least 5, P is necessarily a chordless path. Let it have length l' , joining vertices v_1, \dots, v_l ; by switching, we can ensure that it has all edge labels positive.

Let e be an edge of weight 2 in H ; w.l.o.g we may draw H such that e is the leftmost edge joining vertices 1 and $2L + 1$ (as numbered in Corollaries 2.6.20 and 2.6.21). Any longest rational integer path P' in T_{2k}^4 or $T_{2k}^{4'}$ is at most $L = k - 1$ vertices long. Consider its leftmost vertices v_1, v_2 . If $v_1 = 1$ then a longer chordless path is obtained by starting at $2L + 1$ then proceeding as in P' via 1; if column $V_1 \neq \{1\}$ then both vertices 1 and $L + 1$ are in H (else redraw and take $L + 1$ as 1) so there is a longer path through $2L + 1, 1, v_2$ then proceeding as in P' . So the longest chordless path cannot have all edges rational integers and we may assume that the first edge of P is of weight 2.

Now either the edge between vertices v_{l-1}, v_l of P is weight 2, or it isn't. If it is, we may embed P into the top edge of $T = T_{2l-2}^4$ (or, for $d = -7$, $T = T_{2l-2}^{4'}$ if the second weight 2 edge label is complex conjugate to the first); otherwise, embed into $T = T_{2l}^4$. In either case, all the relevant edges are positive as required. We may now proceed as in case (i) in [15]; the next two paragraphs are essentially identical to that proof.

We can now embed into T those conjugates of v_1, \dots, v_l that are present in H , by placing them in their appropriate columns on the bottom row of T : note that triangular 4-cycles in H may become parallelogram 4-cycles, and vice versa, by this process (if P moved between the top and bottom rows of the original drawing). This induces an embedding G of H in T , though without the signs of the edges yet agreeing. To achieve this agreement, we switch at these newly embedded vertices, if necessary, to ensure that all edges of negative slope have positive sign. We also switch at any vertex in the bottom row that has no incident edge of negative slope, if necessary, to ensure that the incident edge of positive slope has negative sign.

We next claim that, after making these switchings, all edges of the embedding G do indeed have the same sign as the edges of T . First consider an edge of G of positive slope. If not already made to have negative sign, such an edge must be part of a triangular 4-cycle where the two horizontal edges and the edge of negative slope all have positive sign. Hence, by the stated triangular 4-cycle condition, the edge of positive slope must have negative sign. (Note that because both the stated parallelogram 4-cycle condition and the triangular 4-cycle condition hold for H , the triangular 4-cycle condition holds for G .) Finally, every horizontal edge on the second row is part of an hourglass 4-cycle,

which implies that it must have negative sign.

- (iv) Again, consider a maximum length chordless path P in H . If no vertex is charged then P could be embedded in T_{2k}^4 or $T_{2k}^{4'}$. So we may assume that P contains a charged vertex: by the profile of $C_{2k}^{2\pm}$, this must be an end vertex of P . Further, by maximality, P must terminate with a weight 2 edge. Negating if necessary we may assume that the charged vertex is positive, and by switching we may ensure that all edges of P are positive, and by taking the complex conjugate if necessary that the weight 2 edge is ω . Then such a P with k' vertices can be embedded sign-consistently into the top row of $C_{2(k'-1)}^{2+}$. We then proceed as in (iii), which ensures that all horizontal edges, and those of positive or negative slope, have the correct sign. Finally, the triangle condition ensures that the vertical edge must have positive sign as required.

□

We may now complete the proof of Proposition 6.3.17. By Proposition 8 in [15], if G is a charged signed graph then the result holds, so it suffices to prove the following:

Proposition 6.3.27. *For $d = -2, -7$ let G be an \mathcal{L} -graph with $n \geq 11$ vertices, such that every proper connected subgraph of G is equivalent to a subgraph of some $T_{2k}, C_{2k}^{+\pm}, C_{2k}^{2+}$ or T_{2k}^4 . If G contains an edge label of weight 2, then G is equivalent to a subgraph of some $T_{2k}^4, T_{2k}^{4'}$ or C_{2k}^{2+} .*

It follows immediately that a minimal noncyclotomic \mathcal{L} -graph with a weight 2 edge that is not supersporadic can have no more than ten vertices. Since there are also no supersporadic examples with more than ten vertices, Theorem 6.3.12 holds.

Proof. Let G be such a graph: we seek a profile of G . Take a chordless path or cycle P with the maximal number of vertices (given a tie, take P to be a path), and let x and y be the endvertices of P if P is a path, or any two adjacent vertices of P if P is a cycle. Note that no vertex of G is adjacent to x but to no other vertex on P , else we could either grow P to a longer chordless path, or replace a chordless cycle P by a chordless path of equal length. It follows that $G - \{x\}$ (similarly, $G - \{y\}$) is connected, and since it contains at least 10 vertices it has rank at least 5, so P contains at least 5 vertices. Hence by the following Lemma P is necessarily a path, not a cycle:

Lemma 6.3.28. *For $n \geq 5$, G cannot contain a chordless n -cycle.*

Proof. Let G contain a chordless n -cycle on vertices v_1, \dots, v_n . Further, by assumption there exist vertices v, v' (possibly in $\{v_1, \dots, v_n\}$) such that $e_{v,v'} \in \mathcal{L}_2$. Now let G' be the smallest connected subgraph of G to include all of v_1, \dots, v_n, v, v' . If G' is a proper subgraph of G , then we have a contradiction: G' must be equivalent to a subgraph of some $T_{2k}, C_{2k}^{+\pm}, C_{2k}^{2+}, T_{2k}^4$ or

$T_{2k}^{4'}$, but none of those contain both an \mathcal{L}_2 edge and a chordless n -cycle on more than 4 vertices. Thus $G' = G$, and deleting any vertex not from $\{v_1, \dots, v_n, v, v'\}$ gives a disconnected graph.

If $v, v' \in \{v_1, \dots, v_n\}$ G is therefore a chordless n -cycle with $n = |G|$. Delete any vertex of G ; the resulting path on 10 or more vertices is by assumption equivalent to a subgraph of a 4-cyclotomic graph and hence cyclotomic, so a subpath of weight-2 edges is at most 2 edges long. But by Lemmata 6.3.4 and 6.3.7 isolated weight 2 edges or pairs of such are also impossible. So the n -cycle must contain weight 1 edges only, with one of v, v' (w.l.o.g., v) not amongst the v_i . Deleting v gives a subgraph with an n -cycle that must embed into some cyclotomic graph, so necessarily the cycle is uncharged.

Given the connectivity property, G is therefore *either* of the form:

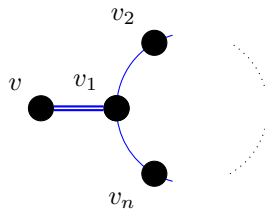

which for $n \geq 5$ induces as a proper subgraph on vertices $v, v_1, v_2, v_n, v_{n-1}$ an \mathcal{L} -graph equivalent to

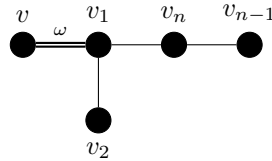

yet no such \mathcal{L} -graph is cyclotomic for any $\omega \in \mathcal{L}_2$;

or, for some $m \geq 1$:

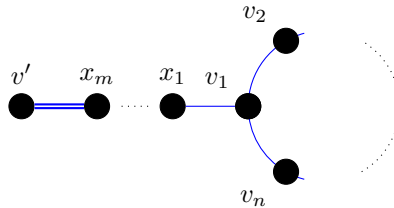

but then the subgraph on vertices v_1, \dots, v_n, x_1 is necessarily a subgraph of some T_{2k} , yet this is impossible: if - for a suitable profile - each $v_i \in V_i$ then, as a neighbour of v_1 , $x_1 \in V_2$ or $x_1 \in V_n$; yet x_1 is not a neighbour of v_3 or v_{n-1} . \square

We may now complete the proof of Proposition 6.3.27.

If there were a vertex not on P adjacent to both x and y but no other vertex on P , then P could be extended to a longer chordless cycle, which is impossible. So $G - \{x, y\}$ is connected.

It has at least 9 vertices and thus rank r at least 5, so by Lemma 6.3.25 it has a uniquely determined profile. As the profiles of $G - \{x\}, G - \{y\}$ are also uniquely determined, they can each be obtained by adding y or x to the profile of $G - \{x, y\}$. Since P is not a cycle, x and y are non-adjacent in G , and all other possible adjacencies of x in G can be read off from the profile of $G - \{y\}$, and all other possible adjacencies of y in G can be read off from the profile of $G - \{x\}$. Thus we can merge the profiles of $G - \{x\}$ and $G - \{y\}$ to obtain a new sequence of columns \mathcal{C} , which we shall show is the profile of G . In this merging, columns $2, 3, \dots, r - 1$ carry over unchanged, and as x, y are the endpoints of a maximal chordless path they must lie in opposite end columns 1 and r .

Now, no vertex in the column of x is adjacent to one in the column of y , else, deleting column 3 of $G - \{x, y\}$ we obtain another proper subgraph of G which thus has a profile that would force all vertices in the column of x to be adjacent to all in the column of y . In particular, this would make x a neighbour of y and thus P a cycle. Hence no vertex in column 1 is adjacent to any in column r , and \mathcal{C} is a non-cycling profile of G . The local conditions of Proposition 6.3.26 hold for G , since they hold for both $G - \{x\}$ and $G - \{y\}$, so by that result G is equivalent to a subgraph of some $T_{2k}, C_{2k}^{+\pm}, C_{2k}^{2+}, T_{2k}^4$ or $T_{2k}^{4'}$. \square

6.4 Summary

6.4.1 $d \leq -17$ or $d \in \{-5, -6, -10, -13, -14\}$

For $R = \mathcal{O}_{\mathbb{Q}(\sqrt{d})}$ where $d \leq -17$ or $d \in \{-5, -6, -10, -13, -14\}$, we have a classification of all minimal noncyclotomic graphs with edge labels from R , whereby such an R -graph G is one of the following:

- A 1-vertex R -graph with large modulus charge and Mahler measure at least 2.618 as in Section 6.2.1 (else all charges $\{0, \pm 1, \pm 2\}$);
- A 2-vertex R -graph with an edge of weight $n \geq 5$ and Mahler measure at least 2.36 as in Section 6.2.2 (else all charges $\{0, \pm 1, \pm 2\}$ and all edge labels from $\mathcal{L} = \mathcal{L}_1$);
- A 2-vertex R -graph with a ± 2 charge and Mahler measure at least 1.722 as in Section 6.2.3;
- Else all charges $\{0, \pm 1\}$ and all edge labels from $\mathcal{L}_1 = \{\pm 1\}$; thus G is a minimal noncyclotomic charged signed graph as classified in [15] with Mahler measure at least λ_0 .

Thus Lehmer's conjecture holds for $d < -17$ and $d \in \{-5, -6, -10, -13, -14\}$: if A is an $\mathcal{O}_{\mathbb{Q}(\sqrt{d})}$ -matrix then $M(A) \geq \lambda_0$.

6.4.2 $d = -15$

For $R = \mathcal{O}_{\mathbb{Q}(\sqrt{-15})}$, we have a classification of all minimal noncyclotomic graphs with edge labels from R , whereby such an R -graph G is one of the following:

- A 1-vertex R -graph with large modulus charge and Mahler measure at least 2.618 as in Section 6.2.1 (else all charges $\{0, \pm 1, \pm 2\}$);
- A 2-vertex R -graph with an edge of weight $n \geq 5$ and Mahler measure at least 2.36 as in Section 6.2.2 (else all charges $\{0, \pm 1, \pm 2\}$ and all edge labels from $\mathcal{L} = \mathcal{L}_1 \cup \mathcal{L}_4$);
- A 2-vertex R -graph with a ± 2 charge and Mahler measure at least 1.722 as in Section 6.2.3 (else all charges $\{0, \pm 1\}$ and all edge labels from $\mathcal{L} = \mathcal{L}_1 \cup \mathcal{L}_4$);
- An \mathcal{L} -graph of at most 3 vertices with a weight 4 edge and Mahler measure at least 2.08 as in Section 6.2.4;
- Else all charges $\{0, \pm 1\}$ and all edge labels from $\mathcal{L}_1 = \{\pm 1\}$; thus G is a minimal noncyclotomic charged signed graph as classified in [15] with Mahler measure at least λ_0 .

Thus Lehmer's conjecture holds for $d = -15$: if A is an $\mathcal{O}_{\mathbb{Q}(\sqrt{-15})}$ -matrix then $M(A) \geq \lambda_0$.

6.4.3 $d = -11$

For $R = \mathcal{O}_{\mathbb{Q}(\sqrt{-11})}$, we have a classification of all minimal noncyclotomic graphs with edge labels from R , whereby such an R -graph G is one of the following:

- A 1-vertex R -graph with large modulus charge and Mahler measure at least 2.618 as in Section 6.2.1 (else all charges $\{0, \pm 1, \pm 2\}$);
- A 2-vertex R -graph with an edge of weight $n \geq 5$ and Mahler measure at least 2.36 as in Section 6.2.2 (else all charges $\{0, \pm 1, \pm 2\}$ and all edge labels from $\mathcal{L} = \mathcal{L}_1 \cup \mathcal{L}_3 \cup \mathcal{L}_4$);
- A 2-vertex R -graph with a ± 2 charge and Mahler measure at least 1.722 as in Section 6.2.3 (else all charges $\{0, \pm 1\}$ and all edge labels from $\mathcal{L} = \mathcal{L}_1 \cup \mathcal{L}_3 \cup \mathcal{L}_4$);
- An \mathcal{L} -graph of at most 3 vertices with a weight 4 edge and Mahler measure at least 2.08 as in Section 6.2.4 (else all charges $\{0, \pm 1\}$ and all edge labels from $\mathcal{L} = \mathcal{L}_1 \cup \mathcal{L}_3$);
- An \mathcal{L} -graph of at most 4 vertices with a weight 3 edge and Mahler measure at least 1.56 as in Section 6.2.5;
- Else all charges $\{0, \pm 1\}$ and all edge labels from $\mathcal{L}_1 = \{\pm 1\}$; thus G is a minimal noncyclotomic charged signed graph as classified in [15] with Mahler measure at least λ_0 .

Thus Lehmer's conjecture holds for $d = -11$: if A is an $\mathcal{O}_{\mathbb{Q}(\sqrt{-11})}$ -matrix then $M(A) \geq \lambda_0$.

6.4.4 $d = -7$

For $R = \mathcal{O}_{\mathbb{Q}(\sqrt{-7})}$, we have a classification of all minimal noncyclotomic graphs with edge labels from R , whereby such an R -graph G is one of the following:

- A 1-vertex R -graph with large modulus charge and Mahler measure at least 2.618 as in Section 6.2.1 (else all charges $\{0, \pm 1, \pm 2\}$);
- A 2-vertex R -graph with an edge of weight $n \geq 5$ and Mahler measure at least 2.36 as in Section 6.2.2 (else all charges $\{0, \pm 1, \pm 2\}$ and all edge labels from $\mathcal{L} = \mathcal{L}_1 \cup \mathcal{L}_2 \cup \mathcal{L}_4$);
- A 2-vertex R -graph with a ± 2 charge and Mahler measure at least 1.722 as in Section 6.2.3 (else all charges $\{0, \pm 1\}$ and all edge labels from $\mathcal{L} = \mathcal{L}_1 \cup \mathcal{L}_2 \cup \mathcal{L}_4$);
- An \mathcal{L} -graph of at most 3 vertices with a weight 4 edge and Mahler measure at least 2.08 as in Section 6.2.4 (else all charges $\{0, \pm 1\}$ and all edge labels from $\mathcal{L} = \mathcal{L}_1 \cup \mathcal{L}_2$);
- An \mathcal{L} -graph of at most 10 vertices with a weight 2 edge and Mahler measure at least 1.35 as in Section 6.3;
- Else all charges $\{0, \pm 1\}$ and all edge labels from $\mathcal{L}_1 = \{\pm 1\}$; thus G is a minimal noncyclotomic charged signed graph as classified in [15] with Mahler measure at least λ_0 .

Thus Lehmer's conjecture holds for $d = -7$: if A is an $\mathcal{O}_{\mathbb{Q}(\sqrt{-7})}$ -matrix then $M(A) \geq \lambda_0$.

6.4.5 $d = -2$

For $R = \mathcal{O}_{\mathbb{Q}(\sqrt{-2})}$, we have a classification of all minimal noncyclotomic graphs with edge labels from R , whereby such an R -graph G is one of the following:

- A 1-vertex R -graph with large modulus charge and Mahler measure at least 2.618 as in Section 6.2.1 (else all charges $\{0, \pm 1, \pm 2\}$);
- A 2-vertex R -graph with an edge of weight $n \geq 5$ and Mahler measure at least 2.36 as in Section 6.2.2 (else all charges $\{0, \pm 1, \pm 2\}$ and all edge labels from $\mathcal{L} = \mathcal{L}_1 \cup \mathcal{L}_2 \cup \mathcal{L}_3 \cup \mathcal{L}_4$);
- A 2-vertex R -graph with a ± 2 charge and Mahler measure at least 1.722 as in Section 6.2.3 (else all charges $\{0, \pm 1\}$ and all edge labels from $\mathcal{L} = \mathcal{L}_1 \cup \mathcal{L}_2 \cup \mathcal{L}_3 \cup \mathcal{L}_4$);
- An \mathcal{L} -graph of at most 3 vertices with a weight 4 edge and Mahler measure at least 2.08 as in Section 6.2.4 (else all charges $\{0, \pm 1\}$ and all edge labels from $\mathcal{L} = \mathcal{L}_1 \cup \mathcal{L}_2 \cup \mathcal{L}_3$);
- An \mathcal{L} -graph of at most 4 vertices with a weight 3 edge and Mahler measure at least 1.56 as in Section 6.2.5 (else all charges $\{0, \pm 1\}$ and all edge labels from $\mathcal{L} = \mathcal{L}_1 \cup \mathcal{L}_2$);

- An \mathcal{L} -graph of at most 10 vertices with a weight 2 edge and Mahler measure at least 1.35 as in Section 6.3;
- Else all charges $\{0, \pm 1\}$ and all edge labels from $\mathcal{L}_1 = \{\pm 1\}$; thus G is a minimal noncyclotomic charged signed graph as classified in [15] with Mahler measure at least λ_0 .

Thus Lehmer's conjecture holds for $d = -2$: if A is an $\mathcal{O}_{\mathbb{Q}(\sqrt{-2})}$ -matrix then $M(A) \geq \lambda_0$.

Chapter 7

Curiosities

7.1 Overview

In this Chapter we adapt the **satgrow** algorithm to determine all \mathcal{L} -graphs with all eigenvalues either $\sqrt{3}$ or $-\sqrt{3}$. We note the relation between these and several sporadic 4-cyclotomic \mathcal{L} -graphs, and deduce a construction for \mathcal{L} -graphs with minimal polynomial $x^2 - n$ for each $n \in \mathbb{Z}$.

7.2 3-cyclotomic Matrices and Graphs

Definition 7.2.1. If an indecomposable \mathcal{L} -matrix M satisfies $M^2 = 3I$, then we describe it (and its associated connected \mathcal{L} -graph) as 3-cyclotomic.

If $M^2 = 3I$ then $\sigma(m) = \{\pm\sqrt{3}\} \subset [-2, 2]$, so M is cyclotomic. Thus all the restrictions of Chapter 2 apply, and in particular if M has entries from $R = \mathcal{O}_{\mathbb{Q}(\sqrt{d})}$ for $d < 0$, then M is necessarily an integer symmetric matrix unless $d \geq -15$. Further, each vertex in the \mathcal{L} -graph of M has weighted degree 3, and thus in any subgraph has weighted degree at most 3.

Any 3-cyclotomic M can be grown from an induced submatrix M' satisfying $\sigma(M') \subseteq [-\sqrt{3}, \sqrt{3}]$ by a modified **satgrow** algorithm such that a vertex is saturated if and only if it has weighted degree 3; we may also use bounded column sets $C_{k'}^3(\mathcal{L})$ instead of $C_{k'}^4(\mathcal{L})$. Proceeding in this way from a seed set of the suitable 2×2 matrices M' , we find that there are only finitely many classes of 3-cyclotomic \mathcal{L} -graphs.

Rational Integer Matrices

Proposition 7.2.2. *If G is a 3-cyclotomic charged signed graph then G is equivalent to one of the charged signed graphs given in Fig. 7.1.*

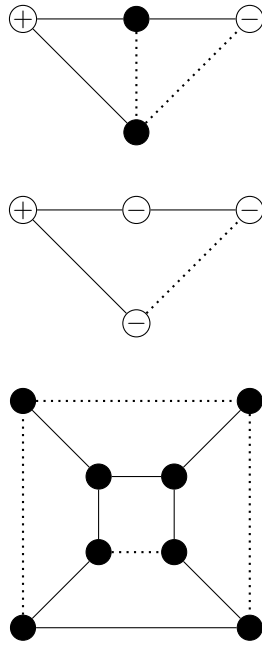

Figure 7.1: The 3-cyclotomic charged signed graphs.

$$d = -1$$

Proposition 7.2.3. *If G is a 3-cyclotomic \mathcal{L} -graph for $d = -1$, then G is equivalent to one of the charged signed graphs given in Fig. 7.1, or one of the \mathcal{L} -graphs given in Fig. 7.2.*

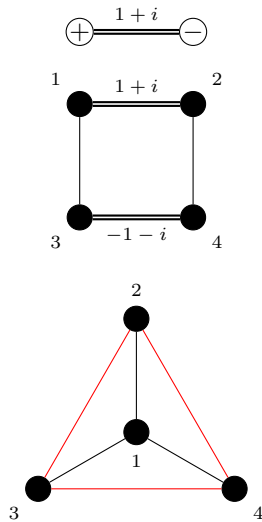

Figure 7.2: The 3-cyclotomic \mathcal{L} -graphs for $d = -1$.

$$d = -2$$

Proposition 7.2.4. *If G is a 3-cyclotomic \mathcal{L} -graph for $d = -2$, then G is equivalent to one of the charged signed graphs given in Fig. 7.1, or one of the \mathcal{L} -graphs given in Fig. 7.3.*

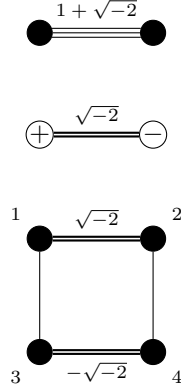

Figure 7.3: The 3-cyclotomic \mathcal{L} -graphs for $d = -2$.

$$d = -3$$

Proposition 7.2.5. *If G is a 3-cyclotomic \mathcal{L} -graph for $d = -3$, then G is equivalent to one of the charged signed graphs given in Fig. 7.1, or one of the \mathcal{L} -graphs given in Fig. 7.4.*

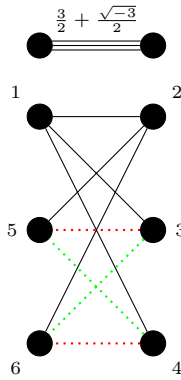

Figure 7.4: The 3-cyclotomic \mathcal{L} -graphs for $d = -3$.

$$d = -7$$

Proposition 7.2.6. *If G is a 3-cyclotomic \mathcal{L} -graph for $d = -7$, then G is equivalent to one of the charged signed graphs given in Fig. 7.1, or one of the \mathcal{L} -graphs given in Fig. 7.5.*

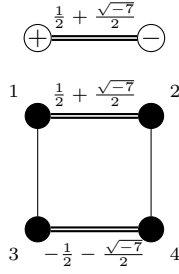

Figure 7.5: The 3-cyclotomic \mathcal{L} -graphs for $d = -7$.

$d = -11$

Proposition 7.2.7. *If G is a 3-cyclotomic \mathcal{L} -graph for $d = -11$, then G is equivalent to one of the charged signed graphs given in Fig. 7.1, or the \mathcal{L} -graph given in Fig. 7.6.*

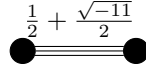

Figure 7.6: The 3-cyclotomic \mathcal{L} -graph for $d = -11$.

$d \leq -13$ or $d \in \{-5, -6, -10\}$

If M is a Hermitian 3-cyclotomic R -matrix for $R = \mathcal{O}_{\mathbb{Q}(\sqrt{d})}$ with $d \leq -13$ or $d \in \{-5, -6, -10\}$, then M is an integer symmetric matrix, since R admits no non-rational integer elements of norm three or less. Thus M is the adjacency matrix of a charged signed graph equivalent to one of the graphs given in Fig. 7.1.

7.3 Connected Sums of Graphs

Definition 7.3.1. Let G and H be n -vertex \mathcal{L} -graphs with matrix representatives M_G, M_H . Then we define the connected sum $G \oplus H$ to be the \mathcal{L} -graph with matrix representative

$$\begin{pmatrix} M_G & I_n \\ I_n & M_H \end{pmatrix}$$

$G \oplus H$ can thus be constructed by attaching each vertex i of G to the corresponding vertex in H by a positive edge.

Proposition 7.3.2. *If $M^2 = mI_n$, then $(M \oplus -M)^2 = (m + 1)I_{2n}$.*

Proof. By multiplication of block matrices,

$$\begin{aligned}
(M \oplus -M)^2 &= \begin{pmatrix} M & I_n \\ I_n & -M \end{pmatrix} \begin{pmatrix} M & I_n \\ I_n & -M \end{pmatrix} = \begin{pmatrix} M^2 + I_n^2 & M - M \\ M - M & I_n^2 + (-M)^2 \end{pmatrix} \\
&= \begin{pmatrix} mI_n + I_n & 0_n \\ 0_n & I_n + mI_n \end{pmatrix} = \begin{pmatrix} (m+1)I_n & 0_n \\ 0_n & (m+1)I_n \end{pmatrix} \\
&= (m+1)I_{2n}
\end{aligned}$$

□

Corollary 7.3.3. *If M is 3-cyclotomic, then $(M \oplus -M)$ is 4-cyclotomic.*

Remark 7.3.4. *The 4-cyclotomic forms $\mathcal{S}_4, \mathcal{S}'_4, \mathcal{S}_8, \mathcal{S}'_8, \mathcal{S}_8^*, \mathcal{S}_8^\dagger, \mathcal{S}_{12}, \mathcal{S}_{16}$ all admit as representative the connected sum of a 3-cyclotomic and its negation.*

Example 7.3.5. The 12-vertex graph \mathcal{S}_{12} given in Fig. 4.14 is necessarily equivalent to the connected sum of the 6-vertex 3-cyclotomic graph from Fig. 7.4 and its negation:

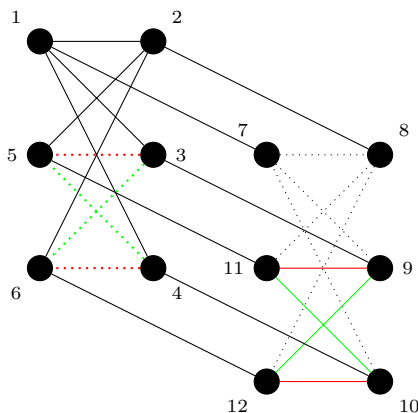

Definition 7.3.6. Let G be an n -vertex \mathcal{L} -graph with matrix representative M . We define the k -th connected power of G , $G^{\oplus k}$ to be the $2^k n$ -vertex \mathcal{L} -graph with matrix representative $M^{\oplus k}$ given iteratively by

$$\begin{aligned}
M^{\oplus 0} &= M \\
M^{\oplus k} &= \begin{pmatrix} M^{\oplus k} & I_n \\ I_n & -M^{\oplus k} \end{pmatrix}
\end{aligned}$$

Proposition 7.3.7. *If $M^2 = mI_n$ then, by induction, $M^{\oplus k} = (m+k)I_{2^k n}$.*

By considering the possible “1-cyclotomic” charged signed graphs we obtain the following results:

Corollary 7.3.8. *For all $n \in \mathbb{N}$, there exists a connected signed graph with all eigenvalues $\pm\sqrt{n}$. That is, for all n there exists an integer symmetric matrix M with all entries from*

$\{-1, 0, 1\}$ and minimal polynomial $x^2 - n$.

Proof. Let $G = \bullet \text{---} \bullet$. Then for all n , $G^{\oplus(n-1)}$ is a connected 2^n -vertex uncharged signed n -hypercube with all eigenvalues $\pm\sqrt{n}$. \square

Example 7.3.9. The first 5 signed graphs generated in this way are

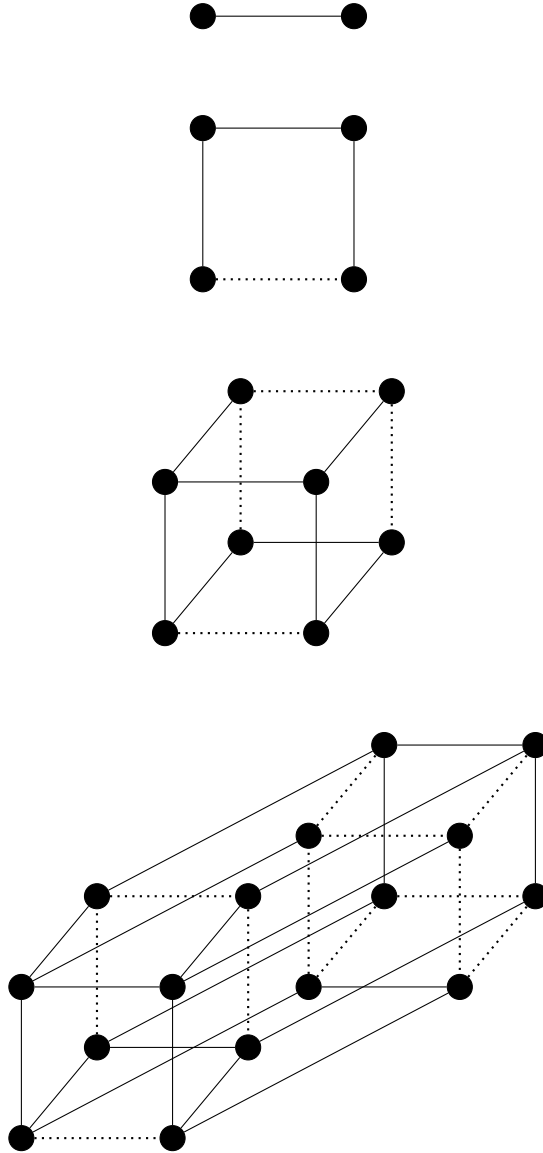

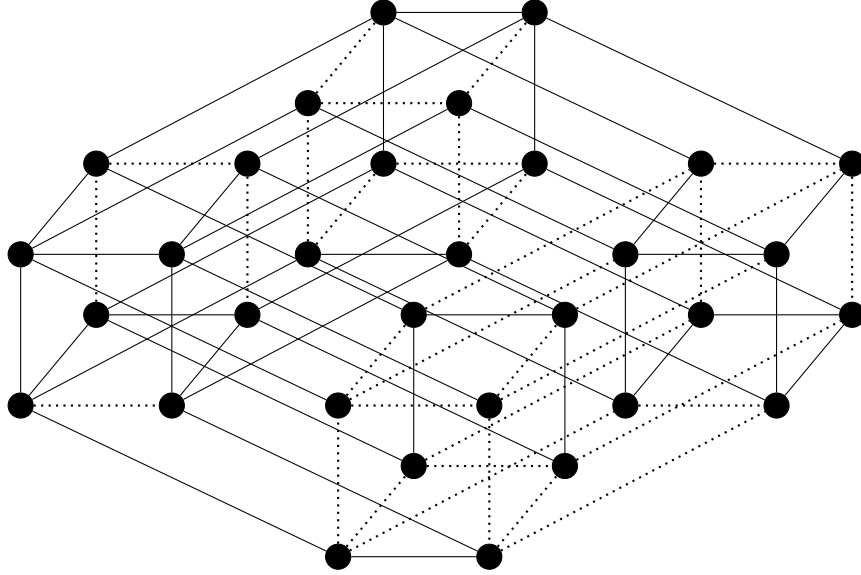

Remark 7.3.10. By Geršgorin's Circle Theorem¹, any uncharged signed n -hypercube H has all eigenvalues in $[-n, n]$; this result shows that for large n we can always do significantly better.

Corollary 7.3.11. For all $n \in \mathbb{N}$, there exists a charged, signed $(n - 1)$ -hypercube (that is, a 2^{n-1} -vertex charged signed graph where each vertex is charged and has $n - 1$ neighbours) with minimal polynomial $x^2 - n$.

Proof. For $n = 1$, let G be the single-vertex charged signed graph \oplus , then take connected powers. □

From the classification of 4-cyclotomics, we can say more:

Corollary 7.3.12. For $n \geq 4$, there exist infinitely many connected signed graphs with all eigenvalues $\pm\sqrt{n}$. That is, for all n there exists infinitely many integer symmetric matrices M with all entries from $\{-1, 0, 1\}$ and minimal polynomial $x^2 - n$.

Proof. For any $k \geq 3$ any matrix representative M of T_{2k} satisfies $M^2 = 4I_{2k}$. Thus any representative $M^{\oplus(n-4)}$ of $(T_{2k})^{\oplus(n-4)}$ satisfies $(M^{\oplus(n-4)})^2 = nI_{2^{n-4}k}$ as required. □

¹See e.g., [10] Section 19.7 Theorem 1

Bibliography

- [1] D.W. Boyd, Small Salem numbers, *Duke Math. J.* **44** (1977), 315-328.
- [2] R. Breusch, On the distribution of the roots of a polynomial with integral coefficients, *Proc. Amer. Math. Soc.* **2** (1951), 939-941.
- [3] P.J. Cameron, J.J. Seidel, S.V. Tsaranov, Signed Graphs, root lattices, and Coxeter Groups *J. Algebra* **164** (1) (1994) 173-209.
- [4] A.L. Cauchy, Sur l'équation à l'aide de laquelle on détermine les inégalités séculaires des mouvements des planètes, Oeuvres complètes, Ilième Série, **9**, Gauthier-Villars, 174-195. (1829).
- [5] E. Dobrowolski, A note on integer symmetric matrices and Mahler's measure, *Canad. Math. Bull.* (to appear).
- [6] D.R. Estes, R.M. Guralnick, Minimal polynomials of integral symmetric matrices, *Linear Algebra Appl.* **192** (1993) 83-99.
- [7] S. Fisk, A very short proof of Cauchy's interlace theorem for eigenvalues of Hermitian matrices, *Amer. Math Monthly* **112** (2005), 118.
- [8] A. Frohlich, M.J. Taylor Algebraic Number Theory *Cambridge studies in advanced mathematics* Cambridge University Press (1991).
- [9] R.A Horn and C.R. Johnson *Matrix Analysis* Cambridge University Press (1985).
- [10] E. Kreyszig Advanced Engineering Mathematics 7th Edition. John Wiley and Sons (1993).
- [11] L. Kronecker, Zwei Sätze über Gleichungen mit ganzzahligen Coefficienten, *J. Reine Angew. Math.* **53** (1857), 173-175.
- [12] D.H. Lehmer, Factorization of certain cyclotomic functions, *Ann. of Math. (2)* **34** (1933), 461-479.
- [13] K. Mahler, On some inequalities for polynomials in several variables, *J. London Math. Soc.* **37** (1962), 341-344.

- [14] J.F.McKee, C.J.Smyth, Integer symmetric matrices having all their eigenvalues in the interval $[-2,2]$, *J. Algebra* **317** (2007) 260-290.
- [15] J.F.McKee, C.J.Smyth, Integer symmetric matrices of small spectral radius and small Mahler measure. [arXiv:0907.0371v1](https://arxiv.org/abs/0907.0371v1)
- [16] J.F. McKee, C.J.Smyth, Salem Numbers, Pisot Numbers, Mahler measure, and graphs, *Experiment. Math.* **14** (2) (2005) 211-229.
- [17] M. Mossinghoff, List of small Salem numbers,
<http://www.cecm.sfu.ca/~mjm/Lehmer/lists/SalemList.html>
- [18] J.H. Smith, Some properties of the spectrum of a graph, in *Combinatorial Structures and their Applications, Proc. Calgary Internat. Conf. Calgary, Alta., 1969*, Gordon and Breach 1970 403-406.
- [19] C. J. Smyth, Mahler measure of one-variable polynomials: a survey. *Conference proceedings, University of Bristol 3-7 April 2006, LMS Lecture Note Series* **352** 322-349.
- [20] C.J. Smyth, On the product of the conjugates outside the unit circle of an algebraic integer, *Bull. London Math. Soc.* **3** (1971), 169-175.
- [21] T. Zaslavsky, Signed Graphs *Discrete Appl. Math.* **4** (1982) 47-74, Erratum: *Discrete Appl. Math* **5** (2) (1983) 248.
- [GAP] The GAP Group, *GAP – Groups, Algorithms, and Programming, Version 4.4.10*; 2008.
<http://www.gap-system.org>.
- [Maxima] Maxima, a Computer Algebra System.
Version 5.13.0 (2007). <http://maxima.sourceforge.net/>
- [PARI] PARI/GP, version 2.3.3, Bordeaux, 2007, <http://pari.math.u-bordeaux.fr/>.
- [S⁺08] W. A. Stein et al., *Sage Mathematics Software (Version 2.10.0)*, The Sage Development Team, 2008, <http://www.sagemath.org>.

Appendix A

Implementation

This appendix contains SAGE source code for the ‘growing’ algorithms used in this thesis, written for the version [S⁺08] available on the ECDF cluster (on which larger tasks were performed via parallelisation). These procedures also depend upon [GAP], [Maxima] and [PARI]. Compatibility has been confirmed with SAGE version 4.0.1, but cannot be guaranteed for future releases.

A.1 Initialisation and Basic Procedures

A.1.1 Field Setup

For each d , we may populate a SAGE session with label sets \mathcal{L}_i as follows:

$d = -1$

```
K1=NumberField(x^2+1, 'u')
u=K1.0
v=1+u
a1=K1(1); a2=K1(-1); a3=u; a4=-u
b1=v; b2=-v; b3=v.conjugate(); b4=-b3
d1=K1(2); d2=K1(-2); d3=2*u; d4=-2*u
chargeset=a1, a2, K1(0)
L1=[a1, a2, a3, a4]
L2=[b1, b3, b3, b4]
L4=[d1, d2, d3, d4]
L1zero=[K1(0), a1, a2, a3, a4]
L2zero=[K1(0), b1, b2, b3, b4]
L12=[a1, a2, a3, a4, b1, b2, b3, b4]
L12zero=[K1(0), a1, a2, a3, a4, b1, b2, b3, b4]
L=[K1(0), a1, a2, a3, a4, b1, b2, b3, b4, d1, d2, d3, d4]
```

$$d = -2$$

```
K2=NumberField(x^2+2,'u')
u=K2.0
w=1+u
a1=K2(1); a2=K2(-1)
b1=u; b2=-u
c1=w; c2=-w; c3=w.conjugate(); c4=-c3
d1=K2(2); d2=K2(-2)
chargeset=a1, a2, K2(0)
L1=[a1, a2]
L2=[b1, b2]
L3=[c1, c2, c3, c4]
L4=[d1, d2]
L1zero=[K2(0), a1, a2]
L2zero=[K2(0), b1, b2]
L12=[a1, a2, b1, b2]
L12zero=[K2(0), a1, a2, b1, b2]
L123zero=[K2(0), a1, a2, b1, b2, c1, c2, c3, c4]
L=[K2(0), a1, a2, b1, b2, c1, c2, c3, c4, d1, d2]
```

$$d = -3$$

```
K3=NumberField(x^2+3,'u')
u=K3.0
v=1/2+u/2
w=3/2+u/2
t=1+u
a1=K3(1); a2=K3(-1); a3=v; a4=-v; a5=v.conjugate(); a6=-a5
c1=w; c2=-w; c3=w.conjugate(); c4=-c3; c5=u; c6=-u;
d1=t; d2=-t; d3=t.conjugate(); d4=-d3
chargeset=a1, a2, K3(0)
L1=[a1, a2, a3, a4, a5, a6]
L3=[c1, c2, c3, c4, c5, c6]
L4=[K3(2), K3(-2), d1, d2, d3, d4]
L1zero=[K3(0), a1, a2, a3, a4, a5, a6]
L13zero=[K3(0), a1, a2, a3, a4, a5, a6, c1, c2, c3, c4, c5, c6]
L=[K3(0), a1, a2, a3, a4, a5, a6, c1, c2, c3, c4, c5, c6, K3(2), K3(-2), d1, d2, d3, d4]
```

$$d = -7$$

```
K7=NumberField(x^2+7,'u')
u=K7.0
v=1/2+u/2
w=3/2+u/2
a1=K7(1); a2=K7(-1)
b1=v; b2=-v; b3=v.conjugate(); b4=-b3
d1=K7(2); d2=K7(-2); d3=w; d4=-w; d5=w.conjugate(); d6=-d5
chargeset=a1, a2, K7(0)
```

```

L1=[a1 , a2]
L2=[b1 , b2 , b3 , b4]
L4=[d1 , d2 , d3 , d4 , d5 , d6]
L1zero=[K7(0) , a1 , a2]
L2zero=[K7(0) , b1 , b2 , b3 , b4]
L12=[a1 , a2 , b1 , b2 , b3 , b4]
L12zero=[K7(0) , a1 , a2 , b1 , b2 , b3 , b4]
L=[K7(0) , a1 , a2 , b1 , b2 , b3 , b4 , d1 , d2 , d3 , d4]

```

$d = -11$

```

K11=NumberField(x^2+11, 'u')
u=K11.0
v=1/2+u/2
a1=K11(1) ; a2=K11(-1)
c1=v ; c2=-v ; c3=v . conjugate () ; c4=-c3
d1=K11(2) ; d2=K11(-2)
chargeset=a1 , a2 , K11(0)
L1=[a1 , a2]
L3=[c1 , c2 , c3 , c4]
L4=[d1 , d2]
L1zero=[K11(0) , a1 , a2]
L13zero=[K11(0) , a1 , a2 , c1 , c2 , c3 , c4]
L=[K11(0) , a1 , a2 , c1 , c2 , c3 , c4 , d1 , d2]

```

$d = -15$

```

K15=NumberField(x^2+15, 'u')
u=K15.0
v=1/2+u/2
a1=K15(1) ; a2=K15(-1)
d1=K15(2) ; d2=K15(-2) ; d3=v ; d4=-v ; d5=v . conjugate () ; d6=-d5
chargeset=a1 , a2 , K15(0)
L1=[a1 , a2]
L4=[d1 , d2 , d3 , d4 , d5 , d6]
L1zero=[K15(0) , a1 , a2]
L=[K15(0) , a1 , a2 , d1 , d2 , d3 , d4 , d5 , d6]

```

A.1.2 Testing Cyclotomicity

Having appropriately configured SAGE as in Section A.1.1, we may construct candidate matrices by iteration over label sets and test them for cyclotomicity with the following function:

```

def isCyclotomic(m):
    C2=PolynomialRing(ComplexField(100), 'x')
    return max([abs(r[0]) for r in C2(m.charpoly()).roots()])<=2

```

Example A.1.1. We construct a matrix representative of T_6 , check that it is 4-cyclotomic, confirm that `isCyclotomic` returns `true` then add a charge to vertex 1 and confirm the graph obtained is noncyclotomic.

```
sage: T6=matrix([[0,1,1,0,1,-1], [1,0,1,-1,0,1], [1,1,0,1,-1,0],
                [0,-1,1,0,-1,-1], [1,0,-1,-1,0,-1], [-1,1,0,-1,-1,0]])
sage: T6^2
[4 0 0 0 0 0]
[0 4 0 0 0 0]
[0 0 4 0 0 0]
[0 0 0 4 0 0]
[0 0 0 0 4 0]
[0 0 0 0 0 4]
sage: isCyclotomic(T6)
True
sage: T6[0,0]=1
sage: isCyclotomic(T6)
False
```

A.2 Testing Equivalence

We may test a pair m_1, m_2 of matrices for equivalence by iterating over the possible conjugates Xm_1X^{-1} (where X is a signed permutation matrix) and testing for equality with m_2 . As this requires testing up to $|\mathcal{L}|^n n!$, it is only suitable for small n and invariants such as the number of charged vertices or presence of edges of a given weight should be considered first!

A.2.1 Support Functions

Given the field K defined in Section A.1.1 and a K -matrix M , `ConjugateMatrix(K,M)` returns \overline{M} as a K -matrix:

```
def ConjugateMatrix(K,m):
    M=Matrix(K,m.nrows(),m.ncols())
    for i in range(m.nrows()):
        for j in range(m.ncols()):
            M[i,j]=K(m[i,j]).conjugate()
    return M
```

Given the field K defined in Section A.1.1, an integer n and a list `oneset` corresponding to \mathcal{L}_1 for K , `SwitchingMatrices` returns the $|\mathcal{L}_1|^n$ possible (complex) switching matrices as a list of K -matrices:

```
def SwitchingMatrices(K,n,oneset):
    switchlist=list()
```

```

base=len(oneset)
for k in range(base^n):
    L=ZZ(k).digits(base)
    while len(L)<n:
        L.append(0)
    S=matrix(K,n,n)
    for j in range(n):
        S[j,j]=oneset[L[j]]
    switchlist.append(S)
return switchlist

```

Given the field K defined in Section A.1.1 and an integer n , `PermutationMatrices` returns the $n!$ permutation matrices as a list of K -matrices:

```

def PermutationMatrices(K,n):
    G=SymmetricGroup(n)
    MS=VectorSpace(K,n)
    X=MS.basis()
    return [Matrix([X[g(i+1)-1] for i in range(n)]) for g in G]

```

A.2.2 Equivalence Testing

For a pair of K -matrices m_1, m_2 of dimension n , with $S = \text{SwitchingMatrices}(K, n, \mathcal{L}_1)$ and $P = \text{PermutationMatrices}(K, n)$ the following function returns `true` if and only if m_1 is equivalent to m_2 after at most $|\mathcal{L}_1|^n n!$ steps:

```

def isEquiv(K,m1,m2,P,S):
    is_equiv=false
    j=0
    m2list=[m2,-m2,-ConjugateMatrix(K,m2),ConjugateMatrix(K,m2)]
    while not(is_equiv) and j<len(P):
        p=P[j]
        pm=p*m1*p^(-1)
        k=0
        while not(is_equiv) and k<len(S):
            s=S[k]
            spm=s*pm*s^(-1)
            if spm in m2list:
                is_equiv=true
            else:
                k=k+1
        j=j+1
    return is_equiv

```

If `m1list` is a list of dimension n K -matrices, then unless all entries of `m1list` are equivalent to m_1 it is quicker to compute all conjugates of m_1 once, comparing each to $m, -m, \bar{m}, -\bar{m}$ for each

m in `m1ist` to establish which are equivalent to m_1 . With $S = \text{SwitchingMatrices}(K, n, \mathcal{L}_1)$ and $P = \text{PermutationMatrices}(K, n)$ the following function returns the sublist of `m1ist` of matrices equivalent to m_1 :

```
def getEquiv(K,m1,m1ist ,P,S):
    m1equivs=list ()
    m1ist2=list ()
    for m2 in m1ist:
        m2list=[m2,-m2,-ConjugateMatrix(K,m2) ,ConjugateMatrix(K,m2)]
        m1ist2.append(m2list)
    for p in P:
        pm=p*m1*p^(-1)
        for s in S:
            spm=s*pm*s^(-1)
            for m2list in m1ist2:
                if spm in m2list:
                    if not(m2list[0] in m1equivs):
                        m1equivs.append(m2list[0])
    return m1equivs
```

Iterating `getEquiv` we may thus reduce a list of matrices modulo equivalence:

```
def reduceModEquivalence(K, m1ist ,P,S):
    candidateList=[m for m in m1ist]
    replist=list ()
    while len(candidateList)>0:
        newrep=candidateList[0]
        replist.append(newrep)
        newrepEquiv=getEquiv(K,newrep , candidateList ,P,S)
        for m in newrepEquiv:
            candidateList.remove(m)
    return replist
```

Finally, if we require only strong equivalence we can use the following:

```
def getStrongEquiv(K,m1,m1ist ,P,S):
    m1equivs=list ()
    m1ist2=list ()
    for p in P:
        pm=p*m1*p^(-1)
        for s in S:
            spm=s*pm*s^(-1)
            for m2 in m1ist:
                if spm==m2:
                    m1equivs.append(m2)
    return m1equivs
```

which gives `reduceModStrongEquivalence` by substituting the call to `getEquiv` for `getStrongEquiv` in `reduceModEquivalence`. Note that if `getStrongEquiv` is run with $P = \{I_n\}$ then it tests for matrices equivalent to m_1 by (complex) switching only.

Example A.2.1. For $d = -1$ we determine all possible cyclotomic triangles with weight 1 edges, then reduce this to a list of representatives:

```
sage: Tlist=list()
sage: for x1 in chargeset:
....:     for x2 in chargeset:
....:         for x3 in chargeset:
....:             for a in L1:
....:                 for b in L1:
....:                     for c in L1:
....:                         m=matrix([[x1,a,b], [a.conjugate(),x2,c], [b.
conjugate(),c.conjugate(),x3]])
....:                             if isCyclotomic(m):
....:                                 Tlist.append(m)
....:
sage: len(Tlist)
576
sage: P3=PermutationMatrices(K1,3)
sage: S3=SwitchingMatrices(K1,3,L1)
sage: time TlistReps=reduceModEquivalence(K1,Tlist,P3,S3)
CPU times: user 10.02 s, sys: 0.18 s, total: 10.21 s
Wall time: 10.21
sage: len(TlistReps)
7
```

The same calculation in a session configured for $d = -2$ (where now $\mathcal{L}_1 = \{\pm 1\}$) gives (after the same construction of `Tlist`)

```
sage: len(Tlist)
88
sage: P3=PermutationMatrices(K2,3)
sage: S3=SwitchingMatrices(K2,3,L1)
sage: time TlistReps=reduceModEquivalence(K2,Tlist,P3,S3)
CPU times: user 1.02 s, sys: 0.03 s, total: 1.05 s
Wall time: 1.05
sage: len(TlistReps)
5
```

A.3 Column sets

For a given k and \mathcal{L} , the naïve column set $C_k(\mathcal{L})$ can easily be constructed by looping over \mathcal{L} . However, for larger k generating the bounded weight column set $C_k^b(\mathcal{L})$ by discarding the

overweight columns of $C_k(\mathcal{L})$ is inefficient; we instead construct such a column set iteratively.

We assume that we wish to construct $C_k^b(\mathcal{L})$ where $b \leq 4$. Then, given $C = C_{k-1}^b(\mathcal{L})$, if $c = (c_1, \dots, c_{k-1}) \in C$ then we require the vectors (c_1, \dots, c_{k-1}, l) such that

$$\left(\sum_{i=1}^{k-1} \text{Norm}(c_i) \right) + \text{Norm}(l) \leq b$$

We determine such vectors with the function `boundedColIterate`:

```

def boundedColIterate(K,C,b,L):
    onelist=list(); twolist=list()
    threelist=list(); fourlist=list()
    newC=list()
    for l in L:
        if K(l).norm()==1:
            onelist.append(l)
        elif K(l).norm()==2:
            twolist.append(l)
        elif K(l).norm()==3:
            threelist.append(l)
        elif K(l).norm()==4:
            fourlist.append(l)
    for c in C:
        currentWeight=ZZ(sum([K(c[i])*K(c[i]).conjugate() for i in range
            (len(c))]))
        if currentWeight<=b:
            newc=[c[k] for k in range(len(c))]
            newc.append(K(0)); newC.append(newc)
        if currentWeight<=b-1:
            for l in onelist:
                newc=[c[k] for k in range(len(c))]
                newc.append(l); newC.append(newc)
        if currentWeight<=b-2:
            for l in twolist:
                newc=[c[k] for k in range(len(c))]
                newc.append(l); newC.append(newc)
        if currentWeight<=b-3:
            for l in threelist:
                newc=[c[k] for k in range(len(c))]
                newc.append(l); newC.append(newc)
        if currentWeight<=b-4:
            for l in fourlist:
                newc=[c[k] for k in range(len(c))]
                newc.append(l); newC.append(newc)
    return newC

```

Then, since $C_0^b(\mathcal{L})$ can be treated as the list containing the empty vector, we can construct

$C_n^b(\mathcal{L})$ for an appropriate field K with the function

```

def generateBoundedCol(K,b,L,n):
    C=[list()]
    for j in range(n):
        C=boundedColIterate(K,C,b,L)
    return C

```

(This gives all k -tuples of weight at most $b \leq 4$ over \mathcal{L} ; for $C_k^b(\mathcal{L})$ the zero vector should be removed.)

Note that if several successive $C_j^b(\mathcal{L})$ are to be computed in a session it is better to compute the first with `generateBoundedCol` and the others by `boundedColIterate` than to run `generateBoundedCol` from scratch for each j ; clearly for a fixed K, \mathcal{L}, b we may also store these column sets for repeated use.

Given any column set C_k (naïve or bounded) we may require the *reduced* column set $C_{k'}(\mathcal{L})$. For this we keep one representative of the class $\{\lambda c \mid \lambda \in \mathcal{L}_1\}$; for a fixed ordering \mathcal{L} we choose as representative c such that the first nonzero entry of c has lowest index in that ordering. For a vector c and a fixed listing \mathcal{L} (such as given in Section A.1.1) we therefore compute the *score* of $c \neq 0$ via

```

def score(c,L):
    r=0
    while c[r]==0: #nonzero c assumed!
        r=r+1
    return L.index(c[r])

```

Then, assuming `colList` is a list of nonzero vectors such that if $c \in \text{colList}$ then $\lambda c \in \text{colList}$ for all $\lambda \in \mathcal{L}_1$, we may obtain a reduced list of representatives `colList` by the procedure

```

def reduceCols(K, colList ,L1,L):
    colListCopy=[C for C in colList]
    repList=list()
    while len(colListCopy)>0:
        c=colListCopy[0]
        L1c=[[l*c[k] for k in range(len(c))] for l in L1]
        scoreMin=min([score(lc,L) for lc in L1c])
        cClassRep=[lc for lc in L1c if score(lc,L)==scoreMin][0]
        repList.append(cClassRep)
        for lc in L1c:
            colListCopy.remove(lc)
    return repList

```

Example A.3.1. For $d = -3$ we construct $C_3^4(\mathcal{L})$:

```
sage: cols3=generateBoundedCol(K3,4,L,3)
```

```

sage: cols3.remove([0,0,0])
sage: cols3Reps=reduceCols(K3,cols3,L1,L)
sage: len(cols3)
594
sage: len(cols3Reps)
99

```

A.4 Growing Algorithms For Cyclotomics and 4-Cyclotomics

Given a Hermitian K -matrix m , vector c from some column set over \mathcal{L} and a charge x from charge set X , we can construct the Hermitian supermatrix

$$m_{c,x} = \begin{pmatrix} m & c \\ \bar{c} & x \end{pmatrix}$$

with the function:

```

def matrixExtendCharged(K,m,c,x):
    n=m.nrows()
    newrows=list([])
    for k in range(n):
        newrowk=(m.rows()[k]).list()
        newrowk.append(c[k])
        newrows.append(newrowk)
    lastrow=[K(z).conjugate() for z in c]
    lastrow.append(K(x))
    newrows.append(lastrow)
    return matrix(newrows)

```

For a field K , column set `cols`, charge set `charges` and list of matrices `mList` we can thus recover all corresponding cyclotomic supermatrices, and identify the matrices for which there are none, with the following:

```

def getCycExtensions(K,mList,cols,charges):
    cycList=list()
    maxList=list()
    for m in mList:
        mSupers=list()
        for c in cols:
            for x in charges:
                newm=matrixExtendCharged(K,m,c,x)
                if isCyclotomic(newm):
                    mSupers.append(newm)
        if len(mSupers)==0:
            maxList.append(m)

```

```

        print "Maximal_found"
    else:
        cycList.extend(mSupers)
        print len(mSupers)
    return cycList, maxList

```

If we set $mList = S_k$, $cols = C_{k'}^4(\mathcal{L})$ and $charges = X$ then `getCycExtensions` implements `equivgrow` - that is, performs a round of reduced bounded weight growing.

For the bounded variant of **equivgrow** we first require the list $rowWeights_l(m)$ of row weights for a matrix m over field K :

```

def rowWeights(K,m):
    return [ZZ(sum([K(m[i,j])*K(m[i,j]).conjugate() for j in range(m.nrows())
    ])) for i in range(m.nrows())]

```

Then for m and some column set $C = \{(c_1, \dots, c_k)\}$ we then define the *safe weight columns* to be the subset of C satisfying

$$rowWeights_l(m) + Norm(c_l) \leq 4 \text{ for all } 1 \leq l \leq k$$

which can be obtained by:

```

def getSafeweightCols(K,m,C):
    wlist=rowWeights(K,m)
    newColList=list()
    for c in C:
        if max([wlist[k]+c[k].norm() for k in range(len(wlist))])<=4:
            newColList.append(c)
    return newColList

```

We can then implement bounded **equivgrow** by modifying `getCycExtensions` to call `getSafeweightCols` for each m . However, we note a further refinement - if we are attempting an extension with a nonzero charge then under the assumption of boundedness we need only consider $c \in C_{k'}^3(\mathcal{L})$ - which we also include:

```

def getCycExtensionsBounded(K,mList,cols,charges):
    weight4List=list();weightNot4List=list()
    cycList=list();maxList=list()
    for v in cols:
        if sum([K(v[i])*K(v[i]).conjugate() for i in range(len(v))])==4:
            weight4List.append(v)
        else:
            weightNot4List.append(v)
    for m in mList:
        mSupers=list()
        weightNot4SafeList=getSafeweightCols(K,m,weightNot4List)

```

```

weight4SafeList=getSafeweightCols(K,m,weight4List)
for c in weightNot4SafeList:
    for x in charges:
        newm=matrixExtendCharged(K,m,c,x)
        if isCyclotomic(newm):
            mSupers.append(newm)
if 0 in charges:
    for c in weight4SafeList:
        newm=matrixExtendCharged(K,m,c,0)
        if isCyclotomic(newm):
            mSupers.append(newm)
if len(mSupers)==0:
    maxList.append(m)
    print "Maximal found"
else:
    cycList.extend(mSupers)
    print len(mSupers)
return cycList,maxList

```

If we set $mList = S_k$, $cols = C_{k'}^4(\mathcal{L})$ and $charges = X$ then `getCycExtensionsBounded` implements bounded `equivgrow` - that is, performs a round of reduced bounded weight growing. This is advantageous when the time required for determining safe weight columns is less than that of testing all of `cols`, which is true for larger matrices or those with higher saturation. In particular, a 4-cyclotomic matrix will be recognised as maximal due to there being no safe weight columns!

Example A.4.1. We demonstrate the proof of Proposition 3.3.1 for $d = -11$.

```

sage: S2=list()
sage: for x1 in chargeset:
....:     for x2 in chargeset:
....:         m=matrix([[x1,v],[v.conjugate(),x2]])
....:         if isCyclotomic(m):
....:             S2.append(m)
....:
sage: len(S2)
3
sage: cols2=generateBoundedCol(K11,4,L,2)
sage: cols2.remove([0,0])
sage: cols2Reps=reduceCols(K11,cols2,L1,L)
sage: time S3,M2=getCycExtensions(K11,S2,cols2Reps,chargeset)
Maximal found
Maximal found
2
CPU times: user 0.46 s, sys: 0.00 s, total: 0.46 s
Wall time: 0.46
sage: cols3=generateBoundedCol(K11,4,L,3)

```

```

sage: cols3.remove([0,0,0])
sage: cols3Reps=reduceCols(K11,cols3,L1,L)
sage: time S4,M3=getCycExtensions(K11,S3,cols3Reps,chargeset)
1
1
CPU times: user 0.90 s, sys: 0.01 s, total: 0.91 s
Wall time: 0.91
sage: cols4=generateBoundedCol(K11,4,L,4)
sage: cols4.remove([0,0,0,0])
sage: cols4Reps=reduceCols(K11,cols4,L1,L)
sage: time S5,M4=getCycExtensions(K11,S4,cols4Reps,chargeset)
Maximal found
Maximal found
CPU times: user 3.04 s, sys: 0.03 s, total: 3.07 s
Wall time: 3.07
sage: len(S5)
0
sage: len(M2)
2
sage: len(M3)
0
sage: len(M4)
2
sage: M2[0]
[      1  1/2*u + 1/2]
[-1/2*u + 1/2      -1]
sage: M2[1]
[      -1  1/2*u + 1/2]
[-1/2*u + 1/2      1]
sage: M4[0]
[      0  1/2*u + 1/2      0      1]
[-1/2*u + 1/2      0      1      0]
[      0      1      0  1/2*u - 1/2]
[      1      0 -1/2*u - 1/2      0]
sage: M4[1]
[      0  1/2*u + 1/2      1      0]
[-1/2*u + 1/2      0      0      1]
[      1      0      0 -1/2*u - 1/2]
[      0      1  1/2*u - 1/2      0]

```

Note that with bounded **equivgrow**, performance improves to

```

sage: time S3,M2=getCycExtensionsBounded(K11,S2,cols2Reps,chargeset)
Maximal found
Maximal found
2
CPU times: user 0.04 s, sys: 0.00 s, total: 0.04 s
Wall time: 0.04

```

```

sage: time S4,M3=getCycExtensionsBounded(K11,S3,cols3Reps,chargeset)
1
1
CPU times: user 0.16 s, sys: 0.00 s, total: 0.16 s
Wall time: 0.16
sage: time S5,M4=getCycExtensionsBounded(K11,S4,cols4Reps,chargeset)
Maximal found
Maximal found
CPU times: user 0.07 s, sys: 0.00 s, total: 0.08 s
Wall time: 0.08

```

If row r of M corresponds to the first unsaturated vertex of G then $rowWeight_l(M) = 4$ for all $l < r$ and so any c returned by `getSafeWeightCols` must satisfy $c_1 = \dots = c_{r-1} = 0$. Thus such a c should be included in a round of saturating growing if and only if $c_r \neq 0$. We may therefore modify `getCycExtensionsBounded` to include this check; setting $C = C_{k'}^4(\mathcal{L})$ it is then an implementation of the **satgrows** algorithm, with the additional refinement of only using saturating additions of safe weight with respect to row weights and charges:

```

def getCycExtensionsBoundedSat(K, mList, cols, charges):
    n=mList[0].nrows()
    weight4List=list(); weightNot4List=list()
    cycList=list(); maxList=list()
    for v in cols:
        if sum([K(v[i])*K(v[i]).conjugate() for i in range(len(v))])==4:
            weight4List.append(v)
        else:
            weightNot4List.append(v)
    for m in mList:
        r=0
        while r<n and sum([K(m[r,j])*K(m[r,j]).conjugate() for j in
            range(n)])==4:
            r=r+1
        if r==n:
            maxList.append(m)
            print "Maximal_found_early"
        else:
            mSupers=list()
            weightNot4SafeList=getSafeweightCols(K,m, weightNot4List)
            weightNot4SatList=list()
            for c in weightNot4SafeList:
                if c[r]!=0:
                    weightNot4SatList.append(c)
            weight4SafeList=getSafeweightCols(K,m, weight4List)
            weight4SatList=list()
            for c in weight4SafeList:
                if c[r]!=0:

```

```

        weight4SatList.append(c)
    for c in weightNot4SatList:
        for x in charges:
            newm=matrixExtendCharged(K,m,c,x)
            if isCyclotomic(newm):
                mSupers.append(newm)
    if 0 in charges:
        for c in weight4SatList:
            newm=matrixExtendCharged(K,m,c,0)
            if isCyclotomic(newm):
                mSupers.append(newm)
    if len(mSupers)==0:
        maxList.append(m)
        print "Maximal_found"
    else:
        cycList.extend(mSupers)
        print len(mSupers)

return cycList,maxList

```

Example A.4.2. We demonstrate the results of Section 3.4.2 for $d = -3$ - any 4-cyclotomic \mathcal{L} -graph with all edges from \mathcal{L}_1 inducing an uncharged triangle has at most 7 vertices - by showing that iteration of **satgrow** terminates with $S_8 = \emptyset$ (appropriate column sets $C_{k'}^4(\mathcal{L}_1 \cup \{0\})$ $k = 3, \dots, 7$ are precomputed).

```

sage: preS3=list()
sage: for a in L1:
....:     for b in L1:
....:         for c in L1:
....:             m=matrix([[0,a,b], [a.conjugate(),0,c], [b.conjugate(),c.
conjugate(),0]])
....:                 if isCyclotomic(m):
....:                     preS3.append(m)
....:
sage: P3=PermutationMatrices(K3,3)
sage: Sw3=SwitchingMatrices(K3,3,L1)
sage: S3=reduceModEquivalence(K3,preS3,P3,Sw3)
sage: len(S3)
2
sage: time S4,M3=getCycExtensionsBoundedSat(K3,S3,cols3Reps,chargeset)
6
8
CPU times: user 1.23 s, sys: 0.01 s, total: 1.24 s
Wall time: 1.24
sage: len(S4)
14
sage: P4=PermutationMatrices(K3,4)
sage: Sw4=SwitchingMatrices(K3,4,L1)

```

```

sage: time S4b=reduceModEquivalence(K3,S4,P4,Sw4)
CPU times: user 149.60 s, sys: 1.64 s, total: 151.24 s
Wall time: 151.27
sage: len(S4b)
7
sage: time S5,M4=getCycExtensionsBoundedSat(K3,S4b,cols4Reps,chargeset)
1,1,1,1,1,1,1
CPU times: user 24.63 s, sys: 0.17 s, total: 24.80 s
Wall time: 24.80
sage: time S6,M5=getCycExtensionsBoundedSat(K3,S5,cols5Reps,chargeset)
1,1
Maximal found early
1,1,1,1
CPU times: user 18.84 s, sys: 0.14 s, total: 18.98 s
Wall time: 18.98
sage: time S7,M6=getCycExtensionsBoundedSat(K3,S6,cols6Reps,chargeset)
1
Maximal found early
Maximal found early
Maximal found early
Maximal found early
Maximal found early
CPU times: user 19.20 s, sys: 0.11 s, total: 19.31 s
Wall time: 19.31
sage: time S8,M7=getCycExtensionsBoundedSat(K3,S7,cols7Reps,chargeset)
Maximal found early
CPU times: user 10.45 s, sys: 0.23 s, total: 10.68 s
Wall time: 10.68
sage: len(S4),len(S5),len(S6),len(S7),len(S8)
(14, 7, 6, 1, 0)
sage: len(M3),len(M4),len(M5),len(M6),len(M7)
(0, 0, 1, 5, 1)

```

A.5 Mahler Measure and Minimal Noncyclotomics

We can compute the Mahler measure of a polynomial P by

```

def mahlerMeasure(P):
    C2=PolynomialRing(ComplexField(100),'x')
    R=[abs(r[0]) for r in C2(P).roots()]
    mahlmeasure=1
    for l in R:
        if l>1:
            mahlmeasure=mahlmeasure*l
    return mahlmeasure

```

For a matrix m its Mahler measure is that of its associated reciprocal polynomial:

```
def assocRecipPoly(m):
    L=PolynomialRing(ZZ, 'z')
    z=L.0
    g=m.charpoly()
    return z^g.degree()*g(z+1/z)
```

giving

```
def matrixMahler(m):
    return mahlerMeasure(assocRecipPoly(m))
```

Given a dimension n matrix m we can delete the k th row and column to recover an induced dimension $n - 1$ submatrix

```
def removeRowCol.k(K,m,k):
    n=m.nrows()-1
    M=Matrix(K,n,n)
    for i in range(k):
        for j in range(k):
            M[i,j]=m[i,j]
        for j in range(k,n):
            M[i,j]=m[i,j+1]
    for i in range(k,n):
        for j in range(k):
            M[i,j]=m[i+1,j]
        for j in range(k,n):
            M[i,j]=m[i+1,j+1]
    return M
```

A dimension n matrix is then minimal noncyclotomic if it is noncyclotomic but each induced submatrix of dimension $n - 1$ is cyclotomic:

```
def isMinNoncyclotomic(K,m):
    k=m.nrows()
    r=0
    allcyc=true
    while allcyc and r<k:
        subm=removeRowCol.k(K,m,r)
        allcyc=isCyclotomic(subm)
        r=r+1
    return allcyc
```

Example A.5.1. We confirm the value of λ_0 for Lehmer's polynomial, that the graph $5U$ given in [15] has Mahler measure λ_0 , and that it is minimal noncyclotomic:

```
sage: Zz=PolynomialRing(ZZ, 'z'); z=Zz.0
```

```

sage: lehmerPoly=z^10+z^9-z^7-z^6-z^5-z^4-z^3+z+1
sage: mahlerMeasure(lehmerPoly)
1.1762808182599175065440703385
sage: A=matrix([[1,1,0,0,0], [1,-1,1,0,0],
               [0,1,0,1,-0],[0,0,1,0,1],[0,0,0,1,1]])
sage: matrixMahler(A)
1.1762808182599175065440703385
sage: isMinNoncyclotomic(K1,A)
True

```

A.6 Growing Algorithms For Minimal Noncyclotomics

For a given column set `cols` (for convenience, not containing the zero vector) and charge set X the following gives an implementation of the `mncyc` algorithm:

```

def getCycMinNonCycExtensions(K, mList, cols, charges):
    cycList=list()
    minNonCycList=list()
    for m in mList:
        for c in cols:
            for x in charges:
                newm=matrixExtendCharged(K,m,c,x)
                if isCyclotomic(newm):
                    cycList.append(newm)
                elif isMinNoncyclotomic(K,newm):
                    minNonCycList.append(newm)
    return cycList, minNonCycList

```

Note that for the results of Chapter 6 we initially use `mncyc` with $C = C_{k'}(\mathcal{L})$ the reduced naïve column set, which is generated by looping over \mathcal{L} . For sufficiently large k both cyclotomic and minimal noncyclotomic supermatrices $m_{c,x}$ of a dimension k matrix m satisfy the condition that

$$\max \text{rowWeights}(m_{c,x}) \leq 4$$

and so we may switch to $c \in C_k^4(\mathcal{L})$ and the bounded `mncyc` algorithm. Incorporating the earlier modifications of `getCycExtensionsBounded` to the pseudocode description, this can be implemented as

```

def getCycMinNonCycExtensionsBounded(K, mList, cols, charges):
    weight4List=list(); weightNot4List=list()
    cycList=list(); minNonCycList=list()
    for v in cols:
        if sum([K(v[i])*K(v[i]).conjugate() for i in range(len(v))]) == 4:
            weight4List.append(v)

```

```

else:
    weightNot4List.append(v)
for m in mList:
    weightNot4SafeList=getSafeweightCols(K,m,weightNot4List)
    weight4SafeList=getSafeweightCols(K,m,weight4List)
    for c in weightNot4SafeList:
        for x in charges:
            newm=matrixExtendCharged(K,m,c,x)
            if isCyclotomic(newm):
                cycList.append(newm)
            elif isMinNoncyclotomic(K,newm):
                minNonCycList.append(newm)
    if 0 in charges:
        for c in weight4SafeList:
            newm=matrixExtendCharged(K,m,c,0)
            if isCyclotomic(newm):
                cycList.append(newm)
            elif isMinNoncyclotomic(K,newm):
                minNonCycList.append(newm)
    print len(cycList),len(minNonCycList)
return cycList,minNonCycList

```

Example A.6.1. We demonstrate the first round of the search for small minimal noncyclotomic graphs for $d = -2$ as in Section 6.3.2.

```

sage: H1=matrix([[1,u],[-u,1]])
sage: H2=matrix([[1,u],[-u,-1]])
sage: H3=matrix([[0,u],[-u,0]])
sage: H4=matrix([[1,u],[-u,0]])
sage: [matrixMahler(m) for m in [H1,H2,H3,H4]]
[1.8832035059135258641689474654, 1, 1, 1]
sage: S2=[H2,H3,H4]
sage: naiveCols=list()
sage: for a in L12zero:
....:     for b in L12zero:
....:         naiveCols.append([a,b])
....:
sage: naiveCols.remove([0,0])
sage: cols2Reps=reduceCols(K2,naiveCols,L1,L)
sage: time S3,MNCYC3=getCycMinNonCycExtensions(K2,S2,cols2Reps,chargeset)
2 24
12 50
13 80
CPU times: user 0.58 s, sys: 0.01 s, total: 0.59 s
Wall time: 0.59
sage: len(MNCYC3)
80
sage: P3=PermutationMatrices(K2,3)

```

```
sage: Sw3=SwitchingMatrices(K2,3,L1)
sage: time MNCYC3Reps=reduceModEquivalence(K2,MNCYC3,P3,Sw3)
CPU times: user 4.71 s, sys: 0.11 s, total: 4.82 s
Wall time: 4.82
sage: len(MNCYC3Reps)
34
```