

**A NEW PROTECTING GROUP STRATEGY FOR  
OLIGONUCLEOTIDE SYNTHESIS**

**GILLIAN TURNER**

**A thesis submitted for the  
degree of Doctor of Philosophy**

**University of Edinburgh**

**1990**



**To my parents**

This thesis is submitted in part fulfilment of the requirements of the degree of Doctor of Philosophy in the University of Edinburgh. Unless otherwise stated the work described is original and has not been previously submitted in whole or in part for any degree at this or any other university.

University of Edinburgh  
March 1990

## **Acknowledgments**

I would like to thank Professor Robert Ramage for his advice and encouragement throughout this work and for the provision of research facilities at Edinburgh University.

I also wish to thank Dr. Tom Brown for his helpful advice concerning this work, Mrs. Sandra Thompson for her assistance in the synthesis of the oligonucleotides, Mr. John Miller and Miss Heather Grant for their help with n.m.r. spectroscopy and my industrial supervisor, Dr. Roy Valentine.

Many thanks go to Dr. Robin Attrill and Dr. David Thomas for their advice and patience in proof-reading this thesis.

I would also like to thank my industrial sponsors, Wendstone Chemicals plc. for financial support.

## ABSTRACT

This thesis describes the development of the various methods available for the synthesis of deoxyoligoribonucleotides. The use of the 2,2-*bis* (4-nitrophenyl)ethyl group was investigated, mainly as a 5'-hydroxyl protecting group on 2'-deoxyribonucleotides, but also as a base protecting group for the O<sup>4</sup>-function of thymidine and the N<sup>6</sup>-exocyclic amine of adenosine. The deprotection conditions required for the removal of this group and its subsequent use in the synthesis of 2'-deoxyribonucleotides utilising phosphoramidite methodology are described. An investigation, by <sup>31</sup>P n.m.r., of the coupling and oxidation steps of the synthesis of DNA is included as well as a brief study of the potential use of zinc iodide as an accelerating agent in the coupling of nucleotides by the phosphotriester method of synthesis.

## TABLE OF CONTENTS

<b>1 INTRODUCTION</b>	<b>1</b>
1.1 HISTORY OF DNA SYNTHESIS	1
1.2 DNA STRUCTURE	2
1.2.1 Primary Structure	2
1.2.2 Secondary Structure	3
1.3 USES OF SYNTHETIC DNA AND RNA	5
1.3.1 Introduction	5
1.3.2 Recombinant DNA Technology	6
1.3.3 Cloning DNA	8
1.3.4 Site-directed Mutagenesis	9
1.3.5 Molecular Structure of Synthetic DNA	10
1.4 CHEMICAL SYNTHESIS	11
1.4.1 Introduction	11
1.4.2 The Phosphodiester Method	12
1.4.3 The Phosphotriester Method	13
1.4.4 The Phosphite-triester Method	30
1.4.5 The H-Phosphonate Approach	39
1.5 PROTECTING GROUPS	41
1.5.1 Introduction	41
1.5.2 Sugar hydroxyl protection	41
1.5.3 Base Protection	47
1.5.4 Phosphorus Protection	51
1.5.5 Current Protecting Group Strategies	51
1.6 SOLID PHASE SYNTHESIS	54
1.6.1 Introduction	54
1.6.2 The Principle of Solid Phase Synthesis	54
1.6.3 Use in Synthesis	55
1.6.4 Automated Synthesis	58
<b>2 DISCUSSION</b>	<b>59</b>
2.1 Problems with DNA synthesis	59
2.2 Bnpeoc as 5'-hydroxyl protection for thymidine	61
2.3 Stability Studies	63
2.4 Solid Phase Synthesis	66
2.5 Alternative Protecting Group Strategies	70
2.6 Bnpeoc as 5'-Hydroxyl Protection for 2'-Deoxyadenosine	74
2.7 Stability Studies	77
2.8 Use of $\beta$ -Cyanoethyl Phosphoramidites	81
2.9 Phosphorus NMR Studies	84
2.10 Base Protection by Bnpeoc	89
2.11 Use of Zinc Iodide in Phosphotriester Synthesis	91
2.12 Conclusions	93
<b>3 EXPERIMENTAL</b>	<b>95</b>
3.1 Notes	95
3.2 Experimental	98
3.3 Stability studies	129
3.4 Phosphorus N.M.R. Studies	135
3.5 Oligodeoxynucleotide Synthesis	140

<b>4 REFERENCES</b>	<b>145</b>
<b>5 Abbreviations</b>	<b>152</b>
<b>6 APPENDIX</b>	<b>153</b>
<b>7 Courses Attended</b>	<b>159</b>

## CHAPTER 1

## INTRODUCTION

**1.1. HISTORY OF DNA SYNTHESIS**

The chemical synthesis of DNA has proved to be one of the most exciting challenges to organic chemists in recent times. The opportunity to investigate the molecules which hold the key to life by carrying the genetic code for each organism, and the chemical complexity of such compounds, has created considerable interest in this area of chemistry.

The basic objective is to join a 5'-OH group on the deoxyribose ring of one nucleotide with the 3'-OH group on another nucleotide *via* a phosphoric acid function. A variety of protecting groups and activating groups have been developed to ensure the required reaction occurs whilst minimising unwanted side-reactions.

The first synthesis of DNA by chemical methods was reported in the 1950s by Todd<sup>1</sup> who successfully made and isolated a dithymidine dinucleotide. Khorana then used and developed the phosphodiester approach for many years finally using it in the synthesis of a biologically active gene<sup>2</sup> in the late 1970s. During this time other chemists including Eckstein<sup>3</sup>, Reese<sup>4</sup> and Letsinger<sup>5</sup> began to explore the phosphotriester approach which, after modification by Cramer<sup>6</sup> and Narang<sup>7</sup>, was also used to make biologically active genetic material<sup>8</sup>. The phosphite approach, first used by Letsinger<sup>9</sup> in the mid 1970s, has been developed rapidly and with the introduction of solid phase synthesis, also proposed by Letsinger<sup>5</sup>, it is now possible to make routinely oligodeoxyribonucleotides using an automated synthesizer.



## 1.2. DNA STRUCTURE

### 1.2.1. Primary Structure

The primary structure of DNA consists of a chain of 2'-deoxy-D-ribose rings linked by 3'-5' phosphodiester bonds with each of the sugars having a base attached at the 1'-position in the  $\beta$ -configuration as shown in fig.1.1.

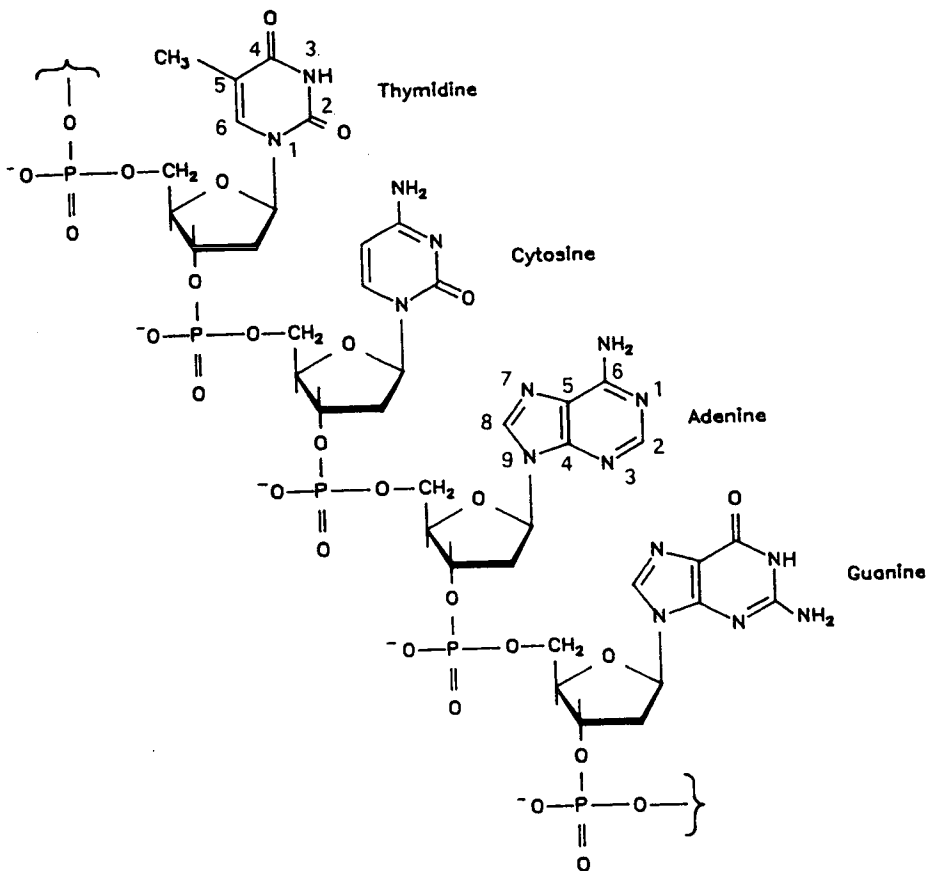

Fig.1.1 Primary Structure of DNA

There are four different bases in DNA, all are heterocycles and are divided into the substituted purines, guanine and adenine, and the substituted pyrimidines, thymine and cytosine. The structure of RNA is similar to DNA, the differences being the occurrence of uracil in place of thymine, and the sugar to which the bases are attached being D-ribose as opposed to 2'-deoxy-D-ribose in DNA, fig.1.2.

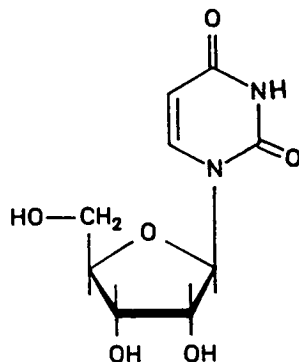

Fig.1.2 Uridine, an RNA Nucleoside

### 1.2.2. Secondary Structure

The presence on three of the bases, adenine, guanine and cytosine, of exocyclic amino functions having the potential to form hydrogen-bonds make oligonucleotides soluble in aqueous rather than organic solvents. The property of hydrogen-bonding is also very important in the formation of the secondary structure of DNA where base pairs are formed between adenine and thymine, and between guanine and cytosine, by the formation of two and three hydrogen-bonds respectively, as in fig.1.3.

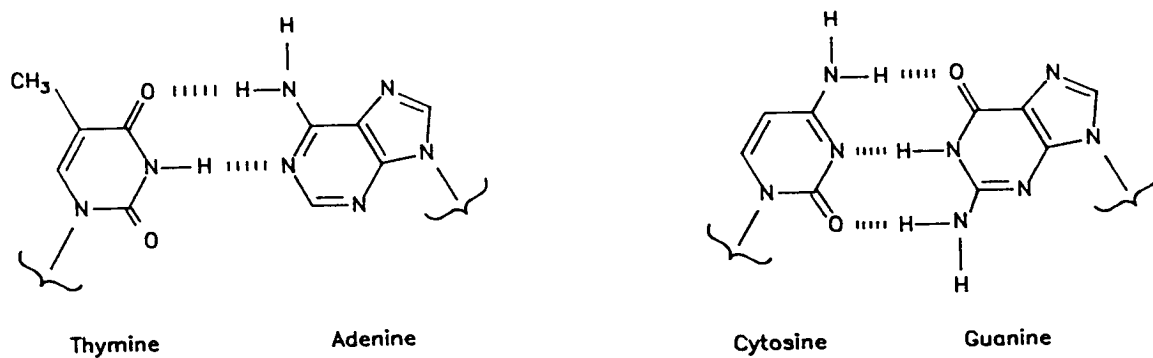

Fig.1.3 Base Pairing in DNA

The natural form of DNA is an antiparallel duplex held together by hydrogen-bonds, fig.1.4. but unwanted secondary structures can also occur such as hairpin loops, in which one part of the strand hydrogen-bonds to another part of the strand containing the complementary sequence of bases,

see fig.1.5.

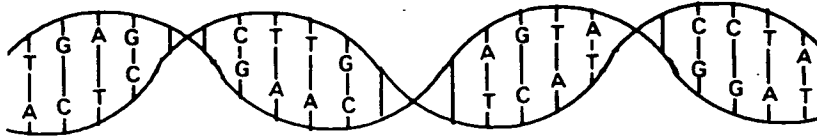

Fig.1.4 A DNA Duplex

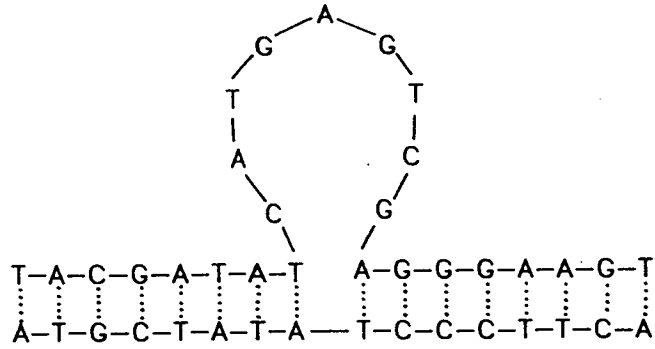

Fig.1.5 A Hairpin Loop in DNA

### 1.3. USES OF SYNTHETIC DNA AND RNA

#### 1.3.1. Introduction

When chemists first gained the knowledge and ability to make synthetic oligonucleotides it was little realised what effect the availability of such compounds would have on the study of genetics and molecular biology. During the last twenty years such synthetic DNA and RNA has found a diverse, and ever increasing, variety of uses.

One of the first problems it was instrumental in solving was the genetic code<sup>10</sup> relating the order of bases along the DNA to the primary structure of the protein produced. From this researchers in molecular biology began to explore the function of various sequences in genes including regulatory signals,<sup>8</sup> specific probes<sup>11</sup> and linkers,<sup>12</sup> and, with the information gained from such studies, used chemically synthesized oligodeoxyribonucleotide segments in the synthesis of a double stranded DNA corresponding to a gene.<sup>13,14</sup>

Today recombinant DNA technology, in which a fragment of synthetic DNA is incorporated into a natural DNA molecule, is probably the major area of application for chemically synthesized DNA. By employing this technique it is possible to make *Escherichia coli* produce a variety of proteins, including medically important ones such as insulin<sup>15</sup> and human growth hormone.<sup>16,17</sup>

Another application of synthetic DNA is in site-directed mutagenesis in which a duplex is constructed containing either a mutation in both strands or in just one strand, the latter resulting in a base-pair mis-match. The mutant DNA is then inserted into a gene whose natural sequence has been deleted.<sup>18,19,20</sup>

In order to obtain the crystal structure of DNA relatively large amounts of

the sequence to be studied are required. Isolation and purification from natural sources can be excessively time consuming and yields only small quantities of DNA so the use of synthetic material has proved invaluable in this area.<sup>21</sup>

### 1.3.2. Recombinant DNA Technology

The use of micro-organisms is not a recent innovation. Such organisms have been used by man for a long time in the production of food, *e.g.* cheese, bread, beer and wine, but until recently such applications were restricted to the use of certain naturally occurring organisms. With the advent of recombinant DNA technology it is possible to genetically alter these, and other organisms, to produce a vast array of useful products, particularly in the areas of agriculture and medicine.

The key to the utilisation of this technology is the cloning of DNA which occurs in three stages. First it is necessary to construct a molecule containing the recombinant DNA, *i.e.* the DNA to be copied. It is at this stage that the synthetic DNA is joined to a DNA vector which will then replicate autonomously in the chosen host cell. Suitable vectors for this application include plasmids, naturally occurring circles of DNA, and  $\lambda$  phage, a virus, both of which will replicate in *Escherichia coli*. In the second stage the recombinant DNA must be introduced into the host cell either by cell takeup from the medium or by the use of infected virus particles assembled to harbour the recombinant DNA molecule. The last stage is the selection of cells which contain the recombinant DNA. Such cells may be identified if the plasmid vector confers antibiotic resistance, or alternatively, individual cells can be cultivated and then identified using a Southern blot, in which labelled, complementary probes determine the presence, or otherwise, of the required recombinant DNA.

With the possibility of synthesizing and cloning genes there is great scope

for the production of proteins, which perform essential roles in the regulation of the metabolic processes, but which occur in such low concentrations in the body that isolation cannot provide enough material for the medical applications in which they are involved. Cloning can provide relatively large amounts of pure protein.

The first synthesis of a functional polypeptide product from a gene of chemically synthesized origin was performed by K. Itakura *et al.*<sup>22</sup> in 1977 with the production of the hormone Somatostatin. This hormone, containing 14 amino acid residues, inhibits the secretion of other hormones including insulin and human growth hormone.

The protein insulin is involved in the regulation of glucose levels in the blood and is normally produced in the pancreas, but in the instance of diabetes mellitus there is a deficiency of this hormone. In some cases it is necessary to treat the sufferer with injections of insulin which until recently have been derived from bovine or porcine pancreas. Since 1982, when the insulin gene was synthesized and inserted into *Escherichia coli*,<sup>15</sup> human insulin has been produced on a large scale for the treatment of diabetes.

Another important hormone to be produced in this way is human growth hormone, a 191 amino acid protein, a deficiency of which leads to dwarfism. This can be treated by replacement therapy. The usual source for such treatment has been human cadavers, but the alternative source now provided by cloning the recombinant DNA in *Escherichia coli*<sup>16,17</sup> has meant that demand may be more readily met.

For the control of pain the body produces peptides called endorphins which are non-addictive alternatives to opiates. Human  $\beta$ -endorphin, a peptide of 31 amino acid residues, has been successfully produced using a synthetic gene

implanted into *Escherichia coli*.<sup>23</sup> The bacteria selectively secrete the peptide into the culture medium from which it is then isolated.

The action of proteins as hormones is only one function of this versatile group of compounds, which can also act as enzymes, catalysing most chemical reactions in the body. Many thousands of enzymes exist naturally but few are currently of industrial importance, those that are being mainly used in food production or for medical treatments. In order to increase the potential of enzymes it is possible to either construct them with synthetic genetic material, or modify existing enzymes by site-directed mutagenesis, both by using recombinant DNA methods.

Protein engineering has benefitted greatly from the improved methods of making synthetic DNA. Molecular biologists are now able to alter precisely a protein by changing one or more of the bases in the DNA which codes for that particular protein. This technology allows the structure of natural and synthetically engineered enzymes and other proteins to be studied in more detail.

Recombinant DNA technology also uses sections of DNA, *e.g.* a gene, from one cell for transplant into another type of cell using a suitable vector. This method does not use synthetic DNA for the implant but may make use of such a compound in the process of cloning the DNA.

### 1.3.3. Cloning DNA

The cloning of DNA, whether it is of natural or synthetic origin, utilises various fragments of synthetic DNA which perform different functions in the process.

One such function is that of primer in which a small piece of DNA or RNA

of complementary sequence binds to the single stranded DNA to be copied and allows DNA polymerase to replicate the remainder of the strand. A synthetic primer has been used in the production of interferons,<sup>24</sup> compounds possessing both antiviral and anticancer properties.

Probes are employed widely in molecular biology as aids to establishing the success of recombinant DNA incorporation. The probes, sequences of DNA complementary to the sequence of interest, are often labelled with <sup>32</sup>P so their progress can be monitored. Synthetic oligonucleotides have been used as specific probes in the determination of yeast iso-1-cytochrome *c* in mRNA structure and function.<sup>11</sup>

Recognition sites are sequences of DNA which are "recognised" by a specific enzyme which, when bonded, will act according to its function.<sup>8</sup> Restriction enzymes are an example of this. They recognise a specific sequence in the DNA and then cleave the two strands leaving either "blunt-ends", where both strands have been severed at the same place, or "sticky-ends", where one cut is several nucleotides further along the duplex than the other. The latter process can be exploited by using a DNA ligase to join a piece of synthetic DNA duplex to these ends which can itself contain a recognition site, thus allowing recognition sites to be placed at the desired position in the oligonucleotide duplex.<sup>12</sup>

#### **1.3.4. Site-directed Mutagenesis**

Synthetic oligodeoxyribonucleotides containing one or more mis-matched bases may still bind to DNA containing a complementary site. Where the mis-matched DNA sequence is used as a primer and then cloned it is possible to produce DNA with any desired mutation at any site. It is also possible to construct deletions, natural sequences with one or more nucleotides removed,



by designing an oligonucleotide to bind to the sequences on each side of the sequence to be deleted, thus producing a hairpin loop in the natural DNA chain. The mis-matched sequence then acts as a primer for the synthesis of the DNA containing the deletion.<sup>18,19</sup>

### 1.3.5. Molecular Structure of Synthetic DNA

In order to study the molecular structure of DNA it is necessary to grow crystals, which requires sufficiently pure DNA in amounts not easily obtainable from natural sources. For this application self-complementary strands of DNA are often used and the crystals analysed using X-ray diffraction. Most natural DNA is thought to be in the right handed helical B form but studies on synthetic oligodeoxyribonucleotide sequences have shown that they can exist in other forms including the left-handed helical B form<sup>21</sup> and the left-handed zigzag or Z form.<sup>25</sup>

By measuring the melting temperature of self-complementary strands of DNA the effect of base pair mis-matches and non-natural bases on the stability of the duplex can be determined.

## 1.4. CHEMICAL SYNTHESIS

### 1.4.1. Introduction

The methods for the chemical synthesis of DNA have advanced greatly since Todd<sup>1</sup> first made a dinucleotide in the 1950s. These advances have resulted in the progression from a coupling reaction using a phosphodiester reagent in solution phase to using phosphotriester-, and phosphite-triester reagents on solid phase today.

The aim of all these various types of coupling procedure is to join a 5'-hydroxyl on one nucleoside with a 3'-hydroxyl on another nucleoside via a bridging phosphate function, thus producing the sugar-phosphate chain which forms the backbone of the DNA structure.

In the first attempts to produce such a linkage the obvious method to use seemed to be the reaction of a nucleotide containing an unprotected phosphate attached to the 5'-hydroxyl with another nucleotide containing a free 3'-hydroxyl group. This method did in fact produce some product but was time consuming and gave low yields. Development of the method led to the use of a protecting group on the phosphate giving the phosphotriester method, which, after extensive modification in order to reduce coupling times, is still used widely today.

It was not until the 1970's that Letsinger<sup>9</sup> saw the possibility of using a phosphite intermediate which would couple much more quickly than the corresponding phosphate, and could then be readily oxidised to the phosphate using iodine and water. This approach has also undergone a lot of development and is now used routinely in conjunction with automated solid phase synthesis methods to produce, on a small scale, synthetic oligonucleotides containing 30 to 40 bases in a few hours.

### 1.4.2. The Phosphodiester Method

This was the first general method to be used in the synthesis of di- and polynucleotides. Khorana *et al.* used and developed the phosphodiester approach for many years from 1958 when they used it to obtain dinucleotides containing the C<sub>5'</sub>-C<sub>3'</sub> linkage<sup>26</sup> to the 1970's when they synthesized the genes for an alanine tRNA<sup>13</sup> and for a tyrosine suppressor tRNA.<sup>2</sup>

The synthesis of a dinucleotide using this method makes use of commercially available nucleotides with one having a protecting group on the 5'-hydroxyl and the 3'-hydroxyl free to react, 1, and the other having the 3'-hydroxyl protected and a phosphate group on the 5'-hydroxyl 2. Both the nucleotides require suitable protection on their bases. The condensation uses either dicyclohexylcarbodiimide (DCCI) or triisopropylbenzenesulphonyl chloride (TPSCI) and gives a protected dinucleotide 3 from which the protecting groups may then be removed, as shown in fig.1.6. Such a dinucleotide could be extended by further condensation reactions if the appropriate 5'-phosphate derivative is obtained.

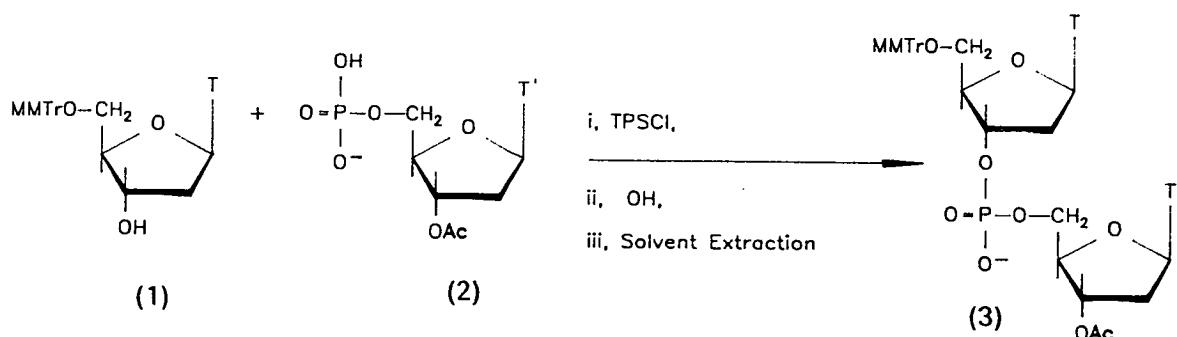

Fig.1.6 The Phosphodiester Approach

This method of synthesis has several drawbacks including long reaction times for the condensations and low yields as chain length increases. Purification is also a long process including anion exchange chromatography

and without improvements in this area synthesizing oligonucleotides of more than a few bases would not be practical.

#### 1.4.3. The Phosphotriester Method

The problems associated with the phosphodiester approach mainly derive from the fact that throughout the synthesis the phosphate linkages are unprotected and this can give rise to several side-reactions. Firstly, the phosphodiester functions are nucleophilic and therefore can cause both side-reactions during the rest of the synthesis and cleavage of internucleotide linkages. Both these possibilities can significantly reduce the yield of the reaction. The poor solubility of such compounds in organic solvents limits the number of processes, such as silica chromatography, which may be used for purification and necessitates the use of techniques involving aqueous solutions. These latter methods of purification such as ion-exchange chromatography involving the use of buffers may result in the loss of acid or base sensitive protecting groups from elsewhere in the oligonucleotide. For these reasons it was recognised that there was a need for a protecting group on the phosphodiester linkage and this led to the development of the phosphotriester method.<sup>27</sup>

This approach was first used by Todd *et al.*<sup>1</sup> in 1955 when he reported the synthesis of the first oligonucleotide but subsequent researchers, including Khorana *et al.*<sup>26</sup>, made use of the apparently simpler phosphodiester method for many years. The scheme used by Todd is shown in fig.1.7.

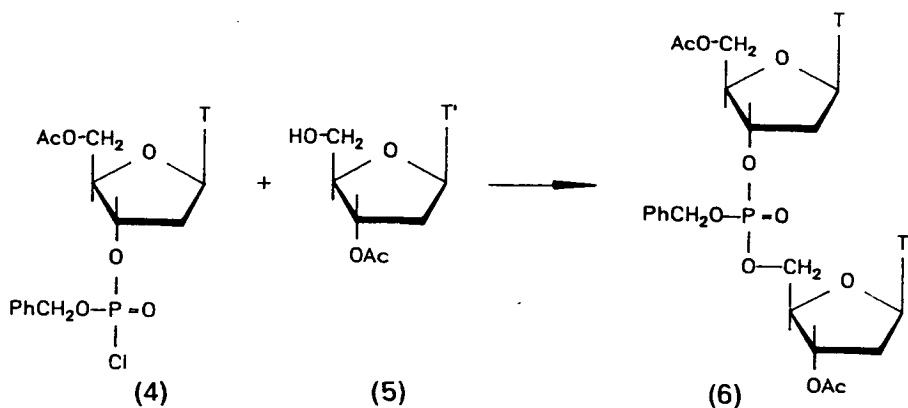

Fig.1.7 Todd's Phosphotriester Approach.

In this synthesis the 5'-acetyl-3'-benzylphosphochloridate nucleotide **4** was reacted with 3'-acetylthymidine **5** to give the fully protected dinucleotide **6**. This approach then remained unused until 1965 when Letsinger *et al.*<sup>5,28</sup> examined the  $\beta$ -cyanoethyl group to protect the internucleotide linkages during oligonucleotide synthesis using a polymer support. As this method of synthesis could only be used on a small scale Letsinger<sup>29,30</sup> then began to look at solution phase synthesis using the phosphotriester approach. Fig.1.8 shows the step by step synthesis of a dinucleotide using Letsinger's solution phase triester method with a  $\beta$ -cyanoethyl protecting group on the phosphate.

The synthesis starts with a 5'-protected thymidine derivative **1** which is reacted with  $\beta$ -cyanoethyl phosphate in the presence of mesitylenesulphonyl chloride to give the phosphodiester **7**. This compound is then reacted with unprotected thymidine in the presence of 2,4,6-triisopropylbenzenesulphonyl chloride to give the fully protected dinucleotide **8**. The protecting groups are removed with aqueous acetic acid followed by ammonium hydroxide to yield a thymidine dimer. Alternatively, by retaining the  $\beta$ -cyanoethyl group on the phosphate it is possible to add further nucleotides by repeating these reactions to produce compounds such as  $(Tp)_2T$  and  $(Tp)_3T$ .

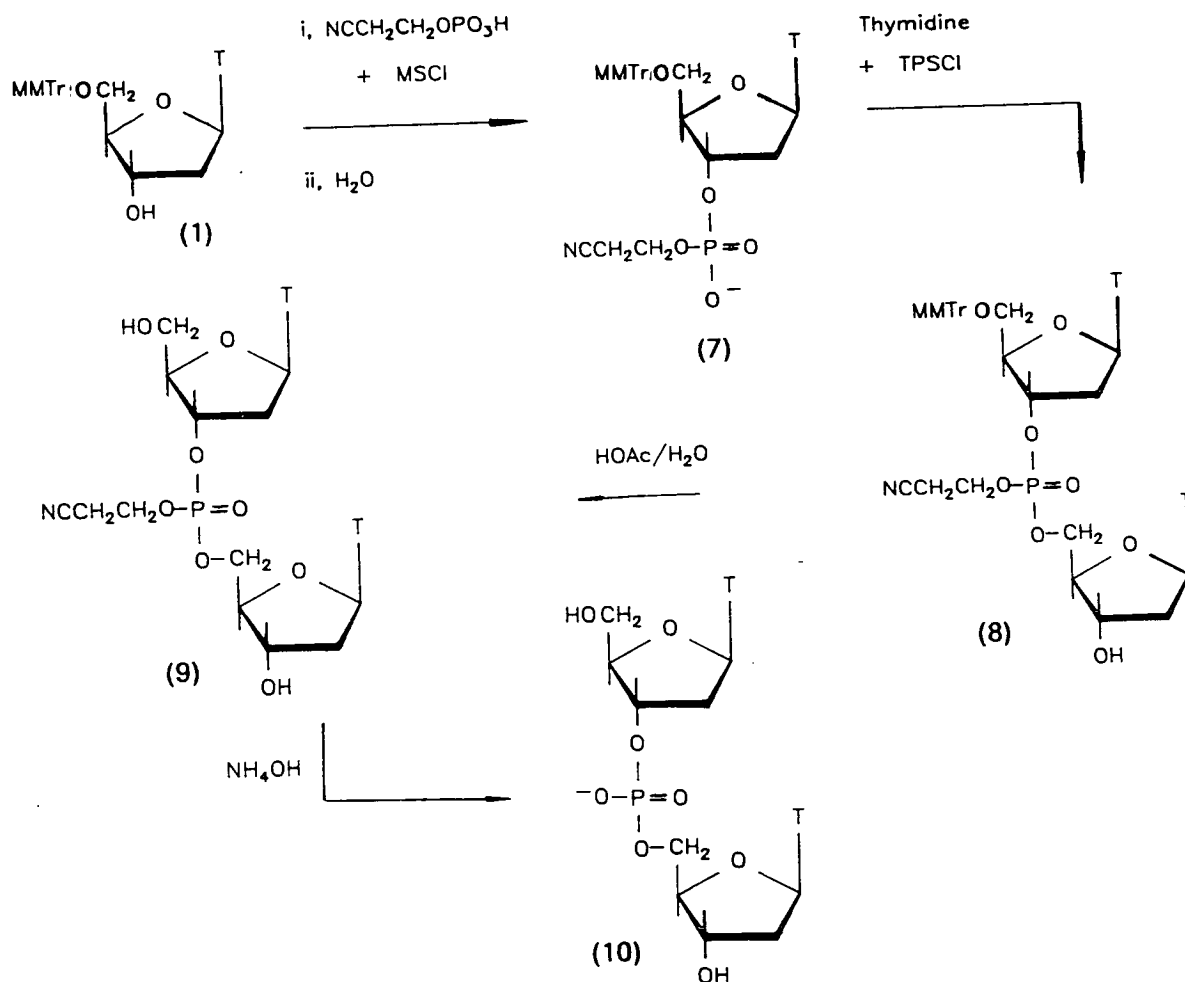

Fig.1.8 Letsinger's Phosphotriester Approach

The above synthesis used unprotected thymidine with which to couple the nucleotide, which as well as giving the desired 3'-5' internucleotidic linkage also produces the unwanted 3'-3' linkage. Letsinger *et al.*<sup>31</sup> sought to remedy this by using the  $\beta$ -benzoylpropionyl group to protect the 3'-position of thymidine. This group can be removed by hydrazine-hydrate which will not affect the other protecting groups on the molecule. The synthesis of oligodeoxyribonucleotides containing bases other than thymidine, and the block synthesis of thymidine oligonucleotides using this method was also reported by Letsinger *et al.*<sup>32</sup>.

Another protecting group was developed for use in phosphotriester synthesis by Eckstein *et al.*<sup>33,34</sup> in 1967. They investigated the 2,2,2-trichloroethyl group in the protection of internucleotide linkages and prepared thymidine dimers, trimers, and tetramers using this protection, as shown in Fig.1.9.

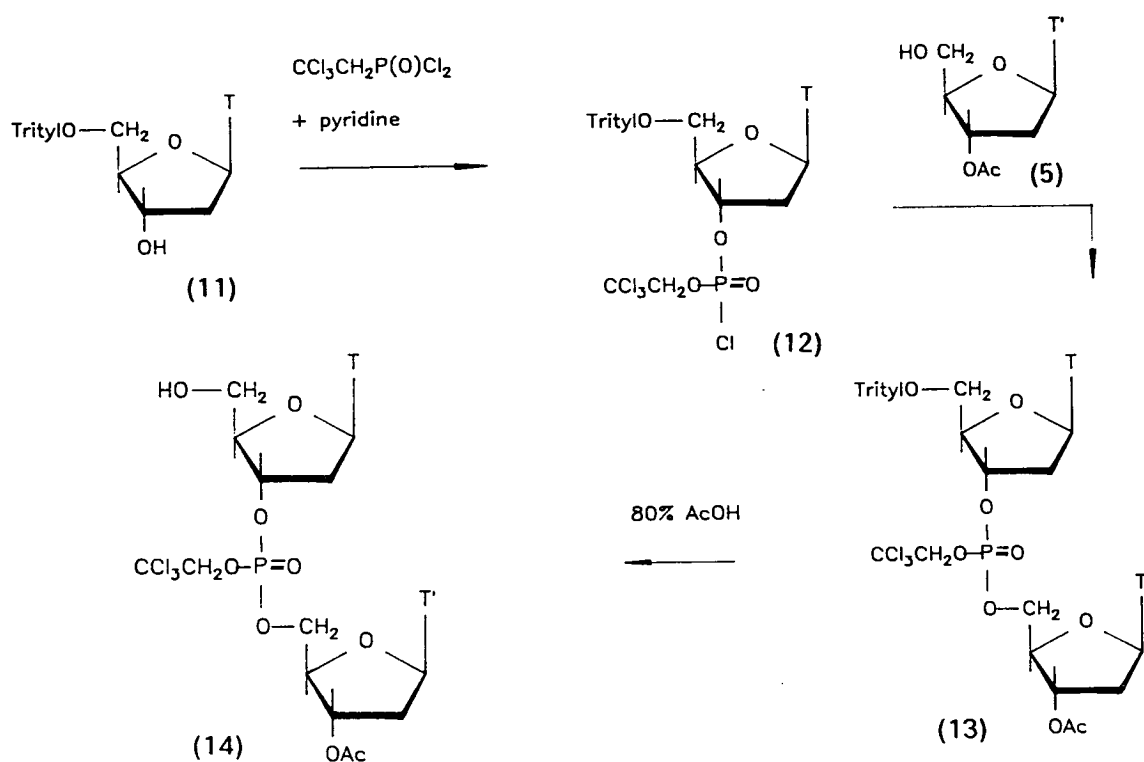

Fig.1.9 Eckstein's Phosphotriester Approach

5'-Tritylthymidine **11** was reacted with 2,2,2-trichloroethyl-phosphodichloridate to give 5'-tritylthymidine-3'-(2,2,2-trichloroethyl)-phosphochloridate **12** as the main product and very little of the disubstituted phosphotriester, bis(5'-tritylthymidine-3')tris(2-chloroethyl) phosphate. The phosphorylated nucleoside was reacted with 3'-acetylthymidine **5** producing a fully protected thymidine dimer **13**, which on treatment with 80% acetic acid to remove the trityl protection, gave a dimer which could be fully deprotected. Alternatively a repetition of the cycle substituting the protected dimer in place

of compound 5 will give a trinucleotide. The tetramer was obtained by block synthesis of two dimers and all the oligonucleotides were finally deprotected with concentrated aqueous ammonia to remove the acetyl groups, and with zinc dust in 80% acetic acid at room temperature to remove the trichloroethyl groups. In 1969 Eckstein *et al.*<sup>3</sup> also reported using this group in the synthesis of short cytidine and adenosine oligodeoxyribonucleotides.

The next proposal of a protecting group came from Reese *et al.*<sup>4</sup> when the use of the phenyl group was suggested. The synthetic pathway to the dimer was similar to Eckstein's and can be seen in fig.1.10.

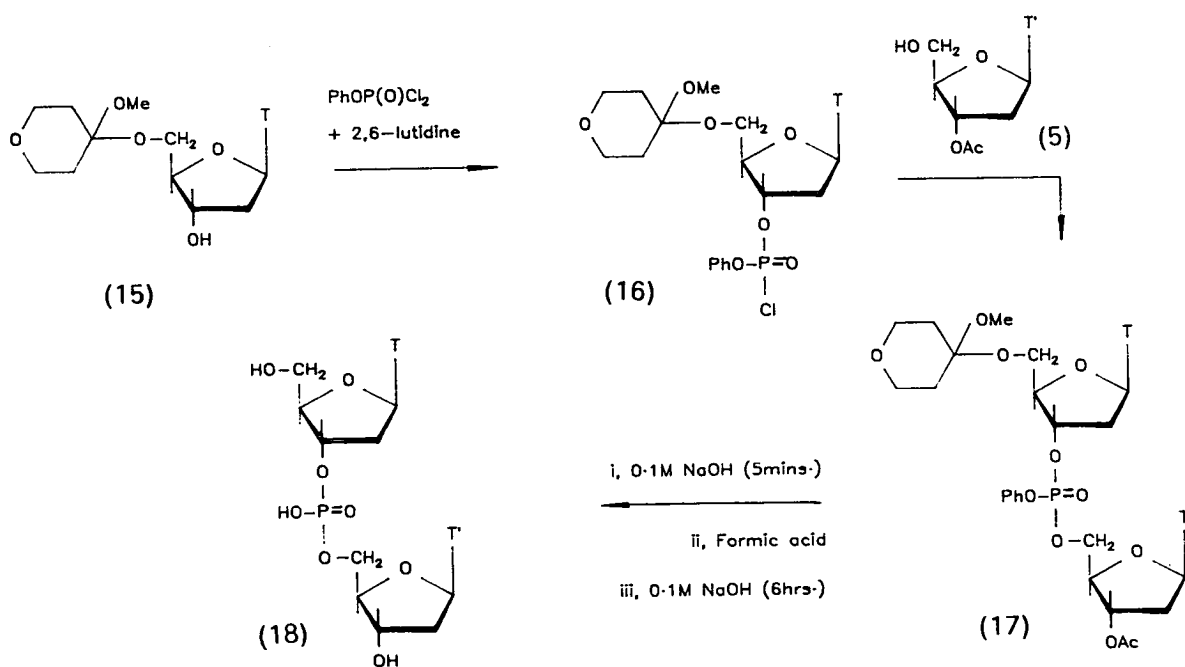

Fig.1.10 Reese's Phosphotriester Approach

In this synthetic strategy Reese used the acid labile methoxytetrahydropyranyl group<sup>35</sup> instead of the previously favoured trityl group to protect the 5'-hydroxyl function. The 5'-methoxytetrahydropyranylthymidine 15 was reacted with phenyl



phosphorodichloridate in the presence of 2,6-lutidine to give a phosphorylated nucleoside 16 to which 3'-acetylthymidine 5 and 2,6-lutidine were added. The resulting dimer 17 was deprotected using a 0.1M NaOH solution for 5 min. to remove the acetyl group, and then a formic acid solution to remove the methoxytetrahydropyranyl group. The phosphate protecting group was removed by treatment with 0.1M NaOH<sub>(aq.)</sub> for 6 hours to yield a protected thymidine dimer 18. Van Boom *et al.*<sup>36</sup> also used this aryl protecting group on internucleotide linkages to make oligoribonucleotides including UpU and UpUpU.

The above method has a potential problem in that the alkaline hydrolysis of the phenyl protected oligonucleotides may proceed with some cleavage of the internucleotide linkage. The incorporation of electron-withdrawing substituents onto the phenyl ring can reduce this problem<sup>27</sup>.

All of the methods for phosphotriester synthesis so far mentioned are generally "one-pot" reactions and so any nucleoside which has not been phosphorylated may subsequently react to give 3'-3' and 5'-5' linkages when the next nucleoside is added. The products of these side-reactions can be difficult to separate from the desired product and so a method which eliminates the formation of such compounds would be an improvement in the phosphotriester approach, enabling oligonucleotides of greater purity and higher yield to be produced.

Cramer *et al.*<sup>6</sup> reported such a method in 1973 when they used both the 2,2,2-trichloroethyl and the  $\beta$ -cyanoethyl group to protect the phosphate group. The synthesis can be seen in fig.1.11.

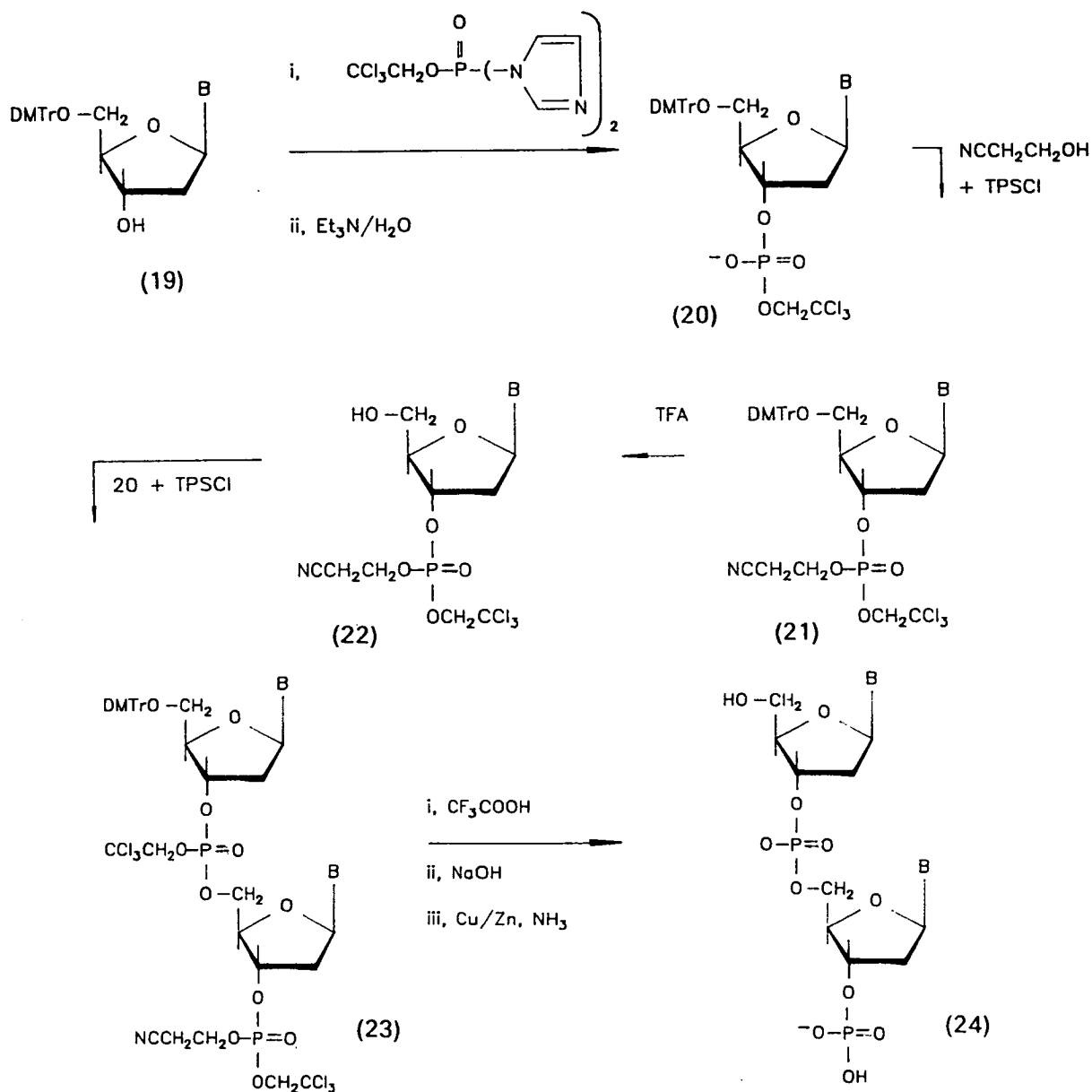

Fig.1.11 Cramer's Phosphotriester Approach

The synthesis starts with a nucleoside protected with the acid labile dimethoxytrityl group 19 and phosphorylates this using 2,2,2-trichloroethylphosphodiimidazolidate and then removes the remaining imidazole with triethylamine and water to afford 20. The nucleotide is condensed with  $\beta$ -cyanoethanol using triisopropylbenzenesulphonyl chloride to give a fully protected triester 21, which is then treated with dilute aqueous

trifluoroacetic acid to remove the dimethoxytrityl group to form 22. Compounds 20 and 22 are reacted with the condensing agent, triisopropylbenzenesulphonyl chloride, to give the protected dimer 23 which can be deprotected using trifluoroacetic acid to remove the dimethoxytrityl group, dilute sodium hydroxide to remove the  $\beta$ -cyanoethyl group, and Cu/Zn then ammonia to remove the 2,2,2-trichloroethyl group, to give 24. Cramer prepared a series of di-, tri-, and tetraoligonucleotides using various combinations of bases with benzoyl protection on deoxycytidine and deoxyadenosine, and acetyl protection on deoxyguanosine exocyclic amino functions.

Narang *et al.*<sup>7</sup> also worked on developing a modified triester method using phenyl, *o*-chlorophenyl, and *p*-methylthiophenyl groups instead of the 2,2,2-trichloroethyl groups used by Cramer. The scheme can be seen in fig.1.12. Starting from thymidine, protected on the 5'-hydroxyl function by monomethoxytrityl 1, Narang produced the phosphitylated nucleoside 26 by addition of the suitably substituted phosphate 25 in the presence of triisopropylbenzenesulphonyl chloride (TPSCI). Compounds 26 and 28 were condensed with triisopropylbenzenesulphonic acid and then treatment with 0.1M sodium hydroxide at 0°C for 30 seconds removed the  $\beta$ -cyanoethyl group to afford 29. At this stage further additions are possible by a repetition of the cycle or the synthesis can be terminated by the addition of 3'-acetylthymidine 5 to give a trinucleotide 30, from which the protecting groups can be removed with acetic acid, concentrated ammonia, and lastly 0.1M sodium hydroxide at room temperature. The *p*-(methylthio)phenyl group was used in the synthesis of larger oligonucleotides and is cleaved by oxidation with N-chlorosuccinimide then treatment with alkali. Using this method Narang synthesized oligodeoxyribonucleotides up to fifteen bases long.



when, in 1975, he described the use of arylsulphonyltriazaoles as condensing agents and also bis(triazolyl)-*p*-chlorophenyl phosphate as a phosphorylating agent. The synthesis of the phosphorylated nucleoside can be seen in fig.1.13.

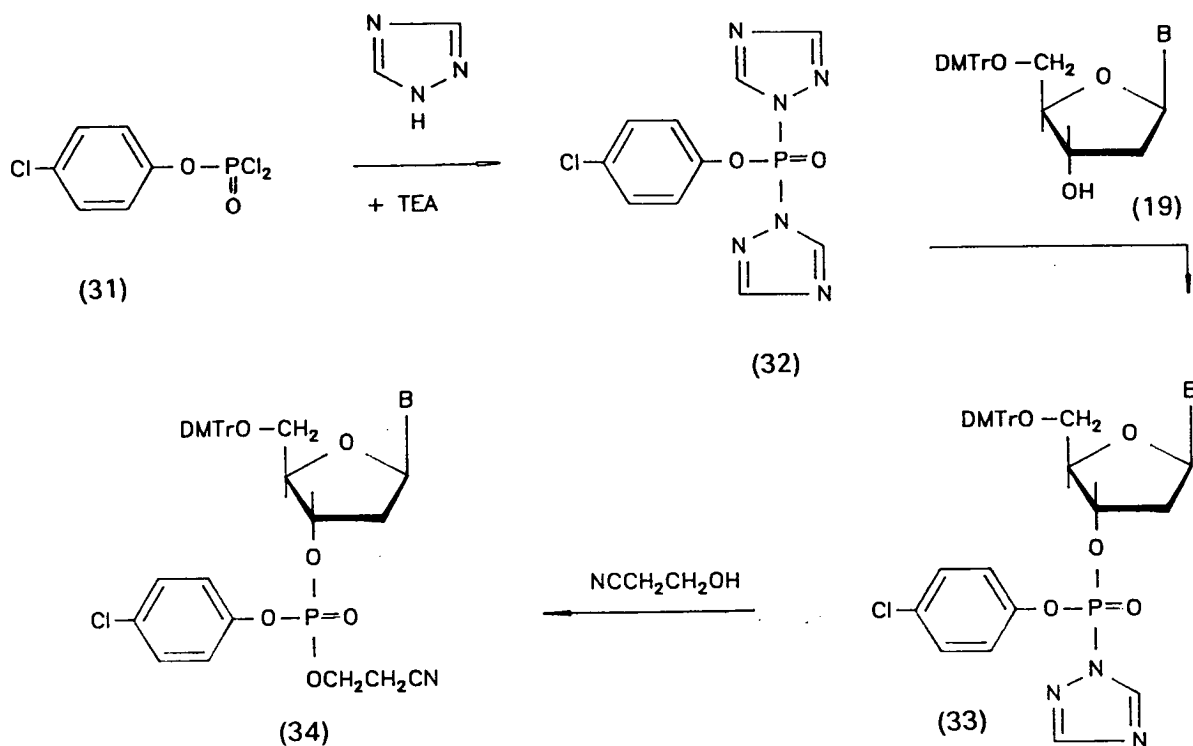
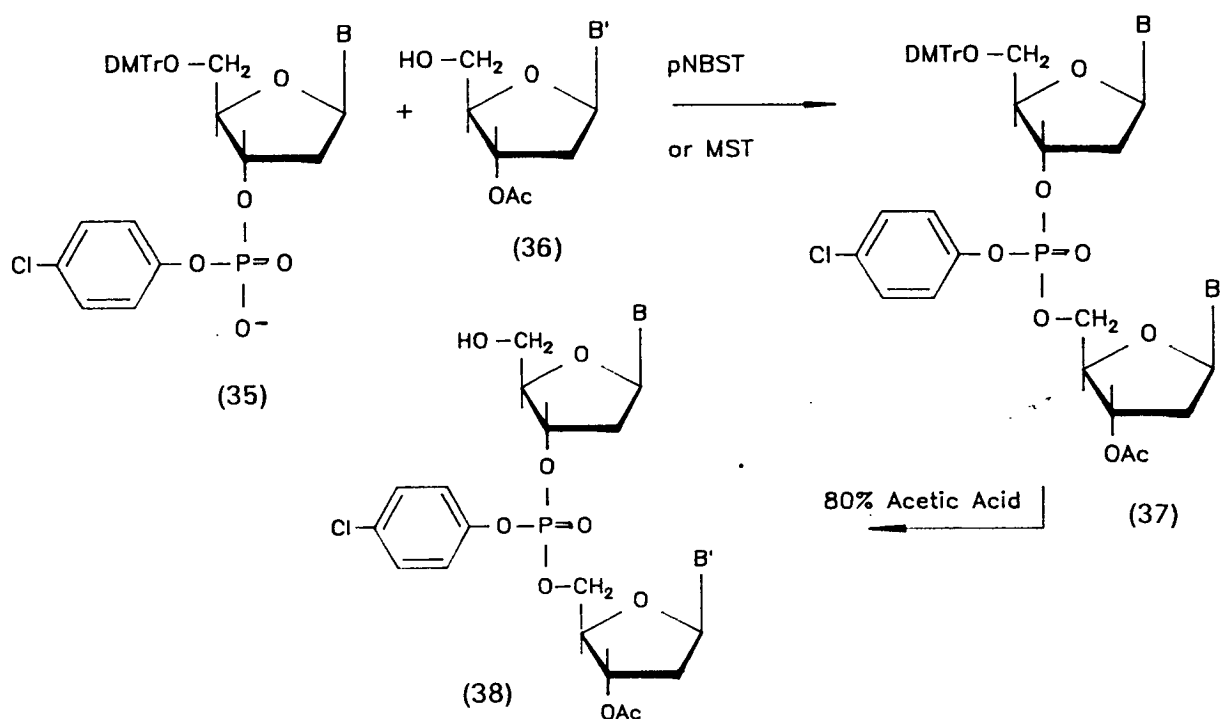

Fig.1.13 Synthesis of a Nucleotide for Narang's Phosphotriester Approach

The phosphorylating agent **32** was formed by the addition of 1,2,4-triazole to *p*-chlorophenyl phosphorodichloridate **31** and the subsequent reaction with a 5'-dimethoxytrityl nucleoside **19** gave a phosphorylated nucleoside **33**. Reaction of **33** with  $\beta$ -cyanoethanol gave the triester **34** which could presumably be deprotected with either sodium hydroxide or triethylamine to commence the synthesis of an oligonucleotide as in fig.1.14. The diester **35** is coupled to a 3'-acetyl nucleoside **36** using one of two new proposed condensing agents, *p*-nitrobenzenesulphonyltriazaole (*p*-NBST) or

mesitylenesulphonyltriazole (MST) to produce a protected dimer 37. The 5'-protecting group can be removed with 80% acetic acid and another cycle of addition repeated if desired and when the synthesis is complete the protecting groups can be removed using sodium hydroxide solution. Using block synthesis in conjunction with this approach Narang produced a hexamer containing guanosine, cytosine, and adenosine residues, and claimed that these new condensing agents increased yields and reduced sulphonation.



*p*-NBST = *p*-nitrobenzenesulphonyltriazole

MST = mesitylene sulphonyltriazole

Fig.1.14 Narang's Phosphotriester Approach using Novel Condensing Agents.

The next development came in the form of arylsulphonyltetrazoles which Narang *et al.*<sup>38</sup> proposed in 1977. These were found to be more reactive than triazoles and triisopropylbenzenesulphonyl chloride. Narang *et al.* synthesized

benzene-, 2,4,6-trimethylbenzene-, and 2,4,6-triisopropylbenzene sulphonyltetrazoles, as in fig.1.15, and found that there was a correlation between the substitution of the benzene ring and the rate of condensation of nucleotides, the phenyl being more reactive than the 2,4,6-trimethylphenyl which was more reactive than the 2,4,6-triisopropylphenyl derivative.

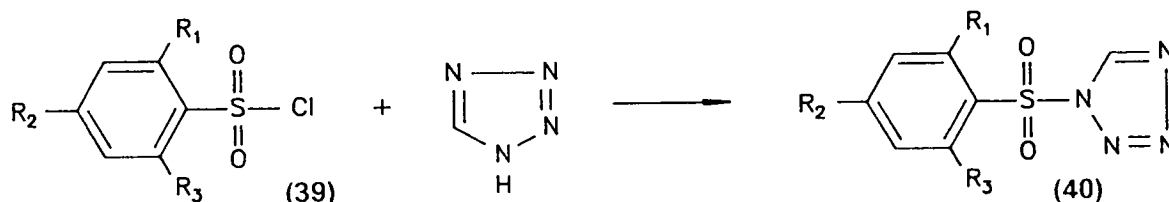

Benzenesulphonyltetrazole  $R_1=R_2=R_3=H$

Mesitylenesulphonyltetrazole  $R_1=R_2=R_3=CH_3$

Triisopropylsulphonyltetrazole  $R_1=R_2=R_3=iPr$

Fig.1.15 Synthesis of Arylsulphonyltetrazoles.

Another condensing agent, 1-mesitylenesulphonyl-3-nitro-1,2,4-triazole **41** (MSNT), fig.1.16, was reported by Reese *et al.*<sup>39</sup> in 1978 when he was investigating the use of the oximate ion in unblocking of oligonucleotide phosphotriester intermediates.

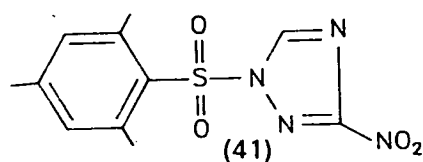
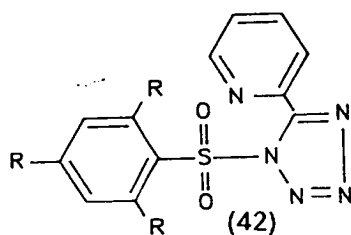

Fig.1.16 1-Mesitylenesulphonyl-3-nitro-1,2,4-triazole.

Reagents previously used for this purpose such as sodium hydroxide cause a significant amount of internucleotide cleavage. The conjugate base of

*syn*-4-nitrobenzaldoxime was shown to be a better nucleophile for this purpose, causing much less cleavage of the internucleotide bonds.<sup>40</sup>

A new class of condensing agent, which gave stereospecific products was announced by Ohtsuka *et al.*<sup>41</sup> who used 1-mesitylenesulphonyl 5-(pyridin-2-yl)tetrazolide (MSPy) and 1-(2,4,6-triisopropylbenzenesulphonyl)-5-(pyridin-2-yl)tetrazolide (TPSPy) 42, fig.1.17, to condense 5'-dimethoxytritylthymidine-3'-O-(2-chlorophenyl)phosphate with 3'-O-benzylthymidine. This reaction gave a single product whereas the same reaction using MSNT as a condensing agent gave two diastereoisomers, the presence of which can cause problems when compounds have to be purified by chromatography.



1-Mesitylenesulphonyl 5-(pyridin-2-yl)tetrazole R=CH<sub>3</sub>

1-(2,4,6-Triisopropylbenzenesulphonyl)-5-(pyridin-2-yl)tetrazolide R=<sup>i</sup>Pr

Fig.1.17 1-Arylsulphonyl 5-(pyridin-2-yl)tetrazolides.

The  $\beta$ -elimination mechanism used to remove the  $\beta$ -cyanoethyl group was also made use of by Pfeleiderer *et al.*<sup>42,43</sup> when the 2-(*p*-nitrophenyl)ethyl (NPE) was proposed as a phosphate protecting group for the phosphotriester approach. The synthetic strategy is outlined in fig.1.18.



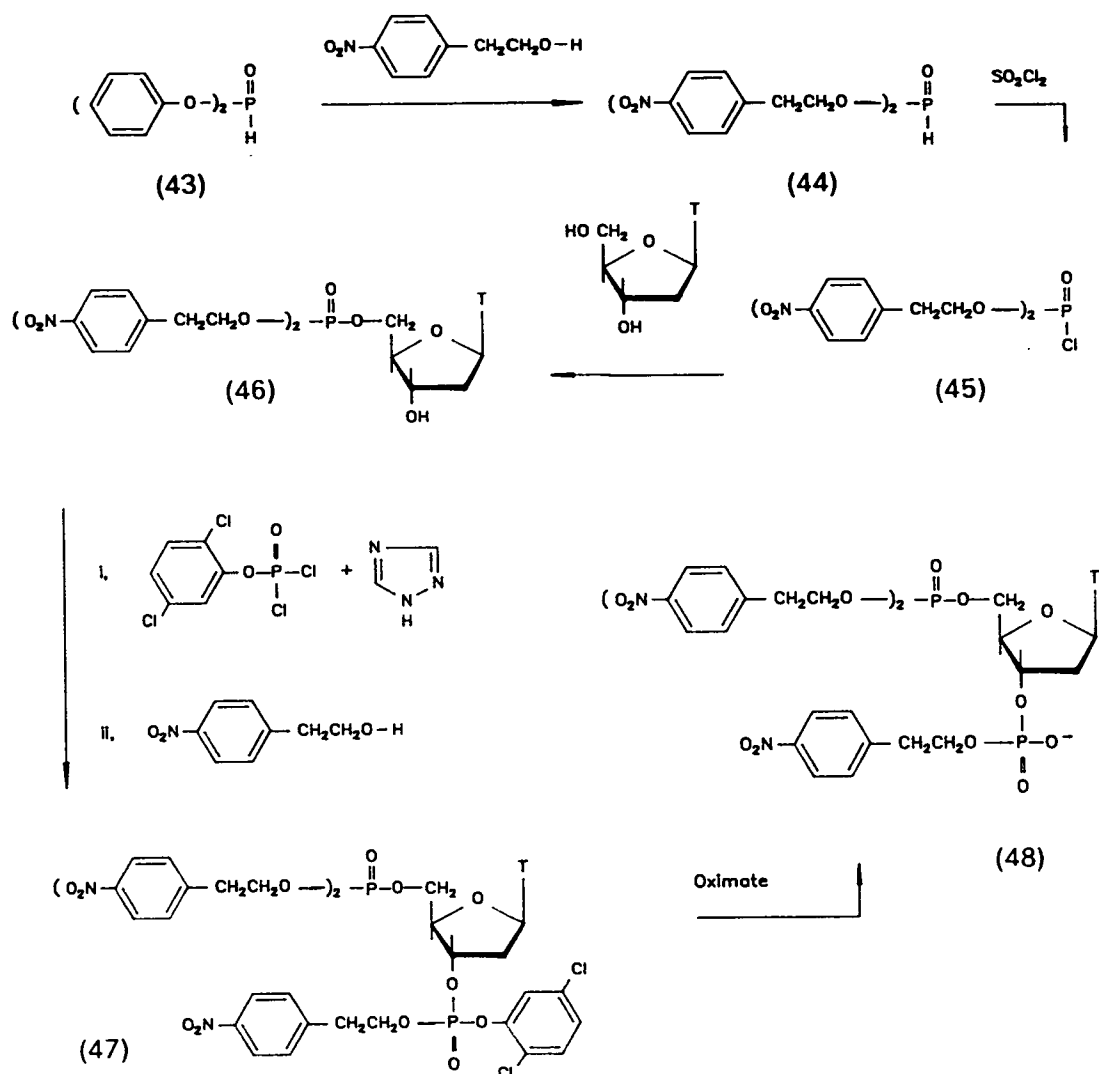
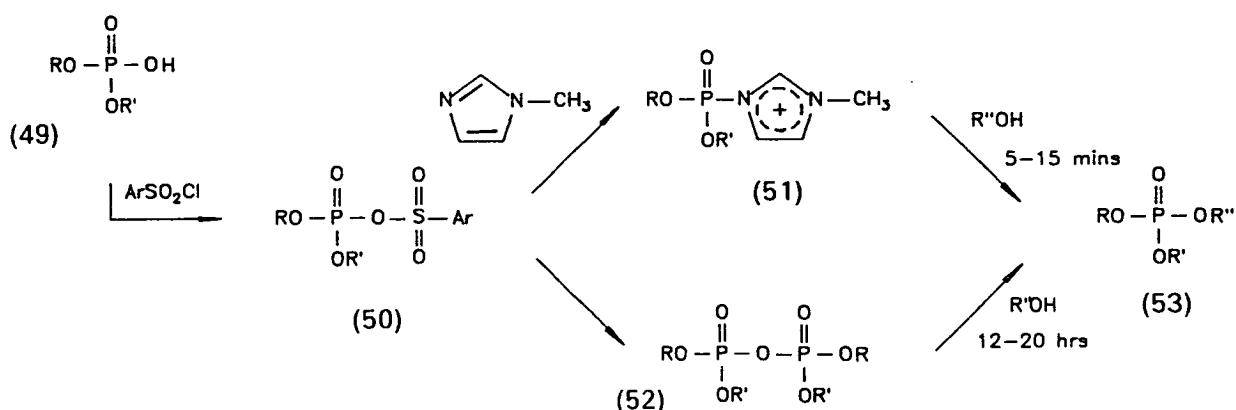

Fig.1.18 Pfeleiderer's Phosphotriester Approach

Diphenylphosphonate **43** was transesterified with 2-(*p*-nitrophenyl)ethanol **44** then converted to bis(*p*-nitrophenylethyl)phosphoromono-chloridate **45** with thionyl chloride. This was reacted with thymidine to give the 5'-phosphorylated nucleoside **46**, to which 2,5-dichlorophenylphosphorodichloridate and 1,2,4-triazole, and subsequently 2-(*p*-nitrophenyl)ethanol, were added to form 5'-bis(*p*-nitrophenylethyl)phosphorylthymidine-3'-(2,5-dichlorophenyl)-(*p*-nitrophenylethyl)phosphate **47**. This could then be deprotected with oximate

to give a diester **48** to which another nucleotide could be linked. At the end of the synthesis the 2-(*p*-nitrophenyl)ethyl group can be removed using 1,5-diazabicyclo[5.4.0]undec-5-ene (DBU) to give the unprotected oligonucleotide, and using this method Pfeleiderer produced a trimer. This method has the advantage that a 3'- or 5'- terminal phosphate group can be incorporated into the final product to give a oligonucleotide with the same number of phosphate ester groups as base-residues, instead of the structures containing one less that result from the usual methods, but Pfeleiderer<sup>44,45</sup> also showed that the 2-(*p*-nitrophenyl)ethyl group could be used as a phosphate protecting group with a trityl group on the 5'-hydroxyl and extending the oligonucleotide from the 3'-end.



R=C<sub>6</sub>H<sub>4</sub>Cl

R'=R''=Protected nucleoside

ArSO<sub>2</sub>Cl=TSPCl or MSCl

X=Cl<sup>-</sup> or ARSO<sub>2</sub>O<sup>-</sup>

Fig.1.19 The Use of N-Methylimidazole with an Arylsulphonyl Chloride.

In 1982 V.A.Efimov *et al.*<sup>46</sup> introduced the use of N-methylimidazole with arylsulphonyl chlorides to produce highly efficient condensing agents for the formation of phosphotriester internucleotide linkages. Yields and the rate of

condensation were both improved by this reagent which forms an intermediate N-methylimidazolium cation 51 possessing a high phosphorylating capability, see fig.1.19.

Sproat and Bannworth<sup>47</sup> then suggested using 1-methylimidazole with 1-mesitylenesulphonyl-3-nitro-1,2,4-triazole (MSNT) which resulted in coupling times being reduced to times comparable to those observed by Efimov<sup>46</sup> but with the advantage that MSNT is easier to handle than mesitylenesulphonyl chloride. Another group of rate accelerating reagents proposed by Efimov *et al.*<sup>48</sup> were oxygen-nucleophilic catalysts, in particular 4-substituted pyridine N-oxides having electron donating substituents, 54, fig.1.20, which are used in conjunction with the arylsulphonyl chlorides previously mentioned by Efimov *et al.*<sup>46</sup>

X = -N(CH<sub>3</sub>)<sub>2</sub>, -OCH<sub>3</sub>, -OCH<sub>2</sub>CH<sub>3</sub>, -OCH<sub>2</sub>C<sub>6</sub>H<sub>5</sub>.

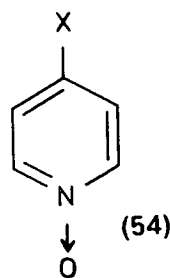

Fig.1.20 4-Substituted pyridine N-oxides

The mechanism of phosphotriester bond formation in the presence of O-nucleophilic catalysts is not fully understood but may be *via* the formation of the N-phosphoryloxypyridinium salt. The authors also report that the reagent reduces modifications of 2-N-acylguanine and thymidine and increases the rate of coupling to times comparable with the phosphite approach. The rate of condensation also interested Matteucci *et al.*<sup>49</sup> who showed that neighbouring-group participation could be used to speed up the coupling reaction between nucleotides by using the 1-methyl-2-(2-hydroxyphenyl)imidazole group for phosphate protection as can be seen in

fig.1.21.

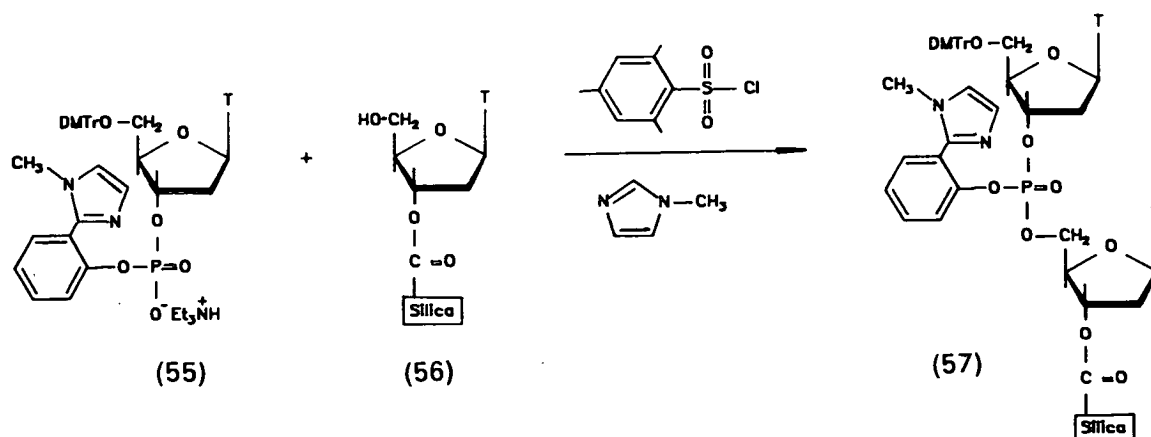

Fig.1.21 1-Methyl-2-(2-hydroxyphenyl)imidazole in Phosphotriester Synthesis

The triethylammonium salt of 5'-dimethoxytritylthymidine-3'-(2-methylimidazole)phenyl phosphate **55** was condensed with thymidine attached to a silica support via its 3'-hydroxyl function **56**, using mesitylenesulphonyl chloride and 1-methylimidazole as condensing agents, to give the protected dimer **57**. This protecting group compares favourably with those previously used and gives a 5-10 fold rate increase over the *p*-chlorophenyl group. The phosphate triester is deprotected at the end of the synthesis using concentrated ammonia at 60°C for 12 hours. Efimov *et al.*<sup>50</sup> improved the previous method by using their 4-substituted derivatives of pyridine N-oxide<sup>48</sup> in place of the 1-methyl-2-(2-hydroxyphenyl)imidazole as phosphate protecting groups and, in particular the 1-oxido-4-alkoxy-2-picolyl derivative **58**, see fig.1.22, showed an increase in the rate of condensation, reducing coupling times to 1-2 mins. on solid phase.

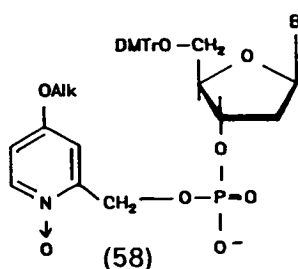

Fig.1.22 Use of the 1-Oxido-4-alkoxy-2-picolyyl Group

The phosphotriester method of oligonucleotide synthesis has thus progressed from a technique requiring 36 hours for a coupling in solution<sup>1</sup> to one needing less than 2 min. on solid phase.<sup>50</sup> With the development of more effective phosphate protecting groups and condensing agents it has reached a stage where the synthesis of a 20-residue oligonucleotide can be performed in 8 hours.<sup>51</sup>

#### 1.4.4. The Phosphite-triester Method

The phosphotriester method has been improved significantly in terms of its yield and rate of condensation in recent years but in the mid 1970s this approach still involved a lengthy coupling step. In 1975 Letsinger *et al.*<sup>9</sup> proposed a new method for oligonucleotide synthesis in an attempt to reduce greatly the time necessary for each nucleotide addition. The new method was based on the observation that phosphorochloridites react rapidly with alcohols to give phosphite-triesters and that these can be easily oxidised to phosphates by iodine and water. The reaction scheme used by Letsinger can be seen in fig.1.23.

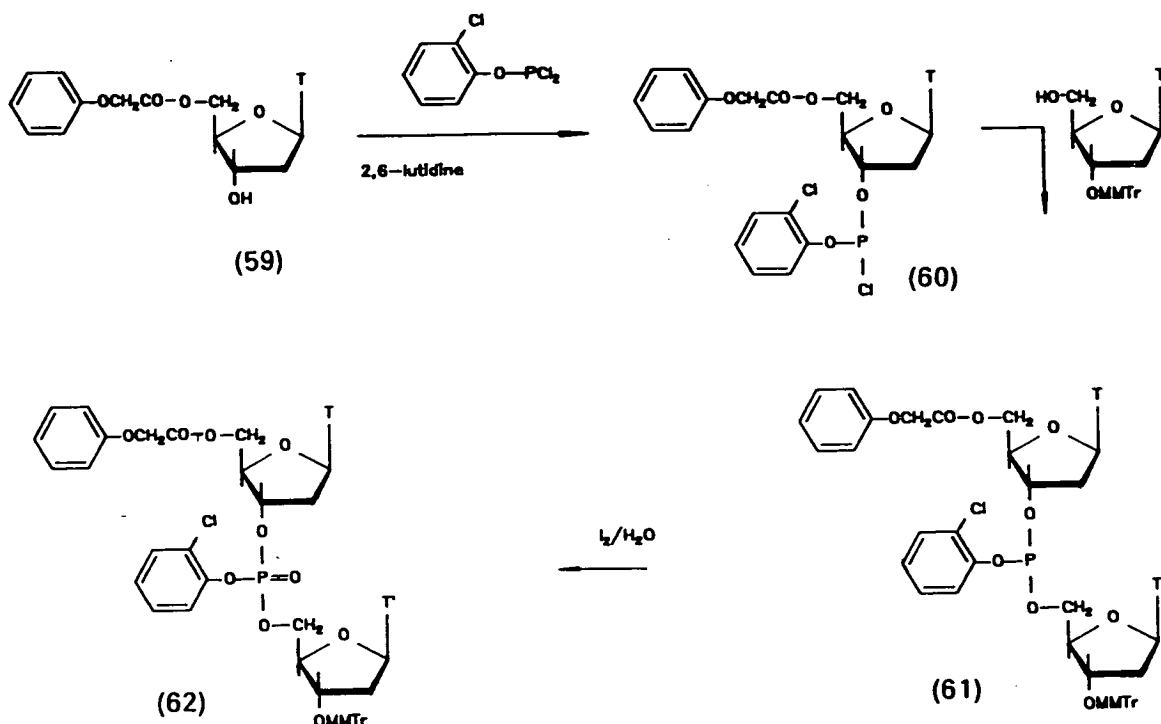

Fig.1.23 Letsinger's Phosphite-triester Approach.

The product 62 contained a natural 3'-5' internucleotide link and was formed by the reaction of 5'-O-phenoxyacetyl-thymidine 59 with *o*-chlorophenyl phosphorodichloridite to give the phosphorylated nucleoside 60. This was coupled with 3'-monomethoxytritylthymidine to give the phosphite dimer 61 which was oxidised by iodine and water to produce a protected thymidine dinucleotide 62. The dimer can be converted to a trimer by cleavage of the phenoxyacetic ester with ammonium hydroxide and a further coupling with another nucleotide, but attempts to synthesize trithymidine from the dimer resulted in low yields. This is probably caused by the instability of the phosphotriester link towards the phosphochloridite reagent. Other protecting groups were considered and the 2,2,2-trichloroethyl group<sup>52</sup> was shown to be suitable. The reaction scheme was similar to that found in fig.1.23 except that 2,2,2-trichloroethyl phosphorochloridite was used in place of *o*-chlorophenyl

phosphorodichloridite and this development made the synthesis of a thymidine tetranucleotide possible. The coupling step in this method takes 5 min. and the whole reaction cycle for each addition takes less than one hour. This method was also shown to be applicable to the synthesis of oligoribonucleotides by Ogilvie *et al.*<sup>53</sup> who made a heptaribonucleotide using the phosphite-triester chemistry described above.

A comparison of phosphate protecting groups for use in oligonucleotide synthesis by the dichloridite procedure was made by Ogilvie<sup>54</sup> in 1980, who investigated the 2,2,2-trichloroethyl, 2,2,2-tribromoethyl, benzyl, methyl,  $\beta$ -cyanoethyl, *p*-chlorophenyl, 2-phenylethyl, and 2-*p*-nitrophenylethyl groups and found that the trichloroethyl, methyl and  $\beta$ -cyanoethyl groups were the most useful, and Matteucci and Caruthers<sup>55</sup> produced several dimers using the methyl group, resulting in yields of over 90%.

One drawback of using dichloride reagents for the condensation reactions is that symmetrical, as well as the desired unsymmetrical, products are formed and these mixtures can be difficult to separate and also can reduce yields. Another problem is the susceptibility to hydrolysis and oxidation of the nucleotides, and for this reason reactive intermediates are generally used as soon as they are prepared.

In 1981 Beaucage and Caruthers<sup>56</sup> proposed a solution to this problem in the form of deoxynucleoside phosphoramidites which can be stored as dry, stable powders and used for oligonucleotide synthesis as shown in fig.1.24. 5'-Dimethoxytritylthymidine **63** is reacted with chloro-*N,N*-dimethylaminomethoxyphosphine to produce a stable phosphorylated nucleoside **64**, which is activated with 1*H*-tetrazole **65** and coupled to 3'-*O*-levulinylthymidine giving a phosphite-triester **66**. Oxidation of **66** with iodine and water affords

the protected dimer 67.

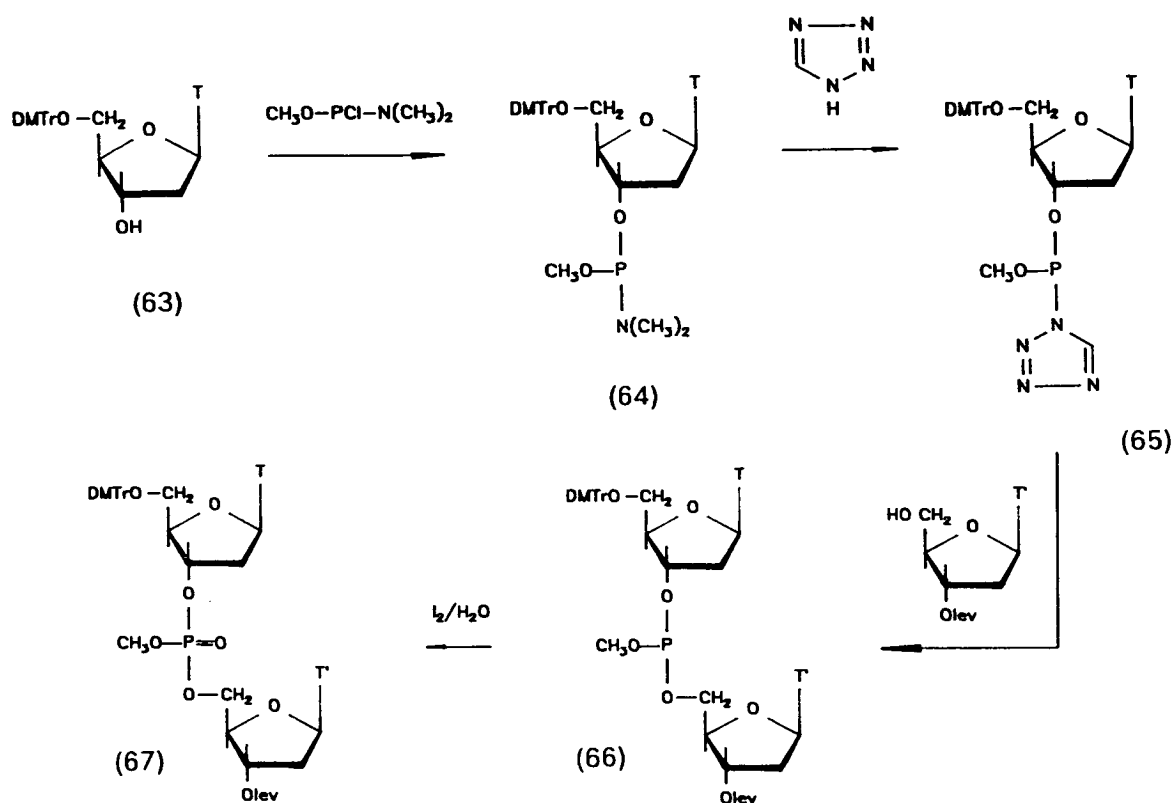

Fig.1.24 Phosphoramidites for the Phosphite-triester Approach.

The *N,N*-dimethylamino phosphoramidites, although used in the synthesis of oligonucleotides<sup>57,58,59</sup> have a variable degree of purity, the major contaminant being the hydrolysis product (the deoxynucleoside phosphonate). They also have a variable stability when dissolved in acetonitrile without activation. These observations led McBride and Caruthers<sup>60</sup> to investigate other deoxynucleoside *N,N*-dialkylaminomethoxyphosphines including those containing the diisopropylamino, morpholino, pyrrolidino, and 2,2,6,6-tetramethylpiperidino groups. The phosphitylating agent used for each derivative was the chloride, see fig.1.25. The pyrrolidino derivative 68c proved to be quite volatile and reactive with atmospheric moisture, the



2,2,6,6,-tetramethylpiperidino derivative 68d was a highly reactive solid, and hence was difficult to handle, but the diisopropylamino 68a and morpholino 68b derivatives were found to be easier to handle, and gave the purer, more stable deoxynucleoside N,N-dialkylamino phosphoramidites which were shown to form dimers by reaction with a suitably protected nucleoside after activation with tetrazole.

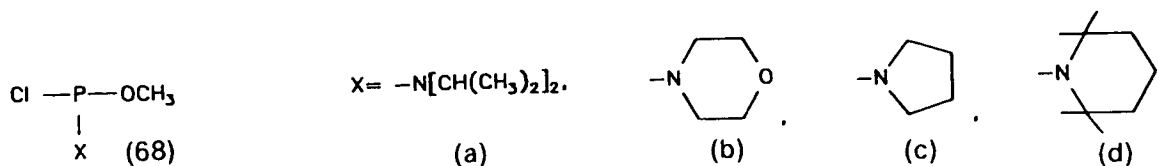

Fig.1.25 Various Phosphitylating Agents.

Adams *et al.*<sup>61</sup> also performed similar experiments when they investigated the stability of N,N-diethyl, N-methyl, N-isopropyl, N,N-diisopropyl phosphoramidites, concluding that the diisopropyl group conferred the most stability. The findings of these investigations provoked interest in the use of the N,N-diisopropyl and N-morpholino groups for phosphorus protection in the synthesis of oligodeoxyribonucleotides by the phosphite-triester method.<sup>62,63,64</sup>

The next combination of phosphorus protecting groups to be examined was the  $\beta$ -cyanoethyl group with the N,N-dialkylamino and the N-morpholino groups by Sinha *et al.*<sup>65</sup> in 1983. The phosphorylated nucleosides were prepared as shown in fig.1.26. A 5'-dimethoxytrityl protected nucleoside 69 is reacted with  $\beta$ -cyanoethyl N,N-dialkylamino/N-morpholino monochloridite 70 to give a phosphorylated nucleoside 71. Of the three phosphorylating agents the  $\beta$ -cyanoethyl-N,N-diisopropylaminomonochloridite gave the best results, and along with the  $\beta$ -cyanoethyl-N-morpholinomonochloride, was used to make phosphoramidites from which oligodeoxyribonucleotides were synthesized.<sup>66</sup> The  $\beta$ -cyanoethyl group has the advantage over the methyl group that it is

cleaved in concentrated ammonia at the same time as the base-protecting groups, whereas the methyl group requires a second treatment with thiophenol in order to obtain a fully deprotected oligonucleotide.

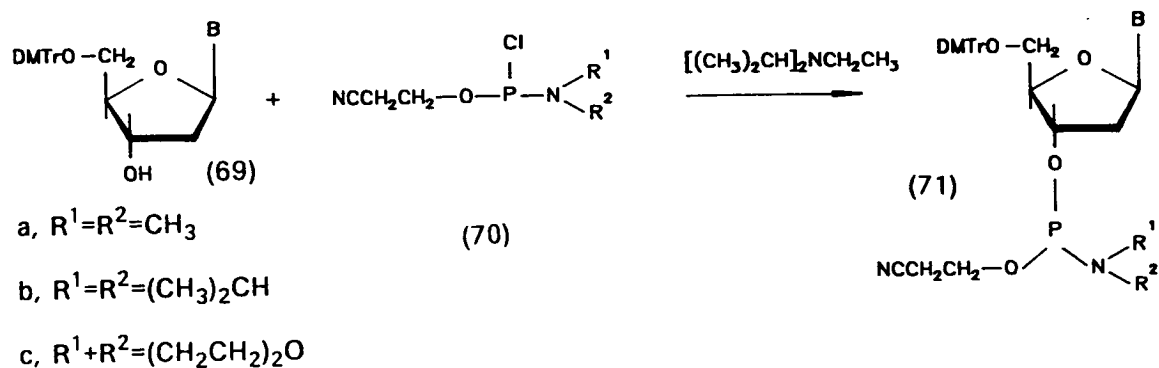

Fig.1.26 Sinha's Phosphorylated Nucleoside.

In an attempt to improve the yields of phosphite-triester reactions in solution phase Pfeleiderer *et al.*<sup>67</sup> used various cyclic amines in conjunction with the methoxy group to prepare thymidine phosphoramidites and then thymidine dimers with varying yields. He also used the *p*-nitrophenylethyl group with cyclic amines to produce a phosphitylating agent, see fig.1.27, which, when reacted with a nucleoside, gave phosphoramidites which were very stable and may possibly have an application in large scale solution synthesis of oligodeoxyribonucleotides.

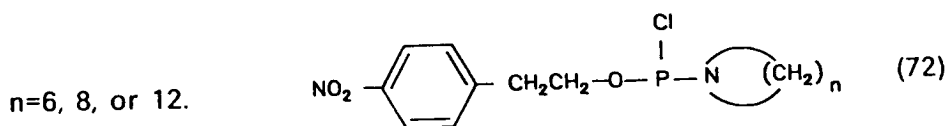

Fig.1.27 Pfeleiderer's Phosphitylating Agent.

Other substituents have been suggested as a replacement for the methyl group, see fig.1.28, and these include the 2-cyano-1,1-dimethylethyl group<sup>68</sup> 73 which can be removed under mildly basic conditions and the *o*-chlorophenyl

group<sup>69</sup> 74, the latter giving a much more stable phosphoramidite than the methyl group produces and was activated with N-methylaniline trifluoroacetate instead of the more commonly used tetrazole, and cleaved by the oximate method.

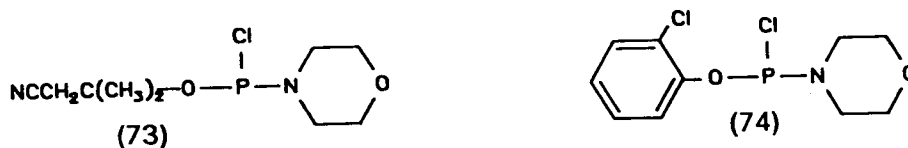

Fig.1.28 Phosphitylating Agents.

In 1979 Dahl<sup>70</sup> made a study of the rates of reaction of phosphoramidites with various substituents on the phosphorus and found that N-substituents showed  $\text{NEt}_2 > \text{N}^i\text{Pr}_2 > \text{N}(\text{CH}_2\text{CH}_2)_2\text{O} > \text{NMePh}$  and O-substituents varied as  $\text{Me} > \text{CH}_2\text{CH}_2\text{CN} > \text{CHMeCH}_2\text{CN} > \text{CMe}_2\text{CH}_2\text{CN} > > \text{C}_6\text{H}_4\text{Cl}$ . This is as expected from inductive and steric effects.

A slightly different approach to the phosphoramidite method was proposed by Uznanski *et al.*<sup>71</sup> who made 5'-O-dimethoxytritylnucleoside 3'-O-phosphordimorpholidites 76 from 5'-O-dimethoxytritylnucleoside 69 and chlorodimorpholinophosphine 75, see fig.1.29. The phosphoramidite 76 can be coupled to a polymer attached nucleoside using tetrazole to give a dimer 77. Subsequently the amidite P-N bond is cleaved by mild acid hydrolysis to afford 78. The 5'-hydroxyl is deprotected with dichloroacetic acid and then further nucleotides can be added. The oxidation is performed at the end of the synthesis, instead of at every step, using iodine and water.

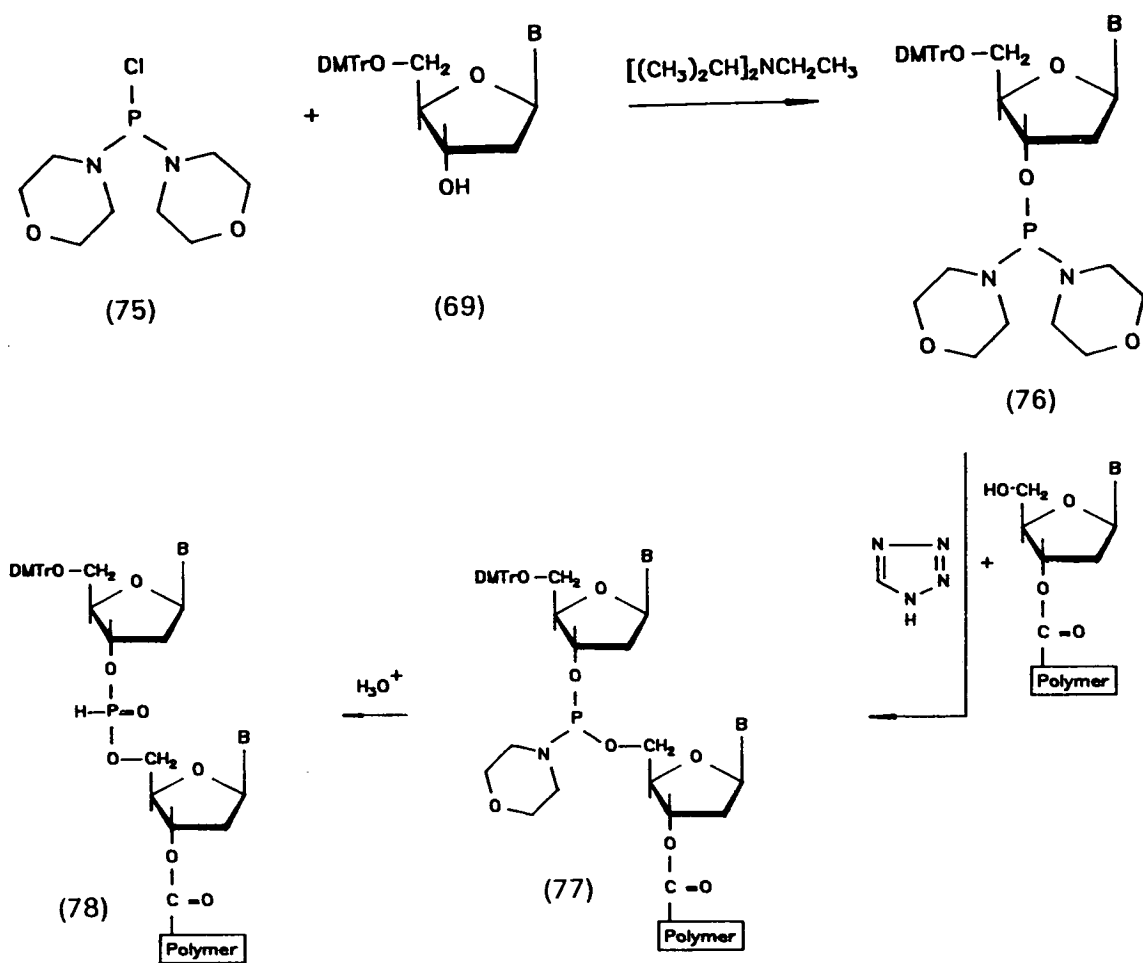

Fig.1.29 Uznanski's Phosphoramidite Method.

A recent development in phosphite-triester chemistry is the use of the 1,1,1,3,3,3-hexafluoro-2-propyl group by Takaku *et al.*<sup>72</sup> who found that the phosphitylating agent 79 could be distilled without thermal decomposition, see fig.1.30.

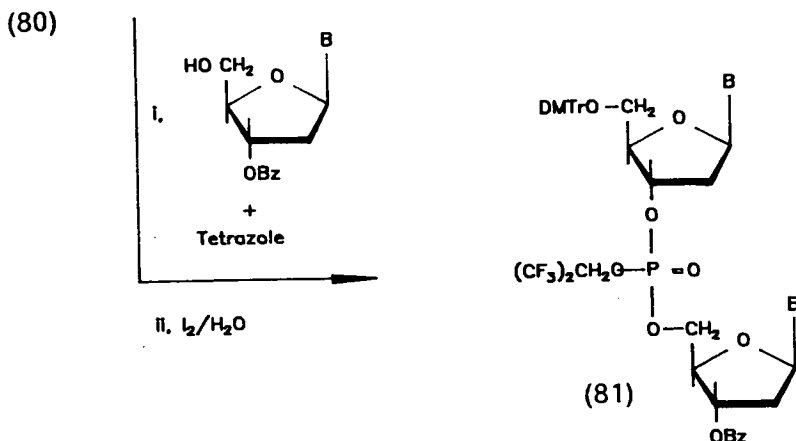
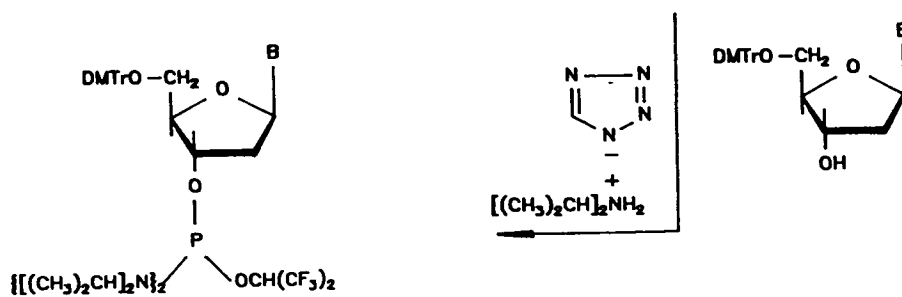
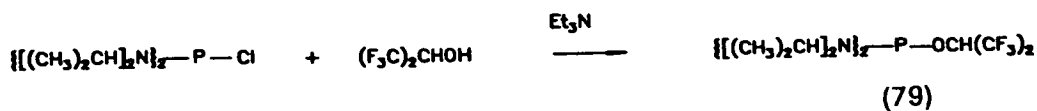

Fig.1.30 Takaka's Phosphoramidite Method.

The phosphitylating agent 79 was reacted with a 5'-O-dimethoxytritylnucleoside by activation with diisopropylammonium tetrazolide to give the phosphoramidite 80 which is then reacted in the usual way with a 3'-protected nucleoside and tetrazole to form a protected dimer 81. The phosphate protecting group is removed at the end of synthesis by treatment with oximate. The authors later refined this method to use 3'-[*bis* (1,1,1,3,3,3-hexafluoro-2-propyl)phosphites]<sup>73</sup> as starting materials and *N*-methylimidazole to couple them to 3'-protected nucleosides.

The phosphite-triester method offers the advantage over the phosphotriester approach of fast coupling reactions but also involves the use

of relatively unstable starting materials and during synthesis reactive  $P^{III}$  intermediates are used giving scope for side-reactions to occur.

#### 1.4.5. The H-Phosphonate Approach

In the two methods previously mentioned, different strategies for the formation of internucleotide bonds exist. In the case of the phosphotriester method the starting nucleotide must be activated by a condensing agent and in the phosphite-triester approach protonation of the starting material must occur to commence the synthesis and hence this method requires anhydrous conditions.

An attempt to combine the advantages of both the phosphotriester approach, with its stable nucleotides, and the phosphite-triester approach, with its speed of reaction, the H-phosphonate method was developed and has been used to synthesize oligodeoxyribonucleotides<sup>74</sup>. An example of this approach to DNA synthesis can be seen in fig.1.31.

A 5'-O-dimethoxytritylnucleoside 3'-H phosphonate **82** was coupled to a nucleoside attached to a polymer support **83** by activation with  $\overline{TPSCl}$ , or similar condensing agent to give a dimer **84**. This could be extended further by acid cleavage of the dimethoxytrityl group and further additions of nucleotides. When the synthesis is completed the oligonucleotide is treated with iodine and water to oxidize the phosphite function to a phosphate **85** and the 5'-hydroxyl-, and base, protection, if any, is removed.

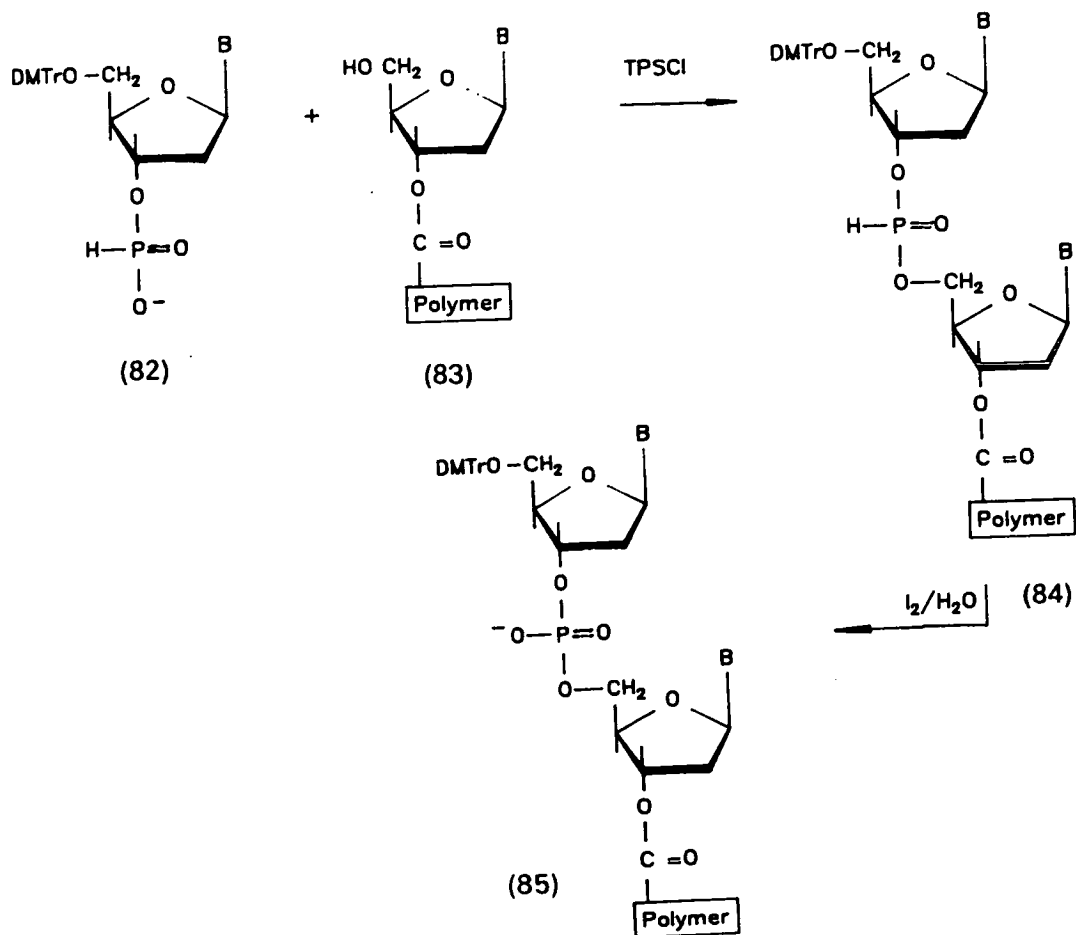

Fig.1.31 The H-Phosphonate Approach.

## 1.5. PROTECTING GROUPS

### 1.5.1. Introduction

The use of protecting groups in synthetic organic chemistry has increased in recent years as the synthesis of larger and more complex molecules has been attempted. By the use of a suitable protecting group it is possible to block temporarily certain reactive sites on a molecule and so allow others to be chemically modified before removing the protecting group. The synthesis of oligonucleotides benefits particularly from the use of protecting groups as the multi-stage syntheses involved can give rise to side-reactions at each stage and lead to a low overall yield of the desired product. Nucleotides contain many potentially reactive sites on the base, sugar and phosphate, and for each area specialised protecting groups are required which have the desired degree of stability under synthesis conditions and are cleaved under conditions which have no detrimental effect on the oligonucleotide. As well as the stability of the protecting group it is also vital to take into consideration how each group fits into the overall protecting group strategy of the molecule. This is especially important where selective deprotection of certain functions in a specific order is necessary during the synthesis of the oligonucleotide.

### 1.5.2. Sugar hydroxyl protection

The 2'-deoxyribose sugar in DNA and ribose in RNA have two and three hydroxyl groups respectively, all of which may require protection during oligonucleotide synthesis. The 5'-hydroxyl, being a primary alcohol function, is more reactive than both the 3'-, and where it occurs, the 2'-hydroxyl functions which are both secondary alcohols. Thus the protecting group strategy for RNA is more complex than that for DNA because, as well as having one more hydroxyl to protect, it has to differentiate between two secondary alcohols. The first groups used for sugar protection were acetyl<sup>1,26</sup> and benzoyl,<sup>75</sup> both



of which are cleaved by alkaline hydrolysis.

### The 5'-Hydroxyl

The most popular method of protecting the 5'-hydroxyl group was developed by Khorana *et al.*<sup>75</sup> in 1962. Previously he had used the trityl group 86a but found that it was too stable in 80% acetic acid and so to make it more labile *p*-methoxy groups were introduced onto the phenyl rings. Each substitution increased the rate of hydrolysis by about a factor of ten and it was finally decided that the dimethoxytrityl group (DMTr) 86c had the required degree of acid lability, fig.1.32.

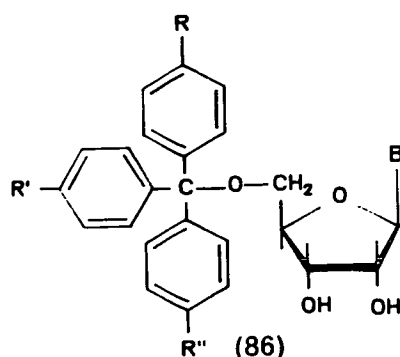

a, R=R'=R''=H b, R=R'=H,R''=OCH<sub>3</sub> c, R=H,R'=R''=OCH<sub>3</sub> d, R=R'=R''=OCH<sub>3</sub>

Fig.1.32 The Trityl Protecting Groups

Base labile protecting groups were also used by Khorana and Weinmann<sup>76</sup> with the investigation of the pivaloyl group (Me<sub>3</sub>CC(O)-), and by Letsinger and Ogilvie<sup>77</sup> who proposed the *p*-nitrophenyl group for 5'-protection. Later Ogilvie and Letsinger<sup>78</sup> introduced the isobutyloxycarbonyl group which has comparable selectivity for the primary hydroxyl to the pivaloyl group and gives better yields than the *p*-nitrophenyl group.

Another acid labile group used was the *tert*-butyldimethylsilyl group<sup>79</sup> which, although cleaved by 80% acetic acid, could also be selectively removed

by tetra-*n*-butylammonium fluoride which has no effect on trityl groups. Gaffney *et al.*<sup>80</sup> also mention using the *tert*-butyldiphenylsilyl group which is deprotected in the same way, and can be used on acid sensitive nucleosides. A group which can also be removed under neutral conditions is the levulinyl (4-oxopentanoyl) group<sup>81</sup>. This has been used for the protection of the 5'-hydroxyl group in RNA synthesis and can be cleaved with hydrazine in pyridine/acetic acid.

In 1978 Chattopadhyaya and Reese<sup>82</sup> suggested using the 9-phenylxanthen-9-yl (pixyl) protecting group, 87, fig.1.33, which is cleaved under the same conditions, and with a comparable acid lability to the dimethoxytrityl group, but whose deoxynucleoside derivatives crystallise more readily than the dimethoxytrityl-deoxynucleosides, hence facilitating purification.

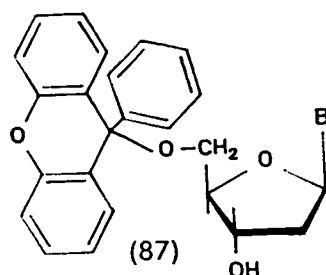

Fig.1.33 A 5'-O-Pixyl Protected Nucleoside

Reese *et al.*<sup>83</sup> introduced the concept of a "protected" protecting group by using the 2-dibromomethylbenzoyl group which is comparatively stable to acid and alkali but when oxidised with silver perchlorate to the aldehyde and then treated with morpholine yields the free nucleoside.

Pfleiderer *et al.*<sup>84</sup> used the  $\beta$ -elimination process to cleave the 2,4-dinitrophenylethoxycarbonyl group with tertiary amines. This group is very sensitive towards bases and is more labile than the  $\beta$ -cyanoethyl group. Chattopadhyaya introduced the fluoren-9-ylmethoxycarbonyl group<sup>85</sup> 88 (Fmoc)

into DNA synthesis from peptide chemistry. This group is also cleaved by  $\beta$ -elimination using a base such as triethylamine or piperidine and its use as a 5'-protecting group, fig.1.34, was demonstrated by the synthesis of thymidine octanucleotide. He also showed that this group was compatible with the phosphoramidite approach on solid phase<sup>86</sup> by making an oligonucleotide and using 1,8-diazabicyclo[5.4.0]undec-7-ene (DBU) to remove the Fmoc group from the hydroxyl function.

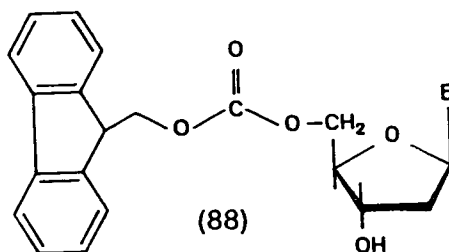

Fig.1.34 Fmoc as a 5'-Protecting Group

The Fmoc group has been recently reported by Gait *et al.*<sup>87</sup> to be useful in RNA synthesis on solid phase but some side-reactions still cause concern when DBU is used for the deprotection.

### The 3'-Hydroxyl

The most frequently used 3'-hydroxyl protecting group is the base labile acetyl group which was first used by Todd<sup>1</sup>, and later by Khorana<sup>76</sup>, for DNA synthesis. Ogilvie and Letsinger used a base labile group on the 5'-hydroxyl in order to introduce the acid labile monomethoxytrityl group onto the 3'-hydroxyl function.

The use of a silyl protecting group for 3'-protection was suggested by Ogilvie *et al.*<sup>88,89</sup> who developed a method for the selective silylation of the 3'-hydroxyl on a ribonucleotide with the TBDMS group. Pfeleiderer *et al.*<sup>84</sup> also used the *p*-nitrophenylethyl group as a 3'-protecting group.

### The 2'-Hydroxyl

The 2'-hydroxyl group occurs only in RNA and must be protected during oligoribonucleotide synthesis. The most popular group to use for this purpose is the acid labile tetrahydropyranyl (THP) group **89** but this has the disadvantage that a mixture of diastereoisomers is formed when it is used to protect a nucleoside and so the methoxytetrahydropyranyl (MTHP) group **90** was developed<sup>36</sup>, see fig.1.35.

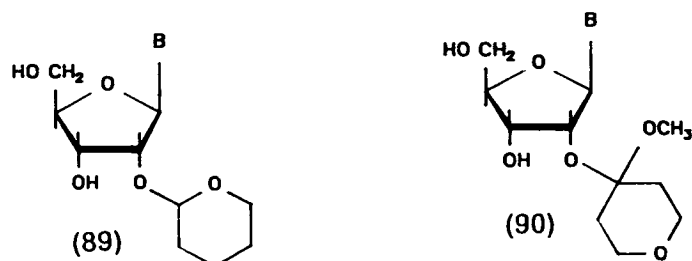

Fig.1.35 The Tetrahydropyranyl Protecting Groups

The next development of this group occurred when van Boom *et al.*<sup>90</sup> exchanged the ring oxygen for sulphur to produce a thioether and for an  $-SO_2-$  group to give a sulphone. These groups are respectively slightly more and considerably less acid labile than the MTHP group and are achiral.

In his search for a protecting group which would be stable to strongly acidic conditions but cleaved at a higher pH (2.5) Reese<sup>91</sup> suggested the 1-[(2-chloro-4-methyl)phenyl]-4-methoxypiperidin-4-yl (Ctmp) group **91**, fig.1.36, which was cleaved faster at pH 2.5 than at pH 1.0.

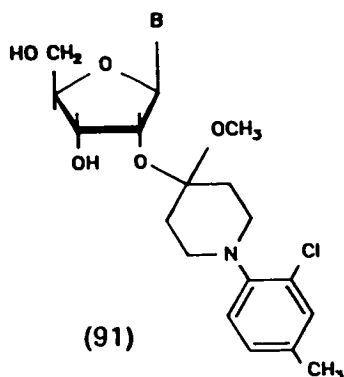

Fig.1.36 The Ctmp Protecting Group

In 1986 Tanaka *et al.*<sup>92</sup> described the use of the *o*-nitrobenzyl group as a 2'-protecting group in the solid phase synthesis of oligodeoxyribonucleotides. This protection was removed by irradiation with UV light in ammonium formate solution. The *tert*-butyldimethylsilyl (TBDMS) group has been used as a 2'-protecting group in conjunction with the H-phosphonate approach by Stawinski *et al.*<sup>93</sup>. TBAF is used to cleave this group.

Recently the use of tetrahydrofuranyl<sup>94</sup> as a more acid labile group than tetrahydropyranyl was proposed. Used with a non-acid labile group on the 5'-hydroxyl this group makes the deprotection of oligonucleotides at the 2'-hydroxyl easier.

### Multiple Hydroxyl Protection

Some protecting groups are used to protect more than one hydroxyl function and an example of this occurs in the reaction between *p*-nitrophenyl chloroformate and a ribonucleoside which results in the formation of a 2',3'-cyclic carbonate<sup>77</sup> which can be removed by alkaline hydrolysis.

A useful method for distinguishing between the 2'- and 3'-hydroxyl on a ribose was developed by Markiewicz<sup>95</sup> who used the

tetraisopropyldisiloxane-1,3-diyl group to protect the 5'- and 3'-hydroxyls leaving the 2'-hydroxyl free to react with another protecting group. The protecting group works by first reacting at one end with the 5'-primary hydroxyl, from which position the 3'-hydroxyl is in the correct place to react intramolecularly with the other end of the reagent. Either the 5'- or 3'- end can be selectively cleaved by use of the correct conditions.

Transient protection is also useful, allowing the base to be protected whilst a temporary protecting group prevents any reaction on the sugar. Reagents used for this purpose include trimethylchlorosilane<sup>96</sup> and isobutyric anhydride<sup>80</sup> which are cleaved by alkaline hydrolysis when the base protection is completed.

### 1.5.3. Base Protection

The heterocyclic bases are permanently protected during DNA synthesis at the exocyclic amino function. A number of N-protecting groups have been developed for this purpose, the most commonly used ones being anisoyl, benzoyl, and isobutyryl<sup>97</sup>. As well as the need to protect these functions it has been shown that the O<sup>4</sup> of thymidine and the O<sup>6</sup> of guanosine may also require some protection during oligonucleotide synthesis. Reese *et al.*<sup>98</sup> showed that guanosine can be acylated on the O<sup>6</sup>-position with arenesulphonyl chlorides and MSNT in pyridine, which implies such side-reactions occur in the synthesis of oligonucleotides by the phosphotriester approach in which these reagents are used. Similar results were also reported by Hata *et al.*<sup>99,100</sup> who showed that guanosine is easily phosphorylated, sulphonated, and silylated at the O<sup>6</sup>-position.

Problems may also be encountered when using the phosphite-triester method of synthesis. Eadie and Davidson<sup>101</sup> discovered chemical modification

of guanosine when using the phosphoramidite approach which generates a fluorescent species, possibly from the displacement of an O<sup>6</sup>-phosphite-triester by N,N-dimethylaminopyridine (DMAP).

Thymidine has also been reported to undergo side-reactions during phosphite-triester synthesis. Gao *et al.*<sup>102</sup> showed that N<sup>3</sup>-methylation of thymidine occurs when the methyl triester of a thymidine oligonucleotide is treated with DBU or triethylamine.

As previously mentioned, the anisoyl, benzoyl, and isobutyryl groups are commonly used for the protection of exo-cyclic amino functions. In 1972 Khorana *et al.*<sup>103</sup> used anisoyl for cytidine **92**, benzoyl for adenosine **93**, and isobutyryl for guanosine **94** protection, fig.1.37, and this protecting group strategy has been extensively used since then although some researchers<sup>97</sup> use benzoyl for cytosine instead of anisoyl. These groups are all deprotected using concentrated ammonium hydroxide.

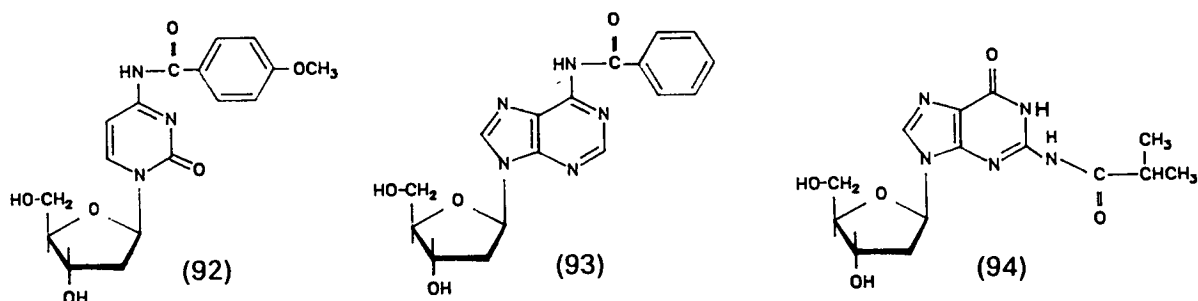

Fig.1.37 Base Protected Nucleosides

As the deprotection of the 5'-hydroxyl of the sugar often involves treatment with acid the problem of depurination, particularly with deoxyadenosine protected with benzoyl, arises. In an effort to prevent this occurring Froe<sup>h</sup>er and Matteucci<sup>64</sup> introduced the N<sup>6</sup>-di-*n*-butylformamide (N<sup>6</sup>-di-*n*-butylaminomethylene) group **95** which greatly reduced the

depurination of the adenosine nucleoside and was cleaved in concentrated ammonium hydroxide, fig.1.38.

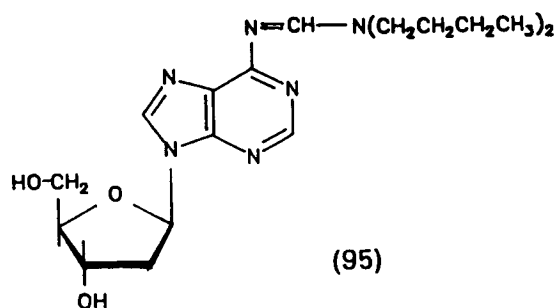

Fig.1.38 N<sup>6</sup>-Di-*n*-butylformamidine Protected Adenosine

The move towards protecting the O<sup>4</sup> function of uridine and the O<sup>6</sup> function of guanosine was initiated by Reese *et al.*<sup>104</sup> who suggested using the phenyl and the 2,4-dimethylphenyl groups to protect uridine, and the 2-nitrophenyl group to protect guanosine. Cleavage of these protecting groups with oximate ion occurs at the same time as the deprotection of the 2-chlorophenyl group from the phosphate function. Later Reese<sup>105</sup> also used the phenyl group to protect the O<sup>4</sup> function of thymidine and removed it in the same way.

Gaffney and Jones<sup>106</sup> were also concerned with O<sup>6</sup>-guanosine protection and investigated the use of the trimethylsilyl group which is cleaved under neutral conditions with TBAF, and a variety of substituted ethyl groups which are cleaved by  $\beta$ -elimination. Chattopadhyaya<sup>107</sup> also used the  $\beta$ -elimination mechanism to cleave the Fmoc protecting group from the cytosine, adenosine, and guanosine exo-cyclic amino functions. When the deprotection was performed with ammonia in pyridine it was complete within 40 min. This is much faster than the several hours required by the conventional amino protecting groups.

Despite the problems of selectivity introduced by using acid labile groups



on both the base and the 5'-hydroxyl, Hata *et al.*<sup>108,109</sup> investigated the use of the monomethoxytrityl (MMTr) group as an amine protecting group on guanosine, adenosine and cytosine and the use of the dimethoxytrityl (DMTr) group on adenosine. Both these groups are deprotected by treatment with 0.01M HCl but remain intact when the DMTr group on the 5'-hydroxyl is deprotected with ZnBr<sub>2</sub>. Hata *et al.*<sup>110</sup> elaborated the trityl group by using the 4,4',4''-tris(anisoyloxy)trityl group to protect the O<sup>6</sup> of adenosine and cleaved it with dilute alkali *via* a 1,6-elimination.

Pfliederer *et al.*<sup>111</sup> used the *p*-nitrophenylethyl (NPE) group to protect cytidine and adenosine on their amino functions and guanosine, thymidine, and uridine on the oxygen of their amide functions. This was an attempt to simplify deblocking procedures as the *p*-nitrophenylethyl group can be deprotected with DBU at the same time as it is removed from the phosphate triester. Pon *et al.*<sup>112</sup> also noticed the need for guanosine protection during oligonucleotide synthesis and made use of Pfliederer's *p*-nitrophenylethyl group to prepare an oligodeoxyribonucleotide containing 36 base residues.

Another use for the β-cyanoethyl group was suggested by Gaffney *et al.*<sup>80</sup> who used it as O<sup>6</sup>-protection for guanosine and cleaved it with DBU.

In 1987 Schulhof *et al.*<sup>113</sup> noted that although conditions for the synthesis of oligonucleotides have become much milder with the introduction of the phosphoramidite method, the groups commonly used for base protection derived from the phosphodiester method and involved overnight treatment with concentrated ammonium hydroxide at 60°C to deprotect them. This deprotection period was reduced to 4 hours at room temperature by using the phenoxyacetyl group on adenosine and guanosine, and isobutyryl on cytidine. The success of these protecting groups was illustrated by the synthesis of an

18 base residue oligodeoxyribonucleotide but it was noticed<sup>114</sup> that the phenoxyacetyl group on guanosine is partially replaced by an acetyl group during the capping procedure with acetic anhydride. This problem was solved by using phenoxyacetic anhydride for capping instead.

Guanosine has also been protected at the O<sup>6</sup>- and N<sup>2</sup>-positions with the (butylthio)carbonyl<sup>115</sup> group which is also cleaved relatively quickly; 3 hours in concentrated ammonia and methanol.

#### 1.5.4. Phosphorus Protection

The protection of the phosphate function is important during DNA synthesis as is illustrated in the improved yields obtained from the phosphotriester approach as against the phosphodiester method. The range of groups that have been used for phosphorus protection includes phenyl and substituted chlorophenyls which are removed with sodium hydroxide,  $\beta$ -cyanoethyl which is removed with concentrated ammonium hydroxide and *p*-nitrophenylethyl removed by DBU, both utilising the  $\beta$ -elimination process, 2,2,2-trichloroethyl removed by zinc/80% acetic acid, and methyl removed by thiophenol. Other groups have been investigated but have been found to be of limited use so far. A more comprehensive account of phosphorus protecting groups can be found in the section on "chemical synthesis".

#### 1.5.5. Current Protecting Group Strategies

As the choice of protecting groups available for the sugar, base and phosphorus function grows, the number of possible protecting group strategies grows with it. When deciding on a particular strategy for protection several factors must be considered, the most important one being that all the groups are compatible with each other *i.e.* the deprotection conditions used for one group during the synthesis will not cleave or modify other protecting groups.



Other considerations include the availability of the protecting group, and the yield in which derivatives can be obtained and their solubility. Some of the protecting group strategies currently in use are discussed below.

For the phosphotriester approach, the method described by Gait<sup>51</sup> uses benzoyl protection for the N<sup>4</sup> function of 2'-deoxycytidine, isobutyryl for the N<sup>2</sup> of 2'-deoxyguanosine, and, in an attempt to eliminate the problem of depurination, di-*n*-butylaminomethylene for the N<sup>6</sup> of 2'-deoxyadenosine. For the 5'-hydroxyl protection either the pixyl or DMTr group can be used, and phosphorus protection takes the form of the 2-chlorophenyl group and use of the triethylammonium salt. The condensing agent used is MSNT and the coupling reaction is accelerated by the use of 1-methylimidazole. The phosphoramidite approach, also described by Gait,<sup>51</sup> involves the use of the same protecting groups on the bases as the phosphotriester method uses and DMTr is generally used for 5'-protection. The phosphorus protection uses either the methyl, or more recently the  $\beta$ -cyanoethyl group, and the N,N-diisopropylamino group with tetrazole as the activating agent.

More recent research<sup>53,116</sup> has indicated that the base labile Fmoc group can be used for DNA synthesis on solid phase, thus eliminating the problem of depurination as no acid labile groups are used. The Fmoc group is attached to the 5'-hydroxyl function and a methyl N,N-diisopropylamino phosphoramidite is used. This approach has been extended to RNA synthesis by Gait *et al.*<sup>87</sup> where the exo-cyclic amino base protection is benzoyl for cytidine and adenosine, and isobutyryl for guanosine. The 5'-protecting group is Fmoc and the 2'-hydroxyl is protected by the acid labile MTHP, and the  $\beta$ -cyanoethyl N,N-diisopropylamino phosphoramidite is used.

Other combinations which have recently been employed in RNA synthesis<sup>117</sup>

include using the acid labile groups pixyl and Ctmp, the pixyl being attached to the 5'-position and the Ctmp group, being stable under the conditions required for removing the pixyl group, protecting the 2'-hydroxyl. The coupling took place via a  $\beta$ -cyanoethyl,N,N-diisopropylamino phosphoramidite function. Another strategy<sup>94</sup> for RNA synthesis involves using 5'-levulinylyl, which is cleaved under neutral conditions, and the 2'-tetrahydrofuranylyl group with the same phosphoramidite as described above.

## 1.6. SOLID PHASE SYNTHESIS

### 1.6.1. Introduction

For most areas of synthesis in organic chemistry reactions are performed in solution and then the product is obtained from the reaction mixture by means of one or more purification techniques, and indeed, the first workers performing oligonucleotide synthesis also used this method. In 1963 Merrifield<sup>118</sup> reported the use of an insoluble solid support in the synthesis of peptides, and later, in 1965 Letsinger<sup>5</sup> also used a polymer support to synthesise di- and trinucleotides. Since these pioneering experiments the concept of solid phase synthesis has been used and developed by many researchers and now is a commonly used technique in the synthesis of oligonucleotides.

### 1.6.2. The Principle of Solid Phase Synthesis

This type of synthesis makes use of a solid support which is insoluble in all the solvents used and to which the growing oligonucleotide is covalently bound *via* a suitable linker. This type of synthesis has several advantages over more conventional methods, the major one being that the time taken to construct an oligonucleotide is drastically reduced as excess reagents can be rinsed away and there is no need for the lengthy chromatographic separation of products at each stage. Another advantage is that the scale of operation can be decreased, thus reducing the amount of protected nucleotide required for each addition. Employing a method involving solid phase synthesis allows the process to be mechanised which can also reduce the amount of labour and synthesis time. However when large amounts (>50 mgs.) of DNA or RNA are required solution methods must still be used.

The solid support is generally in the form of small beads or particles of silica gel,<sup>55,119</sup> polystyrene/divinylbenzene,<sup>5</sup> glass,<sup>47</sup> or polyamide,<sup>120,121</sup> each of

which has a varying degree of loading and rigidity. The growing oligonucleotide is attached to the solid support *via* a linker which is generally a succinate derivative and is cleaved at the end of the synthesis by mild alkaline hydrolysis, using ammonium hydroxide which can also be used to remove the base protecting groups. A spacer is also used to give the oligonucleotide room to grow and its length can have an effect on the final yield of the product.<sup>122</sup>

### 1.6.3. Use in Synthesis

Since it was first proposed many researchers have shown an interest in solid phase synthesis and the phosphotriester and, later, the phosphoramidite methods have been used to produce oligonucleotides. In 1979 Itakura *et al.*<sup>123</sup> performed the first successful phosphotriester synthesis on solid phase. By using a block coupling method they made T<sub>19</sub> in 49% yield. Then Ogilvie *et al.*<sup>124</sup> used a silica gel support in conjunction with the phosphite-triester approach to make an RNA hexamer, and Matteucci and Caruthers<sup>119</sup> used similar conditions to produce a DNA dodecanucleotide in 30% yield. Since then many oligonucleotides have been synthesized, most of them using the phosphoramidite method.

In both approaches to synthesis the resin to be used must first be functionalised by addition of the linker and the first nucleoside to give a loaded support. The outline of the phosphotriester synthesis cycle is shown in fig.1.39.

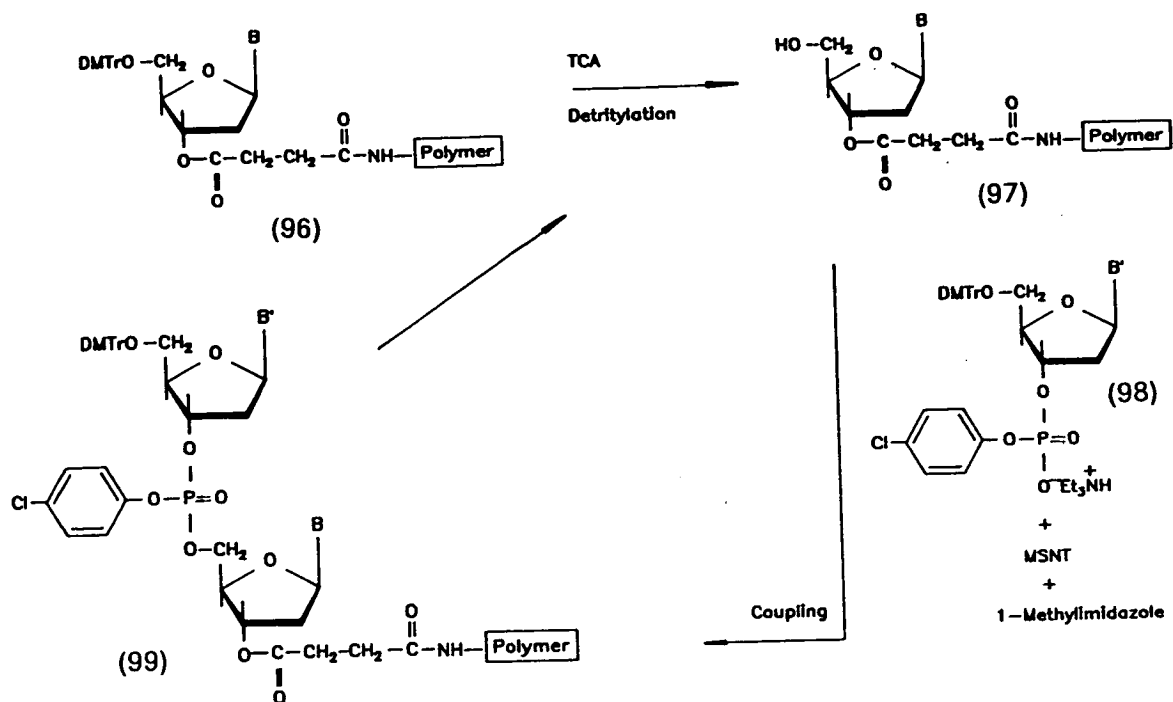

Fig.1.39 The Phosphotriester Solid Phase Synthesis Cycle

The polymer with the nucleoside attached **96** is treated with trichloroacetic acid to deprotect the 5'-hydroxyl affording **97** and then coupled to a suitably protected nucleotide **98** using MSNT as a condensing agent and 1-methylimidazole as an accelerating agent to give a fully protected dimer **99**. The cycle can be continued by detritylating the dimer and coupling to another nucleotide. This is continued until the desired oligonucleotide has been synthesized. At this point the protecting groups are removed and the linker cleaved using ammonium hydroxide.

The phosphite-triester cycle, shown in fig.1.40, is very similar but involves an extra step, an oxidation, to obtain the phosphate function.

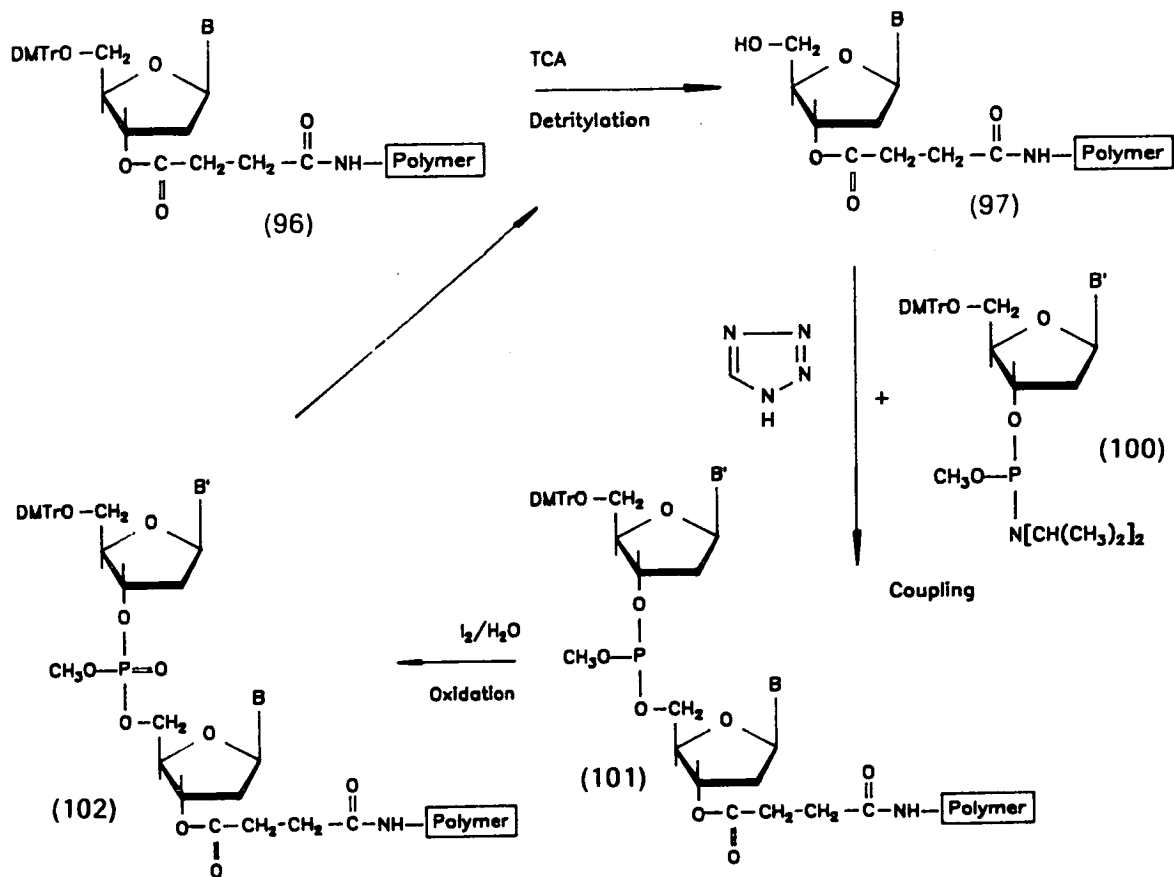

Fig.1.40 The Phosphite-Triester Solid Phase Synthesis Cycle

The dimethoxytrityl group is removed from the polymer attached nucleoside **96** to give a free 5'-hydroxyl **97**. A phosphoramidite nucleotide **100** is activated with tetrazole and coupled to the resin bound nucleoside to form a phosphite-triester dimer **101** which is then oxidised by iodine and water to produce a phosphate linkage **102**. The cycle can be repeated by detritylation of this dimer and addition of further nucleotides until the desired oligonucleotide is made, at which point it is cleaved from the resin using ammonium hydroxide.

An additional step, a capping reaction, can be introduced into the synthesis cycle of either approach. The usual reagent to be employed is acetic anhydride and capping takes place after the oxidation step in the phosphite-triester



method and after the coupling step in the phosphotriester approach. Its function is to protect any unreacted 5'-hydroxyls in order to prevent further nucleotide addition. The inclusion of this step in a synthesis cycle reduces the number of  $n-1$  oligonucleotide impurities which can result if a growing oligonucleotide fails to react during one coupling step, and its purpose is to make separation of the final product easier.

#### **1.6.4. Automated Synthesis**

In the past few years automated oligonucleotide synthesis has been improved by the commercial production of computer controlled DNA synthesizers. When programmed with the desired sequence and loaded with the correct reagents these automatically synthesise DNA without manual intervention. Some machines can construct more than one oligodeoxyribonucleotide sequence at a time but with all automated synthesis the purification still has to be performed manually.

## CHAPTER 2

## DISCUSSION

**2.1. Problems with DNA synthesis**

The chemical synthesis of DNA can be performed by one of two general methods, the phosphotriester method or the phosphite-triester approach, both of which are discussed in part 1.4 in the introduction. These methods have both undergone great improvement since they were first proposed but they are still not without their problems. The phosphotriester method involves the coupling of a phosphate function to an alcohol and as this reaction proceeds relatively slowly an accelerating agent must be added to produce reaction rates which allow the synthesis of DNA to be performed in a matter of hours, instead of days. Although there has been great improvement in the coupling speed of this type of reaction it is still appreciably slower than the phosphite-triester method. This latter approach takes advantage of the fact that  $P^{III}$  compounds are much more reactive than their  $P^V$  equivalents. The coupling reaction involves a phosphite function which, after coupling is completed, can be oxidised to the more stable phosphate.

When considered only in terms of speed the phosphite-triester method seems more desirable but it too has drawbacks. The monomers used in the synthesis of DNA by this method are very reactive, not only towards the alcohol in the synthesis but also towards water and oxygen during storage and use. This problem has been partially resolved by preparing the more stable phosphoramidites which are activated with an acid such as tetrazole immediately before use, but even these compounds are not stable for more than a few days when dissolved in acetonitrile for use on an automated synthesizer.

A second problem with this method of synthesis is the inclusion of an oxidation step involving the use of iodine and water. As most syntheses are performed on solid phase on a small scale the potential problems of bond cleavage, which may occur during this step when it is performed on a larger scale in solution, have not undergone sufficient investigation.

The choice of coupling method is only one source of problems; another comes from the choice of protecting groups and the overall protecting group strategy (see part 1.5). Whether the phosphotriester or phosphite-triester method is chosen the 5'-hydroxyl protecting group most commonly used is 4,4'-dimethoxytrityl (DMTr). This group is removed by treatment with an acid such as di- or trichloroacetic acid which, as well as efficiently removing the DMTr function can also cause depurination (cleavage of the base from the ribose ring), particularly in the case of N<sup>6</sup>-benzoyl-2'-deoxyadenosine. This problem is only significant when large oligodeoxyribonucleotides, or ones containing a high proportion of 2'-deoxyadenosine, are synthesized. In these cases the repeated acid treatment, and consequent increase in depurination, reduces yields and makes purification of the desired sequence more difficult.

There are several solutions to this problem. It is possible to use zinc bromide<sup>125</sup> to remove the trityl group, or the N-protecting group could be changed<sup>64</sup> to make the protected purine less susceptible to acid attack. Another solution is to avoid the acid treatment altogether by using a 5'-protecting group which can be cleaved under different conditions. One such group, 9-fluorenylmethoxycarbonyl (Fmoc), has already been studied<sup>86,87,116</sup> and subsequently we investigated the possibility of using the 2,2-bis(4-nitrophenyl)ethoxycarbonyl (Bnpeoc) group as a 5'-hydroxyl protecting group for use in the synthesis of DNA. The Bnpeoc group had previously been developed and used for amine protection in the synthesis of peptides<sup>126</sup>. Both

the Fmoc and Bnpeoc groups are cleaved by a  $\beta$ -elimination process with a base such as piperidine or DBU. It has been shown that Fmoc is more base labile than Bnpeoc<sup>126</sup>, a factor which it was hoped would lead to greater stability of Bnpeoc derivatives in solvents such as acetonitrile prior to use in automated synthesis.

The use of a base labile group at the 5'-position also allows the use of an acid labile protecting group on the 2'-hydroxyl function during RNA synthesis. This functional group is sometimes protected by the acid labile THP or MTHP groups, both of which show some cleavage during the acid treatment to remove the DMTr group. A base labile group on the 5'-hydroxyl function would be compatible with such groups.

## 2.2. Bnpeoc as 5'-hydroxyl protection for thymidine

In order to investigate the possibility of using the Bnpeoc group for 5'-hydroxyl protection it was necessary to synthesize a nucleotide monomer which could then be converted into an oligonucleotide. It was decided that thymidine would be the most convenient nucleoside to employ for these studies as it could be used without having to consider exocyclic-amine protecting groups. The Bnpeoc group was introduced into the nucleoside by using the chloroformate of 2,2-*bis* (4-nitrophenyl)ethanol. This reacted with the 5'-hydroxyl function to form a carbonate linkage. The primary hydroxyl reacts much faster than the secondary 3'-hydroxyl and so very little of the 3'-protected or 3',5'-diprotected product is observed. The yield of the 5'-protected nucleoside obtained from this reaction is acceptable, and comparable to that obtained when the Fmoc group is used in place of Bnpeoc.

To make the phosphoramidite it was first necessary to make the phosphitylating agent. This could then be reacted with the 5'-protected

nucleoside to give a monomer which could be used for DNA synthesis. The reaction scheme leading to the phosphoramidite is shown in fig.2.1.

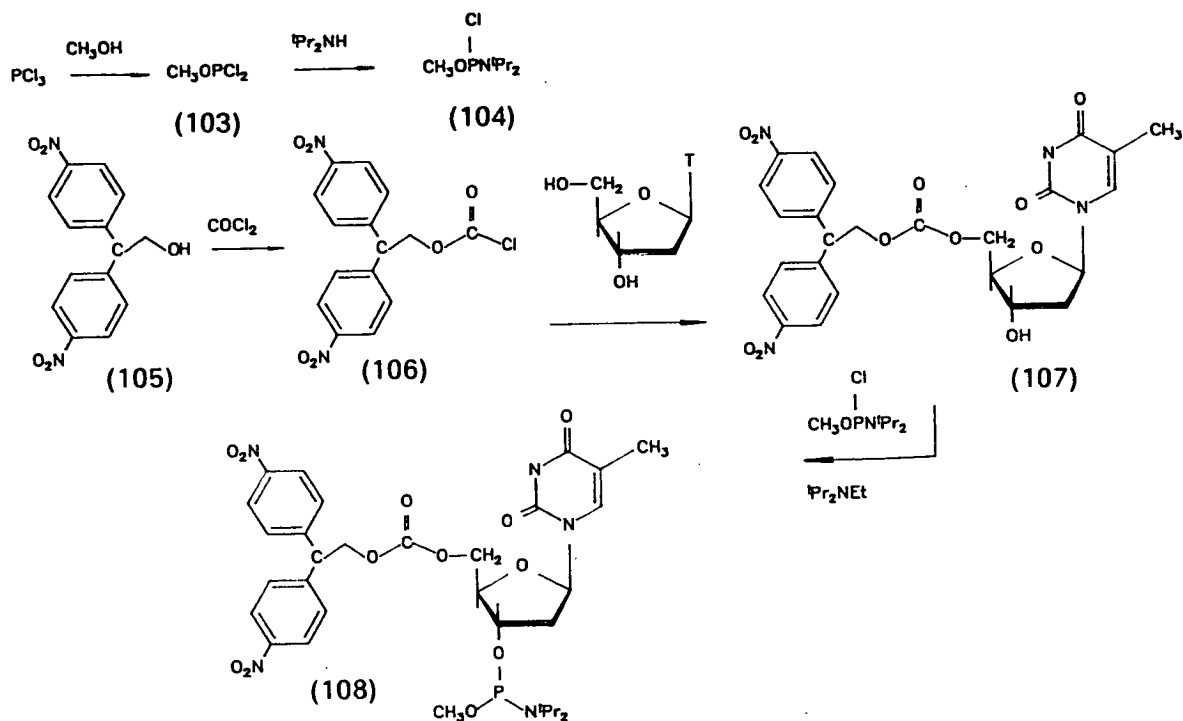

Fig.2.1 Synthesis of a Phosphoramidite

The first step in making the phosphitylating agent is the reaction of phosphorus trichloride with methanol and the isolation of the product by distillation. The reaction, and especially the distillation, resulted in the formation of an explosive yellow phosphorus compound as well as the product, and care should be taken during its synthesis. As phosphorus trichloride is very reactive towards methanol it was expected that using one equivalent of each reagent would provide the best yield of methyl phosphodichloridite 103 but it was found that better yields were obtained when more methanol was added. In the next step two equivalents of the secondary amine, *N,N*-diisopropylamine, were added, one to replace a second chlorine and one to react with the hydrogen chloride which was produced. The product,

*N,N*-diisopropyl methylphosphoramidyl chloride **104**, was distilled from the reaction mixture and, as above, a small amount of the explosive phosphorus compound was also formed.

*2,2-Bis* (4-nitrophenyl)ethanol **105** was obtained by the method described by Florence<sup>126</sup> and was converted to the chloroformate **106** by reaction with phosgene. The nucleoside was protected using the chloroformate **106** in anhydrous conditions to produce a 5'-protected nucleoside **107** in good yield after chromatography. The synthesis of the phosphoramidite **108** was performed under dry, oxygen free conditions in order to obtain the product in the highest purity possible. The phosphoramidyl chloride **104** reacted with the 5'-protected nucleoside **107**, with hydrogen chloride being eliminated, to form a P-O bond onto the 3'-hydroxyl function. This phosphoramidite **108** is isolated as an oil which can be precipitated with hexane to give a powder which is more stable, and may be stored for several months in a freezer without decomposition.

### 2.3. Stability Studies

Once it had been shown that it was possible to obtain thymidine protected at the 5'-position with the Bnpeoc group it was then thought necessary to investigate the stability to various reagents of the carbonate linkage formed, and also to study the deprotection of the Bnpeoc group.

It has previously been shown<sup>126</sup> that the urethane link between the Bnpe group and an amino acid is stable to tertiary amines but can be cleaved by secondary amines such as piperidine and by the bases DBU and DBN. In order to ascertain whether the carbonate linkage would also be stable to tertiary amines several experiments were performed and the stability of 5'-O-Bnpeoc-thymidine **107** was monitored by tlc. It was shown that the

Bnpeoc protected nucleoside was stable to a solution of 10% triethylamine in methylene chloride for 24 hours, and only showed slight cleavage after 7 days. When acetonitrile was used in place of the methylene chloride a small degree of cleavage was observed after 30 min. and deprotection was complete after 24 hours.

N,N-diisopropylethylamine in tetrahydrofuran is used during the synthesis of the phosphoramidite from the 5'-protected nucleoside. When 5'-O-Bnpeoc-thymidine **107** was exposed to 4 equivalents of this amine in tetrahydrofuran over 2 hours no cleavage of the carbonate linkage was observed.

The synthesis of the protected nucleoside involves the use of N,N-dimethylaminopyridine (DMAP) in order to obtain a reasonable yield. To determine whether this reagent could also cause loss of the protecting group 1 equivalent of DMAP was added to 5'-O-bnpeoc-thymidine **107** in methylene chloride and in pyridine. After 24 hours both of these studies showed a small amount of loss of the protecting group from the nucleoside.

As well as looking at the stability of the carbonate link the deprotection of the Bnpeoc group from the nucleoside is also important. The deprotection of the Bnpeoc group proceeds *via* a  $\beta$ -elimination process and non-nucleophilic bases such as DBU (1,8-diazabicyclo[5.4.0]undec-7-ene) **109** and DBN (1,5-diazabicyclo[4.3.0]non-5-ene) **110** can be used to remove this protecting group selectively whilst leaving the exo-cyclic amine protecting groups intact, see fig.2.2.

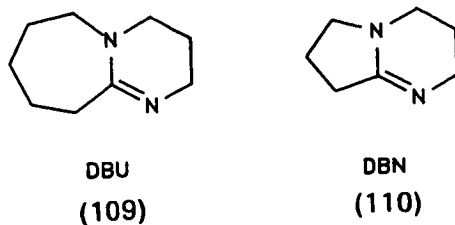
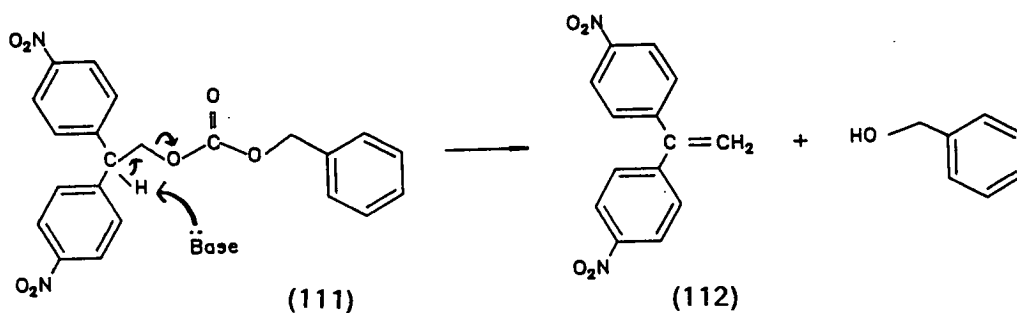

Fig.2.2 Bases used for Deprotection

The mechanism of deprotection is illustrated by the following model system. The elimination reaction is initiated by removal of a proton from the  $\beta$ -position of 2,2-bis(4-nitrophenyl)ethyl benzyl carbonate **111** and proceeds to form 1,1-bis(4-nitrophenyl)ethene **112** and benzyl alcohol, see fig.2.3.

Fig.2.3 The  $\beta$ -Elimination Mechanism

DBU acetate, which had been shown to deprotect Bnpeoc protected amino acids<sup>126</sup> under neutral conditions, was studied initially. 5'-O-Bnpeoc-thymidine **107** was treated with 1 equivalent of DBU acetate in acetonitrile and using tlc it was shown that the nucleoside was slowly deprotected, more than 1 hour being required for complete deprotection to occur. A similar study was also performed on Bnpe benzyl carbonate **111** using 10 equivalents of DBU acetate in acetonitrile and this also took more than one hour to cleave completely. These results indicate that DBU acetate does not perform the deprotection fast enough and so the use of DBU without the acetic acid buffer was explored.



Bnpe benzyl carbonate was treated with 1 equivalent of DBU in acetonitrile and the reaction, monitored by tlc, showed that complete deprotection took only 4 min. With 2 equivalents of DBU the deprotection was completed in 2 min., and it took only 30 seconds with 25 equivalents. The results show that the Bnpe benzyl carbonate link can be cleaved in solution phase and so the next step was to determine the effect of DBU on the nucleoside. 5'-O-Bnpeoc-thymidine **107** was deprotected with 10 equivalents of DBU in acetonitrile and the deprotected nucleoside, thymidine, was isolated by chromatography. The mp, tlc,  $^1\text{H}$  n.m.r. and mass spectrum all confirmed that thymidine had been isolated and tlc showed that the protecting group had been converted to the olefin.

The stability of the Bnpeoc-nucleoside linkage towards tetrazole was also determined by dissolving 5'-O-Bnpeoc-thymidine **107** in acetonitrile and adding tetrazole. Tlc showed it to be completely stable for at least 2 hours.

#### 2.4. Solid Phase Synthesis

The synthesis of an oligonucleotide from a monomer containing the Bnpeoc group as 5'-hydroxyl protection is the next step towards determining the suitability of this group for use in DNA synthesis. All the syntheses were performed on an automated synthesizer and a copy of a synthesis cycle used can be found in appendix 1. The main variations in the syntheses attempted were: i, varying the 5'-hydroxyl protecting group; ii, varying the deprotection times and reagents for the 5'-hydroxyl group; iii, varying the phosphorus protecting group. It was decided that  $(\text{Tp})_5\text{T}$  (A) would be the target oligonucleotide as it contained only thymidine nucleotides and hence needed only one monomer for its preparation and also was long enough to be observed by reverse phase and ion-exchange HPLC.

The sequence prepared by protocol (1) was made as a standard employing

the commonly used protecting groups, DMTr for the 5'-hydroxyl and  $\beta$ -cyanoethyl for phosphorus protection. The deprotection conditions for the DMTr group are 10% trichloroacetic acid in methylene chloride and this takes 50 seconds in each cycle. The sequence made by protocol (2) was synthesized in a similar way but the deprotection conditions had to be modified. From the deprotection conditions previously discussed it can be seen that a solution of DBU in DMF gives the best conditions for removal of the Bnpeoc group but as the effect of DMF on the linker to be used was not certain and it was decided to conduct the deprotection in acetonitrile, extending the time from 50 to 120 seconds in order to allow the complete deprotection to occur. The linker used had to be stable to base and so the succinyl-sarcosyl (SARC) linker<sup>127</sup> was chosen. The synthesis was performed using 5'-O-Bnpeoc-thymidine-3'-N,N-diisopropyl methyl phosphoramidite 108 and then compared with (1A) using reverse phase HPLC. The standard, (1A), showed mainly one peak as would be expected and (2A) showed a small broad peak with a similar retention time. In order to determine whether these oligonucleotides were in fact identical they were both purified using preparative ion-exchange HPLC which will separate sequences according to the number of phosphates they contain. When analysed by ion-exchange HPLC both sequences showed mainly one peak with the same retention time, and in both cases small peaks for all the deletion sequences were present. The main peak in each case was collected and then analysed by reverse phase HPLC. (1A), the standard, showed just one peak but (2A) gave two major peaks and a minor one in close proximity, see appendix 2. A mixed injection of (1A) and (2A) confirmed that one of the peaks from (2A) was the same as the standard. The second major peak was thought to be caused by the N<sup>3</sup>-methylation of thymidine by the methyl protecting group on phosphorus during the treatment with DBU, and the small peak probably resulted from two of the thymidines being methylated. This result has also

been observed by Gao *et al.*<sup>102</sup> using DBU or triethylamine in pyridine and may proceed by the mechanism proposed in fig.2.4.

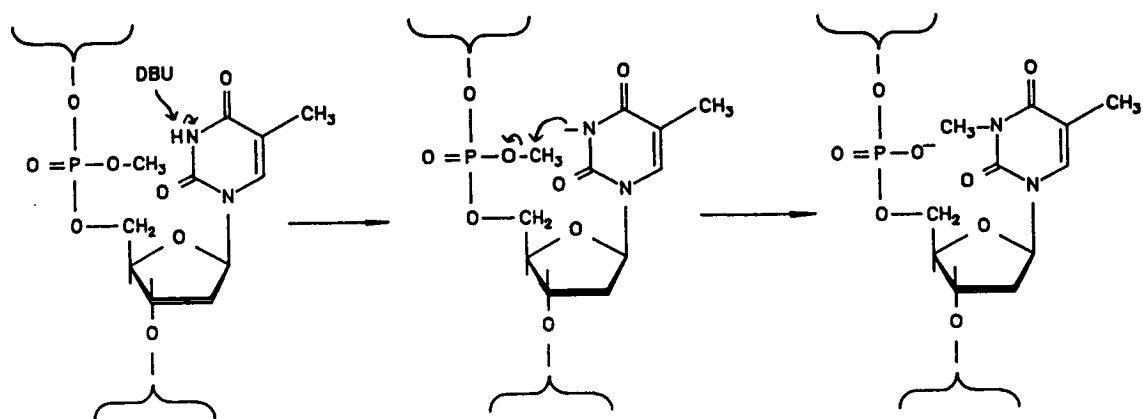

Fig.2.4 The Methylation of Thymidine

The basic DBU molecule abstracts the proton from the N<sup>3</sup>-position leaving a negatively charged species which then attacks the methyl group on phosphorus.

Another problem which occurred with the synthesis of (2A) was the low yield of oligonucleotide produced, as observed by HPLC. The reason for this is unknown but may be due to cleavage of the linker during the DBU treatment. In order to investigate this possibility several more (Tp)<sub>5</sub>T sequences (3A-6A) were synthesized using DMTr as 5'-protection and were treated with DBU. Protocol (3) was run on an automated synthesizer and whilst (A) was still attached to the resin *via* the SARC linker, and whilst still protected at the 5'-end with DMTr, and with methyl protection on the phosphorus, it was washed in a 10% solution of DBU in acetonitrile. After this treatment the DMTr group was removed with trichloroacetic acid, the methyl groups were removed with thiophenol, and the oligonucleotide was cleaved from the resin with concentrated aqueous ammonia. (4A) was synthesized under the same conditions but the DBU in acetonitrile treatment was performed after the

removal of the final 5'-DMTr group.

Reverse phase HPLC analysis showed that the products from both of these protocols had formed in a yield comparable to that of the standard, and so the absence of 5'-protection on a 6-residue oligonucleotide does not cause cleavage of the linker on treatment with DBU in acetonitrile. Both (3A) and (4A) showed interesting results on ion-exchange HPLC. They each displayed four peaks, one of which co-eluted with the standard, (1A), and the others presumably were the mono-, di- and tri- thymidine-methylated compounds as ion-exchange HPLC demonstrated that they consisted mainly of oligonucleotides containing five phosphates by comparison with (1A).

The sequence prepared by protocol (5) was synthesized as above and treated with DBU in acetonitrile before removal of the final 5'-DMTr group but in this case the phosphorus protection was  $\beta$ -cyanoethyl instead of methyl. (6A) was prepared as for (4A) but again substituting the  $\beta$ -cyanoethyl group for the methyl group on phosphorus. Reverse phase HPLC of these two sequences showed that they were not affected by the DBU treatment.

The effect of piperidine on oligonucleotides containing methyl protection on the phosphate functions was investigated with (7A).  $(Tp)_5T$  bound to the resin with the SARC linker and containing the DMTr protecting group on the 5'-hydroxyl was treated with 10% piperidine in acetonitrile for 10 min. before being fully deprotected and cleaved from the resin. Reverse phase HPLC showed a major peak which co-eluted with the standard sample and a small peak which was presumably the oligonucleotide containing the N-methylated thymidine. On ion-exchange HPLC only one peak was observed.

From these experiments it can be concluded that, bases such as DBU and, to a lesser extent, piperidine, result in the N<sup>3</sup>-methylation of thymidine in

oligonucleotides containing methyl protection on phosphorus, and ii, the effect of these bases on the SARC linker attached to a hexamer was not the cause of the reduced yields observed when Bnpeoc was used as a 5'-protecting group.

## 2.5. Alternative Protecting Group Strategies

The need for a modification of the monomer to be used was evident from the results of the solid phase synthesis experiments. The N<sup>3</sup>-methylation of thymidine was a problem which had to be avoided and, in view of the fact that an alternative could not be found for DBU for the deprotection of the Bnpeoc group, the possible solutions were i, to use a protecting group on the N<sup>3</sup>-position of thymidine or ii, to find an alternative phosphorus protecting group.

The investigation of thymidine protection led us to use the anisoyl group on the N<sup>3</sup>-position. This protecting group is cleaved in aqueous ammonia and has previously been used for uridine<sup>128</sup> and cytidine<sup>103</sup>. It was necessary to prepare a phosphoramidite containing this protecting group, the synthesis of which can be seen in fig.2.5, and then determine its viability during the solid phase synthesis of an oligonucleotide. The synthesis starts with the silylation of thymidine **113** by trimethylsilyl chloride, which is used to protect the hydroxyl functions on the ribose ring. The next step is the reaction of the nucleoside with anisoyl chloride and finally the removal of the silyl groups with aqueous pyridine to give N<sup>3</sup>-anisoylthymidine **114**. This reaction gave quite a low yield (37%) which may be due to the sensitivity of the anisoyl chloride to water. The nucleoside was then reacted with Bnpeoc-Cl **106** forming 5'-O-Bnpeoc-N<sup>3</sup>-anisoylthymidine **115** which was converted to the phosphoramidite **116** by use of a phosphitylating agent **104**.

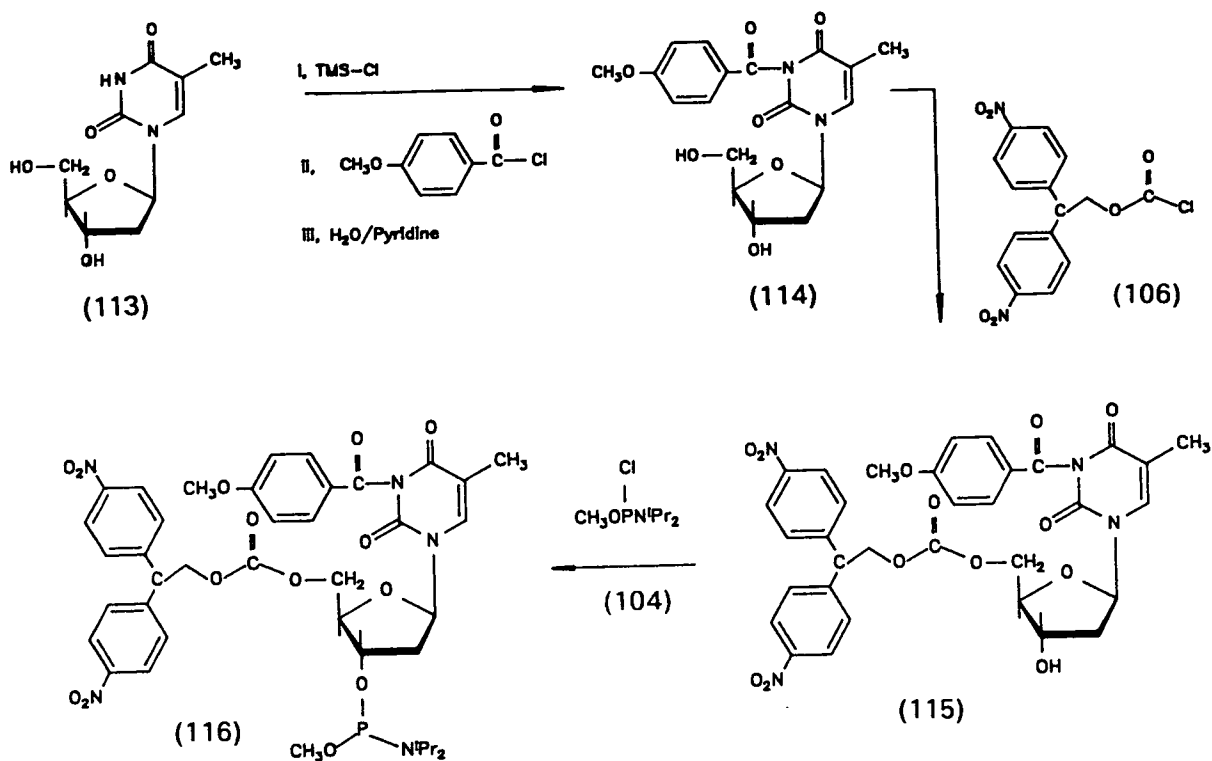

Fig.2.5 Preparation of an N<sup>3</sup>-Protected Phosphoramidite

In order to enable us to compare the Bnpeoc group with Fmoc we also made a similar phosphoramidite using Fmoc as the 5'-hydroxyl protecting group, see fig.2.6.

The synthesis is similar to that for the Bnpeoc derivative, starting with N<sup>3</sup>-anisoylthymidine 114 which was reacted with 9-fluorenylmethyl chloroformate to give 5'-O-(9-fluorenylmethyl)-N<sup>3</sup>-anisoylthymidine 117 in an acceptable yield. The phosphoramidite was obtained using N,N-diisopropylmethylphosphoramidite chloride 104 to give 5'-O-Fmoc-N<sup>3</sup>-anisoylthymidine-3'-O-N,N-diisopropylmethylphosphoramidite 118.

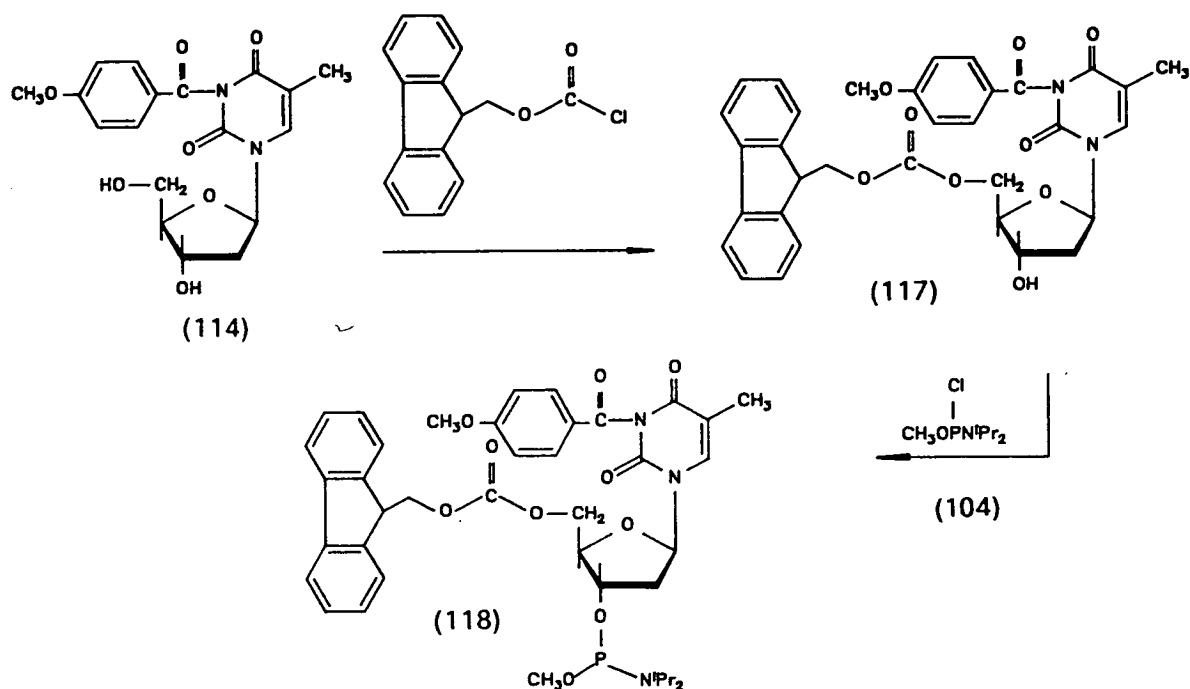

Fig.2.6 Preparation of an Fmoc, $\text{N}^3$ -anisoylthymidine Phosphoramidite

Using phosphoramidite 118 the sequence prepared by protocol (12),  $(\text{Tp})_5\text{T}$ , was synthesized using 10% DBU in acetonitrile for 180 seconds per cycle. Ion-exchange HPLC showed a small peak which had the same retention time as the standard sample. When the phosphoramidite 116 was used in a synthesis (protocol (13)) under identical conditions, no product at all was observed by ion-exchange HPLC. No deletion sequences were observed in either case. In the synthesis using Fmoc as the 5'-protecting group it is not likely that the deprotection time was too short since if that had been the case then it would be expected that the deletion sequences would be visible on the ion-exchange HPLC trace. In the case of Bnpeoc it is possible that the deprotection time was much too short, not even allowing sufficient coupling to take place initially, before the first capping step. The addition of the anisoyl group to thymidine

may provide some steric hinderance during the deprotection step of Bnpeoc with DBU and possibly also during the coupling step.

The second alternative to the N<sup>3</sup>-methylation of thymidine was to alter the phosphorus protecting group. A base labile group could not be used and so the acid labile 2,2,2-triphenylethyl group was investigated. The use of an acid labile group on phosphorus would mean that the oligonucleotide required only one acid treatment at the end of the synthesis and therefore the problems of depurination and cleavage of acid labile 2'-protecting groups would be reduced compared with the use of an acid treatment in each cycle when employing the DMTr group for 5'-protection. To determine whether it was possible to synthesize oligodeoxyribonucleotides using the 2,2,2-triphenylethyl group for phosphorus protection the phosphoramidite monomer was made, see fig.2.7.

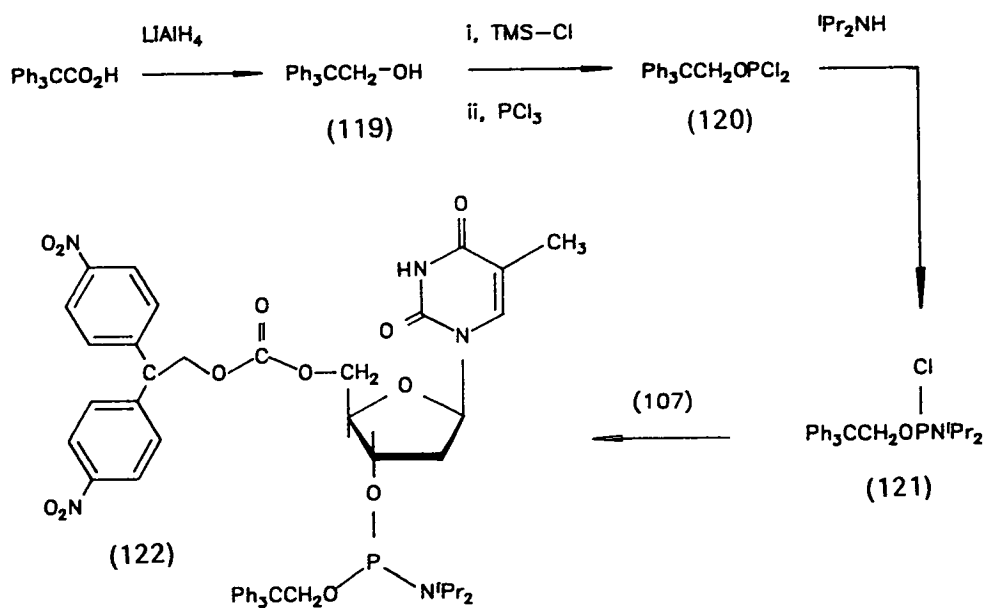

Fig.2.7 Preparation of a 2,2,2-Triphenylethylphosphoramidite

2,2,2-Triphenylethanol 119 was prepared by the reduction of



2,2,2-triphenylacetic acid with lithium aluminium hydride. The trimethylsilyl ether of the alcohol was then prepared and reacted with phosphorus trichloride at low temperature to maximise the yield of the mono-substituted phosphine 120, (see below). The addition to this reagent of N,N-diisopropylamine gave the phosphoramidyl chloride 121 which was reacted with 5'-O-Bnpeoc-thymidine 107 at the 3'-position to give the required phosphoramidite 122 in reasonable yield.

To investigate its rate of coupling the phosphoramidite 122 was dissolved in acetonitrile, and tetrazole and benzyl alcohol were added. The reaction was observed by tlc but after 30 min. the starting material remained unchanged. The lack of reactivity displayed by this phosphoramidite is probably due to the steric bulk of the phenyl rings on the phosphorus protecting group.

A study was made of the optimum conditions required to obtain the mono-substituted phosphine 120 by varying the number of equivalents of alcohol, protected as the trimethylsilyl ether, used, and by altering the temperature at which the reaction was performed. The results, obtained by  $^{31}\text{P}$  n.m.r. analysis and summarised in table 3, show that the best conditions involve the use of 1 equivalent of the silyl ether and a low temperature. Phosphorus trichloride would be more reactive towards the first substitution of the alkoxy group than the second or third substitutions and hence the low temperature enables some increase in selectivity in favour of the desired reaction.

## 2.6. Bnpeoc as 5'-Hydroxyl Protection for 2'-Deoxyadenosine

The problem of N<sup>3</sup>-methylation of thymidine during oligonucleotide synthesis, and the lack of a viable solution, led us to consider using another nucleotide for further investigation of the Bnpeoc group. The three remaining bases all require exo-cyclic amine protection and N<sup>6</sup>-benzoyl-

2'-deoxyadenosine was the example chosen for investigation.

To determine the deprotection conditions for the Bnpeoc group and its use in synthesis a series of stability studies were performed on the 5'-Bnpeoc-protected nucleoside, and then the nucleotide was synthesized and used to make oligonucleotides by a solid phase method. The synthesis of the phosphoramidite can be seen in fig.2.8.

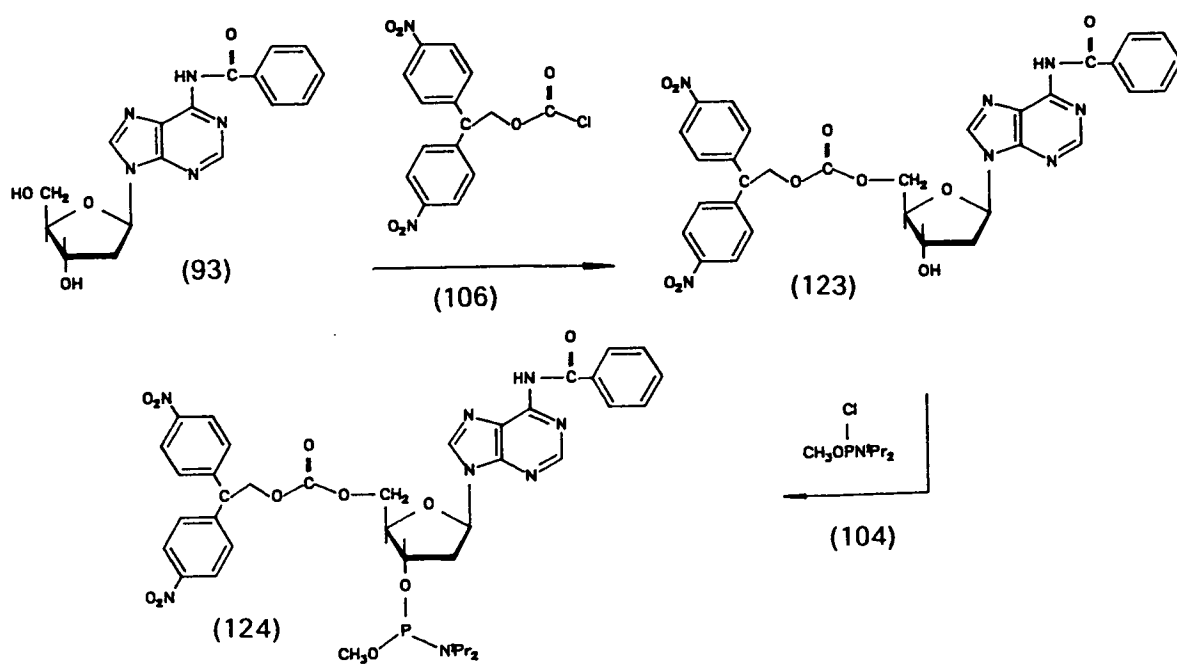

Fig.2.8 Synthesis of a 2'-Deoxyadenosine Phosphoramidite

N<sup>6</sup>-Benzoyl-2'-deoxyadenosine **93** was reacted with chloroformate **106** to give 5'-O-Bnpeoc-N<sup>6</sup>-benzoyl-2'-deoxyadenosine **123** in a reasonable yield. This was converted to the phosphoramidite by reaction with N,N-diisopropylmethylphosphoramidyl chloride **104** to give 5'-O-Bnpeoc-N<sup>6</sup>-benzoyl-2'-deoxyadenosine-3'-O-N,N-diisopropylmethyl phosphoramidite **124** in good yield.

Before commencing with an oligonucleotide synthesis the stability of the Bnpeoc group towards DBU and piperidine was determined. Using 5'-O-Bnpeoc-N<sup>6</sup>-benzoyl-2'-deoxyadenosine 123 dissolved in various solvents, and with varying amounts of DBU added, the time for complete deprotection of the Bnpeoc group from the nucleoside was determined (table 2.) When methylene chloride was used as a solvent with 10 equivalents of DBU the reaction was slow (taking more than 10 min. for complete deprotection). The rate increased when acetonitrile was employed as a solvent (5 min.), and when using DMF the deprotection was complete in 1 min. With a 10 fold increase in the amount of DBU this time was reduced to 15 seconds (100 equivalents of DBU in these experiments is a *ca* 10% solution).

Piperidine was also used in a deprotection study and with 10 equivalents of piperidine in DMF the cleavage of Bnpeoc from the nucleoside took 12 min. and using 100 equivalents this time was reduced to 5 min. As reactions take even longer in solid phase synthesis than in solution, this is too slow to be useful.

The conditions for the attempts at oligonucleotide synthesis using the phosphoramidite 124 are presented in table 6, (9B) and (10B). In the synthesis of (9B) the deprotection was performed using DBU in methylene chloride and, as these conditions result in slow cleavage of the Bnpeoc group, reverse phase HPLC showed all the deletion sequences and a small product peak, confirmed by a mixed injection with the standard, (8B). Similar results were observed on ion-exchange HPLC where all the deletion sequences were seen. When DBU in DMF was used for the deprotection, (10B), reverse phase HPLC showed two peaks, the major one of which co-eluted with the standard sample. Although (10B) contained the desired oligonucleotide the yield was much smaller than would be expected. To determine whether this was due to cleavage of the oligonucleotide from the resin (11B) was made by conventional methods and

was washed with 10% DBU in DMF prior to cleavage from the resin. Ion-exchange HPLC showed that this treatment had not affected the yield or purity of the product.

## 2.7. Stability Studies

By examination of the HPLC traces and determination by u.v. of the quantity of oligonucleotide produced in each synthesis, it can be seen that when Bnpeoc is employed as a 5'-hydroxyl protecting group on either thymidine or N<sup>6</sup>-benzoyl-2'-deoxyadenosine, the yield is much lower than would be expected with (for example) oligonucleotides synthesized using the 5'-DMTr group. The reason in some cases, such as when DBU in methylene chloride is used for the deprotection, may be incomplete removal of the Bnpeoc group, but when solvents such as DMF are used the deletion sequences, which are a sign of incomplete deprotection or coupling, are not observed, but still the yield of product is low. In an attempt to discover the cause of the unsatisfactory yields further experiments were conducted on the linker, on short oligonucleotides, on the oxidation conditions, and on solution phase coupling reactions.

The first experiment tested the stability of the SARC linker to DBU in DMF by suspending resin, functionalised with 5'-O-DMTr-thymidine bound by the linker, in the solution. The resin was then filtered off and washed. When tested with concentrated hydrochloric acid the resin gave an orange solution indicating that the nucleoside was still bound to it after the treatment with DBU, but the filtrate remained colourless when subjected to the same treatment indicating that no loss of the protected nucleoside had taken place.

Several experiments had already been performed to examine the stability to DBU in DMF of hexamers and octamers, joined to the resin by the SARC linker, but it is possible that the growing oligonucleotide may be cleaved from the

resin at an earlier stage in the synthesis. To examine this possibility the polynucleotides (dA), (dA)p(dA), (dA)p(dA)p(dA) and (dA)p(dA)p(dA)p(dA) were synthesized by conventional methods except that the SARC linker was used. Each was washed with a solution of DBU in DMF then cleaved from the resin and the amount of polynucleotide present was determined by u.v. absorbance. When these results were compared with a control experiment which omitted the DBU/DMF wash it was observed that the monomer showed about 5% cleavage from the resin but the dimer, trimer and tetramer were unaffected. The results show that if this cleavage occurs within a synthesis it would only have a slight affect on the final yield and could not be the sole reason for the low yields observed.

The next part of the synthesis cycle to be investigated was the oxidation step involving iodine and water. To test the stability of the Bnpeoc-nucleoside carbonate linkage 5'-O-Bnpeoc-thymidine-3'-O-acetate 125 was synthesized by the route set out in fig.2.9.

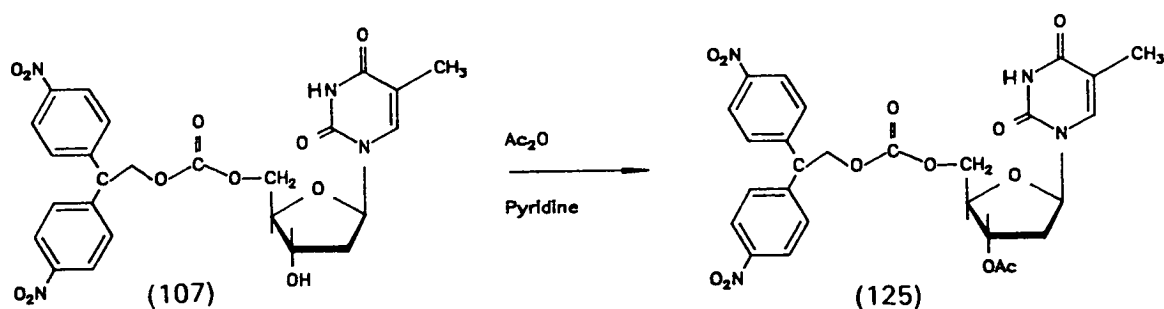

Fig.2.9 Synthesis of a 5',3'-Protected Nucleoside

The fully protected nucleoside was made by the reaction of acetic anhydride with 5'-O-Bnpeoc-thymidine 107 to give 5'-O-Bnpeoc-thymidine-3'-O-acetate 125. This was then treated with a

solution of iodine and water in THF and 2,6-lutidine, as is used during the synthesis, and then 125 was isolated in almost quantitative yield, showing that the carbonate linkage is stable to the oxidising conditions employed.

The important step of coupling was next studied. The reaction of 5'-O-Bnpeoc-N<sup>3</sup>-anisoyl-thymidine-3'-O-N,N-diisopropyl methylphosphoramidite 116 with methanol was followed by tlc and found to be complete within 2 min. Methanol was chosen as the least sterically hindered alcohol available. This reaction was repeated with 5'-O-DMTr-thymidine-3'-O-N,N-diisopropyl/methylphosphoramidite 126 and methanol to give the same results. These results suggest that such nucleotides protected with Bnpeoc do undergo a coupling step in the same way that DMTr-nucleotides do. In order to verify that the product formed was the one desired, the reaction was performed on a larger scale and the product was isolated by chromatography and characterisation showed it to be the required nucleoside-dimethylphosphate 127a. The reaction scheme can be seen in fig.2.10.

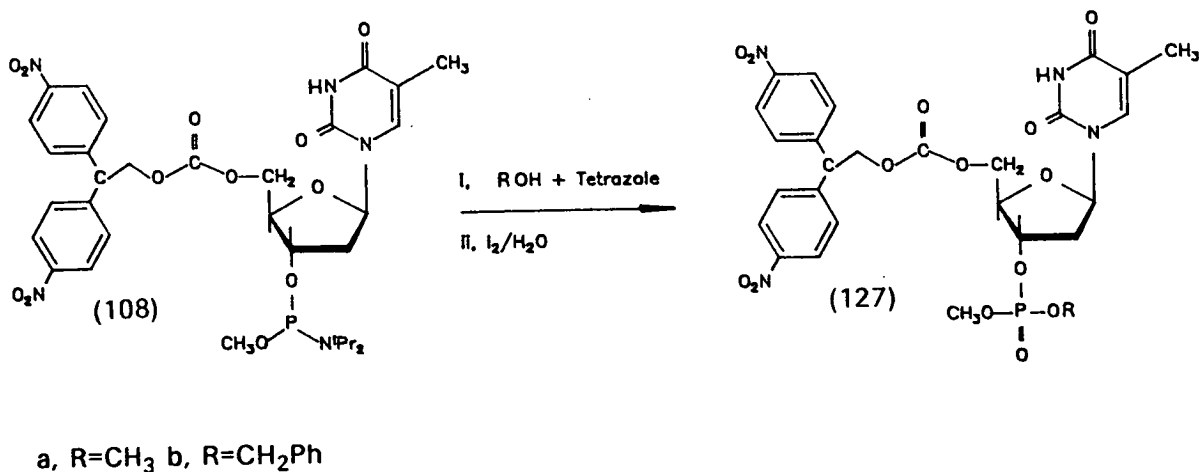

Fig.2.10 Coupling of a Phosphoramidite with an Alcohol

The next step was to repeat this coupling using a more sterically hindered alcohol, for which purpose benzyl alcohol was chosen. 5'-O-Bnpeoc-thymidine-3'-O-N,N-diisopropyl methylphosphoramidite **108** was reacted with benzyl alcohol and tetrazole, then oxidised with iodine and water to give 5'-O-Bnpeoc-thymidine-3'-O-benzylmethylphosphate **127b**. Characterisation confirmed that this was the required product.

The coupling of a phosphoramidite with a 3'-protected nucleoside was attempted to determine whether a nucleoside would be too hindered to couple to a 5'-O-Bnpeoc-protected nucleotide. The nucleoside used was thymidine-3'-O-acetate **5** and was obtained by the scheme shown in fig.2.11.

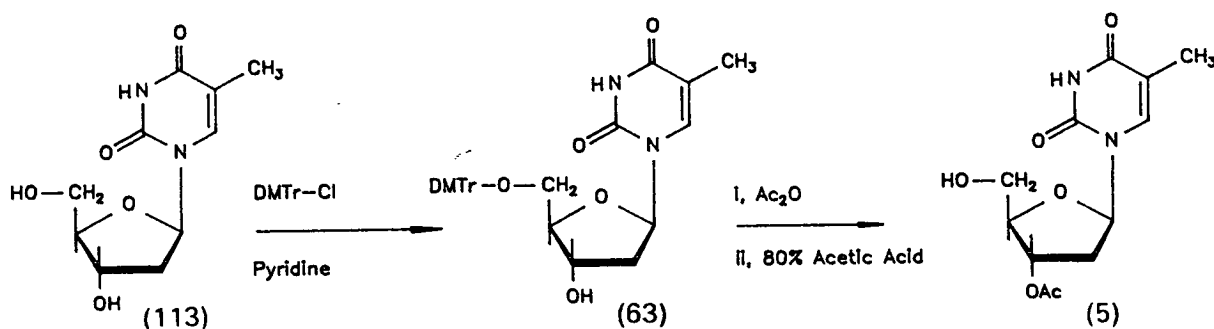

Fig.2.11 Synthesis of a 3'-Protected Nucleoside

Thymidine **113** was reacted with 4,4'-dimethoxytrityl chloride to give the 5'-protected nucleoside **63**. This was further protected by treatment with acetic anhydride and then the 5'-protecting group was removed by aqueous acetic acid to give thymidine-3'-O-acetate **5**.

The coupling reaction took place in solution between 5'-O-Bnpeoc-N<sup>3</sup>-anisoyl-thymidine-3'-O-N,N-diisopropyl methylphosphoramidite **116** and thymidine-3'-O-acetate **5** using tetrazole to

activate the phosphoramidite. The reaction was monitored by tlc and showed the conversion of the phosphoramidite, in the presence of excess nucleoside, to a product, presumably the dimer, in 20 min. This reaction is quite slow, and if it only proceeds at a comparable, or slower rate, on solid phase with excess phosphoramidite then it would account for the reduced yields observed.

## 2.8. Use of $\beta$ -Cyanoethyl Phosphoramidites

The Fmoc group has been investigated as a base labile 5'-hydroxyl protecting group for use in oligonucleotide synthesis with varying phosphorus protection. Its use was first reported with the N,N-diisopropyl methylphosphoramidite<sup>86,116</sup> in which reasonable product yields and purity were obtained. The methyl group is removed by thiophenol and so it remains stable throughout the DBU or piperidine treatment used to remove the Fmoc group. Later Gait *et al.*<sup>87</sup> used the N,N-diisopropyl/ $\beta$ -cyanoethyl phosphoramidite with Fmoc for RNA synthesis. The  $\beta$ -cyanoethyl group is base labile and so may be removed from the internucleotide phosphate function during the DBU treatment employed to cleave the 5'-Fmoc protecting group, leaving a phosphodiester which may undergo side-reactions during the remaining coupling steps.

The synthesis of two (Tp)<sub>5</sub>T oligodeoxyribonucleotides was performed using the 5'-O-Bnpeoc-thymidine-3'-O-N,N-diisopropyl/ $\beta$ -cyanoethyl phosphoramidite 128, the synthesis of which can be seen in fig.2.12. 5'-O-Bnpeoc-thymidine 107 is reacted with phosphitylating agent N,N-diisopropyl  $\beta$ -cyanoethyl phosphoramidyl chloride in anhydrous, oxygen free conditions, to give the desired phosphoramidite 128 in excellent yield.



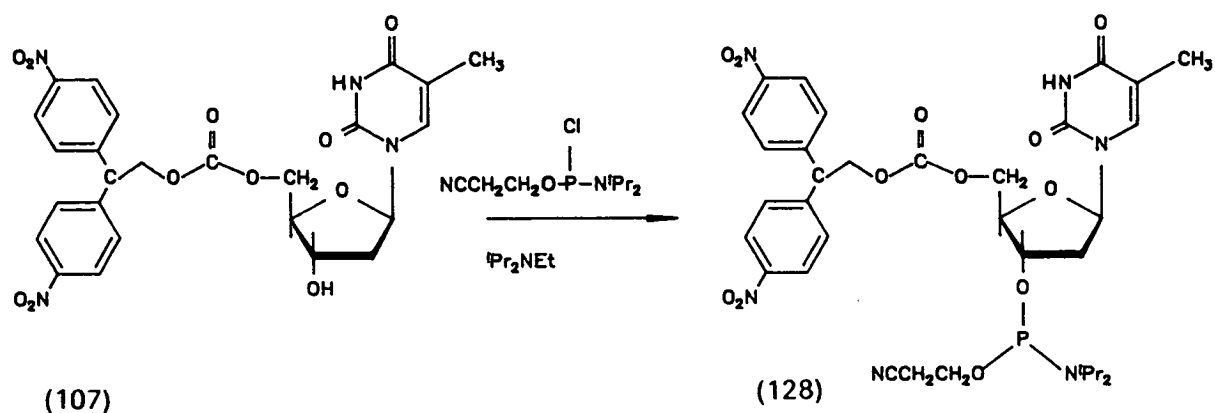

Fig.2.12 Synthesis of a  $\beta$ -Cyanoethyl Phosphoramidite

The synthesis of (A) by protocol 14 was performed using DBU in acetonitrile for the Bnpeoc deprotection and reverse phase HPLC of the product showed several peaks, the major one of which co-eluted with a standard sample of  $(\text{Tp})_5\text{T}$  oligonucleotide (1A). On ion-exchange HPLC several peaks were again observed but the major one was shown to be the desired product by comparison with the standard sample.

The sequence prepared by protocol (15) was synthesized from the phosphoramidite 128 but piperidine in acetonitrile was used for the deprotection step, which was increased from 50 to 600 seconds. Ion-exchange HPLC of the product showed several peaks, one of which co-eluted with the standard sample. Both methods (14) and (15) gave the required product but also showed evidence of deletion sequences, possibly due to insufficient deprotection time, and both gave low yields when compared to a standard DMTr synthesis.

The next two sequences to be synthesized also used the  $\beta$ -cyanoethyl group for phosphorus protection but protocol (16) had the Fmoc group on the 5'-position, and used phosphoramidite 130, the synthesis of which can be seen

in fig.2.13. Thymidine 113 is reacted with 9-fluorenylmethyl chloroformate to give 5'-O-Fmoc-thymidine 129, which is phosphitylated by *N,N*-diisopropyl  $\beta$ -cyanoethylphosphoramidyl chloride to produce the required phosphoramidite 130 in good yield.

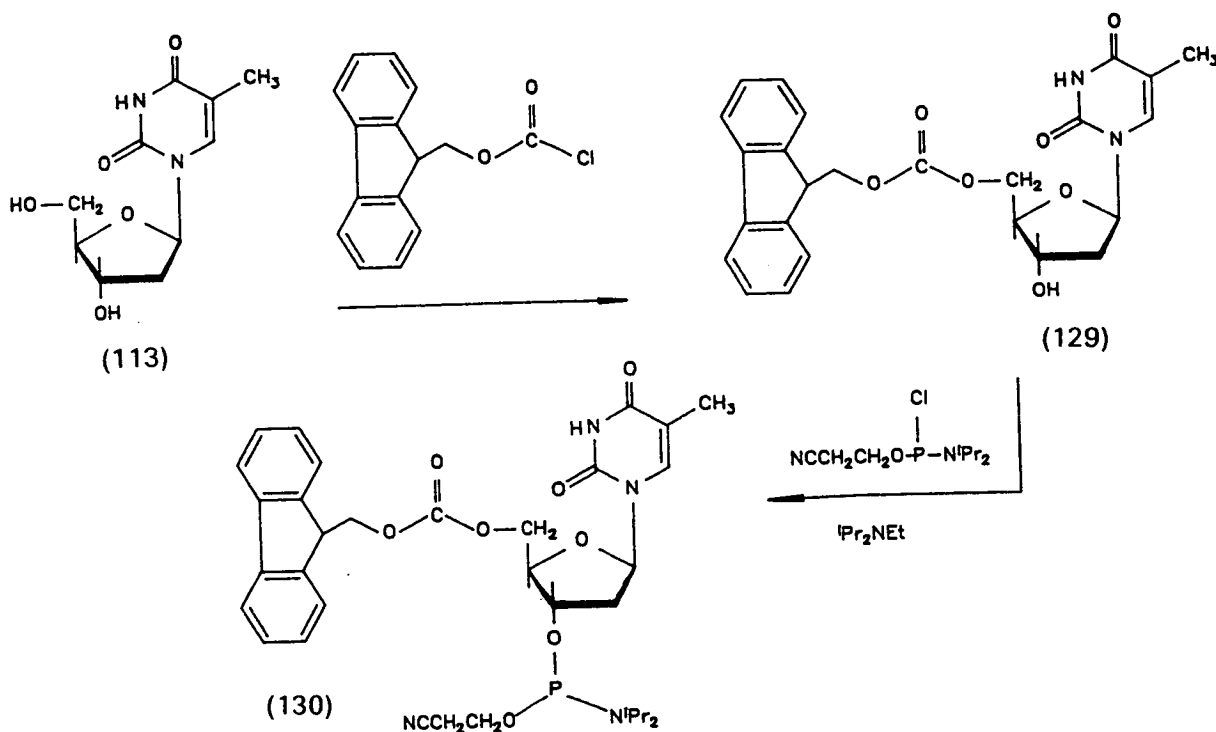

Fig.2.13 Synthesis of a  $\beta$ -Cyanoethyl Phosphoramidite

(16A) and (17A) were prepared to compare the purity and yield of oligonucleotides made from Fmoc-protected phosphoramidites with those synthesized from Bnpeoc-nucleotides. The sequence prepared by protocol (16), (Tp)<sub>5</sub>T, was deprotected using 10% DBU in DMF which should result in a faster deprotection time than when acetonitrile is used as a solvent. Reverse phase HPLC showed the product as the major peak but also indicated that some impurities were present. Sequence A, prepared by protocol (17), was synthesized in the same way except that Bnpeoc was used on the 5'-position and the deprotection time was increased from 100 to 200 seconds. Reverse phase HPLC analysis of the product again showed the desired product as the

major peak, in addition to similar impurities as before. Both (16A) and (17A) looked very similar on hplc and both were low yielding syntheses showing that Bnpeoc compares with Fmoc when allowance is made for a longer deprotection time requirement. However both protecting groups have produced oligonucleotides in disappointing yields by this method of synthesis.

## 2.9. Phosphorus NMR Studies

The coupling of phosphoramidites with methanol, benzyl alcohol and 3'-O-acetyl-thymidine has already been investigated using tlc as a means of monitoring the reactions. This method only shows that the starting material is converted to another compound and cannot provide a clear indication of which reactions are taking place or of what products are formed.

The first coupling reaction to be investigated by  $^{31}\text{P}$  n.m.r. was the reaction between 5'-O-Bnpeoc-thymidine-3'-O-N,N-diisopropyl methylphosphoramidite **108** and 3'-O-benzoyl-thymidine **131**. The pure starting material gave two products when the 3'-protected nucleoside was added, one of which was the addition product, 5'-O-Bnpeoc-thymidine-3'-O-methyl,(3'-O-benzoyl-thymidine) phosphite **132** at 139.9 ppm, and the other peak at 9.3 ppm was probably due to the reaction of the phosphoramidite with water during tetrazole activation to give the phosphonate **134**. When this reaction mixture was oxidised with iodine and water two major peaks appeared at -1.3 and 1.5 ppm, probably due to the desired phosphate **133** and the oxidised phosphonate which would form a phosphate **135** under these conditions; the reactions can be seen in fig.2.14.

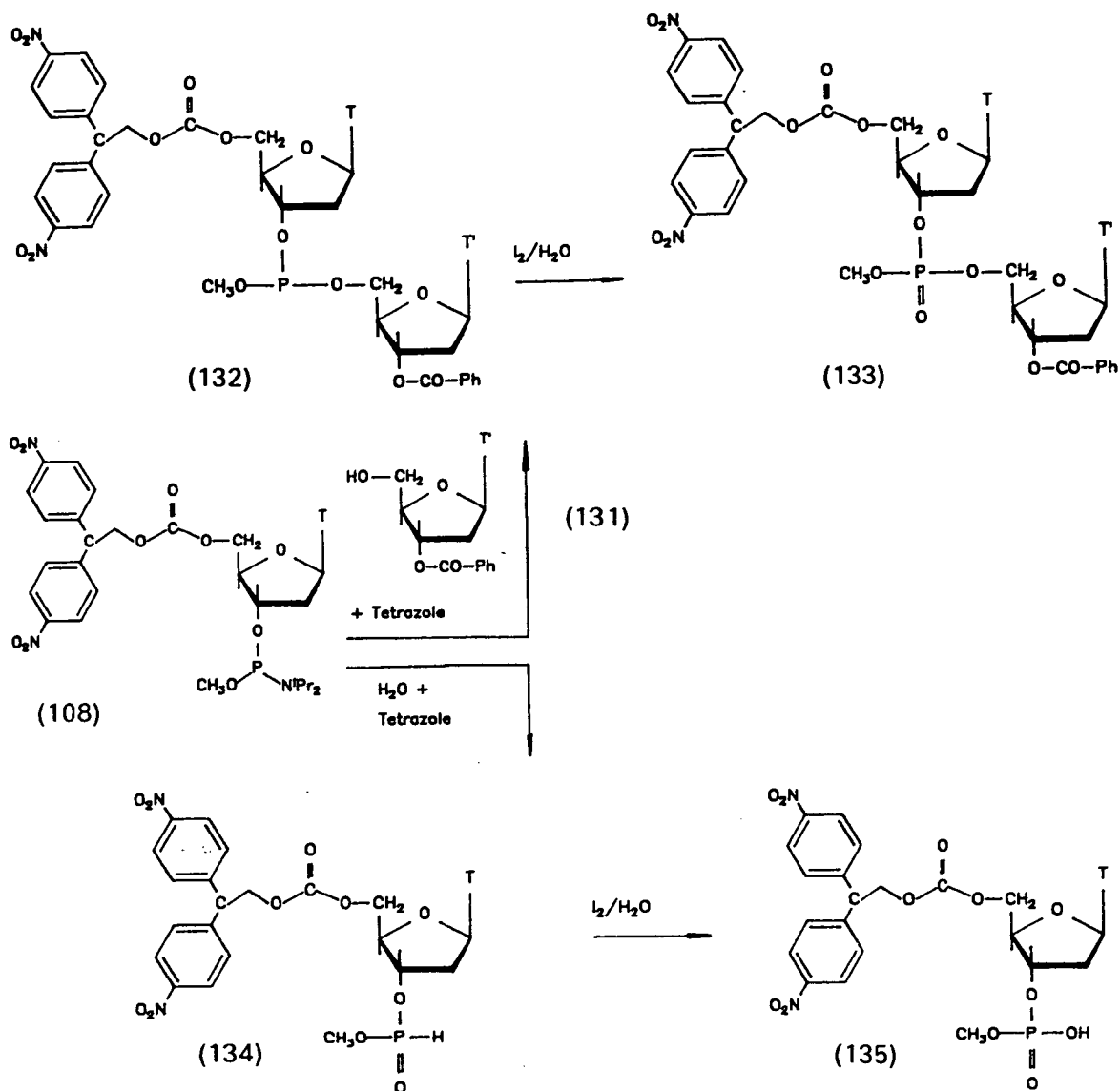
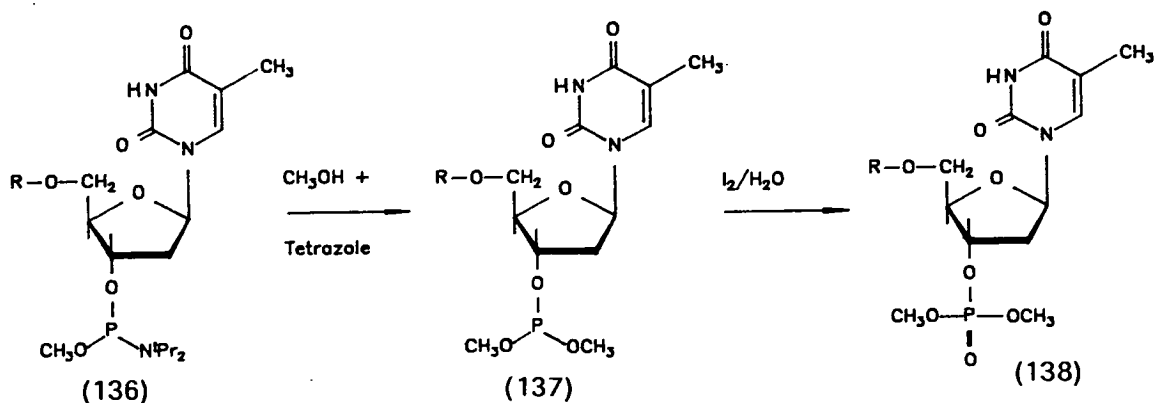

Fig.2.14 Phosphoramidite Coupling Reactions

The next coupling reactions to be tried were those between a series of *N,N*-diisopropyl methylphosphoramidites and methanol. The phosphoramidites were protected with either DMTr, Fmoc or Bnpeoc on the 5'-hydroxyl group. It was decided to use these three different protecting groups to compare their effect, if any, on the coupling and oxidation reactions, and methanol was chosen as it had previously been shown (see synthesis of 127) to couple to a phosphoramidite to form the dimethyl phosphate when oxidised. Each of the

reactions was performed using deuterated acetonitrile as solvent and the  $^{31}\text{P}$  n.m.r. spectrum was recorded on (i), the starting material, (ii), the reaction product with methanol and tetrazole, and (iii), the products after oxidation with iodine and water. During the coupling step it was important that no water was present in the reaction and so the methanol was distilled from magnesium methoxide and the deuterated acetonitrile was obtained from freshly opened vials. The reaction scheme is shown in fig.2.15.



a, R=Bnpeoc

b, R=Fmoc

c, R=DMTr

Fig.2.15 The Coupling of a Phosphoramidite with Methanol

The major peaks observed at each of these stages are shown in table 1, all the spectra were recorded over a spectral width of 20,000 Hz.

Table 1

Compound	$\delta_{\text{P}}$ (36 MHz, CD <sub>3</sub> CN)		
	(a)	(b)	(c)
136	149.0	149.0	148.6
137	140.4	140.3	140.1
138	-0.4,-1.5	-0.5,-1.4	0.9,-0.5,-1.3

The chemical shifts of all three phosphoramidites 136 are, as would be

expected, very similar and the reaction with methanol to form the dimethyl phosphites **137** also leads to compounds with very little difference in their chemical shifts. When these compounds are oxidised with iodine and water in each case at least two products are observed. The peak at 0.9 ppm in the case of **138c** is a minor peak by comparison with the other two.

In order to investigate these products further the spectrum of reaction **138a** was recorded over a spectral width of 2,000 Hz, thus allowing better resolution of the peaks. This spectrum showed two peaks as previously, at -0.4 ppm the peak was very sharp but at -1.5 ppm a very broad peak was observed. The same process was applied to reaction **138b** and again a sharp peak at -0.5 ppm and a very broad peak at -1.4 ppm were observed. When the spectrum of reaction **138c** was recorded over 2,000 Hz four peaks were seen. The one at -0.5 ppm was sharp and the one at -1.3 ppm was broad. These two peaks are similar in chemical shift to those observed in **138a** and **138b**. The two other peaks in **138c** consisted of a small, sharp peak at 1.6 ppm and a broad peak at 0.9 ppm.

In an attempt to assign each of these peaks a proton coupled spectrum of **138c** was recorded over 1,000 Hz on a 81 MHz spectrometer. The two narrow peaks were so small as to be barely visible when coupled, the one at 1.6 ppm showing a small multiplet. The broad peaks were much more intense, the one at 0.9 ppm showed a triplet (which was probably an overlapping doublet of quartets as small side peaks were also observed), the coupling constant being 11 Hz. The peak at -1.3 ppm showed a less well defined triplet (the triplet was probably a doublet of doublets), see appendix 3.

The final set of spectra to be obtained from **138c** were decoupled variable temperature spectra ranging from +60°C to -7°C. At +60°C the signals

appeared as sharp peaks, at +40°C the two major peaks (0.9 ppm and -1.3 ppm) began to get broader, and at +25°C the major peaks became very broad and remained thus at +9°C and -7°C. Throughout this temperature variation the minor peaks (1.6 ppm and -0.5 ppm) remained well defined.

These results suggest that where DMTr, Fmoc and Bnpeoc are used as 5'-hydroxyl protecting groups the reaction of methanol with the phosphoramidite, and the subsequent oxidation, result in several products, the side-reactions taking place during the oxidation step. In the cases where Fmoc and Bnpeoc are used two peaks are observed after the oxidation step, the broad one suggesting a sterically hindered molecule such as the required product which has a nucleoside and two methyl groups attached to the phosphorus, and the sharp peak which may be the result of the nucleoside being cleaved from the phosphate to give dimethyl phosphate. The results can be compared with those obtained from the coupled and variable temperature spectra of reaction 138c where DMTr was used for 5'-hydroxyl protection. The variable temperature experiments suggest that the two broad peaks are the result of the phosphorus being attached to a bulky molecule and the proton coupled spectrum suggests that each broad peak also has a methyl group attached to the phosphorus. As both the required product and the product with one of the methyl groups cleaved and replaced by a proton would give similar proton coupled  $^{31}\text{P}$  n.m.r. spectra it is not possible to determine which peak belongs to which compound. Comparison with the Bnpeoc and Fmoc experiments suggest that if the required product is formed in these experiments then by comparing the chemical shifts the peak at -1.3 ppm is the product. The two narrow peaks are probably due to the nucleoside being cleaved from the phosphate function, and in one case a methyl group is also cleaved, to give methyl and dimethyl phosphate.

From these studies one may conclude that the oxidation of a phosphite to a phosphate by iodine and water can result in the cleavage of one or more groups from the phosphate. These reactions were performed in solution phase with methanol as the nucleophile but it is probable that when a nucleoside is used similar cleavage products will result, and this will cause a reduction in the yield of the oligonucleotide being synthesized.

## 2.10. Base Protection by Bnpeoc

A wide range of groups have been developed for the protection of the heterocyclic bases during oligonucleotide synthesis. One such group, the *p*-nitrophenylethyl group, has been used for the protection of all the bases by Pfeleiderer *et al.*<sup>111</sup> but was found to be more stable to the deprotection reagent, DBU, than was required. The 2,2-*bis* (4-nitrophenyl)ethyl group is more labile towards DBU and it should be possible to introduce the group in the same manner as the *p*-nitrophenylethyl group.

The first objective was protection of the O<sup>4</sup> function of thymidine. Pfeleiderer performed this using the iodide derivative of his protecting group and so 2,2-*bis* (4-nitrophenyl)ethyl iodide was prepared by the scheme shown in fig.2.16.

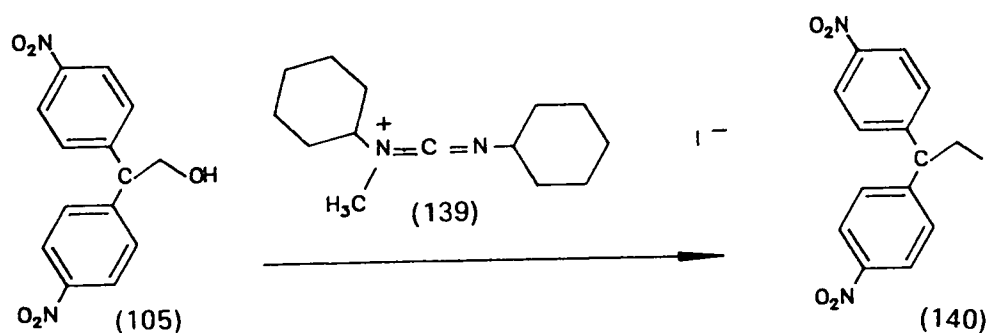

Fig.2.16 Preparation of Bnpe I

2,2-*bis* (4-nitrophenyl)ethanol 105 was reacted with N-methyl-



*N,N*-dicyclohexylcarbodiimidium iodide **139** to give *2,2-bis* (4-nitrophenyl)ethyl iodide **140** in good yield. Previous attempts to produce this compound by reaction of *Bnpe* Cl<sup>126</sup> with sodium iodide in DMF, and reaction of *Bnpe* Br<sup>126</sup> with magnesium to generate the Grignard reagent then reaction with iodine resulted in a mixture of the starting material (*Bnpe* Cl or Br), the product **140** and *1,1-bis* (4-nitrophenyl)ethene. The required compound could not be separated by chromatography or crystallisation from these mixtures but was shown to be present by <sup>1</sup>H n.m.r.

Pfleiderer formed O<sup>4</sup>-*p*-nitrophenylethyl-3'-O-benzoyl-5'-O-MMTr-thymidine by reacting the 5',3'-protected nucleoside with *p*-nitrophenylethyl iodide in the presence of silver carbonate in an S<sub>N</sub>1 alkylation reaction. When a similar reaction was tried using *Bnpe* I only starting material could be isolated.

With the disappointing results obtained using thymidine it was decided to try to protect a different base and 2'-deoxyadenosine was chosen. The 5'- and 3'-hydroxyls were protected by Markiewicz's<sup>95</sup> bifunctional protecting group to give 3',5'-(tetraisopropylidisiloxane-1,3-diyl)-2'-deoxyadenosine **141**. This was then reacted with 1-methyl-3-[*2,2-bis* (4-nitrophenyl)ethoxycarbonyl]imidazolium chloride **142** to form the N<sup>6</sup>-protected 2'-deoxyadenosine **143** as shown in fig.2.17.

The reaction gave the required product in low yield and insufficient material was obtained for deprotection studies. Due to the difficulties in obtaining *Bnpeoc*-protected nucleoside bases and the existence of acceptable alternatives in the form of the benzoyl, anisoyl and isobutyryl groups it was decided not to pursue this area of research any further.

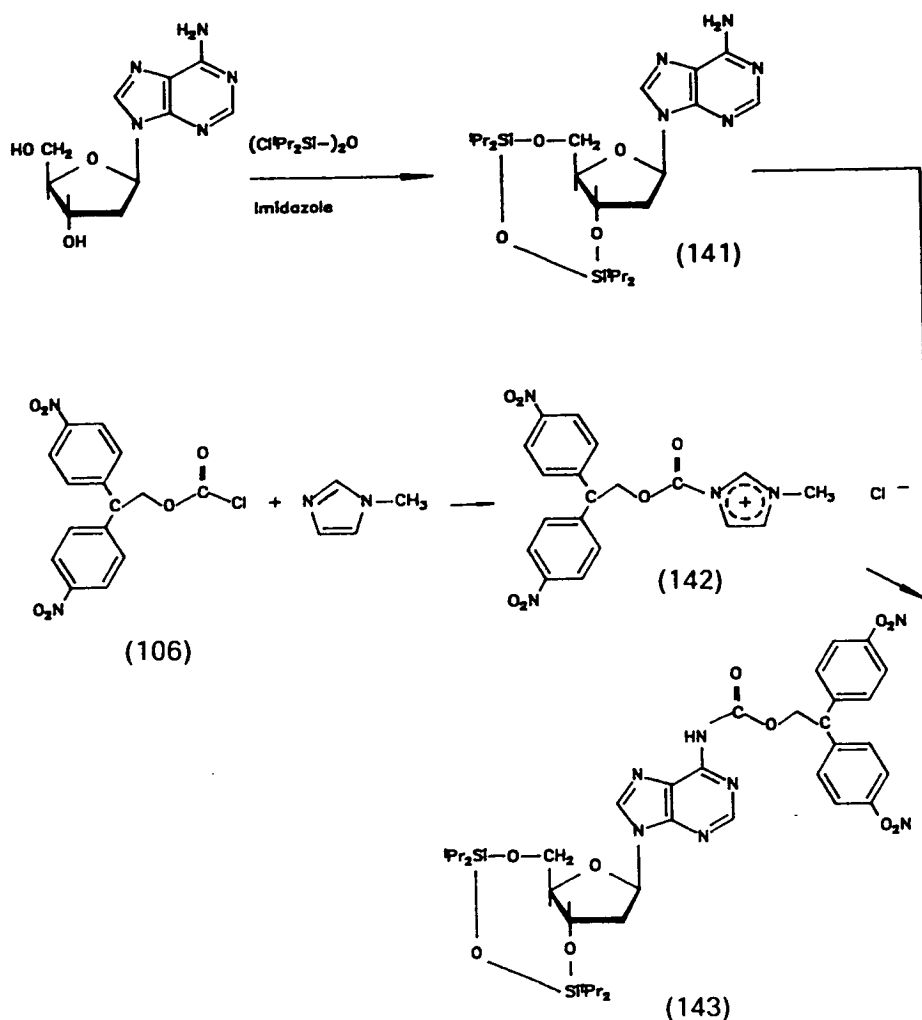

Fig.2.17 Protection of 2'-dA at N<sup>6</sup> with the Bnpeoc Group

### 2.11. Use of Zinc Iodide in Phosphotriester Synthesis

When the phosphotriester method is used for oligonucleotide synthesis an accelerating agent is often used to decrease the time required for each coupling step. The agent generally used is 1-methylimidazole<sup>51</sup>.

In peptide synthesis zinc iodide has been shown to increase the speed of coupling of amino acids<sup>129</sup> and so its use in oligonucleotide synthesis was also investigated.

The use of zinc iodide as a possible accelerating agent in phosphotriester synthesis was explored by studying the coupling times for triethylammonium (5'-O-DMTr-thymidine-3'-O-2-chlorophenyl phosphate) **144** with  $\beta$ -cyanoethanol. This reaction forms a nucleotide **146** from which the 5'-DMTr group can be deprotected and the nucleotide is then able to be coupled to another molecule of the starting material **144**.

The reaction was first performed using tlc as a monitoring system but this failed to show the coupling reaction clearly. Instead it was decided to use  $^{31}\text{P}$  n.m.r. to follow the reaction. A series of three experiments were performed: (i), the coupling of the phosphotriester with  $\beta$ -cyanoethanol using MSNT as the coupling agent; (ii), the same but with the addition of 1-methylimidazole as an accelerating agent; and (iii), the coupling with the addition of zinc iodide to compare its effect on the speed of the coupling step. The reactions were initially performed at room temperature but this resulted in reaction rates which were too fast to measure using the n.m.r. technique so the spectra were recorded at a temperature of  $-30^\circ\text{C}$ .

The results obtained can be seen in tables 4 and 5 in the experimental section, and the reaction is shown in fig.2.18.

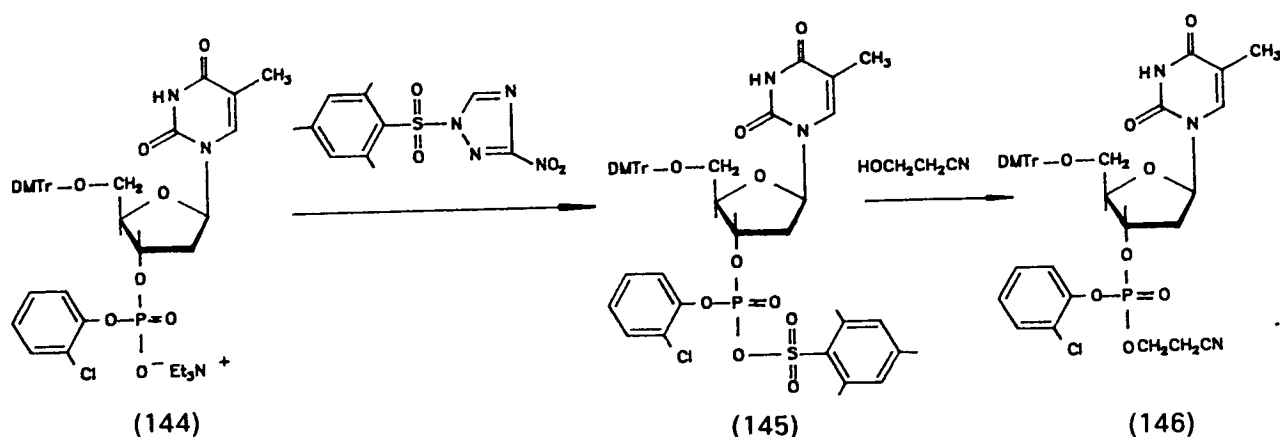

Fig.2.18 Coupling of a phosphate to  $\beta$ -Cyanoethanol

These three compounds gave different chemical shifts using  $^{31}\text{P}$  n.m.r. and so the ratio of product **146** to intermediate **145** could be determined. If water was present in the reaction compound **145** would be converted back to **144** so an excess of MSNT was used to ensure the triethylammonium phosphate **144** remained activated.

When the reaction was performed under the conditions described with MSNT but no accelerating agent it took 31 min. for all compound **145** to be converted to either the product **146**, or the starting material **144**. The reformation of the starting material was probably due to there being insufficient MSNT present. This reaction was repeated adding 1-methylimidazole with the  $\beta$ -cyanoethanol and this gave a reaction time of less than 50 seconds. When zinc iodide was added as an accelerating agent the reaction followed the same pattern as the first reaction and its presence did not result in an increased coupling rate.

The systematic uncritical use of zinc iodide in oligonucleotide synthesis could not be proposed in any event as some loss of DMTr protecting groups, which is already known to occur with zinc bromide<sup>125</sup>, may be expected.

## 2.12. Conclusions

The principle objective of this research has been the introduction of the Bnpeoc protection strategy (recently established in peptide synthesis) into DNA synthesis. This required the preparation of site-specifically protected monomers which was achieved in adequate yield. Following solution studies, these monomers were applied to the automated solid phase method to produce several model nucleotides. However the overall yields in comparison with Fmoc and other protecting group strategies were poor; the underlying chemical nature of Bnpeoc (its greater stability to bases relative to Fmoc, its greater

steric bulk *etc.*) is presumed to be responsible for this. Modifications to the synthetic protocol, such as extending reaction times and moving to dipolar aprotic solvents have been shown to compensate partially for these drawbacks, but more work would be required to reach the level of commercial viability.

Studies of the oxidation step in phosphite-triester synthesis showed that cleavage of protecting groups and nucleosides from phosphorus occurs under the conditions generally employed and although solid phase synthesis may not be affected by these side-reactions any large scale solution phase synthesis almost certainly will be.

## CHAPTER 3

## EXPERIMENTAL

**3.1. Notes**

The melting points were obtained using a Reichert 7905 hot plate and are quoted without correction. Thin layer chromatography was performed using silica gel coated plastic sheets, 60F<sub>254</sub> (Merck) and the solvent systems used were: (A) 10% methanol/ 90% methylene chloride, (B) 50% ethyl acetate/ 50% methylene chloride, (C) 30% ethyl acetate/ 70% toluene, and (D) 40% ethyl acetate/ 60% 40–60°C petroleum ether. The compounds were visualised by u.v. absorption at 254nm and potassium permanganate spray, or where applicable, HCl spray to indicate the position of the dimethoxytrityl containing compounds, or anisaldehyde spray (in acidic ethanol) to reveal sugar containing compounds. Infra-red spectra were measured on a Perkin Elmer 781 spectrometer as a bromoform mull or methylene chloride solution. Ultraviolet spectra were obtained using a Varian Cary 210 spectrometer with distilled acetonitrile as a solvent. Proton N.M.R. spectra were produced using a Bruker WP200 operating at 200MHz or a Perkin Elmer R32 operating at 80MHz, both using tetramethylsilane as a reference. <sup>13</sup>Carbon N.M.R. spectra were recorded on a Bruker WP200 operating at 50MHz or a Bruker WH360 operating at 90MHz. <sup>31</sup>Phosphorus N.M.R. spectra were recorded on a Jeol FX90 operating at 36MHz or a Bruker WP200 operating at 81MHz, both using phosphoric acid as a reference. Mass spectra, both low and high resolution were obtained using a fast atom bombardment (FAB) technique on a Kratos MS50TC, using thioglycerol as a solvent. High performance liquid chromatography (HPLC) analysis was performed on Gilson and Perkin Elmer systems using various reverse phase and ion exchange columns with solvents and gradients as shown below:

**Reverse Phase Systems**Solvent A: 0.1M NH<sub>4</sub>OAc in 100% H<sub>2</sub>OSolvent B: 0.1M NH<sub>4</sub>OAc in 20% CH<sub>3</sub>CN/ 80%H<sub>2</sub>O

<b>System A</b>	
<u>time (min)</u>	<u>%B</u>
0.0	0.0
3.0	0.0
4.0	12.0
25.0	50.0
26.0	100.0
30.0	100.0
32.0	0.0
40.0	0.0

<b>System B</b>	
<u>time (min)</u>	<u>%B</u>
0.0	0.0
33.0	100.0
35.0	100.0
36.0	0.0
40.0	0.0

<b>System D</b>	
<u>time (min)</u>	<u>%B</u>
0.0	0.0
3.0	0.0
4.0	5.0
24.0	45.0
26.0	100.0
28.0	100.0
30.0	0.0

<b>System E</b>	
<u>time (min)</u>	<u>%B</u>
0.0	0.0
3.0	0.0
4.0	20.0
24.0	80.0
26.0	100.0
28.0	100.0
30.0	0.0

<b>System G</b>	
<u>time (min)</u>	<u>%B</u>
0.0	15.0
25.0	100.0
27.0	100.0
30.0	15.0
37.0	15.0

**Ion-exchange Systems**

Solvent A: 0.029M  $\text{KH}_2\text{PO}_4$  in 20%  $\text{CH}_3\text{CN}$ / 80%  $\text{H}_2\text{O}$  pH=6.4

Solvent B: 0.66M  $\text{KH}_2\text{PO}_4$  in 20%  $\text{CH}_3\text{CN}$ / 80%  $\text{H}_2\text{O}$  pH=6.4

<b>System C</b>		<b>System F</b>	
<u>time (min)</u>	<u>%B</u>	<u>time (min)</u>	<u>%B</u>
0.0	10.0	0.0	0.0
2.0	10.0	2.0	0.0
22.0	100.0	22.0	15.0
23.0	100.0	25.0	100.0
26.0	100.0	27.0	0.0
30.0	10.0	35.0	0.0

All solvents were dried using the drying agents indicated and were distilled before use: methylene chloride (calcium hydride), tetrahydrofuran (sodium and benzophenone under  $\text{N}_2$ ), acetonitrile (calcium hydride), pyridine (potassium hydroxide), diethyl ether (sodium), hexane (molecular sieves type 4A), N,N-dimethylformamide (calcium hydride), toluene (phosphorus pentoxide), methanol (magnesium).



### 3.2. Experimental

#### Methyl Phosphodichloridite

##### (103) $\text{CH}_3\text{OPCl}_2$

Methanol (60.8 ml, 1.5 mol), (freshly distilled from Mg) was added dropwise over 2 hours to phosphorus trichloride (88 ml, 1.0 mol) with stirring at  $-20^\circ\text{C}$ , and vented through an air condenser and calcium chloride tube. The reaction was allowed to reach room temperature and left to de-gas overnight. The product was obtained by distillation using a Vigreux column. The fraction boiling at  $90-91^\circ\text{C}$  was collected and redistilled to give the required product as a colourless liquid, (22.75g, 17%); b.p.  $91-92^\circ\text{C}$  (lit  $91.5^\circ\text{C}$ )<sup>130</sup>;  $\delta_{\text{H}}$  (80 MHz,  $\text{CDCl}_3$ ) 3.88 (3H, d,  $\text{CH}_3\text{O}$ ,  $J_{\text{P-O-CH}}$  10.2 Hz);  $\delta_{\text{P}}$  (80 MHz,  $\text{CDCl}_3$ ) 182.3.

#### N,N-Diisopropylmethylphosphonamidyl chloride

##### (104) $\text{CH}_3\text{OP}(\text{Cl})\text{N}^i\text{Pr}_2$

N,N-Diisopropylamine (48 ml, 0.34 mol), (distilled from  $\text{CaH}_2$ ) was added dropwise to a solution methyl phosphodichloridite (103) (16.2 ml, 0.17 mol) stirring in 60 ml of methylene chloride at  $-10^\circ\text{C}$  under argon over 30 min. The reaction was allowed to reach room temperature and then filtered to remove the diisopropylamine hydrochloride. After evaporation of the methylene chloride *in vacuo* and a further filtration the required product was obtained by distillation under reduced pressure as a colourless liquid (12.4g, 37%); b.p.  $84^\circ\text{C}/12\text{mmHg}$  (lit.  $35-36^\circ\text{C}/0.02\text{mmHg}$ )<sup>60</sup>;  $\delta_{\text{H}}$  (81 MHz,  $\text{CDCl}_3$ ) 1.20 (12H, d,  $\text{CH}_3$ ,  $J_{\text{H-C-CH}}$  6.8 Hz), 3.56 (3H, d,  $\text{CH}_3\text{O}$ ,  $J_{\text{P-O-CH}}$  14.1 Hz), 3.80 (2H, m,  $^i\text{Pr CH}_2$ );  $\delta_{\text{P}}$  (80 MHz,  $\text{CDCl}_3$ ) 184.7.

**2,2-Bis (4-nitrophenyl)ethyl chloroformate****(106) BnpeocCl**

The compound was prepared by the method of Florence<sup>126</sup>

2,2-Bis (4-nitrophenyl)ethanol (10.24g, 35.6 mmol) was dissolved in 120 ml of methylene chloride and phosgene (20% solution in toluene), (29.0 ml, 53.3 mmol) was added followed by the addition of N-methylmorpholine (3.92 ml, 35.6 mmol) over 20 minutes. After an hour the solution was filtered to remove the N-methylmorpholine hydrochloride and the solvent was evaporated *in vacuo*. The residue was dissolved in 100 ml of dioxan and the remaining N-methylmorpholine hydrochloride was filtered off. The solvent was evaporated *in vacuo* to give a yellow oil which was crystallised from diethyl ether and chloroform to give the required compound as a white solid, (10.25g, 82%); mp 94–95°C;  $\nu_{\max}$  (bromoform mull) 1775 (C=O), 1595–1610 (aromatic C–C), 1520 and 1350  $\text{cm}^{-1}$  (NO<sub>2</sub>);  $\delta_{\text{H}}$  (80 MHz, CDCl<sub>3</sub>), 4.7–4.9 (3H, m, bnpe  $\beta$ -CH and  $\alpha$ -CH<sub>2</sub>), 7.39 (4H, d,  $J_{\text{AB}}$  8.8 Hz, bnpe aromatic CH's), 8.21 (4H, d,  $J_{\text{AB}}$  8.8 Hz, bnpe aromatic CH's);  $\delta_{\text{C}}$  (50 MHz, CDCl<sub>3</sub>), 48.9 (bnpe  $\beta$ -C), 71.7 (bnpe  $\alpha$ -C), 124.1 (aromatic 3'-C), 129.0 (aromatic 2'-C), 145.5 (aromatic 4'-C), 147.3 (aromatic 1'-C), 150.5 (C=O).

**5'-O-[2,2-Bis (4-nitrophenyl)ethoxycarbonyl]-thymidine****(107) 5'-O-Bnpeoc-T**

Thymidine (1.24g, 5.14 mmol) was co-evaporated twice with dry pyridine and then dissolved in 20 ml of pyridine. 2,2-Bis (4-nitrophenyl)ethyl chloroformate (106) (2.16g, 6.17 mmol) and N,N-dimethylaminopyridine (0.063g, 0.51 mmol) were added and the reaction was stirred at room temperature for 24 hours. The pyridine was removed *in vacuo* and the residue was dissolved in

methylene chloride (50 ml) and washed with water (2x50 ml) and brine (2x50 ml). The solution was dried over sodium sulphate, filtered, and the solvent was removed *in vacuo* to produce a yellow foam which was purified using dry flash chromatography, eluting with 0–10% methanol in methylene chloride, to give the **title compound** as a yellow foam (0.615g, 64%); softening point 103–108°C; tlc  $R_{f(A)}$  0.4;  $\nu_{\max}$  (bromoform mull) 3700–2500 (N–H and O–H), 1745 (C=O), 1575 and 1405  $\text{cm}^{-1}$  ( $\text{NO}_2$ );  $\lambda_{\max}$  ( $\text{CH}_3\text{CN}$ ) 271 nm,  $\epsilon_{\max}$  21000;  $\delta_{\text{H}}$  (200 MHz,  $d_6$ -acetone) 1.73 (3H, s,  $\text{CH}_3$ ), 2.03 (1H, m, 2'–H), 2.23 (1H, m, 2'–H), 3.02 (1H, s, 3'–OH), 4.06 (1H, m, 4'–H), 4.37 (2H, m, 5'–H), 4.70 (1H, m, 3'–H), 4.92 (3H, s, bnpe  $\beta$ -CH and  $\alpha$ - $\text{CH}_2$ ), 6.30 (1H, t,  $J_{\text{AB}}$  6.8 Hz, 1'–H), 7.45 (1H, s, 6–H), 7.72 (4H, d,  $J_{\text{AB}}$  8.8 Hz, bnpe aromatic CH's), 8.22 (4H, d,  $J_{\text{AB}}$  8.8 Hz, bnpe aromatic CH's), 10.05 (1H, br.s, N–H);  $\delta_{\text{C}}$  (50 MHz,  $d_6$ -acetone) 10.8 (5- $\text{CH}_3$ ), 38.6 (2'–C), 48.5 (bnpe  $\beta$ -C), 66.8 (bnpe  $\alpha$ -C), 67.9 (5'–C), 70.0 (3'–C), 83.2 and 84.0 (1'–C and 4'–C), 109.3 (5–C), 122.9 (bnpe 3–C), 128.7 (bnpe 2–C), 134.9 (6–C), 146.5 (bnpe 4–C), 149.6 (4–C), 153.7 (bnpe 1–C), 162.7 (2–C); m/z (FAB) 557 ( $\text{MH}^+$ ) 433; HRMS (FAB) found 557.15198 ( $\text{MH}^+$ ),  $\text{C}_{25}\text{H}_{25}\text{N}_4\text{O}_{11}$  requires 557.15197 (<1ppm).

**5'-O-[2,2-Bis (4-nitrophenyl)ethoxycarbonyl]-thymidine-3'-O-N,N-diisopropyl methyl phosphoramidite**

**(108) 5'-O-Bnpeoc-T-3'-O-N,N- $i$ Pr<sub>2</sub> Me phosphoramidite**

5'-O-[2,2-Bis (4-nitrophenyl)ethoxycarbonyl]-thymidine (**107**) (0.604g, 1.09 mmol) was co-evaporated twice from a 50:50 mixture of pyridine : methylene chloride and then closed with a septum pierced with a needle and placed in an evacuated desiccator overnight. The desiccator was then filled with argon and the flask removed. The nucleoside was dissolved in 4 ml of tetrahydrofuran and to the flask was attached an argon filled balloon allowing pressure equalisation on addition of reagents. N,N-diisopropylethylamine (0.76 ml, 4.4

mmol) and then *N,N*-diisopropylmethylphosphonamidyl chloride (**104**) (0.84 ml, 4.4 mmol) were added and the reaction stirred for 10 min. Methanol (0.13 ml, 3.3 mmol) was added to quench the excess phosphitylating agent and the reaction mixture was poured into 25 ml of argon-saturated ethyl acetate. This was washed with the following argon-saturated solutions: 2x20 ml water; 1x20 ml 10% aqueous sodium carbonate; 2x20 ml brine, then dried over sodium sulphate, (which was filtered off under argon), and the solvent removed *in vacuo* to produce a red/brown oil. This was dissolved in 4 ml of toluene and precipitated into 200 ml of hexane at  $-20^{\circ}\text{C}$ . The precipitate was filtered off and dried overnight in an evacuated desiccator to give the title compound as a pale grey solid (0.632g, 81%); mp  $84-90^{\circ}\text{C}$ ; tlc  $R_{f(B)}$  0.6;  $\nu_{\text{max}}$  (methylene chloride solution) 2960 (C-H), 1750 (C=O), 1595-1610 (aromatic C-C), 1525 and  $1350\text{ cm}^{-1}$  ( $\text{NO}_2$ );  $\delta_{\text{H}}$  (200 MHz,  $\text{CDCl}_3$ ) 1.1-1.2 (12H, m, <sup>i</sup>Pr  $\text{CH}_3$ ), 1.78 (3H, s, 5- $\text{CH}_3$ ), 2.15 (1H, m, 2'-H), 2.40 (1H, m, 2'-H), 3.33 (3H, d,  $J_{\text{P-O-CH}}$  13.3 Hz, - $\text{OCH}_3$ ), 3.5-3.6 (2H, m, <sup>i</sup>Pr CH), 4.16 (1H, m, 4'-H), 4.3 (3H, m, 5'-H and 3'-H), 4.6-4.7 (3H, m, bnpe  $\alpha\text{-CH}_2$  and  $\beta\text{-CH}$ ), 6.22 (1H, t,  $J_{\text{AB}}$  6.8 Hz, 1'-H), 7.20 (1H, s, 6-H), 7.39 (4H, d,  $J_{\text{AB}}$  8.7 Hz, bnpe aromatic H's), 8.19 (4H, d,  $J_{\text{AB}}$  8.8 Hz, bnpe aromatic H's), 10.77 (1H, s, N-H);  $\delta_{\text{C}}$  (50 MHz,  $\text{CD}_3\text{CN}$ ), 11.1 (5- $\text{CH}_3$ ), 23.3 (<sup>i</sup>Pr  $\text{CH}_3$ ), 37.8 (2'-C), 42.3 (d,  $J_{\text{COP}}$  12.3 Hz, - $\text{OCH}_3$ ), 48.6 (bnpe  $\beta\text{-C}$ ), 49.5 (d,  $J_{\text{CNP}}$  17.2 Hz, <sup>i</sup>Pr CH), 66.6 (bnpe  $\alpha\text{-C}$ ), 68.2 (5'-C), 72.0 (2d,  $J_{\text{COP}}$  17.7 Hz, 3'-C), 82.4 (2d,  $J_{\text{CCOP}}$  13.0 Hz, 4'-C), 84.3 (1'-C), 109.9 (5-C), 123.4 (bnpe aromatic 3-C), 128.9 (bnpe aromatic 2-C), 135.2 (6-C), 146.7 (bnpe aromatic 4-C), 149.9 (4-C), 153.9 (bnpe aromatic 1-C), 163.2 (2-C);  $\delta_{\text{P}}$  (81 MHz,  $\text{CDCl}_3$ ), 150.6 and 150.3; m/z (FAB) 718 ( $\text{MH}^+$ ) 734 and 539; HRMS (FAB) found 718.24889 ( $\text{MH}^+$ ),  $\text{C}_{32}\text{H}_{41}\text{N}_5\text{O}_{12}\text{P}$  requires 718.24891 (<1ppm).

**2,2-Bis (4-nitrophenyl)ethyl benzyl carbonate****(111) BnpeocOBz**

2,2-Bis (4-nitrophenyl)ethyl chloroformate (**106**) (1.23g, 3.5 mmol) was dissolved in 10 ml of pyridine. Benzyl alcohol (0.36 ml, 3.5 mmol) and N,N-dimethylaminopyridine (0.021g, 0.18 mmol) were added and the reaction was stirred for 24 hours. The solution was poured into 20 ml of water and extracted with 3x15 ml of methylene chloride. The combined organic extracts were washed with 2x20 ml water, 2x20 ml brine, dried over sodium sulphate and the solvent removed *in vacua*. The remaining oil was purified by flash chromatography, eluting with 0-2% methanol in methylene chloride to give a white solid which was further purified by recrystallisation from chloroform to give the title compound as a white solid (0.49g, 33%); mp 198-200°C; tlc  $R_{f(C)}$  0.6;  $\nu_{max}$  (bromoform mull) 1750 (C=O), 1595-1610 (aromatic C-C), 1520 and 1350 (NO<sub>2</sub>), 860,740 cm<sup>-1</sup> (aromatic C-H);  $\lambda_{max}$  (CH<sub>3</sub>CN) 275 nm,  $\epsilon_{max}$  34000;  $\delta_H$  (80 MHz, CDCl<sub>3</sub>) 4.6 (5H, m, bnpe  $\alpha$ -CH<sub>2</sub>,  $\beta$ -CH and benzyl CH<sub>2</sub>), 7.33 (4H, d,  $J_{AB}$  8.8 Hz, bnpe aromatic C-H's), 7.33 (5H, m, benzyl aromatic C-H's), 8.16 (4H, d,  $J_{AB}$  8.7 Hz, bnpe aromatic C-H's).

**N<sup>3</sup>-Anisoyl-thymidine****(114) N<sup>3</sup>-An-T**

Thymidine (1.08g, 4.45 mmol) was co-evaporated twice with pyridine and then dissolved in 15 ml of pyridine. Trimethylsilyl chloride (5.65 ml, 44.5 mmol) was added and after 30 min. the excess was removed *in vacuo* and anisoyl chloride (2.28g, 13.4 mmol) was added. After stirring for 3 days, 20 ml of water was added and the reaction was stirred for 1 hour to remove the trimethylsilyl groups and then the solvents were removed *in vacua*. The residue was

dissolved in 100 ml of methylene chloride and washed with 2x100 ml of 0.1M aqueous triethylammonium bicarbonate, 1x100 ml water, 1x100 ml brine, dried over sodium sulphate and the methylene chloride removed *in vacuo* to give a pale brown oily solid. This was purified by dry flash chromatography, eluting with 0–5% methanol in methylene chloride to produce the required product as a white foam, (0.61g, 37%); softening point 73–78°C; tlc  $R_{f(A)}$  0.4;  $\nu_{\max}$  (bromoform mull) 3700–3100 (OH), 2940 (aliphatic C–H), 1740 (C=O), 1700 and 1650 (thymidine C=O's), 1600, 1520 and 1430 (aromatic C–C), 860–750  $\text{cm}^{-1}$  (aromatic C–H);  $\lambda_{\max}$  ( $\text{CH}_3\text{CN}$ ) 257 nm,  $\epsilon_{\max}$  18000;  $\delta_{\text{H}}$  (200 MHz,  $\text{CDCl}_3$ ) 1.85 (3H, s, 5- $\text{CH}_3$ ), 2.20 (2H, s, 2'-H), 3.7 (3H, m, 4'-H and 5'-H's), 3.79 (3H, s, - $\text{OCH}_3$ ), 3.86 (2H, m, 3'-H and 5'-OH), 4.35 (1H, s, 3'-OH), 6.15 (1H, t,  $J_{\text{AB}}$  6.3 Hz, 1'-H), 6.90 (2H, d,  $J_{\text{AB}}$  8.9 Hz, anisoyl aromatic C-H's), 7.64 (1H, s, 6-H), 7.82 (2H, d,  $J_{\text{AB}}$  8.8 Hz, anisoyl aromatic C-H's);  $\delta_{\text{C}}$  (50 MHz,  $\text{CDCl}_3$ ) 12.3 (5- $\text{CH}_3$ ), 39.8 (2'-C), 55.6 (- $\text{OCH}_3$ ), 61.9 (5'-C), 70.9 (3'-C), 85.7 (4'-C), 87.0 (1'-C), 110.7 (5-C), 114.5 (anisoyl aromatic 3- and 5-C), 123.6 (anisoyl aromatic 1-C), 133.0 (anisoyl aromatic 2- and 6-C), 136.6 (6-C), 149.4 (4-C), 163.0 (2-C), 165.3 (anisoyl aromatic 4-C), 168.0 (C=O); m/z (FAB) 377 ( $\text{MH}^+$ ) 261 251; HRMS (FAB) found 377.13487,  $\text{C}_{18}\text{H}_{21}\text{N}_2\text{O}_7$  requires 377.13486 (<1ppm).

### 5'-O-[2,2-Bis (4-nitrophenyl)ethoxycarbonyl]-N<sup>3</sup>-anisoyl-thymidine

#### (115) 5'-O-Bnpeoc-N<sup>3</sup>-An-T

N<sup>3</sup>-Anisoyl-thymidine (114) (0.381g, 1.01 mmol) was co-evaporated twice with pyridine and then dissolved in 2 ml of pyridine. 2,2-Bis (4-nitrophenyl)ethyl chloroformate (106) (0.448g, 1.28 mmol) was added and the reaction was stirred for 24 hours. The solvent was evaporated *in vacuo* and the residue was dissolved in 50 ml of methylene chloride and washed with 2x50 ml water, 2x50 ml brine, dried over sodium sulphate, and the methylene

chloride was evaporated *in vacuo* to yield a yellow oil. This was purified using dry flash chromatography, eluting with 0–2% methanol in methylene chloride to give the title compound as a pale yellow foam, (0.390g, 56%); softening point 110–114°C; tlc  $R_{f(A)}$  0.7;  $\nu_{\max}$  (bromoform mull) 3700–3300 (OH), 2960 (aliphatic C–H), 1745 (bnpe C=O), 1660 (amide C=O), 1605, 1510 and 1450 (aromatic C–C), 1520 and 1350 (NO<sub>2</sub>), 870–750 cm<sup>-1</sup> (aromatic (C–H));  $\lambda_{\max}$  277 nm,  $\epsilon_{\max}$  26000;  $\delta_{\text{H}}$  (200 MHz, CDCl<sub>3</sub>) 1.79 (3H, s, 5-CH<sub>3</sub>), 2.12 (1H, m, 2'-H), 2.25 (1H, m, 2'-H), 2.95 (1H, br.s, 3'-OH), 3.82 (3H, s, -OCH<sub>3</sub>), 4.00 (1H, m, 4'-H), 4.30 (3H, s, 3'-H and 5'-H's), 4.58–4.77 (3H, m, bnpe  $\alpha$ -CH<sub>2</sub> and  $\beta$ -CH), 6.17 (1H, t,  $J_{\text{AB}}$  6.4 Hz, 1'-H), 6.89 (2H, d,  $J_{\text{AB}}$  9.0 Hz, anisoyl aromatic H's), 7.33 (1H, s, 6-H), 7.39 (4H, d,  $J_{\text{AB}}$  8.8 Hz, bnpe aromatic H's), 7.81 (2H, d,  $J_{\text{AB}}$  8.9 Hz, anisoyl aromatic H's), 8.14 (4H, d,  $J_{\text{AB}}$  8.7 Hz, bnpe aromatic H's);  $\delta_{\text{C}}$  (50 MHz, CDCl<sub>3</sub>) 12.4 (5-CH<sub>3</sub>), 40.0 (2'-C), 49.3 (bnpe  $\beta$ -C), 55.6 (-OCH<sub>3</sub>), 67.2 (bnpe  $\alpha$ -C), 68.7 (5'-C), 70.6 (3'-C), 83.4 (4'-C), 85.4 (1'-C), 110.8 (5-C), 113.9 (anisoyl 3- and 5-C), 123.7 (anisoyl 1-C), 124.0 (bnpe 3- and 5-C), 129.0 (bnpe 2- and 6-C), 132.9 (anisoyl 2- and 6-C), 135.4 (6-C), 147.1 (bnpe 4-C), 149.2 (4-C), 154.4 (bnpe 1-C), 162.7 (2-C), 165.2 (anisoyl 4-C), 167.7 (anisoyl amide C=O); m/z (FAB) 691 (MH<sup>+</sup>); HRMS (FAB) found 691.18875 (MH<sup>+</sup>), C<sub>33</sub>H<sub>31</sub>N<sub>4</sub>O<sub>13</sub> requires 691.18874 (<1ppm).

**5'-O-[2,2-Bis (4-nitrophenyl)ethoxycarbonyl]-N<sup>3</sup>-anisoyl-thymidine-3'-N,N-diisopropyl methyl phosphoramidite**

**(116) 5'-O-Bnpeoc-N<sup>3</sup>-T-3'-N,N-<sup>i</sup>Pr<sub>2</sub>Me phosphoramidite**

5'-O-[2,2-Bis (4-nitrophenyl)ethoxycarbonyl]-N<sup>3</sup>-anisoyl-thymidine (115) (0.310g, 0.449 mmol) was co-evaporated twice with pyridine and then placed in an evacuated desiccator, closed with a septum pierced with a needle, and left in an evacuated desiccator overnight. The desiccator was then filled with argon and the needle removed. The nucleoside was dissolved in 2 ml of

tetrahydrofuran and an argon filled balloon was attached to the flask. N,N-Diisopropylamine (0.31 ml, 1.8 mmol) and then N,N-diisopropyl methylphosphonamidyl chloride (**104**) (0.35 ml, 1.80 mmol) were added and the reaction was stirred for 10 min. during which the solution turned from yellow to pale brown. Methanol (0.05 ml, 1.3 mmol) was added to quench the excess phosphitylating agent and the reaction was poured into 25 ml of argon saturated ethyl acetate. This was then washed with the following argon saturated solutions: 2x20 ml water; 2x20 ml saturated aqueous sodium carbonate; 1x20 ml brine, and dried over sodium sulphate which was filtered off under argon. The solvent was removed *in vacuo* and the resulting brown oil was dissolved in 4 ml of toluene and precipitated into 200 ml of hexane at  $-20^{\circ}\text{C}$ . The precipitate was filtered off and dried in an evacuated desiccator to give the title compound as a white solid, (0.301g, 79%); softening point  $98-106^{\circ}\text{C}$ ; tlc  $R_{f(B)}$  0.7;  $\nu_{\text{max}}$  (bromoform mull) 2980 (alkyl C-H), 1750 (bnpe C=O), 1660 (anisoyl C=O), 1605, 1310 and 1450 (aromatic C-C), 1520 and 1350 ( $\text{NO}_2$ ),  $870-740\text{ cm}^{-1}$  (aromatic C-H);  $\delta_{\text{H}}$  (200 MHz,  $\text{CDCl}_3$ ) 1.13 (12H, m,  $^i\text{Pr CH}_3$ ), 1.82 (3H, s, 5- $\text{CH}_3$ ), 2.21 (1H, m, 2'-H), 2.45 (1H, m, 2'-H), 3.32 (3H, d,  $J_{\text{COP}}$  13.3 Hz, P-O- $\text{CH}_3$ ), 3.53 (2H, m,  $^i\text{Pr}_2\text{ CH}$ ), 3.84 (3H, s, anisoyl  $\text{CH}_3$ ), 4.17 (1H, m, 4'-H), 4.36 (3H, m, 5'-H's and 3'-H), 4.73 (3H, m, bnpe  $\alpha\text{-CH}_2$  and  $\beta\text{-CH}$ ), 6.22 (1H, t,  $J_{\text{AB}}$  6.4 Hz, 1'-H), 6.91 (2H, d,  $J_{\text{AB}}$  8.9 Hz, anisoyl aromatic H's), 7.30 (1H, s, 6-H), 7.40 (4H, d,  $J_{\text{AB}}$  8.7 Hz, bnpe aromatic H's), 7.84 (2H, d,  $J_{\text{AB}}$  8.9 Hz, anisoyl aromatic H's), 8.18 (4H, d,  $J_{\text{AB}}$  8.7 Hz, bnpe aromatic H's);  $\delta_{\text{C}}$  (50 MHz,  $\text{CDCl}_3$ ) 12.5 (5- $\text{CH}_3$ ), 24.5 ( $^i\text{Pr CH}_3$ ), 39.3 (2'-C), 42.9 (d,  $J_{\text{COP}}$  12.25 Hz, P-O- $\text{CH}_3$ ), 49.3 (bnpe  $\beta\text{-CH}$ ), 50.1 (d,  $J_{\text{CNP}}$  11.9 Hz,  $^i\text{Pr CH}$ ), 55.5 (anisoyl  $-\text{OCH}_3$ ), 67.1 (bnpe  $\alpha\text{-CH}_2$ ), 68.7 (5'-C), 72.1 (2d,  $J_{\text{COP}}$  17.2 Hz, 3'-C), 83.1 (2d,  $J_{\text{CCOP}}$  14.9 Hz 4'-C), 85.5 (2s, 1'-C), 110.8 (5-C), 114.4 (anisoyl aromatic 3- and 5-C), 124.1 (bnpe aromatic 3-C and anisoyl aromatic 1-C), 129.0 (bnpe aromatic 2- and 6-C), 132.9 (anisoyl aromatic 2- and 6-C), 135.0 (6-C), 147 (bnpe aromatic 4-C), 149.0



(4-C), 154.3 (bnpe aromatic 1-C), 162.5 (2-C), 165.0 (anisoyl aromatic 4-C), 167.5 (anisoyl amide C=O);  $\delta_p$  (36 MHz, CDCl<sub>3</sub>) 150.2 and 149.8; m/z (FAB) 852 (MH<sup>+</sup>) 868 820 673 592; HRMS (FAB) found 852.28570 (MH<sup>+</sup>), C<sub>40</sub>H<sub>47</sub>N<sub>5</sub>O<sub>14</sub>P requires 852.28569 (<1ppm).

### 5'-O-(9-Fluorenylmethoxycarbonyl)-N<sup>3</sup>-anisoyl-thymidine

#### (117) 5'-O-Fmoc-N<sup>3</sup>-An-T

N<sup>3</sup>-Anisoyl-thymidine (114) (0.414g, 1.01 mmol) was co-evaporated twice from pyridine and then dissolved in 20 ml of pyridine. 9-Fluorenylmethyl chloroformate (0.344g, 1.33 mmol) was added and the reaction was stirred for 2 hours before removing the solvent *in vacua*. The residue was dissolved in 50 ml of methylene chloride and washed with 2x40 ml water, 2x40 ml brine, dried over sodium sulphate, and the solvent evaporated *in vacuo* to produce a yellow oil. This was purified by dry flash chromatography, eluting with 0-5% methanol in methylene chloride to give the required product as a white foam (0.413g, 63%); softening point 89-92°C; tlc R<sub>f(A)</sub> 0.6;  $\nu_{max}$  (bromoform mull) 3700-3200 (OH), 2940 (alkyl C-H), 1740 (anisoyl amide C=O and fmoc carbonate C=O), 1700 and 1650 (thymidine C=O), 1600, 1510 and 1450 (aromatic C-C), 1250 (ether C-O-C), 840 cm<sup>-1</sup> (aromatic C-H);  $\lambda_{max}$  275 266 272 287 nm,  $\epsilon_{max}$  28000 30000 29000 23000;  $\delta_H$  (200 MHz, CDCl<sub>3</sub>) 1.81 (3H, s, 5-CH<sub>3</sub>), 2.08 (1H, m, 2'-H), 2.29 (1H, m, 2'-H), 3.24 (1H, br.s, 3'-OH), 3.82 (3H, s, -OCH<sub>3</sub>), 4.07 (1H, m, 4'-H), 4.19-4.63 (6H, m, fmoc  $\beta$ -CH and  $\alpha$ -CH<sub>2</sub>, 3'-H and 5'-H's), 6.27 (1H, t, J<sub>AB</sub> 6.4 Hz, 1'-H), 6.92 (2H, d, J<sub>AB</sub> 9.0 Hz, anisoyl aromatic H's), 7.30-7.77 (9H, m, fmoc aromatic H's and 6-H), 7.86 (2H, d, J<sub>AB</sub> 8.9 Hz, anisoyl aromatic H's);  $\delta_C$  (50 MHz, CDCl<sub>3</sub>), 12.4 (5-CH<sub>3</sub>), 40.3 (2'-C), 46.7 (fmoc  $\beta$ -CH), 55.5 (-OCH<sub>3</sub>), 66.9 (fmoc  $\alpha$ -CH<sub>2</sub>), 69.8 (5'-C), 70.8 (3'-C), 84.1 and 85.1 (1'-C and 4'-C), 111.0 (5-C), 114.4 (anisoyl aromatic 3- and 5-C), 120.0 (fmoc tertiary aromatic C), 124.0

(anisoyl aromatic 1-C), 124.7, 127.1 and 127.9 (fmoc tertiary aromatic C's), 132.9 (anisoyl aromatic 2- and 6-C), 135.0 (6-C), 141.2 and 142.9 (fmoc quaternary aromatic C's), 149.2 (4-C), 154.8 (2-C), 165.1 (anisoyl aromatic 4-C), 167.7 (amide C=O); m/z (FAB) 599 (MH<sup>+</sup>); HRMS (FAB) found 599.20292 (MH<sup>+</sup>), C<sub>33</sub>H<sub>31</sub>N<sub>2</sub>O<sub>9</sub> requires 599.20292 (<1ppm).

**5'-O-(Fluorenylmethoxycarbonyl)-N<sup>3</sup>-anisoyl-thymidine-3'-N,N-diisopropyl methyl phosphoramidite**

**(118) 5'-O-Fmoc-N<sup>3</sup>-An-T-3'-N,N-<sup>i</sup>Pr<sub>2</sub> Me phosphoramidite**

5'-O-(9-Fluorenylmethoxycarbonyl)-N<sup>3</sup>-anisoyl-thymidine (117) (0.302g, 0.505 mmol) was co-evaporated twice with pyridine then closed with a septum pierced with a needle and placed in an evacuated desiccator overnight. The desiccator was then filled with argon and the flask removed. The nucleoside was dissolved in 2 ml of tetrahydrofuran and an argon filled balloon was attached to the flask. N,N-Diisopropylethylamine (0.35 ml, 2.02 mmol) and then N,N-diisopropylmethylphosphonamidyl chloride (104) (0.39 ml, 2.02 mmol) were added and the reaction was stirred for 10 min. The solution was then poured into 20 ml of argon saturated ethyl acetate and washed with the following argon saturated solutions: 2x20 ml water; 2x20 ml saturated aqueous sodium carbonate; 1x20 ml brine, dried over sodium sulphate and the solvent removed *in vacuo* to give a pale yellow oil. This was dissolved in 3 ml of toluene and precipitated into 200 ml of hexane at -20°C. The solid was filtered off and dried overnight in an evacuated desiccator to give the required product as a white solid (0.240g, 63%); softening point 81-86°C; tlc R<sub>f(B)</sub> 0.7; ν<sub>max</sub> (bromoform mull) 2960 (alkyl C-H), 1750 (anisoyl amide C=O and fmoc carbonate C=O), 1700 and 1660 (thymidine C=O), 1600, 1520 and 1450 (aromatic C-C), 1260 (ether C-O-C), 850 cm<sup>-1</sup> (aromatic C-H); δ<sub>H</sub> (200 MHz, CDCl<sub>3</sub>) 1.16

(12H, m, <sup>i</sup>Pr CH<sub>3</sub>), 1.83 (3H, s, 5-CH<sub>3</sub>), 2.15 (1H, m, 2'-H), 2.48 (1H, m, 2'-H), 3.36 (3H, d, J<sub>P-CH</sub> 13.3 Hz, P-O-CH<sub>3</sub>), 3.47-3.67 (2H, m, <sup>i</sup>Pr CH), 3.83 (3H, s, anisoyl -OCH<sub>3</sub>), 4.23-4.59 (7H, m, fmoc α-CH<sub>2</sub> and β-CH, 3'-H, 4'-H and 5'-H's), 6.34 (1H, t, J<sub>AB</sub> 6.7 Hz, 1'-H), 6.92 (2H, d, J<sub>AB</sub> 8.8 Hz, anisoyl aromatic H's), 7.25-7.78 (9H, m, fmoc aromatic H's and 6-H), 7.87 (2H, d, J<sub>AB</sub> 8.9 Hz, anisoyl aromatic H's); δ<sub>C</sub> (50 MHz, CDCl<sub>3</sub>) 12.5 (5-CH<sub>3</sub>), 24.5 (<sup>i</sup>Pr CH<sub>3</sub>), 39.6 (2'-C), 42.9 (d, J<sub>COP</sub> 12.2 Hz, P-O-CH<sub>3</sub>), 46.6 (fmoc β-CH), 50.0 (<sup>i</sup>Pr CH), 55.5 (anisoyl O-CH<sub>3</sub>), 66.7 (fmoc α-CH<sub>2</sub>), 69.9 (5'-C), 72.4 (d, J<sub>COP</sub> 16.8 Hz, 3'-C), 83.6 (d, J<sub>COP</sub> 14.6 Hz, 4'-C), 85.1 (2s, 1'-H), 111.1 (5-C), 114.3 (anisoyl aromatic 3- and 5-C), 120.0 (fmoc tertiary aromatic C), 124.2 (anisoyl 1-C), 124.7, 127.1 and 127.9 (fmoc tertiary aromatic C's), 132.9 (anisoyl aromatic 2- and 6-C), 134.8 (6-C), 141.2 and 142.9 (fmoc quaternary aromatic C's), 149.2 (4-C), 154.7 (2-C), 165.0 (anisoyl aromatic 4-C), 167.7 (amide C=O); δ<sub>P</sub> (81 MHz, CDCl<sub>3</sub>) 150.3 and 150.9.

## 2,2,2-Triphenylethanol

### (119) Ph<sub>3</sub>CCH<sub>2</sub>OH

2,2,2-Triphenylacetic acid (4.17g, 14.5 mmol) was dissolved in 400 ml of sodium dried diethyl ether and lithium aluminium hydride (1.13g, 29.7 mmol) was added slowly whilst stirring under nitrogen. The reaction was stirred for 16 hours and turned from a grey suspension to a yellow solution. The reaction was quenched with 2M aqueous potassium hydrogen sulphate and the ether layer was washed with 3x100 ml water, 2x100 ml brine, dried over sodium sulphate and the solvent removed *in vacuo* to afford a white solid which was recrystallised from ethanol to give the required product (3.12g, 78%); mp 105-107°C (lit. 110°C<sup>131</sup>); tlc R<sub>f(D)</sub> 0.5; ν<sub>max</sub> (bromoform mull) 3580 and 3500-3200 (O-H), 2900 (alkyl C-H), 1600, 1490 and 1450 (aromatic C-C), 1100-1000 (aromatic C-H), 750 and 700 cm<sup>-1</sup> (aromatic C-H); δ<sub>H</sub> (80 MHz,

CDCl<sub>3</sub>) 1.62 (1H, s, OH), 4.66 (2H, s, methylene H's), 7.27 (15H, s, aromatic H's);  
 $\delta_C$  (50 MHz, CDCl<sub>3</sub>) 58.7 (ethyl  $\beta$ -C), 70.1 (ethyl  $\alpha$ -CH<sub>2</sub>), 126.4 (aromatic 4-C),  
 128.0 (aromatic 2-C), 129.3 (aromatic 3-C), 145.0 (aromatic 1-C); m/z (FAB) 257  
 (MH<sup>+</sup>-OH) 243.

### 2,2,2-Triphenylethoxyphosphodichloridite

#### (120) Ph<sub>3</sub>CCH<sub>2</sub>OPCl<sub>2</sub>

2,2,2-Triphenylethanol (**119**) (0.167g, 0.608 mmol) was dissolved in 5 ml of methylene chloride and trimethylsilyl chloride (0.154 ml, 1.22 mmol) and triethylamine (0.253 ml, 1.82 mmol) were added. After stirring for 1 hour under nitrogen the triethylamine hydrochloride was filtered off and the solvent removed *in vacuo*. The residue was dissolved in ethyl acetate and the remaining triethylamine hydrochloride was filtered off and the solvent evaporated *in vacuo* to produce a red oil.  $\delta_H$  (200 MHz, CDCl<sub>3</sub>) 0.34 (9H, s, SiCH<sub>3</sub>), 4.97 (2H, s, methylene H's), 7.57 (15H, m, aromatic H's). This was dissolved in 5 ml of methylene chloride and cooled to -78°C, then trichlorophosphine (0.053 ml, 0.608 mmol) was added and the reaction stirred for 6 hours under nitrogen before being allowed to reach room temperature slowly. The solvent was removed *in vacuo* to give the title compound as a colourless oil (0.210g, 92%);  $\delta_H$  (80 MHz, CDCl<sub>3</sub>) 5.26 (2H, d, J<sub>P-O-CH</sub> 7 Hz, -OCH<sub>2</sub>-), 7.25 (15H, m, aromatic H's);  $\delta_P$  (36 MHz, CDCl<sub>3</sub>) 177.4.

**N,N-Diisopropyl-(2,2,2-triphenylethyl)-phosphoramidyl chloride****(121) Ph<sub>3</sub>CCH<sub>2</sub>OP(Cl)N<sup>i</sup>Pr<sub>2</sub>**

Freshly prepared 2,2,2-triphenylethoxyphosphodichloridite (**120**) (1.26g, 3.36 mmol) was dissolved in 5 ml of methylene chloride and N,N-diisopropylamine (0.94 ml, 6.71 mmol) was added. The solution was stirred for 10 min. under nitrogen then the diisopropylamine hydrochloride was filtered off under suction in a dry argon atmosphere, and the methylene chloride was removed *in vacua*. Further diisopropylamine hydrochloride was removed to give the **title compound** as an oil (1.35g, 94%);  $\delta_H$  (80 MHz, CDCl<sub>3</sub>) 1.1–1.2 (12H, m, <sup>i</sup>Pr CH<sub>3</sub>), 3.8 (2H, m, <sup>i</sup>Pr CH), 5.29 (2H, s, methylene H's), 7.23 (15H, m, aromatic H's);  $\delta_P$  (36 MHz, CDCl<sub>3</sub>) 181.2.

**5'-O-[2,2-Bis (4-nitrophenyl)ethoxycarbonyl]-thymidine-3'-O-N,N-diisopropyl 2,2,2-triphenylethyl phosphoramidite****(122) 5'-O-Bnpeoc-T-3'-O-N,N-<sup>i</sup>Pr<sub>2</sub> Ph<sub>3</sub>CCH<sub>2</sub> phosphoramidite**

5'-O-[2,2-Bis (4-nitrophenyl)ethoxycarbonyl]-thymidine (**107**) (0.405g, 0.728 mmol) was co-evaporated with 10% pyridine in methylene chloride then closed with a septum pierced with a needle and left in an evacuated desiccator overnight. The desiccator was filled with argon and the needle removed from the flask and an argon filled balloon attached to the flask. The nucleoside was dissolved in 5 ml of tetrahydrofuran and N,N-diisopropylamine (0.506 ml, 2.91 mmol) and then N,N-diisopropyl-(2,2,2-triphenylethyl)phosphoramidyl chloride, (**121**) (1.28g, 2.91 mmol) were added and stirred for 15 min. under argon before the reaction was quenched with methanol (0.09 ml, 2.18 mmol) and poured into 20 ml of argon-saturated ethyl acetate. This was washed with the following argon-saturated solutions: 1x20 ml water; 2x20 ml 10% aqueous sodium

carbonate; 2x20 ml brine, dried over sodium sulphate and filtered off under argon. The solvent was evaporated *in vacuo* and the residue was dissolved in 5 ml of ethyl acetate and precipitated into 500 ml of hexane at  $-78^{\circ}\text{C}$ . The precipitate was filtered off and dried in an evacuated desiccator to give the **title compound** as a cream solid (0.418g, 60%); softening point  $69-73^{\circ}\text{C}$ ; tlc  $R_{f(B)}$  0.6;  $\nu_{\text{max}}$  (bromoform mull) 2980 (alkyl C-H), 1750 (bnpe C=O), 1720-1650 (thymidine C=O), 1600, 1510 and 1450 (aromatic C-C), 1520 and 1350 ( $\text{NO}_2$ ),  $860-740\text{ cm}^{-1}$  (aromatic C-H);  $\delta_{\text{H}}$  (200 MHz,  $\text{CDCl}_3$ ) 0.99-1.35 (12H, m,  $^i\text{Pr CH}_3$ ), 1.79 (3H, s, 5- $\text{CH}_3$ ), 2.15 (1H, m, 2'-H), 2.44 (1H, m, 2'-H), 3.50 (2H, m,  $^i\text{Pr CH}$ ), 3.93 (2H, s, P- $\text{OCH}_2$ ), 4.16 (1H, m, 4'-H), 4.33-4.39 (3H, m, 3'-H and 5'-H's), 4.62-4.76 (3H, m, bnpe  $\alpha$ - $\text{CH}_2$  and  $\beta$ -CH), 6.18 (1H, m, 1'-H), 7.08-7.35 (16H, m, aromatic phenyl H's and 6-H), 7.40 (4H, d,  $J_{\text{AB}}$  8.4 Hz, bnpe aromatic H's), 8.19 (4H, d,  $J_{\text{AB}}$  8.7Hz, bnpe aromatic H's);  $\delta_{\text{C}}$  (50 MHz,  $\text{CDCl}_3$ ) 12.3 (5- $\text{CH}_3$ ), 24.3 ( $^i\text{Pr CH}_3$ ), 39.2 (2'-C), 43.0 ( $^i\text{Pr CH}$ ), 49.3 (bnpe  $\beta$ -CH), 67.1 (bnpe  $\alpha$ - $\text{CH}_2$ ), 68.7 (5'-C), 69.9 (P- $\text{OCH}_2$ ), 72.0 (3'-C), 83.0 and 84.9 (1'- and 4'-C), 110.7 (5-C), 124.1 (bnpe aromatic 3-C), 127.7 (bnpe aromatic 2-C), 126.1 128.9 and 129.3 (phenyl aromatic 2-, 3- and 4-C's), 135.2 (6-C), 145.4 and 146.0 (bnpe 4-C and  $\text{Ph}_3\text{C-}$ ), 147.2 (phenyl aromatic 1-C), 150.0 (4-C), 154.3 (bnpe aromatic 1-C), 163.5 (2-C);  $\delta_{\text{P}}$  (36 MHz,  $\text{CDCl}_3$ ) 148.9 and 147.8.

**5'-O-[2,2-Bis (4-nitrophenyl)ethoxycarbonyl]-N<sup>6</sup>-benzoyl-2'-deoxyadenosine**

**(123) 5'-O-Bnpeoc-N<sup>6</sup>-Bz-2'-dA**

N<sup>6</sup>-Benzoyl-2'-deoxyadenosine (0.276g, 0.777 mmol), was co-evaporated twice with pyridine and then dissolved in 2 ml of pyridine and 2,2-bis (4-nitrophenyl)ethyl chloroformate (**106**) (0.327g, 0.933 mmol) was added and the reaction was stirred for 18 hours. The solution was then poured into 50 ml of water and extracted with 3x20 ml of methylene chloride. The combined

organic layers were washed with 2x50 ml water, 1x50 ml brine, dried over sodium sulphate and the solvent removed *in vacuo* to yield a pale brown foam. This was purified by dry flash chromatography, eluting with 0–4% methanol in methylene chloride to give the **title compound** as a white foam (0.245g, 47%); softening point 109–113°C; tlc  $R_{f(A)}$  0.4;  $\nu_{\max}$  (bromoform mull) 3700–3100 (O–H and N–H), 2960 (alkyl C–H), 1750 (bnpe C=O), 1700 (amide C=O), 1610 (amide N–H), 1590, 1510 and 1450 (aromatic C–C), 1520 and 1350  $\text{cm}^{-1}$  ( $\text{NO}_2$ );  $\lambda_{\max}$  277 nm,  $\epsilon_{\max}$  25000;  $\delta_{\text{H}}$  (200 MHz,  $\text{CDCl}_3$ ) 2.52 (1H, m, 2'–H), 2.64 (1H, m, 2'–H), 4.20 (1H, m, 4'–H), 4.32 (2H, m, 5'–H), 4.62 (4H, m, 3'–H and bnpe  $\alpha$ - $\text{CH}_2$  and  $\beta$ -CH), 5.01 (1H, br.s, 3'–OH), 6.43 (1H, t,  $J_{\text{AB}}$  6.0 Hz, 1'–H), 7.30 (4H, d,  $J_{\text{AB}}$  8.5 Hz, bnpe aromatic H's), 7.38 (3H, m, benzoyl 3-, 4- and 5-H), 7.93 (2H, s, benzoyl 2- and 6-H), 8.00 (4H, d,  $J_{\text{AB}}$  8.5 Hz, bnpe aromatic H's), 8.08 (1H, s, 2-H), 8.57 (1H, s, 8-H), 9.50 (1H, br.s, amide H);  $\delta_{\text{C}}$  (50 MHz,  $\text{CDCl}_3$ ) 39.8 (2'–C), 48.9 (bnpe  $\beta$ -C), 67.4 (bnpe  $\alpha$ -C), 68.6 (5'–C), 71.2 (3'–C), 84.3 and 84.4 (1'–C and 4'–C), 123.1 (5–C), 123.8 (bnpe aromatic 3–C), 127.7 and 128.5 (benzoyl aromatic 2- and 3–C), 128.9 (bnpe aromatic 2–C), 132.7 (benzoyl aromatic 4–C), 133.1 (benzoyl aromatic 1–C), 141.5 (2–C), 146.1 (bnpe aromatic 4–C), 149.2 and 151.1 (6–C and 4–C), 152.0 (8–C), 154.2 (bnpe aromatic 1–C), 165.1 (amide C=O); m/z (FAB) 670 ( $\text{MH}^+$ ); HRMS (FAB) found 670.18976 ( $\text{MH}^+$ ),  $\text{C}_{32}\text{H}_{28}\text{N}_7\text{O}_{10}$  requires 670.18975 (<1ppm).

**5'-O-[2,2-Bis (4-nitrophenyl)ethoxycarbonyl]-N<sup>6</sup>-benzoyl-2'-deoxyadenosine  
-3'-O-N,N-diisopropyl methyl phosphoramidite**

**(124) 5'-O-Bnpeoc-N<sup>6</sup>-Bz-2'-dA-3'-O-N,N-<sup>i</sup>Pr<sub>2</sub> Me phosphoramidite**

5'-O-[2,2-Bis (4-nitrophenyl)ethoxycarbonyl]-N<sup>6</sup>-benzoyl-  
2'-deoxyadenosine (**123**) (0.255g, 0.336 mmol) was co-evaporated twice with a 50:50 mixture of pyridine : methylene chloride and then placed in an evacuated

desiccator overnight covered with a septum pierced with a needle. The desiccator was filled with argon and an argon filled balloon was attached to the flask. The nucleoside was dissolved in 2 ml of tetrahydrofuran and *N,N*-diisopropylethylamine (0.24 ml, 1.35 mmol) and then *N,N*-diisopropylmethylphosphonamidyl chloride (**104**) (0.26 ml, 1.35 mmol) were added and the reaction was stirred for 10 min. The reaction was quenched with methanol (0.04 ml, 1.01 mmol) and then poured into 20 ml of argon saturated ethyl acetate and washed with the following argon saturated solutions: 1x20 ml water; 2x20 ml saturated aqueous sodium carbonate; 1x20 ml brine, dried over sodium sulphate and filtered in a dry argon atmosphere. The solvent was removed *in vacuo* to give a yellow oil which was dissolved in 3 ml of toluene and precipitated into 100 ml of hexane at room temperature. The precipitate was filtered off and dried overnight in an evacuated desiccator to give the title compound as a white solid (0.219g, 78%); softening point 98–104°C; tlc  $R_{f(B)}$  0.5;  $\nu_{max}$  (bromoform mull) 2960 (alkyl C–H), 1750 (bnpe C=O), 1705 (amide C=O), 1610 (amide N–H), 1590, 1510 and 1450 (aromatic C–C), 1520 and 1350  $cm^{-1}$  ( $NO_2$ );  $\delta_H$  (200 MHz,  $CDCl_3$ ) 1.13 (12H, m, <sup>i</sup>Pr  $CH_3$ ), 2.62 (1H, m, 2'–H), 2.73 (1H, m, 2'–H), 3.33 (3H, 2d,  $J_{POC}$  13.3 Hz,  $-OCH_3$ ), 3.56 (2H, m, <sup>i</sup>Pr CH), 4.25–4.40 (3H, m, 4'–H and 5'–H's), 4.63 (4H, m, bnpe  $\alpha$ - $CH_2$  and  $\beta$ -CH and 3'–H), 6.42 (1H, t,  $J_{AB}$  6 Hz, 1'–H), 7.31–7.52 (7H, m, bnpe aromatic H's and benzoyl 3-, 4- and 5-H), 7.96–8.12 (7H, m, 2-H, bnpe aromatic H's, benzoyl 2- and 6-H), 8.46 (1H, s, 8-H);  $\delta_C$  (50 MHz,  $CDCl_3$ ) 24.4 (<sup>i</sup>Pr  $CH_3$ ), 39.2 (2'–C), 42.8 (d,  $J_{COP}$  12.3 Hz,  $-OCH_3$ ), 49.1 (bnpe  $\beta$ -CH), 50.3 (d,  $J_{CNP}$  17.8 Hz, <sup>i</sup>Pr CH), 67.0 (bnpe  $\alpha$ - $CH_2$ ), 68.6 (5'–C), 72.6 (2d,  $J_{COP}$  18 Hz, 3'–C), 83.6 (2d,  $J_{COP}$  14.4 Hz, 4'–C), 84.5 (2s, 1'–C), 123.5 (5-C0), 124.0 (bnpe aromatic 3-C), 127.8 and 128.6 (benzoyl aromatic 2- and 3-C), 129.0 (bnpe aromatic 2-C), 132.6 (benzoyl aromatic 4-C), 133.4 (benzoyl aromatic 1-C), 141.3 (2-C), 146.2 (bnpe aromatic 4-C), 149.5 (6-C), 151.3 (4-C), 152.2 (8-C), 154.2 (bnpe aromatic 1-C), 164.9



(amide C=O);  $\delta_p$  (36 MHz,  $\text{CDCl}_3$ ), 149.8;  $m/z$  (FAB) 831 ( $\text{MH}^+$ ) 847 652; HRMS (FAB) found 831.28675( $\text{MH}^+$ ),  $\text{C}_{39}\text{H}_{44}\text{N}_8\text{O}_{11}\text{P}$  requires 831.28669 (<1ppm).

**5'-O-[2,2-Bis (4-nitrophenyl)ethoxycarbonyl]-thymidine-3'-O-acetate**

**(125) 5'-O-Bnpeoc-T-3'-OAc**

5'-O-[2,2-Bis (4-nitrophenyl)ethoxycarbonyl]-thymidine (**107**) (0.469g, 0.844 mmol) was co-evaporated with pyridine then dissolved in 8 ml of pyridine and acetic anhydride (0.48 ml, 5.06 mmol) was added and the solution stirred overnight. The pyridine was removed *in vacuo* and the resulting brown oil was dissolved in 50 ml of methylene chloride and washed with 2x30 ml water, 2x30 ml saturated aqueous sodium carbonate, 1x30 ml brine, dried over sodium sulphate and the solvent removed *in vacuo*. The oil obtained was purified by dry flash chromatography, eluting with 0-3% methanol in methylene chloride to produce the **title compound** as a pale brown foam (0.319g, 78%), softening point 98-103°C; tlc  $R_{f(A)}$  0.7;  $\nu_{\text{max}}$  (methylene chloride solution) 2960 (alkyl C-H), 1760-1670 (C=O's), 1525 and 1350  $\text{cm}^{-1}$  ( $\text{NO}_2$ );  $\lambda_{\text{max}}$  ( $\text{CH}_3\text{CN}$ ) 269 nm,  $\epsilon_{\text{max}}$  20000;  $\delta_{\text{H}}$  (200 MHz,  $\text{CDCl}_3$ ) 1.70 (3H, s, 5- $\text{CH}_3$ ), 2.01 (3H, s, acetyl  $\text{CH}_3$ ), 2.04 (1H, m, 2'-H), 2.35 (1H, m, 2'-H), 4.13 (1H, m, 4'-H), 4.34 (2H, m, 5'-H), 4.7 (3H, m,  $\alpha$ - $\text{CH}_2$  and  $\beta$ -CH), 5.12 (1H, m, 3'-H), 6.22 (1H, t,  $J_{\text{AB}}$  8.1 Hz, 1'-C), 7.19 (1H, s, 6-H), 7.37 (4H, d,  $J_{\text{AB}}$  8.8 Hz, bnpe H's), 8.10 (4H, d,  $J_{\text{AB}}$  8.8 Hz, bnpe H's), 9.90 (1H, s, amide H);  $\delta_{\text{C}}$  (50 MHz,  $\text{CDCl}_3$ ) 12.3 (5- $\text{CH}_3$ ), 20.6 (acetyl  $\text{CH}_3$ ), 36.9 (2'-C), 49.3 (bnpe  $\beta$ -CH), 67.3 (bnpe  $\alpha$ - $\text{CH}_2$ ), 68.8 (5'-C), 73.6 (3'-C), 81.7 (4'-C), 84.7 (1'-C), 111.2 (5-C), 124.0 (bnpe aromatic 3-C), 129.0 (bnpe aromatic 2-C), 134.9 (6-C), 146.0 (bnpe aromatic 4-C), 150.3 (4-C), 154.2 (bnpe aromatic 1-C), 163.7 (2-C), 170.3 (acetyl C=O);  $m/z$  (FAB) 599 ( $\text{MH}^+$ ); HRMS (FAB) found 599.16251 ( $\text{MH}^+$ ),  $\text{C}_{25}\text{H}_{27}\text{N}_4\text{O}_{12}$  requires 599.16253 (<1ppm).

**5'-O-(4,4'-Dimethoxytrityl)-thymidine****(63) 5'-O-DMTr-T**

Thymidine (3.207g, 13.25 mmol) was co-evaporated with pyridine then dissolved in 35 ml of pyridine and 4,4'-dimethoxytrityl chloride (5.837g, 17.23 mmol), triethylamine (2.40 ml, 17.23 mmol) and N,N-dimethylaminopyridine (0.081g, 0.66 mmol) were added. The reaction was stirred for 4 hours and then poured into 100 ml water and extracted with 2x400 ml diethyl ether. The combined organic layers were washed with 3x200 ml water, 1x100 ml brine, dried over sodium sulphate, and the solvent was removed *in vacuo* to give a brown oil. This was crystallised from chloroform and diethyl ether to produce the required product as a white, crystalline solid (5.379g, 75%); mp 142–144°C<sup>\*</sup>;  $R_{f(A)}$  0.4;  $\nu_{max}$  (methylene chloride solution) 2940 (alkyl C-H), 1710–1680 (C=O's), 1610, 1510 and 1430  $cm^{-1}$  (aromatic C-C);  $\delta_H$  (80 MHz,  $CDCl_3$ ) 1.34 (3H, s, 5-CH<sub>3</sub>), 2.33 (1H, m, 2'-H), 2.40 (1H, m, 2'-H), 3.37 (2H, m, 5'-H), 3.48 (1H, m, 4'-H), 3.73 (6H, s, -OCH<sub>3</sub>), 4.05 (1H, m, 3'-H), 4.55 (1H, br.s, 3'-OH), 6.38 (1H, t,  $J_{AB}$  6 Hz, 1'-H), 6.78 (4H, d,  $J_{AB}$  8.9 Hz, aromatic H's), 7.25 (4H, d,  $J_{AB}$  8.9 Hz, aromatic H's), 7.24 (5H, m, aromatic H's), 7.55 (1H, s, amide H);  $\delta_C$  (50 MHz,  $CDCl_3$ ) 11.7 (5-CH<sub>3</sub>), 40.8 (2'-C), 55.1 (-OCH<sub>3</sub>), 63.6 (5'-C), 72.3 (3'-C), 84.7 (4'-C), 86.3 (1'-C), 86.7 (DMTr Ar<sub>3</sub>C), 111.1 (5-C), 113.1 (DMTr MeO-aromatic 3-C), 126.9, 127.8 and 128.0 (DMTr phenyl aromatic 2-, 3- and 4-C), 129.9 (DMTr MeO-aromatic 2-C), 135.3 (DMTr MeO-aromatic 1-C), 135.7 (6-C), 144.3 (DMTr phenyl aromatic 1-C), 150.7 (4-C), 158.5 (DMTr MeO-aromatic 4-C), 164.1 (2-C);  $m/z$  (FAB) 545 (MH<sup>+</sup>) 438 303; HRMS (FAB) found 545.22877 (MH<sup>+</sup>), C<sub>31</sub>H<sub>33</sub>N<sub>2</sub>O<sub>7</sub> requires 545.22876 (<1ppm).

\* lit value (Aldrich) 117–121°C

**Thymidine-3'-O-acetate****(5) T-3'-O-Ac**

5'-O-(4,4'-Dimethoxytrityl)-thymidine (**63**) (1.024g, 1.85 mmol) was dissolved in 10 ml of pyridine and acetic anhydride (0.566g, 5.55 mmol) was added and the solution stirred for 24 hours. The pyridine was removed *in vacuo* and the residue dissolved in 50 ml of methylene chloride and washed with 2x100 ml water, 1x100 ml saturated aqueous sodium carbonate, 1x100 ml brine, dried over sodium sulphate, and the methylene chloride was evaporated *in vacuo* to produce a white foam. The nucleoside was then refluxed in 80% aqueous acetic acid for 5 hours and the solvent was removed *in vacuo* to give an orange oil which was purified by dry flash chromatography, eluting with 0-5% methanol in methylene chloride to produce a pale yellow foam. This was further purified by crystallisation from methylene chloride and diethyl ether to give the required product as a white solid (0.043g, 23%); mp 174-175°C;  $R_{f(A)}$  0.8;  $\nu_{max}$  (bromoform mull) 2940 (alkyl C-H), 1730-1660  $cm^{-1}$  (C=O's);  $\delta_H$  (200 MHz,  $d_6$ -DMSO) 1.78 (3H, s, 5-CH<sub>3</sub>), 2.06 (3H, s, acetyl CH<sub>3</sub>), 2.27 (2H, m, 2'-H), 3.63 (2H, m, 5'-H's), 3.98 (1H, m, 4'-H), 5.2 (2H, m, 3'-H and 5'-OH), 6.18 (1H, t,  $J_{AB}$  7 Hz, 1'-H), 7.74 (1H, s, 6-H);  $\delta_C$  (50 MHz,  $d_6$ -DMSO) 12.4 (5-CH<sub>3</sub>), 20.9 (acetyl CH<sub>3</sub>), 36.6 (2'-C), 61.4 (5'-C), 74.8 (3'-C), 83.8 (4'-C), 84.7 (1'-C), 109.8 (5-C), 135.9 (6-C), 150.6 (4-C), 163.8 (2-C), 170.1 (acetyl C=O); m/z (FAB) 285 (MH<sup>+</sup>); HRMS (FAB) found 285.10867 (MH<sup>+</sup>), C<sub>12</sub>H<sub>17</sub>N<sub>2</sub>O<sub>6</sub> requires 285.10867 (<1ppm).

**5'-O-(4,4'-Dimethoxytrityl)-3'-O-benzoyl-thymidine****(63a) 5'-O-DMTr-T-3'-O-CO-Ph**

5'-O-(4,4'-Dimethoxytrityl)-thymidine (**63**) (0.202g, 0.365 mmol) was dissolved in pyridine and benzoic anhydride (0.151g, 0.547 mmol) and N,N-dimethylaminopyridine (0.0089g, 0.073 mmol) were added and the reaction was stirred for 48 hours. It was then poured into 50 ml water and extracted with 4x15 ml methylene chloride. The combined organic layers were washed with 1x50 ml water, 2x50 ml saturated aqueous sodium carbonate, 1x50 ml brine, dried over sodium sulphate, and the solvent was removed *in vacuo* to give a yellow oil. This was purified by dry flash chromatography, eluting with 0-3% methanol in methylene chloride to give the required product as a white foam (0.216g, 92%); softening point 107-111°C; tlc  $R_{f(A)}$  0.7;  $\nu_{max}$  (methylene chloride solution) 2960 (alkyl C-H), 1730-1680 (C=O's), 1610, 1510 and 1430  $cm^{-1}$  (aromatic C-C);  $\delta_H$  (200 MHz,  $CDCl_3$ ) 1.43 (3H, s, 5-CH<sub>3</sub>), 2.60 (2H, m, 2'-H), 3.56 (2H, m, 5'-H's), 3.77 (3H, m, -OCH<sub>3</sub>), 4.30 (1H, m, 4'-H), 5.72 (1H, m, 3'-H), 6.56 (1H, t,  $J_{AB}$  6.0 Hz, 1'-H), 6.84 (4H, d,  $J_{AB}$  8.8 Hz, DMTr aromatic H's), 7.23-7.58 (12H, m, DMTr and benzoyl aromatic H's), 7.66 (1H, s, 6-H), 8.04 (2H, d,  $J_{AB}$  7.1 Hz, benzoyl aromatic H's), 9.66 (1H, br.s, N-H);  $\delta_C$  (50 MHz,  $CDCl_3$ ), 11.6 (5-CH<sub>3</sub>), 38.0 (2'-C), 55.1 (-OCH<sub>3</sub>), 63.6 (5'-C), 75.8 (3'-C), 84.0 and 84.3 (1'-C and 4'-C), 87.1 (DMTr Ar<sub>3</sub>C), 111.6 (5-C), 113.2 (DMTr methoxy aromatic 3-C), 127.1-130.0 (benzoyl aromatic 2- and 3-C, DMTr methoxy aromatic 2-C, and DMTr phenyl aromatic 2-, 3- and 4-C), 133.4 (benzoyl aromatic 4-C), 135.1 (DMTr methoxy aromatic 1-C), 135.3 (6-C), 144.1 (DMTr phenyl aromatic 1-C), 150.6 (4-C), 158.6 (DMTr methoxy aromatic 4-C), 163.9 (2-C), 165.9 (benzoyl aromatic 1-C); m/z (FAB) 649 (MH<sup>+</sup>); HRMS (FAB) found 648.24717 (MH<sup>+</sup>), C<sub>38</sub>H<sub>37</sub>N<sub>2</sub>O<sub>8</sub> requires 648.24715 (<1ppm).

**3'-O-Benzoyl-thymidine****(131) 3'-PhOCO-T**

5'-O-(4,4'-Dimethoxytrityl)-3'-O-benzoyl-thymidine (**63a**) (4.407g, 6.80 mmol) was dissolved in 50 ml of a 1% *p*-toluenesulphonic acid solution in 95% chloroform / 5% methanol and stirred for 10 min. 100 ml of methylene chloride was added to the organic solution which was then washed with 2x50 ml 5% aqueous sodium hydrogen carbonate, 1x100 ml water, 2x100 ml brine, dried over sodium sulphate and the solvent was removed *in vacuo*. The resulting oil was crystallised from ethanol to produce the required compound as a white solid (1.295g, 55%); mp 182–185°C; tlc  $R_{f(A)}$  0.5;  $\nu_{\max}$  (bromoform mull) 3700–3200 (O–H and N–H), 2960 (alkyl C–H), 1730–1630  $\text{cm}^{-1}$  (C=O's);  $\delta_{\text{H}}$  (200 MHz,  $d_6$ -DMSO) 1.80 (3H, s, 5-CH<sub>3</sub>), 2.44 (2H, m, 2'-H), 3.72 (2H, m, 5'-H), 4.17 (1H, m, 4'-H), 5.27 (1H, br.s, 5'-OH), 5.50 (1H, m, 3'-H), 6.31 (1H, t,  $J_{\text{AB}}$  7.2 Hz, 1'-H), 7.49–8.03 (5H, m, aromatic benzoyl H's), 7.80 (1H, s, 6-H), 11.34 1H, s, amide H);  $\delta_{\text{C}}$  (50 MHz,  $d_6$ -DMSO), 12.3 (5-CH<sub>3</sub>), 36.8 (2'-C), 61.5 (5'-C), 75.7 (3'-C), 84.0 and 84.7 (4'-C and 1'-C), 109.9 (5-C), 128.8 and 129.4 (benzoyl aromatic 2- and 3-C), 133.6 (benzoyl aromatic 4-C), 136.0 (6-C), 150.6 (4-C), 163.7 (2-C), 165.3 (benzoyl aromatic 1-C); m/z (FAB) 347 (MH<sup>+</sup>); HRMS (FAB) found 347.12428 (MH<sup>+</sup>), C<sub>17</sub>H<sub>19</sub>N<sub>2</sub>O<sub>6</sub> requires 347.12430 (<1ppm).

**5'-O-[Bis (4-nitrophenyl)ethoxycarbonyl]-3'-O-dimethyl phosphate****(127a) 5'-O-Bnpeoc-T-3'-O-Me<sub>2</sub> phosphate**

5'-O-[2,2-Bis (4-nitrophenyl)ethoxycarbonyl]-thymidine-3'-O-N,N-diisopropyl methylphosphoramidite (**108**) (0.156g, 0.218 mmol) was dissolved in 1 ml of acetonitrile and tetrazole (0.076g, 1.09 mmol) and methanol (0.044 ml, 1.09 mmol) were added and the solution was stirred under nitrogen for 10 min.

A solution of iodine (0.05 M) in water : pyridine : tetrahydrofuran (1:10:40) (4.35 ml, 0.218 mmol) was added and the solution was stirred for a further 10 min. The solvent was removed *in vacuo* and the brown oil remaining was dissolved in 25 ml of methylene chloride and washed with 1x25 ml water, 2x25 ml 10% aqueous sodium thiosulphate, 1x25 ml brine, dried over sodium sulphate and the solvent evaporated *in vacuo* to give a pale brown foam. This was purified by dry flash chromatography, eluting with 0–5% methanol in methylene chloride to give the **title compound** as a pale brown foam (0.047g, 31%); softening point 76–80°C; tlc  $R_{f(A)}$  0.6;  $\nu_{\max}$  (methylene chloride solution) 2960 (alkyl C–H), 1750 (bnpe C=O), 1720–1680 (thymidine C=O's), 1520 and 1350  $\text{cm}^{-1}$  ( $\text{NO}_2$ );  $\lambda_{\max}$  268 nm,  $\epsilon_{\max}$  20000;  $\delta_{\text{H}}$  (200 MHz,  $\text{CD}_3\text{CN}$ ), 1.70 (3H, s, 5'-H), 1.93 (2H, m, 2'-H), 3.70 (6H, d,  $J_{\text{COP}}$  12.1 Hz,  $-\text{OCH}_3$ ), 4.23 (1H, m, 4'-H), 4.30 (2H, m, 5'-H's), 4.75 (3H, m, bnpe  $\alpha$ - $\text{CH}_2$  and  $\beta$ -CH), 4.88 (1H, m, 3'-H), 6.15 (1H, t,  $J_{\text{AB}}$  6.9 Hz, 1'-H), 7.23 (1H, s, 6-H), 7.52 (4H, d,  $J_{\text{AB}}$  8.9 Hz, bnpe *p*-disubstituted aromatic H's), 8.14 (4H, d,  $J_{\text{AB}}$  8.9 Hz, bnpe *p*-disubstituted aromatic H's), 9.56 (1H, br.s, N-H);  $\delta_{\text{C}}$  (50 Hz,  $\text{CD}_3\text{CN}$ ) 11.2 (5- $\text{CH}_3$ ), 37.1 (2'-C), 48.7 (bnpe  $\beta$ -C), 54.0 (d,  $J_{\text{COP}}$  5.0 Hz,  $-\text{OCH}_3$ ), 66.5 (bnpe  $\alpha$ -C), 68.4 (5'-C), 76.4 (d,  $J_{\text{COP}}$  5.0 Hz, 3'-C), 81.7 (d,  $J_{\text{CCOP}}$  6.2 Hz, 4'-C), 84.5 (1'-C), 110.3 (5-C), 123.6 and 129.1 (bnpe 2- and 3-C), 135.5 (6-C), 146.9 (bnpe aromatic 4-C), 150.1 (4-C), 153.9 (bnpe aromatic 1-C), 163.4 (2-C);  $\delta_{\text{P}}$  (36 MHz,  $\text{CD}_3\text{CN}$ ) 0.7;  $m/z$  (FAB) 665 ( $\text{MH}^+$ ) 539; HRMS (FAB) found 665.14957 ( $\text{MH}^+$ ),  $\text{C}_{27}\text{H}_{30}\text{N}_4\text{O}_{14}\text{P}$  requires 665.14959 (<1 ppm).

**5'-O-[Bis (4-nitrophenyl)ethoxycarbonyl]-thymidine-3'-O-benzyl methyl phosphate**

**(127b) 5'-O-Bnpeoc-T-3'-O-Bz Me phosphate**

5'-O-[Bis (4-nitrophenyl)ethoxycarbonyl]-thymidine-3'-O-N,N-diisopropyl methyl phosphoramidite (**108**) (0.201g, 0.280 mmol) was dissolved in 10 ml of

acetonitrile and benzyl alcohol (0.155 ml, 1.40 mmol) then tetrazole (0.098g, 1.40 mmol) were added and the reaction was stirred for 15 min. A solution of iodine (0.1 M) in water : pyridine : tetrahydrofuran (1:10:40) (2.80 ml, 0.28 mmol) was added and after stirring for 10 min. the solvents were evaporated *in vacuo* and the residue was dissolved in 20 ml of methylene chloride. This was washed with 1x20 ml water and the aqueous layer was then extracted with 2x5 ml methylene chloride. The combined organic layers were washed with 1x20 ml 10% aqueous sodium thiosulphate solution, 1x20 ml brine, dried over sodium sulphate and the solvent was removed *in vacuo* to give an oil. This was purified by dry flash chromatography, eluting with 0–5% methanol in methylene chloride to give the **title compound** as a pale brown oil (0.044g, 21%); softening point 56–59°C; tlc  $R_{f(A)}$  0.7;  $\nu_{max}$  (bromoform mull) 2960 (alkyl C–H), 1750 (bnpe C=O), 1690 (thymidine C=O's), 1610, 1530 and 1450 (aromatic C–C), 1520 and 1350  $cm^{-1}$  ( $NO_2$ );  $\delta_H$  (200 MHz,  $CDCl_3$ ) 1.77 (3H, s, 5- $CH_3$ ), 2.14 (1H, m, 2'-H), 2.43 (1H, m, 2'-H), 3.70 (3H, d,  $J_{P-H}$  11.3 Hz,  $-OCH_3$ ), 4.12–4.40 (3H, m, 4'-H and 5'-H's), 4.57–4.80 (3H, m, bnpe  $\alpha$ - $CH_2$  and  $\beta$ -CH), 4.86 (1H, m, 3'-H), 5.05 (2H, d,  $J_{P-H}$  9.3 Hz, benzyl  $-CH_2-$ ), 6.18 (1H, t,  $J_{AB}$  7 Hz, 1'-H), 7.10 (1H, m, 6-H), 7.25–7.41 (9H, m, bnpe aromatic H's and benzyl aromatic H's), 8.18 (1H, d,  $J_{AB}$  8.7 Hz, bnpe aromatic H's);  $\delta_C$  (50 MHz,  $CDCl_3$ ) 12.3 (5- $CH_3$ ), 38.1 (2'-C), 49.3 (bnpe  $\beta$ -C), 54.4 (d,  $J_{COP}$  5.7 Hz,  $-OCH_3$ ), 66.8 (bnpe  $\alpha$ -C), 68.8 (5'-C), 69.8 (d,  $J_{COP}$  5.4 Hz, benzyl  $-CH_2-$ ), 76.5 (3'-C), 82.1 (d,  $J_{CCOP}$  3.1 Hz, 4'-C), 84.8 (1'-C), 111.1 (5-C), 124.1 (bnpe aromatic 3-C), 126.8–128.9 (bnpe aromatic 2-C and benzyl aromatic C's), 134.9 (6-C), 145.9 (benzyl aromatic 1-C), 147.2 (bnpe aromatic 4-C), 149.9 (4-C), 154.1 (bnpe aromatic 1-C), 163.3 (2-C);  $\delta_p$  (36 MHz,  $CDCl_3$ ) -0.3.

**5'-O-(9-Fluorenylmethoxycarbonyl)-thymidine****(129) 5'-O-Fmoc-T**

Thymidine (1.939g, 8.01 mmol) was co-evaporated twice from pyridine and then dissolved in 20 ml pyridine. 9-Fluorenylmethyl chloroformate (2.49g, 9.61 mmol) was added and the reaction was stirred for 6 hours. The pyridine was removed *in vacuo* and the residue was dissolved in 40 ml methylene chloride and washed with 2x40 ml water. The combined aqueous layers were extracted with 20 ml methylene chloride and the combined organic layers were washed with 2x30 ml brine, dried over sodium sulphate, and the methylene chloride was evaporated *in vacua*. The oil obtained was crystallised from methylene chloride and petroleum ether (bp 40–60°C) to give the required product as a white solid (1.856g, 50%); mp 183–186°C; tlc  $R_{f(A)}$  0.5;  $\nu_{\max}$  (bromoform mull) 3500–3200 (O–H), 2960 (alkyl C–H), 1750 (fmoc C=O), 1700 and 1670 (thymidine C=O's), 1490–1450  $\text{cm}^{-1}$  (aromatic C–C);  $\delta_{\text{H}}$  (200 MHz,  $d_6$ -DMSO) 1.69 (3H, s, 5-CH<sub>3</sub>), 2.12 (2H, m, 2'-H), 3.92 (1H, m, 4'-H), 4.20 (1H, m, 3'-H), 4.27–4.30 (3H, m, fmoc  $\alpha$ -CH<sub>2</sub> and  $\beta$ -CH), 4.57 (2H, m, 5'-H's), 5.52 (1H, br.s, 3'-OH), 6.19 (1H, t,  $J_{\text{AB}}$  6.7 Hz, 1'-H), 7.31–7.89 (8H, m, fmoc aromatic H's), 11.33 (1H, br.s, amide N–H);  $\delta_{\text{C}}$  (50 MHz,  $d_6$ -DMSO) 12.3 (5-CH<sub>3</sub>), 38.7 (2'-C), 46.5 (fmoc  $\beta$ -C), 67.6 and 68.9 (5'-C and fmoc  $\alpha$ -CH<sub>2</sub>), 70.2 (3'-C), 83.6 and 84.0 (1'-C and 4'-C), 110.0 (5-C), 120.4, 125.0, 127.3 and 127.9 (fmoc tertiary aromatic C's), 136.0 (6-C), 141.0 and 143.4 (fmoc quaternary aromatic C's), 150.6 (4-C), 154.6 (2-C), 163.9 (C=O);  $m/z$  (FAB) 465 (MH<sup>+</sup>); HRMS (FAB) found 465.16618 (MH<sup>+</sup>), C<sub>25</sub>H<sub>25</sub>N<sub>2</sub>O<sub>7</sub> requires 465.16616 (<1ppm).



**5'-O-(9-Fluorenylmethoxycarbonyl)-thymidine-3'-O-N,N-diisopropyl methyl phosphoramidite**

**(136) 5'-O-Fmoc-T-3'-O-N,N-<sup>i</sup>Pr<sub>2</sub> Me phosphoramidite**

5'-O-(9-Fluorenylmethoxycarbonyl)-thymidine (1.214g, 2.616 mmol) (129) was co-evaporated with 50:50 pyridine : methylene chloride then the flask was closed with a septum pierced with a needle and placed in an evacuated desiccator overnight. The desiccator was then filled with argon and the needle removed. An argon filled balloon was attached to the flask. The nucleoside was dissolved in 15 ml tetrahydrofuran (not completely soluble) and N,N-diisopropylethylamine (1.82 ml, 10.47 mmol) and then N,N-diisopropyl(methyl)phosphoramidyl chloride (104) (2.03 ml, 10.47 mmol) were added. The reaction was stirred for 30 min. before being poured into 100 ml of argon saturated ethyl acetate and washed with the following argon saturated solutions: 2x100 ml water; 1x100 ml saturated aqueous sodium carbonate; 2x100 ml brine. The solution was then dried over sodium sulphate, filtered under argon, and the solvent removed *in vacuo* to give an oil which was dissolved in 6 ml toluene and precipitated into 200 ml hexane at -20°C. The precipitate was filtered off and dried in an evacuated desiccator to give the required product as a white solid (1.205g, 74%); softening point 76-81°C; tlc R<sub>f(B)</sub> 0.5; ν<sub>max</sub> (bromoform mull) 2980 (alkyl C-H); 1750 (fmoc C=O), 1720-1670 (thymidine C=O's), 1460-1370 cm<sup>-1</sup> (aromatic C-C); δ<sub>H</sub> (80 MHz, CDCl<sub>3</sub>) 1.17 (12H, d, J<sub>AB</sub> 6.8 Hz, <sup>i</sup>Pr CH<sub>3</sub>), 1.79 (3H, s, 5-CH<sub>3</sub>), 2.15 (1H, m, 2'-H), 2.44 (1H, m, 2'-H), 3.37 (3H, 2d, J<sub>POC-H</sub> 13.3 Hz, P-O-CH<sub>3</sub>), 3.52-3.73 (2H, m, <sup>i</sup>Pr CH), 4.17-4.59 (6H, m, fmoc α-CH<sub>2</sub> and β-CH, 3'-H, 4'-H and 5'-H's), 6.33 (1H, t, J<sub>AB</sub> 6.7 Hz, 1'-H), 7.17-7.80 (9H, m, 6-H and fmoc aromatic H's); δ<sub>C</sub> (90 MHz, CDCl<sub>3</sub>) 12.3 (5-CH<sub>3</sub>), 24.4 (d, J<sub>CCOP</sub> 7.5 Hz, <sup>i</sup>Pr CH<sub>3</sub>), 39.5 (d, J<sub>CCOP</sub> 5.5 Hz, 2'-C), 42.9 (d, 12.4 Hz, P-O-CH<sub>3</sub>), 46.6 (fmoc β-C), 50.3 (2d, J<sub>C-N-P</sub> 17.4 Hz, <sup>i</sup>Pr CH), 66.7 (fmoc

$\alpha$ -C), 69.8 (5'-C), 72.3 (2d,  $J_{\text{COP}}$  16.8 Hz, 3'-C), 83.3 (2d,  $J_{\text{CCOP}}$  4.6 Hz, 4'-C), 84.7 (2s, 1'-C), 111.1 (5-C), 120.0, 124.7, 127.0 and 127.8 (fmoc tertiary aromatic C's), 135.0 (6-C), 141.1 and 142.9 (fmoc quaternary aromatic C's), 150.2 (4-C), 154.7 (2-C), 163.7 ( $\text{CO}_3$ );  $\delta_{\text{p}}$  (36 MHz,  $\text{CDCl}_3$ ) 150.1 and 149.8;  $m/z$  (FAB) 626 ( $\text{MH}^+$ ); HRMS (FAB) found 626.26312 ( $\text{MH}^+$ ),  $\text{C}_{32}\text{H}_{41}\text{N}_3\text{O}_8\text{P}$  requires 626.26311 (<1ppm).

**5'-O-[9-Fluorenylmethoxycarbonyl]-thymidine-3'-O-N,N-diisopropyl**

**$\beta$ -cyanoethyl phosphoramidite**

**(130) 5'-O-Fmoc-T-3'-O-N,N-<sup>i</sup>Pr<sub>2</sub>- $\beta$ -CNEt phosphoramidite**

5'-O-[9-Fluorenylmethoxycarbonyl]-thymidine (129) (0.443g, 0.955 mmol) was co-evaporated with 50:50 pyridine : methylene chloride then closed with a septum pierced with a needle and placed in an evacuated desiccator overnight. The desiccator was then filled with argon and an argon filled balloon was attached to the flask. The nucleoside was dissolved in 4 ml tetrahydrofuran and N,N-diisopropylethylamine (0.664 ml, 3.82 mmol) then N,N-diisopropyl  $\beta$ -cyanoethyl phosphoramidyl chloride (0.612 ml, 3.82 mmol) were added. The reaction was stirred for 10 min. before methanol (0.12 ml, 2.86 mmol) was added to quench the excess phosphitylating agent. The reaction was poured into 25 ml of argon-saturated ethyl acetate and washed with the following argon-saturated solutions: 2x20 ml water; 1x20 ml saturated aqueous sodium carbonate; 1x20 ml brine. The ethyl acetate solution was dried over sodium sulphate and the solvent removed *in vacua*. The residue was dissolved in 4ml toluene and precipitated into 200 ml of hexane at  $-78^\circ\text{C}$ . The solid was filtered off and dried in an evacuated desiccator to give the required product as a white powder (0.539g, 85%); softening point  $46-49^\circ\text{C}$ ; tlc  $R_{\text{f(B)}}$  0.5;  $\nu_{\text{max}}$  (bromoform mull) 2980 (alkyl C-H), 1750 (fmoc C=O), 1720-1670 (thymidine C=O's),  $1470-1370\text{ cm}^{-1}$  (aromatic C-C);  $\delta_{\text{H}}$  (200 MHz,  $\text{CD}_3\text{CN}$ ) 1.18

(12H, m, <sup>i</sup>Pr CH<sub>3</sub>), 1.76 (3H, 2s, 5-CH<sub>3</sub>), 2.10–2.32 (2H, m, 2'-H), 2.65 (2H, m, <sup>i</sup>Pr CH), 3.28–3.82 (4H, m, β-cyanoethyl CH<sub>2</sub>CH<sub>2</sub>), 3.98–4.35 (4H, m, 3'-H, 4'-H and 5'-H's), 4.38–4.64 (3H, m, fmoc α-CH<sub>2</sub> and β-CH), 6.17 (1H, t, J<sub>AB</sub> 5.0 Hz, 1'-H), 7.25–7.83 (9H, m, fmoc aromatic H's and 6-H); δ<sub>C</sub> (50 MHz, CD<sub>3</sub>CN) 11.1 (5-CH<sub>3</sub>), 19.4 (cyanoethyl β-C) 23.3 (<sup>i</sup>Pr CH<sub>3</sub>), 37.8 (2'-C), 42.5 (d, J<sub>COP</sub> 12.3 Hz, P-O-CH<sub>2</sub>-), 46.1 (fmoc β-C), 57.7 (fmoc α-C), 60.9 (5'-C), 72.3 (d, J<sub>COP</sub> 17.3 Hz, 3'-C), 84.1 (d, J<sub>CCOP</sub> 6.9 Hz, 4'-C), 85.9 (2s, 1'-C), 109.7 (5-C), 116.8 (C≡N), 119.5, 124.3, 126.7 and 127.3 (fmoc tertiary C's), 135.1 (6-C), 140.7 and 143.0 (fmoc quaternary C's), 149.9 (4-C), 154.1 (2-C), 163.3 (CO<sub>3</sub>); δ<sub>P</sub> (36 MHz, CD<sub>3</sub>CN) 148.2; m/z 665 (MH<sup>+</sup>) 447.

**5'-O-[Bis (4-nitrophenyl)ethoxycarbonyl]-thymidine-3'-O-N,N-diisopropyl  
β-cyanoethyl phosphoramidite**

**(128) 5'-O-Bnpeoc-T-3'-O-N,N-<sup>i</sup>Pr<sub>2</sub>-β-CNEt phosphoramidite**

5'-O-[Bis (4-nitrophenyl)ethoxycarbonyl]-thymidine (107) (0.423g, 0.761 mmol) was co-evaporated twice with 10% pyridine in methylene chloride and then the flask was closed with a septum pierced with a needle and placed in an evacuated desiccator overnight. The desiccator was filled with argon and the needle was removed. An argon filled balloon was attached to the flask and the nucleoside was dissolved in 4 ml tetrahydrofuran. N,N-Diisopropylethylamine (0.53 ml, 3.04 mmol) and then N,N-diisopropyl β-cyanoethyl phosphoramidyl chloride (0.49 ml, 3.04 mmol) were added and the reaction was stirred for 10 min. before being quenched with methanol (0.09 ml, 2.28 mmol) and poured into 20 ml of argon-saturated ethyl acetate. This was washed with the following argon-saturated solutions: 1x20 ml water; 2x20 ml saturated aqueous sodium carbonate; 1x20 ml brine, dried over sodium sulphate and the solvent removed *in vacuo* to give a brown oil. The residue was dissolved in 2 ml ethyl

acetate and precipitated into 250 ml of hexane at  $-20^{\circ}\text{C}$ . The solid was filtered off and dried in an evacuated desiccator to give the **title compound** as a grey powder (0.515g, 90%); softening point  $67\text{--}71^{\circ}\text{C}$ ; tlc  $R_{f(B)}$  0.5;  $\nu_{\text{max}}$  (bromoform mull) 2980 (alkyl C-H), 1750 (bnpe C=O), 1720–1660 (thymidine C=O's), 1610, 1510 and 1470 (aromatic C-C), 1520 and  $1350\text{ cm}^{-1}$  ( $\text{NO}_2$ );  $\delta_{\text{H}}$  (200 MHz,  $\text{CDCl}_3$ ), 1.12 (12H, m,  $^i\text{Pr CH}_3$ ), 1.74 (3H, s, 5- $\text{CH}_3$ ), 2.16 (1H, m, 2'-H), 2.42 (1H, m, 2'-H), 2.61 (2H, m,  $^i\text{Pr CH}$ ), 3.48–3.82 (4H, m,  $\text{NCCH}_2\text{CH}_2\text{-}$ ), 4.13 (1H, m, 4'-H), 4.31–4.42 (3H, m, 3'-H and 5-H's), 6.22 (1H, t,  $J_{\text{AB}}$  6.0 Hz, 1'-H), 7.19 (1H, m, 6-H), 7.38 (4H, d,  $J_{\text{AB}}$  8.7 Hz, bnpe aromatic H's), 8.15 (4H, d,  $J_{\text{AB}}$  8.7 Hz, bnpe aromatic H's);  $\delta_{\text{C}}$  (50 MHz,  $\text{CDCl}_3$ ), 12.2 (5- $\text{CH}_3$ ), 20.1 (d,  $J_{\text{CCOP}}$  4.3 Hz, cyanoethyl  $\beta\text{-C}$ ), 24.3 ( $^i\text{Pr CH}$ ), 39.0 (2'-C), 43.1 (d,  $J_{\text{COP}}$  12.4 Hz, cyanoethyl  $\alpha\text{-C}$ ), 49.2 (bnpe  $\beta\text{-C}$ ), 67.0 (bnpe  $\alpha\text{-C}$ ), 68.6 (5'-C), 72.6 (2d,  $J_{\text{COP}}$  15.4 Hz, 3'-C), 82.9 (d,  $J_{\text{CCOP}}$  12.1 Hz, 4'-C), 84.9 (1'-C), 110.9 (5-C), 117.5 ( $\text{-C}\equiv\text{N}$ ), 124.0 and 129.0 (bnpe aromatic 2- and 3-C), 135.3 (6-C), 146.1 and 147.1 (bnpe aromatic 1- and 4-C), 150.1 (4-C), 154.2 (2-C), 163.6 ( $\text{CO}_3$ );  $\delta_{\text{P}}$  (36 MHz,  $\text{CDCl}_3$ ) 149.4;  $m/z$  (FAB) 757 ( $\text{MH}^+$ ) 539; HRMS (FAB) found 757.25981 ( $\text{MH}^+$ ),  $\text{C}_{34}\text{H}_{42}\text{N}_6\text{O}_{12}\text{P}$  requires 757.25981 ( $<1\text{ppm}$ ).

### **N-Methyl-N,N-dicyclohexylcarbodiimidium iodide**

#### **(139) N-Me-DCC iodide**

This compound was prepared by the method of Scheffold and Saladin<sup>132</sup> to give a 74% yield of very pale yellow crystals, mp  $109\text{--}111^{\circ}\text{C}$  (lit.  $111\text{--}113^{\circ}\text{C}$ ).

#### **2,2-Bis (4-nitrophenyl)ethyl iodide**

#### **(140) Bnpe I**

2,2-Bis (4-nitrophenyl)ethanol (1.440g, 5.00 mmol) was dissolved in 50 ml tetrahydrofuran and N-methyl-N,N-dicyclohexylcarbodiimidium iodide (139) (3.487g, 10.00 mmol) was added. The reaction was stirred for 24 hours under

nitrogen at 30°C. The solvent was removed *in vacuo* and the residue was dissolved in 50 ml methylene chloride and washed with 3x25 ml 50 : 50 methanol : water, 2x25 ml 1% aqueous sodium thiosulphate solution, 2x25 ml brine, dried over sodium sulphate and the methylene chloride evaporated *in vacuo* to produce a yellow oil. This was crystallised from chloroform and diethyl ether to give the **title compound** as a yellow solid (1.405g, 71%); mp 139–140°C; tlc  $R_{f(D)}$  0.5;  $\nu_{\max}$  (methylene chloride solution) 2980 (alkyl C–H), 1610 and 1540 (aromatic C–C), 1520 and 1350  $\text{cm}^{-1}$  ( $\text{NO}_2$ );  $\lambda_{\max}$  276 nm,  $\epsilon_{\max}$  21000;  $\delta_{\text{H}}$  (200 MHz,  $\text{CDCl}_3$ ) 3.75 (2H, d,  $J_{\text{AB}}$  7 Hz,  $\alpha\text{-CH}_2$ ), 4.54 (1H, t,  $J_{\text{AB}}$  7 Hz,  $\beta\text{-CH}$ ), 7.41 (4H, d,  $J_{\text{AB}}$  8 Hz, aromatic H's), 8.20 (4H, d,  $J_{\text{AB}}$  8 Hz, aromatic H's);  $\delta_{\text{C}}$  (50 MHz,  $\text{CDCl}_3$ ) 5.6 ( $\alpha\text{-C}$ ), 53.4 ( $\beta\text{-C}$ ), 124.1 (aromatic 3-C), 128.5 (aromatic 2-C), 147.1 and 148.1 (aromatic 1- and 4-C).

### **1-Methyl-3-[2,2-Bis (4-nitrophenyl)ethoxycarbonyl]-imidazolium chloride**

#### **(142) 1-Me-3-Bnpeoc-Im Cl**

Prepared by the method of Pfeleiderer<sup>111</sup>

2,2-Bis (4-nitrophenyl)ethyl chloroformate (**106**) (9.526g, 27.18 mmol) was dissolved in 100 ml of methylene chloride and cooled to 0°C. 1-Methylimidazole (2.16 ml, 27.18 mmol) was added and the reaction was stirred under nitrogen for 15 min. then allowed to reach room temperature. The solid was filtered off and washed with methylene chloride then dried to give the **title compound** as a white solid (10.78g, 92%); mp 160–162°C;  $\nu_{\max}$  (bromoform mull) 2960 (alkyl C–H), 1790 (C=O), 1600 (aromatic C–C), 1520 and 1350  $\text{cm}^{-1}$  ( $\text{NO}_2$ );  $\delta_{\text{H}}$  (200 MHz,  $d_6\text{-DMSO}$ ) 3.88 (3H, s,  $-\text{CH}_3$ ), 4.79 (3H, s, bnpe  $\alpha\text{-CH}_2$  and  $\beta\text{-CH}$ ), 7.62 (4H, d,  $J_{\text{AB}}$  8.4 Hz, bnpe aromatic H's), 7.63 (2H, m, imidazole H's), 8.16 (4H, d,  $J_{\text{AB}}$  8.7 Hz, bnpe aromatic H's), 9.13 (1H, s, imidazole H);  $\delta_{\text{C}}$  (50 MHz,  $d_6\text{-DMSO}$ ) 36.7 ( $-\text{CH}_3$ ), 48.4 (bnpe  $\beta\text{-C}$ ), 70.8 (bnpe  $\alpha\text{-C}$ ), 119.6

and 119.9 (imidazole 4- and 5-C), 124.0 (bnpe aromatic 3-C), 125.1 (imidazole 2-C), 130.0 (bnpe aromatic 2-C), 146.8 and 147.3 (bnpe aromatic 1- and 4-C);  $m/z$  (FAB) 433 ( $MH^+$ ) 397 ( $M-Cl$ ) 83; HRMS (FAB) found 397.11479 ( $MH^+$ ),  $C_{19}H_{17}N_4O_6$  requires 397.11480 (<1ppm).

**3',5'-O-(Tetraisopropylidisiloxane-1,3-diyl)-2'-deoxyadenosine**

**(141) 3',5'-O-<sup>i</sup>Pr<sub>4</sub>Si<sub>2</sub>O-2'-dA**

2'-Deoxyadenosine (2.803g, 10.42 mmol) was co-evaporated twice with pyridine then dissolved in 40 ml of N,N-dimethylformamide. Imidazole (3.124g, 45.89 mmol) then 1,3-dichloro-1,1,3,3-tetraisopropylidisiloxane (3.70 ml, 10.56 mmol) were added and the reaction was stirred for 1 hour. The solvent was evaporated *in vacuo* and the residue was dissolved in 50 ml methylene chloride. The precipitate of imidazole hydrochloride was filtered off and the remaining solution was purified by dry flash chromatography, eluting with 0-2% methanol in methylene chloride to give the required compound as a pale yellow glass (4.897g, 95%); softening point 44-46°C; tlc  $R_{f(A)}$  0.3;  $\nu_{max}$  (bromoform mull) 3480 and 3400 (N-H), 2960-2860 (alkyl C-H), 1540 and 1460  $cm^{-1}$  (aromatic C-H);  $\delta_H$  (80 MHz,  $CDCl_3$ ) 0.97 (228H, m, <sup>i</sup>Pr  $CH_3$  and <sup>i</sup>Pr CH), 2.62 (2H, m, 2'-H's) 3.78-4.00 (3H, m, 4'-H and 5'-H's), 4.85 (1H, m, 3'-H), 5.76 (2H, br.s,  $NH_2$ ), 6.25 1H, t,  $J_{AB}$  6.3 Hz, 1'-H), 7.96 and 8.23 (2H, 2s, 2-H and 8-H);  $\delta_C$  (50 MHz,  $CDCl_3$ ), 12.6 (<sup>i</sup>Pr CH), 16.9 (<sup>i</sup>Pr  $CH_3$ ), 39.7 (2'-C), 61.9 (5'-C), 70.1 (3'-C), 82.3 (4'-C), 84.9 (1'-C), 119.8 (5-C), 138.3 (2-C), 148.5 (6-C), 152.5 (8-C), 155.8 (4-C);  $m/z$  (FAB) 494 ( $MH^+$ ).

**3',5'-O-(Tetraisopropyldisiloxane-1,3-diyl)-N<sup>6</sup>-[2,2-bis(4-nitrophenyl)ethoxy-carbonyl]-2'-deoxyadenosine**

**(143) 3',5'-O-<sup>i</sup>Pr<sub>4</sub>Si<sub>2</sub>O-N<sup>6</sup>-bnpeoc-2'-dA**

3',5'-O-(tetraisopropyldisiloxane-1,3-diyl)-2'-deoxyadenosine (**141**) (0.232g, 0.47 mmol) was dissolved in 10 ml of carbon tetrachloride and 1-methyl-3-[2,2-bis(4-nitrophenyl)ethoxycarbonyl]-imidazolium chloride (**142**) (0.404g, 0.94 mmol) was added and the reaction was refluxed for 3 hours. The solvent was then evaporated *in vacuo* and the residue was purified by flash silica chromatography, eluting with methylene chloride to give the **title compound** as a white foam (0.075g, 20%); softening point 96–99°C; R<sub>f(A)</sub> 0.7; ν<sub>max</sub> (methylene chloride solution) 3400 (N-H), 3050 (aromatic C-H), 2960 and 2880 (alkyl C-H), 1760 (C=O), 1610, 1510 and 1460 (aromatic C-C), 1520 and 1350 cm<sup>-1</sup> (NO<sub>2</sub>); δ<sub>H</sub> (200 MHz, CDCl<sub>3</sub>) 0.99–1.04 (28H, m, <sup>i</sup>Pr CH<sub>3</sub> and CH), 2.66 (2H, m, 2'-H's), 3.87 (1H, m, 4'-H), 4.01 (2H, m, 5'-H's), 4.71 (1H, m, 3'-H), 4.81–4.91 (3H, m, bnpe α-CH<sub>2</sub> and β-CH), 6.29 (1H, t, J<sub>AB</sub> 6.0 Hz, 1'-H), 7.40 (4H, d, J<sub>AB</sub> 8.7 Hz, bnpe *p*-disubstituted aromatic H's), 8.14 (4H, d, J<sub>AB</sub> 8.6 Hz, bnpe *p*-disubstituted aromatic H's), 8.14 (1H, s, 2-H), 8.61 (1H, s, 8-H), 9.14 (1H, s, amide H); δ<sub>C</sub> (50 MHz, CDCl<sub>3</sub>) 12.7 (<sup>i</sup>Pr CH), 17.1 (<sup>i</sup>Pr CH<sub>3</sub>), 39.7 (2'-C), 49.4 (bnpe β-C), 61.5 (5'-C), 66.5 (bnpe α-C), 69.6 (3'-C), 83.3 (4'-C), 85.2 (1'-C), 122.6 (5-C), 123.9 (bnpe aromatic 3-C), 129.0 bnpe aromatic 2-C), 141.4 (2-C), 146.3 and 147.1 (bnpe 1- and 4-C), 148.9 (6-C), 150.6 (4-C), 152.2 (8-C); m/z (FAB) 808 (MH<sup>+</sup>) 494 (M-bnpeoc); HRMS (FAB) found 808.31576 (MH<sup>+</sup>), C<sub>37</sub>H<sub>50</sub>N<sub>7</sub>O<sub>10</sub>Si<sub>2</sub> requires 808.31575 (<1ppm).

### 3.3. Stability studies

#### Stability of 5'-O-Bnpeoc-Thymidine (107) to triethylamine

5'-O-Bnpeoc-thymidine (107) (0.015g, 0.027 mmol) was dissolved in either 1 ml of **a**, 10% triethylamine/ 90% methylene chloride or **b**, 10% triethylamine/ 90% acetonitrile. The stability of the protected nucleoside was monitored by tlc, 5'-O-Bnpeoc-thymidine ( $R_{f(A)}$  0.4) is converted to thymidine ( $R_{f(A)}$  0.2) and 1,1-*bis*(4-nitrophenyl)ethene ( $R_{f(A)}$  0.8). When methylene chloride (**a**) was used as the solvent the nucleoside remained stable for 24 hours, and showed only slight cleavage after 7 days. The acetonitrile solution (**b**) resulted in a small amount of cleavage after 30 min. and was completely cleaved within 24 hours.

#### Stability of 5'-O-Bnpeoc-thymidine (107) to N,N-diisopropylethylamine

5'-O-Bnpeoc-thymidine (107) (7.7mg, 0.014 mmol) was dissolved in 0.5 ml of tetrahydrofuran and N,N-diisopropylethylamine (9.6  $\mu$ l, 0.056 mmol) was added. The stability of the nucleoside was monitored by tlc, (5'-O-Bnpeoc-thymidine  $R_{f(A)}$  0.4), but no change was observed after 2 hours.

#### Stability of 5'-O-Bnpeoc-thymidine (107) to 4-N,N-dimethylaminopyridine

5'-O-Bnpeoc-thymidine (107) (5mg, 0.009 mmol) was dissolved in either 1ml of **a**, methylene chloride or **b**, pyridine and N,N-dimethylaminopyridine (1mg, 0.009 mmol) was added. The stability of the protected nucleoside was determined by tlc: 5'-O-Bnpeoc-thymidine ( $R_{f(A)}$  0.4) is converted to thymidine ( $R_{f(A)}$  0.2) and 1,1-*bis*(4-nitrophenyl)ethene ( $R_{f(A)}$  0.8).

With both methylene chloride and pyridine as the solvent tlc indicated a small amount of cleavage after 24 hours.



### Stability of 5'-O-Bnpeoc-thymidine (107) to tetrazole

5'-O-Bnpeoc-thymidine (107) (0.0056g, 0.010 mmol) was dissolved in a 0.5 M solution of tetrazole in acetonitrile (0.5 ml, 0.025 mmol) and tlc showed that the protected nucleoside was stable for at least 2 hours.

### Deprotection of 5'-O-Bnpeoc-thymidine (107) with DBU acetate

5'-O-Bnpeoc-thymidine (107) (0.010g, 0.018 mmol) was dissolved in 1 ml of acetonitrile and DBU (3.2  $\mu$ l, 0.022 mmol) and acetic acid (1.2  $\mu$ l, 0.022 mmol) were added and the deprotection was followed by tlc: 5'-O-Bnpeoc-thymidine ( $R_{f(A)}$  0.4) is converted to thymidine ( $R_{f(A)}$  0.2) and 1,1-bis(4-nitrophenyl)ethene ( $R_{f(A)}$  0.8). A small degree of cleavage was detected after 3 min. and after 40 min. about 50% of the nucleoside had been deprotected.

### Deprotection of 5'-O-Bnpeoc-thymidine (107) with DBU

5'-O-Bnpeoc-thymidine (107) (0.310g, 0.558 mmol) was dissolved in 5 ml of acetonitrile and DBU (0.83 ml, 5.58 mmol) was added, the pale yellow solution turned dark green. After stirring for 10 min. tlc indicated that the deprotection was completed. The solvent was removed *in vacuo* and the residue was purified by dry flash chromatography, eluting with 0-10% methanol in methylene chloride.

A white, crystalline solid, found to be thymidine, was isolated (0.094g, 70%); mp 183-185°C, (thymidine 187-189°C; tlc  $R_{f(A)}$  0.2;  $\delta_H$  (80 MHz,  $D_6$ -DMSO) 1.77 (3H, s, 5-CH<sub>3</sub>), 2.07 (2H, m, 2'-H), 3.59 (2H, m, 5'-H's), 3.74 (1H, m, 4'-H), 4.24 (1H, m, 3'-H), 4.79 (1H, br.s, 5'-OH), 5.16 (1H, br.s, 3'-OH), 6.16 (1H, t,  $J_{AB}$  6.5 Hz, 1'-H), 7.67 (1H, s, 6-H), 11.17 (1H, br.s, amide H).

### Deprotection of Bnpe benzyl carbonate (111) with DBU acetate

Bnpe benzyl carbonate (111) (0.005g, 0.012 mmol) was dissolved in 1 ml of acetonitrile and DBU acetate (10 equivalents) was added. The deprotection was followed by tlc: bnpe benzyl carbonate ( $R_{f(C)}$  0.6) is converted to benzyl alcohol ( $R_{f(C)}$  0.4) and 1,1-*bis*(4-nitrophenyl)ethene ( $R_{f(C)}$  0.7).

After 30 min. most of the carbonate remained intact.

### Deprotection of bnpe benzyl carbonate (111) with DBU

Bnpe benzyl carbonate (111) (0.010g, 0.024 mmol) was dissolved in 1 ml of acetonitrile and DBU (1 equivalent) was added. The deprotection was followed by tlc: bnpe benzyl carbonate ( $R_{f(C)}$  0.6) is converted to benzyl alcohol ( $R_{f(C)}$  0.4) and 1,1-*bis*(4-nitrophenyl)ethene ( $R_{f(C)}$  0.7). The deprotection was monitored every minute and was complete after 4 min.

The above procedure was repeated using 5 equivalents of DBU and found to be complete after 2 min, and with 25 equivalents of DBU was complete in less than 30 seconds.

### Deprotection of 5'-O-Bnpeoc-N<sup>6</sup>-Benzoyl-2'-deoxyadenosine (123) with DBU

5'-O-Bnpeoc-N<sup>6</sup>-Benzoyl-2'-deoxyadenosine (123) (0.0068g, 0.010 mmol) was dissolved in 1ml of acetonitrile and DBU (1 equivalent) was added. The deprotection was monitored by tlc: 5'-O-Bnpeoc-N<sup>6</sup>-2'-deoxyadenosine ( $R_{f(A)}$  0.4) is converted to N<sup>6</sup>-benzoyl-2'-deoxyadenosine ( $R_{f(A)}$  0.2) and 1,1-*bis*(4-nitrophenyl)ethene ( $R_{f(A)}$  0.8). The deprotection was complete after 10 min.

The above procedure was repeated several times using varying amounts of DBU and different solvents, see table 2.

Table 2

<u>DBU (equivalents)</u>	<u>Solvent</u>	<u>Deprotection Time</u>
1	acetonitrile	10 min.
10	acetonitrile	5 min.
10	CH <sub>2</sub> CH <sub>2</sub>	> 10 min.
10	DMF	1 min.
100	DMF	15 sec.

The procedure was also repeated using 10 equivalents of DBU acetate in DMF and the deprotection was complete after 8 min.

**Deprotection of 5'-O-Bnpeoc-N<sup>6</sup>-benzoyl-2'-deoxyadenosine (123) with piperidine**

5'-O-Bnpeoc-N<sup>6</sup>-benzoyl-2'-deoxyadenosine (123) was dissolved in 1 ml of DMF and piperidine (10 equivalents) was added. The reaction was followed by tlc: 5'-O-Bnpeoc-N<sup>6</sup>-benzoyl-2'-deoxyadenosine ( $R_{f(A)}$  0.4) is converted to N<sup>6</sup>-benzoyl-2'-deoxyadenosine ( $R_{f(A)}$  0.2) and 1,1-bis(4-nitrophenyl)ethene ( $R_{f(A)}$  0.8). The deprotection was complete after 12 min.

The above procedure was repeated using 100 equivalents of DBU in DMF and the deprotection was completed in 5 min.

**Stability of the SARC linker to DBU in DMF**

5'-O-DMTr-thymidine bound to controlled pore glass resin by the SARC linker (0.004g) was suspended in 0.5 ml of 10% DBU in DMF for 10 min. The resin was removed by filtration and was treated with 1 ml of 60% aqueous concentrated hydrochloric acid / 40% ethanol to produce an orange solution. When the filtrate was treated with the same acid solution no orange colour was observed.

### Stability of resin bound 1-, 2-, 3- and 4-residue oligonucleotides to DBU in DMF

The polynucleotides dA, dApdA, dApdApdA, and dApdApdApdA were prepared on an ABI 380b synthesizer and left bound to the resin via the SARC linker. These resin bound polynucleotides were washed with 10% DBU in DMF for 5 min. then cleaved in concentrated aqueous ammonia at 50°C and the amount of oligonucleotide present was determined by measuring the uv absorbance at 260 nm.

The above experiment was repeated without the DBU/DMF as a control. When the results were compared the monomer showed 5% cleavage from the resin but the dimer, trimer and tetramer appeared stable.

### Stability of 5'-O-Bnpeoc-thymidine-3'-O-acetate (125) to I<sub>2</sub>/H<sub>2</sub>O

5'-O-Bnpeoc-thymidine-3'-O-acetate (125) (0.125g, 0.209 mmol) was dissolved in 2 ml of tetrahydrofuran and a solution of iodine (0.1M) in water : 2,6-lutidine : tetrahydrofuran (1:10:40) (4.18 ml, 0.418 mmol) was added. The solution was stirred for one hour then the solvent was removed *in vacua*. The residue was dissolved in 50 ml of methylene chloride and washed with 1x40 ml water, 2x40 ml 10% aqueous sodium thiosulphate solution, 1x40 ml brine, dried over sodium sulphate and the solvent removed *in vacuo* to give a pale yellow foam (0.121g, 97%); tlc R<sub>f(A)</sub> 0.7; <sup>1</sup>H n.m.r. and <sup>13</sup>C n.m.r. were identical with the starting material.

### Coupling of 5'-O-Bnpeoc-N<sup>3</sup>-An-T-3'-O-N,N-<sup>i</sup>Pr<sub>2</sub>/Me phosphoramidite (116) with methanol

5'-O-Bnpeoc-N<sup>3</sup>-An-T-3'-O-N,N-<sup>i</sup>Pr<sub>2</sub>/Me phosphoramidite (116) (0.010g, 0.012 mmol) was dissolved in 0.2 ml acetonitrile and methanol (2 μl, 0.051

mmol) and tetrazole solution (0.5 M) (0.12 ml, 0.06 mmol) were added. The reaction was monitored by tlc: 5'-O-Bnpeoc-N<sup>3</sup>-3'-O-N,N-<sup>i</sup>Pr<sub>2</sub>Me phosphoramidite ( $R_{f(B)}$  0.7) reacted to give a product of  $R_{f(B)}$  0.6 within 2 min.

**Coupling of 5'-O-DMTr-T-3'-O-N,N-<sup>i</sup>Pr<sub>2</sub>Me phosphoramidite with methanol**

5'-O-DMTr-T-3'-O-N,N-<sup>i</sup>Pr<sub>2</sub>Me phosphoramidite (0.011g, 0.016 mmol) was dissolved in 0.2 ml of acetonitrile and methanol (3  $\mu$ l, 0.08 mmol) and tetrazole solution (0.5 M) (0.16 ml, 0.08 mmol) were added. The reaction was monitored by tlc: 5'-O-DMTr-T-3'-O-N,N-<sup>i</sup>Pr<sub>2</sub>Me phosphoramidite ( $R_{f(B)}$  0.6) reacted to give a product of  $R_{f(B)}$  0.5 within 2 min.

**Coupling of 5'-O-Bnpeoc-N<sup>3</sup>-An-T-3'-N,N-<sup>i</sup>Pr<sub>2</sub>Me phosphoramidite (116) with T-3'-OAc (5)**

5'-O-Bnpeoc-N<sup>3</sup>-An-T-3'-N,N-<sup>i</sup>Pr<sub>2</sub>Me phosphoramidite (116) (0.065g, 0.076 mmol) was dissolved in 2 ml of acetonitrile and 3'-O-acetyl-thymidine (5) (0.043g, 0.153 mmol) then tetrazole (0.5M in acetonitrile) (0.76 ml, 0.38 mmol) were added and the reaction was monitored by tlc: 5'-O-Bnpeoc-N<sup>3</sup>-An-T-3'-N,N-<sup>i</sup>Pr<sub>2</sub>Me phosphoramidite ( $R_{f(B)}$  0.7) and 3'-O-acetyl-thymidine ( $R_{f(B)}$  0.1) reacted to give a product at  $R_{f(B)}$  0.3. The reaction was complete after 20 min.

### 3.4. Phosphorus N.M.R. Studies

#### Coupling of 5'-O-Bnpeoc-T-3'-O-N,N-<sup>i</sup>Pr<sub>2</sub>Me phosphoramidite (108) with 3'-O-benzoyl-T (131)

5'-O-Bnpeoc-T-3'-O-N,N-<sup>i</sup>Pr<sub>2</sub>Me phosphoramidite (108) (0.026g, 0.036 mmol) was dissolved in 0.5 ml of CD<sub>3</sub>CN,  $\delta_P$  (36 MHz, CD<sub>3</sub>CN) 149.2, and 3'-O-benzoyl-thymidine (131) (0.062g, 0.18 mmol) and tetrazole (0.013g, 0.18 mmol) were added.  $\delta_P$  (36 MHz, CD<sub>3</sub>CN) 139.9 (45%) and 9.3 (55%). Iodine (0.05M) in water : 2,6-lutidine : THF (1:10:40) (0.71 ml, 0.036 mmol) was added and after 5 min. the solvents were removed *in vacua*. The residue was redissolved in CD<sub>3</sub>CN,  $\delta_P$  (36 MHz, CD<sub>3</sub>CN) -1.3 (49%), -1.5 (37%) and -2.7 (14%).

#### Coupling of 5'-O-Bnpeoc-thymidine-3'-O-N,N-<sup>i</sup>Pr<sub>2</sub>Me phosphoramidite (108) with methanol

5'-O-Bnpeoc-thymidine-3'-O-N,N-<sup>i</sup>Pr<sub>2</sub>Me phosphoramidite (e5) (0.033g, 0.046 mmol) was dissolved in 0.5 ml of CD<sub>3</sub>CN,  $\delta_P$  (36 MHz, CD<sub>3</sub>CN) 149.0. Methanol (9.3  $\mu$ l, 0.23 mmol) and tetrazole (0.016g, 0.23 mmol) were added,  $\delta_P$  (36 MHz, CD<sub>3</sub>CN) 140.4. Iodine (0.1M) in water : pyridine : THF (1:10:40) (0.46 ml, 0.046 mmol) was added and after 10 min. the solvents were evaporated *in vacuo* and the residue was dissolved in 0.5 ml of CD<sub>3</sub>CN,  $\delta_P$  (36 MHz, CD<sub>3</sub>CN) -0.4 and -1.5.

#### Coupling of 5'-O-Fmoc-thymidine-3'-O-N,N-<sup>i</sup>Pr<sub>2</sub>Me phosphoramidite (130) with methanol

5'-O-Fmoc-thymidine-3'-O-N,N-<sup>i</sup>Pr<sub>2</sub>Me phosphoramidite (130) (0.050g, 0.080 mmol) was dissolved in 0.5 ml of CD<sub>3</sub>CN,  $\delta_P$  (36 MHz, CD<sub>3</sub>CN) 149.0. Methanol

(16  $\mu$ l, 0.40 mmol) and tetrazole (0.028g, 0.40 mmol) were added,  $\delta_p$  (36 MHz,  $CD_3CN$ ) 140.3. Iodine (0.1M) in water : pyridine : THF (1:10:40) (0.80 ml, 0.080 mmol) was added and after 10 min. the solvents were evaporated *in vacuo* and the residue was dissolved in 0.5 ml of  $CD_3CN$ ,  $\delta_p$  (36 MHz,  $CD_3CN$ ) -0.5 and -1.4.

**Coupling of 5'-O-DMTr-thymidine-3'-O-N,N-<sup>i</sup>Pr<sub>2</sub>Me phosphoramidite with methanol**

5'-O-DMTr-thymidine-3'-O-N,N-<sup>i</sup>Pr<sub>2</sub>Me phosphoramidite (0.049g, 0.069 mmol) was dissolved in 0.5 ml of  $CD_3CN$ ,  $\delta_p$  (36 MHz,  $CD_3CN$ ) 148.6. Methanol (14  $\mu$ l, 0.35 mmol) and tetrazole (0.024g, 0.35 mmol) were added,  $\delta_p$  (36 MHz,  $CD_3CN$ ) 140.1. Iodine (0.1M) in water : pyridine : THF (1:10:40) (0.69 ml, 0.069 mmol) was added and after 10 min. the solvents were evaporated *in vacuo* and the residue was dissolved in 0.5 ml of  $CD_3CN$ ,  $\delta_p$  (36 MHz,  $CD_3CN$ ) 0.9, -0.5 and -1.3.

**Reaction of  $PCl_3$  with 2,2,2-triphenylethanol (119)**

2,2,2-Triphenylethanol (0.056g, 0.20 mmol) was dissolved in  $CDCl_3$  and phosphorus trichloride (0.012 ml, 0.14 mmol) was added,  $\delta_p$  (36 MHz,  $CD_3CN$ ) 220 ( $PCl_3$ , 41%) and 177 ( $Ph_3CCH_2OPCl_2$ , 59%).

**Reaction of  $PCl_3$  with 2,2,2-triphenylethyl,trimethylsilyl ether**

2,2,2,-Triphenylethyl,trimethylsilyl ether (prepared as for (120)) (0.32g, 0.93 mmol) was dissolved in 5 ml of methylene chloride and phosphorus trichloride (0.082 ml, 0.93 mmol) was added. The reaction was stirred for 5 min. then the solvents were evaporated *in vacuo* to produce a white foam.  $\delta_p$  (36 MHz,  $CD_3CN$ ):

177 [ $Ph_3CCH_2OPCl_2$ , 6%];

165 [(PH<sub>3</sub>CCH<sub>2</sub>O)<sub>2</sub>PCI 11%];

138 [(Ph<sub>3</sub>CCH<sub>2</sub>O)<sub>3</sub>P 28%];

7 [oxidised products 56%].

The above procedure was repeated with varying amounts of the silyl ether and at various temperatures, to give different proportions of the alcohol substituted phosphorus compounds, see table 3.

Table 3

Equivalents of alcohol	Temp °C	Mono- (%)	Di- (%)	Tri-sub. (%)	Oxidised (%)
1	20	6	11	28	56
4	20	0	0	84	16
1	-30	71	17	0	12
1	-78	70	0	0	30

The Reaction of triethylammonium (5'-O-DMTr-thymidine-3'-O-2-chlorophenyl) phosphate with 2-cyanoethanol

Triethylammonium (5'-O-DMTr-thymidine-3'-O-2-chlorophenyl) phosphate (0.053g, 0.064 mmol) was co-evaporated twice with pyridine then dissolved in 0.5 ml of 50:50 pyridine : CD<sub>3</sub>CN. Mesitylenesulphonyl-3-nitro-1,2,4-triazole (0.094g, 0.32 mmol) was added,  $\delta_p$  (36 MHz, CD<sub>3</sub>CN) -20.5. The sample was cooled to -30°C and 2-cyanoethanol (0.022 ml, 0.32 mmol) was added and the reaction was monitored by <sup>31</sup>P n.m.r. at -30°C, see table 4.

$\delta_p$  (36 MHz, CD<sub>3</sub>CN):

-7.0 (Starting material)

-20.1 (Starting material-MSNT complex)

-8.1 (Product)



The product is 5'-O-DMTr-thymidine-3'-O-2-chlorophenyl, $\beta$ -cyanoethyl phosphate.

**Table 4**

Time (min.-sec.)	Starting Material (%)	Product (%)	MSNT Complex (%)
0	0	0	100
1-10	34	15	50
4-10	47	18	35
8-00	51	23	26
11-00	55	24	21
13-50	57	27	16
16-40	58	29	13
19-30	60	29	11
22-30	60	31	9
25-20	62	31	7
28-20	61	33	6
31-10	65	35	0

The above procedure was repeated adding 1-methylimidazole (0.051 ml, 0.64 mmol) as an accelerating agent with the 2-cyanoethanol. Monitoring the reaction under the same conditions showed that the starting material-MSNT complex had been converted to starting material and product within 50 seconds.

The procedure was also repeated adding zinc iodide (0.204g, 0.64 mmol) as a potential accelerating agent with the 2-cyanoethanol. Monitoring the reaction under the same conditions gave the results shown in table 5.

$\delta_p$  (36 MHz,  $CD_3CN$ ):

-7.1 (Starting material)

-20.2 (Starting material-MSNT complex)

-9.6 (Product)

Table 5

<b>Time (min.-sec.)</b>	<b>Starting Material (%)</b>	<b>Product (%)</b>	<b>MSNT Complex (%)</b>
0-00	0	0	100
1-30	0	53	47
4-50	0	71	29
8-10	0	78	22
11-20	0	81	19
25-10	0	90	10
28-10	0	93	7

### 3.5. Oligodeoxynucleotide Synthesis

All syntheses were performed on an ABI 380b DNA synthesizer using 10 mg of functionalised resin. The monomers were dissolved in anhydrous acetonitrile, DBU and piperidine were distilled from potassium hydroxide, and all other reagents were as supplied by ABI or Cruachem. At the end of the synthesis the oligonucleotide was cleaved from the resin by treatment with concentrated aqueous ammonia and the benzoyl protection on the exocyclic amine function of 2'-deoxyadenosine was removed by heating the ammonium hydroxide solution to 50°C for 5 hours. The water and ammonia were removed *in vacuo* and the residue was dissolved in 1 ml of water and analysed by reverse phase and/or ion-exchange HPLC.

5'-O-Protecting groups:

Bnpeoc = 2,2-*bis* (4-nitrophenyl)ethoxycarbonyl;

Fmoc = 9-fluorenylmethoxycarbonyl;

DMTr = 4,4'-dimethoxytrityl.

Phosphorus protecting groups:

N,N-Diisopropylphosphoramidites were used with either methyl or  $\beta$ -cyanoethyl protection. At the end of the synthesis the methyl groups were removed with thiophenol and the  $\beta$ -cyanoethyl groups were removed by the aqueous ammonia treatment.

Resin:

Controlled pore glass (CPG) was used as a solid support and the first nucleoside was attached to it *via* the succinyl-sarcosyl (SARC) linker.

**5'-Deprotection:**

For the Fmoc and Bnpeoc groups this was mainly performed with a 10% solution of DBU in acetonitrile, DMF or methylene chloride, but piperidine in acetonitrile was also used. When using the DMTr group 10% trichloroacetic acid in methylene chloride was used.

The conditions for the syntheses can be seen in table 6.

**Table 6**

Protocol	Sequence	5'-Protection	P-Protection	Deprotection reagent	Deprotection time (s)
1	A	DMTr	$\beta$ -CNEt	TCA/DCM	50
2	A	Bnpeoc	Me	DBU/MeCN	120
3	A	DMTr	Me	TCA/DCM	50
4	A	DMTr	Me	TCA/DCM	50
5	A	DMTr	$\beta$ -CNEt	TCA/DCM	50
6	A	DMTr	$\beta$ -CNEt	TCA/DCM	50
7	A	DMTr	Me	TCA/DCM	50
8	B	DMTr	$\beta$ -CNEt	TCA/DCM	50
9	B	Bnpeoc	Me	DBU/DCM	50
10	B	Bnpeoc	Me	DBU/DMF	50
11	B	DMTr	$\beta$ -CNEt	TCA/DCM	50
12	B	Fmoc	Me	DBU/MeCN	180
13	B	Bnpeoc	Me	DBU/MeCN	180
14	A	Bnpeoc	$\beta$ -CNEt	DBU/MeCN	50
15	A	Bnpeoc	$\beta$ -CNEt	Pip./MeCN	60
16	A	Fmoc	$\beta$ -CNEt	DBU/DMF	100
17	A	Bnpeoc	$\beta$ -CNEt	DBU/DMF	200

where  $A=(Tp)_5T$  and  $B=(dAp)_7dA$ . Pip.=piperidine

The sequences prepared by protocols (1) and (8) were prepared for use in comparative HPLC studies.

(3A) and (5A) were treated with a solution of 10% DBU in acetonitrile for 10 min. before the final DMTr deprotection, removal of the methyl groups from phosphorus, or cleavage of the oligonucleotide from the resin.

(4A) and (6A) were treated with a solution of 10% DBU in acetonitrile for 10 min. after the final DMTr deprotection and before removal of the methyl groups from phosphorus or cleavage of the oligonucleotide from the resin.

The sequence prepared by protocol (7) was treated with a solution of 10% piperidine in acetonitrile for 10 min. before the final DMTr deprotection, removal of the methyl groups from phosphorus or cleavage of the oligonucleotide from the resin.

(11B) was treated with a solution of 10% DBU in DMF for 10 min. after the final DMTr deprotection and before removal of the methyl groups from phosphorus or cleavage of the oligonucleotide from the resin.

The monomers used in protocols (12) and (13) were protected on the N<sup>3</sup>-position of thymidine with the anisoyl group.

#### HPLC Analysis of the oligodeoxynucleotide syntheses

##### (1A) (Standard)

Reverse phase HPLC  $R_{t(A)}$  27 min.

Reverse phase HPLC  $R_{t(B)}$  17 min.

Ion-exchange HPLC  $R_{t(C)}$  13 min.

##### (2A)

Reverse phase HPLC  $R_{t(A)}$  28 min. (small broad peak)

Ion-exchange HPLC  $R_{t(C)}$  13 min.

This peak was isolated using preparative ion-exchange HPLC and then

re-examined on reverse phase HPLC.

Reverse phase HPLC  $R_{t(B)}$  17 min. 18 min. and 19 min. (small peak)

(3A)

Reverse phase HPLC  $R_{t(B)}$  17 min. 18 min. 19 min. and 21 min.

Ion-exchange HPLC  $R_{t(C)}$  8 min.

(4A)

Reverse phase HPLC  $R_{t(B)}$  15 min. 17 min. 18 min. 19 min.

Ion-exchange HPLC  $R_{t(C)}$  6 min.

(5A)

Reverse phase HPLC  $R_{t(B)}$  18 min.

(6A)

Reverse phase HPLC  $R_{t(B)}$  18 min.

(7A)

Reverse phase HPLC  $R_{t(B)}$  16 min. 17 min.

(8B) (Standard)

Reverse phase HPLC  $R_{t(D)}$  19 min.

Reverse phase HPLC  $R_{t(E)}$  27 min.

(9B)

Reverse phase HPLC  $R_{t(D)}$  6 min. 14 min. 16 min. 17 min. 17.5 min. 18 min. 18.5 min. 19 min. (peaks get progressively smaller)

Ion-exchange HPLC  $R_{t(C)}$  4 min. 5 min. 8 min. 12 min. 16 min. 19 min. 22 min. (peaks get progressively smaller), ((8B)  $R_{t(C)}$  24 min.)

(10B)

Reverse phase HPLC  $R_{t(E)}$  26 min. 29 min.

(11B)

Ion-exchange HPLC  $R_{t(C)}$  7 min. ((8B)  $R_{t(C)}$  7 min.)

(12B)

Ion-exchange HPLC  $R_{t(F)}$  15 min. (small peak), ((1A)

$R_{t(F)}$  14 min.)

(13B)

Ion-exchange HPLC  $R_{t(F)}$  no product

(14A)

Reverse phase HPLC  $R_{t(E)}$  25 min. 32 min. 34 min. 35 min. 36 min. 37 min. (small peaks), ((1A)  $R_{t(E)}$  37 min.)

Ion-exchange HPLC  $R_{t(F)}$  3 min. 3.5 min. 4 min. 4.5 min. 5 min.

((1A)  $R_{t(F)}$  5 min.)

(15A)

Ion-exchange HPLC  $R_{t(F)}$  3 min. 4 min. 5 min.

(16A)

Reverse phase HPLC  $R_{t(G)}$  10 min. 15 min. 17 min. 18 min. 19 min.

(small peaks), ((1A)  $R_{t(H)}$  19 min.)

(17B)

Reverse phase HPLC  $R_{t(G)}$  11 min. 16 min. 17 min. 18 min. 19 min.  
(small peaks), ((1A)  $R_{t(H)}$  19 min.)

## CHAPTER 4

## REFERENCES

1. A.M. Michaelson and A.R. Todd, *J. Chem. Soc.* 2632-2638, (1955).
  2. H.G. Khorana, *Science*, **203**, 614-625, (1979).
  3. F. Eckstein and I. Rizk, *Chem. Ber.* **102**, 2362-2377, (1969).
  4. C.B. Reese and R. Saffhill, *Chem. Commun.* 767-768, (1968).
  5. R.L. Letsinger and V. Mahadevan, *J.A.C.S.* **87**, 3526-3527, (1965).
  6. J.C. Catlin and F. Cramer, *J. Org. Chem.* **38**, 245-250, (1973).
  7. K. Itakura, C.P. Bahl, N. Katagiri, J.J. Michniewicz, R.H. Wightman and S.A. Narang, *Can. J. Chem.* **51**, 3649-3651, (1973).
  8. C.P. Bahl, R. Wu, K. Itakura, N. Katagiri and S.A. Narang, *Proc. Nat. Acad. Sci. USA.* **73**, 91-94, (1976).
  9. R.L. Letsinger, J.L. Finnan, G.A. Heavner and W.B. Lunsford, *J.A.C.S.* **97**, 3278-3279, (1975).
  10. M. Nirenberg and P. Leder, *Science*, **145**, 1399-1407, (1964).
  11. J.W. Szostak, J.I. Stiles, C.P. Bahl and R. Wu, *Nature*, **265**, 61-63, (1977).
  12. C.P. Bahl, K.J. Marians, R. Wu, J. Stawinsky and S.A. Narang, *Gene*, **1**, 81-92, (1976).
  13. K.L. Agarwal, H. Buchi, M.H. Caruthers, N. Gupta, H.G. Khorana, K. Kleppe, A. Kumar, E. Ohtsuka, U.L. Rajbhandary, J.H. van de Sande, V. Sgaramella, H. Weber and T. Yamada, *Nature*, **227**, 27-34, (1970).
  14. H.G. Khorana *et al.*\* *J. Biol. Chem.* **251**, 565-570, (1976).
  15. I.S. Johnson, *Science*, **219**, 632-637, (1983).
  16. J.A. Martial, R.A. Hallewell, J.D. Baxter and H.M. Goodman, *Science*, **205**, 602-607, (1979).
  17. D.V. Goeddel, H.L. Heyneker, T. Hozumi, R. Arentzen, K. Itakura, D.G. Yansura, M.J. Ross, G. Miozzari, R. Crea and P.H. Seeburg, *Nature*, **281**, 544-548, (1979).
  18. O.S. Bhanot, S.A. Khan and R.W. Chambers, *J. Biol. Chem.* **254**, 12684-12693, (1979).
- \* K.L. AGARWAL, P. BESMER, H. BÜCHI, M.H. CARUTHERS, P.J. CASHION, M. FRIDKIN, E. JAY, K. KLEPPE, R. KLEPPE, A. KUMAR, P.C. LOEWEN, R.C. MILLER, K. MINAMOTO, A. PANET, U.L. RAJBHANDARY, B. RAMAMOORTHY, T. SEKIYA, T. TAKEYA AND J. HANS VAN DE SANDE.



19. A. Razin, T. Hirose, K. Itakura and A.D. Riggs, *Proc. Natl. Acad. Sci. U.S.A.* **75**, 4268-4270, (1978).
20. S. Gillam and M. Smith, *Gene*, **8**, 99-106, (1979).
21. A.H.-J. Wang, G.J. Quigley, F.J. Kolpak, J.L. Crawford, J.H. van Boom, G. van der Marel and A. Rich, *Nature*, **282**, 680-686, (1979).
22. K. Itakura, T. Hirose, R. Crea and A.D. Riggs, *Science*, **198**, 1056-1063, (1977).
23. K. Nagahari, S. Kanaya, K. Munakata, Y. Aoyagi and S. Mizushima, *The EMBO Journal*, **4**, 3589-3592, (1985).
24. M. Houghton, A.G. Stewart, S.M. Doel, J.S. Emtage, M.A.W. Eaton, J.C. Smith, T.P. Patel, H.M. Lewis, A.G. Porter, J.R. Birch, T. Cartwright and N.H. Carey, *Nucl. Acids Res.* **8**, 1913-1931, (1980).
25. H.R. Drew, R.M. Wing, T. Takano, C. Broka, S. Tanaka, K. Itakura and R.E. Dickerson, *Proc. Natl. Acad. Sci. USA.* **78**, 2179-2183, (1981).
26. P.T. Gilham and H.G. Khorana, *J.A.C.S.* **80**, 6212-6222, (1958).
27. C.B. Reese, *Tetrahedron*, **34**, 3143-3179, (1978).
28. R.L. Letsinger and V. Mahadevan, *J.A.C.S.* **88**, 5319-5325, (1966).
29. R.L. Letsinger and K.K. Ogilvie, *J.A.C.S.* **91**, 3350-3355, (1969).
30. R.L. Letsinger and K.K. Ogilvie, *J.A.C.S.* **89**, 4801-4803, (1967).
31. R.L. Letsinger and P.S. Miller, *J.A.C.S.* **91**, 3356-3359, (1969).
32. R.L. Letsinger, K.K. Ogilvie and P.S. Miller, *J.A.C.S.* **91**, 3360-3365 (1969).
33. F. Eckstein and I. Rizk, *Angew. Chem. Internat. Edit.* **6**, 695-696, (1967).
34. F. Eckstein and I. Rizk, *Angew. Chem. Internat. Edit.* **6**, 949, (1967).
35. C.B. Reese, R. Saffhill and J.E. Sulston, *J.A.C.S.* **89**, 3366-3368, (1967).
36. J.H. van Boom and P.M.J. Burgers, *Chem Comm.* 869-871, (1971).
37. N. Katagiri, K. Itakura and S.A. Narang, *J.A.C.S.* **97**, 7332-7337, (1975).

38. J. Stawinski, T. Hozumi, S.A. Narang, C.P. Bahl and R. Wu, *Nucl. Acids Res.* **4**, 352-371, (1977).
39. C.B. Reese, R.C. Titmas and L. Yau, *Tet. Letts.* **19**, 2727-2730, (1978).
40. C.B. Reese and L. Zard, *Nucl. Acids Res.* **9**, 4611-4626, (1981).
41. E. Ohtsuka, Z. Tozuka and M. Ikehara, *Tet. Letts.* **22**, 4483-4486, (1981).
42. F. Himmelsbach, R. Charubala and W. Pfeleiderer, *Helv. Chim. Acta.* **70**, 1286-1295, (1987).
43. F. Himmelsbach and W. Pfeleiderer, *Tet. Letts.* **23**, 4793-4796, (1982).
44. E. Uhlmann and W. Pfeleiderer, *Tet. Letts.* **21**, 1181-1184, (1980).
45. E. Uhlmann and W. Pfeleiderer, *Helv. Chim. Acta.* **64**, 1688-1689, (1981).
46. V.A. Efimov, S.V. Reverdatto and O.G. Chakhmakhcheva, *Nucl. Acids Res.* **10**, 6675-6694, (1982).
47. B.S. Sproat and W. Bannwarth, *Tet. Letts.* **24**, 5771-5774, (1983).
48. V.A. Efimov, O.G. Chakhmakhcheva and Y.A. Ov. chinnikov, *Nucl. Acids Res.* **13**, 3651-3666, (1985).
49. B.C. Froehler and M.D. Matteucci, *J.A.C.S.* **107**, 278-279, (1985).
50. V.A. Efimov, A.A. Buryakova, I.Y. Dubey, N.N. Polushin, O.G. Chakhm akhcheva and Y.A. Ovchinnikov, *Nucl. Acids Res.* **14**, 6525-6540, (1986).
51. (1984), *Oligonucleotide Synthesis: A Practical Approach*, M.J. Gait. Ed., IRL Press, Oxford, U.K.
52. R.L. Letsinger and W.B. Lunsford, *J.A.C.S.* **98**, 3655-3661, (1976).
53. K.K. Ogilvie and N.Y. Theriault, *Can. J. Chem.* **57**, 3140-3144, (1979).
54. K.K. Ogilvie, N.Y. Theriault, J. Seifert, R.T. Pon and M.J. Nemer, *Can. J. Chem.* **58**, 2686-2693, (1980).
55. M.D. Matteucci and M.H. Caruthers, *Tet. Letts.* **21**, 719-722, (1980).
56. S.L. Beaucage and M.H. Caruthers, *Tet. Letts.* **22**, 1859-1862,

- (1981).
57. E.F. Fisher and M.H. Caruthers, *Nucl. Acids Res.* **11**, 1589-1599, (1983).
  58. H. Seliger, C. Scalfi and F. Eisenbeiss, *Tet. Letts.* **24**, 4963-4966, (1983).
  59. M.A. Dorman, S.A. Noble, L.J. McBride and M.H. Caruthers, *Tetrahedron*, **40**, 95-102, (1984).
  60. L.J. McBride and M.H. Caruthers, *Tet. Letts.* **24**, 245-248, (1983).
  61. S.P. Adams, K.S. Kavka, E.J. Wykes, S.B. Holder and G.R. Galluppi, *J.A.C.S.* **105**, 661-663, (1983).
  62. T. Dorper and E.L. Winnacker, *Nucl. Acids Res.* **11**, 2575-2584, (1983).
  63. G.R. Gough, M.J. Brunden and P.T. Gilham, *Tet. Letts.* **24**, 5321-5324, (1983).
  64. B.C. Froehler and M.D. Matteucci, *Nucl. Acids Res.* **11**, 8031-8036, (1983).
  65. N.D. Sinha, J. Biernat and H. Koster, *Tet. Letts.* **24**, 5843-5846, (1983).
  66. N.D. Sinha, J. Biernat, J. McManus and H. Koster, *Nucl. Acids Res.* **12**, 4539-4557, (1984).
  67. M.W. Schwarz and W. Pfeleiderer, *Tet. Letts.* **25**, 5513-5516, (1984).
  68. J.E. Marugg, C.E. Dreef, G.A. van der Marel and J.H. van Boom, *Recl. Trav. Chim. Pays-Bas* **103**, 97-98, (1984).
  69. J. Fourrey and J. Varenne, *Tet. Letts.* **25**, 4511-4514, (1984).
  70. B.H. Dahl, J. Neilson and O. Dahl, *Nucl. Acids Res.* **15**, 1729-1743, (1987).
  71. B. Uzananski, A. Wilk and W.J. Stec, *Tet. Letts.* **28**, 3401-3404, (1987).
  72. H. Takaku, T. Watanabe and S. Hamamoto, *Tet. Letts.* **29**, 81-84, (1988).
  73. T. Watanabe, H. Sato and H. Takaku, *J.A.C.S.* **111**, 3437-3439, (1989).
  74. P.J. Garegg, I. Lindh, T. Regberg, J. Stawinski, R. Stromberg and C. Henrichson, *Tet. Letts.* **27**, 4051-4054, (1986).

75. M. Smith, D.H. Rammler, I.H. Goldberg and H.G. Khorana, *J.A.C.S.* **84**, 430-440, (1962).
76. G. Weinmann and H.G. Khorana, *J.A.C.S.* **84**, 4329-4341, (1962).
77. R.L. Letsinger and K.K. Ogilvie, *J. Org. Chem.* **32**, 296-300, (1967).
78. K.K. Ogilvie and R.L. Letsinger, *J. Org. Chem.* **32**, 2365-2366, (1967).
79. K.K. Ogilvie and D.J. Iwacha, *Tet. Letts.* **14**, 317-319, (1973).
80. B.L. Gaffney, L.A. Markey and R.A. Jones, *Tetrahedron*, **40**, 3-13, (1984).
81. J.H. van Boom and P.M.J. Burgers, *Recl. Trav. Chim. Pays-Bas*, **97**, 73-80, (1978).
82. J.B. Chattopadhyaya and C.B. Reese, *Chem. Comm.* 639-640, (1978).
83. J.B. Chattopadhyaya, C.B. Reese and A.H. Todd, *Chem. Comm.* 987-988, (1979).
84. W. Pfeleiderer, M. Schwarz and H. Schirmeister, *Chemica Scripta*, **26**, 147-154, (1986).
85. V.C. Gioeli and J.B. Chattopadhyaya, *Chem. Comm.* 672-674, (1982).
86. N. Balgobin and J.B. Chattopadhyaya, *Nucleosides and Nucleotides*, **6**, 461-463, (1987).
87. C. Lehmann, Y. Xu, C. Christodoulou, Z. Tan and M.J. Gait, *Nucl. Acids Res.* **17**, 2379-2390, (1989).
88. G.H. Hakimelahi, Z.A. Proba and K.K. Ogilvie, *Tet. Letts.* **22**, 5243-5246, (1981).
89. G.H. Hakimelahi, Z.A. Proba and K.K. Ogilvie, *Can. J. Chem.* **60**, 1106-1113, (1982).
90. J.H. van Boom, P. van Deursen and J. Meeuwse, *Chem. Comm.* 766-767, (1972).
91. C.B. Reese, H.T. Serafinowska and G. Zappia, *Tet. Letts.* **27**, 2291-2294, (1986).
92. T. Takana, S. Tamatsukuri and M. Ikehara, *Nucl. Acids Res.* **14**, 6265-6279, (1986).
93. J. Stawinski, R. Stromberg, M. Thelin and E. Westman, *Nucl. Acids Res.* **16**, 9285-9298, (1988).

94. S. Iwai and E. Ohtsuka, *Nucl. Acids Res.* **16**, 9443-9456, (1988).
95. W.T. Markiewicz, *J. Chem. Res.(S)*, 24-25, (1979).
96. P.K. Bridson, W.T. Markiewicz and C.B. Reese, *Chem. Comm.* 791-792, (1977).
97. G.S. Ti, B.L. Gaffney and R.A. Jones, *J.A.C.S.* **104**, 1316-1319, (1982).
98. C.B. Reese and A. Ubasawa, *Tet. Letts.* **29**, 2265-2268, (1988).
99. H.P. Daskalov, M. Sekine and T. Hata, *Tet. Letts.* **21**, 3899-3902, (1980).
100. H.P. Daskalov, M. Sekine and T. Hata, *Bull. Chem. Soc. Japan*, **54**, 3076-3083, (1981).
101. J.S. Eadie and D.S. Davidson, *Nucl. Acids Res.* **15**, 8333-8349, (1987).
102. X. Gao, B.L. Gaffney, M. Senior, R.R. Riddle and R.A. Jones, *Nucl. Acids Res.* **13**, 573-584, (1985).
103. K.L. Agarwal, A. Yamazaki, P.J. Cashion and H.G. Khorana, *Angew. Chem. Internat. Ed.* **11**, 451-459, (1972).
104. S.S. Jones, C.B. Reese, S. Sibanda and A. Ubasawa, *Tet. Letts.* **22**, 4755-4758, (1981).
105. C.B. Reese and P.A. Skone, *J.C.S. Perkin Trans. I.* 1263-1271, (1984).
106. B.L. Gaffney and R.A. Jones, *Tet. Letts.* **23**, 2257-2260, (1982).
107. J. Heikkila and J. Chattopadhyaya, *Acta. Chem. Scand.* **B37**, 263-265, (1983).
108. S. Honda, K. Urakami, K. Koura, K. Terada, Y. Sato, K. Kohno, M. Sekine and T. Hata, *Tetrahedron*, **40**, 153-163, (1984).
109. T. Kamimura, M. Tsuchiya, K. Urakami, K. Koura, M. Sekine, K. Shinozaki, K. Miura and T. Hata, *J.A.C.S.* **106**, 4552-4557, (1984).
110. M. Sekine, R. Iwase, N. Masuda and T. Hata, *Bull. Chem. Soc. Japan*, **61**, 1669-1677, (1988).
111. F. Himmelsback, B.S. Schulz, T. Trichinger, R. Charubala and W. Pfeleiderer, *Tetrahedron*, **40**, 59-72, (1984).
112. R.T. Pon, M.J. Damha and K.K. Ogilvie, *Nucl. Acids Res.* **13**, 6447-6465, (1985).

113. J.C. Schulhof, D. Molko and R. Teoule, *Nucl. Acids Res.* **15**, 379-416, (1987).
114. C. Chaix, D. Molko and R. Teoule, *Tet. Letts.* **30**, 71-74, (1989).
115. M. Fujii, S. Yamakage, H. Takaku and T. Hata, *Tet Letts.* **28**, 5713-5716, (1987).
116. Y. Ma and E. Sonveaux, *Nucleosides and Nucleotides*, **6**, 491-493, (1987).
117. T.S. Rao, C.B. Reese, H.T. Serafinowska, H. Takaku and G. Zappia, *Tet. Letts.* **28**, 4897-4900, (1987).
118. R.B. Merrifield, *J.A.C.S.* **85**, 2149-2154, (1986).
119. M.D. Matteucci and M.H. Caruthers, *J.A.C.S.* **103**, 3185-3191, (1981).
120. M.J. Gait, M. Singh, R.C. Sheppard, M.D. Edge, A.R. Greene, G.R. Heathcliffe, T.A. Atkinson, C.R. Newton and A.F. Markham, *Nucl. Acids Res.* **8**, 1081-1096, (1980).
121. M.J. Gait, H.W.D. Matthes, M. Singh, B.S. Sproat and R.C. Titmas, *Nucl. Acids Res.* **10**, 6243-6254, (1982).
122. J. Katzhendler, S. Cohen, E. Rahamin, M. Weisz, I. Ringel and J. Deutsch, *Tetrahedron*, **45**, 2777-2792, (1989).
123. K. Miyoshi and K. Itakura, *Tet. Letts.* **20**, 3635-3638, (1979).
124. K.K. Ogilvie and M.J. Nemer, *Tet. Letts.* **21**, 4159-4162, (1980).
125. E. Ohtsuka, M. Ikehara and D. Soll, *Nucl. Acids. Res.* **10**, 6553-6570, (1982).
126. M.R. Florence, PhD. Thesis, Edinburgh University, (1987).
127. T. Brown, C.E. Pritchard, G. Turner and S.A. Salisbury, *J.C.S. Chem. Comm.* 891-893, (1989).
128. T. Hayakawa, A. Ono and T. Ueda, *Nucl. Acids. Res.* **16**, 4761-4776, (1988).
129. T. Gray, PhD. Thesis, Edinburgh University, (1990).
130. Dictionary of Organophosphorus Compounds, R.S. Edmunson. Ed., Chapman and Hall, (1987).
131. Dictionary of Organic Compounds, Vol.5, Eyre and Spottiswoode Ltd. (pub.) (1965).
132. R. Scheffold and E. Saladin, *Angew. Chem. Internat. Edit.* **11** 229-231, (1972).

CHAPTER 5  
ABBREVIATIONS

Bnpeoc	2,2- <i>bis</i> (4-nitrophenyl)ethoxycarbonyl
Cmpt	1-[(2-chloro-4-methyl)phenyl]- 4-methoxypiperidin-4-yl
DBN	1,5-diazabicyclo[4.3.0]non-5-ene
DBU	1,5-diazabicyclo[5.4.0]undec-5-ene
DCCI	dicyclohexylcarbodiimide
DMAP	N,N-dimethylaminopyridine
DMF	N,N-dimethylformamide
DMTr	4,4'-dimethoxytrityl
DNA	deoxyribonucleic acid
Fmoc	fluoren-9-ylmethoxycarbonyl
HPLC	high performance liquid chromatography
MMTr	4-monomethoxytrityl
MSNT	1-mesitylenesulphonyl-3-nitro-1,2,4-triazole
MSPy	1-mesitylenesulphonyl-5-(pyridin-2-yl)- tetrazolide
MST	mesitylenesulphonyl triazole
MTHP	methoxytetrahydropyranyl
NMR	nuclear magnetic resonance
NPE	2-( <i>p</i> -nitrophenyl)ethyl
<i>p</i> -NBST	<i>p</i> -nitrobenzenesulphonyl triazole
RNA	ribonucleic acid
SARC	sarcosyl
TBAF	tetra- <i>n</i> -butyl ammonium fluoride
TBDMS	<i>t</i> -butyldimethylsilyl
THP	tetrahydropyranyl
TLC	thin layer chromatography
TPSCI	2,4,6-triisopropylbenzenesulphonyl chloride
TPSPy	1-(2,4,6-triisopropylbenzenesulphonyl)- 5-(pyridin-2-yl)tetrazolide

## CHAPTER 6

## APPENDIX

## APPENDIX 1

A typical synthesis cycle used on an ABI DNA synthesizer (see p.66)

SYNTHESIS CYCLE  
VERSION 1.34

Page 1

CYCLE NAME: SSCE103A  
NUMBER OF STEPS: 89  
DATE: Jul 5, 1988  
TIME: 15:57

STEP NUMBER	FUNCTION £ NAME	STEP TIME	STEP ACTIVE FOR BASES							SAFE STEP
			A	G	C	T	5	6	7	
1	10 £18 To Waste	4	Yes	Yes	Yes	Yes	Yes	Yes	Yes	Yes
2	9 £18 To Column	60	Yes	Yes	Yes	Yes	Yes	Yes	Yes	Yes
3	2 Reverse Flush	20	Yes	Yes	Yes	Yes	Yes	Yes	Yes	Yes
4	1 Block Flush	4	Yes	Yes	Yes	Yes	Yes	Yes	Yes	Yes
5	28 Phos Prep	3	Yes	Yes	Yes	Yes	Yes	Yes	Yes	Yes
6	+45 Group 1 On	1	Yes	Yes	Yes	Yes	Yes	Yes	Yes	Yes
7	90 TET to column	2	Yes	Yes	Yes	Yes	Yes	Yes	Yes	Yes
8	19 B+TET To Col 1	3	Yes	Yes	Yes	Yes	Yes	Yes	Yes	Yes
9	90 TET to column	2	Yes	Yes	Yes	Yes	Yes	Yes	Yes	Yes
10	19 B+TET To Col 1	2	Yes	Yes	Yes	Yes	Yes	Yes	Yes	Yes
11	9 £18 To Column	2	Yes	Yes	Yes	Yes	Yes	Yes	Yes	Yes
12	-46 Group 1 Off	1	Yes	Yes	Yes	Yes	Yes	Yes	Yes	Yes
13	+47 Group 2 On	1	Yes	Yes	Yes	Yes	Yes	Yes	Yes	Yes
14	10 £18 To Waste	7	Yes	Yes	Yes	Yes	Yes	Yes	Yes	Yes
15	1 Block Flush	4	Yes	Yes	Yes	Yes	Yes	Yes	Yes	Yes
16	90 TET to column	2	Yes	Yes	Yes	Yes	Yes	Yes	Yes	Yes
17	20 B+TET To Col 2	3	Yes	Yes	Yes	Yes	Yes	Yes	Yes	Yes
18	90 TET to column	2	Yes	Yes	Yes	Yes	Yes	Yes	Yes	Yes
19	20 B+TET To Col 2	2	Yes	Yes	Yes	Yes	Yes	Yes	Yes	Yes
20	9 £18 To Column	2	Yes	Yes	Yes	Yes	Yes	Yes	Yes	Yes
21	-48 Group 2 Off	1	Yes	Yes	Yes	Yes	Yes	Yes	Yes	Yes
22	+49 Group 3 On	1	Yes	Yes	Yes	Yes	Yes	Yes	Yes	Yes
23	10 £18 To Waste	7	Yes	Yes	Yes	Yes	Yes	Yes	Yes	Yes
24	1 Block Flush	4	Yes	Yes	Yes	Yes	Yes	Yes	Yes	Yes
25	90 TET to column	2	Yes	Yes	Yes	Yes	Yes	Yes	Yes	Yes
26	21 B+TET To Col 3	3	Yes	Yes	Yes	Yes	Yes	Yes	Yes	Yes
27	90 TET to column	2	Yes	Yes	Yes	Yes	Yes	Yes	Yes	Yes
28	21 B+TET To Col 3	2	Yes	Yes	Yes	Yes	Yes	Yes	Yes	Yes
29	9 £18 To Column	2	Yes	Yes	Yes	Yes	Yes	Yes	Yes	Yes
30	-50 Group 3 Off	1	Yes	Yes	Yes	Yes	Yes	Yes	Yes	Yes
31	4 Wait	30	Yes	Yes	Yes	Yes	Yes	Yes	Yes	Yes
32	16 Cap Prep	10	Yes	Yes	Yes	Yes	Yes	Yes	Yes	Yes
33	10 £18 To Waste	5	Yes	Yes	Yes	Yes	Yes	Yes	Yes	Yes
34	2 Reverse Flush	5	Yes	Yes	Yes	Yes	Yes	Yes	Yes	Yes
35	1 Block Flush	4	Yes	Yes	Yes	Yes	Yes	Yes	Yes	Yes
36	+45 Group 1 On	1	Yes	Yes	Yes	Yes	Yes	Yes	Yes	Yes
37	22 Cap To Col 1	10	Yes	Yes	Yes	Yes	Yes	Yes	Yes	Yes
38	-46 Group 1 Off	1	Yes	Yes	Yes	Yes	Yes	Yes	Yes	Yes
39	+47 Group 2 On	1	Yes	Yes	Yes	Yes	Yes	Yes	Yes	Yes
40	23 Cap To Col 2	8	Yes	Yes	Yes	Yes	Yes	Yes	Yes	Yes
41	-48 Group 2 Off	1	Yes	Yes	Yes	Yes	Yes	Yes	Yes	Yes
42	+49 Group 3 On	1	Yes	Yes	Yes	Yes	Yes	Yes	Yes	Yes
43	24 Cap To Col 3	8	Yes	Yes	Yes	Yes	Yes	Yes	Yes	Yes

(Continued next page.)





## APPENDIX 2

Preparative ion-exchange HPLC trace of (2A), (see p.67)

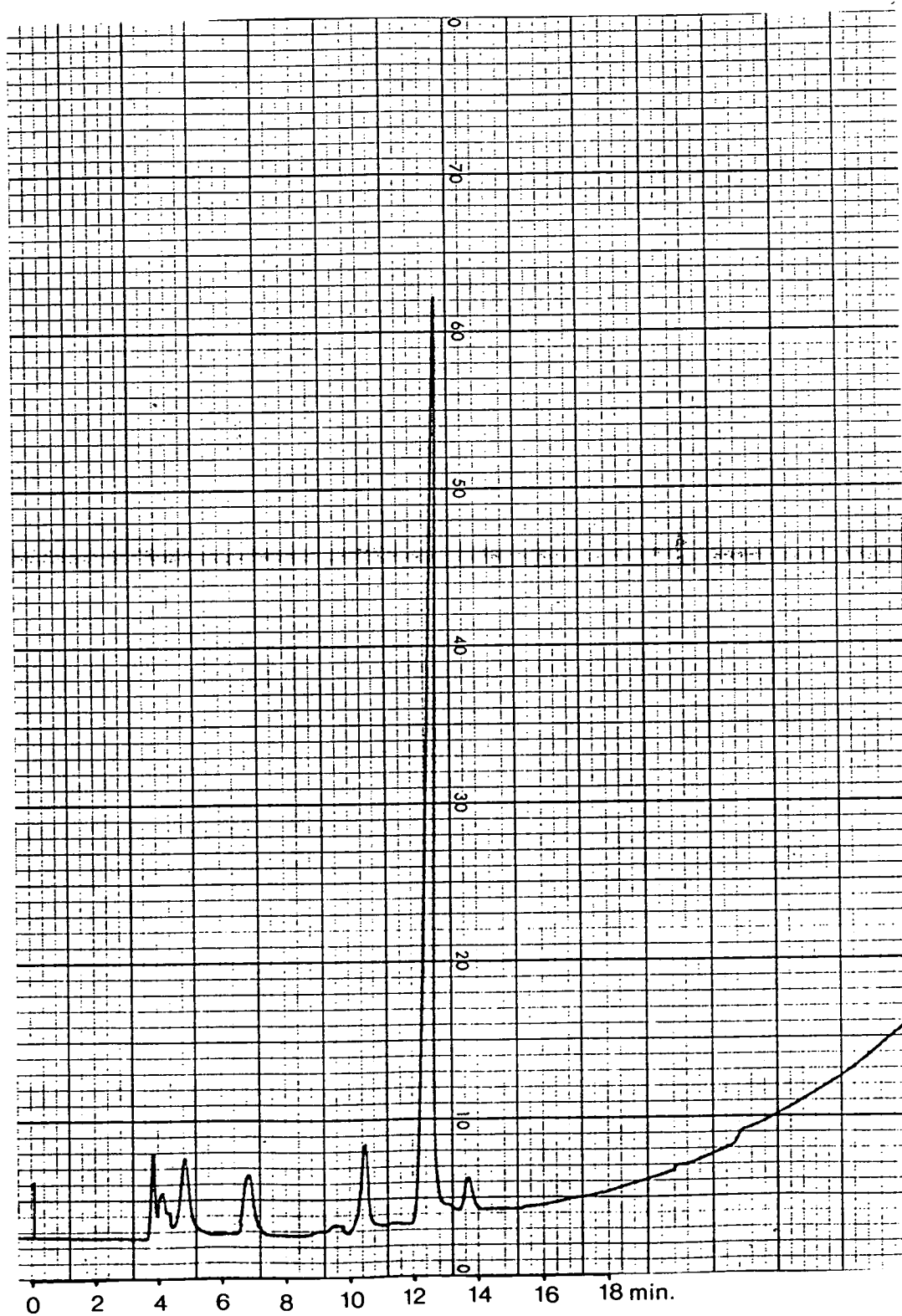

Analytical reverse phase HPLC trace of (2A) after purification by ion-exchange HPLC (see p.67)

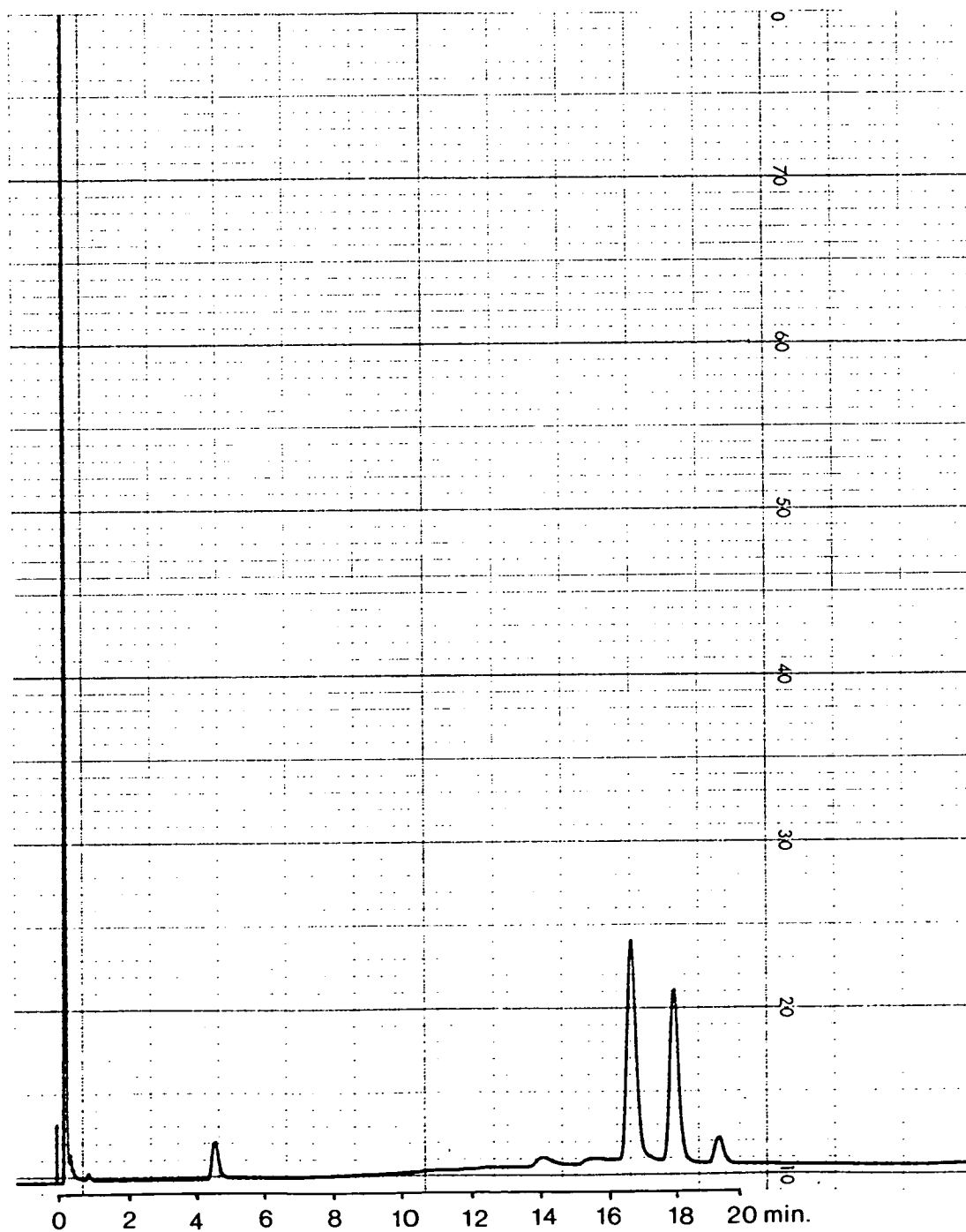

APPENDIX 3  
Proton decoupled phosphorus NMR in  $\text{CD}_3\text{CN}$  (81 MHz)  
at  $+60^\circ\text{C}$  of 138c (see p.87)

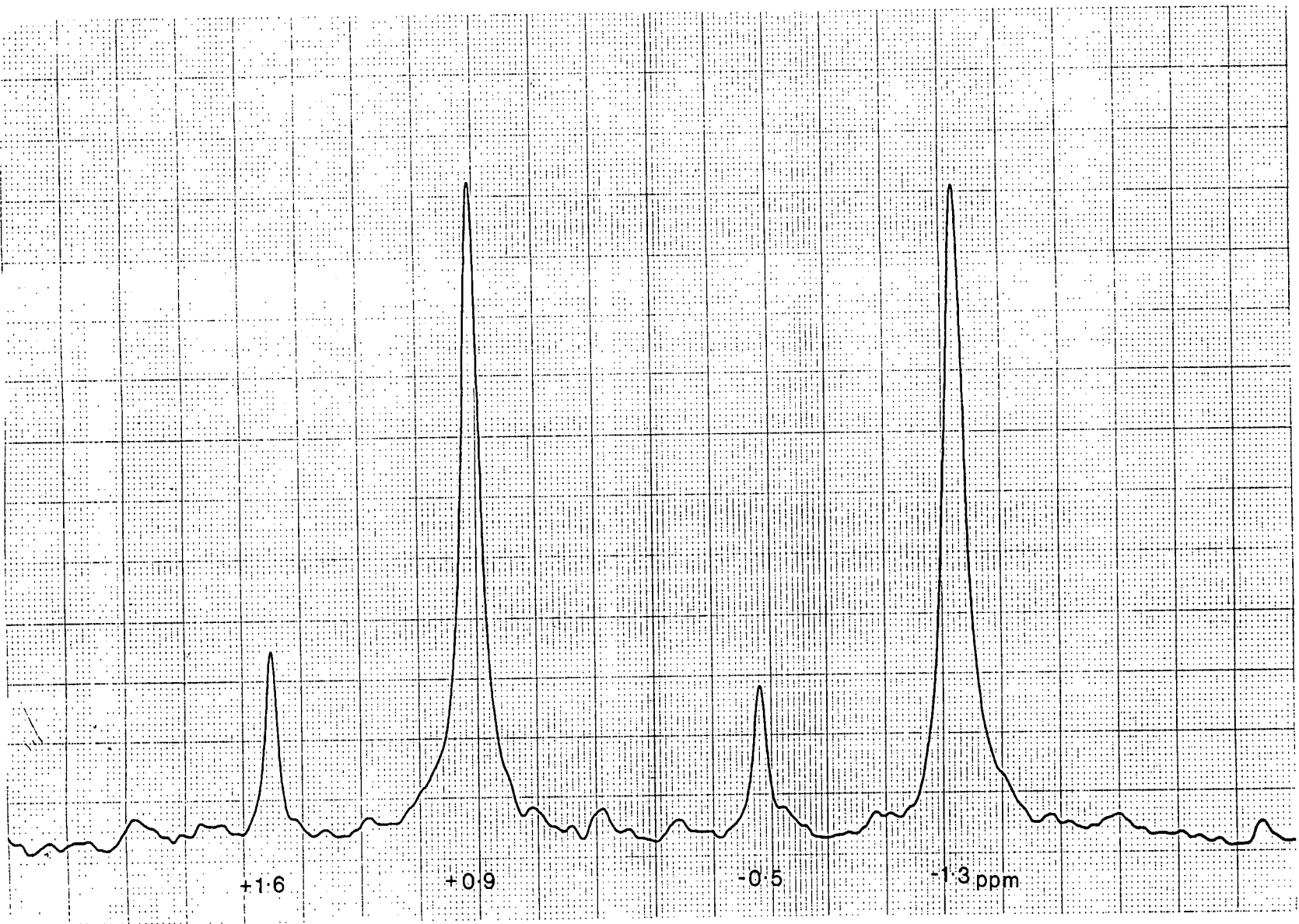

Proton coupled phosphorus NMR in CD<sub>3</sub>CN (81 MHz)  
at +60°C of 138c (see p.87)

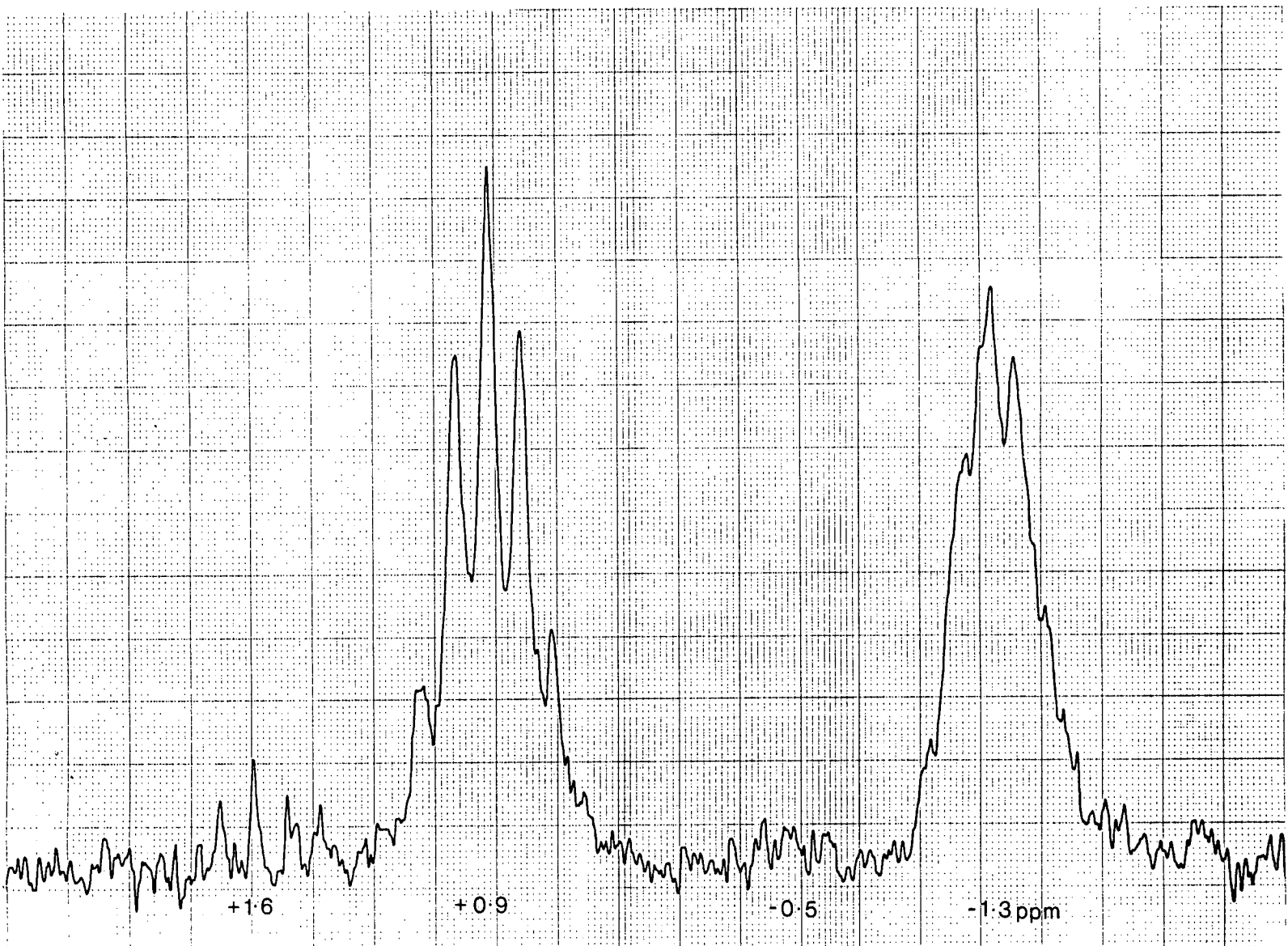

## CHAPTER 7

## COURSES ATTENDED

I have attended the following courses:

Departmental Organic Seminars (various speakers).

Mass Spectrometry (Professor K.R. Jennings, University of Warwick).

X-Ray Crystallography (Dr. A.J. Blake, University of Edinburgh).

Perspectives in Cell Biology (Dr. J. Philips, University of Edinburgh).

Medicinal Chemistry (Dr's. P. Leeson and R. Baker, MSD).

Management Course.

Organic Chemistry Topics (Various lecturers, University of Edinburgh).

The Use of 'SCRIBE'— a text processor (Dr. R.J. Hare, University of Edinburgh).

Modern Methods in NMR Spectroscopy (Dr. I. Sadler, University of Edinburgh).

Medicinal Chemistry (Prof. P.G. Sammes, Brunel University).

Industrial Processes (Various speakers, ICI and Chemical Engineering Dept. Edinburgh University).

# Chemical Communications

Reprinted From

J.Chem. Soc., Chemical Communications.

Issue 14 1989

## A New Base-stable Linker for Solid-phase Oligonucleotide Synthesis

Tom Brown,<sup>a</sup> Clare E. Pritchard,<sup>a</sup> Gillian Turner,<sup>a</sup> and Stephen A. Salisbury<sup>b</sup>

<sup>a</sup> Department of Chemistry, University of Edinburgh, West Mains Road, Edinburgh EH9 3JJ, Scotland

<sup>b</sup> Pharmacia L.K.B. Biochrom Ltd., Science Park, Milton Road, Cambridge CB4 4FJ, England

The succinyl-sarcosyl linker (**1b**), which is stable to prolonged contact with 1,8-diazabicyclo[5.4.0]undec-7-ene but cleaves rapidly with aqueous ammonia, is of potential value in solid-phase oligonucleotide synthesis.

The DMTr<sup>†</sup> group is not ideal for the protection of the 5'-hydroxy function of deoxyribose in solid-phase DNA synthesis<sup>1,2</sup> as acidic deprotection at successive cycles gives rise to depurination, particularly at deoxyadenosine residues.<sup>3,4</sup> This is not a serious problem in small scale synthesis as the acidic treatment is very brief (*ca.* 30 s) but it is a limiting factor in large-scale work when a deprotection time of around

3 min is necessary. In addition, some uncommon nucleosides such as 2-amino-deoxyadenosine are acutely sensitive to acid-catalysed depurination and cannot be used routinely.<sup>3</sup> When the 5'-DMTr-group is used in RNA synthesis in conjunction with acid-labile THP 2'-OH protection, it has been shown that repeated TCA treatment leads to significant loss of THP and subsequent 3' to 2' phosphoryl migration.<sup>5</sup>

Clearly there is a need for an alternative 5'-hydroxy protecting group for certain applications in oligonucleotide synthesis. Recent advances<sup>6,7</sup> indicate that the 5'-Fmoc group can be removed by brief treatment in a suitable base, offering the possibility of a completely acid-free protocol. Unfortunately, the linker conventionally used to attach the oligonucleotide to the support matrix (**1a**) is unstable to DBU and 1% cleavage occurs at each Fmoc-deprotection step.<sup>6</sup>

<sup>†</sup> Abbreviations: DMTr = 4,4'-dimethoxytrityl; Fmoc = 9-fluorenylmethoxycarbonyl; LCAA = long chain alkylamino; CPG = Corning porous glass (controlled pore glass); DBU = 1,8-diazabicyclo[5.5.0]undec-7-ene; DMAP = 4-dimethylaminopyridine; dT = thymidine; A<sup>Bz</sup> = N<sup>6</sup>-benzoyladenine; THP = tetrahydropyran-2-yl; DCCI = dicyclohexylcarbodiimide; TCA = trichloroacetic acid.



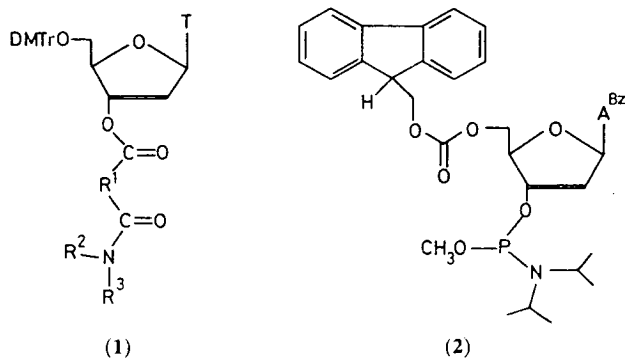

	R <sup>1</sup>	R <sup>2</sup>	R <sup>3</sup>
a	-CH <sub>2</sub> CH <sub>2</sub> -	Me	LCAA-CPG
b	-CH <sub>2</sub> CH <sub>2</sub> -	Me	CH <sub>2</sub> CONH-LCAA-CPG
c	-C <sub>6</sub> H <sub>4</sub> -o-	H	CH <sub>2</sub> CO <sub>2</sub> Et
d	-CH <sub>2</sub> CH <sub>2</sub> -	H	CH <sub>2</sub> CO <sub>2</sub> Et
e	-CH <sub>2</sub> CH <sub>2</sub> -	Me	CH <sub>2</sub> CO <sub>2</sub> Et
f	-CH <sub>2</sub> CH <sub>2</sub> CH <sub>2</sub> -	H	CH <sub>2</sub> CO <sub>2</sub> Et

Piperidine and morpholine can be used as alternatives,<sup>7</sup> but although **(1a)** is more stable to these, Fmoc-deprotection is much slower. The obvious incompatibility of base-labile 5'-protecting groups and **(1a)** prompted us to design a resin-oligonucleotide linker that is resistant to DBU. We have found that the linker **(1b)** suffers less than 5% cleavage after overnight treatment with a 10% solution of DBU in dry dichloromethane or toluene.‡ Under the same conditions scission of **(1a)** is complete in less than 1 h, presumably owing to a mechanism involving deprotonation of the amide nitrogen followed by intramolecular nucleophilic displacement at the ester carbonyl group. Although **(1b)** is stable to DBU, it is hydrolysed in less than 1 h at room temperature by concentrated aqueous ammonia, the standard reagent for removal of an oligonucleotide from the solid support.

The properties of the linkers were demonstrated using the model compounds **(1d)**, **(1e)**, and **(1f)** where reactions could be conveniently monitored by t.l.c. The ester group of **(1d)** is cleaved by 10% DBU in dry dichloromethane in 5 min whereas under the same conditions **(1e)** is essentially unchanged after 24 h and compound **(1f)** is cleaved slowly (5 h). Cleavage of **(1f)** can be assumed to proceed by an intramolecular cyclisation and the formation of a 6-membered ring. An analogous mechanism for **(1d)** produces a 5-membered ring (an *N*-substituted succinimide) and will therefore take place more readily.§ Additional support for this mechanism comes from studies on the phthaloyl linker **(1c)**. When the solid support is treated with 10% DBU, liberation of the nucleoside is extremely fast owing to the rigid conformation imposed by the aromatic ring favouring the intramolecular reaction (50% cleavage in 3.5 min). Hydrolysis of the phthaloyl linker with concentrated aqueous ammonia is relatively slow (35 min).

‡ The resin was functionalised as follows: Fmoc-sarcosine (10 equiv.) and DCCI (5 equiv.) were added to Pierce long-chain alkylamino CPG in a mixture of DMF and dichloromethane. Removal of the Fmoc-group with piperidine in DMF followed by coupling of the sarcosine methylamino group to 5'-DMTr thymidine 3'-*O*-succinate (10 equiv.) in the presence of DCCI (5 equiv.) gave a loading of 20 mequiv. of 5'-DMTrdt/g of dry resin. (DMTr cation assayed colorimetrically at 490 nm).

§ Compounds **(1d)**, **(1e)** and **(1f)** were characterised by f.a.b. mass spectrometry, <sup>1</sup>H n.m.r., and elemental analysis.

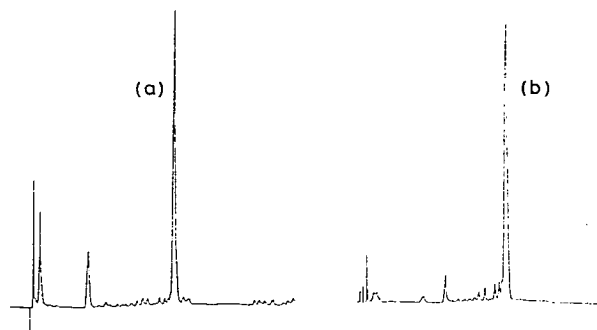

Figure 1. Reverse-phase h.p.l.c.: (a) d(A)<sub>8</sub>DMTr; (b) d(A)<sub>8</sub>FMOc.

Solid-phase DNA synthesis¶ was carried out using the linker **(1b)** and 5'-DMTr-β-cyanoethyl phosphoramidite monomers. The oligonucleotides produced were indistinguishable in terms of purity and yield from those synthesised using linker **(1a)** (Partisil-SAX ion-exchange and C8-reverse-phase h.p.l.c. analysis).

We have demonstrated the value of the sarcosyl linker in conjunction with the 5'-FMOc protected monomer **(2)** by synthesising d(A)<sub>8</sub>.|| The reverse-phase h.p.l.c. chromatograms of the crude product and a sample of d(A)<sub>8</sub> prepared by standard methodology (Figure 1) indicate that both methods produce excellent quality DNA. The choice of capping agent in the FMOc cycle is crucial, as acetic anhydride and DMAP produce some cleavage of the FMOc group. Replacement of DMAP with *N*-methylimidazole gives cleaner synthesis but the best results were obtained using trimethylsilyl chloride (1 min).<sup>8</sup> A more serious problem occurs when unprotected thymidines are exposed to DBU. Deprotonation of the N(3) atom occurs, giving rise to a rapid reaction with the adjacent phosphotriester and the formation of an *N*(3)-methyl thymine residue. Thus, if d(T)<sub>6</sub> is prepared by standard methods using the 5'-DMTr-dT methoxy phosphoramidite and the linker **(1b)**, and the fully protected resin-bound oligonucleotide is treated with 10% DBU in dichloromethane for 10 min, after which time it is liberated from the resin with aqueous ammonia, a mixture of several products is obtained. It can be shown by reverse-phase h.p.l.c. that authentic d(T)<sub>6</sub> is only a minor component. Interestingly, anion-exchange h.p.l.c. failed to separate the mixture and the single peak was shown to coelute with authentic d(T)<sub>6</sub>. The base-promoted methylation of thymidine has been reported previously by Jones.<sup>9</sup> Thymine base protection should clearly be employed in the 5'-FMOc DNA synthesis protocol. A number of suitable protecting groups have been developed.<sup>10</sup>

In conclusion, we suggest that the resin-oligonucleotide linker **(1b)** in combination with 5'-FMOc or similar base-labile protecting groups will provide a viable acid-free protocol for solid-phase oligonucleotide synthesis. The value of this combination in RNA synthesis has recently been demonstrated.<sup>11</sup>

¶ Solid-phase oligonucleotide synthesis was carried out on an Applied Biosystems 380B DNA-synthesiser, using the standard 0.2 μmol β-cyanoethyl or methyl phosphoramidite cycle. The following sequences were prepared using oligonucleotide-resin-linkers **(1a)** and **(1b)** and DMTr monomers.

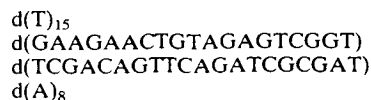

|| 10% DBU in dichloromethane was used to replace TCA but otherwise the standard methoxy-phosphoramidite cycle was used.

Thanks are due to the S.E.R.C. for a studentship (to E. P.), Pharmacia LKB and the Research Corporation Trust for financial support, and Wendstone Chemicals for a studentship (to G. T.).

Received, 1st March 1989; \*\* Com. 9/01201J

### References

- 1 C. B. Reese, *Tetrahedron*, 1978, 3143.
- 2 L. J. McBride and M. H. Caruthers, *Tetrahedron Lett.*, 1982, 245.
- 3 B. L. Gaffney, L. A. Marky, and R. A. Jones, *Tetrahedron*, 1984, 40, 3.
- 4 B. C. Froehler and M. D. Matteucci, *Nucleic Acids Res.*, 1983, 11, 8031.
- 5 C. Christodoulou, S. Agrawal, and M. J. Gait, *Tetrahedron Lett.*, 1986, 27, 1521; C. B. Reese and P. A. Skone, *Nucleic Acids Res.*, 1985, 13, 5215.
- 6 N. Balgobin and J. Chattopadhyaya, *Nucleosides and Nucleotides*, 1987, 6 (1 and 2), 461.
- 7 Y. Ma and E. Sonveaux, *Nucleosides and Nucleotides*, 1987, 6 (1 and 2), 491.
- 8 T. R. Webb and M. D. Matteucci, *Nucleic Acids Res.*, 1986, 14, 7661.
- 9 X. Gao, B. L. Gaffney, M. Senior, R. R. Riddle, and R. A. Jones, *Nucleic Acids Res.*, 1985, 13, 573.
- 10 M. Mag and J. W. Engels, *Nucleic Acids Res.*, 1988, 16, 3525, and references cited therein.
- 11 C. Lehmann, Y.-Z. Xu, C. Christodoulou, Z.-K. Tan, and M. J. Gait, *Nucleic Acids Res.*, submitted for publication.

---

\*\* Original receipt date 17th November 1987.

---