

THE CHARACTERISATION AND EXPRESSION OF OVINE MHC CLASS-II GENES.

A thesis submitted for the degree of Doctor of Philosophy in the
Faculty of Science of the University of Edinburgh.

by

Keith Thomson Ballingall



DECLARATION

All work recorded in this thesis was carried out in the departments of Pathology/Immunology and Biochemistry at the Moredun Research Institute, 408 Gilmerton Road, Edinburgh and in the department of Zoology at the University of Edinburgh between October 1987 and September 1990. All results were obtained by the author unless otherwise stated in the text.

ACKNOWLEDGEMENTS

I am greatly indebted to all the staff and students at the Moredun Research Institute who have helped and encouraged me throughout the three years this thesis took to complete. Special thanks must go to the following people; Harry Wright for teaching me the techniques of molecular biology. Bernadette Dutia for the immunoblotting and Gary Entrican and David Haig for their assistance with tissue culture and the calcium phosphate transfection technique. For their assistance with the FACScan and FACSIV I thank Andrew Sanderson and John Ansell. Thanks must also go to John Spence for his assistance in producing this manuscript and the tables and figures within.

Special thanks must go to all members of staff within the departments of Pathology/Immunology and Biochemistry for providing a friendly and enthusiastic environment in which to work. Thankyou to Annie Mackellor, Kate and Craig Thomson and Gary Entrican for preventing malnutrition affecting this AFRC funded student and to Campbel McCafferty for proof reading this thesis.

Finally I must thank all my supervisors, David Baird, John Ansell and especially David Haig who has guided me through the last three years with his infectious enthusiasum for the subject of immunology and his constant support in all aspects of this work and the production of this manuscript.

I would like to dedicate this thesis to my mother without whose encouragement and support this would not have been possible.

CONTENTS

	<u>PAGE</u>
TITLE.	I
DECLARATION.	II
ACKNOWLEDGMENTS.	III
CONTENTS.	IV
ABBREVIATIONS.	VII
SUMMARY.	IX
HISTORICAL REVIEW AND GENERAL INTRODUCTION.	1
1 Historical review.	2
2 The function of the MHC.	7
3 The genetics of the MHC.	12
4 The ovine MHC.	23
5 Aims of the project.	34
MATERIALS AND METHODS.	36
1 <u>Animals.</u>	37
2 <u>Cosmid library construction.</u>	37
3 <u>Preparation of nucleic acid (DNA/RNA).</u>	40
3.1 Preparation of cosmid (plasmid) DNA.	40
3.2 Small scale preparation of cosmid (plasmid) DNA.	41
3.3 Preparation of genomic DNA from tissues.	42
3.4 Preparation of total cellular RNA.	43
4 <u>Analysis of nucleic acid.</u>	44
4.1 Quantification of nucleic acid.	44
4.2 Restriction endonuclease digestion of DNA.	44

4.3 Agarose gel electrophoresis of DNA.	45
4.4 Isolation of DNA fragments from agarose gels.	46
5 <u>Analysis of specific DNA and RNA sequences by southern and northern blotting.</u>	48
5.1 Analysis of specific DNA sequences (Southern blotting).	48
5.2 Hybridisation to a radiolabelled probe.	48
5.3 Production of a ^{32}P labelled nucleotide probe.	49
5.4 Analysis of specific RNA sequences (Northern blotting).	51
6 <u>Subcloning cosmid DNA fragments into pBS plasmid vectors.</u>	52
6.1 Preparation of JM109 bacterial cells for transformation with recombinant pBS plasmids.	55
6.2 Preparation of the pBS cloning vector.	55
6.3 ligation of pBS vector DNA to insert DNA.	56
6.4 Transformation of JM109 cells.	57
7 <u>Nucleotide sequence analysis.</u>	57
7.1 Annealing the universal primer to double stranded pBS template.	60
7.2 Sequencing reactions.	60
7.3 Sequencing gel electrophoresis.	61
7.4 Analysis and interpretation of autoradiographs.	62
8 <u>Tissue culture materials and methods.</u>	62
8.1 Cells and culture media.	62
8.2 Preparation of frozen L-cell stocks.	63
8.3 Counting cells using a Haemocytometer.	64
9 <u>DNA-mediated gene transfer.</u>	64
9.1 Preparation of DNA.	65
9.2 Transfection technique.	66
10 <u>Indirect fluorescent antibody technique.</u>	67

10.1 Labelling transfected cells with FITC-conjugated antibodies.	68
10.2 Analysis by flow cytometry (FACScan analysis).	69
10.3 Cell sorting (FACS IV).	73
11 <u>Screening panels of monoclonal antibodies against class-II expressing transfected L-cell lines.</u>	74
12 <u>Immunoblots of MHC class-II molecules isolated from transfected L-cell lines.</u>	74
12.1 Lysate production.	75
12.2 SDS-Polyacrylamide gel analysis (SDS-PAGE).	75
EXPERIMENTAL RESULTS.	77
CHAPTER 1. Preliminary experiments.	78
CHAPTER 2. Generation of mouse L-cell lines expressing ovine MHC class-II glycoproteins.	89
CHAPTER 3. Nucleotide sequence analysis of expressed beta genes.	106
CHAPTER 4. Typing of ovine DR specific monoclonal antibodies using the OLA-DR transfected L-cell lines.	116
CHAPTER 5. Analysis of ovine MHC class-II gene expresion	125
GENERAL DISCUSSION.	136

CONTENTSPAGE

REFERENCES.	145
APPENDIX 1 Molecular biological buffers and reagents.	179
APPENDIX 2 Bacteria, bacterial growth medium and antibiotics.	184
APPENDIX 3 Tissue culture and transfection reagents.	186
APPENDIX 4 Equipment and reagent suppliers.	189
APPENDIX 5 Publications resulting from this thesis.	190

ABBREVIATIONS

MHC	Major Histocompatibility Complex.
DNA	Deoxyribonucleic acid.
RNA	Ribonucleic acid.
Tris	(tris[Hydroxymethyl]aminomethane).
TAE	Tris/Acetate/EDTA.
TE	Tris/EDTA.
LB	L-broth.
TB	Terrific broth.
SDS	Sodium dodecal sulphate.
IPA	Isopropanol.
SSC	Sodium chloride/sodium citrate.
MOPS	(3-[N-Morpholino]propanesulphonic acid).
TCA	Trichloroacetic acid.
X-Gal	5-bromo-4-chloro-3-indoyl- β -D-galactosidase.
IPTG	Isopropyl- β -D-thiogalactoside.
TEMED	N,N,N,N-tetramethylethylenediamine.
BPB	Bromophenol Blue.
TK	Thymidine kinase.
DMEM	Dulbecco's modified Eagle's medium.
HAT	Hypoxanthine/Aminopterin/Thymidine.
HBSS	Hank's balanced salt solution.
FITC	Fluorescene isothiocyanate.
FACS	Fluoresence activated cell sorter.
FACscan	Fluorescence activated cell scanner.
HEPES	(N-[2-Hydroxyethyl]piperazine-N'-[2-ethanesulfonic acid]).
EBS	Earle's Balanced saline.
FSC	Forward scatter.
SSC	Side scatter.

ABBREVIATIONS

FL1	Green fluorescence.
FL2	Orange fluorescence.
FL3	Red fluorescence.
PBS	Phosphate buffered saline.
PAGE	Poly acrylamide gel electrophoresis.
MLR	Mixed lymphocyte reaction.
IFA	Indirect fluorescent antibody assay.
RFLP	Restriction fragment length polymorphism.
PCR	Polymerase chain reaction.
Kd	Kilodaltons
g	Grams
m	Meters
l	Litres

During the course of this investigation the following designations of the genes in the HLA-D region have been officially determined: DP β 2 to DPB2, DP α 2 to DPA2, DP β 1 to DPB1, DP α 1 to DPA1, DZ α to DNA, DO β to DOB, DX β to DQB2, DX α to DQA2, DV β to DQB3, DQ β to DQB1, DQ α to DQA1, DR β 1 to DRB1, DR β 2 to DRB2, DR β 3 to DRB3, DR β 4 to DRB4, DR β to DRA.

SUMMARY

The Major histocompatibility complex (MHC) is a multi-gene complex that has been identified in all mammalian species studied. This complex encompasses genes that encode highly polymorphic cell surface glycoproteins involved in the initiation and regulation of the specific immune response to foreign antigen. The multiple genes that make up the major histocompatibility complexes of mouse and man have been extensively characterised to the nucleotide level. These genes have been divided into three distinct groups (class I, class-II and class-III), each encoding serologically and biologically distinct classes of molecule. The class-II genes and their products are the focus of this investigation. The products of these genes are heterodimers composed of an alpha and beta chain non-covalently associated at the cell surface. These chains are the products of a large number of class-II alpha and beta genes found within the class-II region of the MHC. MHC class-II molecules have been implicated in the development of self tolerance, are involved in the recognition of foreign antigen by immunocompetent cells of the immune system, cell-cell communication and are associated with resistance and susceptibility to disease. The characterisation of the MHC genes and their products in animals of economic importance such as the sheep is essential both for the study of fundamental immunology in species other than mouse and man and for more applied disease and vaccine research in the sheep. This project is part of an ongoing study investigating cellular immunology in the sheep. As the MHC class-II genes and their products are central to any work on cellular immunology an effort has been made to characterise the class-II genes and products of the ovine MHC.

Previous work has made use of nucleic acid probes corresponding to different subtypes of the class-II regions of the human and murine MHC to isolate 7 different alpha and 24 different beta genes of the ovine MHC from two cosmid libraries (Deverson et al 1991). In an attempt to identify pairs of alpha and beta genes capable of cell surface expression, all permutations of alpha and beta genes were in turn transfected into mouse L-cells. In the present study two pairs of alpha and beta genes co-expressed and stable ovine MHC class-II expressing L-cell lines were developed. The expressed alpha genes had previously been defined as DR-alpha homologues (DRA) by differential southern hybridisation to human subtype-specific class-II probes. As the association of alpha and beta chains at the cell surface is under isotype specific constraints we predicted that the beta gene products would be DR-beta homologues (DRB). This was confirmed by nucleotide sequence analysis as their sequences presented in this thesis, manifested a higher degree of homology with human DRB than any other subtype. Using the mouse L-cell lines expressing well-defined ovine MHC class-II of a single isotype (ovine DR), DR-specificity was attributed to two panels of monoclonal antibodies. A total of 8 out of 23 anti-sheep class-II specific monoclonal antibodies were typed by FACScan analysis using the expressing L-cell lines and an indirect fluorescent antibody assay (IFA). The specificity of most of these antibodies that had previously been assigned as DR-specific by immunoprecipitation and N-terminal sequencing was confirmed in this study. SDS-PAGE and immunoblotting of L-cell lysates confirmed the antibody specificities and also demonstrated reactivity of monoclonal 1D12 which had not been detected by FACScan analysis. Finally nucleic acid probes generated during the

course of this work were used in preliminary studies to determine the isotype specificity of cosmid cloned beta genes and to examine the expression of ovine class-II genes in mouse L-cells and ovine mesenteric lymph node cells in culture.

HISTORICAL REVIEW AND GENERAL INTRODUCTION TO THE GENES AND

PROTEINS OF THE MAJOR HISTOCOMPATIBILITY COMPLEX

1 HISTORICAL REVIEW

The Major Histocompatibility Complex (MHC) is a multi-gene complex that codes for polymorphic cell surface glycoproteins involved in the presentation of peptide antigens to cells of the immune system. The drive to characterise the MHC of both mouse and man has provided the impetus for many advances in immunological research throughout this century. In this review the historical milestones as well as the experimental techniques that have resulted in our current understanding of the MHC will be presented.

Among the genes clustered together within the MHC are those encoding the classical transplantation antigens. Early studies in cancer research identified a frequent failure to transplant a mouse tumour between outbred members of the same species. Only very occasionally was the transplant successful with the tissue surviving in the recipient for more than three weeks (Tyzzer 1909). At the same time, inbred strains of mice were first being developed in the United States in an attempt to create genetically homogeneous mice by generations of brother/sister mating (Strong 1942). Using these inbred animals Little and Tyzzer were able to demonstrate the successful transplantation between individuals of the same inbred line (Little and Tyzzer 1916). As soon as they attempted to transplant between mice of different strains the tissue was rejected. The first filial generation (F1) resulting from a cross between resistant and susceptible mice were almost all susceptible to the tumour but the second filial generation (F2) all rejected the tumour. These findings could not be explained at the time using the Mendelian laws of genetic inheritance involving a single factor controlling susceptibility and resistance. Little

proposed the multiple factor hypothesis which stated that a successful tissue transplant would depend on the donor and recipient sharing a number of "independently segregating alleles" (Little and Tyzzer 1916). By crossing resistant and susceptible mice and testing the ability of the F1 and F2 generations to reject a tumour it became clear that a large number of genes were involved.

The immune response was first implicated in tumour rejection when Tyzzer described the importance of an inflammatory response in tumour rejection (Tyzzer 1915). Haldane proposed a connection between the immune response to alloantigens and tumour rejection (reviewed by Clark 1968). He suggested that immunity was directed against alloantigens analogous to the blood group antigens identified by Landsteiner in 1902 (reviewed by Graber 1984). These blood group alloantigens present on the surface of red blood cells were targets for an immune response mediated by allospecific antisera when transfused into an incompatible host. The haemagglutination observed was used as the basis for a test for alloantisera and alloantigens. Haldane suggested that similar alloantigens would be found on the surface of tumour cells and it was against these that the immune response was directed. In an attempt to test Haldane's hypothesis and identify such alloantigens, Gorer produced antisera in rabbits against red blood cells from three inbred mouse strains (Gorer 1936). Using the haemagglutination assay he was able to distinguish between the strains using a panel of rabbit antisera. He concluded that the antisera were directed against a series of alloantigens I-IV. At the same time he discovered that a tumour isolated from a mouse strain positive for alloantigen II was rejected by mice negative

for alloantigen II but survived in strains positive for antigen II (Gorer 1938). Therefore he concluded that antigen II and the tumour resistance factor were closely related (Gorer 1937, Gorer 1938).

While Gorer was progressing with this work in Britain, Snell in the United States was involved in the development of congenic strains of inbred mice (Snell et al 1948). From the previous work described by Little he knew that a large number of genes were responsible for the rejection of a transplanted tumour. He therefore tried to produce strains of mice that differed only in a single resistance gene. This was achieved by repeated back crossing of a mouse strain that rejected a tumour with one that did not. Mice were constantly selected for the ability to accept the tumour (The production of congenic strains of mice is reviewed by Melvold 1986). In association with Gorer the congenic strains were tested with antisera against antigen II. They found that the mouse strains that rejected the tumour were negative for antigen II, demonstrating that the gene or genes for antigen II and the resistance gene(s) were likely to be the same (Gorer et al 1948). Snell later called antigen II a histocompatibility antigen, the product of a histocompatibility gene. Antigen II was found by Gorer and Snell to be of principal importance in allograft rejection and was therefore classified as a major histocompatibility antigen. The MHC of mice was later to become known as the histocompatibility antigen-2 complex which is still in use in its abbreviated form, the H-2 complex.

The characterisation of transplantation alloantigens continued using serological and cellular techniques pioneered by Gorer and Snell. The haemagglutination assay was succeeded by the cytotoxicity assay (Gorer and O'Gorman 1956, Terasaki and Rich 1964) as the preferred test for alloantisera and alloantigens. This assay determined antibody specificity by measuring the degree of antibody-specific complement-mediated target cell death. Specific antisera bound to alloantigens at the cell surface, and with the addition of complement, specificity was determined by measuring the degree of cell death either optically or radiochemically by the release of radioactive Chromium from the cytoplasm (Sanderson et al 1964). Combined approaches to alloantigen definition involving inbred mice, tissue transplantation, genetic (breeding studies) analysis and congenic mice in conjunction with serological studies identified at least two loci that encoded the classical transplantation antigens in mice (Hauptfield and Klein 1975, reviewed by Klein 1986). By analysis of the frequency of recombination between these two loci it was concluded that they were located close together in what is now known as the major histocompatibility complex.

Evidence for a further unrelated MHC locus was to come from two unrelated sources. Firstly Bach and Hirschhorn (1964) described the proliferation of murine lymphocytes when mixed with lymphocytes from an unrelated mouse strain. This reaction was termed the mixed lymphocyte reaction (MLR) and could be identified in inbred strains of mice as a function of genes linked to the MHC (Bach and Amos 1967). Serological reagents available at the time could not identify or inhibit the function of the gene products involved in the MLR (Bach et al 1972). However using mouse strains identical

at the previously defined class-I loci but still able to elicit a MLR, alloantisera were produced by inoculation of leucocytes from one strain into another. The alloantisera was found to be cytotoxic to only 15-20% of blood cells (Hauptfield et al 1973, David et al 1973) compared to up to 100% cytotoxicity for antisera directed against the products of previously defined loci (Gorer and O'Gorman 1957). Almost at the same time similar work was being carried out in man using antisera from multiparous women and recipients of skin grafts that matched in all previously defined loci. The alloantisera were found to label only a small proportion of white blood cells using a fluorescence assay (Van Leeuwen et al 1973).

Secondly, experiments on the genetic control of the immune response in guinea pigs and mice immunised with small synthetic polypeptides provided further evidence for a novel MHC locus. Evidence for a genetic component controlling the immune response to complex antigens had been described by various groups (Carlinfanti 1948, Sang and Sobey 1954, Fink and Quin 1953). After immunisation of guinea pigs with small synthetic polypeptides high and low responding strains were identified by comparing antibody titers. By crossbreeding experiments the antibody response was demonstrated to be under the control of a single dominant gene termed an immune response gene (Ir gene) (Levine et al 1963, Levine 1964, McDevitt and Sela 1965). This work was continued in the mouse by McDevitt who identified antipeptide antibody responding and non-responding strains of mice that differed only in the H-2 region. The Ir gene(s) was therefore thought to be associated with the MHC (McDevitt and Chinitz 1969). The Ir gene was eventually mapped to the middle of the H-2 complex (McDevitt et al 1972, Benacerraf and

McDevitt 1972). As the characterisation of the loci controlling the MLR and the peptide Ir genes continued it became clear that a single locus controlled both the MLR and the Ir gene phenomenon (Klein et al 1981). Klein designated the new Ir gene products as MHC class-II molecules and the classical transplantation antigens MHC class-I molecules (Klein 1979).

2 THE FUNCTION OF THE MHC

In spite of the above advances the physiological function of MHC molecules was still unclear. Allograft rejection and stimulation of the MLR could not really be considered a natural physiological function. Experiments performed by Zinkernagel and Doherty (1974) on Lymphocytic Choriomeningitis Virus (LCMV) infection in mice revealed the innate function of MHC molecules. Cytotoxic T-cells generated during LCMV infection killed the mice by destroying brain cells infected with the virus. The cytotoxic T-cells isolated from the spleens of virally infected mice of the H-2k haplotype only killed cells infected with the homologous virus in vitro, ie they were virus (antigen) specific. However they also found that cells from mice of the H-2d haplotype infected with the LCMV were not killed by the initial (H-2k) virus specific cytotoxic T-cells. This suggested that the cytotoxic T-cell antigen receptor recognised not only specific foreign viral antigen but also a host (self) H-2 specific component. This component was eventually identified as a MHC class-I molecule (Zinkernagel and Doherty 1979). MHC class-I molecules therefore act as restriction elements in the immune response. The recognition by T cells of a complex consisting of foreign antigen and self MHC at the cell surface is known as MHC restriction. Viral antigens are representative of endogenously

produced antigens which predominantly associate with MHC class-I molecules expressed at the surface of all nucleated cells. Therefore cytotoxic T-cells with the characteristic surface determinant CD8 and an antigen receptor specific for a self MHC class-I component associated with foreign viral antigen, can destroy any virus infected cell.

On the other hand exogenous antigen (eg: bacterial, fungal or parasite antigens) in association with MHC class-II molecules are recognised by CD4 positive T lymphocytes of helper function. (Benacerraf 1978). The humoral immune response to T cell dependent exogenous antigens is dependent on the differentiation of B-cells to antibody-producing plasma cells. This differentiation is driven by T-helper cells activated following recognition of processed antigen associated with MHC class-II molecules at the surface of an antigen presenting cell (Kappler and Marrack 1976). It had been known for some time that B-cell and T-cell antigen receptors recognise different forms of antigen. B-cell surface immunoglobulin acts as a receptor that recognises native antigenic determinants including protein conformational and structural components (Lanzavecchia 1985). Bound antigen then enters the B-cell by endocytosis where it is processed and presented to the T-cell receptor (Germain 1986). The T-cell receptor on the other hand recognises denatured, unfolded, peptide fragments expressed in association with MHC molecules at the antigen presenting cell surface (Babbitt et al 1985, Townsend et al 1989, Delovitch et al 1988). The endocytosis and selective proteolytic degradation of antigenic peptides within the antigen presenting cell is called antigen processing. It has recently been proposed that endogenous and exogenous antigens follow different pathways within

endosomal compartments of the presenting cell (Morrison et al 1986, Allen 1987). These different pathways determine whether the antigen is associated with MHC class-I or class-II molecules at the cell surface (Townsend et al 1989, Guagliardi et al 1990). It has also been proposed that the invariant chain, a 33kD protein transiently associated with class-II alpha and beta chains during their transport to the cell surface (Jones et al 1979, Long 1985) is involved in protecting the class-II binding site in the endoplasmic reticulum where endogenous antigen is thought to associate with MHC class-I molecules (Teyton et al 1990). The endosomal compartment is where class-II and exogenous antigen are thought to associate.

Variations in specific immune responses by individuals within a population are determined by the individual repertoires of both expressed MHC glycoproteins on antigen presenting cells and T-cell antigen receptor molecules. The extensive polymorphism associated with the MHC class I and II molecules is a major contributing factor to this variation. A consideration of the polymorphism associated with the MHC is therefore essential in the analysis of immune responses within a population.

In their function as restriction elements in presenting peptides to cells of the immune system, MHC molecules are thought to be involved in the selection events that take place in the thymus during the development of the T cell receptor repertoire (Singer et al 1982). These events determine the ability of T-cells to discriminate between self and non-self antigen (self tolerance) (reviewed by Marrack and Kappler 1988). In the thymus, T-cell precursors are selected for by the recognition of an antigen/MHC

complex at the surface of either thymic cortical epithelial antigen presenting cells (Lo and Sprent 1986) or thymic medullary cells (Marrack et al 1988). Those T-cell precursors that recognise self MHC molecules in association with foreign antigen are selected to form the peripheral T-cell pool. Those autoreactive T-cells that recognise self antigen in association with MHC molecules are thought to be negatively selected and do not reach the periphery. This negative selection is thought to occur either by clonal deletion (Burnet 1959, Kappler et al 1988, MacDonald et al 1988), active suppression (Gorcynski and MacRae 1979) or apoptosis ie programmed cell death (Smith et al 1989).

Finally there has been much speculation regarding the association between susceptibility and resistance to disease and particular MHC haplotypes. There are however many influences on susceptibility and resistance to disease which are likely to be determined by many genes from outwith the MHC. Nevertheless susceptibility to many human autoimmune diseases can be linked with particular MHC haplotypes. These include Rheumatoid arthritis which is linked with HLA-DR4 in susceptible individuals (Wordsworth et al 1989), Multiple sclerosis with HLA-DR2 (Cohen et al 1984); Coeliac disease with the allelic specificity HLA-DQw2 (Tosi et al 1983, Jeannet 1986); and Insulin-dependent diabetes mellitus (IDDM) with HLA-DR3 and DR4 (Horn et al 1988, Reviewed by Batchelor and McMichael 1987, Kappes and Strominger 1988). The strongest association between HLA haplotype and susceptibility to disease occurs in ankylosing spondylitis (Brewerton et al 1973). Over 95% of people with this rheumatic disease also have the HLA serological specificity B27 compared with only 7% of control populations. There are a number of hypotheses to explain why many autoimmune diseases

are associated with particular MHC haplotypes. In the case of ankylosing spondylitis one theory is that the MHC molecule itself may be the target of an immune response directed against *Klebsiella* (Geczy et al 1980). Non autoimmune diseases do not show good MHC linked susceptibility or resistance. However in chickens resistance to Marek's disease (caused by a DNA virus of the Herpes group) is closely linked to the chicken MHC B21 haplotype (Simonsen 1987, Martin et al 1989). For most diseases with an immune response component the susceptibility or resistance associations may involve other as yet unidentified genes which are in linkage disequilibrium with the MHC gene. These genes may include the T cell receptor genes, immunoglobulin genes or cytokine genes. It is clear in autoimmune diseases that there is a breakdown in T-cell tolerance as auto-reactive T-cells can frequently be identified (Londei et al 1985). This breakdown may be due to similarities between foreign antigen and self components. Therefore an immune response directed against foreign antigen may crossreact with a self component. This may only occur for certain class-II haplotypes resulting in an association between disease and MHC haplotype. As antigen is only recognised when in association with MHC molecules at the surface of antigen presenting cells the induction by gamma interferon of MHC class-II molecules in a cell type usually class-II negative may result in the presentation of a self antigen to which the immune system is not tolerant (Wraith et al 1989). The relationship between MHC haplotype and disease resistance/susceptibility is therefore a complex area of research with many other factors both genetic, ie from outwith the MHC, as well as environmental factors involved.

3 THE GENETICS OF THE MHC

Intensive study over the last 10 years has resulted in almost a complete gene map of the HLA complex of man and the H-2 of mouse (see Figs 1 and 2). The majority of the genes have been sequenced, the number of alleles at each locus determined and the polymorphic residues identified (reviewed by Guillemot et al 1988). The products of these genes have also been identified and classified by serological, biochemical and cellular techniques. Unravelling the genetic complexity of the MHC of both mouse and man was largely achieved due to rapid technical advances in molecular biology. Since the isolation of the first MHC cDNA gene (Ploegh et al 1980) multiple genes of certain haplotypes of both H-2 and HLA have been cloned and extensively characterised at the nucleotide level (Steinmetz et al 1982). Individual genes cloned in cosmid vectors (which enable up to 47Kb of genomic DNA to be cloned) can be overlapped by a technique called cosmid walking (Evans and Wahl 1987) to form genetic maps. In addition, pulsed-field gradient electrophoresis (Schwartz and Cantor 1984), which separates very large fragments of DNA, has enabled the individual loci to be positioned in the correct order on the appropriate chromosome, 6 in man and 17 in mouse (Flavell et al 1986, Hardy et al 1986, Tokunaga et al 1988). The complex genetic polymorphism of the MHC genes have been studied by restriction fragment length polymorphism (RFLP) analysis involving restriction enzyme digestion followed by southern analysis of genomic DNA using defined MHC gene probes (Holbeck and Nepom 1986, Muggli-Cockett and Stone 1988, reviewed by Bidwell 1988). Finally with the development of the polymerase chain reaction as a method for gene amplification (Saiki et al

1985, White et al 1989), polymorphic alleles of a particular MHC isotype can be isolated and sequenced from the cDNA of unrelated individuals using primers constructed from conserved regions 5-prime and 3-prime of the appropriate MHC gene (Saiki et al 1986).

The development of DNA-mediated gene transfer (transfection) techniques for the expression of cloned genes in mammalian cells (Graham and Van der Eb 1973, Wigler et al 1979) has been extremely valuable for the analysis of individual expressible MHC genes and their products. Normally in cells, multiple expression of MHC genes results in molecules of many different isotypes at the cell surface, which complicates genetic and protein analysis. The transfer and expression of individual cloned genes into eukaryotic cells with an antigenically different MHC background enables a single MHC isotype to be analysed.

The technique of DNA mediated gene transfer was first used for HLA class I gene expression by Barbosa et al (1982); for H-2 class-I genes by Goodenow et al (1981) and for porcine MHC class I genes by Singer et al (1982). In addition this technique has been used for HLA class-II genes by Morrison et al (1986) and H-2 class-II by Malissen et al (1983, reviewed by Malissen 1986). The object of the work presented in this thesis is to employ this technique for the characterisation and analysis of ovine MHC class-II genes and their products.

A summary of our present understanding of the genetics of the human and murine MHC and the biochemistry of their products is described below.

Multiple gene loci comprising the MHC have been identified in all mammalian species studied to date. The HLA is contained within a 3000Kb segment of chromosome 6 and the H-2 within a 2000Kb segment of chromosome 17. Within these complexes are the multiple genetic loci encoding three biochemically and physiologically distinct classes of MHC molecule, class-I, II and III. Each of these loci and the biochemistry of their products will be described individually. The extensive polymorphism identified within the HLA and their products will also be described.

MHC class-I genes and proteins

The class-I loci of man are classified as HLA-A, -B and -C and of mouse H-2-K,-D and -L (Figs 1 and 2). Each locus contains a single functional gene that codes for the alpha heavy chain of classical MHC class-I molecules (Fig 3). These highly polymorphic genes are co-dominantly expressed so an individual heterozygous for all three genes may express up to six different classical class-I antigens at the cell surface. In both the human and murine MHC a large number of extra "non classical" class I gene loci have been identified (Steinmetz et al 1982, Koller et al 1987, Koller et al 1988). These have been extensively studied in mice where approximately 30 gene loci have been identified. 23 of these have been grouped into two regions referred to as thymus leukaemia antigen (Tla) and Q region associated (Qa) (Mellor 1986). Approximately 18 HLA class-I loci have been identified which are divided into three classical and 15 non-classical loci (Guillemot et al 1988). The HLA equivalents of the murine non-classical genes have not yet been satisfactorily identified (Trowsdale 1988).

The MHC class-I glycoproteins (classical transplantation antigens) are found expressed at variable levels on the surface of most somatic cells (Klein 1975). Structurally the cell surface molecules (Fig 3) are heterodimers consisting of a 45Kd-48Kd subunit (which is the product of a polymorphic MHC class-I gene) non-covalently linked to a 12Kd subunit (Beta-2 microglobulin) encoded outwith the MHC on chromosome 2 and 15 in mouse and man respectively. All the polymorphism associated with class-I molecules is located within the large MHC encoded subunit as beta-2 microglobulin is invariant. The non-classical class-I molecules have a much more restricted distribution than classical class-I molecules. They are detected primarily on thymocytes and certain leukaemia cell lines (Flaherty 1981). The molecules are related to classical class-I proteins in their amino acid sequence but are structurally different. They exhibit only limited polymorphism and seem to be unrelated functionally to the classical class-I molecules (Yokoyama et al 1981). The function of these molecules is not clear and is currently under investigation.

Classical MHC class-I molecules are composed of six protein domains: four external, one transmembrane and one intracellular (See Fig 3). One of the external domains is the non-MHC associated beta-2 microglobulin and the remaining five are part of the class-I alpha chain. Each extracellular domain is generally encoded by a separate exon of approximately 90-100 nucleotide base pairs (see Fig 3 and 4). The amino acid sequence and structure of these domains show homology to the variable or constant domains found

within the immunoglobulin molecules. The MHC molecules are therefore described as members of the immunoglobulin supergene family which also includes the T-cell receptor, CD4 and CD8, Thy-1 and N-CAM. (Hunkapiller and Hood 1986, Anderson et al 1988).

MHC class-II genes and proteins

The classical immune response genes (Ir genes) are located within the class-II region of the MHC (HLA-D in man, H-2-I in mouse). A diagrammatical representation of the genetic organisation of the HLA and H-2 complexes are shown in Figs 1 and 2. These diagrams show the 5 classical class-II loci (HLA-DP, DQ, DR, DZ, and DO) in man (reviewed by Kappes and Strominger 1988) and H-2-IA and IE in mouse (reviewed by Klein 1986). MHC Class-II molecules are heterodimers composed of the products of an alpha and beta gene (Fig 3). In man the DP, DQ and DR loci each contain one functional alpha and beta gene pair, which together encode all isotypes of class-II molecules expressed at the cell surface. These three regions also contain a number of pseudogenes (Fig 1), DR4B-II, DRBII and DPA/DPBII (Larhammer et al 1985, Rollini et al 1987, Trowsdale et al 1984), gene fragments (Hass et al 1987) as well as genes of undefined status, DXA/DXB, (Auffray et al 1984). Regions DZ and DO contain a single alpha and beta gene respectively (Serenius et al 1987). Although these genes are transcribed (as the corresponding mRNA has been detected), no protein product has yet been satisfactorily identified.

The mouse MHC class-II region has two subregions IA and IE. These each contain a single expressing alpha and beta gene pair along with a number of pseudogenes (Fig 2).

The MHC class-II molecules are heterodimers composed of two non-covalently associated alpha and beta glycoprotein chains. These two chains have molecular weights of 32-34Kd and 26-28Kd respectively (Jones et al 1978) and are encoded by alpha and beta genes found within the MHC.

The MHC class-II molecules are composed of eight domains, four in the alpha chain and four in the beta chain (Fig 3). In both alpha and beta chains there are two external domains, together with a transmembrane and an intracellular domain. Each is encoded by a separate exon with slight differences in class-II alpha and beta transmembrane domains (Trowsdale 1987) (Fig 4).

The cellular distribution of MHC class-II molecules is more restricted than MHC class-I molecules (Van Leeuwen et al 1973). They are found constitutively on cells involved in the presentation of antigen to T helper lymphocytes, such as monocytes, macrophages, (Winchester et al 1975, Hirschberg et al 1976), dendritic cells (Brooks and Moore 1988), B cells (Kearney et al 1977, Hammerling et al 1975) as well as transiently on cells such as activated T cells in man (Fu et al 1978, Metzgar et al 1979) and sheep (Hopkins et al 1989) but not mice. MHC class-II is also found transiently on many cell types in the presence of class-II inducers such as interferon-gamma (Collins et al 1986) and on resting B-cells in the presence of interleukin 4 (IL4) (Noma et al 1986). The cytokine granulocyte/macrophage colony stimulating factor (GM-CSF) has also been found to induce MHC class-II expression on human eosinophils

Fig 1

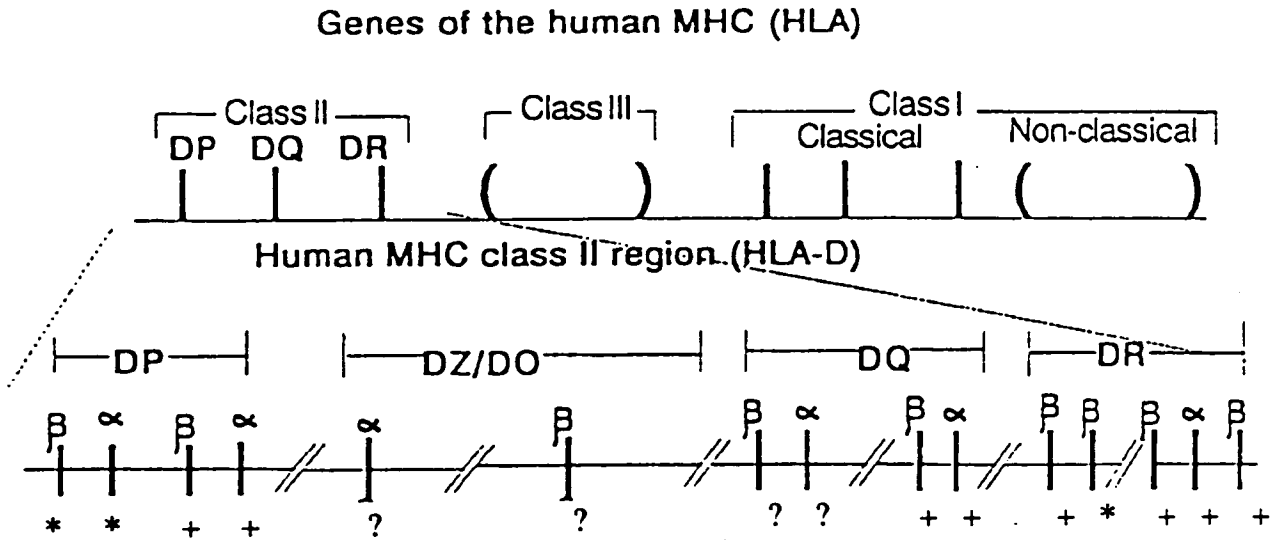

Fig 1 legend.

A diagrammatical representation of 3000 kilobases of the short arm of chromosome 6 showing the arrangement of genes within the HLA. The class-II region has been expanded to reveal the arrangement of alpha and beta genes within the DP, DQ, DZ/DO and DR subregions. The genes encoding MHC class-II molecules are marked +, the pseudogenes (ie genes unable to form a whole mRNA transcript) are marked * and the genes for which no protein product has yet been identified are marked ?. Taken from Trowsdale *et al* 1987.

Fig 2

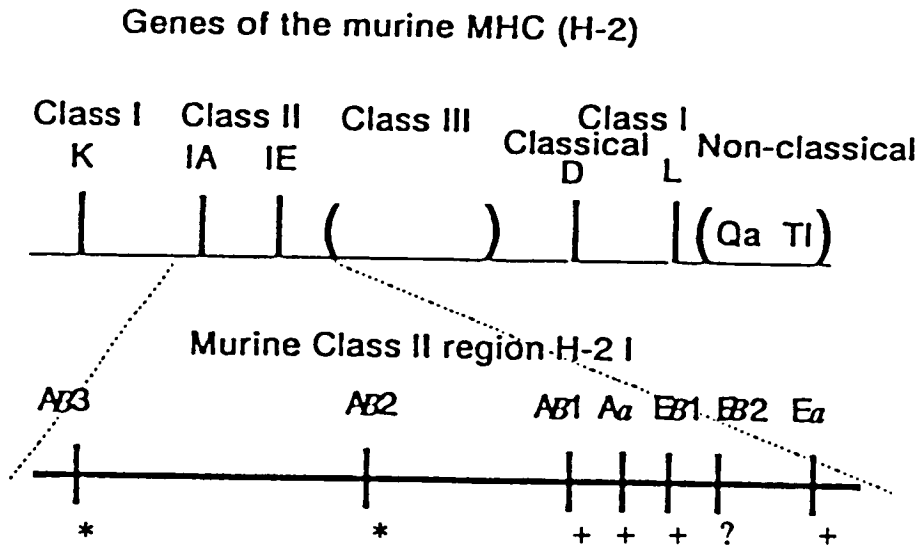

Fig 2 legend.

A diagrammatical representation of 2000 kilobases of murine chromosome 17 (H-2^d haplotype) showing the arrangement of genes within the H-2 complex. The class-II region is expanded to reveal the arrangement of alpha and beta genes. The sequence of AB3 and AB2 indicates that these genes are the murine equivalents of HLA-DPB and DOB. The IA and IE alpha and beta genes are the murine equivalent of HLA -DQ and DR. Genes from which protein has been detected are marked +, pseudogenes * and genes of unknown function ?. Taken from Flavell *et al* 1986 and Trowsdale *et al* 1987.

Fig 3

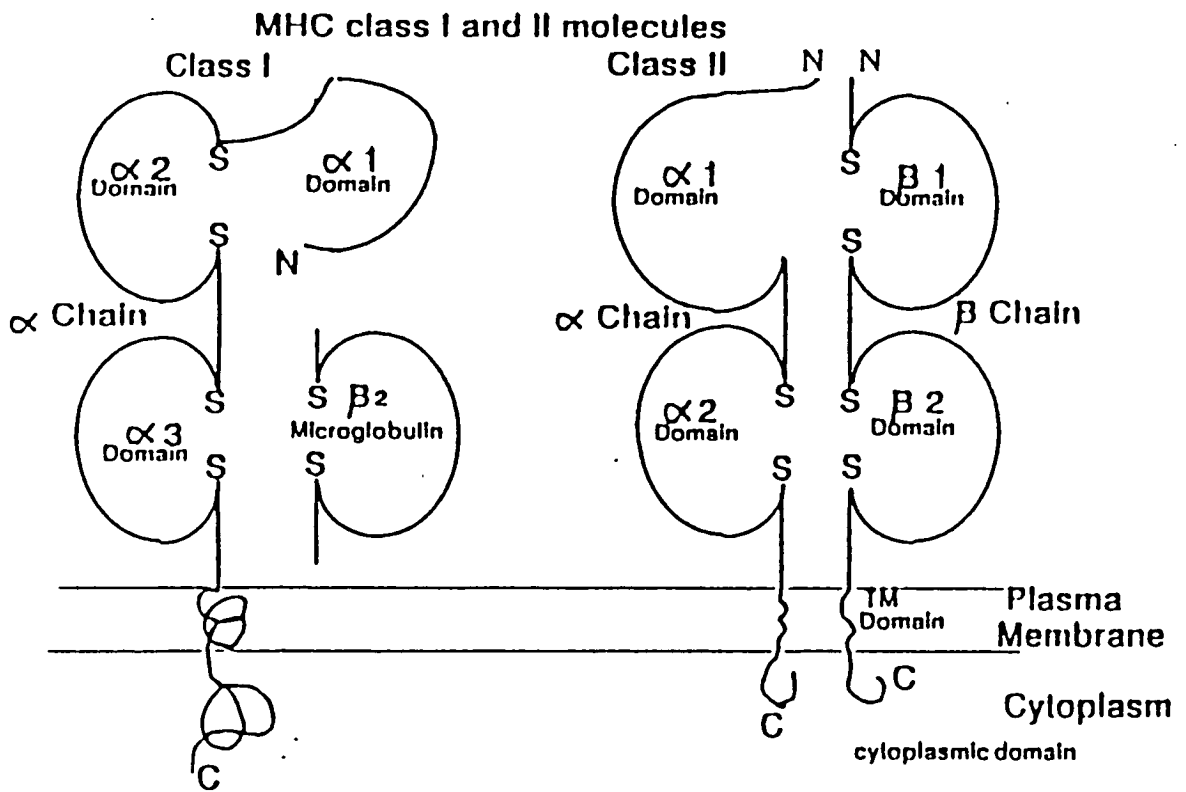

Fig 3 legend

A schematic view of the structure of MHC class-I and II molecules. This shows the domain structure and disulphide bridges involved in their formation. Each extracellular domain is composed of between 90-100 amino acids, the transmembrane domain between 20 and 25 amino acids and the cytoplasmic domain between 8 and 12 amino acids. Each domain is generally encoded by a separate exon (See Fig 4).

Fig 4

Intron / exon organisation of human MHC class II genes

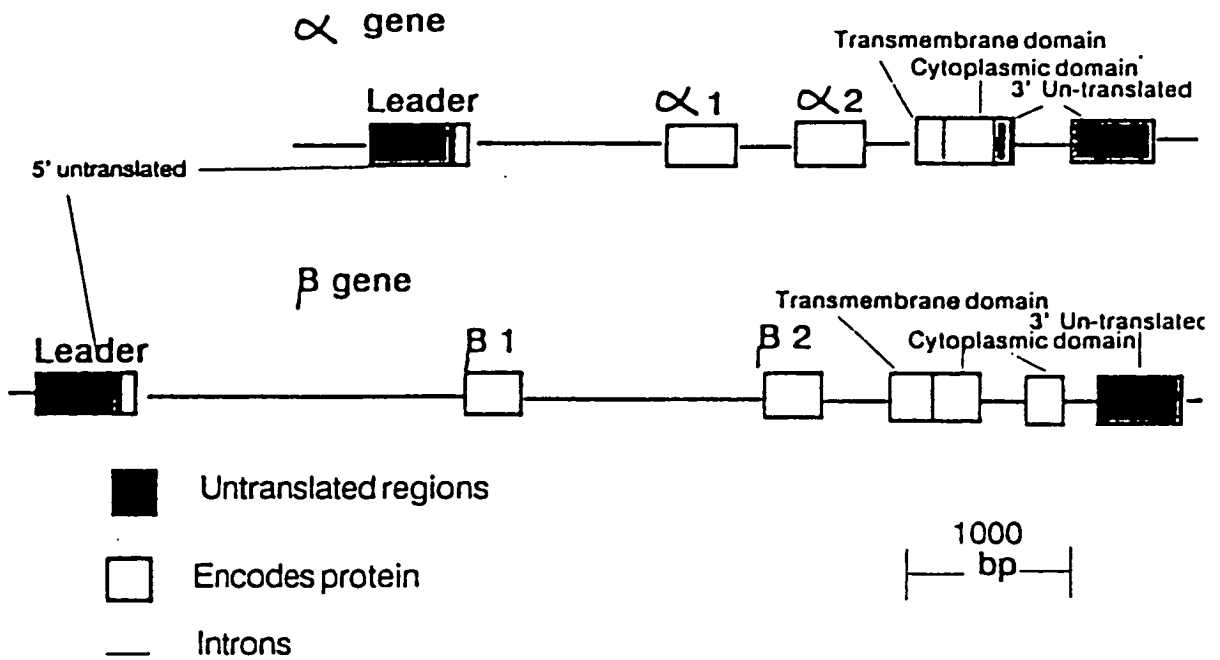

Fig 4 legend

MHC class-II alpha and beta genes are composed of 5 and 6 exons respectively. Exon 1 includes the 5-prime untranslated, encodes the leader (signal) peptide and the first four amino acids of the alpha and beta-1 domains. Exons 2 and 3 encode the remainder of alpha and beta-1 domains as well as the entire alpha and beta-2 domains. Exon 4 encodes the transmembrane and cytoplasmic domains of alpha chains but only part of the cytoplasmic domain of beta chains, the remainder being encoded from exon 5. Exon 5 in alpha genes contains the 3-prime untranslated sequence which is contained in exon 6 for beta genes (Trowsdale 1987, Kappes and Strominger 1988).

(Lucey et al 1989). Likewise tumour necrosis factor (TNF) has been shown to induce the expression of MHC class-II molecules on murine myelomonocytic cell lines as well as augmenting the induction caused by interferon (Chang and Lee 1986).

MHC Class-III genes and proteins

The class-III loci contains genes that code for components of the complement cascade and various unrelated enzymes. These genes and molecules are not the focus of this investigation and will not be discussed further in this review. For a review of the class-III genes and gene products see Carroll and Alper 1987 and Campbell 1987.

Polymorphism associated with MHC genes and proteins

Genetic polymorphism is defined as the occurrence of two or more alleles in a population at a frequency of 1% or higher (Klein 1986). Frequencies less than this are not considered to be polymorphisms but to be most likely the result of recent mutations.

The classical MHC class-I genes (and therefore the corresponding molecules) are highly polymorphic (Parham et al 1988). Most of this polymorphism is detectable using alloantisera and the cytotoxicity assay. MHC class-I polymorphism is the major underlying cause of allograft rejection. HLA class-I loci (see Fig 1) have been identified as having over 20 specificities at the A locus, 50 at the B and at least 8 at the C locus (Strachan 1987). Most of this amino acid sequence variation occurs in the alpha-1 and alpha-2 extracellular domains but minor variations have also

been detected in the trans-membrane and cytoplasmic domains (Parham et al 1988, Andersson et al 1987). These variable residues in the alpha-1 and alpha-2 domains are thought to be exposed in the groove in which foreign antigen associates with MHC class-I. This has been confirmed by X-ray crystallographic studies of HLA-A2 (Bjorkman et al 1988). The "non classical" class-I antigens do not exhibit extensive amino acid polymorphism. Beta-2 microglobulin also does not exhibit polymorphism.

Polymorphism in the MHC class-II molecules can also be detected serologically but most has been detected at the genetic level using restriction fragment length polymorphism (Auffray et al 1984). Polymorphism in MHC class-II genes varies between isotypes (Mellor 1986). DQ is the most highly polymorphic of all the alpha genes and consists of at least eight different allelic variants. DRA and DPA show only very limited polymorphism. The beta genes are all extensively polymorphic with 15 allelic variants of DR, 10 DQ and 6 DP (Klein 1986, Trowsdale 1987). The mouse is similar, IA being the murine homologue of human DQ and polymorphic in both alpha and beta genes. IE is extensively polymorphic in the beta gene as is its human homologue DR (Kappes and Strominger 1988).

4 THE OVINE MHC AND PREVIOUS WORK RELEVANT TO THIS PROJECT

Ovine MHC class-I loci were serologically described using alloantisera produced by inoculation of sheep with allogenic lymphocytes followed by analysis using the cytotoxicity assay (Millot 1974, Ford 1974, Ford 1975, Millot 1979). Serological studies employing the microcytotoxicity assay (Terasaki and MacClelland 1964) within a well-defined population of sheep of

known ancestry (Millot 1979, Millot 1984) suggested the existence of up to 16 class-I alleles present within three loci OLA-A, OLA-B and OLA-C. The class-I molecules were biochemically defined in 1985 (Gogolin-Ewens et al 1985) when heterodimers were immunoprecipitated from sheep lymphocytes using a panel of four monoclonal antibodies. The heterodimers consisted of an alpha chain of 44 Kd and a beta-2 microglobulin molecule of 12 Kd which were distributed in tissues and cells in a similar manner to HLA and H-2 class-I molecules.

Ovine MHC class-II molecules have been characterised using specific monoclonal antibodies (Puri et al 1985 and Hopkins et al 1986). Both groups identified a heterodimer of 32-36Kd and 24-29Kd by immunoprecipitation and SDS-PAGE analysis. The cellular distribution of constitutively expressed ovine MHC class-II molecules was similar to that observed in man, namely on monocytes/macrophages, B-cells, dendritic cells and following activation on T-cells. More recent studies by Puri using a panel of monoclonal antibodies specific for monomorphic determinants of ovine MHC class-II molecules have proposed four distinct, non-overlapping subsets of MHC class-II molecules (Summarised in Puri et al 1987a).

Ovine MHC class-II genes were identified in genomic DNA by southern hybridisation to human and murine class-II probes (Chardon et al 1985). Ovine class-II genes equivalent to HLA-DQ and DR alpha as well as a number of undefined beta genes were isolated from a genomic phage library using human class-II DNA probes (Scott et al 1987). These studies are however incomplete as the full range of genes were not identified. A collaborative project has

therefore been initiated between the Moredun Research Institute (MRI) Edinburgh and the Institute of Animal Physiology and Genetics Research (IAPGR) Cambridge, the aim of which is to fully characterise the class-II genes and gene products of the ovine Major Histocompatibility Complex (MHC).

This collaboration had progressed for three years before the initiation of this project. The results of this collaboration can be summarised as follows:-

Cloning of ovine MHC class-II genes

Ovine MHC class-II genes were isolated from two genomic DNA libraries made by S. Watson and N. Huskisson and screened by H. Wright and E.V. Deverson. These libraries were constructed using the cosmid gene cloning vectors PTL-5 and PTL-6 (Lund et al 1982) by the technique described by Steinmetz et al (1982) (See materials and methods page 37). The cosmid vectors developed by Collins et al (1978) were chosen for the construction of the libraries due to the large amount of ovine genomic DNA (32-47 kilobase pairs) that can be incorporated. This allows the identification of overlapping cosmid clones and eventually a complete map of the class-II region of the ovine MHC will be produced.

Genomic DNA was used as a source of DNA in preference to complementary DNA (cDNA prepared from messenger RNA) for the following reasons a) to construct a contiguous map of the MHC region of the ovine genome from overlapping cosmid clones, b) to identify those alpha and beta gene combinations that will express using endogenous ovine promoter and enhancer sequences when

transfected into mouse L cells, c) to clone genes other than those that are normally expressed in cells, d) to obtain clones containing genes that are expressed but perhaps not in the tissue from which a cDNA library would be prepared and e) to study the regulation of gene expression using sheep regulatory sequences found in genomic DNA but not cDNA.

Screening of cosmid libraries using human and murine class-II gene probes and characterisation of selected clones

The two genomic DNA libraries have been screened for ovine MHC class-II genes by H. Wright at the Moredun research institute and E.V Deverson at IAPGR Cambridge using murine and human MHC class II specific cDNA and genomic probes described in table 1.

Table 1

Subregion

Probe	Name	DNA/cDNA*	Nature of Probe	size(Kb)	Reference
A α	p24.2	DNA	Whole gene	4.8	David 1984
A β	A β pBR	DNA	Whole gene	5.6	Malissen 1983
A β 2	Cos25.1	DNA	β 2 domain	2.0	Larhammer 1985
E α	O2E α	DNA	α 1-> CT tail	3.4	McNicholas 1982
E β	L1E β	DNA	β 1 and β 2 domains	7.2	Kronenberg 1983
E β 2	pBR325E β 2	DNA	β 2 domains->3'UT	3.0	Denaro 1985
DP α	pDA α 13b	cDNA	α 1->3'UT	1.1	Trowsdale 1984
DP β	LC11	DNA	β 1 domain	0.9	Trowsdale 1984
DQ α	10-8	DNA	α 1 and α 2 domains	2.2	Trowsdale 1983
DQ β		cDNA	β 1 and β 2 domains		Wiman 1982
DR α	pDRH2	cDNA	α 1 and α 2->TM	1.3	Lee 1982
DR β	pDR β 1	cDNA	Whole gene	1.2	Long 1982
DZ α	8ba1	DNA	α 1-> stop	1.7	Trowsdale 1985

* Genomic DNA-derived probe or complementary DNA probe (from messenger RNA)

Seven distinct alpha (alpha 1-7) and twenty four beta (beta 1-24) genes or gene fragments present within 31 cosmid clones have been identified.

Several cosmids were found to hybridise strongly with DRA and IEA probes. Also identified were cosmids that hybridised strongly with DQA and IAA probes. DPA gene probes only weakly hybridised with five cosmids and these were subsequently shown to hybridise with DZA with much greater affinity. Therefore the sheep equivalent of the HLA-DPA subregion has not been identified (Deverson et al 1991 in press). The human and murine beta gene probes hybridised strongly with a large number of different cosmids. The human subtype equivalent of the ovine beta genes was not determined as beta genes cross-reacted with all beta subtype specific probes. The 31 cosmid clones have been mapped using five restriction enzymes and the position of the class-II gene or genes within each clone determined by southern hybridisation. Several of the cosmid clones have been linked together to produce a series of clusters (Fig 5). The restriction maps of all 31 cosmids are described in Figs 5, 6, and 7).

Production of monoclonal antibodies against ovine MHC class-II antigens

An initial aim of this project aims was to type panels of monoclonal antibodies for ovine MHC class-II isotype specificity. Monoclonal antibodies directed against ovine MHC class-II molecules have been produced in a number of ways. First of all the most common approach was the generation of xenogenic MHC class-II

Fig 5

Cosmid clusters

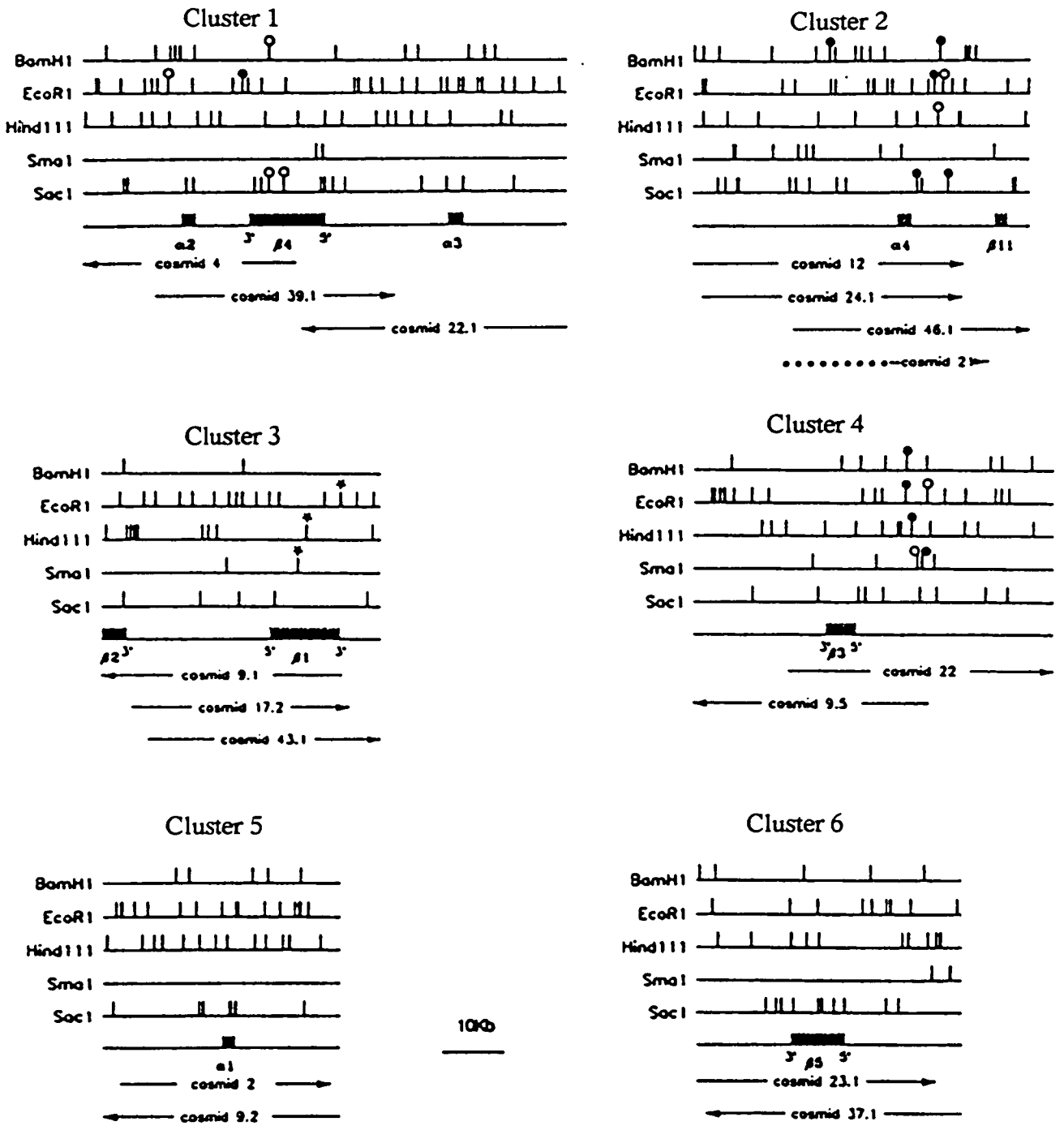

Fig 5 legend.

Cosmid restriction maps obtained using five restriction enzymes. A vertical line indicates a restriction site and the boxes indicate the smallest fragment containing the alpha or beta gene hybridisation signal. The arrows indicate the direction of cloning relative to the cos ends. In cluster 1 the closed circle indicates a restriction site unique to cosmid 4. The open circles indicate a restriction site unique to cosmid 39.1. In cluster 2 a closed circle indicates a restriction site unique to cosmid 12 and an open circle a site unique to cosmid 24.1, 46.1 and 21. In cluster 3 * indicates a site difference within the beta gene which may indicate polymorphism within this gene. In cluster 4 a closed circle indicates a site unique to cosmid 22 and an open circle a site unique to cosmid 9.5. This diagram is reproduced from Deverson *et al* 1991.

Fig 6

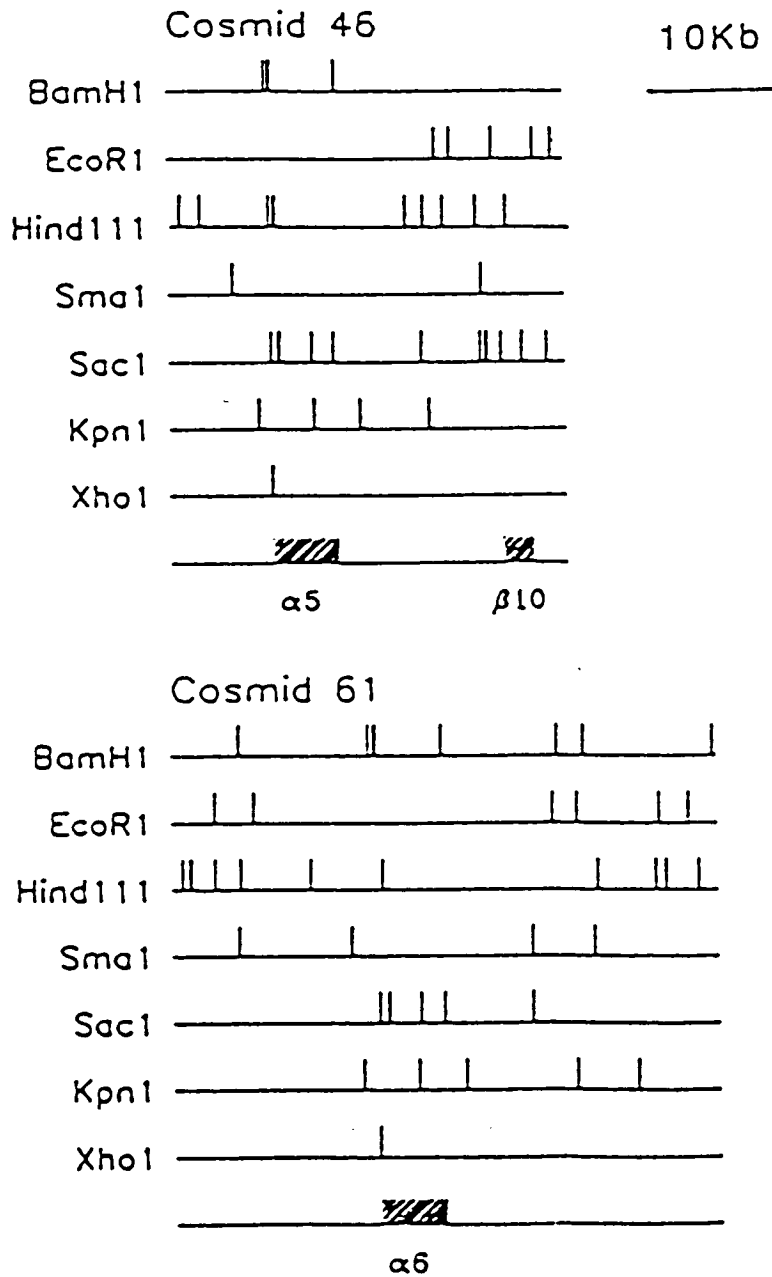

Fig 6 legend.

Restriction maps of cosmids 46 and 61 isolated from a single cosmid library prepared in the cosmid vector PTL6. The alpha genes within these cosmids have identical restriction sites for the area containing the gene however cosmid 46 also contains a beta gene which is absent in 61 indicating that a duplication of the this alpha gene may have occurred. Reproduced from Deverson *et al* 1991.

Fig 7

Cosmid restriction maps

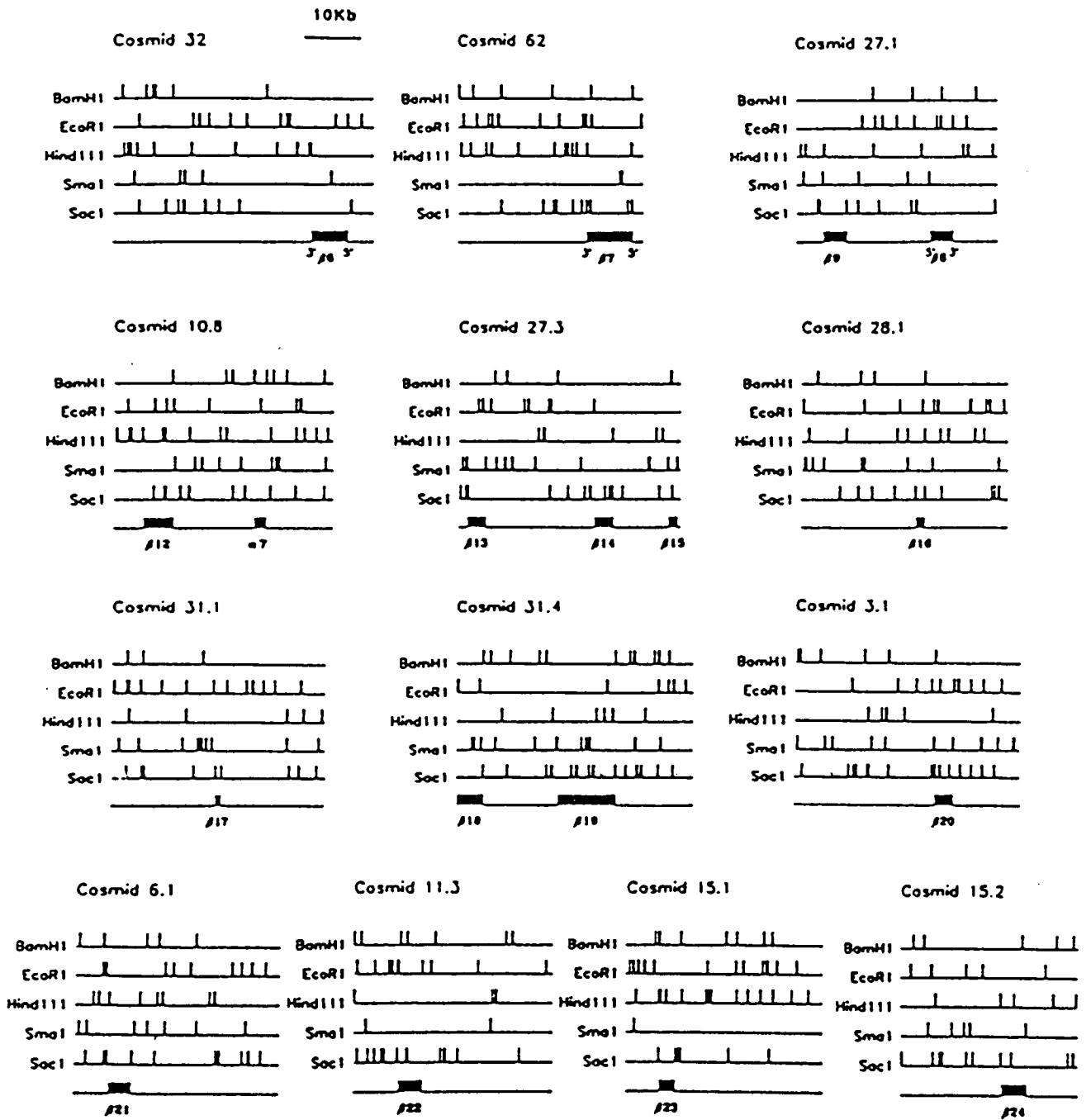

Fig 7 legend.

Restriction maps of single clones containing alpha and beta hybridisation signals. Reproduced from Deverson *et al* 1991 (See appendix 5).

specific antibodies by immunisation of mice (rats in the case of monoclonal SW73.2 see Table 2) with ovine MHC molecules. This technique has provided the majority of antibodies used in this investigation (See table 2). Monoclonal antibodies were raised against either SW73.2 immuno-purified class-II antigen as in the case of most of the VPM antibodies or cell surface class-II as in the case of the majority of the SBU monoclonal antibodies. The immunisation protocols are described by Puri et al 1985 for the SBU antibodies and Hopkins et al 1986, Dutia et al 1990 for the VPM and SW73.2 monoclonal antibodies.

The second approach was to screen monoclonal antibodies raised against murine and human MHC class-II for cross-reactivity with ovine molecules. Allogenic MHC-specific antibodies sometimes react with the MHC molecules of other species. This has been demonstrated for antibodies raised against both human and murine MHC class I and II (Shinohara et al 1978, 1981, Lunney et al 1979, Pierres et al 1981, Spooner et al 1984) and provides an indication of the degree of epitope conservation that the MHC molecules have enjoyed during evolution. The monoclonal SBU 37.68 used in this project (See Table 2) is an allogenicly-derived murine antibody produced by alloimmunisation of splenocytes between A.TH and A.TL mice (Puri et al 1985).

TABLE 2

OVINE MHC CLASS-II SPECIFIC MONOCLONAL ANTIBODIES USED IN THIS STUDY

MONOCLONAL ANTIBODY.	ISOTYPE.	CHAIN SPECIFICITY.	PROPOSED SUBTYPE SPECIFICITY *.
¹ SBU II 28.1, 37.68	IgG1	conformational	DR-like
SBU II 38.27	IgG1	conformational	DQ-like
[‡] SBU II 42.20	IgG1	alpha	DR-like
SBU II 49.1	IgG2a	beta	Pan-specific
SW73.2 (Rat)	IgG2a	beta	Pan-specific
⁺ VPM 1, 3	IgM	ND	ND
VPM 4, 45, 46	IgG2a	beta	ND
VPM 15	IgG2a	ND	ND
VPM 36, 38, 47	IgG1	alpha	ND
VPM 16, 37, 40,	IgG1,	beta	ND
VPM 41, 43, 44	IgG1	beta	ND
VPM 48	IgG2a	alpha	ND
ID12	IgG1	alpha	ND

*Based on N-Terminal sequence analysis (Puri et al 1987c).

¹ The SBU monoclonal antibodies have been described previously (Puri et al 1985, Puri et al 1987a, Puri et al 1987b)

⁺ Veterinary Pathology and Moredun, VPM monoclonal antibodies (Hopkins et al 1986, Dutia et al 1990)

ND, Not determined.

5 AIMS OF THIS PROJECT

31 cosmid clones containing ovine MHC class-II alpha and beta genes had been isolated and partially characterised prior to the work of this thesis (Figs 5, 6, 7). Large numbers of ovine class-II specific monoclonal antibodies had been produced that required further characterisation (Table 2). Using these materials this project aimed to:-

1) Identify combinations of alpha and beta cosmids that co-express after DNA mediated gene transfer into a class-II negative murine fibroblast cell line (L-cell line). This should identify preferential associations of alpha and beta gene products and allow the identification of the subtype of the beta genes which remain uncertain following cross hybridisation studies.

2) Characterise the expressed genes by means of nucleotide sequence analysis.

3) Employ L-cells expressing defined ovine MHC class-II antigens to determine the isotype specificity of two panels of monoclonal antibodies.

The long term aims were:-

1) To use the panel of well-characterised isotype-specific monoclonal antibodies and nucleic acid probes to investigate qualitative and quantitative variation in ovine MHC class-II expression. To use exon-specific probes to define polymorphisms by

restriction fragment length polymorphism (RFLP) and polymerase chain reaction (PCR) and to define the MHC restriction elements involved in specific immune responses to exogenous pathogen antigen. This will allow a) a comparison to be made of individual variations in immune response; b) The elucidation of the accessory function of different antigen presenting cells in different locations; c) The identification of the type of antigen bound by the different subtypes of MHC class-II molecules and d) the effect of antigen/MHC type on T-cell subset stimulation and analysis of subsequent differential cytokine production.

2) To use the transfectants expressing defined ovine MHC class-II in functional studies such as the presentation of antigen to T cell lines and the stimulation of the mixed lymphocyte reaction to type sheep matched at this locus.

3) To investigate various regulatory sequences such as those that govern a) the tissue specific expression of ovine MHC class-II molecules and b) the the ovine interferon regulatory sequences.

MATERIALS AND METHODS

1 ANIMALS

Two unrelated Suffolk rams from the flock maintained at the Institute of Animal Physiology and Genetics Research (IAPGR) Cambridge were used as donors of genomic DNA for cosmid library production. Sheep donors of peripheral blood leucocytes and mesenteric lymph node cells were randomly selected animals from the Suffolk flock maintained at the Moredun Research Institute, Edinburgh. C3H mice originally purchased from Harlen Olac Ltd, (Oxford, England) were supplied from the breeding colony maintained at the Moredun Research Institute, and were used as donors of embryo carrier DNA and spleen cell RNA.

2 COSMID LIBRARY CONSTRUCTION

Prior to this project two genomic libraries were prepared in the cosmid vectors pTL5 and pTL6 (Lund et al 1982) using high molecular weight DNA isolated from sperm and testis, respectively, from two unrelated Suffolk rams. The cloning vectors and construction of the libraries are described in Fig 8. Briefly, high molecular weight genomic DNA was prepared from sperm and testes using the technique described by Flavell et al (1978). The genomic DNA was prepared for cloning by partial digestion with restriction enzyme MboI and ligated to the cosmid vector arms. The linear recombinant cosmid was packaged into bacteriophage heads and transduced into *E.coli* using the techniques described by Steinmetz et al (1982). The screening of these libraries for ovine MHC class-II genes using human and murine nucleic acid probes, characterisation of the clones and production of restriction maps have all been described (Deverson et al 1991 see Figs 5, 6 and 7).

Fig 8

Restriction map of PTL5/6 and diagrammatical representation of the construction of the cosmid libraries.

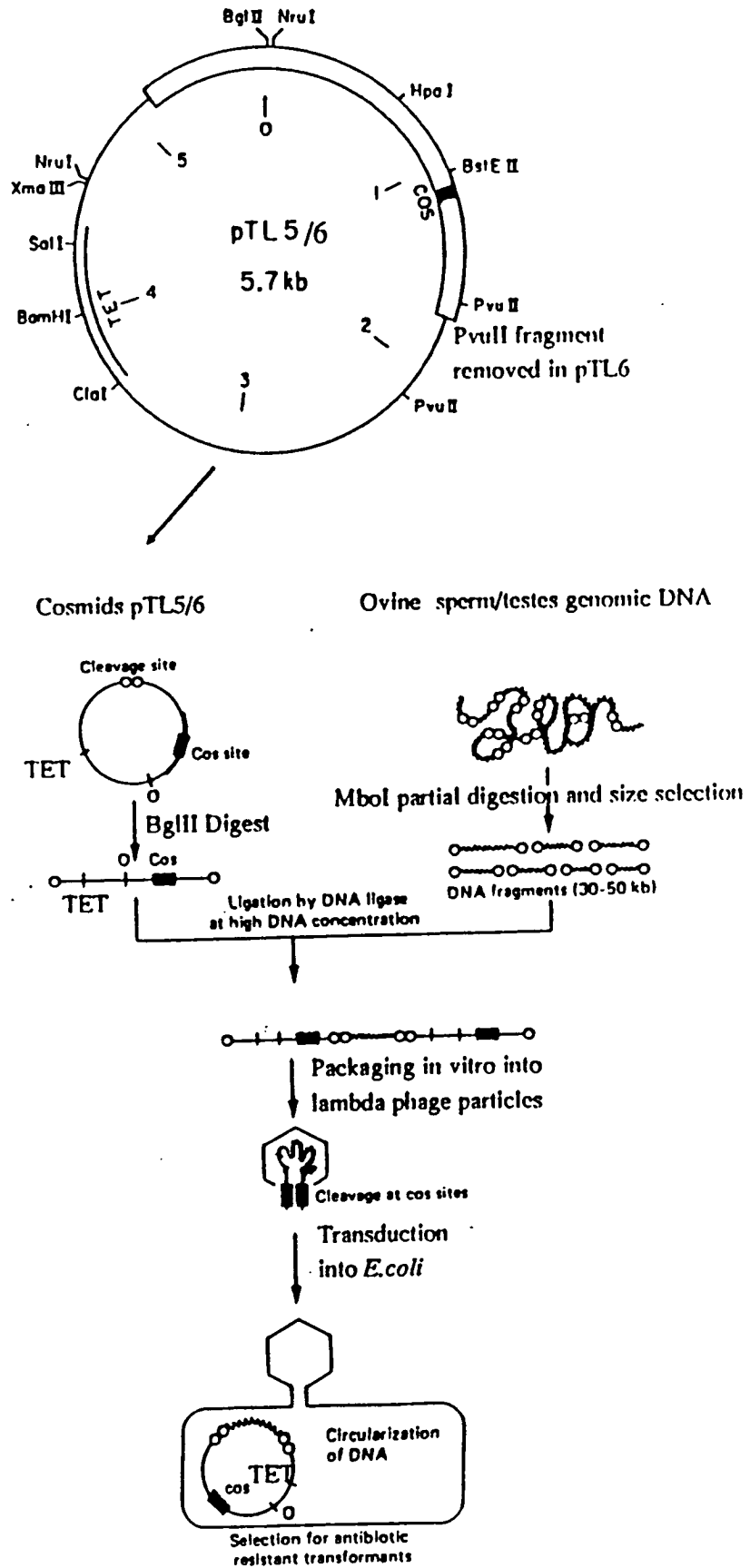

Fig 8 legend.

The restriction map of cosmid vector PTL5/6 is reproduced from Steinmetz *et al* 1982. The open box indicates the fragments derived from lambda phage. The position of the tetracycline gene and cos site are indicated.

The two cosmid libraries were constructed using the technique described by Steinmetz *et al* 1982. Genomic DNA derived from sperm and testes was obtained from two unrelated Suffolk rams. Genomic DNA was partially digested using the restriction enzyme MboI. Fragments between 30 and 50 kilobases were size-selected and ligated with linear vector arms prepared by digestion with BglII as described by Ish-Horowicz and Burke 1981. Concatamers consisting of vector/insert/vector were packaged in vitro into lambda phage particles using the technique described by Hohn and Murray 1977. The lambda particles were transduced into E.coli and transformants selected for tetracycline resistance.

3 PREPARATION OF NUCLEIC ACID (DNA/RNA)

3.1 Preparation of cosmid (plasmid) DNA.

Large amounts of Cosmid DNA (500-1000µg) was prepared by the alkaline extraction technique described by Birnboim (1979), followed by caesium chloride density ultracentrifugation as follows. *E.coli* cultures containing the cosmid of interest were obtained from -70°C frozen stock (see appendix 2) and inoculated into 10ml of Luria-Bertani broth (LB) or terrific broth (TB) (see appendix 2). After incubation at 37°C for 6-8 hours with constant agitation cultures were transferred to 2 litre indented conical flasks containing 250ml of LB or TB and incubation continued for a further 15-16 hours at 37°C with vigorous agitation. The cultures were then cooled on ice and the bacteria harvested by centrifugation at 4000xg for 10 minutes using a Beckman JA-21 centrifuge and JA-14 rotor. The pellet was resuspended and washed in 50ml ice cold glucose buffer (50mM glucose, 25mM Tris/HCL pH8, 10mM EDTA). All subsequent procedures were carried out on ice or at 4°C. After centrifugation at 4000xg for 10 minutes, the pellet was resuspended in 20ml of glucose buffer and the cells lysed by the addition of 5ml of a 20 mg/ml lysozyme solution (Sigma Chemical Co, Poole, England, Cat no L6876) for 5 minutes at room temperature followed by 40ml of freshly prepared Sodium-dodecyl-sulphate/Sodium hydroxide (0.2M NaOH, 1% W/V SDS) solution for 5 minutes at 4°C. Bacterial DNA and contaminating protein were removed by precipitation in 30ml of high salt solution (3M potassium acetate, 1.8M formic acid) on ice for 30 minutes. The precipitate was pelleted by centrifugation for 10mins at 15000xg and the supernatant collected. Plasmid DNA was precipitated from

the supernatant by addition of an equal volume of isopropanol and incubation on ice for 30 minutes, after which the DNA was pelleted by centrifugation at 15000xg for 15mins. The pellet was dissolved in 9ml of Tris/NaCl (0.05M Tris, 0.15M NaCl). 1g/ml Caesium chloride and 80µl/ml of 10mg/ml ethidium bromide (Sigma Chemical Co, Cat no E8751) were added to the DNA solution which was then sealed into 10ml Beckman "quick seal" ultracentrifuge tubes (Beckman Instruments Ltd, High Wycombe England, Cat No 342413) and subjected to gradient ultra-centrifugation on a Beckmann L8M ultracentrifuge for 36 hours at 40000 rpm.

The plasmid band was removed from the ultra-centrifuge tube using a 1ml syringe with 18 Gauge needle (Becton Dickinson, Cat no 5198). The ethidium-bromide was extracted by dialysis with butanol saturated with Tris/EDTA/NaCl pH 8.5 (TEN, see appendix 1). Finally the DNA was precipitated in ethanol (See appendix 1) and dissolved in 500µl of tris/EDTA (TE see appendix 1). The plasmid DNA was quantified (See section 4.1) and resuspended to a final working concentration of 1µg/µl. An EcoRI restriction digest was carried out for identification purposes (See section 4.2).

3.2 Small scale preparation of cosmid (plasmid) DNA (mini-prep):-

This method is used for the rapid isolation of small amounts (10-15µg) of plasmid DNA from bacterial cells. This technique was essentially as 3.1 except on a reduced scale, and omitting the 36 hour ultracentrifugation stage. All reagents were as 3.1.

A 5ml culture was seeded from frozen stock and incubated overnight at 37°C. After harvesting by centrifugation for 10 minutes at 4000xg the pellet was resuspended in 1ml of ice cold

glucose buffer and transferred to 1.5 ml eppendorf microcentrifuge tubes. The cells were pelleted by centrifugation at 13000rpm for 20 seconds and resuspended to 200µl with cold glucose buffer. 400µl of SDS/NaOH solution was added and cells left on ice for 5 minutes. This was followed by the addition of 300µl of high salt solution and the mixture left on ice for 30 minutes. After centrifugation in an eppendorf microcentrifuge tube for 5 minutes at 13000rpm the supernatant was collected and plasmid DNA precipitated by the addition of 0.75ml of isopropanol followed by incubation at -20 for 2 hours. The DNA was pelleted by centrifugation, washed in 70% ethanol, dried and then dissolved in 250µl TE. RNA was digested by the addition of RNase (Sigma Chemical Co, Poole, England, Cat no R7003) to a final concentration of 30µg/ml for 15 minutes at 37°C. Remaining protein was removed by phenol extraction and DNA precipitated in ethanol and dissolved in 20µl of TE.

3.3 Preparation of genomic DNA from tissue:- High molecular weight mouse embryo DNA was prepared for use as carrier DNA in DNA-mediated gene transfer experiments (see materials and methods page 64). The DNA was prepared as follows. 10 pregnant female C3H mice were sacrificed at 17 days gestation and the embryos removed. Approximately 50 embryos were cleared of uterine and placental tissue and placed in liquid nitrogen. These were ground up to a fine powder in a mortar and pestle while frozen and dissolved in 120ml of 8M guanidine hydrochloride, 25mM sodium acetate, 20mM EDTA, pH 7 (GHCL). 25ml of B-mercaptoethanol (Sigma Chemical Co, Poole, England Cat No M-6250) was then added and the solution repeatedly inverted for one hour. The solution was diluted 5-10 fold in water and an equal volume of isopropanol (IPA) added. This was mixed gently until a DNA precipitate formed. The precipitate

was removed and washed twice in IPA and once in 70% ethanol. After drying for 5-10 minutes the precipitate was dissolved in half the volume of TENS (10mM Tris pH 8, 10mM EDTA, 10mM NaCl, 0.5% (W/V) SDS) and 200µg/ml of proteinase K (Sigma Chemical Co, Poole, England, Cat no P9290). The solution was repeatedly inverted for 15 hours and the DNA precipitated in 100mM NaCl plus 1-2 volumes of IPA. The precipitate was washed and dried as before and dissolved in 0.1 TE (1mM Tris, 0.1mM EDTA). The DNA was quantified by spectrophotometry (see materials and methods page 44) and resuspended to 1µg/3µl. The stock was maintained at -20°C.

3.4 Preparation of total cellular RNA:- RNA was prepared for the analysis of ovine MHC class-II gene expression in various cells. Total mesenteric lymph node RNA from sheep was used as a positive ovine MHC class-II control in experiments analysing transfected L-cell RNA, with untransfected L-cells and mouse spleen cells being used as negative controls. The mesenteric lymph nodes were removed from a sheep and washed in Hanks balanced salt solution (See appendix 2). The nodes were dissected into small fragments and a single cell suspension prepared. Usually 1×10^8 cells were collected. The cells were washed in Hanks balanced salt solution (See Appendix 3) and total RNA prepared. Spleens were removed from five C3H mice into Hanks balanced salt solution. In a petri dish cells were flushed from each spleen using a 10ml syringe and needle. 1×10^8 L-cells, mesenteric lymph node cells or spleen cells were homogenised in 5ml of RNA extraction buffer Guanidine isothiocyanate (GIT, see appendix 1) using the technique described by Chirgwin *et al* (1979). Subsequently 0.5ml of 2M sodium acetate, followed by 5ml of water-saturated phenol and 1ml of chloroform:isoamylalcohol (24:1) were added and the mixture shaken

vigorously for 5 minutes. After 10 minutes incubating on ice the solution was centrifuged at 12000 rpm for 30 minutes at 4°C. The aqueous phase, which contained the RNA, was removed and the RNA precipitated by the addition of 5ml isopropanol followed by incubation at -20°C for 1 hour. The precipitate was collected following centrifugation and dissolved in 0.5ml GIT extraction buffer. 0.5ml of isopropanol was again added followed by incubation at -20°C for 1 hour. The precipitate was collected and washed in 70% ethanol, dried and resuspended in 100µl of autoclaved water.

4 ANALYSIS OF NUCLEIC ACID

4.1 Quantification of DNA and RNA:- Nucleic acid was quantified by spectrophotometry using a CE 595 double beam digital UV spectrophotometer (Cecil Instruments). The absorbance of ultra violet light by nucleic acid is measured at 260 and 280nm (Sambrook et al 1989). The absorbance at 260 gives an indication of the concentration of the nucleic acid sample. An absorbance of 1 corresponds to a concentration of 50µg/ml for double stranded DNA and 40µg/ml for RNA. The ratio OD_{260}/OD_{280} is approximately 1.8 and 2 for pure DNA and RNA samples respectively.

4.2 Restriction endonuclease digestion of DNA:- Restriction endonucleases were used to cut double stranded DNA at specific sites for qualitative analysis as well as for the production of DNA fragments with defined end termini for subsequent cloning (See section 7). All reactions involving restriction enzymes were carried out as described by Sambrook et al (1989). Each digestion varied depending on the volume of DNA to be cut, its concentration

and the restriction endonuclease employed. The restriction enzymes were purchased primarily from Gibco-BRL and Boehringer Mannheim and used with the accompanying "REact" buffers following the manufacturers instructions.

For a typical digestion of 1 μ g of DNA at a concentration of 500ng/ μ l and an enzyme of 5 units/ μ l the following or multiples of the following reaction were used. 1 unit of enzyme will cut 1 μ g of DNA in 1 hour. The number of units of restriction enzyme used was always in excess of that required to ensure complete digestion, but the volume of enzyme was never allowed to exceed 10% of the total volume. A typical reaction mixture is:-

DNA concentration	500ng/ μ l
DNA volume	2 μ l
restriction enzyme	1 μ l
10xReact buffer	1 μ l
Distilled Water	6 μ l

The reaction mixture was incubated at 37 $^{\circ}$ C (or at the optimum temperature for the particular restriction enzyme used) for two hours and the digest visualised by agarose gel electrophoresis.

4.3 Agarose gel electrophoresis of plasmid DNA:- For the analysis of DNA resulting from restriction digests, plasmid preparations or genomic DNA, qualitative agarose gel electrophoresis was performed on the Pharmacia mini-gel electrophoresis system using 0.8% w/v agarose gels (Gibco-BRL, Paisley, Scotland, Cat no 5510 UB) containing 0.5 μ g/ μ l of the nucleic acid marker ethidium bromide (Sigma Chemical Co, Cat No E8751).

0.8% w/v agarose solution was prepared by heating agarose in Tris/Sodium acetate/EDTA (TAE) buffer (see appendix 1) to boiling point. The solution was cooled to 45°C and ethidium bromide added to a final concentration of 0.5µg/ml. 200-400ng of DNA in electrophoresis sample buffer (See appendix 1) was added to the gel once it had been immersed in electrophoresis buffer (TAE plus ethidium bromide at a final concentration of 0.5µg/ml).

DNA samples were electrophoresed until the desired resolution was achieved (usually at 60v for 2 hours). An ultraviolet transilluminator was used to view the DNA fragments. A permanent record was obtained by photography using a Polaroid 667 film (Polaroid UK Ltd, Saint Albans, England). The size of the DNA fragments was determined by comparison with known standards generated from lambda phage digested with Hind-III (See appendix 1).

4.4 Isolation of DNA fragments from gels:- For the preparation of a fragment of DNA for use as a probe or for subsequent subcloning low melting point (LMP) agarose (Gibco-BRL, Paisley, Scotland, Cat no 5517 UB) was used to resolve DNA as described above. DNA was recovered by melting the gel at 65°C (this temperature does not cause denaturation of the DNA). 0.8% w/v low melting point agarose solution and gels are prepared as described above except that a preparative comb was used enabling much larger volumes of sample to be applied to the gel. Electrophoresis was performed between 20-30 volts until the desired resolution was achieved ensuring that the current did not exceed 40 milliamps (to avoid melting the gel).

The fragment of agarose containing the DNA of interest was excised from the gel and melted at 65°C in an equal volume (approximately 200-400µl) of Tris/EDTA pH8 (TE8). The agarose was removed by extraction twice with phenol and once with chloroform (see appendix 1). After removal of the aqueous phase the DNA was precipitated in ethanol (see appendix 1) and finally dissolved in TE8.

Alternatively the DNA was removed from the agarose by "gene clean" (Strattech Scientific Ltd, Luton, England). This technique involves removal of DNA using a silica matrix that binds DNA but not the agarose. The Geneclean II kit (Bio 101 Inc) was used as described by the manufacturer. Briefly, the fragment of DNA was removed from an agarose gel and three volumes of 6M sodium iodide (NaI) were added followed by an incubation at 55°C to dissolve the agarose. The silica matrix was then added to bind the DNA. Contaminants (agarose) were removed by eppendorf centrifugation and removal of the supernatant. The silica pellet was washed three times and the DNA recovered from the matrix by incubation at 55°C for 2 minutes in 10-20µl of water.

(5) ANALYSIS OF SPECIFIC DNA AND RNA SEQUENCES BY SOUTHERN AND
NORTHERN BLOTTING

5.1 Analysis of specific DNA sequences (Southern blotting) This is a technique that allows the analysis of specific DNA sequences immobilised on a solid support (usually nitrocellulose or nylon) by hybridisation to specific labelled nucleic acid probes.

DNA fragments separated by agarose gel electrophoresis (section 4.3) were transferred by capillary action from the gel to nylon filters (Hybond-N, Amersham International Plc, Aylesbury, England) where they become immobilised. To aid transfer to Nylon filters the agarose gel was soaked in 0.25M HCl for 10 minutes followed by neutralisation in 0.5M sodium hydroxide (NaOH), 1.5M sodium chloride (NaCl) solution for 30 minutes. The gel was subsequently soaked in 1M ammonium acetate, 0.02M sodium hydroxide solution for 1 hour. DNA was drawn from the gel by placing it on a filter paper wick soaked in 10x sodium chloride/sodium citrate (10x SSC, appendix 1). The ends of the wick were inserted into a tank containing 10x SSC, and the nylon filter, cut to the size of the gel, placed on top of the gel. Two pieces of 10xSSC soaked filter paper cut to gel size and a large amount of paper towel were positioned on top of the filter. A weight was placed on top of all of this and left overnight for the transfer to take place. Care was taken to avoid trapping air bubbles between any of the layers. The SSC is drawn through the gel and the filter, carrying the DNA with it, where it is trapped on the surface of the nylon filter.

The nylon filter was subsequently washed in 2xSSC to remove any agarose particles, then air dried and the bound DNA covalently fixed to the filter by ultraviolet illumination. The filter was then ready for hybridisation to a labelled specific DNA probe.

5.2 Hybridisation to a radiolabelled probe :- The nylon filter was treated with 50% deionised formamide, 5xSSC, 0.1% SDS, 5x Denhards solution (See appendix 1) and 10µg denatured salmon sperm DNA (Sigma type III sodium salt) to prevent non specific binding of the probe. (The volume of prehybridisation solution required is just sufficient to completely wet the filter, usually 10-20ml per 10-20cm²). Prehybridisation proceeded in a rotating cylindrical hybridisation pot at 42°C for 2-4 hours.

5.3 Production of a 32P labelled nucleotide probe:- The desired restriction fragment of DNA to be used as a probe was isolated from a preparative agarose gel (See section 4.4). The probe was labelled using the random oligonucleotide priming method first described by Feinberg and Vogelstein (1984). This method employs random oligonucleotides as primers for the large (Klenow) fragment of DNA polymerase 1 (Gibco-BRL, Paisley, Scotland, Cat No 510-8012SA) to extend. During this extension reaction radiolabelled ³²P dATP (Amersham International PLC, Aylesbury, England, Cat No PB10474) is incorporated into the growing chain.

For example a 10µl radiolabelling reaction for a restriction fragment of DNA was as follows.

Oligonucleotide labelling buffer (OLB see appendix)	2 μ l
Bovine serum albumin (Sigma) (10@g/ml)	0.5 μ l
Denatured probe DNA (200ng)	5 μ l
dATP(1.5mM diluted 1:789)	1 μ l
³² P dATP (10@ci)	1 μ l
Klenow fragment of DNA polymerase 1	0.5 μ l.

The DNA fragment was denatured by boiling for 2-3 minutes followed by rapid cooling on ice. The labelling reaction was left to progress for 6-8 hours after which the percentage incorporation was calculated by precipitation in trichloroacetic acid (TCA). The radioactivity was measured after precipitation of 1 μ l of the labelling reaction and then after 4-5 washes in ethanol which will remove unincorporated ³²P dATP. The ratio of radioactivity before and after washing indicates the percentage incorporation.

The ³²P radiolabelled nucleic acid probe was denatured by boiling for 5 minutes in 90 μ l of deionised formamide before adding to the prehybridisation solution. Hybridisation was carried out at 42°C for 15-24 hours in a rotating cylindrical hybridisation pot.

Following hybridisation the filter was washed to remove unbound radioactive material. This can take place at a number of stringencies. These range between low stringency (high salt, low temperature) and high stringency (low salt, high temperature). Low stringency involves washing the filter in 2xSSC and 0.1% SDS at 42°C with 4 changes of washing solution every 20 minutes. High stringency washing involved two washes as before with the addition of two washes in 0.2xSSC and 0.1% SDS at 55°C.

Autoradiography:- After washing, the filter was wrapped in plastic wrap and placed in an appropriate cassette and autoradiographed at -70°C using Fuji X-ray film (Genetic Research Instrumentation, Dunmow, England) for 24-48 hours depending on the signal. The film was developed as per manufacturer's instructions.

5.3 Analysis of specific RNA sequences (Northern hybridisation)

This technique involves the identification of specific messenger RNA sequences immobilised on a solid support by hybridisation to a ^{32}P -radiolabelled DNA probe. This technique was used to identify alpha and beta gene mRNA's transcribed in class-II expressing cells.

Total RNA was prepared as described in section 3.6 then separated by electrophoresis on a denaturing 1% agarose gel (Lehrach et al 1977), prepared as follows. 1g of agarose was dissolved by heating in 10ml of 10xMOPS/EDTA buffer (See appendix 1) and 87ml autoclaved water. The agarose solution was left to cool to 55°C when 5.1 ml of 37% formaldehyde (Sigma Chemical Co, Poole, England, Cat no F163) was introduced. After mixing the solution was poured into a gel tray and left to set for at least an hour.

10-30 μg of total RNA was dissolved in 5 μl of TE buffer and added to 25 μl of electrophoresis sample buffer (0.75ml deionised formamide, 0.15ml 10xMOPS, 0.24ml of 37% formaldehyde, 0.1ml autoclaved water and 0.08ml of 10% W/V bromophenol blue (Sigma Chemical Co, Poole, England, Cat no 6131)). This was heated at 65°C



for 15 minutes and 1 μ l of ethidium bromide (1mg/ml) was added prior to introducing the samples into the gel. Electrophoresis was carried out in 1xMOPS electrophoresis buffer at 30V (constant voltage) at room temperature for approximately 18 hours.

The gel was prepared for transfer to nylon membranes by soaking for two x 20 minute periods in 10xSSC to remove any remaining formaldehyde. The nylon membrane was prepared by soaking in distilled water for 5 minutes followed by a 5 minute soak in 10x SSC. The transfer was otherwise as already described in section 5.1. The filter was air-dried and RNA covalently bound under UV light for two minutes.

Prehybridisation, hybridisation to a radiolabelled probe, washing of the filter and autoradiography were exactly as described in section 5.2.

(6) SUBCLONING COSMID DNA FRAGMENTS INTO PLASMID VECTORS

In order to prepare large amounts of a specific fragment of cosmid DNA for use either as a radiolabelled probe (Section 5) or for nucleotide sequence analysis (section 8) the fragment is excised by restriction enzymes and subcloned into a plasmid cloning vector using the enzyme T4 DNA ligase. The enzyme T4 DNA ligase catalyses the formation of a phosphodiester bond between the 5-prime phosphate group and the 3-prime hydroxyl group resulting in the joining of the two DNA fragments to produce the recombinant plasmid. The vector used throughout this project was the pBS plasmid (Stratagene, obtained from Nothumbria Biologicals Ltd,

Cramlington, England Cat No 04210401). The recombinant circular plasmid is transfected into the *E.coli* host strain JM109 (See appendix 2) and large amounts can be prepared as described in sections 3.1 and 3.2.

The plasmid vector pBS (Fig 9) uses a simple chromogenic method to discriminate between recombinant and non recombinant vector-transformed cells. The vector includes the amino-terminal fragment of the β -galactosidase gene. When non-recombinant plasmids are transformed into the host bacterial strain JM109 in the presence of the β -galactosidase enzyme substrate and inducer 5-bromo-4-chloro-3-indolyl- β -D-galactoside (X-Gal) (Northumbria Biologicals Ltd Cramlington, England Cat No 070303) and isopropyl- β -D-thiogalactoside (IPTG), (Northumbria Biologicals Cat No 070206) blue bacterial colonies are formed. The blue colour is the product of alpha-complementation between the mutant β -galactosidase gene or F episome in the bacterial strain JM109 and the fragment of the β -galactosidase gene within the pBS vector. This regenerates B-galactosidase activity which is induced by IPTG and is therefore able to convert the colourless substrate X-Gal into a blue chromophore which results in blue bacterial colonies. The insertion of foreign DNA into the pUC multiple cloning site of the pBS vector (See Fig 9) prevents alpha-complementation and results in colourless colonies. To discriminate between these colourless colonies and untransformed bacterial colonies the cells are grown on ampicillin plates (Appendix 2). The plasmid vector contains the ampicillin resistance gene which enables only transformed cells to survive. Therefore on ampicillin plates in the presence of X-Gal only JM109 cells transformed with a recombinant plasmid will result in colourless colonies.

Fig 9

pBS plasmid vector

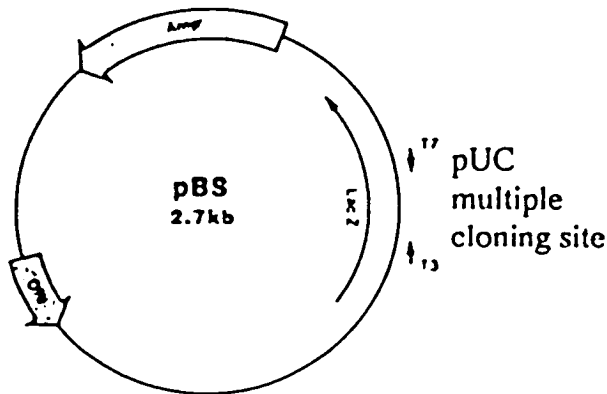

pUC multiple cloning site

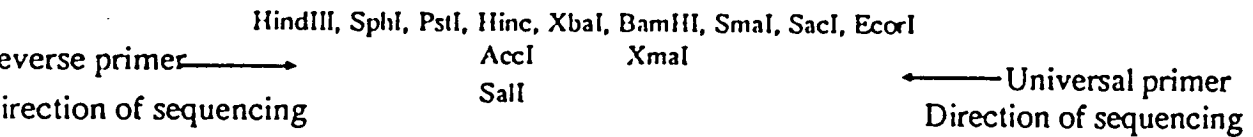

Fig 9 legend.

The pBS plasmid vector is a 2.74kb derivative of plasmid ColEI. It carries the ampicillin resistance gene as well as the N-terminal of the beta-galactosidase gene under the control of an inducible lac promoter. The vector contains the pUC19 multiple cloning site which is flanked by promoter regions where it is possible to anneal primers for forward and reverse sequencing (Yanish-Perron *et al* 1985, Green *et al* 1988).
Reproduced from Northumbria Biologicals catalogue 1990.

The essential steps are as follows:-

6.1 Preparation of JM109 bacterial cells for transformation with recombinant pBS plasmids:- A working stock of JM109 bacteria (Appendix 2) was maintained at 4°C on a minimal agar plate (See appendix 2) in order to ensure retention of the F episome required for the detection of recombinants. A single colony was removed and inoculated into 10ml of LB broth and grown with vigorous agitation overnight. 1ml of this culture was inoculated into 500ml of L broth and grown to an optical density of 0.9 at 600nm. Cells were harvested by centrifugation at 4000xg for 10mins and gently resuspended in 250ml of sterile ice cold 100mM CaCl₂. The cells were left on ice for 30mins and harvested by centrifugation. They were again resuspended in 5ml of 100mM CaCl₂ containing 10% glycerol. The cells were aliquoted into 200µl volumes and stored at -70°C.

6.2 Preparation of the cloning vector:- The plasmid vector and DNA fragment must have compatible nucleotide termini for ligation to occur. The pBS vector contains a multiple cloning site for thirteen specific restriction enzymes (see Fig 9). (This is the site where foreign DNA is inserted into the vector). During the course of this investigation three vector/fragment cloning strategies were used. The vector and fragment were both cut to produce complementary termini with (a) the same restriction enzyme, (b) two restriction enzymes for both vector and fragment or (c) an enzyme that cuts with a blunt end, ie does not produce single-stranded termini. With the first of these there is a high probability that the vector will self-ligate to its own complementary termini. To remove this

probability the vector is dephosphorylated after being cut with the appropriate enzyme. This hydrolyses the phosphate groups at the 5-prime termini so inhibiting self ligation to the 3-prime hydroxyl group. Cutting with two restriction enzymes reduces the chances of self ligation and enables the insert to be cloned in a specific direction. An enzyme that cuts with a blunt end enables other blunt ends to be ligated, although at a reduced efficiency.

To prepare a stock of the pBS vector for ligation to a restriction fragment, 5µg of plasmid DNA were digested with the appropriate restriction enzyme(s). An aliquot was analysed by agarose gel electrophoresis to ensure complete digestion. The vector was purified by phenol extraction and precipitated in ethanol. The dried pellet was resuspended in 25µl of dephosphorylation buffer (see appendix 1) and 1 unit of calf intestinal phosphatase (Northumbria biologicals, Cramlington, England Cat No 021304) was added. The reaction proceeded at 37°C for 30 minutes after which the DNA was again purified by phenol extraction and ethanol precipitation. The DNA pellet was resuspended to a final volume of 100µl to give a final concentration of 50ng/µl.

6.3 Ligation of vector DNA to insert DNA:-The ratio of vector to insert was approximately 1:1. A typical ligation mixture included:-

- (a) 4µl pBS vector stock (cut with the appropriate enzyme(s))
- (b) 5µl insert DNA (200ng)
- (c) 6µl ligase buffer (see appendix)
- (d) 15µl sterile distilled water
- (e) 1µl T4 DNA ligase (GIBCO-BRL)

The ligation reaction proceeded overnight at 15°C and was stopped by the addition of 1µl 0.5M EDTA.

6.4 Transformation of JM109 cells:- A 200µl aliquot of the frozen stock of competent bacterial cells prepared as in 5.1 was removed and slowly thawed on ice. 15µl of the ligation reaction mixture was added to the cells. The mixture was incubated on ice for 30 minutes after which it was heat-shocked at 42°C for 2 minutes. Aliquots of 50 to 100µl were spread evenly over fresh L agar plates (See appendix 1) containing ampicillin and (previously) primed with X-Gal (10µl of a 10% stock solution) and IPTG (10µl of a 2% stock solution) made up in 60 µl of dimethylformamide (Aldrich Chemical Co Ltd, Gillingham, England). The plates were incubated at 37°C and colourless recombinant and blue non-recombinant colonies were visible after 15 hours. The plates were left at 4°C for a further 1 hour for the blue colour to develop clearly. Colourless recombinant colonies were picked using a sterile loop and inoculated into 10ml of L broth. Selected bacteria were grown for 15 hours and a frozen stock prepared (See appendix 2). The plasmid was then purified using the small scale plasmid preparation technique described in 3.2 and analysed by restriction enzyme digestion and agarose gel electrophoresis. The plasmid DNA was stored at -20°C for later use.

(7) NUCLEOTIDE SEQUENCE ANALYSIS:- Nucleotide sequence analysis was carried out in order to characterise beta genes expressed in L-cell transfectants using the dideoxy chain termination technique developed by Sanger et al (1977). This technique involves four separate enzyme-catalysed DNA extension reactions on a single

stranded, primed template obtained from recombinant pBS plasmid DNA. Each reaction contains all the nucleotides required to extend the template (deoxyguanosine triphosphate (dGTP), deoxyadenosine triphosphate (dATP), deoxythymidine triphosphate (dTTP), and deoxycytidine triphosphate (dCTP) but also in each reaction a single dideoxy nucleotide, ddGTP, ddATP, ddTTP or ddCTP. The extension reaction is terminated every time a dideoxynucleotide base is randomly incorporated into the growing chain. This produces a series of fragments for each reaction, each one terminated in a specific dideoxy nucleotide. Using radiolabelled ^{35}S dATP the fragments can be separated by size using polyacrylamide gel electrophoresis and visualised by autoradiography. When all four reaction mixtures are run in adjacent tracks on an acrylamide gel, the nucleotide sequence can be deduced from the resulting autoradiograph (See Fig 10).

All sequencing of the dideoxy chain-termination type carried out in the course of this investigation used the Pharmacia T7 sequencing kit (Pharmacia, Milton-Keynes, England, Cat no 27-1682-01). This uses the enzyme T7 DNA polymerase to catalyse the chain extension. The source of template throughout this investigation was the recombinant pBS plasmid. Five-prime and three-prime of the multiple cloning site are sequences specific for the 17 base universal primer and reverse primer (see Fig 9). These enable the sequence to be determined from both ends (5' and 3') of the cloned DNA insert.

Fig 10

Nucleotide sequencing gel autoradiograph

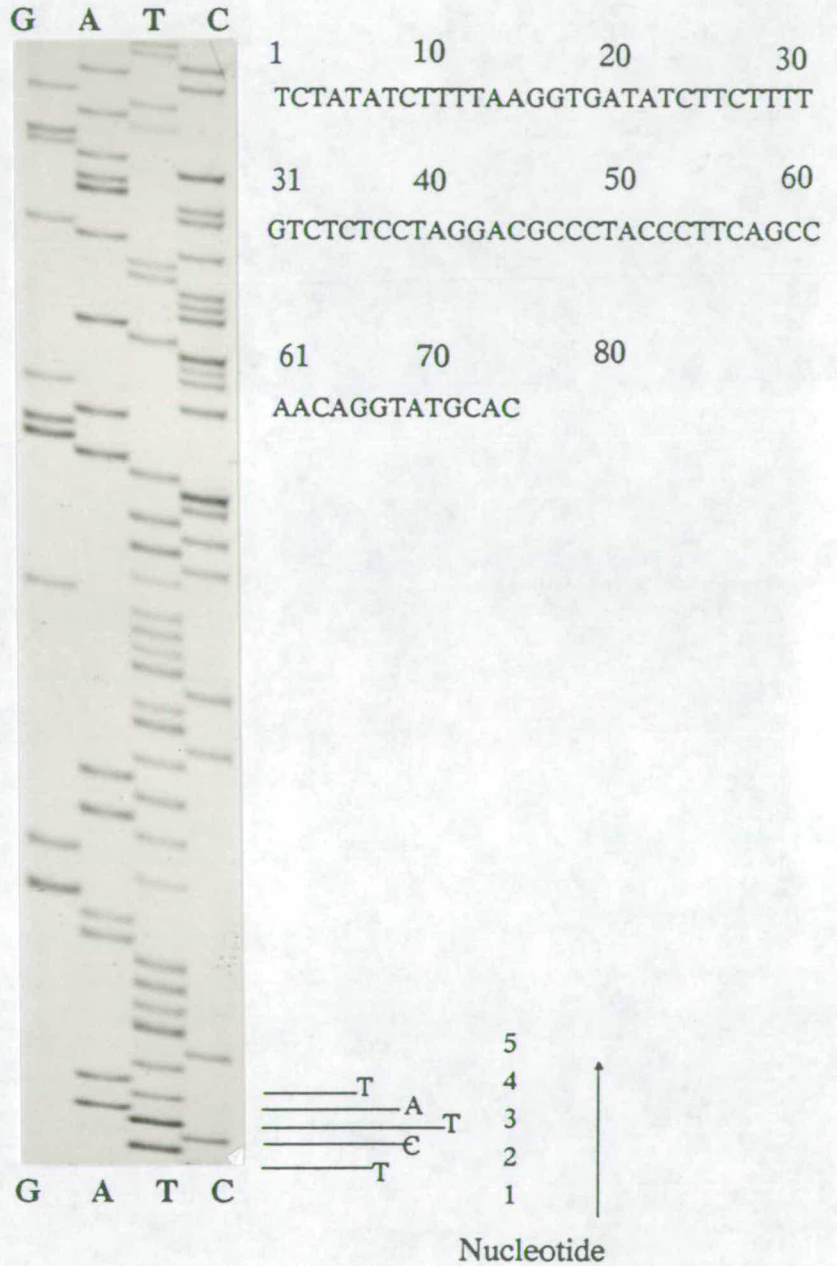

Figure 10 legend.

Nucleotide sequence of a fragment of cosmid 22 (see Fig 5). The four lanes labeled G (Guanine), A (Adenine), T (Thymine) and C (Cytosine) correspond to the dideoxynucleotide added in each extension reaction. The sequence is determined from the base. The lowest band corresponds to a thymine, the next up the ladder is a cytosine followed by another thymine and so on. The final sequence of 73 nucleotides is shown.

The essential methods are as follows:-

7.1 Annealing of the universal primer to double stranded pBS template:- The primer can be annealed to double stranded plasmid DNA provided that the strands are denatured using NaOH. 1.5-2 μ g of plasmid DNA in 8-10 μ l were denatured with the addition of 2 μ l of 2M NaOH. The DNA was incubated at room temperature for 10 minutes after which it was precipitated with 3 μ l of 3M sodium acetate pH4.5, 7 μ l of distilled water and 60 μ l of ethanol. The DNA pellet was resuspended in 10 μ l of distilled water and annealed to the universal primer or reverse primer.

7.2 Sequencing Reactions:- T7 DNA polymerase was diluted to 1.5 units/ μ l in enzyme dilution buffer containing glycerol, bovine serum albumin and dithiothreitol (DTT). The four reactions were carried out in 4 eppendorf tubes labelled Guanine, Adenine, Thymine and Cytosine (G, A, T, C). These names correspond to the dideoxynucleotide to be added. To each tube was added 2.5 μ l of nucleotide mix containing dATP, dCTP, dGTP, and dTTP plus the relevant dideoxy nucleotide. To the primed template 3 μ l of labelling solution was added (dCTP, dGTP and dTTP) plus 10 μ Ci of ³⁵S dATP and 2 μ l of the diluted T7 DNA polymerase. Following incubation at room temperature for 5 minutes, 4.5 μ l aliquots were added to each of the 4 labelled tubes. The reaction was allowed to proceed at 37^oC for 5 minutes and was terminated by the addition of 5 μ l of stop solution (deionised formamide containing EDTA, xylene cyanol and bromophenol blue dyes). 3 μ l aliquots of each reaction mixture were heated at 75-80^oC for 2 minutes to separate the fragments from the template and loaded onto a polyacrylamide sequencing gel.

7.3 Sequencing gel electrophoresis:- Six percent w/v denaturing polyacrylamide gels were formed between two 40cm x 20cm glass plates (coated with "Sigmacote", Sigma Chemical Co, Poole, England, Cat No SL-2, to prevent sticking of the acrylamide) which were separated by 0.4mm spacers. Gels were prepared by dissolving 42g of ultrapure urea in 14.5ml of 40% acrylamide stock solution (See appendix 1), 10ml 10xTBE buffer (Appendix 1) and water to 100 ml. The polymerisation reaction was initiated by the addition of 0.8ml of 10% W/V ammonium persulphate (APS, Bio-Rad, Watford, England, Cat no 161-0700) and 40µl of N,N,N, N-tetramethylethelenediamine (TEMED Bio-Rad Watford, England, Cat no 161-0800). A sharks tooth comb was positioned so that the teeth just touched the surface of the gel to provide the sample loading wells once the gel was immersed in 1xTBE electrophoresis buffer within the BRL model S2 electrophoresis apparatus. The samples were denatured by heating for 2 minutes at 80°C immediately prior to loading. 2.5µl aliquots of each sample were added to each well in the order G, A, T and C. Samples were electrophoresed at 1500v until the bromophenol blue (BPB) marker reached the base of the plates. A second loading of the same four samples was applied to the gel but in adjacent wells and electrophoresis continued until the samples BPB dye fronts of these samples reached the base. A third loading of samples was then applied and electrophoresis continued until these samples BPB dye fronts reached the base of the plate. The plates were separated and the gel fixed in a mixture of 10% acetic acid and 10% methanol for 20 minutes. After removal from the fixative, the gel, still attached to a plate, was transferred to a supporting sheet of Whatman number 1 filter paper and covered with plastic wrap. The gel was dried and and autoradiographed for 15 hours.

7.4 Analysis of autoradiographs:- The nucleotide sequence was translated from the pattern of bands on the autoradiograph (see Fig 10). Comparative computer analysis of the nucleotide sequence, determination of exon boundaries and conversion to amino acid sequence was performed using the Genetics Computer Group (GCG) package (Devereux et al 1984) on the SEQNET molecular biology computer facility of the Science and Engineering Research Council, Daresbury Laboratory, Warrington, England.

(8) TISSUE CULTURE MATERIALS AND METHODS.

8.1 Cells and culture media: a) L-cells:- The mouse fibroblast cell line LTK- (Spandidos and Wilkie, 1983), which is deficient in endogenous thymidine kinase, was obtained from J. Lang (Beatson Institute, Glasgow). These cells were used for the expression of ovine MHC class-II genes after DNA-mediated gene transfer (see section 10). The cells were maintained in culture in Dulbecco's modified Eagles medium (DMEM, Gibco-BRL Ltd, Paisley, Scotland, Cat no 04101965) supplemented with 10% heat-inactivated foetal calf serum (Northumbria Biologicals Ltd, Cramlington, England, Batch no 097) penicillin (100IU/ml), streptomycin (100µg/ml) and glutamine (2mM final conc). L-cells were passaged using a 1:20 split ratio just prior to confluence (every three days). Adherent cells were harvested from the flasks by incubating with 0.2% ethylene diamine tetra acetic acid (EDTA) in PBS (Sigma Chemical Co Ltd Poole, England), followed by a sharp tap. Cells were reseeded in fresh medium within new 75cm² flasks (Nunc, obtained from Gibco-BRL Ltd, Paisley, Scotland). Each flask was gassed with 5% CO₂ in air (British Oxygen Co, Glasgow, Scotland) prior to capping and incubation at 37°C. (Selection media was as above but

also containing hypoxanthine (1.36g/l), aminopterin (0.176g/l) and thymidine (0.338g/l), all prepared from 100 times stock solutions Gibco Ltd, Paisley, Scotland Cat no 043-01 362, 043-01 364 and 043-01 366).

b) Ovine peripheral blood mononuclear cells (PBMC):- PBMC were required for the testing of panels of monoclonal antibodies for MHC class-II specificity using an indirect fluorescence antibody assay (see section 11). 100ml of blood was collected into vacutainers (Becton Dickinson, Oxford England, Cat No 6433) by jugular cannulation of the sheep of interest in the presence of 10IU/ml of preservative-free-heparin (Sigma chemical Co, Poole, England, Cat No H8514) to prevent clotting. The blood was divided into 5 universals and centrifuged at 1800rpm for 10 minutes at 12°C. The buffy coat was removed using a pasteur pipette and diluted with an equal volume of Hanks balanced salt solution (HBSS) containing penicillin/streptomycin, 10IU/ml of PFH and 10% serum. 3ml of the cells were layered over 5ml of lymphoprep (Nycomed, Birmingham, England, Cat No 221395) in a sterile 10ml centrifuge tube. The cells were centrifuged at 2200 rpm for 40 minutes and leucocytes removed from the interphase. The cells were washed twice (1200rpm for 6 minutes) in ice cold HBSS to prevent clumping. The live cells were counted using a haemocytometer (see section 8.3).

8.2 Preparation of frozen L-cell stock:- Cells were removed from 75cm³ tissue culture flasks just prior to confluence and pelleted by centrifugation at 200xg for 5 minutes at 4°C. The pellet was resuspended in 2ml of ice cold freezing solution containing 10% dimethyl sulphoxide (DMSO, Sigma Chemical Co, Poole, England) 30% foetal calf serum (NBL), and 60% DMEM. The cells were sealed

within two 1.5ml cryostat vials (Gibco-BRL, Paisley, Scotland) at 5×10^5 cells/ml and cooled to -70°C at a rate of approximately 1°C per minute and stored for 12-15 hrs prior to placing under liquid nitrogen (British Oxygen Co, Glasgow, Scotland).

Cryostat vials were removed from liquid nitrogen and thawed rapidly in water at 37°C . The cells were placed on ice and washed twice in ice cold medium and reseeded into two $\times 75 \text{ cm}^3$ tissue culture flasks.

8.3 Counting cells using a haemocytometer:- The haemocytometer (Weber Scientific Ltd, Teddington, England) enables the cells within a defined volume to be counted. This count in the presence of 0.05% nigrosine (BDH Ltd, Poole, England) enables live cells to be distinguished from dead cells. The haemocytometer is a glass microscope slide with a 5×5 grid engraved into it. When a glass coverslip is positioned over the grid and the cells added a predetermined volume lies over the grid. By counting the cells and multiplying by 1×10^4 , taking any dilution factor into consideration, the number of cells per ml can be determined.

(9) DNA-MEDIATED GENE TRANSFER AND HAT SELECTION.

Cosmid-cloned ovine MHC class-II genes were introduced into mouse L-cells by DNA-mediated gene transfer using the calcium phosphate technique developed by Graham and Van der Eb (1973) and modified by Wigler (1979). This technique enables cloned genes to be expressed in mammalian cells without the requirement of an expression vector and involves the formation of a complex consisting of DNA (incorporating the genes to be expressed) bound

to a calcium phosphate microprecipitate. The complex is endocytosed by the L-cells, where the DNA becomes stably integrated into the genome of a small number of cells. These cells are selected by co-transformation of a selection gene along with the genes of interest. By selecting for this gene a population of cells effective in integrating and expressing exogenous DNA is selected. Expression of the gene products of interest can then be determined using specific monoclonal antibodies and flow cytometric analysis (FACScan analysis, see section 11). The thymidine kinase gene and HAT selection system is employed as the means of selection in this project. This selection technique developed by Szybalska and Szybalski (1962) requires a cell line deficient in the thymidine kinase gene (Tk-). In the presence of the nucleotide metabolic inhibitor aminopterin, cells deficient in the thymidine kinase gene will die. Cells with the thymidine kinase gene are able to use a salvage pathway for nucleotide synthesis and will survive aminopterin treatment providing thymidine and hypoxanthine are present. Following DNA-mediated gene transfer of the plasmid PTK1 containing the herpes simplex virus thymidine kinase gene into the Tk- L-cell line, only cells that have integrated and expressed the Tk gene will survive HAT selection (reviewed by Old and Primrose 1985).

9.1 Preparation of DNA:- Cosmid DNA was prepared as described in section 3.1. Prior to transfection, DNA was ethanol-precipitated under aseptic conditions and resuspended in sterile 0.1 TE to a final concentration of 1µg/ml.

PTk1 plasmid DNA (Lang et al 1985) was prepared as described in 3.1 and ethanol-precipitated prior to transfection. The Tk plasmid was not linearised prior to transfection. High molecular weight mouse embryo carrier DNA was prepared as already described in 3.3.

9.2 Transfection technique:- LTK- cells:- A near confluent 75 cm³ tissue culture flask of rapidly growing Ltk- cells was split 1:25 into 25cm³ flasks 24 hours prior to the addition of the calcium phosphate/DNA precipitate ($3-5 \times 10^5$ cells per flask). Each flask was gassed, sealed and incubated at 37°C.

The calcium phosphate/DNA complex:- To sterile 10ml plastic round bottomed centrifuge tubes (Gallenkamp, Loughborough, England, Cat No TKV310040T) was added in this order:-

- A) 403ml sterile distilled water (Calculated to give a final volume of 500ml)
- B) 30µl mouse embryo carrier DNA (1µg/3µl)
- C) 100ng of thymidine kinase plasmid PTK1 (calibrated to produce 50-100 colonies per flask)
- D) 6µg of Cosmid DNA containing ovine class-II genes (3µg of alpha cosmid, 3µg beta cosmid)

Each tube was vortexed to ensure complete mixing, then 60µl of CaCl_2 (appendix 3) was added. Following a gentle mix the tubes were capped and left for two-three hours at room temperature to ensure complete mixing.

To labelled 10ml plastic round bottomed tubes, 0.5ml sterile 2x HEPES buffered saline (2xHBS see appendix 3) was added. To each tube the DNA- CaCl_2 solution was slowly added dropwise accompanied by vigorous agitation. The tubes were left for 20-30 minutes for the microprecipitate to form. The precipitate was added directly to the culture media of the previously prepared Ltk negative cells. The flasks were sealed and left overnight for 12-15hrs.

The excess precipitate was removed by washing the cells gently in warm phosphate-buffered saline (PBS). The culture medium was replaced with fresh medium and the flasks gassed with 5% CO_2 in air. The flasks were sealed and incubated at 37°C for 24 hours after which the culture medium was again removed and replaced by HAT selective medium. The cells were gassed and the media replaced every 2 days initially and every 3-4 days subsequently as the colonies developed.

Colonies began to appear after 4-5 days and these were left to develop for two weeks prior to harvest and assay for ovine MHC class-II expression.

(10) INDIRECT FLUORESCENT ANTIBODY TECHNIQUE.

An indirect fluorescent antibody (IFA) technique was used to detect ovine MHC class-II molecules expressed on the surface of transfected mouse L-cells. The DNA-mediated gene transfer technique relies on available murine monoclonal antibodies directed against monomorphic determinants of sheep MHC class-II molecules to recognise the products of transfected genes. Fluorescein isothiocyanate conjugated anti-mouse immunoglobulin (FITC conjugated rabbit-anti-mouse IgG) was used as a second stage reagent and flow cytometric analysis carried out using the fluorescence activated cell scanner (FACscan) (Becton Dickinson, Oxford, England). This assay uses the analytical power of the FACscan to identify small populations of ovine MHC class-II expressing L-cells. The fluorescence activated cell sorter (FACS IV) (Becton Dickinson) is then used to select the MHC class-II expressing cells. The power of the FACS sorter enables a population of cells as low as 1:1000 to be identified and selected. No other available techniques have this ability.

10.1 Labelling transfected cells with FITC conjugated antibodies:-

L-cell colonies surviving HAT selection were pooled and assayed for ovine MHC class-II expression using an IFA assay. This assay employed a cocktail of SBU II monoclonal antibodies (SBU II 28.1, 37.68, 38.27, 42.20 and 49.1 see Table 2) as the first stage reagent and fluorescein isothiocyanate (FITC) conjugated rabbit anti-mouse immunoglobulin (Dakopatts, Glostrup, Denmark Cat no F261) as the second stage reagent.

Transfected cells were removed from 25cm³ tissue culture flasks using 0.2% EDTA in PBS (No trypsin or other proteolytic enzymes were used). Cells were washed once in Earles balanced salt solution (EBS see appendix 3) supplemented with 5ml of 1 molar HEPES buffer pH 7.2-7.4 (Northumbria Biologicals, Cramlington, England), 0.1% w/v sodium azide and 3% fetal bovine serum (Northumbria Biologicals). The cells were pelleted by centrifugation at 1500xg for 5 mins at 4°C. Following resuspension in 50µl (tissue culture supernatant) of a cocktail of SBU II monoclonal antibodies, the cells were incubated for 40 minutes at 4°C with occasional agitation. Unbound antibody was removed by washing three times in EBS. After the final wash, the pellet was resuspended in 50µl of FITC conjugated rabbit anti-mouse IgG (1:50 dilution) and incubated for 40 minutes at 4°C with occasional agitation. Unbound antibody was removed by washing three times in EBS and the cells resuspended to 0.5ml in EBS. Prior to FACS analysis, 100µl propidium iodide (200µg/ml, Sigma Chemical Co Ltd, Poole, England, Cat no P4170) was added in order to distinguish between highly fluorescent dead cells and ovine MHC class-II expressing cells (See section 11.2).

10.2 Analysis by flow cytometry (Becton Dickinson FACScan):- The flow cytometer utilises an argon-ion laser beam (15mA, 488nm) through which a single cell suspension is directed. As cells pass through the laser beam scattered light is detected and electronically converted by the "consort 30" software package (Becton Dickinson) to provide information on five parameters for

each cell. These include cell size (forward light scatter, FSC), intracellular complexity or granularity (side or 90° scatter, SSC), green fluorescence (FL1), orange fluorescence (FL2) and red fluorescence (FL3).

The laser light falls within the wavelengths that excite fluorochromes such as fluorescein isothiocyanate (FITC) and phycoerythrin (PE). The FACScan detects and accumulates data on the green, orange and red fluorescence emitted from each individual cell as it passes through the laser beam. Fluorochromes such as fluorescein isothiocyanate or phycoerythrin may be coupled to cell surface molecules by attaching specific antibodies that are conjugated with the fluorochrome (see section 11.1). By employing fluorescein isothiocyanate conjugated rabbit anti-mouse immunoglobulin as a second stage reagent, ovine MHC class-II expressing cells may be identified using mouse anti-sheep class-II monoclonal antibodies as a first stage reagent. This enables an MHC class-II expressing cell population to be separated from the main body of cells on the basis of surface fluorescence. Once information on all five parameters was accumulated by the instrument (usually for 10000 cells), it was analysed immediately using the analytical software available (consort 30) or stored to disc for subsequent analysis using the Becton Dickinson "lysis" software. The data were displayed graphically in the form of histograms (see Fig 11). The green fluorescence (FL1) emitted when fluorescein isothiocyanate was excited by the laser light was principally used through out this investigation.

The instrument was operated as recommended by the manufacturer. Dead cells were gated out of the analysis using a "live gate". This involves excluding all cells which have absorbed propidium iodide (Kavathas and Herzenberg 1986, Yeh et al 1981). Only dead cells absorb the propidium iodide and these can be distinguished from the main body of cells due to their high orange fluorescence (see Fig 12).

As the instrument is required for the analysis of cells of all phenotypes it must first be calibrated for the populations of cells to be analysed. This ensures that the values FL-1, FL-2, FSC, and SSC fall within the analytical range of the instrument displayed on the screen in the form of histograms or dot plots.

The FACScan was calibrated for the analysis of L-cells using unlabelled Ltk- cells. The parameter settings are shown in table 3.

Table 3

Channel	Data mode	Stage	Level
Forward scatter	linear	Amplifier	1.00
		Detector	-
Side scatter	linear	Amplifier	-
		Detector	318
Log green fluorescence (FL1)	log	Detector	400
Log orange fluorescence (FL2)	log	Detector	350

Fig 11 FACScan analysis of ovine peripheral blood mononuclear cells (PBMC) for size (forward scatter FSC), complexity (side scatter SSC) and MHC class-II expression (FL-1)

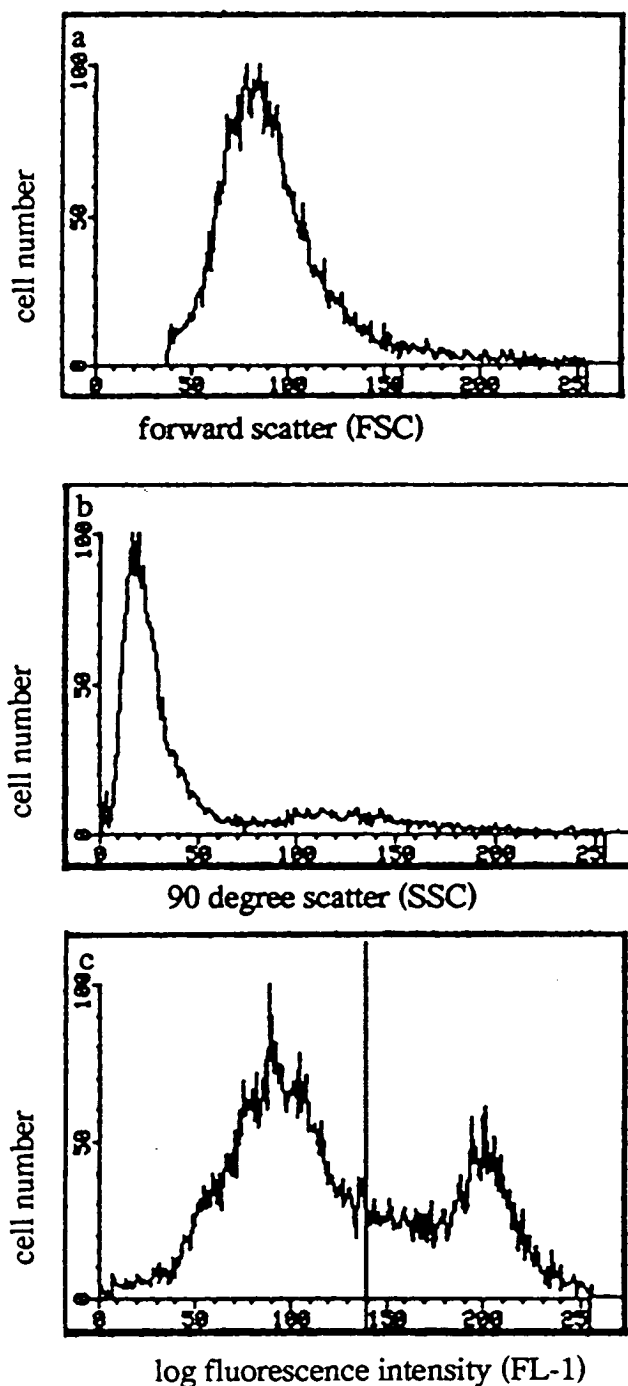

Figure 11 legend.

Three histograms which demonstrate the power of the FACS for the analysis of populations of cells within ovine peripheral blood mononuclear cells (PBMC). a) A histogram showing the range of cell sizes within PBMC. b) The complexity and granularity of PBMC and c) PBMC labelled with the ovine class-II specific monoclonal antibody SBU-II 49.1 as a first-stage reagent and FITC-conjugated rabbit anti-mouse IgG as a second-stage reagent. The vertical line indicates the maximum fluorescence of cells in the control (see Fig 15c) with 2% of cells exceeding this limit. Histogram C shows two peaks, one of class-II negative cells (larger peak) and the other of class-II positive cells (smaller peak) with 38% of the cells to the right of the control gate.

Fig 12

Live gate removal of dead cells for FACS analysis based upon propidium iodide uptake .

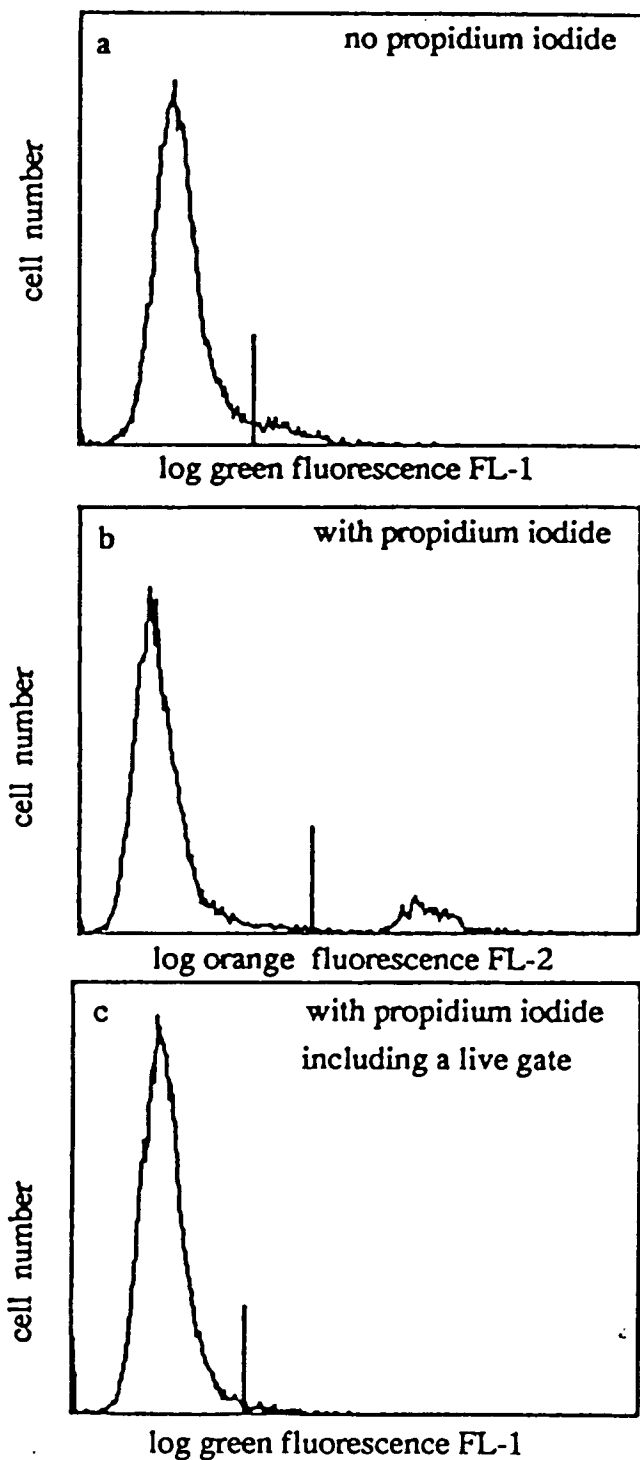

Figure 12 legend.

a) Histogram of LTK- cells with log green fluorescence against cell number. The percentage of cells to the right of the marker is 8%. b) Histogram of the same LTK- cells but with the addition of propidium iodide (PI) (100 μ l of 200 μ l/ml solution) and viewed for log orange fluorescence (FL2). Dead cells which incorporate the PI have a high orange fluorescence ie they will appear further along the FL-2 axis. This population of dead cells is removed from the analysis by incorporating a live gate. The position of this gate is indicated by the marker. Everything to the right of this gate is removed from the FACS analysis . c) Histogram of the LTK- cells viewed again for log green fluorescence and incorporating the live gate. The percentage of cells to the right of the marker is now 0.5% indicating that dead cells formed the majority of cells in the initial 8% identified in histogram a.

These settings were stored to disc and recalled prior to all FACScan analysis of transfected L-cells. Data were accumulated, stored and analysed using "consort 30" and "lysis" software packages (Becton Dickinson). The results of indirect fluorescent antibody labelling and FACScan analysis of transfected L-cells were presented in the form of histograms with log green fluorescent intensity (FL1) on the X axis and cell number on the Y axis.

10.3 Cell sorting:- The isolation of L-cells expressing ovine MHC class-II molecules was achieved using a fluorescent activated cell sorter (Becton Dickinson FACS IV). This operates on the same principal as the FACScan except that sorting gates were arranged to encompass both positive and negative populations. The instrument breaks up the cell suspension into individual droplets each containing a single cell. If a droplet contained a cell that was class-II positive or fell within certain predetermined limits for fluorescence the drop was charged and as the drop passed between two magnetic plates it was deflected into an appropriate container containing culture media. The surviving cells were expanded and resorted until a population of cells was obtained in which greater than 95% expressed the molecules of interest.

11 SCREENING PANELS OF MONOCLONAL ANTIBODIES AGAINST CLASS-II EXPRESSING TRANSFECTED CELL LINES

Monoclonal antibodies produced by our collaborating groups were each individually tested for specificity against defined MHC class-II expressing transfected L-cells. These cells were labelled using the indirect fluorescence technique as described in 9.1,

except that the individual monoclonal antibodies listed in table 2 were used as a first stage reagent as opposed to the cocktail of antibodies (see above). Cells were analysed by FACscan and results were displayed in the form of histograms.

(12) IMMUNOBLOTS OF TRANSFECTED MHC CLASS-II MOLECULES

In order to determine the molecular weight of ovine MHC class-II molecules expressed at the surface of transfected L-cells, immunoblotting was carried out. Cell lysates were separated by one and two-dimensional polyacrylamide gel electrophoresis. The MHC class-II molecules were visualised by blotting the protein onto a nitrocellulose membrane and probing with monoclonal antibodies of known alpha and beta chain specificity. Using protein standards electrophoresed at the same time, an indication of the molecular weight of alpha and beta chains in transfected L-cells could be determined. Immunoblots were carried out in association with B Dutia and K Bird at the Royal (Dick) Veterinary School in Edinburgh.

12.1 lysate production:- 1×10^8 transfected and untransfected cells were harvested by treatment with 0.2% EDTA in PBS. For one-dimensional analysis the cells were lysed in 1ml of 2% NP40 (Sigma Chemical Co Ltd, Poole, England, Cat No N3516) in PBS for 30 minutes on ice. Insoluble material was removed by centrifugation at 3000xg for 10 minutes. The lysates were diluted 1:1 with SDS-PAGE sample buffer (2% w/v sodium dodecyl sulphate, 20% glycerol, 0.125M Tris-HCl pH 6.8) and analysed by immunoblotting. For 2-dimensional analysis 8×10^7 cells were lysed in 1ml of 2% NP40, 2% v/v pharmalyte (Sigma, Chemical Co Ltd, Cat No p0908)

and 8.5M urea. Insoluble material was again removed by centrifugation and 5 μ l aliquots were fractionated by 2D non-equilibrium pH gradient electrophoresis/SDS PAGE. For 2D analysis of alpha chains, 2D pharmalyte in the lysis buffer was replaced with 2% pH 2.5-5 pharmalyte (Sigma chemical Co Ltd, Cat No P1647).

12.2 SDS-PAGE:- 12% linear SDS polyacrylamide gels (Laemmli 1970) were used to fractionate the transfected cell lysates. Gels were prepared in the Bio-Rad mini gel apparatus. Resolving gels were prepared using 4.1ml of acrylamide stock (30% acrylamide, 0.8% bisacrylamide), 3.35ml of water, 0.1ml of 10% SDS and 2.5ml of 1.5M tris buffer pH 8.7. The polymerisation reaction was initiated by the addition of 5 μ l of TEMED (Bio Rad Laboratories Ltd, Watford, England, Cat No 0610800) and 50 μ l of 10% ammonium persulphate (APS, Bio Rad Laboratories Ltd, Cat no 161-0700). Once set, the acrylamide stacking gel was prepared from 1ml of acrylamide stock 6.2ml of water, 0.1ml of 10% SDS and 1.25ml of 1M Tris buffer pH 6.8. This was polymerised by the addition of 10 μ l of TEMED and 50 μ l of 10% APS and layered on top of the resolving gel. The comb was inserted into the stacking gel before it set. 100 μ l of sample were added to the well once immersed in running buffer (0.6% W/V tris, 0.1% W/V SDS and 2.8% W/V glycine). Electrophoresis continued at 200v for approximately 1 hour.

Non-equilibrium pH gradient and PAGE was used for 2D analysis of beta chains (O'Farrell, 1977). The alpha chains were separated by 2D isoelectric focusing followed by PAGE (O'Farrell, 1975). The proteins were transferred to nitrocellulose membranes (Hybond C, Amersham International PLC, Aylesbury, England) using the Ancos

semi-dry blotter. The membrane was cut into strips and class-II detected using alpha and beta-chain specific monoclonal antibodies as a primary reagent followed by alkaline phosphatase conjugated anti-mouse or anti-rat reagents (Sigma Chemical Co Ltd, Poole England) and Bio-Rad alkaline phosphatase substrate (Dutia et al 1990).

EXPERIMENTAL RESULTS

CHAPTER 1

PRELIMINARY EXPERIMENTS

INTRODUCTION

A series of preliminary experiments were carried out to select reagents and test the quality of materials required for the identification of expressible ovine MHC class-II genes in mouse L-cells. These were:-

- 1) Reagents and cells for DNA-mediated gene transfer.

The selection of an L-cell line and titration of the plasmid PTK1 containing the thymidine kinase selection gene.

- 2) DNA mediated gene transfer.

Testing the integrity of the co-transfection technique using exogenous DNA known to express in mouse L-cells.

- 3) Analysis of the integrity and stability of cosmid clones containing ovine MHC class-II genes.

- 4) Selection and titration of the first and second stage indirect fluorescent antibody (IFA) reagents required for detection of ovine MHC class-II molecules expressed at the transfected L-cell surface.

RESULTS**1 SELECTION OF AN L-CELL LINE AND TITRATION OF SELECTION PLASMID PTK1.**

Three L-cell lines (Beatson LTK- and LTK-, Lang et al 1983; Babraham LTK-, Diamond et al 1989) were transfected with an equal concentration (50ng) of PTK1 plasmid DNA using the calcium phosphate technique described in materials and methods page 66. The number (transfection efficiency) and speed of colony development following HAT selection were determined. The most effective cell line was transfected with a series of dilutions of PTK1 selection plasmid to establish a suitable concentration resulting in between 50 and 100 distinct colonies per 25cm² flask following HAT selection.

The Beatson LTK- cell line was found to be the most efficient line both in transfection efficiency (number of cells surviving HAT selection) and speed of HAT-resistant colony development. The LTK- cell line developed only a few colonies (2-5 colonies) whereas the Babraham LTK- cell line developed 10-15 Tk+ colonies but these HAT resistant colonies took up to 5 weeks to develop. The Beatson LTK- cell line was therefore used throughout this study.

The Beatson LTK- cell line (referred to as LTK- from now on) was used to determine the concentration of the PTK1 plasmid required to form between 50 and 100 Tk+ colonies in a 25cm² tissue culture flask seeded initially with 5x10⁵ LTK- cells. Stock PTK1 plasmid DNA at 1µg/µl was diluted in TE buffer and transfected into the

LTK- cell line. Colonies were counted after 14 days of HAT selection (see Table 4). A Ptk1 concentration of 100ng per transfection reaction was used as standard throughout subsequent experiments.

Table 4 TITRATION OF PTK1 PLASMID CONTAINING THE THYMIDINE KINASE SELECTION MARKER

Flask	PTk1 concentration	Number of colonies after 14 days HAT selection
1	1 μ g	confluent
2	500ng	confluent
3	250ng	confluent
4	125ng	170
5	100ng	85
6	50ng	17

2 TESTING THE INTEGRITY OF THE CO-TRANSFECTION TECHNIQUE.

A rat MHC class-I gene in cosmid 15.4 (obtained from J.C Howard. IAPGR, Babraham, Cambridge) which had previously been expressed using DNA-mediated gene transfer was used to test the co-transfection technique. This gene was transfected into the

L-cell line along with the selection plasmid at the predetermined concentration. Expression was determined by indirect fluorescent antibody labelling followed by FACScan analysis using the previously calibrated FACScan (see materials and methods page 67).

Cosmid 15.4 was linearised using the restriction enzyme Nru I (see materials and methods page 44) and 1µg transfected into LTK-cells by DNA mediated gene transfer (materials and methods page 64). Rat class-I expressing L-cells were identified by FACScan analysis (Fig 13) using the anti-rat class-I monoclonal antibody OX18 (Fukumoto et al 1982). The percentage of rat class-I expressing cells in the primary transfected cell line was approximately 40% of the total Tk+ HAT selected colonies. This experiment demonstrated that the technique of DNA-mediated gene transfer into LTK-cells, subsequent indirect fluorescent antibody labelling and FACScan analysis could be effectively performed.

3 QUALITATIVE ANALYSIS OF COSMID CLONES CONTAINING OVINE MHC CLASS-II GENES.

In order to confirm their identity and check the quality of the DNA an EcoRI digest of all cosmids was carried out (materials and methods page 44). The fragments were separated by agarose gel electrophoresis and the restriction map (see Fig 14a and 14b) compared to the original digests prepared by Wright and Deverson (Deverson et al 1991).

Fig 13

FACSCAN analysis of L-cells transfected with a rat MHC class-I gene

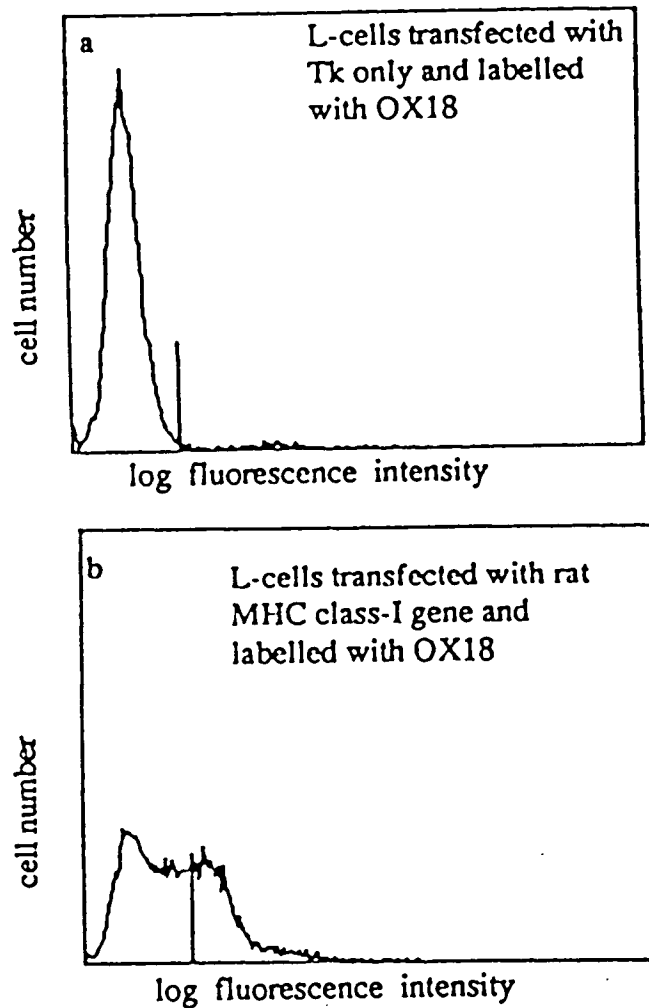

Figure 13 legend.

a) Mouse L-cells transfected with the thymidine kinase gene only. 5×10^5 L-cells were labelled with 50 μ l of 1:10 dilution of monoclonal OX18 (Serotec, Oxford England) specific for monomorphic determinants of rat MHC class-I as a first stage reagent followed by FITC conjugated anti-mouse IgG (Dakopats, Glostrup, Denmark) as the second stage reagent. The percentage of cells to the right of the marker is 0.5%.

b) L-cells transfected with a rat MHC class-I gene in cosmid 15.4 (gift from Dr J.C Howard, IAPGR, Cambridge) and labelled as above. The percentage of cells to the right of the marker is now 40%.

The restriction patterns were identical to earlier restriction maps produced by Deverson and Wright. All the cosmids were of high molecular weight and suitable for transfection by DNA-mediated gene transfer.

4 THE ANALYSIS OF OVINE MHC CLASS-II CELL-SURFACE EXPRESSION (SELECTION AND TITRATION OF REAGENTS FOR INDIRECT FLUORESCENT ANTIBODY ANALYSIS).

In order to titrate the SBU monoclonal antibodies for the optimum detection of ovine MHC class-II glycoproteins, sheep peripheral blood mononuclear cells (PBMC) (obtained as described in material and methods page 63) were labelled with the SBU panel of monoclonal antibodies individually (see Table 2). The SBU monoclonal antibodies were used as a neat hybridoma tissue culture supernatant in order to ensure saturating amounts of antibody. The specificity of the second stage FITC-conjugated rabbit anti-mouse IgG reagent (Dakopats Glostrup, Denmark, Cat no F261) for each of the SBU panel was determined by FACScan analysis (Fig 15). All SBU monoclonal antibodies detected ovine MHC class-II molecules when used as a neat tissue culture supernatant. Dilution of the SBU monoclonal antibodies in Earle's balanced salt solution resulted in a reduction in the percentage of class-II positive cells following FACScan analysis. The second stage FITC reagent was used throughout at a concentration of 1:50 with excellent specific binding to the murine monoclonal antibodies but little detectable non-specific binding properties. Further dilutions of the second stage reagent resulted in a reduction in the fluorescence intensity

Fig 14a

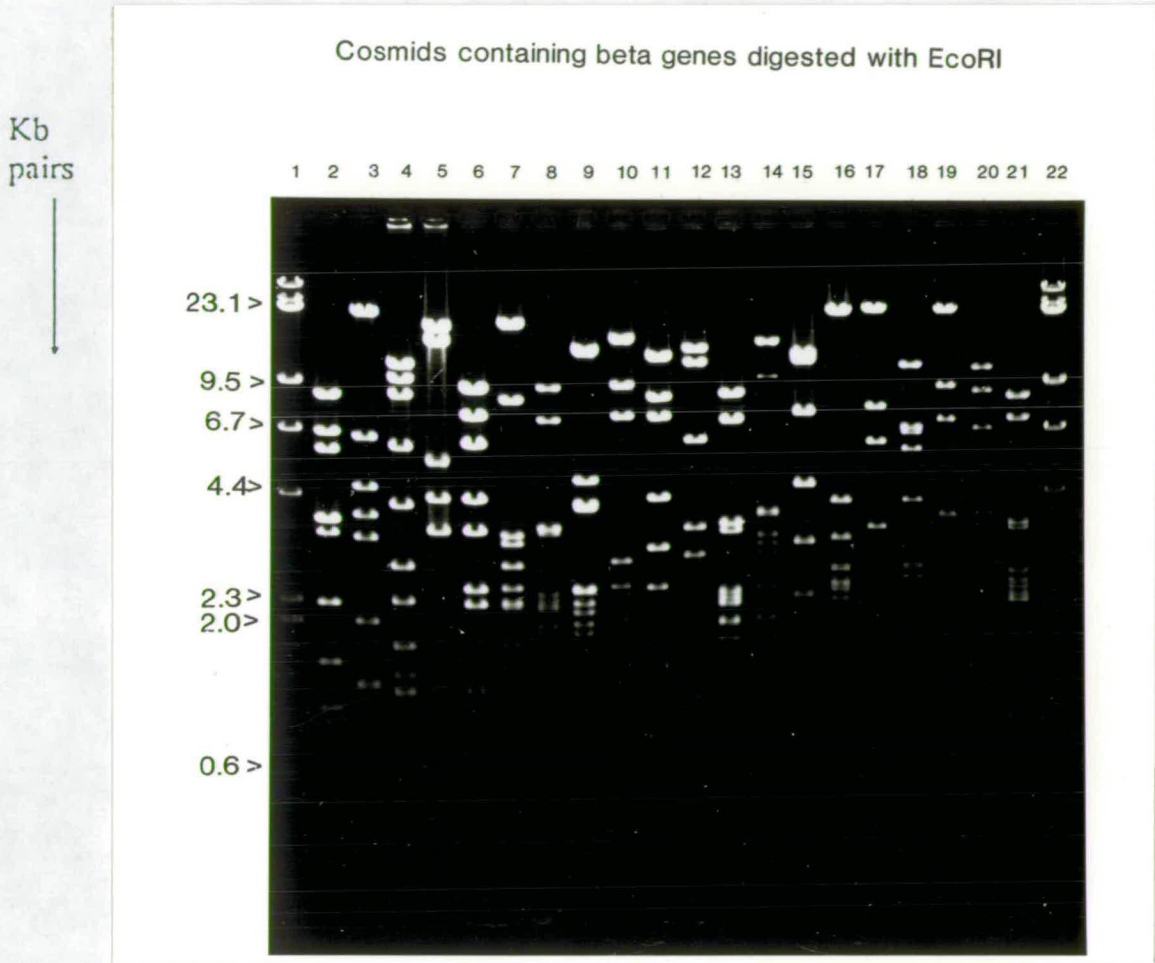

Fig 14a legend.

Lanes 1 and 22 contain lambda phage digested with HindIII to produce a series of size markers in kilobase pairs. Lane 2, cosmid 4; Lane 3, cosmid 22; lane 4, cosmid 32; lane 5, cosmid 36; lane 6, cosmid 62; lane 7, cosmid 3.1; lane 8, cosmid 9.1; lane 9, cosmid 9.2; lane 10, cosmid 9.5; lane 11, cosmid 11.3; lane 12, cosmid 15.2; lane 13, cosmid 17.1; lane 14, cosmid 22.1; lane 15, cosmid 23.1; lane 16, cosmid 27.1; lane 17, cosmid 27.3; lane 18, cosmid 28.1; lane 19, cosmid 31.4; lane 20, cosmid 39.1; lane 21, cosmid 43.1.

Fig 14b

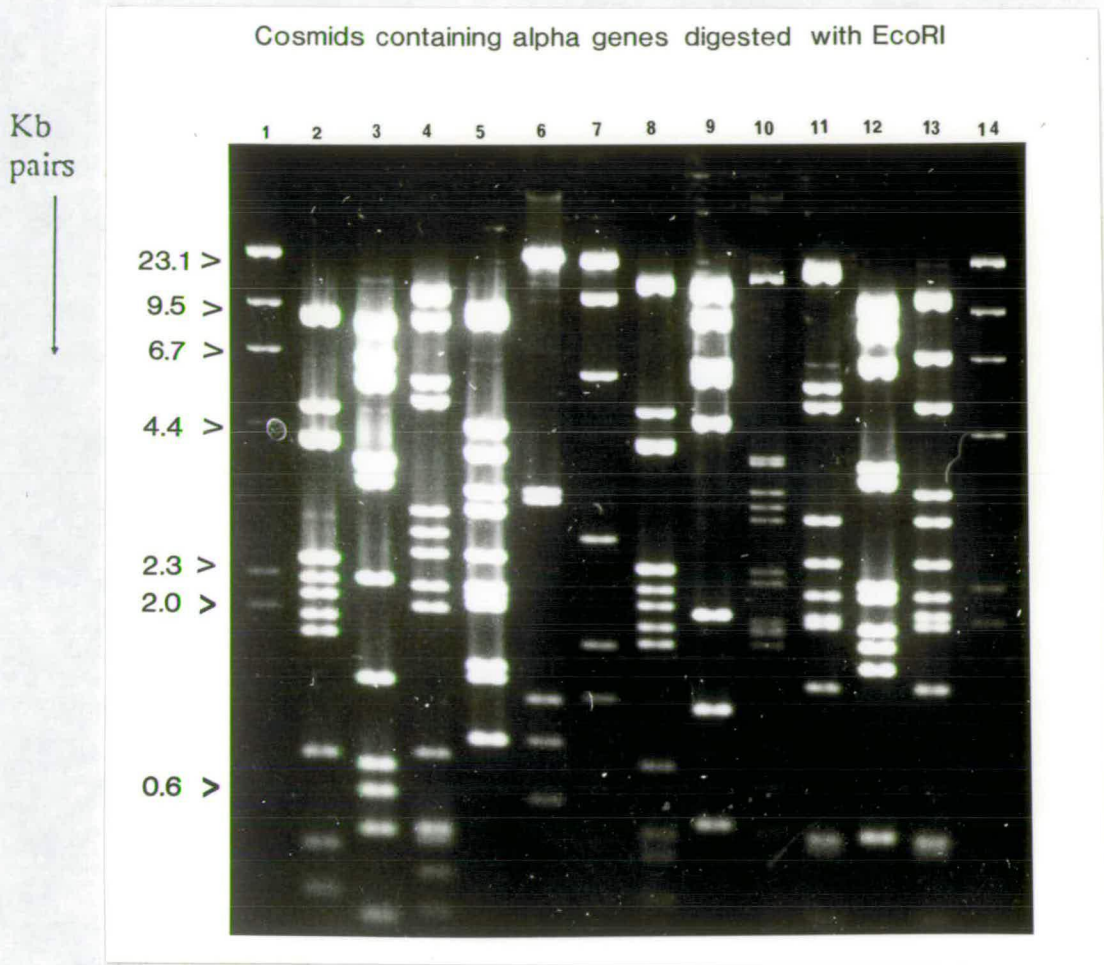

Fig 14b legend.

Lanes 1 and 14 contain lambda phage digested with HindIII to produce a series of size markers in kilobase pairs. Lane 2, cosmid 2; Lane 3, cosmid 4; lane 4, cosmid 12; lane 5, cosmid 21; lane 6, cosmid 46; lane 7, cosmid 61; lane 8, cosmid 9.2; lane 9, cosmid 10.8; lane 10, cosmid 22.1; lane 11, cosmid 24.1; lane 12, cosmid 39.1; lane 13, cosmid 46.1.

Fig 15 Ovine peripheral blood mononuclear cells labelled with the SBU panel of monoclonal antibodies

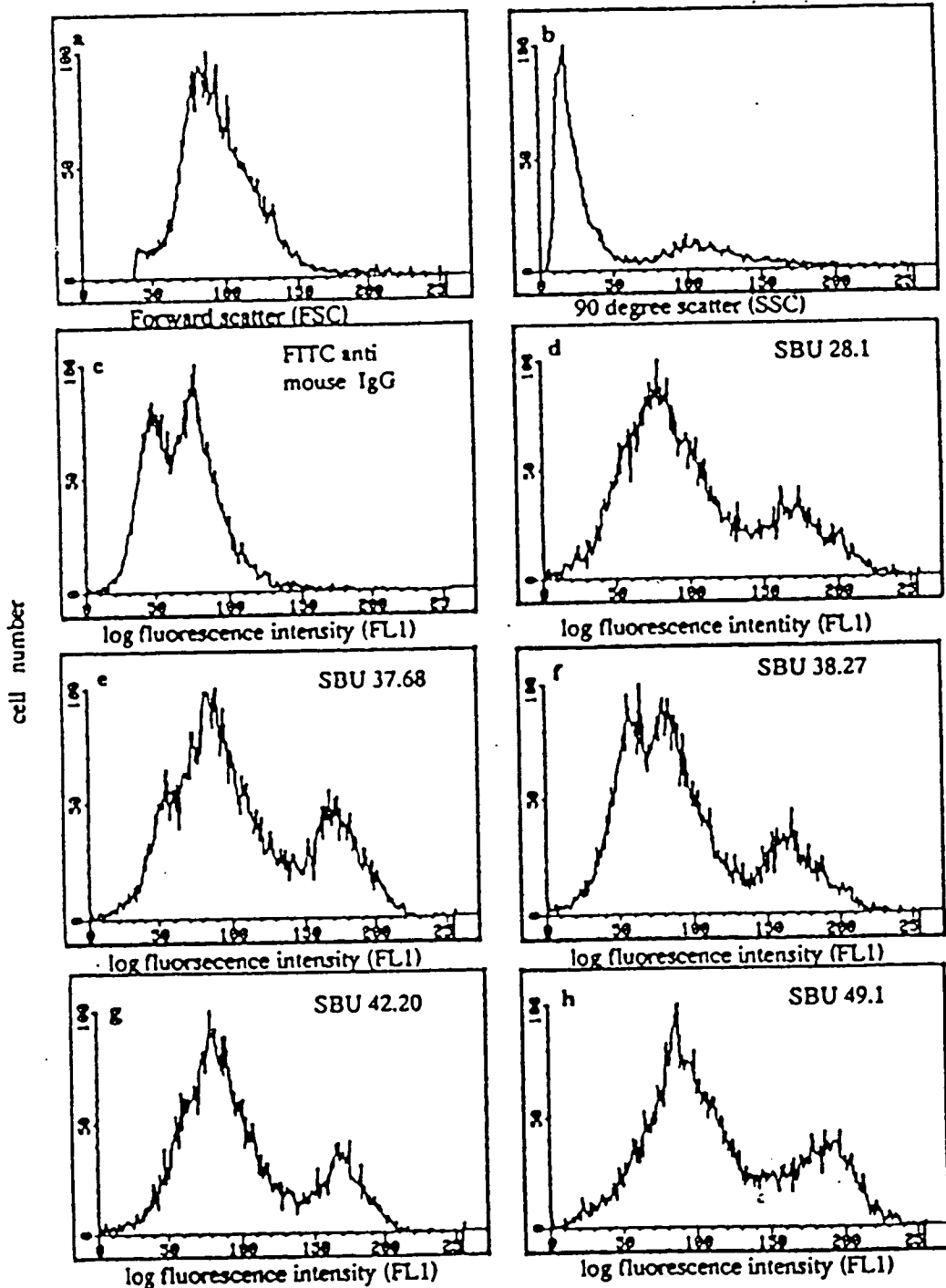

Figure 15 legend.

Peripheral blood mononuclear cells (PBMC) analysed by FACS for a) cell size (Forward scatter FSC), b) cellular complexity/granularity (Side scatter SSC), c) Control using the second stage FITC conjugated anti-mouse IgG only, d) Ovine MHC class-II expression using SBU 28.1 as the first stage reagent followed by FITC conjugated rabbit anti-mouse IgG. Compared to the negative control (c) 29.5% of the cells are expressing ovine MHC class-II molecules at the cell surface. e) PBMC labelled with SBU 37.68. The percentage of positive cells is 33.9%. f) PBMC labelled with SBU 38.27. The percentage of positive cells is 24.4%. g) PBMC labelled with SBU 42.20. The percentage of positive cells is 27.3%. h) PBMC labelled with SBU 49.1. The percentage of positive cells is 38.3%.

of class-II expressing cells. All five monoclonal antibodies detected ovine MHC class-II expression on between 30 and 45% of PBMC when used as a neat tissue culture supernatant and a second stage dilution of 1:50 (See fig 15).

DISCUSSION

This series of experiments allowed the selection and optimisation of reagents required for successful DNA-mediated gene transfer into mouse L-cells and subsequent indirect fluorescent antibody analysis. Valuable control reagents in the form of L-cell lines transfected with PTK1 alone as well as cells transfected with the rat class-I gene were also generated. These cell lines are useful as controls for the analysis of L-cells transfected with ovine MHC class-II genes and analysed with ovine class-II specific monoclonal antibodies. Expression of the rat MHC class-I gene was an important prerequisite to demonstrate the suitability of the reagents required for DNA-mediated gene transfer of ovine MHC class-II genes into mouse L-cells. In addition, rat class-I expressing L-cells were identified using the indirect fluorescent antibody (IFA) assay and FACScan analysis. The specificity of the SBU monoclonal antibodies (all recognising monomorphic determinants expressed at the surface of sheep PBMC) was confirmed. These monoclonal antibodies had previously been assigned subtype specificity based on sequential immunoprecipitation followed by N-terminal sequencing (Puri et al 1987c). All were reported to recognise monomorphic determinants of four non-overlapping class-II subtypes and SBU 49.1 was reported to recognise all beta chains. In order to increase the possibility that ovine MHC class-II molecules

would be detected at the surface of transfected L-cells in subsequent DNA-mediated gene transfer experiments, a cocktail of all 5 SBU monoclonal antibodies listed in table 2 was used as the first stage reagent in the IFA assay.

Some of the cosmids produced in the vectors PTL5 and PTL6 had initially been described as unstable (Deverson et al 1991). The instability resulted in the deletion of the genomic insert leaving a small cosmid consisting of vector only. Repackaging of the cosmids by Wright and Deverson into a new *E.coli* strain solved this problem. The EcoRI digest confirmed the stability of the cosmids and revealed that all were of high molecular weight and undegraded, and therefore suitable for transfection studies.

CHAPTER 2

GENERATION OF MOUSE L-CELL LINES EXPRESSING OVINE MHC
CLASS-II GLYCOPROTEINS

INTRODUCTION

The aim of this series of experiments was to express ovine MHC class-II genes of all isotypes following DNA-mediated gene transfer of mouse L-cells. Cell-surface expression of MHC class-II molecules requires the intracellular association of the products of an alpha and beta gene (Charron and McDevitt 1980). Both alpha and beta genes must therefore be transfected in order to obtain mouse L-cells expressing sheep MHC class-II molecules. There are two principal strategies to obtain expression of transfected genes in mammalian cells. The first involves the transfection of genomic DNA including regulatory sequences essential for gene transcription in the absence of a vector (Herzenberg et al 1984). The second involves the transfection of cDNA which requires an expression vector containing viral promoter and enhancer sequences to drive expression (Lotteau et al 1989). The first approach was adopted in this study as 31 cosmid clones containing ovine MHC class-II genes were available (See Figs 5, 6 and 7 and Deverson et al 1991).

Expression of MHC class-II glycoproteins at the cell surface is normally under isotype and allele specific regulation (Germain et al 1985, Braunstein et al 1987, Lechler 1988, Karp et al 1990). Only isotype-matched HLA class-II molecules (DPA/DPB, DQA/DQB, and DRA/DRB) have been reported at the surface of untransformed cells in vivo. Expression in mouse L-cells would therefore seem to

require transfection of isotype-matched alpha and beta genes. The alpha genes had previously been classed as DQ-like, DR-like and DZ-like by differential hybridisation to HLA class-II probes (See introduction page 27). The beta genes on the other hand could not be assigned to specific isotypes due to extensive cross-hybridisation. To determine which beta gene co-expressed with which alpha gene, all combinations of alpha and beta genes were co-transfected into mouse L-cells. The hypothesis being tested was that MHC class-II molecules expressed on the L-cells would be the products of naturally associating isotype matched alpha and beta genes. The transfection of mouse L-cells with genomic MHC class-II genes by DNA-mediated gene transfer have successfully been carried out for HLA-class-II-DR (Rabourdin-Combre and Mach 1983), DP (Austin et al 1985), DQ (Nakatsuji et al 1987), H-2-class-II-IA, (Malissen et al 1983) and rat class-II (Eccles et al 1986). However no ungulate class-II genes had yet been expressed in this way.

RESULTS

All combinations of cosmid-cloned ovine alpha and beta genes were introduced into mouse L-cells using the DNA-mediated gene transfer technique (Wigler et al 1979, materials and methods page 64) followed by detection of ovine MHC class-II glycoproteins at the cell surface using the indirect fluorescent antibody (IFA) assay and flow cytometric analysis (FACscan analysis, see materials and methods page 67). The transfection technique involves introducing the genes of interest (ovine MHC class-II genes) along with a selection gene (Tk gene in the plasmid PTk1) into the LTk- mouse fibroblast cell line. After selection for expression of the Tk gene in HAT supplemented media (materials and methods page 62), Tk+ colonies are analysed for ovine MHC class-II molecules expressed at the L-cell surface.

Ovine MHC class-II molecules were detected on the surface of L-cells following transfection of four combinations of alpha and beta genes only (see table 5). The two alpha genes in cosmids 46 and 61 were DR-alpha like (by southern hybridisation to human class-II subtype specific probes) and the uncharacterised beta genes were in cosmids 9.5 and 22.

TABLE 5

COMBINATIONS OF COSMIDS CO-TRANSFECTED INTO MOUSE L-CELLS

		ALPHA COSMIDS									
		2	4	21	46	61	9.2	22.1	24.1	39.1	46.1
		+	+	+	+	+	+	+	+	+	+
BETA	4	+	x	x	x	x	x	x	x	x	x
	16	+	x	x	x	x	x	x	x	x	x
COSMIDS	22	+	x	x	x	*	*	x	x	x	x
	32	+	x	x	x	x	x	x	x	x	x
	36	+	x	x	x	x	x	x	x	x	x
	62	+	x	x	x	x	x	x	x	x	x
	3.1	+	x	x	x	x	x	x	x	x	x
	9.1	+	x	x	x	x	x	x	x	x	x
	9.5	+	x	x	x	*	*	x	x	x	x
	10.8	+	x	x	x	x	x	x	x	x	x
	11.3	+	x	x	x	x	x	x	x	x	x
	15.2	+	x	x	x	x	x	x	x	x	x
	17.2	+	x	x	x	x	x	x	x	x	x
	22.1	+	x	x	x	x	x	x	x	x	x
	23.1	+	x	x	x	x	x	x	x	x	x
	27.1	+	x	x	x	x	x	x	x	x	x
	27.3	+	x	x	x	x	x	x	x	x	x
	28.1	+	x	x	x	x	x	x	x	x	x
	31.1	+	x	x	x	x	x	x	x	x	x
	31.4	+	x	x	x	x	x	x	x	x	x
	37.1	+	x	x	x	x	x	x	x	x	x
	39.1	+	x	x	x	x	x	x	x	x	x
	43.1	+	x	x	x	x	x	x	x	x	x

3µg of alpha and 3µg of beta gene containing cosmids (Figs 5, 6, and 7) were transfected into mouse L-cells, selected in HAT media and Tk+ colonies analysed for ovine MHC class-II expression using the indirect fluorescent antibody assay and FACScan analysis.

x Alpha and beta cosmids transfected and analysed for ovine MHC class-II cell surface expression and found to be negative.

* Alpha and beta cosmids transfected and analysed for ovine MHC class-II and found to be positive.

+ Transfection involving only a single cosmid. All were analysed for MHC class-II expression and discovered to be negative.

The four transfected L-cell lines T8.1, T9.2, T15.1 and T15.3 were generated following transfection of ovine DR-alpha genes in cosmids 46 and 61 and beta-gene-containing cosmids 22 and 9.5, see table 6.

Table 6

COSMIDS TRANSFECTED TO PRODUCE THE FOUR OVINE MHC
CLASS-II EXPRESSING MOUSE L-CELL LINES

<u>Cell line</u>	<u>Alpha cosmid</u>	<u>Beta cosmid</u>
T8.1	61	22
T9.2	46	22
T15.1	61	9.5
T15.3	46	9.5

The percentage of MHC class-II expressing L-cells in each primary transfected cell line was approximately 2%. Initially all transfections were carried out using linearised cosmid DNA. In an attempt to increase the yield of positive cells present within the primary transfected cell lines, cosmid DNA was transfected in both its circular and linearised forms. This had no obvious affect on transfection efficiency so all subsequent transfections involved circular cosmid DNA.

L-cell lines where greater than 90% of the cells expressed high

levels of ovine MHC class-II were generated by three cycles of FACS selection. The high expressing cells were sorted (materials and methods page 73), expanded in culture, relabelled with monoclonal antibodies and resorted (see Fig 16).

Transfected L-cell line T8.1 for example was generated by the transfection of the alpha cosmid 61 and beta cosmid 22. After the initial indirect fluorescent antibody (IFA) labelling, 2% of the cells were ovine MHC class-II positive (Fig 16b). These cells were sorted by FACS and represented approximately 1400 positive cells. Twenty percent of these selected cells subsequently formed colonies after 10-14 days in culture. The cells were expanded to near confluence in 25cm² tissue culture flasks containing HAT selection medium, labelled with the SBU cocktail of monoclonal antibodies and analysed by IFA analysis. Eighteen per cent were class-II positive as identified by FACS (see Fig 16c). The brightest 20% representing 20000 cells were sorted by FACS and expanded in culture, harvested and labelled with the cocktail of SBU monoclonal antibodies. After this second round of selection, the percentage of MHC class-II positive cells now amounted to 80%. The brightest 20% of the expressing cells were selected by FACS for a third time resulting in a population of cells >98% class-II positive (Fig 16d). Using fluorescence microscopy the cell line T8.1 after three rounds of sorting was labelled as described in the materials and methods page 68 and compared to the line transfected with PTK1 only see Fig 17. The level of ovine MHC class-II was also found to be comparable to the level of endogenous murine L-cell MHC class-I expression (Fig 18). Labelling the transfected cells with an anti-mouse monoclonal antibody specific for the I-EB chain of the H-2^k haplotype of C3H mice (MCA 180, Serotec) failed to detect the class-II molecules at the cell surface.

Fig 16

Generation of mouse L-cell lines expressing ovine MHC class-II molecules

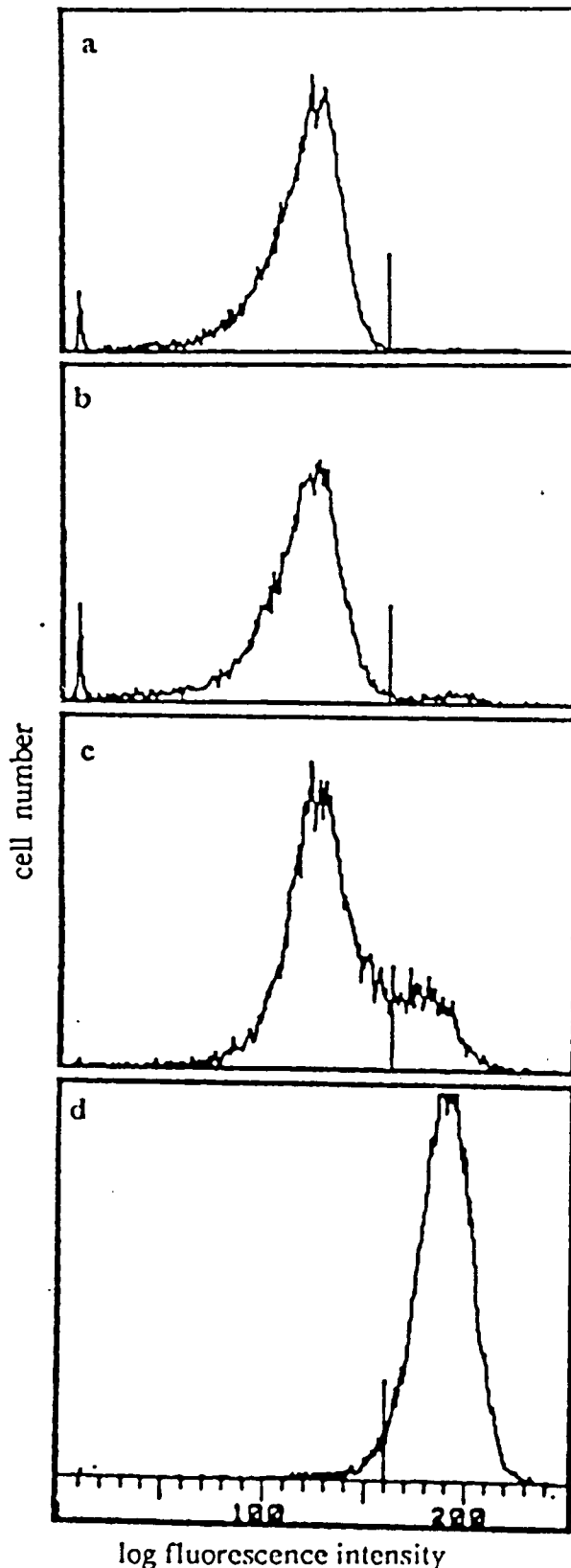

Figure 16 legend.

FACS selection for ovine MHC class-II expressing L-cells. a) L-cells transfected with the Tk gene only and labelled with a cocktail of SBU monoclonal antibodies (SBU 28.2, 37.68, 38.27, 42.20 and 49.1) followed by FITC conjugated anti-mouse IgG.

b) L-cells transfected with ovine DR-A-like gene in cosmid 61 and beta gene in cosmid 22 (T8.1) and labelled as above. The population of highly fluorescent cells (Approximately 2%) was selected by FACS and expanded in culture.

c) The result of the first FACS sort. The population of fluorescent cells is now 25% of the total. The brightest 5% of these cells are selected by FACS and expanded in culture.

d) L-cell line (T8.1) following the third FACS sort. The population of ovine MHC class-II expressing cells now accounts for >98% of the cells.

Fig 17 Cytospin preparations of L-cells lines LTK+ and T8.1 viewed by fluorescence microscopy

a



b

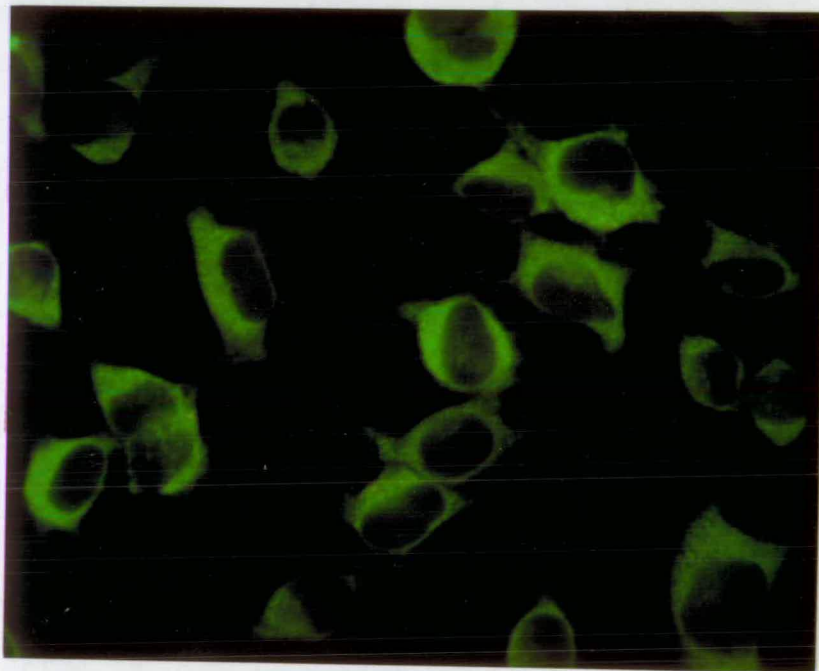

Figure 17 legend.

a) LTK+ cell line labelled with the SBU panel of monoclonal antibodies followed by FITC conjugated anti-mouse IgG. Cytospin preparation viewed X1000 using a Leitz orthoplan microscope.

b) Cell line T8.1 labelled as above showing the intracellular content of ovine MHC class-II glycoproteins. Cytospin preparation viewed X1000

Fig 18

A comparison of ovine MHC class-II and murine MHC class-I expression at the transfected L-cell surface.

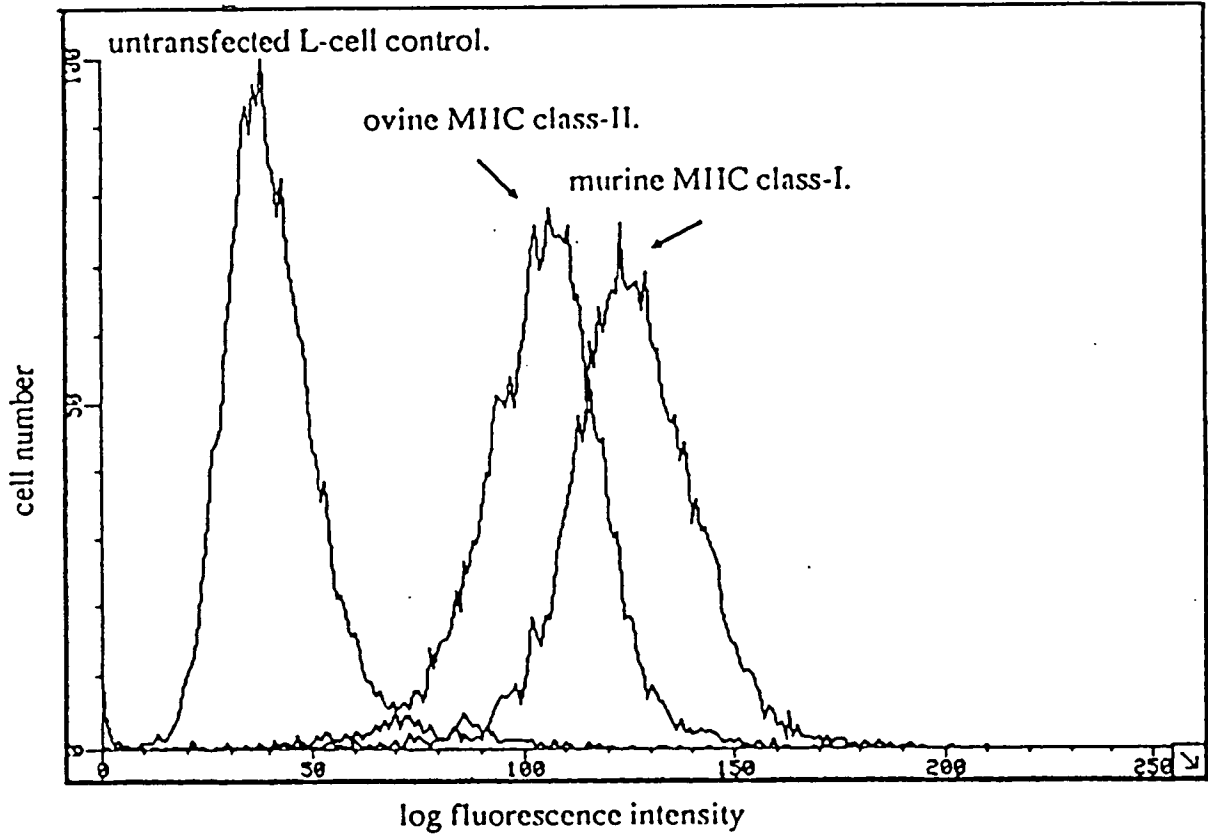

Figure 18 legend.

FACSscan analysis of transfected L-cell line T8.1 labelled with a cocktail of SBU II monoclonal antibodies as a first stage reagent followed by FITC conjugated rabbit anti-mouse IgG as a second stage reagent in order to show the level of ovine MHC class-II expression. The same cells were also labelled with monoclonal antibody OX18 in order to show the endogenous murine MHC class-I expression. The control was untransfected L-cells labelled with the SBU cocktail and second stage reagent.

A similar FACS selection procedure was carried out for all four transfected L-cell lines described in table 6. The level of ovine MHC class-II expression achieved in all four lines is shown in Fig 19. From Fig 19 it is clear that the two lines T8.1 and T9.2 expressed ovine MHC class-II at a higher level than T15.1 and T15.3. The more highly expressing lines were the result of the transfection of cosmids containing alpha and beta genes isolated from the same sheep whereas the lower expressing lines were the result of the transfection of alpha and beta genes isolated from unrelated sheep.

In spite of frequent attempts, the detection of ovine MHC class-II products by indirect fluorescent antibody labelling and FACScan analysis following transfection of all other combinations of alpha and beta genes listed in table 5 was unsuccessful. Nevertheless cells apparently class-II negative by FACScan analysis were sorted in an attempt to recover very small numbers of expressing cells. This "blind sorting" of transfected cells has been used effectively in the selection of shotgun-transfected L-cell lines (Hsu et al 1984, Toyne et al 1990) when no obvious positive population could be identified. Any surviving cells were expanded in culture and reanalysed by FACScan. This invariably confirmed the initial negative results and failed to identify other expressing gene combinations.

Previous analysis of the successfully transfected genes showed that cosmids 46 and 61 were derived from the same library and contained an ovine DR-alpha like gene. The restriction maps of these cosmids shown in Fig 6 are identical for the area covering

Fig 19

Ovine MHC class-II expression at the surface of all four transfected cell lines

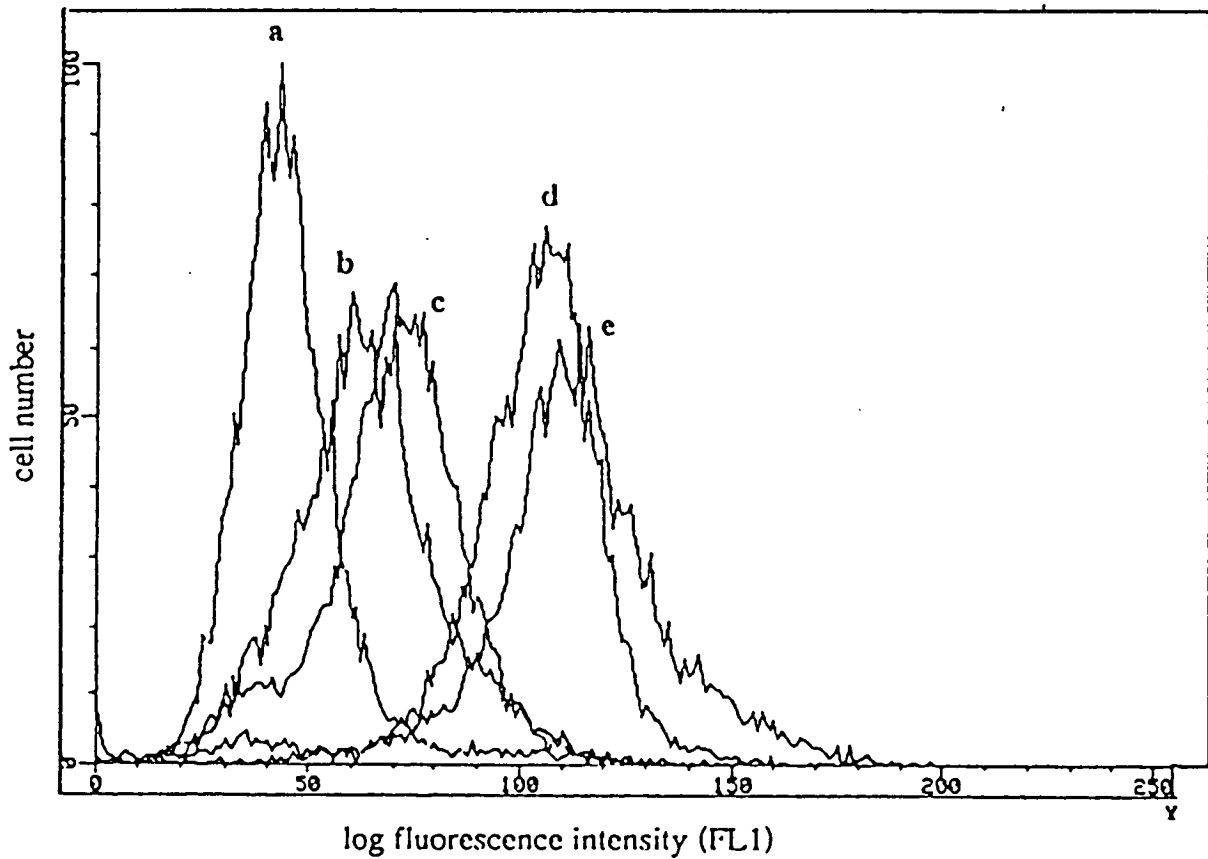

Figure 19 Legend.

FACSscan analysis of transfected cell lines a Ltk+, transfected with Tk only, b T15.1, transfected with ovine alpha gene 46 and ovine beta gene 9.5, c T15.3, transfected with ovine alpha gene 61 and beta gene 9.5, d T8.1 transfected with ovine alpha gene 61 and beta gene 22 and e T 9.2 transfected with alpha gene 46 and beta gene 22, all labelled with the cocktail of SBU II monoclonal antibodies as the first stage reagent and FITC rabbit-anti-mouse IgG as the second stage.

the alpha gene. These genes are therefore considered to be the same gene or possibly a duplication of the gene (Deverson et al 1991). The beta genes in cosmids 9.5 and 22 were isolated from different libraries but once again had identical restriction maps of the area containing the genes (see Fig 7).

DISCUSSION

Four ovine MHC class-II-expressing L-cell lines were generated from the transfection of all combinations of alpha with all beta genes (Table 5). According to our hypothesis, as the products of the DR-alpha like genes in cosmids 46 and 61 showed a functional association with the products of the two uncharacterised beta genes (22 and 9.5) they were thought likely to be DR-equivalent. Nucleotide sequence analysis of the two beta genes described in chapter 3 would test and confirm this hypothesis.

MHC class-II molecules found at the surface of untransformed cells in vivo are associations of alpha and beta chains of the same isotype namely DPA/DPB, DQA/DQB, DRA/DRB, IAA/IAB and IEA/IEB. There is however evidence for mixed isotype (DRA/DQB) cell surface expression in transformed cells (Lotteau et al 1987) and following the transfection of mouse L-cells with human and murine class-II genes (Germain and Quill 1986, Sant and Germain 1987, Sant et al 1987 and Long et al 1988). These mixed-isotype associations have not been satisfactorily identified in normal untransformed cells because the association of the isotype matched alpha/beta pair occurs much more efficiently than the isotype mismatched pair. However in L-cells following DNA-mediated gene transfer there are only the products of transfected alpha and beta genes so inefficient associations may be seen at the cell surface.

What is clear from transfection studies is that the correct cis isotype matched pairing of genomic alpha and beta genes will result in MHC class-II expression at the L-cell surface given optimum transfection conditions. As it has also been demonstrated in

transfected L-cells that expression can occur for certain alleles of alpha and beta genes of mixed isotype, nucleotide sequence analysis would be required to confirm the isotype specificity of uncharacterised beta genes before transfected gene products are considered characterised sufficiently to type monoclonal antibodies (see chapters 3 and 4).

Despite extensive effort, it was not possible to detect expressed ovine MHC class-II gene products on mouse L-cells after the transfection of cosmids containing ovine DQ or DZ-like class-II genes. There are a number of possible explanations for this:-

- 1) The failure of the monoclonal antibodies to detect other non-DR isotype transfected ovine gene products. The analysis of transfected L-cells relied on the ability of available monoclonal antibodies to detect all transfected ovine MHC class-II gene products. In order to increase the chances of detecting all possible ovine MHC class-II products a cocktail of monoclonal antibodies was used as the primary reagent in the indirect fluorescent antibody assay. This cocktail included monoclonal antibodies reported to recognise monomorphic determinants of all sheep MHC class-II molecules such as the pan-beta-specific reagent SBU 49.1, as well as DQ-specific (SBU 38.27) and DR-specific antibodies (28.1, 37.68 and 42.20, see table 2). A cocktail of VPM antibodies that had been reported to immunoprecipitate a sheep DQ-like molecule (Bernadette Dutia, personal communication) was also employed in an attempt to identify DQ-like transfectants, but with no success. The failure to detect other transfected ovine

MHC class-II gene products is therefore more likely to be a result of the failure of these genes to express or their products to associate at the cell surface rather than an inability to detect the expressed gene products.

2) The correct-isotype matched pairing of an apparently complete alpha and beta gene pair was not achieved due to the genes being present in an unexpressible form. Genes incapable of expression may be a result of the cosmid cloning procedure truncating either the gene itself or an essential 5-prime or 3-prime transcription regulatory sequence. Another possibility is that a number of the genes are pseudogenes, ie during expansion and contraction of the MHC the genes have undergone frame-shift mutations or deletions rendering them incapable of encoding a complete message. Alternatively non-expressing genes may simply not encode proteins. An example of each of these possibilities has been identified in the H-2 and HLA complexes (Trowsdale 1987, Kappes and Strominger 1988). The nucleotide sequencing of all alpha and beta genes is at present under way at the Moredun Research Institute and should identify genes not capable of expression as well as their human isotype equivalents. However even this may not guarantee cell surface expression. For example, HLA class-II genes (DXA/DXB) have been identified that are complete and exhibit no obvious pseudogene qualities but are not transcribed (Auffray *et al* 1987). The ultimate proof of the ability of a gene to express a protein product is the transfection of the gene into a mammalian cell and detection of its protein product.

3) The complete range of ovine MHC class-II genes may not have been successfully isolated from the two cosmid libraries. The lack of a contiguous map, plus the fact that a large number of class-II

genes have been isolated from one library but not yet identified in the other suggests that not all representative alpha and beta genes have been cloned. Immunochemical (Puri et al 1987) (Dutia and Hopkins personal communication) evidence for a number of ovine DRB genes and gene products supports this. The production of a new cosmid library from an unrelated sheep is at present underway at Moredun. This library will be screened with ovine as well as human class-II alpha and beta probes and should reveal genes that have not yet been isolated from the previous libraries.

4) The promoters and enhancers that drive expression of ovine DR-like alpha and beta genes in mouse L-cells following co-transfection may not be present or as powerful in other ovine MHC class-II genes. Cosmids 4, 22.1 and 39.1 overlap an area of approximately 90Kb. Within this cluster there are two DQA-like and a single DQB-like gene (see Fig 5). This cluster was repeatedly transfected with no expression being detected. The expression of genomic ovine DQ-like genes may be achieved by transfecting another cell line such as the mouse B lymphoblastoid cell line 3MB2.4 used by Tanigaki et al (1987) for HLA-DQ expression. An ovine cell line such as the fibroblast line ST6 (Norval et al 1983, Entrican et al 1989) may also be tried. This line may also express the ovine invariant chain thought to be associated intracellularly with class-II molecules and possibly involved in cell surface expression and antigen presentation (Hammerling and Moreno 1990).

The possibility that weak promoters and enhancers result in the failure to identify the expressed products of other transfected ovine MHC class-II genes could be resolved by using an expression vector which employs powerful viral regulatory elements to drive

these genes to express. As the genomic genes are too large to clone into an expression vector, attention must turn to the cDNA. HLA-DQ cDNA has been expressed in mouse L-cells using expression vectors that employ powerful viral promoters to drive gene expression (Lechler et al 1990). Therefore the transfection system may have to be modified before ovine DQ-like transfectants can be identified. Fragments of the genomic clones identified from the cosmid libraries could be used as probes or primers to isolate the equivalent cDNA's from a cDNA library or by use of the polymerase chain reaction to amplify the desired gene. These cDNA genes would be cloned and expressed using an expression vector (Wilkinson et al 1989).

CHAPTER 3

NUCLEOTIDE SEQUENCE ANALYSIS OF EXPRESSED BETA GENES

INTRODUCTION

We have been successful in expressing ovine MHC class-II molecules at the surface of mouse L-cells. As already discussed in chapter 2 the functional association between the products of the DRA-like genes in cosmids 46 and 61 and the beta genes within cosmids 22 and 9.5 indicated that the beta genes were most likely DRB-like but the possibility still existed that mixed isotype expression (DRA/DQB) had occurred. The ovine MHC class-II expressing cell lines were intended for use as typing reagents for panels of monoclonal antibodies. For this to occur the isotype specificity of the beta gene had first to be confirmed. This chapter aimed to determine the isotype of the beta genes by nucleotide sequence analysis.

The beta genes in cosmids 22 and 9.5 had been identified in different cosmid libraries produced from genomic DNA isolated from two unrelated sheep, (Deverson et al 1991). As extensive polymorphism is found within the beta genes of the HLA and H-2 complexes we therefore expected that these two genes would exhibit some degree of polymorphism at the nucleotide level as they were isolated from unrelated sheep. The second exon which encodes the first extracellular protein domain (beta-1 domain see Figs 3 and 4) is the region of maximum polymorphism within MHC class-II genes (Germain et al 1985). The second exons were therefore the first to be sequenced for both cosmids 22 and 9.5 and were expected to give an indication of the polymorphism associated with these genes as well as an indication of the human isotype equivalent.

RESULTS

Cosmids 22 and 9.5 had previously been mapped for five restriction enzymes (Fig 7). This revealed a similar restriction map for all five enzymes which was used as a starting point for the cloning strategy employed in sequencing these genes (Fig 20). The beta-1 domain was identified by southern hybridisation using a domain specific probe (SmaI fragment of cosmid 62) and subcloned into the pBS plasmid sequencing vector as described in materials and methods page 56. The nucleotide sequence was determined as described in materials and methods page 57 and compared to all human MHC class-II sequences in the European molecular biology laboratory (EMBL) gene library to identify the human isotype equivalent. By aligning the sequence of the human gene (HLA-DR4, Andersson *et al* 1987) to the ovine gene sequence we were able to map the positions of the other exons within cosmid 22. Fragments containing exons 3, 4, 5 and 6 were cloned and sequenced in a similar manner to the beta-1 domain.

Nucleotide sequence of the second exon encoding the Beta-1 domain. The nucleotide sequence of the second exon of the beta genes 22 and 9.5 is shown in Fig 21. The sequence was identical for both 22 and 9.5 even though these genes were isolated from unrelated sheep. By computer analysis the sequence demonstrated maximum similarity to the human DRB gene as all the top 20 closest

Fig 20

Beta gene cloning and sequencing strategy

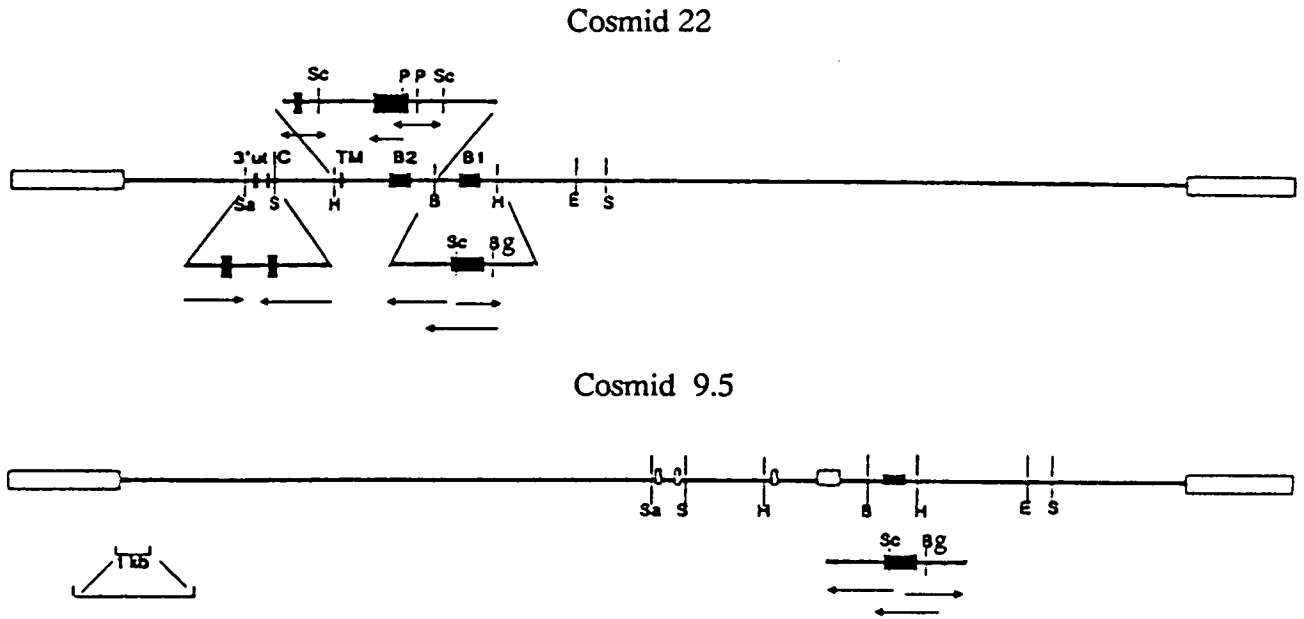

Figure 20 legend

The cloning and sequencing strategy for cosmids 22 and 9.5. The dark boxes represent the exons that have been sequenced and the arrows the extent and direction of sequencing. B1 = beta-1 domain, B2= Beta-2 domain, TM= transmembrane domain, IC= intracytoplasmic domain and 3'UT= three prime untranslated domain. The restriction sites are indicated by vertical lines. Restriction sites include S (SmaI), Sa (SacI), H (HindIII), Sc (ScaI), P (PstI), B (BamHI), Bg (BglII) and E (EcoRI).

Figure 21 legend

The nucleotide sequence of the beta gene in cosmid 22. The boundaries between exons are underlined . The proposed amino acid sequence is displayed beneath the nucleotide sequence using the three letter code.

matches were HLA-DRB genes. A repetitive sequence 3-prime of the exon that had been previously identified as characteristic of DRB genes was also present in the ovine DNA fragment (Kelly et al 1985, Gronen et al 1990). The nucleotide and predicted amino acid sequences of the second exons of the ovine genes was compared to human and bovine equivalent sequences (Table 7). As the sequences of the beta-1 domains of cosmids 22 and 9.5 were identical, coupled with an identical restriction map of the region of the cosmid that includes the gene, they were assumed to be the same gene. The sequence analysis therefore concentrated on the beta gene within cosmid 22.

Nucleotide sequence of the third exon encoding the Beta-2 domain:- As expected this exon was located some 3.5 kb from the second exon. The nucleotide sequence is shown in figure 21. The nucleotide and predicted amino acid homology was compared to human and bovine genes (see Table 7). Once again HLA-DRB demonstrated the highest degree of homology at the nucleotide and the corresponding amino acid levels.

Nucleotide sequence of the Fourth, fifth and sixth exons encoding the transmembrane, intercytoplasmic and 3-prime untranslated domains:- Using the human DRB gene as a guide, we were able to locate the remaining domains of the ovine DR beta gene representing exons 4, 5 and 6. The sequences of these exons are shown in Fig 21. The nucleotide and predicted amino acid homology to human and bovine exons and protein domains are shown in table 7.

TABLE 7

NUCLEOTIDE AND AMINO ACID SIMILARITY BETWEEN HLA-D BETA, BOLA-D BETA AND THE EXPRESSED OVINE BETA GENE FROM COSMID 22.

OLA	EXON 2(B1)	OLA EXON 3(B2)	OLA EXON 4(TM)	REFERENCE
	NA (AA)+	NA (AA)+	NA (AA)+	
HLA-DR	81 (73)	90 (85)	86 (89)	(Andersson et al 1987)
HLA-DQ	71 (62)	74 (70)	77 (75)	(Larhammar et al 1983)
HLA-DP	67 (58)	75 (68)	72 (50)	(Kelly et al 1985)
BOLA-DR	86 (70)	97 (95)	91 (100)	(Groenen et al 1990)
BOLA-DQ	75 (58)	72 (66)	74 (75)	(Groenen et al 1990)

Legend + NA= nucleic acid % similarity; AA- amino acid % similarity. The BOLA-DR gene used in this comparison is A1, and the BOLA DQ is W1 (Groenen et al 1990). Abbreviations: B1, Beta-1 domain., B2, Beta-2 domain., TM, Transmembrane domain

DISCUSSION

To test the hypothesis that the expression of genomic ovine MHC class-II genes following DNA-mediated gene transfer into mouse L-cells favours isotype-matched genes, the nucleotide sequence of expressed beta genes was determined. Of all the beta genes, only those in cosmids 9.5 and 22 co-expressed with the two DR-alpha like genes. The alpha genes had previously been characterised as DRA-like by differential hybridisation to HLA-DR specific probes (Deverson et al 1991). The expressed beta genes on the other hand remained uncharacterised due to the extensive cross-hybridisation between human and murine subtype specific gene probes characteristic of ungulate MHC class-II beta genes (Scott et al 1987, Stolt et al 1989, Sigurdardottir et al 1988, Alexander et al 1987 and Deverson et al 1991). As the products of the two beta genes showed a functional association with those of the two alpha genes, they were thought likely to be DR-equivalent. The nucleotide and predicted amino-acid sequence of the beta gene in cosmid 22 was compared to human (Kelly et al, 1985; Andersson et al, 1987; Larhammer et al, 1983) and bovine beta sequences (Groenen et al, 1990). This comparison led to the conclusion that the expressed ovine beta gene was DR-like (Table 7). We can therefore conclude that in this case the hypothesis has proved to be correct.

Nucleotide sequence analysis of the expressed beta genes confirmed that they are identical. Therefore the ovine MHC

class-II dimers expressed at the surface of all four transfected L-cell lines (T8.1, T9.2, T15.1, T15.3) are identical as both alpha genes 46 and 61 also exhibit identical restriction maps for five restriction enzymes.

The nucleotide sequences of exons 2, 3 and 4 of the beta gene in cosmid 22 were compared with those of the equivalent exons in bovine and human beta genes. This comparison clearly showed that the ovine, bovine and human DRB genes, and hence the encoded proteins, were structurally very similar. The amino acid sequence predicted from the ovine nucleotide sequence indicates that, as in cattle and man, there is a conserved cysteine residue at position 15 in the sheep beta-1 domain that is implicated in disulphide bridge formation to the cysteine at position 79 (Fig 21). Cysteines are also conserved within the beta-2 domain, forming a disulphide bridge between positions 118 and 174. The asparagine at position 19 of the beta-1 domain, which is the site of N-linked glycosylation within human and murine class-II molecules is also conserved. As there is such conservation of the class-II protein structure we would expect such conservation to be maintained when the function of these molecules is examined. Functional studies involving the transfected cells expressing ovine MHC class-II molecules will be carried out at Moredun over the next few years. These include the presentation of parasite antigen to T cell lines (Austin et al 1985) and the stimulation of the mixed lymphocyte reaction (Nakatsuji et al 1987).

The unexpected result of this series of experiments was that the ovine DR-like beta genes were identical at the beta-1 domain despite these genes being isolated from unrelated sheep. The

HLA-DR beta-1 domain is the most highly polymorphic of all human class-II domains. It consists of at least 15 alleles (Trowsdale 1988). This raises questions about the degree of polymorphism associated with this locus in the sheep. Many more sheep will have to be analysed at this locus before the degree of polymorphism can be determined. It is possible that certain alleles occur with an increased frequency within a sheep population. The HLA class-I allele A2 occurs with a frequency of approximately 30% within the Caucasian population (Klein 1986) where as other alleles occur with a frequency between 1 and 10%. As the two sheep used to produce the genomic cosmid libraries were presumably heterozygous at the MHC class-II loci (no selection for homozygosity was carried out) the chances of isolating such an allele which occurs with an increased frequency within the population would increase. The polymerase chain reaction could be used to isolate the beta-1 domain from a large number of sheep using primers identified from this sequence. This would give an indication of the frequency of occurrence of certain alleles as well as the polymorphic residues associated with each.

CHAPTER 4

TYPING OF OVINE DR SPECIFIC MONOCLONAL ANTIBODIES USING THE
OLA-DR TRANSFECTED L-CELL LINES

INTRODUCTION

The use of transfected L-cells to determine antibody specificity against complex families of cell surface molecules has been widely documented for MHC class-I (Kavathas and Herzenberg 1985, Lalor and Herzenberg 1987) and MHC Class-II molecules (Landais et al 1986, Tosi et al 1986, Heyes et al 1986, Tanigaki et al 1987, Klohe et al 1988 and Kawai et al 1989).

This chapter aims to assign ovine DR-like specificity to the panels of monoclonal antibodies listed in table 2 using the indirect fluorescent antibody assay followed by FACScan analysis on the transfected L-cell lines. As all four lines expressed the same class-II molecule at the cell surface we would expect identical results for all four transfected lines. This chapter also aims to confirm the SBU monoclonal antibody specificities determined previously by immunoprecipitation and N-terminal sequencing (Puri et al 1987).

The VPM monoclonal antibodies of known alpha and beta chain specificity were used to determine the molecular weights of alpha and beta chains expressed in transfected cells by one-dimensional SDS-PAGE and immunoblotting. Two-dimensional SDS-PAGE and isoelectric focusing analysis was also carried out on transfected L-cells.

RESULTS

Each transfected L-cell line was used to screen the two panels of monoclonal antibodies listed in table 2, for cell-surface ovine DR-like specificity. SBU antibodies 49.1, 37.68 and 42.20 and VPM antibodies 15, 38, 46, 47 and SW73.2 recognised the class-II expressing cells by indirect fluorescent antibody labelling followed by FACScan analysis (Fig 22). On the other hand the transfected cells were not recognised by SBU 38.27 (Fig 22) VPM 36 or VPM 41 (data not shown) all three of which would be expected to recognise DQ-like molecules on the basis of immunoprecipitation and N-terminal protein sequence analysis (Puri et al, 1987c; Dutia and Hopkins, in preparation). The other two putative DR-specific monoclonal antibodies SBU 28.1 (Puri et al, 1987c) and VPM 37 (Dutia and Hopkins, in preparation) also failed to recognise the transfected gene products (Fig 22). Identical results were obtained for all four ovine DR expressing L-cell lines.

Immunoblot analysis of lysates prepared from transfected L-cells used VPM antibodies with known alpha and beta chain specificities (Dutia et al, 1990) to determine the molecular weights of the alpha and beta chains. Immunoblots against transfected and untransfected cells are shown in Fig 23. Molecular weights of blotted alpha and beta chains were 32-34KDa and 26-28KDa respectively. The anti-human class-II-alpha monoclonal antibody 1D12, (Cohen et al 1987) failed to detect ovine class-II antigen when expressed on the transfected L-cells by IFA analysis but

Fig 22

Screening monoclonal antibodies for ovine DR specificity

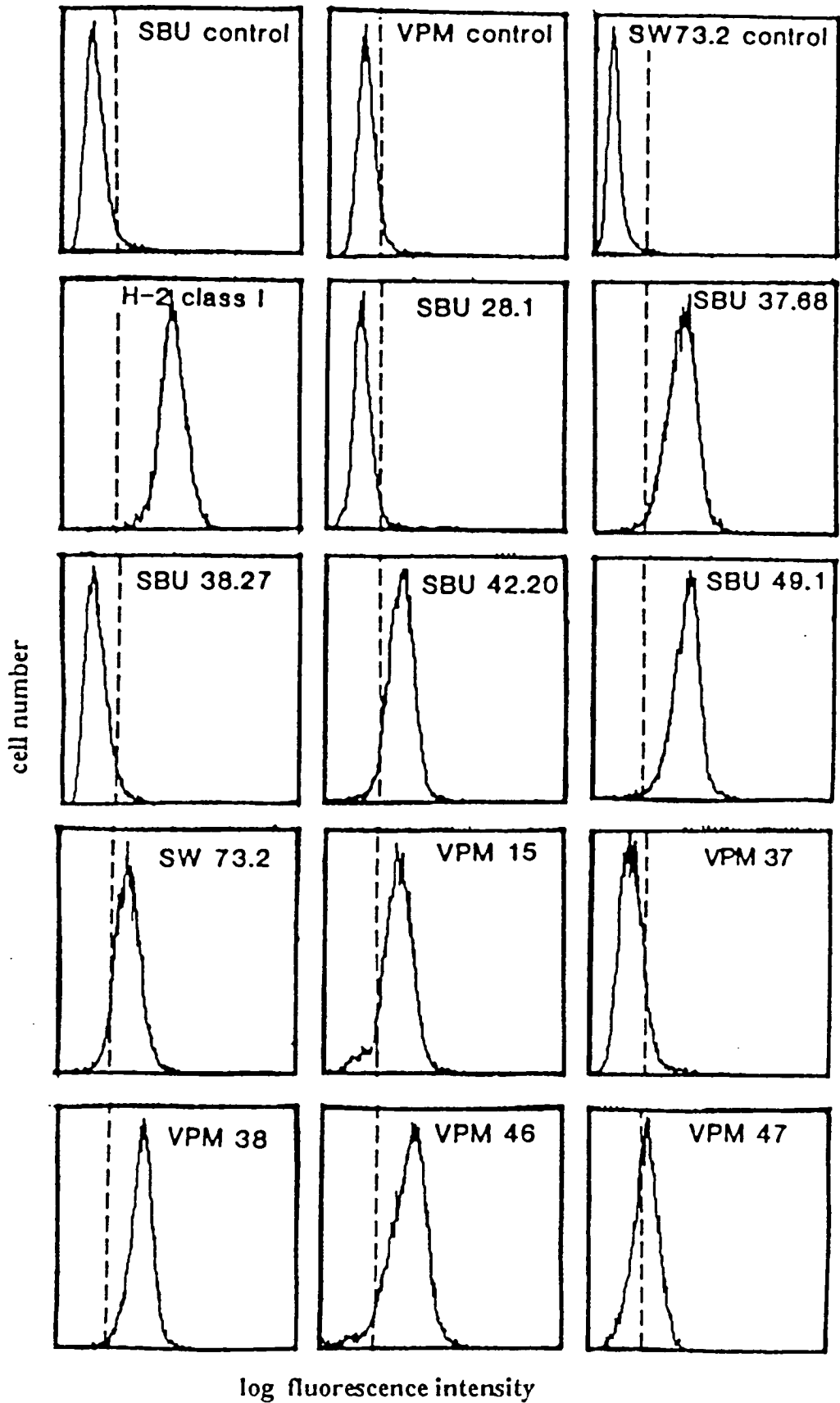

Figure 22 legend

Histograms of the line T8.1 labelled with individual monoclonal antibodies. The controls include anti-sheep MHC class-II monoclonal antibodies reacted with the cell line LTK+ and the rat anti-mouse class-I antibody R1.21.2 (Koch *et al* 1982) against T8.1. The broken line indicates the boundary between negative controls and positive fluorescence for antibodies that recognise the class-II molecules. Other negative antibodies not shown include VPM 1, 2, 3, 4, 16, 17, 36, 43, 44, 45, 48, and ID12.

Fig 23

One-dimensional immunoblots of lysates prepared from L-cell line T8.1

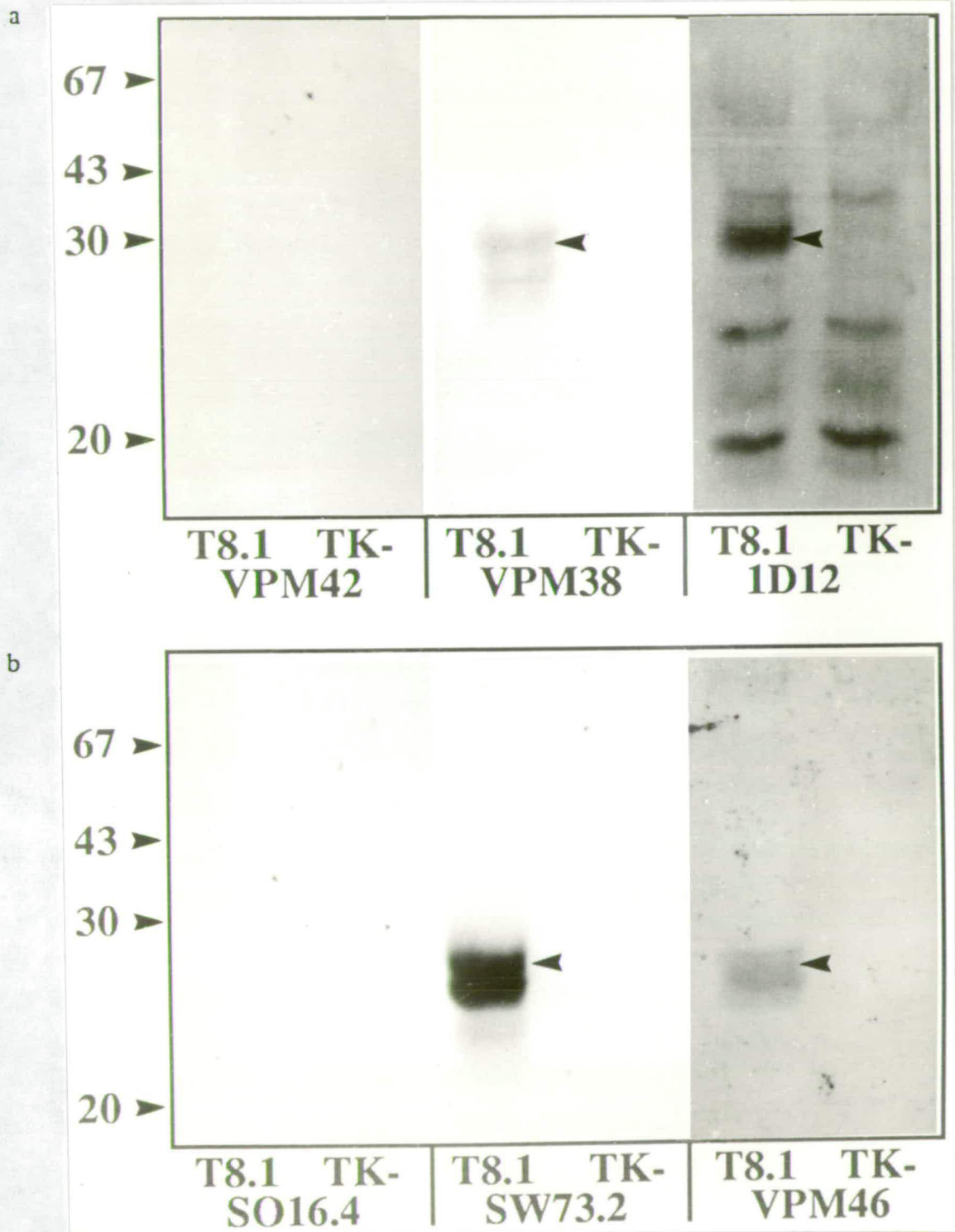

Figure 23 legend.

One-dimensional immunoblots of lysates prepared from T8.1 showing reactivity with a) anti-alpha and b) anti-beta monoclonal antibodies from the VPM series. VPM 42 (an anti-sheep immunoglobulin antibody) and SO 16.4 (an anti-sheep erythrocyte antibody) were used for negative antibody controls.

Fig 24

Two-dimensional immunoblots of lysates prepared from T8.1

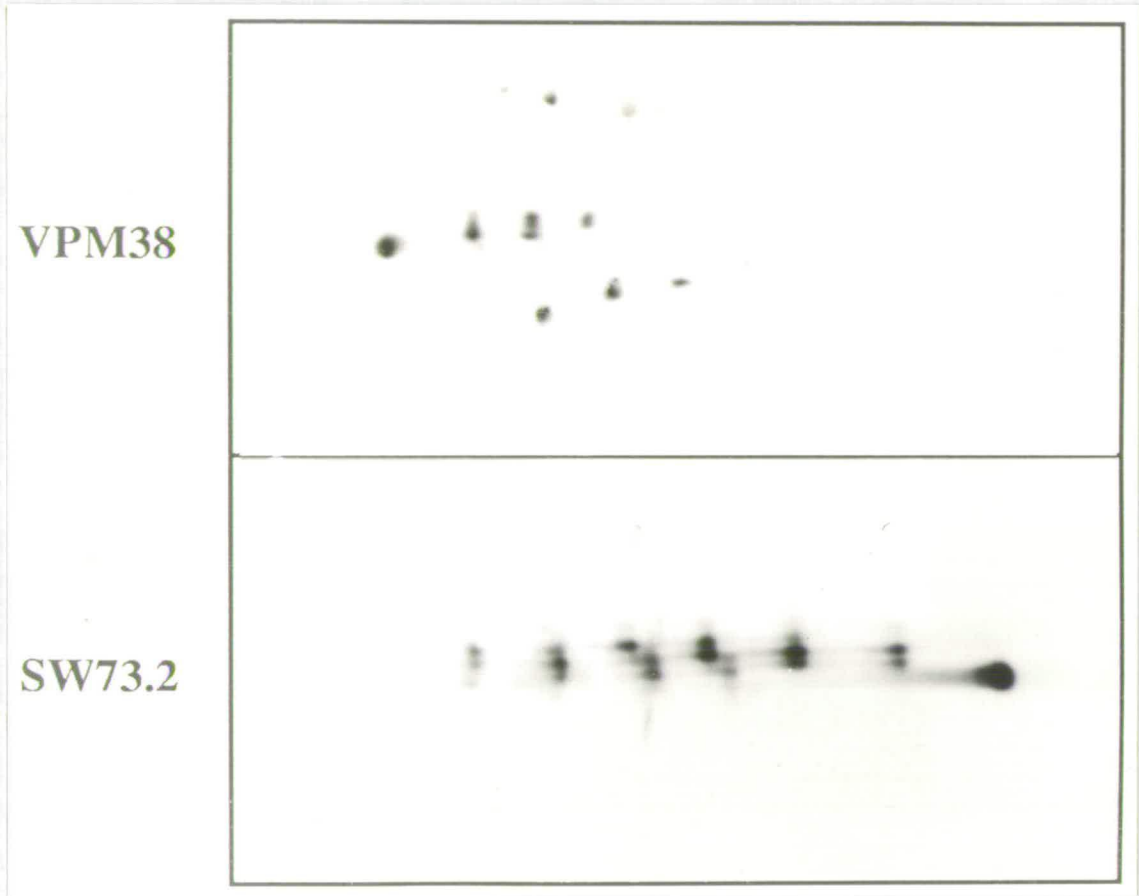

Figure 24 legend.

Two dimensional immunoblots of lysates prepared from T8.1 showing alpha and beta signals identified with anti-alpha monoclonal antibody VPM 38 and anti-beta monoclonal antibody SW73.2.

reacted with the blotted antigen (Fig 23). Two-dimensional immunoblot analysis of transfected cells showed a complex pattern (Fig 24) of alpha and beta chains which may represent the numerous protein processing stages of the class-II alpha and beta chains.

DISCUSSION

The availability of mouse L-cell lines expressing high levels of a single well-defined class-II isotype enables monoclonal antibodies that have been reported to recognise monomorphic determinants of class-II molecules to be typed using an indirect fluorescent antibody (IFA) assay and FACScan analysis. A number of the SBU panel of monoclonal antibodies had previously been typed using sequential immunoprecipitation followed by N-terminal sequencing (Puri et al 1987). In these latter studies the sequence from the N-terminus was compared to the sequences available for HLA and H-2 class-II molecules to identify the human or murine analogue. This chapter has confirmed the DR-like specificity of SBU 49.1. SBU 37.68 and SBU 42.20 but failed to confirm the DR specificity of SBU 28.1. These experiments also assigned DR specificity to the VPM panel of monoclonal antibodies (Dutia et al 1990).

Monoclonal antibodies which reacted with the ovine DRA chain of the transfected class-II molecules included SBU 42.20, VPM 38, VPM 47 and 1D12 (the last by immunoblot only). Monoclonal antibodies which reacted with the ovine DRB included VPM 46 and, as expected, the two previously characterised pan-beta-specific antibodies SBU 49.1 and SW73.2. VPM 15, which also detected the expressing cells, has not yet been analysed for chain specificity. Of particular interest were the reactivities of SBU 37.68 and 42.20

which, by previous analysis, had been designated to react with two non-overlapping subsets of sheep DR-like molecules (Puri *et al* 1987c). Here we demonstrated that both SBU 37.68 and 42.20 recognised determinants on a single DR-like class-II molecule. A possible explanation for this discrepancy could be that the N-terminal sequence analysis undertaken by Puri *et al* (1987) was wrong. This may have occurred because a mixed population of class-II molecules was isolated, which may have been the result of different monoclonal antibody affinities during sequential immunoprecipitation. The transfection technique described here simplifies the analysis of MHC antibody specificity, as only a single ovine MHC class-II isotype is expressed at the cell surface. Another explanation is that the transfected cells expressed an alpha/beta MHC class-II dimer not usually found on sheep cells *in vivo*. Although this hypothesis cannot easily be tested, it would seem unlikely, as alpha genes 46 and 61 and beta gene 22 were isolated from a single sheep and were presumably expressed from their own endogenous sheep-specific promoters and enhancer sequences (since no expression vector was used). Both alpha and beta genes were characterised as DR-like, so the dimer expressed at the L-cell surface would seem likely to be found on sheep cells, and is recognised by several monoclonal antibodies with specificity for a determinant formed between a natural association of alpha and beta chains.

N-terminal sequence analysis had also previously indicated that SBU 28.1 and VPM 37 were specific for ovine DR-like class-II molecules (Puri *et al* 1987c; Dutia and Hopkins, *in preparation*) but ELISA data have shown that these antibodies are not identical. Both these antibodies failed to detect the transfected ovine

DR-like molecules in the present study and the reasons for this are not clear. Further successful transfection of other ovine genes into L-cells may clarify the situation. Immunochemical (Puri et al, 1987b) and molecular biological (Chardon et al, 1985, Scott et al, 1987) evidence indicates that at least three DRB-like genes and gene products may exist in sheep. These are thought to associate with a single DRA-like gene product. Only a single expressing DRB-like gene has been identified in the course of this work (present in cosmids 22 and 9.5), but the rescreening of both libraries with homologous probes prepared from sheep DNA, together with the production of a new library from an unrelated sheep, should hopefully reveal other DRB-like genes capable of expressing with the DRA-like gene found in cosmids 46 and 61. There is a possibility that antibody SBU 28.1 may recognise a determinant formed between the product of an as yet unidentified DRB gene and the expressed DRA gene in cosmids 46 and 61 while antibody VPM 37 may recognise a determinant on the unidentified DRB chain itself.

One-dimensional immunoblots using alpha and beta chain specific monoclonal antibodies indicated that the chains expressed at the surface of transfected cells are similar in size to those expressed at the surface of normal sheep cells (32 kilodaltons for alpha and 28 kilodaltons for beta chains) as described by Hopkins et al (1986). Two-dimensional SDS-PAGE and IEF analysis revealed a large number of signals which presumably represented the different processing stages of the class-II molecules within the L-cells. The growth of the L-cells in an inhibitor of N-linked glycosylation (such as tunicamycin) should reduce the number of signals. These studies are currently underway.

CHAPTER 5

THE EXPRESSION OF OVINE MHC CLASS-II GENE PRODUCTS

INTRODUCTION

Ovine MHC class-II DR isotype specific gene probes and monoclonal antibodies have been generated during the course of these studies. These reagents will be employed in future investigations on the quality and quantity of ovine MHC class-II expression by various cell types during specific immune responses to defined antigens.

The purpose of this series of experiments was to determine whether fragments of ovine beta genes derived from cosmid clones could be used to discriminate between ovine beta isotypes by southern hybridisation. Previous southern hybridisations using isotype specific human and murine beta gene probes were unable to distinguish between the ovine beta isotypes (Deverson et al 1991). The southern hybridisation of all beta cosmids described in Fig 5, 6 and 7 to ovine DR-like and DQ-like beta-1 domain probes might be expected to indicate whether other DRB-like genes existed among the beta cosmids already isolated from the two cosmid libraries.

The expression of ovine MHC class-II genes was analysed in transfected mouse L-cells and mesenteric lymph node cells in

culture using DR-isotype specific gene probes. These experiments aimed to demonstrate effective qualitative and quantitative northern hybridisations using ovine MHC class-II nucleic acid probes.

RESULTS

All cosmids containing beta genes were digested with the restriction enzyme EcoRI and separated by agarose gel electrophoresis in duplicate, as described in materials and methods page 45 (see Fig 14a). The DNA was blotted onto nitrocellulose and one blot hybridised to a 1kb BglIII/BamHI fragment of cosmid 22 (See Fig 25a) (ovine DR) and another to a 400bp Sma fragment of cosmid 62 (See fig 25b) (ovine DQ) as described in materials and methods pages 48-50.

Fig 25a shows the autoradiograph resulting from the hybridisation of the ovine DR probe to all beta cosmids. Fig 25b shows the autoradiograph resulting from the hybridisation of the ovine DQ probe to all beta cosmids. These autoradiographs indicate that only the cosmids containing genes identical to the probe are clearly DR-like ie 22 and 9.5. Very little cross-hybridisation exists between the DR-beta genes in cosmids 22 and 9.5 and the DQ-beta cosmids 36 and 62. Figure 22b shows that the cosmids 36 and 62 containing genes identical to the probe hybridised strongly as did genes in cosmids 22.1 and 39.1. The DRB cosmids 22 and 9.5 demonstrated lower hybridisation to the DQ probe than the DQB cosmids 36, 62, 22.1 and 39.1. Cosmid 4 had previously been identified as containing both DQ-alpha and DQ-beta signals (Deverson et al 1990) but Fig 25a demonstrates that the gene is

Fig 25a

Southern hybridisation of the ovine DR-beta -1domain probe to all beta cosmids

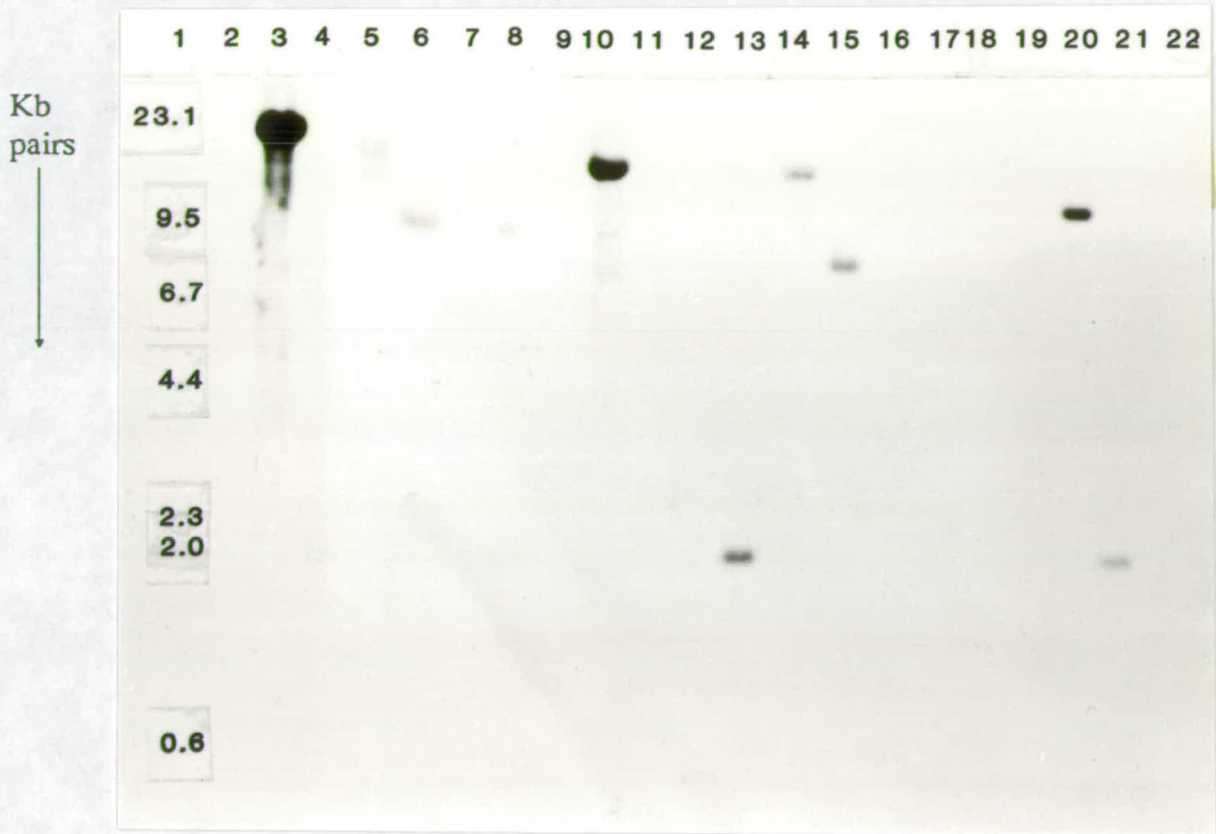

Figure 25a legend.

Autoradiograph of the EcoRI digest of all beta cosmids separated by agarose gel electrophoresis (see Fig 14a) blotted onto a nylon membrane and hybridised to a ^{32}P radiolabelled probe (1Kb BglII-Bam fragment of cosmid 22 containing the beta-1 domain). Lanes 1 and 22 contain lambda HindIII size markers in kilobase pairs. Lane 2, cosmid 4; lane 3, cosmid 22; lane 4, cosmid 32; lane 5, cosmid 36; lane 6, cosmid 62; lane 7, cosmid 3.1; lane 8, cosmid 9.1; lane 9, cosmid 9.2; lane 10, cosmid 9.5; lane 11, cosmid 11.3; lane 12, cosmid 15.4; lane 13, cosmid 17.1; lane 14, cosmid 22.1; lane 15, cosmid 23.1; lane 16, cosmid 27.1; lane 17, cosmid 27.3; lane 18, cosmid 28.1; lane 19, cosmid 31.4; lane 20, cosmid 39.1 and lane 21, cosmid 43.1.

Fig 25b

Southern hybridisation of an ovine DQ-beta-1 domain probe to all beta cosmids



Figure 25b legend.

Autoradiograph of the EcoRI digest of all beta cosmids, (see Fig 14a)hybridised to a ^{32}P radiolabelled 300bp probe (SmaI fragment of cosmid 62 containing the beta-1 domain). The lanes are as described in Fig 25a.

truncated as no beta-1 domain signal was obtained. A number of cosmids demonstrated only limited hybridisation to the two probes (cosmids 32, 9.1, 9.2, 17.1, 23.1 and 43.1) and many did not hybridise to either (cosmids 4, 3.1, 11.3, 15.2, 27.1, 27.3, 28.1 and 31.4).

Northern analysis of transfected cells using a 5kb BamHI fragment of the alpha gene in cosmid 61 and a 1kb BglIII/Bam fragment of the beta gene in cosmid 22 as probes detected ovine MHC class-II alpha signals of identical size to those in the control RNA prepared from sheep mesenteric lymph node cells (Fig 26). No signal was detected from the RNA prepared from C3H mouse spleen cells (the species from which the L-cells were originally isolated) or from Tk only transfected L-cells. Hybridisations using the beta probe were unsuccessful for reasons not yet understood. Control analysis using an murine IEB cDNA probe also failed to detect signals on transfected L-cell DNA.

Northern analysis of ovine mesenteric lymph node cells in culture over a period of time using the sheep DR-alpha probe 61 is shown in Fig 27. This clearly shows a quantitative reduction in the amount of ovine MHC class-II DR-alpha RNA over the period of time the cells were maintained in culture.

Fig 26

Northern analysis of transfected L-cell line T8.1



Figure 26 legend.

Expression of ovine MHC class-II genes in stable transfected L-cell line T8.1. Lanes 1, 2 and 3 contain 10, 20 and 30 μ g of total RNA prepared from cell line T8.1. Lanes 4, 5 and 6 contain 10, 20 and 30 μ g of total RNA prepared from cell line LTK+. Lanes 7, 8 and 9 contain 10, 20 and 30 μ g of total RNA prepared from ovine mesenteric lymph node cells. Lanes 10, 11 and 12 contain 10, 20 and 30 μ g of total RNA prepared from C3H mice spleen cells. The total RNA immobilised on a nylon membrane was hybridised to a 32 P labelled ovine DR-alpha probe (5Kb BamHI fragment of cosmid 61 including the alpha-1, 2 and transmembrane coding regions). Signals can be seen in lanes 1, 2 and 3 corresponding to the transcribed mRNA products of transfected DR-alpha genes. Signals can also be clearly seen in the RNA prepared from ovine mesenteric lymph node cells but no signals were detected from the RNA prepared from murine spleen cells (lanes 10, 11 and 12) or L-cells transfected with the Tk gene only (lanes 4, 5 and 6).

Fig 27

Ovine MHC class-II gene expression in mesenteric lymph node cells maintained in culture

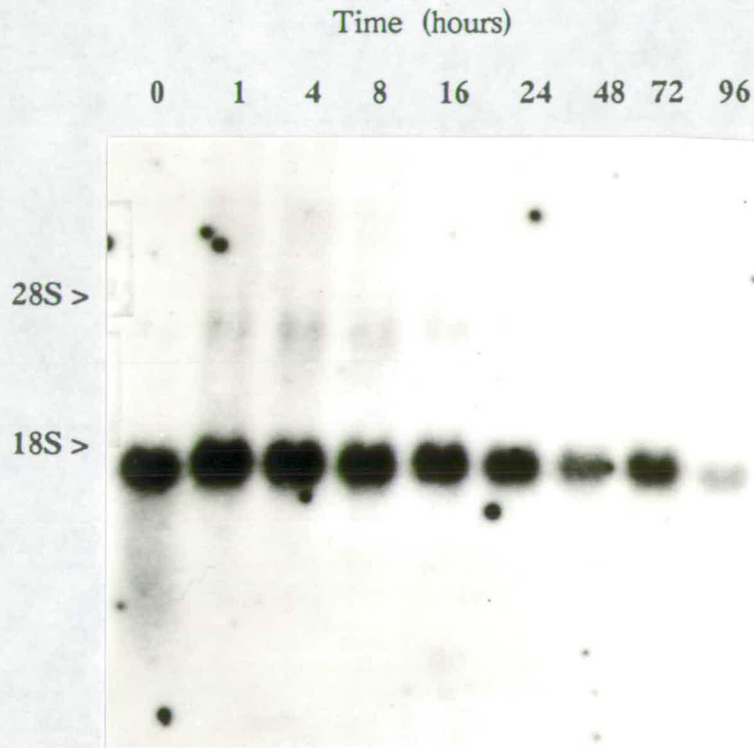

Figure 27 legend.

Ovine MHC Class-II expression in mesenteric lymph node cells over a period of 96 hours in culture. 10 μ g of total RNA prepared at the times indicated was hybridised to an ovine DR-alpha gene probe (5Kb BamHI fragment of cosmid 61). The position of the 28S and 18S rRNA bands are indicated. These are used as size markers and represent 6333 and 2366 nucleotides respectively.

DISCUSSION

This series of experiments demonstrated the value of isotype specific ovine MHC class-II exon specific gene probes. Using the beta-1 domains of ovine DQ-beta and DR-beta genes (prepared from cosmids 62 and 22) we were able to discriminate between DQ-like and DR-like beta genes. As the genes in cosmids 22 and 9.5 were the only cosmids to hybridise with the DR-beta probe we conclude that no other ovine DR-beta genes had been isolated from the two cosmid libraries.

The ovine DQ-beta probe prepared from cosmid 62 (identified by sequence analysis, Deverson *et al* 1991) hybridises strongly to its homologue in cosmid 36 as well as to the genes in cosmids 22.1 and 39.1. The latter two cosmids are grouped together within a cluster that includes two DQ alpha-like genes surrounding a beta gene (see Fig 5). The beta gene within this cluster is clearly also more DQ-like than DR-like. Cosmid 4 is also part of this cluster but does not contain the beta-1 domain as no hybridisation signal was detected. This beta gene must therefore be truncated. A cluster consisting of two DQ-alpha genes surrounding a DQ-beta gene is unique to the sheep. Neither the H-2 or the HLA complexes have this arrangement of IA or DQ genes, although a similar cluster of alpha and beta genes is found within the HLA-DP region. Within this latter region there is a pair of alpha and beta pseudogenes as well as the expressed alpha/beta pair. It is possible that the ovine DQ region also contains such an arrangement of pseudogenes

and expressed alpha and beta genes. Nucleotide sequence analysis of the genes within this cluster may explain why no expression was detected following DNA-mediated gene transfer.

Although the hybridisation was carried out at high stringency,

the DQ probe hybridised to the beta-1 domain within DR cosmids 22 and 9.5 although to a lesser extent than DQ cosmids. The fact that a large number of beta genes demonstrated little or no homology to either the DQ or DR genes in cosmids 62 and 22 indicates that the class-II genes within these cosmids must exhibit a high degree of sequence diversity at the beta-1 domain compared to the expressed DR-beta genes 22 and 9.5 and DQ beta genes 36, 62, 22.1, and 39.1. There are a number of explanations to account for this:- 1) As is the case for cosmid 4 the beta-1 domain is truncated from the rest of the gene. The exceptionally large distance between the exon that encodes the beta-1 domain (second exon) and the remaining four exons (4-6Kb) increases the chances of the beta-1 domain being truncated during the production of the cosmid library. 2) A large number of the beta cosmids may contain isolated exons identified using cDNA probes. A large number of these sequences have been identified in mouse and man (Haas et al 1986). 3) The ovine MHC may contain an isotype distinct from the DP, DQ and DR such as the DY isotype recently identified in cattle (Andersson et al 1988, Andersson and Rask 1988). 4) All initial screening of the cosmid libraries was carried out at low stringency in the "interests of inclusiveness" (Deverson et al 1991) using whole gene cDNA probes. At higher stringency, using beta-1 domain specific probes, highly polymorphic beta-1 domains are possibly not sufficiently homologous for hybridisation to occur.

The nucleotide sequence of these genes is at present being determined at the Moredun Institute. This will explain why many genes failed to hybridise with the ovine DQ and DR beta-1 domain probes. This will also reveal any subtypes of ovine MHC class-II genes that do not have equivalents in the HLA or H-2 such as the bovine DY isotype.

Northern analysis of transfected cells using fragments of the transfected genes as probes showed class-II alpha signals of identical size to those in the control RNA prepared from sheep mesenteric lymph node (MLN) cells (Fig 26). No signal was detected from the RNA prepared from C3H mouse spleen cells (the species from which the L-cells were originally isolated) or from Tk transfected L-cells. This indicates that the mRNA in the transfected L-cell is of similar size to the message within MLN cells and is of sheep origin.

Northern analysis of MLN cells maintained in culture over a period of time indicates a quantitative reduction in the level of ovine MHC class-II DR-alpha mRNA. This reduction in class-II message produced from cells maintained in culture has previously been reported for human and murine peripheral blood leucocytes (Rosa et al 1983).

This series of experiments provides an indication of the uses to which ovine MHC class-II isotype specific nucleic acid probes can be put to. The Moredun Institute has an ongoing programme of research into the immune response of sheep. These nucleic acid

probes and well-characterised isotype specific monoclonal antibody reagents will be employed to study quantitative and qualitative class-II expression during sheep immune responses to defined antigens.

GENERAL DISCUSSION

Ovine MHC class-II molecules were detected at the surface of mouse L-cells following DNA-mediated gene transfer of all combinations of alpha and beta genes isolated from two ovine genomic DNA libraries. Expression was detected using an indirect fluorescent antibody assay and FACScan analysis for four combinations of 2 DR-alpha-like (cosmids 46 and 61) and 2 undefined beta genes (cosmids 22 and 9.5). As the association of alpha and beta chains at the cell surface is under isotype and allele specific constraints, we anticipated that the beta genes would be of the DR isotype. This was confirmed by nucleotide sequence analysis of exons 2, 3, 4, 5 and 6 of the expressed beta gene in cosmid 22. Four L-cell lines expressing high levels of ovine DR-like molecules were generated by cycles of cell sorting using the FACS IV followed by expansion in culture. After three cycles greater than 98% of the cells were ovine MHC class-II positive by FACScan analysis. The DR-like class-II molecules expressed at the surface of the four L-cell lines were identical as both pairs of alpha and beta cosmids had identical restriction maps covering the area in which the gene was located (see Figs 5 and 6). The nucleotide sequence of the second exon (beta-1 domain) of the beta gene in cosmid 9.5 was also identical to that in cosmid 22 despite these genes being isolated from different unrelated sheep. This raises initial doubts about the level of polymorphism associated with this locus in the sheep. Further analysis of this locus using the polymerase chain reaction to amplify the DR-beta genes from a large number of unrelated sheep using primers identified from the sequence presented in this thesis will be carried out at the Moredun Research Institute. This will provide a better indication of the level of polymorphism at this locus in the sheep.

Transfected mouse L-cells expressing ovine MHC class-II DR-like molecules were used as isotype-typing reagents for two panels of monoclonal antibodies using an indirect fluorescent antibody assay and FACScan analysis. Identical results were obtained for all four lines, which confirmed the DR-specificity of most, but not all, of the SBU-II panel of monoclonal antibodies. These had previously been characterised by sequential immunoprecipitation followed by N-terminal protein sequence analysis (Puri et al 1987). The present approach also assigned DR specificity to the VPM panel of monoclonal antibodies. The power of this latter approach in assigning class-II isotype specificity to monoclonal antibodies is that only a single well defined class-II isotype is expressed at the transfected L-cell surface. The alternative approach, involving sequential immunoprecipitation of MHC class-II molecules from class-II expressing cells, is complicated not only by the diverse array of isotypes (DP, DQ and DR in man) being expressed, but also by codominant expression of both alleles and transcomplementation between the products of highly polymorphic alleles. This complicates the isolation of a homogeneous protein sample for N-terminal sequence analysis. The N-terminal sequences published by Puri et al (1987) emphasises this point. They indicate in some cases any one of four aminoacids at certain positions following sequential immunoprecipitation and N-terminal sequence analysis.

Immunoblots of lysates prepared from the ovine DR-expressing transfected L-cell lines identified the molecular size of expressed alpha and beta chains. These corresponded to 32 and 28 kilodaltons respectively. This was identical to the size of the molecules immunoprecipitated by Puri et al (1985) and Hopkins et al (1986). The ovine class-II mRNA isolated from transfected L-cells was also

of similar size to that isolated from ovine mesenteric lymph node cells. This would indicate that the proteins expressed at the surface of mouse L-cells are at least very closely related to that found on the surface of ovine cells. The large number of monoclonal antibodies that recognise determinants on both transfected L-cell and sheep class-II expressing cells confirms this.

During the course of these experiments a number of interesting points arose. Firstly, why did only four of the cosmids contain genes that expressed ovine MHC class-II molecules at the cell surface following DNA-mediated gene transfer?. Secondly, why was the level of ovine MHC class-II expression less for the two lines produced from the transfection of alpha and beta genes isolated from different sheep than the lines produced from the transfection of alpha and beta genes isolated from the same sheep? (see Fig 19). Thirdly, the ratio of cells expressing the thymidine kinase selection gene was between 1:5000 and 1:10000 of the initial 5×10^5 mouse L-cells. Of these cells almost 40% also expressed the transfected exogenous rat class-I gene (See Fig 13) whereas only 2% also expressed transfected ovine MHC class-II alpha and beta genes (see Fig 16).

The first of these questions has been covered extensively in chapter 2 and needs little further discussion. All that needs to be reiterated regarding DNA mediated gene transfer of uncharacterised cosmid cloned genomic DNA that requires an association between the products of two not only expressible but also compatible alpha and beta genes for cell surface expression is that it is remarkable that it works at all. It is therefore not to surprising, given the restraints of this technique as discussed in chapter 2, that only the two alpha genes in cosmids 46 and 61 and

the beta gene in cosmids 22 and 9.5 are expressed. The expression of genomic genes following DNA-mediated gene transfer is notoriously difficult. It is interesting to note that during the 1980's all human class-II isotypes were eventually expressed in mouse L-cells following gene transfer of genomic DNA, but there was a four year gap between the reported expression of HLA-DR (Rabourdin-Combre and Mach 1983) and the expression of HLA-DQ (Nakatsuji et al 1987). This was despite the availability of complete cosmid-cloned and phage-cloned DQ alpha and beta genes (Auffray et al 1984, Boss and Strominger 1984). The principle reason for this is probably due to the tissue-specific promoters and enhancers required for expression of these genes. These regulatory elements normally operate in lymphoid and myeloid cells and may not be as powerful as the DR regulatory elements. Expression of HLA-DQ molecules in transfected L-cells is usually found to be an order of magnitude lower than HLA-DR or endogenous class-I (Wilkinson et al 1990).

The second question regarding the level of MHC class-II expression in transfected cells is interesting from the point of view of regulatory sequences 5-prime of the gene in cosmid 22 but possibly absent in cosmid 9.5. As the beta genes, the transfection technique, the L-cells and the FACS selection were identical for all four transfected cell lines, attention must focus on the regulatory sequences 5-prime of the beta genes. From the map of cosmids 22 and 9.5 (Fig 5, cluster 6) it is clear that cosmid 22 contains approximately 10 kilobases more 5-prime of the beta gene than cosmid 9.5. Studies on the regulation of human MHC class-II gene expression in transfected fibroblasts by Boss and Strominger (1986) identified at least 4 regulatory elements 5-prime of the

gene. These elements are either enhancers that act to increase the level of gene transcription or suppressor sequences that act to reduce gene transcription. It is possible that the gene in cosmid 22 contains such an enhancer sequence that is absent from the gene in cosmid 9.5. This would result in a higher level of gene transcription in cells transfected with alpha genes 46 and 61 and beta gene 22 (all from the same sheep) than from transfectants resulting from the transfection of beta gene 9.5 with 46 and 61.

The third question regarding the difference in the ratios of cells expressing transfected genes is more difficult to explain. To summarise, the ratio of L-cells expressing the transfected thymidine kinase gene is between 1:5000 and 1:10000 of the initial 5×10^5 seeded L-cells. When two genes are involved ie the Tk and rat class-I gene, the percentage of cells expressing the rat class-I gene is approximately 40% of the HAT selected cells. However when three genes are involved ie the Tk and an MHC class-II alpha and beta gene the percentage of cells expressing ovine MHC class-II was only 2% of the HAT selected cells. There was therefore a 20 fold reduction in the efficiency of transfection of three genes compared to two. It is possible that as the mouse L-cells constitutively express their endogenous class-I genes (See Fig 18) as well as beta-2 microglobulin (Malissen 1986) that a related rat class-I gene would also be efficiently expressed. MHC class-II genes on the other hand are not constitutively expressed in mouse L-cells even when cultured in the presence of gamma interferon (Norcross et al 1984). The transfected ovine MHC class-II genes may have to overcome or bypass whatever suppression mechanism exists before transcription of transfected class-II genes may occur.

The initial aim of this project was to develop transfected L-cell lines expressing all isotypes of ovine MHC class-II molecules. Unfortunately, expression was achieved only for the ovine DR-like genes and it still remains a priority to gain expression of DQ-like and further DR-like genes as well as any isotypes unique to the sheep. Only once we have a complete panel of transfectants covering the entire range of ovine MHC class-II molecules will we be able to ascribe monoclonal antibody specificity that is restricted to a single isotype. Using the ovine DR-like transfected cell lines we are able to determine which monoclonal antibodies detect ovine MHC class-II DR-like molecules. The monoclonal antibodies that recognise these molecules may well recognise all ovine MHC class-II molecules ie be pan-isotype specific. SBU 49.1 and SW 73.2 are such antibodies. They are claimed to be pan-beta chain specific (Puri et al 1987, Dutia et al 1990). Other monoclonal antibodies that recognise the transfected cells may also be specific for determinants shared between DR and DQ molecules. Once DQ transfectants are available it will be possible to differentiate between pan-isotype specific and DR and DQ specific monoclonal antibodies. There are also some antibodies that are DR specific (by immunoprecipitation and N-terminal sequencing) that do not recognise the transfected L-cells expressing DR-like molecules. Therefore further DR transfected lines must also be generated. This work will continue at the Moredun Institute.

From hybridisation of alpha and beta probes to cosmids 46 and 61 it is clear that cosmid 46 contains a beta signal that is absent from cosmid 61. The restriction map of the alpha genes is

otherwise identical (see Fig 6). Genomic southern blotting (Deverson et al, 1991) suggests that the alpha genes present within these cosmids represent a duplication of the DR-alpha genes in sheep rather than being the same gene. If this is proved correct then two functional DRA-like genes must exist in the sheep. This would be the first such duplication of DRA-like genes so far described in mammals. Linkage of these clones by cosmid walking would confirm this.

An ultimate aim of the collaborative project, of which the results described in this thesis are but a small part, is to produce a well characterised working map of the class-II region of the ovine MHC. From the ongoing molecular biology being undertaken at the Moredun Institute by H Wright, and taking into account the ongoing biochemical analysis being undertaken at the Royal (Dick) Vet in Edinburgh by B Dutia and J Hopkins, it is possible to speculate about a map of the ovine MHC class-II region (see Fig 28). It has to be emphasised that this map is speculative. The order of the genes is completely unknown apart from linked cosmids described in Fig 5. It is hoped that as this work continues that this map will be refined until it is as well-defined as the H-2 and HLA class-II regions.

Proposed map of the ovine MHC class-II region

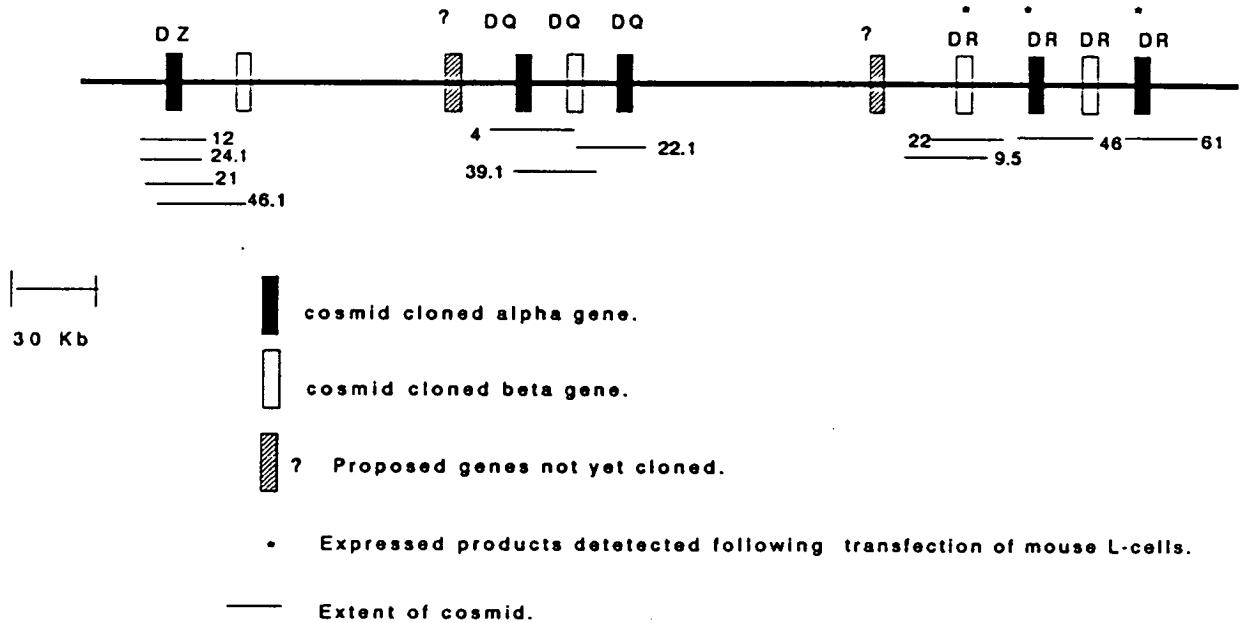

Figure 28 legend.

This figure is a diagrammatical representation of the class-II region of the ovine MHC based on molecularbiological evidence provided by Deverson et al 1991, serological and immunochemical evidence from Puri et al 1987, Dutia et al 1990 and from the results presented in this thesis. The order of the genes is speculative apart from the overlapping cosmids described in Figure 5. No ovine equivalent of the HLA-DP or BoLA-DY genes have yet been identified in the sheep. A large number of beta genes and gene fragments identified from the two cosmid libraries have not been positioned in this map. Further nucleotide sequence analysis, cosmid walking, pulsed field gel electrophoresis and the production of further cosmid libraries will result in a more complete map of this region.

REFERENCES

ALEXANDER, A.J., BAILEY, E and WOODWARD, J.G. (1987) Analysis of the equine lymphocyte antigen system by southern blot hybridisation. *Immunogenetics.*, 25: 47-54.

ALLEN, P.M. (1987) Antigen processing at the molecular level. *Immunology Today.*, 8: 270-273.

ANDERSSON, L. (1988) Class-II characterisation at the DNA level. *Animal genetics.*, 19 (Supplement 1): 32-34.

ANDERSSON, G., LARHAMMAR, D., WIDMARK, E., SERVENIUS, B., PETERSON, P.A and RASK, L. (1987) The class II genes of the human major histocompatibility complex: Organisation and evolutionary relationship of the DR-beta genes. *J. Biol. Chem.*, 262: 8784-8758.

ANDERSON, P., MORIMOTO, C., BREITMEYER, J.B and SCHLOSSMAN, S.F. (1988) Regulatory interactions between members of the immunoglobulin superfamily. *Immunology Today.*, 9: 199-204.

ANDERSSON, L., PAABO, S and RASK, L (1987) Is allograft rejection a clue to the mechanism promoting MHC polymorphism ?. *Immunology Today.*, 8: 206-208.

ANDERSSON, L and RASK, L. (1988) Characterisation of the MHC class-II region in cattle. The number of DQ genes varies between haplotypes. *Immunogenetics.*, 27: 110-120.

AUFFRAY, C., LILLIE, J.W., ARNOT, D., GROSSBERGER, D., KAPPES, D and STROMINGER, J.L. (1984) Isotypic and allotypic variation of human class II histocompatibility antigen alpha chain genes. *Nature.*, 308: 327-333.

AUFFRAY, C., LILLIE, J.W., KORMAN, A., BOSS, J.M and FRECHIN, N (1987) Structure and expression of HLA-DQ alpha and DX alpha genes: interallelic alternate splicing of the HLA-DQ gene and functional splicing of the HLA-DX alpha gene using a retroviral vector. *Immunogenetics.*, 26: 63-73.

AUSTIN, P., TROWSDALE, J., RUDD, C., BODMER, W., FELDMANN, M and LAMB, J. (1985) Functional expression of HLA-DP genes transfected into mouse fibroblasts. *Nature.*, 313: 61-64.

BABBIT, B.P., ALLEN, P.M., MATSUEDA, G., HABER, E and UNANUE, E.R. (1985) Binding of immunogenic peptides to Ia histocompatibility molecules. *Nature.*, 317: 359-361.

BACH, F.H and AMOS, D. (1967) Hu-1 Major Histocompatibility locus in man. *Science.*, 156: 1506-1508.

BACH, F.H., BACH, M.L and KLEIN, J. (1972) Genetic and immunological complexity of major histocompatibility regions. *Science.*, 176: 1024-1027.

BACH, F and HIRSCHHORM, K. (1964) Lymphocyte interaction: A potential histocompatibility assay in vitro. *Science.*, 143: 813-814.

BARBOSA, J.A., KAMARCK, M.E., BIRO, P.A., WEISSMAN, S.M and RUDDLE, F.H. (1982) Identification of human genomic clones coding the major histocompatibility antigens HLA-A2 and HLA-B7 by DNA-mediated gene transfer. Proc. Natl. Acad. Sci. USA., 79: 6327-6331.

BATCHELOR, J.R and McMICHAEL, A.J. (1987) Progress in understanding HLA and disease associations. British Medical Bulletin., 43: 156-183.

BENACERRAF, B. (1978) A hypothesis to relate the specificity of T lymphocytes and the activity of I region-specific Ir genes in macrophages and B lymphocytes. J. Immunol., 120: 1809-1812.

BENACERRAF, B and McDEVITT, H.O. (1972) The histocompatibility-linked immune response genes. Science., 175: 273-279.

BIDWELL, J. (1988) DNA-RFLP analysis and genotyping of HLA-DR and DQ antigens. Immunology today., 9: 18-22.

BIRNBOIM, H.C and DOLY, J. (1979) A rapid alkaline extraction procedure for screening recombinant plasmid DNA. Nucl. Acids Res., 7: 1513-1523.

BJORKMAN, P.J., SAPER, M.A., SAMRAOUI, B., BENNETT, W.S., STROMINGER, J.L and WILEY, D.C. (1987) Structure of human class-I histocompatibility antigen HLA-A2. Nature., 329: 506-512.

BOSS, J.M and STROMINGER, J.L. (1986) Regulation of a transfected human class-II major histocompatibility complex gene in human fibroblasts. Proc. Natl. Acad. Sci. USA., 83: 9139-9143.

BRAUNSTEIN, N.S and GERMAIN, R.N. (1987) Allele-specific control of Ia molecule surface expression and conformation: Implications for a general model of Ia structure-function relationships. Proc. Natl. Acad. Sci. USA., 84: 2921-2925

BREWERTON, D.A., CAFFERY, M., HART, F.D., JAMES, D.C.O., NICHOLLS, A and STURROCK, R.D. (1973) Ankylosing spondylitis and HLA-27. The Lancet., 28: 904-907.

BROOKES, C.F and MOORE, M. (1988) Differential MHC class-II expression on human peripheral blood monocytes and dendritic cells. Immunology., 63: 303-311.

BURNET, F.M. (1959) The clonal selection theory of acquired immunity. Cambridge University press, New York.

CAMPBELL, R.D. (1987) The molecular genetics and polymorphism of C2 and factor B. British Medical Bulletin., 43: 37-49.

CARROLL, M.C and ALPER, C.A (1987) Polymorphism and genetics of human C4. British Medical Bulletin., 43: 50-65.

CARLINFANTI, E. (1948) The predisposition for immunity. J. Immunol., 59: 1-7.

CHARDON, P., KIRSZENBAUM, M., CULLEN, P.R., GEFFROTIN, C., AUFRAY, C., STROMINGER, J.L., COHEN, D and VAIMAN, M (1985) Analysis of sheep MHC using HLA class I, II and C4 cDNA probes. Immunogenetics., 22: 349-358.

CHARRON, D.J and McDEVITT, H.O. (1980) Characterisation of HLA-D region antigens by two-dimensional gel electrophoresis. J. Exp. Med., 152: 18s-37s

CHANG, R.J and LEE, S.H. (1986) Effects of interferon gamma and tumor necrosis factor on the expression of an Ia antigen on a murine macrophage cell line. J. Immunol., 137: 2853-2856.

CHIRGWIN, J.M., PRZYBYLA, A.E., MacDONALD, R.J and RUTTER, J.W (1979) Isolation of biologically active ribonucleic acid from sources enriched in ribonuclease. Biochemistry., 18: 5294-5299.

CLARKE, R.W. (1968) Life and work of J.B.S Haldane. Published by Coward-McCann, New York, 1968.

COHEN, D., COHEN, O., MARCADET, A., MASSART, C., LATRHROP, M., DESCHAMPS, I., HORS, J., SHULLER, E and DAUSSET, J. (1984) Class II HLA-DC B-chain DNA restriction fragments differentiate among HLA-DR2 individuals in insulin-dependent diabetes and multiple sclerosis. Proc. Natl. Acad. Sci. USA., 81: 1774-1778.

COHEN, B.B., CHRICHTON, D.N and STEEL, C.M. (1987) A new set of monoclonal antibodies to human MHC class II alpha chains demonstrates that most alpha epitopes are inaccessible on the living cell. Immunology., 61: 255-260.

COLLINS, J and HOHN, B. (1978) Cosmids: A type of plasmid gene-cloning vector that is packageable in vitro in bacteriophage heads. Proc. Natl. Acad. Sci. USA., 75: 4242-4246.

COLLINS, T., POBER, J.S and STROMINGER, J.L. (1986) Physiologic regulation of class II major histocompatibility complex gene expression. In HLA class II antigens, a comprehensive review of structure and function. Springer Verlag, Berlin p 14

DAVIS, M.M., COHEN, D.I., NIELSON, E.A., STEINMETZ, M., PAUL, W.E and HOOD, L. (1984) Cell-type specific cDNA probes and the murine I region: the localisation and orientation of A-alpha. Proc. Natl. Acad. Sci. USA., 81: 2194-2198.

DAVID, C.S., SCHREFFLER, C and FRELINGER, J.A. (1973) New lymphocyte antigen system controlled by the Ir region of the mouse H-2 complex. Proc. Natl. Acad. Sci. USA., 70: 2509-2514.

DELOVITCH, T.L., SEMPLE, J.W and PHILLIPS, M.L. (1988) Influence of antigen processing on immune responsiveness. Immunology Today., 9: 216-217.

DENARO, M., GUSTAFSSON, K., LARHAMMAR, D., STEINMETZ, M., PETERSON, P.A and RASK, L. (1985) Mouse MHC class II gene E-beta 2 is closely related to E-beta and HLA-DR beta. Immunogenetics., 21: 613-616.

DEVEREUX, J., HAEBERLI, P and SMITHIES, O. (1984) A comprehensive set of sequence analysis programs for the VAX. Nucl. Acid Res., 12: 387-395.

DEVERSON, E.V., HUSKISSON, N., DIAMOND, A.G., HOWARD, J.C., WRIGHT, H., WATSON, S and BALLINGALL, K.T. (1991) Class II MHC genes of the sheep. Animal genetics (in press)

DIAMOND A.G., HOOD, L.E., HOWARD, J.C., WINDLE, M and WINOTO, A. (1989) The class II genes of the rat MHC. J. Immunol., 142: 3268-3273.

DUTIA, B.M., HOPKINS, J., ALLINGTON, M.P., BUJDOSO, R and McCONNELL, I. (1990) Characterisation of monoclonal antibodies specific for alpha and beta chains of sheep MHC class II. Immunology., 70: 27-32.

ECCLES, S.J., TEH, H.S., DIAMOND, A.G and McMASTER, W.P. (1986) Differential expression of RT1 Class II genes in fibroblast cell lines: recognition by allogenic and xenogenic T lymphocytes. Immunology., 59: 29-35.

ENTRICAN, G., HAIG, D.M and NORVAL, M. (1989) Identification of ovine interferons: Differential activities from fibroblastoid cells. Vet. Immunol. and Immunopath., 21: 187-195.

EVANS, G.A and WAHL, GM. (1987) Cosmid vectors for genomic walking and rapid plasmid restriction mapping. Methods in enzymology., 152., 604-610.

FEINBERG, A.P and VOGELSTEIN, B. (1984) A technique for radiolabeling DNA restriction endonuclease fragments to high specific activity. ADDENDUM Anal. Biochem., 137: 266-267.

FEINBERG, A.P and VOGELSTEIN, B. (1982) A technique for radiolabeling restriction endonuclease fragments to high specific activity. Anal. Biochem., 132: 6-13.

FINK, M.A and QUINN, V.A (1953) Antibody production in inbred strains of mice. J. Immunol., 70: 61-67.

FLAHERTY, L. (1981) Tla-region antigens. In The role of the major histocompatibility antigens in immunobiology. Edited by Dorf, M.E. Garland STPM press, New York p 33-58.

FLAVELL, R.A., KOOTER, J.M., DE BOER, E., LITTLE, P.F.R and WILLIAMSON, R. (1978) Analysis of the beta-gamma-globulin gene loci in normal and Hb lepore DNA: Direct determination of gene linkage and intergene distance. Cell., 15: 25-41.

FLAVELL, R.A., ALLEN, H., BURKLE, L.C., SHERMAN, D.H., WANECKG.L and WIDERA, G. (1986) Molecular biology of the H-2 histocompatibility complex. Science., 233: 437-443.

FORD, C.H.J. (1974) A serological investigation of sheep leucocyte antigens. J. Immunogenetics., 1: 345-354.

FORD, C.H.J. (1975) Genetic studies of sheep leucocyte antigens. J. Immunogenetics., 2: 31-40.

FU, S.M., CHIORAZZI, N., WANG., C.Y., MONTAZERI, G., KUNKEL, H.G., KO, H.S and GOTTLIEB, A.B. (1978) Ia-bearing T lymphocytes in man. *J. Exp. Med.*, 148: 1423-1428.

FUKUMOTO, T., McMASTER, W.R and WILLIAMS, A.F. (1982) Mouse monoclonal antibodies against rat histocompatibility antigens. The Ia antigens and expression of Ia class-I antigens in rat thymus. *Eur. J. Immunol.*, 12: 237-243.

GECZY, A.F., ALEXANDER, K and BASHIR, H.V. (1980) A factor(s) in *Klebsiella* culture filtrates specifically modifies an HLA-B27-associated cell surface component. *Nature.*, 283: 782-784.

GERMAIN, R.N. (1986) The ins and outs of antigen processing and presentation. *Nature.*, 322: 687-689.

GERMAIN, R.N., BENTLY, D.W and GUILL, H. (1985). Influence of allelic polymorphism on the assembly and surface expression of class-II MHC (Ia) molecules. *Cell.*, 43: 233-242.

GERMAIN, R.N and QUILL, N. (1986) Unexpected expression of a unique mixed-isotype Class II MHC molecule by transfected L cells. *Nature.*, 320: 72-75.

GOGOLIN-EWENS, K.J., MACKAY, C.R., MERCER, W.R and BRANDON, M.R. (1985) Sheep lymphocyte antigens (OLA). *Immunology.*, 56: 717-723.

GOODENOW, R.S., MacMILLAN, M and ORN, A. (1981) Identification of a BALB/c H-2L gene by DNA mediated gene transfer. *Science.*, 215: 677-679.

GORER, P.A. (1936) The detection of antigenic differences in mouse erythrocytes by the employment of immune sera. *Br. J. exp. Path.*, 17: 42-65.

GORER, P.A. (1937) Further studies on antigenic differences in mouse erythrocytes. *Br. J. Exp. Path.*, 47: 231-250.

GORER, P.A. (1938) The antigenic basis of tumor transplantation. *J. Pathol.*, 47: 231-252.

GORER, P.A., LYMAN, S and SNELL, G.D. (1948) Studies on the genetic and antigenic basis of tumour transplantation. Linkage between a histocompatibility gene and "fused" gene in mice. *Proc. Royal Soc (series B).*, 135: 499-405.

GORCYNSKI, R.M and MACRAE, S. (1979) Suppression of cytotoxic response to histoincompatible cells. *J. Immunol.*, 122: 747-752.

GORER, P.A and O'GORMAN, P. (1957) The cytotoxic activity of isoantibodies in mice. *Transplantation bulletin.*, 3: 142-143.

GRAHAM, F.L and VAN DER EB, A.J. (1973) A new technique for the assay of infectivity of human adenovirus 5 DNA. *Virology.*, 52: 456-467.

GREEN, S., ISSEMANN, I and SHEER, E. (1988) A versatile in vivo and in vitro expression vector for protein engineering. Nucl. Acids. Res., 16: 369.

GROENEN, M.A.M., VAN DER POEL, J.J., DIJKHOF, R.J.M and GIPHART M.J. (1990) The nucleotide sequence of bovine MHC class II DQB and DRB genes. Immunogenetics., 31: 37-44.

GUAGLIARDI, L.E., KOPPLELMAN, B., BLUM, J.S., MARKS, M.S., CRESSWELL, P and BRODSKY, F.M. (1990) Co-localisation of molecules involved in antigen processing and presentation in an early endocytic compartment. Nature., 343: 133-139.

GUILLEMOT, F., AUFRAY, C., ORR, H.T and STROMINGER, J.L. (1988) MHC antigen genes. Molecular Immunology., Edited by Hames, B.D., Glover, D.M., IRL Press.

HAAS, D.A., BOSS, J.M., STROMINGER, J.L and SPIES, T. (1987) A highly diverged beta-1 exon in the DR region of the human MHC: sequence and evolutionary implications. Immunogenetics., 25: 15-20.

HAMMERLING, U., CHIN, A.F., ABBOTT, J and SCHEID, M.P. (1975) The ontogeny of murine B lymphocytes. J.Immunol., 115: 1425-1431.

HAMMERLING, G.J and MORENO, J. (1990) The function of the invariant chain in antigen presentation by MHC class II molecules. Immunology Today, 11: 337-340.

HARDY, D.A., BELL, J.I., LONG, E.O., LINDSTEIN, T and McDEVITT, H.O. (1986) Mapping of the class II region of the human histocompatibility complex by pulsed field gel electrophoresis. *Nature.*, 323: 453-455.

HAUPTFIELD, V., KLEIN, D and KLEIN, J. (1973) Serological identification of an Ir region product. *Science.*, 181: 167-169.

HAUPTFIELD, V and KLEIN, J. (1975) Private and public H-2 antigens as determined by antigen redistribution method. *J. Exp. Med.*, 142: 288-299.

HERZENBERG, L.A., HSU, C., ALBETRI, S and KAVATHAS, P. (1984). Transfection and cloning of genes for membrane antigens using the FACS. *Med. Oncol. and Tumor Pharmacother.*, 1: 219-224.

HEYES, J., AUSTIN, P., BODMER, J., MADRIGAL, A., MAZZILLI, M.C and TROWSDALE, J. (1986) Monoclonal antibodies to HLA-DP-transfected mouse L-cells. *Proc. Natl. Acad. Sci. USA.*, 83: 3417-3421.

HIRSCHBERG. H., KAAKINEN, A and THORSBY, E. (1976) Presence of HLA-D determinants on human macrophages *Nature*, 263: 63-64.

HOHN, B and MURRAY, K. (1977) Packaging recombinant DNA molecules into bacteriophage particles in vitro. *Proc. Natl. Acad. Sci. USA.*, 74: 3259-3263.

HOLBECK, S.L and NEPOM, G.T. (1986) Exon-specific oligonucleotide probes localise HLA-DQ beta allelic polymorphisms. *Immunogenetics.*, 24: 251-258.

HOPKINS, J., DUTIA, B.M and McCONNELL, I. (1986) Monoclonal antibodies to sheep lymphocytes. Identification of MHC Class II molecules on lymphoid tissue and changes in the level of Class II expression on lymph-borne cells following antigen stimulation in vivo. *Immunology.*, 59: 433-438.

HORN, G.T., BUGAWAN, T.L., LONG, C.M and ERLICH, H.A. (1988) Allelic sequence variation of the HLA-DQ loci: Relationship to serology and to insulin-dependent diabetes susceptibility. *Proc. Natl. Acad. Sci. USA*, 85: 6012-6016.

HSU, C., KAVATHAS, P and HERZENBERG, L.A. (1984) Cell-surface antigens expressed on L-cells transfected with whole DNA from non-expressing and expressing cells. *Nature.*, 312: 68-69.

HUNKAPILLER, T and HOOD, L. (1986) The growing immunoglobulin gene superfamily. *Nature.*, 323: 15-16.

ISH-HOROWICZ, D and BURKE, J.F. (1981) Rapid and efficient cosmid cloning. *Nucl. Acids Res.*, 9: 2989- 2999.

JEANNET, M. (1986) Class II HLA antigens in autoimmune and immune-mediated diseases. In *HLA class-II antigens, a comprehensive review of structure and function*. Published by Springer Verlag, Berlin p 489-513.

JONES, P.O. (1980) Selected methods in cellular immunology. Edited by B.B MISCHEL and S.M SHIIGI., Freeman and Co San Francisco.

JONES, P.P., MURPHY, D., HEWGILL, D and McDEVITT, H. O. (1979) Detection of a common polypeptide chain in I-A and I-E subregion immunoprecipitates. *Mol. Immunol.*, 16: 51-60.

KAPLER, J.W and MARRACK, P.C. (1976) Helper T cells recognise antigen and macrophage components similtaneously. *Nature.*, 262: 797-781.

KAPPLER, J.W., STAERZ, U., WHITE, J and MARRACK, P.C. (1988) Self-tolerance eliminates T-cells specific for Mls-modified products of the major histocompatibility complex. *Nature.*, 332: 35-40.

KAPPES, D and STROMINGER, J.L. (1988) Human class-II major histocompatibility complex genes and proteins. *Ann. Rev. Biochem.* 57: 991-1028.

KARP, D.R., TELETSKI, C.L., JARAQUEMADA, D., MALOY, W.L., COLIGAN, J.E and LONG, E.O. (1990) Structural requirements for the pairing of alpha and beta chains in HLA-DR and HLA-DP molecules. *J. Exp. Med.*, 171: 615-628.

KAVATHAS, P and HERZENBERG, L.A. (1986) Handbook of Experimental Immunology. Genetics and molecular immunology. Edited by Weir, D.M., published by Blackwell publications.

KAWAI, J., ANDO, A., SATO, T., NAKATSUJI, T., TSUJI, K and INOKO, H. (1989) Analysis of gene structure and antigen determinants of DR2 antigens using DR gene transfer into mouse L-cells. *J. Immunol.*, 142: 312-317.

KEARNEY, J.F., COOPER, M.D., KLEIN, J., ABNEY, E.R., PARKHOUSE, R.M.E and LAWTON, A.R. (1977) Ontogeny of Ia and IgD on IgM-bearing B lymphocytes in mice. *J. Exp. Med.*, 146: 297-301.

KELLY. A and TROWSDALE. J. (1985) Complete nucleotide sequence of a functional HLA-DP beta gene and the region between the DP beta-1 and DP alpha-1 genes: Comparison of the 5' ends of HLA class II genes. *Nucl. Acids Res.*, 13: 1607-1621.

KLEIN, J. (1986) The natural history of the major histocompatibility complex. Wiley interscience publication

KLEIN, J. (1975) Biology of the mouse histocompatibility-2 complex Springer-Verlag

KLEIN, J. (1979) The major histocompatibility complex of the mouse. *Science.*, 203: 516-521.

KLEIN, J., JURETIC, A., BAXEVANIS, C.N and NAGY, Z.A. (1981) The traditional and a new version of the mouse H-2 complex. *Nature.*, 291: 455-460.

KLOHE, E.P., WATTS, R., BAHL, M., ALBER, C., YU, W-Y., ANDERSON, R., SILVER, J., GREGERSEN, P.K and KARR, R.W. (1988) Analysis of the monoclonal specificities of anti-class-II monoclonal antibodies by using L-cell transfectants expressing HLA class-II molecules. *J. Immunol.*, 141: 1258-1264.

KOLLER, B.H., GERAGHTY, D., ORR, H.T., SHIMIZU, Y and DeMARS, R (1987) Organisation of the human major histocompatibility class-I genes. *Immunol. Res.*, 6: 1-15.

KOLLER, B.H., GERAGHTY, D.E., SHIMIZU, Y., DeMARS and ORR, H.T. (1988) A novel HLA class I gene expressed in resting T lymphocytes. *J. Immunol.*, 141: 897-904.

LALOR, P.A and HERZENERG, L.A. (1987) Transfection of genes encoding lymphocyte differentiation antigens: applications in veterinary immunology. *Vet. Immunol. and Immunopath.*, 17: 291-302.

LANDAIS, D., BECK, B.N., BUERSTEDDE, J-M., DEGRAW, S., KLEIN, D., KOCH, N., MURPHY, D., PIERRES, M., TADA, T., et al. (1986) The assignment of chain specificities for anti-Ia monoclonal antibodies using L-cell transfectants. *J. Immunol.*, 137: 3002-3005.

LANG, J.C., WILKIE, N.M and SPANDIDOS, D.A. (1983) Characterization of eucaryotic transcriptional control signals by assay of Herpes Simplex Virus type 1 thymidine kinase. *J. Gen. Virol.*, 64: 2679-2696.

LANZAVECCHIA, A. (1985) Antigen-specific interactions between T and B cells. *Nature.*, 314: 537-539.

LARHAMMAR, D., HAMMERLING, U., RASK, L and PETERSON, P.A. (1985) Sequence of gene and cDNA encoding murine major histocompatibility complex Class II gene AB2. *J. Biol. Chem.*, 260: 14111-14119.

LARHAMMAR, D., HYLDIG-NEILSON, J.J., SERVENIUS, B., ANDERSSON, G., RASK, L and PETERSON, P.A. (1983) Exon-intron organisation and complete nucleotide sequence of a human major histocompatibility antigen DC-beta gene. *Proc. Natl. Acad. Sci. USA.*, 80: 7313-7317.

LECHLER, R.I. (1988) MHC Class II molecular structure-permitted pairs. *Immunology.*, 9 :76-78.



LEE J.S., TROWSDALE, J and BODMER, W.F. (1982) cDNA clones coding for the heavy chain of human HLA-DR antigen. *Proc. Natl. Acad. Sci. USA.*, 79: 545-549.

LEHRACH. H., DIAMOND. D., WOZNEY. J.M and BOEDTKER. H. (1977) RNA molecular weight determination by gel electrophoresis under denaturing conditions, a critical reexamination. *Biochemistry.*, 16: 4743-4751.

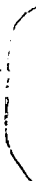

LECHLER, R.I., LOMBARDI, G., BATCHELOR, J.R., REINSMOEN, N and BACH, F.H. (1990) The molecular basis of alloreactivity. *Immunology Today.*, 11: 83-88.

LEVINE, B.B and BENACERRAF, B. (1964) Genetic control in guinea pigs of immune response to conjugates of haptens and poly-L-lysine. *Science.*, 147: 517-518.

LEVINE, B.B., OJEDA, A and BENACERAF, B. (1963) Studies on artificial antigen. The genetic control of the immune response to hapten-poly-L-lysine conjugated in guinea pigs. *J. Exp. Med.*, 118: 953-957.

LITTLE, C.C and TYZZER, E.E. (1916) Further experimental studies on the inheritance of susceptibility to a transplantable tumour carcinoma of the Japanese waltzing mouse. *J. Med. Res.*, 33: 393-435.

LONG, E.O. (1985) In search of a function for the invariant chain associated with Ia antigens. *Surv. Immunol. Res.*, 4: 27-34.

LONG, E.O., WAKE, C.T., STRUBIN, M., GROSS, N., ACCOLLA, R.S., CARREL, S and MACH, B. (1982) Isolation of distinct cDNA clone encoding HLA-DR-beta chains by use of an expression assay. *Proc. Natl. Acad. Sci. USA.*, 79: 7465-7469.

LONDEI, M., BOTTAZZO, F.G and FIELDMAN, M. (1985) Human T-cell clones from autoimmune thyroid glands: specific recognition of autologous cells. *Science.*, 228: 85-98.

- LO, D and SPRENT, J. (1986) Identity of cells that imprint H-2 restricted T-cell specificity in the thymus. *Nature.*, 319: 672-675.
- LOTTEAU, V., SANDS, J., TEYTON, L., TURMEL, P., CHARRON, D and STROMINGER, J.L. Modulation of HLA-class-II antigen expression by sense and antisense DR-alpha cDNA. *J. Exp. Med.*, 169: 351-356.
- LOTTEAU, V., TEYTON, L., BURROUGHS, D and CHARRON, D. (1987) A novel HLA class II molecule (DRA-DQB) created by mismatched isotype pairing. *Nature.*, 329: 339-341.
- LUCEY, D.R., NICKOLSON-WELLER, A and WELLER, P.F. (1989) Mature human eosinophils have the capacity to express HLA-DR. *Proc. Natl. Acad. Sci. USA.*, 86: 1348-1351.
- LUND, T., GROSVELD, F.G and FLAVEL, R.A. (1982) Isolation of transforming DNA by cosmid rescue. *Proc. Natl. Acad. Sci. USA.*, 79: 520-524.
- LUNNEY, J.K and SACHS, D.H. (1979) Transplantation in mature swine: Characteriation of Ia antigen. *J. Immunol.*, 122: 623-627.
- MACDONNALD, H.R., SCHNEIDER, R., LEES, R.K., HOWE, R.C., ACHA-ORBEA, H., FESTENSTEIN, H and ZINKERNAGEL, R.M. (1988) T-cell receptor V-beta use predicts reactivity and tolerance to Mls-encoded antigens. *Nature.*, 332: 40-45.
- MALISSEN, B. (1986) Transfer and expression of MHC genes. *Immunology Today.*, 7 : 106-112.

MALISSEN, B., HUNKAPILLER, T and HOOD, L. (1983) Nucleotide sequence of a light chain gene of the mouse subregion: Ab. Science., 221: 750-754.

MALISSEN, B.M., STEINMETZ, M., McMILLAN, M., PIERRES, M and HOOD, L. (1983) Expression of I-A class II genes in mouse L cells after DNA-mediated gene transfer. Nature., 305: 440-442.

MARTIN, A., DUNNINTON, E.A., BRILES, W.E., BRILES, R.W and SIEGEL, P.B. (1989) Marek's disease and major histocompatibility complex haplotypes in chickens selected for high or low antibody response. Animal Genetics., 20: 407-414.

MARRACK, P and KAPPLER, J. (1988) The T-cell repertoire for antigen and MHC. Immunology Today, 9: 308-313.

McDEVITT, H.O and CHINITZ, A. (1969) Genetic control of the immune response: relationship between immune response and (H-2) type. Science., 163: 1207-1208.

McDEVITT, H.O., DEAK, B.D., SHREFFLER, D.C., KLEIN, J., STIMPFLING, J.H and SNELL, G.D. (1972) Genetic control of the immune response: mapping of the Ir-I locus. J. Exp. Med. 135: 1259-1278.

McDEVITT, H.O and SELA, M. (1965) Genetic control of the antibody response. J. Exp. Med., 122: 517-531.

McNICHOLAS, J., STEIMETZ, M., HUNKAPILLER, T., JONES, P and HOOD, L. (1982) DNA sequence of the gene encoding the EA Ia polypeptide of the balb/c mouse. *Science.*, 218: 1229-1232.

MELLOR, A. (1986) The class I MHC gene family in mice. *Immunology Today.*, 7: 19-24.

MELVOLD, R.W (1986) Inbred, congenic, recombinant-inbred and mutant mouse strains. In the *Handbook of Experimental Immunology 3. Genetics and Molecular immunology.* Edited by Weir, D.M. Blackwell Publications.

METZGAR, R.S., BERTOGLIO, J., ANDERSON J.K., BONNARD, G.D and RUSCETTI, F.W. (1979) Detection of HLA-DRw (Ia-like) antigens on human T lymphocytes grown in tissue culture. *J.Immunol.*, 122: 949-953.

MILLOT, P. (1974) Groupes lymphocytaires chez les ovine: premiers resultats dans la race francaise Prealpe. *First world congress of genetics applied to livestock production.*, 3: 295-299.

MILLOT, P. (1979) Genetic control of lymphocyte antigens in sheep: The OLA complex and two minor loci. *Immunogenetics.*, 9: 509-534.

MILLOT, P. (1984) The OLA major histocompatibility complex of sheep. *Expl. Clin. Immunogen.*, 31-42.

MORRISSON, L.A., LUKACHER, A.E., BRACIALE, V.L., FAN, D.P and BRACIALE, T.J. (1986) Differences in antigen presentation to MHC class-I and class-II restricted influenza virus-specific cytolytic lymphocyte clones. *J. Exp. Med.*, 163: 903-921.

MORRISON, S.L and OI, V.T. (1986) Lymphoid cell gene transfer. *Hand book of experimental immunology 3*, Edited by Weir, D.M, Blackwell publication.

MUGGLI-COCKETT, N.E and STONE, R.T. (1988) Identification of genetic variation in the Bovine Major Histocompatibility complex DR-Beta genes using sequenced Bovine genomic probes. *Animal Genetics.*, 19: 213-225.

NAKATSUJI, T., INOKO, H., ANDO, A., SATO, T., KOIDE, Y., TADAKUMA, T., YOSHIDA, T.O and TSUJI, K. (1987) The role of transfected HLA-DQ genes in the mixed lymphocyte reaction-like condition. *Immunogenetics.*, 25: 1-6.

NOMA, Y., SIDERAS, P., NAITO, T., BERGSTEDT-LINDQUIST, S., AZUMA, C., SEVERINSON, E., TANEBE, T., KINASHI, T., et al (1986) Cloning of cDNA encoding the murine IgG1 induction factor by a novel strategy using SP6 promoter. *Nature.*, 319: 640-645.

NORCROSS, M.A., BENTLEY, D.M., MARGULIES, D.H and GERMAIN, R.W. (1984) Membrane Ia expression and antigen-presenting accessory cell function of L cells transfected with Class II MHC genes. *J. Exp. Med.*, 160: 1316-1334.

NORVAL, M., HEAD, K.W., ELSE, R.W., HART, H and NEILL, W.A. (1981) Growth in culture of adenocarcinoma cells from the small intestine of sheep. *Br. J. Exp. Path.*, 62: 270-282.

O'FARRELL. P.Z., GOODMAN. H.M and O'FARRELL. P.H. (1977) High resolution two-dimensional electrophoresis of basic as well as acidic proteins. *Cell.*, 12: 1133-1142.

OLD, R.W and PRIMROSE, S.B (1985). Introducing genes into mammalian cells in culture. In the Principles of gene manipulation. Published by Blackwell Scientific publications.

PARHAM, P., LONEN, C.E and LAWLOR, D.A. (1988) Nature of polymorphism in HLA-A, B and C molecules. *Proc. Natl. Acad. Sci. USA.*, 85: 4005-4009.

PIERRES, M., REBOUAH, J-P., KOURILSKY, F.M., DOSSETO, M., MERCIER, P., MAWAS, C and MALISSEN, B. (1981) Cross-reactions between mouse Ia and human HLA-D/DR antigens analysed with monoclonal antibodies. *J. Immunol.*, 126: 2424-2429.

PLOEGH, H.L., ORR, H.T and STROMINGER, J.L. (1980) Molecular cloning of a human histocompatibility antigen cDNA fragment. *Proc. Natl. Acad. Sci. USA.*, 77: 6081-6085.

PURI, N.K and BRANDON, M.R. (1987) Sheep MHC class II molecules. *Immunology.*, 62: 575-562.

PURI, N.K., GOGOLIN-EWENS, K.J and BRANDON, M.R. (1987a) Monoclonal antibodies to sheep MHC Class I and II molecules: biochemical characterization of three class I gene products and four distinct subpopulations of class II molecules. *Vet. Immunol. Immunopathol.*, 15: 59-86.

PURI, N.K., GORREL, M.D and BRANDON, M.R. (1987b) Sheep MHC class II molecules: immunochemical characterization. *Immunology.*, 62: 567-573.

PURI, N.K., MACKAY, C.R and BRANDON, M.R. (1985) Sheep lymphocyte antigens (OLA). *Immunology.*, 56: 725-732.

PURI, N.K., WALKER, I.D and BRANDON, M.R. (1987c) N-Terminal amino acid sequence analyses of the A and B polypeptides from four distinct subsets of sheep major histocompatibility complex class II molecules. *J. Immunol.*, 139: 2996-3002.

RABOURDIN-COMBRE, C and MACH, B (1983) Expression of HLA-DR antigens at the surface of mouse L-cells transfected with cloned human genes. *Nature.*, 303: 670-674.

ROLLINI, P., MACH, B and GORSKI, J. (1987) Characterisation of an HLA-DRB pseudogene in the DRw52 supertypic group. *Immunogenetics.*, 25: 336-342.

ROSA, F., HATAT, D., ABADIE, A., WALLACH, D., REVEL, M and FELLOUS, M. (1983) Differential regulation of HLA-DR mRNAs and cell surface antigens by interferon. *EMBO.J.*, 2: 1585-1589.

SAIKI, R.A., BUGAWAN, T.L., HORN, G.T., MULLIS, K.B and ERLICH, H.A. (1986) Analysis of enzymatically amplified B-globulin and HLA-DQA DNA with allele-specific oligonucleotide probes. *Nature.*, 324: 163-166.

SAIKI, R.K., SCHARF, S and FALOONA, F (1985) Enzymatic amplification of beta-globin genomic sequences and restriction site analysis for diagnosis of sickle cell anaemia. *Science.*, 230: 1350-1354.

SAMBROOK, J., FRITSCH, E.F and MANIATIS, T. (1989) *Molecular cloning* Cold spring harbour, laboratory press.

SANT, A.J., BRAUNSTEIN, N.S and GERMAIN, R.N. (1987) Predominant associations of amino-terminal sequences in dictating efficiency of class-II major histocompatibility complex alpha/beta dimer expression. *Proc, Natl. Acad. SCI. USA.*, 84: 8065-8069.

SANDERSON, A.R. (1964) Applications of iso-immune cytotoxicity using radiolabelled target cells. *Nature.*, 204: 250-253.

SANT, A.J and GERMAIN, R.N. (1989) Intracellular competition for component chains determines Class II MHC cell surface phenotype. *Cell.*, 57: 797-805.

SANGER. F., NICKLEN. S and COULSON. A.R. (1977) DNA sequencing with the chain terminating inhibitors. *Proc. Natl. Acad. Sci. USA.* 74: 5463-5467.

SANG, J.H and SOBEY, W.R. (1954) The genetic control of the response to antigenic stimuli. *J. Immunol.*, 72: 52-65.

SCHWARTZ, D.C and CANTOR, C.R. (1984) Separation of yeast chromosome sized DNA's by pulsed field gradient electrophoresis. *Cell.*, 37: 67-75.

SCOTT, P.C., CHOI, C and BRANDON, M.R. (1987) Genetic organisation of the ovine MHC class II region. *Immunogenetics.*, 25: 116-122.

SERVENIUS, B., RASK, L and PETERSON, P.A. (1987) Class-II genes of the human major histocompatibility complex. The DO-beta gene is a divergent member of the class-II beta gene family. *J. Biol. Chem.*, 262: 8759-8766.

SHINOHARA, N., LUNNEY, J.K and SACHS, D.H. (1978) Sharing of Ia between species: molecular localisation of shared Ia determinant simplifies the existence of more than one 1 sublocus of rat MHC. *J. Immunol.*, 121: 637-640.

SHINOHARA, N., SACHS, D.H., NONAKA, N and YAMAMOTO, H. (1981) Phylogenic tracing of Ia genes. *Nature.*, 292: 362-363.

SIGURDARDOTTIR, S., LUNDEN, A and ANDERSSON, L. (1988) Restriction fragment length polymorphism of DQ and DR class-II genes of the bovine major histocompatibility complex. *Animal Genetics.*, 19: 133-150.

SIMONSEN, M. (1987) The MHC of the chicken, genomic structure, gene products, and resistance to oncogenic DNA and RNA viruses. *Vet. Immunol. Immunopath.*, 17: 243-253.

SINGER, D.H., CAMERINI-OTERO, R.D., SATZ, M.L., OSBORNE, B., SACHS, D and RUDIHOFF, S. (1982) Characterisation of a porcine genomic clone encoding major histocompatibility antigen: Expression in mouse L cells. *Proc. Natl. Acad. Sci. USA.*, 79: 1403-1407.

SINGER, A., HATHCOCK, K.S and JONES, R.J. (1982) Self recognition in allogenic thymic chimeras. *J. Exp. Med.*, 155: 339-344.

SMITH, C.A., WILLIAMS, G.T., KINGSTON, R., JENKINSON, E.J and OWEN, J.J.T. (1989) Antibodies to CD3/T-cell receptor complex induce death by apoptosis in immature T-cells in thymic cultures. *Nature.*, 337: 181-184.

SNELL, G.D., CLOUDMAN, A.M and WOODWORTH, E. (1948) Tumour immunity in mice induced with lyophilised tissue as influenced by tumour strain, host strain, source of tissue and dosage. *Cancer Res.*, 8: 429-437.

SPANDIDOS, D.A and WILKIE, N.M. (1983) Host-specificities of papillomavirus, Moloney murine sarcoma virus and simian virus 40 enhancer sequences. *EMBO J.*, 2: 1193-1199.

SPOONER, R.L and FERRONE, S. (1984) Cross reaction of monoclonal antibodies to human MHC class I and class II products with bovine lymphocyte subpopulations. *Tissue antigens.*, 24: 270-277.

STEINMETZ, M., WINOTO, A., MINARD, K and HOOD, L. (1982) Clusters of genes encoding mouse transplantation antigens. *Cell.*, 28: 489-498.

STOLT, H., EDFORS-LILJA, I and ANDERSSON. L. (1989) Analysis of the swine MHC (SLA) by use of human cDNA class-II probes and class-I alloantisera. *Animal Genetics.*, 20: 36-42.

STRACHAN, T. (1987) Molecular genetics and polymorphism of class I HLA antigens. *British Medical Bulletin (HLA in medicine)* 43 : 1-14.

STRONG, L.C. (1942) The origin of some inbred mice. *Cancer Res.*, 2: 531-539.

SZYBALSKA, E.H and SZYBALSKI, W. (1962) Genetics of human cell lines IV. DNA-mediated heritable transformation of a biochemical trait. *Proc. Natl. Acad. Sci. USA.*, 48: 2026-2034.

TANIGAKI, N., TOSI, R., STROMINGER, J.L and COOPER, J. (1987) Immunochemistry of the HLA class-II molecules isolated from a mouse cell transfected with DQ alpha and beta genes from a DR4 haplotype. *Immunogenetics.*, 26: 40-47.

TERASAKI, P and MacCLELLAND, J.D. (1964) Microdroplet assay of human serum cytotoxins. *Nature.*, 204: 998-1000.

TERASAKI, P.I and RICH, N.E. (1963) Quantitative determination of antibody and complement directed against lymphocytes. *J.Immunol.*, 92: 128-138.

TEYTON, L., O'SULLIVAN, D., DICKSON, P.W., LOTTEAU, V., SETTE, A., FINK, P and PETERSON, P.A. (1990) Invariant chain distinguishes between the exogenous and endogenous antigen presentation pathways. *Nature.*, 348: 39-44.

TOKSUSKI, K., SAUERACKER, G., KAY, P.H., CHRISTIANSEN, F.T., ANAND, R and DAWKINS, R.L. (1988) Extensive deletions and insertions in different MHC supratypes detected by pulsed field gel electrophoresis. *J. Exp. Med.*, 168: 933-940.

TOSI, T., TANIGAKI, N., De PREVAL, C., GORSKI, J and MACH, B. (1986) Immunochemical analysis of a cell transfected with an HLA-DR gene reveals a new allogenic specificity within the HLA-DRw52. *Eur. J. Immunol.*, 16: 1603-1608.

TOSI, R., VISMARA, D., TANIGAKI, N., FERRARA, G.B., CICIMARRA, F., BUFFOLANO, W., FOLLO, D and AURICCHIO, S. (1983) Evidence that celiac disease is primarily associated with a DC locus allelic specificity. *Clin. Immunol. and Immunopath.*, 28: 395-404.

TOWNSEND, A., OHLEN, C., BASTIN, J., LJUNGGREN, H-G., FOSTER, L and KARRE, K. (1989) Association of class-I major histocompatibility heavy and light chains induced by viral peptides. *Nature.*, 340: 443-448.

TOYE, P.G., MACHUGH, N.D., BENSAID, A.M., ALBERTI, S., TEALE, A.J and MORRISON, W.I. (1990) Transfection into mouse L cells of genes encoding two serologically and functionally distinct bovine class I MHC molecules from a MHC-homozygous animal: evidence for a second class I locus in cattle. *Immunology.*, 70: 20-26.

TROWSDALE, J. (1987) Genetics and polymorphism: Class II antigens. *British Medical Bulletin (HLA in medicine)*, 43: 15-36.

TROWSDALE, J. (1988) Molecular genetics of the MHC. *Immunology, supplement 1* : 21-23.

TROWSDALE, J., KELLY, A. LEE, J., CARSON, S., AUSTIN, P and TRAVERS, P. (1984) Linkage map of two HLA-SB beta and two HLA SB alpha-related genes: an intron in one of the SB genes contains a processed pseudogene. *Cell.*, 38: 241-249.

TROWSDALE, J., LEE, J., CAREY, J. GROSVELD, F., BODMER, J and BODMER, W. (1983) Sequence related to HLA-DR chain on human chromosome 6: restriction enzyme polymorphism detected with DC chain probes. *Proc. Natl. Acad. Sci. USA.*, 80: 1972-1976.

TROWDALE, J and KELLY, A. (1985) The human HLA class II gene is distinct from genes in the DP, DQ and DR subregions. *EMBO J.*, 4: 2231-2237.

TYZZER, E.E. (1909) A study of inheritance in mice with reference to their susceptibility to transplantable tumours. *J. Med. Res.*, 21: 519-573.

TYZZER, E.E. (1915) The importance of inflammation in the immunity of mice to implanted tumors. *J. Med. Res.*, 32: 201-215.

VAN DER POEL, J.J., GROENEN, M.A.M., DIJKHOF, R.J.M., RUYTER, D and GIPHART, M.J. (1990) The nucleotide sequence of bovine MHC class II alpha genes: DRA, DQA and DYA. *Immunogenetics.*, 35: 30-37.

VAN LEEUWEN, A., SCHUIT, H.R.E and VAN ROOD, J.J. (1973) Typing for MLC.II. The selection of non stimulator cells by MLC inhibition tests using SD identical stimulator cells (MISIS) and fluorescence antibody studies. *Transplant. Proc.*, 5: 1539-1542.

WHITE, T.J., ARNHEIM, N and ERLICH, H.A. (1989) The polymerase chain reaction. *TIG.*, 5: 185-189.

WIGLER, M., PELLICER, A., SILVERSTEIN, S., AXEL, R., URLAUB, G and CHASIN, L. (1979) DNA-mediated transfer of the adenine phosphoribosyl transferase locus into mammalian cells. *Proc. Natl. Acad. Sci. USA.*, 76: 1373-1376.

WILKINSON, D., ALTMANN, D.M., IKEDA, H and TROWSDALE, J. (1990) Analysis of HLA-class-II products by DNA-mediated gene transfer. In *Molecular Biology of HLA class-II antigens.*, Chapter 5., Edited by Silver, J, CRC press.

WIMAN, K., LARHAMMAR, D., CLAESON, L., GUSTAFSSON, K., SCHENNING, L., BILL, P., BOHME, J., DENARO, M and DOBBERSTEIN, B (1982) Isolation and identification of a cDNA clone corresponding to an HLA-DR antigen B chain. *Proc. Natl. Acad. Sci. USA.*, 79: 1703-1707.

WINCHESTER, R.J., FU, S.M., WERNET, P., KUNKEL, H.G., DUPONT, B and JERSILD, C. (1975) Recognition by pregnancy serums of non HLA-A alloantigens selectively expressed on B lymphocytes. *J. Immunol.*, 141: 924-929.

WORDSWORTH, B.P., LANCHBURY, L.S.S., SAKKAS, L.I., WELSH, K.I., PANAYI, G.S and BELL, J.I. (1989) HLA-DR subtype frequencies in rheumatoid arthritis indicate that DRB1 is the major susceptibility locus within the HLA class-II region. *Proc. Natl. Acad. Sci. USA.*, 86: 10049-10053.

WRAITH, D.C., McDEVITT, H.O., STEINMAN, L and ACHA-ORBEA, H. (1989) T-cell recognition as the target for immune intervention in autoimmune disease. *Cell.*, 57: 709-715.

YANISCH-PERRON, C., VIEIRA, J and MESSING, J. (1985) Improved M13 phagecloning vectors and host strains: nucleotide sequences of the M13mp18 and pUC19 vectors. *Gene.*, 33: 103-119.

YEH, C.G., HSI, B and FAULK, W.P. (1981) Propidium iodide as a nuclear marker in immunofluorescence. (II) Use with cellular identification and viability studies. *J. Immunol. Meth.*, 43: 269-275.

YOKOYAMA, K., STOCKERT, E., OLD, L.J and NATHENSON, S. (1981) Structural comparisons of T1 antigens derived from normal and leukemia cells of T1+ and T1- strains and relationship to genetically linked H-2 major histocompatibility complex products. *Proc. Natl. Acad. Sci. USA.*, 78: 7078-7084.

ZINKERNAGEL, R.M and DOHERTY, P.C. (1974) Restriction of in vitro T cell mediated cytotoxicity in lymphocytic choriomeningitis within a syngeneic or semiallogeneic system. *Nature.*, 248: 701-702.

ZINKERNAGEL, R.M and DOHERTY, P.C. (1979) MHC-restricted cytotoxic T cells: studies on the biological role of polymorphic major transplantation antigens determining T cell restriction-specificity, function and responsiveness. *Adv in Immunol.*, 27: 51-177.

APPENDIX 1

MOLECULAR BIOLOGICAL BUFFERS, REAGENTS AND FUNDAMENTAL TECHNIQUES

TE buffer:- 10mM Tris.Cl pH 8 and 0.1mM EDTA pH 8

TAE electrophoresis buffer:- Working concentrations

0.04M Tris-Acetate

0.001M EDTA

50xTAE

242g/l Tris

57.1ml glacial acetic acid

100ml 0.5M EDTA pH8

MOPS/EDTA electrophoresis buffer:-10xMOPS/EDTA Buffer

0.2M MOPS (3-(N-morpholino)propanesulphonic acid

Sigma, Cat no M8899)

50mM sodium acetate

10mM EDTA pH 7. Used at 1x concentration.

TBE electrophoresis buffer:-

Working concentration 0.5x 0.045M Tris-Borate

0.001M EDTA

stock 5x 54g Tris

27.5g Boric acid

20ml 0.5M EDTA dissolved in 1 litre

GIT: RNA extraction buffer:-

23.6g of Guanidine isothiocyanate,
 5ml of 250mM sodium citrate pH 7
 2.5ml of 10% (W/V) N-lauroylsarcosine
 0.36 μ l beta mercaptoethanol
 47ml of water

50X Denharts solution 5g ficol (type 400, Pharmacia)

5g of polyvinylpyrrolidone
 5g of bovine serum albumin and
 water to 500ml.

Oligonucleotide labelling buffer (OLB) was made from the following components (Feinberg and Vogelstein 1984)

Solution O: 1.25M Tris-HCL
 0.125M MgCl₂, at pH 8

Solution A: 1ml solution O,
 18 μ l 2-mercaptoethanol
 5 μ l dCTP (0.1mM in TE pH7)
 5 μ l dTTP " " "
 5 μ l dGTP " " "

Solution B: 2M HEPES pH6.6 with 4M NaOH

Solution C: Hexadeoxynucleotides resuspended to an OD₂₆₀ of 90 OD units/ml.

OLB was produced by mixing solutions A:B:C at a ratio of 100:250:150. The OLB stock solution was stored at -20°C .

Ligase buffer:- 200mM Tris/HCl pH 7.6

50mM MgCl

50mM Dithiothreitol (DTT)

500 $\mu\text{g/ml}$ BSA

ATP to a final concentration of 1mM in the final reaction. Added as required.

Dephosphorilation buffer:- 10mM ZnCl_2

10mM MgCl_2

100mM Tris/HCl pH 7

Formamide (Bio Rad analytical grade) was deionised using a mixed bed resin AG-501-X8 (D). The formamide was mixed with the resin for 8 hours, filtered and stored at -20°C .

Acrylamide stock solution. 95g acrylamide (Sigma Chemical Co, Poole, England Cat no A8887), 5g N,N-methylenebisacrylamide made to 250ml with water)

Ethanol precipitation:- DNA can be precipitated from an aqueous solution by the addition of 0.1 volumes of 3M Sodium acetate followed by 2.5 volumes of 100% ethanol (Hayman Ltd, Witham, England) or an equal volume of 4M ammonium acetate and 4 volumes of ethanol. The precipitate was left to form for at least 2 hours at -20°C or 0.5 hour at -70°C . DNA was collected by centrifugation at

15000xg for 5 minutes. The pellet was washed in 70% ethanol to remove any residual salt and dried in a vacuum dessiccator. The pellet was finally resuspended in an appropriate volume of Tris/EDTA (TE), see appendix 1.

Phenol (BDH) was redistilled at 160°C and stored at -20°C. For use the phenol was equilibrated with tris buffer pH8. The phenol was melted at 68°C and Hydroxyquinilone added to 0.1% (W/V). An equal volume of 0.5M Tris.Cl pH8 was added and the solutions mixed thoroughly. The aqueous phase was removed and an equal volume of 0.1M Tris.Cl pH8 was added. Again the solutions were mixed and the aqueous phase removed. The equilibrated phenol was maintained under 0.1 volume of 0.1M Tris pH8. Phenol was principally used in conjunction with chloroform (FSA) and isoamyl alcohol (Sigma no 1-1885) in the ratio 25:24:1.

Phenol extraction:- In order to remove contaminating protein and insoluble material from an aqueous solution of DNA the solution is extracted twice with a mixture of phenol:chloroform:isoamylalcohol (volume ratio 25:24:1). An equal volume of buffered phenol, chloroform (see appendix 1) was added to the DNA solution and mixed well. The upper aqueous phase was recovered by centrifugation and the procedure repeated. The aqueous phase was recovered and washed in chloroform:isoamylalcohol (volume ratio 24:1) to remove any contaminating phenol. The DNA was finally recovered from the aqueous phase by precipitation in ethanol.

Generation of lambda phage standards:- 100µl of Lambda phage DNA (500ng/µl) (Gibco-BRL, Paisley, Scotland, Cat No 520-52505A) was digested with 100 Units of Hind-III plus 40µl of REact-2 buffer and

250 μ l of water. The reaction was carried out at 37 $^{\circ}$ C for 2 hours and a sample analysed to ensure complete digestion. 200 μ l of electrophoresis sample buffer and 400 μ l of TE (See appendix 1) was then added. The stock was maintained at -20 $^{\circ}$ C and 5 μ l samples applied to the gels as standards. The standards include fragments at 23.1 , 9.5, 6.7, 4.4, 2.3, 2, and 0.6 kb.

APPENDIX 2

BACTERIA, BACTERIAL GROWTH MEDIA AND ANTIBIOTICS

LB		TB	
Bacto-tryptone	10g/l	Bacto-tryptone	12g/l
Bacto-yeast extract	5g/l	Bacto-yeast extract	24g/l
NaCl	10g/l pH 7.5	Glycerol	4ml
		100ml of KH_2PO_4	0.17M
		K_2HPO_4	0.72M

Minimal Medium		5x M9 salts	
Distilled water	750ml	$\text{Na}_2\text{HPO}_4 \cdot 7\text{H}_2\text{O}$	64g/l
5x M9 salts	200ml	KH_2PO_4	15g/l
Glucose 20%	20ml	NaCl	2.5g/l
		NH_4Cl	5g/l

AGAR PLATES:- L-agar plates were prepared by adding 15g/l of bacto-agar to LB. The agar was dissolved by heating to boiling point. Once cooled to 45°C appropriate antibiotics were added and 25 ml poured into plastic petri-dishes to set.

Minimal agar plates were prepared by the addition of 15g/l of bacto-agar to minimal medium.

ANTIBIOTICS:- Ampicillin stock (50mg/ml, Sigma Cat no A9393) in water. Working concentration of 50µg/ml

Tetracyclin stock (5mg/ml, Sigma, Cat no T3258)
in 50% ethanol Working concentration of (50µg/ml)

BACTERIAL CELLS:- Cosmids were maintained in the *E.coli* strain DH1. The preferred host strain for pBS vectors were the recA+ JM101 and the recA- JM109 (Yanisch-Perron, 1985)

PREPARATION OF FROZEN STOCKS OF E.coli:- To 0.85ml of a bacterial culture was added 0.15ml of sterile glycerol. To ensure complete mixing the cells were vortexed for 10 seconds, transferred to sterile eppendorf tubes and frozen at -70°C. Bacterial cells were revived by scraping the surface of the frozen stock with a sterile pipette tip and transferring a small sample to a 10ml bottle containing L-broth.

APPENDIX 3

TISSUE CULTURE AND TRANSFECTION REAGENTS

L-cell growth medium:- Dalbecco's modified Eagles medium (DMEM Gibco-BRL cat no 04101965) supplemented with 10% foetal bovine serum, Glutamine (2mM final concentration), penicillin (100 IU/ml) and streptomycin (100µg/ml). HAT selection medium was as above but also contained hypoxanthine (1.36g/l), aminopterin (0.176g/l) and thymidine (0.388g/l).

Phosphate buffered saline PBS:-

NaCl	60g/l
KCl	4g/l
Na ₂ HPO ₄	1.48g/l
KH ₂ PO ₄	4g/l

made up in sterile water, autoclaved and tissue culture tested before use.

Hank's balanced salt solution:- Powdered stock obtained from Gibco, Cat no 076-1200. The solution was sterilised by 0.2µm membrane filtration.

Earle's balanced salt solution:- 10xEarles

Solution A 2.6g of CaCl₂ in 200ml

Solution B 2g of MgSO₄ in 200ml

Solution C 68g of NaCl, 4g of KCl, 1.4g of Na₂HPO₄ in 600ml

The solutions are mixed together and filter sterilised through a 0.2µm filter.

Working EBS 1xEBS supplemented with

5ml 1M HEPES buffer pH 7.2-7.4

0.1% (W/V) sodium azide

3% serum

to 500ml with sterile distilled water.

CALCIUM PHOSPHATE TRANSFECTION REAGENTS

Calcium chloride (CaCl₂): 2M stock solution (Sigma tissue culture tested). The stock was filter sterilised and stored at -20°C.

Di-sodium phosphate (Na₂HPO₄): 0.2M stock (sigma anhydrous tissue culture tested). Filter sterilised and stored -20°C.

Sodium chloride (NaCl): 1M stock solution (sigma tissue culture tested) Filter sterilised and stored at -20°C.

HEPES: 1M (Northumbria biologicals Ltd).

2x HEPES buffered saline (2xHBS): To 5ml of 1M HEPES was added 0.75ml Na₂HPO₄ and 28.8ml of 1M NaCl. This was made up to 100ml with distilled water and the pH adjusted to approximately 6.95 with HCl.

The pH of the 2xHBS solution was critical to the formation of the calcium phosphate precipitate. Too high a pH resulted in a precipitate that was too particulate and too low a pH prevented the

formation of the precipitate at all. A test precipitate was formed before each transfection to test its consistency. 1M HCl was added dropwise until the precipitate reached the correct consistency.

APPENDIX 4

COMPANY	ADDRESS
Beckman Instruments Ltd,	Progress road, Sands Industrial Estate, High Wicombe, Buckinghamshire, HP12 4JL.
Hayman Ltd,	70 Eastways Industrial Park, Witham, Essex, CM8 3YE.
Sigma Chemical Co Ltd,	Fancy Rd, Poole, Dorset, BH17 7TG.
BDH Ltd,	Broom Rd, Poole, BH124NH.
FSA laboratory suppliers,	Bishop Meadows Rd, Loughborough.
Aldrich Chemical Co Ltd,	The old brick yard, New Rd, Gillingham, Dorset, SP8 4JL.
Gibco-BRL,	PO Box 35, Trident house, Paisley, PA3 4EF.
Ammersham International PLC,	Lincoln Place, Green End, Aylesbury, HP20 2TP.
Dakopatts,	PO Box 1359, DK-2600, Glostrup, Denmark.
Pharmacia LKB Biotechnology,	Pharmacia house, Midsummer boulevard, GB-central, Milton Keynes, MK9 3HP.
Boehringer Mannheim UK Ltd,	Bell lane, Lewes, East Sussex BN7 1LG.
Flow Laboratories,	Woodcock hill, Marefield road, Rickmansworth WD3 1PQ.
Northumbria Biologicals,	South Nelson Ind Est, Cramlington, Northumberland, NE23 9HL.
British Oxygen Company,	150 Polmadie Rd, Glasgow G5 0HN.
Becton Dickinson UK Ltd,	Between towns Rd, Cowley, Oxford, OX4 3LY.
Nycomed UK Ltd,	Nycomed house, 2111 Coventry Rd, Sheldon, Birmingham, B26 3AE.
Serotec,	22 Bankside station approach, Kidlington, Oxford, OX5 1JE.
Poloroid UK Ltd,	Saint Albans, Hertfordshire.
Bio Rad laboratories Ltd,	Caxton Way, Watford Business Park, Watford, Hertfordshire WD1 8RP.
Gallencamp,	Belton Road West, Loughborough, Leicestershire, LE11 0TR.
Genetic Research Instrumentation,	Gene house, Dunmow Rd, Felsted, Dunmow, Essex, CM6 3HD.
Stratech Scientific Ltd,	61-63 Dudley St, Luton, Bedfordshire, LU20
Cecil Instruments Ltd,	Milton Industrial Estate, Milton, Cambridge, CB4 4AZ.
Harlec Olan Ltd,	Oxford, England.

APPENDIX 5

PUBLICATIONS RESULTING FROM THIS THESIS

1) EXPRESSION OF OVINE MHC CLASS-II GENES:- CHARACTERISATION OF OLA-DR-SPECIFIC MONOCLONAL ANTIBODIES., BALLINGALL, K.T., WRIGHT, H., DUTIA, B. M., LANG, J., DEVERSON, E.V., HOWARD, J.C., PURI, N AND HAIG, D. ANIMAL GENETICS IN PRESS.

2) THE USE OF FLOW CYTOMETRY TO DETECT TRANSFECTED GENE PRODUCTS. BUJDOSO, R., SARGAN, D., BALLINGALL, K.T., AND SANDERSON, A. GENE TRANSFER AND EXPRESSION TECHNIQUES, EDITED BY MORRAY, E.J AND WALKER, J.M. 1990

3) EXPRESSION OF MAJOR HISTOCOMPATIBILITY CLASS-II MOLECULES IN THE SHEEP. DUTIA, B., HOPKINS, J., BALLINGALL, K.T., BRANDON , M.R AND McCONNELL, I. PROCEEDINGS OF THE THIRD WORLD CONGRESS ON GENETICS APPLIED TO LIVESTOCK PRODUCTION 1990

4) CLASS-II MHC GENES OF THE SHEEP. DEVERSON, E.V., HUSKISSON, N., DIAMOND, A.G., HOWARD, J.C., WRIGHT, H., WATSON, S AND BALLINGALL, K.T. ANIMAL GENETICS IN PRESS.

EXPRESSION AND CHARACTERISATION OF OVINE MHC-CLASS-II (OLA-DR)
GENES

Short title: Characterisation of ovine MHC class-II genes.

Keywords: Ovine, MHC class-II, genes, monoclonal antibodies,
DNA-mediated gene transfer, expression.

K. T. BALLINGALL, H. WRIGHT, B. M. DUTIA¹, J. HOPKINS¹
J. LANG², E. V. DEVERSON³, J. C. HOWARD³, N. PURI⁴ & D. HAIG.

Moredun Research Institute, 408 Gilmerton Rd, Edinburgh,
Scotland, EH17 7JH.

1 Department of Veterinary Pathology, University of Edinburgh,
Summerhall, Edinburgh, Scotland, EH9 1QH.

2 Beatson Institute for Cancer Research, Gartscube Estate,
Switchback Road, Bearsden, Glasgow, Scotland, G61 1BD.

3 Department of Immunology, AFRC Institute of Animal Physiology
and Genetics Research, Cambridge Research station, Babraham,
Cambridge, England, CB2 4AT.

4 Department of Veterinary Preclinical Sciences, University of
Melbourne, Parkville, 3052, Victoria, Australia.

Address correspondence to K.T Ballingall.

Summary

Previous work made use of nucleic acid probes corresponding to different subtypes of the class-II regions of the human and murine major histocompatibility complex (MHC) to isolate 7 different alpha and 24 different beta genes of the ovine MHC from two cosmid libraries (Deverson *et al* 1991). In an attempt to identify pairs of alpha and beta genes capable of cell surface expression, all permutations of alpha and beta genes were in turn transfected into mouse L-cells. Two pairs of alpha and beta genes co-expressed and stable ovine MHC class-II L-cell lines were developed. The expressed alpha genes had previously been defined as DR-alpha homologues (DRA) by differential southern hybridisation to human subtype specific class-II probes. The expressed ovine beta genes were also assigned as ovine DR-beta homologues (DRB) on the basis of their sequence having a higher degree of similarity with human DRB than any other subtype. A total of 8 out of 23 anti-sheep class-II specific monoclonal antibodies were typed OLA-DR specific by FACScan analysis using the L-cell lines.

Introduction

The major histocompatibility complex (MHC) is a multi-gene complex that codes for highly polymorphic, membrane-associated glycoproteins involved in the initiation, regulation and quality of specific immune responses. MHC class-II molecules are heterodimers requiring the products of both alpha and beta genes for cell-surface expression. The human class-II region (HLA-D region) contains a number of expressed alpha and beta gene pairs (DP, DQ and DR) as well as an approximately equal number of pseudogenes and genes of undefined status (Trowsdale 1988).

We have previously described the identification and characterisation of 7 alpha and 24 beta genes present in clones isolated from two cosmid libraries prepared from the genomic DNA of two unrelated sheep (Deverson *et al.* 1991). Identification of the genes was achieved by screening the libraries with alpha and beta gene probes of human and murine origin. While the alpha genes could be identified as being DR-like, DQ-like and DN-like on the basis of specific hybridisation to the relevant human probes, the subtype-specificity of the beta genes could not be determined in this way because of extensive cross-hybridisation.

In this study we have used DNA-mediated gene transfection into mouse L-cells to determine which of the available ovine MHC class-II alpha and beta genomic DNA clones co-express and which of a panel of ovine MHC class-II specific monoclonal antibodies recognise the defined gene products expressed at the murine L-cell

surface. We also present the nucleotide sequence of the expressed ovine beta gene, which confirms the gene subtype as OLA-DR and therefore also confirms OLA-DR specificity to the panel of sheep MHC class-II specific monoclonal antibodies.

Materials and methods

Animals and source of DNA. The construction and screening of cosmid libraries for ovine MHC class-II genes has been described (Deverson *et al.* 1991). Briefly, two genomic libraries were prepared in the cosmid vectors pTL5 and pTL6 (Lund *et al.* 1982) using high molecular weight DNA prepared from sperm and testis, respectively, from two unrelated Suffolk sheep. Analysis by restriction mapping and Southern hybridisation to subtype specific probes resulted in the identification of 7 distinct alpha genes and 24 beta genes or gene fragments contained within 31 cosmid clones.

Cosmid DNA between 35-50kb was prepared by standard techniques (Sambrook *et al.* 1989). All DNA was prepared for transfection by ethanol precipitation under sterile conditions and resuspension to $1\mu\text{g}/\mu\text{l}$ in sterile TE buffer (10mM Tris, 1mM EDTA pH 7.9. The plasmid PTK1 containing the herpes simplex virus thymidine kinase gene (HSV-tk gene, Lang *et al.* 1983) was used as a selective marker.

Cells and media. The murine fibroblast line Ltk- (Spandidos and Wilkie, 1983) was cultured in 25cm^2 tissue culture flasks (Nunc, Gibco-BRL, Paisley, Scotland) containing 8ml Dulbecco's modified Eagles medium (DMEM, Gibco-BRL, Cat no 04101965) supplemented with 10% (V/V) heat-inactivated fetal bovine serum (FBS: Northumberland Biologicals, Cramlington, Northumberland, England), glutamine (2mM final concentration), penicillin (100IU/ml) and streptomycin

(100 μ g/ml). Cells were maintained in this medium and split 1:20 twice weekly. Selection medium was as above but also contained HAT ie hypoxanthine (1.36g/l), aminopterin (0.176g/l) and thymidine (0.388g/l).

Monoclonal antibodies. Monoclonal antibodies (mAbs) that recognise monomorphic determinants of ovine class-II glycoproteins are listed in Table 1 and have been described previously (Puri *et al.* 1985; Puri *et al.* 1987a; Puri *et al.* 1987b; Hopkins *et al.* 1986; Dutia *et al.* 1990).

DNA-mediated gene-transfer and selection of transfected cells. Transfections were carried out using the calcium phosphate co-precipitation method (Graham and Van der Eb, 1973, as modified by Wigler, 1979). In each instance, 3 μ g each of two cosmid clones respectively containing alpha and beta genes, were added to 100ng of PTK1 plasmid DNA and 10 μ g of high molecular weight mouse embryo carrier DNA. A calcium phosphate microprecipitate was formed to which the DNA was adsorbed. This microprecipitate was then mixed with 5×10^5 exponentially growing L-cells. After an incubation period of approximately 15 hours at 37 $^{\circ}$ C the cells were washed in warm phosphate-buffered saline. They were then left to recover in fresh medium at 37 $^{\circ}$ C for 24 hours before HAT selection. Selection medium was changed every 3 days and surviving colonies allowed to develop for 2-3 weeks. Cells transfected with PTK1 alone were used as negative controls for antibody assays.

Assay for MHC class-II expression. An indirect fluorescent antibody (IFA) technique was used to detect ovine MHC class-II glycoproteins expressed at the mouse L-cell surface. 5×10^5 L-cells were incubated in a cocktail of mouse anti-sheep MHC class-II monoclonal antibodies (SBU 28.1, 37.68, 38.27, 42.20 and 49.1) using saturating amounts ($50 \mu\text{l}$ tissue culture supernatant) for 40 minutes at 4°C . After three washes in cold Earle's balanced salt solution containing 3% fetal bovine serum (FBS) and 0.1% (W/V) sodium azide, the cells were incubated in $50 \mu\text{l}$ of the second-stage reagent (1:50 dilution of fluorescein isothiocyanate, (FITC), conjugated rabbit anti-mouse IgG, Dakopatts, Cat no F261, Glostrup, Denmark). After a further three washes, the cells were analysed by FACScan (Becton Dickinson, Sunnyvale, CA, USA) and positive class-II-expressing cells selected by a FACS IV cell sorter (Becton Dickinson). FACS-selected cells were expanded in culture and sorted a further three times until more than 98% of the cells were expressing MHC class-II glycoproteins.

Screening of monoclonal antibodies against transfected L-cells.

The IFA technique and FACS analysis were used as described above to determine the ability of the mAbs listed in Table 1 to react with transfectants expressing ovine MHC class-II antigens at the cell surface. Positive antibodies were identified as those that resulted in an increase in the fluorescence of the main body of the class-II transfected L-cell line relative to the Ltk+ control (see Fig 4).

The VPM series of antibodies were also screened against transfected class-II expressing cells using one and two-dimensional SDS-PAGE followed by blotting onto nitrocellulose as follows:- 1×10^8 transfected and untransfected cells were harvested by treatment with versene and washed twice in Hanks balanced salt solution (HBSS). For one-dimensional analysis the cells were lysed in 1ml 2% (w/v) NP40 (Sigma Chemical Company, Poole, Dorset) in phosphate buffered saline (PBS) for 30 minutes on ice. Insoluble material was removed by centrifugation at 13000xg for 10 minutes. The lysates were then diluted 1:1 with SDS PAGE sample buffer (2% (w/v) sodium dodecyl sulphate (SDS), 20% glycerol, 0.125M Tris-HCl, pH6.8) and analysed by immunoblotting as previously described (Dutia *et al.* 1990). For 2-dimensional analysis of beta chains, 8×10^7 cells were lysed in 1ml of 2% (w/v) NP40, 2% (v/v) 2D Pharmalyte (Sigma, Poole, Dorset, England) and 8.5M urea. Insoluble material was pelleted by centrifugation at 13000xg for 30 minutes. For 2D analysis of alpha chains, 2D pharmalyte in the lysis buffer was replaced with 2% (V/V) pH 2.5-5 pharmalyte (Sigma). For analysis of beta chains $5 \mu\text{l}$ aliquots were fractionated by 2D non-equilibrium pH gradient electrophoresis/SDS PAGE (O'Farrell *et al.* 1977) and analysed by immunoblotting as described above. $5 \mu\text{l}$ aliquotes of alpha chains were fractionated by 2D-Isoelectric focusing/SDS PAGE (O'Farrell, 1975) and similarly analysed.

Nucleotide sequencing. The second exons (encoding the beta-1 domains) of expressible beta genes were identified by southern hybridisation and subcloned into the plasmid vector Bluescribe+ (Vector cloning systems, San Diego, CA, USA). Sequencing was carried out by the dideoxy chain termination method (Sanger *et al.* 1977) using T7 DNA polymerase (Pharmacia, Uppsala, Sweden). Comparative computer analysis of the nucleotide sequence, determination of exon boundaries and conversion to amino acid sequence was performed using the University of Wisconsin Genetics Computer Group (UWGCG) package (Devereux *et al.* 1984) on the SEQNET molecular biology computer facility of the Science and Education Research Council, Daresbury, laboratory (Warrington, England).

RESULTS

Generation of transfected L-cell lines expressing ovine MHC class-II glycoproteins:- Following transfection into mouse L-cells of all permutations of the alpha and beta cosmids described by Deverson *et al.*(1991) four combinations of alpha and beta genes were identified that gave rise to expression of ovine MHC class-II antigens at the L-cell surface. These were combinations of either of two alpha genes (DRA-like cosmids 46 and 61) and either of two beta genes (cosmids 9.5 and 22). L-cell lines expressing high levels of the ovine MHC class-II were generated by three cycles of FACS selection using a cocktail of ovine MHC class-II specific mAbs and expansion in culture (Fig 1).

All transfectants that were initially class-II negative by FACScan analysis were nevertheless sorted by FACS in case a very small population of class-II expressing cells could be isolated. Any surviving cells were expanded in culture and reanalysed by FACScan. This invariably confirmed the initial negative results and failed to identify any further expressible genes.

Nucleotide sequence analysis. The nucleotide sequences of exons 2, 3, 4, 5 and 6 of the expressible beta gene 22 (Deverson *et al.* 1991) were determined. The cloning and sequencing strategies are shown in Figure 2. The nucleotide sequences of all exons except the 5-prime untranslated region are shown in Figure 3. The 5-prime untranslated region was not located. The second exon of beta gene 9.5, corresponding to the beta-1 domain, was also sequenced. This

was found to be identical to the beta-1 domain in cosmid 22, even though these genes were isolated from unrelated sheep. The remainder of the region containing the class-II gene in cosmid 9.5 showed an identical restriction map to the gene in cosmid 22 (Fig 2). The nucleotide and predicted amino-acid sequences of the beta gene in cosmid 22 were compared to human (Kelly *et al.* 1985; Anderson *et al.* 1987; Larhammer *et al.* 1983) and bovine beta sequences (Groenen *et al.* 1990). This comparison led to the conclusion that the ovine gene was DR-like (Table 2).

Screening of monoclonal antibodies. Each transfected L-cell line was used to screen the two panels of monoclonal antibodies for cell-surface ovine DR-like specificity (Fig 4) with identical results being obtained for all four lines. SBU antibodies 37.68, 42.20 and 49.1, VPM antibodies 15, 38, 46 and 47 and rat antibody SW73.2 all recognised the class-II expressing cells. On the other hand the transfected cells were not recognised by SBU 38.27, (Fig 4) VPM 36 or VPM 41 (data not shown), all three of which on the basis of N-terminal sequence analysis would be expected to recognise DQ-like molecules (Puri *et al.* 1987c; Dutia *et al.* 1990). The other two putative DR-specific monoclonal antibodies, SBU 28.1 (Puri *et al.* 1987c) and VPM 37 (Dutia and Hopkins, in preparation) also failed to recognise the transfected gene products (Fig 4).

Immunoblotting analysis of transfected L-cell class-II glycoproteins. The VPM antibodies with known alpha and beta chain specificities (Dutia *et al.* 1990) were used to determine the

molecular weights of the alpha and beta chains expressed in transfected cells and separated by one dimensional polyacrylamide gel electrophoresis. Immunoblots against transfected and untransfected cells are shown in Fig 5. Molecular weights of blotted alpha and beta chains were 32-34KDa and 26-28KDa respectively. The anti-human class-II-alpha monoclonal antibody 1D12 which does not react with human or ovine cell surface class-II molecules (Cohen *et al.* 1987, Dutia *et al.* 1990) failed to detect ovine class-II antigen when expressed on the transfected L-cells but reacted with the blotted antigen (Fig 5a). Two-dimensional immunoblot analysis of transfected cells showed a complex pattern (Fig 5b) of alpha and beta chains which may represent the numerous protein-processing stages of the class-II alpha and beta chains.

DISCUSSION.

The isolation and partial characterisation of 7 alpha and 24 beta gene or gene fragments from two ovine genomic DNA libraries has recently been described. The alpha genes could be differentiated from one another by hybridisation to human subtype specific class-II probes whereas the beta genes showed extensive cross hybridisation (Deverson *et al.* 1991). In the present study four ovine MHC class-II-expressing L-cell lines were generated by the transfection of all combinations of alpha and beta genes. The two expressed alpha genes in cosmids 46 and 61 were derived from the same library and were found to have identical restriction maps for the region containing the alpha gene. These genes had previously been designated as DR-equivalent by hybridisation (Deverson *et al.* 1991) and limited sequencing (unpublished observation). Of all the beta genes only those in cosmids 9.5 and 22 co-expressed with the two alpha genes. As the products of these two beta genes showed a functional association with those of the two alpha genes, they were thought likely to be DR-equivalent. The sequence analysis of the beta genes clearly showed that they were DR-like. Interestingly, the normally highly polymorphic second exon was found to be identical in these two genes, a finding which confirmed previous restriction mapping results that had identified similarities between the cosmids. This was in spite of the fact that these beta genes were isolated from unrelated sheep.

Despite extensive effort, it was not found possible to express any of the isolated DQ or DN-like genes in the mouse L-cells. This lack of success is more likely to be due to the integrity of the cosmid cloned genes than a failure of the monoclonal antibodies to detect further transfected gene products as pan-specific and DQ specific (as determined by biochemical methods) monoclonal antibodies were used in the screening panel. The complete nucleotide sequencing of all alpha and beta genes is at present under way and will determine whether a gene is a pseudogene, the nature of its subtype and whether the appropriate transcription promoters and enhancer sequences exist.

The nucleotide sequences of exons 2, 3 and 4 of the beta gene in cosmid 22 were compared with those of the equivalent exons in bovine and human beta genes. This comparison showed that the ovine, bovine and human DRB genes shared extensive sequence similarity and the encoded proteins are therefore likely to be structurally very similar. The amino acid sequence predicted from the ovine nucleotide sequence indicated that, as in cattle and man, there is a conserved cysteine residue at position 15 in the sheep beta-1 domain that is implicated in disulphide bridge formation to the cysteine at position 79 (see Fig 3). Cysteines are also conserved within the beta-2 domain, forming a disulphide bridge between positions 118 and 174. The asparagine at position 19 of the beta-1 domain, which is the site of N-linked glycosylation within human and murine class-II molecules is also conserved. The predicted N-terminal amino acid sequence of this beta protein

differs from that of the class-II molecules immunoprecipitated by SBU 37.68. These latter molecules possessed between 1 and 3 cysteine residues between positions 13-15 and did not have an asparagine at position 19 (Puri *et al.* 1987c).

Using the transfected L-cell lines, ovine DR-like specificity was assigned to two panels of monoclonal antibodies known to recognise monomorphic determinants of ovine MHC class-II glycoproteins (Fig 4). Monoclonal antibodies which reacted with the alpha chain of the transfected class-II molecules included SBU 42.20, VPM 38, VPM 47 and 1D12 (by immunoblot only). Monoclonal antibodies which reacted with the ovine DRB included VPM 46 and, as expected, the two previously characterised pan-beta-specific antibodies SBU 49.1 and SW 73.2. VPM 15, which also detected the transfected cells, cannot be analysed for chain specificity as it does not react with blotted class-II molecules. Of particular interest were the reactivities of SBU 37.68 and 42.20 which, by previous analysis, had been designated to react with two non-overlapping subsets of sheep DR-like molecules (Puri *et al.* 1987c). Here we demonstrated that both SBU 37.68 and 42.20 recognised determinants on a single DR-like class-II molecule. The transfection technique described here simplifies the analysis of MHC antibody specificity, as only a single defined subtype of ovine MHC class-II is expressed at the cell surface.

N-terminal sequence analysis had previously indicated that SBU 28.1 and VPM 37 were specific for monomorphic determinants of ovine DR-like class-II molecules (Puri *et al.* 1987c, Dutia *et al.* 1990)

but ELISA data have shown that these antibodies are not identical (B Dutia unpublished observation). Both these antibodies failed to detect the transfectant ovine DR-like molecules in the present study and the most likely explanation is that they recognise another DR-like molecule expressed in the sheep. Immunochemical (Puri *et al.* 1987b) and molecular biological (Chardon *et al.* 1985, Scott *et al.* 1987) evidence indicates that there are at least three DRB-like genes and gene products are expressed in the sheep. These are thought to associate with a single DRA-like gene product. VPM 37 is beta chain specific and must therefore recognise the product of a different beta gene from that expressed here. SBU 28.1 does not react with isolated alpha and beta chains and may therefore recognise a conformational determinant formed between the alpha chain and an as yet unidentified DR-beta chain. Only a single expressing DRB-like gene has been identified in the course of this work (present in cosmids 22 and 9.5), but the rescreening of both libraries with homologous probes prepared from sheep DNA, together with the production of a new library from an unrelated sheep, should reveal other DRB-like genes capable of expressing with the DRA-like gene found in cosmids 46 and 61.

There is some evidence from hybridisation of alpha and beta probes to cosmids and from restriction mapping and genomic southern blotting (Deverson *et al.* 1991) to suggest that the alpha genes 46 and 61 may represent a duplication of the DR alpha genes in sheep. If this is proved to be correct then two functional DRA-like genes may exist in sheep.

In conclusion, we have been successful in transfecting ovine MHC class-II genes into L-cells. The beta gene nucleotide sequence together with the alpha gene southern hybridisation data of Deverson *et al.* (1991) identifies the gene pair as DR-like. The transfection technique is therefore useful in identifying expressible genes, and has enabled DR-like specificity to be assigned to several monoclonal antibodies. The generation of a larger panel of transfected lines covering all sheep class-II subtypes is presently being attempted. This will give a more complete picture of the specificity of available anti-class-II monoclonal antibodies and increase the understanding of the functional gene organisation within the ovine MHC.

ACKNOWLEDGEMENTS. The authors would like to thank John Ansell and Andrew Sanderson for their help and advice with flow cytometry, and Kay Bird for her assistance with immunoblots.

ABBREVIATIONS.

BOLA, Bovine leucocyte antigen. ELISA, Enzyme linked immunosorbant assay. FACS, Fluorescent activated cell sorter. FITC, Fluorescein isothiocyanate. HAT, hypoxanthine, aminopterin and thymidine. HBSS, Hank's balanced saline. HLA, Human leucocyte antigen. HSV, Herpes simplex virus. IEF, Isoelectric focusing. mAb, Monoclonal antibody. OLA, Ovine leucocyte antigen. PAGE, polyacrylamide gel electrophoresis. PBS, Phosphate buffered saline. SDS, sodium dodecyl sulphate. SSC, saline, sodium citrate. TE, Tris/EDTA. Tk, Thymidine kinase.

TABLE 1

OVINE MHC CLASS-II SPECIFIC MONOCLONAL ANTIBODIES USED IN THIS STUDY

MONOCLONAL ANTIBODY	ISOTYPE	CHAIN SPECIFICITY	PROPOSED SUBTYPE SPECIFICITY *
¹ SBU II 28.1, 37.68	IgG1	conformational	DR-like
SBU II 38.27	IgG1	conformational	DQ-like
SBU II 42.20	IgG1	alpha	DR-like
SBU II 49.1	IgG2a	beta	Pan-specific
SW73.2 (Rat)	IgG2a	beta	Pan-specific
⁺ VPM 1, 3	IgM	ND	
VPM 4, 45, 46	IgG2a	beta	
VPM 15	IgG2a	ND	
VPM 36, 38, 47	IgG1	alpha	
VPM 16, 37, 40,	IgG1,	beta	
VPM 41, 43, 44	IgG1	beta	
VPM 48	IgG2a	alpha	
ID12	IgG1	alpha	

*Based on N-Terminal sequence analysis (Puri *et al.* 1987c).

¹ The SBU monoclonal antibodies have been described previously (Puri *et al.* 1985; Puri *et al.* 1987a; Puri *et al.* 1987b).

⁺VPM monoclonal antibodies (Hopkins *et al.* 1986; Dutia *et al.* 1990). ND, Not determined.

TABLE 2

SIMILARITY BETWEEN HLA-D BETA, BOLA-D BETA AND THE EXPRESSED OVINE BETA GENE FROM COSMID 22.

	OLA EXON 2(B1)	OLA EXON 3(B2)	OLA EXON 4(TM)	REFERENCE
	NA (AA)+	NA (AA)+	NA (AA)+	
HLA DR	81 (73)	90 (85)	86 (89)	(Andersson <i>et al.</i> 1987)
HLA DQ	71 (62)	74 (70)	77 (75)	(Larhammar <i>et al.</i> 1983)
HLA DP	67 (58)	75 (68)	72 (50)	(Kelly <i>et al.</i> 1985)
BOLA DR	86 (70)	97 (95)	91 (100)	(Groenen <i>et al.</i> 1990)
BOLA DQ	75 (58)	72 (66)	74 (75)	(Groenen <i>et al.</i> 1990)

Legend ⁺ NA= nucleic acid % similitaty; AA- amino acid % similarity The BOLA DR gene used in this comparison is A1, and the BOLA DQ is W1 (Groenen *et al.*1990). Abbreviations: B1, Beta-1 domain., B2, Beta-2 domain., TM, Transmembrane domain

FIG 1 Legend: FACS selection for class-II expressing cells:, (i) L-cells transfected with Tk only (LTk+) and labelled with a cocktail of SBU monoclonal antibodies (SBU 28.1, 37.68, 38.27, 42.20 and 49.1) followed by FITC-IgG anti-mouse Ig as the second stage reagent.

(ii) L-cells transfected with sheep DRA-like cosmid 46 and DRB-like cosmid 22 (T8.1) and labelled as before. The population of highly fluorescent cells (approximately 2%, 2000 cells) was selected and expanded.

(iii) First FACS sort. The population of positive fluorescent cells was 25%. The brightest 5% of these cells were selected and expanded.

(iv) L-cell line (T8.1) after the third FACS sort. The population consisted of >98% cells expressing sheep MHC class-II glycoproteins.

FIG 2. The cloning and sequencing strategy for cosmids 22 and 9.5. The dark boxes represent the exons that have been sequenced and the arrows the extent and direction of sequencing. B1 = Beta-1 domain, B2 = Beta-2 domain, TM = transmembrane, IC =

intra-cytoplasmic domain and 3' UT = three-prime untranslated domain. The restriction sites are indicated by vertical lines. Restriction enzymes include P (PstI), S (SmaI), Sa (SacI), H (Hind III), Sc (Sca), B (Bam HI), Bg (Bgl II), E (EcoRI).

FIG 3 The nucleotide sequence of the beta gene exons in cosmid 22. The boundaries between exons are underlined. The proposed amino acid sequence is displayed beneath the nucleotide sequence using the three letter code.

FIG 4 legend: Fluorescent histograms of the line T8.1 (see Fig 1) labelled with individual monoclonal antibodies. The controls include cocktails of the SBU and VPM panels of anti-sheep MHC class-II monoclonal antibodies reacted with the mock transfected line Ltk+, and the rat anti-mouse class-I antibody R1.21-2, (Koch *et al.* 1982) against T8.1. The broken line indicates the boundary between negative controls and positive fluorescence for antibodies that recognise the class-II molecules. Other negative antibodies not shown include VPM 1, 2, 3, 4, 16, 17, 36, 43, 44, 45, 48 and ID12.

FIG 5a legend: 1-D immunoblot of lysates prepared from T8.1 and the untransfected line TK- showing reactivity with (i) anti-alpha and (ii) anti-beta chain monoclonal antibodies from the VPM series, SW73.2 and ID12 (see table 1). In addition VPM 42 (an anti-sheep

immunoglobulin antibody) and SO 16.4 (an anti-sheep erythrocyte antibody) were used for negative antibody controls. Monoclonal antibody 1D12 recognises additional bands the identity of which are not clear.

FIG 5b legend: 2-D immunoblot of lysates prepared from T8.1 showing alpha and beta signals identified with anti alpha mAb VPM38 and anti beta mAb SW73.2.

REFERENCES

Andersson G., Larhammar D., Widmark E., Servenius B., Peterson P.A. & Rask L. (1987) The class-II genes of the human major histocompatibility complex: Organisation and evolutionary relationship of the DR-beta genes. *Journal of biological chemistry* 262, 8748-8758.

Chardon P., Kirszenbaum M., Cullen P.R., Geffrotin C., Auffray C., Strominger J.L., Cohen D. & Vaiman M. (1985) Analysis of sheep MHC using HLA class-I, II and C4 cDNA probes. *Immunogenetics* 22, 349-35.

Cohen B.B., Chrichton D.N. & Steel C.M. (1987) A new set of monoclonal antibodies to human MHC class-II alpha chains demonstrates that most alpha epitopes are inaccessible on the living cell. *Immunology* 61 225-229.

Devereux J., Haeberli P. & Smithies O. (1984) A comprehensive set of sequence analysis programs for the VAX. *Nucleic acid research* 12 387-395.

Deverson E.V., Huskisson N., Diamond A.G., Howard J.C., Wright H., Watson S. & Ballingall K.T. (1991) Class-II MHC genes of the sheep. *Animal Genetics* (in press).

Dutia B.M., Hopkins, J., Ballingall, K.T., Bird, K., Brandon, M.R. & McConnell, I. (1990) Expression of major histocompatibility class-II molecules in the sheep. *Proceedings of the 4th world congress on genetics applies to livestock production*. XVI 400-403.

Dutia B.M., Hopkins J., Allington M.P., Bujdoso R. & I McConnell. (1990) Characterisation of monoclonal antibodies specific for alpha and beta chains of sheep MHC class-II. *Immunology* 70 27-32.

Feinberg A.P. & Vogelstein B. (1984) A technique for radiolabeling DNA restriction endonuclease fragments to high specific activity. *ADDENDUM. Analytical Biochemistry* 137 266-267.

Graham F.L. & Van Der Eb A.J. (1973) A new technique for the assay of infectivity of human adenovirus 5- NA. *Virology* 52 456-467.

Groenen M.A.M., Van Der Poel J.J., Dijkhof R.J.M. & Giphart M.J. (1990) The nucleotide sequence of bovine MHC class-II DQB and DRB genes. *Immunogenetics* 31 37-44.

Hopkins J., Dutia B.M. & McConnell I. (1986) Monoclonal antibodies to sheep lymphocytes. Identification of MHC Class-II molecules on lymphoid tissue and changes in the level of Class-II expression on lymph-borne cells following antigen stimulation *in vivo*. *Immunology* 59 433-438.

- Kelly A. & Trowsdale J. (1985) Complete nucleotide sequence of a functional HLA-DP beta gene and the region between the DP beta-1 and DP alpha-1 genes: comparison of the 5' ends of HLA class-II genes. *Nucleic Acid Research* 3 1607-1621.
- Lang J.C., Wilkie N.M. & Spandidos, D.A. (1983) Characterization of eucaryotic transcriptional control signals by assay of Herpes Simplex Virus type-1 thymidine kinase. *Journal of General Virology* 64 2679-2696.
- Larhammar D., Hammerling U., Rask L. & Peterson P.A. Sequence of gene and cDNA encoding murine major histocompatibility complex Class-II gene AB2, *Journal of Biological Chemistry* 260 14111-14119.
- Larhammar D., Hyldig-Neilson J.J., Serenius B., Andersson G., Rask L. & Peterson P.A. (1983) Exon-intron organisation and complete nucleotide sequence of a human major histocompatibility antigen DC-beta gene. *Proceedings of the National Academy of Science USA* 80 7313-7317.
- Lund T., Grosveld F.G. & Flavell R.A. (1982) Isolation of transforming DNA by cosmid rescue. *Proceedings of the National Academy of Sciences USA* 79 520-524.
- O Farrell P.Z., Goodman H.M. & O Farrell P.H. (1977) High resolution two-dimensional electrophoresis of basic as well as acidic proteins. *Cell* 12 1133-1177.

Puri N.K., Gogolin-Ewens K.J. & Brandon M.R. (1987a) Monoclonal antibodies to sheep MHC class-I and II molecules: biochemical characterization of three class-I gene products and four distinct subpopulations of class-II molecules. *Veterinary Immunology and Immunopathology* 15 59-86.

Puri N.K., Gorrel M.D. & Brandon M.R. (1987b) Sheep MHC class-II molecules: immunochemical characterization. *Immunology* 62 567-573.

Puri N.K., Mackay C.R. & Brandon M.R. (1985) Sheep lymphocyte antigens (OLA). *Immunology* 56 725-732.

Puri N.K., Walker I.D. & Brandon M.R. (1987c) N-Terminal amino acid sequence analyses of the A and B polypeptides from four distinct subsets of sheep major histocompatibility complex class-II molecules. *Journal of Immunology* 139 2996-3002.

Sambrook J., Fritsch E.F. & Maniatis T. In: *Molecular cloning*, Second Edition. Cold spring harbour, Laboratory press.

Sanger F., Nicklen S. & Coulson. A.R. (1977) DNA sequencing with the chain terminating inhibitors. *Proceedings of the National Academy of Sciences USA* 74 5463-5467.

Scott P.C., Choi C. & Brandon M.R. (1987) Genetic organisation of the ovine MHC class-II region. *Immunogenetics* 25 116-122.

Spandidos D.A. & Wilkie, N.M (1983) Host-specificities of papillomavirus, Moloney murine sarcoma virus and simian virus 40 enhancer sequences. *EMBO Journal* 2 1193-1199.

Trowsdale, J.(1988) Molecular genetics of the MHC. *Immunology Supplement* 1 21-23.

Van Der Poel J.J., Groenen M.A.M., Dijkhof R.J.M., Ruyter D. & Giphart M.J. (1990) The nucleotide sequence of bovine MHC class-II alpha genes: DRA, DQA and DYA. *Immunogenetics* 35 30-37.

Wigler M., Pellicer A., Silverstein S., Axel R., Urlaub G. & Chasin L. (1979) DNA-mediated transfer of the adenine phosphoribosyl transferase locus into mammalian cells. *Proceedings of the National Academy of Sciences USA* 76 1373-1376.

FIG 1

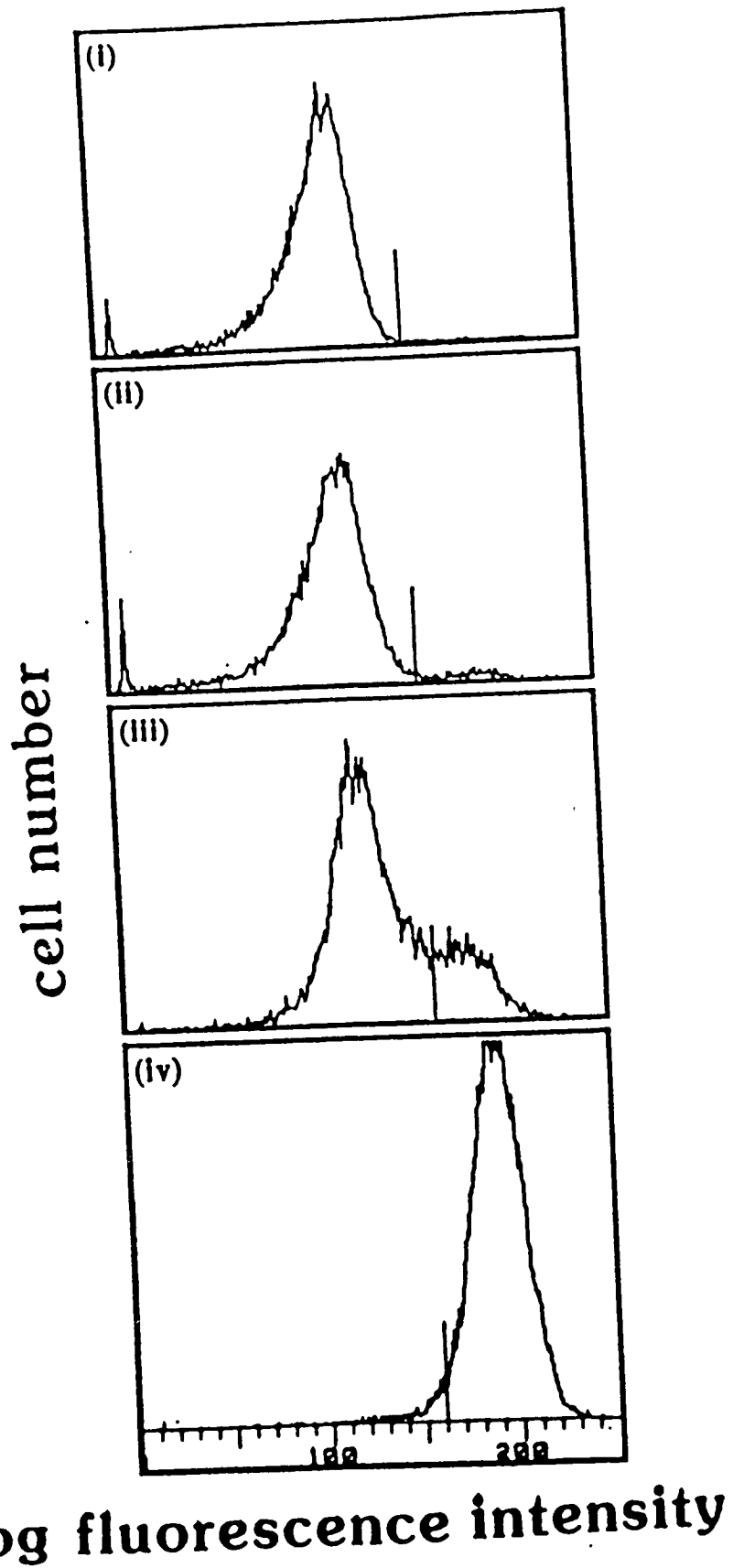

Fig 2

BETA COSMID CLONING AND SEQUENCING STRATEGY

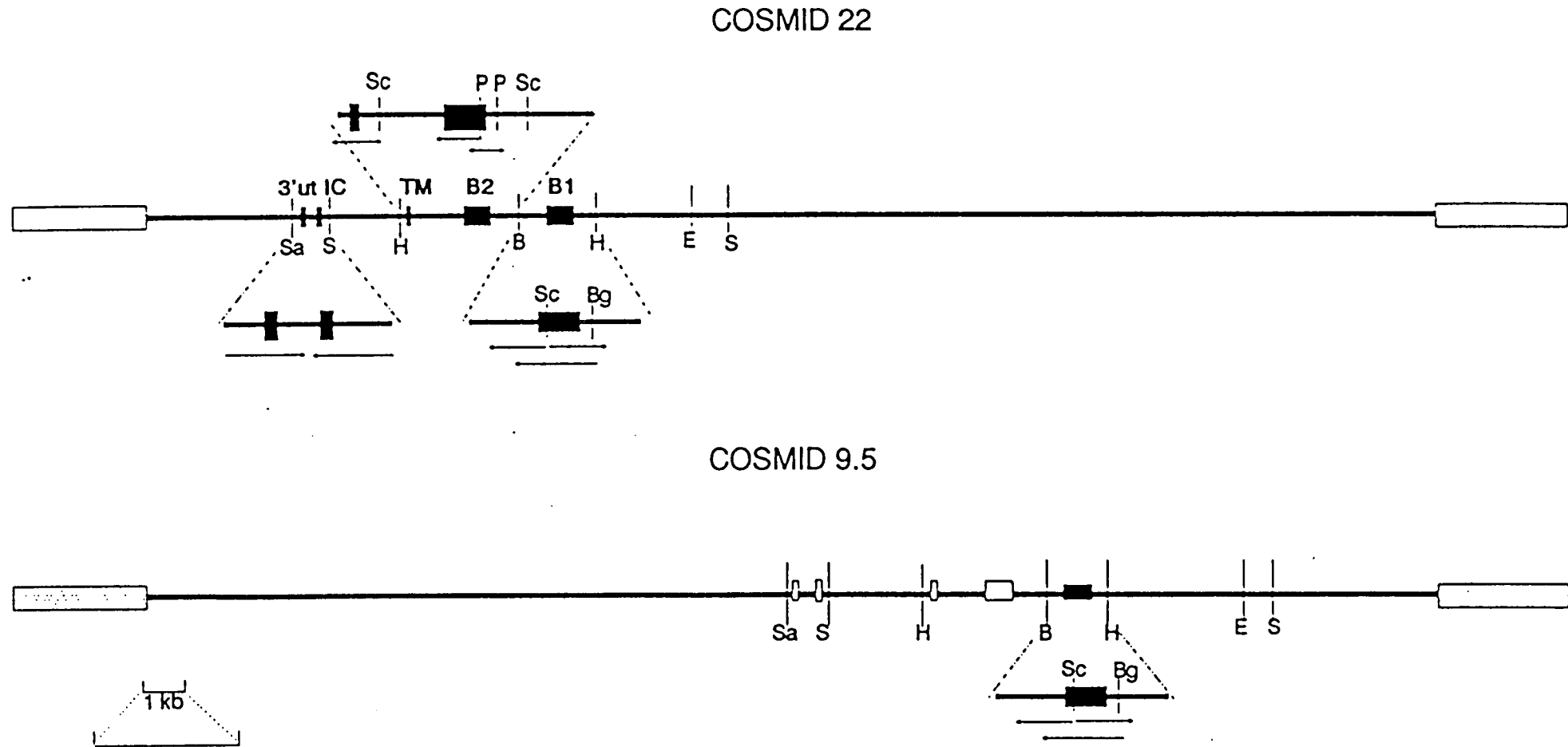

Fig 4

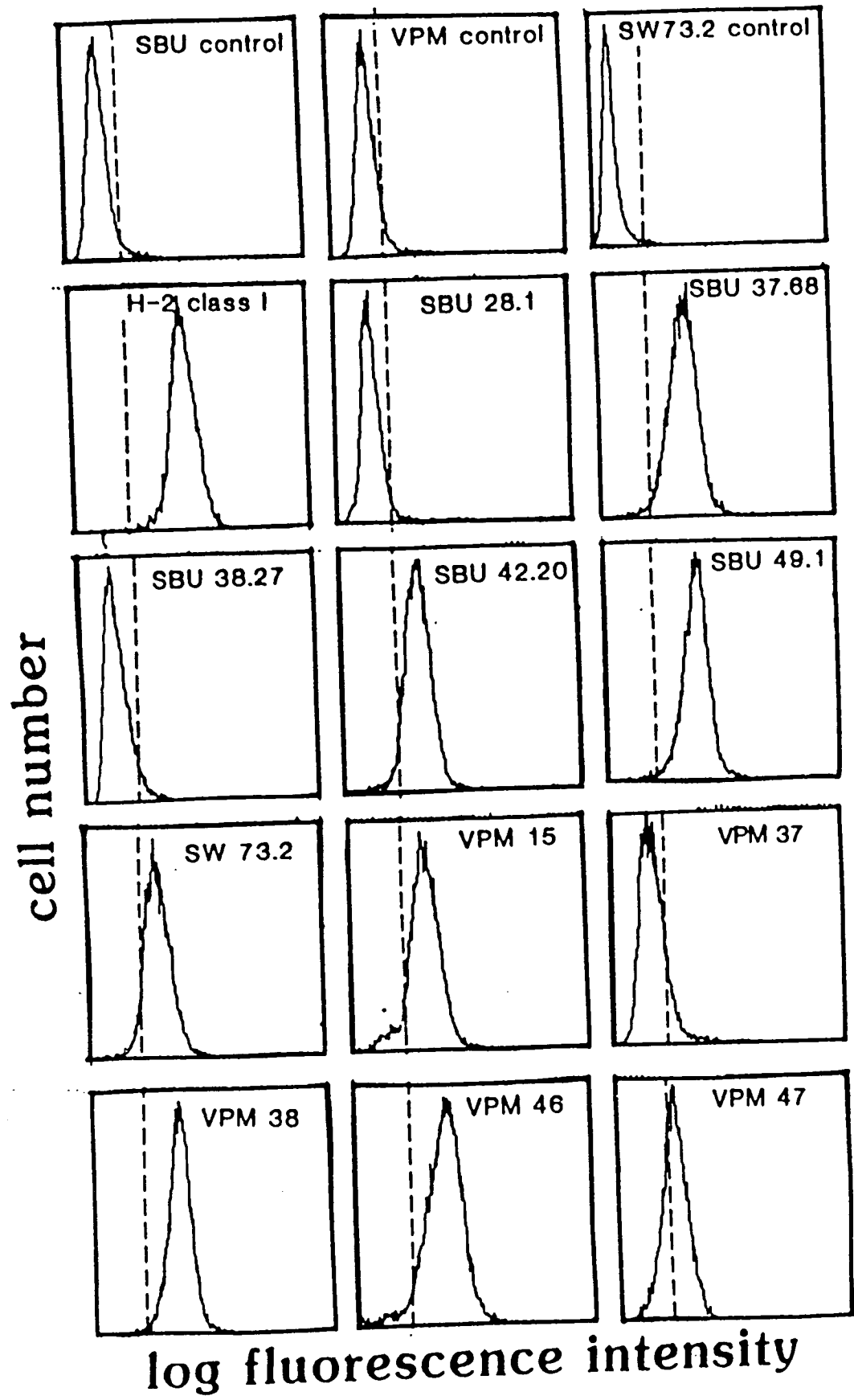

Fig 5a

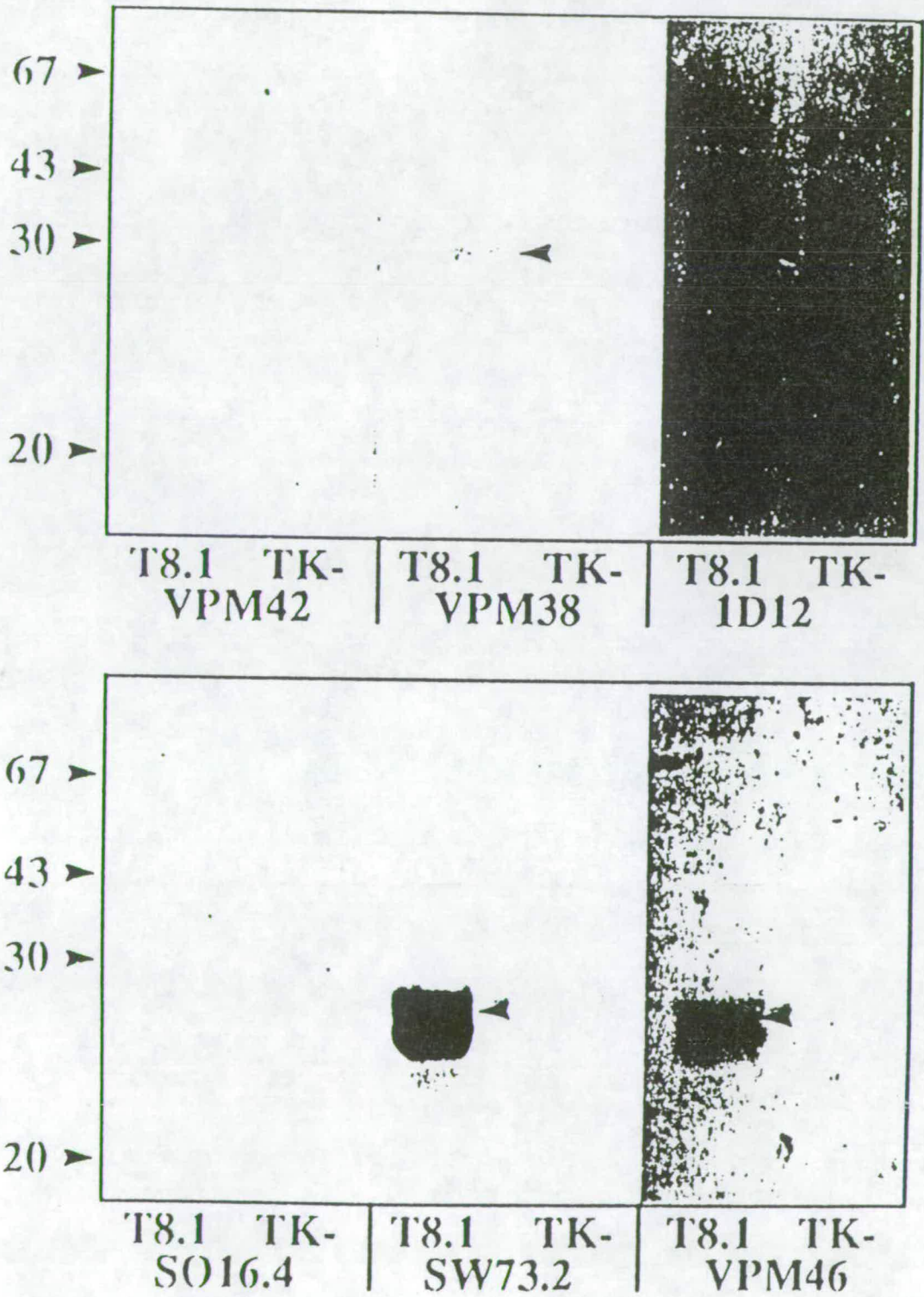
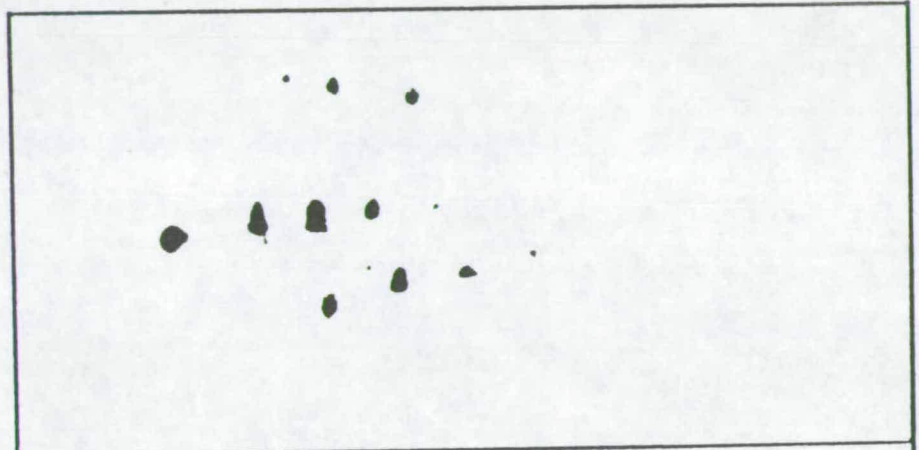

Fig5b

VPM38



SW73.2

