

The investigation of metabolic bone disease by in vivo neutron  
activation analysis.

by

Richard Eastell

A thesis submitted for the  
degree of Doctor of Medicine  
at

Edinburgh University

1984



# UNIVERSITY OF EDINBURGH

## ABSTRACT OF THESIS (Regulation 7.9)

Name of Candidate ..... RICHARD EASTELL .....

Address .....

Degree ..... MD ..... Date ..... 1984 .....

Title of Thesis ..... THE INVESTIGATION OF METABOLIC BONE DISEASE BY IN VIVO NEUTRON  
..... ACTIVATION ANALYSIS. ....

A technique for measuring total body calcium (TBCa) by in vivo neutron activation analysis (IVNAA) was described. It had a precision of 1.8% for a dose of 13 mSv. TBCa was measured in 40 healthy volunteers and the mean value (SD) for 20 men was 1143g (134g) and for 20 women it was 821g (124g).

A formula for predicting TBCa (TBCap) from height in men and from span and years postmenopause in women was derived. The results from patient groups were expressed as a ratio of TBCa to TBCap, the calcium ratio (CaR).

The mean CaR in eight women with wrist fracture was 1.00 (0.10, SD) and in 14 women with vertebral fractures was 0.87 (0.06, SD). The latter group had a significantly lower CaR than the female controls of 1.00 (0.07, SD,  $P < 0.001$ ). The TBCa was normalized for span alone to obtain an index reflecting the bone lost since the menopause, the osteopaenia index. Patients with vertebral fractures all had values below 0.78 and so this was considered the fracture threshold.

A low mean value for CaR was found in 14 patients with primary hyperparathyroidism. Significant increases in TBCa were found in four out of seven patients followed for up to 34 months postoperatively. The initial mean CaR was 0.85 ( $P < 0.001$ ).

Seven women with osteomalacia due to malabsorption had a low mean TBCa and osteopaenia index ( $P < 0.001$ ). One patient who was remeasured after eight months of vitamin D therapy had an 18% increase in TBCa, the largest increase found in any patient in the present study.

Twelve patients were measured prior to, or shortly after, renal transplantation. The eight men had a mean CaR of 0.93 ( $P < 0.05$ ) and the four women a mean value of 0.82. There was no significant change following renal transplantation over an average of 17 months. This result was attributed to a balance between the healing of renal osteodystrophy and the osteopaenic effect of steroid therapy.

Forty-one men studied after peptic ulcer surgery had a low mean CaR of 0.94 (0.07, SD,  $P < 0.01$ ). The reduction in bone mass was similar for patients after partial gastrectomy and for those after vagotomy and drainage procedures. The hypothesis was proposed that bone disease after peptic ulcer surgery was due to secondary hyperparathyroidism caused by calcium malabsorption and not by subclinical osteomalacia. This was supported by the following findings. Plasma 25-hydroxycalciferol was normal when compared with season-matched controls. However, there were low plasma calcium and high parathyroid hormone levels compared with age-matched controls. Dietary calcium was normal but 7-day calcium retention was increased when the calcium was given as a solution.

CONTENTS.

PAGE NO.

Title page	1.
Abstract	2.
Contents	3.
Chapter 1. Introduction.	6.
Chapter 2. Methods.	
A. Neutron activation analysis.	
1. Principle.	18.
2. Total body calcium.	18.
3. Forearm calcium.	20.
B. 7-day calcium retention.	23.
C. Biochemical estimations.	26.
D. Social history.	28.
E. Body measurements.	28.
F. Statistical methods.	29.
G. Consent.	30.
Chapter 3. Control groups for TBCa and seasonal variation of plasma 25-OHD.	
A. Patients.	31.
B. Results.	32.
C. Discussion.	43.
D. Summary.	50.

Chapter 4. Postmenopausal osteoporosis: women presenting with fractures.

A. Patients.	52.
B. Results.	54.
C. Discussion.	64.
D. Summary.	68.

Chapter 5. Primary hyperparathyroidism.

A. Patients.	70.
B. Results.	71.
C. Discussion.	79.
D. Summary.	83.

Chapter 6. Women with osteomalacia.

A. Patients.	84.
B. Results.	84.
C. Discussion.	92.
D. Summary.	96.

Chapter 7. Renal transplantation.

A. Patients.	97.
B. Results.	98.
C. Discussion.	109.
D. Summary.	110.

Chapter 8. Peptic ulcer surgery.	
A. Outline of study.	112.
B. Study design.	112.
C. Results.	114.
D. Discussion.	137.
E. Summary.	152.
Chapter 9. Conclusions: the value of TBCa measurements in the investigation of metabolic bone disease.	154.
Statistics Appendix.	157.
Acknowledgements.	160.
References.	162.
Reprints of published works.	183.

## CHAPTER 1. INTRODUCTION.

Total body calcium measurements were first described in 1968 (Chamberlain et al., 1968, and Palmer et al., 1968). Five other groups have since reported their methods (Table 1a).

The two groups from the United States (Nelp et al., 1972, and Cohn et al., 1976a) have reported their results as absolute values and this allows comparison between healthy volunteers and patient groups. The present study was planned to test their findings and extent their studies, some of which were based on small numbers of patients (Table 1b). Recently the groups based at the Hammersmith Hospital in London and in Leeds have started reporting their results in absolute values (Hesp et al., 1982, Horsman et al., 1983).

All the types of metabolic bone disease shown in Table 1b were investigated in the present study. In addition, groups of patients with osteomalacia, wrist fractures, and patients who have had renal transplantation and peptic ulcer surgery involving operations other than partial gastrectomy were studied.

In the previous studies of TBCa there has been a tendency to describe abnormalities in bone mass in different groups but not to relate these to other measurements such as biochemical changes. Such relationships will be pursued in the present study.

The methods used in this study are described in Chapter 2. The reference ranges for TBCa, biochemical measurements, dietary intakes, and body measurements are established in Chapter 3. Here a formula is described for predicting TBCa from age and body size. In

Table 1a. Precision, accuracy, and dose for TBCa measurements.

Results are expressed as coefficient of variation. The method of Kennedy et al.(1982) was used in the present study.

<u>Neutron source</u>	<u>Precision</u>	<u>Accuracy</u>	<u>CaR, controls</u>	<u>Dose (mSv)</u>	<u>Reference</u>
Cyclotron	2 - 3	-	-	10	Chamberlain et al.(1968)
Cyclotron	2	5.2	-	20	Nelp et al.(1972)
2 neutron generators	2 - 3.5	4.5	-	10	Boddy et al.(1973)
Plutonium-beryllium	1	-	7.0	2.8	Cohn et al.(1976)
Cyclotron	2	4	-	10	Spinks et al.(1977)
Cyclotron	1.8	-	6.5	13	Kennedy et al.(1982)
Neutron generator	3	-	-	10	Horsman et al.(1973)

Table 1b. Cross sectional studies of TBCa in patients with metabolic bone disease.

<u>Patient group</u>	<u>Number</u>	<u>Reference</u>
Controls	79	Cohn et al.(1976)
	8	Nelp et al.(1972)
Osteoporosis	44	Aloia et al.(1978)
	26	Chesnut et al.(1977)
	17 (pre-treatment)	Hesp et al.(1982)
Renal failure (on dialysis)	53	Cohn et al.(1974)
	26	Denney et al.(1973)
Hyperparathyroidism	8 (pre-operative)	Cohn et al.(1973)
Partial gastrectomy	18	Zanzi et al.(1977)



keeping with the convention adopted by Cohn et al.(1974) the ratio of TBCa to predicted TBCa is termed the calcium ratio ( $Ca_R$ ).

The TBCa of women with spontaneous vertebral fractures is described in Chapter 4 and  $Ca_R$  is calculated to determine whether the reduction in bone mass is simply due to age and body size. An attempt is made to determine a fracture threshold by normalizing the TBCa for body size alone. Similarly, women with wrist fracture are studied.

The results of TBCa are also described in Chapters 5 and 6 for women with primary hyperparathyroidism and women with osteomalacia. The concept of a fracture threshold is tested on these groups. The effect of these disturbances in calcium metabolism on bone mass is assessed by calculating  $Ca_R$  and the effect of therapy on bone mass is described. An attempt is made to relate the biochemical findings to the changes in bone mass.

The mean TBCa of patients on haemodialysis for end-stage renal disease is normal according to reports from the United States (Cohn et al., 1975, Denney et al., 1973). The results of TBCa in Scottish patients is described and the effect of renal transplantation is noted. This has not been studied by TBCa measurements before, but studies using other techniques for measuring bone mass have shown large falls in bone mass in the first year after transplantation (Aird and Pierides, 1977, Lindsay et al., 1976). There has been a recent trend towards using lower doses of steroids to prevent transplant rejection and this would be expected cause less of a reduction in bone mass (McGeown et al., 1977). The changes in bone mass are related to the dramatic biochemical changes after this operation.

Finally, this technique is applied to patients after peptic ulcer surgery in Chapter 8. TBCa has been reported to be low in patients after partial gastrectomy (Zanzi et al., 1977). However no technique has shown a reduction in bone mass in patients following the newer types of operation for peptic ulcer.

Partial gastrectomy (Figure 1a) was the commonest operation performed for peptic ulcer between the 1930's and the mid-1960's (Figure 1d). Many patients have undergone this procedure and its effects on calcium metabolism have been reported extensively. The effects on calcium metabolism of the newer operations that were introduced have not been studied in such detail. The operations of vagotomy and drainage with either a pyloroplasty or a gastroenterostomy (Figure 1b) became popular in the mid-1960's (Figure 1e) until highly-selective vagotomy (Figures 1c and 1f) was introduced as it was considered to give rise to fewer complications. These trends in popularity of operation technique were described recently in a British Medical Journal leading article (1981).

The different effects of each of these operations on the anatomy of the upper gastrointestinal tract permit study of the effects of duodenal bypass, reduction of acid secretion, vagotomy, and partial gastrectomy by combining the patients in different combinations. For example, the effect of duodenal bypass can be studied by combining the results of patients with Polya partial gastrectomy (with and without vagotomy) with gastroenterostomy (with and without vagotomy) and comparing them with the results from those with Billroth I partial gastrectomy, vagotomy and

pyloroplasty, and highly-selective vagotomy.

In the conclusion in Chapter 9 an attempt is made to assess the value of TBCa measurements in the study of metabolic bone disease.

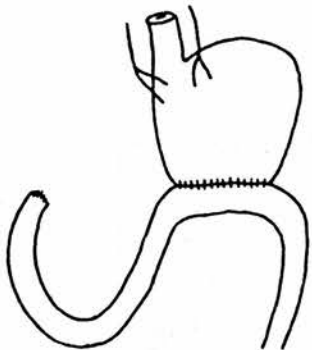

POLYA GASTRECTOMY

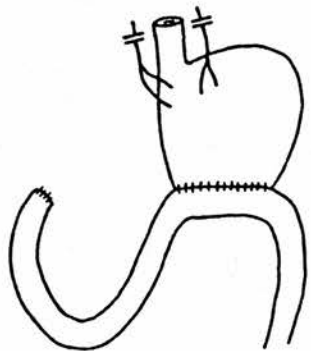

POLYA GASTRECTOMY AND VAGOTOMY

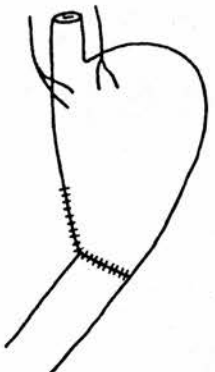

BILLROTH I GASTRECTOMY

Figure 1a. Partial gastrectomy for peptic ulcer.

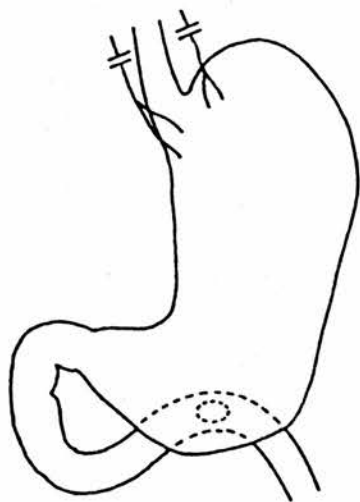

VAGOTOMY  
AND  
GASTROENTEROSTOMY

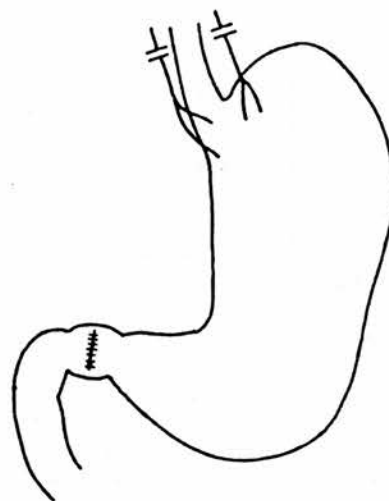

VAGOTOMY  
AND  
PYLOROPLASTY

Figure 1b. Vagotomy and drainage procedure for peptic ulcer.

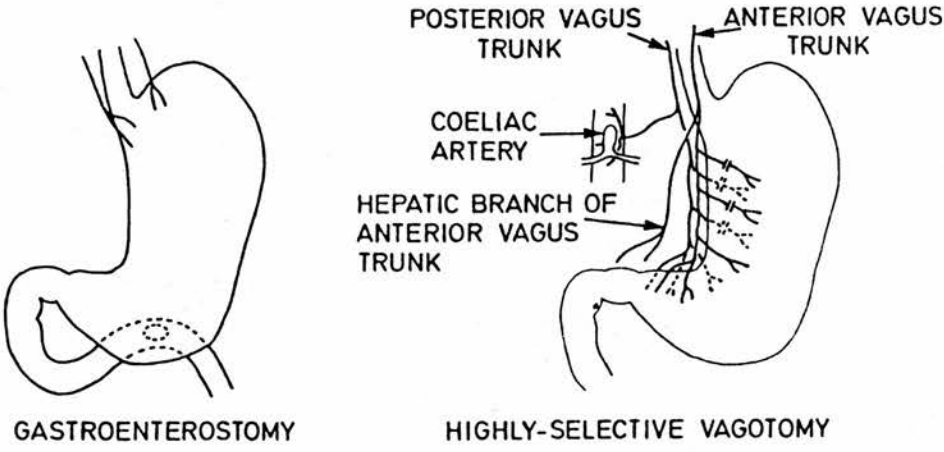

Figure 1c. Gastroenterostomy and highly-selective vagotomy for peptic ulcer.

OPERATIONS FOR PEPTIC ULCER AT THE WESTERN GENERAL HOSPITAL, EDINBURGH : GASTRECTOMY

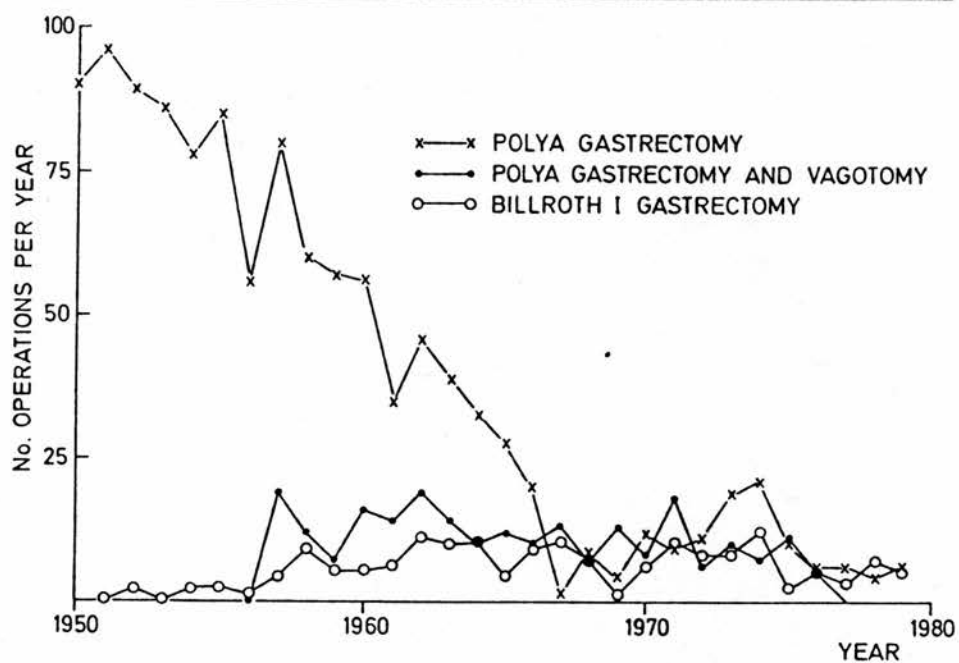

Figure 1d. Annual rate of partial gastrectomy operations.

OPERATIONS FOR PEPTIC ULCER AT THE WESTERN GENERAL HOSPITAL, EDINBURGH : VAGOTOMY AND "DRAINAGE"

---

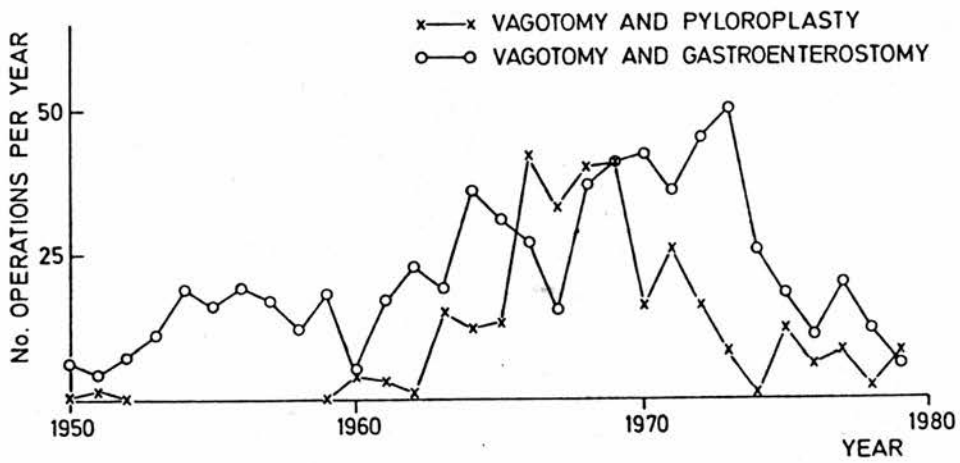

Figure 1e. Annual rate of vagotomy and drainage operations.



OPERATIONS FOR PEPTIC ULCER AT THE WESTERN GENERAL HOSPITAL, EDINBURGH : GASTROENTEROSTOMY AND HIGHLY-SELECTIVE VAGOTOMY

---

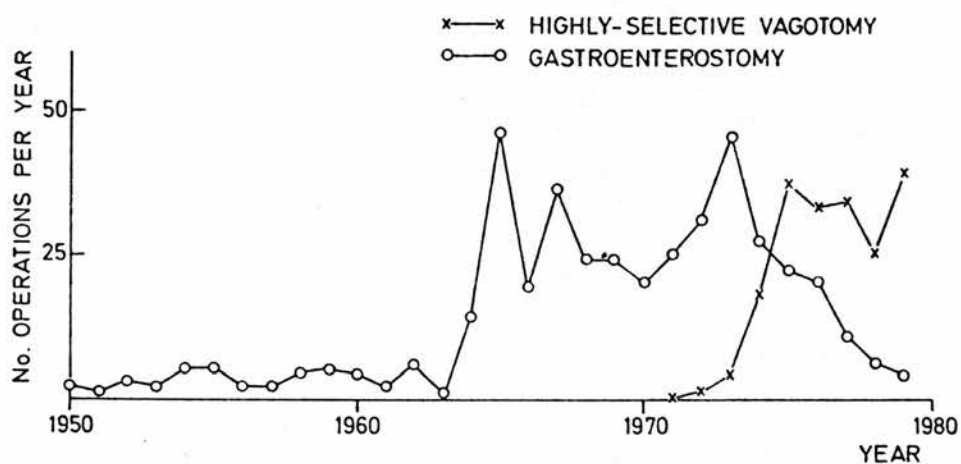

Figure 1f. Annual rate of gastroenterostomy and H.S.V. operations.

## CHAPTER 2. METHODS.

### A. NEUTRON ACTIVATION ANALYSIS.

#### 1. Principle.

The patient is exposed to a beam of partially-moderated fast neutrons. These induce the reaction  $^{48}\text{Ca}(n,\gamma)^{49}\text{Ca}$ . The  $^{49}\text{Ca}$  decays with a half-life of 8.8 minutes and emits gamma-rays at 3.1 MeV which are detected by sodium iodide crystals.

$^{48}\text{Ca}$  makes up 0.186% of elemental calcium and calcium makes up 25.7% of the dry weight of bone (Pelligrino and Blitz, 1965). In health, 99% of total body calcium is present in bone (Heaney, 1963) and so TBCa is closely related to skeletal mass.

#### 2. Technique for measuring total body calcium (TBCa).

This has been described by Kennedy et al. (1982).

##### a. Activation.

The neutron beam was produced by the MRC Cyclotron in Edinburgh (Williams et al., 1979). The mean energy of the neutrons was 6.5 MeV. The patient stood in a kiosk made from 3 cm thick polyethelene sheets mounted on a turntable (Figure 2a). The sheets acted as premoderators to reduce the energy of the neutrons. A fixed neutron dose was given to the patient in two successive irradiations each lasting about 22 seconds with the kiosk rotating through 180 degrees in 18 seconds between the two irradiations. The patient was positioned 5.4m from the cyclotron target. The total radiation dose was measured by a tissue-equivalent ionization chamber and was 1.68 mGy. The total dose equivalent received was 13.2 mSv (1.7 rem). A sodium carbonate

standard was activated simultaneously. This was used to correct for any variation in the activation procedure.

b. Measurement of induced activity.

The patient was transferred from the Cyclotron to a whole-body counter with a mean transit time of six minutes. Four sodium iodide crystals (15 cm in diameter and 10 cm thick) were mounted in the whole-body counter (Figure 2b). The patient was scanned four times over 2 m, and each scan took five minutes. The gamma-ray spectrum between 0 and 4 MeV was recorded on a multi-channel analyser. A 20-minute background count using a non-activated phantom was then subtracted from the patient's spectrum and the difference was punched out on paper tape for spectral analysis.

c. Spectral analysis.

Gamma-ray spectra for calcium, sodium, chlorine, phosphorus, and potassium were fitted to the patient's spectrum by the least squares technique (Smith and Tothill, 1979). The amount of calcium calculated in this way was divided by the count from the sodium carbonate standard which had been counted for 20 minutes and an allowance made for radioactive decay. A calcium value in grams was obtained but allowance had to be made for the effects of body height, fat thickness, and the gap between the patient and the wall of the box (see below).

d. Reproducibility.

This was assessed by repeatedly activating a phantom filled with a solution of a known amount of calcium salt and by repeatedly activating a skeleton encapsulated in tissue-equivalent rubber. The reproducibility was expressed as the

coefficient of variation (CV) and was 1.7% for a calcium content of 1000 g and 1.3% for a calcium content of 700 g. In a smaller subject with TBCa of 500 g the CV would rise to 3%.

e. Measurement corrections.

Allowances were made for height as the neutron flux diminished away from the centre of the beam, for fat as this attenuates the neutron beam, and for the air gap between the box and the patient as this also attenuates the beam. Experiments with fluid-filled phantoms allowed the following equation to be derived.

$TBCa = \text{Measured calcium} \times \text{height correction} \times \text{depth correction} \times \text{fat correction} \times \text{wall correction}$

where,

$$\text{height correction} = 0.5 \times (\text{height} - 1.5)^2 + 1$$

$$\text{depth correction} = 1.6 \times (\text{depth} - TST - 0.2) + 1$$

$$\text{fat correction} = 3.6 \times ((TST + LST)/2) + 1$$

$$\text{wall correction} = 1.0 \times (\text{wall separation} - \text{depth}) + 1$$

where,

TST was trunk skinfold thickness

LST was limb skinfold thickness

3. Technique for measuring forearm calcium (FCa).

a. Activation.

The bones of the non-dominant forearm were activated in an irradiation chamber for 10 minutes as described by Smith and Tothill (1979) and shown in Figure 2c. The irradiation dose for four measurements, averaged over the forearm, was 70 mSv (7 rem) to the bone and 30 mSv (3 rem) to the skin.

WHOLE BODY IRRADIATION

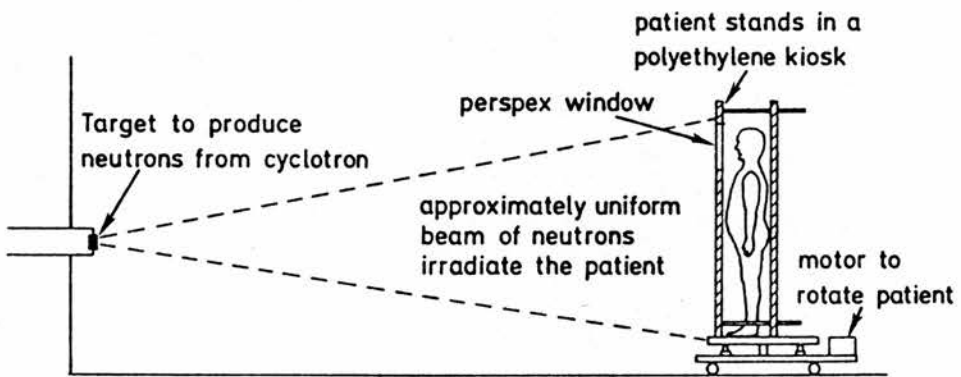

Figure 2a. Irradiation chamber for TBCa measurements.

## WHOLE BODY COUNTER

Vertical section :

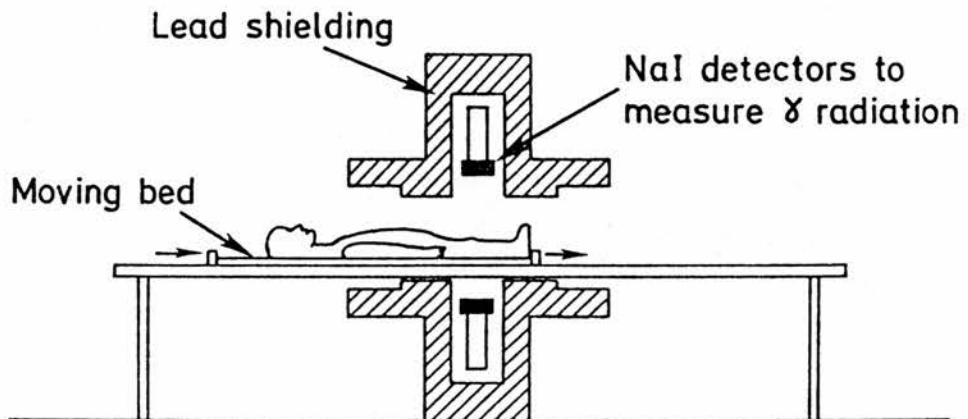

Figure 2b. Whole body counter.

b. Measurement of induced activity.

The patient was transferred to the ~~part-body~~ with a transit time of one minute. The counter was made of two sodium iodide crystals which were 15 cm in diameter and 10 cm thick and were encased in lead (Figure 2d). Counting lasted for 1000 seconds.

c. Spectral analysis.

This was performed as for TBCa.

d. Reproducibility.

This was estimated as 2.1% by repeatedly activating a cadaver limb. In practice it was 2.6% due to patient movement.

e. Normalization.

Tothill et al.(1979) attempted to normalize for body size by dividing the FCa value by the cube of the height. The resulting CV of the normal range was higher than that for TBCa and make it less suitable was comparison between groups. In the present studies FCa was only used for measuring changes in bone mass. Smith et al.(1981) have shown that both absolute measurements of FCa and changes in FCa relate closely to results of photon absorptimetry of the forearm.

B. 7-DAY CALCIUM RETENTION.

The method of Mallette et al.(1975) was used. A background count was made for 5 minutes in the energy range 1.18 to 1.46 MeV using the whole-body counter (Figure 2b). After an overnight fast the patient was given 37 to 111 kBq (1 to 3 microCi) of <sup>47</sup>Ca in a calcium chloride solution containing 90 mg calcium. Two hours later a second count was made on the whole-body counter. The patient was

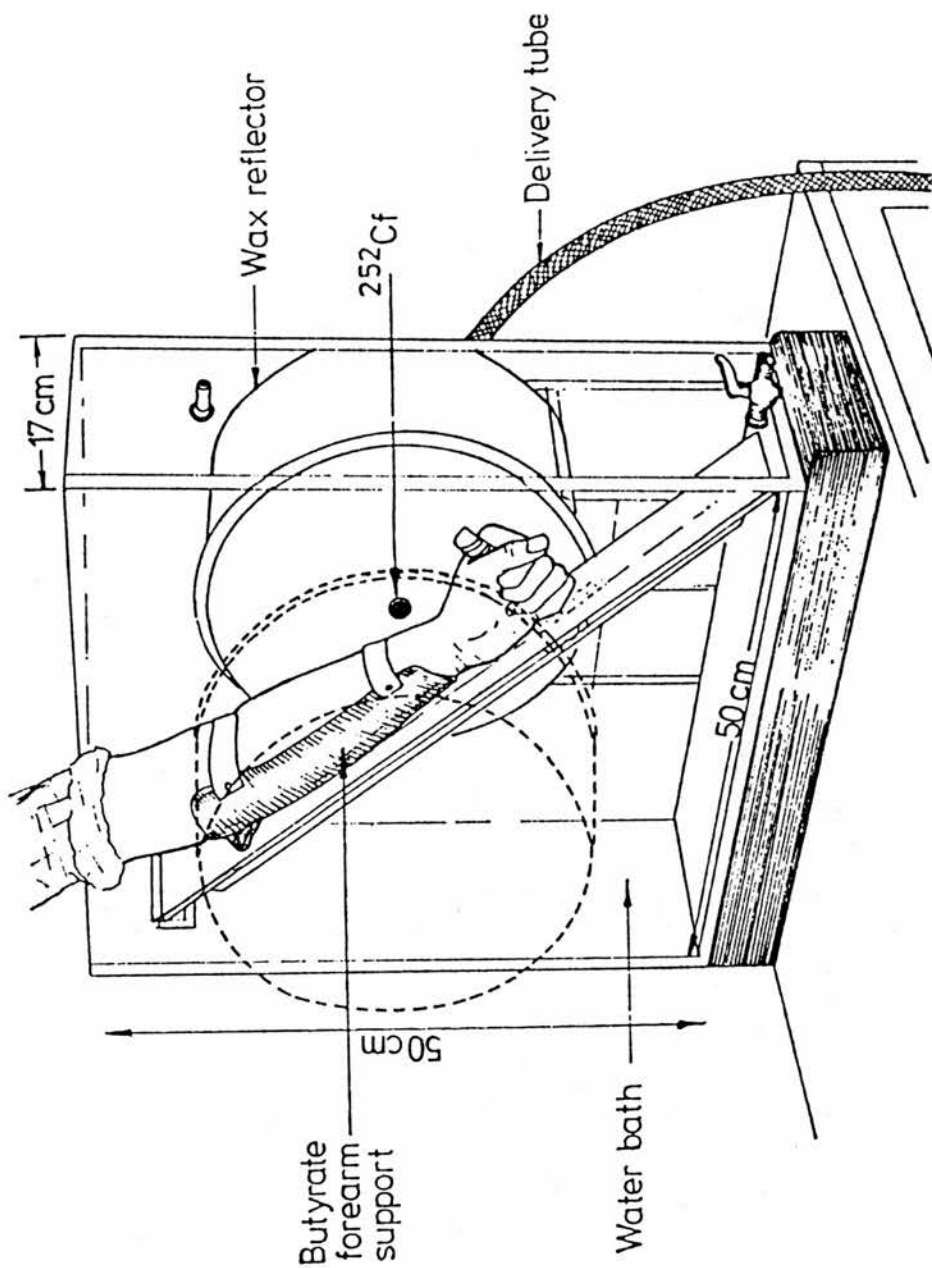

Figure 2c. Irradiation chamber for  $F_{Ca}$  measurements.



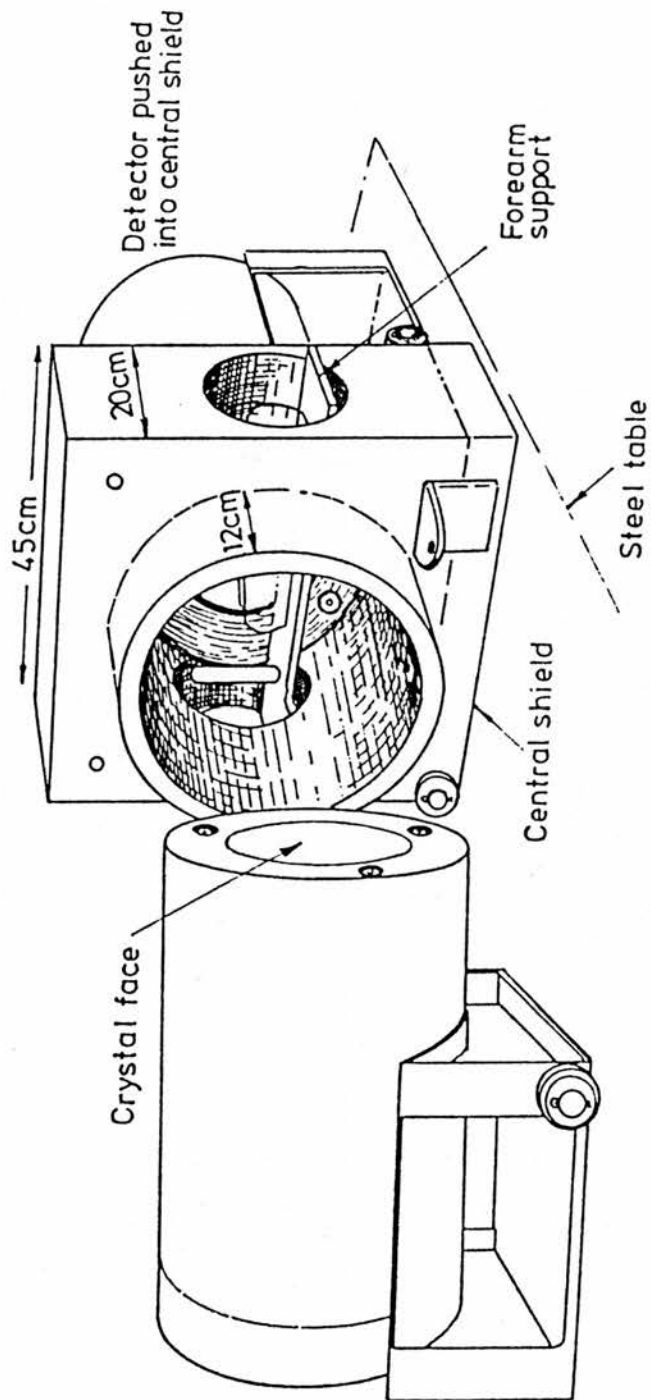

Figure 2d. Detection apparatus for FCa measurements.

fasted for a further two hours. Seven days later a third measurement was made. It was assumed that by this time all the  $^{47}\text{Ca}$  in the faeces had been excreted. A standard solution of  $^{47}\text{Ca}$  was counted shortly after the patient to allow for radioactive decay. The reproducibility of the method was reported as 5.4% by Mallette et al. (1975).

### C. BIOCHEMICAL ESTIMATIONS.

Blood was taken in the non-fasting state and without tourniquet. Samples for parathyroid hormone (PTH) estimation were put into tubes in melting ice, centrifuged immediately, and stored at  $-20^{\circ}\text{C}$  until the study was completed. The plasma samples were then assayed in batches with samples from the same patient in the same batch. A similar approach was used for plasma 25-hydroxycalciferol (25-OHD), although there was less hurry in centrifuging the sample. The remaining plasma biochemical analysis was usually performed on the day of sampling.

Twenty-four hour collections of urine were made into bottles without preservative. Clear instructions were given in writing about the timing of the collection and advice given on the avoidance of gelatin-rich food. An aliquot of the sample was frozen at  $-20^{\circ}\text{C}$ .

Plasma 25-OHD was measured using the competitive protein-binding assay of Preece et al. (1974). This assay uses serum from vitamin D-deficient rats as the binding protein and dextran-coated charcoal to remove unreacted  $^{26(27)}\text{-}^3\text{H-}25\text{-hydroxycholecalciferol}$ . The assay was preceded by chromatography. The sensitivity was 12.5 pg and the effective

sensitivity was 1.3 nmol/l. The intra-assay variation was 8.3% and the inter-assay variation was 8 to 16.5%, depending on the concentration. In this assay 25-OHD<sub>2</sub> was as effective as 25-OHD<sub>3</sub> at displacing labelled 25-OHD<sub>3</sub> from rat serum binding protein and 40 times more effective than vitamin D<sub>3</sub>. Other steroids showed no significant cross-reaction in this assay (Preece et al., 1974).

Plasma PTH was measured by radioimmunoassay using a modification of the method of Woo and Singer (1974). The assay used guinea-pig antiserum to bovine PTH, bovine PTH as the standard, and radioiodinated bovine PTH as the labelled hormone. The antiserum was directed mainly against the N-terminal part of the PTH molecule. The serum and antiserum were incubated at 4° C for 3 days and then radioiodinated bovine PTH was added and incubation continued for a further three days at 4° C. The hormone-antiserum complex was precipitated by the addition of donkey anti-guinea-pig antiserum (and not by charcoal as used by Woo and Singer, 1974) and the radioactivity in the bound fraction was counted. The inter-assay variation was 10 to 12% and the effective sensitivity was 0.16 to 0.18 mcg/l.

Plasma calcium and urine calcium were measured by atomic absorption spectroscopy. The plasma calcium was corrected to an albumin of 40 g/l (this was approximately the mean value in the control group) using the formula recommended by the Lancet leading article (1979) with a correction factor of 0.02 mmol Ca/g albumin. Magnesium was also measured by atomic absorption spectroscopy, inorganic phosphate by a colorimetric method, and alkaline phosphatase by the method of Kind and King (1954).

#### D. SOCIAL HIST.

Alcohol consumption was expressed as the number of units consumed during a typical week. Unit equivalences were half a pint of beer, a measure of spirits, a glass of sherry, or a glass of wine (Chick, 1982). Patients were classified as abstainers, previous drinkers, moderate drinkers (less than 16 units per week - the mean per capita consumption in the United Kingdom), or heavy drinkers.

Cigarette consumption was expressed as the number of cigarettes smoked during a typical week. All cigarettes were considered equivalent. The categories were designed to allow comparison with the groups of Lee (1976). For pipe and cigar smokers one ounce of tobacco (28 g) was taken as equivalent to 20 cigarettes.

The tables published by the Office of Population Censuses and Surveys (1970) were used. Occupation was taken as that pursued for most of the person's life except for a married woman where it was taken as that of her husband.

#### E. BODY MEASUREMENTS.

Height was measured in metres, to the nearest cm, using a wall-mounted ruler with sliding headpiece. Armspan was also measured in metres, to the nearest cm, using graph paper mounted on the wall. Weight was measured in kilograms, to the nearest 0.1 kg, using an Avery beam balance. Patients wore light indoor clothing.

Skinfold thickness was measured at four sites, to the nearest

mm, using Harpenden calipers (British Indicators Ltd, St Albans, Herts). The biceps site was ~~was~~ the midpoint of the muscle with the arm hanging vertically. The triceps site was taken as the point equidistant between the olecranon and acromion processes. The subscapular site was below the inferior angle of the scapula at 45 degrees to the vertical. The suprailiac site was above the iliac crest in the midaxillary line. These four skinfold measurements could be used to predict percent body fat using the tables of Durnin and Womersley (1974).

Lean body mass (LBM) was calculated from body weight (W) and percent body fat (F) using the following equation:

$$\text{LBM} = W - (W \times F/100)$$

Ideal weight (IW) was predicted from height using the tables given in the Statistical Bulletin of the Metropolitan Life Insurance company (no.40, 1959). These tables included an assessment of body frame. All patients were assumed to be of medium frame in keeping with the convention adopted by others (eg. Baird et al., 1974). The percent of body weight above the ideal weight (%IW) was calculated :

$$\%IW = (W - IW)/W \times 100$$

Body mass index (BMI) was calculated from height (H) and weight thus:

$$\text{BMI} = W/H^2$$

#### F. STATISTICAL METHODS.

The standard methods for t-test, chi-square, Wilcoxon rank sum, regression (single and multiple) were performed as described by Armitage (1971). The analysis of data from patients

after peptic ulcer surgery was performed on a mainframe computer (Digital Equipment Corporation, DEC-20) using a statistical package produced by the Pennsylvania State University ("Minitab"). Methods which were complex or unusual are described in the Appendix.

Levels of significance are designated by asterisks in the tables. One, two, and three asterisks indicate  $P < 0.05$ ,  $P < 0.01$ , and  $P < 0.001$ , respectively.

#### G. CONSENT.

Informed consent was obtained in writing from all patients. The studies were approved by the hospital ethics committee and by the Administration of Radioactive Substances Advisory Committee (ARSAC).

CHAPTER 3. CONTROL GROUPS FOR TBCa AND SEASONAL VARIATION OF PLASMA 25-OHD.

A. PATIENTS.

1. Controls for TBCa.

Forty volunteers aged 40 to 70 years, 20 men and 20 women, responded to adverts placed in the hospital newsletter, the newspaper of a local factory and of the local police station, and to a published interview with the Edinburgh Evening News and with BBC Radio Scotland's "Good Morning Scotland". Other volunteers were excluded from the study as they suffered from disease, or were taking therapy, likely to affect bone mass. Women with fractures of the wrist, hip, or vertebra were excluded.

The following measurements were made: serum or plasma calcium, phosphate, magnesium, alkaline phosphatase, albumin, PTH, 25-OHD, creatinine, and thyroxine; full blood count; 24-hour urinary excretion of calcium, phosphate, magnesium, hydroxyproline, and creatinine; weight, height, armspan, body thickness, skinfold thickness at four sites; and TBCa. These measurements were made between April 1979 and April 1981 and during all seasons.

2. Controls for plasma 25-OHD.

Twenty-six members of hospital staff agreed to participate. Those subjects taking vitamin D supplements or using ultraviolet lamps were excluded from the study. Measurement of the following were made at monthly intervals between December 1978 and December 1979: serum or plasma calcium,

phosphate, magnesium, alkaline phosphatase, albumin, and 25-OHD.

A record was kept of holidays and sun-bathing activities. Height, weight, and skinfold thickness were measured. A dietary history for calcium and vitamin D was made by a Senior Dietician in December 1979 using the method of 7-day recall. The number of hours of sunshine at the Royal Botanical Gardens in Edinburgh were given by the Meteorological Office.

## B. RESULTS.

### 1. Controls for TBCa.

#### a. Reasons for exclusion.

Nine patients were excluded from the study for the following reasons: osteoarthritis (3), anticonvulsant therapy (2), women with wrist fractures (2), alcoholism (1), and coeliac disease (1). The two women with wrist fracture were included in the study of patients with wrist fracture.

#### b. Source of volunteers.

Twenty-nine of the volunteers worked in the hospital, four in the local factory, four in the local police station, and three had read or heard one of the two interviews.

#### c. Number of fractures.

Twenty-seven of the volunteers had never sustained a fracture; the remainder had fractured the ankle (6), wrist (3 men), clavicle (2), nose (2), jaw (1), finger (1), and toe (1). No volunteer had fractured the hip or vertebra.

#### d. Total body calcium.

The TBCa in the men ranged from 886 to



1428g with a mean of 1143g and SD of 134g (Figure 3a). The CV of this group was 11.7% before normalization. The method used for normalization is given in the Appendix. The closest relationship was found to be between TBCa and height with body weight and age showing no significant relationship with TBCa. The formula for predicting TBCa ( $TBCa_p$ ) was:

$$TBCa_p = a \times H^{2.07}$$

$$r = 0.83$$

$$P < 0.001$$

where, a was 347

H was height

TBCa can be expressed as a ratio of  $TBCa_p$  to give a calcium ratio, or  $Ca_R$ , as described by Cohn et al. (1974). The mean and SD of  $Ca_R$  in the men were 1.000 and 0.062. Thus by normalization the CV of the male controls was reduced from 11.7% to 6.2% (Figure 3a). The men from whom this formula was derived were aged 42 to 69 years and were 1.64 to 1.90m tall.

The TBCa in the women ranged from 598 to 1036g with a mean of 821g and SD of 124g (Figure 3b). The CV of this group was 15.2% before normalization. The method used for normalization is given in the Appendix. The closest relationship was found to be between TBCa and span and TBCa and years postmenopause. Body weight showed no significant relationship with TBCa. The formula for predicting TBCa ( $TBCa_p$ ) in women was:

$$TBCa_p = a \times S^{1.69} \times e^{-0.015 \times ypm}$$

$$r = 0.89$$

$$P < 0.001$$

where, S was armspan,

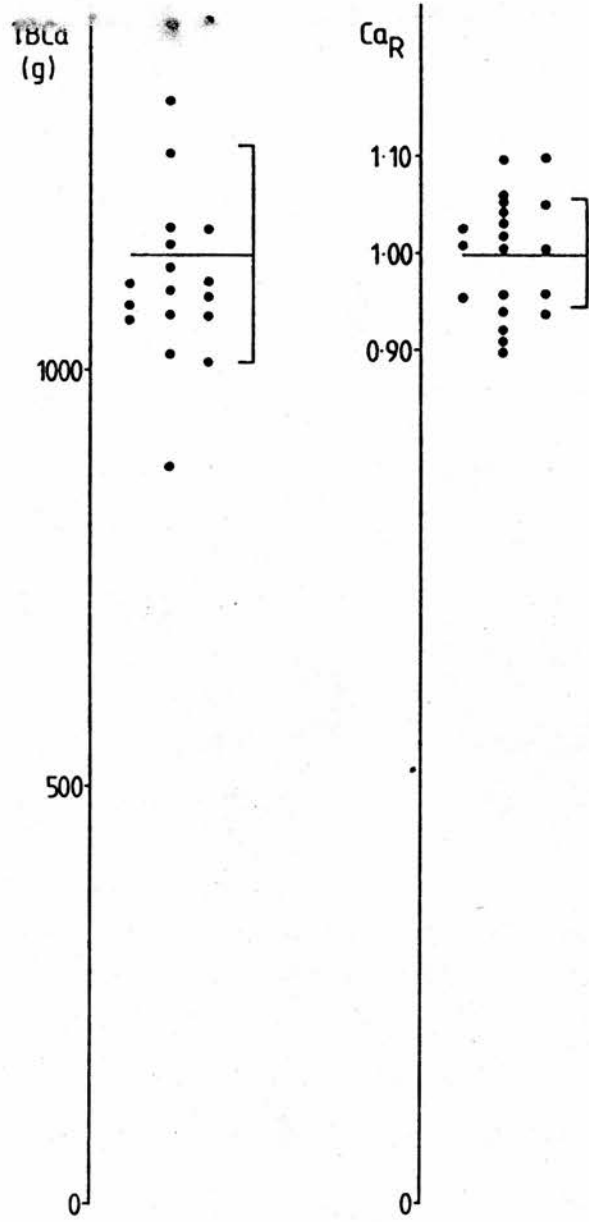

Figure 3a. Total body calcium and calcium ratio in male controls.

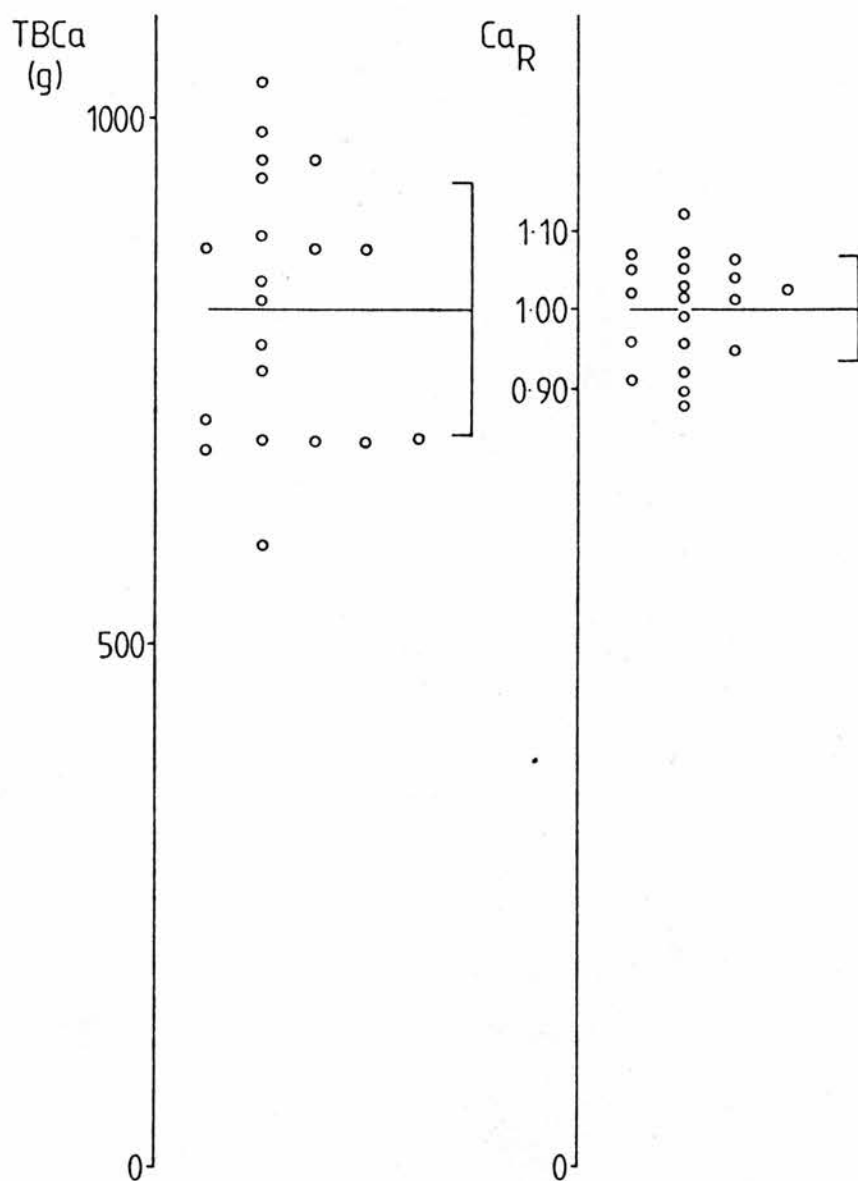

Figure 3b. Total body calcium and calcium ratio in female controls.

ypm was years postmenopause,

a was 399.

In the analysis it was assumed that the rate of bone loss after the menopause was exponential. The estimated rate of bone loss was 1.5%/year. This is shown in Figure 3c. In this Figure the term  $TBCa/a \times S^{1.69}$  is used. The expression  $a \times S^{1.69}$  predicts TBCa from armspan for a woman at the time of the menopause and the expression  $TBCa/a \times S^{1.69}$  will be referred to as the osteopaenia index as it attempts to predict the amount of bone lost since the time of the menopause.

The mean and SD for  $Ca_R$  in the women was 1.000 and 0.066 (Figure 3b). Thus the CV was reduced from 15.2% to 6.6% by normalization. The women from whom this formula was derived were 0 to 22 years postmenopause and of armspan 1.50 to 1.75m.

#### e. Biochemistry.

The results are shown in Table 3a. The results of plasma alkaline phosphatase and 25-OHD were logarithmically transformed as their distributions were skewed. There was no difference in plasma biochemistry between the men and women but the men had higher 24-hour urinary excretion of phosphate ( $P < 0.01$ ), creatinine ( $P < 0.001$ ), and hydroxyproline ( $P < 0.01$ ). The men also had higher creatinine clearance ( $P < 0.001$ ).

There was a direct relationship between 24-hour urinary excretion of creatinine and lean body mass ( $r = 0.85$ ,  $P < 0.001$ ) and this is shown in Figure 3d. In other groups collections of urine were considered incomplete if the urinary creatinine was outwith the 95% confidence limits for a given lean body mass.

Plasma calcium and serum albumin were not closely related.

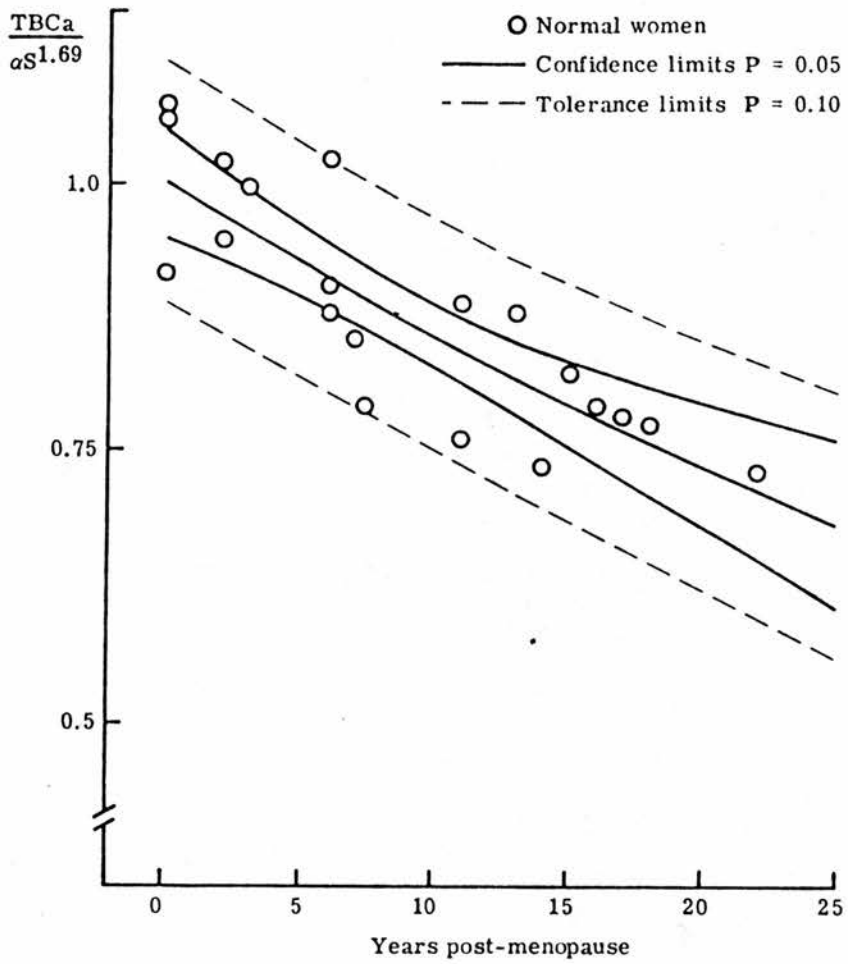

Figure 3c. Osteopaenia index and years postmenopause in the female controls.

Table 3a. Biochemical results in the 60 control subjects. Results are expressed as mean (SD). Statistical comparisons are made using an unpaired t-test between male and female TBCa controls.

<u>Variable</u> (units).	<u>TBCa - Male.</u>	<u>TBCa - Female.</u>	<u>25-OHD - all.</u>
Number	20	20	20
<u>Plasma.</u>			
Alkaline phosphatase (u/l)	50	50	51
[log <sub>e</sub> -transformed]	3.91 (0.25)	3.91 (0.22)	3.94 (0.30)
Phosphate (mmol/l)	1.01 (0.16)	1.11 (0.16)	1.20 (0.17)
Calcium (mmol/l)	2.37 (0.06)	2.38 (0.09)	2.35 (0.12)
Corrected calcium (mmol/l)	2.37 (0.09)	2.35 (0.08)	
Magnesium (mmol/l)	0.83 (0.09)	0.80 (0.05)	0.77 (0.06)
Albumin (g/l)	41.9 (3.1)	43.4 (2.9)	
25-OHD (nmol/l)	31	36	20
[log <sub>e</sub> -transformed]	3.43 (0.41)	3.58 (0.61)	3.01 (0.57)
PTH (mcg/l)		0.16 (0.09)	
Creatinine (mmol/l)	0.08 (0.01)	0.07 (0.01)	
<u>Urine.</u>			
Calcium (mmol/24hr)	5.75 (2.77)	4.70 (2.11)	
Magnesium (mmol/24hr)	4.25 (2.15)	3.41 (1.32)	
Creatinine (mmol/24hr)	17.3 (3.8) <sup>***</sup>	10.1 (1.5)	
Hydroxyproline (mmol/24hr)	339 (83) <sup>**</sup>	258 (67)	
Phosphate (mmol/24hr)	34.0 (11.2) <sup>**</sup>	23.1 (7.7)	
Creatinine clearance (ml/s)	2.36 (0.45) <sup>***</sup>	1.76 (0.38)	

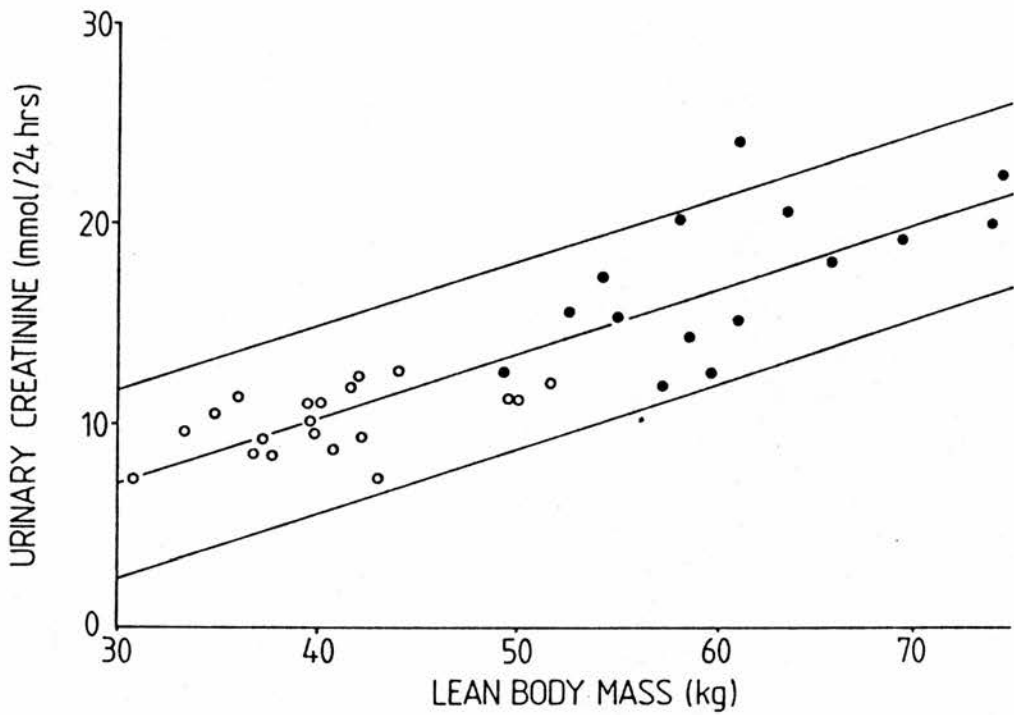

Figure 3d. Urinary creatinine and lean body mass in the male (●) and female (○) controls. The lines indicate the regression line with 95% confidence limits.

Thus when the standard formula given in the methods section was applied the CV of the control group increased (Table 3a).

f. Age and body measurements.

These are shown in Table 3b. The men had greater armspan, height, weight, and lean body mass than the women. This greater weight was not due to fat as the women had greater percent body fat ( $P < 0.01$ ). No difference was shown between the sexes in BMI or percent overweight.

2. Controls for plasma 25-OHD.

a. Reasons for exclusion.

Six patients were excluded from the study. Four of these left the hospital, one took vitamin D supplements, and one used an ultraviolet lamp.

b. Biochemistry.

The results of samples taken in 1979 are shown in Table 3a. They had higher levels of plasma phosphate ( $P < 0.02$ ) and lower levels of plasma 25-OHD ( $P < 0.01$ ) than the controls for TBCa.

There was a marked seasonal variation in plasma 25-OHD as shown in Figure 3e. The peak value occurred 6 weeks after the maximum daily hours of sunshine. The maximum mean value of plasma 25-OHD occurred in July and was 43.1 nmol/l and this fell to 22.7 nmol/l in February.

Plasma 25-OHD increased by 2.5 times the basal value, on average, following nine holidays spent sunbathing, compared with an increase of only 1.4 times the basal value following six holidays with no sunbathing.



Table 3b. Age and body measurements in controls for TBCa and plasma 25-OHD. Results are expressed as mean (SD). Statistical comparisons are made using an unpaired t-test between male and female TBCa controls and between male and female 25-OHD controls.

<u>Variable</u> (units).	<u>TBCa - Male.</u>	<u>TBCa - Female.</u>	<u>25-OHD - Male.</u>	<u>25-OHD - Female.</u>
Number	20	20	11	9
Age (yr)	54.4 (8.8)	57.5 (6.5)	33.5 (10.2)	34.0 (13.9)
Postmenopause (yr)		8.9 (7.0)		
Armspan (m)	1.83 (0.09)***	1.65 (0.07)		
Height (m)	1.78 (0.08)***	1.61 (0.06)	1.79 (0.05)***	1.65 (0.04)
Weight (kg)	81.8 (11.3)***	63.3 (11.1)	77.2 (9.0)***	60.2 (4.3)
Overweight (%)	12.2 (12.2)	10.6 (12.5)	5.9 (11.6)	1.0 (6.5)
Body mass index (kgm <sup>-2</sup> )	25.8 (3.8)	24.2 (2.9)	24.1 (1.7)**	22.0 (1.4)
Body fat (%)	26.0 (10.4)	35.5 (7.6)**	19.4 (9.4)*	28.1 (4.8)
Lean body mass (kg)	59.8 (7.0)***	40.5 (5.4)	61.9 (4.3)***	43.2 (3.5)

HOURS OF SUNSHINE PER MONTH IN EDINBURGH (Royal Botanical Gardens) AND 25-OHD LEVELS

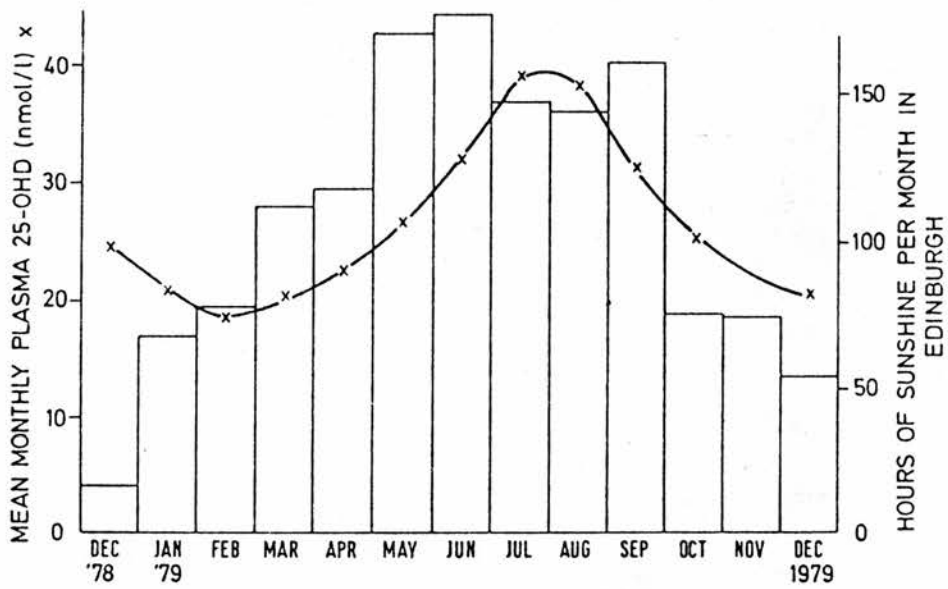

Figure 3e. Plasma 25-OHD in the controls and the number of hours of sunshine per month in Edinburgh.

There was no significant relationship between plasma 25-OHD and dietary vitamin D intake.

The results of plasma biochemistry grouped by season are shown in Table 3c. The summer peak of plasma 25-OHD was associated with a fall in plasma magnesium ( $P < 0.02$ ), a rise in plasma phosphate ( $P < 0.05$ ), and an autumnal rise in plasma alkaline phosphatase ( $P < 0.05$ ). The groups were compared using a paired t-test. Periodic regression analysis also showed significant cyclical variations in plasma 25-OHD ( $P < 0.001$ ) and magnesium ( $P < 0.05$ ).

c. Age and body measurements.

These are shown in Table 3b. They were 25 years younger, on average, than the controls for TBCa, and had less body fat ( $P < 0.01$  for the women).

d. Dietary history.

In 19 subjects the mean daily calcium intake was 1280mg (SD, 360mg), and the mean daily vitamin D intake was 2.6microgram (SD, 1.2microgram). The recommended daily intake of calcium is 500mg (DHSS) and only one volunteer took less than this.

C. DISCUSSION.

1. Controls for TBCa.

The mean values of TBCa in men and women were 1143g and 821g, respectively. Two other groups have reported absolute TBCa in healthy volunteers. In the report of Cohn et al.(1976) the mean values for six men and ten women aged 50 to 59 years were 996g and 804g, respectively. The controls in the present study were taller than those of Cohn et al.(1976), the men by 10cm and the women by 2cm and this would account for these lower values. Nelp et al.(1972) measured eight men of mean age 34 years and

Table 3c. Seasonal changes of mean values of plasma biochemistry in 20 control subjects. Statistical comparison was made between the mean values underlined using a paired t-test.

<u>Variable (units).</u>	<u>Winter</u>	<u>Spring</u>	<u>Summer</u>	<u>Autumn</u>	<u>P</u>
Alkaline phosphatase (u/l)	-	<u>48</u>	48	<u>54</u>	<0.05
Phosphate (mmol/l)	1.12	<u>1.08</u>	<u>1.21</u>	1.18	<0.02
Calcium (mmol/l)	2.32	2.30	2.30	2.34	N.S.
Magnesium (mmol/l)	<u>0.81</u>	0.78	<u>0.77</u>	0.78	<0.05
25-OHD (nmol/l)	<u>24</u>	29	<u>41</u>	26	<0.001

found a mean TBCa of 1093g. These volunteers were 3cm shorter than our own. The mean height of the volunteers in the present study was more than that in previous studies as they included 4 policemen.

These same two groups also normalize TBCa for body size. Nelp et al.(1972) predict TBCa from (height)<sup>3</sup>. Cohn et al.(1976) predict TBCa from age, height and total body potassium. This last measurement is an assessment of lean body mass. In the present study lean body mass did not improve the F-statistic in the multiple regression analysis (see Appendix).

Armspan related to TBCa closer than did height in the female volunteers of the present study. The use of armspan rather than height allowed a fairer comparison with the women with vertebral fractures who lose height with each fracture.

The formula for predicting TBCa in women assumed an exponential rate of loss of bone mass after the menopause and this was calculated at 1.5%/year. Cohn et al.(1976) reported a rate of loss of 1.1%/year in women after the age of 55 years.

The rate of bone loss after the menopause may not be exponential. Newton-John and Morgan (1970) reviewed 20 cross-sectional studies of changes in bone mass with age in women and they concluded that the loss was linear. Lindsay et al.(1978) reported a rate of bone loss of 2.6%/year in the first four years after bilateral oophorectomy and this subsequently fell to 0.75%/year. The menopause is only one event signalling a gradual fall in plasma oestradiol levels. The further a woman is away from the menopause the poorer her memory of its exact timing.

Newton-John and Morgan (1970) also concluded that the rate of bone loss after the age of 40 to 45 years in women was 1%/year and

after the age of 50 to 65 years in men was 0.6%/year. No significant fall in bone mass with age was found in the men of the present study.

Normalization of TBCa for body size and age lowered the CV of the normal range to 6.2% in men and 6.6% in women. Cohn et al.(1976) reported CV after normalization of 7.8% in men and 7.1% in women. Thus a reduction of TBCa in a patient of more than 15% below the mean can be detected with 95% confidence.

The age range of the controls is narrower than that of Cohn et al.(1976) and so more caution is required when comparing groups. For example, no woman was more than 22 years postmenopause. Thus the formula for  $TBCa_p$  cannot be applied to women past this age.

Half of the volunteers were more than 10% above their ideal weight. This is representative of the British population. Baird et al.(1974) reported that between the ages of 50 and 65 years 43% of men and 50% of women are more than 10% above their ideal weight. As discussed above, the men were taller than the volunteers of Cohn et al.(1976) and Nelp et al.(1972). They were also 4cm taller than men of a similar age in the study of Baird et al.(1974). This may have been due to inclusion of four police officers in our group.

Plasma concentrations of alkaline phosphatase, phosphate, calcium, magnesium, creatinine and albumin were similar to those previously reported by Ladenson (1980). The samples were collected throughout the year and so would not be expected to show the effect of season described below. The plasma PTH was below the effective sensitivity of the assay in 50% of cases. This is a higher proportion than that reported by Woo and Singer (1974) who found that only 10% of their controls were below this level. The

statistical analysis of PTH results was made more difficult by this and the methods used are given in the Appendix.

## 2. Controls for plasma 25-OHD.

The seasonal variation in plasma 25-OHD is well-known and the results from six other studies along with the present one are shown in Table 3d. The action of ultraviolet light on the skin contributes more vitamin D than does the diet. The peak in plasma 25-OHD follows the maximum daily hours of sunshine when the wavelengths 280 to 305 nm are contributing most to ultraviolet light.

The plasma 25-OHD levels shown in Table 3d show surprisingly little effect of latitude. The results for hospital workers living in Tromso in Norway (69 ° North) are as high as those of nurses in St.Louis in the U.S.A.(38 ° North). Foods such as milk and margarine are fortified with vitamin D in the U.S.A., Australasia, Denmark, Norway, and Sweden. Lund and Sorensen (1979) reported that 60% of the elderly population of Denmark take vitamin D supplements in the winter. Such dietary factors may be important in towns such as Tromso, north of the Arctic Circle, where there is no daylight for two months of the year. One further explanation may be differences in assay technique. The proposal by Fraser (1983) that diet is an unimportant source of vitamin D may apply to Britain where vitamin D fortification of food is less than elsewhere, and where vitamin D supplements are not regularly taken by the elderly, but it may not apply world-wide.

The summer rise in plasma 25-OHD is probably the cause of the other biochemical changes noted here and reported by others. Thus a

Table 3d. The effect of latitude on plasma 25-OHD.

<u>Town (Country)</u> <u>Latitude</u>	<u>Group under study</u>	<u>No.</u>	<u>Age (yr)</u>	<u>Sex</u>	<u>Mean 25-OHD (nmol/l)</u> <u>Winter - Summer</u>	<u>Reference</u>
Tromsø (Norway) 69° 34' N	Hospital staff	25	32	M + F	52 - 84	Vic et al. (1980)
Dundee (Scotland) 56° 27' N	Outdoor workers Indoor workers Geriatric patients	20 9 20	41 32 84	M M F	45 - 90 30 - 60 20 - 35	Devgun et al. (1981)
Edinburgh (Scotland) 55° 56' N	Hospital staff	20	34	M + F	23 - 43	Present study
Copenhagen (Denmark) 55° 40' N	Blood donors Out-patients	596	18 - 93	M + F	48 - 86	Lund and Sorensen (1979)
London (England) 51° 30'	Hospital staff	11	24 - 45	M + F	48 - 90	McLaughlan et al. (1974)
London (England) 51° 30' N	Schoolchildren Students, staff Geriatric patients	198	7 - 86	M + F	29 - 56	Stamp and Round (1974)
St Louis (U.S.A.) 38° 40' N	Nurses	13		F	50 - 72	Haddad and Stamp (1974)



rise in 25-OHD may cause increased calcium absorption with an associated increased urinary calcium excretion (Robertson et al., 1974, Morgan et al., 1972). This would tend to increase plasma calcium with a resulting fall in plasma PTH and rise in plasma phosphate (Aitken et al., 1973, Frank and Carr, 1957, Iwanami et al., 1959, Josephson and Dahlberg, 1952, Vik et al., 1980) and fall in plasma magnesium (shown by Frank and Carr, 1957, but not by Vik et al., 1980). Osteomalacia would heal in response to the increased plasma 25-OHD (Aaron et al., 1974) with a rise in bone mass (Aitken et al., 1973) and a fall in plasma alkaline phosphatase (shown by Devgun et al., 1981, and by Josephson and Dahlberg, 1952, but not by Vik et al., 1980, or by McLaughlin et al., 1974).

The large seasonal changes in plasma 25-OHD make season-matching of groups under study important. Throughout the present study individual plasma 25-OHD are related to the reference range for that month. Measurements were made only in winter and spring in the studies of calcium metabolism after peptic ulcer surgery and wrist fracture. For the other groups the plasma 25-OHD was measured at presentation. The seasonal variation in other biochemical measurements are taken into account in the interpretation of data and explains the difference between the TBCa control group (taken throughout the year) and the plasma 25-OHD control group (taken in December).

The two to three-fold rise in plasma 25-OHD that follows a vacation spent sunbathing confirms the unpublished results of de Silva and Taylor quoted by Stanbury and Mawer (1978). In the present studies patients were questioned about sunshine exposure.

D. SUMMARY.

1. In 20 male volunteers aged 42 to 69 years the mean TBCa was 1143g with a CV of 11.7%. Total body calcium could be predicted from height ( $TBCa_p$ ). Calcium ratio ( $Ca_R$ ) was the ratio of observed and predicted TBCa. The CV of  $Ca_R$  was 6.2%.

2. In 20 female volunteers aged 46 to 66 years the mean TBCa was 821g with a CV of 15.2%. Total body calcium could be predicted from armspan and years postmenopause and the  $Ca_R$  calculated as for the men. The CV of  $Ca_R$  was 6.6%.

3. Reference ranges were derived from the data of the healthy volunteers for the following: plasma alkaline phosphatase, phosphate, calcium, albumin, magnesium, PTH, 25-OHD; urinary calcium, phosphate, magnesium, creatinine, and hydroxyroline; and dietary intake of calcium and vitamin D.

4. A relationship between urinary creatinine and lean body mass was described which allowed assessment of the completeness of urinary collections.

5. Several measurements of body size were made to allow comparison with other groups.

6. Monthly reference ranges were established for Edinburgh in 1979 and the seasonal variation and its relationship to numbers of hours of sunshine was noted. The seasonal variation in plasma magnesium,

phosphate, and alkaline phosphatase were described to show the importance of season-matching of groups under study.



CHAPTER 4. POSTMENOPAUSAL OSTEOPOROSIS: WOMEN PRESENTING WITH FRACTURES.

A. PATIENTS.

1. Vertebral fractures.

Fifteen women aged 48 to 71 years were referred to the endocrine clinic for treatment of osteoporosis. Back pain had been present for less than two years in 11 of these women. All patients had two or more fractures present on a lateral radiograph of the thoracolumbar spine.

A search was made for factors which may have accelerated bone loss, such as malabsorption or renal failure, by clinical examination and by the following investigations: serum or plasma alkaline phosphatase, phosphate, calcium, magnesium, albumin, PTH, 25-OHD, creatinine, iron, iron-binding capacity, ferritin, vitamin B12, folic acid, and thyroxine; full blood count; 24-hour urinary excretion of calcium, phosphate, magnesium, hydroxyproline, and creatinine; isotope bone scan and bone biopsy when indicated; and TBCa.

Nine patients were treated with alphacalcidol 0.5micrograms/day, ethinyloestradiol 20 micrograms/day for 3 weeks in every 4, and calcium supplements as calcium lactate gluconate (Sandocal) 4 Tablets daily (equivalent to 40 mmol calcium/day). Total body calcium and the above biochemical tests were repeated after 9 months' therapy. The remaining six patients were unable to tolerate this treatment or they entered the study towards its completion.

## 2. Wrist fractures.

Thirty women aged 45 to 75 years were recruited from the fracture clinic. During the winter and spring of 1979 approximately 60 patients who had fractured their wrists in the preceding month were invited to participate in a trial on the effect of treatment on osteoporosis.

Blood was taken without tourniquet in the non-fasting state for alkaline phosphatase, phosphate, calcium, magnesium, albumin, PTH, 25-OHD, creatinine, thyroxine and full blood count. Calcium and creatinine concentrations were measured on an early morning specimen of urine.

Twenty-eight women were allocated randomly to one of the four treatment groups.

1. Placebo (lactose 1 b.d.).
2. Ethinyloestradiol 20 micrograms/day, 3 weeks in 4.
3. Alphacalcidol 0.5 micrograms/day and Sandocal 2 b.d.
4. Treatments 2 and 3.

Forearm calcium and plasma biochemistry was measured at 0, four, eight, and 12 months. Unfortunately, eight patients withdrew from the study because of the side-effects of oestrogen such as depression, breast discomfort, and anxiety about the potential side-effects of oestrogen. Two patients in treatment group 4 changed to group 3 because of side-effects from the oestrogen. Only six patients in groups 2 and 4 completed the study compared with 15 patients in groups 1 and 3. The results of the initial measurements of patients in this group along with changes in the group given placebo are described below.

TBCa was measured in six of the patients taking placebo and in two of the volunteers who had fractured their wrists. These eight women also had measurement of 24-hour urinary excretion of calcium, phosphate, magnesium, hydroxyproline, and creatinine.

## B. RESULTS.

### 1. Vertebral fracture group.

#### a. TBCa.

The mean and SD of TBCa in women with vertebral fracture were 649 g and 87 g. This was significantly lower than in female controls ( $P < 0.001$ ).

The mean and SD of osteopaenia index were 0.69 and 0.06 and the results are shown in Figure 4a. All the women with vertebral fracture had indices of 0.78 or below and thus had a deficit in bone mass of more than 22% of the TBCa predicted for a woman of similar armspan at the time of the menopause.

The formula for  $TBCa_p$  could not be applied to six of the women as they were more than 22 years postmenopause. In the remaining nine the mean  $Ca_R$  was significantly reduced at 0.87 (SD, 0.06) compared with controls ( $P < 0.001$ ), and this is shown in Figure 4b. Factors which may have caused such reduction in bone mass were identified in five of these nine patients. These were prednisolone therapy for polymyalgia rheumatica, phenytoin therapy for epilepsy, previous history of thyrotoxicosis, atrophic gastritis, and moderate renal impairment (creatinine clearance of less than 0.33 ml/s).

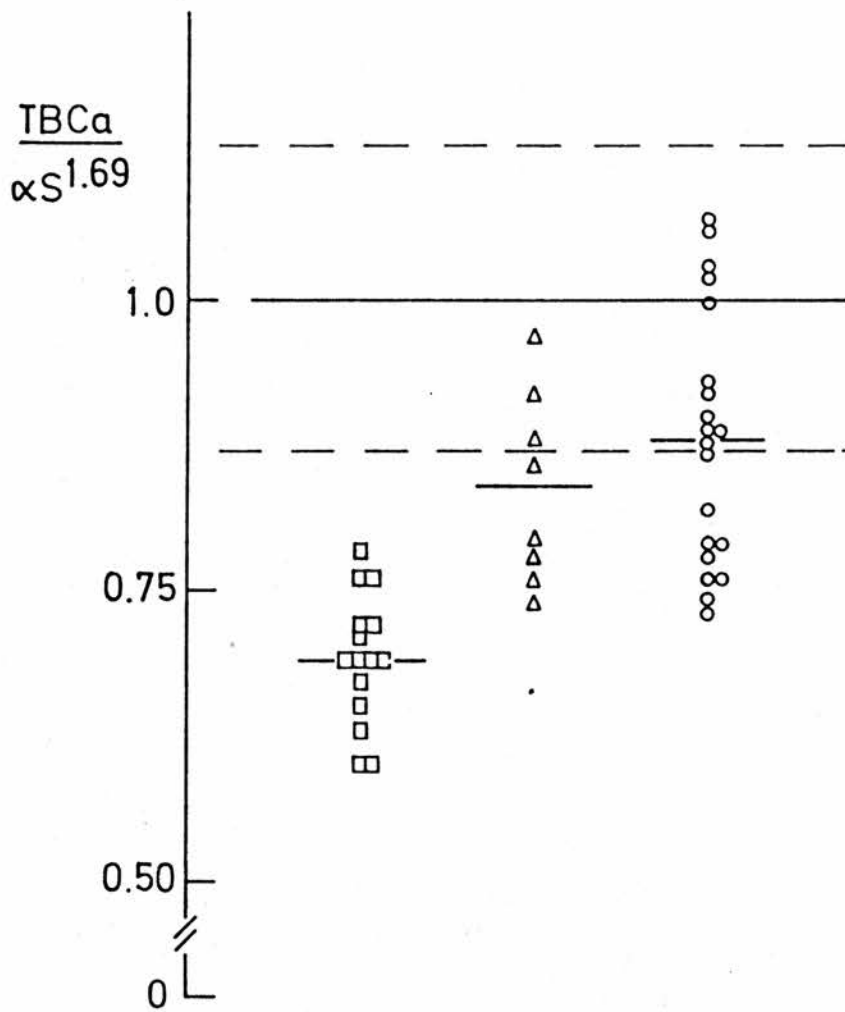

Figure 4a. Osteopaenia index in women with vertebral fracture ( $\square$ ), women with wrist fracture ( $\Delta$ ), and female controls (O). Broken lines indicate mean and 2SD of calcium ratio in female controls.

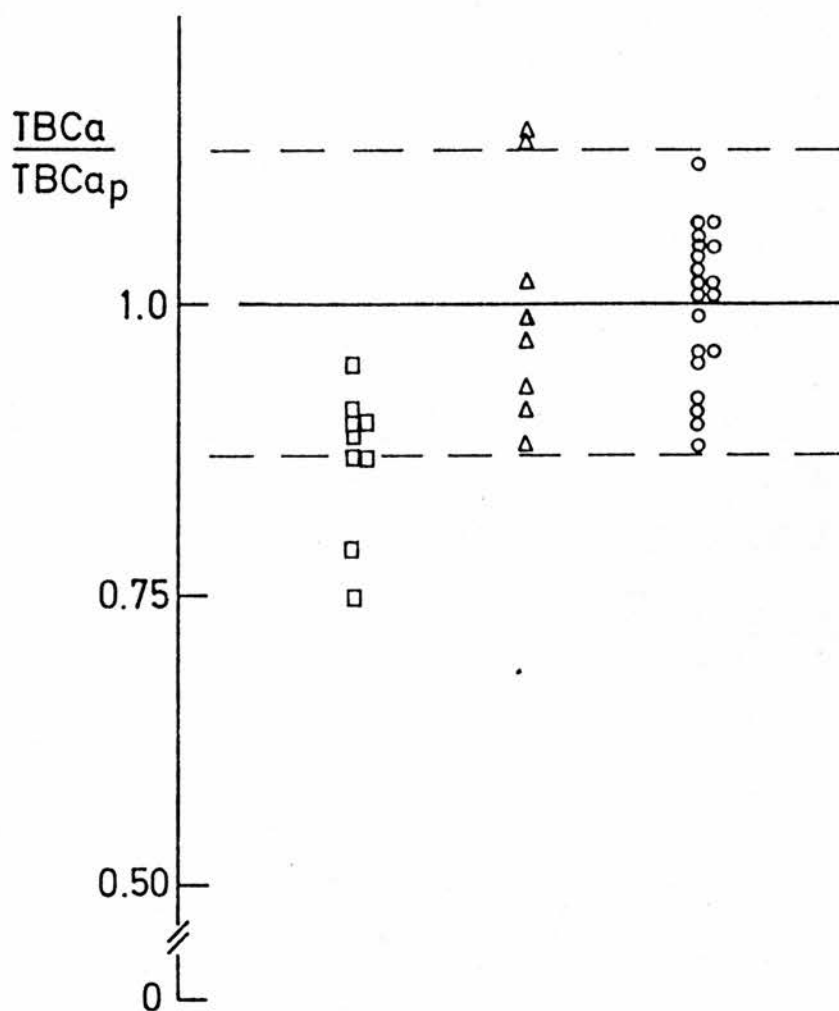

Figure 4b. Calcium ratio in women with vertebral fracture ( $\square$ ), women with wrist fracture ( $\Delta$ ), and female controls (O). Broken lines indicate mean and 2SD of calcium ratio in female controls.



### b. Biochemistry.

These results are shown in Table 4a where they are compared with the results of the female controls for TBCa. There was a significant reduction in creatinine clearance ( $P < 0.02$ ) and five women with vertebral fractures had values below 1 ml/s (60 ml/min). The plasma PTH was elevated ( $P < 0.02$ ) but in no case above the laboratory reference range. There was a significant reduction in the serum albumin ( $P < 0.01$ ).

### c. Age and body measurements.

These are shown in Table 4b where they are compared with female controls for TBCa. Women with vertebral fractures were older and had had earlier menopauses than controls. They also had shorter height for armspan due to their fractures and this is shown in Figure 4c.

### d. Effect of treatment.

The pre-treatment values for body measurements, biochemistry, and TBCa are shown in Table 4c. The nine women who were treated had similar characteristics to the whole group (Tables 4a and 4b).

Treatment had no significant effect on any biochemical variable. The mean increment in TBCa of 2.1% over nine months failed to reach significance.

## 2. Wrist fracture group.

### a. TBCa.

The mean and SD of TBCa in women with wrist fracture were 787g and 72g. This was not significantly different from female controls.

**Table 4a. Biochemical results in women with vertebral and wrist fractures.** Results are expressed as mean (SD) and compared with the female controls for TBCa.

<u>Measurement (units).</u>	<u>Vertebral fracture. Female controls. Wrist fracture (all).</u>				<u>Wrist fracture (Ca).</u>
	15	20	30	8	
<u>Number</u>	56	51	64	60	
<u>Plasma.</u>					
Alkaline phosphatase (u/l)	4.03 (0.31)	3.90	4.70 (0.26) ***	4.10 (0.35)	
[log <sub>e</sub> -transformed]					
Phosphate (mmol/l)	1.09 (0.13)	1.11	1.11 (0.14)	1.10 (0.16)	
Calcium (mmol/l)	2.38 (0.09)	2.38	2.39 (0.07) ***	2.36 (0.07)	
Magnesium (mmol/l)	0.82 (0.08)	0.80	0.86 (0.06)	0.82 (0.06)	
25-OHD (nmol/l)	39.6	35.9	41.7	41.8	
[log <sub>e</sub> -transformed]	3.73 (0.63) *	3.58	3.07 (0.60) *	3.30 (0.63)	
PTH (mcg/l)	0.25 (0.08)	0.16	0.20 (0.08)		
<u>Urine.</u>					
Calcium (mmol/24hr)	3.7 (1.7)	4.7		4.4 (2.1)	
Magnesium (mmol/24hr)	2.8 (1.2)	3.4		3.7 (1.4)	
Creatinine (mmol/24hr)	8.8 (3.2)	10.1		11.3 (2.7)	
Hydroxyproline (mmol/24hr)	257 (104) *	258		252 (72)	
Creatinine clearance (ml/s)	1.21 (0.57) *	1.73		1.70 (0.35)	
Phosphate (mmol/24hr)	23.7(11.7)	23.1		25.2 (8.9)	

Table 4b. Age and body measurements in women with fractures and in female controls for TBCa. Results are expressed as mean (SD). Statistical comparisons were made using unpaired t-test between fracture patients and female controls.

<u>Variable</u> (units).	<u>Vertebral fracture.</u>	<u>Controls.</u>	<u>Wrist fracture (all).</u>	<u>Wrist fracture (TBCa).</u>
Number	15	20	30	8
Age (yr)	64.7 (6.9)**	57.5	59.7 (5.8)	61.6 (3.6)
Postmenopause (yr)	21.9 (8.4)***	8.9	11.4 (5.8)	11.3 (5.7)
Armspan (m)	1.66 (0.07)	1.65		1.66 (0.06)
Height (m)	1.57 (0.08)	1.61	1.62 (0.06)	1.65 (0.05)
Weight (kg)	57.2 (9.8)	63.3	65.0 (7.3)	67.8 (8.0)
Overweight (%)	5.0 (15.3)	10.6	13.5 (12.1)	14.5 (9.9)
Body mass index ( $\text{kgm}^{-2}$ )	23.1 (3.2)	24.2	24.8 (2.7)	24.9 (2.1)
Body fat (%)	32.7 (4.5)	35.5		36.6 (4.8)
Lean body mass (kg)	38.3 (5.9)	40.5		42.7 (3.4)

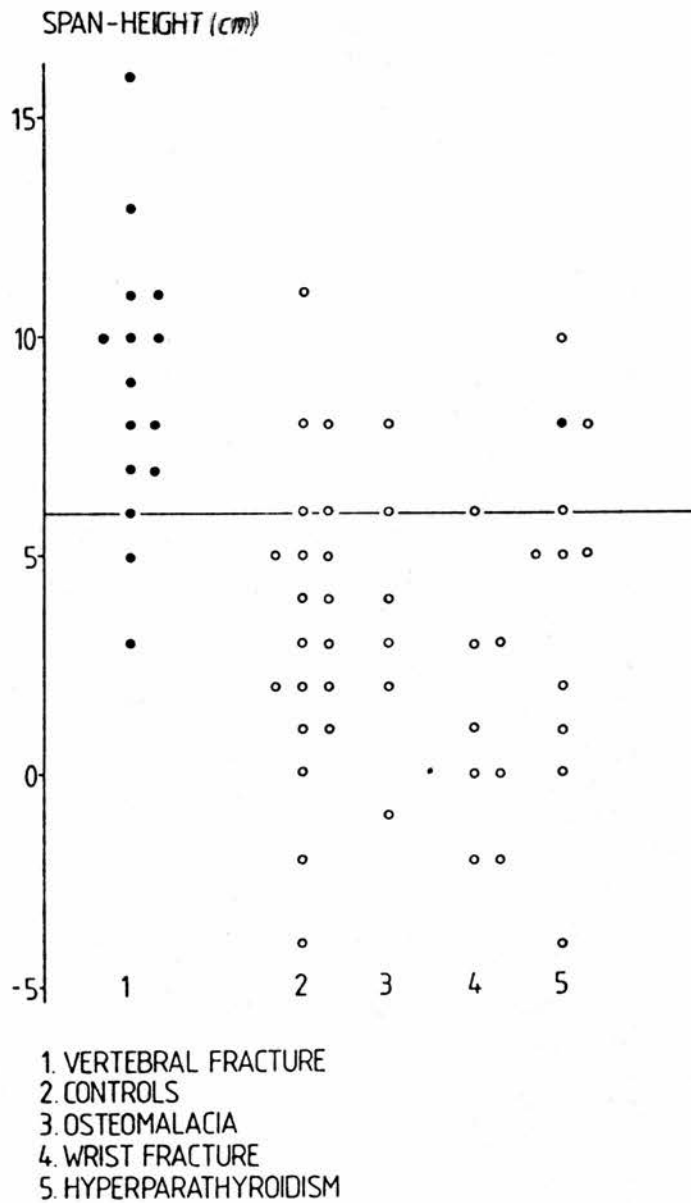

Figure 4c. Span minus height in five groups of women. Closed circles indicate those women who have suffered a vertebral fracture.

Table 4c. The effect of treatment on the results of women with vertebral fracture. Results are expressed as mean

<u>Variable (units).</u>	<u>Initial measurement.</u>	<u>Change.</u>
Age (yr)	64.3 (7.2)	
Postmenopause (yr)	23.2 (9.9)	
Height (m)	1.57 (0.10)	
Weight (m)	55.2 (10.9)	
Duration of treatment (mths)	9.4 (2.7)	
<u>Plasma.</u>		
Alkaline phosphatase (u/l)	59	-8.7 (4.9)
Phosphate (mmol/l)	1.09 (0.15)	-0.06(0.07)
Calcium (mmol/l)	2.38 (0.08)	0.03(0.04)
Magnesium (mmol/l)	0.82 (0.09)	-0.01(0.04)
25-OHD (nmol/l)	43	
PTH (mcg/l)	0.25 (0.08)	
<u>Urine.</u>		
Calcium (mmol/24hr)	3.36 (1.47)	0.70(0.94)
Magnesium (mmol/24hr)	2.91 (0.93)	-0.35(0.51)
Phosphate (mmol/24hr)	23.0 (9.0)	-6.7 (5.8)
Hydroxproline (mmole/24hr)	275 (95)	-51 (49)
Creatinine clearance (ml/s)	1.49 (0.55)	
<u>IVNAA.</u>		
TBCa (g)	636 (108)	16 (10)
Ca <sub>R</sub>	0.84 (0.07)	
Osteopaenia index (g/m <sup>1.69</sup> )	0.68 (0.07)	

The mean and SD of osteopaenia index were 0.84 and 0.08, as shown in Figure 4a. Three of the eight women had values below 0.78. However, none of these women had span - height values of more than 6 cm (Figure 4c).

The mean and SD for  $Ca_R$  were 1.00 and 0.10, and were therefore no different from controls (Figure 4b).

#### b. Biochemistry.

These are shown in Table 4a where they are compared with female controls for TBCa. The women with wrist fracture had significant elevations in plasma alkaline phosphatase ( $P < 0.001$ ), magnesium ( $P < 0.001$ ), and PTH ( $P < 0.02$ ), and a significant reduction in plasma 25-OHD ( $P < 0.05$ ). The blood samples were taken between February and June 1979.

The initial results of plasma 25-OHD and the results from samples taken at 4-monthly intervals thereafter in patients not taking oestrogens (as they increase 25-OHD binding protein) are shown in Figure 4d. Only three results fell below the reference range and in each case plasma calcium and PTH were normal and in two of the three alkaline phosphatase was normal.

In those patients given placebo there were falls over the period of a year in plasma alkaline phosphatase, magnesium, and PTH, but these changes were not statistically significant.

#### c. Age and body measurements.

These are shown in Table 4b where they are compared with female controls for TBCa. The results of those patients studied by TBCa are listed separately as the remaining patients did not have armspan or skinfold thickness measured. There were no significant differences between the wrist

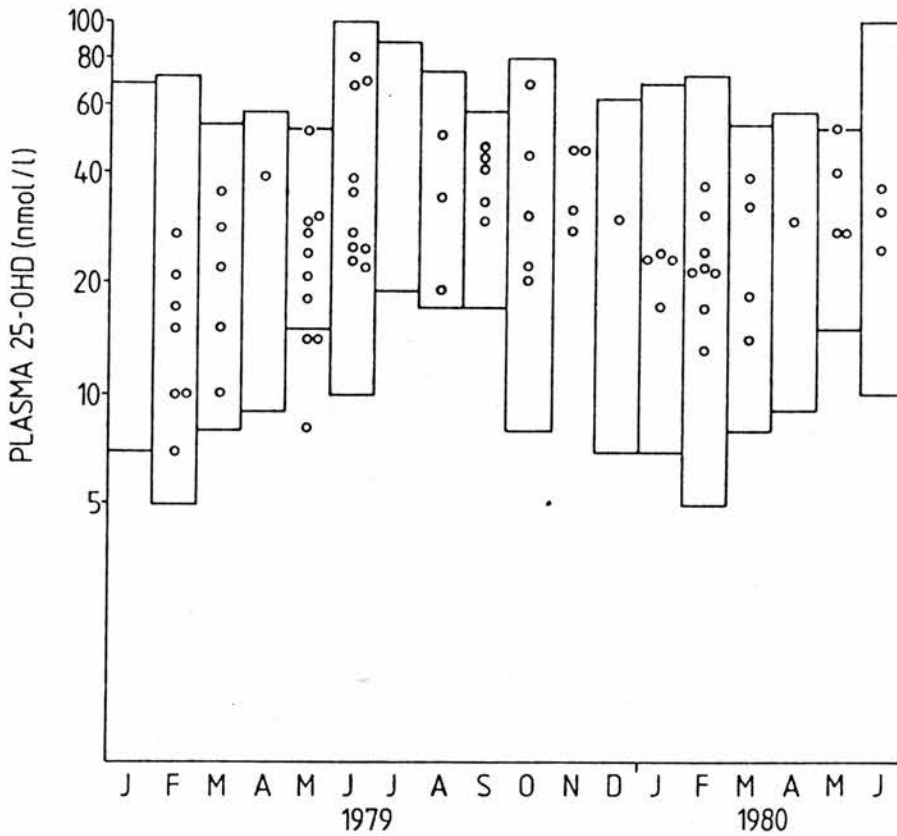

Figure 4d. Plasma 25-OHD in women with wrist fracture on no treatment. The bars represent mean and 2SD after logarithmic transformation of plasma 25-OHD values in controls.

fracture group and controls or between the wrist fracture group and the subgroup studied by TBCa.

### C. DISCUSSION.

#### 1. Vertebral fractures.

The range of osteopaenia index in this group was 0.60 to 0.78 and this suggests that they have a 22 to 40% reduction in bone mass. Most of the women had sustained their first vertebral fracture recently and so a reduction in bone mass must occur before this fracture occurs in a postmenopausal woman.

In a personal communication Dr. R. Hesp passed on the armspan and TBCa measurements of 14 women with vertebral fractures and who were aged 56 to 81 years. The TBCa results had already been published (Hesp et al., 1982). TBCa was measured by IVNAA using the cyclotron at the Hammersmith Hospital, London, as the source of neutrons (Spinks et al., 1977). The osteopaenia index was calculated as described above and the mean and SD were 0.66 and 0.08, with all cases below 0.80. Two women had values between 0.78 and 0.80. The mean value was similar to that found in the present study of 0.69.

Although osteopaenia index has not previously been applied to TBCa results the calcium bone index described by McNeill and Harrison (1977) is a similar concept. They measured part-body calcium (trunk and thighs) by IVNAA and express the result as a proportion of that found in a subject of the same sex and height under the age of 55 years. The mean and SD for controls of mean age 64 years were 0.88 and 0.13. In patients with osteoporosis of mean age 56 years the corresponding results were 0.69 and 0.11. These



results are similar to those of the present study in which the osteopaenia index of female controls of mean age 58 years was 0.98 and that of women with vertebral fractures was 0.69. Indices such as calcium bone index and osteopaenia index may prove useful in predicting which women are likely to benefit from measures aimed at prevention of loss of bone mass.

The low TBCa in these women was partly due to early menopause. If this were the only factor then  $Ca_R$  would have been the same as for the controls. As it was 13% lower there must either have been an increased rate of bone loss or a low bone mass at the time of the menopause.

Two other groups have reported values of TBCa similar to those found in the present study. Cohn et al.(1974) reported mean and SD for TBCa of 688g and 94g. Nelp et al.(1972) reported mean and SD for TBCa of 590g and 108g. Some patients in the study of Cohn et al.(1974) had only vertebral demineralization shown on the lateral spine radiograph and no vertebral fractures. Nonetheless these results are similar to the mean and SD described here of 645g and 87g. Cohn et al.(1974) also reported a mean  $Ca_R$  of 0.82, a result lower than that of 0.87 described here. This discrepancy may be due to the higher rate of loss of bone mass found in the present study and used in the equation to predict TBCa.

Factors known to accelerate bone loss were identified in some of the patients. The mean creatinine clearance was lower than that found in controls and this may have been the reason for the increase in plasma PTH. Lemann et al.(1979) have shown that when creatinine clearance falls below 50 to 80 ml/min (0.83 to 1.33 ml/s) the plasma PTH rises. Half of the women with vertebral

fracture had creatinine clearance below these values. This secondary hyperparathyroidism may have accelerated bone loss. The mild renal impairment may also have affected the synthesis of calcitriol, the form of vitamin D most active in promoting calcium absorption in the gut.

The low bone mass of women with vertebral fractures is not the only factor which predisposes to fracture. In the patients with hyperparathyroidism described in chapter 5 low osteopaenia indices were found in the absence of vertebral fractures. This is also true of the women with osteomalacia described in chapter 6.

Frost (1981) proposed that osteoporosis was caused by low bone turnover which allowed bone matrix to age and become more brittle. Aaron (1977) described a similar defect found in histological sections of bone from patients with osteoporosis and she termed this defect "autoclasis". Similarly, Ralis (1983) describes a bone quality defect that can be detected more commonly in elderly subjects with femoral neck fracture than in elderly controls. This defect can be demonstrated by microradiography, by tetracycline labelling of decalcified bone, or by undecalcified bone which is shattered by the microtome in an abnormal manner. Although Ralis has not studied women with vertebral fracture it is possible that such a bone quality defect is also present in this group.

TBCa measurements have good reproducibility and this technique has been used by others to describe small changes in bone mass following therapy for osteoporosis (eg. Chesnut et al., 1977). In the present group the numbers were so small that the rise in bone mass found was not significant. No control group was used as all

patients were referred for therapy of osteoporosis and Marshall and Nordin (1977) had shown that the therapy used here was effective in making the calcium balance positive in osteoporotic women.

## 2. Wrist fractures.

The osteopaenia indices and  $Ca_R$  in this group were similar to the age-matched and sex-matched controls. Nordin et al. (1980b) have shown a reduction in trabecular bone volume in the iliac crest between the ages of 55 and 65 years. Trabecular bone contributes much less to TBCa than cortical bone. It may be that those women who fracture their wrists lose trabecular bone faster than cortical bone. The distal radius contains a higher proportion of trabecular bone than elsewhere in the skeleton (about 50%) but changes in the iliac crest may not reflect changes in the distal radius.

These women were unfortunate in slipping on the ice during a particularly cold winter and had the controls fallen similarly they too may have fractured their wrists. This would explain why the TBCa did not differ between these two groups. A further factor may be obesity. Twenty-seven of the 30 women with wrist fractures were above their ideal weight and this weight would be transmitted through the wrist during a fall onto the outstretched hand.

The slight increase in plasma alkaline phosphatase shortly after the fracture may be due to fracture healing. In the placebo-treated group plasma alkaline phosphatase fell over the following year. In patients with femoral neck fracture plasma alkaline phosphatase rises to a peak of up to five times the basal value about four weeks after the fracture (Sharland and Overstall,

1978). The other biochemical differences from controls were probably seasonal as the blood samples of the wrist fracture group were taken between February and June (see Chapter 3). Plasma 25-OHD followed the normal seasonal cycle and in this respect differ from women with femoral neck fracture who have low levels (Lund et al., 1975).

#### D. SUMMARY.

1. In 14 women who had recently sustained a spontaneous vertebral fracture the mean TBCa was reduced to 649g. The mean  $Ca_R$  was also reduced to 0.87 indicating that the low TBCa was not due to the effect of age alone.

2. TBCa was adjusted to allow for body size alone (osteopaenia index) in order to try and establish a theoretical fracture threshold. All patients had osteopaenia indices below 0.78. When this index was calculated for the data of Hesp et al.(1982) all their patients with vertebral fractures had values of 0.80 or below.

3. In the women with vertebral fractures there was a reduction in mean creatinine clearance and an associated rise in plasma PTH. The renal impairment and the hyperparathyroidism may have accelerated the rate of bone loss. In some individuals diseases or drug therapy likely to accelerate the rate of bone loss could be identified.

4. In 8 women who had fractured their wrists the mean TBCa was

787g. This was no lower than controls, and the mean  $Ca_R$  was also normal.

5. Patients with wrist fracture show the normal seasonal variation in plasma 25-OHD. There was an initial increase in plasma alkaline phosphatase, magnesium, and PTH, but these returned towards normal over the year following the fracture.

## CHAPTER 5. PRIMARY HYPERPARATHYROIDISM.

### A. PATIENTS.

Fourteen patients with primary hyperparathyroidism were referred to the endocrine clinic between 1978 and 1982. Two of these patients were identified in the screening tests performed on other groups in the present study, one woman with wrist fracture and a man following Polya partial gastrectomy.

In addition to clinical examination the following measurements were made: height, armspan, weight, skinfold thickness; plasma alkaline phosphatase, calcium, magnesium, albumin, PTH, 25-OHD, creatinine; discriminant function analysis was performed by the method of Watson et al.(1980) from plasma phosphate, urea, bicarbonate, chloride, and erythrocyte sedimentation rate; the renal threshold for phosphate was calculated by the method of Bijvoet (1977) from measurements of plasma and urinary phosphate and creatinine made in the fasting state on a two-hour collection of urine; 24-hour urinary excretion of calcium, phosphate, magnesium, hydroxyproline, and creatinine; hydrocortisone suppression test performed by the method of Dent and Watson (1968); radiograph of hands; and TBCa. TBCa, and plasma and urinary biochemistry measurements were repeated after parathyroidectomy.

## B. RESULTS.

### 1. Patient details.

The complications of primary hyperparathyroidism found in this group are shown in Table 5a. The clinical examination also identified conditions likely to accelerate bone loss in four patients. These were diabetes mellitus (2), rheumatoid arthritis (1), and peptic ulcer surgery (1).

Ten of 11 patients underwent successful neck exploration. The adenomata weighed between 0.17 and 1.59g. In the patient with the unsuccessful neck exploration a venous sampling study suggested the adenoma was in the mediastinum. However the adenoma was not found at a second, sternum-splitting operation. Of the three patients who have not undergone surgery one refused surgery and two were considered not to require surgery as the hypercalcaemia was mild.

Hand radiographs showed subperiosteal erosions in one patient only.

### 2. TBCa.

The mean and SD of TBCa in the 11 women with primary hyperparathyroidism were 664g and 119g. This was 19% below the result for age- and sex-matched controls. In the men the mean value was 1061 g.

The mean and SD of osteopaenia index in the women were 0.73 and 0.12 (Figure 5a). Seven of the 11 women had values below 0.78, the level below which spontaneous vertebral fractures were found (Chapter 4). Only one of these had back pain, loss of height, and radiological evidence of vertebral fracture. The span - height

Table 5a. Complications of primary hyperparathyroidism in 14 patients.

<u>Complication.</u>	<u>Number.</u>
Renal calculi.	6
Peptic ulcer.	6
Hypertension.	2
Fracture - wrist.	1
- vertebra.	1
Gout.	1
Confusional state.	1



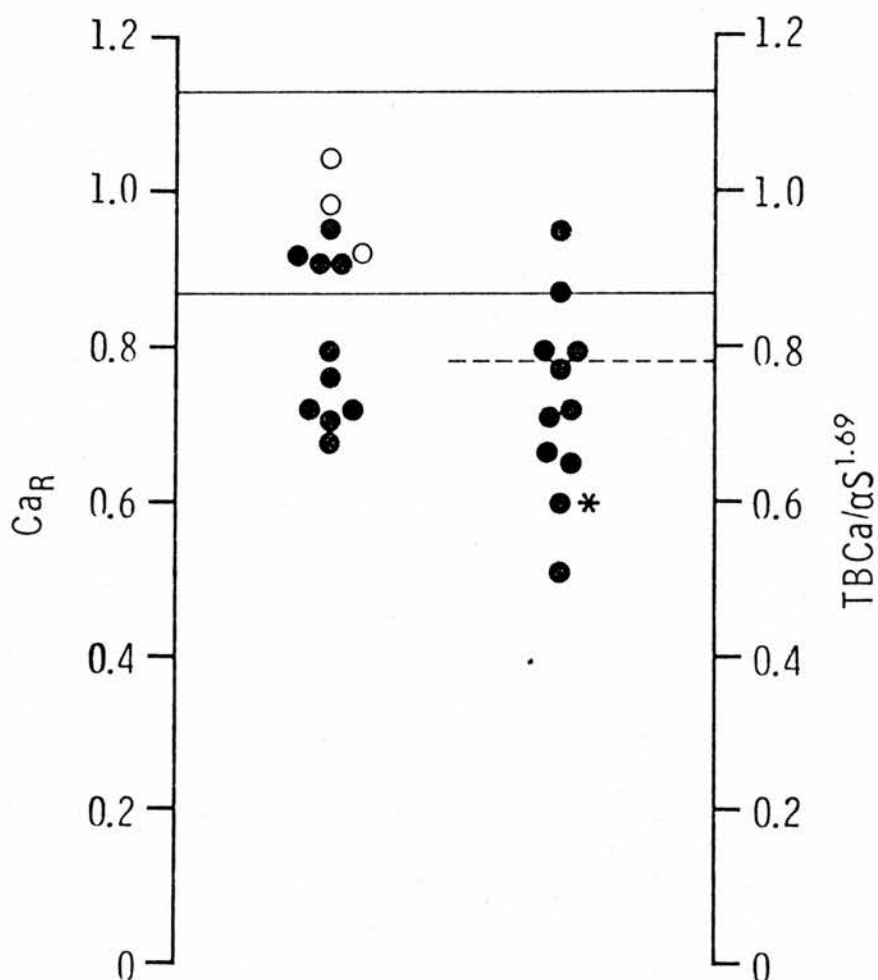

Figure 5a. Calcium ratio and osteopaenia index in men (O) and women (●) with primary hyperparathyroidism. Solid lines represent mean and 2SD of calcium ratio in controls. The broken line indicates the theoretical fracture threshold. The asterisk indicates the patient with vertebral fracture.

values in eight of the remaining ten women were less than 6cm, the value above which vertebral fractures were associated (Figure 4c).

Ten of the 11 women were less than 22 years postmenopause and so the formula for  $TBCa_p$  could be applied. The mean and SD of  $Ca_R$  were 0.81 and 0.11 (Figure 5a). This highly significant reduction ( $P < 0.001$ ) was still found when the data from the patients with rheumatoid arthritis and diabetes mellitus were excluded.

There was no significant relationship between  $Ca_R$  and plasma calcium or alkaline phosphatase. The six patients with subnormal  $Ca_R$  did not have higher plasma alkaline phosphatase than those with normal  $Ca_R$ .

In the seven patients remeasured after parathyroidectomy there was a mean rise in TBCa of 49 g. This rise did not reach significance. The least significant change using TBCa is 5.1%. Four patients had rises above this (range 7.2 to 20.4%, see Figure 5c). Only one of these patients had an elevated plasma alkaline phosphatase.

### 3. Biochemistry.

The results are shown in Table 5b where they are compared with those from the 40 controls for TBCa. There was a significant elevation in plasma alkaline phosphatase compared with controls ( $P < 0.001$ ) and this difference remained even when the result from the patient with subperiosteal erosions was excluded from the comparison. Three patients had values above the laboratory reference range. There were also significant elevations in plasma magnesium and PTH and in urinary calcium ( $P < 0.01$ ,  $P < 0.001$ , and  $P < 0.02$ , respectively). There was elevation of plasma calcium and detectable or elevated PTH in all cases as shown in Figure 5b.

Table 5b. Biochemical results in patients with primary hyperparathyroidism. Results are expressed as mean (SD) and compared with the controls for TBCa. Results marked + exclude the data from men.

<u>Measurement (units).</u>	<u>Hyperparathyroidism.</u>	<u>Controls.</u>
Number	14	40
<u>Plasma.</u>		
Alkaline phosphatase (u/l)	68	51
[log <sub>e</sub> -transformed]	4.22 (0.29) ***	3.90
Phosphate (mmol/l)	0.85 (0.18) ***	1.05
Calcium (mmol/l)	2.66 (0.10) ***	2.38
Magnesium (mmol/l)	0.86 (0.04) **	0.81
25-OHD (nmol/l)	21.6	33.3
[log <sub>e</sub> -transformed]	3.08 (0.93)	3.51
PTH (mcg/l)	0.51 (0.51) ***	0.16
<u>Urine.</u>		
Calcium (mmol/24hr)	8.8 (5.1) *	5.2
Magnesium (mmol/24hr)	5.1 (2.5)	3.8
Creatinine (mmol/24hr)+	12.4 (4.6)	10.1
Hydroxyproline (mmol/24hr)	417 (252)	295
Creatinine clearance (ml/s)+	1.76 (0.75)	1.73

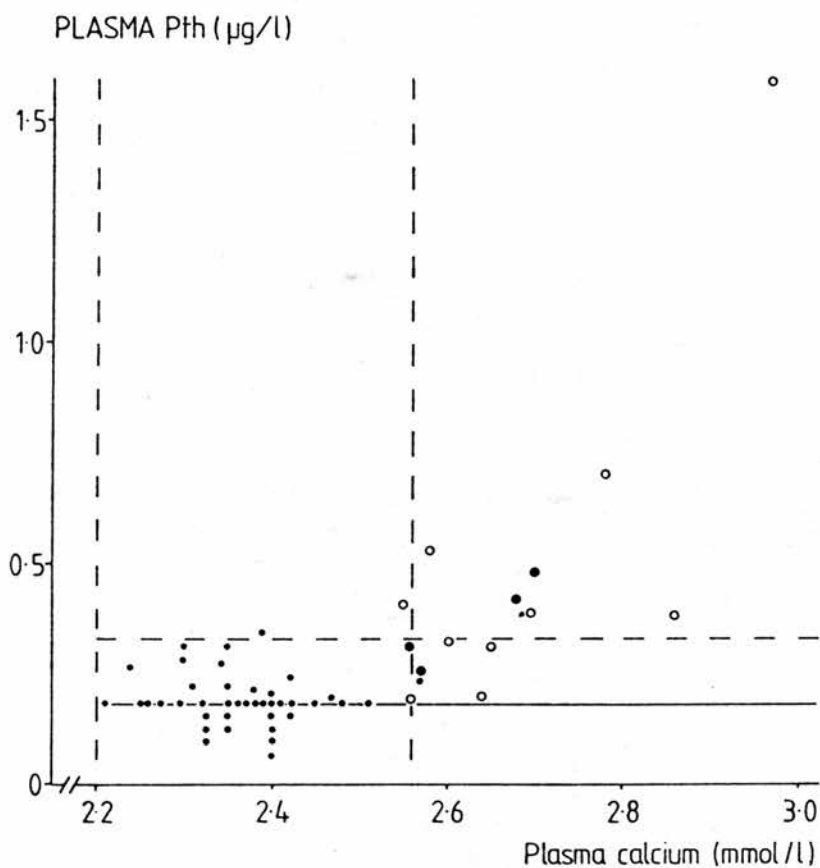

Figure 5b. Plasma PTH and calcium in the TBCa controls (small circles) and in patients with primary hyperparathyroidism.  
 Patients with surgically-proven adenomas are represented by open circles. Broken lines represent mean and 2SD of the results from TBCa controls. The solid line represents the lower limit of sensitivity of the PTH assay.

There was a significant reduction in plasma phosphate ( $P < 0.001$ ).

Discriminant function analysis correctly classified the patients in 12 cases. The patient with subperiosteal erosions was not classified correctly nor was the one patient who refused surgery.

The mean  $TmP/GFR$  was  $0.68 \text{ mmol/l}$  (SD,  $0.25$ ) and five out of eight patients had low values. Five out of six patients showed no suppression of plasma calcium during the hydrocortisone suppression test. The remaining case underwent a PTH catheter study which suggested an adenoma in the thymus. As the hypercalcaemia was mild operation was deferred.

Seven patients were remeasured six to 32 months post-operatively. In all cases plasma calcium fell to normal or low (1 case). There were significant falls in plasma calcium (by  $0.34 \text{ mmol/l}$ ,  $P < 0.001$ ), and in magnesium (by  $0.09 \text{ mmol/l}$ ,  $P < 0.05$ ), and a significant rise in plasma phosphate (by  $0.26 \text{ mmol/l}$ ,  $P < 0.05$ ). The mean fall in plasma alkaline phosphatase of  $26 \text{ u/l}$  did not reach significance.

#### 4. Age and body measurements.

These are shown in Table 5c where they are compared with the female controls for TBCa. The 11 women were of similar chronological and postmenopausal age and similar body size to the female controls. The three men were more overweight than the male controls, and one of the men was obese (49% above ideal weight).

Table 5c. Age and body measurements in patients with hyperparathyroidism and in female controls for TBCa. Results are expressed as mean (SD).

<u>Variable (units).</u>	<u>Female patients.</u>	<u>Controls.</u>	<u>Male patients.</u>
Number	11	20	3
Age (yr)	54.5 (10.5)	57.5	48
Postmenopause (yr)	7.8 (9.2)	8.9	
Armspan (m)	1.63 (0.06)	1.65	1.82
Height (m)	1.58 (0.06)	1.61	1.73
Weight (kg)	59.8 (9.6)	63.3	86.5
Overweight (%)	8.8 (17.8)	10.6	27
Body mass index ( $\text{kgm}^{-2}$ )	23.9 (3.8)	24.2	28.9
Body fat (%)	33.8 (4.9)	35.5	25.7
Lean body mass (kg)	39.2 (4.5)	40.5	64.2

### C. DISCUSSION.

There has been one previous study of absolute measurements of TBCa in patients with primary hyperparathyroidism. Cohn et al.(1973) measured eight such patients and they had a mean  $Ca_R$  of 0.89, a result similar to that of 0.85 found in the 14 patients described here.

Bone mass has been measured in this group of patients using other techniques. Genant et al.(1973) found a 13% reduction in bone mass in 65 patients using photon absorptiometry of the third digit. Dalen and Hjern (1974) found a 10% reduction in 10 patients using X-ray spectroscopy of the radius and ulna. Pak et al.(1975) divided their 30 patients into postmenopausal women and others (men and premenopausal women). Bone mass was measured by photon absorptiometry of the radius. In the postmenopausal women it was reduced by 22% and in the others it was normal. Seeman et al.(1982) described a reduction in lumbar spine and radius density using double and single photon absorptiometry. The midradius density was normal and this suggests that trabecular bone is affected more than cortical bone.

Osteopaenia is thus a common feature of primary hyperparathyroidism, particularly in the postmenopausal woman. Dauphine et al.(1975) reported an increased incidence of vertebral fracture in such patients. More than half the patients in the present study had osteopaenia indices less than 0.78 and yet only one sustained vertebral fracture. This is discussed in Chapter 4.

Figure 5c shows the changes in TBCa in the seven patients of the present study along with the five patients of Cohn et al.(1973)

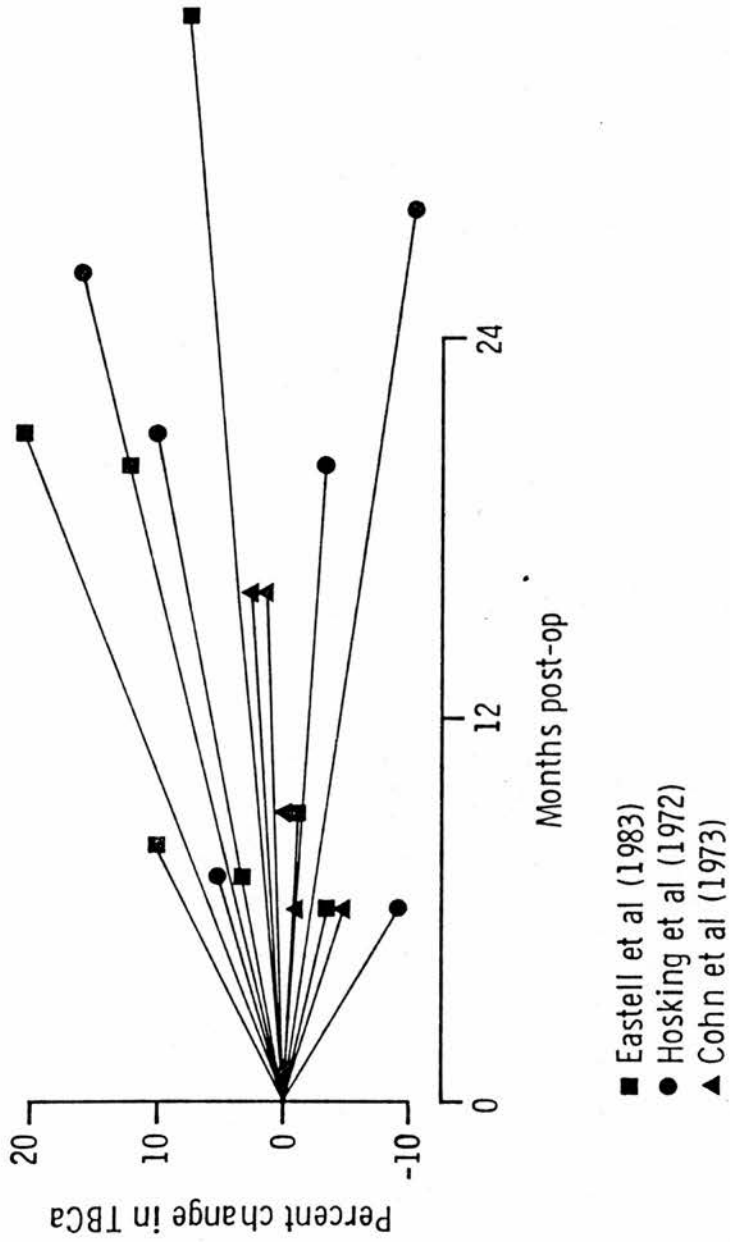

Figure 5c. Changes in TBca following parathyroidectomy in 19 patients with primary hyperparathyroidism.



and the seven patients of Hosking et al.(1972). The mean change in TBCa - these 19 patients over an average period of 15 months was a rise of 1.6%. The 95% confidence intervals of this change were -2.1% to 5.3%. Thus even if a larger series were able to show a significant rise it is unlikely that this would be more than 5.3%. Only two of these 19 patients had radiological changes of primary hyperparathyroidism and these two had rises of 12 and 16%. Although little change in bone mass may occur in patients with no radiological abnormalities this may not be the case in the small group of patients with abnormalities.

Genant et al.(1973) found a seven percent rise in X-ray spectrophotometry of the third digit one to three years post-operatively. Nine percent of their patients had subperiosteal erosions and 34% raised plasma alkaline phosphatase. In most series of patients with primary hyperparathyroidism only 10 to 20% of patients have elevated alkaline phosphatase.

Dalen and Hjern (1974) found a four percent increase over one year using the mean result of changes in X-ray spectrophotometry at seven sites in ten patients. No patient had radiological changes of primary hyperparathyroidism.

These studies show that primary hyperparathyroidism causes a substantial reduction in bone mass, particularly in the postmenopausal woman. In the absence of radiological evidence of osteitis fibrosa there is only partial recovery of this deficit following surgery. It is likely that early surgery would prevent osteopaenia but as primary hyperparathyroidism is a common disorder in the postmenopausal woman a randomized trial of surgery in women without radiological changes of hyperparathyroidism is needed.

The clinical features and biochemical findings are similar to those reported by others (Potts, 1978, and Paterson, 1974). There are two findings which are relevant to the interpretation of results from the patients after peptic ulcer surgery, as described in Chapter 8.

Plasma magnesium was higher in patients with primary hyperparathyroidism than in controls and fell following parathyroidectomy. Nordin (1976) described reduced urinary magnesium excretion in primary hyperparathyroidism. These results do not agree with those of Mallette et al. (1974) or of King and Stanbury (1970) who found hypomagnesaemia in 14 and 19% of cases of primary hyperparathyroidism, respectively. They did not report changes with surgery.

Assay of plasma PTH is troublesome as this hormone exists in various forms in the blood. Even though the assay used in the present study is directed mainly against the N-terminal end of PTH most of what is measured is probably inactive. Fenton et al. (1978) report an upper limit of normal of 30 ng/l for plasma PTH using a cytochemical bioassay whereas the upper limit of normal of the TBCa controls in the present study was 330 ng/l. The differences between the antisera of the different assays was shown by Raisz et al. (1979) who used four assays on sera from the same patients with primary hyperparathyroidism and found that the percent of cases with elevated PTH varies from 27 to 87. In the present study 8 of the 14 patients had elevated PTH.

#### 4. SUMMARY.

1. In 14 patients with primary hyperparathyroidism there was a reduction in  $Ca_R$  to a mean of 0.85. Only one of these patients had radiological evidence of hyperparathyroidism.
2. The osteopaenia index was lower than the theoretical fracture threshold in seven out of the eleven women. However, only one had a vertebral fracture.
3. Following removal of the parathyroid adenoma four out of seven patients had significant rises in TBCa. The mean increase in TBCa of the group of 49g and was not significant.
4. The biochemical changes showed no relationship to the changes in TBCa. The changes in plasma calcium and phosphate were as expected, but the fall in plasma magnesium from an initially high value was a new finding.

## CHAPTER 6. WOMEN WITH OSTEOMALACIA.

### A. PATIENTS.

Seven women with osteomalacia were referred to the endocrine clinic. All patients had malabsorption syndrome and their diagnoses are shown in Table 6a. The diagnosis of osteomalacia was based on the typical biochemical changes of hypocalcaemia and hyperphosphatasia which responded to vitamin D therapy, or on the typical bone biopsy changes.

Measurements were made of the following prior to initiation of therapy with vitamin D: plasma calcium, phosphate, magnesium, alkaline phosphatase, 25-OHD, PTH; urinary calcium and creatinine; radiological skeletal survey; and TBCa.

Treatment with vitamin D depended on the policy of the physician in charge of case. Five patients received vitamin D<sub>2</sub> 300,000 units intramuscularly at intervals according to the biochemical response, one patient received oral vitamin D<sub>2</sub> 50,000 units weekly, and one patient received alphacalcidol 1 microgram per day.

Repeat biochemical measurements were made in all patients except one who died shortly after the first measurement.

### B. RESULTS.

#### 1. TBCa.

The mean and SD of TBCa in the seven women with osteomalacia were 596 g and 75 g. This was 27% below the mean for

Table 6a. Causes of osteomalacia in seven women.

<u>Patient</u> <u>no.</u>	<u>Age.</u>	<u>Cause.</u>
1	38	Crohn's disease (for 15 years). Small bowel resection (2 months previously).
2	71	Vagotomy and gastroenterostomy (8 years previously) Bacterial colonization.
3	82	Polya partial gastrectomy (27 years previously).
4	64	Crohn's disease (for 21 years). Vagotomy and pyloroplasty (12 years previously).
5	84	Vagotomy and gastroenterostomy (22 years previously).
6	63	Malabsorption syndrome of undetermined cause.
7	69	Crohn's disease (for one year). Right hemicolectomy (one year previously). Polya partial gastrectomy (one year previously).

female controls.

The mean and SD of osteopaenia indices were 0.67 and 0.08 and this is shown in Figure 6a. Six of the seven women had osteopaenia indices below 0.78, the level below which vertebral fractures occur. However, the patients did not complain of back pain or loss of height and had normal (span - height) values (see Figure 4c). A lateral radiograph of the lumbar spine of patient number four is shown in Figure 6b. The results of quantitative bone histology on this patient are shown in Table 6b. The excess osteoid is a feature of osteomalacia but the trabecular bone volume was high. The osteopaenia index in this patient was 0.69.

$Ca_R$  could not be calculated as five of the women were more than 23 years postmenopause. None of the patients had Looser's zones.

Three patients had repeat measurements of TBCa and their results are shown in Table 6c. The increases were 4, 7, and 18%, the largest rise being associated with the greatest fall in alkaline phosphatase.

## 2. Biochemistry.

The results are shown in Table 6d where they are compared with reference ranges derived from the results of the female controls for TBCa. All patients had hyperphosphatasia and hypocalcaemia. One patient received low-dose vitamin D before the first measurement and she had a low-normal 25-OHD and a normal PTH (patient no.4). All others had plasma 25-OHD values which were low, or at the lower limit of the reference range for that month, and PTH which was high, or at the upper limit of the reference range. The six cases from whom urinary collections were obtained all had

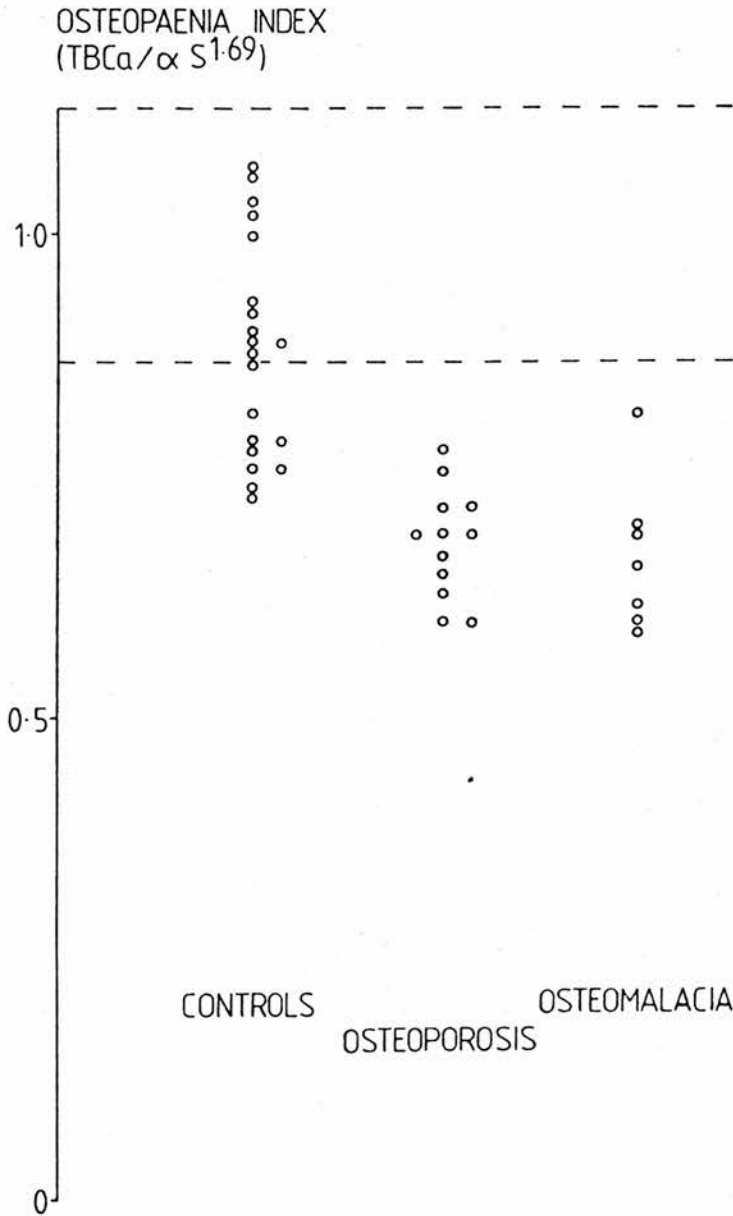

Figure 6a. Osteopaenia index in women with osteomalacia compared with women with vertebral fracture and female controls. Broken lines indicate mean and 2SD of calcium ratio in female controls.



Figure 6b. Lateral radiograph of the lumbar spine in patient no.4  
with osteomalacia.



Table 6b. Quantitative histology of bone in patient no.4 with osteomalacia.

<u>Variable.</u>	<u>Value.</u>	<u>Reference range.</u>
Trabecular bone volume (%)	21.2	10.7 - 19.9
Osteoid volume (%)	33.2	0.9 - 2.3
Osteoid surface (%)	87.5	4.7 - 12.5
Osteoid index	37.9	16 - 21
Resorption surface (%)	10.5	2.6 - 4.4

Table 6c. The effects of treatment with vitamin D on plasma biochemistry and TBCa in 7 women with osteomalacia.

<u>Patient no.</u>	<u>Interval</u> (months)	<u>Plasma calcium</u> (mmol/l)		<u>Alkaline phosphatase</u> (u/l)		<u>TBCa</u> (g)	
		<u>Initial</u>	<u>Final</u>	<u>Initial</u>	<u>Final</u>	<u>Initial</u>	<u>Final</u> (% change)
1	11	1.73	2.19	112	135	582	624 (7%)
2	3	2.02	2.33	165	80	568	
3	25	2.15	2.35	113	64	532	
4	19	1.92	2.40	210	73	593	
5	Died	2.08		116		555	
6	8	2.03	2.33	137	65	582	686 (18%)
7	3	2.14	2.38	105	76	759	791 (4%)

Table 6d. Biochemical results in seven women with osteomalacia. Means for plasma 25-OHD and PTH after logarithmic transformation. Reference range derived from female controls for TBCa (mean and 2SD). One patient had previously received vitamin D (+). Statistical comparisons were made using an unpaired t-test between patients and female controls for TBCa.

<u>Patient no.</u>	<u>Alk. Phos.</u> (u/l)	<u>Phosphate</u> (mmol/l)	<u>Calcium</u> (mmol/l)	<u>Magnesium</u> (mmol/l)	<u>25-OHD</u> (nmol/l)	<u>PTH</u> (mcg/l)	<u>Urine calcium</u> (mmol/24hr)	<u>Urine creatinine</u> (mmol/24hr)
1	112	0.75	1.73	0.60	0 (Feb)	0.67	0.10	1.2
2	165	0.83	2.02	1.07	6 (Apr)	0.32	0.76	7.0
3	113	0.67	2.15	0.88	13 (Mar)	0.73	0.49	21.5
4+	210	0.66	1.92	0.87	16 (Jan)	<0.17	0.50	4.3
5	116	0.98	2.08	1.09	12 (Mar)	0.45	1.44	8.2
6	137	0.60	2.03	0.94	3 (Oct)	0.56	-	-
7	105	1.49	2.14	0.91	10 (Mar)	0.34	1.01	7.1
<u>MEAN</u>	4.89 ***	0.85 *	2.01 ***	0.91 ***	1.86 ***	0.51 ***	0.84 ***	8.2
<u>SD</u>	0.25	0.31	0.15	0.16	1.00	0.17	0.40	7.0

hypocalciuria. Although they had significantly lower urinary creatinine than controls  $(P < 0.001)$  this was appropriate for their low lean body mass (see Figure 3a).

The effects of treatment are shown in Table 6c. In five patients the plasma calcium and alkaline phosphatase fell into the reference range. The remaining patient (patient number one) had a flare-up of her Crohn's disease with weight loss during her 11-month follow up period.

### 3. Age and body measurements.

The results are shown in Table 6e. They were older by 10 years and lighter by 16 kg when compared with the female controls. The reduction in weight was due to a reduction in both body fat and lean body mass. They were, on average, 16 years more past the menopause than the female controls and the mean armspan was 5 cm less. The two latter factors would usually be associated with a reduction in TBCa.

### C. DISCUSSION.

The low values of TBCa and osteopaenia index in the women with osteomalacia was due in part to the long time interval since the menopause (mean, 24 years). The contribution of this factor could not be assessed by the equation for  $TBCa_p$  as most of the women were more than 22 years postmenopause. Back pain and loss of height were not complaints in this group and this is confirmed by the normal (span - height) values shown in Figure 4a.

Patient number four illustrates this point well and the results of her quantitative bone histology and a photograph of the

Table 6e. Age and body measurements in women with osteomalacia and in female controls for TBCa. Results are expressed as mean (SD).

<u>Variable (units).</u>	<u>Osteomalacia.</u>	<u>Controls.</u>
Number	7	20
Age (yr)	67.3 (15.3)	57.5
Postmenopause (yr)	24.2 (14.4) *	8.9
Armspan (m)	1.60 (0.06)	1.65
Height (m)	1.57 (0.05)	1.61
Weight (kg)	47.6 (5.7) ***	63.3
Overweight (%)	-12.7 (12.3) ***	10.6
Body mass index (kgm <sup>-2</sup> )	19.4 (2.7) ***	24.2
Body fat (%)	26.8 (4.9) **	35.5
Lean body mass (kg)	34.7 (3.1) **	40.5

lateral lumbar spine radiograph are shown in Table 6b and Figure 6b. This patient had an osteopaenia index of 0.69, a value below the threshold found for women with spontaneous vertebral fracture, yet no vertebral fracture is present. The bone biopsy shows excess osteoid but high trabecular bone volume. As vertebrae are composed of 50% trabecular bone they may be less affected by osteopaenia than other bones which are composed of more cortical bone. This case illustrates that TBCa measurement only gives a rough guide to the bone mass of the vertebrae and that in bone disease that affects cortical bone more than trabecular bone the result may be misleading.

There are few reports on bone mass in patients with osteomalacia. Morgan et al.(1970) reported metacarpal cortex thickness in 17 of their 23 patients with osteomalacia following gastric surgery and they had lower values than age- and sex-matched controls after gastric surgery without osteomalacia.

Hosking et al.(1972) measured TBCa in six patients for six to 36 months following treatment. Increases in TBCa ranged from three to 30%. In the present series changes of four to 18% were found over three to 11 months in three patients.

The diagnosis of osteomalacia on biochemical grounds alone can be difficult. Paterson (1974) considers that hypocalcaemia, hypophosphataemia, and hyperphosphataemia are usually, but not always present in osteomalacia. Nordin et al.(1980) consider that a low plasma 25-OHD along with a raised plasma PTH signify osteomalacia. Table 6c shows that most of these biochemical abnormalities were present in most of the patients.

Confirmation of the diagnosis may be by the finding of

Looser's zones on the radiological survey, the response of biochemical measurements and bone mass to vitamin D therapy, or the presence of excess osteoid and reduced bone formation rate in the bone biopsy. None of the patients in the present study had Looser's zones. Five of the six patients followed for up to 25 months showed return of plasma calcium and alkaline phosphatase to the normal range; the remaining patient had active Crohn's disease during the follow-up period and weight loss. Three patients had bone biopsies and each of these confirmed the diagnosis.

Looser's zones are present only in advanced cases of osteomalacia and bone biopsy is a painful procedure that may necessitate a general anaesthetic. As patients with osteomalacia are commonly old and frail the third method for diagnosing osteomalacia is preferable. Thus in Chapter 8 the diagnosis of biochemical osteomalacia is based on the abnormal biochemical findings listed above which return to normal one year after vitamin D therapy with an associated rise in bone mass.

Osteomalacia was due to malabsorption syndrome in all cases. This reflected the referral practices within the hospital. Most patients were old and all were women and this follows the pattern found in an Edinburgh study more than 10 years previously by Chalmers (1968).

Meredith and Rosenberg (1980) reported that 5% of patients with Crohn's disease have osteomalacia, and that 70% have low 25-OHD levels. This may be due to the depletion of the bile salt pool in this condition when it affects the terminal ileum. Bile salts facilitate the absorption of vitamin D. Although dietary vitamin D is not the major source of vitamin D the depleted bile

salt pool may affect the normal enterohepatic circulation of vitamin D and its metabolites.

Of the 93 patients described by Chalmers (1968), 32 had undergone partial gastrectomy. Osteomalacia has been described after vagotomy and pyloroplasty (Mitchell et al., 1971) but not after vagotomy and gastroenterostomy. Two patients in the present study had this latter operation and one of these had bacterial colonization of the stomach that responded well to antibiotics.

#### D. SUMMARY.

1. The mean TBCa in seven women with osteomalacia was 596g, and was 27% lower than the mean for female controls.
2. Six out of seven patients had osteopaenia indices below the theoretical fracture threshold, but none had vertebral fractures.
3. Changes in TBCa following treatment ranged from 4 to 18%, the largest change was associated with the largest fall in plasma alkaline phosphatase.



## CHAPTER 7. RENAL TRANSPLANTATION.

### A. PATIENTS.

Eight men and 4 women aged 20 to 51 years (mean, 35.9) were studied. They had been on maintenance haemodialysis for 4 to 54 months (mean, 23). The causes of renal failure were chronic glomerulonephritis (6), polycystic kidney disease (2), chronic pyelonephritis (1), obstructive nephropathy (1), malignant hypertension (1), and Goodpasture's syndrome (1). Two patients had hypercalcaemia due to secondary hyperparathyroidism at the time of operation, one had aluminium-induced osteomalacia, and one had osteomalacia treated with alphacalcidol.

Nine patients received kidneys from cadavers and three from related donors. Anti-rejection treatment was given as described by McGeown et al. (1977). Azathioprine was given at a dose of 3 mg/kg/day and prednisolone at a dose of 20 mg/day. Subacute rejection episodes (average of 1 per patient, range 0 to 3) were treated with prednisolone 200 mg/day and reduced to 20 mg/day over 10 days. This dose was reduced to 10 mg/day over 10 to 33 months unless chronic rejection developed (2 cases) and then the dose was increased to 20 mg/day.

Initial measurements of TBCa were made in the week prior to surgery in the three patients receiving kidneys from related donors, and within 8 weeks of surgery in the remainder. Subsequent measurements were made at about 6-monthly intervals for up to 33 months (mean, 17 months).

Plasma calcium values were available immediately prior to

operation and were subsequently measured monthly along with magnesium, ~~protein~~ and creatinine. Plasma phosphate values were also available from before operation. Plasma PTH and 25-OHD and urinary calcium, magnesium, phosphate, hydroxyproline, and creatinine were measured when the initial TBCa measurement was made. Radiographs were taken when considered appropriate by the physician in charge.

## B. RESULTS.

### 1. TBCa.

Initial values for TBCa and  $Ca_R$  are shown in Table 7a. The mean initial  $Ca_R$  values in the 8 men showed a 7% reduction below the mean for male controls and in the 4 women an 18% reduction below the mean for female controls. Three of the four women and two out of the eight men had  $Ca_R$  values less than 2 SD below the mean for the controls.

The two men who underwent parathyroidectomy 4 and 20 months after renal allotransplantation had increases in TBCa of 66g (8%) over 10 months and 29g (3%) over 18 months, respectively. In the remainder the mean change was calculated from the initial and final measurements and was - 0.9%/year, with 95% confidence intervals of -3.2 to 1.4%/year (Figure 7a).

### 2. Biochemistry.

The initial biochemistry results are shown in Table 7b and 7c. The elevated plasma creatinine fell gradually but never into the normal range (Figure 7b). Two patients underwent parathyroidectomy and so their data are excluded from the following

Table 7a. Initial TBCa results in patients undergoing renal transplantation.

<u>TBCa(g).</u>	<u>MEN</u>	<u>WOMEN</u>
Renal failure.	1006	685
Controls.	1143	821

Ca<sub>R</sub>.

Renal failure.	0.93*	0.82***
Controls.	1.00	1.00

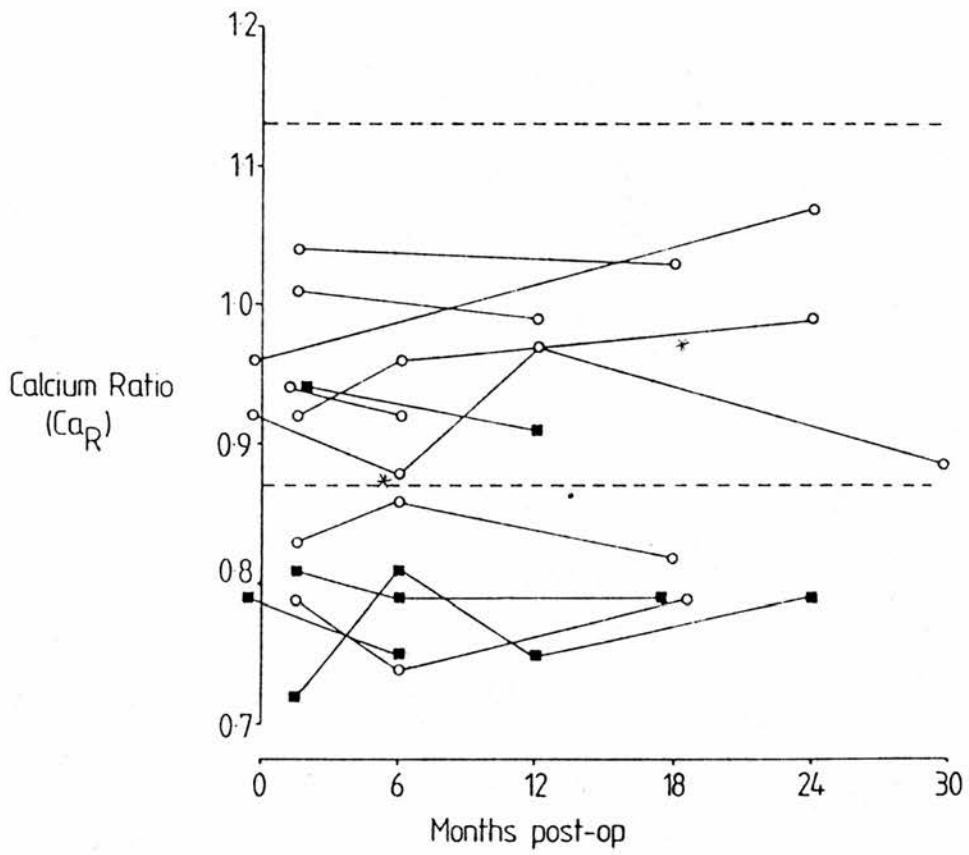

Figure 7a. Changes in calcium ratio in men (●) and women (■) following renal transplantation. Broken lines indicate mean and 2SD of calcium ratio in controls. Asterisks indicate the two patients who underwent parathyroidectomy.

results.

The plasma alkaline phosphatase and phosphate (Table 7c) and plasma magnesium (Figure 7c) all fell into the normal range. Plasma calcium gradually increased over the first 6 months such that the mean value was at the upper limit of the reference range for the 30-month follow-up period (figure 7c). The plasma PTH was elevated even in the presence of hypercalcaemia (Figure 7d). These high plasma PTH levels were associated with low creatinine clearances as shown in Figure 7e where they are compared with the results from male and female controls (for TBCa).

### 3. Age and body measurement.

This group was younger than the controls for TBCa (Table 7d). They were also lighter due to a reduction in body fat.

### 4. Radiology.

Seven out of the 12 patients had ectopic calcification. This was confined to the arterial wall except in one case with a calcified abdominal lymph node. In one patient radiographs of the hand were taken annually for four years and there was no progression in the arterial calcification despite persistent hypercalcaemia.

Table 7b. Initial biochemical values in patients undergoing renal transplantation. Statistical comparison was made using an unpaired t-test.

<u>Measurement (units).</u>	<u>12 PATIENTS.</u>	<u>40 CONTROLS.</u>
	Mean (SD)	Mean (SD)
<u>Plasma.</u>		
Alkaline phosphatase (u/l)	73.2	49.4
[log <sub>e</sub> transformed]	4.29(0.62)*	3.90(0.23)
Phosphate (mmol/l) <sup>1</sup>	1.80(0.50)***	1.05(0.17)
Calcium (mmol/l) <sup>1</sup>	2.43(0.31)	2.38(0.07)
Magnesium (mmol/l)	1.25(1.27)	0.81(0.05)
25-OHD (nmol/l) <sup>2</sup>	16.5	33.5
[log <sub>e</sub> transformed]	2.80(0.52)***	3.51(0.51)
PTH (mcg/l)	0.98(0.92)**	0.16(0.09)
Creatinine (mmol/l)	0.52(0.47)**	0.08(0.02)
<u>Urine.</u>		
Calcium (mmol/24hr)	0.83(0.56)***	5.20(2.46)
Magnesium (mmol/24hr)	3.7 (2.5)	3.8 (1.8)
Phosphate (mmol/24hr)	15.5 (13.9)**	28.1 (10.8)
Creatinine (mmol/24hr)	10.9 (5.6)	13.2 (4.5)
Hydroxyproline (mmol/24hr)	298 (118)	294 (84)

Notes.

1. These measurements were made pre-operatively in all cases.
2. Two out of 12 patients had low 25-OHD compared with season-matched controls.

Table 7c. Changes in plasma biochemistry in ten patients following renal transplantation.

<u>Variable (units)</u>	<u>Initial value</u>	<u>Mean change (%)</u>	<u>P</u>
Alkaline phosphatase (u/l)	72.2	-54	N.S.
Phosphate (mmol/l)	1.69	-51	<0.02
Calcium (mmol/l)	2.34	8	<0.05
Magnesium (mmol/l)	1.26	-29	<0.002
Parathyroid hormone (mcg/l)	0.82	-71	N.S.

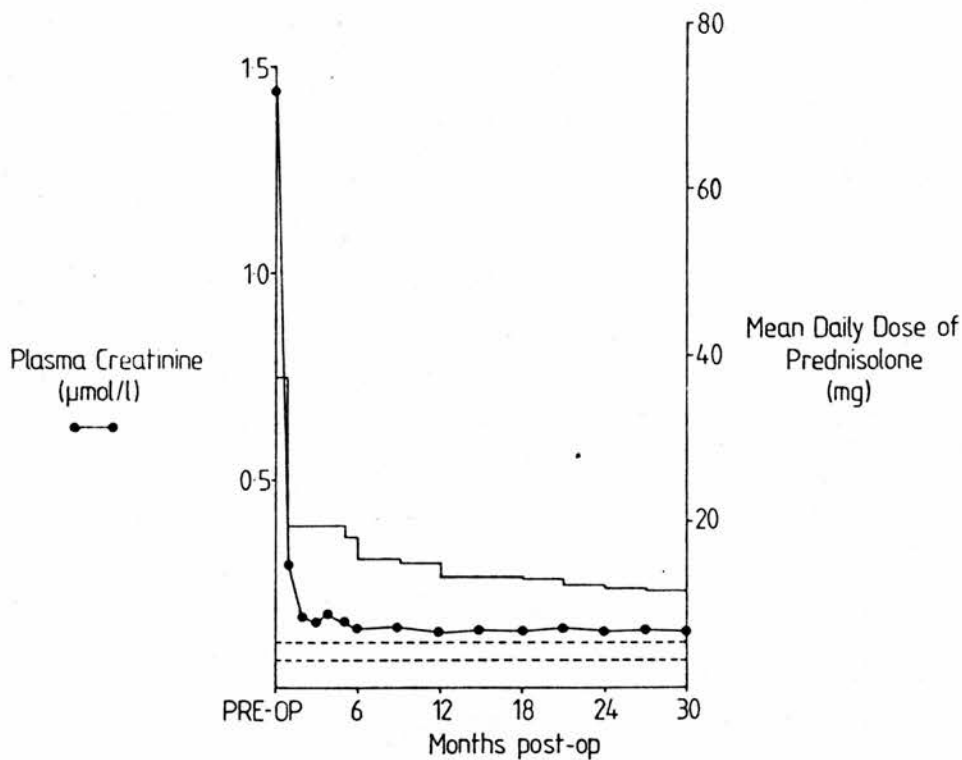

Figure 7b. Changes in mean plasma creatinine and in mean daily dose of prednisolone in patients following renal transplantation. Broken lines indicate laboratory reference range for plasma creatinine.



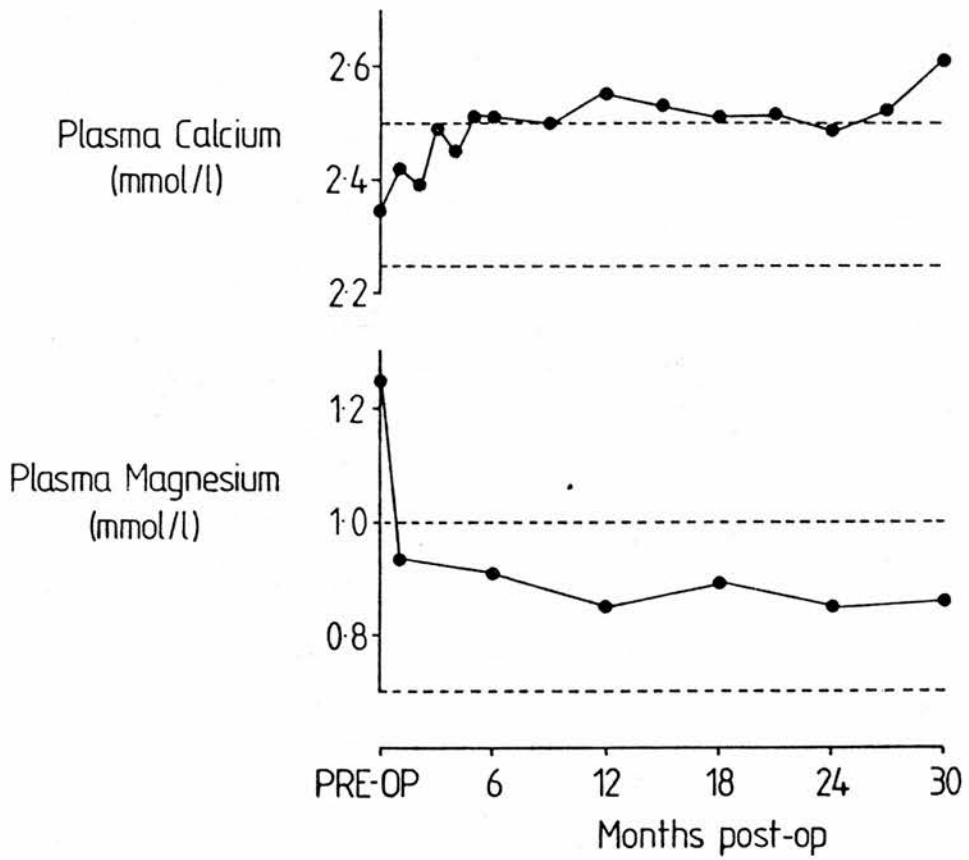

Figure 7c. Changes in mean plasma calcium and mean plasma magnesium in patients after renal transplantation. Broken lines indicate laboratory reference ranges. The results exclude the data from two patients who underwent parathyroidectomy.

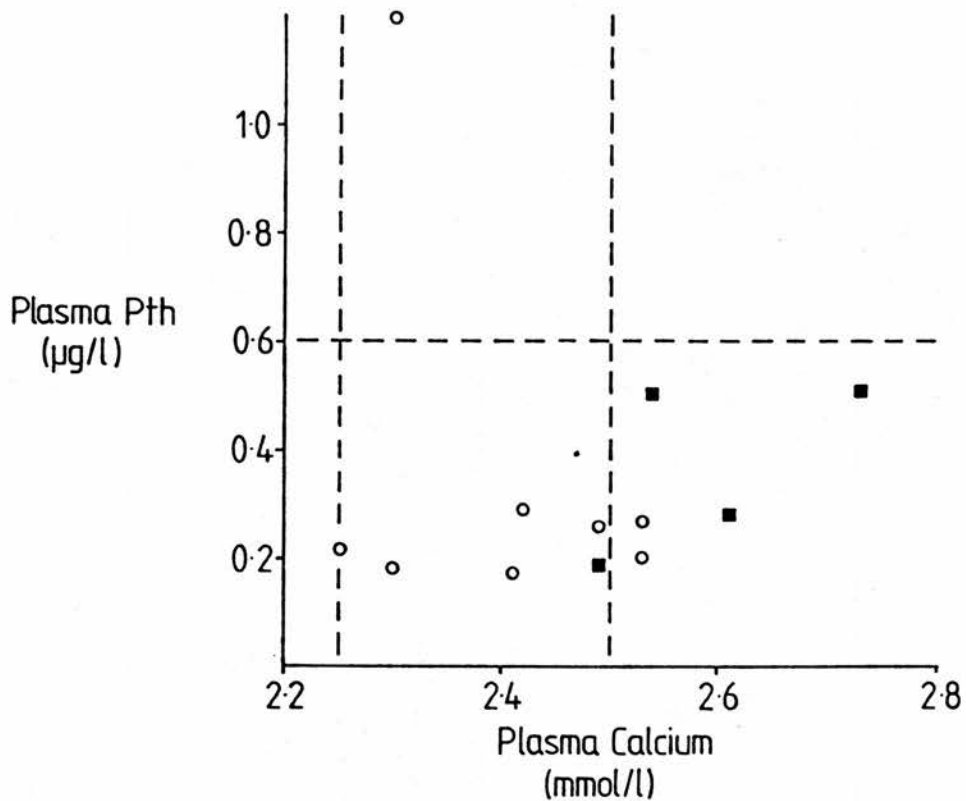

Figure 7d. Plasma PTH and calcium in men (O) and women (■) following renal transplantation. Broken lines indicate laboratory reference ranges.

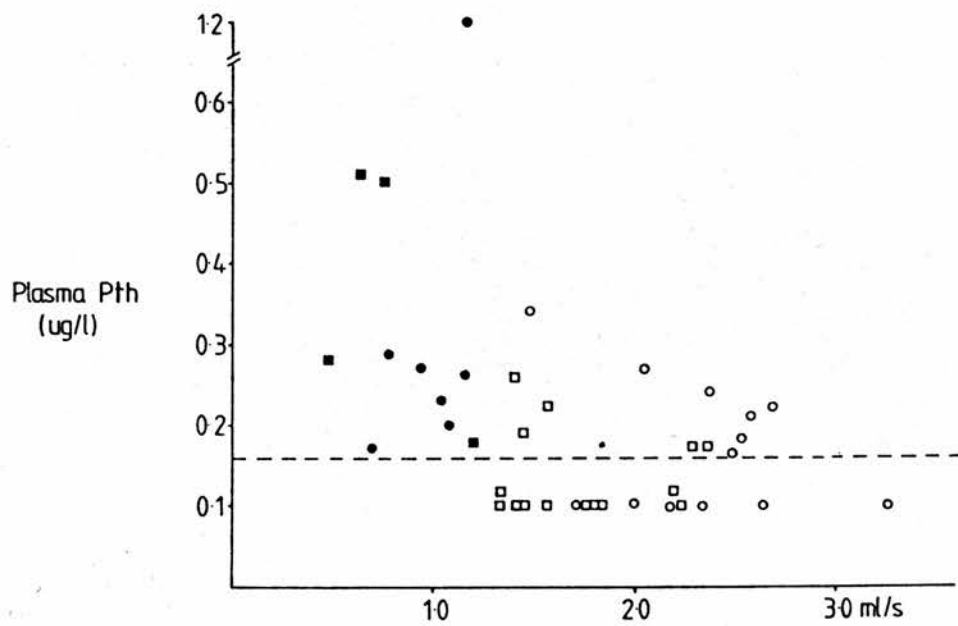

Figure 7e. Plasma PTH and creatinine clearance in men (●) and women (■) after renal transplantation compared with male (○) and female (□) TBCa controls.

Table 7d. Age, duration on haemodialysis, and body measurements in patients undergoing renal transplantation. Statistical comparisons were made using an unpaired t-test between male patients and male TBCa controls.

<u>Variable (units).</u>	<u>Mean(SD)</u>	
	<u>MEN</u>	<u>WOMEN</u>
Age (years)	35.9 (11.2)	
Duration on dialysis (months)	23 (18)	
Number	8	4
Armspan (m)	1.77(0.08)	1.56(0.07)
Height (m)	1.74(0.08)	1.53(0.06)
Weight (kg)	66.8 (6.3) ***	43.3 (4.5)
Overweight (%)	-2.5 (7.1) ***	-16.5 (4.7)
Body mass index (kgm <sup>-2</sup> )	22.2 (1.6) **	18.4 (0.8)
Fat (%)	15.8 (4.3) **	20.3 (1.3)
Lean body mass (kg)	56.3 (6.6)	34.5 (4.0)

### C. DISCUSSION.

The annual reduction in TBCa of 0.2% was not statistically significant and was much smaller than the 7% fall in metacarpal bone density described by Lindsay et al.(1976). Aird and Pierides (1977) showed a 5.1 to 5.4%/year fall in lower femur density in the first year after renal transplantation. Both groups used a higher dose of steroid and this could account for the more rapid bone loss compared with the changes in the present study.

The insignificant change in TBCa contrasts with the dramatic biochemical changes. The time-course of the return of plasma alkaline phosphatase, phosphate, and magnesium to normal, along with a reduction in plasma PTH almost to normal, corresponds with the bone biopsy findings of Bortolotti et al.(1977). They showed that the marrow fibrosis, excess osteoid, and increased bone resorption had resolved by 16 to 20 months after renal transplantation.

The persistent mild hypercalcaemia has been described in 21% of the 386 patients reported by Chatterjee et al.(1976), David et al.(1973), Ibels et al.(1978), and Lee et al.(1973). It is associated with normal or raised plasma PTH levels (Kleerekoper et al., 1975). This elevation may be due to the persistently impaired renal function (Figure 7e). Lemann et al.(1979) have shown that plasma PTH rises when creatinine clearance falls below 50 to 80 ml/min (0.83 to 1.33 ml/s).

The initial low TBCa differs from the findings of others. Cohn et al.(1975) and Denney et al.(1973) reported normal mean TBCa values in patients on haemodialysis. The type of bone disease was reported to affect TBCa, the lowest values being found in those

with osteomalacia and normal or high values in those with hyperparathyroidism. In the present series the low TBCa may have been due to a higher frequency of osteomalacia but unfortunately bone biopsies were not performed.

The healing of renal osteodystrophy after renal transplantation might be expected to be associated with an increase in TBCa, particularly in the patients with a predominantly osteomalacia type of bone disease. In the present series this effect was countered by the osteopaenic effect of the steroids. Ectopic calcification was present in more than half the subjects but was almost always confined to blood vessel walls and was unlikely to have contributed much to TBCa (Denney et al., 1973). Once the renal osteodystrophy has healed the action of the steroids is unopposed and may be potentiated by the commonly associated mild hyperparathyroidism. This might account for the findings of Andresen and Nielsen (1982) of a low bone density in patients 67 months after renal transplantation; the mean value of bone mineral concentration of the radius and ulna was 25% below age- and sex-matched controls.

#### D. SUMMARY.

1. There was a reduction in mean  $Ca_R$  in 12 patients undergoing renal transplantation.
2. The mean annual reduction in TBCa was -0.9% and the 95% confidence limits were -3.2 to 1.4%. These changes were much smaller than noted previously and may have been due to the lower

dose of steroids used to prevent transplant rejection.

3. In the two patients who had parathyroidectomy for hypercalcaemia the rises in TBCa were 3 and 8%.

4. There were large changes in plasma calcium, magnesium, phosphate, alkaline phosphatase, and PTH following renal transplantation. These changes were not related to the changes in TBCa.

5. Hypercalcaemia was a common finding after the operation and was associated with detectable or raised plasma PTH. These levels of plasma PTH were probably due to persisting impairment of renal function.

## CHAPTER 8. PATIENTS AFTER PEPTIC ULCER SURGERY.

### A. OUTLINE OF STUDY.

This group of patients was larger than the previous ones and they were more extensively investigated. An attempt was made to demonstrate not only that bone mass was reduced in these patients but also to try and identify the cause of this reduction.

The study was designed to determine the degree of osteopaenia using TBCa measurements. Measurement of biochemical variables, in particular plasma 25-OHD and PTH, were made along with tests of calcium absorption and assessment of dietary calcium. The body size, age, and social habits were taken into account. Finally, an attempt was made to reverse the osteopaenia using vitamin D and calcium therapy and measuring the response using forearm calcium (FCa).

Many previous studies have been made on patients following Polya partial gastrectomy as this was the most popular operation up to the mid-1960's. In the present study the results of patients having this type of operation are separated from those having the more recently developed operations to determine whether the advances in surgical technique have reduced the frequency of disturbed calcium metabolism.

### B. STUDY DESIGN.

#### 1. Patient selection.

The patients were selected from a register of



patients who had undergone peptic ulcer surgery at the Western General Hospital, Edinburgh. The patients studied were one to 25 years postoperative. Between the years 1953 and 1977 there were 990 operations for peptic ulcer of the type described in the Introduction.

The results of the selection process are shown in Table 8a. Only patients aged 50 to 70 years who lived in the Edinburgh postal district were studied. From a list of these patients further selection was as follows. Four male and four female patients from each of three time intervals were selected using tables of random numbers. These three time intervals were one to five, six to 15, and 16 to 25 years postoperative. This would have yielded 24 patients for each of the seven types of operation.

In order to increase the numbers of men after Polya partial gastrectomy a total of 80 were selected by random numbers. There was no follow-up of clinic non-attenders.

## 2. Study options.

All patients underwent full clinical examination lasting one hour. This was to assess the symptoms arising from the peptic ulcer surgery, and fracture incidence, current therapy, sunshine exposure, tobacco and alcohol consumption, occupation, and to determine the presence of disease or the use of drugs likely to affect calcium metabolism. The physical examination included the measurement of height, weight, and skinfold thickness at four sites.

Blood was taken without tourniquet in the non-fasting state for alkaline phosphatase, phosphate, calcium, magnesium, albumin,

25-OHD, PTH, lactate dehydrogenase, urea, and full blood count. A urine sample was tested with "Labstix" indicator strips for glucose, protein, blood, and urobilinogen, and sent for analysis of calcium and creatinine. At this time other investigations such as chest radiographs were taken when appropriate.

The patients were seen between January and May of 1979 and between January and May of 1980. Those patients seen in 1979 were invited to join a study on the effect of vitamin D and calcium on FCa. Patients were treated with placebo (lactose, one tablet twice a day) or calcium and vitamin D (25mcg vitamin D<sub>2</sub> and 20 mmol of calcium daily). At each visit measurements were made of height, weight, FCa, and the above biochemical measurements. Tablets were returned at the end of the study so that they could be counted to give an estimate of compliance.

Those patients seen in 1980 and those on placebo in the treatment study were invited to have measurement of TBCa, 7-day calcium retention, dietary calcium assessment, and urinary calcium, magnesium, phosphate, hydroxyproline, and creatinine.

### C. RESULTS.

#### 1. Patient selection and reasons for exclusion.

Table 8a summarizes the number of patients remaining after each step in the selection process. Fourteen patients were excluded from further study after the clinical assessment. Six of these suffered from diseases likely to affect calcium (primary hyperparathyroidism, 1, carcinoma of the breast, bronchus and prostate, 5). Eight were taking vitamin D

Table 8a. Selection of patients after peptic ulcer surgery.

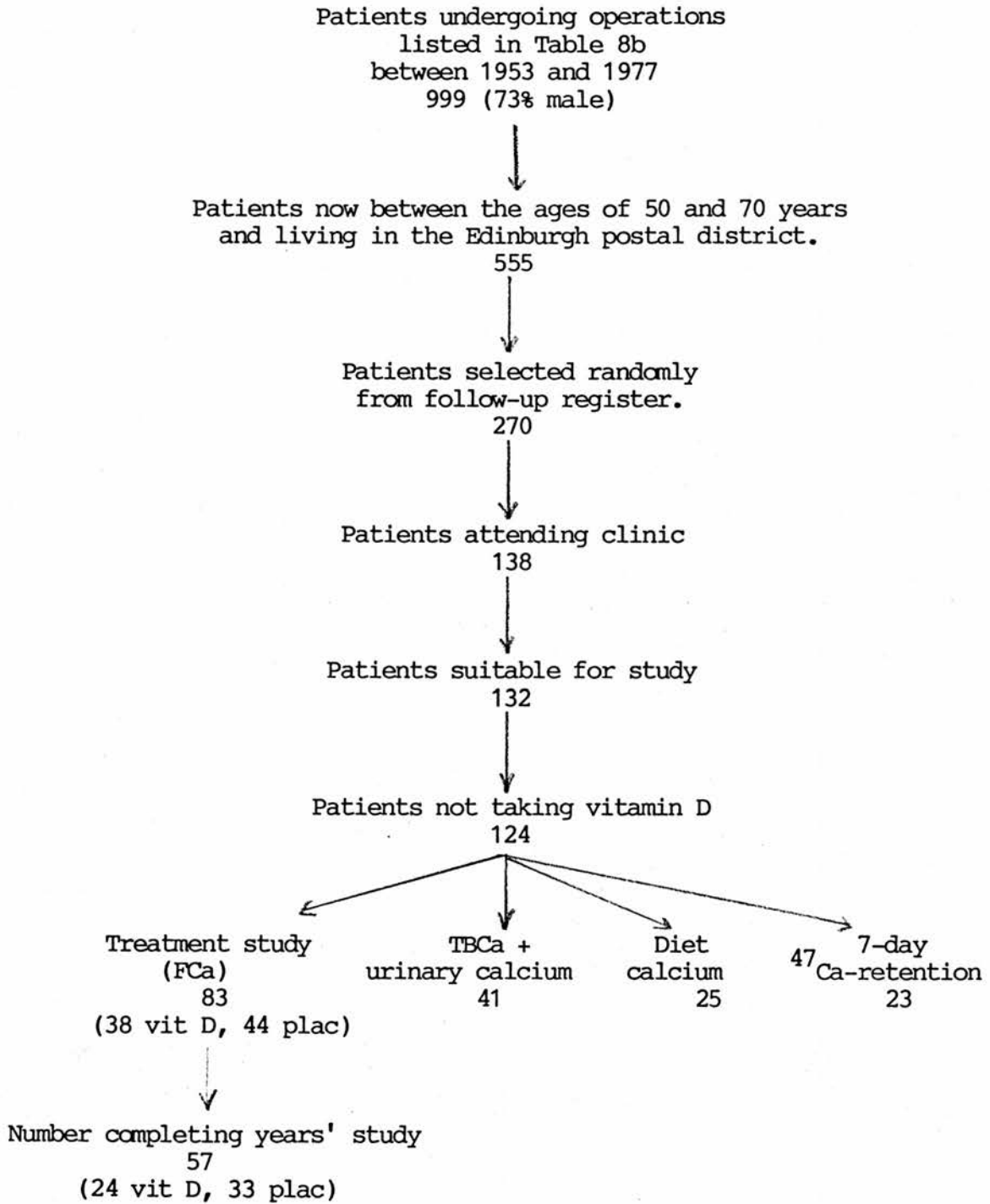

supplements as multivitamin preparations (not prescribed for the treatment of osteomalacia). Only the body measurements of these eight patients are included in the results.

Twenty-six of the patients who started the one year treatment study left the study either because they left Edinburgh or because they could not afford the time off work. Each visit took about one hour. No patient left the study due to drug side-effects.

Two patients agreed to TBCa measurement but were not measured due to lung calcification in one and ankylosing spondylitis in the other. The biochemical results of these two patients are included in the results.

The sex and operation type of the patients included in the study are shown in Figure 8b.

## 2. TBCa.

The mean and SD for TBCa in 41 men after peptic ulcer surgery were 977g and 92g. This was 15% below the mean for male TBCa controls and this reduction was highly significant ( $P < 0.001$ ). Part of this reduction was due to the shorter stature of the men after surgery. Their mean height was 1.70m and this was 8cm less than the controls. Eight men were less than 1.64m tall (the lowest value for the male controls) and so the formula for  $TBCa_p$  could not be applied to these. In the remainder the mean  $Ca_R$  was 0.94 (SD, 0.07) and this was a significant reduction ( $P < 0.01$ ). Six of the 33 patients had values of  $Ca_R$  below the reference range (i.e. 18%). If the patients after surgery were divided into those who had partial gastrectomy and those who had other procedures both groups had reduced mean  $Ca_R$  values of 0.95 and 0.94, respectively. Both

Table 8b. Sex and operation type in patients after peptic ulcer surgery.

<u>Operation</u>	<u>Male</u>	<u>Female</u>	<u>Male + Female</u>
Polya partial gastrectomy	36	6	42
Polya + vagotomy	12	0	12
Billroth I partial gastrectomy	10	6	16
Pyloroplasty + vagotomy	16	7	23
Gastroenterostomy + vagotomy	13	3	16
Gastroenterostomy	12	5	17
Highly selective vagotomy	5	1	6
-----			
Total	104	28	132
-----			

results were statistically significant ( $P < 0.05$  and  $P < 0.02$ , respectively).

No other factors could be related to  $Ca_R$ . There was no significant effect of time since operation, biochemical measurements, calcium absorption, body fat, or smoking or drinking habits.

### 3. Biochemistry.

The results of plasma biochemistry are shown in Table 8c. Patients were divided into three groups: men after Polya partial gastrectomy and men after other operations, and women after all types of ulcer operation. Their results are compared with controls for TBCa who were of similar age.

Multiple regression analysis was applied to each biochemical variable so that the effects of sex and operation type could be assessed. This analysis tested the effect of partial gastrectomy, vagotomy, duodenal bypass, and acid reduction (see Introduction)

Plasma calcium was reduced in all men compared with controls ( $P < 0.001$ ) but this was not found in the women. Multiple regression only showed up the significant effect of sex ( $P < 0.05$ ) with no effect of operation procedure. Twenty-one percent of patients were hypocalcaemic. After correction for albumin 11% of patients were hypocalcaemic.

Plasma calcium showed positive correlations with plasma 25-OHD ( $r = 0.34$ ,  $P < 0.001$ ) and with serum albumin ( $r = 0.34$ ,  $P < 0.001$ ). No other biochemical variable was related to plasma calcium.

Plasma phosphate was not significantly different from controls. Multiple regression analysis again showed an effect of

Table 8c. Plasma biochemistry in patients after peptic ulcer surgery and in TBCa controls. Results are expressed as mean (SD). Statistical comparisons were made using unpaired t-tests between patients and sex-matched controls.

<u>Variable (units).</u>	<u>Polya-male</u>	<u>Other ops-male</u>	<u>Controls-male</u>	<u>All ops-female</u>	<u>Controls-female</u>
Alk. Phos. (u/l)	63	59	50	61	50
[log <sub>e</sub> -transformed]	4.14(0.30)***	4.08(0.29)**	3.91	4.12(0.21)**	3.91
Phosphate (mmol/l)	0.98(0.15)	1.00(0.02)	1.01	1.15(0.19)	1.11
Calcium (mmol/l)	2.30(0.11)***	2.30(0.10)***	2.37	2.35(0.12)	2.38
Corrected Ca (mmol/l)	2.32(0.12)	2.32(0.10)*	2.37	2.34(0.11)	2.35
Magnesium (mmol/l)	0.83(0.06)	0.84(0.07)	0.83	0.83(0.06)	0.80
Albumin (g/l)	40.9 (3.6)	41.1 (3.1)	41.9	42.4 (2.5)	43.4
25-OHD (nmol/l)	20	21	31	23	31
[log <sub>e</sub> -transformed]	3.00(0.60)	3.03(0.58)	3.43	3.15(0.70)	3.58
PTH (mcg/l)	0.26(0.10)***	0.20(0.16)	0.16	0.27(0.08)***	0.16

sex. Women had higher plasma phosphate than men ( $P < 0.002$ ).

Plasma magnesium was elevated compared with controls ( $P < 0.01$ ).

The reference range of plasma alkaline phosphatase was calculated from the results of the controls after logarithmic transformation. The upper limit of normal was calculated as mean plus 2 SD and was 77u/l. This was lower than the laboratory reference value of 85u/l. Twenty patients had values above 77u/l and this was 16% of the total.

Three SD above the mean for controls was 98u/l. Five patients had values above this. Alkaline phosphatase electrophoresis revealed the source as liver in three, intestine in one, and bone in one. In the patient with elevated alkaline phosphatase of bone origin the plasma 25-OHD was also low for the season at 7 nmol/l in April. However the plasma calcium, phosphate, and PTH were normal in this case.

Of the five patients who had alkaline phosphatase values above 98 u/l three took part in the treatment study. Two received vitamin D and calcium and the alkaline phosphatase fell from 108 to 83 u/l in one and 105 to 74 u/l in the other; the patient treated with placebo also showed a fall in alkaline phosphatase from 122 to 102 u/l!

The results of plasma 25-OHD are shown related to season-matched controls in Figure 8a. Nine out of 121 patients had low values (i.e.7%). The details of plasma biochemistry in these nine patients are shown in Table 8d. No patient had the classical pattern of results for osteomalacia with low plasma calcium and phosphate and high alkaline phosphatase and PTH.

Plasma PTH results are shown along with age and sex-matched



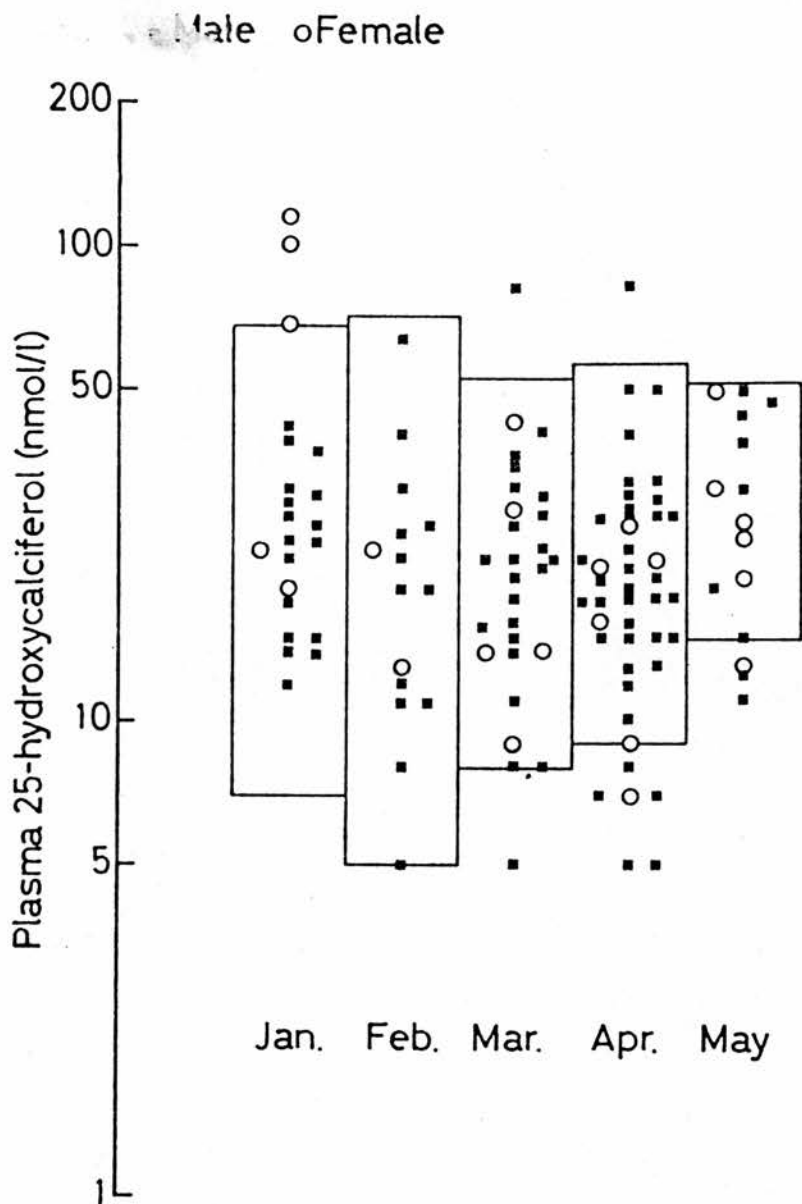

Figure 8a. Plasma 25-OHD in men (■) and women (○) after peptic ulcer surgery. The bars represent mean and 2SD after logarithmic transformation of 25-OHD values in controls.

Table 8d. Details of nine patients with low plasma 25-OHD levels.

<u>Operation</u>	<u>Age</u> (yr)	<u>Sex</u>	<u>Post-op</u> (yr)	<u>25-OHD</u> (nmol/l)	<u>Ca</u> (mmol/l)	<u>Phos</u> (mmol/l)	<u>Alk Phos</u> (u/l)	<u>PTH</u> (mcg/l)
Polya + vag	58	M	17	5	2.07	1.13	77	0.33
Polya + vag	59	M	9	11	2.17	0.87	72	<0.18
Billroth I	61	M	12	7	2.42	0.84	58	0.22
Py1 + vag	57	F	14	7	2.32	1.35	106	0.28
Py1 + vag	58	F	15	13	2.15	1.03	50	<0.18
Py1 + vag	69	M	10	5	2.12	1.19	81	0.16
GE + vag	63	M	17	7	2.23	1.04	85	-
GE	69	M	8	5	2.44	-	59	0.56
GE	59	M	11	8	2.18	0.90	82	<0.18

controls in Figures 8b and 8c. The statistical analysis is made difficult as some patients had values below the lower limit of sensitivity of the PTH assay. The statistical methods are described in detail in the Statistics Appendix and are referred to here as the Fisher Exact Test and the Swan test. Using the Fisher Exact test patients after peptic ulcer surgery had significantly elevated PTH levels (men after Polya partial gastrectomy,  $P < 0.02$ , men after other ops,  $P < 0.03$ , women,  $P < 0.001$ ). The results of Swan analysis are shown with the other biochemical results in Table 8c. The mean PTH values are significantly higher in men and women after peptic ulcer surgery, the mean PTH level being 60% higher than in controls.

Plasma PTH rises as renal function declines to a creatinine clearance of less than 50 to 80 ml/min (Lemann et al., 1979). This 40 to 66% reduction in renal function is equivalent to plasma urea of 9 to 15 mmol/l (Kassirer, 1971). Only four patients had urea values above 9 mmol/l and their PTH values were 0.22, 0.27, and 0.56 mcg/l (one value missing). Exclusion of these results made no differences to the results of the statistical analyses.

Eight of the urine collections were judged incomplete from the urinary creatinine and lean body mass relationship described in Chapter 3. In the remainder there were significant reductions in urinary calcium, phosphate, hydroxyproline, and creatinine (Table 8e). These measurements were only made in the male patients. As discussed previously these men were shorter than the controls and this would be expected to affect the urinary excretion of creatinine and possibly of minerals. In order to allow for this 13 pairs of men of similar height (within 3cm) were compared and their

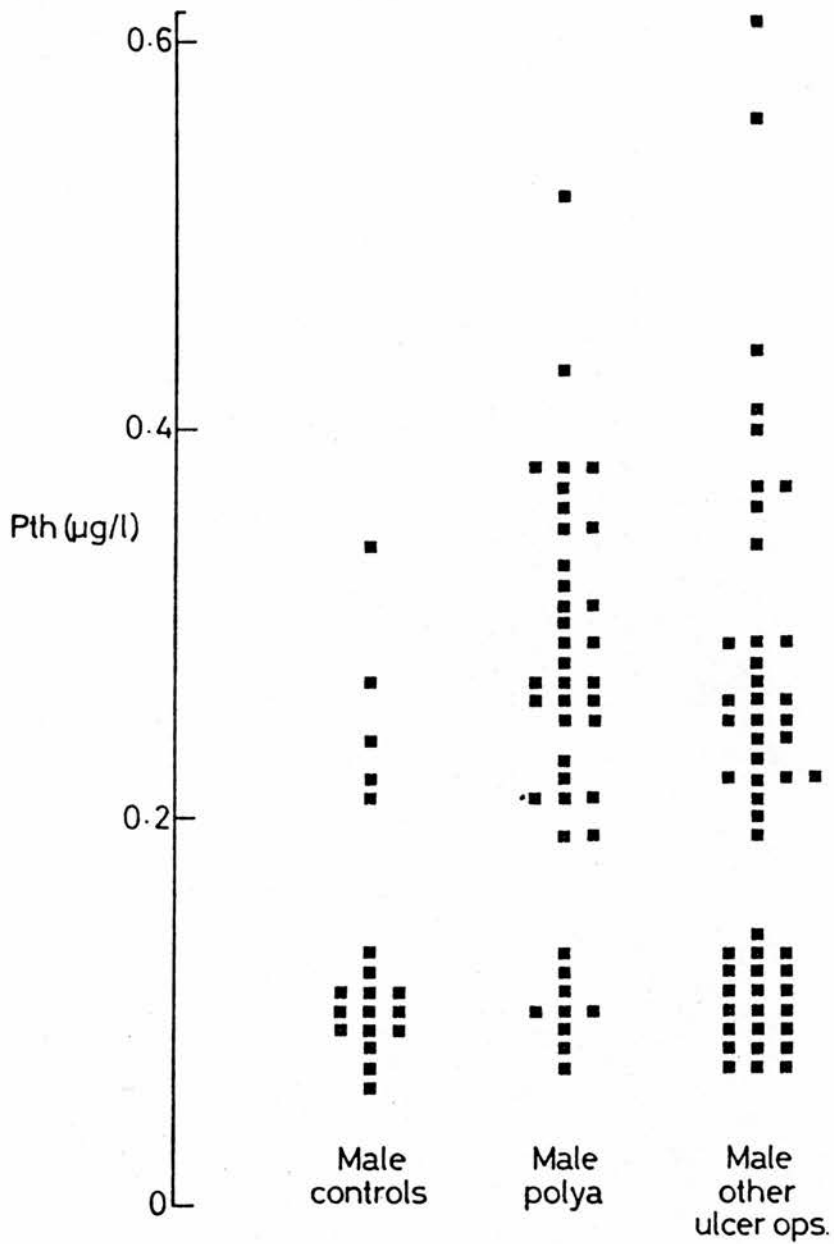

Figure 8b. Plasma PTH results in men after peptic ulcer surgery compared with male TBCa controls.

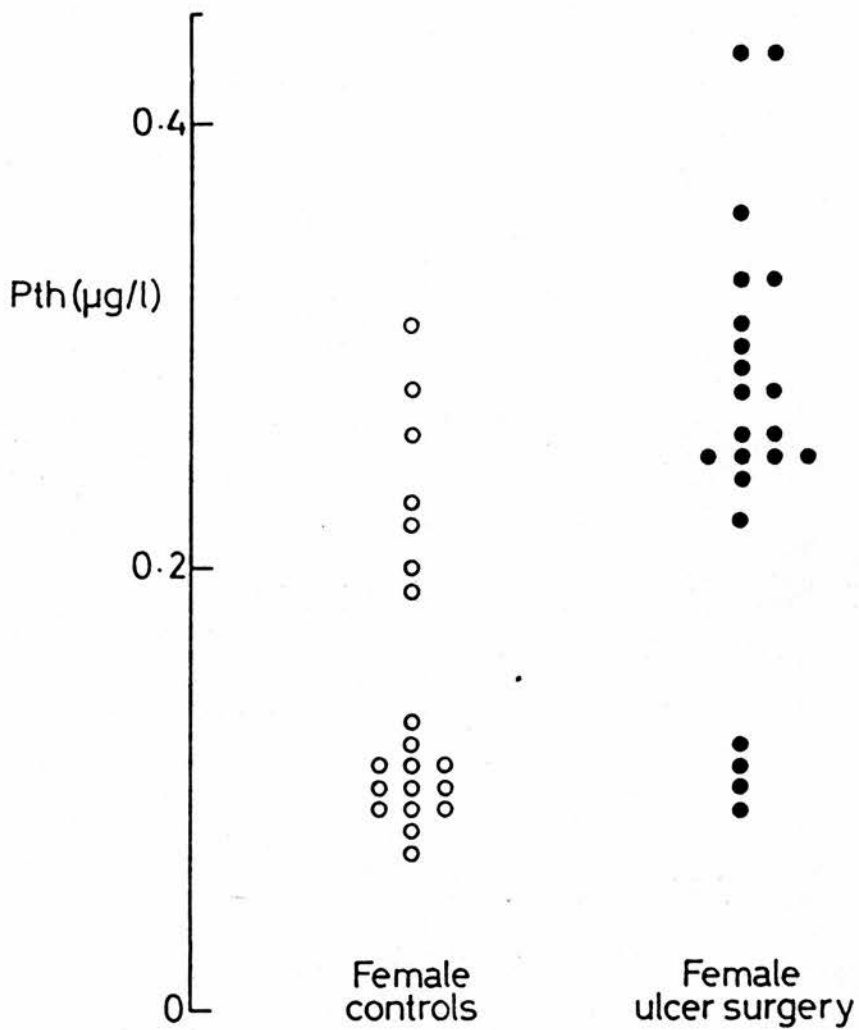

Figure 8c. Plasma PTH results in women after peptic ulcer surgery compared with female TBCa controls.

results are shown in Table 8e. The urinary calcium showed a significant reduction ( $P < 0.01$ ), but not the other urinary constituents.

#### 4. 7-day calcium retention.

This was measured in 21 men and 2 women. The results are shown in Figure 8d. The reference range used in this Figure was that of Mallette et al. (1975). Their control group was 14 men of mean age 37 years who were taking a mean daily calcium intake of 800 mg/day.

Sixteen of the 23 patients after peptic ulcer surgery had results above the reference range. The mean 7-day retention was 50% (10%, SD), compared with the mean for the control group of Mallette et al. (1975) which was 38% (4%, SD). This difference was highly significant ( $P < 0.001$ ). Patients with partial gastrectomy had significantly higher values than those with other operations (mean of 56% cf. 47% for other operations,  $P < 0.02$ ). These multiple comparisons were made using analysis of variance.

The mean PTH was higher in the 16 patients with high 7-day calcium retention than in those with normal values (Wilcoxon rank sum,  $P < 0.05$ ), as shown in Figure 8e. There was no significant relationship between 7-day calcium retention and dietary calcium, or plasma calcium, alkaline phosphatase, or 25-OHD.

Eight patients were restudied after four months treatment with vitamin D and calcium. Change in 7-day calcium retention ranged from -18% to +15% with a mean value of +1% (SD, 11%). The change in 7-day calcium retention was not related to initial plasma 25-OHD or rise in 25-OHD. The mean rise over these four months in plasma

Table 8e. Results of urine biochemistry in men after peptic ulcer surgery and male controls for TBCa. Results are expressed as mean (SD). Statistical comparisons are made using an unpaired t-test for the unmatched groups and a paired t-test for the matched groups.

<u>Variable (units)</u>	<u>ALL MEN</u>		<u>HEIGHT-MATCHED MEN</u>	
	<u>Ulcer op</u>	<u>Controls</u>	<u>Ulcer op</u>	<u>Controls</u>
Number	33	17	13	13
Calcium (mmol/24hr)	3.7(2.1)*	5.8(2.8)	3.1(1.3)**	5.4(3.0)
Magnesium (mmol/24hr)	4.4(1.5)	4.3(2.2)	4.9(1.5)	4.1(2.3)
Creatinine (mmol/24hr)	12.7(3.2)***	17.3(3.8)	13.3(3.2)	16.3(3.8)
Hydroxyproline (mmol/24hr)	261 (80)**	339 (83)	237 (90)	304 (60)
Phosphate (mmol/24hr)	25 (6)**	34 (11)	26 (6)	34 (12)

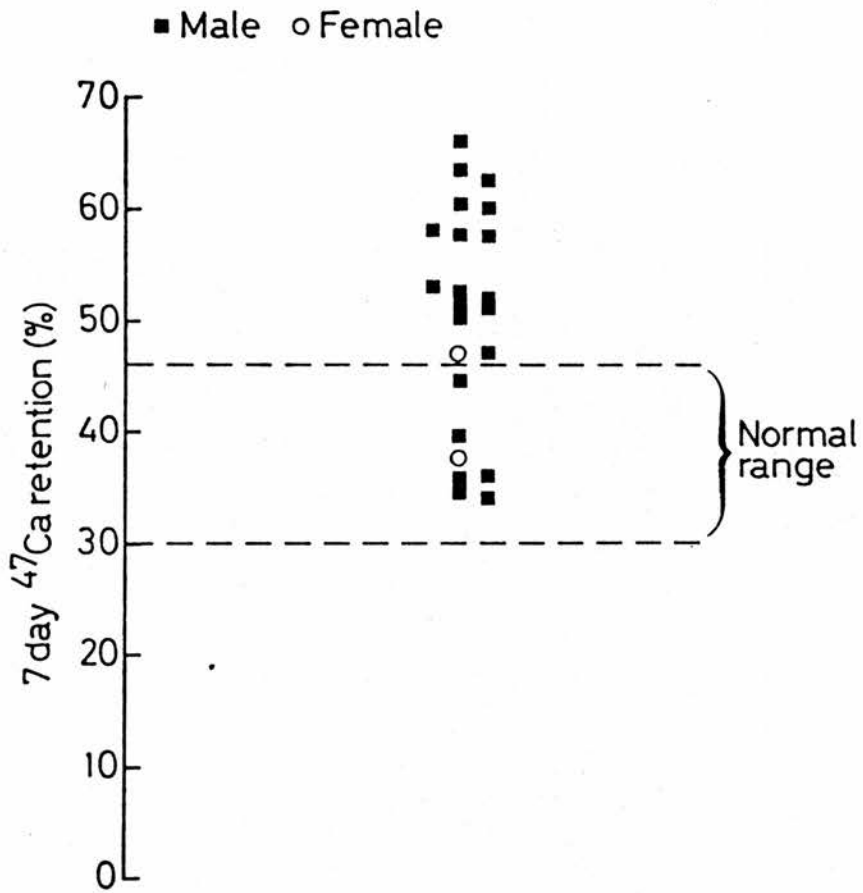

Figure 8d. Seven-day calcium retention in men (■) and women (○) after peptic ulcer surgery. Broken lines represent the reference range.



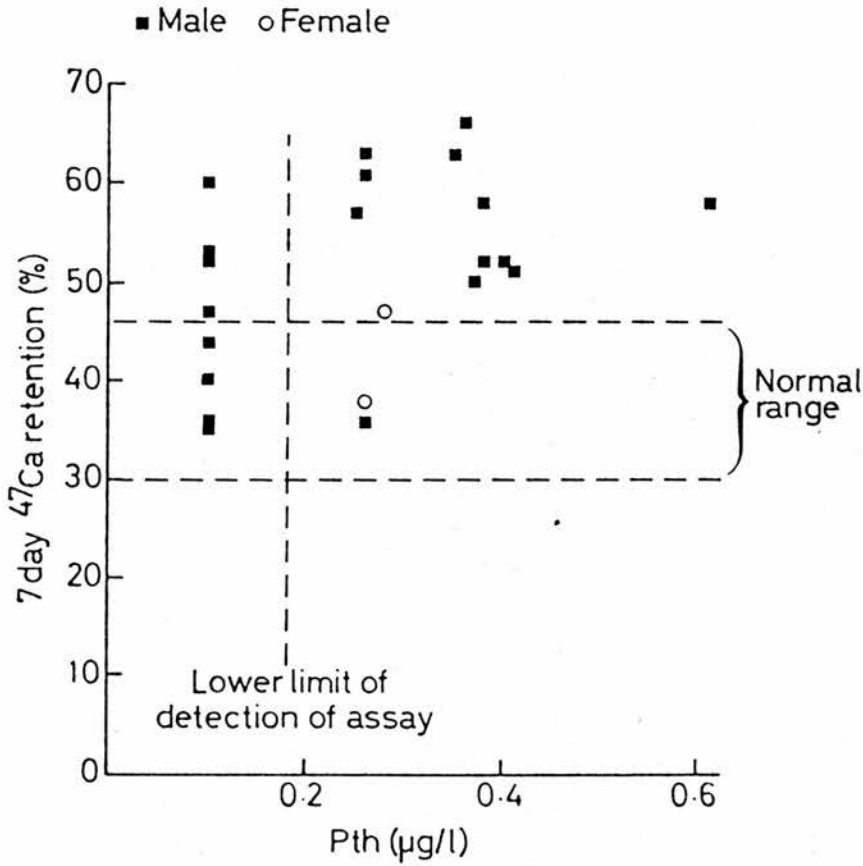

Figure 8e. Seven-day calcium retention in men (■) and women (○) after peptic ulcer surgery related to plasma PTH. Broken lines represent the lower limit of detection of the PTH assay and the reference range for 7-day calcium retention.

25-OHD was 24nmol/l.

#### 5. Dietary calcium and vitamin D.

The mean and SD of daily calcium intake were 980g and 470g. This was based on the dietary assessment of 25 patients.

The mean and SD of daily vitamin D intake was 5.3mcg and 4.2mcg. This was based on results of 13 of the above 25 patients. Two patients were taking vitamin D supplements. When their data was excluded the mean and SD of vitamin D intake were 3.9mcg and 2.5mcg. There was no significant relationship between vitamin D intake and plasma 25-OHD.

#### 6. Age and body measurements.

The results are shown in Table 8f where they are compared to those of the TBCa controls. The mean age of patients after peptic ulcer surgery was three to six years more than in controls. As a result the women were also more years postmenopause than the female controls.

The men were shorter than controls. This affected the interpretation of the results of TBCa and urinary biochemistry and is discussed in those sections.

Both men and women after peptic ulcer surgery were lighter than controls. There was no significant fall in weight postoperatively (95% confidence intervals, -1.4% to +1.1%). Weight does not affect TBCa once allowance has been made for height and body fat.

The three variables which related to body fat, namely, percent

body fat, body mass index, and percent overweight, were all significantly reduced in patients after peptic ulcer surgery.

Multiple regression analysis was applied as described for biochemistry to the estimates of body fat. There was no significant effect of sex or operation procedure.

Lean body mass was lower in patients after peptic ulcer surgery than in controls. This may have been due to their shorter stature. To allow for this the data for lean body mass was normalized in a similar manner to TBCa, to derive a predicted lean body mass ( $LBM_p$ ).

$$LBM_p = a \times (\text{height})^X$$

where,  $a = 10.8$  for women,

$a = 26.3$  for men,

$X = 2.76$  for women,

$X = 1.42$  for men.

By dividing LBM by  $LBM_p$  a LBM ratio could be obtained. In the controls this was 1.00 (0.10, SD) in men and 1.00 (0.07, SD) in women. This was reduced to 0.91 in men after other peptic ulcer operations ( $P < 0.05$ ) but the reduction was not significant in men after Polya partial gastrectomy (mean, 0.95) or in women (mean, 0.98).

## 7. Social history.

The results of alcohol consumption estimates are shown in Table 8g. There was no relationship between alcohol consumption and lactate dehydrogenase or mean corpuscular volume. The figures are compared with the Scottish population as a whole in

Table 8f. Age and body measurements in patients after peptic ulcer surgery and in TBCa controls. Results are expressed as mean (SD). Statistical comparisons were made using unpaired t-tests between patients and sex-matched controls.

<u>Variable (units).</u>	<u>Polya-male</u>	<u>Other ops-male</u>	<u>Controls-male</u>	<u>All ops-female</u>	<u>Controls-female</u>
Number	48	57	20	27	20
Age (yr)	60.5 (0.6)**	59.6 (7.0)*	54.4	60.3 (5.3)*	57.5
Postmenopause (yr)				13.2 (8.4)	8.9
Height (m)	1.71(0.08)**	1.70(0.06)***	1.78	1.56(0.06)	1.61
Weight (kg)	68.7(11.2)***	64.4 (9.9)***	81.8	53.6 (8.6)**	63.3
Overweight (%)	3.5(16.3)**	-2.4(14.3)***	12.2	-0.3(15.8)*	10.6
Body mass index (kgm <sup>-2</sup> )	23.6 (3.7)*	22.3 (3.3)***	25.8	21.9 (3.5)*	24.2
Body fat (%)	21.6 (6.6)**	20.5 (6.5)***	26.5	31.7 (5.0)**	35.5
Lean body mass (kg)	53.3 (5.9)***	50.6 (4.8)***	59.8	36.3 (4.7)	40.5
Postoperative (yr)	16.5 (6.6)	9.8 (4.0)		9.9 (5.7)	
Weight gain postop. (%)	2.1 (7.3)	-0.8 (6.2)		-2.8 (8.3)	

Table 8g. Alcohol consumption in patients after peptic ulcer surgery. Values in parentheses are percentages.

<u>Consumption</u>	<u>Men</u>	<u>Women</u>
Always abstinent	6 (6)	2 (7)
Heavy, now abstinent	5 (6)	1 (4)
Moderate	56 (53)	23 (85)
Heavy	38 (36)	1 (4)

Table 8h. Cigarette consumption in patients after peptic ulcer surgery. Values in parentheses are percentages.

<u>Consumption</u>	<u>Men</u>	<u>Women</u>
Non-smoker	28 (27)	7 (26)
Light	13 (12)	4 (15)
Moderate	54 (51)	14 (52)
Heavy	10 (10)	2 (7)

the discussion.

Cigarette consumption is shown in Table 8h. 72% of the men and 74% of the women smoked cigarettes. Again the results are compared with the Scottish population as a whole in the discussion.

Social class distribution was similar to the population of Britain with 11% in Class I, 19% in Class II, 11% in Class III(non-manual), 37% in Class III(manual), 15% in Class IV, and 5% in Class V. None were in class VI.

#### 8. The changes in FCa and biochemistry following treatment with vitamin D and calcium.

The initial characteristics of the two treatment groups are shown in Table 8i. The treatment and placebo groups were of similar age and years postoperative but the treatment group had a greater preponderance of patients after partial gastrectomy and of women. The results in initial biochemistry were similar in the two groups.

The effects of treatment are shown in Table 8j. The plasma 25-OHD doubled following one years' treatment with vitamin D and calcium. There were significant falls in plasma PTH (by 37%), alkaline phosphatase (by 12%), and magnesium (by 5%). There were no significant changes in FCa, plasma calcium or phosphate, or in urinary calcium. There were no significant changes in the group given placebo. Comparison between the treatment and placebo groups showed a significant change in plasma 25-OHD only.

The seasonal variation in biochemistry in the patients treated with placebo was calculated as in Chapter 3. The pattern of change was similar, with a significant rise in plasma 25-OHD from 28 to 39

Table 8i. Details of treatment groups. Results are expressed as mean (SD).

<u>Variable (units)</u>	<u>Calcium and vit D</u>	<u>Placebo</u>	<u>All patients</u>
Number	24	33	132
Age (yr)	59.0 (5.5)	62.3 (5.0)	60.1
Post-op (yr)	12.4 (6.2)	12.2 (7.2)	12.3
Sex ratio (M/F)	1.4	2.7	3.9
Op type (Polya/others)	0.85	1.20	0.69
<u>Plasma</u>			
Alkaline phosphatase (u/l)	69 (18)	64 (22)	64
Phosphate (mmol/l)	1.04(0.19)	1.03(0.13)	1.02
Calcium (mmol/l)	2.33(0.09)	2.31(0.09)	2.31
Magnesium (mmol/l)	0.84(0.07)	0.84(0.05)	0.84
25-OHD (nmol/l)	26 (21)	27 (16)	25
PTH (mcg/l)	0.25(0.09)	0.25(0.10)	0.24
<u>Urine</u>			
Calcium:creatinine (mmol/l:mmol/l)	0.29(0.17)	0.38(0.21)	0.39

Table 8j. Effects of treatment with calcium + vitamin D or placebo. Results expressed as mean and 95% confidence intervals (C.I.).

<u>Variable</u> (units)	CALCIUM AND VITAMIN D		PLACEBO	
	<u>Mean</u>	<u>C.I.</u>	<u>Mean</u>	<u>C.I.</u>
<u>Plasma</u>				
Alkaline phosphatase (u/l)	-8*	-16 to -1	-2	-6 to 2
Phosphate (mmol/l)	0.05	-0.03 to 0.12	0.01	-0.12 to 0.14
Calcium (mmol/l)	0.05	-0.01 to 0.12	0	-0.07 to 0.06
Magnesium (mmol/l)	-0.04**	-0.07 to -0.01	-0.01	-0.04 to 0.01
25-OHD (nmol/l)	26***	14 to 38	-1	-8 to 6
PTH (mcg/l)	-0.09*	-0.16 to -0.01	-0.05	-0.11 to 0
<u>Urine</u>				
Calcium:creatinine (mmol/l:mmol/l)	0.10	-0.05 to 0.25	-0.02	-0.14 to 0.10
<u>IVNAA</u>				
Forearm calcium (%)	0.37	-1.74 to 2.49	0.58	-1.21 to 2.38



nmol/l ( $P < 0.01$ ). The seasonal variation of plasma 25-OHD showed the pattern (Figure 8f). The plasma calcium was maximal in the autumn, magnesium lowest in the summer, phosphate highest in the summer, and alkaline phosphatase lowest in the summer, but none of these changes reached statistical significance.

The mean and SD for compliance were 77% and 17%.

#### D. DISCUSSION.

##### 1. New findings in the present study.

The nature of metabolic bone disease after peptic ulcer surgery has been studied by many research groups. The discussion will be long as a result. In order to highlight those findings which are new these will be summarized first. This will be followed by a comparison with previous work and this section will be organized in the same order as the results section. Finally, an attempt will be made to interpret these results.

The new findings are:

1. The demonstration of low bone mass in patients undergoing operations for peptic ulcer surgery other than Polya partial gastrectomy.

2. The failure of this reduction in bone mass to respond to treatment with vitamin D and calcium.

3. The demonstration of normal plasma 25-OHD levels compared with season-matched controls.

4. The demonstration of high plasma PTH levels after all operations for peptic ulcer surgery.

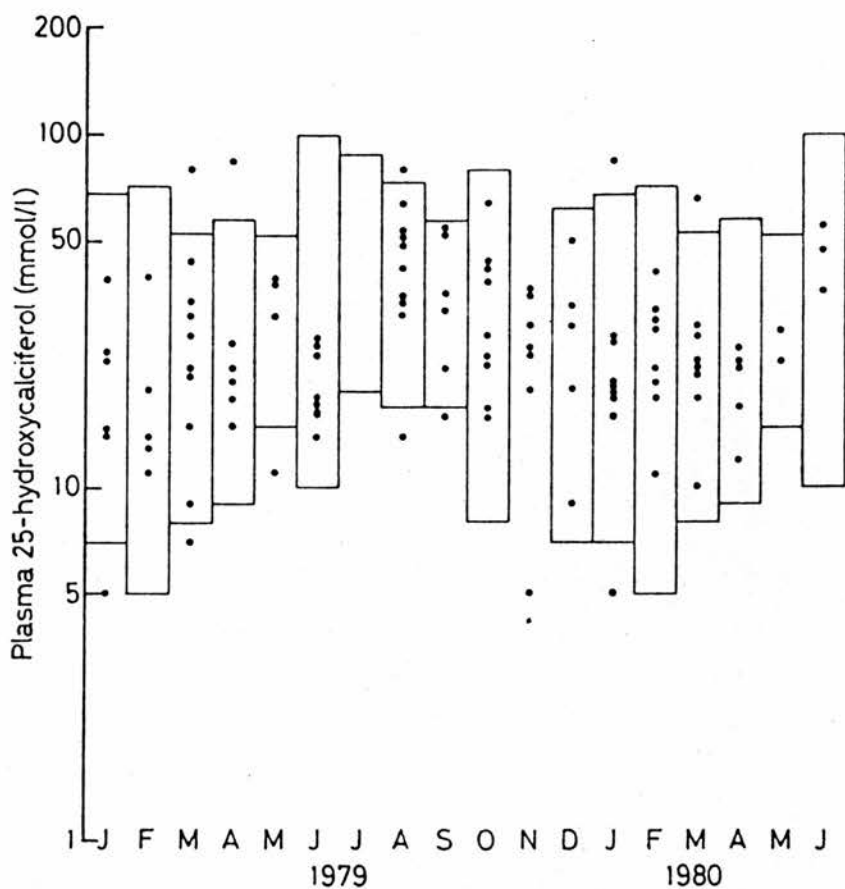

Figure 8f. Plasma 25-OHD in patients after peptic ulcer surgery treated with placebo for a year. The bars represent mean and 2SD after logarithmic transformation of 25-OHD values in controls.

5. The finding of high 7-day calcium retention after patients with and without partial gastrectomy for peptic ulcer surgery.

A comparison is now made with previous work.

## 2. Bone mass.

Total body calcium values of 18 men after partial gastrectomy were reported by Zanzi et al.(1977). Low values were found in six of these men.

Larger groups of patients have been studied using photon absorptiometry of the wrist. Blichert-Toft et al.(1979) found a mean reduction of 7.3% and Aukee et al.(1975) a mean reduction of 7.4%. Both groups were studying men after partial gastrectomy. These results were similar to the mean reduction of 5.3% found in men after partial gastrectomy in the present studies.

Bone mass has been measured in patients after partial gastrectomy by 5 different techniques based on radiographs of bones. Metacarpal index was found to be reduced by Clark et al.(1964), Deller and Begley (1963), Morgan et al.(1966), and Pryor et al.(1971). Spine scores assessed by the method of Barnett and Nordin (1960) were found to be reduced by Deller and Begley (1963) and Eddy (1971), but not by Clark et al.(1964) or by Pryor et al.(1971). The femoral neck as measured by the Singh Index was found to be normal by Deller and Begley (1963). Radiogrammetry of the bones of the hands and feet showed a reduction of the toes (Arman et al., 1970) and of the hands of patients with high plasma alkaline phosphatase or bone pains (Pridie et al., 1968). Fujita et al.(1971) found reduced clavicular cortex thickness.

No significant reduction in bone mass had previously been demonstrated in studies of patients after operations other than partial gastrectomy (Morgan et al., 1966, Blichert-Toft et al., 1979, Irving et al., 1983).

Three factors have been shown to further reduce bone mass in patients after partial gastrectomy. These were the interval since operation (Alhava et al., 1974, Pryor et al., 1971), consumption of alcohol (Nilsson and Westlin, 1972), and body fat (Pulvertaft, 1968). None of these factors showed a significant effect on TBCa in the present study.

### 3. Biochemistry.

Comparison between different studies is difficult as the populations studied differ and the methods of biochemical estimation vary. Thus the age, sex-ratio, and operation types might be expected to alter the results as well as the conditions under which the blood or urine were collected. The approach adopted here is to study only cross-sectional studies of unselected cases and compare the proportion of cases above or below the quoted laboratory reference range. This method is not ideal as the population on which the reference range is not usually described and the ranges vary greatly from study to study. For example, the lower limit of normal for calcium varies from 2.00 to 2.35 mmol/l. Each biochemical variable will now be considered in turn.

There are 12 reports of plasma calcium which were based on a total of 2887 patients after peptic ulcer surgery (Alhava et al., 1974, Aukee and Jussila, 1972, Blichert-Toft et al., 1979, Deller et al., 1964, Eddy, 1971, Jones et al., 1962, Morgan et al., 1965a,

Pryor et al., 1971, Schofield et al., 1967, Tougaard et al., 1977, Wastell, 1969, Weldon et al., 1970). The proportion of patients varied from 0 to 16%, compared with 21% in the present study. The largest group of patients were the 1228 reported by Morgan et al.(1965a). In this study 16% of patients after Polya partial gastrectomy and 9% of patients after vagotomy and drainage procedure were hypocalcaemic. After correction for specific gravity these percentages were reduced to 5% and 4%, respectively. In the present study plasma calcium was related to serum albumin and correction for serum albumin reduced to proportion of patients who were hypocalcaemic. Plasma calcium has not been shown to be affected significantly by operation type or interval since operation.

There are nine reports of plasma phosphate which were based on 1214 patients after peptic ulcer surgery (Alhava et al., 1974, Aukee and Jussila, 1972, Blichert-Toft et al., 1979, Deller et al., 1963, Tougaard et al., 1977, Wastell, 1969). In two of these studies there was a reduction in plasma phosphate (Aukee and Jussila, 1972, and Eddy, 1971) and in one study an increase (Alhava et al., 1974). In no study was the sample taken in the fasting state. Plasma phosphate increases after the menopause and so the higher values found in women compared with men in the present study were to be expected.

There have been two reports of plasma magnesium which were based on 180 patients after peptic ulcer surgery. Blichert-Toft et al.(1979) found normal mean plasma magnesium in 153 patients and Tougaard et al.(1977) found a reduction in the mean plasma magnesium in 27 patients. These results contrast with the present

study in which an elevated plasma magnesium was found.

There have been 17 reports of plasma alkaline phosphatase which are based on 3542 patients after peptic ulcer surgery (Alhava et al., 1974, Aukee and Jussila, 1972, Blichert-Toft et al., 1979, Clark, 1963, Deller et al., 1964, Eddy, 1971, Garrick et al., 1971, Higgins and Pridie, 1966, Jones et al., 1962, Morgan et al., 1965a, Pryor et al., 1971, Schofield et al., 1967, Thompson et al., 1966, Tougaard et al., 1977, Wall et al., 1967, Wastell, 1969, and Wheldon et al., 1970). High values were found in 13.2% of these patients compared with 16% in the present study. The largest series was that of Morgan et al. (1965a) who found elevated plasma alkaline phosphatase levels in 6% of patients with peptic ulcer, 8% of patients after vagotomy and drainage procedure, and 12% of patients after partial gastrectomy. Only six of their 1228 patients had osteomalacia. The commonest cause of high alkaline phosphatase in their study was Paget's disease of bone. Treatment with vitamin D for four months did not reduce plasma alkaline phosphatase in patients who had high plasma alkaline phosphatase of undetermined cause. Morgan et al. (1965a) found no effect of the time interval since operation on plasma alkaline phosphatase. In a later study of these patients Ambler et al. (1970) showed that increasing age, blood group O, and Polya partial gastrectomy were all associated with high levels.

There have been four reports of plasma 25-OHD which have been based on 62 patients after partial gastrectomy (Imiwari et al., 1980, Lilianfeld-Toal et al., 1977, Schoen et al., 1978, and Tougaard et al., 1977). Eleven out of 40 patients had low values. These results were not compared with season-matched controls. In

two of the studies over a third of patients were taking vitamin D supplements and so the results of these patients are not included in the above discussion. No relationship was found between plasma 25-OHD and time interval since operation (Shoen et al., 1978) or with plasma calcium (Tougaard et al., 1977). In the present study a positive correlation was found between plasma calcium and 25-OHD. Such a relationship has not been demonstrated previously unless the results of healthy and osteomalacic patients are combined (Stanbury and Mawer, 1978). This raises the possibility that in the present group of patients there is a subgroup that is osteomalacic. However, no individual fulfilled the criteria for the biochemical diagnosis of osteomalacia with low plasma calcium and 25-OHD and high plasma alkaline phosphatase and PTH.

There have been two reports of plasma PTH based on 42 patients after Polya partial gastrectomy (Joffe et al., 1973, and Tougaard et al., 1977). The assay used by Tougaard et al. (1977) was that of Christensen (1976) which measured intact PTH and so the results were lower than those in the present study in which mainly N-terminal PTH was measured. The mean plasma PTH level in patients after partial gastrectomy was 55% higher than controls (compared to 64% higher than controls in the present study). Joffe et al. (1973) used the method of Schopman et al. (1970) which measures N-terminal PTH and the mean level in 15 patients after partial gastrectomy was 0.29 mcg/l, a value similar to the mean of 0.27 mcg/l found in the present study. As their study included no controls they concluded that PTH was normal after partial gastrectomy. An indirect method of measuring plasma PTH levels is to measure urinary cyclic AMP. Lilianfeld-Toal et al. (1977) found elevated levels of this after

partial gastrectomy thus giving further support to the presence of hyperparathyroidism in these patients.

There has been one report on urinary calcium based on patients after partial gastrectomy (Clark et al., 1964). This showed urinary calcium excretion of less than 2.5 mmol/24hr in 18% of patients compared with 35% of patients in the present study. There have been no previous study on unselected patients of urinary magnesium, phosphate, or hydroxyproline.

#### 4. Calcium absorption.

Measurements of calcium absorption are affected by dietary calcium and by the amount of calcium carrier given with the radioactive calcium. The amount of the label absorbed may be estimated by whole body counting at 7 days (as in the present study) or by measuring the radioactivity in blood, urine, or faeces. A different isotope of calcium may be given intravenously to allow for its disappearance rate from plasma. As a result of these differences it is difficult to compare studies.

Two groups have found increased calcium absorption after partial gastrectomy (Agnew and Holdsworth, 1971, and Arman and Reizenstein, 1969), one group found normal absorption (Gregory and van Uelft, 1972) and one group reduced absorption (Ikkos et al., 1975).

Agnew and Holdsworth (1971) measured 7-day calcium retention of  $^{47}\text{Ca}$  given with 100mg calcium carrier as milk in 17 patients after partial gastrectomy. Retention was higher than in controls.

Arman and Reizenstein (1969) measured 14-day calcium retention of  $^{47}\text{Ca}$  given with 135mg calcium carrier as calcium chloride in



eight patient with the dumping syndrome following Polya partial gastrectomy. Retention was higher than in controls and could be reduced by giving the calcium carrier as milk (Arman et al., 1970) or by treating the patients with oral calcium for two to six months. A similar effect of milk on calcium absorption in patients after partial gastrectomy was shown by Deller (1966).

Gregory and van Uelft (1972) measured radioactivity on blood after giving radiocalcium orally with 20mg of calcium carrier in 25 men after partial gastrectomy. They found normal absorption.

Ikkos et al.(1975) measured urinary radioactivity after giving two isotopes of calcium, one orally and one intravenously in 17 patients after partial gastrectomy. They found reduced calcium absorption.

The present study is the only one to study patients after operations for peptic ulcer other than partial gastrectomy. As it is increased after these the mechanism is most likely to be related to the reduction of acid secretion by the stomach. Acid solubilizes dietary calcium as calcium chloride. Calcium will be poorly solubilized in the absence of this acid and therefore not available for absorption. In response to this there will be a fall in plasma calcium, a rise in plasma PTH, and a rise in plasma calcitriol. Thus when calcium is given in a solubilized form as calcium chloride calcium it is hyperabsorbed. The reduction in calcium absorption is more marked when the calcium is given with milk than in patients who have not had peptic ulcer operations. Thus there is a paradox in that calcium absorption appears high when tested with solubilized calcium salts but is actually low when the calcium is taken with food.

## 5. Dietary calcium and vitamin D.

The mean daily intake of calcium in the men in the present study was 1030 mg and this was similar to that found by Pulvertaft (1968) in 37 men after partial gastrectomy of 1090 mg, and by Agnew and Holdsworth (1971) in nine patients after partial gastrectomy of 1100 mg. The mean dietary intake in the U.K. is 1000 mg (Nordin, 1976) and the mean values of controls in the studies of Pulvertaft (1968) and of Ekbon and Hed (1965) were 1340 and 880 mg. It is likely that calcium intake is normal in patients after peptic ulcer surgery. The one group to whom this conclusion does not apply is those patients with lactose intolerance causing weight loss and diarrhoea. Ekbon and Hed (1965) found that in this group the daily calcium intake was 650 mg.

Vitamin D intake was 4.3 mcg/day in the present study and 3.9 mcg/day in 37 men after partial gastrectomy reported by Pulvertaft (1968). The controls in the latter study took 5.1 mcg/day and in the present study 2.6 mcg/day. Thus vitamin D intake is normal after peptic ulcer surgery.

## 6. Age and body measurements.

In the present study the patients after peptic ulcer surgery were older, shorter, and lighter than the controls. The mean age difference of four years was unlikely to affect the results substantially.

The reasons for the increased height in the male controls are given in Chapter 3. The height difference affected interpretation of the results of TBCa, weight, and urinary minerals. Eight of the

men were shorter than the shortest male control for TBCa. In estimating the effect of height on lean body mass a formula for predicting lean body mass was used. In order to assess the effect of height on urinary mineral excretion the patients were matched for size.

The low weight was due to reduced body fat. Thus body mass index, % overweight, and % body fat were all lower than in controls. There was only a small reduction in lean body mass after correction for height. The finding of reduced weight has been thoroughly reported in patients after peptic ulcer surgery (Cox et al., 1964, Golligher et al., 1968, Pryor et al., 1971, Wastell, 1969, and Wheldon et al., 1970). However, patients after peptic ulcer patients are, on average, at their ideal weight and it is the rest of the population who are, on average, 10% overweight! A further point of interest is that there is no study which shows that patients lose weight after the operation (Pryor et al., 1971, and Wall et al., 1967). The low weight may be partly related to smoking. As shown in the present study patients after peptic ulcer surgery smoke more than the general population. Indeed, smoking may result in poor healing of peptic ulcers and hence necessitate peptic ulcer surgery (Shearman and Finlayson, 1982). Smoking is associated with a mean reduction in weight of 6 kg (Khosla and Lowe, 1971).

## 7. Social history.

The Office of Population Censuses and Surveys carried out a survey of drinking habits just five months before the start of the present study (Wilson, 1980a). The survey reports on

the alcohol consumption of 1134 men and women over the age of 20 years. In order to compare with the present study the survey's groups are changed to abstainers, moderate drinkers, and heavy drinkers (see Chapter 2 for definitions). The proportions of the men in the survey in each group were 22%, 50%, and 28%, respectively. In men after peptic ulcer surgery the proportions were 11%, 53%, and 36%. This difference was significant using a chi-squared analysis ( $P < 0.05$ ). The proportions of women in the survey in each group were 45%, 52%, and 3%. In women after peptic ulcer surgery the proportions were 11%, 85%, and 4%. This difference was also significant ( $P < 0.01$ ).

The increased alcohol consumption may be underestimated by this comparison as the figures given by Wilson (1980a) are for all adults. By the age of 50 years mean alcohol consumption has fallen by 25% compared with 20-year-olds.

Lee (1976) carried out a survey of the smoking habits of 4483 adults over 35 years in the United Kingdom. In order to allow comparison with the present study the groups in the survey are changed to non-smokers, light smokers (less than 10 cigarettes a day), and heavy smokers (more than 10 cigarettes a day). In the men of the survey the proportions in each group were 37%, 14%, and 49%, respectively. In men after peptic ulcer surgery the proportions were 28%, 12%, and 60%. This difference did not reach statistical significance. In the women of the survey the proportions were 61%, 14%, and 25%. In women after peptic ulcer surgery the proportions were 26%, 15%, and 59%. This difference was significant ( $P < 0.001$ ).

Consumption of cigarettes and alcohol slow ulcer healing and so may make such patients more likely to require peptic ulcer

surgery (Shearman and Finlayson, 1982).

Bone mass may be affected by smoking. Daniell (1976) showed that smoking was associated with increased risk of vertebral fracture and reduced bone mass (as measured by metacarpal cortical area) in non-obese postmenopausal women. Alcoholism reduces bone density further in patients after partial gastrectomy (Nilsson and Westlin, 1972).

Smoking may be the cause of the reduced body fat in these patients (see above). It may also be the cause of premature death of patients after peptic ulcer surgery. Ross et al. (1982) studied the same patient population as in the present study and found an excess mortality due to smoking-related diseases.

The social class distribution was similar to that of the UK population in 1975.

#### 8. Changes in bone mass and biochemistry following treatment with vitamin D and calcium.

Alhava et al. (1975) studied the effect of vitamin D and calcium on bone density and biochemistry. They studied 86 patients who had undergone partial gastrectomy. Thirty-two were given no treatment, 27 oral calcium (50 mmol/day), and 27 oral calcium and vitamin D (25mcg/day). Thus the vitamin D dose was the same as in the present study but the calcium was 2.5 times more. They measured bone density by photon absorptiometry of the distal left radius for a period of eight months. In the men there was a 5% increase on calcium ( $P < 0.05$ ) and a 9% increase on calcium and vitamin D ( $P < 0.005$ ). No significant change was shown in the 23 women. There was a fall in plasma alkaline phosphatase in the men treated with

vitamin D and a rise in urinary calcium to creatinine ratio in all treated groups. Plasma calcium and phosphate did not change and plasma 25-OHD and PTH were not measured.

The major criticism of the study of Alhava et al.(1975) is that no information was given about the initial vitamin D status of the population. The study was carried out on the Arctic Circle at Kuopio in Finland. In a report of plasma 25-OHD at a similar latitude in Norway, Vik et al.(1980) show that during the winter normal plasma levels are maintained by vitamin D supplements.

In the study of Morgan et al.(1965a) fifteen patients with alkaline phosphatase levels raised for reasons unknown were treated with vitamin D. Five received placebo, five vitamin D 17.5 mcg/week, and five vitamin D 250 mcg/week, intramuscularly. After four months there was no fall in plasma alkaline phosphatase or rise in calcium. This study took place in the U.K. and is further evidence that this group of patients in this country are not vitamin D-deficient.

In the placebo-treated group of the present study the plasma 25-OHD remained normal throughout the year. In those treated with vitamin D the plasma 25-OHD levels doubled. This rise is smaller than would be expected from the study of MacLennan and Hamilton (1977). They treated 15 geriatric patients for four months with 12.5 mcg vitamin D /day and found the plasma 25-OHD rise from 22 to 53 nmol/l. This was half the dose used in the present study. Although the compliance rate was estimated at 77% in the present study the method of estimating compliance is crude. It is likely that the compliance of the geriatric in-patients was better than in the present study. An alternative explanation of this discrepancy

would be that patients after peptic ulcer surgery malabsorb vitamin D. Absorption of vitamin D was normal after partial gastrectomy in patients without steatorrhoea (Gertner et al., 1977, and Thompson et al., 1966).

#### 9. The cause of low TBCa after peptic ulcer surgery.

The most likely cause of osteopaenia after peptic ulcer surgery is malabsorption of calcium and its associated secondary hyperparathyroidism. The evidence may be summarized as follows:

- a. Bone mass is reduced after all types of operation for peptic ulcer.
- b. The osteopaenia is associated with increased fracture incidence.
- c. Dietary intake of calcium in these patients is usually normal.
- d. The absorption of solubilized calcium in these patients is increased. However, when the calcium is given with milk it is poorly absorbed.
- e. Patients have hypocalcaemia, hypocalciuria, and secondary hyperparathyroidism.
- f. Plasma 25-OHD shows the normal seasonal fluctuation and is normal.
- g. Treatment with vitamin D and calcium reversed some of the biochemical abnormalities but did not cause an increase in bone mass.
- h. The excess of osteoid that has been demonstrated in the bone biopsies from these patients (Bordier et al., 1968, and Garrick et al., 1971) could be due to secondary hyperparathyroidism rather than osteomalacia.

i. Low dietary calcium has been associated with an increased fracture incidence in Yugoslavia (Matkovic et al., 1979). Metabolic balance studies have shown that below a certain calcium intake the calcium balance becomes negative (Gallagher and Riggs, 1978, Whedon, 1981). After peptic ulcer surgery dietary calcium is less available for absorption and so these patients may require a higher dietary calcium intake than the general population to remain in calcium balance.

Three other factors may contribute to the osteopaenia in these patients. Smoking has been associated with reduced bone density and increased fracture incidence in non-obese, postmenopausal women (Daniell, 1976). Alcoholism has been associated with reduced bone mass in men after partial gastrectomy (Nilsson and Westlin, 1972). Reduced body fat has been associated with reduced oestrone levels in postmenopausal women and with reduced bone density (Christiansen, 1981).

#### E. SUMMARY.

1. The mean reduction in  $Ca_R$  in men after peptic ulcer surgery was 5.3%. This reduction was associated with all types of operation.
2. After peptic ulcer surgery there was a reduction in plasma and urinary calcium, an increase in plasma magnesium, alkaline phosphatase, and PTH, and no difference from season-matched controls in plasma phosphate and 25-OHD.



3. There was an increase in 7-day calcium retention especially in patients after partial ~~parathyroidectomy~~. High retention results were associated with high plasma PTH levels.

4. Dietary calcium and vitamin D were similar to controls.

5. Low body weight was due to reduced body fat. It was associated with all types of operation and was no different from the pre-operative weight.

6. Alcohol consumption was higher than the Scottish population as a whole and smoking was more common in the women than in the U.K. population.

7. Treatment with vitamin D and calcium for one year had no effect on bone mass as assessed by FCa. There was an increase in plasma 25-OHD and falls in plasma PTH, alkaline phosphatase, and magnesium.

CHAPTER 9. CONCLUSIONS: THE VALUE OF TBCa MEASUREMENTS IN THE INVESTIGATION OF METABOLIC BONE DISEASE.

The main advantage of TBCa over the other methods of assessing bone mass is the low coefficient of variation of the normal range. It is compared with other techniques in Table 9a. This allows easy separation of normal from abnormal and in the present study demonstrated reduced bone mass in patients with vertebral fracture, primary hyperparathyroidism, osteomalacia, chronic renal failure on haemodialysis, and after peptic ulcer surgery. In addition a reduction in an individual of more than 15% is likely to be detected by this technique.

The second advantage of TBCa measurements is the avoidance of sampling error as the whole skeleton is assessed. Thus the changes in TBCa after renal transplantation or after parathyroidectomy represent long-term changes in calcium balance. This has the limitation that if one bone is of interest, such as the radius in women with wrist fracture, then one cannot make be certain that changes in the whole skeleton are reflected in this bone. This was also a problem in predicting vertebral fractures from TBCa measurements as some types of metabolic bone disease affect preferentially cortical or trabecular bone.

The third advantage of TBCa measurements is their good reproducibility as this allows small changes to be measured. However photon absorptiometry has a similar reproducibility and a lower radiation dose and the apparatus for this technique is now commercially available.

The demonstration of a fracture threshold in patients with spontaneous vertebral fracture is one finding which may prove

Table 9a. Methods for measuring bone mass in vivo. Only studies reporting findings relevant to the present study and published in the last ten years are included.

<u>Method</u>	<u>Precision</u>	<u>Reference range</u>	<u>Reference</u>
	CV	CV	
Whole bone density by X-ray densitometry of 3rd metacarpal	2 - 3	13	Lindsay et al.(1976)
X-ray spectrometry of			
1. Distal forearm	3.2	13(M) 22(F)	Dalen and Hjern (1974)
2. Lumbar spine	10.0	15	
3. Calcaneous	3.4	13	
Photon absorptiometry			
1. Finger	2	11	Genant et al.(1973)
2. Forearm	1.4 - 3.5	11 - 16	Aukee et al.(1975) Blichert-Toft et al.(1979) Pak et al.(1975)
IVNAA			
1. Forearm	2.6	-	Smith and Tothill (1979)
2. Trunk	6.6	9	Harrison et al.(1975)
3. Total body	1.8	6.5	Kennedy et al.(1982)

useful in the future. If those women at risk from such fractures could be identified then the bone loss might be prevented by appropriate drug therapy. However, a prospective study of healthy volunteers would be required before the method could be used in this way.

The drawbacks of the method are several. Firstly, neutron sources are generally expensive and not widely available. Secondly, the dose of radiation is higher than other methods although well within the safety limits for radiation workers. Thirdly the effects of ectopic calcification is unknown.

Attempts have been made to predict TBCa from bone density measurements using techniques such as photon absorptiometry which have a lower radiation dose. Cohn et al.(1974) and Hesp et al.(1982) find a close relationship between bone mineral content of the distal radius and TBCa ( $r = 0.78, 0.77$ ). Similarly, Hesp et al.(1982) and Horsman et al.(1983) find a close relationship between bone mineral content of the lower femur and TBCa ( $r = 0.76, 0.76$ , respectively). Horsman et al.(1983) used this relationship to predict TBCa from lower femur bone density and the standard error of the estimate was 80g. The authors felt this figure was unacceptably high.

The relationship of bone density and TBCa was close because both measurements are dependent on body size. Indeed, the relationship between  $(\text{height})^{2.07}$  and TBCa in the men of the present study was even closer ( $r = 0.83$ )! Cohn et al.(1974) normalized TBCa for body size ( $\text{Ca}_R$ ) and bone mineral content of the radius for radius width and the correlation coefficient was only 0.45. At present there is no substitute for measuring TBCa.

APPENDIX: STATISTICAL METHODS.

Three statistical methods were used which need further explanation.

1. Regression analysis applied to logarithmically-transformed data.

This technique was applied to TBCa measurements and body size and to lean body mass and its relationship to height.

$$\text{If, } Y \propto X^n$$

$$\text{Then, } \log_e (Y) = n \times \log_e (X)$$

Regression of  $\log_e (Y)$  on  $\log_e (X)$  gives  $n$  as the regression coefficient.

In the example of TBCa,  $Y$  is TBCa and  $X$  can be age, years postmenopause, height, span, or lean body mass.

In men,

<u>Variable</u>	<u>Regression coefficient</u>	<u>Correlation coefficient</u>	<u>P</u>
Age	-0.38	-0.54	<0.02
Height	2.07	0.84	<0.001
Armspan	1.80	0.74	<0.001
Weight	0.21	0.54	N.S.
Lean body mass	0.54	0.54	<0.02

In women,

Age	-0.89	-0.66	<0.005
Height	2.18	0.56	<0.02
Armspan	2.24	0.63	<0.005
Weight	0.36	0.42	N.S.
Lean body mass	0.57	0.48	<0.05

Multiple regression may be applied if TBCa were likely to be dependent on several variables. In postmenopausal women it would be expected that age and body size would affect TBCa independently. The closest relationship (as judged by the coefficient of correlation) was between TBCa and armspan and years postmenopause. The following equations were used to derive this relationship.

$$\text{TBCa} = s^n \times e^{X \times \text{yprn}}$$

after logarithmic transformation to base e,

$$\log_e (\text{TBCa}) = C + n \times \log_e (s) + X \times \text{yprn}$$

apply multiple regression equation to the data from the female controls:

$$\log_e (\text{TBCa}) = 5.99 + 1.69 \times \log_e (s) - 0.015 \times \text{yprn}$$

$$\text{i.e. TBCa} = 399 \times s^{1.69} \times e^{-0.015 \times \text{yprn}}$$

with  $r = 0.89$ , and  $P < 0.001$ .

When lean body mass was included in the analysis  $r$  was not increased.

## 2. Analysis of the PTH results.

This was difficult as some results were below the lower limit of sensitivity of the assay. Two approaches were used.

### a. Fisher's Exact Test.

The total number of patients was halved and the higher and lower 50% were put into a 2 x 2 contingency table (Fisher's Exact Test):

In the men,

	ULCER OPS	CONTROLS	TOTALS
HIGH	51	4	55
LOW	41	15	56
TOTALS	92	19	111

In the women,

	ULCER OPS	CONTROLS	TOTALS
HIGH	17	4	21
LOW	5	16	21
TOTALS	22	20	42

Applying tables for Fisher's Exact Test the significance values for men and women were  $P < 0.01$  and  $P < 0.001$ .

b. Swan analysis.

This analysis is named after the statistician who described it and the program is available on the Digital Equipment Corporation computer at the Clinical Research Centre, Watford Road, Harrow. The analysis assumes that the data is normally distributed and predicts the value of the censored data from the known data. The method has the advantage that the results can be expressed as mean and SD.

## Acknowledgements.

I would like to thank my supervisor, Dr Andrew Doig, and my colleagues, Dr Michael Smith, Dr Norman Kennedy, Dr Peter Tothill, and Professor John Strong, for their help and encouragement in writing this thesis.

The research work was funded by a grant from the Medical Research Council to Professor Strong and Dr Tothill, both of whom supervised the project of setting up the method of TBCa.

The measurements of FCa and TBCa were made by Dr Kennedy who was assisted by Mrs Elizabeth Law. The plasma 25-OHD assay was set up by Miss Francis Pearson under the direction of Dr Peter Ashby. Miss Pearson also measured urinary minerals. Plasma PTH was measured by Mr NS Brown in the laboratory of Dr John Seth. The remainder of the plasma biochemistry was performed by Dr DB Horn. The bone histology was interpreted by Dr George Smith. Mrs Jane Virden supplied tablets and estimated drug compliance.

I wish to thank the physicians and surgeons of the Western General Hospital, Edinburgh, for allowing me to study their patients. The patients in the gastric follow-up clinic were under the care of Mr WP Small; those undergoing renal allotransplantation were under Dr JL Anderton, Dr RJ Winney, Professor GD Chisholm, Mr DW Hamer-Hodges, and Mr TB Hargreaves; those with osteomalacia were under Dr W Sircus, Dr A Ferguson, and Dr MA Eastwood; those with osteoporosis and primary hyperparathyroidism were under the care of Professor JA Strong, Professor CRW Edwards, and Dr PL Padfield; and those with wrist fractures under the care of Mr Abernethy, Mr Fulford, and Mr Scott. I am also grateful to the volunteers who acted as controls - members of hospital staff, the WRVS etc.



Although the TBCa measurements, biochemical measurements, and histological interpretation were performed by others, I designed the studies, recruited the patients and performed the clinical assessment and investigations. I arranged their treatment and follow-up and was responsible for the data analysis and interpretation of results.

References.

Aaron JE, Gallagher JC, Nordin BEC. Seasonal variation in histological osteomalacia in femoral neck fractures. Lancet 1974; 2:84-85.

Aaron JE. Autoclasia - a mechanism of bone resorption and an alternative explanation for osteoporosis. Calcif Tissue Res 1977; 22(S):247-54.

Agnew JE, Holdsworth CD. The effect of fat on calcium absorption from a mixed meal in normal subjects, patients with malabsorptive disease, and patients with partial gastrectomy. Gut 1971; 12:973-77.

Aird EGA, Pierides AM. Photon absorptiometry of bone after successful renal transplantation. Br J Radiol 1977; 50:350-56.

Aitken JM, Anderson JB, Horton PW. Seasonal variations in bone mineral content after the menopause. Nature 1973; 241:59-60.

Aitken JM, Gordon S, Anderson JB, et al. Seasonal variations in calcium and phosphorus homeostasis in man. In: Clinical aspects of metabolic bone disease. Frame B, Parfitt AM, Duncan H, eds. Amsterdam: Excerpta Medica, 1973:80-84.

Alhava EM, Aukee S, Karjalainen P. Bone mineral after partial gastrectomy 1. Scand J Gastroenterol 1974; 9:463-66.

Alhava EM, Aukee S, Karjalainen P, Kettunen K, Juuti M. The influence of calcium and calcium + vitamin D2 treatment on bone mineral after partial gastrectomy. Scand J Gastroenterol 1975; 10:689-93.

Aloia JF, Cohn SH, Ross P, et al. Skeletal mass in postmenopausal women. Am J Physiol 1978; 235:E82-87.

Ambler J, Green AG, Pulvertaft CN. A study of total serum alkaline phosphatase activity in men following partial gastrectomy. Gut 1970; 11:255-57.

Andresen J, Nielsen HE. Interrelationship between metacarpal bone mass and bone mineral content in renal transplant recipients. Acta Radiologica Diagnosis 1982; 23:513-16.

Arman E, Reizenstein P. Studies in the dumping syndrome IV. Effect of calcium therapy on calcium metabolism and osteopaenia in gastrectomized patients. Am J Dig Dis 1970; 15:455-62.

Arman E, Nilsson LH, Reizenstein P. Studies in the dumping syndrome VI. Calcium deficiency after partial gastrectomy. Am J Dig Dis 1970; 15:455-62.

Armitage P. Statistical methods in medical research. Oxford: Blackwell, 1971.

Aukee S, Jussila J. The functional state of the gastrointestinal tract before, and one and six years after ulcer surgery. Scand J

Gastroenterol 1972; 7:329-36.

Aukee S, Alhava EM, Karjalainen P. Bone mineral after partial gastrectomy II. Scand J Gastroenterol 1975; 10:165-69.

Baird IM, Silverstone JT, Grimshaw JJ, Ashwell M. Prevalence of obesity in a London borough. Practitioner 1974; 212:706-14.

Barnett E, Nordin BEC. The radiological diagnosis of osteoporosis: a new approach. Clin Radiol 1960; 11:166-74.

Bijvoet OLM. Kidney function in calcium and phosphate metabolism. In: Avioli LV, Krane SM, eds. Metabolic bone disease, vol I. New York: Academic Press, 1977:80-141.

Blichert-Toft M, Beck A, Christiansen C, Transbol I. Effects of gastric resection and vagotomy on blood and mineral content. World J Surg 1979; 3:99-102.

Boddy K, Holloway I, Elliot A. A simple facility for total body in vivo activation analysis. Int J Appl Radiat Isot 1973; 24:428-29.

Bordier P, Matrajt H, Hioco D, Hepner GW, Thompson GR, Booth CC. Subclinical vitamin D-deficiency following gastric surgery: histological evidence in bone. Lancet 1968; 1:437-440.

Bortolotti GC, Feletti C, Scolari MP, Bonomini V. Subclinical bone pathology after kidney transplantation in man. Calcif Tissue Res 1977; 22supp:486-89.

Chalmers J. Osteomalacia. A review of 93 cases. J R Coll Surg Edinb 1968; 13:255-75.

Chamberlain MJ, Fremlin JH, Peters DK, Philip H. Total body calcium by whole body neutron activation: a new technique for study of bone disease. Br Med J 1968; 2:581-83.

Chatterjee SN, Massry SG, Friedler RM, Singer FR, Berne TV. The incidence of persistent secondary hyperparathyroidism after renal transplantation. Surg Gynecol Obstet 1976; 143:440-42.

Chesnut III CH, Nelp WB, Baylink JD. Effect of methandrostenolone on postmenopausal bone wasting as assessed by changes in total mineral mass. Metabolism 1977; 26:767-77.

Chick J. Epidemiology of alcohol use and its hazards. Br Med J 1982; 38:3-8.

Christiansen C, Jensen GF, Hummer L, Transbol I. Possible pathogenesis of postmenopausal osteoporosis. Calcif Tissue Int 1981; 33(S):153.

Christiansen MS. A sensitive radioimmunoassay of parathyroid hormone in human serum using a specific extraction procedure. Scand J Clin Lab Invest 1976; 36:313-22.

Clark CJ. Malabsorption following partial gastrectomy. J R Coll Surg Edinb 1963; 9:52-60.

Clark CJ. Postgastrectomy bone disease. Proc Roy Soc Med 1964;  
57:580-82.

Clark CJ, Crooks J, Dawson AA, Mitchell PEG. Disordered calcium metabolism after Polya partial gastrectomy. Lancet 1964; 1:734-38.

Cohn SH, Ellis KJ, Caselnova RC, Asad SN, Letteri JM. Correlation of radial bone mineral content with total body calcium in chronic renal failure. J Lab Clin Med 1975; 86:910-19.

Cohn SH, Ellis KJ, Wallach S, et al. Absolute and relative deficit in total skeletal calcium and radial bone mineral in osteoporosis. J Nucl Med 1974; 15:428-35.

Cohn SH, Roginsky MS, Aloia JF, Ellis KJ, Shukla KK. Alterations in skeletal calcium and phosphorus in dysfunction of the parathyroids. J Clin Endocrinol Metab 1973; 36:750-55.

Cohn SH, Vaswani A, Zanzi I, Ellis KJ. Effect of aging on bone mass in adult women. Am J Physiol 1976a; 230:143-48.

Cohn SH, Vaswani A, Zanzi I, et al. Changes in body chemical composition with age measured by total-body neutron activation. Metabolism 1976b; 25:85-95.

Cox AG, Bond MR, Podmore DA, Rose DP. Aspects of nutrition after vagotomy and gastroenterostomy. Br Med J 1964; 1:465-69.

Dalen N, Bjorn B. Bone mineral content in patients with primary hyperparathyroidism without radiological evidence of skeletal changes. *Acta Endocrinol* 1974; 75:297-304.

Daniell HW. Osteoporosis of the slender smoker. *Arch Intern Med* 1976; 136:298-304.

Dauphine RT, Riggs BL, Sholz DA. Back pain and vertebral crush fractures: an unemphasized mode of presentation for primary hyperparathyroidism. *Ann Intern Med* 1975; 83:355-57.

David DS, Sakai S, Brennan BL, et al. Hypercalcaemia after renal transplantation. Long-term follow-up data. *N Engl J Med* 1973; 289:398-401.

Deller DJ, Begley MD. Calcium metabolism and the bones after partial gastrectomy I. Clinical features and radiology of the bones. *Aust Ann Med* 1963a; 12:282-93.

Deller DJ, Edwards RG, Addison M. Calcium metabolism and the bones after partial gastrectomy II. The nature and the cause of the bone disorder. *Aust Ann Med* 1963b; 12:295-309.

Deller DJ, Begley MD, Edwards RG, Addison M. Metabolic effects of partial gastrectomy with special reference to calcium and folic acid. *Gut* 1964; 5:218-25.

Deller DJ. Radiocalcium absorption after partial gastrectomy. Am J Dig Dis 1966; 11:10-19.

Denney JD, Sherrard DJ, Nelp WB, Chesnut III CH, Baylink DJ. Total body calcium and long-term calcium balance in chronic renal failure. J Lab Clin Med 1973; 82:226-40.

Dent CE, Watson L. The hydrocortisone test in primary and tertiary hyperparathyroidism. Lancet 1968; 2:662-64.

Devgun MS, Paterson CR, Martin BT. Seasonal changes in the activity of serum alkaline phosphatase. Enzyme 1981; 26:301-05.

DHSS. Recommended daily amounts of food energy and nutrients for groups of people in the United Kingdom. Report on health and social subjects, no.15. London: HMSO, 1980.

Durnin JVGA, Womersley J. Body fat assessed from total body density and its estimation from skinfold thickness: measurements on 481 men and women aged from 16 to 72 years. Br J Nutr 1974; 32:77-97.

Eddy RL. Metabolic bone disease after gastrectomy. Am J Med 1971; 50:442-49.

Ekblom K, Hed R. Calcium studies in partially gastrectomized patients with special reference to the oral intake of calcium. Acta Med Scand 1965; 178:193-201.



Fenton S, Somers S, Heath DA. Preliminary studies with the sensitive cytochemical assay for parathyroid hormone. Clin Endocrinol 1978; 9:381-84.

Frank HA, Carr MH. Normal serum electrolytes with a note on seasonal and menstrual variations. J Lab Clin Med 1957; 49:247-52.

Fraser DR. The physiological economy of vitamin D. Lancet 1983; 1:969-72.

Frost HM. Mechanical microdamage, bone remodelling, and osteoporosis: a review. In: DeLuca HF, Frost HM, Jee WSS, Johnson CC, Parfitt AM, eds. Osteoporosis: recent advances in pathogenesis and treatment. Baltimore: University Park Press, 1981:185-90.

Fujita T, Okuyama Y, Handa N, et al. Age-dependent bone loss after gastrectomy. J Am Geriatr Soc 1971; 19:840-46.

Gallagher JC, Riggs BL. Current concepts in nutrition. Nutrition and bone disease. N Engl J Med 1978; 298:193-95.

Garrick R, Ireland AW, Posen S. Bone abnormalities after gastric surgery: a prospective histological study. Ann Intern Med 1971; 75:221-25.

Genant HK, Heck LL, Lanzl LH, Rossman K, Horst JV, Paloyan E.

Primary hyperparathyroidism. A comparative study of clinical, biochemical, and radiological manifestations. *Radiology* 1973; 109:513-24.

Gertner JM, Lilburn M, Domenach M. 25-hydroxycholecalciferol absorption in steatorrhea and postgastrectomy osteomalacia. *Br Med J* 1977; 1:1310-12.

Goligher JC, Pulvertaft CN, deDombal FT, et al. Five- to eight-year results of Leeds/York controlled trial of elective surgery for duodenal ulcer. *Br Med J* 1968; 2:781-87.

Gregory MM, van Uelft R. Calcium absorption following gastric resection. *Am J Gastroenterol* 1972; 57:34-40.

Habener JF, Potts JT. Parathyroid physiology and primary hyperparathyroidism. In: Avioli LV, Krane SM, eds. *Metabolic Bone Disease*, vol.2. New York: Academic Press, 1978:1-147.

Haddad JG, Stamp TCB. Circulating 25-hydroxyvitamin D in man. *Am J Med* 1974; 57:57-62.

Harrison JE, Williams WC, Watts J, McNeill KG. A bone calcium index based on partial-body calcium measurements by in vivo activation analysis. *J Nucl Med* 1975; 16:116-22.

Heaney RP. Evaluation and interpretation of calcium kinetic data in man. *Clin Orthop* 1963; 31:153-83.

Hesp R, Bydder M, U, Reeve J, Spinks TJ. Regional bone density measurements compared to total body calcium in osteoporosis. *Metab Bone Dis Rel Res* 1982; 4:169-73.

Higgins MP, Pridie PB. Postgastrectomy osteomalacia: incidence after no-loop and other types of gastrectomy. *Br J Surg* 1966; 53:881-85.

Horsman A, Simpson M, Burkinshaw L, Pearson D. The estimation of total body calcium from measurements of the peripheral skeleton. In: Dixon AStJ, Russell RGG, Stamp TCB, eds. *Osteoporosis, a multi-disciplinary problem*. London: The Royal Society of Medicine, 1983:89-96.

Hosking DJ, Chamberlain MJ, Fremlin JH. Changes in total body calcium content in primary hyperparathyroidism. *Clin Sci* 1972; 43:627-37.

Hosking DJ, Chamberlain MJ, Fremlin JH, James H. Changes in total body calcium and sodium in osteomalacia. *Br Med J* 1972; 1:19-22.

Ibels LS, Alfrey AC, Huffer WE, Weil III R. Aseptic necrosis of bone following renal transplantation; experience in 194 renal transplant recipients and review of the literature. *Medicine* 1978; 57:25-45.

Ikkos DG, Nikolaou A, Alevizaki CC. Intestinal calcium absorption 0

- 30 years postgastrectomy: study with a double isotope radiotechnique. In: Kuhlencordt F, Kruse HP, eds. Calcium metabolism, bone and metabolic bone disease. Berlin: Springer-Verlag, 1975:341-42.

Imawari M, Kozawa K, Akanuma Y, Koizumi S, Itakura H, Kosaka K. Serum 25-hydroxyvitamin D and vitamin D-binding protein levels after partial and total gastrectomy. Gastroenterology 1980; 79:255-58.

Irving AD, Smith G, Catto GRD. Does metabolic bone disease follow truncal vagotomy and gastroenterostomy. Br Med J 1983; 287:1516.

Iwanami M, Osiba S, Yamada T, Yoshimura H. Seasonal variations in serum inorganic phosphate and calcium with special reference to parathyroid activity. J Physiol (Lond) 1959; 149:23-33.

Joffe BI, Haking WHL, Seftel HC, Bremner CG. Parathyroid hormone concentrations in postgastrectomy patients. S Afr Med J 1973; 47:659-60.

Jones CT, Williams JA, Cox EV, Meynell MJ, Cooke WT, Stammers FAR. Peptic ulceration: some haematological and metabolic consequences of gastric surgery. Lancet 1962; 2:425-28.

Josephson B, Dahlberg G. Variations in the cell-content and chemical composition of the human blood due to age, sex and season. Scand J Clin Lab Invest 1952; 4:216-36.

Kassirer JP. Clinical evaluation of kidney function - glomerular function. N Engl J Med 1971; 285:385-89.

Kennedy NSJ, Eastell R, Ferrington CM, et al. Total body neutron activation analysis of calcium: calibration and normalization. Phys Med Biol 1982; 27:697-707.

Khosla T, Lowe CR. Obesity and smoking habits. Br Med J 1971; 4:10-13.

Kind PRN, King EJ. Estimation of plasma phosphatase by determination of hydrolysed phenol with amino-antipyrine. J Clin Pathol 1954; 7:322-26.

King RG, Stanbury SW. Magnesium metabolism in primary hyperparathyroidism. Clin Sci 1970; 39:281-303.

Kleerekoper M, Ibels LS, Ingham JP, et al. Hyperparathyroidism after renal transplantation. Br Med J 1975; 2:680-82.

Ladenson JH. Clinical chemistry of disorders of mineral homeostasis. In: Sonnerwirth AC, Jarett L, eds. Gradwohl's clinical laboratory methods and diagnosis, vol I. St Louis: Mosby, 1980:324-50.

Leader. After gastrectomy. Br Med J 1981; 282:1096-97.

Leader. Serum calcium. Lancet 1979; 1:858-59.

Lee DBN, Goldman R, Gonick HC. Hypercalcaemia after kidney transplant. N Engl J Med 1973; 289:1256.

Lee PN. Statistics of smoking in the United Kingdom. London: Tobacco Research Council, 1976:36.

Lemann J, Adams ND, Gray RW. Urinary calcium excretion in human beings. N Engl J Med 1979; 301:535-41.

Lilienfeld-Toal Hv, Mackes KG, Kodrat G, Ochs H, Sonnenberg A. Plasma 25-hydroxyvitamin D and urinary cyclic AMP in German patients with subtotal gastrectomy (Billroth II). Am J Dig Dis 1977; 22:633-36.

Lindsay R, Hart DM, MacLean A, et al. Bone responses to termination of oestrogen treatment. Lancet 1978; 1:1325-27.

Lindsay R, McPherson SG, Anderson JB, Smith DA. The value of bone density measurements in predicting the risk of developing avascular necrosis following renal transplantation. Calcif Tissue Res 1976; 21 (supp):242-46.

Lund B, Sorensen OH. Measurement of 25-hydroxyvitamin D in serum and its relation to sunshine, age and vitamin D intake in the Danish population. Scand J Lab Invest 1979; 39:23-30.

Lund B, Sorensen OH, Christensen AB. 25-hydroxycholecalciferol and fractures of the proximal femur. *Lancet* 1975; 2:300-02.

McGeown MG, Kennedy JA, Loughridge WGG, et al. One hundred kidney transplants in the Belfast City Hospital. *Lancet* 1977; 2:648-51.

McLaughlin M, Fairney A, Lester E, Raggatt PR, Brown DJ, Wills MR. Seasonal variation in serum 25-hydroxycholecalciferol in healthy people. *Lancet* 1974; 1:536-38.

MacLennan WS, Hamilton JC. Vitamin D supplements and 25-hydroxyvitamin D concentrations in the elderly. *Br Med J* 1977; 2:859-61.

McNeill KG, Harrison JE. Measurement of the axial skeleton for diagnosis of osteoporosis by neutron activation analysis. *J Nucl Med* 1977; 18:1136-37.

Mallette LE, Bilezikian JP, Heath DA, Aurbach GD. Primary hyperparathyroidism: clinical and biochemical features. *Medicine* 1974; 53:127-46.

Mallette LE, Sode JE, Marx SJ, Georges LP, Aurbach GD. Total body retention of orally administered Ca-47 in primary hyperparathyroidism. *J Clin Endocrinol Metab* 1975; 40:582-88.

Marshall DH, Nordin BEC. The effect of 1 $\alpha$ -hydroxyvitamin D<sub>3</sub> with and without oestrogen on calcium balance in post-menopausal women. *Clin Endocrinol* 1977; 7(supp):159-68.

Matkovic V, Kostial K, Simonovic I, et al. Bone status and fracture rates in two regions of Yugoslavia. *Am J Clin Nutr* 1979; 32:450-59.

Meredith SC, Rosenberg IH. Gastrointestinal-hepatic disorders and osteomalacia. *Clin Endocrinol Metab* 1980; 9:131-50.

Mitchell ABS, Glass D, Morton Gill A. Osteomalacia following vagotomy and pyloroplasty. *Postgrad Med J* 1971; 47:233-37.

Morgan DB, Paterson CR, Woods CG, Pulvertaft CN, Fourman P. Search for osteomalacia in 1228 patients after gastrectomy and other operations on the stomach. *Lancet* 1965a; 2:1085-88.

Morgan DB, Rivlin RS, Davis RH. Seasonal changes in the urinary excretion of calcium. *Am J Clin Nutr* 1972; 25:652-54.

Morgan DB, Spiers FW, Pulvertaft CN, et al. Effects of age on the loss of bone after gastric surgery. *Lancet* 1966; 2:772-73.

Morgan DB, Hunt G, Paterson CR. The osteomalacia syndrome after stomach operations. *Q J Med* 1970; 39:395-410.

Nelp WB, Denney JD, Murano R, et al. Absolute measurements of total body calcium (bone mass) in vivo. *J Lab Clin Med* 1972; 79:430-38.

Newton-John HF, Morgan DB. The loss of bone with age, osteoporosis and fractures. *Clin Orthop* 1970; 71:229-52.



Nilsson BE, Westlin NE. The fracture incidence after gastrectomy. *Acta Orth Scand* 1971; 137:533-34.

Nilsson BE, Westlin NE. Femur density in alcoholism and after gastrectomy. *Calcif Tissue Res* 1972; 10:167-70.

Nordin BEC. Nutritional considerations. In: Nordin BEC, ed. *Calcium, phosphate and magnesium metabolism*. Edinburgh: Churchill Livingstone, 1976:5-7.

Nordin BEC. Plasma calcium and plasma magnesium homeostasis. In: Nordin BEC, ed. *Calcium, phosphate and magnesium metabolism*. Edinburgh: Churchill Livingstone, 1976:215-16.

Nordin BEC, Heyburn PJ, Peacock M, et al. Osteoporosis and osteomalacia. *Clin Endocrinol Metab* 1980; 9:177-205.

Nordin BEC, Horsman A, Crilly RG, Marshall DH, Simpson M. Treatment of spinal osteoporosis in postmenopausal women. *Br Med J* 1980; 280:451-54.

Office of population censuses and surveys. *Classification of occupation*. London: HMSO, 1970:1-101.

Pak CYC, Stewart A, Kaplan R, Bone H, Notz C, Browne R. Photon absorptiometric analysis of bone density in primary hyperparathyroidism. *Lancet* 1975; 2:7-8.

Palmer HE, Nelp WB, Murano R, Rich C. The feasibility of in vivo neutron activation analysis of total body calcium and other elements of body composition. *Phys Med Biol* 1968; 13:269-73.

Paterson CR. *Metabolic disorders of bone*. Oxford: Blackwell, 1974.

Peacock M, Heyburn PJ, Aaron JE. Vitamin D resistant hypophosphataemic osteomalacia: treatment with 1 $\alpha$ -hydroxyvitamin D<sub>3</sub>. *Clin Endocrinol* 1977; 7(supp):231-37.

Pellegrino ED, Blitz RM. The composition of human bone in uraemia. *Medicine* 1965; 44:397-418.

Preece MA, O'Riordan JLH, Lawson DEM, Kodicek E. A competitive protein-binding assay for 25-hydroxycholecalciferol and 25-hydroxyergocalciferol in serum. *Clin Chim Acta* 1974; 54:235-42.

Pridie RB, Higgins PM, Yates JR. Bone changes following gastrectomy. *Clin Radiol* 1968; 19:148-53.

Pryor JP, O'Shea MJ, Brooks PL, Datar GK. The long term metabolic consequences of partial gastrectomy. *Am J Med* 1971; 51:5-10.

Pulvertaft CN. Gastric resection and metabolic bone disease. *Postgrad Med J* 1968; 44:618-20.

Raisz LG, Yajnik CH, Bockman RS, Bower BF. Comparison of commercially available parathyroid hormone immunoassays in the

differential diagnosis of hypercalcaemia due to primary hyperparathyroidism or malignancy. *Ann Int Med* 1979; 91:739-40.

Ralis ZA. Bone weakness in the elderly. *Hospital Update* 1983; 9:1381-91.

Robertson WG, Gallagher JC, Marshall DH, Peacock M, Nordin BEC. Seasonal variations in urinary excretion of calcium. *Br Med J* 1974; 4:436-37.

Ross AHMcL, Smith MA, Anderson JR, Small WP. Late mortality after surgery for peptic ulcer. *N Engl J Med* 1982; 307:519-22.

Schoen MS, Lindenbaum J, Roginsky MS, Holt PR. Significance of serum levels of 25-hydroxycholecalciferol in gastrointestinal disease. *Am J Dig Dis* 1978; 23:137-42.

Schofield PS, Watson-Williams EJ, Sorrell VF. Vagotomy and pyloric drainage for peptic ulcer. Long-term results. *Arch Surg* 1967; 95:615-24.

Schopman W, Hackeng WHL, Lequin RM. A radioimmunoassay for parathyroid hormone in man. *Acta Endocrinol* 1970; 63:643.

Seeman E, Wahner HW, Offord KP, Kumar R, Johnson WJ, Riggs BL. Differential effects of endocrine dysfunction on the axial and appendicular skeleton. *J Clin Invest* 1982; 69:1302-09.

Sharland DE, Overstall PW. Alkaline phosphatase: changes in serum

levels after fracture. Br Med J 1978; 1:620.

Shearman DJC, Finlayson NDC. Diseases of the gastrointestinal tract and liver. Edinburgh: Churchill Livingstone, 1982:169-91.

Smith MA, Elton RA, Tohill P. The comparison of neutron activation analysis and photon absorptiometry at the same part-body site. Clin Phys Physiol Meas 1981; 2:1-7.

Smith MA, Tohill P. Development of apparatus to measure calcium changes in the forearm and spine by neutron activation analysis using californium-252. Phys Med Biol 1979; 24:319-29.

Smith MA, Tohill P, Kennedy NSJ, Eastell R. Total body calcium by neutron activation analysis. In: Dixon ASTJ, Russell RGG, Stamp TCB, eds. Osteoporosis, a multi-disciplinary problem. London: The Royal Society of Medicine, 1983:121-25.

Spinks TJ, Bewley DK, Ranicar ASO, Joplin GF. Measurement of total body calcium in bone disease. J Radioanal Chem 1977; 37:345-55.

Stamp TCB, Round JM. Seasonal changes in human plasma levels of 25-hydroxyvitamin D. Nature 1974; 247:563-65.

Stanbury SW, Mawer EB. Physiological aspects of vitamin D metabolism in man. In: Lawson DEM, ed. Vitamin D. London: Academic Press, 1978:303-41.

Statist Bulletin Metropol Life Ass Co 1960:41.

Thompson GR, Neale G, Watts JM, Booth CC. Detection of vitamin D deficiency after partial gastrectomy. Lancet 1966; 1:623-26.

Thompson GR, Lewis B, Booth CC. Vitamin D absorption after partial gastrectomy. Lancet 1966; 1:457-58.

Tothill P, Smith MA, Simpson JD, Chew I, MacPherson JN, Winney RJ, Strong JA. In: Nuclear activation techniques in the life sciences. Int Atom Ener Agency: Vienna, 1979: 687-99.

Tougaard L, Rickers H, Rodbro P, et al. Bone composition and vitamin D after Polya gastrectomy. Acta Med Scand 1977; 202:47-50.

Vik T, Try K, Stromme JH. The vitamin D status of man at 70 degrees north. Scand J Clin Lab Invest 1980; 40:227-32.

Wall AJ, Ungar B, Baird CW, Langford IM, Mackay IR. Malnutrition after partial gastrectomy. Influence of site of ulcer and type of anastomosis and role of gastritis. Am J Dig Dis 1967; 12:1077-86.

Wastell C. Long-term clinical and metabolic effects of vagotomy with either gastrojejunostomy or pyloroplasty. Ann R Coll Surg Engl 1969; 45:193-211.

Watson L, Moxham J, Fraser P. Hydrocortisone suppression test and discriminant analysis in differential diagnosis of hypercalcaemia.

Lancet 1980; 1:1320-25.

Wheldon GD. Osteoporosis. N Engl J Med 1981; 305:397-98.

Wheldon EJ, Venables CW, Johnson ID. Late metabolic sequelae of vagotomy and gastroenterostomy. Lancet 1970; 1:437-40.

Williams JR, Bonnett DE, Parnell CJ. The fixed horizontal neutron therapy beam at Edinburgh: dosimetry and radiation protection. Br J Radiol 1979; 52:197-208.

Wilson P. Drinking habits in the United Kingdom. Population Trends 1980; 22:14-18.

Wilson P. Drinking in England and Wales. London: HMSO, 1980:3.

Woo J, Singer FR. Radioimmunoassay for human parathyroid hormone. Clin Chim Acta 1974; 54:161-68.

Zanzi I, Schoen M, Roginsky MS, Ellis KJ, Holt P, Cohn SH. Skeletal mass and serum levels of 25-hydroxyvitamin D in postgastrostomy patients. In: Norman EW, ed. Proc third workshop vitamin D. Asilomar, California, 1977:859-61.

Abstracts of papers presented at scientific meetings.

Eastell R, Kennedy NSJ, Smith MA, Simpson JD, Strong JA, Tothill P.  
The assessment of postmenopausal bone loss by whole-body  
neutron-activation analysis. J Bone Joint Surg 1981; 63B:295.

Eastell R, Kennedy NSJ, Smith MA, Tothill P, Simpson JD, Strong JA.  
Total body calcium measurements in osteoporosis. Calcif Tissue Int  
1981; 33(S):160.

Eastell R, Kennedy NSJ, Smith MA, Tothill P, Anderton JL. Changes  
in total body calcium after renal allotransplantation: effect of  
low-dose steroid regime. Scott Med J 1984; 29:43-44.

Eastell R, Pearson F, Brown NS, Kennedy NSJ, Smith MA, Simpson JD,  
Strong JA, Tothill P. Secondary hyperparathyroidism following  
peptic ulcer surgery is not due to biochemical osteomalacia. Scott  
Med J 1983; 28:194.

## Total body neutron activation analysis of calcium: calibration and normalisation

N S J Kennedy<sup>†</sup>, R Eastell<sup>‡</sup>, C M Ferrington<sup>†</sup>, J D Simpson<sup>†</sup>,  
M A Smith<sup>§</sup>, J A Strong<sup>‡</sup> and P Tothill<sup>§</sup>

<sup>†</sup> Department of Medical Physics and Medical Engineering,

<sup>‡</sup> Department of Medicine, Western General Hospital, and

<sup>§</sup> Department of Medical Physics and Medical Engineering, Royal Infirmary,  
Edinburgh, Scotland

Received 14 September 1981, in final form 22 December 1981

**Abstract.** An irradiation system has been designed, using a neutron beam from a cyclotron, which optimises the uniformity of activation of calcium. Induced activity is measured in a scanning, shadow-shield whole-body counter. Calibration has been effected and reproducibility assessed with three different types of phantom. Corrections were derived for variations in body height, depth and fat thickness. The coefficient of variation for repeated measurements of an anthropomorphic phantom was 1.8% for an absorbed dose equivalent of 13 mSv (1.3 rem). Measurements of total body calcium in 40 normal adults were used to derive normalisation factors which predict the normal calcium in a subject of given size and age. The coefficient of variation of normalised calcium was 6.2% in men and 6.6% in women, with the demonstration of an annual loss of 1.5% after the menopause. The narrow range should make single measurements useful for diagnostic purposes.

### 1. Introduction

Total body neutron activation analysis is now established as one of the most important methods of determining the elemental composition of the human body. It can be used to determine both the absolute amount and changes with time of certain body elements, in particular calcium, sodium, chlorine, phosphorus and nitrogen (Cohn 1981).

In the technique, the subjects are exposed to a beam of partially moderated fast neutrons which induces amongst others the reactions  $^{48}\text{Ca}(n, \gamma)^{49}\text{Ca}$ ,  $^{23}\text{Na}(n, \gamma)^{24}\text{Na}$ ,  $^{37}\text{Cl}(n, \gamma)^{38}\text{Cl}$ ,  $^{31}\text{P}(n, \alpha)^{28}\text{Al}$  and  $^{14}\text{N}(n, 2n)^{13}\text{N}$ . The radioactive isotopes produced then decay, emitting  $\gamma$ -rays which can be readily detected in a whole-body counter.

If the reproducibility of the method were good then small changes in the body elements with time might be detected relatively easily. Absolute quantification of the elements is more difficult, because of the natural variation in body dimensions and the difficulty of obtaining a suitable variable phantom of known composition for calibration. To overcome these problems several different approaches have been made. Nelp *et al* (1972) made repeated measurements on five cadavers of different sizes and then ashed the skeletons to determine the calcium content. Cohn and Dombrowski (1971) and Cohn *et al* (1972) used only one size of phantom for activation and depended on the invariant response of a 54-detector whole-body counter (Cohn *et al* 1969). Three sizes of phantom were used by Williams *et al* (1978); their patients



were then graded into three groups according to body habitus. Two different sizes of phantom were used by Spinks *et al* (1977) and the effects of varying thickness or adding wax around these phantoms were studied by Spinks (1979). The effect of varying the thickness of the trunk and thighs was also studied by McNeill *et al* (1974). Oxby and Brooks (1979) have tackled the problem of varying body dimensions by designing a complex phantom of variable shape and content.

This paper describes the technique used in Edinburgh to measure total body calcium (TBCa) with a high degree of precision and also our methods of overcoming the problems mentioned above. The technique of evaluating whether a subject contains a normal amount of calcium is in two parts. Firstly, corrections to eliminate the effects of variations in activation and detection efficiency due to varying body dimensions are made. This enables the absolute amount of calcium in the subject in grams to be evaluated and requires a variety of phantom measurements. Secondly, the normal predicted total body calcium is calculated using a formula derived from the results of a group of healthy normal volunteers aged 40–70 years. These results were used to obtain a range of normal values of the body elements of interest.

Total body calcium measurements of normal volunteers have also been made by Nelp *et al* (1972), Cohn *et al* (1976), Aloia *et al* (1978), and Chesnut *et al* (1981). Where appropriate, the results of these studies and the data presented in this paper will be compared and discussed.

## 2. Method

### 2.1. Neutron activation

The neutron source used for patient activation was a cyclotron producing neutrons of mean energy 6.5 MeV by the reaction of 15 MeV deuterons on a beryllium target (Williams *et al* 1979). During irradiation the subject was positioned in a moderator kiosk made from 3 cm thick polyethylene sheets mounted on a turntable. The thickness of the premoderator was chosen, after preliminary measurements, in order to minimise the variation in the thermal neutron flux through the patient. This was measured using a  $^{235}\text{U}$  fission chamber with and without a cadmium shield; in a phantom 24 cm

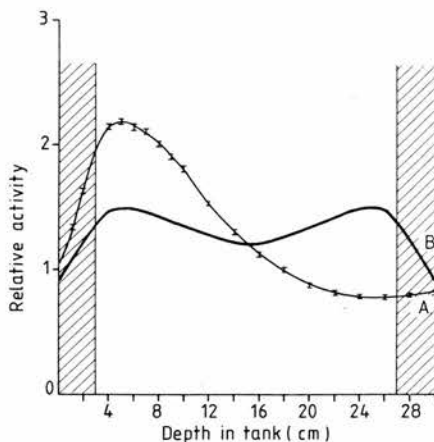

**Figure 1.** The thermal neutron flux profile through a water tank of depth 30 cm; A, with unilateral irradiation; B, with bilateral irradiation. Using the first and last 3 cm (shaded areas) as premoderator, the profile through a subject 24 cm deep may be observed.

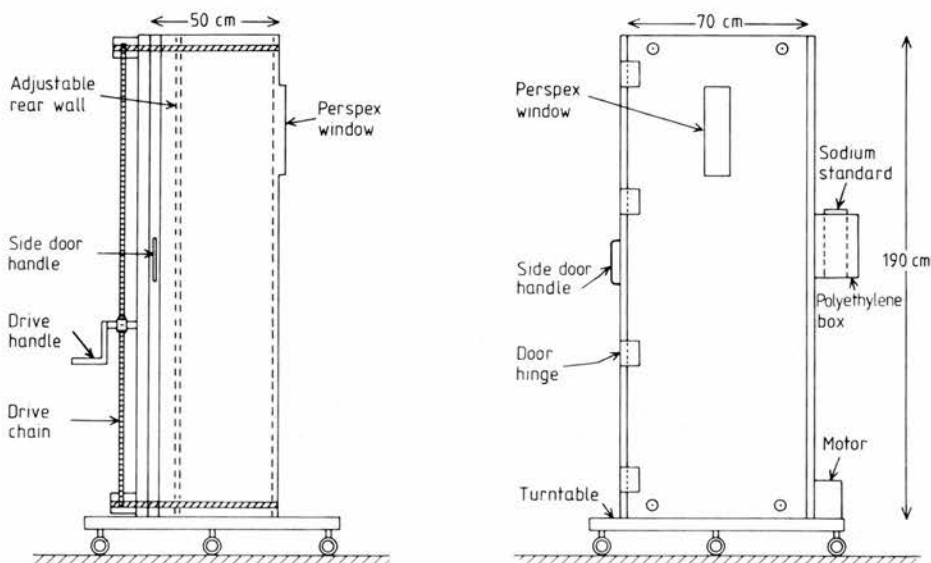

**Figure 2.** The irradiation enclosure. The rear wall is brought forward until the subject's trunk is in contact with both the front and rear walls. The depth of the perspex window was chosen so that the effect on the thermal neutron profile was equal to that of the 3 cm thick polyethylene walls.

deep this variation was  $\pm 7\%$  (figure 1) and in a limb phantom 12.5 cm in diameter the variation was  $\pm 13\%$ . The back wall of the kiosk was movable and was adjusted so that the subject's trunk was in contact with both the front and back walls (figure 2). This contact kept the subject in the correct position and gave extra support. The fixed neutron dose was given to the patient in two successive irradiations each lasting about 22 s, with the kiosk rotating through  $180^\circ$  in 18 s after the first irradiation and before the second. These times were checked with a stopwatch and a decay correction applied if necessary. The target to subject distance was 5.4 m.

Using a Geiger-Müller tube sheathed in 3 mm of  ${}^6\text{LiF}$ , the photon absorbed dose was measured as 0.4 mGy. The total dose, measured at the position of the pelvis using a tissue-equivalent ionisation chamber, was 1.68 mGy, and was nearly constant with depth through the patient. Using a neutron quality factor of 10 therefore, the total dose equivalent received by the patient was 13.2 mSv. This dose was controlled by the neutron monitor chamber of the beam and the irradiation calibrated by activating simultaneously a container of  $\text{Na}_2\text{CO}_3$  in a polyethylene jacket mounted on the side of the moderator kiosk. Possible long term variations in the neutron beam distribution were monitored by weekly measurements of the Bush phantom.

## 2.2. Measurement of induced activity

After irradiation, the patient was transferred to a shadow-shield whole-body counter containing four 15 cm diameter  $\times$  10 cm thick sodium iodide detectors, two above and two below the bed, arranged in line across the patient. The separation of the upper and lower counters was 40 cm. Four 200 cm scans at constant speed, each lasting five minutes, were then performed. The scan direction was simply reversed at the end of each scan. The time from the end of the irradiation to the start of the first scan was measured and was usually about 6 min.

The patient spectrum, covering the energy range 0–4 MeV, was recorded on a multichannel analyser. A twenty minute background count, measured using an inactive phantom, was then subtracted from the patient spectrum and the difference was punched out on paper tape for computer analysis.

### 2.3. Spectral analysis

The data were analysed by fitting five standard spectra, those of calcium, sodium, chlorine, phosphorus and potassium to the smoothed subject spectrum in the energy range 1.0–3.4 MeV, using a least squares technique (Smith *et al* 1976, Smith and Tothill 1979). The standard spectra were obtained by separately filling a phantom of human dimensions with appropriate solutions, activating the phantom and then recording the spectra on the whole-body counter. When the best possible fit to the subject's spectrum had been obtained, the amount of each standard required to make up the spectrum was listed. These amounts were then divided by the count from a twenty minute scan of the  $\text{Na}_2\text{CO}_3$  standard. The values for each element were then corrected for radioactive decay.

In addition to the major elements of interest, some nuclides are activated which interfere with the measurement of the elements under analysis. The main interfering reaction in the measurement of calcium is the  $^{37}\text{Cl}(n, p)^{37}\text{S}$  reaction, since the  $^{37}\text{S}$  produced has a 5.06 min half-life and a gamma-ray energy of 3.1 MeV. The correction applied to the calcium content, obtained by activating chlorine in a water-filled phantom was 3.1% of the chlorine count corrected back to the reference time. By similar methods, the reaction  $^{39}\text{K}(n, 2n)^{38}\text{K}^m$  was found to contribute 0.9% of the total counts in the chlorine region (2.00 to 2.32 MeV) and the  $^{24}\text{Mg}(n, p)^{24}\text{Na}$  reaction contributed 0.8% of the total counts measured in the sodium region (2.57 to 2.92 MeV) when the composition of reference man (IRCP 1975), was assumed. The interferences from the last two reactions were regarded as negligible.

## 3. Results

### 3.1. Reproducibility

The reproducibilities of the measurements of calcium, sodium, chlorine and phosphorus were investigated by repeatedly measuring a phantom which consisted of hollow polyethylene sections containing known amounts of the elements of interest (Bush 1946). The water-filled weight of the phantom was 68.5 kg and its height 172 cm. Three separate filling mixtures were used (see table 1) and these mixtures were irradiated 3, 3 and 7 times respectively. In the final mixture, the total amounts

**Table 1.** Contents of phantoms (in g).

Element	Phantom composition			Reference man (IRCP 23)
	1	2	3	
Calcium	600	802	1009	1000
Sodium	60	70	84	100
Chlorine	50	61	70	95
Phosphorus	455	455	455	780
Potassium	120	120	130	140

of the various elements were similar to those in reference man (IRCP 1975) with the exception of phosphorus where more recent results imply that the quoted content is too high. There was no significant dependence of the counts obtained per gram of element on the ratio of the various elements in the phantom. The reproducibilities (coefficients of variation (CV)) of the measurements of the various elements, obtained from the 13 irradiations of the phantom, using the same dose as given to the patient, were  $\pm 1.7\%$  for calcium,  $\pm 2.2\%$  for sodium,  $\pm 4.3\%$  for chlorine and  $\pm 4.3\%$  for phosphorus. The values of the CV for calcium, sodium and chlorine reflect almost entirely the counting statistics for these elements. For a small female with only 500 g of calcium the CV for calcium would increase to about 3.0%. The reproducibility of the measurement of calcium was also investigated by repeatedly measuring a phantom consisting of a human skeleton with approximately 700 g calcium encapsulated in tissue-equivalent rubber. The reproducibility in this case, determined from 10 measurements, was 1.8% for calcium and 2.1% for sodium.

### 3.2. Measurement corrections

In this section the corrections required to allow for the influence of body habitus on the combined activation and counting efficiency are determined. These corrections are essential for accurately calculating the absolute amount of calcium in the subject.

*3.2.1. Effect of height.* The thermal neutron fluence at a depth of 5 cm, over an area 185 cm high and 60 cm wide at the subject irradiation position, was uniform to within  $\pm 8\%$  with the maximum incident neutron flux around 85 cm above the chamber floor. The effect of varying height was tested by altering the height of the water filled phantom over the range 150 cm to 193 cm by inserting wax spacers between the various sections. The phantom was measured twice at each of five different positions. The range 150 cm to 172 cm was investigated by removing the pelvis section. The results obtained were fitted by the power law:

$$\% \text{ loss of counts} = 0.5 (\text{subject height} - 1.5)^2 \times 100 \quad \text{height} > 1.5 \text{ m.}$$

*3.2.2. Effect of body build and body fat.* The effect of variations in thickness of the subject, measured along the beam direction, was investigated using sections of the solution-filled phantoms of different sizes, but similar heights. Two repeated measurements were made at each of five different thicknesses i.e. 11, 14, 16, 18 and 24 cm. The decrease in measurement efficiency was 1.8% per cm increase in thickness of the chest section and 1.4% per cm increase in diameter of the limb section.

*3.2.3. Effect of wall separation.* Ideally the front and back premoderator sections of the activation chamber are positioned just to touch the subject's trunk at the front and back. The separation of the walls is dependent, therefore, on the subject's depth measured along the beam direction (figure 2). Due to patient apprehension in some cases this is not possible and the walls are positioned further back than normal. The effect of this extra separation was investigated by repeatedly measuring both the solution-filled and the skeletal phantoms, increasing the wall separation each time up to an air gap of 10 cm. Two repeated measurements were made at each of three different positions. The decrease in activation efficiency was 1.0% per cm increase in the air gap.

3.2.4. *Absolute calibration of calcium.* Using the results from sections 3.2.1 to 3.2.3, the mass of calcium in the subject in grams was calculated from the equation:

$$\text{TB Ca} = \text{measured calcium} \times \text{height correction} \times \text{depth correction} \\ \times \text{fat correction} \times \text{wall correction}$$

where

$$\text{height correction} = 0.5 (\text{subject height} - 1.50)^2 + 1 \quad \text{height} > 1.5 \text{ m}$$

$$= 1 \quad \text{height} \leq 1.5 \text{ m}$$

$$\text{depth correction} = 1.6 (\text{Subject depth} - \text{TST} - 0.2) + 1$$

$$\text{fat correction} = 3.6 \left( \frac{\text{TST} + \text{LST}}{2} \right) + 1$$

$$\text{wall correction} = 1.0 (\text{wall separation} - \text{subject depth}) + 1.$$

All measurements are in metres and TST = mean torso skinfold thickness of subject, i.e. the mean of the subscapula and iliac crest measurements; LST = mean limb skinfold thickness of subject, i.e. the mean of the biceps and triceps measurement; 1.6 = mean fractional loss per m increase in depth; 3.6 = mean fractional loss per m increase in fat; 0.2 = reference depth, i.e. the depth of the trunk section of the solution filled phantom. The depth correction makes the assumption that the depths of the various limbs scale in proportion to the depth of the trunk.

The number of counts obtained per gram of element was checked by repeatedly activating three phantoms of different sizes similar to the Bush phantom but with the calcium and phosphorus contained in solid rods which simulated the human skeleton (Battye *et al* 1971). The results obtained for sodium and chlorine agreed within experimental error. However the calcium was on average 3.1% low and the phosphorus result 11.2% low compared with elements dispersed in solution. This effect might well be explained by the difference in the combined efficiency of activating and detecting the calcium and phosphorus when they are uniformly distributed in the phantom compared with when they are contained in a simulated skeleton. This effect has also been noted by Spinks *et al* (1977). The necessary change was therefore made to the conversion factor for calcium to give counts per gram of the element. The difference between the results of calcium and phosphorus was due to the fact that the latter undergoes a fast neutron reaction.

#### 4. Normalisation procedures

To establish the range of normal values for total body calcium, 40 normal volunteers were measured: twenty males (six aged 40–49, eight aged 50–59 and six aged 60–69) and twenty females (two aged 40–49, ten aged 50–59 and eight aged 60–69). All the subjects were active and in good health. None had any history of disease that might be expected to influence calcium metabolism, and all had normal blood and urine biochemistry. There was a large variation in the total body calcium results for both groups (table 2). The females ranged from 596 to 1036 g with a mean of  $821 \pm 15.2\%$  (CV), while the males ranged from 886 to 1428 g with a mean of  $1143 \pm 11.7\%$ . Since the total body composition of the various elements is clearly related to the subject's build, a mean value based on sex alone is inadequate. Therefore the dependence of the measured TB Ca on height, span, weight, lean body mass (calculated from the

**Table 2.** Data for normal controls.

	Means and percent coefficients of variation	
	Male (CV)	Female (CV)
Number	20	20
Height (m)	1.770 (4.7)	1.622 (4.2)
Span (m)	1.843 (4.7)	1.655 (4.4)
Weight (kg)	81.8 (13.8)	63.7 (17.2)
Calcium (g)	1143 (11.7)	821 (15.1)

skinfold thickness measurement), age and number of years post-menopause was investigated by multiple linear regression analysis.

For males, this gave a formula for predicted total body calcium in grams (TBCa<sub>p</sub>),

$$\text{TBCa}_p = 347 (\text{height})^{2.07} \quad (r = 0.84, P < 0.001).$$

Total body calcium was also found to be strongly dependent on span

$$\text{TBCa}_p = 384 (\text{span})^{1.80} \quad (r = 0.74, P < 0.001).$$

Height and span are measured in metres. Perhaps because the spread in age was small no significant dependence of total body calcium on age was observed. Weight and lean body mass also proved to be unimportant. The biological variation in normal TBCa due to size could be reduced by expressing the subjects result in terms of the ratio TBCa/TBCa<sub>p</sub>. When height was used in the formula the CV in the male controls was reduced to 6.2%.

For the female controls, multiple regression gave

$$\text{TBCa}_p = 399 (\text{span})^{1.69} \exp(-0.015 Y) \quad (r = 0.90, P < 0.001)$$

where span was measured in metres and  $Y$  is the subject's years post-menopause. This gave a highly significant correlation with an annual loss of calcium after the

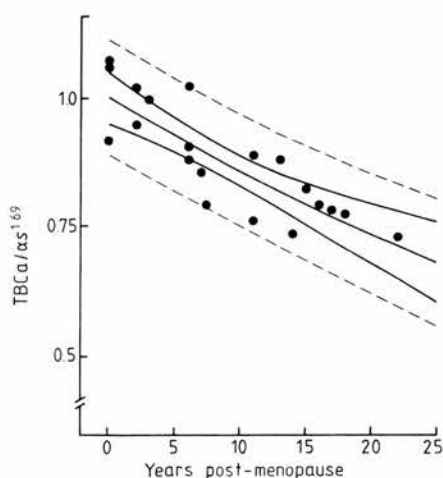

**Figure 3.** Total body calcium of normal women, normalised using the span ( $s$ ), plotted against years post-menopause. The line representing a loss of 1.5% per annum is plotted with confidence and tolerance limits.  $\alpha$  is a constant = 399; ●, normal women; —, confidence limits,  $P = 0.05$ ; ---, tolerance limits,  $P = 0.10$ .

menopause of 1.5% (figure 3). An equally good correlation was obtained if a linear relationship between calcium and years post-menopause was assumed. Total body calcium, for the female controls, was also found to be strongly dependent on height

$$\text{TBCa}_p = 443 (\text{height})^{1.57} \exp(0.016 Y) \quad (r = 0.87, P < 0.001).$$

Since total body calcium was more strongly correlated with span than with height and as height may be significantly reduced in patients with osteoporosis, it was decided to use span rather than height as a variable for normalisation for women. The coefficient of variation of total body calcium in normal women  $\text{TBCa}/\text{TBCa}_p$ , after normalisation improved to 6.6%.

The possibility was investigated that the correction factors, applied to the raw data, described in section 3.2.4 could be replaced with an extra normalisation factor, namely weight. Regression analysis performed on the uncorrected data for the male controls gave a low correlation with height,  $r = 0.40$ , compared to the corrected data,  $r = 0.84$ . The introduction of weight as a normalisation factor improved the correlation considerably

$$\text{TBCa}_p^1 = C_M (\text{height})^{2.15} (\text{weight})^{-0.34} \quad (r = 0.80)$$

where the superscript indicates that this equation refers to the raw data, uncorrected for the height, build and body fat corrections derived in section 3.2.4.

A similar effect was obtained, using the uncorrected female data, after the introduction of a normalisation factor for weight

$$\text{TBCa}_p^1 = C_F (\text{span})^{1.66} (\text{weight})^{-0.18} \exp(-0.016 Y) \quad (r = 0.89)$$

where  $C_M$  and  $C_F$  are constants.

This contrasts with the case of the corrected data, both male and female, where weight proved to be unimportant. Therefore to a large extent the correction factors described in section 3.2.4 and the introduction of weight as a normalisation factor fulfil a similar function. The cv of the  $\text{TBCa}^1/\text{TBC}_p^1$  ratio was 7.0% for both men and women. When the ratio is used, the units of  $\text{TBCa}_p^1$  can be left as  $^{49}\text{Ca}$  counts. However, using the results from the calculations of  $\text{TBCa}_p$ , the values  $C_M = 1447$  and  $C_F = 870$  will give  $\text{TBCa}_p^1$  in grams of calcium.

## 5. Discussion

The technique of total body neutron activation analysis presented in this paper with its precision of 1.8% on phantoms is suitable for detecting small changes in total body calcium. The process of correcting for varying body dimensions is most important for the accurate determination of the absolute amount of calcium in the body. When the corrections described in section 3.2.4 were applied to the raw data for our normal male volunteers they increased the estimated body calcium by 16% on average. The importance of such corrections has also been emphasised by Spinks (1979). Using a similar irradiation system, he found correction factors for total thickness and wax layer thickness which were close to ours. McNeill *et al* (1974) also studied the effect of body thickness on the efficiency of activation and measurements of calcium in the trunk. They found a reduction of calcium counts of  $5\% \text{ cm}^{-1}$ . Their figure was somewhat higher than ours, probably because their Pu-Be sources were a fixed distance apart and fairly close to the subject's skin. Correction for body stature is important not only for absolute calcium determinations, but also for studying changes over a

period if the subject is likely to alter in weight. Some treatments which lead to osteodystrophy, or which are designed to avoid the condition, are liable in themselves to change the amount of fat in the body.

The establishment of a normal range of total body calcium for men and women is vital if full use is to be made of the absolute values. Total body calcium measurements of normal volunteers have been made by Nelp *et al* (1972), Cohn *et al* (1976), Aloia *et al* (1978) and Chesnut *et al* (1981). Partial body (trunk) measurements have been made by Harrison *et al* (1975) and by McNeill and Harrison (1977). The most comprehensive of these studies is that of Cohn *et al* (1976). They derived equations for predicting normal values based on measurements on 79 normal individuals, 48 in the age range covered by this study. Their whole body counter corrects for variations in response due to different body dimensions, but no attempt was made to separate variations in activation efficiency from the biological variations of actual calcium content in the normal population studied.

The equations developed by Cohn *et al* (1976), which incorporate height, age and total body potassium levels, therefore included a consideration of measurement errors, as well as statistical variations. The coefficient of variation of normalised total body calcium was 7.8% for men and 7.1% for women. As a result of the different approach to normalisation and because Cohn *et al* (1976) assumed a uniform age of menopause at 55, our values of total body calcium are not directly comparable with theirs. As in this study, Cohn *et al* (1976) found total body calcium in males to be dependent approximately on height squared. These results are in slight disagreement with the total body calcium study of Nelp *et al* (1972) and the partial body studies (trunk) of Harrison *et al* (1975) who found a near cubic relationship between calcium and height.

The percentage of calcium lost by normal women after the menopause of 1.5% per year from this study is slightly higher than that of 1.1% determined by Cohn *et al* (1976). They also calculated a rate of calcium loss of 0.4% per annum between the ages of 35 and 55. This is probably the combination of a lower (if existent) pre-menopausal bone loss and a higher post-menopausal loss from those normal women who were post-menopausal before the age of 55.

Although multiple regression analysis on our male data gave a mean loss of calcium with age of 0.1% per year, this result was not significantly non-zero. Cohn *et al* (1976) reported a mean annual loss of calcium for the average man of 0.70% after 50 years of age. However it is interesting to note that their result, which was obtained by omitting their data for men over 80, leads to such a low predicted value of calcium for older men that the majority of their own male subjects aged 67 and over have  $\text{TBCa}/\text{TBCa}_p$  values substantially greater than one.

In section 4 it was shown that the introduction of weight as a normalisation factor applied to the raw data, rather than using the correction factors described in section 3.2.4, implied that total body calcium was dependent partly on  $(\text{weight})^{-0.34}$  for males and  $(\text{weight})^{-0.18}$  for females. These values are in broad agreement with the exponent determined by Cohn *et al* (1976) of  $-0.25$  (see appendix Cohn *et al* 1976, substituting  $K_p$  for  $K$ ). We obtained no significant dependence on weight after multiple regression analysis was performed on the final data because of the correction factors used in section 3.2.4. For the determination of a narrow normal range of calcium values the use of weight as an extra normalisation factor would appear to be almost as good, and would be simpler than determining and applying the various correction factors for height, body fat and thickness. The success of weight as a normalisation factor presumably depends on its close correlation with body thickness. However the body



correction factors described in section 3.2.4 are important for the accurate determination of the absolute amount of calcium in grams in individuals whose size or shape differs, even by only a few centimetres, from the phantom used for calibration. The values of the correction factors are only applicable to the experimental arrangement used in this study. However if other research groups were able to calculate accurately the absolute amount of calcium in grams in their patients then the equations for  $TBCa_p$  derived from our normal controls could be used to calculate the  $TBCa/TBCa_p$  ratio.

We believe that the best approach is the one we have adopted, of first trying to establish an accurate measure of whole body calcium, making correction for all the variables likely to affect activation and detection efficiency, and then deriving normalisation factors which take into account variations of calcium with size, age and sex. The narrow ranges for normal subjects that we have observed, with coefficients of variation of 6.2% for men and 6.6% for women, may allow the technique of total body neutron activation analysis of calcium to be a useful diagnostic procedure.

### Acknowledgments

We wish to express our gratitude to the staff of the MRC Cyclotron Unit at Edinburgh, in particular Mr T Saxton and Mr J Williams, for their considerable cooperation and assistance, Mr L Mackie and Mr H Easton for skillful workshop services and Mrs Elisabeth Law for technical assistance. We should also like to thank Mr T J Spinks and Professor K Boddy for allowing us to use their phantoms.

This work was supported by grants from the Scottish Home and Health Department and from the Medical Research Council.

### Résumé

Analyse par activation neutronique du calcium de corps entier: calibration et normalisation.

Nous avons réalisé un système d'irradiation, utilisant un faisceau de neutrons émis par un cyclotron, qui optimise l'uniformité de l'activation du calcium. L'activité induite est mesurée par un compteur corps entier à balayage 'shadow shield'. Nous avons calibré les mesures et testé leur reproductibilité à partir de trois types différents de fantômes. Nous en avons déduit des corrections pour les variations de la taille du corps, de la profondeur et de l'épaisseur de la graisse. Le coefficient de variation pour les mesures répétées sur un fantôme anthropomorphe est de 1,8% pour une dose absorbée équivalente à 13 mSv (1,3 rem). Nous avons utilisé les mesures du calcium global du corps chez 40 adultes normaux pour déduire les facteurs de normalisation qui prédisent le taux normal du calcium chez un sujet d'âge et de taille donnés. Le coefficient de variation du calcium normalisé est de 6,2% chez l'homme et de 6,6% chez la femme avec une perte annuelle de 1,5% après la ménopause. Cette faible dispersion des valeurs rendrait utile une seule mesure à des fins diagnostiques.

### Zusammenfassung

Ganzkörper-Neutronenaktivierungsanalyse von Kalzium: Kalibrierung und Normierung.

Mit Hilfe eines Neutronenstrahls aus einem Zyklotron wurde ein Bestrahlungssystem konstruiert zur Optimierung der Gleichförmigkeit der Kalziumaktivierung. Die induzierte Aktivität wurde in einem Ganzkörperzähler mit Schattenschutz gemessen. Eine Kalibrierung wurde durchgeführt. Die Reproduzierbarkeit wurde mit drei verschiedenen Phantomtypen bestimmt. Korrekturen für Änderungen der Körperhöhe, -tiefe und -dicke wurden abgeleitet. Der Variationskoeffizient für Wiederholungs-Messungen an einem anthropomorphen Phantom betrug 1,8% für eine Äquivalentdosis von 13 mSv (1,3 rem). Messungen des Ganzkörper-Kalziums bei 40 gesunden Erwachsenen wurden benutzt um Normierungsfaktoren

abzuleiten, die den normalen Kalziumgehalt eines Menschen bei vorgegebener Größe und Alter vorher-sagen können. Der Variationskoeffizient von normiertem Kalzium var 6.2% bei Männern und 6.6% bei Frauen, mit einem jährlichen Verlust von 1.5% nach der Menopause. Der eingeschränkte Bereich könnte einzelne Messungen für diagnostische Zwecke brauchbar machen.

## References

- Aloia J F, Cohn S H, Ross P, Vaswani A, Abesamis C, Ellis K and Zanzi I 1978 *Am. J. Physiol.* **235** E82
- Battye C K, Knight V, Marshall T O, Knight A and Godfrey B E 1971 *Nucl. Instrum. Methods* **92** 601
- Bush F 1946 *Br. J. Radiol.* **19** 14
- Chesnut C H, Lewellen T K and Nelp W B 1981 in *Proc. Int. Symp. on Osteoporosis, Jerusalem, Israel*
- Cohn S H 1981 *IAEA At. Energ. Rev.* **18** 599
- Cohn S H and Dombrowski C S 1971 *J. Nucl. Med.* **12** 499
- Cohn S H, Dombrowski C S, Pate H R and Robertson J S 1969 *Phys. Med. Biol.* **14** 645
- Cohn S H, Shukla K K, Dombrowski C S and Fairchild R G 1972 *J. Nucl. Med.* **13** 481
- Cohn S H, Vaswani A, Zanzi I, Aloia J F, Roginsky M S and Ellis K J 1976 *Metabolism* **25** 85
- Harrison J E, Williams W C, Watts J and McNeill K G 1975 *J. Nucl. Med.* **16** 116
- IRCP 23 1975 *Reference Man: Anatomical Physiological and Metabolic Characteristics* Publication No. 23 (Oxford: Pergamon)
- McNeill K G and Harrison J E 1977 *J. Nucl. Med.* **18** 1136
- McNeill K G, Kostalas H A and Harrison J E 1974 *Int. J. Appl. Radiat. Isot.* **25** 347
- Nelp W B, Denny J D, Murano R, Hinn G M, Williams J L, Rudd T G and Palmer H E 1972 *J. Lab. Clin. Med.* **79** 430
- Oxby C B and Brooks K 1979 *Phys. Med. Biol.* **24** 440
- Smith M A and Tothill P 1979 *Phys. Med. Biol.* **24** 319
- Smith M A, Tothill P, Simpson J D, MacPherson J N, Merrick M V, Strong J A and Boddy K 1976 *Californium-252 Radiobiology and Medical Applications*, U.S. Department of Energy Conference 760436 (Springfield, VA: NTIS) p 217
- Spinks T J 1979 *Phys. Med. Biol.* **24** 976
- Spinks T J, Bewlay D K, Ranicar A S O R and Joplin G F 1977 *J. Radioanal. Chem.* **37** 345
- Williams E D, Boddy K, Harvey I and Haywood J K, 1978 *Phys. Med. Biol.* **23** 405
- Williams J R, Bonnett D E and Parnell C J 1979 *Br. J. Radiol.* **52** 197

# The Assessment of Postmenopausal Osteoporosis by Total Body Neutron Activation Analysis

R. EASTELL, N.S.J. KENNEDY, M.A. SMITH, J.D. SIMPSON, J.A. STRONG, and P. TOTHILL

Department of Medicine, Western General Hospital, Edinburgh, and Department of Medical Physics and Medical Engineering, Western General Hospital and Royal Infirmary, Edinburgh, UK.

Address for correspondence and reprints: Dr. R. Eastell, Northwick Park Hospital, Watford Road, Harrow, Middlesex HA1 3UJ, UK.

## Abstract

Total body calcium (TBCa) was measured using a cyclotron for in vivo neutron activation analysis (IVNAA) in 20 healthy women, 15 women with vertebral compression fractures, and 8 women with wrist fractures. The precision of the technique, using phantoms, was 1.8% for a dose of 13 mSv. A formula for predicted TBCa ( $TBCa_p$ ) was derived from the 20 normal women based on span and years postmenopause. The coefficient of variation of TBCa after normalization in the normal women was 6.6%. The mean TBCa values for the vertebral and wrist fracture groups were 69% and 84% of  $TBCa_p$  for women at the time of the menopause. The low TBCa in the wrist fracture group was attributable to postmenopausal bone loss. Of the low TBCa in the vertebral fracture group, about half the loss could be attributed to postmenopausal age and half to other factors.

**Key Words:** Activation-Analysis-Osteoporosis.

## Introduction

In vivo neutron activation analysis (IVNAA) is an established technique for measuring total body calcium (TBCa) and has been described by five other groups (Chamberlain et al., 1968; Cohn et al., 1976a; Palmer et al., 1968; Spinks et al., 1977; Kennedy et al., 1979) as well as by ourselves (Kennedy et al., 1982). Since 99% of TBCa is present in bone (Heary, 1963), IVNAA can be used to measure bone mass and in this way avoid the errors in sampling from different parts of the skeleton. Two other groups have reported TBCa in women with postmenopausal osteoporosis (Chesnut et al., 1977; Cohn et al., 1974).

In this report we describe a formula for predicting TBCa from the span and postmenopausal age based on a study of 20 normal women. This formula is then used to compare the bone mass of women with vertebral or wrist fractures with their expected bone mass. The degree of osteopenia associated with these two types of fracture is also calculated.

## Patients and Methods

Twenty women aged 46-66 years were selected from volunteers who answered requests circulated in the hospital, in a factory, in the local press, and on BBC Radio Scotland. The criteria for selection were based on age (40-70 years) and the absence of a past history of back pain, fragility fractures, artificial menopause, rheumatic, hepatic, renal, or endocrine diseases, exposure to steroid or anticonvulsant therapy, or excessive alcohol intake. Screening tests to exclude occult malabsorption and disorders of calcium metabolism or of renal or hepatic function were undertaken as follows: serum or plasma calcium, phosphate, magnesium, alkaline phosphatase, albumin, parathyroid hormone, 25-hydroxycalciferol, iron, iron-binding capacity, ferritin, vitamin B<sub>12</sub> and folic acid, urinary calcium, phosphate, magnesium, hydroxyproline and creatinine clearance, and a full blood count.

Eight women with wrist fracture, aged 56-69 years, were selected from a consecutive series of patients attending the orthopedic clinic. Selection was made on the same basis as for the volunteers. Measurements of TBCa and of plasma and urine as for the normal women were made 1 year after the fracture.

Fifteen women aged 48-71 years were referred to the endocrine clinic for medical therapy of their vertebral osteoporosis. Back pain had been present for less than 2 years in 11 of the 15 women. At least two collapsed vertebrae were seen on a lateral radiograph of the thoracolumbar spine in all patients. No selection was made of these patients, and the same investigations as already described were performed together with isotope bone scans and bone biopsy when indicated.

TBCa was measured by IVNAA using the MRC cyclotron in Edinburgh (Williams et al., 1979) as the source of neutrons. The induced radiation was measured using four sodium iodine detectors mounted in a whole-body counter. Computer analysis of the spectrum and the value of a standard irradiated simultaneously with the subjects gave the TBCa in <sup>45</sup>Ca counts. The long-term precision, based on anthropomorphic phantom measurements, was 1.8% (coefficient of variation, CV) for a dose of 13 mSv (1.3 rem) (Kennedy et al., 1982). The effect on measurement efficiency due to variation in body size was determined experimentally. Calcium counts were converted to grams of calcium using a correction formula from phantom measurements. Biologic variation due to size and age was then reduced using multiple regression analysis of height, arm span, weight, age and years postmenopause, and lean body mass (% body fat was obtained using skin calipers) (Durnin and Womersley, 1974). The factors relating most closely to TBCa were found to be arm span and years postmenopause.

Informed consent was obtained from all patients. The study protocol was approved by the Hospital Ethics Committee and by ARSAC (Administration of Radioactive Substances Advisory Committee).

## Results

The TBCa in normal women was  $820 \pm 124$  g (mean  $\pm$  standard deviation, SD). This gave a CV of 15.1% before any allowance was made for span or postmenopausal age. The greatest reduction in variance was achieved using the following formula to obtain the predicted TBCa ( $TBCa_p$ ):

$$TBCa_p = \alpha s^{1.69} e^{-0.015y} \quad (r = 0.90, P < 0.001)$$

where:

$TBCa_p$  is in grams  
 $\alpha = 399$   
 $s =$  arm span in meters  
 $y =$  years postmenopause

The arm span not only related more closely to TBCa than height but also eliminated the error due to loss of height associated with vertebral fractures. The formula applied to perimenopausal women and to women up to 22 years postmenopause. The regression is based on an exponential loss of bone mass starting at the time of the menopause. The estimated rate of bone loss was 1.5% per year. The ratio  $TBCa/TBCa_p$  has been defined by Cohn et al. as the calcium ratio ( $Ca_R$ ) (Cohn et al., 1974) and for our normal women was 1.00 with a CV of 6.6%.

The TBCa in women with vertebral and wrist fractures was  $649 \pm 87$  g and  $787 \pm 72$  g, respectively (mean  $\pm$  SD). The values of span and postmenopausal age are shown in **Table I**. In the women with wrist fractures the  $Ca_R$  was  $1.00 \pm 0.10$ , which was normal (**Fig. 1**). Six of the 15 women with vertebral fracture had postmenopausal ages greater than 22 years. This was the greatest postmenopausal age among the normal women; the formula for  $TBCa_p$  cannot be extrapolated to cover the women in this group who were more than 22 years past the menopause. In the remaining 9 women the  $Ca_R$  was  $0.87 \pm 0.06$ , significantly lower than in normal women ( $P < 0.01$ ). Factors that may have contributed to this excessive bone loss were identified in 5 of the 9 patients, namely, prednisolone therapy for polymyalgia rheumatica, phenytoin therapy for epilepsy, previous history of thyrotoxicosis, atrophic gastritis, and moderate impairment of renal function (creatinine clearance 20 ml/min).

When TBCa was normalized for span alone ( $TBCa/\alpha s^{1.69}$ ), i.e.,  $y = 0$  in the equation for  $TBCa_p$ , an estimate of osteopenia in the patients with fractures could be made by comparing the values with the  $Ca_R$  of the normal women (**Fig. 2**). The  $TBCa/\alpha s^{1.69}$  for women with vertebral and wrist fractures and for normal women were  $0.69 \pm 0.06$ ,  $0.84 \pm 0.08$ , and  $0.88 \pm 0.11$ , respectively (mean  $\pm$  SD). All the women with vertebral fractures had values less than 0.78, but 3 of the 8 women with wrist fractures and 5 of the 20 normal women also had values below 0.78.

**Table I.** Span and postmenopausal age in normal women and women with vertebral and wrist fractures. The years postmenopause in the vertebral fracture group were significantly higher than in the normal women ( $P < 0.002$ ).

Group	Number	Span (m) Mean $\pm$ SD	Postmenopausal age (yr) mean $\pm$ SD
Normal women	20	1.65 $\pm$ 0.07	8.9 $\pm$ 7.0
Vertebral fracture	15	1.66 $\pm$ 0.07	21.9 $\pm$ 8.4
Wrist fracture	8	1.66 $\pm$ 0.06	12.0 $\pm$ 5.9

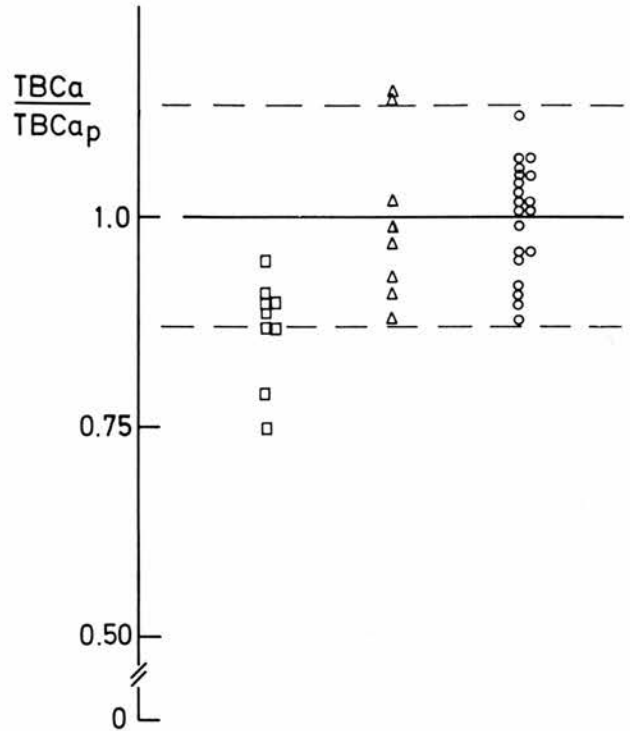

**Fig. 1.** Calcium ratio ( $Ca_R$ ) in normal women ( $\circ$ ), women with wrist fracture ( $\Delta$ ), and women with vertebral fracture ( $\square$ ). Horizontal lines are mean  $Ca_R \pm 2$  SD for normal women.

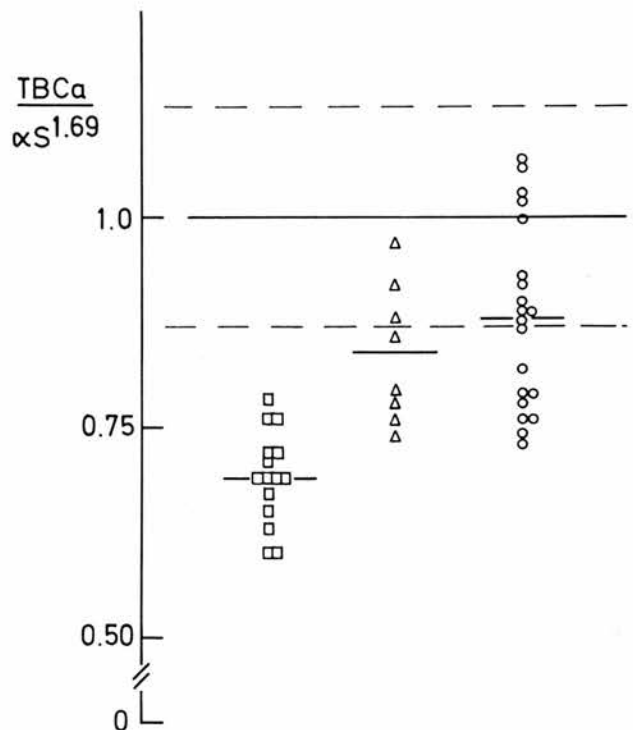

**Fig. 2.** Total body calcium normalized for span ( $TBCa/\alpha s^{1.69}$ ) in normal women ( $\circ$ ), women with wrist fracture ( $\Delta$ ), and women with vertebral fracture ( $\square$ ). Horizontal lines are mean  $Ca_R \pm 2$  SD for normal women.

## Discussion

TBCa for the normal women ( $820 \pm 124$  g) was similar to that reported by Cohn et al. (1976b), namely,  $804 \pm 106$  g for normal women aged 50–59 years. The TBCa for women with vertebral fractures ( $649 \pm 87$  g) resembled that described by Chesnut et al. (1977) (mean  $688 \text{ g} \pm 94$  g) and Cohn et al. (1974) (mean  $590 \text{ g} \pm 108$  g). However, some of the patients in the latter two groups did not have vertebral compression fractures but only demineralized vertebrae.

Different formulae for  $\text{TBCa}_p$  have been reported. Cohn et al. (1976b) use age from birth, height, and total body potassium: the latter two also may be age dependent. Nelp et al. (1972) predict TBCa from the cube of the patient's height. In the present report it was noted that span was more effective than height in reducing variance, and we would prefer to use span, as it is unaffected by the height loss due to vertebral compression fractures.

The CV of  $\text{TBCa}_p$  in normal women was 6.6% as compared with 7.1% reported by Cohn et al. (1976b). The latter group found that the rate of bone loss after the age of 55 years was 1.1% per year compared with the rate of 1.5% per year after the menopause in our group.

The  $\text{Ca}_R$  was 0.87 in the women with vertebral fractures, similar to the value of 0.82 found by Cohn et al. (1974). An early menopause in these two groups of women may explain in part their osteopenia. Additional factors, including a low TBCa at the time of the menopause or an accelerated loss of bone after the menopause, must also have been present. The normal  $\text{Ca}_R$  in the women with wrist fractures suggests that they were not specifically prone to fracture compared with other postmenopausal women.

Expressions such as  $\text{TBCa}/\alpha\text{s}^{1.69}$  to describe the degree of osteopenia have not been reported previously. Although the sample size of 15 was small, in this group of women vertebral crush fractures occurred when total body calcium was below 80% of that predicted from span alone, i.e.,  $\text{TBCa}/\alpha\text{s}^{1.69}$  less than 0.78. However there was some overlap of these values with the other groups of women. It may be possible, therefore, to predict those women likely to sustain a vertebral fracture and to recommend treatment, estrogens, for example, aimed at preventing further loss of bone mass.

*Acknowledgement:* We would like to thank our orthopedic colleagues at the Western General Hospital for allowing us to study their patients.

We also thank the volunteers, in particular the WRVS. Mrs. E. Law and the MRC cyclotron staff assisted with patient measurements.

R. Eastell was funded by the Medical Research Council and N.S.J. Kennedy by the Scottish Home and Health Department.

## References

- Chamberlain M.J., Fremlin J.H., Peters D.K. and Philip H.: Total body calcium by whole body neutron activation: new technique for study of bone disease. *Br. J. Med.* **2**:581-583, 1968.
- Chesnut C.H. III, Nelp W.B., Baylink D.J. and Denney J.D.: Effect of methandrostenolone on postmenopausal bone wasting as assessed by changes in total bone mineral mass. *Metabolism* **26**:267-277, 1977.
- Cohn S.H., Ellis K.J., Wallach S. et al.: Absolute and relative deficit in total-skeletal calcium and radial bone mineral in osteoporosis. *J. Nucl. Med.* **15**:428-435, 1974.
- Cohn S.H., Vaswani A., Zanzi I. and Ellis K.J.: Effect of aging on bone mass in adult women. *Am. J. Physiol.* **230**:143-148, 1976a.
- Cohn S.H., Vaswani A., Zanzi I. et al.: Changes in body chemical composition with age measured by total-body neutron activation. *Metabolism* **25**:85-95, 1976b.
- Durnin J.V.G. and Womersley J.: Body fat assessment from total body density and its estimation from skinfold thickness: measurements on 481 men and women aged 16 to 72 years. *Br. J. Nutr.* **32**:77-97, 1974.
- Heaney R.P.: Evaluation and interpretation of calcium-kinetic data in man. *Clin. Orthop.* **31**:153-183, 1963.
- Kennedy A.C., Boddy K., Williams E.D. et al.: Whole body elemental composition during drug treatment of rheumatoid arthritis: a preliminary study. *Ann. Rheum. Dis.* **38**:137-140, 1979.
- Kennedy N.S.J., Eastell R., Ferrington C. et al.: Total body neutron activation analysis of calcium: calibration and normalization. *Phys. Med. Biol.* **27**:697-707, 1982.
- Nelp W.B., Denney J.D., Murano R. et al.: Absolute measurements of total body calcium (bone mass) in vivo. *J. Lab. Clin. Med.* **79**:430-438, 1972.
- Palmer H.E., Nelp W.B., Murano R. and Rich C.: The feasibility of in vivo neutron activation analysis of total body calcium and other elements of body composition. *Phys. Med. Biol.* **13**:269-279, 1968.
- Spinks T.J., Bewley D.K., Ranicar A.S.O. and Joplin G.F.: Measurement of total body calcium in bone disease. *J. Radioanal. Chem.* **37**:345-355, 1977.
- Williams J.R., Bonnett D.E. and Parnell C.J.: The fixed horizontal neutron therapy beam at Edinburgh: dosimetry and radiation protection. *Br. J. Radiol.* **52**:197-208, 1979.

Received: December 14, 1982

Revised: April 26, 1983

Accepted: May 10, 1983

## RÉSUMÉ

Le calcium corporel total (Ca CT) a été mesuré par activation neutronique in vivo avec l'aide d'un cyclotron chez 20 femmes en bonne santé, 15 femmes ayant un tassement vertébral et 8 femmes atteintes de fracture de l'extrémité inférieure du radius. La précision de la technique, évaluée sur des fantomes, est de 1,8 pour cent pour une dose de 13 mSv. Une formule permettant de prédire le CaCT à partir du délai écoulé depuis la ménopause a été calculée pour les 20 femmes normales. Le coefficient de variation du CaCT après normalisation est de 6,6 pour cent dans la population témoin. Les valeurs moyennes du CaCT dans le groupe avec fracture vertébrale et dans celui avec fracture du radius étaient respectivement égales à 69 et 84 pour cent du CaCT des femmes au moment de leur ménopause. Le CaCT réduit dans le groupe avec fracture du radius peut être attribué à la perte osseuse post-ménopausique. La réduction du CaCT dans le groupe avec tassements vertébraux peut être imputée pour moitié environ à l'état post-ménopausique et pour moitié à d'autres facteurs.