

A STATISTICAL ANALYSIS OF HEART RATE, BLOOD PRESSURE AND  
RESPIRATION IN HEALTHY MAN AND POST-OPERATIVE PATIENT

M. J. CAMPBELL

**DAMAGED**

**TEXT**

**IN**

**ORIGINAL**

**TEXT BOUND INTO  
THE SPINE**

**BEST COPY**

**AVAILABLE**

Variable print quality

This thesis has been composed by myself and, except where indicated, is entirely my own work.

*M. J. Campbell*

M.J. Campbell

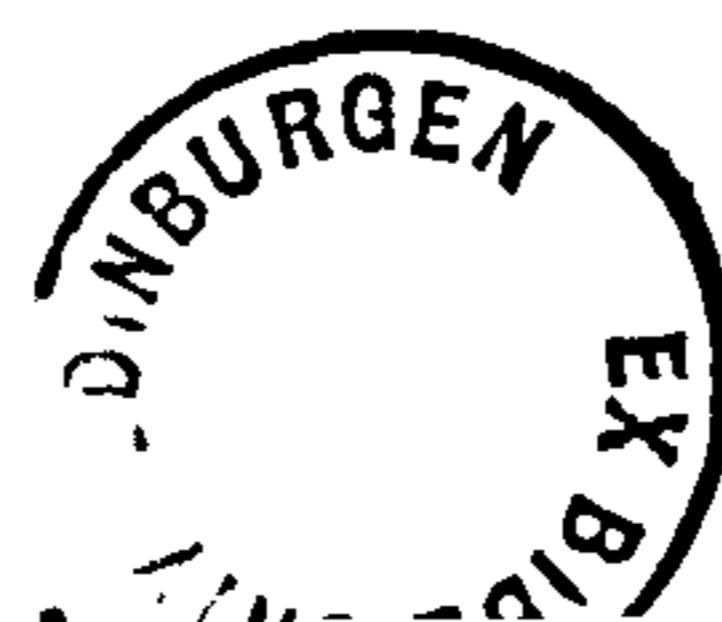

## CONTENTS

|   | Page |
|---|------|
| Acknowledgements  |      |
| Preface   | 1    |
| Chapter 1   | 4    |
| Introduction and data collection                                |      |
| Initial processing of post-operative patients' data             |      |
| Analysis of extrasystoles                                       |      |
| Chapter 2   | 21   |
| Probability structure of blood pressure and heart rate          |      |
| Introduction  |      |
| Literature review   |      |
| Preliminary analysis of blood pressure                          |      |
| Outliers from ambulatory subjects                               |      |
| Stationarity  |      |
| Distribution of run lengths                                     |      |
| Degrees of freedom  |      |
| A comparison of heart rate and heart interval distributions     |      |
| Long term heart-rate distributions from post-operative patients |      |
| Curve fitting to heart-rate distributions                       |      |
| Curve fitting to blood-pressure distributions                   |      |
| Discussion  |      |
| Chapter 3   | 85   |
| Equidistant sampling and point process analysis of heart beats  |      |
| Literature review   |      |
| Spectral analysis of point processes                            |      |
| Approximation to point-process periodogram                      |      |
| The time dependent Poisson process                              |      |
| Point processes with ancillary variables                        |      |
| The point spectrum and the 'sampled' spectrum                   |      |
| Simulation study  |      |
| Discussion  |      |

|            |   |     |
|------------|---|-----|
| Chapter 4  | Frequency analysis of the records of the post-operative patients and the ambulatory subjects<br>Spectral analysis of heart rate and blood pressure<br>Significance tests<br>Distribution of variance over frequency<br>Analysis of ambulatory subject records<br>Digital filtering<br>Discussion  | 115 |
| Chapter 5  | The effect of respiration on heart rate and blood pressure<br>Literature review<br>Experimental methods<br>Results : description<br>Analysis of mean heart rate<br>Analysis of heart rate variability<br>Cross-spectral and phase analysis<br>Regression of phase against frequency<br>Analysis of breath-holding experiments<br>Discussion | 145 |
| Chapter 6  | Physiological models<br>Literature review<br>Model fitting to post-operative patient data<br>Box-Jenkins model fitting  | 213 |
| Chapter 7  | Summary and conclusions<br>Further work   | 227 |
| Appendix A | A review of spectral analysis and digital filtering<br>Spectral analysis<br>Variable lag models<br>Comparison of computer programs<br>Effect of extrasystoles<br>Digital filtering<br>Hannan's lag estimation   | 234 |

## Appendix C A description of the computer programs

|            |     |
|------------|-----|
| GRAM       | 272 |
| GRAPH      | 274 |
| INHIST     | 277 |
| INTER      | 279 |
| LAG        | 281 |
| PSPEC      | 285 |
| SAMPLE     | 289 |
| SIMUL      | 292 |
| SUCCHIST   | 295 |
| SYSTOLE    | 296 |
| References | 298 |

The pages following p 305 have been defectively reproduced. The Library has tried to trace the author in order to provide a replacement but without success.

M. Simpson

(Queens Librarian) 1984.



## ACKNOWLEDGMENTS

I would like to thank my supervisor, Professor D.E.M. Taylor, formerly of the Department of Physiology, Edinburgh, who initiated this project and provided me with the data and much encouragement. Many grateful thanks are due to Mr. P.R. Fisk, of the Department of Statistics, Edinburgh, whose advice and very careful reading of the manuscript greatly improved it. I am particularly grateful to Dr. D.J. Hitchings, formerly of the Department of Physiology, Edinburgh, who gave constant enthusiasm and much practical advice and who devised and built much of the electrical apparatus used during the project. I also owe a debt to Professor B. McA. Sayers, of Imperial College, London, who supplied me with the ambulatory subjects' data, and who suggested the study of the number of degrees of freedom per point, the run-length distributions and the stationarity of the means and variances. Thanks are also due to 31 volunteers in the experiments, and to Mrs. A Walters who typed what must have been a difficult script.

PREFACE

This thesis is concerned with the problem of obtaining a full description of the physiological variables of heart rate and blood pressure. The results should then be useful in the design of machines that measure or monitor these variables, and for research workers who wish to analyse data derived from these variables.

The original impetus for this thesis came from a desire by Mr. (now Professor) D.E.M. Taylor of the Department of Physiology, Edinburgh to improve the design of a patient monitoring device (PAWS). A large amount of data had been collected from post-operative patients in a coronary care unit. The electrocardiogram and arterial blood-pressure had been recorded continuously for periods of upto an hour, and from these were derived the beat-by-beat heart rate and the mean arterial blood pressure. A description of the variability and stability of these two parameters would contribute to the design of a patient monitoring device and should improve the ability of the device to discriminate between normal and abnormal situations.

It is well known that respiration can, on occasions, be a major source of variability of heart rate and blood pressure, and a separate study was carried out to investigate the effect of respiration on heart rate. The effects of respiration on blood pressure were not studied since this would have required catheterization of healthy subjects.

Further data were kindly supplied by Professor B. McA. Sayers

of Imperial College, London ( Ref. E.E.C. Contract No. 297/76/12 ECI UK.)  
 These consisted of the arterial systolic and end-diastolic pressures for each heart beat from two healthy subjects. A two hour stretch of record was examined and during the monitoring the subjects conducted normal activities, hence the term 'ambulatory' monitoring.

The questions that we are going to ask are concerned with the structure and stability of the data. Clearly the sampling distributions of the variables need to be examined, and the nature and properties of the outliers. We also wish to know how the sequential nature of the data affects the amount of information contained in it and to examine the sampling distribution of the mean and variance so that the effect of averaging can be estimated. Stability of the data is another aspect to be examined ; for how long does the blood pressure, for example, remain within defined limits and on average how long does it remain stationary? Further useful information can be obtained by studying the frequency distribution of the data. From this we can estimate the contribution to the variability of various frequency bands, for example the variability due the the respiratory effect and from activities such as the vasomotor response.

The structure of this thesis is as follows: Chapter 1 is concerned with data collection and preprocessing, and with the detection and analysis of outliers. In Chapter 2 we examine the stability and stationarity of the patient and ambulatory monitoring data and, in more detail, the structure of the patient data. Chapter 3 is concerned with the theoretical problems associated with the spectral analysis

of unequally spaced observations of which heart beats are an obvious example, in preparation for Chapter 4, where the analysis of the data in the frequency domain is considered. Chapter 5 deal with the effect of respiration on heart rate and blood pressure and Chapter 6 discusses modelling aspects of the control systems involved. A summary and conclusion <sup>are</sup> / given in Chapter 7. Appendix A deals with the mathematical and practical aspects of spectral analysis and digital filtering and Appendix B gives a physiological background to the central and reflex control of heart rate and blood pressure. A description of the computer programs is given in Appendix C. The methods of analysis are described in detail, in the hope that the thesis may prove useful to workers wishing to apply time series methods to records of heart rate, blood pressure and respiration.

## CHAPTER 1.

### INTRODUCTION AND DATA COLLECTION

Observations made sequentially in time form a time series. The analysis of time series is studied within a wide range of disciplines, including engineering, statistics and physiology. The objectives of time series analysis are classified by Chatfield (1975, p.7) as description, explanation, prediction and control. The principal aim of this thesis is to apply the methods of time series analysis to provide a description and explanation of the physiological variables of heart rate, blood pressure and respiration in man.

Jenkins and Watts (1968, p.10) state that there are basically two types of time series problems; those that require model building and those that lead to frequency response studies. We have concentrated mainly on frequency response studies. There are several reasons for adopting this approach; firstly the heart rate is very often oscillatory and a frequency approach would appear more natural; secondly there are difficulties in fitting acceptable models to time series, especially when dealing with large quantities of data and thirdly, if an empirical model were fitted it would be difficult to give it a meaningful physiological interpretation. The main tool used in the frequency approach is spectral analysis and a description of this method is given in Appendix A.

Time series methods were first applied in physiology to neuronal spike trains, and an extensive literature has grown up around this. Moore, Perkel and Segundo (1966) gave a review of the subject. The

similarity of neuronal spike trains to heart beats is close; neuronal spikes appear as a sequence of points in time. However, the number of external physiological factors influencing the heart beat is large and the simple models used for neuronal spike trains are not readily applicable to heart beats. The reasons for this were discussed by Ten Hoopen and Bongaarts (1969).

Cyclic variations have been demonstrated in heart rate since Ludwig's (1847) discovery of sinus arrhythmia, which is the variation of heart rate ascribed to respiration. The literature on this is now extensive and will be reviewed in Chapter 5. If we restrict attention to the spectral analysis of heart rate then the literature is comparatively recent. Loos (1968), referred to by Luczak and Laurig (1973), investigated heart rate variability with relation to mental workload, and found three main peaks in the heart rate spectrum:

- 1) a peak around 0.1 Hz., which he called the basic frequency,
- 2) a peak between 0.2 and 0.35 Hz., which corresponded to the respiration cycle,
- 3) a peak corresponding to the mental workload.

Luczak and Laurig (1973) determined the respiration cycle as lying between 0.25 Hz., and 0.4 Hz., but in every case studied the peak was only a local maximum of the spectrum. The overall maximum lay at a frequency between 0.05 and 0.15 Hz., mainly at about 0.1 Hz., which they ascribe to a fundamental frequency of the physiological system. Sayers (1971, 1973) gave spectra of heart rate similar to those of Luczak and Laurig (1973). In addition to respiratory and fundamental (or vasomotor) peak frequencies, Sayers also described a peak at around 0.05 Hz., which he attributed to the thermoregulatory

system. Hyndman et al., (1971) described a feedback mechanism of the arterial blood-pressure control system in man which could explain the vasomotor oscillations. The system described was strongly non-linear and they claimed that for this reason, if the rate of respiration were sufficiently high and the depth adequate, the vasomotor oscillations would cease and only the respiratory frequencies would appear in the system. This would also occur if the respiratory frequency was near the vasomotor frequency. The authors backed up their arguments with experimental demonstrations of the effects. Sayers (1971, 1973) and Kitney (1974) described a possible scheme for the thermoregulatory system. Superficial blood flow is altered to change the rate of skin heat loss, and the flow changes are made by adjustments in the blood pressure. The oscillations occur at around 0.025 Hz., and are presumed to produce heart rate oscillations at about this frequency. They claim that peaks in the heart rate spectrum do occur at about this frequency in man when resting. Kitney (1975) described experiments involving a subject dipping his hand into hot and cold water at regular intervals. He demonstrated entraining of the heart rate by the thermal stimulus at about 0.025 Hz. Unfortunately he did not give a cross-spectral analysis to indicate coherency and phase relationships. Sayers (1973) made the important point that the properties that enable the system to oscillate are also those that enable it to maintain precise control over disturbances, and that the appearance or absence of oscillations is irrelevant to its overall behaviour.

Hyndman and Gregory (1975) also showed spectra similar to those previously described, in this case for both heart rate and blood

pressure. They claimed that the low frequency (0 - 0.2) Hz. power changed with the mental workload. Possible reasons for this were a change in the delay time of the feedback loop or a change in sensitivity of the blood pressure receptors with mental workload.

Chess, Tam and Caloresu (1975) conducted carefully controlled experiments on decerebrate cats. They performed spectral analyses of the heart period (the time between each beat), under four conditions of neural input to the heart; intact, vagal only, sympathetic only and no control at all. (Appendix B gives an explanation of these terms). In common with the other authors they found three easily identifiable rhythms with spectral peaks  $P_1$ ,  $P_2$ ,  $P_3$ . The peak  $P_3$  corresponded to respiratory sinus arrhythmia, and will be discussed in Chapter 5. The other two peaks were at much lower frequencies. A correlation was found between  $\log P_1$  and  $\log \underline{HP}$ , where  $\underline{HP}$  is the mean heart period in the interval of time considered. They also found a correlation between  $\log P_2$  and  $\log \underline{HP}$ . An increase in  $\underline{HP}$  was usually associated with increased vagal activity. It was also found that  $P_1$  and  $P_2$  were largest for vagal only activity, and were greatly reduced by vagotomy. These findings suggested that the rhythms were part of the closed loop vagal control of heart rate. It was suggested that the control was mediated via blood pressure and baroreceptors. It was also thought that sympathetic activity did not contribute to these rhythms, but rather tended to oppose changes in heart period.

Orr and Hoffman (1974) gave a very clear exposition of time series methods applied to heart rate. They were investigating a



90 minute cycle in heart rate over 24 hours. They applied bias-free high pass filters to remove the circadian rhythm and then used periodograms to detect the cycle, and complex demodulation to investigate changes in phase. (See Appendix A for a summary of these methods). They found evidence for this rhythm in all 12 subjects that they studied. One theory is that this cycle is perhaps an endogenous rhythm present throughout the 24 hour day, representing a rest-activity cycle of the nervous system. The amplitude of the rhythm seemed to be modulated by a circadian (24 hr.) rhythm. However, the modulating circadian rhythm was not phase locked to the waking/sleeping circadian rhythm of each subject.

Womack (1971) applied modern time series methods to the analysis of sinus arrhythmia. For the resting subject he obtained peaks in both the heart rate and respiration spectra at about 0.1 Hz. The major issue in Womack's paper seems not to elucidate facts about sinus arrhythmia but to confirm the power of the various statistical techniques involved. He simulated the heart rate from the respiration cycle by use of Fourier transforms. The simulations seemed to describe the original data well, but in general subjects differed sufficiently that one subject could not be simulated from another's respiration data. The inverse problem, that of determining the respiration cycle from the heart rate data was also tackled but not with such clear results. In conclusion, the last paper illustrated the use of spectral analysis for investigating sinus arrhythmia but did not contribute anything new to the theory of that phenomenon.

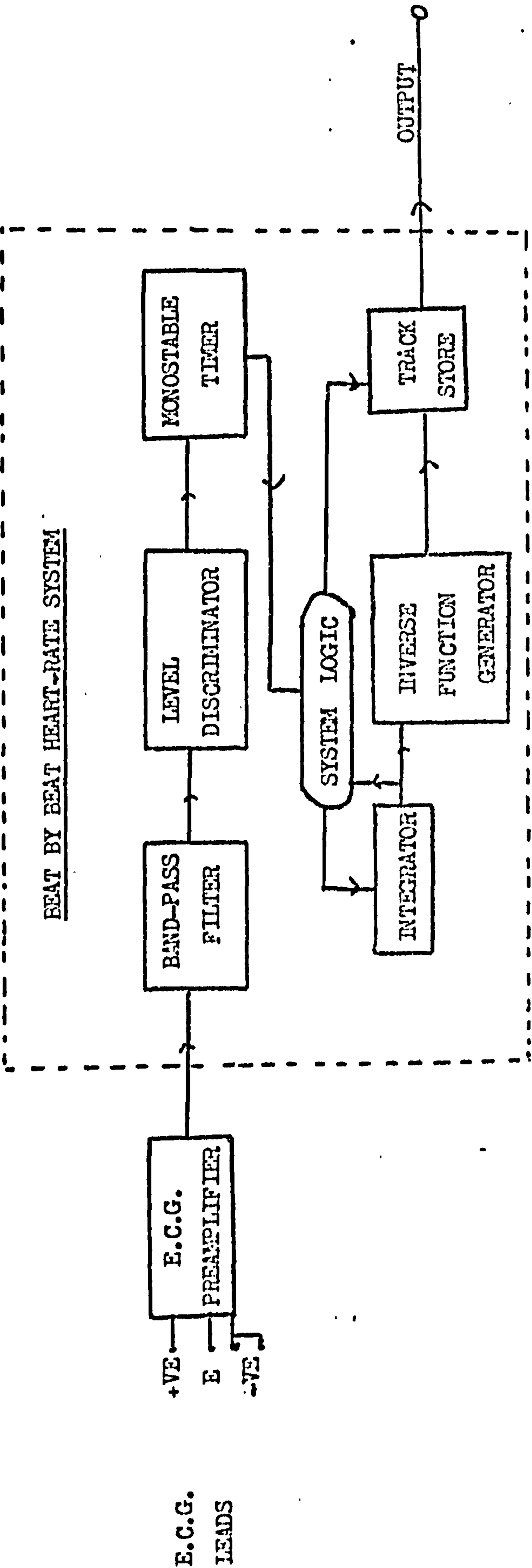

THE SYSTEM INCORPORATES FREQUENCY AND TIME DISCRIMINATION FOR RELIABLE QRS RECOGNITION

Figure 1.1 A block diagram describing the method by which the QRS complexes were detected and the heart-rate derived from them.

Initial processing of post-operative patient's data

The heart rate and blood pressure data used in this study were taken from patients at an intensive care ward at the Edinburgh Royal Infirmary, over the years 1972-1974. The type of operation undergone by each patient is given in Table 4.1. As part of routine care, the electrocardiogram and the arterial blood pressure of each patient were continuously monitored and it was a simple matter to record both onto an F.M. magnetic tape for subsequent analysis. The electrocardiogram was taken from chest electrodes and the arterial blood pressure recorded from a radial artery by means of an indwelling cannula

The methods of data collection given here are summarised in Campbell (1974). Analogue processing was carried out by means of a parallel hybrid computer (EAL TR48). Figure 1.1 gives a block diagram describing the methods by which the QRS complexes were detected. The E.C.G. was obtained from a 4 lead electrode system described in Appendix B. The QRS complexes were detected by a series of electronic filters and level discriminators and the R-R interval calculated from a monostable timer. The heart rate was calculated from the R-R interval by an inverse function generator. The heart rate as opposed to the heart interval was calculated because the purpose of the monitoring was a clinical assessment of the patient, and the heart rate is more acceptable among doctors and nurses than is the heart interval. If there was uncertainty in the location of a QRS complex, for example because of excessive noise from the electrodes, then the machine output a 'flag' of one machine unit. This detection method has been tested in the Physiology Department at Edinburgh over many

hours and it has been found that less than 1/3 of all readings were faulty in detecting the QRS complexes. The mean blood pressure was calculated as the ratio of the integral of the arterial blood pressure recording over one beat and the interval of that beat, the start of systole being taken as the start of the beat. The scaling factor employed by the analog computer was that 1 machine unit represented either 200 bts/min. for the heart rate or 200 mm. Hg for the blood pressure. Thus the absolute accuracy of the measurements was limited by the accuracy of the digital voltmeter. The error was estimated to be well within 1 bt/min and 1 mm. Hg.

The heart rate and blood pressure signals were output to a DART data logger. They were held in store for the duration of the next heart beat, after which the store was updated. This store was sampled independently at a maximum rate of 1 sample/sec. This method of sampling has the advantage that it is on-line and the disadvantage that fast beats may be missed and beats slower than 60 bts/min. will be sampled twice. The biases due to this method of sampling are discussed in Chapter 3.

The data were initially processed to eliminate the 'flags' and replace them with an exponentially weighted mean. However, when the data were examined it was found that, on occasions, there appeared very fast beats which did not seem to come from the normal heart beat. These beats can be attributed to extrasystoles, which are caused by premature depolarization of a secondary pacemaker to the heart. They can be classified into atrial, nodal or ventricular extrasystoles depending on the secondary pacemaker (Ganong, 1963). Appendix B

Figure 1.2

Examples of extrasystoles

(obtained by Professor D.E.M. Taylor)

ATRIAL AND VENTRICULAR EXTRASYSTOLES

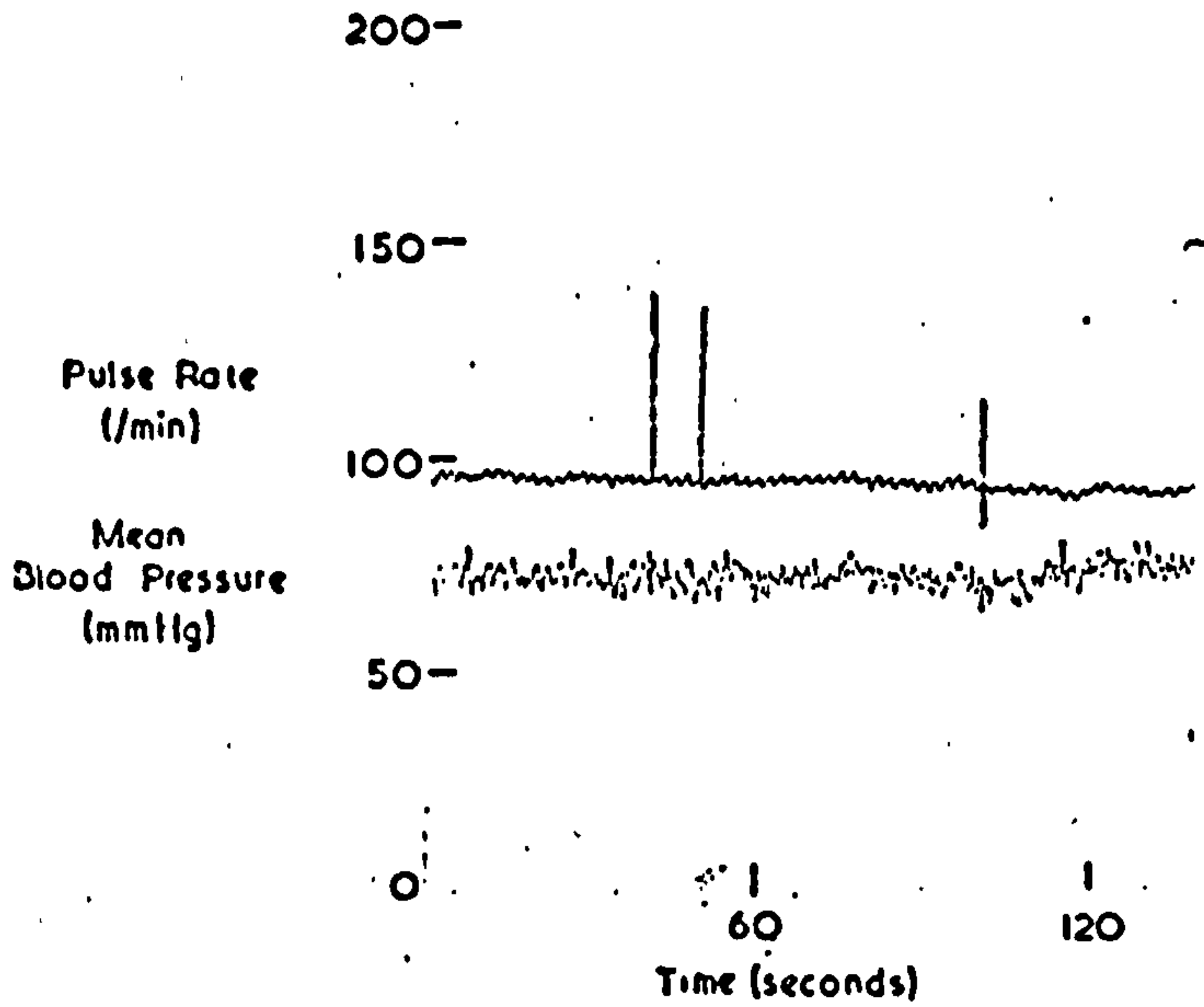

VENTRICULAR EXTRASYSTOLES

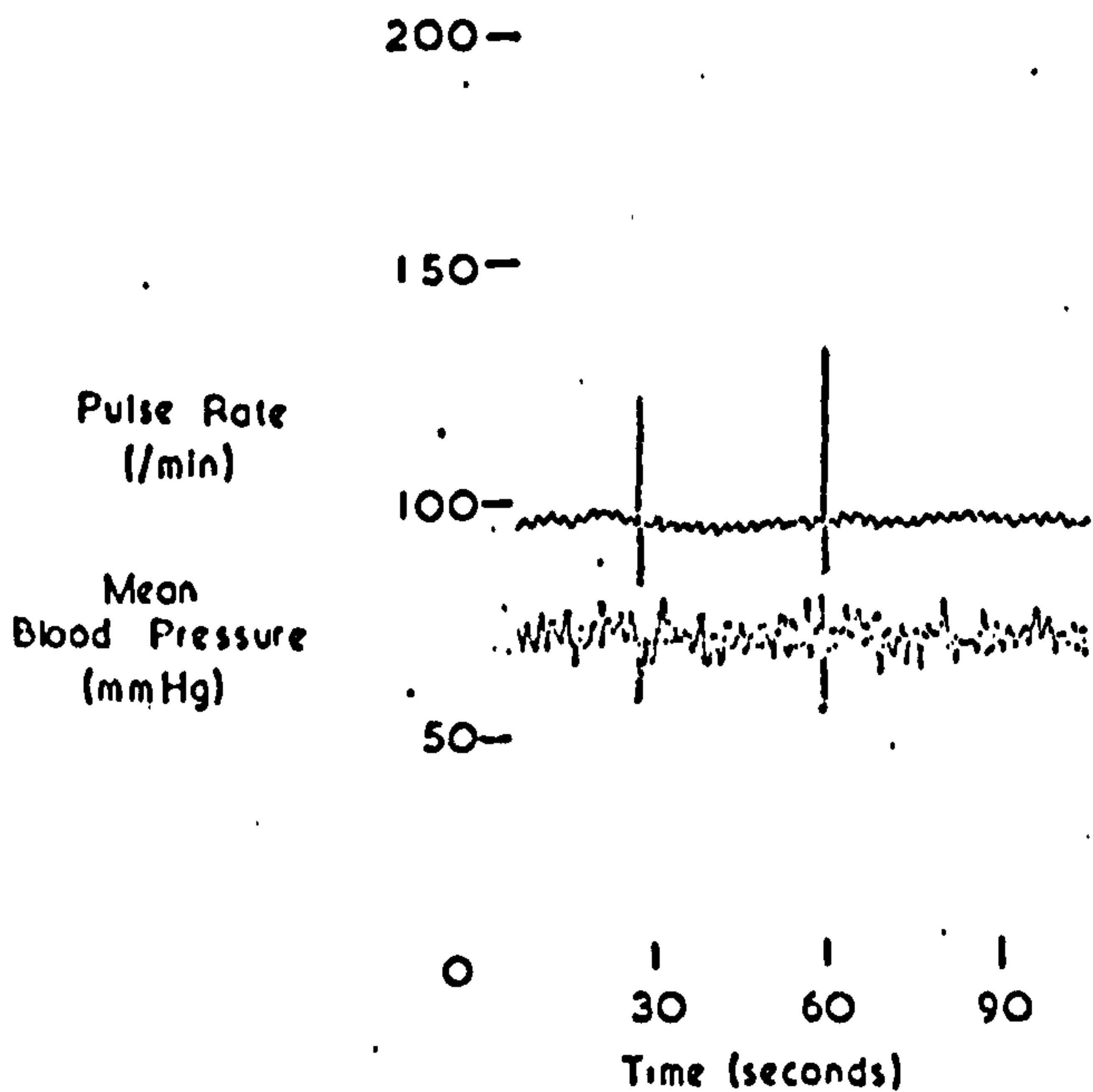

describes the electrical activity of the heart. Atrial extrasystoles can be distinguished from ventricular because the latter are followed by a compensatory pause which is longer than the normal heart interval. The two can be described as follows. The ventricular impulse depolarises the ventricles prematurely, and the normal impulse from the SA node that would have discharged the ventricles does not produce a beat. It is not until the succeeding SA nodal impulse that the heart beats again. In the case of an atrial extrasystole, the impulse from the atrium depolarises the SA node, which must repolarise and then depolarise to firing level before it can initiate another beat. Thus ventricular extrasystoles do not interrupt the regular SA nodal discharge, whereas atrial extrasystoles intercept and 'reset' the normal rhythm. They are 'quite common' in the normal healthy heart (Ganong 1963). An example of extrasystoles is shown in Figure 1.2. The top photograph shows two atrial extrasystoles and one ventricular extrasystole, which is followed by a compensatory pause. None of these appears to affect the mean blood pressure. The bottom photograph shows two ventricular extrasystoles, both followed by a compensatory pause. Both extrasystoles appear to be coincident with a momentary drop in the mean blood pressure.

An analysis of extrasystoles was given in Manley (1973). He described the theories of point process analysis and evolutionary spectral analysis. The latter theory was originally described by Priestley (1965). Manley applied these methods to extrasystole data from two patients, the data having been collected immediately prior to the death of the patients. The conclusion he drew was that the point spectrum of the extrasystoles becomes much more variable as

death approaches. However, the number of extrasystoles upon which each spectrum was calculated was extremely small, the total for one subject being 46, and so it would be difficult to generalise these results. Manley asserted that a point spectrum of the heart beats may be useful in a monitoring scheme.

The presence of extrasystoles in the data, however, can severely affect the spectral analysis of heart rate. It is demonstrated in Appendix A that if the input data contain large peaks, that is a relatively small number of points account for a large proportion of the variance, then the spectrum will show oscillations, with a period which can be related to the distance between the peaks in the input data. The effect of this is to lose any other information that the spectrum could reveal such as small amplitude cycles in the input data. It was therefore felt necessary to remove the extrasystoles from the input stream.

Although they are easy to spot visually when the heart-beat intervals are plotted graphically, and easy to spot by ear if the heart beats are relayed through a loudspeaker, it is less easy to write down a simple criterion for detecting extrasystoles. If they are greater than 200 beats/min. they are indistinguishable from machine 'flags', which we wish also to remove. The method employed was to compute a continuously updated exponentially weighted variance and exponentially weighted mean and to replace all points that were 5 times the standard deviation from that mean.

A program SYSTOLE (Appendix C) was written to implement this

method. Let us say that we have a finite time series  $x_1, \dots, x_n$ . We denote the exponentially weighted mean at time  $t$  by  $e_t$  and the exponentially weighted variance and standard deviation by  $v_t$  and  $s_t$  respectively, with a weighting factor of  $a$ . The formulae employed were

$$e_t = ax_t + (1-a)e_{t-1} \quad t \geq 2, \\ v_t = a(x_t - e_t)^2 + (1-a)v_{t-1} \quad t \geq 2, \quad 0 \leq a \leq 1,$$

and  $s_t = \sqrt{v_t}$ .

For  $t = 1$  we put  $e_t = x_t$  and  $v_t$  was put at an arbitrary value of 10, which was felt to be a reasonable value based on observations of the raw data and previous calculations of the exponentially weighted variance.

A point  $x_t$  was rejected if  $|x_t - e_{t-1}| > 5 s_{t-1}$ . In this case  $x_t$  was replaced by  $e_{t-1}$ . The program printed all rejected points so that a visual check could be made as well. Values of  $a$  were taken between 0.5 and 0.005 and it was found that a value of 0.01 gave a satisfactory correspondence between points rejected by the program and those that would have been rejected visually.

With such arbitrary starting values, the functions will take some time to settle down to reasonable estimates. Thus a particular scrutiny must be made of values rejected in the first 300 points. An additional hazard is that if the series becomes very stable even slight perturbations would be rejected as extrasystoles. It was decided that if  $|x_t - e_{t-1}| \leq 10$ , then  $x_t$  would not be rejected. Further trouble would arise if the first point in the series were an extrasystole, and so these were examined before the start of the program. In addition a sudden change of level would mean that a



large number of points would be rejected consecutively. It was decided that if more than 3 points were rejected in a row, then the program would be stopped and restarted at the new level. Replacing the exceptional (extrasystole or machine noise) values with an exponentially weighted mean is not wholly satisfactory, because we are in effect passing the data through a filter which is not bias free. A better method would be to take into account values occurring after the exceptional value as well as those before. Unfortunately it would be difficult to determine whether the values after an exceptional point were themselves exceptional. Out of the 15 patient data sets examined, only 2, patients 7-73 and 8-73 yielded more than 9 detectable points in an hour. These two gave 32 and 19 extrasystoles respectively in approximately an hour. However, since it takes just two extrasystoles to upset a spectral analysis, it was felt worthwhile eliminating them.

#### Initial processing of the ambulatory subjects' data

The data from the ambulatory subjects was collected from a continuous recording of arterial pressure using a small intra-arterial catheter with a magnetic tape recorder developed by Bevan et al (1969). The subjects were free to perform normal tasks whilst the data was recorded. Uses of this recorder are described in ISAM 77 (2nd Symposium on Ambulatory Monitoring). The preprocessing of the data is described by Sayers et al (1978). Two subjects were studied. The records consist of the peak systolic blood pressure and the preceding end-diastolic pressure, from which the pulse pressure could be calculated. In each case there were about 8000 data points, which

given a heart rate of about 70 bts/min., represents about two hours of continuous monitoring. The data were almost artefact-free and the few artefacts found were replaced by the previous, normal blood pressure level. The data were searched for outliers in the same way as for the post-operative patients and the intervals between outliers were recorded and analysed in the next section.

### Analysis of extrasystoles

Manley (1973) in his thesis claimed that immediately prior to death the patients he was studying showed strong autocorrelations in the extrasystoles that they generated. In two patients, 7-73 and 8-73 the number of extrasystoles as determined by SYSTOLE was sufficient to enable an investigation to be made into possible autocorrelation. We wish to test whether the extrasystoles occurred randomly in time, because if this is the case then autocorrelations may be a useful warning, since our patients were not near death at the time of the recording. Table 1.1 gives the interval in seconds between extrasystoles detected by SYSTOLE. We also recorded the interval between outliers above the mean in beats of the ambulatory subjects since these subjects were normal and provided a quantity of beats. The systolic pressure of Subject A2 was excluded because very few outliers were detected.

A point process can depart from randomness in time in several ways, and Cox and Lewis (1966) discuss three main types of test:

- a) tests for trend,
- b) tests for correlation between the intervals,
- c) tests for a Poisson process (Poisson processes will be discussed in Chapter 3)

If the tests all had equal power, then if a series satisfied (c) i.e. it was a Poisson process, it would clearly satisfy (a) and (b). However, in general the simpler tests are more powerful and it is usual to proceed (a), (b), (c) .

A general test for trend is the Wald-Wolfowitz test for runs above and below the median. If a trend were present in the extrasystole intervals then we would expect fairly long runs above or below the median interval. On the null hypothesis of no trend, the number of runs,  $r$ , has expected value

$$\hat{\mu}_r = 1 + (2n_+ n_-) / n$$

and variance 
$$\hat{\sigma}_r^2 = (\hat{\mu}_r - 1)(\hat{\mu}_r - 2) / (n + 1) ,$$

where  $n_+$  and  $n_-$  are

For small values of  $r$  the significance limits have been tabulated (e.g. Siegel, 1956 ).

A simple, non-parametric test of serial correlation of the intervals is given in Cox and Lewis (1966, p 166). We compute the rank-correlation statistic

$$R_1 = \sum_{i=1}^{n-1} r_{i+1} r_i ,$$

where  $r_i$  is the rank of the  $i$  th interval. It can be shown that for a renewal process ( i.e. independent intervals ) then

$$E(R_1) = (n - 1)(n + 1)(3n + 2)/12$$

$$\text{and } \text{Var}(R_1) = (5n^6 + 16n^5 - 14n^4 - 80n^3 - 35n^2 + 64n + 44)/720(n-1) .$$

By ignoring the distribution of the intervals we lose some efficiency. If the interval had come from an exponential distribution then a more efficient test can be devised. In place of the ranks  $r_i$  we compute the so-called exponentially ordered scores

$$e_i = \sum_{j=1}^i 1/(n-j+1) \quad , \quad i=1, \dots, n \quad ,$$

and find 
$$R_1' = \sum_{i=1}^{n-1} e_{i+1} e_i \quad .$$

Here,  $e_i$  is the exponentially ordered score associated with  $r_i$ .

For a renewal process

$$E(R_1') = n-2 + \frac{\log n + \gamma}{n} + \frac{1}{2n^2} + O\left(\frac{1}{n^2}\right)$$

$$\text{and } \text{Var}(R_1') = \frac{n^3 - 6n^2 + 24n}{(n-2)(n-3)} - 2\log n + O\left(\frac{\log^3 n}{n}\right) \quad ,$$

where  $\gamma$  is Euler's constant = 0.5772

The rank test will tend to emphasize correlations between short intervals whereas the exponential score test will emphasize correlation between long intervals.

Finally we examine whether the intervals could form a Poisson Process. One consequence of this would be that the mean interval would be approximately equal to the standard deviation of the intervals. The coefficient of variation of 7-73 is 0.99 and that of 8-73 is 1.18. Cox and Lewis (1966, p.176) state that a range of values between 0.8 and 1.2 are consistent with a Poisson Process.

A suitable test statistic is

$$S = \frac{2}{t_n - 1} \sum_{i=1}^n (n-i+1) X_{(i)} \quad ,$$

where  $t_n$  is the sum of all the intervals and  $X_{(i)}$  is the  $i$ 'th smallest interval. Under the null hypothesis of a Poisson Process the distribution of  $S$  tends rapidly with increasing length of time to a Gaussian distribution with mean  $\frac{1}{2}n$  and variance  $n/12$ .

From Table 1.2 we can see that the series of extrasystoles from subjects 7-73 and 8-73 satisfy all tests with regard to serial correlation and non-Poisson behaviour, except a just significant result for  $R_1^2$  for subject 8-73. From the data we can see that there is some evidence for clustering of the longer intervals. However, taking the tests together, there is little evidence that the extrasystoles are anything but randomly distributed as a Poisson Process.

Thus a useful adjunct to patient monitoring would appear to be the examination of the intervals between extrasystoles for serial correlation or trends, and sound the alarm if either became evident. However, further study is clearly needed, firstly because the sampling procedure that we employed meant that almost certainly we have not detected all the extrasystoles in the records, and secondly because we have only examined records from two patients.

When we consider the tests on the outliers in the blood pressure variables in Table 2.1 we see that the only record to exhibit significant correlation is the systolic pressure of subject A1. In fact this is caused almost entirely by the two very long periods with no outliers that are adjacent to each other at the end of the record. From these data therefore the outliers in blood pressure appear to be randomly distributed in time.

TABLE 1.1      Extrasystoles for patients 7-73 and 8-73 and outliers  
for ambulatory subjects A1 and A2

Intervals (secs)

Patient 7-73            n=31

200 422 37 159 291 3 84 16 109 33 171 80 202 6 52 87 79 121 15 51 31  
 5 23 28 9 205 347 227 32 84 139

Patient 8-73            n=18

54 7 9 7 432 655 196 190 83 185 406 13 139 7 27 42 173 110

Intervals (beats)

Subject A1 (systolic)    n=19

899 329 495 285 183 141 139 63 107 37 137 116 145 162 156 118 163 1442  
 1326

Subject A1 (diastolic)   n=12

377 1253 263 68 491 418 53 142 138 460 591 1605

Subject A2 (diastolic)   n=27

247 56 63 49 41 32 151 50 16 58 12 76 47 49 65 17 27 9 75 7 18 24 46  
 9 24 273 48

Table 1.2      Tests of randomness on intervals

Extrasystoles

| Test               | Statistic |      | Observed | Expected | Expected | $Z = \frac{X-E}{\frac{S}{\sqrt{2}}}$ |
|--------------------|-----------|------|----------|----------|----------|--------------------------------------|
|                    |           |      | Value X  | value E  | s.d. S   |                                      |
| Trend              | r         | 7-73 | 17       | 16.42    | 2.65     | 0.01                                 |
|                    |           | 8-73 | 8        | 10.00    | 1.95     | 0.77                                 |
| Serial Correlation | $R_1$     | 7-73 | 7636.5   | 7600     | 475      | 0.08                                 |
|                    |           | 8-73 | 1718.0   | 1507     | 127      | 1.66                                 |
| Serial Correlation | $R_1'$    | 7-73 | 33.45    | 29.13    | 4.86     | 0.79                                 |
|                    |           | 8-73 | 24.00    | 16.19    | 3.49     | 2.09                                 |
| Non-Poisson        | S         | 7-73 | 14.5     | 16.5     | 1.61     | 0.93                                 |
|                    |           | 8-73 | 8.65     | 9        | 1.20     | 0.13                                 |

Ambulatory subject outliers

| Test               | Statistic |          | Observed | Expected | Expected | Z    |
|--------------------|-----------|----------|----------|----------|----------|------|
|                    |           |          | Value X  | Value E  | s.d. S   |      |
| Serial Correlation | $R_1$     | A1 syst  | 2039     | 1770     | 145      | 1.85 |
|                    |           | A1 diast | 459      | 452      | 300      | 0.02 |
|                    |           | A2 diast | 4900     | 5035     | 339.5    | 0.40 |
| Serial Correlation | $R_1'$    | A1 syst  | 24.62    | 17.19    | 3.61     | 2.06 |
|                    |           | A1 diast | 10.89    | 10.26    | 1.80     | 0.35 |
|                    |           | A2 diast | 29.43    | 27.14    | 4.67     | 0.48 |
| Non-Poisson        | S         | A1 syst  | 9.94     | 9.50     | 1.26     | 0.35 |
|                    |           | A1 diast | 7.32     | 6.00     | 1.00     | 1.32 |
|                    |           | A2 diast | 15.03    | 13.5     | 1.50     | 1.02 |

## CHAPTER 2 : PROBABILITY STRUCTURE OF BLOOD PRESSURE AND HEART RATE

### Introduction

As variables, heart rate and blood pressure differ fundamentally in that the heart beat is a dimensionless event whereas blood pressure is a continuous variable in time. We can 'discretize' the blood pressure by examining the signal only at distinct points such as the peak systolic point or the end-diastolic point. We can then regard the sequence of peak systolic points and the sequence of end-diastolic points as values taken by two distinct random variables, and so consider their separate and joint probability structures. In a similar manner we can consider the probability structure of the intervals between each beat, the heart interval, or the successive values of the heart rate, the reciprocal of the heart interval.

The first device that one would normally associate with the investigation of probability structures is the histogram. Particularly for short data stretches this will give some idea of the clustering of the variables, and the proportion of outliers. For longer sections, non-stationarities in the mean tend to obscure many of the details in the histograms. However, histograms do not display any of the time-dependent features of the data. We can use the sample autocorrelation function, defined in Appendix A to give us a summary of the time-dependence although it is very susceptible to non-stationarities and is often difficult to interpret usefully, beyond telling us that the data are correlated. Also it only measures linear correlation. A useful question to ask is, because of autocorrelation, how is averaging affected? With independent observations we can reasonably assess the



accuracy of the mean, but not with autocorrelated variables. A further question about variables in time is, given an observation, what is the distribution of the next observation, or the next two, etc.? An answer to these questions should tell us something about the stability of the variable, how often does it suddenly jump, and how often does it exhibit slow changes. We would also like to know, typically, what length of data can be regarded as stationary in both mean and variance. This is also concerned with averaging, where we want to eliminate short term variation but not confound it with the long term variation. The long term variation may appear, from the short term point of view, as a non-stationarity. For example a long term cycle would appear as an almost linear trend if viewed for only a short period of time.

For data that appear reasonably stationary we can make a more detailed examination of the probability distribution by using histograms. In particular, we shall see in the literature review that this has often been done in the past. We can then attempt a more complete description of the data by fitting theoretical distributions to the observed points. The most obvious candidate is the Normal distribution and it is useful to examine whether the observed points are Normally distributed because many statistical tests depend upon this assumption. Two ways in which a distribution may depart from Normality are when it is not symmetric and when a large number of points appear in the tails. Either can seriously upset a statistical test and so for the purposes of describing a signal these departures should be recorded.

For data that are not stationary in mean we can either study the probability distribution about a slow moving trend, or split the data up into sections that are short enough to be regarded as stationary. We could then ask what kind of distributions best describe the variables and further, how do the parameters of the distributions change with time.

### Literature Review

Early literature concerning heart rate tended to assume that it was approximately constant and did not attach a probability structure to it at all. The mean heart rate was calculated by counting the number of heart beats that occurred in one minute, or some shorter fraction. The idea of the heart interval, defined as the time between successive peaks in the QRS complex of the E.C.G., as a random variable has only been explored more thoroughly with the development of automatic methods of detecting the QRS complex. A probability structure can then be associated with the random variable and the mean and variance calculated in the usual way. Varni et al., (1971) investigated the variability of heart rate under various physiological controls.

In recent years quite a few simple techniques have been developed for a fairly rapid assessment of the variability of heart rate. This is often necessary for an accurate diagnosis of a heart condition. The most straightforward method is the use of the cardiogram, which is simply a plot of interval length against interval number, demonstrated for instance by Söderström (1950). This method gives a quick and easy indication of changes in variability, and of predominant cycles. Other techniques that have been developed include the interval histogram and the joint rate histogram or scattergram. The latter is a two dimensional plot of heart interval against the succeeding, adjacent, heart interval; that is, we plot the  $i$ th heart interval on the  $y$  axis and the  $i + 1$ th interval on the  $x$  axis, for all intervals  $i = 2, \dots, n$  say. A discussion of the main features of

the interval histogram has been given by Ten Hoopen and Bongaarts (1969). From the interval histogram we can readily assess the shortest, longest and the mean intervals as well as the spread of the intervals, their standard deviation and skewness (defined as  $(\text{mean-mode})/\text{standard deviation}$ ). A possible drawback of this method of presenting the data is that the ordering of the data is lost. We could obtain an idea of the ordering by plotting two interval histograms; one of intervals which succeed an interval greater than the mean, and the other of intervals succeeding an interval less than the mean. By comparing the two interval histograms we can get some idea of the independence of the intervals. Total independence would imply more or less identical histograms. Ten Hoopen and Bongaarts (1969) discuss possible class widths and the number of classes to be used in estimating the histogram. The class width is partly determined by the measuring accuracy of the apparatus, but clearly it must not be taken too narrow or a histogram with a very uneven profile would be obtained. They illustrate the use of the interval histogram, the joint rate histogram and the cardio-tachogram by considering healthy subjects and patients with atrial fibrillation who are producing extrasystoles.

A common feature of the histograms is their multimodality. An oscillating time series will give a histogram which has a U-shaped distribution. Newell (1965) discusses an analogous problem of finding the probability distribution function of a sinusoid. Strictly speaking a deterministic function does not have a probability function, but it can be thought of as having a frequency distribution. Alternatively we can think of sampling any point along

the curve at random and examining the frequency distribution of the values at this point. Let us say we have a variable  $x(t) = a + b\cos(t)$ . Sampling  $x(t)$  at random along the  $t$  axis is equivalent to sampling at random in the range  $(0, \pi)$ . Within this range the probability of sampling at a point on the  $t$  axis in a section of length  $\delta s$  is  $\delta s/\pi$ . Thus the probability of obtaining a value  $x_0$  of  $x(t)$  in a section of length  $\delta x_0$  is

$$\frac{\delta x_0}{\pi (b^2 - (x_0 - a)^2)^{\frac{1}{2}}}, \text{ for } x_0 \text{ in } (a \pm b).$$

This equation describes a U-shaped curve. For  $a=0$  and  $b=1$  the distribution can also be described by what is known as a Pearson Type I curve. The fitting of Pearson curves to heart rate data will be discussed later. A characteristic of this type of curve is that a large proportion of the observations are at the extreme ends of the range. It will be shown later that respiration can cause the heart rate to behave as a sinusoid and produce bimodal histograms. It is only by careful balancing of the population size against the class width that we can hope to pick out multimodality. Ten Hoopen suggested that the skewness often encountered in heart rate histograms may be a consequence of diffuse and latent peaks.

The joint rate histogram or scattergram (Rowlands, 1970; Stinton, 1972) is more easily employed as an on-line analogue device rather than for retrospective calculation, and can be very useful in confirming various heart diagnoses. Thus for atrial fibrillation we find the joint rate histogram gives a circular cluster of points, confirming that the intervals are approximately independent of each other. For normal sinus rhythm the joint rate histogram shows a dense cluster of points lying on the main diagonal. For respiratory

sinus arrhythmia we get a greater tendency for the points to form a narrow ellipse.

Ectopic beats show up well thus:

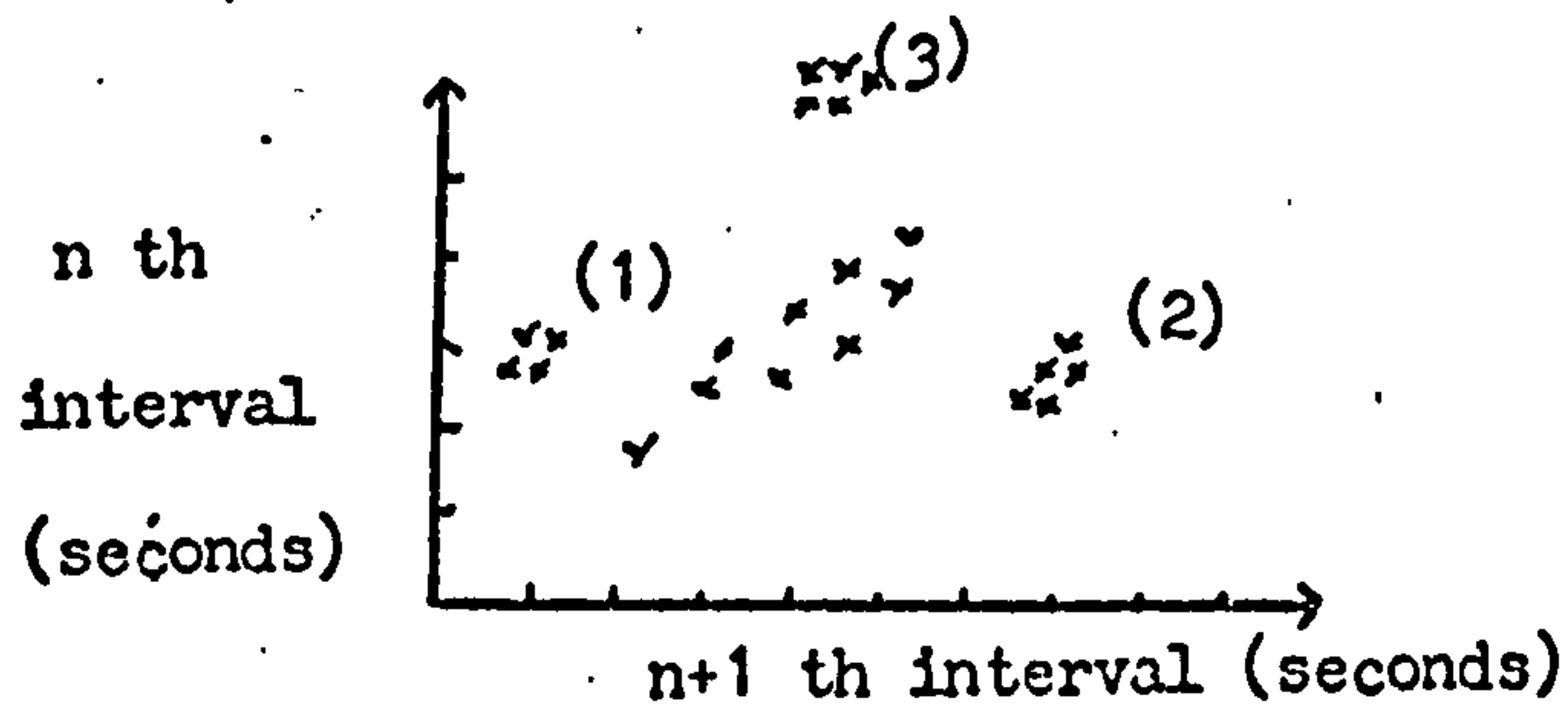

Figure 2.1. The joint rate histogram (from Rowlands, 1970)

Four main clusters are shown. The cluster on the diagonal represents normal sinus rhythm. An ordinary beat followed by a premature beat is plotted to the left of the diagonal in cluster (1). This is followed by a compensatory pause which is plotted in cluster (2) and then an ordinary beat, cluster (3). This method of presentation is well suited to the analysis by statistical cluster techniques.

For a very large number of points, histograms tend to have very similar shapes. Ten Hoopen (1969) shows that a comparison of histograms composed of fewer points would indicate that they had different distributions. However, care must be taken because with too few points only the variability of the intervals would be presented. Ten Hoopen (1969) points out the difficulties of applying the theories of stochastic processes or random phenomena to heart interval distributions, which are dependent on a large number of factors and which are restricted in both upper and lower limits by physiological considerations.

Jennings et al., (1974) have compared heart interval and heart rate distributions for 10 subjects, each with about 2,500 intervals. A number as large as this is likely to obliterate any multimodality since the signal would probably not remain stationary for so long. They found that 4 out of 10 heart period distributions satisfied Kolmogorov-Smirnov tests for goodness-of-fit to a normal distribution, whereas none of the heart rate curves did. They also found that the heart period curves were skewed negatively, i.e. the left tail was disproportionately large, whereas the heart rate curves were skewed positively, and also leptokurtic, which means there were more observations clustering around the mean than with the normal distribution. For these reasons they advocate the use of heart interval instead of heart rate for assessing cardiac performance.

Taylor (1971) and Taylor et al., (1975) state that the distribution about an exponentially weighted mean of both heart rate and blood pressure showed no significant difference from a normal distribution up to 3 standard deviations from the mean. Taylor et al., (1975) studied 27 patients and stated that in the 54 heart rate and blood pressure records obtained, 50 could be described by a normal distribution except for the extreme tails, as judged by a  $\chi^2$  goodness of fit test. This would imply that the weighted mean eliminated factors which can cause skewness, such as trends or slow oscillations. However it is difficult to see how a factor such as leptokurticity could be corrected by this method.

### Methods

The data collection methods are described in Chapter 1 and also

Appendix B. We have three distinct types of data. The post-operative patient data consist of heart rate and blood pressure sampled at one second intervals by a data logger for periods of upto an hour. The data from ambulatory subjects is of the systolic and end-diastolic blood pressure for a period of about two hours. The healthy subjects' data consist of successive heart intervals for periods of about 5 minutes.

The main analyses in this Chapter will be of the blood pressure variables, principally because we have extensive blood pressure records of the ambulatory subjects, but also because these have been less intensively studied in the past. In addition physicians pay more attention to blood pressure than heart rate, and it is likely for reasons to be discussed later that the former gives more information about the condition of a subject.

#### Preliminary analysis of blood pressure

The first step in any analysis was to print the data on a line-printer, and then perform a line-printer plot (using the program GRAPH) to examine them visually. In this way we can very often spot outliers, and look for trends.

Table 2.1 gives some summary statistics of the variables recorded from the ambulatory subjects, and from the mean blood pressure of those post-operative subjects with substantial data sets. From these we can see that subject A2 has the same overall diastolic pressure as subject A1; but that the mean systolic pressure is higher, giving a correspondingly greater mean pulse pressure. In addition his data are much more variable. The overall mean blood pressure<sup>s</sup> of the post-



operative patients are quite close, mainly about  $\bar{t}/100$  mm. Hg, and they show less variability than the ambulatory subjects, not surprisingly since the patients were confined to bed.

In order to examine the short term variability the data were split into successive sections of 200 points. For each section, the mean and standard deviation (s.d.) were calculated, giving two sequences from which the overall mean and the s.d. of the mean can be calculated, and also the overall s.d. and the s.d. of the s.d.'s. These figures are also given in Table 2.1. They show that about a short term mean the variability of systolic blood pressure is similar for the two subjects at about 10 mm. Hg, although subject A2 has a less variable diastolic pressure. The variabilities of the blood pressure of the post-operative patients are in fact quite close to each other at about 8 mm. Hg, except for subjects 11-73 and 15-73 who had less variable results than the others.

#### Cutliers of ambulatory subjects

In Chapter 1 we described methods of detecting outliers and tests for possible randomness in the intervals between outliers. In this section we briefly examine the effect of outliers on the variance of the blood pressure of the ambulatory subjects. Values of 0.90 and 0.99 were tried for the exponential weighting constant  $\lambda$ . The sums of squares due to the outliers about the moving average, and also the sums of squares of the other points from the moving average are given in Table 2.2. The total sums of squares are computed about the arithmetic

mean. From the total we subtract the sum of squares due to outliers and the sum of squares about the moving average to obtain the residual sum of squares due to the moving average. This is not strictly correct because  $a$  was not chosen to minimise the residual sum of squares, and so we do not have orthogonality between the partitions. In particular a poor choice of  $a$  may result in a negative sum of squares. However, we can think of the ratio of the residual sum of squares to the total as the amount of variability accounted for by the moving average.

The choice of  $a = 0.99$  picks out most of the outstanding outliers, and while  $a = 0.90$  picks out many more minor ones, their contribution to the sum of squares due to outliers is not great. By comparing the two sets of values in Table 2.2 we can see that, by giving more weight to the recent events, the value  $a = 0.90$  follows the process more closely and so reduces the 'about moving average' row.

The squared absolute value of the transfer function of the exponentially weighted filter is given by

$$|H(w)|^2 = \frac{(1 - a)^2}{1 - 2a \cos 2\pi w + a^2}$$

for example Chatfield (1975). For  $a = 0.99$  the half power point is  $w = 0.0016$  cycles/beat or a cycle length of about 625 beats; for  $a = 0.90$  the half power point is  $w = 0.017$ , cycle length = 58 beats. Thus by using  $a = 0.90$  we are removing a wider band of low frequencies than for  $a = 0.99$ .

The results from Table 2.2 show that, for subject A1 at least,

the outliers, although only 1% of the population, amount in some cases to 11% of the total sum of squares. It is perhaps worth noting that for a random sequence of normally distributed variables, the contribution to the sums of squares of those values four standard deviations from the mean is 0.1%. A high proportion of the variability associated with the systolic and diastolic pressures of Subject A2 can be accounted for by a slowly fluctuating mean level. Allowing for this trend, the variability of the systolic pressures for A1 and A2 are surprisingly close with a standard deviation of about 10 mm. Hg which is about the same as the standard deviations about the short term mean given in Table 2.1. In each case the diastolic pressure and the pulse pressure exhibit less variation than the systolic pressure. From visual inspection of the data it was noticed that an outlier in pulse pressure can be caused by either a high systolic or a high diastolic point. However occasionally they occur together, so that the two outliers produce a pulse pressure of normal size.

### Stationarity

A major question that was posed in the Preface concerned the length of data that could be regarded as stationary in mean and in standard deviation. A method for testing stationarity is described by Kendall and Stuart Vol III (1967).

If we have a sequence of values  $x_1, x_2, \dots, x_N$  then a reverse arrangement is defined as occurring when

$$x_j > x_i \quad j > i \quad , \quad i=1, \dots, N-1 \quad .$$

We write  $A_i$  as the total number of reverse arrangements for  $x_i$  and

put  $A = \sum A_i$ . If the sequence were random, then  $E(A) = N(N-1)/4$  and the variance is  $(2N^3 + 3N^2 - 5N)/72$ . For  $N > 10$  and for a random sequence the distribution of  $A$  is approximately Gaussian. This method is more appropriate for testing for trends and abrupt changes in level than for other types of non-stationarity where the level returns to its original value. However these types of non-stationarity may give clues about the state of a subject.

For the ambulatory subjects' data we considered short sequences of 5, 10, 15 or 20 beats. For each we computed the mean and variance and then considered them over lengths of 100, 300 and 500 beats. Kendall's 'reverse arrangement' statistic was calculated for each sequence of short term means and variances over the different numbers of beats. For each case, the means and variances were tested for trend at the 1% level. The approximate percentage of sequences that were found not significant is given in Table 2.3 for both the means and the variances.

In addition to the blood pressure data, a set of artificial data was tested to see what kind of non-stationary sequences the test detected. The form of the artificial data was a set of random numbers of variance unity, with an added deterministic variable defined by

$$x_i = 0 \quad i=1,100$$

$$x_i = (i-100) \times 0.02 \quad i=101,200$$

$$x_i = 1 \quad i=201,300$$

This was repeated 20 times, to produce 6000 data points.

The random data show that the test correctly decides that the variance is stationary for all sets. When we look at the series of means in the 300 beat period, none of the series is considered stationary, which is correct. For sets of length 100 beats, about two-thirds are considered stationary by the test, which is again correct. However, for sets of length 500 we find that as the number of points taken in each average is increased, so does the number of stationary sequences. This is because the sequence of points from 300 to 500 of a set of length 500 has the same mean level as the sequence from 1 to 200 and from this the test may decide that the sequence is stationary.

Table 2.3 shows the expected result that longer averages show fewer significant trends, but that if we consider the results over longer periods we are more likely to find trends. In addition, only a small proportion of the long periods for means for subject A2 can be regarded as trend-free, as would be expected from the results on the sums of squares about the moving averages. However, what is immediately apparent from the Table is that the variances are much more often stationary than the means. For example, for sets of length 300, the smallest percentage of variances that are stationary is 75% whereas for means the corresponding figure is 25%

This result confirms the impression given by looking at the line-printer plots of the data, that the average level varies by quite an amount, but that the variability about that average is relatively stable.

FIGURE 2a

PERCENTAGE OF RUNS WITHIN GIVEN LIMITS

SUBJECT A2 SYSTOLIC BLOOD PRESSURE

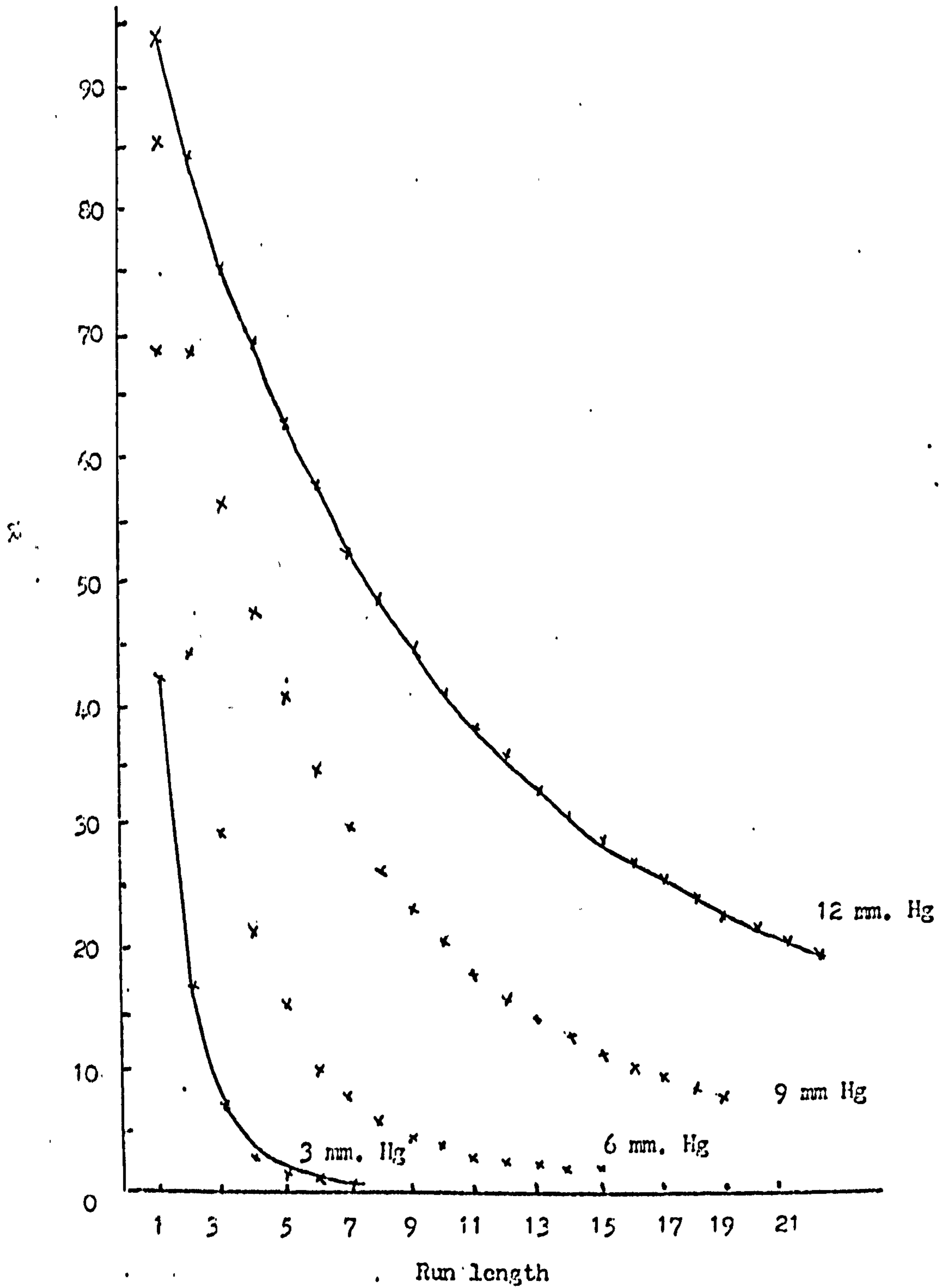

### Distribution of run lengths

A run is defined as a sequence of observations  $x_t$  such that

$$|x_n - x_t| < k, \quad \text{for } t > n,$$

where  $k$  is a specified parameter.

A run of length  $m$  is one in which there are  $m-1$  successive values of  $x_t$  within  $k$  of  $x_n$ . For each value  $x_n$ ,  $n > 0$  we have a run of a particular run length, although the run length may be constrained by the end of the sequence. From histograms of run lengths we can derive tables showing the proportion of times that a sequence of a given length is within a certain distance of the original value. This is useful for measuring the stability of the data.

There are several methods of calculating the frequencies of run lengths. One method would be to consider each point in the series in turn and compute the run lengths from it, building up a frequency table of run lengths. One disadvantage of this is that any outlier is likely to be the termination point of several runs. An alternative would be to count only non-overlapping runs. Again we have to beware of outliers, since the point following an outlier is likely to be unusual, so the procedure that was followed was to allow a point in between runs. Both methods produced similar histograms, and the non-overlapping runs were studied in more detail since these are less likely to be correlated.

Figure 2a shows the proportion of sequences within 3, 6, 9 and 12 mm. Hg of the starting value for each run length for the systolic

FIGURE 2b

LOGARITHM OF PERCENTAGE OF RUNS WITHIN GIVEN LIMITS

SUBJECT A2    SYSTOLIC BLOOD PRESSURE

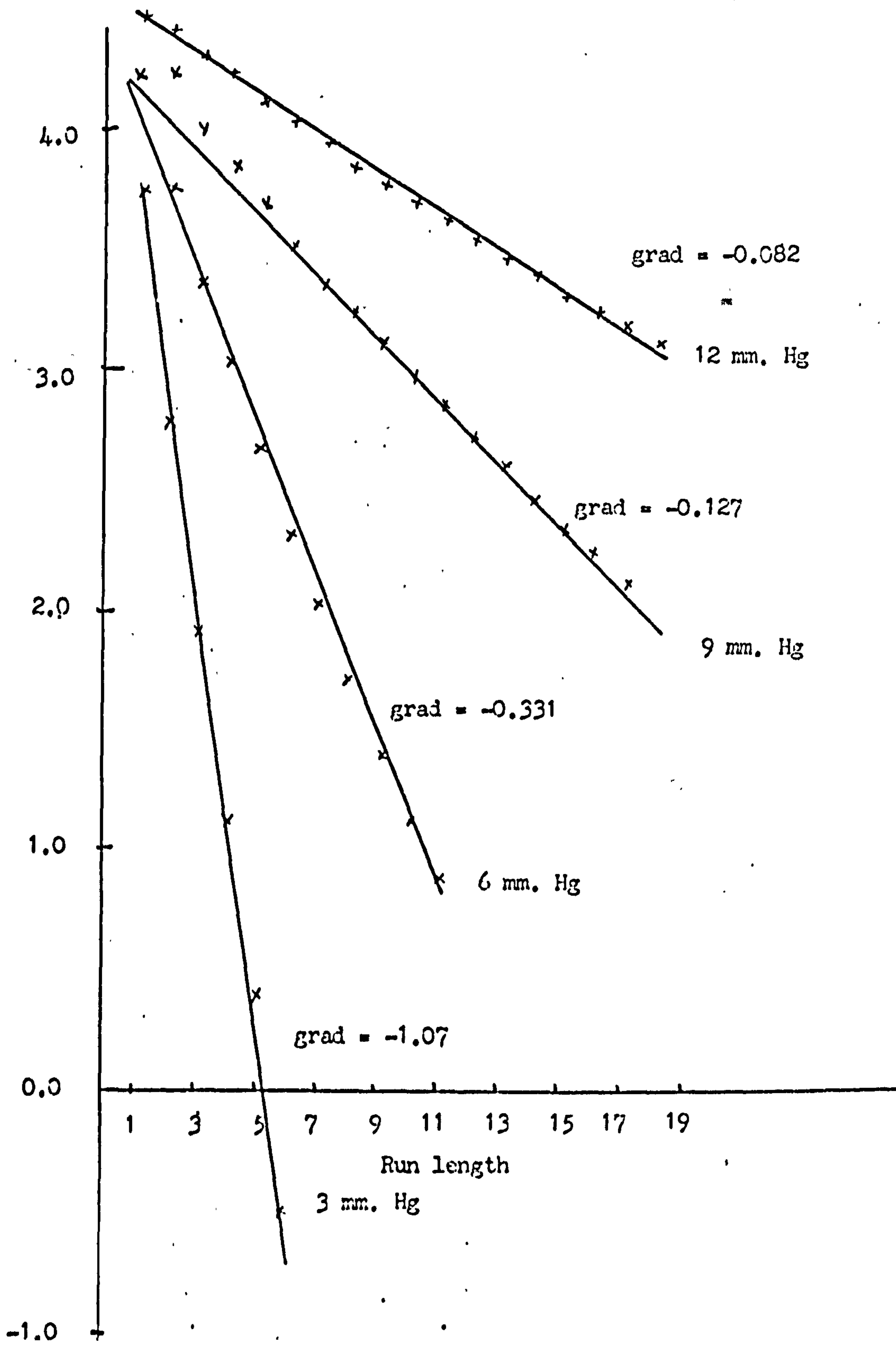



pressure of subject A2. The curves are strongly suggestive of an exponential decline and so the natural logarithm was plotted against run length, as in Figure 2b. The logarithmic transformation produced a very nearly linear relationship between  $\log p$  and run length.

We investigated a number of possible explanations for this phenomenon.

$$\text{Let } P_1 = \text{Prob} ( |X_{t+1} - X_t| > k ) ,$$

$$P_2 = \text{Prob} ( |X_{t+2} - X_t| > k \quad \text{and} \quad |X_{t+1} - X_t| < k ) ,$$

$$P_3 = \text{Prob} ( |X_{t+3} - X_t| > k , |X_{t+2} - X_t| < k \quad \text{and} \quad |X_{t+1} - X_t| < k ) ,$$

etc..

Then, given that we can estimate probabilities from proportions, the plotted proportions estimate the quantities  $P_1, P_2, \dots, P_n$ . Now let  $P_{2/1} = \text{Prob} ( |X_{t+2} - X_t| > k \text{ given that } |X_{t+1} - X_t| < k )$  and similarly for  $P_{3/21}$  etc.

Then we can show that

$$P_2 = P_{2/1} (1 - P_1) ,$$

$$P_3 = P_{3/21} (1 - P_{2/1})(1 - P_1) ,$$

$$P_4 = P_{4/321} (1 - P_{3/21})(1 - P_{2/1})(1 - P_1) .$$

In order to produce the observed relationships we require

$$P_n = s P_{n-1} , \quad \text{where } s \text{ is a constant.}$$

From the above we require, in general

$$P_n = \frac{P_{n/n-1} (1 - P_{n-1/n-2}) P_{n-1}}{P_{n-1/n-2}} .$$

so that

$$s = \frac{P_{n/n-1}(1 - P_{n-1/n-2})}{P_{n-1/n-2}}$$

In order for this expression to be constant we need

$$P_{n/n-1} = P_{n-1/n-2} = \dots = P_{2/1} = r \text{ (say) .}$$

To examine the theoretical implications of this result we consider a random sequence of Normally distributed variables  $X_1, \dots, X_t, X_{t+1}, \dots$ , with variance  $\sigma^2$ .

Now let  $P_n(S) = \text{Prob} \{ |X_{t+n} - X_t| = S_n, |X_{t+n-1} - X_t| = S_{n-1}, \text{ etc. } \}$

and  $P_{n/n-1}(S) = \text{Prob} \{ |X_{t+n} - X_t| = S_n \text{ given } |X_{t+n-1} - X_t| = S_{n-1} \text{ and } |X_{t+n-2} - X_t| = S_{n-2} \text{ etc. } \}$ ,

Then we can show that

$$P_n(S) \propto \exp \left[ -\frac{1}{2\sigma^2} \left\{ \frac{n}{n+1} \sum_1^S S_i^2 \right\} + \frac{1}{\sigma^2(n+1)} \sum_{i \neq j} S_i S_j \right],$$

$$\text{and } P_{n/n-1}(S) \propto \exp \frac{-n}{2(n+1)\sigma^2} \left( S_n - \frac{\sum_1^{n-1} S_j}{n} \right)^2.$$

Thus we see that the conditional distributions are not equal to each other, but will converge as  $n$  increases, in the sense that they are Normal distributions, mean  $\sum_1^{n-1} S_j/n$  and variance  $(n+1)/n$ .

An alternative way of looking at the situation is to consider that  $|X_t - X_n| > k$  is an event occurring at time  $t$ , or at time  $t-n$  from an origin at time  $n$ . By looking at non-overlapping run lengths we are considering times from an arbitrary starting point until an event. In this kind of situation it is common practice to plot the logarithm of what is known as the Survivor Function against time (Cox and Lewis, 1966, Chpt 1).

The survivor function in this case is

$$\begin{aligned} P_n^i &= \text{Prob} (\text{Run length is } > n) , \\ &= \text{Prob} ( |X_{t+1} - X_t| < k, \dots, |X_{t+n} - X_t| < k ) \\ &= (1 - P_{n/n-1}) P_{n-1}^i . \end{aligned}$$

When the proportion of run lengths greater than  $n$  is plotted against  $n$ , we again find that the log proportion is linear in  $n$ . Cox and Lewis (1966) discuss this situation, and show that if a process is Poisson, then the distribution of intervals is exponential. However, the converse is not necessarily true and the intervals need not be independent when distributed exponentially. However, they require one property of a Poisson process, namely that

$$\text{Prob} (\text{interval} < t) = 1 - e^{-\lambda t}$$

where  $\lambda$  is the rate of occurrence of the events. Thus the slope of the graph of  $\log 1-P$  against  $t$  is  $-\lambda$  and  $\lambda$  can be shown to be the inverse of the expected run length, and so measures the degree of variability in the series generating the runs (since a highly variable series would be expected to have only short runs.)

Thus we could look upon the termination of a run as an event in point process theory, where a run would be equivalent to an interval. The fact that the runs are distributed approximately exponentially means that the probability of an event, i.e. a blood pressure exceeding a limit is the same for each beat, and so the probability of an event occurring gets steadily greater the longer the interval lasts.

Table 2.4 gives the slopes of the straight lines fitted in

figure 2a, for subjects A1 and A2, and also the mean arterial pressure for patients 9, 12, 15 and 16-73. The intervals chosen for the ambulatory subjects are 3, 6, 9 and 12 mm. Hg, to give a range of values across one standard deviation. The variability of the patients' blood pressure was much lower, and so the range studied here was 1, 2, 3 and 4 mm. Hg. In the case of patient 15-73, this range was too great and only the first limit produced a monotonically descending graph. Above this, some of the run lengths became very long indeed. The table can be used either to compare subjects or to examine the distribution of a particular signal. The greater the absolute value of the slope, the greater the proportion of the signal which is outside the set limits

We can see from the table that diastolic pressures tend to be less variable than systolic pressures, with pulse pressure in the middle. Of the four patients, three had very similar mean blood pressure distributions, and the other, 15-73, was much less variable.

Finally we examined the autocorrelation structure of the runs to see whether the length of a run is independent of any other run. The autocorrelations are presented in Table 2.5 for subjects A1 and A2, for the run limit of 3 mm. Hg. If the intervals were independent, then each autocorrelation can be shown to have expected value zero, and approximate standard error  $1/\sqrt{n}$ , where  $n$  is the number of points in the series. We can see from the table that the only significant autocorrelations appear in diastolic blood pressure for subject A1. However, for both systolic and diastolic pressure, all but one of the autocorrelations are positive, indicating that for this subject run lengths close to each other are positively correlated. For subject

A2, however, none of the autocorrelations are significant, and the distribution of the negative signs would indicate that we have no evidence that the run lengths are anything but random.

The positive autocorrelations for subject A1 probably reflect a greater stability, especially in diastolic blood pressure. When the system has settled down, the runs will tend to be long, with only the occasional point interrupting the run, and so starting a new one.

#### Degrees of freedom

The concept of the number of degrees of freedom per point seems closely linked to the correlation structure of the series. If the 1st autocorrelation is near unity, then a point can be almost exactly predicted from the preceding one, little new information is gained from new points, and so the degrees of freedom per point are low. On the other hand, if the autocorrelation structure is zero, then the series is random, and so the degrees of freedom per point is high.

Degrees of freedom are usually associated with variances from Gaussian distributions and indicate the number of linearly independent squared terms into which the variance can be divided. It can then be shown that the variances are distributed as chi-squared distributions, the form of the distribution being determined by the number of degrees of freedom. Blackman and Tukey (1959, p21) discuss the use of degrees of freedom for applications to time series analysis, especially spectral analysis. Given the mean and variance of some positive

estimate, they suggest that the distribution of the estimate can be approximated by a chi-squared distribution. We can estimate which chi-squared distribution by choosing it so that, apart from a common scaling factor, it has the same mean and variance as the estimate. A  $\chi_k^2$  distribution has mean  $k$  and variance  $2k$ . The estimated parameter  $k$  is called the equivalent number of degrees of freedom of the estimate.

For example, given an estimate of a variance which has mean  $M$  and variance  $V$ . We wish to find  $k$  such that  $M = ck$  and  $V = 2c^2k$ , where  $c$  is an arbitrary constant. Eliminating  $c$  we find that

$$k = 2M^2 / V.$$

One problem is to link this concept, which necessarily deals with variance-like quantities distributed as chi-squared to an ordinary time series which is possibly Gaussian. A suggested method is via the variability of the mean of a sequence of points. If the estimated variance of the mean of  $r$  successive points is  $S_r^2$ , and the variance of the individual points is estimated as  $S^2$ , then we have

$$S_r^2 = S^2 / \text{d.o.f.} \quad (2.1)$$

In the simplest case of independent Normally distributed points with constant variance  $\sigma^2$  this is consistent with the Blackman-Tukey definition. In this case the expected variance of the mean is  $M = \sigma^2 / r$ , and we can show that the expected variance of this variance is  $V = 2 \sigma^4 / r^3$ , (for example Kendall and Stuart, 1967, Vol III p56). Thus the equivalent number of degrees of freedom is  $2M^2 / V = r$ .

We have not shown the equivalence holds for correlated structures but it seems reasonable that in this case  $d.o.f. < r$ , so that  $d.o.f. / r < 1$ . Further work is also needed to see how close the distributions from real data are to chi-squared distributions.

One problem is that it is unlikely that  $d.o.f./r$  would be independent of  $r$ . We will have to estimate  $S_r^2$  and  $S^2$  from the data. Given that the total number of observations  $N$  is much bigger than  $r$  we can calculate the means of successive sets of  $r$  observations,  $\bar{x}_1, \bar{x}_2, \dots, \bar{x}_m$  and then compute the variance of these by

$$S_r^2 = \frac{\sum_{i=1}^m (\bar{x}_i - \bar{x})^2}{(m-1)} = \frac{\sum_{i=1}^m \bar{x}_i^2 - \left( \sum_{i=1}^m \bar{x}_i \right)^2 / m}{(m-1)}. \quad (2.2)$$

Table 2.6 shows the variance of the means of different length sequences, and also the degrees of freedom per point for the blood pressure of the ambulatory subjects and for that of the intensive care patients. It is clear that the variance decreases much less rapidly than the sequence length  $n$ . This is due to the non-stationarities in the data which will not be removed by averaging. We see for example, that subject A2, for which a large proportion of the variability of systolic blood pressure could be accounted for by a slow moving average, has a much smaller percentage reduction in the variance of the mean than A1.

An example of the connection between the idea of degrees of freedom and the correlation structure is given by the following series of equations.

$$\text{Var} \left( \frac{x_1 + \dots + x_n}{n} \right) = \frac{1}{n^2} \left\{ \sum_i \text{Var}(x_i) + \sum_{i \neq j} (n - |i-j|) \text{Cov}(x_i, x_j) \right\}$$

If we assume the  $x_i$  s are identically distributed we get,

$$\text{Var} \left( \frac{x_1 + \dots + x_n}{n} \right) = \frac{1}{n^2} \{ nC_0 + 2(n-1)C_1 + \dots + 2C_{n-1} \} ,$$

where  $C_0$  is the variance of the  $x_i$  s and  $C_1, C_2, \dots, C_{n-1}$  are the covariances of order 1, 2 etc..

We then get

$$\text{d.o.f./pt} = \frac{n^2 C_0}{nC_0 + 2(n-1)C_1 + \dots + 2C_{n-1}} \times \frac{1}{n} ,$$

$$\text{d.o.f. / pt.} = \frac{1}{1 + \frac{2(n-1)}{n} R_1 + \dots + \frac{2}{n} R_{n-1}} , \quad (2.3)$$

where  $R_1 = C_1 / C_0$  etc..

In particular if all the  $x_i$  s are random then  $E(R_1) = E(R_2) = \dots = 0$ , and the expected d.o.f. / r = 1.

We can observe the accuracy of equation (2.3) by substituting the observed autocorrelations, given in table 2.7, and comparing the results to Table 2.6. For a sequence of length 10, from equation (2.3) we find the following :

|             | A1       |           | A2       |           |
|-------------|----------|-----------|----------|-----------|
|             | systolic | diastolic | systolic | diastolic |
| d.o.f. / pt | 0.1631   | 0.1858    | 0.1038   | 0.1103    |



These are very close indeed to the values given in Table 2.6.

The formulae show that an asymptotic value for the d.o.f. / pt. can be obtained if

$$S_n = \sum_{i=1}^n (n-i)R_i / n \text{ converges.}$$

In the case of the ambulatory subjects' data, non-stationarities mean that the  $R_i$  do not rapidly tend to zero, so that  $S_n$  diverges and d.o.f. / pt. tends to zero.

A simple case where convergence holds is when

$$X_t = aX_{t-1} + \epsilon_t \quad \text{where } \epsilon_t \text{ are i.i.d.}$$

In this case  $E(R_n) = a^n$ , and d.o.f. / pt can be shown to be

$$\text{d.o.f. / pt.} = \frac{1-a}{1+a} \quad (2.4)$$

If we substitute an estimate of  $R_1$  for  $a$  in equation (2.4), the following results are obtained.

| d.o.f./pt. | Systolic      | Diastolic | Pulse Pressure |
|------------|---------------|-----------|----------------|
| A1         | 0.163         | 0.175     | 0.337          |
| A2         | 0.018         | 0.036     | 0.111          |
|            | Mean Pressure |           |                |
| 9-73       | 0.185         |           |                |
| 12-73      | 0.141         |           |                |
| 15-73      | 0.099         |           |                |
| 16-73      | 0.049         |           |                |

These values compare with those of Table 2.6, generally falling at about the 10 level, or between 10 and 30 sequence length. Since a disadvantage of definition (2.1) is that the value is dependent, in general, on the sequence length, I suggest that (2.3) is more useful as a working linear approximation to what is usually a non-linear situation. Clearly the data are not necessarily 1st order autoregressive but Table 2.7 shows that the autocorrelations are declining steadily with increasing lag, so that it should be adequate as a rough indication of the real situation. The definition in (2.3) is a rather more precise statement of the ideas discussed at the beginning of this section.

#### A comparison of heart rate and heart interval distributions

The heart intervals were measured for a period of time when the subject was resting and also when the subject was breathing regularly to a metronome. Histograms of both the intervals and the corresponding heart rates were calculated from the resting period by the program INHIST. The mean, variance, standard deviation and range were also calculated. In general the class width used for the heart-interval histograms was 0.02 seconds and that used for the heart-rate histograms was 2 bts/min. Extrasystoles were easily spotted in the histogram, and when these occurred the mean and standard deviation were recalculated omitting these points. A clear distinction was found between the heart-rate histograms obtained when the subject was resting, and those obtained when the subject was breathing in time to a metronome. All of the former were unimodal, but the latter in general were bimodal. This point has been discussed in the literature

FIGURE 2.2

HEART INTERVAL AND HEART RATE  
HISTOGRAMS FOR SUBJECT 22(3)

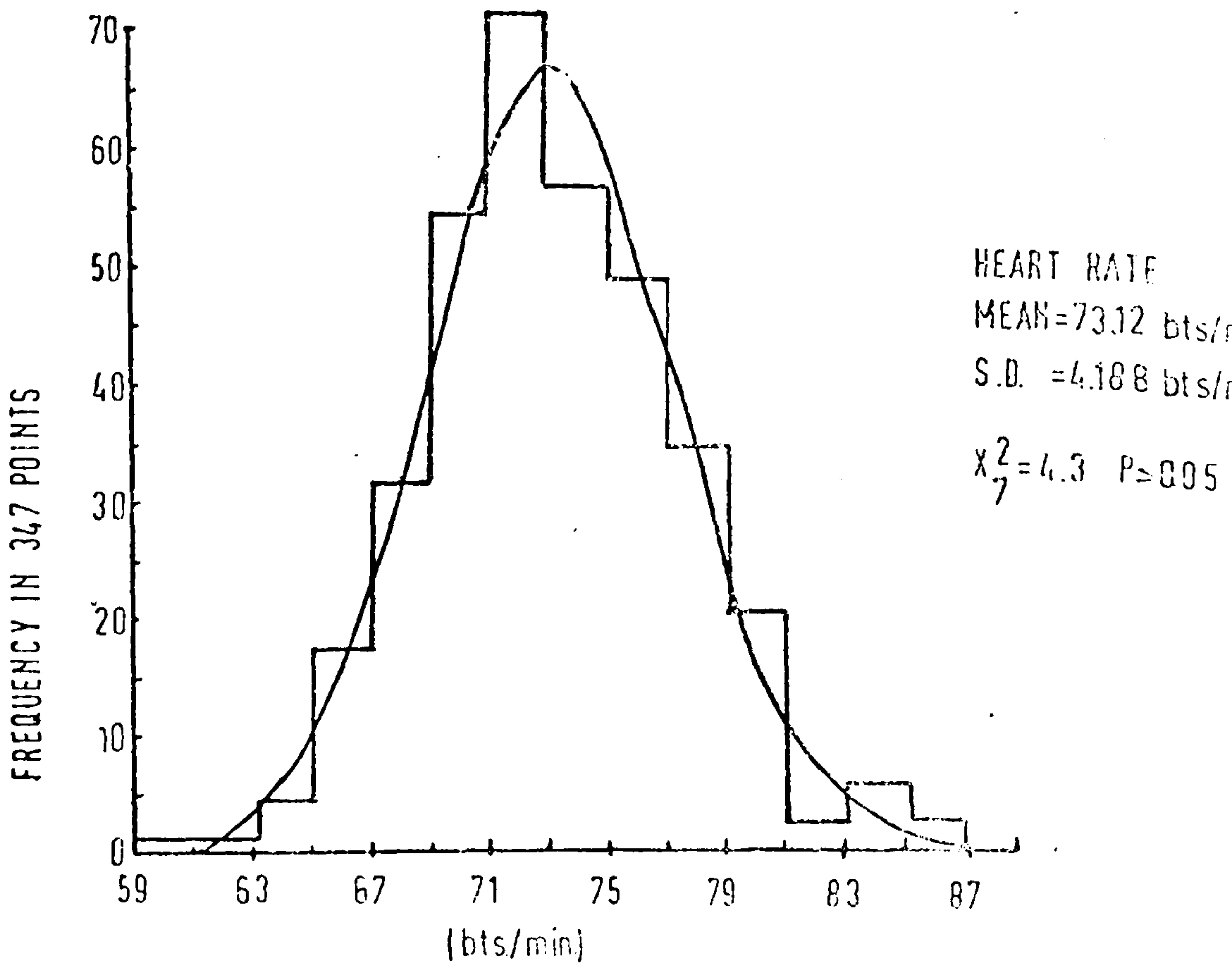
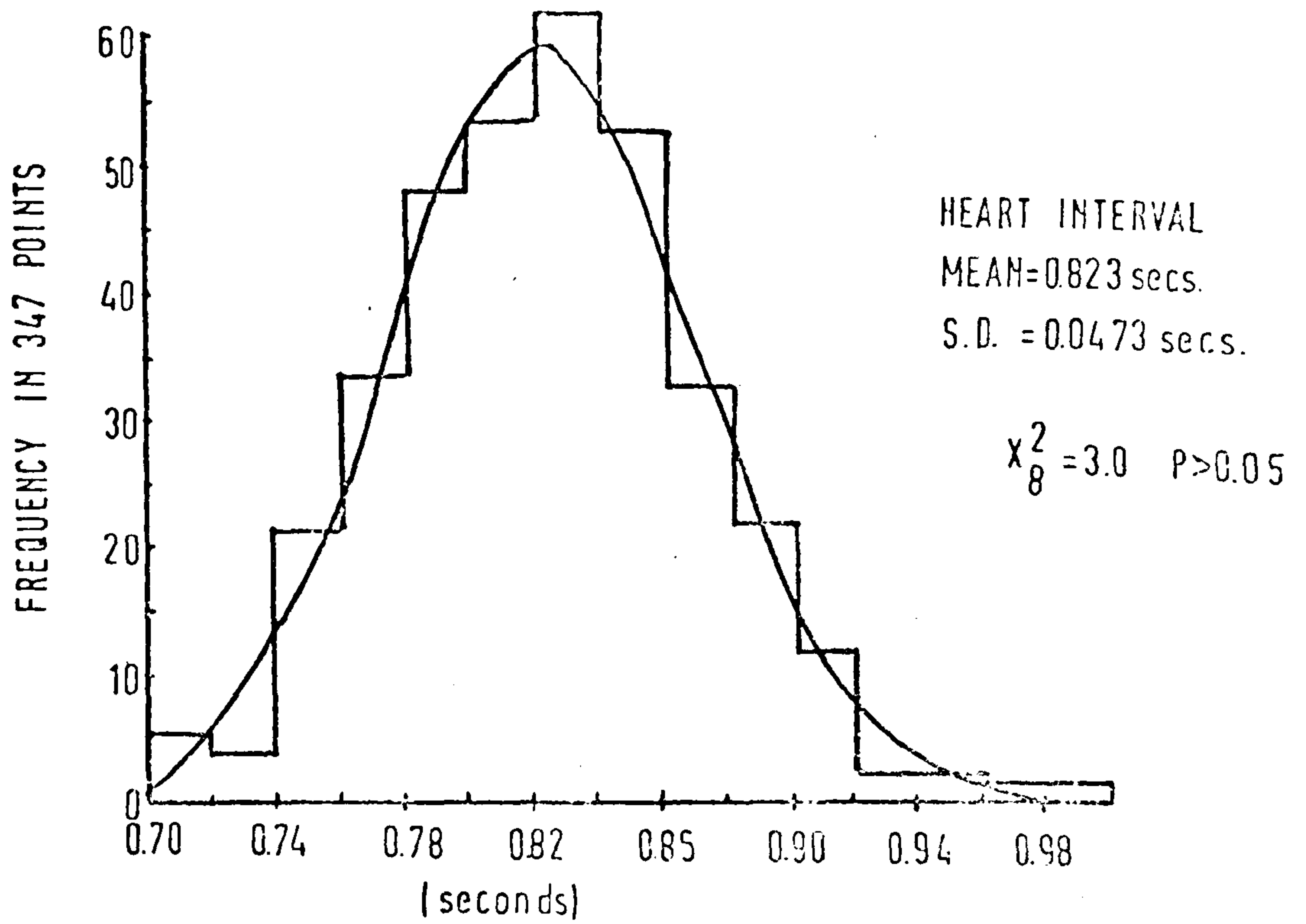

review. An example and comparison of the heart rate and heart interval histograms is shown for one subject in Figure 2.2.

A test for normality was carried out on all the heart rate and heart interval distributions for the resting subjects. A  $\chi^2$  test was used, and not the Kolmogorov-Smirnov test described in some of the literature, for several reasons. The Kolmogorov-Smirnov test requires the raw data to be ordered and a cumulative frequency distribution to be calculated; a program to do this for large sections of data was not readily available. In addition Cox and Hinkley (1975, p.69) state that often the test is not very sensitive to departures from the null hypothesis in the tails of the distribution. We are particularly interested in departures from normality in the tail (see for example Taylor, 1971). Kendall and Stuart (1967, Chapter 30, discuss the application and limitations of the  $\chi^2$  test. One disadvantage is that the observations must be grouped into classes. Since we are sampling from a continuous distribution we must lose information by such a grouping. However, we can only measure the heart interval with finite accuracy which naturally gives us some form of grouping. For any goodness-of-fit test where only the raw data is given, the parameters of the distribution, the mean and variance for the normal distribution, have to be estimated from the data. The use of the  $\chi^2$  test enables a simple adjustment to be made to allow for the fact that the parameters have been estimated, whereas the procedure is not so simple for the Kolmogorov-Smirnov test or other goodness-of-fit tests. Kendall and Stuart (1967, p.440) recommend that classes with approximately equal probabilities should be used for the  $\chi^2$  test, and they discuss methods for determining

the optimum number of classes. It was decided not to follow this recommendation, but rather to use equal width class intervals, because the groups had already been calculated for plotting histograms. This also meant that each subject would have the same class intervals. The number of points in the distribution of the heart beats for healthy subjects was roughly 350 and so the effect on the power of the test by following the above procedure was small. If, in any class, the expected number of points predicted by the normal distribution was less than 5, then neighbouring classes were combined so that each class had an expected frequency of at least 5. The mean and standard deviation used in the test were calculated from the revised grouping. The class intervals in grouping the heart interval and heart rate distributions were 0.02 seconds and 2 bts/min. respectively. It was found that the range of the heart rate distribution was roughly 20 bts/min. and so the interval chosen gave about 10 classes. This produced a reasonable number of degrees of freedom for the  $\chi^2$  test.

A further description of the curves can be obtained by calculating the moments about the mean and the Pearson beta coefficients. Yule and Kendall (1965) Chapter 7, discuss these methods. If  $z_i$  is the mid-point of the  $i$  th group in a frequency table of  $r$  classes, with corresponding frequency  $f_i$ , then the  $n$  th order moment is defined as

$$m_n = \sum_{i=1}^r f_i (z_i - z)^n / N \quad .$$

Here  $N$  is the total number of points appearing in the frequency table and  $z$  is the mean of the distribution. It can be seen that  $m_1 = 0$  and  $m_2$  equals the variance of the distribution. If the underlying assumption is that the histogram is an approximation to a continuous

frequency distribution, and the distribution tapers to zero in both directions, then we can apply a correction for the grouping effect suggested by Sheppard (1898):

$$m_2^c = m_2 - h^2/12,$$

$$m_3^c = m_3,$$

$$m_4^c = m_4 - \frac{1}{2}h^2m_2 + \frac{7}{240}h^4.$$

where  $m_i^c$ ,  $i=2,3,4$  are the corrected moments and  $h$  is the common width of the groups.

Pearson's beta coefficients are defined as

$$b_1 = (m_3^c)^2 / (m_2^c)^3,$$

$$b_2 = m_4^c / (m_2^c)^2.$$

It can be shown that for a unimodal, moderately skewed curve, such as those of the heart interval and heart rate distribution, the definition of skewness given at the beginning of the chapter ( (mean - mode)/standard deviation) can be shown to be

$$\text{skewness} = \frac{b_1 (b_2 + 3)}{2(5b_2 - 6b_1 - 9)}$$

The sign can be judged from the position of the mode relative to the mean. The coefficient  $b_2$  measures a property known as kurtosis. For the normal distribution  $b_2 = 3$ . Distributions with values of  $b_2$  greater than 3 are called leptokurtic and those with values of  $b_2$  less than 3 are called platykurtic. A program MOMENT was written to calculate the moments with Sheppard's corrections, Pearson's beta and the coefficient of skewness. We can use the beta coefficients as an additional test for normality. Since the  $\chi^2$  test is based on the

squared difference between the observed and expected frequencies, it does not take into account any regular distribution in the sign of the differences. The distribution of  $b_1$  and  $b_2$  when taken from a normal population are tabulated in Table 34c of 'Biometrika Tables for Statisticians, Vol I. The significance levels of these tables are calculated for ungrouped data. We presume that the grouping effect would not affect the significance levels greatly, since grouped data was used in Example 35, p.63 of the tables. This seems reasonable if the estimate for the kurtosis using grouped data is close that which would be obtained using ungrouped data.

Table 2.8 gives the result of the  $\chi^2$  test for the null hypothesis of a normal distribution with the mean and standard deviation calculated from the grouped data. Here Sheppard's correction was not used in computing the standard deviation. Tabulated are the  $\chi^2$  statistic, the degrees of freedom and the appropriate significance level. The degrees of freedom are calculated from the number of classes in the grouping. We have to subtract one degree of freedom since given a fixed sample size all but one of the group sample frequencies are independent and two degrees of freedom must be deducted for the two parameters estimated from the observations. From the table we see that in 7 out of 21 cases the heart interval distribution does not differ significantly from normal, and in 10 out of 21 cases the heart rate distribution does not differ significantly from normal. On 5 occasions both the heart rate and the heart interval distributions from the same subject are not significantly different from normal. For 2 subjects the heart interval distribution can be described as normal whereas the corresponding heart rate

distribution does differ from normal and on 5 occasions the reverse situation occurs. From this we can only conclude that for these data the normal distribution will describe the observed distribution for about one third of the cases and there does not seem to be a justification for stating that the heart intervals are more often distributed normally compared with heart rates. Table 2.9 shows the coefficient of skewness and the degree of kurtosis for both the heart interval and heart rate distributions. In 11 out of 21 cases the heart interval distribution is negatively skewed and the heart rate distribution for the same subject is positively skewed. On 4 occasions the reverse situation occurs. The remaining 5 are either both positively or both negatively skewed, but in these cases one coefficient was very close to zero. The kurtosis coefficients are all in the region of 3, except for subject no.12. Excluding this one, the mean kurtoses were 3.84 and 3.64 for the heart interval and heart rate distributions respectively. The heart interval distribution for subject 9, which satisfied the  $\chi^2$  criterion for normality, had a kurtosis which, from the Biometrika tables, was significant at the 1% level on the null hypothesis of a normal distribution. A similar level of significance was obtained for the kurtoses of the heart rate distributions of subjects 18 and 24(2), so that out of 21 subjects 6 heart interval distributions and 8 heart rate distributions could be described as normal.

The overall impression is that there is very little to choose between heart interval and heart rate distributions for closeness to normality. It cannot be asserted with any great confidence that the heart interval distribution is negatively skewed and the heart rate



distribution positively skewed in general, as mentioned in the literature. It would appear that for both distributions the degree of kurtosis is in the region of 3, with a bias greater than 3. That is, for the majority of the distributions, the observations clustered closer to the mean than would be predicted by the normal distribution.

For a series of heart intervals with a small variance compared with the mean (i.e. a small coefficient of variation) the non-linear operation of taking the inverse, to transform the heart interval to a heart rate, can be approximated by a linear operation. Write  $y_t$  for the heart period in seconds at time  $t$  and assume  $y_t$  is distributed normally, mean  $\mu$  and variance  $\sigma^2$ . Let us say that  $\frac{\sigma}{\mu} = \epsilon$  where  $\epsilon$  is small and positive. The transformation to heart rate is  $x_t = 60/y_t$ .

There is a finite probability that  $y_t = 0$  and thus  $x_t = \infty$ , which would mean that  $x_t$  does not have a finite mean. However, by Chebychev's inequality (Feller Vol.I, p.233)

$$P \{ |y_t - \mu| \geq r \} \leq \sigma^2 / r^2$$

and in particular  $P(y_t \leq 0) < P(|y_t - \mu| \geq \mu) \leq \sigma^2 / \mu^2 = \epsilon^2$  which is very small.

In practice, of course, the heart interval distribution is bounded and we can never have a heart interval of zero length. Thus the operation of taking the inverse is quite legitimate. The moment generating function for  $y_t$  is  $E(e^{vy_t}) = \exp(v\mu + \frac{\sigma^2 v^2}{2})$ , (see for example Mayer (1970) p.212).

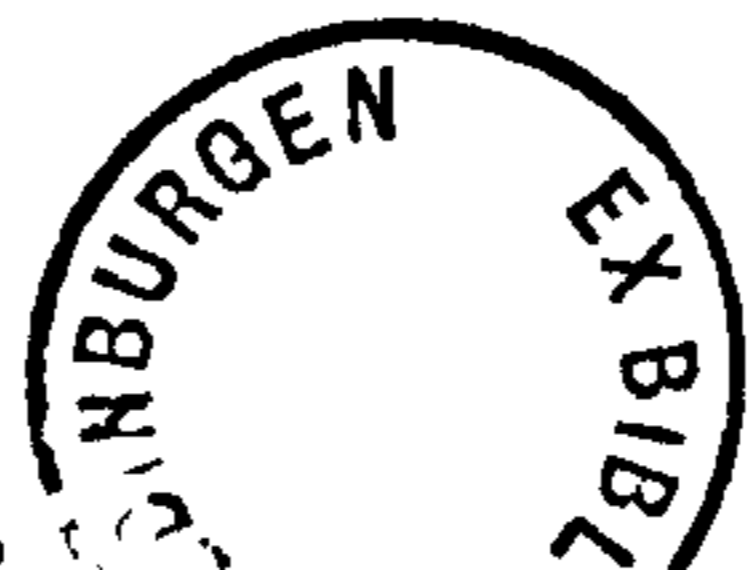

The moment generating function of  $x_t$  is

$$E(e^{vx_t}) = E(e^{\frac{60v}{y_t}}) = \frac{1}{\sigma \sqrt{2\pi}} \int_{-\infty}^{\infty} e^{\frac{60v}{y_t}} e^{-\frac{(y_t - \mu)^2}{2\sigma^2}} dy_t$$

Put  $s = \frac{y_t - \mu}{\sigma}$ ,  $\sigma ds = dy_t$  and we get

$$E(e^{vx_t}) = \frac{1}{\sqrt{2\pi}} \int_{-\infty}^{\infty} e^{\frac{60v}{\sigma s + \mu}} e^{-\frac{1}{2}s^2} \sigma ds = \frac{1}{\sqrt{2\pi}} \int_{-\infty}^{\infty} e^{\frac{60v}{\mu}} \left(1 + \frac{\sigma s}{\mu}\right)^{-1} e^{-\frac{1}{2}s^2} ds$$

We can expand  $\left(1 + \frac{\sigma s}{\mu}\right)^{-1}$  as  $1 - \epsilon s + \epsilon^2 s^2 \dots$  and if we ignore terms in  $\epsilon^2$  and greater we get

$$E(e^{vx_t}) = \frac{e^{\frac{60v}{\mu}}}{\sqrt{2\pi}} \times \int_{-\infty}^{\infty} \exp\left(-\frac{60v}{\mu} \frac{\sigma s}{\mu} - \frac{1}{2}s^2\right) ds$$

$$= \frac{\exp\left(\frac{60v}{\mu} + \frac{1}{2} \left(\frac{60v}{\mu^2}\right)^2 v^2\right)}{\sqrt{2\pi}} \int_{-\infty}^{\infty} \exp\left[-\frac{1}{2}\left(s + \frac{60v\sigma}{\mu^2}\right)^2\right] ds = \exp\left\{\frac{60v}{\mu} + \frac{1}{2}\left(\frac{60v}{\mu^2}\right)^2 v^2\right\}$$

This is the moment generating function of a Normal distribution with mean  $\frac{60}{\mu}$  and variance  $\left(\frac{60\sigma}{\mu^2}\right)^2$ . This result can be demonstrated by use of the data from subject 22. In both heart rate and heart interval the derived frequency distribution does not differ significantly from normal with the subject at rest. This result occurred for both experiments (2) and (3), which will be described in Chapter 5. The heart interval data for subject 22(2) has mean 0.86 seconds and standard deviation 0.043 seconds, and using the approximation given above the corresponding heart rate distribution should have mean 69.77 bts/min. and standard deviation 3.483 bts/min. The sample mean and standard deviation of heart rate are 70.21 and 3.566 bts/min. For 22(3) the heart interval distribution has mean 0.82 secs., with standard deviation 0.047 secs. which would imply, by the formula, a mean and standard deviation of 73.17 bts/min and 4.194 respectively.

FIGURE 23 HEART RATE HISTOGRAMS FOR SUBJECT 21 (2), REGULAR RESPIRATION

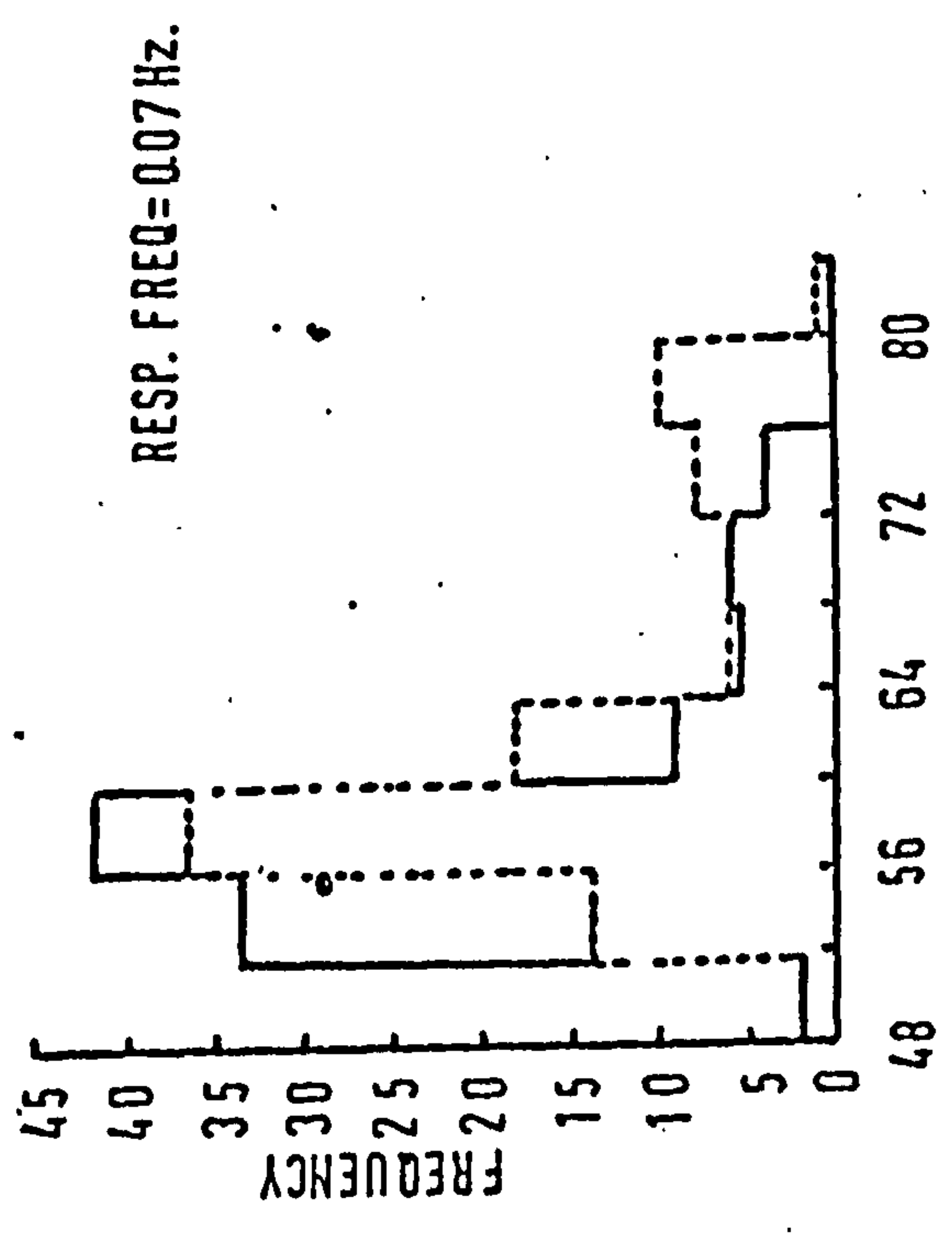
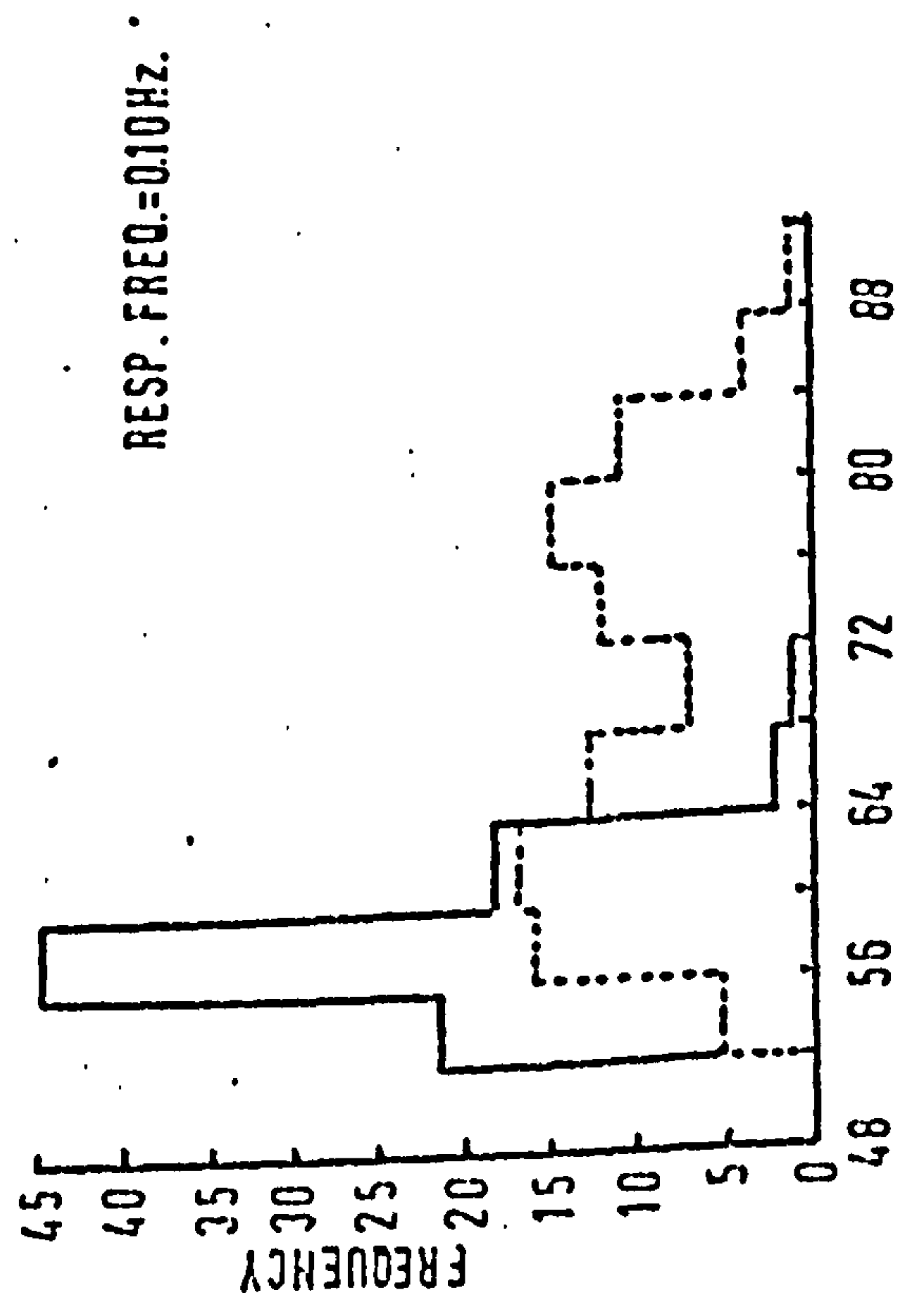
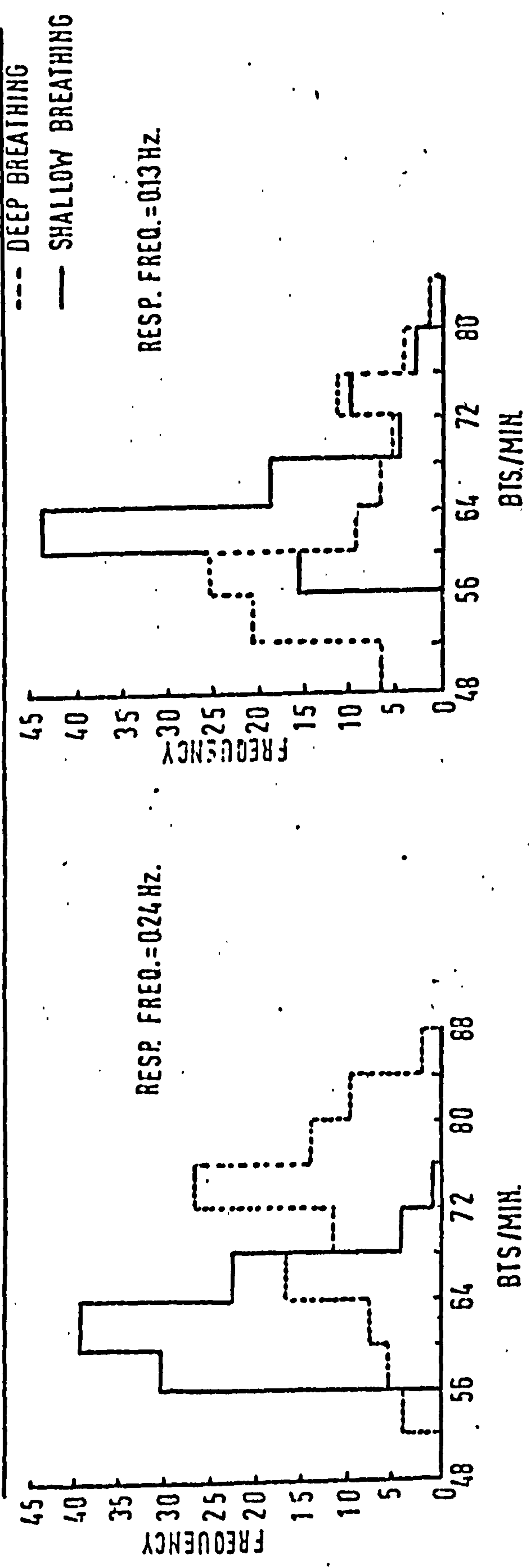

This compares with the sample mean and standard deviation of 73.12 bts/min and 4.188 bts/min. respectively. A comparison of the heart interval and heart rate curves for subject 22(3) is given in figure 2.2.

### Regular respiration

The onset of regular breathing in time to a metronome has a marked effect on the heart rate and interval distribution. The effect is shown in figure 2.3 for subject 21(2) for four different respiration frequencies with deep and shallow breathing. The quantitative results will be discussed in more detail in Chapter 5. Each histogram in figure 2.3 consists of approximately 120 points, about one third the number of points in the histograms for the subjects at rest. Bimodality is apparent in all 4 histograms for deep breathing, but is only present at 0.07 Hz. respiration frequency for shallow breathing, and in this case the bimodality is not as clearly marked as for the deep breathing. It is clear from the graphs that the spread of the distributions is much greater for deep breathing than for shallow. The main mode of both distributions is lower for the slowest frequency than for the fastest, the difference being greater for deep breathing. Illustrations of the heart rate during paced respiration are given in Chapter 5, and it is evident that the bimodality that is shown here results from sampling a regularly oscillating variable.

### Long term heart-rate distributions from post-operative patients

The data collected from the post-operative patients, in the form heart rate and blood pressure sampled at one second intervals,

**FIGURE 2.4 HEART RATE HISTOGRAM FOR**

**PATIENT 13-73**

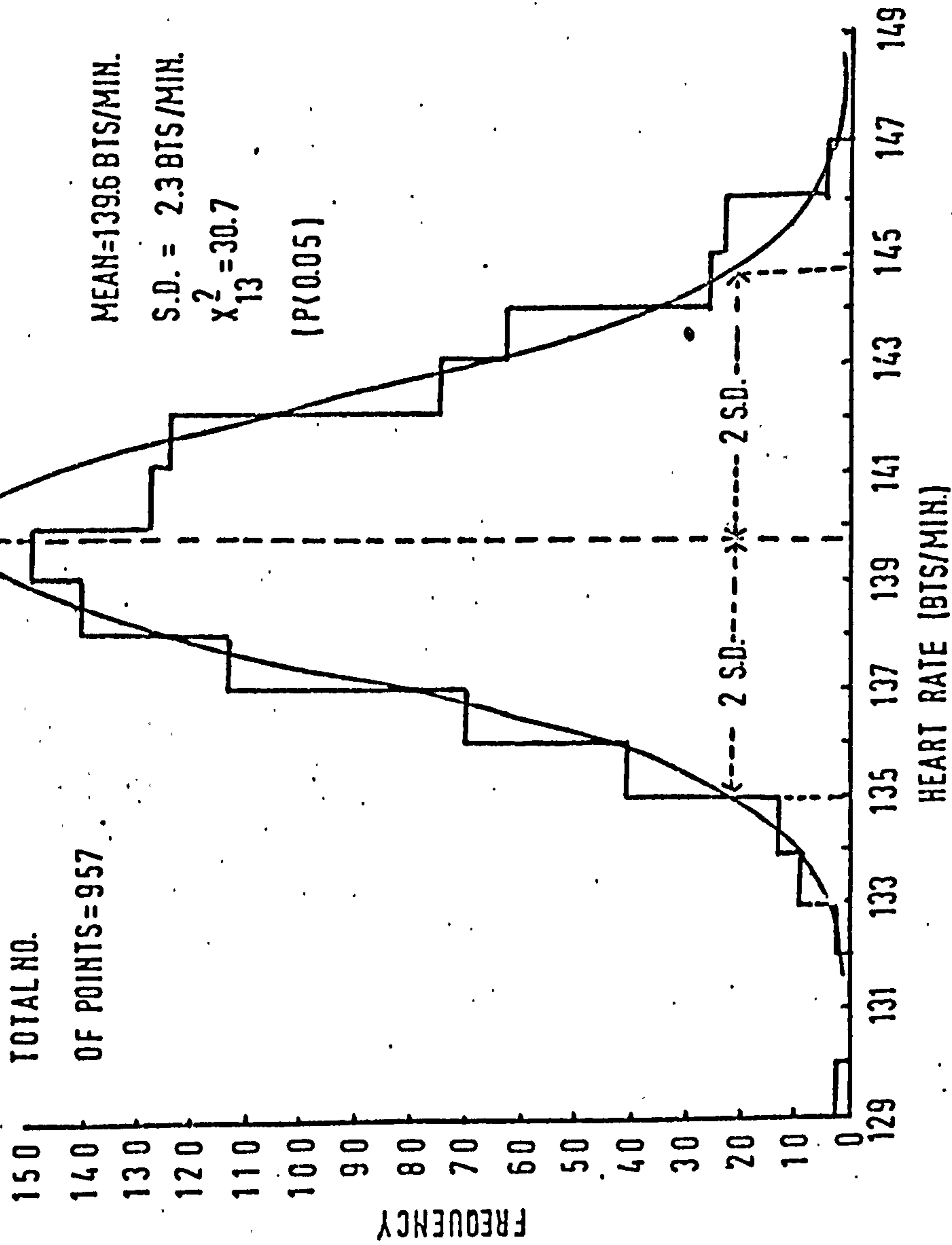

was described in Chapter 1 and the effect of sampling on the distribution was discussed there. In this section discussion is restricted to the type of distributions resulting from the sampling operation. A list of the patients studied is given in Table 4.1. Between 2,000 and 3,500 points were available for subjects 7-73 - 10-74, with about 900 points each for 2-73, 3-72 and 4-72. The heart rates were not converted back into heart intervals, partly because much of the medical literature in this area only discusses heart rate, and also to avoid introducing further errors by division on the computer.

The previous analysis of heart interval and heart rate distributions shows that it does not seem to matter which distribution is taken with regard to the appropriateness of the normality assumption.

An initial frequency table for the heart rate and blood pressure of each patient was compiled containing at least 900 consecutive points. The class widths were 2 bts/min and 2 mm. Hg. respectively. The heart rate distributions yielded 3 cases 7-73, 10-73 and 15-73 in which a normal curve gave a good fit over the whole distribution as judged by the  $\chi^2$  goodness-of-fit test at the 5% level. Two of the remaining 10 distributions were markedly bimodal, and 9-73 was not described by a normal distribution because the mode of the distribution was considerably in excess of that predicted by a normal distribution with the same mean and variance. The other 7 distributions had larger tails than would be predicted by the normal distribution. Figure 2.4 illustrates the case of excessively large

tails for subject 13-73. It was found that the  $\chi^2$  statistic was only exceeded if the distribution outside two standard deviations from the mean was included. This is in agreement with what has been found by other authors, for example Taylor (1971).

The data were then sectioned into groups of 200 points each, and successive histograms of the heart rate were calculated, together with the corresponding mean and variance. The number 200 represents a compromise between taking too many points and losing the finer features of the distribution through non-stationarities, and taking too few points in which case even gross features may be lost in the sampling variability. Ten Hoopen and Bongaarts (1971) and Campbell (1974) also discuss this feature. A program SUCCHIST was written to compute the histograms. A class width of 1 bt/min was taken, which was judged to be considerably wider than the measurement error in the heart rate. An example of the output of SUCCHIST is given in Figure 2.5 for subject 9-73. The figure displays an unusual type of frequency distribution. The heart rate is virtually constant at 92 bts/min with 95% of the distribution concentrated within  $\pm 1$  bt/min. of the mean. The other 5% are scattered within  $\pm 20$  bts/min. of the mean, the scatter being more widespread above than below the mean. A graph of the raw data also reveals a very constant heart rate. It is very probable that this result is due to a cardiac pacemaker implanted in the heart.

#### Curve fitting to the heart rate distributions

The records for many of the patients extended over an hour, which meant that about 19 successive histograms of 200 points each

FIGURE 2.5 SUCCESSIVE HEART-RATE HISTOGRAMS  
OF 200 POINTS EACH FOR SUBJECT 9-73

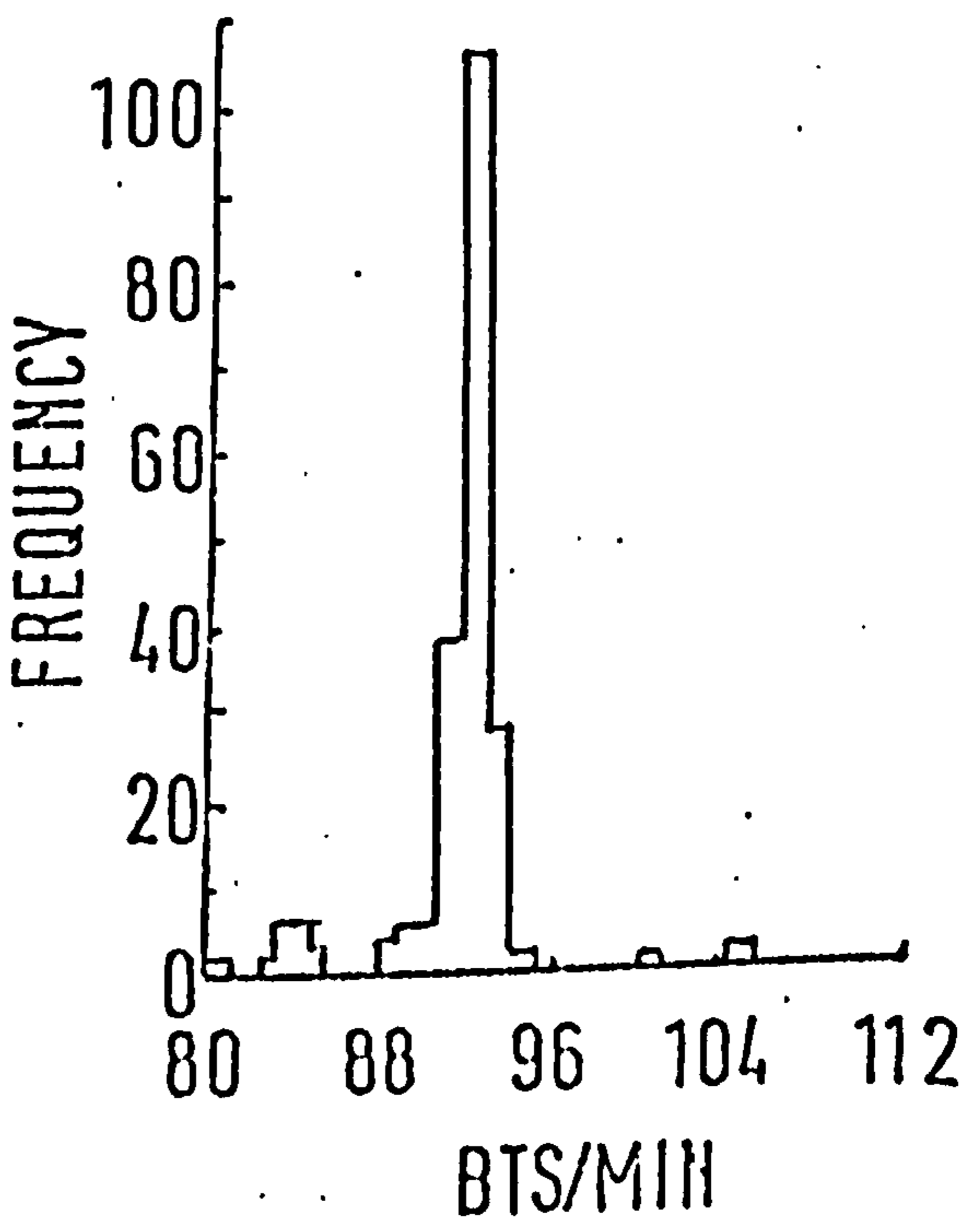
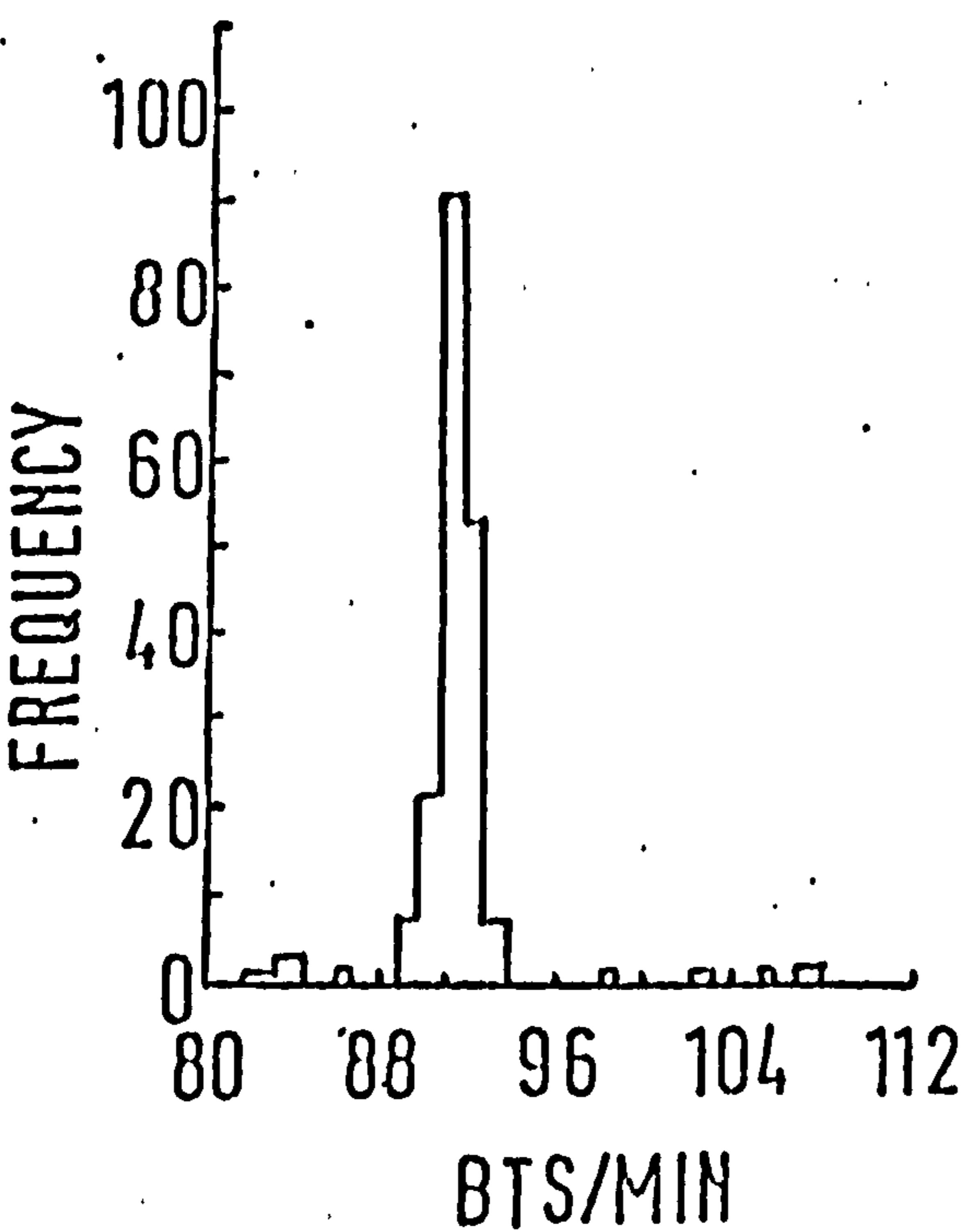
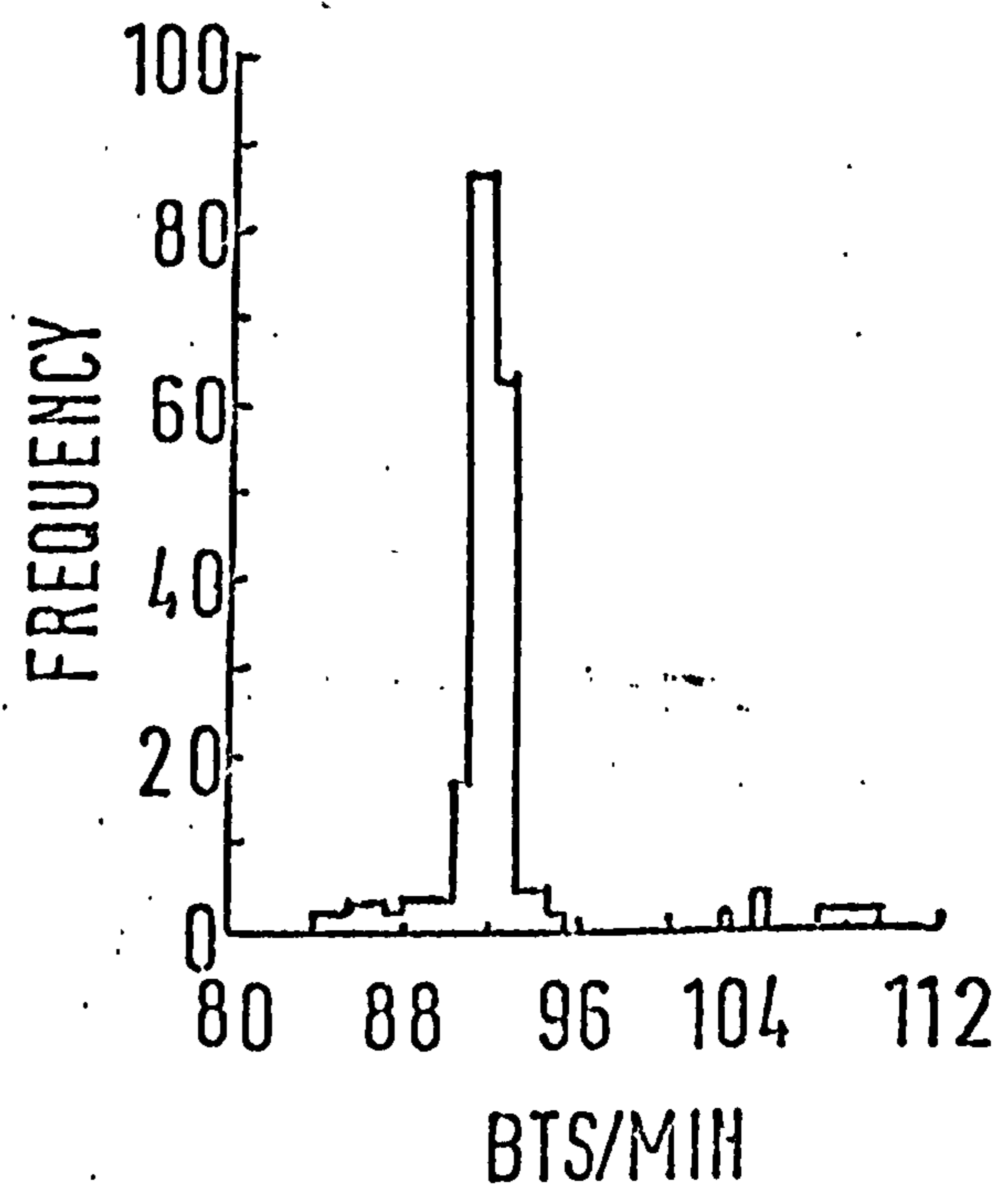
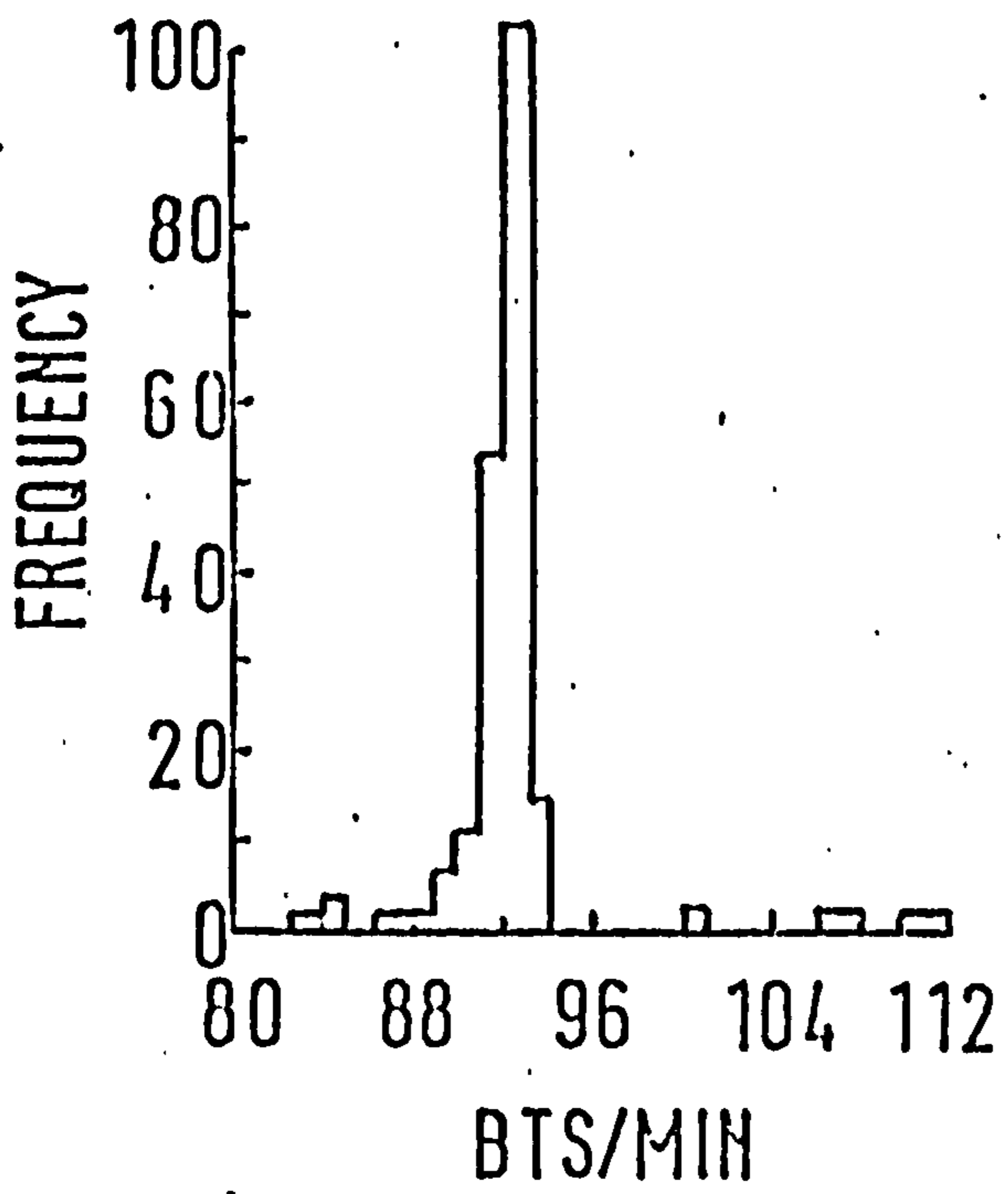



could be calculated from each patient. It was found that the heart rate data from 6 patients: 7-73, 10-73, 12-73, 13-73, 14-73 and 16-73 showed unimodal distributions with an approximately bell shaped curve. The others were either multimodal or of the form displayed in Figure 2.5. In the unimodal cases however, it was found that there were a few points, amounting to 2-3% of the distribution which lay away from the main body of the distribution. Some of these outliers were identifiable as extrasystoles, sometimes with a compensatory pause, because their values were very much higher than the overall mean. However, other points, although not in the main body of the distribution, lay within  $\pm 20$  bts/min. of the mean. It is possible that these are also extrasystoles, in the sense that these beats may not be triggered by the s.a. node and so are not 'normal' but it is impossible to check without a record of the E.C.G. It was decided to omit these points when fitting theoretical distributions to the observed ones. This is justifiable if we want to describe the main features of the distribution. A theoretical distribution which accounted for all of the points would be extremely complicated.

The most common unimodal distribution with an approximately bell-shaped curve is, of course, the normal distribution. A test of normality was applied to all the successive histograms which gave unimodal frequency distributions. Table 2.10 gives the results of a  $\chi^2$  test applied to each distribution, together with the degrees of freedom, the significance level and the percentage of points that have been omitted in each case. The class width of 1 bt/min. meant that in some cases, where the variance was small, a low number of degrees of freedom was obtained for the  $\chi^2$  test. However, because of the

limited accuracy of the measurements, it was not felt justifiable to decrease the class width in order to increase the degrees of freedom. It was found that for patients 10-73, 12-73, 13-73 and 14-73 a normal distribution would successfully describe the observed distribution approximately two-thirds of the time. For a total of 73 histograms of 200 points each, 52 histograms gave non-significant results for a  $\chi^2$  test for normality. Some care is needed in interpreting this result because at the 5% significance level we would expect about 4 histograms to be significantly different from normal even when all the histograms are, in fact, generated by a normally distributed random variable. The histograms from patients 7-73 and 16-73, although unimodal and roughly bell-shaped are not well described by the normal distribution. We examined the skewness and kurtosis coefficients (defined on page 45) for each histogram. Table 2.11 reveals that the histograms of 16-73 in general have both a high skewness coefficient and a high kurtosis coefficient, so that it is not surprising that the normal distribution was not successful in describing them. The non-normal distributions of 12-73 and 14-73 are all leptokurtic, with only a small skewness coefficient. Those for 7-73, 10-73 and 13-73 can be either leptokurtic or platykurtic.

The skewness and kurtosis coefficients for 7-73 suggest a near normal distribution. It was decided to fit a wider range of theoretical frequency distributions to the data, in the hope of seeing gradual changes in the parameters with time, and perhaps link changes in distribution with clinical changes in the patient. The theoretical distributions were chosen from the Pearson set of curves. Elderton and Johnson (1963) give details for fitting these curves.

The advantage of this set is that the normal distribution is a special case, and they can represent a wide class of unimodal frequency distributions. Other possible two-parameter distributions are the log-normal and the Cauchy distributions. The criteria for deciding which curve to fit is discussed below. For the first few histograms a Pearson Type I, or beta distribution was selected.

The curve equations were

$$P(x) = \frac{x^{\theta_2-1} (1-x)^{\theta_3-1}}{B(\theta_2, \theta_3)} \quad 0 \leq x \leq 1, \quad (25)$$

$$\text{where } B(\theta_2, \theta_3) = \int_0^1 x^{\theta_2-1} (1-x)^{\theta_3-1} dx.$$

The range of  $x$  is between 0 and 1. In order to scale the heart rate distribution we subtract from each class interval the value of the lower edge of the lowest class interval and divide the intervals by the range of the distribution. A third parameter  $\theta_1$  was also included in the above formula, to enable an arbitrary zero point to be taken. The effect was to replace  $x$  by  $x-\theta_1$  and the range of integration was then  $(\theta_1, 1+\theta_1)$ . By including  $\theta_1$  we were able to apply the same translation to each histogram of 7-73 and examine shifts in position of the distribution.

A program MAXLIKE 11 (Finney and Lawley) was used to obtain the values of the parameters. The program employed a numerical routine to find the values that maximised the likelihood function, and a  $\chi^2$  goodness-of-fit test was also carried out. A series of histograms

FIGURE 2.6

SUCCESSIVE HEART RATE HISTOGRAMS OF 200 POINTS EACH

WITH FITTED BETA CURVE FOR PAWS 773

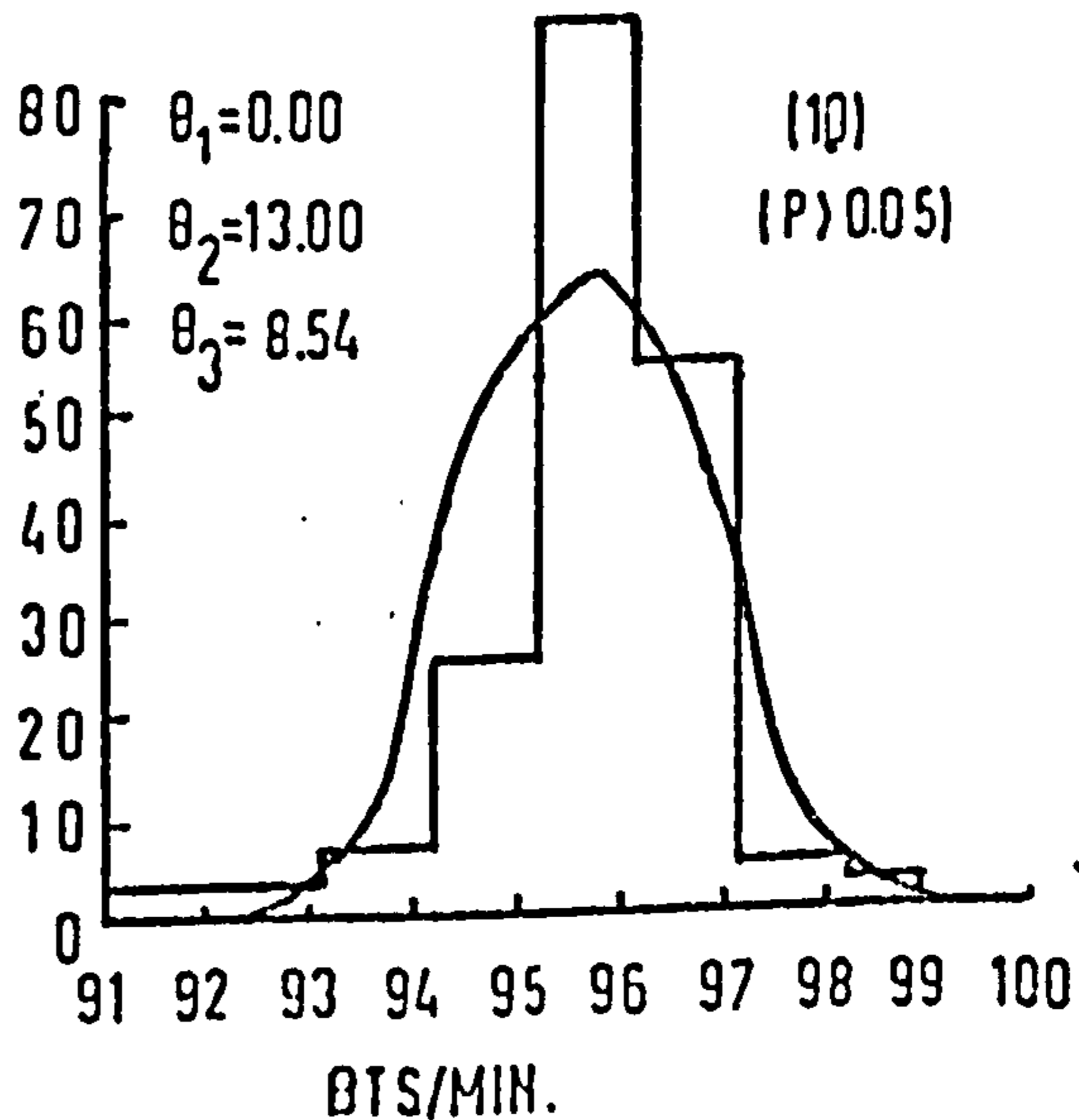
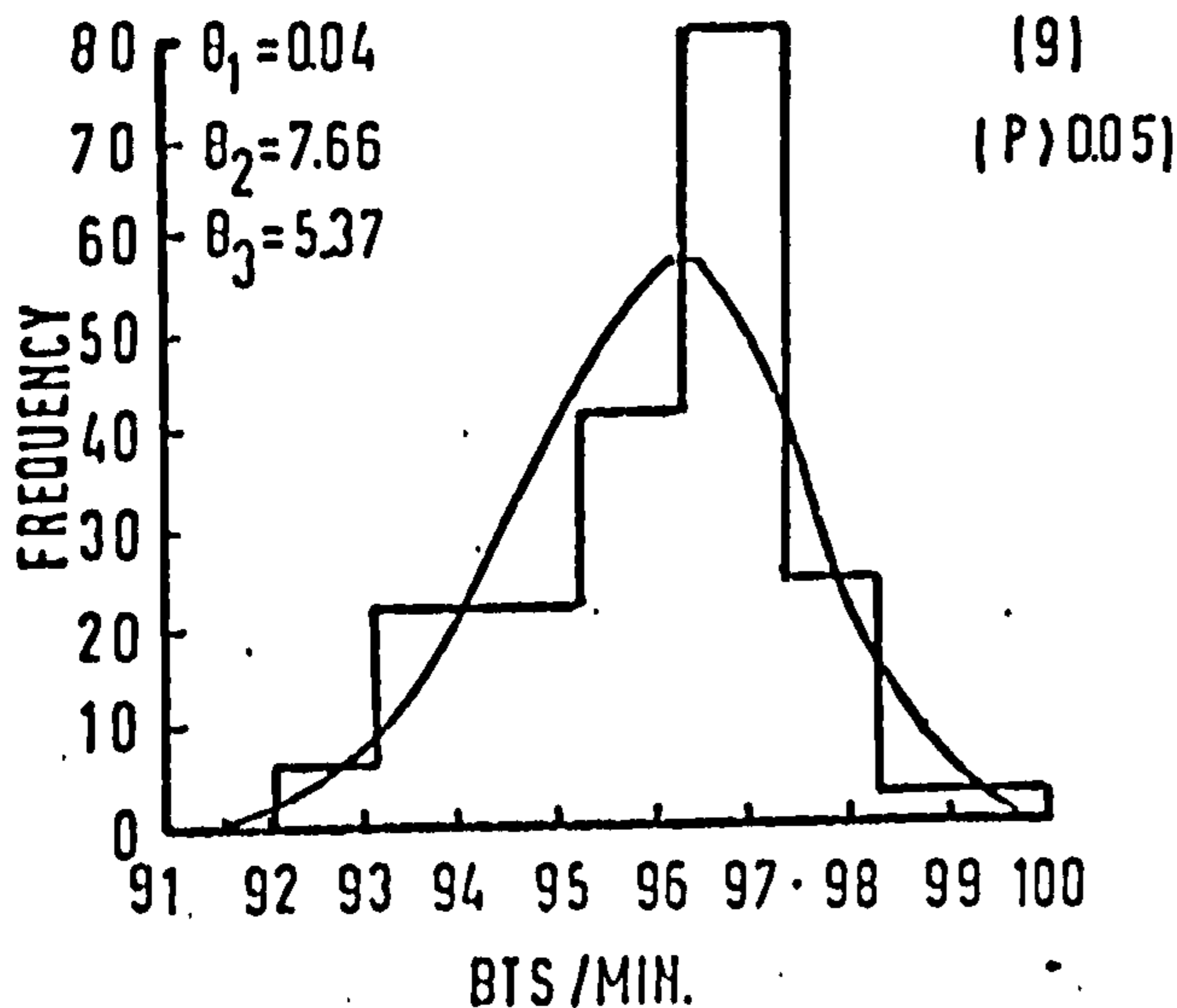
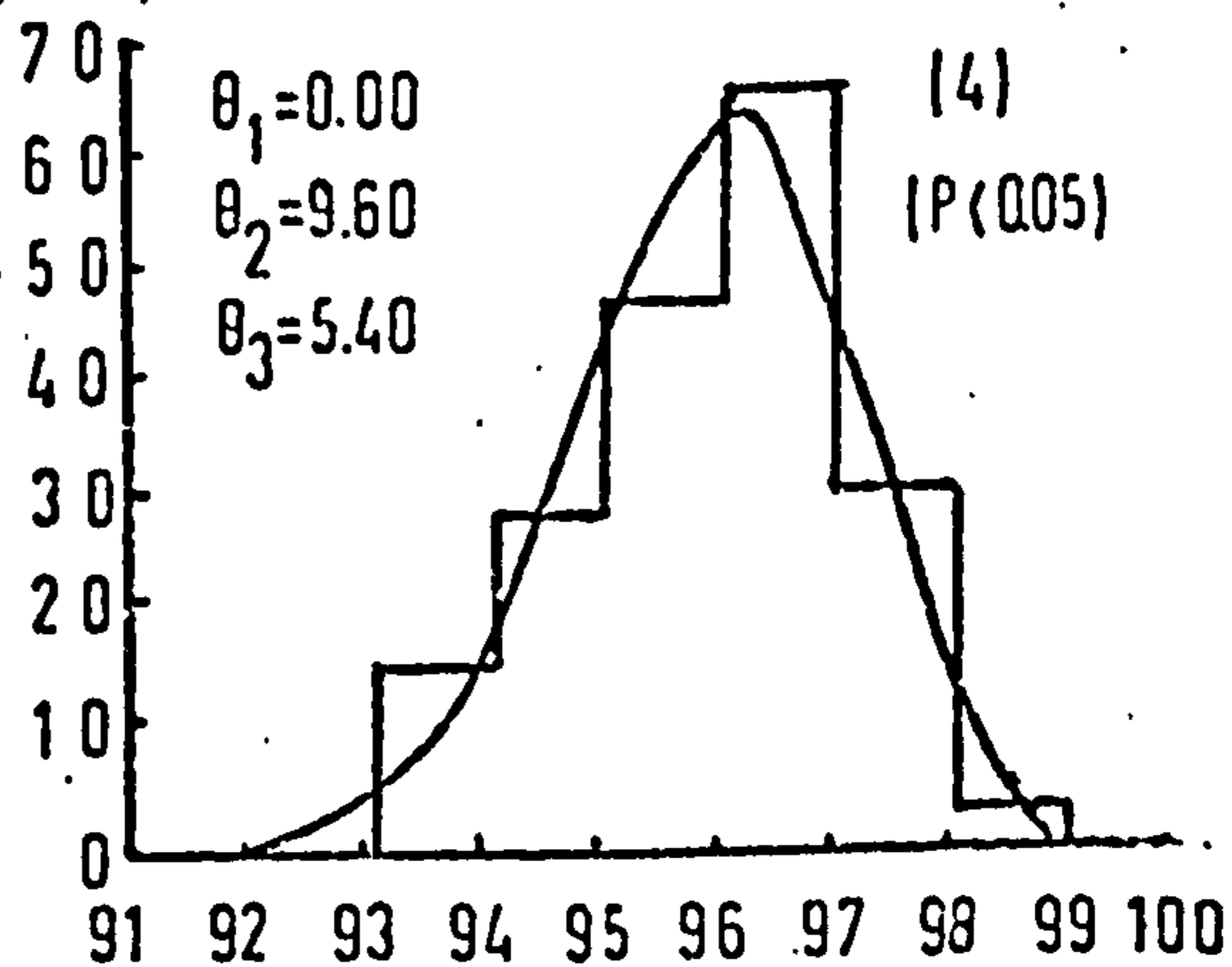
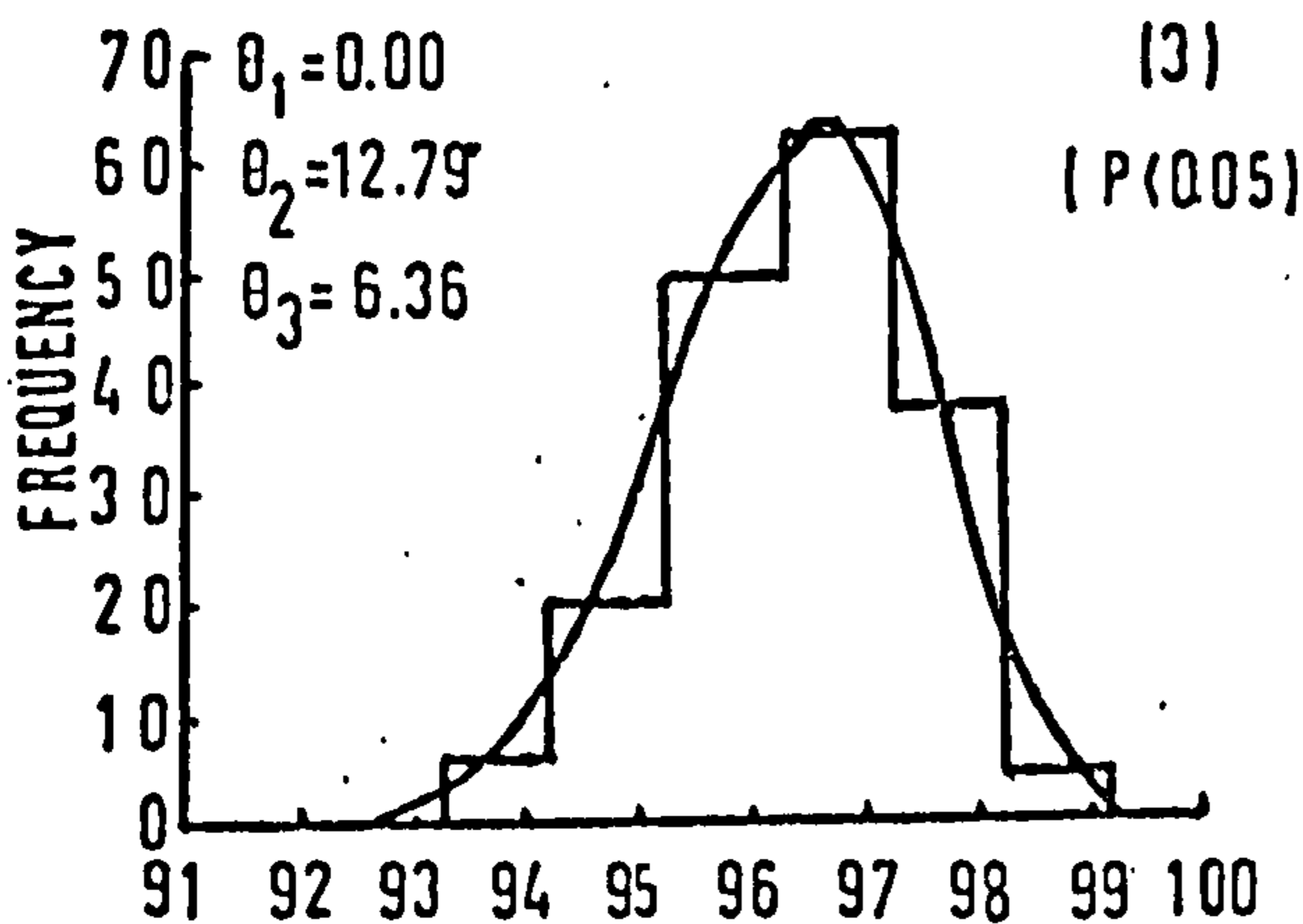
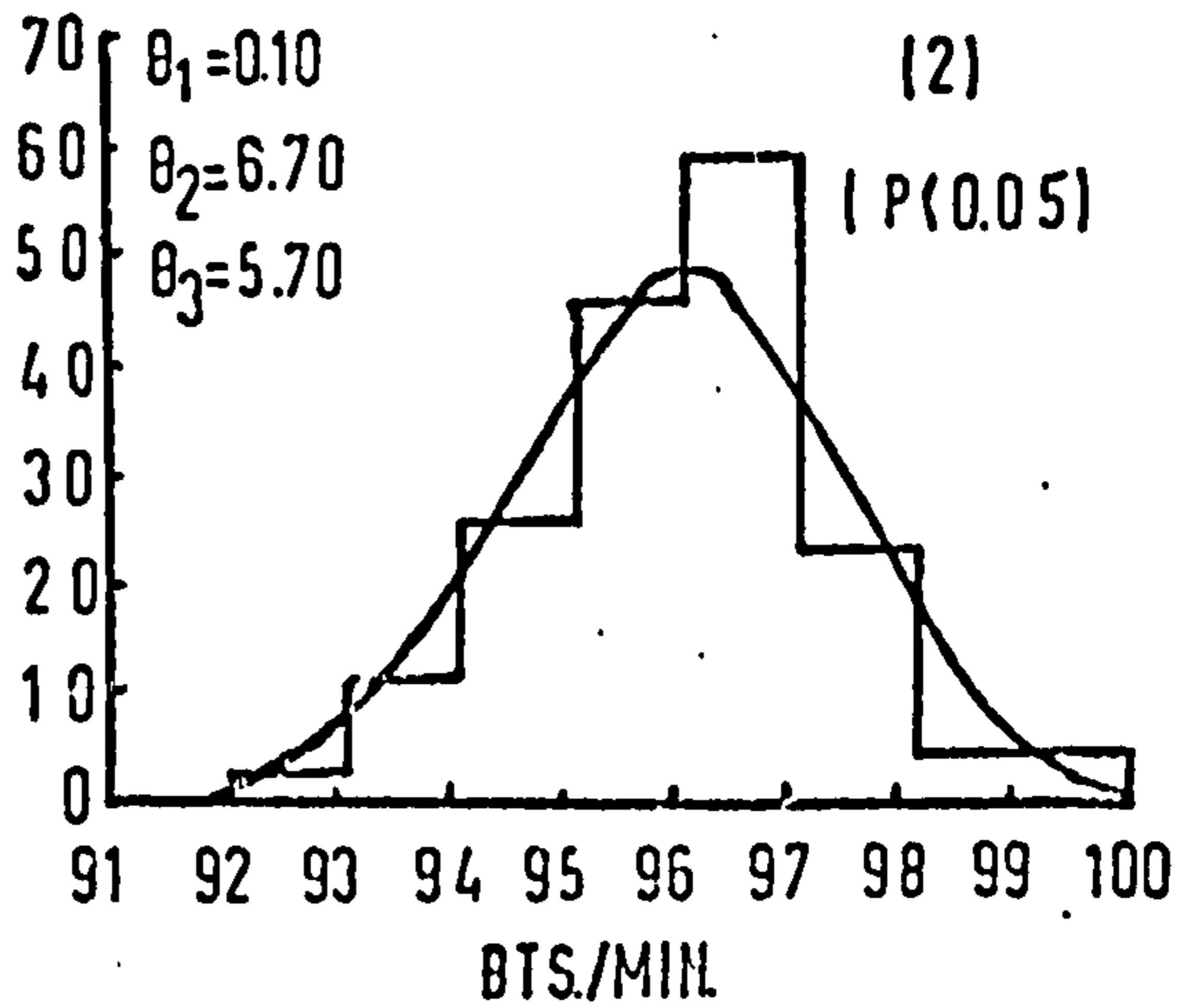
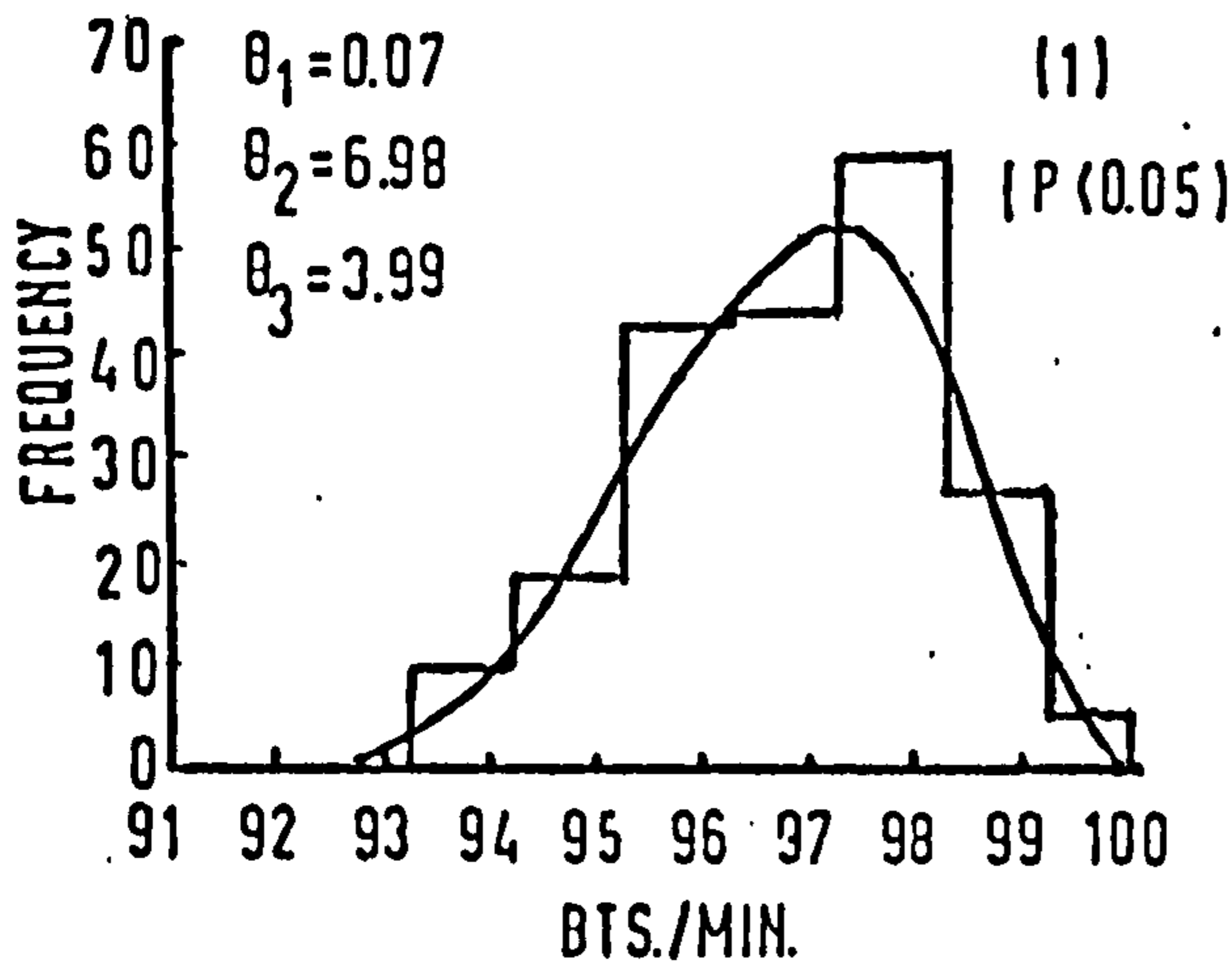

from 7-73 and the best fitting beta curves are shown in Figure 2.6 together with the parameters  $\theta_1, \theta_2, \theta_3$  and the result of the  $\chi^2$  test. A non-significant result indicates a good fit. The beta distribution cannot deal with unusually large modes, so that in Figure 2.6 we find that the distribution can describe histograms 1, 2, 3 and 4 but not 9 and 10. Overall the beta distribution successfully described histograms 1-8 and histogram 17. The main reason for a lack of fit was that the modes of the curves were greater than would be predicted by a Pearson curve with the same mean and standard deviation. Examination of the data in the region of histograms 9 and 10 revealed long strings of constant values, the result of a machine fault. Possibly the store in the data logger stuck at one value for periods of time for this subject. In this case we have detected a machine fault by departures from an observed distribution.

A more useful method of detecting changes in distribution would be, if possible, to define a single value parameter which could be plotted within given limits. Elderton and Johnson (1969) describe a Pearson coefficient kappa estimated by

$$\hat{k} = \frac{b_1(b_2 + 3)^2}{4(4b_2 - 3b_1)(2b_2 - 3b_1 - 6)}$$

This coefficient is used to determine which type of Pearson curve would best describe the observed distribution. There are three main types of Pearson curve, labelled Type I, Type IV and Type VI. The beta distribution is a Type I form. The use of kappa is similar to the method of determining whether a 2nd order curve is elliptic,

FIGURE 27 PEARSON'S KAPPA FOR SUCCESSIVE HISTOGRAMS OF

PATIENT 7-73

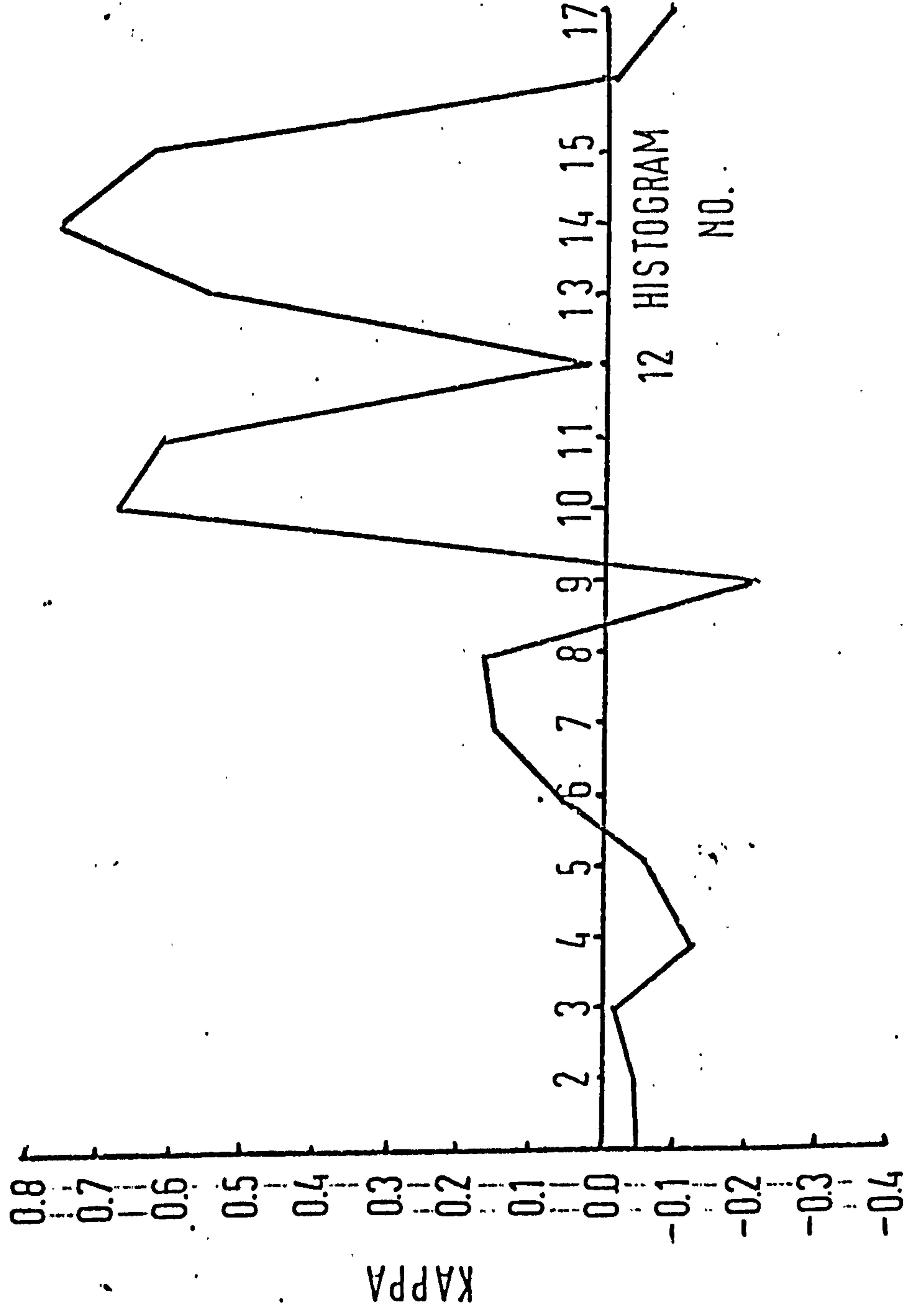

circular or hyperbolic by observing whether the roots of its generating equation are real and unequal, real and equal or imaginary. In this case we have that  $\hat{k} \leq 0$ ,  $0 \leq \hat{k} \leq 1$  and  $\hat{k} > 1$  indicates a Type I, Type IV and Type VI respectively. If  $\hat{k} = 0$  the distribution is classed as Type II and if in addition  $b_2 = 3$  then the best fit distribution would be the normal distribution. Program MOMENT calculates the coefficient kappa after calculating the moments of the distribution and the beta coefficients. Figure 2.7 shows k for 15 successive histograms for 7-73. We see that, out of the Pearson set, a Type I or Type II would fit at the start of the period and then a Type IV, until histogram 9 when the distribution changes abruptly, to return to a Type I at histogram 16. This explains the reason for choosing a Type I to fit the initial histograms. For histogram 7 and 8 a Type IV distribution was also fitted, but with only marginal improvements in goodness-of-fit test compared with fitting a Type I distribution. Histogram 9 was the point at which the string of constant values appeared. It seems from this example, that in the case of unimodal heart rate distributions, the coefficient kappa could provide a useful indication of changes in distribution.

#### Curve fitting to blood pressure distributions

The blood pressure distributions were treated in the same way as the heart rate distributions. Histograms of 900 or more consecutive points with a class width of 2 mm. Hg. were plotted and for each subject an attempt was made to fit normal curves. Out of 15 subjects only two, 13-73 and 16-73, could be described as having normal distribution judged by the  $\chi^2$  test applied at the 5% level of

FIGURE 2.8 BLOOD PRESSURE HISTOGRAM FOR

PATIENT 16-73

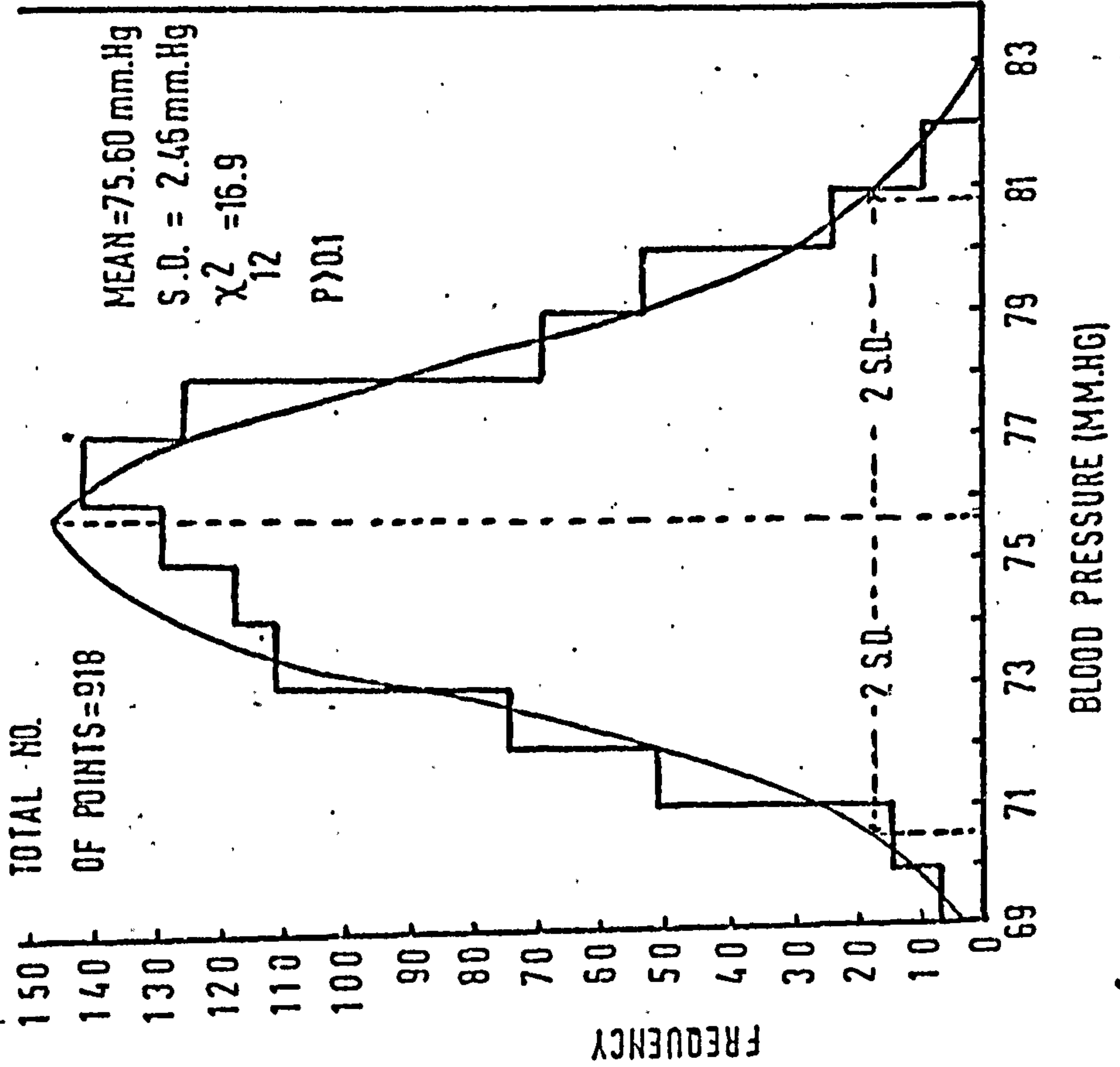



significance. The other distributions were rather flat-topped and broad for a normal distribution, i.e. they were platykurtic. The blood pressure distribution, together with the best fit normal curve, is shown in Figure 2.8.

Successive histograms of 200 points were plotted with a class width of 2 mm. Hg, except for 16-73 where the variance was low and so a value of 1 mm. Hg was used. It was found that for all patients except 9-73, 8-74, 9-74 and 10-74 the successive histograms were in general unimodal; a  $\chi^2$  test for normality was applied to each of these histograms. The results of  $\chi^2$  test are given in Table 2.10. Where the histogram is multimodal the  $\chi^2$  statistic was not calculated but the significance level was given as  $P < 0.01$ . There were far fewer points that could be described as 'outliers' than in the heart-rate distributions, and in general all the points in the frequency table were included in the curve fitting. Out of a total of 145 histograms of 200 points each, 94 were judged not significantly different from normal by the  $\chi^2$  test at the 5% level of significance. At this level, about 7 histograms would have been rejected even if all the histograms had been generated by a normally distributed random variable. At the 1% level, 107 out of 145 histograms would be accepted as normal. The figure given for the 5% level is comparable to that for the successive heart rate histograms at the same significance level.

## Discussion

What we have attempted in this Chapter is to obtain a description of the various signals under study in the time domain. The main method of description was the use of summary statistics such as the mean, variance and first order autocorrelation. Within these we also described some of the sampling characteristics of the mean and variance. From these we went on to study how autocorrelation affects the variability of averages. A further feature of time-series is non-stationarity, which implies that the mean and variance are evolving in time (for stationarity defined as 'weak' (Appendix A)). We studied the series for departures from stationarity and also for stability.

One of the difficulties of calculating summary statistics is that they are often quite numerous, and what one would like, in place of pages of tables and graphs are a few 'summaries of a summary'. This was the reasoning behind the attempts to summarize the run-length graphs with a simple best-fit straight line ; the approximation of the d.o.f. per point by a single number and the classification of successive histograms by beta distributions. Clearly an overall statistic is rather simplistic, it does not describe the data as well as a graph or a table. However, it can be useful because the detail in a graph or table may obscure the general description of the data. In particular it may help in discrimination for example, to distinguish between different subjects where to compare two numbers is much easier than to compare two graphs.

Sometimes, the fact that the data appear to have a common

form leads us to a greater generalization, For example, the empirical observation that the proportion of run lengths, when plotted as a logarithm against run length, is approximately linear leads us to the idea of the termination of a run as an event process.

Our data were not chosen with discrimination in mind. The ambulatory subjects and the post-operative patients differed in many ways and the measurement of blood pressure was different in the two cases. Because of this it was surprising that the degrees of freedom per point were similar in each case, lying between 0.1 and 0.2 for an average of 10 observations. From this we can perhaps infer, from equation (2.3)

that their correlation structures are quite similar. This we can confirm from Table 2.7, where subject A1 (systolic) compares with patient 9-73 and subject A2 (diastolic) compares with patient 16-73. Comparing the two systolic pressures of subjects A1 and A2, the effect of the slow trend in A2 was to reduce to d.o.f. per point from nearer 0.2 to nearer 0.1.

Although for both patients and subjects the general result that the means were less stationary than the variances was true, it was clear that the means of the post-operative patients were more often stationary than those of the ambulatory subjects. This is what we would expect from their different situations. As a corollary of this we found that the short term variability of the data, excluding outliers, was quite similar for the two ambulatory subjects, and that the range of variability for the post-operative patients was not great.

Plotting histograms is useful in screening for wild points and for giving an 'at a glance' picture of how a distribution is behaving under different conditions. Continuously updated electronic displays of these are useful in patient monitoring, although much information is lost.

When discussing the sampling distribution of heart beat intervals, we must remember that the intervals are not necessarily independent. It is difficult to make any general statements comparing the distribution of heart interval and heart rate. Jennings et al. (1974) have suggested that for long sets of data the heart interval is to be preferred for Normality assumptions to the heart rate, but we have found that for 5 minute stretches of data from healthy subjects there is little to choose between the two. We also showed theoretically that given a low coefficient of variation then if the heart interval is distributed Normally, then so is the heart rate, with the same coefficient of variation. This has not been mentioned previously in the literature.

For the post-operative patients we have studied both long data sets and consecutive short data sets. The heart rate distributions of 200 points were seen to fall into 3 categories: nearly constant unimodal and multimodal. The unimodal distributions were sometimes accompanied by a 'noise' of points outside the main distribution. This is in contrast to the healthy subjects, who when at rest and not breathing in time to a metronome, gave unimodal heart rate distributions with a very small proportion of extrasystoles, which were clearly marked when they occurred. Six of the post-operative patients

showed heart rate distributions which were unimodal and of these the Normal curve successfully described 70% of all cases. However for patient 7-73 only 4 distributions out of 18 could be described as Normal. Further examination for this subject revealed that a Pearson's beta curve would well describe the data for 9 out of 18 histograms, and that for the others a machine fault had disrupted the distributions. It would appear that for these patients the distributions contained two sets of points. One set, the majority, displayed a unimodal distribution, and the other a scattering of points within  $\pm 20$  bts/min. of the mean. Perhaps the latter set result from a heart rate control that is less efficient and rigid than that of the healthy subjects. It may be that the blood pressure control system is still efficient in the post-operative patient since there is not the same scatter of points outside the main body of the distribution for blood pressure. About twice as many blood pressure histograms as heart rate histograms were approximately bell-shaped, and about 70% of these could be described by the Normal distribution at the 5% level.

Heart rate and blood pressure are both controlled by homeostatic mechanisms. Any variable that is subject to feed-back control would be expected to show clustering around some pre-set point, which would result in a unimodal distribution unless some powerful disturbance, such as respiration, caused it to oscillate. The Normal distribution can often describe biological distributions, usually of independent variables which is not the case here. As can be seen, it is only moderately successful

TABLE 2.1SUMMARY STATISTICS OF BLOOD PRESSURE

|                            | <u>OVERALL</u> |         |         |       |
|----------------------------|----------------|---------|---------|-------|
| <u>Subject A1</u>          |                |         |         |       |
|                            | Mean           | Minimum | Maximum | S.D.  |
| Systolic Pressure          | 102.83         | 24      | 195     | 13.65 |
| Diastolic Pressure         | 54.67          | 13      | 129     | 10.10 |
| Pulse Pressure             | 48.15          | 0       | 111     | 10.91 |
| <u>Subject A2</u>          |                |         |         |       |
| Systolic Pressure          | 128.81         | 68      | 266     | 27.03 |
| Diastolic Pressure         | 58.30          | 20      | 173     | 16.60 |
| Pulse Pressure             | 70.50          | 0       | 174     | 13.85 |
| <u>Mean Blood Pressure</u> |                |         |         |       |
| 7-73                       | 94.93          | 17      | 168     | 13.96 |
| 9-73                       | 97.94          | 28      | 165     | 14.89 |
| 11-73                      | 81.92          | 61      | 97      | 7.30  |
| 12-73                      | 108.33         | 35      | 155     | 10.09 |
| 15-73                      | 93.16          | 81      | 139     | 6.18  |
| 16-73                      | 106.40         | 36      | 157     | 7.06  |

SETS OF 200 POINTS

|                            |              |                               |
|----------------------------|--------------|-------------------------------|
| <u>Subject A1</u>          |              |                               |
|                            | s.d. of mean | mean s.d. (with s.d. of s.d.) |
| Systolic Pressure          | 8.31         | 10.59 (2.86)                  |
| Diastolic Pressure         | 5.32         | 8.45 (2.19)                   |
| <u>Subject A2</u>          |              |                               |
| Systolic Pressure          | 24.61        | 10.32 (2.36)                  |
| Diastolic Pressure         | 15.15        | 6.67 (2.20)                   |
| <u>Mean Blood Pressure</u> |              |                               |
| 7-73                       | 4.62         | 8.84 (5.43)                   |
| 9-73                       | 7.07         | 8.37 (5.80)                   |
| 11-73                      | 0.83         | 4.23 (0.27)                   |
| 12-73                      | 5.53         | 9.59 (6.98)                   |
| 15-73                      | 2.99         | 4.12 (0.83)                   |
| 16-73                      | 6.20         | 7.44 (4.12)                   |

Table 2.2  
Distribution of sums of squares due to outliers (with number)  
and moving average

$\alpha = 0.99$

| <u>Subject A1</u>    | Systolic |          | Diastolic |         | Fulse Pressure |           |
|----------------------|----------|----------|-----------|---------|----------------|-----------|
|                      | s.s.     | %        | s.s.      | %       | s.s            | %         |
| Due to outliers      | 158      | 11.1(47) | 38        | 4.8(17) | 105            | 11.6 (53) |
| About moving average | 804      | 56.5     | 578       | 73.4    | 616            | 67.9      |
| Residual             | 462      | 32.4     | 171       | 21.8    | 186            | 20.5      |
| Total                | 1424     |          | 787       |         | 906            |           |

Subject A2

|                      |      |        |      |         |      |           |
|----------------------|------|--------|------|---------|------|-----------|
| Due to outliers      | 41   | 0.7(8) | 57   | 2.7(38) | 247  | 16.5 (28) |
| About moving average | 918  | 16.3   | 353  | 16.5    | 492  | 32.9      |
| Residual             | 4675 | 83.0   | 1725 | 80.8    | 757  | 50.6      |
| Total                | 5634 |        | 2135 |         | 1494 |           |

$\alpha = 0.90$

Subject A1

|                      |      |          |     |         |     |          |
|----------------------|------|----------|-----|---------|-----|----------|
| Due to outliers      | 177  | 12.4(88) | 50  | 6.4(42) | 107 | 11.8(75) |
| About moving average | 588  | 41.3     | 440 | 55.8    | 507 | 55.9     |
| Residual             | 656  | 46.3     | 298 | 37.8    | 292 | 32.3     |
| Total                | 1424 |          | 787 |         | 906 |          |

Subject A2

|                      |      |         |      |         |      |         |
|----------------------|------|---------|------|---------|------|---------|
| Due to outliers      | 42   | 0.7(21) | 69   | 3.3(69) | 65   | 4.3(43) |
| About moving average | 518  | 9.2     | 206  | 9.7     | 350  | 23.4    |
| Residual             | 5074 | 90.1    | 1859 | 87.1    | 1080 | 72.3    |
| Total                | 5634 |         | 2135 |         | 1495 |         |

Table 2.3      Percentage of sections containing stationary means  
and variances\*

(mean, variance)

Subject A1: Systolic

length of average(bts)

|                   | 5     | 10    | 15    | 20    |
|-------------------|-------|-------|-------|-------|
| length of section |       |       |       |       |
| 100               | 70,86 | 81,90 | 82,90 | 94,97 |
| 300               | 50,73 | 58,77 | 77,81 | 73,81 |
| 500               | 40,80 | 47,80 | 44,94 | 53,80 |

Subject A1: Diastolic

|     |       |       |       |       |
|-----|-------|-------|-------|-------|
| 100 | 76,91 | 75,91 | 73,91 | 92,97 |
| 300 | 65,77 | 73,81 | 73,96 | 77,88 |
| 500 | 60,67 | 60,60 | 56,75 | 67,67 |

Subject A2: Systolic

|     |       |        |       |       |
|-----|-------|--------|-------|-------|
| 100 | 61,94 | 76,100 | 82,90 | 96,99 |
| 300 | 38,92 | 50,77  | 58,85 | 73,88 |
| 500 | 0,93  | 13,60  | 19,88 | 13,93 |

Subject A2: Diastolic

|     |       |       |       |        |
|-----|-------|-------|-------|--------|
| 100 | 70,91 | 84,89 | 90,92 | 95,99  |
| 300 | 31,96 | 46,85 | 50,81 | 69,92  |
| 500 | 20,87 | 20,87 | 31,94 | 20,100 |

\*For example, for each section of length 100 beats we take sequences of length 5 beats, and compute the mean and variance of each. We then apply the test to decide if the sequences of 20 means and 20 variances depart significantly from stationarity.



Table 2.3 (ctd.)Subject 9-73

| length of section | length of average (bits) |       |       |       |
|-------------------|--------------------------|-------|-------|-------|
|                   | 5                        | 10    | 15    | 20    |
| 100               | 66,89                    | 82,84 | 91,91 | 95,95 |
| 300               | 67,83                    | 67,83 | 75,83 | 75,83 |
| 500               | 0,43                     | 14,43 | 29,43 | 43,43 |

Subject 12-73

|     |       |        |        |        |
|-----|-------|--------|--------|--------|
| 100 | 91,95 | 91,95  | 92,88  | 100,97 |
| 300 | 57,86 | 57,100 | 71,100 | 43,100 |
| 500 | 25,50 | 25,25  | 25,75  | 25,50  |

Subject 15-73

|     |       |        |        |        |
|-----|-------|--------|--------|--------|
| 100 | 82,87 | 87,95  | 93,95  | 100,97 |
| 300 | 67,92 | 83,100 | 83,100 | 83,100 |
| 500 | 29,86 | 43,86  | 29,100 | 43,100 |

Subject 16-73

|     |        |       |        |       |
|-----|--------|-------|--------|-------|
| 100 | 82,87  | 84,87 | 93,95  | 89,97 |
| 300 | 25,100 | 32,75 | 50,100 | 32,83 |
| 500 | 29,71  | 29,57 | 29,86  | 29,86 |

Artificial data

|     |        |        |         |         |
|-----|--------|--------|---------|---------|
| 100 | 63,98  | 62,100 | 67,94   | 75,100  |
| 300 | 0,95   | 0,95   | 0,95    | 0,95    |
| 500 | 33,100 | 75,92  | 100,100 | 100,100 |

Gradient: log proportion/run length

## Subject A1

| Limit (mmHg) | Systolic<br>Slope | Diastolic<br>Slope | Pulse Pressure<br>Slope |
|--------------|-------------------|--------------------|-------------------------|
| 3            | -0.806            | -0.613             | -0.769                  |
| 6            | -0.342            | -0.253             | -0.313                  |
| 9            | -0.182            | -0.128             | -0.118                  |
| 12           | -0.092            | -0.063             | -0.064                  |

## Subject A2

| Limit (mmHg) | Systolic<br>Slope | Diastolic<br>Slope | Pulse Pressure<br>Slope |
|--------------|-------------------|--------------------|-------------------------|
| 3            | -1.070            | -0.500             | -0.776                  |
| 6            | -0.331            | -0.157             | -0.297                  |
| 9            | -0.127            | -0.161             | -0.132                  |
| 12           | -0.082            | -0.030             | -0.059                  |

| Limit (mmHg) | Patient 9-73<br>mean B.P. | 12-73<br>Mean B.P. | 15-37<br>Mean B.P. | 16-73<br>Mean B.P. |
|--------------|---------------------------|--------------------|--------------------|--------------------|
| 1            | -1.442                    | -1.301             | -0.698             | -1.397             |
| 2            | -1.043                    | -0.800             | -                  | -0.829             |
| 3            | -0.761                    | -0.600             | -                  | -0.726             |
| 4            | -0.601                    | -0.533             | -                  | -0.585             |

Tabulated are the slopes of the best fit straight lines of log proportion against run length as shown in figure 2b

## Autocorrelation of run length: limit 3 mmHg

| lag     | A1       |           | A2       |           |
|---------|----------|-----------|----------|-----------|
|         | Systolic | Diastolic | Systolic | Diastolic |
| 1       | 0.030    | 0.071     | 0.029    | 0.037     |
| 2       | 0.039    | 0.078     | 0.021    | -0.011    |
| 3       | -0.004   | 0.060     | 0.010    | -0.008    |
| 4       | 0.027    | 0.034     | 0.039    | 0.001     |
| 5       | 0.024    | 0.004     | -0.000   | -0.009    |
| 6       | 0.018    | 0.036     | -0.021   | 0.002     |
| 7       | 0.036    | 0.059     | 0.043    | 0.009     |
| 8       | 0.016    | 0.032     | 0.038    | -0.002    |
| 9       | 0.014    | 0.049     | -0.010   | 0.273     |
| 10      | 0.023    | 0.019     | -0.001   | 0.018     |
| 2 x s.e | 0.043    | 0.046     | 0.043    | 0.047     |

**TEXT BOUND INTO  
THE SPINE**

Table 2.6  
Degree<sup>s</sup> of freedom per point

## Subject A1

| Sequence length | Systolic |           | Diastolic |           | Pulse Pressure |           |
|-----------------|----------|-----------|-----------|-----------|----------------|-----------|
|                 | Var.     | d.o.f./pt | Var.      | d.o.f./pt | Var.           | d.o.f./pt |
| 1               | 186.32   | -         | 102.01    | -         | 119.03         | -         |
| 10              | 111.53   | 0.17      | 54.66     | 0.19      | 55.34          | 0.22      |
| 30              | 94.69    | 0.07      | 40.49     | 0.09      | 42.29          | 0.09      |
| 50              | 87.89    | 0.04      | 37.07     | 0.06      | 41.48          | 0.06      |
| 70              | 86.20    | 0.03      | 34.48     | 0.04      | 39.87          | 0.04      |
| 90              | 80.42    | 0.03      | 32.49     | 0.03      | 36.36          | 0.04      |
| 110             | 79.79    | 0.02      | 31.17     | 0.03      | 34.99          | 0.03      |

## Subject A2

| Sequence length | Systolic |           | Diastolic |           | Pulse Pressure |           |
|-----------------|----------|-----------|-----------|-----------|----------------|-----------|
|                 | Var.     | d.o.f./pt | Var.      | d.o.f./pt | Var.           | d.o.f./pt |
| 1               | 730.62   | -         | 275.56    | -         | 191.82         | -         |
| 10              | 673.46   | 0.11      | 250.48    | 0.11      | 131.51         | 0.15      |
| 30              | 647.17   | 0.04      | 242.44    | 0.04      | 121.20         | 0.05      |
| 50              | 638.68   | 0.02      | 239.48    | 0.02      | 117.52         | 0.03      |
| 70              | 630.29   | 0.02      | 236.62    | 0.02      | 115.15         | 0.02      |
| 90              | 620.08   | 0.01      | 236.03    | 0.01      | 114.01         | 0.02      |
| 110             | 626.89   | 0.01      | 234.50    | 0.01      | 113.59         | 0.02      |

## Post-operative patients - Mean blood pressure

| Sequence length | Patient 9-73 |           | 12.-73 |           | 15-73 |           | 16-73  |           |
|-----------------|--------------|-----------|--------|-----------|-------|-----------|--------|-----------|
|                 | Var.         | d.o.f./pt | Var.   | d.o.f./pt | Var   | d.o.f./pt | Var    | d.o.f./pt |
| 1               | 146.12       | -         | 202.93 | -         | 25.95 | -         | 600.91 | -         |
| 10              | 92.31        | 0.16      | 110.10 | 0.183     | 18.37 | 0.141     | 521.71 | 0.115     |
| 30              | 80.53        | 0.07      | 62.31  | 0.109     | 13.07 | 0.066     | 484.43 | 0.041     |
| 50              | 66.26        | 0.04      | 57.97  | 0.070     | 11.59 | 0.045     | 490.59 | 0.024     |
| 70              | 60.50        | 0.04      | 45.25  | 0.064     | 10.68 | 0.035     | 447.94 | 0.019     |

TABLE 2.7     Low lag autocorrelations of blood pressure from  
ambulatory subjects

| lag | A1       |           | A2       |           |
|-----|----------|-----------|----------|-----------|
|     | systolic | diastolic | systolic | diastolic |
| 1   | 0.7203   | 0.7019    | 0.9646   | 0.9299    |
| 2   | 0.6103   | 0.6061    | 0.9420   | 0.9091    |
| 3   | 0.5593   | 0.5203    | 0.9304   | 0.8952    |
| 4   | 0.5088   | 0.4217    | 0.9246   | 0.8885    |
| 5   | 0.4509   | 0.3434    | 0.9163   | 0.8812    |
| 6   | 0.4235   | 0.2997    | 0.9059   | 0.8743    |
| 7   | 0.4091   | 0.2792    | 0.8978   | 0.8690    |
| 8   | 0.4093   | 0.2710    | 0.8901   | 0.8635    |
| 9   | 0.4167   | 0.2832    | 0.8838   | 0.8589    |
| 10  | 0.4391   | 0.3017    | 0.8797   | 0.8547    |
|     | 9-73     | 12-73     | 15.73    | 16.73     |
|     | mean     | mean      | mean     | mean      |
| 1.  | 0.688    | 0.572     | 0.819    | 0.906     |
| 2.  | 0.643    | 0.639     | 0.678    | 0.883     |
| 3.  | 0.583    | 0.546     | 0.621    | 0.861     |
| 4.  | 0.551    | 0.449     | 0.646    | 0.840     |
| 5.  | 0.525    | 0.369     | 0.698    | 0.844     |
| 6.  | 0.500    | 0.316     | 0.654    | 0.826     |
| 7.  | 0.494    | 0.277     | 0.586    | 0.813     |
| 8.  | 0.483    | 0.267     | 0.465    | 0.807     |
| 9.  | 0.465    | 0.250     | 0.433    | 0.798     |
| 10. | 0.475    | 0.234     | 0.447    | 0.791     |

intervals and heart-rate for the resting subject

| Subject No. | Heart Interval |        |            | Heart Rate     |        |           |
|-------------|----------------|--------|------------|----------------|--------|-----------|
|             | $\chi^2$ stat. | d.o.f. | sig. level | $\chi^2$ stat. | d.o.f. | sig level |
| 6           | 66.4           | 17     | **         | 25.1           | 10     | *         |
| 7           | 17.4           | 6      | **         | 37.8           | 4      | **        |
| 8           | 169.0          | 7      | **         | 55.0           | 4      | **        |
| 9           | 18.7           | 12     | NS         | 29.8           | 7      | **        |
| 10          | 61.0           | 9      | **         | 78.3           | 11     | **        |
| 11          | 22.1           | 5      | **         | 23.1           | 6      | **        |
| 12          | 185.0          | 3      | **         | 306.0          | 2      | **        |
| 13          | 34.2           | 13     | **         | 44.3           | 8      | **        |
| 14          | 13.9           | 8      | NS         | 7.5            | 7      | NS        |
| 16          | 27.5           | 14     | *          | 17.3           | 12     | NS        |
| 17          | 45.4           | 11     | **         | 23.5           | 14     | NS        |
| 18          | 26.7           | 10     | **         | 7.9            | 10     | NS        |
| 19          | 13.8           | 8      | NS         | 1.4            | 4      | NS        |
| 20          | 54.0           | 12     | **         | 67.5           | 12     | **        |
| 21(2)       | 28.0           | 9      | **         | 18.1           | 13     | NS        |
| 21(3)       | 24.0           | 13     | *          | 17.0           | 12     | NS        |
| 22(2)       | 3.6            | 5      | NS         | 2.7            | 4      | NS        |
| 22(3)       | 13.9           | 8      | NS         | 4.3            | 7      | NS        |
| 24(2)       | 8.7            | 9      | NS         | 17.2           | 10     | NS        |
| 25(2)       | 11.3           | 11     | NS         | 21.7           | 9      | **        |
| 25(3)       | 52.1           | 9      | **         | 69.5           | 5      | **        |

The figures in brackets denote the 2nd or 3rd series of experiments described in Chapter 5. Given a frequency table for each subject with  $r$  groups, where there is an expectation of at least 5 observations in each group, then the  $\chi^2$  statistic is calculated from 
$$\chi^2 = \sum_{i=1}^r \frac{(O_i - E_i)^2}{E_i}$$
 where  $O_i$  are the number of observations

in group  $i$  and  $E_i$  are the corresponding number predicted by a normal distribution with the same mean and variance as the observed distribution. The degrees of freedom(d.o.f. =  $r-3$ ). The significance level indicators are \*\* = (prob. < 0.01), \* = (0.05 < prob < 0.01) and NS = (prob  $\geq$  0.05) .

Table 2.9

Skewness and kurtosis for heart-rate and heart interval distributions for resting subjects.

| Subject No. | Skewness |        | Kurtosis |       |
|-------------|----------|--------|----------|-------|
|             | H.R.     | H.I.   | H.R.     | H.I.  |
| 6           | -0.511   | +0.188 | 2.83     | 2.34  |
| 7           | -0.030   | +0.115 | 6.31     | 4.75  |
| 8           | +0.183   | -0.082 | 4.72     | 4.38  |
| 9           | -0.354   | +0.670 | 4.07     | 6.02  |
| 10          | +0.732   | -0.416 | 7.95     | 4.69  |
| 11          | +0.487   | -0.259 | 3.44     | 2.88  |
| 12          | -1.385   | +5.413 | 30.32    | 46.87 |
| 13          | -0.510   | +1.244 | 2.64     | 3.16  |
| 14          | +0.080   | +0.133 | 3.11     | 3.43  |
| 16          | +0.266   | +0.009 | 2.69     | 2.92  |
| 17          | +0.317   | -0.017 | 2.87     | 2.43  |
| 18          | -0.383   | +0.135 | 7.76     | 4.02  |
| 19          | -0.035   | +0.023 | 2.80     | 2.82  |
| 20          | -0.354   | +0.540 | 2.59     | 2.88  |
| 21(2)       | -0.221   | +0.097 | 3.03     | 2.84  |
| 21(3)       | +0.367   | +0.068 | 3.73     | 3.00  |
| 22(2)       | +0.059   | -0.177 | 3.44     | 3.68  |
| 22(3)       | -0.039   | +0.136 | 2.98     | 3.13  |
| 24(2)       | -0.141   | -0.198 | 2.68     | 4.60  |
| 25(2)       | -0.109   | +0.247 | 2.87     | 3.42  |
| 25(3)       | -0.565   | +0.756 | 4.38     | 5.46  |

The figures in brackets denote the 2nd or 3rd series of experiments described in Chapter 5. Pearson's beta coefficients are defined as

$$b_1 = \mu_3^c / \mu_2^c \quad \text{and} \quad b_2 = \mu_4^c / (\mu_2^c)^2$$

where  $\mu_2^c$ ,  $\mu_3^c$  and  $\mu_4^c$  are the second, third and fourth order moments about the mean respectively (with Sheppard's correction).

$$\text{The skewness} = \frac{b_1(b_2 + 3)}{2(5b_2 - 6b_1 - 9)} \quad \text{and} \quad \text{kurtosis} = b_2$$



Table 2.10

Results of  $\chi^2$  test for normality on successive histograms  
of 200 points each of heart rate for the post-operative  
patients

PAWS 7-73

| Hist. no.  | 1   | 2    | 3   | 4   | 5   | 6   | 7   | 8    | 9     |
|------------|-----|------|-----|-----|-----|-----|-----|------|-------|
| $\chi^2$   | 5.8 | 2.4  | 8.9 | 9.8 | 7.7 | 1.5 | 9.6 | 13.3 | 193.8 |
| d.o.f.     | 3   | 1    | 2   | 3   | 3   | 2   | 3   | 4    | 3     |
| sig. level | NS  | NS   | *   | *   | NS  | NS  | *   | **   | **    |
| % excl.    | 17  | 12.5 | 4.5 | 4   | 8   | 0.5 | 0   | 2.5  | 2.5   |

| Hist. no.  | 10   | 11   | 12  | 13  | 14 | 15   | 16   | 17   | 18   |
|------------|------|------|-----|-----|----|------|------|------|------|
| $\chi^2$   | 36.3 | 8.7  | 9.7 | 3.7 | -  | 12.5 | 24.4 | 12.9 | 19.6 |
| d.o.f.     | 2    | 1    | 2   | 1   | -  | 2    | 3    | 4    | 3    |
| sig. level | **   | **   | **  | **  | ** | **   | **   | **   | **   |
| % excl.    | 1.5  | 11.0 | 19  | 4   |    | 0    | 1    | 11.5 | 4.5  |

PAWS 8-73

| Hist. no.  | 1   | 2   | 3   | 4    | 5   | 6    | 7  | 8   |
|------------|-----|-----|-----|------|-----|------|----|-----|
| $\chi^2$   | 47. | 61. | 76. | 679. | 81. | 11.8 | -  | 43. |
| d.o.f.     | 2   | 3   | 4   | 3    | 5   | 3    | -  | 3   |
| sig. level | **  | **  | **  | **   | **  | **   | ** | **  |
| % excl.    | 1   | 2   | 1.5 | 2    | 0   | 3    |    | 2   |

PAWS 10-73

| Hist. no.  | 1    | 2   | 3    | 4   | 5   | 6    | 7  | 8  | 9     |
|------------|------|-----|------|-----|-----|------|----|----|-------|
| $\chi^2$   | 12.3 | 4.0 | 15.1 | 7.9 | 7.8 | 12.5 | -  | -  | 150.2 |
| d.o.f.     | 3    | 4   | 7    | 6   | 5   | 8    |    |    | 8     |
| sig. level | **   | NS  | *    | NS  | NS  | NS   | ** | ** | **    |
| % excl.    | 0    | 1   | 5.5  | 1.5 | 0   | 1    |    |    | 2     |

| Hist. no.  | 10  | 11   | 12  | 13   | 14  | 15  | 16  | 17   |
|------------|-----|------|-----|------|-----|-----|-----|------|
| $\chi^2$   | 7.9 | 10.7 | 2.3 | 19.6 | 2.2 | 7.7 | 9.4 | 30.4 |
| d.o.f.     | 5   | 5    | 4   | 6    | 4   | 4   | 5   | 6    |
| sig. level | NS  | NS   | NS  | **   | NS  | NS  | NS  | **   |
| % excl.    | 1   | 2.5  | 0   | 0    | 0.5 | 0   | 0.5 | 0    |

PAWS 12-73

| Hist. no.  | 1   | 2    | 3   | 4  | 5    | 6   | 7   | 8  | 9   | 10  |
|------------|-----|------|-----|----|------|-----|-----|----|-----|-----|
| $\chi^2$   | 4.6 | 11.1 | 1.6 | -  | 11.2 | 4.3 | 6.2 | -  | 5.7 | 5.6 |
| d.o.f.     | 4   | 4    | 3   | -  | 5    | 3   | 4   | -  | 4   | 3   |
| sig. level | NS  | *    | NS  | ** | *    | NS  | NS  | ** | NS  | NS  |
| % excl.    | 0.5 | 0.5  | 1.5 |    | 4    | 0.5 | 1.5 |    | 0   | 0   |

| Hist. no.  | 11  | 12  | 13  | 14  | 15  | 16   | 17  | 18  | 19   |
|------------|-----|-----|-----|-----|-----|------|-----|-----|------|
| $\chi^2$   | 4.5 | 2.0 | 1.3 | 7.5 | 1.1 | 14.2 | 0.9 | 2.6 | 15.9 |
| d.o.f.     | 3   | 4   | 3   | 4   | 4   | 5    | 3   | 3   | 6    |
| sig. level | NS  | NS  | NS  | NS  | NS  | *    | NS  | NS  | *    |
| %excl.     | 2   | 1.5 | 0   | 1   | 0.5 | 1    | 0   | 0.5 | 0.5  |

PAWS 13-73

| Hist. no.  | 1   | 2   | 3   | 4   | 5   | 6   | 7   | 8    | 9   |
|------------|-----|-----|-----|-----|-----|-----|-----|------|-----|
| $\chi^2$   | 7.9 | 7.1 | 3.2 | 7.1 | 6.4 | 5.5 | 9.7 | 10.9 | 8.7 |
| d.o.f.     | 7   | 8   | 6   | 8   | 8   | 6   | 7   | 8    | 7   |
| sig. level | NS  | NS  | NS  | NS  | NS  | NS  | NS  | NS   | NS  |
| % excl.    | 0   | 0   | 0   | 0.5 | 0   | 0   | 0.5 | 0    | 0   |

| Hist. no.  | 10  | 11  | 12   | 13   | 14   | 15  |
|------------|-----|-----|------|------|------|-----|
| $\chi^2$   | 5.8 | 7.8 | 14.5 | 13.1 | 12.6 | 7.7 |
| d.o.f.     | 6   | 6   | 8    | 6    | 3    | 4   |
| sig. level | NS  | NS  | NS   | *    | **   | NS  |
| % excl.    | 0   | 0   | 0    | 1    | 2    | 0   |

PAWS 14-73

| Hist. no.  | 1    | 2   | 3   | 4   | 5   | 6  | 7   | 8   | 9   | 10   |
|------------|------|-----|-----|-----|-----|----|-----|-----|-----|------|
| $\chi^2$   | 0.96 | 8.9 | 1.2 | 2.5 | 6.7 | -  | 3.4 | 8.3 | 5.7 | 12.7 |
| d.o.f.     | 3    | 5   | 3   | 4   | 3   | -  | 3   | 3   | 3   | 3    |
| sig. level | NS   | NS  | NS  | NS  | NS  | ** | NS  | *   | NS  | **   |
| % excl.    | 1    | 2   | 1   | 1.5 | 0   |    | 0   | 0   | 0   | 1.5  |

Table 2.10(Ctd.)

PAWS 14-73

| Hist. no.  | 11  | 12  | 13  | 14  | 15  | 16  | 17  | 18   | 19  |
|------------|-----|-----|-----|-----|-----|-----|-----|------|-----|
| $\chi^2$   | 8.4 | 2.3 | 3.8 | 3.9 | 7.4 | 5.4 | 5.9 | 15.5 | 1.9 |
| d.o.f.     | 3   | 3   | 3   | 3   | 3   | 3   | 4   | 3    | 2   |
| sig. level | *   | NS  | NS  | NS  | NS  | NS  | NS  | **   | NS  |
| % excl.    | 0   | 0   | 1   | 1   | 2.5 | 2   | 2   | 0.5  | 0   |

PAWS 15-73

| Hist. no.  | 1     | 2    | 3    | 4  | 5    | 6 | 7 | 8 |
|------------|-------|------|------|----|------|---|---|---|
| $\chi^2$   | 102.1 | 38.1 | 47.8 | -  | 69.0 | - | - |   |
| d.o.f.     | 4     | 3    | 4    | -  | 3    |   |   |   |
| sig. level | **    | **   | **   | ** | **   |   |   |   |
| % excl.    | 5     | 6    | 4    |    | 6    |   |   |   |

PAWS 16-73

| Hist. no.  | 8    | 9   | 10  | 11  | 12  | 13  | 14  | 15   | 16  |
|------------|------|-----|-----|-----|-----|-----|-----|------|-----|
| $\chi^2$   | 15.9 | 2.6 | 6.4 | 9.9 | 1.7 | 6.3 | 6.3 | 10.6 | 9.2 |
| d.o.f.     | 2    | 2   | 2   | 3   | 3   | 2   | 3   | 2    | 2   |
| sig. level | **   | NS  | *   | *   | NS  | *   | NS  | **   | **  |
| % excl.    | 2    | 4   | 0   | 0   | 0   | 0   | 0   | 0    | 0   |

| Hist. no.  | 17  | 18 | 19   |
|------------|-----|----|------|
| $\chi^2$   | 8.1 | -  | 15.6 |
| d.o.f.     | 3   | -  | 3    |
| sig. level | *   | ** | **   |
| % excl.    | 0   | 0  | 5.5  |

PAWS 9-74

| Hist. no.  | 1   | 2    | 3   | 4    | 5    | 6    | 7    | 8   |
|------------|-----|------|-----|------|------|------|------|-----|
| $\chi^2$   | 27  | 11.1 | 8.1 | 86.0 | 10.8 | 11.5 | 11.9 | 4.4 |
| d.o.f.     | 3   | 4    | 3   | 3    | 3    | 3    | 3    | 4   |
| sig. level | **  | *    | *   | **   | *    | *    | *    | NS  |
| % excl.    | 2.5 | 2.5  | 3   | 3    | 6    | 5    | 4    | 0.5 |

The  $\chi^2$  test was not carried out if the histograms were clearly non-normal, for example if they were bimodal, and in these cases the result was either not tabulated or left as a blank and the significance level given as \*\* .

Significance level (sig. level) NS-( $P > 0.05$ ); \*-( $0.05 \geq P > 0.01$ ); \*\*-( $P \leq 0.01$ )

The row labelled ' % excl. ' gives the percentage of points that were omitted from the goodness-of-fit test for a normal distribution because they were not part of the main body of the distribution.

Table 2.11      Skewness and kurtosis statistics for non-normal distributions of Table 2.3

7-73

|           |       |       |       |       |       |       |       |       |
|-----------|-------|-------|-------|-------|-------|-------|-------|-------|
| Hist. no. | 3     | 4     | 7     | 8     | 9     | 10    | 11    | 12    |
| Kurtosis  | 2.5   | 3.8   | 2.5   | 2.3   | 2.5   | 2.9   | 5.5   | 4.4   |
| Skewness  | +0.27 | -0.08 | +0.27 | -0.22 | -0.09 | +0.48 | +0.23 | +0.34 |

|           |       |       |       |       |       |
|-----------|-------|-------|-------|-------|-------|
| Hist. no. | 13    | 15    | 16    | 17    | 18    |
| Kurtosis  | 6.5   | 4.8   | 5.2   | 2.9   | 3.3   |
| Skewness  | -0.38 | +0.34 | -0.32 | +0.14 | -0.40 |

10-73

|           |      |       |       |       |       |
|-----------|------|-------|-------|-------|-------|
| Hist. no. | 1    | 3     | 9     | 14    | 20    |
| Kurtosis  | 1.9  | 3.9   | 2.7   | 3.2   | 3.8   |
| Skewness  | 0.01 | +0.09 | -0.16 | -0.55 | -0.33 |

12-73

|           |       |       |       |       |
|-----------|-------|-------|-------|-------|
| Hist. no. | 2     | 5     | 16    | 19    |
| Kurtosis  | 5.2   | 5.3   | 3.1   | 3.9   |
| Skewness  | -0.11 | -0.02 | +0.02 | +0.06 |

13-73

|           |      |       |
|-----------|------|-------|
| Hist. no. | 13   | 14    |
| Kurtosis  | 2.83 | 2.7   |
| Skewness  | 0.01 | +0.02 |

15-73

|           |       |       |       |       |
|-----------|-------|-------|-------|-------|
| Hist. no. | 8     | 10    | 11    | 18    |
| Kurtosis  | 4.8   | 12.7  | 5.1   | 9.4   |
| Skewness  | -0.22 | -0.01 | +0.00 | +0.48 |

16-73

|           |       |      |      |      |      |      |      |      |
|-----------|-------|------|------|------|------|------|------|------|
| Hist. no. | 1     | 2    | 3    | 4    | 5    | 6    | 7    | 8    |
| Kurtosis  | 5.4   | 6.0  | 4.9  | 7.0  | 9.4  | 11.2 | 9.4  | 8.1  |
| Skewness  | +16.5 | +9.0 | -2.8 | +1.4 | +2.7 | +6.0 | +9.5 | +8.1 |

Table 2.11(Ctd.)16-73

|           |       |      |      |      |      |       |      |       |
|-----------|-------|------|------|------|------|-------|------|-------|
| Hist. no. | 10    | 11   | 13   | 15   | 16   | 17    | 18   | 19    |
| Kurtosis  | 2.2   | 3.4  | 2.3  | 2.5  | 3.0  | 27.6  | 8.2  | 2.7   |
| Skewness  | -0.02 | 0.14 | 0.13 | 0.40 | 0.27 | -37.4 | -2.6 | -0.00 |

Table 2.12 Results of  $\chi^2$  test for normality on successive histograms  
of 200 points each of blood pressure for the post-operative  
patients

PAWS 7-73

| Hist. no.   | 1  | 2  | 3    | 4    | 5   | 6   | 7    | 8  | 9  |
|-------------|----|----|------|------|-----|-----|------|----|----|
| $\chi^2$    | -  | -  | 12.4 | 330. | 6.4 | 8.0 | 13.5 | -  | -  |
| d.o.f.      | -  | -  | 6    | 7    | 6   | 6   | 7    | -  | -  |
| sig. level. | ** | ** | NS   | **   | NS  | NS  | NS   | ** | ** |

| Hist. no.  | 10   | 11  | 12 | 13 | 14   | 15   | 16   | 17  | 18   |
|------------|------|-----|----|----|------|------|------|-----|------|
| $\chi^2$   | 25.1 | 9.8 | -  | -  | 21.9 | 10.5 | 10.4 | 7.9 | 15.9 |
| d.o.f.     | 7    | 7   | -  | -  | 8    | 6    | 8    | 8   | 5    |
| sig. level | **   | NS  | ** | ** | *    | NS   | NS   | NS  | **   |

PAWS 8-73

| Hist. no.  | 1   | 2    | 3    | 4   | 5   | 6    | 7  | 8   | 9  |
|------------|-----|------|------|-----|-----|------|----|-----|----|
| $\chi^2$   | 6.5 | 11.0 | 10.1 | 4.2 | 2.5 | 11.0 | -  | 4.4 | -  |
| d.o.f.     | 7   | 6    | 9    | 6   | 6   | 7    | -  | 6   | -  |
| sig. level | NS  | NS   | NS   | NS  | NS  | NS   | ** | NS  | ** |

10-73

| Hist no.   | 1    | 2    | 3    | 4    | 5    | 6    | 7  | 8  | 9  |
|------------|------|------|------|------|------|------|----|----|----|
| $\chi^2$   | 13.1 | 10.9 | 10.4 | 14.1 | 10.5 | 25.3 | -  | -  | -  |
| d.o.f.     | 6    | 8    | 9    | 11   | 10   | 11   | -  | -  | -  |
| sig. level | *    | NS   | NS   | NS   | NS   | **   | ** | ** | ** |

| Hist. no. | 10 | 11   | 12   | 13   | 14   | 15   | 16  | 17   | 18  | 19   | 20   |
|-----------|----|------|------|------|------|------|-----|------|-----|------|------|
| $\chi^2$  | -  | 23.7 | 10.7 | 14.0 | 31.4 | 36.6 | 8.2 | 14.4 | 3.8 | 68.2 | 17.5 |
| d.o.f.    | -  | 7    | 7    | 7    | 11   | 8    | 7   | 6    | 6   | 7    | 11   |
| sig.level | ** | **   | NS   | NS   | **   | **   | NS  | *    | NS  | **   | NS   |

Table 2.12(Ctd.)

PAWS 11-73

| Hist. no.  | 1   | 2    | 3   | 4   | 5   | 6   | 7    | 8   | 9    |
|------------|-----|------|-----|-----|-----|-----|------|-----|------|
| $\chi^2$   | 6.2 | 11.4 | 5.5 | 4.8 | 6.5 | 7.7 | 10.3 | 3.6 | 12.0 |
| d.o.f.     | 7   | 7    | 7   | 5   | 6   | 6   | 7    | 6   | 6    |
| sig. level | NS  | NS   | NS  | NS  | NS  | NS  | NS   | NS  | NS   |

| Hist. no   | 10  | 11  | 12   | 13   | 14   | 15  | 16  |
|------------|-----|-----|------|------|------|-----|-----|
| $\chi^2$   | 9.4 | 4.0 | 11.2 | 15.1 | 16.8 | 8.5 | 6.8 |
| d.o.f.     | 7   | 6   | 9    | 6    | 6    | 8   | 8   |
| sig. level | NS  | NS  | NS   | *    | *    | NS  | NS  |

PAWS 12-73

| Hist no.   | 1   | 2   | 3   | 4  | 5   | 6    | 7  | 8  | 9  | 10  |
|------------|-----|-----|-----|----|-----|------|----|----|----|-----|
| $\chi^2$   | 6.1 | 3.7 | 6.0 | -  | 5.2 | 12.6 | -  | -  | -  | 3.9 |
| d.o.f.     | 7   | 7   | 5   | -  | 5   | 9    | -  | -  | -  | 4   |
| sig. level | NS  | NS  | NS  | ** | NS  | NS   | ** | ** | ** | NS  |

PAWS 13-73

| Hist no.   | 1   | 2   | 3   | 4   | 5  | 6   | 7   | 8  | 9    |
|------------|-----|-----|-----|-----|----|-----|-----|----|------|
| $\chi^2$   | 7.9 | 5.7 | 8.4 | 7.3 | -  | 5.6 | 4.8 | -  | 23.6 |
| d.o.f.     | 7   | 8   | 7   | 6   | -  | 7   | 7   | -  | 8    |
| sig. level | NS  | NS  | NS  | NS  | ** | NS  | NS  | ** | **   |

| Hist. no.  | 10   | 11  | 12  | 13  | 14  | 15   |
|------------|------|-----|-----|-----|-----|------|
| $\chi^2$   | 17.2 | 5.2 | 9.9 | 5.8 | 6.1 | 88.7 |
| d.o.f.     | 7    | 7   | 7   | 6   | 6   | 10   |
| sig. level | *    | NS  | NS  | NS  | NS  | **   |

PAWS 14-73

| Hist. no.  | 1    | 2   | 3    | 4   | 5    | 6    | 7   | 8    | 9   | 10   |
|------------|------|-----|------|-----|------|------|-----|------|-----|------|
| $\chi^2$   | 10.6 | 7.8 | 10.8 | 4.9 | 11.3 | 14.0 | 9.4 | 13.4 | 3.5 | 11.0 |
| d.o.f.     | 9    | 10  | 7    | 7   | 8    | 8    | 8   | 6    | 8   | 11   |
| sig. level | NS   | NS  | NS   | NS  | NS   | NS   | NS  | *    | NS  | NS   |



Table 2.12 (Ctd)

| Hist. no.  | 11  | 12   | 13   | 14  | 15  | 16  | 17   | 18   | 19   |
|------------|-----|------|------|-----|-----|-----|------|------|------|
| $\chi^2$   | 4.5 | 13.4 | 25.2 | 9.7 | 3.6 | 2.3 | 12.5 | 14.9 | 14.4 |
| d.o.f.     | 7   | 8    | 13   | 7   | 9   | 7   | 7    | 7    | 7    |
| sig. level | NS  | NS   | *    | NS  | NS  | NS  | NS   | *    | *    |

PAWS 15-73

| Hist. no.  | 1    | 2    | 3   | 4    | 5    | 6   | 7   | 8   | 9    | 10   |
|------------|------|------|-----|------|------|-----|-----|-----|------|------|
| $\chi^2$   | 14.1 | 11.2 | 4.9 | 13.1 | 10.3 | 5.6 | 9.9 | 7.3 | 16.6 | 31.8 |
| d.o.f.     | 5    | 5    | 4   | 7    | 3    | 3   | 5   | 5   | 6    | 6    |
| sig. level | *    | NS   | NS  | NS   | *    | NS  | NS  | NS  | *    | **   |

| Hist. no.  | 11  | 12  | 13   | 14  | 15   | 16   | 17   | 18   | 19   |
|------------|-----|-----|------|-----|------|------|------|------|------|
| $\chi^2$   | 5.1 | 9.4 | 11.5 | 5.3 | 21.8 | 80.8 | 39.9 | 15.8 | 47.1 |
| d.o.f.     | 4   | 6   | 6    | 6   | 6    | 9    | 7    | 5    | 6    |
| sig. level | NS  | NS  | NS   | NS  | **   | **   | **   | **   | **   |

PAWS 16-73

| Hist. no.  | 1   | 2    | 3   | 4   | 5   | 6   | 7   | 8   | 9   |
|------------|-----|------|-----|-----|-----|-----|-----|-----|-----|
| $\chi^2$   | 5.9 | 17.4 | 3.1 | 8.3 | 7.7 | 3.5 | 7.6 | 5.6 | 6.3 |
| d.o.f.     | 6   | 7    | 8   | 6   | 6   | 6   | 6   | 6   | 5   |
| sig. level | NS  | *    | NS  | NS  | NS  | NS  | NS  | NS  | NS  |

| Hist. no.  | 10  | 11   | 12  | 13  | 14  | 15   | 16  | 17 | 18  | 19   |
|------------|-----|------|-----|-----|-----|------|-----|----|-----|------|
| $\chi^2$   | 5.3 | 16.7 | 8.9 | 5.0 | 9.2 | 18.9 | 9.0 | -  | 7.2 | 22.4 |
| d.o.f.     | 4   | 5    | 4   | 5   | 6   | 4    | 4   | -  | 6   | 7    |
| sig. level | NS  | **   | NS  | NS  | NS  | **   | NS  | ** | NS  | **   |

CHAPTER 3: EQUIDISTANT SAMPLING AND POINT PROCESS ANALYSIS OF  
HEART BEATS

Heart beats, when defined by the peak of the QRS complex, can be thought of as events occurring at unique points in time. The times of the events completely describe the process. This is in contrast to the normal situations dealt with in time series analysis where either a continuous variable is sampled at equidistant points in time or the number of events in a fixed interval of time is recorded. An example of the former is a blast furnace temperature which is recorded at regular intervals and an example of the latter is the number of Canadian Lynx furs recorded each year by the Hudson Bay Company. In dealing with heart beats two approaches seem possible. Either we can sample the tachicardiograph in some manner at equidistant points and then proceed with conventional time-series analysis or we can use the more recently developed methods of point process analysis.

Literature review

In this review only those methods that have been employed to obtain an analysis of heart beats will be covered. The main source of papers and references is Ergonomics Vol.16 (1973). Others include Sayers (1971), Loos (1968) and Chess, Tam and Caleresu (1975). Various methods of conducting equidistant sampling of heart beats are described by Luczak and Laurig (1973).

1) Constant interpolation.

Figure 3.1 Constant interpolation method of sampling heart beat (from Luczak and Laurig, 1973). Let  $(x_k)$  be a series of heart beat intervals so that  $x_k = t_k - t_{k-1}$ , where the beats occur at times  $t_1, \dots, t_k, \dots$  and let  $(r_i)$  be the interpolated values at equally spaced intervals  $\Delta t$ . For a completely random time series the best prediction for a value at time  $k + \Delta t$  is the value at time  $k$ . Thus we take  $r_i = x_k$  if  $t_{k-1} < i \Delta t \leq t_k$ .

2) Linear interpolation

Figure 3.2 Linear interpolation method of sampling heart beat (from Luczak and Laurig, 1973).

We can look upon heart rate as being proportional to external factors which affect it and presume that the heart rate changes in order to adapt to changing external parameters. In this case it would be

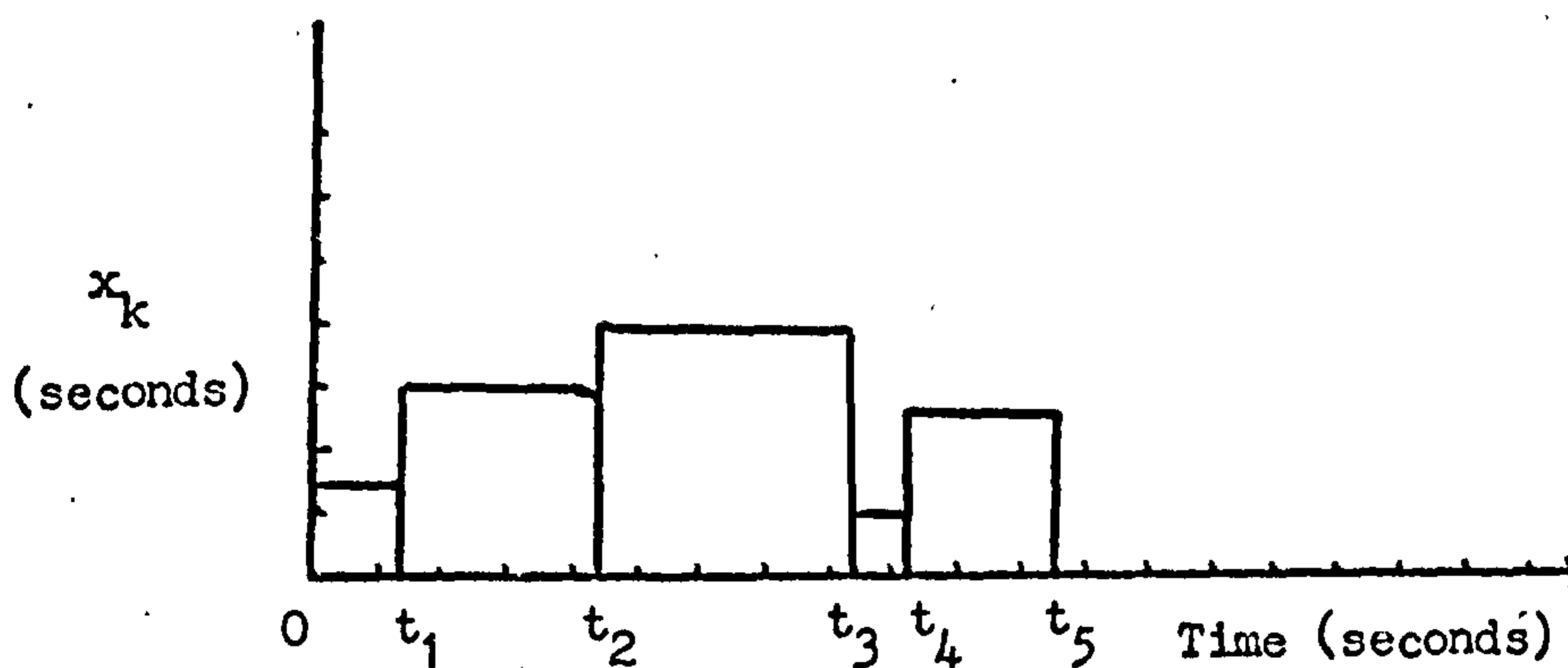
better to interpolate by a linear function than by a constant function. We assume that the value of the heart interval is associated with the end of the interval. In this case we put

$$r_i = (x_k - x_{k-1}) \frac{(i \Delta t - t_{k-1})}{t_k - t_{k-1}} + x_{k-1} \quad \text{if } t_{k-1} < i \Delta t \leq t_k$$

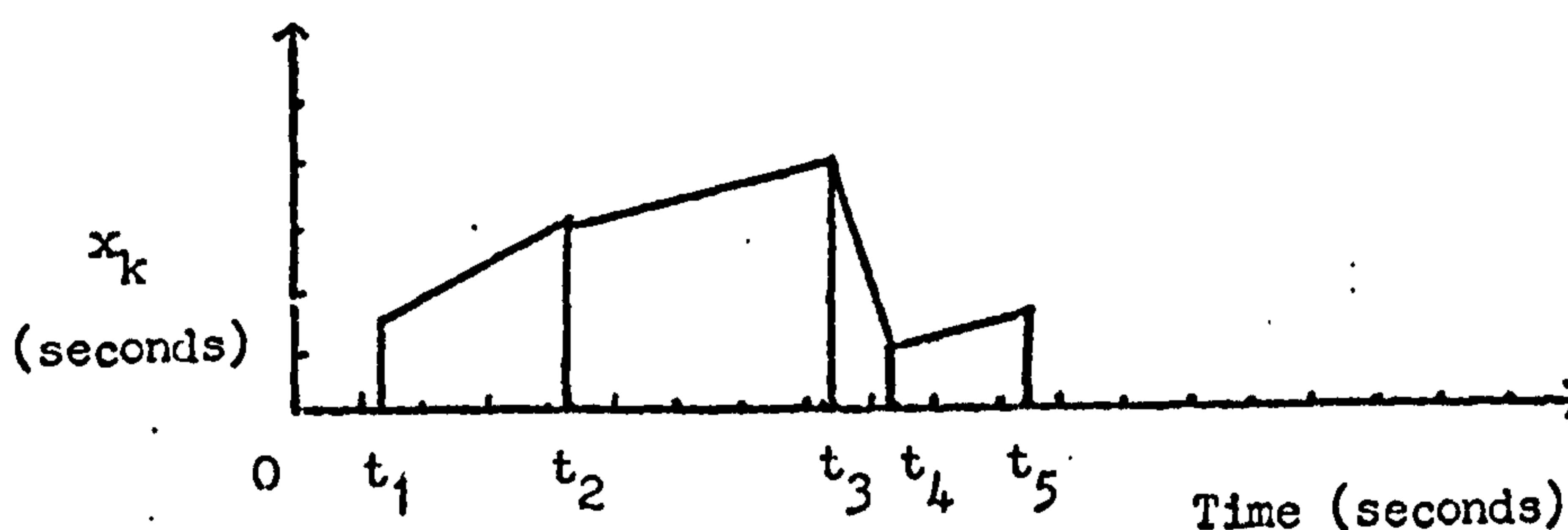
Mulder (1973) used Lagrange interpolation and Womack (1971) used 2nd and 3rd order polynomials but showed there was no real improvement over linear interpolation.

### 3) High rate sampling

Because we can only measure the peak of the QRS complex with finite accuracy we can look upon each heart beat as having finite width  $\Delta t$  and a finite height. Classical spectral analysis of such processes is quite valid. Thus we can take a sample  $(r_i)$  at successive intervals  $\Delta t$ , which is zero everywhere except when there is a heart beat in  $\Delta t$ , when  $(r_i)$  takes a finite value, say 1. The problem with this method is that a large amount of storage is required.

### 4) Point process approach

We consider 'events' occurring in a haphazard way in space or time. For example an event could be an electrical spike from a neuron or a heart beat. If the  $i$  th event occurs at time  $t_i$  we define the counting process  $(N(t))$  as

$$N(t) = i \quad \text{for } t_i < t \leq t_{i+1}$$

Thus  $N(t)$  is the number of events up to time  $t$ , starting at 0. We assume in all that follows that two events cannot happen simultaneously and put

$$\delta N(t) = N(t + \delta t) - N(t) \quad \text{and} \quad dN(t) = \lim_{\delta t \rightarrow 0} \delta N(t) \text{ as } \delta t \rightarrow 0 .$$

This definition was given by Bartlett (1963a) and is also given in Cox and Lewis (1966, p.73). Since we are considering intervals open at the lower end and closed at the higher end, and the limit is taken only for +ve values of  $\delta t$  as  $\delta t \rightarrow 0$ , it is clear that the limit exists and is equal to 0 or 1 depending on whether an event has occurred at time  $t$  or not. Other authors, for example Lewis (1970) make the definition  $dN(t) = \lim_{\delta t} \delta N(t)$  as  $\delta t \rightarrow 0$ , i.e. a formal differential.

This leads to problems since  $N(t)$  is not differentiable unless one is prepared to admit Dirac delta functions. The Bartlett definition, which we will adopt, enables one to think of the process ( $dN(t)$ ) as being zero everywhere except where an event occurs, in which case it takes the value 1.

Priestly (1963), in the discussion of Bartlett (1963) generalized the problem of relating a point process to a continuous process. We consider a linear transformation of  $dN(t)$  of the form

$$Y(t) = \int_{-\infty}^{\infty} w(t-\tau) dN(\tau) = \sum_{s=-\infty}^{\infty} w(t-T_s) ,$$

where the weight function  $w(t)$  satisfies

$$w(t) = 0, \quad t < 0; \quad \int_{-\infty}^{\infty} w(t) dt = 1, \quad \int_{-\infty}^{\infty} w^2(t) dt < \infty .$$

This method has been developed, apparently independently, by

French and Holden (1971) for the sampling of neuronal spike trains. The method could also be applied to heart beats. We assume that we wish to sample  $n$  events at intervals  $\Delta t$ . In this case the highest frequency we can examine is  $f_N = 1/2 \Delta t$ , (see for example Appendix A). Effectively what we want to do is to replace each of the spikes by a continuous function, and to sum these functions at the sampling points. Any symmetrical peaked curve would suffice, even the normal curve. French and Holden chose the function  $w(\theta) = \sin \theta / \theta$  because this leads to considerable simplification. Applying this form of  $w(t)$  we get that

$$Y(t) = \int_{-\infty}^{\infty} \frac{\sin((t - \tau) 2 \pi f_N) dN(\tau)}{(t - \tau) 2 \pi f_N} .$$

This becomes

$$Y(t) = \sum_{i=1}^n \frac{\sin((t - t_i) 2 \pi f_N \Delta t)}{(t - t_i) 2 \pi f_N \Delta t} ,$$

which reduces to

$$Y(t) = \sum_{i=1}^n \frac{\sin\{(t - t_i) \pi\}}{\pi (t - t_i)}$$

If this function is calculated at points  $t = m$ , where  $m$  is an integer, this further reduces to

$$Y(m \Delta t) = \sum_{i=1}^n \frac{-\sin \pi t_i}{\pi (m - t_i)} . \quad (3.1)$$

This is computationally simple since, given the  $t_i$ 's, the sines need only be calculated once. Sayers (1971) and Chess et al., (1975) calculated the spectrum of intervals as if they were equidistant. This gives a spectrum in terms of cycles/interval. In order to

convert the frequency to cycles/sec., it is necessary to multiply by the mean heart interval.

It will be demonstrated that for calculating the heart rate spectrum each method gives approximately the same results. If a periodicity is present in the data, a spectral analysis of the data sampled by each method will show a peak at the frequency of the periodicity. However, when correlating the heart beats with other variables such as blood pressure or respiration, care is needed to ensure that the method of sampling does not induce phase changes between the variables.

#### Spectral analysis of point processes

Sampling the data by the methods given above does appear rather artificial and it would be more satisfying to perform an analysis directly on the data. In addition working directly with the data may lead to a closer understanding of the underlying structure of the data. We can work either with the counting process  $N(t)$  or with the interval series  $(x_t)$ . Bartlett (1963a, 1963b) gave a spectral analysis for the counting process  $N(t)$ . Cox and Lewis (1966) developed this theory and also included a complementary analysis of the interval process. More recently Cox (1972) has discussed the problem where a point process is dependent on a number of functions, deterministic and stochastic.

#### Definition

A point process is said to be completely stationary if the joint distribution of the number of events in  $k$  fixed intervals is invariant

under translation for all  $k = 1, 2, 3, \dots$ . A point process is said to be weakly stationary or '2nd order stationary' if

- a) The distribution of the number of events in a fixed interval  $(t, t + \tau)$  is invariant under a translation of the interval on the time axis, that is the distribution of  $(N(t + \tau) - N(t))$  is identical to the distribution of  $(N(t + \tau + h) - N(t + h))$  for any  $t, \tau$  and  $h$ .
- b) The joint distribution of the number of events in two fixed intervals  $(t_1, t_1 + \tau_1)$  and  $(t_2, t_2 + \tau_2)$  are invariant under a translation of both intervals on the time axis. That is, the joint distribution of  $(N(t_1 + \tau_1) - N(t_1), N(t_2 + \tau_2) - N(t_2))$  is identical to the joint distribution of  $(N(t_1 + \tau_1 + h) - N(t_1 + h), N(t_2 + \tau_2 + h) - N(t_2 + h))$  for any  $t_1, \tau_1, t_2, \tau_2$  and  $h$ .

Essentially we will follow the development given by Cox and Lewis (1966), Chapters 4 and 5. Since we are basically interested in how the heart beat is behaving in time, and how it relates to other variables in time we will only consider the time dependent counting process  $N(t)$ . Cox and Lewis (1966) pp.87-112, also develop the analysis of intervals and demonstrate how each approach is useful and how each gives differing but complementary results. When considering the probability structure of a process it is helpful to imagine an infinity of realizations. When a statement of probability is made about a function at a particular point  $t$ , this is theoretically derived by considering all possible realizations at that time  $t$ . In practice, of course, we have only one realization and it is only with assumptions such as stationarity given above that inference about the variable at time  $t$  can be made from the performance of the variable



at other times.

We can put  $E(dN(t)) = \lambda(t)$ . For a stationary point process  $\lambda(t) = \lambda$ , say, a constant. We can define a covariance function, for  $\tau > 0$  as

$$\begin{aligned} \mu(t, t + \tau) &= E( (dN(t) - E(dN(t))) (dN(t + \tau) - E(dN(t + \tau))) ) , \\ &= E(dN(t)dN(t + \tau)) - E(dN(t))E(dN(t + \tau)) , \\ &= E(dN(t)dN(t + \tau)) - \lambda(t)\lambda(t + \tau) . \end{aligned}$$

If we assume stationarity then the autocovariance is independent of  $t$  and we get

$$\mu(\tau) = E(dN(t)dN(t + \tau)) - \lambda^2, \quad \tau > 0 .$$

Now since  $dN(t) = 0$  or  $1$  we have that  $E(dN(t)) = P(dN(t) = 1) = \lambda$ .

$$\begin{aligned} \text{Thus } \mu(\tau) &= \text{Prob}(dN(t) = dN(t + \tau) = 1) - \lambda^2 , \\ &= \lambda \text{Prob}(dN(t + \tau) = 1 \mid dN(t) = 1) - \lambda^2 . \end{aligned} \quad (3.2)$$

We define  $e(t) = \text{Prob}(\text{event at } t \mid \text{event at } 0)$ .

$$\text{Then } \mu(\tau) = \lambda e(\tau) - \lambda^2 \text{ for } \tau > 0 .$$

We also have that for  $\tau < 0$ ,  $\mu(\tau) = \mu(-\tau)$ .

The assumption that more than one event do not occur simultaneously is formalized to the assumption that the probability of more than one event occurring in a small interval of length  $\delta t$  is  $o(\delta t)$  as  $\delta t \rightarrow 0$  (Cox and Lewis 1966, p.60)

This implies that  $\text{Prob.}(dN(t + \delta t) = dN(t) = 1)$  is  $o(\delta t)$  as  $\delta t \rightarrow 0$ , which for finite  $\lambda$  implies  $e(\delta t) \rightarrow 0$  as  $t \rightarrow 0$ . However, clearly  $\text{Prob}(\text{event at } 0 \mid \text{event at } 0) = 1$  and so  $e(t)$  is a discontinuous function of  $t$  at  $t = 0$ . A way around this difficulty is to make  $e(t)$  a continuous function by defining  $e(0) = 0$  and to define the complete

autocovariance as  $\mu_c(\tau) = \lambda D(\tau) + \lambda (e(\tau) - \lambda)$  ,

where  $D(\tau)$  is the Dirac delta function  $D(\tau) = 1 \quad \tau = 0$  ,  
 $= 0 \quad \tau \neq 0$  .

By analogy to the continuous spectral density function (Appendix A) we get the spectral density function for  $N(t)$  as

$$f_c(w) = \frac{1}{2\pi} \int_{-\infty}^{\infty} e^{-i\tau w} \mu_c(\tau) d\tau ,$$

and  $g(w) = 2\pi f_c(w) = \lambda + \int_{-\infty}^{\infty} e^{-i\tau w} \mu(\tau) d\tau$  , (3.4)

where  $\mu(\tau)$  is continuous at  $\tau = 0$  .

If consistent estimates can be made of the first and second order moments of the process from a single realization, then the process is termed ergodic. (See for example Yaglom (1962, p.3-8).) It can be shown that the series is ergodic if  $\lim_{T \rightarrow \infty} \frac{1}{T} \int_0^T \mu(\tau) d\tau = 0$  as  $T \rightarrow \infty$  . This can be satisfied if  $\mu(\tau) \rightarrow 0$  as  $\tau \rightarrow \infty$  or if  $\mu(\tau)$  is the sum of a function approaching zero as  $\tau$  increases and several periodic terms.

For  $w$  defined for non-negative values only we write

$$g_+(w) = 2\lambda + 2 \int_0^{\infty} e^{-i\tau w} \mu(\tau) d\tau . \quad (3.5)$$

An estimate for  $g_+(w)$  can be derived by analogy to the periodogram for equidistant time series.

$$\text{Define } J_N(w) = \sqrt{\frac{2}{t_n}} \int_0^{t_n} e^{itw} dN(t) = \sqrt{\frac{2}{t_n}} \sum_{s=1}^n e^{it_s w} ,$$

and then  $I_N(w) = J_N(w) J_N^*(w)$  ,

where the events occur at times  $t_1, \dots, t_n$  , the subscript  $n$  refers

to the counting process  $N(t)$  and  $*$  denotes complex conjugate.

We can estimate  $c(\tau)$  by  $\hat{e}(\tau) = n^{-1} \sum_{s=1}^n \sum_{k=0}^{n-s} D(t_s + k - t_k - \tau)$

and show that  $\hat{g}_+(w) = I_N(w)$ ,

where  $\hat{g}_+(w)$  is the estimate of  $g_+(w)$  obtained by substituting  $\hat{e}(\tau)$  for  $e(\tau)$  in (3.5) and (3.3).

Cox and Lewis (1966, p.129) show that  $E\{\hat{g}_+(w)\} = g_+(w)$  for  $w > 0$ , but that at  $w = 0$   $E(\hat{g}_+(0)) = 4 E(N(t_n)^2) \div t_n$ , which is not  $g_+(0)$ . It is difficult to avoid this bias and in the following smoothing procedure to obtain consistent estimates for the theoretical spectrum, the value of zero is omitted. The uniform weighting method for smoothing has the advantage of simplicity. We calculate the spectrum at frequencies  $w_p = 2\pi p/n$  and calculate

$$\tilde{g}_+(w_i) = \sum_{p=c-\frac{1}{2}k+\frac{1}{2}}^{c+\frac{1}{2}k-\frac{1}{2}} \frac{\hat{g}_+(w_p)}{k},$$

where  $k$  is the number of points over which the smoothing is performed and  $c$  is an integer if  $k$  is odd and an integer plus  $\frac{1}{2}$  if  $k$  is even.

Bartlett (1963b) derived a quadratic weighting scheme where the weights are given by  $h_p = B(1 - \frac{p^2}{A})$  where  $A$  and  $B$  are constants. Cox and Lewis (1966, p.131) point out that for  $n$  not very large the mean square error for the quadratically weighted estimate will usually not be smaller than the mean square error for the uniformly weighted estimate.

Approximation to the point-process periodogram

Given a series of points  $Y(t)$ ,  $t=0,1,\dots,T$ , where  $Y(t)$  is computed by the French-Holden algorithm given by equation (3.1), we can compute a finite Fourier transform

$$X(w) = \sqrt{\frac{2}{t_n}} \sum_{t=0}^T Y(t) e^{iwt} \quad (3.6)$$

We made an investigation Campbell (1979)<sup>a</sup> into how closely  $X(w)$  approximates  $J_N(w)$ , defined in the previous section, in magnitude and phase for all  $0 < w < \pi$ . If we substitute the general expression for  $Y(t)$  just before equation (3.1) into equation (3.6) we get

$$X(w) = \sqrt{\frac{2}{t_n}} \sum_{t=0}^T \sum_{i=1}^n \frac{\sin \pi (t-t_i)}{\pi (t-t_i)} e^{iwt}$$

Reversing the order of summation, this can be rewritten as

$$X(w) = \sqrt{\frac{2}{t_n}} \sum_{i=1}^n e^{iwt_i} \sum_{t=0}^T \frac{\sin \pi (t-t_i)}{\pi (t-t_i)} e^{iw(t-t_i)}$$

If we write the second sum as  $Z(t_i, w)$  then we have

$$X(w) = \sqrt{\frac{2}{t_n}} \sum_{i=1}^n e^{iwt_i} Z(t_i, w)$$

Clearly we would like  $Z(t_i, w)$  to be close to 1 for all values of  $t_i$  and  $w$ .

If we substitute  $\theta = T/2 - t_i$ , and  $\alpha_1 = \pi + w$ ,  $\alpha_2 = \pi - w$ , then  $Z(t_i, w)$  can be written

$$\begin{aligned}
& \frac{1}{2} \sum_{t=-T/2}^{T/2} \frac{\sin(t+\theta) \alpha_1}{\pi(t+\theta)} + \frac{1}{2} \sum_{t=-T/2}^{T/2} \frac{\sin(t+\theta) \alpha_2}{\pi(t+\theta)} \\
& + \frac{1}{2} \sum_{t=-T/2}^{T/2} \frac{1 - \cos(t+\theta) \alpha_1}{\pi(t+\theta)} - \frac{1}{2} \sum_{t=-T/2}^{T/2} \frac{1 - \cos(t+\theta) \alpha_2}{\pi(t+\theta)} \quad (3.7)
\end{aligned}$$

where  $0 < \alpha_2 < \alpha_1 < 2\pi$ .

Convergence follows from the fact that, for  $0 < \alpha < 2\pi$ ,

$$\sum_{t=-\infty}^{\infty} \frac{\sin(t+\theta) \alpha}{\pi(t+\theta)} = 1 \quad \text{and} \quad \sum_{t=-\infty}^{\infty} \frac{1 - \cos(t+\theta) \alpha}{\pi(t+\theta)} = 0,$$

for any value of  $\theta$ . (See for example, Sneddon 1961, 'Fourier Series', Routledge and Kegan Paul).

#### Estimation of bias

We can make (3.7) as close to unity as we wish simply by computing the function  $Y(t)$  for large negative through to large positive values of  $t$ . Since  $Y(t) \rightarrow 0$  as  $|t| \rightarrow \infty$ , it is worth investigating how far (3.7) is from unity for finite  $T$ . French and Holden (1971) evaluated  $Y(t)$  for  $t$  between 0 and  $t_n$  so that the upper limit of the summation is the integer part of  $t_n / \Delta t$ , where  $\Delta t$  is the sampling interval. Let us assume that  $T$  is this upper limit, and also, without loss of generalization that it is divisible by 2, so that (3.7) can be written as a symmetrical sum. Let  $T/2 = k$ . It can then be shown that

$$\sum_{t=-k}^k \frac{\sin(t+\theta) \alpha}{\pi(t+\theta)} = \frac{1}{\pi} \int_0^{\alpha} \cos \theta s \frac{\sin(k + \frac{1}{2})s}{\sin \frac{1}{2}s} ds, \quad (3.8)$$

and that

$$\sum_{t=-K}^K \frac{1 - \cos(t + \theta)\alpha}{\pi(t + \theta)} = \frac{1}{\pi} \int_0^\alpha \frac{\sin \theta s \sin(k + \frac{1}{2})s ds}{\sin \frac{1}{2}s} \quad (3.9)$$

If we integrate the right-hand side of (3.8) by parts we get

$$1 = \frac{\cos(k + \frac{1}{2})\alpha}{\pi(k + \frac{1}{2})} \left\{ \frac{\cos \theta \alpha}{\sin \frac{1}{2}\alpha} - \frac{4}{\alpha} \right\} + O(k^{-2}),$$

and since  $\alpha > 0$  this expression is  $1 + O(k^{-1})$ . When  $\alpha = \pi$ ,  $\cos(k + \frac{1}{2})\alpha = 0$ , and so for fixed  $k$  this value of  $\alpha$  yields the closest value of the expression to unity. The distance from unity is determined by  $(k\alpha)^{-1}$  which is largest when both  $\alpha$  and  $k$  are small.

In a similar manner we can integrate the right-hand side of (3.9) by parts to give

$$- \frac{\cos(k + \frac{1}{2})\alpha \sin \theta \alpha}{\pi(k + \frac{1}{2}) \sin \frac{1}{2}\alpha} + \frac{2\theta}{k + \frac{1}{2}} + O(k^{-2}).$$

Happily the term  $2\theta/(k + \frac{1}{2})$ , which need not be small, is eliminated when we substitute the above expression into the imaginary part of (3.7) and get

$$\frac{1}{2} \left\{ \frac{\cos(k + \frac{1}{2})\alpha_2 \sin \alpha_2 \theta}{(k + \frac{1}{2}) \sin \frac{1}{2}\alpha_2} - \frac{\cos(k + \frac{1}{2})\alpha_1 \sin \alpha_1 \theta}{(k + \frac{1}{2}) \sin \frac{1}{2}\alpha_1} \right\}$$

This expression is  $O(k^{-1})$  and is zero when  $\alpha_1 = \alpha_2 = \pi$ .

From the definitions of  $\alpha_1$  and  $\alpha_2$ ,  $w$  is small when  $\alpha_1$  and  $\alpha_2$  are near  $\pi$ , and  $w$  is near  $\pi$  when  $\alpha_1$  and  $\alpha_2$  are small.

Thus (3.7) becomes

$$Z(t_i, w) = 1 + O((k(\pi - w))^{-1}) + i O((k(\pi - w))^{-1}) .$$

This means that both the amplitude and phase distortions of  $X(w)$  are  $O((k(\pi - w))^{-1})$  and thus small if either  $k$  is large or  $w$  is not close to  $\pi$ . This has been programmed as a subroutine INTER, (Campbell 1979b) and Appendix C.

#### Use of the algorithm

We have shown that the point-process periodogram, calculated via the French-Holden algorithm is close to the periodogram  $I_N(w)$  calculated directly, provided we chose the Nyquist frequency well above all frequencies of interest. Note that we have not investigated how closely the estimated spectrum may resemble a postulated theoretical one, given the right data. As Lewis(1970) has pointed out, calculating the periodogram directly can be very costly in computer time, and using equidistant sampling points enables the periodogram to be calculated via the Fast Fourier Transform which can prove very much faster for long series..

One disadvantage with the algorithm is that we have band-limited the signal, and so that anything occurring faster than the Nyquist frequency will be aliased at a lower frequency.. In particular, if we were examining the heart-rate spectrum we would not be able to discover if the system generating the heart beats operated faster than about 0.5 Hz. , which is the usual upper limit. One feature worth mentioning is that  $Y(t)$  can be calculated for any value of  $t$  and gives us an easily interpretable 'intensity' function, since the more frequent the events, the larger  $Y(t)$ .

### Point process models

Ten Hoopen and Reuver (1967) fit a probabilistic model of heart rate to the intensity function  $e(t)$ . They consider heart beats to be the result of a stationary point process where the beats are subject to random delays. These processes are also discussed by Cox and Lewis (1966, p.204) and by Srinivasan (1973). Ten Hoopen and Reuver (1967) define a fundamental process  $\eta$  to be a stationary sequence of events with a joint probability density of  $k$  successive intervals  $\eta_k(a_1, a_2, \dots, a_k)$ . In addition they define a  $\eta'$  process of delays, independent of the  $\eta$  process, also stationary and with joint probability density function of  $k$  successive delays  $\eta'_k(b_1, b_2, \dots, b_k)$ . The authors derive properties of this process when the intervals are normally distributed and either form a Markov process or are independently distributed. This model would seem to describe a beating heart quite well, where the fundamental process could describe the electrical impulses coming from the sinoatrial node and the delay is the time taken for an impulse to reach the ventricle. Ten Hoopen and Reuver (1967) state that another advantage of the model is that in many cases the probability density function of the R-R intervals is nearly normal. From the sample intensity function the standard deviation of the  $\eta$  and the  $\eta'$  process can be estimated for different assumptions about the probability distributions. The authors compared three patients with atrial fibrillation and three normal subjects. They tentatively concluded that the pacemaker variability was greater for the patients than for the normal person. Successive intervals for the patients appeared to be independent of one another, whereas for the normal subject they appeared to be negatively correlated.



### The time dependent Poisson process

A fundamental model in point processes is the Poisson process. The conditions for a point process to be a Poisson process are that as  $h \rightarrow 0$

$$P(N(t+h) - N(t) = 0) = 1 - \lambda h + o(h) ,$$

$$P(N(t+h) = 1) = \lambda h + o(h),$$

and that the random variable  $(N(t+h) - N(t))$  is independent of the number and position of the events in  $(0, t)$ .

A generalization of this model is the time dependent Poisson process, discussed by Cox and Lewis (1966, p.78) where now we assume that  $\lambda$  is a function  $\lambda(t)$  of time. In this case we can show that the probability that the next event is at  $t_{i+1}$ , given an event at  $t_i$  is

$$P(t_{i+1} | t_i) = \lambda(t_i) \exp - \int_{t_i}^{t_{i+1}} \lambda(u) du .$$

Also it can be shown that the series of events  $(s_1, s_2, \dots)$  where  $s_i = \int_0^{t_i} \lambda(u) du$  form a Poisson process of constant unit rate.

Let  $(0, u)$  be a time interval in which the events at times  $t_1, t_2, \dots, t_n$  occur. We can write the joint probability distribution function of the events in the time interval  $(0, u)$  and the number of events as

$$f(t_1, t_2, \dots, t_n; n) = \prod_{i=1}^n \lambda(t_i) \exp \left[ - \int_0^u \lambda(u) du \right] . \quad (3.6)$$

It will be shown that for regular, deep respiration, the heart beats show clear evidence of cycling. A possible model for this, discussed by Lewis (1970) is the time dependent Poisson process with cyclically varying rate  $\lambda(t)$ .

$$\begin{aligned} \text{We put } \lambda(t) &= \exp(\alpha + k_s \sin w_0 t + k_c \cos w_0 t) , \\ &= \lambda \exp(k \sin(w_0 t + \theta)) , \end{aligned} \quad (3.7)$$

where  $\alpha$ ,  $K_s$  and  $K_c$  are constants,  $w_0$  is the frequency of the cycle,  $K = (K_s^2 + K_c^2)^{\frac{1}{2}}$  and  $\theta = \tan^{-1}(K_c / K_s)$ .

Lewis (1970) states that (3.7) is to be preferred to

$$\lambda(t) = \alpha + k_s \sin w_0 t + k_c \cos w_0 t, \quad (3.8)$$

because (3.7) leads to simpler results and (3.8) could give a negative  $\lambda(t)$ , which would be difficult to avoid.

If we substitute (3.7) into (3.6) and take logs we get the log likelihood

$$\log Lk(t_1, \dots, t_n; n) = n\alpha - e^{\alpha t_0} L_0(K) + K \cos \theta \sum_{s=1}^n \sin(w_0 t_s) + K \sin \theta \sum_{s=1}^n \cos(w_0 t_s). \quad (3.9)$$

In this equation and the following ones  $L_j(K)$  is a modified Bessel function of the first kind of order  $j$ . This is not the usual notation for a modified Bessel function, but is used to avoid a conflict with the notation for a periodogram. A description of Bessel function is given in Jeffries and Jeffries (1962, Chapter 21). The observations enter only through  $n$ ,  $\sum_{s=1}^n \sin(w_0 t_s)$  and  $\sum_{s=1}^n \cos(w_0 t_s)$  and so these are sufficient statistics for the parameters  $(\alpha, K, \theta)$  at frequency  $w_0$ . We put  $A(w_0) = \sum_{s=1}^n \cos(t_s w_0)$  and  $B(w_0) = \sum_{s=1}^n \sin(t_s w_0)$  and differentiate (3.9) to obtain the maximum likelihood estimators.

These are  $\hat{\theta} = \tan^{-1}(A(w_0) / B(w_0))$ ,

and  $e^{\hat{\alpha}} = \frac{n}{t_0} \times \frac{1}{L_0(K)} = \hat{\lambda}$ ,

where  $K$  is the solution of the equation

$$\frac{1}{n} (A^2(w_0) + B^2(w_0))^{\frac{1}{2}} = \frac{L_1(K)}{L_0(K)}.$$

$A(w_0)$  and  $B(w_0)$  are the components of the raw spectrum  $G_+(w_0)$  given before, and so the phase of the heart rate signal is just the phase associated with the Fourier transform of the counting process.

Point processes with ancillary variables

Bartlett (1966) gave an analysis of what he termed 'line processes', which essentially are point processes with ancillary variables. An example would be the times of vehicles passing a particular point on a road, and associated with these would be the velocities of the vehicles. In our case we consider an ancillary variable  $Y(t)$  where  $Y(t)$  could be either the mean blood pressure associated with each heart beat, or the respiration depth at the time of each heart beat. We consider  $Y(t)$  to be a continuous variable in time and assume we can only observe it as  $y_1, y_2, \dots$  at times  $t_1, t_2, \dots$  of the point process. In the same way as for the point process we can calculate the Fourier transform of the process  $(Y(t)dN(t))$ .

$$\text{Put } J_Y(w) = \sqrt{\frac{2}{t_n}} \int_0^t e^{itw} Y(t) dN(t) = \sqrt{\frac{2}{t_n}} \sum_{s=1}^n e^{it_s w} y_s$$

Then we can define the periodogram of the process as

$$I_Y(w) = \frac{2}{t_n} \left| \int_0^{t_0} Y(t) dN(t) e^{iwt} \right|^2 = \frac{2}{t_n} \left| \sum_{s=1}^n y_s \cos wt_s + i \sum_{s=1}^n y_s \sin wt_s \right|^2$$

$$= \frac{2}{t_n} ( C^2(w) + D^2(w) ), \text{ where } C(w) = \sum_{s=1}^n y_s \cos wt_s \text{ and } D(w) = \sum_{s=1}^n y_s \sin wt_s$$

We can define the cross-periodogram between  $(dN(t))$  and  $(Y(t)dN(t))$  as

$$I_{NY}(w) = J_N(w) J_Y^*(w) \text{ where } * \text{ denotes the complex conjugate. It is}$$

easy to show that the cross-periodogram phase is given by

$$\hat{\phi}(w) = \tan^{-1} \frac{A(w)D(w) - C(w)B(w)}{B(w)D(w) + A(w)C(w)}$$

$$\hat{\phi}(w) = \tan^{-1} \frac{A(w)}{B(w)} - \tan^{-1} \frac{C(w)}{D(w)} \quad (3.10)$$

The phase is the difference between the arguments of the Fourier transforms of the processes  $(dN(t))$  and  $(Y(t)dN(t))$ .

However, assume that the continuous function  $Y(t)$  is deterministic with an added random error and is of the form

$$Y(t) - \bar{Y} = A \sin(\omega_0 t + \psi) + \epsilon_t \text{ where } \epsilon_t \text{ is } N(0, \sigma^2) \text{ , } (3.11)$$

where  $Y(t)$  is defined in the interval  $(0, t_0)$  and  $\bar{Y}$  is the mean of  $Y(t)$  in that interval. We can estimate  $\psi$  from the observed values of  $Y(t)$ ,  $y_1, y_2, \dots, y_n$ , by the method of least squares. We get that

$$\hat{\psi} = \tan^{-1} \frac{C(\omega_0) \sum \sin^2 \omega_0 t_s - D(\omega_0) \sum \sin \omega_0 t_s \cos \omega_0 t_s}{D(\omega_0) \sum \cos^2 \omega_0 t_s - C(\omega_0) \sum \sin \omega_0 t_s \cos \omega_0 t_s} \quad (3.12)$$

The summation is taken from  $s = 1$  to  $s = n$ .

The estimated phase difference between  $Y(t)$  and  $dN(t)$  at  $\omega_0$  is given by  $\hat{\phi}_1(\omega_0) = \hat{\theta} - \hat{\psi}$  which is not the same as (3.10) for  $w = \omega_0$ .

If the observations  $t_1, t_2, \dots, t_n$  were equally spaced in time then  $\sum \sin \omega_0 t_s \cos \omega_0 t_s \approx 0$  and  $\sum \sin^2 \omega_0 t_s = \sum \cos^2 \omega_0 t_s \approx n/2$  and so  $\hat{\psi}$  would simplify to  $\tan^{-1}(C(\omega_0)/D(\omega_0))$ , and so would be the cross-periodogram phase at  $\omega_0$ . The result (3.12) shows that if we assume  $(dN(t))$  to be a time dependent Poisson process with parameter  $\lambda(t)$  given by (3.7) and that the ancillary variable is of the form given

by equation (3.11) then we would have to estimate the phase between them by  $\hat{\phi}_1(w_0)$  and not from the cross-periodogram phase given by  $\hat{\phi}(w_0)$ .

A further complication would occur if the heart intervals were viewed as coming from a continuous process  $X(t)$  where  $X(t)$  is given by

$X(t) - \bar{X} = B \sin(w_0 t + \beta) + \epsilon'_t$  (3.13) where  $\epsilon'_t$  is  $N(0, \sigma^2)$  and  $\bar{X}$  is the mean of  $X(t)$  in  $(0, t_0)$ . Again we assume we can only observe the process at times  $t_1, \dots, t_n$  with values  $x_1, \dots, x_n$ . In the same way as before a least squares estimate of  $\beta$  is given by

$$\hat{\beta} = \tan^{-1} \left\{ \frac{E(w_0) \sum \sin^2 w_0 t_s - F(w_0) \sum \sin w_0 t_s \cos w_0 t_s}{F(w_0) \sum \cos^2 w_0 t_s - E(w_0) \sum \sin w_0 t_s \cos w_0 t_s} \right\} \quad (3.14)$$

where  $E(w_0) = \sum x_s \cos w_0 t_s$  and  $F(w_0) = \sum x_s \sin w_0 t_s$  and the summation is taken from  $s=1$  to  $s=n$ .

Again, if the observations were equally spaced in time, then  $\hat{\beta}$  reduces to  $\tan^{-1}(E(w_0)/F(w_0))$  and the estimated cross-periodogram phase between  $X(t)$  and  $Y(t)$  at  $w_0$  is equal to  $\hat{\beta} - \hat{\psi}$ .

In all the above models the assumption is that the frequency  $w_0$  of the model is known. In many cases this may be true, for instance in queuing there is often a time-of-day effect. For paced respiration however, the frequency is only known approximately and will have to be estimated more accurately. For this purpose the periodogram is in many cases more effective than the spectrum because the latter tends to diffuse peaks over a range of frequencies.

It can be shown that a time dependent Poisson process with parameter

$\lambda(t)$  given by equation (3.7) will generate a series of points

whose periodogram  $I_N(w)$  will have maximum ordinate at frequency  $w_0$ .

In the same way the periodogram of the process  $Y(t)$  and of the

intervals  $X(t)$  given above will also have a maximum at frequency  $w_0$ .

### Probability distribution of point process models

The intervals between events coming from a Poisson process with parameter can be shown to have a probability density function

$P(X = x) = \lambda e^{-\lambda x}$ ,  $x \geq 0$ . For a time-dependent Poisson process with parameter  $\lambda(t)$ , given that an event occurred at time  $t$ , then the probability density function of the interval to the next event is  $\lambda(t+x) \exp\left\{-\int_t^{t+x} \lambda(u) du\right\}$ .

If the heart beats form a Poisson process, or a time-dependent Poisson process, then we would have expected the interval histograms of Chapter 2 to show an exponential form which they clearly do not. A model of the form (3.13) may be more appropriate to describe the heart intervals under forced respiration. However, the choice of an underlying model does not affect the methods of computing the spectrum of a point process. We will not discuss the sampling properties of the theoretical spectrum for various models because there are considerable difficulties beyond the simple Poisson model. The sampling properties of spectra calculated from time series with equispaced points will be discussed in Appendix A.

### Methods used in this study

The data for the healthy subjects was obtained in the form of

the intervals between the heart beats and the depth of respiration at the time of each heart beat. Further details are given in Chapter 5. With these data it was possible to try three different methods of spectral analysis; of the counting process, of the intervals, and of equidistant sampled points.

#### Sampling: healthy subjects

Suppose we are given a series of intervals  $x_1, x_2, \dots, x_n$ , in seconds, together with a series of respiration records  $y_1, y_2, \dots, y_n$  in mm. Hg. The signal  $y_j$  is measured at a time  $t_j = \sum_{s=1}^j x_s$ . We sample the signals at the points  $j \Delta t, j=1, 2, \dots$ , where  $\Delta t$  is the sampling interval. We calculate the results in beats/min in order to be able to compare them with those of the post-operative patients. If  $t_{K-1} < j \Delta t \leq t_K$ , then the sampled values of the heart rate and respiration are given by

$$r_j = \frac{60}{x_{K-1}} + \frac{j \Delta t - t_{K-1}}{t_K - t_{K-1}} \left\{ \begin{array}{cc} \frac{60}{x_K} & - \frac{60}{x_{K-1}} \end{array} \right\}, \quad (3.15)$$

$$y_j = y_{K-1} + \frac{j \Delta t - t_{K-1}}{t_K - t_{K-1}} (y_K - y_{K-1})$$

A computer program SAMPLE was written to implement these equations.

There remain several questions - how often do we sample and do we get different results from calculating the heart rate instead of the heart interval? We have to balance between sampling too frequently, introducing a high correlation between the data points, and sampling too infrequently and losing information from the higher

frequencies. One method that would compromise between the two is to take as many sampling points as there are events, and so the sampling interval would be  $\bar{t} = t_0 / n$ , where  $n$  is the number of points in the total time  $t_0$ . However this would mean changing the sampling interval for each subject. A range of sampling intervals between 0.5 and 2.0 seconds was tried on one subject, with no marked difference on the resulting spectra. For convenience 1.0 seconds was chosen as the sampling interval for the remaining subjects which is quite close to the average heart interval for a normal person of about 0.8 secs.<sup>1</sup> Since heart rate is simply the inverse of heart interval, the two variables should be exactly  $180^\circ$  out of phase. This was verified by calculating the cross-spectral phase from both the sampled heart rate data and the sampled heart interval data by BMDX92 as described in Appendix A. Sets of data from 3 different subjects were examined and the phase between respiration and heart interval and the phase between respiration and heart rate were calculated. In each case the difference between the two measurements of phase was almost exactly  $180^\circ$  at each frequency. The results of Chapter 2 show there is nothing to choose between heart interval and heart rate for normality assumptions.

Another question is whether the sampling introduces any bias into the phase between heart rate and respiration. Equation 3.15 can be written as

$$r_j = 60 \left[ \frac{1}{x_{K-1}} + \frac{(j \Delta t - \sum_{i=1}^{K-1} x_i)}{x_K^2} - \frac{(j \Delta t - \sum_{i=1}^{K-1} x_i)}{x_K x_{K-1}} \right]$$

This is a highly non-linear relationship between the  $x_i$ 's and the

<sup>1</sup> This would imply that frequencies above 0.5 Hz. would be aliased.

Reasons for believing this to be unimportant are discussed in Appendix A.



FIGURE 3.3 POINT SPECTRUM AND HEART-RATE

SPECTRUM FOR SUBJECT 10

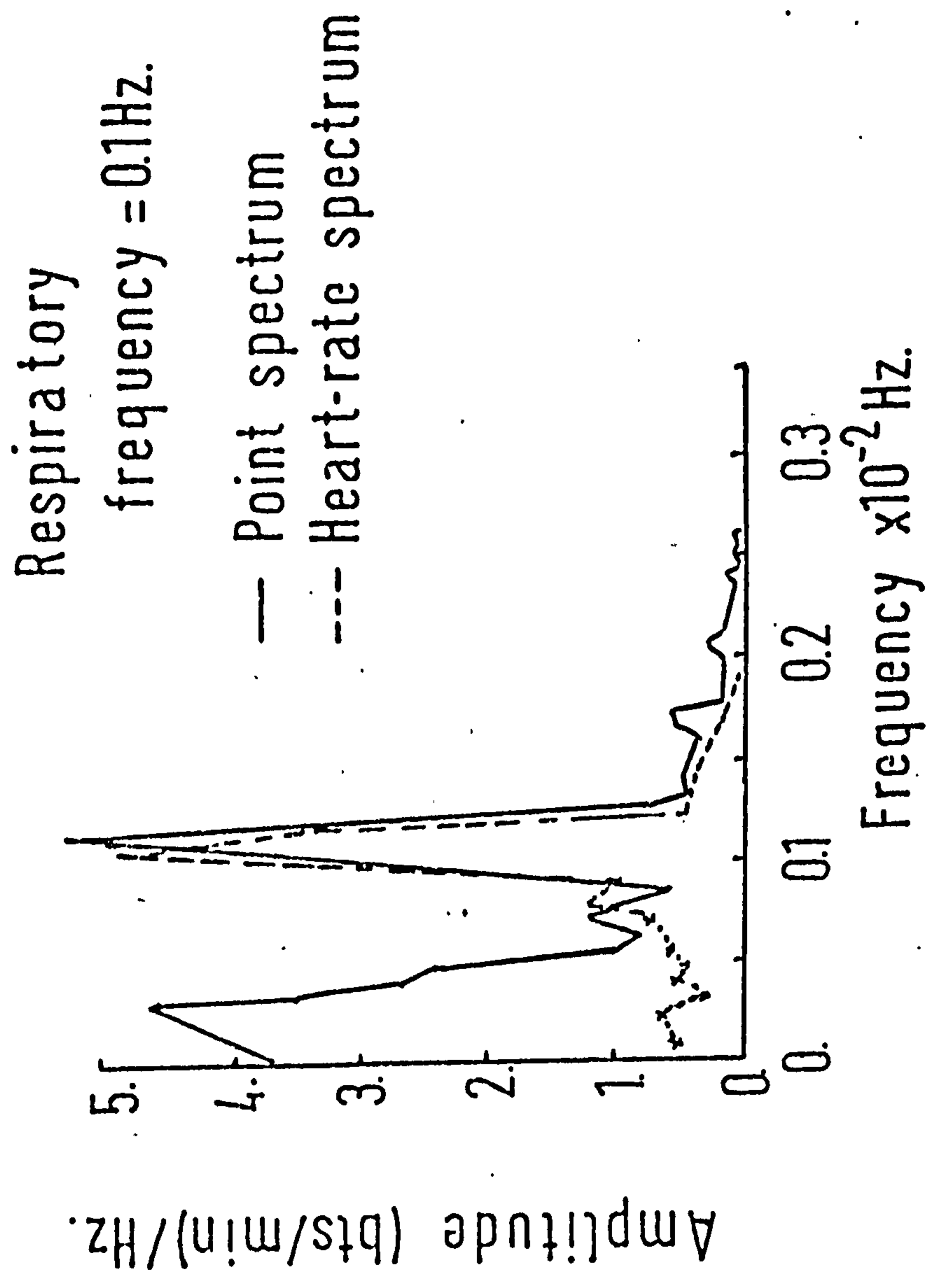

$r_j$ 's and the standard technique of investigating phase changes of linear filters by taking Fourier transforms would not be practical in this case.

#### Sampling: post-operative patients

The method of sampling the data from the post-operative patients described in Chapter 1 implied that the heart beat is not sampled until after the second beat of the interval has occurred. This method is similar to the constant interpolation method of Luczak and Laurig except if  $t_{k-1} < j \Delta t \leq t_k$  we put  $r_j = 60/x_{k-1}$ . The ancillary variable  $y_{k-1}$  in this case is the mean blood pressure over the period  $(t_{k-2}, t_{k-1})$ . It would be of interest to know whether the phase between the heart rate and blood pressure is affected by the method of sampling. This is investigated later by a simulation technique.

#### Point-spectrum and 'sampled' spectrum.

A program PSPEC was written which calculated the periodogram of the counting process as

$$I_N(\omega) = \frac{2}{t_n} \left[ \left\{ \sum_s \cos \omega t_s \right\}^2 + \left\{ \sum_s \sin \omega t_s \right\}^2 \right]$$

The spectrum was then estimated by either a linear or quadratic smoothing of  $I_N(\omega)$  as described previously. Figure 3.3 shows the smoothed point spectrum applied to heart intervals from Subject 10 of the respiration study. The subject was breathing regularly to a metronome at a rate of one breath every 10 seconds. We can see how the point spectrum is successful in detecting a cycle in the heart

beats of the same frequency. The data were also sampled by SAMPLE and the spectrum then calculated by BMDX92, as described in Appendix A. This is also displayed in Figure 3.3, where we can see that there is a close relation between the two spectra. Both types of spectra are successful in detecting cycles in the heart beat, but it is of interest to note that BMDX92, which uses the Fast Fourier Transform, took 2.5 seconds CPU time on an IBM370, compared with about 2 minutes CPU time for PSPEC on an ICL System 4. This is one of the major reasons for calculating the spectrum via SAMPLE and BMDX92 rather than directly by PSPEC. Unfortunately the Fast Fourier transform cannot be applied to non-equispaced data points.

#### Simulation study

In an attempt to investigate possible phase changes induced by the sampling methods a simulation study was undertaken. A program SIMUL was written to simulate heart rate and respiration/blood pressure. The assumptions were that the heart interval and respiration/blood pressure signals were of the form (3.13) and (3.11) respectively. Two sinusoids of given mean, amplitude and relative phase were generated, and the random variation was simulated by a subroutine GAUSS (IBM Scientific Subroutines). The signals were converted to a point process by a form of backward extrapolation. Any point  $t$  was chosen on the time axis and the corresponding interval

$x_t = \frac{60}{h} (\mu_x + B \sin(\omega_0 t) + \epsilon_t)$  calculated, where  $\mu_x$  and  $B$  are the input mean and amplitude of the signal and  $\epsilon_t$  is the generated

Gaussian random noise with mean zero and given standard deviation.

The ancillary variable  $y_t = \mu_y + A \sin(\omega_0 t + \beta)$  was also calculated where  $\beta$  is the relative phase between the signals. We then calculated

$t - x_t$  which is the time the previous beat occurred and from which we can calculate the previous heart interval and so on. The resulting intervals and the corresponding ancillary variable formed the input to SAMPLE and the output of SAMPLE processed by BMDX92 as described in Appendix A. A program SAMPLE2 was written to simulate the method of sampling employed by the data logger, and the output of this program was also processed by BMDX92. The heart rate was simulated with a mean 72 bts/min and amplitude 5 bts/min., and the blood pressure with mean 90 mm. Hg. and amplitude 5 mm.Hg. The added random noise had zero mean and a standard deviation varying from 1 to 10 bts/min. The phase between the two signals was fixed for a given frequency. In each case about 120 points were generated.

Table 3.1 shows the simulated frequency, phase and noise standard deviation. In every case the maximum ordinate of the HFD spectrum was in the region of the simulated frequency. The values of the phase and coherency given in the table are those at the maximum cross-spectrum ordinate. Column 2 of the table gives the phase and coherency resulting from the data sampled by the method given in equation 3.15. Column 3 gives the same statistics for the same data for the heart interval, i.e. with  $x_k$  replacing  $60/x_k$  in 3.15. Column 4 gives the results for the same data but in this case the data was sampled by SAMPLE2, in order to simulate the DART procedure. Column 5 gives the phase  $\hat{\beta} - \hat{\psi}$  at the simulated frequency  $w_0$  where  $\hat{\psi}$  and  $\hat{\beta}$  are obtained from (3.12) and (3.14) respectively.

It will be seen from the table that all methods detect cycles

in the data with reasonable accuracy. The frequency associated with the spectral peak is in each case close to the simulated one. The phase results are not quite so accurate, but this is not surprising since the additive random noise will have a direct effect on the phase. The phase appears to be measured less accurately at a simulated phase of zero than for a phase of  $50^\circ$ . For the limited type of data provided by the simulation, both the linear interpolation and the beat-delayed constant interpolation methods give quite reasonable results, and it appears that we have not been misled by the sampling methods of the DART data logger. It was also found that the cross-periodogram  $I_{NY}(w)$  had a clearly marked peak at the simulated frequency. The phase results calculated directly from the point process were again in agreement with the simulated phase, although the cross-periodogram phase, without the benefit of smoothing, seems more vulnerable to disturbance by the added noise. If the heart intervals, which were output from SIMUL, were input directly into BMDX92 as if they were at one second intervals, then the cross-spectrum showed a peak at about  $w_0 \bar{x}$ , where  $\bar{x}$  is the mean heart interval in seconds and  $w_0$  is the frequency of the simulated series. The value of the phase at the cross-spectrum peak was in agreement with the simulated phase in each case.

An additional analysis was conducted on the heart interval data of 3 healthy, resting subjects who took part in the sinus arrhythmia study described in Chapter 5. The observations were processed by SAMPLE for linear interpolation to equidistant data points, and also processed by SAMPLE2, to simulate the method of sampling employed by the DART. The spectrum and the cross-spectrum of the two series were

FIGURE 34 PHASE BETWEEN SAMPLED DATA AND  
BEAT-DELAYED SAMPLE DATA (SUBJECT 20)

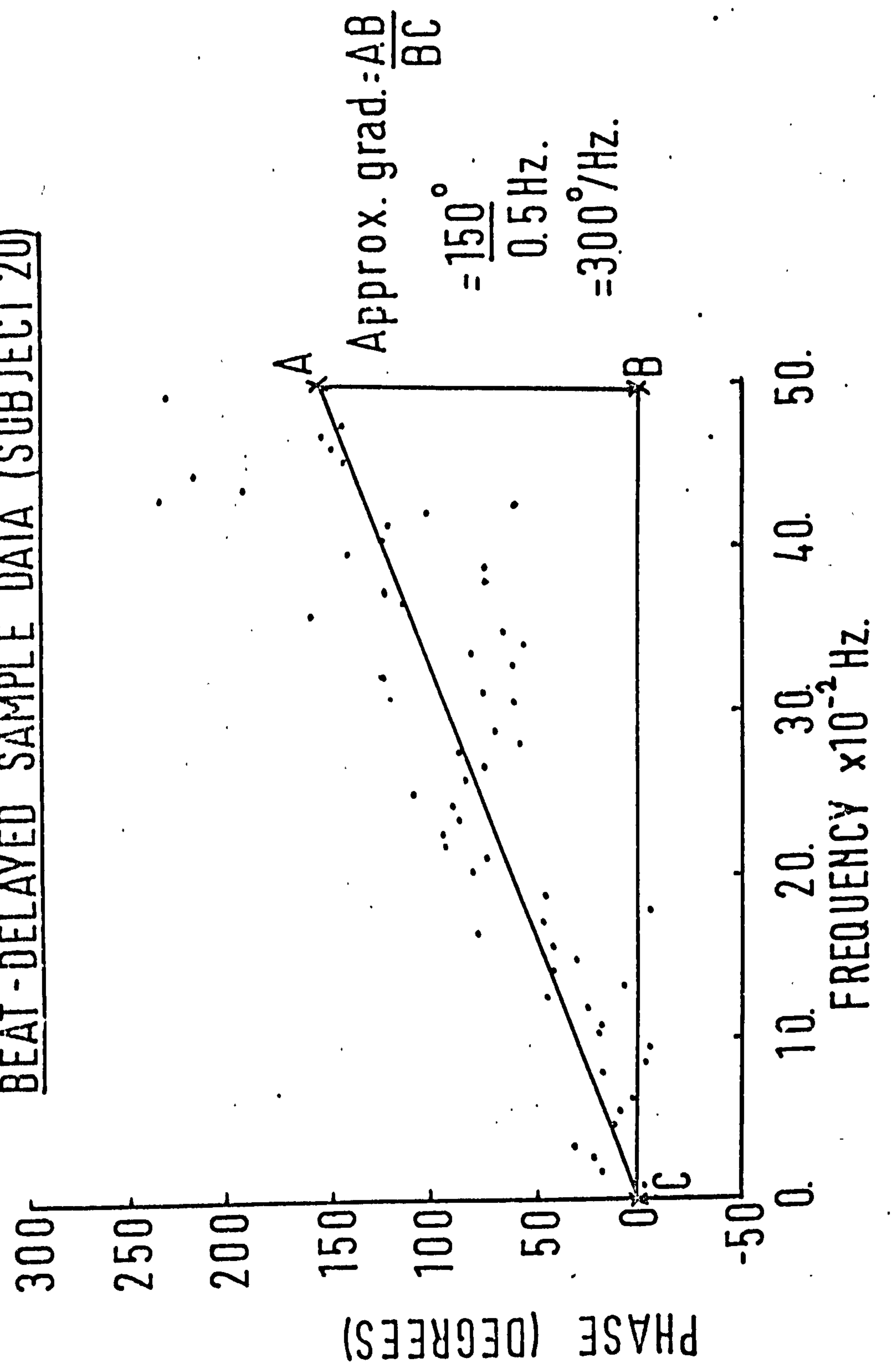

then calculated by BMDX92. It was found that for each subject the heart interval spectra for the two methods were very similar. The heart-interval spectrum for the DART simulation was not as smooth as the constant interpolation spectrum, but the basic features and the main peaks were present in each case. The phase of the cross-spectrum is interesting, as illustrated in Figure 3.4 for subject 20 of the sinus arrhythmia study. It was found that the phase difference between the two data sets increase roughly linearly from 0 degrees as the frequency increased from 0 to 0.5 Hz. If the two series were identical, but had been lagged by a constant amount, then we would have expected a linear phase relationship, with the phase/frequency graph passing through the origin. In fact, the lag is one heart beat, which is variable, but still gives us an approximately linear phase. For interest we can derive an approximate mean heart rate from the graph. If we take the gradient of the phase/frequency curve to be 300 degrees / Hz., then this can be shown to be equivalent to a lag of  $300/360 = 5/6$  seconds. If we are prepared to assume that the heart rate distribution is symmetric about the mean, then it is shown in Appendix A that the mean heart rate is given by  $60/(5/6) = 72$  bts/min.

### Discussion

The theory of point processes has been developed in some detail because it would seem to provide a natural base for an analysis of heart beats. However, in all the medical literature on the subject the implicit assumption has been that the heart rate is a continuous function of time which could only be viewed at particular points in time which were the heart beats. This underlies the interpolation

techniques covered in the literature review. It has been shown that for analysing the spectra of regularly recurring point processes the spectra calculated from equidistant sampled data points is probably as effective for detecting cycles as the direct point spectrum. In addition the former method has the overwhelming advantage in speed and efficiency. However the results from these two approaches differ considerably for phase measurements. We have shown that the 'natural' measure of phase for a counting process  $dN(t)$ , the argument of the Fourier transform of  $dN(t)$ , is the maximum likelihood estimate of the parameter  $\hat{\theta}$  in the time dependent Poisson process with parameter  $\lambda(t)$  given by (3.7). This is very different from the parameter  $\hat{\beta}$ , the least squares estimate if the intervals are assumed to be sinusoidal. We have shown that the cross-spectrum phase obtained by sampling the data and processing with program BMDX92 gives an accurate estimate of the phase when sinusoidal models of the form (3.11) and (3.13) are adopted. This measure of phase seems more closely associated with an intuitive measure such as would be obtained if we examined the tachycardiogram and the respiratory signal together. However, it is difficult to know how to interpret the phase  $\hat{\theta}$ .

The original contributions in this Chapter are : 1) we have shown that the method of French and Holden gives asymptotically unbiased estimates of the point-process spectrum, and we have provided estimates of the bias in the finite case; 2) by simulation and theoretical studies we have shown that the two approaches of viewing the heart beat as a point process and as a continuous variable which is irregularly sampled in time produce similar spectra but different phase estimates; 3) the method of sampling by the DART data logger will result in a useful spectrum but with a phase distortion which increases approximately linearly with frequency.



TABLE 3.1: PHASE AND COHERENCY RESULTS FOR SIMULATED DATA

| 1                               |    |    | 2   |      | 3     |      | 4     |      | 5     |
|---------------------------------|----|----|---|------|-------|------|-------|------|-------|
| <u>Simulated H.R.</u>           |    |    | <u>Sampled Heart Rate, analysed by BMDX92</u> |      |       |      |       |      |       |
| Freq. Phase Noise<br>(bts/min.) |    |    | Phase   | Coh. | Phase | Coh. | Phase | Coh. | Phase |
| 0.07                            | 50 | 1  | 51  | 1.00 | 130   | 1.00 | 48    | 0.99 | 49    |
| 0.07                            | 50 | 5  | 52  | 0.99 | 129   | 0.99 | 51    | 0.99 | 53    |
| 0.07                            | 50 | 10 | 52  | 0.99 | 130   | 0.99 | 45    | 0.99 | 53    |
| 0.10                            | 0  | 1  | -1  | 1.00 | -179  | 1.00 | 0     | 0.99 | -1    |
| 0.10                            | 0  | 5  | -4  | 0.99 | -176  | 0.99 | -3    | 0.98 | 1     |
| 0.10                            | 0  | 10 | 1   | 0.98 | 178   | 0.98 | 2     | 0.98 | -5    |

Column 1 - Simulated data, phase in degrees, standard deviation of noise in bts/min.

Column 2 - Linear interpolation of heart rate

Column 3 - Linear interpolation of heart interval

Column 4 - Constant interpolation of heart rate, one beat delayed

Column 5 - Direct estimate of phase at frequency of simulation.

CHAPTER 4. Frequency analysis of the records of the post-operative patients and the ambulatory subjects

Spectral analysis of heart rate and blood pressure

In Chapter 1 we dealt with the initial processing of the heart rate and blood pressure records, and in Chapter 3 we investigated methods of equidistant sampling. We are now at the stage to apply the methods of spectral analysis and digital filtering to the data. These methods are reviewed in Appendix A. The reasons for employing spectral analysis have been touched upon in Chapter 1. There is strong evidence that oscillations are present in both heart-rate and blood pressure and we wish to determine three aspects of the oscillations: how many of the data records exhibit cycles, what proportion of the variance can be attributed to cycles and whether there is a regular phase relationship between the heart-rate and blood pressure cycles.

Initially a spectral analysis using program BMD02T (Dixon, 1970) was carried out. Sets of 300 consecutive points were analysed. Afterwards, however, all the data were processed by BMDX92 (Dixon, 1972). The reasons for preferring BMDX92 are given in Appendix A. The treatment of the data for spectral analysis was similar to the treatment for the frequency distribution study. Initially the entire data set for each patient was subject to a spectral analysis. The use of the Fast Fourier Transform by BMDX92 meant that this computation was possible. It was found, however, that non-stationarities became readily apparent and dominated the result. Only where marked oscillations persisted throughout the data set, such as the respiration cycle in the blood pressure records for patients 13-73 and 16-73, were these apparent in the overall spectrum. The spectrum for the heart

rate records of patients 15-73 and 16-73 displayed a large peak at zero frequency and comparatively low power elsewhere. It would be possible to remove this peak by the use of high-pass filtering, but the filters available with the BMD programs were not suitable. Any temporary oscillations in either the heart-rate or blood pressure would be detected by the overall spectrum. Thus, the next part of the analysis was to section the data into non-overlapping lengths of between 4 and 8 minutes and to analyse consecutive data sets. Program BMDX92 operates more efficiently if the number of points in the data set is a power of 2, and so sets containing 256 or 512 consecutive points were employed. The spectrum was calculated at intervals of 0.008 Hz., which in general yielded 4 degrees of freedom for each spectral estimate. This value would be quite low if we were investigating the spectrum of a random process, but we are in effect looking for deterministic signals and we wish to obtain a high degree of resolution.

The type of operation undergone by each patient is given in Table 4.1. At the time of the analysis all the patients were in a clinically stable state; there were no periods of abnormal fibrillation, neither were there large numbers of ectopic beats. The patients were either free breathing or on demand respirators. The fifteen patients contributed a total of 111 sections of data, with 256 points in each section. To interpret the spectra it was decided to put each into one of three classes. A Class 1 spectrum implied that there were clear peaks in the spectrum which were significantly greater than would be expected on the underlying assumption that the data were random noise. A Class 2 spectrum implied that peaks were present, but that there was

much background variation which meant that although the peaks were identifiable by eye, it was within the bounds of possibility that they were due to random events. A Class 3 spectrum was one of two types; either there were no distinguishable peaks present at all, or the only peak was at zero frequency. In cases where doubt existed whether a peak was present or not, the spectrum was classified as Class 3.

Table 4.2 shows how the spectra from each patient were classified. The 111 heart rate spectra divided into Classes 1,2,3 in the proportion 13:33:65 whereas the blood pressure spectra in the same way were divided 79:21:11. This meant that 59% of the heart rate spectra were indistinguishable from random noise, and only 12% showed clearly identifiable peaks. The reverse situation occurred for the blood pressure spectra, with 71% showing clearly identifiable peaks and only 10% being totally uninformative.

Examples of the heart-rate and blood pressure spectra are shown in Figures 4.1 and 4.2 a. The top half of Figure 4.1 shows Class 1 spectra for subject 4-72(1). In both the heart rate and blood pressure there appear to be two peaks, one centred at about 0.055 Hz. and a larger one at 0.275 Hz.. It is apparent from the discussion in Chapter 1 that the peak at 0.275 Hz. is due to respiration. There is no other physiological explanation for a cycle with such a high frequency. The other peak may be the so-called vasomotor peak, resulting from oscillations in the blood pressure control system, but it is at a lower frequency than that reported by Sayers (1973). It is possible that this peak could result from the thermal control system described by Sayers (1973) and Kitney (1974). Unfortunately it would

HEART RATE AND BLOOD PRESSURE SPECTRA  
SUBJECT 4-72.

FIGURE 4.1

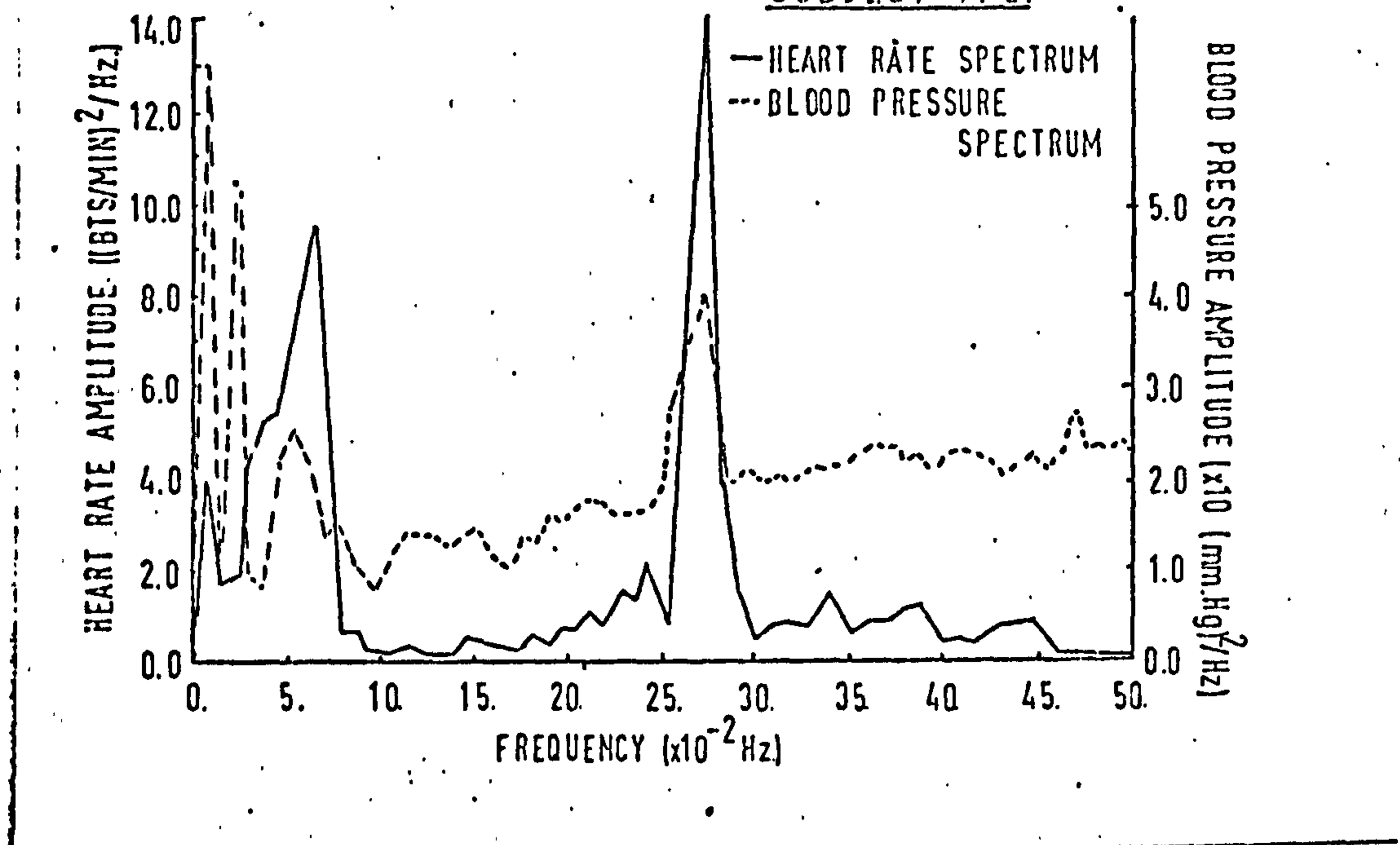

HEART RATE AND BLOOD PRESSURE SPECTRA  
SUBJECT 12-73.

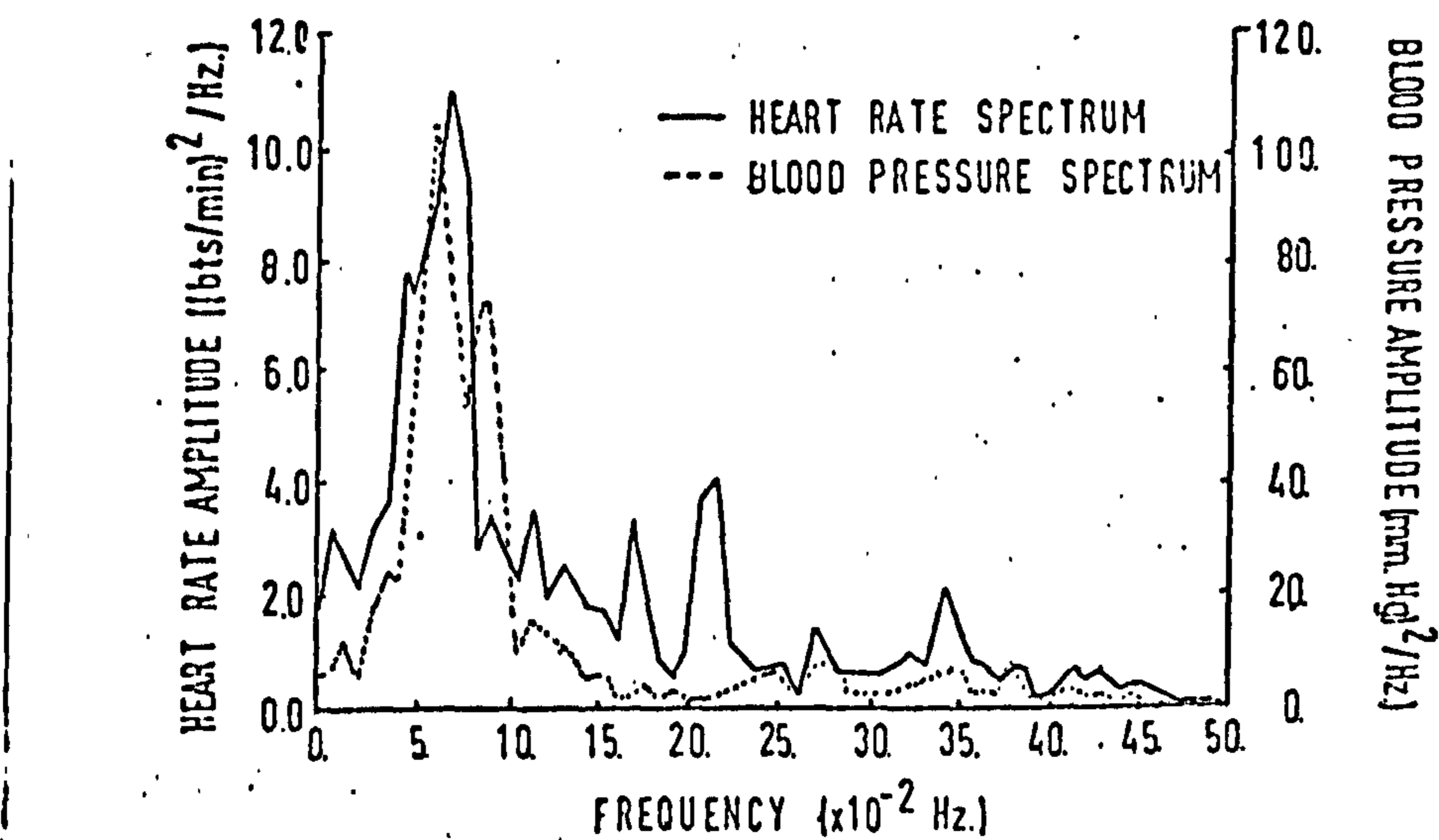

seem impossible to decide retrospectively which mechanism is responsible for the peak. The lower half of Figure 4.1 shows Class 1 spectra for 12-73(2). These are very similar to those presented by Sayers (1973). We see now that the respiration peak has disappeared from the blood-pressure spectrum, and it is only faintly marked in the heart-rate spectrum, possibly, at 0.23 Hz.. In this case we find that both spectra are dominated by a peak in the region of 0.06 Hz.. Again, it is impossible to ascribe a definite cause to this peak but it is closer in frequency to the thermal component quoted in the literature than to the vasomotor component. The top half of Figure 4.2 shows a Class 2 heart-rate spectrum and a Class 1 blood-pressure spectrum for 7-73(1). The heart-rate spectrum reveals two peaks in the low frequency range, at 0.04 and 0.07 Hz.. Also present is a larger peak at 0.24 Hz.. The blood-pressure spectrum shows only one peak, at about 0.27 Hz.. This is interesting because, if the high frequency peaks in each spectrum were due solely to respiration, we would expect them to be at the same frequency. The lower half of Figure 4.2 shows a Class 1 blood-pressure spectrum and a Class 3 heart-rate spectrum for 14-73(1). We see that there are no apparent peaks in the heart-rate spectrum at all, whereas the blood-pressure spectrum shows two clearly marked peaks at 0.03 Hz. and 0.18 Hz..

Table 4.2 gives the frequencies at which the spectral peaks occur. It will be noted that respiratory peaks in blood pressure occurred for subjects 4-72, 7-73, 8-73, 11-73, 13-73, 14-73, 15-73 and 10-74. These appeared sometimes with, and sometimes without, a lower frequency peak. It is possible, for those subjects with no higher frequency peak in the blood-pressure spectrum, that respiration was

HEART RATE AND BLOOD PRESSURE SPECTRA  
SUBJECT 7-73

FIGURE 4.2 a

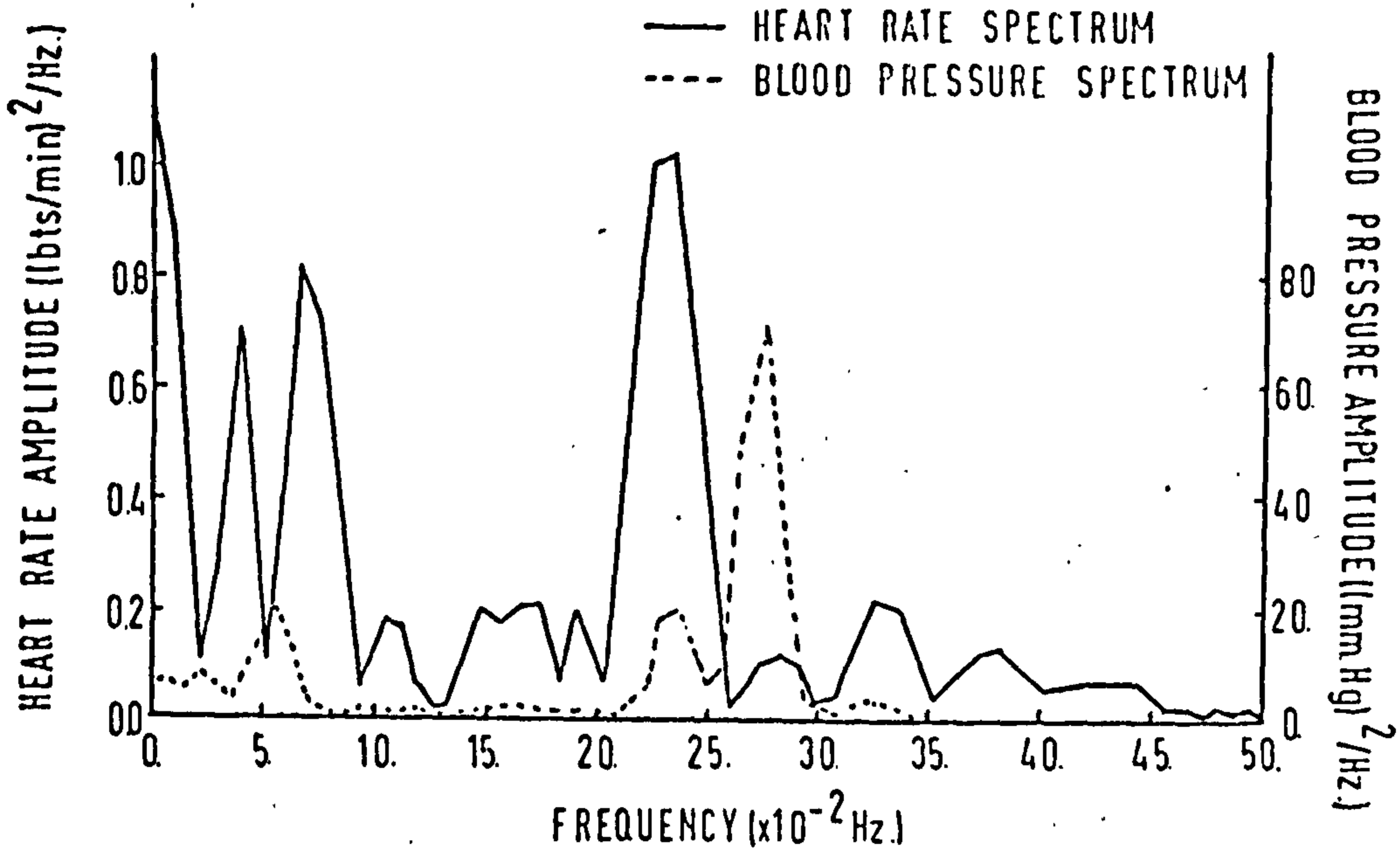

HEART RATE AND BLOOD PRESSURE SPECTRA

SUBJECT 14-73

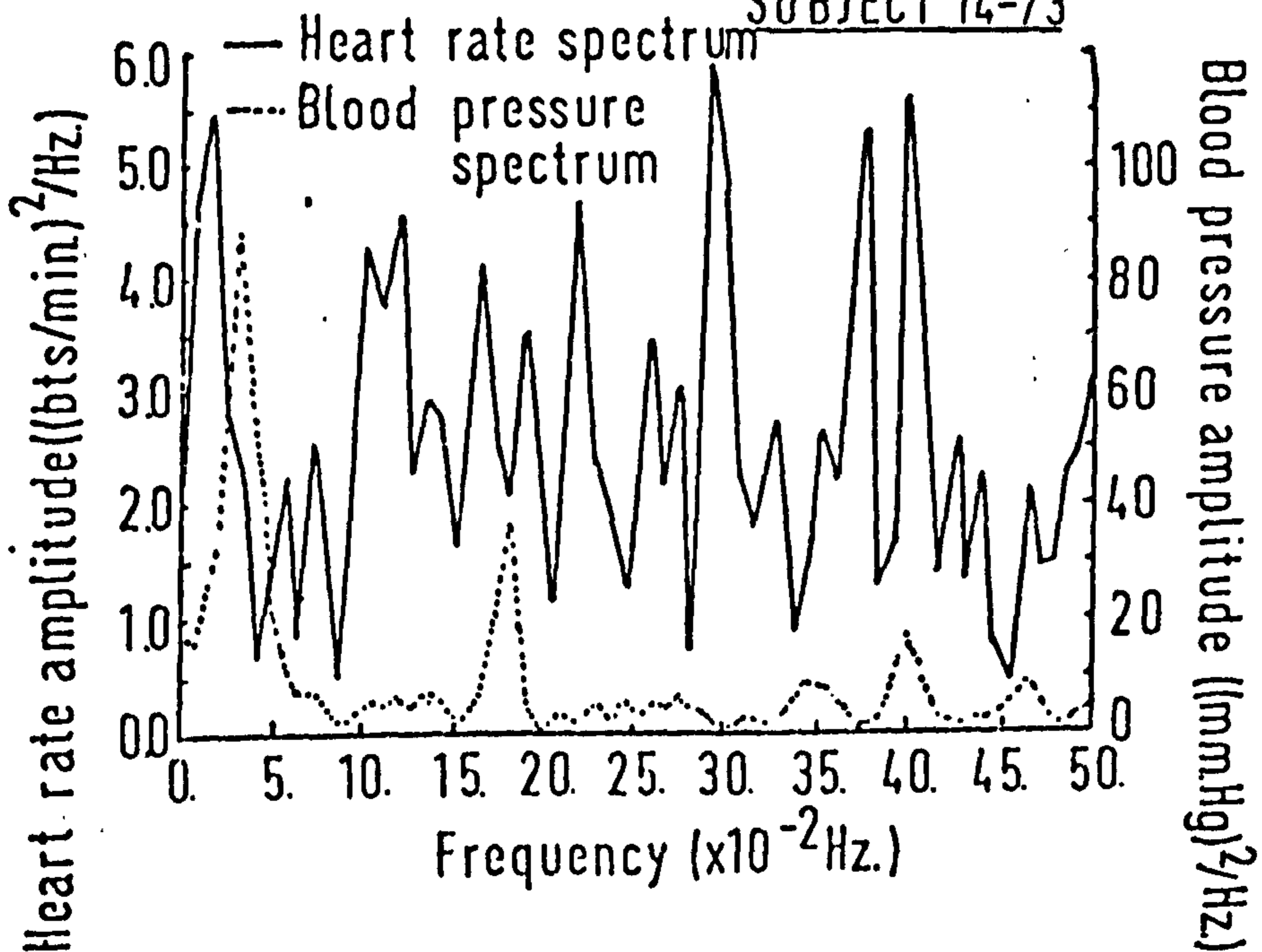

slow and the respiration peak was confused with the vasomotor peak. Out of the 46 Class 1 and 2 heart-rate spectra, only 11 showed peaks at frequencies attributable to respiration.

Further information was obtained from the heart-rate and blood-pressure data by calculating the cross-spectrum, phase and coherency between them. These statistics are defined in Appendix A. A peak in the cross-spectral amplitude at a particular frequency would indicate a cycle in either or both of the two series. The coherency measures the degree of linear correlation between the two series, and gives an indication of the intensity of the common signal between them at a particular frequency. It attaches a degree of confidence to the phase. A high coherency at a particular frequency between the two series does not necessarily imply that there is a common cycle at that frequency in the data. The criteria for detecting a common cycle in both heart rate and blood pressure were coincident peaks in both the heart-rate and blood-pressure spectra, together with a peak in the cross-spectral amplitude and a high coherency value at that frequency. Table 4.3 gives the spectrum amplitude and the cross-spectrum statistics where these criteria were met. A negative phase implies that the blood-pressure is in advance of the heart rate. The coherency estimates in some cases are possibly underestimated when the phase was changing rapidly with frequency; methods of avoiding this are discussed in Appendix A, one method being to align the series to bring them more closely in phase. Peaks attributable to respiration in both the heart-rate and blood-pressure spectra were found in 4-72(1), 4-72(2), 7-73(1), 14-73(1), 15-73(4) and 10-74. The respiration frequency ranged from 0.18 Hz. to 0.25 Hz. and the phase from  $-31^{\circ}$  to  $-143^{\circ}$ .



This meant that in each case the heart-rate cycle lagged behind the blood-pressure cycle. With only 6 points it is difficult to test for a correlation between phase and frequency, but this seems unlikely since subjects 4-72(1), 4-72(2) and 10-74 all showed a respiratory peak at 0.273 Hz., with phases  $-143^{\circ}$ ,  $-121^{\circ}$  and  $-86^{\circ}$  respectively.

Another factor which would influence the phase of the blood-pressure signal relative to the heart-rate signal is the position of the cannula in the radial artery. For each patient, the tip of the transducer was placed as close to the heart as was feasible. For the majority of patients this was where the artery entered the chest, but for some it was possible only to go as far as the elbow. The lag between the actual heart beat and the recorded blood-pressure pulse will depend on the distance and the pulse velocity. It could range from 20 to 120 milliseconds, which at a frequency of, say, 0.25 Hz., could produce a change of phase of between 2 and  $10^{\circ}$ . This fact was borne in mind when the phase results were interpreted.

Several subjects displayed two low-frequency peaks in the cross-spectral amplitude which corresponded to high values of the coherence. For example 10-73 showed several cross-spectra with peaks at 0.055 Hz. and 0.070 Hz. and the cross-spectrum from subject 9-74(1) showed peaks at 0.023 Hz. and 0.078 Hz.. It is tempting to ascribe the higher of these two peaks to the vasomotor frequency, and the lower to thermal variation. Indeed, a frequency of 0.023 Hz. would correspond to a cycle length of 40 seconds, a fundamental of the thermal control system mentioned by Kitney (1974). However, where the frequencies are fairly close together, such as the peaks for 10-74, we cannot place too much

confidence in the presence of two peaks, especially since the spectral resolution was only 0.08 Hz.. The phase results at low frequencies were not consistent, possibly because the cycles were not all generated by the same mechanisms. In general the phase between heart rate and blood pressure in the region of 0.055 Hz. was positive, but there were exceptions, for example the phase of 15-73(1) is  $-76^\circ$  at 0.055 Hz. and the phase of 15-73(4) is  $-68^\circ$  at 0.047 Hz.. For subject 12-73(12), the spectrum showed two low frequency peaks. The phase for the peak with lower frequency is negative, whereas that for the other is positive. The degree of confidence that we can place in these results is discussed in the next section.

#### Significance tests

A pertinent question with regard to the detection of cycles is whether the peaks in a spectrum could be due to random events. Tests of significance of spectral peaks are described in Appendix A. For clearly marked spectral peaks, we were confident that they represented cycles in the data, but for less clearly marked peaks the following test was used. The periodogram ordinate  $I(w_j)$  was calculated at each frequency  $w_j = 2\pi j/n$ ,  $j=1,2,\dots,n$ , where  $n$  is the number of points in the series (assumed even for arithmetical convenience). The value of

$$k = \max_{0 < j \leq \frac{1}{2}n-1} \left[ \frac{I(w_j)}{\sum_{j=1}^{\frac{1}{2}n-1} I(w_j)} \right] \text{ was found.}$$

On the null hypothesis that the observations are independent normal random variables with zero mean and a common variance the distribution of  $k$  can be found (Fisher, 1929). It can be shown, for example Hannan (1970, p.472) that the test is asymptotically valid for non-normal

observations. A value of 256 should prove a sufficiently large number of points to justify an asymptotic approximation. A discussion of the test is given in Appendix A and the results in Table 4.3 indicate which peaks are not significant (NS) according to this test.

#### Distribution of variance over frequency

The spectrum of a time series can be thought of as a device for allocating components of variance to different frequencies. It is shown in Appendix A that if the periodogram  $I(w_j)$  is calculated at discrete frequencies  $w_j = 2\pi j/n$ ,  $1 \leq j \leq n/2$ , where  $n$  is the number of points of the series (taken as even) then each ordinate can be regarded as a component of variance with 2 degrees of freedom (except at  $j = 0, n/2$  where we have only 1 degree of freedom) and the sum of all the ordinates is equal to the variance of the series. If we make an allowance for the smoothing then we can express the spectrum in the same way. It was decided to divide the frequency range 0 - 0.5 Hz. into three. The first interval was taken to be (0 - 0.016)Hz. and it was assumed that any variability in this region would be due to long term trends and non-stationarities. Any large peak at zero frequency would tend to contaminate neighbouring peaks. The second interval was taken to be (0.023 - 0.125)Hz. This region was deemed the 'vasomotor' region, since all cycles to do with vasomotor activity occurred in this region. The remaining interval was (0.133 - 0.500)Hz., and this was termed the respiratory interval since all recognisable respiratory activity occurred in this region. The intervals are disjoint because of the finite resolution of the spectrum.

Table 4.4 shows the distribution of the variance over these

frequency bands for each subject. The figures in each frequency band for a particular subject were obtained by taking the average of the variance in that band for each 256 point segment for that subject. The sum of the variances in the three bands for a particular segment is, in fact, less than the total variance for the data of that segment because the program BMDX92 automatically subtracts a linear trend from the points. In most cases, however, the overall variance was close to the sum of the spectral estimates in the three sections, despite the approximation made to allow for the smoothing of the spectrum. If the input data were completely random, we would expect each fundamental frequency of the form  $w_j = 2\pi j/n$  to have the same expected value, and the variances in the three frequency bands would be in the proportion 4:22:74. It can be seen that this ratio is approximated quite closely by the heart rate spectra of 8-73, 9-73, 11-73, 16-73 and 8-74 and by the blood pressure spectrum of 8-74. It is confirmed in Table 4.2 that the spectra from these subjects all belong to Class 3, that is, there were no discernable peaks in the spectrum. Note that each of these subjects had had a mitral valve replacement operation, although there is no practical reason why this should affect the result.

We exclude subjects 8-73, 9-73, 11-73, 16-73 and 8-74 and compute the average variance for the heart rate for each frequency group. The result shows a fairly even distribution of variance over the three groups, in proportion 0.95:1.07:1.99 (bts/min)<sup>2</sup>. Thus about half the variance about a linear trend is accounted for over a 256 second period by cycles between 2 and 12 seconds in length, and cycles up to about 50 seconds in length accounted for about 75% of the variance. Implicit in this statement is the assumption that there is very little

contribution to total variance at frequencies higher than 0.5 Hz.. It is impossible to investigate this possibility with data that has been sampled every second, but, for example, Taylor et al., (1975) lend weight to this assumption. One problem in the interpretation of the above result is that a respiratory peak in the spectrum is likely to increase the contribution to total variance from the respiratory interval but random noise, which has an even distribution of variance over frequency, will also contribute more to the respiratory interval since that contains a wider frequency range.

The distribution of the variance over a longer time period was also calculated. This has previously been considered by Taylor et al., (1975). The long term spectra were restricted to the '73' subjects, since more data was available for them. The number of consecutive points for each subject was 2048, a power of 2, which is about 35 minutes of data. The spectrum ordinates were split into 4 groups: (0 - 0.004) Hz. to correspond to Taylor's greater than 5 minutes cycle length; (0.006 - 0.033) Hz. to correspond to cycle lengths between 5 minutes and 30 seconds; (0.035 - 0.125) Hz. for vasomotor activity and (0.127 - 0.5) Hz. for respiratory activity. Following Taylor et al., (1975) the results are given as percentages for each subject and shown in Table 4.5. The percentages are easily obtained as the ratio of the sum of the spectral ordinates in each frequency interval to the sum of all the spectral amplitudes. From the Table it is immediately apparent that there is a wide variation between subjects. It has been pointed out that only on rare occasions were discernable peaks present in the overall spectrum, and that the spectrum was either wildly varying or concentrated most of the variance at zero frequency. The heart rate

spectra for subjects 12-73 and 15-73 show a very high concentration of variance at frequencies less than 0.004 Hz.. The average percentage variance less than 0.004 Hz. is about 23%, which is a figure comparable to those given by Taylor. However, the standard error is so large that not much reliability can be attached to this value.

Of the blood-pressure spectra for the data sets of 256 points, only two, 2-72 and 8-74 show approximately the distribution expected for random noise, and Table 4.3 shows that the spectra from these subjects are all in Class 3. Excluding these two, the average variance in the 3 frequency groups (0 - 0.016), (0.023 - 0.125) and (0.133 - 0.50) are 7.3, 9.5 and 9.2 (mm. Hg)<sup>2</sup> respectively. This is a fairly even distribution and shows that about 72% of the variance about a linear trend over 256 points can be accounted for by frequencies greater than 0.023 Hz.. Blood-pressure spectra from the longer data sets of 2048 points again show a wide variation between subjects. Overall 35% of the variance is concentrated in a frequency band between 0 and 0.004 Hz., a figure comparable with that given by Taylor et al. (1975), but again the standard error is large.

The observation that the blood-pressure spectra are relatively noise free compared with the heart-rate spectra appears to be a new result. The fact that heart rate is subject to random noise not found in the blood pressure would suggest that it is the afferent signal and that blood pressure is the efferent. Blood pressure and heart rate are to some extent interdependent, however, in the Hering-Breuer reflex for example. The emphasis in the rest of this chapter will be on the

the blood pressure records, and then look, for the intensive care records, at the relative phases between heart rate and blood pressure.

#### Analysis of ambulatory subject records

The blood pressure records taken from the ambulatory subjects were of a different form to the intensive care patient records. The systolic and diastolic pressures were recorded, but not the heart rate or the time of the beats. In this case the spectral analysis will have to be of the form cycles/beat instead of cycles/second. As pointed out by Cox and Lewis (1966,p86) , analyses of intervals are not equivalent to analyses of counts and so contribute different information about the system. However both methods should reveal cycles, and if we know the mean interval we can convert from cycles/beat to cycles/unit time.

#### Trend removal

The program BMDX92 automatically removes a linear trend, but in this case, in the light of the way the data was seen to behave on a line-printer plot, we decided to remove the trend initially, using a double exponential filter as described in Appendix A.

Given that  $\{ x_t \}$  is the original time series we calculate

$$y_t = ay_{t-1} + (1-a)x_t \quad , \quad (4.1)$$

$$\text{then } z_t = az_{t+1} + (1-a)y_t \quad , \quad (4.2)$$

$$\text{and finally } u_t = z_t - \frac{(1-a)^2}{1+a^2} \quad , \quad (4.3)$$

The initial values are  $y_1 = x_1$  and  $z_n = y_n$  , and  $0 < a < 1$  .

Equation (4.1) represents the first order autoregressive filter going forwards, equation (4.2) represents the same filter going backwards,

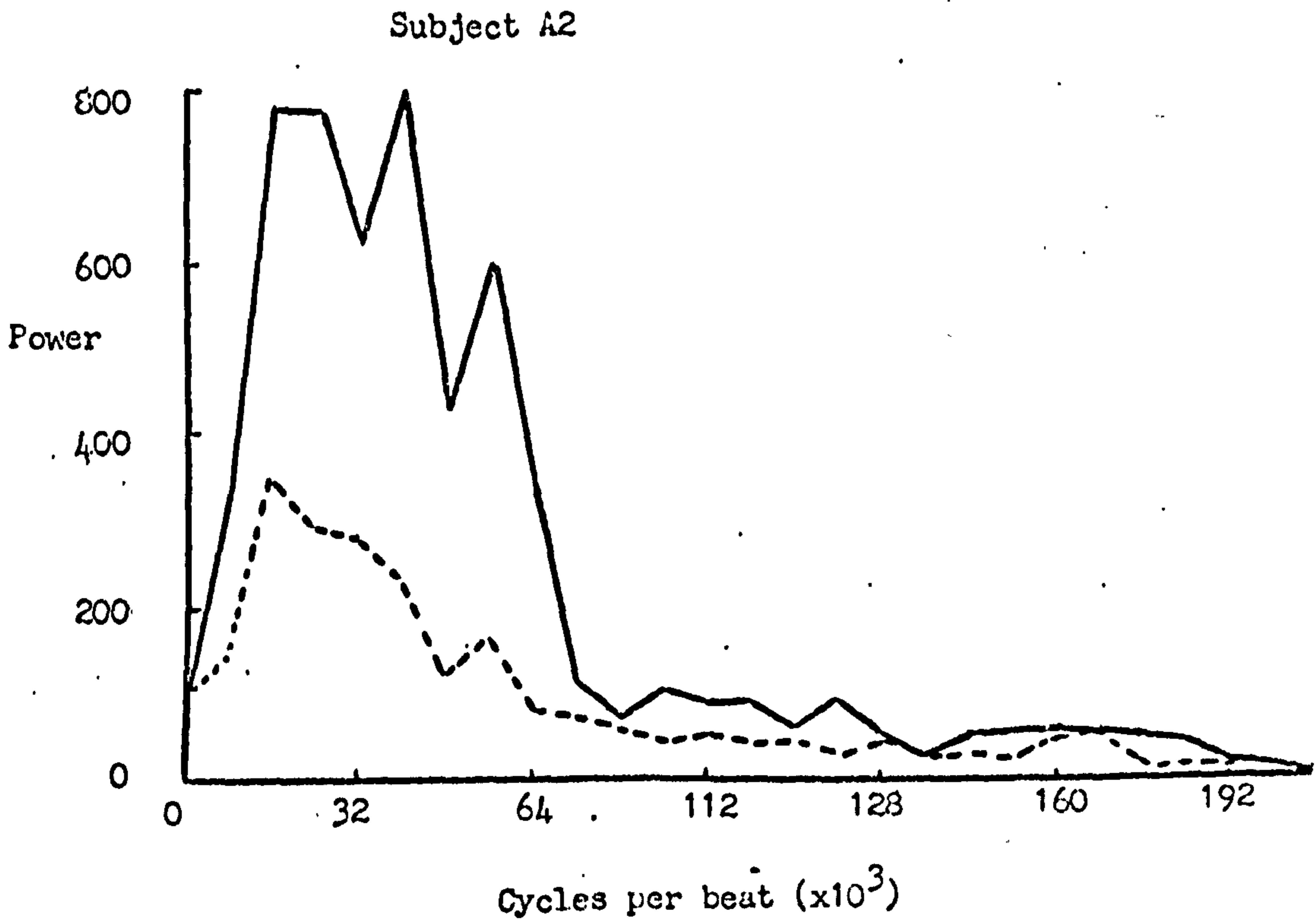
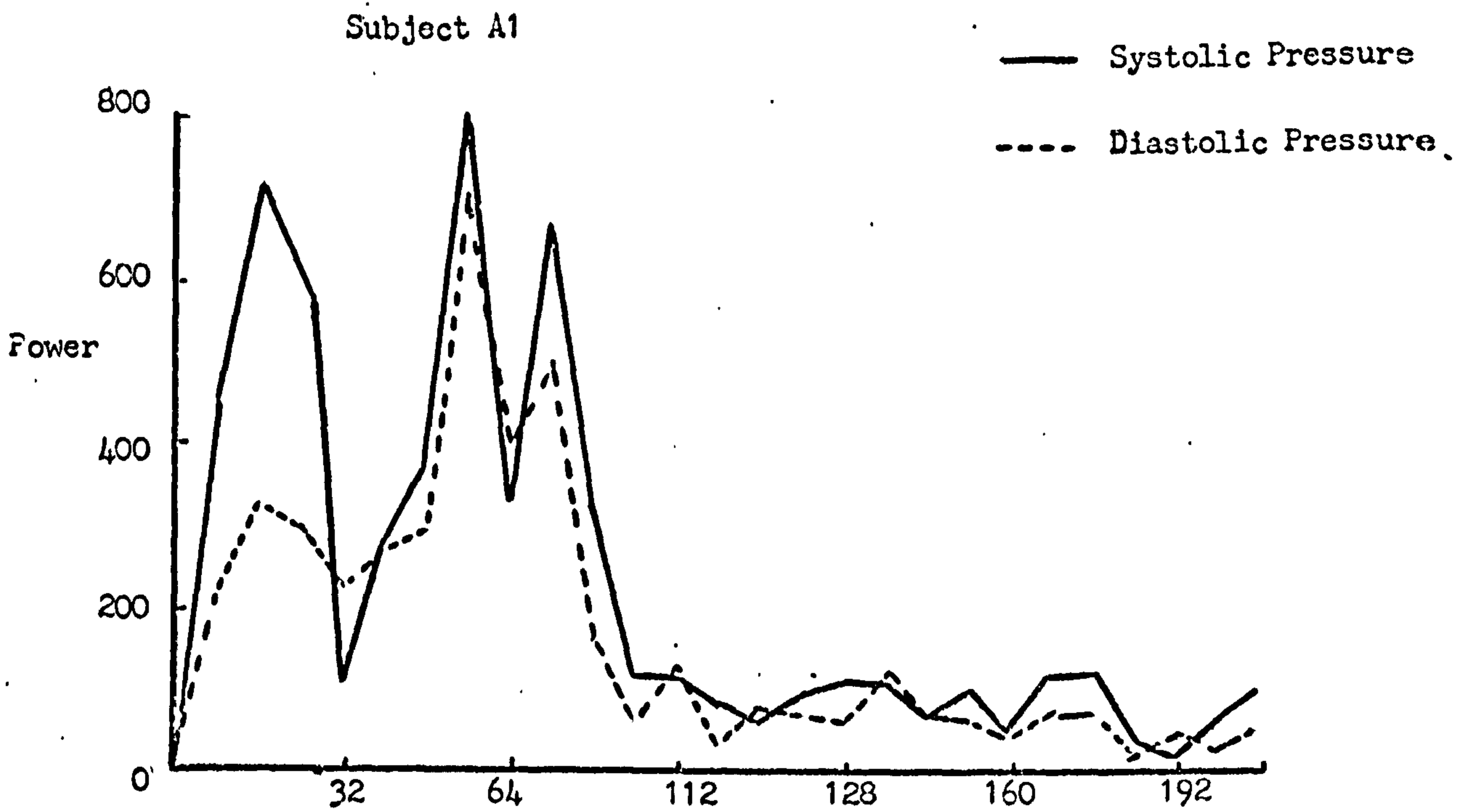



and  $u_t$  is the final output trend; it is preferable to  $z_t$  because it gives a transfer function

$$H(w) = (1-b) \frac{b \cos w}{1-b \cos w}, \text{ where } b = \frac{2a}{1+a^2},$$

which is simpler than the transfer function of  $z_t$ , given in Appendix A.

Since the transfer function is real valued there has been no overall shift in phase introduced by the procedure. In order to obtain trend-free data we calculate  $x_t^i = x_t - u_t$ .

Two values of  $a$  were tried, 0.8 and 0.95, which gave filters with half power points of 0.034 and 0.008 cycles per unit time respectively. The former follows the data more closely than the latter, and so clearly will remove a set of frequencies with a higher upper limit.

#### Spectral analysis of blood pressure from ambulatory subjects

Spectral analysis of the filtered blood pressure data was carried out using program BMDX92, Dixon (1972), as described in Appendix A. The spectra of the first 512 detrended points are shown in Figure 4.2b for subjects A1 and A2. The detrending was carried out using  $a=0.95$ . It is immediately apparent that the greatest power appeared at the low frequency end of the spectrum. For subject A1 there appear to be three low frequency peaks, at 0.016, 0.056 and 0.072 cycles / beat, or wavelengths of about 62, 18 and 14 beats, in both systolic and diastolic pressure. For subject A2, the power of the systolic pressure is concentrated in a narrower band, with peaks at about 0.024, 0.040 and 0.056 cycles/beat. Again the diastolic-pressure spectrum reflects

FIGURE 4.2c

BLOOD-PRESSURE SPECTRA FROM AMBULATORY SUBJECTS  
(EVERY THIRD BEAT)

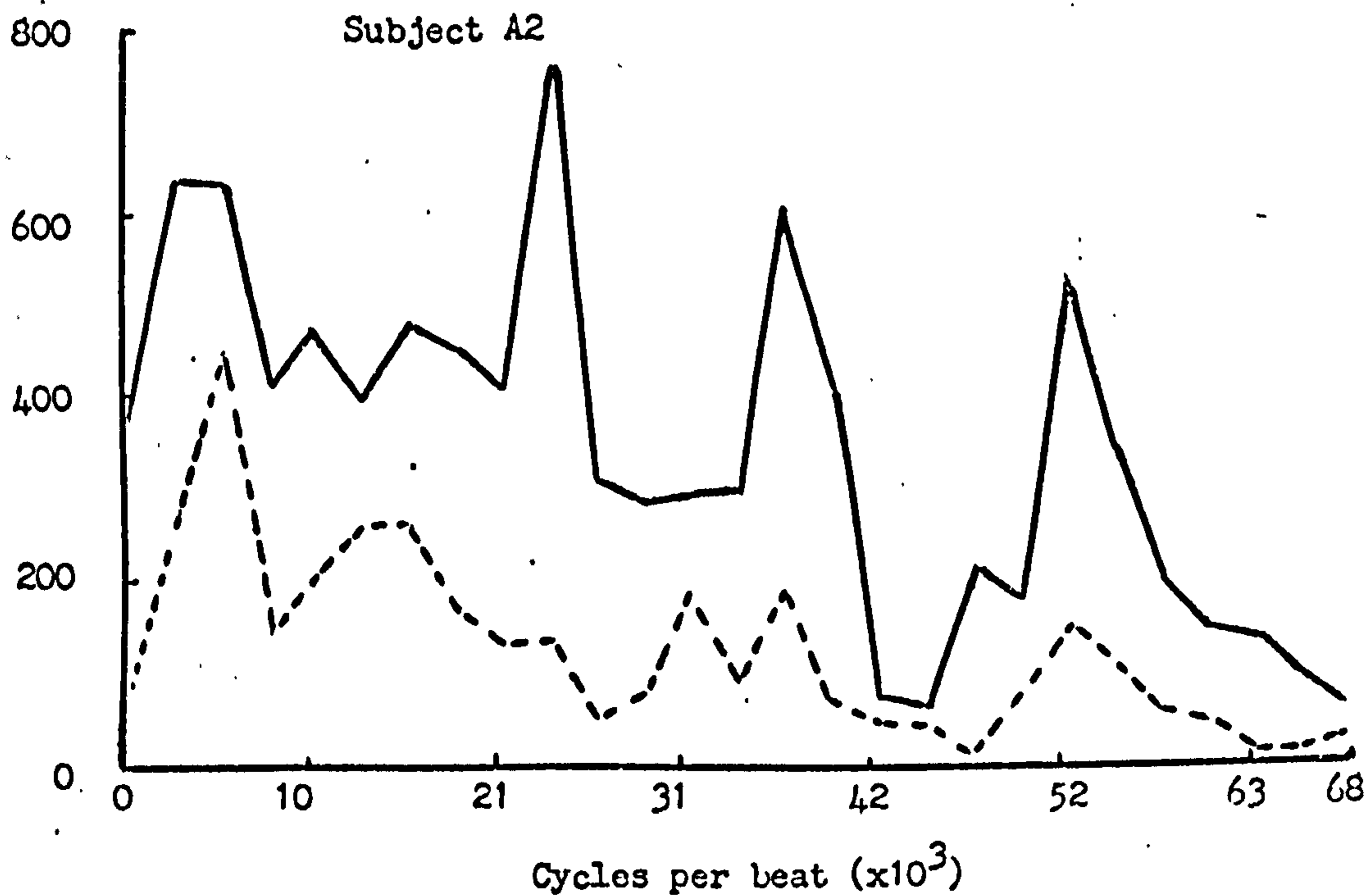
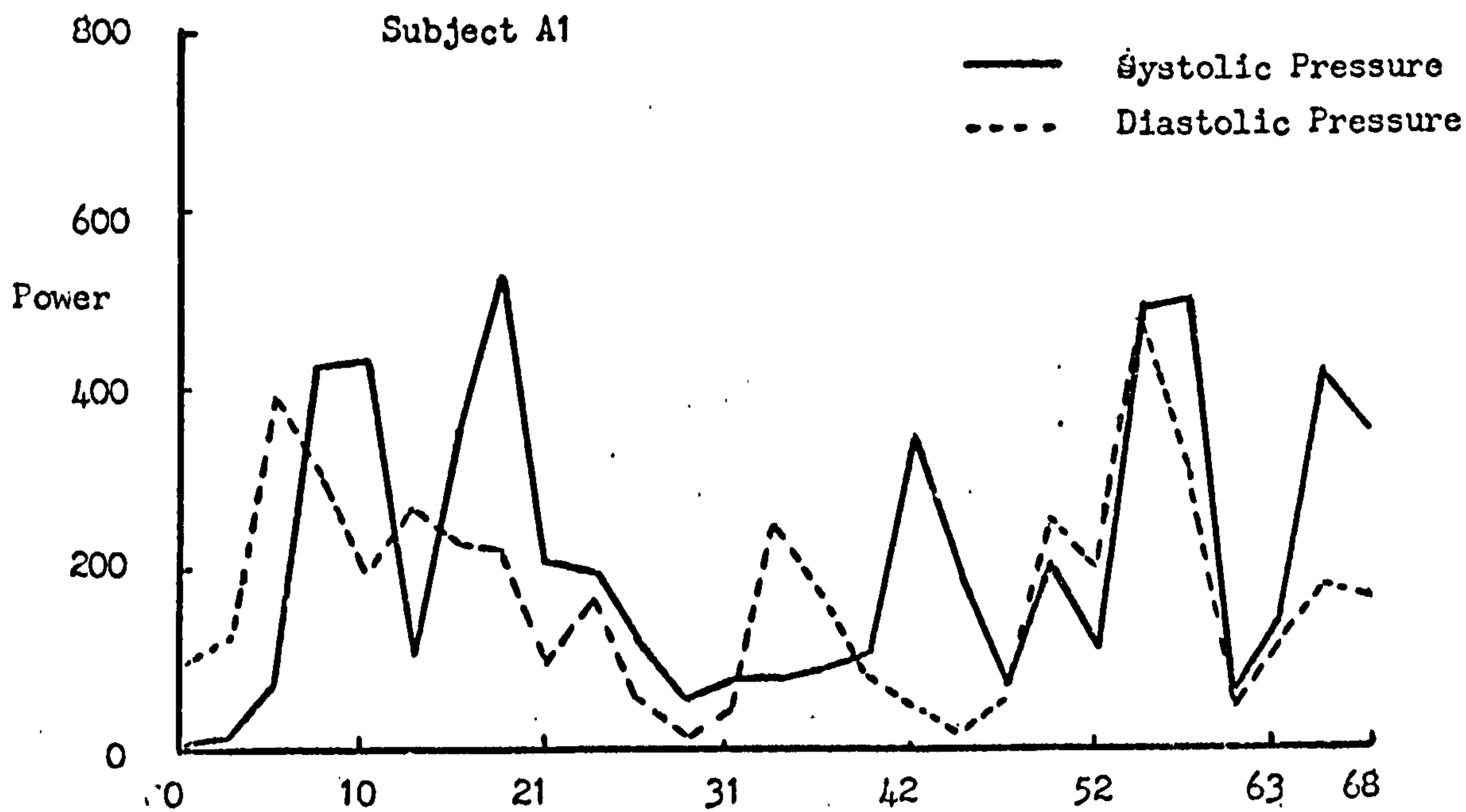

the systolic except for the peak at 0.040 cycles/beat and at a lower level. The systolic-pressure spectrum for subject A2 was also calculated using the autoregressive filter with  $\alpha = 0.80$ . The results were as expected ; the peak at 0.024 cycles was eliminated and the other two appeared at a reduced level.

One problem with these spectra is that they are at low frequencies, where contamination by leakage from the filter and from the taper are likely. An attempt was made to shift the frequencies up the scale by looking at every third beat for a period of 1536 beats. However, in this case the peaks disappeared and we decided that this was probably too long a period in which to study cycles in blood pressure, especially in view of the stationarity results given in Chapter 2. When every third beat over a period of 512 beats was examined, we obtained the spectra given in Figure 4.2c. The spectra largely confirm those given in Figure 4.2b. For subject A1 in Figure 4.2c there unexpectedly appears a local peak at about 0.042 cycles per beat. For subject A2 we again have three peaks, at about 0.024, 0.036 and 0.052 cycles per beat. With diastolic pressure there are peaks at 0.052 and 0.073 cycles/beat for subject A2. For both subjects, the cross-spectrum between systolic and diastolic pressure peaked at the same frequencies as the two univariate spectra, and the phase between the cycles at these frequencies was zero in each case.

For subject A1 we could postulate the presence of a thermoregulatory cycle at about 0.018 cycles/beat and a vasomotor cycle at 0.055 cycles/beat which produces two side lobes at  $0.055 \pm 0.018$  cycles/beat as

a result of modulation of the vasomotor cycle by the thermoregulatory one. A similar state of affairs may be acting in the case of subject A2, but here we do not have a side lobe above the postulated vasomotor frequency of 0.052 cycles/beat, except a very minor one at 0.073 cycles/beat. Possibly the peak at 0.036 is the main vasomotor cycle (although most unlikely since it is so slow) and the peak at 0.052 is the result of modulation of the vasomotor cycle and the thermoregulatory one at 0.024 cycles/beat.

### Digital filtering

Effects that do not persist throughout the length of the data may not show up in the spectrum. A closer look was taken at the heart rate/blood pressure data, firstly by the simple expedient of plotting them against time, and then filtering the data to reduce random noise and to be more frequency specific. The program employed was EMDOIT (Dixon, 1970) and its method of operation is described in Appendix A. It is pointed out in the Appendix that indiscriminate use

FIGURE 4.3 SIMULATED HEART RATE AND BLOOD PRESSURE

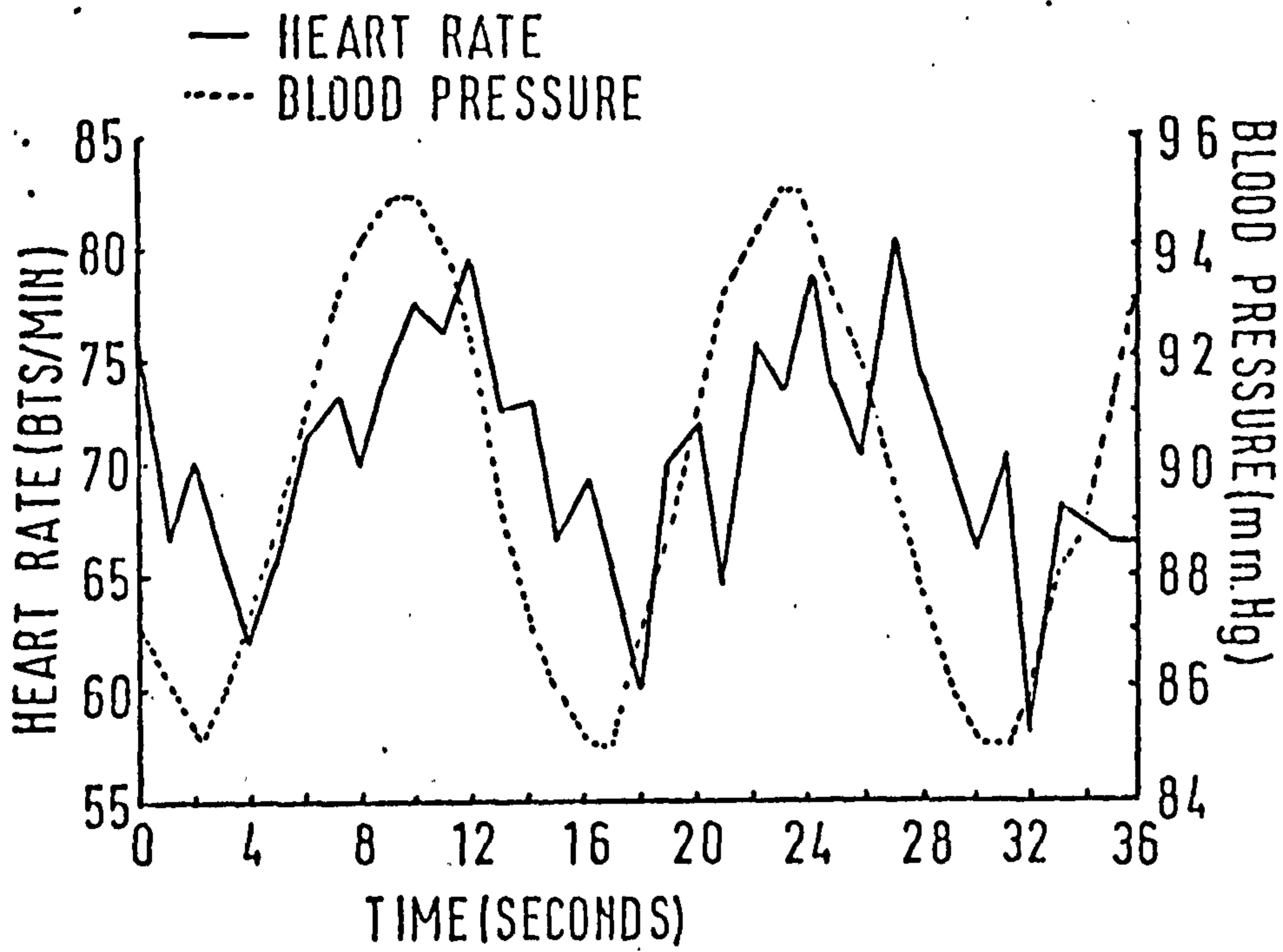

SIMULATED HEART RATE AFTER FILTERING

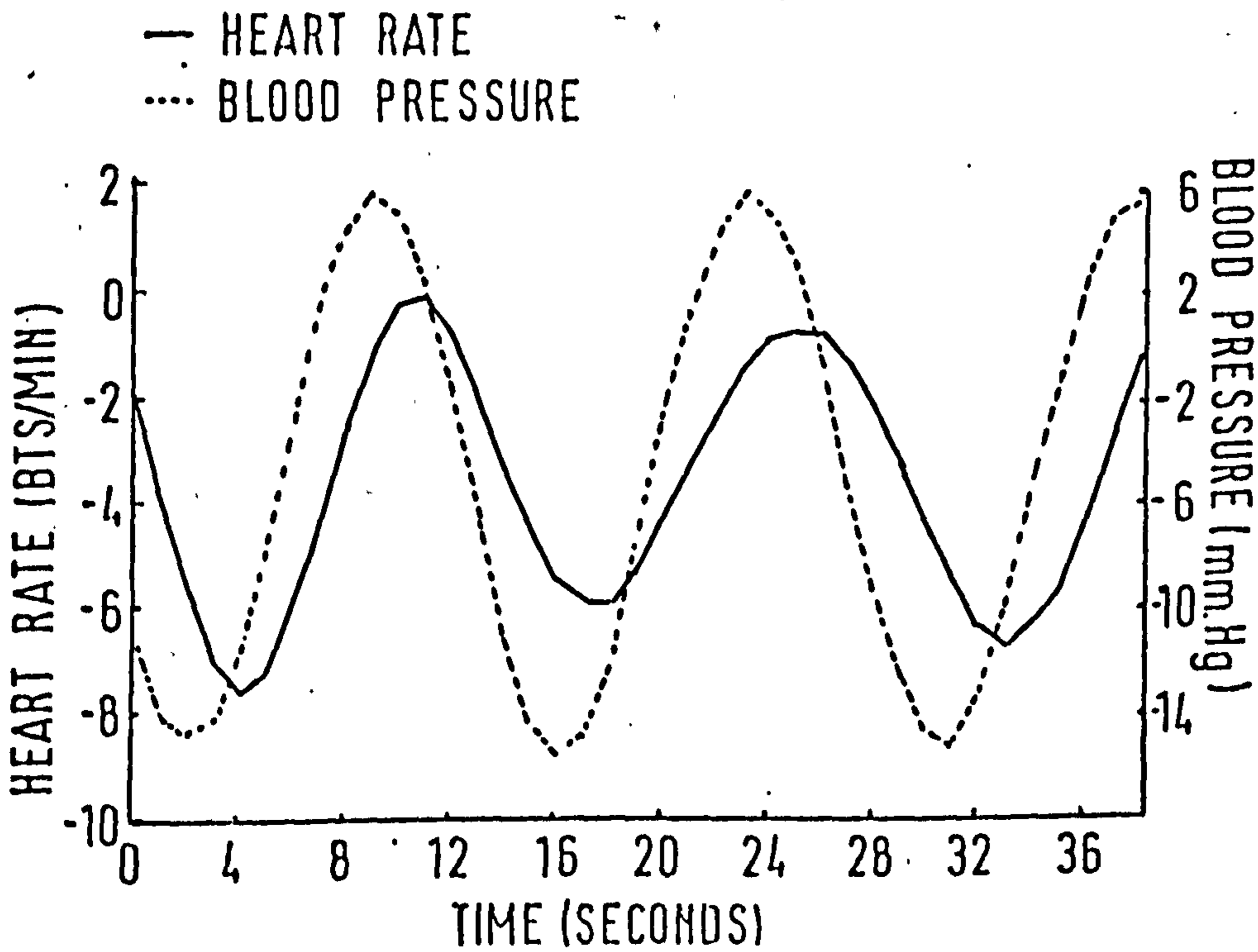

of filtering can give very misleading results (see also Granger and Hatanoha 1964, p.41). An example of this can be shown by applying the rectangular filter of BMDO1T to the heart-rate data of 14-73. As can be seen from Figure 4.2, the spectrum in the region of 0.077 Hz. is close to zero and the overall spectrum does not appear to contain any deterministic components. However, the output from BMDO1T was a clearly oscillating series of quite large amplitude. Superimposition of the raw and filtered series seemed to indicate little relationship between the two. A further demonstration was obtained by applying the filter to data made up of artificially generated and shuffled Gaussian random noise. Again the filter produced a regularly oscillating function which is, of course, totally misleading.

It may appear, from the above examples, that filtering is of no intrinsic value. However it can be valuable in isolating deterministic components of a signal. A program SIMUL was used to generate two artificial series to simulate heart rate and blood pressure, and these were sampled by SAMPLE to produce equidistant data points, as described in Chapter 3. The heart rate series was generated as a sinusoid with mean 72 bts/min and amplitude 5 bts/min, and the blood pressure series was also generated as a sinusoid, with mean 90 mm Hg and amplitude 10 mm Hg. The random noise was added to the heart rate data and was approximately normally distributed, and had zero mean and standard deviation 5 bts/min. The frequency of the deterministic components was 0.07 Hz., with a phase between signals of  $50^\circ$ . The top half of Figure 4.3 shows the raw data of the two series plotted against time. It is difficult by eye to determine the frequency and phase. The spectra of the two series showed clearly marked peaks at

HEART RATE (RAW AND FILTERED DATA) FIGURE 4.4  
SUBJECT 7-73(1)

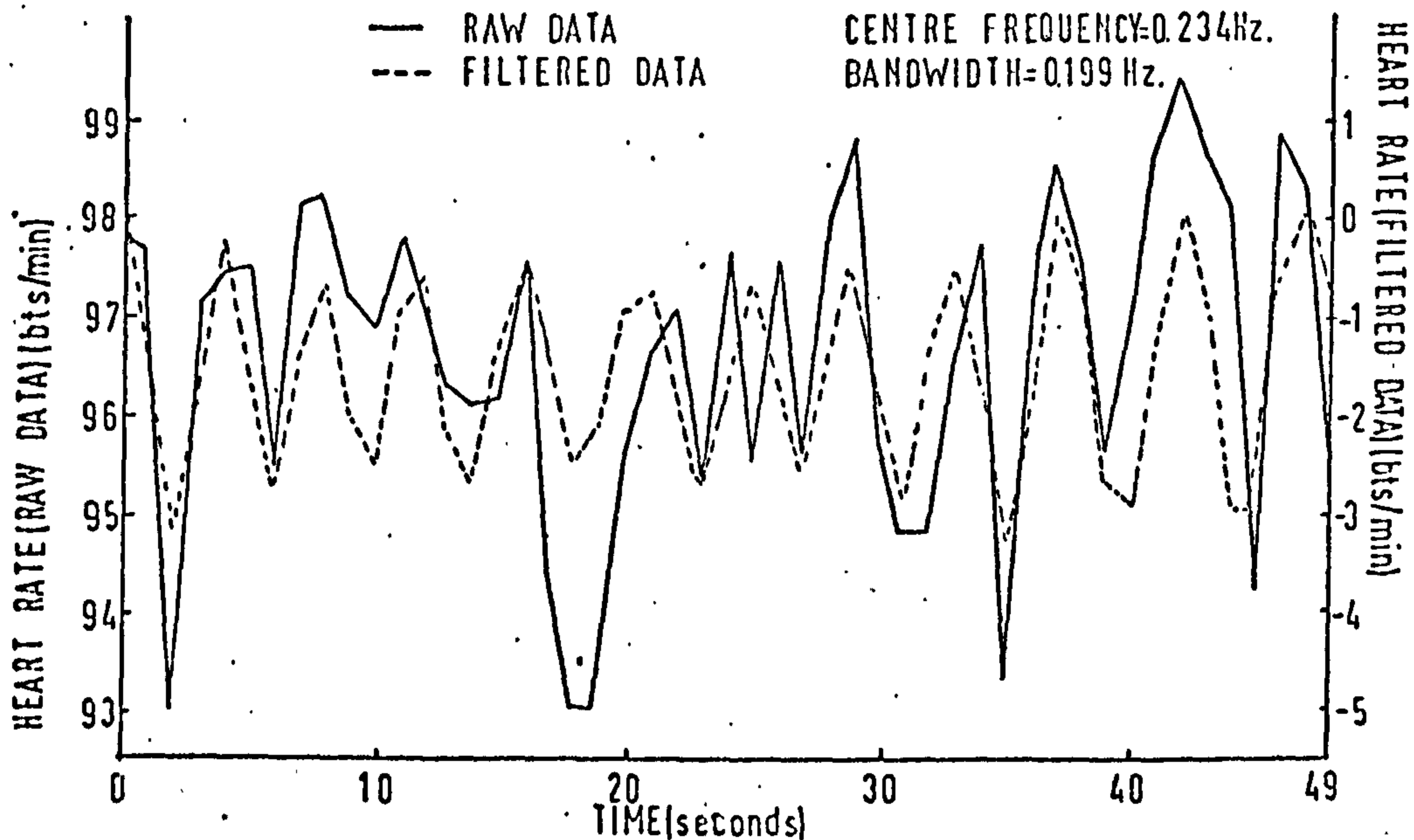

BLOOD PRESSURE (RAW AND FILTERED DATA)  
SUBJECT 7-73

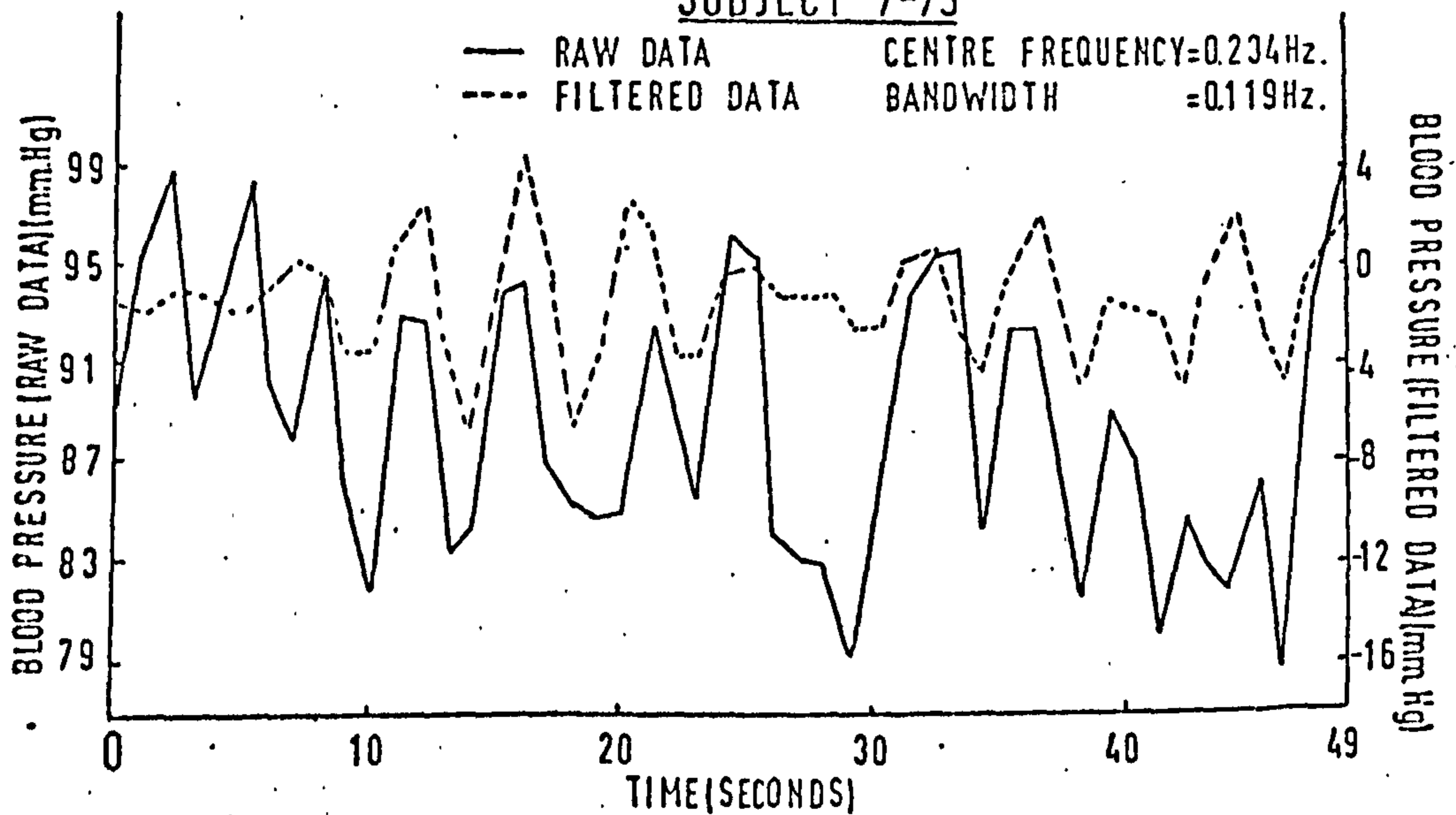

FILTERED HEART RATE AND BLOOD PRESSURE DATA FIGURE 4.5

SUBJECT 7-73(1)

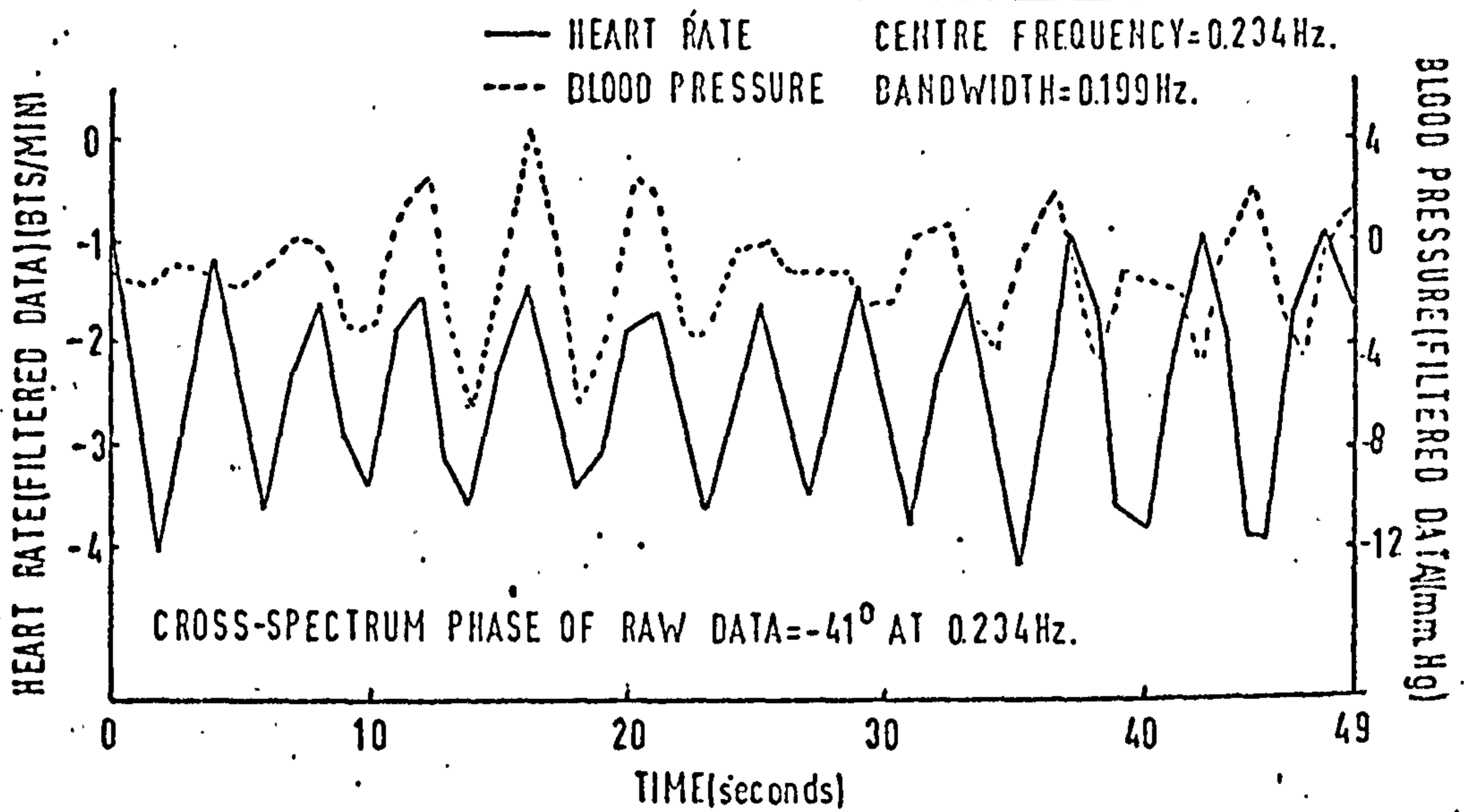

FILTERED HEART RATE AND BLOOD PRESSURE DATA

SUBJECT 4-72.

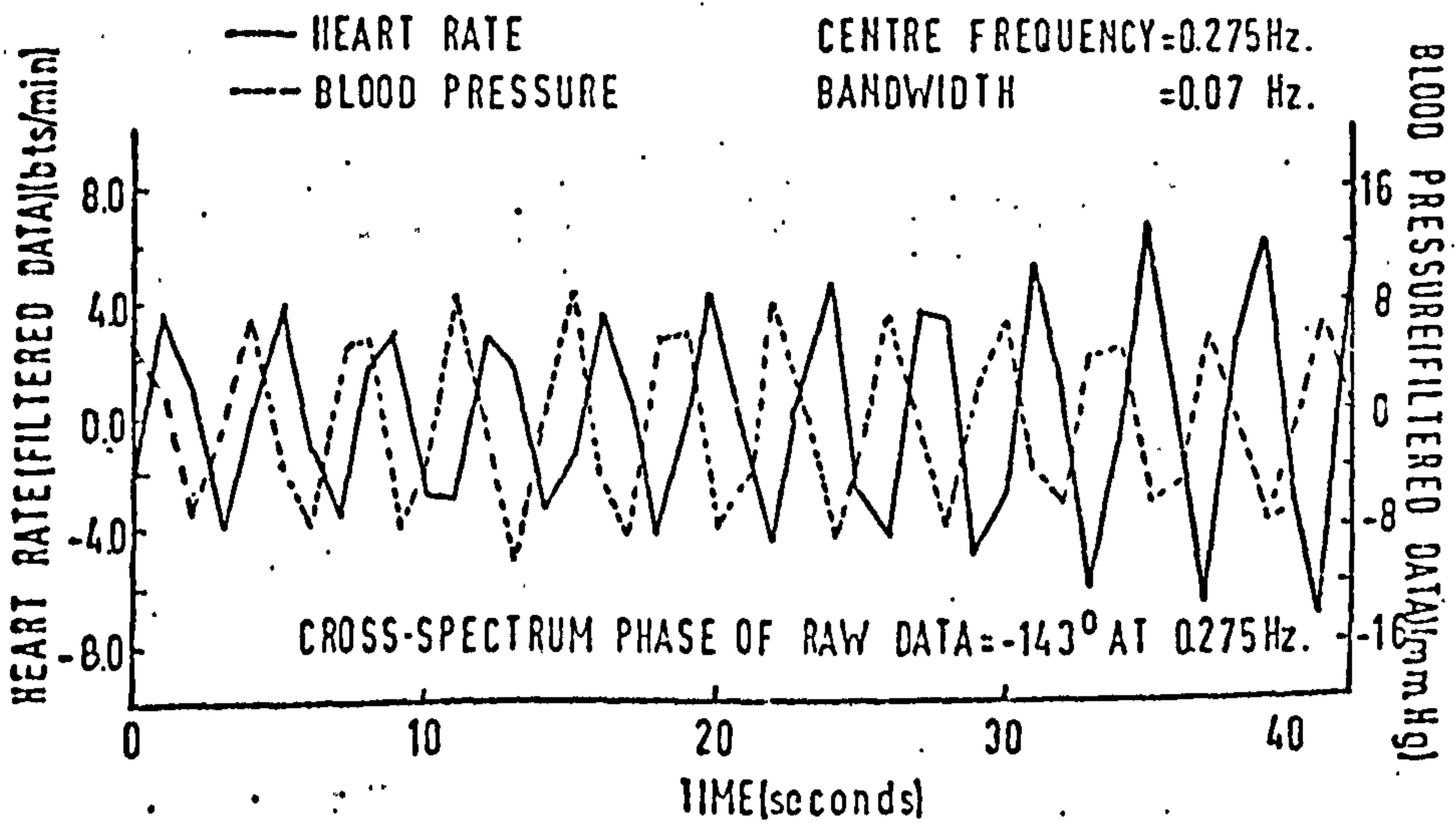



about 0.07 Hz., and so the data was filtered with an approximately rectangular filter, centered on 0.07 Hz., with bandwidth 0.1 Hz. The bottom half of Figure 4.3 shows the two filtered series plotted together against time. It can be seen that the two filtered series show cycles with frequency 0.07 Hz., and that the measured phase between them, estimated as a lag of 2 seconds in a cycle of length 14 seconds, is about  $50^\circ$ . It was felt, therefore, that it would be of value to filter data which have well defined spectral peaks. This was because the filter would smooth irregularities from the data and indicate how the amplitude and phase of the series were changing through time. It seemed sensible, however, to take the precaution of plotting the raw and filtered data together to ensure that the filter was not generating its own cycles.

A rectangular filter centered at the respiratory spectral peak was applied to the heart-rate and blood-pressure data from subjects 7-73 and 4-72. Figure 4.4 shows the heart-rate and blood-pressure records for 7-73, where the raw data and the filtered data are plotted together against time. The filter seems to follow the cycles in the data reasonably well. This was also the case for 4-72 (not shown). Figure 4.5 shows the results of the filter for 7-73 and 4-72. In each case we see that the phasic relationship between heart rate and blood pressure is not constant.

We can see that an advantage of using filters is that many of the irregularities have been smoothed out. When plotting heart rate against blood pressure, as in Figure 4.5, we cannot compare amplitudes since the two quantities are not measured in the same units, but we

FIGURE 1.6 HEART RATE AND BLOOD PRESSURE SUBJECT 12-73

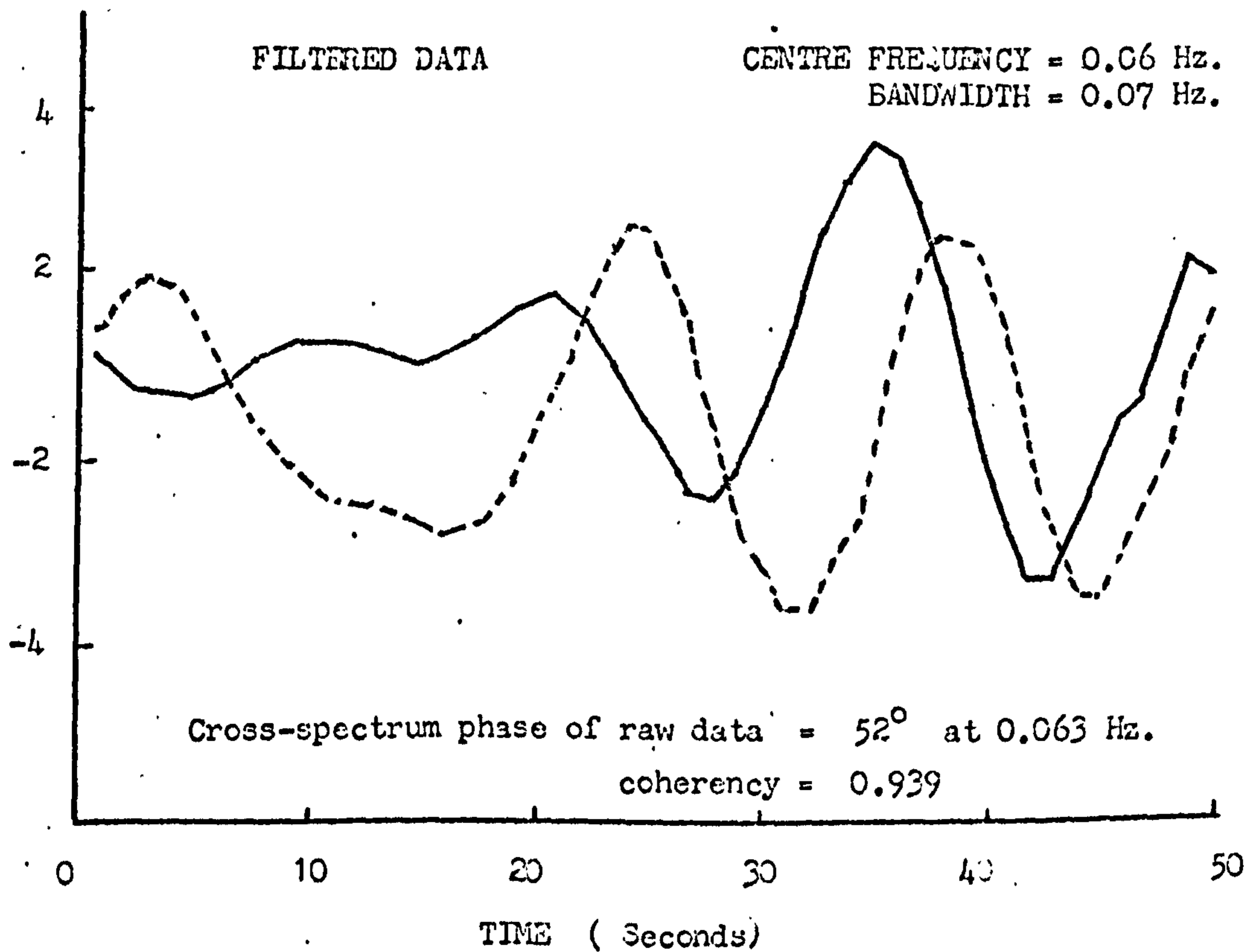
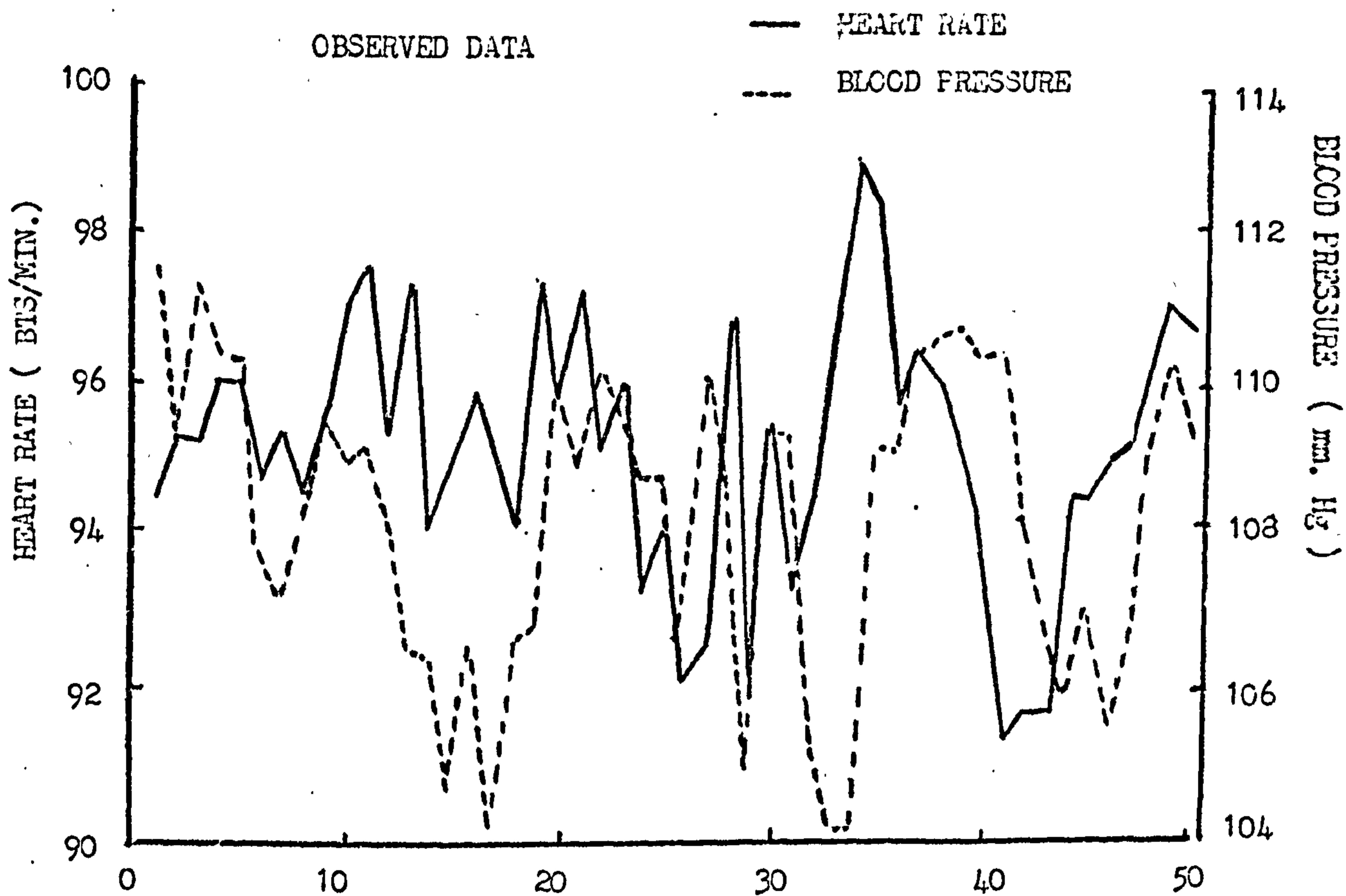

can examine the phase between the two signals. It would appear that the heart rate cycle is quite regular for 7-73, whereas the blood-pressure cycle appears to change phase and amplitude quite quickly. At one point in time the two cycles are completely in phase, but at another they become the reverse. The cross-spectrum phase at 0.234 Hz. is given in Table 4.3 as  $-41^{\circ}$ , which is possibly an averaging over  $-180^{\circ}$  to  $0^{\circ}$ . The fact that the heart rate and blood pressure change phase relative to each other may explain the peaks at separate frequencies in Figure 4.1. Subject 4-72 shows a more constant relationship with either the blood pressure leading the heart rate by about one third of a cycle, or  $120^{\circ}$ , or the heart rate leading the blood pressure by two thirds of a cycle. This is approximately in agreement with the cross-spectrum estimate of phase in Table 4.3, which gives a phase of  $-143^{\circ}$ . We cannot determine which came first in this type of situation but if we restrict the phase to  $180^{\circ}$  either side of  $0^{\circ}$ , then the sign on the cross-spectrum phase indicates blood pressure leading heart rate.

It is not easy to make any generalizations about the cycles at the vasomotor frequency. The top half of figure 4.6 shows the heart rate and blood pressure of subject 12-73, plotted at a section where vasomotor oscillations appear to be present. The bottom half shows the results of the filter, centred at 0.06 Hz. and with bandwidth 0.07 Hz., for both signals. Comparing the two graphs it appears reasonable that the filter is really following a low frequency cycle and that it is not generating an artefact. Again we find that the cycles are not in phase and that the phase is changing. In this case it appears that the heart rate is leading the blood pressure, again in

agreement with the cross-spectral analysis of Table 4.3, which gives a relative phase of about  $52^\circ$  at frequency 0.063 Hz. , with coherency of 0.939.

### Discussion

This Chapter is complementary to Chapter 2 in that there we investigated the time dependent aspects of the data and here we investigated the frequency dependent aspects. Cycles in the data can be regarded as a sort of non-stationarity in that the mean level is changing with time, and if the cycle amplitude alters the variance of the signal will also be non-stationary. We have shown that cycles often appear in both the post-operative patients and the ambulatory subjects. This is important for patient monitoring in that it helps characterise the signal. It is also interesting in its own right. Previous investigators have shown that cycles exist in healthy subjects; we have shown that they still exist after subjects have undergone cardiac surgery.

The mechanisms in vasomotor and sinus arrhythmia phenomena are not independent but interact. Sinus arrhythmia will be discussed in Chapter 5 where it will be shown to depend on the frequency of respiration. Sayers (1971) points out that sinus arrhythmia will only be distinguishable from the vasomotor frequencies if a) the frequencies are sufficiently far apart and b) the amplitude of the respiration signal is not so high as to entrain the heart rate signal. This is a possible explanation of the lack of peaks due to respiration in the heart-rate spectra but it does not explain, for example, why in 14-73 we have a clearly marked respiratory peak in the blood-pressure spectrum but not in the heart-rate spectrum. It should not be too surprising

to find a comparative lack of cycles in heart rate and blood pressure at the vasomotor frequency for the intensive care patients. The patients were observed lying peacefully in bed, and cycles normally only result from negative feed-back control systems when the system is disturbed in some way. The cycles after a disturbance should disappear after a short time as system regains normality.

However, there were clear vasomotor signals from the ambulatory subjects and also what would appear to be modulation by the thermoregulatory signal. This is in confirmation of Charnock (1977) and would appear to be a new observation for ambulatory subjects.

The problem in allowing for cycles in a patient monitoring system is that they are episodic. We found no general rule to determine when they would occur or how long they would persist. Clearly we should design a system so that it could cope with variables fluctuating at these frequencies ; it should also function when they are not.

A final point is to consider alternatives for looking at cycles. The combination of the power spectrum and digital filtering is reasonable in that it can cope with changing phase. However, it is possible to envisage phase changes that would upset a power spectrum, for example a  $180^{\circ}$  phase shift at the mid-point of the series. The phase spectrum, defined via the phase of the Fourier transform may deal with this situation but, without knowing whether a cycle is present in the first place, it is difficult to know via the phase spectrum whether a cycle does exist.

In summary, 13 out of 111 heart-rate and 79 out of 111 blood-pressure spectra gave results that could be clearly interpreted as indicating the presence of cycles. The cycles were loosely divided into three groups, those due to trend, those due to vasomotor activity and those due to respiration. There were 6 cross-spectra in which the heart rate and blood pressure could be correlated at a frequency so high that it could only be due to respiration. There were 26 cross-spectra with peaks between 0.023 Hz. and 0.086 Hz., and with a correspondingly high coherency value. The phases for the respiration frequencies were consistent in that the blood pressure was always in advance of the heart rate. At the vasomotor frequencies, however, there did not seem to be any consistent results and the digital filtering indicated that heart rate and blood pressure may change phase relative to each other. For data sets of 256 points, 25% of the heart rate variance and 28% of the blood pressure variance was concentrated in cycles with frequency less than 0.016 Hz.. However, subjects varied greatly within and between themselves.

TABLE 4.1 PATIENT DATA

| <u>Name</u> | <u>Type of operation</u>            |
|-------------|-------------------------------------|
| 2-72        | Mammary artery inplant              |
| 4-72        | Mitral valve replacement            |
| 7-73        | Coronary artery surgery             |
| 8-73        | Mitral valve replacement            |
| 9-73        | Mitral valve replacement            |
| 10-73       | Aortic valve replacement            |
| 11-73       | Mitral valve replacement            |
| 12-73       | Aortic valve replacement            |
| 13-73       | Aorta-coronary bypass graft         |
| 14-73       | Aortic valve replacement            |
| 15-73       | Aortic valve replacement            |
| 16-73       | Mitral and aortic valve replacement |
| 8-74        | Mitral and aortic valve replacement |
| 9-74        | Mitral and aortic valve replacement |
| 10-74       | Mitral and aortic valve replacement |

TABLE 4.2 WARD RECORDS: A SUMMARY OF THE SPECTRAL ANALYSES

| Patient Identification<br>Number (and spectrum<br>number) | H.R.<br>Class | Peak frequencies<br>(Hz.) | B.P.<br>Class | Peak frequencies<br>(Hz.) |
|---|---------------|---------------------------|---------------|---------------------------|
| 2-72  | 2             | 0.109, 0.273              | 2             | 0.109                     |
| 4-72(1)   | 1             | 0.063, 0.273              | 1             | 0.055, 0.273              |
| 4-72(2)   | 1             | 0.063, 0.273              | 1             | 0.047, 0.273              |
| 4-72(3)   | 1             | 0.070, 0.258              | 2             | 0.258                     |
| 7-73(1)   | 2             | 0.063, 0.242              | 2             | 0.063, 0.266              |
| 7-73(2)   | 2             | 0.023                     | 3             | -                         |
| 7-73(3)   | 3             | -                         | 3             | -                         |
| 7-73(4)   | 3             | -                         | 2             | 0.047, 0.297              |
| 7-73(5)   | 3             | -                         | 2             | 0.070, 0.273              |
| 7-73(6)   | 2             | 0.055, 0.242              | 2             | 0.039                     |
| 7-73(7)   | 3             | -                         | 2             | 0.063, 0.273              |
| 7-73(8)   | 2             | 0.055                     | 1             | 0.055, 0.266              |
| 8-73(1)   | 3             | -                         | 1             | 0.039, 0.156              |
| 8-73(2)   | 3             |                           | 1             | 0.188                     |
| 8-73(3)   | 3             |                           | 1             | 0.055, 0.188              |
| 8-73(4)   | 3             |                           | 1             | 0.188                     |
| 8-73(4)   | 3             |                           | 1             | 0.188                     |
| 8-73(5)   | 3             |                           | 1             | 0.055, 0.188              |
| 8-73(6)   | 3             |                           | 2             | 0.188                     |
| 8-73(7)   | 3             |                           | 1             | 0.055, 0.188              |
| 8-73(8)   | 3             |                           | 1             | 0.078, 0.195              |
| 8-73(9)   | 3             |                           | 1             | 0.055, 0.078, 0.203       |
| 8-73(10)  | 3             |                           | 1             | 0.078, 0.203              |
| 8-73(11)  | 3             |                           | 1             | 0.039, 0.086, 0.188       |



TABLE 4.2 CONT.

| Patient Identification<br>Number (and spectrum<br>number) | H.R.<br>Class | Peak frequencies<br>(Hz.) | B.P.<br>Class | Peak frequencies<br>(Hz.) |
|---|---------------|---------------------------|---------------|---------------------------|
| 9-73(1)   | 3             | -                         | 2             | 0.031                     |
| 9-73(2)   | 2             | 0.320                     | 3             | -                         |
| 9-73(3)   | 3             | -                         | 3             | -                         |
| 9-73(4)   | 3             | -                         | 3             | -                         |
| 9-73(5)   | 3             | -                         | 2             | 0.070                     |
| 9-73(6)   | 3             | -                         | 3             | -                         |
| 9-73(7)   | 3             | -                         | 2             | 0.016                     |
| 9-73(8)   | 3             | -                         | 2             | 0.039                     |
| 9-73(9)   | 3             | -                         | 2             | 0.039                     |
| 10-73(1)  | 3             | -                         | 1             | 0.055                     |
| 10-73(2)  | 2             | 0.086                     | 2             | 0.055                     |
| 10-73(3)  | 1             | 0.023, 0.039,<br>0.102    | 1             | 0.047                     |
| 10-73(4)  | 1             | 0.016, 0.102              | 1             | 0.055                     |
| 10-73(5)  | 1             | 0.031                     | 2             | 0.008                     |
| 10-73(6)  | 2             | 0.008                     | 3             | -                         |
| 10-73(7)  | 2             | 0.008                     | 2             | 0.055                     |
| 10-73(8)  | 2             | 0.023                     | 2             | 0.039                     |
| 10-73(9)  | 2             | 0.008                     | 2             | 0.055                     |
| 10-73(10)   | 1             | 0.016, 0.070              | 1             | 0.070                     |
| 10-73(11)   | 2             | 0.008                     | 1             | 0.031                     |
| 10-73(12)   | 1             | 0.031                     | 1             | 0.016, 0.070              |
| 10-73(13)   | 2             | 0.008                     | 1             | 0.031, 0.063              |

TABLE 4.2 CONT.

| Patient Identification<br>Number (and spectrum<br>number) | H.R.<br>Class | Peak frequencies<br>(Hz.) | B.P.<br>Class | Peak frequencies<br>(Hz.) |
|---|---------------|---------------------------|---------------|---------------------------|
| 11-73(1)  | 3             | -                         | 1             | 0.055, 0.211              |
| 11-73(2)  | 3             | -                         | 1             | 0.055, 0.203              |
| 11-73(3)  | 3             | -                         | 1             | 0.055, 0.195              |
| 11073(4)  | 2             | 0.063                     | 1             | 0.195                     |
| 11-73(5)  | 3             | -                         | 1             | 0.070, 0.180              |
| 11-73(6)  | 3             | -                         | 1             | 0.039, 0.172              |
| 11-73(7)  | 3             | -                         | 1             | 0.164                     |
| 11-73(8)  | 3             | -                         | 1             | 0.156                     |
| 11-73(9)  | 3             | -                         | 2             | 0.023, 0.195              |
| 11-73(10)   | 3             | -                         | 2             | 0.055, 0.203              |
| 11-73(11)   | 3             | -                         | 1             | 0.070, 0.203              |
| 12-73(1)  | 2             | 0.070                     | 1             | 0.055                     |
| 12-73(2)  | 1             | 0.031                     | 1             | 0.055                     |
| 12-73(3)  | 3             | -                         | 1             | 0.063                     |
| 12-73(4)  | 3             | -                         | 1             | 0.047                     |
| 12-73(5)  | 2             | 0.008                     | 1             | 0.063                     |
| 12-73(6)  | 2             | 0.023                     | 2             | 0.031, 0.055              |
| 12-73(7)  | 2             | 0.008                     | 2             | 0.016                     |
| 12-73(8)  | 3             |                           | 1             | 0.055                     |

TABLE 4.2 CONT.

| Patient Identification<br>Number (and spectrum<br>number) | H.R.<br>Class | Peak frequencies<br>(Hz.) | B.P.<br>Class | Peak frequencies<br>(Hz.) |
|---|---------------|---------------------------|---------------|---------------------------|
| 13-73(1)  | 3             | -                         | 1             | 0.063, 0.203              |
| 13-73(2)  | 3             | -                         | 1             | 0.055, 0.195              |
| 13-73(3)  | 3             | -                         | 1             | 0.016, 0.067, 0.195       |
| 13-73(4)  | 2             | 0.273                     | 1             | 0.047, 0.203              |
| 13-73(5)  | 3             | -                         | 1             | 0.203                     |
| 13-73(6)  | 3             | -                         | 1             | 0.016, 0.203              |
| 13-73(7)  | 3             | -                         | 1             | 0.016, 0.063, 0.203       |
| 13-73(8)  | 2             | 0.008                     | 1             | 0.008, 0.055, 0.203       |
| 13-73(9)  | 2             | 0.016                     | 1             | 0.016, 0.063, 0.203       |
| 14-73(1)  | 3             | -                         | 1             | 0.031, 0.180              |
| 14-73(2)  | 2             | 0.008                     | 1             | 0.039, 0.180              |
| 14-73(3)  | 2             | 0.008                     | 1             | 0.008, 0.031, 0.203       |
| 14-73(4)  | 2             | 0.008                     | 1             | 0.008, 0.195              |
| 14-73(5)  | 2             | 0.008                     | 1             | 0.039, 0.195              |
| 14-73(6)  | 3             | -                         | 1             | 0.008, 0.033, 0.195       |
| 14-73(7)  | 2             | 0.172                     | 1             | 0.023, 0.188              |
| 14-73(8)  | 2             | 0.023, 0.234              | 1             | 0.008, 0.031, 0.195       |
| 14-73(9)  | 3             | -                         | 1             | 0.023, 0.047, 0.188       |
| 15-73(1)  | 1             | 0.016, 0.039              | 1             | 0.023, 0.172              |
| 15-73(2)  | 3             | -                         | 1             | 0.031, 0.172              |
| 15-73(3)  | 3             | -                         | 1             | 0.031, 0.172              |
| 15-73(4)  | 2             | 0.041                     | 1             | 0.039, 0.188              |
| 15-73(5)  | 3             | -                         | 1             | 0.016, 0.180              |
| 15-73(6)  | 3             | -                         | 1             | 0.016, 0.180              |
| 15-73(7)  | 3             | -                         | 1             | 0.016, 0.180              |

TABLE 4.2 CONT.

| Patient Identification<br>Number (and spectrum<br>number) | H.R.<br>Class | Peak frequencies<br>(Hz.) | B.P.<br>Class | Peak frequencies<br>(Hz.) |
|---|---------------|---------------------------|---------------|---------------------------|
| 16-73(1)  | 3             | -                         | 1             | 0.375                     |
| 16-73(2)  | 3             | -                         | 1             | 0.375                     |
| 16-73(3)  | 3             | -                         | 1             | 0.375                     |
| 16-73(4)  | 3             | -                         | 1             | 0.375                     |
| 16-73(5)  | 3             | -                         | 1             | 0.375                     |
| 16-73(6)  | 2             | 0.055                     | 1             | 0.398                     |
| 16-73(7)  | 2             | 0.031                     | 1             | 0.398                     |
| 16-73(8)  | 3             | -                         | 1             | 0.398                     |
| 16-73(9)  | 3             | -                         | 1             | 0.398                     |
| 16-73(10)   | 3             | -                         | 1             | 0.156, 0.398              |
| 16-73(11)   | 3             | .                         | 1             | 0.398                     |
| 8-74(1)   | 3             | -                         | 3             | -                         |
| 8-74(2)   | 3             | -                         | 3             | -                         |
| 8-74(3)   | 3             | -                         | 3             | -                         |
| 8-74(4)   | 3             | -                         | 3             | -                         |
| 9-74(1)   | 2             | 0.078                     | 1             | 0.039, 0.078              |
| 9-74(2)   | 3             |                           | 1             | 0.078                     |
| 9-74(3)   | 1             | 0.063, 0.078              | 1             | 0.078                     |
| 9-74(4)   | 2             | 0.086                     | 1             | 0.031, 0.086              |
| 9-74(5)   | 2             | 0.078                     | 1             | 0.070                     |
| 9-74(6)   | 1             | 0.070                     | 1             | 0.039, 0.063              |
| 10-74   | 1             | 0.055, 0.261              | 1             | 0.273                     |

KEY

H.R. = Heart rate

B.P. = Blood Pressure

Class 1 = Clearly identifiable peaks in the spectrum

Class 2 = Peaks possibly present, but large amount of random noise, making identification difficult.

Class 3 = Spectrum wildly varying, no interpretation in terms of cycles possible.

TABLE 4.3. PEAKS IN THE CLASS 1 SPECTRA

| Name      | Spectrum amplitude |           |            | Cross-spectrum |      |                    |       |      |
|-----------|--------------------|-----------|------------|----------------|------|--------------------|-------|------|
|           | Freq.<br>(Hz.)     | H.R.      | B.P.       | Freq.<br>(Hz.) | Amp. | Phase <sup>o</sup> | Coh.  | d.of |
| 4-72(1)   | {0.055             | 7.4       | 2.4(N.S.)  | {0.055         | 3.5  | -16                | 0.823 | 4.6  |
|           | {0.063             | 9.6       | 2.1(N.S.)  | {0.063         | 3.3  | -21                | 0.725 | 4.6  |
|           | 0.273              | 15.0      | 3.9        | 0.273          | 4.2  | -143               | 0.551 | 4.6  |
| 4-72(2)   | 0.063              | 4.6(N.S.) | 3.8(N.S.)  | 0.063          | 11.5 | -61                | 0.864 | 4.6  |
|           | 0.273              | 10.5      | 24.3       | 0.273          | 48.6 | -121               | 0.962 | 4.6  |
| 10-73(3)  | {0.039             | 20.94     | 224.8      | {0.039         | 45.4 | 69                 | 0.662 | 4.0  |
|           | {0.047             | 12.05     | 337.4      | {0.047         | 55.6 | 8.0                | 0.872 | 4.0  |
|           | {0.102             | 6.7       | 27.9(N.S.) | {0.102         | 9.5  | 124.7              | 0.699 | 4.0  |
|           | {0.109             | 6.0       | 65.9(N.S.) | {0.109         | 9.0  | 77.9               | 0.455 | 4.0  |
| 10-73(4)  | 0.016              | 30.2      | 176.4      | 0.106          | 47.6 | -121               | 0.652 | 4.0  |
|           | 0.055              | 4.9(N.S.) | 167.9      | 0.055          | 25.2 | 88                 | 0.878 | 4.0  |
|           | 0.102              | 7.2(N.S.) | 25.0(N.S.) | 0.102          | 10.2 | 99                 | 0.765 | 4.0  |
| 10-73(10) | 0.016              | 47.6      | 41.4       | 0.016          | 36.5 | -22                | 0.822 | 4.0  |
|           | 0.070              | 9.7       | 125.4      | 0.070          | 30.2 | 51                 | 0.866 | 4.0  |
| 10-73(12) | 0.070              | 7.1       | 44.0       | 0.070          | 16.4 | 80                 | 0.926 | 4.0  |
| 9-74(1)   | 0.078              | 10.5      | 39.2       | 0.078          | 19.4 | 121                | 0.959 | 6.0  |
| (3)       | 0.063              | 5.7       | 25.5       | 0.063          | 10.7 | 129                | 0.885 | 6.0  |
|           | 0.078              | 5.8       | 33.0       | 0.078          | 11.8 | 90                 | 0.851 | 6.0  |
| (4)       | 0.086              | 8.1       | 38.0       | 0.086          | 17.0 | 87                 | 0.976 | 6.0  |
| (5)       | {0.070             | 6.9       | 55.0       | 0.070          | 15.7 | 90                 | 0.804 | 4.0  |
|           | {0.078             | 7.04      | 28.3       | 0.078          | 13.5 | 108                | 0.957 | 4.0  |
| (6)       | 0.063              | 4.4(N.S.) | 35.3       | 0.063          | 11.1 | 86.7               | 0.889 | 4.0  |
|           | 0.070              | 10.3      | 24.1       | 0.070          | 15.1 | 75.5               | 0.960 | 4.0  |
| 15.73(1)  | 0.172              | 1.54      | 86.1       | 0.172          | 5.8  | -114               | 0.609 | 4.0  |

Abbreviations - H.R. - Heart rate spectrum (units (bts/min)<sup>2</sup>/Hz.)

B.P. - Blood pressure spectrum (units (mm.Hg)<sup>2</sup>/Hz.)

Coh. - Coherency.

TABLE 4.4. AVERAGE VARIANCE IN FREQUENCY BANDS

| Name  | Heart rate (bts/min) <sup>2</sup> |             |             | Blood pressure (mm. Hg) <sup>2</sup>    |             |             |
|---|-----------------------------------|-------------|-------------|---|-------------|-------------|
|   | 0-0.016                           | 0.023-0.125 | 0.133-0.500 | 0-0.-16                                 | 0.023-0.125 | 0.133-0.500 |
|   | Hz.                               | Hz.         | Hz.         | Hz.                                     | Hz.         | Hz.         |
| 2-72  | 0.1                               | 0.9         | 6.1         | 0.5                                     | 2.0         | 5.0         |
| 4-72  | 0.1                               | 1.9         | 3.8         | 4.4                                     | 1.6         | 3.4         |
| 7-73  | 0.4                               | 0.2         | 0.5         | 7.9                                     | 14.2        | 16.9        |
| 8-73  | 0.3                               | 1.0         | 2.8         | 1.4                                     | 2.7         | 2.4         |
| 9-73  | 0.2                               | 0.8         | 1.9         | 39.5                                    | 21.4        | 29.0        |
| 10-73   | 1.7                               | 2.0         | 0.9         | 23.9                                    | 13.9        | 8.6         |
| 11-73   | 3.9                               | 21.1        | 67.8        | 1.2                                     | 6.4         | 10.6        |
| 12-73   | 1.4                               | 0.8         | 1.1         | 17.6                                    | 40.9        | 19.8        |
| 13-73   | 0.8                               | 1.4         | 3.5         | 8.5                                     | 8.7         | 9.0         |
| 14-73   | 0.9                               | 0.5         | 1.3         | 1.8                                     | 2.5         | 3.4         |
| 15-73   | 3.1                               | 1.3         | 1.4         | 4.1                                     | 5.1         | 3.9         |
| 16-73   | 0.4                               | 1.6         | 6.1         | 0.3                                     | 0.6         | 2.9         |
| 8-74  | 11.1                              | 49.8        | 207.0       | 3.0                                     | 13.8        | 44.8        |
| 9-74  | 0.8                               | 0.7         | 0.6         | 2.1                                     | 3.4         | 0.5         |
| 10-74   | 0.2                               | 0.9         | 0.7         | 0.1                                     | 2.4         | 9.8         |
| $\bar{x}$   | 0.95                              | 1.07        | 1.99        | 7.3                                     | 9.5         | 9.2         |
| Mean values excluding 8-73, 9-73, 11-73<br>16-73 and 8-74 |                                   |             |             | Mean values excluding 2-72 and<br>8-74. |             |             |

TABLE 4.5 PERCENTAGE VARIANCE OVER 2048 POINTS

(frequency bands in Hz.)

| Name  | Heart rate (bts/min) <sup>2</sup> |       |       |       | Blood pressure (mm. Hg) <sup>2</sup> |       |       |       |
|-------|-----------------------------------|-------|-------|-------|--------------------------------------|-------|-------|-------|
|       | 0                                 | 0.006 | 0.035 | 0.127 | 0                                    | 0.006 | 0.035 | 0.127 |
|       | 0.004                             | 0.033 | 0.125 | 0.500 | 0.004                                | 0.033 | 0.125 | 0.500 |
| 7-73  | 24.1                              | 16.8  | 15.6  | 43.5  | 49.9                                 | 13.4  | 13.9  | 22.8  |
| 8-73  | 9.1                               | 14.5  | 16.6  | 59.8  | 33.8                                 | 18.7  | 19.1  | 28.4  |
| 9-73  | 5.3                               | 8.4   | 22.3  | 64.0  | 13.1                                 | 36.5  | 14.4  | 35.8  |
| 10-73 | 20.4                              | 42.7  | 17.3  | 19.6  | 74.3                                 | 14.6  | 6.2   | 4.8   |
| 11-73 | 2.5                               | 6.5   | 18.5  | 72.4  | 5.4                                  | 7.5   | 31.4  | 55.8  |
| 12-73 | 70.5                              | 7.8   | 6.8   | 14.8  | 47.4                                 | 17.6  | 19.0  | 18.6  |
| 13-73 | 7.2                               | 16.4  | 19.3  | 57.1  | 19.5                                 | 18.2  | 30.2  | 32.1  |
| 14-73 | 8.4                               | 18.2  | 16.5  | 56.9  | 22.1                                 | 19.4  | 16.5  | 42.0  |
| 15-73 | 84.8                              | 5.7   | 3.5   | 5.9   | 62.0                                 | 19.5  | 5.3   | 13.2  |
| 16-73 | 1.9                               | 5.2   | 18.7  | 74.2  | 17.9                                 | 5.1   | 12.5  | 64.4  |



CHAPTER 5 THE EFFECT OF RESPIRATION ON HEART RATE AND BLOOD PRESSURE

The literature review will cover the effect of respiration on both heart rate and blood pressure, since they are equally important aspects of the cardiovascular system. However for the analysis section of this chapter it proved impossible for ethical reasons to obtain signals for respiration, heart rate and blood pressure, and so only the heart rate response to respiration has been studied.

Literature review

It has long been established that respiration affects both heart rate and blood pressure in man and animals, and to study the systems involved we need to consider both effects together. However, these systems concern the whole subject of cardiovascular control, an area which is very complicated and still hotly debated, for example in Mauck and Hockman (1967). We therefore restrict ourselves to a fairly brief review, and discuss some of the basic physiology in Appendix B.

The variation of heart rate with respiration was first discovered in 1847 by C. Ludwig and is now termed sinus arrhythmia. Heymans (1929), quoted in Davies and Neilson (1967a) suggested three possible mechanisms to explain the effect:

- a) a central transmission of neural excitation from the respiratory to the heart-rate centres in the brain;
- b) the effect of blood pressure changes caused by inspiration on pressure receptors either on the venous side or the left side of the heart;
- c) impulses from stretch receptors inside the lungs affecting the vagal centre both directly and indirectly via the respiratory centre.

No alternative mechanisms have been proposed which are radically different, and all subsequent literature has been devoted to ascertaining the extent to which each of the three is important.

Bainbridge (1920) proposed that factor (b) was the sole cause of sinus arrhythmia: he experimented on cats and claimed that the regulation of the response was primarily by the heart itself, via the 'Bainbridge' effect. This, he postulated, was a reflex action by the heart to increase the heart rate, triggered by increased venous return. In Appendix B recent results on the 'Bainbridge' effect are discussed. The results of Bainbridge, however, were ignored and contradicted by Anrep et al., (1936) who conducted a careful study of sinus arrhythmia in dogs and came to the conclusion that the respiratory effect is mediated mainly through the vagus. They decided that factors (a) and (c) inhibit the vagal tone, thereby increasing the heart rate. Factor (c) also produces an opposite, but lesser, effect due to afferent impulses from the lungs and thorax stimulating the respiratory centre and thus reducing its inhibitory effect on the vagal tone.

Anrep et al., associated a rise of heart rate with inspiration and a fall of heart rate with expiration. The fact that blood pressure changes could not be associated with respiration in the same way was shown by Visscher et al., (1924), also working on dogs. They showed that the respiratory wave in arterial blood pressure is the resultant of a number of factors affecting the output of the heart, some causing increased pressure and some opposing it. On inspiration the most important effect is the lowering of the intra-

thoracic pressure facilitating the flow of blood to the atria of the heart. This gives an increased venous return, increasing the cardiac output and thus increasing the arterial pressure. In opposition to this is the increased resistance to the flow in the blood vessels in the lung during inspiration, due to the vessels being stretched. This latter effect is not significant compared with the former in normal breathing.

It emerges that the time scale of events is as follows; at the beginning of inspiration there is a slight fall in arterial blood pressure due to the increased resistance in the pulmonary circuit. After about 3 beats the increased blood flow has crossed the lungs and arrived at the left side of the heart, causing the arterial pressure to rise. Expiration, on the other hand, after a preliminary rise, causes a fall in pressure. The rise is due to the freer passage of blood through the lungs in the first or second beat of expiration, and the fall due to decreased supply of blood to the right heart. This latent period means that if there are about 6 heart beats per respiration cycle, the inspiratory effect is not apparent until expiration thus giving a rise in pressure during expiration and a fall during inspiration. The depth of respiration and the extent of change in pressure within the thorax are also factors to be considered; the greater the depth of respiration, the greater the variation in arterial pressure and the sooner a breath will counter-act the effects of the previous breath and establish its own effects.

Lauson et al., (1946) to a large extent confirmed Visscher's

findings in man: in quiet breathing they found only very slight rhythmic variations in blood pressure, which might easily be missed. They showed that expiration does not give the same large change in blood pressure as does inspiration, partly, it is believed, because of venous valves which do not allow large decreases in blood supply.

Manzotti (1953) measured sinus arrhythmia during breath holding experiments. He showed that marked fluctuations continued for about 5 seconds after a subject took a deep breath and held it. From this he concluded that in this case a central mechanism is unlikely, since the fluctuations ceased after 5 seconds, and that a stretch mechanism is also unlikely since a delay due to stretch receptors would be well below 1 second. Thus he adopted the hypothesis that sinus arrhythmia is most probably caused by changes in blood flow and blood distribution. Thus it would be possible to link sinus arrhythmia with the respiratory blood pressure wave of Visscher. This hypothesis is attractive since Manzotti found that the delay in the response of the heart rate to respiration is of the same order as that of the blood pressure wave to respiration. Manzotti suggested that the aortic baroreceptors were the sensory receptors for the blood flow/heart-rate response.

Clynes (1960) dismissed the blood flow effect in man on the grounds that the heart rate response to a rapid negative impulse breath (out-in) is quite marked, and yet the blood would not have had time to move far whilst the lungs were deflating and inflating. Clynes showed that the heart rate response to inspiration was biphasic in nature. There was an immediate increase in heart rate

at inspiration, reaching a peak after 3 beats, followed immediately by a slow beat and then gradually increasing to normal. He also found that the heart rate response to expiration was similar but with a smaller amplitude.

Davies and Neilson (1967a), in a series of controlled experiments, obtained direct contradictions to these results. They obtained a much smaller increase in the heart rate response to inspiration, and the drop below normal heart rate was only of the order of 1 or 2 beats/min compared with Clynes' 15 beats/min. The most dramatic difference, however, was the heart rate response to expiration. Davies and Neilson found it very difficult to measure this response and concluded that, in fact, the response was negligible or non-existent. This fact was also concluded by Manzotti. The differences are hard to explain, but Davies and Neilson show that posture is an important factor; their subjects were seated whereas those of Clynes were lying down. In addition, Davies and Neilson took precautions to keep the subject's glottis open whilst breath-holding, whereas Clynes does not mention it. This avoided increasing the pressure inside the lungs. The average response obtained by Davies and Neilson to an inspiration showed a small delay, never more than 1 second, before the onset of a fast rise in heart rate. The maximum was reached within 3 heart beats and for the next 6 heart beats the heart rate decelerated, going below normal after  $5\frac{1}{2}$  seconds and then gradually returning to normal.

The mechanism they invoked for sinus arrhythmia is directly related to the work of Visscher. On inspiration, the fall in blood

pressure could give rise to an immediate increase in heart rate. The rapid drop after 3 beats in heart rate corresponds directly to the increased blood pressure as the extra blood provoked by inspiration crosses the lungs and arrives at the left side of the heart. Davies and Neilson thus concluded that the stretch receptor mechanism for heart rate increase was not proven, and that sinus arrhythmia in resting man was brought about solely by inspiration producing changes in blood flow, thus, to an extent in agreement with Bainbridge (1920).

In a succeeding paper in the same journal, Davies and Neilson (1967b) investigated the rhythmical fluctuations in heart rate that occur after exercise in man. They concluded that the phenomenon was respiratory in origin and was an exaggerated form of sinus arrhythmia. They decided that the greater part of the effect in this case was probably due to bouts of vagal activity, reinforced by the blood pressure effect. They also stated that breath-holding for periods of about 16 seconds abolished the fluctuations, although the graphs presented in the paper do not conclusively demonstrate this fact.

The result of Davies and Neilson (1967a) that there is a constant lag in the heart rate response to respiration is in agreement with the findings of Angelone and Coulter (1964). They studied one subject only and determined the heart rate response for respiration frequencies ranging from 1 to 40 breaths per minute. They measure respiration by the thorax diameter, and studied constant amplitude respiration i.e. the maximum and minimum thorax diameters were constant. In view of the importance of their

results we reproduce their main graph as figure 5.1

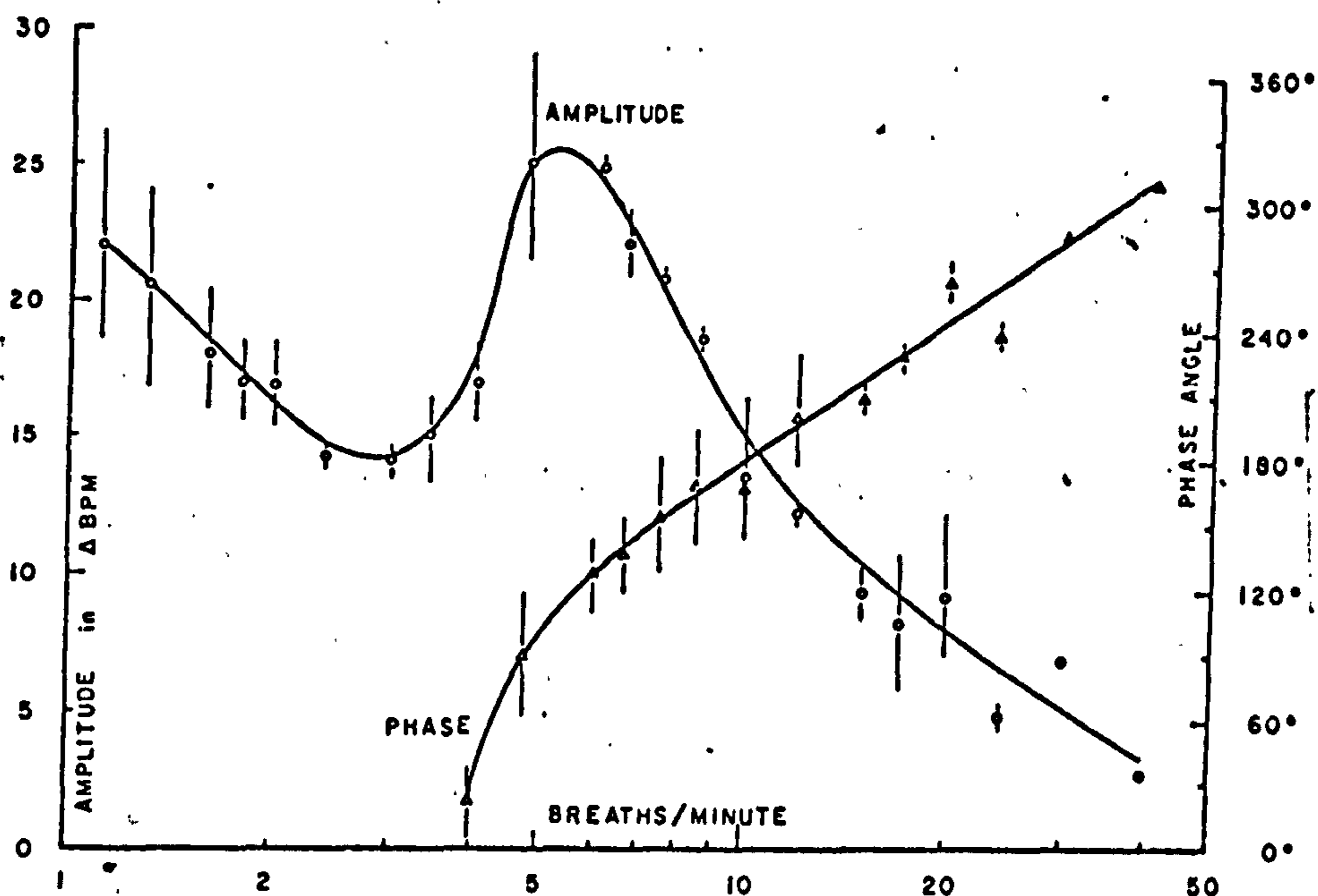

Figure 5.1. Amplitude and phase of the heart rate response to respiration (reproduced from Angelone and Coulter (1964) figure 3 p481). Vertical lines on the phase and amplitude graphs represent standard deviations.

The amplitude was measured simply as the difference between the maximum and minimum heart rates averaged over the fixed frequency respiration period. The phase as measured directly from the respiration and heart rate tracings and zero phase defined when the heart rate and expiration cycles were in phase, which occurred for very low respiration rates, Angelone and Coulter described the results as if respiration were a forcing function to a system of which heart rate is the response. From Figure 5.1 it can be seen

that for quite a wide range the phase increases linearly with the respiration rate. At about 10 breaths/minute we have a phase difference of  $180^{\circ}$ , which implies that at this frequency, which is about that of normal respiration, the heart rate is increasing with inspiration and decreasing with expiration. This is the state of affairs described in many medical textbooks. At first sight these results are entirely in agreement with those of Davies and Neilson (1967a) and were discussed by them, in that a constant lag between inspiration and heart rate would lead to a phase changing linearly with respiration rate. However, this would not give the results reported by Angelone and Coulter; the in-phase relationship between expiration and heart rate at low respiration rates, or the  $180^{\circ}$  out-of-phase relationship at about 10 breaths/minute.

Phase measurements between heart rate and respiration were also made by Levy et al., (1966). They used dogs with bypassed hearts in their experiments. They measured phase as the time between the onset of inspiration and either the minimum of the heart rate curve or the maximum of the heart rate curve, expressed as a percentage of the respiratory period. The results indicated that with intact vagi the heart rate began to accelerate slightly, before the beginning of each respiratory cycle. When the vagi were sectioned, the heart rate increased approximately synchronously with the onset of inspiration. However, after vagotomy the respiratory period approximately doubled, the average heart rate increased and the amplitude of the respiratory heart rate response was decreased to one third of its original value. Thus they concluded that the interaction between the respiratory centre and the heart rate centres



in the brain (factor (a) ) was the main influence in sinus arrhythmia. The results of vagotomy show that the effect is principally mediated through the parasympathetic nervous system, but that the sympathetic system is also to be considered as having a part in the effect, since vagotomy does not totally abolish the effect.

We return to the respiratory waves in blood pressure with a paper by Manoach et al., (1971). He showed that there were two possible sources of respiratory blood pressure waves. When respiration in cats was paralysed by curare, blood pressure waves still occurred at the rate of central respiratory activity, as measured by electrodes on the phrenic nerve. However he also obtained waves if central respiratory activity was paralysed and artificial respiration applied. The former he associated with vasomotor waves and stated that a rise in arterial blood pressure is accompanied by vasoconstriction. The latter he called peripheral respiratory waves, and stated that a rise in arterial blood pressure is accompanied by vasodilation. Joels and Samueloff (1956) have shown that the pressure variations that continue when mechanical respiratory activity is abolished are themselves stopped when central respiratory activity is stopped. Manoach (1971), in agreement with Visscher (1924), but not with Lauson et al., (1946), showed that inspiration and expiration each produce effects in the blood pressure lasting about 8 seconds for the cat; both biphasic but opposite in direction. Thus if the inspiration time lies between 0.5 and 8 seconds then we get interference between the two signals. However, he claimed that these blood pressure effects were independent of sinus arrhythmia.

An excellent paper by Valentinuzzi and Geddes (1974) described experiments on both humans and anaesthetized dogs. The humans were asked to conduct different breath-holding experiments, after inspiration and after expiration, following either natural or deep breathing. In each case the heart rate was seen to continue oscillating, at about the respiration rate or slightly lower. This is in direct contradiction to the results of Manzotti (1958) and also to that of Davies and Neilson (1967b). The differences are hard to explain, although Manzotti conducted positive pressure breath-holding and showed that this increased the mean heart rate. This increase may have obscured any oscillations that were present. Valentinuzzi and Geddes (1974) also obtained results showing an oscillating heart rate from spontaneous apnoea (held respiration) in anaesthetised dogs. The same results were obtained when respiration was paralysed in dogs by the use of drugs. These results led them to propose a central mechanism for sinus arrhythmia, consisting of two oscillators (the respiratory centre and the heart rate centre) loosely connected by a network; the degree of coupling is probably modified by signals arriving from the periphery. This model enables the effect of frequency and depth of respiration to modify the respiratory heart rate response. They found that deep, slow breathing increased the amplitude response of the heart rate to respiration, but either fast or shallow breathing or both did not affect the heart rate very much. Thus an important new extension of factor (a) above is the possibility that the cardiac centre may cycle by itself as well as being coupled to the respiratory centre. Unfortunately they did not consider an earlier paper by Sroufe (1971). He investigated the effects of depth and rate of breathing on the heart rate and the heart rate variability.

He measured the mean and standard deviation of the heart rate of human subjects, who took part in fixed-frequency breathing experiments for periods of 5 minutes for each frequency. The frequency range considered was (0.23-0.30) Hz.. He stated that the respiration rate affected only the heart rate variability, faster breathing producing a less variable heart rate than normal breathing. He claimed that respiration rate does not affect the mean heart rate, but that respiration depth affected both the mean heart rate and the heart rate variability. Deep breathing produced a faster and more variable heart rate than did normal breathing, and shallow breathing had the opposite effect. Sroufe (1971) was only interested in how the respiration could affect the heart beat as an indicator of mental stress in psychological experiments, and did not investigate the physiological implications of his results, or measure the phase or frequency response between heart rate and respiration.

A paper in which the physiology of sinus arrhythmia is studied is one by Chess, Tam and Caleresu (1975). This paper is also discussed in Chapter 1 with regard to low frequency rhythms. The authors experimented on cats in various states of neuronal control. The cats were decerebrate to avoid the use of drugs which may affect the vagal tone. An important difference between their methods and those of previous workers is that they allowed the animals to breathe naturally, and were able to elucidate the heart-rate/respiratory effects by cross-spectral analysis. There were four states of control: intact, vagal only, sympathetic only and none. They showed that with vagal only control sinus arrhythmia was present but with sympathetic only control, or with no control, the sinus arrhythmia was much

reduced. They concluded that sinus arrhythmia was mediated principally through the vagus nerves, but that there was also some contribution via the sympathetic nerves and to a lesser extent from non-neural factors. This is in agreement with Levy et al., (1966) and was also found by McCrady et al., (1966) who showed that there was a heart rate response to inspiration after vagotomy but that the time taken to respond was increased.

Recent investigations by Freyschuss and Melcher (1975, 1976) and Melcher (1976) are directly related to the work of Manzotti (1958) and Davies and Neilson (1967b). They conducted breathing experiments on healthy males in which they measured heart rate, tidal volume and oesophageal pressure. They were unable to demonstrate any sinus arrhythmia effect during inspiratory and expiratory apnoea, or during positive pressure ventilation. In order to eliminate any possible central component, and yet to stimulate breathing under natural conditions, they enclosed the subjects in an 'iron lung', which reduced the pressure on the outside of the chest, to produce inspiration. When the subjects reported that they were not consciously breathing, the heart rate was measured and a marked sinus arrhythmia effect was observed. They attributed the response entirely to a cardiovascular reflex, or Bainbridge reflex, and discounted the central component almost entirely.

Finally, another paper which describes the application of modern time-series techniques to the study of sinus arrhythmia is that of Womack (1971), which has already been mentioned in Chapter 1. He sampled respiratory data at equal time intervals and used first

and second order polynomials to extrapolate the heart rate. He calculated the frequency response function and the phase for the system and obtained similar results to those in figure 4.1, except that at low breathing frequencies Womack's frequency response function decreased with decreasing frequency. This discrepancy could be explained either because Angelone and Coulter studied only one subject, compared with Womack's sixteen, or because Womack does not seem to have ensured that constant amplitude breathing was maintained.

#### Discussion of literature review

It would appear from the recent literature that the main mechanism for sinus arrhythmia is still disputed. The papers by Valentinuzzi and Geddes (1974) and Freyschuss and Melcher (1975) seem to be directly contradictory when considering inspiratory and expiratory apnoea. It is impossible to be sure that the experimental conditions were exactly the same, but Valentinuzzi and Geddes expressed surprise that their results differed from those of Manzotti (1958) and Davies and Neilson (1967a). It is difficult to deny a positive result, and so the question is why the other authors failed to note the heart rate oscillations during apnoea. Manzotti (1958) noted a rise in heart rate associated with positive pressure breath holding and this could obscure the oscillations. Body position is another important factor in any effect related to the lungs; the subjects of Davies and Neilson (1967a) and Manzotti were sitting, whereas those of Valentinuzzi and Geddes (1975) and Freyschuss and Melcher (1975) were supine. The subjects of Valentinuzzi and Geddes held their breath for comparatively long periods, and it is perhaps because the heart rate oscillations were

not given time to establish themselves that they were not discovered by the other authors. The experiments employing negative pressure induced respiration by Freyschuss and Melcher (1975) appear to give a convincing demonstration of a reflex component, but it does not necessarily follow that there was no central component present simply because there was no respirational effort by the subject. Conversely, it is difficult to imagine how the results of Davies and Neilson (1967b) can be due to a central component.

It is important to note the differences between experimental animals and the intact human. The animals are being treated in highly unnatural circumstances and any inferences drawn from the animal experiments to intact humans must be made with caution. Indeed, Melcher (1976) postulated that the heart rate changes found in animals by earlier workers was of a different nature to those in the intact human, partly because of species difference, but also because anaesthesia could have a major influence on the results.

Perhaps it is unfortunate that authors tend to emphasize one effect at the expense of the others. Whilst we can safely discount the pulmonary stretch receptor effect, at present caution would indicate that the case for a single effect is not proven. The consensus of opinion is that respiratory sinus arrhythmia is probably a reflex action of the heart, but that the effect can be influenced by central nervous activity in the medulla.

The justification for the present study is twofold. It would be of interest to continue the work of Angelone and Coulter (1965)

to investigate the various hypotheses related to sinus arrhythmia. Their method of measuring phase by taking the time between onset of inspiration and the heart rate maxima and minima, also described by Levy et al., (1966) is open to criticism in that when dealing with peaks in a cycle we are dealing with abnormal rather than normal phenomena, as pointed out by Granger and Hatanaka (1964, p211). The measurements of the phase and the frequency response function could be made more accurately using cross-spectral analysis, and it was decided to make an attempt to quantify the sinus arrhythmia effect by these methods. These results might then be used to assess the contribution by respiration to heart-rate variability of intensive care patients. If the normal amplitude and frequency response function could be made more accurately using cross-spectral analysis, and it was decided to make an attempt to quantify the sinus arrhythmia effect by these methods. These results might then be used to assess the contribution by respiration to heart-rate variability of intensive care patients. If the normal amplitude and frequency range of sinus arrhythmia could be identified, then it may be possible to incorporate these statistics into a better design for patient monitoring devices. Respiration data for the post-operative patients were not available and so experiments were set up to measure the respiratory heart-rate response of normal healthy individuals.

#### Experimental methods used in this study

The experiments were carried out in four series. In the initial series only the ECG was recorded. In the second the heart interval and the respiration were recorded for a rest period and 8 different breathing frequencies. In the third series the heart rate

and respiration were recorded for a rest period, 8 different breathing frequencies at normal breathing depth, 4 breathing frequencies with deep breathing and then 4 breathing frequencies with shallow breathing. Several of the subjects were studied in more than one series. The physical data of the subjects is given in Table 5.1.

The experiments were conducted at various times of the day, this factor being thought unlikely to affect the results. The electrodes used to measure the ECG were a 4 lead system described in Appendix B. Each subject was given a few minutes rest period after the electrodes had been fastened to his chest, both to improve the conductivity of the electrodes and to allay any nervousness felt by the subject.

In the first series the subjects, consisting of 4 males and 4 females, sat quietly out of sight of instruments, and the ECG was recorded onto an FM tape recorder for periods between 15 and 20 minutes. No instructions were given with regard to breathing. This was to simulate, to some extent, the ward patients' data. The tape recording was afterwards run back and the output fed to an analog device for detecting the QRS complex which also timed the intervals between heart beats. The intervals as they occurred or the instantaneous heart rate obtained by dividing the interval in seconds into 60 could be output onto paper tape, or the heart rate sampled at one second intervals by a DART data logger could be output. These methods are discussed in Chapter 3. Using the tape recorder and marking the magnetic tape, it was possible to play the same section of tape through the data logger several times and so be able



to check the repeatability of the instantaneous estimates, or to compare the sampled data with the instantaneous. The data from two subjects were treated in this way. A rough comparison between two different estimates of the instantaneous heart-rate was made in each case. The rates were expressed in terms of 1 volt, the scale being 1 bt/minute equivalent to 0.005 volts. The results were expressed to 4 decimal places. In the comparison the last two decimal places appeared to be somewhat arbitrary, but the first two had a very high degree of repeatability. Thus the results were accurate to about 1 bt/min.. A comparison between the instantaneous and the sampled data is discussed in Chapter 3.

In the second and third series of experiments the ECG was fed directly to the analog device and the heart beat intervals and the respiration signal fed directly to the data logger. This outputted the interval and the value of the respiration signal at the time of the second beat of the interval onto paper tape. The signal was also displayed on an oscilloscope so that the instrument settings could be adjusted and the subject's performance continuously monitored. The breathing cycle was monitored using a chest bellows. This was connected to a micromanometer (Greer 1958), which outputted a continuous voltage proportional to the pressure in the tube. Figure B.2 in Appendix B gives a photograph of the set-up. In this way, an analogue of the inspiration signal could be measured. Angelone and Coulter (1965) criticised this method because the thorax could be held expanded whilst breathing was continued and so give misleading results. However this did not happen for normally breathing subjects. The method is considerably less sophisticated than measuring the

expiratory volume or even the thorax diameter, but it does give an accurate indication of the onset of inspiration and expiration, and a somewhat less accurate measure of depth of breathing. It has the advantage of being relatively comfortable for the subject and easy to set up for the experimenter. The time lag, due to the volume of air in the rubber tube between the signal and effect, was judged to be negligible.

In the second and third series the subjects were seated out of sight of the equipment except for the manometer. It was found that by watching the manometer the subjects could easily adjust their breathing to a regular and steady cycle. About five minutes duration of heart intervals and breathing depth were recorded before any fixed frequency breathing was started, as a control for the fixed frequency breathing and also as a test for the equipment settings. The subjects were then requested to listen to a prerecorded tape of a metronome and to breathe in time to the beats, counting 5 beats during inspiration and 5 during expiration. The first part of the tape was for practising, and gave the fastest rate (15 breaths/min) and the slowest ( $4\frac{1}{2}$  breaths/min.). If the subject had not mastered the breathing by then, the practice section could be replayed. In fact all the subjects learnt the exercises within a few minutes, although several found difficulty with one or other exercise.

Initially in the second series, subjects were analysed for four different frequencies. However, preliminary results indicated a need for more frequencies after which eight were analysed. Thus, after the practice the tape contained eight sections of recorded

metronome frequencies, for periods of between 3 and 6 minutes each. Between each section there was either a gap or the tape was stopped, both to give the subjects a rest and to try to ensure some degree of independence between the results. The order of the metronome frequencies in Hz. was 0.240, 0.100, 0.143, 0.078, 0.125, 0.091, 0.111 and 0.083. The order was deliberately selected to mix low, medium and high frequencies and to try and avoid compounding errors. However, because the beats were prerecorded all subjects were given the same order of frequencies to breathe. This is a potentially serious source of error if the heart rate of each subject performed to a particular time pattern, say a steadily decreasing trend throughout the experiment, because the pattern would be indistinguishable from the frequency effects. However, before the experiments this was felt to be unlikely and the results do not appear to show any particular time-dependent effects. The advantages of the recorded beats are convenience, and accuracy, since if the metronome were to be continually reset it would require to be retimed on each occasion. It was decided to alter the metronome frequency rather than, say, having the subject count different numbers of beats to try and reduce the amount of conscious timing by the subject.

In the third series the initial procedure was identical to that of the second. However, on completing this the subjects rested and were then requested to breathe the first 4 frequencies again, watching the manometer needle. They were asked to breathe shallowly, keeping the manometer needle in the top quadrant of the dial. They were allowed to stop after 2 minutes at each frequency, so that none became breathless. After a rest, they again repeated the first 4

Figure 5.2

Examples of raw data

Subject 15

Free breathing

Respiration signal

Heart Interval ↓

E.C.G.

Sweep rate 0.5 cm/sec.

Subject 1

Breathing frequency

0.137 Hz.

Sweep rate 0.5 cm/sec.

Subject 8

Breathing frequency

0.083 Hz.

Sweep rate 0.2 cm/sec.

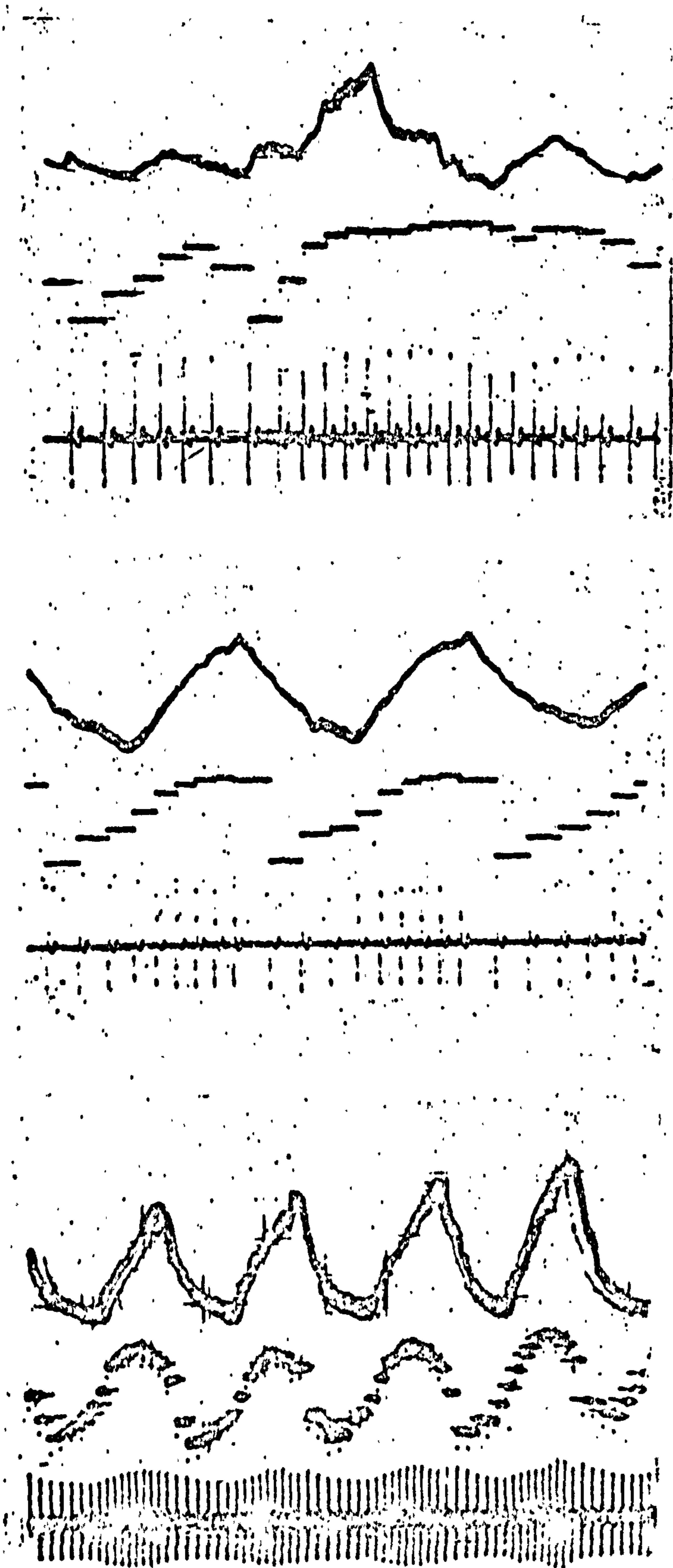

frequencies, this time breathing as deeply as they could, trying to give a full scale deflection to the manometer needle. Again, they only kept this up for about 2 minutes at each frequency.

Fig.52 shows the data as output to the data logger. The top tracing in each photograph shows the manometer output. The centre one is a step function relating to the value of the heart interval, the length of each step being the duration of the following interval. However it was unavoidable that the plot should be an inverse, that is the longer intervals are plotted downwards. This means that the upwards curve indicates an increasing heart rate. The bottom tracing shows the ECG with the QRS complex sharply defined. Thus we see that the machine seems to be tracing the peaks very accurately. Photograph (a) illustrates how the breathing signal can have a very erratic nature. We can see inspiration with no corresponding H.R. increase and also heart rate change with no apparent breathing change. Photograph (b) illustrates the sometimes grave difficulties in applying phasic methods to the signals. The heart interval is clearly periodic, with the same period as the breathing cycle. However it is almost monotonic for the whole cycle increasing for part of the expiration cycle and all of the inspiration cycle. An analysis of lags may be more fruitful in this case. Photograph (c) shows a clearly oscillating heart period, in which the heart-rate is in advance of the respiration signal. In this case a phase analysis is more easily interpreted. The results in (b) occurred in one subject only.

The fourth series of experiments was conducted some time after the other three, and was an attempt to repeat the results of Valentinuzzi and Geddes (1974), and resolve some of the contradictions in the literature with regard to breath-holding experiments. Six subjects were studied, and their electrocardiograms and respiration were measured as before. Each subject went through a sequence of exercises in which he was asked to breathe normally for about two minutes and then to hold his breath for as long as possible. In some sequences the respiration was paced with a metronome, which was stopped when the subject held his breath. In these cases, the subject was given either a 6 or a 10 second respiration cycle. In some sequences the subjects held on inspiration and in others on expiration. They were given practice runs to try and keep the glottis open and to avoid building up pressure in the lungs. In a further sequence, hyperventilation for one minute preceded the breath-holding manouvre. The subjects conducted the exercises lying down and then repeated them sitting.

The purpose of these experiments was to explore some of the differences in methodology mentioned in the literature such as posture, the effect of hyperventilation and whether the subject held his breath on inspiration or on expiration.

FIGURE 5.3

SPECTRA OF TWO SUCCESSIVE HEART-RATE

SECTIONS OF 400 POINTS EACH

SUBJECT NO. 2

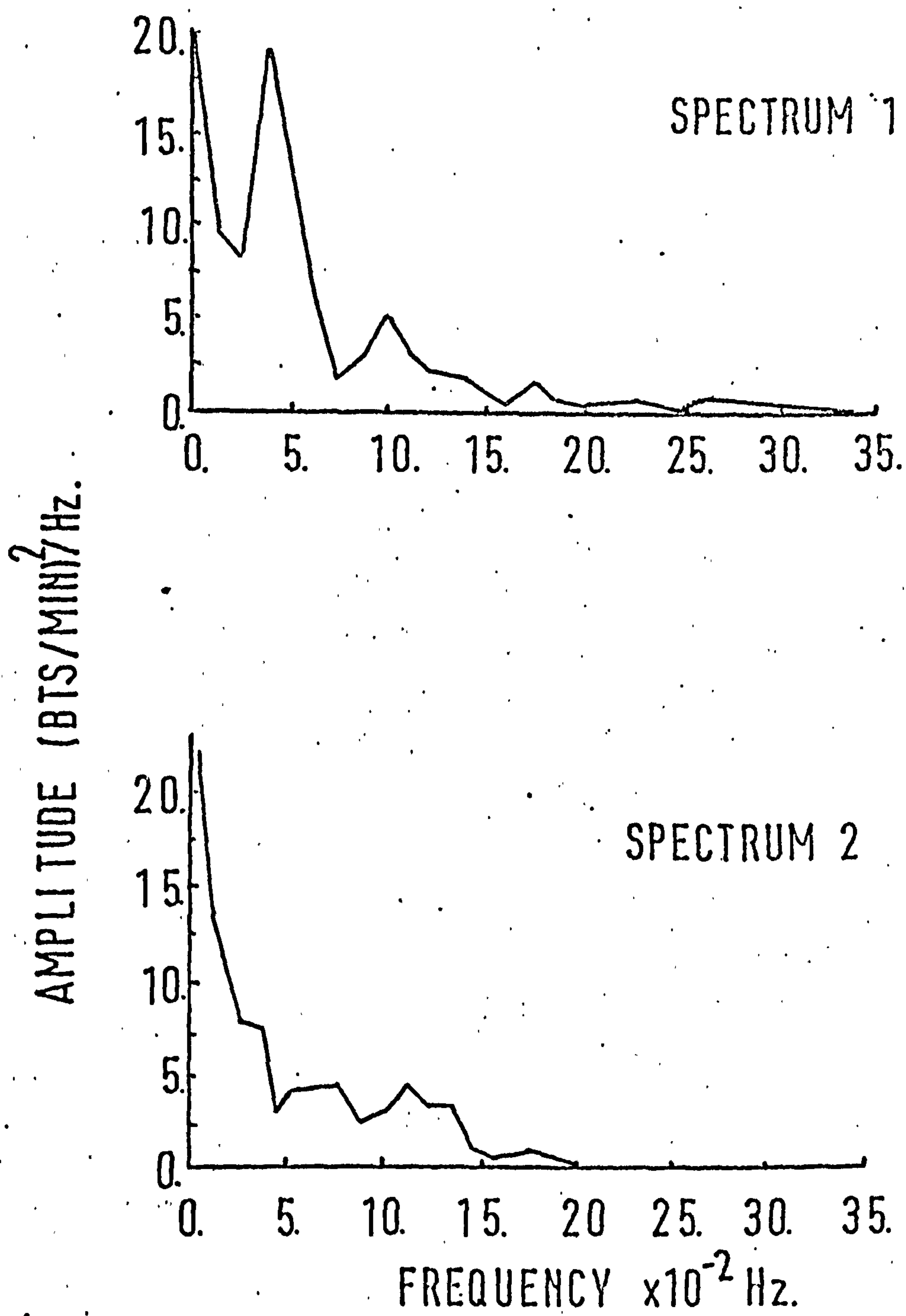

### Data processing

The data were sampled either by the data logger or by the program SAMPLE (see Appendix C). The sampled data were processed by BMD X92 (described in Appendix A). The output of the program gave the spectrum of the heart rate for series 1 and of the heart rate and breathing, the cross-spectrum, phase and coherency between the two signals for series 2 and 3. In general a resolution of between 0.08 and 0.16 Hz. was used, which gave between 4 and 8 degrees of freedom per spectral estimate.

The means and standard deviations of the raw data for both heart rate and respiration were calculated using INHIST (Appendix D). As indicated in Chapter 3, it was decided to use the standard deviation of the heart rate as a measure of heart rate variability and the standard deviation of the respiration signal as a measure of breathing depth.

### Results: description

The series 1 experiments did not produce very clear results. Figure 5.3 gives the heart rate spectra for two successive sets of data of 300 points each. The spectra in this case appeared not to differ from those produced by a random signal with added trend. It was felt that since heart rate can depend to a large extent on respiration, a possible reason for the widely varying heart rate could be that respiration, which was unmonitored, was also widely varying. It was for this reason that the series 2 experiments were devised to monitor and also to control the respiration. The series 3 experiments followed to give control of the depth of breathing. The differences



FIGURE 5.4 SPECTRA FOR RESTING SUBJECTS

— HEART RATE SPECTRUM --- RESPIRATION SPECTRUM

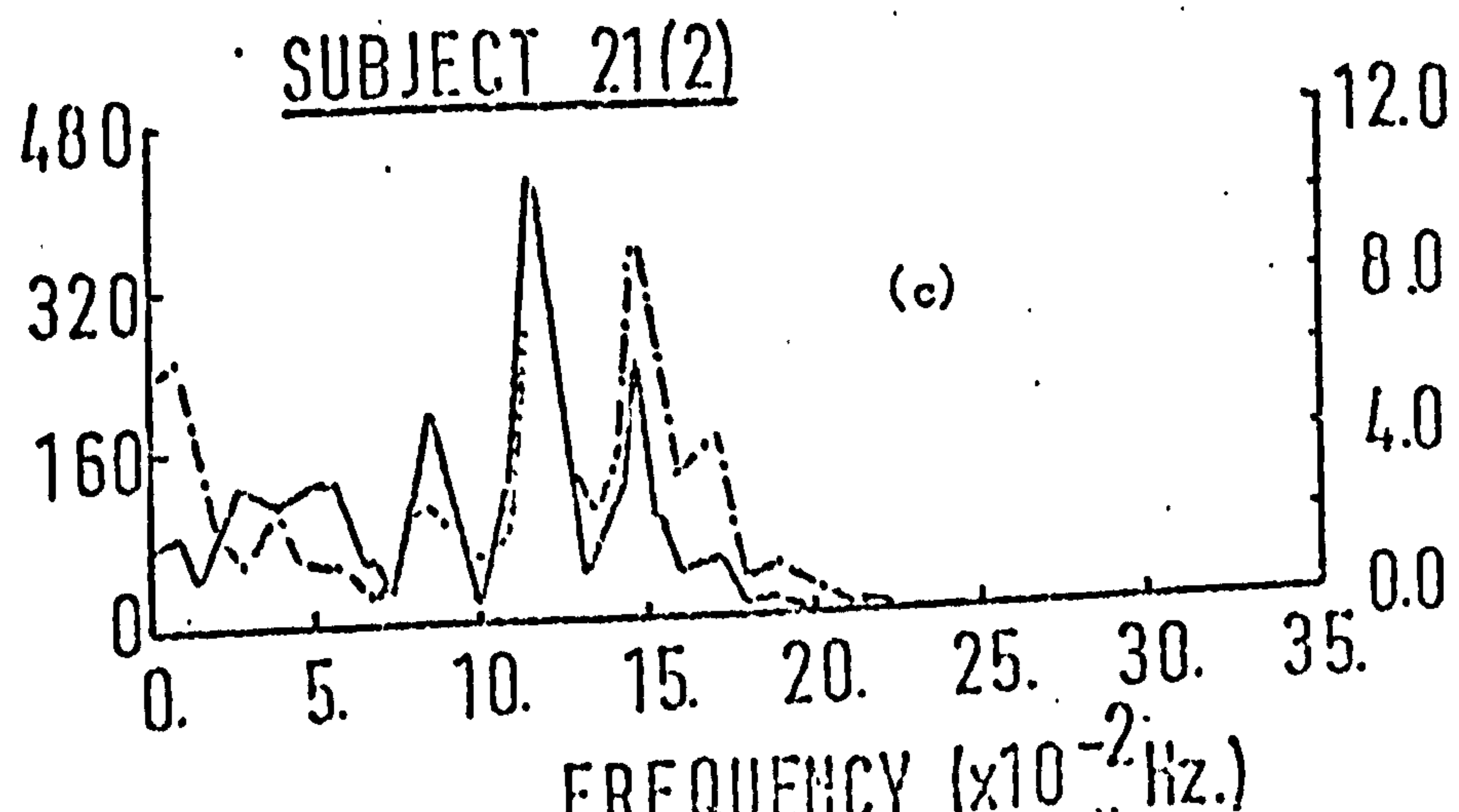
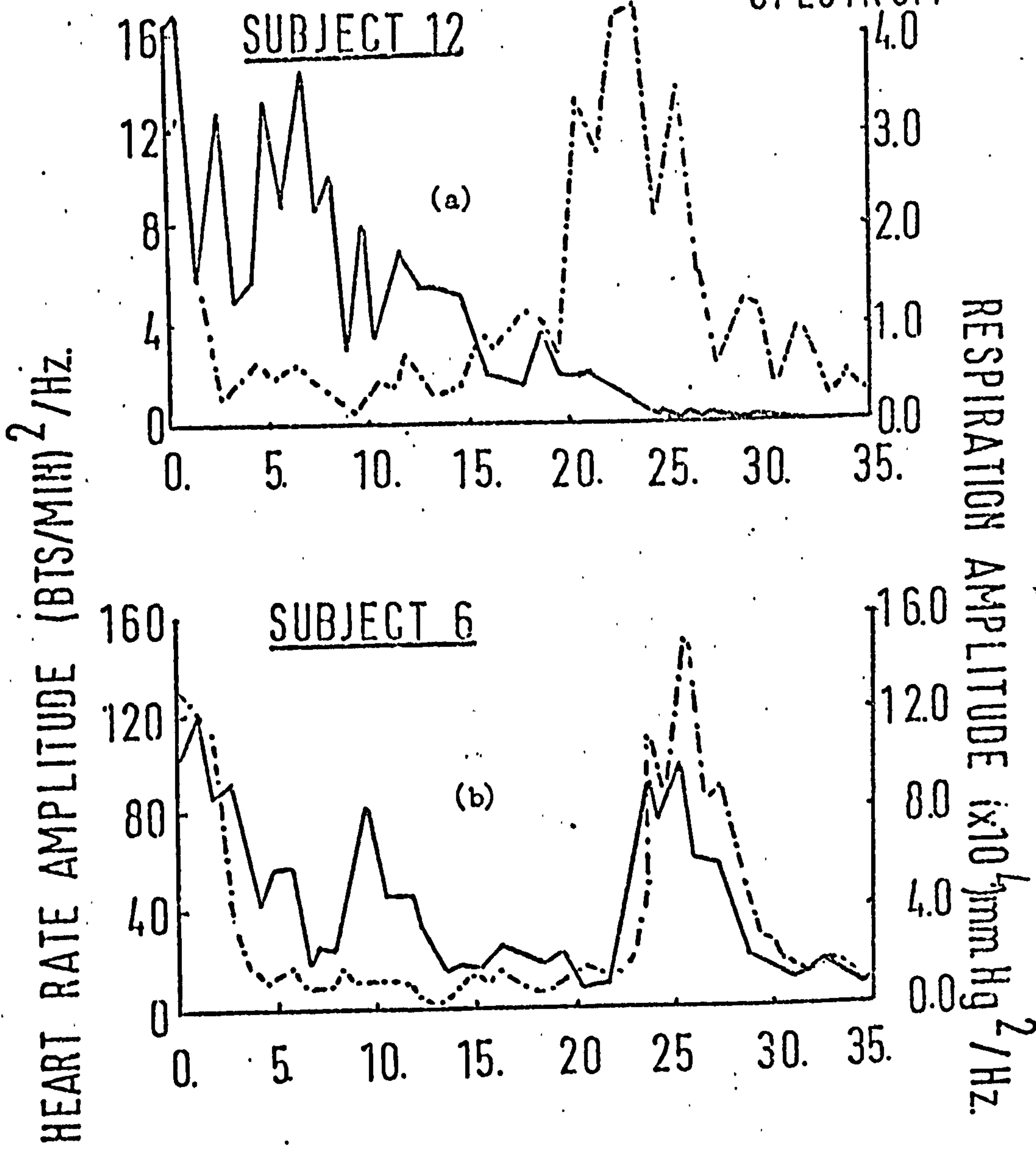

between the results for controlled and uncontrolled respiration will be discussed later.

Out of the 20 subjects studied in the series 2 and 3 experiments, the 74 year old subject, no.15, gave no recognizable spectra and so has been excluded from the discussion. A total of 4 subjects were studied twice, and so there were 23 separate studies in total. The spectra of the heart rate for the resting subjects gave 3 different types of graph which are illustrated in figure 5.4. There were four subjects who failed to show any signs of sinus arrhythmia, and of these three did not show any regular breathing pattern. The spectrum of the fourth, subject no.12, is illustrated in figure 5.4a. A further 14 subjects gave non-significant local peaks in the heart rate spectrum which could, however, be correlated convincingly with the respiration because of the high coherency values at the frequencies corresponding to the peaks. Figure 5.4b illustrates this type of spectrum. The third type of spectrum, occurring in 5 subjects, is shown when the only peak in the heart rate spectrum is correlated with a peak in the respiration spectrum. This is illustrated in figure 5.4c.

In the 18 spectra exemplified by figures 5.4a and 5.4b, a peak in the region of 0.007 Hz. was present. This has been discussed in Chapter 1 and Chapter 4 and is almost certainly the vasomotor oscillations, related to the blood pressure oscillations which are independent of the respiration. In some cases this peak will also be compounded with the thermal peak at a lower frequency. Independence of respiration is indicated both by the low coherency with respiration

FIGURE 5.9 HEART-RATE AND RESPIRATION SPECTRA:  
VOLUNTARY RESPIRATION RATE=0.24 Hz.

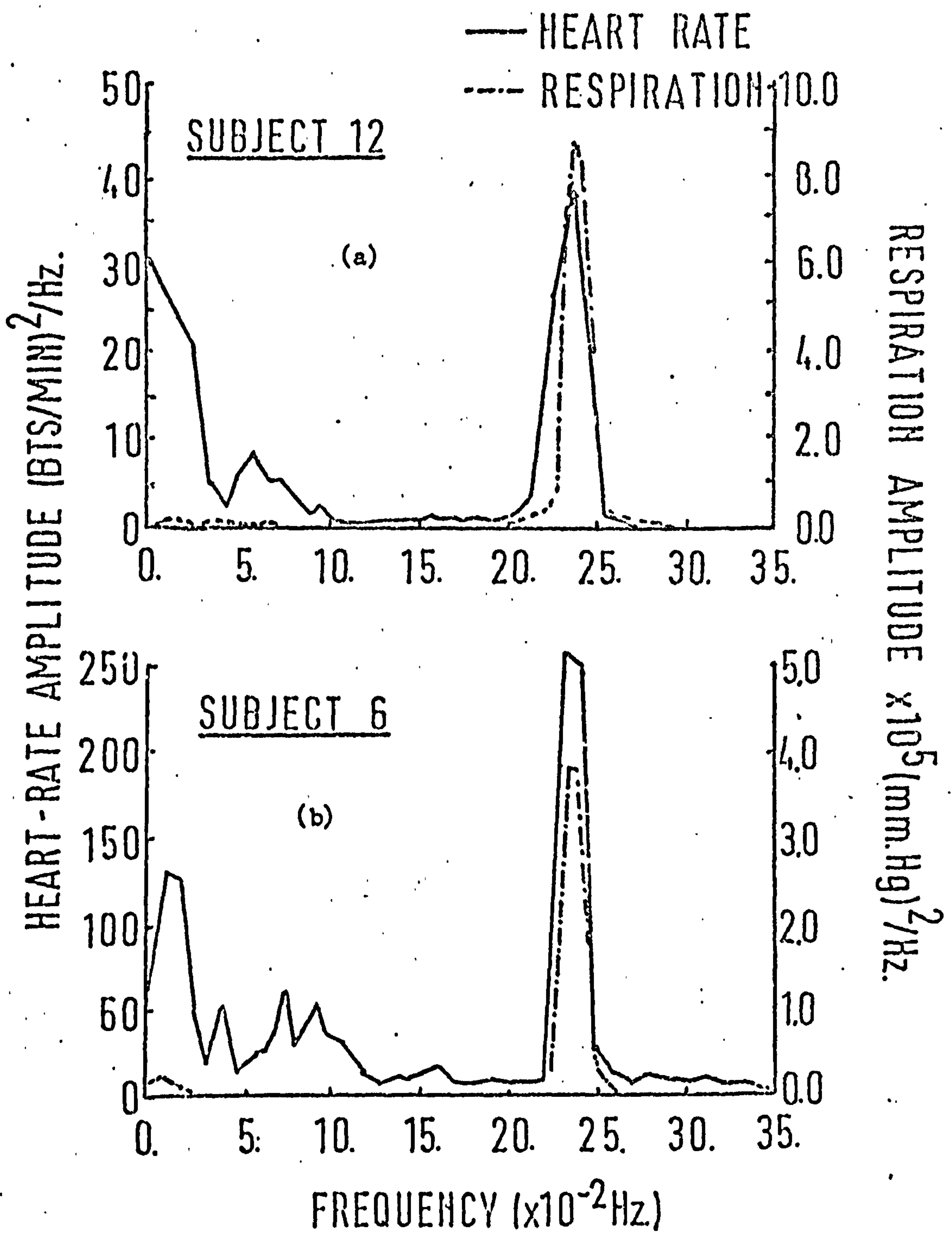
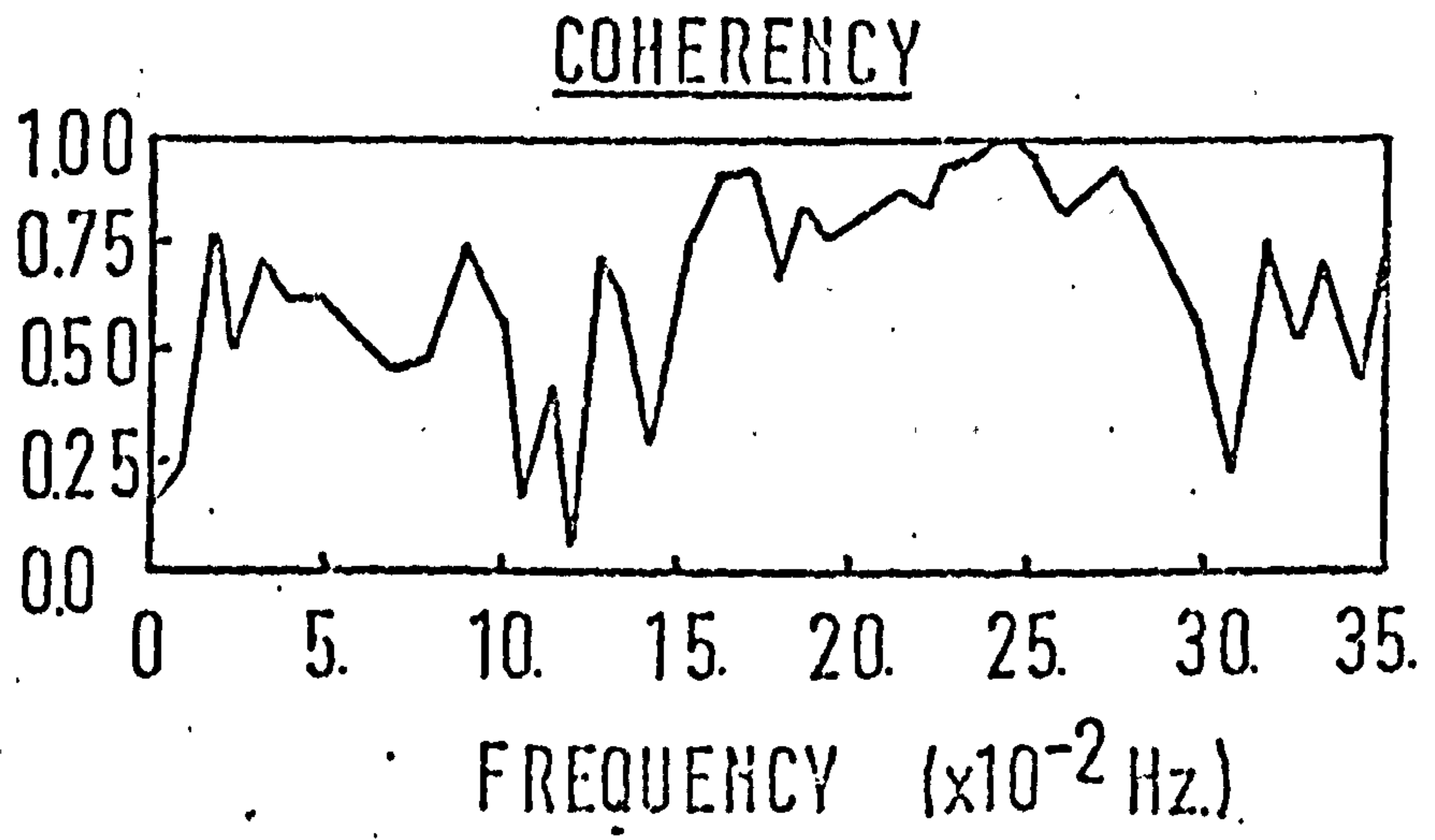
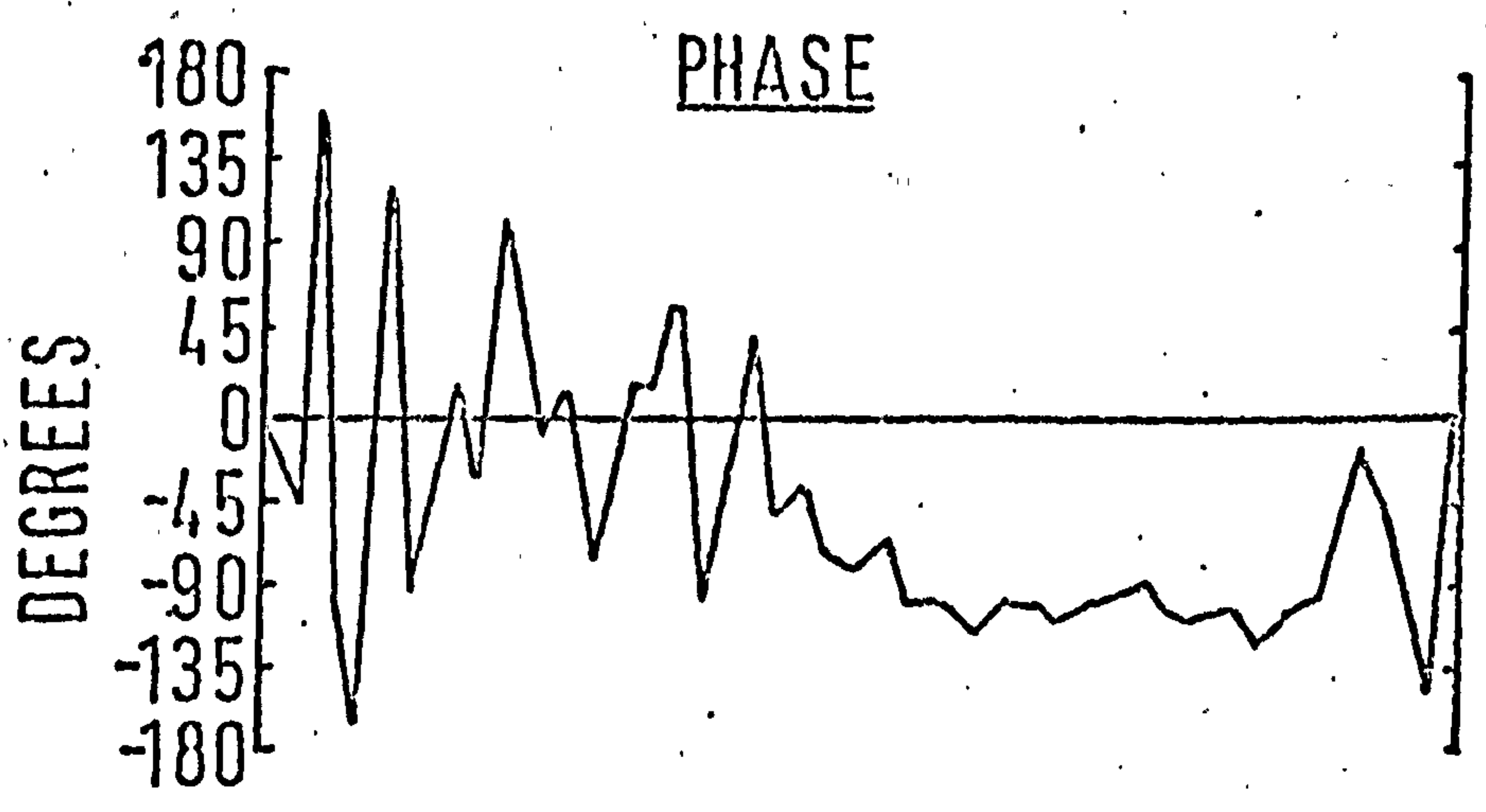
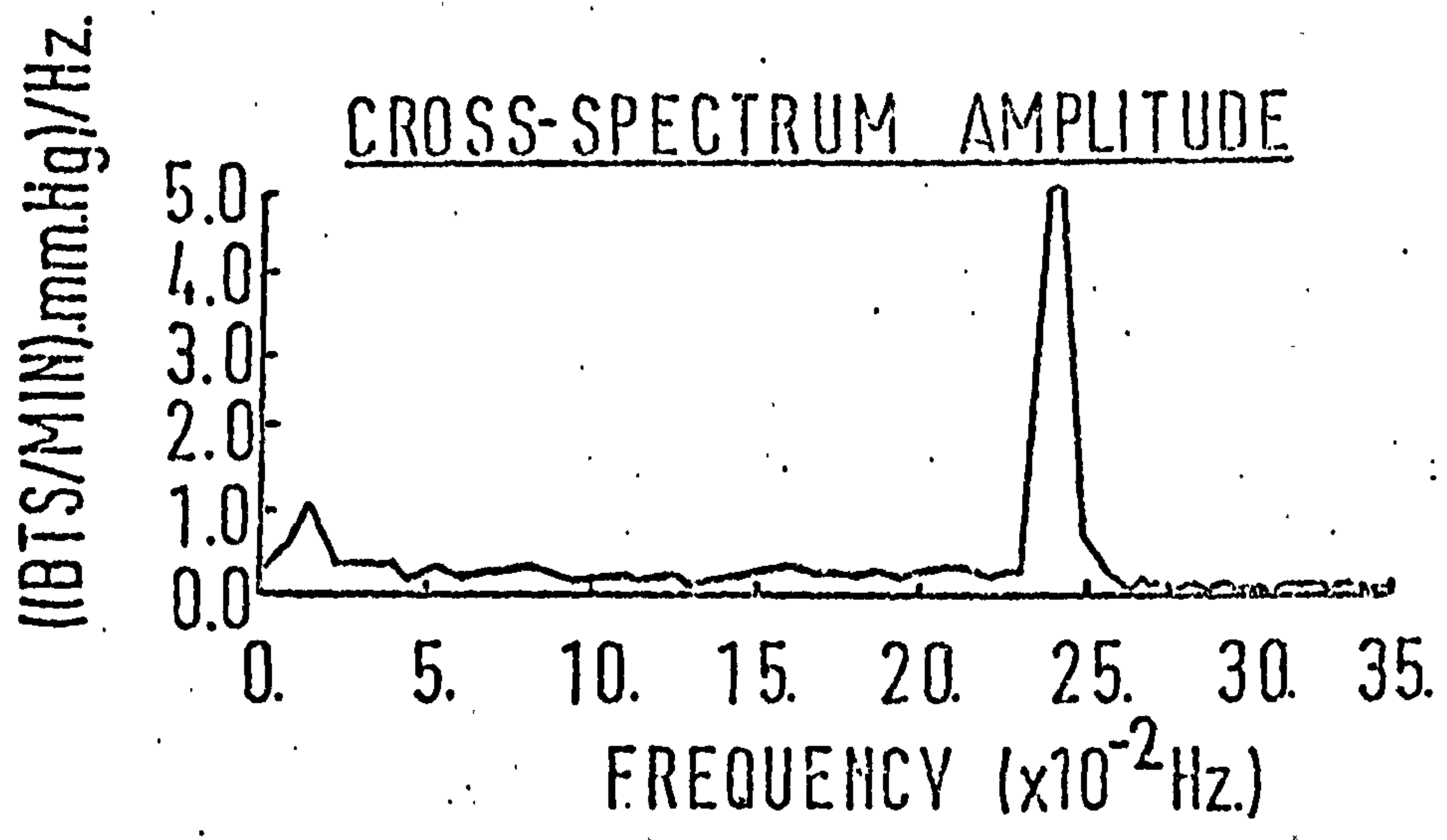

FIGURE 5.6 · CROSS-SPECTRAL ANALYSIS OF HEART RATE

AND RESPIRATION FOR SUBJECT 6

RESPIRATION RATE=0.



and by the lack of a corresponding peak in the respiration spectrum at this frequency. For subject 12, (figure 5.4a), the peak in the respiration spectrum at around 0.23 Hz. indicated that the respiration was fairly regular at around 15 breaths/minute, but there was no apparent effect on the heart rate at this frequency. The amplitude of the respiration spectrum peak at this point is low compared with the respiration spectra peaks of all the other subjects, save subject 24(3), which may account for the lack of effect in the heart rate.

When a subject started breathing in time to a metronome, it was noted that the heart rate was almost immediately entrained by the respiration signal. This is reflected in the spectra, as shown in figure 5.5a, again for subject no.12. We see that almost all the heart rate energy is concentrated at the respiratory frequency and the amplitude of the heart rate and respiration peaks have increased by factors of 25 and 100 respectively. Figure 5.5b shows a situation where the heart rate is not totally entrained by the paced respiration, and we obtain two peaks in the heart-rate spectrum, vasomotor and respiratory.

Figure 5.6 shows the cross-spectrum, phase and coherency (defined in Appendix A) for the same data used to produce figure 5.5a. Note that the cross-spectrum and coherency are both maximum at the respiratory frequency of 0.25 Hz. We have 4.38 degrees of freedom for the phase estimate, and a coherency greater than 0.9 at the respiration frequency. Table 5.1 of Granger and Hatanaka (1964) would give us a maximum 95% confidence interval for the phase of  $\pm 4^\circ$ . The assumptions for this result are not met by the data in this case,

# FIG. 5.7 HEART RATE AND RESPIRATION-OUTPUT FROM DIGITISER

## SUBJECT 25

— HEART RATE

--- RESPIRATION DEPTH

Metronome setting = 0.143 Hz.

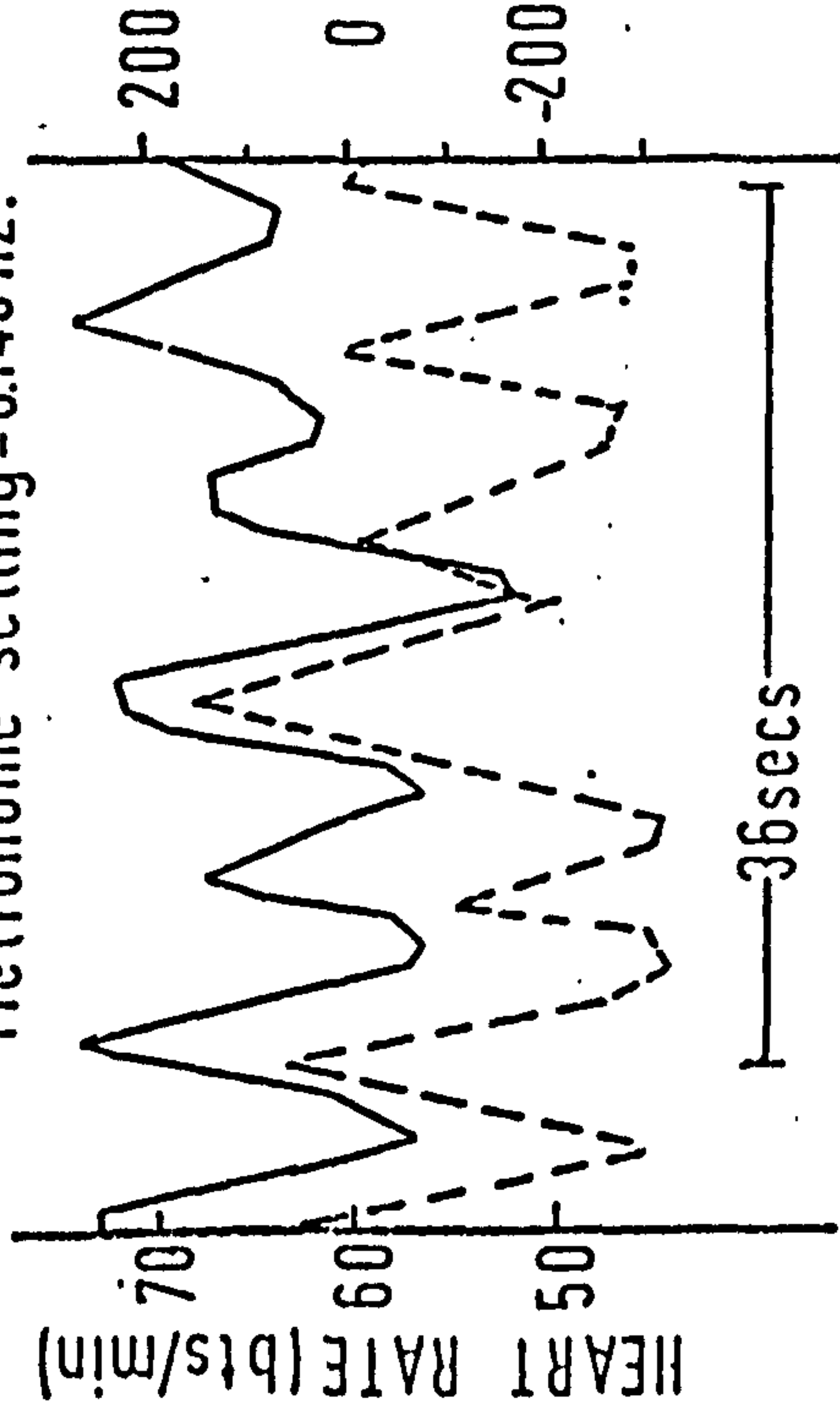

Estimated frequency =  $5/36 = 0.139$  Hz.

Estimated lag over 6 peaks = -1.0 sec.

Phase estimate =  $1 \times 360 \times 0.139 = -50^\circ$

Cross-Spectrum phase estimate =  $-46^\circ$

Metronome setting = 0.077 Hz.

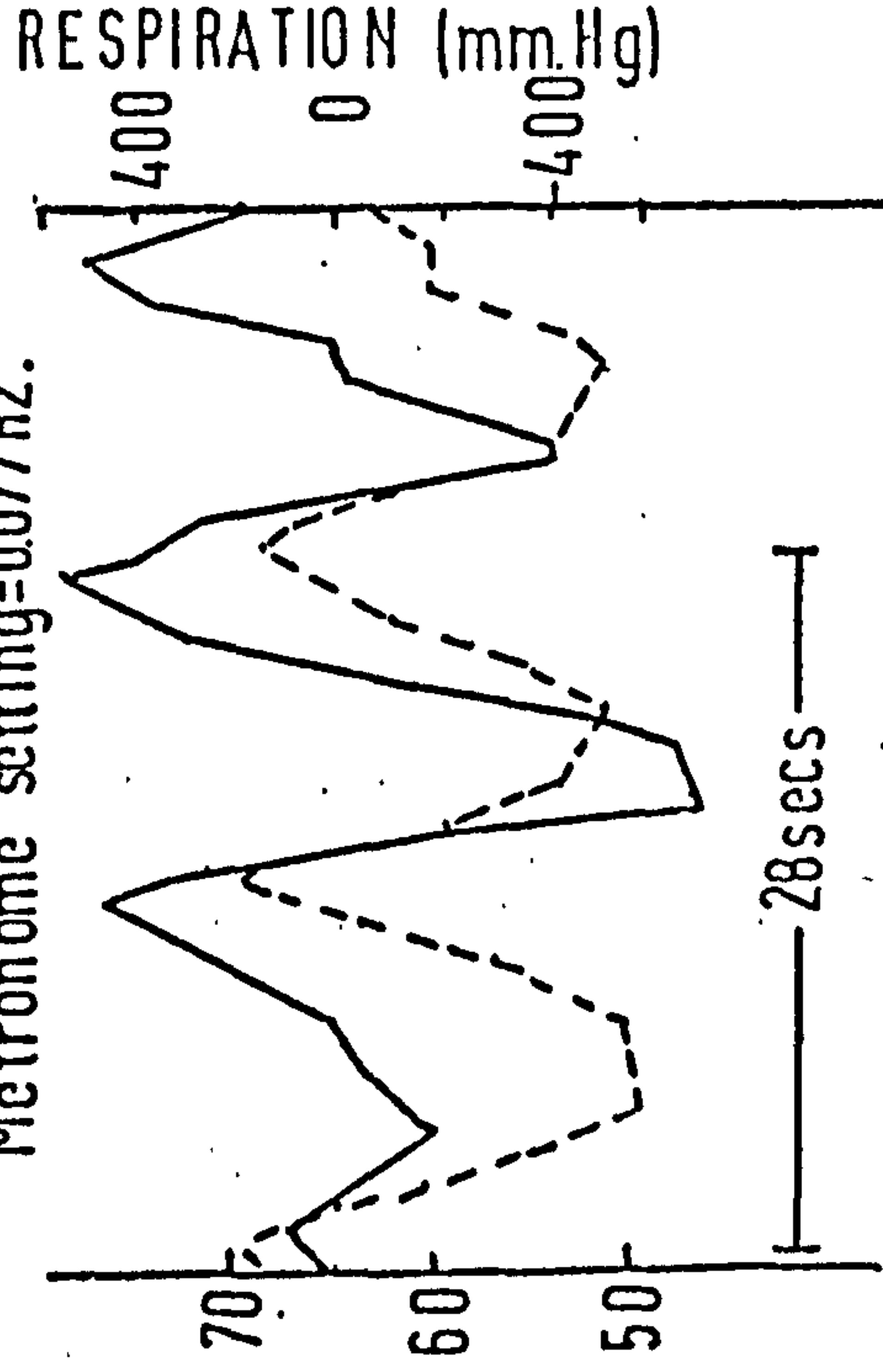

Estimated frequency =  $2/28 = 0.071$  Hz.

Estimated lag over 3 peaks = 1.0 sec.

Phase estimate =  $1 \times 360 \times 0.071 = 26^\circ$

Cross-Spectrum phase estimate =  $51^\circ$

as shown in Chapter 4, but nevertheless we can be reasonably confident in the accuracy of the results. It is noticeable that the phase/frequency graph is fairly smooth and constant in the region of the respiratory frequency.

Figure 5.7 illustrates how the frequency and phase calculated by cross-spectral analysis correspond closely to that which would be estimated from the raw data. The output from the digitiser, sampled every second by SAMPLE, for two respiration frequencies for subject no.625 are shown. From the first, measuring the respiration, we have 6 peaks in a period of 36 seconds, giving us an estimated frequency of 0.139 Hz.. If we estimate the lag between the respiration peaks and the heart rate peaks, the average lag is -1 second, which corresponds to a phase of  $-1 \times 360 \times 0.139 = -50^\circ$ , negative since we are measuring relative to the heart rate. The cross-spectrum peak is at 0.137 Hz. and gives a phase of  $-45^\circ$ . The second graph shows 2 cycles in the space of 28 seconds, giving a frequency of 0.071 Hz. The average lag between peaks this time is 1 second, giving a phase of  $1 \times 360 \times 0.071 = 26^\circ$ . The cross-spectrum peaks is at 0.074 Hz. and the phase is  $51^\circ$ . It is not surprising that the phase estimate from the graph is not very accurate since we are estimating it from only two points. However the cross-spectrum phase still shows the heart rate in advance of respiration, which is interesting, especially when compared with the faster respiration frequency, when heart rate lags respiration. Although the estimates seem fairly good for frequency and phase in this example, it should serve to show the difficulties of measuring them from a graph, where we have no standardization as to measuring from peaks, troughs or a median

line. In addition measuring the amplitude response from the graph would be very difficult.

There are several methods of determining the respiration frequency more accurately from the respiration spectrum, but ultimately limits are imposed by finite record length. The spectrum was usually calculated at intervals of 0.08 Hz. and if it appeared that the peak lay between two consecutive spectrum estimates, a weighted mean was taken as the frequency estimate. Thus, if we obtained respiration spectrum amplitudes  $p_1$  and  $p_2$  at frequencies  $f_1$  and  $f_2$ , where  $p_1$  and  $p_2$  are of the same order, and are greater than all other amplitudes in the spectrum and  $f_2 - f_1 = 0.08$  Hz. then the estimated frequency is given by  $\hat{f} = (p_1 f_1 + p_2 f_2) / (p_1 + p_2)$ .

#### Distribution of heart-rate variability

The heart-rate data taken when the healthy subjects were resting can be compared with that of the post-operative patients. For healthy subjects 6, 7 and 8 the data were sampled with sampling intervals 0.5, 0.75 and 1.0 seconds, yielding spectra with frequencies up to 1.00, 0.67 and 0.50 Hz. respectively. It was found that the heart-rate spectrum above 0.5 Hz. was virtually zero. This was in agreement with, for example, the results of Hyndman and Gregory (1975). Thus a sampling interval of 1.0 second would produce all the information required.

The heart-rate spectrum was divided into three frequency intervals, as in Chapter 4. The three intervals were (0 - 0.016), (0.023 - 0.125) and (0.133 - 0.500) Hz. to correspond to the trend,



vasomotor and respiratory components of the heart rate. The intervals are disjoint because we have a finite resolution of the spectrum. The heart-rate variance was calculated for each frequency band for each subject and is given in Table 5.9. It can be seen that the subjects vary quite considerably between themselves. The results for each spectrum were expressed as a percentage of the total spectrum variance. Overall the mean percentage in each of the three groups was  $19.9 \pm 1.9$ ,  $50.3 \pm 3.1$ ,  $30.0 \pm 2.9$  respectively. Thus, for the resting subjects, approximately half the variance about a linear trend in a 5 minute interval could be found in the frequency band (0.023 - 0.125) Hz.

#### The effect of respiration on the heart-rate

We wish to investigate the effects that frequency and depth of respiration have on the level and variability of the heart rate. From the series 2 and 3 experiments we have a large number of observations of the heart rate for a given subject and respiration frequency. However, because the heart beats are highly correlated, we cannot regard the series of heart beats as independent replicates of the experiment and so we simply took the mean and standard deviation of the series as measures of the level and variability of the heart-rate. These two statistics give a very crude summary of some of the information available in the series; clearly other statistics could also be computed and analysed, such as higher moments or correlation coefficients. However, the mean and standard deviation appear to be of immediate physiological interest.

The data were analysed by means of the analysis of variance.

Components of the total variance of the observations are associated with variance between subjects and between frequencies. The observations are assumed to result from a model where the subject and frequency effects are additive, and the variance of the residual term, having allowed for the subject and frequency effects, is the same for each subject/frequency cell. For exact significance testing we require that the residual term is normally distributed. Tables 5.2 and 5.3 give the mean and standard deviation of the heart rate for uncontrolled respiration depth at each metronome frequency. Tables 5.4 and 5.5 give the mean and standard deviation of the heart rate and the standard deviation of respiration for deep, shallow and uncontrolled respiration depth.

#### Analysis of Means

The mean heart rate of all the subjects at rest was tested for male/female ordering. Representing female by F and male by M the means are ordered FFMFMFMFMFFMFMFMFM. If we assign ranks 1,2,3 etc. to the results and sum the female ranks we get  $\text{sum}=74$ . Applying the Wilcoxon rank test (Documenta Geigy 1971 p124) with  $m=8$  and  $n=12$  we get a 5% confidence interval of (58-110). Since our result lies in this range, we cannot say that the male/female ordering is anything but random.

The data analysis was conducted by means of the GENSTAT computer package (Rothamstead Experimental Station, 1973). This program uses a technique of iterative weighted linear regression to obtain maximum likelihood estimates of the parameters of a linear model used to describe the data. The advantage of the program is that it enables different models to be tried easily. The importance

of different effects can be estimated and the residuals can be examined for outliers and departures from normality. The output of the program can be used to give an analysis of variance for the data.

The first six subjects to be tested with fixed breathing frequencies were subjects numbers 7, 11, 12, 13, 24 and 25. Only four fixed respiration frequencies were taken and also a section of non-paced respiration. It was found that this did not give very many points for the frequency/phase analysis, and so after this 8 frequencies were analysed. A two way analysis of variance was conducted firstly on these six subjects with the following result:

| Source              | Sum of squares | D.O.F. | Mean Square | Mean Square Ratio |
|---------------------|----------------|--------|-------------|-------------------|
| Between subjects    | 4079.18        | 5      | 815.84      | 110.70            |
| Between frequencies | 33.19          | 4      | 8.30        | 1.13              |
| Residual            | 147.37         | 20     | 7.37        |                   |
| Total               | 4259.74        | 29     |             |                   |

$$F_{5,20}(0.05) = 2.71 \quad F_{4,20}(0.05) = 2.87$$

The analysis shows that practically all the variance of the observations can be associated with the variability between subjects, and that no real frequency effect can be discerned.

Following this result, a greater number of subjects and a greater range of frequencies were studied. Subjects 21-25 appeared in both the Series 2 and Series 3 experiments and so we have replication in some of the columns. There were three missing values,

and these were estimated by the program to minimise the residual sum of squares, and then the analysis was conducted with the estimated values. The estimates were 81.9, 81.9 and 60.7 bts./min for subjects 23(2), 23(3) and 19 respectively. The analysis of variance table is given below.

| Source              | Sum of squares | D.O.F. | Mean Square | Mean Square Ratio |
|---------------------|----------------|--------|-------------|-------------------|
| Between subjects    | 8785.34        | 14     | 627.52      | 50.49             |
| Between frequencies | 859.09         | 8      | 107.39      | 8.64              |
| Residual            | 1690.22        | 136    | 12.43       |                   |
| Total               | 11334.65       | 158    |             |                   |

Provided the analysis of variance requirements are satisfied by the data, we can test for the subject and frequency effects by comparing the mean square ratio to an  $F$  statistic with the appropriate degrees of freedom. It can be seen, however, from Table 5.3, that the standard deviations of the observations vary considerably between subjects and frequencies. The individual heart-rate values are correlated, so we cannot deduce the variance of the mean heart rate from these figures, but it is apparent that this variance will vary considerably between subjects and frequencies. However, in view of the large number of individual values that make up the mean, the variance of the mean will be much smaller than the variance of the observations. For example, the largest standard deviation in Table 5.3 is 16.4 bts./min, which is close to the residual mean square in the above analysis of variance, and we would expect the variance of the mean to be much smaller than this.

We can test for homogeneity of the variance of the sample means between subjects and between frequencies by methods described by Han (1969) and Shukla (1972). In general these required large amounts of computation, but Han described an approximate test which employed a variance ratio statistic. In order to test for homogeneity for columns, the row effects are removed from the observed mean heart-rate by subtracting the row mean from each observed mean in that row. The column variances are then computed and the ratio of the maximum to the minimum variance found. Han (1969) gives an approximate distribution for this ratio on the assumption of equal variances. From our data, for the columns the ratio is 7.1 and for the rows it is 4.4, neither of which is significant at the 5% level. We can estimate the residuals by removing the frequency and subject effects, and a histogram plot of these did not appear significantly different from a normal curve. However, a plot of the residuals against the fitted values indicated that possibly the spread of the residuals increased with the mean. The analysis of variance was then conducted on the logarithms of the means, which gave the following result:

| Source              | Sum of squares | D.O.F. | Mean Square | Mean Square Ratio |
|---------------------|----------------|--------|-------------|-------------------|
| Between subjects    | 1.6034         | 14     | 0.1145      | 55.45             |
| Between frequencies | 0.1443         | 8      | 0.0180      | 8.74              |
| Residual            | 0.2809         | 136    | 0.0021      |                   |
| Total               | 2.0286         | 158    |             |                   |

As can be seen, the mean square ratio is almost unchanged by this transformation. From statistical tables (e.g. 'Biometrika')

tables (1966) ) it can be seen that even at the 0.1% level, the tabulated values of  $F_{14,136}$  and  $F_{8,136}$  do not approach the levels attained by the mean square ratio. The conclusion is that there is a highly significant frequency of breathing effect on the mean heart rate.

The mean values of the untransformed data for the eight frequencies were estimated to be 72.83, 72.38, 72.16, 74.57, 72.10, 73.43, 75.23, 79.56 bts./min in order of increasing frequency, <sup>with s.e. 2.16 bts./min</sup> so that it can be seen that there is a gradual increase in mean heart rate with breathing frequency, with the highest breathing rate, 0.24 Hz., giving the highest mean value.

The residual term in the analysis of variance of the transformed data can be further split by allowing for a between repetitions, and a repetition x subject interaction component of variance with 1 and 2 degrees of freedom respectively, since there were 3 subjects who performed the experiments twice.

The analysis then becomes

| Source                 | Sum of squares | D.O.F. | Mean square | Mean Square Ratio |
|------------------------|----------------|--------|-------------|-------------------|
| Between subjects       | 1.6034         | 14     | 0.1145      | 84.8              |
| Between frequencies    | 0.1443         | 8      | 0.0180      | 13.3              |
| Between repetitions    | 0.0344         | 1      | 0.0344      | 25.5              |
| Repetitions x subjects | 0.0669         | 2      | 0.0335      | 24.8              |
| Residual               | 0.1796         | 133    | 0.0014      |                   |
| Total                  | 2.0286         | 158    |             |                   |

The residual sum of squares has been reduced by about one third for the loss of only 3 degrees of freedom. The large mean square ratios associated with the between repetitions and repetitions x subjects interaction implies that there were significant differences in the mean heart rates for the subjects on the two occasions, and that different subjects reacted in different ways. These effects are probably due to a large extent to subject 23 whose overall untransformed mean heart rates for the <sup>two</sup> occasions were 75.00 and 86.44 bts/min.

The series 3 experiments were conducted to analyse the effect of depth of breathing on the level and variability of the heart rate. The results are given in Table 5.4 for deep (D), shallow (S) and uncontrolled depth (U) respiration. No respiration record was taken from subject 23 because of a recording error. The respiration signal was measured by chest bellows, as has been described previously, and the standard deviation of the digitised signal is displayed in Table 5.5. This standard deviation is intended as a measure of depth of breathing, although clearly the correspondence is not perfect. However, looking at Table 5.5, it is clear that standard deviation is much larger for deep than for shallow breathing, although the depths varied considerably between subjects. The mean values of the standard deviation of breathing (SdBr) (with standard errors) were estimated to be 134(6) mm Hg, 260(22) mm Hg and 369(21) mm Hg for shallow, uncontrolled and deep breathing respectively, which agrees with the order we would expect. The corresponding mean values for the frequency of breathing effect were 253, 242, 250 and 269 mm Hg, each with a standard error of about 30 mm Hg, at frequencies 0.24, 0.14,

0.10 and 0.07 Hz. respectively. Thus it appeared that there was a small increase in SdBr at the lowest frequency. This would correspond with the observation that it is easier to breathe deeply when breathing slowly.

From Table 5.4 it is clear that depth of breathing has an important effect on the mean heart rate. The overall means were 77.32, 70.05, and 77.01 bts/min for deep, shallow and uncontrolled breathing, with standard errors of about 1.5 bts/min. Thus it would appear that shallow breathing decreased the mean heart rate below normal. It is possible that the frequency of breathing effect on the mean heart rate could be accounted for by the variation with frequency of depth of breathing. However, this is unlikely for several reasons. A previous result showed that slower breathing was accompanied by a decrease in heart rate. If this effect were due to depth of breathing, we would expect the depth of breathing to have decreased, but in fact the opposite had occurred. Another reason was that the mean values of the SdBr did not appear significantly different at the different frequencies compared with the standard error, and this result was confirmed by an analysis of variance of the SdBr.

Thus we could conduct a straight-forward analysis on the mean heart rates of Table 5.4. The design of the experiment suggested a split-plot analysis. However, depth of breathing cannot be regarded as a treatment which is uniform over all subjects and the requirements of the split-plot model are unlikely to be met. A two-way analysis of variance was conducted, but the error distribution of



the residuals appeared markedly non-normal, and no suitable transformation seemed likely to make it so. However, the mean effects, subtracting the overall mean, were estimated as 3.45, 0.42, -0.81 and -3.06 bts/min at frequencies 0.25, 0.14, 0.10 and 0.07 Hz. respectively, each with standard error of  $\pm 0.9$  bts/min. Thus, once again we can say that the mean heart rate increased as the breathing became more rapid.

A comparison between the mean heart rates under controlled breathing and those for the subject at rest is of interest. Including the rest period there were 13 separate sets of observations made on each subject in Series 3, and so we ranked them from 1 to 13 in order of increasing magnitude of mean heart rate. Ties were awarded with a fractional rank so that the total sum remained 91. The mean ranks are shown in the following table.

|         |   | Metronome setting (Hz.) |        |       |       |
|---------|---|-------------------------|--------|-------|-------|
|         |   | 0.24                    | 0.14   | 0.10  | 0.07  |
| Resting | D | 11.875                  | 9.250  | 6.875 | 5.625 |
| 8.000   | S | 5.000                   | 3.625  | 3.000 | 2.250 |
|         | U | 11.250                  | 10.000 | 8.625 | 5.625 |

This shows clearly the effects of deep and shallow breathing, and the effect of frequency of breathing on the mean heart rate. The rank for the unpaced resting subject is higher than any of the ranks for the shallow breathing subjects, and lies in the mid-frequency range for the deep and uncontrolled depth breathing.

Thus we can say that, for the subjects studied, fast respiration increased mean heart rate above the resting level, and slow breathing decreased it below the resting level. Shallow breathing reduced the mean heart rate. The results for uncontrolled depth respiration suggested that the subjects breathed deeply when the respiration was paced, since the ranks for deep (D) breathing are very similar to those for uncontrolled (U) breathing, but this cannot be confirmed since the respiration depth was not measured for the resting subject.

#### Analysis of heart-rate variability

The standard deviation (s.d.) of the heart-rate was taken as a measure of heart-rate variability. The figures in brackets in Table 5.4 are the s.d.'s corresponding to the mean values in the table. However, we cannot analyse the figures in the same way; since a model with normally distributed errors to analyse the means would be in conflict with the same model used to analyse the s.d.'s. If a sequence of independent random variables were normally distributed, then the mean would be normally distributed, but the standard deviation would not. The variance, in fact, would be distributed proportionally to a chi-square distribution. One method of dealing with this would be to transform the standard deviations. It can be shown (for example, Kendall and Stuart (1966) Vol.III p.9 1), that for a series of independent, normally distributed random variables of size  $n$ , with variance  $\sigma^2$  and sample variance  $s^2$ , then for large  $n$   $\log s$  is approximately normal with mean  $\log \sigma$  and variance  $2/(n-1)$ . This is not necessarily the case for correlated variables, but it is reasonable to suppose that the logarithmic transformation will improve the shape of the distribution towards normality. The same

transformation has been employed by Day and Fisher (1936) in an analysis of variability of plant sizes.

The analysis was conducted in the logs of the s.d.'s of heart-rate for the 15 subjects who tried the 8 different breathing frequencies. The missing values were estimated as 5.22, 5.22 and 4.84 bts/min for subjects 23(2), 23(3) and 19(2) respectively by the GENSTAT program. The values were included in the analysis of variance with the following result:

| Source              | Sum of squares | D.O.F. | M.S.  | M.S.R. |
|---------------------|----------------|--------|-------|--------|
| Between subjects    | 20.95          | 14     | 1.50  | 28.30  |
| Between frequencies | 5.86           | 8      | 0.73  | 13.77  |
| Residual            | 7.22           | 136    | 0.053 |        |
| Total               | 34.03          | 158    |       |        |

A histogram plot of the residuals did not reveal any gross departure from normality except for one extreme point for subject 15(2), frequency 5. A plot of the residuals against the fitted values also did not reveal any systematic deviations. In view of the very large value of the mean square ratio, when compared with the tabulated values at the 0.1% level of  $F_{14,136}$  and  $F_{8,136}$  we can have no hesitation in saying that both the between subjects and the between frequencies variability contributes significantly to the total variance.

In ascending order of frequency, the mean values of the s.d.'s for each frequency are 2.20, 2.15, 2.18, 2.13, 2.02, 2.07, 1.93,

with s.e. 0.11 bts/min

1.68 bts/min) so that it can be seen that the large between frequencies mean square is not due to a single frequency, but to a general progression of decreasing s.d. with increasing frequency.

Once again we can subdivide the residual sum of squares to allow for the fact that three of the subjects were tested twice.

| Source                 | Sum of squares | D.O.F. | M.S.  | M.S.R. |
|------------------------|----------------|--------|-------|--------|
| Between subjects       | 20.95          | 14     | 1.50  | 33.2   |
| Between frequencies    | 5.86           | 8      | 0.73  | 16.2   |
| Between repetitions    | 0.55           | 1      | 0.55  | 12.2   |
| Repetitions x subjects | 0.66           | 2      | 0.33  | 7.3    |
| Residual               | 6.01           | 133    | 0.045 |        |
| Total                  | 34.03          | 158    |       |        |

Again we see that there is a large contribution to the sum of squares for between repetitions, and also for repetitions x subjects interaction. These effects are probably due almost entirely to subject 23, whose mean untransformed s.d.'s for the two occasions were 9.87 and 5.96 bts/min, whereas the other two subjects had values that were close each time.

#### Analysis of covariance

In an analysis of plant size variability, Day and Fisher (1936) point out that two populations that differ greatly in their average size would naturally differ in their variances, and they suggest that an allowance for the different means be made by an analysis of

covariance of the means and standard deviations in the populations observed. We would expect the standard deviation to be roughly proportional to the mean, and for this reason a logarithmic transformation was suggested, which might also improve the distributions towards normality. The log (mean) will be regarded as the independent variate and the log (s.d.) as the independent variate, since it is the variation of the latter that is required, after allowance has been made for variation in the mean.

The overall regression term was calculated to be  $-0.21$  units, which shows that log (s.d.) decreased for a unit increase in log (mean).

The analysis of the log (s.d.) (adjusted for log (mean) )

became:

| Source              | Sum of squares | D.O.F. | Mean square | Mean Sq.Ratio |
|---------------------|----------------|--------|-------------|---------------|
| Between subjects    | 16.69          | 14     | 1.19        | 22.45         |
| Between frequencies | 4.25           | 8      | 0.53        | 10.00         |
| Regression          | 0.008          | 1      | 0.008       | 0.15          |
| Residual            | 7.21           | 135    | 0.053       |               |
| Total               | 28.16          |        |             |               |

The regression has a very small effect on the residual sum of squares and the effect of allowing for the mean has clearly not altered the analysis. If the s.d. had been proportional to the mean, we would have expected a positive regression term. Nevertheless, the analysis on the corrected log (s.d.'s) is still worthwhile in case

the frequency of breathing effect in the log (s.d.) could have been accounted for by variations in the mean heart rate.

#### Depth of breathing effect

From Table 5.5 it is clear that depth of breathing has an important effect on the standard deviation of heart rate. However, for the same reasons as those given for the analysis of the mean heart rate an analysis of variance would be difficult to interpret, and so the analysis was restricted to computing mean effects. The average s.d.'s for the deep, uncontrolled depth and shallow breathing were estimated as 8.73, 6.57 and 5.35 bts/min with approximate standard error 0.4 bts/min, and thus it appeared that in increased breathing depth was accompanied by an increased standard deviation of heart rate. The mean frequency effects were estimated to be 5.05 (0.37), 6.71 (0.59), 7.50 (0.53) and 8.27 (0.55) bts/min., ( $\pm$ s.e.) at frequencies 0.24, 0.14, 0.10 and 0.07 Hz. respectively, suggesting that the s.d. of heart rate increased with decreased breathing frequency. A bivariate regression was conducted on heart rate s.d. against breathing frequency and SdBr. The regression coefficients were estimated as  $-18.4 \pm 0.44$  (bts/min)/Hz. for breathing frequency and  $0.009 \pm 0.002$  (bts/min)/unit pressure for SdBr. Since both coefficients are large in comparison to their standard errors they support the previous remarks that increased breathing depth and decreased breathing frequency are accompanied by increased heart rate variability. Compared with the resting level, a paired 't' test showed a significant decrease at the 1% level in the s.d. at 0.24 Hz. and a non-significant increase in s.d. at 0.07 Hz. for uncontrolled depth breathing.

Again it is of interest to examine the relative ranking of the results. The mean ranks were:

|         |   | Metronome setting (Hz.) |       |       |          |
|---------|---|-------------------------|-------|-------|----------|
|         |   | 0.24                    | 0.14  | 0.10  | 0.07 Hz. |
| Resting | D | 6.31                    | 10.69 | 11.12 | 12.25    |
| 5.06    | S | 1.94                    | 3.50  | 5.94  | 7.56     |
|         | U | 4.06                    | 5.63  | 7.75  | 9.19     |

The results are again uniform in both respiration depth and frequency. The standard deviation of heart rate increased with decreasing respiration frequency for each of the three breathing depths. It was increased above resting level by deep breathing and reduced by shallow breathing. Comparing the results of uncontrolled depth respiration with those of the resting state, it appeared that fixed frequency respiration increased the standard deviation of heart rate at all but the fastest frequencies.

#### Cross-spectral analysis and phase

Table 5.7 gives the cross-spectral amplitudes for each subject at each of the breathing frequencies. They are the maximum peaks in each cross-spectrum. When a peak was evident over several adjacent resolved frequencies then the sum of the amplitudes at these frequencies was taken. Frequency 0 indicates where there was no conscious breathing control. The figures in this column were shown if there was a definite peak in the heart-rate spectrum. The overall mean of the amplitudes at each frequency for deep, shallow and uncontrolled depth breathing were calculated and the standard error

**TEXT BOUND INTO  
THE SPINE**



(a) CROSS-SPECTRUM AMPLITUDE BETWEEN HEART RATE AND RESPIRATION

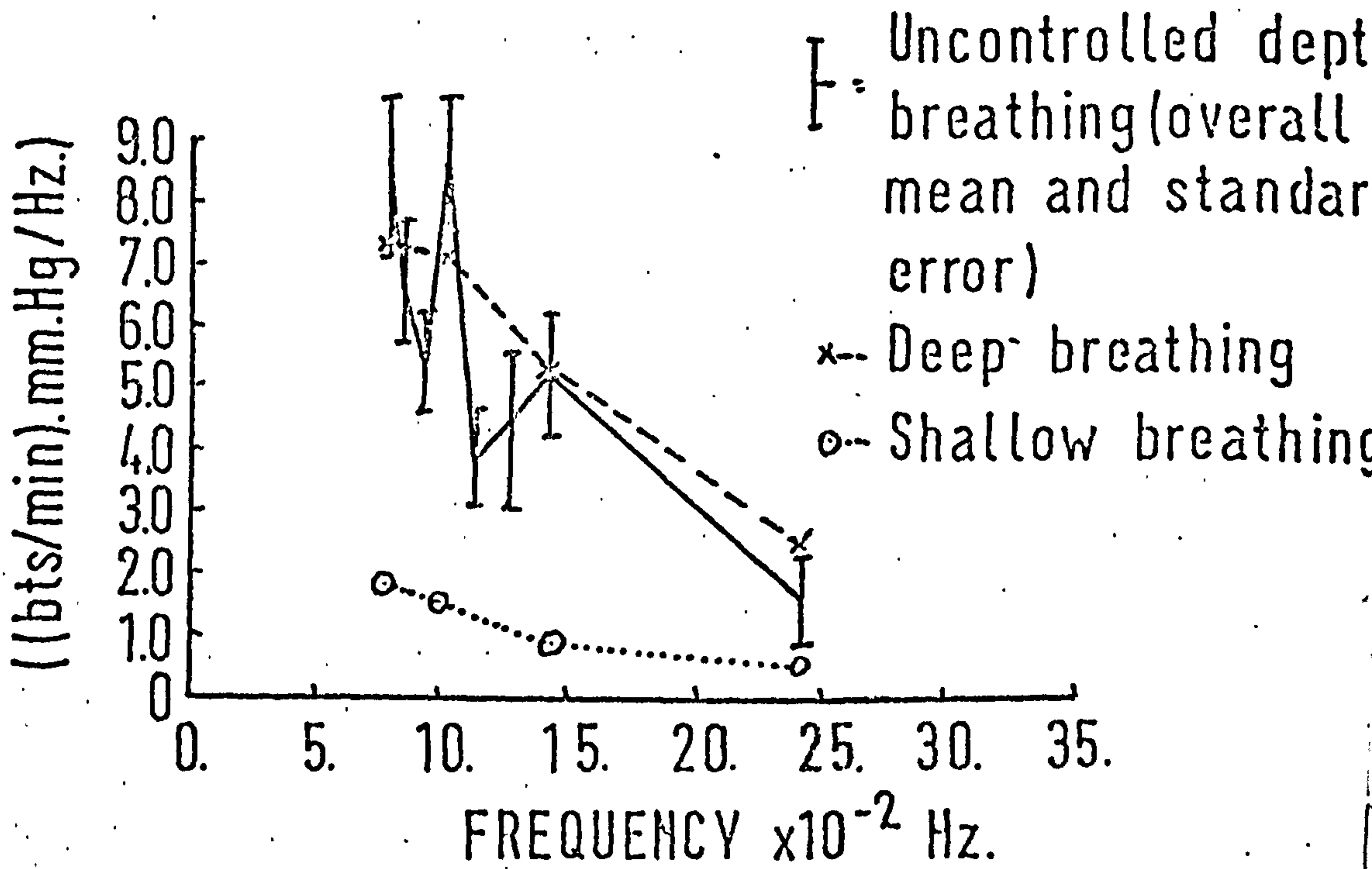

(b) HEART-RATE RESPONSE (CROSS-SPECTRUM AMPLITUDE ÷ RESPIRATION SPECTRUM AMPLITUDE)

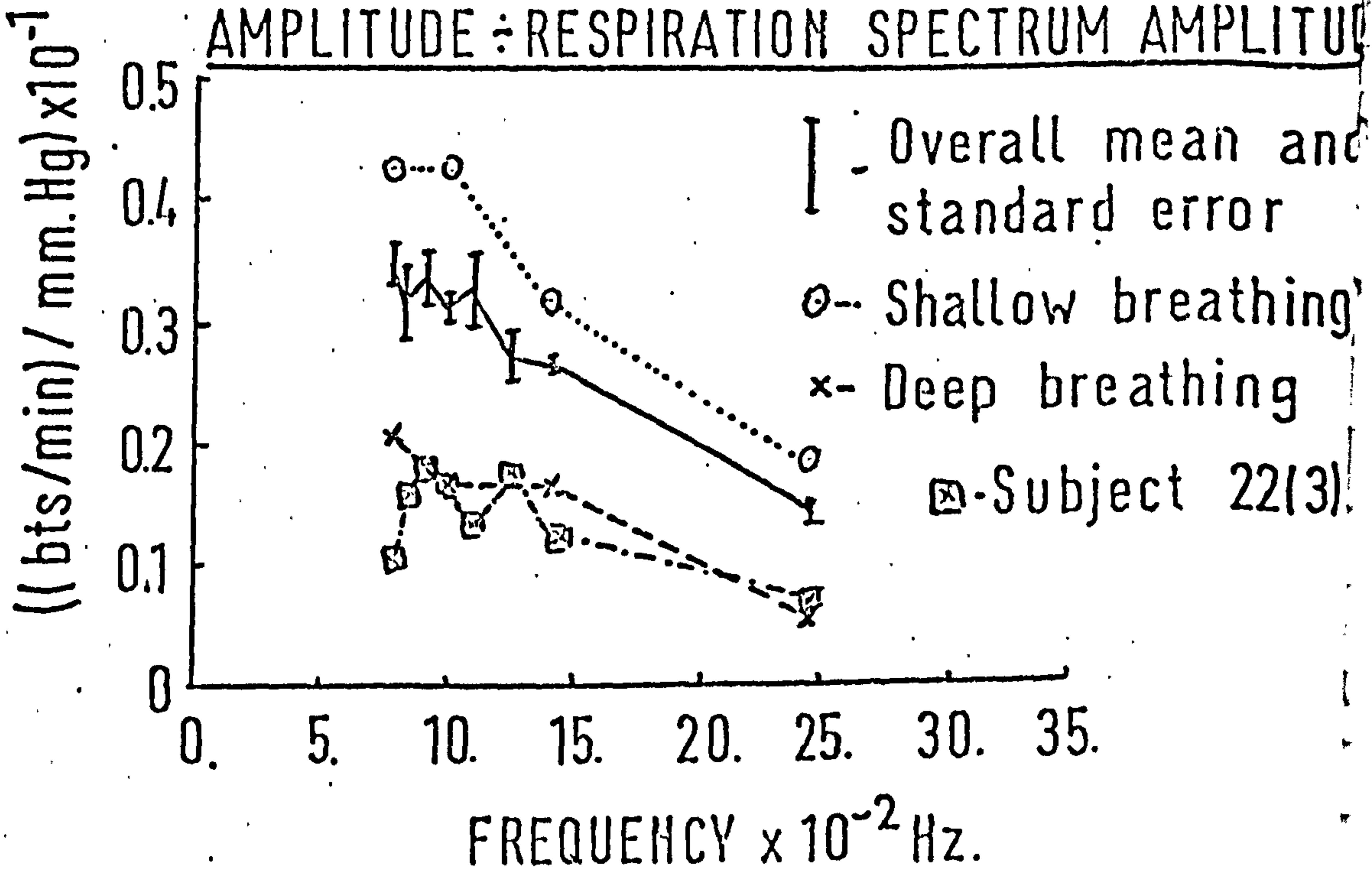

of the mean for the uncontrolled depth breathing obtained. The results were plotted against frequency and are displayed in figure 5.8a. The frequency estimates were the metronome settings and are only approximate since the subjects did not all follow the metronome exactly.

The graph appears similar to that of Angelone and Coulter (1964), as illustrated in the literature review in figure 5.1. It can be seen that the amplitude decreases with increasing frequency and that there appear to be two peaks, one at 0.07 Hz. and the other at 0.1 Hz., although these must be regarded with caution because of the large standard errors. Because it is physically impossible, or very difficult, to breathe much slower than 0.07 Hz. it is not very meaningful to ask the result of extrapolating the results below that figure. The means of the deep and shallow breathing cross-spectral amplitudes are also shown but these are not sufficiently resolved to distinguish peaks, and just show a decreasing amplitude with increasing frequency, the deep breathing amplitude being slightly higher than the overall mean and the shallow breathing amplitude much lower.

The cross-spectral amplitude between heart rate and respiration is influenced by both these signals and in an attempt to measure only the heart rate response to respiration the cross-spectral amplitudes of Table 5.7 were divided by the corresponding respiration spectral amplitudes. The respiration amplitudes were calculated as a sum over the same frequencies as the cross-spectrum. The mean and the standard error of the mean were calculated and the results displayed in figure 5.8b which shows that the mean is decreasing with increasing

frequency. This is to be compared with the results of Womack (1971) who gave the same results for only a single subject. The results appear to be more or less in agreement except that Womack showed a peak at about 0.1 Hz., with the amplitude decreasing at lower frequencies. However, we can also choose one subject who gave similar results, as illustrated by subject 22(3) in figure 5.8b.

The mean heart rate response appeared to be much flatter than the mean cross-spectrum amplitude, with no marked peak at 0.1 Hz. as before. One reason for the comparative lack of peaks is that subjects vary considerably in their heart rate response function, and the averaging simply reflects the wide variety. If we restrict attention to frequencies 1-4 which are clearly separated and for which we have the most data, then in 36 data sets the peak frequency occurred 18 times at frequency (4), 10 times at frequency (3) and 6 times at frequency (2), with 2 equal within the limits of accuracy.

One noticeable feature of the results is that deep breathing produced a smaller frequency response than the shallow, in contrast to the results for the cross-spectrum amplitudes. A 't' test of the differences between the responses at deep and shallow breathing gave an estimated 't' statistic of 4.1 with 27 degrees of freedom, which under the null hypothesis of equal frequency responses is significant at 0.5%. The results show that the increase in the respiration spectrum in going from shallow to deep breathing at a particular breathing frequency is considerably larger than the corresponding increase in the cross-spectral amplitude.

AND RESPIRATION FOR SUBJECT 25(2)

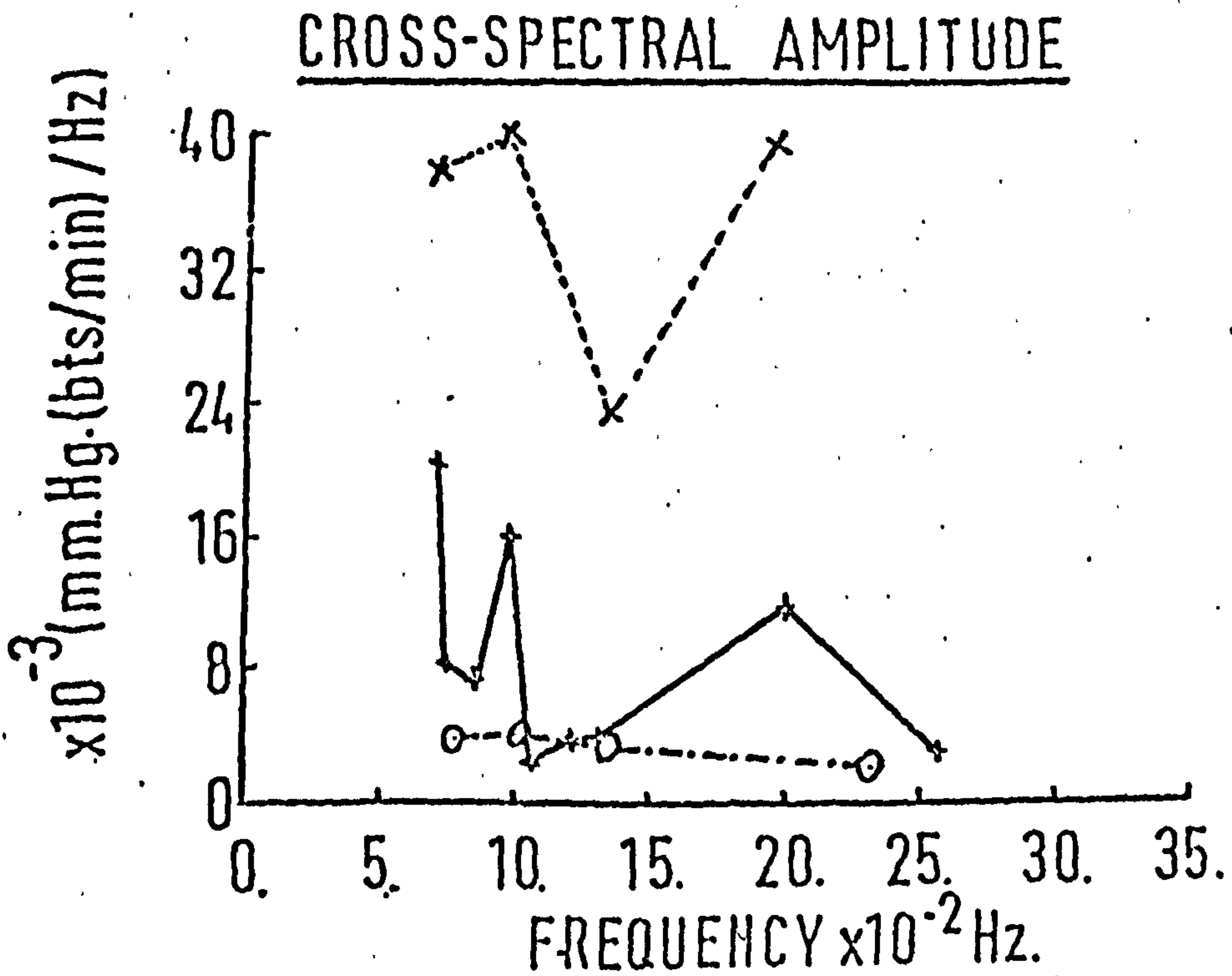
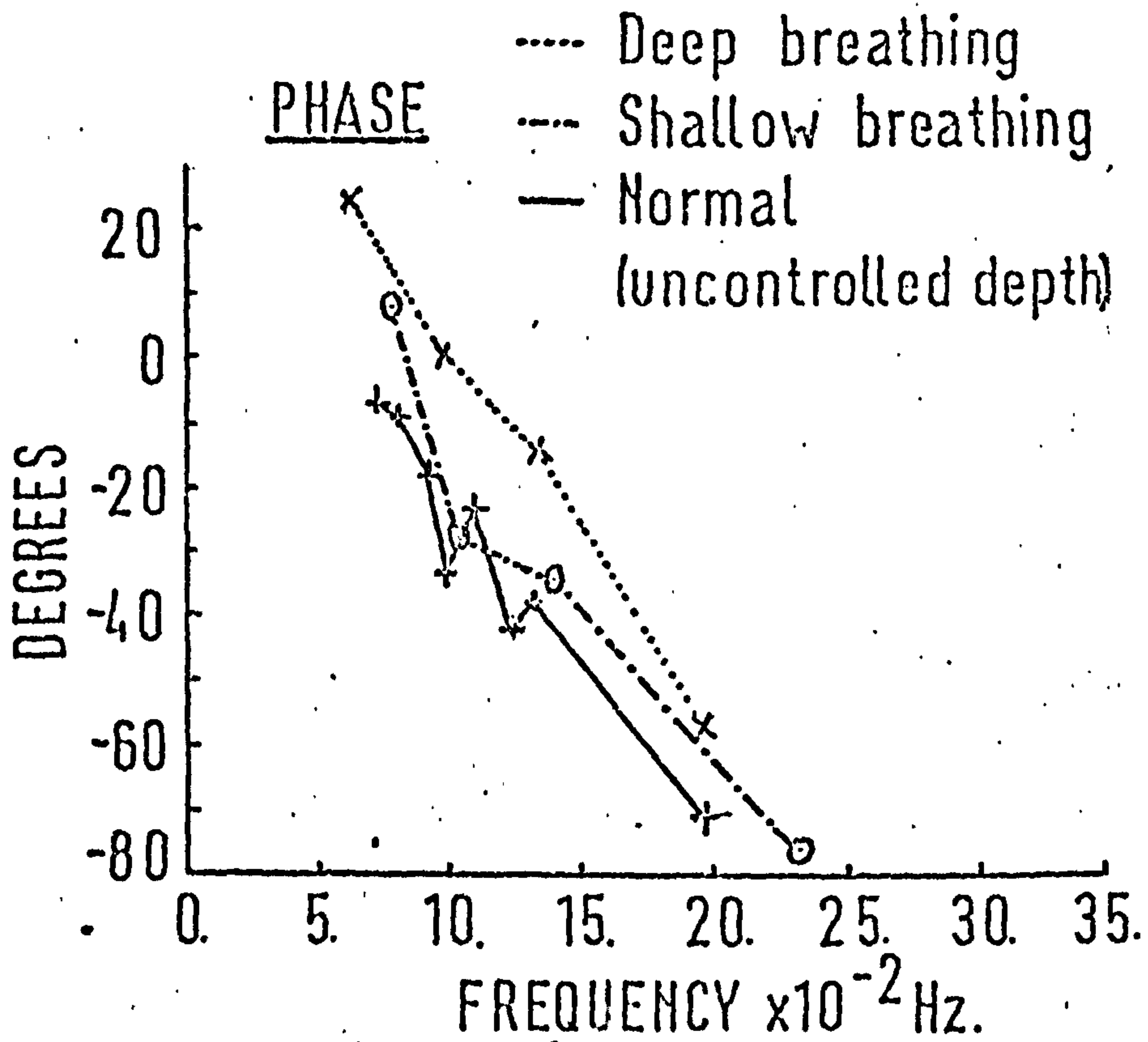

Regression of phase against frequency

The phase between heart rate and respiration was obtained from the cross-spectrum and is shown in Table 5.6 together with the frequency of the cross-spectral peak. The frequencies in each column agree quite well with the metronome frequency save the first column where there is a fairly large range in the highest frequency. It is also clear from inspection that on some occasions subjects varied quite considerably in their phase for deep, shallow and uncontrolled depth breathing, but no consistent pattern could be detected. A graph of phase against frequency showed a well-defined downward trend, but with the phase scattered quite widely at each of the respiratory frequencies. An illustration for one subject is given in figure 5.9. There was a suggestion of a 'flattening off' at the higher frequencies suggesting either a higher order curve or a non-linear relationship. In the analysis a logarithmic transformation of frequency was tried and this concurred with engineering practice of plotting phase against log frequency.

The analysis was conducted using the GLIM computer package (Nelder and Wedderburn, 1972), which computed the residual sum of squares for a number of different regression models. The advantage of the program is that it enabled different models to be tried easily.

The different hypotheses were the following:

$$\begin{aligned}
 H_0 : & \quad \theta_{ijk} = a \quad , \quad i = 1, \dots, 7, j = 1, \dots, 4, \\
 H_1 : & \quad \theta_{ijk} = a + bx_{ijk} \quad \quad \quad k = 1, 2, 3 \quad . \\
 H_2 : & \quad \theta_{ijk} = a_i + bx_{ijk} \quad , \\
 H_3 : & \quad \theta_{ijk} = a_i + b_i x_{ijk} \quad , \quad \text{where } a_i, b_i \text{ and } c_i \text{ are} \\
 H_4 : & \quad \theta_{ijk} = a_i + b_i x_{ijk} + c_i x_{ij}^2 \quad , \quad \text{constants,}
 \end{aligned}$$

where  $\theta_{ijk}$  is the measured phase for subject  $i$  at metronome frequency  $j$  and depth  $k$ , and  $x_{ijk}$  is the frequency or log (frequency) of respiration. The residual sum of squares under each hypothesis  $R(H)$  was computed.

| SOURCE                   | S.S.   | D.F. | MEAN SQUARE |
|--------------------------|--------|------|-------------|
| Linear $R(H_0) - R(H_1)$ | 184700 | 1    | 184700      |
| $R(H_1) - R(H_2)$        | 24100  | 6    | 4017        |
| $R(H_2) - R(H_3)$        | 21150  | 6    | 3525        |
| $R(H_3) - R(H_4)$        | 10720  | 7    | 1531        |
| $R(H_4)$                 | 49330  | 63   | 783         |
| Log $R(H_0) - R(H_1)$    | 187800 | 1    | 187800      |
| $R(H_1) - R(H_2)$        | 16510  | 6    | 2752        |
| $R(H_2) - R(H_3)$        | 32610  | 6    | 5435        |
| $R(H_3)$                 | 53080  | 70   | 758         |
| Total                    | 290000 | 83   |             |

The residual sum of squares for the quadratic model and the log model are comparable, but the log model requires fewer parameters and also has a smaller mean square; thus it is to be preferred. The ratio of the quadratic sum of squares with the residual is not significant when compared with an  $F$  statistic with 7 and 63 degrees of freedom, and so a linear model would appear to describe the data

quite well. There are very significant differences between subjects with regard to their phase/frequency relationships.

To investigate the effect of depth of breathing on the regression, a different series of models was set up.

$$\begin{aligned}
 H_2' & : \quad \theta_{ijk} = c_k + dx_{ijk}, & k=1,2,3, \text{ for deep, shallow} \\
 H_3' & : \quad \theta_{ijk} = c_k + d_k x_{ijk}. & \text{and uncontrolled respiration} \\
 & & \text{depth.}
 \end{aligned}$$

The analysis of variance became

| SOURCE                | S.S.   | D.F. | M.S.   | M.S.R. |
|-----------------------|--------|------|--------|--------|
| Log $R(H_0) - R(H_1)$ | 187800 | 1    | 184700 |        |
| $R(H_1) - R(H_2')$    | 6640   | 2    | 3320   | 2.72   |
| $R(H_2') - R(H_3')$   | 460    | 2    | 230    | < 1    |
| $R(H_3')$             | 95100  | 78   | 1219   |        |
| Total $R(H_0)$        | 290000 | 83   |        |        |

The 5% point of  $F_{2,78}$  is 3.13 so that we could not conclude that there was any depth of respiration effect. For controlled depth respiration, it was noticed that for 6 out of 7 cases the deep breathing produced a steeper gradient than the shallow, and in the one exception, subject no. 17, the error was very large. However, even on the assumption that deep and shallow breathing produce the steeper gradient equally probably, the probability of 6 out of 7 is still quite large (0.125) and so there is no evidence of a difference between deep and shallow breathing in this respect.

We can also test whether the sex of a subject influences the phase/frequency relationship. We have

$$H_3'' : \theta_{ijk} = c_k + e_{km} x_{ijk} \quad \text{where } m=1 \text{ if the subject is male and } m=2 \text{ if the subject is female.}$$

We then find that

| SOURCE               | S.S.  | D.F. | M.S. | M.S.R. |
|----------------------|-------|------|------|--------|
| $R(H_2') - R(H_3'')$ | 780   | 1    | 780  | < 1    |
| $R(H_3'')$           | 94780 | 79   | 1200 |        |

The mean square ratio is less than one, so we conclude that there is no significant difference between the sexes.

A linear phase/ frequency relationship would indicate a fixed lag between the respiration signal and the heart-rate. For example, if the heart-rate at time  $t$  could be expressed as proportional to the respiration signal at time  $t - \hat{k}$ , then the phase  $\theta(w)$  in radians at frequency  $w$  could be written

$$\theta(w) = \theta(0) - 2\pi \hat{k} w.$$

If this were the case the  $\hat{k}$  the regression coefficient between phase and frequency would give a suitable estimate of the lag between respiration and heart-rate, and the intercept would indicate where in the breathing cycle the heart-rate response began.

Melcher (1976) gave a figure of about 3 seconds for the lag, and if we combine this with Angelone and Coulter's (1964) result of zero phase at 0.1 Hz. then we obtain  $\theta(0) = 360 \times 3 \times 0.1 = 108^\circ$ . This would imply that the heart-rate response began about one quarter of



FIGURE 5.10

BREATH-HOLDING EXPERIMENT HEART RATE

SUBJECT 26 POSITION SUPINE

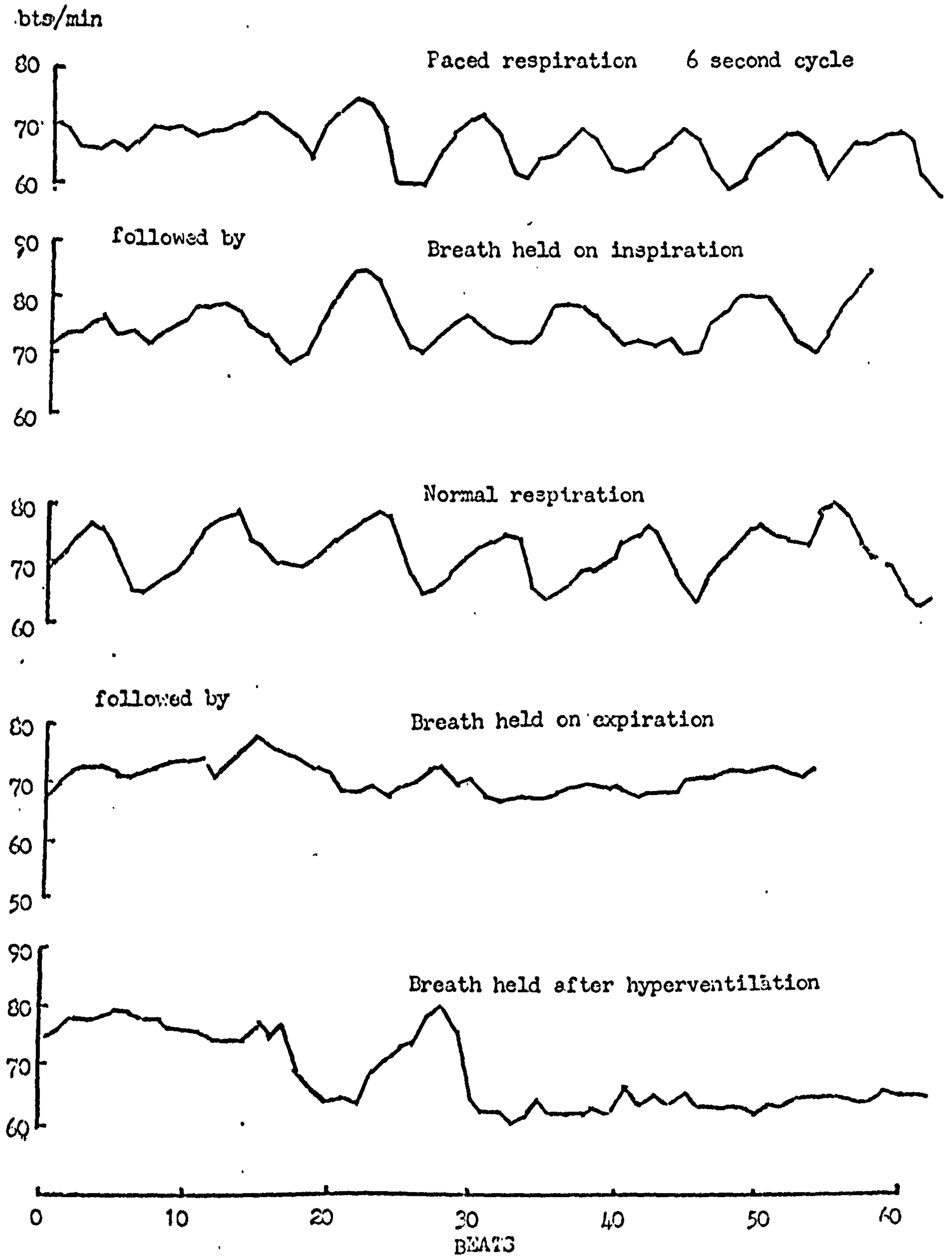

a cycle in advance of the respiration peak, or about half way through inspiration. From our results the least-squares straight line was estimated as  $G(w) = 108^\circ - 813^\circ w$ , with standard errors of  $10^\circ$  and  $68^\circ$  respectively for the two estimated parameters. The intercept compares well with that obtained from the literature. The lag estimated from the slope was  $2.26 \pm 0.19$  seconds, which compares with the result  $2.28 \pm 0.21$  seconds as the average lag from the regression coefficients calculated for each row of Table 5.6. The range of these lags was (0.73 - 4.28) seconds. This large variation does not appear to depend on any physical characteristics, since the lags vary considerably within subjects. However, corresponding to the previous result for gradients, deep breathing was associated with a longer lag than shallow breathing in 6 out of 7 cases.

We have shown previously that with fixed frequency breathing both the heart rate and respiration signal are cyclic in most cases and that phase measures a real lag in the system. Thus it would appear that the lag is anything but stable, and about the only consistent fact to emerge is that it is positive. It is likely that the lag depends not only on the time for blood to cross the pulmonary circuit but also on many other factors which at present we have been unable to discover.

#### Analysis of breath-holding experiments

A typical result from the breath-holding experiments is shown in figure 5.10. The top line shows the heart rate resulting from a respiration cycle of length six seconds, with the subject supine and breathing to a metronome. It shows the normal heart-rate cycle seen in

FIGURE 5.11

BREATH-HOLDING EXPERIMENT

HEART RATE

SUBJECT 27

POSITION SUPINE

beats/min.

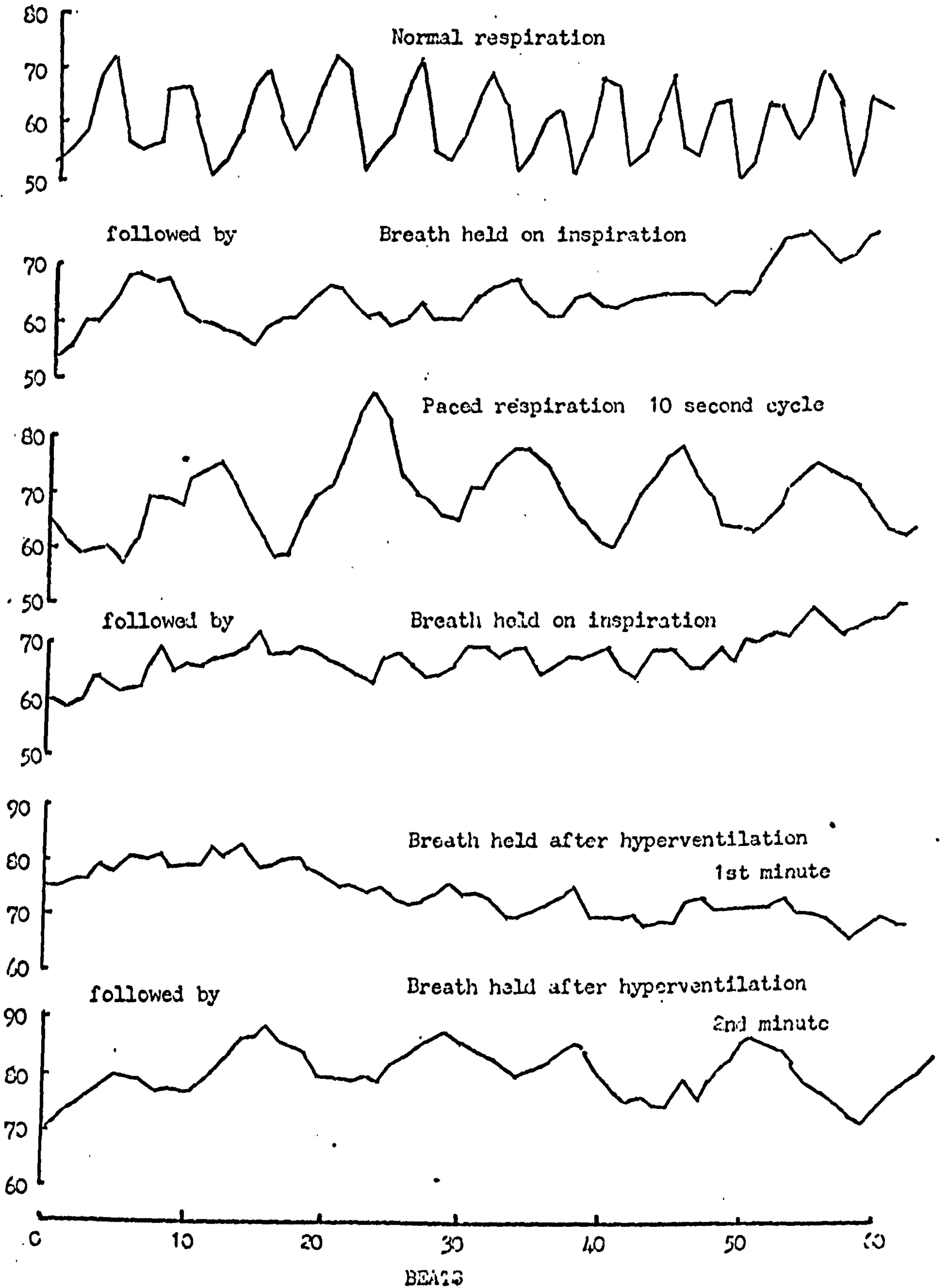

the previous experiments, with a slower rise in heart rate than fall and an amplitude of about 10 beats. The second line shows the heart rate following breath-holding on inspiration after the paced respiration. We can see a clearly oscillating heart rate, with rather longer cycles than the previous line. The third line shows, again, a clearly oscillating heart rate, this time the respiration unpaced, followed by the heart rate after breath-holding on expiration. On this occasion it is difficult to see any cycle in the tracing. The last line shows the result of breath-holding after hyperventilation. Again it is difficult to see any cycle in the heart rate.

Figure 5.11 shows another subject with similar results. Again the first two lines show normal cyclic heart rate due to respiration followed by a less well marked cycle when respiration ceases on inspiration. The second pair show a slower heart rate cycle with a 10 second period due to paced respiration, which this time is not followed by any marked heart beat cycle after breath-holding on inspiration. The third pair of lines show the heart rate after hyperventilation and display a rather interesting phenomenon. The subject managed to hold his breath for two minutes and for the first minute there is not much evidence of any cycles in the heart rate. However in the second minute, displayed below, the subject started to show very definite heart rate oscillations.

There was no clear evidence of heart beat cycles during breath-holding when the subjects were sitting. For one subject during all exercises the heart rate simply rose and then steadied, suggesting

FIGURE 5.12

Periodogram of heart rate for breath-holding

experiments

Subject 26

position supine

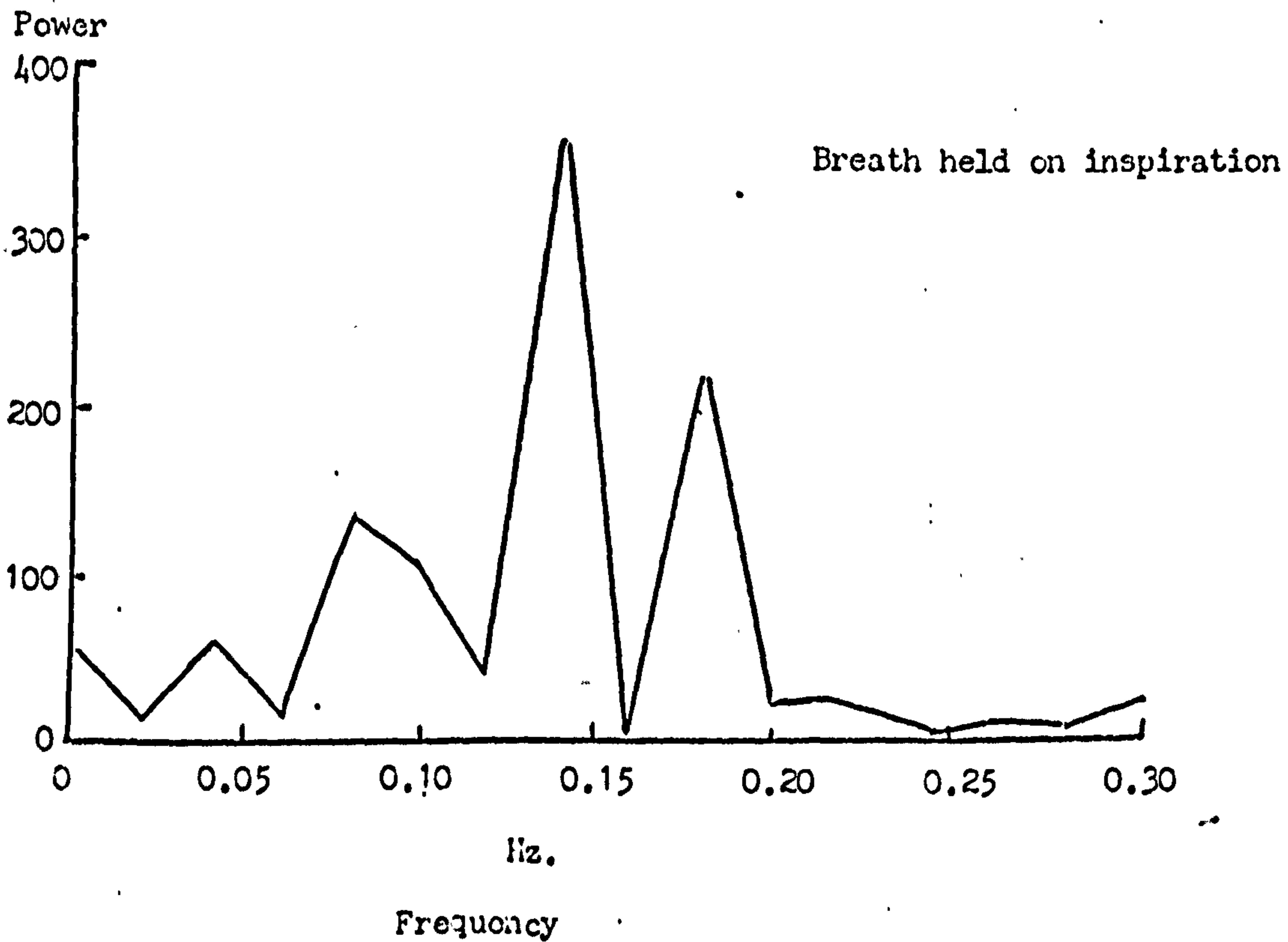
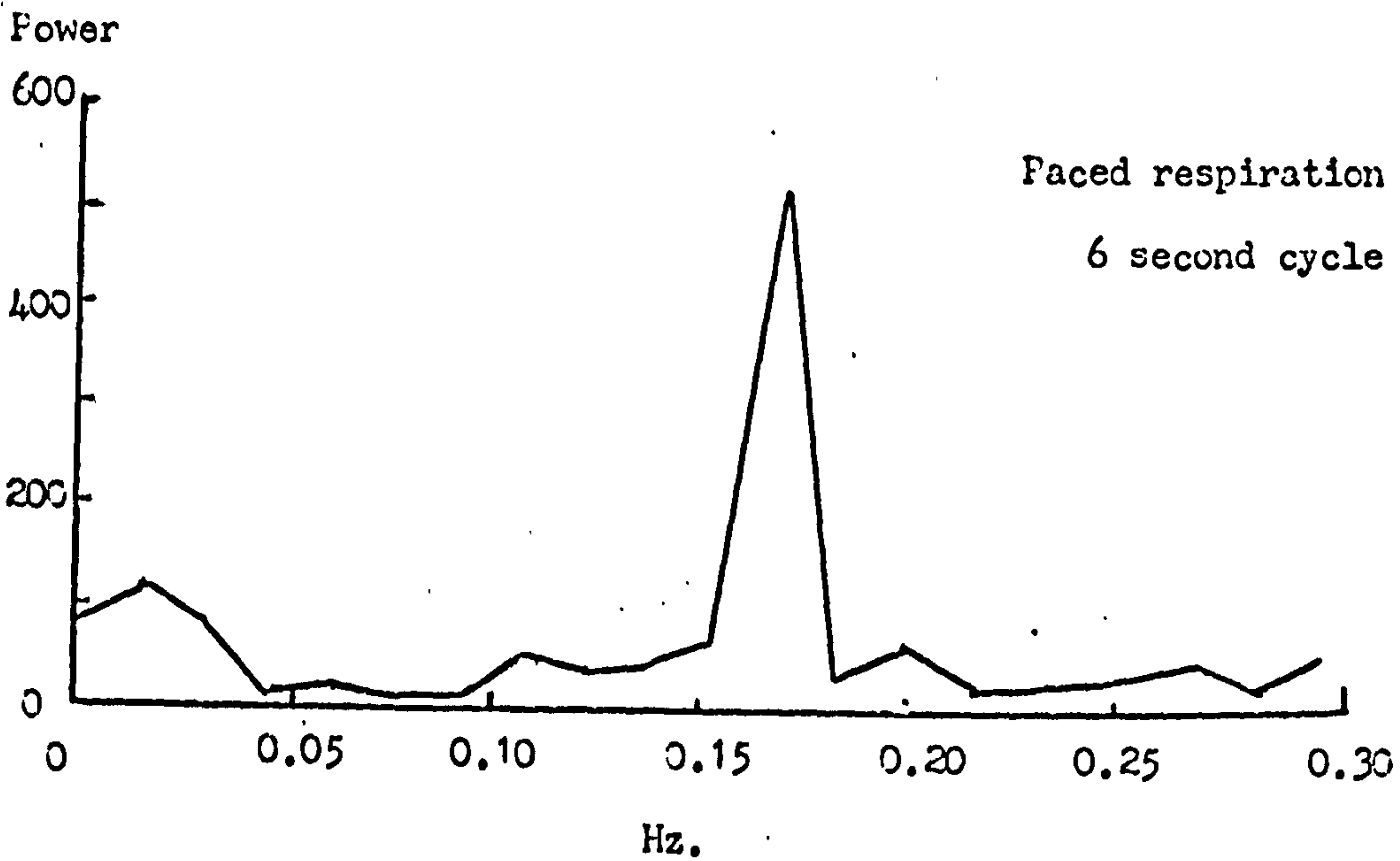

possibly that his throat was closed and pressure was building up in his lungs.

One of the problems with these signals is trying to decide whether a cycle is really present or not. The standard techniques for detecting cycles are based on the idea of a regularly occurring cycle together with a large amount of random noise. Periodogram analysis with Fisher's test (1929, Appendix A) are difficult to interpret in the present situation, as we shall show. The data for subject 26 was converted to fixed time intervals by the subroutine INTER (Appendix C) and then the periodogram calculated. These are shown in figure 5.12 for the data in the top two lines of figure 5.10. The first periodogram shows clearly the effect of the paced respiration, with a peak at about 0.17 cycles/sec. The second shows a peak at 0.14 cycles/sec. and a lesser one at 0.17 cycles/sec.. Together they are just significant. The graph in figure 5.10 shows that the reason for two peaks is that the cycle is changing frequency, and is slowing down near the end of the line. The problem in applying Fisher's test is that it was designed for constant frequency cycles and may have low power if the cycles change frequency.

A non-parametric test for general cyclic behaviour has been described by Kendall and Stuart (Vol III, 1967, p410) For each point in the series  $x_1, x_2, \dots, x_n$  we calculate a marker  $u_i$  such that

$$\begin{aligned} u_i &= 1 && \text{if } x_i < x_{i+1} > x_{i+2} \\ &= 1 && \text{if } x_i > x_{i+1} < x_{i+2} \\ &= 0 && \text{otherwise} . \end{aligned}$$

Ties are treated as single observations.

Thus  $u_i$  takes the value 1 at turning point in the series, i.e. a peak or a trough, and 0 otherwise. We calculate  $p = \sum_{i=1}^{n-2} u_i$  and it can be shown (e.g. Kendall and Stuart(1967)) that for a random series

$$E(p) = 2(n-2)/3 ,$$

$$\text{Var}(p) = (16n-29) / 90 ,$$

and that the distribution of  $p$  tends rapidly with increasing  $n$  to a Normal distribution.

The test was applied to the seven breath-holding periods shown in figures 5.10 and 5.11 with the following results.

| Subject                 | $p$ | $E(p)$ | s.d.( $p$ ) | $Z=(p-E(p))/s.d.(p)$ |
|-------------------------|-----|--------|-------------|----------------------|
| 26 (on inspiration)     | 16  | 35.3   | 4.61        | 4.19**               |
| 26 (on expiration)      | 16  | 25.0   | 3.86        | 2.33*                |
| 26 (after hypervent.)   | 21  | 26.0   | 3.96        | 1.26                 |
| 27 (on insp.)           | 18  | 32.0   | 4.39        | 3.19**               |
| 27 (on insp.)           | 25  | 32.0   | 4.39        | 1.59                 |
| 27 (after hypervent. 1) | 20  | 28.7   | 4.16        | 2.09                 |
| 27 (after hypervent. 2) | 17  | 30.0   | 4.25        | 3.06**               |

This confirms the observation that there were cycles present after breath-holding on inspiration. One slightly unexpected result is that the test indicates the presence of cycles in the heart rate after expiration for subject 26. This would concur with the results in the literature, but possibly is the result of studying several significance tests simultaneously.

Thus we have confirmed the presence of cycles in the heart rate during breath-holding. Another interesting result is the appearance of cycles, confirmed by the test, during the second minute of breath-holding by subject 27 after hyperventilation. In fact, this phenomenon is also shown by Valentinuzzi and Geddes (1974,p94, fig. 4d), where a subject gave cycles in the heart rate some 30 seconds into breath-holding after hyperventilation. However, Valentinuzzi and Geddes do not comment on the fact that the heart-rate preceding the oscillation is level and not cyclic.

### Discussion

The heart-rate spectra of the resting subjects compare well with those found by other authors. The low frequency peaks found in 18 out of the 23 spectra displayed a frequency range of (0.031 - 0.125) Hz., which indicated not only that subjects varied considerably within themselves but also that the peaks were probably not all due to the same source. The contrast between the heart-rate spectrum of figure 5.4a and that of figure 5.5a for the same subject is interesting; the first spectrum was calculated when the subject was resting and the second when he was breathing in time to a metronome. It gives a convincing demonstration that the sinus arrhythmia effect can be readily elicited by regular respiration but that it is not necessarily present when the subject is not breathing consciously, even when he is breathing regularly. In only 5 out of the 23 heart-rate spectra were there clearly defined spectral peaks corresponding to respiration. However, conscious respiration is clearly a very effective method of entraining the heart rate.



The analysis of the heart rate means and standard deviations has to a large extent confirmed and quantified the results of Sroufe(1971). For the subjects studied it was shown that deep breathing increased the heart rate variability, on average by about 2.15 bts/min and that shallow breathing reduced the mean heart rate by about 7 bts/min and the heart rate variability by about 1.2 bts/min. We also demonstrated that a high respiration rate reduced the standard deviation of heart rate and increased the mean heart rate by 0.2 and 4.5 bts/min respectively, and a low respiration rate increased the s.d. by about 4.5 bts/min. and lowered the mean by 2.3 bts/min on average. The latter results were not found by Sroufe and appear to be new to the literature. Sroufe only considered a limited range (0.23 - 0.30 ) for respiration frequency, which could explain his negative results.

The design of the experiment could have been improved by including a second resting period at the end of the breathing exercises. This would have provided an additional control to check the physiological response to the stimulation of being made to breathe in time to a metronome. It could be argued that the responses are partly due to psychological factors ; that the constraint of regular breathing produces stress, for example. However, it is unlikely that the responses would be two-way, for example a reduction as well as an increase in mean heart rate. Also it would be difficult to explain the fact that the responses are , in general, uniform with the stimulus. For example, the response to uncontrolled respiration lies inbetween deep and shallow breathing , and the variability of heart rate decreases uniformly with increasing respiration rate.

It is difficult to determine to what extent these results can be generalized to the population. The subjects studied were in no way a random sample and were comparatively few in number. In general the subjects were younger than the average population, and were fit and healthy at the time of the experiments ( except for subject no 15). The increased heart rate due to rapid and deep breathing probably reflects the effects of hyperventilation; this is also mentioned in Melcher (1976) and by Donevan et al., (1962). Possibly there is also a response due to the increased work of breathing. The decrease in heart rate with slow and shallow breathing is less easy to explain and we have found nothing in the literature to supply a physiological explanation. It is possible that with shallow breathing an increase in vagal tone reduced the heart rate. The changes in heart-rate variability reflect the effect of sinus arrhythmia which, as was shown by the frequency response function, was greater for deep and slow than for fast and shallow breathing.

The frequency response and phase results obtained by Angelone and Coulter (1964) and Womack (1971) have been studied carefully. These authors presented evidence for a peak in the frequency response function at about 0.1 Hz.. This peak was not apparent in the overall frequency response function in the present study. However, both Womack and Angelone and Coulter only display one subject and, as illustrated, it was possible for us to select one subject who showed a similar sort of frequency response function. At first sight it was disappointing not to obtain a local maximum in the frequency response function at 0.1 Hz. because of the implication that this would indicate a system

resonance at the vasomotor frequency. However, the results of the heart-rate spectral analysis for the relaxed subjects showed such a wide variation in the frequency of the vasomotor cycle that we would expect any resonance to appear with an equally wide frequency range, and also the frequency of the vasomotor cycle did not necessarily coincide with the frequency of the largest response for controlled breathing. For example, the vasomotor peak for subject no. 6 was 0.1 Hz. but the maximum frequency response was at 0.14 Hz..

The phase results were not as clear as those obtained by Angelone and Coulter or Womack. At low frequencies heart rate was in advance of respiration and at higher frequencies it lagged behind, with the zero phase point in the region (0.07 - 0.13) Hz. The average phase declined at a rate of  $81^{\circ}$  for every six cycles per minute increase in the breathing frequency.

The breath-holding experiments to a large extent confirm the results of Valentinuzzi and Geddes (1974) and contradict those authors who claimed there was no heart rate cycle during breath-holding. We have shown, however, that the response can be difficult to elicit, and is best displayed when the subject is supine and holds on inspiration. The main question is whether this cycle is evidence for a central component in respiratory sinus arrhythmia. The answer would be that the cycle appears different from the normal respiratory cycle. It is usually slower than the normal cycle and fluctuates considerably in frequency. Since we have shown in Chapter 4 and in the first part of this one that heart rate is often subject to vasomotor oscillations,

it is more likely that this is what we are seeing at present, particularly since in most situations the clearly observed respiratory-heart rate response ceased immediately on breath holding. However, the frequency of these cycles was rather faster than the normal vasomotor cycle and for subject 26 in one sequence the cycles continued for a short while at near the respiratory frequency, so that the effect of an entrainment on the vasomotor oscillations would seem to only gradually disappear. The bottom two pictures in figure 5.2, showing the heart rate increasing during expiration can be explained if we postulate an expiratory effect on the heart rate, and although this has been denied by Davies and Neilson (1967) , it has been claimed by Valentinuzzi and Geddes and also by Freyschuss and Melcher (1976). Thus our results are broadly in agreement with the hypothesis that respiratory sinus arrhythmia is brought on by inspiration and expiration causing blood pressure changes, which affect the cardiac or arterial reflexes.

We do not know the origin of the slowly developing heart rate fluctuations after hyperventilation. Possibly they have the same mechanism as the other cycles during breath-holding. They may result from strain on the subject as he uses up his available oxygen and builds up carbon dioxide in the blood, but if the subject had been stressed we may have expected the heart rate to rise, which did not happen.

From the view point of signal analysis we have shown that respiration can account for 30% of the heart rate variability, and so for patient monitoring it would appear advantageous to monitor respiration

in addition to heart rate and blood pressure in order to improve trend detection algorithms. The presence of a heart-rate response indicates a responsive baroreflex system, and perhaps breathing experiments similar to the ones we have conducted could be employed with post-operative patients to test for this responsiveness.

TABLE 5.1 PHYSICAL CHARACTERISTICS OF SUBJECTS

| Subject No. | Initials | Height cms. | Weight kg. | Age yrs. | Sex | Series |   |   |
|-------------|----------|-------------|------------|----------|-----|--------|---|---|
|             |          |             |            |          |     | 1      | 2 | 3 |
| 1           | K.G.     | 165         | 73.0       | 20       | M   | X      |   |   |
| 2           | F.J.C.   | 174         | 60.3       | 20       | M   | X      |   |   |
| 3           | A.L.     | 173         | 60.6       | 20       | M   | X      |   |   |
| 4           | K.H.     | 168         | 57.3       | 24       | F   | X      |   |   |
| 5           | E.M.C.   | 163         | 54.1       | 21       | F   | X      |   |   |
| 6           | H.M.H.   | 168         | 54.0       | 19       | F   |        | X |   |
| 7           | M.S.     | 179         | 65.3       | 20       | M   |        | X |   |
| 8           | H.V.     | 180         | 65.5       | 19       | F   |        | X |   |
| 9           | A.Mc.V.  | 169         | 64.4       | 18       | M   |        | X |   |
| 10          | J.C.     | 174         | 71.2       | 21       | M   |        | X |   |
| 11          | C.Mc.D.  | 173         | 61.7       | 20       | F   |        | X |   |
| 12          | W.T.W.   | 179         | 69.9       | 26       | M   |        | X |   |
| 13          | P.E.     | 173         | 71.2       | 19       | M   |        | X |   |
| 14          | S.B.     | 172         | 71.8       | 59       | M   |        | X |   |
| 15          | T.C.     | 180         | 57.3       | 74       | M   |        | X |   |
| 16          | J.Cal.   | 150         | 45.9       | 35       | F   |        |   | X |
| 17          | J.McN.   | 174         | 57.3       | 22       | M   |        |   | X |
| 18          | M.McG.   | 168         | 63.5       | 21       | F   | X      | X |   |
| 19          | J.U.     | 187         | 72.1       | 24       | M   | X      | X |   |
| 20          | J.F.W.   | 175         | 60.5       | 24       | F   | X      |   | X |
| 21          | E.C.     | 173         | 60.3       | 22       | M   |        | X | X |
| 22          | C.T.     | 170         | 74.0       | 29       | F   |        | X | X |
| 23          | M.J.C.   | 175         | 71.7       | 24       | M   |        | X | X |
| 24          | D.J.H.   | 178         | 64.0       | 31       | M   |        | X | X |
| 25          | H.H.     | 164         | 57.0       | 21       | F   | X      | X | X |

TABLE 5.2

MEAN HEART RATE (BTS/MIN)

| FREQ. (Hz.) | SUBJECT NUMBER (AND SERIES NUMBER) |       |       |       |       |       |       |       |       |       |       |       |       |       |       |       |       |       |       |      |      |      |       |       |       |
|-------------|------------------------------------|-------|-------|-------|-------|-------|-------|-------|-------|-------|-------|-------|-------|-------|-------|-------|-------|-------|-------|------|------|------|-------|-------|-------|
|             | 7(2)                               | 11(2) | 12(2) | 13(2) | 24(2) | 25(2) | 6(2)  | 8(2)  | 9(2)  | 10(2) | 14(2) | 15(2) | 18(2) | 19(2) | 21(2) | 22(2) | 23(2) | 24(2) | 25(2) |      |      |      |       |       |       |
| -           | 61.8                               | 84.4  | 45.0  | 60.7  | 76.7  | 71.0  | 64.0  | 95.3  | 64.3  | 82.8  | 71.7  | 84.4  | 75.9  | 62.4  | 67.9  | 70.2  | -     | 85.2  | 67.4  | 73.1 | -    | 89.0 | 59.1  |       |       |
| 0.240       | 64.8                               | 78.8  | 47.8  | 65.1  | 81.0  | 78.2  | 64.5  | 94.9  | 76.5  | 85.3  | 71.6  | 84.3  | 84.7  | 64.1  | 85.5  | 73.9  | 81.8  | 82.3  | 79.7  | 74.2 | 88.0 | 90.7 | 64.7  |       |       |
| 0.100       | 67.5                               | 80.6  | 49.7  | 58.1  | 77.6  | 81.2  | 66.4  | 88.0  | 67.7  | 82.2  | 72.2  | 81.4  | 74.6  | 63.8  | 71.9  | 70.5  | 75.5  | 76.8  | 67.8  | 74.0 | 88.2 | 83.3 | 60.0  |       |       |
| 0.143       | 64.1                               | 85.0  | 49.4  | 60.8  | 80.7  | 76.3  | 63.9  | 89.3  | 70.3  | 76.0  | 70.6  | 84.4  | 77.7  | 65.6  | 72.4  | 69.2  | 73.0  | 74.9  | 71.3  | 74.8 | 89.6 | 86.4 | 59.2  |       |       |
| 0.078       | 64.7                               | 80.4  | 52.2  | 57.6  | 78.5  | 75.3  | 65.7  | 82.2  | 68.1  | 70.7  | 71.6  | 82.8  | 64.7  | 80.4  | 52.2  | 57.6  | 78.5  | 65.7  | 82.2  | 68.1 | 70.7 | 71.6 | 82.8  |       |       |
| 0.125       | -                                  | -     | -     | -     | -     | -     | 68.3  | 82.9  | 70.3  | 74.7  | 72.3  | 83.5  | -     | -     | -     | -     | -     | 68.3  | 82.9  | 70.3 | 74.7 | 72.3 | 83.5  |       |       |
| 0.091       | -                                  | -     | -     | -     | -     | -     | 68.2  | 81.3  | 66.9  | 71.9  | 71.5  | 80.1  | -     | -     | -     | -     | -     | 68.2  | 81.3  | 66.9 | 71.9 | 71.5 | 80.1  |       |       |
| 0.111       | -                                  | -     | -     | -     | -     | -     | 64.0  | 82.1  | 71.4  | 74.7  | 71.0  | 74.8  | -     | -     | -     | -     | -     | 64.0  | 82.1  | 71.4 | 74.7 | 71.0 | 74.8  |       |       |
| 0.083       | -                                  | -     | -     | -     | -     | -     | 66.4  | 82.0  | 69.8  | 72.5  | 70.0  | 75.0  | -     | -     | -     | -     | -     | 66.4  | 82.0  | 69.8 | 72.5 | 70.0 | 75.0  |       |       |
| FREQ. (Hz.) | 18(2)                              | 19(2) | 21(2) | 22(2) | 23(2) | 16(3) | 17(3) | 21(3) | 22(3) | 23(3) | 24(3) | 25(3) | 18(2) | 19(2) | 21(2) | 22(2) | 23(2) | 24(2) | 25(2) | 6(2) | 8(2) | 9(2) | 10(2) | 14(2) | 15(2) |
| -           | 75.9                               | 62.4  | 67.9  | 70.2  | -     | 75.3  | 85.2  | 67.4  | 73.1  | -     | 89.0  | 59.1  | 75.9  | 62.4  | 67.9  | 70.2  | -     | 85.2  | 67.4  | 73.1 | -    | 89.0 | 59.1  |       |       |
| 0.240       | 84.7                               | 64.1  | 85.5  | 73.9  | 81.8  | 85.4  | 82.3  | 79.7  | 74.2  | 88.0  | 90.7  | 64.7  | 84.7  | 64.1  | 85.5  | 73.9  | 81.8  | 82.3  | 79.7  | 74.2 | 88.0 | 90.7 | 64.7  |       |       |
| 0.100       | 74.6                               | 63.8  | 71.9  | 70.5  | 75.5  | 77.9  | 76.8  | 67.8  | 74.0  | 88.2  | 83.3  | 60.0  | 74.6  | 63.8  | 71.9  | 70.5  | 75.5  | 76.8  | 67.8  | 74.0 | 88.2 | 83.3 | 60.0  |       |       |
| 0.143       | 77.7                               | 65.6  | 72.4  | 71.8  | 75.9  | 76.8  | 78.1  | 71.3  | 74.8  | 89.6  | 86.4  | 59.2  | 77.7  | 65.6  | 72.4  | 71.8  | 75.9  | 78.1  | 71.3  | 74.8 | 89.6 | 86.4 | 59.2  |       |       |
| 0.078       | 75.2                               | 63.8  | 66.4  | 69.2  | 73.0  | 74.3  | 74.9  | 65.8  | 68.6  | 87.7  | 92.3  | 58.6  | 75.2  | 63.8  | 66.4  | 69.2  | 73.0  | 74.9  | 65.8  | 68.6 | 87.7 | 92.3 | 58.6  |       |       |
| 0.125       | 72.6                               | 62.0  | 68.4  | 66.4  | 75.4  | 73.7  | 74.1  | 65.3  | 70.8  | 87.4  | 90.1  | 63.5  | 72.6  | 62.0  | 68.4  | 66.4  | 75.4  | 74.1  | 65.3  | 70.8 | 87.4 | 90.1 | 63.5  |       |       |
| 0.091       | 74.7                               | 64.5  | 66.7  | 67.6  | 72.3  | 73.0  | 74.6  | 64.3  | 71.5  | 84.4  | 87.4  | 58.0  | 74.7  | 64.5  | 66.7  | 67.6  | 72.3  | 74.6  | 64.3  | 71.5 | 84.4 | 87.4 | 58.0  |       |       |
| 0.111       | 75.7                               | 60.6  | 65.7  | 71.4  | 73.7  | 69.9  | 72.2  | 67.2  | 76.5  | 82.5  | 84.8  | 59.6  | 75.7  | 60.6  | 65.7  | 71.4  | 73.7  | 72.2  | 67.2  | 76.5 | 82.5 | 84.8 | 59.6  |       |       |
| 0.083       | 72.9                               | -     | 66.6  | 72.2  | 72.4  | 70.4  | 72.6  | 65.7  | 71.4  | 83.7  | 87.2  | 59.7  | 72.9  | -     | 66.6  | 72.2  | 72.4  | 72.6  | 65.7  | 71.4 | 83.7 | 87.2 | 59.7  |       |       |

TABLE 5.3

## STANDARD DEVIATION OF HEART RATE ( BTS/MIN)

| FREQ. (Hz.) | SUBJECT NUMBER (AND SERIES NUMBER) |       |       |       |       |       |       |       |       |       |       |       |       |       |       |       |       |       |       |       |       |       |       |       |
|-------------|------------------------------------|-------|-------|-------|-------|-------|-------|-------|-------|-------|-------|-------|-------|-------|-------|-------|-------|-------|-------|-------|-------|-------|-------|-------|
|             | 7(2)                               | 11(2) | 12(2) | 13(2) | 24(2) | 25(2) | 6(2)  | 8(2)  | 9(2)  | 10(2) | 14(2) | 15(2) | 18(2) | 19(2) | 21(2) | 22(2) | 23(2) | 16(3) | 17(3) | 21(3) | 22(3) | 23(3) | 24(3) | 25(3) |
| -           | 3.6                                | 3.5   | 1.8   | 5.6   | 5.4   | 11.3  | 6.0   | 4.5   | 5.2   | 6.5   | 2.2   | 13.0  | 5.4   | 3.5   | 7.0   | 3.6   | -     | 7.3   | 7.5   | 6.6   | 4.2   | -     | 6.6   | 3.2   |
| 0.240       | 6.4                                | 7.8   | 3.0   | 5.0   | 5.6   | 5.8   | 5.3   | 3.8   | 6.4   | 8.2   | 5.0   | 14.5  | 6.4   | 2.5   | 5.9   | 2.8   | 6.4   | 6.0   | 4.9   | 3.5   | 3.5   | 6.7   | 5.7   | 4.5   |
| 0.100       | 4.3                                | 6.2   | 4.4   | 7.3   | 9.3   | 5.4   | 8.8   | 10.8  | 10.1  | 14.3  | 5.2   | 13.6  | 10.5  | 4.7   | 14.0  | 4.4   | 10.5  | 11.3  | 9.0   | 4.4   | 5.9   | 5.9   | 9.1   | 4.4   |
| 0.143       | 7.6                                | 9.5   | 7.0   | 6.2   | 6.8   | 9.7   | 7.9   | 6.6   | 8.6   | 11.6  | 4.4   | 14.2  | 8.4   | 5.1   | 9.5   | 3.8   | 8.4   | 8.8   | 7.3   | 4.0   | 5.0   | 7.4   | 7.4   | 2.5   |
| 0.078       | 4.2                                | 3.4   | 7.7   | 8.8   | 8.8   | 7.5   | 10.4  | 13.7  | 11.4  | 13.0  | 11.8  | 13.7  | 10.3  | 6.6   | 11.8  | 3.9   | 10.3  | 10.0  | 8.1   | 5.9   | 5.3   | 7.6   | 7.6   | 5.2   |
| 0.125       | -                                  | -     | -     | -     | -     | -     | 9.1   | 8.2   | 8.6   | 13.5  | 13.5  | 12.8  | -     | -     | -     | 4.7   | 9.7   | 7.7   | 6.4   | 4.2   | 5.9   | 9.7   | 9.7   | 4.4   |
| 0.091       | -                                  | -     | -     | -     | -     | -     | 8.3   | 11.5  | 8.7   | 16.4  | 11.2  | 13.5  | -     | -     | -     | 5.2   | 12.1  | 10.0  | 8.0   | 5.1   | 6.5   | 9.7   | 9.7   | 3.4   |
| 0.111       | -                                  | -     | -     | -     | -     | -     | 9.0   | 9.4   | 11.1  | 12.3  | 3.4   | 13.8  | -     | -     | -     | 4.3   | 11.5  | 11.5  | 8.0   | 4.2   | 6.7   | 9.2   | 9.2   | 3.1   |
| 0.083       | -                                  | -     | -     | -     | -     | -     | 9.4   | 12.3  | 11.5  | 12.8  | 3.7   | 14.0  | -     | -     | -     | 5.5   | 10.7  | 8.7   | 10.0  | 4.9   | 5.7   | 9.6   | 9.6   | 5.0   |
| FREQ. (Hz.) | 18(2)                              | 19(2) | 21(2) | 22(2) | 23(2) | 16(3) | 17(3) | 21(3) | 22(3) | 23(3) | 24(3) | 25(3) | 18(2) | 19(2) | 21(2) | 22(2) | 23(2) | 16(3) | 17(3) | 21(3) | 22(3) | 23(3) | 24(3) | 25(3) |
| -           | 5.4                                | 3.5   | 7.0   | 3.6   | -     | 7.3   | 7.5   | 6.6   | 4.2   | -     | 6.6   | 3.2   | 5.4   | 3.5   | 7.0   | 3.6   | -     | 7.3   | 7.5   | 6.6   | 4.2   | -     | 6.6   | 3.2   |
| 0.240       | 6.4                                | 2.5   | 5.9   | 2.8   | 6.4   | 6.0   | 6.4   | 4.9   | 3.5   | 6.7   | 5.7   | 4.5   | 6.4   | 2.5   | 5.9   | 2.8   | 6.4   | 6.0   | 4.9   | 3.5   | 3.5   | 6.7   | 5.7   | 4.5   |
| 0.1000      | 14.1                               | 4.7   | 14.0  | 4.4   | 10.5  | 11.3  | 10.1  | 9.0   | 4.4   | 5.9   | 9.1   | 4.4   | 14.1  | 4.7   | 14.0  | 4.4   | 10.5  | 11.3  | 9.0   | 4.4   | 5.9   | 5.9   | 9.1   | 4.4   |
| 0.143       | 12.5                               | 5.1   | 9.5   | 3.8   | 8.4   | 8.8   | 8.5   | 7.3   | 4.0   | 5.0   | 7.4   | 2.5   | 12.5  | 5.1   | 9.5   | 3.8   | 8.4   | 8.8   | 7.3   | 4.0   | 5.0   | 7.4   | 7.4   | 2.5   |
| 0.078       | 13.2                               | 6.6   | 11.8  | 3.9   | 10.3  | 10.0  | 12.1  | 8.1   | 5.9   | 5.3   | 7.6   | 5.2   | 13.2  | 6.6   | 11.8  | 3.9   | 10.3  | 10.0  | 8.1   | 5.9   | 5.3   | 7.6   | 7.6   | 5.2   |
| 0.125       | 14.4                               | 3.5   | 8.7   | 4.7   | 9.7   | 10.8  | 7.7   | 6.4   | 4.2   | 5.9   | 9.7   | 4.4   | 14.4  | 3.5   | 8.7   | 4.7   | 9.7   | 10.8  | 6.4   | 4.2   | 5.9   | 9.7   | 9.7   | 4.4   |
| 0.091       | 14.3                               | 5.9   | 9.6   | 5.2   | 12.1  | 11.4  | 10.0  | 8.0   | 5.1   | 6.5   | 9.7   | 3.4   | 14.3  | 5.9   | 9.6   | 5.2   | 12.1  | 11.4  | 8.0   | 5.1   | 6.5   | 9.7   | 9.7   | 3.4   |
| 0.111       | 13.4                               | 3.5   | 7.6   | 4.3   | 11.5  | 11.5  | 8.3   | 8.0   | 4.2   | 6.7   | 9.2   | 3.1   | 13.4  | 3.5   | 7.6   | 4.3   | 11.5  | 11.5  | 8.3   | 4.2   | 6.7   | 9.2   | 9.2   | 3.1   |
| 0.083       | 14.5                               | -     | 9.1   | 5.5   | 10.1  | 10.7  | 8.7   | 10.0  | 4.9   | 5.7   | 9.6   | 5.0   | 14.5  | -     | 9.1   | 5.5   | 10.1  | 10.7  | 8.7   | 4.9   | 5.7   | 9.6   | 9.6   | 5.0   |



Table 5.4

## MEAN AND STANDARD DEVIATION OF HEART RATE (BTS/MIN.)

## SERIES 3 EXPERIMENTS

| Subject Number | Resting state | Frequency (Hz.) |            |             |             |             |
|----------------|---------------|-----------------|------------|-------------|-------------|-------------|
|                |               |                 | 0.25       | 0.14        | 0.10        | 0.07        |
| 1              |               | D               | 93.0 (4.2) | 81.9 (8.6)  | 85.1 (10.6) | 83.4 (11.0) |
|                |               | S               | 79.7 (3.8) | 74.0 (5.0)  | 77.5 (6.2)  | 71.3 (5.1)  |
|                |               | U               | 90.7 (5.7) | 86.4 (7.4)  | 83.3 (9.1)  | 90.1 (9.7)  |
| 2              |               | D               | 86.2 (9.8) | 75.9 (13.9) | 78.1 (11.2) | 75.5 (13.0) |
|                |               | S               | 75.4 (6.7) | 71.1 (9.7)  | 69.7 (9.5)  | 69.3 (10.0) |
|                |               | U               | 85.4 (6.0) | 76.3 (8.8)  | 77.9 (11.3) | 74.3 (10.0) |
| 3              |               | D               | 70.0 (7.6) | 68.1 (9.3)  | 61.5 (8.6)  | 62.0 (7.9)  |
|                |               | S               | 61.2 (3.5) | 57.1 (2.7)  | 62.9 (4.4)  | 57.4 (5.4)  |
|                |               | U               | 64.7 (4.5) | 59.2 (2.5)  | 60.0 (4.4)  | 58.6 (5.2)  |
| 4              |               | D               | 89.8 (6.8) | 76.9 (6.3)  | 73.4 (8.9)  | 75.4 (8.7)  |
|                |               | S               | 77.8 (4.3) | 77.0 (4.3)  | 73.6 (6.2)  | 72.2 (7.5)  |
|                |               | U               | 78.8 (3.3) | 79.4 (4.2)  | 80.6 (6.5)  | 76.2 (8.0)  |
| 5              |               | D               | 94.3 (7.2) | 81.6 (11.2) | 77.2 (12.2) | 72.1 (11.3) |
|                |               | S               | 67.4 (2.0) | 70.3 (6.7)  | 71.5 (7.6)  | 74.2 (9.0)  |
|                |               | U               | 82.3 (6.4) | 78.1 (8.5)  | 76.8 (10.1) | 74.9 (12.1) |
| 6              |               | D               | 85.0 (4.8) | 87.7 (9.3)  | 82.7 (8.5)  | 80.8 (10.0) |
|                |               | S               | 81.0 (4.1) | 82.5 (5.0)  | 78.4 (5.4)  | 80.9 (4.8)  |
|                |               | U               | 88.0 (5.9) | 89.6 (5.3)  | 88.2 (5.0)  | 87.7 (5.9)  |
| 7              |               | D               | 69.4 (5.8) | 70.0 (8.4)  | 63.7 (7.8)  | 68.6 (12.8) |
|                |               | S               | 58.1 (3.6) | 58.1 (3.2)  | 56.1 (4.1)  | 57.0 (5.0)  |
|                |               | U               | 79.7 (4.0) | 71.3 (7.3)  | 67.8 (9.0)  | 65.8 (8.1)  |
| 8              |               | D               | 83.3 (5.3) | 77.2 (5.3)  | 71.9 (5.2)  | 69.4 (8.0)  |
|                |               | S               | 71.2 (1.8) | 71.5 (3.7)  | 67.3 (4.8)  | 69.0 (6.0)  |
|                |               | U               | 74.2 (4.2) | 74.8 (4.4)  | 74.0 (3.5)  | 68.6 (4.0)  |

TABLE 5.5 STANDARD DEVIATION OF BREATHING SIGNAL (mm.Hg.)

| Subject<br>No. |   | Frequency (Hz.) |         |         |         |
|----------------|---|-----------------|---------|---------|---------|
|                |   | 1(0.25)         | 3(0.14) | 2(0.10) | 4(0.07) |
| 24             | D | 298             | 370     | 366     | 452     |
|                | S | 127             | 124     | 160     | 152     |
|                | U | 211             | 255     | 295     | 311     |
| 16             | D | 332             | 238     | 244     | 311     |
|                | S | 108             | 101     | 119     | 106     |
|                | U | 152             | 170     | 165     | 177     |
| 25             | D | 297             | 263     | 264     | 260     |
|                | S | 87              | 92      | 81      | 79      |
|                | U | 159             | 93      | 128     | 150     |
| 20             | D | 355             | 257     | 195     | 274     |
|                | S | 150             | 144     | 129     | 135     |
|                | U | 124             | 158     | 220     | 203     |
| 17             | D | 597             | 605     | 556     | 554     |
|                | S | 117             | 146     | 166     | 207     |
|                | U | 367             | 302     | 318     | 331     |
| 23             | D |                 |         |         |         |
|                | S |                 |         |         |         |
|                | U |                 |         |         |         |
| 21             | D | 449             | 422     | 430     | 500     |
|                | S | 172             | 144     | 139     | 150     |
|                | U | 524             | 448     | 523     | 450     |
| 22             | D | 358             | 355     | 329     | 386     |
|                | S | 136             | 161     | 132     | 174     |
|                | U | 208             | 244     | 297     | 294     |

TABLE 5.6 PHASE BETWEEN HEART RATE AND BREATHING SIGNAL (WITH FREQUENCY)

(Frequency in brackets is the respiration spectrum peak)

| Subject No. |   | Frequency (Hz.) |            |            |            |
|-------------|---|-----------------|------------|------------|------------|
|             |   | 1(0.25)         | 2(0.14)    | 3(0.10)    | 4(0.07)    |
| 24          | D | -81(0.242)      | -39(0.125) | 34(0.102)  | 88(0.074)  |
|             | S | -132(0.242)     | -43(0.141) | 48(0.101)  | -46(0.071) |
|             | N | -110(0.235)     | -35(0.131) | 20(0.098)  | 97(0.068)  |
| 16          | D | -29(0.174)      | 32(0.102)  | 66(0.087)  | 76(0.086)  |
|             | S | -118(0.297)     | -48(0.156) | -7(0.116)  | 62(0.067)  |
|             | N | -99(0.302)      | -40(0.131) | 38(0.099)  | -60(0.149) |
| 25          | D | -58(0.196)      | -13(0.136) | 0(0.097)   | 26(0.070)  |
|             | S | -79(0.229)      | -34(0.136) | -27(0.099) | 10(0.078)  |
|             | N | -72(0.199)      | -39(0.133) | -33(0.098) | -6(0.072)  |
| 20          | D | -48(0.168)      | -9(0.114)  | 6(0.090)   | 29(0.065)  |
|             | S | -17(0.194)      | -22(0.141) | -6(0.102)  | 16(0.074)  |
|             | N | -17(0.200)      | -32(0.140) | -17(0.100) | 22(0.075)  |
| 17          | D | -44(0.181)      | 63(0.137)  | 65(0.100)  | 128(0.074) |
|             | S | -173(0.242)     | -43(0.141) | 5(0.098)   | 115(0.072) |
|             | N | -97(0.247)      | -52(0.137) | 3(0.100)   | 39(0.072)  |
| 23          | D |                 |            |            |            |
|             | S |                 |            |            |            |
|             | N |                 |            |            |            |
| 21          | D | -20(0.149)      | -14(0.135) | 55(0.093)  | 53(0.078)  |
|             | S | -50(0.198)      | -31(0.133) | 8(0.094)   | 46(0.077)  |
|             | N | -12(0.198)      | 4(0.133)   | 47(0.099)  | 83(0.071)  |
| 22          | D | -63(0.203)      | 13(0.142)  | 61(0.103)  | 79(0.078)  |
|             | S | -43(0.234)      | 27(0.141)  | 52(0.099)  | 86(0.075)  |
|             | N | -44(0.238)      | 29(0.137)  | 90(0.100)  | 85(0.072)  |

Table 5.7 Cross-spectral amplitudes between heart-rate and respiration

$$\frac{((\text{bts/min}) \times \text{mm. Hg}) / \text{Hz.}}{x10^{-4}}$$

| Subject | Frequency (Hz.)   |       |       |       |       |       |       |       |      |
|---------|-------------------|-------|-------|-------|-------|-------|-------|-------|------|
|         | 0.240             | 0.100 | 0.143 | 0.078 | 0.125 | 0.091 | 0.111 | 0.053 |      |
| 6       | -                 | 0.2   | 5.4   | 6.4   | 15.7  | 21.6  | 5.8   | 2.7   | 4.4  |
| 7       | 0.1               | 0.3   | 3.2   | 1.1   | 4.0   | 0.6   | 1.3   | 0.1   | 0.1  |
| 8       | -                 | 0.6   | 13.0  | 7.0   | 15.0  | 1.1   | 2.3   | 6.5   | 8.5  |
| 9       | 0.1               | 0.8   | 5.0   | 3.2   | 9.7   | 3.2   | 4.0   | 2.1   | 10.0 |
| 10      | -                 | 1.7   | 13.0  | 4.9   | 22.0  | 10.0  | 12.0  | 11.0  | 15.0 |
| 11      | 0.1               | 0.7   | 4.0   | 2.3   | 4.3   |       |       |       |      |
| 12      | -                 | 1.1   | 5.8   | 1.9   | 14.0  |       |       |       |      |
| 13      | 0.2               | 0.9   | 4.2   | 5.1   | 4.6   |       |       |       |      |
| 15      | No spectral peaks |       |       |       |       |       |       |       |      |
| 16      | 0.4               | 0.9   | 9.5   | 1.5   | 2.5   | 3.0   | 2.3   | 2.5   | 2.9  |
| 16(D)   | -                 | 3.0   | 8.3   | 5.1   | 5.5   |       |       |       |      |
| 16(S)   | -                 | 0.2   | 1.7   | 1.6   | 2.5   |       |       |       |      |
| 17      | 0.6               | 0.7   | 13.4  | 6.0   | 13.7  | 2.5   | 6.5   | 2.5   | 4.8  |
| 17(D)   | -                 | 2.1   | 13.2  | 12.7  | 10.4  |       |       |       |      |
| 17(S)   | -                 | 0.1   | 1.4   | 1.1   | 2.1   |       |       |       |      |
| 18      | 0.2               | 1.9   | 16.2  | 12.5  | 7.2   | 9.3   | 10.5  | 3.2   | 11.0 |
| 19      | 0.04              | 0.7   | 2.8   | 0.7   | 3.1   | 0.5   | 8.9   | 6.7   | -    |
| 20      | 0.4               | 0.6   | 2.2   | 1.5   | 7.4   | 0.7   | 2.1   | 0.9   | 3.5  |
| 20(D)   | -                 | 2.3   | 3.5   | 1.6   | 6.6   |       |       |       |      |
| 20(S)   | -                 | 0.8   | 2.1   | 0.9   | 2.9   |       |       |       |      |
| 21(2)   | 12.4              | 14.5  | 20.2  | 14.4  | 8.6   | 5.8   | 8.8   | 6.2   | 5.6  |
| 21(3)   | 2.0               | 5.3   | 26.1  | 14.3  | 15.5  | 5.1   | 9.3   | 5.1   | 9.0  |
| 21(D)   | -                 | 4.1   | 7.3   | 6.4   | 11.1  |       |       |       |      |
| 21(S)   | -                 | 1.2   | 1.0   | 1.2   | 1.7   |       |       |       |      |
| 22(2)   | 0.5               | 0.7   | 3.0   | 3.8   | 3.3   | 1.5   | 3.7   | 1.3   | 2.6  |
| 22(3)   | -                 | 1.3   | 4.3   | 3.7   | 9.1   | 1.2   | 3.8   | 1.3   | 8.2  |
| 22(D)   | -                 | 0.4   | 3.4   | 3.1   | 4.4   |       |       |       |      |
| 22(S)   | -                 | 0.5   | 1.2   | 0.7   | 1.5   |       |       |       |      |

Table 5.7 (Ctd.)

| Subject | Frequency (Hz.) |       |       |       |       |       |       |       |       |
|---------|-----------------|-------|-------|-------|-------|-------|-------|-------|-------|
|         | -               | 0.240 | 0.100 | 0.143 | 0.078 | 0.125 | 0.091 | 0.111 | 0.083 |
| 23(2)   | -               | 1.1   | 8.7   | 8.9   | 13.0  | 3.9   | 3.1   | 5.2   | 5.1   |
| 24(2)   | 0.2             | 0.6   | 12.0  | 3.0   | 4.0   |       |       |       |       |
| 24(3)   | 0.4             | 0.5   | 5.7   | 3.4   | 3.0   | 2.7   | 3.7   | 4.7   | 3.2   |
| 24(D)   | -               | 1.7   | 9.5   | 5.3   | 8.6   |       |       |       |       |
| 24(S)   | -               | 0.4   | 2.9   | 0.7   | 1.2   |       |       |       |       |
| 25(2)   | 0.4             | 0.8   | 4.8   | 4.5   | 1.7   |       |       |       |       |
| 25(3)   | 0.2             | 1.1   | 4.1   | 3.5   | 2.0   | 0.3   | 2.6   | 0.2   | 0.8   |
| 25(D)   | -               | 3.8   | 3.9   | 2.3   | 3.8   |       |       |       |       |
| 25(S)   | -               | 0.2   | 0.4   | 0.3   | 0.4   |       |       |       |       |
| Mean    | 1.14            | 1.61  | 6.84  | 4.35  | 6.83  | 4.29  | 5.34  | 3.66  | 5.93  |
| s.e.    | 0.76            | 0.42  | 0.97  | 0.65  | 0.88  | 1.29  | 0.81  | 0.70  | 1.01  |

(2) - Series 2      (3) - Series 3 uncontrolled depth

(D) - Series 3 deep breathing      (S) - Series 3 shallow breathing

Table 5.8

Heart-rate response ( Cross-spectrum amplitude/  
respiration spectrum )

|         |   | ((bts/min)/mm. Hg)/Hz. |       |       |       |       |       |       |       |
|---------|---|------------------------|-------|-------|-------|-------|-------|-------|-------|
| Subject |   | Frequency (Hz.)        |       |       |       |       |       |       |       |
|         |   | 0.240                  | 0.100 | 0.143 | 0.078 | 0.125 | 0.091 | 0.111 | 0.083 |
| 6       | -   | 0.005                  | 0.038 | 0.049 | 0.037 | 0.015 | 0.029 | 0.028 | 0.020 |
| 7       | -   | 0.020                  | 0.009 | 0.010 | 0.023 | 0.016 | 0.041 | 0.034 | 0.032 |
| 8       | -   | 0.006                  | 0.024 | 0.017 | 0.026 | 0.024 | 0.031 | 0.028 | 0.030 |
| 9       | 0.018   | 0.022                  | 0.042 | 0.028 | 0.050 | 0.028 | 0.048 | 0.041 | 0.043 |
| 10      | -   | 0.009                  | 0.028 | 0.016 | 0.022 | 0.026 | 0.023 | 0.024 | 0.021 |
| 11      | 0.020   | 0.027                  | 0.058 | 0.050 | 0.123 |       |       |       |       |
| 12      | -   | 0.007                  | 0.011 | 0.003 | 0.005 |       |       |       |       |
| 13      | 0.023   | 0.014                  | 0.035 | 0.025 | 0.038 |       |       |       |       |
| 14      | -   | 0.018                  | 0.021 | 0.031 | 0.015 | 0.021 | 0.018 | 0.014 | 0.012 |
| 15      | No spectral peaks   |                        |       |       |       |       |       |       |       |
| 16      | 0.036   | 0.025                  | 0.077 | 0.055 | 0.057 | 0.071 | 0.069 | 0.104 | 0.078 |
| 16(D)   | -   | 0.011                  | 0.044 | 0.049 | 0.038 |       |       |       |       |
| 16(S)   | -   | 0.036                  | 0.093 | 0.068 | 0.094 |       |       |       |       |
| 17      | 0.035   | 0.009                  | 0.030 | 0.026 | 0.033 | 0.032 | 0.037 | 0.034 | 0.032 |
| 17(D)   | -   | 0.005                  | 0.018 | 0.018 | 0.017 |       |       |       |       |
| 17(S)   | -   | 0.005                  | 0.038 | 0.031 | 0.026 |       |       |       |       |
| 18      | 0.044   | 0.022                  | 0.045 | 0.034 | 0.048 | 0.051 | 0.060 | 0.090 | 0.045 |
| 19      | 0.005   | 0.004                  | 0.006 | 0.014 | 0.013 | 0.016 | 0.021 | 0.019 | 0.020 |
| 20      | 0.032   | 0.015                  | 0.022 | 0.015 | 0.042 | 0.023 | 0.038 | 0.029 | 0.041 |
| 20(D)   | -   | 0.010                  | 0.020 | 0.020 | 0.073 |       |       |       |       |
| 20(S)   | -   | 0.018                  | 0.043 | 0.023 | 0.056 |       |       |       |       |
| 21(2)   | Respiration frequencies do not correspond with metronome settings |                        |       |       |       |       |       |       |       |
| 21(3)   | 0.020   | 0.005                  | 0.016 | 0.014 | 0.015 | 0.016 | 0.018 | 0.017 | 0.018 |
| 21(D)   | -   | 0.008                  | 0.015 | 0.013 | 0.016 |       |       |       |       |
| 21(S)   | -   | 0.018                  | 0.026 | 0.020 | 0.032 |       |       |       |       |

| Subject                   | Frequency (Hz.) |        |        |        |        |        |        |        |       |
|---------------------------|-----------------|--------|--------|--------|--------|--------|--------|--------|-------|
|                           | 0.240           | 0.100  | 0.143  | 0.078  | 0.125  | 0.091  | 0.111  | 0.083  |       |
| 22(2)                     | 0.013           | 0.007  | 0.016  | 0.012  | 0.010  | 0.017  | 0.018  | 0.014  | 0.015 |
| 22(3)                     | -               | 0.007  | 0.010  | 0.010  | 0.018  | 0.013  | 0.019  | 0.013  | 0.017 |
| 22(D)                     | -               | 0.004  | 0.012  | 0.009  | 0.013  |        |        |        |       |
| 23(2)                     | -               | 0.014  | 0.031  | 0.032  | 0.032  | 0.036  | 0.041  | 0.004  | 0.039 |
| 24(2)                     | 0.017           | 0.012  | 0.035  | 0.026  | 0.030  |        |        |        |       |
| 24(3)                     | 0.067           | 0.012  | 0.026  | 0.036  | 0.029  | 0.024  | 0.040  | 0.029  | 0.035 |
| 24(D)                     | -               | 0.009  | 0.025  | 0.029  | 0.020  |        |        |        |       |
| 24(S)                     | -               | 0.009  | 0.013  | 0.030  | 0.028  |        |        |        |       |
| 25(2)                     | 0.024           | 0.024  | 0.050  | 0.054  | 0.055  |        |        |        |       |
| 25(3)                     | 0.012           | 0.024  | 0.020  | 0.015  | 0.021  | 0.029  | 0.017  | 0.018  | 0.030 |
| 25(D)                     | -               | 0.019  | 0.023  | 0.017  | 0.022  |        |        |        |       |
| 25(S)                     | -               | 0.019  | 0.022  | 0.012  | 0.036  |        |        |        |       |
| Mean                      | 0.0136          | 0.0306 | 0.0266 | 0.0347 | 0.0269 | 0.0334 | 0.0318 | 0.0311 |       |
| Standard error<br>of mean | 0.0013          | 0.0032 | 0.0029 | 0.0041 | 0.0037 | 0.0037 | 0.0064 | 0.0039 |       |

TABLE 5.9 DISTRIBUTION OF VARIANCE FOR RESTING SUBJECTS

| Subject<br>No. | Variance (bts/min) <sup>2</sup> |                     |                     |          | % of total            |                     |                     |
|----------------|---------------------------------|---------------------|---------------------|----------|-----------------------|---------------------|---------------------|
|                | Frequency range (Hz)            |                     |                     |          | Frequency range (Hz.) |                     |                     |
|                | 0.0<br> <br>0.016               | 0.023<br> <br>0.125 | 0.133<br> <br>0.500 | Total    | 0.0<br> <br>0.016     | 0.023<br> <br>0.125 | 0.133<br> <br>0.500 |
| 6              | 98.8                            | 214.3               | 106.8               | 419.9    | 23.5                  | 51.0                | 25.4                |
| 7              | 9.0                             | 69.9                | 21.3                | 100.2    | 9.0                   | 69.8                | 21.3                |
| 8              | 17.5                            | 58.6                | 58.3                | 134.3    | 13.0                  | 43.6                | 43.4                |
| 9              | 50.0                            | 248.2               | 87.5                | 385.7    | 13.0                  | 64.4                | 22.6                |
| 10             | 170.7                           | 214.4               | 106.8               | 491.8    | 34.7                  | 43.6                | 21.7                |
| 11             | 30.2                            | 70.6                | 54.8                | 155.6    | 19.4                  | 45.4                | 35.2                |
| 12             | 9.9                             | 28.5                | 8.0                 | 46.4     | 21.4                  | 61.4                | 17.2                |
| 13             | 90.8                            | 99.2                | 33.8                | 223.8    | 40.6                  | 44.3                | 15.1                |
| 14             | 15.0                            | 28.3                | 17.8                | 61.1     | 24.5                  | 46.4                | 29.1                |
| 16             | 96.9                            | 240.0               | 378.8               | 715.7    | 13.5                  | 33.5                | 52.9                |
| 17             | 136.8                           | 523.0               | 209.5               | 869.3    | 15.7                  | 60.2                | 24.1                |
| 18             | 64.1                            | 183.1               | 180.0               | 427.2    | 15.0                  | 42.9                | 42.1                |
| 19             | 7.9                             | 39.4                | 5.0                 | 52.3     | 15.1                  | 75.3                | 9.6                 |
| 20             | 48.5                            | 24.1                | 91.0                | 163.6    | 29.7                  | 14.7                | 55.6                |
| 21(2)          | 152.0                           | 359.3               | 260.5               | 771.8    | 19.7                  | 46.6                | 33.7                |
| 21(3)          | 54.3                            | 457.0               | 170.8               | 682.1    | 8.0                   | 67.0                | 25.0                |
| 22(2)          | 3.8                             | 27.0                | 41.5                | 72.3     | 5.2                   | 37.4                | 57.4                |
| 24(2)          | 71.7                            | 204.4               | 89.3                | 365.4    | 19.6                  | 60.0                | 24.4                |
| 25(2)          | 108.3                           | 190.6               | 150.3               | 449.2    | 24.1                  | 42.4                | 33.5                |
| 25(3)          | 36.1                            | 75.4                | 32.0                | 143.5    | 25.2                  | 52.5                | 22.3                |
| 24(3)          | 58.0                            | 193.9               | 52.3                | 304.2    | 19.1                  | 63.7                | 17.2                |
| 22(3)          | 59.7                            | 82.7                | 62.5                | 203.9    | 29.1                  | 40.4                | 30.5                |
|                |                                 |                     |                     | mean %   | 19.9                  | 50.3                | 30.0                |
|                |                                 |                     |                     | variance | 8.7                   | 14.0                | 13.2                |



## CHAPTER 6

### Physiological models

The previous chapters have been devoted mainly to a description of data taken from the post-operative patients and the healthy subjects. It would be useful also to fit models to the data. This would not only help to understand how the data behave, but also describe the data more succinctly. In effect the number of points describing the data would be reduced to the few parameters of the model.

### Literature review

The application of mathematical models to physiological systems is fraught with difficulties. In many cases the systems are so variable that a very complex model is required to describe the system adequately. Physiological modelling contrasts with modelling in other subject areas. In engineering, for example, the correct model to apply in any one situation is very often known and we may wish to examine this model in a large number of simulated circumstances to discover any effects that cannot be tested in the real system. A model of a nuclear power station can be tested for the effects of a system overload, for example. In economics, models are very often used for prediction in time. In physiology, however, neither of these uses of models is of much interest. In general the data from a physiological model are compared with the results of the real system in order to highlight relationships between the various physiological parts that have been built into the model. However, the fact that a particular model describes the data well does not imply that the model is correctly interpreting reality. In one of the first papers

on heart-rate modelling, Clynes (1960) described the phenomenon of sinus arrhythmia by assuming that it was effected only through stretch receptors in the lungs. He obtained a very good description of the data using this model. However, the model was shown to be built upon false premises by Davies and Neilson (1967) who proposed that sinus arrhythmia in man at rest was mainly dependent on blood flow changes.

Valentinuzzi et al., (1972) give a block diagram for a model of the blood pressure control system. Although not a mathematical model, it does give an indication of the pathways that might mediate the blood pressure. An outline of their model is given below in fig.6.1.

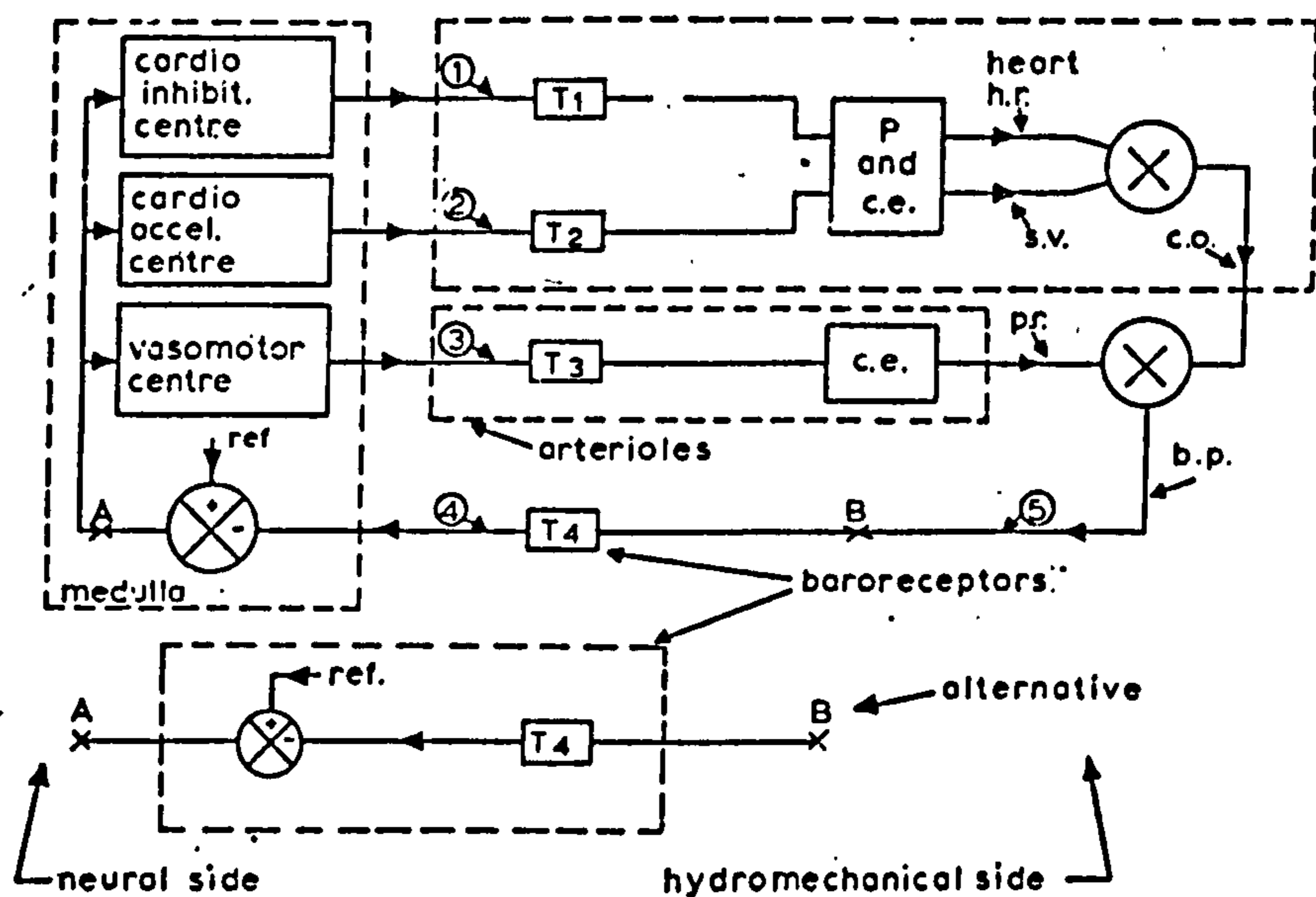

Figure 6.1. Blood pressure regulating system (Valentinuzzi et al., 1972)

A description of the physiological principles underlying the model is given in Appendix B. Note that the model is one of feedback control, with at least three branches descending from the medulla. The cardiovascular variables that directly affect the blood pressure are peripheral resistance (p.r.), stroke volume (s.v.) and heart rate (h.r.). The boxes marked  $T_1$ ,  $T_2$  and  $T_3$  are thought of as elements (transducers) capable of translating neural information into physiological effects such as heart-rate changes, and contraction variations. The box  $T_4$  represents the baroreceptors, transmitting information to the medulla. The circles with crosses inside represent 'multipliers' condensing heart-rate and stroke volume to produce cardiac output, and then cardiac output and peripheral resistance to produce blood pressure. The resultant blood pressure is compared with a hypothesised reference value in the medulla or in the baroreceptors, and the control centres take action to reduce any measured difference. One possible criticism of the model is the probability (for example Ganong (1963 p.442) that there is no separate cardio-acceleratory centre and that an increase in heart rate is due to discharge of the sympathetic nerves to the heart. However, models of this type are of value because they clearly describe the methods by which physiological control is achieved.

Valentinuzzi et al., (1972) quote a linear model due to Royston which describes the relationships between heart rate and blood pressure as

$$R(t) = R_0 + S_0(P_0 - P(t)) - S_1(dP(t)/dt) \quad (6.1)$$

where  $R(t)$  is the heart-rate averaged over a short period of time and

$P(t)$  is the average blood pressure over a cardiac cycle. The constants  $P_0$  and  $P_r$  refer to the basal heart-rate and a reference blood pressure respectively. In the light of the feed-back model, this relationship is clearly only an approximation which will hold provided the peripheral resistance and stroke volume remain constant. Valentinuzzi et al., (1972) use the equation to estimate the constant  $S_0$ , termed the heart-rate sensitivity in situations where the blood pressure was held constant at two different levels, and the heart rate difference observed. The heart rate sensitivity is then the ratio of the heart rate difference to the blood pressure difference, since  $dP/dt = 0$ . Hyndman et al., (1971) show a much simpler feed-back control model for blood pressure control, but with essentially the same ideas. They make the point that feed-back mechanisms are subject to spontaneous rhythms as the controlled variable oscillates about the preset reference point. Hyndman et al., (1971) illustrate the phenomenon of entrainment; in this case the blood pressure oscillations entrained by respiration. They show that the magnitude of the disturbance required to produce entrainment is much higher for frequencies slower than the spontaneous frequency than for those faster or near the spontaneous one. Hyndman (1972) gives a detailed model of the human cardiovascular system by building up a series of differential equations relating to various components of the system. Kitney (1974) proposes a very similar model to that of Hyndman to explain the human thermoregulatory system. Under normal circumstances the system can be said to be 'free running', and produces a number of frequency components in the heart rate spectrum spread throughout the frequency range (0-0.1Hz.). However, when subject to a strong external influence the system can be entrained.

Kitney's method of producing entrainment was to have the person dip his hand alternately into cold and warm water. He showed that the mathematical model correctly predicted the entrainment of the heart beat by the external signal.

Chick and Womack (1975) have attempted to model the human respiratory/heart rate system using a mathematical model. They used equidistantly sampled data points of heart rate and respiration obtained in the same way as in Chapter 3. A description of the model is as follows. Let  $x_1, x_2, x_3, \dots$  be the heart rate observations with corresponding respiration signal  $y_1, y_2, y_3, \dots$  and let the predicted value of the heart rate by the model at time  $n$  be  $v_n$ . Then the model employed by the authors is

$$v_n = a_0 y_n + \dots + a_k y_{n-k} - b_1 v_{n-1} - \dots - b_k v_{n-k}. \quad (6.2)$$

They presume that the initial values  $v_1, \dots, v_k$  are taken as equal to the observed values  $x_1, \dots, x_k$  but this is not stated explicitly. The parameters  $(a_0, \dots, a_k)$  and  $(b_1, \dots, b_k)$  are estimated by minimising the sum  $\sum (x_n - v_n)^2$ . Thus, effectively, a model is built and the parameter estimated by comparing the output of the model with the output of a real system. Presumably the initial values  $v_1, \dots, v_k$  are taken as equal to the observed values. A slight generalisation of the model is to allow an 'added' signal corresponding to the non-respiratory part of the heart rate signal. This consists of adding a function  $r_n$  to the right-hand side of equation 6.1, where  $r_n$  can be written

$$r_n = c_0 P_0(n) + c_1 P_1(n) + \dots + c_\ell P_\ell(n).$$

In this equation  $c_0, \dots, c_\ell$  are unknown parameters of the added

signal and the  $P_j$ s ( $j=0, \ell$ ) are orthogonal polynomials of order  $j$ . Chick and Womack imply that the number,  $\ell$ , of parameters required in equation (6.3) can be chosen as the value that gives the most satisfactory estimate of the added signal. However they do not show how the non-respiratory signal is measured in the real system, and imply that the parameters  $c_0, \dots, c_\ell$  are estimated together with the other parameters by minimising the total squared error as before. The number  $k$  can be taken as a value that gives a satisfactorily small squared error sum. However, they do not justify the fact that the number of parameters  $a_0, \dots, a_k$  in equation (6.2) is one plus the number of parameters  $b_1, \dots, b_k$ , or discuss whether a better fit might be obtained if this restriction were lifted. The authors give a visual demonstration that a reasonable fit to some real data can be achieved using  $k=5$  and  $l=3$ . Unfortunately they do not give values of the coefficients, or demonstrate convincingly the goodness of fit of the model.

#### Model fitting to the intensive-care patient data

Prediction of the immediate heart rate from the respiration is unlikely to be of much practical help in patient monitoring, and does not give much insight into the physiological mechanisms involved. This may not be the case with the patient heart-rate/Blood-pressure data, where we have equation (6.1) describing a possible theoretical model which could be investigated. However, an important difference between the heart-rate/blood-pressure data and the heart-rate/respiration data is that the former involves feedback, i.e. the heart-rate affects the blood pressure as well as vice versa, whereas for the latter the respiration is consciously controlled and is unlikely to be affected

by the heart rate. Chatfield (1975, p.224) warns against the use of cross-spectral analysis when feedback is present and also comments on difficulties in parameter estimation. Valentinuzzi et al., (1972) avoid the problem by keeping the blood pressure constant, effectively opening the loop.

Given that the data had already been collected, it seemed worthwhile to see whether a model such as (6.1) could describe the data at all. Writing  $dP(t)/dt$  as  $(P(t)-P(t-1))/\Delta t$  where  $\Delta t$  is the sampling interval, we can rearrange (6.1) to give

$$R(t) = a + bP(t) + cP(t-1)$$

where  $a$ ,  $b$  and  $c$  are constants.

The data, consisting of the heart rate and mean arterial blood pressure sampled every second from patient 4-72, were divided into groups of 50 points each and the above model fitted by the GLIM computer program (Nelder and Wedderburn, 1972). The program used a method of modified least-squares to find parameter estimates that minimised the mean square error between the observed and predicted heart rate. It was found that the parameter values varied considerably from group to group, but that for a section of 5 consecutive groups comparative stability was obtained. A regression model was fitted to the data from the first 3 groups combined. The regression terms were added to the model one by one and each time the total squared difference between the observed and predicted heart rates was calculated. It was found that  $P(t)$  did not give a significant reduction in the sum of squares, but that  $P(t-1)$  did. This is not surprising if we consider figure 4.5, where the data for this patient

are shown, filtered in the region of the respiration frequency. The blood pressure peaks are in many cases 1 second behind the heart rate peaks. Further terms were added to the model until only small reduction in the sum of squares were obtained. The resulting model is given below.

$$\begin{aligned}
 R(t) = & 7.6 - 0.17 P(t) + 1.03P(t-1) + 0.12P(t-2) + 0.26P(t-3) \\
 & -0.06P(t-4) + 0.92P(t-5) - 0.20P(t-6) - 0.82P(t-7) - 0.31P(t-8)
 \end{aligned}
 \tag{6.4}$$

The residual sum of squares was reduced from  $787.2 \text{ (bts/min)}^2$  with 149 d.o.f. to  $365.9 \text{ (bts/min)}^2$  with 140 d.o.f. The heart-rate and blood pressure spectra of 4-72, shown in figure 4.1, show a large peak at about 0.275 Hz attributable to respiration. Figure 4.5 shows a cycle of approximately 4 seconds which may explain the large coefficient at  $P(t-5)$ , 4 seconds from  $P(t-1)$ . By taking the Fourier transform of (6.4) we can obtain the frequency interpretation of the model, as described in Appendix A. We find that in the frequency domain, the equation has 3 local maxima, at 0.050, 0.206 and 0.297 Hz, with increasing magnitude. We can see from figure 4.1 that the first and last correspond to the thermal and respiratory peaks of the spectrum, although the frequencies are not quite exact. The second peak may possibly be an artefact due to the fact that the equation does not describe the data exactly.

The same model was fitted to the succeeding 150 data points, with the following result.



$$\begin{aligned}
 R(t) = & 40.7 - 0.69P(t) + 0.29P(t-1) + 0.45P(t-2) - 0.24P(t-3) \\
 & + 0.26P(t-4) + 0.57P(t-5) - 0.06P(t-6) - 0.11P(t-7) \\
 & - 0.12P(t-8).
 \end{aligned}$$

The residual sum of squares in this case was reduced from 816.1 (bts/min)<sup>2</sup> with 149 d.of. to 532.8 (bts/min)<sup>2</sup> with 140 d.of. In the frequency domain this equation shows only two peaks, at 0.125 Hz and at 0.297 Hz. We can explain the latter as the respiration peak, but cannot explain the former; possibly it corresponds to a vasomotor component. We can see that most of the parameter values have changed considerably, showing that the system cannot be regarded as stationary.

Fitting models of this kind is the time domain equivalent of cross-spectral analysis in the frequency domain, and in general we require fewer parameters with these models to describe the data adequately. However, as with cross-spectral analysis, we have the problem of estimating the transfer function in the presence of feedback, as mentioned earlier. This is one of the reasons why it seemed more expedient in Chapter 4 to consider the two spectra simultaneously, rather than the cross-spectrum on its own. At most we have shown that it is possible to account for about 40% of the heart rate variability by prediction from the blood pressure. This, in itself, does not necessarily imply a direct physiological link since both can be affected by external factors, such as respiration. The problem of feedback led to the approach described in the next section.

### Box-Jenkins Model fitting

Granger and Morris (1976) give an example where two variables are generated by a bivariate, autoregressive scheme with feedback, and they show that the model obeyed by one variable, eliminating the other, can be described by what is known as an autoregressive, moving average model. These models can be fitted by a scheme due to Box and Jenkins (1970). The method is mainly intended for forecasting and for assessing the parameters of control systems. However, Box-Jenkins modelling has been successfully applied to describe ecological data by Jenkins (1975), where feedback is definitely operating. For these reasons it was felt that a Box-Jenkins model might be useful for describing the heart-rate/blood-pressure data, and in highlighting the correlations structure of the data. The process of fitting and estimating Box-Jenkins models is quite involved and it was felt that since the models are adequately described elsewhere a detailed review was not appropriate here. The methods are dealt with in detail in Box and Jenkins (1970) and outlined in Chatfield (1975), Chapters 3 and 4. A useful worked example is given in Chatfield and Prothro (1973). The Box-Jenkins programs for identification and estimation of the parameters are available as USID and USES.

Given a univariate time series  $x_1, x_2, \dots, x_n$  the basic Box-Jenkins model is of the form

$$x_t + a_1 x_{t-1} + \dots + a_p x_{t-p} = b_0 \epsilon_t + b_1 \epsilon_{t-1} + \dots + b_q \epsilon_{t-q} \quad (6.5)$$

Defining the backward shift operator  $B$  as  $B(x_t) = x_{t-1}$ , we can write equation 6.3 as

$$(1 + a_1 B + \dots + a_p B^p) x_t = (b_0 + b_1 B + \dots + b_q B^q) \epsilon_t \quad (6.6)$$

In equation (6.5) and (6.6)  $a_1, \dots, a_p, b_0, b_1, \dots, b_q$  are parameters to be estimated from the observations. The  $\varepsilon_t$  are unobserved, independent random variables with common mean 0 and common variance  $\sigma^2$ . The right-hand side of equation 6.6 is termed the moving average (MA) and can be thought of as the output of a finite linear filter with random input. The left-hand side of equation 6.6 is termed the autoregression (AR). An autoregressive model is similar to a multiple regression model except that  $x_t$  is regressed not on independent variables but on past values of  $x_t$ . Equation 6.6 is described as an autoregressive-moving average (ARMA) model. Box and Jenkins (1970) show that this kind of model can be used to describe a large number of time series with only a small number of parameters.

For data that are not stationary, Box and Jenkins suggest a differencing operation given by  $\nabla x_t = x_t - x_{t-1}$ . The differencing operator is applied, more than once if necessary, until the resulting differenced data do appear stationary, and then an ARMA model is fitted to the differenced data. If marked oscillations, or seasonalities, are present in the data then these can be removed by a differencing operator of the form  $\nabla^{(s)} = x_t - x_{t-s}$ , where  $s$  is the period of the oscillations. For seasonal data with a period that is not an integral number of the sampling interval more complicated procedures are required to remove the seasonalities.

An attempt was made to examine whether a simple Box-Jenkins model could explain blood pressure oscillations. One particular patient, 13-73, was chosen, because of a large peak in the blood pressure spectrum at 0.2 Hz. which meant that the periodicity could

be removed simply by a differencing operation  $\nabla^{(5)} = x_t - x_{t-5}$ . A section of data containing 200 points was examined. It was found that sections longer than this gave unacceptably long computer processing times.

After following the Box-Jenkins procedure a model was obtained with the equation

$$(1 - 0.628B) w_t = (1 - 0.948B)(1 - 0.945B^5) \varepsilon_t ,$$

where  $w_t = \nabla \nabla^{(5)} x_t$ . (6.7)

The Box-Jenkins program gives a  $\chi^2$  goodness-of-fit test for one step ahead predictions based on the sum of squares of the autocorrelations of the residuals. The estimated  $\chi^2$  for model (6.7) was 52.2 with 37 degrees of freedom, which is non-significant at 5%, implying that the model is adequate for one step ahead predictions. In addition the residuals were plotted and did not give any visual indication of non-randomness. The residual variance was  $2.42 \times 10^4$  units.

The factors 0.948 and 0.945 are close to 1, and suggest that we should difference the  $\varepsilon_t$ , that is calculate  $\nabla \nabla^{(5)} \varepsilon_t$ . If this were done the factors  $\nabla \nabla^{(5)}$  would effectively cancel on each side of the equation which would imply that a first order autoregression would suffice. The parameter for this model was estimated and the resulting equation was

$$(1 - 0.68B)x_t = \varepsilon_t . \quad (6.8)$$

In this case however the  $\chi^2$  goodness of fit statistic was 100.4 with 48 d.o.f., which is significant at 0.5%, and implies that the model does not adequately describe the data. The residual variance in this case was  $3.62 \times 10^4$  units.

Following the Box-Jenkins procedure, a model was fitted to the next section of 200 points, using the same differencing as before.

The model that was obtained was

$$(1 + 0.75B)(1 + 0.15B^5)w_t = (1 - 0.96B)(1 - 0.83B^5) \epsilon_t$$

$$\text{where } w_t = \nabla \nabla^5 x_t .$$

This gave a  $\chi^2$  statistic of 84.5 with 36 d.o.f. which is significant at 0.5%, implying an inadequate fit to the data. The residual variance was  $3.83 \times 10^4$  units.

It is apparent that the model has changed considerably. This is one aspect of non-stationary which is also clear from the successive spectra of the data which show a change, sometimes abrupt, from one spectrum to the next.

The results from Box-Jenkins modelling were rather disappointing. Perhaps the non-stationarities were such that we could not regard the data as stationary, for even short periods of time. The method requires skill and time, and possibly the rather complicated models obtained, and the unsatisfactory nature of the fit, is evidence of lack of skill rather than any short-comings in the method for encompassing these data. No further model fitting was attempted.

### Discussion

The work on empirical model fitting to the sampled data was very limited and met with limited success. It was felt that the heart-rate/blood-pressure system is too complicated to hope that fairly simple models based solely on the heart-rate and blood pressure would be adequate. The models are likely to be constantly evolving

in time and vary considerably from person to person. In general it was felt that a picture of the heart-rate and blood-pressure spectra is likely to be more useful for obtaining information about the patient, than a string of parametric models.

CHAPTER 7Summary and conclusions

In summary, the heart rate and blood pressure records of 15 post-operative patients, the blood pressure records of two normal, ambulatory subjects and the heart rate and respiration records of 25 healthy subjects were studied. The purpose of the study was to obtain a reasonable description of the variables so as to provide useful information for patient monitoring and physiological assessment.

The initial step in any analysis was to plot out the data and examine it visually for trends, abrupt changes and outliers. Two patients, nos. 7-73 and 8-73 displayed a large number of outliers, tentatively identified as extrasystoles. In these two cases the interval between extrasystoles appeared random and could be described by a Poisson distribution. This is potentially useful since other studies indicated that non-random extrasystoles are possible signals of an impending patient crisis. The outliers from the ambulatory blood pressure records are also reasonably random, except that there were long stretches in which no outliers appeared, so that the data were not well described by a Poisson distribution. When free from outside disturbances, the heart rate from healthy subjects displayed a unimodal distribution, which could be described by a Normal curve in about one third of all cases. Neither the heart-interval distribution nor the heart-rate distribution was consistently closer to a Normal distribution. Of the post-operative patients, only 3 subjects, 7-73, 10-73 and 15-73 gave overall heart-rate distributions that could be

described as Normally distributed and 2 subjects, 1373 and 1673, gave overall blood-pressure distributions that could also be described as Normally distributed. Patient 9-73 displayed a very constant heart rate, possibly the result of an implanted cardiac pacemaker. The heart-rate distributions of the healthy subjects displayed very few outliers or wild points. In contrast, the heart-rate distributions of the post-operative patients contained a large number of outliers. These distributions showed a 'scatter' of points about the main body of the distribution, possibly the result of less efficient heart-rate control. Excluding these points, the heart-rate distributions from the post operative patients were in general unimodal but with a smaller dispersion than those of the healthy subjects. The effect of conscious respiration was to make the distributions markedly bimodal.

A more detailed examination was made of the sampling statistics of the various blood pressure measurements of the post-operative patients and the ambulatory subjects. The effect of averaging on the variables was considered, for example what gain in precision is obtained from considering the half-minute averages as opposed to the individual observations? This has a bearing on the interpretation of clinical observation and the design of measuring instruments. The concept of the number of degrees of freedom per point was examined theoretically and empirically, and it was shown that in general the degrees of freedom per point are non-linear with increasing number of data points. However, for the simple cases of independence and Markov processes, an expression could be obtained. The degrees of freedom were calculated for different data lengths for the blood pressure records of the ambulatory subjects and the post-operative patients. For short data lengths, the value was found to lie between 0.1 and 0.2 d.o.f. / pt..



The stability of the blood pressure data was examined by considering the distribution of run lengths, i.e. the proportion of the data that lie within say,  $\pm 3$  mm. Hg for a given number of beats. It was found that in most cases the distribution showed a characteristic negative exponential shape with increasing run length. This would imply that the probability of a beat terminating the run was approximately constant for each beat of the run, and so the probability of obtaining a run of a given length decreases steadily as the run length increases. For the ambulatory subjects the stability of different variables differs, but it was found that at least 87% of observations were within 12mm. Hg of the preceding observation, for both subjects for systolic and diastolic pressures.

A further investigation was conducted into the stationarity of the means and variances of the blood pressure variables. The mean and variance were calculated over short data sets, and then considered for stationarity over different intervals of time, using Kendall's reverse arrangement statistic. The results showed the expected result that the longer averages were more stable, and that the percentage of stationary sections decreased as the length of each section was increased. A further interesting result was that the variances showed a much higher percentage stationarity than the means for both the ambulatory subjects and the post-operative patients. For example, for data sections of length 300 beats, the smallest percentage of stationary sets was 25% for the means, and 75% for the variances. This confirms the impression gained from observing the raw data, that although the blood pressure level may change for one reason or another, such as

24 hour cycles, the variation about that level is not subject to the same influences.

Various methods of calculating the spectrum from the heart beats were discussed and it was proved that the method of French and Holden gave asymptotically unbiased results in amplitude and phase when compared with the point process spectrum. However for short data stretches biases were likely and suggestions were made to avoid them. It was empirically demonstrated that with the type of data expected, all methods gave approximately the same result. When calculating the heart-rate spectra, a linear extrapolation between the beats was taken with digital sampling at the rate of one sample/sec as this provided a fast algorithm and a useful method of interpreting the relative phase between heart rate and respiration.

The spectral analysis of the heart rate from the healthy subjects gave clear results with many of the features mentioned in the literature. At least two peaks were apparent in the spectrum; one in the region (0.05 - 0.10) Hz. which has been termed the vasomotor frequency, and the other in the region (0.20 - 0.30) Hz., which correlated with respiration. These peaks were not apparent in the majority of the heart-rate spectra from the post-operative patients. However, a much larger proportion of the blood-pressure spectra from the patients gave results that could indicate the presence of cycles, particularly in the respiratory, but also in the vasomotor region. In addition, spectral analysis of the blood-pressure records from the ambulatory subjects also revealed peaks in the vasomotor region and in the so-called thermoregulatory region.

This suggests that blood pressure is closely involved in cardiovascular control, and is susceptible to various control mechanisms. The fact that heart rate does not show these influences so clearly may mean that heart rate is independent of them, or more likely, is subject to many other disturbing influences which are not reflected back directly to blood pressure but which disguise or swamp the effect of the control mechanisms. The phase results from 6 records of 4 patients who displayed a respiratory heart-rate response suggested that in the region of a respiratory frequency of 0.2 Hz. the blood pressure cycle was in advance of the heart rate cycle. The results from Chapter 5 showed that with healthy subjects breathing at this frequency, the heart-rate cycle lagged the respiration. This would suggest that at this frequency the blood pressure cycle was more closely in phase with respiration than was the heart-rate cycle.

In Chapter 5 we attempted to quantify the respiratory heart rate response. We showed that the heart rate can be easily entrained by respiration, and that respiration affected both the level and the variability of heart rate. The responses were consistent in the sense that, compared with the resting state, if a greater stimulus than normal has one effect then a lesser stimulus has the opposite effect. For example, a high respiration rate reduced the heart-rate variability by about 4.5 bts/min on average, whereas a low rate increased it by about the same amount. Deep breathing increased the heart-rate variability by about 2.2 bts/min and shallow breathing reduced it by about 1.2 bts/min. The phase/respiratory-frequency graphs were linear in the range (0.07 - 0.2) Hz., declining through about  $100^\circ$  in

that range, and passing through the zero phase point at about 0.1Hz..

The breath-holding experiments revealed that, contrary to many claims, there may be cycles in the heart rate during voluntary apnea. However, because the cycles appear infrequently and different to those of respiratory sinus arrhythmia, it was concluded that the main mechanism for the respiratory heart-rate response is unlikely to be a central one. Instead, the evidence appears to be in favour of a cardiac or baroreceptor reflex, and the cycles appearing during breath-holding are due to other factors, such as vasomotor oscillations. It was of interest that prior to voluntary respiration, the sinus arrhythmia effect did not play a major part in the heart-rate variability but at the onset of regular respiration in time to a metronome, practically all the heart-rate variability could be accounted for by respiration.

We examined the distribution of variance over frequency for the post-operative patient records in both short (256 sec.) and long (2048 sec.) sections. For heart rate we found that about 25% of the variance about a linear trend for short records was concentrated at cycles of greater than 50 seconds cycle length. For long records about 23% of the variance was concentrated in cycles longer than 250 seconds. In blood pressure the corresponding results were 28% for short records and 35% for long records.

### Further work

A study that would be of particular interest would be the simultaneous analysis of heart rate, blood pressure and respiration, in both the healthy subject and the post-operative patient. For the ambulatory subjects, clearly studies of the kind described in this thesis need to be carried out on more subjects, in order to establish broadly based criteria of stability and resolution. For patient monitoring, it would appear that a measure of the respiration would sometimes enable a large proportion of the variance to be accounted for. In addition to monitoring for trend, it may also be useful to monitor for changes in distribution by such parameters as the variance, kurtosis and Pearson's kappa.

Spectral analysis could prove useful for patient monitoring, but does hide real effects such as phase changes. It is best supported by additional information such as plots of filtered data, or phase plots. Signs of thermoregulatory, vasomotor or respiratory activity can provide evidence that these control mechanisms are at least functioning, which may be useful in assessing a patient's condition.

The distributional study carried out here, considering run lengths, degrees of freedom and short-term distributions, together with the more traditional statistics such as the mean and variance, is one that could be carried out usefully on many types of physiological measurement, and in future this type of study is likely to be carried out on other physiological variables besides blood pressure and heart rate.

APPENDIX ASpectral Analysis and Digital Filtering

This appendix covers the general theory of the methods of spectral analysis and digital filtering which have been applied in the previous chapters. A description of the computer programs that have been employed is included and also the proofs of some results which had been deferred to the appendix. For further reading Kendall (1973) and Chatfield (1975) give basic introductions to time series analysis, Jenkins and Watts (1968) and Granger and Hatanaka (1964) are valuable works on spectral analysis and Hannan (1960, 1970) and Anderson (1971) are very useful reference books for the mathematical theory of time series analysis.

Definitions

A discrete-time dependent random process may be defined as a set of random variables  $(X_t, t = 0, \pm 1, \pm 2, \dots)$  where  $(t=0, \pm 1, \pm 2, \dots)$  are the times at which the process is defined. In practice, we can often make only one observation at a given time, resulting in a finite observed sample  $(x_t, t=1, \dots, n)$ . It is helpful to think of the observed series as just one realization of an infinite set of time series that might have been observed. A major part of time series analysis is the estimation of the statistical properties of the generating process from the observed series. We will assume here that the observations are equidistant in time.

We will adopt the notation  $E(X_t)$  for the expectation of  $X_t$  (see for example Cramér (1946) p.170-71). The mean and variance of

a random process may then be defined as

$$\mu_t = E(X_t) \quad , \quad \sigma_t^2 = E((X_t - \mu_t)^2) \quad . \quad (A1)$$

we can also define the autocovariance as

$$\gamma(t,s) = E( (X_t - \mu_t)(X_s - \mu_s) ) \quad . \quad (A2)$$

In general  $\mu_t, \sigma_t^2, \gamma(t,s)$  will be functions of time, but an important class of series are those in which the first-order and second-order moments are not functions of the time of observation.

A series is said to be 'weakly stationary' or 'stationary to the second order' if  $E(X_t) = \mu, E((X_t - \mu)^2) = \sigma^2$ , independently of  $t$ , and  $E(X_t - \mu)(X_s - \mu) = \gamma(t-s) = \gamma(k)$ , where  $t-s = k$ .

We define the autocorrelation function as  $\rho(k) = \gamma(k) / \sigma^2$ . (A3)

Many of the results in time series analysis are derived by assuming the series to be stationary in the above sense.

Given a realization  $(x_t, t = 1, \dots, n)$  of a stationary process, we can estimate the mean, variance and covariance as

$$\bar{x} = \frac{1}{n} \sum_{t=1}^n x_t \quad , \quad (A4)$$

$$s^2 = \frac{1}{n} \sum_{t=1}^n (x_t - \bar{x})^2 \quad , \quad (A5)$$

$$\text{and } C_k = \frac{1}{n-k} \sum_{t=1}^{n-k} (x_t - \bar{x})(x_{t+k} - \bar{x}) \quad , \quad (A6)$$

The factor  $(n-k)$ , instead of  $n$  in (A6) would give an unbiased estimate of the autocovariance function (i.e.  $E(C_k) = \gamma(k)$ , where  $C_k = nC_k / (n-k)$ ). However, Parzen (1964) and Jenkins and Watts (1968, p.179) state that the denominator  $n$  in many cases gives an

estimate with a smaller mean square error defined by  $E( (\gamma(k) - c_k)^2 )$ .

### Frequency analysis and the spectrum

The major part of this thesis is devoted to the analysis of various phenomena in the frequency domain. We are looking for cyclical events in the data, for reasons discussed in Appendix B. A natural model for this kind of data is one of the form

$$X_t = A \cos(w_0 t + \theta) + Z_t \quad (A7)$$

In this equation,  $w_0$  is called the frequency of variation,  $\theta$  is called the phase and  $Z_t, t=1,2,\dots$  are a series of independent random variables representing the superimposed noise, with the assumption that  $E(Z_t) = 0$ . In this case  $w_0$  is measured in radians/unit time and so  $w_0 t + \theta$  is measured in radians. Jenkins and Watts (1968) put  $f_0 = w_0 / 2\pi$  which has units of cycles/unit time, usually cycles/sec. or Hz.. Note that for any frequency  $w$ , with  $wt$  in radians and  $t$  an integer, we have for the discrete process that

$$\begin{aligned} \cos(w + k\pi)t &= \cos wt && \text{for } k \text{ an even integer,} \\ &= \cos(\pi - w)t && \text{for } k \text{ an odd integer.} \end{aligned}$$

so that any model with a frequency greater than  $\pi$  radians/unit time can be expressed in terms of a model with a frequency between 0 and  $\pi$ .

For sampled data, therefore, all information about cycles in the data is contained in the frequency band  $(0, \pi)$  radians/unit time. Any higher frequency cycles in the series will appear as cycles in that range. The frequency  $\pi$  radians/unit time is termed the Nyquist frequency and if the observations are  $\Delta t$  seconds apart, then the Nyquist frequency is  $\pi / (\pi 2 \Delta t) = .1 / (2 \Delta t)$  cycles/second. This



means that if we were sampling the data once every second we would be unable to fit models with frequencies higher than 0.5 Hz.. Clearly, before the sampling interval is decided it is important to discover the range of possible cycles in the heart rate. The usual method for a continuous signal is to choose a small value of  $\Delta t$  so as to give a wide frequency range. However, since heart beats are a discrete signal, sampling more often than the fastest beat will not yield additional information. It is possible that the process generating the heart beat oscillates at high frequency, but to examine this would require more information than that offered by the inter-beat interval. We can examine heart beats as a time-dependent Poisson process, discussed in Chapter 3, and from this and from physiological considerations (Appendix B) we can show that we almost certainly do not introduce any important aliases if we sample once every second.

If we consider  $A$  and  $\theta$  fixed constants in (A7), then  $X_t$  is not stationary according to the definition given earlier because  $E(X_t)$  will change with time. To apply the theory of stationary random processes  $A$  is assumed a random variable, mean zero, and  $\theta$  is assumed to have a uniform distribution on  $(0, 2\pi)$ . We assume  $E(Z_t^2) = \sigma^2$  and that  $Z_t$ ,  $A$  and  $\theta$  are mutually independent. These are then fixed for a single realization of the process. We then find that  $E(X_t) = 0$  and  $\gamma(k) = E(X_t X_{t+k}) = \frac{1}{2} E(A^2) \cos \omega_0 k + \sigma^2 \delta_{ok}$ , where  $\delta_{ok} = 0$  if  $k \neq 0$  and  $\delta_{ok} = 1$  if  $k = 0$ .

This result has been generalized to all stationary process as the Wiener-Khinchine theorem which states that the sequence of autocovariances  $\gamma(k)$  for a discrete stationary process with finite

variance can always be represented in the form

$$\gamma(k) = \int_0^{\pi} \cos wk \, dF(w), \quad (A8)$$

where  $F(w)$  is a monotonically increasing function and bounded. It can be shown that  $F(w)$  has a direct physical interpretation as the contribution to the variance of the series which is accounted for by frequencies in the range  $(0, w)$ . For  $k=0$ ,  $\gamma(0) = \sigma^2 = \int_0^{\pi} dF(w) = F(\pi)$ .

Thus the total variance of the series is accounted for by the contributions in  $(0, \pi)$ . When  $F(w)$  is differentiable we put  $dF(w)/dw = f(w)$ . The function  $F(w)$  is called the spectral distribution function and  $f(w)$  the spectral density function (or simply the spectrum). For continuous  $f(w)$ , (A8) can be thought of as a cosine transform. The inverse transform to obtain  $f(w)$  is given by the formula

$$f(w) = \frac{1}{\pi} \sum_{k=-\infty}^{\infty} e^{-ikw} \gamma(k), \quad 0 \leq w \leq \pi$$

$$= \frac{1}{\pi} \left( \gamma(0) + 2 \sum_{k=1}^{\infty} \gamma(k) \cos kw \right) \text{ since } \gamma(k) = \gamma(-k). \quad (A9)$$

Thus we define the spectrum as the Fourier transform of the autocovariance function.

### Estimating the spectrum

The most straight-forward method of estimating the spectrum from observations  $(x_t, t = 1(1)n)$  would be to substitute  $C_k$  for  $\gamma(k)$  in (A9) for values of  $k$  up to  $n-1$ . This can be written

$$f(w) = (C_0 + 2 \sum_{k=1}^{n-1} C_k \cos kw) / \pi. \quad (A10)$$

This can be re-arranged as

$$f(w) = \left[ \left\{ \sum_{t=1}^n (x_t - \bar{x}) \cos wt \right\}^2 + \left\{ \sum_{t=1}^n (x_t - \bar{x}) \sin wt \right\}^2 \right] / n, \quad (A11)$$

$$= I_n(w) \quad .$$

Formula (A11) has been used by several of the earlier workers in time series such as Schuster (1897). Schuster termed  $I_n(w)$  the periodogram, but a better term is perhaps the sample spectrum, given by Jenkins and Watts (1968). Alternative derivations of (A11) can be obtained either as an estimate of  $E(A^2)$  when fitting a model of the form (A1) by the method of least squares for various values of  $w$ , or as the square of the modulus of the finite Fourier transform of the original series at each frequency  $w$ .

It is easy to show that as  $n$  tends to infinity  $\lim E(I_n(w)) = \pi f(w)$  but unfortunately the variance of  $I_n(w)$  about  $f(w)$  does not decrease with  $n$ . Fisher (1929) showed that if the data were normally distributed independent random variables with mean zero and variance  $\sigma^2$ , then  $2 I_n(w) / \sigma^2$  is distributed as a  $\chi^2$  with 2 degrees of freedom (except for  $w = 0, n$ , when the distributions have only 1 degree of freedom). The theoretical spectrum of the data in this case is  $f(w) = \sigma^2 / \pi$ . The variance of a  $\chi^2$  distribution with 2 degrees of freedom is 4 and is independent of  $n$ . We can see that the variance of  $I_n(w)$  about  $f(w)$  does not decrease as  $n$  increases and so in no sense can  $I_n(w)$  be thought of as a good estimator of  $f(w)$ .

#### Smoothing the spectrum

Daniell (1946) suggested that to reduce the variance of the

spectral estimate the ordinates of the periodogram should be averaged. Let  $w$  be the frequency at which we wish to estimate the spectrum and  $m$  be the number of consecutive ordinates over which we wish to average. We assume that  $w$  is not equal to 0 or  $\pi$  and that  $m$  is even. We then construct a set of consecutive integers,  $B_w$ , such that half the set  $(w_j: w_j = 2\pi j/n, j \in B_w)$  is less in value than  $w$ .

We then put

$$\hat{f}(w) = \frac{1}{m} \sum_j I_n(w_j), \text{ for all } j \text{ in } B_w \quad (A12)$$

For  $w$  near 0, where  $j$  may be less than zero, we use the fact that  $I_n(w_{-j}) = I_n(w_j)$ . For  $w$  near  $\pi$ , where  $j$  may be greater than  $n/2$ , we have that  $\cos(\pi + 2\pi j/n) = \cos(\pi - 2\pi j/n)$  and so from (A11)  $I_n(\pi + 2\pi j/n) = I_n(\pi - 2\pi j/n)$ . Neighbouring periodogram ordinates  $2\pi/n$  rads./unit time apart can be shown to be asymptotically uncorrelated, so the variance of (A12) will be of order  $1/m$ . Thus, by making  $m \rightarrow \infty$  and  $m/n \rightarrow 0$  as  $n \rightarrow \infty$  we obtain a consistent estimator for the spectrum. The estimator (A12) may be biased because

$$E(\hat{f}(w)) = \frac{1}{m} \sum_j f(w_j),$$

which is not equal to  $f(w)$  unless  $f(w_j)$  is linear for  $j$  in  $B_w$ . Thus in order to estimate the spectrum we have to choose a suitable value for  $m$ . A large value of  $m$  will result in a small variance but a large bias and in addition we would obtain only  $(n/m)$  independent spectral estimates in  $(0, \pi)$ . Another difficulty with too large a value of  $m$  is that genuine peaks in the spectrum may be smoothed out.

An alternative method of reducing the variance of the periodogram is to apply weights to the coefficients  $C_k$  in (A10). A standard

weighting function, named Tukey-Hanning after J. Tukey and J.V.Hann, is

$$\lambda_k = \left(1 + \cos \frac{\pi k}{M}\right) \quad k = 0, \dots, M$$

$$\lambda_k = 0 \quad k > M$$

Here  $M$  is an arbitrary integer to be chosen by the user, but generally  $M < n/3$ . It can be shown that, for  $\hat{f}(w)$  estimated by the Tukey-Hanning method from a series of independent random variables  $x_t$  with variance  $\sigma^2$ , that Variance  $(\hat{f}(w)) \approx \frac{4M}{5n} \sigma^2$ ,  $w \neq 0, \pi$ .

We also have that  $E(\hat{f}(w)) = f(w)$  and so by making  $n \rightarrow \infty$  faster than  $M \rightarrow \infty$  we can obtain consistent estimators for the spectrum.

This method is equivalent to calculating a truncated version of (A10)

$$f_1(w) = \frac{1}{\pi} \left( C_0 + 2 \sum_{k=1}^m C_k \cos wk \right), \quad w = \frac{\pi j}{M}, \quad j = 0, \dots, M,$$

and then smoothing these by weights  $(\frac{1}{4}, \frac{1}{2}, \frac{1}{4})$  to give

$$f(w) = \frac{1}{4} f_1(w - \pi/M) + \frac{1}{2} f_1(w) + \frac{1}{4} f_1(w + \pi/M), \quad w \neq 0, \pi,$$

$$f(0) = \frac{1}{2} f_1(0) + \frac{1}{2} f_1(\pi/M), \quad f(\pi) = \frac{1}{2} f_1(\pi) + \frac{1}{2} f_1(\pi - \pi/M).$$

There are similar problems in deciding a value of  $M$  as there are in determining  $m$  for smoothing the periodogram. Since only  $M$  autocovariances have to be calculated, the Tukey-Hanning method offered considerable computational advantages and was used frequently in the past. Recently, however, a superior method of computing the periodogram known as the Fast Fourier Transform (see for example Chatfield 1975, p.145) has become available and has meant that it is now computationally easier in many cases to calculate the raw periodogram and then smooth it.

Distribution of variance over frequency

If we sum (A10) over frequencies  $w_j = 2\pi j/n$  we get

$$\sum_{j=1}^n I_n(w_j) = \sum_{j=1}^n C_0 + 2 \sum_{j=1}^n \sum_{k=1}^{n-1} C_k \cos w_j k \quad .$$

The double summation in the right-hand expression is interchangeable, so the second term of this expression is equal to zero since

$$\sum_{j=1}^n \cos w_j k = 0, \quad k \neq 0.$$

$$\text{Thus } \sum_{j=1}^n I_n(w_j) = \sum_{t=1}^n (x_t - \bar{x})^2 \quad .$$

Using the fact that  $I_n(\pi + \frac{2\pi j}{n}) = I_n(\pi - \frac{2\pi j}{n})$  we can write the

above equation as

$$2 \sum_{j=1}^{n/2} I_n(w_j) / n = \sum_{t=1}^n (x_t - \bar{x})^2 / n \quad , \text{ assuming } n \text{ to be even.} \quad (\text{A13})$$

This is the sample equivalent of the theoretical result displayed after (A8) that the variance of the time series can be accounted for by the spectrum in  $(0, \pi)$  . Thus, we can see how the variance may be split into frequency bands ( $w_j = 2\pi j/n$ ) by using the periodogram ordinates.

Significance tests

In Chapter 4 we needed a test to examine whether a time series contained one or more strictly periodic components. If the observations are normally distributed random variables with mean zero and variance  $\sigma^2$ , then  $2I_n(w)/\sigma^2$  is distributed as a  $\chi^2$  with 2 degrees of freedom. However, we cannot use this result directly to test the maximum ordinate of a periodogram because we do not know  $\sigma^2$ , and the maximum of a set of  $\chi^2$  variables will itself not be

distributed as a  $\chi^2$ . Fisher (1929) discussed the distribution of  $g_r = r$  th greatest of  $I(w_j) / \sum_{j=1}^n I(w_j)$ ,  $0 < j \leq [\frac{1}{2}(n-1)]$  where square

brackets denote integer part, and  $n$  is the number of points in the series. As  $n \rightarrow \infty$ ,  $P(g_r > n^{-1}(x + \log_e n))$  converges to  $1 - \exp(-e^{-x})$ . In many cases studied in Chapter 4 we have  $n = 256$  which at the 0.05 and 0.01 probability levels gave significant points of  $g_r$  as 0.0333 and 0.0396. Generalizations of this result are discussed in Jenkins and Watts (1968, p.253) and also in Hannan (1971, p.467). We assume that

$$x_t = \mu + \rho \cos(t\theta + \phi) + y_t \text{ where } y_t = \sum_{j=-\infty}^{\infty} h_j \varepsilon_{t-j}, \quad \sum_{j=-\infty}^{\infty} |h_j| |j|^\delta < \infty \quad \delta > 0$$

Here  $\mu$ ,  $\rho$ ,  $\theta$ ,  $\phi$ , and the  $h_j$ s are unknown constants and the  $\varepsilon_t$  are normally distributed independent random variables. The random variables  $y_t$  expressed as a linear combination of the  $\varepsilon_t$ s are known as a linear process. The null hypothesis is  $\rho = 0$ , against  $\rho > 0$ , with  $\mu$ ,  $\theta$  and  $\phi$  unknown. Under the null hypothesis it is demonstrated in Hannan (1970) that the above asymptotic expression for  $P(g_r > n^{-1}(x + \log_e n))$  holds true if  $I(w_j)$  is replaced by  $I(w_j)/f(w_j)$ , where  $f(w_j)$  is the theoretical spectral value at  $w_j$ . The assumption of normality can be removed provided moments 'of sufficiently high order' exist (Hannan, 1970, p.472). This would seem to be a reasonable requirement for the observations with which we are dealing. It is further shown that if the spectrum is estimated by Daniell's method and, in the notation of the previous section, we have  $m \rightarrow \infty$ ,  $n \rightarrow \infty$  and  $m/n \rightarrow 0$ , then the asymptotic results are true when  $f(w_j)$  is replaced by  $\hat{f}(w_j)$ , the estimated spectral value at frequency  $w_j$ .

### Bivariate processes

When analysing, say, heart rate and blood pressure, we are interested in the relationships between the two series. Let us say that we have  $n$  observations  $(x_1, y_1), \dots, (x_n, y_n)$  of a discrete random process  $(X_t, Y_t)$ . In a similar manner to the univariate case we can define  $E(X_t) = \mu_X$ ,  $E(Y_t) = \mu_Y$ ,  $E(X_t - \mu_X)(X_{t+k} - \mu_X) = \gamma_{XX}(k)$ ,  $E(Y_t - \mu_Y)(Y_{t+k} - \mu_Y) = \gamma_{YY}(k)$  and  $E(X_t - \mu_X)(Y_{t+k} - \mu_Y) = \gamma_{XY}(k)$ .

The cross-correlation function is defined as

$$\rho_{XY}(k) = \gamma_{XY}(k) / \sqrt{(\gamma_{XX}(0) \gamma_{YY}(0))} .$$

By analogy with equation (A9) we can define the cross-spectrum as the Fourier transform of the cross-covariance function, thus

$$f_{XY}(w) = \frac{1}{\pi} \sum_{k=-\infty}^{\infty} \gamma_{XY}(k) e^{-iwk} . \quad (A13)$$

Note that this is not necessarily a real quantity, because  $\gamma_{XY}(k)$  is not necessarily equal to  $\gamma_{XY}(-k)$ . Thus the cross-spectrum can be split into real and imaginary parts;  $f_{XY}(w) = c(w) - iq(w)$ , where

$$c(w) = \frac{1}{\pi} \sum_{k=-\infty}^{\infty} \gamma_{XY}(k) \cos wk , \quad (A14)$$

$$\text{and } q(w) = \frac{1}{\pi} \sum_{k=-\infty}^{\infty} \gamma_{XY}(k) \sin wk . \quad (A15)$$

This enables us to write

$$f_{XY}(w) = \alpha_{XY}(w) \exp(i\phi_{XY}(w)) , \quad (A16)$$

$$\text{with } \alpha_{XY}(w) = \sqrt{c^2(w) + q^2(w)} , \quad (A17)$$

$$\text{and } \phi_{XY}(w) = \tan^{-1}(-q(w)/c(w)) , \quad (A18)$$

where  $\alpha_{XY}(w)$  is termed the cross-spectral amplitude and  $\phi_{XY}(w)$  is termed the phase spectrum.



Another useful quantity is the coherency defined as

$Ch(w) = \alpha_{XY}(w) / ((f_X(w)f_Y(w))^{1/2})$  where  $f_X(w)$  and  $f_Y(w)$  are the spectra of the individual processes  $X_t, Y_t$ . It can be shown that  $0 \leq Ch(w) \leq 1$  and that the coherency measures the linear correlation between two components of a bivariate process at frequency  $w$ . For  $Ch(w)$  near 1, the two processes are closely correlated at frequency  $w$ . Therefore in order to describe completely a cross-spectrum we need three measures, the cross-spectrum amplitude, the phase and the coherency.

As an illustration of these definitions, let us consider two processes given by

$$X_t = Z_{1,t}$$

$$\text{and } Y_t = X_{t-d} + Z_{2,t}$$

where  $(Z_{1,t})$  and  $(Z_{2,t})$  are uncorrelated random processes with means zero and variances  $\sigma_Z^2$  and where  $d$  is an integer.

$$\begin{aligned} \text{Then we find that } \gamma_{XY}(k) &= \sigma_Z^2 & k = d, \\ &= 0 & \text{otherwise,} \end{aligned}$$

$$\begin{aligned} \text{and } \rho_{XY}(k) &= 1/\sqrt{2} & k = d \\ &= 0 & \text{otherwise.} \end{aligned}$$

$$\text{Thus } f_{XY}(w) = \sigma_Z^2 e^{-iwd} / \pi, \quad \alpha_{XY}(w) = \sigma_Z^2 / \pi,$$

$$f_X(w) = \sigma_Z^2 / \pi, \quad f_Y(w) = 2\sigma_Z^2 / \pi.$$

Thus if one time series is simply a time delayed version of the other with lag  $d$ , then the phase between them is a linear function of frequency with gradient  $-d$ . This result can be generalized for integer random variable  $d$ . In this case

$$E(Z_{1,t} Z_{1,t+k-d}) = \sigma_Z^2 \text{Prob}(d = k).$$

$$\text{Thus } f_{XY}(w) = \frac{1}{\pi} \sum_{k=-\infty}^{\infty} \gamma_{XY}(k) e^{-iwk} = \frac{\sigma^2}{\pi} \sum_{k=-\infty}^{\infty} \text{Prob}(d=k) e^{-iwk} = \frac{\sigma^2}{\pi} E_d(e^{-iwd}) .$$

This can be simplified by making the assumption that the distribution of  $d$  is symmetric about  $d = d_0$ . Then

$$f_{XY}(w) = \sigma^2 \sum_{k=-\infty}^{\infty} P(d-d_0 = k-d_0) e^{-iw(k-d_0)} .$$

Putting  $k_1 = k-d_0$  we get

$$\begin{aligned} f_{XY}(w) &= \sigma^2 e^{-iwd_0} \sum_{k=-\infty}^{\infty} P(d-d_0 = k_1) e^{-iwk_1} , \\ &= \sigma^2 e^{-iwd_0} \left( P(d-d_0 = 0) + 2 \sum_{k_1=1}^{\infty} P(d-d_0 = k_1) \cos wk_1 \right) . \end{aligned}$$

The quantity inside the summation is real and so the phase is simply

$$\phi_{XY}(w) = -wd_0 \text{ as before.}$$

In general the phase will be

$$\phi_{XY}(w) = -\tan^{-1} \left\{ \frac{E(\sin wd)}{E(\cos wd)} \right\}$$

If we reduce the angle  $(wd)$  by a fixed amount  $wE(d)$ , then we have to compensate the phase by the same amount.

$$\text{Thus } \phi_{XY}(w) = -wE(d) - \tan^{-1} \left\{ \frac{E(\sin w(d-E(d)))}{E(\cos w(d-E(d)))} \right\} .$$

### Estimation of the cross-spectrum and computer programs

The methods of estimating the cross-spectrum are the same as for the spectrum. Either a Fourier transform of the weighted cross-covariance is taken, or the cross-periodogram, defined by

$$I_{xy}(w) = \left( \sum_{t=1}^n x_t e^{iwt} \right) \left( \sum_{t=1}^n y_t e^{-iwt} \right) / n$$

is calculated, and smoothed by the methods used in periodogram analysis.

For large scale computing of the spectrum there are many advantages in pre-programmed packages. The disadvantages are that one is restricted in range and scope to the package limitations because they are not easy to alter. The two methods of calculating the spectrum, via the autocovariance coefficients and by directly smoothing the periodogram have been written into the BMD Biomedical Computer Programs series as BMD02T and BMDX92 respectively (Dixon 1970, 1972). Both programs have been used in the analysis of heart rate and blood pressure.

The restrictions of BMD02T are that only 1000 points/series may be input, and the maximum lag  $M$  to which the autocovariances are calculated is 199. The advantages are that the original series, the autocovariances and the cross-covariances are printed and plotted as well as the spectrum, cross-spectral amplitude, phase and coherency. Large advantages are gained from plotting the data since general effects can be seen at a glance and 'odd' points or outliers can be readily detected. The program contains several optional procedures for preprocessing the data. Preprocessing is usually carried out when prior knowledge has been obtained about the spectrum. Factors such as known cyclic behaviour produce peaks in the spectrum and since most estimation procedures are efficient throughout the spectrum only for relatively flat spectra, it is considered better to remove the cyclic effect first. Of course this is not necessary if

it is only the cyclic effect that one is interested in. The program BMD02T permits a transformation of the form  $\tilde{x}_t = x_{t+1} - B x_t$  where  $|B| < 1.0$ . The factor B would be chosen to produce a relatively flat spectrum. In practice the transformation is too restricted to be of much use. It would have been useful to transform with  $B = \pm 1$ , and also to include 'seasonal' differencing of the form  $\tilde{x}_t = x_t - x_{t-l}$ , where  $l$  is the cycle length of the 'seasonal' effect, necessarily an integer.

A more useful optional procedure given in BMD02T is a detrending of the series by subtracting a linear trend

$$\tilde{x}_t = x_t - \bar{x} - b(t - \bar{t}),$$

where  $\bar{x}$  and  $\bar{t}$  are the means of  $x_t$  and  $t$ , and  $b$  is the least-squares linear regression coefficient. If this procedure is not carried out, a simple mean is subtracted from the data. Having read the input series, say  $(x_t, y_t)$ ,  $t = 1, \dots, n$ , the program computes the auto-covariances and the cross-covariance up to the prescribed lag  $M$ , and then calculates the raw spectrum by equation (A11), and the cross-spectrum by the same method with  $C_k$  replaced by the cross-covariance function. Finally the cross-spectral amplitude, phase and coherency are printed and plotted.

Program BMDX92 has better subroutines available for preprocessing the data, but is surprisingly limited in the procedures for plotting the output information. The data may be prefiltered using the moving

average filter of the form  $\sum_{m=-p}^p h_m x_{t+m}$ . The values of  $h_m$  determine

the type of filter applied to the data. A discussion of filtering is given later in this Appendix. Program BMDX92 allows for both low pass and band pass filters, and on specification of the frequency response function required, will calculate suitable coefficients  $h_m$  of the moving average. The series is detrended in a similar manner to BMD02T although in this case the detrending is not optional, and the regression coefficients are not output. The detrended series is then multiplied by a cosine taper of the form

$$W_t = \begin{cases} 0.5(1 - \cos((t - \frac{1}{2})/r)) & t = 1, \dots, r \\ 1 & t = r + 1, \dots, n-r \\ 0.5(1 - \cos((n - t + \frac{1}{2})/r)) & t = n-r+1, \dots, n \end{cases}$$

where  $r = [n/10]$  and  $[x]$  denotes integer part of  $x$ .

If we look upon the finite series as the result of viewing an infinite series through a rectangular window, then the Fourier transform of the finite series will have certain undesirable features compared with the Fourier transform of the infinite series because of the rectangular window. For example, the spectrum of an infinite sinusoid would theoretically display a single spike at the sinusoid frequency. The spectrum of a finite sinusoid of length  $n$  would display a broader peak at the sinusoid frequency and side lobes spaced  $2\pi/n$  radians/sec. apart around the main peak. The cosine taper is designed to reduce these effects by 'smoothing' the edges of the rectangular window. The resulting series  $\tilde{x}_t = W_t \tilde{x}_t$  is followed by zeros until the series contains a total of  $N$  elements, where  $N$  is the smallest power of 2 greater than  $n$ . Program BMDX92 employs the Fast Fourier transform algorithm which is only efficient when the

number of points in the data is highly composite i.e.  $n = a b c$  where  $a, b, c$  are integers. In this case we require  $N = 2^3$  which is achieved by adding zeros. We are not introducing false information by this method because when dealing with a finite series all points outside the series are implicitly assumed zero. The finite Fourier transforms of the resulting series are computed two at a time. Let  $(x_t)$  and  $(y_t)$ ,  $t = 0, \dots, N-1$ , denote the two series. The finite Fourier transform  $(\dot{v}_t)$  of the complex series  $(v_t) = (x_t) + (iy_t)$  is obtained by means of a subroutine. The finite Fourier transforms  $(\overset{0}{x}_t)$  and  $(\overset{0}{y}_t)$  of  $(x_t)$  and  $(y_t)$  are obtained from the formulae

$$\overset{0}{x}_t = (\overset{0}{v}_t + \overset{0}{v}_{N-t}^*)/2 \quad , \quad \overset{0}{y}_t = (\overset{0}{v}_t - \overset{0}{v}_{N-t}^*)/2i$$

which are evaluated only for  $t = 0, 1, \dots, N/2$ . Here  $\overset{0}{v}_t^*$  is the complex conjugate of  $\overset{0}{v}_t$ . If the total number of series is odd then an all zero series is created to complete the last pair to be transformed.

The spectrum for  $x_t$  is estimated from

$$\hat{f}_x(w_k) = c \sum_{t=(k-\frac{1}{2})d}^{(k+\frac{1}{2})d} \overset{0}{x}_t \overset{0}{x}_t^* \quad (A19)$$

where  $k = 0, \dots, b$ ;  $d = N/2b$ ;  $c = (s(d-1) \sum_{t=1}^n w_t^2)^{-1}$ ;  $w_k = 2\pi ks/2b$ ,

$k = 0, \dots, b$ ;  $s$  is the sampling rate after prefiltering and  $b$  (a power of 2) is the number of frequency bands specified by the user. The program description of BMDX92, (Dixon, 1972) incorrectly includes a divisor of 4 in (A19). The actual program does divide (A19) by 4, but computes  $x_t$  and  $y_t$  without the divisor of 2 given above. In evaluating (A19) use is made of the fact that

$$\overset{0}{x}_t = \overset{0}{x}_{-t}^* \quad \text{and} \quad \overset{0}{x}_t = \overset{0}{x}_{N-t}^*$$

The spectrum for  $y$  is estimated in the same way and the cross-spectrum calculated from

$$\hat{f}_{XY}(w_k) = c \sum_{t=(k-\frac{1}{2})d}^{(k+\frac{1}{2})d} x_t y_t^* .$$

It is easily seen that this is a simple averaging of the cross-periodogram over  $m = 2d$  frequencies  $w_k$ . The appropriate number of degrees of freedom in the  $\chi^2$  distribution is thus  $n/b$ .

The spectrum estimates  $\hat{f}_x(w_k)$  and  $\hat{f}_y(w_k)$  are printed and plotted against  $w_k$ . The cross-spectral parameters are:

$$\begin{aligned} \text{amplitude} &= |\hat{f}_{xy}(w_k)| , \\ \text{phase} &= 180 \arg(\hat{f}_{xy}(w_k)) / \pi^\circ , \\ \text{and coherence} &= \hat{f}_{xy}(w_k) / \sqrt{(\hat{f}_x(w_k)\hat{f}_y(w_k))} . \end{aligned}$$

These values are printed but unfortunately the program does not provide an option for plotting them.

It is important to realise that the spectral estimates computed by BMDX92 contain common factors. For example, when  $d = 2$  both  $\hat{f}_x(w_k)$  and  $\hat{f}_x(w_{k+1})$  will contain the factor  $\dot{x}_{2k+1} \dot{x}_{2k+1}^*$ , the former as the first term in the summation and the latter as the last term in the summation of (A19). This fact has important consequences if we wish to estimate the variance contributed by a cyclic component. For example if we have a cycle with frequency  $2\pi 2k/4b$  then we would expect  $\dot{x}_{2k} \dot{x}_{2k}^*$  to be large and  $\dot{x}_{2k-1} \dot{x}_{2k-1}^*$  and  $\dot{x}_{2k+1} \dot{x}_{2k+1}^*$  to be relatively small. Thus we could estimate the variance due to the cyclic component by dividing the spectral estimate  $\hat{f}_x(w_k)$  by  $c$ .

However, if the frequency of the cycle were  $2\pi(2k+1)/4b$  then  $\hat{x}_{2k+1}^o \hat{x}_{2k+1}^*$  would be large, and the contribution to the spectrum would appear in both  $\hat{f}_x(w_k)$  and  $\hat{f}_x(w_{k+1})$ . If we added the spectral ordinates at  $w_k$  and  $w_{k+1}$  to estimate the variance in that frequency band, then we would double the contribution due to the cyclic component. However, for series which do not seem to contain fixed frequency cycles, the variance estimate obtained by adding all the spectral ordinates was close to the sample variance. In general it was lower than the sample variance, because of the effects of the cosine filter and the detrending. The user has to select a value  $b$ , the number of frequency bands to be resolved. This automatically gives the bandwidth  $m$  and thus the variance of the spectral estimates. Selecting a value of  $b$  is thus equivalent to deciding the maximum lag  $M$  to calculate in BMD02T but usually there is a much greater restriction in choice. It is wise to select a value of  $b$  so that the number of degrees of freedom  $n/b$  is at least 4, and preferably greater than 6. Of course too small a value of  $b$  will give a very poor resolution and a large bias. In deciding a value of  $M$  the recommended procedure is to try several in the region  $1/20 \leq M/n \leq 1/3$  and to try and compromise between too smooth and too erratic a curve.

When analysing long series, the rather artificial procedure of adding zeros used in BMDX92 can be avoided by dividing the series into lengths equal to a power of 2. It was found that a straightforward analysis of a long series, say 1000 points was unproductive, partly because we rarely obtained 'good' recordings for that length



of time and also because the signals were unlikely to remain stationary over the period. In general, series of lengths 512 and 256 were taken with BMDX92 resolving into 64 or 32 frequency bands between 0 and 0.5 Hz., which gave either 4 or 8 degrees of freedom for each frequency. For BMD02T, series of length 300 and 900 were examined. The lags chosen for the former were between 50 and 90 points, with 60 as a compromise. A comparison between the two methods for series of about the same length showed that they both gave approximately the same shaped spectra. Major peaks in one would be reflected in the other. However, it was found that BMD02T seemed to be more sensitive to transients and in several cases gave an uninformative spectrum compared with BMDX92, due to the presence of odd large beats which had not been removed as extrasystoles.

Program BMDX92 required less control cards for its operation, took half the time and cost to run as BMD02T and had better precautions against leakage. In some circumstances, for instance when the two series are identical for a long lag  $d$  between them, then it is advisable to realign the two series to be more nearly in phase, that is replace, say,  $y_t$  by  $y_{t+d}$ , before calculating the cross-spectrum and phase. This is discussed in Jenkins and Watts (1968, p.399). In this case the lag  $d$  is best estimated from the cross-covariance function which is calculated by BMD02T. However, in most cases, for reasons of speed and ease of application BMDX92 was used ~~in the majority of cases~~ for calculating the spectral and cross spectral estimates.

### Effect of extrasystoles

In Chapter 1 it was pointed out that occasionally there occurred very fast beats in the heart rate signal, called extrasystoles, which were not part of the normal process. The fact that they can completely distort the spectrum is shown if we consider two, at say twice the normal heart rate,  $j$  seconds apart. These may be ten times the distance from the mean of normal beats that might have occurred at these times. Then from A6  $C_k$  will be considerably greater when  $k = j$  than when  $k \neq j$ . If we estimate the spectrum by the Tukey-Hanning method of applying weights to the  $C_k$  in A10 then  $\hat{f}_1(w)$  will be dominated by  $C_j$  provided  $j \leq M$  and the coefficient of  $C_j$  is  $\frac{2}{\pi} \lambda_j \cos wj$ . Thus the spectrum will appear to oscillate with period equal to the distance between extrasystoles. This unusual phenomenon was observed in several heart rate spectra which had been calculated before the extrasystoles had been removed.

### Digital filtering and complex demodulation

Cross-spectral analysis is a very useful tool for determining the phase between two time series. However the methods are dependent on the assumptions of stationarity, and if the phase is changing over the period of time in consideration, the results will show only the overall effects. A theory has been developed (Priestley 1965, 1970; Subba Rao and Tong, 1973) to deal with certain types of non-stationarity, when the non-stationary changes are slow in comparison with the frequencies being examined. However the theory is computationally quite difficult to implement and we have considered here only the computationally simpler but more primitive methods of filtering and complex demodulation.

### Digital filters

The principal use of filtering, digital or otherwise, is to smooth the data to be analysed. In general a filter acts on the time history of the data in some way. The most usual form of the filter is a linear one, and for discrete data the general relationship between the raw data  $x_t$  and the smoothed data  $\tilde{x}_t$  is

$$\tilde{x}_t = \sum_{j=-\infty}^{\infty} x_{t-j} h_j \quad (\text{A20})$$

where the  $h_j$ 's are known constants. We are assuming that the data are sampled every second, and so all frequencies will be expressed in Hz..

If we take a Fourier transform of A20 we get a relationship of the form

$$\tilde{x}(w) = H(w) x(w) \quad -\pi \leq w \leq \pi \quad (\text{A21})$$

Here  $H(w)$  is called the transfer function or the frequency response of the filter, and describes the way the filter modifies the data at different frequencies. In a similar notation to that of the cross-spectrum we can put  $H(w) = G(w)e^{-\phi(w)}$  where  $G(w) = |H(w)|$  is termed the gain of the filter, and  $\phi(w)$  is the phase. If  $h_{-j}$  in A20 then  $H(w)$  will be real and  $H(w) = G(w)$ . In this case  $H$  is called a symmetric filter and the phase is thus 0 or multiples of  $\pi$ . For example, the Tukey filter from A12 is given by  $\tilde{x}_t = 0.5x_t + 0.25(x_{t-1} + x_{t+1})$ . The frequency response is  $H(w) = 0.5 + 2(0.25)\cos w$

$$= \cos^2 \frac{w}{2}, \quad -\pi \leq w \leq \pi$$

A computationally more efficient filter is obtained by using recursive techniques. We can describe a recursive filter by the formula  $\tilde{x}_t = \alpha \tilde{x}_{t-1} + (1 - \alpha)x_t$  ( $0 \leq \alpha \leq 1$ ).

The frequency response is  $H(w) = \frac{1 - \alpha}{1 - \alpha e^{-iw}}$  which is complex and

will phase shift the data. The gain is given by  $G(w) = \frac{1 - \alpha}{(1 - 2\alpha \cos w + \alpha^2)^{\frac{1}{2}}}$

$-\pi \leq w \leq \pi$ . This is symmetric about  $w = 0$ , monotonically decreasing from  $w = 0$  to  $w = \pi$ . This type of filter is termed a low pass filter, meaning that it gives greater weight to the lower frequencies in the data. By decreasing  $\alpha$ , increased weight will be given to the higher frequencies. We can use two recursive filters to obtain a zero phase-shift filter, by filtering once forwards and filtering the second time backwards. Thus

$$\tilde{x}_t = \alpha \tilde{x}_{t-1} + (1 - \alpha)x_t$$

$$\tilde{\tilde{x}}_t = \alpha \tilde{\tilde{x}}_{t+1} + (1 - \alpha)\tilde{x}_t$$

The transfer function between  $\tilde{\tilde{x}}_t$  and  $x_t$  is  $H(w) = \frac{(1 - \alpha)^2}{1 - 2\alpha \cos w + \alpha^2}$ .

This is a real function and so has phase of zero or multiples of  $\pi$ , and thus the filter does not phase shift the data.

A high pass filter is one that removes low frequencies and trend from the data, and transmits a greater proportion of higher frequencies. One method of obtaining high pass filtered data is simply to subtract the output of a low pass filter from the original data. Orr and Hoffman (1974) employed this method to obtain zero phase-shift highpass filtered data. In this way they were able to remove low frequency effects such as circadian rhythms in order to examine a postulated 90 minute cycle.

Often we wish to examine data in the region of a particular

frequency, and to exclude both higher and lower frequency effects. One method of doing this is to select weights  $h_j$  in equation A20 so as to give a frequency response function with a peak at the frequency of interest. For example, if we wished to examine data in the region of frequency  $w_0$ , we could put

$$h_j = \cos w_0 j \quad -M \leq j \leq M$$

$$h_j = 0 \quad |j| > M.$$

Then if the original data was  $x_t = \cos wt$  then A20 becomes

$$\tilde{x}_t = \sum_{j=-m}^m \cos w_0 j \cos w(t-j)$$

which can be shown to be equal to

$$\tilde{x}_t = \frac{\sin\left(\frac{2M+1}{2}(w_0-w)\right)}{\sin\left(\frac{w_0-w}{2}\right)} x \cos wt$$

thus the transfer function in this case is

$$H(w) = \frac{\sin\left(\frac{2M+1}{2}(w_0-w)\right)}{\sin\left(\frac{w_0-w}{2}\right)} \quad (\text{A22})$$

This equation is illustrated in figure A1.

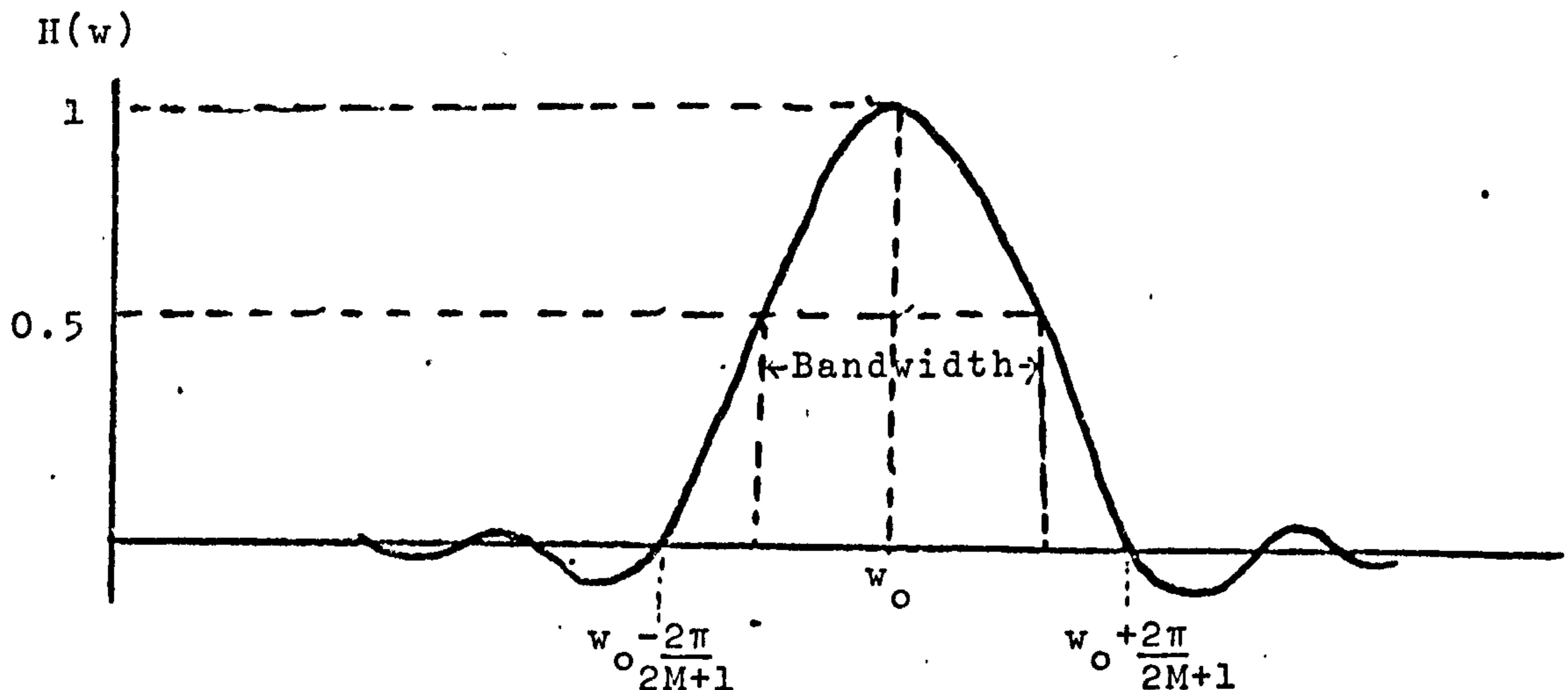

Figure A1. A transfer function given by equation A22.

From figure A1 we can see that the maximum weighting is given to frequencies in the region of  $w_0$ . This method, with modifications, has been programmed as BMDOLT. The first modification is to reduce the side lobes as shown in figure A1 by the application to the  $h_j$ 's of a cosine taper of the form  $(0.54 + 0.46 \cos \frac{j\pi}{M})$ . This is almost identical to the cosine taper used in BMDX92. This will give maximum weight to the observations near the time being considered. In order to study a greater range of frequencies, and to obtain a more nearly rectangular filter, several of the above triangular shaped filters are employed, spaced  $\pi/M$  units apart. If  $p$  is the number of triangular filters that make up the general filter, the weighting coefficients become

$$h_0 = \frac{2p}{M}$$

$$h_j = \frac{4}{M} \left[ 0.54 + 0.46 \cos \frac{j\pi}{M} \right] \cos jw_0 \frac{\sin(pj\pi/M)}{\sin(j\pi/M)}, -M \leq j \leq M, j \neq 0. \quad (A23)$$

The bandwidth of this filter is defined, in this case, to be  $|w_1 - w_2|$  where  $H(w_1) = H(w_2) = 0.5$  and  $w_1 \neq w_2$ .

Filtering must be undertaken with care to avoid inducing cycles in the filtered data that were not in the original. The fact that cycles may be induced was shown by Slutsky in 1937 and is discussed in Granger and Hatanaka (1964, p.41). If we have a relationship of the form A21 for a filter, and  $\hat{f}(w)$  is the spectrum of the raw data and  $\hat{f}_1(w)$  is the spectrum of the smoothed data then it can be shown that  $\hat{f}_1(w) = H^2(w) \hat{f}(w)$ . Thus if the input data were random noise and we applied a filter with transfer function A22, then the spectrum would resemble the square of figure A1. This would imply that the filtered data were nearly cyclic with frequency  $w_0$ , especially if

the bandwidth of the filter were narrow. If the filtering effect were not taken into account, the original may be thought cyclic as well. For this reason, the original spectral shape must be taken into account before filtering, and for band pass filtering the centre of the filter should be at a spectral peak.

### Hannan's lag estimation

A simple model for the heart-rate/respiration system would be a lead-lag model, where possibly we could put respiration leading heart rate by a fixed amount. Methods of estimating lags between signals have been developed by Hannan and Thomson (1971, 1973). Their methods avoid the necessity of estimating the phase between the signals, which may be an advantage if the phase is changing rapidly with frequency (Jenkins and Watts, 1968, p.399-400).

Given a bivariate time-series  $(x_1, y_1), \dots, (x_n, y_n)$ , we find the Fourier transforms

$$\overset{0}{x}(s) = \frac{1}{\sqrt{n}} \sum_{j=1}^n x_j \exp\left\{\frac{is2\pi j}{n}\right\}, \quad \overset{0}{y}(s) = \frac{1}{\sqrt{n}} \sum_{j=1}^n y_j \exp\left\{\frac{is2\pi j}{n}\right\}.$$

We put  $I'_{(x)}(w_s) = \overset{0}{x}(s)\overset{0}{x}^*(s)$ ,  $I'_{(y)}(w_s) = \overset{0}{y}(s)\overset{0}{y}^*(s)$  and

$I'_{(xy)}(w_s) = \overset{0}{x}(s)\overset{0}{y}^*(s)$ , where \* denotes complex conjugation and  $w_s = \frac{2\pi s}{n}$ .

These definitions differ from those given in (A11) in that the mean has not been subtracted from the data. We wish to estimate the lag between the two signals at frequency  $w_0$ , which is between 0 and  $\frac{1}{2}$ . In the same way as Daniell's method of smoothing periodograms we consider a band of frequencies, centred at  $w_0$ , and containing  $m$

fundamental frequencies  $w_s = 2\pi s/n$ . The cross-spectrum  $f_{XY}(w)$  is estimated at  $w = w_0$  ( $\neq 0, \pi$ ) by

$$\hat{f}_{XY}(w_0) = \frac{1}{M} \sum_0 I'_{(XY)}(w_s) ,$$

where  $\sum_0$  is the sum over  $m$  fundamental frequencies in the band, as before. We put  $\hat{p}(\tau) = \sum_0 I'_{(XY)}(w_s) e^{-i\tau s}/m$  and estimate the lag between the two signals at frequency  $w_0$  as the value  $\hat{\tau}$  of  $\tau$  which maximises

$$\hat{q}(\tau) = \left| \sum_0 I'_{(XY)}(w_s) e^{-i\tau s} / m \right|^2 \quad (\text{A24})$$

Hannan and Thomson (1971, 1973) derive properties of  $\hat{q}(\tau)$  and showed that under certain conditions it is a consistent estimator of the lag between the two signals at a particular frequency.

The justification for the method is quite simple. In the following equations the summations are from 1 to  $n$  unless indicated. For  $s = 0$  we have that  $\bar{x}(0) = \sum x_j / n$  and so  $I'_x(0) = (\sum x_j)^2 / n$ . Thus from (A13) we have that

$$\sum_s I'_x(w_s) - I'_x(0) = \sum_j x_j^2 - (\sum_j x_j)^2 / n .$$

We can also show that

$$\sum_s I'_{xy}(w_s) - I'_{xy}(0) = \sum_j x_j y_j - \frac{\sum_j x_j \sum_j y_j}{n} , \quad (\text{A25})$$

and this is the covariance between the two series.

We define  $C'_{xy}(\tau)$  as

$$C'_{xy}(\tau) = \sum_{j=1}^{n-\tau} x_j y_{j+\tau} - \frac{\sum_{j=1}^{n-\tau} x_j \sum_{j=1}^{n-\tau} y_{j+\tau}}{n}$$

and so the left hand side of (A25) can be expressed as  $C'_{xy}(0)$ .



Let  $(y_j)$  be a time-delayed version of  $x_j$ , thus  $y_j = x_{j-d}$ , for  $j > d$ .

Assume the relationship is not defined for  $0 \leq j \leq d$ .

$$\begin{aligned} \text{Then } \quad \overset{0}{y}(s) &= \frac{1}{\sqrt{n}} \sum_{j=1}^m x_{j-d} \exp\left(\frac{is2\pi j}{n}\right) \\ &= \frac{1}{\sqrt{n}} \exp\left(\frac{is2\pi d}{n}\right) \sum_{j=1}^n x_{j-d} \exp\left(\frac{is2\pi (j-d)}{n}\right) . \end{aligned}$$

$$\text{Thus } \exp\left(\frac{-is2\pi d}{n}\right) \overset{0}{y}(s) - \overset{0}{x}(s) = \frac{1}{\sqrt{n}} \left[ \sum_{j=1-d}^0 x_j \exp\left(\frac{is2\pi j}{n}\right) - \sum_{j=n-d+1}^n x_j \exp\left(\frac{is2\pi j}{n}\right) \right]$$

For fixed  $d$ , the expression in square brackets is bounded and so as  $n$  increases we have approximately

$$\exp\left(\frac{-is2\pi d}{n}\right) \overset{0}{y}(s) \approx \overset{0}{x}(s) .$$

$$\text{Thus, for large } n, \quad I'_{xy}(w_s) \exp(-i\tau w_s) \approx I'_x(w_s) \exp(-iw_s(\tau - d)) .$$

The maximum of  $\hat{q}(\tau)$  in this case would occur when  $\tau = d$ , and could be related to the variance of  $(x_j)$  in the frequency band around  $w_0$ . By restricting the sum to a band of frequencies in the region of  $w_0$ , we can consider the lag between two signals at specified frequencies. This method of measuring lag has another advantage over the method of maximising the cross-covariance function in that the lag estimates are not restricted to integer amounts of the sampling interval.

A program LAG (Appendix C) was written to calculate  $\hat{q}(\tau)$  for various values of  $\tau$  using a Nottingham Algorithms Group subroutine to calculate the Fast Fourier transforms. The data were the heart rate,  $x_t$ , and the respiration,  $y_t$ . The maximum could be estimated by an iterative technique. An attempt was made to estimate the lag between

heart rate and respiration by this method. It was found that, for the regular respiration data,  $\hat{q}(\tau)$  had a very flat peak in the region of the expected lag, and that could not be identified with any great accuracy. A possible explanation for this is to be found when the cross-periodogram is examined in the region of the respiration frequency,  $w_0$ , say. For regular respiration  $I'_{xy}(w)$  has a large peak at  $w = w_0$  and is small elsewhere. Thus we can write

$$\hat{p}(\tau) = \frac{1}{m} I'_{xy}(w_0) e^{-i\tau w_0} .$$

$$\text{Therefore } |\hat{p}(\tau)|^2 \approx \frac{1}{m^2} |I'_{xy}(w_0)|^2 |e^{-i\tau w_0}|^2 .$$

$$\text{Now } |e^{-i\tau w_0}|^2 = 1 \text{ so that } |\hat{p}(\tau)|^2 \approx \frac{1}{m^2} |I'_{xy}(w_0)|^2 .$$

Thus in this case  $\hat{q}(\tau)$  is approximately independent of  $\tau$  and so could not be used for estimating  $\hat{\tau}$  .

Hannan and Thomson (1971), in the proof of the properties of  $\hat{q}(\tau)$  required the series  $(x_n)$  and  $(y_n)$  to have absolutely continuous spectra and also for them to be purely non-deterministic in the sense that no component was purely predictable, linearly or non-linearly. A cyclic signal contains a deterministic component, and so this method does not seem to be the best one for estimating the lag between the signals. A better method would seem to be to derive the lag from the phase of the cross-spectrum at a peak of the cross-spectral amplitude, and this was carried out in Chapter 5.

APPENDIX BA short review of cardiac physiology

The purpose of this appendix is to cover the methods of measuring the E.C.G. and to describe the principles of heart rate control. The appendix forms a background for a discussion of the results of the heart rate and blood pressure analysis and the results of the sinus arrhythmia study. A basic description of cardiac physiology is given in Ganong (1963) and a readable, though somewhat simplified account is given in Berne and Levy (1972). For a more detailed description of reflex control of heart rate Heymans and Neil (1958) remains a standard text.

Blood circulation in the body

Figure B1  
(see over)

Figure B.1. Schematic diagram of the circulation of the blood through the body. The arteries are drawn in heavy print on the right and the veins in light print on the left. (Reproduced from Berne and Levy (1972) p.4).

Figure B.1. shows the pathway of the blood through the body. The heart in man has four chambers; the left and right atria and the left and right ventricles. The heart consists of two pumps in series; the right heart to propel blood through the lungs for exchange of oxygen and carbon dioxide (the pulmonary circulation) and the left heart to propel blood to all other tissues of the body (the systematic circulation). The parts of the heart normally beat in sequence. Contraction of the atria (atrial systole) is followed by contraction of the ventricles (ventricular systole) and during diastole all four chambers are relaxed.

### Electrical activity

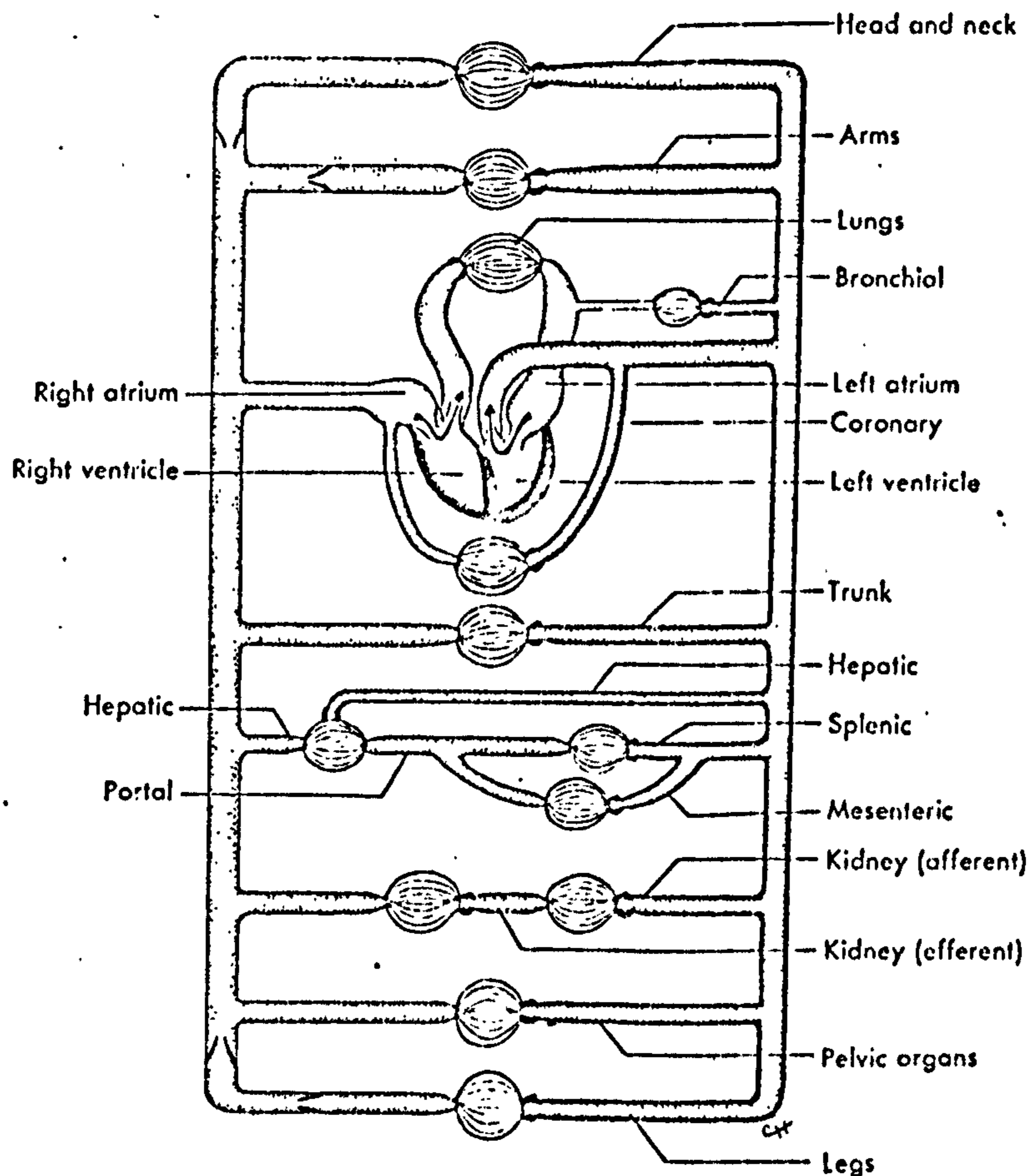
The nervous system exercises control over various aspects of the behaviour of the heart including the frequency at which it beats. However, cardiac function is not completely dependent on the intact nervous system. Cardiac tissue has an inherent property to initiate and regulate its own beat and the heart will continue to beat even when removed from the body. At least some cells in the walls of all four cardiac chambers are capable of initiating beats. The region of the mammalian heart that ordinarily discharges most rapidly is the sinoatrial or SA node, which is the natural pacemaker of the heart. Other regions that may initiate beats under special circumstances are called ectopic pacemakers. The most important of these is the

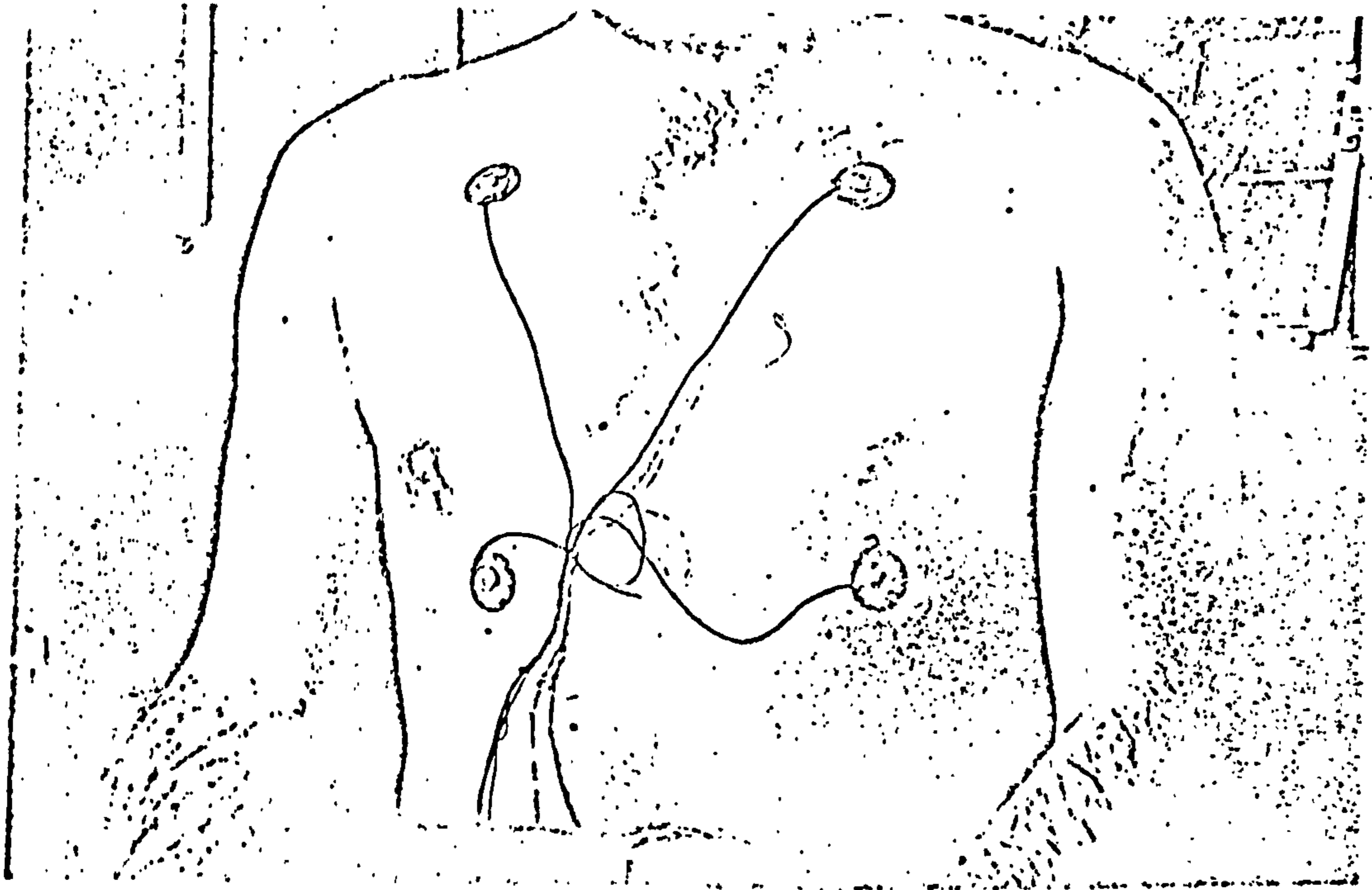

Figure B.2 Position of the electrodes used in the respiration experiments on healthy subjects.

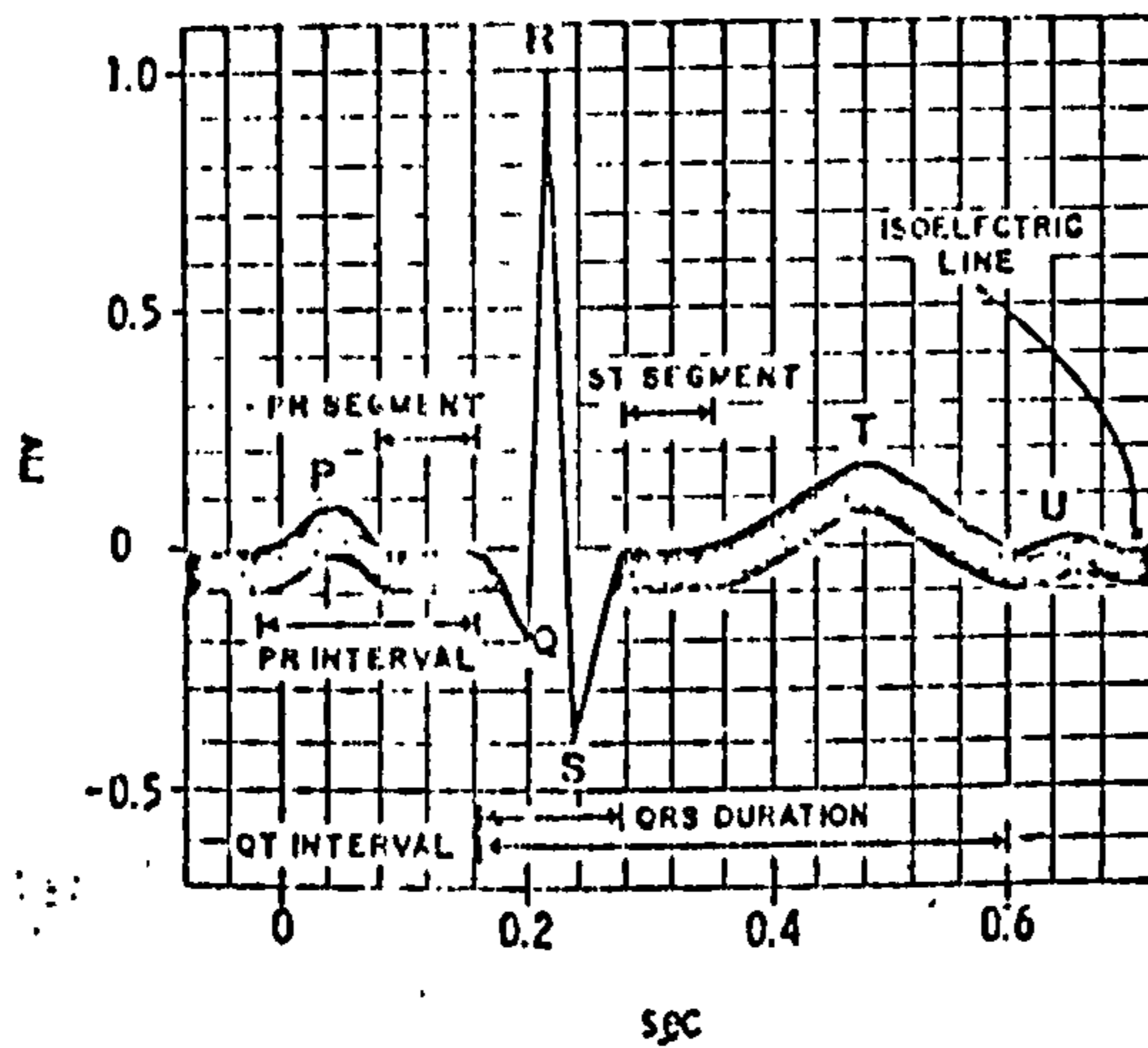

Figure B.3 A normal E.C.G. (Reproduced from Ganong (1963) p401.)

atrioventricular (AV) node. It contains the same cell types as the SA node, but fewer pacemaker cells. The electrical impulses originate at the SA node, and depolarize the atria first. They then travel to the AV node, where after a delay, they proceed through fibers known as the bundle of His to the rest of the heart, when the ventricles depolarize. Both the AV and the SA nodes are located in the right heart. Muscular contraction closely follows the depolarization of the muscle.

### The electrocardiogram

The body is a good conductor of electricity and so the fluctuations in potential that represent the algebraic sum of the action potentials around the heart can be recorded from the surface of the body. The record of these fluctuations is the electrocardiogram or E.C.G. In the experiments on healthy subjects an augmented unipolar 4 lead system was employed. The position of the electrodes on the chest is shown in Figure B.2. In the order left to right, top to bottom these were labelled A,B,C and D and then we have lead V<sub>4</sub> over the apex of the heart, the fifth intercostal space in what is known as the V<sub>4</sub> position. In a volume conductor, the sum of the potentials of an equilateral triangle with a current source at the centre is zero at all times. Thus if leads A,B and C are connected to a common terminal an indifferent electrode with near zero potential is obtained. The potential at D, the active or exploring electrode is then measured relative to this zero potential. In this way artefact muscle noise can be taken into account since it will affect all 4 electrodes in some way. Thus with unipolar leads the actual potential at the site of the live electrode can be measured.

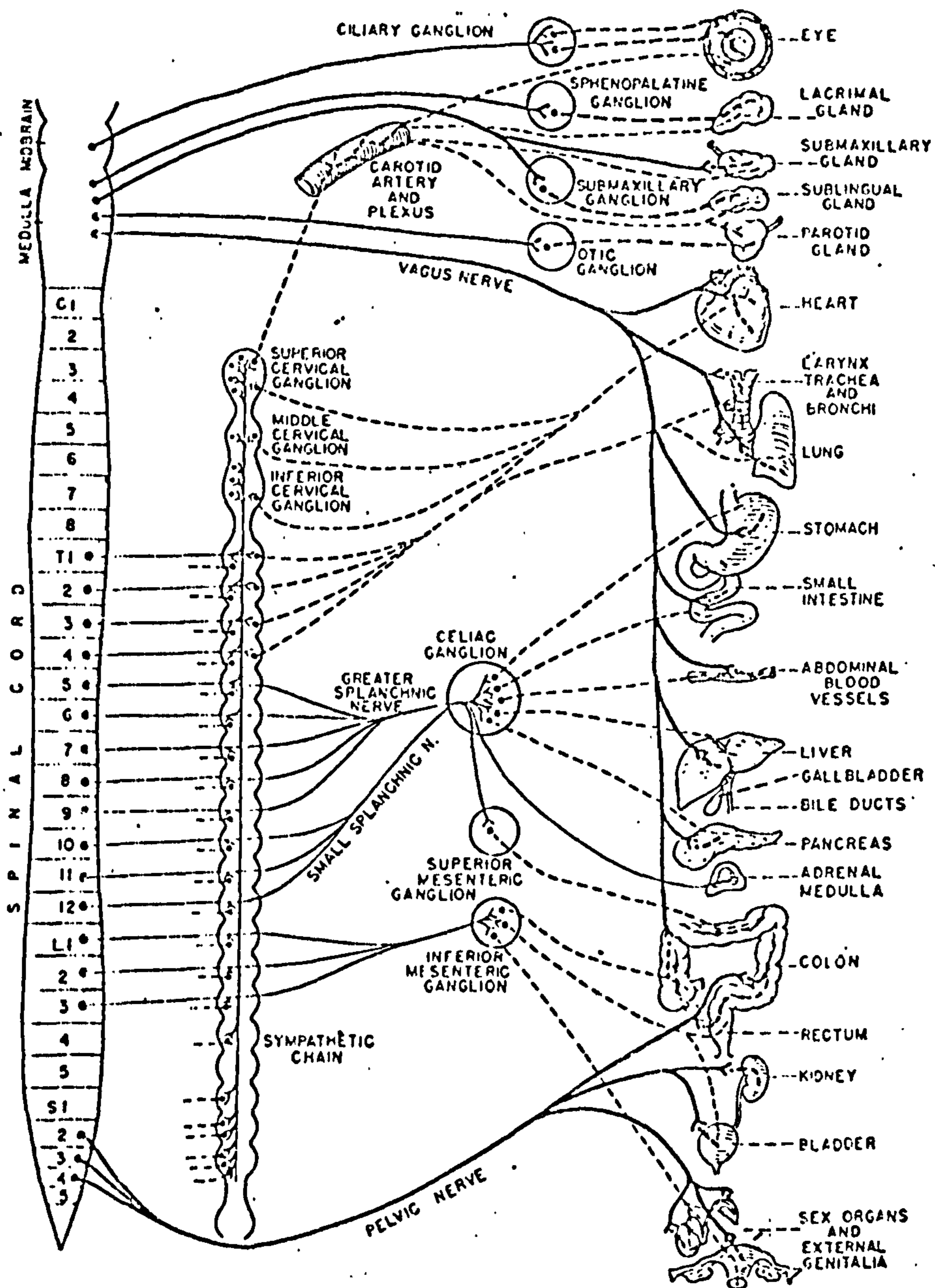

Fig B.4. Diagram of the efferent autonomic pathways. Preganglionic neurons are shown as solid lines, postganglionic neurons as dotted lines. The heavy lines are parasympathetic fibers; the light lines are sympathetic.

The E.C.G. is usually measured in millivolts and displayed on an oscilloscope. A typical E.C.G. is displayed in Figure B.3. The P wave represents the depolarization of the atria, triggered by the SA node. The ventricular depolarization produces the QRS complex and the ST segment and the T wave are the result of ventricular repolarization. The effects produced by atrial repolarization are normally submerged in the QRS complex. The timing of the heart beats in the experiments was taken from the top of the R wave. The method of detection of this R wave peak is described in Chapter 1.

#### Nervous control of heart rate

Many bodily functions are controlled within fairly narrow limits. Those such as blood pressure, heart rate and temperature involve the autonomic nervous system. This consists of both the efferent (or motor) pathways from the brain to the organs and also the afferent pathways in the opposite direction. The efferent pathways are shown in Ganong (Figure B.4, which is reproduced from Ganong, 1963, p.147). The autonomic nervous system is divided, functionally and structurally, into the sympathetic system, with neurons leaving the middle and lower spinal cord and the parasympathetic with neurons coming from the medulla oblongata of the brain stem and also from the sacral segments of the spinal cord. As can be seen from the figure, the main pathway for the parasympathetic system to the heart is the vagus nerve. The vagus arises in the medulla oblongata, and at the heart divides into two, the right segment passing to the SA node and the left to the AV node. Under normal conditions the SA node is under a continuous influence from



both divisions of the autonomic nervous system. The sympathetic system exerts an acceleratory influence on the pacemaker, whereas the parasympathetic system imposes an inhibitory effect. Changes in heart rate usually involve a reciprocal action between the two divisions. Thus acceleration of the heart beat is produced by a diminution of parasympathetic activity and a concomitant increase in sympathetic activity; deceleration is usually evoked by a reversal of the mechanisms. Ordinarily, in healthy, resting subjects the parasympathetic discharge, or 'tone', is predominant. Abolition of parasympathetic influences usually elicits a pronounced heart rate increase, whereas decrease of sympathetic activity usually results in only a slight slowing of the heart. The nucleus of the vagus in the medulla is sometimes known as the cardioinhibitory centre or the heart rate centre.

Respiration is also subject to neural control from the medulla oblongata, from an area known as the respiratory centre. This is made up of an inspiratory and an expiratory centre. The lungs contain stretch receptors that relay impulses via the efferent fibres in the vagus. In this way, during an inspiration an inhibitory effect acts on the inspiratory centre, causing inspiration to cease and expiration to begin. Depth of breathing increases after vagotomy (sectioning the vagus) in otherwise intact animals. Homeostatic control of blood pressure can be brought about by another part of the medulla oblongata known as the vasomotor centre. This gives a continuous discharge through the sympathetic vasoconstrictor nerves to maintain a degree of constriction in the blood vessels.

The control mechanism by which the autonomic nervous system operates is known as closed-loop negative feedback. Feedback is the return of part of the output of a system to the system itself for the purpose of influencing and automatically regulating the further operation of the system. A practical example of this is the operation of a central heating system in a room. Information about the room temperature is fed to a thermostat and compared to the preset temperature control. If the room temperature is below the preset value, the heating comes on until the preset value is reached, and if it is above the preset value the heating is not switched on. In practice the actual room temperature will oscillate about the preset value. The feedback is described as negative because an increase in room temperature is followed by reduced activity of the heating system, whereas a decrease in room temperature results in increased activity of the heating system.

A comprehensive review of central nervous control of heart rate has been given by Mauck and Hockman (1968). They discuss the relative importance of sympathetic and parasympathetic control and point out a large number of controversies and contradictions in the literature. They stress the importance of working with unanaesthetized preparations and point out differences of species, type and depth of anaesthesia, stimulus parameters and recording procedures that make interpretation and comparison of experimental results very difficult. They state that the arbitrary division of certain neural areas as 'centres' imposes severe limitations upon any attempt to understand the integrative action of the nervous system as a whole.

### Reflex control

There are several areas in the heart itself that are in part responsible for control of the heart rate. These are described extensively in Heymans and Neil (1958). A well known phenomenon, known as Marcy's law of the heart, shows that an increase in arterial blood pressure can produce a decrease in heart rate. This has been described as a baroreceptor reflex, and it has been demonstrated that the effect is dependent on areas known as baroreceptors. The latter are stretch receptors located in the walls of the heart itself and in the blood vessels entering and leaving the heart. The current theory (Berne and Levy, 1972, p.145) is that for relatively large increases in blood pressure vagal activity is primarily responsible for the heart rate response, but that for small increases of blood pressure within the normal range reciprocal changes in both sympathetic and vagal activity occur. Another reflex, known as the chemoreceptor reflex has a complicated history and is the subject of some controversy. The chemoreceptors are receptor cells also located on blood vessels in the region of the heart (the carotid sinus and the aortic arch) and are sensitive to changes in the chemistry of the blood. They play an important part in the regulation of respiration. Their stimulation can produce either an increase or a decrease in heart rate depending on factors such as the rate of respiration. The vasomotor centre integrates efferent impulses from both the arterial baroreceptors and from the chemoreceptors.

An example of the interaction of the chemoreceptors and the

vasomotor centre is provided by the phenomenon of Mayer waves (incorrectly described also as Traube-Hering waves in some literature, for example Ganong, 1963, p.443). These are slow, regular oscillations in arterial pressure that occur with a period of about 20 to 40 seconds in situations of low blood pressure. They are especially common after hemorrhage. When blood pressure is low the blood flow in the region of the chemoreceptors is poor. The stagnation of the blood stimulates the chemoreceptors, resulting in vasoconstriction, an increase in blood pressure and an improvement in blood flow. This removes the stimulus and so the pressure falls and a new cycle is initiated.

Finally we describe two reflexes which Heymans and Neil give as 'of uncertain origin'. In 1915 it was shown by Bainbridge that an intravenous injection of blood or saline produced increased heart rate in anaesthetized dogs. Since that time a large amount of controversy has been generated by the phenomenon. Heymans and Neil (1958) state that they believe that the phenomenon exists and is important in conditions of increased circulation, whereas Ganong (1963) states that it is an inconstant phenomenon of doubtful physiological significance. The other reflex discussed by Heymans and Neil (1958), is respiratory sinus arrhythmia, the variation of heart rate with respiration. This is discussed in much more detail in Chapter 5. It has been postulated that interthoracic pressure decreases during inspiration and this causes an increased venous return which elicits the Bainbridge reflex. It is not certain, however, that this is simply a reflex and the relative importance of central control and reflex factors involved in respiratory sinus arrhythmia are also discussed in Chapter 5:

All programs in this Appendix were written in FORTRAN 4 and were designed to be run on the Edinburgh Multi-Access System (EMAS) using an I.C.L. 4-70 computer. In general, the programs were run from a teletype, which is defined by Fortran stream FT5. The program contained a subroutine (usually named HD) which gave instructions via the teletype to the user. The data input from the teletype can be read in format-free specification (i.e. READ ,X) which has the advantage that any kind of data may be read , separated merely by spaces. Where data processing was required the data file, which was stored on disk, was defined as FT6 and the processed data was written as a file on disk as FT7. Where a large amount of output was expected, the printing was carried out on the line printer.

Subroutine GRAM

This subroutine computes a frequency table for an array, given the group interval width and the number of points in the array. The maximum and minimum values of the array are found and the range printed. The lower bound of the first group interval is taken as the integer part of the lowest value in the array. This will usually ensure a simple spacing, since the specified group interval in general will be 0.5, 1.0 or 2.0. Group intervals containing no points are not printed.

Structure

## GRAM(X, M, STEP)

|      |                    |  |
|------|--------------------|--|
| X    | REAL ARRAY (M)     | (Input) : data                                     |
| K    | INTEGER ARRAY(500) | (Output): number of points in each group interval. |
| M    | INTEGER            | (Input) : number of points in series.              |
| STEP | REAL               | (Input) : group interval width.                    |
| A    | REAL               | (Output): largest value in data.                   |
| B    | REAL               | " : smallest value in data.                        |
| N1   | INTEGER            | (Work) : Integer part of A.                        |
| N2   | INTEGER            | " : " " " B.                                       |

Restrictions

Maximum number of points = 2000,

Maximum number of groups = 500,

Minimum range of variable = 1.0 units.

Language : FORTRAN      Streams : (FT6,.LP)

```
DIMENSION X(N),K(500)
A=X(1)
B=X(1)
DO 3 I=1,500
3 K(I)=0
DO 1 I=1,N
IF(X(I).GT.A) A=X(I)
IF(X(I).LT.B) B=X(I)
1 CONTINUE
N1=INT(A)
N2=INT(B)
IF(B.LT.0.0) N2=N2-1
WRITE(6,9)N
9 FORMAT(' THE NUMBER OF POINTS IS',I6)
WRITE(6,10)B
10 FORMAT(' LOWEST POINT EQUALS',F7.3)
WRITE(6,11)A
11 FORMAT(' HIGHEST POINT EQUALS',F7.3///)
DO 2 I=1,N
C=N2
J=0
6 C=C+STEP
J=J+1
IF(X(I).GT.C) GOTO 6
K(J)=K(J)+1
2 CONTINUE
J=0
C2=N2
5 C2=C2+STEP
J=J+1
IF(K(J).EQ.0) GOTO 5
P=C2-STEP
WRITE(6,7)(P,C2,K(J))
7 FORMAT(2F11.5,I12)
IF(C2.LT.A) GOTO 5
RETURN
END
```

Program (GRAPH)

This program is used to produce line printer plots across the page of any time series. The program uses a subroutine PLOTX to do all the work and so this is the only program listed. Scaling is automatic and after 120 points have been plotted a new page is automatically selected.

StructureFormal Parameters

|      |            |   |
|------|------------|---|
| N    | INTEGER    | (Input) : number of points in series    |
| IA   | INTEGER    | (Input) : name of series (4 characters) |
| X(N) | REAL ARRAY | (Input) : time series                   |



Program GRAPH

Language : Fortran 4

Listing

SUBROUTINE PLOTX(N, IA, X)

C  
C  
C

TO PLOT GRAPHS ACROSS THE PAGE

DIMENSION X(N), A(120), IS(12)

DATA AST, BL /1H\*,1H /

NP=0

J=1

7 XMIN=X(J)

XMAX=X(J)

IF (X(J).NE.0) GOTO 6

J=J+1

GOTO 7

6 CONTINUE

DO 2 I=1,N

IF (X(I).LE.XMIN) XMIN=X(I)

IF (X(I).GT.XMAX) XMAX=X(I)

2 CONTINUE

C  
C  
C

TO COMPUTE SCALING FACTOR. THERE ARE 50 PLOTTING LINES PER PAGE

XSCAL= (XMAX-XMIN)/50.0

ISCAL=INT(XSCAL)+1

TOP=XMIN+50.0\*ISCAL

18 WRITE(6,1) IA

1 FORMAT('1 SUBJECT NUMBER',3X,A4///)

IT1=INT(TOP)

T2=FLOAT(IT1)+ISCAL/2.0

DO 12 K=1,51

T1=T2

T2=T2-ISCAL

DO 31 J=1,120

31 A(J)=BL

DO 11 I=1,120

IF (X(I)-T1) 4,4,11

4 IF (X(I)-T2) 11,11,5

5 A(I)=AST

11 CONTINUE

C  
C  
C

TO COMPUTE THOSE VALUES THAT LIE WITHIN THE REQUIRED LINES

K1=K/5

K1=K-K1\*5

IF(K1-1) 13,14,13

14 VAL=T1-ISCAL/2.0

WRITE(6,15) VAL,A

15 FORMAT(F10.0,'+',120A1)

GOTO 12

## Program GRAPH (subroutine PLGTX) (Ctd.)

```
13 WRITE(6,16) A .
16 FORMAT(11X,'-',120A1)
12 CONTINUE
   WRITE(6,19)
19 FORMAT(13X,12(9X,1H ))
   NS=10+120*NP
   NT=120*(NP+1)
   J=1
   DO 20 I=NS,NT,10
   IS(J)=I
20 J=J+1
```

C  
C  
C

```
   ANNOTATING X AXIS

   WRITE(6,21) IS
21 FORMAT(13X,12I10)
   N=N-120
   IF(N) 22,22,23
23 CONTINUE
   DO 24 I=1,N
   IE=120+I
   AX=X(IE)
24 X(I)=AX
   IF(N-120) 25,26,26
25 CONTINUE
   DO 27 I=N,120
27 X(I)=0.0
26 NP=NP+1
   GOTC 18
22 RETURN
   END
```

Description

The input data for this program are the heart intervals and respiration depths from the experiments described in Chapter 5. The different sections of data are separated by a pair of zeros and a positive real number, and the data are terminated by two pairs of zeros. The program computes the mean and standard deviation of the heart rate and respiration and employs the subroutine GRAM to compute the frequency table for each section.

StructureFormal parameters

|       |                   |  |
|-------|-------------------|--|
| STEP  | REAL              | (Input) : group interval for heart rate. |
| STEP1 | REAL              | (Input) : " " " respiration.             |
| T,AG  | TEXT              | (Input) : name of data set.              |
| X     | REAL ARRAY (2000) | (Input) : heart interval data.           |
| Y     | REAL ARRAY (2000) | (Input) : respiration data.              |
| S     | REAL              | (Work) : sum of X .                      |
| S1    | REAL              | " : " " Y .                              |
| SS    | REAL              | (Work) : sum. of squares of X .          |
| SS1   | REAL              | " : " " " " Y .                          |
| SD    | REAL              | (Output): standard deviation of X.       |
| SD1   | REAL              | (Output): standard deviation of Y.       |

Listing

Language : FORTRAN 4                      Streams : (FT5, .TT), (FT6, DATA), (FT7, .LP)

DIMENSION X(2000),Y(2000)

READ ,STEP,STEP1

READ(5,15)T,AG

15 FORMAT(2A4)

WRITE(7,16) T,AG

16 FORMAT(' HISTOGRAMS FOR ',2A4).

2 M=0

S=0

```
S1=0
SS=0
SS1=0
DO 3 J=1,2000
  READ(6,4) Y(J),X(J)
4  FORMAT(3X,F7.0,4X,F6.0)
  A1=X(J)
  IF(A1.EQ.0.0) GOTO 13
  X(J)=60/(A1*0.00003)
  M=M+1
  S=S+X(J)
  S1=S1+Y(J)
  SS1=SS1+Y(J)*Y(J)
3  SS=SS+X(J)*X(J)
13 SS=SS-S*S/M
  SS=SS/(M-1)
  S=S/M
  SS1=SS1-S1*S1/M
  SS1=SS1/(M-1)
  S1=S1/M
  SD=SQRT(SS)
  SD1=SQRT(SS1)
  WRITE(7,5)S,SS,SD
5  FORMAT(' MEAN,VARIANCE AND S.D. OF X S ',3F12.6)
  CALL GRAM(X,M,STEP)
  WRITE(7,6)S1,SS1,SD1
6  FORMAT(' MEAN,VARIANCE AND S.D. OF Y S ',3F12.6)
  READ(6,4)X1,X2
  IF(X1.NE.0.0) GOTO 2
  STOP
END
```

Subroutine INTERDescription

This subroutine is used to interpolate a point process by means of the French-Holden algorithm, with modifications discussed in Chapter 3 and described by Campbell (1979b)

SUBROUTINE     INTER (N,M,M1, ISIZE, T,W,D,DT,Z,Y, IFAULT)

Formal parameters

|                        |                         |        |   |   |
|------------------------|-------------------------|--------|---|---|
| <u>N</u>               | Integer                 | input  | : | number of events  |
| <u>M</u>               | Integer                 | output | : | number of sampled values as a power of two                        |
| <u>M1</u>              | Integer                 | output | : | number of sampled values inside interval defined by point process |
| <u>ISIZE</u>           | Integer                 | input  | : | maximum store available for sampled values                        |
| <u>T</u>               | Real array (N)          | input  | : | times of events   |
| <u>W</u>               | Real                    | input  | : | upper limit of spectrum in cycles per unit time                   |
| <u>DT</u>              | Real                    | output | : | sampling interval   |
| <u>Z</u>               | Real array ( <u>N</u> ) | output | : | values of the sines   |
| <u>Y</u>               | Real array ( <u>M</u> ) | output | : | sampled values  |
| <u>IFAU</u> L <u>T</u> | Integer                 | output | : | fault indicator   |

IFAULT = 0 : no error  
IFAULT = 1 : M exceeds  $2^{**}21$   
IFAULT = 2 : M exceeds ISIZE

SUBROUTINE INTER(N,M,M1,ISIZE,T,W,DT,Z,Y,IFAU)LT)

C  
C  
C TO INTERPOLATE A POINT PROCESS , T, TO INTERVALS SPECIFIED BY DT

REAL T(N),Z(N),Y(ISIZE)  
DATA PI,SMALL/3.14159265,1.0E-6/  
DT=0.5/W  
M1=(T(N)-T(1))/DT+1  
I1=2

C  
C  
C TO COMPUTE NUMBER OF INTERPOLATED VALUES AS A POWER OF TWO

DO 1 K=2,21  
I1=I1\*2  
IF(I1.GT.M1) GOTO 2  
1 CONTINUE  
IFAU)LT=1  
RETURN  
2 M=I1  
IFAU)LT=2  
IF(M.GT.ISIZE) RETURN  
IFAU)LT=0  
PLUS=1.0

C  
C  
C COMPUTE NUMBER OF SAMPLING POINTS PRECEDING POINT PROCESS.

M2=(M-M1)/2  
IF(MOD(M2,2).EQ.0) PLUS=-PLUS  
DO 3 I=2,N  
T(I) = (T(I)-T(1))/DT  
Z(I)=SIN(PI\*T(I))  
3 CONTINUE  
Z(1) = 0.0  
T(1) = 0.0  
B=-M2  
DO 5 K=1,M  
Y(K) = 0.0  
DO 4 J=1,N  
A = B - T(J)

C  
C  
C THE NEXT TWO INSTRUCTIONS AVOID DIVISION BY VERY SMALL NUMBERS

X = PI \* PLUS  
IF (ABS(A).GT.SMALL) X = Z(J)/A  
Y(K) = Y(K) + X  
4 CONTINUE  
Y(K)=Y(K)\*PLUS/PI  
PLUS=-PLUS  
B=B+1.0  
5 CONTINUE  
RETURN  
END

\*\*\*END

???

Description

This program computes the coefficient  $q(\gamma)$  for Hannan's method of estimating lags which is described in Appendix A. For a given frequency  $w_0$  the spectra at  $w_0$  are estimated for the two series  $(x(t), y(t))$  by Daniell's method of averaging periodograms. The coefficient  $q(\gamma)$  is output in steps  $DT$  from  $T$  to  $T1$ , which are set by the user. The periodograms are calculated by means of a subroutine CO6NAAF (Nottingham Algorithms Group).

Restriction

The number of points for each series must be a power of 2.

StructureFormal parameters

|           |                       |   |
|-----------|-----------------------|---|
| FOUR      | SUBROUTINE            | : to calculate Fourier transforms.                    |
| TI        | SUBROUTINE            | : instructions to user.                               |
| X         | REAL ARRAY(1024)      | (Input): first series of input data.                  |
| Y         | REAL ARRAY(1024)      | (Input): second series of input data.                 |
| ILIST     | INTEGER ARRAY(21)     | (Work): work space for CO6NAAF.                       |
| A,B,A1,B1 | DOUBLE PRECISION(513) | : Fourier coefficients calculated by CO6NAAF.         |
| M         | INTEGER               | (Input): number of periodograms in spectral estimate. |
| N         | INTEGER               | (Input): number of points in series ( a power of 2)   |
| M1        | INTEGER               | (Input): $M1=2*\text{LOG}_2 N$                        |
| W         | REAL                  | (Input): frequency of spectral estimates.             |
| T         | REAL                  | (Input): initial value of $\gamma$ .                  |
| T1        | REAL                  | (Input): final value of $\gamma$ .                    |
| DT        | REAL                  | (Input): step value of $\gamma$ .                     |
| PER1      | REAL                  | (Work): periodogram of X.                             |
| PER2      | REAL                  | (Work): periodogram of Y.                             |
| RCROSS    | REAL                  | (Work): real and imaginary parts of cross-            |
| A1CROSS   |                       | periodogram.  |

|      |   |      |  |
|------|---|------|--|
| RE   | } | REAL | (Work) : parameters for estimating $q(\tau)$ . |
| AIM  |   |      |  |
| Q    |   | REAL | (Work) : lag function of $\tau$ .              |
| COHS |   | REAL | (Work) : coherency square.                     |

Listing

Language : Fortran 4      Streams : (FT5,.TT),(FT6,DATA),(FT7,.LP).

```

DOUBLE PRECISION A(513),B(513),A1(513),B1(513)
DIMENSION X(1024),Y(1024),ILIST(21)
CALL TI
READ ,M,N,M1
READ(6,1)(X(I),Y(I),I=1,N)
12 READ ,W,T,T1,DT
   IF(W.EQ.0) GOTO 11
1  FORMAT(2F10.4)
   N2=N/2
   N1=N2+1
   CALL FOUR(A,B,A1,B1,M1,N,N1,N2,X,Y,ILIST)
   FREQ=N*W
   INIT=K-M/2-1
   IFIN=K+M/2-1
   SUM1=0
   SUM2=0
C  CALCULATING PERIODOGRAMS
   DO 4 I=INIT,IFIN
     PER1=A(I)*A(I)+B(I)*B(I)
     PER2=A1(I)*A1(I)+B1(I)*B1(I)
     SUM1=SUM1+PER1
4  SUM2=SUM2+PER2
   SUM1=SUM1/M
   SUM2=SUM2/M
   WRITE(7,6) SUM1,SUM2,W
6  FORMAT(//,' SMOOTHED PERIODOGRAM VALUES ',2F15.4,' AT FREQUENCY ',
1F10.4,' HZ. ')
   WRITE(7,8)
8  FORMAT(///'   LAG(SECS)  VALUE OF Q   COH. SQ. ')
10 CONTINUE
   SUMRE=0
   SUMTM=0

```



## C CALCULATING Q(TAU)

```

DO 5 I=INIT,IFIN
RCROSS=A(I)*A1(I)+B(I)*B1(I)
A1CROSS=B(I)*A1(I)-A(I)*B1(I)
W1=(I-1)*3.141592*T/N
C=COS(W1)
S=SIN(W1)
RE=C*RCROSS+S*A1CROSS
AIM=C*A1CROSS-S*RCROSS
SUMRE=SUMRE+RE
5 SUMIM=SUMIM+AIM
Q=SUMRE*SUMRE+SUMIM*SUMIM
Q=Q/(M*M)
COHS=Q/(SUM1*SUM2)
WRITE(7,9)T,Q,COHS
9 FORMAT(3F12.5)
T=T+DT
IF(T.LE.T1) GOTO 10
GOTO 12
11 CONTINUE
STOP
END

```

## SUBROUTINE TI

```

WRITE(5,2)
WRITE(5,1)
1 FORMAT(' ENTER THE CENTRE FREQUENCY, IN HZ. ',//,
2' THE LOWER AND UPPER BOUNDS OF THE LAG ESTIMATE ',
3' AND THE LAG INCREMENT ')
2 FORMAT('//' ENTER THE NUMBER OF BANDS PER ESTIMATE (EVEN) ',//,
4' THE NUMBER OF POINTS (POWER OF TWO), AND M1=2*LOG2(N) ',//)
RETURN
END

```

## SUBROUTINE FOUR(A,B,A1,B1,M1,N,N1,N2,X,Y,ILIST)

```

DOUBLE PRECISION A(N1),B(N1),A1(N1),B1(N1)
DIMENSION X(N),Y(N),ILIST(21)
DO 2 I=1,N2
A(I)=X(I)
2 B(I)=X(I+N2)
CALL CO6AAF(A,B,N1,.FALSE.,M1,ILIST)

```

A1(N1)=A(N1)

B1(N1)=B(N1)

DO 3 I=1,N2

A1(I)=A(I)

B1(I)=B(I)

A(I)=Y(I)

3 B(I)=Y(I+N2)

CALL CO6AAF(A,B,N1,.FALSE.,M1,ILIST)

RETURN

END

Description

The program computes the point spectrum of a point process  $(x_j, j=1, \dots, n)$  where  $x_j$  is the time of occurrence of the  $j$  th heart beat. The periodogram is calculated as

$$I_n(w_k) = \frac{1}{\sqrt{2\pi n}} \left( \sum_{j=1}^n \cos w_k x_j \right)^2 + \left( \sum_{j=1}^n \sin w_k x_j \right)^2,$$

for  $w_k = 2\pi k \text{ RES}/8$ , where RES is the required resolution of the spectrum and must be greater than or equal to  $8n^{-1}$  to ensure uncorrelated spectral estimates. The maximum frequency calculated is  $w = \pi$ .

The periodogram is smoothed and the spectrum estimated either by

$$\hat{f}(\tilde{w}) = \sum_{j=s}^{s+7} I_n(w_j) / 8,$$

or 
$$\hat{f}(\tilde{w}) = (-3I_n(w_s) + 3I_n(w_{s+1}) + 7I_n(w_{s+2}) + 9I_n(w_{s+3}) + 9I_n(w_{s+4}) + 7I_n(w_{s+5}) + 3I_n(w_{s+6}) - 3I_n(w_{s+7})) / 32$$

The first method is simple uniform smoothing and the <sup>second</sup> is quadratic smoothing after Bartlett (1963). The frequency  $\tilde{w}$  at which the spectrum is estimated is calculated as  $\sum_{j=s}^{s+7} w_j / 8$ . The frequencies were grouped so that  $s = 8p+1$  where  $p$  is an integer. We do not wish to calculate the periodogram at frequencies less than  $2\pi/n$  and we use the parameter STOP to ensure this.

Structure

Formal parameters

|     |                   |         |  |
|-----|-------------------|---------|--|
| HD  | SUBROUTINE        | :       | instructions to user.                                      |
| TI  | "                 | :       | titles for output.   |
| N   | INTEGER           | (Input) | : number of data points.                                   |
| X   | REAL ARRAY (1000) | (Input) | : data.  |
| Y   | REAL ARRAY (8)    | (Work)  | : periodograms.  |
| RES | REAL              | (Input) | : resolution of spectrum.                                  |
| K   | INTEGER           | (Input) | : =0 for uniform smoothing,<br>=1 for quadratic smoothing. |
| M   | INTEGER           | :       | count parameter.   |

W REAL : frequency of spectral estimate in radi  
 W1 REAL : average frequency in degrees.  
 V REAL : periodogram frequency.  
 Z REAL : smoothed spectral estimate.  
 STOP REAL : minimum periodogram frequency.

Flowchart

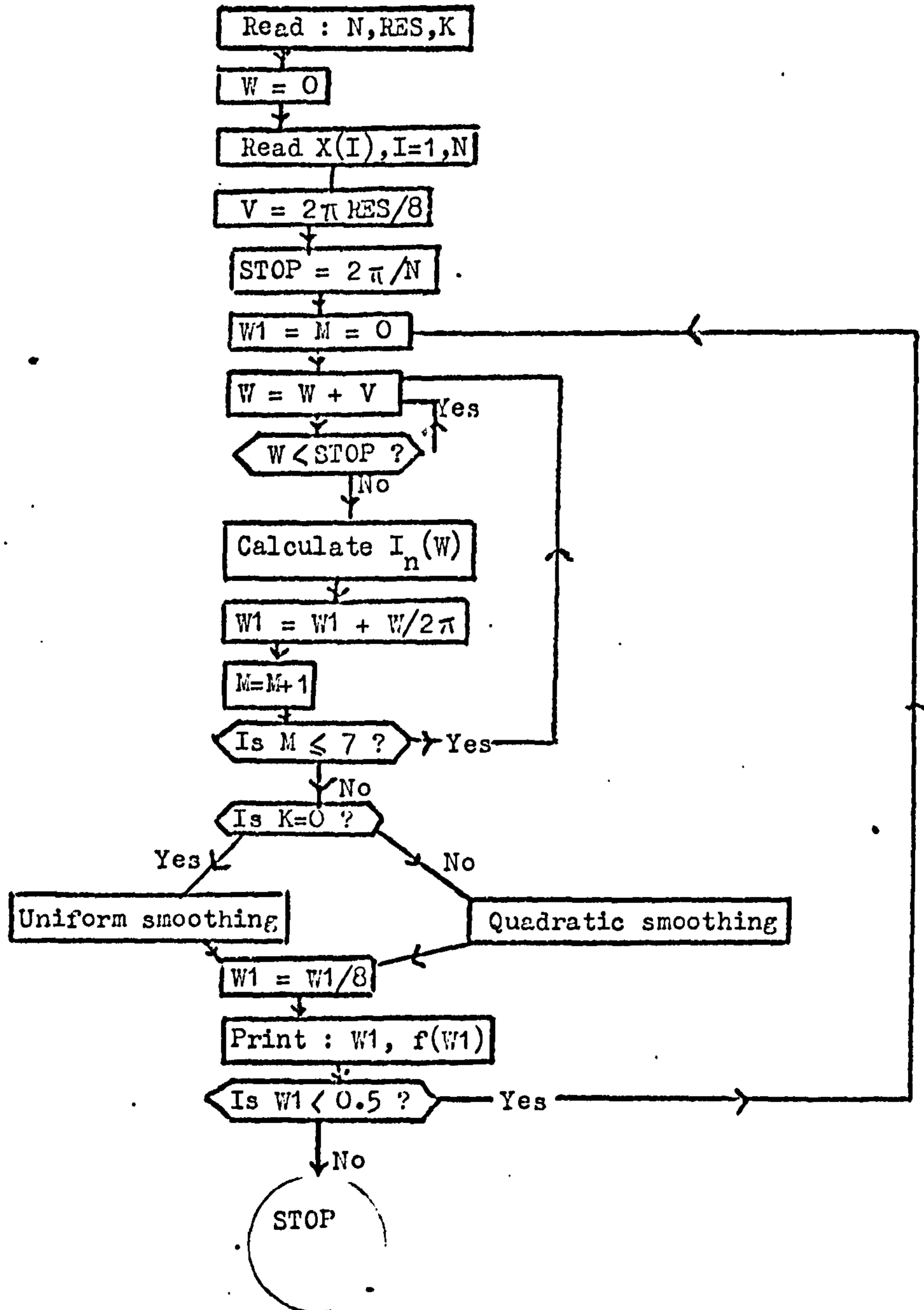

Listing

DIMENSION X(1000),Y(8)

CALL HD

READ ,N

READ ,RES

READ ,K

READ(6,2)(X(I),I=1,N)

2 FORMAT(4X,F10.3)

V=6.2831853\*RES/8

STOP=6.2831853/N

W=0

I=0

SQ=6.2831853\*N

SQ=SQRT(SQ)

7 M=0

W1=0

9 W=W+V

IF(W.LT.STOP) GOTO 9

M=M+1

A=0

B=0

C CALCULATING PERIODOGRAM

DO 4 J=1,N

T=W\*X(J)

A=A+COS(T)

4 B=B+SIN(T)

W1=W/6.2831853+W1

Y(M)=A\*A+B\*B

IF(M.LE.7) GOTO 9

IF(K.LE.0) GOTO 11

C QUADRATIC SMOOTHING

Z=3\*(Y(2)+Y(7)-Y(1)-Y(8))+7\*(Y(3)+Y(6))+9\*(Y(4)+Y(5))

Z=Z/(32\*SQ)

GOTO 12

C UNIFORM SMOOTHING

11 Z=Y(1)+Y(2)+Y(3)+Y(4)+Y(5)+Y(6)+Y(7)+Y(8)

Z=Z/(8\*SQ)

12 W1=W1/8

I=I+1

WRITE(7,8)(I,W1,Z)

IF(W1.LT.0.5) GOTO 7

8 FORMAT(I4,F6.3,F6.2)

STOP

END

SUBROUTINE HD

WRITE(5,1)

1 FORMAT(' ENTER NO. OF POINTS AND RESOLUTION IN HZ. (GE 8/N) ')

WRITE(5,2)

2 FORMAT(' ENTER A ) FOR UNIFORM SMOOTHING OR A \* FOR QUADRATIC ')

RETURN

END

SUBROUTINE TI

WRITE(7,1)

1 FORMAT(' POINT SPECTRUM ')

WRITE(7,2)

2 FORMAT(' I FREQ. SPECTRUM ')

RETURN

END

Description

This program carries out the sampling operation on the heart-rate and respiration data to obtain equ-distant data points, by linear interpolation and it is described in detail in Chapter 3. Precautions have to be taken when the heart interval is very much shorter than the sampling interval, and also when the heart interval is longer than the sampling interval. In the first case the heart interval may be overlooked by the sampling operation and in the second the heart interval would be sampled more than once. These operations are best described by means of a flow chart.

Flow chart

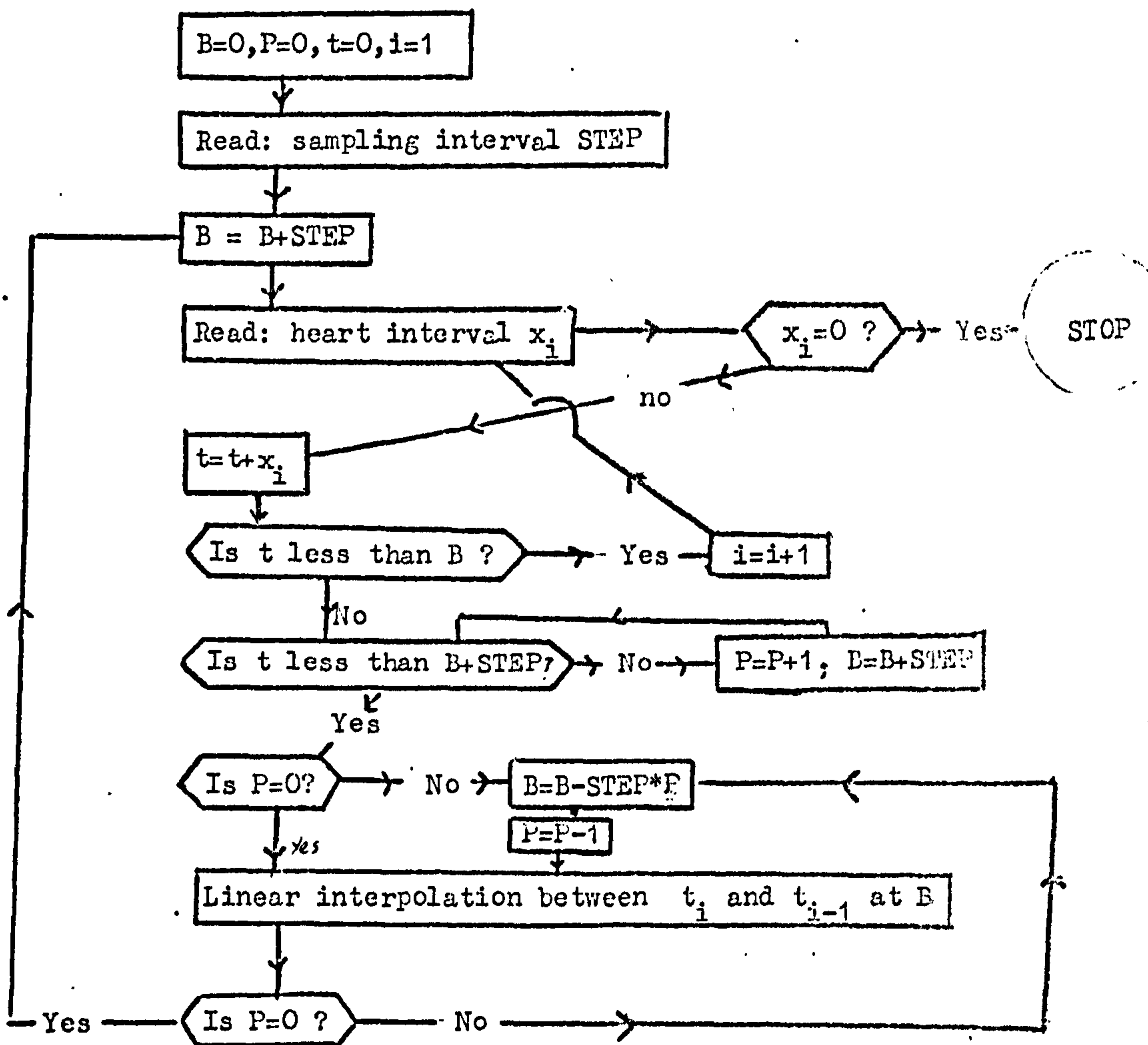

The data consist of pairs of numbers corresponding to the instantaneous heart rate and respiration depth of the healthy subjects and are output by the data logger. The different sections of data correspond to different respiration rates and are separated by a pair of zeros and a positive real number on separate cards. The pair of zeros informs the program that a section has ended and the positive real number informs it that there is more data to be analysed.

### Structure

#### Formal parameters

|      |            |  |
|------|------------|--|
| X.   | REAL       | Input : heart interval.                                |
| Y    | REAL       | Input : respiration depth.                             |
| X1   | REAL ARRAY | Output: sampled heart rate.                            |
| Y1   | REAL ARRAY | Output: " respiration depth.                           |
| STEP | REAL       | Input : sampling interval.                             |
| T    | REAL       | Work : time of next beat.                              |
| Z    | REAL       | " : " " last beat.                                     |
| B    | REAL       | " : time of sample.                                    |
| P    | REAL       | " : count for number of beats between sampling points. |
| I    | INTEGER    | " : array parameter.                                   |

### Listing

Language : FORTRAN 4      Streams : (FT5,.TT),(FT6,DATA),(FT7,SAMPDATA)

DIMENSION X1(2000),Y1(2000)

READ ,STEP

11 I=0

T=0

B=0

P=0

1 B=B+STEP

I=I+1

3 Z=T

READ(6,4) Y,X

Y2=Y

X2=X



```
4 FORMAT(3X,F7.0,4X,F6.0)
  S=X*0.00003
  IF(X.EQ.0.0) GOTO 7
  X=60/S
  IF(I.NE.1) GOTO 10
  X1(1)=X
  Y1(1)=Y
  I=I+1
  GOTO 3
10 CONTINUE
  T=S+T
  IF(T.LE.B) GOTO 3
  9 IF(T.LE.(B+STEP)) GOTO 8
  P=P+1
  B=B+STEP
  GOTO 9
  8 CONTINUE
  2 THETA=(B-STEP*P-Z)/S
  X1(I)=X2+THETA*(X-X2)
  Y1(I)=Y2+THETA*(Y-Y2)
  IF(P.EQ.0) GOTO 1
  I=I+1
  P=P-1
  GOTO 2
  7 I=I-1
  WRITE(5,5) I
  5 FORMAT(I6)
  WRITE(7,6)(X1(J),Y1(J),J=1,I)
  6 FORMAT(2F10.4)
  C=0.0
  WRITE(7,6)C,C
  READ(6,12) X
  12 FORMAT(4X,F6.0)
  IF(X.NE.0.0) GOTO 11
  STOP
  END
```

## Program SIMUL

This program is used to generate two sinusoids with a given phase difference,  $\theta^\circ$ , to test the accuracy of the cross-spectral phase measurements and the filtering techniques described in Chapters 4 and 5. Normally distributed random noise of given standard deviation is added to the heart rate signal.

At time  $t$  the heart rate and respiration are given by

$$X(t) = B\sin(2\pi wt) + A + V,$$

$$Y(t) = B_1\sin(2\pi (wt + \theta/360)) + A_1,$$

where  $V$  is a normally distributed random variable with zero mean and given standard deviation and  $A, A_1, B, B_1$  are given constants.

We calculate the heart interval as  $60/X(t)$ , and then compute the above formulae again at  $t = t - 60/X(t)$ . The program employs two IBM Scientific Subroutines, GAUSS and RAND, to simulate the random variable.

### Structure

#### Formal parameters

|        |            |   |
|--------|------------|---|
| HD     | SUBROUTINE | : instructions to user.                     |
| A      | REAL       | (Input): mean heart rate.                   |
| B      | REAL       | (Input): amplitude of heart rate sinusoid.  |
| A1     | REAL       | (Input): mean of respiration signal.        |
| B1     | REAL       | (Input): amplitude of respiration sinusoid. |
| W      | REAL       | (Input): frequency of sinusoids in Hz.      |
| PHASE  | REAL       | (Input): phase between signals.             |
| T      | REAL       | (Input): starting value in time.            |
| R      | REAL       | (Input): standard deviation of added noise. |
| N      | INTEGER    | (Input): number of points to be simulated.  |
| IX     | INTEGER    | (Work) : arbitrary 9 digit integer.         |
| V      | REAL       | (Work) : value of random variable.          |
| X(500) | REAL ARRAY | (Output): simulated heart rate.             |
| Y(500) | REAL ARRAY | (Output): simulated respiration.            |

Program SIMUL

Listing

Language : FORTRAN 4            Streams : (FT5,.TT),(FT7,SIMDATA)

DIMENSION X(500),Y(500)

CALL HD

IX=369258147

READ ,N,W,PHASE,T,A,B,A1,B1

READ ,R

NM=N

1 D=W\*T\*6.2831853

D1=(W\*T+PHASE/360)\*6.2831853

CALL GAUSS(IX,R,V)

X(N)=B\*SIN(D)+A+V

Y(N)=B1\*SIN(D1)+A1

S=60/X(N)

X(N)=S\*100000/3

C HEART INTERVALS SCALED AS IF OUTPUT BY DATA LOGGER

T=T-S

N=N-1

IF(N.NE.0) GOTO 1

WRITE(7,2)(Y(I),X(I),I=1,NM)

2 FORMAT(3X,F7.0,4X,F6.0)

STOP

END

SUBROUTINE HD

WRITE(5,1)

1 FORMAT(' ENTER N, FREQUENCY OF CYCLES(HZ), PHASE BETWEEN  
1 SIGNALS (DEGREES), TIME OF ENDING, MEAN AND S.D. HEART RATE ')

WRITE(5,2)

2 FORMAT(' AND MEAN AND AMPLITUDE OF RESPIRATION AND S.D. NOISE ')

RETURN

END

SUBROUTINE GAUSS(IX,S,V)

A=0.0

DO 50 I=1,12

CALL RAND(IX,IY,Y)

IX=IY

50 A=A+Y

V=(A-6.0)\*S

RETURN

END

SUBROUTINE RAND(IX,IY,YFL)

IY=IX\*65539

IF(IY)5,6,6

5 IY=IY+2147483647

6 YFL=IY

YFL=YFL\*.4656613E-9

RETURN

END

Program SUCCHISTDescription

This program employs the subroutine GRAM to compute successive heart-rate and blood-pressure frequency tables with a given number of points in each. The program terminates when a zero is read,

Restrictions

The number of points per frequency table must be less than 1000.

StructureFormal parameters

|       |               |   |   |
|-------|---------------|---|---|
| TI    | SUBROUTINE    | : | instructions to user.                     |
| GRAM  | SUBROUTINE    | : | calculates frequency tables.              |
| STEP  | REAL Input    | : | group interval width for heart rate.      |
| STEP1 | REAL Input    | : | " " " " blood pressure.                   |
| N     | INTEGER Input | : | number of points in each frequency table. |
| PA,WS | FORMAL Input  | : | name of data set.                         |

Listing

```

DIMENSION X(1000),Y(1000)

INTEGER COUNT

CALL TI
READ(5,5) PA,WS
5 FORMAT(2A4)
READ ,N
READ ,STEP,STEP1
COUNT=1
WRITE(6,6) PA,WS
6 FORMAT(' SUCCESSIVE HISTOGRAMS FOR ',2A4///)
7 DO 1 I=1,N
  READ(7,2) X(I),Y(I)
2 FORMAT(4X,F4.0,6X,F4.0)
  IF(X(I).EQ.0.0) GOTO 3
  Y(I)=Y(I)/50.0
1 X(I)=X(I)/50.0
  WRITE(6,4) COUNT,PA,WS
4 FORMAT(///' THE BATCH NUMBER EQUALS',I4,' FOR',2A4)
  COUNT=COUNT+1
  CALL GRAM(X,N,STEP)
  GOTO 7
3 STOP
END

```

270.

Program SYSTOLE

Description

This program is used to remove machine noise and extrasystoles from heart rate and blood pressure data which was supplied by the DART data logger. The data were in the form of two 4 digit numbers which corresponded to millivolts on the analogue computer. A value of 50 mV. represented 1bt/min. heart rate or 1 mm. Hg blood pressure. Machine noise was occasionally output from the data logger with a different format from normal, in which case the program would output error messages and stop. Alternatively, when the system was uncertain of the position of a QRS complex, a value 9999 mV. was output from the data logger and detected by SYSTOLE.

The detection of extrasystoles is discussed in Chapter 1, and the algorithm used is given there. The advantage of the method is the the data are processed sequentially and so large amounts of storage are not required.

Structure

Formal parameters

|   |               |  |
|---|---------------|--|
| X | REAL ARRAY(2) | (Input) : heart rate and blood pressure values.            |
| Y | REAL ARRAY(2) | (Input) : initial values of heart rate and blood pressure. |
| F | REAL ARRAY(2) | (Output) : exponentially weighted mean.                    |
| S | REAL ARRAY(2) | (Work) : " " variance.                                     |
| T | REAL ARRAY(2) | (Work) : square root of S.                                 |
| N | INTEGER       | (Input) : number of points to be analysed.                 |

Starting values

$$S = .10 \quad , \quad F(2) = 0.01x_2 + 0.99x_1 \quad .$$

If a zero value for X(1) is read then the program terminates.

Language:FORTRAN 4 Streams : (FT5,.TT),(FT6,DATA),(FT!,.LP)

```
DIMENSION X(2),Y(2),F(2),S(2),T(2)
REAL(5,9) N
9 FORMAT(I4)
  READ(6,2) Y(1),Y(2)
  READ(6,2) X(1),X(2)
  DO 10 I=1,2
    X(I)=X(I)/50
    S(I)=10.0
    F(I)=0.01*X(I)+0.99*Y(I)
10 T(I)=SQRT(S(I))
  DO 1 I=1,N
    READ(6,2) X(1),X(2)
  2 FORMAT(4X,F4.0,6X,F4.0)
    DO 1 I=1,N-2
      READ(6,2) X(1),X(2)
  2 FORMAT(4X,F4.0,6X,F4.0)
      DO 11 J=1,2
        IF (X(J).EQ.0.0) GOTO 8
        X(J)=X(J)/50
        IF (X(J).NE.199.98) GOTO 4
        WRITE(5,3) X(J),I
  3 FORMAT(' NOISE = ',F10.5,' AT I=',I5)
        X(J)=F(J)
  4 G=X(J)-F(J)
        IF (ABS(G).LE.(5.0*T(2))) GOTO 5
        IF (ABS(G).LE.10.0) GOTO 5
        WRITE(5,6) X(J),I,J
  6 FORMAT(' EXTRASYSTOLF',F10.5,' AT I=',I5,I5)
        X(J)=F(J)
  5 F(J)=0.01*X(J)+0.99 F(J)
        S(J)=0.01*(X(J)-F(J))*(X(J)-F(J))+0.99*S(J)
11 T(J)=SQRT(S(J))
    WRITE(7,7)X(1),X(2)
  7 FORMAT(2F10.5)
  1 CONTINUE
  8 CONTINUE
  STOP
  END
```

REFERENCES

- ANDERSON, T.W. (1971). *The Statistical Analysis of Time Series*  
New York. Wiley.
- ANGELONE, A. and COULTER, M. (1964). "Respiratory sinus arrhythmia:  
a frequency dependent phenomenon." *J.Appl.Physiol.* 19(3) :  
479-482.
- ANGELONE, A. and COULTER, M. (1965). "Heart rate response to held lung  
volume". *J.Appl.Physiol.* 20: 464-468.
- ANREP, G.V., PASCUAL, W. and ROSSCHER, R. (1936). "Respiratory variations  
of heart rate. I. Reflex mechanism of the respiratory arrhythmia.  
II. The central mechanism of the respiratory arrhythmia and the  
interrelations between the central and reflex mechanisms".  
*Proc.Roy.Soc.B.* 119: 191-217, 218-230.
- BAINBRIDGE, F.A. (1920). "The relation between respiration and the pulse  
rate". *J.Physiol.(Lond.)* 54: 192-202.
- BARTLETT, M.S. (1963a). "The spectral analysis of point processes".  
*J.Roy.Statist.Soc.B.* 25:264-296.
- BARTLETT, M.S. (1963b). "Statistical estimation of density functions".  
*Sankhya, Series A,* 25(3) : 245-254.
- BARTLETT, M.S. (1966). "The spectral analysis of line processes".  
*Proc. 5th Berkley Symp.Math.Stat.* Univ. of California Press.  
pp.135-153.
- BERNE, R.E. and LEVY, M.N. (1972). "Cardiovascular Physiology".  
Saint Louis : C.V.Mosby Co.
- "BIOMETRIKA TABLES FOR STATISTICIANS". (1966) Pearson, E.S. and  
Hartley, H.D. 3rd Ed. Cambridge : University Press.
- BOX, G.E.P. and JENKINS, G.M. (1966). "Time Series Analysis Forecasting  
and Control". San Francisco : Holden-Day.
- CAMPBELL, M.J. (1974). "Processing and analysis of beat-by-beat  
estimates of heart rate and mean arterial pressure in man".  
*J.Physiol.(Lond.)* 244 : 17-18P.
- CHATFIELD, C. (1975). "The analysis of time-series: theory and practice".  
London : Chapman and Hall.
- CHATFIELD, C. and PROTHERO, W.L. (1973). "Box-Jenkins seasonal  
forecasting - a case study". *J.Roy.Statist.Soc.A.* 136 : 1-30.
- CHESS, G.F., TAM, R.M.K. and CALERESU, F.R. (1975). "Influence of  
cardiac neural inputs on rhythmic variations of heart period".  
*Am.J.Physiol.* 228(3) : 775-80.



- CHICK, D.R. and WOMACK, B.F. (1975). "Approximate identification and digital simulation of the respiration-heart rate system." *Medical Instrumentation* 9(1) : 15-20.
- CLYNES, M. (1960). "Respiratory sinus arrhythmia - laws derived from computer simulation". *J.Appl.Physiol.*15(5) : 863-874.
- COX, D.R. (1972). "The statistical analysis of dependencies in point processes". in Lewis (ed.) (1972).
- COX, D.R. and LEWIS, P.A.W. (1966). "The statistical analysis of series of events". London : Methuen.
- COX, D.R. and HINKLEY, D.V. (1975). "Theoretical Statistics". London : Chapman and Hall.
- CRAMER H.J. (1946). "Mathematical methods in statistics." Princeton Univ. Press.
- DANIELL, P. . (1946). in discussion after Bartlett, M.S. "On the theoretical specification and sampling properties of autocorrelated time series". *Roy.Statist.Soc.Statistical Journal Suppl.* 8: 88-110 .
- DAVIES, C.T.M. and NEILSON, J.M.M. (1967a). "Sinus arrhythmia in man at rest". *J.Appl.Physiol.*22(5) : 947-955.
- DAVIES, C.T.M. and NEILSON, J.M.M. (1967b). "Disturbance of heart rhythm during recovery from exercise in man". *J.Appl.Physiol.*22(5) : 943-946.
- DAY, B. and FISHER, R.A. (1936). "The comparison of variability in populations having unequal means: an example of the analysis of covariance with multiple dependent and independent variates". *Annals of Eugenics*37(7) : 333-348.
- DIXON, W.J. (1970). "BMD Biomedical Computer Programs". Univ. of California Press.
- DIXON, W.J. (1972). "BMD Biomedical Computer Programs, x-series supplement". Univ. of California Press.
- DOCUMENTA GEIGY (1971). *Scientific Tables* 7th ed. Manchester : Geigy.
- DONEVAN, R.F., ANDERSON, N.M., SCHELING, P., PAJEP, O. and MCGREGOR, M. (1962). "Influence of voluntary hyperventilation on cardiac input". *J.Appl.Physiol.* 17 pp.487-491.
- DORNHORST, A.C., HOWARD, D. and LEATHHEART, G.L. (1952). "Respiratory variations in blood pressure". *Circulation* 6 : 553-558.
- ELDERTON, W.P. and JOHNSON, N.L. (1969). "Systems of Frequency Curves". Cambridge University Press.
- FELLER, W. (1968). "An Introduction to Probability Theory and its Applications". Vol.1. 3rd.Ed. London : Wiley.
- FINNEY, D.J. and LAWLEY, D.N. (1971). 'Maxlike 11', Dept. of Statistics, University of Edinburgh.

- FISHER, R.A. (1929). "Tests of significance in harmonic analysis".  
Proc.Roy.Soc.A. 125 : 54-59
- FRENCH, A.S. and HOLDEN, A.V. (1971). "Alias-free sampling of neuronal spike trains". Kybernetik 8 : 165-171.
- FREYSCHUSS, U. and MELCHER, A. (1975). "Sinus arrhythmia in man: Influence of tidal volume and oesophageal pressure." Scand.J.clin. Lab.Invest. 35 pp.487-496
- FREYSCHUSS, U. and MELCHER, A. (1976) "Respiratory sinus arrhythmia in man: Relation to cardiovascular pressures". Scand.J.clin.Lab.Invest. 36 pp.221-229.
- GANONG, W.F. (1963). "Review of Medical Physiology". Los Altos : Lange.
- GRANGER, C.W.J. and HATANAKA, M. (1964). "Spectral Analysis of Economic Time Series". Princeton University Press.
- GRANGER, C.W.J. and MORRIS, M.J. (1976). "Time Series Modelling and Interpretation". J.Roy.Statist.Soc.A 139 : 246-257.
- GREER, J.R. (1958). "A sensitive and defocussing photo-electric pressure transducer". Elec.Eng.30 : 436-439.
- GUYTON, A. and HARRIS, J. (1951). "Pressoreceptor - autonomic oscillation. A probable cause of vasomotor waves". Am.J.Physiol. 165 : 153-66.
- HAN, C. (1969). "Testing the homogeneity of variances in a two way classification". Biometrics 25(1) pp.153-158.
- HANNAN, E.J. (1960). "Time Series Analysis". London : Methuen.
- HANNAN, E.J. (1970). "Multiple Time Series". New York : Wiley.
- HANNAN, E.J. and THOMSON, P.J. (1971). "The estimation of coherence and group delay". Biometrika 58(3) : 469-81.
- HANNAN, E.J. and THOMSON, P.J. (1973). "Estimating group delay". Biometrika 60(2) : 241-253
- HEYMANS, C. and NEIL, E. (1958). "Reflexogenic Areas of the Cardiovascular System". London : Churchill.
- HYNDMAN, B.W. (1970). "A digital simulation of the human cardiovascular system and its use in the study of sinus arrhythmia". Ph.D. Thesis, Imperial College, London.
- HYNDMAN, B.W., KITNEY, R.I. and SAYERS, B.McA. (1971). "Spontaneous rhythms in physiological control systems". Nature (Lond.) 233 : 339-341.
- HYNDMAN, B.W. and GREGORY, J.R. (1975). "Spectral analysis of sinus arrhythmia during mental workload". Ergonomics 18(3) : 255-270

- JEFFRIES, H. and JEFFRIES, B.S. (1962). "Methods of Mathematical Physics." 3rd Edn. Cambridge University Press.
- JENKINS, G.M. and WATTS, D.G. (1968). "Spectral Analysis and its Applications". San Francisco : Holden-Day.
- JENKINS, G.M. (1975). "The interaction between the muskrat and mink cycles in North Canada". Univ. of Lancaster, Dept. of Systems Engineering Technical Report.
- JENNINGS, J.R., STRINGFELLOW, J.C. and GRAHAM, M. (1974). "A comparison of the statistical distributions of beat by beat heart rate and heart period". Psychophysiology 11(2) : 207-210.
- JOELS, N. and SAMUELOFF, M. (1956). "The activity of the medullary centres in diffusion respiration". J.Physiol.(Lond.) 133 : 360-372.
- KENDALL, M.G. (1973). "Time-Series". London : Griffin.
- KENDALL, M.G. and STUART, A. (1967). "The Advanced Theory of Statistics". 2nd Edn. London : Griffin.
- KITNEY, R.I. (1974). "The analysis and simulation of the human thermoregulatory system". Med. and Biol.Eng. 12 : 57-65.
- KITNEY, R.I. (1975). "The Influence of thermally elicited vasomotor activity on the baroreceptor reflexes". J.Physiol.(Lond.) 242 : 77-78P.
- LAUSON, H.R., BLOOMFIELD, R. and COURNAND, A. (1946). "The influence of respiration on the circulation in man". Am.J.Med. 1 : 335-352.
- LEVY, M.N., DE GEEST, H. and ZIESKE, H. (1966). "Effect of respiratory centre activity on the heart". Circulation Research 18 : 67-78.
- LEWIS, P.A.W. (1970). "Remarks on the theory, computation and application of the spectral analysis of series of events". J.Sound Vib. 12(3) : 353-375.
- LEWIS, P.A.W. (1972). (Ed.). "Stochastic Point Processes." New York : Wiley.
- LUCZAK, H. and LAURIG, W. (1973). "An analysis of heart rate variability". Ergonomics 16(1) : 85-97.
- McGRADY, J.D., VALBONA, C. and HOFF, H.E. (1966). "Neural origin of the respiratory heart-rate response". Am.J.Physiol. 211(2) : 323-29.
- MANLEY, D.C.E. (1973). "Spectral analysis of non-stationary point processes". Ph.D. Thesis, U.M.I.S.T.
- MANOACH, M., GITTER, S., LEVINGER, I.M. and STRICOR, S. (1971). "On the origin of respiratory waves in circulation.  
1. The role of the chest pump.  
2. The influence of inspiration and expiration.  
Pfleugers Arch. 325 : 40-60.

- MANZOTTI, M. (1958). "The effect of some respiratory manoeuvres on the heart rate". *J.Physiol. (Lond.)* 144 : 541-557.
- MAUCK, H.P. and HOCKMAN, C.H. (1967). "Central nervous system mechanisms mediating cardiac rate and rhythm". *American Heart Journal* 74(1) : 96-109.
- MAYER, P. (1970). "Introductory probability and statistical applications". 2nd Edn. London : Addison-Wesley.
- MELCHER, A. (1976). "Respiratory sinus arrhythmia in man. A study in heart rate regulatory mechanisms". *Acta Physiologica Scandinavica Suppl.* 435 pp.1-31.
- MOORE, G.P., PERKEL, D.H. and SEGUNDO, J.P. (1966). "Statistical analysis and functional interpretation of neural spike data". *Ann.Rev.Physiol.* 28 : 493-522.
- MULDER, G. (1973). "Mental load and the measurement of heart rate variability". *Ergonomics* 16(1) : 68-83.
- NELDER, J.A. and WEDDERBURN, R.W.M. (1972). "Generalized Linear Models". *J.Roy.Statist.Soc.A.* 135 : 370-384.
- NEWELL, D.J. (1965). "Unusual frequency distributions". *Biometrics* 21 : 165-168.
- ORR, W.C. and HOFFMAN, H.J. (1974). "A 90-minute biorhythm: methodology and data analysis using modified periodograms and complex demodulation". *I.E.E.E. Trans. on Bio-med Eng. B.M.E.* 21(2) : 130-143.
- PARZEN, E. (1964). "An approach to empirical time series analysis". *J.Res.Nat.Bur.Std.* 68(1) : 937-951.
- PRIESTLEY, M.B. (1965). "Evolutionary spectra and non-stationary process". *J.Roy.Statist.Soc. B* 27 : 204-237.
- ROTHAMSTEAD EXPERIMENTAL STATION (1973). "Genstat Manual". The Program Library Unit, Edinburgh Computing Centre.
- ROWLANDS, D.J. and TAYLOR, C. (1970). "Cardiac rhythm display using the joint rate histogram". *Cardiovasc.Res.* 4 : 551-60.
- SAYERS, B.McA. (1971). "The analysis of cardiac interbeat interval sequences and the effects on mental workload". *Proc.Roy.Soc.Med.* 64: 707-710.
- SAYERS, B.McA. (1973). "Analysis of heart rate variability". *Ergonomics* 16(1) : 17-32.
- SCHUSTER, A. (1898). "On the investigation of hidden periodicities". *Jour.Terrest.Mag. & Elec.Eff.* 3:

- SHEPPARD, W.F. (1898). "Calculation of the most probable values of frequency constants". Proc.Lond.Math.Soc. 29 : 353-80.
- SHUHLA, G.K. (1972). "An invariant test for the homogeneity of variance in a two-way classification". Biometrics 28(4) pp.1063-1072.
- SODERSTROM, N. (1950). "What is the reason for ventricular arrhythmia in cases of auricular fibrillation?". American Heart Journal 40 : 212-223.
- SRINIVASAN S.K. (1973). "Stochastic point processes and their applications". London : Griffin.
- SROUFE, A.L. (1971). "Effects of depth and rate of breathing on heart rate and heart rate variability." Psychophysiology 8(5) : 648-655.
- STINTON, P., TINKER, J., VICKERY, J.C. and VALIL, S.P. (1972). "The scattergram - a new method for continuous electrocardiographic monitoring". Cardiovasc.Res. 6(4) : 350-55.
- TAYLOR, D.E.M. (1971). "Computer assisted patient monitor systems". Bio-Med.Eng. 6(12) : 560-566.
- TAYLOR, D.E.M., WHAMOND, J.S., HITCHINGS, D.J., HULLINGER, M. and BEGG, D. (1975). "Short-term variability of pulse rate and blood pressure in cardiac surgery patients". Cardiovasc.Res. 9(5) : 734-40.
- TEN HOOPEN, M. and BONGAARTS, J. (1969). "Probabilistic characterization of R-R intervals". Cardiovasc.Res. 3 : 218-226.
- TEN HOOPEN, M. and REUVER, H.A. (1967). "Analysis of sequences of events with random displacements applied to biological systems". Math. Biosciences 1 : 599-617.
- VALENTINUZZI, M.E., HOFF, H.E., GEDDES, L.A. and POWELL, T. (1972). Control parameters of the blood pressure regulatory system Part 1 - Heart rate, sensitivity, Part 2 - Open-loop gain, reference pressure and basal heart rate. Med. & Biol.Eng. 10(5) : 584-608.
- VALENTINUZZI, M.E. and GEDDES, L.A. (1974). "The central component of the respiratory heart rate response". Cardiovasc.Res. Centre Bulletin 12(4) : 87-103.
- VARII, J.G., CLARK, G.R. and GIDDEN, D.B. (1971). "Analysis of cyclic heart-rate variability". Psychophysiology 8 : 406-413.
- VISSCHER, M.B., RUPP, A. and SCOTT, F.H. (1924). "The respiratory wave in arterial blood pressure". Am.J.Physiol. 70 : 586-606.
- WALKER, A.M. (1971). "On the estimation of a harmonic component in a time series with stationary independent residuals". Biometrika 58(1) : 21-36.

WOMACK, B.F. (1971). "The analysis of respiratory sinus arrhythmia using spectral analysis and digital filtering". I.E.E.E. Trans. Biomed.Eng. 18(6) : 399-409.

YAGLON, A.M. (1962). "An Introduction to the theory of stationary random functions". Englewood Cliffs N.J. : Prentice-Hall.

YULE, G.J. and KENDALL, M.G. (1965). "An Introduction to the theory of statistics". 14th ed. London : Griffin.

ADDITIONAL REFERENCES

- BLACKMAN, R.B. and TUKEY, J.W. (1959). The Measurement of Power Spectra. New York : Dover.
- CAMPBELL, M.J. (1979a) "A note on the sampling of a point process for spectral analysis." J. Sound & Vib. 62(3) : 471-473 .
- CAMPBELL, M.J. (1979b). "Sampling a stationary point process". Algorithms section of J. Roy. Statist. Soc. Series C.
- CHAFFNOCK, D.M. (1977). "Continuous time spectral analysis of intervals between events in stationary point processes." J. Roy. Statist. Soc. B. 39(1) 43-55.
- I.S.A.M. 1977. Proceedings of the Second International Symposium on Ambulatory Monitoring. (Eds.) Stott, P.D., Raftery, B.F., Sleight, P., and Goulding, L. London : Academic Press.
- SAYERS, B. McA., ELLIS, N.W., and GREEN, H. (1978), "Minimum and Maximum Requirements for Physiological Measurement : Intra-arterial Pressure. A Pilot Study Report." Engineering in Medicine Laboratory, Imperial College, London.
- SIEGAL, S., (1956). Non-parametric Statistics . New-York : McGraw Hill .
- BEVAN A., HONOUR, A.J., and STOTT, P.G. (1969), "Direct arterial pressure recording in unrestrictd man." Clinical Science 36, 329-344 .

The pages following page 305 have been defectively reproduced.

The Library have tried to trace the author in order to provide a replacement but without success.

M. Simpson.

(Thesis Librarian) 1984.



**PAGE  
NUMBERING  
AS ORIGINAL**

## TIME AND ACCURACY

The time taken by the algorithm is proportional to  $\underline{N}$  and to  $\underline{N} \times \underline{M}$ . On an ICL 4-70 we found that for  $(\underline{N}, \underline{M})$  between (26,32) and (780,1024) the time  $t$ , in E.T.U. s is approximately given by

$$t = 0.00037 \underline{N} (M+8)$$

The accuracy of the Fourier transform of the interpolated values as an approximation to the Fourier transform of the counting process at a particular frequency will depend on  $u$  and on  $\underline{M}$ . However for  $u$  less than half the Nyquist frequency and  $\underline{M}$  greater or equal to 32 the error in the amplitudes of the Fourier transform was found to be within 2%.

- BARTLETT, M.S. (1963). The spectral analysis of point processes (with discussion). J. Roy. Statist. Soc. B 25, 264-296.
- CHARNOCK, D.M. (1977). Spectral analysis of intervals between events in stationary bivariate point processes. J. Roy. Statist. Soc. B 39, 230-237.
- COX, D.R. and LEWIS, P.A.W. (1966). The statistical analysis of series of events. London : Methuen.
- FRENCH, A.S. and HOLDEN, A.S. (1971a). Alias-free sampling of neuronal spike trains. Kybernetik 8, 165-171.
- (1971b). Frequency domain analysis of neurophysiological data. Computer Programs in Biomedicine 1, 219-234.
- (1971c). Semi-on-line implementation of an alias-free sampling system for neuronal signals. Computer Programs in Biomedicine 2, 1-7.
- HYNDMAN, B.W. and GREGORY J.R. (1975). Spectral analysis of sinus arrhythmia during mental loading. Ergonomics 18, 255-270.
- LEWIS, P.A.W. (1970). Remarks on the theory, computation and application of the spectral analysis of series of events. J. Sound. Vib. 12, 353-375.
- MONRO, D.M. (1976). Algorithm AS 97. Real discrete fast Fourier transform. Appl Statist. 25, 166-172.
- PETERKA, R.J., SANDERSON, A.C. and O'LEARY D.P. (1978). Practical considerations in the implementation of the French-Holden algorithm for sampling of neuronal spike trains. I.E.E.E. Trans.Biomed.Eng. 25, 192- 195.

## Processing and analysis of beat-by-beat estimates of heart rate and mean arterial pressure in man

BY M. J. CAMPBELL. *Department of Physiology, University of Edinburgh, Edinburgh EH8 9AG*

In studying the cardiovascular system it is unusual to examine records running over several hours, because of problems of data storage and of achieving adequate reliability over the whole length, especially in the face of fluctuating e.c.g. patterns. We have made records of the electrocardiogram and arterial blood pressure continuously for 8 hr, from patients after major heart surgery. The arterial blood pressure was recorded from a radial artery by an indwelling cannula. Initial storage was done by an F.M. tape-recorder.

Analog processing was carried out by a parallel hybrid computer (EAL TR48), where the QRS complexes were detected with better than 99% reliability and the instantaneous heart rate in beats/min thus derived from the QRS intervals. If there was uncertainty in the location of the QRS complex an indication was given by outputting a 'flag' of one machine unit. The mean blood pressure was calculated as the ratio of the integral of the arterial blood pressure recording over one beat and the interval of that beat, the start of systole being taken as the start of the beat. The instantaneous heart rate and blood pressure were sampled by a DART data logger (General Automation) and the results punched on to paper tape, either at regular intervals or for each heart beat.

The first stage of the digital analysis was to process the data to eliminate the 'flags' and replace them with an exponentially weighted mean, because, although only 1% of the results, they can seriously affect the spectrum estimates. The spectra and cross-spectrum were determined using the BMD X 92 program and from these sinus arrhythmia, Mayer waves and other phasic fluctuations could be detected. Successive histograms of the sampled heart rate and blood pressure, and also of the beat-by-beat recordings were calculated. The accuracy of the heart rate recording was estimated to be within 1 beat/min, and so this was taken as the interval width for that histogram. Approximately 200 points were taken for each histogram, so that the general shape of the histogram would not be affected by trend effects (Ten Hoopen & Bongaarts, 1969). Histograms of the recordings about a 5 min exponentially weighted mean (Taylor, 1971) and joint-interval histograms were also calculated. These methods

[P.T.O.]

are leading to a mathematical description of short-term biological variability in pulse rate and mean arterial blood pressure.

This work was supported by grants from the Scottish Home and Health Department, and the basic TR48 computer was provided by the Wellcome Trust.

#### REFERENCES

- TAYLOR, D. E. M. (1971). *Bio-med. Engng* 6, 560-566.  
TEN HOOPEN, M. & BONGAARTS, J. P. M. (1969). *Cardiovasc. Res.* 3, 218-226.

A NOTE ON THE SAMPLING OF A POINT PROCESS FOR SPECTRAL ANALYSIS

1. INTRODUCTION

Lewis [1] has described the spectral analysis of point processes, computing the spectrum from the Fourier transform of the event sequence. In particular he mentioned (p. 370) that it was not possible to use the fast Fourier transform algorithm to compute the periodogram, and this could lead to severe problems with computing time. French and Holden [2] have described a simple and quick method of transforming the series by convolving it with the function  $\sin x/x$  to form a continuous function which can then be sampled at equidistant time intervals. The advantage of this method is that then the periodogram of the point process can be estimated by the fast Fourier transform. Lewis [3] also described this method but mentioned the possibility of bias when using the method, as compared with computing the periodogram directly. The method has attractions even for comparatively short series, since one can think of the transformed series as a kind of continuous intensity function, taking large values in the vicinity of an event and becoming small when events are infrequent. The purpose of this note is to investigate the degree of bias, and to suggest a method of reducing it for short series. Practical considerations when implementing the method are described by Peterka *et al.* [4].

2. CONVERGENCE OF THE METHOD

Given a realization of a point process with events occurring at times  $t_0 = 0, t_1, \dots, t_n$ , and with counting process  $N(t)$ , the spectrum of the process can be computed via the finite Fourier transform [5]:

$$H(\omega) = \frac{1}{\sqrt{(\pi t_n)}} \int_0^{t_n} e^{i\omega t} dN(t) = \frac{1}{\sqrt{(\pi t_n)}} \sum_{s=0}^n e^{i\omega t_s} \tag{1}$$

Using the method of French and Holden [2], one computes

$$Y(\omega) = \frac{1}{\sqrt{(\pi t_n)}} \sum_{r=0}^b x(r) e^{i\omega r},$$

where

$$x(r) = \sum_{s=0}^n \frac{\sin u (r\Delta t - t_s)}{u (r\Delta t - t_s)}.$$

The variable  $X(r)$  gives the sampled values of the process at the points  $r\Delta t$ , where  $\Delta t$  is the sampling interval. The frequency  $u$  is chosen so that it becomes the Nyquist frequency of the sampled process, i.e.,  $u = \pi/\Delta t$ , and one evaluates  $Y(\omega)$  in the interval  $(0, u)$ . In practice  $u$  is chosen to be greater than the highest frequency of interest in the process and from  $u$  one can find  $\Delta t$ . Substituting the formula for  $X(r)$  into  $Y(\omega)$  one obtains

$$Y(\omega) = \frac{1}{\sqrt{(\pi t_n)}} \sum_{r=0}^b \sum_{s=0}^n \frac{\sin \pi (r\Delta t - t_s)/\Delta t}{\pi (r\Delta t - t_s)/\Delta t} e^{i\omega r\Delta t}.$$

By reversing the order of summation, this can be rewritten as

$$Y(\omega) = \frac{1}{\sqrt{(\pi t_n)}} \sum_{s=0}^n e^{i\omega t_s} \sum_{r=a}^b \frac{\sin \pi (r - t_s/\Delta t)}{\pi (r - t_s/\Delta t)} e^{i\omega \Delta t (r - t_s/\Delta t)}.$$

If the second sum is written as  $Z(t_s, \omega)$  then one has

$$Y(\omega) = \frac{1}{\sqrt{(\pi t_n)}} \sum_{s=0}^n e^{i\omega t_s} Z(t_s, \omega).$$

Clearly one would like  $Z(t_s, \omega)$  to be close to unity for all values of  $t_s$  and  $\omega$ .

If one substitutes  $\theta = t_s/\Delta t$ ,  $\alpha_1 = \pi + \omega \Delta t$  and  $\alpha_2 = \pi - \omega \Delta t$  then  $Z(t_s, \omega)$  can be written as

$$\begin{aligned} \frac{1}{2} \sum_{r=a}^b \frac{\sin (r + \theta)\alpha_1}{\pi (r + \theta)} + \frac{1}{2} \sum_{r=a}^b \frac{\sin (r + \theta)\alpha_2}{\pi (r + \theta)} + \frac{i}{2} \sum_{r=a}^b \frac{1 - \cos (r + \theta)\alpha_1}{\pi (r + \theta)} \\ - \frac{i}{2} \sum_{r=a}^b \frac{1 - \cos (r + \theta)\alpha_2}{\pi (r + \theta)}, \end{aligned} \quad (2)$$

where  $0 < \alpha_2 < \alpha_1 < 2\pi$ . Convergence follows from the fact that, for  $0 < \alpha < 2\pi$

$$\sum_{r=-\infty}^{\infty} \frac{\sin (r + \theta)\alpha}{\pi (r + \theta)} = 1 \quad \text{and} \quad \sum_{r=-\infty}^{\infty} \frac{1 - \cos (r + \theta)\alpha}{\pi (r + \theta)} = 0$$

(see, for example, references [6], p. 404, and [7], p. 27), so that as  $a \rightarrow -\infty$  and  $b \rightarrow \infty$ ,  $Y(\omega) \rightarrow H(\omega)$ .

### 3. ESTIMATION OF BIAS

The value of expression (2) can be made as close to unity as one wishes simply by computing the function  $X(r)$  for large negative through to large positive values of  $r$ . Since  $X(r) \rightarrow 0$  as  $|r| \rightarrow \infty$ , it is worth investigating how far expression (2) is from unity for finite  $a$  and  $b$ . French and Holden [2] evaluated  $X(r)$  for  $r\Delta t$  between 0 and  $t_n$ , so that the upper limit of the summation in expression (2) would be the integer part of  $t_n/\Delta t$ . Assuming that  $m$ , the number of values of  $X(r)$ , is odd, one can put  $k = (m - 1)/2$  and rewrite expression (2) as a symmetrical sum by changing the dummy variable to  $p = r - k$  and  $\theta$  to  $-t_s/\Delta t + k$ . It can be shown [7] that for  $0 < \alpha < 2\pi$

$$\sum_{p=-k}^k \frac{\sin (p + \theta)\alpha}{\pi (p + \theta)} = \frac{1}{\pi} \int_0^\alpha \cos \theta t \frac{\sin (k + \frac{1}{2})t}{\sin \frac{1}{2}t} dt, \quad (3)$$

$$\sum_{p=-k}^k \frac{1 - \cos (p + \theta)\alpha}{\pi (p + \theta)} = \frac{1}{\pi} \int_0^\alpha \sin \theta t \frac{\sin (k + \frac{1}{2})t}{\sin \frac{1}{2}t} dt. \quad (4)$$

If the right-hand side of equation (3) is integrated by parts one obtains

$$1 - \frac{\cos (k + \frac{1}{2})\alpha}{\pi (k + \frac{1}{2})} \left\{ \frac{\cos \theta \alpha}{\sin \frac{1}{2}\alpha} - \frac{4}{\alpha} \right\} + O(k^{-2}),$$

and since  $\alpha > 0$  this expression is  $1 + O(k^{-1})$ . When  $\alpha = \pi$ ,  $\cos (k + \frac{1}{2})\alpha = 0$ , and so for fixed  $k$  this value of  $\alpha$  yields the closest value of the expression to unity. The distance from unity is determined by  $(k\alpha)^{-1}$  which is largest when both  $\alpha$  and  $k$  are small.

In a similar manner one can integrate the right-hand side of equation (4) by parts to give

$$-\frac{\cos(k + \frac{1}{2})\alpha \sin \theta \alpha}{(k + \frac{1}{2}) \sin \frac{1}{2}\alpha} + \frac{2\theta}{k + \frac{1}{2}} + O(k^{-2}).$$

Happily the term  $2\theta/(k + \frac{1}{2})$ , which need not be small, is eliminated when one substitutes the above expression into the imaginary part of expression (2) to give

$$\frac{i}{2} \left\{ \frac{\cos(k + \frac{1}{2})\alpha_2 \sin \alpha_2 \theta}{(k + \frac{1}{2}) \sin \frac{1}{2}\alpha_2} - \frac{\cos(k + \frac{1}{2})\alpha_1 \sin \alpha_1 \theta}{(k + \frac{1}{2}) \sin \frac{1}{2}\alpha_1} \right\}.$$

This expression is  $O(k^{-1})$  and is zero when  $\alpha_1 = \alpha_2 = \pi$ .

From the definitions of  $\alpha_1$  and  $\alpha_2$ ,  $\omega$  is small when  $\alpha_1 = \alpha_2 = \pi$  and  $\omega$  is near  $\pi$  when  $\alpha_2$  is small. Thus expression (2) becomes

$$Z(t, \omega) = 1 + O((k(\pi - \omega))^{-1}) + i O((k(\pi - \omega))^{-1}).$$

This means that both the amplitude and phase distortions of  $H(\omega)$  are  $O((k(\pi - \omega))^{-1})$  and thus small if either  $k$  is large or  $\omega$  is not close to  $\pi$ .

#### 4. DISCUSSION AND CONCLUSION

In this note it has been shown that the difference in the periodogram ordinate of a point process computed directly or via the French-Holden algorithm is negligible if the number of sampling points is large, or the frequency of the ordinate is not near  $\pi$ . This is in agreement with Peterka *et al.* [4] who suggest that the upper 2% of frequency components should be rejected. If the number of sampling points is not large, then a method of increasing them is to sample  $X(r)$  outside the interval  $(0, t)$ . One useful method is to compute equal numbers either side of  $(m - 1)\Delta t/2$  such that the total number of sampled points is a power of 2, to facilitate the use of the fast Fourier transform.

MRC Pneumoconiosis Unit,  
Llandough Hospital,  
Penarth CF6 1XW, Wales

M. J. CAMPBELL

(Received 25 September 1978)

#### REFERENCES

1. P. A. W. LEWIS 1970 *Journal of Sound and Vibration* 12, 353-375. Remarks on the theory, computation and application of the spectral analysis of series of events.
2. A. S. FRENCH and A. V. HOLDEN 1971 *Kybernetik* 8 165-171. Alias free sampling of neuronal spike trains.
3. P. A. W. LEWIS (Editor) 1971 *Stochastic Point Processes: Statistical Analysis, Theory and Applications*. New York: Wiley.
4. R. J. PETERKA, A. C. SANDERSON and D. P. O'LEARY 1978 *Institute of Electrical and Electronic Engineers, Transactions on Biomedical Engineering* 25, 192-195. Practical considerations in the implementation of the French-Holden algorithm for sampling of neuronal spike trains.
5. D. R. COX and P. A. W. LEWIS 1966 *The Statistical Analysis of Series of Events*. London: Methuen.
6. E. C. TITCHMARSH 1939 *The Theory of Functions*. London: Oxford University Press second edition.
7. I. N. SNEDDON 1961 *Fourier Series*. London: Routledge and Kegan Paul.