

CARRIER DETECTION IN DUCHENNE  
MUSCULAR DYSTROPHY

Lesley C. Freeman BSc.

A thesis presented for the degree  
of  
Doctor of Philosophy  
of the  
University of Edinburgh  
in the  
Faculty of Medicine

1984



## ABSTRACT

The identification of apparently healthy carriers of the lethal, X-linked gene for Duchenne muscular dystrophy (DMD) is of importance for genetic counselling purposes. At present the accepted most reliable test for determining DMD carrier status is the estimation of serum creatine kinase activity. However, approximately one third of genetic carriers remain undetected by this method. This study was designed to evaluate other possible methods of DMD heterozygote recognition with a view to improving the carrier detection rate.

There is considerable evidence to suggest a generalised membrane defect is responsible for the degenerative muscle fibre alterations which occur in DMD. Increased intracellular calcium has been implicated as an early biochemical change which would account for many of the membrane abnormalities reported. Several changes exhibited by DMD erythrocytes could be attributed to an increased intraerythrocytic calcium content. If this increased calcium level is related to the primary defect then, according to the Lyon hypothesis, a proportion of erythrocytes from a genetic carrier of DMD should manifest this abnormality. The relative intraerythrocytic calcium content of individual erythrocytes within DMD patient, DMD carrier and control erythrocyte populations were examined. Quantitative measurement of the elemental content of single erythrocytes was carried out using electron probe X-ray microanalysis (EPXMA). However the extremely low level of intraerythrocytic calcium and the wide variation in relative calcium concentrations of each erythrocyte population render EPXMA insufficiently sensitive to be capable of distinguishing two erythrocyte populations within a DMD carrier.

An alternate approach to the demonstration of cellular mosaicism is the additional measurement of secondary biochemical parameters which, if non-correlated, could improve the carrier detection rate over that obtained using serum creatine kinase estimation alone. Serum levels of haemopexin and myoglobin were found to be raised significantly in a series of 10 DMD patients compared to 10 age and sex matched, normal, healthy controls. Measurements of serum pyruvate kinase, haemopexin and myoglobin levels were then carried out in a series of 15 DMD carriers and 15 age matched, normal, healthy women, in conjunction with serum creatine kinase estimation. The mean serum pyruvate kinase activity of the DMD carrier group was significantly higher than that of the control group but this test selected only 4/14 (28.5%) carriers and failed to identify 3 carriers whose serum creatine kinase levels were within normal limits. The mean serum haemopexin level of the carrier group was not significantly different from that of the control group. The mean serum myoglobin level of the carrier group was significantly higher than that of the control group. Nine of 15 (60%) carriers had myoglobin levels outside the 95% confidence limits. However serum myoglobin was within normal limits in all 3 carriers with normal serum creatine kinase levels. Discriminant analysis suggested that combining serum myoglobin and creatine kinase measurements might improve the detection rate. Serum levels of myoglobin and creatine kinase were measured in a series of 20 DMD carriers (all with serum creatine kinase activities within normal limits) and 20 age matched, normal, healthy women. Three of 20 (15%) carriers had myoglobin levels outside the calculated 95% confidence limits but all 3 had serum creatine kinase activities close to the 95th percentile of the control series. The positive correlation between serum myoglobin and creatine kinase levels implies the

combined use of these tests may be of value only in cases where the subjects' creatine kinase level is borderline normal. Otherwise the results of this study suggest the additional measurement of either serum pyruvate kinase or haemopexin in combination with serum creatine kinase estimation will have little value in DMD carrier detection.

## ACKNOWLEDGEMENTS

I would like to thank my supervisor Professor A.E.H. Emery for his guidance, encouragement and enthusiasm throughout the course of this project. I would also like to thank Professor D.A.T. Dick (University of Dundee) for teaching me the "art" of microanalysis; the MRC Clinical and Population Cytogenetics Unit for allowing me use of the S180 and Mr. Alan Ross for his helpful comments in that area.

My thanks are also due to Anthea Springbett and Susan Holloway for statistical advice; Sandy Bruce for the excellent photographic work; Becki Ney, Carol MacKenzie and Ingrid Jeffery for typewriting and Dr.s' Rosalind Skinner and Ewan Millar and Mrs. Peggy Lewis for sample collection.

I am extremely grateful for all who provided samples for this project.

Finally I would like to acknowledge financial support for this research studentship from the Medical Research Council.

DECLARATION

I hereby declare that this thesis does not include work submitted for any other degree or professional qualification of this or any other university or institution of learning.

This thesis has been composed by myself and the work described in it is my own.

DEDICATION

This thesis is dedicated to my father Charles Freeman, 1914-1968

## ABBREVIATIONS

AAS	atomic absorption spectrophotometry
ADP	adenosine diphosphate
ATP	adenosine triphosphate
Ca <sup>++</sup>	calcium
CANP	calcium activated neutral protease
CK	creatine kinase
CTC	chlorotetracycline
DMD	Duchenne muscular dystrophy
EDTA	ethyleneglycol-bis (aminoethylether) N <sup>1</sup> , N-tetra acetic acid
EMG	electromyography
EPXMA	electron probe x-ray microanalysis
ESR	electron spin resonance spectroscopy
eV	electron volts
FIET	forearm ischaemic exercise test
G-6-PDH	glucose-6-phosphate dehydrogenase
HK	hexokinase
Hpx	haemopexin
LDH	lactate dehydrogenase
Mg <sup>++</sup>	magnesium
My	myoglobin
NADP	nicotinamide-adenine dinucleotide
NADPH	nicotinamide-adenine dinucleotide phosphate, reduced
NS	not significant
PAGE	polyacrylamide gel electrophoresis
P/B ratio	peak to background ratio
PK	pyruvate kinase
r	correlation coefficient



$r_s$  Spearman's rank correlation coefficient  
RIA radioimmunoassay  
SD standard deviation  
SEM scanning electron microscopy  
TDW triple distilled, deionised water  
Yrs years

## INDEX

	Page
ABSTRACT	i
ACKNOWLEDGEMENTS	iv
DECLARATION	v
DEDICATION	vi
ABBREVIATIONS	vii
<u>CHAPTER 1: INTRODUCTION</u>	
1-1. DEFINITION OF THE MUSCULAR DYSTROPHIES	1
1-2. DUCHENNE MUSCULAR DYSTROPHY	2
1-2.1. Clinical Features	2
1-2.2. Treatment	3
1-2.3. Antenatal Diagnosis	4
1-2.4. Screening	5
1-3. PATHOGENESIS	6
1-3.1. Vascular Hypothesis	6
1-3.2. Neurogenic Hypothesis	6
1-3.3. Membrane Hypothesis	7
1-3.3.i. Investigations on Non-muscle Cells	8
1-3.3.ii. Involvement of Calcium	16
1-4. GENETIC COUNSELLING	18
1-5. CLASSIFICATION OF DMD CARRIERS	19
1-6. DMD CARRIER DETECTION	20
1-6.1. Clinical Features	20
1-6.2. Investigations on Muscle :	21
1-6.3. Investigations on Body Fluids	22
1-6.4. Other Methods	25

CHAPTER 2: CALCIUM

2-1. INTRODUCTION	27
2-1.1. Calcium in Duchenne Muscle	27
2-1.2. Duchenne Erythrocyte Calcium	30
2-1.3. Erythrocyte Calcium Measurement	32
2-1.4. Electron Probe X-Ray Microanalysis	33
2-2. MATERIALS AND METHODS: FLUORESCENT STAINS	37
2-2.1. Erythrocytes Stained with 3,5,7,2',4'-Penta- hydroxyflavanol (Morin)	38
2-2.2. Lymphocytes Stained with 3,5,7,2',4'-Penta- hydroxyflavanol (Morin)	39
2-2.3. Erythrocytes Stained with Chlorotetracycline (CTC)	39
2-3. MATERIALS AND METHODS: ELECTRON PROBE X-RAY MICROANALYSIS (EPXMA)	41
2-3.1. Preparation of Samples: "Thick Section" Technique	42
2-3.2. Preparation of Standards: "Thick Section" Technique	42
2-3.3. EPXMA: "Thick Section" Technique	43
2-3.4. Blood Treated with Ionophore A23187 and a Calcium Complexing Agent	49
2-3.5. Preparation of Samples: "Thin Section" Technique	50
2-3.6. Preparation of Standards: "Thin Section" Technique	50
2-3.7. EPXMA: "Thin Section" Technique	51
2-4. RESULTS: FLUORESCENT STAINS	53
2-4.1. Erythrocytes and Lymphocytes Stained with 3,5,7,2',4'-Pentahydroxyflavanol (Morin)	53
2-4.2. Erythrocytes Stained with CTC	53
2-5. RESULTS: EPXMA	56
2-5.1. Effect of the Fixative-Buffer on Erythrocytes	56
2-5.2. Comparison of "Thick Section" and "Thin Section" Techniques	56

2-5.3. Erythrocyte Populations Examined	58
2-5.4. Albumin Protein Standards	62
2-5.5. Blood Treated with Ionophore A23187 and a Calcium complexing Agent	67
2-5.6. Summary of Results Obtained in Subjects Studied	67
2-6. DISCUSSION: FLUORESCENT STAINS	71
2-7. DISCUSSION: EPXMA	73

### CHAPTER 3: CREATINE KINASE

3-1. INTRODUCTION	79
3-2. MATERIALS AND METHODS	84
3-3. RESULTS	89
3-4. DISCUSSION	101

### CHAPTER 4: PYRUVATE KINASE

4-1. INTRODUCTION	107
4-2. MATERIALS AND METHODS	110
4-2.1. Serum Pyruvate Kinase	110
4-2.2. Effect of Storage on Serum Pyruvate Kinase Activity	112
4-3. RESULTS	114
4-4. DISCUSSION	122

CHAPTER 5: HAEMOPEXIN

5-1. INTRODUCTION	127
5-2. MATERIALS AND METHODS	129
5-3. RESULTS	131
5-4. DISCUSSION	141

CHAPTER 6: MYOGLOBIN

6-1. INTRODUCTION	145
6-2. MATERIALS AND METHODS	149
6-3. RESULTS	153
6-4. DISCUSSION	170

CHAPTER 7: COMBINED TESTS

7-1. INTRODUCTION	177
7-2. MATERIALS AND METHODS	180
7-2.1. Discriminant Analyses	180
7-2.2. Summary of Relationships between Serum Proteins Measured	180
7-3. RESULTS	181
7-3.1. Discriminant Analyses	181
7-3.2. Summary of Relationships between Serum Proteins Measured in DMD Carriers and Controls, Group A	181
7-4. DISCUSSION	188
7-4.1. Discriminant Analyses	188
7-4.2. Summary of Relationships between Serum Proteins Measured in this Study	190

REFERENCES

192

APPENDIX I

216

APPENDIX II

217

APPENDIX III

218

TABLES, FIGURES AND PLATES

Page

CHAPTER 2: CALCIUM

TABLE	2.1.	45
"	2.2.	60
"	2.3.	61
"	2.4.	68
"	2.5.	70
FIGURE	2.1.	47
"	2.2.	59
"	2.3.	63
"	2.4.	65
"	2.5.	66
"	2.6.	69
PLATE	2.1.	55
"	2.2.	57
"	2.3.	64

CHAPTER 3: CREATINE KINASE

TABLE	3.1.	91
"	3.2.	92
"	3.3.	96
"	3.4.	97
"	3.5.	99
FIGURE	3.1.	90
"	3.2.	93
"	3.3.	94

CHAPTER 4: PYRUVATE KINASE

TABLE	4.1.	117
"	4.2.	118
FIGURE	4.1.	115
"	4.2.	116
"	4.3.	120
"	4.4.	121

CHAPTER 5: HAEMOPEXIN

TABLE	5.1.	133
"	5.2.	134
"	5.3.	136
"	5.4.	137
FIGURE	5.1.	132
"	5.2.	138
"	5.3.	139
"	5.4.	140

CHAPTER 6: MYOGLOBIN

TABLE	6.1.	155
"	6.2.	156
"	6.3.	160
"	6.4.	161
"	6.5.	165
"	6.6	166



FIGURE	6.1.	154
"	6.2.	157
"	6.3.	159
"	6.4.	162
"	6.5.	163
"	6.6	168
"	6.7.	169

CHAPTER 7: COMBINED TESTS

TABLE	7.1.	182
"	7.2.	187
FIGURE	7.1.	185

The number of molecules contained in a given volume of gas is called the number of molecules. All are considered to have the same kinetic energy of the molecules, which will go progressively lower as the temperature falls. The molecules suffer only in their walls of the vessel, and with the usual amount of internal motion and the rate of progress of the Brownian motion.

The number of molecules contained in a given volume of gas is called the number of molecules. All are considered to have the same kinetic energy of the molecules, which will go progressively lower as the temperature falls. The molecules suffer only in their walls of the vessel, and with the usual amount of internal motion and the rate of progress of the Brownian motion.

CHAPTER 1: INTRODUCTION

1-1. DEFINITION OF THE MUSCULAR DYSTROPHIES

The muscular dystrophies represent a group of genetically inherited, myopathic disorders. All are characterised by their primary involvement of the voluntary muscles, which undergo progressive degeneration and necrosis. The disorders differ widely in their mode of inheritance as well as the age at onset of clinical symptoms and the rate of progression of the disease process.

There are several forms of muscular dystrophy reported to have an X-linked, recessive inheritance. Of these the most severe form of muscular dystrophy, named after Duchenne (1868) and the more benign Becker type (Becker and Keiner 1955) have both been well characterised. The families described by Emery and Dreifuss (1966), Rotthauwe et al. (1972), Thomas et al. (1972) and others, may represent further forms of X-linked, recessive muscular dystrophy.

## 1-2. DUCHENNE MUSCULAR DYSTROPHY (DMD)

Duchenne muscular dystrophy (DMD) is inherited in an X-linked recessive manner. DMD occurs only in males but females with an abnormal X chromosome constitution may also manifest the disease.

The locus (or loci) for DMD is considered to be present on the proximal part of the short arm of the X chromosome. However the nature of the specific gene defect involved is unknown.

The incidence of the disease has been reported as 1 in 3,000 live male births. One third of these cases are considered to be new mutations (Emery, 1980).

### 1-2.1. Clinical Features

Boys with DMD appear physically normal at birth. Although the disease can be diagnosed at the preclinical stage (by measurement of serum creatine kinase activity) usually clinical investigation is undertaken when the boy is 3-5 years of age, following observations of unsteady walk, frequency of falling and difficulty climbing stairs. In the early stages of the disease proximal muscle weakness and wasting is apparent. Calf hypertrophy is an early feature. The waddling gait and Gowers manoeuvre (when standing up from the floor the boy "walks" up his legs with his arms) are characteristic.

An elevated serum creatine kinase activity and/or the typical abnormal histology seen on muscle biopsy confirm diagnosis.

Muscle weakness and atrophy progress relentlessly, particularly in the proximal muscle groups although there is also involvement of the distal musculature. Dependent upon contractures and relentlessly

increasing weakness the affected boy becomes wheelchair-bound at approximately 10 years of age. Cardiac involvement is usually apparent at this stage. There is progressive skeletal distortion and eventually muscle weakness and thoracic deformity lead to chronic respiratory insufficiency. Death by the age of 16-20 years is usually the result of a respiratory infection or cardiac failure.

## 1-2.2. Treatment

As yet there is no effective treatment for DMD. Over the years many drugs have been used in clinical trials but despite occasional unconfirmed claims to the contrary no therapeutic agent has succeeded in arresting the dystrophic process. Since the nature of the gene defect is unknown, selection of specific drugs have mainly been based on hypotheses related to pathogenesis or on results observed in animal models.

Drug trials in DMD patients are inherently difficult to undertake due, at least in part, to the erratic course of the disease and the difficulty of matching controls. Consequently many past trials have been considered to be of little value. Dubowitz and Heckmatt (1980) have critically assessed therapeutic trials in DMD. A standardized protocol for evaluation of potential DMD drug treatments has been established (Brooke et al., 1981).

Therapeutic trials have involved the use of various amino acids, vitamins, anabolic and cortico-steroids, nucleotides, proteinase inhibitors and other agents. Most recent are those exploring the use of calcium antagonists.

### 1-2.3. Antenatal Diagnosis

Mahoney et al. (1977) first suggested using serum creatine kinase estimation of fetal blood, sampled in utero, in order to determine the homozygosity or normality of an "at risk" for DMD male fetus. (a fetus whose mother is a definite DMD carrier or has a high probability of being a DMD carrier). Fetal serum creatine kinase activities in normal male fetuses have been measured (Emery, 1980). Elevated fetal serum creatine kinase values have been found in terminated "at risk" pregnancies where abnormal muscle histology was also reported (Mahoney et al., 1977; Emery et al., 1979).

Although Mahoney et al. (1977) and Dubowitz et al. (1978) have reported the birth of normal boys from "at risk" pregnancies where fetal serum creatine kinase activities were normal, sadly the birth of affected boys following measurement of normal levels of fetal serum creatine kinase (Ionasescu et al., 1978; Golbus et al., 1979) indicate the unreliable nature of this test for antenatal diagnosis.

The most promising technique with the potential of both detection of DMD carriers and antenatal diagnosis involves recombinant deoxyribonucleic acid (DNA) technology. This method permits the isolation of deoxyribonucleic acid sequences corresponding to the whole genome of a subject or the expressed sequences of a given cell type. Probes which are gene-specific are then used to study the consequence of genetic mutation. Deoxyribonucleic acid sequence polymorphisms can be used in the construction of a map of the human genome, allowing the development of a possible antenatal diagnostic test for DMD, even in the absence of an understanding of the biochemical lesion. The application of this technique to muscular dystrophy has been discussed by Jones (1980) and Housman (1983). Harper et al. (1982) reported the isolation of 3 human X

specific probes from a human X-chromosome specific library and the same group (Harper et al., 1983) have recently described the use of linked DNA polymorphisms for genotype prediction in families with DMD.

#### 1-2.4. Screening

The blood level of creatine kinase in DMD neonates is elevated in the absence of clinical symptoms. This finding has been exploited as a screening test for the detection of DMD neonates in the newborn male population. Zellweger and Antonik (1975) proposed that neonatal creatine kinase estimation should be carried out as a screening procedure for all male neonates. These authors discuss the complex ethical considerations involved in screening for DMD when no cure can be offered. Certainly supportive treatment can be started at an earlier age and parents would have the opportunity of planning for life with a future handicapped child. Perhaps more importantly, such a method might prevent second DMD cases in a family when the mother has been diagnosed as a carrier following the post-natal diagnosis of her DMD son.

A recent report on neonatal screening by creatine kinase assay detected 12 cases of DMD (later confirmed by muscle biopsy) in a male neonate population of 71,091, an incidence of 1 in 5,924 (Dellamonica et al., 1983).

Screening the female neonate population by creatine kinase assay as a method of DMD carrier detection has not, until recently been considered a viable proposition (due to lack of sensitivity of the technique). However, Nicholson and co-workers (1982) have reported a creatine kinase assay system which they propose has the required sensitivity for neonatal carrier detection.

### 1-3. PATHOGENESIS OF DMD

The primary genetic lesion responsible for DMD has yet to be determined. Many attempts have been made to explain the pathogenesis of the disease. Three major hypotheses have emerged, two of which (the vascular and neurogenic hypotheses) have been mainly discounted in favour of the membrane hypothesis.

#### 1-3.1. Vascular Hypothesis

The vascular hypothesis was formulated following the report by Démos (1961) of a decreased blood circulation time exhibited by DMD patients. This led to the suggestion that the dystrophic process might be due to occlusion of the muscle microcirculation, causing chronic anoxia in areas of muscle and leading to necrosis. The injection of beads into the microcirculation of healthy experimental animals resulted in the artificial production of muscle lesions similar to those found in dystrophic muscle (Hathaway et al., 1970). However, there have been conflicting reports concerning blood flow in human dystrophic muscle (Bradley et al., 1975). Overall there is little evidence to suggest an ischaemic lesion is responsible for the progressive degenerative changes which occur in DMD.

#### 1-3.2. Neurogenic Hypothesis

McComas et al. (1971) considered the myopathic changes evident in dystrophic muscle might be due to some abnormality of the motor neurones - the "sick" motor neurone hypothesis. Analyses of motor neurones in DMD



patients demonstrated decreased numbers of motor units per muscle cell (McComas et al., 1974), disputed by Ballantyne and Hansen (1974) who reported normal numbers in Duchenne muscle. Furthermore Jerusalem et al., (1974) and Harriman, (1976) could find no abnormality in the motor end plates of dystrophic muscle by electron microscopy.

The conflicting data reported have been discussed by Sica and McComas (1978).

### 1-3.3. Membrane Hypothesis

The membrane hypothesis (reviewed by Rowland, 1980) developed following observations on the apparent "leakiness" of DMD muscle, with raised serum levels and decreased muscle levels of several muscle-residing enzymes. Aldolase was the first enzyme reported to be abnormally raised in Duchenne sera (Schapira et al., 1953). However it has been the elevated level of serum creatine kinase in DMD boys which has been used for diagnostic purposes due to its consistently raised level even in clinically asymptomatic newborn DMD cases (Heyck et al., 1966).

The hypothesis considers that the degenerative muscle changes that occur in DMD are resultant of a genetic lesion which leads to an abnormal sarcolemma. The defective membrane may be the result of either a functionally or structurally altered protein. Rowland (1980) has discussed in detail the evidence implying a disturbance in sarcolemmal integrity, both from the concept of a "leaky" membrane (functional abnormality) and the concept of physical interruptions in the sarcolemma (structural abnormality). Such interruptions or delta lesions have been found by electron microscopy (Mokri and Engel, 1975; Carpenter and Karpati, 1979). As Rowland (1980) points out both abnormalities may be

involved in the dystrophic process. Mokri and Engel (1975) have demonstrated an abnormal permeability of the muscle cell membrane to horseradish peroxidase in the vicinity of the delta lesions. An abnormal permeability of Duchenne muscle fibres to Procion Yellow has also been found (Bradley and Fulthorpe, 1978). Schotland et al, (1977; 1980) demonstrated that the intramembranous particles demonstrated in muscle membranes by freeze-fracture analysis were decreased in number in DMD (confirmed by Shotton, 1982), suggesting an alteration in the molecular structure of Duchenne muscle membranes.

### 1-3.3i. Investigations on Non-Muscle Cells

There is considerable evidence that the membrane abnormality which appears to be expressed in DMD affects not only muscle tissue but is a generalised membrane defect. Certainly recognition of the primary defect in DMD may be confounded by the variable muscle degenerative changes and the infiltration by both adipose and connective tissues in Duchenne muscle. This and technical reasons, such as the scarcity of human muscle biopsy material, led to the examination of non-muscle cells in order to assess the validity of this hypothesis.

Many abnormalities have been reported in non-muscle cells from DMD patients, however it has been suggested that at least some of these abnormalities might be due to a circulating plasma factor (Siddiqui and Pennington, 1977; Lloyd and Emery, 1981) or be secondary changes resultant from a basic biochemical defect (or defects) located elsewhere in the cell (Lucy, 1980). Non-muscle tissues investigated have included fibroblasts and several peripheral blood cell types, although most investigations have focused on the erythrocyte.

Reports concerning the examination of cultured skin fibroblasts from

Duchenne patients have led to conflicting data. Wyatt and Cox (1977) reported abnormal inclusion bodies in fibroblasts from 4 DMD subjects not present in cells from 15 controls. This was disputed by Cullen and Parsons (1977) who examined fibroblasts from 4 DMD and 4 normal cell lines in a "blind" study and failed to find abnormal inclusions. Connolly et al. (1979) compared the organisation of microtubules from Duchenne and normal fibroblasts, considering a defect in the microtubule system might explain DMD membrane alterations, but they were unable to find differences between Duchenne and control cells. Jones and Witowski (1979) examined the collision efficiencies of Duchenne and control fibroblasts using a viscometer and reported the DMD fibroblasts to be less adhesive than normal cells. They suggested this phenomenon was possibly due to an altered surface membrane of the DMD cells.

Using one-dimensional polyacrylamide gel electrophoresis (PAGE) Pena et al. (1978) reported no consistent abnormality in the protein patterns of Duchenne fibroblasts compared to control cells. Workers from the same group described the lack of a fibroblast protein (molecular weight approximately 56,000 daltons) in Duchenne cells using a more sensitive two-dimensional PAGE technique in combination with double-label autoradiography. This protein was reported to be consistently absent from Duchenne fibroblasts originating from 6 patients, which were compared to 6 control cell lines (Rosenmann et al., 1982). However the difference between Duchenne and control fibroblasts in this study has very recently been determined as being due to a difference in skin biopsy site (Thompson et al. 1983).

Gelman and co-workers (1980) reported a decreased activity of lysosomal dipeptidyl aminopeptidase I in DMD fibroblasts compared to fibroblasts from age and sex matched controls. They further reported

the catalytic function of this enzyme appeared to be unimpaired and that the decreased activity might be due to fewer molecules being present in the DMD cells, implying the DMD cells were metabolically altered.

More recently this group have reported DMD lysosomal membranes have altered biochemical and morphological characteristics (Gelman et al., 1981; Davis et al., 1982a). However, the significant alteration in dipeptidyl aminopeptidase I activities observed in DMD lysosomes were not found in lysosomes from 2 definite and 3 possible carriers compared to those from sex matched controls (Davis et al., 1982b).

Kohlschutter et al. (1976) could find no abnormality in the phospholipid or fatty acid composition of DMD fibroblasts. Examining the stimulated turnover of phosphatidylinositol and phosphatidate in fibroblast cell lines from 3 DMD patients and 3 controls, Rounds et al. (1980) found an increase in concanavalin A-induced phosphatidate labelling and a decrease in phosphatidylinositol labelling in the DMD cells (i.e. the rate of resynthesis of phosphatidylinositol from phosphatidate may be decreased in Duchenne fibroblasts).

Statham and Dubowitz (1979) studied calcium exchange in fibroblasts using radioactively labelled calcium ( $^{45}\text{Ca}$ ) and found this process was similar in cultures from both Duchenne and control cell lines.

Despite leucocytes being a relatively easily accessible tissue in which to demonstrate the hypothesised membrane defect in DMD, few studies have concentrated on them and most of these reports remain unconfirmed. However, considerable attention has been focused on the lymphocyte capping phenomenon first reported to be exhibited by both DMD patient and carrier lymphocytes by Verrill et al. (1977).

The biochemical basis of the capping process is not well understood but it may require normal fluidity and an adequate ATP supply (Verrill et al., 1977) and may involve actin, microfilaments and microtubules (Nicholson and Sugars, 1982). Verrill and co-workers (1977) reported decreased lymphocyte cap formation in both Duchenne patients and their mothers compared to normal male controls. Several workers reported similar findings (Bader, 1979; Hö et al., 1980; Horenstein and Emery, 1980) whilst others could not find this abnormality, including Nicholson and Sugars (1982) who reviewed all the reports and suggested discrepancies could have arisen due to methodological differences and/or due to the use of controls which were unmatched with regard to age or sex, since they found cap formation to increase with increasing age.

Scholte and Busch (1980) investigated several leucocyte enzymes in both DMD patients and carriers in order to test the integrity of the plasma membrane and cytosolic components. Whilst 5'-nucleotidase activity (located on the plasma membrane) was reported to be increased in Duchenne leucocytes, cytosolic enzymes were not significantly altered in DMD patients, but phosphorylase activity was found to be significantly decreased in DMD carriers. Four of 7 definite carriers (57%) exhibited decreased phosphorylase activity whilst only 2 of 7 (28%) had elevated serum creatine kinase levels.

Hausmanowa-Petrusewicz et al. (1980) measured DMD carrier leucocyte triglycerides, total lipids, malate dehydrogenase and palmitate oxidation in a pilot study. All measurements except palmitate oxidation were reported to improve carrier selection over that obtained using serum creatine kinase carrier assessment alone.

There have been two unconfirmed reports relating to possible

Duchenne platelet abnormalities. Murphy et al. (1973) found both a significantly decreased initial rate of serotonin  $^{14}\text{C}$  uptake in DMD platelets and a slightly decreased serotonin level. Démos (1973) reported decreased diphenoloxidase activity in platelets from patients with DMD and DMD carriers. The significance of these reported abnormalities remains unclear.

A vast number of morphological, biophysical and biochemical characteristics of Duchenne erythrocytes have been investigated. In some cases both interpretation of reported abnormalities and confirmation of these studies have been made more difficult due to the lack of standardisation of preparational procedures.

Erythrocyte shape alterations are known to occur in certain disease processes. Following a report by Morse and Howland (1973) describing surface alterations in dystrophic mice erythrocytes using scanning electron microscopy (SEM), Matheson and Howland (1974) investigated the surface morphology of erythrocytes from patients with congenital muscular dystrophy and (3) DMD carriers. These authors reported the in vitro formation of a large proportion (between 20-98%) of distorted erythrocytes -- termed echinocytes (Bessis, 1973) in DMD erythrocytes visualised by both light microscopy and SEM. Between 34-39% echinocytes were found in the DMD carriers compared to approximately 3% in controls.

Lumb and Emery (1975) investigated a larger series of DMD patients and carriers and confirmed the light microscopy findings of Matheson and Howland (1974). However Lumb and Emery (1975), Miale et al. (1975) and Tagliavini et al. (1979) considered echinocyte measurement would have little value in DMD carrier detection. Subsequently Matheson et al. (1976) reported an inability to confirm

the findings of Matheson and Howland (1974) and expressed doubts as to the reproducibility of the procedure. Solton (1977) could find no significant erythrocyte shape abnormalities in DMD cells.

In a "double blind" study in which erythrocytes were not pre-treated prior to fixation Miller et al. (1976) described an increased but variable percentage of abnormally shaped erythrocytes -- termed stomatocytes (Bessis, 1973) in DMD patients and carriers by SEM.

Wakayama et al. (1978) found a decreased density of intramembranous particles in DMD erythrocytes, evidence in favour of a generalised membrane defect in DMD. However Lloyd et al. (1981) in a "blind" study (using glycerol as fixative) could not confirm this report, finding no significant difference in the total number of intramembranous particles in DMD patients or controls and suggesting the gluteraldehyde fixative used by Wakayama et al. (1978) may decrease the intramembranous particle count.

Measurements of the viscoelastic properties of erythrocyte membranes were carried out by Percy and Miller (1975) who reported both DMD patient and carrier erythrocytes demonstrated a decreased deformability. This was confirmed by Brain et al. (1978) and Nash and Wyard (1982) but disputed by Somer et al. (1979), who could find no significant differences in membrane deformability (by either microsieving or from flow channel measurements) between Duchenne and control erythrocytes.

Butterfield (1977) examined the physical state of the Duchenne erythrocyte membrane by electron spin resonance spectroscopy (ESR) and found an increased ESR spectral amplitude ratio in these membranes. The abnormal ESR produced by DMD erythrocyte membranes has been confirmed by other workers using different spin labels

Sato et al., 1978; Wilkerson et al., 1978; Laurent et al., 1980). The observed abnormalities of the ESR could result from alterations in either protein or lipid conformation or organisation or, as suggested by Lucy (1980), be consistent with increased rigidity of the Duchenne erythrocyte membrane.

Bosmann et al. (1976) reported the electrophoretic mobility of Duchenne erythrocytes to be increased compared to the electrophoretic mobility of control cells, indicating DMD erythrocyte membrane surfaces were more negatively charged than corresponding control membranes. This altered electrokinetic property could be attributed to either a redistribution of negatively charged sites or to an absolute increase in sialic acid components of the erythrocyte surface.

Fisher et al. (1976) reported an increased osmotic fragility exhibited by Duchenne erythrocytes compared to control cells. Adornato et al. (1977) did not support this finding, but Lloyd and Nunn (1978), Somer et al. (1979) and Ruitenbeek et al. (1979) have confirmed the report of Fisher and his colleagues. The increased osmotic fragility of Duchenne erythrocytes is indicative of an altered membrane organisation in these cells. Danieli and Marchesini (1980) found adenosine triphosphate (ATP) depletion enhanced the abnormal osmotic response of DMD erythrocytes. These authors found the mean rate of haemolysis of ATP depleted erythrocytes to be greater in 4 definite DMD carriers compared to that of 37 controls and suggested 53% of their possible carrier series investigated would have been classed as heterozygotes (taking the maximum control value as cut-off). This method, if confirmed may be a valuable carrier detection test.

The lipid composition of the erythrocyte membrane was first reported to be altered in muscular dystrophy by Kunze et al. (1973).



However many reports since then have yielded conflicting data on both the phospholipid and neutral lipid composition of the Duchenne erythrocyte membrane. These reports have been reviewed in detail by Plishker and Appel (1980) who consider part of the discrepancy might have resulted from auto-oxidation and from other deficiencies in experimental design. Overall Plishker and Appel suggest there are no major alterations in the predominant membrane lipids in DMD erythrocytes.

Howland and Iyer (1977) reported a significant decrease in palmitoleic acid in both DMD and DMD carrier erythrocyte membranes. However other workers could find no difference in erythrocyte palmitoleic acid content in either DMD subjects (Plishker and Appel, 1980) or in DMD carriers (McLaughlin and Engel, 1979) compared to controls.

Several erythrocyte membrane enzymes have also been examined in DMD. Brown et al. (1967) observed that ouabain, which inhibits the rate of ATP hydrolysis by adenosine triphosphatase (ATPase) in normal erythrocytes, stimulated Duchenne erythrocyte ghost ATPase. Peter et al. (1969); Araki and Mawatari (1971); Niebroj-Dobosz (1976) and Pearson (1978) also found stimulation of the DMD ATPase by ouabain. Another positive effect, decreased inhibition of the ATPase of DMD erythrocyte ghosts by ouabain, has been reported by others (Mawatari et al., 1976; Siddiqui and Pennington, (1977) whilst a negative effect (inhibition to a normal extent) was reported by Hodson and Pleasure (1977); Souweine et al. (1978) and Ruitenbeek, (1979). The highly variable results obtained may be explained at least in part as being due to sub-optimal assay conditions used in some experiments and differences in erythrocyte ghost preparation. Plishker and Appel (1980) suggest the variable results might demonstrate a membrane

abnormality influenced by erythrocyte ghost preparation rather than an abnormality of the ATPase. The activity of the calcium-stimulated-magnesium-dependent ATPase in Duchenne erythrocytes has been discussed in 2-1.2.

Mawatari et al. (1976) first reported that the stimulation of erythrocyte membrane adenylate cyclase by epinephrine that occurred in normal erythrocytes did not occur in Duchenne cells. Wacholtz et al. (1979) also found DMD erythrocyte membrane adenyl cyclase to be insensitive to epinephrine. However Fischer et al. (1978) found no epinephrine stimulation in normal cells. Rowland et al. (1980) suggested adenylate cyclase activity may have been partially inhibited by the use of theophylline (to block phosphodiesterase action) in the assay used by Fischer et al.

A high endogenous phosphorylation of spectrin band II was reported in erythrocyte membranes from Duchenne patients (Roses et al., 1975) and DMD carriers (Roses et al., 1976a) compared to control erythrocytes.

### 1-3.3.ii. Involvement of Calcium

It has been suggested that a membrane abnormality which allows leakage of muscle-residing enzymes at an early stage of the disease process may also permit the ingress of calcium (via the extracellular fluid) leading eventually to cell necrosis (Wrogemann and Pena, 1976; Oberc and Engel, 1977). Excessive accumulation of calcium within muscle fibres could lead to myofibrillar overcontraction; activation of calcium sensitive proteases (which will in turn damage the myofibrils) and inhibition of protein synthesis.

An uncontrolled influx of calcium would lead to mitochondrial calcium sequestration and a subsequent diversion from ATP formation, thereby decreasing the energy supply to the calcium pumping mechanism of the muscle cell membranes and resulting in intracellular calcium overload (Wrogemann and Pena, 1976). Certainly ultrastructural studies have shown an increased calcium precipitation in mitochondria, nuclei and sarcoplasmic reticulum of dystrophic fibres (Oberc and Engel, 1977). Also, in other cell systems where membrane injury brings about cell necrosis and death the influx of calcium has been required for the effect (Schanne et al., 1979). The decreased uptake of calcium by DMD sarcoplasmic reticulum (Samaha, 1977; Wood et al., 1978) could result in an elevated intracellular calcium concentration (Cullen and Mastaglia, 1980). By inducing necrosis experimentally in normal muscle in vitro (using nerve stimulation in the presence of acetylcholinesterase inhibitor) Leonard and Saltpeter (1979) suggested the necrotic changes produced were mediated through acetylcholine-induced calcium influx, implying similar changes in Duchenne muscle might result from a calcium-overloaded sarcoplasmic reticulum.

Experimental evidence implicating a role for calcium in the dystrophic process has been discussed for muscle in 2-1.1. and for erythrocytes in 2-1.2.

1-4. GENETIC COUNSELLING

Without, as yet, an effective treatment for DMD, genetic counselling of females "at risk" of carrying the disease must aim to prevent the birth of affected boys.

Such "at risk" females will be counselled on the probability of their having an affected boy, based on pedigree and biochemical data (see Emery 1980). They will be offered advice on contraception. If the decision to go ahead with a pregnancy is made then amniocentesis for fetal sexing can be offered, with resultant selective abortion of a male child, pregnancy with a female child being allowed to go to term.

Clearly this is a most unsatisfactory situation since only 50% boys aborted will have DMD. Also up to 50% daughters born will be carriers of DMD who may, in turn, transmit the disease to their children.

1-5. CLASSIFICATION OF DMD CARRIERS

Transmission of the X-linked, recessive DMD gene is through female carriers. DMD carriers are normally classified by genetic evidence in the following way:

- (1) Definite carriers
- (2) Probable carriers
- (3) Possible carriers

Definite carriers are mothers of one (or more) DMD son(s) who also have either an affected brother(s) or other affected male relative(s) through the female line.

Probable carriers are mothers of two (or more) DMD sons who have no other family history of the disease. Probable carriers are considered almost certainly to carry the DMD gene (Bayesian analysis). Theoretically, however, the DMD sons of a probable carrier could be the result of a new mutation during embryogenesis.

Possible carriers are either mothers of one DMD son (but with no other family history of the disease) or sisters of DMD boys.

Much greater difficulty lies in assessing the true carrier status of the possible carrier since 1/3 of DMD cases are considered to be new mutations occurring during the boys embryogenesis.

A genetic carrier of DMD has a 50% probability of producing an affected son and the same probability of giving birth to a carrier daughter. Recognition of DMD carriers is therefore of great importance in order to enable genetic counselling to be given.

## 1-6. DMD CARRIER DETECTION

Many of the abnormalities seen in DMD have been found to a less severe extent in DMD carriers. The measurement of these abnormal parameters forms the basis of DMD carrier detection work.

A small percentage of women who carry the gene for DMD show clinical muscle wasting and weakness to a varying degree but others are apparently clinically normal. The most sensitive method of DMD carrier recognition (serum creatine kinase estimation) can detect up to 70% of heterozygotes. However, there is considerable overlap between levels in the carrier and control populations. The great variability in expression of heterozygosity can be explained in terms of random X chromosome inactivation (Lyon, 1962).

The Lyon hypothesis considers the inactivation of either the maternally or paternally derived X chromosome occurs entirely randomly early on in fetal life. That once inactivated the situation is irreversible and all subsequent cells derived from the original will exhibit the same inactivated chromosome. Following the inactivation process a female's cells will consist of a mosaic reflecting the X-chromosome pattern present during embryogenesis. Only the germ cells escape inactivation.

### 1-6.1. Clinical Symptoms

Moser and Emery (1974) estimated approximately 8% DMD carriers exhibit clinical symptoms, ranging from pseudohypertrophy of the calf muscles to overt muscle wasting and weakness.

Using manual muscle testing Roses et al. (1976b: 1977a) found muscle weakness in a high percentage of female relatives of DMD patients.

## 1-6.2. Investigations on Muscle

The pathological changes that occur in Duchenne muscle have been well characterised (see Cullen and Mastaglia, 1980) and may be used diagnostically. There have been reports of muscle biopsies from some DMD carriers exhibiting similar pathological features (but to a variable and milder degree) using light (Dubowitz, 1963; Emery, 1963, 1965a) and electron microscopy (Milhorat et al., 1966; Roy and Dubowitz, 1970; Afifi et al., 1973). Often, however, workers have expressed difficulty in interpreting the significance of the minimal changes seen in some biopsies. Maunder-Sewry and Dubowitz (1981) have attempted to quantify the pathological features shown by Duchenne carrier muscle to aid such interpretation. Interestingly, carriers demonstrating pathological muscle alterations but possessing normal serum creatine kinase levels have been reported (Roy and Dubowitz, 1970). Further work on carrier muscle related to calcium measurement has been discussed in Section 2-1.1

Quantitative electromyography (EMG) has been used in carrier detection with varying degrees of success (Gardner-Medwin, 1968; Moosa et al., 1972; Valli et al., 1976). Some authors believe the technique to be capable only of distinguishing DMD carriers from controls as a group and to be of little value in individual cases (Hausmanowa-Petrusewicz et al., 1977). Overall more studies are necessary to assess fully the usefulness of this essentially complex method of carrier detection.

Using muscle biopsy material, muscle protein turnover was examined first in 10 DMD carriers (Ionasescu et al., 1971) then in larger series of DMD carriers (Ionasescu et al., 1973; 1975; 1976). In each of these studies an increased in vitro amino acid incorporation by polyribosomes

was found in a very high percentage of DMD carrier samples compared to controls in 46/47 (97.8%) definite and 47/87 (54%) possible carriers in the 1976 study). Several carriers with a normal creatine kinase level were reported to have an increased polyribosomal amino acid incorporation. The method has been suggested as an adjunct to routine carrier detection work (Ionasescu et al., 1975). However Tomkins et al. (1982) reported both in vitro muscle protein and ribonucleic acid incorporation in DMD carrier muscle to be normal.

Monkton et al. (1981) compared the in vitro uptake of tritiated leucine in single muscle fibres of muscle biopsies from DMD carriers (3 obligate and 11 possible) and 10 controls. All 3 obligate carriers and 7/11 (36%) possible carriers were reported to have an abnormally increased uptake of tritiated leucine into some muscle fibres, consistent with heterozygote mosaicism. However increased leucine uptake could be due to muscle fibre regeneration resulting from injury other than that due to the dystrophic process, as stated by Monkton et al. (1981). This preliminary study awaits confirmation.

### 1-6.3. Investigations on Body Fluids

Altered serum levels of many muscle-specific proteins have been reported in patients with DMD (discussed in detail by Pennington, 1980) consistent with the concept of a "leaky" membrane (see 1-3.3.). Raised serum levels of such proteins in DMD carriers are thought to be resultant of the population of dystrophic muscle fibres within the Lyonised carrier muscle. This would at least partially explain the extremely wide range of serum protein levels obtained within the carrier population, even in the case of serum creatine kinase activity, the most reliable and routinely applied carrier detection test (Emery, 1980). Interpreting



raised serum creatine kinase activity as indicative of carrier status results in approximately 70% genetic carriers being identified. The remaining 30% with normal serum creatine kinase levels could conceivably have (following Lyonisation) too few dystrophic muscle fibres to result in an abnormal serum level of this enzyme. As the widely accepted most sensitive method of carrier detection, considerable work has been done in attempts to improve the sensitivity of serum creatine kinase estimation (discussed fully in Chapter 3).

Leyburn et al. (1961) investigated serum levels of aldolase, glutamic oxalacetic transaminase and glutamic pyruvic transaminase in a series of DMD carriers and controls but found no significant difference in the levels of these enzymes in the two groups.

Emery (1964) examined the isoenzyme patterns of lactate dehydrogenase (LDH) in both DMD carrier muscle and sera. Whilst the level of the isoenzyme LDH-5 was decreased in carrier muscle, serum LDH isoenzymes were not significantly different in carriers and controls.

Roses et al. (1977) reported serum LDH-5 measurement to be a better indicator of carrier status than serum creatine kinase estimation.

This was disputed by Burt and Emery (1979) who found LDH-5 selected 0/6 (0%) and 1/22 (5%) definite and possible DMD carriers respectively, compared to 4/6 (67%) and 6/22 (27%) selected by serum creatine kinase.

Serum pyruvate kinase measurement has also been investigated as a method of carrier detection following the reports of Alberts and Samaha (1974). Work relating to this enzyme has been discussed in Chapter 4.

Various combinations of serum enzymes have also been investigated (Chapter 7).

Studies involving the serum proteins haemopexin and myoglobin have been discussed in Chapters 5 and 6, respectively.

The urinary excretion of creatine relative to creatinine has been

shown to be raised in many muscle wasting conditions, including DMD. The altered urinary composition is considered to be due to the decreased muscle uptake of creatine resulting in creatinuria and decreased creatinine excretion. Leyburn et al. (1961) examined the creatine/creatinine ratio in the urine of a series of DMD carriers and controls but found the mean ratios were not significantly different comparing the two groups, confirmed by Maskrey et al. (1979). Maskrey and co-workers (1979) also reported no significant difference in the mean molar ratio of the amino acid 3-methylhistidine relative to creatinine (considered to represent the in vivo rate of myofibrillar protein catabolism) in their series of 11 carriers and 10 controls.

Frearson et al. (1981), using two dimensional electrophoresis, reported the presence of additional protein spots (named C and D) on the urine electropherograms of DMD patients. Spot C was variably present in urine samples from 12/21 (57%), and spot D from 3/21 (14%) definite DMD carriers. Spot C (molecular weight 26,000 daltons) was also present in urine from patients with other neuromuscular diseases and in a small percentage of controls. Frearson et al. (1981) consider spot C to be a non-specific indicator of muscle damage and suggest its possible use in carrier detection work particularly in pregnant women where serum creatine kinase estimation becomes unreliable.

#### 1-6.4. Other Methods

Non-muscle cell membrane abnormalities reported in DMD carriers have been discussed in Section 1-3.3.ii.

Abnormal electrocardiograms (ECG) with patterns similar to the Duchenne ECG have been reported in 3/18 (16%) DMD carriers (Mann et al., 1968) but are considered rare (Lane et al., 1980). Other ECG abnormalities have been found in comparison of carrier and control groups, including an increased amplitude sum (R-S) in lead V<sub>1</sub> (Emery, 1969a; Lane et al., 1979). In a sizable series (31 DMD carriers and 112 normal women), Lane et al. (1980) reported electrocardiographic abnormalities and a lack of correlation between ECG and serum creatine kinase activity in the carrier group, implying the possible value of including ECG measurements in carrier probability calculations.

Whilst ECG has the appeal of being a non-invasive procedure with routine application in other fields, several tests suggested as methods of carrier detection involve complex and technically exacting procedures not easily applied. The measurement of limb blood flow and estimation of whole body potassium and rubidium half-life fall into this category. Démos et al. (1962) reported DMD carriers to have a decreased peripheral circulation time. However, Emery and Schelling (1965) could find no significant difference in limb blood flow in Duchenne carriers and controls.

A significantly decreased total body potassium level in DMD patients and carriers compared to controls was reported by Bland et al. (1964; 1967) and Nagai et al. (1969) who found a decreased whole body potassium level in 4/15 (37%) fathers of patients as well. Nagai and co-workers (1969) also reported an altered metabolism (a decreased

half-life of rubidium chloride ( $^{86}\text{Rb}$ ) in a small series of DMD carriers. Bradley et al. (1971) was unable to confirm either finding and considered neither of value in carrier detection.

Stephens et al. (1980) examined one effect of exercise on the metabolic response of DMD carriers. The maximal work capacity of the carriers and their age matched controls was determined using a cycle ergometer. No significant abnormality of either the dynamic or metabolic exercise response was found in the Duchenne carriers compared with the controls, although the maximal work capacity of the carrier group was slightly decreased.

More recently Stephens et al. (1982) reported a small increase in collagen type III in the muscle of some carriers; the increase could have resulted from connective tissue infiltration or, as Stephens suggests, may be indicative of a primary role of collagen in DMD.

The contract within a system is defined as the set of all the activities that are necessary to produce a product or service. The contract is defined as the set of all the activities that are necessary to produce a product or service. The contract is defined as the set of all the activities that are necessary to produce a product or service.

The contract within a system is defined as the set of all the activities that are necessary to produce a product or service. The contract is defined as the set of all the activities that are necessary to produce a product or service. The contract is defined as the set of all the activities that are necessary to produce a product or service.

## CHAPTER 2: CALCIUM

The contract within a system is defined as the set of all the activities that are necessary to produce a product or service. The contract is defined as the set of all the activities that are necessary to produce a product or service. The contract is defined as the set of all the activities that are necessary to produce a product or service.

## 2-1. INTRODUCTION

The current routinely applied method of carrier detection, the estimation of serum creatine kinase activity, relies on the abnormal leakage of the enzyme from carrier muscle. However, such measurements are secondary phenomena and may be far removed from the primary lesion. The possibility of attaining a detection rate approaching 100% genetic carriers may only reside in either the demonstration of cellular mosaicism or the measurement of some abnormality directly resultant of the primary defect.

There is increasing evidence to imply that intracellular calcium may play an important role in the dystrophic process. There have been reports of increased intracellular calcium levels and altered calcium transport properties in DMD cells.

### 2-1.1. Calcium in Duchenne Muscle

Cullen and Fulthorpe (1975) postulated that an abnormal influx of calcium through the sarcolemma of Duchenne muscle might be responsible for some of the morphological changes characteristic of the disease.

Bodensteiner and Engel (1978) investigated a large series of muscle biopsies and found non-necrotic, large-dark fibres 12 times more frequently in DMD than in other neuromuscular disorders. In the Duchenne biopsies 43% of the eosinophilic (large-dark) fibres exhibited increased intracellular calcium when treated with calcium stains.

Emery and Burt (1980) succeeded in demonstrating a significant increase in the proportion of eosinophilic, increased-calcium-content fibres in muscle from male fetuses at risk of DMD. Since the calcium-positive

fibres appeared in advance of the gross changes evident in DMD muscle at a later stage it was concluded that such fibres must represent a very early structural alteration. Consequently the increased intracellular calcium level may represent an early biochemical change in the disease.

Bertorini et al. (1982) combined a histochemical study of calcium-positive fibres in Duchenne muscle with chemical analysis. Using atomic absorption spectrophotometry these authors found the calcium content of DMD muscle was 50% higher than that of controls. No relationship was evident between the number of calcium positive fibres demonstrated histochemically and the actual calcium content in 6 DMD patients. The calcium level in Duchenne muscle did not decrease with patient age, further evidence that increased intracellular calcium occurs early in the disease process.

Using the extremely sensitive technique of electron probe X-ray microanalysis (EPXMA) Maunder et al. (1977) found a consistent elevation of the calcium to phosphorus ratio in interstitial cell nuclei in Duchenne muscle and in myonuclei in both DMD and DMD carrier muscle (Maunder-Sewry and Dubowitz, 1979). This group confirmed the increased amount of calcium in Duchenne muscle using X-ray fluorescence spectrometry (Maunder-Sewry et al., 1980).

Normal mammalian muscle loaded with calcium in vitro has been found to exhibit a similar pattern of calcium accumulation as that seen in degenerating muscle, using increased calcium in the buffer and measurement by EPXMA (Oberc and Engel, 1977) and by use of the calcium-specific ionophore A23187 (Publicover et al., 1978). These observations led Oberc and Engel (1977) to propose that in pathologically altered muscle fibres a damaged plasmalemma results in an influx of calcium,

accumulation of the ion by organelles and resultant calcification, leading to structural damage and decreased functional ability.

Following the report by Busch et al. (1972) of a calcium activated sarcoplasmic protein factor in normal mammalian muscle which preferentially attacks Z bands, a significantly increased activity of calcium activated neutral protease (CANP) was found in Duchenne muscle (Kar and Pearson, 1976). CANP and possibly a calcium activated serine protease were shown to decrease troponin I and C (a very early event in muscle cell degradation) in normal mammalian muscle (Ebashi and Sugita, 1979). These observations led to the suggestion that intracellular calcium in Duchenne muscle reaches a level sufficient to activate CANP, resulting in myofibrillar overcontraction and disassembly and eventually cell necrosis (Cullen and Mastaglia, 1980). It has also been suggested that the intramembraneous particles demonstrated in muscle membranes by freeze-fracture analysis and present in reduced numbers in DMD muscle (Schotland et al., 1977) might be decreased in DMD due to the action of calcium activated proteases in this tissue (Lucy, 1980). Calcium dependant proteolysis has, very recently, been reviewed by Ishiura (1983).

However, the increased protein breakdown seen in Duchenne muscle has been considered to be mediated through prostaglandins (Horrobin et al., 1978; Rodemann et al., 1982). Using rat skeletal muscle treated with ionophore A23187 (to increase the intracellular calcium concentration) Rodemann and co-workers (1982) found the calcium induced proteolysis was not decreased in the presence of CANP inhibitors. But protein breakdown in ionophore-treated muscle was decreased both in the presence of lysosomal protease inhibitors and prostaglandin synthesis inhibitors.



Abnormalities of calcium homeostasis in Duchenne muscle could also result in the abnormal release of muscle enzymes (a consistent feature of DMD). An increased efflux of both creatine kinase and lactate dehydrogenase have been observed in normal human skeletal muscle in vitro upon raising the calcium level of the incubating medium (Anand and Emery, 1980). The accelerated enzyme efflux could be partially reversed upon addition of Verapamil (a calcium blocker thought to inhibit the transmembrane influx of calcium) to the bathing medium (Anand and Emery, 1982).

Few studies have centred on calcium transport in Duchenne muscle. Samaha (1977) reported a decreased uptake of calcium by the sarcoplasmic reticulum in DMD muscle. Yagiela and Benoit (1979) found that treatment of normal skeletal muscle with quinidine (a drug thought to inhibit calcium binding to the sarcoplasmic reticulum and inhibit mitochondrial calcium uptake and storage) resulted in muscle degeneration which was reversed in the presence of Verapamil.

#### 2-1.2. Duchenne Erythrocyte Calcium

The potential significance of the involvement of calcium in the dystrophic process in muscle and the increasing evidence pointing to a generalised membrane defect have led to the examination of calcium homeostasis in DMD erythrocytes.

Many of the erythrocyte abnormalities in DMD (discussed in Chapter I) are consistent with an increased intraerythrocytic calcium content or an altered sensitivity of Duchenne erythrocytes to calcium. Several of these abnormalities have been reproduced in normal erythrocytes by artificially increasing the intraerythrocytic calcium level, including

decreased deformability (Weed et al., 1969); increased potassium efflux (Dise et al., 1977); increased echinocyte formation (White, 1974) and decreased osmotic fragility (Dise et al., 1977).

Calcium fluxes in Duchenne erythrocytes have been examined. Mollman et al. (1980) found calcium was transported at a faster rate by DMD erythrocytes inside-out vesicles, compared to controls but also found the transport protein of the ion to have a decreased affinity in the Duchenne cells. Shoji (1981), however, reported both the influx and efflux rates of calcium to be similar in both Duchenne and age-matched control intact erythrocytes.

A significant finding which suggests DMD erythrocytes may be attempting to correct an increased intracellular level of calcium involves the report of an increased activity of calcium-stimulated-magnesium-dependant adenosine triphosphatase ( $\text{Ca}^{2+}$ -stimulated  $\text{Mg}^{2+}$ -dependant-ATPase). Hodson and Pleasure (1977) reported an increased activity of this enzyme in Duchenne erythrocyte membranes compared to controls, as did Luthra et al. (1979). Luthra and co-workers extended the investigation to include a study of a cytoplasmic activator protein factor present in erythrocytes (calmodulin) which stimulates  $\text{Ca}^{2+}$ -stimulated  $\text{Mg}^{2+}$ -dependant-ATPase, but could find no evidence that the activator was altered in Duchenne cells. Ruitenbeek (1979) confirmed the increased activity of  $\text{Ca}^{2+}$ -stimulated  $\text{Mg}^{2+}$ -dependant ATPase in DMD erythrocytes but found no significant alteration in the affinity of this enzyme for calcium in Duchenne cells. Hausmanowa-Petrusewicz et al. (1977) reported a significantly increased mean activity of  $\text{Ca}^{2+}$ -stimulated  $\text{Mg}^{2+}$ -dependant-ATPase in erythrocytes from a series of 24 DMD carriers compared to 10 female controls.

A recent report which does not agree with the above findings is

that of Johnsson et al. (1983) who studied a small series of 13 DMD patients and 7 normal control boys. Despite using an experimental procedure designed to preserve calmodulin, these authors found  $\text{Ca}^{2+}$ -stimulated  $\text{Mg}^{2+}$ -dependant-ATPase activity was not significantly different comparing the two groups.

### 2-1.3. Erythrocyte Calcium Measurement

Normal erythrocytes contain a very low level of calcium which, at equilibrium, comprises of calcium bound to the membrane, calcium bound to cytoplasmic buffers and ionised calcium in the aqueous phase. Calcium, thought to be at an intracellular concentration of less than  $10^{-6}\text{M}$  (Schatzmann, 1975), is maintained at a low level due to the impermeability of the erythrocyte membrane to this ion (Ferriera and Lew, 1976) and to the active extrusion of intracellular calcium by a powerful calcium pump, the  $\text{Ca}^{2+}$ -stimulated  $\text{Mg}^{2+}$ -dependant-ATPase (Schatzmann and Vincenzi, 1969). An increase in free intraerythrocytic calcium accelerates the pump mechanism in such a way that a two fold increase in calcium concentration leads to a six fold increase in pumping, whilst a ten fold increase in calcium concentration accelerates the pump seventy fold. The cytoplasmic activator protein calmodulin also interacts with this pump to regulate physiological calcium levels (Cox et al., 1982).

Estimates of intraerythrocytic calcium have been seriously hindered by the extremely low level of calcium present within erythrocytes which are surrounded by plasma containing a considerably greater level of calcium. Techniques devised in attempts to overcome these problems have mainly involved artificially increasing the

the intraerythrocytic calcium pool, for example by disrupting the erythrocyte membranes and incorporating calcium buffers or by the use of ionophores (Bookchin and Lew, 1980; Simons, 1982). None of these methods offer the possibility of measuring calcium in individual erythrocytes. If, as evidence suggests, DMD erythrocytes contain an increased calcium level, and if the raised intraerythrocytic calcium content is related to the primary defect then the measurement of calcium in individual erythrocytes from a genetic carrier of DMD may demonstrate, according to the Lyon hypothesis, (Lyon, 1962) two erythrocyte populations; a normal population and a population manifesting an increased level of calcium. To investigate this possibility, relative intraerythrocytic calcium levels were compared by use of fluorescent stains. Electron probe x-ray microanalysis (EPXMA) was employed to give a quantitative assessment of individual intraerythrocytic calcium levels.

#### 2-1.4. Electron Probe X-Ray Microanalysis (EPXMA)

The technique of EPXMA is essentially a non-destructive method which can be applied to the localization and identification of chemical elements intracellularly. Qualitative and quantitative elemental analysis can be carried out using either a scanning or transmission mode electron microscope and is based on the measurement of the resultant x-radiation produced following excitation of the sample by an electron beam. X-ray spectra produced fall into two categories; characteristic and continuous. The characteristic x-ray spectrum of each element involves the emission of an x-ray spectrum of discrete spectral lines with wavelengths characteristic of that element and with

intensities related to elemental concentration. Such x-rays are emitted when incidence electrons (from the electron beam) expel electrons from the inner orbitals of the atoms in the specimen and electrons from orbitals further out fall into the vacancies. For a given element the characteristic x-rays, since they have the same energy, form a group, resulting in a peak in the spectrum of emitted x-rays. Each element has more than one characteristic peak. However, only the  $K\alpha$  peak (resulting from an L shell to K shell electron transition within the atom) and the  $K\beta$  peak of higher energy but lower amplitude (resulting from an M shell to K shell transition) are of importance when considering the elements potassium and calcium.

In the x-ray spectrum potassium  $K\beta$  and calcium  $K\alpha$  peaks overlap. The considerably higher potassium content in the erythrocyte compared to calcium results in interference from potassium  $K\beta$  counts in the channels set for calcium  $K\alpha$  measurements. Therefore, preparative techniques retaining both ions were unsuitable for this study.

The continuous x-ray spectrum consists of a continuous band of wavelengths starting with a minimum wavelength, rising to a peak (maximum intensity) then falling in intensity at longer wavelengths. The continuum is generated when the incident electrons undergo incremental deceleration in the specimen. The continuous x-rays form the background in the x-ray spectrum and can be used in the estimation of the specimen mass. The peak/background ratio (P/B ratio) of an element (the ratio of characteristic to continuous x-rays) is employed to indicate the mass concentration of that element in the specimen.

The energy-dispersive detector is the one of choice in this work. In energy-dispersive EPXMA, x-rays generated by the specimen impinge upon a detector made of lithium-treated silicon. Upon striking the

detector each x-ray photon releases its energy resulting in the production of an electric pulse. The current pulse formed (proportional to the x-ray energy) is amplified and converted to a voltage pulse, the height of which is proportional to the energy of the incident x-ray. The height of the voltage pulse is then measured by a pulse height analyser and stored in a computer which possesses many channels. Five hundred channels are usually used, each collecting pulses within a range of 20 eV. The information accumulated in the computer after a significant period of time forms a spectrum whose ordinate is the x-ray energy. The abscissa represents the number of pulses proportional to the number of x-rays (of this particular energy) which entered the detector. The spectrum can be stored in the computer and recorded digitally on teletype.

Resolution (ability to separate two adjacent peaks) is measured as the full peak width at half maximum intensity and even at maximum resolution the width of the peak (the result of pulses from a single element being spread over several channels) decreases the relative height of the peak and lowers the P/B ratio. The P/B ratio determines sensitivity. When the concentration of the element being analysed is very low the actual mass of the element is very small. Consequently count rates are low and to achieve statistically meaningful results sufficient counts at the peak must be accumulated to differentiate them from background counts. With low counting rates counting times greater than 100 seconds must be used, which may involve errors due to instrumental drift, contamination deposition and beam current fluctuations.

Using the "thick section" technique (where a "thick section" is one in which the incident electron beam is wholly absorbed) quantitation is carried out by producing a calibration curve from peak/background ratio

measurements on a series of standards. If the conditions of analysis are kept the same for standards and specimens then the calibration curve can be used to obtain the mass concentration in the specimens. For this technique the background is measured using separate regions of the spectrum which do not contain peaks. These background channels are situated close to the peaks being assayed so that when x-ray absorption occurs in the specimen it is similar in both peak and background. In the "thin section" technique the incident electron beam is not wholly absorbed and so there will inevitably be some scattered electrons in the column and therefore additions to the background from the film, support grid and specimen holder. Using a low atomic number material (such as nylon) minimises this contribution. For analysis of the results additional to the background measured as described above, an area of film free from sample is analysed and this background subtracted from the results to exclude the contribution.

Blood samples were taken from the following groups of subjects:

- (1) Two DMD patients
- (2) Two DMD carriers
- (3) Six male controls
- (4) Eight female controls

#### DMD Patients

DMD patients had been previously diagnosed on genetic, clinical and biochemical evidence and in most cases confirmed by abnormal histology of muscle biopsy. Blood samples were taken when the DMD patients attended the muscle clinic in the Department of Human Genetics at the Western General Hospital, Edinburgh.

#### DMD Carrier

DMD carriers were classified in the following way:

Those women who are definite carriers on genetic evidence, i.e. - have at least one DMD son and at least one other affected male relative through the female line (2 subjects).

Throughout the thesis DMD patients and carriers have been identified in terms of their family number, followed by their generation number and finally the subject's personal number within that generation. All pedigrees have been listed in Appendix I.

#### Controls

Control subjects were normal, healthy males or females with no history of neuromuscular disease.



All subjects used in this thesis were volunteers who gave informed consent and, where applicable, parental consent was obtained as well. Blood samples (other than DMD patient samples) were taken either in the Department of Human Genetics or at the subject's home.

All chemicals used throughout this thesis were purchased from BDH Chemicals Ltd., Dorset, U.K. unless otherwise stated.

5-10 ml venous blood samples were obtained by venepuncture, collected into heparinised tubes and immediately processed in one of the following ways:

- (A) Air-dried blood smears were prepared on glass microscope slides.
- (B) Erythrocytes were deposited on 'slides as a fine spray via a nitrogen gas delivery of 25 pounds per square inch for 3 seconds (sec's) through a 0.6 mm gauge needle, across the end of a capillary tube filled with blood. The needle was sealed to an adapted 25 cm<sup>3</sup> syringe through pressure tubing and a pressure gauge to the nitrogen cylinder and positioned 3 cm from the capillary tube. The distance and height of the capillary tube from the 'slides was set at 11.3 cm and 7.5 cm respectively. This procedure was carried out in a fume cupboard.

#### 2-2.1. Erythrocytes Stained with 3,5,7,2',4'-Pentahydroxyflavanol (Morin)

Optimal staining conditions were obtained using the following protocol, adapted from Pearse (1972):

- (1) Blood samples processed as stated in (A) or (B) were brought to 85% ethanol for 5 minutes (min's).
- (2) Stained in 0.2% Morin in 85% ethanol (Analar grade) containing 0.5% acetic acid (5 min's).
- (3) Washed in 70% ethanol (2 sec's).

(4) Washed in distilled water (2 sec's).

(5) Mounted in distilled water using glass coverslips.

### Control Slide

One from each batch of slides stained was pre-treated (10 min's.) by immersion in 1% aqueous hydrochloric acid.

Stained blood samples were examined by fluorescence microscopy using a Leitz Ortholux microscope (Leitz Instruments Ltd., Luton, UK) with fluorescent attachment; X54 oil immersion objective and filters K530, BG12 (15 mm) and BG12 (3 mm).

### 2-2.2. Lymphocytes Stained with 3,5,7,2',4',-Pentahydroxyflavanol (Morin)

Lymphocytes were prepared from heparinised blood samples according to the protocol described by Böyum (1968) and stained and examined under the conditions stated in Section 2-2.1. Cells from 4 normal male and 4 normal female subjects were examined.

### 2-2.3. Erythrocytes Stained with Chlorotetracycline (CTC)

Optimal staining conditions were obtained using 1 mM CTC (United States Biochemical Corporation, Ohio, USA) dissolved in Tris buffered Ringer's (pH 7.4 at 37°C) containing per litre:

mM	
134.00	Sodium chloride
10.00	Tris
1.28	Calcium chloride
0.56	Magnesium chloride
1.00	Sodium dihydrogen phosphate

#### 4.70 Potassium chloride

adjusted to the pH with sodium hydroxide. A 1 in 30 dilution of whole blood to 1 mM CTC in Tris buffered Ringer's was incubated for 60 min's at 37°C with gentle agitation. Air dried blood smears were prepared following this procedure and examined by fluorescence microscopy as described in Section 2-2.1.

#### Control Slide

One from each batch of slides were treated as described in Section 2-2.1. (control slide)

2-3. MATERIALS AND METHODS: ELECTRON PROBE X-RAY MICROANALYSIS (EPXMA)

Blood samples from the following groups of subjects were analysed:

- (1) Five patients with DMD
- (2) Three DMD carriers
- (3) Two male controls
- (4) Five female controls

DMD Patients

As defined in Section 2-2.

DMD Carriers

DMD carriers were classified in the following way:

- (1) Those women who are definite carriers on genetic evidence - have at least one DMD son and at least one other affected male relative through the female line (2 subjects).
- (2) Those women who are possible carriers on genetic evidence but considered "definite" carriers on combined genetic and biochemical evidence - having one DMD son and a first degree female relative with a serum creatine kinase level greater than 1.5 x 95th percentile of the control series (1 subject).

Controls

As defined in Section 2-2.

5-10 ml venous blood samples taken by venepuncture were collected into heparinised tubes and immediately processed.

### 2-3.1. Preparation of Samples: "Thick Section" Technique

All apparatus used throughout this study, including the graphite stubs, were hydrochloric acid-washed and rinsed three times using triple distilled, deionised water (TDW) to eliminate calcium contamination. All reagents were prepared using TDW.

Heparinised blood samples were centrifuged using an MSE bench centrifuge (MSE Ltd, Crawley, UK) immediately following collection (10 min's, 1250 g). Both plasma and buffy coat were removed and the erythrocytes then washed twice in isotonic saline (0.9%). 0.5 ml washed erythrocytes were transferred to 5 ml modified Millonig fixative-buffer (for fixative-buffer preparation refer to Appendix III). After 5 minutes the fixed erythrocytes were centrifuged (5 min's, 150 g, MSE centrifuge) and the fixative washings discarded.

Following one post-fixative wash (isotonic saline), the erythrocytes were resuspended to a 20% v/v suspension in isotonic saline. Drops of the suspension were then transferred onto graphite stubs, the erythrocytes being spread across the stub using glass coverslips. After air-drying the stubs were stored in a vacuum desiccator prior to analysis, within a 48 hour (hr) period.

Quantitation of the measurements was achieved by analysis of a series of albumin standards containing known amounts of calcium.

### 2-3.2. Preparation of Standards: "Thick Section" Technique

Calcium standards of molarity 0, 1, 2 and 4  $\mu\text{mol}$  calcium per gram albumin were produced by the addition of appropriate dilutions of a commercially prepared  $1 \text{ mgml}^{-1}$  calcium nitrate solution in TDW to

dialysed bovine plasma albumin Cohn fraction V (dialysis of albumin described in Appendix III).

Final calcium concentrations of the albumin standards were measured by atomic absorption spectrophotometry (AAS). AAS was carried out by Mr. G. Moon of the Dept. of Biochemistry, Animal Diseases Research Association, Edinburgh.

One drop of each prepared standard was placed onto a graphite stub, being spread evenly over the surface using a glass coverslip and then frozen in liquid isopentane cooled in liquid nitrogen. The standards were then freeze-dried prior to storage in a vacuum dessicator and subsequent analysis within a 48 hr period.

To determine the extent of interference of the potassium  $K\beta$  peak on the measurement of the calcium  $K\alpha$  peak a potassium standard was prepared. Preparation and analysis of the potassium standard was the same as that of the calcium standards except potassium chloride solution was added to the albumin to produce a standard of 76.7  $\mu\text{mol}$  potassium per gram albumin (confirmed by AAS).

### 2-3.3. EPXMA: "Thick Section" Technique

EPXMA of prepared samples and standards was carried out using a Jeol JSM -35 scanning electron microscope (Jeol Ltd, Tokyo, Japan). The microscope was fitted with a Kevex (Kevex Corp., California, USA) energy dispersive, lithium-drifted silicon detector which was coupled to a pulse height analyser and computer (Link Systems Ltd, Buckinghamshire UK). Specimens were examined at  $45^\circ$  to the electron beam and all instrument parameters including distance of the detector from sample, beam current and condenser current were standardised for each EPXMA session.

Windows (groups of channels counted) were set for potassium, calcium and two backgrounds (refer to Table 2.1. and Figure 2.1.).

Analysis was performed at 30 kV accelerating voltage for a live counting time of 200 sec's per erythrocyte. High count rates were used (1000-2000 counts per sec.) and count rates corrected for dead time (time required to detect an x-ray photon and process its pulse).

Only intact erythrocytes were analysed. Following selection of an erythrocyte, magnification was increased to  $\times 10,000$  and the electron beam focused over the entirety of the cell. Charging rarely occurred but samples affected by charging were not analysed. "Thick section" EPXMA was carried out in collaboration with Professor D.A.T. Dick, University of Dundee.

Computation of raw data used standard EPXMA theory. The computer program used was developed by Professor Dick.

Total background x-ray counts for both potassium  $K\alpha$  and calcium  $K\alpha$  peaks were assessed by use of the measurements of background BA and BB.

Following subtraction of the appropriate amount of background the remaining x-ray counts in the potassium window were considered to be the potassium  $K\alpha$  peak.

Counts in the calcium window after appropriate background subtraction and subtraction of 1/30th of the counts in the potassium  $K\alpha$  peak (to overcome interference of any remaining potassium  $K\beta$  counts in the calcium window) were considered to be the true calcium  $K\alpha$  peak. The calculations used from raw data to P/B ratio can be summarised as follows:

Channels (Energies)	Total X-ray Counts
2920-3100	RBA
3240-3360	RK

Table 2.1. Description of Windows set for EPXMA and Source of X-rays Counted

Name (Abbreviation)	Window	Energies of channels (no. of channels set) KeV	Counts arriving in these channels attributable to:
1st background (BA)	2920-3100 (10)	2920-3100	background only (positioned to avoid peak interference)
Potassium K $\alpha$ (K)	3240-3360 (7)	3240-3360	(a) counts due to background (b) actual potassium counts
Calcium K $\alpha$ (Ca)	3660-3720 (4)	3660-3720	(a) possible counts arising from potassium K $\beta$ (due to K $\beta$ and CaK $\alpha$ peak overlap) (b) counts due to background (c) actual calcium counts
2nd background (BB)	3800-3980 (10)	3800-3980	background only (positioned to avoid peak interference)



Table 2.1. (continued)

When iron was measured the following windows were also set:		Window	Counts arriving in these channels attributable to:
Name (Abbreviation)	Energies of channels (no. of channels set) KeV		
3rd background (B3)	6020-6200 (10)		background only (positioned to avoid peak interference)
Iron K $\alpha$ (Fe)	6280-6520 (13)		(a) counts due to background (b) actual iron counts
4th background (B4)	6600-6780 (10)		background only (positioned to avoid peak interference)

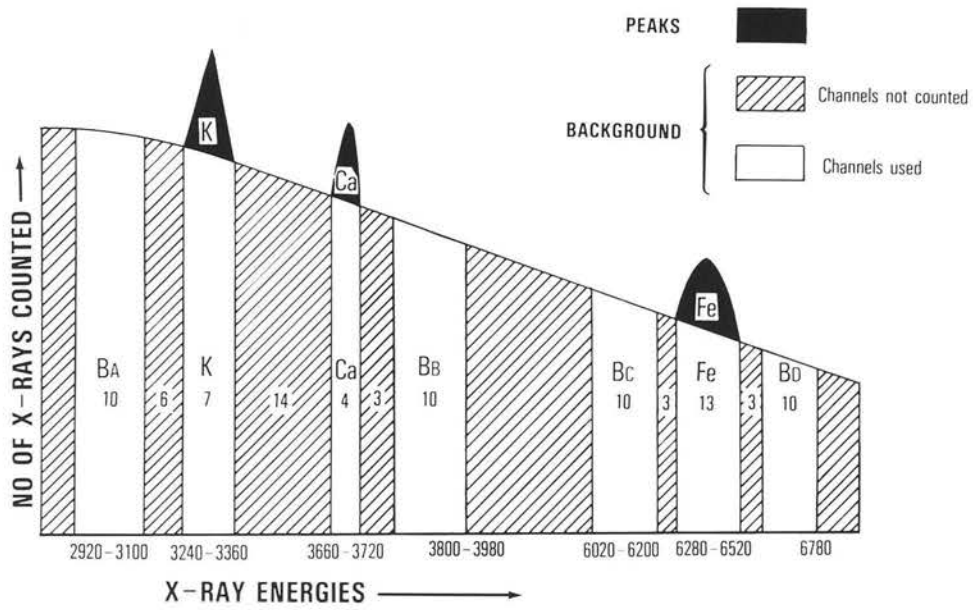

3660-3720 RCa

3800-3980 RBB

where:

Prefix R = raw data

K = potassium

Ca = Calcium

BA = 1st background

BB = 2nd background

BK = total background for potassium

PK = peak for potassium

KC = correction for potassium

BCa = total background for calcium

PCa = peak for calcium

#### Potassium

$$K \left[ RBA - \frac{14.5}{29.5}(RBA - RBB) \times \frac{7}{10} \right]$$

$$BK = (0.357 \times RBA) + (0.343 \times RBB)$$

$$PK = RK - BK$$

$$KC = 0.033 \times PK$$

#### Calcium

$$Ca \left[ RBB + \frac{10}{34}(RBA - RBB) \times \frac{4}{10} \right]$$

$$BCa = (0.118 \times RBA) + (0.282 \times RBB)$$

$$PCa = RCa - BCa - KC$$

$$P/BCa = PCa/BCa$$

The amount of calcium per gram dry weight for each erythrocyte was calculated using the calcium P/B ratio and the formula derived

from regression analysis of the calcium standards.

Using known figures for erythrocyte mass and cell water content (equivalent to 0.33 g haemoglobin per 0.67 ml H<sub>2</sub>O) calcium expressed as per gram cell water was equivalent to calcium per gram cell solid x 0.5.

#### 2-3.4. Blood Treated with Ionophore A23187 and a Calcium Complexing Agent

One 10 ml sample of fresh, heparinised normal, female control blood having undergone the washing procedure described in Section 2-3.1. was divided into three aliquots. Treatment to each aliquot of erythrocytes prior to fixation was as follows:

- (1) 0.5 ml washed erythrocytes underwent no further treatment prior to fixation.
- (2) 0.1 ml of a 1 mgml<sup>-1</sup> stock solution of ionophore A 23187 (Calbiochem, Herts, UK) in 85% ethanol was diluted 1 in 10 (isotonic saline) and this solution added to 5 ml of a 10% v/v (erythrocyte in saline suspension). Following incubation (30 min's at 37°C) and centrifugation (5 min's, 1250 g, MSE centrifuge) the washings were discarded and the erythrocytes given one wash (isotonic saline) prior to fixation.
- (3) 1 ml packed erythrocytes were incubated in 5 ml 0.1 mM ethylene diamine tetra acetic acid (EDTA) in isotonic saline, 30 min's at 37°C. Treated erythrocytes were centrifuged (5 min's 1250 g, MSE centrifuge), the washings discarded and the erythrocytes given one wash (isotonic saline) prior to fixation.

In all cases the resultant treated erythrocytes were fixed as described in Section 2-3.1. and analysed under the conditions stated in Section 2-3.3. Fifteen erythrocytes from each aliquot were analysed.

#### 2-3.5. Preparation of Samples: "Thin Section" Technique

Erythrocyte collection, washing and fixation procedure were as described in Section 2-3.1. Drops of the 20% v/v fixed erythrocyte in saline suspension were transferred onto carbon coated nylon mesh grids (Graticles Ltd, Kent, UK) covered with a layer of formvar (0.5% in chloroform, air-dried).

The grids were pre-treated with 1% aqueous alcian blue solution (alcian blue GX, Gurr Ltd, Dorset, UK) to facilitate adhesion of the erythrocytes, briefly washed with TDW and allowed to dry. Drops of the erythrocyte suspension were left in contact with the grids for 1 minute. After this time excess fluid was drained and the preparation air-dried. Location of erythrocytes on the grids was checked by light microscopy. Samples were stored in a vacuum desiccator and analysed within a 48 hour period. A minimum of 20 erythrocytes from each grid were analysed per session.

#### 2-3.6. Preparation of Standards: "Thin Section" Technique

As described in Section 2-3.2. Drops of the albumin standards containing known amounts of calcium (confirmed by ASS) were smeared across formvar-coated grids and freeze dried.

## 2-3.7. EPXMA: "Thin Section" Technique

EPXMA of prepared samples and standards was carried out using a Cambridge Stereoscan S180 electron microscope (Cambridge Instruments Ltd., Cambridge, UK) used in transmission mode. The microscope was fitted with a Kevex energy dispersive, lithium-drifted silicon detector coupled to a pulse height analyser and computer (Link Systems Ltd.).

Windows for potassium, calcium and two backgrounds were set as in Section 2-3.3. Additionally, windows were set for iron and two further backgrounds (details given in Table 2.1.).

Specimens were examined at  $45^{\circ}$  to the electron beam and all instrument parameters were standardised for each EXPMA session.

Analysis was performed at 25 kV accelerating voltage for a live counting time of 300 sec's per erythrocyte. Only intact erythrocytes positioned away from the grid bars were analysed. Following selection of an erythrocyte, magnification was increased to x 10,000 and the electron beam focused over the entirety of the cell. Samples affected by charging were not analysed.

Computation of the raw data first involved subtraction of background contribution resultant of film, support, grid and specimen holder (refer to Section 2-1.4.) but otherwise was as described in Section 2-3.3.

Peak/background ratios for iron were calculated as follows:

For channels set refer to Table 2.1.

Channels (Energies)	Total X-ray counts
6020-6200	RB3



6280-6520 RFe

6600-6780 RB4

where:

Prefix R = raw data

B3 = third background set

PFe = peak for iron

BFe = background for iron

$BFe = (0.65 \times RB3) + (0.65 \times RB4)$

$PFe = RPF - BFe$

$P/B \text{ ratio Fe} = PFe/BFe$

B4 = fourth background set

2-4. RESULTS: FLUORESCENT STAINS

2-4.1. Erythrocytes and Lymphocytes Stained with 3,5,7,2',4',-  
Pentahydroxyflavanol (Morin)

All cells prepared by method A or B (described in Section 2-2.) and from all subjects used (DMD patients: 2 III<sub>2</sub>, 5 III<sub>3</sub> and 6 II<sub>2</sub>; DMD carriers 11 II<sub>13</sub> and 15 II<sub>4</sub>; 4 normal male and 4 normal female controls) exhibited a uniform, dull, yellow-green fluorescence when examined by fluorescence microscopy. It was not possible to see any differences in fluorescence intensity in any given population of cells. Method B appeared to generate less background fluorescence (surrounding the erythrocytes) than Method A.

Preparations which had been pre-treated with hydrochloric acid demonstrated a considerably reduced (greater than 95% loss) fluorescence.

Approximately 1% granulocytic leucocytes on whole blood smears (prepared by method A) exhibited a bright white-yellow fluorescence.

Cells prepared by method A have been shown in Plate 2.1.

2-4.2 Erythrocytes Stained with Chlorotetracycline (CTC)

All cells prepared by method A or B (refer to Section 2-2.) and from all subjects used (2 normal males and 4 normal females) exhibited only very slight background fluorescence surrounding each cell which was entirely absent from preparations which had been pre-treated with hydrochloric acid.



Approximately 2% of the total leucocyte population of whole blood smears contained highly fluorescent, multi-lobed nuclei. (refer to Plate 2.1.).

Plate 2.1. Whole Blood Smears (original magnification x 540) Stained with Fluorescent Stains:

Upper: Stained with Morin

All erythrocytes demonstrated a background yellow-green fluorescence.

Positioned centrally in the photograph is a brightly fluorescent granulocytic leucocyte. Approximately 1% of the total leucocyte population fluoresced in this manner.

Lower: Stained with Chlorotetracycline

All erythrocytes demonstrated only very slight background fluorescence.

Positioned centrally in the photograph is a leucocyte containing a highly fluorescent multi-lobed nucleus. Approximately 2% of the total leucocyte population fluoresced in this manner.

*Handwritten text, likely bleed-through from the reverse side of the page.*

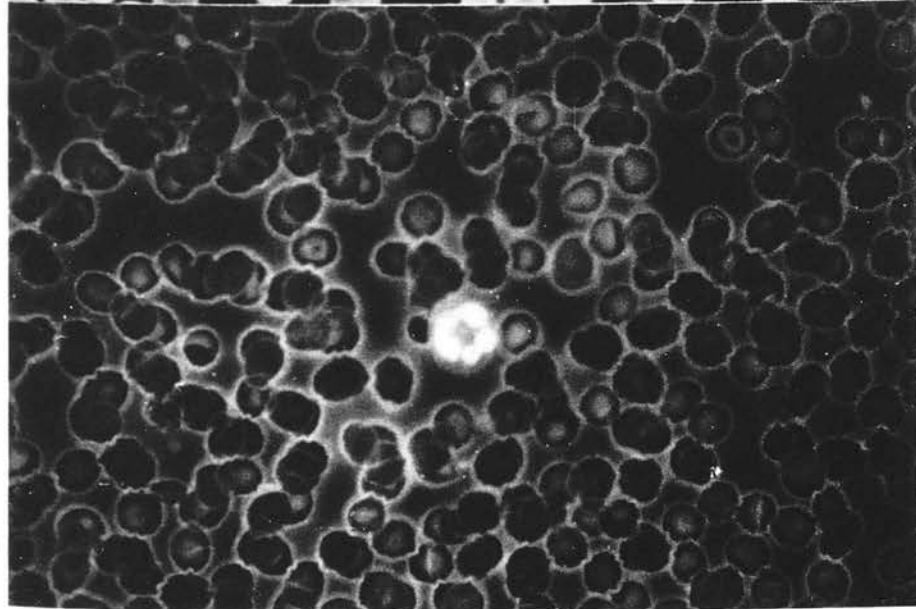
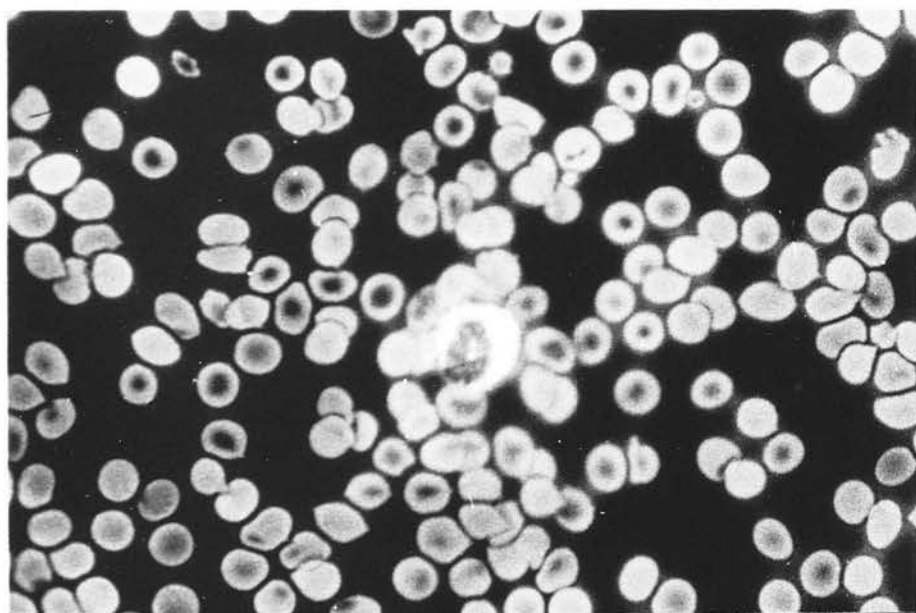

## 2-5. RESULTS: EPXMA

### 2-5.1. Effects of the Fixative-Buffer on Erythrocytes

From the action of the fixative-buffer on the erythrocytic membrane, greater than 95% of the intraerythrocytic potassium content was released (confirmed by AAS). Remaining potassium was measured and the appropriate (small) correction subtracted from the calcium peak.

For the effects of washing and fixation processes on the erythrocyte X-ray spectrum (refer to Plate 2.2.),

### 2-5.2 Comparison of "Thick Section" and "Thin Section" Techniques

Some difficulty was encountered in distinguishing erythrocytes from the suspending matrix using the "thick section" technique, whilst erythrocytes were much easier to visualise using the "thin section" EPXMA.

X-ray spectra of specimens (erythrocytes and albumin protein standards) obtained using both techniques were similar except with regard to contributions made by specimen supports (and these support-derived peaks did not influence calcium measurement).

"Thin section" EPXMA demonstrated a very slight improvement in technique sensitivity (in terms of a slightly increased P/B ratio) compared to that observed using the "thick section" technique. However this increased sensitivity was not sufficient to improve on the information obtained from use of the "thick section" technique.

Apart from the differences between "thick section" and "thin section" techniques cited above, for the purposes of this study

Plate 2.2. Photographs from the Oscilloscope Screen:

Upper Left complete X-ray spectrum of an unfixed erythrocyte. Following the marker peak are visible peaks for phosphorus, sulphur, chlorine, potassium  $K_{\alpha}$ , then  $K_{\beta}$ , and iron.

Lower Left magnified area of X-ray spectrum from an unfixed erythrocyte showing phosphorus (P), sulphur (S), chlorine (Cl) and potassium  $K_{\alpha}$  and  $K_{\beta}$  peaks.

Upper Right complete X-ray spectrum of a fixed erythrocyte with greater than 95% of the potassium removed. In this case, following the marker peak are visible peaks for silicon, phosphorus, sulphur, chlorine, potassium  $K_{\alpha}$  (which is markedly reduced), calcium (previously swamped by potassium), and iron. The white stippled spectrum represents the contribution to the total spectrum due to film, support grid and specimen holder (using the "thin section" technique).

Lower Right magnified area of X-ray spectrum from a fixed erythrocyte showing phosphorus (P), sulphur (S), and chlorine (Cl) peaks followed by a greatly reduced potassium  $K_{\alpha}$  peak and small calcium (Ca) peak (masked by potassium  $K_{\beta}$  peak in upper left spectrum).

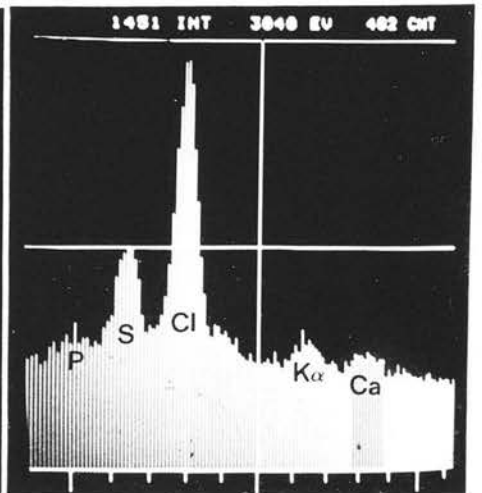
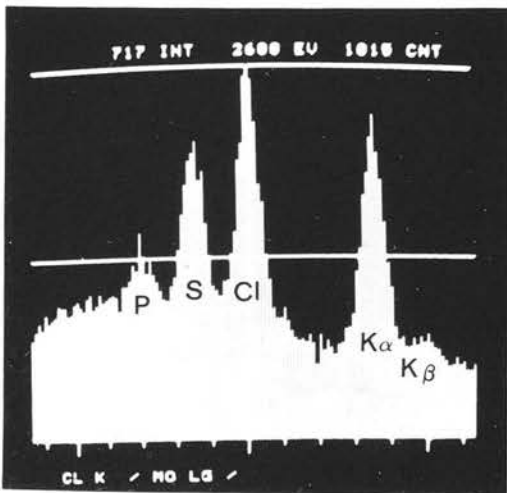
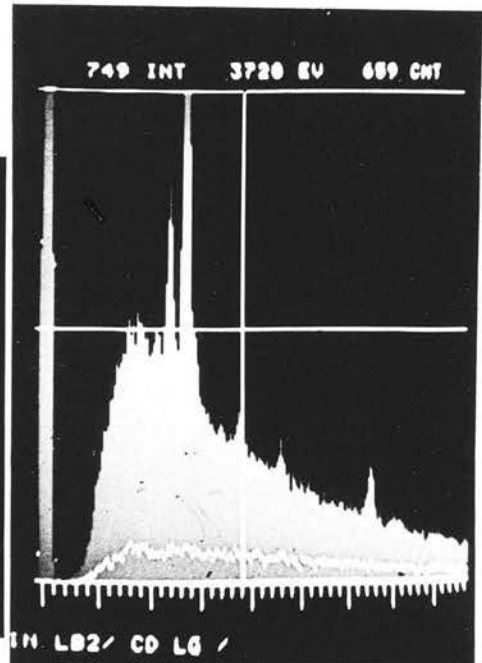
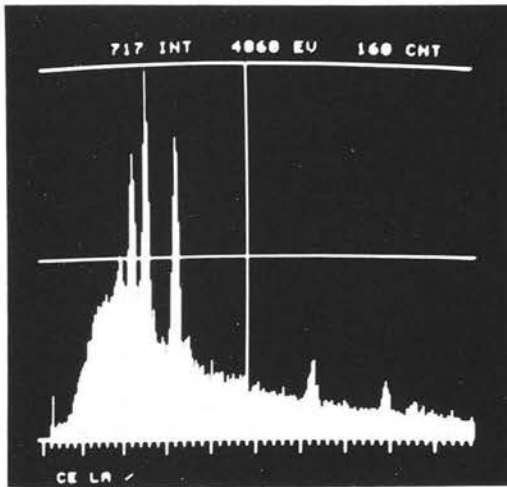

both methods produced reasonably comparable results and hence these results have been discussed together.

Even with the slightly increased P/B ratio of the "thin section" technique the calcium peak was hardly ever visually distinguishable from the background, indicating that these measurements were on the borderline of sensitivity of the EPXMA technique. Whilst it was evident from the measurements made that reliable absolute calcium values could not be obtained it was considered that relative quantitation would be acceptable, providing sensitivity were sufficient to enable the recognition of a normal and an abnormal population of erythrocytes within a DMD carrier sample.

### 2-5.3. Erythrocyte Populations Examined

There was wide variation in relative calcium concentrations in erythrocytes from one individual. In one normal female control (aged 24 years) in which 33 erythrocytes were examined, the coefficient of variation (CV) was 12% (refer to Figure 2.2). Note that measurements made, unless otherwise stated, fell within a normal distribution when tested by Kolmogorov- Smirnov test (Siegel, 1956).

Repeated measurements on one erythrocyte were not always possible due to sample damage by the electron beam (refer to Table 2.2., noting the decreasing calcium concentration measured with each subsequent analysis). When such measurements were carried out without apparent sample damage ensuing (Table 2.3.), the coefficient of variation of calcium measurements (expressed either as P/B ratio or as the calcium concentration  $\mu\text{molml}^{-1}$  cell water) was extremely high (CV = 50% for calcium P/B ratio).

Figure 2.2. Erythrocyte Calcium Measurements of One Normal Female  
Control Sample

$\bar{m}$  mean

SD standard deviation

CV coefficient of variation



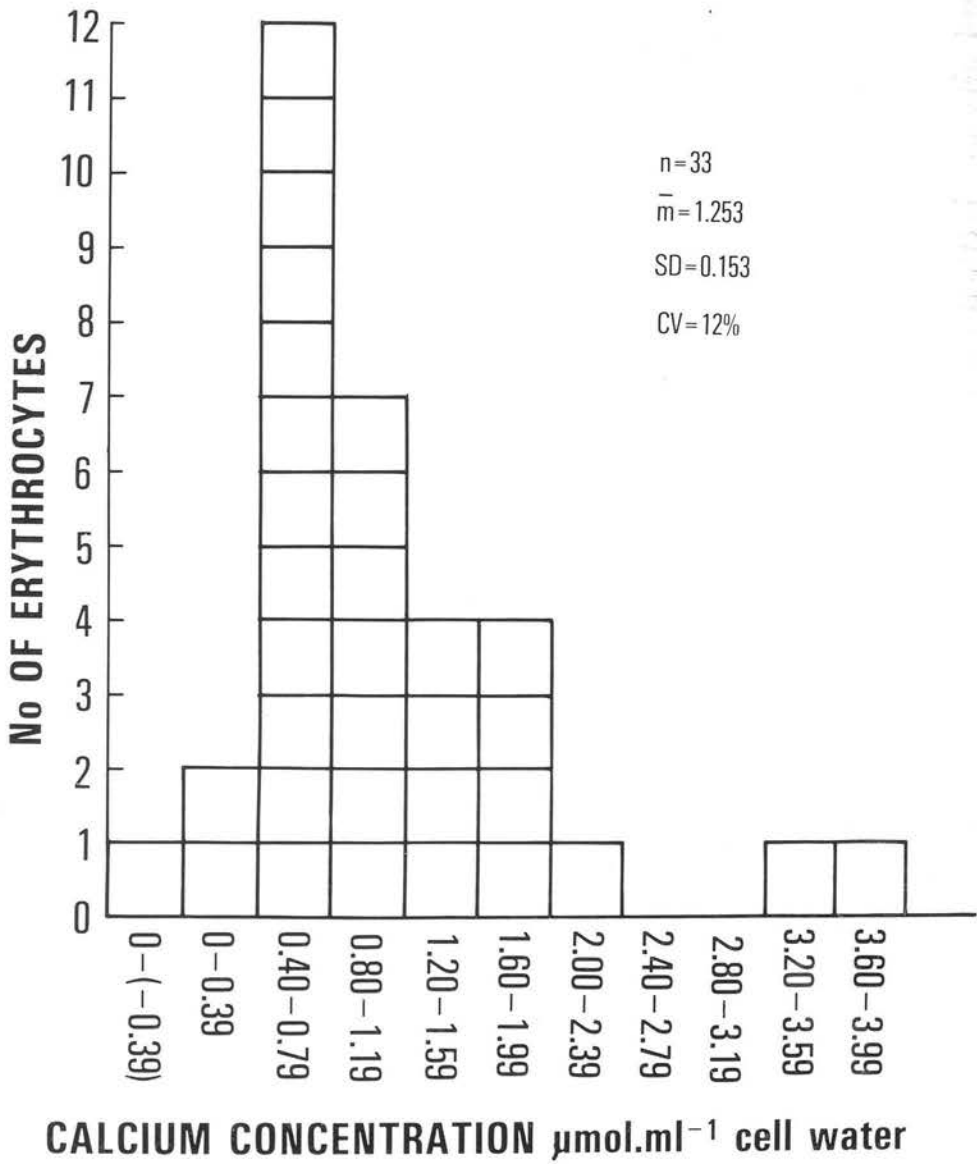

Table 2.2. Repeated Measurements on One Erythrocyte using EPXMA

No. of measurement (in order made)	peak/back. ratio calcium(PBCa)	Calcium <sub>i</sub> concentration μmolml <sup>-1</sup> cell water	peak/back. ratio iron(PBFe)	PBCa/PBFe
1	0.018	0.422	0.545	0.032
2	0.015	0.376	0.518	0.028
3	- 0.025	- 0.238	0.564	- 0.045

Table 2.3. Repeated Measurements on One Erythrocyte using  $^{45}\text{Ca}$

No. of measurement (in order made)	peak/back. ratio calcium(PBCa)	Calcium concentration $\mu\text{molml}^{-1}$ cell water [Ca]	peak/back. ratio iron(PBFe)	PBCa/PBFe
1	0.031	0.621	0.637	0.048
2	0.052	0.944	0.622	0.083
3	0.050	0.913	0.646	0.077
4	0.036	0.698	0.595	0.061
5	0.038	0.729	0.600	0.063
6	0.075	1.297	0.603	0.124
7	0.044	0.821	0.619	0.072
8	0.011	0.314	0.595	0.019
9	0.011	0.314	0.616	0.018
10	0.039	0.744	0.572	0.067

	Mean	SD	CV
PBCa	0.039	0.019	50
PBFe	0.610	0.022	4
PBCa/PBFe	0.063	0.031	50
[Ca]	0.740	0.292	40

SD standard deviation  
CV coefficient of variation

Note that in both Tables 2.2. and 2.3. intraerythrocytic iron measurements were much more stable than those of calcium. Variation in intraerythrocytic iron levels was much smaller than variation encountered with calcium measurements (in Table 2.3. CV=4% for iron P/B ratio). Relating calcium to iron measurements in each erythrocyte studied did not decrease the variation encountered (refer to Table 2.3.).

Intraerythrocytic measurements of calcium and iron in one normal female subject, aged 32 years, made on 2 separate occasions (7 days apart) were assessed using one way analysis of variance. For calcium the F value = 5.85 ( $p < 0.01$ ) whilst for iron  $F = 0.95$ ,  $p = NS$ .

A scatter diagram demonstrated the lack of relationship between intraerythrocytic calcium and iron measurements within a population of erythrocytes from one normal male subject aged 30 years (refer to Figure 2.3.). The correlation coefficient ( $r$ ) of these 2 measurements,  $r = 0.16$ , was not significant.

#### 2-5.4. Albumin Protein Calcium Standards

For the complete X-ray spectrum of a freeze-dried, albumin protein calcium standard (measured using the "thick section" technique) refer to Plate 2.3.

EMPMA of albumin protein standards containing known amounts of calcium (confirmed by AAS) demonstrated a reasonably linear relationship between calcium and P/B ratio using both the "thick section" (refer to Figure 2.4.) and "thin section" (refer to Figure 2.5.) techniques.

Figure 2.3. Scatter Diagram of Calcium and Iron Measurements in  
an Erythrocyte Population from One Normal Control

Correlation Coefficient

$r = 0.16, p = NS$

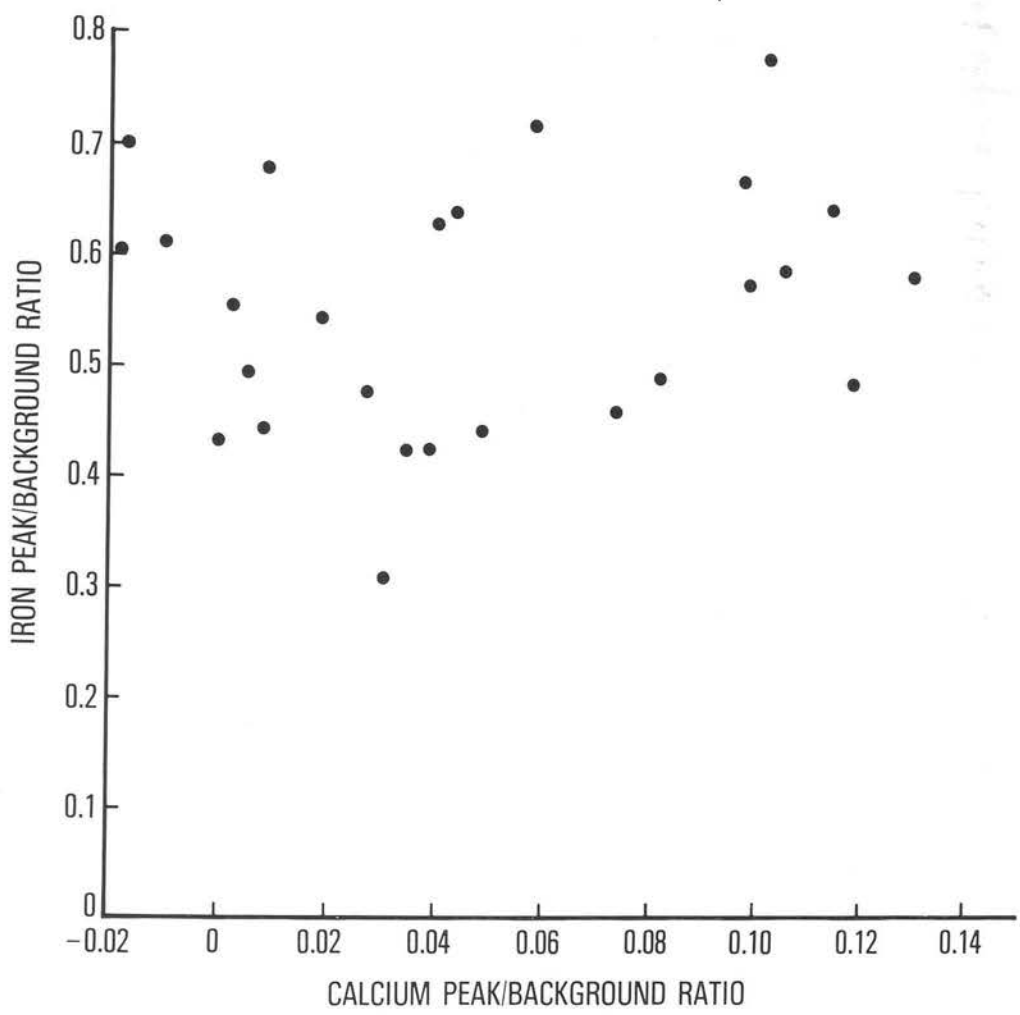

Plate 2.3. Photograph from the Oscilloscope Screen:

Complete x-ray spectrum of a freeze-dried albumin protein standard ("thick section" technique). The first small peak is of silicon (an impurity in the graphite stub), followed by a large chlorine peak. The centre line marks the calcium peak.

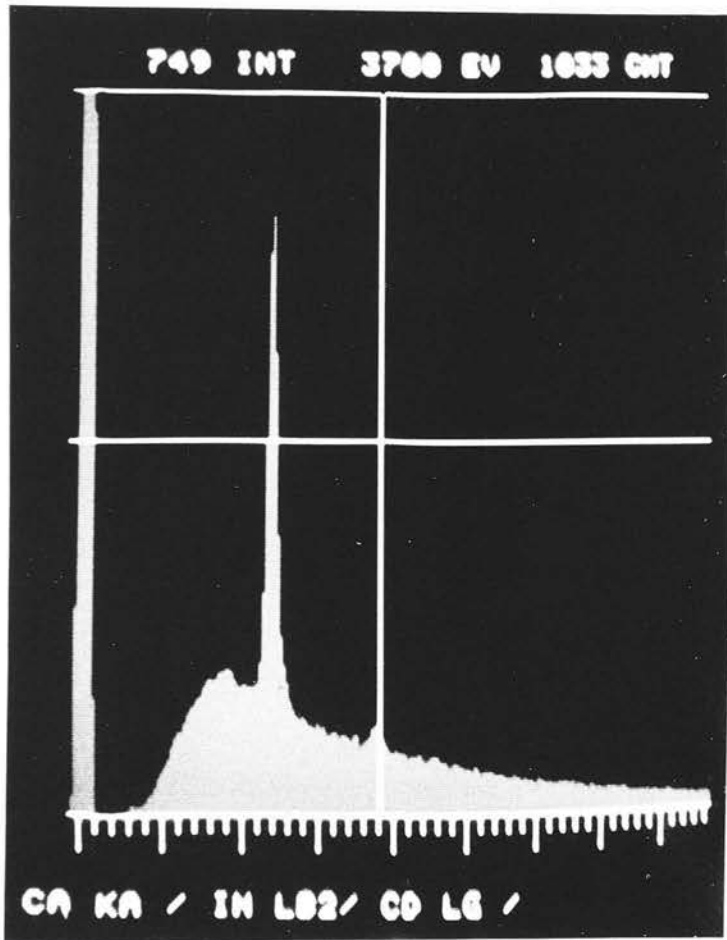



Figure 2.4. Calcium Calibration Curve ("Thick Section" Technique)

This graph shows the relationship between measured peak/background ratio and concentration of calcium from albumin standards which contain known concentrations of calcium and varying concentrations of chloride.

Equation for the Line

$$P/B \text{ ratio} = - 0.0207 + 0.0217Ca$$

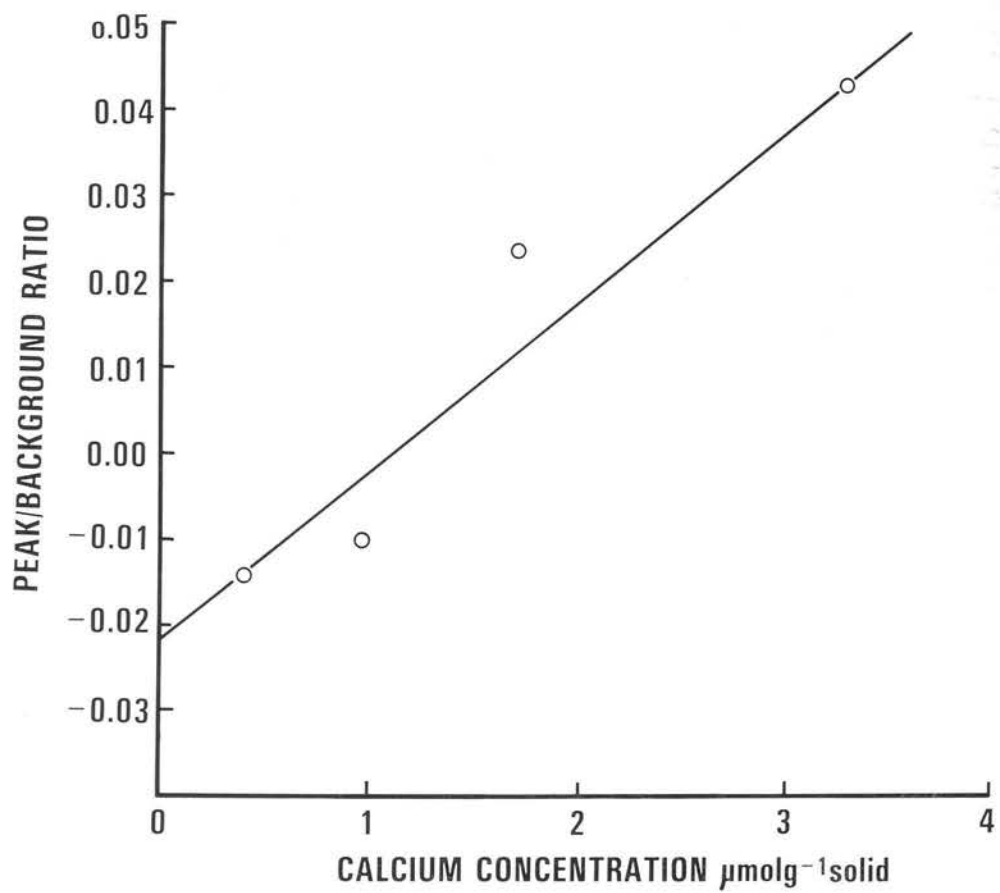
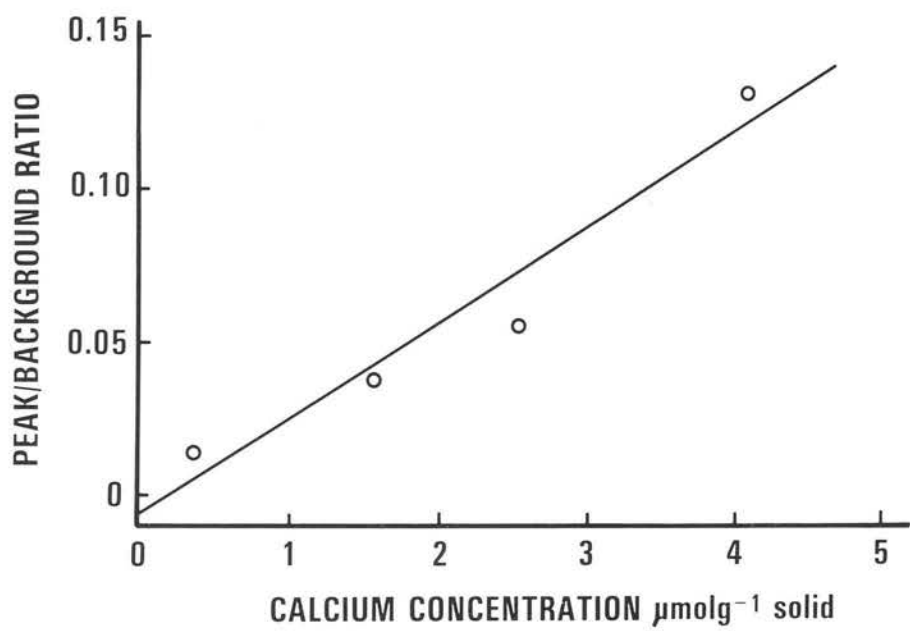

Figure 2.5. Calcium Calibration Curve ("Thin Section" Technique)

This graph shows the relationship between measured peak/background ratio and concentration of calcium from albumin standards which contain known concentrations of calcium and varying concentrations of chloride.

Equation for the Line

$$P/B \text{ ratio} = - 0.0063 + 0.0311Ca$$



## 2-5.5 Blood treated with Ionophore A23187 and a Calcium Complexing Agent

To confirm that measurements made were of intraerythrocytic calcium within the samples, erythrocytes with artificially increased and artificially decreased calcium levels were analysed and the mean calcium concentrations compared to the mean calcium concentration of untreated erythrocytes from the same sample. Ionophore A23187 was used to increase intraerythrocytic calcium and the mean calcium concentration was significantly higher than that of untreated cells. EDTA was the calcium chelating agent used to decrease intraerythrocyte calcium. However, although the mean calcium concentration of EDTA-treated cells was lower than that of untreated cells it was not significantly lower (refer to Table 2.4).

## 2-5.6. Summary of Results Obtained in Subjects Studied

Calcium measurements in populations of erythrocytes from 5 DMD patients, 3 DMD carriers, 2 normal male and 5 normal female control subjects have been summarised in Figure 2.6. and Table 2.5.

Table 2.4. Blood treated with Ionophore A23187 and a Calcium Complexing Agent

Erythrocyte Aliquot No.	Mean Calcium Concentration $\mu\text{mol}\cdot\text{ml}^{-1}$ cell water	Level of Significance
1. Untreated	0.72	-
2. Treated with Ionophore A23187	3.67	$p < 0.05$
3. Treated with EDTA	0.37	NS

p level of significance using unpaired t test comparing aliquots nos. 1 and 2

NS not significant using unpaired t test, comparing aliquots nos. 1 and 3

for unpaired t test, refer to Snedecor and Cochran, 1967

Figure 2.6. Measurements in Erythrocyte Populations of Subjects

Examined:

2 normal male controls

5 DMD patients

and (overleaf):

5 normal female controls

3 DMD carriers

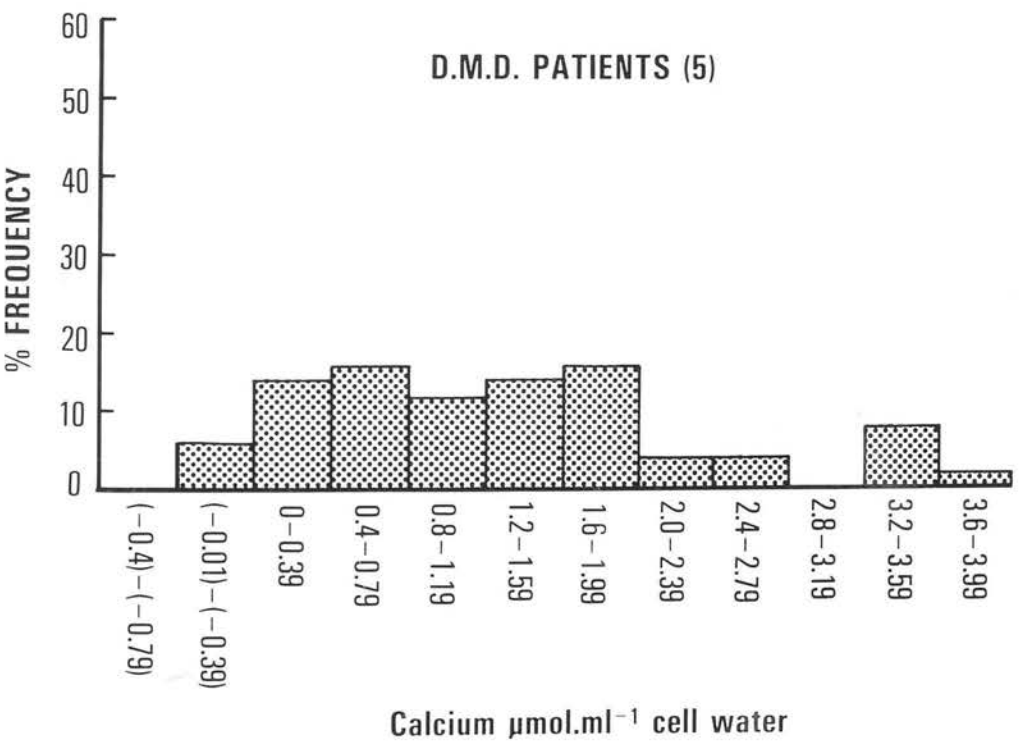
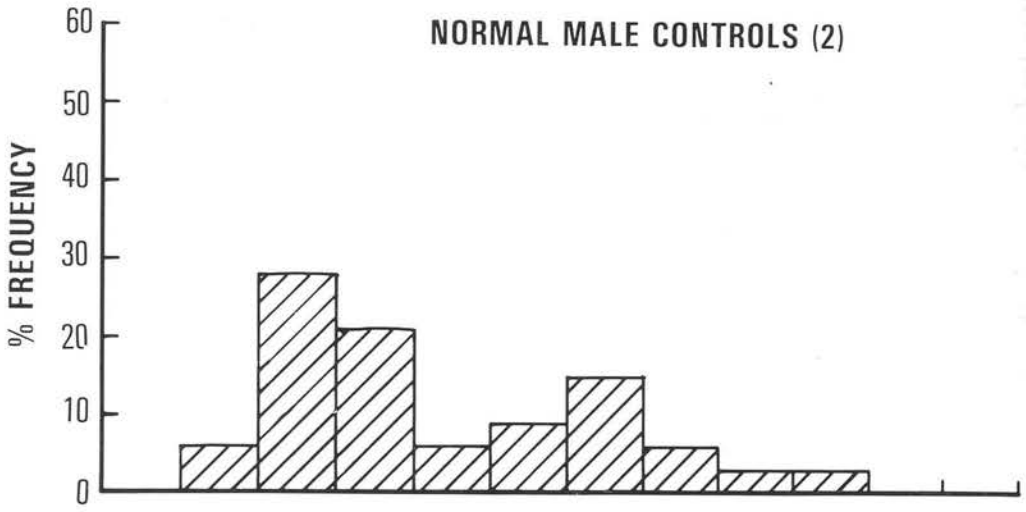



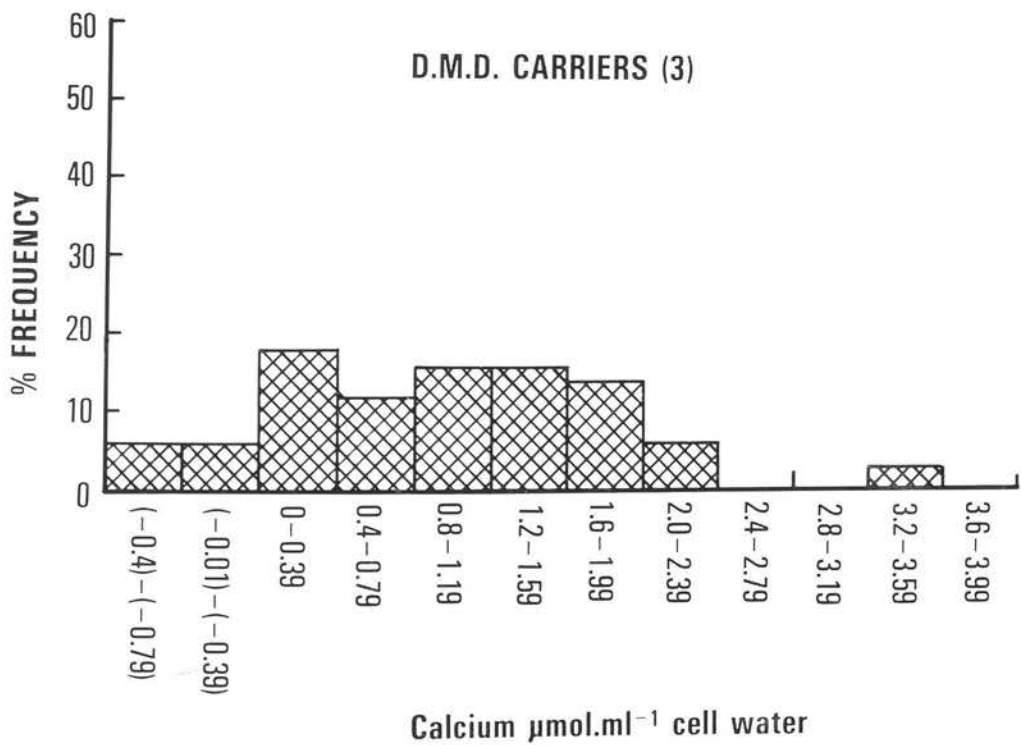
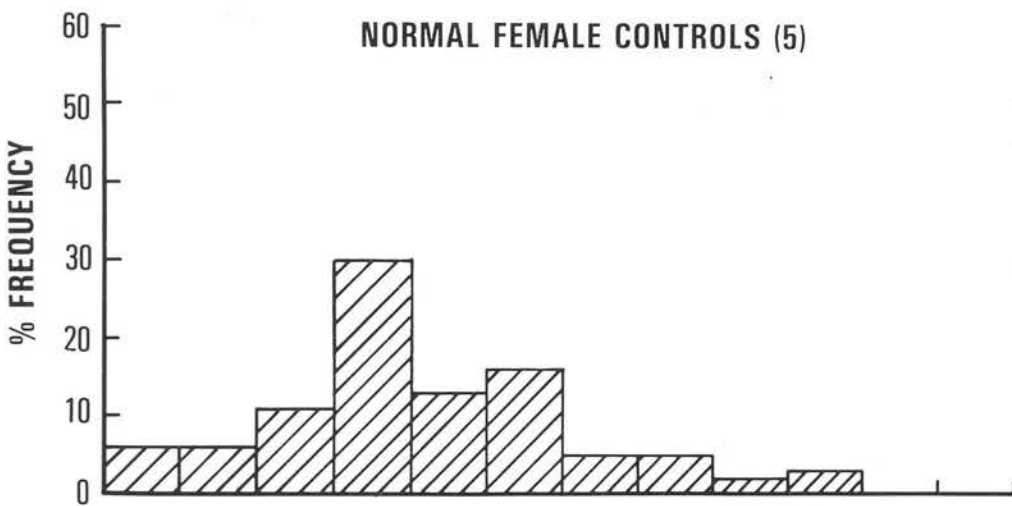

Table 2.5. Summary of Mean Intraerythrocytic Calcium Measurements in Subjects Studied

	Subject Pedigree No.	Mean Erythrocyte Calcium Measurement $\mu\text{mol}\cdot\text{ml}^{-1}$ cell water
<u>Normal Controls</u>		
Females (n=5)		0.20., 0.46, 0.98, 1.0.1, 1.38
Males (n=2)		0.42, 1.56
<u>DMD</u>		
Patients (n=5)	7 IV <sub>2</sub> , 5 III <sub>3</sub> , 4 III <sub>2</sub> ,	0.35, 0.49, 1.30, 1.64, 1.90
	1 II <sub>2</sub> , 3 IV <sub>4</sub>	
Carriers (n=3)	11 II <sub>13</sub> , 20 II <sub>4</sub> , 15 II <sub>4</sub>	0.55, 0.96, 1.52

The 'flavanol stain (Morin) and the antibiotic chlorotetracycline (CTC) have been used successfully as fluorescent chelate probes for calcium in biological systems including dystrophic muscle (Emery and Burt, 1980) and pancreatic acinar cells (Chandler and Williams, 1978).

The conditions employed in this study were selected to favour fluorescence resulting from calcium binding to the fluorescent probes over fluorescence produced by the binding of other divalent cations. The lack of fluorescence found in the hydrochloric acid, pre-treated control slides (in the case of both stains) suggested the fluorescence observed in untreated cells studied resulted from fluorescent probe binding of calcium.

Spraying erythrocytes or lymphocytes onto glass slides (refer to Section 2-2., method B) appeared to slightly reduce background fluorescence when compared to method A (probably by physically separating cells from surrounding suspending fluid on impact with the glass slides). However, despite the slight improvement observed using method B, neither fluorescent stain (Morin or CTC) was sufficiently sensitive to detect differences in erythrocyte (or lymphocyte) calcium levels in any subject group. Technical and physiological factors affecting intraerythrocytic calcium distributions in cell populations have been discussed more appropriately in Section 2-7.

The failure of these fluorescent chelate probes in this study emphasise the need for a technique of greater sensitivity in order to explore the possibility of finding proof of the Lyon hypothesis (via calcium measurement) in blood cells from a DMD carrier.

The very small percentage of leucocytes (in the case of: Morin, 1%; CTC, 2%) which exhibited considerable fluorescence compared to other cells may represent activated neutrophils since it has been suggested that an increase in intracellular calcium level is involved in the activation process (Romeo et al., 1975).

At present EPXMA is the only technique which offers the possibility of measuring calcium in individual erythrocytes. Many factors affect intraerythrocytic calcium measurements obtained by EPXMA, including, of primary importance, the sensitivity of the technique itself.

In EPXMA discrimination of the peak from the background on which it is superimposed is critical (refer to Section 2-1.4.). In this study calcium P/B ratios were very low and, as stated in Section 2-6.2., the absolute calcium measurements obtained could not be considered reliable. However relative quantitation would be of value if technique sensitivity were such that a population of erythrocytes containing an increased calcium concentration could be distinguished from cells with a normal intraerythrocytic calcium content in a DMD heterozygote.

There was very considerable variation in relative calcium concentrations measured in erythrocytes from one sample (refer to Section 2-6.3.). Differences in intraerythrocytic calcium content may involve the preparative procedure and EPXMA measurement as well as actual physiological differences in ionic concentrations within the erythrocytes themselves.

Removal of the buffy coat and washing the erythrocytes to remove trapped plasma were both necessary steps to eliminate calcium contamination of the erythrocyte membranes. Washing erythrocytes in isotonic saline has been shown not to extract intraerythrocytic calcium (Harrison and Long, 1969). However the effects of fixation and post-fixation procedures on erythrocyte calcium content are subject to controversy. To minimise the possible loss of calcium from its physiological site, oxalate was added to the fixative-buffer as a

precipitating agent, since this ion has a low solubility as the calcium salt.

The extremely low permeability of the erythrocyte membrane to calcium effectively excluded the possibility of the preparative procedure introducing calcium into freshly treated erythrocytes. However a non-specific physical process of accumulation of extracellular calcium ions around the erythrocyte cell surfaces has been demonstrated after air-drying of the cells in a suspending medium containing calcium (Kimsey and Burns, 1973). Wiley and Shaller (1977) considered calcium ions might bind to phosphate leaking from the erythrocytes, causing surface contamination. Chemical elements may be re-distributed during air-drying from a fluid suspension. Lechenne et al. (1977) found mean X-ray intensities varied significantly in different areas of the same support when measuring sodium and potassium content in air-dried erythrocytes. Gullasch et al. (1974) comparing air-drying and cryoprotocols also concluded that local electrolyte distribution patterns were not preserved by air-drying, but Chandler and Battersby (1976) observed similar elemental distributions in air-dried, freeze dried and frozen cells. It is extremely difficult to assess the effects of this preparative procedure on erythrocyte calcium content and therefore how the results obtained relate to the in vivo state.

Certainly, interference of potassium on the X-ray microanalysis of calcium was successfully reduced by using formaldehyde in the fixative-buffer (refer to Section 2-6.1.) and the small amount of remaining potassium measured, and corrected for, in the appropriate channels. High counts in the calcium channels could conceivably be obtained if more than one cell were excited by the electron beam. However, microscopic examination made this unlikely (unless erythrocytes were positioned

directly above one another). Lower counts might be due to excitation of less than the totality of the cell (due to a drift in the position of the electron beam). Negative results would occur if the actual background counts were also lower than calculated and the calcium  $K\alpha$  counts also low, which would result in nett counts of less than zero.

Actual physiological differences in intraerythrocytic calcium levels within an erythrocyte population may be correlated to the age of the cells. Certainly the distribution of electrolyte concentrations within a population of erythrocytes cannot be considered to be uniform since the cells range in age between 0-120 days and biochemical changes that occur during cell ageing are reflected by differences in ionic regulation and content. Iacelle et al. (1973) suggested that normal senescent erythrocytes are characterised by an increased intracellular calcium concentration and this could account for higher values found in certain cells within erythrocyte populations studied.

Appropriate standards are required in EPXMA since both standards and specimens must react similarly under the electron beam. In this study freeze-dried albumin standards were selected for their resemblance to the cell matrix. However there remains a slight possibility that the differences in the response of albumin standards and erythrocytes to EPXMA contributed adversely to calcium measurement. Negative P/B ratios found in the presence of actual quantities of calcium in the standards (refer to the calcium calibration curves: Figures 2.4. and 2.5) demonstrated the difficulty in placing the base line for these measurements as zero P/B for zero calcium.

In all erythrocyte populations examined the width of distributions of calcium measurements prevented the possibility of selecting

erythrocytes with an increased intraerythrocytic calcium level from within a population of normal erythrocytes in a DMD heterozygote. Expressing intraerythrocytic calcium measurements relative to those of iron (a tightly bound element representative of cell mass) did not appreciably decrease the considerable variation in calcium measurements encountered. Comparison of intraerythrocytic calcium and iron levels in blood samples taken from one normal subject on different occasions indicated that whilst intraerythrocytic iron measurements (both within and between occasions) were of comparable levels, measurements of intraerythrocytic calcium were much more consistent with one another within one sample than with equivalent analyses made on different occasions.

Eaton et al. (1973) used the ratio of calcium to aluminium counts to demonstrate a relative increase in erythrocyte calcium in irreversibly sickled erythrocytes compared to sickle cells of normal morphology. These workers found irreversibly sickled erythrocytes contained approximately 8 x as much calcium as undistorted sickle cells. Although erythrocyte shape alterations related to intracellular calcium level have been reported in DMD (refer to Section 2-1.2) erythrocyte deformity equivalent to sickled cells has not been observed. This suggests it would be unlikely that increased calcium (if present) in Duchenne erythrocytes would attain the level of this ion Eaton et al. (1973) observed in irreversibly sickled cells. Unfortunately in the study of Eaton et al. (1973) no reference was made to the potassium  $K_{\beta}$  peak interference on calcium measurement or method of correction of this interference (if any) used.

Measurements on blood treated to artificially increase or decrease the intraerythrocytic calcium level confirmed that it was



this ion being measured in samples studied (refer to Section 2-5.5). However, whilst the results obtained using ionophore A23187 to increase intraerythrocytic calcium levels were significantly higher than control levels the decrease in intraerythrocytic calcium level achieved using the chelator EDTA did not reach statistical significance.

The ionophore A23187 is known to selectively transport calcium (and other divalent cations) across cellular membranes including the erythrocyte membrane (White, 1974). The effectiveness of EDTA at removing erythrocytic calcium (and other divalent cations) however, is less clear. Whilst Harrison and Long (1969) reported the removal of greater than 90% erythrocytic calcium by treatment with EDTA, Palek (1977) could not confirm this finding and suggested an absence of calcium at external membrane sites accessible to EDTA extraction. The problem in determining at what level the calcium measured relates to the amount of intraerythrocytic calcium rather than to calcium closely associated to the erythrocyte membrane makes interpretation of these data on EDTA treated erythrocytes very difficult. Furthermore, since measurement of intraerythrocytic calcium in non-chelator-treated cells represents the use of EPXMA at the borderline of sensitivity, measurements in erythrocytes where calcium has been artificially decreased will be even more subject to errors induced by operating under such conditions.

There was a very slight suggestion of a possible trend in some DMD patients studied towards an increased mean intraerythrocytic calcium level relative to such measurements made in controls and DMD carriers studied. Overall, however, the very wide variation in intraerythrocytic calcium measurements encountered in all subject groups prevented the possibility of demonstrating (if present) either:

a significant relative increase in intraerythrocytic calcium measurements in DMD patients compared to levels in control subjects or (dependant upon the previous point) identification of two populations of cells within a DMD carrier (a population containing an increased intraerythrocytic calcium content and a population containing a normal amount of this ion) which would be a successful demonstration of the Lyon hypothesis.

Until a method which successfully demonstrates cellular mosaicism in genetic DMD carriers becomes available it may not be possible to attain a figure approaching 100% correct genetic DMD heterozygote recognition. However the DMD carrier detection rate (approximately 70%) achieved by the current most routinely applied test (serum creatine kinase estimation) may be improved upon by the additional measurement of other non-correlated serum proteins (explored in subsequent Chapters).

*[Faint, illegible text]*

*[Faint, illegible text]*

*[Faint, illegible text]*

*[Faint, illegible text]*

### CHAPTER 3: CREATINE KINASE

*[Faint, illegible text]*

*[Faint, illegible text]*

*[Faint, illegible text]*

*[Faint, illegible text]*

*[Faint, illegible text]*

*[Faint, illegible text]*

*[Faint, illegible text]*

*[Faint, illegible text]*

*[Faint, illegible text]*

*[Faint, illegible text]*

*[Handwritten notes in right margin]*

3-1. INTRODUCTION

Altered serum activities of many muscle-specific enzymes have been reported in patients with muscle disease. Extensive studies have shown an elevated serum level of the enzyme creatine kinase (ATP: creatine N - phosphotransferase E.C. 2.7.3.2.) to be a sensitive indicator of muscle defect or damage.

Creatine kinase (CK), molecular weight 80,000 daltons, catalyses the reversible conversion of creatine to phosphocreatine:

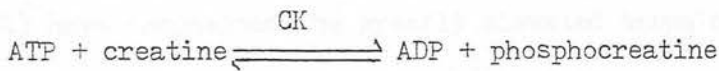

where:

ATP = adenosine triphosphate

ADP = adenosine diphosphate

and has a role in the maintenance of constant cellular levels of ATP. The enzyme is found in highest concentration in skeletal and cardiac muscle and is also present in brain but not other tissues.

Significantly increased serum creatine kinase activities have been reported in the following conditions:

- (1) acute myocardial infarction
- (2) muscular dystrophies
- (3) metabolic myopathies
- (4) polymyositis
- (5) skeletal muscle damage
- (6) extreme exertion in normal individuals
- (7) tetanus
- (8) cerebral vascular incident

(9) hypothyroidism

(10) the onset of psychosis

In these conditions, the elevation of serum creatine kinase level is resultant of enzyme leakage from diseased or damaged tissue. Early pregnancy (King et al., 1972) and steroid therapy (but possibly not the contraceptive pill (Simpson et al., 1974) have been reported to decrease serum creatine kinase activity.

Ebashi et al. (1959) first suggested the use of serum creatine kinase as a biochemical diagnostic test for muscular dystrophy. Following this report many workers (Dreyfus et al., 1960; Aebi et al., 1961) have documented the greatly elevated serum creatine kinase levels in DMD patients, although the serum activity has been shown to decrease considerably with disease progression (Pearce et al., 1964a).

Creatine kinase isoenzymes have been reviewed very recently by Lang and Wurzburg (1982) who describe the "cytoplasmic" creatine kinase isoenzymes MM, MB and BB and additionally a mitochondrial creatine kinase isoenzyme Mt. The creatine kinase isoenzymes MM, MB and BB (regarded as skeletal muscle type, cardiac muscle type and brain type respectively) have been investigated in muscular dystrophy and controversy exists regarding the isoenzyme patterns found. Only MM isoenzyme has been found in serum from normal individuals by most authors, whilst some have reported MB is also present in cases of DMD (Somer et al., 1976). Silverman et al. (1976) suggested creatine kinase isoenzyme analysis may be of value in the differentiation of DMD from Becker Dystrophy in sporadic cases.

Okinaka et al. (1959) first investigated the use of serum creatine kinase estimation as a method of DMD carrier detection. Since then many authors (Dreyfus and Schapira 1961; Emery 1965b; Dreyfus et al.,

1966; Thompson et al. , 1967) have reported elevated serum creatine kinase activities in a high proportion of DMD carriers and verified the usefulness of this test. Approximately two thirds of the carriers of the DMD gene are considered to exhibit significantly increased serum creatine kinase activities (Emery, 1969b; Pennington, 1981). The estimation of this enzyme is accepted as the single most reliable test that can be applied in the detection of carrier status (Emery, 1980).

Several methods have been employed in attempts to improve the detection efficiency of serum creatine kinase. Moser and Vogt (1974) reported that serum creatine kinase levels decrease with increasing age in carriers but not in normal women, but Zatz and Otto (1980a) could not find significant differences in mean serum creatine kinase levels in a series of adult carriers examined over a period of years. However, Zatz et al. (1976) and Nicholson et al. (1979) found the mean creatine kinase activities of young suspected carriers to be higher than the corresponding activities of their carrier mothers. Also Moser et al. (1980) reported that the probability of identifying a carrier by serum creatine kinase analysis was greater than 90% at school age but decreased to 68% in adults. This work suggests the detection efficiency of serum creatine kinase may be improved by measuring creatine kinase activities of suspected carriers at an early age, taking into account that creatine kinase activities are higher in normal female children than in adult females (Bundey et al., (1979).

The effect of exercise on carrier serum creatine kinase activities has also been examined. In a study by Hudgson et al. (1967) some carriers demonstrated significantly increased post-exercise serum

creatine kinase levels not exhibited by controls. Recent work by Gaines et al. (1982) showed a significant exercise effect on several carrier creatine kinase levels and to a lesser extent in control subjects, although no control levels exceeded the normal range. Other workers however, using varied exercise loads, have been unable to find a significant exercise effect in carrier serum creatine kinase activities (Hughes et al., 1971; Thomson et al., 1975).

Hausmanowa-Petrusewicz and co-workers (1980) reported that intravenous hydrocortisone raised serum creatine kinase activity in a high percentage of DMD carriers studied. Of particular interest, several carriers with normal creatine kinase levels were reported to respond to hydrocortisone injection with an increase in their serum creatine kinase levels. However, this preliminary study awaits confirmation.

Lane and Radoff (1981) examined serum creatine kinase and blood alcohol levels in a small group of DMD carriers before and after alcohol infusion. They did not find the elevation in serum creatine kinase response to ethanol challenge reported in cases of alcoholic myopathy.

Roses and co-workers (1977b) suggested that measurement of serum lactate dehydrogenase isoenzyme 5 (LDH-5) might be superior to serum creatine kinase analysis in carrier detection and reported some DMD carriers with normal creatine kinase levels but elevated levels of serum LDH-5 isoenzyme. However, other workers (Burt and Emery 1979; Somer et al., 1980) have failed to confirm either the greater sensitivity of this isoenzyme in carrier detection or the lack of correlation between serum LDH-5 isoenzyme and creatine kinase levels found by Roses' group.

The increased serum creatine kinase activities found in a very high percentage of DMD patients and in a considerable proportion of carriers have been widely documented. As the accepted most reliable test for determining carrier status, the serum creatine kinase test has been employed in this study in two ways:

- (a) to compare the carrier detection efficiency of serum creatine kinase with that of other serum tests;
- (b) to examine whether other tests used in combination with serum creatine kinase improved the carrier detection capability over that of serum creatine kinase alone.

Comparisons of the carrier detection efficiency of serum creatine kinase have been made with serum pyruvate kinase, serum haemopexin and serum myoglobin measurements and these have been discussed in the relevant chapters (Chapters 4,5, and 6, respectively). The use of these tests in combination is discussed in Chapter 7.



3-2. MATERIALS AND METHODS

Serum creatine kinase activities were determined during everyday activity in the following groups of subjects:

- (1) Ten patients with DMD together with 10 age -matched, normal boys.
- (2) Carrier and control group A, comprising 15 DMD carriers and 15 age-matched normal, healthy women.
- (3) Carrier and control group B, comprising 20 DMD carriers selected as having serum creatine kinase activities within the 95th percentile of the control series and 20 age-matched normal, healthy women,

DMD Patient and Control Group

DMD patients were diagnosed as described in Section 2-2.

Single blood samples were taken when the DMD patients attended the Muscle Clinic in the Department of Human Genetics, Western General Hospital, Edinburgh.

Age-matched controls were normal, healthy boys with no history of neuromuscular disease.

DMD Carrier and Control Group A

- (1) Those women who are definite carriers on genetic evidence, i.e. have at least one DMD son and at least one other affected male relative through the female line (9 subjects).

- (2) Those women who are probable carriers on genetic evidence, i.e. have 2 or more affected sons but no other family history of DMD (2 subjects).
- (3) Those women who are possible carriers on genetic evidence but considered "definite" carriers on combined genetic and biochemical evidence,
- having one DMD son, a serum creatine kinase level greater than  $1.5 \times 95\text{th percentile}$  in the control series and a first degree female relative with a serum creatine kinase level greater than  $1.5 \times 95\text{th percentile}$  in the control series (3 subjects)
  - having one DMD son and a first degree female relative with a serum creatine kinase level greater than  $1.5 \times 95\text{th percentile}$  of the control series (1 subject).

#### DMD Carrier and Control Group B

These carriers are more appropriately defined in Section 6-2.

Age matched controls for Group A and B were normal, healthy females with no history of neuromuscular disease.

5-10 ml venous blood samples were obtained by venepuncture and collected into plastic tubes containing no anticoagulant. Blood samples were allowed to clot for a minimum of 45 minutes at room temperature prior to centrifugation (15 min's, 1250g, MSE centrifuge) to ensure it was cell free. Two blood samples were obtained 4-7 days apart from all subjects in carrier and control group A. In these cases the mean activity of creatine kinase of both samples was used. In all other groups creatine kinase estimations were from single serum samples.

Three plasma samples were included in carrier group B since no

significant differences have been found between serum and plasma creatine kinase levels (Rosalki, 1967 and Lum and Gambino, 1974)

All sera were stored in aliquots at  $-70^{\circ}\text{C}$  overnight for analysis within 24 hours of collection. Whole blood may be stored at room temperature for about 24 hours (Pennington, 1980), sera for 48 hours and frozen sera at  $-20^{\circ}\text{C}$  for at least one month without serum creatine kinase activity being significantly decreased (Spikesman and Brock 1969). All sera were frozen and thawed once only since repeated freezing and thawing has been reported to result in a rapid decrease in serum creatine kinase activity (Pearce et al. 1964b).

No samples analysed showed signs of haemolysis, with the exception of the second sample obtained from a carrier in group A where slight haemolysis had occurred. Although creatine kinase has been reported absent from erythrocytes (Ebashi et al. 1959) haemolysis is thought to liberate erythrocyte adenylate kinase which could interfere in the assay. However, adenosine monophosphate, an inhibitor of adenylate kinase is included in the kit reaction mixture and so this sample was analysed.

Serum creatine kinase activities were measured by a commercially available kit Calbiochem-Behring "Stat Pack" (Hoechst UK Ltd.) which is based on the method of Rosalki (1967). In this procedure serum creatine kinase activity is assayed by measurement of the rate of reaction in the direction of ATP formation. The ATP produced is measured indirectly (by means of coupled enzyme reactions) as an increase in ultra-violet absorbance resultant of the reduction of nicotinamide-adenine dinucleotide phosphate. The reaction may be described by the following equations which are shown overleaf.

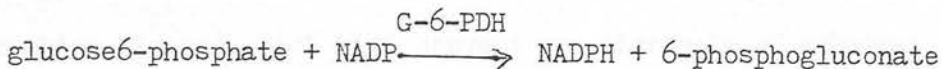
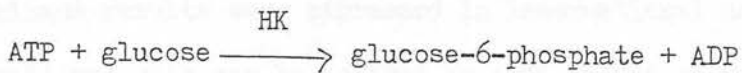
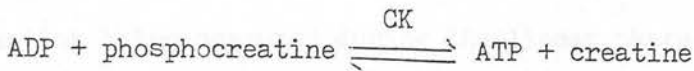

where:

HK = hexokinase

G-6-PDH = glucose-6-phosphate dehydrogenase

NADP = nicotinamide-adenine dinucleotide phosphate

NADPH = nicotinamide-adenine dinucleotide phosphate, reduced.

The rate of change in absorbance at 340 nm (measured spectrophotometrically) is proportional to the activity of creatine kinase in the sample.

Samples were analysed according to kit instructions using a Pye Unicam SP8-100 recording spectrophotometer with temperature control (Pye Unicam Ltd., Cambridge, UK). Commercially prepared control sera (normal and high creatine kinase activity) were run with each sample batch. Assays were performed at 340 nm and 30°C using glass cuvettes with a 1 cm light path and water as blank. Serum samples were warmed to 30°C prior to assay. Only samples with creatine kinase activities greater than 250 IU l<sup>-1</sup> were diluted and re-assayed, since a dilution effect resulting in increased enzymic activity on dilution of serum with an initially high creatine kinase activity has been noted (Spikesman and Brock, 1969). Distilled, deionised water was used as diluent in these cases.

Samples and control sera of known creatine kinase activity were run in duplicate and the mean result used. Creatine kinase activities were obtained by calculating the change in absorbance ( $\Delta A$ ) for a five minute period, where:

$$\Delta A = A_f - A_i$$

$A_i$  = initial absorbance

$A_f$  = final absorbance

the reaction being measured during the linear phase.

Creatine kinase results were expressed in international units (IU), where an international unit may be defined as that amount of enzyme (creatinase kinase) which will convert one micromole of substrate (phosphocreatine) in one minute under standard conditions.

### 3-3. RESULTS

For distributions of serum creatine kinase activities in DMD patients, DMD carrier Group A and their matched controls refer to Figure 3.1.

Technical variation in measurement of this enzyme expressed as the coefficient of variation (CV) was  $CV = 0.5\%$ . In one normal 25-year old female subject, who underwent no strenuous exercise over the period of study, biological variation (7 serum samples taken over an 8-hour period) was  $CV = 18.9\%$  (refer to Figure 3.3).

In this and subsequent chapters tabulated means and standard deviations have been reported untransformed in order to summarise results obtained. Non-parametric statistical tests have been used to compare and assess the relatively small DMD patient and matched control groups. Non-parametric analyses have also been carried out when non-normal distributions have been found in the DMD carrier or their matched control groups. The reference for each statistical test used has been cited by the relevant test at first time of usage.

#### DMD Patient and Control Group

For mean and individual serum creatine kinase activities in the DMD patient and control group, refer to Tables 3.1. and 3.2. respectively.

A significant difference ( $p < 0.01$ ) was found between serum creatine kinase levels in DMD patients compared to their matched controls by Wilcoxon test (Seigel, 1956). There was no overlap between the results of the two groups.

Serum creatine kinase activity decreased significantly with increasing subject age in the DMD patients, shown by Spearman's rank correlation coefficient,  $r_s = -0.81$ ,  $p < 0.01$  (Seigel, 1956). There was no overlap

Figure 3.1. Distribution of Serum Creatine Kinase Levels in DMD Patients, DMD Carriers and Age and Sex Matched Controls

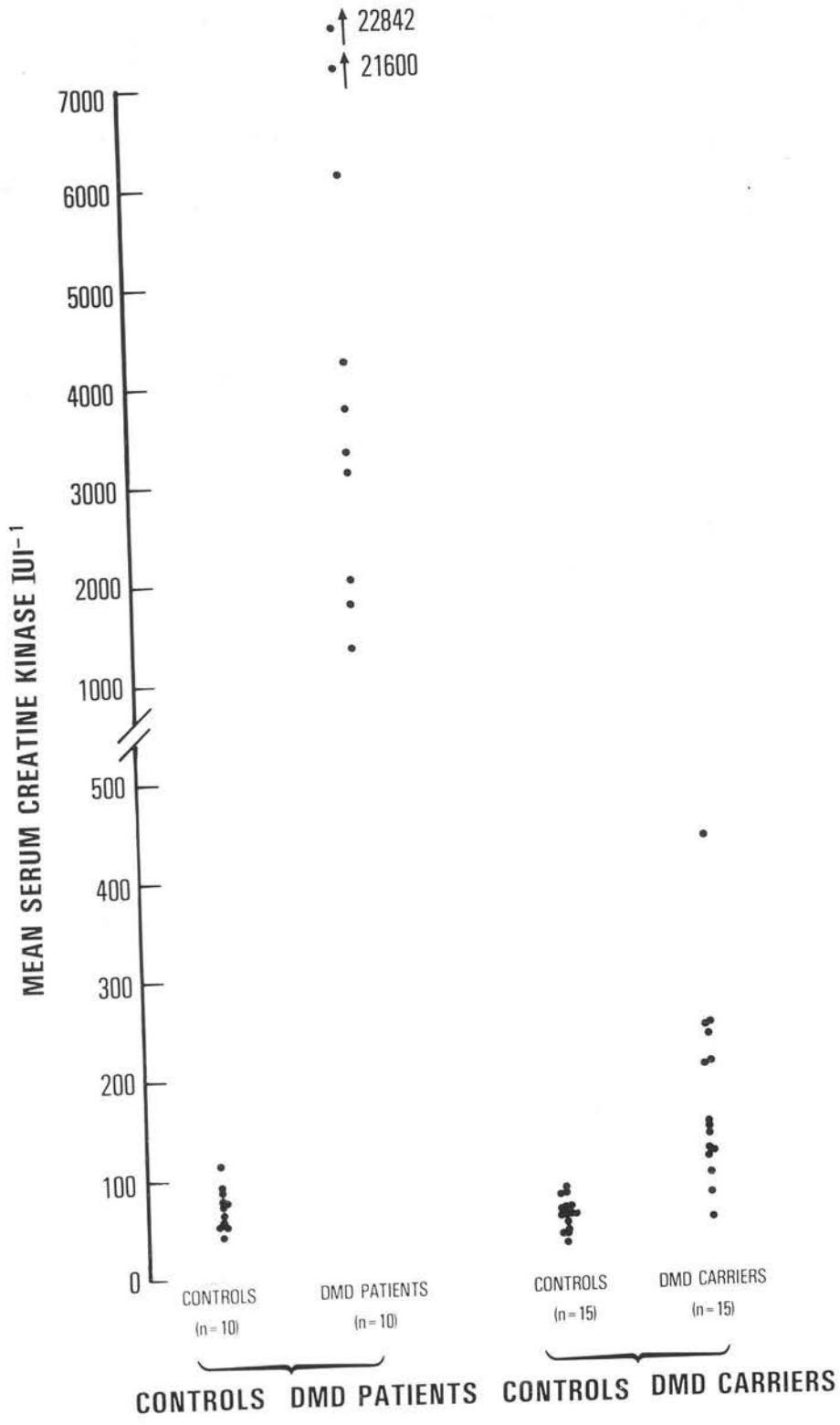



Table 3.1. Mean Serum Creatinine Kinase Levels in DMD Patients and Their Age and Sex Matched Controls

		SERUM CREATINE KINASE IU <sup>-1</sup>		
	Mean	SD	Actual range	Level of significance
Controls (n = 10)	63.3	21.5	33 - 105	p < 0.01
DMD Patients (n = 10)	6948.5	8168.5	1253 - 22,842	

SD standard deviation

p level of significance by Wilcoxon test

Table 3.2. Individual Serum Creatine Kinase Levels in DMD Patients and their Age and Sex Matched Controls

AGE AND SEX MATCHED CONTROLS			DMD PATIENTS		
Subject	CK	Subject	Age	CK	
No. & Age	IU <sup>-1</sup>	Pedigree	Yrs.	IU <sup>-1</sup>	
		No.			
1 7	48	6 II <sub>2</sub>	5	22842	
2 8	69	1 II <sub>2</sub>	6	21600	
3 8	33	2 III <sub>2</sub>	6.75	6026	
4 9	47	7 IV <sub>2</sub>	9	3240	
5 10	47	3 IV <sub>1</sub>	9	4147	
6 11	80	4 III <sub>2</sub>	10	1253	
7 11	82	5 III <sub>3</sub>	10.5	3672	
8 11	55	8 III <sub>3</sub>	10.5	3024	
9 13	105	9 III <sub>4</sub>	13	1701	
10 14	67	10 I <sub>2</sub>	14	1980	

CK serum creatine kinase

Figure 3.2. Relationship Between Serum Creatine Kinase Level  
and Age in DMD Carrier and Control Group A

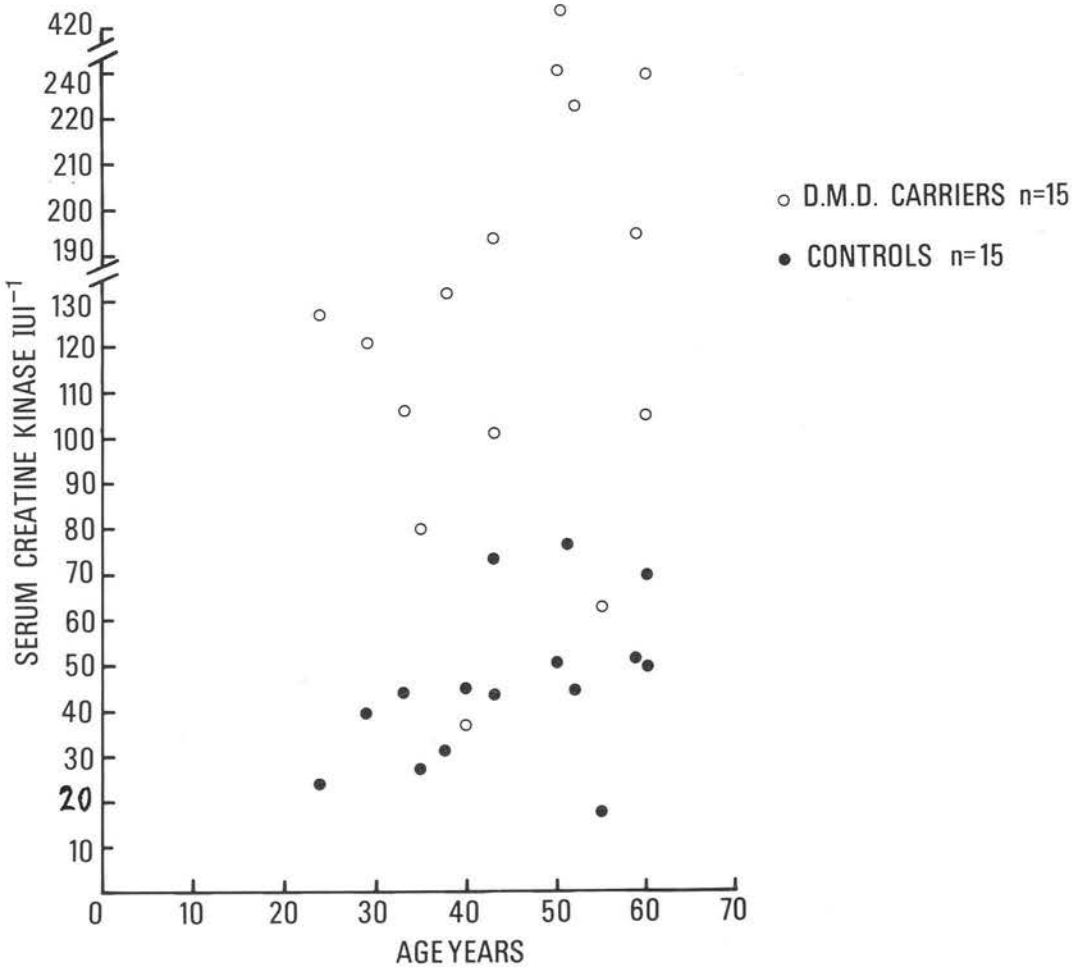

Figure 3.3 Alterations in Serum Creatine Kinase Activity in One Normal Female Subject over an 8-hour Period

$$\bar{m} = 19 \text{ IUl}^{-1}$$

$$\text{SD} = 3.6$$

$$\text{CV} = 18.9\%$$

hr hour  
 $\bar{m}$  mean  
SD standard deviation  
CV coefficient of variation

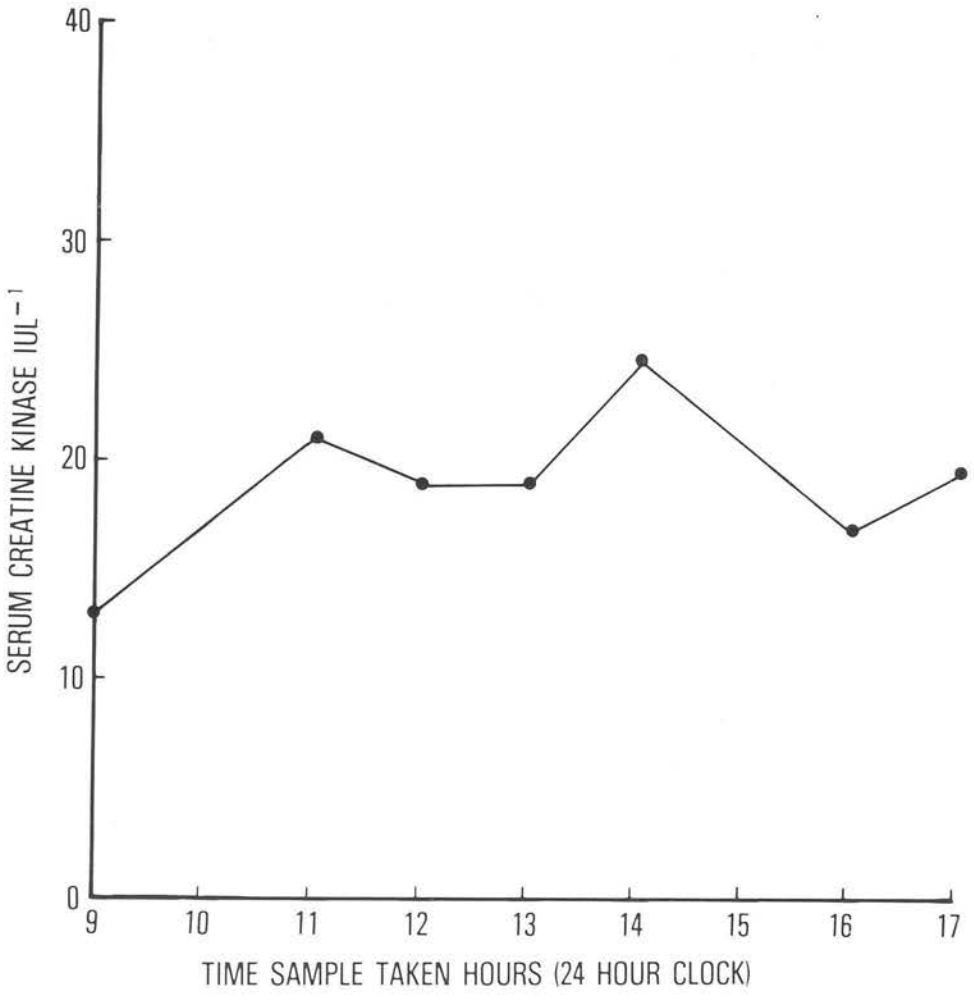

between the enzyme levels of these two groups. A significant positive correlation was found between serum creatine kinase activity and age in the healthy control boys ( $r_s' = 0.60$ ,  $p < 0.05$ ). Note that in this case (and subsequently when relevant) where a number of tied observations have occurred within a group of measurements the Spearman's rank correlation coefficient,  $r_s$ , has been replaced by the modified Spearman's rank correlation coefficient,  $r_s'$ .

Relationships between serum creatine kinase activity and other serum proteins studied in these subjects have been discussed in the relevant subsequent chapters.

#### DMD Carrier and Control Group A

For mean and individual serum creatine kinase levels in this DMD carrier and control group refer to Tables 3.3 and 3.4. respectively.

Mean serum creatine kinase activities in both DMD carriers and their controls were found to be normally distributed by Kolmogorov-Smirnov test (Seigel, 1956) and therefore these groups were compared parametrically. However, methodology, reagents and equipment for creatine kinase estimation were the same as those used routinely for DMD carrier detection purposes by Department of Human Genetics, Edinburgh, where in this considerably larger study involving 94 DMD carriers and 200 controls, (Emery, 1981), serum creatine kinase activities in control women were not normally distributed. Therefore DMD carrier and control Group A were also compared non-parametrically.

A significant difference was found between mean serum creatine kinase activities in the Group A DMD carriers and controls by Students paired t test (Snedicor and Cochran; 1967) ( $p < 0.025$ ) confirmed by Wilcoxon test ( $p < 0.01$ ).

Table 3.3. Mean Serum Creatine Kinase Levels in DMD Carriers and Their Age and Sex Matched Controls

SERUM CREATINE KINASE IU L <sup>-1</sup>				
	Mean	SD	Actual range	Level of significance
Controls (n = 15)	46.0	17.4	18 - 77	
DMD Carriers (n = 15)	157.9	96.0	37 - 423	$P < 0.025$ $P' < 0.01$

SD standard deviation

P level of significance by Students paired t test

P' level of significance by Wilcoxon test



Table 3.4. Individual Serum Creatine Kinase Levels in DMD Carriers and Their Age and Sex Matched Controls

AGE AND SEX MATCHED CONTROLS					DMD CARRIERS				
CK IU <sup>-1</sup>				Subject	CK IU <sup>-1</sup>				
Subject				Pedigree	Age				
No. & Age	1st	2nd	Mean	No.	Yrs.	1st	2nd	Mean	
1 24	27	20	24	10 II <sub>2</sub>	24	<u>213</u>	41	<u>127</u>	
2 30	33	47	40	11 II <sub>13</sub>	29	<u>123</u>	<u>119</u>	<u>121</u>	
3 31	44	44	44	12 III <sub>4</sub>	33	<u>103</u>	<u>108</u>	<u>106</u>	
4 33	23	30	27	13 II <sub>2</sub>	35	83	76	80	
5 34	30	31	31	14 III <sub>1</sub>	38	<u>179</u>	86	<u>133</u>	
6 40	52	38	45	15 II <sub>4</sub>	40	37	36	37	
7 41	80	66	73	16 II <sub>1</sub>	43	<u>228</u>	<u>160</u>	<u>194</u>	
8 44	42	46	44	17 II <sub>4</sub>	43	<u>115</u>	<u>87</u>	<u>101</u>	
9 49	49	52	51	18 II <sub>5</sub>	50	<u>206</u>	<u>255</u>	<u>231</u>	
10 50	63	<u>90</u>	77	10 I <sub>2</sub>	51	<u>327</u>	<u>519</u>	<u>423</u>	
11 52	48	42	45	19 II <sub>3</sub>	52	<u>263</u>	<u>182</u>	<u>223</u>	
12 54	19	17	18	20 II <sub>4</sub>	55	56	69	63	
13 58	49	<u>54</u>	52	21 II <sub>1</sub>	59	<u>195</u>	<u>194</u>	<u>195</u>	
14 61	49	50	50	22 III <sub>8</sub>	60	<u>269</u>	<u>189</u>	<u>230</u>	
15 60	65	75	70	23 I <sub>1</sub>	60	<u>100</u>	<u>110</u>	<u>105</u>	

elevated levels underlined

CK serum creatine kinase

Note that in this and subsequent tables an elevated level signifies a serum level greater than the 95th percentile of the control series.

12/15 (80%) of Group A DMD carriers had mean serum creatine kinase activities raised above  $86 \text{ IU l}^{-1}$ , the upper 95th percentile of serum creatine kinase activity in the Department of Human Genetics control series cited earlier (Emery, 1981). This 95th percentile based on a control series of 200 normal women was considered superior to that calculated using 15 normal control women.

In normal control no. 10 (refer to Table 3.4) creatine kinase activity measured in the second serum sample ( $90 \text{ IU l}^{-1}$ ) was raised slightly above the 95th percentile of the control series, however, the mean serum creatine kinase level of this subject was within the normal range. In 2 DMD carriers (10 II<sub>2</sub> and 14 III<sub>1</sub>) creatine kinase levels greater than the 95th percentile of the control series were found in only one of two serum samples taken, however mean results remained outwith normal limits.

A significant relationship was found between mean serum creatine kinase activity and age in both DMD carrier and control groups ( $r_s = 0.76$ ,  $p < 0.01$  and  $r_s = 0.54$ ,  $p < 0.05$  respectively); refer to Figure 3.2.

Other proteins measured on the serum samples from these subjects have been listed in Table 3.5. Relationships and comparisons of serum creatine kinase with serum pyruvate kinase, haemopexin and myoglobin and their combined use in carrier detection have been discussed in the relevant subsequent chapters.

#### DMD Carrier and Control Group B

DMD carriers in this group, having known genetic carrier status but serum creatine kinase levels less than the 95th percentile of the control series, were selected to assess the carrier detection capability

Table 3.5. Summary of Tests Carried out on the Same Serum Samples from All Subject Groups

	Creatine Kinase	Pyruvate Kinase	Haemopexin	Myoglobin
DMD Patients and their Age and Sex Matched Controls	X		X	X
DMD Carriers and their Age and Sex Matched Controls Group A	XX	XX	X	X
DMD Carriers and their Age and Sex Matched Controls Group B	X			X
X	single serum sample			
XX	two serum samples taken on different occasions			

of serum myoglobin measurement. Therefore the single serum sample creatine kinase estimations made on these carriers and their age and sex matched controls have been detailed in the appropriate chapter (refer to Section 6-3. and Table 6.6).

### 3-4. DISCUSSION

As a particularly sensitive marker of DMD, the level of serum creatine kinase was considerably elevated in all the DMD patients studied, with no overlap in levels of this enzyme between the DMD patients and their matched controls. The significant decline in the level of serum creatine kinase with increasing age in the Duchenne subjects is considered to reflect the decreasing muscle bulk and activity of these patients with disease progression. Conversely, serum creatine kinase levels in the healthy, age matched control boys increased significantly with increasing age, demonstrating the increasing muscle development and growth occurring in these subjects. Meltzer (1971) reported serum creatine kinase activities in normal males peaked between the ages of 10-19 and 40-49 years.

Several workers (Gardner-Medwin et al., 1971; Bunday et al., 1979; Tippett et al., 1982) have also reported the non-Gaussian distribution of serum creatine kinase activities found in the 200 adult females used as a control series by the Department of Human Genetics, Edinburgh (refer to Section 3-3.). Gale and Murphy (1979) concluded from their analysis of published data that the Normal assumption was not justified in the case of serum creatine kinase distribution in DMD carriers either.

The wide fluctuation in serum creatine kinase level exhibited by several of the DMD carriers investigated is often noted where multiple sample testing has been carried out (Gardner-Medwin et al., 1971; Bradley and Keleman, 1979).

The reported effects of age on serum creatine kinase level appear complex and remain controversial. Some workers have not found a consistent relationship between the level of this enzyme and age in DMD carriers (Gardner-Medwin et al., 1971; Zatz and Otto, 1980a) whilst others have reported serum creatine kinase activity to decrease with increasing

DMD carrier age (Moser and Vogt, 1974; Lange and Zatz, 1979). In normal females the level of serum creatine kinase may be highest pre-menarche, decrease around menarche, decrease slightly through adult life and then rise slightly after age 40 (Smith et al., 1979; Bunday et al., 1979; Lane and Roses, 1981). Some workers, however, found no consistent alteration in serum creatine kinase level and age in normal women (Thomson, 1968; Meltzer, 1971) whilst others (Perry and Fraser, 1973; Sweetin and Thomson, 1973) consider the enzyme level increases with increasing age or following the menopause. These studies of age effects on serum creatine kinase levels in normal women have been discussed in detail by Lane and Roses (1981). The variation in serum creatine kinase activity found in different age groups may be hormonal in origin, reflecting alterations in oestrogen level (Shumate et al., 1979; Lane and Roses, 1981). Certainly serum creatine kinase levels appear to be higher in states consistent with lowered oestrogen levels relative to the adult woman. Also, levels of this enzyme appear to be lower when oestrogen levels are increased, as in pregnancy (King et al., 1972) although the smaller more transient increase represented by use of the contraceptive pill, or by the menstrual cycle, do not appear to suppress the level of serum creatine kinase in normal women (Pearce et al., 1964b; Bunday et al., 1979; Tippett et al., 1982).

In this study serum creatine kinase levels in both the DMD carrier group and their age matched controls exhibited a significant positive correlation with age. Ten of the women in each group were age 40 or older and so clearly the results obtained in both subject groups will reflect mainly the influence of this particular age range. In the DMD carriers studied the variation in serum creatine kinase activity with age may reflect a decreased oestrogen level with a concomitant increase in serum creatine kinase activity in the post menopausal carriers (as has

been discussed in normal women) or reflect the action of other age related factors such as possible decreased renal clearance of the enzyme in older women. In the case of the DMD carrier group the results did not agree with those of comparable studies (Gardner-Medwin et al., 1971; Lange and Eatz, 1979). This may be explained, at least in part, by the different age range selected in each study leading to a possible influence on results according to the proportion of younger (pre menarchal and/or menarchal) to older (post menopausal) women. The results observed in the normal female controls, taking into account the large proportion of women over 40 years of age, agree with those of Perry and Fraser, 1973; Sweetin and Thomson, 1973; Bunday et al., 1979; Lane and Roses, 1981.

The overlap in distribution between serum levels of creatine kinase in the DMD carriers and their matched controls indicated the necessity for precise measurements of this enzyme in suspected DMD carriers to enable reliable genetic counselling to be given. In the Department of Human Genetics, Edinburgh, the probability of a consultand being a DMD heterozygote is calculated using Bayesian theory, employing combined information from pedigree data and serum creatine kinase measurement (Emery and Holloway, 1977; Emery, 1980). In these calculations the actual serum creatine kinase level of the consultand is taken into account by examining the "h" value and the ratio of the proportions of normal women to DMD carrier women with this enzyme level calculated from the distribution of levels of this enzyme observed in the Department in a series of controls and genetic DMD carriers (Emery 1981). The serum creatine kinase levels of the suspected carriers' first degree female relatives of child bearing age and also the presence of healthy sons and brothers are incorporated into the probability calculations.

Clearly it is important to be aware of any factors which might influence serum creatine kinase measurements undertaken for genetic

counselling purposes. Apart from the apparently complex effects of age and the conditions listed in Section 3-1. other factors which influence serum levels of this enzyme have been investigated.

The significant decrease in serum creatine kinase activity observed in normal women during early pregnancy reported by King et al. (1972) and Bunday et al. (1979) and in DMD carriers by Emery and King (1971) emphasise the difficulty involved in determining the carrier status of a pregnant suspected DMD heterozygote. However most (Perry and Fraser, 1973; Simpson et al., 1974; Tippett et al., 1982) but not all workers (Paterson and Lawrence, 1972) considered use of the contraceptive pill did not significantly alter serum creatine kinase activity. Similarly, most reports (Pearce et al., 1964b; Perry and Fraser, 1973; Simpson et al., 1974) considered the stage of the menstrual cycle did not influence serum levels of this enzyme, although Paterson and Lawrence (1972) found serum creatine kinase activity was lower in days 12-26 of the 'cycle than in days 1-11 in their subjects.

Standard exercise tests have been suggested as a way of improving the detection efficiency of serum creatine kinase measurements in DMD heterozygote detection and therefore work on effects of exercise has been discussed in Section 3-1. It would appear that normal daily activity does not significantly influence serum creatine kinase levels, at least in normal women (Pearce et al., 1964b).

Meltzer (1971) reported that mean serum creatine kinase levels were higher in Negroes than Caucasians. Clearly this could result in erroneous DMD heterozygosity risks should the serum creatine kinase estimation of a consultant of one ethnic origin be compared to reference enzyme levels from women of a different race.

Diurnal and seasonal variations in serum creatine kinase levels have also been noted. Gale and Murphy (1979) concluded from their survey



of the literature that serum creatine kinase activity increased during the course of the day. In this study results from measurements on one healthy female, taken under conditions of everyday activity, (refer to Figure 3.4.) suggest there is a fluctuation in creatine kinase level between the hours of 9 a.m. and 5 p.m. Smith et al. (1979), in a large study involving 625 normal females, noted serum creatine kinase levels were at their lowest in February and peaked in August. Percy et al. (1982a) reported a different seasonal variation of serum creatine kinase activities in DMD carriers (whose enzyme measurements were lowest in November and at their highest in May) than in control females (where creatine kinase levels were lowest in May and highest in November). In neither situation were the differences between mean creatine kinase activities at the extremes statistically significantly different, however Percy et al. (1982a) concluded that the reliability of serum creatine kinase estimation in DMD heterozygote recognition could be improved by consideration of the season. Smith et al. (1979) considered the seasonal fluctuation might be related to seasonal hormonal changes.

An intrafamilial correlation with serum creatine kinase levels has been noted in certain families (Sibert et al., 1979; Tippett et al., 1982). Also, unexplained occasional high serum creatine kinase measurements in normal women have been noted by Thomson, (1968) and this study (female control no. 10, refer to Table 3.4.). Consequently it would appear that not all factors capable of influencing serum creatine kinase levels in either DMD carriers or normal women are yet fully understood.

Quite apart from physiological factors, serum creatine kinase activities may be altered by treatment of the sample prior to assay and by the method of assay itself. Pearce et al. (1964b) reported serum levels of creatine kinase decreased rapidly following repeated cycles of freezing and thawing. Dilution of DMD carrier serum prior to assay can

increase the measured activity of the enzyme, which Thomson (1969) considers may be due to the presence of inhibitors of creatine kinase in serum. Such inhibitors might, at least partially, account for the considerable variation in DMD carrier serum creatine kinase levels (Pennington, 1977). The various assay systems for creatine kinase measurement used by different laboratories have been discussed in detail by Gale and Murphy (1979). With different biochemical bases these methods may well have different sensitivities and hence DMD carrier recognition capabilities.

Despite taking all these factors into consideration substantial improvement in DMD heterozygote detection may only be obtained by supplementary information from the additional measurement of one or more non-correlated parameter(s).

CHAPTER 4: PYRUVATE KINASE

195  
196  
197  
198  
199  
200  
201  
202  
203  
204  
205  
206  
207  
208  
209  
210  
211  
212  
213  
214  
215  
216  
217  
218  
219  
220  
221  
222  
223  
224  
225  
226  
227  
228  
229  
230  
231  
232  
233  
234  
235  
236  
237  
238  
239  
240  
241  
242  
243  
244  
245  
246  
247  
248  
249  
250  
251  
252  
253  
254  
255  
256  
257  
258  
259  
260  
261  
262  
263  
264  
265  
266  
267  
268  
269  
270  
271  
272  
273  
274  
275  
276  
277  
278  
279  
280  
281  
282  
283  
284  
285  
286  
287  
288  
289  
290  
291  
292  
293  
294  
295  
296  
297  
298  
299  
300

4-1. INTRODUCTION

Pyruvate kinase (ATP: pyruvate phosphotransferase E.C.2.7.1.40) is a glycolytic enzyme, glycolysis providing an important source of energy to muscle and other tissues. Pyruvate kinase catalyses the following reaction, which provides a physiological rate limiting step in ATP formation:

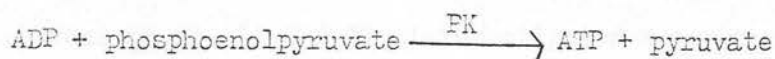

where:

ADP = adenosine diphosphate

ATP = adenosine triphosphate

FK = pyruvate kinase

The enzyme is present in many tissues in one of two isoenzyme forms, type M or type L (with the exception of hepatocytes in which both forms are present). Type M (molecular weight 250,000 daltons) may be further divided by electrophoretic mobility into type M<sub>1</sub> found in skeletal and cardiac muscle and brain; type M<sub>2</sub> found in liver, lung, leucocytes and adipose tissue, type M<sub>3</sub> present in intestine, testes and ovary and type M<sub>4</sub> present in smooth muscle and kidney. Type L (molecular weight 208,300 daltons) is found in liver and erythrocytes and differs from type M kinetically and in its response to ATP; alanine; fructose 1,6-diphosphate and in its temperature sensitivity.

Significantly increased serum pyruvate kinase activities have been reported associated with the following conditions:

- (1) acute myocardial infarction
- (2) muscular dystrophies

(3) alcoholic myopathy

(4) polymyositis

(5) severe hepatitis

In conditions (1) to (4) increased serum pyruvate kinase activities are considered to be due to leakage of type M<sub>1</sub> pyruvate kinase from diseased or damaged muscle. In a case of severe hepatitis reported to have raised serum pyruvate kinase activity, the enzyme exhibited type L properties.

Harano et al. (1973) first investigated serum pyruvate kinase activities in DMD and reported elevated activities of this enzyme in all 20 DMD subjects studied. Even severely affected DMD patients whose serum creatine kinase activities had decreased to normal levels retained elevated serum pyruvate kinase activities. Since then, several workers have confirmed that a very high proportion of DMD patients do have raised serum pyruvate kinase activities (Alberts and Samaha, 1974; Weinstock et al., 1977; Zatz et al., 1978).

The possibility that serum pyruvate kinase might be more sensitive than serum creatine kinase in DMD carrier detection was examined by Alberts and Samaha (1974). In a series of 29 DMD patients, 26 carriers and 35 controls, all DMD subjects had increased serum pyruvate kinase activities as did 5 of 7 (71%) definite, 3 of 4 (75%) probable and 7 of 15 (46%) possible DMD carriers. Only 2 definite, 1 probable and 1 possible carrier were reported to have raised serum creatine kinase activities. Alberts and Samaha (1974) stated pyruvate kinase was 3 times as sensitive as creatine kinase in detecting the carrier state.

Other workers could not confirm these observations. Hardy et al. (1977) investigated 21 control subjects and 17 DMD carriers. Five carriers (29%) had elevated serum pyruvate kinase activities but 11

(64%) had raised serum creatine kinase activities. None of the carriers whose serum creatine kinase activity fell within normal limits were found to have elevated serum pyruvate kinase activities. Similarly, Yamuna et al. (1977) and Seay et al. (1978) found serum creatine kinase to be superior to serum pyruvate kinase in carrier detection. These workers, in contrast to the results of Alberts and Samaha, reported that carriers with normal serum creatine kinase activities also exhibited normal serum pyruvate kinase activities and considered the combined use of these two parameters would not be of value in carrier detection.

However, others (Percy et al. 1979; Zatz et al. 1980; Zatz and Otto, (1980b) do consider that carrier detection efficiency is improved by measurement of both parameters.

## 4-2. MATERIALS AND METHODS

### 4-2.1. Serum Pyruvate Kinase

Total serum pyruvate kinase activity was measured during everyday activity in the following group of subjects.

- (1) Carrier and control group A, comprising 15 DMD carriers and 15 age-matched normal, healthy women.

The carriers and controls were selected as stated in 3-2. Blood samples were collected and processed according to the protocol described in 3-2.

Two blood samples were obtained 4-7 days apart from all subjects. The mean activity of serum pyruvate kinase of both samples was used. Other analyses were also carried out on different aliquots of these serum samples as described in Table 3.5.

All sera were analysed within 6 hours of collection since controversy exists regarding the stability of Type M pyruvate kinase isoenzyme. There have been reports that this isoenzyme is stable in frozen sera stored for at least one year (Harano et al., 1973). More recently, however, other workers have reported that all pyruvate kinase isoenzymes progressively lose activity upon freezing (Zatz et al., 1978; Percy et al., 1978). Zatz et al. (1978) found that the pyruvate kinase activity of sera stored at  $-20^{\circ}\text{C}$  for two months was reduced to half its initial level.

Certainly serum pyruvate kinase activity decreases rapidly when blood is kept at room temperature. In this study the activity of the enzyme decreased by 44.7% over a 24 hour period (refer to 4-2.2).

With the exception of the second sample obtained from one DMD

carrier (8 III<sub>3</sub>) no sera showed any sign of haemolysis. This one slightly haemolysed serum sample was not analysed due to possible assay interference.

Total serum pyruvate kinase activity was measured using a commercially available kit, Boehringer Mannheim test-combination (Boehringer Corporation London Ltd., East Sussex, U.K.), based on the method of Beisenherz et al. (1953). In this assay system pyruvate kinase activity is measured as the rate of reaction in the direction of pyruvate formation. A coupled enzymic reaction measures pyruvate produced indirectly as the decrease in reduced nicotinamide adenine dinucleotide absorbance at 340 nm. The reaction may be described by the following equations:

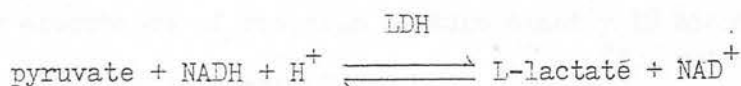
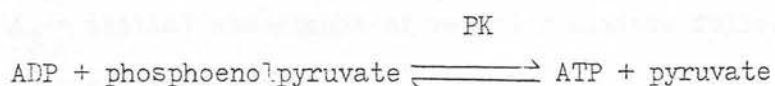

where:

NADH = nicotinamide-adenine dinucleotide, reduced

NAD<sup>+</sup> = nicotinamide-adenine dinucleotide

LDH = lactate dehydrogenase

The rate of change in absorbance at 340 nm was measured (spectrophotometrically) using a Pye Unicam SP8-100 recording spectrophotometer with temperature control. Assays were carried out at 25°C using glass cuvettes with a 1 cm light path and air as a blank. Serum samples were warmed to 25°C prior to assay. Pyruvate kinase activities were measured using halved quantities of serum and all



reagents but otherwise as according to kit instructions.

All samples were run in duplicate and the mean results used. Pyruvate kinase activities were obtained by calculating the change in absorbance (A) for 10 minute period:

$$A = (A_f - A_i)$$

where:

$$A_i = A_1 - A_2$$

$$A_f = A_3 - A_4$$

$A_1$  = initial absorbance of reaction mixture  
(serum and all reagents except ADP)

$A_2$  = absorbance of reaction mixture (serum and all reagents except ADP) exactly 10 minutes after measurement  $A_1$

$A_3$  = initial absorbance of reaction mixture following addition of ADP

$A_4$  = absorbance of reaction mixture exactly 10 minutes after measurement of  $A_3$

Pyruvate kinase results were expressed in International Units (IU) defined as before (Chapter 3).

#### 4-2.2. Effect of Storage of Serum on Pyruvate Kinase Activity

Total serum pyruvate kinase activity was measured during everyday activity in one normal, healthy 24 year old female subject.

A single blood sample was collected at 11 a.m. and processed according to the protocol described. Eight aliquots from the serum sample were stored at room temperature (23°C) and analysed over a 24-hour period (from time of collection). A further 2 aliquots were

stored at 4°C and - 70°C respectively and analysed at 24-hours from time of collection. The method of analysis was as described in 4-2.1. Each aliquot was analysed in duplicate and the mean result used.

#### 4-3. RESULTS

For distributions of serum pyruvate kinase levels in the DMD carrier and control group studied refer to Figure 4.1.

Technical variation in serum pyruvate kinase measurement expressed as coefficient of variation (CV) was 0.9%.

In one normal female control aged 25 years, biological variation of pyruvate kinase activity in 10 serum samples (taken between 11 a.m. and 12 noon; not less than 24 hours apart and analysed four hours from time of collection) was CV = 16.2%.

Storage of serum from one individual for 24 hours at room temperature (refer to Section 4-2.2.) resulted in a 44.7% loss in pyruvate kinase activity. Less than 1.2% loss in activity occurred following four hours storage at room temperature. Aliquots of this serum sample stored at 4°C and -70°C lost 26.5% and 14.5% pyruvate kinase activity respectively after a 24-hour period (refer to Figure 4.2.).

For mean and individual serum pyruvate kinase levels refer to Tables 4.1. and 4.2. respectively.

In this and subsequent chapters the precise ages of the control subjects have been omitted from tables listing individual results but may be found in the comparable tables in Section 3-3. Mean serum pyruvate kinase activities in both DMD carriers and their controls were not normally distributed but log base 10 ( $\log_{10}$ ) pyruvate kinase levels fitted within the normal distribution (Kolmogorov-Smirnov test).

A significant difference was found between  $\log_{10}$  mean serum pyruvate kinase levels in the DMD carriers tested compared to their matched controls (Students paired t test,  $p < 0.001$ ). However, there was a large degree of overlap between results in the two groups.

Figure 4.1. Distribution of Serum Pyruvate Kinase Levels in DMD Carriers and Age and Sex Matched Controls

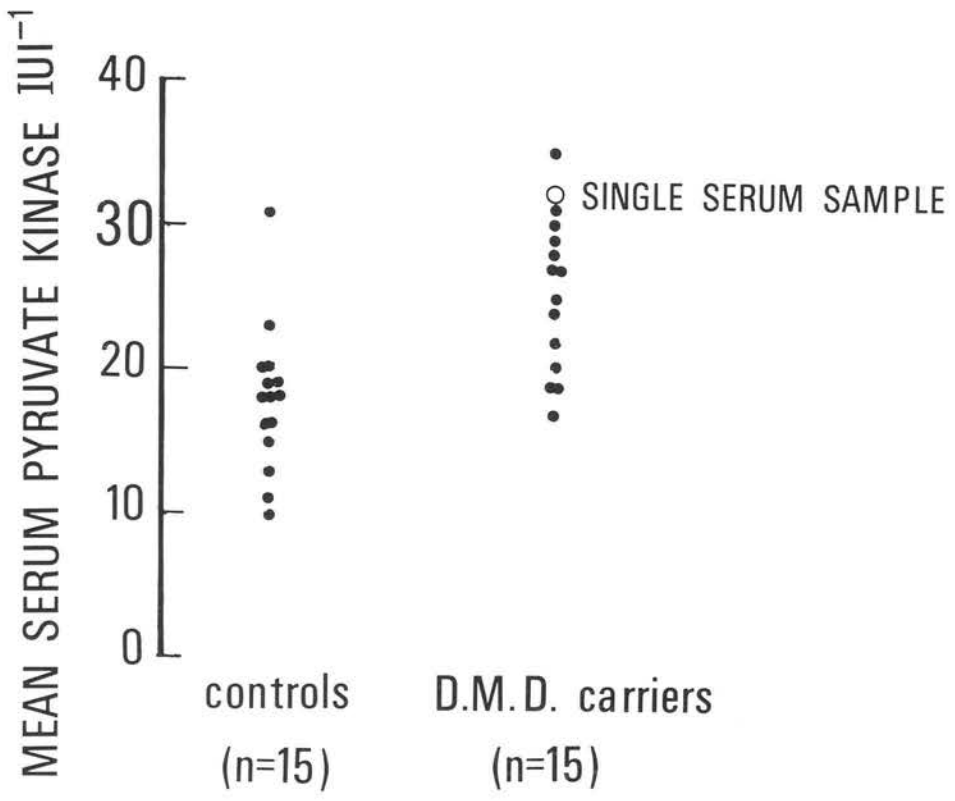

Figure 4.2. Decrease in Pyruvate Kinase Activity Observed in Serum Aliquots Stored at 23°C, 4°C and - 70°C

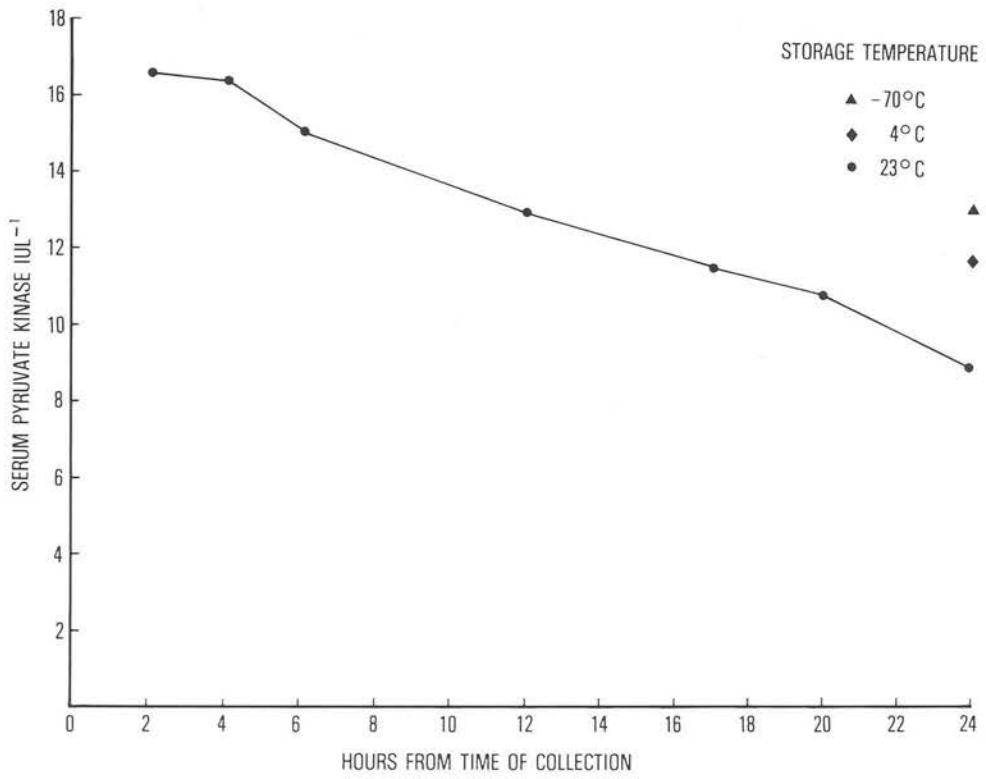

Table 4.1. Mean Serum Pyruvate Kinase Levels in DMD Carriers and their Age and Sex-matched Controls

		SERUM PYRUVATE KINASE IU l <sup>-1</sup>			
		Mean	SD	Actual range	Level of significance
Controls					
(n = 14) <sup>x</sup>		17.7	5.2	17 - 35	
DMD Carriers					p < 0.001
(n = 14) <sup>x</sup>		25.2	5.3	10 - 31	

<sup>x</sup> DMD carrier 17 II<sub>4</sub> and matched control no. 8 omitted from all calculations  
<sup>p</sup> Level of significance by Students paired t test  
<sup>SD</sup> Standard deviation



Table 4.2. Individual Serum Pyruvate Kinase Levels in DMD Carriers and their Age and Sex Matched Controls

AGE AND SEX MATCHED CONTROLS					DMD CARRIERS						
Subject No.	PK IUl <sup>-1</sup>			Mean CK IUl <sup>-1</sup>	Subject Pedigree No.	Age Yrs.	PK IUl <sup>-1</sup>			Mean CK IUl <sup>-1</sup>	
	1st	2nd	Mean				1st	2nd	Mean		
1	18	22	20	24	10 II <sub>2</sub>	24	21	17	19	<u>127</u>	
2	17	23	20	40	11 II <sub>13</sub>	29	18	19	19	<u>121</u>	
3	29	17	23	44	12 III <sub>4</sub>	33	30	24	27	<u>106</u>	
4	13	18	16	27	13 II <sub>2</sub>	35	20	24	22	80	
5	29	32	31	31	14 III <sub>1</sub>	38	<u>40</u>	18	29	<u>133</u>	
6	13	12	13	45	15 II <sub>4</sub>	40	18	22	20	37	
7	16	14	15	73	16 II <sub>1</sub>	43	26	22	24	<u>194</u>	
8	22	13	18	44	17 II <sub>4</sub>	43	32	H	32 <sup>†</sup>	<u>101</u>	
9	18	18	18	51	18 II <sub>5</sub>	50	26	28	27	<u>231</u>	
10	22	15	19	77	10 I <sub>2</sub>	51	<u>28</u>	<u>28</u>	<u>28</u>	<u>423</u>	
11	20	15	18	45	19 II <sub>3</sub>	52	19	<u>51</u>	<u>35</u>	<u>223</u>	
12	11	11	11	18	20 II <sub>4</sub>	55	17	17	17	63	
13	13	25	19	52	21 II <sub>1</sub>	59	30	32	<u>31</u>	<u>195</u>	
14	10	10	10	50	22 III <sub>8</sub>	60	<u>35</u>	25	<u>30</u>	<u>230</u>	
15	16	15	16	70	23 I <sub>1</sub>	60	26	23	25	<u>105</u>	

elevated levels underlined

H haemolysed sample, PK not measured  
 † single sample result  
 PK serum pyruvate kinase  
 CK serum creatine kinase

95% confidence limits were calculated from the regression of  $\log_{10}$  mean serum pyruvate kinase levels on age in the control subjects (Snedicor and Cochran; 1967). Although no significant relationship was found between  $\log_{10}$  mean serum pyruvate kinase activities and age in the DMD carrier group ( $r = 0.48$ ), a significant negative regression of logged mean results of this enzyme on age were found in the control subjects ( $r = -0.53$ ,  $p < 0.01$ ). 4/14 (28.5%) DMD carriers had  $\log_{10}$  mean serum pyruvate kinase levels outwith the calculated 95% confidence limits. (refer to Figure 4.3.). Age correcting the DMD carrier results did not alter the number of carriers detected by this enzyme. The age corrected, single serum result on DMD carrier 17 II<sub>4</sub> was not outside the calculated upper 95% confidence limit.

Mean serum pyruvate kinase and creatine kinase activities were significantly correlated in the DMD carrier group ( $r_s = 0.69$ ,  $p < 0.01$ ) but no significant relationship was found between these enzymes in the control subjects ( $r_s = -0.17$ ), shown in Figure 4.4.

There was a significant correlation between serum pyruvate kinase activity (first serum sample measurement) and the serum level of haemopexin in the DMD carrier group ( $r_s = 0.45$ ,  $p < 0.05$ ) which was not found in the matched controls ( $r_s = 0.14$ ).

No significant relationship was evident between serum levels of pyruvate kinase (first serum sample) and myoglobin in either the DMD carriers ( $r_s = 0.39$ ) or their matched controls ( $r_s^1 = 0.19$ ).

Figure 4.3. Relationship Between Serum Pyruvate Kinase and Age in  
DMD Carriers and Age and Sex Matched Controls

A. DMD Carriers

Equation for the line:  $y = 1.22 + 0.003x$

$r = 0.48$ ,  $p = \text{NS}$

B. Controls

Equation for the line:  $y = 1.48 - 0.0055x$

$r = -0.53$ ,  $p < 0.05$

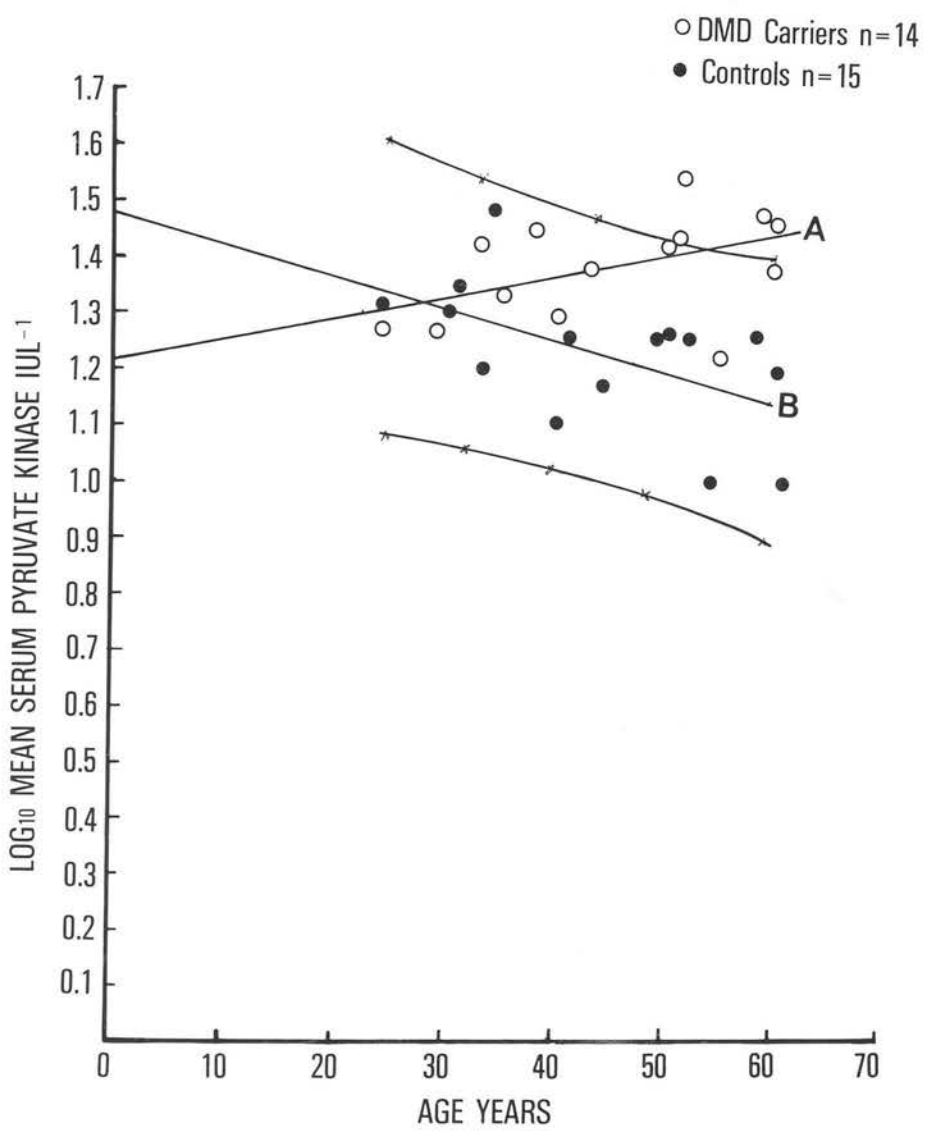

Figure 4.4. Relationship Between Serum Pyruvate Kinase and Creatine Kinase Levels in DMD Carriers and their Age and Sex Matched Controls

DMD Carriers

Spearman's Rank Correlation Coefficient

$$r_s = 0.69, p < 0.01$$

Controls

Spearman's Rank Correlation Coefficient

$$r_s = - 0.17, p = NS$$

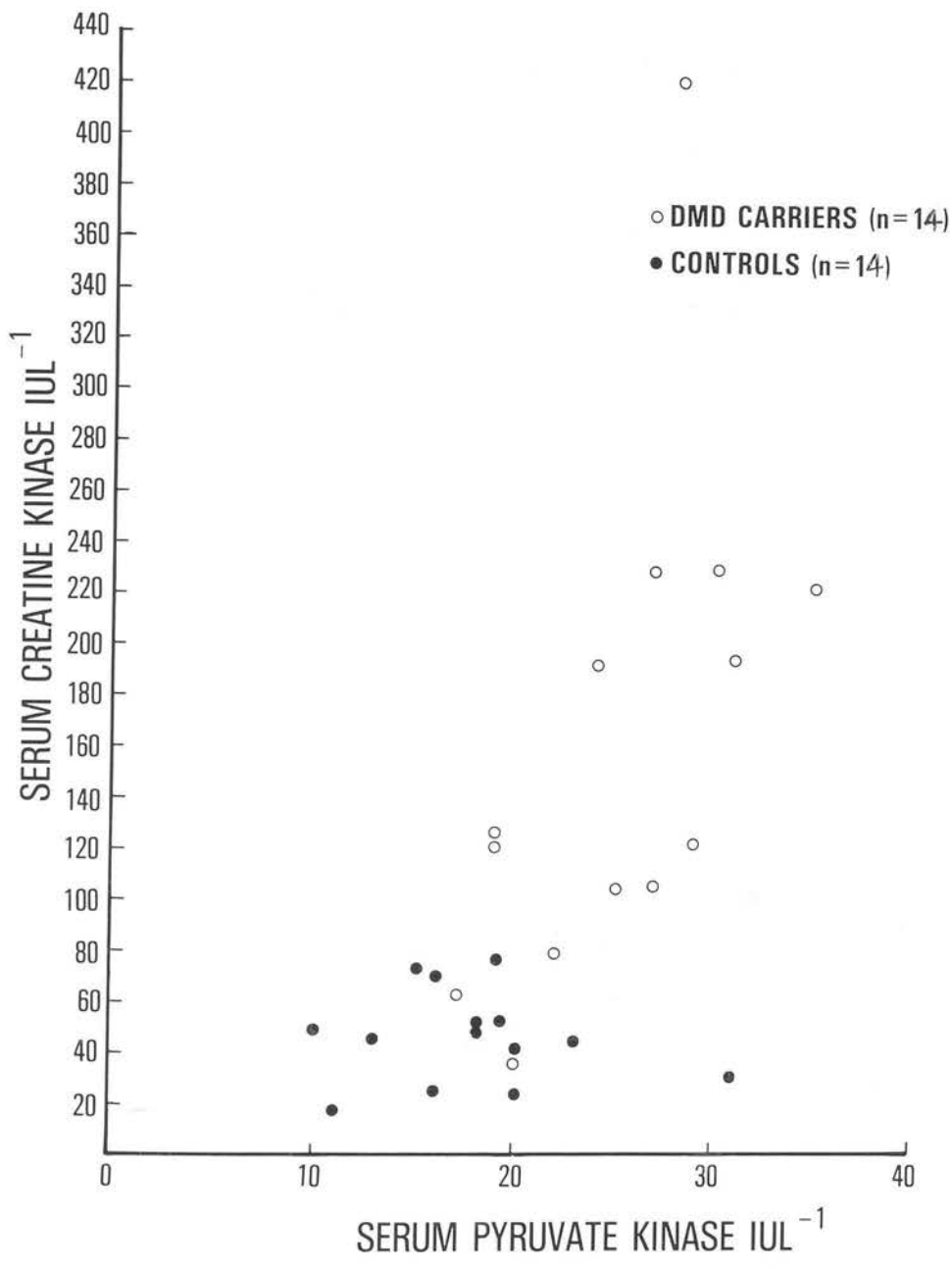

The rapid decrease of pyruvate kinase activity to almost half initial level following 24 hour storage of serum at room temperature (23°C) demonstrated the unstable nature of this enzyme, also reported by Smith and Thomson (1977). These workers, in comparison with serum creatine kinase measurement had commented on the unsuitability of assaying pyruvate kinase activity on posted serum samples (since some serum creatine kinase assays for use in DMD carrier detection must, of necessity, be performed on samples which may have been in the post for 2 - 3 days, and yet produce acceptable results; refer to Chapter 3). In this study, whilst 4 hours at room temperature had resulted in only a small decrease in serum activity (1.2%) a much greater (14.5%) loss of pyruvate kinase activity had occurred following freezing at - 70°C and subsequent analysis 24 hours later. Zatz et al. (1980) and Percy et al. (1979) also found pyruvate kinase activity progressively decreased on freezing (by approximately 50% at - 20°C following a two month period in the former study). Zatz et al. (1980) considered the results of some studies (Hardy et al., 1977; Yamuna et al., 1977) may have been affected by the use of frozen stored samples. Certainly these results dispute the frozen stability of pyruvate kinase M isoenzyme for up to one year reported by Valentine and Tanaka (1966).

In agreement with Hardy et al. (1977) and Zatz et al. (1980) serum pyruvate kinase levels were not normally distributed but log (base 10) activities of this enzyme fitted within a Gaussian distribution. However some other workers did not state whether normality of distribution had been tested for and did not log-transform data prior to analysis (Alberts and Samaha, 1974; Sage et al., 1979; Seay et al., 1978).

These differences in treatment of samples prior to enzyme assay; in

assay systems used and in the treatment of data produced all severely adversely affect the comparison of work from different centres. However, despite such differences most centres have reported significantly higher serum pyruvate kinase activities in DMD carriers compared to control subjects, as was found in this study (Alberts and Samaha, 1974; Sage et al., 1979; Zatz et al., 1980; Muir et al., 1983).

Whilst no significant relationship was found between  $\log_{10}$  mean serum pyruvate kinase activity and age in the DMD carriers studied (in agreement with Smith and Thomson, 1977) a significant negative correlation was evident in their matched controls. Both Sage et al. (1979) and Zatz et al. (1980) found serum pyruvate kinase activities were significantly higher in normal children compared to normal adults. Sage et al. (1979) also reported that in the DMD carriers (of all categories) tested, 75% of those with elevated serum levels of pyruvate kinase were less than 20 years of age. Such findings suggest that the report of Percy et al. (1979) which contradicted the findings of this study (in that  $\log_{10}$  serum pyruvate kinase levels were found to be significantly correlated in DMD carriers but not in controls) may, at least in part, have reflected alterations due to the different age groups studied. Percy et al. (1979) used DMD carriers between 17 - 60 years of age, whilst in this study the youngest carrier was in her mid-twenties.

The percentage of DMD carriers in this study who had serum levels of enzyme outside calculated 95% confidence limits was very low in the case of serum pyruvate kinase (4/14; 28.5%) compared to serum creatine kinase (11/14; 78.5%). Furthermore, the 4 DMD carriers selected by serum pyruvate kinase measurement also had elevated serum creatine kinase levels. These results indicate the lack of usefulness of serum pyruvate kinase measurements in DMD heterozygote recognition (in the age range studied) both alone, or in combination with serum creatine kinase measurement,



in agreement with the studies of Yamuna et al. (1977); Hardy et al. (1977); Smith and Thomson (1977) and Seay et al. (1978). Alberts and Samaha in 1974 had reported serum pyruvate kinase measurement was more sensitive than serum creatine kinase in DMD carrier detection and yet, in a later study from this centre encompassing the earlier data, Sage et al. (1979) stated that serum pyruvate kinase was more likely to be elevated in young (less than 20 years old) suspected carriers and was less sensitive in detecting carriers over 20 years.

Percy et al. (1979) and Zatz et al. (1980) considered heterozygote recognition was improved by combined measurement of both serum pyruvate kinase and creatine kinase levels. However both these groups of workers reported a much greater percentage of their genetic DMD carriers investigated had serum pyruvate kinase activities elevated above each centres' calculated "normal" limits than was found in this and other studies (Yamuna et al., 1977; Smith and Thomson, 1977 and Seay et al., 1978). This is difficult to interpret since serum enzyme levels may be resultant of the influence of many factors related to the subjects studied and/or methodology used (discussed fully in Section 3-4). For example, ethnic origin has been reported to influence serum enzyme levels (Meltzer, 1971). Percy et al. (1979) found a similarly high percentage of DMD heterozygotes studied had elevated levels of serum creatine kinase as well as serum pyruvate kinase (70% in each case), as did Zatz and co-workers in 1980 (71% and 78.5% respectively). However, in the study of Percy et al. (1979) only 2/20 (10%) genetic DMD carriers whose serum creatine kinase levels were considered to be within "normal" limits had elevated levels of serum pyruvate kinase whilst Zatz et al. (1980) found 2/14 (14.2%) such carriers. When the apparent improvement in DMD carrier detection is small considerable precautions must be taken to ensure factors other than the subjects heterozygosity have not resulted

in falsely elevated enzyme levels.

Percy et al. (1979) used single serum sample determinations, whilst in the study of Zatz et al. (1980), where multiple serum enzyme determinations were carried out, one elevated enzyme level was considered indicative of DMD carrier status. Seay et al. (1978) found in their study that two definite (and one possible) DMD carrier had single serum sample elevations of pyruvate kinase activity and yet the mean value of two estimations fell within "normal" limits. Similarly, in this study two DMD carriers had elevated serum pyruvate kinase activities of single samples and yet mean results were within the calculated 95th percentile of the control series. In the case of serum creatine kinase estimations Seay et al. (1978) found that where single serum sample elevations of creatine kinase activity occurred the mean value of two such estimations was always elevated as well. A similar situation was found in this study (refer to Table 3.4). Such results demonstrate the superior separation between DMD carrier and control groups by use of serum creatine kinase as compared to serum pyruvate kinase.

In this study serum levels of pyruvate kinase and creatine kinase were significantly correlated in the DMD carrier group but not in the controls (also found by Hardy et al., 1977; Percy et al., 1979; Zatz et al., 1980 and Zatz and Otto, 1980b), as were serum levels of pyruvate kinase and haemopexin. Interestingly, serum levels of pyruvate kinase and myoglobin were not significantly correlated in the DMD carriers studied (or in the controls). However the one carrier selected by serum pyruvate kinase measurement (19 II<sub>3</sub>) also had an elevated level of serum myoglobin.

Discriminant analysis involving serum measurements of creatine kinase, pyruvate kinase, haemopexin and myoglobin (discussed in detail in chapter 7) resulted in a DMD carrier detection rate of 12/14 (85.7%), with 14/14 (100%) controls correctly classified. Discriminant analysis

employing only serum creatine kinase and pyruvate kinase measurements resulted in only 11/14 (78.6%) DMD carriers (and all 14 controls) being correctly classified. Muir et al. (1983), using discriminant analysis found serum creatine kinase to be the most discriminating variable of three serum enzymes measured. These workers found 14/21 (67%) definite DMD carriers were correctly classified using combined measurement of serum creatine kinase and serum pyruvate kinase, however two control subjects were misclassified. Using serum creatine kinase measurement alone the same percentage of DMD carriers were correctly classified (67%) and no misclassification of controls occurred.

These results suggest there is little value to be gained by combined measurement of serum pyruvate kinase with serum creatine kinase in DMD carrier detection in the age range studied. However Zatz et al. (1983) in a preliminary report has suggested that serum pyruvate kinase may be a more reliable test for genetic counselling purposes than serum creatine kinase in pregnant suspected DMD carriers. Serum creatine kinase levels tend to decrease in early pregnancy in DMD carriers (refer to Chapter 3) whilst Zatz et al. (1983) found that in 5 women of varying DMD heterozygote risks, non-pregnant and pregnant serum pyruvate kinase estimations did not alter significantly. If this finding is confirmed serum pyruvate kinase may be of value in the difficult cases where genetic counselling has been requested when the suspected carrier is already pregnant.

CHAPTER 5: HAEMOPEXIN

1000

5-1. INTRODUCTION

Haemopexin, molecular weight 70,000 daltons (Hrkal and Muller-Eberhard, 1971), is a serum glycoprotein with beta<sub>1</sub> -mobility (Hershko, 1975). As a transport protein haemopexin is involved in the catabolism of the haem moiety of haemoglobin and may also serve as a transporter of haem from other sources such as myoglobin (Hayem-Levy et al., 1973). Following intravascular haem release the serum proteins haptoglobin, haemopexin and albumin interact to prevent the glomerular filtration of haem. When haptoglobin is depleted, remaining haem is bound by haemopexin and albumin. Haemopexin binds haem in an equimolar ratio (Muller-Eberhard, 1970) and the resulting haem-haemopexin complex is sequestered by hepatic parenchymal cells (Hershko, 1975).

Haemopexin is synthesized exclusively in the liver and released into the circulation. The clearance of circulating haemopexin by the reticulo-endothelial system is accelerated by formation of the haem-haemopexin complex. Under normal conditions very little haemopexin is excreted in the urine (Berggard, 1961). Elevated levels of serum haemopexin have been reported associated with the following:-

- (1) Duchenne muscular dystrophy
- (2) polymyositis
- (3) myasthenia gravis
- (4) rheumatoid arthritis
- (5) certain forms of cancer
- (6) diabetes mellitus

In the case of DMD and polymyositis, Adornato et al. (1978a) suggested elevated levels of serum haemopexin might be a response to the increased level of myoglobin found in such sera since injection of myoglobin and

muscle crush injury both raise serum haemopexin levels in monkeys. These workers further suggested that elevated serum haemopexin levels found in patients with myasthenia gravis might be due to either a slight leakage of myoglobin (previously unsuspected) or the reflection of a dysimmune state.

Decreased levels of serum haemopexin have been reported in haemolytic disease (due to the rapid clearance of the haem-haemopexin complex; in liver disease (caused by a decreased synthesis of haemopexin) and in severe renal disease, when haemopexin is lost in the urine.

An abnormality in the immunoelectrophoretic pattern of serum from both DMD patients and their mothers was identified as haemopexin by Askanas (1966a and 1966b). Following this work, Danieli and Angelini (1976a) measured serum haemopexin using radial immunodiffusion in 62 DMD carriers and 26 normal women and found the mean carrier serum haemopexin level was significantly higher than that of controls. They reported that the combined use of serum haemopexin and creatine kinase determinations raised the level of carrier detection in their series of definite and probable carriers from 70% to 87% (Danieli and Angelini, 1976b). Some carriers with normal serum creatine kinase values were reported to have elevated levels of serum haemopexin (Danieli and Angelini, 1976b).

Other workers (Percy et al., 1978; Adornato et al., (1978a) have confirmed that an increased amount of serum haemopexin does occur in a proportion of DMD carriers, although some (Tagliavini et al., 1979; Schiffer et al., 1979) consider the overlap between carrier and control measurements limits the usefulness of serum haemopexin as a method of carrier detection.

Serum levels of haemopexin were measured during everyday activity in the following groups of subjects:

- (1) 10 patients with DMD together with 10 age-matched, normal healthy boys.
- (2) Carrier and control group A comprising 15 DMD carriers and 15 age-matched, normal healthy women.

DMD patients, carriers and controls were selected as stated in 3-2. Blood samples were processed according to the protocol described in Section 3-2.

All sera were stored in aliquots at  $-70^{\circ}\text{C}$ , being frozen and thawed once only and warmed to room temperature prior to analysis within 6 weeks of collection. Frozen sera may be stored at  $-70^{\circ}\text{C}$  for at least 8 weeks without significantly affecting the haemopexin level (Adornato et al., 1978).

Other analyses were also carried out on different aliquots of these serum samples as described in Table 3.5.

None of the samples analysed showed signs of haemolysis.

Serum haemopexin levels were measured by commercially available radial immunodiffusion "M-Partigen" plates (Behringwerke A.G., West Germany). These plates use a standard radial immunodiffusion technique. The plates contain an agar gel incorporated with a rabbit anti-human-haemopexin antibody. Haemopexin standards or test sera placed in wells of equal diameter diffuse out radially through the gel. Circles of precipitation form around the wells due to the reaction between anti-human haemopexin antibody and the haemopexin present in the standard or test sera. The diameter of each precipitation circle is

proportional to the concentration of haemopexin within the standard or sample.

The wells on each plate were loaded with 5  $\mu$ l undiluted serum using the same syringe (10  $\mu$ l Hamilton syringe, Hamilton Bonaduz A.G., Switzerland). Great care was taken over accurate loading of the syringe and sample delivery. The syringe was rinsed several times (distilled water) and dried between each sample delivery.

Three commercially prepared standards of known haemopexin concentration: "protein-standard-serum B" solutions no. I (haemopexin 28  $\text{mgdl}^{-1}$ ), no. II (haemopexin 54  $\text{mgdl}^{-1}$ ) and no. III (haemopexin 120  $\text{mgdl}^{-1}$ ) (Behringwerke A.G.) were assayed on each plate and standard curves for each plate constructed from them. In each case DMD patient or carrier sera were assayed on the same plate as their matched control sera.

Having filled all wells the lids were replaced tightly and the plates left at room temperature for 48 hours to develop. The plates were then photographed and diameters of the precipitation rings measured on 4 x enlargements. 4 independent measurements of circle diameter were made on each well and the mean value used (Percy *et al.* 1981),

The squared mean diameters of the standard precipitation rings ( $\text{mm}^2$ ) plotted as a function of the standard concentrations produced standard curves for each plate which were used to determine the haemopexin concentrations of the samples.



5-3. RESULTS

For distributions of serum haemopexin levels in all groups studied refer to Figure 5.1.

There was <3% loss in haemopexin activity in serum stored at - 70°C for up to 6 weeks (with one cycle of freeze/thaw).

Variation in measurements between plates of the same batch expressed as the coefficient of variation (CV) was 3-4%. Technical variation expressed as CV was 0.7%, and biological variation measured in one normal 25-year old female subject (7 serum samples taken over a 6-week period) was CV = 7%.

DMD Patient and Control Group

Mean and individual serum haemopexin values in the DMD patient and control group have been summarised (Tables 5.1. and 5.2. respectively).

There was a significant difference between serum haemopexin levels in DMD patients and their matched controls (Wilcoxon test,  $p < 0.05$ ), but considerable overlap between the two groups.

No significant relationship was found between serum haemopexin level and age in either DMD patients (Spearman rank correlation coefficient,  $r_s = -0.32$ ) or their controls ( $r_s = -0.17$ ).

Serum haemopexin and creatine kinase levels were not positively correlated in either DMD patients ( $r_s = 0.14$ ) or their controls ( $r_s = 0.08$ ).

No significant relationship was found between serum haemopexin and myoglobin in the DMD patient group ( $r_s = 0.04$ ) or the controls ( $r_s = 0.47$ ) although there appeared to be a trend towards a relationship between these proteins in the control group.

Figure 5.1. Distribution of Serum Haemopexin Levels in DMD Patients, DMD Carriers and Age and Sex Matched Controls

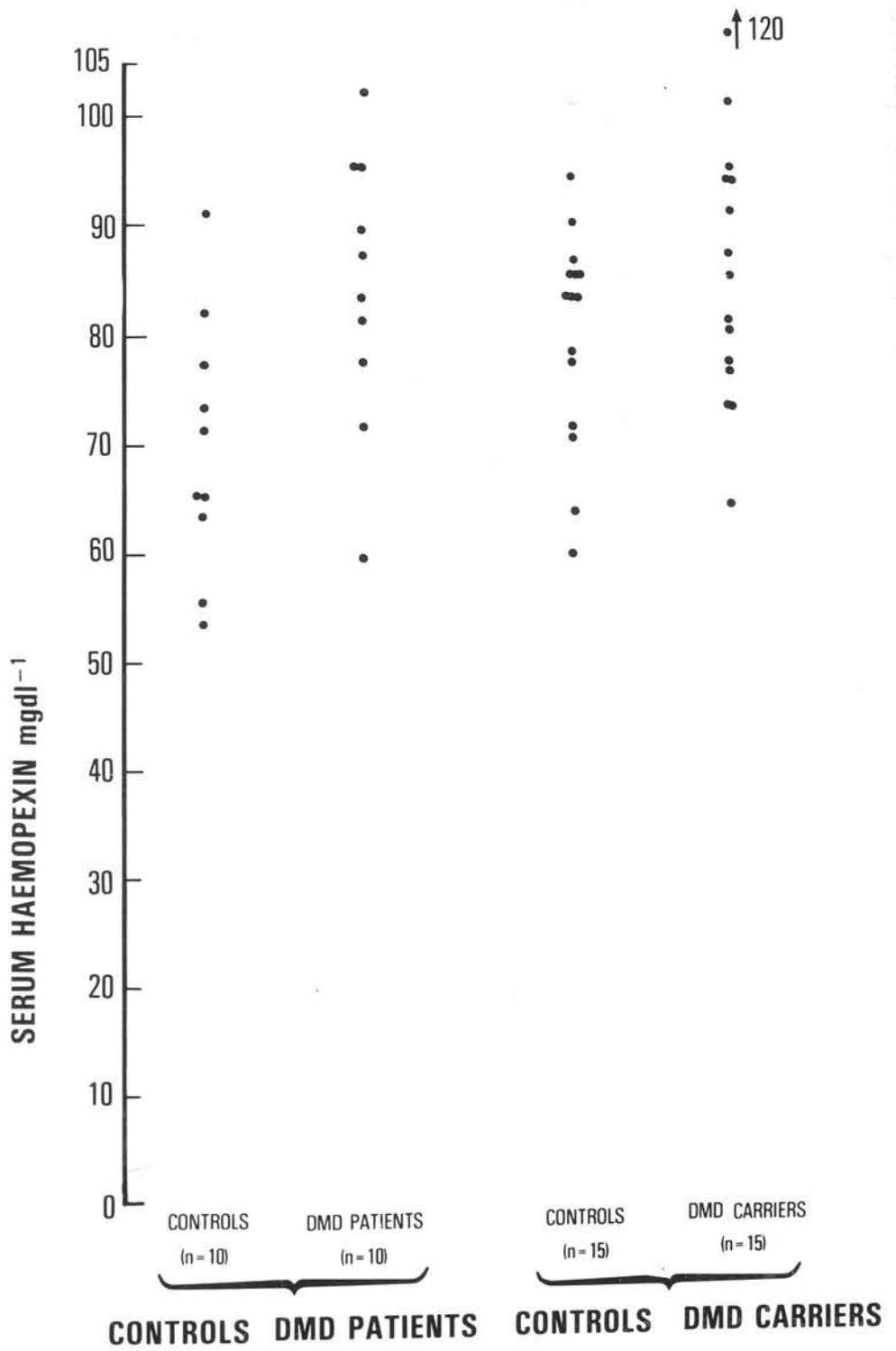

Table 5.1. Mean Serum Haemopexin Levels in DMD Patients and their Age and Sex-matched Controls

		SERUM HAEMOPEXIN $\text{mgdl}^{-1}$			
		Mean	SD	Actual range	Level of significance
Controls					
	(n = 10)	69.5	11.8	53 - 91	
DMD patients					$P < 0.05$
	(n = 10)	83.9	12.7	59 - 112	

SD standard deviation  
 p level of significance, Wilcoxon test

Table 5-2. Individual Serum Haemopexin Levels in DMD Patients and their Age and Sex-matched Controls

AGE AND SEX MATCHED CONTROLS			DMD PATIENTS			
Subject No.	Hpx mgdl <sup>-1</sup>	CK IUl <sup>-1</sup>	Subject No.	Age Yrs.	Hpx mgdl <sup>-1</sup>	CK IUl <sup>-1</sup>
			Pedigree			
1	65	48	6 II <sub>2</sub>	5	87	22842
2	77	69	1 II <sub>2</sub>	6	95	21600
3	63	33	2 III <sub>2</sub>	6.75	81	6026
4	82	47	7 IV <sub>2</sub>	9	102	3240
5	65	47	3 IV <sub>1</sub>	9	83	4147
6	91	80	4 III <sub>2</sub> *	10	89	1253
7	55	82	5 III <sub>3</sub> *	10.5	77	3672
8	73	55	8 III <sub>3</sub> *	10.5	71	3024
9	71	105	9 III <sub>4</sub> *	13	59	1701
10	53	67	10 I <sub>2</sub> *	14	95	1980

\* wheelchair bound  
 CK serum creatine kinase  
 Hpx serum haemopexin

## DMD Carrier and Control Group

For mean and individual haemopexin levels in DMD carriers and their matched controls refer to Tables 5.3. and 5.4. respectively.

Serum haemopexin levels in DMD carriers and controls were normally distributed (Kolmogorov-Smirnov test). There was no significant difference between levels of haemopexin in DMD carriers compared to their matched controls (Student's paired t test). There was considerable overlap between the results of the two groups.

The relationship between level of haemopexin and age was just significant in the carrier group ( $r = 0.52$ ,  $p < 0.05$ ) but no significant relationship ( $r = 0.06$ ) was exhibited by the control group (refer to Figure 5.2.). 95% confidence limits were calculated using the formula cited in Section 4-3.1. In 1/15 (6.6%) carriers the serum haemopexin level was raised above the calculated upper 95% confidence limit.

Serum haemopexin and creatine kinase levels were correlated in the DMD carrier ( $r_s = 0.63$ ,  $p < 0.01$ ) but not in the control series ( $r_s = 0.02$ ). Refer to Figure 5.3.

The relationship between serum haemopexin and pyruvate kinase levels has been discussed in Chapter 4.

No significant relationship was found between serum haemopexin and myoglobin levels in the DMD carrier group ( $r_s = 0.34$ ) however the relationship between these proteins just reached significance in the matched control group ( $r'_s = 0.47$ ,  $p < 0.05$ ). Refer to Figure 5.4. For serum myoglobin measurements in all groups studied refer to Chapter 6.

Table 5.3. Mean Serum Hamopexin Levels in DMD Carriers and their Age and Sex Matched Controls

		SERUM HAEMOPEXIN mgdl <sup>-1</sup>			
		Mean	SD	Actual range	Level of significance
Controls					
	(n = 15)	79.4	9.8	59 - 94	
DMD Carriers					p = NS
	(n = 15)	86.0	13.8	64 - 120	

SD standard deviation

NS not significant

p level of significance, Students paired t test

Table 5.4. Individual Serum Haemopexin Levels in DMD Carriers and Age and Sex Matched Controls

AGE AND SEX MATCHED CONTROLS			DMD CARRIERS			
Subject No.	Hpx mgdl <sup>-1</sup>	CK IUl <sup>-1</sup>	Subject Pedigree No.	Age Yrs.	Hpx mgdl <sup>-1</sup>	CK IUl <sup>-1</sup>
1	83	27	10 II <sub>2</sub>	24	94	<u>213</u>
2	63	33	11 II <sub>13</sub>	29	73	<u>123</u>
3	90	44	12 III <sub>4</sub>	33	80	<u>103</u>
4	94	23	13 II <sub>2</sub>	35	76	83
5	70	30	14 III <sub>1</sub>	38	77	<u>179</u>
6	83	52	15 II <sub>4</sub>	40	64	37
7	59	80	16 II <sub>1</sub>	43	85	<u>228</u>
8	85	42	17 II <sub>4</sub>	43	81	<u>115</u>
9	78	49	18 II <sub>5</sub>	50	95	<u>206</u>
10	83	63	10 I <sub>2</sub>	51	94	<u>327</u>
11	85	48	19 II <sub>3</sub>	52	87	<u>263</u>
12	71	19	20 II <sub>4</sub>	55	73	56
13	85	49	21 II <sub>1</sub>	59	91	<u>195</u>
14	77	49	22 III <sub>8</sub>	60	101	<u>269</u>
15	86	65	23 I <sub>1</sub>	60	<u>120</u>	<u>100</u>

elevated levels underlined

Hpx serum haemopexin

CK serum creatine kinase



Figure 5.2. Relationship between Serum Haemopexin Level and Age in DMD Carriers and their Age and Sex Matched Controls

A. DMD Carriers

Equation for the line:  $y = 58.11 + 0.62x$

$r = 0.52, p < 0.05$

B. Controls

Equation for the line  $y = 78.56 + 0.02x$

$r = 0.02, p: NS$

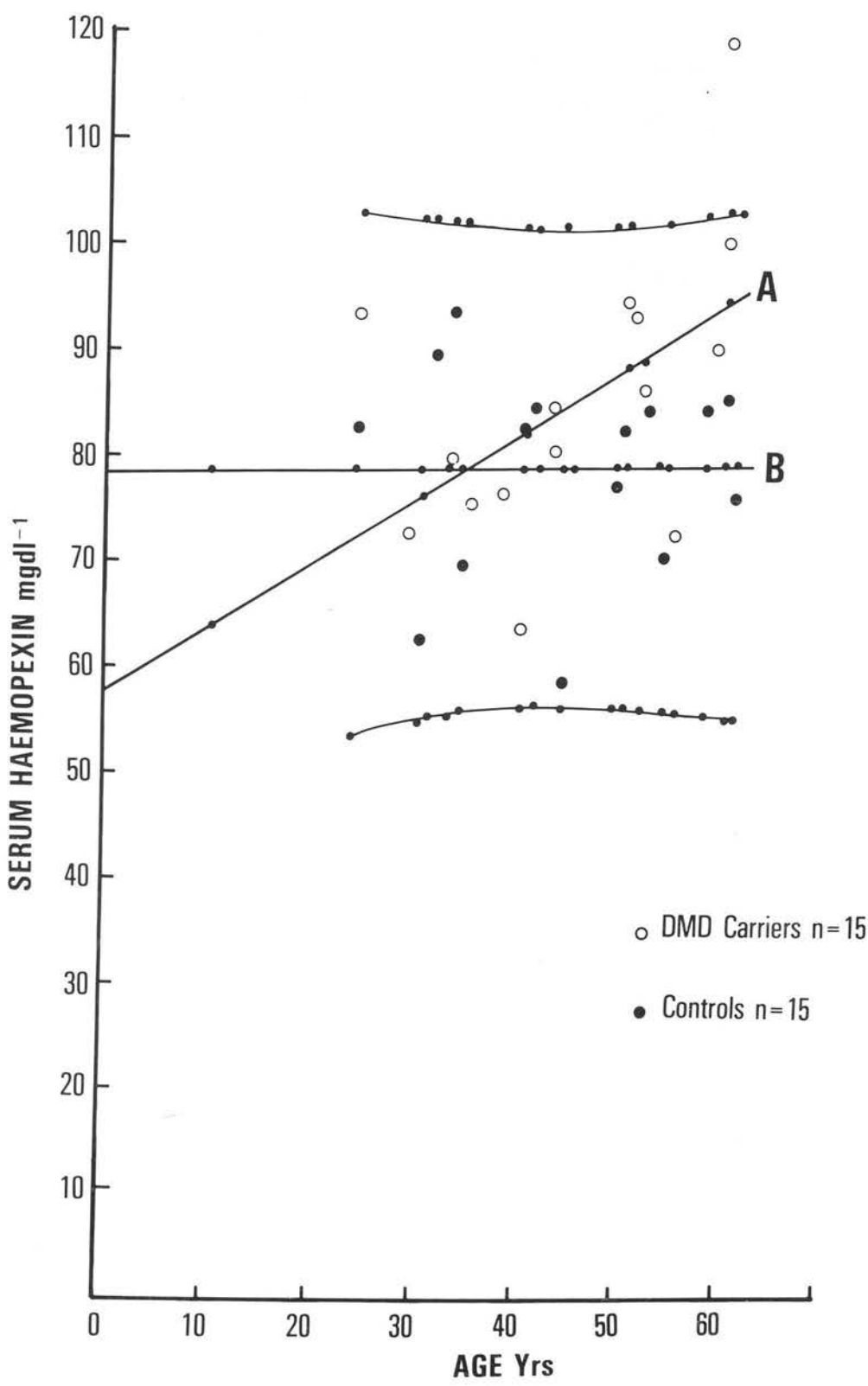

Figure 5.3. Relationship Between Serum Haemopexin and Creatine Kinase Levels in DMD Carriers and Their Age and Sex Matched Controls

DMD Carriers

Spearman's Rank Correlation Coefficient

$$r_s = 0.63, p < 0.01$$

Controls

Spearman's Rank Correlation Coefficient

$$r_s = 0.02, p = NS$$

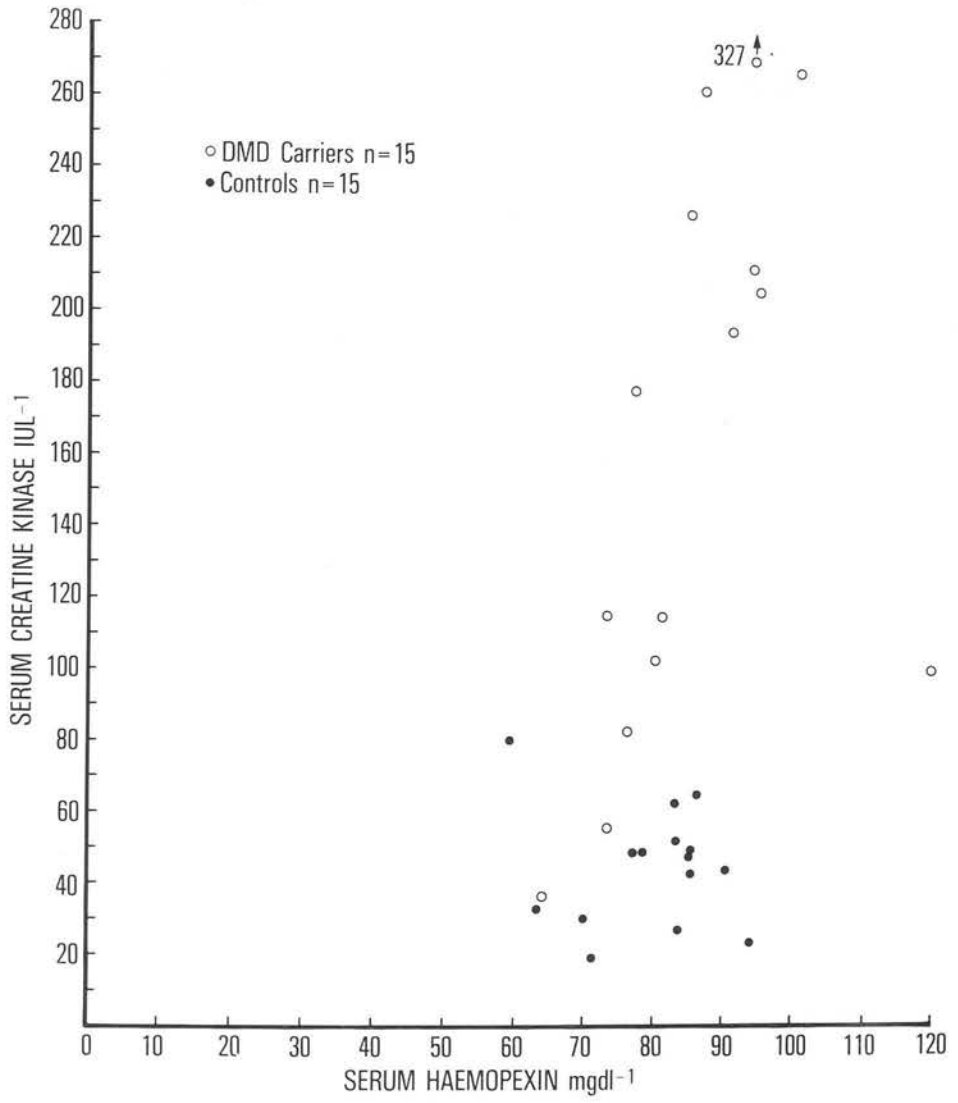

Figure 5.4. Relationship between Serum Haemopexin and Myoglobin Levels in DMD Carriers and their Age and Sex Matched Controls

DMD Carriers

Spearman's Rank Correlation Coefficient

$$r_s = 0.34, p = \text{NS}$$

Controls

Spearman's Rank Correlation Coefficient

$$r_s' = 0.47, p < 0.05$$

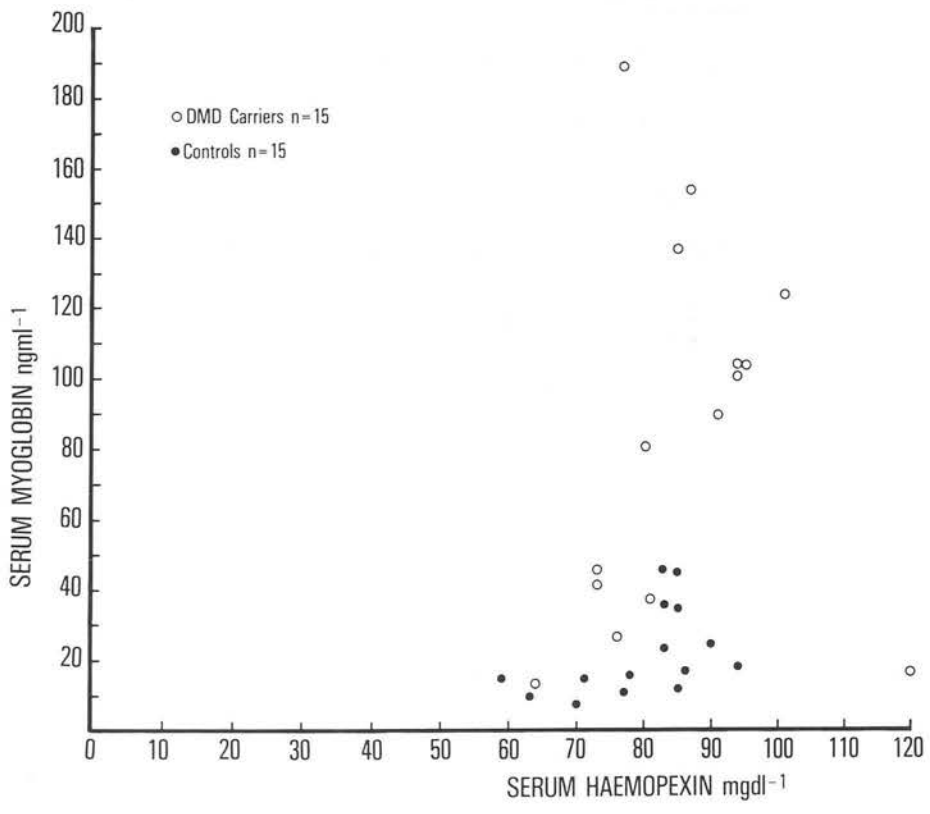

The stability of haemopexin in serum stored frozen ( $-70^{\circ}\text{C}$ ) for up to a 6-week period ( $< 3\%$  loss in activity) was in agreement with the study of Adornato et al. (1978a) who found  $< 5\%$  loss in activity (stored  $-70^{\circ}\text{C}$  for 8 weeks).

Using the method of Percy et al. (1981) a similar level of variation in measurements between plates (of the same batch) was found in this study (3-4%) to the study of Percy et al. (about  $\pm 2\%$ ).

Although serum haemopexin levels were significantly increased in DMD patients compared to their controls, the considerable overlap between values indicated the minimal discriminatory power of this protein in the separation of these two groups. The weak discriminatory power of serum haemopexin in the selection of Duchenne patients from their controls implied the selection of DMD carriers from their control group would be weaker still, since DMD carriers overall manifest either a lesser degree of biochemical abnormality or no demonstrable biochemical alteration from the norm. In fact this was the case, no significant difference was found in DMD carrier haemopexin levels compared to their matched controls. Both Lane et al. (1979) and Bunday (1981) were also unable to find a significant difference in serum haemopexin level in DMD carriers compared to their controls, whilst Tagliavini et al. (1979) found a statistical difference between serum haemopexin measurements in these two groups but stated that the variability of the results limited the usefulness of this test in carrier detection.

Danieli and Angelini (1976b) and Adornato et al. (1978a) reported significantly raised serum haemopexin levels in DMD carriers compared to controls and found a greater separation between these subject groups than

had other workers. However, in both of these reports, mean control haemopexin levels were, on average, about 18% lower than mean values in studies where control subjects were in the same age range as carriers (Percy et al., 1981; Lane et al., 1979) or where controls were age matched to the carriers used, as in this study. Percy et al. (1981) considered such differences in mean control haemopexin values may have been ethnic in origin or due to an age effect.

Lower serum haemopexin values have been reported in healthy children compared to healthy adults (Hanstein and Muller-Eberhard, 1968). In this study haemopexin levels in control boys tended to be in a lower range than haemopexin measurements made in the control women studied, whilst no significant age relationship was found in either group considered independently. Percy et al. (1981) found serum haemopexin levels in normal women < 20 years and > 50 years of age were significantly different from one another but reported no significant age relationship in the women between 20 - 50 years.

In this study a weak positive correlation was found between serum haemopexin and age in DMD carriers, which was not present in their matched controls. An increase in serum haemopexin level with increasing age could reflect a concomitant decrease in clearance efficiency of this protein. Age correcting the DMD carrier haemopexin results did not alter the number found out with the calculated 95% confidence limits. If carriers > 50 years of age were omitted from the calculation, the positive regression of haemopexin on age became non-significant. The results of Percy et al. (1981) suggested serum haemopexin levels are lower in women under 20 years; remain at fairly constant level between 20 - 50 years and increase in women > 50 years of age. Such a pattern could be resultant of a hormonal influence, haemopexin levels being affected by



premenarchal, menarchal and postmenopausal states.

Whilst no significant relationship was found between serum haemopexin and creatine kinase levels in either the DMD patients or their matched controls, a significant correlation between these proteins was evident in the DMD carrier group (not present in their matched controls). This was contrary to the findings of Percy and co-workers (1981) who reported a lack of correlation between serum haemopexin and creatine kinase measurements in their series of definite carriers of DMD. Mostacciuolo et al. (1980) cited a non-significant correlation coefficient ( $r$ ) for serum haemopexin and creatine kinase measurements of  $r = 0.279$ , but did not state to which subject group (DMD carriers or control women) this investigated figure referred. Clearly a significant correlation between serum haemopexin and creatine kinase levels decreases the likelihood of the combined usage of these parameters improving the DMD carrier detection capability over that obtained using serum creatine kinase estimation alone. Percy et al. (1981) found the combined use of serum haemopexin and creatine kinase measurements raised the DMD carrier detection rate in a series of 23 carriers and 104 controls from 27% (haemopexin alone) and 65% (creatin kinase alone) to 82% with 5% controls misclassified (using logistic discrimination involving both proteins). However, Schiffer et al. (1979); Tagliavini et al. (1979); Bunday, (1981) and this study were unable to find an enhancement of carrier detection efficiency by use of measurements of both serum haemopexin and creatine kinase.

In the discriminant analysis involving haemopexin and creatine kinase measurements undertaken in this study, haemopexin made a negative contribution (discussed in Chapter 7). In the discriminant analyses involving all 4 variables; haemopexin, creatine kinase, pyruvate kinase and myoglobin (and other combinations of 3 of these measurements) haemopexin decreased the discriminatory ability to select DMD carriers from their controls

(refer to Section 7-4.).

Amongst other sources resulting in haemopexin production, Askanas (1966b) and Adornato et al. (1978a) considered haemopexin could be produced as a response to myoglobin release from muscle. The significant relationship found between serum haemopexin and myoglobin levels in the normal control women and the trend towards such a relationship in the normal control boys studied are consistent with this theory. The lack of relationship between these two serum proteins in the DMD patient and the DMD carrier groups could be due to an increased rapidity in clearance of the myoglobin-haemopexin complex (following abnormal muscle leakage of myoglobin and concomitantly increased haemopexin release) or, in the Duchenne boys, be affected by the decreased muscle mass and consequent reduction in serum myoglobin in the 5 wheelchair-bound patients (asterisked in Table 5.2.).

Overall this study demonstrated the inability of serum haemopexin measurement to discriminate between DMD carriers and their controls, when used either alone or in combination with serum creatine kinase estimation.

Myoglobin is a low molecular weight (17,800 daltons) protein possessing a haem-containing prosthetic group (Kagen, 1973). As a respiratory protein, myoglobin is capable of reversibly binding molecular oxygen and is involved in oxygen storage and transport within striated muscle tissues. It is a muscle-specific protein synthesized exclusively in skeletal and cardiac muscle, absent from smooth muscle (Kagen and Gurevich, 1967) and found in highest concentration in muscle dependent upon oxidative metabolism.

Myoglobin released into the circulation is rapidly removed, filtered by the renal glomerulus and excreted in the urine. Therefore, under normal conditions the blood level of myoglobin in healthy individuals is very low.

Significant myoglobinaemia occurs as a consequence of myoglobin release from muscle cell destruction or serious membrane damage. Elevated levels of serum myoglobin have been reported associated with the following:

- (1) acute myocardial infarction
- (2) muscular dystrophies
- (3) metabolic myopathies including:
  - (i) myophosphorylase deficiency
  - (ii) alcoholic myopathy
- (4) myositis syndromes including:
  - (i) polymyositis
  - (ii) systemic lupus erythematosus
- (5) skeletal muscle damage
- (6) extreme exertion in normal individuals

In these conditions the raised level of serum myoglobin represents a specific indicator of muscle cell damage. However, elevated levels may also result from impaired excretion of myoglobin and have been reported associated with severe renal failure. Roxin et al. (1979) found a positive correlation between galactose elimination rate and serum myoglobin levels in patients with liver failure and suggested the liver also has a role in myoglobin elimination.

Myoglobinuria has been examined in acute myocardial infarction and in some metabolic myopathies. However, Roxin and his colleagues (1979) found no correlation between the urinary excretion of myoglobin and the serum myoglobin level in normal subjects. They considered that urinary excretion of myoglobin implied either a functional renal tubular defect or a concentration of myoglobin in the primary urine in excess of the maximal tubular reabsorbing capacity of the kidney or both.

Investigations of the myoglobin content of muscle from patients with muscular dystrophy preceded measurements of serum myoglobin levels. A decreased concentration of myoglobin has been reported in both human dystrophic muscle (Biörck, 1949; Buscaino, 1965) and in affected muscle from murine muscular dystrophy model Bar Harbour strain 129 (Perkoff and Tyler, 1958). Reports of the existence of possible variants of myoglobin in dystrophic muscle (Perkoff, 1964; Miyoshi et al., 1968) have not been confirmed (Rowland et al., 1968a) and may have been artefactual.

Rowland et al. (1968b) were unable to identify myoglobin in the serum of six patients with DMD. This failure was probably due to a lack of assay sensitivity. With the development of more sensitive immunoassay systems, several research groups detected elevated serum myoglobin levels in patients with DMD. Adornato et al. (1978b) measured

myoglobin using a complement fixation immunoassay and Ando et al. (1978) used a counterimmuno-electrophoresis technique (the lower limits of sensitivity of these assays were  $150 \text{ ngml}^{-1}$  and  $300 \text{ ngml}^{-1}$ , respectively). In both cases the methods were not sufficiently sensitive to detect serum myoglobin in normal control subjects.

Nishikai and Reichlin (1977) and Miyoshi et al. (1978) measured serum myoglobin using radioimmunoassay (RIA) systems which had much greater assay sensitivities (lowest detection sensitivities  $1 \text{ ngml}^{-1}$  and  $0.3 \text{ ngml}^{-1}$ , respectively). Such systems were capable of detecting myoglobin even in the amounts present in the serum of normal control subjects. The myoglobin assay used by Adornato et al. (1978b) demonstrated myoglobinaemia in 14 of 18 (77%) DMD patients. Utilising extremely sensitive RIA methods, most workers since then have reported elevated serum myoglobin levels in all DMD patients studied (Miyoshi et al., 1978; Hische and Van der Helm, 1979; Kiessling and Beckmann, 1981a; Nicholson, 1981).

Measurement of serum myoglobin as a method of carrier detection was first investigated by Adornato et al. (1978b) who looked at a series of definite DMD carriers both before and after a forearm ischaemic exercise test (FIET). 9 of 16 (56%) were reported to have demonstrable myoglobinaemia both before and after FIET and one carrier following FIET only. Of 27 female relatives of DMD patients also examined, 4 were said to have myoglobinaemia before FIET and 5 more following FIET only. Four of the carriers with myoglobinaemia had normal serum creatine kinase levels.

Kagen et al. (1980), using a similar complement fixation immunoassay, reported 7 of 16 (43%) possible DMD carriers and 6 of 16 (37%) female relatives of DMD patients had myoglobinaemia without the use of FIET. They also found no direct correlation between serum

myoglobin and creatine kinase levels in these women.

Employing RIA, other workers (Miyoshi et al., 1978; Ando et al., 1980; Nicholson, 1981) have reported increased levels of serum myoglobin in a high proportion of DMD carriers compared to controls, although the degree of elevation of serum myoglobin in DMD carriers has been found to be lower than that of DMD patients.

Despite some workers (Nørgaard-Hansen et al., 1978; Nicholson, 1981) reporting a correlation between serum levels of myoglobin and creatine kinase in DMD carriers not found by Adornato et al. (1978b), most (Ando et al., 1980; Lucci et al., 1980; Nicholson, 1981) but not all (Fitzsimmons et al., 1980) consider serum myoglobin measurements may be a valuable inclusion in tests used in DMD carrier detection.

Serum levels of myoglobin were determined during everyday activity in the following groups of subjects:

- (1) Ten patients with DMD together with 10 age-matched, normal healthy boys.
- (2) Carrier and control group A, comprising 15 DMD carriers and 15 age-matched, normal healthy women.
- (3) Carrier and control group B, comprising 20 DMD carriers with normal creatine kinase levels (of which 3 samples were plasma) and 20 age-matched, normal, healthy women.

The DMD patients, their matched controls and the DMD carriers and controls of group A were selected as stated in Section 3-2.

The DMD carriers of group B were classified in the following way:

- (1) Those women who are definite carriers on genetic evidence, i.e. - have at least one DMD son and at least one other affected male relative through the female line (12 subjects)  
- have daughters with DMD sons and other affected male relatives through the female line (1 subject).
- (2) Those women who are probable carriers on genetic evidence i.e. have two or more affected sons but no other family history of DMD (7 subjects).

Controls of group B were age-matched to the carriers and were normal, healthy women volunteers with no history of neuromuscular disease.

Blood samples were processed according to the protocol described in Section 3-2.

With the exception of 4 DMD carrier samples of group B which had been stored at  $-20^{\circ}\text{C}$  for a maximum of 6 years all sera were stored in aliquots at  $-70^{\circ}\text{C}$  and frozen and thawed once only for analysis within 9 months of collection, although repeated cycles of freezing and thawing serum have been reported to have no effect on myoglobin (Hische and Van der Helm, 1979).

Other analyses were also performed on different aliquots of these serum samples as described in Table 3.5.

In the case of the carrier sera which had been stored at  $-20^{\circ}\text{C}$  for a maximum of 6 years (refer to Table 6.6.) serum creatine kinase activity had previously been measured at the time of taking the samples by the Department of Human Genetics for genetic counselling purposes. Both the commercial kit and methodology of creatine kinase measurement used at that time were as employed in this study.

Three plasma samples were included in carrier group B since no significant differences have been found between serum and plasma myoglobin levels (Rosano and Kenny, 1977).

None of the samples analysed showed signs of haemolysis, however, haemoglobin is not thought to interfere with the assay (Hische and Van der Helm, 1979).

Serum myoglobin levels were measured by a commercially available RIA kit "Myok" (Cis UK Ltd.) following the procedure suggested by the manufacturers. The kit employs a standard RIA technique which may be summarised by the following equations:



Antigen (myoglobin  
in sample or  
standard)  $\longrightarrow$  Antigen-Antibody  
Complex

Antibody (rabbit  
+ anti-human  
myoglobin antibody)

$^{125}\text{I}$ -Antigen  $\longleftarrow$   $^{125}\text{I}$ -Antigen-Antibody  
(radioactively  
labelled myoglobin) Complex

The antibody used has an equal affinity for both myoglobin standards and myoglobin present in samples. Competitive binding to a limited number of antibody binding sites occurs between radioactively-labelled myoglobin and myoglobin present in the sample. Unlabelled myoglobin binding to the antibody reduces the amount of radioactively-labelled bound fraction. Following an incubation period, bound and free iodinated myoglobin are separated by precipitation of the bound fraction using polyethylene glycol in which a second antibody has been pre-precipitated and is present in excess. After decanting the supernatants the radioactivity of the precipitate is counted in a scintillation counter. The amount of radioactively-labelled myoglobin bound is inversely related to the concentration of myoglobin in the sample or standard.

For greater sensitivity, the half hour preincubation of samples with antibody (in the absence of tracer) was followed. Tubes were vortex-mixed, centrifugation was carried out at  $+4^{\circ}\text{C}$  using a multisample centrifuge and supernatants were decanted by inverting the entire batch of tubes and

blotting the rims. A Packard auto-gamma scintillation spectrometer was used and the precipitates counted for one minute per tube. Samples, standards and a control serum of known myoglobin concentration were run in duplicate in each assay. The mean nett counts per minute of each myoglobin standard were used to construct a standard curve of percentage binding versus concentration of myoglobin, and unknown sample myoglobin levels determined by comparison with this curve.

Samples from two DMD patients with very high serum myoglobin levels were reassayed according to kit instructions, using the zero standard as diluent.

The lower limit of sensitivity of this RIA system was  $8 \text{ ngml}^{-1}$  (the amount of myoglobin causing a 5% decrease of initial binding ability).

Serum myoglobin and creatine kinase measurements of DMD carrier group B and their matched controls were subjected to discriminant analysis to determine whether the combined use of both parameters would improve DMD heterozygote selection from control subjects over the separation obtained using serum creatine kinase alone. Measurements were logged (base 10) prior to analysis and serum myoglobin levels below the sensitivity of the RIA system used were taken as  $8 \text{ ngml}^{-1}$  (for method of discriminant analysis used and detailed explanation of terms employed, refer to Chapter 7).

Distributions of serum myoglobin levels in all groups studied have been shown in Figure 6.1.

Repeated measurement of serum myoglobin from one normal 24-year old female subject gave a within-batch coefficient of variation of 4.8%. Less than 4% loss in myoglobin level occurred in serum measured following 8 weeks storage at  $-70^{\circ}\text{C}$  and subsequently remeasured 9 months later (separate aliquot of sample stored  $-70^{\circ}\text{C}$  throughout and thawed once only).

#### DMD Patient and Control Group

In the DMD patient and control group (mean and individual myoglobin values summarised in Tables 6.1. and 6.2. respectively) all the DMD patients had considerably elevated serum myoglobin levels compared to control values, with no overlap between results of the two groups. Two controls (numbers 3 and 4) had myoglobin levels below the sensitivity of the RIA system employed ( $<8 \text{ ngml}^{-1}$ ). The difference between Duchenne dystrophy patients and their matched controls was significant by Wilcoxon test ( $p < 0.01$ ). Using this non-parametric test enabled all 20 results to be taken into account.

There was a general trend in the Duchenne patients studied towards a decrease in serum myoglobin level with increasing age. Serum myoglobin was significantly correlated with age in the DMD patient group ( $r_s = -0.79$ ,  $p < 0.01$ ) but not in their controls ( $r'_s = 0.27$ ) (refer to Figure 6.2.). When the Duchenne dystrophy group were subdivided into pre-wheelchair and post-wheelchair subjects,

Figure 6.1. Distribution of Serum Myoglobin Levels in DMD Patients, Their Age and Sex Matched Controls and in DMD Carrier Groups A and B and Their Respective Age and Sex Matched Controls

N.B. The following subjects had serum myoglobin levels below the sensitivity of the RIA system used:

2 normal controls (boys)

1 normal female control (Group B)

1 DMD carrier (Group B)

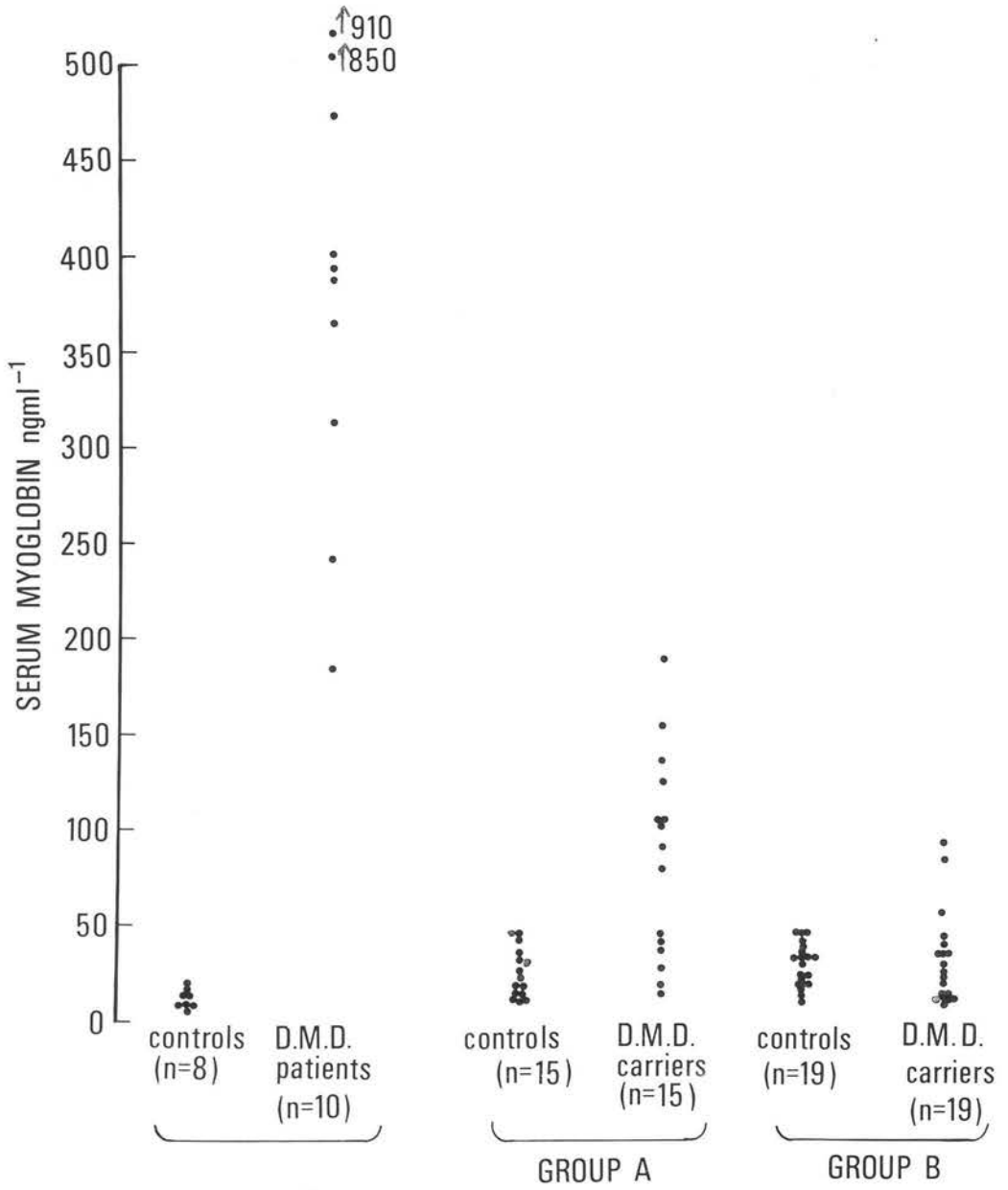

Table 6.1. Mean Serum Myoglobin Levels in DMD Patients and Their Age and Sex Matched Controls

		SERUM MYOGLOBIN ngml <sup>-1</sup>		Level of significance
		Mean	SD	
Controls	(n = 8) <sup>x</sup>	12.3	4.0	
				*-20 nm <sup>2</sup>
DMD Patients	(n = 8) <sup>x</sup>	476.7	259.1	p < 0.01
				185-910

x \* DMD Patients 2 III<sub>2</sub> and 7 I<sub>2</sub> and their matched controls no.'s 3 and 4 omitted from calculation of mean and SD  
 nm myoglobin below measurable level  
 SD standard deviation  
 p level of significance by Wilcoxon test (including patients and controls omitted from calculation of mean and SD)

Table 6.2. Individual Serum Myoglobin Levels in  
DMD Patients and their Age and Sex Matched Controls

AGE AND SEX MATCHED CONTROLS			DMD PATIENTS			
Subject No.	My ngml <sup>-1</sup>	CK IUl <sup>-1</sup>	Subject Pedigree No.	Age Yrs.	My ngml <sup>-1</sup>	CK IUl <sup>-1</sup>
1	10	48	6 II <sub>2</sub>	5	910	22,842
2	20	69	1 II <sub>2</sub>	6	850	21,600
3	nm <sup>‡</sup>	33	2 III <sub>2</sub>	6.75	475	6026
4	nm <sup>‡</sup>	47	7 IV <sub>2</sub>	9	242	3240
5	12	47	3 IV <sub>1</sub>	9	402	4147
6	17	80	4 III <sub>2</sub> <sup>+</sup>	10	367	1253
7	10	82	5 III <sub>3</sub> <sup>+</sup>	10.5	395	3672
8	12	55	8 III <sub>3</sub> <sup>+</sup>	10.5	390	3024
9	10	105	9 III <sub>4</sub> <sup>+</sup>	13	185	1701
10	8	67	10 II <sub>7</sub> <sup>+</sup>	14	315	1980

+ wheelchair bound  
 nm<sup>‡</sup> myoglobin below measurable level  
 My serum myoglobin  
 CK serum creatine kinase

Figure 6.2. Relationship Between Serum Myoglobin and Age in DMD Patients and Age and Sex Matched Controls

DMD Patients

Spearman's Rank Correlation Coefficient

$$r_s = 0.79, p < 0.01$$

Controls

Spearman's Rank Correlation Coefficient

$$r_s = 0.27, p = \text{NS}$$

Note that 2 controls had serum myoglobin levels below the sensitivity of the RIA system and therefore are not presented on the graph



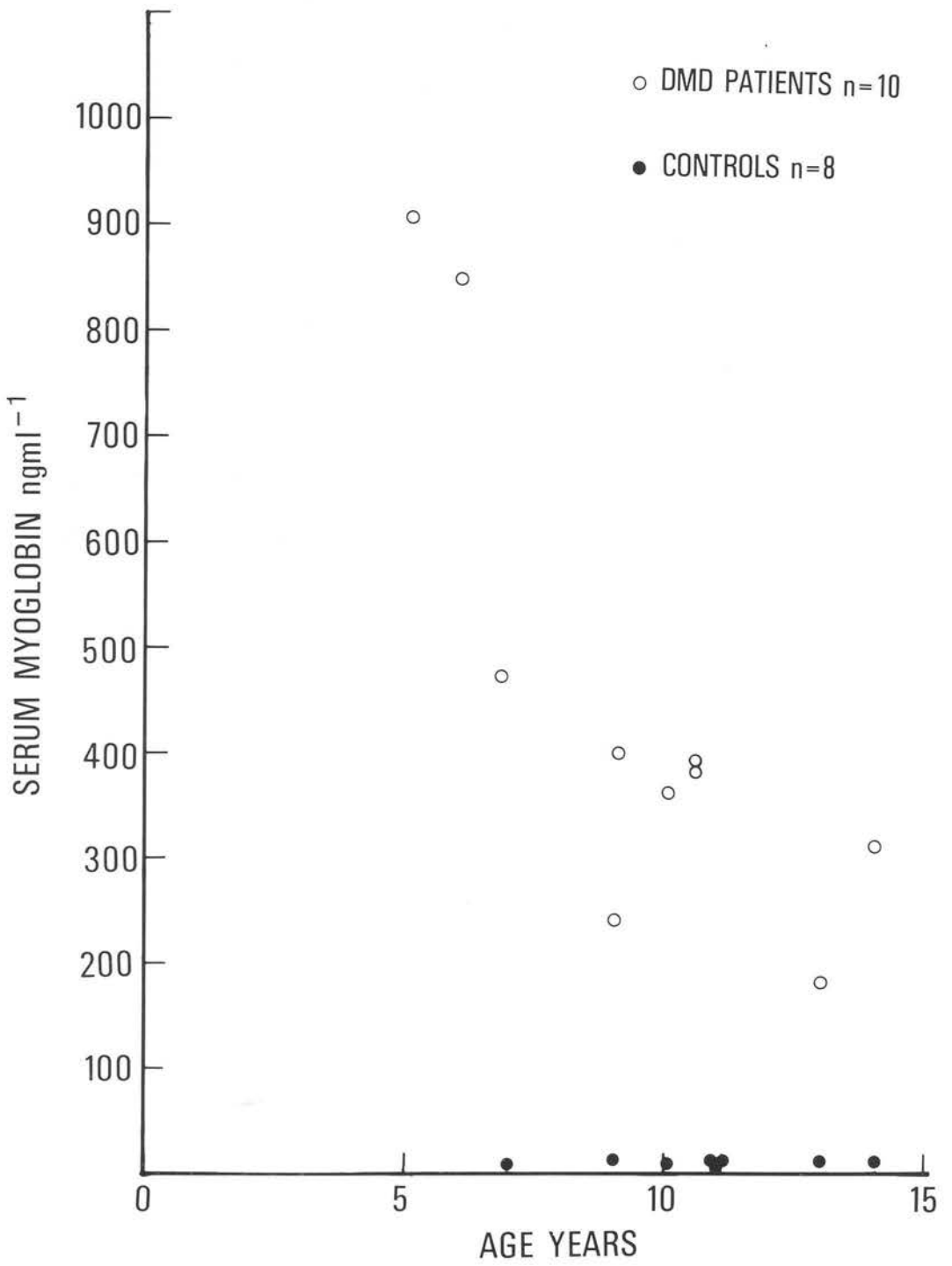

(refer to Table 6.2.) the relationship of myoglobin and age remained significant in the pre-wheelchair group ( $r_s = -0.97$ ,  $p < 0.05$ ) but became non-significant in the post-wheelchair subjects ( $r_s = 0.56$ ).

Serum myoglobin and creatine kinase levels were significantly correlated in DMD patients ( $r_s = 0.88$ ,  $p < 0.01$ ) but not in their matched controls ( $r'_s = 0.42$ ), shown in Figure 6.3.

The relationship between serum myoglobin and haemopexin levels in the DMD patient and control group has been discussed in Chapter 5.

#### DMD Carrier and Control Group A

For mean and individual myoglobin levels in DMD carrier and control group A refer to Tables 6.3. and 6.4.

A significant difference was found between serum myoglobin levels in DMD carrier group A compared to their controls (Wilcoxon test,  $p < 0.01$ ) although some overlap was found between results in the two groups.

Serum myoglobin levels did not appear to be normally distributed. However, using an adaptation of the method of Herrera (1958) a cumulative log probability plot of myoglobin levels in control subjects was reasonably linear (refer to Figure 6.4.). The adaptation of the method involved taking the best straight line fit seen by eye. Using this method the 95th percentile of the control series was found to be  $46 \text{ ngml}^{-1}$ . 9 of 15 (60%) DMD carriers group A had serum myoglobin results greater than the 95th percentile of the control series.

No significant relationship was found between serum myoglobin level and age in either the Group A DMD carriers ( $r_s = 0.036$ ) or their controls ( $r'_s = -0.035$ ).

Serum myoglobin and creatine kinase levels were significantly correlated in DMD Group A carriers ( $r_s = 0.79$ ,  $p < 0.01$ ) but not in the matched controls ( $r'_s = 0.14$ ). (refer to Figure 6.5.)

Figure 6.3. Relationship Between Serum Myoglobin and Serum Creatine Kinase Levels in DMD Patients and their Age and Sex Matched Controls

DMD Patients

Spearman's Rank Correlation Coefficient

$$r_s = 0.88, p < 0.01$$

Controls

Spearman's Rank Correlation Coefficient

$$r'_s = 0.42, p = \text{NS}$$

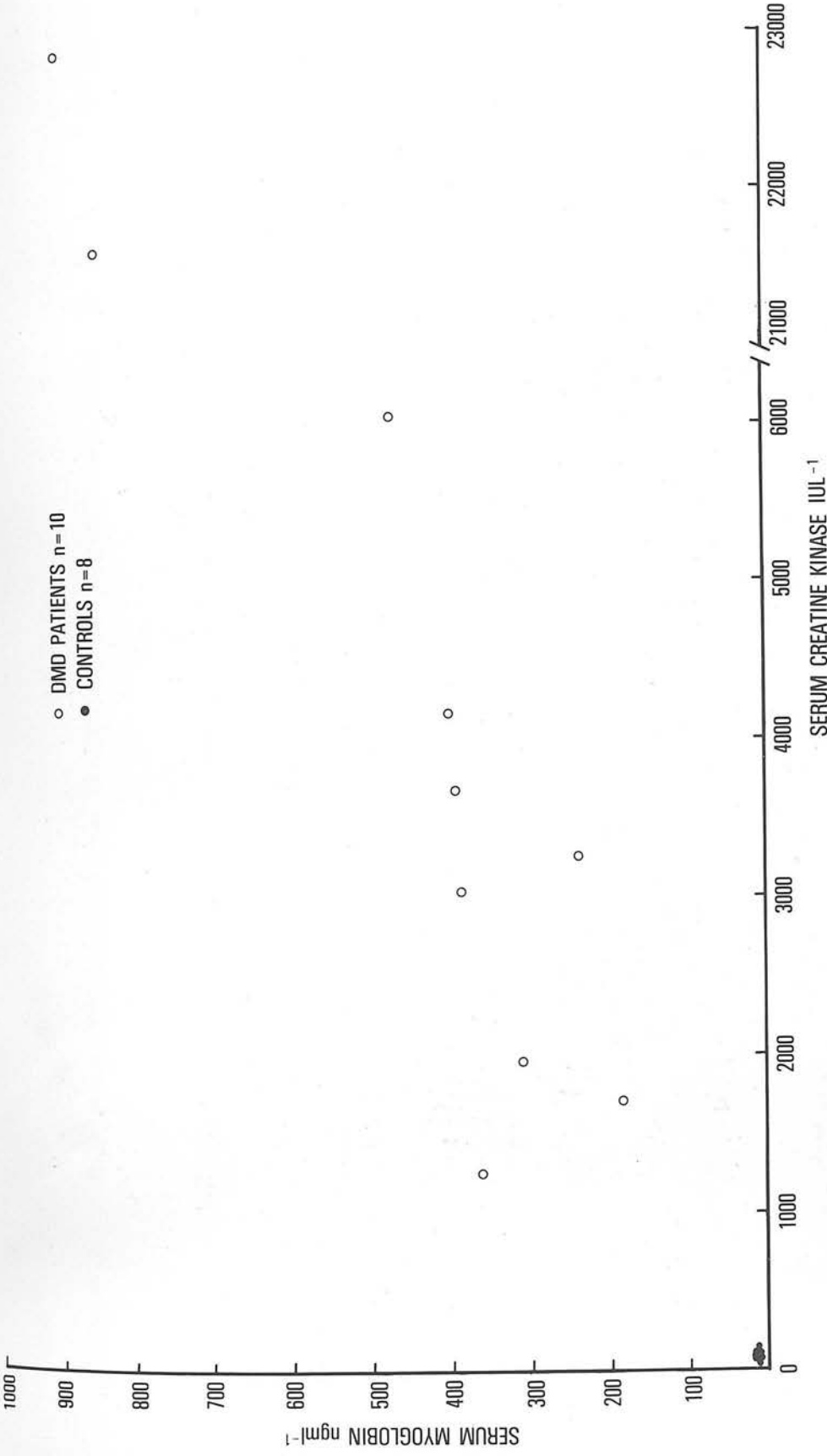

SERUM CREATINE KINASE IU L<sup>-1</sup>

SERUM MYOGLOBIN ngml<sup>-1</sup>

○ DMD PATIENTS n=10  
● CONTROLS n=8

Table 6.3. Mean Serum Myoglobin Levels of DMD Carriers Group A and Their Age and Sex Matched Controls

		SERUM MYOGLOBIN $\text{ngml}^{-1}$			
		Mean	SD	Actual range	Level of significance
Controls	(n = 15)	22.8	12.0	10 - 46	
DMD Carriers	(n = 15)	85.0	53.5	14 - 190	$p < 0.01$

SD standard deviation  
 p level of significance by Wilcoxon test

Table 6.4. Individual Serum Myoglobin Levels in DMD Carriers of Group A and their Age and Sex Matched Controls

AGE AND SEX MATCHED CONTROLS			DMD CARRIERS			
Subject No.	My ngml <sup>-1</sup>	CK IUl <sup>-1</sup>	Subject Pedigree No.	Age Yrs.	My ngml <sup>-1</sup>	CK IUl <sup>-1</sup>
1	24	27	10 II <sub>2</sub>	24	<u>105</u>	<u>213</u>
2	10	33	11 II <sub>13</sub>	29	46	<u>123</u>
3	25	44	12 III <sub>4</sub>	33	<u>81</u>	<u>103</u>
4	18	23	13 II <sub>2</sub>	35	27	83
5	18	30	14 III <sub>1</sub>	38	<u>190</u>	<u>179</u>
6	46	52	15 II <sub>4</sub>	40	14	37
7	15	80	16 II <sub>1</sub>	43	<u>138</u>	<u>228</u>
8	12	42	17 II <sub>4</sub>	43	38	<u>115</u>
9	16	49	18 II <sub>5</sub>	50	<u>105</u>	<u>206</u>
10	36	63	10 I <sub>2</sub>	51	<u>102</u>	<u>327</u>
11	35	48	19 II <sub>3</sub>	52	<u>155</u>	<u>263</u>
12	15	19	20 II <sub>4</sub>	55	42	56
13	45	49	21 II <sub>1</sub>	59	<u>90</u>	<u>195</u>
14	11	49	22 III <sub>8</sub>	60	<u>125</u>	<u>269</u>
15	17	65	23 I <sub>1</sub>	60	17	<u>100</u>

elevated levels underlined

My serum myoglobin  
CK serum creatine kinase

Figure 6.4. Cumulative Percentage Frequency of the Logarithm's  
of Serum Myoglobin Values in Controls

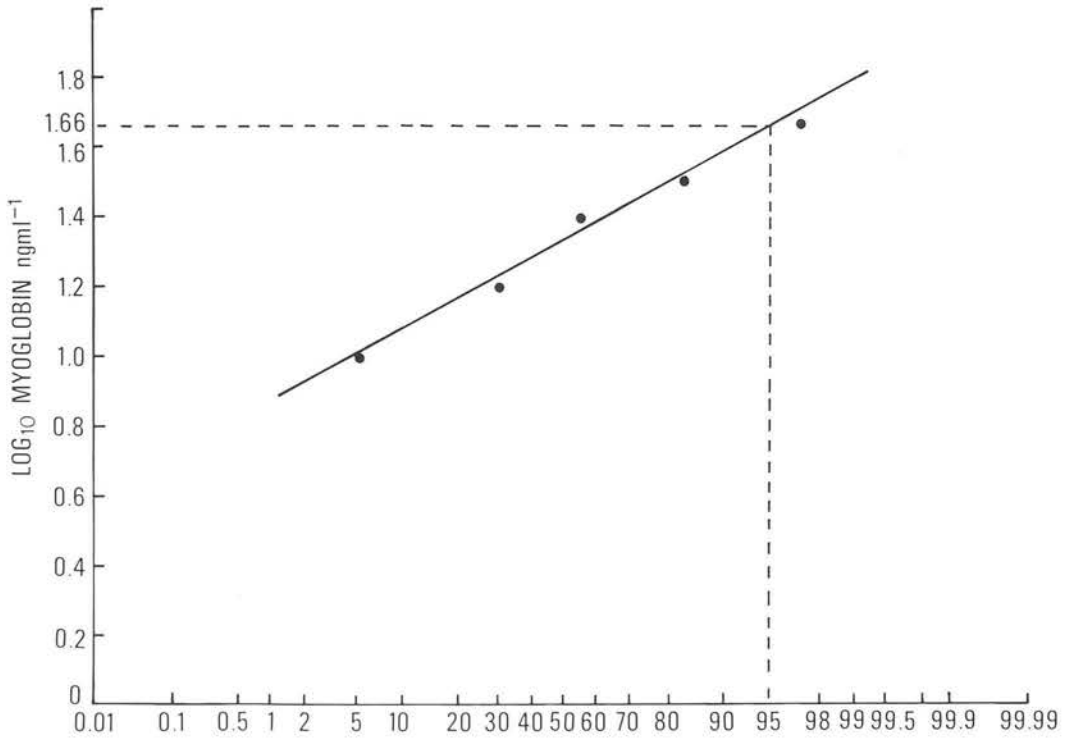



Figure 6.5. Relationship Between Serum Myoglobin and Serum Creatine Kinase in Group A DMD Carriers and Their Age and Sex Matched Controls

DMD Carriers

Spearman's Rank Correlation Coefficient

$$r_s = 0.79, p < 0.01$$

Controls

Spearman's Rank Correlation Coefficient

$$r_s = 0.14, p = NS$$

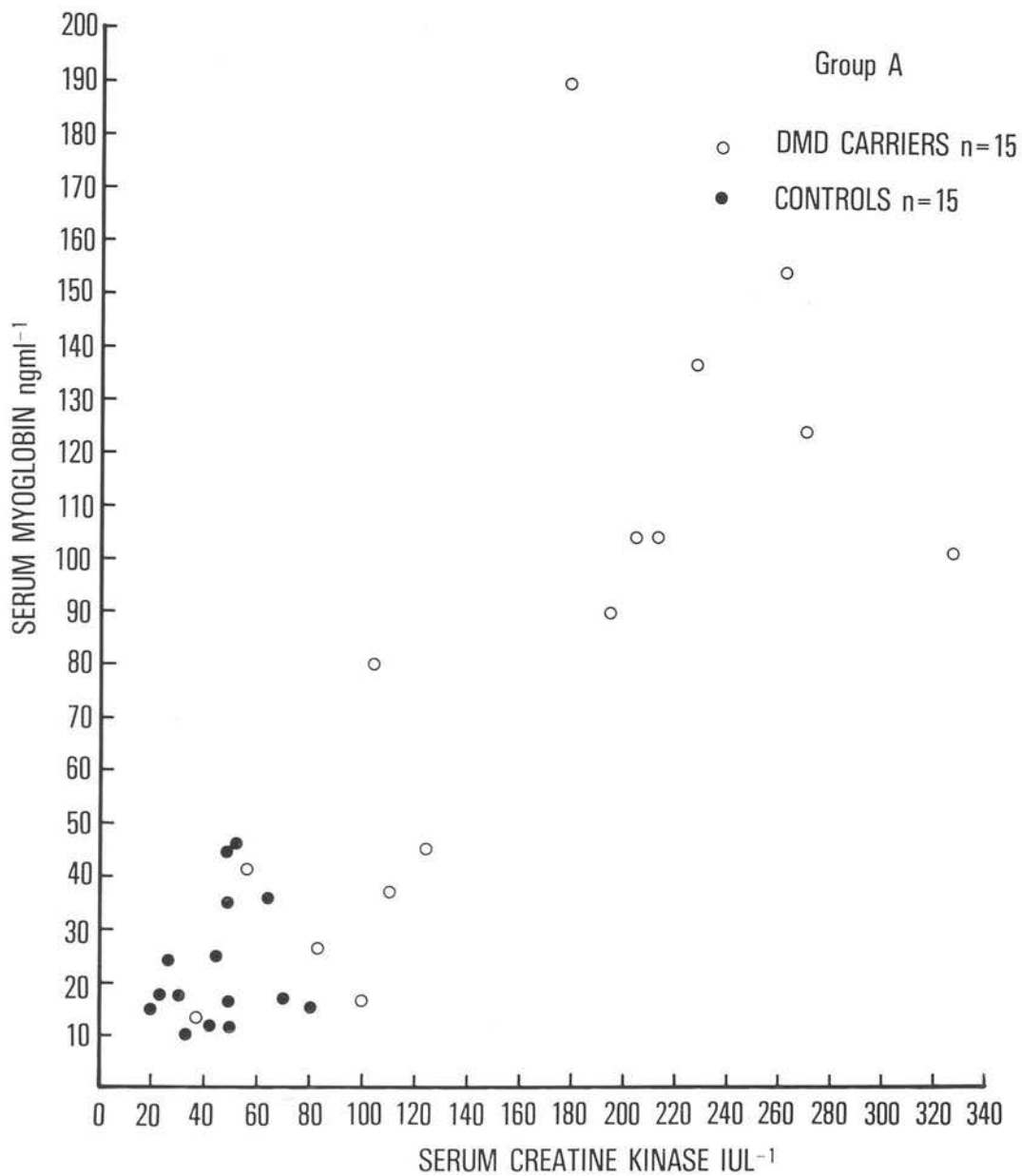

Of the 6 DMD carriers whose serum myoglobin levels were within the 95th percentile of the control series, 3 of these subjects had serum creatine kinase activities that were outwith the 95th percentile of the control series, whilst 3 carriers were considered "normal" by both tests.

The relationship between serum myoglobin and the proteins pyruvate kinase and haemopexin in DMD carriers and controls of Group A have been discussed in Chapters 4 and 5 respectively.

The results of this study and the findings from the discriminant analyses (discussed in Chapter 7) implied the possibility of an improvement in DMD carrier detection capacity by combined use of serum myoglobin and creatine kinase measurements over that obtained using serum creatine kinase estimation alone. Therefore a group of known genetic carriers of DMD whose serum creatine kinase activities did not exceed the 95th percentile of the control series for this enzyme, along with age and sex matched normal, healthy women were investigated (DMD Carrier and Control Group B).

#### DMD Carrier and Control Group B

For mean and individual serum myoglobin levels in this group of DMD carriers and controls refer to Tables 6.5. and 6.6. respectively.

There was no significant difference between serum myoglobin levels in DMD carriers and their matched controls by Wilcoxon test. Considerable overlap was present between myoglobin levels in these two groups of subjects.

3/20 (15%) Group B DMD carriers had serum myoglobin levels greater than  $46 \text{ ngml}^{-1}$ , the calculated 95th percentile of the control series (refer to Figure 6.4.).

One carrier (36 I<sub>2</sub>) and one control (number 26) had serum myoglobin levels below the sensitivity of the RIA system used.

Similarly to the results of Group A, no significant relationship

Table 6.5. Mean Serum Myoglobin Levels in DMD Carriers of Group B and Their Age and Sex Matched Controls

	SERUM MYOGLOBIN ngml <sup>-1</sup>			
	Mean	SD	Actual range	Level of significance
Controls (n = 18) <sup>x</sup>	27.0	11.3	nm*-45	
DMD Carriers with normal CK levels (n = 18) <sup>x</sup>	31.2	24.5	nm*-93	p = NS

x DMD carriers 24 III<sub>5</sub> and 36 I<sub>2</sub> and matched controls nos. 26 and 31 omitted from calculation of mean and SD  
 nm\* myoglobin below measurable level  
 SD standard deviation  
 NS not significant by Wilcoxon test (including DMD carriers and controls omitted from calculation of mean and SD)

Table 6.6. Individual Serum Myoglobin Levels in DMD Carriers of Group B and their Age and Sex Matched Controls

AGE AND SEX MATCHED CONTROLS				DMD CARRIERS			
Subject No. & Age	My ngml <sup>-1</sup>	CK IUl <sup>-1</sup>	Subject Pedigree No.	Age Yrs.	My ngml <sup>-1</sup>	CK IUl <sup>-1</sup>	
16 31 9		45	24 III <sub>12</sub>	32	14 <sup>+</sup>	64 <sup>+</sup>	
17 37 41		49	24 III <sub>6</sub>	35	10	22	
18 35 33		43	25 III <sub>7</sub>	35	25	52	
19 35 45		33	26 II <sub>2</sub>	36	11	41	
20 36 19		38	27 III <sub>1</sub>	37	<u>23</u>	71	
21 38 35		62	24 III <sub>10</sub>	38	<u>52</u> <sup>+</sup>	83 <sup>+</sup>	
22 39 20		21	28 II <sub>2</sub>	39	19	33	
23 39 10		24	29 III <sub>2</sub>	39	35 <sup>s</sup>	29	
24 40 24		37	30 II <sub>1</sub>	40	40 <sup>s</sup>	71	
25 40 15		24	31 II <sub>4</sub>	40	9 <sup>s</sup>	38	
26 41 nm <sup>‡</sup>		30	24 III <sub>5</sub>	41	8	43	
27 41 16		52	32 III <sub>4</sub>	42	13	29	
28 42 30		33	33 III <sub>2</sub>	42	15	48	
29 42 20		39	34 I <sub>1</sub>	42	42	80	
30 50 36		79	35 II <sub>3</sub>	42	10 <sup>s</sup>	44	
31 44 12		30	36 I <sub>2</sub>	44	nm <sup>‡</sup>	25	
32 47 33		44	37 IV <sub>3</sub>	47	29	45	
33 47 33		24	38 III <sub>2</sub>	47	35	70	
34 50 23		48	39 II <sub>2</sub>	50	23	62	
35 65 45		51	24 II <sub>3</sub>	71	<u>82</u> <sup>+</sup>	83 <sup>+</sup>	

elevated levels underlined

nm<sup>‡</sup> myoglobin below measurable level  
 + plasma  
 s serum stored - 20°C

was found between serum myoglobin and age in either Group B DMD carriers ( $r'_S = 0.08$ ) or their matched controls ( $r'_S = 0.16$ ).

Serum myoglobin and creatine kinase measurements were significantly correlated in Group B DMD carriers ( $r'_S = 0.77$ ,  $p < 0.01$ ), in agreement with Group A carrier results. These proteins were also significantly correlated in Group B controls ( $r'_S = 0.45$ ,  $p < 0.05$ ) whilst no such relationship was evident in Group A controls.

Discriminant analysis of serum myoglobin and creatine kinase measurements using all Group B DMD carriers and their controls gave the following standardised canonical discriminant function coefficients:

serum creatine kinase: 1.242

serum myoglobin: - 0.807

The negative sign of the myoglobin coefficient indicated that this parameter made a negative contribution towards the separation of carriers from controls (for detailed explanation of the analysis refer to Chapter 7). The greater size of the serum creatine kinase coefficient demonstrated the larger contribution this enzyme made to the analysis compared to serum myoglobin. 13/20 (65%) DMD carriers were correctly classified as carriers in this analysis but only 11/20 (55%) of controls were correctly classified, leaving an unacceptably high number of controls misclassified: 9/20 (45%). (refer to Figure 6.7.) For comparison the analysis was repeated using serum creatine kinase alone. In this analysis the same number of carriers were correctly classified (13/20; 65%) and a larger number of controls were correctly classified (14/20; 70%), the misclassification of control subjects being 6/20 (30%).

Figure 6.6. Relationship Between Serum Myoglobin and Serum Creatine Kinase in Group B DMD Carriers (with Serum Creatine Kinase Levels Within the Normal Range) and Their Age and Sex Matched Controls

- A. 95th Percentile of the Control series for Serum myoglobin
- B. 95th Percentile of the Control Series for Serum Creatine Kinase

DMD Carriers ○

Spearman's Rank Correlation Coefficient

$$r_s' = 0.77, p < 0.01$$

Controls ●

Spearman's Rank Correlation Coefficient

$$r_s' = 0.45, p < 0.05$$

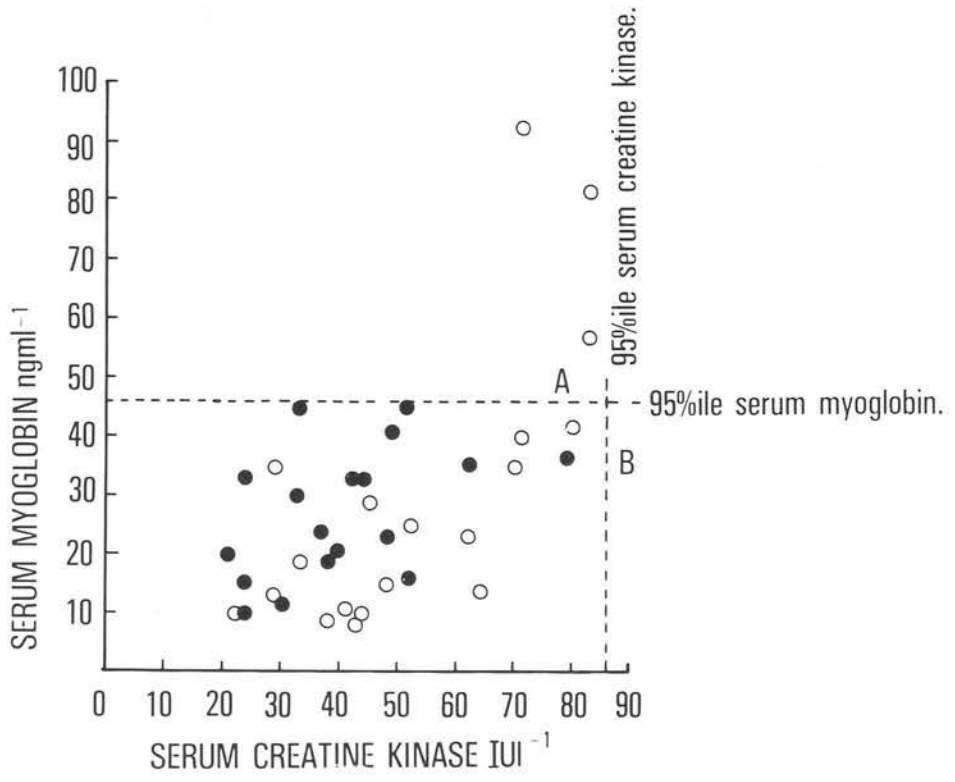

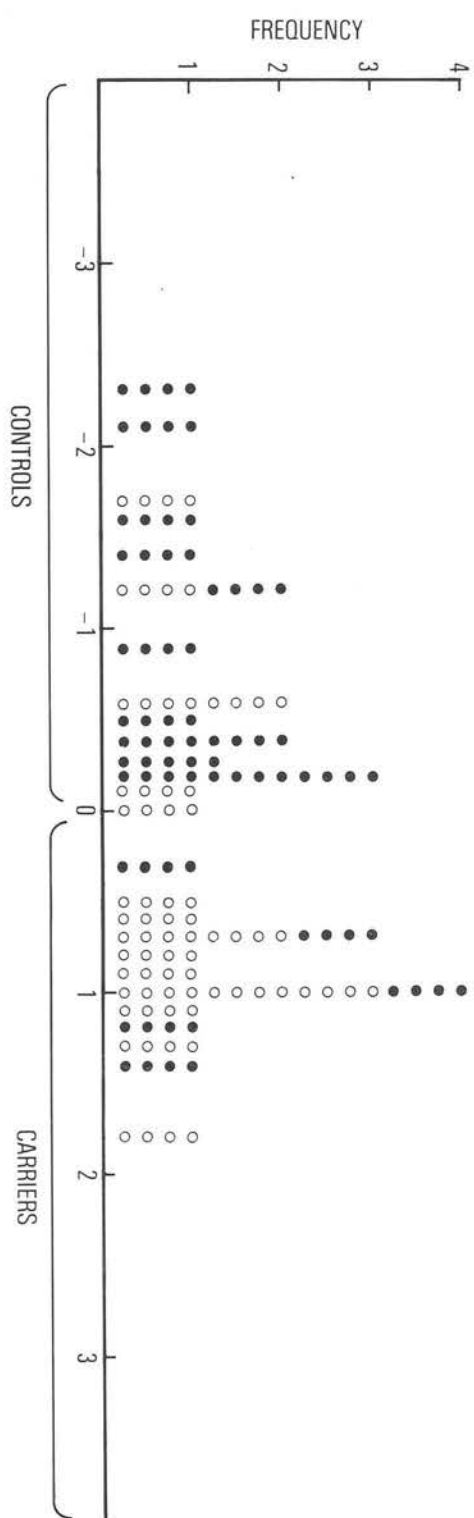
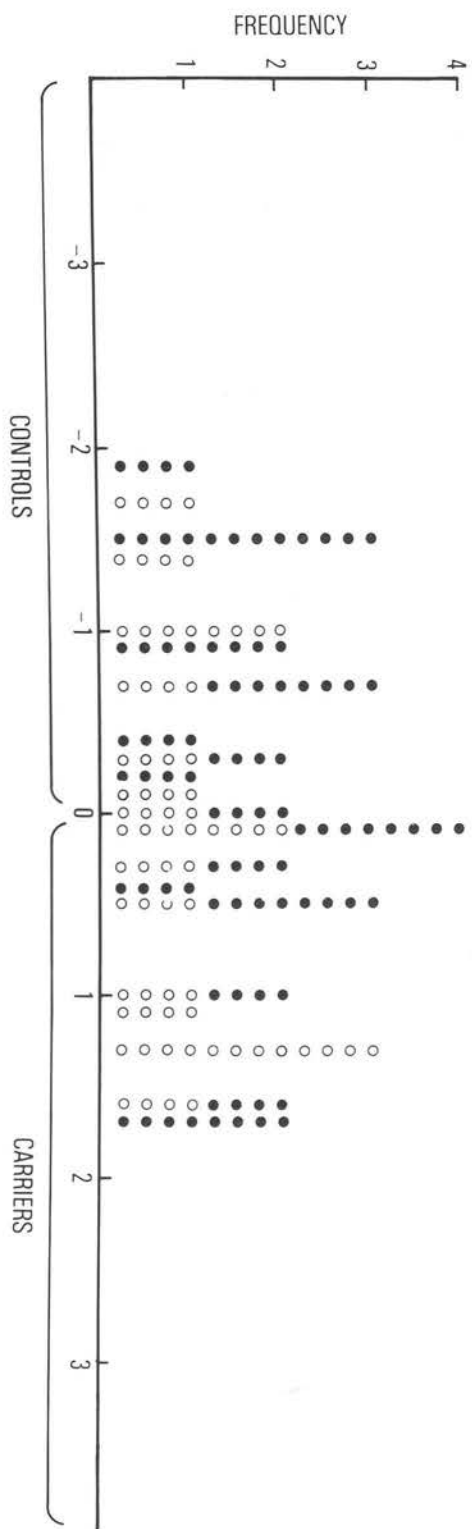

Figure 6.7. Discriminant Analysis of Group B Carriers and Controls:  
Computer Generated Graphs

Upper Graph: Discriminant analysis using serum  
myoglobin and creatine kinase  
measurements

Lower Graph: Repeat of discriminant analysis above  
omitting serum myoglobin measurements

Note that all subjects whose results fall into the  
area on the graph denoted as "CONTROLS" would be  
classified as normal women and those falling into the  
area marked "CARRIERS" would be classified as DMD  
heterozygotes.



The good stability of myoglobin in serum stored frozen ( $-70^{\circ}\text{C}$ , 9 months) was in agreement with the study of Roxin et al. (1979), where no significant alteration in myoglobin level occurred following storage at  $-25^{\circ}\text{C}$  for 2 years. Continued stability in serum, despite repeated cycles of freeze/thaw, has also been noted (Hische and Van der Helm, 1979).

The greatly elevated serum myoglobin levels found in all DMD patients studied compared to control subjects has been reported by other workers employing RIA systems (Miyoshi et al., 1978; Hische and Van der Helm, 1979; Kiessling and Beckmann, 1981a). Such a good separation between DMD patients and their matched controls by use of this test indicated the possibility of finding a reasonable proportion of genetic carriers of DMD with elevated serum myoglobin levels compared to their controls. In fact this was the case, 9/15 (60%) DMD carriers Group A had serum myoglobin levels greater than the 95th percentile of the control series. Other workers using RIA have also reported a high percentage of genetic carriers of DMD with increased levels of serum myoglobin: Miyoshi et al., in 1978 (70%); Ando et al. in 1980 (71%) and Nicholson in 1981 (78%). In each case, however, the separation between DMD carrier and control groups has been much smaller than that observed between Duchenne patient and control groups.

Rosano and Kenny (1977), Nicholson (1981) and this study found serum myoglobin measurements in normal control populations to be non-Gaussian. Other workers (Miyoshi et al., 1978; Ando et al., 1980; Lucci et al., 1980) have not indicated whether they have tested for normality of serum myoglobin distribution. Clearly uncorrected non-normality in the distribution of this protein could adversely affect

the interpretation of results in such studies.

Serum myoglobin level decreased significantly with increasing age in the Duchenne patients (in agreement with Kiessling and Beckmann, 1981a; Nicholson, 1981). Kagen et al. (1980) considered there was a tendency for serum myoglobin to be lower in older less active DMD patients than in younger ambulatory DMD subjects. In this study, separating the DMD patients into pre- and post-wheelchair groups resulted in the relationship with age losing significance in the latter group whilst remaining significant in the ambulatory patients. However the small number of subjects used (n = 10) requires caution in interpretation of these results. Kiessling and Beckmann (1981a) examined 50 DMD patients and also found serum myoglobin levels diminished significantly with increasing age. This diminution in serum myoglobin level may be result of the gradual decrease in effective muscle mass which occurs during the degenerative course of Duchenne dystrophy, although other factors including level of exercise and renal clearance of myoglobin may also play a part. Nicholson (1981) reported serum myoglobin levels decreased with increasing age in wheelchair-bound DMD patients but found serum myoglobin slightly but significantly increased as age advanced in ambulant patients. Nicholson considered the situation in ambulant patients to be related to an apparent increasing muscle bulk (in patients less than 6 years old) prior to disease progression overtaking physical growth.

In this study all DMD carriers (Group A and B) and their matched controls (with one exception in Group B) fell within the 24-60 year age group. In this age range there was no evidence of any relationship between serum myoglobin and age in any group studied. Similar results, in the age range 17-60 years, were found by Nicholson (1981). However, in Nicholson's study a group of normal women greater than 60 years of age, were found to have significantly increased serum myoglobin levels

compared to those less than 60 years of age, which might be related to a slight decrease in glomerular filtration rate which occurs with increasing age (Roxin et al., 1979).

A significant positive correlation between serum measurements of myoglobin and creatine kinase found in the DMD patients examined in this study was in agreement with the findings of Nørgaard-Hansen et al., (1978) and Kiessling and Beckmann (1981a). Such a relationship would tend to indicate the diminution in release of these muscle specific proteins through gradually decreasing numbers of muscle fibres during the disease process. Whilst the lack of relationship found between these serum proteins in DMD patients reported by Adornato et al. (1978b) and Kagan et al. (1980) could be at least partially explained by the lack of assay sensitivity in these studies, Hische and Van der Helm (1979) used a sensitive RIA test and also failed to detect a significant correlation. Kiessling and Beckmann (1981b) considered these results may have been affected by misinterpretation of diluted high myoglobin measurements. However, Kagen (1981) suggested the lack of correlation could be resultant of a greater diurnal variation in serum myoglobin levels compared to serum creatine kinase measurements and kinetics might also be involved (since the longevity of myoglobin in plasma is not comparable to that of enzymes).

Several workers have reported the significant positive correlation between serum levels of myoglobin and creatine kinase in DMD carriers also found in this study (Nørgaard-Hansen et al., 1978; Ando et al., 1980; Nicholson, 1981). In the relatively large study of Nicholson (1981) the correlation between these two proteins was significant in both categories of DMD carriers examined (definite, n = 23 and possible, n = 33). In terms of carrier detection potential the closer the

correlation the lesser the likelihood of the use of both parameters improving DMD heterozygote recognition. However, Nicholson (1981) found 18/23 (78%) definite carriers had increased serum myoglobin levels of which 7/23 (30%) were carriers with normal serum creatine kinase measurements. As explained in Section 6.3., following discriminant analysis involving all 4 parameters measured in Group A carriers, serum myoglobin levels were investigated in 20 genetic carriers of DMD whose serum creatine kinase levels were within the 95th percentile of the control series. Only 3/20 (15%) of these (Group B) carriers had serum myoglobin values outwith the 95th percentile of the control series. In these 3 carriers, serum creatine kinase measurements were close to the upper 95th percentile of the control series (see Figure 6.6.) and in these cases, with reference to the "h" value involved in assessing risk of DMD heterozygosity (refer to Section 3.4.), each would have been given a greater probability of being a DMD heterozygote than the other carriers examined (with lower serum creatine kinase levels). These results indicated the minimal gain achieved by the additional use of serum myoglobin measurement in testing for DMD carrier status in non-pregnant women of the age range studied.

Fitzsimmons et al. (1980) considered serum myoglobin estimation had no advantage over serum creatine kinase measurement in DMD carrier detection work. In a small study, Nørgaard-Hansen and Hein-Sørensen (1982) reported only one of 6 (16.6%) definite carriers of DMD had an elevated serum myoglobin level in the absence of an elevated serum creatine kinase measurement, whilst in one (16.6%) carrier only serum creatine kinase activity was elevated. In 3 (50%) of the carriers neither protein was outside their "normal" range and in one (16.6%) carrier both of these serum proteins were elevated. In 1980 Ando et al. had concluded

that serum myoglobin estimation was a valuable inclusion in DMD carrier detection tests although in their study only 2/14 (14.2%) carriers (and these were both possible DMD carriers) demonstrated an elevated level of serum myoglobin and yet serum creatine kinase activities were within Ando and his co-workers "normal" range (not clearly defined). One of 14 (7.1%) of these carriers showed an elevation in serum creatine kinase activity, although serum myoglobin remained within the "normal" range, whilst 3/14 (21.4%) and 8/14 (57.1%) DMD carriers were considered to have levels of both proteins that were "normal" or elevated respectively. Assessment of the true improvement in DMD heterozygote detection capability obtained by the use of both serum myoglobin and creatine kinase measurements in such studies (already only a small apparent improvement) is extremely difficult. The situation is complicated by the possibility that the actual level of serum creatine kinase activity (in terms of the "h" value discussed earlier and in Chapter 3) may have detected those carriers selected by an elevated serum myoglobin level alone, as was the case in this study.

A similar relationship between serum levels of myoglobin and creatine kinase in control subjects as that found in DMD carriers would obviously aid recognition using these two parameters. In this study the relationship between serum myoglobin and creatine kinase measurements did not reach significance in the Group A control subjects although there was a trend towards a significant positive correlation between these proteins which was significant in the Group B controls. Roxin *et al.* (1979), in a study involving 42 healthy women, and Nicholson and Walls (1983), investigating 50 healthy females, also found serum myoglobin and creatine kinase levels were significantly positively correlated.

The results of the discriminant analysis of serum myoglobin and

creatine kinase levels in Group B carriers and controls showed that inclusion of myoglobin values contributed adversely to the analysis. No improvement in the number of carriers correctly identified (13/20; 65%) was obtained by the addition of myoglobin levels to this analysis than was found by the analysis of serum creatine kinase results alone. Furthermore, using both parameters together or serum creatine kinase alone, unacceptably high percentages of controls were misclassified as carriers (9/20; 45% and 6/20; 30% respectively).

However, in certain categories of DMD heterozygote (outside the scope of this thesis) the measurement of serum myoglobin might be of value. The assessment of DMD carrier status by measurement of serum creatine kinase activity is adversely affected in young girls up to and including the teenage years and in pregnant women by, in the former an increased and, in the latter a decreased level of the enzyme (refer to Chapter 3). Nicholson and Walls (1983) have very recently reported that serum myoglobin levels in pre- and post-menarchal teenagers and in women of varying stages of pregnancy did not differ from menstruating, post-menopausal or non-pregnant women, whilst serum creatine kinase activities differed widely between these subject groups. Obviously, confirmation of this study and evidence that pre-pubertal to teenage DMD carriers and pregnant DMD heterozygotes exhibited similar trends are required. However, in such situations, full account should be taken of other factors which might affect the serum level of this protein. Bombardieri et al. (1981) and Nicholson and Walls (1983) have reported a significant diurnal variation in serum myoglobin level in normal control subjects, not paralleled by serum creatine kinase activity (a 39% decrease in serum myoglobin level from 9 am to 6 pm in Bombardieri et al.'s study, a 20% decrease between 9 am and 5 pm in Nicholson and Wall's study). Konagaya et al. (1982) found that in 5/11 (45.4%) DMD carriers serum myoglobin



increased significantly following a standard exercise test, with 2/11 (18.1%) control females exhibiting a small but non-significant increase following exercise. Other factors, including smoking and the use of the contraceptive pill have been reported not to affect serum myoglobin levels in control women (Nicholson and Walls, 1983). Clearly much more research is required in both young and pregnant DMD carrier and matched control categories before the possible useful potential of serum myoglobin in these subjects can be assessed fully.

Faint, illegible text covering the upper portion of the page, likely bleed-through from the reverse side.

CHAPTER 7: COMBINED TESTS

Faint, illegible text covering the lower portion of the page, likely bleed-through from the reverse side.

Many possible tests of DMD carrier detection have been reported in attempts to improve the rate of heterozygote recognition above that achieved by the routinely used serum creatine kinase test. The difficulty lies in estimating the likelihood of a subject being a DMD carrier or not when distributions between DMD heterozygote and normal populations overlap. One approach has been to apply several different tests to a series of DMD carriers. Radu et al. (1968), in a study involving 21 genetic DMD carriers, examined a battery of tests including serum enzymes, EMG's and muscle biopsies. These workers reported 21/21 (100%) genetic DMD carriers were successfully identified by the combined results of all these tests. However, the necessity of employing correct confidence limits and the possibility of generating false positive results by chance in normal subjects if enough tests are performed, have been pointed out (Tukey, 1977). Schiffer et al. (1979); Hausmanowa-Petrusewicz et al. (1980) and Lane et al. (1979) have all submitted DMD carrier groups of varying size to an extensive variety of different possible tests for DMD carrier recognition. Of the considerable range of tests employed few were considered by the authors to be of possible value in DMD heterozygote detection, these were: muscle biopsy in the absence of abnormal serum creatine kinase measurement (Schiffer et al., 1979); examination of peripheral blood cells and serum creatine kinase measurement following hydrocortisone injection (Hausmanowa-Petrusewicz et al., 1980). Lane et al. (1979) comparing a series of 12 DMD carriers with 12 control women also found most tests failed to distinguish DMD heterozygotes from normals, however 11/12 (91.7%) DMD carriers and 10/12 (83.3%) controls were correctly identified by manual muscle testing. The DMD carrier

group also exhibited ECG abnormalities and these workers considered such measurements may have value in testing DMD carriers whose serum creatine kinase levels are within "normal" limits.

Percy et al. (1980) achieved a DMD carrier detection rate of 87% with correct classification of 98% control subjects by measurement of serum levels of creatine kinase, pyruvate kinase, lactate dehydrogenase and haemopexin analysed by logistic discrimination. However Percy et al. (1982b) considered that up to one third of genetic DMD carriers remained indistinguishable from controls using logistic discrimination of these 4 tests. Zatz and Otto (1980b) reported that discriminant analysis involving both serum creatine kinase and pyruvate kinase measurements correctly selected 25/30 (83.3%) and serum pyruvate kinase 24/30 (80%) DMD carriers. The combined analysis of both serum enzymes appeared to give a slight improvement in carrier detection rate (1/30, 3.3%). However it should be noted that the discriminatory power of serum pyruvate kinase reported by Zatz and Otto (1980b) was higher than that obtained by this and other studies (refer to Chapter 4).

Muir et al. (1983) very recently employed discriminant analysis involving serum measurements of creatine kinase, pyruvate kinase and aldolase. Fourteen of the 21 (67%) genetic carriers were identified by the discriminant analysis involving log (base 10) serum creatine kinase; 11/21 (52%) using log(base 10) serum pyruvate kinase and 7/21 (33%) by log (base 10) serum aldolase. Since no further increase in discrimination occurred using discriminant analysis of combined log (base 10) serum creatine kinase and pyruvate kinase measurements than had occurred by use of the former measurement alone Muir et al. concluded that serum creatine kinase was sufficient by itself and that the other tests applied did not improve DMD

## 7-2. MATERIALS AND METHODS

### 7-2.1. Discriminant Analysis

Measurements of creatine kinase; pyruvate kinase; haemopexin and myoglobin made on serum samples from the DMD carrier and matched control group (labelled A in Chapter 6), referred to in Table 3.5., were combined and analysed using discriminant analysis. The SPSS computer program used for this purpose (Nie et al ., 1975) was run by Dr. Susan Holloway, Department of Human Genetics, University of Edinburgh.

All serum results were logged (base 10) prior to analysis in order to aid group discrimination and at least partially normalise some of the data. The results of all 4 tests were combined in the first analysis. Subsequently different combinations of either 3 or 2 tests were analysed separately. One DMD carrier (17 II<sub>4</sub>) and matched control no. 8 were omitted from all analyses since pyruvate kinase was not measured in the second sample from this carrier (refer to Section 4-2.).

### 7-2.2. Summary of Relationships between Serum Proteins Measured in this Study.

The relationship between proteins measured in this study have been discussed in the relevant preceding chapters and have been summarised in this chapter.

## 7-3. RESULTS

### 7-3.1. Discriminant Analyses

For results of the discriminant analyses undertaken using all 4 serum tests and with different combinations of either 3 or 2 tests refer to Table 7.1. When the discriminant analysis program was run employing only the logged results of serum creatine kinase estimation 12/14 (85.7%) of Group A DMD carriers and 13/14 (92.9%) controls were correctly classified. DMD carriers 15 II<sub>u</sub> and 20II<sub>u</sub> and matched control no.10 were misclassified.

The computer generated graphs of the discriminant analyses involving all 4 serum tests and involving serum pyruvate kinase, haemopexin and myoglobin tests can be seen in Figure 7.1.

### 7-3.2. Summary of Relationships between Serum Proteins Measured in DMD Carriers and Controls, Group A.

In this study serum creatine kinase levels were significantly positively correlated to serum levels of pyruvate kinase; haemopexin and myoglobin in the DMD carriers Group A, but no significant relationship was evident between these serum proteins in their age and sex matched controls.

Serum pyruvate kinase was significantly positively correlated to serum levels of haemopexin in this DMD carrier group although no such relationship was evident in their controls. No significant relationship was found between serum levels of pyruvate kinase and myoglobin in either subject group.

There was no significant relationship between serum measurements

Table 7.1. Various Combinations of the Serum Protein Measurements Made in DHD Carrier and Control Group A used in Discriminant Analyses (Listed in Descending Order of Percentage Correct Classification of Subjects)

Standardised Canonical Discriminant Function Coefficient (Tests included in each analysis underlined)	No. (and %) correct	Misclassified Subjects
	Classification	
	DHD Carriers	Controls
(i) $\frac{\text{CK} : \text{PK} : \text{Hpx}}{\text{CK} \quad 0.874}$	12/14	15 II <sub>4</sub>
PK 0.347	(85.7%)	20 II <sub>4</sub>
Hpx -0.147		
(ii) $\frac{\text{CK} : \text{PK} : \text{My}}{\text{CK} \quad 0.701}$	"	15 II <sub>4</sub>
PK 0.284	"	20 II <sub>4</sub>
My 0.232	"	

Note that all results were logged (base 10) prior to discriminant analysis

(i) - (ix) list each discriminant analysis

CK serum creatine kinase

PK serum pyruvate kinase

Hpx serum haemopexin

My serum myoglobin

Table 7.1. Continued

Standardised Canonical Discriminant Function Coefficient (tests included in each analysis underlined)	No. (and %) correct	Misclassified Subjects
	Classification	
	DMD Carriers	Controls
(iii) $\frac{\text{CK} : \text{PK}}{\text{CK}} \quad 0.833$ $\text{PK} \quad 0.335$	12/14 (85.7%)	14/14 (100%)
		15 II <sub>4</sub> 20 II <sub>4</sub>
(iv) $\frac{\text{CK} : \text{My}}{\text{CK}} \quad 0.783$ $\text{My} \quad 0.316$	"	"
		15 II <sub>4</sub> 20 II <sub>4</sub>
(v) $\frac{\text{CK} : \text{Hpx} : \text{My}}{\text{CK}} \quad 0.817$ $\text{Hpx} \quad -0.158$ $\text{My} \quad 0.340$	"	"
		13 II <sub>2</sub> 15 II <sub>4</sub>
(vi) $\frac{\text{CK} : \text{PK} : \text{Hpx} : \text{My}}{\text{CK}} \quad 0.735$ $\text{PK} \quad 0.293$ $\text{Hpx} \quad -0.172$ $\text{My} \quad 0.255$	11/14 (78.6%)	14/14 (100%)
		15 II <sub>4</sub> 20 II <sub>4</sub> 23 I <sub>1</sub>



Table 7.1. Continued

Standardised Canonical Discriminant Function Coefficient (Tests included in each analysis <u>underlined</u> )	Mo. (and %) correct	Misclassified Subjects
	Classification	
	DND Carriers	Controls
(vii) $\frac{CK : Hpx}{CK} \quad 1.037$ $\frac{Hpx}{Hpx} \quad -0.118$	$\frac{12/14}{(85.7\%)}$	15 II <sub>4</sub> 20 II <sub>4</sub> no.7 no.10
(viii) $\frac{PK : Hpx : My}{PK} \quad -0.477$ $\frac{Hpx}{Hpx} \quad 0.045$ $\frac{My}{My} \quad -0.735$	$\frac{10/14}{(71.4\%)}$	13 II <sub>2</sub> 15 II <sub>4</sub> 20 II <sub>4</sub> 23 I <sub>1</sub> no.13
(ix) $\frac{PK : My}{PK} \quad 0.472$ $\frac{My}{My} \quad 0.723$	$\frac{10/14}{(71.4\%)}$	13 II <sub>2</sub> 15 II <sub>4</sub> 20 II <sub>4</sub> 23 I <sub>1</sub> no.13

Figure 7.1. Discriminant Analyses of Group A Carriers and Controls:  
Computer Generated Graphs

Upper Graph: Discriminant analysis using serum creatine  
kinase, pyruvate kinase, haemopexin and  
myoglobin measurements

Lower Graph: Repeat of discriminant analysis above  
omitting serum creatine kinase measurements

Note that all subjects whose results fall into the area on the  
graph denoted as "CONTROLS" would be classified as normal women  
and those falling into the area marked "CARRIERS" would be  
classified as DMD heterozygotes.

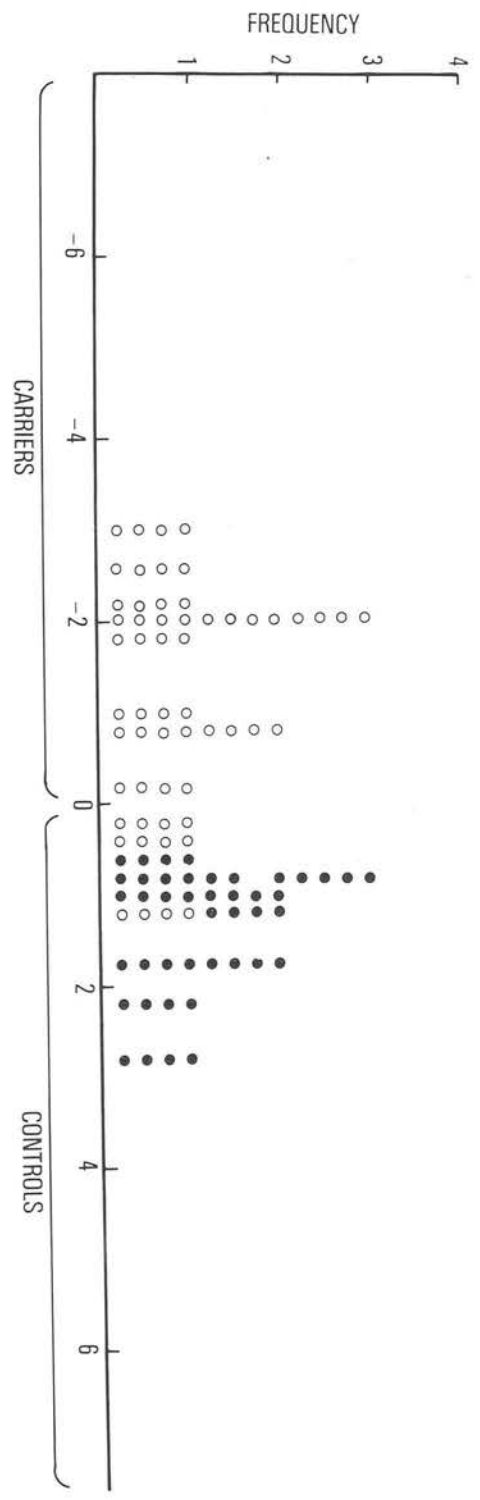
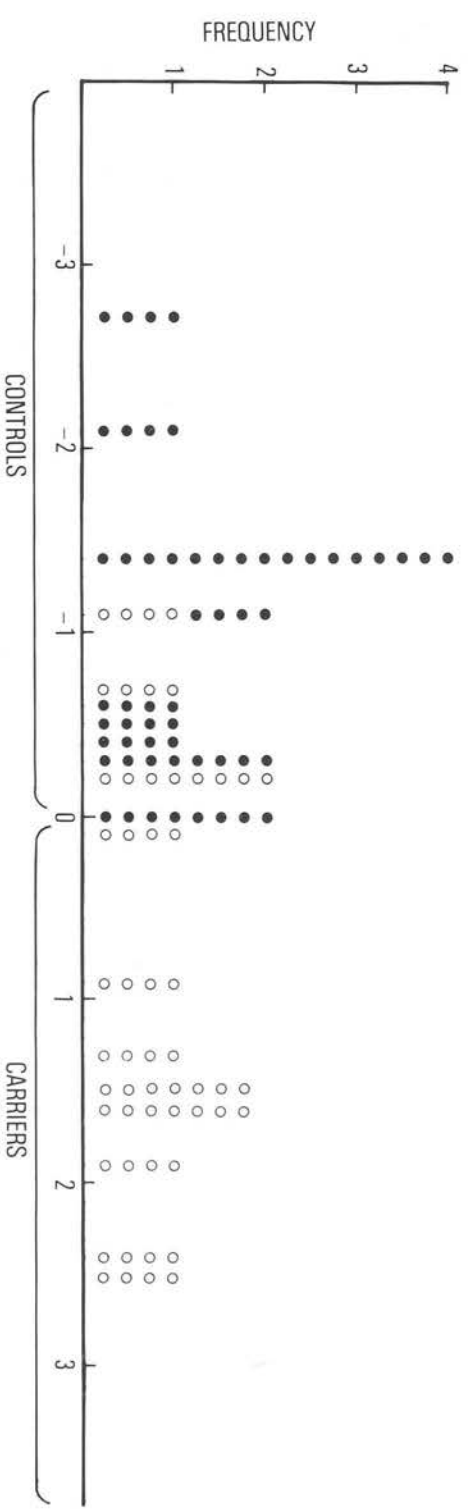

of haemopexin and myoglobin in DMD carriers, Group A, but this relationship was significant in the control subjects.

For a summary of these relationships refer to Table 7.2.

Using the confidence limits for the control series calculated for each serum protein individually (refer to Chapters 3,4,5 and 6) of the 14 DMD carriers of Group A examined (excluding DMD carrier 17 II<sub>4</sub> from the series of 15) in 3/14 (21.4%) of these DMD carriers (13 II<sub>2</sub>; 15 II<sub>4</sub>; 20II<sub>4</sub>) serum measurements of all 4 proteins were within the calculated 95th percentile of each control series.

Table 7.2. Summary of Relationships between Serum Proteins Studied

A: DHD Carriers					B: Age and Sex Matched Controls				
	CK	PK	Hpx	My		CK	PK	Hpx	My
CK	/	+	+	+	CK	/	NS	NS	NS
PK	+	/	+'	NS	PK	NS	/	NS	NS
Hpx	+	+	/	NS	Hpx	NS	NS	/	+'
My	+	NS	NS	/	My	NS	NS	+	/

+ significant positive correlation ( $p < 0.01$ )  
 +' significant positive correlation ( $p < 0.05$ )  
 NS not significant

all correlations by Spearman's rank correlation coefficient (or the modified Spearman's rank correlation coefficient)

## 7-4. DISCUSSION

### 7-4.1. Discriminant Analyses

From the magnitude of the standardised canonical discriminant function coefficient in the discriminant analysis involving all 4 serum tests (note that in all the discriminant analyses undertaken in this study results discussed were logged base 10, prior to analysis) it can be seen that serum creatine kinase made by far the largest contribution of the variables, between 2.5 and 3 times that of either serum pyruvate kinase or myoglobin (refer to Table 7.1., vi). The latter 2 variables made similar levels of positive contribution towards the discriminant function whilst serum haemopexin provided only a smaller and negative contribution to the analysis.

In most of the discriminant analyses undertaken which involved combinations of 2 or 3 serum tests, in each case both the nature and levels of contribution of each variable to the discriminant function obtained was similar to that shown in the discriminant analysis involving all 4 serum tests. In discriminant analyses which included serum creatine kinase this variable always made the largest positive contribution to the discriminant function concerned and both serum pyruvate kinase and serum myoglobin made similar levels of contribution (relative to one another) in these analyses. Serum haemopexin was found to be the least important variable in all discriminant analyses undertaken. By omitting serum haemopexin as a variable from the discriminant analysis using all 4 serum tests, DMD heterozygote recognition increased from 11/14 (78.6%) to 12/14 (85.7%).

When serum creatine kinase was not included as one of the variables in the discriminant analyses (refer to Table 7.1., vii and viii) the

number of subjects correctly classified decreased (relative to the number of subjects correctly identified in discriminant analyses which included serum creatine kinase as a variable). In these analyses serum myoglobin made the greatest positive contribution of the variables.

None of the discriminant analyses involving 2, 3 or 4 variables improved on the number of DMD heterozygotes correctly classified by discriminant analysis employing serum creatine kinase as sole variable (12/14, 85.7%). However one control subject misclassified by the discriminant analysis involving serum creatine kinase alone was correctly classified by several discriminant analyses which employed serum creatine kinase and either 1 or 2 further variables (refer to Table 7.1., i - v).

Comparison of the contributions of each of the variables to the discriminant analyses undertaken clearly demonstrated serum creatine kinase to have by far the greatest DMD carrier discriminatory power of the variables examined. Of the remaining serum tests investigated, examination of the standardised canonical discriminant function coefficients for each variable in each discriminant analysis implied that serum myoglobin was the next most discriminating variable.

The possibility that serum myoglobin, when used additionally to serum creatine kinase, might improve DMD heterozygote selection over that obtained using serum creatine kinase as sole determinant was explored in Chapter 6. In fact discriminant analysis of Group B carriers and controls (20 genetic DMD carriers whose serum creatine kinase levels were within the calculated 95th percentile of the control series and 20 age matched normal women) using both serum creatine kinase and serum myoglobin indicated that inclusion of serum myoglobin as a variable adversely affected discrimination between these DMD carriers and control subjects.

Overall the results of this study indicate that (in the subject age

range studied) using discriminant analysis as a method of DMD carrier detection, when serum creatine kinase is present as a variable little advantage is gained from the additional use of serum measurements of pyruvate kinase, haemopexin and myoglobin, either singly or in combination.

#### 7-4.2 Summary of Relationships between Serum proteins measured in this study

The possible mechanisms involved in the abnormal release of muscle-residing proteins into the bloodstream of DMD patients have been discussed in detail by Pennington (1977) and Rowland (1980). Elevated (above the 95th percentile of the control series) serum levels of these muscle-specific proteins in DMD heterozygotes are thought to originate from the population of dystrophic cells within Lyonised DMD carrier muscle (refer to Sections 1-3.3. and 1-6.3.).

Of the serum proteins investigated in this study the serum levels of myoglobin and the serum activities of the muscle isoenzyme forms of creatine kinase and pyruvate kinase are thought to derive from leakage from the muscle cell cytosol compartment. In the case of serum haemopexin (a transport protein of haem) it has been suggested that elevated levels of this protein occur in response to an abnormal muscle leakage of myoglobin (refer to Chapter 5).

The leakage process involved in muscle-specific protein release is itself more complex than a simple relationship to molecular size (see Pennington 1977) and has yet to be elucidated. Furthermore, following release of proteins into the bloodstream many factors influence the actual serum level measured. The factors known to interact with each serum protein studied have been discussed in the



relevant preceding Chapters (3,4,5 and 6). Overall the serum proteins examined in this study ultimately depend, either directly (or in the case of haemopexin, indirectly) on the population of muscle cells manifesting the abnormal X chromosome within the DMD heterozygote, it was felt that differences affecting each protein (due to the muscle-leakage process and due to other factors influencing serum levels) might result in different DMD carrier detection capabilities for each protein. In fact, in the subjects studied serum creatine kinase estimation achieved the greatest number of correctly classified DMD carriers. The significant correlations in DMD heterozygotes between the serum levels of each of pyruvate kinase, haemopexin, and myoglobin were apparently too high to enable the identification of DMD carriers who remained unselected by serum creatine kinase.

The lack of relationship between serum haemopexin and myoglobin measurements in the DMD carriers studied (discussed fully in Chapter 5) may have arisen due to an increased renal clearance of the haemopexin-myoglobin complex following a possible increased muscle release of myoglobin and consequent generation of haemopexin in these subjects.

The DMD carriers of Group A who remained unidentified by any of the 4 serum tests (or by discriminant analysis employing combinations of these tests) may represent DMD heterozygotes in whom, following Lyonisation, there are too few muscle fibres to attain serum levels considered to be elevated in any of the muscle-specific proteins studied.

## REFERENCES

- Adornato, B.T., Corash, L. and Engel, W.K. (1977). Erythrocyte Survival in Duchenne Dystrophy. *Neurology (Minneapolis)*, 27, 1093-1094
- Adornato, B.T., Engel, W.K. and Foidart-Desalle, M. (1978a). Elevations of Haemopexin Levels in Neuromuscular Disease. *Archives of Neurology*, 35, 577-580
- Adornato, B.T., Kagen, L.J. and Engel, W.K. (1978b). Myoglobinaemia in Duchenne Muscular Dystrophy Patients and Carriers: A New Adjunct to Carrier Detection. *Lancet*, 2, 499-501
- Aebi, U., Richterich, R., Stillhart, H., Colombo, J.P. and Rossi, E. (1961). Progressive Muskeldystrophie. III. Serum-enzyme bei der Muskeldystrophie in Kindersalter. *Helvetica Paediatrica Acta*, 16, 543-564
- Afifi, A.K., Bergman, R.A. and Zellweger, H. (1973). A Possible Role for Electron Microscopy in Detection of Carriers of Duchenne Type Muscular Dystrophy. *Journal of Neurology, Neurosurgery and Psychiatry*, 36, 643-650
- Alberts, M.C. and Samaha, F.J. (1974). Serum Pyruvate Kinase in Muscle Disease and Carrier States. *Neurology (Minneapolis)*, 24, 462-464
- Anand, R. and Emery, A.E.H. (1980). Calcium Stimulated Enzyme Efflux from Human Skeletal Muscle. *Research Communications in Chemical Pathology and Pharmacology*, 28, 541-550
- Anand, R. and Emery, A.E.H. (1982). Calcium Stimulated Enzyme Efflux from Human Skeletal Muscle: Effect of a Calcium Blocker. 5th International Congress on Neuromuscular Diseases, Marseille, France, 12-18th September, Abstract 15.4
- Ando, T., Kato, T., Ohsawa, M. and Fukuyama, Y. (1980). Myoglobinaemia in Duchenne Muscular Dystrophy Carriers. *Brain and Development*, 2, 87-88
- Ando, T., Shimizu, T., Kato, T., Ohsawa, M. and Fukuyama, Y. (1978). Myoglobinaemia in Children with Progressive Muscular Dystrophy. *Clinica Chimica Acta*, 85, 17-22
- Araki, S. and Mawatari, S. (1971). Ouabain and Erythrocyte-Ghost Adenosine Triphosphatase - Effects in Human Muscular Dystrophies. *Archives of Neurology*, 24, 187-190
- Askanas, W. (1966a). Identification of the Agent Responsible for the Abnormal Electrophoretic Pattern of Serum in Duchennes' Progressive Muscular Dystrophy. *Life Sciences*, 5, 1767-1773
- Askanas, W. (1966b). Immunoelectrophoretic Investigations of the Serum of Carriers of Duchennes' Progressive Muscular Dystrophy. *Life Sciences*, 5, 1775-1780

- Bader, P.I. (1979). Lymphocyte Capping in Duchenne Muscular Dystrophy. *Lancet*, 2, 306. (Letter)
- Ballantyne, J.P. and Hansen, S. (1974). New Method for the Estimation of the Number of Motor Units in a Human Muscle. 2. Duchenne, Limb-girdle, Facioscapulohumeral and Myotonic Muscular Dystrophies. *Journal of Neurology, Neurosurgery and Psychiatry*, 37, 1195-1201
- Becker, P.E. and Keiner, F. (1955). Eine neue X-Chromosomale Muskeldystrophie. *Archiv für Psychiatrie und Nervenkrankheiten*. 193, 427-448
- Beisenherz, V.G., Boltze, H.J., Bücher, T., Czok, R., Garbade, K.H., Meyer-Arendt, E. and Pfeleiderer, G. (1953). Diphosphofruuctose-aldolase, Phosphoglycerinaldehyde-Dehydrogenase, Milchsäure-Dehydrogenase, Glycerophosphat-Dehydrogenase und Pyruvate Kinase aus: Kaninch en muskulator in einem Arbeitsgang. *Zeitschrift für Naturforschung*, 8, 555-577
- Berggard, I. (1961). Proteins, Glycoproteins and Mucopolysaccharides in Normal Human Urine. 1. Fractionation of Non-Dialyzable Materials by Ultrafiltration and by Zone Electrophoresis. *Arkiv för Kemi*, 18, 291-313
- Bertorini, T.E., Bhattacharya, S.K., Palmieri, G.M.A., Chesney, C.M., Pifer, D. and Baker, B. (1982). Muscle Calcium and Magnesium Content in Duchenne Muscular Dystrophy. *Neurology (Ny)*, 32, 1088-1092
- Bessis, M. (1973). In: Red Cell Shape. Eds. Bessis, M., Weed, R.I. and Leblond, P.F. Springer-Verlag: New York, 34, pp 1-24
- Biörck, G. (1949). On Myoglobin and its Occurrence in Man. *Acta Medica Scandinavica (Suppl. 226)*, 133, 1-216
- Blahd, W.G. and Cassen, B. and Lederer, M. (1964). Decreased Body Potassium in Non-Dystrophic Relatives of Patients with Muscular Dystrophy. A Biochemical Trait. *The New England Journal of Medicine*, 270, 197-198
- Blahd, W.G., Lederer, M. and Cassen, B. (1967). The Significance of Decreased Body Potassium Concentrations in Patients with Muscular Dystrophy and Non-Dystrophic Relatives. *The New England Journal of Medicine*, 276, 1349-1352
- Bodensteiner, J.B. and Engel, A.G. (1978). Intracellular Calcium Accumulation in Duchenne Dystrophy and other Myopathies: A Study of 567,000 Muscle Fibres in 114 Biopsies. *Neurology (Minneapolis)*, 28, 439-446
- Bombardieri, S., Clerico, A., Riente, L. and Chicca, M.G.D. (1981). Circadian Variations of Serum Myoglobin (MB) Levels in Normal Subjects and in Patients with Polymyositis. V Congress of European Nuclear Medicine Society, Pisa, Abstract 138
- Bookchin, R.M. and Lew, V.L. (1980). Progressive Inhibition of the Ca Pump and Ca:Ca Exchange in Sickle Red Cells. *Nature*, 284, 561-563

- Bosmann, H.B., Gersten, D.M., Griggs, R.C., Howland, J.L., Hudecki, M.S., Katyare, S. and McLaughlin, J. (1976). Erythrocyte Surface Membrane Alterations: Findings in Human and Animal Muscular Dystrophies. *Archives of Neurology*, 33, 135-138
- Böyum, A. (1968). A One-Stage Procedure for Isolation of Granulocytes and Lymphocytes from Human Blood. *Scandinavian Journal of Clinical and Laboratory Investigations*, 21, 21.
- Bradley, W.G. (1977). In: *Pathology of Human Muscular Dystrophies*. Ed. Rowland, L.P. Excerpta Medica, Amsterdam. International Congress Series 404. pp. 672-677
- Bradley, W.G. and Fulthorpe, J.J. (1978). Studies of Sarcolemmal Integrity in Myopathic Muscle. *Neurology (Minneap.)*, 28, 670-677
- Bradley, W.G., Gardner-Medwin, D., Haggith, J., Walton, J.N. and Hesp, R. (1971). Duchenne Muscular Dystrophy. Use of Rubidium Chloride Rb86 in the Detection of Carriers of the Gene. *Archives of Neurology*, 25, 193-197
- Bradley, W.G. and Keleman, J. (1979). Genetic Counseling in Duchenne Muscular Dystrophy. *Muscle and Nerve*, 2, 325-328
- Bradley, W.G., O'Brien, M.D., Walder, D.N., Murchison, D., Johnson, M. and Newell, D.J. (1975). Failure to Confirm a Vascular Cause of Muscular Dystrophy. *Archives of Neurology*, 32, 466-473
- Brain, M.C., Kohn, I., McComas, A.J., Missirlis, Y.F., Rathbone, M.P. and Vickers, J. (1978). Red-cell Stability in Duchenne Syndrome. *The New England Journal of Medicine*, 298, 403. (Letter)
- Brooke, M.H., Griggs, R.C., Mendell, J.R., Fenichel, G.M., Shumate, J.B. and Pellegrino, R.J. (1981). Clinical Trial in Duchenne Dystrophy I. The Design of Protocol. *Muscle and Nerve*, 4, 186-197
- Brown, H.D., Chattopadhyay, S.K. and Patel, A.B. (1967). Erythrocyte Abnormality in Human Myopathy. *Science*, 157, 1577-1578
- Bunday, S. (1981). A Genetic Study of Duchenne Muscular Dystrophy in the West Midlands. *Journal of Medical Genetics*, 18, 1-7
- Bunday, S., Crawley, J.M., Edwards, J.H. and Westhead, R.A. (1979). Serum Creatine Kinase Levels in Pubertal, Mature, Pregnant and Postmenopausal Women. *Journal of Medical Genetics*, 16, 117-121
- Burt, D. and Emery, A.E.H. (1979). Serum LDH-5 in Carriers of Duchenne Muscular Dystrophy. *Neurology (Minneap.)* 29, 239-241
- Buscaino, G.A. (1965). Muscular Myoglobin Content and Serum Iron Concentration in Progressive Muscular Dystrophy and other Neuromuscular Diseases. *Proceedings of the 8th International Congress of Neurology*. Excerpta Medica, Amsterdam: 2, pp. 199-208
- Busch, W.A., Stromer, M.H., Goll, D.E. and Suzuki, A. (1972). Ca<sup>2+</sup>-Specific Removal of Z lines from Rabbit Skeletal Muscle. *Journal of Cell Biology*, 52, 367-381

- Butterfield, D.A. (1977). Electron Spin Resonance Investigations of Membrane Proteins in Erythrocytes in Muscle Diseases. *Biochimica et Biophysica Acta*, 470, 1-7
- Carpenter, S. and Karpati, G. (1979). Duchenne Muscular Dystrophy: Plasma Membrane Loss Initiates Muscle Cell Necrosis Unless it is Repaired. *Brain*, 102, 147-161
- Chandler, J.A. and Battersby, S. (1976). X-Ray Microanalysis of Ultrathin, Frozen and Freeze-Dried Sections of Human Sperm Cells. *Journal of Microscopy*, 107, 55-65
- Chandler, D.E. and Williams, J.A. (1978). Intracellular Divalent Cation Release in Pancreatic Acinar Cells During Stimulus Secretion Coupling. *Journal of Cell Biology*, 76, 386-399
- Connolly, J.A., Kalnins, V.I. and Barber, B.H. (1979). Microtubule Organisation in Fibroblasts from Dystrophic Chickens and Persons with Duchenne Muscular Dystrophy. *Nature*, 282, 511-513
- Cox, J.A., Comte, M. and Stein, E. A. (1982). Activation of Human Erythrocyte  $Ca^{2+}$ -Dependant  $Mg^{2+}$ -Activated ATPase by Calmodulin and Calcium: Quantitative Analysis. *Proceedings of the National Academy of Sciences of the USA*, 79, 4265-4269
- Cullen, M.J. and Fulthorpe, J.J. (1975). Stages in Fibre Breakdown in Duchenne Muscular Dystrophy. *Journal of the Neurological Sciences*, 24, 179-200
- Cullen, M.J. and Mastaglia, F.L. (1980). Morphological Changes in Dystrophic Muscle. *British Medical Bulletin*, 36, 145-152
- Cullen, M.J. and Parsons, R. (1977). Inclusion Bodies in Muscular Dystrophy. *Lancet*, 2, 929. (Letter)
- Danieli, G.A. and Angelini, C. (1976a). Duchenne Carrier Detection. *Lancet*, 2, 90. (Letter)
- Danieli, G.A. and Angelini, C. (1976b). *Lancet*, 2, 415-416 (reply to letter)
- Danieli, G.A. and Marchesini, P. (1980). Osmotic Fragility of Erythrocytes in Duchenne Muscular Dystrophy Patients and Carriers. In: *Muscular Dystrophy Research: Advances and New Trends*. Eds. Angelini, C., Danieli, G.A. and Fontanari, D. *Excerpta Medica*. Amsterdam. *International Congress Series*, 527. pp 101-107
- Davis, M.H., Gelman, B.B. and Gruenstein, E. (1982a). Decreased Structure-Linked Latency of Lysosomal Dipeptidyl Aminopeptidase-I Activity in Duchenne Muscular Dystrophy Fibroblasts. *Neurology*, (Ny), 32, 486-491
- Davis, M.H., Pato, C.N., Grinvalsky, H. and Gruenstein, E. (1982b). Identification of a Biochemical Difference Between Male and Female Human Fibroblasts: Implications for the Expression of Duchenne Muscular Dystrophy. *Neurology* (Ny), 32, 951-957

- Dellamonica, G., Collombel, C., Cotte, J. and Addis, P. (1983). Screening for Neonatal Duchenne Muscular Dystrophy by Bioluminescence Measurement of Creatine Kinase in a Blood Sample Spotted on Paper. *Clinical Chemistry*, 29, 161-163
- Démos, J. (1961). Mesure des Temps de Circulation chez 79 Myopathies. *Révue Française d'Études Clinique*, 6, 876-887
- Démos, J. (1973). Platelet Diphenoloxidases in Progressive Muscular Dystrophy. *Clinical Genetics*, 4, 79-90
- Démos, J., Drefus, J.C., Schapira, F. and Schapira, B. (1962). Anomalies Biologiques chez les Transmetteurs Apparemment sains de la Myopathie. *Révue Canadienne de Biologie*, 21, 587-597
- Démos, J., Tuil, D.G., Katz, P.C., Berthelon, M.A., Dautreux, B. and Premont, N. (1981). Diphenoloxidase in X-Linked Recessive (Duchenne) Muscular Dystrophy. *Human Genetics*, 59, 154-160
- Dise, C.A. Goodman, D.B.P., Lake, W.C. Hodson, A. and Rasmussen, H. (1977). Enhanced Sensitivity to Calcium in Duchenne Muscular Dystrophy. *Biochemical and Biophysical Research Communications*, 79, 1286-1292
- Drefus, J.C. and Schapira, G. (1961). Technique de Dosage de la Creatine Phosphokinase du Serum. *Révue Française d'Études Clinique et Biologie*, 6, 700-703
- Dreyfus, J.C., Schapira, F. and Demos, J. (1960). Étude de la Creatine Kinase Sérique chez les Myopathes et Leurs Familles. *Révue Française d'Études Clinique et Biologie*, 5, 384-386
- Drefus, J.C., Schapira, F., Demos, J., Rosa, R. and Schapira, G. (1966). The Value of Serum Enzyme Determinations in the Identification of Dystrophic Carriers. *Annals of the New York Academy of Sciences of the USA*. 138, 304-314
- Dubowitz, V. (1963). Myopathic Changes in Muscular Dystrophy Carriers. *Proceedings of the Royal Society of Medicine*, 56, 810-812
- Dubowitz, V. and Heckmatt, J. (1980). Management of Muscular Dystrophy. *British Medical Bulletin*, 36, 139-144
- Dubowitz, V., van Iddekinge, B., Rodeck, C.H., Campbell, S., Singer, J.D., Scheuerbrandt, G. and Moss, D.W. (1978). *Lancet*, 1, 9. (Letter)
- Duchenne, G.S. (1868). Recherches sur la Paralysis Musculaire Pseudohypertrophique ou Paralysis Myo-Sclerosique. *Archives générales de Médecine*, 11, 5, 179, 305, 421, 552
- Duncan, C.J. (1978). Role of Intracellular Calcium in Promoting Muscle Damage: A Strategy for Controlling the Dystrophic Condition. *Experientia*, 34, 1531-1535
- Eaton, J.W., Skelton, T.D., Swofford, H.S., Kolpin, C.E. and Jacob, H.S. (1973). Elevated Erythrocyte Calcium in Sickle Cell Disease. *Nature*, 246, 105-106

- Ebashi, S. and Sugita, H. (1979). The Role of Calcium in Physiological and Pathological Processes of Skeletal Muscle. In: Current Trends in Nerve and Muscle Research. Eds. Aguayo, A.J. and Karpati, G. Excerpta Medica, Amsterdam. International Congress Series, 455, pp 73-84
- Ebashi, S., Toyokura, Y., Momoi, H. and Sugita, H. (1959). High Creatine Phosphokinase Activity of Sera of Progressive Muscular Dystrophy. Journal of Biochemistry (Tokyo), 46, 103-104
- Emery, A.E.H. (1963). Clinical Manifestations in Two Carriers of Duchenne Muscular Dystrophy. Lancet, 1, 1126-1128
- Emery, A.E.H. (1964). Electrophoretic Pattern of Lactate Dehydrogenase in Carriers and Patients with Duchenne Muscular Dystrophy. Nature, 201, 1044-1045
- Emery, A.E.H. (1965a). Muscle Histology in Carriers of Duchenne Muscular Dystrophy. Journal of Medical Genetics, 2, 1-7
- Emery, A.E.H. (1965b). Carrier Detection in Sex-Linked Muscular Dystrophy. Journal de Génétique Humaine, 14, 318-329
- Emery, A.E.H. (1969a). Abnormalities of the Electrocardiogram in Female Carriers of Duchenne Muscular Dystrophy. British Medical Journal, 2, 418-420
- Emery, A.E.H. (1969b). Genetic Counselling in X-Linked Muscular Dystrophy. Journal of Neurological Sciences, 6, 579-587
- Emery, A.E.H. (1980). Duchenne Muscular Dystrophy: Genetic Aspects. British Medical Bulletin, 36, 117-122
- Emery, A.E.H. (1981). Prevention of Duchenne Muscular Dystrophy: Genetic Counselling and Prenatal Diagnosis, In: New Approaches to Nerve and Muscle Disorders. Basic and Applied Contributions. Eds. Kidman, A.D., Tomkins, J.K. and Westerman, R.A. Excerpta Medica, Amsterdam. International Congress Series, 546, pp 332-341
- Emery, A.E.H. and Burt, D. (1980). Intracellular Calcium and the Pathogenesis and Antenatal Diagnosis of Duchenne Muscular Dystrophy. British Medical Journal, 48, 355-357
- Emery, A.E.H., Burt, D., Dubowitz, V., Ricker, I., Donnai, D., Harris, R. and Donnai, P. (1979). Antenatal Diagnosis of Duchenne Muscular Dystrophy. Lancet, 2, 847-849
- Emery, A.E.H. and Dreifuss, F.E. (1966). Unusual Type of Benign X-Linked Muscular Dystrophy. Journal of Neurology, Neurosurgery and Psychiatry, 29, 388-342
- Emery, A.E.H. and Holloway, S. (1977). Use of Normal Daughters' and Sisters' Creatine Kinase Levels in Estimating Heterozygosity in Duchenne Muscular Dystrophy. Human Heredity, 27, 118-126

- Emery, A.E.H. and King, B. (1971). Pregnancy and Serum-Creatine-Kinase in Potential Carriers of Duchenne, X-Linked Muscular Dystrophy. *Lancet*, 1, 1013.
- Emery, A.E.H. and Schelling, J.L. (1965). Limb Blood Flow in Patients and Carriers of Duchenne Muscular Dystrophy. *Acta Genetica et Statistica Medica*, 15, 337-344
- Engel, W.K. (1977). Integrative Histochemical Approach to the Defect of Duchenne Muscular Dystrophy. In: Pathogenesis of Human Muscular Dystrophies. Ed. Rowland, L.P. *Excerpta Medica*, Amsterdam, pp.277-309
- Ferriera, H.G. and Lew, V.L. (1976). Use of Ionophore A23187 to Measure Cytoplasmic Ca Buffering and Activation of the Ca Pump by Internal Calcium. *Nature*, 259, 47-49
- Fischer, S., Tortolero, M., Piau, J.P., Delauny, J. and Shapira, G. (1978). Protein Kinase and Adenylate Cyclase of Erythrocyte Membrane from Patients with Duchenne Muscular Dystrophy. *Clinica Chimica Acta*, 88, 437-440
- Fisher, E.R., Silvestri, E., Vester, J.W., Nolan, S., Ahmad, U. and Danowski, T.S. (1976). Increased Erythrocytic Osmotic Fragility in Pseudohypertrophic Muscular Dystrophy. *Journal of the American Medical Association*, 236, 955.
- Fitzsimmons, J.S., McLachlan, J.I., Reeves, W.G., Marriott, D.W. Woolfson, A.M.J. and Mayhew, J. (1980). Carrier Detection in Duchenne Muscular Dystrophy. *Journal of Medical Genetics*, 17, 165-169
- Frearson, N., Taylor, R.D. and Perry, S.V. (1981). Proteins in the Urine Associated with Duchenne Muscular Dystrophy and Other Neuromuscular Diseases. *Clinical Science*, 61, 141-149
- Gaines, R.F., Pueschel, S.M., Sassaman, E.A. and Driscoll, J.L. (1982). Effect of exercise on Serum Creatine Kinase in Carriers of Duchenne Muscular Dystrophy. *Journal of Medical Genetics*, 19, 4-7
- Gale, A.N. and Murphy, E.A. (1979). The Use of Serum Phosphokinase in Genetic Counseling for Duchenne Muscular Dystrophy. *Journal of Chronic Diseases*, 32, 639-651
- Gardner-Medwin, D. (1968). Studies of the Carrier State in the Duchenne Type of Muscular Dystrophy, Part 2: Quantative Electromyography as a Method of Carrier Detection. *Journal of Neurology, Neurosurgery and Psychiatry*, 31, 124-134
- Gardner-Medwin, D., Pennington R.J.T. and Walton, J.N. (1971). The Detection of Carriers of X-Linked Muscular Dystrophy Genes. *Journal of the Neurological Sciences*, 13, 459-474
- Gelman, B.B., Davis, M.H., Morris, R.E. and Gruenstein, E. (1981). Structural Changes in Lysosomes from Cultured Human Fibroblasts in Duchenne's Muscular Dystrophy. *Journal of Cell Biology*, 88, 329-337



- Gelman, B.B., Papa, L., Davis, M.H. and Gruenstein, E. (1980). Decreased Lysosomal Aminopeptidase I Activity in Cultured Human Skin Fibroblasts in Duchenne's Muscular Dystrophy. *Journal of Clinical Investigation*, 65, 1398-1406
- Godin, D.V. Bridges, M.A. and Macleod, P.J.M. (1978). Chemical Compositional Studies of Erythrocyte Membranes in Duchenne Muscular Dystrophy. *Research Communications in Chemical Pathology and Pharmacology*, 20, 331-349
- Golbus, M.S., Stephens, J.D., Mahoney, M.J., Hobbins, J.C., Haseltine, F.P., Caskey, C.T. and Banker, B.Q. (1979). *New England Journal of Medicine*, 300, 860-861
- Gullasch, J. and Kaufmann, R. (1974). Energy Dispersive X-Ray Microanalysis in Soft Biological Tissues: Relevance and Reproducibility of the Results as Dependant on Specimen Preparation. In: *Microprobe Analysis as Applied to Cells and Tissues*. Eds. Hall, T., Echlin, P. and Kaufmann, R. Academic Press, London, pp 175-190
- Hanstein, A. and Muller-Eberhard, U. (1968). Concentration of Serum Haemopexin in Healthy Children and Adults and in those with a Variety of Hematological Disorders. *Journal of Laboratory Clinical Medicine*, 71, 232-239
- Harano, Y., Adair, R., Vignos, P.J., Miller, M. and Kowal, J. (1973). Pyruvate Kinase Isoenzymes in Progressive Muscular Dystrophy and in Acute Myocardial Infarction. *Metabolism*, 22, 493-501
- Hardy, M.F., Gardner-Medwin D. and Pennington, R.J.T. (1977). Serum Pyruvate Kinase in Carriers of Duchenne Muscular Dystrophy. *Journal of the Neurological Sciences*, 32, 137-139
- Harper, P.S., Murray, J.M., Davies, K.E., Meredith, L., O'Brien, T. and Williamson, R. (1982). X-Chromosome Specific DNA Probes and Duchenne Muscular Dystrophy. 5th International Congress on Neuromuscular Diseases. Marseille, France, 12th-18th September. Abstract 13.2
- Harper, P.S., O'Brien, T., Murray, J.M., Davies, K.E., Pearson, P. and Williamson, R. (1983). The Use of Linked DNA Polymorphisms for Genotype Prediction in Families with Duchenne Muscular Dystrophy. *Journal of Medical Genetics*, 20, 252-254
- Harriman, D.G.F. (1976). A Comparison of the Fine Structure of Motor End-Plates in Duchenne Dystrophy and in Human Neurogenic Diseases. *Journal of the Neurological Sciences*, 28, 233-247
- Hathaway, P.W., Engel, W. and Zellweger, H. (1970). Experimental Myopathy after Microarterial Embolization Comparison with Childhood X-Linked Pseudohypertrophic Muscular Dystrophy. *Archives of Neurology*, 22, 365-378
- Harrison, D.G. and Long, C. (1969). Calcium Content of Human Erythrocytes. *Journal of Physiology*, 199, 367-381

- Hausmanowa-Petrusewicz, I., Niebroj-Dobosz, I., Borkowska, J., Lukasik, E. and Liszewska-Pfejfer, D. (1977). Carrier Detection in Duchenne Dystrophy. In: Pathogenesis of Human Muscular Dystrophies. Ed. Rowland, L.P. Excerpta Medica, Amsterdam. International Congress Series 404, pp 32-41
- Hausmanowa-Petrusewicz, I., Niebroj-Dobosz, I., Borowska, J., Lukasik, E., Kominek, M., Denbec, I. and Szmidt, E. (1980). Comparison of Different Methods in X-Linked Dystrophy Carriers Detection. In: Muscular Dystrophy Research: Advances and New Trends. Eds. Angelini, C., Danieli, G.A. and Fontanari, D. Excerpta Medica, Amsterdam. International Congress Series 527. pp 108-117
- Hayem-Levy, A. and Havez, R. (1973). Isolement et Étude de L'Hémopexine Humaine. Clinica Chimica Acta, 47, 113-122
- Herrera, L. (1958). The Precision of Percentiles in Establishing Normal Limits in Medicine. Journal of Laboratory and Clinical Medicine, 52, 34-42
- Mershko, C. (1975). The Fate of Circulating Haemoglobin. British Journal of Haematology, 29, 199-204
- Heyck, H., Laudahn, G and Carsten, P.M. (1966). Enzymaktivitätsbestimmungen bei Dystrophia Musculorum Progressiva. IV. Mitteilung. Die Serumenzymkinetic im Praktischen Stadium des Typus Duchenne Während der Ersten Lebensjahre. Klinische Wochenschrift, 44, 695-700
- Hische, E.A.H. and Van der Helm, M.J. (1979). The Significance of the Estimation of Serum Myoglobin in Neuromuscular Diseases. Journal of the Neurological Sciences, 43, 243-251
- Ho, A.D., Reitter, B., Stojakowitz, S., Fiehn, W. and Weisser, J. (1980). Capping of Lymphocytes for Carrier Detection in Duchenne Muscular Dystrophy: Technical Problems and a Review of the Literature. European Journal of Pediatrics, 134, 211-216
- Hodson, A. and Pleasure, D. (1977). Erythrocyte Cation-Activated Adenosine Triphosphatases in Duchenne Muscular Dystrophy. Journal of the Neurological Sciences, 32, 361-369
- Horenstein, A.L. and Emery, A.E.H. (1980). Human Lymphocyte Capping in Duchenne Muscular Dystrophy. Neurology, (Minneapolis) 30, 1330-1332
- Horrobin, D.F., Morgan, R., Karmali, R.A., Manku, M.S., Karmazyn, M., Ally, A. and Mtabaji, J.P. (1978). The Role of Prostaglandins and Calcium Accumulation in Muscular Dystrophy. Medical Hypotheses, 3
- Housman, D. (1983). Cloning in on the Gene for Duchenne Muscular Dystrophy. Trends in the Neurosciences, 6, 115-117
- Howland, J.L. and Iyer, S.L. (1977). Erythrocyte Lipids in Heterozygous Carriers of Duchenne Muscular Dystrophy. Science, 198, 309-310
- Hrkal, A. and Muller-Eberhard, U. (1971). Partial Characterization of the Heme-binding Serum Glycoproteins Rabbit and Human Hemopexin. Biochemistry, 10, 1746-1750

- Hudgson, P., Gardner-Medwin, D., Pennington, R.J.T. and Walton, J.N. (1967). Studies of the Carrier State in the Duchenne type of Muscular Dystrophy. Part I (Effect of Exercise on Serum Creatine Kinase Activity). *Journal of Neurology, Neurosurgery and Psychiatry*, 30, 416-419
- Hughes, R.C., Park, D.C., Parsons, M.E. and O'Brien, M.D. (1971). Serum Creatine Kinase Studies in the Detection of Carriers of Duchenne Dystrophy. *Journal of Neurology, Neurosurgery and Psychiatry*, 34, 527-530
- Ishiura, S. (1983). Calcium-Dependant Proteolysis in Living Cells. *Life Sciences*, 29, 1079-1087
- Ionasescu, V., Radu, H. and Nicolescu, P. (1975). Identification of Duchenne Muscular Dystrophy Carriers. *Archives of Pathology*, 29, 436-441
- Ionasescu, V., Zellweger, H. and Burmeister, L. (1976). Detection of Carriers and Genetic Counselling in Duchenne Muscular Dystrophy by Ribosomal Protein Synthesis. *Acta Neurologica Scandinavica*, 54, 442-452
- Ionasescu, V., Zellweger, H. and Cancilla, P. (1978). Fetal Serum Creatine-phosphokinase not a Valid Predictor of Duchenne Muscular Dystrophy. *Lancet*, 2, 1251. (Letter)
- Ionasescu, V., Zellweger, H. and Conway, T.W. (1971). A New Approach for Carrier Detection in Duchenne Muscular Dystrophy. *Neurology*, (Minneap.) 21, 703-709
- Ionasescu, V., Zellweger, H., Shirk, P. and Conway, T.W. (1973). Identification of Carriers of Duchenne Muscular Dystrophy by Muscle Protein Synthesis. *Neurology*, (Minneap.) 23, 497-502
- Jerusalem, F., Engel, A.G. and Gomez, M.R. (1974). Duchenne Dystrophy. II. Morphometric Study of Motor-End Plate Fine Structure. *Brain*, 97, 123-130
- Johnson, R., Somer, H., Karli, P. and Saris, N-E. (1983). Erythrocyte Flexibility, ATPase Activities and Ca Efflux in Patients with Duchenne Muscular Dystrophy, Myotonic Muscular Dystrophy and Congenital Myotonia. *Journal of the Neurological Sciences*, 58, 399-407
- Jones, G.E. and Witkowski, J.A. (1979). Reduced Adhesiveness between Skin Fibroblasts from Patients with Duchenne Muscular Dystrophy. *Journal of the Neurological Sciences*, 43, 465-470
- Jones, K.W. (1980). Muscle Cell Differentiation and Genetic Engineering *British Medical Bulletin*, 36, 173-180
- Kagen, L.J. (1973). Myoglobin, Biochemical, Physiological and Clinical Aspects. Columbia University Press: New York
- Kagen, L.J. (1981). Reply to Letter. *Muscle and Nerve*, 4, 257.

- Kagen, L.J. and Butt, A. (1977). Myoglobin Binding in Human Serum. *Clinical Chemistry*, 23, 1813-1818
- Kagen, L.J. and Gurevich, R. (1967). Precipitin Reactions of Anti-Human Myoglobin Serum with Several Human and Animal Muscle Extracts. *Immunology*, 12, 667-673
- Kagen, L.J., Houssavi, S., Miller, S.L. and Tsairis, P. (1980). Serum Myoglobin in Muscular Dystrophy. *Muscle and Nerve*, 3, 221-226
- Kalofoutis, A., Jullien, G. and Spanos, V. (1977). Erythrocyte Phospholipids in Duchenne Muscular Dystrophy. *Clinica Chimica Acta*, 74, 85-87
- Kar, N.C. and Pearson, C.M. (1976). A Calcium-Activated Neutral Protease in Normal and Dystrophic Human Muscle. *Clinica Chimica Acta*, 73, 293-297
- Kiessling, W.R. and Beckmann, R. (1981a). Serum Levels of Myoglobin and Creatine Kinase in Duchenne Muscular Dystrophy. *Klinische Wochenschrift*, 59, 347-348
- Kiessling, W.R. and Beckmann, R. (1981b). Duchenne Muscular Dystrophy - Does Serum Myoglobin Correlate with Serum Creatine Kinase? *Muscle and Nerve*, 4, 257. (Letter)
- Kinsey, S.L. and Burns, L.C. (1973). Electron Probe Microanalysis of Cellular Potassium Distribution. *Annals of the New York Academy of Sciences*, 204, 486-500
- King, B., Spikesman, A. and Emery, A.E.H. (1972). The Effect of Pregnancy on Serum Levels of Creatine Kinase. *Clinica Chimica Acta*, 36, 267-269
- Kohlschutter, A., Wiesmann, U.N., Herschkowitz, N.N. and Ferber, E. (1976). Phospholipid Composition of Cultivated Skin Fibroblasts in Duchenne's Muscular Dystrophy. *Clinica Chimica Acta*, 70, 463-465
- Konagaya, M., Takayanagi, T., Konagaya, Y. and Sobue, I. (1982). The Fluctuation of Serum Myoglobin Levels in Duchenne Muscular Dystrophy and the Carrier. *Journal of the Neurological Sciences*, 55, 259-265
- Kunze, D., Reichmann, G., Egger, E., Leuschner, G. and Eckhardt, H. (1973). Erythrocytenlipide Bei Progressiver Muskeldystrophie. *Clinica Chimica Acta*, 43, 333-341
- Lacelle, P.L., Kirkpatrick, F.H. and Udkow, M. (1973). Relation of Altered Deformability, ATP, DPG and Ca<sup>++</sup> Concentrations in Senescent Erythrocytes. In: *Erythrocytes, Thrombocytes, Leucocytes*. Eds. Gerlach, E., Moser, K., Deutsch, E. and Wilmanns, W. Thieme, Stuttgart, pp. 49-52
- Lake, W., Rasmussen, H. and Goodman, D.B.P. (1977). Effect of Ionophore A23187 upon Membrane Function and Ion Movement in Human and Toad Erythrocytes. *Journal of Membrane Biology*, 32, 93-113

- Lanc, R.J.M., Gardner-Medwin, D. and Roses, A.D. (1980). Electrocardiographic Abnormalities in Carriers of Duchenne Muscular Dystrophy. *Neurology*, 30, 497-501
- Lane, R.J.M., Maskrey, P., Nicholson, G.A., Siddiqui, F.Q.R., Nicholson, M., Gascoigne, P., Pennington, R.J.T., Gardner-Medwin, D. and Walton, J.W. (1979). An Evaluation of Some Carrier Detection Techniques in Duchenne Muscular Dystrophy. *Journal of the Neurological Sciences*, 43, 377-394
- Lane, R.J.M. and Radoff, F.M. (1981). Alcohol and Serum Creatine Kinase Levels. *Annals of Neurology*, 10, 581-582
- Lane, R.J.M. and Roses, A.D. (1981). Variation of Serum Creatine Kinase Levels with Age in Normal Females: Importance for Genetic Counselling in Duchenne Muscular Dystrophy. *Clinica Chimica Acta*, 113, 75-86
- Lang, H. and Würzburg, U. (1982). Creatine Kinase, an Enzyme of Many Forms. *Clinical Chemistry*, 28, 1439-1447
- Lange, K. and Zatz, M. (1979). A New Method for the Analysis of Age Trends in CPK Levels with Application to Duchenne Muscular Dystrophy. *Human Heredity*, 29, 154-160
- Laurent, M., Daveloose, D., Leterrier, F., Fischer, S. and Schapira, G. (1980). A Spin Label Study of the Erythrocyte Membranes in Duchenne Muscular Dystrophy. *Clinica Chimica Acta*, 105, 183-194
- Lechenne, C.P., Bronner, C. and Kirk, R. (1977). Electron Probe Microanalysis of Chemical Elemental Content of Single Human Red Cells. *Journal of Cell Physiology*, 90, 117-126
- Leonard, J.P. and Saltpeter, M.M. (1979). Agonist-Induced Myopathy at the Neuromuscular Junction is Mediated by Calcium. *Journal of Cell Biology*, 82, 811-819
- Leyburn, P., Thomson, W.H.S. and Walton, J.W. (1961). An Investigation of the Carrier State in the Duchenne Type Muscular Dystrophy. *Annals of Human Genetics*, 25, 41-49
- Lloyd, S. and Emery, A.E.H. (1981). A Possible Circulating Plasma Factor in Duchenne Muscular Dystrophy. *Clinica Chimica Acta*, 112, 85-90
- Lloyd, S., Emery, A.E.H. and Brown, J.N. (1981). Erythrocyte Membrane Studies. *Neurology (Ny)*, 31, 1371. (Letter)
- Lloyd, S.J. and Nunn, M.G. (1978). Osmotic Fragility of Erythrocytes in Duchenne Muscular Dystrophy. *British Medical Journal*, 2, 252.
- Lucci, B., Dotti, C. and Camellini, L. (1980). Myoglobinaemia and Duchenne Carrier Detection. In: *Muscular Dystrophy Research: Advances and New Trends*. Eds. Angelini, C., Danieli, D.A. and Fontanari, D. International Congress Series, 527. *Excerpta Medica: Amsterdam*, pp 291-292

- Lucy, J.A. (1930). Is there a Membrane Defect in Muscle and Other Cells? *British Medical Bulletin*, 36, 193-197
- Lun, G. and Gambino, S.R. (1974). A Comparison of Serum Versus Heparinized Plasma for Routine Chemistry Tests. *American Journal of Clinical Pathology*, 61, 108-113
- Lumb, E.M. and Emery, A.E.H. (1975). Erythrocyte Deformation in Duchenne Muscular Dystrophy. *British Medical Journal*, 3, 467-468
- Luthra, H.G., Stern, L.E. and Kim, H.D. (1979).  $(Ca^{2+} + Mg^{2+})$ -ATPase of Red Cells in Duchenne and Myotonic Dystrophy: Effect of Soluble Cytoplasmic Activator. *Neurology*, (Minneap.), 29, 835-841
- Lyon, H.F. (1962). Sex Chromatin and Gene Action in the Mammalian X-Chromosome. *American Journal of Human Genetics*, 14, 135-148
- McComas, A.J., Sica, R.E.P. and Campbell, M.J. (1971). "Sick" Motoneurons. A Unifying Concept of Muscle Disease. *Lancet*, 1, 321-325
- McComas, A.J., Sica, R.E.P. and Upton, A.R.M. (1974). Multiple Muscle Analysis of Motor Units In Muscular Dystrophy. *Archives of Neurology*, 30, 249-251
- McLaughlin, J. and Engel, W.K. (1979). Lipid Composition of Erythrocytes, Findings in Duchenne's Muscular Dystrophy and Myotonic Atrophy. *Archives of Neurology*, 36, 351-354
- Mabry, C.C., Roeckel, I.E., Munich, R.L. and Robertson, D. (1965). X-Linked Pseudohypertrophic Muscular Dystrophy with a Late onset and Slow Progression. *The New England Journal of Medicine*, 273, 1062-1070
- Mahoney, M.J., Haseltine, F.P., Hobbins, J.C., Banker, E.Q., Caskey, C.T. and Golbus, M.S. (1977). Prenatal Diagnosis of Duchenne's Muscular Dystrophy. *The New England Journal of Medicine*, 297, 968-973
- Mann, C., Deleon, A.C., Perloff, J.K., Simanis, J. and Horrigan, F.D. (1963). Duchenne's Muscular Dystrophy: The Electrocardiogram in Female Relatives. *American Journal of the Medical Sciences*, 255, 371-381
- Maskrey, P., Harris, C.I., Milne, G., Lane, R.J.M. and Pennington, R.J.T. (1979). Urinary Excretion of  $\beta$ -Methylhistidine and Creatine in Carriers of Duchenne Muscular Dystrophy. *Clinica Chimica Acta*, 94, 89-91
- Matheson, D.W., Engel, W.K. and Derrer, E.C. (1979). Erythrocyte Shape in Duchenne Muscular Dystrophy. *Neurology*, (Minneap.), 26, 1182-1183
- Matheson, D.W. and Howland, J.L. (1974). Erythrocyte Deformation in Human Muscular Dystrophy. *Science*, 184, 165-166

- Maunder, C.A., Gorodetsky, R., Yarom, R. and Dubowitz, V. (1980). Element Analysis of Skeletal Muscle in Duchenne Muscular Dystrophy using X-ray Fluorescence Spectrometry. *Muscle and Nerve*, 3, 502-508
- Maunder-Sewry, C.A. and Dubowitz, V. (1979). Myonuclear Calcium in Carriers of Duchenne Muscular Dystrophy. An X-ray Microanalysis Study. *Journal of the Neurological Sciences*, 42, 337-347
- Maunder-Sewry, C.A. and Dubowitz, V. (1980). Morphological and X-ray Microanalytical Studies in Carriers of DMD. 8th Symposium on Current Research in Muscular Dystrophy and Allied Neuromuscular Diseases. Newcastle upon Tyne, UK, 3-5th January, Abstract 54
- Maunder-Sewry, C.A. and Dubowitz, V. (1981). Needle Muscle Biopsy for Carrier Detection in Duchenne Muscular Dystrophy. I. Light Microscopy, Histology, Histochemistry and Quantitation. *Journal of the Neurological Sciences*, 49, 305-324
- Maunder-Sewry, C.A., Yarom, R. and Dubowitz, V. (1977). Electron-Microscopic X-ray Microanalysis of Normal and Diseased Human Muscle. *Journal of the Neurological Sciences*, 33, 323-324
- Mawatari, S., Schonberg, M. and Olarte, M. (1976). Biochemical Abnormalities of Erythrocyte Membranes in Duchenne Dystrophy - Adenosinetriphosphatase and Adenyl Cyclase. *Archives of Neurology*, 33. 489-493
- Meltzer, H.Y. (1971). Factors Affecting Serum Creatine Phosphokinase Levels in the General Population: The Risk of Race, Activity and Age. *Clinica Chimica Acta*, 33, 165-172
- Miale, T.D., Frias, J.L. and Lawson, D.L. (1975). Erythrocytes in Human Muscular Dystrophy. *Science*, 187, 453.
- Milhorat, A.T., Shafiq, S.A. and Goldstone, L. (1966). Changes in Muscle Structure in Dystrophic Patients, Carriers and Normal Siblings seen by Electron Microscopy; Correlation with Levels of Serum Creatine Phospho-Kinase (CPK). *Annals of the New York Academy of Sciences*, 138, 246-292
- Miller, S.E., Roses, A.D. and Appel, S.H. (1976). Scanning Electron Microscopy Studies in Muscular Dystrophy. *Archives of Neurology*, 33, 172-174
- Miyoshi, K., Saito, S., Hisaomi, K., Kondo, A., Iwasa, M., Hayashi, T. and Yagita, M. (1978). Radioimmunoassay for Human Myoglobin, Methods and Results in Patients with Skeletal Muscle or Myocardial Disorders. *Journal of Laboratory and Clinical Medicine*, 92, 341-352
- Miyoshi, K., Saito, K., Kuryu, Y., Oshima, Y., Nakano, M. and Kawai, H. (1968). Myoglobin Subfraction: Abnormality in Duchenne Type of Progressive Muscular Dystrophy. *Science*, 159, 736-737

- Hokri, B. and Engel, A.G. (1975). Duchenne Dystrophy: Electron Microscopic Findings Pointing to a Basic or Early Abnormality in the Plasma Membrane of the Muscle Fiber. *Neurology*, (Minneapolis), 25, 1111-1120
- Hollman, J.E., Cardenas, J.C. and Pleasure, D.E. (1980). Alteration of Calcium Transport in Duchenne Erythrocytes. *Neurology*, (Minneapolis) 30, 1236-1239
- Honkton, G., Marusyk, H. and Pehowich, E. (1981). A Method for the Detection of Carriers of Duchenne Muscular Dystrophy - A preliminary Report. *American Journal of Human Genetics*, 32, 978-986
- Moosa, A., Brown, B.H. and Dubowitz, V. (1972). Quantitative Electromyography: Carrier Detection in Duchenne Type Muscular Dystrophy using a New Automatic Technique. *Journal of Neurology, Neurosurgery and Psychiatry*, 35, 841-844
- Morse, P.F. and Howland, J.L. (1973). Erythrocytes from Animals with Genetic Muscular Dystrophy. *Nature*, 245, 156-157
- Moser, H. and Emery, A.E.H. (1974). The Manifesting Carrier in Duchenne Muscular Dystrophy. *Clinical Genetics*, 5, 271-284
- Moser, H. and Vogt, J. (1974). Follow-up Study of Serum Creatine Kinase in Carriers of Duchenne Muscular Dystrophy. *Lancet*, 2, 661-662
- Moser, H., Vogt, J., Otz, E.R. and Colombo, J.P. (1980). Age Dependant Carrier Detection Rate by Serum-CX Determination in Duchenne Muscular Dystrophy (DMD). In: *Muscular Dystrophy Research: Advances and New Trends*. Ed's. Angelini, G., Danielli, G.A. and Fontanari, D. Excerpta Medica, Amsterdam. International Congress Series 527, pp 298.
- Mostacciolo, M.D., Danielli, G.A., Zannoni, G. and Bonfante, A. (1980). Assessment of a Combined Creatine Kinase-Haemopexin Test for Duchenne Carrier Detection. In: *Muscular Dystrophy Research: Advances and New Trends*. Eds. Angelini, G., Danielli, G.A. and Fontanari, D. International Congress Series 527, Excerpta Medica: Amsterdam, pp299.
- Muir, V.A., Knoke, J., Martin, A., Vignos, P. and McKusick, A. (1983). Improved Detection of DMD Heterozygotes using Discriminant Analysis of Creatine Kinase Levels. *American Journal of Medical Genetics*, 14, 125-134
- Muller-Eberhard, U. (1970). Haemopexin. *The New England Journal of Medicine*, 283, 1090-1094
- Murphy, D.L., Mendell, J.R. and Engel, H.K. (1973). Serotonin and Platelet Function in Duchenne Muscular Dystrophy. *Archives of Neurology*, 28, 239-242
- Nagai, J., Sugita, H., Linuma, T.A., Furukawa, T. and Yachiro, S. (1969). Body-Potassium Concentration and Subidium Metabolism Determined by Whole-Body Counting in Duchenne Muscular Dystrophy and its Genetic Carrier State. *Journal of Nuclear Medicine*, 10, 1-7



- Nash, G.B. and Wyard, S.J. (1982). Measurement of Erythrocyte Membrane Elasticity as a Diagnostic Aid in Duchenne Muscular Dystrophy. *Journal of Medical Genetics*, 19, 262-265
- Nicholson, G.A., Gardner-Medwin, D., Pennington, R.J.T. and Walton, J.N. (1979). Carrier Detection in Duchenne Muscular Dystrophy. Assessment of the Effect of Age on Detection Rate with Serum Creatine Kinase Activity. *Lancet*, 1, 692-694
- Nicholson, G.A., McLeod, J.G. and Griffiths, L. (1982). Creatine Kinase in Serum Samples Dried on Paper: An Assay Suitable for Duchenne Muscular Dystrophy Carrier Detection by Mail. 5th International Congress on Neuromuscular Diseases. Marseille, France, 12-18th September, Abstract. MO33
- Nicholson, G.A. and Sugars, J. (1982). An Evaluation of Lymphocyte Capping in Duchenne Muscular Dystrophy. *Journal of the Neurological Sciences*, 53, 511-518
- Nicholson, L.V.B. (1981). Serum Myoglobin in Muscular Dystrophy and Carrier Detection. *Journal of the Neurological Sciences*, 51, 411-426
- Nicholson, L.V.B. and Walls, T.J. (1983). Variations of Serum Myoglobin Levels in Normal Individuals. *Journal of the Neurological Sciences*, 62, 41-58
- Nie, N.H., Hull, C.H., Jenkins, J.G., Steinbrenner, K. and Bent, D.H. (1975). In: *Statistical Package for the Social Sciences*, 2nd Ed. McGraw-Hill, New York
- Niebroj-Dobosz, I. (1976). Erythrocyte Ghosts ( $\text{Na}^+ + \text{K}^+$ ) ATPase Activity in Duchenne's Dystrophy and Myotonia. *Journal of Neurology*, 214, 61-69
- Nishikai, M. and Reichlin, M. (1977). Radioimmunoassay of Serum Myoglobin in Polymyositis and Other Conditions. *Arthritis and Rheumatism*, 20, 1514-1518
- Nørregaard-Hansen, K., Lademann, A. and Nørgaard-Pedersen, B. (1978). Potential of Radioimmunoassay of Myoglobin in Amniotic Fluid and Serum in Prenatal Diagnosis of Duchenne Muscular Dystrophy. *Lancet*, 2, 1250.
- Nørregaard-Hansen, K. and Hein-Sørensen, O. (1982). Significance of Serum Myoglobin in Neuromuscular Diseases and in Carrier Detection of Duchenne Muscular Dystrophy. *Acta Neurologica Scandinavica*, 66, 259-266
- Oberc, M.A. and Engel, W.K. (1977). Ultrastructural Localization of Calcium in Normal and Abnormal Skeletal Muscle. *Laboratory Investigation*, 36, 566-577
- Okinaka, S., Sugita, H., Momoi, H., Tokoura, Y., Kumagai, H., Ebashi, S. and Fujie, Y. (1959). Serum Creatine Kinase and Aldolase Activity in Neuromuscular Disorders. 84th Annual Meeting of the American Neurologists Association. Atlantic City, N.J., USA. pp 62.

- Palek, J. (1977). Red Cell Calcium Content and Transmembrane Calcium Movements in Sickle Cell Anaemia. *Journal of Laboratory and Clinical Medicine*, 89, 1365-1374
- Paterson, Y. and Lawrence, E.F. (1972). Factors Affecting Serum Creatine Phosphokinase Levels in Normal Adult Females. *Clinica Chimica Acta*, 42, 131-139
- Pearce, J.M.S., Pennington, R.J.T. and Walton, J.N. (1964a). Serum Enzyme Studies in Muscle Disease, Part II: Serum Creatine Kinase Activity in Muscular Dystrophy and in other Myopathic Disorders. *Journal of Neurology, Neurosurgery and Psychiatry*, 27, 96-99
- Pearce, J.M.S., Pennington, R.J.T. and Walton, J.N. (1964b). Serum Enzyme Studies in Muscle Disease. Part I: Variation in Serum Creatine Kinase Activity in Normal Individuals. *Journal of Neurology, Neurosurgery and Psychiatry*, 27, 1-4
- Pearse, A.G.E. (1972). In: *Histochemistry*, 3rd Ed., Churchill Livingstone: Edinburgh, 2, pp 1137-1407
- Pearson, T.W. (1978).  $(Na^+ + K^+)$  ATPase of Duchenne Muscular Dystrophy Erythrocyte Ghosts. *Life Sciences*, 22, 127-132
- Pena, S.D.J., Vust, A., Tucker, D., Hamerton, J.L. and Wrogeman, K. (1978). Biochemical Investigations in Cultured Skin Fibroblasts from Patients with Duchenne Muscular Dystrophy. *Clinical Genetics*, 14, 50-54
- Pennington, R.J.T. (1977). Serum Enzymes. In: *Pathogenesis of Human Muscular Dystrophy*. Ed. Rowland, L.P. Excerpta Medica, Amsterdam. International Congress Series, 404, pp 341-349
- Pennington, R.J.T. (1980). Clinical Biochemistry of Muscular Dystrophy. *British Medical Bulletin*, 36, 123-126
- Pennington, R.J.T. (1981). Biochemical Aspects of Muscle Disease. In: *Disorders of Voluntary Muscle*. Ed. Walton, J.N., Churchill Livingstone: Edinburgh, pp 488-516
- Percy, M.E., Andrews, D.F. and Thompson, M.W. (1980). Discriminant Analysis of Four Serum Tests in the Identification of Carriers of Duchenne Muscular Dystrophy. *American Journal of Human Genetics*, 32, Abstract 370
- Percy, M.E., Andrews, D.F. and Thompson, M.W. (1981). Duchenne Muscular Dystrophy Carrier Detection using Logistic Discrimination: Serum Creatine Kinase and Hemopexin in Combination. *American Journal of Medical Genetics*, 8, 397-409
- Percy, M.E., Andrews, D.F. and Thompson, M.W. (1982a). Serum Creatine Kinase in the Detection of Duchenne Muscular Dystrophy Carriers: Effects of Season and Multiple Testing. *Muscle and Nerve*, 5, 58-64

- Percy, M.E., Andrews, D.F. and Thompson, M.W. (1982b). Duchenne Muscular Dystrophy Carrier Detection using Logistic Discrimination: Serum Creatine Kinase, Hemopexin, Pyruvate Kinase and Lactate Dehydrogenase in Combination. *American Journal of Medical Genetics*, 13, 27-38
- Percy, M.E., Chang, L.S., Murphy, E.G., Oss, I., Verellen-Dunoulin, C. and Thompson, M.W. (1979). Serum Creatine Kinase and Pyruvate Kinase in DMD Carrier Detection. *Muscle and Nerve*, 2, 329-339
- Percy, M.E., Chang, L.S., Verellen, C. and Thompson, M.L. (1978). Serum Hemopexin in Duchenne Muscular Dystrophy. *Canadian Federation of Biochemical Societies Proceedings, Abstract*, 368
- Percy, A.K. and Miller, M.E. (1975). Reduced Deformability of Erythrocyte Membranes from Patients with Duchenne Muscular Dystrophy. *Nature*, 258, 147-148
- Perkoff, G.T. (1964). Studies of Human Myoglobin in Several Diseases of Muscle. *The New England Journal of Medicine*, 270, 263-269
- Perkoff, G.T. and Tyler, F.H. (1958). Estimation and Physical Properties of Myoglobin in Various Species. *Metabolism: Clinical and Experimental*, 7, 751-759
- Perry, T.B. and Fraser, F.C. (1973). Variability of Serum Creatine Phosphokinase Activity in Normal Women and Carriers of the Gene for Duchenne Muscular Dystrophy. *Neurology (Minneap.)*, 23, 1316-1323
- Peter, J.B., Worsfold, M. and Pearson, C.M. (1969). Erythrocyte Ghost Adenosine Triphosphatase (ATPase) in Duchenne Dystrophy. *Journal of Laboratory and Clinical Medicine*, 74, 103-108
- Plishker, G.A. and Appel, S.H. (1980). Red Blood Cell Alterations in Muscular Dystrophy: The Role of Lipids. *Muscle and Nerve*, 3, 70-81
- Publicover, S.J., Duncan, C.J. and Smith, J.L. (1978). The Use of A23187 to Demonstrate the Role of Intracellular Calcium in Causing Ultrastructural Damage in Mammalian Muscle. *Journal of Neuropathology and Experimental Neurology*, 37, 544-557
- Radu, H., Migea, S., Torok, Z., Bordeianu, L. and Radu, A. (1968). Carrier Detection in X-Linked Duchenne Type Muscular Dystrophy. *Journal of the Neurological Sciences*, 6, 289-300
- Rao, G.A., Siler, K. and Larkin, E.C. (1978). Palmitoleic Acid in Erythrocytes from Carriers of Duchenne Muscular Dystrophy. *Science*, 200, 1416 .
- Rennie, M.J., Nathan, M., Edwards, R.H.T., Rosochacki, S., Bates, P. and Millward, D.J. (1981). Intracellular Plasma and Urine 3-Methylhistidine as an Index of Muscle Wasting and Repair. In: *Amino Acid Analysis*. Ed. Rattenbury, J.M. Ellis Horwood Ltd., Chichester, U.K., pp 210-224

- Reville, J.J., Goll, D.E., Stromer, M.H., Robson, R.M. and Dayton, W.R. (1976). A  $\text{Ca}^{2+}$ -Activated Protease Possibly Involved in Myofibrillar Protein Turnover. *Journal of Cell Biology*, 70, 1-8
- Rodemann, P., Waxman, L. and Goldberg, A.L. (1982). The Stimulation of Protein Degradation in Muscle by  $\text{Ca}^{2+}$  is Mediated by Prostaglandin  $\text{E}_2$  and Does Not Require the Calcium-Activated Protease. *Journal of Biological Chemistry*, 257, 8716-8723
- Romeo, D., Zabucchi, G., Miani, N. and Rossi, F. (1975). Ion Movement across Leucocyte Plasma Membrane and Excitation of their Metabolism. *Nature*, 253, 542-544
- Rosalki, S.B. (1967). An Improved Procedure for Serum Creatine Phosphokinase Determination. *Journal of Laboratory and Clinical Medicine*, 69, 696-705
- Rosano, T.G. and Kenny, M.A. (1977). A Radioimmunoassay for Human Serum Myoglobin: Method Development and Normal Values. *Clinical Chemistry*, 23, 69-75
- Rosenmann, E., Kreis, C., Thompson, R.G., Dobbs, M., Hamerton, J.L. and Wrogemann, K. (1982). Analysis of Fibroblast Proteins from Patients with Duchenne Muscular Dystrophy by Two-Dimensional Gel Electrophoresis. *Nature*, 298, 563-565
- Roses, A.D., Herbstreith, M.H. and Appel, S.H. (1975). Membrane Protein Kinase Alteration in Duchenne Muscular Dystrophy. *Nature*, 254, 350-351
- Roses, A.D., Herbstreith, M.H., Metcalf, B. and Appel, S.H. (1976a), Increased Phosphorylated Components of Erythrocyte Membrane Spectrin Band II with Reference to Duchenne Muscular Dystrophy. *Journal of the Neurological Sciences*, 30, 167-178
- Roses, A.D., Roses, M.J., Miller, S.E., Hull, K.L. and Appel, S.H. (1976b). Carrier Detection in Duchenne Muscular Dystrophy. *The New England Journal of Medicine*, 294, 193-198
- Roses, A.D., Roses, M.J., Nicholson, G.A. and Roe, C.R. (1977). Lactate Dehydrogenase Isoenzyme 5 in Detecting Carriers of Duchenne Muscular Dystrophy. *Neurology (Minneap.)*, 27, 414-421
- Roses, M.J., Nicholson, M.T., Kircher, C.S. and Roses, A.D. (1977). Evaluation and Detection of Duchenne's and Becker's Muscular Dystrophy Carriers by Manual Muscle Testing. *Neurology (Minneap.)*, 27, 20-25
- Rotthauwe, H.W., Mortier, W. and Beyer, H. (1972). Neuerer Typ einer Recessiv X-Chromosomal Vererbten Muskeldystrophie: Scapulo-humero-distale Muskeldystrophie mit Fruhzeitigen Kontraktwen und Herzrhythmuus Forungen. *Humangenetik*, 16, 181-200

- Rounds, P.S., Jepson, A.B., McAllister, D.J. and Howland, J.L. (1980). Stimulated Turnover of Phosphatidylinositol and Phosphatidate in Normal and Duchenne-Dystrophic Human Skin Fibroblasts. *Biochemical and Biophysical Research Communications*, 97, 1384-1390
- Rowland, L.P. (1980). Biochemistry of Muscle Membranes in Duchenne Muscular Dystrophy. *Muscle and Nerve*, 3, 3-20
- Rowland, L.P., Dunne, P.B., Penn, A.S. and Maher, E. (1968a). Myoglobin and Muscular Dystrophy. *Archives of Neurology*, 18, 141-150
- Rowland, L.P., Layzer, R.B. and Kagen, L.J. (1968b). Lack of Some Muscle Proteins in Serum of Patients with Duchenne Dystrophy. *Archives of Neurology*, 18, 272-276
- Rowland, L.P., Willner, J., Cerri, C., DiMauro, S. and Miranda, A. (1980). Approaches to the Membrane Theory of Duchenne Muscular Dystrophy. In: *Muscular Dystrophy, Research Advances and New Trends*: Eds. Angelini, C., Danieli, G.A. and Fontanari, D. *Excerpta Medica, Amsterdam. International Congress Series*, 527, pp 3-13
- Roxin, L-E., Venge, P., Friman, G. and Hällgren, R. (1979). Radioimmunoassays of Human Myoglobin in Serum and Urine. *Scandinavian Journal of Clinical Laboratory Investigation*, 39, 37-46
- Roy, S. and Dubowitz, V. (1970). Carrier Detection in Duchenne Muscular Dystrophy. A Comparative Study of Electron Microscopy, Light Microscopy and Serum Enzymes. *Journal of the Neurological Sciences*, 11, 65-79
- Ruitenbeek, W.I.M. (1979). Membrane-Bound Enzymes of Erythrocytes in Human Muscular Dystrophy. *Journal of the Neurological Sciences*, 41, 71-80
- Ruitenbeek, W.I.M., Edixhoven, M.J. and Scholte, H.R. (1979). Osmotic Stability of Erythrocytes in Human Muscular Dystrophy before and after Phospholipase Treatment. *Clinica Chimica Acta*, 94, 259-266
- Sage, J., Inati, Y. and Samaha, F. (1979). The Importance of Serum Pyruvate Kinase in Neuromuscular Diseases and Carrier States. *Muscle and Nerve*, 2, 390-393
- Samaha, F.J. (1977). Sarcotubular System in the Muscular Dystrophies. In: *Pathogenesis of Human Muscular Dystrophies*. Ed. Rowland, L.P. *Excerpta Medica, Amsterdam*, pp 633-639
- Sato, B., Nishikida, K., Samuels, L.T. and Tyler, F.H. (1978). Electron Spin Resonance Studies of Erythrocytes from Patients with Duchenne Muscular Dystrophy. *The Journal of Clinical Investigation*, 61, 251-259
- Schanne, F.A.K., Kane, A.B., Young, E.B. and Farber, J.L. (1979). Calcium Dependence of Toxic Cell Death: A Final Common Pathway. *Science*, 206, 700-702

- Schapira, G., Dreyfus, J.C. and Schapira, F. (1953). L'Élevation du Taux de L'Aldolase Serique: Test Biochimique de Myopathies. La Semaine des Hopitaux de Paris, 29, 1917-1920
- Schatzmann, H.J. (1975). Active Calcium Transport and  $Ca^{2+}$ -Activated ATPase in Human Red Cells. In: Current Topics in Membranes and Transport. Eds. Bronner F. and Leinzeller, A. Academic Press, New York, 6, 125-168
- Schatzmann, H.J. and Vincenzi, F.F. (1969). Calcium Movements Across the Membrane of Human Red Cells. Journal of Physiology, 201, 369-395
- Schiffer, D., Palmucci, L., Bertolotto, A. and Monga, G. (1979). The Detection of Duchenne Carriers. Multifactorial Investigation. The Italian Journal of Neurological Sciences, 1, 37-45
- Scholte H.R. and Busch, H.F.M. (1980). Decreased Phosphorylase Activity in Leucocytes of Duchenne Carriers. Clinica Chimica Acta, 105, 137-139
- Schotland, D.L., Bonilla, E. and VanMeter, M. (1977). Duchenne Dystrophy: Alteration in Plasma Membrane Structure. Science, 196, 1005-1107
- Schotland, D.L., Bonilla, E. and Wakayama, Y. (1980). Application of the Freeze Fracture Technique to the Study of Human Neuromuscular Disease. Muscle and Nerve, 3, 21-27
- Seay, A.R., Ziter, F.A., Wu, L.H. and Wu, J.T. (1978). Serum Creatine Phosphokinase and Pyruvate Kinase in Neuromuscular Disorders and Duchenne Dystrophy Carriers. Neurology, (Minneap.) 28, 1047-1050
- Seigel, S. (1956). Non-Parametric Statistics for the Behavioural Sciences. McGraw-Hill, Tokyo, Japan, pp 47-51, 75-82, 202-212
- Sha'afi, R.I., Rodan, S.B., Hintz, R.L., Fernandez, S.M. and Rodan, G.A. (1975). Abnormalities in Membrane Microviscosity and Ion Transport in Genetic Muscular Dystrophy. Nature, 254, 525-526
- Shoji, S. (1981). Calcium Flux of Erythrocytes in Duchenne Muscular Dystrophy. Journal of the Neurological Sciences, 51, 427-435
- Shotton, D.M. (1982). Quantative Freeze Fracture Electron Microscopy of Dystrophic Muscle Membrane. Journal of the Neurological Sciences, 57, 161-190
- Shumate, J.B., Brooke, M.H., Carroll, J.E. and Davis, J.E. (1979). Increased Serum Creatine Kinase after Exercise: A Sex-Linked Phenomenon. Neurology (Minneap.), 29, 902-904
- Sibert, J.R., Harper, P.S., Thompson, R.J. and Newcombe, R.G. (1979). Carrier Detection in Duchenne Muscular Dystrophy. Archives of Disease in Childhood, 54, 534-537

- Sica, R.E.P. and McComas, A.J. (1978). The Neural Hypothesis of Muscular Dystrophy. *Canadian Journal of Neurological Sciences*, 5, 189-197
- Siddiqui, P.Q.R. and Pennington, R.J.T. (1977). Effect of Ouabain upon Erythrocyte Membrane Adenosine Triphosphatase in Duchenne Muscular Dystrophy. *Journal of the Neurological Sciences*, 34, 365-372
- Silverman, L.M., Mendell, J.R., Sahenk, Z. and Fontana, M.B. (1976). Significance of Creatine Phosphokinase Isoenzymes in Duchenne Dystrophy. *Neurology (Minneapolis)*, 26, 561-564
- Simons, T.J.B. (1982). A Method for Estimating Free Ca Within Human Red Blood Cells, with an Application to the Study of their Ca-Dependent K Permeability. *Journal of Membrane Biology*, 66, 235-247
- Simpson, J., Zellweger, H., Burmeister, L.F., Christee, R. and Nielsen, M.K. (1974). Effect of Oral Contraceptive Pills on the Level of Creatine Phosphokinase with Regard to Carrier Detection in Duchenne Muscular Dystrophy. *Clinica Chimica Acta*, 52, 219-223
- Smith, I. and Thomson, W.H.S. (1977). Carrier Detection in X-Linked Recessive (Duchenne) Muscular Dystrophy: Pyruvate Kinase Isoenzymes and Creatine Phosphokinase in Serum and Blood Cells. *Clinica Chimica Acta*, 78, 439-451
- Smith, I., Elton, R.A. and Thomson, W.H.S. (1979). Carrier Detection in X-Linked Recessive (Duchenne) Muscular Dystrophy: Serum CPK in Premenarchal, Menstruating, Post menopausal and Pregnant Normal Women. *Clinica Chimica Acta*, 98, 207-216
- Snedecor, G.W. and Cochran, W.G. (1967). *Statistical Methods*. 6th Edition. Iowa State University Press, USA, pp 92-94, 100-106, 155-156, 258-298
- Solton, H.C. (1977). Echinocytes in Families with Duchenne Muscular Dystrophy. *Journal of Medical Genetics*, 14, 276-278
- Somer, H., Chien, S., Sung, L.A. and Thurn, A. (1979). Erythrocytes in Duchenne Dystrophy: Osmotic Fragility and Membrane Deformability. *Neurology (Minneapolis)*, 29, 519-522
- Somer, H., Dubowitz, V. and Donner, M. (1976). Creatine Kinase Isoenzymes in Neuromuscular Diseases. *Journal of the Neurological Sciences*, 29, 129-136
- Somer, H., Willner, J., DeCresce, R.P., Willner, J. and Sommer, M. (1980). Duchenne Carriers: Lactate Dehydrogenase and Isoenzyme 5 in Serum and Muscle. *Neurology (Minneapolis)*, 30, 206-209
- Souweine, G., Bernard, J.C., Lasne, Y. and Lachanet, J. (1978). The Sodium Pump of Erythrocytes from Patients with Duchenne Muscular Dystrophy - Effect of Ouabain on the Active Sodium Flux and on (Na<sup>+</sup>, K<sup>+</sup>)ATPase. *Journal of Neurology*, 217, 287-294

- Spikesman, A.M. and Brock, D.J.H. (1969). The Significance of the Dilution Effect in Serum Creatine Kinase Diagnosis of Muscular Dystrophy. *Clinica Chimica Acta*, 26, 387-389
- Statham, H.E. and Dubowitz, V. (1979). Duchenne Muscular Dystrophy: <sup>45</sup>Ca Exchange in Cultured Skin Fibroblasts and the Effect of Calcium Ionophore A23187. *Clinica Chimica Acta*, 96, 225-231
- Stephens, H.R., Duance, V.C., Dunn, M.J., Bailey, A.J. and Dubowitz, V. (1982). Collagen Types in Neuromuscular Diseases. *Journal of the Neurological Sciences*, 53, 45-62
- Stevens, H., Reynolds, L., Vanasse, M., Patterson, J., Hall, G., Bloom, S., Whittaker, K., Moss, D. and Dubowitz, V. (1980). Dynamic and Metabolic Studies in Association with Exercise in Carriers of Duchenne Muscular Dystrophy. 8th Symposium on Current Research in Muscular Dystrophy and Allied Neuromuscular Diseases, Newcastle upon Tyne, UK, 3rd-5th January, Abstract 49
- Sweetin J.C. and Thomson, W.H.S. (1973). Revised Normal Ranges for 6 Serum Enzymes, *Clinica Chimica Acta*, 48, 49-63
- Tagliavini, J., Ottonelle, S., Grassi, E., Marchini, C., Rossi, G.L., Lucci, D., Parma, M. and Reggiani, L. (1979). Carrier Detection in Duchenne Muscular Dystrophy. *Neurology*, 29, 1423-1425
- Tanaka, T., Harano, Y., Sue, F. and Morimura, H. (1967). Crystallization, Characterization and Metabolic Regulation of Two Types of Pyruvate Kinase Isolated from Rat Tissues. *The Journal of Biochemistry*, 62, 71-79
- Thomas, P.K., Calne, D.B. and Elliot, C.F. (1972). X-Linked Scapulo-peroneal Syndrome. *Journal of Neurology, Neurosurgery and Psychiatry*, 35, 208-215
- Thompson, M.W., Murphy, E.G. and McAlpine, P.J. (1967). An Assessment of the Creatine Kinase Test in the Detection of Carriers of Duchenne Muscular Dystrophy. *Journal of Pediatrics*, 71, 82-93
- Thompson, R.G., Nickel, B., Finlayson, S., Meuser, R., Hamerton, J.R. and Wrogemann, K. (1983). 56K Fibroblast Protein not Specific for Duchenne Muscular Dystrophy but for Skin Biopsy Site. *Nature*, 304, 740-741
- Thomson, W.H.S. (1968). Determination and Statistical Analysis of the Normal Ranges for Five Serum Enzymes. *Clinica Chimica Acta*, 21, 469-478
- Thomson, W.H.S. (1969). The Biochemical Identification of the Carrier State in X-Linked Recessive (Duchenne) Muscular Dystrophy. *Clinica Chimica Acta*, 26, 207-221
- Thomson, W.H.S., Sweetin, J.C. and Hamilton, I.J.D. (1975). ATP and Muscle Enzyme Efflux after Physical Exertion. *Clinica Chimica Acta*, 59, 241-245



- Tippett, P.A., Dennis, N.R., Machin, D., Price, C.P. and Clayton, B.E. (1982). Creatine Kinase Activity in the Detection of Carriers of Duchenne Muscular Dystrophy: Comparison of Two Methods. *Clinica Chimica Acta*, 121, 345-359
- Tomkins, J.K., Collins, S.P., Baker, W.C. and Kidman, A.D. (1982). In Vitro Skeletal Muscle Protein and RNA Incorporation in Neuromuscular Disease. *Journal of the Neurological Sciences*, 54, 59-68
- Tukey, J.W. (1977). Some Thoughts on Clinical Trials, Especially Problems of Multiplicity, 198, 679-684
- Valentine, W.N. and Tanaka, K.R. (1966). Pyruvate Kinase: Clinical Aspects. In: *Methods in Enzymology*. Ed. Wood, W., Academic Press, New York, 2, pp 468-473
- Valli, G., Scarlato, E. and Contartese, M. (1976). Quantitative Electromyography in the Detection of the Carriers in Duchenne Type Muscular Dystrophy. *Journal of Neurology*, 212, 139-149
- Verrill, H.L. Pickard, N.A. and Gruemer, H-D. (1977). Diminished Cap Formation in Lymphocytes from Patients and Carriers of Duchenne Muscular Dystrophy. *Annals of Neurology*, 23, 2341-2343
- Wacholtz, M.C., Raible, D.G., Jackowski, S., Rodan, S.B., Rodan, G.A. and Sha'afi, R.I. (1979). Adenylate Cyclase and ATPase Activities in Red Cell Membranes of Patients and Genetic Carriers of Duchenne Muscular Dystrophy. *Clinica Chimica Acta*, 96, 255-259
- Wakayama, Y., Hodson, A., Pleasure, D., Bonilla, E. and Schotland, D.L. (1978). Alteration in Erythrocyte Membrane Structure in Duchenne Muscular Dystrophy. *Annals of Neurology*, 4, 253-256
- Weed, R.I., LaCelle, P.L. and Merrill, E.W. (1969). Metabolic Dependence of Red Cell Deformability. *Journal of Clinical Investigation*, 48, 795-809
- Weinstock, I.M., Behrendt, J., Wiltshire, H.E., Kelemen, J. and Louis, S. (1977). Pyruvate Kinase: Diagnostic Value in Neuromuscular Disease. *Clinica Chimica Acta*, 30, 415-422
- White, J.G. (1974). Effects of an Ionophore A23187 on the Surface Morphology of Normal Erythrocytes. *American Journal of Pathology*, 77, 507-578
- Wiley, J.S. and Shaller, C.C (1977). Selective Loss of Calcium Permeability on Maturation of Reticulocytes. *Journal of Clinical Investigation*, 59, 1113-1119
- Wilkerson L.S., Perkins, R.C. Jr., Roelofs, R., Swift, L., Dalton, L.R. and Park, J.H. (1978). Erythrocyte Membrane Abnormalities in Duchenne Muscular Dystrophy Monitored By Saturation Transfer Electron Paramagnetic Resonance Spectroscopy. *Proceedings of the National Academy of Sciences*, 75, 838-841

- Wood, D.S., Sorenson, M.M., Eastwood, A.B., Charash, W.E. and Reuben, J.P. (1978). Duchenne Dystrophy: Abnormal Generation of Tension and  $Ca^{++}$  Regulation in Single Skinned Fibres, *Neurology* (Minneapolis), 28, 447-457
- Wrogemann, K and Pena, S.D.J. (1976). Mitochondrial Calcium Overload: A General Mechanism for Cell necrosis in Muscle Disease. *Lancet*, 1, 672-674
- Wyatt, P.R. and Cox, D.M. (1977). Duchenne's Muscular Dystrophy: Studies in Cultured Fibroblasts. *Lancet*, 1, 172-174
- Yagiela, J.A. and Benoit, P.W. (1979). Skeletal Muscle Damage from Quinidine. *The New England Journal of Medicine*, 301, 437. (Letter)
- Yamuna, S., Valmikinathan, K., Burt, D. and Emery, A.E.H. (1977). Serum Pyruvate Kinase in Carriers of Duchenne Muscular Dystrophy. *Clinica Chimica Acta*, 79, 277-279
- Zatz, M., Frota-Pessoa, O., Levy, J.A. and Peres, C.A. (1976). Creatine-Phosphokinase Activity in Relatives of Patients with X-Linked Muscular Dystrophies - A Brazilian Study. *Journal de Génétique Humaine*, 2, 135-168
- Zatz, M. and Otto, P.A. (1980a). Effect of Age on the Detection Rate in Duchenne Muscular Dystrophy. *Journal of the Neurological Sciences*, 47, 407-410
- Zatz, M., and Otto, P.A. (1980b). The Use of Concomitant Serum Pyruvate-Kinase (PK) and Creatine-Phosphokinase (CPK) for Carrier Detection in Duchenne's Muscular Dystrophy through Discriminant Analysis. *Journal of the Neurological Sciences*, 47, 411-417
- Zatz, M., Passos, M.R. and Bortolini, E.R. (1983). Serum Pyruvate-Kinase (PK) Activity During Pregnancy in Potential Carriers for Duchenne Muscular Dystrophy. *American Journal of Medical Genetics*, 15, 149-151
- Zatz, M., Shapiro, L.J., Campion, D.S., Kaback, M.M. and Otto, P.A. (1980). Serum Pyruvate-kinase and Creatine Phosphokinase in Female Relatives and Patients with X-Linked Muscular Dystrophies (Duchenne and Becker). *Journal of the Neurological Sciences*, 46, 267-279
- Zatz, M., Shapiro, L.J., Campion, D.S., Oda, E. and Kaback, M.M. (1978). Serum Pyruvate-Kinase (PK) and Creatine Phosphokinase (CPK) in Progressive Muscular Dystrophies. *Journal of the Neurological Sciences*, 36, 349-362
- Zellweger, H. and Antonik, A. (1975). Newborn Screening for Duchenne Muscular Dystrophy. *Pediatrics*, 55, 30-34

Pedigrees.

Pedigrees have been listed in numerical order of  
Family number

Note: Elevated serum creatine kinase levels were considered to be those greater than the 95th percentile of the control series. In this study, in all the families where elevated activities of this enzyme in female relatives of DMD carriers were cited as additional relevant information in the determination of DMD carrier status, actual serum creatine kinase levels in these relatives were all greater than 1.5 X 95th percentile of the control series (refer to Appendix II).

FAMILY NO 1

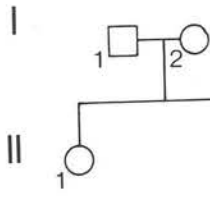

FAMILY NO 2

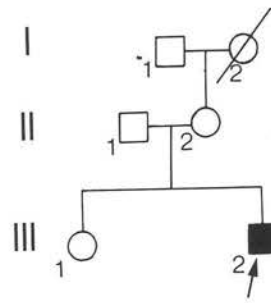

FAMILY NO 3

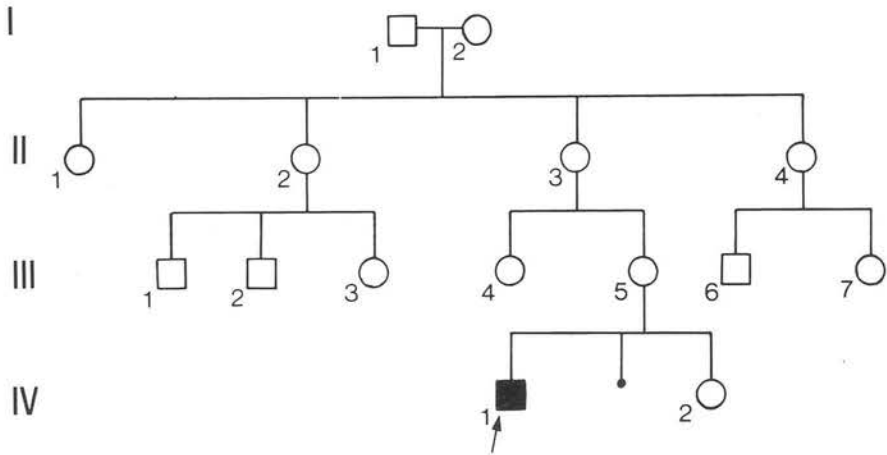

FAMILY NO 4

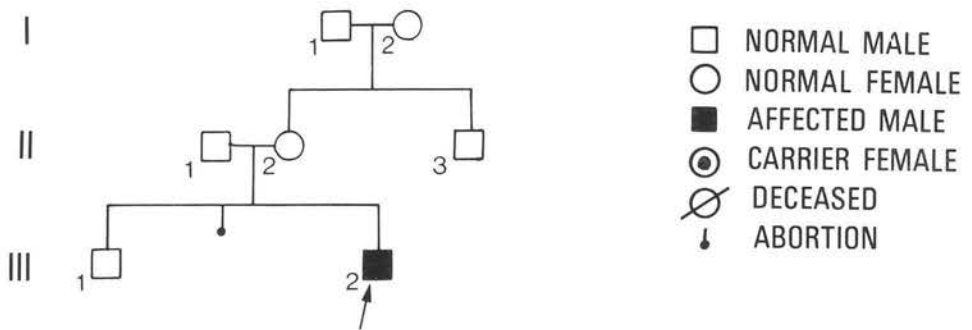

- NORMAL MALE
- NORMAL FEMALE
- AFFECTED MALE
- CARRIER FEMALE
- ⊘ DECEASED
- ⋮ ABORTION

FAMILY NO 5

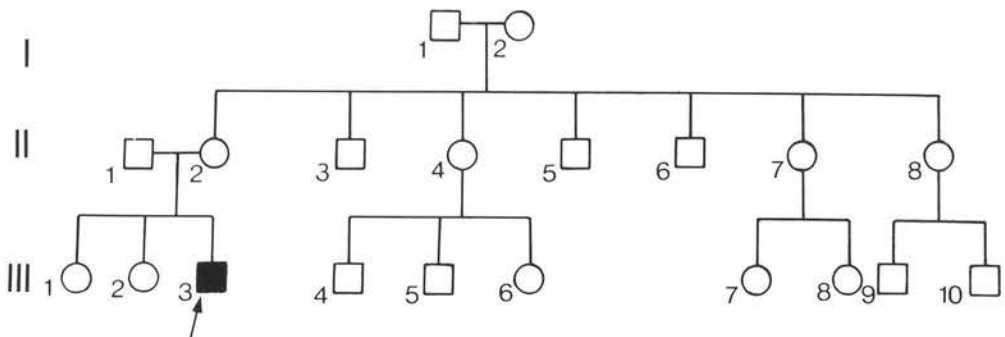

FAMILY NO 6

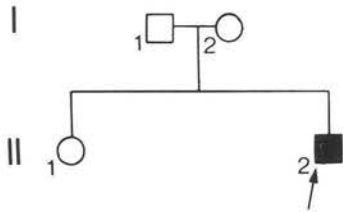

FAMILY NO 7

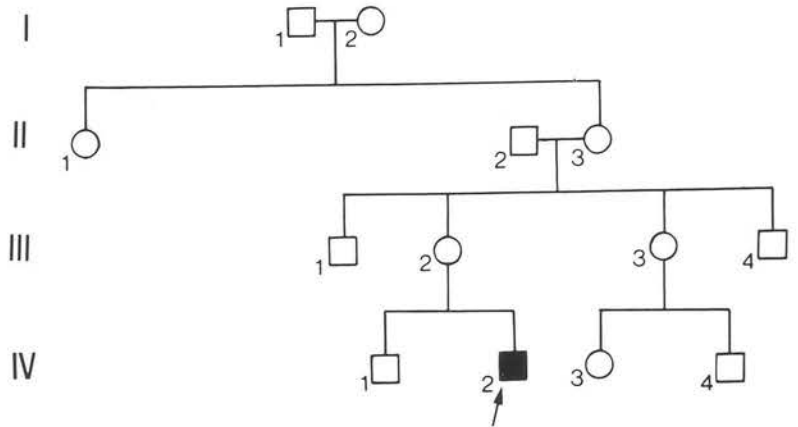

FAMILY NO 8

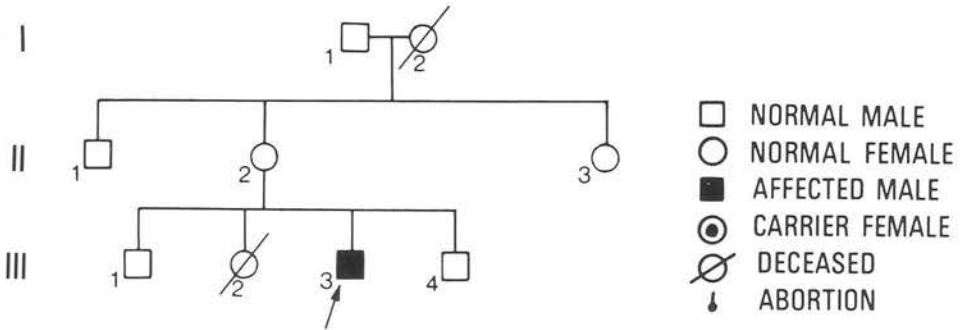

- NORMAL MALE
- NORMAL FEMALE
- AFFECTED MALE
- ⊙ CARRIER FEMALE
- ⊘ DECEASED
- ↓ ABORTION

FAMILY NO 9

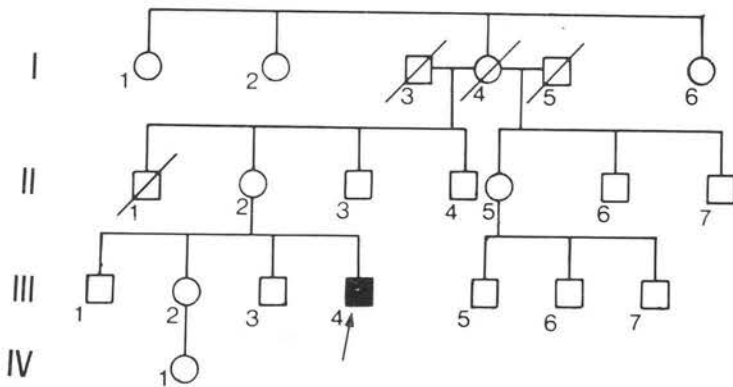

FAMILY NO 10

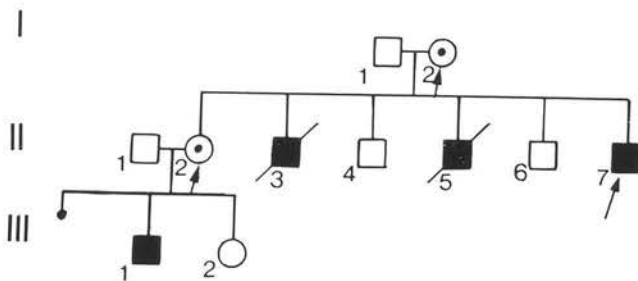

FAMILY NO 11

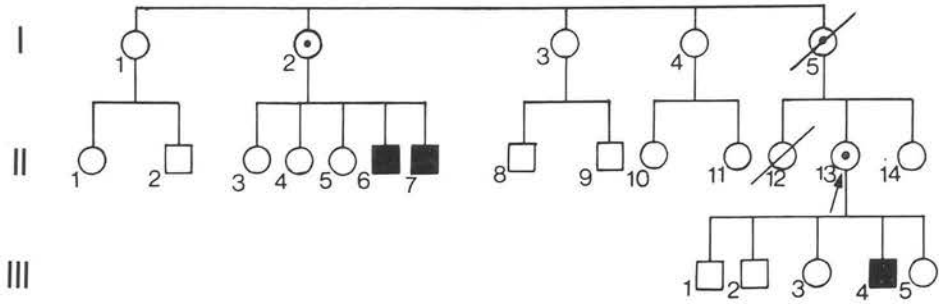

FAMILY NO 12

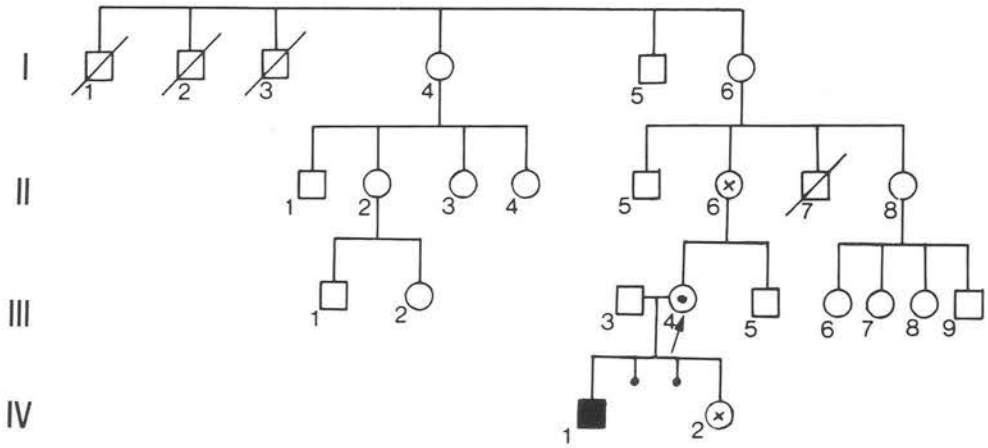

FAMILY NO 13

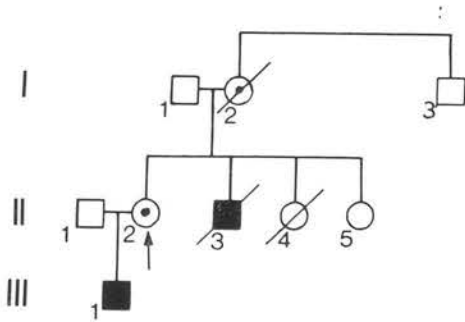

FAMILY NO 14

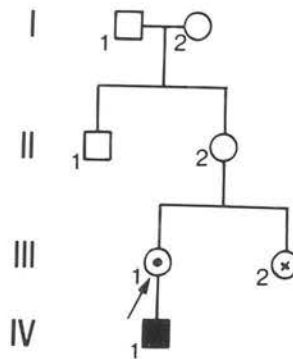

- NORMAL MALE
- NORMAL FEMALE
- AFFECTED MALE
- CARRIER FEMALE
- ⊘ DECEASED
- ↓ ABORTION
- ⊗ FEMALE RELATIVE WITH SERUM CREATINE KINASE LEVEL  $>1.5 \times 95^{\text{th}}$  PERCENTILE OF THE NORMAL CONTROL SERIES

FAMILY NO 15

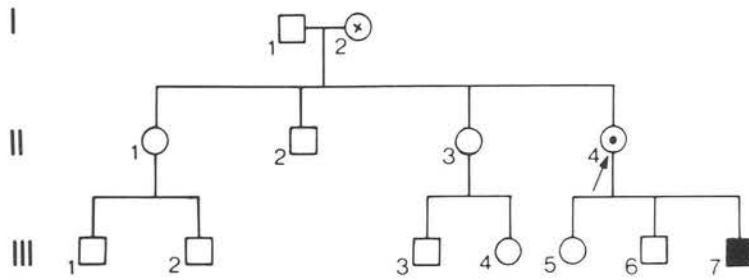

FAMILY NO 16

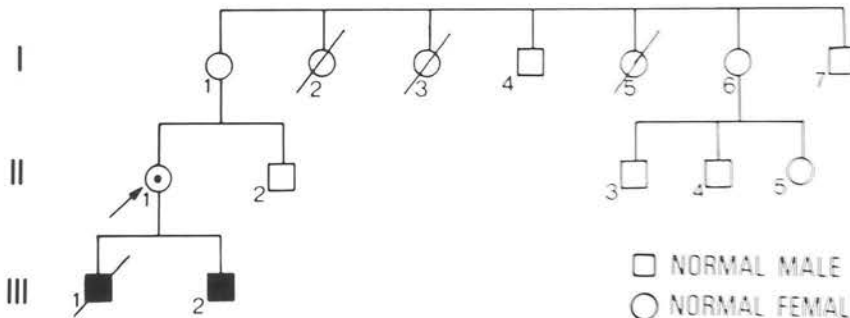

- NORMAL MALE
- NORMAL FEMALE
- AFFECTED MALE
- ⊙ CARRIER FEMALE
- ⊘ DECEASED
- ⊗ FEMALE RELATIVE WITH SERUM CREATINE KINASE LEVEL >1.5~95th PERCENTILE OF THE NORMAL CONTROL SERIES

FAMILY NO 17

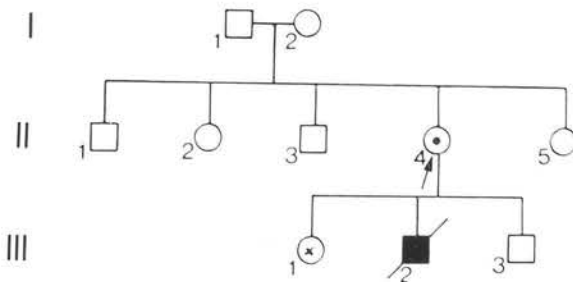

FAMILY NO 18

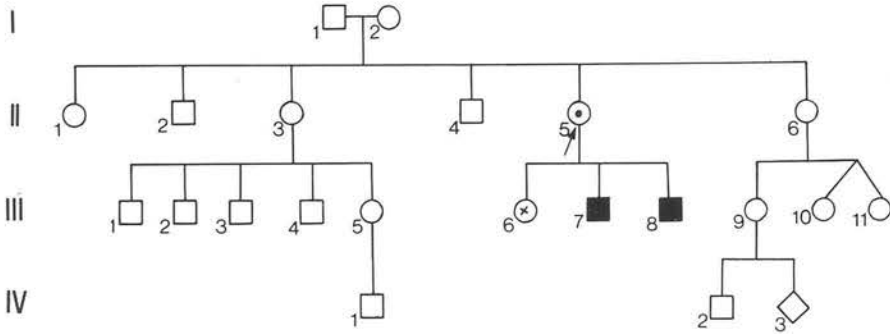

FAMILY NO 19

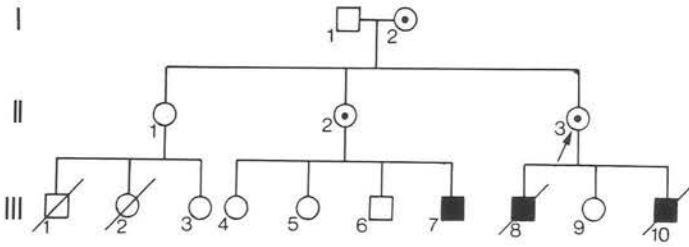

- NORMAL MALE
- NORMAL FEMALE
- AFFECTED MALE
- CARRIER FEMALE
- ⊘ DECEASED
- ↓ ABORTION
- ⊗ FEMALE RELATIVE WITH SERUM CREATINE KINASE LEVEL >1.5×95th PERCENTILE OF THE NORMAL CONTROL SERIES
- ⊖ ⊖ DIZYGOTIC TWINS
- ◇ SEX UNKNOWN

FAMILY NO 20

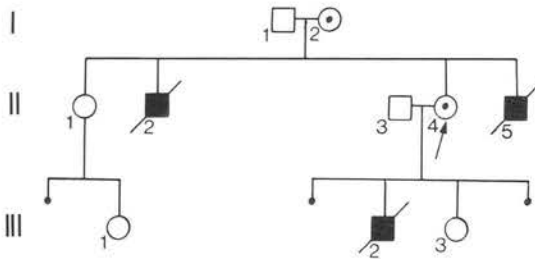

FAMILY NO 21

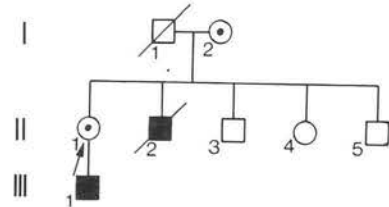



FAMILY NO 22

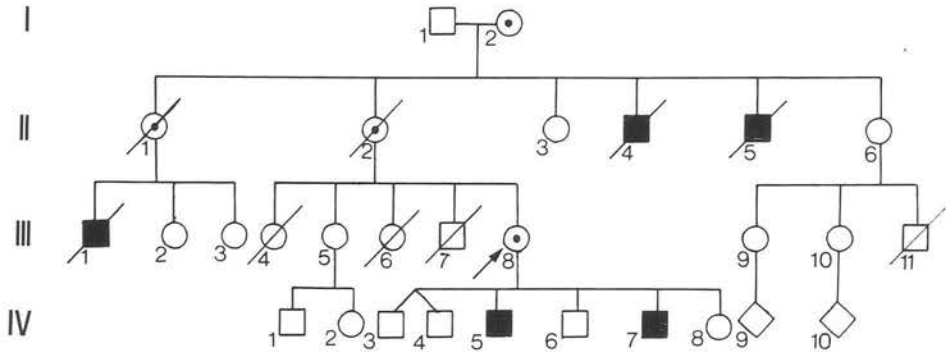

FAMILY 23

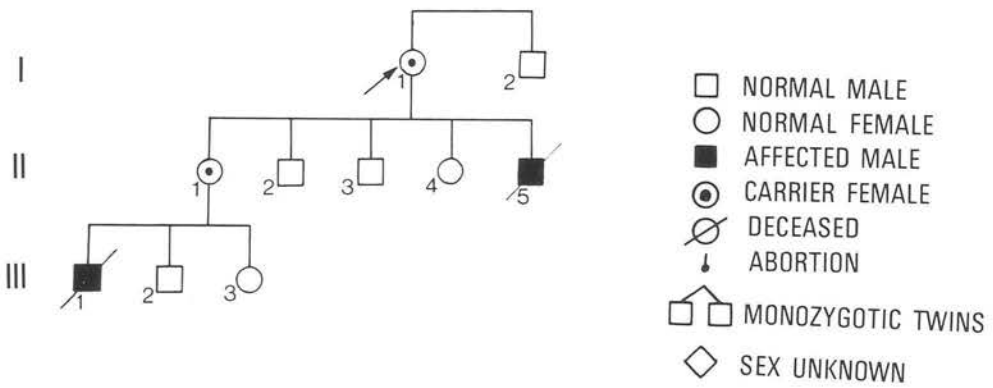

FAMILY 24

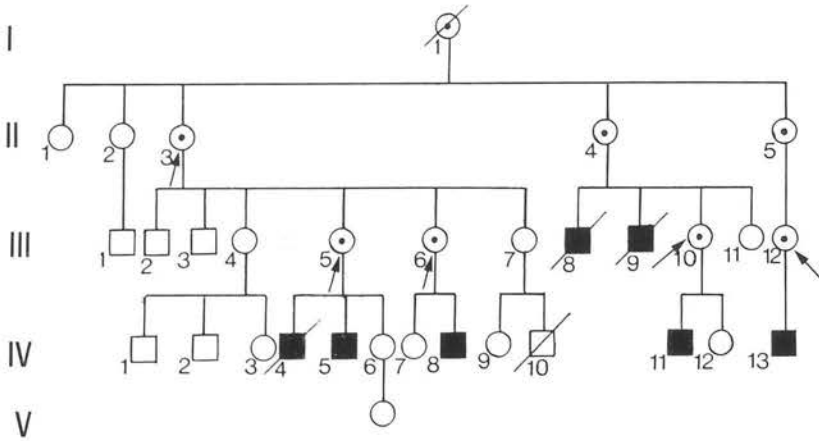

FAMILY NO 25

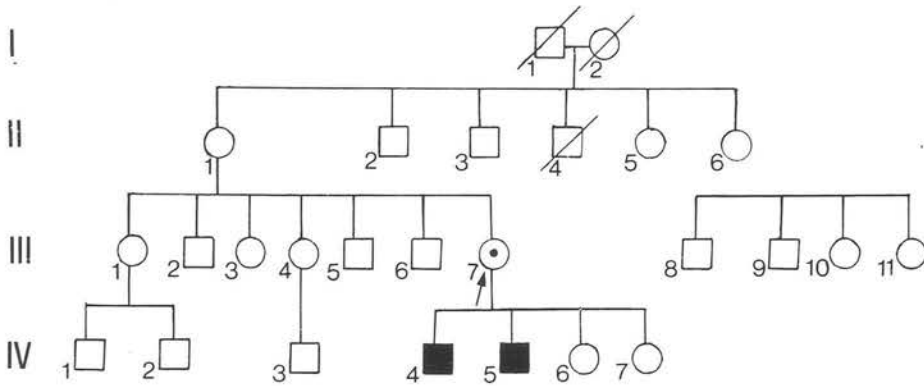

FAMILY NO 26

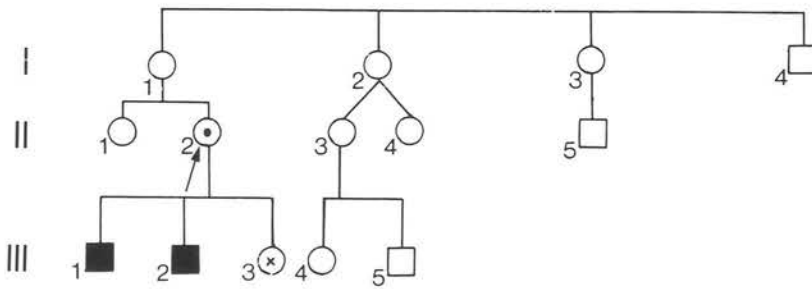

FAMILY NO 27

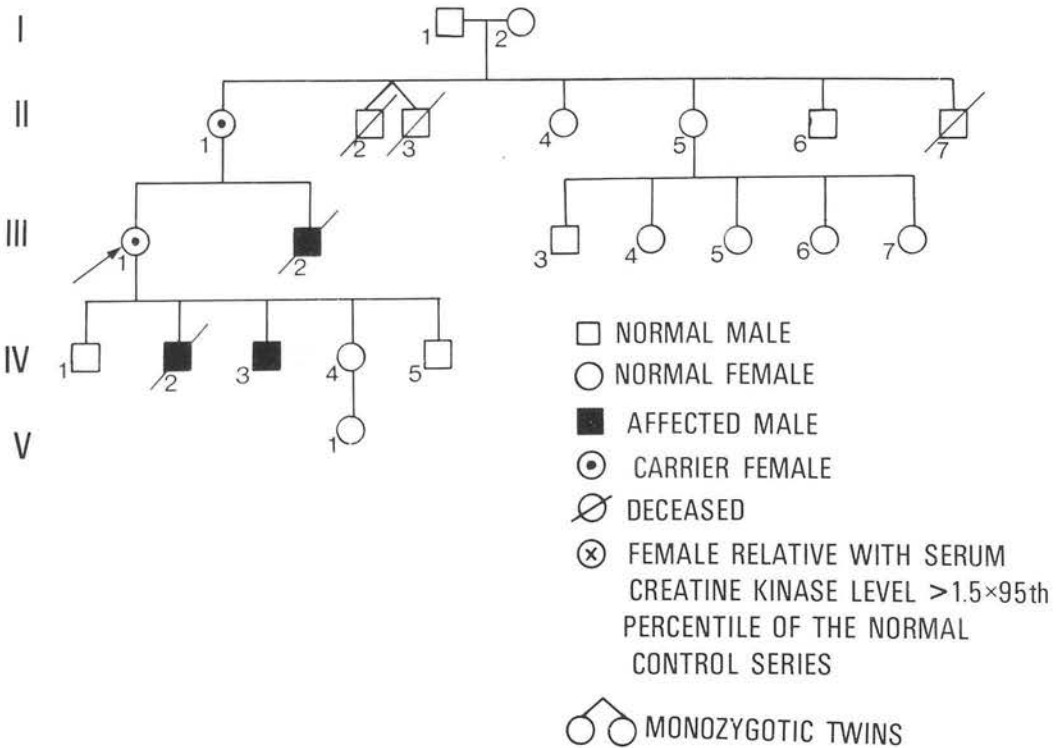

FAMILY NO 28

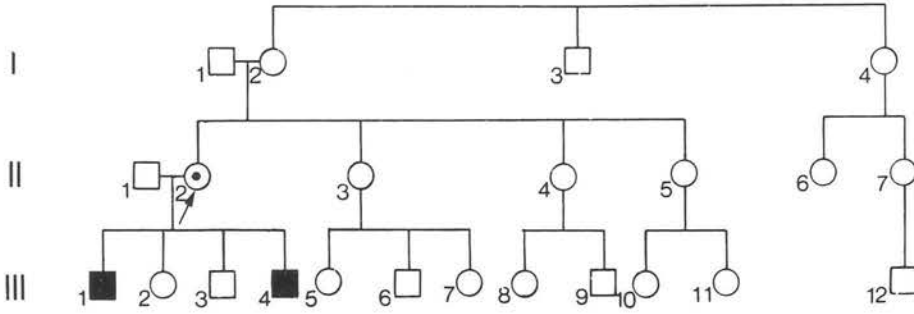

FAMILY NO 29

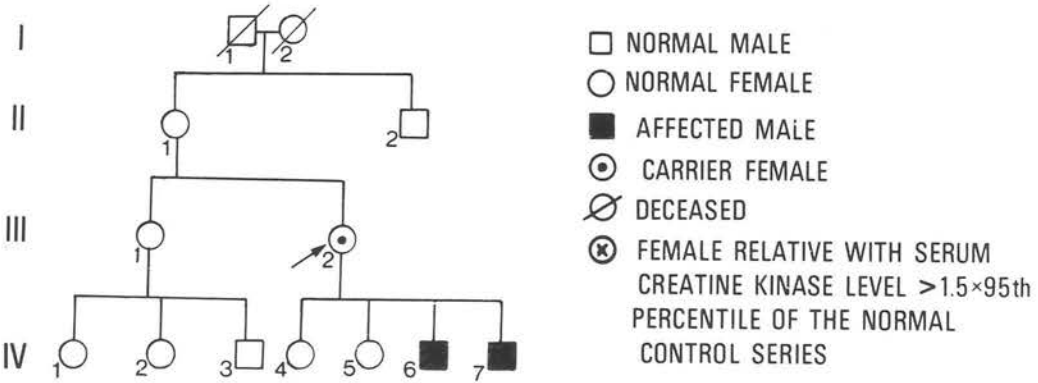

FAMILY NO 30

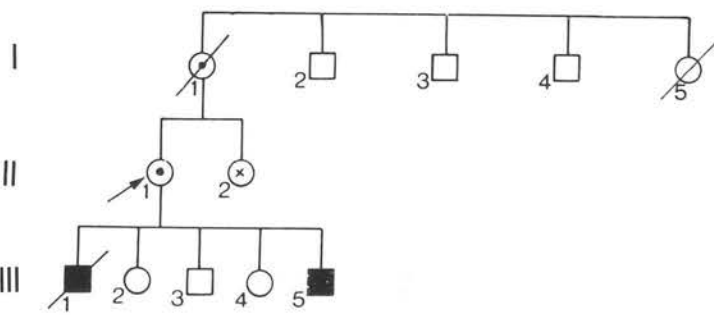

FAMILY NO 31

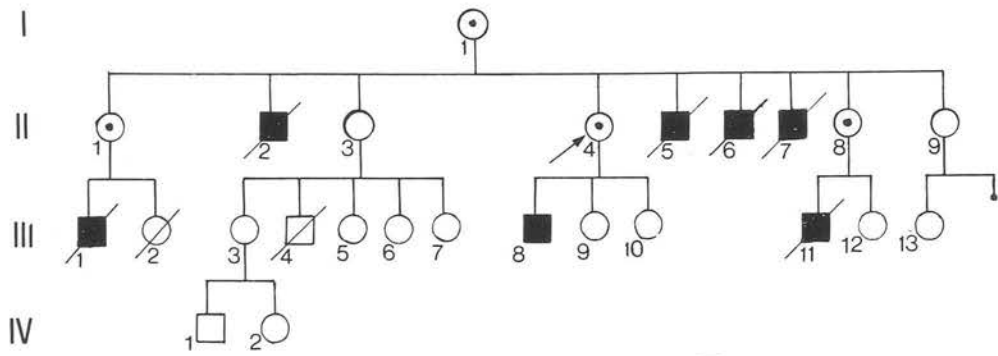

- NORMAL MALE
- NORMAL FEMALE
- AFFECTED MALE
- CARRIER FEMALE
- ⊘ DECEASED
- ↓ ABORTION

FAMILY NO 32

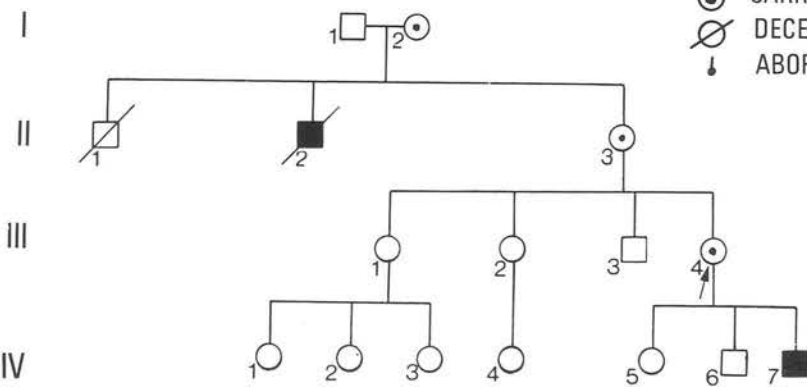

FAMILY NO 33

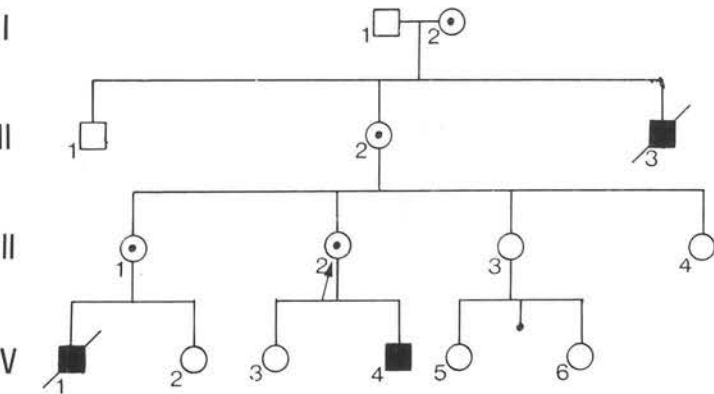

### FAMILY NO 34

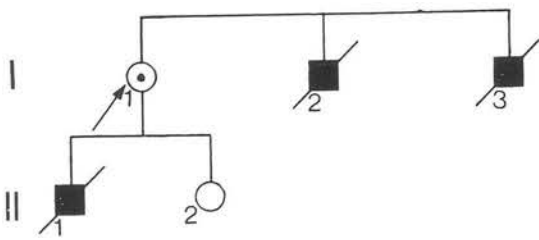

- NORMAL MALE
- NORMAL FEMALE
- AFFECTED MALE
- ⊙ CARRIER FEMALE
- ⊘ DECEASED
- ↓ ABORTION
- ■ DIZYGOTIC TWINS

### FAMILY NO 35

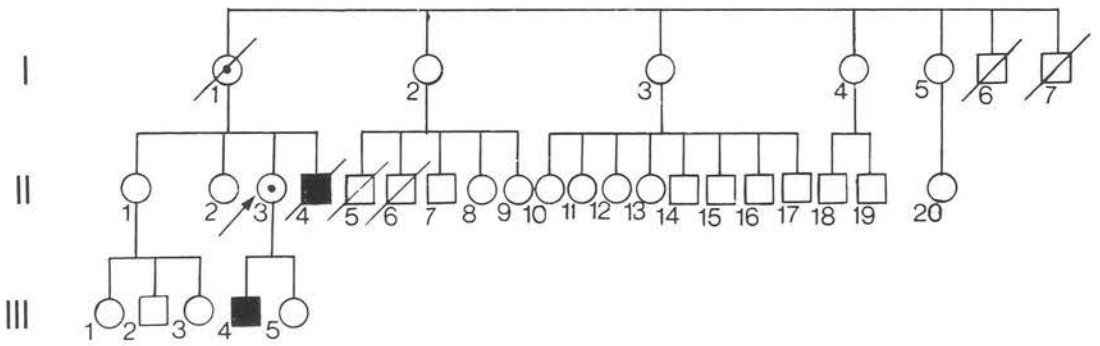

### FAMILY NO 36

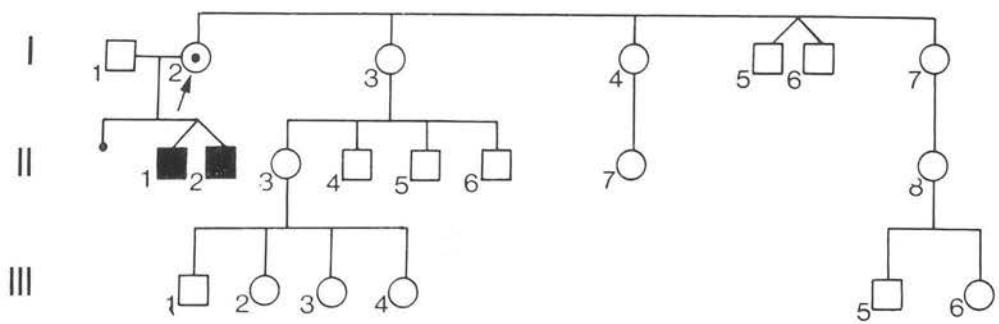

FAMILY NO 37

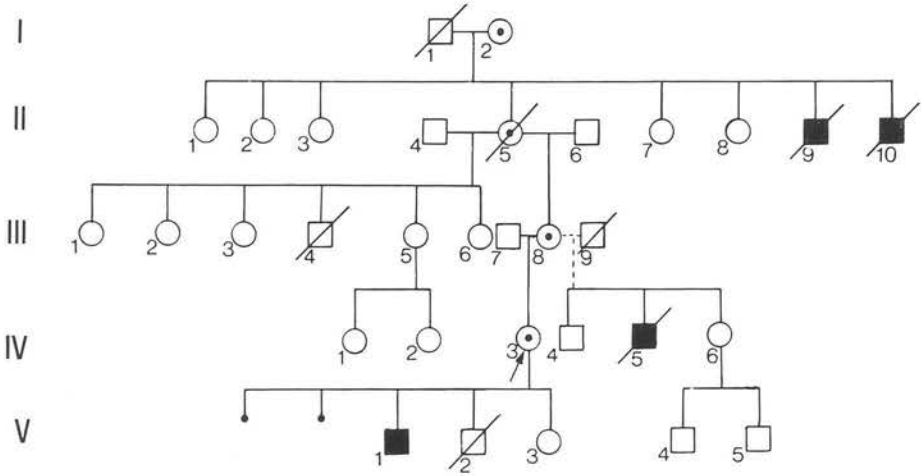

FAMILY NO 38

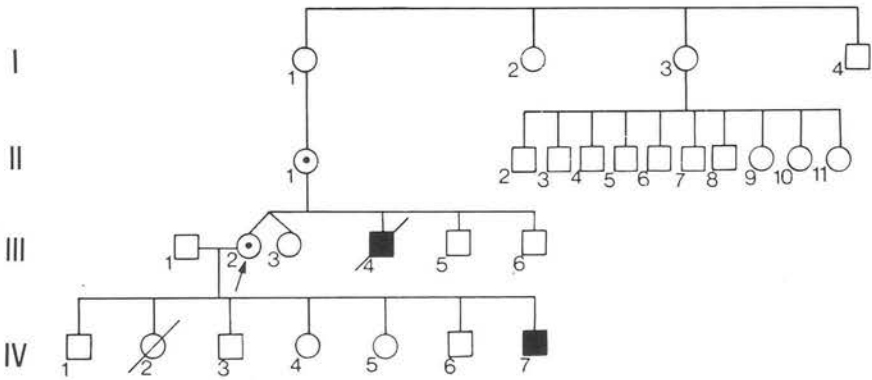

FAMILY NO 39

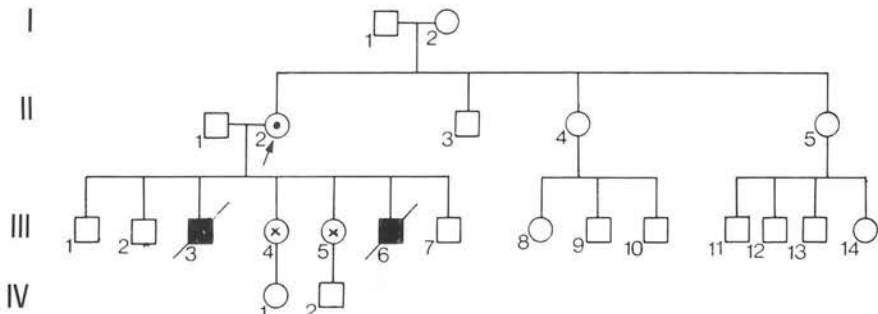

- NORMAL MALE
- NORMAL FEMALE
- AFFECTED MALE
- ⊙ CARRIER FEMALE
- ∅ DECEASED
- ⊗ FEMALE RELATIVE WITH SERUM CREATINE KINASE LEVEL >1.5×95th PERCENTILE OF THE NORMAL CONTROL SERIES
- ⊖ DIZYGOTIC TWINS

APPENDIX II

Female relatives with serum creatine kinase levels greater than  
1.5 x 95th percentile of the control series

Subject Pedigree No.	Mean CK IUl <sup>-1</sup>
12 II <sub>6</sub>	474
12 IV <sub>2</sub>	160
14 III <sub>2</sub>	440
15 I <sub>2</sub>	149
17 III <sub>1</sub>	1159
18 III <sub>6</sub>	288
26 III <sub>3</sub>	151
30 II <sub>2</sub>	489
33 IV <sub>3</sub>	275
39 III <sub>4</sub>	668
39 III <sub>5</sub>	529