

DESIGN AND OPTIMIZATION OF THREE FIELD EXCITATION FLUX SWITCHING MOTORS  
FOR HYBRID ELECTRIC VEHICLES

ZHAFIR AIZAT HUSIN

THESIS SUBMITTED IN PARTIAL FULFILMENT OF THE REQUIREMENT  
FOR THE AWARD OF THE DEGREE OF MASTER OF ENGINEERING

FAKULTI KEJURUTERAAN ELEKTRIK DAN ELEKTRONIK  
UNIVERSITI TUN HUSSEIN ONN MALAYSIA

2015

# CHAPTER 1

## INTRODUCTION

### 1.1 Introduction

Hybrid Electric Vehicles (HEV), by means of merge of an Internal Combustion Engine (ICE) plus another electric traction motors are mostly consider as the primarily proficient green vehicles. DC machines, induction machines (IMs), switch reluctance machines (SRMs), and interior permanent magnet synchronous machines (IPMSMs) are the four major types of electric machines as potential candidates for HEV drives as depicted in Figure 1.1. DC motors have been familiar in electric propulsion because their torque–speed characteristics suit the traction requirements well and their simple control. In the advanced research, the brushes are replaced with slippery contacts since the DC motor requires high maintenance mostly because of the mechanical commutator (brush). Nevertheless, DC motor is unfavorable because this kind of motor comes out with huge structure, low reliability and low efficiency [1-3].

IM drive is mainly established machinery between assorted brushless motor drives. Cage IMs are largely acknowledged as the most potential contestant due to their ruggedness, consistency, low cost, low maintenance and capability to function in unreceptive environments [4]. Conversely, IM drives encompass drawbacks for example low efficiency, high loss, low inverter-usage factor and low power factor which are more concern for the large power and high power motor and that pressed them away from the battle of HEVs electric propulsion system [5].

SRMs are familiarly known to have a possible potential for HEV applications. SRMs have exact benefits for instance rugged and simple configuration, outstanding torque-speed characteristics, low manufacturing cost and simple control but several drawbacks for HEV applications outweigh the bonus such as torque

ripple and acoustic noise generation. The benefits and drawbacks point out above are relatively important for drive applications [6-7].

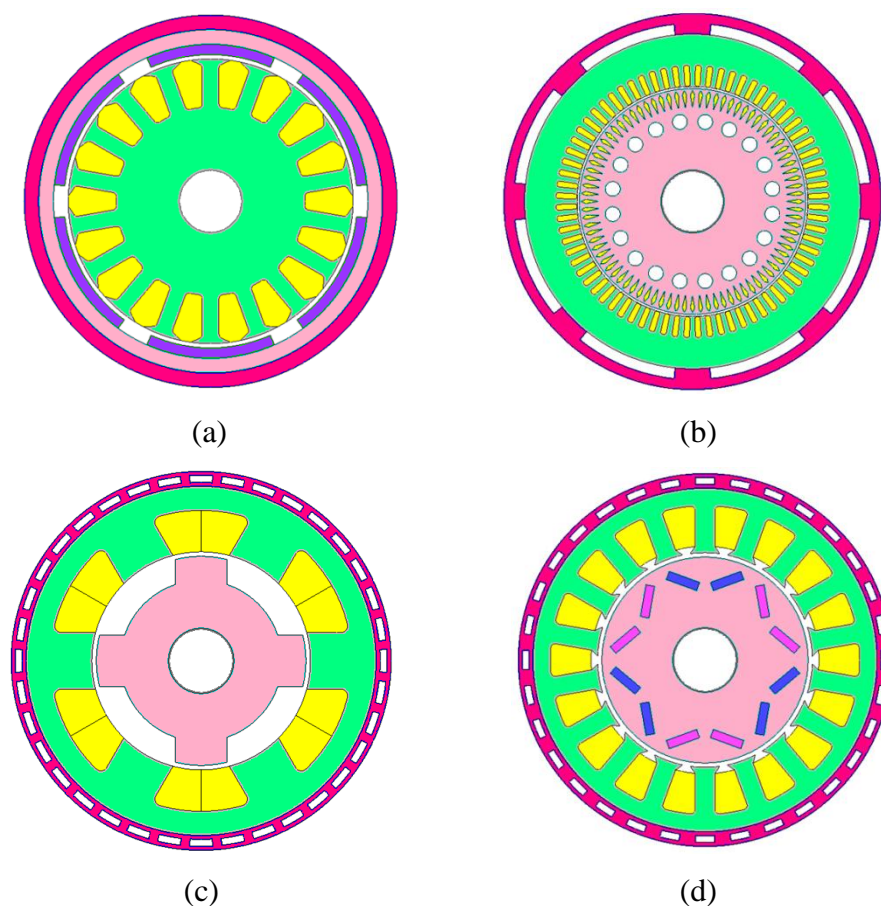

Figure 1.1: Four main candidates of electric machine for HEV drive  
 (a) DC motor (b) IM (C) SRM (d) IPMSM

In proportion as EVs and HEVs got popular, the increase in annual usage of rare-earth magnet has enlarged not only the price of Neodymium (Nd), but also Dysprosium (Dy) which was indispensable to afford the rare-earth magnet with high coercivity as the additives. This would cause severe concerns such as high cost, security issues and supply shortage. Therefore, continuous research and development on electric machines with high power density, vigorous rotor structure as well as with no rare-earth magnet would be very important.

PMSMs are a competitive challenge to other motors for HEV. Famous automakers like Lexus, Honda and also Toyota have adopted in their HEVs. In opposition, the use of these motors have a low impact on the efficiency at the high-

speed range due to the enhance amount in iron loss as well as risk of magnetic faults [8]. The only machine that already installed for HEVs is IPMSM where it has developed to enhance power density of the machine [9-12]. Despite of fine operated and superior performances, this machine do not miss approached by deficiency for instance IPMSM now have complex form and configuration that give difficulty to undertake the process of optimizing the design of this motor. The use of PM will result in a constant state of flux and cannot be controlled as well a burden because of expensive rare earth magnet prices. Thus, field excitation flux switching motor (FEFSM) with a new form has been created as a new candidate that can address these problems in which the uses of permanent magnet is totally excluded while the field excitation coil (FEC) is located on the stator [13-14]. The proposed motor has a simple and easy structure and it is expected to provide much higher power density and torque [15-17].

## **1.2 Problem Statement**

There are four major types of electric machines currently used in HEV drives namely DC machine, induction machine (IMs), permanent magnet synchronous machines (PMSMs) and also switch reluctance machine (SRMs). However, there exist several drawbacks in each motor such as unstable current, asynchronous speed, high volume permanent magnet, and noisy. In addition, the cost of permanent magnet (PM) used in IPMSM is expensive and this would increase the cost of the vehicles. To overcome the problems, continuous research and development on electric machines with no or less rare-earth magnet, stable current, synchronous speed and silent would be very important.

As one of the candidates a new structures of field excitation flux switching motor (FEFSM) in which the use of PM is totally excluded and DC FEC is used as main flux source. In this research, feasibility studies on FEFSM based on 2D-FEA are examined and the proposed motor weight to be designed is less than 35kg, resulting in that the proposed FEFSM promises to attain the maximum power density better when compared to that existing IPMSM.

### 1.3 Objectives

The objectives of this research are:

- (i) To design and investigate the operating principle of Three Phase and Single Phase Field Excitation Flux Switching Motors (FEFSMs) as an alternative candidate of non-PM machine.
- (ii) To analyze various rotor pole configurations for Three Phase and Single Phase FEFSMs.
- (iii) To evaluate the performances of the improved Three Phase and Single Phase FEFSMs for HEV drives.

### 1.4 Methodology

Commercial FEA package, JMAG-Designer ver.13.1, released by Japan Research Institute (JRI) is used as 2D-FEA solver in this research. Various slot pole combination of FEFSMs are designed, improved and analyzed to meet the requirements of conventional HEVs. The general work flow of research methodology is depicted in Figure 1.2 and details are explained as in Chapter 3.

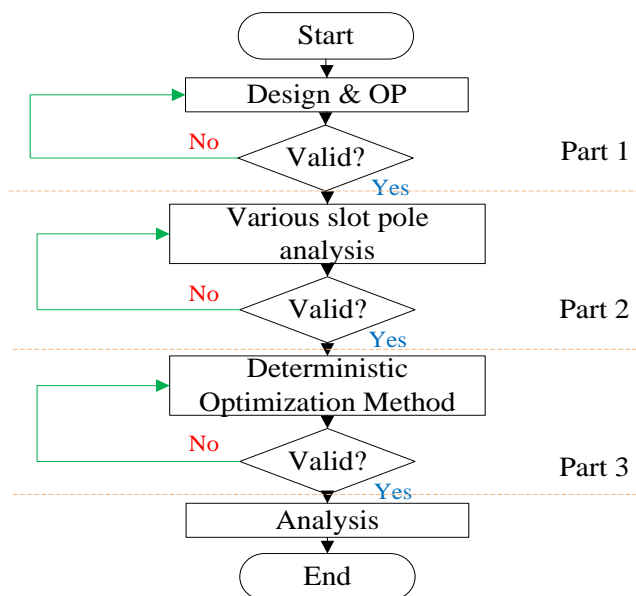

Figure 1.2: General work flow of research methodology

## 1.5 Scope of work

The scope of work is only simulation assessment and divided into three parts based on the objectives are listed as follows:

- (i) The design restrictions, target specifications and parameters of the proposed FEFSMs for HEV applications are listed in Table 1.1 are identical with existing IPMSM used in Lexus RX400h [12-13]. The electrical restrictions related with the inverter such as maximum 650V, 375V DC bus voltage and maximum 360A, inverter current are set for three phase and single phase, respectively. Assuming water jacket system is employed as the cooling system for the machine, the limit of the current density is set to the maximum  $30A_{\text{rms}}/\text{mm}^2$  for armature winding and  $30A/\text{mm}^2$  for FEC, respectively. The outer diameter, the motor stack length, the shaft radius and the air gap of the main part of the machine design being 264mm, 70mm, 30mm and 0.8mm respectively. Initially, coil arrangement test is done to investigate the operating principle of FEFSMs according to conventional three phase and single phase system, respectively.

Table 1.1: Design Restrictions and Specifications of FEFSMs [12-13]

| Items  | IPMSM  | 3 $\phi$ FEFSM | 1 $\phi$ FEFSM |
|--|--------|----------------|----------------|
| Max. DC-bus voltage inverter (V)   | 650    | 650            | 375            |
| Max. inverter current ( $A_{\text{rms}}$ )                                       | 360    | 360            | 360            |
| Max. current density in armature winding, $J_A$ ( $A_{\text{rms}}/\text{mm}^2$ ) | 30     | 30             | 30             |
| Max. current density in excitation winding, $J_E$ ( $A/\text{mm}^2$ )            | NA     | 30             | 30             |
| Stator outer diameter (mm)   | 264    | 264            | 264            |
| Motor stack length (mm)  | 70     | 70             | 70             |
| PM weight (kg)   | 1.1    | 0              | 0              |
| Air gap length (mm)  | 0.8    | 0.8            | 0.8            |
| Maximum speed (r/min)  | 12,400 | >12,400        | >12,400        |
| Maximum torque (Nm)  | 333    | >210           | >70            |
| Maximum power (kW)   | 123    | >123           | >41            |
| Machine weight (kg)  | 35     | <35            | <35            |
| Power density (kW/kg)  | 3.5    | >3.5           | >1.17          |

- (ii) The performances of FEFSMs for three phase and single phase at various rotor poles are analyzed at open circuit condition and short circuit condition such as coil test, flux linkage, induced voltage, cogging torque, torque and power.

- (iii) The best selected slot pole combination such as 12S-14P, 8S-4P and 8S-8P are improved and optimized by using deterministic optimization method until the targeted torque more than 210Nm (three phase) and 70Nm (single phase) while power more than 123kW (three phase) and 41kW (single phase), respectively are achieved.

## 1.6 Thesis outlines

This thesis deals with the design studies on field excitation flux switching motor (FEFSM) for HEV applications. The thesis is divided into 5 chapters and the summary of each chapter are listed as follows:

- (i) Chapter 2: Review on Flux Switching Motor (FSM)  
The second chapter describes some introduction and classifications of FSM including the example of FEFSM, the operating principle and the proposed FEFSM for HEV applications.
- (ii) Chapter 3: Design of FEFSM for HEV applications  
The third chapter describes the design restrictions & specifications of the proposed FEFSM with similar restriction and specifications of IPMSM used in HEV are examined using commercial 2D-FEA, JMAG-Studio ver. 13.1, released by JSOL Corporation. Some equations are listed to find the suitable slot pole combinations, to set the end time and also frequency for each combinations, respectively.
- (iii) Chapter 4: Performances analysis of FEFSMs  
This chapter is divided into three parts. The operating principle and the initial design configuration are explained in Part 1. Part 2 explained the performances at various slot pole combinations of three phase and single phase, respectively. Since the initial performances of output torque and power are far from the target requirements of 210Nm, 123kW for three phase and 70Nm, 41kW for single phase, design improvements using “deterministic optimization method” to treat several design parameters for 12S-14P, 8S-4P and 8S-8P are conducted until the target performances are achieved. The comparison between the initial and final design of FEFSMs are discussed in Part 3. The improved design not

only successfully achieved the target performances with much higher power and torque density, but also obtained much higher mechanical strength which is strong enough to operate at maximum speed of 20,000r/min.

(iv) Chapter 5: Conclusion

The final chapter describes and concludes the summary of the research and pointed out some future works for design improvements. As an example, the size of the motor could be reduced to decrease the weight of the machine, thus increase the power density.



## CHAPTER 2

### LITERATURE REVIEW

#### 2.1 Introduction to Electric Motor

An electric motor is a device that converts electrical energy into mechanical energy. Electric motors can be divided into two types which are alternating current (AC) electric motors and direct current (DC) electric motors as been demonstrated by the British scientist Michael Faraday in 1821 [18]. Electric motors always associate with involving rotating coils which are driven by the magnetic force. This force is produced by a reaction between magnetic field and magnetic current.

Apparently the difference between DC motor and AC motor is AC motors are powered from alternating current (AC) while DC motors are powered from direct current (DC), such as batteries, DC power supplies or an AC-to-DC power converter. Since DC motor's wound field is constructed with brushes and commutator. The cost, speed limit and less life expectancy is difficult to overcome.

DC motor should be widely accepted for HEV drives because they can use a battery as a DC supply as it have an advantage of simple control principle but the problem which is caused by commutator and brush, make them less reliable and unsuitable for maintenance-free drives. In contrast, AC induction motors do not use brushes. They are very rugged and have long life expectancies. Furthermore, the basic difference between DC and AC motor is speed control. The speed of a DC motor and AC motor is controlled by varying the armature winding's current and by varying the frequency, respectively [19].

AC electric motor can be classified as induction motors (IMs), synchronous motors (SMs), and switch reluctance motors (SRMs). IM is well suited to applications requiring constant speed operation. It is made up of the stator, or stationary winding, and the rotor. It is called "IMs" because the rotor voltage is induced in the rotor windings instead of physically connected by wires.

Furthermore, it is built without the main DC field circuit at all. The distinguishing feature of IMs is that no DC field current is required to run the motor. It operates on the basis of interaction of induced rotor currents and the air gap field [20].

The first reference to the term SRMs was made by Nasarin 1969 and the term became popular from 1980s onwards, through the efforts of the first commercial exploiters of the technology, Switched Reluctance Drives Ltd. SRMs does not contain any permanent magnet and the operation of the stator is the same as brushless DC motor while the rotor is only consist only of laminating iron. The operation of the SRM where the salient poles tend to align to minimize reluctance in normal operation leads to high normal forces acting on the stator structure. Harmonics of these normal forces will resonates the natural frequency resonant modes of the stator structure thus producing acoustic noise [21].

SMs are AC motors that have a field circuit supplied by an external DC source. The stator has electromagnets results in the creation of magnetic field which rotates in time with the oscillations of the line current [20]. SMs can be classified as permanent magnet (PMSMs), field excitation (FESMs), hybrid excitation (HESM) and flux switching motor (FSM). FSM can be further classified as permanent magnet (PM), field excitation (FE) and hybrid excitation (HE). Figure 2.1 illustrates the classification of main types of Electric Motors.

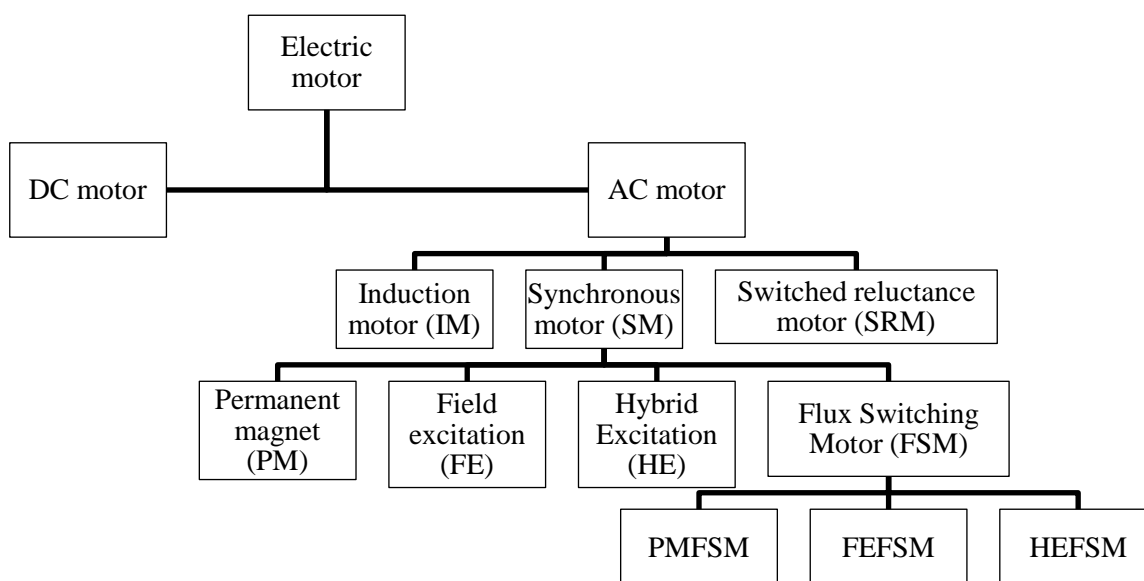

Figure 2.1: The Classification of the main types of Electric Motors

## 2.2 Review on electric motors used in HEV

As has been mentioned previously, among different types of electric machines, there are four main types that are viable for HEVs and are namely, DC machines, IMs, SRMs and IPMSMs. DC motors have been prominent in electric propulsion because their torque–speed characteristics suit the traction requirements well, and their control of the orthogonal disposition of field and armature mmf is simple. Since DC motor requires high maintenance mainly due to the presence of the mechanical commutator (brush), as the research advances the brushes are replaced with slippery contacts. However, DC motor drives have a few demerits such as low efficiency, bulky construction, and low reliability [1-2].

At the moment, IM drive is the most mature technology among various brushless motor drives. Cage IMs are broadly established as the most possible candidate for the electric propulsion of HEVs, due to their ruggedness, reliability, low cost, low maintenance, and ability to operate in hostile environments. However, IM drives have demerits such as low efficiency, high loss, low power factor, and low inverter-usage factor, which are more serious for the high speed and large power motor and that pushed them out from the race of HEVs electric propulsion system [5].

Meanwhile, SRMs are gaining much attention and are documented to have a probable for HEV applications. These motors have specific advantages such as simple and rugged construction, low manufacturing cost, simple control, and outstanding torque-speed characteristics. However, several disadvantages for HEV applications prevail over the advantages. They are acoustic noise generation and torque ripple. All of the above mentioned advantages and disadvantages are quite vital for vehicle applications [6-7].

On the other hand, PMSMs are becoming more and more eye-catching and most proficient of competing with other motors for the electric propulsion of HEVs. In fact, they are adopted by eminent automakers such as Honda, Toyota, for their HEVs. However, at a very high speed range, the efficiency may reduce because of increase in iron loss and also there is a risk of magnetic faults [8].

One example of successfully developed electric machines for HEVs is IPMSM which has been employed primarily to increase the power density of the machines [9-12]. In spite of their good performances and well operated, IPMSMs installed in HEV, have some demerits such as the present IPMSM has a multifaceted shape and structure which are quite complicated to perform the design optimization. Secondly, the constant flux from PM is hard to control especially at light load high speed operating points. In the meantime, the volume of PM used in IPMSM is very high and costly.

### 2.3 Flux Switching Motor

Generally, the flux switching motor (FSM) can be categorized into three groups that are permanent magnet flux switching motor (PMFSM), field excitation flux switching motor (FEFSM), and hybrid excitation flux switching motor (HEFSM). Both PMFSM and FEFSM has only PM and field excitation coil (FEC), respectively as their main flux sources, while HEFSM combines both PM and FEC as their main flux sources. Figure 2.2 illustrates the general classification of FSM.

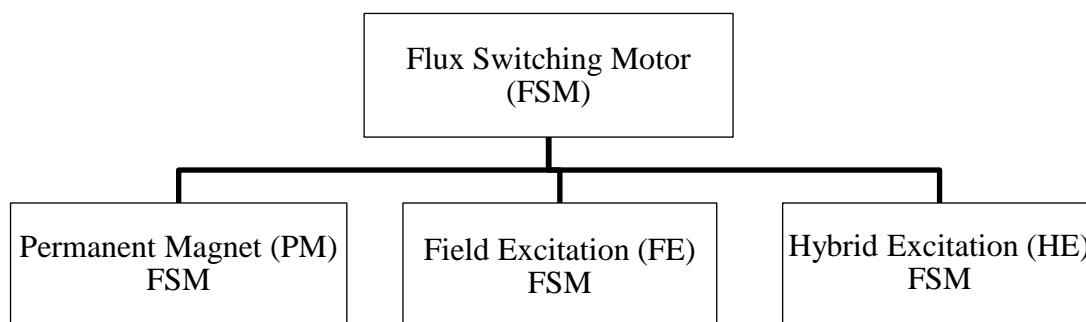

Figure 2.2: Classification of Flux Switching Motor (FSM)

FSM consists of the rotor and stator. The rotor consist of only single structure which is iron core thus allowing its simple construction and inherent robustness to be retained while both field and armature windings are on the stator. These contribute to major advantages where all brushes are eliminated, whilst complete control is maintained over the field flux. The operation of the motor is based on the principle of switching flux. The term “flux switching” is coined to describe machines in which the stator tooth flux switches polarity following the motion of a salient pole rotor

[23]. All excitation sources are on the stator with the armature and field allocated to alternate stator teeth.

Flux is produced in the stator of the machine by permanent magnet or by dc current flowing in the field winding. The orientation of the field flux is then simply switched from one set of stator poles to another of stator poles by reversing the polarity of the current in the armature winding. In the case of inner-rotor flux switching machines (FSMs) that have been studied, the rotor pole number  $N_r$  is normally designed as close to stator slot number  $N_s$  to maximize the performances of the machine [24].

There is very little study has been carried out, an appropriate number of pole for the machines must be determined to find the optimal performances. As studied in [25-26], the analysis has done for  $N_r$  ranges from 14 to 26 and  $N_s$  is fixed at 12. All of them concluded their analysis by choosing 12S-22P as the most suitable for the proposed three-phase outer rotor PMFSM because  $N_r$  equal 22 exhibits the highest back-emf and lowest cogging torque. However, the analysis presented is only focus on the principle of back-emf and cogging torque characteristic. Other parameters such as generated magnetic flux, output torque and power also may need to investigate in order to find the optimal performances and suitable to be further optimized [27]. As the proposed motor to be applied for HEV applications, the high torque and power density capability is one of particularly importance parameters besides of back-emf and cogging torque.

### **2.3.1 Permanent Magnet Flux Switching Motor**

Permanent magnet flux switching motor (PMFSM) is a simple construction. The stator consists of PM and armature windings and due to this it provides some advantages such easy cooling of all active parts and better suitability for high speed applications [28].

PMFSM is popular due to high power density, efficiency and it uses PM to generate flux. Unfortunately, the generated flux produced is fixed and will not change-diverged which means it is constant flux because of characteristics of the PM.

As usage of HEV increased, the increase of the usage of rare earth magnet results in increase of the cost. This would cause serious concern about high cost.

The general operating principle of the PMFSM is illustrated in Figure 2.3, where the black arrows show the flux line (flux direction) of PM as an example. From the figure, when the relative position of the rotor poles and a particular stator tooth are as in Figure 2.3(a), the flux-linkage corresponds to one polarity. However, the polarity of the flux-linkage reverses as the relative position of the rotor poles and the stator tooth changes as shown in Figure 2.3(b), i.e., the flux linkage switches polarity as the salient pole rotor rotates [29].

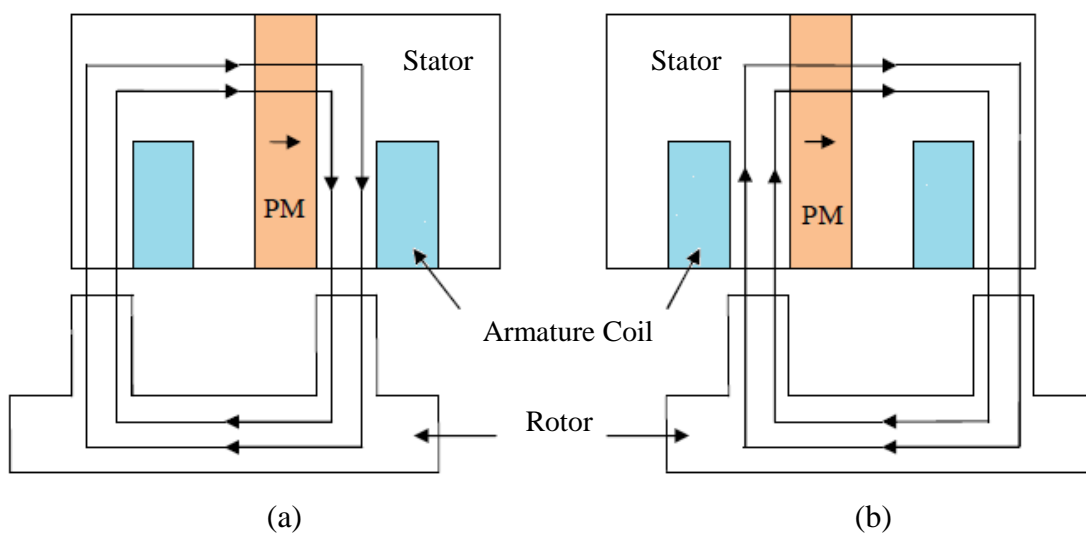

Figure 2.3: Principle operation of PMFSM (a) Flux linkage correspond to one polarity (b) Flux linkage switch polarity as the salient pole rotates [29]

### 2.3.2 Field Excitation Flux Switching Motor

Field Excitation Flux Switching Motor (FEFSM) is distinct from PMFSM. Instead of PM it uses FE to generate flux. The stator composed of laminated iron core, armature coils and DC field excitation coils (FECs) as the only field mmf source. The rotor is made of only laminated iron core similar with SRM. The external DC source is applied to produce the magnetic field by make sure that current is flowing through to the winding.

Even the construction of FEFSM is not simple though PMFSM because of the external DC source, the good is FEFSM can control flux. Apart from that, there is no uses of rare-earth magnet resulting in reduce cost-up.

The operating principle of the FEFSM is illustrated in Figure 2.4. Figure 2.4 (a) and (b) show the direction of the FEC fluxes (blue arrow) into the rotor while Figure 2.4 (c) and (d) illustrate the direction of FEC fluxes into the stator which produces a complete one cycle flux. Similar with PMFSM, the flux linkage of FEC switches its polarity by following the movement of salient pole rotor which creates the term “flux switching”. Each reversal of armature current shown by the transition between Figures 2.4(a) and (b), causes the stator flux to switch between the alternate stator teeth [13].

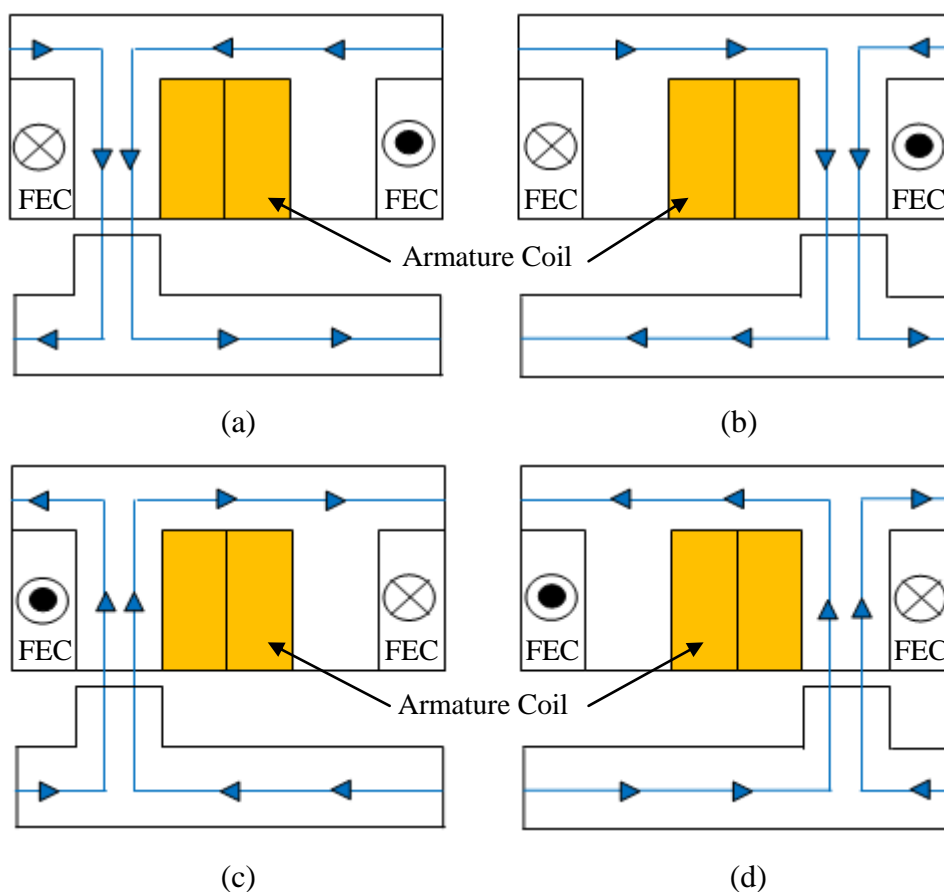

Figure 2.4: Principle operation of FEFSM (a)  $\theta_e=0^\circ$  and (b)  $\theta_e=180^\circ$  flux moves from stator to rotor (c)  $\theta_e=0^\circ$  and (d)  $\theta_e=180^\circ$  flux moves from rotor to stator [13]

### 2.3.3 Hybrid Excitation Flux Switching Motor

Hybrid Excitation Flux Switching Motor (HEFSM) is the combination of PM and FE. HEFSM has significantly less magnet and higher torque density than those of a conventional PMFSM. To easily adjust the main flux, which is fixed in PMFSM, HEFSM were developed to improve the starting/low-speed torque and high-speed flux-weakening capabilities, which are required for HEV [30].

However, in addition to its inherent relatively low torque density, it has a long end winding for the field windings, which overlap the armature windings. Unfortunately, the foregoing hybrid-excited machines having magnets on the stator also suffer from these disadvantages. Firstly, the DC excitation field is in series with the field excited by magnets, which limits the flux-adjusting capability due to low permeability of magnets.

Secondly, the flux path of DC excitation significantly reduces the main flux excited by magnets and even short circuits the magnet. In the meantime, torque density may be significantly reduced. In addition, the use of PM will give concern about cost-up because of the price is expensive. Apart from that, HEFSM usually have complicated 3-D structure and thus result in difficult to analyze and manufacture.

The operating principle of the proposed HEFSM is illustrated in Figure 2.5, where the red and blue line indicate the flux line (flux direction) from PM and FEC, respectively. In Figure 2.5(a) and (b), since the direction of both PM and FEC fluxes are in the same polarity, both fluxes are combined and move together into the rotor, hence producing more fluxes with a so called hybrid excitation flux. Furthermore in Figure 2.5(c) and (d), where the FEC is in reverse polarity, only flux of PM flows into the rotor while the flux of FEC moves around the stator outer yoke which results in less flux excitation [29].



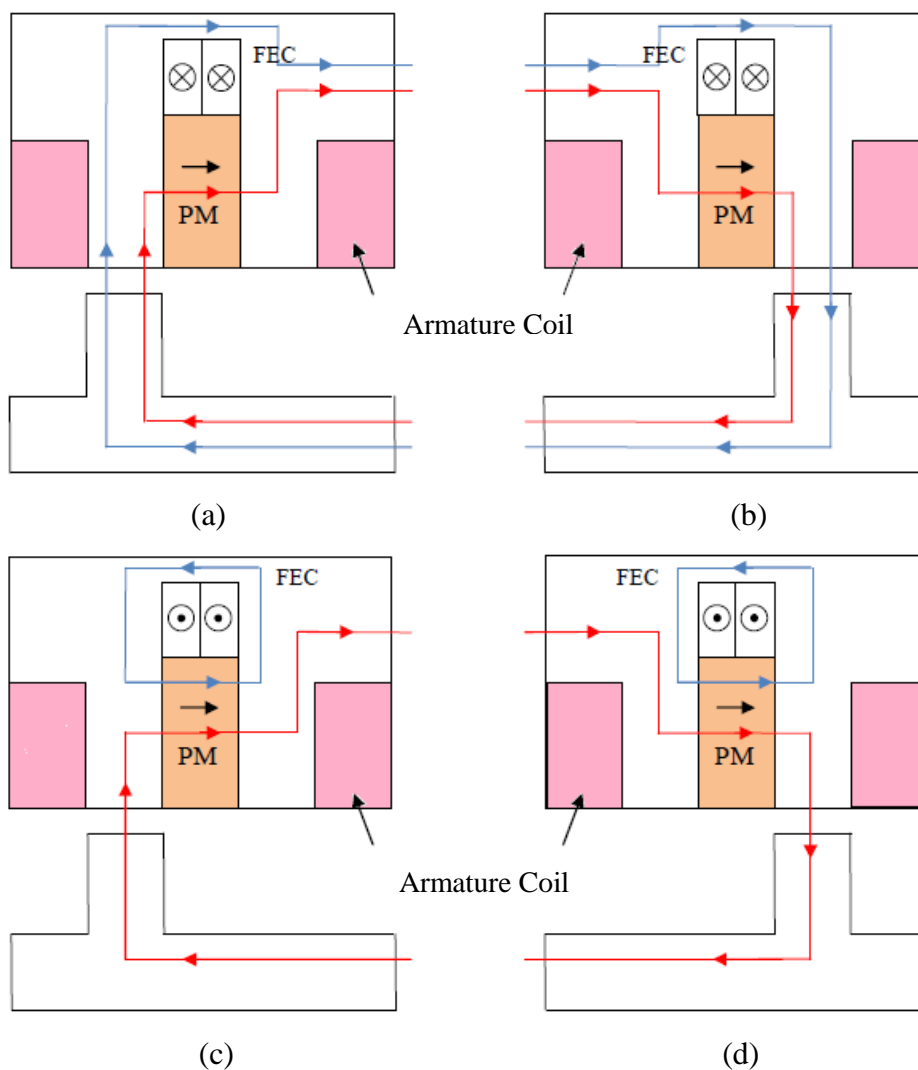

Figure 2.5: Principle operation of HEFSM (a)  $\theta_e=0^\circ$  - more excitation (b)  $\theta_e=180^\circ$  - more excitation (c)  $\theta_e=0^\circ$  - less excitation (d)  $\theta_e=180^\circ$  - less excitation [29]

## 2.4 IPMSM Vs FEFSM

Based on the overview and classifications of various FSMs that have been discussed, PMFSM, FEFSM and HEFSM have their own advantages and disadvantages. Among the three types of FSM which are PMFSM, FEFSM and HEFSM, FEFSM is the best type to consider. This is because FEFSMs have many advantages over disadvantages as compared to both PMFSM and HEFSM. FEFSM do not adopt the usage of PM because PM is a rare-earth magnet that is costly for practical usage. In the meantime, IPMSM which has been installed in existing HEV also adopt the usage of rare-earth PM and possess several drawbacks.

### 2.4.1 IPMSM drawbacks

In spite of their good performances and well operated as mentioned in [9-12], IPMSMs installed in HEV, have some drawbacks to be solved as follows:

- (i) The three-phase armature windings are wound in the form of distributed windings which results in much copper loss and high coil end length.
- (ii) The mechanical stress of the rotor depends on the number of PM bridges. High number of bridges not only increases the mechanically weak points but also causes much flux leakage between the PMs that will degrade the performance of the machine.
- (iii) The present IPMSM has a complex shape and structure which is relatively difficult to perform the design optimization.
- (iv) The constant flux from PM is difficult to control especially at light load high speed operating points.
- (v) The volume of PM used in IPMSM is very high, more than 1.0kg, which increases the cost of the machine.
- (vi) There are windings at the rotor resulting in not robust rotor structure for high speed applications.

### 2.4.2 Research on FEFSM for HEV

Early examples of FEFSM, the three-phase 12S-10P, 12S-8P and 12S-14P FEFSMs are developed as shown in Figure 2.6 (a), (b) and (c), respectively. The 12S-10P FEFSM in Figure 2.6 (a) is designed in which the PM is removed from the stator and half of the armature coil slots in the upper layer are placed with the FEC windings as explained in [31]. The FEC-1 and FEC-2 are arranged with alternate DC current source polarity to produce two flux polarities that can give much flux sources. However, since the isolated and unused stator teeth shown in red circle in Figure 2.6 (a) reduce the performance of the machine, further investigations into improvements of the machine design of three phase FEFSMs should be made. Next, the 12S-8P FEFSM is designed with segmental rotor as shown in Figure 2.6 (b) [32]. Whereas

segmental rotors are used traditionally to control the saliency ratio in synchronous reluctance machines (SynRM), the primary function of the segments in this design is to provide a defined magnetic path for conveying the field flux to adjacent stator armature coils as the rotor rotates. Unfortunately, the flaws of segmental rotor are less robust and complicated as compared to salient rotor resulting in not suitable for high speed applications. As the advance research, 12S-14P FEFSM with non-overlap winding and salient pole rotor with all stator teeth is used as shown in Figure 2.6 (c) is designed to achieve higher torque and power density. Regrettably, the fundamental performance of this design for instance DC FEC flux linkage, has produced low flux resulting in lower output torque and power as well as high torque ripple [33].

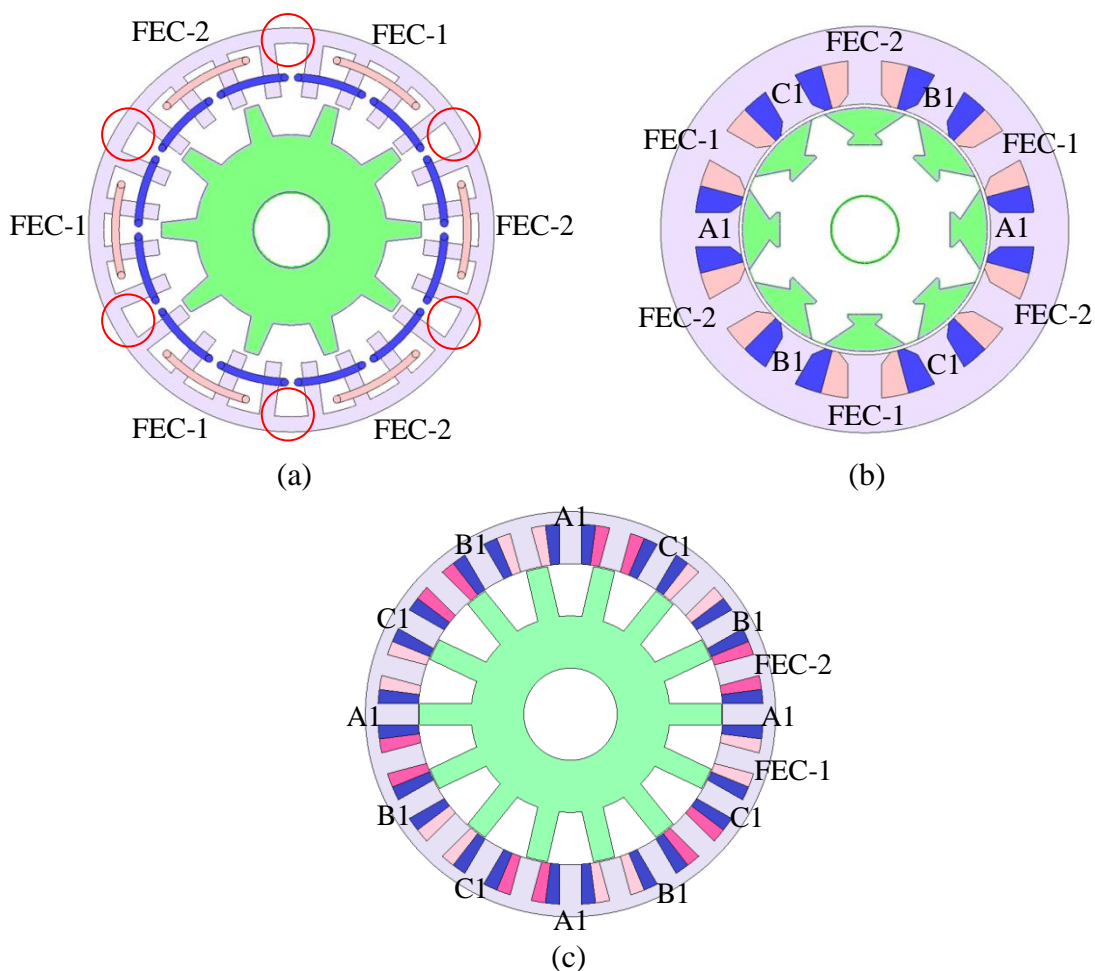

Figure 2.6: Example of FEFSMs (a) 3-phase 12S-10P  
 (b) 3-Phase 12S-8P segmental rotor (c) 3-phase 12S-14P

## CHAPTER 3

### METHODOLOGY

#### 3.1 Introduction

An analytical study, Finite Element Analysis (FEA) study based on reluctant network is used to evaluate magnetic flux is needed to design the FEFSM. Using FEA based on JMAG-Designer Software allows obtaining information that is not available through an actual device test because it gives us substantially greater insight into the device's performance. JMAG is simulation software for electromechanical design striving to be easy to use while providing versatility to support users from conceptual design to comprehensive analyses. JMAG can accurately capture and quickly evaluate complex physical phenomena inside of machine [34]. Generally, the project implementation is divided into 3 parts which are design, analysis and optimization. The general flow of research methodology is illustrated in Figure 3.1.

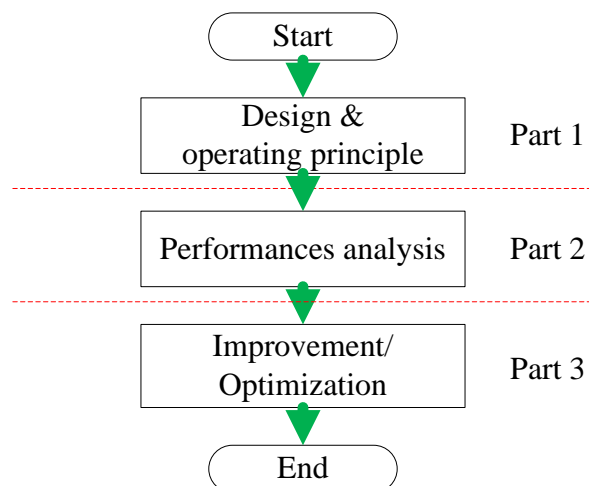

Figure 3.1: General work flow of project implementation

### 3.2 Part 1: Design and operating principle investigation

In design part, it is divided in 2 portions for instance Geometry editor and JMAG-Designer. Geometry editor is used to design each part of motor separately such as rotor, stator, armature coil, and FEC while the materials, conditions, circuit, mesh setting and simulation are developed by using JMAG-Designer. Electrical steel 35H210 is used for rotor and stator body whereas copper is used for armature coil and FEC, respectively. The work flows of the motor design are illustrated in Figure 3.2.

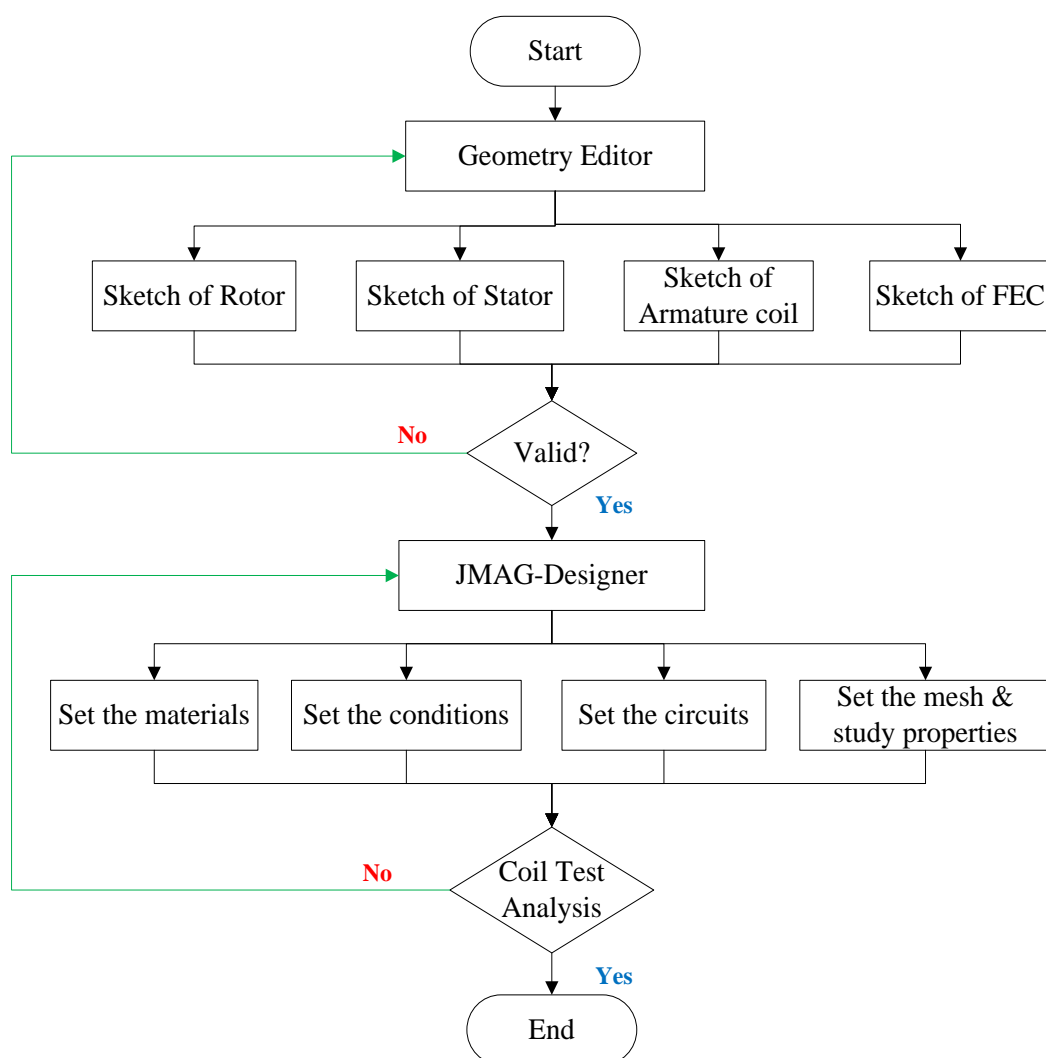

Figure 3.2: Work flow of motor design in Geometry Editor and JMAG-Designer

### 3.2.1 The proposed FEFSM for HEV

In order to overcome the problem of heavy rare earth PM in existing IPMSM, PMFSM, HEFSM and also initial design of segmental rotor FEFSM and non-overlap winding, a new structure of 12S-10P FEFSM in which the usage of PM is totally excluded, replacement of segmental rotor by salient rotor, all stator teeth used and non-overlap winding is substituted by overlap winding is designed as shown in Figure 3.3. The novelty of this proposed design are robust rotor structure and suitable for high speed application for HEV drive with high torque and power capabilities [12]. In the meantime, the study on various slot pole combinations shall be done to ensure the best combination of slot plot to give higher output torque and power. The selections of the initial design FEFSMs are based on the main geometrical dimensions identical to existing IPMSM in which the stator outer diameter, stack length and shaft are set respectively to 132mm, 70mm and 30mm with following assumptions below and design parameters of FEFSMs are shown in Table 3.1.

- (i) The initial rotor radius is selected based on rotor radius of general machine of approximately 60% to 75% of the machine outer radius.
- (ii) The FEC and armature coil slot opening angle are set to be half of the stator slot opening angle.
- (iii) The width of both slots is set to be similar along the coil depth. Furthermore, the total coil slot area of both FEC and armature coil is less than the stator teeth area so that all fluxes from both coils is expected to have sufficient space to flow in the stator yoke, without magnetic saturation.
- (iv) The stator outer core thickness is set to be half of the stator inner teeth length with the assumptions that the fluxes are divided into two parts.
- (v) The outer rotor pole angle is set by dividing the total stator tooth opening angle to the number of rotor poles by assuming that all fluxes from stator will have sufficient space to flow into the rotor. Small rotor pole width will prevent some amount of flux from the stator to flow to the rotor part, resulting in flux saturation. In contrast, larger rotor pole width will easily receive all flux from the stator, but will easily distribute the flux on the rotor resulting in some of the flux leak or flow unnecessary.

- (vi) The depth of rotor pole is set to be 1/3 of the rotor radius to give much depth for the flux to flow while keeping the suitable distance of the rotor inner part to avoid flux saturation and to keep the acceptable rotor mechanical strength, simultaneously.
- (vii) To ensure flux moves from stator to rotor equally without any flux leakage, the design of the proposed machine is defined as in Equation 3.1.

$$\sum \text{Stator Tooth Width} = \sum \text{Rotor Tooth Width} \quad (3.1)$$

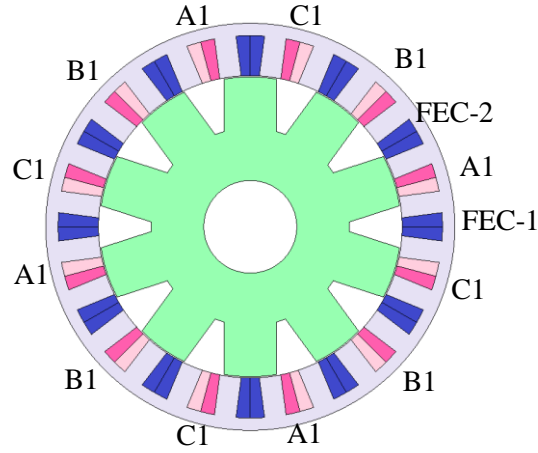

Figure 3.3: The proposed 12S-10P FEFSM

Table 3.1: Design parameters of FEFSMs

| Items                            | 3 $\phi$ FEFSM | 1 $\phi$ FEFSM |
|----------------------------------|----------------|----------------|
| Rotor radius [mm]                | 97.2           | 97.2           |
| Rotor pole width [mm]            | 16.8           | 10.3           |
| Rotor pole depth [mm]            | 33.2           | 33.2           |
| FEC width [mm]                   | 7.0            | 8.9            |
| FEC depth [mm]                   | 26             | 22.02          |
| Armature coil depth [mm]         | 26             | 22.02          |
| Armature coil width [mm]         | 7.0            | 8.9            |
| Number of turns of armature coil | 8              | 8              |

### 3.3 Part 2: Analysis

In the proposed FEFSM, the relationship between the number of rotor pole and stator slot for the three-phase and single-phase can be express as in Equation 3.2 [35],

$$N_r = N_s \left(1 \pm \frac{k}{2q}\right) \quad (3.2)$$

where  $N_r$  is the number of rotor poles,  $N_s$  is the number of stator slots,  $k$  is the natural number, and  $q$  is the number of phases. For the proposed motor,  $q$  equals to 3 and 1 for three phase and single phase, respectively while  $N_s$  equals to 12 for three phase and 8 for single phase. Lastly,  $N_r$  is even numbers that varies from 10, 14, 16, 20, 22 and 4, 8, 12 for three phase and single phase, correspondingly. The work flow of the analysis part is illustrated in Figure 3.4 and the performances of the FEFSMs at various rotor pole numbers is analyzed at open circuit and short circuit condition, respectively.

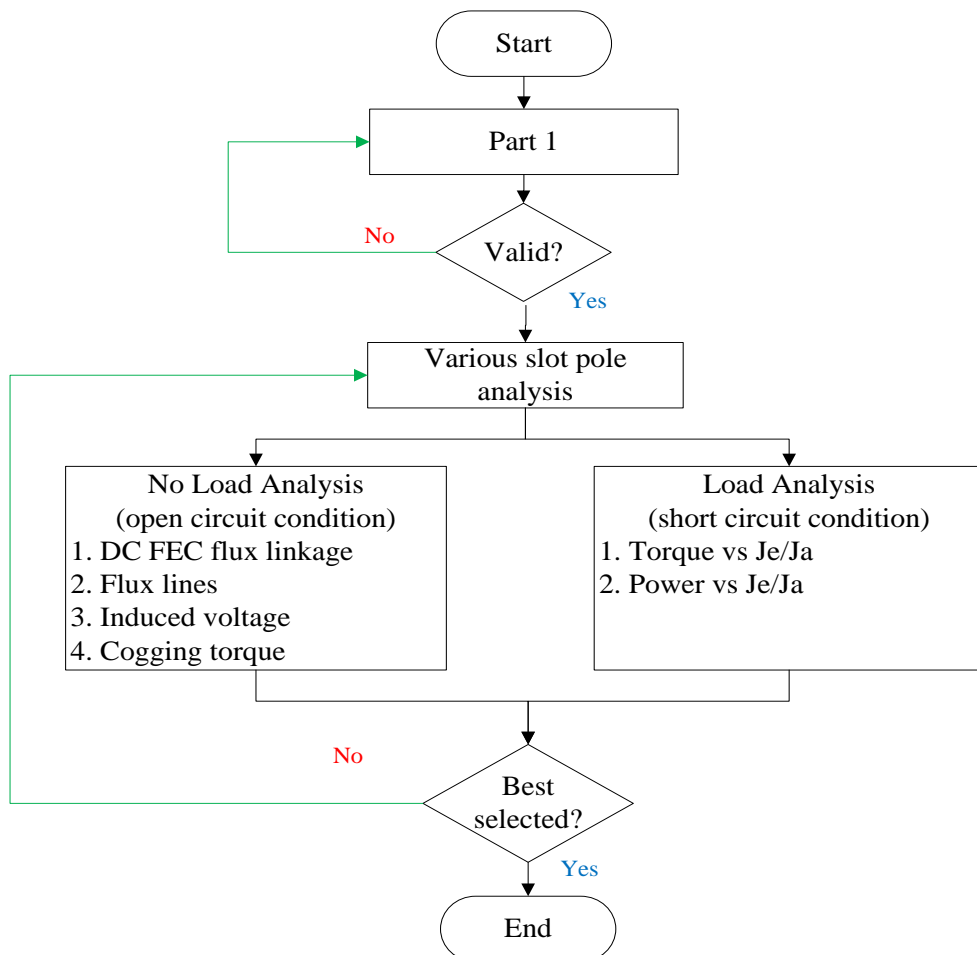

Figure 3.4: Work flow of motor analysis



### 3.3.1 Open Circuit Condition

In this proposed motor, the motor rotation through  $1/N_r$  of a revolution, the flux linkage of armature has one periodic cycle and thus, the frequency of back-emf induced in the armature coil is  $N_r$  times of the mechanical rotational frequency. In general, the mechanical rotation frequency,  $f_m$  and the electrical frequency,  $f_e$  for the proposed three phase machine can be expressed as in Equation 3.3 and end time,  $T$  is calculated using Equation 3.4 while for the proposed single phase machine it can be expressed as in Equation 3.3 or Equation 3.5 as long as one cycle flux is formed and end time,  $T$  is calculated using Equation 3.4,

$$f_e = N_r f_m \quad (3.3)$$

$$T = \frac{1}{F_e} \quad (3.4)$$

$$f_e = 2N_r f_m \quad (3.5)$$

where  $f_e$ ,  $N_r$  and  $f_m$  is the is the electrical frequency, number of rotor poles and mechanical rotation frequency, respectively. Assuming only one water-jackets system is employed as a cooling system, the current density threshold is set to be  $30A_{\text{rms}}/\text{mm}^2$  and  $30A/\text{mm}^2$ , respectively, for armature winding and FEC. The number of turns,  $N$ , per armature coil and FEC is defined by Equations 3.6 and 3.7, with the filling factor of motor,  $\alpha$ , set as 0.5.

$$N_a = \frac{J_a \alpha S_a}{I_a} \quad (3.6)$$

$$N_e = \frac{J_e \alpha S_e}{I_e} \quad (3.7)$$

Where  $N$ ,  $J$ ,  $\alpha$ ,  $S$  and  $I$  are number of turns, current density, filling factor, slot area and input current, respectively. For the subscript  $a$  and  $e$  respectively represent armature coil and FEC. In open circuit condition (no load analysis), only FEC current

## REFERENCES

- [1] C. C. Chan, "The state of the art of electric, hybrid, and fuel cell vehicles", Proc. IEEE, vol. 95, no. 4, pp.704–718, Apr. 2007.
- [2] A. Emadi, J. L. Young, K. Rajashekara, "Power electronics and motor drives in electric, hybrid electric, and plug-in hybrid electric vehicles", IEEE Trans. Ind. Electron., vol.55, no.6, pp.2237-2245, Jan. 2008.
- [3] D. W. Gao, C. Mi, and A. Emadi, "Modeling and simulation of electric and hybrid vehicles", Proc. IEEE, vol. 95, no. 4, pp. 729–745, April 2007.
- [4] C. C. Chan, "The state of the art of electric and hybrid vehicles", Proc. IEEE, vol. 90, no. 2, pp. 247–275, Feb. 2002.
- [5] T. Wang et al., "Design characteristics of the induction motor used for hybrid electric vehicle," IEEE Trans. Magn., vol. 41, no. 1, pp. 505–508, Jan. 2005.
- [6] J. Malan and M. J. Kamper, "Performance of a hybrid electric vehicle using reluctance synchronous machine technology", IEEE Trans. Ind. Appl., vol. 37, no. 5, pp. 1319–1324, Sep./Oct. 2001.
- [7] K. M. Rahman, B. Fahimi, G. Suresh, A. V. Rajarathnam, and M. Ehsani, "Advantages of switched reluctance motor applications to EV and HEV: Design and control issues", IEEE Trans. Ind. Appl., vol. 36, no. 1, pp. 111– 121, Jan./Feb. 2000.
- [8] T. M. Jahns, and V. Blasko, "Recent advances in power electronics technology for industrial and traction machine drives", Proc. IEEE, vol. 89, no. 6, pp. 963–975, June 2001.
- [9] K. C. Kim, C. S. Jin, and J. Lee: "Magnetic shield design between interior permanent magnet synchronous motor and sensor for hybrid electric vehicle", IEEE Transaction on Magnetics, vol. 45, no.6 pp.2835–2838, June 2009.
- [10] M. Kamiya, "Development of traction drive motors for the Toyota hybrid systems", IEEJ Trans. Ind. Appl., vol.126, no.4, pp.473-479, Apr. 2006.
- [11] M.A. Rahman: "IPM Motor Drives For Hybrid Electric Vehicles", International Aegean Conference on Electrical Machines and Power Electronics, Sept. 2007.
- [12] R. Mizutani: "The present state and issues of the motor employed in Toyota HEVs", Proc. of the 29th Symposium on Motor Technology in Techno-Frontier, 2009.

- [13] E. Sulaiman, T. Kosaka, and N. Matsui, "A New Structure of 12Slot-10Pole Field Excitation Flux Switching Synchronous Machine for Hybrid Electric Vehicles", IEEE 14th European Conference on Power Electronics and Applications, pp. 1-10, Sept. 2011.
- [14] E. Sulaiman, N. Matsui and T. Kosaka, "Design Study and Experimental Analysis of Wound Field Flux Switching Motor for HEV Application", IEEE International Conference on Electrical Machines, pp. 1269-1275, Sept. 2012.
- [15] E. Sulaiman, T. Kosaka, and N. Matsui, "Design and Analysis of High-Power/ High-Torque Density Dual Excitation Switched-Flux Machine for Traction Drive in HEVs", Renewable & Sustainable Energy Review, submitted for 3rd review, Jan 2014.
- [16] E. Sulaiman, T. Kosaka, N. Matsui, and M. Z. Ahmad, "Design Studies on High Torque and High Power Density Hybrid Excitation Flux Switching Synchronous Motor for HEV Applications," in IEEE International Power Engineering and Optimization Conference, 2012, pp. 333–338, June 2012.
- [17] E. Sulaiman, T. Kosaka, and N. Matsui: "High power density design of 6slot-8pole hybrid excitation flux switching machine for hybrid electric vehicles", IEEE Trans. on Magn., vol.47, no.10 pp. 4453-4456, Oct. 2011.
- [18] History of Electric Motor. Access on November 29, 2013 [http://en.wikipedia.org/wiki/Electric\\_motor](http://en.wikipedia.org/wiki/Electric_motor)
- [19] Difference between AC and DC Motors. Access on November 29, 2013. <http://www.ohioelectricmotors.com/what-is-the-difference-between-an-ac-motor-and-a-dc-motor-673#ixzz2CdnjLwIg>.
- [20] Jerry Bednarczyk, PE, Induction Motor Theory. Access on November 29, 2013. <http://www.pdhone.org/courses/e176/e176content.pdf>
- [21] Pragasen Pillay & William Cai, An investigation into vibration in switched reluctance motors. Access on November 29 2013. <http://www.fleadh.co.uk/srm.htm>
- [22] What is synchronous motor. Access on November 29, 2013. [http://en.wikipedia.org/wiki/Synchronous\\_motor](http://en.wikipedia.org/wiki/Synchronous_motor).
- [23] S. E. Rauch and L.J. Johnson, 'Design principles of flux-switch alternators', Tans. AIEE, vol. 74 pt. III, pp. 1261-1268, 1955.

- [24] J.T. Chen, and Z. Q. Zhu, "Influence of rotor pole number on optimal parameters in flux-switching PM brushless AC machines by the lumped parameter magnetic circuit model," *IEEE Trans. Ind. Appl.* , vol. 46, no. 4, pp. 1381-1388, Jul/Aug 2010.
- [25] Y. Wang, M.J. jin, J. Shen et al, "An outer-rotor flux switching permanent magnet machine for traction applications," *IEEE Energy Conversion Congress and Exposition*, pp. 1723-1730, 2010.
- [26] W. Fei, P. Chi, K. Luk, S. Member, J. X. Shen, Y. Wang, and M. Jin, "A Novel Permanent-Magnet Flux Switching Machine With an Outer-Rotor Configuration for In-Wheel Light Traction Applications," *IEEE Transactions on Industry Applications*, vol. 48, no. 5, pp. 1496–1506, 2012.
- [27] E. Sulaiman and T. Kosaka, "Parameter Sensitivity Study for Optimization of Field Excitation Flux Switching Synchronous Machine for HEV", *IEEE Conference on Industrial Electronic and Applications*, pp. 52-57, July 2012.
- [28] Z. Q. Zhu, and J. T. Chen, "Advanced Flux-Switching Permanent Magnet Brushless Machines," *IEEE Trans. Magnetics*, vol. 46, no.6 pp. 1447–1453, June 2010.
- [29] Zhu, Z.Q: "Switched flux permanent magnet machines: Innovation continues", in *Proc. Int. Conf. on Electrical Machines and Systems*, pp.1-10, Aug. 2011.
- [30] E. Spooner, S. A. W. Khatab, and N. G. Nicolaou, "Hybrid excitation of AC and DC machines," in *Proc. IEE Int. Conf. Elect. Mach. Drives*, pp. 48–52, Sep. 1989.
- [31] J. T. Chen, Z. Q. Zhu, S. Iwasaki, and R. Deodhar: "Low cost flux-switching brushless AC machines", *IEEE Vehicle Power and Propulsion Conf., VPPC 2010*, Lille, France, Sept. 2010.
- [32] A. Zulu, B. Mecrow, and A. Armstrong: "A wound-field three-phase flux-switching synchronous motor with all excitation sources on the stator", *IEEE Trans. Industry Applications*, Vol.46, pp.2363-2371, Nov. 2010.
- [33] F. Khan, E. Sulaiman, Z. A. Husin and M. F. Omar, "Performances Comparison of 12S-14P FEFSM with overlap and non-overlap windings for HEV", *IEEE Student Conf. Research and Development*, pp.1-6, Dec. 2014.

- [34] JMAG Software. Access on December 11, 2013  
<http://www.jmag-international.com/>
- [35] E. Hoang, M. Lecrivain, and M. Gabsi: “A new structure of a switching flux synchronous polyphased machine with hybrid excitation”, in Proc. Eur. Conf. Power Electron. Appl., pp.1–8, Sep. 2007.