

AN-AHP BASED LOAD SHEDDING ALGORITHM TO MITIGATE POWER  
SYSTEM BLACKOUT

NORZARIRA BINTI MOHD SALLEH

A project report submitted in  
partial fulfillment of the requirement for the award of the  
Degree Master of Electrical Engineering

Faculty of Electrical and Electronic Engineering  
Universiti Tun Hussein Onn Malaysia

JANUARY 2015

## **ABSTRACT**

This work investigated one of the load shedding methods, namely the Analytical Hierarchy Process (AHP) on an actual power system in Universiti Malaysia Pahang (UMP) in Pekan, Pahang to improve its reliability and stability. The objective of choosing and implementing this technique to the power system was to obtain an optimal load shedding strategy for UMP, Pekan Campus which currently does not have one but dependent on the persons-in-charge to do the load shedding based on their own expertise and experience to the system without any proper guidelines. By using AHP, the prioritization of load to be shed is achieved based on selected criteria and alternatives that has been extracted from the UMP, Pekan Campus electrical distribution. All the pertinent load data were inserted into Microsoft Excel and the AHP algorithm developed then applied to analyze which load to be shed first and so on. The result obtained shows that AHP method chooses the load with the highest volume as highest priority load to be shed. The load with highest volume in term of power supplied is chosen to be the first load to be shed in this power system.

## **ABSTRAK**

Kerja ini mengkaji salah satu kaedah menumpahkan beban, iaitu Proses Analisis Hierarki (AHP) pada sistem kuasa sebenar di Universiti Malaysia Pahang (UMP) di Pekan, Pahang untuk meningkatkan kebolehpercayaan dan kestabilannya. Objektif memilih dan melaksanakan teknik ini untuk sistem kuasa ini adalah untuk mendapatkan strategi penumpahan beban yang optimum untuk UMP, Kampus Pekan yang pada masa ini tidak mempunyai sistem yang tertentu tetapi bergantung kepada orang-orang yang bertanggungjawab untuk melakukan penumpahan beban berdasarkan kepakaran mereka sendiri dan pengalaman kepada sistem tersebut tanpa sebarang garis panduan yang betul. Dengan menggunakan AHP, keutamaan menumpahkan beban akan dicapai berdasarkan kriteria yang dipilih dan alternatif yang telah diekstrak daripada pengagihan elektrik UMP, Kampus Pekan. Semua data beban berkaitan dimasukkan ke dalam Microsoft Excel dan algoritma AHP yang dibangunkan kemudian digunakan untuk menganalisis beban yang akan disingkirkan dahulu dan sebagainya. Keputusan yang diperolehi menunjukkan bahawa kaedah AHP memilih beban dengan bacaan yang paling tinggi sebagai beban yang terdahulu untuk disingkirkan. Beban dengan bacaan tertinggi dari segi kuasa yang dibekalkan adalah dipilih untuk menjadi beban pertama yang disingkirkan dalam sistem kuasa ini.

## CONTENTS

TITLE	i
DECLARATION	ii
DEDICATION	iii
ACKNOWLEDGEMENT	iv
ABSTRACT	v
CONTENTS	vii
LIST OF TABLES	ix
LIST OF FIGURES	x
LIST OF SYMBOLS AND ABBREVIATIONS	xii
CHAPTER 1	1
1.1 Project background	1
1.2 Problem statement	2
1.5 Project objectives	3
1.4 Project scope	3
1.5 Thesis overview	4
1.6 Summary	5
CHAPTER 2	
<b>Error! Bookmark not defined.</b>	
2.1 What is load shedding?	6
2.2 The National Grid	7
2.3 Electrical power outage events in Malaysia	8

2.4	Previous method of load shedding	10
2.5	Why Analytical Hierarchy Process (AHP) is selected	13
2.6	Analytical Hierarchy Process (AHP)	14
2.7	Summary	15
CHAPTER 3		
<b>Error! Bookmark not defined.</b>		
3.1	Background of the system	16
3.2	Does the system need a properly planned load shedding procedure?	19
3.3	AHP process	19
3.4	Summary	31
CHAPTER 4		
<b>Error! Bookmark not defined.</b>		
4.1	UMP, Pekan Campus electrical distribution system	31
4.2	Analysis of the results	35
4.3	Discussion	49
CHAPTER 5		
<b>Error! Bookmark not defined.</b>		
5.1	Conclusion	51
5.2	Recommendations for further work	51
REFERENCES		53

**LIST OF TABLES**

Table 3.1: Table of Random Index	24
Table 4.1: Power supplied (Total Connected Load)	33
Table 4.2: Operating load (Maximum Demand)	33
Table 4.3: Pair-wise comparison table matrix	36
Table 4.4: Product of pair-wise comparison matrix and root of the product for criteria	36
Table 4.5: Random Consistency Index	38
Table 4.6: Final score of the load shedding	47
Table 4.7: Ranking for each of alternatives to be shed	50

## LIST OF FIGURES

Figure 2.1: Electrical power transmission and distribution system	8
Figure 3.1: Location of UMP, Pekan Campus	17
Figure 3.2: Single Line Diagram of UMP, Pekan Campus	19
Figure 3.3: Flow chart of the hierarchy structure	21
Figure 3.4: Flow chart of AHP method	22
Figure 3.5: Step 1 in AHP	25
Figure 3.6: Step 2 in AHP	28
Figure 3.7: Step 3 in AHP	30
Figure 4.1: Relationship between the parameter	34
Figure 4.2: Single Line Diagram of UMP, Pekan Campus	35
Figure 4.3: Graph for Weight of criteria	38
Figure 4.4: Weight of criteria in Microsoft Excel	39
Figure 4.5: The 7th root of product for alternatives	40
Figure 4.6: Weight of criteria	41
Figure 4.7: Graph for ‘Weight of Alternatives in Power Supplied’	43
Figure 4.8: Pie chart of ‘Percentage of Weight of Alternatives in Power Supplied	43
Figure 4.9: Graph for ‘Weight of Alternatives in Operating Load’	45
Figure 4.10: Pie chart of ‘Percentage of Weight of Alternatives in Operating Load	45
Figure 4.11: Relationship between each criteria and alternatives	46
Figure 4.12: Matrix multiplication between criteria and alternatives	47
Figure 4.13: Graph of final ranking of the load shedding	48

Figure 4.14: Graph for percentage of final score for each of the alternatives	48
Figure 4.15: Flow chart for load shedding using AHP method for UMP, Pekan Campus	49

## LIST OF SYMBOLS AND ABBREVIATIONS

<i>AHP</i>	Analytical Hierarchy Process
<i>Alt</i>	Alternatives
<i>SS</i>	Substation
<i>HV</i>	High voltage
<i>LV</i>	Low voltage
<i>CI</i>	Consistency index
<i>RI</i>	Random index
<i>CR</i>	Consistency ratio
<i>MW</i>	Mega-watt
$\Sigma$	Summation



# CHAPTER 1

## INTRODUCTION

### 1.1 Project background

A blackout is a total loss of power to an area and is the most serious form of power outage that can occur. Blackout is a cutoff of electrical power, especially as a result of a shortage and power stations tripping, a mechanical failure, or overuse by consumers. Outages may last from a few minutes to a few days depending on the nature of the blackout and the configuration of the electrical network.

The process of extracting or removing low priority loads from the system to prevent it from collapsing and keep the remaining portion operational is known as Load Shedding [1]. Hence, a key step for preventing blackout is conducting a proper and effective control action in an emergency state to halt system deterioration and restore it to normality [2]. Load shedding is now considered as a powerful tool to avoid system wide blackout [2].

In the load shedding scheme, to stop further declining of system frequency is by shedding or removing any load that is non-vital and let the vital and most critical loads become the remaining portion in the power system. By removing the low priority loads from the system, the stability between the power supplied and load demand could be brought back. Thus, for load shedding to be effective in halting the system from collapsing, the load need be differentiated into non-vital, semi-vital and vital, so that

in the event of an emergency an optimal load-shedding strategy could be quickly executed.

Thereby, in this hypothetical study situation worked with Analytic Hierarchy Process (AHP) to remove load by ranking them according to their priority. AHP is a decision making tool based on expert judgements that has been successfully applied in design and operation for the power system [3]. By earning the first rank means that the priority is less as the load shedding module aims is to ensure power continuity to only vital and most critical loads in the power system. The module begins with non-vital loads and follows by semi-vital loads removal. The vital loads can only be removed if the system is disturbed by large disturbances such as major generation outages.

## **1.2 Problem statements**

The main attentiveness of this study is to rank the load in hierarchy according to their priority as the option to assist the system operator to decide which load to be curtailed or removed first and next during the disturbances to the power system using one of the load shedding methods called Analytical Hierarchy Process (AHP).

The un-equality of the power supplied and load demand will lead to the system disturbances or collapse. To avoid system from down or collapse, some of the non-vital loads need to be removed from the system instantly. In order to select which load to be removed, the AHP is the best method to ensure the removed load is the least important to the system.

## **1.5 Project objectives**

In order to ensure the developed load shedding scheme is ideal for the selected electrical power system. The objectives of this project are as follows:

- a) To implement the AHP in the load shedding scheme
- b) To propose the AHP load shedding scheme to the UMP, Pekan Campus
- c) To illustrate the load shedding flow for UMP, Pekan Campus electrical distribution system

## **1.4 Project scopes**

The hypothetical study system is executed using Microsoft Excel Software application and only focus on Analytic Hierarchy Process (AHP) method for load shedding scheme. The performance of the AHP method will be evaluated by using the actual relevant input data. Due to the constraint of getting the latest input data, the following important points will be taken into consideration:

- a) The hypothetical study system is executed to rank load priority for load shedding scheme as one of the protection system for the power system infrastructure in UMP, Pekan Campus
- b) For this analysis, only power supplied and load operating demands were taken into consideration
- c) The type of disturbance considered in this analysis was large contingency such as major generator outages or important transmission line outages

## **1.5 Thesis overview**

The report was layout as follows:

### **Chapter 1 – Introduction**

This chapter is briefly an introduction to load shedding and the importance of the load shedding to the power system. The interest of the research is towards Analytical Hierarchy Process (AHP) and salient points which taken into consideration had also clearly stated at the end of the chapter.

### **Chapter 2 – Literature Review**

This chapter discussed on past researches on several load shedding method and why Analytical Hierarchy Process (AHP) is the most suitable method for this study case compared to the others method. It was properly structured for future reference purposes.

### **Chapter 3 - Methodology**

In this chapter discussed on background of the power system in UMP, Pekan Campus and why the system need load shedding to ensure the smoothness of the supplied if any disturbance occurs. Illustration of the system also attached in this chapter to provide clear introduction of the system studied.

### **Chapter 4 – Result, Analysis and Discussion**

The findings of the research were discussed and presented in a graph, pie chart and tabulated data in this chapter 4. The analysis of the results is also being discussed in this chapter for each criteria and alternative selected.

## **Chapter 5 – Conclusion and Recommendation Works**

The final parts of the report discussed and concluded the importance of the finding which definitely is very helpful as a guide to the person in charge for better protection for the power system network during major contingencies. It also focused on the future proposal to improve the findings as the system may change due to the surrounding needs. And why the findings decision should be that way as the best load shedding scheme to the system approached.

### **1.6 Summary**

This chapter is mostly discussed on the introduction to the electric power system and load shedding and to give out better understanding on the importance of the load shedding to the power system to ensure the system still being able to supply power even during major disturbance. In doing research there must have salient points that have to be taken into consideration and it is well stated.

## CHAPTER 2

### LITERATURE REVIEW

#### 2.1 What is load shedding?

Load shedding is an emergency control action to ensure system stability by shedding system load. The emergency load shedding would only be used if the frequency or voltage falls below a specified frequency or voltage threshold. Typically, the load shedding protects against excessive frequency or voltage decline by attempting to balance real and reactive power supply and demand in the system.

The load shedding scheme sheds amount of load in the power system until the available generation could supply the balance of the loads. If the power system is unable to supply its active and reactive load demands, the under-frequency and under-voltage condition will be intense.

To prevent the post-load shedding problems and over loading, the location bus for the load shedding will be determined based on the load importance, cost and distance to the contingency location. Coordination between amount of spinning reserve allocation and load shedding can reduce total costs that generation companies should pay in the emergency conditions [7].

The number of load shedding steps, amount of load that should be shed in each step, the delay between the stages, and the locating of shed load are the important objects that should be determined in the load shedding algorithm. In load shedding scheme, usually several stages is composed with each stage is characterized by

frequency or voltage threshold, amount of load and delay before tripping. The objective of an effective load shedding scheme is to curtail a minimum amount of load and provide a quick, smooth and safe transition of the system from an emergency to a normal equilibrium state [8].

## **2.2 The National Grid**

In every country in the world, there is a standard system known as The National Grid system used to transmit electricity to all over the country. The national grid system is the network of cables which transport electricity from the power stations to homes, factories and other places that require it. National Grid Malaysia is the high-voltage electric power transmission network in Peninsular Malaysia. It is operated and owned by Tenaga Nasional Berhad (TNB) while the two other electrical grids in Sabah and Sarawak operated by Sarawak and Sabah Electricity Sdn Bhd (SESB). The system expands the whole of Peninsular Malaysia, connecting electricity generation stations owned by TNB and Independent Power Producers (IPPs) to energy consumers.

TNB is the largest utility company whom owned, managed and operated the National Grid which links the TNB power station and IPPs to the distribution network. The grid is connected to Thailand's transmission system in the north and Singapore's transmission system in the south. More than 420 substations in Peninsular Malaysia are linked together by the extensive network of transmission lines operating at 132kV, 275kV and 500kV voltage levels.

The power stations of TNB produce electricity at high currents. Electricity transmission at high currents would encounter a large resistance in the transmission wire and therefore lose a lot of its energy as heat. To prevent this, the current generated is passed through a step up transformer. The high voltage electricity is carried along overhead lines and underground cables referred to as the supergrid. The voltage is the

reduced in several stages making before reaching the end user. The voltage reduction is made in step down transformers as per shown in Figure 2.1 below:

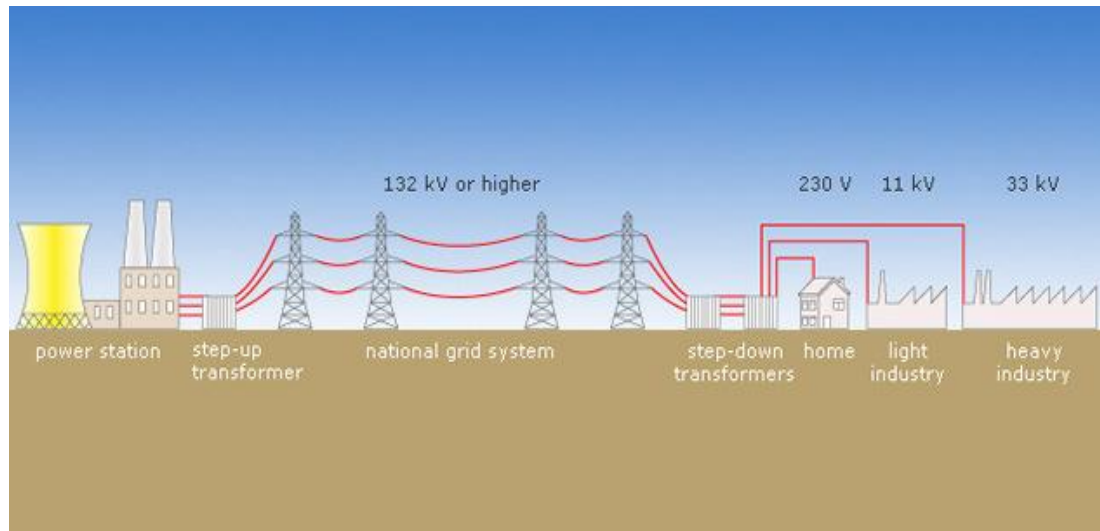

**Figure 2.1: Electrical power transmission and distribution system**

The generated output at 11kV/ 20kV is stepped up by the transformer to 132kV, 275kV and 500kV to be transmitted via transmission line and distributed to the substation. Some of the co-generator will have direct connection to the transmission line and distribute to the customers within specific area such as industrial complexes. Most of the factories received 11kV electricity from the substation to be stepped down with their own built infrastructure for more power reliability. The electricity will be stepped down via transformer to 415 V and 240 V for small factories, individual houses and residential premises.

### 2.3 Electrical power outage events in Malaysia

There were several major power outages have occurred in the country of Malaysia due to the tripped event at the main transmission lines that affected wide range of area as per below:



- i. In July 31, 1992, a bolt of lightning during a thunderstorm had strike a grid comprising four power lines between Paka and Teluk Kalong in Terengganu which caused massive power failure in the peninsular Malaysia at 3 pm. Fifteen of power stations on the west coast were put out of action. The grid was one of the two network supplying power to the west coast and due to this failure affected the Paka power station to trip. The power blackout happened for almost six to ten hours in the most affected states.

The corrective measures taken by TNB was to build an alternative transmission line between Terengganu and the south of the peninsular to improve its protection system in the power transmission system and TNB has allocated 30% spare capacity at any one time in its power generation system. A portable power station also provided by TNB in densely populated areas to ensure supply is enough.

- ii. A transmission line near Paka power station tripped causing all power stations in Peninsular Malaysia to collapse resulting in a massive power failure in August 3, 1996. The cascading effect of the trip shut down supply in sequence at all power stations. Supply was black to normal by 11pm at Paka and Dungun in Terengganu, Kalumpang and Rawang in Selangor, Cheras in Kuala Lumpur and Damansara in Petaling Jaya.

TNB recommended that dependence on power generated from these stations to be reduced to lower the risk of major system failure and TNB was expected to spend between RM50mil to RM100mil per year in the next five years to improve reliability and security of nation's electricity distribution.

- iii. There were series of blackout happened in Malaysia in 2013. On June 27, 2013, another severe blackout was reported during peak hour 5.36pm at Sarawak which is claimed to be originated from Bakun Dam causing a trip for the rest of the generators across the grid resulting of severe traffic congestion in the major cities. In July 2013 several power outages also occurred in Kuala Lumpur and Selangor.

Throughout the contingencies, one of the solutions to control the huge losses to the industry affected is by having load shedding scheme and the scheme must be effective to ensure the smoothness of the operation during the trip.

## **2.4 Previous method of load shedding**

Load shedding has been practiced by many and through various techniques and approach such as:

### **2.4.1 Under Frequency Load Shedding (UFLS)**

UFLS is one of the methods to avoid blackout from happen. The conventional UFLS system is designed to recover the balance of generation and consumption following a generator outage or sudden load increase. The loads to be shed by this system are constant load feeders and are not selected adaptively. In other words always the same loads are dropped from the system, regardless of the location of disturbance. In this method loads are classified in three groups of non-vital, semi-vital and vital loads [6]. The trend is to shed non-vital loads. However in severe conditions, semi-vital loads may also be shed.

The outage of a major generating unit in the power system may cause transfer of high amount of power in long distances which can reduce voltage stability margin of the system. In this situation occurrence of another contingency may cause voltage instability, though the system is stable in terms of frequency. After occurrence of the system disturbance, frequency initially decreases and then it might become unstable due to voltage problem. The return of frequency is due to load dependency on voltage and frequency.

Conventional UFLS scheme is designed to maintain the balance of generation and consumption following power deficiencies which may be the consequence of generator or tie-line outages. Whenever frequency of the system falls below predetermined thresholds and it remains below the thresholds for a certain time, parts of the system load are shed in some predetermined steps.

### 2.4.2 Breaker Interlock Scheme

The simplest method in load shedding scheme which signals are automatically sent to load breakers to open when a generator breaker or a grid connection is lost for any reason. It acts very fast since there is no processing required and decisions about the amount of load to be shed were made long before the fault occurred.

### 2.4.3 Under Voltage Load Shedding (UVLS)

UVLS has been successfully deployed in many systems throughout the world to protect local systems from voltage collapse. Alternatives to improve reactive margin and voltage profile in a voltage sensitive area include new generation, new transmission facilities, and shunt compensation. For low probability events and extreme contingencies, UVLS may be the most economical solution in preventing voltage collapse.

For systems that implement UVLS, it is recommended that UVLS should be automatic. If a system has an existing manual UVLS scheme, it should be replaced or supplemented with an automatic UVLS scheme. The two schemes should then be properly coordinated in terms of voltage pick-up, time delay, and the amount of load to be shed. The load to be manually shed should not be part of the automatic scheme. UVLS schemes should also be properly coordinated with other load shedding schemes within the same system and in neighboring systems.

A voltage collapse of part of the electrical system is an indication that for the existing conditions and contingencies, some portion of the combined generation and transmission system has been operated beyond its capability. Voltage collapse can also be a symptom of a much larger problem, and when the system starts to collapse, there is a real danger that the localized problem will cascade into wider areas. The purpose of proper system planning and

operating philosophies is for the system to function reliably, and failing that, to contain the impacts of disturbances to localized areas. UVLS can be useful tool to protect the system from voltage collapse, or uncontrolled loss of load or cascading.

#### **2.4.4 Programmable Logic Controller-Based Load Shedding**

The use of Programmable Logic Controllers (PLCs) for automatic sequencing of load has become an important part of substation automation in recent years. The application of PLCs in industrial load management and curtailment schemes started in the early 1980s. However, it wasn't until power management systems were combined with microprocessor based PLCs that distributed fast load shedding systems became a reality. With a common type of PLC-based load shedding scheme, load shedding is initiated based on the system frequency deviations and/or other triggers. The circuit breaker tripping can be programmed based on the system loading, available generation, and other specific logics. Each subsystem is equipped with a PLC that is programmed to shed a preset sequence of loads. This static sequence is continued until the frequency returns to a normal condition. Modification of the logic requires changing of the latter-logics that are programmed in the PLCs.

PLC-based load shedding scheme offers many advantages over the frequency-based scheme since they have access to information about the actual operating status of the power system. However monitoring of the power system is limited to the sections of the system that are connected to the data acquisition system. This drawback is further compounded by the implementation of pre-defined load priority tables in the PLC. These load reduction tables are executed sequentially to curtail blocks of load until a preset load shedding level is achieved. This process may be independent of the dynamic changes in the system loading, generation, or operating configuration. The system-wide operating conditions are often missing from the PLC's decision-making process resulting in insufficient or excessive load shedding. In addition, the

load shedding systems response time (time period for which the load shedding trigger is detected by the PLC or relay up to the time when the trip signal is received by the circuit breaker) during transient disturbances is often too long requiring for even more load to be dropped. The state-of-the-art load shedding system uses real-time system-wide data acquisition that continually updates a computer based real-time system model. This system produces the optimum solution for system preservation by shedding only the necessary amount of load and is called Intelligent Load Shedding.

## **2.5 Why Analytical Hierarchy Process (AHP) is selected**

Throughout the literature review stages, a few methods have been taken into consideration and finally the AHP method has been selected based on the following reasons:

- a) AHP is unique in handling a situation with many criteria to consider making this technique the best method in offering an alternative to a load shedding scheme.
- b) AHP is considered as a new method being practiced in a load shedding scheme for an islanded power system
- c) This AHP-based load shedding algorithm is simpler in concept as the load shedding decision is determined based on the information such as criteria and alternatives. It is also considered to be much faster when it comes to compare alternatives as the previous methods are more difficult and complex.
- d) By applying AHP to the load shedding scheme, the damage and loss can be reduced to a minimum level. Moreover, the requirement for alternative or additional power supply to the other loads can also be determine in maintaining the situation before it comes to worst.

## 2.6 Analytical Hierarchy Process (AHP)

The analytic hierarchy process (AHP) is a structured technique for organizing and analyzing complex decisions. Based on mathematics and psychology, it was developed by Thomas L. Saaty in the 1970s and has been extensively studied and refined since then. It has particular application in group decision making and is used around the world in a wide variety of decision situations, in fields such as government, business, industry, healthcare, and education.

Rather than prescribing a "correct" decision, the AHP helps decision makers find one that best suits their goal and their understanding of the problem. It provides a comprehensive and rational framework for structuring a decision problem, for representing and quantifying its elements, for relating those elements to overall goals, and for evaluating alternative solutions [2],[10].

Once the hierarchy is built, the decision makers systematically evaluate its various elements by comparing them to one another two at a time, with respect to their impact on an element above them in the hierarchy. In making the comparisons, the decision makers can use concrete data about the elements, but they typically use their judgments about the elements' relative meaning and importance. It is the essence of the AHP that human judgments, and not just the underlying information, can be used in performing the evaluations [2],[10].

The AHP converts these evaluations to numerical values that can be processed and compared over the entire range of the problem. A numerical weight or priority is derived for each element of the hierarchy, allowing diverse and often incommensurable elements to be compared to one another in a rational and consistent way. This capability distinguishes the AHP from other decision making techniques. In the final step of the process, numerical priorities are calculated for each of the decision alternatives. These numbers represent the alternatives' relative ability to achieve the decision goal, so they allow a straightforward consideration of the various courses of action. [2],[10].

The basic procedures of AHP as follows: [9]

- a) Develop the weights for the criteria by
  - developing a pairwise comparison matrix for each criterion
  - normalizing the resulting matrix
  - averaging the values in each row to get the corresponding rating
  - calculating and checking the consistency ratio
- b) Develop the ratings for each decision alternative for each criterion by
  - developing a pair wise comparison matrix for each criterion
  - normalizing the resulting matrix
  - averaging the values in each row to get the corresponding rating
  - calculating and checking the consistency ratio
- c) Calculate the weighted average rating for each decision alternative. Choose the one with the highest score.

## **2.7 Summary**

This chapter gives an overview on the various methods used in order to achieve the goal or objective to build a consistent power system and to avoid further declining of the system frequency and why the research is implemented Analytical Hierarchy Process (AHP) method to the study case.

## CHAPTER 3

### METHODOLOGY

#### 3.1 Background of the system

Universiti Malaysia Pahang (UMP) was established by the Government of Malaysia on February 16, 2002 and it was set up as a competency based technical university which specializes in the fields of engineering and technology. UMP is located on the east coast state of Pahang, the biggest state in Peninsular Malaysia with vast areas of rainforest endowed with a wide range of biodiversities and natural resources.

UMP, Pekan Campus is about 50 km away from Gambang Campus, is set to be the main campus of UMP after its full completion in 2015 tentatively. Upon its completion, the permanent campus will be able to accommodate a total number of 10,000 students and 2,000 staff. The location is in the vicinity of ever growing industrial zone especially automotive industry such as Mercedes-Benz, Suzuki, Volkswagen, Isuzu and DEFTECH which acts as a catalyst for research collaboration, academic proliferation and to foster collaboration and expertise.

Currently, there are three (3) faculties, namely Faculty of Electrical & Electronics Engineering, Faculty of Mechanical Engineering and Faculty of Manufacturing Engineering have made their way to the campus which is surrounded by sea breeze of the South China Sea as seen in Figure 3.1.





**Figure 3.1 : Location of UMP, Pekan Campus**

UMP offers a wide range of skills-based tertiary education programmes and practical-based tertiary education in engineering and technology to produce competent engineers. Its application oriented curriculum integrates theory and practice in the concept of a teaching factory, emphasizing experiential and action learning, task oriented and problem solving.

As for research, UMP focuses on applied research and industrial projects to enrich the teaching and learning processes as well as to promote the commercialization of research products, thus exposing students to the latest research and development activities in the industries.

The university's campuses are fully equipped with the latest information and communication technology (ICT) systems, including wireless broadband internet connections to facilitate the university's electronic based e-Learning and e-Management activities. UMP is committed to the development of human capital and

technology to fulfill the needs of industries as well as to contribute to the country's overall development.

The electrical infrastructure at UMP, Pekan Campus was fed by Tenaga Nasional Berhad (TNB) via single 11kV to a 11kV consumer HT panel copper busbar, 25kA, 630A or known main Busbar 1. This Busbar 1 is connected to the other five busbar which act as five alternatives out of seven alternatives in this study while the other two alternatives comes from one of the five busbar as per shown in Figure 3.2 below:

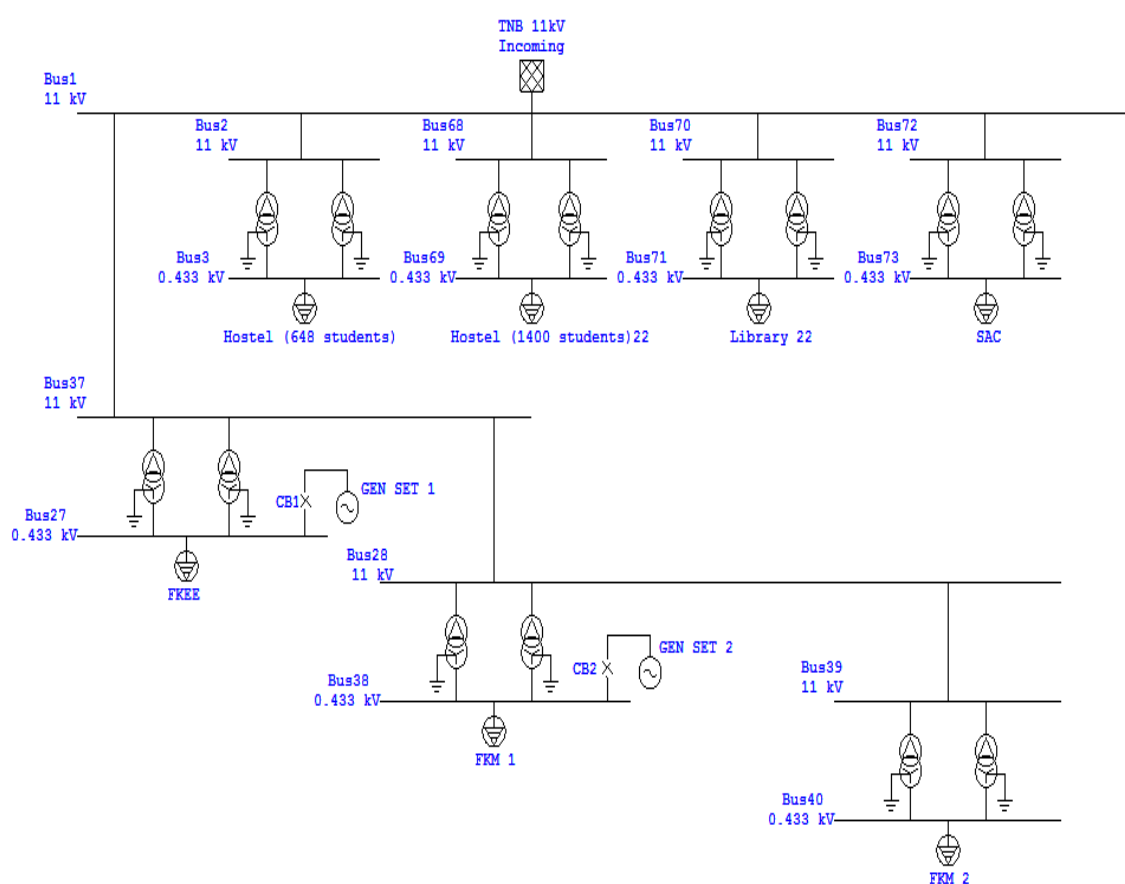

**Figure 3.2 : Single Line Diagram of UMP, Pekan Campus**

Based on Single Line Diagram in Figure 3.2, the seven alternatives are seven substation which are Faculty of Electrical & Electronics Engineering (FKEE), Faculty of Mechanical Engineering 1 (FKM 1), Faculty of Mechanical Engineering 2 (FKM 2), Library, Hostel for 1400 students, Hostel for 648 students, Students Activity

Centre. There are only two standby generator set to accommodate power supply to FKEE and FKM 1.

The power system in UMP is not properly arranged as each of the building is under different consultant. There are no such Ring System in this power system with each one of the substation is fed by different feeder.

### **3.2 Does the system need a properly planned load shedding procedure?**

Since UMP, Pekan Campus does not have any power system protection scheme as been told by the person-in-charge, this hypothetical study situation was undertaken to help the person-in-charge remove the selected load systematically if any breakdown or contingency happen in future.

Curently, the person-in-charge just select the load to be shed manually based on their experienced without any proper guidelines. Thus, the Analytical Hierarchy Process (AHP) is the suitable method of doing selection during major similar shutdown in future as a reference to guide the person-in-charge.

### **3.3 AHP process**

AHP is a framework for problem solving that organizes judgements into a hierarchy of criteria that influence decisions [4] and it was developed by Professor Thomas L. Saaty in the 1970s and has been extensively studied and refined since then [5]. The AHP is a kind of heuristic algorithm which is one that provides good approximate solutions to a given problem [6]. Often in employing such an algorithm one may be able to precisely measure the goodness of the approximation.

In exploring through AHP method, the steps of AHP are to develop the weights for criteria, then develop the rating of each of the alternatives for each of the criteria and calculate the overall weights and finally determine the priority. In order to verify whether

the values were within acceptable range, consistency Ratio (CR) is calculated and if the values were less than 0.1, it is then assumed to be consistent and the pair wise comparison matrix is within the acceptable tolerance. This AHP method is applied using Microsoft Excel Software to do all the calculation and it is applicable to all the users to solve their complex decision making process and will produce the desired results on a priority basis.

These days, there are various versions of AHP existed. Initially, AHP was designed to calculate the  $n$ th root of the product of the pair-wise comparison values in each row of the matrices and then normalizes the aforementioned  $n$ th root of products to get the corresponding weights [19]. Meanwhile the modified AHP version normalizes the pair-wise comparison values within each of the matrices and then averages the values in each row to get the corresponding weights and ratings [19].

Since both versions give almost the same results, the original method has been chosen to be implemented in this heuristic study. Typically the process of AHP analysis can be shown in three main steps as shown in both Figure 3.3 and Figure 3.4 below:

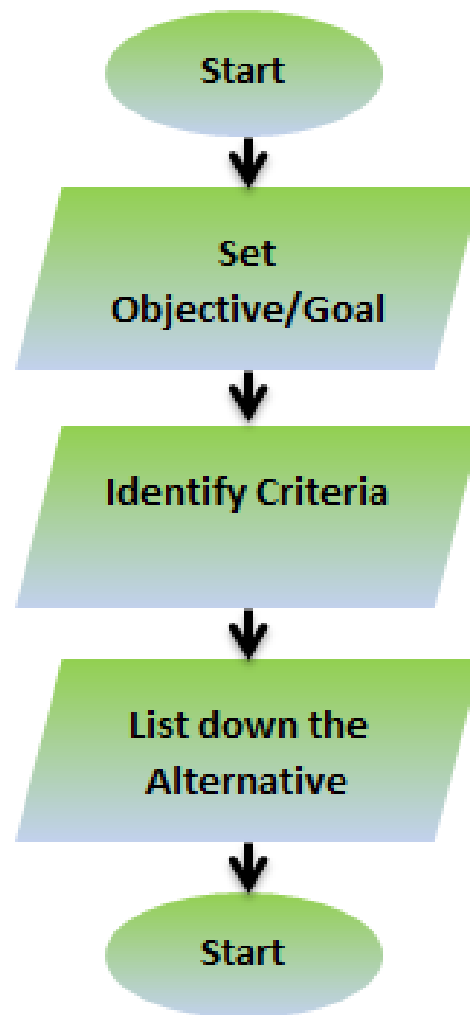

**Figure 3.3 : Flow chart of the hierarchy structure**

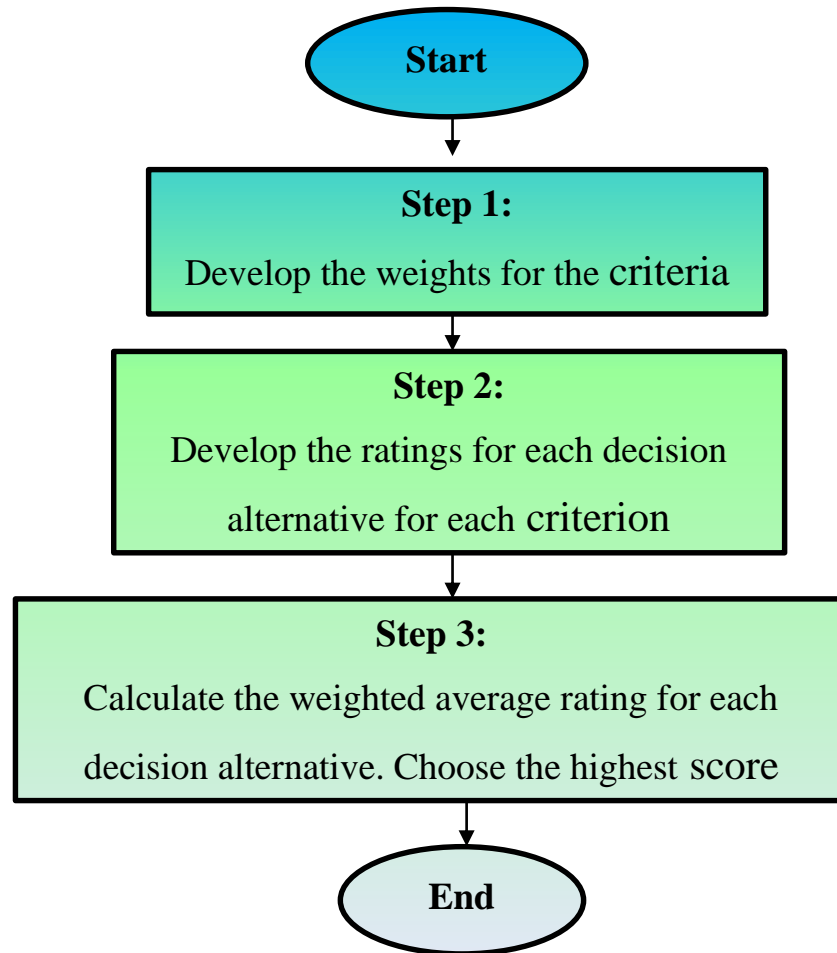

**Figure 3.4 : Flow Chart of the AHP method**

**Step 1: Develop the weights for the criteria: [3],[8],[9]**

- a) First, develop a single pair-wise comparison matrix for the criteria as shown in the equation below:

$$A_C = \begin{matrix} & C_1 & C_2 & \cdots & C_n \\ \begin{matrix} C_1 \\ C_2 \\ \vdots \\ C_n \end{matrix} & \begin{bmatrix} a_{11} & a_{12} & \cdots & a_{1n} \\ a_{21} & a_{22} & \cdots & a_{2n} \\ \vdots & \vdots & \ddots & \vdots \\ a_{n1} & a_{n2} & \cdots & a_{nn} \end{bmatrix} & , i = 1,2,\dots,n; j = 1,2,\dots,n \end{matrix} \quad (3.1)$$

where,  $C_1, C_2, \dots, C_n$  representing the criteria,  
 $a_{ij}$  represents the rating of  $C_i$  with respect to  $C_j$

- b) Then, multiply the values in each row together and calculates the  $n$ th root of the said product as shown in the equation below:

$$\mathbf{n^{th} root of product} = \sqrt[n]{\mathbf{product of each row}} \quad (3.2)$$

where  $n$  = positive integer number

- c) After that, normalizing the aforementioned  $n$ th root of products to get the appropriate weights by using the formula given in equation 3.3:

$$\mathbf{Weight} = \frac{\mathbf{n^{th}root of product}}{\sum(\mathbf{n^{th}root of product})} \quad (3.3)$$

- d) Lastly, perform the Consistency Ratio (CR) by using the formula as shown below:

$$\mathbf{CR} = \frac{\mathbf{CI}}{\mathbf{RI}} \quad (3.4)$$

The value of Random index (RI) can be found using Table 3.1 where Random Index (RI) is a constant and it is a standard for AHP analysis.

**Table 3.1: Table of Random Index**

n	1	2	3	4	5	6	7	8	9	10
RI	0	0	0.58	0.9	1.12	1.24	1.32	1.41	1.45	1.49

\*Note: Value of C.R must be less than the allowable value of 0.10. Therefore, the consistency of the judgment matrix should be within an acceptable tolerance. But if the consistency ratio is greater than 0.10 then the subjective judgment needs to be revised.

While the value for Consistency Index (CI) can be found by using this equation:

$$CI = \frac{\mathbf{Lambda}_{max} - n}{n - 1} \quad (3.5)$$

and for Lambda\_Max,

$$\mathbf{Lambda}_{Max} = \frac{\sum(\sum \mathbf{column}_{each\ alternative} \times \mathbf{weight}_{per\ row})}{n} \quad (3.6)$$

where:  $\sum \mathbf{column}$  is the summation of pair-wise values of each alternative vertically and  $n$  is a positive integer number.



## REFERENCES

- [1] Shokooh, F., Dai, J. J., Shokkoh, S., Tastet, J., Castro, H., Khandelwal, T. & Donner, G.. An Intelligent Load Shedding (ILS) System Application in a Large Industrial Facility. *Industry Applications Conf, 2005. Fourtieth IAS Annual Meeting Conf. Record of the 2005, 1*. 2005. pp. 417 - 425.
- [2] Rad,B.F, Abedi, M. An Optimal Load-Shedding Scheme during Contingency Situations Using Meta-Heuristics Algorithms with Application of AHP Method. *IEEE 11<sup>th</sup> International Conference in Brasov, 22-24 May 2008*
- [3] H.H.Goh, B.C.Kok. Application of Analytic Hierarchy Process (AHP) in Load Shedding Scheme for Electrical Power System. *Environment and Electrical Engineering (EEEIC), 2010 9th International Conference on 16-19 May 2010*.
- [4] R. K. Rietz, S. Suryanarayanan. A Review of the Application of Analytic Hierarchy Process to the Planning and Operation of Electric Power Microgrids. *Power Symposium, 2008. NAPS '08. 40th North American, 28-30 Sept. 2008*.
- [5] Hak-Man Kim, Tetsuo Kinoshita, Yujin Lim. Talmudic Approach to Load Shedding of Islanded Microgrid Operation Based on Multiagent System. *Journal of Electrical Engineering & Technology Vol. 6, No. 2, pp. 284~292, 2011 DOI: 10.5370/JEET.2011.6.2.284*
- [6] Kunz, J. The Analytical Hierarchy Process (AHP). *Eagle City Hall Location Options Task Force. February/March 2010*.
- [7] Faizah Husain, Nur Aishah Sulaiman, Khairil Afendy Hashim, Abd. Manan Samad. A Study on TNB Transmission Line Route Sustainability and Suitability Using GIS-AHP. *2012 IEEE Control and System Graduate Research Colloquium (ICSGRC 2012)*.

- [8] Thomas L. Saaty. Decision making with the analytic hierarchy process. *Int. J. Services Sciences, Vol. 1, No. 1, 2008*
- [9] [http://en.wikipedia.org/wiki/Analytic\\_hierarchy\\_process](http://en.wikipedia.org/wiki/Analytic_hierarchy_process).
- [10] IEC 60354: Loading guide to oil immerse power transformer
- [11] IEC 60076-1: Power transformer part 1: General
- [12] IEC 60076-8: Power transformer application guideline
- [13] JKR Standard, LS12: Specification for 11kV High Voltage Ring Main Unit distribution switchgear.
- [14] JKR Standard, LS13: Specification for 11kV High voltage underground cable.