

REAL TIME AIR QUALITY REPORTING SYSTEM

SHA-SHA SHELYNA BINTI MOHD SHARIFF

A thesis submitted in

Fulfillment of the requirement for the award of the

Degree of Master of Electrical Engineering

FACULTY OF ELECTRICAL AND ELECTRONIC ENGINEERING

UNIVERSITI TUN HUSSEIN ONN MALAYSIA

SEPTEMBER 2015

ABSTRACT

This paper presents a project entitled Real Time Air Quality Reporting System, which can detect readings of the air pollution index (API) in the surrounding area of the device is connected with a cheaper cost compared detector system air pollution index (API) available in the market. A project and a new strategy presented is to use a combination of the Arduino software along with the GSM system and hardware by using dust sensors to detect reading as a tool for reading the air pollution index (API). The Reading of air pollution index (API) in unhealthy condition is detected, the system will be sent unhealthy condition to smartphone using short messaging system (SMS). In this way information about the unhealthy condition of IPU will quickly known for ease of initial steps and security measures taken.

ABSTRAK

Kertas ini membentangkan projek yang bertajuk Real Time Air Quality Reporting System yang dapat mengesan bacaan indeks pencemaran udara (IPU) di kawasan persekitaran alat tersebut diletakan dengan kos yang lebih murah berbanding system alat pegesan indeks pencemaran udara (IPU) yang terdapat dipasaran. Satu cadangan dan strategi baru dibentangkan adalah dengan menggunakan gabungan antara software Arduino berserta system GSM dan hardware dengan menggunakan alat pengesan habuk sebagai alat mengesan bacaan indeks pencemaran udara (IPU). Keadaan bacaan (IPU) yang tidak sihat jika dapat dikesan akan dihantar ke telefon pintar dengan menggunakan system pesanan ringkas (SMS). Dengan kaedah ini maklumat mengenai keadaan IPU yang tidak sihat akan cepat diketahui di sesebuah kawasan bagi memudahkan langkah awal dan langkah keselamatan diambil.

CONTENTS

TITLE	PAGE
DECLARATION	ii
DEDICATION	iii
ACKNOWLEDGEMENT	iv
ABSTRACT	xiii
TABLE OF CONTENTS	v
LIST OF FIGURE	ix
LIST OF TABLE	x
LIST OF ABBREVIATIONS	xi
LIST OF APPENDIX	xii

CHAPTER 1 INTRODUCTION

1.1	Projects Background	1
	1.1.1 Air Pollution Index (API)	2
1.2	Problem Statement	5
1.3	Objective	5
1.4	Project Scope	6

CHAPTER 2 LITERATURE REVIEW

2.1	Introduction	7
2.2	Related Studies	8
2.3	Summary List Of Related Study	11

CHAPTER 3 METHODOLOGY

3.1	Introduction	13
3.2	The Development of Flow Chart	13
3.3	System Design	15
3.4	Hardware Selection and Development Platform	17
	3.4.1 Air Particle Optical Sensor	17
	3.4.2 Arduino Mega	21
	3.4.3 SIM900 GSM/GPRS shield for Arduino	26

3.4.3.1	Installation	29
3.4.4	Display	33
3.5	Software Development	34
3.5.1	Software selection	34

CHAPTER 4 RESULT AND ANALYSIS

4.1	Introduction	35
4.2	Hardware Design	36
4.3	Arduino Program	40
4.4	Data Sampling	44
4.5	Testing Project	45
4.6	Results of Dust Density using Sharp Optical Dust Sensor	48
4.7	Data Sensitivity By Data Sheet Of GP2Y1010AU0F Dust Sensor	52
4.8	Result Testing Using Of GP2Y1010AU0F Dust Sensor	54

CHAPTER 5 CONCLUSION

5.1	Conclusion`	57
5.2	Recommendation and Future Works	58

REFERENCE	59
APPENDIX	62

LIST OF FIGURES

	LIST	PAGE
3.1	Methodology flowchart	14
3.2	Block diagram of API Monitoring System	15
3.3	Compact Optical Dust Sensor (GP2Y1010AU0F)	17
3.4	Output Voltage versus Dust Density	18
3.5	Parameter for Optical Sensor	18
3.6	Internal schematic	19
3.7	Absolute Maximum Ratings	19
3.8	Recommended input condition for LED input terminal	20
3.9	Input Condition for LED Input Terminal	20
3.10	Sampling Timing of Output Pulse	20
3.11	Arduino Mega	21
3.12	Block Diagram of the AVR Architecture	22
3.13	SREG – AVR Status Register	24
3.14	The Parallel Instruction Fetches and Instruction Executions	24

3.15	Single Cycle ALU Operation	25
3.16	SIM900 GSM shield for Arduino	26
3.17	Hardware SIM900 GSM/GPRS shield for Arduino	28
3.18	Bottom Map SIM900 GSM/GPRS shield for Arduino	28
3.19	UART Multiplexer	29
3.20	Connect the Arduino board	29
3.21	Connect the UART Interface as FT232	29
3.22	An Example For Software-Serial Connection	30
3.23	Com Switch	31
3.24	RI behavior of data calling as a receiver	31
3.25	RI behavior of URC or receive SMS	31
3.26	Mobile telephone for display the reading of API	33
3.27	Arduino IDE	34
4.1	Connection six pins on Sharp Sensor GP2Y1010AU0F	36
4.3	Circuit Design	37
4.4	Connection Between Sharp Sensor GP2Y1010AU0F With Circuit	37
4.5	Connection Between Arduino Mega and SIM900 GSM/GPRS	38
4.6	Connection Sharp Sensor GP2Y1010AU0F , Circuit Design , Audrino Mega And SIM900 GSM/GPRS	38
4.7	Connection Sharp Sensor GP2Y1010AU0F, Circuit Design, Audrino Mega, SIM900 GSM/GPRS and Arduino Software	39
4.8	Done Compiling	40
4.9	Compiling Sketch	40
4.10	Done uploading	41

4.11	Data Collection From Sensor	42
4.12	Location Of Portable Air Quality Monitoring	43
4.13	Location 1 Of Sharp GP2Y1010 Optical Dust Sensor	44
4.14	Location 2 Of Sharp GP2Y1010 Optical Dust Sensor	44
4.15	Location 3 Of Sharp GP2Y1010 Optical Dust Sensor	44
4.16	Location 4 Of Sharp GP2Y1010 Optical Dust Sensor	45
4.17	Location 5 Of Sharp GP2Y1010 Optical Dust Sensor	45
4.18	Comparison Data Sampling 5 Location With Air Sampler For Table 4.1	47
4.19	Comparison Data Sampling 5 Location With Air Sampler For Table 4.2	48
4.20	Comparison Data Sampling 5 Location With Air Sampler For Table 4.3	49
4.21	Comparison Data Sampling 5 Location With Air Sampler For Table 4.4	50
4.22	Sensitivity GP2Y1010AU0F Dust Sensor Using Cigarette Mild Seven	51
4.23	Output Voltage vs. Dust Density	52
4.24	Data sampling cigarette Mild Seven From Sensor	53

LIST OF TABLE

	LIST	PAGE
1.1	API system adopted in Malaysia	3
1.2	API and Health Implications (Daily Targets)	3
2.1	Summary List Of Related Studies	11
3.1	Specifications	27
3.2	Electrical Characteristics	27
3.3	RI Behavior Output	30
3.4	The status of the NETSTATUS LED	32
3.5	API and Air Pollution Level	33
4.1	Data Sampling Of Sharp GP2Y1010 Optical Dust Sensor	46
4.2	Data Sampling Of Sharp GP2Y1010 Optical Dust Sensor	48
4.3	Data Sampling Of Sharp GP2Y1010 Optical Dust Sensor	49
4.4	Data Sampling Of Sharp GP2Y1010 Optical Dust Sensor	50

LIST OF ABBREVIATIONS

LIST OF APPENDIX

APPENDIX A Source Code

CHAPTER 1

INTRODUCTION

1.1 Projects Background

In the era of globalization challenges, health is an important element in our lives. Various diseases involving respiratory such as asthma and cough, acute cardiovascular disease and adverse pregnancy outcomes can be acquired chiefly derived from polluted air. Besides that, air pollution could have the greatest impact on the environment. Global warming phenomena that threaten our earth in recent years is closely related to the level of air pollution that caused by vast amount of carbon emission from vehicle petrol and diesel combustion, waste from ever-expanding production industry, uncontrolled combustion of fossil fuel and open-air burning in the waste management site. To know the quality of the air around us is very important. For this project, the aim of the project is to develop a low cost,

portable air pollution index (API) monitoring system in real time. The Air Pollution Index (API) is a simple and generalized way to describe the air quality, which is used in Malaysia. It is calculated from several sets of air pollution data. The project using a hardware and software to measure the dust density in the air and display the API reading in the hand phone by the SMS (short message service). The system must be robust and provide constant accurate reading and will help user get information about a API air pollution in the someplace such at home where the sensor placed. It will help user know the unhealthy condition when the system design will send information of the API condition using the SMS received.

1.1.1 Air Pollution Index (API)

Ministry of Natural Resources and Environment stated that there are many sources of air pollutions in Malaysia such as from industries, development activities, motor vehicles, power generation, land clearing and open burning and forest fires. Wisconsin Department of Natural Resources mentions that the specific pollutant, its concentration in the air, the length of time of exposure, human own health conditions and the environmental quality of the area are all factors in how air pollution affects human's health [1].

The API is an index for reporting daily air quality. Air pollution index normally includes the major air pollutants that could hard to human health. API provides understandable information about the air pollution to the public. Malaysian Air Quality Index (MAQI) follows closely to Pollutant Standard Index (PSI) develop by United States Environmental Agency (EPA). The air pollutant included in Malaysia's API are carbon monoxide (CO), nitrogen dioxide (NO₂), sulphur dioxide (SO₂), ozone (O₃) and suspended particulate matter less than 10 microns in size (PM₁₀) [4]. Table 1.1 shows API system adopted in Malaysia.

API	Air Pollution Level
0 - 50	Good
51 - 100	Moderate
101 - 200	Unhealthy
201 - 300	Very unhealthy
301 - 500	Hazardous
500+	Emergency

Table 1.1 API system adopted in Malaysia

API	Air Pollution Level	Health Implications
0 - 50	Excellent	No health implications
51 - 100	Good	No health implications
101- 150	Slightly Polluted	Slight irritations may occur, individuals with breathing or heart problems should reduce outdoor exercise.
151- 200	Lightly Polluted	Slight irritations may occur, individuals with breathing or heart problems should reduce outdoor exercise.
201- 250	Moderately Polluted	Healthy people will be noticeably affected. People with breathing or heart problems will experience reduced endurance in activities. These individuals and elders should remain indoors and restrict activities.

251-300	Heavily Polluted	Healthy people will be noticeably affected. People with breathing or heart problems will experience reduced endurance in activities. These individuals and elders should remain indoors and restrict activities.
300+	Severely Polluted	Healthy people will experience reduced endurance in activities. There may be strong irritations and symptoms and may trigger other illnesses. Elders and the sick should remain indoors and avoid exercise. Healthy individuals should avoid out door activities.

Table 1.2 API and Health Implications (Daily Targets)

1.2 Problem Statement

Air pollution index (API) is basically a scale to gauge the severity or how polluted the air is. The greater number of the API represents the more dangerous the air quality to human health. The unpredictable weather that occurred in our country in recent months has exposed our environment towards to natural disasters especially fire which results in hazy environment. Haze will definitely affect the API in that particular area where the fire occurs. On the other hand, industrial waste such as unreacted gas could also affect the API especially the area nearby the industrial area. Nowadays, individual who wants to have an API system has to pay a fortune because the installation cost is very high and expensive. The size is also large and not portable. These systems are usually used by government's bodies and large companies who own industrial plants to monitor the air quality. This project has been proposed to produce a cheaper version of API system and portable using cheaper materials costs, readily available Arduino microcontroller and GSM system.

1.3 Objective

There are few objectives that need to be achieved at the end of this project. The objectives of this project are:

- i) To design a low cost and portable air pollutant index (API) using particle and gas sensor;
- ii) To integrate the sensor, Arduino microcontroller and GSM module to form a complete API system.
- iii) To transmit and receive Air pollution index (API) data via short message service (SMS) using GSM.

1.4 Project Scope

In order to achieve the objectives of the project, several scopes have been outlined. The following are the scopes of the project:

- i) Use a suitable sensor and signal conditioning circuit to detect air quality pollutant at surrounding.
- ii) Create suitable program coding for reading a data from sensor to Arduino microcontroller.
- iii) Create a suitable command GSM system to send the data received from Arduino microcontroller and send data using by short message service (SMS).

CHAPTER 2

LITERATURE REVIEW

2.1 Introduction

This chapter will discuss about the literature review from previous research related to this master's project. Literature review is a process of collecting and analyzing data and information which are relevant to this study. The required data and information are collected through variable sources such a journal's, articles, reference books, and online databases. The previous projects give some ideas and understanding on the basic principles involved in this study.

2.2 Related Studies

Srinivas D., [11] developed Public Transportation Infrastructure such as buses, which have fixed and reliable routes along high volume corridors using a custom-made Mobile Sensing Box (MSB). MSB includes a microcontroller board with add-on sensors, a peripheral GPS receiver and a cellular modem. Connecting to the bus battery would provide the power supply needed to operate this model. Used two pollution sensors to measure carbon monoxide and particulate matter concentrations.

Adrew L., [12] designed and implemented a new generation of detectors, nanotechnology based metal oxide semiconductors such as ZnO semiconductor to substitute the typical analytical tools and adapt or extend the air quality monitoring system. In fact these solid state gas sensors offer an excellent opportunity for implementation in environmental monitoring due to light weight, extremely small size, robustness, low cost and also as they can be installed anywhere to collect data covering extensive areas. The air quality data can eventually be transmitted through a Wireless GIS network system to the general public.

Kim, S. and Paulos, E. [13] designed and implemented a system called Air that able to measure, visualize, and share indoor air quality. A DC 1100 air quality is used to measure the level of indoor pollutant, an AVR-based Arduino which transplant inside the air quality monitor, and an iPod Touch is used to process, visualize and transmit the data wireless to the Arduino. The data will be reported every 15 seconds at the same time the Arduino will encode the data into a series of audio tones like a modem and will be read by iPod Touch via microphone port. The data can be shared from central server in real-time by using Wi-Fi networking.

Rajiv P., and Khedo K., [14] presented a wireless sensor network air pollution monitoring system (WAPMS). The sensor networks are dense wireless networks of small, low-cost sensors, which collect and disseminate environmental data. Wireless

sensor networks facilitate monitoring and controlling of physical environments from remote locations with better accuracy. They have applications in a variety of fields such as environmental monitoring, indoor climate control, surveillance, structural monitoring, medical diagnostics, disaster management, emergency response, ambient air monitoring and gathering sensing information in hospitable locations. Its system design more easy to user with develop an architecture to define nodes and their interaction, Visualization of collected data from the WSN using statistical and user-friendly methods such as tables and line graphs, generation of reports on a daily or monthly basis as well as real-time notifications during serious states of air pollution for use by appropriate authorities and Provision of an index to categorize the various levels of air pollution, with associated colours to meaningfully represent the seriousness of air pollution.

Zakaria, N., S., [15] designed a low cost API system for a Rice Mill Factory located in Pering, Kedah Darul Aman. The factory needs to provide a good air quality surrounding not only for its employee but also for the neighbouring villagers. A 24 hours production time also contributed to its pollution factor and the level of exposure endured by the employee during the work shift needs to be considered as well. Rice Husk/Dust Air Particle Sensor using ZigBee Wireless Sensor Network was developed using SHARP GP2Y1010AU0F optical dust sensor as the measurement tools, an Arduino Fio board was used as the development board for its expansion capabilities using ZigBee Wireless Modules. A point to point approached was developed with the data being transmitted back to its host computer, and a serial port was used to read the HEX string data. Parallax Microcontroller Acquisition to Excel (PLX DAQ) software is used to read the string data and save it to Microsoft Excel software. Using Visual Basic Application on Microsoft Excel, a graph displaying the dust measurement can be viewed on the real time basis. Conclusively, the sensor and methods used for this project was substantial enough to monitor the dust density for reducing the dust pollution in the Rice Mill Factory.

Sung, J.O and Wan, Y.C [16] developed a RF wireless sensor module with optimal communication condition to monitor indoor air quality in a room or office. The monitoring work can be done by web-based monitoring system together with other home networking system by using PDA (Personal Digital Assistant). There are several sensors for instance; temperature sensor, humidity sensor, Carbon Dioxide sensor and flying dust sensor were built in the RF transmitter board for monitoring the room environment. An Intel 8051 microcomputer was used to control the power switches of consumer electronics through signals received from PC or PDA.

Phang Qili [17] has presented a room dust monitoring system. The main objective of the system was to monitor the dust concentration of a room and show the readings on a personal computer in real time. These systems used an Arduino Uno controller work based on a Shinyei PPD20V particle sensor to measure the dust concentration in a room. The readings taken from the sensor will be sending to computer to show in real time using Graphical User Interfacing (GUI) by using Visual Basic program. The result was taken in several conditions including clean room, dusty room, room with cooking haze and room with cigarette smoke. The result varied with the condition of the room. With this device, the awareness of the effects of human activities on indoor pollutants can be rose up and thus lead to human health and well-being.

2.3 Summary List Of Related Study

Table 2.1 shows the summary of related studies regarding air pollution index measurements.

Table 2.1: Summary List Of Related Studies

PROJECT TITLE	AUTHOR	PROJECT DESCRIPTION
Real- time Air Quality Monitoring Through Mobile Sensing in Metropolitan Areas	Srinivas D, Department Of Computer Science , Rutgers University, NJ 08854-8091.	Using a custom-made Mobile Sensing Box(MSB) that includes a microcontroller board with add-on sensors, a peripheral GPS receiver and a cellular modem to measure carbon monoxide and particulate matter concentrations.
Air pollution monitoring and GIS modeling: a new use of nanotechnology based solid state gas sensors	Adrew L., Remote Sensing and GIS FoS, School of Advanced Technologies, Asian Institute of Technology, Klongluang, 12120 Pathumthani, Thailand, 25 February 2005.	Use a nanotechnology based metal oxide semiconductors such as ZnO semiconductor and gas sensor for detect a air pollution .
InAir: sharing indoor air quality measurements and visualizations.	Kim, S., & Paulos, E. In Proceedings of the 28th international conference on Human factors in computing systems.ACM:2010. pp.1861-1870.	Use a Arduino and Ipod Touch for the system design and Limited for indoor design. The advantage is increased awareness of, and reflection on air quality.
A Wireless Sensor Network Air Pollution Monitoring System	Rajiv P., Kavi K. Khedo, Department of Computer Science and Engineering, University of Mauritius, Reduit, Mauritius.	This system design display by colour node for aleart a air pollution in area detected in computer,the data able to save in the system design for future reference.

<p>Rice Husk/Dust Air Particle Sensor using Zigbee Wireless Sensor Network</p>	<p>Zakaria,S., Degree of Master Thesis. Universiti Tun Hussien Onn Malaysia; 2013.</p>	<p>Using Optical dust sensor (Sharp) and Zigbee Module, practical and low cost, only limited for measuring the respirable dust in a Rice Mill factory to maintain its good air quality policy</p>
<p>Room environment monitoring system from PDA terminal.</p>	<p>Oh, S. J., & Chung, W. Y. In Intelligent Signal Processing and Communication Systems, 2004.ISPACS 2004. Proceedings of 2004 International Symposium.IEEE: 2004. pp. 497-501.</p>	<p>control by PDA terminal and RF wireless sensor module and easily replaced but difficult to control more than one sensor</p>
<p>Room Dust Monitoring System</p>	<p>P. Qili, Bachelor Degree Thesis.Universiti Tun HussienOnn Malaysia; 2013.</p>	<p>Use a Shinyei PPD 20V particle sensor and Visual Basic for detected condition of the room</p>

CHAPTER 3

METHODOLOGY

3.1 Introduction

This chapter explains about the project's methodology that has been applied in the project. It is the guideline used in completing the project from the very beginning until the end. The methodology consists of several activities that have been performed in order to ensure that the project can be completed successfully.

3.2 The Development of Flow Chart

Figure 3.1 shows the flowchart of the research in completing the API Monitoring System project.

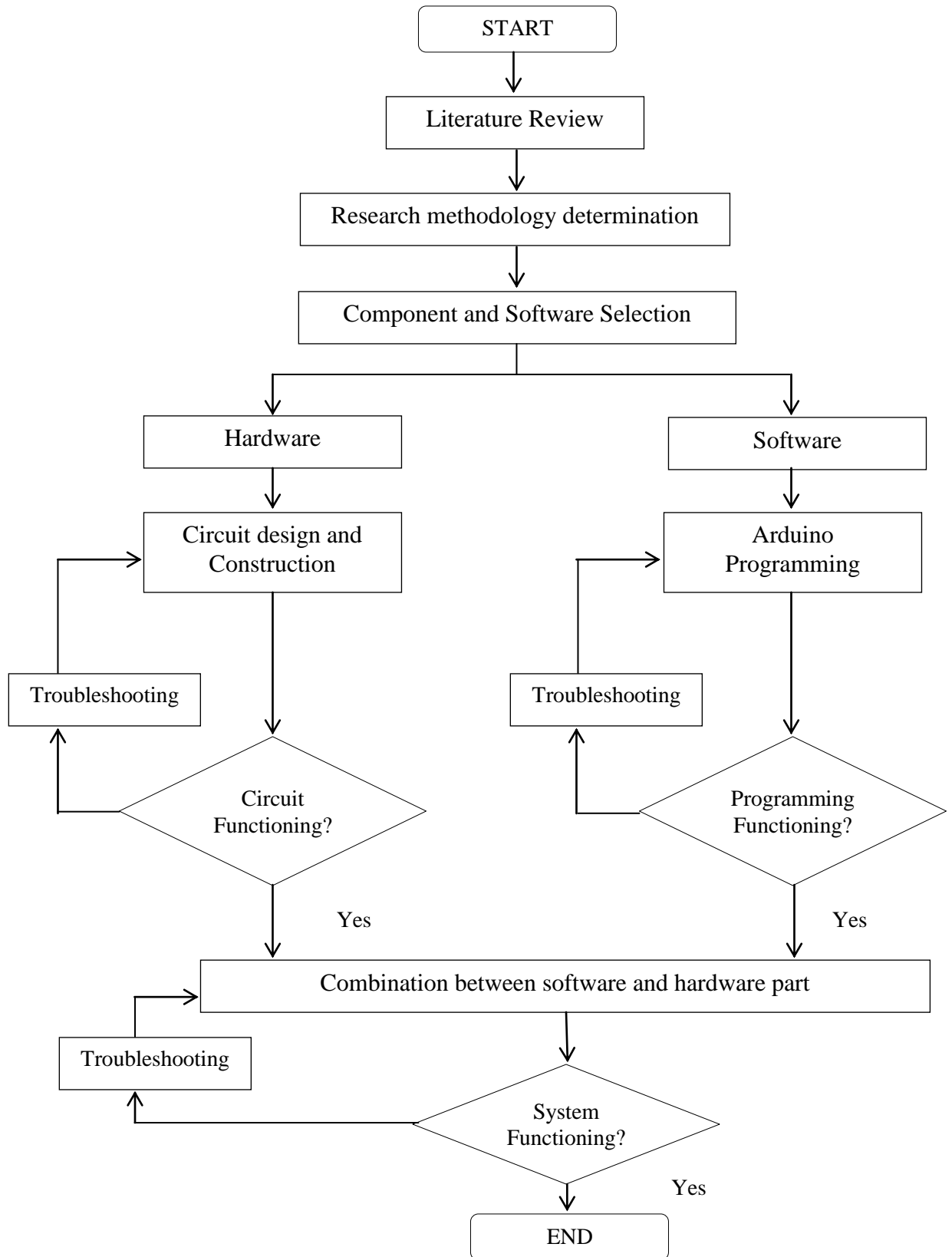

Figure 3.1: Methodology flowchart

3.3 System Design

In this section, the progress of designing a real time air quality reporting system will be discussed in detail. Therefore, this chapter deals with the design and construction of the actual system as shown in Figure 3.2. The system can be categorized into two parts as below:

- i. Hardware development part
- ii. Software development part

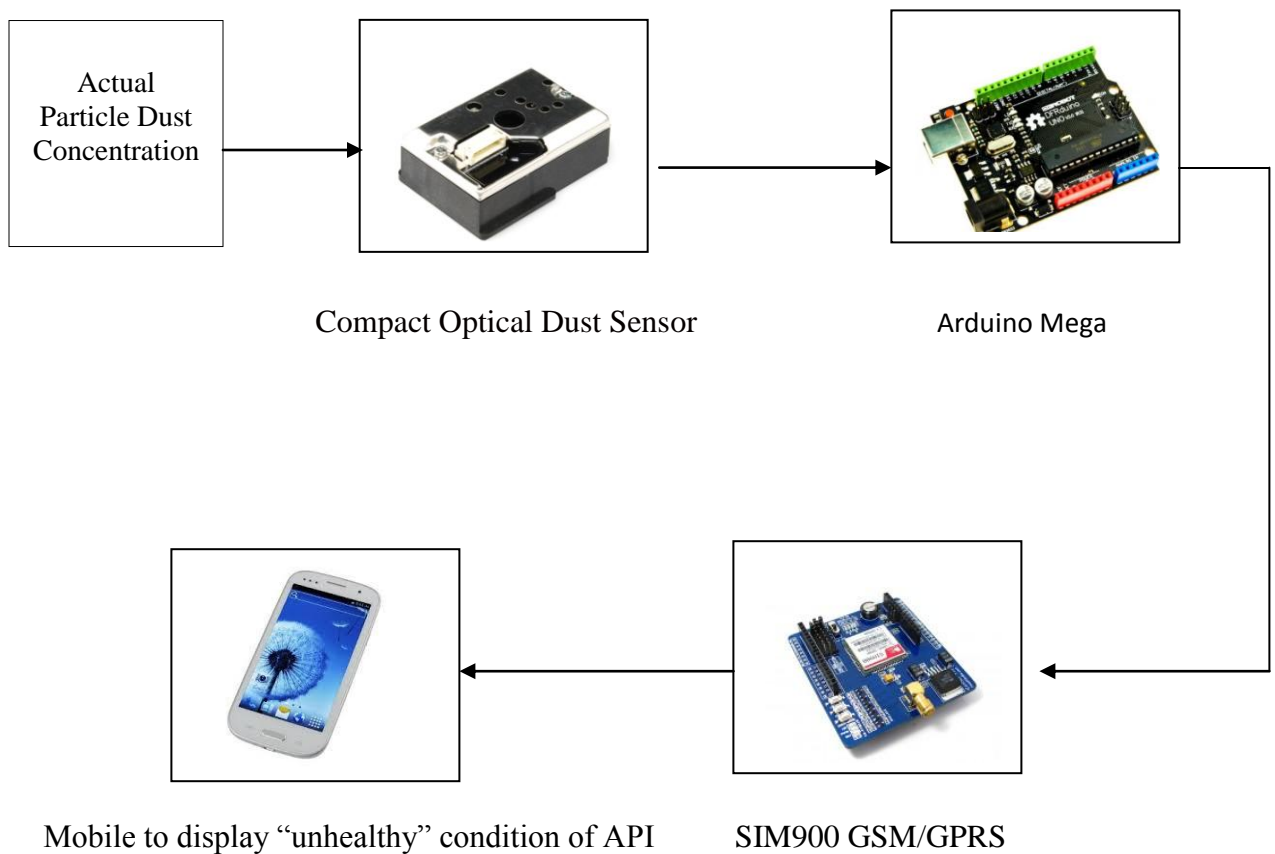

Figure 3.2: Block diagram of API Monitoring System

From Figure 3.2, the first stage in developing the Compact Optical Dust Sensor (GP2Y1010AU0F) will be detecting dust in the air. The sensors have a dust sensor by optical sensing system. An infrared emitting diode (IRED) and a phototransistor are diagonally arranged into this device. It detects the reflected light of dust in air. The particle sensor detects the concentration of particle in environment and converts it into a voltage signal. Sharp's GP2Y1010AU0F is an optical air quality sensor, designed to sense dust particles. An infrared emitting diode and a phototransistor are diagonally arranged into this device, to allow it to detect the reflected light of dust in air. It is especially effective in detecting very fine particles like cigarette smoke, and is commonly used in air purifier systems. The sensor has a very low current consumption (20mA max, 11mA typical), and can be powered with up to 7VDC. The output of the sensor is an analog voltage proportional to the measured dust density, with a sensitivity of 0.5V/0.1mg/m³.

In this project, arduino DFRduino UNO R3 is used. The collected data will be sent to the arduino board to analyse the data. The analysed data is then sent to the user's mobile phone through GSM board.

3.4 Hardware Selection and Development Platform

Hardware selection is one of the crucial parts of the project as it will determine the accuracy and reliability of the results. The following subsection explains the hardware selection and the development platform.

3.4.1 Air Particle Optical Sensor (Compact Optical Dust Sensor)

GP2Y1010AU0F as shown in Figure 3.3 is a dust sensor by optical sensing system. An infrared emitting diode (IRED) and a phototransistor are diagonally arranged into this device. It detects the reflected light of dust in air. Especially, it is effective to detect very fine particle like the cigarette smoke. In addition it can distinguish smoke from house dust by pulse pattern of output voltage.



Figure 3.3: Compact Optical Dust Sensor (GP2Y1010AU0F)

Applications

- Detecting of dust in the air.
- Example: Air purifier, Air conditioner, Air monitor

Features

- Compact, thin package (46.0 × 30.0 × 17.6 mm)
- Low consumption current (I_{cc}: MAX. 20 mA)
- The presence of dust can be detected by the photometry of only one pulse
- Enable to distinguish smoke from house dust
- Lead-free and RoHS directive compliant

Figure 3.4 shows the Output Voltage vs. Dust Density for the optical sensor. The sensor is based on one operation principle; a light beam is emitted into the measurement chamber. When dust is present, the light is refracted by particles and the amount of scattered light is detected.

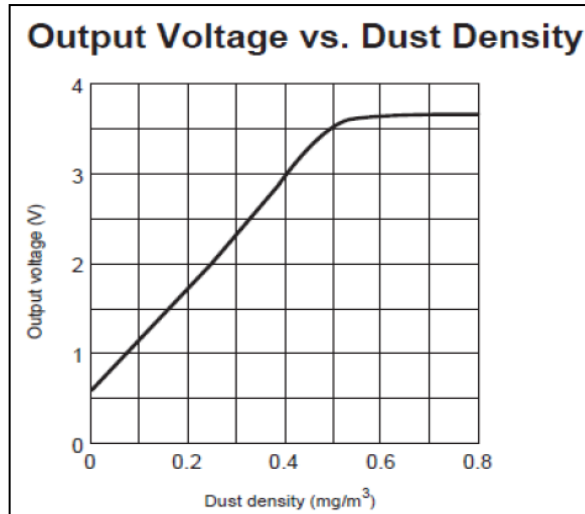

Figure 3.4: Output Voltage versus Dust Density

Figure 3.5 shows the important typical parameters for optical sensor. According to the sensitivity parameter declared by Sharp GP2Y1010AU0F optical sensor is V/(0.1mg/m³) means that each increment in voltage output is per 0.1mg/m³ of particle volumes. The maximum output voltage can be read by the sensor is (+-) 3.6V which is returns the dust density level to 0.5mg/m³. According to the Malaysia Ambient Air Pollution Level, the TSP maximum level is 260µg/m³ = 0.26mg/m³. The rating level is still within the specified range of the sensor. Thus, the system will give an output warning in visual (e.g. LED blinking) if the pollution level is above the maximum range stated [1].

(T_a=25°C, V_{CC}=5V)

Parameter	Symbol	Conditions	MIN.	TYP.	MAX.	Unit
Sensitivity	K	*1 *2 *3	0.35	0.5	0.65	V/(0.1mg/m ³)
Output voltage at no dust	V _{OC}	*2 *3	0	0.9	1.5	V
Output voltage range	V _{OH}	*2 *3 R _L =4.7kΩ	3.4	–	–	V
LED terminal current	I _{LED}	*2 LED terminal voltage = 0	–	10	20	mA
Consumption current	I _{CC}	*2 R _L =∞	–	11	20	mA

Figure 3.5: Parameter for Optical Sensor

Figure 3.6 show an internal schematic of a Sharp GP2Y1010AU0F optical sensor. In the internal of the sensor, on the sensor have a hole for to trap dust or smoke particle. Besides that, the sensor have an amplifier circuit and IRED for complete the operation of sensor. Form Figure 3.7, the supply voltage for the sensor is rated from -0.3V until +7V and this project, 5V is used as a power supply. Figure 3.8 shows the recommended input condition for LED input terminal.

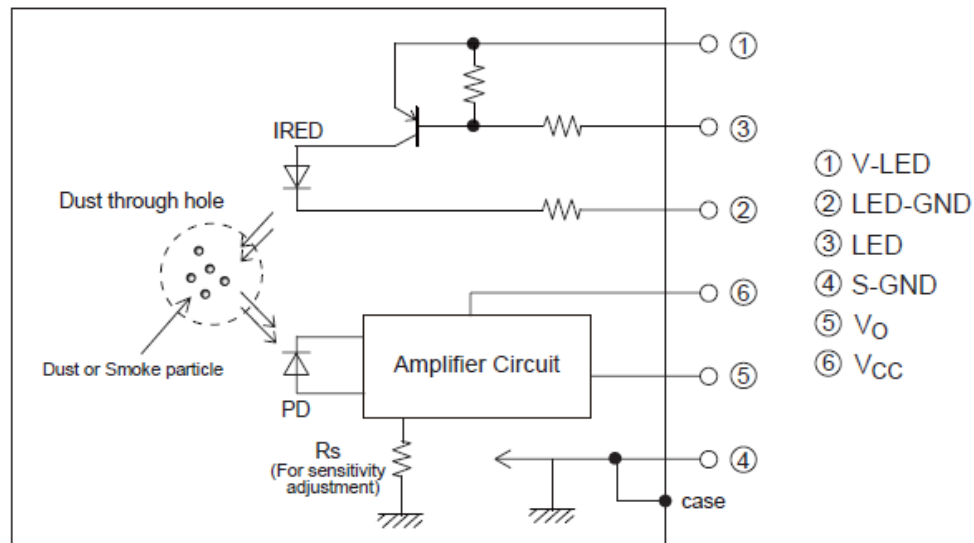

Figure 3.6: Internal schematic

($T_a=25^\circ\text{C}$)

Parameter	Symbol	Rating	Unit
Supply voltage	V_{CC}	-0.3 to +7	V
*1 Input terminal voltage	V_{LED}	-0.3 to V_{CC}	V
Operating temperature	T_{opr}	-10 to +65	$^\circ\text{C}$
Soldering temperature	T_{sol}	-20 to +80	$^\circ\text{C}$

*1 Open drain drive input

Figure 3.7: Absolute Maximum Ratings

Parameter	Symbol	Value	Unit
Pulse Cycle	T	10 ± 1	ms
Pulse Width	P _w	0.32 ± 0.02	ms
Operating Supply voltage	V _{CC}	5 ± 0.5	V

Figure 3.8: Recommended input condition for LED input terminal

Parameter for pulse cycle uses a range between 10ms and 1ms, followed by pulse width with a range from 0.32ms until 0.02ms. For the dust sensor, 5V is used as a power supply. Figure 3.9 shows an Input Condition for LED Input Terminal of the sensor and Figure 3.10 show a sampling timing of output pulse for the Sharp GP2Y1010AU0F optical sensor.

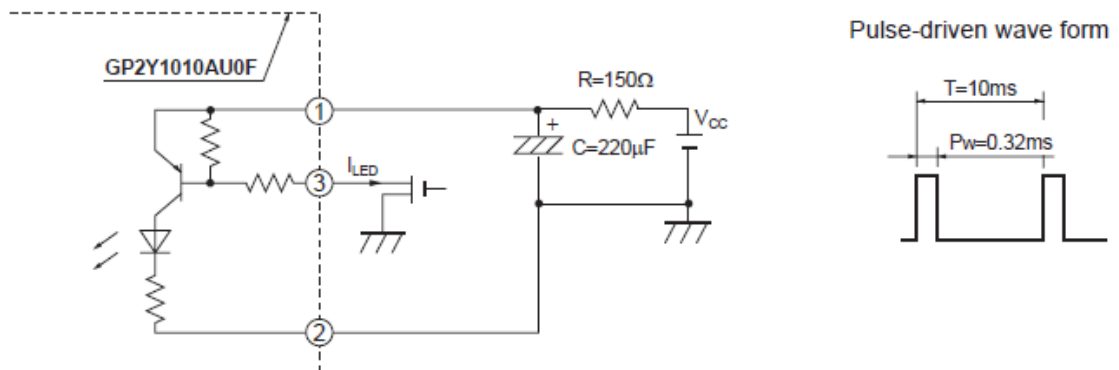

Figure 3.9: Input Condition for LED Input Terminal

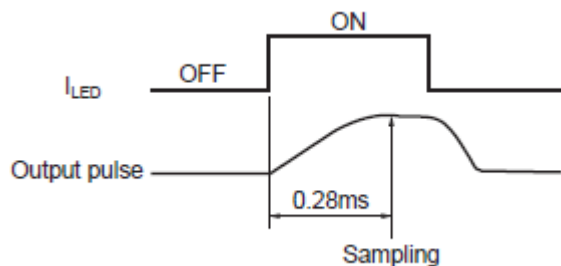

Figure 3.10: Sampling Timing of Output Pulse

3.4.2 Arduino Mega

Figure 3.11 shows the Arduino Mega [2]. The Arduino Mega is a microcontroller board based on the ATmega1280. It has 54 digital input/output pins of which 14 can be used as PWM outputs, 16 analog inputs, 4 UARTs hardware serial ports, a 16 MHz crystal oscillator, a USB connection, a power jack, an ICSP header, and a reset button. It contains everything needed to support the microcontroller; simply connect it to a computer with a USB cable or power it with an AC-to-DC adapter or battery to get started. The Mega is compatible with most shields designed for the Arduino Duemilanove or Diecimila.



Figure 3.11 : Arduino Mega

The Arduino Mega can be powered via the USB connection or with an external power supply. The power source is selected automatically. External (non-USB) power can come either from an AC-to-DC adapter (wall-wart) or battery. The adapter can be connected by plugging a 2.1mm center-positive plug into the board's power jack. Leads from a battery can be inserted in the Gnd and Vin pin headers of the POWER connector. The board can operate on an external supply of 6 to 20 volts. If supplied with less than 7V, however, the 5V pin may supply less than five volts and the board may be unstable.

If more than 12V is used, the voltage regulator may overheat and damage the board. The recommended range is 7 to 12 volts.

Figure 3.12 show a block diagram of the AVR Architecture. In order to maximize performance and parallelism, the AVR uses Harvard architecture with separate memories and buses for program and data. Instructions in the program memory are executed with a single level pipelining. While one instruction is being executed, the next instruction is pre-fetched from the program memory. This concept enables instructions to be executed in every clock cycle. The program memory is In-System Reprogrammable Flash memory.

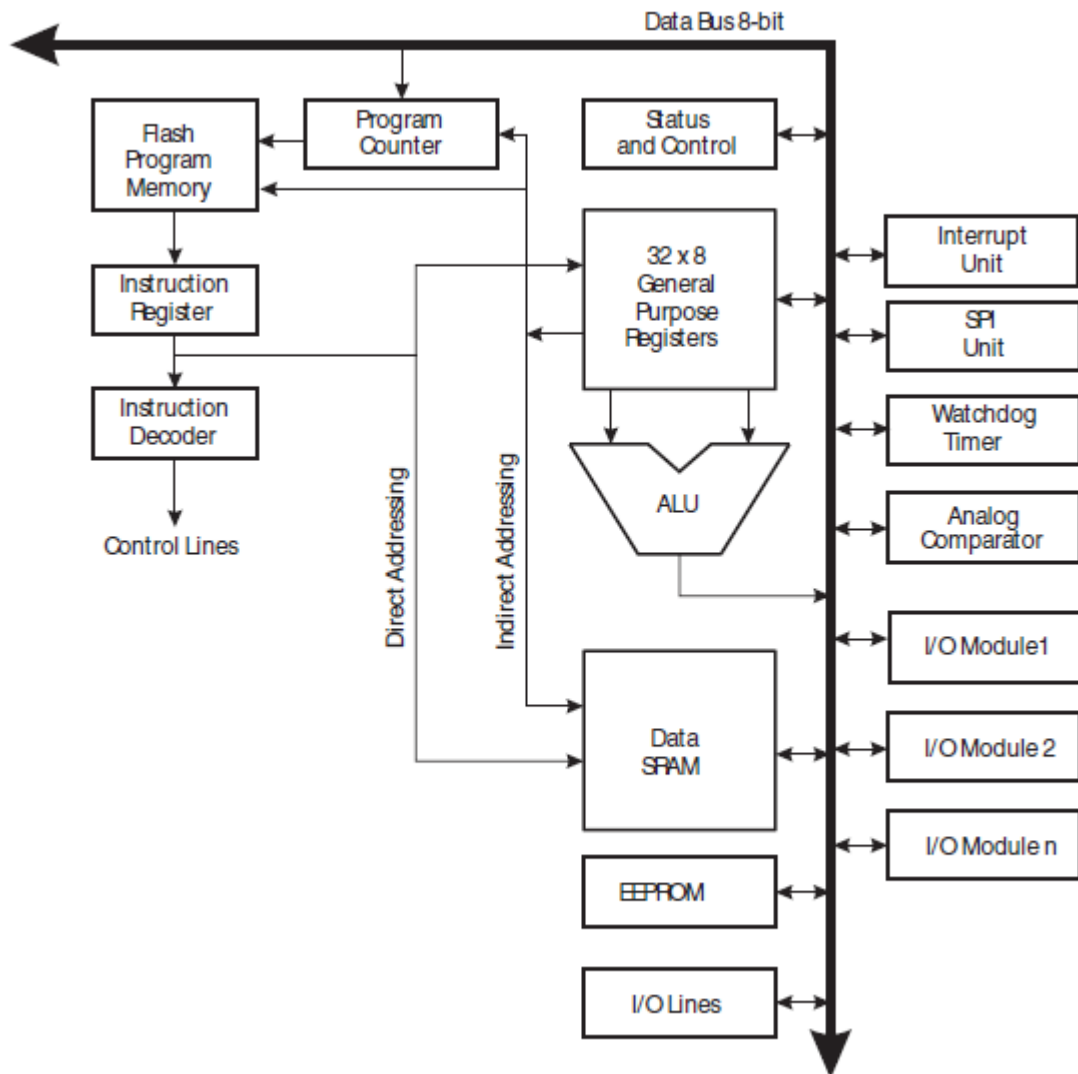

Figure 3.12: Block Diagram of the AVR Architecture

Figure 3.13 show a SREG AVR status register for a Arduino Mega. The symbol in the schematic is show as a :

• **Bit 7 – I: Global Interrupt Enable**

The Global Interrupt Enable bit must be set for the interrupts to be enabled. The individual interrupt enable control is then performed in separate control registers. If the Global Interrupt Enable Register is cleared, none of the interrupts are enabled independent of the individual interrupt enable settings. The I-bit is cleared by hardware after an interrupt has occurred, and is set by the RETI instruction to enable subsequent interrupts.

• **Bit 6 – T: Bit Copy Storage**

The Bit Copy instructions BLD (Bit Load) and BST (Bit Store) use the T-bit as source or destination for the operated bit. A bit from a register in the Register File can be copied into T by the BST instruction, and a bit in T can be copied into a bit in a register in the Register File by the BLD instruction.

• **Bit 5 – H: Half Carry Flag**

The Half Carry Flag H indicates a Half Carry in some arithmetic operations. Half Carry Is useful in BCD arithmetic.

• **Bit 4 – S: Sign Bit, $S = N \oplus V$**

The S-bit is always an exclusive or between the Negative Flag N and the Two's Complement Overflow Flag V.

• **Bit 3 – V: Two's Complement Overflow Flag**

The Two's Complement Overflow Flag V supports two's complement arithmetic's.

• **Bit 2 – N: Negative Flag**

The Negative Flag N indicates a negative result in an arithmetic or logic operation.

- **Bit 1 – Z: Zero Flag**

The Zero Flag Z indicates a zero result in an arithmetic or logic operation.

- **Bit 0 – C: Carry Flag**

The Carry Flag C indicates a carry in an arithmetic or logic operation.

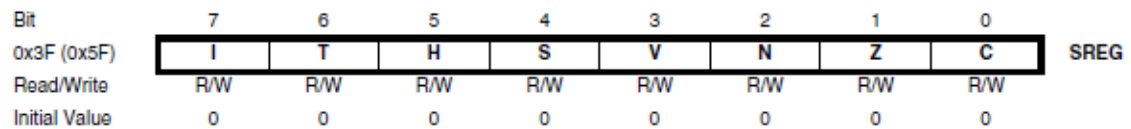

Figure 3.13: SREG – AVR Status Register

Figure 3.14 shows the parallel instruction fetches and instruction executions enabled by the Harvard architecture and the fast-access Register File concept. This is the basic pipelining concept to obtain up to 1 MIPS per MHz with the corresponding unique results for functions per cost, functions per clocks, and functions per power-unit.

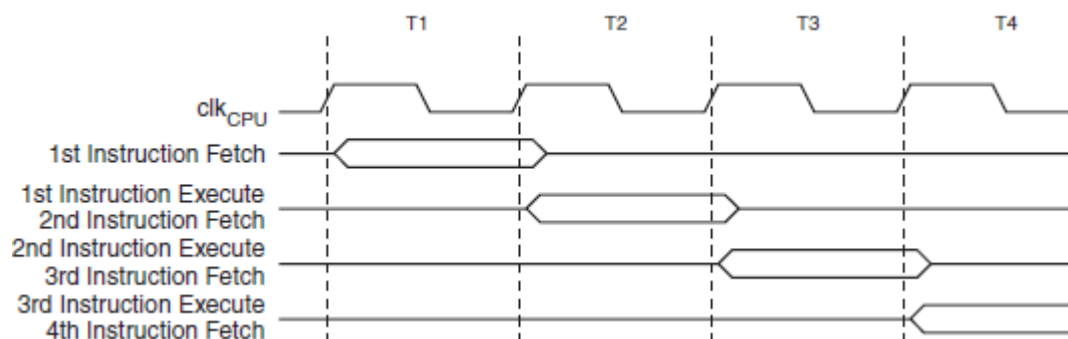

Figure 3.14 : The Parallel Instruction Fetches and Instruction Executions

Figure 3.15 shows the internal timing concept for the Register File. In a single clock cycle an ALU operation using two register operands is executed, and the result is stored back to the destination register.

REFERENCE :

- [1] SensorApp (2010). *Sharp Dust Sensor and Arduino*. Retrieved October 15, 2014, from <http://sensorapp.net/sharp-dust-sensor-and-arduino/>
- [2] DfRobot (2014). *LCD Keypad Shield for Arduino*. Retrieved December 5, 2014 from http://www.dfrobot.com/index.php?route=product/product&product_id=51
- [3] SensorApp (2010). *Sharp Dust Sensor and Arduino*. Retrieved October 15, 2014 from http://www.myduino.com/index.php?route=/product&search=gsm&product_id=25
- [4] DfRobot (2014). *LCD Keypad Shield for Arduino*. Retrieved December 5, 2014 from http://www.dfrobot.com/index.php?route=product/product&product_id=51
- [5] Peters, A., Dockery, D.W., Muller, J.E., & Mittleman, M.A. *Increased Particulate Air Pollution and The Triggering of Myocardial Infarction*. *Circulation* 2001;103:2810e5.
- [6] DfRobot (2014). *LCD Keypad Shield for Arduino*. Retrieved December 24, 2014, from http://www.myduino.com/index.php?route=product/product&search=gsm&product_id=259
- [7] SoftwareApp (2010) *Arduino Application and Guide* Retrieved November 5, 2014, from <http://arduino.cc/en/guide/introduction>
- [8] Wallace, L., & Howard-Reed, C. *Continuous Monitoring Of Ultrafine, Fine, And Coarse Particles in A Residence For 18 Months in 1999-2000*. *J Air Waste Manag Assoc* 2002;52:828e44.

- [9] Daud, Z., Ridzuan, M.,B. & Ahmad, Z. (2014). *Laporan Pemantauan Kualiti Udara PM10 and TSP*. UTHM Commercial Sdn.Bhd.
- [10] National Research Council: Committee on Air Quality Management in the United States, Board on Environmental Studies and Toxicology, Board on Atmospheric Sciences and Climate, Division on Earth and Life Studies (2004). *Air Quality Management in the United States*. National Academies Press. ISBN 0-309-08932-8.
- [11] Devarakonda, A. *Real- time Air Quality Monitoring Through Mobile Sensing in Metropolitan Areas*, Department of Computer Science , Rutgers University, NJ 08854-8091.
- [12] Ang, A., L., *Air pollution monitoring and GIS modeling: a new use of nanotechnology based solid state gas sensors*, Remote Sensing and GIS FoS, School of Advanced Technologies, Asian Institute of Technology, Klongluang, 12120 Pathumthani, Thailand, 25 February 2005.
- [13] Kim, S., & Paulos, E. (2010, April). *InAir: sharing indoor air quality measurements and visualizations*. In Proceedings of the 28th international conference on Human factors in computing systems.ACM:2010. pp.1861-1870.
- [14] Rajiv P. and K. K. Khedo, *A Wireless Sensor Network Air Pollution Monitoring System* Department of Computer Science and Engineering, University of Mauritius, Reduit, Mauritius.
- [15] Zakaria, N., S., *Rice Husk/Dust Air Particle Sensor Using Zigbee Wireless Sensor Network*. Degree of Master Thesis. Universiti Tun Hussien Onn Malaysia; 2013.
- [16] Oh, S. J., & Chung, W. Y. *Room environment monitoring system from PDA terminal*. In Intelligent Signal Processing and Communication Systems,

2004.ISPACS 2004.Proceedings of 2004 International Symposium.IEEE: 2004. pp. 497-501.

- [17] P. Qili. *Room Dust Monitoring System*. Bachelor Degree Thesis.Universiti Tun HussienOnn Malaysia; 2013.
- [18] Ahmad. M., *PM10 and Total Suspended Particulates (TSP) Measurements In Various Power Stations*; The Malaysian Journal of Analytical Sciences, Vol 11, No 1 (2007): 255-261.
- [20] SensorApp (2010). *Sharp Dust Sensor and Arduino*. Retrieved January 27, 2015, from <http://www.howmuchsnow.com/arduino/airquality/>.
- [21] SensorApp (2010). *Sharp Dust Sensor and Arduino*. Retrieved January 27, 2015, from <https://github.com/Trefex/arduino-airquality/blob/master/aq5s/aq5s.ino>.
- [22] SensorApp (2010). *Sharp Dust Sensor and Arduino*. Retrieved January 27, 2015, from <http://developer.mbed.org/users/kirchnet/code/DustSensorDisplay5110/raw-annotate/99fdd85b4929/main.cpp>
- [23] SensorApp (2010). *Sharp Dust Sensor and Arduino*. Retrieved January 27, 2015, from http://www.iqa.mddefp.gouv.qc.ca/contenu/calcul_en.htm