

AC MOTOR SPEED PERFORMANCE IMPROVEMENT USING FUZZY LOGIC
CONTROL

MOHD AZKAR BIN SIDIK

A thesis submitted in partial
fulfillment of the requirement for the award of the
Degree of Master of Electrical Engineering

Faculty of Electrical and Electronic Engineering
Universiti Tun Hussein Onn Malaysia

JUNE, 2015

ABSTRACT

This project focuses on the fuzzy logic controller design to control single phase induction motor. The controller strategy is done through phase angle control method. The phase angle is controlled by controlling the firing angle delay of the triac. This controller system is implemented and simulated using MATLAB Simulink software. The performance of the single phase induction motor are investigated and compared with the PID controller. Based on the simulation, fuzzy logic controller is suitable to control single phase induction motor because it can reduce the rise time, settling time, peak time and overshoot to 0.10s, 0.17s, 0.29s and 0.09 % OS respectively. The comparison between fuzzy logic controller and PID controller shows that the fuzzy logic controller gives better performance response with the rise time (T_r), the settling time (T_s), peak time (T_p) and overshoot (% OS) are 0.08s, 0.08s, 0.05s and 0.004% smaller than PID controller.

ABSTRAK

Fokus projek ini adalah membina pengawal logik fuzzy untuk mengawal motor induksi satu fasa. Strategi pengawalan adalah menggunakan kaedah kawalan sudut fasa. Sudut fasa dikawal dengan mengawal masa tunda bagi triac. Sistem pengawal ini dilaksanakan dan disimulasi menggunakan perisian MATLAB Simulink. Prestasi motor induksi satu fasa dikaji dan dibandingkan dengan sistem pengawal PID. Berdasarkan kepada keputusan simulasi, pengawal logic fuzzy adalah sesuai digunakan untuk mengawal motor induksi satu fasa apabila ia dapat mengurangkan masa naik (T_r), masa puncak (T_p), masa menetap (T_s) dan peratus lonjakan (% OS) adalah 0.10s, 0.29s, 0.17s dan 0.09 %. Perbandingan antara pengawal logic fuzzy ini dengan pengawal PID menunjukkan bahawa pengawal logic fuzzy memberikan prestasi yang lebih baik dengan masa naik (T_r), masa puncak (T_p), masa menetap (T_s) dan peratus lonjakan (% OS) adalah 0.08s, 0.08s, 0.05s dan 0.09 % lebih kecil dari pengawal PID.

CONTENTS

TITLE	i
DECLARATION	ii
DEDICATION	iii
ACKNOWLEDGEMENT	iv
ABSTRACT	v
ABSTRAK	vi
CONTENTS	vii
LIST OF TABLES	ix
LIST OF FIGURES	x
LIST OF SYMBOLS AND ABBREVIATIONS	xiii
LIST OF APPENDICES	xiv
CHAPTER 1 INTRODUCTION	1
1.1 Introduction	1
1.2 Problem Statement	3
1.3 Aim and Objectives	3
1.4 Project Scopes	4
1.5 Report Outline	4
CHAPTER 2 LITERATURE REVIEW	6
2.1 Introduction	6

2.2	Related Work	6
2.3	Research Comparison	15
2.4	Single Phase Induction Motor	16
2.4.1	Principle Operation of Capacitor Start Run Induction Motor	17
2.5	Triac Application	19
2.6	PID Controller	20
2.7	Fuzzy Logic Controller	21
CHAPTER 3 METHODOLOGY		23
3.1	System Architecture	25
3.2	Modelling the Single Phase Induction Motor in Simulink with Triac	25
3.3	PID Controller	26
3.4	Design of Fuzzy Logic Controller	27
3.4.1	Define Input and Output Variables	28
3.4.2	Membership Functions and Linguistic Variables	29
3.4.3	Rule Base for the Fuzzy Logic Controller	31
3.4.4	Defuzzification Method	34
3.5	Implementation of Fuzzy Logic Controller Model	35
3.5.1	Firing Pulse Subsystem	36
3.5.2	Modelling Single Phase Induction Motor with Triac	38
CHAPTER 4 RESULT AND ANALYSIS		40
4.1	Introduction	40
4.2	Analysis of Voltage Output to the Motor Winding	40
4.3	Analysis of Triac Firing Pulse Delay and Speed	47
4.4	PID Controller Dynamic Response	52
4.5	Fuzzy Logic Controller Dynamic Response	53
CHAPTER 5 CONCLUSION		55
5.1	Conclusion	55
5.2	Recommendation and Future Works	56
REFERENCES		57
VITA		61

LIST OF TABLES

2.1	The Proposed Fuzzy Characteristic	11
2.2	Comparison of Responses between PI and FLC Controller	12
2.3	Comparison Table of Induction Motor Specification using PID and Fuzzy Logic	15
2.4	Comparison between Each Research	16
2.5	The effect of PID controller parameters	
3.1(a)	Input variables error	29
3.1(b)	Input variables change of error	30
3.1(c)	Output variables firing pulse delay	30
3.2	Triangular Membership Function output variables	32
3.3	Single phase induction motor parameter	39
4.1	Simulation result of the triac firing pulse delay and Vrms	46
4.2	The proposed firing angle for difference speed	51
4.3	Dynamic response parameters specification for PID controller system	53
4.4	Dynamic response parameter specification of Fuzzy Logic Controller	54
4.5	Comparison between Open Loop System and Fuzzy Logic Controller	54

LIST OF FIGURES

2.1	Layout of the proposed controller in unity feedback control system	7
2.2	Coding and simulation environment	7
2.3	Second order linear plant controlled by the PIDFLC	8
2.4	A system block diagram using PIC16F877A	8
2.5	Real time PID response	9
2.6	Real time fuzzy controller response	10
2.7	FLC architecture	10
2.8	System response for PI and FLC for change in the operating point	11
2.9	MATLAB Simulink model of the induction motor using fuzzy logic controller	13
2.10	The dynamic response of the induction motor with PID and Fuzzy Logic Controller starting under Load with Step as reference speed.	14
2.11	The dynamic response of the induction motor with PID and Fuzzy Logic Controller starting under Load with Trapezoidal as reference speed.	14
2.12	Single phase induction motor structure	17
2.13	Schematic Representation of Capacitor Start Run Induction Motor	18
2.14	Phasor Diagram of Capacitor Start Run Induction Motor	19
2.15	Triac symbol for circuit diagrams	19
2.16	Block diagram for PID controller	20
2.17	A typical fuzzy control system schema	22
3.1	Flowchart for overall project activity	24

3.2	Block diagram of the fuzzy logic controller	25
3.3	Single phase induction motor with triac	26
3.4	PID controller block diagram	27
3.5	PID controller parameters	25
3.6	Basic structure of fuzzy logic controller	28
3.7	Fuzzy Inference System diagram	29
3.8(a)	Fuzzy Membership Function for input error	30
3.8(b)	Fuzzy Membership Function for Input Change of Error	31
3.8(c)	Fuzzy Membership Function for output firing pulse delay	31
3.9	Rules Editor in MATLAB	32
3.10	The surface view of the fuzzy logic controller	34
3.11	Defuzzification output when input $e = 0$ and $ce = 0$	35
3.12	Fuzzy logic controller model in simulink	36
3.13	Triac firing pulse subsystem	37
3.14	Pulse generating model	37
3.12	Simulink model for single phase induction motor with triac	38
4.1(a)	The characteristic for voltage when delay = 0 ms	41
4.1(b)	The characteristic for voltage when delay = 1 ms	41
4.1(c)	The characteristic for voltage when delay = 2 ms	42
4.1(d)	The characteristic for voltage when delay = 3 ms	42
4.1(e)	The characteristic for voltage when delay = 4 ms	43
4.1(f)	The characteristic for voltage when delay = 5 ms	43
4.1(g)	The characteristic for voltage when delay = 6 ms	44
4.1(h)	The characteristic for voltage when delay = 7 ms	44
4.1(i)	The characteristic for voltage when delay = 8 ms	45
4.1(j)	The characteristic for voltage when delay = 9 ms	45
4.2	The relationship of the triac firing pulse delay and V_{rms}	46
4.3(a)	Firing pulse delay for $W_{ref} = 2000$ rpm	47
4.3(b)	Firing pulse delay for $W_{ref} = 1900$ rpm	47
4.3(c)	Firing pulse delay for $W_{ref} = 1800$ rpm	48
4.3(d)	Firing pulse delay for $W_{ref} = 1700$ rpm	48

4.3(e)	Firing pulse delay for $W_{ref}= 1600$ rpm	48
4.3(f)	Firing pulse delay for $W_{ref}= 1500$ rpm	49
4.3(g)	Firing pulse delay for $W_{ref}= 1400$ rpm	49
4.3(h)	Firing pulse delay for $W_{ref}= 1300$ rpm	49
4.3(i)	Firing pulse delay for $W_{ref}= 1200$ rpm	50
4.3(j)	Firing pulse delay for $W_{ref}= 1100$ rpm	50
4.3(k)	Firing pulse delay for $W_{ref}= 1000$ rpm	51
4.4	The relationship between speed and firing angle delay	52
4.5	Dynamic response for PID controller	52
4.6	Dynamic response for fuzzy logic controller	53

LIST OF ABBREVIATIONS

AC	Alternating Current
AI	Artificial Intelligent
DC	Direct Current
FLC	Fuzzy Logic Controller
FPGA	Field Programmable Gate Array
MATLAB	MATrix LABoratory
PIC	Programmable Interface Controller
PID	Proportional Integral Derivative
SPIM	Single Phase Induction Motor
TRIAC	TRiode for Alternating Current

LIST OF APPENDICES

APPENDIX	TITLE	PAGE
A	Text file format for Fuzzy Inference System (FIS)	61
B	Sample of FIS Evaluation	63
C	A listing of information on the FIS generated using the <i>showfis</i> command	65

CHAPTER 1

INTRODUCTION

1.1 Introduction

Single phase A.C supply plays important roles in electrical usage because it is commonly used for general purpose electrical purpose in domestic or commercial applications where three phase power supply is not available. Based on this supply, single phase induction motors become one of the most widely used for numerous domestic and industrial applications like home appliances, industrial control system, and automation because of their it offer lower maintenance, reliable and smaller motor size. Single phase induction motor has been covered most servo application in robotics, machine tools and positioning devices.

Normally, it has two winding, main and auxiliary while auxiliary winding has more turns than winding has [1]. Traditional single phase induction motor run directly from AC voltage at one speed only. The improvement in ac motor control enable the speed of single phase induction motor to be run on variable speed, which can reduce power consumption, acoustic noise and mechanical vibration. The critical aspect in AC motor industry is the role of the researcher/ engineer to control the speed of an AC motor that being used. Traditionally, the AC motor is controlled by two classical strategies, vector control and torque control. Vector control and direct torque control are the two classical strategies to control synchronization and asynchronous of induction motor [2].

Basically, single phase induction motor is widely use in our daily application because of their ability to operate from a single phase power supply. Since it is impossible to reliably operate at unstable range, simple voltage control (open loop

control) is limited to controlling in a narrow range. The speed of the single phase AC induction motor can be adjusted either by applying the proper supply voltage amplitude and frequency (called volts per hertz) or by the changing of supply voltage amplitude with constant frequency (slip control) [3]. To make it is possible to operate reliably even in the unstable range, it is necessary to detect the rotational speed of the motor and use a voltage control mechanism (closed loop control) that reduces the speed error when compared to a set value [4].

The speed of induction motor can be control by controlling the voltage applied to the stator voltage. With the enhanced technology in power electronics, a number of semiconductor devices have been introduced in voltage control application. The use of solid state components like the triac for the control of ac drives have been widely used in recent years for several industrial and home applications [5]. The voltage applied to the stator winding of the single phase induction motor can be control to achieve the desired speed by controlling the firing angle of the triac that are used this project.

For efficient control strategies, the speed of the single phase induction motors need to be controlled properly. The control of the stator voltage is needed in order to control the speed. It is because the voltage is directly proportional to the motor speed. For this reason, the phase control technique can be applied for single phase induction motor control. In this technique, a power device known as triac can be used. Triac is a power electronics device which conduct based on the gate pulses it receive rather than the supply voltage [6]. Triac is connected in series with the motor, and hence by controlling the gate pulse of the Triac, speed of the induction motor is controlled smoothly and effectively with less power consumption [7].

Mostly, for closed loop system, conventional or intelligent control techniques were used to provide signal to the firing angle circuit [5]. As the advancement of the technology, the use of intelligent system to control the induction motor is required because of the traditional controllers does not give the satisfactory results when loading variation condition. In recent years, the artificial intelligent (AI) technique, such as fuzzy logic controller has shown high potential for induction motor application [8].

1.2 Problem Statement

Most of the application of control systems nowadays used the Proportional Integrated Derivative (PID) controller. Although the PID controller is simple and easy to practice, the linear PID control method is not working well in ac induction motor drive because of the nonlinearity properties of induction motor. The traditional controller such as PID controller does not give a satisfactory response when loading various conditions and different control parameters. In recent years, the artificial intelligent (AI) techniques such as fuzzy logic controller have shown high potential for induction motor application. The needs for an intelligent system controller that has the capability to control nonlinear, uncertain systems is important to improve the performance of induction motor speed controller. In fact, a new controller is need to be develop using intelligent system to guarantee the stable operation even there is a change in the parameter of the induction motor and sudden load variation.

1.3 Aim and Objectives

The aim of this project is to improve the performances of a speed control of AC motor. It will be done by developing a fuzzy logic controller (FLC) .The controller has the ability to control the TRIAC phase angle delay using pulse fuzzy logic controller (FLC). The output of the controller is used to control the speed of a single phase induction motor (SPIM). In order to achieve this aim, the objectives of this project are describes as follows:

- (i) To study the characteristic of single phase induction motor and the effect of triac firing angle delay on the single phase induction motor speed.
- (ii) To design and develop closed loop simulation model of fuzzy logic controller using MATLAB-Simulink platform
- (iii) To observe the performances of fuzzy logic controller by simulation
- (iv) To analyze the results from the fuzzy logic controller and compare with the PID controller

1.4 Project Scopes

The scopes and limitation of this project are given below:

- (i) The simulation model is based on the single phase induction motor running 240 V 50 Hz ac voltage supply.
- (ii) The control system used in this project was fuzzy logic controller (intelligent control)
- (iii) The control strategy is done through phase angle control method
- (iv) Triac is used to control the voltage supplied to the single phase induction motor.
- (v) The simulation model of the fuzzy logic controller is developed using Matlab-Simulink software.
- (vi) The reference speed of motor is 1500 rpm
- (vii) The range of time delay generation of the triac firing pulse is between 0 to 9 ms.

1.5 Report Outline

This report is divided to four chapters and the first chapter briefly describes the introduction of this project. This chapter represents the overview of the project includes the problem statement, the objectives of the project.

In chapter 2, the literature review of the previous projects that is related to this project is discussed. All these projects then are compared about the advantages and disadvantages.

The methodology of the proposed project explained in chapter 3. The methodology is divided into three parts. The first part is to study the single phase induction motor characteristics. The second part is to develop design and simulation model for the fuzzy logic controller using Matlab-Simulink.

Chapter 4 discusses the result and analysis of the fuzzy logic controller that included the dynamic response of the motor speed. This chapter highlights the overall of the project outcomes with the simulation result that is obtained using MATLAB Simulink.

Chapter 5 is the final chapter that entails the conclusion of the project design and the recommendations for the future project.

CHAPTER 2

LITERATURE REVIEW

2.1 Introduction

The design and development of fuzzy logic controller (FLC) to improve the single phase induction motor performance need an extensive study and research of the previous papers and projects. In this chapter, the previous works that have been accomplished by other researchers will be discussed.

2.2 Related Work

Zeyad Assi Obayed, Nasri Sulaiman and M.N Hamidon [9] have developed a fuzzy logic controller using VHDL for implementation of field programmable logic array (FPGA) to control position in AC motor. The controller accepts two types of digital outputs, the first one is the plant (Y_p) and the second one is the desired output (Y_d) and deliver control action signal as a digital output. It also accept 8 bit digital signal that represent the gain parameter needed by the controller and the other two bits signal to select the type of the controller. Figure 2.1 shows the general layout of the controller in a unity feedback control system.

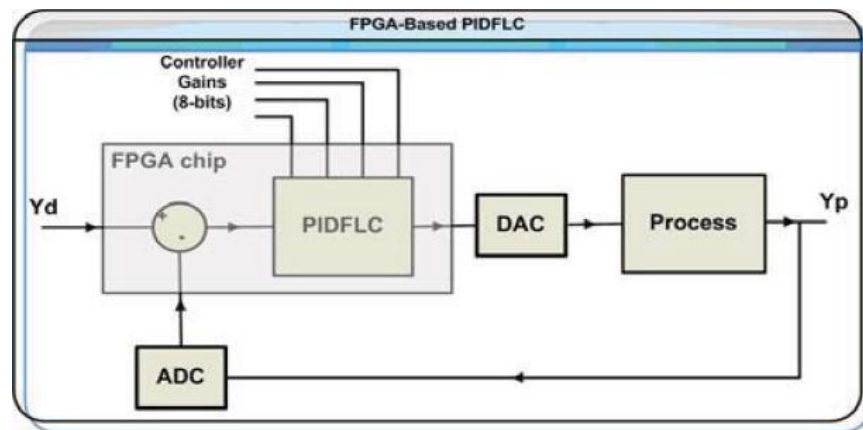

Figure 2.1: Layout of the proposed controller in unity feedback control system

In this paper, Altera Quartus 2 version 9.0 software has been used to get the simulation and timing result as well as synthesized design. Besides that, ModelSim simulation program is used for the purpose of the simulation for all tests for the proposed design. The same design has been done in Matlab environment. For comparison purposes, ModelSim store the simulation data in text files, these file have been used in Matlab to convert it to decimal vectors, and the use vectors to plot the analog response. Figure 2.2 describes the coding and simulation environment for the design.

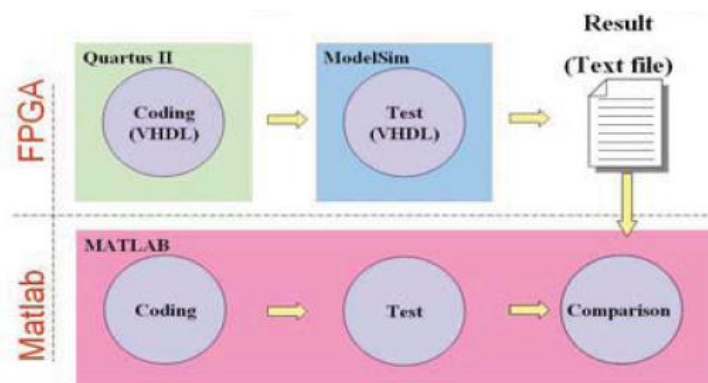

Figure 2.2: Coding and simulation environment

The result of the second order linear plant of the developed PIDFLC is shown in Figure 2.3.

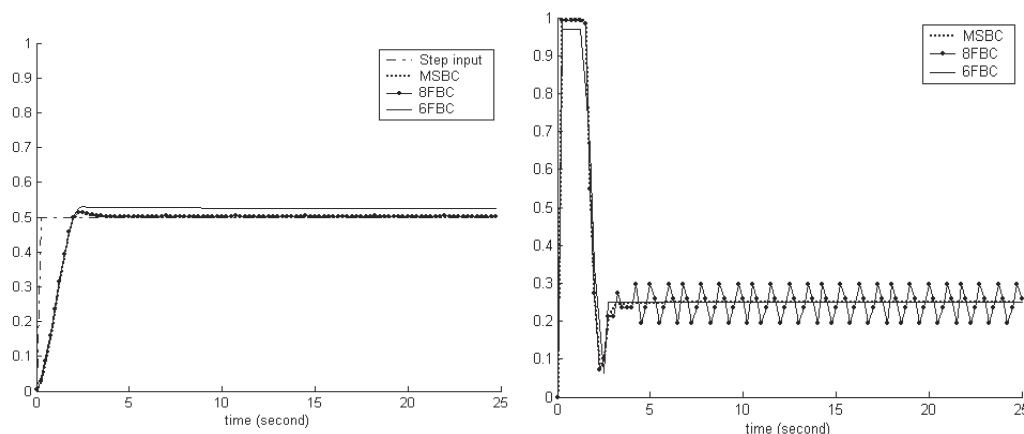

Figure 2.3: Second order linear plant controlled by the PIDFLC

(a) Step Response (b) Control action

T.D Dongale, S.R Jadhav, S.V Kulkarni, T.G Kulkarni, R.R Mudholkar and M.D Uplane [10], have describe the implementation of the controller based on PID and Fuzzy Logic strategies. They have made the comparative performances analysis exploring of Fuzzy Logic control strategies and PID control strategies. In this project, a system to control speed of three phase motor have been developed using PIC16F877A microcontroller which includes with inverter design, gate drive circuit and isolation. Figure 2.4 shows the system block diagram for the system that have been developed.

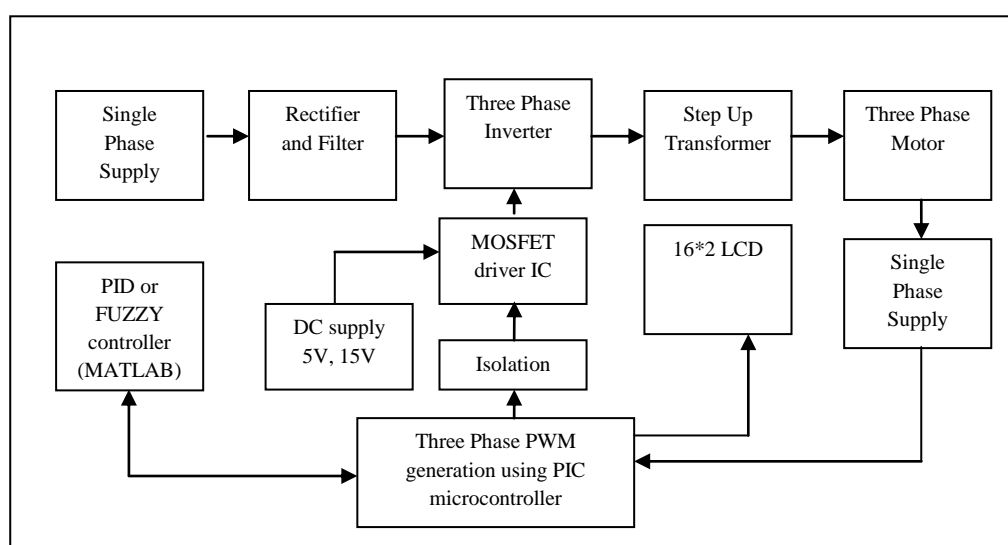

Figure 2.4: A system block diagram using PIC16F877A

The model of for PID and Fuzzy Logic controller have been developed using MATLAB-SIMULINK for real time motor speed control. For the PID model, the actual speed of the motor is sensed by the speed sensor using PIC controller and it sent serially to Simulink. The transfer function of the system is the second order type the exhibit overshoot and large settling time which form the metrics of performance in the previous study. The real time PID response is illustrated in Figure 2.5.

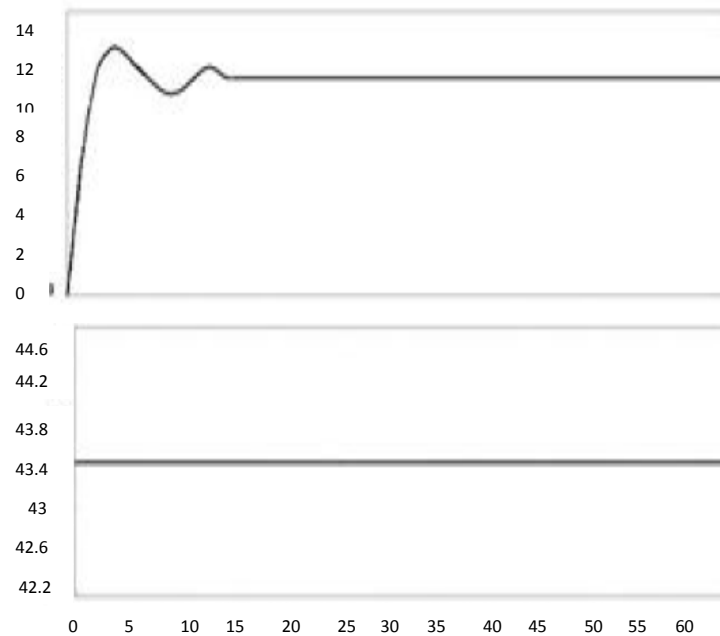

Figure 2.5 Real time PID response

For the fuzzy logic controller, the reference speed is set as a constant. Error block generate the output which is the error between actual speed and the set speed that is applied to one input of fuzzy controller and other to store the error in the memory to compute the change in error. Multiplexer combine both inputs and give it to Fuzzy logic controller. Real time scope is used observe the actual behavioral of the system. The instrument block is used to send the output of Fuzzy Logic Controller to PIC. The Fuzzy controller in this project is design using Mamdani method as a Fuzzy Inference Scheme (FIS). The real time Fuzzy logic controller response is shown in Figure 2.6.

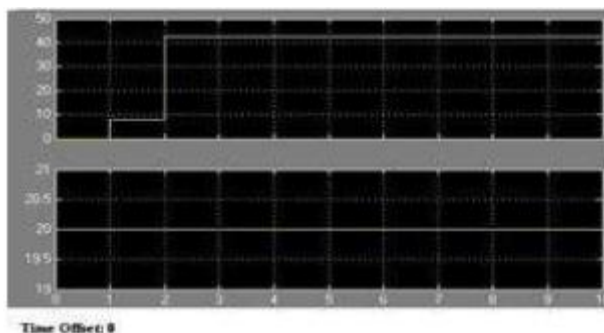

Figure 2.6: Real time fuzzy controller response

Ebrahim Abd El Hamid Mohamed Ramaden *et al* [11], have proposed a fuzzy system that has been supplied to a permanent magnet DC motor via a configuration of H-Bridge. In this paper, a fuzzy logic control (FLC) system and a conventional proportional-integral (PI) controller for speed control of DC motor have been implemented using Field Programmable Gate Array (FPGA) circuit. The architecture of the fuzzy logic controller that has been developed is shown in Figure 2.7.

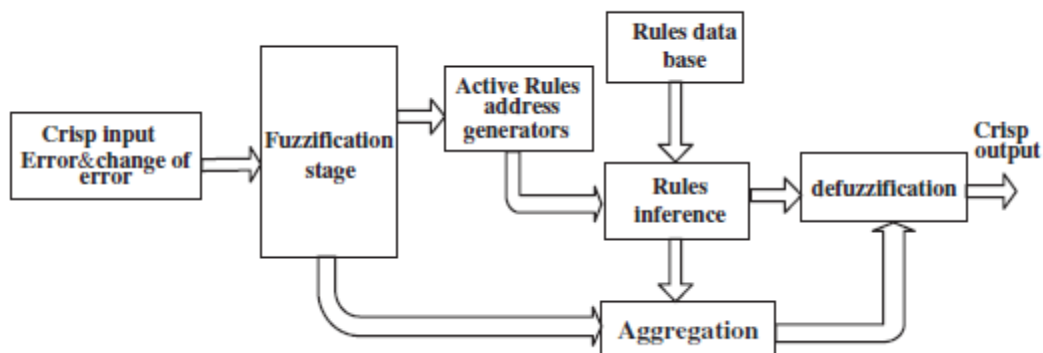

Figure 2.7: FLC architecture

In the proposed fuzzy system as in Figure 2.7, the fuzzification process is performed by reading out from the system's memory the value of membership function of activated sets and also codes of these sets. The characteristic parameters of the fuzzy logic system are elaborated in Table 2.1.

Table 2.1: The proposed fuzzy characteristics

Fuzzy inference system	Mamdani FIS
Inputs	2
Input Resolution	8 bit
Output	1
Output resolution	8 bit
Antecedent MF's	7 triangular per fuzzy se
Antecedent MF degree of truth resolution	8 bit
Consequent MF's	7 triangular per fuzzy se
Antecedent MF degree of truth resolution	8 bit
Aggregation method	MAX
Implication method	MIN
Defuzzification method	Center of Gravity (COG)

The DC motor response of the PI and FLC controller are described in Figure 2.8. From the results, the PI controller performances result in the lack of smooth transition between the required speed and the present of overshoot and higher rise time. For the FLC controller, less oscillation, zeros overshoot and less rise time. This project describes that the performances of FLC is better than PI controller. The detail information about the comparison is elaborated in Table 2.2.

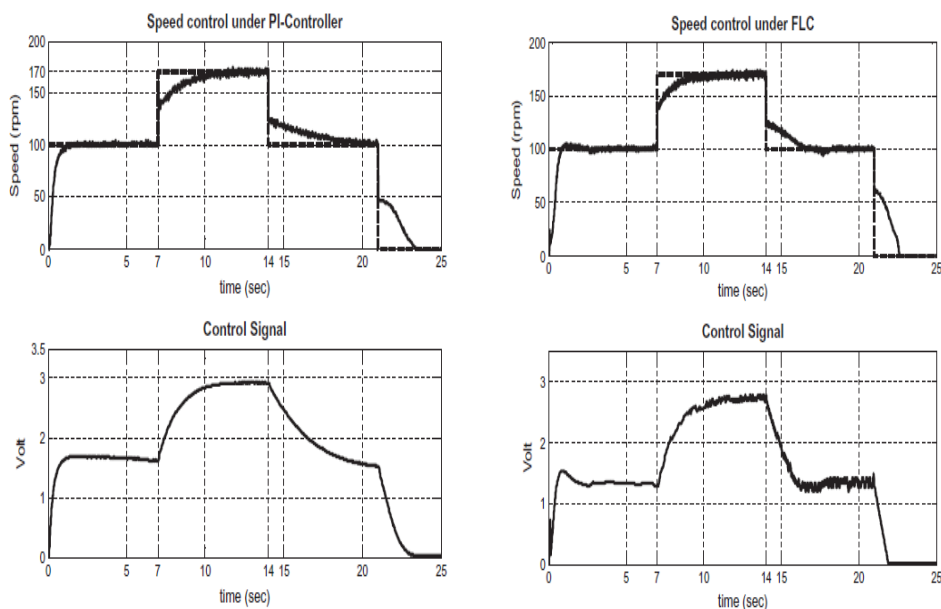

Figure 2.8: System response for PI and FLC for change in the operating point

Table 2.2: Comparison of responses between PI and FLC controller

	PI controller	PI-FLC
Rise time (s)	0.8050	0.7368
Settling time (s)	6.5390	6.886
Overshoot (rpm)	3.6364	1.75
Peak time (s)	4.2800	1.08
RMSE without load	15.3512	11.5399
RMSE with load		
Under – 10% load	14.6333	14.3861
Under – 20% load	16.8462	15.6657
Under – 25% load	20.5089	16.7217

Gaddam Malleshham [12] has explained the application of fuzzy logic in speed systems in electrical machine which is for DC motor and AC motor. In this work, a controller designed based on proportional, derivatives and integral fuzzy reasoning. The output quantity and fuzzy speed controller is employed to the outer loop used the speed error and rate of change as the inputs. The performance of the fuzzy logic controller evaluated by simulation the result for different operating conditions and the result then compared with the conventional controller using Integral of Time by Absolute Error criterion.

The dynamic model of the induction motor using fuzzy logic is developed in the MATLAB Simulink using the induction motor equation. Figure 2.9 shows the MATLAB-SIMULINK model of the induction motor using Fuzzy Logic controller.

The result from the simulation was tested for different reference input with load of 20Nm at 1 second and without load is described in Figure 2.10 and 2.11.

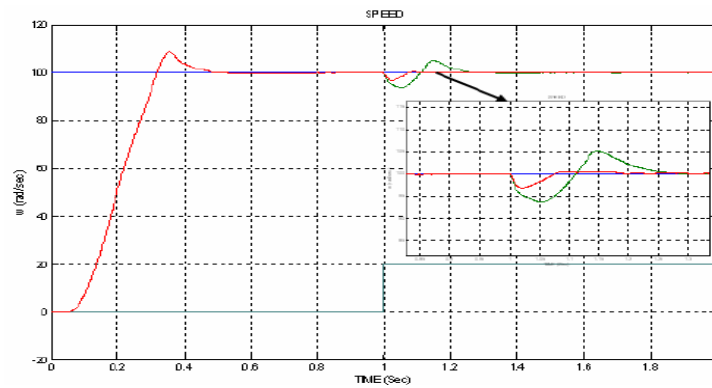

Figure 2.10: The dynamic response of the induction motor with PID and fuzzy logic controller starting under load with step as reference speed

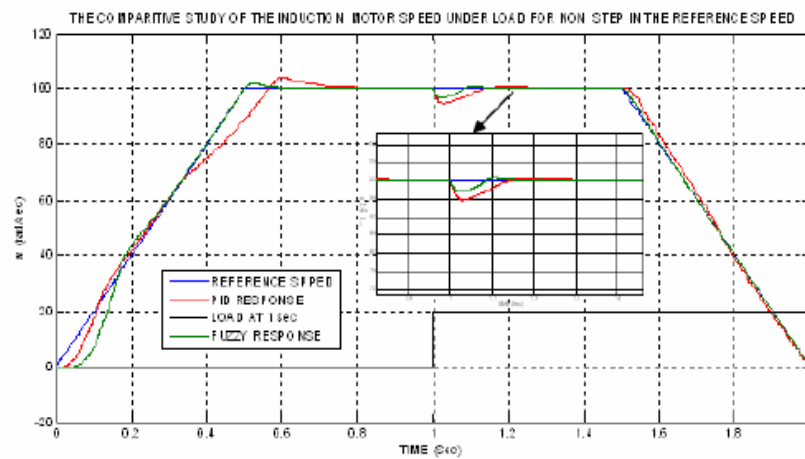

Figure 2.11: The dynamic response of the induction motor with PID and fuzzy logic controller starting under load with trapezoidal as reference speed.

The overall investigation of the controller in this project has been concluded in the Table 2.3:

Table 2.3: The comparison table of induction motor specification using PID and fuzzy logic

Different types of load		% Max imum peak over shoot (% M_p)	Setting Time (sec) t_s	Steady State error (e_{ss})	IAE
Step input without load	PID Controller	8.7117	0.4790	0.196741	20.640
	Fuzzy Logic Controller	7.8947	0.4310	0.195009	20.617
Step input With load	PID Controller	8.7117	1.1200	1.0655	20.816
	Fuzzy Logic Controller	7.8947	1.0330	0.874	20.728
Trapezoidal without load	PID Controller	----	----	----	51.227
	Fuzzy Logic Controller	---	---	---	50.102
Trapezoidal with load	PID Controller	----	----	----	51.988
	Fuzzy Logic Controller	---	---	---	50.124

2.3 Research Comparison

From the previous subtopic, some related research topics have been discussed regarding to the application of fuzzy logic in the speed control of electrical motors that have been done previously. The comparison between the previous works is summarized in Table 2.4.

The related works that have been summarized in Table 2.4 focused on the improvement on the 3 phase ac induction motor and the DC motor. Most of the controllers in the previous works are complicated to design and involved higher cost motors. The improvement of single phase ac motor based on intelligent system need to be develop because there are probably more single phase induction motors in use today than the total of all the other types of motor.

Table 2.4: Comparison between each research

No.	Research Title	Advantages	Disadvantages
1	Design of Fuzzy Logic Controller for AC Motor Based on Field Programmable Gate Array	The memory block of fuzzy logic controller design was generated using MegaWizard Plug In Manager to ensure the good design of position control in AC motor.	The simulation result only based on the triangular fuzzy membership function.
2	Performance Comparison of PID and Fuzzy Control Technique in Three Phase Induction Motor Control	Able to monitor the sensed speed by Hall Effect sensor and send it serially to Simulink design for PID and Fuzzy Logic control technique.	The comparison of the PID and fuzzy controller only be done for three phase induction motor
3	Embedded System Based on Real Time Fuzzy Motor Speed Controller	The design of the controller using the Spartan 3E FPGA which is embedded 90 nm technology reduce the die size and cost, increase manufacturing efficiency and address the wider range of application	The implementation of the fuzzy logic controller only done for DC motor
4	Improvement in Dynamic Response of Electrical Machine with PID and Fuzzy Logic Based Controller	The performance comparison was investigated are clearly mentioned the different for both DC and AC motor at difference reference input	The design of the controller is quite complicated

2.4 Single Phase Induction Motor

Single phase induction motor characteristics is similar to 3-phase induction motor except single phase induction motor did not has starting torque and it required some extra arrangement for making it self starting. It must be converted to a type which is not a single phase induction motor in the sense as ordinary used and it will become to a single phase induction motor when it is running and after a point of speed.

Construction of a single phase induction motor similar to the construction of three phase induction motor having squirrel cage rotor, except that the stator is wound with single phase motor. When the stator winding is given a single phase supply, the magnetic field is produced and the motor rotates at a speed slightly less than synchronous speed N_s [13]. Stator winding is also provided with a 'starting

winding' which is used only for starting purpose. This can be understood from the schematic of single phase induction motor in Figure 2.12.

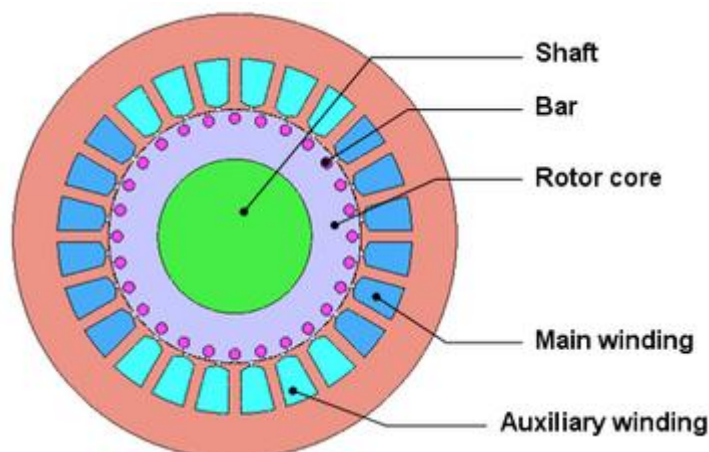

Figure 2.12: Single phase induction motor structure

The single phase induction motors are made self starting by providing an additional flux by some additional means. Single phase induction motors are classified as:

- (i) Split-phase induction motor
- (ii) Capacitor start induction motor
- (iii) Capacitor start run induction motor
- (iv) Shaded pole induction motor

2.4.1 Principle Operation of Capacitor Start- Run Induction Motor

The working principle and construction of capacitor start inductor motors and capacitor start capacitor run induction motors are almost the same. The single phase induction motor is not self starting because the magnetic field produced is not rotating type. In order to produce rotating magnetic field there must be some phase difference. In case of split phase induction motor we use resistance for creating phase difference but here we use capacitor for this purpose. The current flowing through the capacitor leads the voltage.

Figure 2.13 illustrates schematic representation of capacitor start and capacitor start run induction motor. As shown in the Figure 2.13, capacitor start inductor motor and capacitor start capacitor run induction motor consist of two

winding, the main winding and the auxiliary winding. Auxiliary winding are connected to a capacitor so the current flowing in the capacitor i.e I_{st} leads the applied voltage by some angle, ϕ_{st} . as shown in Figure 2.14

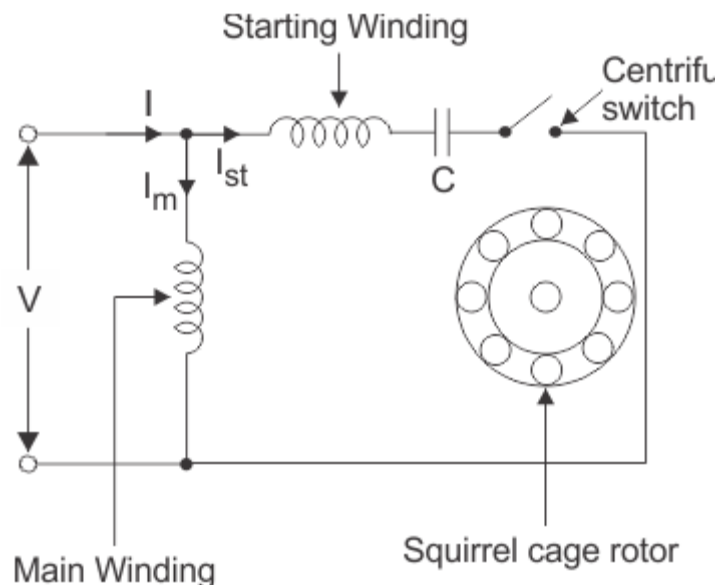

Figure 2.13: Schematic representation of Capacitor Start Run induction motor

The running winding is inductive in nature so, the current flowing in running winding lags behind applied voltage by an angle, ϕ_m . Large phase angle differences between these two currents which produce a resultant current, I and this will produce a rotating magnetic field. Since the torque produced by these motors depends upon the phase angle difference, which is almost 90° . So, these motors produce very high starting torque.

In case of capacitor start induction motor, the centrifugal switch is provided so as to disconnect the starting winding when the motor attains a speed up to 75 to 80% of the synchronous speed but in case of capacitor start capacitors run induction motor there is no centrifugal switch so, the capacitor remains in the circuit and helps to improve the power factor and the running conditions of single phase induction motor.

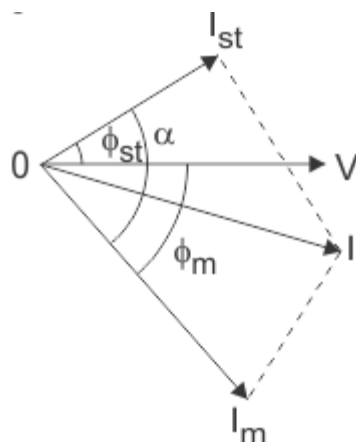

Figure 2.14: Phasor diagram of capacitor Start Run induction motor

2.5 Triac Application

The triac is a power electronics device that are usually use for ac switching applications because it ability to control the current flow over both halves of an alternating cycle. Several schemes of motor control especially single phase motors are available however the triac control still remains a cheap and an easy method of implementing speed control for many applications where the low torque is required [14].

The main advantage of triac is the device can be used to control current switching on both halves of an alternating waveform allows much better power utilization. However the triac is not suitable for some high power applications where the switching is more difficult. Figure 2.15 shows the triac symbol for circuit diagram.

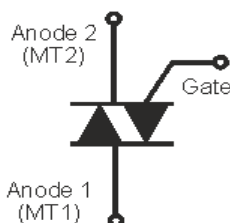

Figure 2.15: Triac symbol for circuit diagrams.

As illustrated in Figure 2.15, the triac symbol demonstrates the operation of the triac. It can be viewed as two back to back thyristors. It consists of 3 terminals which are the gate and two other terminals known as “Anode” or “Main Terminal

(MT)”. Most technique used to control the firing angle of triac for single phase induction motor under closed loop system use digital component such as timers, comparators, and passive components [14].

The triac is an electronic component that is widely used in many circuit applications, ranging from light dimmers through to various forms of AC control. It is generally only used for lower power applications, thyristors generally being used for the high power switching circuits. The triac is driven to change the trigger phase angle for ac voltage, reducing the speed by reducing RMS voltage [15].

2.6 PID Controller

The most commonly used algorithm for controller design is Proportional-Integral Derivative (PID) and it is most widely used controller in the industry. It is a closed loop controller. The working principle of PID controller is done by calculating the processed measured value and the desired reference point.

The objective of the controller is to minimize the error by changing the inputs of the system. Figure 2.16 describes the block diagram of PID controller.

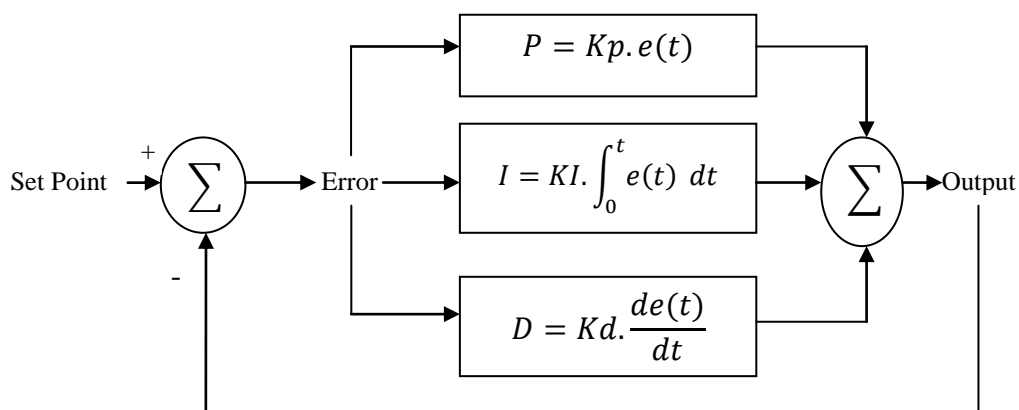

Figure 2.16: Block diagram of PID controller

There are 3 parameters for the PID controller measurement which is called the proportional, integral and derivative. The control mechanism such as speed control of a motor is contributed by the summation of the three parts in which P value depend upon current error; I on the accumulation of the previous error and D predict the future error based on current rate change. The output of the system is given by the equation (2.1):

$$C(s) = K_p \cdot e(t) + K_i \cdot \int e(t) + K_d \cdot \frac{de(t)}{dt} \quad (2.1)$$

Based on the equation (2.1), the effect of increasing parameters K_P , K_I and K_D can be explained in Table 2.5.

Table 2.5: The effect of PID controller parameter

Parameter	Rise Time, T_r	Overshoot, $\%OS$	Settling Time, T_s	Steady State Error, e_{ss}	Stability
K_P	Decrease	Increase	Small Change	Decrease	Degrade
K_I	Decrease	Increase	Increase	Decrease Significantly	Degrade
K_D	Minor Decrease	Minor Decrease	Minor Decrease	No Effect	Improved if K_D small

PID controller has all the necessary dynamics: fast reaction on change of the controller input (D mode), increase in control signal to lead error towards zero (I mode) and suitable action inside control error area to eliminate oscillations (P mode) [16].

2.7 Fuzzy Logic Controller

Fuzzy Logic was proposed for the first time by Lotfi Zadeh in 1965. The fuzzy logic controller is the most efficient controller as it handles non linearity and it independent of plant model [17]. Currently, it has been applied in many control system such as to control digital camera, washing machine, aircraft engine and control surface and many industrial process.

The fuzzy logic controller has four main components: (1) The “rule base” holds the knowledge, in the form of a set rules, of how best to control the system. (2) The inference mechanism evaluates which control rules are relevant at the current time and then decides what the input to the plant should be. (3) The fuzzification interface simply modifies the inputs so that they can be interpreted and compared to the rules in the rules base. And (4) the defuzzification interface convert the conclusion reached by the inference mechanism into the inputs to the plant [18].

Fuzzy logic control are easily designed and developed by combining the theoretical infrastructure of the fuzzy logic and real world based control problems. This type of intelligent control systems allow solving control problems via more accurate , effective and efficient logical and mathematical approaches [19]. Figure 2.17 shows a typical fuzzy control system schema [20].

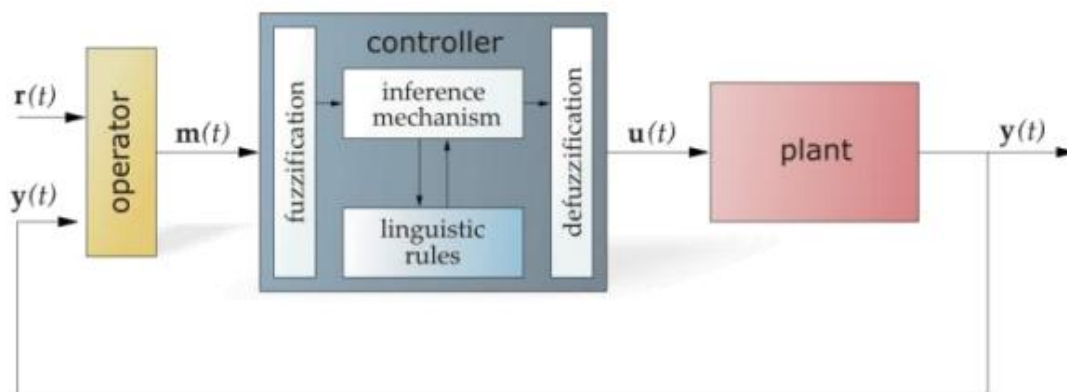

Figure 2.17: A typical fuzzy control system schema [20].

Generating the rules for fuzzy control system is often the most difficult step in the design process. It usually requires some expert knowledge of the plant dynamics. This knowledge could be in the form of an intuitive understanding gained from experimenting, or it could come from a plant model which is then used in a computer simulation [21].

CHAPTER 3

METHODOLOGY

The idea of this project is to design a fuzzy logic controller (FLC) that is used to improve the performance of single phase induction motor (SPIM). In this project, a triac is used to control the voltage and power output to the single phase induction motor. A triac is basically a bidirectional electronic switch, which can conduct current in both positive and negative direction when it is triggered. The firing pulse delay triggered is generated by the fuzzy logic controller. This chapter explained detail the design of fuzzy logic controller (FLC) to generate differences value firing pulse delay (α) using fuzzy logic controller in MATLAB Simulink platform.

The overall development of this project is illustrated in the flowchart in Figure 3.1. The fundamental process of designing fuzzy logic controller is to develop the membership function (MF) of the system. Once the fuzzy logic controller achieved the best performance, it will be test to make sure it can produce the optimum results. When the optimum results are achieved, fuzzy logic controller is successfully created. The fuzzy logic controller then will be used to control the ac induction motor speed. The test will be done via simulation using MATLAB Simulink.

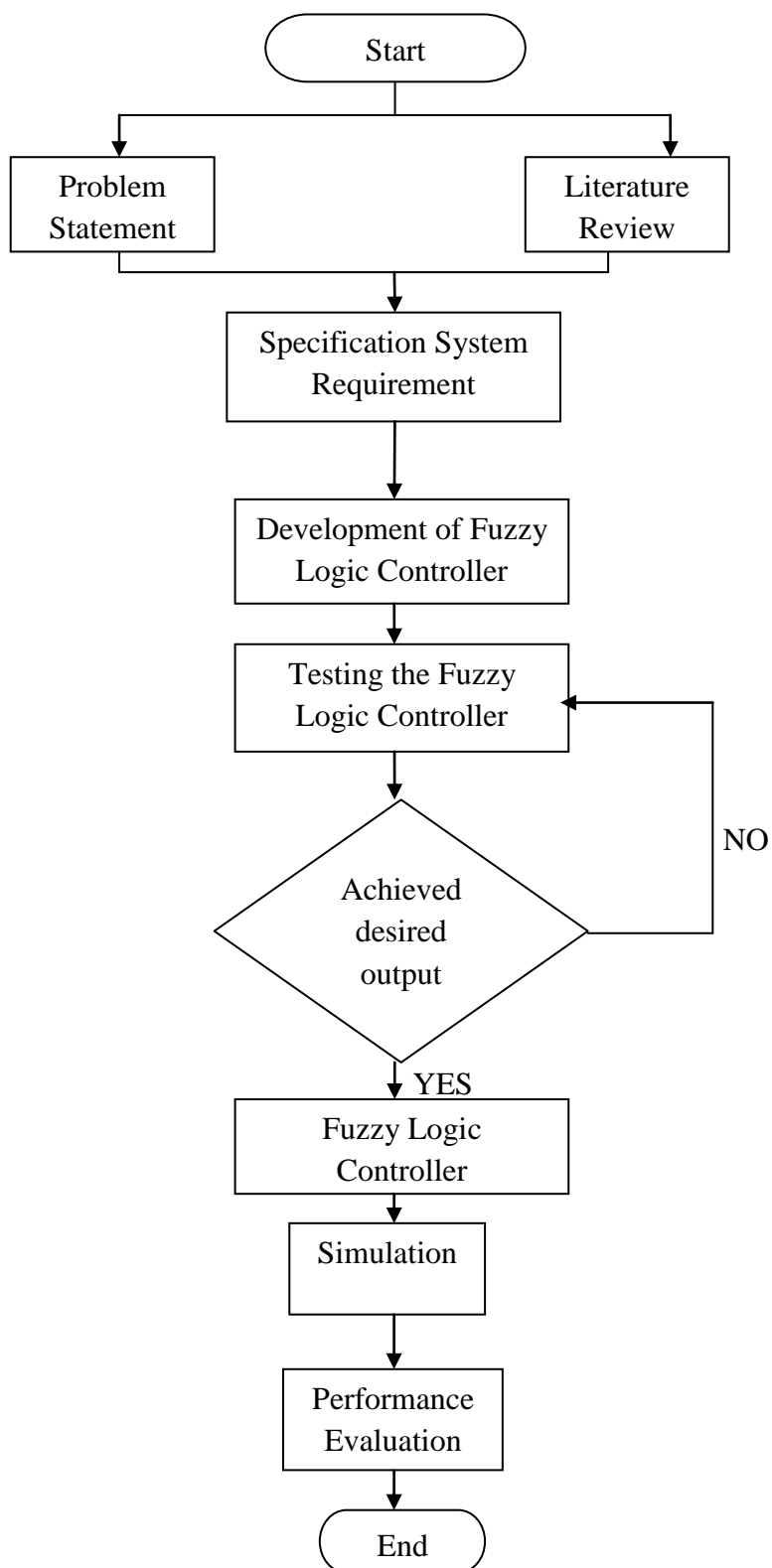

Figure 3.1: Flowchart for overall project activity

REFERENCES

1. Jianming Yao, *Single Phase Induction Motor Adjustable Speed Control using DSP and Microcontroller*, Course Project for ECE734 Fall Semester 2000 at UW-Madison
2. Junmin Shen, Whenzan Dai, The Research of Closed Loop Control of AC motor based on J-M transformation control, *2010 3rd International Conference on Advanced Computer Theory and Engineering (ICACTE)*.
3. *Single Phase AC Induction Motor Control Reference Design* ", Designer Reference Manual, Motorola
4. Kazuya Shirataha, *Speed Control Method of Various types of Speed Control Motor*, Oriental Motor
5. Olisa Innocent Emenike, Aravin C.V, Gobbi.R, An Investigation of Closed Loop Control of Single Phase Induction Motors Using Industrial Components, *2011 IEEE Conference on Sustainable Utilization and Development in Engineering and Technology (STUDENT)*, The University of Nottingham, Semenyih, Selangor, Malaysia 20-21 October 2011
6. Chee-Hoe Pang, Jer-Vui Lee, Yea-Dat Chuah, Yong-Chai Tan an N. Debnach, Design of a Microcontroller Based Fan Motor Controller for Smart Home Environment, *International Journal of Smart Home*, Vol. 7, No.4, July, 2013
7. Y.V Niranjan Kumar, P. Hima Bindu, A. Divya Sneha, A. Sravani, A Novel Implementation of Phase Control Technique for Speed Control Induction Motor using ARDUINO, *International Journal of Emerging Technology and Advanced Engineering*, Volume 3, Issue 4, April 2013
8. Rajaji, L, Kumar. C, Adaptive Neuron Fuzzy Based Soft Starting of Voltage Control Induction Motor Drive, *Southeastcon, 2008*, IEEE, April 2008, pp. 448-453

9. Zeyad Assi Obaid, Nasri Sulaiman, M.N. Hamidon, Design of Fuzzy Logic Controller for AC Motor Based on Field Programmable Gate Array, *Proceeding of 2009 IEEE Student Conference on Research and Development (SCOReD 2009)* , 16-18 Nov. 2009, UPM Serdang, Malaysia
10. T.D Dongale, S.R Jadhav, S.V Kulkarni, T.G Kulkarni, R.R Mudholkar and M.D Uplane, Performance Comparison of PID and Fuzzy Control Technique in Three Phase Induction Motor Control, *International Journal on Recent Trend in Engineering and Technology*, Vol. 7, No. 2, March 2012.
11. Ebrahim Abd El Hamid Mohamed Ramaden, Embedded System Based on Real Time Fuzzy Motor Speed Controller, *Ain Sham Engineering Journal*,(2014) 5, 399-409
12. Gaddam Mallesham , Improvement in Dynamic Response of Electrical Machine with PID and Fuzzy Logic Based Controller, *Proceeding of the World Congress on Engineering and Computer Science 2007*, WCECS, October 24-26,2007, San Francisco, USA.
13. Prachi M. Palpankar, Sanraj Harle, Tushar Karade, Suraj Lekurwale, Speed Control of Induction Motor using Triac, *Proceeding of 18th IRF International Conference*, 11th January 2015, Pune, India.
14. Olisa Innocent Emenike, Aravind C. V and Gobbi.R, An investigation for Closed Loop Control of Single Phase Induction Motors using Industrial Component, *2011 IEEE Conference on Sustainable Utilization and Development in Engineering Technology*, The University of Nottingham, Semenyih, Selangor, Malaysia, 20-21 October 2011.
15. Larry Grover, Jonathan Guy, Closed Loop Control Benefit AC Motor, Aircare Automation, Austin, Texas, *Power Electronics Technology*, June 2005.
16. K Smriti Rao, Ravi Mishra, Comparative Study of P, PI and PID Controller for Speed Control of VSI-Fed Induction Motor, *International Journal Engineering Development and Research (IJEDR)*, Volume 2, Issue 2, 2014.
17. Divya Asija, Speed Control of Induction Motor using Fuzzy-PI Controller, *2nd International Conference on Mechanical and Electronics Engineering (ICMEE 2010)*, 2010.
18. Kevin M. Passino, Stephen Yurkovich, *Fuzzy Control*, Addison Wesley.

19. Utku Kose, Fundamental of Fuzzy Logic with and Easy-to-use, Interactive Fuzzy Control Application, *International Journal of Modern Engineering Research (IJMER)*, Vol. 2, Issue 3, May-June 2012 pp-1198-1203.
20. J. Theler, A software-based fuzzy logic controller (2008) Retrieved from WorldWide Web:http://ib.cnea.gov.ar/~thelerg/melon/doc/html/ch03s02.html#estructura_controlador
21. Dirman Hanafi, Yousef Moh Abueejela, Mohd Fauzi Zakaria, Wall Follower Autonomous Robot Development Applying Fuzzy Incremental Controller, *Scientific Research, Intelligent Control and Automation 2013*,4, 18-25
22. Tze-Fun Chan, Keli Shi, Applied Intelligent Control of Induction Motor Drives, *IEEE Press*, 2011
23. Nizamabad, Speed Control of Induction Motor Using Fuzzy Logic Controller, *National Conference of Electrical Sciences (NCES-12)*, 2012
24. W. Shepherd, L.N. Hulley and D.T.W. Liang, *Power Electronics and Motor Control*, Cambridge University Press, Second Edition, 1995
25. R. Arulmozhiyal, K. Baskaran, N.Devarajan, J. Kanagaraj, Real Time Matlab Interface for Induction Motor Drive using dsPIC30F4011, *International Journal of Computer Application* (0975-8887) Volume 1 No. 5.
26. Casey Igelheart, Jonathan Marques, Carlos Ramirez-Leon, Yinan Li, Farhad Ashrafzadeh and Stacy Walson, *Robust PID type Fuzzy Logic Controller for Variable Speed Motor Drives*, Department of Engineering, Western Kentucky University, Bowling Green, KY42101, U.S.A.
27. Ashutosh Mishra, Prashant Choudary, Artificial Neural Network Based Controller for Speed Control of an Induction Motor using Indirect Vector Control method, *International Journal of Power Electronics and Drive Systems (IJPEDS)*, Vol. 2, No.4, December 2012, pp 402-408
28. Satean Tunyasrirut, Tianchai Suksri, and Sompong Srilad, Fuzzy Logic Control for a Speed Control of Induction Motor using Space Vector Pulse Width Modulation, *World Academy of Science, Engineering and Technology* 25,2007
29. Ahmed M Kassim, Fuzzy Logic Based Self-Tuning PI Controller for High Performance Vector Control Induction Motor Fed by PV-Generator, *WSEAS Transaction on Systems*, Issue 1, Volume 12, January 2013

30. John G. Cleland and M.Wayne Turner, *Fuzzy Logic Control of Electric Motors and Motor Drives: Feasibility Study*, Environmental Protection Agency, National Risk Management Research Laboratory, Cincinnati, OH 45268, United States
31. Deepak Bharadwaj and L.N Das, Design and Development and Hardware Implementation of Fuzzy Knowledge Based Intelligent Temperature Control System, *International Journal of Engineering, Science and Systems (IJEST)*, Vol. 3, No. 6, June 2011.
32. D.D Neema, R.N Patel and A.S Thoke, Speed Control of Induction Motor using Fuzzy Logic Base, *International Journal of Computer Application (0975-8887)*, Volume 33, No.5, November 2011.
33. Hossein Saberi and Mohammag Bagher Bannae Sharifian, An Improved Direct Torque Control Using Fuzzy Logic Controllers and Adaptive Observer, *2012 2nd International eConference on Computer and Knowledge Engineering (ICCKE)*, October 18-19, 2012.
34. Mohammed S. El-Moghany, Basil M. Hamed, Two Axes Sun Tracker using Fuzzy Logic Controller via PIC16F877A, *The 4th International Engineering Conference- Towards Engineering of 21st Century*, 2012
35. Pravallica Vinnakota, *Motor Control with Aduino : A Case Study in Data Driven Modelling and Control Design*, MathWorks, ECE Digital Edition, April 2013

VITA

The author was born in 28 of August 1981 in Kelantan, Malaysia. He went to Sekolah Menengah Sains Tengku Muhammad Faris Petra, Kota Bharu, Kelantan for his secondary school. He pursued his degree at the Universiti Putra Malaysia, Serdang, Malaysia and graduated with the B. Eng (Hons) in Computer and Communication System in 2004. Upon graduation, he works as a Researcher in Mimos Bhd, Malaysia. In 2013, he attended the Graduate Studies of Universiti Tun Hussein Onn Malaysia (UTHM), Malaysia and admitted into the Master program in Electrical Engineering. He is currently a Lecturer in Politeknik Malaysia.