



DESIGN OF A SHUNT ACTIVE POWER FILTER TO MITIGATE THE HARMONICS CAUSED BY NONLINEAR LOADS

D. M. Soomro, M. A. Omran, and S. K. Alswed

Department of Electrical Power Engineering, Faculty of Electrical and Electronic Engineering,
Universiti Tun Hussein Onn Malaysia (UTHM)
86400 Parit Raja, Batu Pahat, Johor, Malaysia

E-Mail: dursoomro@uthm.edu.my, omranmohamed346@yahoo.com, sageralswed@yahoo.com

ABSTRACT

Application of non-linear electrical devices has led to a distortion in the output sine waveforms of source current and voltage. It may lead equipment (connected to it) to overheat and sometimes cause damage. This paper concentrates on the design and application of three-phase shunt active power filter (SAPF) by using p-q theory to mitigate the harmonics which are created by nonlinear loads. To obtain result for this paper, the MATLAB / Simulink was used as a simulation tool. The achieved results are within the recommended IEEE-519 standard i.e. less than 5% and also the power factor (PF) of the system to almost unity.

Key words: Shunt Active Power Filter (SAPF) • Power Quality (PQ) • Total Harmonic Distortion (THD) • Power Factor(PF)

INTRODUCTION

Power quality (PQ) issues are becoming a major concern of today's power system (PS) engineers. Harmonics play a significant role in deteriorating PQ, called harmonic distortion (HD). HD in the electrical distribution system is increasing day to day due to the widespread use of nonlinear loads. Significant considerations of these pressures can possibly raise consonant voltage and current in an electrical PS to inadmissible abnormal states that can antagonistically affect the system. IEEE standards have characterized cutoff points for harmonic voltages and harmonic currents (Tsengenes and Adamidis, 2010), (Chapman, 2001). It has been observed that, in distribution system current harmonics cause serious harmonic problems in distribution feeders for sensitive consumers. Some technology solutions have been reported in order to solve PQ issues (Tsengenes and Adamidis, 2010), (Chapman, 2001), (Ao. Douglas, et al., 2010).

Initially, passive filters (combinations of capacitors and inductors) were used to mitigate the PQ problems. These approaches were extensively used in high voltage DC transmission (HVDC) for filtering the harmonics on the AC and DC sides. However, this approach is unsuitable at the distribution level as passive filters can only correct specific load conditions or a particular state of the PS. These filters are unable to follow the changing system conditions. Thus, the active power filter (APF) was introduced to compensate harmonics and reactive power.

There are three types of APFs which are shunt APF, series APF, and hybrid APF (i.e. the combination of active and passive filters)(Badi, 2012)(Chaughule, Nehete, and Shinde, 2013).

The purpose of an APF as a power line conditioner is to repay the utility line current waveform with the goal that it approximates a sine wave in phase with the line voltage when a nonlinear load is connected with the system. Classically, shunt power line conditioner (shunt passive filter) consists of tuned LC filters. High pass filters are used to suppress harmonics. While power capacitors are utilized, to enhance the PF of the utility/mains. However, these

conventional methods have the limitations of fixed compensation, large size and can also excite resonance conditions (Tsengenes and Adamidis,2010), (Chapman, 2001). Hence, SAPFs are introduced as a viable alternative to compensate harmonics and improve PF.

This paper is focusing on the application of SAPF in treating the harmonics distortion in the distribution system by determining low Total Harmonic Distortion (THD) value and improving the system's PF.

SHUNT ACTIVE POWER FILTER DESIGN

Effect of harmonics

Harmonics in PS can turn into the wellspring of a mixture of unwelcome impacts. For example, harmonics can cause signal interference, overvoltage, data loss, and circuit breaker failure, as well as equipment heating, breakdown, and harm. Any dissemination circuit serving modern electronic gadgets will contain some degree of harmonic frequencies. The greater the power drawn by nonlinear loads, cause higher the level of voltage and current distortion as shown in Figure 1.

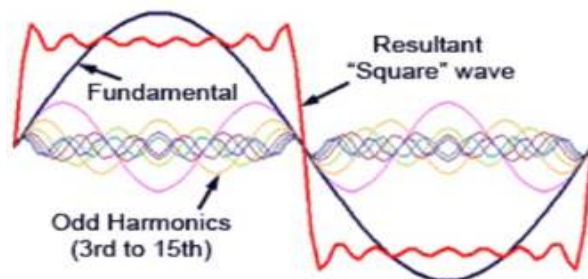

Figure 1: Effect of harmonics on voltage or current waveform (Chaughule, et al., 2013)

HD in power distribution system can be measured by using equation (1)

$$\%THD = \frac{\sqrt{\sum I_n^2}}{I_1} \times 100 \quad (1)$$



Where $n = 2, 3, 4, 5, \dots$

APFs are becoming a viable alternative to passive filters and are gaining market share speedily as their cost becomes competitive with the passive variety, one of the most common type of APF to reduce the harmonic current distortion is SAPF (Ten genes and Adamidis, 2010).

Principle of SAPF

The shunt-connected APF, with a self-controlled dc bus, has a topology similar to that of a static compensator (STATCOM) used for reactive power compensation in power transmission systems. SAPF compensates load current harmonics by injecting equal but opposite harmonic compensating current. In this case, the SAPF operates as a current source injecting the harmonic components generated by the load but phase shifted by 180° . Figure 2 shows the connection of a SAPF compensating the harmonic load currents.

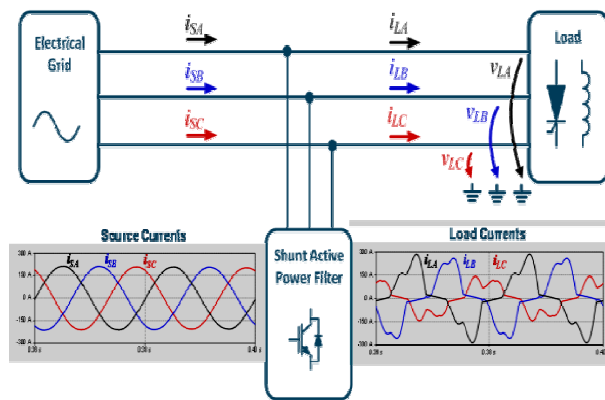

Figure 2: Connection of a SAPF

Design SAPF based on instantaneous PQ theory

The instantaneous active and reactive power theory or simply the p-q theory is based on a set of instantaneous values of active and reactive powers defined in the time domain. There are no restrictions on the voltage or current waveforms, and it can be applied to three-phase systems with or without a neutral wire for three-phase generic voltage and current waveforms. Thus, it is valid not only in the steady state, but also in the transient state (Priya and Balu, 2014), (Gopal, Rama and Yarnagula, 2014). This theory is very efficient and flexible in designing controllers for power conditioners based on power electronics devices. Other traditional concepts of power are characterized by treating a three-phase system as three single-phase circuits. The p-q Theory first uses Clarke transformation to transform voltages and currents from the a, b, and c to $\alpha\beta 0$ coordinates and then defines instantaneous power in these coordinates. Hence, this theory always considers the three-phase system as a unit, not a superposition or sum of three single-phase circuits (Priya and Balu, 2014).

The p-q Theory can be defined in three-phase systems with or without a neutral conductor. Three instantaneous powers: the instantaneous zero-sequence power P_0 , the instantaneous P , and the instantaneous Q are

defined from the instantaneous phase voltages and line currents on the $\alpha\beta 0$ axes as represented in equation (2).

$$\begin{bmatrix} P_0 \\ P \\ Q \end{bmatrix} = \begin{bmatrix} V_0 & 0 & 0 \\ 0 & V_\alpha & V_\beta \\ 0 & -V_\beta & V_\alpha \end{bmatrix} \begin{bmatrix} I_0 \\ I_\alpha \\ I_\beta \end{bmatrix} \quad (2)$$

Let us consider a three phase, instantaneous phase system voltages V_α , V_β and V_γ and I_α , I_β and I_γ which are the instantaneous line currents. Since zero sequence power in three phase, three wire system is always zero, the equation (2) becomes:

$$\begin{bmatrix} P \\ Q \end{bmatrix} = \begin{bmatrix} V_\alpha & V_\beta \\ -V_\beta & V_\alpha \end{bmatrix} \begin{bmatrix} I_\alpha \\ I_\beta \end{bmatrix} \quad (3)$$

In the proceeding discussion, the α and β currents will be set as functions of voltages and the real power (P) and imaginary power (Q) respectively to explain the physical meaning of the power defined in the p-q theory (Priya and Balu, 2014). Equation (3) can be written as:

$$\begin{bmatrix} I_\alpha \\ I_\beta \end{bmatrix} = \begin{bmatrix} V_\alpha & V_\beta \\ -V_\beta & V_\alpha \end{bmatrix}^{-1} \begin{bmatrix} P \\ Q \end{bmatrix} \quad (4)$$

The three phase instantaneous power p is given by:

$$P = v_\alpha i_\alpha + v_\beta i_\beta + v_\gamma i_\gamma$$

If current and voltages from α and β variables are replaced to their equivalent a , b , and c variables in equation (3), the instantaneous Q will be:

$$Q = V_\alpha I_\beta - V_\beta I_\alpha$$

$$Q = \frac{1}{\sqrt{3}} [(V_\alpha - V_\beta)I_\gamma + (V_\beta - V_\gamma)I_\alpha + (V_\gamma - V_\alpha)I_\beta]$$

$$Q = \frac{1}{\sqrt{3}} [V_{ab}I_\gamma + V_{bc}I_\alpha + V_{ca}I_\beta] \quad (5)$$

This expression is similar to that implemented in some instruments for measuring the three-phase reactive power. The difference is that voltage and current phases are used in those instruments. Here, instantaneous values of voltage and current are used instead (Priya and Balu, 2014) (Gopal, Rama and Yarnagula, 2014) (Adam, Zbant and Livint, 2013). According to p-q theory real and reactive powers can be written as:

$$P = \bar{P} + \bar{P}_0, Q = \bar{Q} + \bar{Q}_0, \text{ and } P_0 = V_0 I_0 \quad (6)$$

where:

P = The active power for a three phase system with or without neutral conductor in steady state or during transients and it is representing the total instantaneous energy flow per second between source and load.

Q = The imaginary power and proportional to the quantity of energy that is being exchanged between the phases of the system. It does not contribute to energy transfer between source and load at any time.

P_0 = Active power due to zero sequence components.

\bar{P} = The average value of the instantaneous real power and is transferred from the power source to the load. It is the only desired power component to be supplied by the power source and due to fundamental active current.



\bar{P} =Alternating value of the instantaneous real power exchanged between the power source and the load through the a-b-c coordinates. Since alternating value of the instantaneous real power does not involve any energy transference from the source to load, it must be compensated. It is due to harmonic currents.

\bar{Q} =Average value of the instantaneous imaginary power, exchanged between system phases and does not imply transfer of energy between power sources and load. The choice of compensation of average value of the instantaneous imaginary power depends on reactive power compensation and is due to fundamental reactive current.

\tilde{Q} =Alternating value of the instantaneous imaginary power exchanged between system phases and does not imply transfer of energy between power source and load. Since alternating value of the instantaneous imaginary power is unwanted, it must be compensated. It is also due to harmonic currents. All these powers are explained in Figures 3.

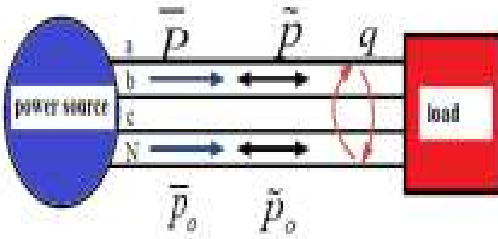

Figure 3: The concept of different powers between power source and load (Priya and Balu, 2014)

The basic idea behind the shunt current compensation is illustrated in Figure 4. It shows a source supplying power to nonlinear load that is being compensated by the filter. Actually SAPF is shunt compensator. We assumed that the SAPF behaves as three phase controlled current source that can generate harmonics in phase opposition depending upon current reference i_{ca}^* , i_{cb}^* and i_{cc}^* (Tekeet al., 2011).

The calculated active power of the load can be separated into its average (P) and oscillating (\tilde{P}) parts. Likewise, the load reactive power can be separated into its average (Q) and oscillating (\tilde{Q}) parts. Then, undesired portions of the p and q of the loads that should be

compensated are selected.

The reason for incorporating minus sign in the compensating power is to emphasize that the compensator must inject harmonics in perfect phase opposition. Remember that convention of current in direction is selected as shows in Figure 4 that source current is the sum of load currents and filter current. Inverse Clarke transformation from α, β , and 0 to be coordinates is applied then to calculate the compensating current references i_{ca}^* , i_{cb}^* and i_{cc}^* instantaneously.

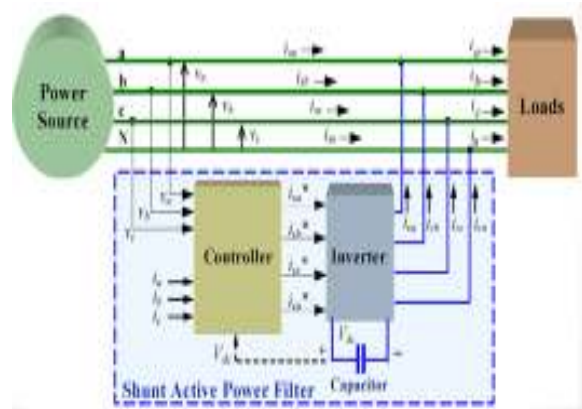

Figure 4: SAPF in 3-phase system (Priya and Balu, 2014)

METHODOLOGY

In this paper MATLAB/SIMULINK is used as a tool to implement the proposed SAPF in different load conditions. Mainly, there are two simulations; first simulation is with non-linear load while the second one is with SAPF connected.

First simulation setup

The simulation diagram is as shown in Figure 5. Three phase supply which is feeding non-linear load with R-L parameters along with 3-phase full bridge diode rectifier is considered for simulation. The values of simulation parameters are shown in the Table 1.

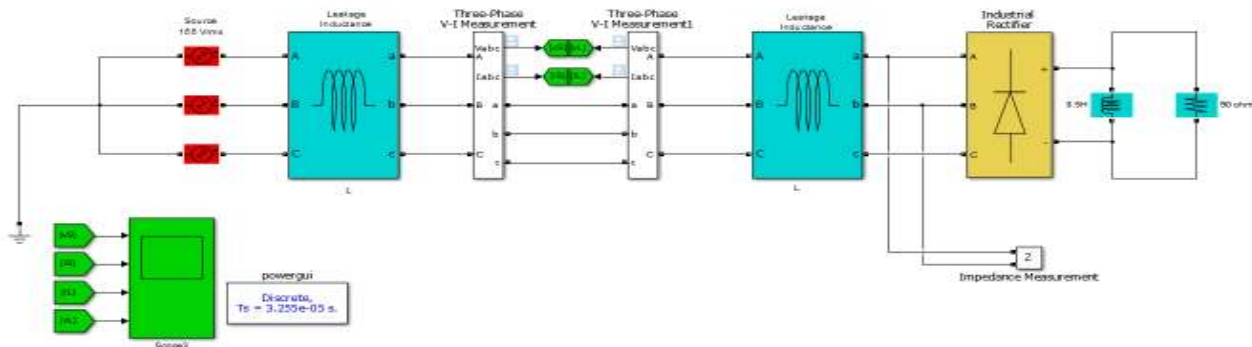

Figure 5: First simulation setup in MATLAB/Simulink with nonlinear load



Second simulation setup

To investigate the working of designed SAPF, it is connected to Figure 5 under different conditions of suddenly connected *R-L* load of 60 Ω, 50 mH and unbalanced *R-L* load of 5, 10, 15 Ω on each phase respectively as shown in Figure 6.

signal of the comparator which is used to activate the inverter power switching.

There are two inputs for the hysteresis band which is the reference current and the new injection current as shown in Figure 8.

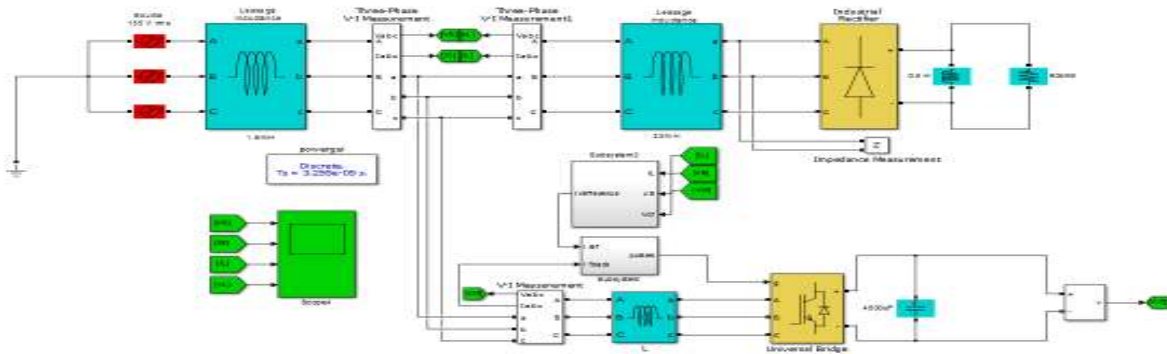

Figure 6: Second simulation setup with SAPF

P-Q and current compensation calculation

This is the heart of APF. PQ theory algorithm for calculation of P, Q and compensation current are implemented as given below in Figure 7. Embedded MATLAB function block is used to implement all the mathematical operations involved in the algorithm. Figure 7 shows all the blocks required for calculation of compensation current. In that Clarke transform to calculate real, reactive and zero sequence power and stationary frame at compensated reference current generate by using PI controller. The SAPF at using DC link capacitor and DC link reference voltage and actual voltage compared to the voltage to be regulated. Then inverse Clarke transform to calculate three phase compensated reference current.

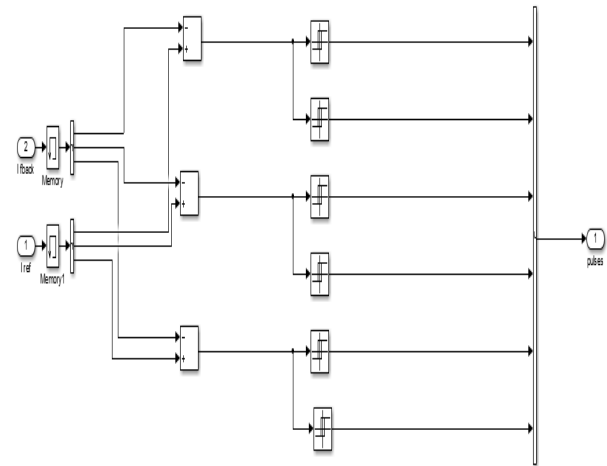

Figure 8: Hysteresis current control

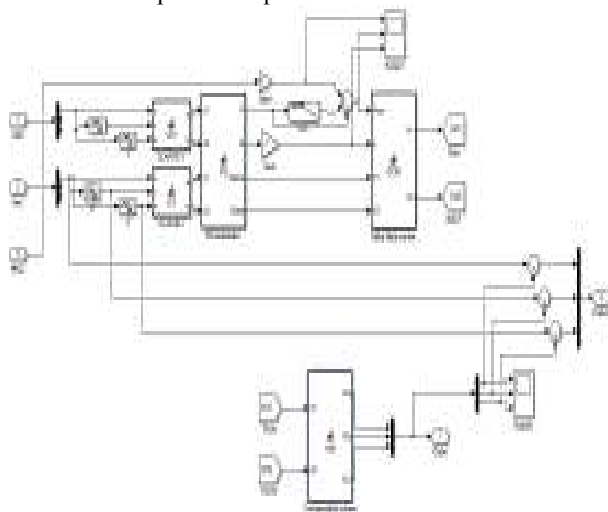

Figure 7: Blocks required for calculation of compensation current

The load current, by forcing it to follow (Mohapatra and Babu, 2010) is achieved by switching the action of an inverter to keep the current within the hysteresis band (Zaveri and Chudasama, 2012). The load currents are sensed and compared with respective command current by hysteresis band. The output

The error between reference current and the new injection current are fed to the six relays. This signal will guide the inverter's switching to compensate the harmonic current.

PI controller

To control DC bus voltage, it is required to take care of little amount of power flowing into DC capacitor, thus compensating for switching and conduction losses. The dc link voltage control loop does not require being as fast as it responds to steady state operating condition. The actual DC link voltage is compared with a reference DC link voltage and passed through a PI controller. To maintain dc-link voltage at a fixed reference value, the dc-link capacitor requires a certain amount of real power, which is directly

The hysteresis band current controller

The principle of hysteresis current control is very simple. The purpose of the current controller is to control



proportional to the difference between the reference and actual voltages. The control signal coming from PI controller to regulate DC link voltage can be expressed as:

$$P_{dc-link} = K_p(V_{dc-ref} - V_{dc}) + K_i \int (V_{dc-ref} - V_{dc} dt) \quad (7)$$

Where K_p and K_i are proportional and integral gains of the PI controller.

Figure 9: PI controller

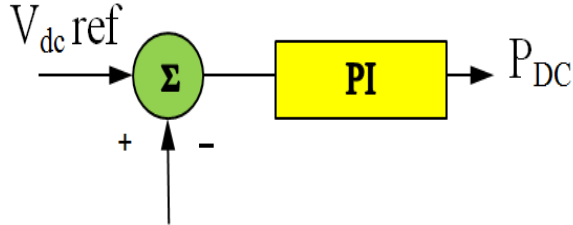

By increasing proportional gain (K_p), it reduces rise time and steady-state error. It also causes increase in the overshoot and settling time. Similarly increase of integral gain K_i reduces steady state error, and increases overshoot and settling time. The control diagram of PI controller is as shown in Figure 9.

Simulation Parameters

Table 1: Simulation parameters used in this paper

Parameter	Value
Source voltage (rms)	155 V
Source frequency (F)	50 Hz
Source resistance (R_s)	1 mΩ
Source inductance (L_s)	1e-3 mH
Case 1: Load (R-L)	90 Ω, 0.5H
Case 2: Additional load of R-L	90 Ω, 0.5H
Case3: Additional Unbalanced R load with R-L load	5, 10, 15 Ω on each phase respectively With 90 Ω, 0.50H
DC link capacitor (C_{dc})	4500 μF
Inductor filter	3.5 mH
DC link PI controller	$K_p = 25, K_i = 20$
DC link Reference voltage	450 V

RESULTS AND DISCUSSION

The simulation results of voltage, current and THD are obtained with MATLAB tool to analyze the performance of SAPF without and with compensation as shown in Figure 10, 11, 12, 13 and 14.

Case 1 (R-L load)

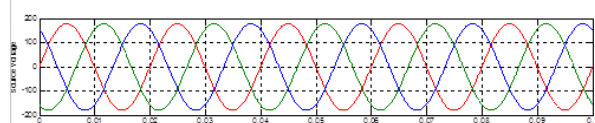

Figure 10: Source voltage without and with SAPF

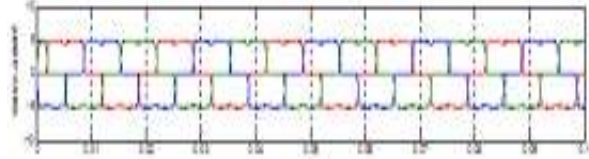

Figure 11: Source current without SAPF

Figure10 presents source voltage waveform, in which it is found that there is no distortion. But in the waveform of current, distortion is present there as shown in Figure11. In that case THD found was 28.59 % as shown in Figure 12.

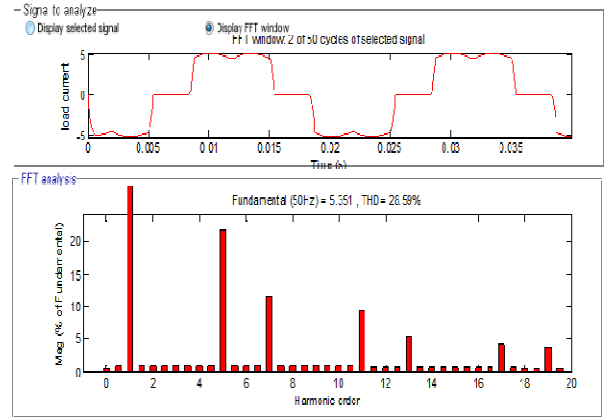

Figure 12: THD without SAPF

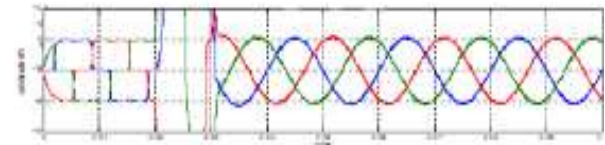

Figure 13: Current with SAPF

Figure 13 presents the current waveform without and with the application of SAPF, which was applied at 0.02seconds.The resultant current harmonic was mitigated and THD was reduced from 28.59% to 1.77% as shown in Figure 14.The minimized THD below 5% confirms the achievement of IEEE-519 standard. Also the observed PF was improved from 0.782to 0.9993 as shown in Table 2.

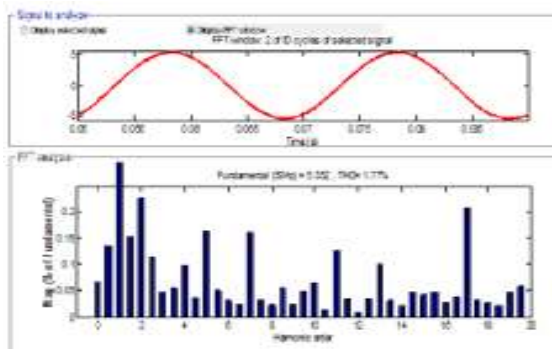

Figure 14: Analysis of THD with SAPF



Case 2 (Additional R-L load with R-L load)

Figure 15 show the harmonic current signal without SAPF. Figures 16 and 17 display the simulation results obtained in the HD analysis of the load current with nonlinear R-Land suddenly connected R-Lloads. The THD was 27.65%.The highest harmonics were the 5thand the 7threpresenting 20.13%and 12.55% respectively of the fundamental. On the other hand, the PF was reduced to more poor level i.e. less than 0.778 as shown in Table 2.

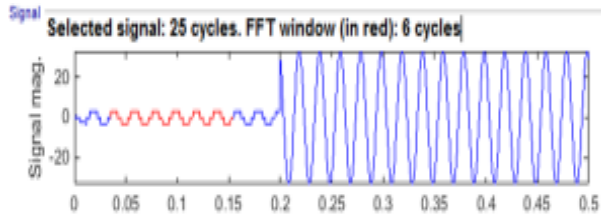

Figure 15: Current waveform without SAPF

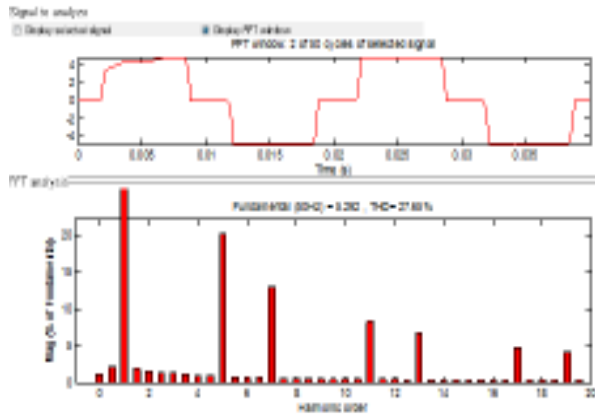

Figure 16: An analysis of THD without SAPF

The SAPF was connected to the harmonic distorted system at time t=0.2sec to mitigate the effect. On the other hand, suddenly connected R-L load was connected at 0.3sec. It can be seen that the filter takes only 0.021 sec for the shunt APF to follow the change of the load current as shown in Figure 17.

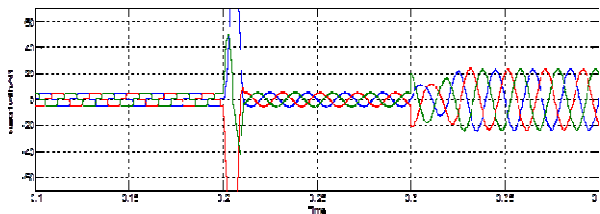

Figure 17: Analysis of signal with SAPF

By connecting SAPF, the THD was reduced from 27.65% to 1.82%, which matches the IEEE 519 standard limits as shown in Figures 17 and 18. The PF was also improved from 0.778 to 0.9987.

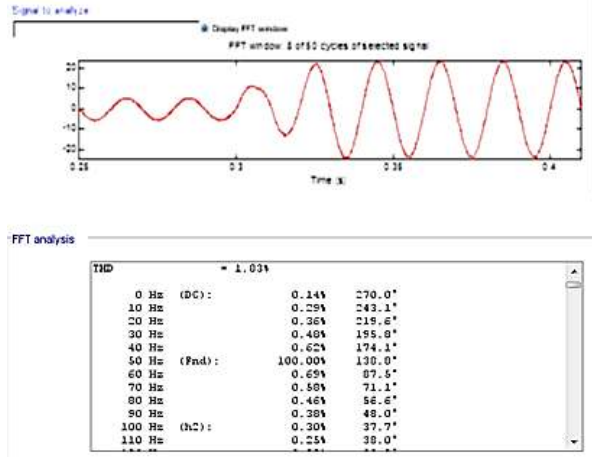

Figure 18: Analysis of THD with SAPF

Case 3 (Unbalanced R load with R-L load)

In this case SAPF was investigated with R-L load with additional unbalanced R load. The time of simulation was from 0sec to 1sec. The Figures 19, 20 and 21 depict all the results without and with SAPF. Figure 19 shows the voltage waveforms as pure but the waveform of current is distorted.

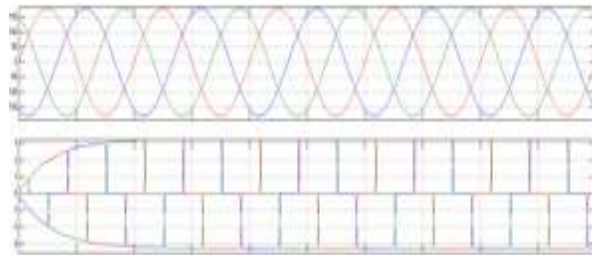

Figure 19: Waveforms of voltage and current without SAPF

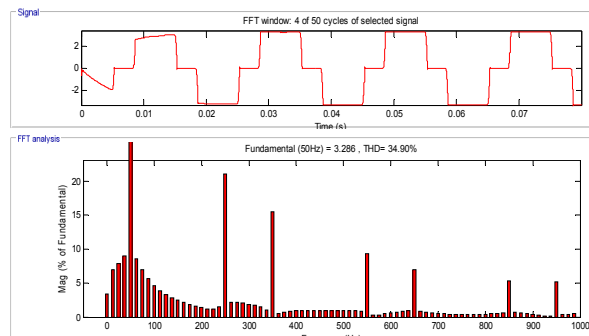

Figure 20: Analysis of THD without SAPF

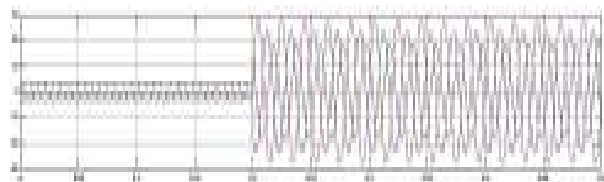

Figure 21: Waveforms of current with unbalanced load



In Figure 20, the observed THD was 34.90%. While the PF reduced to 0.688. The effect of additional unbalance R load can be seen connected at 0.2sec in the Figure 21 to investigate how the SAPF worked, while it was connected to test case 3 at 0.1sec.

When the SAPF was connected, it generated reference current to inject in the system to cancel the harmonic current as shown in Figure 22. The corresponding current waveform is as shown in Figure 23. Analysed THD shows that it was reduced to 1.58% from 34.90% and also the PF was improved to 0.998 as shown in Figures 24 and given in Table 2.

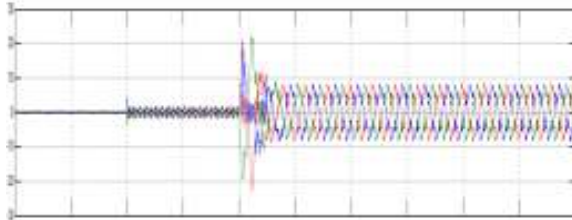

Figure 22: Generated current by SAPF

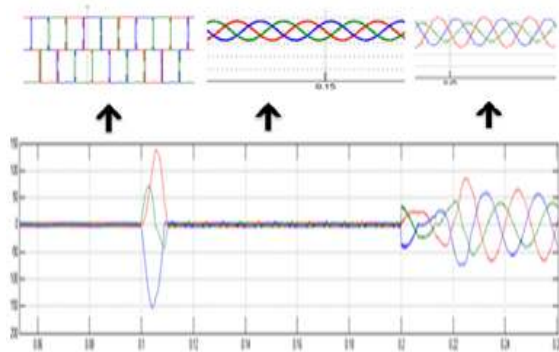

Figure 23: Waveform of current with SAPF

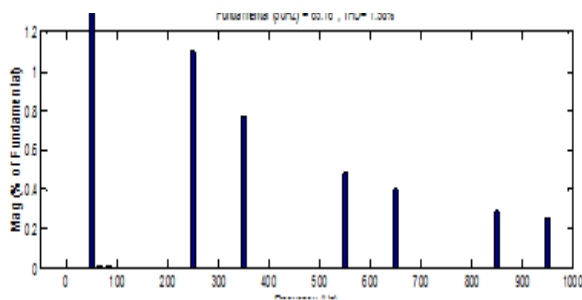

Figure 24: Analysis of THD with SAPF

The resulting THD of the current and PF without and with SAPF are summarised in Table 2. While Table 3 gives a glance by describing the harmonic orders of all simulations without and with SAPF.

CONCLUSION

The designed three phase SAPF based on instantaneous p-q theory was simulated in MATLAB/SIMULINK by using different load conditions i.e. $R-L$

load, suddenly connected $R-L$ load, and additional unbalance R load. Its application was successfully proved and the validity achieved by minimizing the harmonics and improving PF as summarised in Table 2. Consequently, the supply current is almost pure sinusoidal. THD observed was found to be within the prescribed limits of 5% as recommended by IEEE-519 standard.

Table 2: shows the results of simulations

Operation condition	Without SAPS		With SAPF	
	%THD	PF	%THD	PF
$R-L$ load	28.59	0.782	1.77	0.9993
$R-L$ with additional R load	27.65	0.778	1.82	0.9987
$R-L$ load with R unbalanced load	34.90	0.688	1.58	0.9982

Table 3: Harmonic orders of all cases without and with SAPF

Case		Harmonic orders %							THD %	
		3 th	5 th	7 th	9 th	11 th	13 th	15 th		17 th
RL load	Without APF	0.46	22.35	11.8	0.40	8.88	5.45	0.48	4.84	28.59
	With APF	0.01	1.31	0.74	0.00	0.52	0.41	0.00	0.31	1.77
RL with sudden load	Without APF	0.43	22.28	10.88	0.07	9.12	5.45	0.40	4.66	27.65
	With APF	0.00	0.87	0.26	0.00	0.52	0.11	0.00	0.06	1.82
RL with unbalance load	Without APF	2.48	21.06	15.53	1.00	9.34	6.96	0.40	5.32	34.90
	With APF	0.00	1.10	0.77	0.00	0.48	0.40	0.00	0.21	1.58

For future research

Simulation of APF for voltage harmonics compensation can be made by using universal PQ conditioner (UPQC).

Experimental investigations can be made on SAPF by developing a prototype model in the laboratory to verify the simulation results for both PI and hysteresis controllers.

REFERENCES

- Testa, M. F. Akram, R. Burch, G. Carpinelli, G. Chang, and V. Dinavahi. (2007). Interharmonics: Theory and Modeling, IEEE Transactions on Power Delivery, 22, pp. 2335-2348.
- Absalla, I, I. Rao, K. S.R. and Perumal, N. (2011). Cascaded Multilevel Inverter Based Shunt Active Power Filter In Four-Wire Distribution System. IEEE, 978(1), pp.4577--4584.
- Adam, G., Zbant, A. and Livint, G, (2013). New Simulink control block for single phase shunt active power filters. In Advanced Topics in Electrical Engineering (ATEE), 2013 8th International Symposium on IEEE, pp.1-4.



- Aniket V. Kulkarni, Dept of Electronics and Telecommunication PES Modern College of engineering Pune 411005, Automatic Power Factor Correction to reduce the power requirement. *International Journal on Advanced Computer Theory and Engineering (IJACTE)*.
- Badi, Manjulata. (2012). Power quality improvement using passive shunt filter, tcr and tsc combination. Diss. National Institute of Technology, Rourkela-769008, India.
- Chapman, D. (2001). Voltage dips. Power quality application guide. *Filters under Non Ideal Mains Voltages, SPEEDAM 2010 International Symposium on Power Electronics, Electrical Drives, 5(1)*, pp.1--10.
- Chaugule, B. I. Nehete, A. L. and, Shinde, R. (2013). Reduction In Harmonic Distortion Of The System Using Active Power Filter In Matlab Simulink. *International Journal of Computational Engineering Research, 3(6)*, pp.59--64.
- G, Tsengenes. and G, Adamidis. (2010). "A New Simple Control Strategy for Shunt Active Power Filters under Non Ideal Mains Voltages," *SPEEDAM 2010 International Symposium on Power Electronics, Electrical Drives, Automation and Motion*.
- Gopal, M. Rama, and Sobharani Yarnagula. (2014). "Simulation and Analysis of Shunt Active Power Filter for Power Quality Improvement." *International Journal of Advanced Trends in Computer Science and Engineering, 3(1)*, pp.26--31.
- H. Akagi, E.H. Watanabe, and M. Aredes. (2007). "Instantaneous power theory and applications to power conditioning," *Electrical Engineering*.
- Ibrahim, S. Prakash, S. and Bhardwaj A. (2013). "Power Quality Improvement Performance Using Hybrid (Solar Wind) Energy for Distributed Power Generation." *2(10)*, pp.412--413.
- Sebasthirani, K. and Porkumaran, K . (2013). Efficient Control of Shunt Active Power Filter With Self-Adaptive Filter Using Average Power Algorithm. *International Journal of Emerging Technology and Advanced Engineering, 3(5)*, pp.178-183.
- Teke, A. Saribulut, L. Meral. M.E. and Tumay, M. (2011). Active Power Filter: Review of Converter Topologies and Control Strategies. *Gazi University Journal of Science, 24(2)*, pp.283-289.
- Usaman, H. and Musa, S. (2013). "Harmonic mitigation single shunt active power filter with fuzzy logic controller for the improvement of power quality" *Australian International Academic Centre, 1(2)*, pp.28--33.
- Zaveri, N. and Chudasama, A. (2012). Control Strategies for Harmonic Mitigation and Power Factor Correction Using Shunt Active Filter under Various Source Voltage conditions. *International Journal for Electrical Power and Energy Systems, 42(2012)*, pp.661--671.
- Chapman, D. (2001). Voltage dips. Power quality application guide. *5(1)*, pp.1—10.
- Ao, S. I. Douglas, C. Grundfest, W. S. and Burgstone, J. (2010). *Proceedings of the World Congress on Engineering and Computer Science. II*, pp. 978-988. 2010, San Francisco, USA
- Priya, M. S. and Balu, U. S. (2014) Simulation Results of A Shunt Active Power Filter using P-Q Theory Power Components Calculations . *International Journal Of Advance Research In Computer Science And Management Studies, 2 (2)*, pp, 247-254 .