

Effect of Heat Compression on the Tensile Strength of PALF/Sugarcane Bagasse for Disposable Plate

Mohammad Sukri Mustapa^{1, a}, Saiful Din Sabdin^{1, b}, Erween Abd Rahim^{1, c},
Md Saidin Wahab^{1, d} And Yusri Yusof^{1, e}

¹Faculty of Mechanical Engineering, Universiti Tun Hussein Onn Malaysia, Batu Pahat, Malaysia.

^asukri@uthm.edu.my; ^bsaifulkdh@yahoo.com, ^cerween@uthm.edu.my, ^dsaidin@uthm.edu.my,
^eyusri@uthm.edu.my,

Keywords: Tensile properties, Tearing strength, Pineapple leaf fibers, Sugarcane bagasse

Abstract. This paper presents the results of heat compression effect on tensile properties in manufacturing process of disposable plate from Pineapple Leaf Fibers (PALF) based material. The plate was made of PALF and sugarcane bagasse waste as alternatif to polystyrenes to promote the green technology effort on food packaging material. Two different spesimens were produced with different composition of PALF/sugarcane bagasse, N2T8 (20% Pineapple leaf fiber and 80% sugarcane bagasse and N8T2 (80% pineapple leaf fiber and 20% sugarcane bagasse). The specimens were produced on a hot press machine at different compressing temperature, 50°C, 100°C and 150°C with constant pressure of 0.024 MPa at 10 minutes. Tensile and tearing tests were carried out on the specimens to determine the tensile and tearing properties. The results shown that the N2T8 speciment compressed at 50°C gives higher tensile and tearing strength of 22 MPa and 2 MPa ,respectively. This range of properties is expected to be good enough for the requirement of disposable plate and it has a potential as a raw material for strength and lightweight of disposable plate manufacturing.

Introduction

Since 1904, paper plates have become a staple in almost every household. The traditional plastic plate materials which are made from reinforced glass fibers are expensive and also harmful to the environmental. Packaging materials, including recycled paper, have to comply with a basic set of criteria concerning safety. Natural fibers have been proven to offer an advantages such as low cost and low density compared to glass fibers [1-2]. Increasing awareness in environment throughout the world has resulted in utilizing natural fibers as reinforcements in composite industry as it offer as renewable resources [3-4].

Johor is a major producer of pineapples in Malaysia with an area of 9,830 hectares, which is 57% of the acreage in [5]. Today, the pineapple become popular with a variety of products on the market. The PALF can be used as disposable plate and from the literature, there have been rapid growths in research of using different natural fiber for paper plate. Hence, the aim of this study is to investigate the processability of PALF and sugarcane bagasse as a raw material for disposable plate at different heat compression temperature. The tensile and tearing strength behavior were investigated.

Material and experimental

PALF and sugarcane bagasse waste (Fig. 1) used were received from Pineapple and farm which located at Batu Pahat Johor. The schematic process used for material preparation and to produce the paper plate as shown in Fig. 2. The PALF and sugarcane bagasse were cut and washed with water to remove dirt. The PALF was immersed in water with sodium hydroxide at the ratio of 10:1. Then the water was heated to a temperature of 100°C at 20 minutes for 24 hours. The fiber was blended using commercial blender machine and mix with sugarcane bagasse at different composition (80/20) and (20/80), respectively. A mold size (34 cm (length) x 34 cm (Width) x 13 cm (thick) and heat

compression machine, as shown in Fig. 3, were used for 24 mm size paper plate production. The samples were then dried in an oven at temperature set on 60 °C for 24 hours.



Fig. 1 PALF and sugarcane bagasse waste .

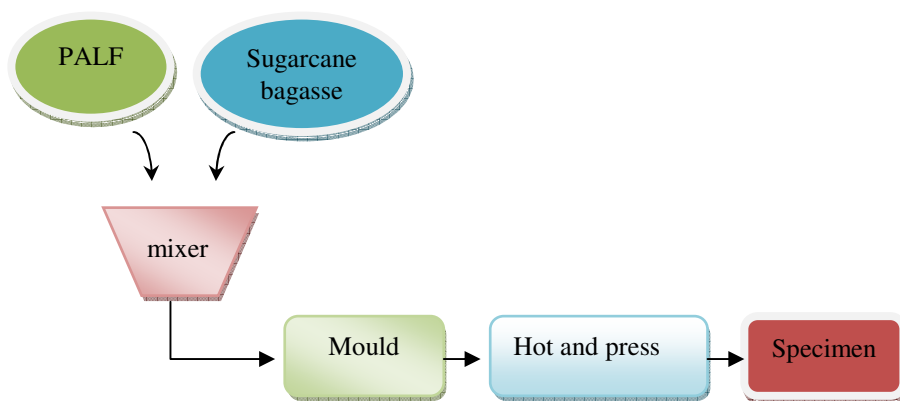

Fig. 2 Schematic of specimen preparation .

Two different testing were conducted; tensile and tearing test. Fig. 4 shows the specimen design for the testing according to the ASTM D828 for tensile and ASTM D689 for tearing.

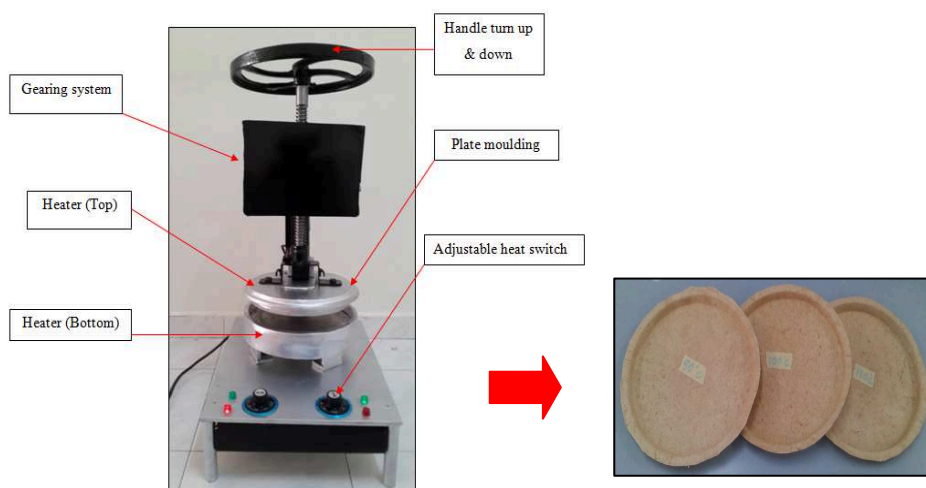

Fig. 3 Hot press machine for disposable plate producing

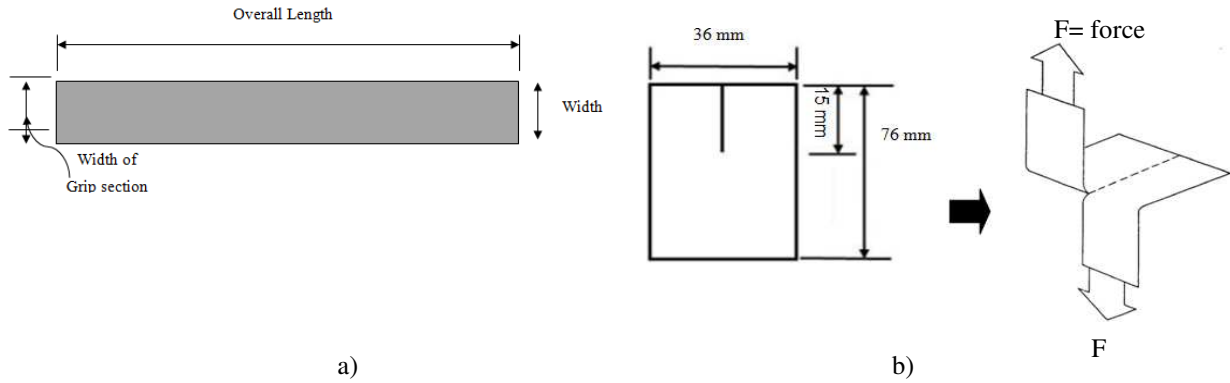

Fig. 4 Specimens geometry for a) Tensile test b) Tearing test

Results

Tensile strength is a very important property to describe the general strength of paper [6]. Fig. 5 shows the result of tensile strength at different pressing temperature for two different samples. From the results, the tensile properties was increased when the heat compression increased. In addition, higher composition of sugarcane bagasse (80%) shows higher tensile properties. On the other hand, the increase of pressing temperature will reduce the tearing properties as show in Fig. 6.

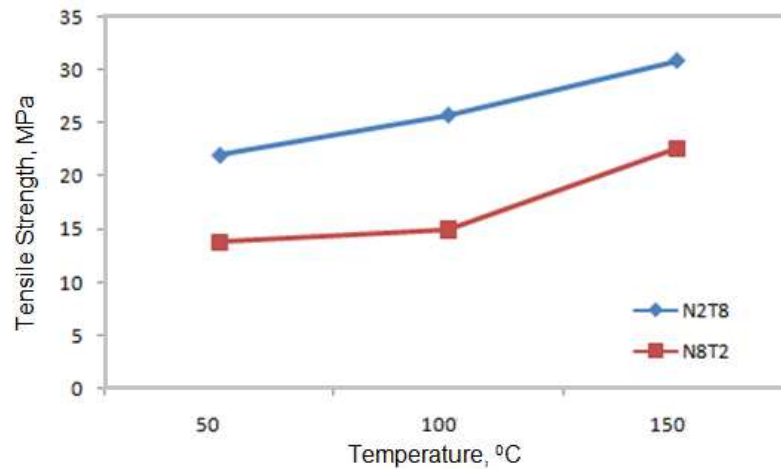

Fig. 5 Effect of heat compression on tensile strength

In tearing resistance of paper based product is increased with increasing fiber length with lower degree of bonding [7]. The results show that in decrement not stable with heat compression temperature while increased. The strength of the fiber burden imposed tearing test the effects of increased of 4.05 MPa from the initial test and decreased at a temperature of 100° C and picked up a fairly constant temperature of 150° C for specimen N8T2. Differently with N2T8 it clearly constant and stability decrease with increase heat treatment as shown in Fig. 7. However, the standard deviation was still acceptable. The only reason to explain this is that composites can withstand load immediate impact but if the tearing applied slowly, fibers tend to slip out of the matrix and leave the weak points or stress concentrated areas. No doubt, this will reduce the elongation and lower strength. Despite this improved impact strength, there is a slight decrease in the 10% weight PALF load. The energy-absorbing mechanism of fracture built in the composites includes utilization of energy required to de-bond the fibers and pull them completely out of the matrix using a weak interface between fiber and matrix [8].

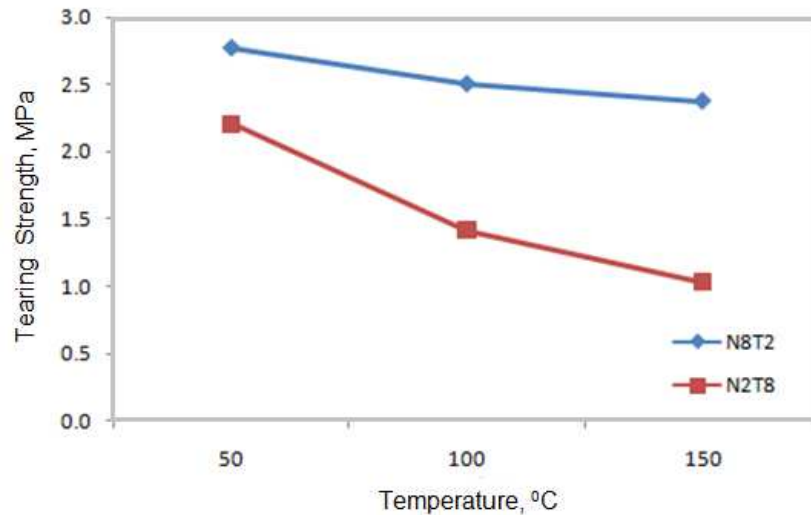

Fig. 6 Effect of heat compression on tearing strength

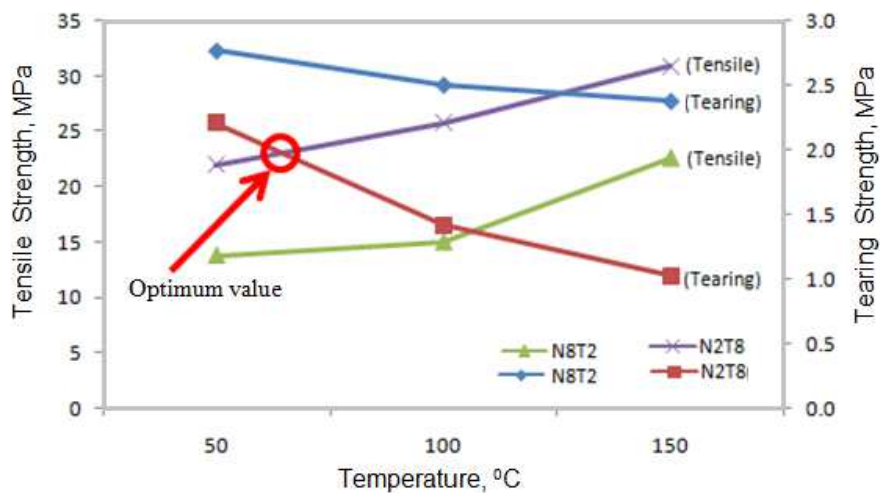

Fig. 7 The optimum heat compression on tensile and tearing strength

Conclusion

This research work provide a basic information on nature fiber development forms waste material for plate disposal. The presented work is related to the mechanical behaviour and the effect of heat compression for tensile and tearing strength. The heat compression temperature influence the tensile strength and elongation properties as well as the tearing properties. The optimum value for heat compression was 50°C on tensile and tearing strength is 21.99 MPa and 2.21 MPa, respectively.

References

- [1] M.P. Westman, L.S. Fifield, K.L. Simmons, S.G. Laddha, T.A. Kafentzis, Natural Fiber Composites: A Review, U.S. Department of Energy, Pacific Northwest National Laboratory (2010).
- [2] S.P. McLaughlin, Properties of Paper Made From Fibers of Hesperaloe Funifera (Agavaceae) 1. Economic Botany 54-2(2000) 192-196.
- [3] R. Mangal, N.S. Saxena, M.S. Sreekala, S. Thomas, K. Singh, Thermal Properties of Pineapple Leaf Fiber Reinforced Composites. Materials Science and Engineering A339 (2003) 281-285.
- [4] C. Pavithran, P.S. Mukherjee, M. Brahmakumar, A.D. Damodaran, Impact Properties of Natural Fibre Composites. Journal of Materials Science Letters. 6 (1987) 882-884.

[5] Information on <http://ms.wikipedia.org/wiki/Nanas>

[6] C. Pokhrel, Determination of strength properties of pine and its comparison with birch and eucalyptus. Saimaa University: Bachelor's Thesis. (2010)

[7] K. Hanna, Some aspects on strength properties in paper composed of different pulps. Karlstad University: Project's Report (2010)

[8] L. Uma Devi, S.S. Bhagawan, S. Thomas, Mechanical Properties of Pineapple Leaf Fiber-Reinforced Polyester Composites. *Journal of Applied Polymer Science*. 64 (1997) 1739-1748.