

Animal cognition (reasoning) in the light of genetic ideas

I.I. Poletaeva , O.V. Perepelkina, Z.A. Zorina

Lomonosov Moscow State University, Department of Biology, Moscow, Russia

The historical overview is presented of genetic experiments in L.V. Krushinsky's laboratory in Moscow State University. L.V. Krushinsky stated the three-component concept of animal behavior. He claimed that animal behavior has not only innate species specific behavior and the learning ability, but should be supplemented by another mental category, reasoning the ability for elementary logic operations. Being rather lonesome at the beginning, Krushinsky got the spiritual support from D.K. Belyaev and B.L. Astaurov. The attempt to study the genetic bases of reasoning ability was performed in Krushinsky's lab using the trait "extrapolation problem solving", which meant the ability of an unexperienced naïve animal to find the food bait when it moved aside and disappeared from (not "in") the view. The selection for high scores of this trait in the hybrid rat population (Norway rat × laboratory strain cross) was started. Initially the hybrid rats solved this problem in the statistically significant proportions, while the animals from further selection generations demonstrated the dramatic increase of anxiety (in spite of extensive handling of these animals), which made further experiments impossible. Much later another selection experiment started in which mice of a genetically heterogeneous population were selected for high scores of extrapolation problem and concomitantly for the lack-of-anxiety signs during the testing procedure. This selection for a cognitive trait produced some positive results, although the direct response to selection was very weak. The data obtained show the intricate connection between the mouse ability to solve the problem and the processes of anxiety, which in turn looks as non-uniform by its nature and mechanisms. The data from experiments performed in classical genetics should be combined with the new knowledge concerning the role of single genes determining animal behavior.

Key words: animal behavior; cognitive tests; selection; anxiety; rats; mice.

КАК ЦИТИРОВАТЬ ЭТУ СТАТЬЮ:

Поletaева И.И., Перепелкина О.В., Зорина З.А. Когнитивные способности животных (рассудочная деятельность) в свете генетических представлений. Вавиловский журнал генетики и селекции. 2017;21(4):421-426. DOI 10.18699/VJ17.260

HOW TO CITE THIS ARTICLE:

Poletaeva I.I., Perepelkina O.V., Zorina Z.A. Animal cognition (reasoning) in the light of genetic ideas. Vavilovskii Zhurnal Genetiki i Seleksii = Vavilov Journal of Genetics and Breeding. 2017;21(4):421-426. DOI 10.18699/VJ17.260

Received 01.03.2017
Accepted for publication 23.03.2017
© AUTHORS, 2017

 e-mail: ingapoletaeva@mail.ru

КОГНИТИВНЫЕ СПОСОБНОСТИ ЖИВОТНЫХ (РАССУДОЧНАЯ ДЕЯТЕЛЬНОСТЬ) В СВЕТЕ ГЕНЕТИЧЕСКИХ ПРЕДСТАВЛЕНИЙ

И.И. Поletaева , О.В. Перепелкина, З.А. Зорина

Московский государственный университет
им. М.В. Ломоносова, биологический факультет, Москва, Россия

В статье кратко описана история генетических исследований в лаборатории, созданной Л.В. Крушинским в МГУ. Л.В. Крушинский выдвинул концепцию, согласно которой поведение животного складывается из трех компонентов. Он утверждал, что оно формируется на основе врожденных видоспецифических реакций, способности к обучению и элементарной рассудочной деятельности (т.е. способности к элементарным логическим операциям). Первоначально идеи Крушинского не встретили поддержки, хотя они нашли понимание у Д.К. Беляева и Б.Л. Астаурова. В лаборатории Л.В. Крушинского была сделана попытка генетического исследования признака «способность к экстраполяции». Эту способность обнаруживает не имеющее аналогичного опыта животное, когда оно находит приманку, которая, двигаясь, исчезла из поля зрения. На основе гибридной популяции крыс (пасюк × лабораторная крыса) был начат отбор на высокие показатели этого признака. Решение этой задачи в исходной гибридной популяции было статистически достоверным, однако крысы последующих поколений селекции стали обнаруживать настолько высокий уровень тревожности (несмотря на интенсивное приручение), что эксперимент продолжить не удалось. Позднее на основе генетически гетерогенной популяции мышей был начат другой селекционный эксперимент. Селекцию проводили одновременно на два признака: высокие показатели решения задачи на экстраполяции и против проявлений тревожности в этом тесте. В целом ответ на отбор был слабым – в начальных поколениях селекции мыши этой линии (ЭКС) решали задачу несколько лучше, чем контрольные неселектированные животные, но в более поздних поколениях картина стала нестабильной. Полученные при этом данные свидетельствуют, что существует тесная связь между способностью мыши к решению когнитивного теста и процессами, определяющими тревожность, которая, в свою очередь, представляется неоднородной по своей природе и механизмам. Результаты экспериментов, проводимых на основе подходов классической генетики, в настоящее время можно сопоставлять с данными по роли отдельных генов, участвующих в формировании и функции сложных нервных сетей.

Ключевые слова: поведение животных; когнитивные тесты; селекция; тревожность; крысы; мыши.

The notion of animal reasoning (or cognition) has rather fuzzy borders, as modern neurobiologists tend to consider as cognitive such behavioral traits as classical and instrumental conditioning, exploration and even habituation (Reznikova, 2007). According to some views, animal cognition is the capacity to use the learned skills in the new environments (Reznikova, 2007), and this assumption is based on numeral examples in the animal world. Although it should be mentioned, that animal cognition involves not only those traits, which requires brain plasticity (i. e., learning ability), but also the ability to solve the logic problems of different structure (Poletaeva, Zorina, 2014). These phenomena could be approximately subdivided into two groups, one of them being the “basic” cognitive abilities (including elementary logic tasks, spatial memory and orientation) and second category which includes abilities of a much more complicated nature (the concept formation, numerical competence, analogical reasoning, etc.). Molecular genetic techniques now permit researchers to change the level of expression in many genetic elements, including those which code for the important brain enzymes and regulatory elements. This makes it possible to elucidate (at least partly) their role in the signaling pathways, which are involved in the plasticity phenomena and in the cognitive processes of more complicated nature.

In the middle of 1950s, the first L.V. Krushinsky paper, in which extrapolation “reflexes” were described, was published, not in biological journal, but in “Problems in Cybernetics” edited by mathematician Alexey A. Liapunov. In the early 1960s, the scientific contacts of D.K. Belyaev and L.V. Krushinsky started, which gradually transformed into the real friendship and partnership.

The notion of “extrapolation ability” was developed by L.V. Krushinsky several years later. After pioneer works of E. Tolman in early 1930s (Tolman, 1932) the experiments of Krushinsky’s lab were one of the first attempts to overcome the domineering of pseudo-Pavlovian point of view, according to which animal and human cognition starts and ends in the domain of conditioned reflexes of different complexity.

Krushinsky’s concept of animal reasoning ability implied the subject’s capacity to apprehend (grasp) the empirical (physical) laws which function in the environment and which determine the connections of objects and events (Krushinsky, 1990).

Initially, although B.L. Astaurov and D.K. Belyaev shared Krushinsky’s views on animal reasoning, these ideas were not accepted by the majority of behavior physiologists: it took 10–15 years before these ideas gained attention. During this period a large experimental data base on reasoning ability in many vertebrate species was collected by Krushinsky and his colleagues, and outlined in Krushinsky’s first monograph “The development of animal behavior: Normal and abnormal aspects” (and the English version of this book was issued in USA almost immediately).

Krushinsky and his team evaluated animal reasoning ability basing on animals’ performance in specially designed laboratory tests. The extrapolation test was the “simplest” among these tests (Krushinsky, 1990). This test evaluated an animal’s ability to extrapolate the direction of a food stimulus movement after it disappears from animal’s view behind the opaque screen (moving to the left or to the right from the vertical gap

in the screen, which just seconds ago permitted to feed from the food cup). The successful solution of extrapolation test was evaluated in animals which had no previous experiment in solving the analogous tasks, thus the scores of its first presentation were considered to be the most informative index of this ability. The solution of this test had been analyzed in dozens of vertebrate species, rodents (rats and mice of different groups) being among them (Krushinsky, 1990). At the end of 1960’s, N.V. Timofeev-Ressovsky visited to Krushinsky’s lab and was impressed by the body of evidence concerning elementary logic task solution (extrapolation problem) by animals in many different species. He asserted that the important development of this field lied in behavior genetics direction. This coincided with the ideas and plans of Krushinsky himself, and the tests of extrapolation ability in several inbred strains started. Interstrain differences were examined, though differences in mice olfaction were detected, and mouse experiments were stopped, as (when olfaction control was used) the overall proportion of correct task solutions was not different from the chance level (lab albino rats proved to be unable to solve the extrapolation task as well – their scores of correct solutions was not different from the 50 % chance level). Several months later a student, L.M. Dyakova (Kouznetzova), began experiments with wild gray rats (these animals were really difficult to handle) and their hybrids with laboratory rats (Krushinsky et al., 1975). This experimental work was difficult to implement, as the progeny of wild × domesticated rats needed to be raised in a manner that they did not fear humans (i. e., that they were tame), otherwise it was not possible to address whether they could solve the extrapolation problem. But the results were convincing. These hybrid rats (and their wild parents as well, although the samples were smaller as wild rats were too difficult to handle) demonstrated a statistically significant prevalence of correct choices proportion, and some of these rats were able to solve even the complicated task version (when the obstacle was introduced for the detour way of an animal). The scheme of rat extrapolation is presented at Fig. 1.

Comparative work on the extrapolation task solution was also undertaken in wild red foxes and farm foxes in Novosibirsk. As the fur farms in United States and Europe (including Russia) already existed for about seventy years, it became evident that behavioral differences in farm foxes (in comparison to wild forms) might exist and M.N. Sotskaya, a postgraduate zoology student, began work exploring this possibility. The subjects of her initial experiments were wild red foxes, either from zoo (raised in cages), or foxes which were bred from the cub age in children summer camps (where extensive handling and environmental enrichment had been provided). All foxes were able to solve not only the “ordinary” extrapolation test, but also the a version where the subject, in order to follow the invisible trajectory of food, was forced to move partly in the direction, opposite to food movement direction. M.N. Sotskaya next travelled to Novosibirsk and spent several weeks in extrapolation experiments with several dozen caged foxes (of different coat color genotypes). The results obtained were very convincing. All cage animals (including tame and nontame subjects of the important D.K. Belyaev and L.N. Trut selection experiment) were able to solve the extrapolation task at the nonrandom level, the proportion of correct choices in the farm

fox group was significantly lower than that of red foxes, and there were no indications that the farm foxes could solve the complicated version of the task.

The work in foxes and rats revealed important differences in the ability to solve the extrapolation problem. The wild forms were superior to domesticated ones. It was not possible to proceed with fox experiments, but work on rats continued. The individuals with the highest extrapolation scores were mated and the similar selection was performed among their progeny and the progeny of the next generation. The results were disappointing. Although rats from F2–F4 generation were able to solve the task in variable degrees, their behavior during these tests was largely affected by the elevated anxiety. This was the case in spite of the fact that these rats (derived from wild *Rattus norvegicus*) were handled extensively. They were not afraid of human hands and routine manipulations, including their habituation to the test chamber and the possibility to drink milk from the central opening (from which the food bait moved away disappearing in the left or right directions during the experimental procedure *per se*). But they showed the overt fear reaction as soon as the experiment started (the first task presentation), which made any further experiment impossible (Krushinsky et al., 1975). This selection experiment was stopped.

As it was demonstrated in further years, only few genetic groups of mice were able to find the position of invisibly displaced food reward at statistically significant non-random level. The extrapolation ability in mice with the Rb (8, 17) 1 Iem (Robertsonian chromosomal fusion of chromosomes 8 and 17) was analyzed in more detail. The extrapolation ability in mice was tested using a device somewhat modified from that for other animals (Fig. 2). This modification permitted to minimize animal handling, leaving an animal in the box between task presentations. It was confirmed that most of inbred mice from several strains (i. e., CBA, DBA/2, C57Br, A/He, BALB/c, 101/HY and their hybrids as well) were not able to solve this task. At the same time mice with fusion of chromosomes 8 and 17 (Rb (8, 17) 1 Iem) were able to solve the task regardless of the type of genetic

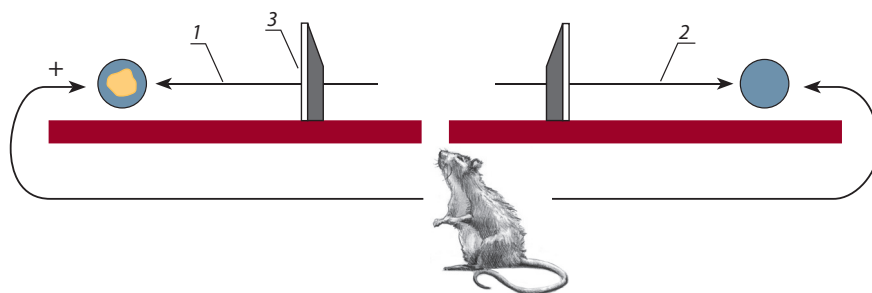

Fig. 1. Rat extrapolation test design (schematic view).

The opaque solid screen has the vertical gap in the middle, via this gap the rat begins to drink milk. The food cup starts to move to the left or to the right. The correct solution for animal (1) is to move leftwards, while the approach to the other side of the screen (2) is the incorrect solution. Animal can follow the direction of movement via gap only for several centimeters, as the valve (3) prevent to see the full trajectory of the food stimulus.

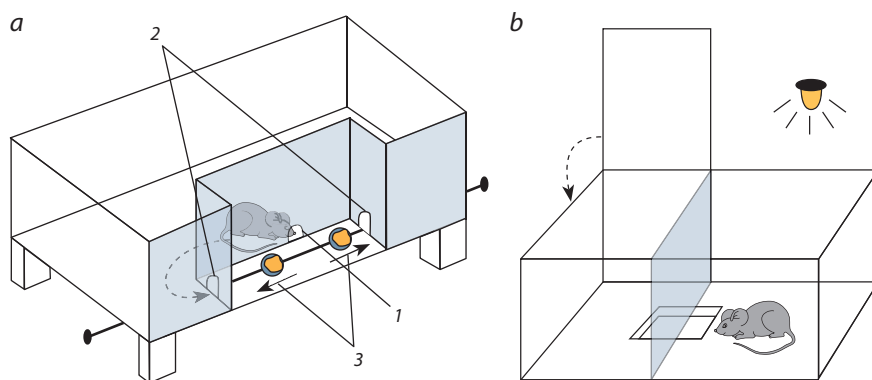

Fig. 2. Extrapolation (a) and “puzzle-box” (b) designs for mouse experiments.

a – the murine version of extrapolation box allows investigators to not handle animal during six test presentations, minimizing interference which could induce the anxiety in the test subjects. The front wall of the experimental box is solid and non-transparent with a small opening at the center of its base. A hungry and thirsty mouse starts to drink milk from the small food cup placed behind the central opening, this food cup is moved in one of two directions. Another cup is for odor and noise control. 1 – the central opening for the start of experiment; 2 – side openings to which animal can approach (according its’ choice, i. e. correct or incorrect) after the food disappears from the central opening; 3 – the direction of food cup movement.

b – “puzzle box” test. The device is a variant of light-dark box, when light and dark compartments are connected via small underpass. This underpass could be hidden by wooden shavings which cover it up to the floor surface level, or blocked by the light plastic-carton “plug” which an animal can displace either moving it aside or taking it by teeth.

background, as several groups with this Rb of different origin were analyzed (Poletaeva et al., 1993; Leitinger et al., 1994).

There were three selection experiments for large and small relative brain weight, described in more detail elsewhere (Poletaeva et al., 1993; Poletaeva, Zorina, 2014), in which two mouse strains were created respectively (with more or less similar outcome in all three attempts). In these experiments the interstrain behavior differences were the following. The Large brain (LB) mice were more able to solve the extrapolation task, they also learned instrumental skill more efficiently while they were less anxious in EPM (elevated plus maze) and less prone to depression in comparison to Small brain (SB) strain.

The next step was the attempt to create a “smart” mouse strain via selection involving mating individuals who demonstrated high scores of correct extrapolation task solutions (EX strain) and comparing these individuals to mice of non-selected heterogeneous population, labeled CoEX (Perpelkina et al., 2011, 2014, 2015). The selection criterion was rather strict – the parents of the next generation should needed to demonstrate not only high extrapolation scores, but also the lack of anxiety signs when an animal was placed in the extrapolation test environment (Poletaeva,

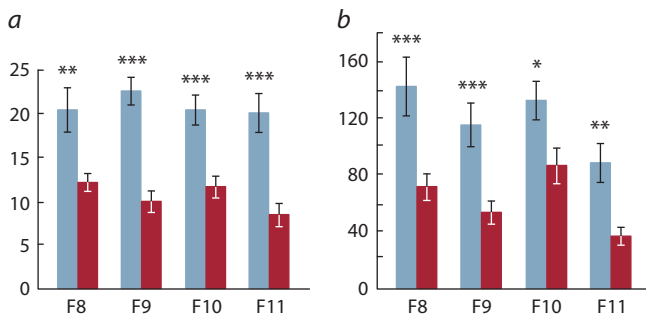

Fig. 3. Neophobia (neophagophobia) test indices in EX (grey columns) and CoEX (black columns) male mice.

a – number of approaches to the food cup with small cubicles of cheese were, and *b* – the time (sec) spent by eating cheese.

*, **, *** – significantly different from the respective values for CoEX mice, $p < 0.05, 0.01, 0.01$, respectively (t-test).

Zorina, 2014). This was done to insure that animals do not display a “refusal” to solve the task (the not-approach the central opening for 180 s), or display no “null” responses, which means that animal drinks milk from the central cup, but do not approach any side opening for 120 s. Mice from first selection generations (generations F4–F9) solved extrapolation task in statistically significant proportion of cases (Fisher ϕ test), while control mice performance varied. At the same time, EX mice were less anxious in the elevated plus maze test (thus the selection for fearless mice was successful). However, starting from F10 onwards the stable EX prevalence above the chance level was no longer stable.

In these generations, CoEX mice demonstrated variable levels of correct task solutions, as well as variable levels of fear-anxiety indices (not always significantly different from those of EX mice). It looked as if the selection experiment had failed to obtain the expected differences in terms of the cognitive trait that was selected for.

It is possible that the initial selection success was inhibited by some unidentified factor, which prevented the improvement of the trait, preventing changes in the “cognitive” status of the selected EX strain using only the extrapolation task. As such, another cognitive task was used – the “puzzle-box” (or burrowing) test (see Fig. 2). In this test, the mouse is placed into a brightly lit compartment of a box with two compartments which have an “underpass” in the partition between these parts (Ben Abdallah et al., 2011). The animal can escape the brightly lit part using this underpass into the dark compartment of the same box. The underpass could be unimpeded, or blocked either by wood shavings or a plug (made from cardboard and plastic), which could be removed by the animal. The task performance was evaluated by the mean latency of the escape reaction and by the proportion of mice, which were able to solve the most difficult stages of this test – the two tests when the underpass was blocked by a plug. The performance of EX mice in this test was significantly better than that of CoEX) up to the present F17 generation (Perepelkina et al., 2014, 2015).

Successful solution of this test is based on the animal’s ability to understand the rule of “object permanence” (i. e., objects which have been in a certain place and still exist after being

made invisible). This ability was classified as “cognitive” according to Piaget concepts (Zucca et al., 2007). The lack of selection success in the extrapolation scores in our experiment could mean that the trait “correct solution the extrapolation task” is rather complicated. The correct solution of extrapolation task requires an optimal constellation of various cognitive functions, thus respective genetic elements could not be easily selected for the “positive variants”. The analysis of variability of animal behavior in this task shows that in order to solve this task correctly the animal should reveal: (i) the relatively low anxiety level (fearlessness) in the relatively new environment of the test; (ii) the ability to remember (for seconds or dozens of seconds) the direction of movement of disappeared food; (iii) the ability to perform the quick approach to the respective place (to the new position of the food cup), which requires a simple logical (cognitive) operation. The subject has also be able to “resist” the innate behavior pattern to alternate the direction of search (Senechal et al., 2007) (in our experiments the direction of food movement changed according to quasi-random order and sometimes the food moved in the same direction, but not more than twice in succession).

Our data on EX and CoEX mice demonstrated that EX mice are significantly more tolerant to the novel environment in comparison to control CoEX animals. EX mice performance in the neophagophobia (or hyponeophagia) test, in which the consumption of the new food in the new, not frightening environment was estimated, was higher than in controls (Fig. 3) (Golibrodo et al., 2014). The Fig. 3 illustrates that EX mice from selection generations F9–F11 (thus including generations in which no selection success in the trait in question had been noted) were significantly superior over CoEX mice in number of approaches to the new food (*a*) and time, spent eating the new food (*b*). This means that reaction to novelty in EX mice was not inhibited (by fear). Similar differences were obtained for the further selection generations (data not presented).

According to technique used the reported extrapolation experiments were performed at a relatively rapid pace, which allowed animal to perform several identical tasks in close succession. As such, our analysis of extrapolation capacity in these animals concerns only the short time intervals/namely seconds or dozens of seconds (instead of dozens of minutes or hours). This means that the processes of short-term and recent memory could be involved, and these phenomena could be an important variable in the mouse brain capacity to perform adequately. Thus the respective analysis should take into consideration the variety of processes involved in memory trace fixation.

The success of extrapolation task solution is based on two main indices – the first one is the percentage of correct choices in a given group of animals at the first task presentation. This index is especially important as in these cases animals faced this problem for the first time (i. e., have no analogous experience), and so previous learning could not influence the solution. This index could be significantly different or not from the 50 % chance level. The cumulative data on six successive extrapolation trials are also an important index of ability to solve the problem as no instrumental learning for such correct solution occurred during this short series (and even during the series which included up to 30 task presentations, unpublished data). In general the ability to solve this

task (as reasoning ability index by L.V. Krushinsky) which was tested experimentally (and had been revealed in many species), emerged in situations in which neither instinctive endowments nor previous training could help an animal to solve it. This may especially be true for the cases, when the need to solve such task emerges accidentally and the general pattern of the problem is not similar to previous experience of the animal. According to A.R. Luria's definition (2003) these are cases, when a subject has no "ready-made" reaction to respond, and the reaction should follow quickly.

Summarizing this text we should mention that our experimental attempt to select mouse strain with increased ability to solve the "cognitive", elementary logic task is the unique one, judging by the state of published materials. There were successful genetic experiments when high and low learners of different tasks were successfully bred (Tryon and Roman lines being the best known among them) (Driscoll, Battig, 1982; Innis, 1992), but no data were reported on selection for high and low performance success in radial maze or/and Morris water maze paradigms. It is obvious that it was not by chance. At the same time numerous QTL data concerning spatial learning and memory and other cognitive traits are available (e.g., De Bundel et al., 2011). These experiments, most often performed in mice, have found performance success changes after gene expression manipulations (knockouts, knock-ins, etc.) suggesting that expression in these genes is important in spatial learning ability (Mohammed, 2000; Josselyn et al., 2001; Scott et al., 2002; Silva, 2003; Champiaux, Changeux, 2004; McQuade et al., 2004; Powell, 2006; Ren et al., 2007; Duffy et al., 2010; O'Connor et al., 2010; De Bundel et al., 2011; Fujino et al., 2011) and some other traits as well (Braidia et al., 2002; Dziewczapolski et al., 2009; to cite but few).

This bulk of evidences also suggests that numerous signaling pathways, acting in the interconnected brain structures (hippocampus, prefrontal cortex, striatum), are involved in "cognitive" traits phenotypes. These general genetic techniques (QTL, GWAS, etc.) have also been used to study the genetics of cognitive traits of different complexities (Owen et al., 1997; Shapiro, 2001; Milhaud et al., 2002; Nadler et al., 2006; Knowles et al., 2014; to cite but few). Other new approaches, including network concept (Dong, Horvath, 2007; Mizumori, Tryon, 2015) and optogenetics techniques (Kos et al., 2013; Allen et al., 2015) can be used to better understand these issues. Although it is also important to note that artificial selection as an alternative approach could also bring positive knowledge as animals of lines with low and high scores of definite behavioral trait are usually much better adapted than animals with artificially induced deficit or excess of certain gene product. The real perspective in genetic research in the field of genetics of cognitive abilities would lie in the comprehensive combination of classical and new methods of analysis.

Acknowledgments

This study was supported by the Russian Foundation for Basic Research, project 16-04-01169, and Program AAA-A16-11602166005-1.

Conflict of interest

The authors declare no conflict of interest.

References

- Allen B.D., Singer A.C., Boyden E.S. Principles of designing interpretable optogenetic behavior experiments. *Learn. Mem.* 2015;22:232-238. DOI 10.1101/lm.038026.114.
- Ben Abdallah N.M., Fuss J., Trusel M., Galsworthy M.J., Bobsin K., Colacicco G., Deacon R.M., Riva M.A., Kellendonk C., Sprengel R., Lipp H.-P., Gass P. The puzzle box as a simple and efficient behavioral test for exploring impairments of general cognition and executive functions in mouse models of schizophrenia. *Exp. Neurol.* 2011;227:42-52. <http://dx.doi.org/10.1016/j.expneurol.2010.09.008>.
- Braidia D., Sacerdote P., Panerai A.E., Bianchi M., Aloisi A.M., Iosue S., Sala M. DNA fragmentation factor 45 knockout mice exhibit longer memory retention in the novel object recognition task compared to wild-type mice. *Physiol. Behav.* 2002;76:315-332.
- Champiaux N., Changeux J.P. Knockout and knockin mice to investigate the role of nicotinic receptors in the central nervous system. *Prog. Brain Res.* 2004;145:235-251.
- De Bundel D., Schallier A., Loyens E., Fernando R., Miyashita H., Van Liefferinge J., Vermoesen K., Bannai S., Sato H., Michotte Y., Smolders I., Massie A. Loss of system x(c)- does not induce oxidative stress but decreases extracellular glutamate in hippocampus and influences spatial working memory and limbic seizure susceptibility. *J. Neurosci.* 2011;31:5792-5803.
- Dong J., Horvath S. Understanding network concepts in modules *BMC Syst. Biol.* 2007;1;24. <http://www.biomedcentral.com/1752-0509/1/24>.
- Driscoll P., Battig K. Behavioral, emotional and neurochemical profiles of rats selected for extreme differences in active, two-way avoidance performance. *Genetics of the Brain*. Ed. I.Lieblich. Amsterdam: Elsevier Biomedical Press, 1982;95-123.
- Duffy L., Cappas E., Lai D., Boucher A.A., Karl T. Cognition in transmembrane domain neuregulin 1 mutant mice. *Neuroscience.* 2010;170:800-807.
- Dziewczapolski G., Glogowski C.M., Maslah E., Heinemann S.F. Deletion of the alpha 7 nicotinic acetylcholine receptor gene improves cognitive deficits and synaptic pathology in a mouse model of Alzheimer's disease. *J. Neurosci.* 2009;29:8805-8815.
- Fujino T., Leslie J.H., Eavri R., Chen J.L., Lin W.C., Flanders G.H., Borok E., Horvath T.L., Nedivi E. CPG15 regulates synapse stability in the developing and adult brain. *Genes Dev.* 2011;25:2674-2685.
- Golibrodo V.A., Perepelkina O.V., Lilp I.G., Poletaeva I.I. The behavior of mice selected for cognitive trait in hyponeophagia test. *Zh. Vyssh. Nerv. Deiat. Im. I.P. Pavlova.* 2014;64:639-645. Russian. PMID:25975140.
- Innis N.K. Tolman and Tryon. Early research on the inheritance of the ability to learn. *Am. Psychol.* 1992;47:190-197. PMID:1567088.
- Josselyn S.A., Shi C., Carlezon W.A. Jr., Neve R.L., Nestler E.J., Davis M. Long-term memory is facilitated by cAMP response element-binding protein overexpression in the amygdala. *J. Neurosci.* 2001;21:2404-2412. PMID:11264314.
- Knowles E.E., Mathias S.R., McKay D.R., Sprooten E., Blangero J., Almasy L., Glahn D.C. Genome-wide analyses of working-memory ability: a review. *Curr. Behav. Neurosci. Rep.* 2014;1:224-233.
- Kos A., Loohuis N.F., Glennon J.C., Celikel T., Martens G.J., Tiesinga P.H., Aschrafi A. Recent developments in optical neuromodulation technologies. *Mol. Neurobiol.* 2013;47:172-185. DOI 10.1007/s12035-012-8361-y.
- Krushinsky L.V. *Experimental Studies of Elementary Reasoning. Evolutionary, Physiological and Genetic Aspects of Behavior.* New Delhi: Oxonian Press, 1990.
- Krushinsky L.V., Astaurova N.V., Kouznetzova L.V., Otchinskaya E.I., Poletaeva I.I., Romanova L.G., Sotskaya M.N. The Role of genetic factors in determining the extrapolation ability in animals. *Current Problems in Behavioural Genetics*. Eds. V.K. Fedorov, V.V. Ponomarenko. Leningrad: Nauka, 1975;98-110.
- Leitinger B., Poletaeva I.I., Wolfer D.P., Lipp H.-P. Swimming navigation, open-field activity, and extrapolation behavior of two inbred mouse strains with Robertsonian translocation of chromosomes 8 and 17. *Behav. Genet.* 1994;24:273-284. PMID:7945157.

- Luria A.R. *The Essentials in Neuropsychology*. Academia Publ. Center, 2003.
- McQuade J.M.S., Vorhees C.V., Xu M., Zhang J. Cognitive function in young and adult IL (interleukin)-6 deficient mice. *Behav. Brain Res.* 2004;153:423-429.
- Milhaud J.M., Halley H., Lassalle J.M. Two QTLs located on chromosomes 1 and 5 modulate different aspects of the performance of mice of the B × D Ty RI strain series in the Morris navigation task. *Behav. Genet.* 2002;32:69-78.
- Mizumori S.J., Tryon V.L. Integrative hippocampal and decision-making neurocircuitry during goal-relevant predictions and encoding. *Prog. Brain Res.* 2015;219:217-242. DOI 10.1016/bs.pbr.2015.03.010.
- Mohammed A.H. Genetic dissection of nicotine-related behaviour: a review of animal studies. *Behav. Brain Res.* 2000;113:35-41. PMID:10942030.
- Nadler J.J., Zou F., Huang H., Moy S.S., Lauder J., Crawley J.N., Threadgill D.W., Wright F.A., Magnuson T.R. Plasticity, large-scale gene expression differences across brain regions and inbred strains correlate with a behavioral phenotype. *Genetics.* 2006;174:1229-1236.
- O'Connor R.M., Finger B.C., Flor P.J., Cryan J.F. Metabotropic glutamate receptor 7: At the interface of cognition and emotion. *Eur. J. Pharmacol.* 2010;639:123-131.
- Owen E.H., Logue S.F., Rasmussen D.L., Wehner J.M. Assessment of learning by the Morris water task and fear conditioning in inbred mouse strains and F1 hybrids: implications of genetic background for single gene mutations and quantitative trait loci analyses. *Neuroscience.* 1997;80:1087-1099.
- Perepelkina O.V., Golibrodo V.A., Lilp I.G., Poletaeva I.I. Selection of laboratory mice for the high scores of logic task solutions: the correlated changes in behavior. *Adv. Biosci. Biotechnol.* 2014;5:294-300. <http://dx.doi.org/10.4236/abb.2014.54036>.
- Perepelkina O.V., Golibrodo V.A., Lilp I.G., Poletaeva I.I. Selection of mice for high scores of elementary logical task solution. *Dokl. Biol. Sci.* 2015;460:52-56. DOI 10.1134/S0012496615010159. PMID: 25773252.
- Perepelkina O.V., Markina N.V., Golibrodo V.A., Lilp I.G., Poletaeva I.I. Selection of mice for high level of extrapolation capacity with cobcommitant low anxiety level. *Zh. Vyssh. Nerv. Deyat. Im. I.P. Pavlova.* 2011;61:742-749.
- Poletaeva I.I., Romanova L.G., Popova N.V. Genetic aspects of animal reasoning. *Behav. Gen.* 1993;23:467-475. <http://dx.doi.org/10.1007/BF01067982>.
- Poletaeva I.I., Zorina Z.A. Physiological and genetic approaches to study animal cognitive behavior. *Russ. J. Cogn. Sci.* 2014;1:31-55.
- Powell C.M. Gene targeting of presynaptic proteins in synaptic plasticity and memory: across the great divide. *Neurobiol. Learn. Mem.* 2006;85:2-15.
- Ren K., Thinschmidt J., Liu J., Ai L., Papke R.L., King M.A., Hughes J.A., Meyer E.M. alpha7 Nicotinic receptor gene delivery into mouse hippocampal neurons leads to functional receptor expression, improved spatial memory-related performance, and tau hyperphosphorylation. *Neuroscience.* 2007;145:314-322.
- Reznikova Z. *Animal Intelligence. From Individual to Social Cognition*. Cambridge: Cambridge University Press, 2007.
- Scott R., Bourchuladze R., Gossweiler S., Dubnau J., Tully T. CREB and the discovery of cognitive enhancers. *J. Mol. Neurosci.* 2002;19:171-177. PMID12212777.
- Senechal Y., Kelly P.H., Cryan J.F., Natt F., Dev K.K. Amyloid precursor protein knockdown by siRNA impairs spontaneous alternation in adult mice. *J. Neurochem.* 2007;102:1928-1940.
- Shapiro M. Plasticity, hippocampal place cells, and cognitive maps (reprinted). *Arch. Neurol.* 2001;58:874-881. www.archneurol.com.
- Silva A.J. Molecular and cellular cognitive studies of the role of synaptic plasticity in memory. *J. Neurobiol.* 2003;54:224-237. PMID: 12486706.
- Tolman E.C. *Purposive behavior in animals and man*. London, Appleton-Century, 1932.
- Zucca P., Milos N., Vallortigara G. Piagetian object permanence and its development in eurasian jays (*Garrulus glandarius*). *Anim. Cogn.* 2007;10:243-258. <http://dx.doi.org/10.1007/s10071-006-0063-2>.