

The Design of Mobile Control Car Security System

Jiwa Abdullah

Abstract—The present car alarm systems are still of no match to the well-equipped thieves. It is just a matter of seconds to break through the system. This paper introduces and describes the design of mobile controlled car security system offering higher level of car security features. The mobile controlled car security is capable of providing an effective two-way communications between the alarm system and the car owner. This system is able to notify the car owner immediately when intrusion is detected. Additionally, the car owner can remotely control any of the car features anytime at anywhere via a phone call. Based on the GSM positioning concept, this system has the potential to provide car location information to assist in stolen vehicle recovery therefore providing enhancement over the conventional car alarm system.

Index Terms—Car security; PIC microcontroller; mobile phones; hardware design; firmware development.

I. INTRODUCTION

It was reported that as many as 1000 cars were stolen monthly in Malaysia in the year 2007. The existing vehicle alarm systems are of no match to the well-equipped thieves. In the United States, there are already many transportation companies and vehicle manufacturers that employ Global Positioning System (GPS) based location and tracking system combined with conventional cellular communication for stolen vehicle recovery as well as for constant monitoring of vehicle fleet management. However there are situation where the GPS system cannot perform well such as at underpasses and indoor parking. Most cars are still using the conventional alarm system which is easily handled by car thief. One major problem in those car alarms is tuning and adjustment. There may be so many car alarms that are too sensitive, while the rest can withstand a major earthquake without a single beep. Consequently, the public loose interest in the car alarms since they could be falsely triggered. Another weak point is that, it has limited capability to interact with its owner. In addition, the conventional alarm systems did not provide any means in assisting the recovery of stolen vehicle. The remainder of this paper is organized as follows. Section II describes the design specifications for MCCA. Section III describes briefly the PIC microcontroller as the main processor unit. Section IV describes the design of MCCA hardware system. Section V describes the design of MCCA firmware. Lastly Section VI concludes the paper.

II. MCCA SYSTEM DESIGN SPECIFICATIONS

A. System Description

An overview of the complete system requirement will be

Manuscript received April 6, 2010; revised February 8, 2011.

Jiwa Abdullah is with the Dept of Communication Engineering, Faculty of Electrical and Electronic Engineering University Tun Hussein Onn Malaysia, Batu Pahat, Malaysia(email:jiwa@uthm.edu.my).

presented before detailing the specifications for each individual sub-section of MCCA system. The specifications developed in this section are sufficiently detailed to allow for the subsequent hardware design. The Mobile-Controlled Car Security (MCCA) system is intended to offer various levels of security incomparable with a typical car alarm. The system requires user to install a mobile transceiver which operates in conjunction with the main control unit of the vehicle alarm system. MCCA will provide standard security features similar or better to the existing conventional alarm system. In addition, MCCA will also offer advance features such as the capability of notifying the car owner immediately when the system detects intrusion, the ability to arm and disarm security features remotely and able to interact reliably with the user.

B. System Specifications

Essentially, MCCA consists of a mobile transceiver, main control unit utilize PIC controller, handheld remote control device, and several supplementary circuits that support this security system. The MCCA configuration is shown in Figure 1.

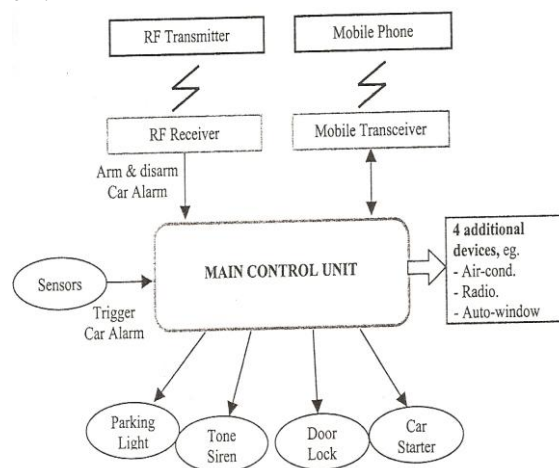

Fig. 1. MCCA System Configuration

The MCCA consists of PIC main control unit together with a mobile transceiver, which is implemented inside the car. The PIC main control units have the ability to control the mobile transceiver in calling its owner when intrusion is detected. The system operates in a similar manner to a typical vehicle alarm and user can remotely arm or disarm the alarm by handheld remote transmitter. In the arm state, the sensor will detect any signal to trigger the alarm. The alarm once triggered will immediately initiates a series of output signal to disable the car engine, switches on the flashlights and siren and immediately notify user via phone call. Similar to other mobile phones, the mobile transceiver in the MCCA system is detectable by the Main Switching Centre (MSC) of the GSM network as long as the phone is turned ON. This suggests that once user activates the MCCA system, the MSC will know which cell site the mobile transceiver belongs to and hence the location of the car. In

the event the car thief had successfully access the vehicle, the mobile transceiver will immediately call to the owner and indirectly, indicates its location through the MSC. By requesting location information from the MSC, user will be able to recover his stolen car. The system operation is illustrated as in Figure 2.

C. System Function and Features

The MCCS system has the minimum functionality necessary to be a useful vehicle security system. This system provides standards features as well as special features as shown in Table 1.

TABLE 1 FEATURES OF MCCS

Features	
1.	Indicator LED to indicates alarm in the arm and disarmed state.
2.	Disable starter once alarm is armed
3.	Lock or unlock doors remotely
4.	Parking light flashes and siren sounds in a specific sequence indicating armed, disarmed and triggered state for pre-intrusion alert
5.	Switches on or off panic state remotely for pre-intrusion alert
6.	The mobile transceiver immediately notifies the owner through a phone call when the alarm is triggered.
7.	User can remotely control any of the vehicle accessories from anywhere at anytime via phone call.
8.	Able to provide location detection capability via the GSM network with the involvement of third party (Location services provider)

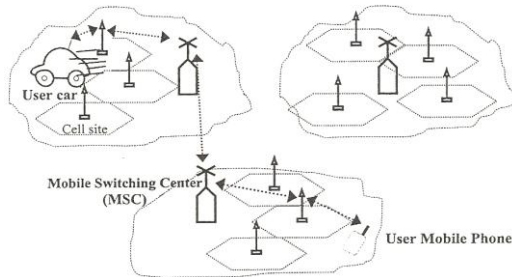

Fig. 2. Graphical Depiction of MCCS Operation

III. PIC16C57 MICROCONTROLLER

A. Overview

PIC is a very low current device that takes less than 2mA with a clock oscillator speed of 4Mhz. At lower speed, 32 kHz, it only draws 15uA and when the clock is stopped, PIC requires a very low voltage supply ranging from 2.5V and 6.25V making it a very low power device. A PIC needs only a resistor and capacitor to be added to the clock oscillator pins to operate. In contrast to other microcontrollers, PIC requires less external components. The PIC16C57 is one of the low-cost, high performances, 8-bit, fully static, EPROM/ROM-based CMOS microcontroller. Figure 3 shows a simplified block diagram for PIC 16C57.

B. Processor Architecture

PIC16C57 was designed based on Harvard architecture which uses separate memory banks for program storage, processor stack, and variable RAM. Hence, program and data are accessed on separate buses. This improves bandwidth over von Neumann architecture where program and data are fetched on the same bus. A 12-bit wide

program memory access bus fetches a 12-bit instruction in a single cycle. All the 33 instructions are executed in a single cycle (4 MHz ~ 20 MHz). The Harvard architecture is able to execute instructions while the next instruction is being fetched from memory. This means that current instruction was fetched during the previous instruction's execution allowing the instruction to be executed in only one instruction cycle while the next instruction is being read in.

C. Register

The data memory in PIC16C57 can be further broken down into general-purpose RAM and special function register (SFR). It can directly or indirectly address its register files and data memory. PIC 16C57 has a highly symmetrical instruction set that enable it to carry out any operation on any register using various types of addressing mode. Fig. 3 shows the registers in the PIC16C57. It consists an 8-bit ALU and working registers. The ALU is a general-purpose unit that performs arithmetic and Boolean Functions between data in the working register and any file register. All the arithmetic operations are two's complement in nature. In two-operand instructions, typically one operand is the working register (W). The other operand may be a file register or an immediate constant. In the execution of a single operand instruction, the operand is either the W register or a file register. Depending on the instruction executed, the ALU may affect the values of the Carry (C), Digit Carry (DC) and Zero (Z) in the status register.

D. IO Ports

The I/O register can be written under program control. Read instruction always read the I/O pins independent of the pins' input or output modes. On RESET, all I/O are defined as inputs since the I/O control registers (TRIS A, TRIS B and TRIS C) are set. Figure 4, shows the equivalent circuit for I/O port pin. PIC16C57 microcontroller consists of three I/O port; port A, port B, port C. Port A is 4-bit I/O register. Only the low order 4 bits are used (RA0-RA3). Bits 4-7 are unimplemented and read as '0's. Port B and port C is an 8-bit I/O register (RB0-RB7) and (RC0-RC7) respectively. Each of these ports is assigned a unique address: 05H, 06H and 07H respectively. Each port has two registers associated with it, the TRIS (Tri State) register and the port register. The TRIS register controls whether particular pin on a port is configured as an input pin or an output pin. Once the ports are configured, the user may then read or write information to the port using the port register address. The output driver control registers are loaded with the content of the W register by executing TRIS instruction. A '1' from a TRIS register bits put the corresponding output driver in a hi-impedance mode. A '0' put the contents of the output data latch on the selected pins enabling the output buffer. The TRIS registers are *write-only* and are set upon RESET.

E. Memory Organization

PIC16C57 memory is organized into program memory and data memory. For devices with more than 512 bytes of program memory, a paging scheme is used. Program memory pages are accessed using one or two STATUS Register bits. For devices with a data memory register file of more than 32 registers, a banking scheme is used. Data

memory banks are accessed using the File Selection Register (FSR). PIC16C57 has one 11-bit Program Counter capable of addressing a 2K x 12 program memory space. Figure 6 shows the PIC16C57 program memory map and stacks. Accessing locations above physically implement address will cause a wraparound. A NOP at the RESET vector location will cause a restart. The RESET vector for the PIC16C57 is at 7FF'h'.

F. Development Tools

PIC16C57 microcontroller is supported by several types of hardware and software development tools:

- PICMASTER In-Circuit Emulator
- ICEPIC Low-Cost In-Circuit Emulator
- MPLAB Integrated Development Software
- PRO MATE II Universal Programmer
- MPASM Assembler

The MPASM Universal Macro Assembler is a PC-hosted symbolic assembler. MPASM offers full featured macro capabilities, conditional assembly, and several sources and listing formats. It generates various object code formats that support different kinds of software used to program the PIC such as PICBasic, PBASIC and C2C Compiler. MPASM also supports Hex, Decimal and Octal source listing formats. In this paper C2C Compiler is used to develop a program for the PIC16C57's operation in the MCCS system.

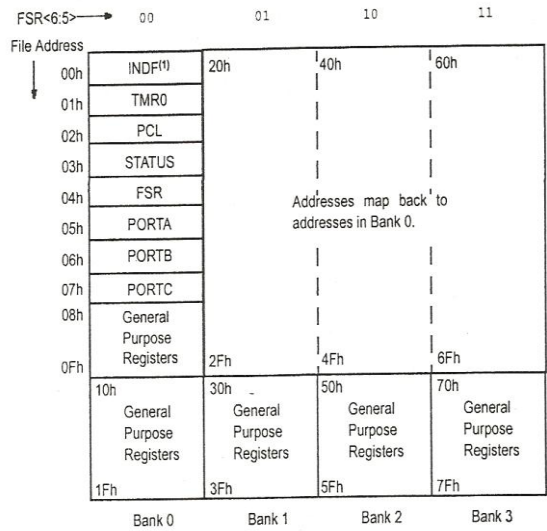

Fig. 5. Program Memory Map

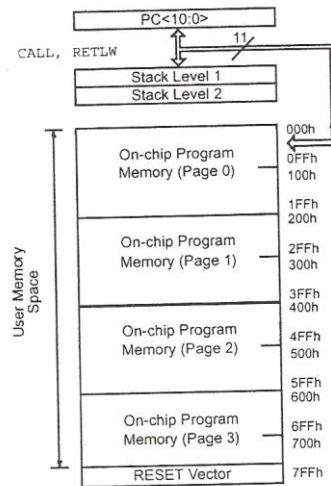

Fig. 6. Program Memory Map and Stacks

IV. MCCS HARDWARE DESIGN

A. Hardware Division

The hardware design for the MCCS system is divided into four main parts:

- PIC main control unit,
- RF remote control unit,
- PIC-car accessories interface unit,
- PIC-mobile phone interface unit.

The PIC main control unit acts as the brain of the MCCS system. It is responsible to centralize the entire individual interface units and at the same time, monitoring the operation of the MCCS system. The RF remote control unit provides an interface for the user to arm and disarm their car alarm remotely over short distances. Next, the car accessories interface unit produces a reliable connection between the main control unit and car element such as siren, parking lights, car starter, door locks and so forth. Lastly, the PIC-mobile phone interface unit enables the communication between the connection between the PIC control unit and the mobile phone. It allows the PIC main control unit to control the mobile transceiver's function in dialing to its owner and also receiving calls from its owner for control purpose. In general, all the four units are interconnected as illustrated in Figure 7.

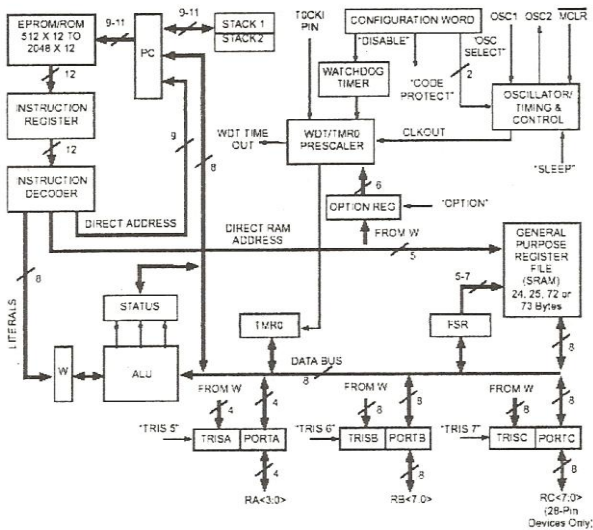

Fig. 3. Block diagram of PIC16C57

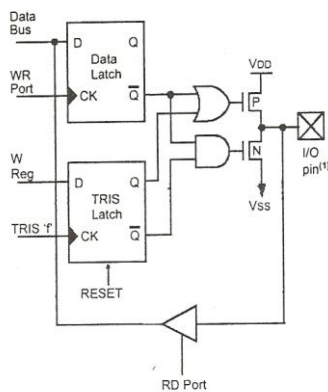

Fig. 4. Equivalent Circuit of I/O

B. PIC Main Control Unit

The PIC main control unit interconnects the RF remote control unit, car accessories and the mobile phone together to execute the proper security control commands. The PIC16C57 is chosen, because of a few advantages: TTL compatible, Low power consumption, contain 20 I/O pins and it is a single chip to accomplish the entire task required in this project. Table 2 shows the pin configurations for the connection between the PIC and the other three interface units. Figure 8 shows the PIC16C57 schematic circuit implemented in the MCCS system. A voltage regulator (78L05) is used to provide a constant voltage of 5 volts to the PIC circuit. An external oscillator comprises of a crystal (10MHz) and two capacitors (30pF) function as an external clock to set the speed of PIC in executing an instruction.

TABLE 2 PIN CONFIGURATION OF PIC 16C57 IN MCCS

Port	Pin	Configuration
A Output Port	A0	Additional controlled devices
	A1	Additional controlled devices
	A3	Additional controlled devices
	A4	Additional controlled devices
B Output Port	B0	Car Starter
	B1	Parking lights
	B2	Car siren
	B3	Disarm state indicator LED (red)
	B4	Arm state indicator LED (Green)
	B5	Green button (mobile transceiver) control pin
	B6	Red button (mobile Transceiver) control pin
C Input Port	C0	Car sensor or door switch
	C1	RF remote control signal (red button)
	C2	RF remote control signal (blue button)
	C3	Valid DIMF tone signal (DTMF IC)
	C4	D0 (DTMF IC)
	C5	D1 (DTMF IC)
	C6	D2 (DTMF IC)
	C7	Incoming call signal (mobile transceiver)

C. RF Remote Control Unit

The RF remote control unit comprises of a handheld transmitter and a receiver. The receiver is integrated with the main control unit in the vehicle. This receiver generates two different outputs which can be fed into pin C1 and C2 of PIC. It indicates whether a red button or a blue button of the transmitter is pressed. As seen from Figure 9a and 9b, both the RF transmitter and receiver have similar components. However, the RF transmitter employs a single chip, PT2262 to encode the data address pin into a serial coded waveform suitable for RF modulation while the paired receiver uses a PT2262 IC to decode the serial coded waveform back to the original binary data.

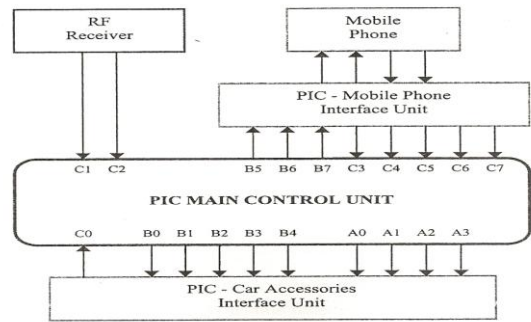

Fig. 7. PIC Based MCCS Schematic Diagram

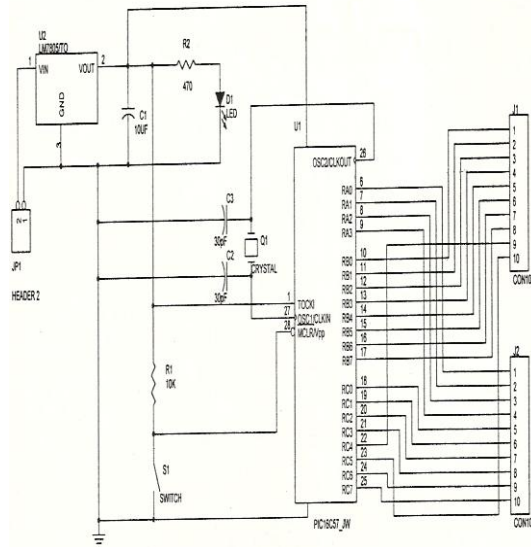

Fig. 8. Connection to/from PIC

D. PIC-Car Accessories Interface Unit

The function of this unit is to provide a reliable interface between the PIC main control unit which, operates at 0-5V (TTL IC) and all the car elements such as parking lights and car radio that operates in the 12V range. Basically, the interface unit consists of electronic switches, optocouplers, and relays between the output pins of PIC and the car element. Figure 8 shows the connections of various car accessories to its corresponding PIC I/O pins through the interface unit. Referring to Figure 7, pin B1 from PIC is connected to the parking lights via an electronic switch made up from a transistor, an optocoupler and relay. This is to enable a 5V signal From PIC to operate the parking lights, which requires a voltage of 12V and high current from the car battery. Besides that, electronic switches using optocouplers will provide a safety measure by preventing the 12V supply current from flowing into and destroying the PIC. Figure 10 shows the electronic switch that is implemented in this interface unit. The vibration sensor that is used in the MCCS system needs a 12V supply. Since, PIC can only supports up to 5V voltage, the sensors installed in the car communicate with the PIC microcontroller through the optocoupler as shown in Figure 11.

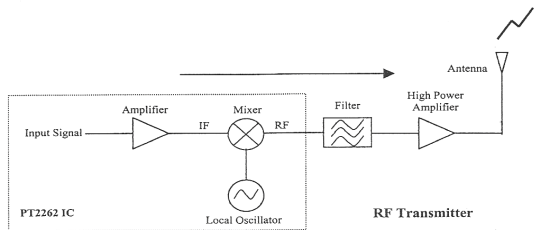

Fig. 9a. Block diagram of RF Transmitter

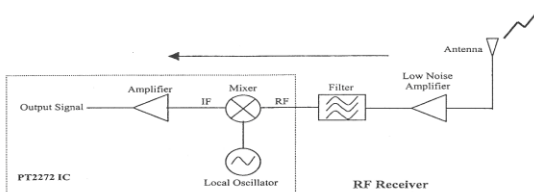

Fig. 9b. Block diagram of RF Receiver

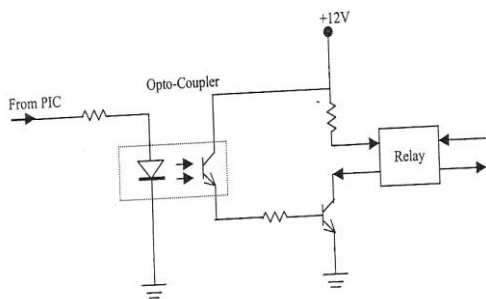

Fig. 10. Switching circuit used in PIC-car accessories interface unit

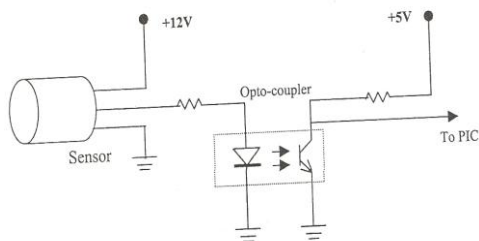

Fig. 11. Connection between PIC and sensor

E. PIC-Mobile Transceiver Interface Unit

This unit has two main functions: it enables the PIC to autodial the mobile phone notifying its owner when the alarm is triggered. Secondly, it enables the PIC to answer any incoming calls that allow the car owner to control the car accessories such as air-conditioning and radio. The connections between the mobile transceiver and PIC main control unit through the interface unit are shown in Figure 12. In this project, a mobile phone (Sagem DC 715) is used as the mobile transceiver, which was fixed in the car together with the PIC main control unit. In general the functions of MCCA are:

- controlling the transceiver for autodialing a specific number,
- answering an incoming call and ending a call in progress,
- detecting numbers pressed by owner to control car elements,
- providing feedback signals in the form of sequential tones.

In order to accomplish these functions, five signals are required. These are *DTMF* signal, incoming call signal, feedback signal, green button control signal and red button control signal.

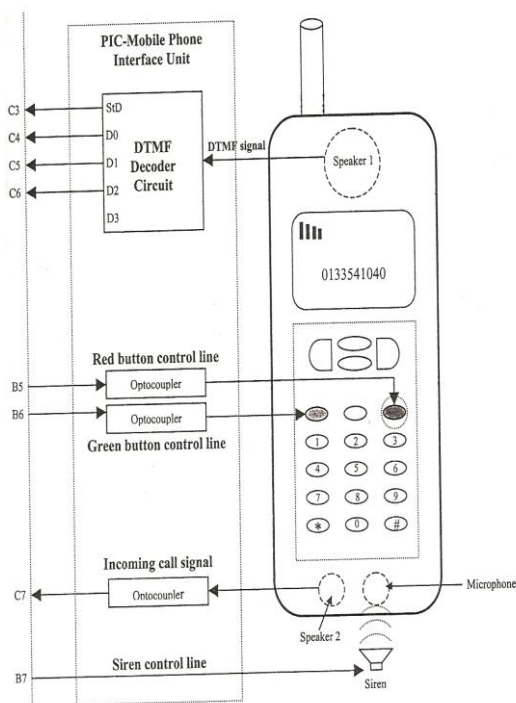

Fig. 12 Circuit Connections to the mobile phone

1) DTMF Signal

The DTMF signal is generated each time the owner presses a button on the keypad. Every Button on the mobile phone’s keypad excluding the green, red and arrow buttons has a pair of frequency associated with it. As mentioned earlier, PIC should be able to detect any number pressed by owner to control car elements. When the owner pressed any number on keypad, its associated dual tone frequencies are generated. PIC detects these frequencies using a DTMF decoder circuit. Figure 14 shows the DTMF decoder circuit that is implemented in the PLI card. This decoder circuit uses a MT8870 single IC. The IC detects any valid DTMF frequency from the phone line, decodes it into binary data and produce binary output at Q1, Q2, Q3 and Q4 as shown in Table 2. When the owner calls back to control any car alarm elements, he is required to press a certain number on the keypad. Since each different numbers has a different pairs of frequencies, this will provide the necessary identification for PIC to detect a particular number pressed by owner. For example, when the owner presses a ‘1’, the mobile transceiver in the car captures the associated DTMF (697 Hz+1209Hz) via its *speaker 1*. That DTMF frequency is then fed into a DTMF decoder circuit. The DTMF decoder IC detects the frequencies, decodes it’s as ‘1’ and produces an appropriate binary output ‘0001’. This binary data is then sent into the PIC through pin C3, C4, C5 and C6 thus enable the PIC to execute the correct command (switch *On* or *OFF* device #1 alternately).

	1209Hz	1336Hz	1447Hz
697Hz	1	2	3
770Hz	4	5	6
852Hz	7	8	9
941Hz	*	0	#

Fig. 13. DTMF frequencies for keypad numbers

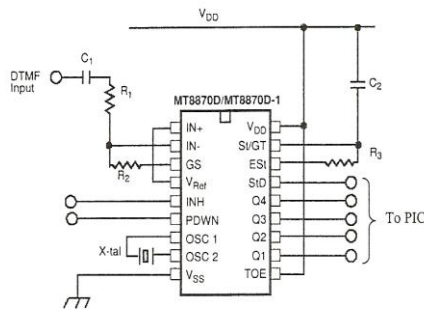

Fig. 14. DTMF decoder circuit used in PIC-mobile transceiver interface unit

TABLE 3 MT8870 BINARY OUTPUT FOR A SPECIFIC DTMF INPUT SIGNAL

Digit	Q4	Q3	Q2	Q1
1	0	0	0	1
2	0	0	1	0
3	0	0	1	1
4	0	1	0	0
5	0	1	0	1
6	0	1	1	0
7	0	1	1	1
8	1	0	0	0
9	1	0	0	1
0	1	0	1	0
*	1	0	1	1
#	1	1	0	0

2) Incoming Call Signal

When the car owner calls to his car, the transceiver of the MCCS receives the call and it will ring. The PIC actually detects an incoming call by capturing the ringing signal from speaker 2 of the transceiver. This ringing signal is passed through an optocoupler and fed into the PIC via pin C7. When PIC detects the input ringing signal, it can control the mobile transceiver to answer the phone call. The circuit used to detect ringing signal is shown in Figure 15.

3) Feedback Signal

When owner call to his car to control any of the car accessories, a feedback signal is send back to the owner in the form of sequential tone to inform the status of the controlled device through the feedback siren, where it is connected to pin B7 of PIC microcontroller.

4) Green Button Control Signal

This control signal enables the PIC main control unit to control the mobile transceiver for autodialing functions and to answer an incoming call. When the MCCS alarm system is triggered, PIC will sequentially generate logic '1' as a control signal at its output pin B5 for two times. This pin is connected to the mobile transceiver's green button via an optocoupler. As seen from Figure 16, the green button consists of a switch that can be switch ON whenever both the tracks on the PCB are connected (Usually, the switch is connected by a piece of carbon sheet under the button when the button is pressed).Therefore an optocoupler (controlled by PIC) is used as another electronic switch, to substitute the button switches. It can be assumed that the green button is pressed once when PIC send a control signal to the optocoupler. For the mobile transceiver used here, the green button is pressed twice to automatically dial the number that was previously set in its memory. Thus PIC needs to send control signal twice to the optocoupler to accomplish the

auto dialing function. If let say, the PIC detect incoming call, it will also control the optocoupler to answer the call using the similar concept.

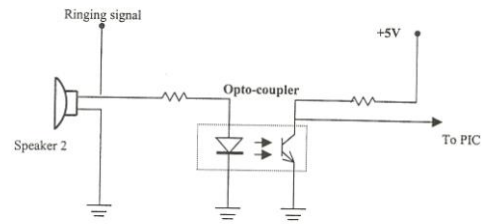

Fig. 15. Ringing signal detector circuit

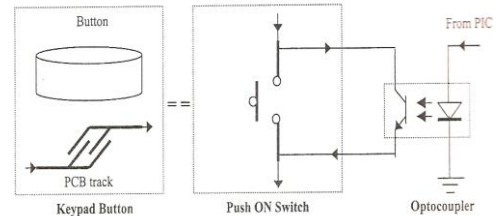

Fig. 16. Equivalent circuit for keypad button

5) Red Button Control Signal

Similar to the green button control signal technique, the red button control signal (Pin B6) enable the PIC to control the mobile transceiver to end a call in progress via an optocoupler that represent the red button.

V. MCCS FIRMWARE DESIGN

A.

C2C is the abbreviation for C2C-plus C compiler for PIC and Scenix processors. C2C compiler is chosen for this project because it can support C source codes that are readily inserted into the generated assembly file. C2C-plus compiler supports a subset of C programming language which is listed below:

- If, else, while, for, return, break, continue, extern, switch, case, default;
- Goto and labels;
- Char, short, in, long (16-bit and 8-bit unsigned numbers), void;
- One-dimensional arrays, const variable arrays;
- Functions with no/one/many parameters and void /char/short return types;
- Const char* function parameter;
- #include, #define, #undef, #ifdef, #ifndef, #else, #endif.

Table 3 lists some of the important C2C commands that are used in writing the program for PIC16C57 in this project. The table also includes the functions represented by each command.

B. Universal Programmer

ALL-11 Universal Programmers consists of a universal programmable memory or configuration including EPROM, EEPROM, FLASH, PLD, Serial PROM, and microcontrollers from Motorola, Microchip, Intel and many more. This programmer has a high speed CPU and a standard memory capacity of 1Mbit that can be expended up to 16Mbytes to allow many more EPROM and FLASH to be programmed. ALL-11 Universal Programmer contains a high speed serial port interface to connect the programmer

to any PC Windows 98 or XP.

TABLE 3: C2C BASIC COMMANDS AND THEIR FUNCTIONS

Command
<i>Set_tris_a(expression);</i>
<i>Set_tris_b(expression);</i>
<i>Set_tris_c(expression);</i>
<i>Output_port_a(expression);</i>
<i>Output_port_b(expression);</i>
<i>Output_high_port_a(NUMBER);</i>
<i>Output_low_port_a(NUMBER);</i>
<i>Input_port_a(void);</i>
<i>Input_pin_port_a(NUMBER);</i>
<i>Delay_ms(expression);</i>

C. MCCS Firmware Development

The operation of the MCCS system and thud the software writing is divided into five states namely: DISARM STATE, ARM STATE, PANIC STATE, TRIGGERED STATE, and PHONE CONTROL STATE. In the following sections, flow charts are used to organize the program logic for MCCS operation in the various states. These flow charts directly show how MCCS system operates in every state. The MCCS program is thus developed step by step referring to these flow chart.

1) Disarm State

The disarm state in MCCS system means that the alarm system is not active or in the resting condition. During this state, the alarm system will not sense or simply ignore any intrusion that occurs. Figure 17 shows the flow chart illustrating the program logics for the disarm-state operation. The program logic for MCCS system operation in the disarm state is summarized as below.

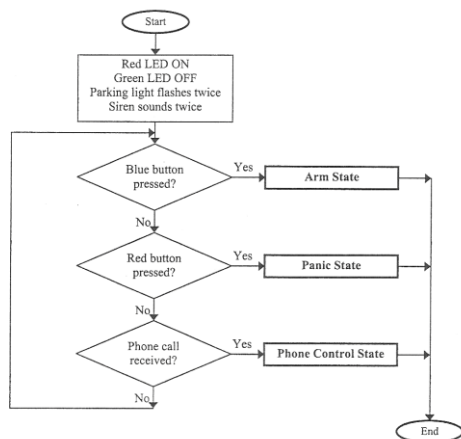

Fig. 17. The program logic in disarm state

- When the alarm system is first turned on, the system is automatically set to disarm state. This is indicated by:
 - Red indicator LED turns ON
 - Green indicator LED remains OFF
 - Parking lights flash twice and the car siren sounds twice
- Next, if any of the buttons of the remote control is pressed, the PIC will detect whether the blue or red button of the RF remote control is pressed. If blue button

is pressed, the alarm system goes into ‘arm state’; if red button is pressed, the alarm system goes into ‘panic state’.

- Next, the PIC continues to detect whether there is any incoming phone calls, if yes, the alarm system goes into phone control state but if not, the PIC will repeat step 2 and 3 endlessly.

2) Arm State

In the arm state, the alarm system is active. The car sensor is ready to sense any intrusion that occurs. Figure 18 illustrates the program logic for MCCS operation in the arm state which can be summarized as follows:

- The alarm system when in the arm state is indicated by the features as below:
 - Red indicator LED turns OFF
 - Green indicator LED turns ON
 - Parking lights flash once and the car siren sounds once
- When any button from the remote control is pressed, PIC will check whether a blue or red button is pressed. If the blue button is pressed, the alarm system goes into the ‘disarm state’ (alternately). If red button is pressed, the system goes into ‘panic state’.
- Then if the PIC detects an incoming call, the alarm system automatically switches to ‘phone control state’.
- If not then, the PIC detects any intrusion; the alarm system goes into the ‘triggered state’. If not, the PIC continues the loop by repeating step 2, 3 and 4 continuously as long as alarm system is still in the ‘arm state’.

3) Panic State

The panic state is meant to produce an alert effect to the public in case of emergency. This particular state can be activated via the red button of the remote control or through the owner mobile phone. Figure 19 shows the flowchart representing the program logic for MCCS operation in the panic state which is summarized as follows:

- The panic state is indicated by the features as below:
 - Red indicator LED remains ON
 - Green indicator LED remains ON
 - Parking lights flash and the car siren sounds continuously in a sequential manner
- When any button from the remote control is pressed, PIC will check whether a blue or a red button is pressed. If the blue button is pressed, the alarm system goes into the ‘disarm state’. If red button is pressed, the system switches into ‘arm state’.
- Then if the PIC detects an incoming call, the alarm system automatically switches to ‘phone control state’.
- Next, the PIC checks how long do the alarm system remains in the panic state. If the alarm system continues to stay in the panic state for more than 30 seconds, the alarm system switches to ‘arm state’. Or else, the PIC repeats steps 2, 3 and 4 if the duration is than 30 seconds

4) Triggered State

The alarm system is triggered when the car sensors detect any intrusion. Once intrusion is detected, MCCS provides security features such as flashing the parking lights, sounding the car siren and immediately notifies its owner via phone call. Figure 20, shows the flow chart illustrating

the program logic in the triggered state.

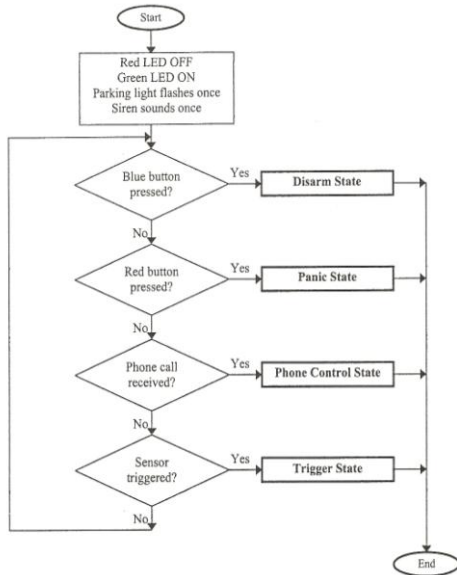

Fig. 18. The program in the arm state

According to Figure 20, MCCS program logic in the triggered state summarized as follows:

- The panic state is indicated by the features as below:
 - Red indicator LED remains ON
 - Green indicator LED remains ON
 - Parking lights flash and the car siren sounds continuously in sequential manner.
- Next, the alarm system automatically dials to its owner to notify its owner about the intrusion.
- Then PIC checks whether any buttons of the remote control is pressed. If the blue button is pressed, alarm system goes into the disarm state. If red button pressed, the system switches into arm state.
- Then PIC detects whether the outgoing call is answered by its owner, if yes, the alarm system automatically switches to 'phone control state'.
- After 30 seconds, if the PIC does not receive any responds from the owner the PIC will shut off the parking lights and sirens. Then it repeats step 2, 3, 4 and 5 until the PIC receive an appropriate respond from the owner.

5) Phone Control State

The alarm system allows the owner to control any of the car accessories such as to switch ON or OFF the air conditioning unit, and switch the modes or states of the alarm via a phone call. Figure 21 shows the program logic for operation in the phone control state.

Based on the flow chart in Figure 21, the MCCS program logic in the phone control state is summarized as below:

- When the alarm system switches into the phone control state, the feedback siren sounds for three times to indicate the alarm system had successfully answered the phone call.
- Then the PIC detects whether the owner had pressed any number.
- If PIC detects number 1-4, the PIC switches ON/OFF alternately, these four additional controlled devices respectively.
- If number 5 is pressed, the panic switches ON or OFF alternately.

- If number 6 is pressed, the alarm system goes into 'arm state' or 'disarm state' alternately.
- PIC will continue to repeat step 2, 3, 4 and 5 until number 7 is pressed which, ends the phone control state.
- During the phone control state, if the PIC does not detect any valid number within 20 seconds, the phone control state ends immediately and returns to its previous state.

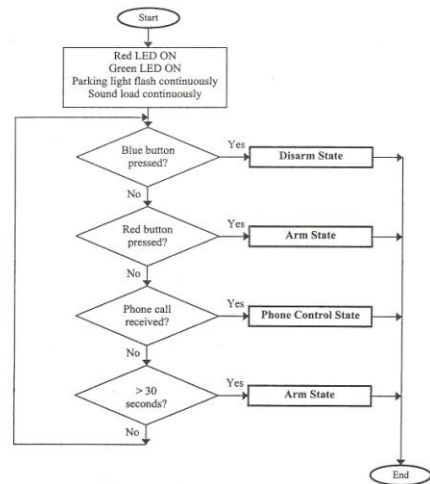

Fig. 19. The program logic in the panic state

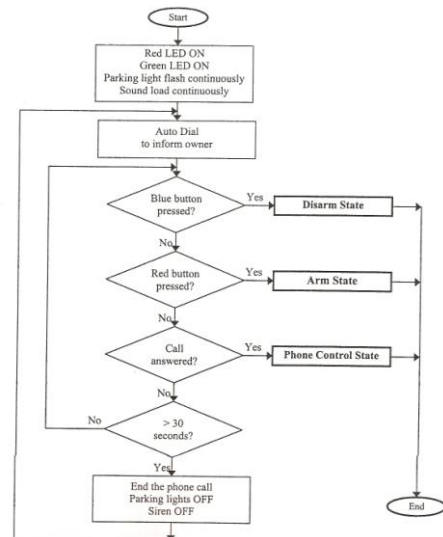

Fig. 20. Program logic in the triggered state

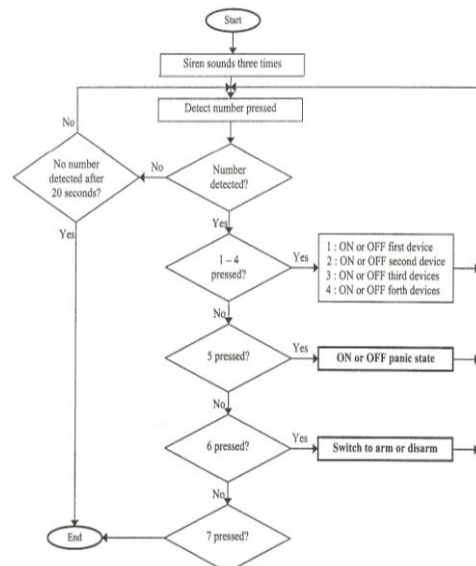

Fig. 21. The program logic in the phone control state

VI. CONCLUSION

The MCCA system provides an effective two-way communication that gives higher level of security features compared to the conventional car alarm system. MCCA system is capable of alerting its owner immediately when intrusion is detected. Additionally, the car owner can remote controlled any security features and check its status at all times through a phone call. The system also has a potential to offer vehicle location detection capability based on GSM positioning concept. Currently, a mobile phone unit was used as a transceiver. To reduce production cost, a simpler transceiver which can access GSM network can be built as a substitute for the mobile phone. Currently the MCCA system uses a single main control unit to coordinate the functions of each isolated interface units. This will cause the whole system to shut down if the power supply is cut off. Alternatively, MCCA system can be built using two control units instead of one. Future MCCA system could be implemented using short messages services, which is more flexible rather than using DTMF technique. Lastly, by

adding vehicle location information, MCCA could be the one that every car owner wishes for in securing their cars.

ACKNOWLEDGMENT

I would like to thank University Tun Hussein Onn Malaysia for sponsoring the project.

REFERENCES

- [1] J.D. Gibson(Ed), "The Mobile Communications Handbook." 2nd Ed, CRC Press Ltd., USA, 1999.
- [2] L.Harte, R.Levine and G.Livingston, "GSM Superphones." McGraw Hill, New York, pp105-116, 1999.
- [3] R.A. Steuermagel, "The Cellular Connection, A Guide to Cellular Telephones.", John Wiley, New York, 2000.
- [4] C.Y.Lee, "Mobile Cellular Telecommunications Analog and Digital Systems." 2nd Ed., McGraw Hill, Lisbon, 1995.
- [5] M, Janes, "Microcontroller Cookbook", Newnes, 1997.
- [6] P.Spacor, "Microcontroller Technology", Prentice Hall, USA, 1993.
- [7] R. Ludwig and P. Bretchko, "RF Circuit Design-Theory and Applications." Prentice Hall, USA, 2000.
- [8] J.J.Carr, "RF Circuit Design", 3rd McGraw Hill, Brisbane, 2001.
- [9] R.K. Jugren, "Automotive Electronics Handbook." 2nd Ed., McGraw Hill, New York, 1999.