

# **ANALYSIS OF FIBER NONLINEARITY FOR VARIOUS POWER LEVELS IN DWDM SYSTEM**

**SHAHRUL RADZI BIN MAD ZAKI @ ABDULLAH**

A project report submitted in partial  
fulfillment of the requirement for the award of the  
Degree of Master of Electrical Engineering

Faculty of Electrical and Electronic Engineering  
Universiti Tun Hussein Onn Malaysia

JULY 2013

## ABSTRACT

DWDM technology is known as a kind of technology for coupling and transmitting an optical signals of different wavelength over the same fiber. Such technology is important in order to expand the capacity of optical fiber communication system and to meet the growing demands of bandwidth. However, there are some limiting factors related to the data rate and capacity in DWDM system. These limiting factors can be linear or nonlinear. Theoretically, the nonlinearities in fiber arise as the number of data channel, transmission length, data rate and input power level increase. In this project, the objective is focused towards analyzing on the nonlinearities effect by compensating the linear effect in the fiber. Dispersion Compensation Fiber (DCF) and linear loss EDFA compensation have been used in single mode fiber (SMF) channel to ensure the communication quality for the design. The proposed DWDM transmission system with 8, 16 and 32 channels for 10Gbps with a channel spacing of 0.8nm was designed and simulated using Optisystem software. The BER performance with various input power levels in the range of -10dBm up to 10dBm, and fiber length greater than 50km are analyzed. It has been shown that for fixed length of the fiber, the only variable that can be manipulated to lower the nonlinear contribution is the input power. The higher the input power the higher the nonlinear contribution. However, if the input power is low, the bit rate should be low to maintained transmission at the expected BER (BER  $< 10^{-12}$ ).

## ABSTRAK

Teknologi DWDM dikenali sebagai satu teknologi gandingan dan penghantaran isyarat-isyarat optik pada panjang gelombang yang berbeza dalam gentian yang sama. Teknologi sedemikian penting dalam memperluaskan kapasiti sistem komunikasi gentian optik dan memenuhi permintaan lebar jalur yang semakin meningkat. Walau bagaimanapun, terdapat beberapa faktor yang menghadkan kadar data dan kapasiti pada sistem DWDM. Faktor-faktor tersebut boleh jadi lurus atau ketaklurusan. Secara teori, ketaklurusan di dalam gentian meningkat apabila bilangan saluran data, panjang penghantaran, kadar data dan kuasa masukan meningkat. Dalam projek ini, kami memberi fokus dan menganalisis kesan ketaklurusan dengan menghilangkan kesan lurus di dalam gentian. Dispersion Compensation Fiber (DCF) dan menghilangkan kehilangan lurus EDFA digunakan dalam SMF untuk memastikan kualiti penghantaran dalam rekabentuk. Sistem penghantaran DWDM yang dicadangkan dengan 8, 16 dan 32 saluran dan 10Gbps dengan jarak saluran sebanyak 0.8nm telah direkabentuk dan disimulasikan menggunakan perisian Optisystem. Prestasi BER dengan beberapa nilai kuasa masukan dalam julat -10dBm ke 10dBm dan panjang gentian melebihi 50km telah dianalisis. Ia menunjukkan pada panjang gentian yang ditetapkan, pembolehubah yang boleh dikaji untuk merendahkan kesan ketaklurusan dalam fiber ialah hanya kuasa masukan. Semakin bertambah kuasa masukan, semakin meningkat kesan ketaklurusan. Walau bagaimanapun, jika kuasa masukan direndahkan, kadar data seharusnya direndahkan juga untuk memastikan penghantaran dalam julat BER yang diterima ( $BER < 10^{-12}$ ).

## TABLE OF CONTENTS

	<b>DECLARATION</b>	<b>ii</b>
	<b>ACKNOWLEDGEMENT</b>	<b>iii</b>
	<b>ABSTRACT</b>	<b>iv</b>
	<b>ABSTRAK</b>	<b>v</b>
	<b>TABLE OF CONTENTS</b>	<b>vi</b>
	<b>LIST OF TABLES</b>	<b>viii</b>
	<b>LIST OF FIGURES</b>	<b>ix</b>
	<b>LIST OF ABBREVIATIONS</b>	<b>xi</b>
<b>CHAPTER 1</b>	<b>INTRODUCTION</b>	<b>1</b>
	1.1 Project Background	1
	1.2 Problem Statement	3
	1.3 Objectives	4
	1.4 Scopes of Work	4
	1.5 Thesis Outline	5
<b>CHAPTER 2</b>	<b>LITERATURE REVIEW</b>	<b>6</b>
	2.1 Overview	6
	2.2 Fiber Nonlinearity	6
	2.3 Type of Fiber Nonlinearities	8
	2.3.1 Scattering Phenomena	8
	2.3.1 Refractive Index Phenomena	11
	2.4 DWDM System	13
	2.4.1 EDFA in DWDM System	15
	2.4.2 Optical SNR and Transmitted Power Requirements of DWDM Systems	16

2.4.3	Application of DWDM	17
2.5	Previous Work	18
<b>CHAPTER 3</b>	<b>METHODOLOGY</b>	<b>23</b>
3.1	Overview	23
3.2	Project Flow Chart	24
3.3	DWDM System Block Diagram	26
3.4	Transmitter Part	27
3.5	Transmission Channel	30
3.6	Receiver Part	31
3.6	Nonlinearity Effects of DWDM System Model Developed with Optisystem Software	32
<b>CHAPTER 4</b>	<b>RESULTS AND DISCUSSION</b>	<b>35</b>
4.1	Introduction	35
4.2	Using PRBS and NRZ Generator to Drive MZM	35
4.3	Performance Analysis	42
4.3.1	Effects of Input Power on The System Performance	42
4.3.2	Effects of Bit Rate on The System Performance	47
4.3.3	Effects of Fiber Length on The System Performance	50
<b>CHAPTER 5</b>	<b>CONCLUSION AND RECOMMENDATION</b>	<b>54</b>
5.1	Conclusion	54
5.2	Recommendation and Future Work	55
	<b>REFERENCES</b>	<b>56</b>
	<b>APPENDIX</b>	<b>59</b>

**LIST OF TABLES**

<b>TABLE NO.</b>	<b>TITLE</b>	<b>PAGE</b>
2.1	List of Research	22
3.1	Parameters of SMF and DCF	31
4.1	Parameters Used for Simulation	36
4.2	Parameters Used for Various Input Power Level	43
4.3	Parameters Used for Difference Bit Rate	47
4.4	Data of BER versus Input Power	49
4.5	Parameter Used for Difference Fiber Length	50
4.6	Data of BER versus Fiber Length	51

## LIST OF FIGURES

FIGURE NO.	TITLE	PAGE
1.1	General DWDM Functional Schematic Diagram	3
2.1	SBS Threshold Effects	9
2.2	(a) Transmitted Optical Spectrum	10
	(b) SRS Effect Seen at Receiver	10
2.3	Refractive Index of Silica vs. Optical Power	11
2.4	Spectrum Before and After The Fiber	13
2.5	DWDM System of $n$ Channel	14
2.6	Principle of EDFA	16
2.7	Graph of Power in dBm versus Amplifier Spacing (Kms)	17
2.8	The Eye Diagram for Different Distances with Non Linear Effects	19
2.9	Simulation Model of 32-Channel DWDM System	19
2.10	The Eye Diagram of DWDM System in With Linear Loss and Dispersion has been Compensated	20
2.11	The Numerical Setup or The FWM-based Wavelength Converter	20
2.12	The Eye Diagram for 11 Channels	21
2.13	Dispersion Slope vs. MFD for Experimental Data	21
3.1	Project Flow Chart	25
3.2	(a) Proposed DWDM System Block Diagram and (b) Structure of Optical Transmitter for 1 Channel	26
3.3	Transmitter Part	27
3.4	Symbol of NRZ Generator in Optisystem	28
3.5	Mach-Zehnder Device Structure	29
3.6	Symbol of CW Laser in Optisystem	30

3.7	Receiver Part	32
3.8	Nonlinearities Effect of DWDM System Model Developed with Optisystem; (a) Transmitter Part, (b) Transmission Channel and (c) Receiver Part.	34
4.1	Electrical wave modulated by PRBS with NRZ Generator in time domain	37
4.2	Wavelength Spectrums of 8 Channels DWDM Behind the MUX	37
4.3	Wavelength spectrums of 8 channels DWDM with 0.8nm channel spacing. (a) after dispersion compensating fiber (DCF) and (b) after EDFA.	38
4.4	Wavelength spectrums filtered by optical Bassel filter for respective channel.	39
4.5	Eye Diagram and BER value for respective channel.	40
4.6	Eye Diagram of DWDM system (a) without Compensation Measures and (b) with Linear loss and Dispersion Compensated	42
4.7	Graph BER versus Input Power of (a) 8 channels (b) 16 channels and (c) 32 channels of DWDM system	45
4.8	The Eye Diagram for Channel 8 of (a) 8 Channels (b) 16 Channels (c) 32Channels at Power Levels of 10dBm.43	46
4.9	Graph BER versus Input Power at 30Gbps Bit Rate (a) 16 channels and (b) 32 channels of DWDM system	48
4.10	Graph BER versus Input Power for 10Gbps, 20Gbps and 30Gbps Bit Rate for 16 channels DWDM design	49
4.11	Graph BER versus Fiber Length for -10dBm, 0dBm and 10dBm	51
4.12	Eye Diagram for Input Power Levels of (a) -10dBm (b) 0dBm (c) 10dBm at Fiber Length 72km	53



**LIST OF ABBREVIATIONS**

TDM	Time Division Multiplexing
DWDM	Dense Wavelength Division Multiplexing
LAN	Local Area Network
BER	Bit Error Rate
SNR	Signal Noise Ratio
EDFA	Erbium Doped Fiber Amplifier
SBS	Stimulated Brillouin Scattering
SRS	Stimulated Raman Scattering
SPM	Self Phase Modulation
CPM	Cross Phase Modulation
FWM	Four Wave Mixing
PRBS	Pseudo Random Bit Sequence
NRZ	Non-Return to Zero
MZM	Mach-Zehnder Modulator

## **CHAPTER 1**

### **INTRODUCTION**

#### **1.1 Project Background**

Over the last decade, fiber optic cables have been installed by carriers as the backbone of their interoffice networks, therefore becoming the mainstay of the telecommunications infrastructure. Using Time Division Multiplexing (TDM) technology, carriers now routinely transmit information at 2.4 Gb/s on a single fiber, with some deploying equipment that quadruples that rate to 10 Gbps. [1] The revolution in high bandwidth applications and the explosive growth of the Internet, however, have created capacity demands that exceed traditional TDM limits. As a result, the once seemingly inexhaustible bandwidth promised by the deployment of optical fiber in the 1980s is being exhausted. In order to meet growing demands for bandwidth, a technology called Dense Wavelength Division Multiplexing (DWDM) has been developed that multiplies the capacity of a single fiber. DWDM systems being deployed today can increase a single fiber's capacity sixteen fold, to a throughput of 40 Gbps.[6] This cutting edge technology when combined with network management systems and add-drop multiplexers enables carriers to adopt optically based transmission networks that will meet the next generation of bandwidth demand at a significantly lower cost than installing new fiber.

DWDM technology can be applied to different areas in the telecommunication networks, which includes the backbone networks, the residential access networks, and also the Local Area Networks (LANs). Among these three areas, developments in the DWDM-based backbone network are leading the way, followed by the DWDM-based LANs. The development of this systems take advantage of advanced optical technology (e.g., tunable lasers, narrowband optical filters, etc.) to generate many wavelengths in the range around 1550 nm. ITU-T Recommendation G.692 defines 43 wavelength channels, from 1530 to 1565 nm, with a spacing of 1000Hz, each channel carrying an OC192signal at 10 Gbps. However, systems with wavelength channels of more than 43wavelengths have been introduced, and systems with many more wavelengths are on the experimenter's workbench. [2]

Currently, commercial systems with 16, 40, 80, and 128 channels (wavelengths)per fiber have been announced. Those with 40 channels have channel spacing of 100 GHz, and those with 80 channels have channel spacing at 50 GHz. This channel separation determines the width of the spectral (wavelength) narrowness of each channel, or how close (in terms of wavelength) the channels are. 40 channel DWDM systems can transmit over a single fiber an aggregate bandwidth of 400 Obis (10 Gbps per channel). It is estimated that at 400 Gbps, more than 10,000 volumes of an encyclopedia can be transmitted in 1 second. The number of channels also depends on the type of fiber. A single strand of single-mode fiber can transmit over 80 km without amplification, but placing eight optical amplifiers in cascade, the total distance is extended to over 640 km (this is typical for 80-channel systems at 10 Gbps per channel).There is a race among companies and experimenters to break new records; longer distances, more channels, and higher bit rates frequently make the news. And this trend is expected to continue until all limits of physics for this technology have been reached and pushed back. [10],[13]

Figure 1.1 shows the general DWDM schematic for four channels. Each optical channel occupies its own wavelength. The system consists of four main parts which are transmitters, combining signals (Multiplexer), transmission on fiber, separating signals (Demultiplexer) and receivers. Each part performs different function that will be explained in detail in Chapter 3.

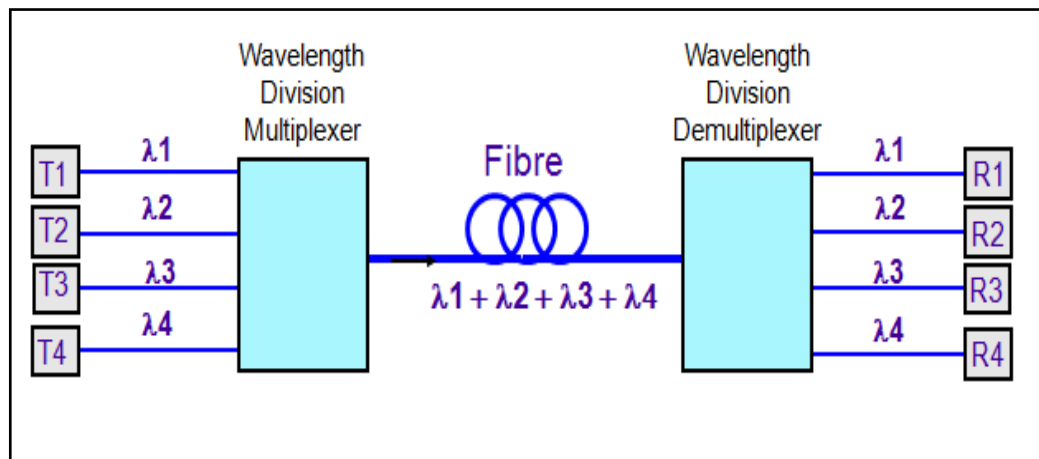


Figure 1.1: General DWDM Functional Schematic Diagram[3]

This thesis presents the analysis of fiber nonlinearity for various power levels of individual channels in DWDM system which involved in modeling the proposed system using suitable commercial optical system simulator; Optisystem for performance characterization.

## 1.2 Problem Statement

The demand for data communication is growing rapidly due to the increasing popularity of the internet and other factors. In order to meet the growing demands for bandwidth, a technology called Dense Wavelength Division Multiplexing (DWDM) has been developed. However, the DWDM systems have a constraint to use because of optical fiber nonlinearities. In a long distance transmission of DWDM system, power level, channel spacing and optical amplifier are needed to consider. Decrease the channel spacing were increase the fiber nonlinearities effect and cause the performance degradation of optical system. Understanding the effects of optical fiber nonlinearities is crucial in order to optimize system performance. In this project, the effects of optical fiber nonlinearities are evaluated in conjunction with various power levels of DWDM transmission systems.

### 1.3 Objective

1. To investigate the characteristics and performance of DWDM technique.
2. To design a 16 and 32 channel DWDM system using Optisystem software.
3. To analyze the fiber nonlinearity for various power levels in 16 and 32 channel DWDM system for optimum BER performance.

### 1.4 Scope of Work

The scope of work in this project is:

- Literature study on fiber nonlinearity
  - Review on nonlinearities effects in fiber optic especially on the DWDM system
- Design and analysis;
  - The theoretical analysis of the DWDM technique.
- System characterization;
  - Modeling and simulation of the DWDM system; where the system that combines together multiple signals and sends them at the same time along a fiber, with transmissions taking place at different wavelengths.
- Result analysis and system optimization;
  - Fiber nonlinearity analysis and optimization for various power levels of individual channels in DWDM system.

## 1.5 Thesis Outline

This thesis comprises of five chapters and is organized as follows:

Chapter 1 discusses the project background, problem statement, objectives, scope of project and followed by the thesis outline. Chapter 2 gives an introduction on fiber nonlinearity in optical system, some fundamental theories of DWDM system, SNR and transmitted power requirements of DWDM systems and its applications.

The DWDM system design is describe briefly in Chapter 3. A theoretical model of DWDM system for nonlinearities analysis with 8, 16 and 32 channels is developed using Optisystem and the important parameters that have been used in this project are clearly stated in this Chapter

The next chapter discusses the analysis results obtained from performing DWDM simulations. Chapter 5 gives the conclusions for the whole project. Besides that, it also provides suggestion for future recommendation where the proposed system can be modify to enable the simulation to be more practical and continuously.

## CHAPTER 2

### LITERATURE REVIEW

#### 2.1 Overview

This chapter constituting two parts which briefly covers the fiber nonlinearity of an optical system and the basics of DWDM system characteristics. The first part describes the types of fiber nonlinearities which are scattering phenomena and refractive index phenomena. The second part is dedicated to DWDM system which includes the principle of DWDM system, EDFA in DWDM system, SNR and transmitted power requirements of DWDM systems and its applications.

#### 2.2 Fiber Nonlinearity

Nonlinearities refer to optical phenomena involving a nonlinear response to a driving light field. [3]Lasers allow generating light with very high intensities. These can give rise to a number of nonlinear effects, the most important of which are:

- i. Parametric nonlinearities occur in certain crystal materials with  $\chi^{(2)}$  nonlinearity, giving rise to effect light frequency doubling, sum and

difference frequency generation, and parametric amplification (nonlinear frequency conversion).

- ii. The Kerr effect raises the refractive index by an amount which is proportional to the intensity, leading to effect light self-focusing, self-phase modulation and four-wave mixing.
- iii. Spontaneous and Stimulated Brillouin Scattering is the interacting of light with "acoustical phonon" and typically involved counter propagating waves.
- iv. Two-photons absorption is a process where two photons are simultaneously absorbed, leading to an excitation for which a single photon energy would not be sufficient.

There are also a number of other effects which are not directly based on optical nonlinearities but are nevertheless affecting optical phenomena as follows [4]:

- i. Saturation of gain occurs particularly in lasers and amplifiers. Similarly, there are nonlinear losses in saturable absorbers, e.g. in SESAMs used for passive mode locking or Q switching.
- ii. Photorefractive effects are observed in certain ferroelectric crystal such as LiNbO<sub>3</sub>. They are used for holographic data storage, and can be detrimental in nonlinear frequency conversion.
- iii. There are various kinds of effects involving heating, e.g. thermal lancing in laser gain media or thermal detuning of optical resonators.

In optical fibers, there is a particularly long interacting length combined with the high intensity resulting from a small area. Therefore, nonlinearities can have strong effect in fiber. Particularly, the effects related to the  $\chi^{(3)}$  nonlinearity; Kerr Effect, Raman Sattering, Brillouin Scattering are often important, despite of the



relatively weak intrinsic nonlinear coefficient of silica: either they act as essential nonlinearities for achieving certain function (e.g. pulse compression, or they constituted limiting effect in high power fiber, lasers and amplifiers).

Strong nonlinearities also occur at intensities which are high enough to cause ionization in the medium. This can lead to optical breakdown, possibly even associated with damage of the material. In gases, extremely high optical intensities can be applied, which can lead to high harmonic generation. [4]

## **2.3 Types of Fiber Nonlinearities**

There are several types of fiber nonlinearities that can further limit the performance of any fiber optic transmission system including those that use DWDM. These nonlinearities fall into two broad groups: scattering and refractive index phenomena.[5]

### **2.3.1 Scattering Phenomena**

One subtype of these phenomena is known as Stimulated Brillouin Scattering (SBS), which is caused by the interaction between the optical signal and acoustic waves in the fiber. The result is that power from the optical signal can be scattered back towards the transmitter. SBS is a narrow band process that affects each channel in a DWDM system individually, but which is even more pronounced in STM64/OC192 systems, due to the greater power levels required for their transmission. The SBS effect has a threshold optical power. When the SBS threshold is exceeded, a significant fraction of the transmitted light is redirected back toward the transmitter. This results in a saturation of optical power that reaches the receiver, as well as the problem associated with optical signals being reflected back into the laser. [6] Figure 2.1 shows that as the launch power is increased above the threshold, there is a dramatic increase in the amount of backscattered light.

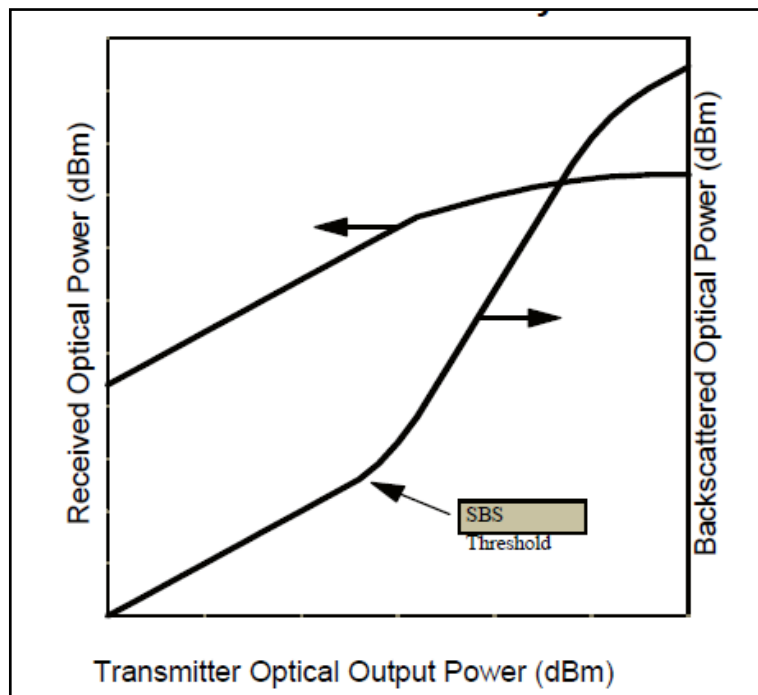
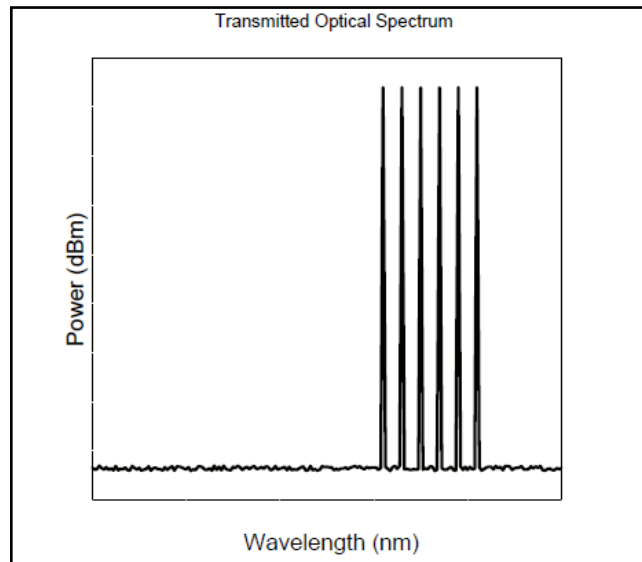
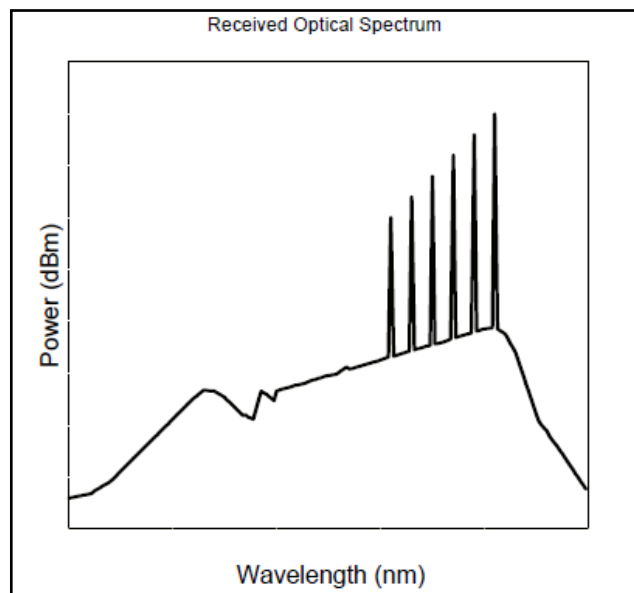


Figure 2.1: SBS Threshold Effects [6]

A second form of scattering is known as Stimulated Raman Scattering (SRS), which is prompted by the interaction of the optical signal with silica molecules in the fiber. This interaction can lead to the transfer of power from shorter wavelength, higher photon energy channels, to longer wavelength, lower photon energy channels. SRS is much less of a problem than SBS. Its threshold is close to 1 Watt, nearly a thousand times higher than SBS. [6] Unlike SBS, SRS is a wideband phenomena that affects the entire optical spectrum that is being transmitted. SRS can actually cause a spectrum of equal amplitude channels to tilt as it moves through the fiber. Moreover, its impact worsens as power is increased and as the total width of the DWDM spectrum widens. [11] One way to combat this phenomena is to use moderate channel powers as well as a densely packed channel plan that minimizes the overall width of the spectrum. [6] Figure 2.2(a) and (b) show what would happen to six wavelength that are transmitted through a series of optical amplifiers and long intermediate lengths of fiber.



(a)



(b)

Figure 2.2: (a) Transmitted Optical Spectrum and (b) SRS Effect Seen at Receiver Input [6]

### 2.3.2 Refractive Index Phenomena

The most serious is the fact that the refractive index of glass is dependent on the optical power going through the material. [6] The general equation for the refractive index of the core in an optical fiber is:

$$n = n_0 + n_2 * P/A_{\text{eff}} \quad [19]$$

where  $n_0$  is the refractive index of the fiber core at low optical power levels.  $n_2$  is the nonlinear refractive index coefficient. It is equal to  $2.35 \times 10^{-20} \text{ m}^2/\text{W}$  for silica.

$P$  is the optical power in Watts and  $A_{\text{eff}}$  is the effective area of the fiber core in square meters

The equation shows that two strategies for minimizing nonlinearities due to refractive index power dependence are to minimize the amount of power,  $P$ , that is launched and maximize the effective area of the fiber,  $A_{\text{eff}}$ . Figure 2.3 shows the relationship of the refractive index versus optical power. It can be seen the magnitude of the change in refractive index is relatively small. It becomes important since the interaction length in a real fiber optic system can be hundreds of kilometers.[6]

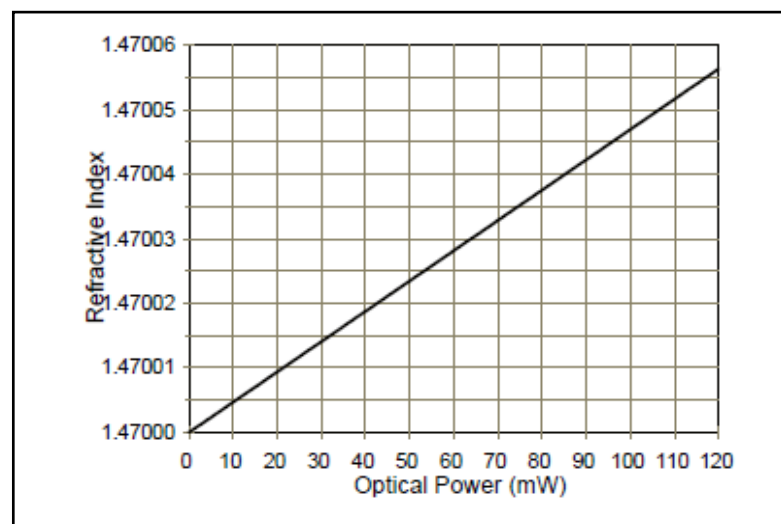


Figure 2.3: Refractive Index of Silica vs. Optical Power [6]

This group of nonlinearities includes self-phase modulation (SPM), cross-phase modulation (XPM), and four-wave mixing (FWM). These are caused because the index of refraction, and hence the speed of propagation in a fiber, is dependent on the intensity of light a dependency that can have particularly significant effects in long haul applications. SPM, which refers to the modulation that a light pulse has on its own phase, acts on each DWDM channel independently. The phenomena causes the signal's spectrum to widen and can lead to crosstalk or an unexpected dispersion penalty. The spectral broadening caused by SPM produces dispersion like effects which can limit transmission rates in some long-haul optical communication system, depending on the fiber type and its chromatic dispersion. By contrast, XPM is due to intensity fluctuations in another channel and is an effect that is unique to DWDM systems. XPM is a similar effect to SPM except that overlapping but distinguishable pulses, possessing or polarizations are involved.[8],[9]

Finally, four-wave mixing refers to the nonlinear combination of two or more optical signals in such a way that they produce new optical frequencies. Generally FWM effect occur when if the three light pulses, having different wavelength and travelling through single fiber, interact together to generate a new pulse.[7] If the three wavelength  $\lambda_1, \lambda_2$  and  $\lambda_3$  are propagating through single fiber, these wavelengths will interact to generate a new pulse  $\lambda_4$  according to equation;

$$\lambda_4 = \lambda_1 + \lambda_2 - \lambda_3 [18]$$

Figure 2.4 shows an interfering signal to the original signal that produces the new wavelength. FWM signal power depends on several factors such as spacing between the channels, channel input power, and dispersion of the transmission fiber. FWM signals are eliminated by increasing the spacing between the channels, increasing the chromatic dispersion of the transmission fiber, decreasing the average input power per channel.[18] All three types of refractive index phenomena can be controlled either through careful choice of channel power or increases in channel spacing.

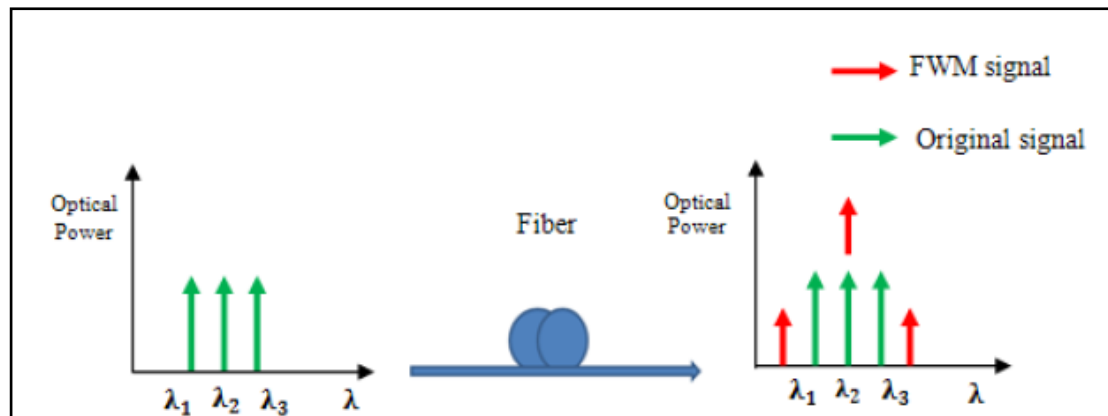


Figure 2.4: Spectrum Before and After The Fiber[18]

## 2.4 DWDM system

Dense Wavelength Division Multiplexing (DWDM) is a technology that allows multiple information streams to be transmitted simultaneously over a single fiber at data rates as high as the fiber plant will allow (e.g. 2.4 Gbps). The DWDM approach multiplies the simple 2.4 Gbps system by up to 16 times, giving an immense and immediate increase in capacity using embedded fiber. A sixteen channel system (which is available today) supports 40 Gb/s in each direction over a fiber pair, while a 40 channel system under development will support 100 Gb/s, the equivalent of ten STM64/OC192 transmitters. The benefits of DWDM over the first two option adding fiber plant or deploying STM64/OC192 for increasing capacity are clear.[1]

DWDM technology utilizes a composite optical signal carrying multiple information streams, each transmitted on a distinct optical wavelength. Although wavelength division multiplexing has been a known technology for several years, its early application was restricted to providing two widely separated wideband wavelengths, or to manufacturing components that separated up to four channels. Only recently has the technology evolved to the point that parallel wavelengths can be densely packed and integrated into a transmission system, with multiple, simultaneous, extremely high frequency signals in the 192 to 200 THz range. By

conforming to the ITU channel plan, such a system ensures interoperability with other equipment and allows service providers to be well positioned to deploy optical solutions throughout their networks.[2],[10]

The most common form of DWDM uses a fiber pair one for transmission and one for reception. Systems do exist in which a single fiber is used for bidirectional traffic, but these configurations must sacrifice some fiber capacity by setting aside a guard band to prevent channel mixing, they also degrade amplifier performance. In addition, there is a greater risk that reflections occurring during maintenance or repair could damage the amplifiers. In any event, the availability of mature supporting technologies, like precise demultiplexers and Erbium Doped Fiber Amplifiers (EDFA), has enabled DWDM with eight, sixteen, or even higher channel counts to be commercially delivered. [2]

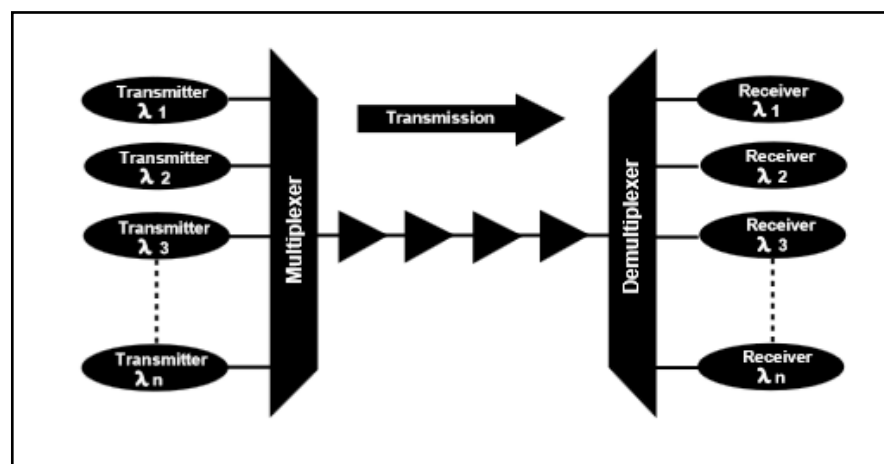


Figure 2.5:DWDM System of  $n$  Channel [1]

With signals as precise and as dense as those used in DWDM, there needed to be a way to provide accurate signal separation, or filtration, on the optical receiver. Such a solution also needed to be easy to implement and essentially maintenance free. Early filtering technology was either too imprecise for DWDM, too sensitive to temperature variations and polarization, too vulnerable to crosstalk from neighboring channels, or too costly. This restricted the evolution of DWDM. In order to meet the requirements for higher performance, a more robust filtering technology was

developed that makes DWDM possible on a cost effective basis, the in fiber Bragg grating. The new filter component, called a fiber grating, consists of a length of optical fiber wherein the refractive index of the core has been permanently modified in a periodic fashion, generally by exposure to an ultra- violet interference pattern. The result is a component which acts as a wavelength dependent reflector and is useful for precise wavelength separation. In other words, the fiber grating creates a highly selective, narrow bandwidth filter that functions somewhat like a mirror and provides significantly greater wavelength selectivity than any other optical technology.[10] The filter wavelength can be controlled during fabrication through simple geometric considerations which enable reproducible accuracy . Because this is a passive device, fabricated into glass fiber, it is robust and durable.

#### **2.4.1 EDFA in DWDM system**

The advent of the Erbium Doped Fiber Amplifier (EDFA) enabled commercial development of DWDM systems by providing a way to pump lasers are then used to transfer high levels of energy to the special fiber, energizing the Erbium ions which then boost the optical signals that are passing through. Significantly, the atomic structure of Erbium provides amplification to the broad spectral range required for densely packed wavelengths operating in the 1550nm region, optically boosting the DWDM signals. Instead of multiple electronic regenerators, which required that the optical signals be converted to electrical signals then back again to optical ones, the EDFA directly amplifies the optical signals.[10] Hence the composite optical signals can travel up to 600 km without regeneration and up to 120 km between amplifiers in a commercially available, terrestrial, DWDM system.



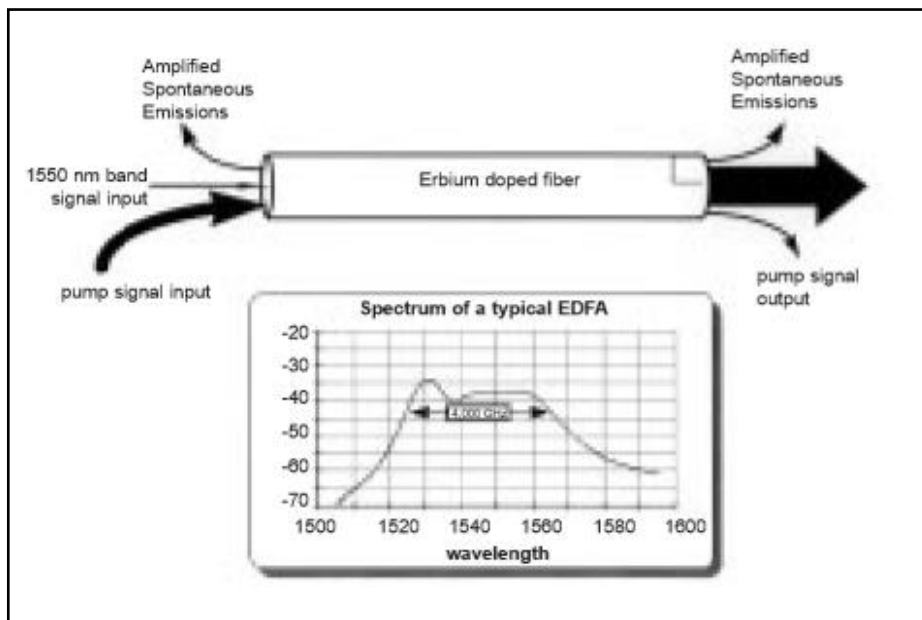


Figure 2.6: Principle of EDFA [1]

#### 2.4.2 Optical SNR and Transmitted Power Requirements of DWDM Systems

The bit error rate (BER) performance of a DWDM channel is determined by the optical SNR that is delivered to the photodetector. In a typical commercial system, an optical SNR of approximately 20 dB, measured in a 0.1 nm bandwidth, is required for an acceptably low BER of 10<sup>-15</sup>. This acceptable SNR is delivered through a relatively sophisticated analysis of signal strength per channel, amplifier distances, and the frequency spacing between channels. [1] For a specific SNR at the receiver, the amount of transmit power required in each channel is linearly proportional to the number of amplifiers as well as the noise and SNR of each amplifier, and is exponentially proportional to the loss between amplifiers. Because total transmit power is constrained by present laser technology and fiber nonlinearities, the workable key factor is amplifier spacing. This is illustrated in Figure 2.7 by showing the relationship for a fiber plant with a loss of 0.3 dB/km, a receiver with a 0.1 nm optical bandwidth, and optical amplifiers with a 5 dB noise figure. The system illustrated is expected to cover 600 km and the optical SNR required at the receiver is 20 dB measured in the 0.1 nm bandwidth.

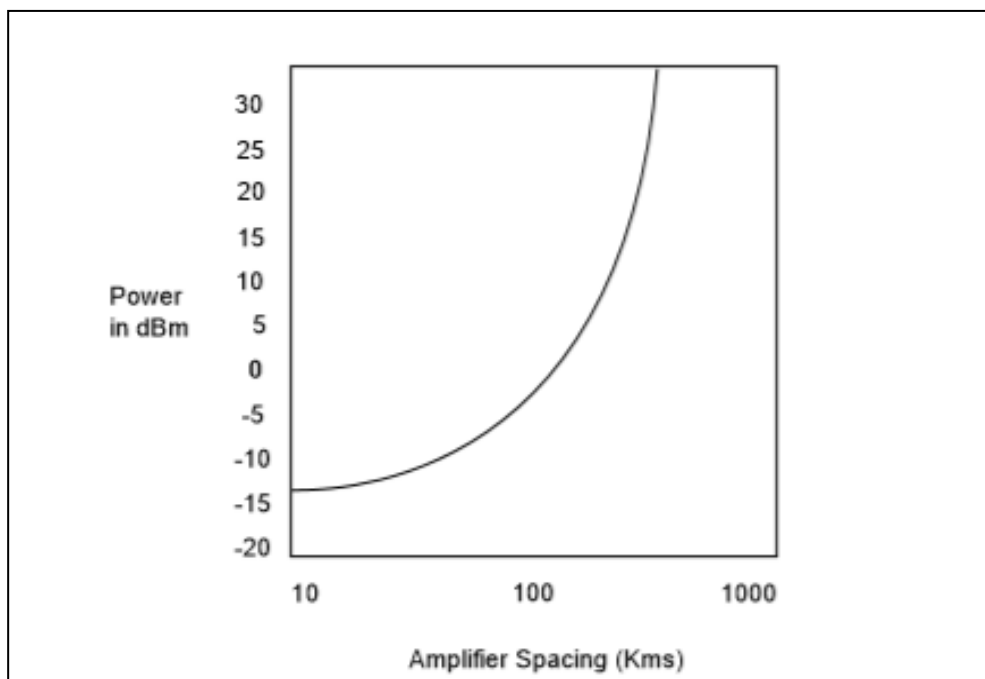


Figure 2.7: Graph of Power in dBm versus Amplifier Spacing (Kms) [1]

### 2.4.3 Applications for DWDM

As occurs with many new technologies, the potential ways in which DWDM can be used are only beginning to be explored. Already, however, the technology has proven to be particularly well suited for several vital applications.

- DWDM is ready made for long-distance telecommunications operators that use either point-to-point or ring topologies. The sudden availability of 16 new transmission channels where there used to be one dramatically improves an operator's ability to expand capacity and simultaneously set aside backup bandwidth without installing new fiber.
- This large amount of capacity is critical to the development of self-healing rings, which characterize today's most sophisticated telecom networks. By deploying DWDM terminals, an operator can construct a 100% protected, 40 Gbps ring, with 16 separate communication signals using only two fibers.

- Operators that are building or expanding their networks will also find DWDM to be an economical way to incrementally increase capacity, rapidly provision new equipment for needed expansion and future proof their infrastructure against unforeseen bandwidth demands.
- Network wholesalers can take advantage of DWDM to lease capacity, rather than entire fibers, either to existing operators or to new market entrants. DWDM will be especially attractive to companies that have low fiber count cables that were installed primarily for internal operations but that could now be used to generate telecommunications revenue.
- The transparency of DWDM systems to various bit rates and protocols will also allow carriers to tailor and segregate services to various customers along the same transmission routes. DWDM allows a carrier to provide STM4/OC12 service to one customer and STM16/OC48 service to another all on a shared ring.
- In regions with a fast growing industrial base DWDM is also one way to utilize the existing thin fiber plant to quickly meet burgeoning demand.

## **2.5 Previous Work**

Abdelhamid, Kouninef Belkacem, Mohammed Beljacem and Kheroua Mohamed [13] compares the performances of DWDM system with four channels using a conventional single mode fiber (SMF) or non zero dispersion shifted fiber (NZDSF). The simulation using OptSim software where the chromatic dispersion compensation and non linear phenomenon in the fiber are also included in the simulation. In this paper the best result taken into account are linear phenomena that was obtained with Corning Leaf fiber is very suitable for long haul distance. Figure 2.8 shows the the eye diagram for different distances with non linear effects for Corning Leaf fiber.

	Without SPM and XPM	With SPM and XPM
BER	$10^{-9}$	$10^{-9}$
Maximale Distance(km)	2000	1000

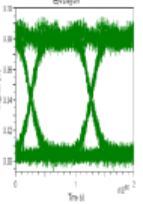
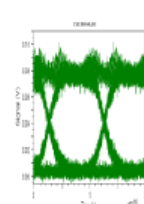
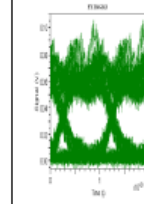
Distance (km)	140	280	1000
BER	$10^{-39}$	$10^{-33}$	$10^{-9}$
Eye Diagram			

Figure 2.8: The Eye Diagram for Different Distances with Non Linear Effects [13]

Gao Yan, Zhang Ruixia, Du Weifeng, and Cui Xiaorong [15] designed optical fiber communication system with 32 channels and simulated by Optisystem. Based on their simulation, the model which can inhibit dispersion and fiber linear loss has been successfully manufactured. Figure 2.9 shows the design of Simulation Model of 32-Channel DWDM System for this paper and Figure 2.10 shows the output

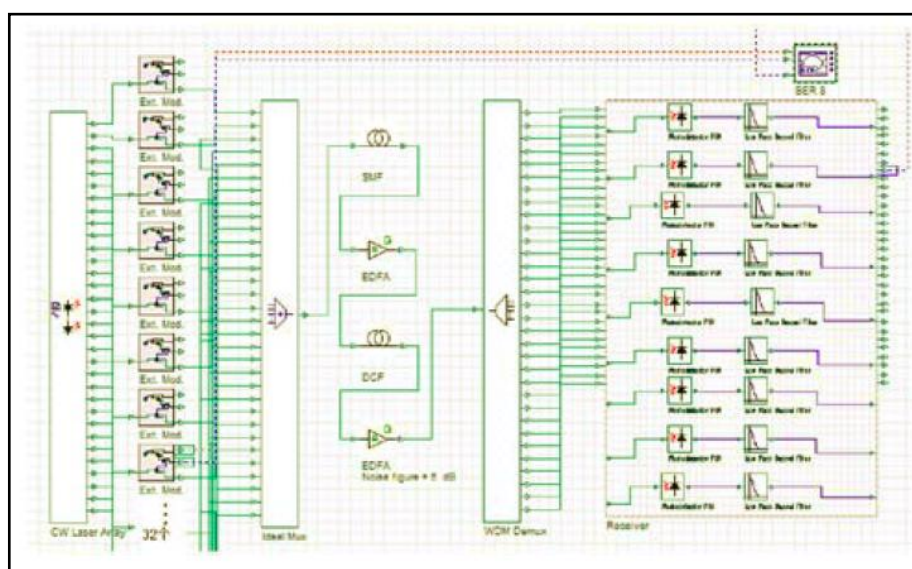


Figure 2.9: Simulation Model of 32-Channel DWDM System [15]

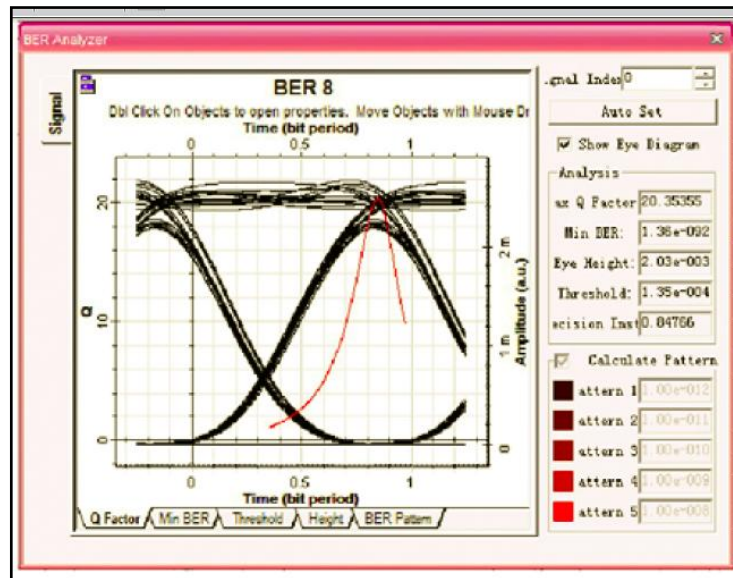


Figure 2.10: The Eye Diagram of DWDM System in With Linear Loss and Dispersion has been Compensated [15]

Nazmi A.Mohammad, Mahmoud M.Ragab and Moustafa H.Aly [7] demonstrate four-wave-mixing (FWM) based on wavelength  $1.55\mu\text{m}$  using four different types of optical fibers. The results show that the DCF optical fiber has been shown to be a good candidate for wavelength conversion compared to the other commercial fibers. The numerical setup for the FWM-based wavelength converter is shown in Figure 2.11 below.

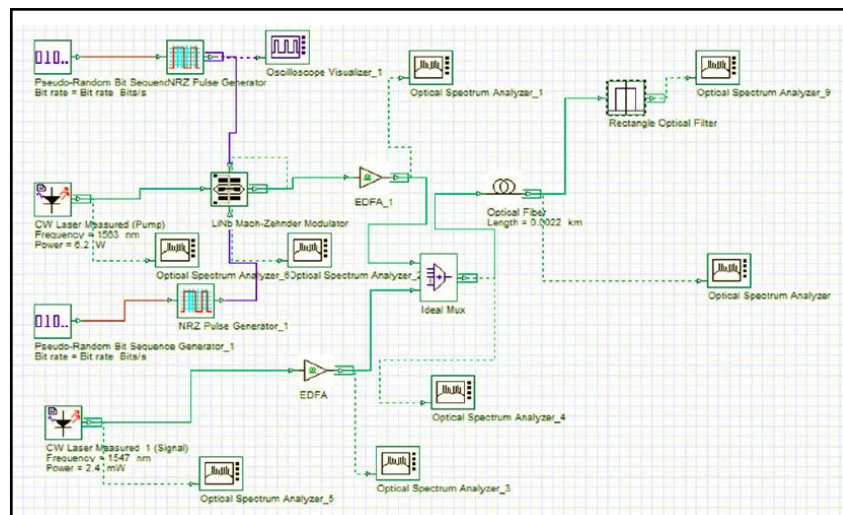


Figure 2.11: The Numerical Setup or The FWM-based Wavelength Converter [7]

Iftikhar Rasheed, Muhammad Abdullah, Shahid Mehmood, and Mahwish Chaudhary [16] analyzed the impact of cross phase modulation (XPM), four wave mixing (FWM) and stimulated Raman scattering (SRS) on DWDM communication system. The analysis was done on the basis of result obtained from simulation in OptiSystem. This paper shows how the non linearity's increase in optical fiber communication system by increasing the input power and number of input channels. Figure 2.12 shows the output result for 11 channels , 3dBm input power with channel spacing is 110GHz.

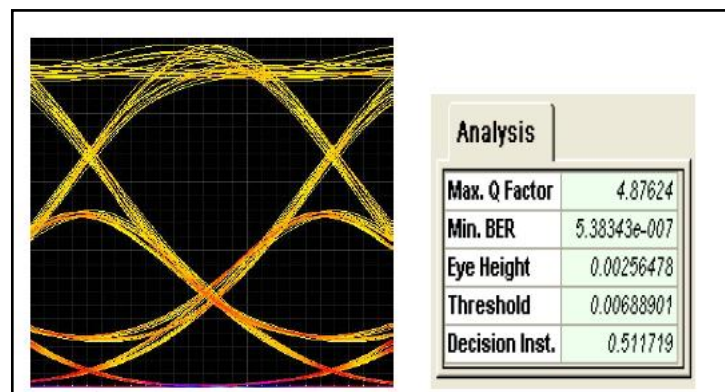


Figure 2.12: The Eye Diagram for 11 Channels [16]

Kazumasa Ohsono, Tomoyuki Nishio, Takahiro Yamazaki, Tomomi Onose, Kotaro Tan [23] developed a low non-linear non-zero dispersion shifted single-mode fiber with an enlarged mode field diameter(MFD) by optimizing the design of the fiber profile. Figure 2.13 below shows the developed fiber achieved target characteristics of low non-linearity and low dispersion slope.

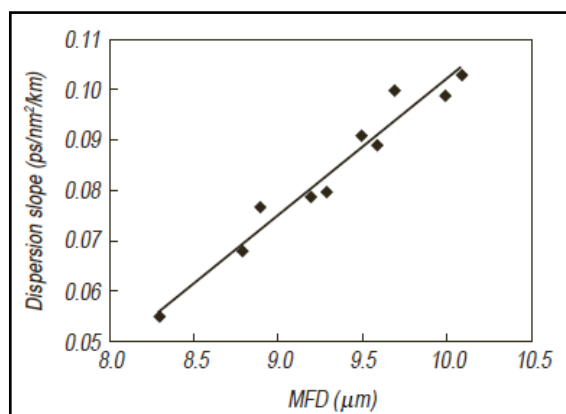


Figure 2.13: Dispersion Slope vs. MFD for Experimental Data. [23]

Table 2.1: List of the research

No	Title of Journal	Software	DWDM	Length of fiber	Medium of transmission	Performance measure
			No. of channel			
1	Used of Fibers in Long Distance Telecommunication DWDM systems <i>Abdelhamid, Kouninef Belkacem, Mohammed Beljacem and Kheroua Mohamed,</i>	OptiSim	4	Up to 1000km	SMF + Tera Light, True Wave, Corning Leaf and DCF	BER Eye diagram
2	Point-to-Point DWDM System Design and Simulation <i>Gao Yan, Zhang Ruixia, Du Weifeng, and Cui Xiaorong</i>	Optisystem	32	50km	SMF + DCF	Eye diagram
3	Four- Wave-Mixing Based Wavelength Conversion Using Different Types of Fibers <i>Nazmi A.Mohammad, Mahmoud M.Ragab and Moustafa H.Aly</i>	Optisystem	2	2.2m to 22m	SMF and LEAF	Output Power
4	Analysis Of Fiber Nonlinearity For Various Power Levels In Dwdm System	Optisystem	8, 16 and 32	36km, 72km and 120km	SMF + DCF	BER Eye diagram

## **CHAPTER 3**

### **METHODOLOGY**

#### **3.1 Overview**

This chapter describes the details explanation of the methodology that has been used in this project. Chapter 3 is one of the important parts that act as the guidelines in order to accomplish the project. The most important aspect during the methodology stage is the design of Dense Wavelength Division Multiplexing (DWDM) system for nonlinearities analysis and simulation process at various power levels. A theoretical model of DWDM system for nonlinearities analysis with 8, 16 and 32 channels was developed. The first part of the development represents the general system block diagram of nonlinear DWDM system consists of transmitter and receiver and the basic optical communication components. DWDM simulation model using Optisystem can be found in the last section of this chapter. The parameters that have been used in this project are clearly stated.



In general, the overall methodology for this project comprises of three steps as shown in next flow chart and briefly discussed as follow:

i) Literature review

Generally this section involves the study of previous researches or literature review. All the design parameters such as input power levels, wavelengths, channel spacing and fiber length have been studied before entering the next stage which is design and simulation.

ii) Design and Simulation

Design of nonlinear DWDM system and simulating the proposed project using Optisystem software.

iii) Result and analysis

Finally each result obtained from the simulation is compared to get the best BER performance.

### **3.2 Project Flow Chart**

The overall project flow is shown in Figure 3.1.

## REFERENCES

- [1] The Applied Technologies Group, *Dense Wavelength Division Multiplexing*, One Apple Hill, 1997
- [2] Shaowen Song, IEEE Canadian Review - Spring, Printemps, 2001.
- [3] A. Nolasco Pinto, Paulo Almeida and J. Ferreira da Rocha, *Intra-Channel Nonlinear Effects in Dispersion Compensated DWDM Optical Networks*, Institute of Telecommunications, 2001.
- [4] A. Djupsjobacka, G. Jacobsen and B.Tromborg, *Dynamic Stimulated Brillouin Scattering Analysis*, *J.Lightw. Technol.*, Vol. 18,No. 3, pp. 416-424, March 2000.
- [5] I.P. Kaminow, *Optical Fiber Telecommunications*, Elsevier Press IV, 2002.
- [6] David R. Goff, *The Effects of Fiber Nonlinearities*, Olson Technology, Inc., 2007.
- [7] Nazmi A.Mohammad, Mahmoud M.Ragab and Moustafa H.Aly,,: Four-Wave- Mixing Based Wavelength Conversion Using Different Types of Fibers, *International Journal of Engineering Science and Technology (IJEST)*, Vol. 4, No.1, Jan 2012.

- [8] Alan Willner and SyangMyau Hwang, *Transmission of Many WDM Channels Through a Cascade of EDFAs in Long distance Links and Networks*, IEEE0733–872/95 Journal of Lightwave Technology.
- [9] Joseph M. Kahn and Keang-Po Ho, *Ultimate Spectral Efficiency Limits in DWDM Systems*, Optoelectronic and Communications Conference, Yokohama, Japan, July 2002.
- [10] Mir Muhammad Lodro and Muhammad Ali Joyo, *32-Channel DWDM System Design and Simulation by Using EDFA with DCF and Raman Amplifiers*, IPCSIT vol. 27 (2012) IACSIT Press, Singapore, 2012.
- [11] Bo Xu and Maité Brandt-Pearce, *Analysis of Noise Amplification by a CW Pump Signal Due to Fiber Nonlinearity*, IEEE Photonics Technology Letters, Vol. 16, No. 4, April 2004.
- [12] Fang Juanni, *The Effect of SRS to DWDM Optical System*, 2010 International Conference on Electrical and Control Engineering, 2010 IEEE DOI 10.1109/ ICECE.2010.577
- [13] Abdelhamid, Kouninef Belkacem, Mohammed Beljacem and Kheroua Mohamed, *Used of Fibers in Long Distance Telecommunication DWDM systems*, International Journal of Computer Science and Telecommunications, Vol3, pp. 39-42, Dec 2012.
- [14] Jong-Hyung Lee, *Analysis and Characterization of Fiber Nonlinearities with Deterministic and Stochastic Signal Sources*, PhD Thesis, University of Virginia, February 2000.
- [15] Gao Yan, Zhang Ruixia, Du Weifeng, and Cui Xiaorong, *Point-to-Point DWDM System Design and Simulation*, International Symposium on Information Processing (ISIP'09), ISBN 978-952-5726-02-2, pp 090-092, August 21-23, 2009.

- [16] Iftikhar Rasheed, Muhammad Abdullah, Shahid Mehmood, and Mahwish Chaudhary, *Analyzing the Nonlinear Effects at Various Power Levels and Channel Counts on the Performance of DWDM based Optical Fiber Communication System*, IEEE, 978-1-4673-4451-7/12, 2012.
- [17] Paul L.Kelley, Ivan P. Kaminow and Govind P. Agrawal, *Nonlinear Fiber Optics*, Academic Press 2001.
- [18] A.Selvamani and Mr.T.Sabapathi, Suppression of Four Wave Mixing by Optical Phase Conjugation in DWDM Fiber Optic Link, *International Conference on Recent Advancements in Electrical, Electronics and Control Engineering*, 2011
- [19] Ivan P. Kaminow and Thomas L. Koch, *Optical Fiber Telecommunication IIIA*, Academic Press 1997
- [20] N.M. Nawawi, *Investigation of Mach-Zehnder Device Based on Polymer Material*, B.Eng. Thesis, Universiti Teknologi Malaysia, 2006.
- [21] Bo-ning HU, Wang Jin, Wang Wei and Rui-mei Zhao, Analysis of Dispersion Compensation with DCF based on Optisystem, *2nd International Conference on Industrial and Information Systems*, 2010
- [22] International Telecommunication Union (2009), *ITU Recommendations*, from <http://www.itu.int/ITU-T/recommendations/index.aspx?ser=G>
- [23] Kazumasa Ohsono, Tomoyuki Nishio, Takahiro Yamazaki, Tomomi Onose, Kotaro Tan, *Low Non-linear Non-zero Dispersion-shifted Fiber for DWDM Transmission*, Hitachi Cable Review No.19, August 2000.