



UDC 621.311

Improving the quality of electricity in the power supply systems of the mineral resource complex with hybrid filter-compensating devices

Yurii A. SYCHEV, Roman Yu. ZIMIN✉

Saint Petersburg Mining University, Saint Petersburg, Russia

How to cite this article: Sychev Yu.A., Zimin R.Yu. Improving the quality of electricity in the power supply systems of the mineral resource complex with hybrid filter-compensating devices. Journal of Mining Institute. 2021. Vol. 247, p. 132-140. DOI: 10.31897/PMI.2021.1.14

Abstract. The urgency and necessity of choosing and justifying the structures of hybrid filter-compensating devices based on series and parallel active filters to improve the quality of electricity in the power supply systems of enterprises of the mineral resource complex is shown. Mathematical models of hybrid filter compensating devices based on parallel and series active filters have been developed. Based on these mathematical models, computer simulation models of the indicated hybrid structures have been developed. The results of simulation showed the effectiveness of the correction of power quality indicators in terms of reducing the level of higher harmonics of current and voltage, as well as voltage deviations. The degree of influence of filter-compensating devices on the power quality indicators, which determine the continuity and stability of the technological process at the enterprises of the mineral resource complex, have been revealed. It has been established that a hybrid filter-compensating device based on a parallel active filter can reduce the level of higher harmonics of current and voltage by more than 90 and 70 %, respectively, and based on a series active filter, it can reduce the level of higher harmonics of voltage by more than 80 %. Based on the simulation results, the possibility of compensating for the reactive power of a hybrid structure based on parallel active and passive filters has been revealed. The possibility of integrating hybrid filter-compensating devices into more complex multifunctional electrical systems for the automated improvement of the quality of electricity is substantiated, as well as the expediency and prospects of their use in combined power supply systems based on the parallel operation of centralized and autonomous sources of distributed generation.

Ошибка! Закладка не определена. **Key words:** hybrid structures; higher harmonics; voltage dips; power quality; non-linear load; filter-compensating devices; electromagnetic compatibility; harmonic distortion

Introduction. Modern electrotechnical complexes of industrial enterprises of the mineral resource complex are characterized by an intensive spread of non-linear load in the form of frequency-controlled electric drive systems of technological units. This negatively affects the level of power quality in terms of non-sinusoidal voltage and current [3]. The values of power quality indicators determine the level of efficiency and reliability of the networks and power supply systems of enterprises of the mineral resource complex (MRC), as well as certain types of electrical equipment.

Formulation of problem. The problem of ensuring the quality of electricity and electromagnetic compatibility of electrical equipment is relevant for the enterprises of the MRC. The level of power quality has a direct impact on the service life of the main electrical equipment, the stability of the operation of electrical installations, the amount of additional energy losses in the elements of power supply systems, vibration in electric motors. In particular, according to research results [5, 7] it was found that the value of additional energy losses in electrical machines, due to the presence of higher harmonics of current and voltage, can reach 25 % of the level of total losses. Also it has been revealed [8, 12], that in the presence of harmonic distortions in the network that exceed the standards of GOST 32144-2013, the service life of asynchronous motors can be reduced by 1.5-2 times, capacitor units for reactive power compensation – by five or more times. For submersible asynchronous electric motors of oil production plants with a voltage drop of more than 70 % of the nominal value, the critical duration of the voltage dip under the stability condition is 0.15 s [4, 14].

Existing technical solutions. To compensate for higher harmonics of current and voltage, a number of technical means and solutions are used, which can be divided into three classes: passive, active and hybrid [1].



The passive class of devices affects the resistances of sections of the network or the ratio of resistances at any point in the network. The main disadvantages of such devices are the limited spectrum of compensated harmonics and the impossibility of adaptive adjustment to changes in the harmonic spectrum of the network [11].

Active devices have the property of adaptability, allow to compensate for the full spectrum of higher harmonics from 2 to 40 orders of magnitude and the ability to integrate into systems for automated improving the quality of electricity [15]. However, a significant drawback of such means is their high cost and the impossibility of their use in networks with capacitor units for power factor correction due to the presence of resonance phenomena [2, 10].

Hybrid filters are formed from a combination of active and passive devices. The use of active filters together with passive filters allows you to adjust the parameters of the latter. Also, combined use with passive filters in hybrid systems allows you to reduce the nominal parameters of active filters [18, 26, 27]. Hybrid devices are classified according to the following criteria: the type of connection between the active and passive parts, as well as the method of connection to the compensated network. It should also be noted that hybrid filter-compensating devices (FCDs) improve the quality of electricity in several ways simultaneously, i.e. have the property of multifunctionality. Moreover, such devices are able to compensate for voltage dips and deviations [16, 22].

Mathematical models of hybrid filter compensating devices. The main topologies of hybrid FCD are various combinations of active and passive filters. The presence of the passive part makes it possible to reduce the mass-dimensional indicators of the active part by reducing the rated power of the power elements, which are the most expensive in the composition of the FCD.

Based on the power quality indicators, for which continuous monitoring is needed in the conditions of the power supply systems of the MRC, it is advisable to consider two main structures [9, 17, 25, 28]:

- hybrid based on parallel active and passive filters ensuring compensation of higher harmonic components (HHC) in current from the side of non-linear load and voltage deviations from the supply network (hybrid FCD N 1);
- hybrid based on series active and passive filters providing compensation for HHC and voltage dips from the source side and higher harmonics of the current from the non-linear load side (hybrid FCD N 2).

In the course of mathematical and computer simulation modeling of these FCDs, the following basic assumptions and limitations were adopted:

- power elements of active filters are adopted by ideal keys (zero resistance in the open state, infinitely high resistance in the closed state);
- the state of each power switch is described by the K_{inv} function, which takes the value 0 if the key is closed, and value 1 if the key is open;
- during one step of integration, all non-linearities are considered as linear dependencies [23].

The structure of hybrid FCD N 1 is shown in Fig. 1, a.

The mathematical model of hybrid FCD N 1 is based on the following expressions [9, 14, 25]:

$$\begin{aligned}
 u_{grid}(t) &= \Delta u_{grid}(t) + u_{pfa}(t) = \Delta u_{grid}(t) + u_{pf}(t) = \Delta u_{grid}(t) + u_{nll}(t); \\
 u_{pfa}(t) &= u_{pf}(t) = u_{nll}(t); \\
 i_{grid}(t) &= i_{paf}(t) + i_{pf}(t) + i_{nll}(t); \\
 u_{paf}(t) &= u_{Lf}(t) + u_{inv}(t); \\
 u_{Lf}(t) &= L_f \frac{di_{inv}(t)}{dt}; \\
 u_{inv}(t) &= K_{inv}(t) u_{dc}(t),
 \end{aligned} \tag{1}$$

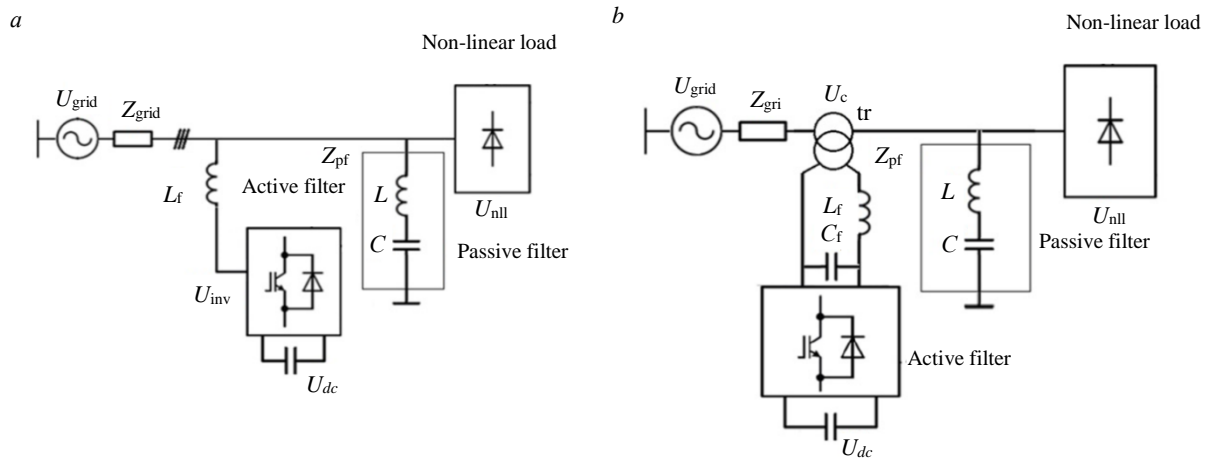

Fig. 1. Structures of hybrid FCD N 1 (a) and N 2 (b)

where $u_{grid}(t)$ – grid instantaneous voltage value; $\Delta u_{grid}(t)$ – instantaneous line voltage drop from the source to the point of connection of the hybrid FCD N 1 and $\Delta u_{grid}(t) = i_{grid}(t)Z_{grid}$; $u_{paf}(t)$ – instantaneous voltage value on a parallel active FCD; $u_{pf}(t)$ – instantaneous voltage value at passive FCD; $u_{nll}(t)$ – instantaneous voltage value across a non-linear load; $i_{grid}(t)$ – instantaneous current value in the network; $i_{paf}(t)$ – instantaneous current value of active FCD; $i_{pf}(t)$ – instantaneous current value of the passive FCD; $i_{nll}(t)$ – instantaneous current value of non-linear load; $u_{inv}(t)$ – instantaneous voltage value at the output of the active filter inverter; $u_{Lf}(t)$ – instantaneous value of the voltage drop across the inductance of the active filter; L_f – inductance at the output of an active FCD; $i_{inv}(t)$ – instantaneous current value of the active FCD inverter; $K_{inv}(t)$ – modulating function characterizing the degree of IGBT transistors switching on and off; $u_{dc}(t)$ – voltage on the plates of the capacitor of the active FCD [10, 11].

The structure of hybrid FCD N 2 is shown in Fig. 1, b.

The mathematical model of the hybrid FCD N 2 is based on the following expressions [8, 10, 11]:

$$u_{grid}(t) = \Delta u_{grid}(t) + u_c(t) + u_{pf}(t) = \Delta u_{grid}(t) + u_c(t) + u_{nll}(t);$$

$$u_{grid}(t) = i_{grid}(t)Z_{grid} + u_c(t) + u_{nll}(t);$$

$$i_{grid}(t) = i_{paf}(t) + i_{nll}(t);$$

$$u_c(t) = K_{tr}u_{cf}(t);$$

(2)

$$u_{cf}(t) = u_{Lf}(t) + u_{inv}(t);$$

$$u_{Lf}(t) = L_f \frac{di_{inv}(t)}{dt};$$

$$u_{inv}(t) = K_{inv}(t)u_{dc}(t),$$

where $u_c(t)$ – instantaneous value of the compensating high voltage on the transformer; K_{tr} – transformation ratio; $u_{cf}(t)$ – instantaneous voltage value on capacitor plates [21, 23].

The control system of the active part (parallel active filter) of the hybrid PKU N 1 is implemented on the basis of phase transformations and phase synchronization of reference values.

The control system measures the phase voltages of the network (u_a, u_b, u_c) and transforms them into a two-phase system $\alpha\beta$ as follows:

$$u_\alpha = u_a - \frac{u_b + u_c}{2};$$

(3)

$$u_\beta = \frac{\sqrt{3}}{2}(u_b - u_c).$$



Phase transformations make it possible to determine the angle φ between the imaging vector of the distorted grid voltage and its projection onto the axis α . The nature of the change and the value of the angle φ contains information about the level of distortion, the presence of higher harmonics, the phase shift of the voltage and current of the compensated network. Initial guides:

$$\begin{aligned}\cos\varphi &= u_{\alpha}/u_{sm}; \\ \sin\varphi &= u_{\beta}/u_{sm}; \\ u_{sm} &= \sqrt{u_{\alpha}^2 + u_{\beta}^2}.\end{aligned}\tag{4}$$

The phase synchronization unit corrects the angle φ to a value φ' corresponding to the sinusoidal shape of the grid voltage curve. Further, the reference currents in the coordinate system $\alpha\beta$ are determined by following expressions:

$$\begin{aligned}i_{ref\alpha} &= i_{ref} \cos\varphi'; \\ i_{ref\beta} &= i_{ref} \sin\varphi',\end{aligned}\tag{5}$$

where i_{ref} – current reference signal. Followed by (3), the reverse phase transformation is carried out:

$$\begin{aligned}i_{refa} &= i_{ref\alpha}; \\ i_{refb} &= \frac{\sqrt{3}i_{ref\beta} - i_{ref\alpha}}{2}; \\ i_{refc} &= \frac{-\sqrt{3}i_{ref\beta} - i_{ref\alpha}}{2}.\end{aligned}\tag{6}$$

After that, non-linear load currents are subtracted from the reference sinusoidal currents determined by expression (6) (i_{na}, i_{nb}, i_{nc}):

$$\begin{aligned}i_{oa} &= i_{refa} - i_{na}; \\ i_{ob} &= i_{refb} - i_{nb}; \\ i_{oc} &= i_{refc} - i_{nc}.\end{aligned}\tag{7}$$

Based on the currents (i_{oa}, i_{ob}, i_{oc}) received, control pulses of the power switches of the active filter inverter are formed. The currents i_{oa}, i_{ob}, i_{oc} give information about the presence of higher harmonics of the current, which must be compensated by a parallel active filter as part of a hybrid FCD N 1.

Simulation modeling of structures of hybrid filter compensating devices. Taking into account expressions (1), (2) based on the structures shown in Fig.1, *a* and *b*, computer simulation models of hybrid FCD N 1 and N 2 have been developed in the Simulink MATLAB software package, taking into account the parameters and characteristics of the existing power supply systems of MRC enterprises.

In these virtual models, control systems for active parts of FCD N 1 and N 2 are implemented. The simulation model using the example of FCD N 1 is shown in Fig.2.

The parameters of the oil field distribution network were taken as the initial data for simulation modeling [20]. A 6 kV field overhead line with a length of 3 km with a three-phase short circuit power of 250 MVA and a 6/0.4 kV borehole transformer with a power of 100 kVA were adopted as a power supply source. The non-linear load was modeled by means of a three-phase bridge uncontrolled rectifier (Larionov's circuit) with an active-inductive load with a power of 80 kVA. During the simulation, the active filter was tuned to suppress the higher harmonics of the current from numbers 2 to 40, inclusive, since according to the requirements of GOST 32144-2013, it is this range of higher harmonics that is taken into account when determining the voltage distortion level [13, 24]. Most series active filters are tuned to a certain range of higher harmonics, more expensive modifications with more complex algorithms can be tuned to suppress individual harmonics [31].

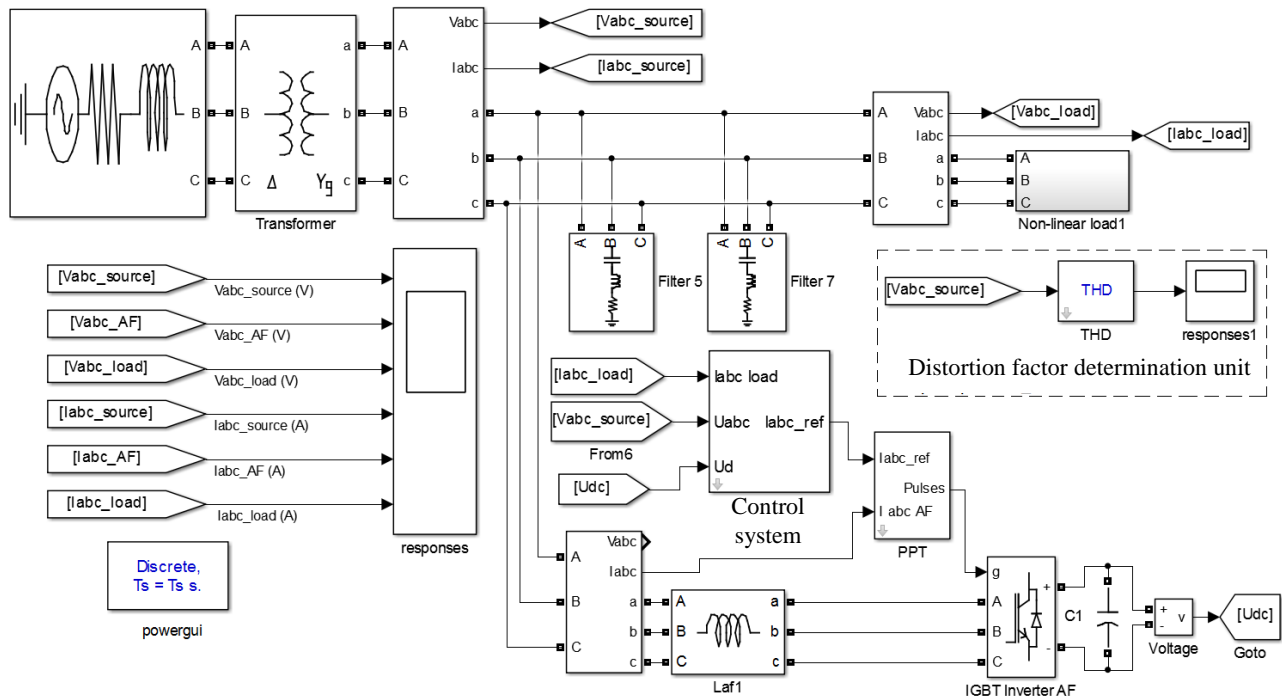

Fig.2. Simulation model of the power supply system of MRC with hybrid FCD N 1

Figure 2 shows the block for determining the distortion factor using the example of the voltage source “Vabc_grid”. For the rest of the parameters, similar blocks are used, built into the “Interface” block, where the main parameters and simulation models are set.

When developing a simulation model, the parameters of the supply network and the connected load were set in relative units, where the average values of the powers and resistances of the elements were taken as the basis. In this case, the values of the load power in the hours of maximum were taken as the basic ones. Modeling was carried out using the example of oil production plants, where the power of submersible technological electrical installations can exceed several hundreds of kW [6]. Also, during the simulation, the level of distortion of the load current was set in the range from 9 to 30 %, and the level of distortion of the grid voltage – from 2 to 15 %, which corresponds to the results of experimental studies in oil production networks [7].

According to the simulation results, the degree of reduction of the coefficients was obtained, characterizing the presence of higher harmonic components in the network before and after the application of the FCD: $\Delta THD_I - 91$, $\Delta THD_U - 72$, $\Delta K_{I5} - 96$, $\Delta K_{U5} - 75$, $\Delta K_{I7} - 97$, $\Delta K_{U7} - 68$ % (THD_I , THD_U – total harmonic components for current and voltage, respectively; K_{I5} , K_{I7} , K_{U5} , K_{U7} – coefficients of the 5th and 7th harmonic components for current and voltage, respectively). The degree of reduction using the example of THD_U and THD_I is determined as follows:

$$\Delta THD_U = \frac{THD_{U1} - THD_{U2}}{THD_{U1}} \cdot 100 \%;$$

$$\Delta THD_I = \frac{THD_{I1} - THD_{I2}}{THD_{I1}} \cdot 100 \%,$$

where THD_{U1} , THD_{I1} – coefficients before using FCD; THD_{U2} , THD_{I2} – coefficients after application of FCD.

Reduction rates for coefficients K_{I5} , K_{U5} , K_{I7} , K_{U7} are defined similarly:

$$\Delta K_{U5} = \frac{K'_{U5} - K''_{U5}}{K_{U5}} \cdot 100 \%;$$

$$\Delta K_{U7} = \frac{K'_{U7} - K''_{U7}}{K_{U7}} \cdot 100 \%;$$

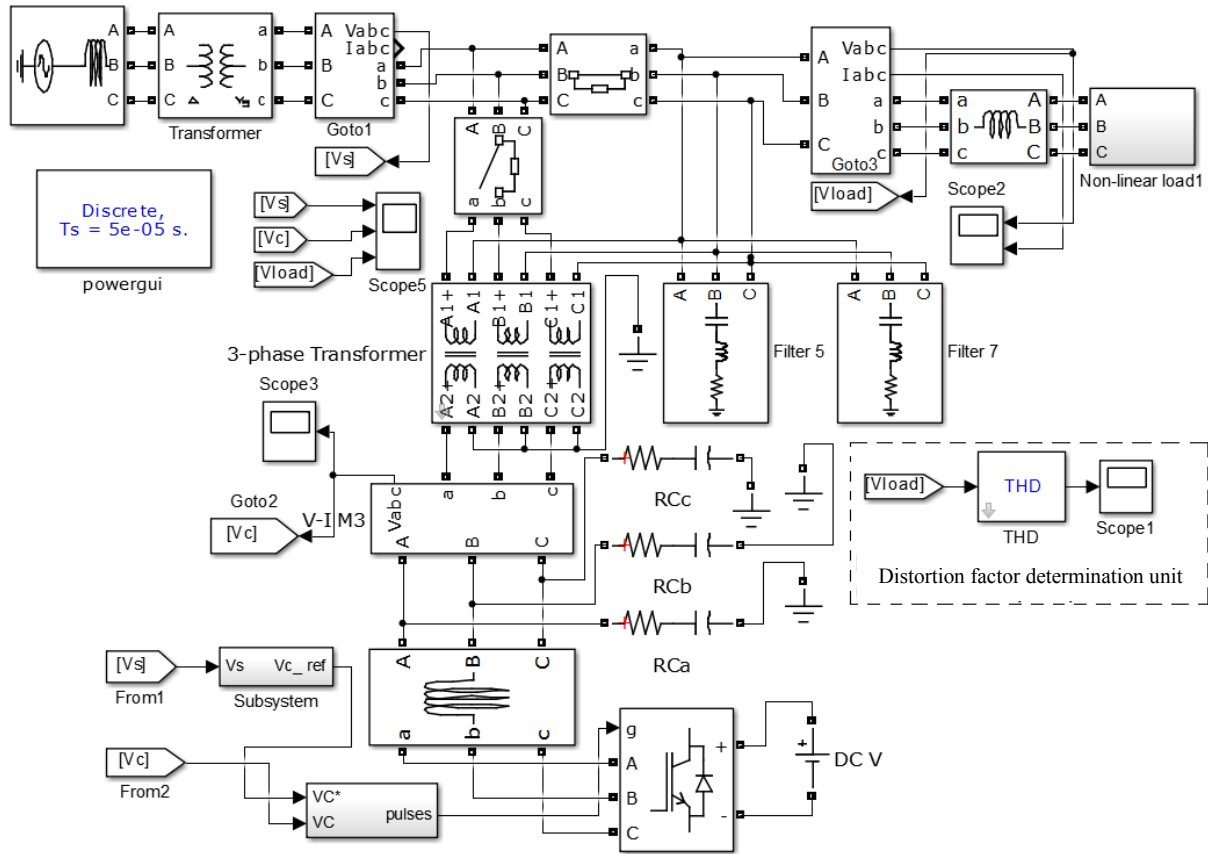

Fig.3. Simulation model of the power supply system of MRC with hybrid FCD N 2

$$\Delta K_{I5} = \frac{K'_{I5} - K''_{I5}}{K_{I5}} \cdot 100 \%;$$

$$\Delta K_{I7} = \frac{K'_{I7} - K''_{I7}}{K_{I7}} \cdot 100 \%;$$
(9)

where K'_{U5} , K'_{I5} – coefficients before using FCD; K''_{U5} , K''_{I5} – coefficients after using FCD.

Hybrid FCD N 1 with an active part of a parallel type allows compensation of the HGS current in the network and compensation of reactive power to ensure the power factor k_m close to 1 in the conditions of MRC enterprises. Energy indicators of work without FCD N 1 (with FCD N 1): $P = 0.292$ (0.293) p.u., $Q = 0.067$ (0.001) p.u., $k_m = 0.974$ (0.999).

The simulation model of the hybrid FCD N 2 is shown in Fig.3.

The control system of the series active filter as part of the hybrid FCD N 2 is implemented on the basis of transformations of a three-phase supply voltage system into direct, negative and zero sequence components (Fortescue transforms) [30, 34]. The selected components of the positive sequence of the grid voltage are reference values for compensating for dips, deviations and voltage distortions with a series active filter as part of the hybrid FCD N 2.

In the course of simulation, oscillograms of the voltage waveform in the power supply system were recorded before and after the connection of FCD N 2. Also, according to the simulation results, the degree of reduction in the level of harmonic voltage distortions was obtained: $\Delta THD_U = 85$, $\Delta K_{U5} = 96$, $\Delta K_{U7} = 96$ %. The corresponding degrees of reduction were determined similarly to FCD N 1 according to expressions (8) and (9).

Analysis of simulation results. Based on the simulation results, the ability of a hybrid FCD based on a parallel active filter to compensate the higher harmonics of current and voltage simultaneously with the power factor correction of the network was revealed. In particular, with the use of hybrid FCD N 1, the value of the total harmonic component has decreased by 93.16 % in terms of



current and by 72.14 % in terms of voltage, and the power factor has also increased by 12.35 %. This feature allows us to consider hybrid FCD N 1 as multifunctional devices and to create more complex electrical complexes and systems for the automated electricity quality improvement on their basis [29, 35]. At the same time, it was found that the use of hybrid FCD N 1 increases the amount of consumed active power by 0.4 %, which is associated with active losses in the power switches of the active part of the FCD when compensating for higher harmonics.

Based on the simulation results, it was found that hybrid FCD N 2 with a series active part is capable of creating a voltage addition to normalize the grid voltage level in case of its deviation due to load connection in long power transmission lines conditions. When simulating, the effective voltage value at the moment of connecting the load is 0.84 p.u. (the nominal value is taken as the basis), which is unacceptable according to the requirements of GOST 32144-2013. When hybrid FCD N 2 is connected, a voltage addition (ΔU) is created, the effective value is 1 p.u.:

$$\delta U = \frac{U_{\text{nom}} - U_{\text{load}}}{U_{\text{nom}}} \cdot 100 \% = \frac{1 - 0.84}{1} \cdot 100 \% = 16 \% \quad (10)$$

Hybrid FCD N 2 on the basis of a series active filter, simultaneously with the compensation of voltage dips, is able to suppress higher voltage harmonics, which also confirms the multifunctionality of the device. In this case, the level of voltage harmonics is reduced by 85 %.

Also, the presence of an active part, despite its high cost, in the form of a parallel or series active filter as part of hybrid structures, significantly increases the efficiency of current and voltage higher harmonics suppression. In particular, the presence of a parallel active filter in the structure of hybrid FCD N 1 significantly increases the efficiency of compensation for higher current harmonics (THD_I without an active part decrease from 29.09 to 14.25 %, and with an active one – to 2 %). The presence of a series active filter in the structure of hybrid FCD N 2 significantly increases the efficiency of compensation for higher voltage harmonics (THD_U without an active part decrease from 14.38 to 8.48 %, and with an active one – to 2.14 %).

Discussion. The considered structures of hybrid FCD can be used within the framework of a single electrical complex for automated improvement of the electricity quality in networks and power supply systems of various structures. [19]. Hybrid FCD based on serial and parallel active filters are capable of suppressing higher harmonics of current and voltage, correcting the power factor, compensating for voltage deviations in the conditions of MRC, where the active power of individual technological units varies from several tens to several hundreds of kW, the voltage distortion level is from 1 to 20 %, the level of current distortion is from 4 to 60 %.

On the basis of such structures, more advanced universal expansion joints can be created [32, 33] as a part of flexible AC transmission systems for the conditions of MRC enterprises. The considered hybrid structures have a variable structure, which makes it possible to use them in combined power supply systems based on the parallel operation of centralized and autonomous sources, when in case of emergency modes, the power supply mode changes, as well as when part of an irresponsible non-linear load is disconnected. The subject of further research is the analysis of the influence of indicators of power supply and power consumption modes on the efficiency level of hybrid FCD.

Conclusion. The main types of hybrid FCD based on parallel and series active filters have been identified, the use of which makes it possible to increase the level of power quality in the conditions of power supply systems of MRC enterprises in terms of key indicators, including the value of higher harmonics of voltage and current, as well as voltage deviations. A hybrid FCD based on a parallel active filter is able to compensate the reactive power of the load node, bringing the power factor closer to 1.

The simulation results showed sufficient, in accordance with the requirements of GOST 32144-2013, the efficiency of improving the electricity quality by the developed hybrid FCD, in particular, the hybrid FCD based on a series active filter reduces the level of deviation of the grid voltage by 15 % and seven times – the degree of its distortion. A hybrid FCD based on a parallel active filter can bring the power factor of the network closer to 1, reduce the level of current distortion by ten



times, and voltage distortion by four times. Combined use of active and passive filters more than doubles the efficiency of correcting the level of higher harmonics of current and voltage.

The simulation results proved the multifunctionality of the analyzed hybrid FCD and the possibility of their use in the framework of more complicated electrical complexes and systems for automated power quality improvement, in particular, in flexible alternating current transmission systems (FACTS).

REFERENCES

1. Tonkal V.E., Novosel'tsev A.V., Denisjuk S.P. et al. Energy balance in electrical circuits. Kiev: Naukova dumka, 1992, p. 312 (in Russian).
2. Gamazin S.I., Nenakhov A.I. Application of thyristor compensators in power supply systems. *Glavnyi energetik*. 2014. N 4, p. 55-58 (in Russian).
3. German-Galkin S.G., Dmitriev B.F. Investigation into spectral characteristics of multilevel semiconductor inverters. *Elektrotehnika*. 2014. N 3, p. 45-53.
4. Ershov M.S., Konkin R.N. Method of experimental determination of parameters of power supplies of industrial power supply systems. *Promyshlennaya energetika*. 2017. N 2, p. 34-39 (in Russian).
5. Kozyaruk A.E. Modern effective electric drives of production and transport mechanisms. *Elektrotehnika*. 2019. N 3, p. 33-37 (in Russian).
6. Litvinenko V.S., Dvoynikov M.V. Methodology for determining the parameters of drilling mode for directional straight sections of well using screw downhole motors. *Journal of Mining Institute*. 2020. Vol. 241, p. 105-112. DOI: 10.31897/PMI.2020.1.105
7. Abramovich B.N., Ustinov D.A., Sychev Yu.A., Shkljarskiy A.Ya. The methods of voltage dips and distortion compensation in electrical networks of oil production enterprises. *Oil Industry*. 2014. N 8, p. 110-112 (in Russian).
8. Portnyagin N.N., Yershov M.S., Barbasov P.Ju., Chernev M.Ju. Modelling influence of non-linear loading's level on quality of the electric power of electrotechnical systems. *Izvestiya vysshikh uchebnykh zavedenii. Elektromekhanika*. 2017. Vol. 60. N 1, p. 61-66. DOI: 10.17213/0136-3360-2017-1-61-66 (in Russian).
9. Pashkevich N.V., Pashkevich M.A., Petrova T.A. Management of the environmental and economic risk of the mining and metallurgical waste negative impact. *Journal of Mining Institute*. 2005. Vol 166, p. 68-70 (in Russian).
10. Pronin M.V., Vorontsov A.G. Electromechanotronic complexes and their modeling by interconnected subsystems. St. Petersburg: Ladoga, 2017, p. 220 (in Russian).
11. Rozanov Yu.K., Lapanov M.G., Kiselev M.G. Multifunctional power quality regulator based on a power electronic converter. *Elektrotehnika*. 2014. N 8, p. 51-59 (in Russian).
12. Rozanov Yu.K., Burman A.P., Shakaryan Yu.G. Managing electricity flows and improving the efficiency of power systems. Moscow: Izdatelskii dom MEI, 2012, p. 336 (in Russian).
13. Teterin N.V., Bolshunova O.M. Mathematical description of microwave contact level controller for liquid agent. *Journal of Mining Institute*. 2010. Vol 186, p. 151-158 (in Russian).
14. Khabibullin M.M., Meshcheryakov V.N. The active power filter with a common dc link and a control system based on the relay control voltage. *Instruments and Systems. Monitoring, Control, Diagnostics*. 2014. N 7, p. 26-33.
15. Shakaryan Yu.G., Fokin V.K., Likhachev A.P. Steady-State Operating Modes of Electric Power Systems with Flexible Power Transmission Network Devices. *Elektrichestvo*. 2013. N 12, p. 2-13 (in Russian).
16. Costabeber A., Tentii P., Mattavelli P. Distributed cooperative control of low-voltage residential microgrids. 3rd IEEE International Symposium on Power Electronics for Distributed Generation Systems (PEDG), 25-28 June, 2012, Aalborg, Denmark, 2012, p. 457-463. DOI: 10.1109/PEDG.2012.6254042
17. Gridina E.B., Kovshov S.V., Antonenko T.I., Miroshnichenko A.K. Development of fire safety measures aimed at preventing and responding to spontaneous combustion in brown coal mines. *Naukovyi Visnyk Natsionalnoho Hirnychoho Universytetu*. 2020. N 6, p. 96-101. DOI: 10.33271/nvngu/2020-6/096
18. Fediuk R.S., Stoyushko N.Y., Yevdokimova Y.G. et al. Device for limiting single phase ground fault of mining machines. *IOP Conference Series: Earth and Environmental Science*. 2017. Vol. 87. Iss. 3, p. 032009. DOI:10.1088/1755-1315/87/3/032009
19. Gulkov Y.V., Turyshcheva A.V., Kopteva A.V. Research of grounding systems of electrical complexes in the conditions of permafrost soils. Proceedings of the 2019 IEEE Conference of Russian Young Researchers in Electrical and Electronic Engineering (El-ConRus), 28-31 January, 2019, St. Petersburg and Moscow, Russia, 2019, p. 969-972. DOI: 0.1109/EIConRus.2019.8657119
20. Kovalchuk M.S., Poddubniy D.A. Ensuring the Reliable Operation of the Pumping Units by Efficient State Diagnosis. All-Russian research-to-practice conference "Ecology and safety in the technosphere: current problems and solutions" (EST 2018), 22-24 November, 2018, Yurga, Russia, 2019. Vol. 224. Iss. 1, p. 012032. DOI: 10.1088/1755-1315/224/1/012032
21. Litran S.P. Comparative Analysis of Compensation Strategies for Series APF Based on the Electric Power Dual Formulation. Proceedings of the 11th IEEE International Conference on Compatibility, Power Electronics and Power Engineering (CPE-POWERENG), 4-6 April, 2017, Cadiz, Spain, 2017, p. 199-204. DOI: 10.1109/CPE.2017.7915169
22. Litran S.P., Salmeron P. Design Criteria of a Control Strategy for Hybrid Power Filters Based on Current and Voltage Detection. *International Transactions on Electrical Energy Systems*. 2015. Vol. 25. Iss. 3, p. 419-432. DOI: 10.1002/etep.1850
23. Litran S.P., Salmeron P. Electromagnetic Compatibility Analysis of a Control Strategy for a Hybrid Active Filter. *Electric Power Systems Research*. 2017. Vol. 144, p. 81-88. DOI: 10.1016/j.epsr.2016.11.014
24. Pai F., Tseng P., Huang J. Design of a dynamic voltage restorer with cascade inverter. Proceedings of the 2016 IEEE International Conference on Power and Renewable Energy (ICPRE), 21-23 October, 2016, Shanghai, China, 2016, p. 172-176. DOI: 10.1109/ICPRE.2016.7871195



25. Pashkevich M.A., Petrova T.A. Development of an operational environmental monitoring system for hazardous industrial facilities of Gazprom Dobycha Urengoy. *Journal of Physics: Conference Series*, 14-17 May, 2019, St. Petersburg, Russia, 2019. Vol. 1384. N 1, p. 012040.
26. Tenti P., Spiazzi G., Buso S. et al. Power supply distribution system for calorimeters at the LHC beyond the nominal luminosity. *Journal of Instrumentation*. 2011. Vol. 6, p. 1-17. DOI: 10.1088/1748-0221/6/06/P06005
27. Revuelta P.S., Litran S. P., Thomas J.P. Active Power Line Conditioners: Design, Simulation and Implementation for Improving Power Quality. Amsterdam: Elsevier, 2016, p. 420.
28. Serzhan S.L., Trufanova I.S., Malevannyi D.V. Substantiation of the Draghead Application as a Mining Unit in Conditions of Solid Minerals Deep-Sea Mining. *IOP Conference Series: Earth and Environmental Science*. 2019. Vol. 272. Iss. 2, p. 1-6. DOI: 10.1088/1755-1315/272/2/022048
29. Skamyin A.N., Kovalchuk M.S. Energy efficiency improving of reactive power compensation devices. Proceedings of the 2018 IEEE Conference of Russian Young Researchers in Electrical and Electronic Engineering (EIConRus), 29 January – 1 February, 2018, Moscow, Russia, 2018, p. 780-783. DOI: 10.1109/EIConRus.2018.8317207
30. Thomas J.P. Assessment on Apparent Power Indices with Hybrid Active Power Filters. Proceedings of the 11th IEEE International Conference on Compatibility, Power Electronics and Power Engineering (CPE-POWERENG), 4-6 April, 2017, Cadiz, Spain, 2017, p. 181-186. DOI: 10.1109/CPE.2017.7915166
31. Thomas J.P. Practical Evaluation of Unbalance and Harmonic Distortion in Power Conditioning. *Electric Power Systems Research*. 2016. Vol. 141, p. 487-499. DOI: 10.1016/j.epsr.2016.08.012
32. Ustinov D. A Increase of Dynamic Stability of Alternating Current Electric Drives at Short-Term Violations of Oilfield Power Supply. Proceedings of the 12th International Scientific and Technical Conference “Dynamics of Systems, Mechanisms and Machines” (Dynamics), 13-15 November, 2018, Omsk, Russia, 2018, p. 1-5. DOI: 10.1109/Dynamics.2018.8601457
33. Valles A.P., Revuelta P.S. A New Distributed Measurement Index for the Identification of Harmonic Distortion and/or Unbalance Sources Based on the IEEE Std. 1459 Framework. *Electric Power Systems Research*. 2019. Vol. 172, p. 96-104. DOI: 10.1016/j.epsr.2019.03.007
34. Xu X. Novel current-tracking control for hybrid active power filter with injection circuit and its engineering application. Proceedings of the 2016 IEEE International Conference on Power and Renewable Energy (ICPRE), 21-23 October, 2016, Shanghai, China, 2016, p. 269-274. DOI: 10.1109/ICPRE.2016.7871214
35. Zagrivnyi E.A., Malarev V.I., Kopteva A.V. Studying the operating mode of the down-hole electrode heater for the production of high-viscosity oil. Proceedings of the 2019 IEEE Conference of Russian Young Researchers in Electrical and Electronic Engineering (EIConRus), 28-31 January, 2019, St. Petersburg and Moscow, Russia, 2019, p. 1110-1113. DOI: 10.1109/EIConRus.2019.8656868

Authors: **Yurii A. Sychev**, Candidate of Engineering Sciences, Associate Professor, sychev_yua@pers.spmi.ru, <https://orcid.org/0000-0003-0119-505X> (Saint Petersburg Mining University, Saint Petersburg, Russia), **Roman Yu. Zimin**, Post-graduate Student, zimin_ryu@pers.spmi.ru, <https://orcid.org/0000-0002-0498-8904> (Saint Petersburg Mining University, Saint Petersburg, Russia).

The authors declare no conflict of interests.

The paper was received on 20 January, 2021.

The paper was accepted for publication on 1 February, 2021.