

# LINEAR QUADRATIC REGULATOR (LQR) CONTROLLER DESIGN FOR DC SERVO MOTOR

HARTINI SHARNINAYATI BINTI HARON

A project report submitted in  
fulfillment of the requirement for the award of the  
Master of Electrical Engineering

Faculty of Electrical and Electronic Engineering  
Universiti Tun Hussein Onn Malaysia

JULY 2013

## **ABSTRACT**

This project is focused mainly on designing and implementing Linear Quadratic Regulator (LQR) controller and PID controller for a Dc servo motor. The PID and LQR controller are used to control the speed and position of the Dc servo motor, with a specified performance requirement. To ensure that the controller satisfies the requirement, simulation using MATLAB/Simulink software will be performed to obtain the optimum PID and LQR controller parameters. The obtained parameters are then used to implement LQR controller to the real Dc servo motor. The performance of the LQR controller will then be compared with that of PID controller.

## ABSTRAK

Projek ini memfokuskan kepada merekabentuk dan mengaplikasikan pengawal kawalan kuadratik Linear (LQR) dan pengawal PID untuk servo motor arus terus. Pengawal PID dan pengawal LQR digunakan untuk mengawal kelajuan dan kedudukan servo motor arus terus, dengan spesifikasi yang ditetapkan. Untuk memastikan bahawa pengawal itu memenuhi spesifikasi yang telah ditetapkan, simulasi menggunakan perisian MATLAB / Simulink akan dilaksanakan untuk mendapat parameter pengawal PID dan pengawal LQR yang optimum. Parameter yang diperolehi akan diaplikasikan bersama pengawal LQR untuk servo motor arus terus yang sebenar. Prestasi pengawal LQR kemudian akan dibandingkan dengan pengawal PID.

## CONTENTS

CHAPTER	TITLE	PAGE
	<b>TITLE</b>	<b>i</b>
	<b>DECLARATION</b>	<b>ii</b>
	<b>DEDICATION</b>	<b>iii</b>
	<b>ACKNOWLEDGEMENT</b>	<b>iv</b>
	<b>ABSTRACK</b>	<b>v</b>
	<b>ABSTRAK</b>	<b>vi</b>
	<b>CONTENTS</b>	<b>vii</b>
	<b>LIST OF TABLES</b>	<b>xi</b>
	<b>LIST OF FIGURES</b>	<b>xii</b>
	<b>LIST OF SYMBOLS</b>	<b>xv</b>
	<b>LIST OF APPENDICES</b>	<b>xvii</b>
<b>CHAPTER 1</b>	<b>INTRODUCTION</b>	
1.1	Overview	1
1.2	Problem Statement	3
1.3	Objectives	3
1.4	Scope Of Project	4
1.5	Summaries Chapter	4
<b>CHAPTER 2</b>	<b>LITERATURE REVIEW</b>	
2.1	Introduction	6
2.2	Dc Servo Motor	7
2.3	PID Controller	8
	2.3.1 Proportional Gain $K_p$	9
	2.3.2 Integral Gain $K_i$	9

2.3.3	Derivative Gain $K_d$	10
2.4	Introduction Of Linear Quadratic Regulator	10
2.5	Hardware Description	11
2.5.1	Microcontroller (Arduino)	12
2.5.2	Motor(ID23005)	13
2.5.3	3 Channel Encoder	14
2.5.4	Two Channel Optical Encoder	15
2.5.5	IC L298(Motor Driver)	16
2.6	Previous Case Study	18
2.6.1	Linear Quadratic Regulator(LQR) Speed Control For DC Motor Using MC68HC11	18
2.6.2	Optimal PID Speed Control Of Brushless DC Motor Using LQR Approach	19
2.6.3	DC Motor Controller Using Linear Quadratic Regulator (LQR) Algorithm Implementation On PIC	20
2.6.4	PID Controller Design For Controlling DC Motor Speed Using MATLAB Application	21
2.6.5	Hydropter Modeling And Control	21
2.6.6	A Novel Method on Selection of Q and R Matrices In the Theory Of Optimal Control	22
2.6.7	MATLAB Based Real Time Control Implementation Of DC Servo Motor Using PCI Card	22
2.7	Conclusion	23
<b>CHAPTER 3</b>	<b>METHODOLOGY</b>	
3.1	System Overview	24

3.2	Flowchart PID Controller Design For Dc Servo Motor	25
3.3	Flow Chart LQR Controller Design For Dc Servo Motor	27
3.4	Mathematical Model (Dc Servo Motor)	28
3.5	Transfer Function	30
3.6	State Space	32
3.7	Block Diagram	36
3.8	PID controller Design	37
	3.8.1 Manual Tuning	38
	3.8.2 Setting PID Parameter Using Simulink	38
3.9	LQR Controller Design	39
	3.9.1 Setting Of LQR Control Parameter	41
3.10	Speed Control Of Dc Servo Motor By PID Of LQR Controller Using Arduino	42
3.11	Position Control Of Dc Servo Motor By PID Of LQR Controller Using Arduino	43
3.12	Conclusion	43
<b>CHAPTER 4</b>	<b>RESULT AND ANALYSIS</b>	
4.1	Introduction	45
4.2	Design Requirement	46
4.3	Position Of Dc servo Motor	46
	4.3.1 Open Loop System	46
	4.3.2 PID Controller	48
	4.3.3 LQR Controller	51
	4.3.4 Comparison PID Controller and LQR Controller	53
4.4	Speed Of Dc Servo Motor	55
	4.4.1 Open Loop System	58
	4.4.2 PID Controller	56
	4.4.3 LQR Controller	60

4.4.4	Comparison PID Controller and LQR Controller	62
4.5	Result From Hardware	64
4.5.1	Determine Relationship of Voltage Supply and Motor Speed	64
4.5.2	Relationship Between Times and Position	67
4.5.3	Output Response From Encoder	67
4.5.4	Output Response Motor Forward and Reverse	69
4.6	Conclusion	70
<b>CHAPTER 5</b>	<b>CONCLUSION AND RECOMMENDATION</b>	
5.1	Conclusion	72
5.2	Recommendation and Future Work	72
5.2.1	Mathematical Modeling of Motor Response	73
5.2.2	Hardware Improvement	73
5.2.3	Software Improvement	73
	<b>REFERENCES</b>	74
	<b>APPENDICES</b>	76

**LIST OF TABLES**

3.1	Effect of Increase a Parameter Independently	38
4.1	Comparison Output Response of Position Dc Servo Motor	54
4.2	Comparison Output Response of Speed Dc Servo Motor	63
4.3	Relationship of Voltage Supply and Motor Speed	65



## LIST OF FIGURE

2.1	Block Diagram PID Controller	8
2.2	LQR Block Diagram	10
2.3	Arduino Mega 2560	12
2.4	Motor ( ID 23005 )	13
2.5	3 Channel encoder	14
2.6	Two Channel Optical Encoder	15
2.7	IC L298	16
2.8	Pin Connection for L298	17
2.9	Linear Axis Model	18
3.1	Flow Chart PID Controller Design For Dc Servo Motor	25
3.2	Flow Chart LQR Controller Design For Dc Servo Motor	27
3.3	Schematic Diagram Of Dc Servo Motor	28
3.4	Block Diagram an Armature Controller of Position Dc Servo Motor	31
3.5	Block Diagram of an Armature Controller of Speed Dc Servo Motor	32
3.6	Block Diagram PID Controller For Control Speed and Position Dc Servo Motor	36
3.7	Block Diagram LQR Controller For Control Speed and Position Dc Servo Motor	37
3.8	Block Diagram of PID Controller with Dc Servo Motor System	39

3.9	Optimal feedback controller (LQR)	40
3.10	Functional Block diagram of Closed Loop Speed Control System of Dc Servo Motor	42
3.11	Functional Block diagram of Closed Loop Position Control System of Dc Servo Motor	43
3.12	Implement with Hardware	44
4.1	Open Loop System for Position Dc servo motor	47
4.2	Response for Open Loop system	47
4.3	Pole Zero Map For Open Loop Position Dc servo Motor	48
4.4	PID Controller for Position Dc Servo Motor	49
4.5	Output Response PID Controller	49
4.6	Pole Zero Map For PID Controller	50
4.7	LQR Controller for Position Dc Servo motor	51
4.8	Output Response for LQR Controller	52
4.9	Pole Zero Map For LQR Controller Position Dc servo Motor	53
4.10	Comparison Output Response for Position Dc Servo Motor.	55
4.11	Open loop System for Speed Dc Servo Motor	56
4.12	Open Loop Response for Speed Dc Servo Motor	57
4.13	Pole Zero map For Open Loop Speed Dc Servo Motor	58
4.14	PID Controller for Speed Dc Servo Motor	58
4.15	Output Response for PID Controller	59
4.16	Pole Zero Map For PID Controller Speed Dc Servo Motor	60
4.17	LQR Controller For Speed Dc Servo Motor	61
4.18	Output Response for LQR Controller	61
4.19	Pole Zero Map for LQR Controller Speed Dc Servo Motor	62
4.20	Comparison Output Response PID Controller and LQR Controller	64

4.21	Determine Speed of Dc Servo Motor	65
4.22	Graph Speed Versus Voltage Supply	66
4.23	Open Loop Response for Position	67
4.24	Output From Motor Encoder	68
4.25	Output From Motor Encoder	68
4.26	Output Response when Motor Forward	69
4.27	Output Response When Motor Reverse	69

**LIST OF SYMBOLS**

<b>Symbol</b>	<b>Description</b>
PID	Proportional Integral Derivative Controller
LQR	Linear Quadratic Regulator Controller
Dc	Direct Current
$R_a$	Armature resistance
$L_a$	Armature inductance
$V_a(t)$	Supply voltage
$I_a(t)$	Motor current
$\omega_m(t)$	Angular Velocity
$\theta_m(t)$	Output position
$e_b(t)$	Back emf
$T(t)$	Motor output torque
$J_m$	Motor inertia
B	Viscous friction coefficient
$K_T$	Torque constant
$K_B$	Voltage constant
$K_p$	Proportional gain

$K_i$	Integral gain
$K_d$	Derivative gain
$T_p$	Peak time
$T_r$	Rise time
$T_s$	Settling time
Os%	Percentage of overshoot
$e_{ss}$	Steady state error

**LIST OF APPENDICES**

<b>APPENDIX</b>	<b>TITLE</b>	<b>PAGE</b>
A	MATLAB (m file) for speed of Dc servo motor	76
B	MATLAB (m file) for position of Dc servo motor	78
C	Coding ( test encoder )	80
D	Coding ( forward and reverse motor )	82
E	Code ( Open Loop Position)	83
F	Coding ( PID Position )	86
G	Coding ( PID Speed )	90
H	Gantt chart for Master Project 1 (PS 1)	96
I	Gantt chart for Master Project 2 (PS 2)	97

## **CHAPTER 1**

### **INTRODUCTION**

This chapter will focus on the brief introduction of the project to be carried out. The important overview or description including the problem statement, project objectives, project scopes and expected result are well emphasized in this part.

#### **1.1 Overview**

In industries, the application of a motor control system is important to operation of some process. Dc servo motor systems are also widely used in various fields of technology. They are used in power plants to generate electrical power and in industrial occupancies to furnish the required mechanical motive power to drive mechanical machinery and control various industrial processes. Ranging from robotics manipulators to the disk drive of a computer, Dc servo motor acts as one of the vital part. For both applications, the position control of the motor is the major part to be given attention. Efforts made on controlling the position of Dc servo motor result in so many types of the control scheme for the mentioned purpose. For instance, there is micro controller-based control, PC based control, adaptive control, optimal control, etc. Some of these control schemes will

be explained and discussed briefly in this study an average home in Malaysia uses a dozen or more electric motors. In some application the Dc servo motor required to maintain its desired speed when load is applied or disturbance occur. This kind of system can be controlled using PID, Fuzzy, LQR and other more.

The PID algorithm that is added to the motor becomes a closed loop system. The system is implemented using MATLAB software and PID algorithm is tuned by changing the value of Proportional gain,  $K_p$ , Integral gain,  $K_i$  and Derivative gain,  $K_d$  to get a speed and position of the motor which is less overshoot increase settling time and increase rise time.

Linear Quadratic Regulator (LQR) controller is introduced in order to control the Dc servo motor speed and position. MATLAB/Simulink is used to design and tune the LQR controller and be simulated to mathematical model of the Dc servo motor.

The Linear Quadratic Regulator (LQR) controller is a new method of controlling the motor. Linear Quadratic Regulator (LQR) is theory of optimal control concerned with operating a dynamic system at minimum cost. The function of Linear Quadratic Regulator (LQR) is to minimize the deviation of the speed and position of the motor. The speed of the motor is specifying that will be the input voltage of the motor and the output will be compare with the input.

The advantages of used LQR are it is easy to design and increases the accuracy of the state variables by estimating the state. The nice feature of the LQR control as compared to pole placement is that instead of having to specify where a eigenvalues should be placed a set of performance weighting are specified that could have more intuitive appeal. The result is a control that is guaranteed to be stable.



## 1.2 Problem Statement

The PID controller, which has proportional, integral and derivative elements, is widely applied in feedback control of industrial processes. These controllers are described with their simple structure and principle. PID controllers also provide good performance for various systems. However, PID method in many cases such as parameter variations or disturbances is not appropriate. In order to overcome some problems that faced by PID controller, the other type of control methods can be developed such as Linear-Quadratic Regulator (LQR) optimal control. LQR is a control scheme that gives the best possible performance with respect to some given measure of performance. The performance measure is a quadratic function composed of state vector and control input.

The problem encounter when dealing with Dc servo motor is the lag of efficiency and losses. In order to eliminate this problem, controller is introduced to the system. There's few types of controller but in this project, LQR controller is chosen as the controller for the Dc servo motor. The problem encounter when dealing with servo motor is the lag of efficiency and losses. In order to eliminate this problem, controller is introduced to the system. There's few types of controller but in this project, LQR controller is chosen as the controller for the Dc servo motor. This is because LQR controller helps get the output, where decrease settling time and rise time, minimal overshoot and little error.

## 1.3 Objective

The objectives of this project are:

- i. To design LQR Controller and PID controller for Dc servo motor.
- ii. To control speed and position of motor using LQR controller and PID controller.
- iii. To compare the result between PID and LQR controllers.

## **1.4 Scope of Project**

The main scope of this project is to build a controller system for Dc servo motor.

- i. Design and produce the simulation of the LQR controller.
- ii. Implement LQR ( Linear Quadratic Regulator ) controller to actual Dc servo motor.
- iii. Compare simulation result of PID and LQR controller with the actual Dc servo motor

## **1.5 Summaries Chapter**

This report is discussed in five main chapters. The contents of each chapter are explained as the state below.

In Chapter 1, a background and introduction of the project report. Problem statement, Objective, and scope of project are also included in this chapter.

In Chapter 2, the theory and literature study is focused on preparation of the project. The topic which further discussed in this chapter is a Dc servo motor system. Besides that, the several of control approaches such as PID, LQR controller as propose controller are also discussed. Lastly, the components are used in this project and previous study related to this project are also discussed.

In Chapter 3, the mathematical modeling of DC servo motor is discussed. It can be represent in state space equation and transfer function. The principle and physical criteria also has been study in detail. The design requirement of the Dc servo motor system is set to design the controller. The PID control method is discussed to control the Dc servo motor system for speed and position motor. The parameter of PID is tune using Simulink block and MATLAB programming is used to get the suitable gain  $K_p$ ,  $K_i$  and  $K_d$ . The LQR control method is discussed to control the Dc servo motor for speed and

position motor. The effect of optimal control depends on the selection of weighting matrices  $Q$  and  $R$ .

In Chapter 4 display the result of the open loop system for the Dc servo motor system and the result of closed loop system with PID, LQR and propose controller. The comparison among these two controllers also presented in this chapter. This chapter is also discussed result when implemented controller with hardware.

In Chapter 5, the overall discussion and conclusion of the project are made. A few commendations also have been included for the future work.

## **CHAPTER 2**

### **LITERATURE REVIEW**

#### **2.1 Introduction**

This chapter discussed about Dc servo motor, controller and previous case study. The important studies which have been done previously by other research works. Literature review was an ongoing process throughout the whole process of the project. It is very essential to refer to the variety of sources in order to gain more knowledge and skills to complete this project. These sources include reference books, thesis, and journals.

## 2.2 Dc Servo Motor

A Dc servo motor is a device that converts direct current electrical energy into rotational mechanical energy through the interaction of two magnetic fields to move the load. The principle operation of a Dc servo motor consists of magnetic field and electrical field that interact with each other to produce a mechanical force. A Dc servo motor is an automatic device that uses error sensing feedback to correct the performance of a mechanism. The term correctly applies only to the systems where the feedback or error correction signals help to control mechanical position and speed or other parameters.

A common type of Dc servo motor provides position and speed control. Dc servos motor commonly electrical or partially electronic in nature, using an electric motor as the primary means of creating mechanical force. Usually, Dc servos motor operated on the principle of negative feedback, where the control input is compared to the actual position or speed of the mechanical system as measured by some sort of transducer at the output. Any difference between the actual and wanted values (error signal) is amplified and used to drive the system in the direction necessary to reduce or eliminate the error.

Today, Dc servo motor used in automatic machine tools, satellite tracking antennas, remote control airplanes, automatic navigation systems on boats and planes, and anti-aircraft gun control systems.

The Dc servo motor is paired with some type of encoder to provide position and speed feedback. In the simplest case, only the position is measured. The measured position of the output is compared to the command position, the external input to the controller. If the output position differs from that required, an error signal is generated which then causes the motor to rotate in either direction, as needed to bring the output shaft to the appropriate position. As the positions approach, the error signal reduces to zero and the motor stops.

More sophisticated Dc servo motors measure both the position and also the speed of the output shaft. They may also control the speed of their motor, rather than always running at full speed. Both of these enhancements, usually in combination

with a PID control algorithm, allow the Dc servo motor to be brought to its commanded position more quickly and more precisely, with less overshooting.

The Dc servo motors were developed with synchros as their encoders[2]. Encoder at Dc servo motor would be possible to electrically differentiate their position or speed signal to obtain actual speed or position signal, PID and LQR controllers that can make use of such a speed signal generally warrant a more precise encoder..

### 2.3 PID Controller

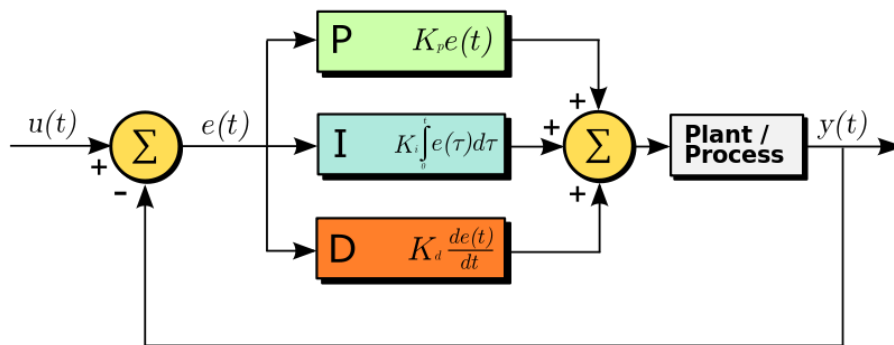

Figure 2.1: Block Diagram PID Controller

PID Control (proportional-integral-derivative) is by far the widest type of automatic control used in industry. Even though it has a relatively simple algorithm/structure, there are many subtle variations in how it is applied in industry. A proportional–integral–derivative controller (PID controller) is a generic control loop feedback mechanism widely used in industrial control systems. A PID controller will correct the error between the output and the desired input or set point by calculating and give an output of correction that will adjust the process accordingly. A PID controller has the general form

$$u(t) = K_p e(t) + K_i \int_0^t e(\tau) d\tau + K_d \frac{de}{dt} \quad (2.1)$$

where

$K_p$ : Proportional gain, a tuning parameter

$K_i$ : Integral gain, a tuning parameter

$K_d$ : Derivative gain, a tuning parameter

$e$ : Error = SP - PV

$t$ : Time or instantaneous time (the present)

$\tau$ : Variable of integration; takes on values from time 0 to the present  $t$ .

The PID controller calculation (algorithm) involves three separate parameters the Proportional, the Integral and Derivative values. The Proportional value determines the reaction to the current error, the Integral determines the reaction based upon the sum of recent errors and the Derivative determines the reaction to the rate at which the error has been changing. The weighted sum of these three actions is used to adjust the process via a control element such as the position of a control valve, the power supply of a heating element or DC servo motor speed and position.

### 2.3.1 Proportional Gain, $K_p$

Greater values typically mean faster response since the greater the error, the larger the proportional term compensation. An excessively large proportional gain will lead to process instability and oscillation.[1]

### 2.3.2 Integral Gain, $K_i$

Larger values imply steady state errors are eliminated more quickly. The trade-off is larger overshoot: any negative error integrated during transient response must be integrated away by positive error before we reach steady state.[1]

### 2.3.3 Derivative Gain, $K_d$

Larger values decrease overshoot, but slows down transient response and may lead to instability due to signal noise amplification in the differentiation of the error.[1]

## 2.4 Introduction of Linear Quadratic Regulator

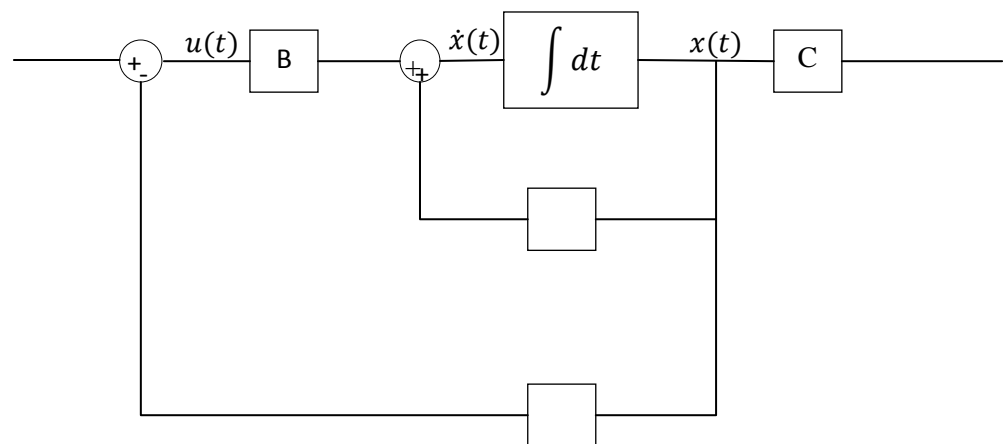

Figure 2.2 : LQR Block Diagram

Linear quadratic regulator or LQR is commonly used technique to find the state feedback gain for a closed loop system[20]. This is the optimal regulator, by which the open-loop poles can be relocated to get a stable system with optimal control and minimum cost for given weighting matrices of the cost function. On the other hand, by using the optimal regulator technique, that freedom of choice is lost for both discrete-time and continuous-time systems, because, in order to get a positive-definite Riccati equation solution, there are some areas where the poles cannot be assigned.

In this project, LQR is proposed to control the speed and position of the Dc servo motor. Where, the settings of a (regulating) controller governing either a machine or process are found by using a mathematical algorithm that minimizes a



cost function with weighting factors supplied by a human (engineer) in Layman's terms. The cost (function) is often defined as a sum of the deviations of key measurements from their desired values.

The advantage of LQR is can give better performances of the system by controlling the motor speed and position. Often the magnitude of the control action itself is included in this sum so as to keep the energy expended by the control action itself limited. The LQR algorithm is, at its core, just an automated way of finding an appropriate state-feedback controller

A description of the linear Quadratic Regulator ( LQR ) system considered in this work is show in equation (2.2)

$$A^T.P+PA-PBR^{-1}B^T.P+Q=0 \quad [12] \quad (2.2)$$

This equation is called the Algebraic Ricatti Equation (ARE). For a symmetric positive-definite matrix P. The regulator gain K is given by:

$$K=T^{-1}(T.)^{-1}B.P=R^{-1}B^T.P \quad (2.3)$$

Where the cost function is

$$J= \int x(t)^T Qx(t)+u(t)^T Ru(t)dt \quad (2.3)$$

## 2.5 Hardware Description

This part discuss hardware used for this project, example microcontroller( Arduino), motor driver(L298), Dc servo motor(ID23005), and encoder.

### 2.5.1 Microcontroller (Arduino)



Figure 2.3: Arduino Mega 2560

In this project, Arduino Mega 2560 board is used. It is having Atmega 2560 microcontroller of Atmel Corporation. Programming in a project is done in c and c++ language by using Arduino libraries. Arduino is microcontroller board with a universal serial bus (USB) plug to connect to computer and number Of connection sockets that wired to external electronics such motor, relay, light sensor, microphone and others.[14]. This is specification for Arduino Mega 2560.

Microcontroller	: ATmega2560
Operating Voltage	: 5V
Input Voltage (recommended)	: 7-12V
Input Voltage (limits)	: 6-20V
Digital I/O Pins	: 54 (of which 14 provide PWM output)
Analog Input Pins	: 16
DC Current per I/O Pin	: 40 mA
DC Current for 3.3V Pin	: 50 mA

Flash Memory	: 256 KB of which 8 KB used by bootloader
SRAM	: 8 KB
EEPROM	: 4 KB
Clock Speed	: 16 MHz

### 2.5.2 Motor ( ID23005)



Figure 2.4 : Motor (ID23005)

The ID23005 series are ideal motors for applications using a simple Dc brush drive for cost sensitive applications. In addition, the higher inertia armatures provide improved motor to load inertia matching for medium to high inertia loads. This motor used for this project for control speed and position. Combination motor, motor encoder and rail encoder created Linear Axis Motor. Below are specifications for this motor.

Continuous Stall Torque	: 0.402 Nm
Peak Stall Torque	: 2.825 Nm
No Load Max. Speed	: 6000 RPM

Continuous Rated Torque	: 0.360Nm
Peak Rated Torque	: 0.72 Nm
Rated Speed	: 3400 RPM
Rated Power	: 128Watts /0.17HP
Inductance	: 6.40 mH
Resistance	: 2.23 ohms
Max. Terminal Voltage	: 60 Vdc
Torque Constant	: 0.121 Nm/A
Voltage Constant	: 0.121 V/rad/sec
Motor Inertia	: 0.00006286 Kg-m <sup>2</sup>
Motor Weight	: 1.588Kg

### 2.5.3 3Channel Encoder



Figure 2.5 : 3 Channel Encoder

While the velocity can be determined from position measurements, encoders are able to provide a separate output which is proportional to the velocity. Encoders are widely used as position transducers in robotics and machine tools. Generally, they

are divided into two types: absolute and incremental and each of these forms consists of three elements: optical receiver, a light source and code wheel. 3 channel encoder have 3 output channel A,B and Z. The encoder used for differential line drivers. This encoder received power requirement until 125mA/5VDC and maximum operating frequency is 500KHz.

#### 2.5.4 Two Channel Optical Encoders

While the velocity can be determined from position measurements, encoders are able to provide a separate output which is proportional to the velocity[18]. Encoders are widely used as position transducers in robotics and machine tools. Two channel optical encoder is a rail encoder. The encoder connected with motor. These encoders may be quickly and easily mounted in a motor.



Figure 2.6 : Two Channel Optical Encoder

Features of two channel optical encoder:

- Two Channel Quadrature Output with Optional Index Pulse
- Quick and Easy Assembly
- No Signal Adjustment Required
- External Mounting Ears Available
- Low Cost
- Resolutions Up to 1024 Counts Per Revolution

- Small Size
- -40°C to 100°C Operating Temperature
- TTL Compatible
- Single 5 V Supply

### 2.5.5 IC L298 (Motor Driver)

This is a dual bidirectional motor driver. It is a high voltage, high current dual full-bridge driver designed to accept standard TTL logic levels and drive inductive loads such as relays, solenoids, Dc motor and stepping motors. Two enable inputs are provided to enable or disable the device independently of the input signals. The emitters of the lower transistors of each bridge are connected together and the corresponding external terminal can be used for the connection of an external sensing resistor. An additional supply input is provided so that the logic works at a lower voltage.

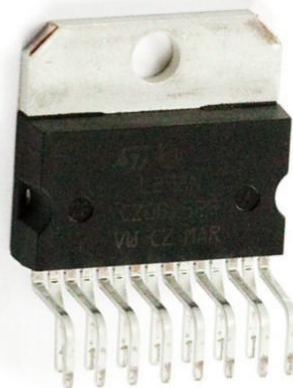

Figure 2.7 :IC L298

Speciation of IC L298:

- Operating supply voltage up to 46V
- Total Dc current up to 4A
- Low saturation voltage.
- Over temperature protection
- Logical "0" input voltage up to 1.5 V (High noise humidity)

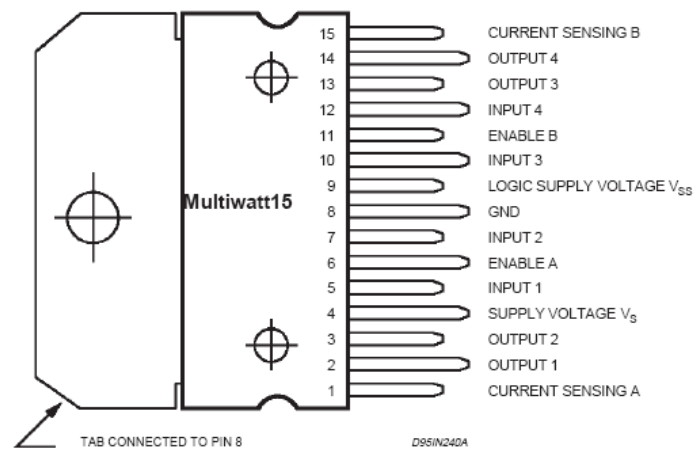

Figure 2.8 : Pin Connection For L298



Figure 2.9 : Linear Axis Model

Figure 2.9 show model linear axis. The Linear Axis positioning system includes a Dc brush servo motor (ID23005), a belt mechanism, and two optical encoders (one on the motor and the other on the travel cart)[15]. This model is used for this project to measured speed and position of motor.

## 2.6 Previous Case Study

There are a lot of researchers done similar with this project, mostly by foreign manufacturers, university and colleges.

2.6.1 Title : Linear Quadratic Regulator(LQR) Speed Control For DC Motor Using MC68HC11

Author : Che Ku Mohd Faizul Bin Che Ku Mohd Salleh [3]  
(Universiti Malaysia Pahang,)



This project is a contribution to developed Linear Quadratic regulator (LQR) speed control for DC motor using MC68HC11. The performance measure is a quadratic function composed of state vector and control input. Based on LQR control law (linear time invariant system) will be obtained via solving the algebraic Riccati equation. The system is applied for the speed control of servo motor. To measure the performance have to be minimized contains output error signal and differential control energy. The LQR controller doesn't need to feedback full state just the controller received signal error only. Matrix Q can be determined from the roots of the characteristic equation. When the poles for the closed loop system are assigned, the existences of LQR controller are derived. At the DC motor control system, the feedback information on the motor can provide error detector signal. The control loops and to improve the reliability fault condition that may damage the motor based on comparator. The scopes of this project are to choose the optimal value feedback gain on the order grab the stable system and to describe how a MC68HC11 can be used to implement a speed Linear Quadratic Regulator feedback control in the unstable system. The project used G340 servo driver, the driver is a monolithic DC servo motor controller proved all active functions necessary for a complete closed loop system. To developed this system used MATLAB software, C programming and WP11 software window.

## 2.6.2 Title : Optimal PID Speed Control Of Brushless DC Motors Using LQR Approach

Author : Gwo-Ruey yu, Rey-Chue Hwang[4] (I-shou University, Taiwan)

This journal is developing Optimal positioning control of a DC servo motor using sliding mode. The journal discusses methodology that is applied to control the position of a DC servo motor. The Linear Quadratic Regulator (LQR) and the sliding mode control there used for control position of DC servo motor. The control strategy is realized through the digital signal processor (DSP). The servo motor very important part at this system. The system using servo motor to control positing of the servo motor. The technique to control position of DC servo motor carried out

through the TMS320F243d DSP chip. These control strategies are not only the optimal performance could be obtained but the robustness is guaranteed. State space model used to design DC servo motor. The system design using MATLAB. There have methodology; three different controllers used of the positioning control of the dc servomotor were utilized. The first is the LQR technique by state feedback. The second is the traditional sliding mode control. The last is the control strategy using LQR with sliding mode. Furthermore, their performances are compared under three different conditions. These cases are system at nominal condition, model uncertainty and the existence of disturbance respectively. The design method of LQR with sliding mode control has been presented in this journal. The proposed control law is implemented on a DSP chip to command the position of a dc servomotor.

### 2.6.3 Title : DC Motor Controller Using Linear Quadratic Regulator (LQR) Algorithm Implementation On PIC

Author : Nur Iznie Afrah Binti Mohd Isa [5] ( Universiti Malaysia Pahang )

This project is a contributed to developed DC motor controller using Linear Quadratic Regulator (LQR) algorithm implementation on PIC. Linear Quadratic Regulator algorithm is a one of controller method to control a system. In this project, LQR was implemented on the PIC microcontroller to control DC motor. The system was builder to minimize the deviation of the speed of Dc motor. The speed of dc motor based on the diving voltage at dc motor; when the diving voltage is higher it will increase the speed of the dc motor. The state space of dc motor was derived, based on state space LQR controller was designed using the MATLAB software. This project concentrates on derivation of the mathematical model of dc servo motor and gets the value of K in LQR algorithm. K is the gain of the close loop system. To get the value of K, the state-space of the servomotor must be define first. Therefore, LQR algorithm was used by means to minimize the deviation of the dc motor speed. The LQR is used to tune the value of Q and R. The value of Q and R is tuned to get the stable system. Clifton Precision Servo Motor Model JDH-2250-HF-2C-E was used in this project.

#### 2.6.4 Title : PID Controller Design For Controlling DC Motor Speed Using MATLAB Application

Author : Mohamed Farid Bin Mohamed Faruq [6]( Universiti Malaysia Pahang)

This project is a contributed to developed PID controller design for DC motor using MATLAB application. A proportional–integral–derivative controller (PID controller) is a generic control loop feedback mechanism widely used in industrial control systems. PID controller will defined the error between the output and the desired input or set point by calculating and give an output of correction that will adjust the process accordingly. Firstly, for develop this project have to development of PID controller using MATLAB/Simulink software. The mathematical mode of dc motor developed using Ziegler-Nichols method and trial and error method. The control algorithm is builder in the Matlab/Simulink software and compiled with Real-Time Window Target. The Real-Time Window Target Toolbox includes an analog input and analog output that provide connection between the data acquisition card (PCI-1710HG) and the simulink model. The system used Litton - Clifton Precision Servo DC Motor JDH-2250.

#### 2.6.5 Title : Hydropter Modeling And Control

Author : Amine Merdassi[7]( Ecole Polytechnique, Federale De Lausanne)

This project about Hydropter Modeling and Control. The Hydropter is a sailing boat using hydrofoils (lifting surfaces operating in liquids). The hydrofoils generate enough lift to carry the boat and balance the forces produced by the sails. The main drawback of this type of system is the lack of stability with respect to waves and the difficult steering. The procedure of hydropter modeling and describes different approaches to control the system. It is a fastand strongly nonlinear system. The control schemes are computed based on a simplified model of the system. The hydropter model is derived using Lagrange-Euler Approach. The first control

approach is based on optimal control scheme. Linear Quadratic Regulator (LQR) theory is used to design a state feedback controller. The goal is to use LQR theory to suppress flutter and to maintain stability of the closed loop system. The second control approach consists of a standard way to control nonlinear systems. The idea is to use optimization-based Model Predictive Control (MPC). The goal is to generate reference input and state trajectories in order to change dynamically the setpoints.

#### 2.6.6 Title : A Novel Method on Selection of Q and R Matrices In the Theory Of optimal Control

Author : Omer Oral, Levent Cetin, Erol Uyar[8],( Dokuz Eylul University, Turkiye)

This project is a method to translate the system performance objective into a cost function to design a simple linear quadratic control systems. The LQR design are determined by time domain specification. In order to get optimal parameters, formulation through time domain specification are obtained. Experimental of crane base model was used to get the control oscillation with the specified specification. In this theory also shown that the matrices of Q and R are not carried out by trial and error method, with a mathematical method to specify steady and transient response system. This method is possible to meet the requirement of designing LQR and other closed loop characteristics.

#### 2.6.7 Title : MATLAB Based Real Time Control Implementation Of DC Servo Motor Using PCI Card

Author : Ananya Roy, Aditya Gazta, Suneet Sahadevan[9],( National Institute of Technology Rourkela)

This project are built to design the MATLAB based real time control application implementation of DC servo motor by using PCI Card 1716. Two methods are applied which are speed or position control of the DC servo motor. With the help of tuned PID

controller, the closed loop of control system get efficient speed control. The experiment began with running the servo with open loop which are connected to PCI card and go through the scope and get the simulation response for the loop, which the result of output motor not in the track of input. Therefore a modeling has been design using a MATLAB while the PID controller for the deisgn. The output finally track with the input of servo motor. To perform a control using MATLAB through PCI card, a set up from PC and UDP are performed. Total time delay are 0.009s to complete the loop and finally able to control the motor .

## **2.7 Conclusion**

The literature review is focused on preparation of the project. From the literature review, PID controller usually used to control Dc servo motor system. Besides that, several controllers approach such as LQR and PID controller as propose controller are also discussed.

## **CHAPTER 3**

### **METHODOLOGY**

In this chapter, method and alternatives that have been used for designing the controller are discussed and explained in detail, including step for getting the state-space model of the dc servomotor, PID design, LQR design, hardware configuration and the implementation of PID and LQR controller on microcontroller (arduino).

#### **3.1 System Overview**

Linear Quadratic Regulator (LQR) controller design for servo motor consists of two main parts in designing mathematical model for controller (LQR) and servo motor. In this project, PID controller and LQR controller is designed using MATLAB software. Then, the PID and LQR controller are compared with the designed system generated. This PID controller and LQR controller can compare each other to find out which controller had a better speed control and position of the motor.

## REFERENCES

1. R. Radzi (2010). Dc Motor Speed Control Using Fuzzy Logic Controller. University Technology Malaysia.
2. Upson, A.R.; Batchelor, J.H. (1978) [1965].Synchro Engineering Handbook. Beckenham: Muirhead Vactric Components. pp.7, 67–90.
3. Che Ku Mohd Faizul Bin Che Ku Mohd Salleh,(2008), Linear Quadratic Regulator (LQR) Speed Control for DC Motor Using MC68HC11,Universiti Malaysia Pahang,
4. Gwo-Ruey Yu, Rey Chue Hwang,(2004), Optimal PID Speed Controller of Brushless DC Motors Using LQR Approach, I-Shou University,Taiwan,
5. Nur Iznie Afrah Binti Mohd Isa,(2008), DC Motor controller using Linear Quadratic Regulator (LQR) Algorithm Implementation On PIC, Universiti Malaysia Pahang.
6. Mohamed Farid Bin Mohamed Faruq,(2008), PID Controller Design for Controller DC Motor Speed Using MATLAB Application, Universiti Malaysia Pahang.
7. Amine Merdassi Hydropter Modeling And Control, Ecole Polytechnique, Federale De Lausanne.
8. Omer Oral, Levent Cetin, Erol Uyar, (2010), A Novel Method on Selection of Q and R Matrices In the Theory Of optimal Control, Dokuz Eylul University, Turkiye, International Journal of Systems Control (Vol.1-2010/Iss.2), pp. 84-92
9. Ananya Roy,Aditya Gazta,Suneet Sahadevan, (2010-2011), MATLAB Based Real Time Control Implementation Of DC Servo Motor Using PCI Card, National Institute of Technology Rourkela.

10. Katsuhiko Ogata,(1995),Discrete Time Contro System, 2<sup>nd</sup> edition, Prentice Hall,Upper Saddle River,New Jersey 07458
11. Nise, N.S., (2008), Control Systems Engineering. Fifth edition ed.John Wiley & Sons, Inc.
12. Jeffrey B.Burl (1999), Linear Optimal Control H<sub>2</sub> and H<sub>∞</sub> Method, 2<sup>nd</sup> edition, Addison Wesley Longman,Inc
13. Ogata, K., Modern Control Engineering. 2002: Prentice Hall, Pearson Education International.
14. Simon Monk(2012), Programming Arduino Getting Started with Sketches, 1<sup>st</sup> Edition, Mc Graw Hill
15. Peter Dorato,Chaouki Abdallah, Vito Cerone, (1995), Linear Quadratic Control An Introduction, Prentice-Hall, Inc.A Division of Simon & Schuster,Inc. Englewood Cliffs, New Jersey 07632.
16. Kari J.Astrom and Tero Hagglund, (2006), Advanced PID Control, Instrument, System, and Automation Society.
17. Charles L.Phillips, H. Troy Nagle, (1995), Digital Control System Analysis And Design, 3<sup>rd</sup> edition, Prentice Hall,Inc. A Person Education Company. Upper Saddle River, New Jersey 07458.
18. Aleksandra Selezneva(2007), Modeling and Synthesis of Tracking Control for the Belt Drive System, Lappeenranta University Technology.
19. Ruba M.K. Al-Mulla Hummadi,(2012), Simulation Optimal Speed Control For A Dc Motor Using Linear Quadratic Regulator (LQR), Journal Of Engineering, Volume 18 March 2012, pp 340-348.
20. Brian D.O.Anderson,John B.Moore (1989), Optimal Control Linear Quadratic Methods,Prentice-Hall, A Division of Simon & Schuster, Englewood Cliffs, NJ 07632.
21. Lab-Volt Ltd.,Digital Servo Motor Control,1<sup>st</sup> Edition,Canada,2010.ISBN 978-2-89640-391-2