

STUDY ON PRECAST LIGHTWEIGHT FOAMED CONCRETE SANDWICH
PANEL (PLFP) CONNECTION UNDER FLEXURAL LOAD

NUR SHAHREENA BTE MAHADI

A thesis submitted in
fulfillment of the requirement for the award of the
Degree of Master of Civil Engineering

Faculty of Civil and Environmental Engineering
Universiti Tun Hussein Onn Malaysia

JULY 2013

ABSTRACT

Rapid growth of population has led to increasing demands on fast, affordable and quality housing. Nowadays, the construction industry in Malaysia has shifted from conventional method system towards Industrialized Building System (IBS). New technology investigation has been carried out to study the structural behavior of Precast Lightweight Foamed Concrete Sandwich Panel or PLFP as a load bearing wall system by previous researchers. In view of this, an experimental study is carried out to investigate the behavior of vertical connection for Precast Lightweight Foamed Concrete Sandwich Panel (PLFP). In this study, eight specimens comprised of plane surface connections and one panel as control without connection is cast and test under flexural loading until failure. The material used is foamed concrete with density $1700 - 1800 \text{ kg/m}^2$ as the overall fill and mortar as the connection in-fill. The objective of this study is to determine the load capacity and behavior of the connected panel with different length over depth ratio (aspect ratio of 0.83, 1.25 and 2.5). The behavior of the connection is studied through their load-deflection characteristic upon loading, load capacity, mode of failure and strain distribution. The relationship between aspect ratio and behavior of the panel were also observed. It was found that the higher aspect ratio, the more critical flexure failure at the connection occurred. The load capacity of the panel reduces by 30 to 60 percent of load with declination aspect ratio from 0.83 to 2.5.

ABSTRAK

Pertumbuhan pesat penduduk telah membawa kepada peningkatan permintaan terhadap perumahan yang cepat, berkualiti dan mampu dimiliki. Kini industri pembinaan di Malaysia juga telah beralih daripada sistem kaedah konvensional ke arah Sistem Bangunan Perindustrian (IBS). Kaedah teknologi baru telah dijalankan untuk mengkaji tingkah laku struktur panel pratuang sanwic yang diperbuat dari konkrit berbuisa foam atau PLFP sebagai beban gelas sistem dinding oleh penyelidik terdahulu. Dalam hal ini, satu kajian eksperimen telah dijalankan untuk menyiasat tingkah laku sambungan menegak untuk (PLFP). Dalam kajian ini, lapan spesimen yang terdiri daripada sambungan dalam-satah dan satu panel sebagai kawalan tanpa sambungan difabrikasi dan diuji di bawah pembebanan lenturan sehingga gagal. Bahan yang digunakan ialah konkrit berudara dengan ketumpatan 1700 - 1800 kg/m³ sebagai isian keseluruhan dan mortar digunakan untuk isian sambungan. Objektif kajian ini adalah untuk membandingkan kapasiti beban dan tingkah laku panel apabila disambungkan dengan aspek nisbah panjang dengan kedalaman (0.83,1.25,2.5). Kelakuan sambungan dikaji melalui ciri-ciri beban-pesongan apabila dikenakan beban, gambaran kegagalan dan pengedaran ketegangan. Hubungan antara aspek nisbah dan tingkah laku panel juga diperhatikan. Didapati bahawa, nisbah aspek yang lebih kecil menyebabkan kegagalan lenturan yang lebih kritikal di bahagian sambungan berlaku. Kapasiti beban panel berkurangan 30 ke 60 peratus beban dengan nisbah aspek pertambahan daripada 0.83 ke 2.5.

CONTENTS

TITLE	i
DECLARATION	ii
DEDICATION	iii
ACKNOWLEDGEMENT	iv
ABSTRACK	v
ABSTRAK	vi
CONTENTS	vii
LIST OF TABLE	xii
LIST OF FIGURE	xiii
LIST OF APPENDICES	xviii
CHAPTER 1 INTRODUCTION	1
1.1 Background of study	1
1.2 Problem Statement	3
1.3 Objective	3
1.4 Scope of Study	4

CHAPTER 2	LITERATURE REVIEW	5
2.1	Introduction	5
2.2	Precast lightweight foamed concrete sandwich panels (PLFP)	6
2.3	Precast Concrete Connection	7
2.4	Design Criteria for Precast Concrete Connections	7
2.4.1	Strength	7
2.4.2	Ductility	8
2.4.3	Durability and influence of volume change	8
2.5	Connections between load bearing wall	8
2.6	Wall to wall connections	9
2.7	Types of connections	10
2.7.1	Vertical connection	11
2.7.2	Types of vertical connections	12
2.8	Behaviour of connection under bending, tension shear and compression	15
2.8.1	Tension and bending in connection	16
2.8.2	Shear in connection	16
2.8.3	Compression in connection	16
2.9	Foamed concrete	17
2.9.1	Manufacture of foamed concrete	17
2.9.2	Materials	18
2.9.2.1	Portland cement	18

2.9.2.2	Water	19
2.9.2.3	Sand	19
2.9.2.4	Foaming agent	20
2.9.3	Characteristic Properties of foamed concrete	20
2.7.4	Advantage of foamed concrete	22
2.10	Crack Evaluation in Concrete Walls	23
2.11	Structural Wall Elements	26
2.12	Review of Past Studies	28
CHAPTER 3	METHODOLOGY	35
3.1	Introduction	35
3.2	Research Procedure	37
3.3	Laboratory Works	38
3.4	Connection Profile	41
3.5	Materials	41
3.5.1	Wythe	41
3.5.2	Core	42
3.5.3	Reinforcement	43
3.5.4	Shear connectors	43
3.5.5	Capping	43
3.6	Fabrication of PLFP	44
3.6.1	Formwork	44
3.6.2	Preparation of Fabrication of steel reinforcement	44

	3.6.3 Preparation of foamed concrete	45
	3.6.4 Casting	47
3.7	Material Testing	49
	3.7.1 Cube Test	49
	3.7.2 Splitting Tensile Test	50
	3.7.3 Young's Modulus	52
3.8	Preliminary Test	53
3.9	PLFP Panel Testing	53
CHAPTER 4	RESULT ANALYSIS AND DISCUSSION	55
4.1	Introduction	55
4.2	Objectives	57
4.3	Mechanical Properties of Panels	58
	4.3.1 Density	58
	4.3.2 Cube Test Analysis	59
	4.3.3 Tensile Strength at 28 Days	62
	4.3.4 Young's Modulus at 28 Days	63
4.4	Preliminary Experimental Results	67
4.5	Experimental Results	68
	4.5.1 Ultimate Strength Capacity	68
	4.5.2 Crack Pattern and Mode of Failure	71
	4.5.3 Load Horizontal Deflection Profile	74
	4.5.4 Load Strain Relationship	80
	4.5.5 Comparison with Control Panel	86

CHAPTER 5	CONCLUSSION AND RECOMMENDATION	88
5.1	Conclusion	88
5.2	Limitation	90
5.3	Recommendation for Future Research	91
	REFERENCES	92
	APPENDIX	95

LIST OF TABLES

1	Thermal conductivity of foam concrete compared with other materials.	21
2	Comparison of vertical joint connection details.	31
3	Details of specimens	39
4	Mix proportion and the strength of the foamed concrete at 7,14 and 28 days	46
5	Foam Concrete Ratio	46
6	Dimensions and Details Specimens for Actual Experimental Programme	56
7	Experimental results of density for PLFP after 28 days exposed to the air.	59
8	Compressive Strength foamed concrete at 7, 14 and 28 Days for PLFP Panel	60
9	Compressive Strength of mortar at 28 Days for PLFP Panel	60
10	Tensile strength foamed concrete for PLFP panels	63
11	Young's Modulus of PLFP Panels at 28 Days	66
12	Ultimate Failure Load for PLFP panels	70
13	Crack pattern with different aspect ratio of panel PA-1 to PA8	72

LIST OF FIGURES

2.1	Typical Precast Concrete Sandwich Panel	6
2.2	PLFP details specimens	6
2.3	Exterior forces and joint force system	10
2.4	Force carried by vertical connection	11
2.5	Hinge connection	12
2.6	In-plane connection with dry pack and continuity bars	13
2.7	groove connection	14
2.8	Forces in keyed connection	14
2.9	Types of mechanical mechanicals connection	15
2.10	Typical cracks pattern in concrete walls in various conditions.	25
2.11	Reinforcement details and loading set-up	28
2.12	Specimens and reinforce details of the cast in situ connections	29
2.13	Types of connection	30

2.14	Test specimen set-up	31
2.15	Shear test on connection	32
2.16	Crack pattern under four point bending test	33
2.17	Test setup	33
3.1	The Components of PLFP	36
3.2	Flow Chart of the Methodology	37
3.3	Dimension of PLFP a) side view b) front view	40
3.4	Reinforce of connection plan side (upper view)	41
3.5	Foam generator	42
3.6	Core dissertation	42
3.7	Example of the shear connectors	43
3.8	Capping	43
3.9	Formwork for PLFP panels	44
3.10	The 1st step is to place the first layer of strand and foam concrete wythe.	47
3.11	The 2nd step is to place the insulation layer (polystyrene) and the wythe ties.	47
3.12	The 3rd step is to place the second layer of strand and foam concrete wythe.	48
3.13	The 1 st step is to put the panel side by side and tight	48

	together with the gap is 25mm.	
3.14	The 2 nd step is to place the dry grout mix into the connection	48
3.15	Cube Specimens	49
3.16	Compressive Strength Testing Machine	50
3.17	Specimen positioned in a testing machine for determination of splitting tensile strength	51
3.18	Test specimens placing at Universal Testing Machine with attachment of Compressmeter	53
3.19	Magnus frame	54
3.20	Testing setup under four point bending test	58
4.1	Splitting tensile test	62
4.2	Hooke's Law	64
4.3	Diagram of terms that used in Young's Modulus formula	65
4.4	Young's Modulus for Samples PA-3 (S1) (wet density 1700 kg/m ³)	66
4.5	Crack Pattern on Pilot Test PA-1	67
4.6	Load versus Deflection for PA-1	68

4.7	Ultimate Strength versus Aspect Ratio for Panels PA-2 to PA-7	69
4.8	Crack and crush on the diagonal angle approximately 45° at the top of panel PA-2 and PA-3	73
4.9	Flexural crack at the connection concrete joint of panel PA-5	73
4.10	Flexural crack at bottom of panel PA- 6 and reinforcement bar in the connection were bent. a) back side b) front side	74
4.11	LVDT position	75
4.12a	Load- deflection profile for panel PA-3	76
4.12b	Load-deflection profile for panel PA-3 across the width.	76
4.13a	Load- deflection profile for panel PA-5	77
4.13b	Load-deflection profile for panel PA-3 across the width.	77
4.14a	Load- deflection profile for panel PA-6	78
4.14b	Load-deflection profile for panel PA-6 across the width.	78
4.15	Strain gauges position	80
4.16a	Load- strain profile at the top and bottom of the connection for PA-3 with 900mm panel height	81

4.16b	Load- strain profile at the top and bottom of the connection for PA-5 with 600mm panel height	81
4.16c	Load- strain profile at the top and bottom of the connection, PA-6 with 300mm height	82
4.17a	Load- strain profile at the connection for PA-3	83
4.17b	Load- strain profile at the connection for PA-5	83
4.17c	Load- strain profile at the connection for PA-6	84
4.18a	Load- strain profile at the centre of the PLFP panel for PA-3	85
4.18b	Load- strain profile at the centre of the PLFP panel for PA-5	85
4.18c	Load- strain profile at the centre of the PLFP panel for PA-6	86
4.19	Deflection across the width between control panel PA-8 and PA-5	87
4.2	Deflection across the width between control panel PA-8 and PA-5	87

LIST OF APPENDICES

APPENDIX	TITLE	PAGE
A	Young's Modulus sample Calculation	95
B	Crack pattern	97
C	Deflection across length of panel	102
D	Load strain profile	105
E	General bending calculation and Design load calculation	114

CHAPTER 1

INTRODUCTION

1.1 Background Of Study

The construction industry in Malaysia has shifted from conventional method system towards Industrialized Building System (IBS) that uses precast concrete. Precast concrete is defined as concrete which is cast in some location other than its position in the finished structure. It is produced by casting concrete in a reusable mold and then cured in a controlled environment, transported to the construction site and assembled at its designed location. According to the definition by construction industry development board Malaysia (CIDB), IBS design is the building systems in which structural components are manufactured in a factory, on or off site, transported, and assembled into a structure with minimal additional site works (CIDB Malaysia, 2001).

The rapid growth of population has led to increasing demands on fast, affordable and quality housing. Efforts have been taken to move from the traditional building construction technique to a more innovative construction method to meet these demands. The development of science and technology has contributed to the introduction of new construction techniques and materials in the construction industry. Among the new techniques or system that has emerged are precast concrete and sandwich precast concrete panel. It is predicted that these panels could and would be extensively used in the future especially in a multi -storey building construction. This is due to its high strength to weight ration, fast construction and

competitive overall cost. An extensive investigation has been carried out to study the structural behavior of Precast Lightweight Foamed Concrete Sandwich Panel or PLFP as a load bearing wall system by previous researchers. However, the number of studies on the connection for precast panels is very small and limited to solid precast panel made from conventional concrete.

In the precast wall load bearing structures, there is panel to panel connection such as wall - floor, wall - foundation, wall - roof and wall - wall etc. the panel to panel connection can be categorized as horizontal connection and vertical connection. Horizontal connection are the wall- floor and wall- roof connection while vertical connection is the connection between wall panels that are side by side in the same floor. Jointing system between shear walls constitutes an essential link in the lateral load-resisting systems, and their performance influence the pattern and distribution of lateral forces among the vertical elements of a structure. The connections between panels are extremely important since they affect both the speed of erection and the overall integrity of the structure.

There are four types of vertical connection in precast load bearing wall that is groove and tongue, in-plane, keyed and mechanical connection. In this study, it will be focused plane surface vertical connection only. Test is conducted under flexure to investigate the bond stress between the connection with different aspect ratio panel.

1.2 Problem Statement

In Malaysia, industrialized building system (IBS) had started many decades ago but until now it is still experimenting with various prefabricated method. The governments of Malaysia also encourage the use of IBS and insist that the office building projects shall have at least 70% IBS component. To encounter demands from the growing population and migration of people to urban areas in this country, alternative construction method is required to provide fast and affordable quality housing and environmental efficient. One of the alternatives that already been studied is Precast Lightweight Sandwich Panel. Before we can introduce new innovative construction method, the construction details are an important factor in building design. There has not been any study on Precast Lightweight Foamed Concrete Sandwich Panel (PLFP) connection. Connection is important to transfer loads and also for stability. With regard to the structural behaviour, the ability of the connection to transfer forces is the most essential property. Every aspect of the panel behavior must be analysed. This study will only focus on analyzing the performance of two small scale PLFP walls with U-bent bars connection under bending in term of load-displacement relationship, modes of failure and its ultimate load capacity when connected.

1.3 Objective

This research is to investigate the behavior of precast lightweight foamed concrete sandwich panel PLFP with vertical connection. The objectives of this study are:

- 1) To develop and construct the connection between PLFP panel using normal mortar concrete fill.
- 2) To determine the structural behavior of PLFP panel with vertical connection in term of load carrying capacity, deflection and strain distribution
- 3) To determine the relationship of load capacity of the connected panel with aspect ratio.

1.4 Scope Of Study

The scope of study will be focused on experimental work on the design connection of load bearing PLFP panels. The size of the panels is 900mm height, 600 mm height and 300mm height with the same 370mm width and 90mm thick. Connection used is vertical connection which uses plane surface type of connection. The connected wall is justified to be under bending situation due to settlements and also beam deflection. Eight panels were used in this experiment with the same type of connection including one panel for pilot and one panel as control with no connection. The material used is foamed concrete with density $1700 - 1800 \text{ kg/m}^3$ as for the panel and the in-fill of the connection is normal mortar with a cement-sand ratio of 1:3. The reinforcement bar 4mm diameter and shear connectors 3mm diameter of mild steel used in this experiment. All of the panels were tested under flexure test.

Test results were used to analyse the behavior of connection in terms of:

- i. Modes of failure
- ii. Load bearing capacity
- iii. Load-displacement profile
- iv. Load-strain profile

CHAPTER 2

LITERATURE REVIEW

2.1 Introduction

The precast sandwich panel is produced with a layered structural system which consists of core material acting with the high strength facing material. Various forms of sandwich construction already been studied by combining different material as its core and wydth. A typical concrete sandwich panel is shown in Figure 2.1 that combines insulation with inner and outer wydth. There is much effort has been expended in the area of precast lightweight sandwich panel as the innovative construction method. PLFP is one of the previous study already been done. As to stabilize the precast components, the connections design plays an important role in the precast concrete structure. The stability of the construction is depending on strength itself, construction method and the connection capacity. The role of the connection is to transfer efficiently the internal forces from one element to another that will produce sufficient strength of the elements. BS 8110 requires that the connections are designed to maintain the standard of protection against weather, fire and corrosion of the structure.

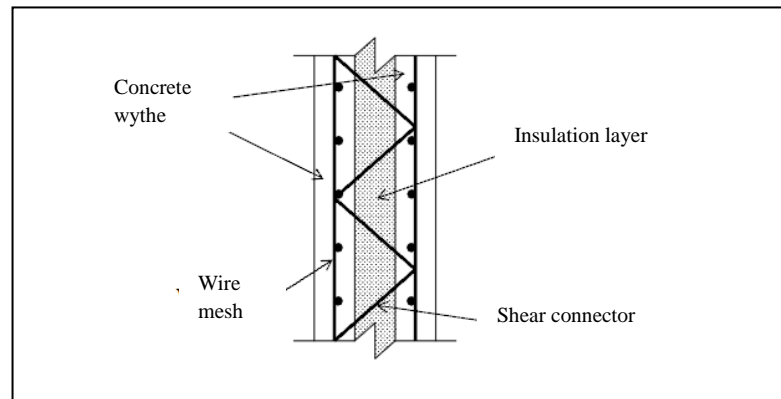

Figure 2.1 : Typical Precast Concrete Sandwich Panel

2.2 Precast Lightweight Foamed Concrete Sandwich Panel, PLFP

Precast lightweight foamed concrete sandwich panel is an alternative sandwich structure component that can meet the rapid housing demand in Malaysia. It consists of lightweight foamed concrete as the wythes layer and polystyrene core as the insulation layer. Shear connectors are embedded across each layer to allow load shearing between wythes. Stiffness of the shear connectors and its ability to transfer load between wythes will determine the strength and stability of PLFP. Figure 2.2 shows the PLFP layout with single shear connector.

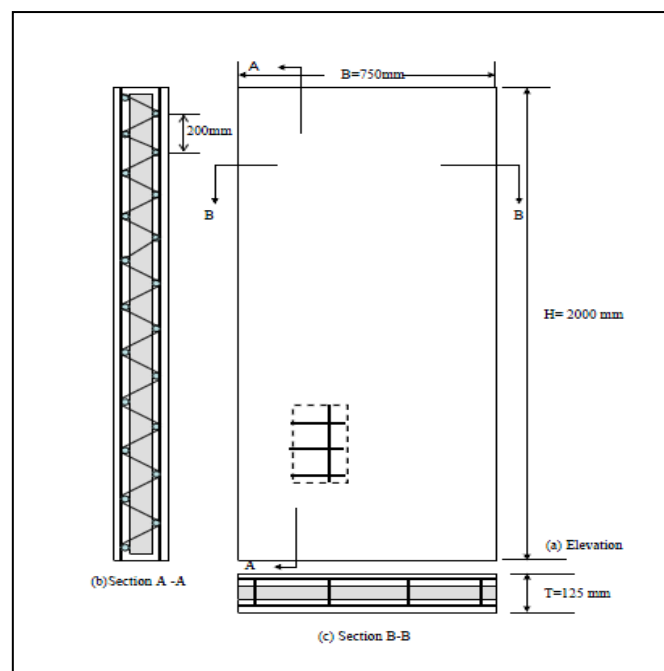

Figure 2.2 : PLFP details specimens (Noridah,2011)

2.3 Precast Concrete Connection

Connections can be defined as those system used for connecting one precast component to another and also to connect precast components to the structural frame of cast-in-situ, steel or masonry (Waddell, 1974). Precast concrete construction needs connection for assembling phase and provides quality of strength and durability of the construction. Connection is specially design to support resisting loads carried out during construction and the service life of the structure. The load may consist of dead load, live load and service loads, earthquake and wind forces, shrinkage and creep of concrete, temperature stresses and others loading resulting from the construction. Connection should be able to transmit shear, axial loads, moment and torsion either singly or in combination to resist all the loads and force.

2.4 Design Criteria For Precast Concrete Connections

A connection is the total construction including the ends of the precast components, which meet at it. The performance of precast concrete systems depends on the behavior of connections. The configuration of connection affects the constructability, stability, strength, flexibility and residual force in the structure. Connection design is the most important considerations for the successful construction of precast reinforced concrete structures (Loo and Yao 1995).The main criteria for the serviceability performance of connections are: strength, ductility, durability and influence of volume change

2.4.1 Strength

Connection must be able to resist forces induced by dead and live gravity loads, wind, earthquake and pressure from nature failure. Even though Malaysia does not encounter earthquake but it occur to nearby country like Indonesia in the past few

years whereby many high-rise building in Malaysia has been affected as well. Joints strength is categorized by the type of induced stresses that is compressive, tensile, flexural, tensional and shears.

2.4.2 Ductility

Ductility is the ability of connections to take large deformation without failure. Ductility plays a significant role in statically indeterminate structures by allowing redistribution of overstressed from one critical section to another thus delaying local failure.

2.4.3 Durability and Influence of Volume Change

Durability of connection exposed to weather is affected by cracking or spalling of concrete. Improper detailing results in local cracking and spalling due to restraint of movement or stress concentration. Shortening effects of creep, shrinkage and temperature reductions cause tensile stresses must be considered in the design.

2.5 Connections Between Load Bearing Wall

Precast load bearing wall structure needs to carry the axial load from the upper floors. The external wall should also resist the lateral load induced by the wind and in some condition is earthquake. Connection for load bearing wall panels is an important part to support the structural system as the stability of the structure depending on efficiency of the connection to transmit loads and forces from each component. Connections that transfer vertical or lateral loads from panel to panel may differ according to the particular building. Gravity load transfer often can be achieved with simple weld plate connections because of concretes inherent strength

in compression. Mechanical reinforcement splice connections may be required to provide uniform load paths for tensile forces (Freedman,1999).

Most of the literature of the previous study in precast construction methods of connection is using the mechanical connection (i.e welding, bolting, plate slot etc.); such as in Figure 2.5. There is very little research has been carried on the ultimate strength (flexure and shear strength) of cast-in-situ connections between precast panels (Pang, 2002).

2.6 Wall To Wall Connection

Wall to wall connection are made to position and secure the walls. With proper design and construction, they are capable of carrying lateral loads from shear wall or frame action. The most practical connection is one that allows realistic tolerances and performs transfer of load between panels. It also is desirable that the connection requires no grouting or at the very least a minimum amount of field grouting. Horizontal joint and connection details of exterior bearing walls are especially critical. Vertical joints may be designed so that the adjacent wall panels form one structural unit (coupled), or act independently. In addition to the vertical shear force transfer due to lateral loads, vertical joints also may be subject to shear forces induced by differential loads upon adjacent panels. The exterior forces subjected to different forces are shown in Figure 2.3.

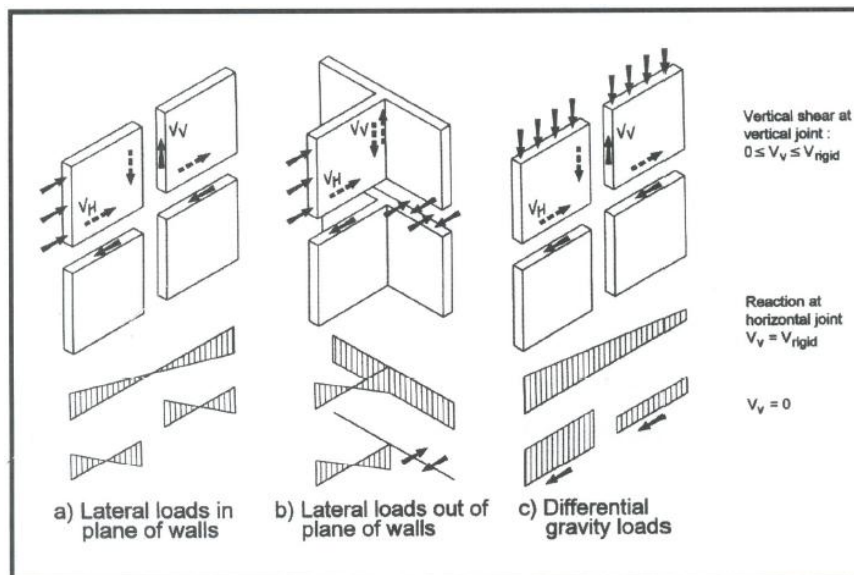

Figure 2.3 : Exterior forces and joint force system

2.7 Types Of Precast Walls Connection

The connections are an integral part of the structural support system for vertical gravity dead and live load as well as for the transfer of horizontal in-plane forces from the floor diaphragm action. There are two principle types of joint in precast wall panels:

- 1) Vertical joint for the purpose of transferring vertical shear forces from one wall component to the next with minimum relative movement (Wall-wall).
- 2) Horizontal wall to floor and wall to foundation joint for the transferring of comprehensive, tensile and shear from one component to others (wall-floor, wall-foundation).

2.7.1 Vertical Connection

Vertical connection is the panel's side to side connection. The function of the vertical connection is to transfer the vertical shear forces between the elements. In addition, this connection is also required to withstand bending and shear forces from a flat surface perpendicular to the wall. Factor should be considered in designing the verticals connection which includes:

- i. Provide the reinforcement across the joint at least two joints in the upper and the lower panels. Reinforcement and extension also acts as a binder between adjacent panels
- ii. The strength of the reinforcement or the material used in connection.
- iii. All connection are filled with mortar to protect the condition from the temperature and weather.

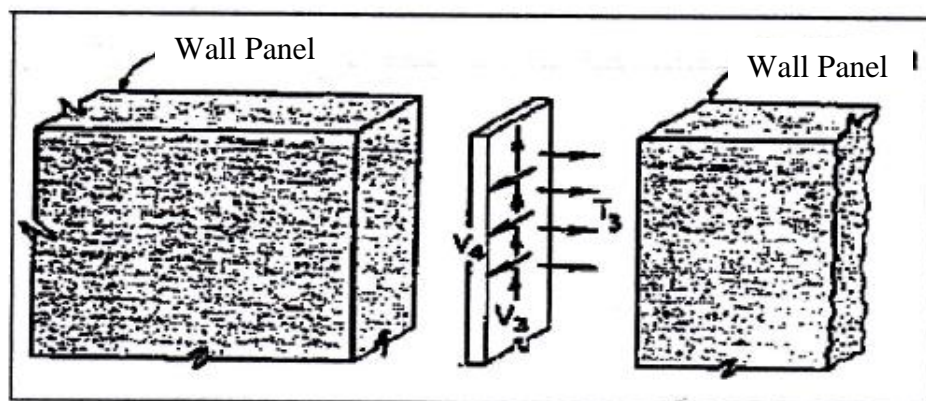

Figure 2.4 Force carried by vertical connection (Norulhuda, 2008)

2.7.2 Types Of Vertical Connection

There are several types of vertical connection in panels. The vertical connection includes:

- i. Hinge connection
- ii. Plane surface connection
- iii. Groove joint connection
- iv. Keyed connection
- v. Mechanical connection

i) Hinge connection

Hinge connection transfer compression, shear and tension but not moment. Connection between floor levels is generally open, so the panel will resist the lateral load (Norhafizah, 2008).

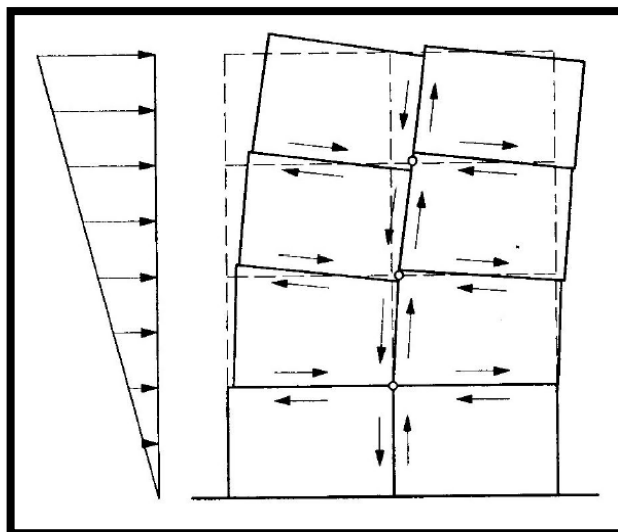

Figure 2.5 :Hinge connection

ii) Plane surface connection

Plane surface connection can be simple design as shown in Figure 2.6. this connection is either plane with grout only or combine with reinforcement. The in-fill can be various type of material including mortar, epoxy and etc.

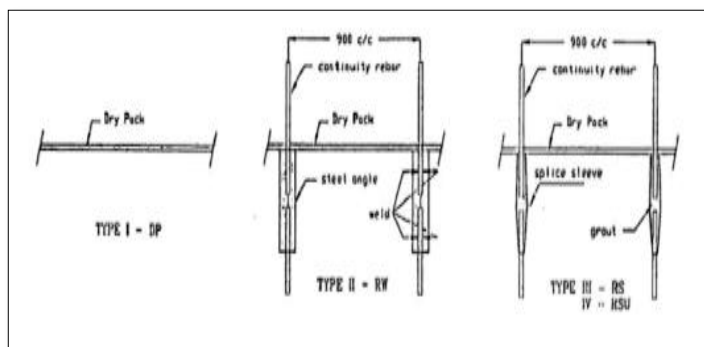

Figure 2.6.: In-plane connection with dry pack and continuity bars
(J.S. West,1993)

iii) Groove joint connection

Grove connection can be filled with glue or mortar. The strength of this connection are reliable to shear force which can causes cracks on the surface of mortar due to shrinkage, creep and temperature effects.

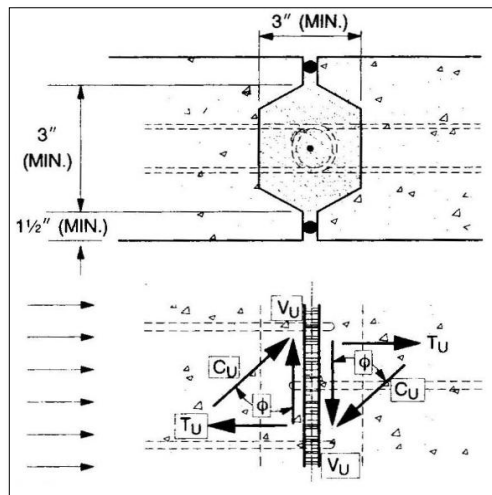

Figure 2.7 : Groove connection (Norhafizah,2008)

iv) Keyed joint connection

Keyed connection can be made with or without reinforcement bar. There is similar deformation behavior show that the reinforced joints are stronger.

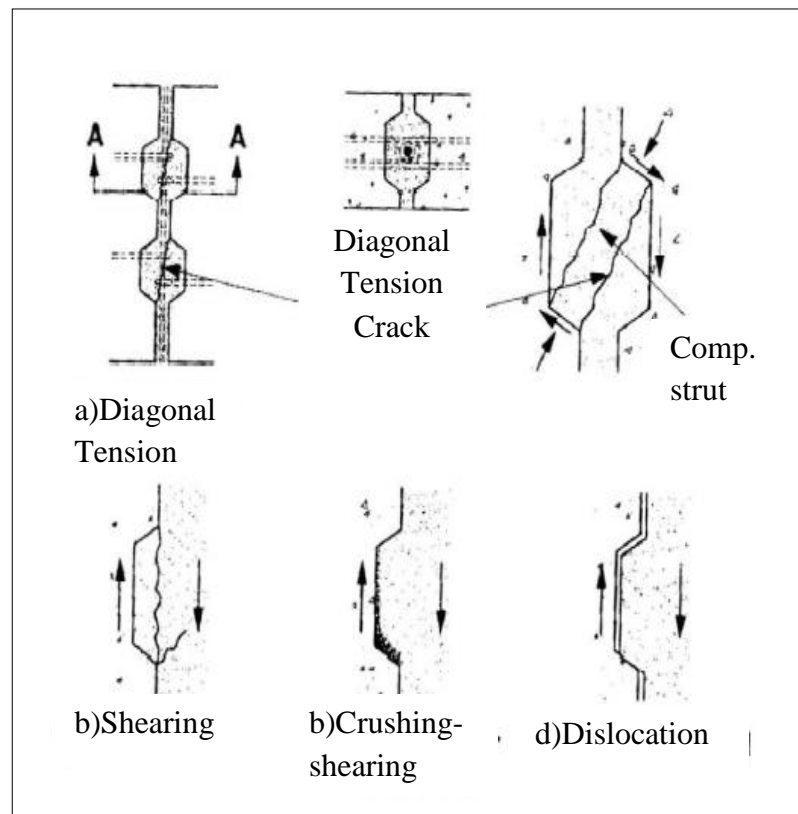

Figure 2.8: Keyed connection (J.S. West,1993)

v) Mechanical connection

Mechanical connection consists of anchor devices built into the wall panel. plates, angles and bars is used to connect each components. The strength of this connection depends on the capacity of the device loads transmitted through it.

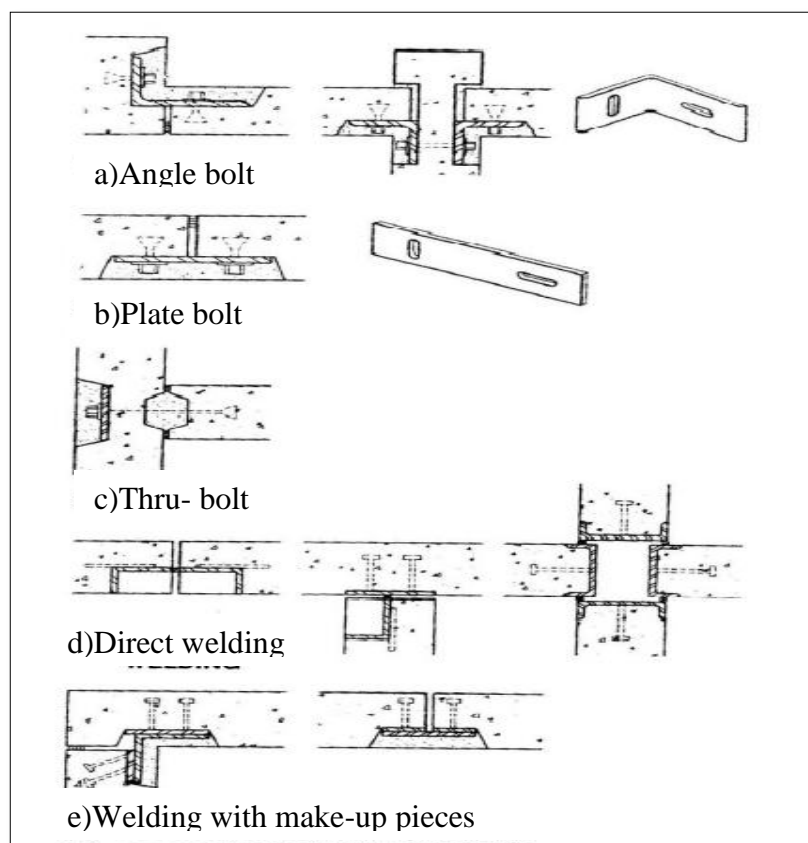

Figure 2.9: Types of mechanical mechanicals connection

2.8 Behavior of connection under Tension, Bending, Shear and Compression

Design of structural connection component must involve consideration of their different behaviors when subjected to tension, compression, bending, shear or a combination between the three (Bjorn Engstrom at el.,2008). These behaviors of connection will be discussed as follow.

2.8.1 Tension and Bending Connection

Tension and bending in connections between precast concrete components can be developed by one of the following:

- i. Bolting
- ii. Post-tensioning
- iii. Welding of projecting reinforcing bars
- iv. Projection of a reinforcing bar from one member into cast-in-situ concrete or a grout sleeve in an adjacent member

2.8.2 Shear in Connections

For shear in precast concrete connection, shear resistance between the components is developed by providing keys (keys shape) to concrete. Keys can be obtained by coating the roughened surface of the hardened concrete with neat-cement slurry immediately before casting the fresh concrete. Besides the keys in the concrete, the amount of reinforce steel projecting through the interface also will affect the ultimate shear strength than concrete with keys. Therefore, in order to develop good shear connection, the optimum percentage of reinforcing steel in the interface should be used.

2.8.3 Compression in connection

Compression between precast components will be carried out by filling the connection with concrete or grout. To produce high compression capacity shrinkage should be avoided by dry-packing or by using an expending agent such as aluminum powder. High concentrations of bearing stress occur near the edges, pads of soft material may be used, or the concrete should be confined by encasing the member in steel to prevent the danger of splitting or cracking.

2.9 Foamed Concrete

Foamed concrete is a cementation material having a minimum of 20 percent (by volume) of mechanically entrained in the plastic mortar (Jones,2005).Other definition according to Aldridge (2005), the term foamed concrete is misleading with vast majority of concretes containing no large aggregates, only fine and extremely lightweight foamed concrete materials containing only cement, water and foamed, so the product should be more accurately described as having an air content of more than 25 % which distinguishes it from highly air entrained.

Basic form of foamed concrete is made with cement, water, sand and foam agent. Foam or bubbling agent is used to absorb humidity for as long as the product is exposed to atmosphere, allowing hydration process of the cement to continue for its ever- continuing strength development.

Foam concrete can be alternative material for construction due to its low density, high workability and excellent thermal properties. In lightweight foamed concrete, the density is determine by the amount of foamed added to the basic cement; this way the strength of the concrete is controlled.

2.9.1 Manufacture Of Foamed Concrete

Foamed concrete is produced by entrapping small bubbles of air in cement paste. Mechanical foaming can be described in two principles ways:

- i. By pre-foaming a suitable foaming agent with water producing base mix and stable preformed aqueous foam separately and then thoroughly blending foam into the base mix that consist of water, sand and cement.
- ii. In mixed foaming, the surface active agent is mixed along with base mix ingredients and during the process of mixing; foam is produced resulting in cellular structure in concrete.

Pre-formed foaming is preferred to mix-forming technique due to the following advantages:

- (i) Lower foaming agent requirement
- (ii) A close relationship between amount of foaming agent used and air content of mixture.

To get a high performance and quality foamed concrete, the materials and procedures are very important. Various material, equipments and mixing procedure are discussed as below.

2.9.2 Materials

The components of foam concrete mixture should be set by their functional role in order as follows:

2.9.2.1 Portland Cement

There are many types of Portland cement such as high alumina cement, super sulphate and special cement. According to (BS 12: Part 1:2000) ordinary Portland cement is usually used as main binder for foamed concrete.

Portland cement is made from limestone, clay and ferric oxide as a flux. It is based as calcium silicate cement which is produced by firing to partial fusion at high temperature approximately 1500 °C.

2.9.2.2 Water

The amount of water to be added to mix is depends upon the moisture content of the sand where 40 – 50 litres of water is used for every 100 kilograms (100lbs) of cement. Additional water is added as a content of the foam, thereby bringing the total water cement ratio up to the order to 0.6. in general, when the amount of the foam is increased, as for the lighter densities, the amount of water can therefore decreased. The water cement ratio should be kept as low as possible in order avoid unnecessary shrinkage in the moulds.

However, it should remembered that if the amount of water that added to the cement and sand in the first instance is too low, the necessary moisture to make a workable mix will be extracted from the foam when it is added, thereby destroying some of the foam which is naturally an expensive way to adding water to the mix. . Where the water content of the mix would be inadequate to ensure full hydration of the cement, water will be extracted from the foam and might lead to its disintegration. On the other hand whilst high w/c ratios do not significantly affect the porosity of the foamed concrete they do promote segregation and increase drying shrinkage (Gambhir, 2004). Tests should be carried out on any particular mix which is required so that the resulting cellular concrete will have a flowable and creamy consistency.

2.9.2.3 Sand

Recommend that only fine sands suitable for concrete (to BS 882:1992) or mortar (to BS 1200: 1976) having particle sizes up to about 4 mm and with an even distribution of sizes should be used for foamed concrete to prevent settlement in a lightweight mixture and lead to collapse of the foam during mixing.

2.9.2.4 Foaming Agent

Foaming agent is defined as air entraining agent. Air entraining agents are organic materials. When foaming agents added into the mix water, it will produce discrete bubbles cavities which become incorporated in the cement.

There are two types of foaming agents can be used to produce foam either Synthetic or protein based foaming agents (surfactants). Because of the possibility of degradation by bacteria and other organisms, natural protein based agents (i.e. fatty acid soaps) are rarely used to produce foamed concrete for civil engineering works.

2.9.3 Characteristic Properties Of Foamed Concrete

The characteristic properties of foamed concrete consist of compressive strength, tensile strength, shear strength, shrinkage, acoustic and thermal insulation, and fire resistance.

The strength of concrete generally from the strength of the hardening cement paste which is, in turn, originates from hydration products. Compressive strength of foamed concrete is influenced by many factor such as density, age, curing method, component and mix proportion. A relationship exists between the density and the strength where compressive strength of foamed concrete reduces with decreasing density. Study done by Kearsley et al., (2001) has reported that the compressive strength of the foam concrete decreases exponentially with a reduction in density of the foam concrete.

Tensile strength of foam concrete can be as high as 0.25 of its compressive strength with a strain around 0.1% at a time of rupture depends on its curing method. For shear strength, it is varies between 6% and 10% of the compressive strength (Noridah, 2009).

The shrinkage of foam concrete reduces with density, which is attributed to the lower paste content affecting the shrinkage in low-density mixes. Shrinkage properties in foamed concrete occur during the setting stage.

Foam concrete has high fire resistant which is greatly superior to the normal concrete. It also has high sound absorption due to its porosity. Thermal conductivity of foamed concrete depends on density, moisture content and ingredient of the material. As it is largely function of density, it does not really matter whether the product is moist cured or autoclaved as far as thermal conductivity is concerned. The amount of the pores and their distribution are also critical for thermal insulation. Below is Table 1 in which thermal conductivity of foam concrete is compared with that of other materials.(Yun,2003).

Table 1: thermal conductivity of foam concrete compared with other materials.
(Yun, 2003)

Material	Density(kg/m ³)	Thermal Conductivity W/mk
Marble	2700	2.9
Concrete	2400	1.3
Porous clay brick	2000	0.8
Foam concrete	1200	0.38
Foam concrete	1000	0.23
Foam concrete	800	0.18
Foam concrete	600	0.14

Other properties are as described below (Norazila, 2010):

i. Air void

The pore structure of cementations material, predetermined by its porosity, permeability and pore size distribution is a very important characteristic as it influences the properties such as strength and durability. As foam concrete being a self-flowing and self-compacting concrete and without coarse aggregate, the possibilities of the entrapped air is negligible. The air-void

distribution is one of the most important micro properties influencing strength of foam concrete. Foam concrete with narrower air-void distributions shows higher strength. Because of the uniform shape (characterized by shape factor) of air-voids, its influence on strength is negligible (Kearsley et al., 2001).

ii. Density

Foam concrete can be formed with the desired density and requirement. The density of foam concrete is 300 kg/m^3 up to 1800 kg/m^3 to suit different application. Usually, the lower densities of $400\text{-}600 \text{ kg/m}^3$ are ideal for thermal insulation applications. The density range $800\text{-}1000 \text{ kg/m}^3$ is utilized for making pre-cast blocks for non load bearing walling masonry in framed structures while the foam concrete range from 1200kg/m^3 to 1800 kg/m^3 is structural grade material utilized for in-situ casting of structural load bearing walls and roofs of low rise individual or group housing schemes or manufacture of reinforced structural cladding or partitioning panels or for making pre-cast blocks for loadbearing walling masonry for low-rise buildings. Density can be either in fresh or hardened state. Fresh density is required for mix design and casting control purposes.

2.9.4 Advantages of Foamed Concrete

Foamed concrete have many advantages such as it can reduced dead load of wet concrete allows longer span to be poured un propped. Besides that foamed concrete also economies the design of supporting structure such as foundation and walls of lower floors, ecological compatibility, possesses high workability, good fire resistance, thermal and sound insulation properties.

Foam concrete has excellent thermal insulating properties due to its cellular microstructure. The thermal conductivity of foam concrete of density 1000 kg/m^3 is reported to be one-sixth the value of typical cement sand mortar (Aidrige et al., 2001).

In term of fire resistance, as compared to vermiculite concrete, lower densities of foam concrete is reported to have exhibited better fire resistance, while with higher densities, this trend is stated to be reversed (Aldrige et al., 2005). Kearsley and Mostert (2005) studied the effect of cement composition on the behaviour of foam concrete at high temperature and concluded that foam concrete containing hydraulic cement with an Al₂O₃/CaO ratio higher than two can withstand temperatures as high as 1450 °C without showing sign of damage.

Foam concrete usage can save the time period to settle the project and also more easy to labor finish the project. No special skill is required in using the system. It is fully adoptable or at least adaptable into existing concrete or prefabrication plants, adding only a foaming agent into the mixer at a precise dose, which is discharged from a foam generator. Foamed concrete may later be pumped using conventional concrete pumps.

Reduction in dead weights contributes substantially to savings in reinforcing steels in foundations. The dimensions and therefore, the overall quantity of steel reinforcement in foamed concrete can be reduced by as much as 50% (Norazila, 2010). Foamed concrete can be produced right on the spot of construction and be casted according to necessary shapes by pumping straight to where it is required.. Savings are also substantial in transportation, crane- and man-handling related activities as well as in raw materials, as no gravel is required to produce foamed concrete but sand, cement, water and air, with the resulting mortar/paste subsequently embedded in the foam.

2.10 Crack Evaluation in Concrete Walls

Cracks in concrete are very important aspects not only for the aesthetic appearance. They can be the cause of leaks from rain that could cause rusting to reinforcement. It also can be the first signs of a potential wall collapse. In normal circumstances is difficult to obtain a structure free of any cracks because there is many factors that can contribute to cracking, such as expansion and shrinkage temperature, hydration heat during concrete hardening etc.

Most cracks are results from the following actions:

1. Volumetric change caused by plastic shrinkage or expansive chemical reactions within hardened concrete, creep and thermal stresses.
2. Stress because of bending, shear or other moments caused by transverse loads.
3. Direct stress due to applied loads or reactions or internal stresses due to continuity, reversible fatigue load, long-term deflection, environmental effects or differential movements in structural system.

Formations of cracks from the second and the third action where external loads results in direct and bending stresses causing flexural, bond and diagonal tension cracks. According to BS 8110:Part 2 : 1985, for the common structure is sufficient of the cracks width that occur not exceeding 0.3mm. Causes of typical cracks in concrete walls are explained, based on the location and pattern of the cracks as shown in Figure 2.10.

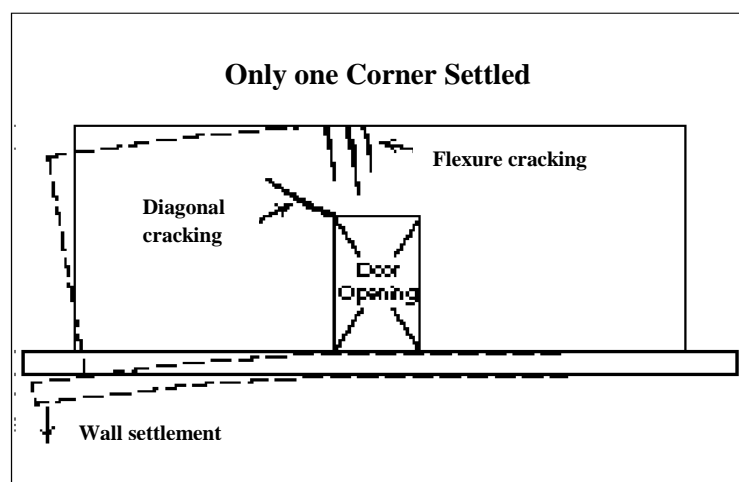
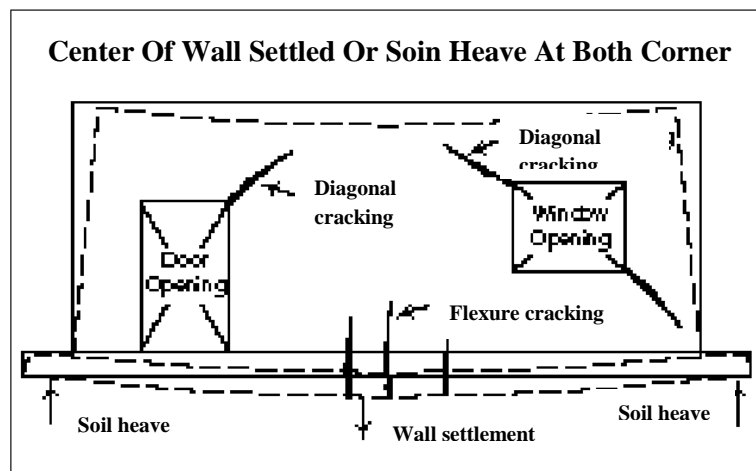

REFERENCES

- Aitcin P.C, Mehta P.K (1990). *Effect of Coarse-Aggregate Characteristics on Mechanical Properties of High-Strength Concrete*. ACI Mater. J., 87: 103-107.
- Aldridge,D., In Dhir, R.K., Newlands,M.D. & McCarthy A. (2005) .*Use of foamed concrete in construction*, London,pp:1-14
- American Concrete Institute (1989). *ACI 213R. Guide for Structural Lightweight Aggregate Concrete*. Farmington Hills,MI, American Concrete Institute.
- Arturo E. S., R. A. Magana, M. K. Tadros, X. Huo (1994). *Experimental Study of Joint Connections In Precast Concrete Walls*, Vol II. Fifth U.S. National on Earthquake Engineering.
- ASTM C496-86(1989) "*Standard test method for splitting tensile strength of cylindrical concrete specimens*", Annual Book of ASTM Standards Society for Testing and Materials, Vol. 04-02, pp.259-262.
- CIDB Malaysia. (2001). "*Manual for Assessment of Industrialised Building System CIDB*, Kuala Lumpur.
- Benayoune, A.A.A Samad., A.A. Abang Ali, D.N. Trikha (2006). "*Response of Precast Reinforced Composite Sandwich Panels to Axial Loading.*" Journal of Construction and Building Materials.
- Benayoune . A.A.A Samad., A.A. Abang Ali, D.N. Trikha, S.H.M. Ellinna. (2008). "*Flexural behaviour of pre-cast concrete sandwich composite panel – theoretically investigation.*" Journal of Construction and Building Materials,580-592.
- Bjorn E. et.al (2008). *Structural Connections for Precast Buildings*. Switzerland: International Federation for Structural Concrete.
- British Standard Institutions. (1994). *BS8110:Part 2.Additional Consideration in the Use of Lightweight Aggregate Concrete*. British Standard Association.
- British Standard Institutions. (1994). *Foamed Concrete Composition and Properties*. 165-168. British Cement Association.
- British Standard Institutions.(1997)*BS8110: Part 1. Design Objective and General Recommendation*. British Standard Association.
- Bruce A. Suprenant and Kim D. Basham (1993). *Evaluating Cracks In Concrete Walls*. The Aberdeen Group. University of Wyoming, Laramie.

- Burachat C. and Pichai N. (2004). *Vertical Shear Strength of Joints in Prefabricated Loadbearing Walls*, Bachelor Thesis, Thammasat University.
- Freedman S. (1999), *Loadbearing Architecture Precast Concrete Wall Panels*. PCI Journal.
- Gambhir, M.L. (2004). *Concrete Technology*. Tata McGraw Hill. New Delhi.
- Jones, M.R. & McCarthy, A. (2005)., *Behaviour and Assessment of Foamed Concrete For Construction Application*. In Dhir, R.K., Newlands, M.D, London:61-88
- Kearsley, E.P. Wainwright, P.J. (2001), *Porosity and Permeability of Foamed Concrete*. Cement and Concrete Research 31, 805–812
- Kearsley, E.P. & Mostert (2005)., *Designing Mix Composition of Foamed Concrete with High Fly ash Content*.
- Loo. Y.C. and Yao. B.Z. (1995). *Static and repeated load test on precast concrete beam-to-column connections*, PCI Journal, Vol. 40, No.2, March-April, pp. 106-115.
- Mansur M.A., K.L. Tan b, A.E. Naaman. (2010). *Strength Of Bolted Moment Connections In Ferrocement Construction*. Cement & Concrete Composites, 32, 532–543.
- McCormick, F.C. (1967), *Rational proportioning of preformed foam cellular concrete*. ACI Material Journal, 64, 104-109.
- Mohammad M., Mohd Z.J., Ali A.M., Shatirah A., Mohamed J., Rafiepour N., Mohammadhassani A., Sinaei H., Heydar R. E. and Ghanbari F. (2011). *Bending stiffness and neutral axis depth variation of high strength concrete beams in seismic hazardous areas: Experimental investigation*. International Journal of the Physical Sciences Vol. 6(3), pp.-494.
- Nehdi, M., Djebbar, Y. & Khan (2011), A. *Neutral network model for preformed foam cellular concrete*. ACI Mater J, 98, pp. 402-409.
- Noridah M. and Muhammad H. M. (2011). “*Testing of Precast Lightweight Foamed Concrete Sandwich Panel With Single and Double Symmetrical Shear Truss Connectors Under Eccentric Loading.*”, Journal of Advanced Materials Research, Vols. 335-336, pp. 1107-1116.
- Noorulhuda A.S. (2008), *Kajian Terhadap Sambungan Mengufuk Dinding Galas Beban Bagi Struktur Konkrit Pra Tuang Menggunakan Kimpalan*, Tesis Sarjana Muda, Universiti Teknologi Malaysia.

- Nor Hafizah A.H (2008), *Kajian Terhadap Sambungan Mengufuk Dinding Galas Beban Bagi Struktur Konkrit Pra Tuang Menggunakan Bolt*, Tesis Sarjana Muda , Universiti Teknologi Malaysia.
- Norazila K. (2010). *An Investigation On Effect Of Quarry Dust As Sand Replacement On Compressive And Flexural Strength Of Foam Concrete*, Bachelor Degree thesis, Universiti Malaysia Pahang.
- Ooi E. K. (2010), *The Connection Between Precast Aerated Sandwich Concrete wall Panels*, Bachelor Degree thesis, Universiti Teknologi Malaysia.
- Pan Zhihua , Fujiwara H. and Wee T.(2007),” *Preparation of high performance foam concrete from cement, sand and mineral admixture*, journal of Wulan University of technology-material Science.edition,June.
- Patil S. S., A. N. Shaikh and B. R. Niranjana (2013). *Experimental and Analytical Study on Reinforced Concrete Deep Beam*. International Journal of Modern Engineering Research .Vol.3, Issue.1, pp-45-52.
- Soudki K.A , Rizkalla S.H. and Leblane, B. (1995). “*Horizontal Connections for Precast Concrete Shear Walls Under Cyclic Deformations – Part 1: Mild Steel Connections*, “ PCI JOURNAL, V.40,No.4,July-August,pp,78-96.
- Waddle, Joseph J. (1974).*Precast concrete; Precast concrete connection*.pp, 137.
- Yun Bai (2003).*Thermal Conductivity*. Blackwell, UK.
- West J.S. (1993). *Behaviour Of Precast Concrete Shear Wall Connections Under Large Reversed Cyclic Shear Loads*. Structural Engineering and Construction Research and Development Facility Department of Civil Engineering, University of Manitoba Winnipeg, Manitoba.