

DC Conductivity of Polymer Nanocomposites for Different Types and Amount of Nanofiller

Nor Akmal Mohd Jamail, Mohamed Afendi Mohamed Piah, Nor Asiah Muhamad, R.A. Zainir, Nur Faizal bin Kasri, and Qamarul Ezani Kamarudin

Abstract: Polymer nanocomposites for HV insulation have been extensively being studied in recent years because of its unique properties and ability to enhance electrical performance. Electrical conduction of polymer nanocomposites have been used as one of the tool to monitor its dielectric behaviour. This paper present the experiment result for polarization and depolarization current and conductivity value to find the patterns and trends of DC conductivity. Then this experiment result will be compared with results from previous researches studies on current and conductivity analysis with different method and samples. The analysis result shown that DC conductivity exhibits significant reduction with addition of any types of nanofiller at right amount. However right percentage of nanofiller added is not same for different type of materials. This was due to decreasing of initiation probability of short circuit treeing in the insulation. The conductivity analysis shows that addition of nanofiller into the polymer improved its insulation properties.

Keywords: Polymer nanocomposite, DC conductivity, dielectric, nanofiller

1. Introduction

Nanocomposite material application in field of dielectric and electrical insulation had attracted many researchers' attention recently. Polymer nanocomposite materials as a new insulation material have been given attention because properties of the original material can be drastically improved by adding a few percent of nano-sized filler. This material had widely used as power apparatus and cables insulator. Polymer nanocomposites are made by adding nanometer sized fillers are homogenously dispersed into the matrix of polymers composite. The filler is dispersed homogenously in the composite matrix by a certain weight percentages (wt%). The fillers added to the matrix are just in small quantity, typically less than about 10 wt%. Polyethylene or epoxy resin are widely used as insulators in industrial applications and based material of many recent studies, while SiO_2 , Al_2O_3 , MgO , TiO_2 or layer silicates (LS) and nano clay are typical nanofillers.

Many researchers have been conducted to determine the electrical properties such as dielectric breakdown strength, partial discharge resistance, space charge and conduction current measurement of polymer nanocomposite insulator [1-6]. However, these dielectric measurements are not adequate because they do not reveal information on the polarization current, depolarization current, and the variation conductivity of nanocomposite. Nonetheless, without the accurate information these parameters, it is difficult to determine the cause for the degradation of the insulator.

A lot of research had been done on electrical properties of polymer nanocomposite as insulating material. F. Ciuprina and I. Plesa had done a research on DC conductivity and the variation of the real part of the complex conductivity with the frequency for three formulations of nanocomposites obtained from polyethylene filled with nanoparticles of Al_2O_3 , SiO_2 and TiO_2 [1].

Research also have been conducted by [2] on electrical conduction at various applied electric fields. It has been found that the conduction current shows a minimum at a 1% b.w. concentration nano alumina particles. Researchers [3, 4] studied DC conduction of MgO/LDPE nanocomposite. They found that the addition of MgO nano-filler leads to the improvement of DC electrical insulating properties of LDPE.

Received: September 15th, 2012. Accepted: May 31st, 2013

The PDC patterns of mineral oil, biodegradable oil and paper as transformers insulation have been studied by many researchers such as [5-7]. But until now, there are no investigations on PDC done for LLDPE/NR nanocomposite as a new insulation. Study on the PDC pattern of polymer nanocomposite is required as an increasing number of power utilities nowadays choose polymer nanocomposite as a new insulation due to its unique properties. This paper shows the comprehensive reviewed and analysis based on the studied done by previous researchers to identify and compared the DC conductivity patterns and trends for different types of nano filler of the polymer nanocomposite insulating materials.

2. Sample and Material Preparation

LLDPE used in this study is a commercial linear low density polyethylene manufactured by Titan Chemical, Malaysia. It has a density of 0.918 g/cm³ and melt index of 25g/10 min. While the filler used is nanoparticle of titanium oxide made in China with a particle size of about <50nm. This filler has nearly spherical shape with surface area of about 100 m²/g. The filler was dried before use. Natural rubber grade SMR CV 60 supplied by Taiko Plantations Sdn Bhd was used for blending and mixing with LLDPE and nanofiller. The polyethylene nanocomposites were prepared by melt mixing at 165⁰C using a Brabender mixer with chamber size of 50 cm³. The mixer has a high shear force and the screw speed was controlled at 35 rpm with the mixing time of 2 min. The polymer nanocomposites were finally prepared into square shape of 10cm x 10cm with the thickness of 3 mm by hot melt pressing at 1 tone pressure at 170⁰C for 10 min.

To validate the finding, experiment result had been compared with published result by research below for different sample of nanocomposite. Three types of polyethylene nanocomposites were prepared by researchers [1] with nanofillers of SiO₂, TiO₂ and Al₂O₃. The content of nanoparticles of the tested formulations was 2, 5 and 10 wt%. The average nanoparticle diameter was 40 nm for Al₂O₃ and 15 nm for SiO₂ and TiO₂. Researchers [2] have studied the electrical conduction processes in linear low density polyethylene (LLDPE) filled with nano alumina particles. LLDPE used in this study is a commercial linear low density polyethylene from Atofina. It has a density of 0.934 g/cm³, a melt index of 0.87 g/10 min. Nanoparticles of aluminium oxide from Degussa with a particle size of about 13 nm was used as filler.

Researchers [3, 4] studied DC conduction of MgO/LDPE nanocomposite. The employed polymer was a LDPE mixed with MgO nanofiller. The average diameter of MgO nanofiller was several tens of nm. Before kneading, MgO nanofiller was subjected to surface treatment with a silane coupling agent, and to the jet grinding treatment. The master batch with a high concentration of MgO nanofiller was firstly prepared using the twin-screw extruder.

Researchers [8] studied surface potential decay and dc conductivity of TiO₂-based Polyimide Nanocomposite Films. Polyimide/TiO₂ (PI/TiO₂) nanocomposite films containing surface modified nano-TiO₂ particles by employing silane coupling agent were prepared using in-situ dispersion polymerization process with 70 μm thickness was used. Table 1 shows the compound formulations and designation of the test samples.

Table 1. Compound formulations and designation

Test Sample	Nanofiller Constituents Composition %wt	Designation
LLDPE-NR/TiO ₂	1	B1
	3	B3
	5	B5
Polyimide/TiO ₂ [1]	1	P1
	3	P3
	5	P5
	7	P7
LLDPE/Alumina[2]	0	PE-0
	1	PE-1
	5	PE-5
	10	PE-10

3. Experiment Setup and Procedures

A. PDC Measurement Technique

The polarization currents measurement is performed by applying a DC voltage step on the dielectric materials and depolarization current is measured by removing the dc voltage source incorporating with a switch which turn on to short circuit at the under tested objects. The dc voltage applied was 1000V for about 10,000 seconds for polarization and depolarization time. The principles of PDC measurement is shown in Figure 1.

The polarization (charging) current through the object can thus be expressed as [5, 6, 9-11]:

$$i_p(t) = c_o u_o \left[\frac{\sigma}{\epsilon_r} + f(t) \right] \quad (1)$$

Once the step voltage is replaced by a short circuit, a depolarization current is built up. The magnitude of the depolarization current is expressed as [5, 6, 9-11]:

$$i_d(t) = c_o u_o [f(t) - f(t + t_c)] \quad (2)$$

where t_c is the time during which the voltage has been applied to the test object.

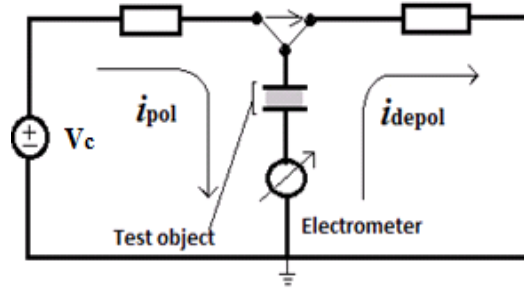

Figure 1. Principle of test arrangement for PDC measurement

B. Conduction Current Measurement System

The polarization and depolarization currents through the samples were recorded at TNBR Bangi by using PDC equipment as shown in Figure 2. A voltage step of 1000 V was applied to each sample. The sample had been mounted using three terminal electrode test cell.

From the measurements of polarization and depolarization currents, it is possible to estimate the DC conductivity σ , of the test object. If the test object is charged for a sufficiently long time so that $f(t + t_c) \cong 0$, equation (1) and equation (2) can be combined to express the dc conductivity of the composite dielectric as [5, 6, 9-11]:

$$\sigma \approx \frac{\epsilon_o}{c_o u_o} [i_p(t) - i_d(t)] \quad (3)$$

All the obtained data are run and plotted using MATLAB. From the plotted figures, the trend and pattern of the conductivity will be determined, either an upward or a downward trend is expected. The conductivity values presented in this paper for each material represent the DC conductivities. All the measurements were made at ambient temperature (27 °C).

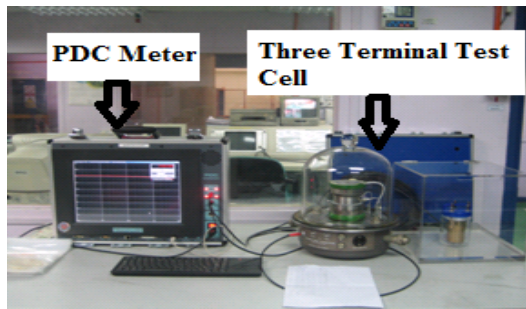

Figure 2. PDC measurement set up

Figure 3 shows the electrode configuration and the experimental setup for the conduction current measurement [3, 4]. A gold electrode of 40 mm in diameter was formed by vacuum evaporation on one side of the film. On the other side, a gold electrode of 26 mm in diameter was formed as the main electrode and a gold electrode of 32 mm in inner diameter and 40 mm in outer diameter was formed as the guard electrode. The conduction current measurement was performed at 303 K. The conduction current at 10 min after the DC voltage application was employed to determine the volume resistivity.

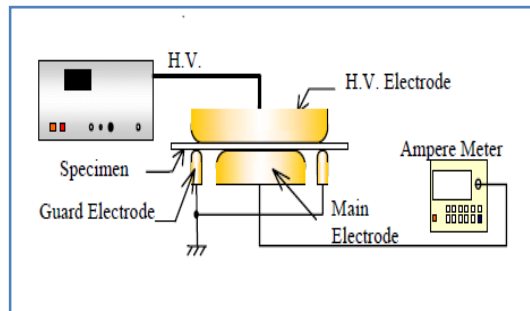

Figure 3. Conduction current measurement system [3, 4]

The DC conductivity test was done in the oven, with a 20 mm diameter gold electrodes on both sides at 6.5 kV for 1 hour. The testing temperature was fixed at 30°C to avoid the influence of small temperature fluctuation in the room on measured current[8]. From both conduction current measurements set up, it shows that the electrode using by PDC measurement set up is different with researchers [3, 4]. The injected voltage and measurement period also differ from both experiments. Even though there are some different, results from both experiment can be used to determined the DC conductivity of the samples.

4. Results and Discussion

A. Current Analysis

A.1. Based on Experiment

The results for polarization and depolarization currents measured for samples B1-B5 are shown in Figure 4 and Figure 5. Based on the plotted graph, it was found that adding of TiO₂ nanofiller from 1 %wt to 5 %wt, the value of current was increased significantly. These results agree with the fact that the TiO₂ nanofiller is a reactive semiconductor filler and it is not good for dielectric application.

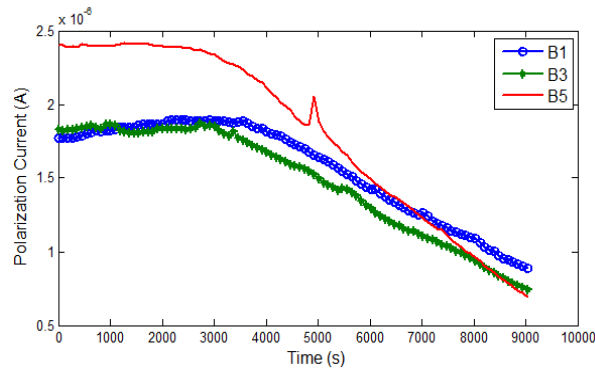

Figure 4. Polarization current values for sample B1, B3 and B5

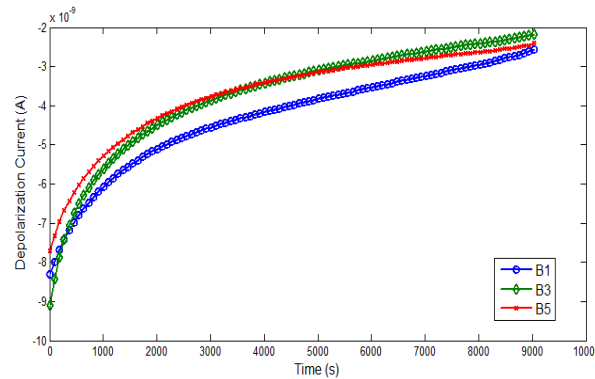

Figure 5. Depolarization current values for sample B1, B3 and B5

A.2. Others Researchers

The results for currents measured for TiO₂ based polyimide nanocomposite at different % amount added are shown in Figure 6. From the results, it can be concluded that adding nanoparticles into dielectrics can improve its electrical properties. However, different amount of nanofillers will give different results. As 1 % and 3% samples reduce the conductivity to the lowest point, it can be known that a small amount of nanofillers is separated inside the dielectric with a certain wide distance, which can be known as 'extra traps' for the dielectric, and therefore improve the insulation property.

However, if more nanoparticles adding into the dielectrics, for example, 5% sample has a better insulation property than the pure sample, but its conductivity is higher than 1% and 3% samples. This is because that some of the nanofillers are too closed to each other, and each nanoparticle has an interaction zone around it, which results some overlap of interaction zones. For 7% sample or higher amount nano dielectrics, the probability of interaction zones overlap is getting higher and higher, and therefore, the nanoparticles may align together, which helps the charges moving across the dielectric.

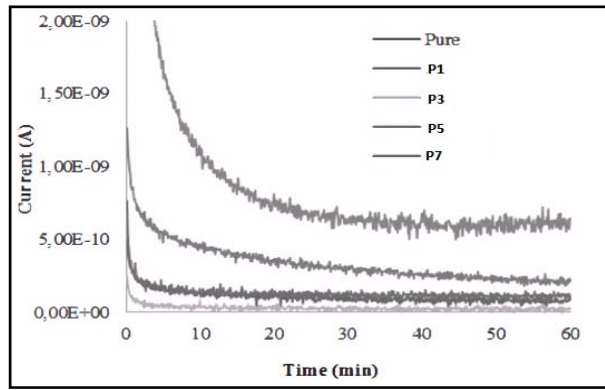

Figure 6. Current for TiO₂ based polyimide nanocomposite at different % amount added [8]

Figure 7 shows I-V characteristic in alumina nanoparticles filled LLDPE samples. The conduction current in the PE-1 sample is lower than the sample without any alumina nanoparticles. This means that the addition of small amount of alumina hinders the movement of charge in the bulk of the material. As the amount of alumina increases the conduction current in the PE-5 increases significantly compared to the PE-0. The conduction current in the PE-10 sample showing significant reduction at lower voltages but becoming very high once the applied voltage exceeds 5 kV[2].

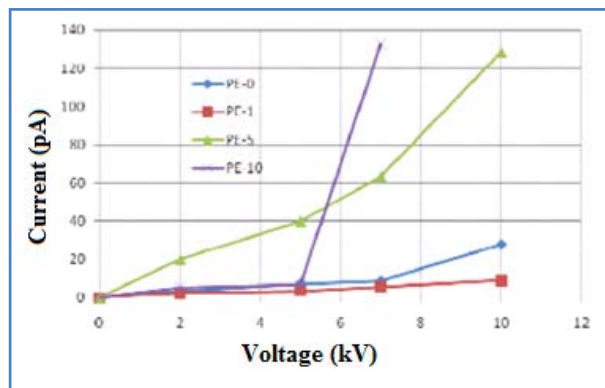

Figure 7. I - V characteristics in alumina nanopartilces filled LLDPE samples at 20°C [2].

B. Conductivity Analysis

B.1. Based on Experiment

Polarization and depolarization current measurement enables estimation to be made on the condition (moisture and ageing) of insulation with different conductivities. From Equation (3), it proves that conductivity of the insulation is influenced by polarization and depolarization current values.

Figure 8 shows conductivity variations for sample LLDPE-NR/TiO₂ at different amount of nanofiller. From the figure, it shows that the conductivity level of LLDPE-NR/TiO₂ increases when TiO₂ nanofiller increases from 1 %wt to 5 %wt. It shows that changes in %wt of TiO₂ nanofiller tend to affect the conductivity of the samples. The conductivity level increased due to the properties of TiO₂ nanofiller as semiconductor filler. This property is not good for insulator and dielectric properties.

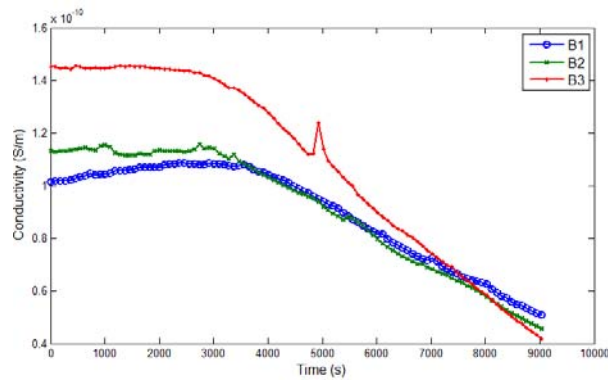

Figure 8. Conductivity variations for sample LLDPE-NR/TiO₂ at different amount of nano filler

B.2. Others Researchers

Figure 9 shows the influence of the MgO nanofiller content on the volume resistivity under the field application of 40 or 80 kV/mm. The volume resistivity was calculated by multiplying the applied field and the main electrode area to the reciprocal of conduction current. The open sign is each value of three measurements in each condition. The volume resistivity of the film with MgO nanofiller under each applied field was higher than that without MgO nanofiller. Above the MgO nanofiller content of 1 or 2 phr, the volume resistivity of the film with MgO nanofiller show saturated value [3, 4].

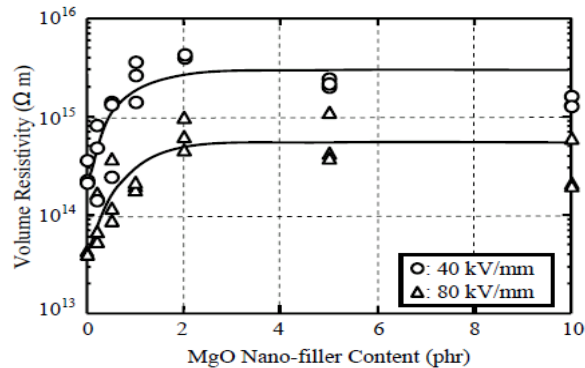

Figure 9. The influence of the MgO nano-filler content on the volume resistivity [3, 4].

5. Conclusion

In conclusion, it can be concluded that DC conductivity measurement can be used to compare nano dielectrics properties. Different types of nanofiller and percentage of concentration will give different values of current and conductivity. It can be observed, changes in insulation polarization and depolarization current values tend to affect the value of conductivity. From the results, it can be concluded that adding nano particles into LLDPE nanocomposite can reduce the PDC values. However, different amount of nanofillers will give different results. It has been found that the conduction current shows a minimum at a 1% b.w. concentration nano alumina and titanium particles. Besides, the volume resistivity of LDPE is increased by addition of MgO nanofiller.

Acknowledgement

The authors gratefully acknowledge the Malaysia Ministry of Higher Education, Universiti

Teknologi Malaysia under grant (Qj130000.7123.00J09 and R.J130000.7823.4F097) and Universiti Tun Hussein Onn Malaysia for financial support, TNB Research Sdn Bhd for equipment support and Taiko Plantation Sdn Bhd as a supplier of Natural Rubber.

References

- [1] F. Ciuprina and I. Plesa, "DC and AC conductivity of LDPE nanocomposites," in *Advanced Topics in Electrical Engineering (ATEE), 2011 7th International Symposium on*, 2011, pp. 1-6.
- [2] G. Chen, J. T. Sadipe, Y. Zhuang, C. Zhang and G. C. Stevens, "Conduction in linear low density polyethylene nanodielectric materials," in *Properties and Applications of Dielectric Materials, 2009. ICPADM 2009. IEEE 9th International Conference on the*, 2009, pp. 845-848.
- [3] Y. Murakami, M. Nemoto, S. Okuzumi, S. Masuda, M. Nagao, N. Hozumi and Y. Sekiguchi, "DC conduction and electrical breakdown of MgO/LDPE nanocomposite," *Dielectrics and Electrical Insulation, IEEE Transactions on*, vol. 15, pp. 33-39, 2008.
- [4] S. Masuda, S. Okuzumi, R. Kurniant, Y. Murakami, M. Nagao, Y. Murata and Y. Sekiguchi, "DC conduction and electrical breakdown of MgO/LDPE nanocomposite," in *Electrical Insulation and Dielectric Phenomena, 2007. CEIDP 2007. Annual Report - Conference on*, 2007, pp. 290-293.
- [5] N. A. Muhamad, B. T. Phung, T. R. Blackburn and K. X. Lai, "Polarization and Depolarization Current (PDC) tests on biodegradable and mineral transformer oils at different moisture levels," in *Power Engineering Conference, 2009. AUPEC 2009. Australasian Universities*, 2009, pp. 1-6.
- [6] T. K. Saha and P. Purkait, "Investigation of polarization and depolarization current measurements for the assessment of oil-paper insulation of aged transformers," *Dielectrics and Electrical Insulation, IEEE Transactions on*, vol. 11, pp. 144-154, 2004.
- [7] T. Gradnik, M. Babuder and M. Koncan-Gradnik, "Estimation of water content in power transformers in service by polarization and depolarization current measurements," in *Dielectric Liquids, 2008. ICDL 2008. IEEE International Conference on*, 2008, pp. 1-4.
- [8] Y. Zhuang, J. Zha and G. Chen, "Surface potential decay and dc conductivity of TiO₂ based polyimide nanocomposite films," in *Electrets (ISE), 2011 14th International Symposium on*, 2011, pp. 155-156.
- [9] T. K. Saha, M. K. Pradhan and J. H. Yew, "Optimal Time Selection for the Polarisation and Depolarisation Current Measurement for Power Transformer Insulation Diagnosis," in *Power Engineering Society General Meeting, 2007. IEEE, 2007*, pp. 1-7.
- [10] C. Ekanayake, T. K. Saha, H. Ma and D. Allan, "Application of polarization based measurement techniques for diagnosis of field transformers," in *Power and Energy Society General Meeting, 2010 IEEE*, pp. 1-8.
- [11] T. K. Saha and P. Purkait, "Investigation of an expert system for the condition assessment of transformer insulation based on dielectric response measurements," *Power Delivery, IEEE Transactions on*, vol. 19, pp. 1127-1134, 2004.



Nor Akmal Mohd Jamail is a lecturer of University Tun Hussein Onn Malaysia since 2008 and currently a PhD student at Institute of High Voltage & High Current (IVAT) Faculty of Electrical Engineering Universiti Teknologi Malaysia. She received the Bachelor degree in Electrical Engineering from Universiti Teknologi Malaysia in 2005 and M.Eng in Power System from University of Tun Hussein Onn Malaysia in 2007. She is doing research in area of condition monitoring of high voltage equipment and polymer insulating materials.



Mohamed Afendi Mohamed Piah was born in Taiping, Perak, on November 8, 1963. He is an associate professor at Faculty of Electrical Engineering, Universiti Teknologi Malaysia (UTM) and a fellow member of the Institute of High Voltage and High Current (IVAT). He received the B.Elect. Eng. degree from UTM in 1986, M.Sc in Power System from University of Strathclyde, UK in 1990 and PhD in High Voltage Engineering from UTM in 2004. He was appointed as an assistant director (Test and Calibration Division) of IVAT from 1996-2000 and Deputy Director of IVAT from 2007-2009. He has been involved in testing and calibration of high voltage equipments. His research interests include high voltage insulation diagnostic and co-ordination, electrical discharges, polymer nanocomposites insulating materials and insulator condition monitoring.

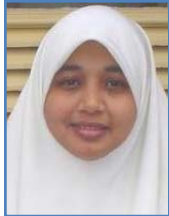

Nor Asiah Muhamad is currently a Senior Lecturer at Institute of High Voltage & High Current (IVAT) Faculty of Electrical Engineering Universiti Teknologi Malaysia since 2003. Received her PhD degree from University of New South Wales, Australia in 2010, Master degree in Electrical Power Engineering from University of South Australia in 2006 and Bachelor degree in Electrical and Electronic Engineering from Universiti Teknologi PETRONAS, Malaysia in 2002. She doing research in area of condition monitoring high voltage equipment, dielectric insulation material test , HV equipment faults diagnosis.



R.A. Zainir was born in Penang, Malaysia in 1987. She received the B. Eng (Electrical) from Universiti Teknologi Malaysia, Johor, Malaysia in 2011. Currently, she's pursuing her Master degree at Institute of High Voltage and High Current (IVAT) in Faculty of Electrical Engineering, UTM Skudai, Johor. Her research interest includes PDC measurement and software development for condition monitoring.



Nur Faizal bin Kasri is currently a Master student at Institute of High Voltage & High Current (IVAT) Faculty of Electrical Engineering Universiti Teknologi Malaysia. He received the Bachelor degree in Electrical - Mechatronic Engineering from Universiti Teknologi Malaysia in 20011. He is doing research in area of condition monitoring of high voltage equipment.



Qamarul Ezani Kamarudin was born in Kelantan, Malaysia in 1981. He received the Bachelor degree in Mechanical Engineering from Universiti Teknologi Malaysia, Johor, Malaysia in 2006. He is currently working as an instructor at Faculty of Mechanical and Manufacturing Engineering, Universiti Tun Hussein Onn Malaysia.