

ENHANCING FUEL BURNING EFFICIENCY BY REGULATE SPARK PLUG
VOLTAGE SUPPLY

MASLINA BINTI MOHD ARIFFIN

A project report submitted in partial fulfillment of the requirement for the award of the
Master of Electrical Engineering

Faculty of Electrical and Electronic Engineering
Universiti Tun Hussein Onn Malaysia

JANUARY 2013

ABSTRACT

Nowadays, fuel consumption, fuel efficiency and fuel economy is number one priority for people. The need to reduce fuel consumption is because oil reserves are running low and the cost of gasoline will only increase day by day. The benefits of increased fuel economy is significant energy, cost saving, reducing greenhouse emission, improved air quality and etc. To increase the fuel efficiency, many fuel efficient vehicles was created. Fuel-efficient vehicles are extremely important because we need to cut our fuel consumption and find other way of powering cars. Thus, this research introduced the system that can reduce fuel consumption and improve car performance when the car battery voltage is increase. This system use ac power supply replacing the car battery to get the dc power supply. Also, the system enables to increase voltage from 12 volt to 16 volt supplied to spark plug to enhance fuel burning efficiency. Aims of project are to improve car performance and reduce fuel consumption. To meet the desired aim of this research, the experiment to measure car performance using power performance that are produce from current voltage and the experiment similarly concept with combustion process was done. From that experiment, the system had improved car performance and lessing fuel consumption to 33% when the voltage increases to 16V.

ABSTRAK

Kini, penggunaan, kecekapan dan juga penjimatan minyak adalah keutamaan nombor satu kepada rakyat. Keperluan untuk mengurangkan penggunaan minyak adalah disebabkan rizab minyak semakin berkurangan atau harga untuk minyak meningkat. Kepentingan untuk menjimatkan minyak adalah kerana kepentingan tenaga, menjimatkan wang, mengurangkan pencemaran rumah hijau, meningkatkan kualiti udara dan lain-lain. Untuk meningkatkan kecekapan minyak, banyak kenderaan dgn keupayaan kecekapan minyak telah direka. Kenderaan dengan kecekapan minyak adalah sangat penting kerana kita perlu mengurangkan penggunaan minyak dan mencari jalan lain untuk meningkatkan kuasa kereta. Oleh sebab itu, kajian ini memperkenalkan satu sistem yang boleh mengurangkan penggunaan minyak dan juga meningkatkan prestasi kereta apabila voltan bateri kereta dinaikkan. Sistem ini menggunakan kuasa arus ulang-alik sebagai menggantikan bateri kereta untuk mendapatkan arus terus. Selain itu, system ini boleh meningkatkan bateri dari 12V kepada 16V dan dibekalkan kepada palam pencucuh untuk meningkatkan kecekapan pembakaran bahan api. Tujuan kajian ini adalah untuk meningkatkan prestasi kereta dan mengurangkan penggunaan minyak. Untuk memenuhi matlamat yang dikehendaki, eksperimen untuk menilai prestasi kereta menggunakan prestasi kuasa yang dihasilkan daripada arus dan voltan dan eksperimen seakan-akan konsep proses pembakaran telah dilakukan. Daripada eksperimen tersebut, sistem itu dapat meningkatkan prestasi kereta dan mengurangkan penggunaan minyak sebanyak 33% apabila voltan ditingkatkan kepada 16V.

CONTENTS

TITTLE	ii
DECLARATION	iii
DEDICATION	iv
ACKNOWLEDGEMENT	v
ABSTRACT	vi
TABLE OF CONTENTS	viii
LIST OF TABLES	xi
LIST OF FIGURES	xii
LIST OF SYMBOLS & ABBREVIATION	xiv
CHAPTER 1 INRODUCTION	1
1.1 Project Background	1
1.2 Problem Statement	2
1.3 Project Objective	3
1.4 Project Scopes	3
CHAPTER 2 LITERATURE REVIEW	5
2.1 Overview of Development	5
2.2 The development in Fuel Efficiency and Fuel	5

	Consumption for a Car	
2.3	Differences / Similarities Method	7
CHAPTER 3 METHODOLOGY		9
3.1	Research design	9
3.1.1	Ignition System Block Diagram	11
3.2	Project Block Diagram	14
3.3	Hardware Development	17
3.3.1	Transformer	17
3.3.2	Rectifier	19
3.3.3	Filter Capacitor	21
3.3.4	Synchronous Pulse-Width Modulation (PWM)	23
3.3.5	Voltage Regulator	24
	3.3.5.1 Circuit operation	26
	3.3.5.1.1 Timer 555	27
	3.3.5.2 Voltage and Current Relationship	29
	3.3.5.2.1 Analysis for the Switch	
	Closed	30
	3.3.5.2.2 Analysis for the Switch	
	Open	30
3.3.6	Ignition Coil	33
	3.3.6.1 Turning up the Voltage	37
	3.3.6.2 Coil Polarity	38
3.3.7	Electricity in Spark Plug	38
CHAPTER 4 RESULT AND DISCUSSION		41

4.1	Experiment 1: Determine the Relationship Car Performance with Car Battery Voltage	41
4.1.1	Experiment Procedure (Relationship Voltage and Current)	42
4.1.1.1	Experiment Result Analysis	43
4.1.2	Experiment Procedures (Relationship Voltage with Lamp Brightness)	46
4.1.2.1	Experiment Result Analysis	47
4.2	Experiment 2: Determine the Fuel Consumption Relationship with the Increases of the Voltage	48
4.2.1	Experiment Procedure (Relationship Voltage with Fuel consumption)	49
4.2.1.1	Experiment Procedure When Using Constant Fuel and Voltage	50
4.2.1.2	Experiment Result Analysis	52
4.3	Discussion	56
CHAPTER 5 CONCLUSION AND FUTURE RECOMMENDATION		58
5.1	Conclusion	58
5.2	Recommendation	59
REFERENCE		61
VITA		64
APPENDIX		
A.	LM555 Timer	65

LIST OF TABLES

4.1	Relationship Voltage and Current	43
4.2	Relationship of Power Performance and Voltage	44
4.3	Experimental Brake Lamp Parameters	46
4.4	Relationship Lamp Brightness with Voltage and Current	47
4.5	Experimental PVC Pipe, Spark Plug and Fuel Parameters	50
4.6	Result for using Constant Fuel and Constant voltage	52
4.7	Comparison Voltage and Ring Movement Using Lowest Fuel	53
4.8	Selected Data \cong 130mm	55

LIST OF FIGURES

3.1	Flow Chart Process Flow	10
3.2	Process of Ignition System	11
3.3	Ignition System Block Diagram	12
3.4	Schematic diagram of Ignition Coil System with using 16V System	14
3.5	The detail of the System in Ignition System	15
3.6	Block Diagram for Enhancing Fuel Burning Efficiency by Regulate Spark Plug Voltage Supply	15
3.7	Circuit Connection of the 12V to 16V System	16
3.8	The Model of Transformer	17
3.9	Step-Down Transformer	18
3.10	Model of Rectifier	19
3.11	This is the Internal Diagram of Rectifier about Where to Connect the Input (AC) and the Output (DC)	20
3.12	Connection of Filter Circuit	22
3.13	Circuit Connection of Transformer, Rectifier and Filter	22
3.14	Output Waveform from Filter Circuit	23
3.15	Pulse-Width Modulation (PWM)	24
3.16	Concept of Voltage Regulator	25
3.17	Ideal voltage Regulator would Respond to a Change in Load Current Demand	25
3.18	Circuit Connection of 12V to 16V Regulator	26
3.19	LM555 Timer	27
3.20	An Astable Circuit for Timer 555	28
3.21	Timer 555 Output Square Wave	28
3.22	Buck-Boost Converter Waveform	32

3.23	Ignition Coil	33
3.24	Construction of Ignition coil	34
3.25	Ignition Coil are Electrically Connected [18]	34
3.26	Primary and Secondary Form a Step-Up Transformer	35
3.27	Switch Open (initial)	35
3.28	Switch Closed	36
3.29	Field Stabilized	37
3.30	Switch Opened	37
3.31	The spark Plug is in the Center of the Four Valves in Each Cylinder	38
3.32	Spark Plug Cutaway	39
4.1	The Ammeter	42
4.2	The Voltmeter	42
4.3	Experiment Setup for Relationship Voltage and Current	43
4.4	The Electric Arc on Spark Plug using Different Voltage	43
4.5	Graph of Voltage (V) versus Current (mA)	44
4.6	Graph of Voltage (V) versus Power Performance (w)	45
4.7	The System Block Diagram Using Brake Lamp	46
4.8	Brake Lamp	46
4.9	Light meter	47
4.10	Graph Voltage versus Lamp Brightness	48
4.11	Combustion Process	49
4.12	PVC Pipe	50
4.13	Experiment Setup Diagram for Constant Fuel and Constant Voltage	51
4.14	Real experiment setup for constant fuel and voltage	51
4.15	Close-Up the Real Experiment Setup for Constant Fuel and Voltage	52
4.16	The Fuel was Measured	53
4.17	Graph Voltage (V) versus Piston Movement (mm)	55
4.17	Graph Voltage (V) versus Fuel (ml) with Reference Piston Movement \cong 130mm	55
4.17	Graph Voltage (V) versus Fuel (ml) with Reference Piston Movement \cong 130mm	55

LIST OF SYMBOLS & ABBREVIATION

V	-	Voltage
DC/DC	-	Direct current to direct current converter
DC _{bus}	-	Direct current bus voltage
FPGA	-	Field Programmable Gate Array
kV	-	Kilo-Volt
PWM	-	Pulse-Width Modulation
AC	-	Alternating current
DC	-	Direct Current
I _s	-	Secondary current
I _p	-	Primary current
P _s	-	Power to the secondary
P _p	-	Power to the primary
SW1	-	Switch 1
HV	-	High Voltage
PVC	-	Polyvinyl chloride

CHAPTER 1

INTRODUCTION

1.1 Project Background

Nowadays, fuel consumption of a car or vehicle is the major issues to take into account especially when buying a car. The benefits of an increase fuel economy is significant of energy, cost saving, reducing greenhouse emission, improved air quality [3] and etc. the research justification shows that fuel consumption also can be reduce if the car battery voltage is increase. This research is about a system that enabling the increase of car battery voltage from 12 volt to higher voltage (12 to16 volt) supplied to spark plug to enhance fuel burning efficiency. However the voltage supplied to other component in the car remain at 12 volt. The importance of this research is the efficiency will lead to a better car performance that reducing fuel consumption.

Recently, fuel efficiency has become an extremely important topic because of the rising of gas price, the need to cut our carbon footprints, and the need to cut dependence on oil-rich nations. When oil prices rise, people's thought naturally jump into an alternative fuel sources such as fuel efficient vehicle, Biodiesel, gas prices, Hydrogen economy, fuel cell and etc [6]. To increase the fuel efficiency, many fuel efficient vehicles was created. Fuel-efficient vehicles are extremely important because the need to

cut our fuel consumption and find other way of powering cars, and nowadays fuel-efficient vehicles are really popular such as hybrid cars, electric cars, natural gas vehicles and etc. This car will give passengers maximum efficiency when they use it. Also, to improve the fuel efficiency, fuel cell is being used to generate electrical power. A fuel cell is an electrochemical energy conversion device that converts the chemicals hydrogen and oxygen into water, and in the process of producing electricity. The other electrochemical devices are battery. A battery has all of its chemicals stored inside, and it converts those chemicals into electricity tool [6].

The fuel consumption also is a major issue in the world. This is because oil reserves are running low so that we need to cut our fuel consumption or the cost of gasoline will gets higher. To reduce the fuel consumption, Biodiesel is used. Biodiesel is an alternative or addition to standard diesel fuel that is made from biological ingredients instead of petroleum (or crude oil). Biodiesels are usually made from plant oils or animals fat through a series of chemical reactions. It is both non-toxic and renewable because biodiesel essentially comes from plants and animals, the sources can be replenished through farming and recycling [6].

Many researchers and engineers are making many efforts to find way to save our energy in this world. We as the user should be more supportive with this problem.

1.2 Problem Statement

Recently low fuel consumption is one of the main criteria when buying a car. Reducing fuel consumption means saving money and, more importantly, helps the environment. Nowadays the use of fuel is an ongoing expenses year by year. To reduce the fuel consumption we need to get the optimum efficiency of the car.

Fuel efficiency will become everyone's number one priority during the increasing of petrol prices. The fact is we have to act that a large portion of our monthly income goes into maintaining and supplying our car. This is even worse if we drive a less fuel-efficient car. In general, the larger our car is, the less fuel-efficient it is as it takes more petrol to drive or move the car. Nowadays most up-to-date engine technologies has succeeded in improving fuel-efficiency, but this benefit is null and void

by the addition of mass and power need for added features like automatic transmission, for instance.

It seems like there is the increasing demand for more fuel efficiency and environmental friendly cars coupled with the consumer drive for more comfort and safety [8] but for young generation, speed and stylish of a car is more important. The demand for electric power in cars will increase more electrical loads that were added in the cars [8]. These issues have vice versa, whether to transform the car to high performance that will increasing the fuel consumption but low performance will reduce the fuel consumption.

Therefore, in this research are proposing a system to improve our delivered to engine with no jeopardize electronic device. The problem with a modern car is too many electronic devices that demanding high stabilizes voltage to ensure the cars high performance is less. Therefore a system or method to improve the engine performances especially the injection part without changing the other electronic device input voltage.

1.3 Project Objectives

The objective of this research is:

- 1) To measure car performance relationship with car battery voltage. In order to meet the growing electrical power demands with minimum fuel consumption the car battery will be increase to get the maximum car performances.
- 2) To improve burning efficiency, thus leading to the reducing of fuel consumption and minimize costs. Increasing the car battery voltage would improve the ignition performance and it is an advantage to combustion speed.

1.4 Project Scopes

This research is primarily concerned to the increasing of car battery voltage which is concerned about the fuel consumption and performance of a car. In order to achieve the objectives of the research, several scopes had been outlined. The scopes of this research are:

- 1) The battery voltage will be increase from 12V to 16V.
- 2) Understanding about the electricity in the spark plug, where the burning efficiency at ignition system will reduce fuel consumption.
- 3) The voltage at the other component in the car will remain 12V without change.
- 4) Limitation in this research, due to mechanical constraint the research will be done with a similar mechanism of car.

CHAPTER 2

LITERATURE REVIEW

2.1 Overview of Development

Many researchers concerns about the fuel consumption of cars or vehicles since the world fuel are increasing year by year. It is becoming a big issue to take part into this account. Here, the research activities that related to the electronic ignition to reduce the fuel consumption and to improve fuel efficiency.

2.2 The Development in Fuel Efficiency and Fuel Consumption for a Car

Here in this section, a quick overview with different examples of work were done. In the journal [8], with the increasing demands for more fuel efficiency and environmentally friendly car coupled with the consumer drive for more comfort, safety and luxury car has led to the introduction of more electrical and electronic system to passenger cars. This is further impacted by the current trends in automotive industry to replace mechanical and hydraulic system with their electrical counterparts. Here, the problem tries to obtain that the dc-dc based architecture system is a potential solution for a more efficient and stable automotive electrical power system. The system complies with a demanding requirements of the automotive industry in terms of current and voltage surges. The application method that is being use is mathematical model for 3-phase, 4kW and 42V

Lundell alternator average electrical equivalent circuit will be presented along with the DC/DC converter based architectures for dual-voltage systems. The performance of the 42V Lundell alternator with the interleaved six-phase buck dc-to-dc converter system is modelling using simulink software to assess the effectiveness of the model and its transient behaviour [8].

In [9], the piezoelectric actuator, there is a new technology in automotive system, where it is high performances, low emission and less fuel consumption. Piezoelectric actuators require a high DC_{bus} voltage to obtain high performance. The FPGA controlled coupled inductor boost is presented as a good option to solve high boosting requirements in automotive applications. High power efficient converters with reduced size output filter can be obtained by interleaving and controls these types of converters. The FPGA implementation ensures good dynamic performance, reliability and high computational performances resulting in high efficiency overall characteristic [9].

Another research in order to get the less fuel consumption is to study the adjustability of spark plug gaps in different ignition systems in search of optimum spark plug gap [10], traditional contact-controlled inductive storage ignition system and superposing high ignition system were used in engine respectively. Generally, increasing the spark plug gap at a certain extent can improve the ignition capability and save the petrol. Also, increasing the spark plug gap can improve the ignition performance and at the same time high energy ignition device must be used. Increasing the ignition energy is an advantage to the burning nucleus shaping at the earlier combustion, and can quicken the combustion speed and suppress engine knock [10].

Furthermore in [11], Hybrid electrical vehicles have been receiving increased attention because of their inherent advantages such as improving fuel efficiency, reducing unwanted emission and having potential to enhance dynamic performance. Here the problem tries to presents a new power flow control strategy for a variable speed engine-generator based series hybrid electric vehicle. The proposed power flow controller makes it possible that the ICE operates at its optimal fuel efficiency points without degrading desired dynamic performance. The proposed of power flow control method can increase the lifetime of the battery through minimizing its charge and discharge cycles. The engine's specific fuel consumption maps obtained by off-line

experiments have been applied to the proposed power flow control method [11]. The speed of the engine is directly controlled according to the load power via controlling its angle of the throttle valve. Also, the proposed power flow control method present an appropriate power reference generation strategy for the battery module to achieve optimal fuel efficiency and to get desired dynamic performance at the same time [11].

Other than that, in [12] in order to get the improvement of fuel economy, Gerald J. Rohwein [12] has conducted research entitles an efficient, power enhanced ignition system. Spark ignition engines typically have ignition system that develop 20-30kV for breakdown of the spark plug gap and deliver current pulses in the range of 30-100mA. Most of energy is dissipated by the resistance in the transformer, spark plug wires, and spark plugs. Requirements for increased ignition power and energy will have to be met with higher efficiency ignition system. Improved efficiency can be achieved by utilizing peaking capacitor in the secondary circuit, preferably with a low loss spark coil [12]. Enhanced power ignitions that deliver higher power and more energy than conventional ignition systems will improve fuel economy and lower hydrocarbon emission in many vehicles. Because the lean burn limits are extended, high power ignition also improve starting, cold running and transient throttle response. High voltage peaking capacitors delivered the highest power and the most economical for upgrading a conventional spark plug system [12].

2.3 Differences / Similarities Method

From the literature review, the differences on paragraph 1 is the research is about to increase the voltage to 42V with 4 kW, where the dc-dc based architecture system is a potential solution for more efficient and stable automotive electrical power system. This 42V power system architecture is for luxury cars only [8]. For second paragraph the research used high step-up DC/DC converter for interfacing the standard 12V battery with high voltage with using the FPGA [9]. The research for third paragraph is using the different spark plug gap to get improvement in ignition energy [10]. The next research in the literature review is also different, where the paper presents new power flow control strategy for a variable speed engine-generator based series hybrid electric vehicle [11].

Lastly, the research is about to improved efficiency by utilizing peaking capacitor in the secondary circuit with a low-loss spark coil [12].

From the description on literature review, the similarities on this overall literature review are all changes or add-ons in the electronic engine is to achieve the objective of less fuel consumption, increase the fuel efficiency with high car performance and also to save money.

CHAPTER 3

METHODOLOGY

3.1 Research Design

This research is concerning about performance and fuel efficiency of a car which gain from increasing the car battery voltage. In this research, we measuring the voltage in the ignition system in the car, which is the burning of the spark plug when the car battery voltage is increase from 12V to 16V. The flow of the process is shown in Figure 3.1 below:

The purpose of the ignition system is:

- 1) It must control the spark and timing of the spark plug firing to match varying engine requirements, and [5]
- 2) It must increase battery voltage to a point where it will overcome the resistance offered by the spark plug gap and fire the plug [5].

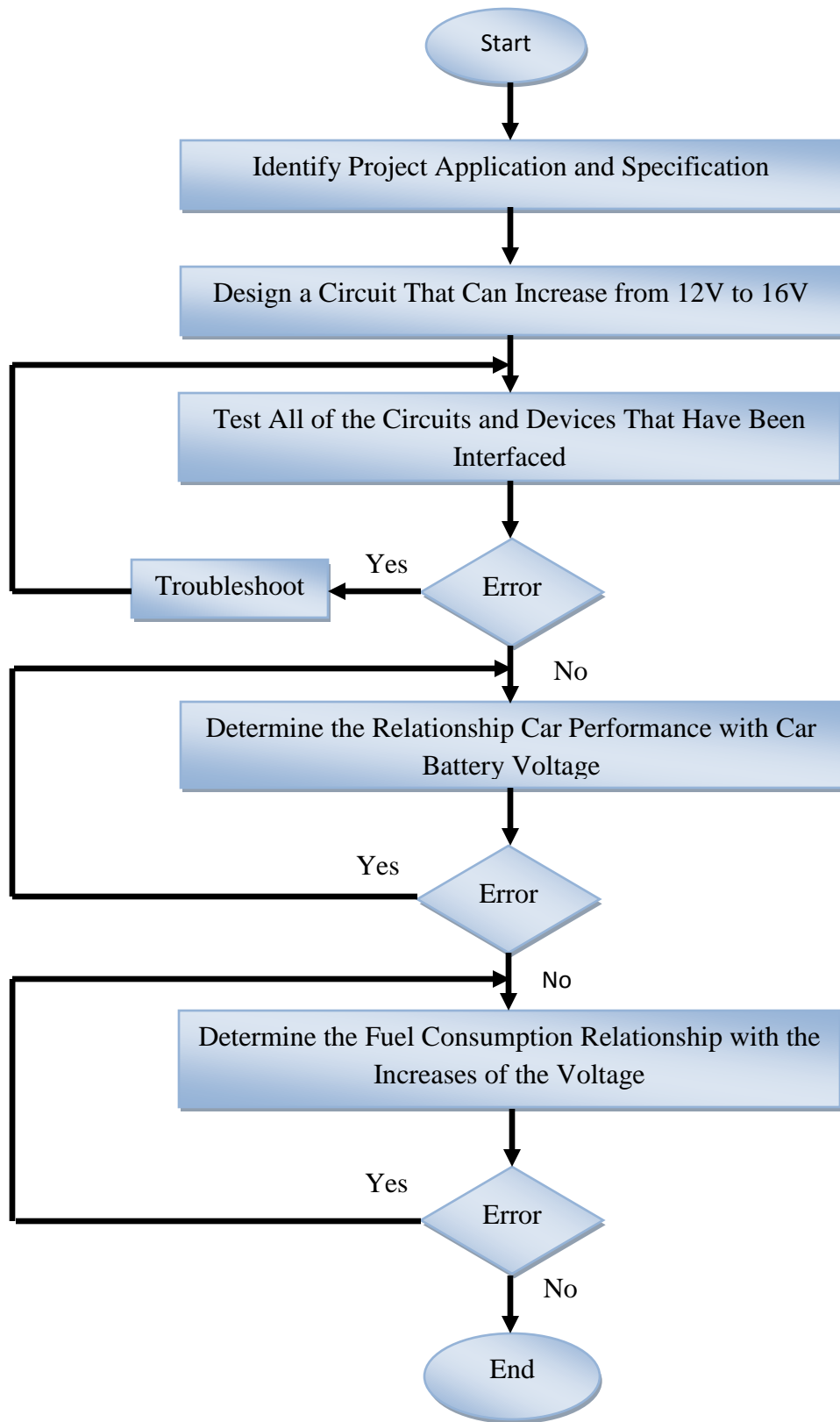

Figure 3.1: Flow Chart Process Flow

Figure 3.1 shows the flow chart of process flow in this research. This research starts with identify applications and specifications in the ignition system, the overall part that involved in ignition system and the function of ignition system in car engine. After that, select the suitable component and then design the circuit that will increase the battery voltage from 12V to 16V. Then, test the circuit that has been interfaced. After that, determine the relationship car performance with car batter voltage. Last but not least, determine the fuel consumption with the increases of voltage.

3.1.1 Ignition System Block Diagram

The ignition system consists of a variety of component, some of which are dependent upon the specific ignition system design. The ignition system creates and distributes a high voltage (up to 40kV or more) and send to spark plug [18]. A high voltage arc occurs across the gap of a spark plug inside the combustion chamber. The spark rises the temperature of the air-fuel mixture and starts the combustion processes inside the cylinder [18].

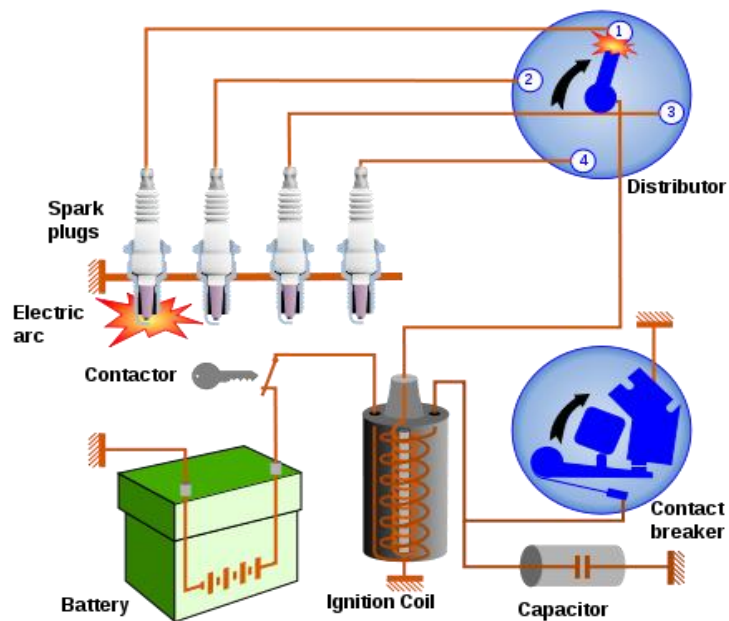

Figure 3.2: Process of Ignition System

Figure 3.2 shows the process of ignition system. The component of an ignition system includes spark plug, distributor, capacitor, contact breaker, ignition coil and battery. The method is to show the increasing of voltage to the spark plug and how that can reduce the fuel consumption. The process will discuss on Figure 3.3 that show the block diagram for ignition system.

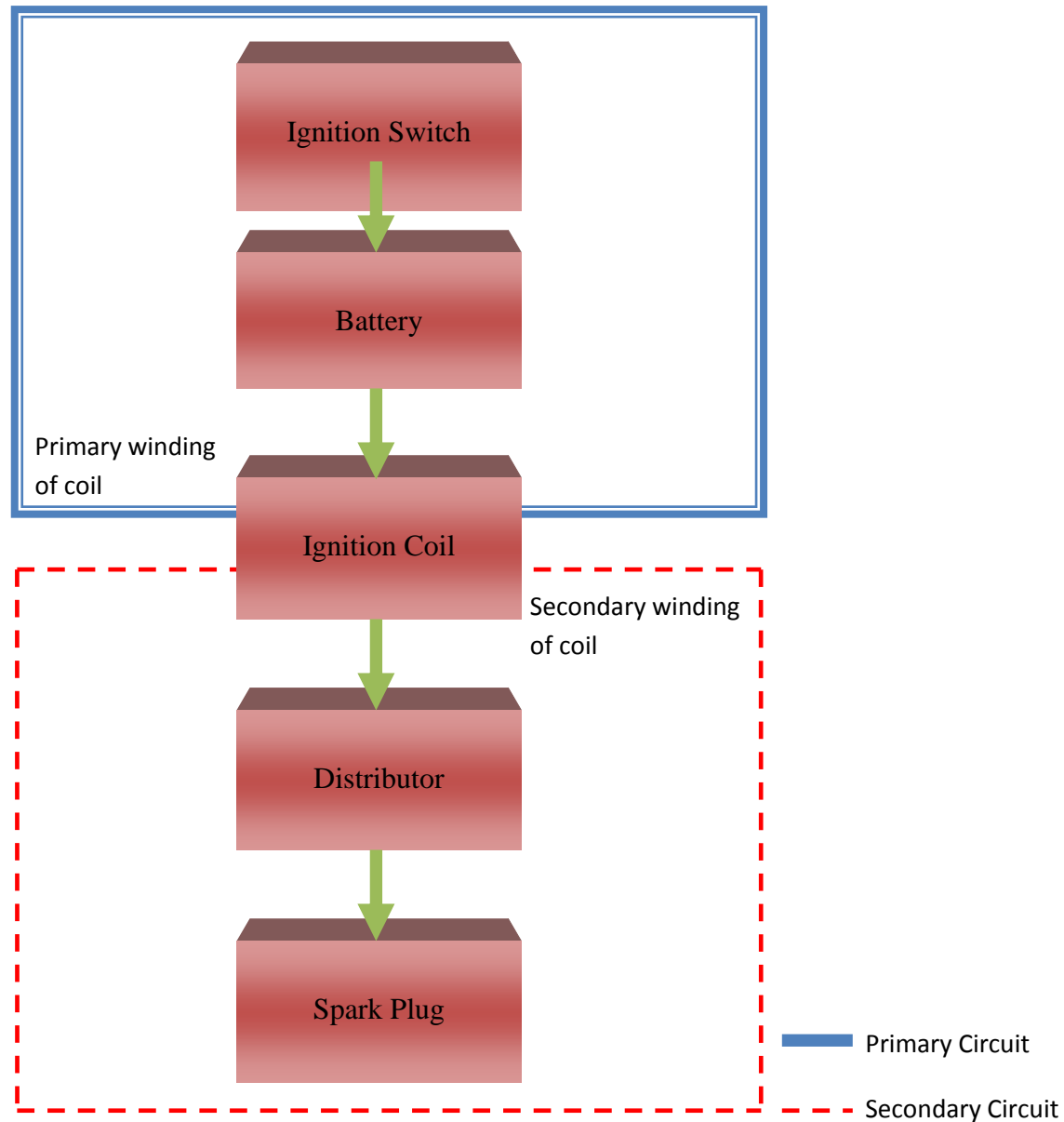

Figure 3.3: Ignition System Block Diagram

Figure 3.3 shows the ignition system block diagram. The ignition system is divided into two sections, the primary circuit and the secondary circuit. The low voltage primary circuit operates a battery voltage and is responsible for generating the signal to fire the spark plug at the exact right time and sending that signal to the ignition coil. The ignition coil is the component that converts the 12 volt signal into the high voltage charge. Once the voltage is stepped up, it goes to the secondary circuit which then directs the charge to the correct spark plug at the right time.

The process start when insert the key in the ignition switch to Run position, from that current sending from the battery through a wire directly to the positive side of the ignition coil. Inside the coil is a series of copper windings that loop around the coil over a hundred times before exiting the negative side of the coil. From there, a wire takes this current over to the distributor and is connected to a special on/off switch, called the points. When the points are closed, this current goes directly to ground.

When current flows from the ignition switch, through the windings in the coil, then to ground, it builds a strong magnetic field inside the coil. The distributor cam rotates in time with the engine. As it rotates, the cam pushes the points open and closed. Every time the points open, the flow of current is interrupted through the coil, thereby collapsing the magnetic field and releasing a high voltage surge through the secondary coil windings. This voltage surge goes out the top of the coil and through the high-tension coil wire.

The coil wire goes from the coil directly to the center of the distributor cap. Under the cap is a rotor that is mounted on top of the rotating shaft. The rotor has a metal strip on the top that is in constant contact with the center terminal of the distributor cap. It receives the high voltage surge from the coil wire and sends it to the other end of the rotor which rotates past each spark plug terminal inside the cap. As the rotor turns on the shaft, it sends the voltage to the correct spark plug wire, which in turn sends it to the spark plug. The voltage enters the spark plug at the terminal at the top and travels down the core until it reaches the tip. It then jumps across the gap at the tip of the spark plug, creating a spark suitable to ignite the fuel-air mixture inside that cylinder.

3.2 Project Block Diagram

Figure 3.4 show the schematic diagram of the ignition system and where the system should be placed in the ignition system. The system would be placed before the ignition coil and will give more stabilize to the car battery.

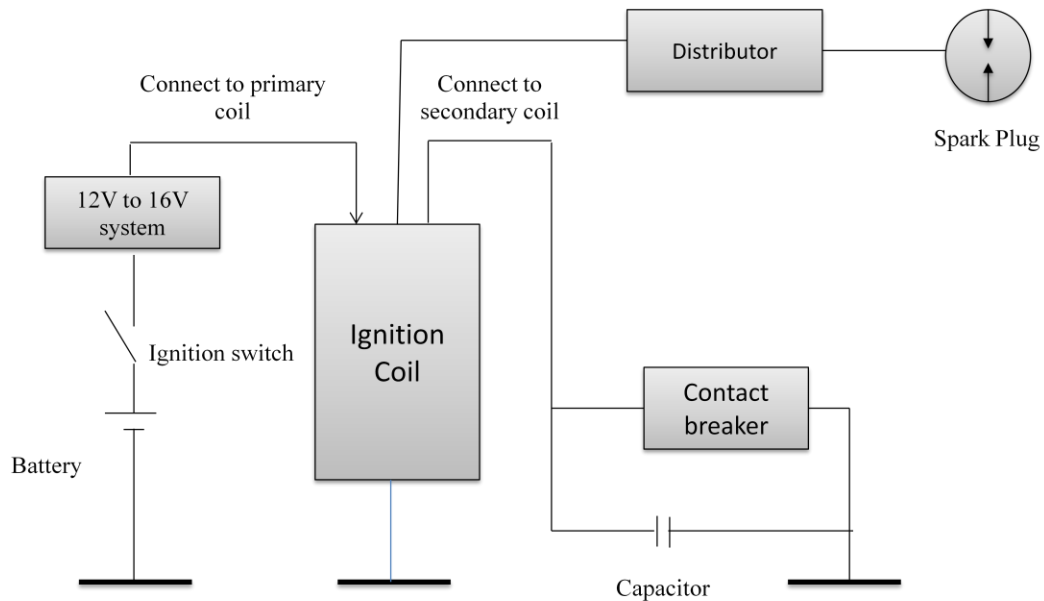

Figure 3.4: Schematic Diagram of Ignition Coil System with Using 16V System

As mention earlier, this research just involves the system to spark plug and the other component in car maintains 12V. Figure 3.5 shows more detail of the system should be placed. The system start from the car battery and then through the system that will increase to 16V. The system connected with the primary and secondary ignition coil and then the secondary coil will connected with the spark plug and produce the high voltage to jump the air gap at the spark plug.

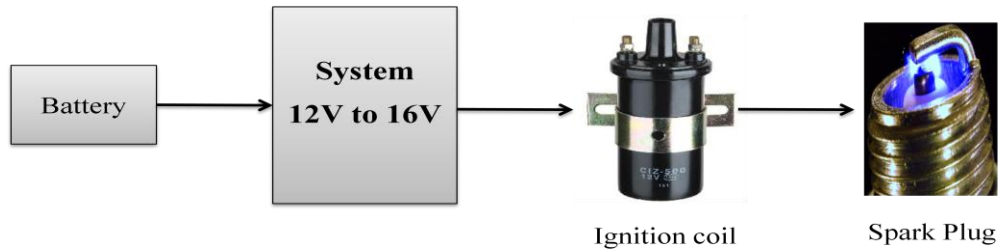

Figure 3.5: The Detail of the 12V to 16V System in Ignition System

All ignition system applies battery voltage (close to 12V) to the positive side of the ignition coil and pulse the negative side to the ground. In this research, the methods are to increasing the car battery voltage from 12V to 16V to the spark plug. Increasing the battery voltage can improve the ignition performance where it can quicken the combustion speed and suppress engine knock. At the engine high speed, the mixture combustion time is forced to be shortened and the combustion speed increase. This research will also show the car performance is increase and less fuel consumption. Figure 3.6 shows the block diagram for the system of this research.

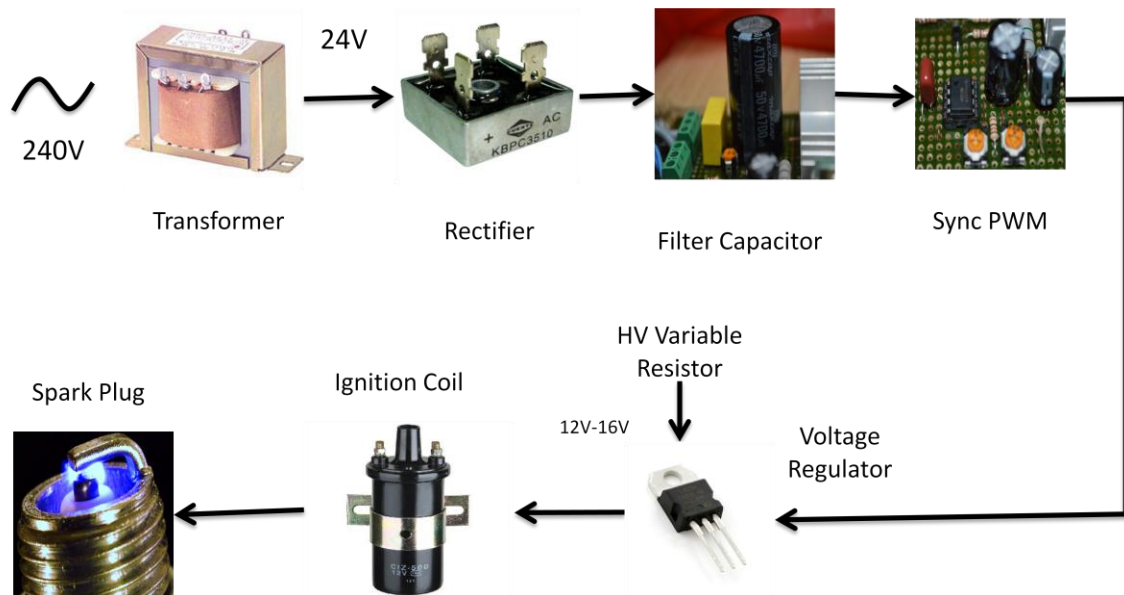

Figure 3.6: Block Diagram for Enhancing Fuel Burning Efficiency by Regulate Spark Plug Voltage Supply

Figure 3.6 shows the block diagram for enhancing fuel burning efficiency by regulate spark plug voltage supply. The current from AC supply 240V through the transformer. The transformer with turns ratio 10:1 will step down the voltage to 24V with 6A of current. Because of this research is about to change the voltage in car battery (V_{dc}) so that, rectifier are used to change the ac supply to the dc. Then the filter capacitor used to produce an output voltage that is close to purely dc. The capacitor holds the output voltage at a constant level. After that, voltage regulator is used to maintain a constant dc output voltage regardless of changes in its input voltage or its load current demand. The voltage from 12V to 16V will measure using the high voltage potential meter. The voltage that produces will control from the synchronous pulse-width modulation circuit. Then, to ignite the voltage, the ignition coil is used. An ignition coil is a step-up transformer. A step-up transformer can increase the voltage across the secondary winding to several thousand volts (enough to jump the air gap of a spark plug). Last but not least, the spark plug will create an arc, which ignites the compressed air/fuel charge. The arc is developed across the spark plug electrodes. Figure 3.7 shows the circuit connection of the system. The detail of the block diagram and circuitry function will be explained in hardware development.

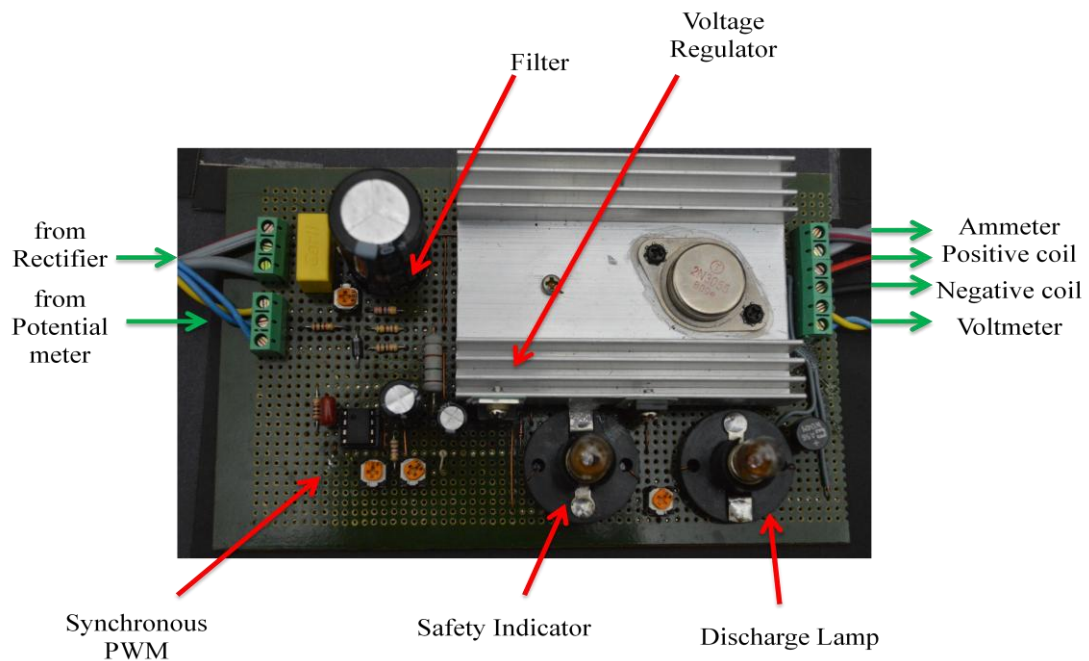

Figure 3.7: Circuit Connection of the 12V to 16V System

3.3 Hardware Development

This section will be discuss about components that had been used included transformer, rectifier, filter capacitor, synchronous pulse width modulation (PWM), voltage regulator, ignition coil and spark plug.

3.3.1 Transformer

Transformers are made up of inductors that are in close proximity to each other, yet are not electrically connected. An alternating voltage applied to the primary induces an alternating voltage in the secondary. At the same time, the primary and secondary are electrically isolated, so no actual current is transferred between the two circuits. Therefore, a transformer provides ac coupling from primary to secondary while providing physical isolation between the two circuits [21]. Figure 3.8 shows the model of transformer.

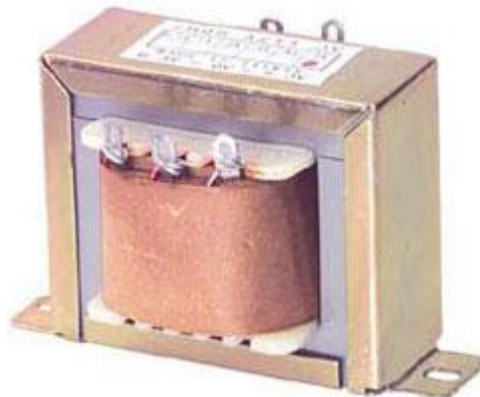

Figure 3.8: The Model of Transformer

There are three types of transformer: step-up, step-down and isolation. In this research, the step-down transformer is use to step down the voltage from alternating

current (AC), 240V to 24V. The Figure 3.9 shows the step-down transformer. This project is not using the real battery car but using the AC power supply to get the easy connecting to the circuit, so that, the transformer is fundamental reason for the superiority of this system to step down the voltage from AC source.

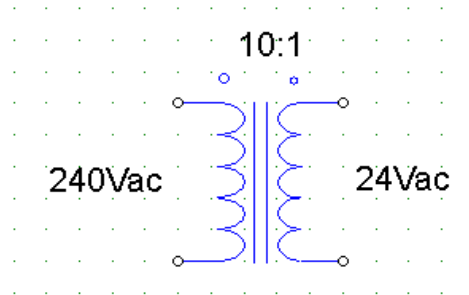

Figure 3.9: Step-Down Transformer

The turns ratio of transformer is the ratio of the number of turns in the primary to the number of turns in the secondary [21]. In this research, the step-down transformer shown in Figure 3.9 is shown to have a turns ratio of 10:1, which mean the transformer that use in this project are ten turns in the primary for each turn in the secondary.

The turns ratio of a transformer is equal to the voltage ratio of the component. By formula,

$$\frac{N_s}{N_p} = \frac{V_s}{V_p} \quad (3.0)$$

Where, N_s = the number of turns in the secondary

N_p = the number of turns in the primary

V_s = the secondary voltage

V_p = the primary voltage

Ideally, transformers are 100% efficient. This means that the ideal transformer transfers 100% of its input power to the secondary. By formula

$$P_s = P_p \quad (3.1)$$

Since power equals the product of voltage and current,

$$V_s I_s = V_p I_p \quad (3.2)$$

$$\frac{I_p}{I_s} = \frac{V_s}{V_p} \quad (3.3)$$

So, the current ratio is the inverse of the voltage ratio. This mean, in this research, for a step-down transformer, $I_s > I_p$. The secondary current in this research is 6A so that's mean $6A > 0.6A$.

3.3.2 Rectifier

A rectifier is electrical device which is used to convert alternating current (AC) current source to direct current (DC). After the current and voltage through the transformer to 24Vac, the rectifier will take the part of its function. This research is about to change the battery car voltage, so that the rectifier is use to convert current form transform that in AC to DC. Figure 3.10 shows model of the rectifier and figure 3.11 shows the internal diagram of rectifier about where to connect the input (AC) and the output (DC).



Figure 3.10: Model of Rectifier

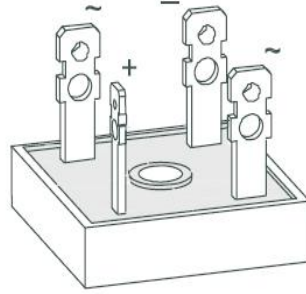

Figure 3.11: This is the Internal Diagram of Rectifier about Where to Connect the Input (AC) and the Output (DC)

Rectifiers have many uses, but are often found serving as components of DC power supplies and high-voltage direct current power transmission systems. Rectification may serve in roles other than to generate direct current for use as a source of power.

In this research, the full-wave rectifier is used. The peak load voltage for a full-wave rectifier is found as

$$V_{L(pk)} = \frac{V_{s(pk)}}{2} - 0.7 \quad (3.4)$$

The full-wave rectifier produces twice as many output pulses (per input cycle). For this reason, the average load voltage for the full-wave rectifier is found as

$$V_{ave} = \frac{2V_{L(pk)}}{\pi} \quad (3.5)$$

or

$$V_{ave} = 0.637V_{L(pk)} \quad (3.6)$$

Where $0.637 \cong 2/\pi$. So that, the transformer is rated at $24V_{ac}$. Therefore, the value of $V_{s(pk)}$ is found as

$$V_{s(pk)} = \frac{24V_{ac}}{0.707} = 33.95V \quad (3.7)$$

The peak load voltage is now found as

$$V_{L(pk)} = \frac{V_{s(pk)}}{2} - 0.7 = 16.98V - 0.7V = 16.28V \quad (3.8)$$

Finally, the dc load voltage is found as

$$V_{ave} = \frac{2V_{L(pk)}}{\pi} = \frac{32.56V}{\pi} = 10.36V \quad (3.9)$$

Once the peak and average load voltage values are known, it is easy to determine the values of $I_{L(pk)}$ and I_{ave} .

$$I_{L(pk)} = \frac{V_{L(pk)}}{R_L} \quad (3.10)$$

and

$$I_{ave} = \frac{V_{ave}}{R_L} \quad (3.11)$$

3.3.3 Filter Capacitor

The purpose of the filter is to produce an output voltage that is close to purely dc. The capacitor holds the output voltage at a constant level, and the inductor smooth the current from the rectifier and reduces the peak current in the diodes from that of the current.

Filter consists of large value of capacitor connected across the load resistor. This capacitor offers a low reactance to the ac components and very high impedance to dc, so that the ac components in the rectifier output find low reactance path through capacitor and only a small part flows through R , producing small ripple at the output as shown in figure 3.14.

Here $X_c (= 1/2\pi fC)$, the impedance of capacitor) should be smaller than R . Because, current should pass through C and C should get charged. If C value is very small, X_c will be large and hence current flows through R only and no filtering action

takes place. The capacitor, C gets charged when the diode (in the rectifier) is conducting and gets discharged (when the diode is not conducting) through R .

$$V = V_m \sin \omega t \quad (3.12)$$

When the input voltage is greater than the capacitor voltage, C gets charged. When the input voltage is less than that of the capacitor voltage, C will discharge through R . The stored energy in the capacitor maintains the load voltage at a high value for a long period. The diode conducts only for a short interval of high current. The waveforms are as shown in figure 3.14. Capacitor opposes sudden fluctuations in voltage across it. So the ripple voltage is minimized.

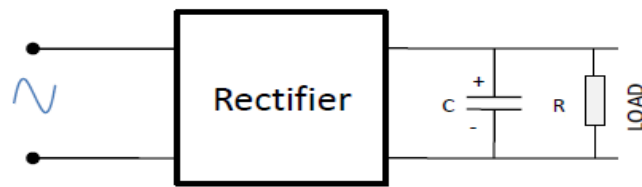

Figure 3.12: Connection of Filter Circuit

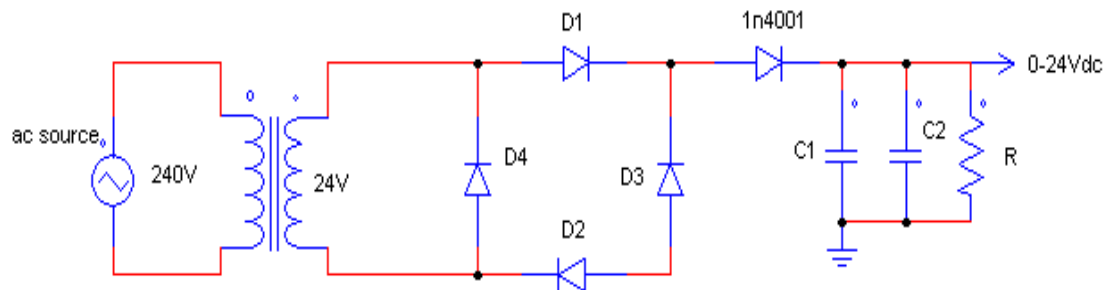

Figure 3.13: Circuit Connection of Transformer, Rectifier and Filter

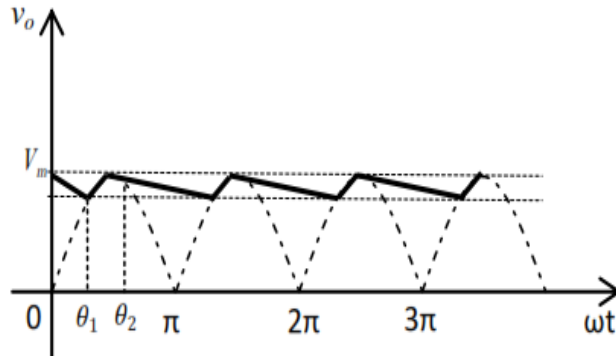

Figure 3.14: Output Waveform from Filter Circuit

The discharging of the capacitor depends upon the time constant CR . Hence the smoothness and the magnitude of output voltage depend upon the value of capacitor C and R . As the value of C increases the smoothness of the output also increases. But the maximum value of the capacitor is limited by the current rating of the diode. Also decrease in the value of R increases the load current and makes the time constant smaller. The ripple factor in capacitor filter is given by:

$$V_r(\text{rms}) = \frac{I_{dc}}{4\sqrt{3}fC} = \frac{2.4I_{dc}}{C} = \frac{2.4V_{dc}}{RC} \quad (3.13)$$

3.3.4 Synchronous Pulse-Width Modulation (PWM)

In a PWM system, a signal is used to vary the pulse width of a rectangular waveform while not affecting its total cycle time. PWM used in efficient voltage regulators. By switching voltage to the load with the appropriate duty cycle, the output will approximate a voltage at the desired level. The switching noise is usually filtered with an inductor and capacitor. The waveform of PWM shows in figure 3.15. The ignition coil will operate like a switch on and off to the electric arc at spark plug.

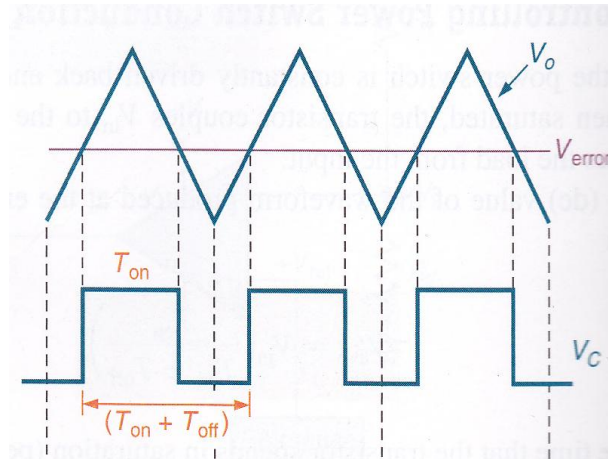

Figure 3.15: Pulse-Width Modulation (PWM)

3.3.5 Voltage Regulator

The ideal voltage regulator maintains a constant dc output voltage regardless of changes in its input voltage or its load current demand. From this research, the rectifier is used to convert the ac output of a transformer to pulsating dc. This pulsating dc is then applied to filter, which reduces the variations in the rectifier output. Finally the filtered dc is applied to a voltage regulator. Figure 3.16 shows the concept of a voltage regulator. This regulator serves two purposes:

- (i) It reduces the variations (ripple) in filtered dc.
- (ii) It maintains a relatively constant output voltage regardless of minor changes in load current demand or input voltage.

REFERENCE

- [1] William J. Walker, Jr. "Spark Plug and Method of Construction Thereof". US Patent 7,944,135 B2, 2011
- [2] John Anthony Burrows, "Spark Plug". United States Patent US RE41, 672 E, 2010.
- [3] Q. Binh Dam, "The MPG Survey: Questioning the Biased perception of Automobile Fuel Economy". *IEEE Energy 2030*. School of Electrical and Computer Engineering, Georgia Institute of Technology 777 Atlantic Drive NW, Atlanta. GA 30332-02-50, 2008.
- [4] Alex Curie, "A short Course in Ignition System, Family Car part", [Online], Available: <http://www.familycar.com/Classroom/ignition.htm>, [Retrieved June 04, 2012].
- [5] "Reference Library. Ignition System. Auto Zone", [Online] Available: http://www.procarcare.com/icarumba/resourcecenter/encyclopedia/icar_resource_center_encyclopedia_ignition.asp#How, [Retrieved June 04, 2012]
- [6] Karim Nice. "How Automobile Ignition Systems Work. How Stuff Work". [Online], Available: <http://auto.howstuffworks.com/ignition-system3.htm>. [Retrieved June 05, 2012]
- [7] Glenn Elert, "Voltage of a Car Battery" Retrieved 2011. [Online], Available: <http://hypertextbook.com/facts/2001/ThiMeaganLe.shtml>. [Retrieved June 05, 2012]
- [8] M.A. Shrud, A.Bousbaine, A.S.Ashur, R.Thorn, A.Kharaz, "42V Power System Architecture Development" University of Derbt UK, University of Al-Fateh, Tripoli, Libya, Victoria University, Australia. 2008

- [9] Chiaberge M., Botto G., De Giuseppe M. "An FPGA Controlled DC/DC Step-Up Converter for Automotive Applications", Mechatronics Laboratory, Politecnico Di Tarno.
- [10] GU Yufeng, FANG Zongde. "Experimental Study on Different Ignition System Matching Different Spark Plug Gap". International Conference on Computational Intelligence and Natural Computing. 305-308. 2009
- [11] Hyunjae Yoo, Byung-Geuk Cho, Seung-Ki Sul, Sang-min Kim, Yongho Park. "A Power Flow Control Strategy for Optimal Fuel Efficiency of a Variable Speed Engine-Generator based Series Hybrid Electric Vehicle". 2009.
- [12] Gerald J. Rohwein, "An Efficient, Power-Enhanced Ignition System", IEEE Transaction on Plasma Science, vol. 25, no. 2. 1997
- [13] Dakshina M. Bellur and Marian K. Kazimierczuk. "DC-DC Converters for Electric Vehicle Application". Energy Conversion Science for Operations and Security of Large-Scale Systems. 2007
- [14] Su man Dwari and Leila Parsa. "A Novel High Efficiency High Power Interleaved Coupled-Inductor Boost DC-DC Converter for Hybrid and Fuel Cell Electric Vehicle". Department of Electrical, Computer, and System Engineering. 2007
- [15] Hua Bai and Chris Mi. "The Impact of Bidirectional DC-DC Converter on The Inverter Operation and Battery Current in Hybrid Electric Vehicles". 8th International Conference on Power Electronics-ECCE Asia.2011
- [16] "Lm1577/Lm2577 Series Simple Switcher Step-Up Voltage Regulator". June 1999, [Online], Available: <http://www.eleccircuit.com/12v-to-16v-dcdc-converter-with-lm2577>, [Retrieved June 16, 2012]
- [17] "The Green Spark Plug, Est 1980. How Spark Plug Works".2010. [Online] Available: <http://www.gsparkplug.com/shop/how-spark-plugs-work>. [Retrieved November 28, 2012]
- [18] James D. Halderman, 7th edition, "Automotive Engines Theory and Servicing", Pearson, Prentice hall, Professional Technician Series.
- [19] Russell Carrigan & Richard R. Kent, "Automotive Engine Performance", Techone, Thomson Delmar Learning.

- [20] S. Srinivasan, Formerly Principle Tamil Nadu Polytechnic Madurai, “Automotive Engines”, Tata McGraw-Hill Publishing Company Limited, New Delhi.
- [21] Robert T. Paynter, 6th Edition, “Introductory Electronic Devices and Circuits”, Prentice Hall.
- [22] John W. Tontsch Theodore F. Bogart, Jr. E. Charles Alvarez, “Fundamental Circuit Analysis”, Science Research Associates, INC.