

IWAN J. AZIS^a

Complex Interplay of Factors in the Institutional Model of Decentralization: Theory and Application

Abstract

The Institutional Model of Decentralization (IMD) is elaborated and used to explain two things: first, how the hypothesized improvements in efficiency and growth after decentralization may fail to materialize; second, how the interplay among economic, administrative and institutional factors affect the welfare outcome of decentralization, given the widespread local capture following political decentralization. Rather than exerting direct effects, however, the mechanism is complex, involving intangibles and feedback effects. When applied to actual cases in some regions, a particular method capable of capturing complex inter-relations and quantifying intangibles is therefore used. It is revealed that people's participation plays the most critical role in reducing capture while simultaneously maximizing welfare. As the quality of local leaders is found to be decisive in influencing the outcome, a typology of leaders is subsequently constructed.

Keywords: institutional factors, participation, decentralization, welfare, local capture

Introduction

Decentralization is a multi-dimensional phenomenon, encompassing several interconnected aspects. Its theoretical supports originate in the informational advantage and coordination (policy enforcement) capability of local government. Although informational advantage can be secured by adopting a pro-market policy, a market system alone may not be sufficient to establish an effective coordination at the local level unless the decision making is decentralized. A more decentralized system, particularly on fiscal front, is also superior for promoting economic growth (United Nations 1991, Oates 1994, Bruno and Pleskovic 1996).¹ No wonder the World Bank embraced decentralization as one of the major governance reforms on its agenda (World Bank 2000, Burki–Perry–Dillinger 1999).

Yet, the experience in many countries shows that the performance after decentralization has not always been consistent with the promise. Growth can be lower, and overall welfare conditions may not improve, if not worsen. Imperfections in local provision and poorly trained local bureaucrats are among the suggested reasons (Prud'homme 1994, Tanzi

^a Asian Development Bank, E-mail: iazis@adb.org; and Cornell University 213 West Sibley Hall Ithaca, NY 14853, USA, E-mail: ijal@cornell.edu

¹ Other justifications for decentralization include: raising efficiency through reduced transaction costs, diffusing social and political tensions, strengthening people's participation, and ensuring political and cultural autonomy.

2002). Problems due to lack of coordination in extracting bribes at the local level can also lead to ‘excess’ rent extraction (Shleifer–Vishny 1993), although some argued that corruption should be more difficult to commit under decentralization (Huther–Shah 1998). The most significant risk of decentralization is the spread of *local capture* especially in regions with a high degree of income disparity. Although the verdict regarding the relative proneness of local and national governments is still out (Bardhan–Mookherjee 2005), in general the likelihood of capture by elites is greater at the local than at the national level. The possibility of power sharing between contesting parties is typically smaller at the local than at the national level. Some analysts consequently suggest that the justification for decentralization should be based on the political economy explanation (Besley–Coate 1999), and to be successful decentralization should entail democratic, fiscal, and administrative components (Manor 1999, Binswanger 1999).

There are a large number of studies on fiscal federalism and administrative decentralization (transfer of authority to local governments). Literature on institutional economics dealing with political decentralization are also numerous. Yet, theoretical and empirical work on how these different dimensions interact to affect growth and welfare is curiously scanty. By using the *Institutional Model of Decentralization* (IMD), in this paper I try to delineate the interactions between institutions, regional growth and a more broadly-defined welfare.² The starting point is to delve into the theoretical concept of regional incentives by way of comparing ‘rewards’ and ‘punishment’ for adopting growth-enhancing policy. Once the basic concept is established, a greater variety of institutional factors to reflect the property of local accountability are introduced, ranging from local capture, people’s participation, initial conditions, and the quality of local leaders. Incorporating these factors in the analysis of decentralization constitutes the essence of IMD. The empirical application based on a series of field surveys in one of the emerging economies that went through a major decentralization programme is discussed in the last Section.

Incentives for Regional Growth: Rewards and Punishment

The basic premise of decentralization-growth nexus is that local governments are more efficient at providing infrastructure and public services compared to the higher levels of government (Oates 1972). Greater efficiency is thus at the centre of the relation between decentralization and higher rates of economic growth (Martinez-Vazquez–McNab 2003); however, overall efficiency is not always aligned with private efficiency. With enhanced authority after decentralization, local leaders may put private benefits above social benefits, depending on how they perceive the implication on their probability of staying in

² *Institutional Model of Decentralization* (IMD) was first explained in Azis (2008) and elaborated further in Azis (2010). One of the consequential issues that emerged in IMD is the relation between policy and institutions. Negative welfare effect can be the result of wrong policies, but it can also be the product of right policies with wrong institutions. In some cases, policy matters more than institution (Henry–Miller 2008), in others institution matters more (Rodrik–Subramania–Trebby 2002, Easterly–Levine 2002). Referring to the case in Sub-Saharan Africa, Sachs (2003) argues that institution matters but not for everything.

power. When private benefit rules, incentives to foster growth become secondary, and when private motives produce a detrimental impact on regional resources, growth falters.

Let p^g = probability that local government stays in power if it fosters growth; and p^c = probability that local government stays in power if it kills growth by intensifying local capture. The latter could occur because local governments have had few incentives either to resist capture or to rein in competition for rents (e.g., Bardhan and Mookherjee, 2005; and Shleifer & Treisman, 2005 for the case of Russia). Denote C for the benefits accrued to local officials through local capture; and R^r for regional-own revenues, the size of which is determined by the local rates that include both tax rates and other revenue collection rates, θ , and regional output Y^r . The share of central government revenues (from additional growth) going to local governments is denoted by α . Thus, $\alpha.t.Y$ is the actual revenue received by local governments where $t.Y$ is central government's total revenue. How much local government will value growth is therefore proportional to $\alpha.t.Y$. Central government can use α as the “carrot” in promoting regional growth.

Define $PROB = p^g / p^c$, the value of which depends on whether local officials are appointed (by the centre) or locally elected. If they are appointed, then the centre can presumably choose $PROB$ freely and make it as high as it wants. If they are elected locally, the outcome depends on the ability of central government to affect the outcome of the election, e.g., not endorsing specific candidates. Thus, the centre can use $PROB$ as the “stick.” If, however, the centre has little control over the election outcome, and capture becomes an important factor, $PROB$ may be less than unity, i.e., local government may be more likely reelected if it kills growth than if it fosters it. Local governments chooses growth only if the incentive is higher than the incentive to obtain private benefits from local capture:³

$$p^g . (\alpha.t.Y + R^r) > p^c . C \quad (1)$$

or

$$PROB . (\alpha.t.Y + \theta.Y^r) > C \quad (2)$$

Another way to put it, local governments are more likely to choose growth under the following conditions: stronger “stick” (higher $PROB$), larger “carrot” (higher α), higher national growth potential (higher Y), more effective generation of national tax revenues (higher t), and higher local-own revenues $\theta.Y^r$. On the other hand, one can also focus on the efforts to lower private benefits from local capture, C , by attacking the negative factors such as corruption, weak legal system, and ineffective law enforcement.

The above formula provides a way of identifying a set of policies without singling out “non-economic factors” often cited just for convenience. In reality, not all countries can alter policies for either historical or political reasons. In such a case, the focus can be directed towards exploring new instruments to complement the existing ones. Take the case of α . It is important to distinguish between ex-ante and ex-post α . If central and

³ Social benefits (e.g., enhanced growth and welfare) and private benefits (e.g., resources appropriated for private use) can be generated simultaneously. Put in the context of motivation and incentive to obtain benefits, social and private benefits can be in a competitive mode. That is, local leaders' incentive to obtain private benefits from local capture may either forgo or exceed the incentive to obtain social benefits. Alternatively, the reverse may hold as in inequality (2): i.e., local leaders' incentive to obtain social benefits (e.g., from enhanced growth and welfare) exceeds the incentive to obtain private benefits.

regional governments can commit to a tax-sharing schedule or to a particular arrangement of centre-local transfer, the two will be the same. But if central government desperately needs funds to keep down its deficit, the ex-ante α may be higher than the ex-post α . The one which is relevant to local governments' decisions is the ex-post α . If a proportion of national revenues has been fixed, a new fraction of revenues, say λ , can be introduced. The point being that central government can control a policy instrument that will function as the “carrot”:

$$PROB.[(\lambda(Y^r) + \alpha).t.Y + \theta.Y^r] > C \quad (3)$$

One could erroneously imply that by raising θ , *ceteris-paribus*, growth incentives could be enhanced; however, higher θ can deter investment and growth of Y^r by discouraging investors to come and do business in the region (see also footnote 4). Thus, the level of Y^r can be inversely related to the size of θ .

Assuming no income leakage, consider the following:

$$Y^r = Y^r(K^r, L^r, N^r) \quad (4)$$

where K^r , L^r , and N^r are capital, labour and other inputs, respectively. Decomposing the regional capital stock into: (a) initial stock adjusted by the depreciation rate $\overline{K}_0^r (1 - \delta)$; and (b) the regional investment flow ΔK^r , and considering that ΔK^r is inversely related to the regional tax and other revenue rates θ ; that is, $\Delta K^r = f(\theta)$ where $\frac{\partial f(\theta)}{\partial \theta} < 0$, the total regional-own revenue is:

$$R^r = \theta.Y^r \{[\overline{K}_0^r (1 - \delta) + f(\theta)], L^r, N^r\} \quad (5)$$

A fundamental growth equation is thus obtained by combining (3) and (5):

$$PROB.\{(\lambda(Y^r) + \alpha).t.Y + \theta.Y^r [(\overline{K}_0^r (1 - \delta) + f(\theta)), L^r, N^r]\} > C \quad (6)^4$$

Consequently, central government can use the “stick” ($PROB$ and C) and the “carrot” (λ , α) to foster growth. Note also from (6), that a growth-oriented strategy at the national level (higher Y) can help fulfil the inequality. Without a stick-and-carrot system, the incentives for local leaders to obtain private benefits through local capture can be greater than the incentives to foster growth.

Nevertheless, the ultimate goal of regional development goes beyond just growth. A broadly-defined welfare should be more appropriate to use. The problem is that once a multi-dimensional goal is considered, various trade-offs emerge, where different institutional factors play different roles in affecting welfare. A further complication appears with respect to the complex relations between local capture and the goal, where institutions including capture interact among themselves as well as with welfare. To

4 Two important points worth noting. Since increased capital is often accompanied by increased imports (income leakage), the true R^r is likely lower than that stated in (5). Notice also that if local governments fervently want to raise θ , regional-own revenues may at first increase. As regional investment begins to be affected adversely by higher θ , total revenues will decline. Thus, the policy choice concerning θ depends on the initial condition. If the current θ is so high that it lies to the right of optimal θ^* (defined as θ that gives the highest level of R^r), raising it further will kill growth. Reducing θ^* under such circumstances will raise not only the regional-own revenues but also investment flows and hence growth.

establish such a more realistic system where institutions are endogenous, requires a model framework beyond just the fundamental growth equation as in (6). This task is taken next.

Endogenous Institutions and Regional Welfare

Theoretical Framework

Rules, organizations, beliefs, internalized norms, and implied regularity of behaviours, which constitute “institution”, define the incentive structure of societies and economies (North 1993, 1995). The system is in equilibrium if the implied regularity of behaviours to follow the rules are best-responses to the beliefs and internalized norms that are formed by the implied regularity of behaviours (Greif 2006).⁵ Many policies may fail to achieve their objectives because the institution in which these policies or rules were elements, was not in equilibrium.⁶ It is therefore important to understand how various institutions interact among themselves and how the interactions influence the welfare outcome.

Figure 1

How Local Capture Affects Welfare: Full Framework

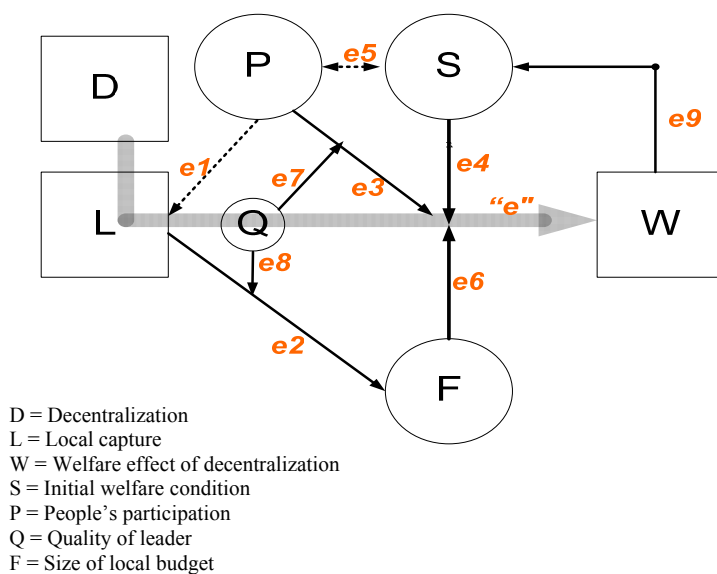

A framework capturing the interplay of institutional factors is shown in Figure 1. Decentralization policy (D) with direct election for local leaders generates ‘local capture’

⁵ Persistence or inertia, institutional path dependence, or steady-state equilibrium in institutional setting are among the terms used to describe the study of endogenous institutional change.

⁶ Equilibrium in a more practical term means that there is no individual or a group of individuals that has an incentive to deviate from an agreement or what is previously agreed. In other words, an institution that is in equilibrium consists of rules in which targeted individuals have incentives to follow the rules. Thus, a law regulating issuance of driving licenses may not be effective because bribing public officials renders it more profitable and time-saving.

(L). However, the effect of L on local welfare (W) varies: in some regions the effect is positive (“positive local capture”), in others it results in a “negative local capture.” Among various factors that determine the effect of L on W, three stand out: initial welfare condition (S), people’s participation (P), and size of local budget (F). Note that the resulting W determines the subsequent level of initial condition S, that is, the steady-state level of initial welfare is influenced by any perturbations in the system that lead to changes in W, hence S in the subsequent period. The implied mechanisms also explicate the persistent gap between poor and rich regions observed in many countries.

The key question is how the interplay of all these factors influences the way local capture influences welfare. The extent and severity of accountability problems and local capture depend on the following factors: (1) Pre-existing distribution of power at the local level, e.g., allocation of social and economic power within communities; (2) Lobby and campaign contributions by wealthier groups; (3) Fairness and regularity of elections; and (4) Transparency in local decision-making processes. Establishing these conditions may require institutional and bureaucratic reforms, yet it is precisely this type of reform that is the most difficult to conduct. Overcoming institutional factors is always more difficult than choosing the policy itself. It is complicated, involving a strong path-dependence, and often frustrating. Absence of this reform, however, a higher local capture almost certainly produces lower benefits of decentralization.

Literature on institutional perspectives stresses the importance of *participatory* process. The degree of political participation differs between countries and regions. One of the most determining factors is the initial welfare condition or social structure represented, among others, by the human development index (HDI) and the level of poverty and income inequality. Greater inequality and a larger proportion of the poor imply a smaller fraction of informed voters or lower political awareness, i.e., upward mobility at the end tends to raise political awareness more significantly than at the higher end (concavity). When awareness is low, critical voices and the process of check-and-balance are constrained. This can limit the quality of public services and the welfare outcome of decentralization in general (Azis 2010).

These are all associated with the *quality* factors. Each of them can be adversely affected by the intensity of local capture. While quality is important, the number and size of activities (e.g., public services) also influence the overall performance. The *quantity* that local government can generate depends not only on the budget size but also on the management of it.⁷ Ironically, under some circumstances, the size of the budget can be positively affected by local capture, that is, if local leader is of Type-A (to be explained later), and local elites are powerful and wealthy. Under such circumstances, local policy makers can operate using resources in excess of the official budget. Thus, given *quality* factors, greater local capture can still be welfare-improving (relation e2 in Figure 1).

To reiterate the key problem, it is important to understand how the spread of local capture (L) during an election determines the welfare outcome of decentralization (W).

⁷ Revenue decentralization and central-local financial transfer without clear expenditure assignment are likely inconsistent with “money follow function” principle. They are not welfare enhancing, especially when the capacity of budget management is limited and are prone to corruption and overprovision.

More particularly, how the effect is influenced by the extent of people's participation (P), the initial level of welfare (S), and the size of local budget (F). As argued earlier, the extent of participation is influenced by the initial welfare through informed voters and high political awareness.

Based on the analysis of implied behaviours in a coordination game (see Azis 2010 and Azis–Wiharja 2009), the role of leaders' quality (Q) is critical. However, in reality, the effect of L on W associated with Q can be ambiguous; some leaders are able to take advantage of capture to augment local budget (Type-A leader), others may fail to do so (Type-B); see relation e8.⁸ Also, in some cases local leaders are effective in motivating local citizens to participate in most development programmes, while in others this may not be the case (relation e7).

The dynamics is captured among others through relation e9. For example, low initial welfare (S) as a result of negative local capture will negatively affect W and S in the subsequent period. Through relation e5, this may be associated with a low level of participation (P), creating a persistent evolution of low-welfare states and low-quality institutions (endogenous institutions). The possibility that local capture can generate positive welfare effects provides a more complex yet useful analysis with direct policy implications. It can be shown, for example, that policies to enable greater participation are superior to others because the welfare effect is higher given a level of capture.

Local capture L , participation P , and initial welfare S (poverty and inequality) represent the *quality* component of institutions. The size of local budget F , on the other hand, represents the *quantity*. Consider the following general form of welfare function:

$$W(.) = W(L, S, P, F) \quad (7)$$

Under a standard condition,

$$\frac{\partial W(.)}{\partial L} < 0; \quad \frac{\partial W(.)}{\partial S} > 0; \quad \frac{\partial W(.)}{\partial P} > 0; \quad \frac{\partial W(.)}{\partial F} > 0.$$

Since F is affected by L , decomposing (7) into quality and quantity components:

$$W(.) = H(L, S, P).F(L) \quad (8)$$

where $\frac{\partial H(.)}{\partial L}$ and $\frac{\partial F(L)}{\partial L}$ are marginal quality and quantity, respectively.

Taking the derivative of (8):

$$\frac{\partial W(.)}{\partial L} = \frac{\partial F}{\partial L} H(.) + \frac{\partial H(.)}{\partial L} F(L) \quad (9)$$

In most cases, $\frac{\partial H(.)}{\partial L} < 0$. However, a good quality leader capable of motivating participation (relation e7) may generate $\frac{\partial H(.)}{\partial L} > 0$, making the sign of $\frac{\partial W(.)}{\partial L}$ indeterminate.

⁸ It is wrong to suggest that the central and the provincial governments should retreat into minimalist role. On the contrary, they should play an activist role in conducting the necessary reforms. It is also the responsibility of the centre to facilitate institutional supports for a successful decentralization. These include supplying technical services toward building local capacity, promoting mobilization of people in local participatory development, helping to set quality standards, auditing and evaluation, providing supra-local support to local finance (including being responsible in the coordination efforts to optimize externalities across regions), and investing, when necessary jointly with local government, in infrastructure.

As discussed earlier, on the quantity side, the effect of local capture can be negative or positive depending on the type of local leader (relation e2). If local leader is of a favourable type (Type-A), e.g., motivated to foster regional welfare by augmenting the size of local budget available for development, the first term of equation 9 can be positive. Otherwise, it will be negative (Type-B). Thus, from quantity and quality perspectives the net effect of rising local capture on welfare depends on the quality of local leader (Q).

While the signs of $\frac{\partial H(.)}{\partial L}$ and $\frac{\partial F(L)}{\partial L}$ are uncertain, somewhere in between there exists a critical value of $H(.)$ and $F(.)$ such that the effect of rising local capture leads to

$$\frac{\partial W(.)}{\partial L} > 0.$$

When this occurs, the system produces a backward-bending curve that generates multiple equilibria as shown in Figure 2.⁹

Figure 2

Local Capture and Welfare: Alternative Strategies

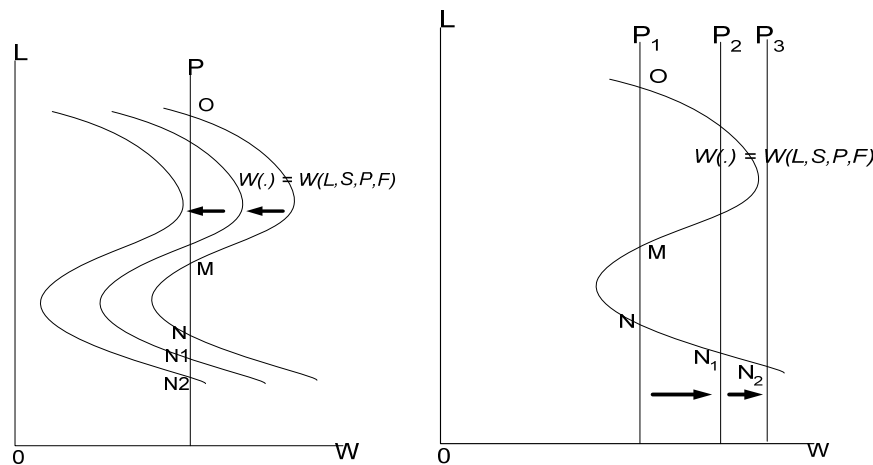

The goal is either to raise W given local capture L , or, minimize local capture L given W . The latter is equivalent to finding lowest L along the vertical line P . Reducing income inequality and poverty will facilitate such a goal since shifting the bending curve leftward will guarantee a new equilibrium with lower intensity of local capture (e.g., $N1$ and $N2$ in the left panel of Figure 2).¹⁰

An alternative strategy to insure a low capture is to raise participation; this is depicted by a rightward shift of the vertical line P in the right panel of Figure 2. This turns out to be

⁹ Note that participation (P) is independent of capture. Many studies have revealed that participation is influenced by factors such as socio-culturally prescribed family (household heads, spouses, age range), and gender roles (married woman with children); see Beard (2005). While defining participation is not easy, at least the following elements should be entailed: representation, empowerment, benefits for all, and poverty reduction (Blair 2000).

¹⁰ Recall that lower inequality and poverty tend to raise political awareness that can reduce the intensity of local capture.

superior as it produces not only lower capture supported by greater accountability, but also higher welfare.

To complement the above analysis of quality component, a corresponding typology of local leaders is constructed, in which alternative behaviours of leaders with respect to quantity component (local budget) is taken into account (see Table 1). Although the main sources of regional revenues are central grant and local taxes, local leaders may find additional sources from local capture, $L \in [0,1]$, where $L=0$ means no local capture and $L=1$ indicates that the region is fully captured (“owned” by elites). The presence of local capture can result in an increase, a decrease, or an unchanged local budget, depending on how local leaders use the additional resources. Type-A leader will take advantage of the capture to increase the amount of local resources beyond the official budget. A “Complete progress” is achieved when participation and/or initial welfare condition is high, and at the same time local leader is of Type-A. If $\frac{\partial H(.)}{\partial L} < 0$, even with a type-A leader, the expected outcome is “Incomplete progress,” confirming the key role of participation and initial conditions. Type-B leader leaves the local budget unchanged for any degree of local capture, while Type-C leader has a strong tendency to appropriate local funds either for private benefits or to exercise “return-the-favour” behaviour. Either way, it reduces the amount of local resources available for development purposes.

Table 1

Typology of Local Leader and Decentralization Outcome

	$\frac{\partial F(L)}{\partial L} > 0$ Type-A Leader	$\frac{\partial F(L)}{\partial L} = 0$ Type-B Leader	$\frac{\partial F(L)}{\partial L} < 0$ Type-C Leader
$\frac{\partial H(.)}{\partial L} > 0$ High participation and/or low inequality/poverty	Complete progress	Propitious	Stagnant
$\frac{\partial H(.)}{\partial L} < 0$ Low participation and/or high inequality/poverty	Incomplete progress	Deviating	Deteriorating

To reflect the dynamic implications of this theoretical exposition, specific functions with assigned numerical values are needed. As shown in the next Sub-section, to understand better the interactions among institutional factors and how the interplay can influence welfare, a series of sensitivity analysis are conducted using the example of a specific welfare function.

Welfare Function: An Example

Reiterating equation 8, the welfare function is decomposed into quantity and quality components. $F_i(L)$ denotes the quantity component under different local leader types ($t=A,B,C$), where $F_A'(L)>0$, $F_B'(L)=0$, and $F_C'(L)<0$. Ideally, the entire amount of funds acquired through local capture is added to the local budget, i.e., local budget equals to central grant plus local taxes plus the funds acquired from local capture. The value of $F(L)$ is indexed as the fraction of how the value of real amount of local budget deviates from its ideal amount. Suppose different types of local leader takes the following functions:

Type-A: $F_A(L) = c_1 + c_2L^{c_3}$ where $0 < c_1, c_2, c_3 < 1$ and $0 < c_1 + c_2 < 1$ (10)

Type-B: $F_B(L) = c_1$ where $0 < c_1 < 1$ (11)

Type-C: $F_C(L) = c_1 - c_2L^{c_3}$ where $0 < c_1, c_2, c_3 < 1$ and $0 < c_1 - c_2 < 1$ (12)

Consider Type A: $F(L)=0.6+0.3\sqrt{L}$; Type B: $F(L)=0.6$; Type C: $F(L)=0.6-0.3\sqrt{L}$. Plots of Type-A, Type-B, and Type-C local leaders are illustrated in Figure 3.

Figure 3

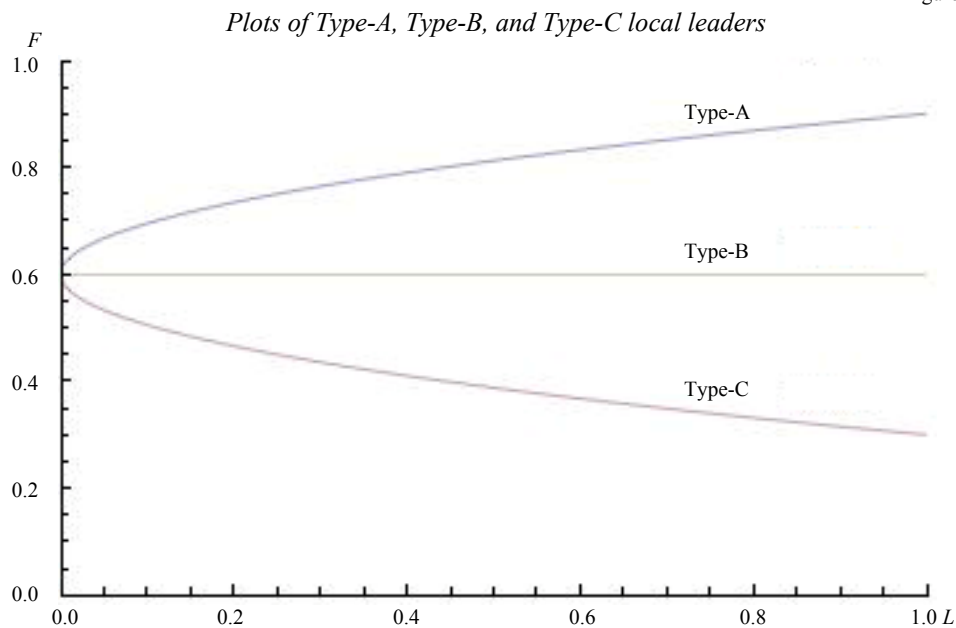

On the quality component, participation is one of the critical factors. Since lower initial welfare (labelled S in Figure 1) implies a smaller fraction of informed voters or lower political awareness, and hence lower participation (P) is an increasing function of initial welfare (S). Moreover, an increase of initial welfare at a lower level tends to raise participation more significantly than at a higher level (concavity). Given population, the degree of people’s participation is $P \in [0,1]$. Furthermore, the initial welfare is indexed such that $S \in [0,1]$ where $S=0$ implies zero welfare and $S=1$ indicates perfect welfare. An example of participation function is as follows

$$P(S)=S^c \tag{13}$$

where $0 < c < 1$ indicates the speed of increase in participation as S increases. The participation curves for some values of c are shown in Figure 4.

Figure 4

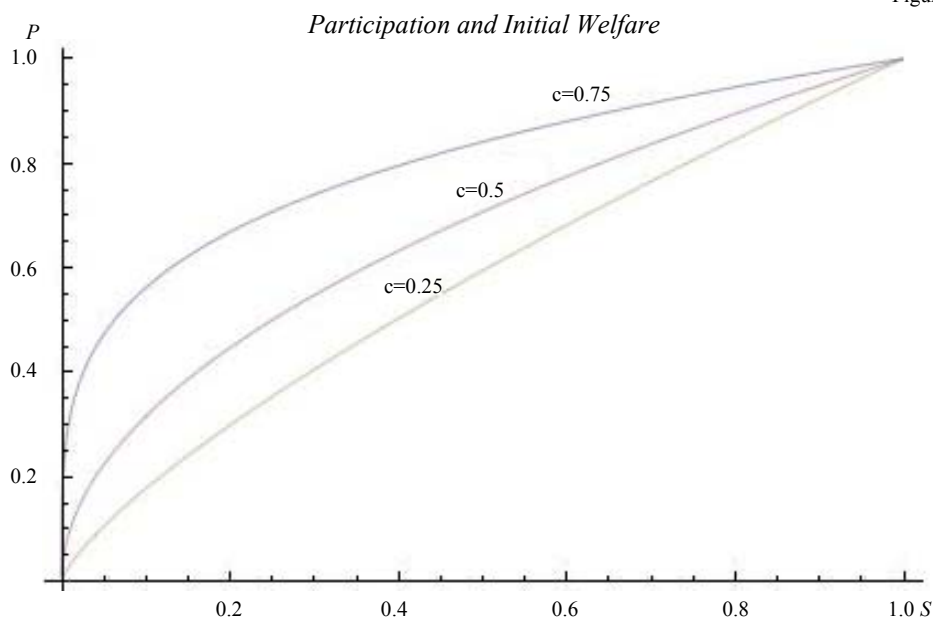

Given (13), the quality component of welfare $H(P,L,S)$ can be reduced to $H(P,L)$. Indexing quality factors, $H \in [0,1]$ it is specified that $H=0$ means no participation for any values of L , and $H=1$ indicates full participation. Consider the quality function of the following form

$$H(P,L) = P^{b_1} a \frac{L(L - b_2)^2}{b_3} \tag{14}$$

Parameter a ($0 < a < 1$) denotes the region’s business climate, where a larger value reflects a more conducive business environment, and parameter b_1 denotes an index of income inequality (e.g. GINI index). Parameter b_2 measures the sensitivity of welfare on income inequality (b_1), while b_3 measures the efficiency and effectiveness of local government’s management. The latter is associated with administrative decentralization, which is one of the three dimensions of decentralization (Filippetti and Sacchi, 2013).

Assigning the following values to the above equation, $a=0.1$, $b_1=0.5$, $b_2=0.7$, and $b_3=0.25$, and participation is $P=0.3$, if equations 10, 11 and 12 take the following forms,

$$\text{Type-A: } F_A(L) = 0.6 + 0.3\sqrt{L} \tag{10a}$$

$$\text{Type-B: } F_B(L) = 0.6 \tag{11a}$$

$$\text{Type-C: } F_C(L) = 0.6 - 0.3\sqrt{L} \tag{12a}$$

the plot of welfare function along $L \in [0,1]$ can be derived as shown in Figure 5. The shape of the curve is very similar to that in Figure 2, implying multiple equilibria, but different

shapes obviously can be generated using different forms of welfare function and different values of parameters.

Figure 5

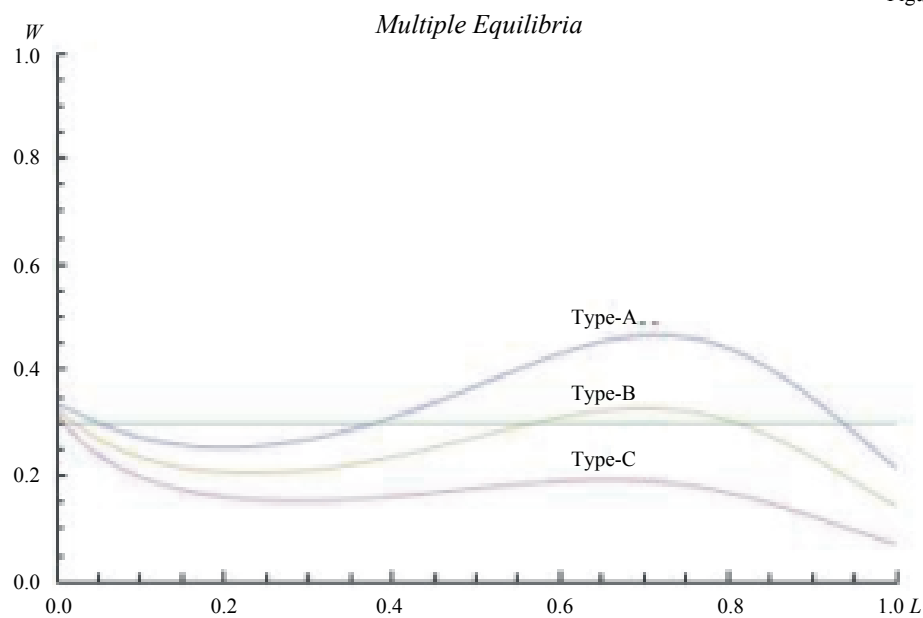

To the extent that the post-decentralization performance depends on the region’s ability to attract business activity, even with high local capture, if the size of parameter a is large and the local leader is of Type-A, welfare tends to improve. Only at an extremely high level of capture does welfare start to decline, albeit slightly. Such a pattern is independent of the level of participation (P), and to some extent also independent of the business climate. Of course, higher participation is likely to generate greater welfare (left panel of Figure 6).

Figure 6

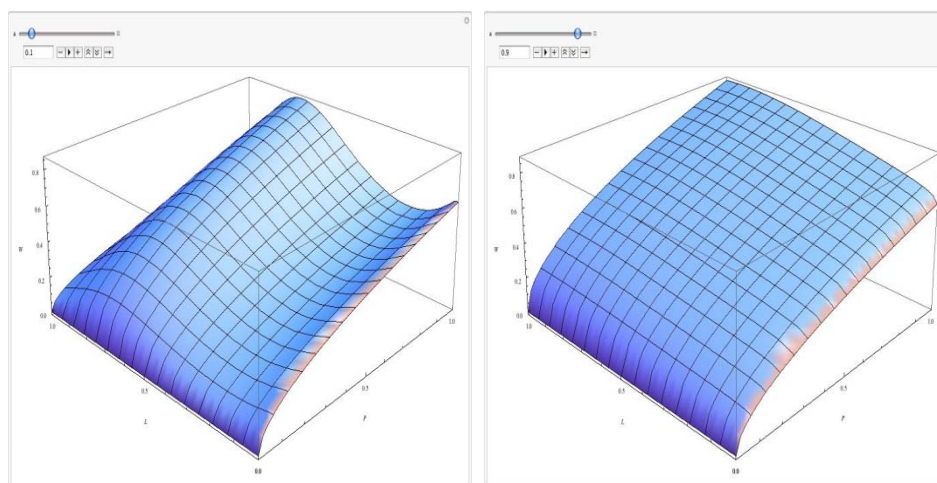
Sensitivity Analysis: Business Climate

If the region fails to create a favourable business climate, at a low range of capture welfare tends to decline as the degree of capture increases. The relation turns complimentary (higher capture produces higher welfare) when local capture is relatively high but not extremely high. This is because the “quantity” factors in equation 8 become more dominant, such that for Type-A leader, the funds and other resources acquired from the capture tend to augment local budget. This pattern is not affected by the level of participation (P). The right panel of Figure 6 shows that along the P-axis higher participation produces higher welfare.

The ability of local leaders to influence people’s participation depends on the prevailing social and political structure. In the model, the income inequality (GINI index, where $0 < b_1 < 1$) is used as a proxy for such a structure. To evaluate the role of this index in the capture-welfare nexus, one has to consider the sensitivity of the highest achievable welfare to the degree of local capture. There are two possible scenarios: highest welfare can be achieved with lower capture, and highest welfare can be achieved only if local capture is high. Obviously, the former is more desirable, at least in a moral sense. Using b_2 to reflect this condition, low b_2 is more ideal than high b_2 ($0 < b_2 < 1$).

In an ideal situation (low b_2), when income inequality is low, a higher welfare can still be achieved even with growing local capture. But this is only up to a certain point ($L = 0.5$). Beyond that point, local leaders cannot afford to maintain the level of welfare, presumably because they are compelled to return the favour of local elites who supported their candidacy. Under this scenario, a small increase of participation can significantly improve local welfare. As participation continues to grow, improvements taper off (concavity). While a similar pattern is also observed in a high inequality environment (high b_1), welfare improvements are more sensitive to the interplay of capture and participation. Only with a higher participation can the same level of capture result in a higher welfare (compare the two panels in Figures 7).

Figure 7

Sensitivity Analysis: Welfare is Less Sensitive to Social Structure (Income Inequality)

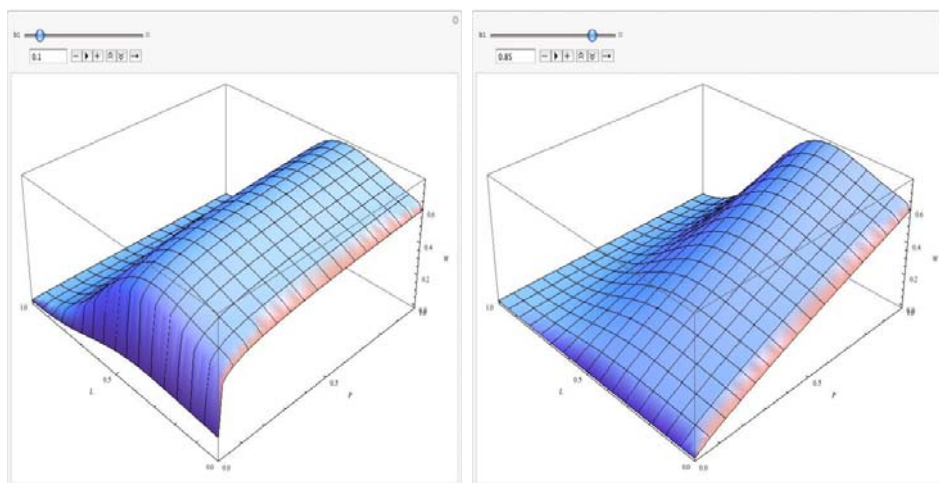

Consider the case where the social structure plays a very significant role in determining welfare (high b_2). When income inequality is low (small b_1), welfare may first increase with growing capture until it reaches the peak. As local capture becomes more widespread, welfare starts to fall. The highest welfare is thus achieved when local capture is limited. This applies irrespective of the level of participation (right panel of Figure 8). On the other hand, if income inequality is high, welfare tends to be lower given the whole range of participation. At a certain level of capture, welfare improvements will take place only if the level of participation increases. Like in the previous low b_2 scenario, the interplay of capture and participation clearly has an important role in determining the level of welfare; more so than in the case of low inequality (compare the two panels in Figure 8).

Figure 8

Sensitivity Analysis: Welfare is Sensitive to Social Structure (Income Inequality)

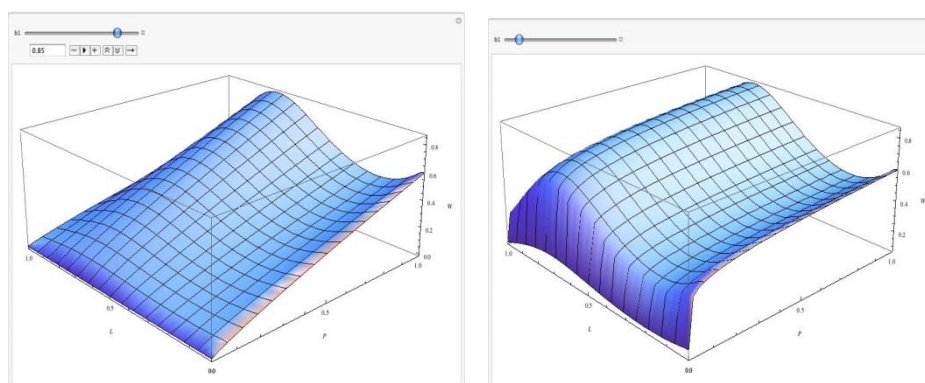

The impact of administrative decentralization is best explained by varying the size of b_3 to reflect the different management quality of local government. Given a level of participation, when local capture increases, welfare can move in either direction depending on the extent to which local leaders are capable of managing their tasks efficiently (getting things done) and effectively (getting things done to worthwhile effect).¹¹ The closer b_3 to unity ($0 < b_3 < 1$), the better is the quality of local management.

Depicted in the left panel of Figure 9, when b_3 is relatively low (set at 0.35), and local capture is also relatively small, within a certain range, welfare and capture move in the opposite direction: higher capture causes welfare to decrease, albeit slightly. As capture reaches a very high level, the relation between the two becomes complimentary. While a similar pattern is observed if the quality of local government's management is good, the welfare outcome is generally better (right panel of Figure 9).

Figure 9

Sensitivity Analysis: Quality of Local Government's Management

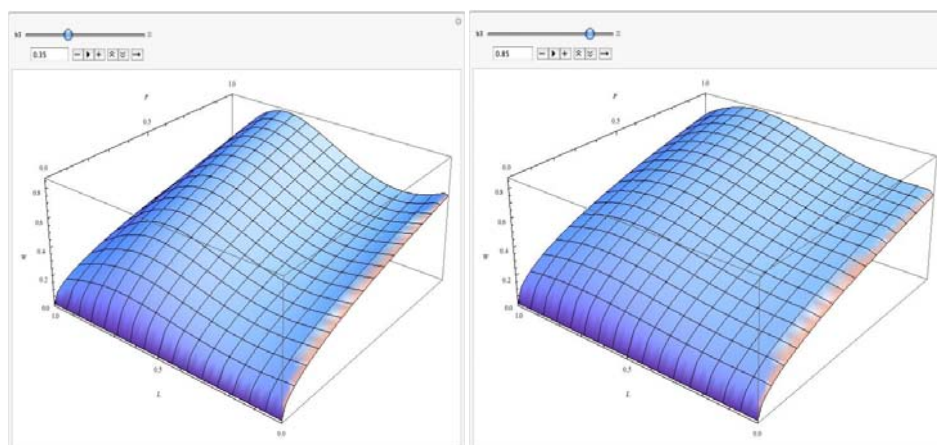

A Case Study

The results of applying the above IMD are discussed in this Section. The approach taken was by conducting a field survey to measure the intensity of the complex interrelations among institutional factors depicted in Figure 1. The ultimate purpose of the survey is to generate a consistent ranking of the three factors (participation P; local budget F; and initial conditions Q) in IMD by treating the complex interplay of different factors. Given the complexity and intangible factors involved, the *Analytic Hierarchy Process* (AHP) and the *Analytic Network Process* (ANP) were used, the detail of which is discussed in the Appendix. The field survey was conducted in seven regions throughout Indonesia over the

¹¹ Busy and seemingly efficient operations do not always produce the best outcome. Less-busy ones may indicate that the local government is in control and know what to do to provide the best services to the people.

period of 2008-2009.¹² One way to structure the relations among institutional factors and the welfare effect of decentralization is by placing all the relevant factors in a hierarchy, where the highest level (objectives) determines welfare criteria, and under each criterion, the importance of relevant institutional factors is determined.¹³ When feedback influences are considered, where factors in each level in the hierarchy can influence and be influenced by factors in other levels, a network is formed. Both the hierarchy and the network used in the survey are shown in the Appendix.

Table 2

Results of Field Survey: For Group in Hierarchy Model

Super Decision				Expert choice			
PALU							
Name	Ideals	Normals	Raw	Overall Inconsistency = .25			
1People's Partici	1	0.364146	0.604568	1People's Partici	364		
2Initial condition	0.966851	0.352075	0.584528	2Initial condition	352		
3Available Budget	0.779296	0.283778	0.471138	3Available Budget	284		
JAMBI							
Name	Ideals	Normals	Raw	Overall Inconsistency = .17			
1People's Partici	0.909111	0.401597	0.642985	1People's Partici	402		
2Initial condition	0.354626	0.156655	0.250816	2Initial condition	157		
3Available Budget	1	0.441747	0.707268	3Available Budget	442		
MATARAM							
Name	Ideals	Normals	Raw	Overall Inconsistency = .04			
1People's Partici	1	0.601918	1	1People's Partici	602		
2Initial condition	0.144856	0.087192	0.144856	2Initial condition	087		
3Available Budget	0.516498	0.31089	0.516498	3Available Budget	311		
MALANG							
Name	Ideals	Normals	Raw	Overall Inconsistency = .03			
1People's Partici	1	0.52247	0.99987	1People's Partici	522		
2Initial condition	0.523064	0.273285	0.523057	2Initial condition	273		
3Available Budget	0.390922	0.204245	0.390917	3Available Budget	204		
BANJARMASIN							
Name	Ideals	Normals	Raw	Overall Inconsistency = .02			
1People's Partici	0.692824	0.289886	0.557808	1People's Partici	289		
2Initial condition	0.697165	0.291702	0.561303	2Initial condition	276		
3Available Budget	1	0.418412	0.805122	3Available Budget	405		
BANDUNG							
Name	Ideals	Normals	Raw	Overall Inconsistency = .11			
1People's Partici	1	0.527833	1	1People's Partici	528		
2Initial condition	0.264558	0.139642	0.264558	2Initial condition	140		
3Available Budget	0.629981	0.332525	0.629981	3Available Budget	333		
SEMARANG							
Name	Ideals	Normals	Raw	Overall Inconsistency = .07			
1People's Partici	1	0.426469	0.713323	1People's Partici	433		
2Initial condition	0.455387	0.194208	0.324838	2Initial condition	253		
3Available Budget	0.889448	0.379322	0.634464	3Available Budget	374		

As displayed in Table 2, with the exception of two regions, *Jambi* and *Banjarmasin*, results from the group survey indicate that people's participation (P) is generally ranked highest among factors that determine the welfare effect of local capture. Notice that for

12 Although at the beginning popular demand for decentralization was not strong enough to push for an immediate change, for purely political reasons, the Indonesian government proceeded with a big-bang decentralization in 1999 (became operational in 2001). The mixed results in terms of post-decentralization performance make Indonesia suitable for model validation. The country managed to avoid a chaotic situation despite the abrupt change, and some regions have enjoyed the benefits of the policy. Yet, the resulting outcome in other regions has been disappointing, not according to what the theory suggests.

13 The AHP uses relative measurements (ratio scales) derived from paired comparisons. Ratio scales are a fundamental kind of number amenable to performing the basic arithmetic operations of addition and subtraction within the same scale, multiplication and division of different scales, and combining the two operations by meaningfully weighting and adding different scales to obtain a unidimensional scale. Hence, they are very useful not only for capturing perceptions towards welfare criteria and institutional factors, but also for synthesizing the priority results that requires some arithmetic operations.

Palu, the least developed among seven regions, the second most important factor after participation is not the availability of local budget (F), but instead the initial welfare condition (S). This is consistent with the premise that the persistence of a poor region is caused by the low initial condition (path dependence). Similarly, for the relatively well-to-do region, *Malang*, the second most important factor is also the initial welfare condition. While *Malang* is already developed (higher S), all factors, including participation, tend to result in a “positive local capture,” reinforcing the region’s welfare condition. Perception of respondents in that region corroborate the hypothesis.

Table 3

Results of Field Survey: For Group, Individuals, and Combined in Hierarchy Model

Hierarchy						
Group Survey						
Summarized result of the group survey in 7 regions based on Hierarchy model (Using Super Decision and Expert Choice software)						
Super Decision					Expert choice	
Name	Rank	Ideals	Normals	Raw	Rank	
1People's Participation	1	0.93609511	0.436124866	0.76595211	1	0.443099225
2Initial condition	3	0.41671289	0.194145702	0.340972015	3	0.20007053
3Available Budget	2	0.70685427	0.329322192	0.578377832	2	0.319149594
Individual Survey						
Summarized result of the individual survey in 4 regions based on Hierarchy model (Using Super Decision software)						
Name	Rank	Ideals	Normals	Raw		
1People's Participation	1	0.73421686	0.377562735	0.691382905		
2Initial condition	3	0.40464311	0.208083135	0.381036434		
3Available Budget	2	0.61913245	0.318381897	0.58301257		
Combination of Group and Individual surveys						
Summarized result of the group and individual survey based on Hierarchy model (Using Super Decision)						
Name	Rank	Ideals	Normals	Raw		
1People's Participation	1	0.82903366	0.405788734	0.727712989		
2Initial condition	3	0.41063366	0.200993648	0.360448		
3Available Budget	2	0.66154094	0.323805844	0.580690577		

All seven regions combined, the ranking shows that participation is indeed the most critical factor (the weight being 0.436 using *Super Decision*, and 0.443 using *Expert Choice*), followed by the size of local budget (0.329 and 0.319, respectively); see Table 3.¹⁴ The ranking remains the same for the individuals category, the geometric means of which are shown in the second (middle) part of Table 3. When the results of group and individuals survey are combined, the weights for participation and local budget are 0.406 and 0.324, respectively.

¹⁴ Super Decision is an experimental software capable of calculating the super-matrix operations involved in the ANP-type of network. By removing the feedback components, it can produce a priority ranking similar to that based on AHP-type of hierarchy. Expert Choice, on the other hand, is specifically designed for AHP.

Table 4

Sensitivity Analysis: Removing One Region at a Time for Group and Individuals in the Hierarchy Model

Hierarchy									
Sensitivity Analysis(Individual and Group) by excluding region by region									
1.Palu									
	Individual				Group				
Name					Rank	Ideals	Normals	Raw	
1People's Participati					1	0.9258	0.4494	0.7968	
2Initial condition					3	0.3622	0.1758	0.3117	
3Available Budget					2	0.6955	0.3376	0.5985	
2.Jambi									
	Individual				Group				
Name	Rank	Ideals	Normals	Raw	Rank	Ideals	Normals	Raw	
1People's Participati	1	0.813	0.432	0.784	1	0.9407	0.4422	0.7886	
2Initial condition	3	0.35	0.186	0.337	3	0.4281	0.2012	0.3589	
3Available Budget	2	0.549	0.292	0.529	2	0.6671	0.3136	0.5593	
3.Mataram									
	Individual				Group				
Name	Rank	Ideals	Normals	Raw	Rank	Ideals	Normals	Raw	
1People's Participati	1	0.686	0.354	0.642	1	0.9258	0.4133	0.7327	
2Initial condition	3	0.407	0.21	0.381	3	0.497	0.2219	0.3933	
3Available Budget	2	0.637	0.328	0.595	2	0.7448	0.3325	0.5894	
4.Malang									
	Individual				Group				
Name					Rank	Ideals	Normals	Raw	
1People's Participati					1	0.9258	0.4232	0.7327	
2Initial condition					3	0.4012	0.1834	0.3175	
3Available Budget					2	0.7802	0.3566	0.6174	
5.Banjarmasin									
	Individual				Group				
Name	Rank	Ideals	Normals	Raw	Rank	Ideals	Normals	Raw	
1People's Participati	1	0.697	0.364	0.659	1	0.9842	0.4668	0.8075	
2Initial condition	3	0.43	0.224	0.406	3	0.3825	0.1814	0.3138	
3Available Budget	2	0.593	0.309	0.56	2	0.6671	0.3164	0.5474	
6.Bandung									
	Individual				Group				
Name	Rank	Ideals	Normals	Raw	Rank	Ideals	Normals	Raw	
1People's Participati	1	0.748	0.366	0.69	1	0.9258	0.4225	0.7327	
2Initial condition	3	0.438	0.214	0.404	3	0.4495	0.2051	0.3557	
3Available Budget	2	0.709	0.347	0.655	2	0.7205	0.3288	0.5702	
7.Semarang									
	Individual				Group				
Name					Rank	Ideals	Normals	Raw	
1People's Participati					1	0.9258	0.4378	0.7751	
2Initial condition					3	0.4106	0.1941	0.3437	
3Available Budget					2	0.6803	0.3217	0.5695	

The robustness of the results is tested by conducting two types of sensitivity analysis: dynamic analysis, and removing one region at a time. The first type is done for each set of questionnaires, the results of which indicate that the most sensitive factor for poverty is participation; for inequality is the initial welfare condition; and for growth and HDI is the size of local budget. Thus, if local development needs to focus more on poverty alleviation, efforts have to be made to raise people's participation. Field observations corroborate such a finding: the welfare effects of decentralization with local capture in regions where people are more politically aware and actively participate in various local development programmes tend to be more positive. The second sensitivity analysis reveals that in all cases, the superiority of participation (P) continues to hold (Table 4). The survey results are therefore fairly robust.

Table 5

Results of Field Survey: For Individuals in Network Model

Network(Individual's geometric mean)				
JAMBI				
ANP				
Name	Rank	Ideals	Normals	Raw
1People's Participation	3	0.470977795	0.224316683	0.428350904
2Initial condition	2	0.638308832	0.304012909	0.580537309
3Available Budget	1	0.896066878	0.426777944	0.814966396
MATARAM				
ANP				
Name	Rank	Ideals	Normals	Raw
1People's Participation	1	0.796528566	0.352012708	0.777336689
2Initial condition	3	0.671627639	0.300617182	0.657223917
3Available Budget	2	0.716403781	0.32065884	0.701039823
BANDUNG				
ANP				
Name	Rank	Ideals	Normals	Raw
1People's Participation	1	0.667566395	0.337707543	0.667566395
2Initial condition	3	0.423094747	0.214034549	0.423094747
3Available Budget	2	0.666475413	0.337156056	0.666475413
Individual survey				
Summarized result of the survey in 3 regions based on network model (Using Super Decision software)				
Name	Rank	Ideals	Normals	Raw
1People's Participation	2	0.630326285	0.29875847	0.605760718
2Initial condition	3	0.566064191	0.269440723	0.544494766
3Available Budget	1	0.753518886	0.35866752	0.724806658

Unlike the case of the hierarchy model, results from the network model with feedback effects are mixed. For example, in *Mataram* and *Bandung* the geometric means point to participation being the most important, but for *Jambi* the size of local budget is the most important factor determining the welfare effect of decentralization (Table 5). Yet, when the three cases are combined, the geometric means ranks the size of local budget highest, followed by participation.

It is important to note, that during the field survey the network model was applied only to individuals, not groups, and only a limited number of regions was covered. Nonetheless, the fact that people's participation (P) and the size of budget (F) stand out as important factors in explaining the welfare effect of decentralization confirms the IMD's conjecture that quality and quantity factors jointly play an important role in the analysis of decentralization.

Conclusions

The focus of this paper is on how the interrelations among different dimensions of decentralization – fiscal, administrative and institutional – affect regional growth and welfare. By using the *Institutional Model of Decentralization* (IMD), it is first shown that when private benefits to local leaders exceeds social benefits, regional growth after decentralization may falter. That is, post-decentralization efficiency often predicted by the theory stays as an unrealized hypothesis. With widespread local capture occurring in many countries following political decentralization, the next question of interest is by what mechanism can the effect of local capture on decentralization outcome be explained?

By expanding the objective from growth to a more broadly-defined welfare, it is shown that the interactions among initial conditions, the effective size of the budget, people's participation, and the quality of local leaders affects the way local capture influences regional welfare. The interactions are complex, non-linear, and may generate multiple equilibria. As the quality of local leaders, including their capacity to motivate participation, determines the outcome, a typology of leaders is constructed. Different types of self-reinforcement factors dictate leader's behaviour, this in turn can reinforce different outcomes, establishing the evolution between welfare and institution (implying endogenous institutions). Based on the sensitivity analysis, it is also conjectured that the nature and intensity of each factor's role in different countries vary depending on the country's social, political and economic structure.

Applied to the case of seven regions in Indonesia, the theoretical prediction of IMD is substantiated. On the group category, given local capture, people's participation is generally ranked the highest among factors that govern the welfare effect of decentralization. It plays the most critical role in reducing the capture while simultaneously maximizing the welfare. The persistence of initial condition is also verified by the fact that it is ranked high, only in two extreme cases is it ranked second, i.e., in the least developed (*Palu*) and very well-to-do region (*Malang*). In the latter, all factors including participation result in a "positive local capture," reinforcing the region's welfare condition. The survey also reveals that regions identified as "deteriorating" and having low participation tend to be poor, and they are persistently so. Not only does this corroborate the critical role of initial condition, but it also suggests that in a democratic system like Indonesia, decentralization is welfare-enhancing only for regions under "complete" progress, not for all regions.

Given that a multiple equilibria scenario after decentralization is common, not unique for Indonesia, an institutional reform following a shift from centralized to decentralized system in any country is warranted; however, the reform ought to take account of the potential interactions among institutional factors and characteristics as described in IMD, not just aim at minimizing transaction costs.

Appendix: Brief Explanations of AHP and ANP

Let $A_1, A_2, A_3, \dots, A_n$ be n elements in a matrix within a hierarchy. The pairwise comparisons on pairs of elements (A_i, A_j) are represented by an n -by- n matrix $A = (a_{ij})$, where $i, j = 1, 2, 3, \dots, n$. Define a set of numerical weights $w_1, w_2, w_3, \dots, w_n$ that reflects the recorded comparisons,

$$\begin{array}{c}
 \begin{array}{cccc}
 & A_1 & A_2 & \dots & A_n \\
 A_1 & \boxed{w_1/w_1} & w_1/w_2 & \dots & w_1/w_n \\
 & \dots & \dots & \dots & \dots \\
 A_n & \boxed{w_n/w_1} & w_n/w_2 & \dots & \boxed{w_n/w_n}
 \end{array} \\
 A =
 \end{array}$$

The scales used in the pairwise comparisons in AHP are based on Saaty’s scaling system (Saaty, 1996), i.e., from 1 to 9. Since every row is a constant multiple of the first row, A has a unit rank. By multiplying A with the vector of weights w ,

$$Aw = nw$$

To recover the scale from the matrix ratios, the following system ought to be solved:

$$(A-nI)w = 0$$

Clearly, a nontrivial solution can be obtained only if $\det(A-nI)$ vanishes, i.e., the *characteristic equation* of A . Hence, n is an *eigenvalue* and w is an *eigenvector* of A . Given that A has a unit rank, all its eigenvalues except one are zero. Thus, the *trace* of A is equal to n . If each entry in A is denoted by a_{ij} , then $a_{ij} = 1/a_{ji}$ (reciprocal property) holds, and so does $a_{jk} = a_{ik} / a_{ij}$ (consistency property). By definition, $a_{ii} = a_{jj} = 1$, that is, when comparing two same elements. Therefore, if we are to rank n number of elements, i.e., A is of the size n -by- n , the required number of inputs from the paired comparisons is less than n^2 ; it is equal only to the number of entries of the sub-diagonal part of A . Hence, if there are three elements in a particular level of a hierarchy, only three pairwise comparisons are required. In general, the precise value of w_i/w_j is barely known, simply because the pairwise comparisons are only an estimate, suggesting that there are some perturbations. While the reciprocal property still holds, the consistency property

does not. By taking the largest eigenvalue denoted by $\bar{\lambda}_{max}$,

$$A^p \cdot w^p = \bar{\lambda}_{max} \cdot w^p$$

where A^p is the actual, or the given, matrix (perturbed from matrix A). Solving the above gives a consistent matrix whose entries are w_i/w_j ; it is a consistent estimate of A , although

A^P itself does not need to be consistent. A^P will be consistent if and only if $\bar{\lambda}_{max} = n$. As long as the precise value of w_j/w_i cannot be given, which is common in real situations due to the bias in the comparisons, $\bar{\lambda}_{max}$ is always greater than or equal to n ; hence, a measure of consistency can be derived based on the deviation of $\bar{\lambda}_{max}$ from n . When more than two elements are compared, the notion of consistency can be associated with *transitivity* condition: if $A_1 \succ A_2$ and $A_2 \succ A_3$, then $A_1 \succ A_3$. It should be clear that in solving for w , the *transitivity* assumption is not strictly required; the inputted comparisons do not have to reflect a full consistency. Yet, as shown above, the resulting matrix and the corresponding vector remain consistent. It is this consistent vector w that reflects the priority ranking of the elements in each level. Hence, in a standard hierarchy with three levels (goals, criteria, and alternatives), the elements in each level are pairwise compared with respect to elements in the level above it, and the resulting vector at the bottom level reflects the priority ranking of the alternatives.

Figure A1

Role of Institutional Factors in Decentralization: Hierarchy Model

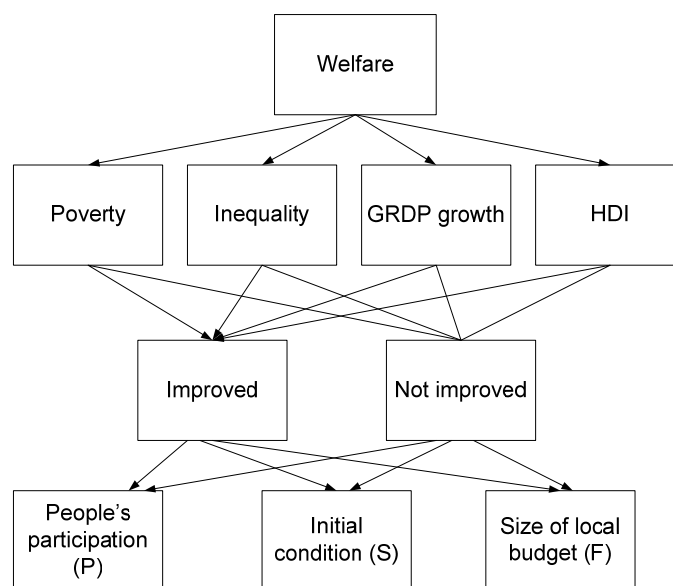

To test the model framework for decentralization using AHP, the hierarchy shown in Figure A1 is used. Maximizing local welfare is the goal, and four indicators are identified: poverty, inequality, local output growth (GRDP growth), and human development index (HDI). These indicators are to be prioritized by using pairwise comparison matrix from which the eigen-vector reflecting the consistent ranking is derived. After clarifying whether in the respective region, each of the indicators has improved or not, the next step is to rank the importance of the determinants of those welfare indicators. As discussed before, of all possible determinants, three stand out: people's participation (P), initial condition (S), and size of local budget (F). By taking into account the consistent ranking

of welfare indicators and institutional factors, the overall results can be synthesized. In some regions, a modified structure of the ANP-type of network is used in which feedback effects capturing the performance of each factor (improved or not improved) are identified. Unlike AHP, a network model recognizes two-way dependence relationships that exist among variables). With feedback, the alternatives can depend on the criteria as in a hierarchy but they may also depend on each other. The criteria themselves can depend on the alternatives and on each other. Hence, it involves a network rather than a hierarchy. With such a feature, the results are more stable because one considers the influence on and survival in the face of other influences.

Figure A2

Role of Institutional Factors in Decentralization: Network Model

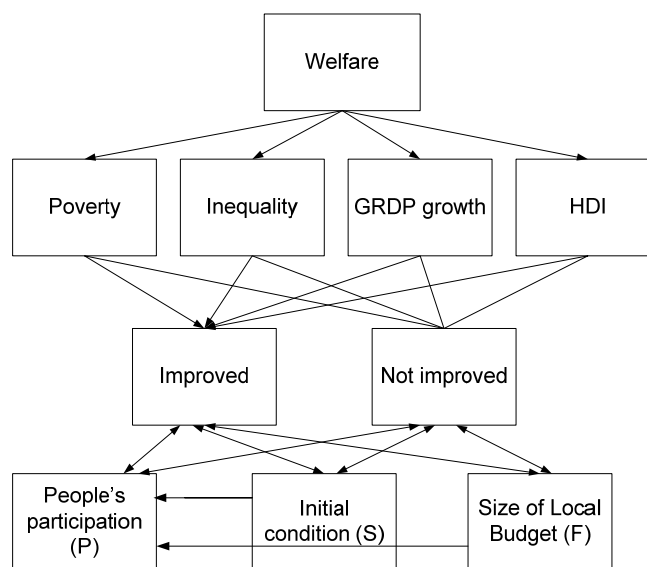

The network framework used in the survey is shown in Figure A2. Notice that the 2-way arrows indicate the feedback effects between the bottom level and the level above it, and between some elements in the same level (size of local budget and initial welfare condition influence participation).

While in a hierarchy-based model a set of pairwise comparison matrices are used, the presence of feedback influences in a network model requires a *supermatrix* that contains a set of sub—matrices. This supermatrix should capture the influence of elements in a network on other elements in that network. Denoting a cluster by C_h , $h = 1, \dots, m$, and assuming that it has n_h elements $e_{h1}, e_{h2}, e_{h3} \dots, e_{h n_h}$, Figure A3 shows the supermatrix of such a hierarchy:

Figure A3

Supermatrix of a Hierarchy

$$W = \begin{matrix} & \begin{matrix} c_1 & c_2 & \dots & c_{n-2} & c_{n-1} & c_n \end{matrix} \\ \begin{matrix} c_1 \\ \vdots \\ c_2 \\ \vdots \\ c_n \end{matrix} & \begin{bmatrix} \begin{matrix} e_{11} & \dots & e_{1n} \end{matrix} & \begin{matrix} e_{21} & \dots & e_{2n} \end{matrix} & \dots & \begin{matrix} e_{(n-2)1} & \dots & e_{(n-2)n} \end{matrix} & \begin{matrix} e_{(n-1)1} & \dots & e_{(n-1)n} \end{matrix} & \begin{matrix} e_{n1} & \dots & e_{nn} \end{matrix} \\ \begin{matrix} 0 & 0 & \dots & 0 & 0 & 0 \end{matrix} \\ \begin{matrix} W_{21} & 0 & \dots & 0 & 0 & 0 \end{matrix} \\ \begin{matrix} 0 & W_{32} & \dots & 0 & 0 & 0 \end{matrix} \\ \vdots \\ \begin{matrix} 0 & 0 & \dots & W_{n-1, n-2} & 0 & 0 \end{matrix} \\ \begin{matrix} 0 & 0 & \dots & 0 & W_{n, n-1} & I \end{matrix} \end{bmatrix} \end{matrix}$$

Figure A4

Supermatrix of a Holarchy

$$W = \begin{matrix} & \begin{matrix} c_1 & c_2 & \dots & c_{n-2} & c_{n-1} & c_n \end{matrix} \\ \begin{matrix} c_1 \\ \vdots \\ c_2 \\ \vdots \\ c_n \end{matrix} & \begin{bmatrix} \begin{matrix} e_{11} & \dots & e_{1n} \end{matrix} & \begin{matrix} e_{21} & \dots & e_{2n} \end{matrix} & \dots & \begin{matrix} e_{(n-2)1} & \dots & e_{(n-2)n} \end{matrix} & \begin{matrix} e_{(n-1)1} & \dots & e_{(n-1)n} \end{matrix} & \begin{matrix} e_{n1} & \dots & e_{nn} \end{matrix} \\ \begin{matrix} 0 & 0 & \dots & 0 & 0 & W_{1,n} \end{matrix} \\ \begin{matrix} W_{21} & 0 & \dots & 0 & 0 & 0 \end{matrix} \\ \begin{matrix} 0 & W_{32} & \dots & 0 & 0 & 0 \end{matrix} \\ \vdots \\ \begin{matrix} 0 & 0 & \dots & W_{n-1, n-2} & 0 & 0 \end{matrix} \\ \begin{matrix} 0 & 0 & \dots & 0 & W_{n, n-1} & 0 \end{matrix} \end{bmatrix} \end{matrix}$$

When the bottom level affects the top level of the hierarchy, a form of network known as *holarchy* is formed, the supermatrix of which will look like the one displayed in Figure A4. Notice that the entry in the last row and column of the supermatrix in Figure A3 is the identity matrix I corresponding to a loop at the bottom level of the hierarchy. This is a necessary aspect of a hierarchy viewed in the context of supermatrix. On the other hand, the entry in the first row and last column of a holarchy in Figure A4 is nonzero, indicating that the top level depends on the bottom level. The entries of sub-matrices in W_{ij} are the ratio scales derived from paired comparisons performed on the elements within the clusters themselves according to their influence on each element in another cluster (outer dependence) or elements in their own cluster (inner dependence). The resulting *unweighted supermatrix* is then transformed into a matrix, each of whose columns sums to unity to generate a stochastic supermatrix. The derived weights are used to weight the elements of the corresponding column blocks (cluster) of the supermatrix, resulting in a *weighted supermatrix*, which is also stochastic. The stochastic nature is required for the reasons described below. The typical entry of Figure A5 supermatrix is shown in Figure A6.

Figure A5

Supermatrix of a Network

$$W = \begin{matrix} & \begin{matrix} C_1 & C_2 & \dots & C_N \end{matrix} \\ \begin{matrix} C_1 \\ C_2 \\ \vdots \\ C_N \end{matrix} & \begin{bmatrix} e_{11}e_{12} \dots e_{1n_1} & e_{21}e_{22} \dots e_{2n_2} & \dots & e_{N1}e_{N2} \dots e_{Nn_N} \\ W_{11} & W_{12} & \dots & W_{1N} \\ W_{21} & W_{22} & \dots & W_{2N} \\ \vdots & \vdots & \dots & \vdots \\ W_{N1} & W_{N2} & \dots & W_{NN} \end{bmatrix} \end{matrix}$$

Figure A6

Entry in the Supermatrix of a Network

$$W_{ij} = \begin{bmatrix} W_{i1}^{(j_1)} & W_{i1}^{(j_2)} & \dots & W_{i1}^{(j_{n_j})} \\ W_{i2}^{(j_1)} & W_{i2}^{(j_2)} & \dots & W_{i2}^{(j_{n_j})} \\ \vdots & \vdots & \dots & \vdots \\ W_{in_i}^{(j_1)} & W_{in_i}^{(j_2)} & \dots & W_{in_i}^{(j_{n_j})} \end{bmatrix}$$

Since an element can influence the second element directly and indirectly through its influence on some third element and then by the influence of the latter on the second, every such possibility of a third element must be considered. This is captured by squaring the weighted matrix; however, the third element also influences the fourth, which in turn influences the second. These influences can be obtained from the cubic power of the weighted supermatrix. As the process is performed continuously, one will have an infinite sequence of influence matrices denoted by W^k , $k = 1, 2, \dots$. The question is, if one takes the limit of the average of a sequence of N of these powers of the supermatrix, will the result converge, and, is the limit unique? It has been shown that such a limit exists given the stochastic nature of the weighted supermatrix (Saaty, 2001). There are three cases to consider in deriving W^k : (1) $\lambda_{max} = 1$ is a simple root and there are no other roots of unity in which case given the nonnegative matrix W is *primitive*, we have $\lim_{k \rightarrow \infty} W^k = we^T$, implying that it is sufficient to raise the primitive stochastic matrix W to large powers to yield the limit outcome; (2) there are other roots of unity that cause cycling, in which case Cesaro sum is applied; and (3) $\lambda_{max} = 1$ is a multiple root, in which case Sylvester's formula with $\lambda_{max} = 1$ is applied. For further details, see Saaty (2001) and Azis

(2009). In practice, one simply needs to raise the stochastic supermatrix to large powers to read off the final priorities in which all the columns of the matrix are identical and each gives the relative priorities of the elements from which the priorities of the elements in each cluster are normalized to one. The powers of the supermatrix do not converge unless it is stochastic, because then its largest eigenvalue is one. When a convergence fails to achieve (a cyclic case), the average of the successive matrices of the entire cycle gives the final priorities (Cesaro sum), in which the limit cycles in blocks and the different limits are summed, averaged and again normalized to one for each cluster. At any rate, raising the stochastic supermatrix to large powers gives what is known as *limiting supermatrix*. Hence, there are three supermatrices to be used: (1) the original unweighted supermatrix of column eigenvectors obtained from pair wise comparison matrices of elements; (2) the weighted supermatrix in which each block of column eigenvectors belonging to a cluster is weighted by the priority of influence of that cluster, rendering the weighted supermatrix column stochastic; and (3) the limiting supermatrix obtained by raising the weighted supermatrix to large powers. To apply the network model, our survey team used *Super Decision* software, and for the hierarchy model, the team used *Super Decision* and *Expert Choice*.

REFERENCES

- Azis, I. J. (2009): *Crisis, Complexity, and Conflict* Emerald, United Kingdom.
- Azis, I. J. (2008): Institutional Constraints and Multiple Equilibria in Decentralization *Review of Urban and Regional Development Studies* 20 (1): 22–33.
- Azis, I. J. (2010): Endogenous Institution in Decentralization *Peace Economics, Peace Science and Public Policy* 16 (2): Article 12
- Azis, I. J. – Wiharja, M. (2010): Theory of Endogenous Institutions and Evidence from an In-depth Field Study in Indonesia *Economic & Finance Indonesia* 58 (3): 309–334.
- Bardhan, P. – Mookherjee, D. (2005): *Decentralization, Corruption and Government Accountability: An Overview* Handbook of Economic Corruption edited by Rose-Ackerman, S. and Elgar, E.
- Beard, V. A. (2005): Individual Determinants of Participation in Community Development in Indonesia *Environment and Planning C: Government and Policy* 23 (1): 21–39.
- Besley, T. – Coate, S. (1999): *The Public Critique of Welfare Economics: An Exploration* NBER Working Papers 7083, National Bureau of Economic Research, Inc., Cambridge, MA, USA.
- Binswanger, H. (1999): *Technical Consultation on the Decentralization of Rural Development* Proceedings of FAO conference, Rome, 16-18 December 1997, FAO, Rome.
- Blair, H. (2000): Participation and Accountability at the Periphery: Democratic Local Governance in Six Countries *World Development* 28 (1): 21–39.
- Bruno, M. – Pleskovic, B. (eds.) (1996): *Annual World Bank conference on development economics* World Bank, Washington, DC.
- Burki, S. J. – Perry, G. – Dillinger, W. (eds.) (1999): *Beyond the center. Decentralizing the state*. The World Bank, Washington D.C.
- Easterly, W. – Ross, L. (2002): *Tropics, Germs, and Crops: How Endowments Influence Economic Development* NBER Working Papers 9106, National Bureau of Economic Research, Inc., Cambridge, MA, USA.
- Eggertsson, T. (1996): No Experiments, Monumental Disasters: Why It Took a Thousand Years To Develop a Specialized Fishing Industry in Iceland *Journal of Economic Behavior and Organization* 30 (1): 1–23.
- Filippetti, A. – Sacchi, A. (2013): *Varieties of decentralization, institutional complementarities, and economic growth: evidence in OECD countries* National Research Council of Italy and Birkbeck University of London (UK), in press
- Greif, A. (2006): *Institutions and the Path To The Modern Economy* Cambridge University Press, N.Y.

- Henry, P. B. – Miller, C. (2008): *Institutions vs. Policies: A Tale of Two Islands* NBER Working Paper No. 14604, December, National Bureau of Economic Research, Inc., Cambridge, MA, USA.
- Huther, J. – Shah, A. (1998): *Applying a simple measure of good governance to the debate on fiscal decentralization* Policy Research Working Paper, Series 1894, The World Bank, Washington D.C.
- Londregan, J. B. – Poole, K. T. (1996): Does High Income Promote Democracy? *World Politics* 49 (1): 1–30.
- Manor, J. (1999): *Explaining the last wave of decentralizations* *The Political Economy of Democratic Decentralization* World Bank, Washington DC.
- Martinez-Vazquez, J. – McNab, R. M. (2003): Fiscal decentralization and economic growth *World development* 31 (9): 1597–1616.
- North, D. C. (1993): *Prize Lecture, The Sveriges Riksbank Prize in Economic Sciences in Memory of Alfred Nobel* Lecture to the memory of Alfred Nobel, December 9.
- North, D. C. (2005): *Understanding the process of economic change* Princeton University Press, Princeton.
- Oates, W.E. (1972): *Fiscal Federalism*. Harcourt Brace Jonanovitch, New York.
- Oates, W.E. (1994): Federalism and government finance In Quigley, J.M. and Smolensky, E. (eds.) *Modern Public Finance* pp. 125–151. Harvard University Press, Cambridge, MA, USA.
- Prud'homme, R. (1994): *On the Dangers of Decentralization* Policy Research Working Paper, No. 1252, World Bank, Washington, DC.
- Rodrik, D. – Subramanian, A. – Trebbi, F. (2002): *Institutions Rule: The Primacy of Institutions over Geography and Integration in Economic Development* NBER Working Paper No. 9305, October. Cambridge, MA, USA.
- Sachs, J. (2003): Institutions Matter, but Not for Everything *IMF Finance and Development* 40 (2), June 2003.
- Saaty, T. L. (1996): *Fundamentals of decision making and priority theory with the analytic hierarchy process* RWS Publication, Pittsburgh.
- Saaty, T. L. (2001): *Decision making with dependence and feedback: The analytic network process* RWS Publication, Pittsburgh.
- Shleifer, A. – Vishny, Robert W. (1993): Corruption *The Quarterly Journal of Economics* 108(3): 599–617.
- Shleifer, A. – Treisman, D. (2005): A Normal Country: Russia After Communism *Journal of Economic Perspectives* 19 (1): 151–174.
- Tanzi, Vito (2002): Pitfalls of Decentralization In: Ahmad, E. and Tanzi, V. (eds.) *Managing Fiscal Decentralization* pp. 17–30: Routledge, London and New Work.
- United Nations (1991): *Fiscal decentralisation and the mobilisation and use of national resources for development: Issues, experiences and policies in the ESCAP region* United Nations, New York.
- World Bank (2000): *The World Development Report 1999/2000* The World Bank, Washington, D. C. and Oxford University Press, Oxford.