

Medical Devices and Devices for Control of the Environment,
Substances, Materials and Products
UDC 615.47:616-072.7

Original article

<https://doi.org/10.32603/1993-8985-2021-24-2-78-86>

A Medical Hardware-Software System for Remote Monitoring of Heart Diseases

Talat M. Magrupov¹, Zafar M. Yuldashev², Seit P. Abdihalikov¹✉

¹Tashkent State Technical University n. a. I. Karimov, Tashkent, Uzbekistan

²Saint Petersburg Electrotechnical University, St Petersburg, Russia

✉ seit-abdihalikov@rambler.ru

Abstract

Introduction. Wireless diagnostics of patients' functional state is important for ensuring timely detection and treatment of diseases. In this article, the development of a medical hardware-software system for remote monitoring of the state of biological objects is considered on the example of cardiovascular diseases.

Aim. To develop a medical hardware-software system for remote monitoring of the main cardiovascular parameters and to expand the scope of medical remote telemetry equipment, which can eventually lead to improved medical services.

Materials and methods. On the example of cardiovascular diseases, an analysis of the existing medical hardware-software system for remote monitoring of the state of biological objects was carried out, taking into account the cardiac monitoring of the electrocardiogram. This method is widely used for in the diagnostics and treatment of cardiovascular diseases.

Results. A method was proposed for creating a hardware-software system for remote monitoring of the main cardiovascular parameters to ensure timely detection and treatment of diseases. The general structure of such a system, including its advantages and disadvantages and the routing of information, is described. The proposed technology of prolonged remote monitoring of the patient's health state makes it possible to increase the efficiency of detecting dangerous heartbeat arrhythmia by about 30 %.

Conclusions. The proposed system solves the problem of registering biological parameters without significant interference in the patient's vital activity, which allows typical conditions to be traced. Remote data collection also facilitates the load on medical personnel, reduces the number of contacts with patients and improves their psychological state.

Keywords: heart diseases, hardware-software system, remote monitoring, sensors, electrocardiogram, telemetry equipment quality

For citation: Magrupov T. M., Yuldashev Z. M., Abdihalikov S. P. A Medical Hardware-Software System for Remote Monitoring of Heart Diseases. Journal of the Russian Universities. Radioelectronics. 2021, vol. 24, no. 2, pp. 78–86. doi: 10.32603/1993-8985-2021-24-2-78-86

Conflict of interest. The authors declare no conflicts of interest.

Submitted 15.03.2021; accepted 06.04.2021; published online 29.04.2021



Приборы медицинского назначения, контроля среды, веществ, материалов и изделий

Оригинальная статья

Аппаратно-программный медицинский комплекс дистанционного мониторинга показателей сердечных заболеваний

Т. М. Магруппов¹, З. М. Юлдашев², С. П. Абдихаликов^{1✉}

¹Ташкентский государственный технический университет
им. И. Каримова, Ташкент, Узбекистан

²Санкт-Петербургский государственный электротехнический университет "ЛЭТИ"
им. В. И. Ульянова (Ленина), Санкт-Петербург, Россия

✉ seit-abdihalikov@rambler.ru

Аннотация

Введение. В системе здравоохранения одной из важных задач является создание аппаратно-программного комплекса в области дистанционного мониторинга основных физиологических показателей сердечно-сосудистой системы (ССС) человека для беспроводной диагностики функционального состояния больного и обеспечения своевременного выявления и лечения заболеваний. В связи с этим актуальной становится задача совершенствования метода, свойств и характеристик построения аппаратно-программного медицинского комплекса для дистанционного мониторинга состояний биообъектов на примере заболеваний ССС.

Цель работы. Разработка аппаратно-программного медицинского комплекса для дистанционного мониторинга показателей сердечно-сосудистой системы, расширение области применения приборов медицинской телеметрии, повышение качества оказываемых медицинских услуг.

Материалы и методы. Произведен анализ существующих положений организации медицинского аппаратно-программного комплекса для дистанционного мониторинга состояний биологических объектов на примере сердечных заболеваний с учетом кардиомониторирования электрокардиограммы, который является наиболее часто используемым и широко распространенным методом исследования в клиниках для диагностики и лечения заболеваний ССС.

Результаты. Предложен способ создания аппаратно-программного комплекса в области дистанционного мониторинга основных физиологических показателей ССС человека для беспроводной диагностики функционального состояния больного и обеспечения своевременного выявления и лечения заболеваний. Разработана общая структура аппаратно-программного комплекса с учетом его возможностей и преимуществ. Использование предложенной технологии дистанционного длительного мониторинга состояния здоровья пациента позволяет повысить эффективность выявления опасных нарушений сердечного ритма до 30 %.

Заключение. Комплекс решает задачу регистрации биологических параметров без значительного вмешательства в деятельность пациента, что позволяет фиксировать его типичные состояния. Дистанционный сбор данных также облегчает работу медицинского персонала, снижение количества контактов с пациентами улучшает психологическое состояние последних.

Ключевые слова: сердечные заболевания, аппаратно-программный комплекс, дистанционный мониторинг, датчики, электрокардиограмма, качество телемедицинской системы

Для цитирования: Магруппов Т. М., Юлдашев З. М., Абдихаликов С. П. Аппаратно-программный медицинский комплекс дистанционного мониторинга показателей сердечных заболеваний // Изв. вузов России. Радиоэлектроника. 2021. Т. 24, № 2. С. 78–86. doi: 10.32603/1993-8985-2021-24-2-78-86

Конфликт интересов. Авторы заявляют об отсутствии конфликта интересов.

Статья поступила в редакцию 15.03.2021; принята к публикации после рецензирования 06.04.2021; опубликована онлайн 29.04.2021

Introduction. In modern medicine, important problems are: reducing the time for examining patients, increasing the accuracy of diagnostics, conducting remote consultations, analyzing and processing primary

information in highly specialized centers, ensuring long-term storage of information about patients in digital form, as well as, if necessary, gaining access to information about a patient with remote distance [1–3].

In case of heart diseases, the following possibilities of electrocardiography occupy an important place: analysis of electrocardiograms (ECG) gives a rather high reliability of medical reports; the method is highly sensitive, but non-specific; ease of registration, relatively low cost of the survey with high information content; excellent opportunity to assess the patient's condition in the dynamics of observation; the ability to automatically analyze ECG samples and highlight life-threatening situations, for example, monitoring arrhythmias, ST segment depression; extensive experience in clinical practice and knowledge of this method by the majority of doctors.

Considering these advantages of electrocardiography, the following advantages can be achieved in telemedicine:

- speeds up the process of providing medical care allows you to make a quick decision when establishing the diagnosis of a patient from a distance;
- achieve a sufficiently high reliability of medical reports with the participation of experienced specialists;
- provides opportunities for remote observation of the patient's condition and assessment of his condition in the dynamics of observation;
- allows remote monitoring of arrhythmia and basic ECG indicators;
- provides the ability to quickly analyze ECG samples and take the necessary medical attention.

ECG is the most frequently used and widespread research method in clinics, which has given rise to many options for developments in telemedicine and, accordingly, remote analysis and methods of transferring electrocardiogram samples.

One of the main areas of telemedicine is the transmission of an electrocardiogram signal over a distance. The transmission method should provide the least loss and distortion at the fastest speed.

Currently, the need for telemedicine technologies is due to a number of problems that health authorities, the executive branch and doctors and patients themselves constantly face. This is to provide timely medical care to patients from a remote distance at remote distances, including bedside monitoring, as well as monitoring and tracking the condition of critically ill patients, as well as chronically ill, which is an urgent task [4].

This article analyzes the existing provisions of the organization of a medical hardware-software complex

for remote monitoring of the states of biological objects on the example of heart disease. Known, commercially available devices for medical telemetry do not provide a given amount of received information and flexibility of connection. Foreign devices of the Apple and Samsung brands are expensive and have an insufficient set of sensors and communication protocols, which does not allow them to be widely used in biomedical research. The known method of automated remote assessment of parameters of motor activity, respiration and pulse of a person or animal. The technical result is the absence of the need for accurate positioning in terms of distance relative to a person or an animal and an improvement in the quality of the non-contact analysis of the patient's movements, the pattern of his breathing and heartbeat. The disadvantage of this method is the lack of technical implementation, incompleteness as a method of biomedical diagnostics and the lack of methods for connecting to the network [5, 6].

A method for creating a hardware-software complex in the field of remote monitoring of the main physiological parameters of the cardiovascular system (CVS) of a person for wireless diagnostics of the functional state of a patient and ensuring timely detection and treatment of diseases is proposed. The general structure of the hardware-software complex, the passage of diagnostic information, its capabilities and advantages have been developed.

In this regard, the increase in the efficiency of diagnostics, treatment and the return of patients to an active life are associated, first of all, with the timely detection of diseases and the rapid provision of qualified medical care, including by means of telemedicine.

In this direction, work has been carried out to develop a multi-level intelligent system for remote monitoring of the condition of patients with chronic, sugar and heart diseases [1, 7–10].

In this regard, the work proposes the creation of a hardware and software complex in the field of remote monitoring of the main physiological indicators of the cardiovascular system (CVS) of a person for wireless diagnostics of the functional state of the patient and ensuring the timely detection and treatment of diseases. Here, the main attention is paid to the study of methods, properties and characteristics of constructing a hardware-software medical complex for remote monitoring of the state of biological objects using the example of diseases of the cardiovascular system.

Methods. The main task of designing technical means for monitoring biological objects is to create adequate models of processes using modern mathematical tools and to develop correct methods of information processing based on the most modern approach in information-measuring systems [11, 12].

When determining the way of organizing the structural diagram of the hardware-software complex, the main attention should be paid to: high reliability and immunity from interference; the method of building the architecture of the biomedical system for recording and processing physiological signals, which increases the functionality of the complex and its manufacturability; mathematical model of distribution and physical presentation of data for solving the problem of identifying parallel processes; the method of providing the function of registration, storage, processing, analysis of a number of physiological signals: pulse, body temperature, electrocardiograms, etc.

As a result of the analysis of the existing provisions of this problem, a method is proposed for creating a hardware-software complex for remote monitoring of diseases of the cardiovascular system [13, 14].

Monitoring vital activity parameters using a hardware-software medical complex should improve the patient's quality of life during the examination and allow to quantitatively assess the response of the patient's cardiovascular system to stress tests, to establish the effectiveness of the stimulation regime used and the therapy performed in patients with implanted pacemakers and in many other pathologies.

The proposed hardware and software complex is designed for autonomous automatic continuous remote monitoring of the parameters of the vital activity of a bioorganism and further processing (systematization and analysis) of the data obtained and has wide configurations. You can choose a configuration option depending on your requirements. In accordance with the provided requirements, the number of sensors in transmitting diagnostic devices (patients) and the area of wireless communication can be changed. The set of sensors allows for a deep and continuous analysis of the state of the cardiovascular system, blood flow and respiration of the patient. Each sensor individually has the ability to investigate a variety of diagnostic indicators (signs) necessary for effective treatment and prevention of diseases [15–17].

Fig. 1 shows the structure of the basic version of the medical complex. In it, the diagnostic information

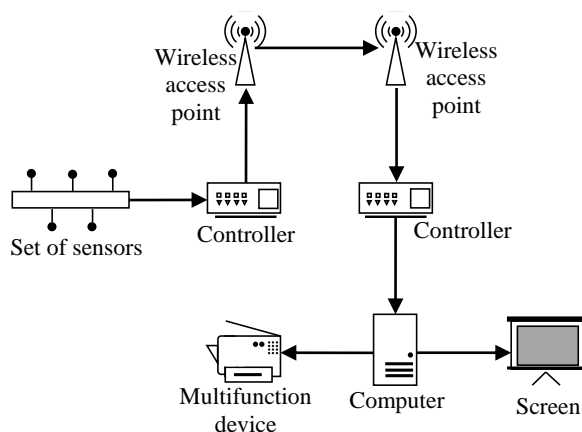

Fig. 1. Diagnostic information routing

goes through several stages of conversion, from sensors to the consumer. In this case, the use of four sensors is proposed.

Each of the four sensors individually provides a variety of diagnostic indicators (signs) necessary for effective treatment and prevention of diseases and allows:

- analyze electrocardiograms, which gives a fairly high reliability of medical reports, the proposed method is highly sensitive, but nonspecific, provides the ability to automatically analyze ECG samples and isolate life-threatening situations, for example, monitoring arrhythmias, ST segment depression in the ECG, and there is also extensive experience in using electrocardiography in clinical practice, this method has been mastered by most doctors;

- increase the detection of cardiac arrhythmias in rare paroxysmal conditions and supplement the results of other methods of examination of cardiac patients, optimize the control of antiarrhythmic and anti-anginal therapy;

- timely identify transient processes in the body and ensure the possibility of an emergency response;

- justify the need for hospitalization, optimize the quality and terms of rehabilitation, identify the side effects of pharmacotherapy;

- carry out long-term diagnostics, which helps to identify the conditions characteristic of the cardiovascular system and observe the dynamics of oxygen and blood saturation.

An autonomous unit is responsible for collecting vital signs in the complex under consideration, which includes:

- wireless communication module (2.4 GHz), providing high speed data transfer with low power consumption;

– a set of sensors that detect the heart rate, heart biopotentials, blood flow velocity and control the respiration of the bioorganism;

– a controller that switches signals, optimizes data transmission and provides the ability to control and deeply configure an autonomous unit.

Fig. 2 shows a block diagram of the hardware part of the complex with the structure of a stationary unit.

Storage, processing and visualization of the received data is provided by a stationary unit, consisting of:

- a wireless communication module;
- a controller performing preliminary processing of data that is transmitted further through communication channels;
- a computer that provides the ability to receive data via communication channels and the functioning of the software (SW) included in the complex;
- software for systematization, storage, processing and visualization of medical indicators.

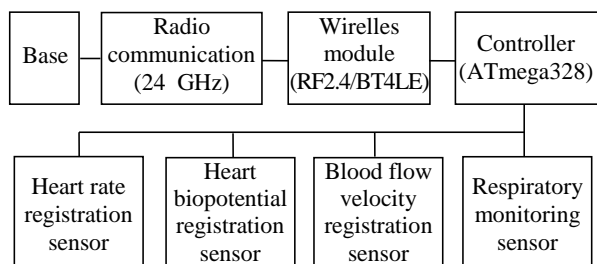

Fig. 2. A block scheme describing the hardware part of the system

The proposed hardware part of the complex – the device differs from the existing ones in that integrated sensors are used as sensitive elements, as well as in the fact that this device uses radio communication to transmit and control biomedical parameters and software that matches the operation of not only sensors, but also several devices telemetry in the network of the complex.

Therefore, we can conclude, that the proposed modernized device allows, along with expanding the scope of its application, to obtain reliable and more accurate indicators of the biological activity of the patient, which corresponds to the task.

The device of the medical telemetry complex consists of two independent units connected by a wireless network.

The first block is a switch, conventionally called a signal receiver (Fig. 3). It provides the transfer of the received information to a personal computer (PC) through a sequence of electrically connected circuitry

devices, via the PC USB port. At the same time, the ft232 serial port converter directly connected to the PC is responsible for the communication between the microcontroller and the PC, which ensures the coordination of the USB and UART interfaces, the microcontroller is used to communicate with the PC the UART interface and executes the program to form an access point for communication through the radio receiver module [9, 10].

The second unit, conventionally called a transmitter, is an integrated insertion device (Fig. 4) of a radio transmitter module that provides communication over a wireless channel. In this case, the microcontroller provides control of a radio transmitter electrically connected to it, which provides waiting for transfer commands from the PC. It allows the possibility of monitoring and feedback using input / output devices, is electrically connected to the controller and is an indicator, which is an LED, buttons for entering information and a set of sensors, also electrically connected to the microcontroller. It differs in that the set of sensors, as part of the transmitter, consists of an integrated MAX30100 sensor, which provides the ability to conduct pulse oximetry and heart rate monitoring,

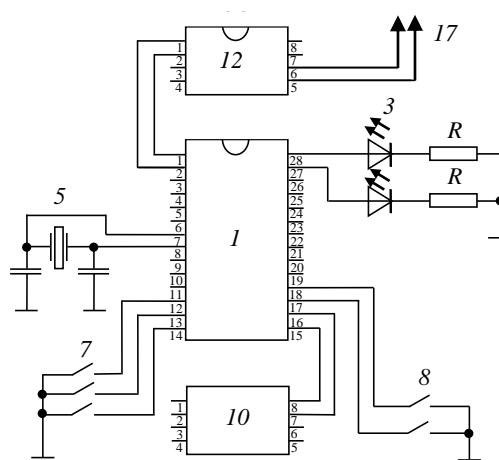

Fig. 3. A receiving unit of the proposed medical system

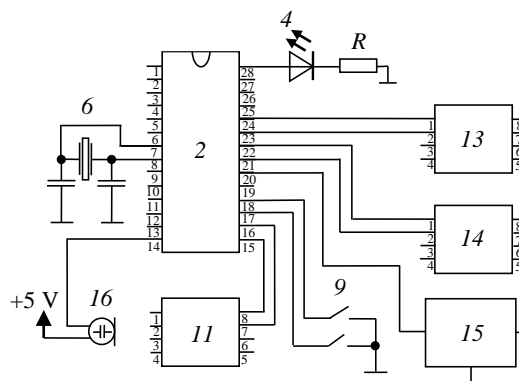

Fig. 4. A transmission unit of the proposed system

an integrated GY-521 sensor, which is a 3-axis gyroscope and accelerometer, an LM35 sensor, which is a temperature sensor and microphone, as well as using the esp8266 Wi-Fi module as a radio unit of a radio receiver and a radio transmitter.

Fig. 3 and 4 define the contents of the blocks: Microchip ATmega 328P microcontroller (1, 2) for each transmitter and receiver unit, indicator LEDs with limiting resistors (3, 4), circuits setting clock signals for microcontrollers of quartz resonators and capacitors (5, 6), programmable buttons for entering information (7, 8, 9), an ESP8266 Wi-Fi radio transmitter and receiver, which include an antenna (10, 11), a serial port signal to a USB signal (12), sensors: an integrated pulse oximetry sensor and heart rate monitoring MAX30100 (13), an integrated 3-axis gyroscope and accelerometer GY-521 (14), an LM35 temperature sensor (15), and an electroforming microphone (16).

The proposed device works as follows: the microcontroller (1) polls the sensors, after which it packs the data and sends it via a radio transmitter (10). On the receiving side, microcontroller (2) activates the operation of the radio receiver (11) and waits for data to be received by this receiver, which, after being loaded into the microcontroller's memory (1), are unpacked. Further, the microcontroller (1) prepares the data for sending via the serial port (17) and after receiving the polling signal via this port, it sends data via it. A serial to USB converter (12) matches the transmitted signals with the levels and protocols of the computer.

Results. As a result, it becomes possible to process, store and transfer data on a computer. The authors have tested the system with both one transmitter and two. The use of the medical telemetry device proposed by the authors will significantly simplify the collection and transmission of biomedical data through the automation of processes through modern microprocessor and controller technology and the development of integrated sensors, as well as through the use of a program created for microcontrollers.

The principle of software organization has been developed, which allows visualizing the information received (Fig. 5). It has an intuitive interface, but at the same time has broad capabilities and is intended for processing biomedical data on an autonomous transmitter, coming from measuring sensors and transmitting the results to the receiving module. The receiving module, in turn, sends the data to the personal computer. The program can be used in biomedical data collection systems at medical institutions, or in laboratory research. The program collects and calculates the following parameters: heart rate (HR), blood oxygen saturation, body temperature, state and activity of the patient.

The program performs the following functions: determination of the arithmetic mean of the input parameters and the subsequent packing of data and their transfer via radio communication channels, including Wi-Fi. An important task here is the parallel collection of data and their timely receipt by the attending physician, when observing the objects under study (patients). It speeds up the processing of measurement

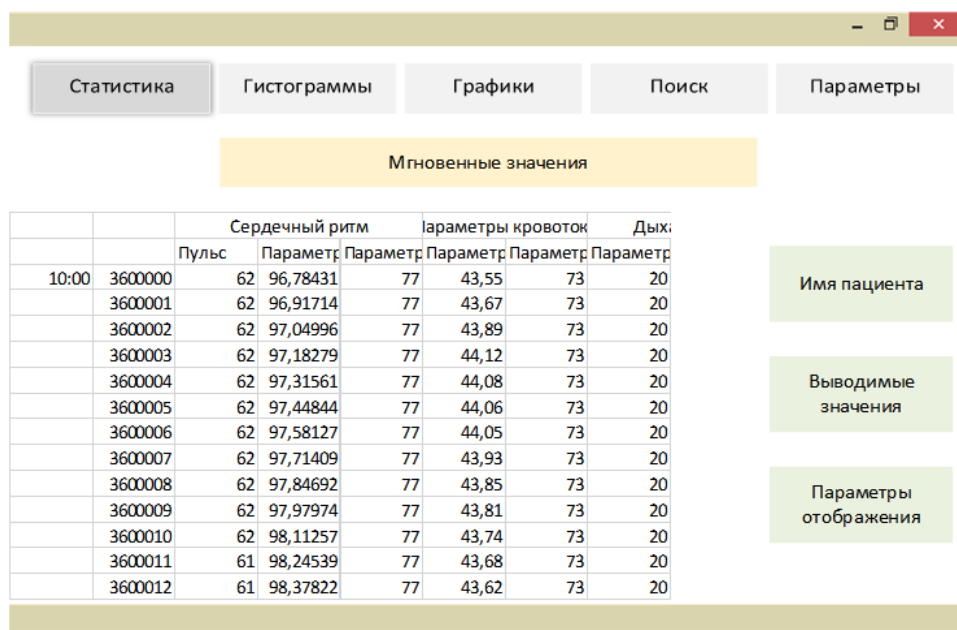

Fig. 5. User interface (UI) of the proposed hardware-software system

results, due to their timely availability, and reduces the likelihood of errors inevitable when processing a large amount of input data, reduces labor costs for diagnosing and transferring data, as a result, increasing the efficiency of research and treatment, and also increasing labor productivity.

This program is executed using the C++ programming language and used in the construction of a medical complex and systems for monitoring the parameters of the vital activity of stationary and non-stationary objects under study.

The proposed hardware-software medical complex for remote monitoring of heart disease indicators, as a telemedicine system, has the following advantages:

- it allows you to quickly and efficiently provide specialized planned and emergency medical care, organize consultations with the virtual participation of leading specialists, conduct and demonstrate remotely controlled examinations, diagnostic manipulations;
- provides the possibility of organizing remote educational lectures and seminars with demonstration of rare and atypical clinical cases and broadcasting of indications of diagnostic equipment directly from foci of epidemics, natural and man-made disasters; optimizes the healthcare management system;
- provides patients and qualified cardiologists with an additional communication channel;
- increases the efficiency of the "ambulance" service, medical assistance and reduces travel expenses;
- ease of registration, relatively low cost of the survey with high information content;
- increases the detection of side effects of pharmacotherapy over time;
- monitors and evaluates the patient's condition in the dynamics of observation;
- facilitates the work of medical personnel, reduces the number of contacts with patients and improves the psychological state of the latter through remote data collection;
- conducts registration of biological parameters without significant interference in the patient's life;
- provides an excellent opportunity to assess the patient's condition in the dynamics of observation.

The use of the module for monitoring of diagnostically significant indicators of patients in the structure of the software complex makes it possible to automate the process of monitoring a large group (up to

50 people) of patients – users of the remote monitoring complex. Assessment of the dynamics of changes in diagnostically significant indicators allows us to clarify the nature of the development of the disease, to use the prognosis of health status to improve the treatment technology, its personification, taking into account the characteristics of the patient's disease. The use of the technology of remote long-term monitoring of the patient's health state makes it possible to increase the efficiency of detecting dangerous heart disorders up to 30 %.

Conclusion. The existing provisions of the organization of a medical hardware-software complex for remote monitoring of the states of biological objects are analyzed using the example of heart diseases. A method is proposed for creating a hardware-software complex in the field of remote monitoring of the main physiological parameters of the cardiovascular system (CVS) of a person for wireless diagnostics of the functional state of a patient and ensuring timely detection and treatment of diseases, as well as structural organization and its characteristics. The general structure of the hardware-software complex, the passage of diagnostic information, its capabilities and advantages have been developed.

The developed complex has wide configuration possibilities. The number of transmitting diagnostic devices (patients) in the complex, the wireless coverage area and the number of sensors can be changed in accordance with the imposed requirements. In the basic configuration, it is possible to work with 50 transmitting diagnostic devices with a coverage area of up to 50 meters. The use of repeaters makes it possible to further expand the coverage area of the complex.

The complex performs solutions to the problem of recording biological parameters without significant interference in the patient's activity, which makes it possible to record his typical states. Remote data collection also facilitates the work of medical personnel; reducing the number of contacts with patients improves the psychological state of the latter. The use of the technology of remote long-term monitoring of the patient's health state makes it possible to increase the efficiency of detecting dangerous heart disorders up to 30 %, makes it possible to increase the number of patients whose health condition will be carefully monitored by the doctor.

References

1. Yuldashev Z. M., Pustozerov E. A., Anisimov A. A. *Mnogourovnevaya intellektualnaya sistema udalennogo monitoringa sostoyaniya zdorovya lyudey s chronicheskimi zabolevaniyami*. *Biotekhnosfera*. 2016, no. 5 (47), pp. 2–8. (In Russ.)
2. Anisimov A. A., Glazova A. Yu., Pustozerov E. A., Yuldashev Z. M. Remote health monitoring systems for people with chronic diseases. St Petersburg, Publishing house of SPbGETU, 2018, pp. 183. (In Russ.)
3. Kostin A., Balashov Yu. Design of devices for primary processing of electrocardiosignals for remote monitoring. *Chip News*. 2003, no. 8, pp. 46–50. (In Russ.)
4. Nguen Ch. T., Yuldashev Z. M. An algorithm for detection of atrial fibrillation episodes and generation of alarm signals used in a cardiac rhythm remote monitoring system. *Biomedical engineering*. 2018, vol. 51, iss. 1, pp. 51–55.
5. Anishchenko L. N., Vasil'ev I. A., Zhuravlev A. V., Ivashov S. I., Razevig V. V. Method for automated re-mote assessment of motor activity, respiration and pulse parameters of a human or animal. Pat. RU 2 463 949 C2 IPC A61B 5/0205 (2006/01). Publ. 20.04.2012. Bul. 29. (In Russ.)
6. Proshin E. M., Putilin E. O. Device for remote recording of the patient's heartbeat and breathing processes. Pat. RU 2 496 410 C1 IPC A61B 5/0205, A61B 8/02 (2006.01). Publ. 27.10.2013. (In Russ.)
7. Pustozerov E. A., Yuldashev Z. M. *Distsyonyonny monitoring sostoyaniya bolnyx sahnym diabetom*. *Med. Technique*. 2014, no. 2, pp. 15–18. (In Russ.)
8. Willits I., Keltie K., Craig J., Sims A. WatchBP Home A for opportunistically detecting atrial fibrillation during diagnosis and monitoring of hypertension: a NICE Medical Technology Guidance. *Appl Health Econ Health Policy*. 2014, vol. 12, iss. 3, pp. 255–265. doi: 10.1007/s40258-014-0096-7
9. Magrupov T. M., Khaydarov A. X., Abdihalikov S. P. Methods of organization of medical hardware and software complex for remote monitoring of biological objects. *Sci.-tech. and information-analytical j. TUIT*. 2018, no. 3 (47), pp. 75–82.
10. Abdihalikov S. P. *Apparatno – programmnyy kompleks dlya distantsionnogo monitoringa sostoyaniya biologicheskix obektov*. *Sb. tr. XXXII Vseross. nauth.-tehn. conf. Ryazarl*. 2019, pp.186–188. (In Russ.)
11. Nguen Ch. T. Remote monitoring system for online detection of atrial fibrillation episodes. *IV Mezhdunar. nauth.-tehn. conf. Tambov*, 2017, pp. 501–502. (In Russ.)
12. Magrupov T., Magrupova M., Abdihalikov S., Ripka D. ECG signal processing algorithms to determine heart rate. *IEEE Intern. Conf. on Electrical Eng. and Photonics (EExPolytech)*. St Petersburg, 2020, pp. 132–135. doi: 10.1109/EExPolytech50912.2020.9243961
13. Nemirko A. P., Manilo L. A., Kalinichenko A. N. *Mathematical analysis of biomedical signals and data*. M., Fizmatlit, 2017, 248 p.
14. Abdihalikov S. P., Ripka D. S. *Hardware and Software Medical Complex Monitoring of Vital Signs of the Patient*. *IEEE Conf. of Russian Young Researchers in Electrical and Electronic Engineering (EConRus)*. St Petersburg, 2020, pp. 1456–1459.
15. Abdihalikov S. P., Magrupov T. M. *Algoritmicheskoe i programmnoe obespechenie pribora meditsinskoy telemektrii II Sb. tez., XIV mezhdun. kongressa «Kardiostim-2020»*. SPb, 27–29 Feb. 2020, 156 p.
16. Kohts D. *Measurement, control and regulation with PIC microcontrollers*. M., MK-PRESS, 2015, 304 p. (In Russ.)
17. Magda Y. *Modern microcontrollers. Architecture, programming, device development*. M., DMK Press., 2012, 222 p. (In Russ.)

Information about the authors

Talat M. Magrupov, Dr. Sci. (Eng.) (1984), Professor (1987) of the Head of the Instrument Making Department (1993), Professor of the Department of Biomedical Engineering (2011) of the I. Karimov Tashkent State Technical University. The author of more than 180 scientific papers. Area of expertise: computer technology, Instrument making, Hardware and software of medical equipment and technology.
Address: Tashkent State Technical University, 2 Universitetskaya St., Tashkent 100095, Uzbekistan
E-mail: talatmt@rambler.ru

Zafar M. Yuldashev, Dr. Sci. (Eng.) (1999), Professor (2001), Chief of the Department of Biotechnical Systems of Saint Petersburg Electrotechnical University. The author of 256 scientific publications. Area of expertise: medical instrumentation; biomedical engineering; processing and analysis of biomedical signals.
Address: Saint Petersburg Electrotechnical University, 5 Professor Popov St., St Petersburg 197376, Russia
E-mail: yuld@mail.ru

Seit P. Abdihalikov, graduated from the Tashkent State Technical University with a degree in Nanotechnology (2011), the Tashkent State Technical University with a degree in Measurement and Control Instruments and Methods (by industry-medical devices) (2013), senior lecturer at the Department of Biomedical Engineering Tashkent State Technical University n. a. I. Karimov. The author of 15 scientific publications. Area of expertise: study of a method for constructing a hardware and software complex for remote monitoring of diseases of the cardiovascular system. Address: Tashkent State Technical University, 2 Universitetskaya St., Tashkent 100095, Uzbekistan
E-mail: seit-abdihalikov@rambler.ru
<https://orcid.org/0000-0003-2143-0176>
