

“CLOCK IN THE ROCK” – IN-SITU C-14 ROCK SURFACE EXPOSURE DATING APPLICATIONS

Mihály Molnár¹, István Major¹, A.J. Timothy Jull^{1,2}

¹Hertelendi Laboratory of Environmental Studies, MTA Atomki – Isotoptech Zrt, 4026 Debrecen, Bem tér 18/c, Magyarország, molnar.mihaly@atomki.mta.hu

²NSF Arizona AMS Laboratory, 1118 East Fourth St, Tucson, AZ 85721 USA

Summary: Cosmic rays interact not only with the atmosphere, but also with material at the surface of the Earth. Thus C-14 can be produced directly in a rock surface by the effect of cosmic-ray neutron effects. The goal of the research is to develop the capability of the Hertelendi Laboratory for Environmental Sciences (HEKAL) in the field of cosmogenic radionuclides produced in situ by the action of cosmic radiation. Our aim is to construct a small line for the extraction of cosmogenic C-14 from quartz, making a system compatible with the online capabilities of the new MICADAS accelerator mass spectrometer (AMS) at HEKAL in Debrecen. We have tested the chemical blank level, cross contamination effect and reproducibility of MICADAS gas ion source application in in-situ rock surface exposure dating.

Keywords: rock surface, in-situ C-14, preparation, dating, AMS.

Introduction

The capability to routinely measure low concentrations of stable and radioactive cosmogenic nuclides has led to new methods for addressing long-standing geologic and climatic questions and has provided insights into rates and styles of surface processes. The exposure age of a rock is the time elapsed since it has been exposed to cosmic irradiation (i.e. when the accumulation of the produced cosmogenic nuclides began). The different physical and chemical properties of the six most widely used nuclides: He-3, Be-10, C-14, Ne-21, Al-26, and Cl-36, make it possible to apply the surface exposure dating methods on rock surfaces of virtually any lithology at any latitude and altitude, for exposures ranging from 10^2 to 10^6 years using the right combination of nuclides. The terrestrial in situ cosmogenic nuclide method is revolutionizing the manner in which we study landscape evolution. Concentrations of single or multiple nuclides can be measured on a particular rock surface or sediment to obtain exposure time and/or erosion rate, fluvial incision rates, denudation rates of entire drainage basins, burial histories, scarp retreat, fault slip rates. The ages of climatic variations recorded by moraine and alluvial sediments can also be directly determined.

The build-up of nuclides due to cosmic-ray interactions can take several pathways. For C-14 and Be-10, spallation reactions of oxygen by high-energy neutrons are predominant at the surface (Gosse and Phillips, 2001). The potential for using in situ C-14 to determine exposure ages of Holocene

landforms and quantify erosion rates in rapidly eroding areas is widely recognized (e.g. Lal 1991; Gosse et al. 1996). On the other hand, the potential of in situ C-14 ($t_{1/2}=5730$ a) to be used in concert with a longer-lived cosmogenic nuclide, like Be-10 ($t_{1/2}=1,387$ Ma) allows the identification of complex exposure histories of surface landforms (e.g. Miller et al. 2006). Application of cosmogenic in situ C-14 became widespread only in the last few years due to methodological improvements (White et al., 2011.; Hippe et al.2009), however significant progress is still necessary before it becomes a routine method for the AMS C-14 laboratories.

Experimental

Despite its great potential, the impact of in situ C-14 on cosmogenic nuclides research to date has been limited primarily because of the difficulty of measuring in situ C-14 concentrations in terrestrial rocks. In situ C-14 has been measured routinely in lunar material and meteorites for decades (Goel and Kohman 1962; Jull et al. 1998), but C-14 concentrations in terrestrial rocks are typically 2–3 orders of magnitude lower. Measuring the in situ C-14 inventory of terrestrial rocks, therefore, requires complete removal of contaminant C-14 from sources such as CO₂ and other atmospheric gases, organic matter, and secondary carbonate, which are often present in quantities equivalent to or exceeding the in situ component.

Lifton et al. (2001) developed an extraction system and protocols at the University of Arizona Lab that were used successfully to isolate and extract in situ C-14 from terrestrial quartz, which includes melting grains using a lithium metaborate (LiBO₂) flux and oxidizing liberated carbon to CO₂. Yokoyama et al. (2004) isolated in situ C-14 from quartz through step-wise heating and using a mixture of carrier gases (He-O₂-CO-CO₂). Naysmith (2007) constructed an extraction system similar to the original Arizona system and followed the Lifton method protocols with minor modifications. Finally, Hippe et al. (2009) developed an extraction system that uses an electron bombardment furnace capable of reaching temperatures of 1550–1600 °C, which allows the melting of quartz grains without the use of a fluxing agent.

Our plan is to construct a gas preparation and cleaning vacuum line for the extraction of cosmogenic C-14 from quartz, making a system compatible with the online capabilities of the new MICADAS type dedicated C-14 accelerator mass spectrometer (AMS) at ATOMKI (Molnár et al, 2013a). The line would be based on the system described by Pigati et al. (2010) which is a further developed version of the Lifton method. It is proposed to develop a simplified extraction system that is smaller and cheaper to build than the earlier published designs, and to reduce the amount of time required for an extraction. Success of this strategy to start a new in situ C-14 extraction laboratory was recently published by Goehring et al (2014).

Results and conclusion

In the case of a realistic sample size and published examples, we expect about 20-30 μg carbon after the whole pretreatment process before C-14 analyses. Thus in situ produced C-14 separation in CO_2 form from purified quartz needs a dedicated, compact and high purity vacuum extraction line to minimize recent carbon contamination and to make sample cross-talk (memory effect) as low as possible. Although our HEKAL AMS Lab at Atomki (Debrecen) had already successfully developed and tested reliable online C-14 extraction and preparation lines, these are designed for normal size (milligram C) AMS samples (Molnár et al. 2013b). One of the main advantage of our new MICADAS type compact AMS C-14 system is that it has an enhanced gas ion source interface which makes it ideal for very small size ($< 50 \mu\text{g}$ C) sample C-14 analyses (Molnár et al 2013a, Wacker et al 2013) (Figure 1.).

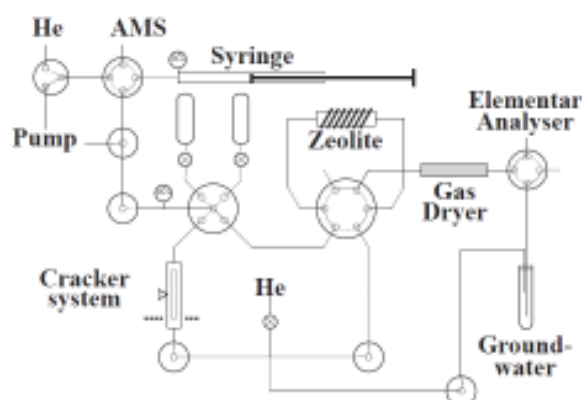

Figure 1. Layout of the connection of CO_2 gas ampoule cracker system to the MICADAS gas ion source interface.

One of the key analytical parameters of in situ C-14 studies by AMS technique is the chemical blank level as this directly limits the detection level (maximal measurable exposure age) and the total uncertainty of the analyses, which is especially important in case of such small sizes samples (Pigati et al, 2010). Direct gas measurement of CO_2 samples by gas ion source instead of the routinely applied graphite based C-14 AMS measurements would lead to significantly better process blank level as during graphitization, the normally applied sample dilution, all added/used chemicals and extra preparation steps rise the final AMS blank level in the preparation process (Table 1.).

In the experiments for testing ampoule cracker based CO_2 AMS analyses blank level and memory effect at HEKAL Laboratory we have reached about 5 μA ^{12}C ion current at the high energy side of the AMS, which resulted better than 1% counting statistics on the Ox-II C-14 standard gas samples. Furthermore we have seen as low as 46 kyrs BP cracker blank C-14 age level,

which is very promising in the respect of good detection limit for in situ exposure dating.

Table 1. CO₂ gas ampoule racker based AMS analyses blank level and memory effect test at HEKAL.

AMS Lab code (DeA-)	Sample name/info	sample C (mg)	¹² C (μA) ion current	C-14 pMC abs.	pMC unc. (1σ)	C-14 age (yr BP)	+-(y)
2379.4.2	Ox-II -14 std gas	0.150	4.4	134.07	1.10	-2,355	66
2380.4.1	tank fossil CO ₂ blank test gas	0.150	4.9	1.22	0.20	35,371	1,339
2380.4.2	tank fossil CO ₂ blank test gas	0.150	5.1	0.77	0.14	39,145	1,474
2380.5.1	Cracker blank test CO ₂ gas	0.080	4.9	0.91	0.09	37,726	787
2380.5.2	Cracker blank test CO ₂ gas	0.080	4.1	0.64	0.10	40,535	1,204
2380.5.3	Cracker blank test CO ₂ gas	0.080	4.4	0.30	0.08	46,799	2,132

Accordingly, we are going to run standard materials prepared by the international CRONUS project, which has produced several intercomparison materials of well-defined nuclide concentrations (Jull et al. 2013). This would serve as a demonstration of the feasibility of the approach..

Acknowledgement

This research was supported by the European Union and the State of Hungary, co-financed by the European Social Fund in the framework of TÁMOP 4.2.4. A/2-11-1-2012-0001 ‘National Excellence Program’ and the project ENVIKUT (TÁMOP-4.2.2.A-11/1/KONV-2012-0043).

References

- Goehring, B.M. Schimmelpfennig, I. Schaefer, J. M. **2014** Capabilities of the Lamonte-Doherty Earth Observatory in situ ¹⁴C extraction laboratory updated. *Quaternary Geochronology* 19, p. 194-197
- Goel PS, Kohman TP. **1962**. Cosmogenic carbon-14 in meteorites and terrestrial ages of “finds” and craters. *Science* 136(3519):875–6.
- Gosse JC, Reedy RC, Harrington CD, Poths J. **1996**. Overview of the workshop on secular variations in production rates on Earth. *Radiocarbon* 38(1):135–47.
- Gosse J.C. and Phillips F.M. **2001**. Terrestrial in situ cosmogenic nuclides: theory and application. *Quaternary Science Reviews* 20, 1475}1560

- Hippe K, Kober F, Baur H, Ruff M, Wacker L, Wieler R. **2009**. The current performance of the in situ ^{14}C extraction line at ETH. *Quaternary Geochronology* 4(6): 493–500.
- Jull AJT, Vlodut S, Donahue DJ, Sinsterson JM, Reedy RC, Masarik J. **1998**. ^{14}C depth profiles in Apollo 15 and 17 cores and lunar rock 68815. *Geochimica et Cosmochimica Acta* 62(17):3025–36.
- Jull, A.J.T. Scott, E.M. Bierman, P. **2013**. The CRONUS-Earth inter-comparison for cosmogenic isotope analysis. *Quaternary Geochronology*, available on-line (in press): <http://dx.doi.org/10.1016/j.quageo.2013.09.003>
- Lal D. **1991**. Cosmic ray labeling of erosion surfaces: in situ nuclide production rates and erosion models. *Earth and Planetary Science Letters* 104(2–4):424–39.
- Lifton NA, Jull AJT, Quade J. **2001**. A new extraction technique and production rate estimate for in situ cosmogenic ^{14}C in quartz. *Geochimica et Cosmochimica Acta* 65(12):1953–69.
- Miller, G.H., Briner, J.P., Lifton, N.A., Finkel, R.C. **2006**. Limited ice-sheet erosion and complex exposure histories derived from in situ cosmogenic Be-10, ^{26}Al , and C-14 on Baffin Island, Arctic Canada. *Quaternary Geochronology*, 1, 74-85.
- Molnár M, Rinyu L, Veres M, Seiler M, Wacker L, Synal H-A. **2013a**. EnvironMICADAS: a mini ^{14}C AMS with enhanced Gas Ion Source Interface in the Hertelendi Laboratory of Environmental Studies (HEKAL), Hungary. *Radiocarbon*, Vol 55, Nr 2–3, p 338–344
- Molnár M, Janovics R, Major I, Orsovski J, Gönczi R, Veres M, Leonard AG, Castle SM, Lange TE, Wacker L, Hajdas I, Jull AJT. **2013b**. Status report of the new AMS ^{14}C sample preparation lab of the Hertelendi Laboratory of Environmental Studies (Debrecen, Hungary) *Radiocarbon*, Vol 55, Nr 2–3, p 665–676
- Naysmith P. 2007. Extraction and measurement of cosmogenic in situ ^{14}C from quartz [unpublished manuscript]. *University of Glasgow*. 94 p.
- Pigati, J.S., Lifton, N.A., Jull, A.J.T., Quade, J., **2010**. A simplified in situ cosmogenic ^{14}C extraction system. *Radiocarbon* 52, 1236e1243.
- Wacker L., Fahrni S.M., Hajdas I., Molnar M., Synal H.-A., Szidat S., Zhang Y.L. **2013**. A versatile gas interface for routine radiocarbon analysis with a gas ion source. *Nuclear Instruments and Methods in Physics Research B* 294 pp 315–319
- White, D., Fülöp, R.H., Bishop, P., Mackintosh, A., Cook, G. **2011**. Can in-situ cosmogenic C-14 be used to assess the influence of clast recycling on exposure dating of ice retreat in Antarctica? *Quat. Geochron.* 6, 289-294;
- Yokoyama Y, Caffee MW, Southon JR, Nishiizumi K. **2004**. Measurements of in situ produced ^{14}C in terrestrial rocks. *Nuclear Instruments and Methods in Physics Research B* 223–224:253–8.