

Model Reference Adaptive Control of SRM Drives

László Számel

Budapest University of Technology, Department of Electrical Machines and Drives

1111 Budapest, Egrý József u. 18, Hungary

Phone: (+36) 1-463-2971, Fax: 1-463-3600

E-mail: szamel@hszk.bme.hu

Keywords

Switched Reluctance drives, Adaptive control, Simulation

Abstract

The paper proposes a model reference adaptive control method for SRM drives. The main goal of the drive control is to improve dynamical performance by compensating for the motor nonlinearities. The proposed ripple reduced method changes only the turn-on and the turn-off angle in function of the speed and current reference. One of the advantages of using this method is that it does not need the real-time calculation or measuring the motor torque. Simulation and experimental results are presented.

Introduction

In motion control systems are robustness against parameter changes and disturbance rejection of main interest. The model reference adaptive control has the following features:

- It makes the compliance of the system with varying operational conditions possible and ensures the behavior of the controlled system according to the prescribed reference model.
- It means such a special type of adaptive systems which results in nonlinear control systems. This is the reason why the analytical analysis is completed by Lyapunov stability criterion or by hyper-stability principle.
- Its planning and application is closely related to the using of computer methods.
- Simple realisation of the control algorithm.

In this paper the application of a model reference adaptive control to switched reluctance motors is presented.

Drive system

The block scheme of the examined drive system with switched reluctance motor (SRM) is shown in Fig.1. A SRM of 6/8 pole and 4 kW rated power was used.

The supply unit consists of three main blocks, namely the RECTIFIER, the FILTER and the INVERTER. The inverter is a pulsed width modulated (PWM) one, marked with QP in the figure and it contains one-one switching transistor per phase and a brake chopper, not shown in the figure. The common point of phase windings is supplied by the PWM inverter. It is of autonomous operation and has an inner current control loop. The other ends of phase windings are connected to the phase switching transistors.

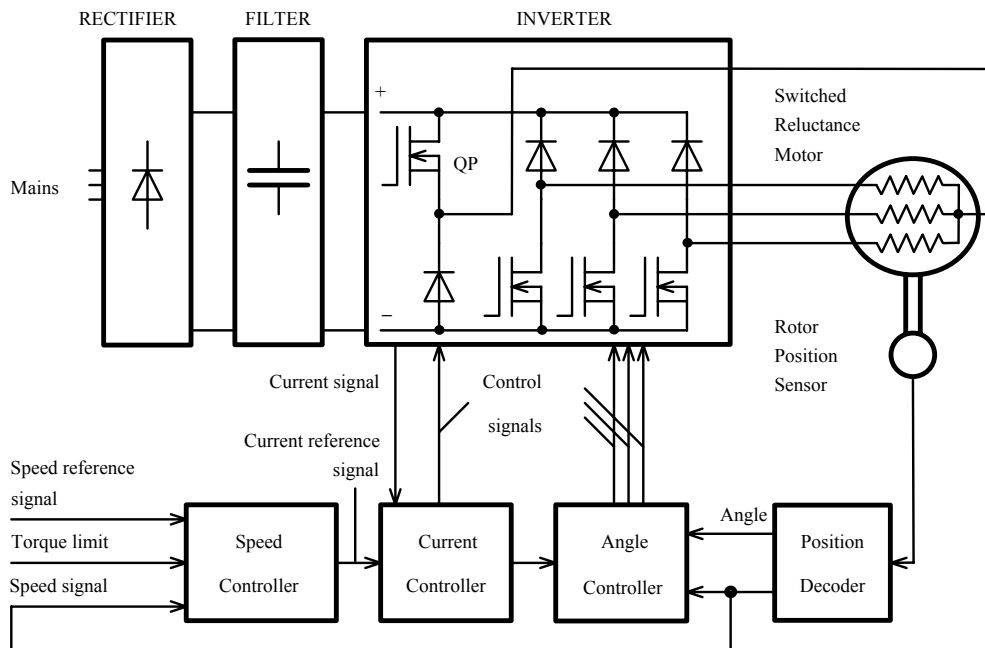

Fig.1. Block scheme of drive system

It follows from the operational principle of SRM that its phase windings are to be excited at a well determined angle of the rotor position in an appropriate order. This is why a Rotor Position Sensor is to be mounted on the shaft of the motor. In our case the position sensor is a resolver. It can be calculated from the pole numbers that the phase switchings have to follow each other by 15 degree. The resolver is supplied by an oscillator circuit, their signals are evaluated by a Position Decoder.

The Position Decoder has two outputs: the Angle and Speed signals. Based on the two signals, the Angle Controller composes the Control signals for the phase switching transistors.

Fundamentally, SRM drives have two control loops, the outer one is the speed loop, Speed Controller and the inner one is the current loop, Current Controller. The output signal of the Speed Controller serves for a Current reference signal of the Current Controller. The hardware and software tools together fulfil the two-loop control. The Current Controller produces the control signal for the PWM inverter, and receives the Current signal from the PWM inverter at the same time.

At testing and fault detection there is a possibility to connect an intelligent terminal or a computer via RS 232 series data line to the drives. The fundamental part of the control unit is a single-chip microcontroller. It contains a clock generator with 12 MHz, an 256x8 on-chip RAM, four 16 bit timer/counters, a fast 32 bit division unit and a 16 bit multiplication unit, 12 multiplexed input 8-bit A/D converter with programmable reference voltage, two full duplex serial interfaces, a compare/capture unit.

Control of SRM Drives

Current control

The Current Controller is totally based on its hardware solution. Based on the current reference signal, it controls the PWM inverter of fix frequency by installing an analog controller. The current feedback also comes from the PWM inverter.

For the control of the sum of phase currents (Fig.1.) it is suitable a simpler four-transistor inverter and is not necessary a six-transistor one as in the case of control of phase currents independently from each other. But the detriment of the previous solution is that the torque pulsation can be decreased in a smaller degree by changing the turn-on and turn-off angles.

Namely, in the case of the constant current reference signal the current increase is limited by the switched-off, but conducting phase current as the regulator controls the sum of two phase currents. The increase of the phase current at starting the conducting state can be forced by the modification of the current reference signal:

$$i_r = u \sum_{j=1}^3 C_j + \sum_{j=1}^3 (1-C_j) \cdot i_j \quad (1)$$

where:

- i_r is the current reference signal,
- i_j is the current signal of phase j ,
- u is the output of the speed controller,
- C_j is the control signal of phase j (0 or 1).

The supplement of the first member of Eq. 1 makes the overlap of the phase conduction possible, while the effect of second member is to increase the reference signal with the current of the switched-off, but not current-free phase.

Speed control

A model reference adaptive control is used for the speed control [4]. Such an adaptive control has been succeeded to elaborate by using a suitable chosen Ljapunov function which can be compensated by changing the gain of the speed control loop.

The controlled loop has been approximated by an integral element. The time constant of the closed current control loop has been neglected. The control consists of a P-element with the gain K_p . The input of the P-element contains not only the control fault signal but an adaptation signal as well. Applying the signal adaptation control, a P type controller with K_p gain can ensure zero speed error as the adaptation signal can produce a current reference signal to compensate the loading current at zero speed error.

The feature of the closed speed control loop has been taken into consideration by a parallel control model to be expressed by an one-storage proportional element. The Ljapunov function has been chosen in such a way that the model fault should be decreased asymptotically and the gain of the speed control loop and the load should be compensated. In this case we have had to assume that the change of the loop gain and the load is smaller than the speed of the adaptation.

After the deduction the following adaptation algorithm will be valid.

$$g(t) = \gamma_1 (\omega_r - \omega) \int \varepsilon (\omega_r - \omega) dt + \gamma_2 \int \varepsilon dt \quad (2)$$

where:

- ω is the speed,
- ω_r is the speed reference signal,
- ε is the model error,

γ_1 and γ_2 are the free parameters of the adaptation.

In the case of the sampled procedure the adaptation algorithm will be as follows:

$$\begin{aligned} g[k] &= g_1[k] (\omega_r[k] - \omega[k]) + g_2[k], \\ g_1[k] &= g_1[k-1] + \Gamma_1 \varepsilon[k] (\omega_r[k] - \omega[k]), \\ g_2[k] &= g_2[k-1] + \Gamma_2 \varepsilon[k]. \end{aligned} \quad (3)$$

It follows from the deduction that the asymptotical stability is valid if the model fault does not change the sign. If the sign will change then the adaptation has to be stopped for one sampling step in general.

The control in recursive form supplemented with the adaptation algorithm will be as follows:

$$\begin{aligned} u[k] &= u[k-1] + K_i \varepsilon[k] + K_p ((1 + g_1[k])e[k] - (1 + g_1[k-1])e[k-1]), \\ g_1[k] &= g_1[k-1] + \Gamma_1 \varepsilon[k] (\omega_r[k] - \omega[k]) \end{aligned} \quad (4)$$

where:

$u[k]$	is the output of speed controller at the k-th sampling period,
$e[k]$	is the error signal,
$\varepsilon[k]$	is the model error,
$\omega[k]$	is the speed feedback signal,
$\omega_r[k]$	is the speed reference signal,
$g_1[k]$	is an adaptation signal,
$[k-1]$	is the previous sampling period,
Γ_1	is a positive constant,
K_p, K_i	are the proportional and the integral constants.

This control has been tested by the simulation program developed in the Department. First the adaptation has been examined without load and current limitation as the motor and the adaptation do contain non-linearities. In the interest of the adaptation stability the speed of change of the adaptation signal g_1 has to be limited. The signal g_1 can results in the significant oscillations without limitations as the change of the signal is possible in discrete times.

The current limitation can results in further problems. This limitation hinders the tracking of the model, to the effect of the above the signal g_1 will be too large or it can change in the reverse direction. For the elimination of the above problem the signal g_1 is not to be changed in the period of the limitation.

The digital output signal determined by the software is converted by a D/A converter to an analog reference signal. The control tasks are fulfilled at every 12th sampling period. The speed feedback signal is determined by calculating the difference between the actual position value and the previous one of the resolver to digital converter. The measuring period ensures an accuracy of ± 5 rpm.

Angle control

The Position Decoder in Fig.1. contains the resolver to digital converter, the oscillator circuit and two latches. The resolver to digital converter is set to a 12-bit resolution, which corresponds to a disc with 4096 marks. The microcontroller reads the code at every sampling period in and calculates the speed at every 12th sampling period. In such a way the Angle signal of rotor and the Speed signal are calculated by the software.

The smallest digit bit of the digital output of the resolver to digital converter gets to the input of one port of the microcontroller. The Timer 2 circuit of the microcontroller counts the change of this signal. By the counting the angle resolution is divided into halves, which corresponds to a disc with 2048 marks. At matching the contents of Timer 2 and compare register, the output signal of compare register changes to a level, determined earlier. All three motor phases have one-one compare register and one-one output belonging to them. Three outputs control one-one phase switching IGBT via the Buffer circuit.

The user program calculates the firing angle at every 15 degree, it sets the contents of compare register and prepares the output to start the firing at matching the compare events. The output signal change, induced by the hardware of microcontroller starts an interrupt request at the same time, based on which the interrupt routine loads the compare register with a value corresponding to the turn-off angle and prepares the output for switching-off the transistor.

As Timer 2 can count in one direction only, it is unable to follow the reverse of speed through the hardware. For this reason and because of starting problems, the user program controls the outputs directly taking the position angle of Resolver to digital converter into account below a predetermined speed. At small speeds the time-lag caused by sampling and the calculation result in a small angle-error. This additional error is smaller than 2% related to the 15 degree range below 150 rpm. The frequent shift between control modes can be avoided by applying a suitable hysteresis band.

At high speeds the application of the firing in-advance is necessary, which the software completes by using the Speed signal. As a result of calculations, the contents of compare register will change.

It is worth remarking that a minimal turn-on time is necessary for the safe operation of PWM inverter of fixed frequency. The minimal turn-on time results in a minimal voltage at the star-point of motor phase windings. Because of the minimal voltage at no- and a small load, either small or zero speed reference signal will result in a high speed of the motor. To prevent this detrimental effect the Current controller reads the Current signal in by the help of an inner analog-digital converter of the microcontroller and will intervene in the process if it seems necessary.

There are two ways for solving the above problem: either we inhibit the PWM inverter for some strokes or we switch off the phase transistors accomplishing a secondary chopping. The latter solution has been chosen, represented by the arrow between the Current Controller and the Angle Controller in Fig.1.

Ripple reduced control method

The ripple free operation can be realized only with a current waveform depending on the angle, speed and torque [5]. The proposed ripple reduced method changes only the turn-on and the turn-off angle in function of the speed and current reference. The optimum turn-on and turn-off angles of the SRM drive has been determined by computer simulation based on the measured results of the analysed drive. The optimum solution has been fulfilled by four cycles embedded into each other. Two outer cycles give the current and speed reference signals, while two inner ones provide the turn-on and turn-off angles. By this one-one optimum angle pair can be determined to all operating points.

It can be considered an interesting result that the criteria of the minimum torque pulsation does not provide an optimum solution in all cases. The torque pulsation will be minimum in the speed-current plane only in that case if the torque of the motor is relatively small. For this reason a good result can be achieved in such a way if the relative, i.e. compared to the torque of motor, torque pulsation is minimised

The angle control of the drive determines the actual turn-on and turn-off angles with a two-variable interpolation from the results stored in a look-up table and calculated by the above method.

Results

In Fig. 2 and Fig.3 two of many executed simulations are shown. Fig. 2 shows the run-up with speed controller of PDF-type (an integral element with Proportional and Derivative Feedback [6]), while Fig. 3 with model reference adaptive control (Eq. 2, Eq. 3) and in both cases with turn-on and turn-off angles depending on the speed and current reference and with current reference compensation (Eq. 1). The effect of sharp load-change ($t=600$ ms) can be also seen.

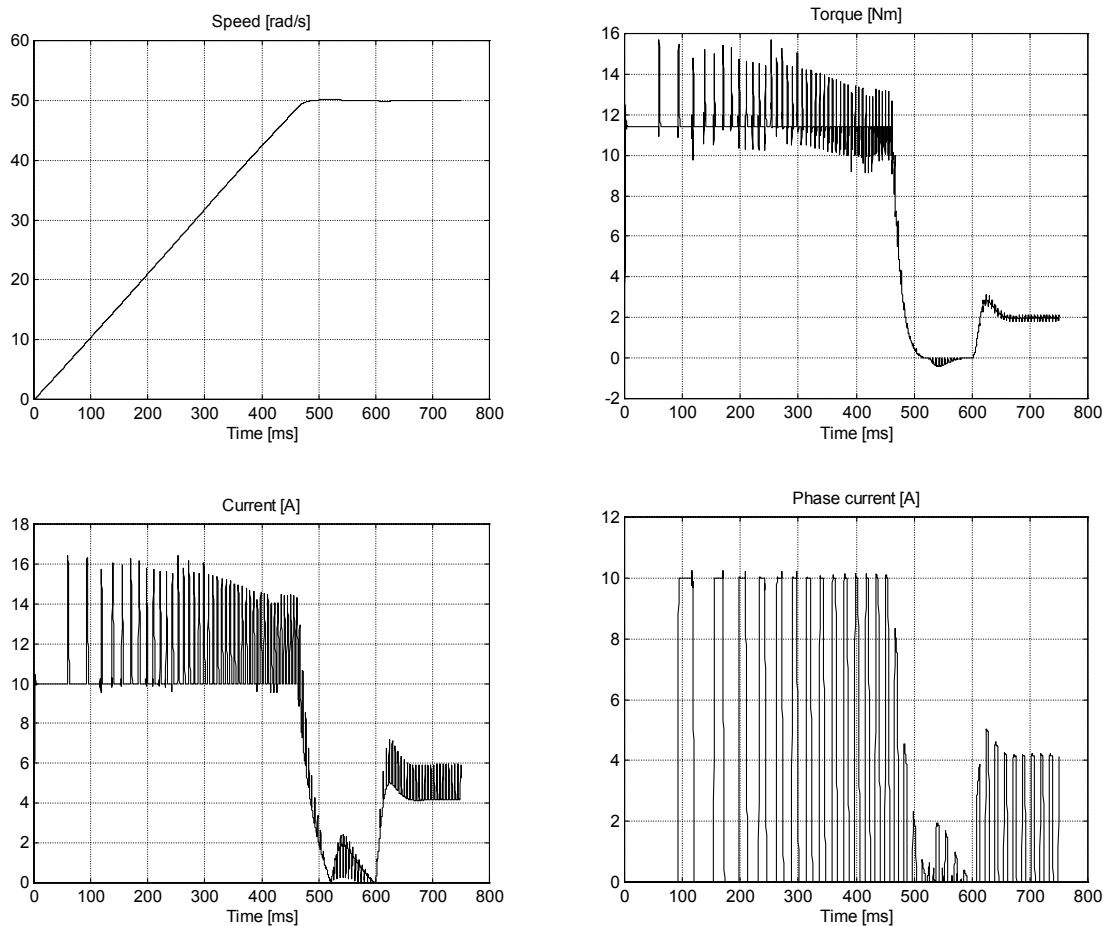

Fig. 2. Simulation results with speed controller of PDF-type.

The tests were completed by the described drive system. The test results have supported our theoretical investigations. The oscillograms in the following figures illustrate some typical starting curves and wave forms. The loading machine was a DC motor. Its inertia is about a triple of that of SRM.

The experiences show that the model reference adaptive control suggested in this paper works without overshooting. Though this method requires a longer calculation period it is less sensible to the variations of parameters.

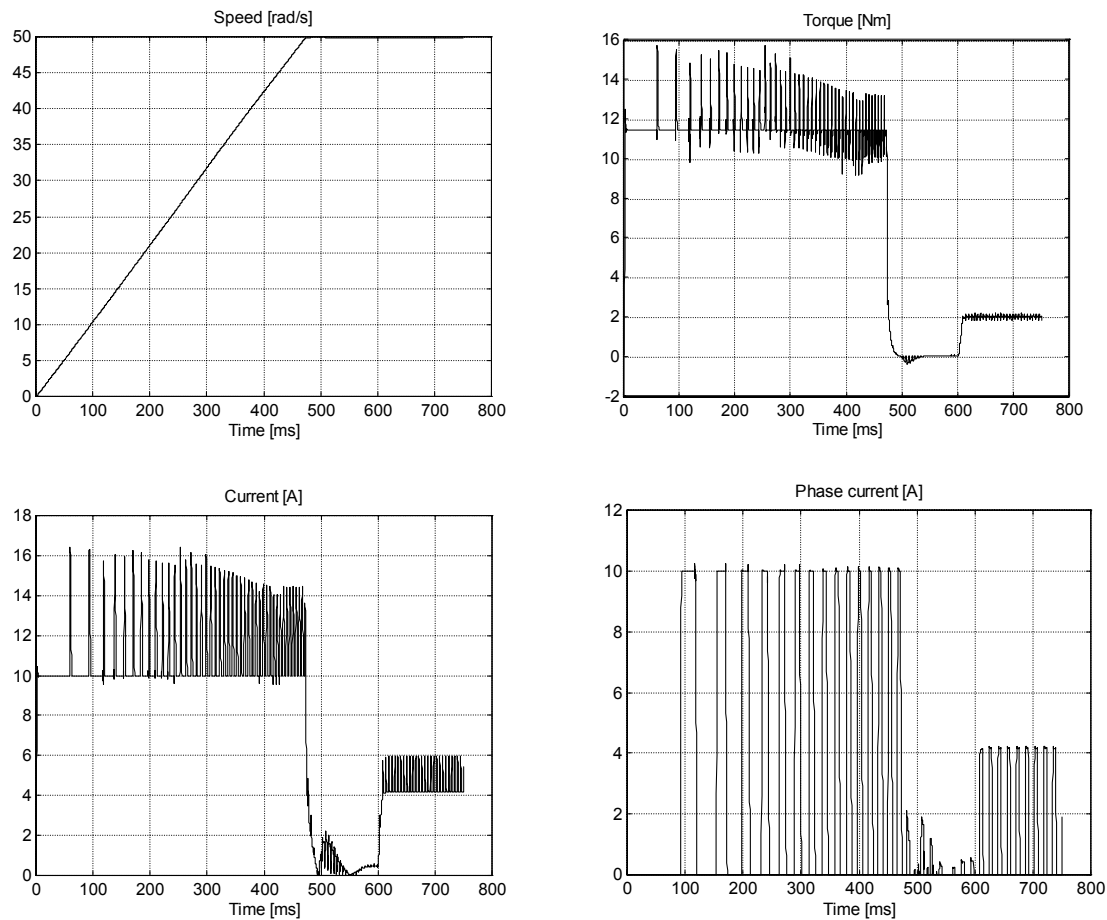

Fig. 3. Simulation results with model reference adaptive speed control.

Figs. 4. and 5. show the speed and current curves in the course of starting without current reference compensation. In all figures the upper curve is the speed (1000 rpm), the lower one is the current flowing in the common point of stator windings (10 A/div). Figs. 4. and 5. are related to the no-load operation mode. A PDF-type control is applied in the case of Fig 4., while a model reference adaptive control (MRAC) is used in the case of Fig. 5.

Conclusions

The paper proposes a simple control method for SRM drives. The proposed ripple reduced control method changes only the turn-on and the turn-off angles depending on the speed and current reference. The modification of the current reference is suggested for a simpler four-transistor inverter. The experiences show that the model reference adaptive control suggested in this paper works without overshooting. Though this method requires a longer calculation period it is less sensible to the variations of parameters.

The simulations and experimental results demonstrate that the proposed method is a promising tool to control the SRM drives.

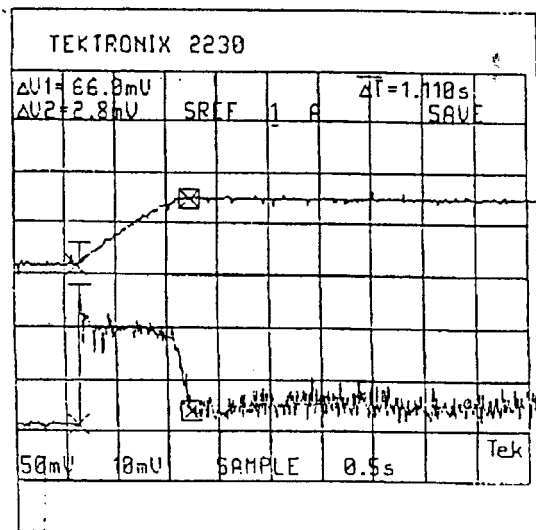

Fig. 4. Oscillograms of the speed and current, PDF-type control.

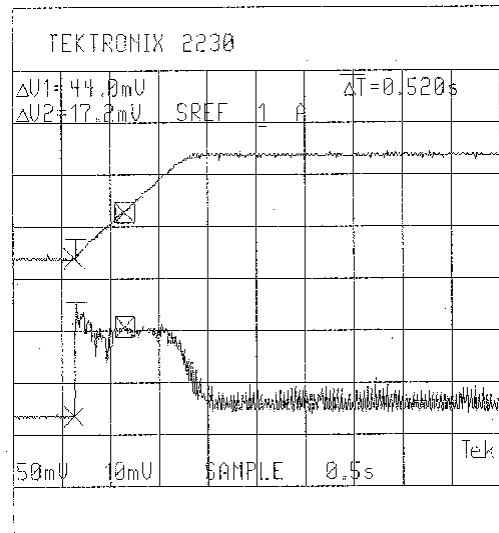

Fig. 5. Oscillograms of the speed and current, MRAC-type control.

Acknowledgements

This paper was supported by the Hungarian Academy of Science (Bolyai Scholarship), by the Hungarian National Scientific Funds (OTKA Ref. No.T032469) and by the Hungarian Ministry of Education (FKFP Ref. No. 0530/2000) for which the author express their sincere gratitude.

References

- [1] Miller, T.J.E.: *Brushless permanent-magnet reluctance motor drives*, Oxford University Press. 1989
- [2] Diep, M.V. - Szamel, L.: *Up-to-date Control Strategy in the Regulators of Robot Drives*, PEMC'90, Budapest. 1990. pp. 811-815
- [3] Bose, B.K. - Miller, T.G.E.: *Microcomputer Control of Switched Reluctance Motor*, IEEE/IAS Annual Meeting. 1985. pp. 542-547.
- [4] Borka, Jozsef. - Szamel, Laszlo: *Modern Strategy for Controlling Robot Drives*, Conference Automation'92, Budapest. 1992. pp. 392-401
- [5] Stankovic, Alexander. - Tadmor, Gilead: *On Torque Ripple Reduction in Current-Fed Switched Reluctance Motors*, IEEE Transactions on Industrial Electronics, Vol. 46, No. 1, February 1999. pp. 177-183
- [6] Szamel, Laszlo: *Ripple reduced control of switched reluctance motor drives*, EDPE2001, International Conference on Electrical Drives and Power Electronics, pp. 48-53, Podbanské (Slovak Republik), 3-5 October 2001.