

Cite this: DOI: 10.1039/c0xx00000x

www.rsc.org/xxxxxx

ARTICLE TYPE

Mimics of Small Ribozymes Utilizing a Supramolecular Scaffold

Tuomas A. Lönnberg,^{*a} Mia Helkearo,^a Attila Jancsó^b and Tamás Gajda^{*b}

Received (in XXX, XXX) Xth XXXXXXXXXX 20XX, Accepted Xth XXXXXXXXXX 20XX

DOI: 10.1039/b000000x

5 For elucidating the mechanism of the general acid/base catalysis of the hydrolysis of RNA phosphodiester bonds, a number of cleaving agents having two cyclen moieties tethered to a 1,3,5-triazine core have been prepared and their ability to bind and cleave UpU studied over a wide pH range. Around neutral pH, the cleaving agents form a highly stable ternary complex with UpU and Zn^{II} through coordination of the uracil N3 and the cyclen nitrogen atoms to the Zn^{II} ions. Under conditions where the triazine core exists

10 in the deprotonated neutral form, hydrolysis of UpU, but not of ApA, is accelerated by approximately two orders of magnitude in the presence of the cleaving agents, suggesting general base rather than metal ion catalysis. The probable mechanism of the observed catalysis and implications to understanding the general acid/base-catalyzed phosphodiester hydrolysis by ribozymes are discussed.

Introduction

15 An increasing number of cases are reported, where nucleobases of a ribozyme function as general acid/base catalysts for the cleavage of phosphodiester bonds.¹ General acid/base catalysis of RNA cleavage has been extensively studied with simple buffer acids and bases, such as imidazole, morpholine or acetic acid. In

20 such systems, the observed catalysis is so weak that high buffer concentrations have to be employed, making elimination of medium effects difficult. The results are, hence, somewhat controversial and still open to various interpretations.² One approach to bring the local concentration of the general acid/base

25 catalyst to a sufficient level without causing undesired solvent effects is to anchor the catalyst close to the scissile phosphodiester linkage. Perhaps the most obvious way to achieve this would be to exploit Watson-Crick base-pairing between two complementary oligonucleotides. Owing to the stacking of

30 contiguous base-pairs such hybridization, however, forces the 5'-leaving group into an equatorial position within the phosphorane intermediate, effectively preventing cleavage.³

In this paper we apply another type of scaffold for bringing a catalytic group close to the phosphodiester linkage of uridylyl-

35 3',5'-uridine (UpU). The underlying idea is to anchor the catalyst to the uracil bases with the aid of a scaffold that is sufficiently flexible to allow the departing 5'-linked nucleoside to adopt an apical position within the phosphorane intermediate. The anchoring is based on the strong binding of Zn^{II} chelates of small

40 azacrowns to the deprotonated N3 atom of a uracil base, first reported by Kimura.⁴ The soundness of this approach has been previously demonstrated with related di- and trinuclear azacrown derivatives (**1a**, **1b**), which have been shown to form a highly

45 stable complex with UpU. The binuclear bis(azacrown) compound (**1b**) lacks the catalytic functionality since both of its Zn^{II}-chelates are engaged in binding to the uracil bases, but still

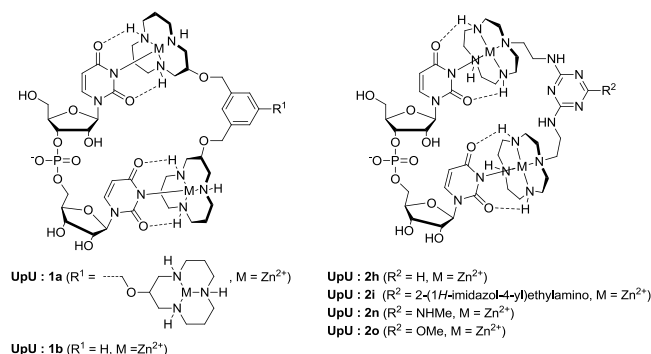

50 **Fig. 1** Complexes of UpU with bi- and trinuclear Zn^{II} chelates of 1,5,9-triazacyclododecane (**1a** and **1b**) and cyclen (**2h**, **2i**, **2n** and **2o**).

allows the uncatalyzed cleavage of UpU to proceed at an unaltered rate. The third Zn^{II}:azacrown unit of **1a** operates as a catalytic center, promoting the hydrolysis of UpU 100-fold compared to the corresponding monomeric compound.⁵ In other

55 words, even though the bi- and trinuclear Zn^{II}:azacrown compounds bind tightly with UpU, they still allow the cleavage of its phosphodiester bond to take place.

In the new scaffolds (**2h**, **2i**, **2n** and **2o**) employed in the present work, the two UpU anchoring Zn^{II}:cyclen chelates are

60 linked to a common 1,3,5-triazine core instead of the benzene core applied in **1b**. The former has potential to function as a “shuttle” mediating proton transfer from the attacking 2'-hydroxy function to a non-bridging oxygen of the phosphorane intermediate and, finally, to the leaving group. A similar

65 mechanism has been proposed for catalysis by the hammerhead and hairpin ribozymes, with a guanine base transferring a proton from the attacking 2'-oxygen to the *pro-R_p* non-bridging phosphoryl oxygen.⁶ It should be noted that the Zn^{II} chelate of cyclen is a poorer catalyst for phosphodiester cleavage than the

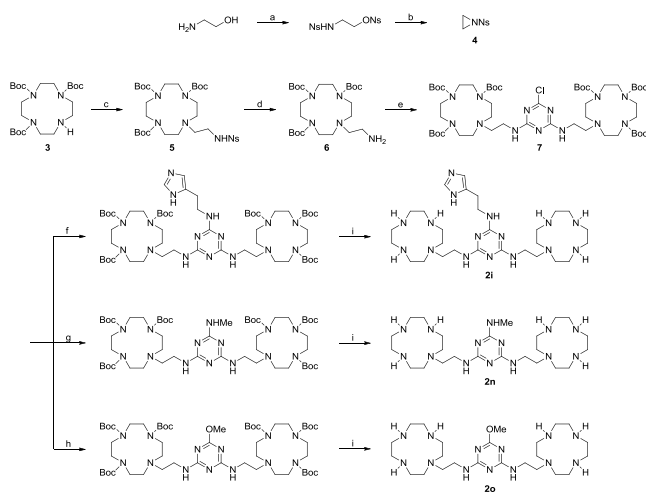

Scheme 1 Preparation of the cleaving agents **2i**, **2n** and **2o**. Reagents and conditions: (a) 4-nitrobenzenesulfonyl chloride, pyridine, CH_2Cl_2 , (b) KOH, H_2O , CH_2Cl_2 , (c) **4**, MeCN, (d) thioglycolic acid, DBU, DMF, (e) cyanuric chloride, DIPEA, MeCN, (f) histamine, DIPEA, MeCN, (g) methylamine, EtOH, (h) NaOMe, MeOH, (i) TFA, CH_2Cl_2 , MeOH.

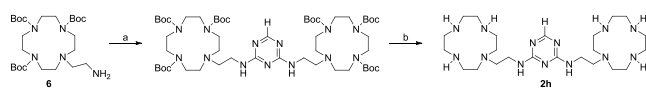

Scheme 2 Preparation of the cleaving agent **2h**. Reagents and conditions: (a) 2,4-dichlorotriazine, DIPEA, MeCN, (b) TFA, CH_2Cl_2 , MeOH.

Zn^{II} chelate of the previously used 1,5,9-triazacyclododecane.⁷ It is, hence, expected that the cyclen moieties are only engaged in binding with the uracil bases and are catalytically inactive (Fig. 1). Four different cleaving agents were prepared, differing only in the substituent at position 6 of the triazine ring. In compounds **2h**, **2n** and **2o**, the role of this substituent is simply to adjust the pK_a value of the triazine core, whereas the histamine sidearm of **2i** has the potential to function as a general acid/base catalyst on its own.

Results and discussion

Preparation of the cleaving agents

Synthesis of the 1,3,5-triazine-based cleaving agents **2i**, **2n** and **2o** is presented in Scheme 1. First, a 2-aminoethyl sidearm was attached to the free secondary amino function of N^4,N^7,N^{10} -trityt-butoxycarbonylcyclen (**3**)⁸ by ring-opening of N -4-nitrobenzenesulfonylaziridine (**4**), prepared from ethanolamine as previously described for several other aminoalcohols.⁹ Subsequent removal of the 4-nitrobenzenesulfonyl group afforded Boc-protected aminoethyl-functionalized cyclen (**6**) which was used to displace two of the chloro substituents of cyanuric chloride, giving the protected non-substituted scaffold (**7**). Finally, the last chloride was displaced by histamine, methylamine or methanol, the Boc protections were removed and the products were converted to free amines (**2i**, **2n** and **2o**, respectively) by passing them through an OH^- -form strong cation exchange resin. In the synthesis of **2h**, 2,4-dichlorotriazine was used instead of cyanuric chloride and the product thus obtained

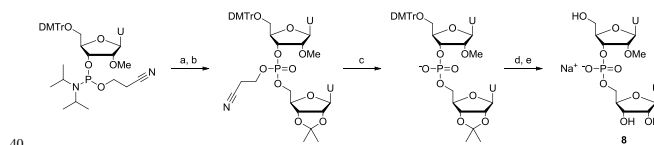

Scheme 3 Preparation of 2'-*O*-methyluridylyl-3',5'-uridine (**8**, **mUpU**). Reagents and conditions: (a) 2',3'-*O*-isopropylideneuridine, 1*H*-tetrazole, MeCN, (b) I_2 , 2,6-lutidine, THF, H_2O , (c) NH_3 , MeOH, (d) HCl, H_2O , (e) Dowex 50Wx8 (Na^+), H_2O .

was deprotected and passed through an OH^- -form strong cation exchange resin to yield **2h** as the free amine (Scheme 2).

Preparation of 2'-*O*-methyluridylyl-3',5'-uridine

For a nonreactive UpU mimic to be used as a target when determining the stability of the complexes, 2'-*O*-methyluridylyl-3',5'-uridine (**8**) was prepared by tetrazole-promoted coupling of commercially available 5'-*O*-(4,4'-dimethoxytrityl)-2'-*O*-methyluridine-3'-(2-cyanoethyl)- N,N -diisopropylphosphoramidite and 2',3'-*O*-isopropylideneuridine (Scheme 3). Removal of the cyanoethyl, dimethoxytrityl and isopropylidene protections and subsequent treatment with Na^+ -form strong cation exchange resin afforded **8** as the sodium salt.

Determination of the stability of the complexes by potentiometric and spectrophotometric titrations

In order to have thermodynamic data on the interaction between Zn^{II} and the 1,3,5-triazine-based ligands, as well as between UpU and the binuclear Zn^{II} complexes, we have studied the protonation of **8** (**mUpU**) and **2n** (**L**), the complex formation in the $\text{Zn}^{\text{II}}:\text{L}$, $\text{Zn}^{\text{II}}:\text{mUpU}$ binary, and in the $\text{Zn}^{\text{II}}:\text{mUpU}:\text{L}$ ternary systems. The determined formation constants and derived data for the relevant equilibria are listed in Table 1. The species distribution curves of the $\text{Zn}^{\text{II}}:\text{L}(\text{mUpU})$ systems are depicted in Fig. 2.

The protonation constants of **mUpU** (**8**) are almost identical with those of UpU.¹⁰ Since the interaction of Zn^{II} with **mUpU** is rather weak, slight hydrolysis of Zn^{II} was observed above pH 8.5 in the $\text{Zn}^{\text{II}}:\text{mUpU}$ system. Therefore only the data below pH 8.5 were considered during our evaluation, and the hydroxo complexes of Zn^{II} were taken into account.¹¹ Under these conditions the formation of two binary complexes was detected. In $\text{Zn}(\text{HmUpU})$ the metal ion is very likely coordinated to one of the uracil-N3 nitrogen atom. Its deprotonation ($\text{pK} = 8.08$) is probably related to the formation of a mixed hydroxo species ($\text{Zn}(\text{HmUpU})(\text{OH})$).

Over the studied pH range, five protonation steps of **L** (**2n**) can be observed (Table 1). At pH 7 both cyclen rings are doubly protonated. The first two and the second two protonation constants show the expected statistical differences (~ 0.9), and their average (10.77 and 8.59) agrees well with the protonation constants of N -alkyl mono-substituted cyclens.¹² The fifth protonation is related to the 1,3,5-triazine ring.

At first sight, the speciation diagrams in Figure 2 show a complicated picture, however, the composition of the formed species are, in fact, rather obvious. The presence of two azacrowns allow the formation of mono- and dinuclear complexes, and due the acid-base properties of the non-bonded nitrogens and coordinated water molecules, both may have several different protonation states (an example illustrating the excellence of the fits of the potentiometric data is included as

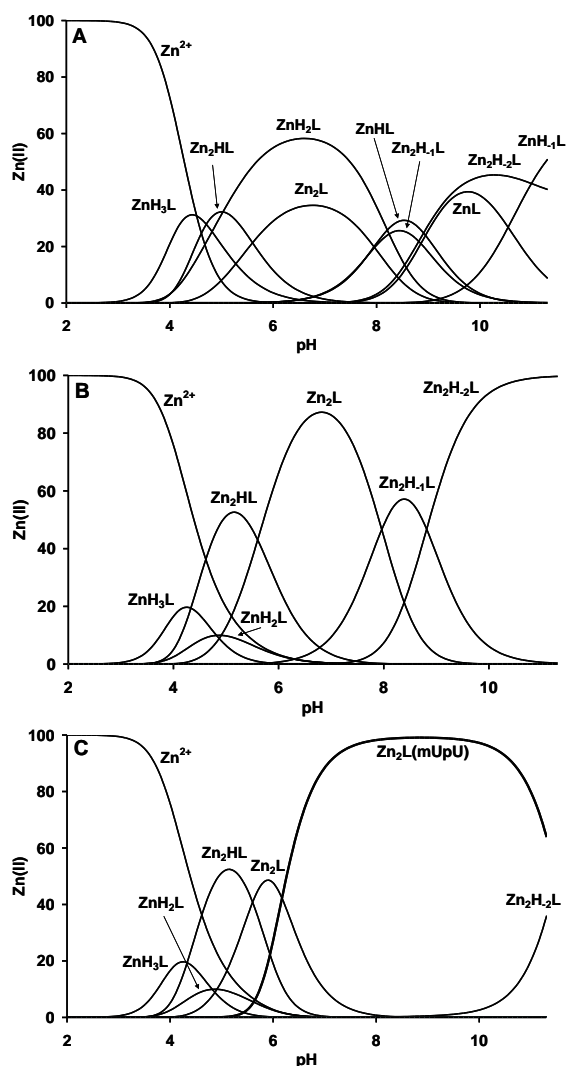

Fig. 2 Species distribution curves for the Zn^{II} complexes in the $Zn^{II} / L / mUpU = 1/1/0$ (A), $2/1/0$ (B) and $2/1/1$ (C) systems ($T = 25\text{ }^\circ\text{C}$, I (NaCl) = 0.1 mol L^{-1} , $[L] = 1\text{ mmol L}^{-1}$).

5 supporting information). In the protonated mononuclear Zn^{II} complexes the metal ion is coordinated to one of the macrocyclic units, while the other one, and the 1,3,5-triazine ring in ZnH_3L , is protonated. This is supported by the almost identical $\log K$ values related to Zn^{II} binding to the tri-, di- and mono-protonated ligand
 10 ($\log K_3$, $\log K_4$ and $\log K_5$ in Table 1).

Although, Kimura and his coworkers reported a number of equilibrium studies on Zn_2 -bis(cyclen) complexes related to the equilibria $Zn_2L + X = Zn_2LX$ (where $X = OH^-$, 1-methylthymine, TpT etc.)^{4,13,14}, to our knowledge only a single paper reports
 15 complete solution equilibrium study on the formation of binary $Zn(II)$ complexes of bis-cyclen derivatives.¹⁵ However, the ligands reported in ref. 15 contained 1,4-phenylene spacers, and the macrocyclic units possessed aminoalkyl pendant arms, which may also coordinate to the metal ions. As a consequence, latter
 20 ligands provided two separated binding sites for the metal ions. In contrast, the relatively large difference between the binding constants of the first and second metal ion to **L** ($\log K_6$ and $\log K_{10}$ in Table 1, $\Delta \log K = 5.4$) may indicate the weak binding of the second cyclen ring to the metal ion in ZnL , too. Such ‘earmuff’

Table 1 Formation constants ($\log \beta_{pqrs}$) and some derived equilibrium data of the Zn^{II} complexes of **8** (**mUpU**) and **2n** (**L**) ($I = 0.1\text{ M NaCl}$, $T = 298\text{ K}$).^a

$pqrs^b$ (species)	$\log \beta_{pqrs}$	$pqrs^b$ (species)	$\log \beta_{pqrs}$
1101 ($Zn(HmUpU)$)	13.12 ± 0.09	1-110 ($ZnL(OH)$)	5.24 ± 0.06
1001($Zn(HmUpU)(OH)$)	5.04 ± 0.09	2110 (Zn_2HL)	31.76 ± 0.05
1310 (ZnH_3L)	37.75 ± 0.05	2010 (Zn_2L)	26.16 ± 0.05
1210 (ZnH_2L)	32.94 ± 0.05	2-110 ($Zn_2L(OH)$)	18.19 ± 0.06
1110 ($ZnH_2L(OH)^c$)	24.73 ± 0.06	2-210 ($Zn_2L(OH)_2$)	9.38 ± 0.06
1010 ($ZnHL(OH)^c$)	15.78 ± 0.06	2011 ($Zn_2L(mUpU)$)	35.70 ± 0.03

Derived data for relevant equilibria

$$\log K_1 (Zn^{2+} + HmUpU = Zn(HmUpU)) = 3.80$$

$$\log K_2 (Zn(HmUpU) + OH^- = Zn(HmUpU)(OH)) = 5.67$$

$$\log K_3 (Zn^{2+} + H_3L = ZnH_3L) = 14.10^d$$

$$\log K_4 (Zn^{2+} + H_2L = ZnH_2L) = 13.58^d$$

$$\log K_5 (Zn^{2+} + HL = ZnHL) = 13.96^d$$

$$\log K_6 (Zn^{2+} + L = ZnL) = 15.78$$

$$\log K_7 (ZnH_2L + OH^- = ZnH_2L(OH)) = 5.54$$

$$pK_8 (ZnH_2L(OH) = ZnHL(OH) + H^+) = 8.95$$

$$pK_9 (ZnHL(OH) = ZnL(OH) + H^+) = 10.54$$

$$\log K_{10} (ZnL + Zn^{2+} = Zn_2L) = 10.38$$

$$\log K_{11} (ZnL(OH) + Zn^{2+} = Zn_2L(OH)) = 12.95$$

$$\log K_{12} (Zn_2L + OH^- = Zn_2L(OH)) = 5.78$$

$$\log K_{13} (Zn_2L(OH) + OH^- = Zn_2L(OH)_2) = 4.94$$

$$\log K_{14} (Zn_2L + mUpU = Zn_2L(mUpU)) = 9.54$$

$$\log K_{15} (Zn_2L + H_2mUpU = Zn_2L(mUpU) + 2H^+) = -9.11 (-7.94 \text{ at } 90^\circ\text{C})$$

^a The protonation constants of **mUpU** and **L** are $\log \beta_{0101} = 9.74 \pm 0.02$, $\log \beta_{0201} = 18.65 \pm 0.02$, and $\log \beta_{0110} = 11.25 \pm 0.04$, $\log \beta_{0210} = 21.53 \pm 0.04$, $\log \beta_{0310} = 30.55 \pm 0.04$, $\log \beta_{0410} = 38.70 \pm 0.04$, $\log \beta_{0510} = 42.99 \pm 0.04$, respectively. ^b p, q, r and s are the stoichiometric coefficients for Zn^{II} , H^+ , **L** (**2n**) and **mUpU** (**8**), respectively. ^c main species, other protonation isomers may also exist. ^d the following values were used for the pKs of non zinc-bounded cyclen ring: $\log \beta_{0210}/2 = 10.77$ and $(\log \beta_{0410} - \log \beta_{0210})/2 = 8.59$

-like coordination is highly stable for some bis(1,4,7-triazacyclononane) derivatives.¹⁶ Although, the relatively rigid 2,4-substituted triazine spacer would prefer the formation of similar structure in the present case, even its partial formation is rather
 40 surprising considering the tetradentate nature of cyclen ring.

In the absence of aminoalkyl pendant arms, the metal ions in the dinuclear Zn_2L species are stronger Lewis acids than those reported in ref 15, therefore the deprotonation of metal bound water molecules take place at *c.a.* 2 units lower pH. The $\Delta \log K =$
 45 $\log K_{12} - \log K_{13} = 0.84$ value corresponds to the statistical difference, and thus indicates no interaction between the two metal centers in the dinuclear monohydroxo species ($Zn_2L(OH)$).

In equimolar solutions of Zn^{II} and **L**, considerable amounts of binuclear complexes are present (Fig. 2A). This is the
 50 consequence of the two identical binding sites in **L**, since under such conditions statistical considerations predict nearly equal amounts of ligand bound in mono- and binuclear complexes.

In the $Zn^{II}:L:mUpU$ system our potentiometric study indicated the formation of a single very stable ternary complex
 55 ($Zn_2L(mUpU)$), which is the sole species over a wide pH-range

(Fig. 2C). **mUpU** fits into the scaffold created by the Zn_2L complex almost ideally, since the value of $\log K_{14}$ ($= 9.54$ for the reaction $Zn_2L + mUpU = Zn_2L(mUpU)$) is nearly twice as high as the respective constant for the process $Zn:cyclen + uridine = Zn:cyclen(uridine)$, $\log K = 5.2$.¹³

The Zn_2L -**mUpU** interaction has also been studied by UV-spectrophotometric titrations both at 25 °C and 90 °C (Fig. 3 and 4). The decrease in the UV absorbance of **mUpU** at 260 nm upon addition of the Zn_2L complex at 25 °C and pH 8.8 results from the binding of the dinuclear species to the base moieties of **mUpU** (Fig. 3). The spectrophotometric data depicted in Fig. 3 have been quantitatively evaluated in two different ways. Taking into account the formation constants determined by potentiometry for the binary complexes, the spectrophotometric data allowed the calculation of the formation constant of the ternary species $\log \beta_{2011} = 35.37 \pm 0.06$, which agrees well with the value determined by potentiometric measurements (see Table 1). Furthermore, we also calculated an apparent stability constant for the $Zn_2H_xL + H_xmUpU = Zn_2L(mUpU)$ reaction ($\log K_{app} = 5.98(3)$), which can be directly compared to the value determined

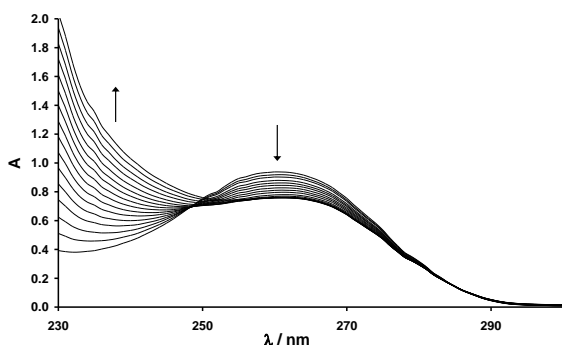

Fig. 3 UV-absorption spectrum of **mUpU** ($55 \mu\text{mol L}^{-1}$ aqueous solution) titrated with a solution that contained Zn^{II} and **L** in a 2:1 ratio ($[L]_{tot}=1.55 \text{ mmol L}^{-1}$) at pH 8.9 ($T = 25 \text{ }^\circ\text{C}$, $I(\text{NaCl}) = 0.1 \text{ mol L}^{-1}$).

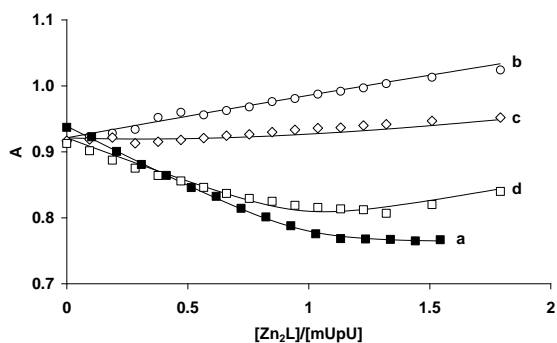

Fig. 4 UV spectrophotometric titration (260 nm) of **mUpU** ($55 \mu\text{mol L}^{-1}$) with a solution that contained Zn^{II} and **L** in a 2:1 ratio ($[L]_{tot}=1.55 \text{ mmol L}^{-1}$) at pH = 8.9, $T = 25 \text{ }^\circ\text{C}$ (a, ■), $\text{pH}^* = 5.0$, $T = 90 \text{ }^\circ\text{C}$ (b, ○), $\text{pH}^* = 6.0$, $T = 90 \text{ }^\circ\text{C}$ (c, ◇) and $\text{pH}^* = 7.0$, $T = 90 \text{ }^\circ\text{C}$ (d, □) ($I(\text{NaCl}) = 0.1 \text{ mol L}^{-1}$).

at 90 °C (see later). The measured and calculated absorbances at 260 nm are shown in Fig. 4 (curve a).

In order to have quantitative data on the stability of the ternary $Zn_2L(mUpU)$ complex at the temperature used for the kinetic measurements, we performed UV-spectrophotometric titrations between $\text{pH}^* = 5 - 7$ at 90 °C. The UV-titrations made at several

pH^* allowed us to follow the $Zn_2L + H_2mUpU = Zn_2L(mUpU) + 2H^+$ reaction (Figure 4, curve b-d). At $\text{pH}^* = 5$ (Figure 4, curve b) the formation of the ternary species is negligible, therefore curve b reflects the increasing amount of the binary Zn_2L species (which also absorbs at 262 nm at this temperature). On the other hand, at $\text{pH}^* 7$ (curve d) the majority of the added Zn_2L complex transforms into the ternary species until a 1:1 ratio of Zn_2L and **mUpU** is reached. These data indicate the formation of the $Zn_2L(mUpU)$ ternary complex also at 90 °C. The equilibrium constant determined for the above reaction at 90 °C is $\log K_{15} = -7.94 \pm 0.06$. The corresponding constant at 25 °C is $\log K_{15} = -9.11$, which indicates that with increasing temperature the formation of the ternary complex shifts to a lower pH-range. At $\text{pH}^* = 7$ we also calculated the apparent stability constants for the $Zn_2H_xL + H_xmUpU = Zn_2L(mUpU)$ reaction ($\log K_{app} = 5.10 \pm 0.08$). The latter value shows tight binding of Zn_2L to **mUpU** even at this higher temperature.

Reaction pathways and product distribution

Hydrolytic reactions of UpU were followed at 90 °C over a pH^* range of 3.52 – 10.21 in the presence of a 12-fold excess of the

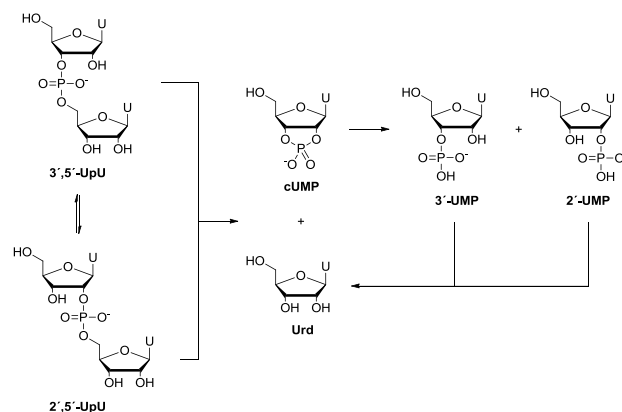

Scheme 4 Hydrolytic reaction pathways of UpU.

cleaving agent and at $\text{pH}^* 7.42$ as a function of the concentration of the cleaving agent or UpU by analyzing the composition of the aliquots withdrawn from the reaction mixture at appropriate time intervals by RP HPLC. In all cases, 2 eq. of $Zn(\text{NO}_3)_2$ relative to the cleaving agent were used. The reactions were started by mixing a small amount of the UpU stock solution with the reaction buffer prethermostated to 90 °C to give the desired UpU concentration and quenched by cooling the aliquots to 0 °C. The products were characterized by spiking with authentic samples.

Over the entire pH^* range studied and regardless of whether the cleaving agent is present in excess or not, the same product distribution is observed (Scheme 4). Disappearance of UpU is accompanied by formation of uridine and comparable amounts of uridine 2'- and 3'-monophosphates. Only traces of the initially formed uridine 2',3'-cyclic monophosphate are detected, owing to its rapid hydrolysis to the 2'- and 3'-monophosphates. Below $\text{pH}^* 8$, mutual isomerization of 3',5'- and 2',5'-UpU is also observed.

For the experiments carried out in the presence of an excess of the cleaving agent, pseudo first-order rate constants for the disappearance of UpU were obtained by applying the integrated first-order rate law to the time-dependent diminution of the

relative peak area of UpU. When the reaction rate was studied as a function of UpU concentration at a constant limiting concentration of the cleaving agent, initial rates were obtained as slopes of the plots of the combined peak area of all the monomeric products (2',3'-cUMP, 3'-UMP, 2'-UMP and uridine) as a function of reaction time.

Dependence of rate on cleaving agent concentration

To verify the catalytic activity of the binuclear Zn^{II} :cyclen compounds synthesized, cleavage of UpU was followed at various concentrations (0 – 80 $\mu\text{mol L}^{-1}$) of the methylamino derivative **2n** ($T = 90\text{ }^\circ\text{C}$; $\text{pH}^* = 6.57$). Cleavage of ApA was followed under the same conditions for comparison. The dependence of the observed pseudo first-order rate constant for the cleavage of UpU and ApA as a function of **[2n]** is presented in Fig. 5.

Cleavage of UpU follows simple first-order kinetics and attains a rate acceleration of nearly two orders of magnitude at sufficiently high concentrations of the dizinc complex of **2n**. The observed first-order rate constant for the reaction may be expressed by eqn. (1).

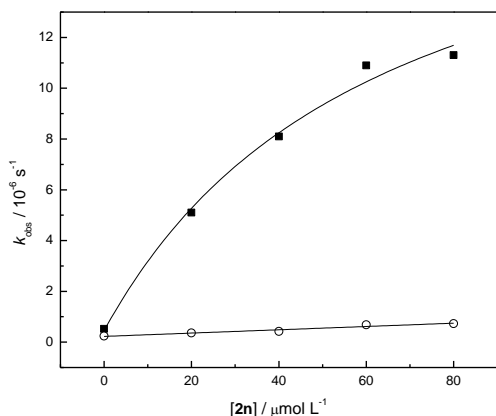

Fig. 5. Pseudo first-order rate constants for the cleavage of UpU (■) and ApA (○) as a function of the concentration of the cleaving agent **2n** at $90\text{ }^\circ\text{C}$, $\text{pH}^* = 6.57$, $I(\text{NaClO}_4) = 0.10\text{ mol L}^{-1}$, $[\text{UpU}] = [\text{ApA}] = 5.0\text{ } \mu\text{mol L}^{-1}$.

$$k_{\text{obs}} = k_{\text{uncat}} + k_{\text{cat}} \frac{[\mathbf{2n}]}{K_d + [\mathbf{2n}]} \quad (1)$$

k_{uncat} and k_{cat} are the first-order rate constants for the spontaneous and **2n**-catalyzed hydrolysis, respectively, and K_d is the dissociation constant for the complex between UpU and **2n**: $2Zn^{II}$. The observed dissociation constant is $\log K_d = -4.2 \pm 0.2$, in reasonable agreement with the corresponding value obtained by spectrophotometric titrations at $\text{pH}^* = 7$, taking into account the difference in pH^* ($\log K_d = -\log K_{\text{app}} = -5.1$). In contrast to the cleavage of UpU, cleavage of ApA is hardly accelerated by **2n**, indicating that binding of the nucleobases to the Zn^{II} :cyclen moieties of the cleaving agent is essential for catalytic activity. In principle, one might argue that only one of the azacrown chelates is engaged in UpU binding, the other one serving as an

intracomplex catalyst. The potentiometric studies, however, show that the complex having both of the cyclen moieties bound to uracil is overwhelmingly the most stable species. This finding is also consistent with the earlier observations of Kimura, according to which binding of 1,4-bis[(1,4,7,10-tetraazacyclododecan-1-yl)methyl]benzene to TpT is much stronger than to 1-methylthymine.¹⁴ Furthermore, it has been previously shown that the related binuclear Zn^{II} :azacrown complex **1b**: $2Zn^{II}$ does not catalyze the cleavage of UpU, even though its Zn^{II} :1,5,9-triazacyclododecane moieties are known to be better catalysts for phosphodiester cleavage than the Zn^{II} :cyclen moieties of **2n**: $2Zn^{II}$.⁵ It seems, hence, extremely unlikely that the observed rate acceleration by **2n** would be due to metal ion catalysis. In all likelihood, the same conclusion holds also for the other cleaving agents **2h**, **2i** and **2o**.

Stoichiometry of the reactive complex

The fact that the **2n**-catalyzed cleavage of UpU follows simple first-order kinetics suggests 1:1 stoichiometry for the reactive UpU:**2n** complex. For more compelling evidence, a Job's plot

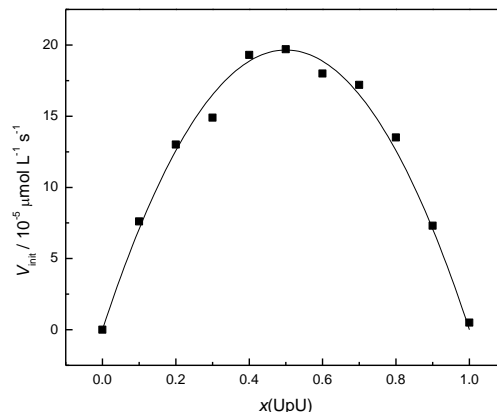

Fig. 6 Initial rate for the cleavage of UpU by **2n** at $90\text{ }^\circ\text{C}$, $\text{pH}^* = 6.39$, $I(\text{NaClO}_4) = 0.10\text{ mol L}^{-1}$, $[\text{UpU}] + [\mathbf{2n}] = 50\text{ } \mu\text{mol L}^{-1}$.

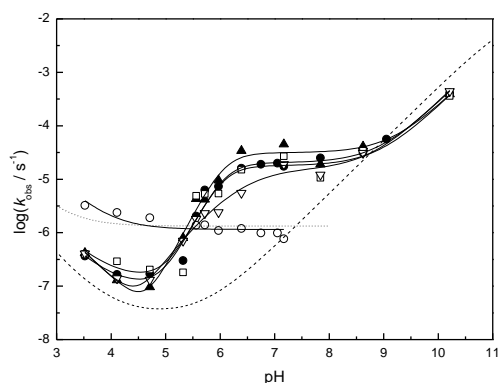

Fig. 7 pH-rate profiles for the cleavage of UpU in the absence (dashed line) and in the presence of the cleaving agents **2h** (□), **2i** (▽), **2n** (●) and **2o** (▲) and the isomerization of UpU in the absence (dotted line) and in the presence of **2n** (○) at $90\text{ }^\circ\text{C}$, $I(\text{NaClO}_4) = 0.10\text{ mol L}^{-1}$, $[\mathbf{2}] = 0 / 60\text{ } \mu\text{mol L}^{-1}$.

was constructed by measuring the initial rate of the cleavage of UpU at pH* 6.39 as a function of the mole fraction of **2n**, keeping the total concentration of UpU and **2n** constant: [UpU] + [2n] = 50 μmol L⁻¹. The plot, presented in Fig. 6, has the shape of a downward-opening parabola with a maximum at $x(\text{UpU}) = x(\mathbf{2n}) = 0.5$. As expected and also borne out by the titration studies with **2n** and **8**, one molecule of UpU binds to one molecule of **2n** to form the reactive complex.

pH-Rate profiles

The pH-rate profiles for the disappearance of UpU in the

Table 2 Rate constants for the partial reactions of cleavage and isomerization of UpU in the presence of the cleaving agents **2h**, **2i**, **2n** and **2o** ($T = 90\text{ }^{\circ}\text{C}$, $I(\text{NaClO}_4) = 0.10\text{ mol L}^{-1}$).

	2h ^[a]	2i ^[a]	2n ^[a]	2n ^[b]	2o ^[a]	isom. with 2n
$k_1 / 10^{-4}\text{ mol}^{-1}\text{ L s}^{-1}$	10 ± 10	14 ± 6	9 ± 5	11 ± 6	14 ± 5	90 ± 30
$k_2 / 10^{-7}\text{ s}^{-1}$	1 ± 1	0.2 ± 0.7	0.9 ± 0.5	0.5 ± 0.6	0.1 ± 0.4	12 ± 1
$k_3 / \text{mol}^{-1}\text{ L s}^{-1}$	0.3 ± 0.1	0.26 ± 0.06	0.34 ± 0.06	0.35 ± 0.05	0.5 ± 0.1	-
$k_4 / 10^{-2}\text{ mol}^{-1}\text{ L s}^{-1}$	4 ± 3	4 ± 1	4 ± 1	4 ± 2	3 ± 1	-
$\text{p}K_{\text{a}1} + \text{p}K_{\text{a}2}$	12.2 ± 0.4	11.4 ± 0.7	12.2 ± 0.1	-	12.16 ± 0.2	-
$\text{p}K_{\text{a}1}$	-	6.5 ± 0.2	-	-	-	-
$\text{p}K_{\text{a}2}$	-	4.9 ± 0.5	-	-	-	-

^a Calculated using eqn. (2). ^b Calculated using eqn. (3).

ternary complex under these conditions. Under the experimental conditions, *i.e.* between pH* 3.52 and 10.21, the observed rate constant for the cleavage of UpU, $k_{\text{cl}}^{\text{obs}}$, may be expressed by eqn. (2).

$$k_{\text{cl}}^{\text{obs}} = k_1[\text{H}^+] + k_2 + \frac{k_3[\mathbf{2}][K_{\text{a}1}K_{\text{a}2}]}{[\text{H}^+]^2 + K_{\text{a}1}K_{\text{a}2}} + \frac{k_4K_{\text{W}}}{[\text{H}^+]} \quad (2)$$

$K_{\text{a}1}$ and $K_{\text{a}2}$ are the acidity constants of the two uracil bases (deprotonation of N3 upon complexation with Zn^{II}:cyclen), $[\mathbf{2}]$ is the concentration of the cleaving agent used (0 or 60 μmol L⁻¹), k_2 is the first-order rate constant for the pH-independent cleavage of UpU and k_1 , k_3 and k_4 are the second-order rate constants for the hydronium ion, cleaving agent and hydroxide ion catalyzed cleavage of UpU, respectively. Assuming identical binding of **mUpU** and UpU to the dizinc complex of **2n**, the equilibrium data obtained at 90 °C by spectrophotometric titrations allows one to calculate the concentration of the reactive ternary species at any pH*, providing a more accurate treatment of the kinetic data in the case of this ligand. Thus eqn. (2) is simplified to eqn. (3).

$$k_{\text{obs}}^{\text{cl}} = k_1[\text{H}^+] + k_2 + k_3[\text{Zn}_2 : \mathbf{2n} : \text{UpU}] + \frac{k_4K_{\text{W}}}{[\text{H}^+]} \quad (3)$$

The rate and equilibrium constants obtained by nonlinear least-squares fitting of the experimental data to eqns. (2) and (3) are presented in Table 2. With **2n**, the rate constants obtained by using eqns. (2) and (3) are in good agreement, supporting the validity of our description of kinetic data. The deprotonation of the two N3 nitrogens is strongly cooperative, and the respective dissociation constants cannot be separated based on the kinetic data (or even by the potentiometric measurements at 25 °C), except in the case of **2i**. Therefore, for the other cleaving agents, only the sum $\text{p}K_{\text{a}1} + \text{p}K_{\text{a}2}$ has been tabulated.

presence (60 μmol L⁻¹) or absence¹⁷ of the cleaving agents are presented in Fig. 7. In the absence of any cleaving agents, cleavage of UpU becomes first-order in [OH⁻] at pH* 6 and remains so until quantitative deprotonation of the attacking 2'-hydroxy function is reached around pH* 12.5.¹⁷ In contrast, in the presence of the cleaving agents, the reaction becomes roughly second-order in [OH⁻] at pH* 4, pH-independent at pH* 6 and finally first-order in [OH⁻] at pH* 8. No data for the hydrolysis promoted by the cleaving agents **2h**, **2i**, **2n** and **2o** could be obtained at pH* < 4 owing to the instability of the UpU:2Zn^{II}:2

Hydronium ion catalyzed hydrolysis of UpU

At pH < 4, cleavage of UpU is first-order in [H₃O⁺] both in the presence and in the absence of the cleaving agents **2h**, **2i**, **2n** and **2o**. Under these conditions, the uracil bases remain protonated and uncomplexed with the Zn^{II}:cyclen moieties and, hence, no rate acceleration by the cleaving agents is expected. In fact, between pH 3.5 and 4 a modest acceleration is observed but it seems that on going to more acidic solutions this difference in the rates of catalyzed and spontaneous reactions disappears. In other words, under acidic conditions there is no contribution to the cleavage of UpU by **2h**, **2i**, **2n** or **2o** but the reaction proceeds as previously described¹⁷ even when the cleaving agents are present in a considerable excess.

Cleaving agent catalyzed hydrolysis of UpU

Between pH 5 and 6, the cleavage of UpU is second-order in [OH⁻] in the presence of the cleaving agents **2h**, **2n**, **2o**, and **2i** and nearly pH-independent in the absence thereof. Over this relatively narrow pH range, two pH-dependent equilibria prevail, *viz.* coordination of the N3 atoms of the uracil bases to the Zn^{II} ions of the binuclear Zn^{II} complexes of **2h**, **2i**, **2n** and **2o** with concomitant deprotonation. For the coordination equilibria of **2h**, **2n** and **2o**, the average $\text{p}K_{\text{a}}$ value obtained from eqn. (2) is $(\text{p}K_{\text{a}1} + \text{p}K_{\text{a}2}) / 2 = 6.1$, in excellent agreement with the spectrophotometric titration curve obtained at 90 °C for the complex of 2'-*O*-methyluridylyl-3',5'-uridine (**8**) and **2n**:2Zn^{II} ($\text{p}K = 6.2$). With the histamine derivative **2i**, eqn. (2) gives $\text{p}K_{\text{a}1} = 6.5$ and $\text{p}K_{\text{a}2} = 4.9$. The considerable difference between the two equilibrium constants in the case of **2i** is in all likelihood attributable to the coordination ability of the imidazole ring. In other words, in the dinuclear complex **2i**:2Zn^{II} the imidazole ring is probably coordinated to one of the Zn^{II} ion and this 5N-coordinated zinc has reduced binding ability to the N3 nitrogens

of UpU as compared to the other, 4N-coordinated one. Therefore the Zn^{II} promoted deprotonation of UpU takes place in two separate steps.

Under conditions where the cleaving agent promoted hydrolysis of UpU prevails, the triazine core of the cleaving agents is in the deprotonated neutral ionic form,¹⁸ suggesting that the cleaving agents function as general base catalysts. The possibility of general acid catalysis cannot be ruled out, however, due to the instability of the UpU:2Zn^{II}:2 ternary complexes under conditions where the triazine core of the cleaving agents would be protonated. Mutual isomerization of 2',5'- and 3',5'-UpU is

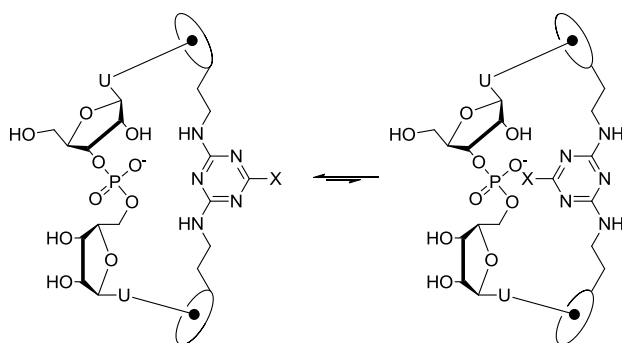

Fig. 8 Two possible conformations of the UpU:cleaving agent complex, with the substituent X oriented away from (left) or towards (right) the phosphodiester bond.

neither facilitated nor retarded by any of the cleaving agents.

The second-order rate constants for the cleaving agent catalyzed hydrolysis of UpU, k_3 , are nearly identical for **2h**, **2i**, **2n** and **2o**. In other words, the catalytic activity of the cleaving agents is largely independent on the substitution at the 6-position of the triazine ring, even when a potential general acid/base catalyst is attached (the histamine function of **2i**). In all likelihood, the substituent at the 6-position is oriented away from the scissile phosphodiester bond in the reactive complex which, in turn, suggests that the N3 atom is oriented towards it (Figure 8).

Based on data reported for 2-substituted 4,6-diaminotriazines, the pK_a value of the triazine ring at 25 °C can be estimated as 3.96, 5.28 and 3.54 for **2h**, **2n** and **2o**, respectively.¹⁸ In other words, the difference in basicity of nearly 2 logarithmic units is not reflected in the catalytic activity of the cleaving agents. The observed general base catalysis is, hence, probably attributable to sequential specific base and general acid catalysis, with the attacking 2'-OH being deprotonated in a rapid pre-equilibrium step and proton transfer from the general acid (the protonated triazine) taking place concerted with rate-limiting P-O bond fission.¹⁹ In this kind of mechanism, the effects of the basicity of the general acid/base catalyst are opposite in the two steps: higher basicity shifts the pre-equilibrium to favor the reactive deprotonated species but at the same time retards proton transfer at the rate-limiting step. Apparently, in the present case these two effects completely cancel each other out, indicating that proton transfer from the general acid to the leaving group must be nearly complete at the rate-limiting step. Finally, it should be pointed out that direct general base catalysis, *i.e.* abstraction of the proton from the 2'-OH by the cleaving agent at the rate-limiting step, should result in strong dependence of the reaction rate on the pK_a ,

of the triazine ring.

Together with the exocyclic amino functions at C2 and C4, N3 of the triazine ring forms a conjugated network of hydrogen bond donors and acceptors that, upon tautomerization, may abstract and release a proton at any of the three nitrogen atoms. More specifically, this network could mediate proton transfer from the attacking 2'-OH to the phosphorane intermediate and, ultimately, to the departing 5'-oxygen, closely mimicking the proposed action of the catalytic guanine moiety in hammerhead and hairpin ribozymes (Scheme 5A). One of the amino groups of the 2,6-diaminotriazine core could deprotonate the attacking 2'-OH in a pre-equilibrium step and the other one protonate the departing 5'-

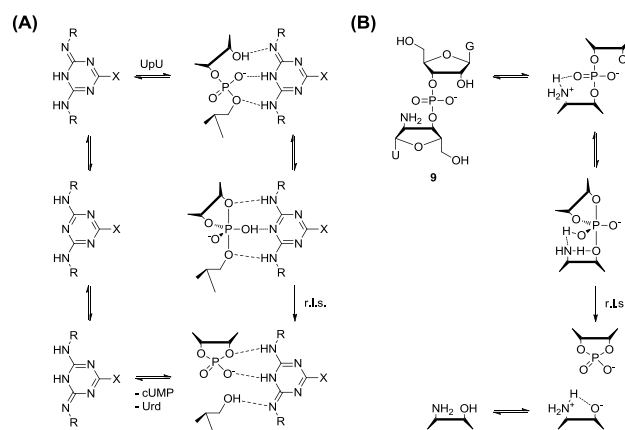

Scheme 5 Proposed mechanisms for (A) cleavage of UpU by **2h**, **2i**, **2n** and **2o** and (B) spontaneous cleavage of guanylyl-(3',3')-(2'-amino-2'-deoxyuridine) (**9**).

oxyanion in the rate-limiting step. In addition, the protonated N3 of the triazine ring may interact with the nonbridging oxygen atoms by hydrogen bonding. In the initial state, the proposed hydrogen bond between the protonated triazine N3 and the nonbridging oxygen atoms of the phosphodiester linkage is probably a weak one because the monoanionic phosphodiester is only weakly basic. Upon the attack of the 2'-oxyanion on the phosphorus, however, the basicity of the nonbridging oxygen atoms increases, strengthening the hydrogen bond. In the phosphorane intermediate, the proton actually resides on one of the nonbridging oxygen atoms. Upon breakdown of this intermediate, basicity of the nonbridging oxygen atoms decreases again and negative charge builds up on the departing 5'-oxygen. The 2,6-diaminotriazine core of the cleaving agents may respond to these changes by accepting a proton from a nonbridging oxygen at N3 and donating another from an exocyclic amino function to the developing 5'-oxyanion.

Although in the present case the catalytic effect of a cleaving agent having the triazine ring protonated could not be studied, previously obtained similar results with simpler model systems tend to support the idea of the deprotonated triazine as a general base catalyst. For example, the cleavage of guanylyl-(3',3')-(2'-amino-2'-deoxyuridine) (**9**) exhibits a highly similar pH-rate profile but in that case the reaction is first-order in [HO⁻] between pH 4 and 6.²⁰ Because the system is not complicated by coordination equilibria between the nucleobases and cleaving agents this first-order dependence in [HO⁻] could be directly attributed to deprotonation of the 2'-amino group. In other words, the 2'-amino function in its deprotonated form is a general base

catalyst, promoting the cleavage of **9**. Also in this case, the observed general base catalysis was interpreted in terms of sequential specific base and general acid catalysis, as discussed above (Scheme 5B).¹⁹

5 Hydroxide ion catalyzed hydrolysis of UpU

At pH 8, hydrolysis of UpU in the presence of the cleaving agents **2h**, **2i**, **2n** and **2o** becomes first-order in [OH⁻]. The observed base catalysis in all likelihood refers to rate-limiting departure of the uridine 5'-oxyanion from the marginally stable dianionic phosphorane intermediate formed by attack of the 2'-oxyanion on the phosphorus atom.²¹ The second-order rate constant of the reaction is essentially independent on the presence of the cleaving agents, suggesting that complex formation between UpU and the cleaving agent as such has only a minor impact on the hydrolysis of UpU and the rate acceleration observed at lower pH is due to the ability of the 2,6-diaminotriazine moiety to facilitate proton transfer from the attacking nucleophile to the phosphorane intermediate and eventually to the departing oxyanion.

Conclusions

The cleaving agents presented in this paper form highly stable complexes with UpU through coordination of Zn^{II} by the cyclen moieties of the cleaving agent and the N3 atoms of the uracil bases. The 1,3,5-triazine core linking the Zn^{II}:cyclen anchors, in turn, functions as a general acid/base catalyst, shuttling a proton from the attacking nucleophile to the leaving group. The catalytic effect is independent on the basicity of the triazine ring, suggesting that deprotonation of the attacking 2'-OH takes place in a pre-equilibrium step and proton transfer to the leaving group is largely complete in the rate-limiting step.

30 Experimental section

UV spectrophotometric titrations

The pH of 55 μmol L⁻¹ solutions of mUpU (**8**) in 50 mmol L⁻¹ buffers (MES, HEPES or CHES) were adjusted to the desired value (pH = 8.9 at 25 °C, pH* = 5 – 7 at 90 °C. In the latter case the pH of the solutions was measured at 298 K, and extrapolated to 363 K using the known pK_a values of the buffer acids at 363 K (throughout the paper the extrapolated pH is designated as pH*).² 2.5 mL of these solutions were placed in a quartz cell having an optical path of 1.0 cm. The temperature of the cell housing block was adjusted to 25.0 ± 0.1 °C (or 90 ± 1 °C) and the UV spectra were measured in the wavelength range 200 – 300 nm by a Unicam Helios α spectrophotometer. A more concentrated solution of the ligand **2n** (1.55 mmol L⁻¹) and Zn^{II} (3.1 mmol L⁻¹) was added portionwise and the UV-spectrum was measured after each addition. The spectrum of the buffer was subtracted and the dilution of the solution was taken into account before treatment of the data. Equilibrium data from the spectrophotometric titrations were calculated using the PSEQUAD computer program.³

50 pH-Metric measurements

The protonation and coordination equilibria were investigated by potentiometric titrations in aqueous solution (*I* = 0.1 M NaCl and *T* = 298.0 ± 0.1 K) under argon atmosphere using an automatic

titration set including a PC controlled Dosimat 665 (Metrohm) autoburette and an Orion 710A precision digital pH-meter. The Metrohm Micro pH glass electrode (125 mm) was calibrated⁴ via the modified Nernst equation (eqn. 4).

$$E = E_0 + K \log[\text{H}^+] + J_{\text{H}}[\text{H}^+] + \frac{J_{\text{OH}}K_{\text{w}}}{[\text{H}^+]} \quad (4)$$

*J*_H and *J*_{OH} are fitting parameters in acidic and alkaline media for the correction of experimental errors, mainly due to the liquid junction and to the alkaline and acidic errors of the glass electrode; *K*_w = 10^{-13.75} M² (10^{-12.4} M² at 90 °C) is the autoprotolysis constant of water.⁵ The parameters were calculated by the non-linear least squares method. The complex formation was characterized by the following general equilibrium process (eqns. 5 and 6).

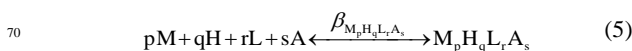

$$\beta_{\text{M}_p\text{H}_q\text{L}_r\text{A}_s} = \frac{[\text{M}_p\text{H}_q\text{L}_r\text{A}_s]}{[\text{M}]^p[\text{H}]^q[\text{L}]^r[\text{A}]^s} \quad (6)$$

M denotes the metal ion, *H* the hydrogen ions, *L* the nonprotonated ligand **2n**, while *A* stands for mUpU (**8**). Charges are omitted for simplicity, but can be easily calculated taking into account the composition of the fully protonated ligands (H₅L⁵⁺ and H₂A). The corresponding formation constants (β_{M_pH_qL_rA_s} ≡ β_{pqs}) were calculated using the PSEQUAD computer program.

The protonation constants were determined from 3 independent titrations (60 – 80 data points per titration). The complex formation constants were evaluated from 5 – 10 independent titrations (60 – 100 data points per titration), depending on the complexity of the system. The metal-to-ligand ratios varied between 1:4 – 1:1 and 2:1 – 1:2 in the binary Zn^{II} – mUpU and Zn^{II} – **2n** systems, respectively, with the Zn^{II} concentration in the range of 0.7 – 1.6 mmol L⁻¹. In the Zn^{II} – **2n** – mUpU ternary system the concentration ratios were 2:1:1, 1.5:2:1 and 1:1:1, with the Zn^{II} concentration in the range of 0.7 – 1.6 mmol L⁻¹.

The comparison of the forward and backward titration curves revealed slow kinetics of complex formation processes in the Zn^{II} – **2n** systems between pH 3.5-5. To minimize the errors due to the slow kinetics, considerably increased equilibration time has been applied between pH 3.5-5, which resulted 4-8 h titration time, depending on the metal-to-ligand ratio.

Kinetic measurements

Reactions were carried out in sealed tubes immersed in a thermostated water bath, the temperature of which was adjusted to 90 °C within ± 0.1 °C. The hydronium ion concentration of the reaction solutions was adjusted with formate, acetate, MES and HEPES buffers and sodium hydroxide and checked with a pH meter. The ionic strength of the solutions was adjusted to 0.10 mol L⁻¹ with NaClO₄. The initial substrate concentration in the kinetic runs was typically 5 μmol L⁻¹. The composition of the samples withdrawn at appropriate time intervals was analyzed by HPLC on a Hypersil-Keystone Aquasil C18 column (4 × 150 mm, 5 μm) using 0.06 mol L⁻¹ acetate buffer and MeOH as an eluent. For the first 10 min, only buffer was used, after which the

amount of MeOH was increased linearly from to 30% during 5 min and kept there for another 5 min. The observed retention times (t_R , min) for the hydrolytic products of UpU were as follows: 16.0 (3',5'-UpU), 15.3 (2',5'-UpU), 6.5 (Urd), 5.2 (2'-UMP), 4.6 (3'-UMP), 3.8 (2',3'-cUMP). The products were characterized by spiking with authentic samples. For the experiments carried out in the presence of an excess of the cleaving agent, pseudo first-order rate constants for the disappearance of UpU were obtained by applying the integrated first-order rate law to the time-dependent diminution of the relative peak area of UpU. When the reaction rate was studied as a function of UpU concentration at a constant limiting concentration of the cleaving agent, initial rates were obtained as slopes of the plots of the combined peak area of all the monomeric products (2',3'-cUMP, 3'-UMP, 2'-UMP and uridine) as a function of reaction time.

Acknowledgements

Financial support from the Academy of Finland and from the Hungarian Scientific Research Found (OTKA K63606) is greatly acknowledged.

Notes and references

^a Department of Chemistry, University of Turku, FIN-20014, Turku, Finland. Fax: +358 2 333 6700; Tel: +358 2 333 6777; E-mail: tuano@utu.fi

- ^b Department of Inorganic and Analytical Chemistry, University of Szeged, Address, H-6701, P.O. Box 440, Szeged, Hungary. Fax: +36 62 544 054; Tel: +36 62 420 505; E-mail: tamas.gajda@chem.u-szeged.hu
- † Electronic Supplementary Information (ESI) available: Synthetic details and ¹H and ¹³C NMR spectra for compounds **5**, **6**, **7**, **2h**, **2i**, **2n**, **2o** and **8**, ³¹P NMR spectrum for compound **8** and an example illustrating the fitting of the potentiometric data. See DOI: 10.1039/b000000x/
- 1 S. A. Strobel, *Nat. Chem. Biol.*, 2005, **1**, 5; P. C. Bevilacqua and R. Yajima, *Curr. Opin. Chem. Biol.*, 2006, **10**, 455.
 - 2 D. M. Perrault and E. V. Anslyn, *Angew. Chem. Int. Ed. Engl.*, 1997, **36**, 432; M. Oivanen, S. Kuusela and H. Lönnberg, *Chem. Rev.*, 1998, 961; R. Breslow, S. D. Dong, Y. Webb and R. Xu, *J. Am. Chem. Soc.*, 1996, **118**, 6588; A. J. Kirby and R. E. Marriott, *J. Chem. Soc., Perkin Trans. 2*, 2002, 422.
 - 3 D. A. Usher and A. H. McHale, *Proc. Natl. Acad. Sci. USA*, 1976, **73**, 1149.
 - 4 S. Aoki and E. Kimura, *Chem. Rev.*, 2004, **104**, 769; E. Kimura, T. Shiota, M. Koike, M. Shiro and M. Kodama, *J. Am. Chem. Soc.*, 1990, **112**, 5805.
 - 5 Q. Wang and H. Lönnberg, *J. Am. Chem. Soc.*, 2006, **128**, 10716.
 - 6 P. B. Rupert and A. R. Ferré-D'Amaré, *Nature*, 2001, **410**, 780; M. Martick and W. G. Scott, *Cell*, 2006, **126**, 309; J. Han and J. M. Burke, *Biochemistry*, 2005, **44**, 7864.
 - 7 S. Kuusela and H. Lönnberg, *J. Phys. Org. Chem.*, 1993, **6**, 347; S. Kuusela and H. Lönnberg, *J. Phys. Org. Chem.*, 1992, **5**, 803.
 - 8 E. Kimura, S. Aoki, T. Koike and M. Shiro, *J. Am. Chem. Soc.*, 1997, **119**, 3068.
 - 9 J. Farràs, X. Ginesta, P. W. Sutton, J. Taltavull, F. Egeler, P. Romea, F. Urpí and J. Villarasa, *Tetrahedron*, 2001, **57**, 7665.
 - 10 N. Ogasawara and Y. Inoue, *J. Am. Chem. Soc.*, 1976, **98**, 7048.
 - 11 C. F. Baes and R. E. Mesmer, *The hydrolysis of Cations*, John Wiley & Sons, New York, 1976.
 - 12 P. Davies and K. Wainwright, *Inorg. Chim. Acta*, 1999, **294**, 103.
 - 13 M. Shionoya, E. Kimura and M. Shiro, *J. Am. Chem. Soc.*, 1993, **115**, 6730.
 - 14 E. Kimura, M. Kikuchi, H. Kitamura and T. Koike, *Chem. Eur. J.*, 1999, **5**, 3113.

- 15 C. Anda, A. Bencini, E. Berni, S. Ciattina, F. Chuburu, A. Danesi, C. Giorgi, H. Handel, M. Le Baccon, P. Paoletti, R. Tripier, V. Turcy and B. Valtancoli, *Eur. J. Inorg. Chem.*, 2005, 2044.
- 16 R. Haidar, M. Ipek, B. DasGupta, M. Yousaf, and L.J. Zompa, *Inorg. Chem.* 1997, **36**, 3125.
- 17 P. Järvinen, M. Oivanen and H. Lönnberg, *J. Org. Chem.*, 1991, **56**, 5396.
- 18 T. Tashiro, *J. Heterocyclic Chem.*, 2002, **39**, 615.
- 19 M. Kosonen and H. Lönnberg, *J. Chem. Soc., Perkin Trans 2*, 1995, 1203.
- 20 M. Ora, H. Linjalahti and H. Lönnberg, *J. Am. Chem. Soc.*, 2005, **127**, 1826.
- 21 H. Lönnberg, R. Strömberg and A. Williams, *Org. Biomol. Chem.*, 2004, **2**, 2165.
- 22 H. S. Harned, B. B. Owen, *The Physical Chemistry of Electrolytic Solutions*, Reinhold Pub., New York, 1958.
- 23 L. Zékány, I. Nagypál, G. Peintler, *PSEQUAD for chemical equilibria*, Technical Software Distributors, Baltimore, 1991.
- 24 F. J. C. Rosotti, H. Rosotti, in *The determination of stability constants*, McGraw-Hill Book Co., New York, 1962, pp. 149.
- 25 E. Högfeldt, in *Stability Constants of Metal-Ion Complexes, Part A. Inorganic Ligands*, Pergamon, New York, 1982, pp. 32.