

Web-based Monitoring System for Power Electronics Devices on Off-grid Solar Power Generator

Amirul Luthfi^{1*}, Eka Putra Waldi¹, Darmawan¹, Baharudin¹, dan Budi Sunaryo²

¹Jurusan Teknik Elektro, Fakultas Teknik, Universitas Andalas, Padang, Sumatera Barat, Indonesia

²Program Studi Teknologi Rekayasa Komputer Jaringan, Fakultas Teknologi Industri, Universitas Bung Hatta, Padang, Sumatera Barat, Indonesia

*Corresponding author, e-mail: amirulluthfi@eng.unand.ac.id

Abstract— Power electronic devices are the main component of the solar power generation system. This study proposes a web-based monitoring system which presents power electronic performance parameter in a real-time across an internet connection. The investigation takes ACS712 and PZEM-004T for the power converter performance measuring and Arduino Mega 2560 with an ethernet shield for data acquisition and transmission. This paper describes the schematic design of the hardware and also explains the software work-flow and structure. The test and calibration on the sensor's voltage and current to standard digital multi-meter Tektronix DMM4050 show the sensor able to accurately read the converter performance parameter and meet the standard IEC-61724. The functionality test on the web-based information system indicates the designed user interface to present the power electronic performance parameter of the solar power generator.

Keywords: Monitoring System, Power Electronics and Solar Power

1. Introduction

The solar power generator is becoming more popular due to its economic value and reduced fossil fuel reserves. However, a solar power generator's economic value depends on the performance due to its ability to power harvested. Installing a monitoring system on solar power generation systems helps anomaly detection, so the solar power generator's performance and economic value are maintained. The solar power generation monitoring system takes output power and the environmental aspect consists of sunlight intensity and temperature of photovoltaic as observe parameter. This monitoring system allows the detection of a system failure or performance degradation based on the comparison of output power to predicted input power from the environment aspect [1]–[9].

The system failure and decreased performed caused by several aspects, like connection corrosion, photovoltaic degradation, and power electronic malfunction [7]. The environmental parameter based solar power generation monitoring system only allow detection of system failure in general. It did not reach out to the malfunction problem's in-depth analysis, requiring an on-site parameter measurement to recognise the

malfunction. This study proposes a web-based monitoring system designed to display power electronic devices' performance parameter in the solar power generation system. This system allowing maintain and analyse of the performance of power electronics using a web-based user interface. So, applying this proposed system to solar power generator allows off-site electrical parameter measurement. The performance parameter also presents on a table and graphic so that system malfunction easier to be analysed.

2. Off-grid Solar Power Generator

Off-grid solar power generator consists of a solar panel, charger controller, battery, and inverter, as shown in Fig 1a. Meanwhile, Fig 1b show another version of the solar power system which performed the integrated power electronic devices that use in this study. The solar panel is the main component for solar energy converter to direct current (DC) electricity. However, this DC electricity power requires a DC-AC converter called an inverter so that it compatible with electrical devices. In the other hand, this solar power generator system involves a battery include its charge controller for energy storage and power stability. Based on these, the power electronics

Received date 2020-11-22, Revised date 2021-03-08, Accepted date 2021-03-26

<https://doi.org/10.25077/jnte.v10n1.851.2021>

This work is licensed under a [Creative Commons Attribution-ShareAlike 4.0 International License](https://creativecommons.org/licenses/by-sa/4.0/).

devices have a crucial function on the off-grid solar power generator, so it takes a monitoring system to observe the performance, which is the objective of this study [10]–[14].

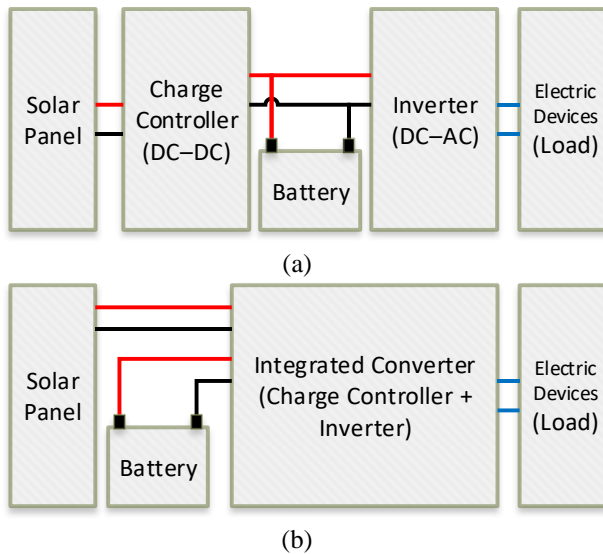

Figure 1. Wiring Diagram of Off-grid Solar Power Generator with (a) Separate Converter and (b) Integrated Converter

3. Web-based Monitoring System for Power Electronics Devices on Off-grid Solar Power Generator

The power electronic device performance observes by measured the power flow parameter, which can be determined based on the voltage and current. The integrated converter on off-grid power generator requires three set sensors consist of two set DC voltage and current sensor and one PZEM-004T Energy Sensor utilize as AC voltage and current sensor, as shown in Fig 2. This study takes a linear hall effect current sensor ACS758-50A as a DC current sensor and a voltage divider circuit as a DC voltage sensor. Meanwhile, PZEM-004T

operate to AC voltage and current sensor, real power measurement, and power factor calculation.

The first DC voltage and current sensor use to observe the converter devices' input power, while the second ones apply as power flow monitoring of the battery. Meanwhile, PZEM-004T embed to track the output power of the solar power generator. Each sensor connected to Arduino Mega 2560, where the DC voltage and current sensor connected to an analog pin and PZEM-004T attach to the serial communication pin, as present in Table 1. Table 1 also shows the connectivity between Arduino and Ethernet Shield to allow data transmission to the server. This connectivity enables the Arduino to read the sensor's converter performance data and send it to the server using the ethernet shield.

Table 1. Arduino Mega 2560 Pin Configuration

Input/Output Devices	Arduino Pin
DC Voltage Sensor #1	A8
DC Voltage Sensor #2	A10
DC Current Sensor #1	A9
DC Current Sensor #2	A11
PZEM-004T TX/RX	Serial 3 (14 & 15)
Ethernet Shield	10, 11, 12 & 13

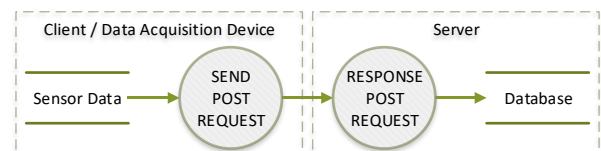

Figure 3. Data Flow Diagram

The data transmission process from the Arduino to the database in the server involves the post method, as shown in Figure 3. The Arduino send the data by a send post request to a PHP page on the server. This PHP file response to the post request and execute a SQL query to store the data into the database. The installed web-based user interface on

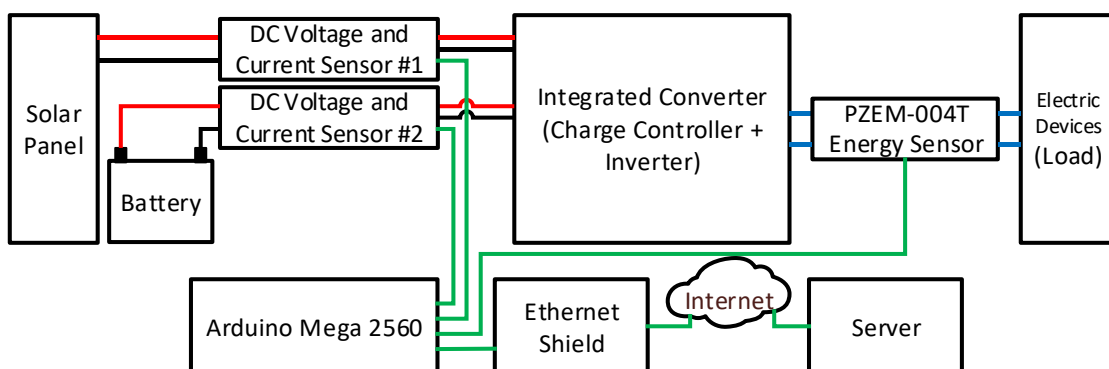

Figure 2. The Proposed Web-based Monitoring System Hardware Schematics

the server enables displaying stored data in the database, so this schema allows monitoring converter performance using a website.

The proses from sensor data sampling and transmitting are iterating each second in this research. The data transmission period can be reduced and increased, depended on server capacity and internet connection quality. The monitoring web-pages design has a similar refresh rate to the data sampling rate, so the web-based user interface shows converter performance data a real-time.

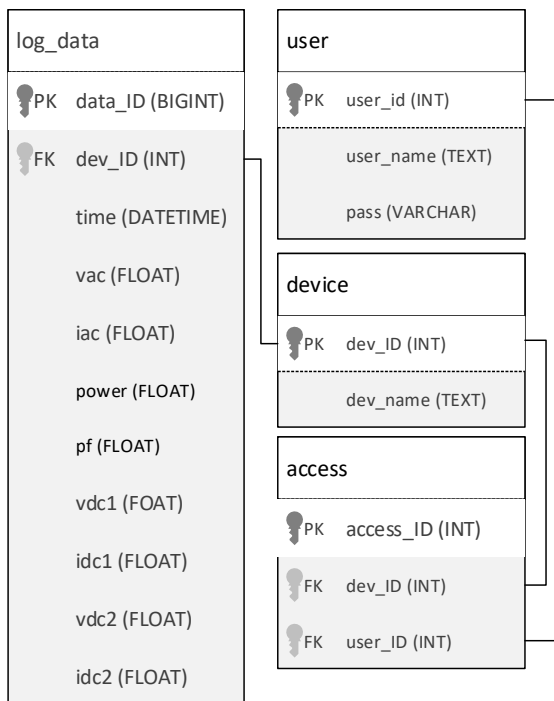

Figure 4. Entity Relationship Diagram of Database

Figure 4 show the database structure of the proposed monitoring system. On the database, the received data from Arduino save into log_data table. This database enables to receive data from many acquisition devices, which the connected device identifies using the dev_id attributes. This system also supports multiple user usage, allowing the user to access each acquisition device. Moreover, this system supports shared device features where one device can access by many users, depending on the authorization setting on the access table.

4. Result and Discussion

A monitoring system requires an accurate measurement device to deliver correct data to the database. This study takes a standard digital multi-meter Tektronix DMM4050 for sensor calibration and sensor accuracy measurement. This

observation also employs a standard laboratory bench power supply and a high-power resistor to simulate measuring voltage and current. The DC voltage and current sensor, which has a linear voltage output calibrate by comparing multi-meter measurement voltage with quantisation level reading of Arduino. The PZEM-004T energy sensor not calibrated, because it was pre-calibrated on the production process. Table 2 show the measurement deviation of each sensor reading compares to standard instrument DMM4050. Based on the average percentage error value, it can conclude that the sensor has accurate measurement because error data less than 2 %. The average error of measurement results in acceptable limits of IEC-61724 standard [15], so the sensor qualifies as a measurement instrument for the monitoring system.

Table 2. Sensor Accuracy of Web-based Monitoring System

Sensor	Measurement Result		Error (%)	Error in Average (%)
	Sensor	Standard Instrument		
DC Voltage Sensor #1	4.95 V	5.03 V	1.59	0,67
	10.12 V	10.08 V	0.40	
	15.05 V	14.98 V	0.47	
	20.08 V	20.06 V	0.10	
	25.17 V	24.97 V	0.80	
DC Voltage Sensor #2	4.91 V	4.98 V	1.41	0.61
	10.09 V	10.03 V	0.60	
	15.00 V	15.08 V	0.53	
	19.98 V	20.03 V	0.25	
	25.00 V	25.04 V	0.24	
DC Current Sensor #1	-10.21 A	-10.08 A	1.29	0.97
	-4.92 A	-4.95 A	0.40	
	5.10 A	5.02 A	1.59	
	10.03 A	9.97 A	0.60	
DC Current Sensor #2	-10.08 A	-9.98 A	1.00	1,42
	-5.15 A	-5.03 A	2.39	
	5.16 A	5.05 A	2.18	
	10.08 A	10.07 A	0.1	
PZEM-004T AC Voltage	216.5 V	216.6 V	0.05	0.10
	216.3 V	216.5 V	0.09	
	216.0 V	216.2 V	0.09	
	216.2 V	216.2 V	0.00	
	215.8 V	215.2 V	0.28	
PZEM-004T AC Current	0.82 A	0.80 A	2.50	1.79
	1.65 A	1.70 A	2.94	
	2.52 A	2.50 A	0.80	
	3.27 A	3.30 A	0.90	

Figure 5 show the user interface of the proposed web-based monitoring system for power electronic devices on the solar power generator. The user interface has four web pages consist of real-time monitoring pages, login pages, and table and graph pages which display a data logger. The real-time monitoring pages test show the systems enabling for load and display the last data on the log_data

table in the database, which indicates the user interface system able to present a monitoring system in real-time. Then, the evaluation of login pages denotes the system execute authorization process, which only authorized user can log in into the system. The investigation of graph and table pages also show that both systems work well. The graph page allows a user to load graph in several sampling periods, while the table page permits a user to access data at several time intervals. The table page also allows export of the data into a spreadsheet file. Based on this result, the user interface able to run all designed purpose.

5. Conclusion

The evaluation of web-based monitoring system for power electronic devices on the solar power generation indicates the proposed method enables to perform a performance analysis of power converter unit through the user interface, where the system allows to present and to log the electrical parameter on the web pages. This study also confirms the accurate electrical parameter measurement in order to the measuring accuracy meet the standard IEC-61247, where each sensor has an average reading deviation below 2%. This result denotes the web-based monitoring system capable of employing as a performance analysis instrument for power electronic devices on the solar power generator.

Acknowledgement

Research reported in Jurnal Nasional Teknik Elektro was supported by Engineering Faculty of Andalas University under award number “093/UN.16.09.D/PL/2020.”

Reference

- [1] W. Mar Myint Aung, Y. Win, and N. Win Zaw, “Implementation of Solar Photovoltaic Data Monitoring System,” *Int. J. Sci. Eng. Technol. Res.*, vol. 7, no. 8, pp. 2278–7798, 2018.
- [2] I. M. Moreno-Garcia *et al.*, “Real-time monitoring system for a utility-scale photovoltaic power plant,” *Sensors (Switzerland)*, vol. 16, no. 6, pp. 1–25, 2016, doi: 10.3390/s16060770.
- [3] A. Ahrary, M. Inada, and Y. Yamashita, “Solar power monitoring system ‘SunMieru,’” *Smart Innov. Syst. Technol.*, vol. 73, pp. 216–224, 2018, doi: 10.1007/978-3-319-59424-8_20.
- [4] V. Beránek *et al.*, “New monitoring system for photovoltaic power plants’ management,” *Energies*, vol. 11, no. 10, 2018, doi: 10.3390/en11102495.
- [5] S. Patil, M. Vijayalashmi, and R. Tapaskar, “SOLAR ENERGY MONITORING SYSTEM USING IoT,” *Indian J.Sci.Res.*, vol. 15, no. 2, pp. 149–155, 2017, [Online]. Available: https://www.ijsr.in/upload/1455558654Chapter_26.pdf%0Ahttps://www.mendeley.com/catalogue/solar-energy-monitoring-system-using-iot/.

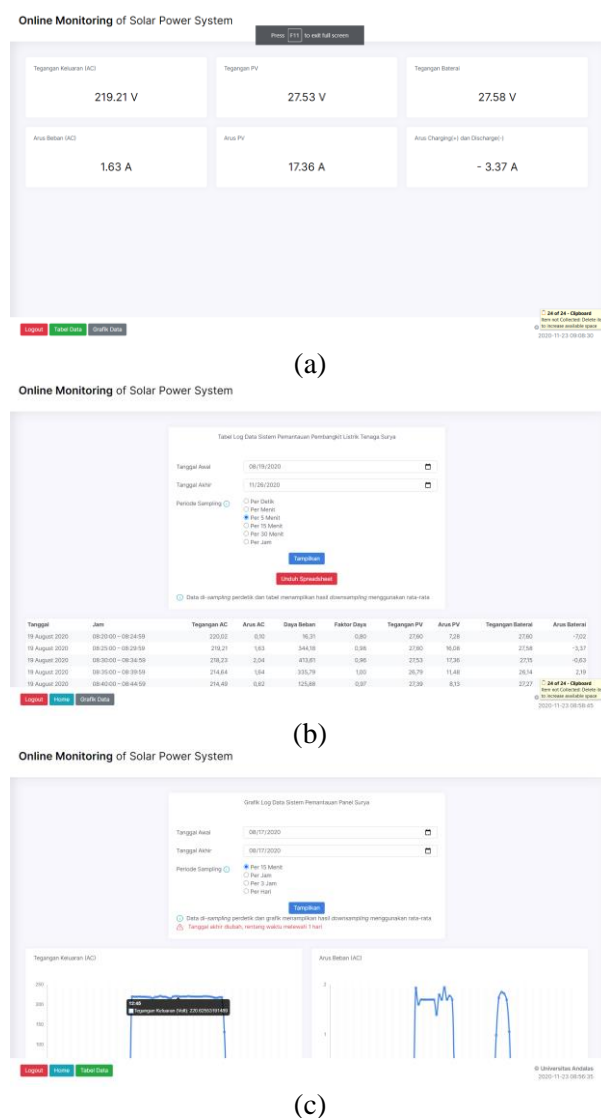

Figure 5 The User Interface of Web-based Monitoring System for present (a) real-time monitoring ,(b) table view data logger, and (c) voltage and current curve

- [6] N. R. Muthu and D. Devaraj, "Development and Performance Analysis of IoT Based Real Time Solar PV Monitoring System," vol. 120, no. 6, pp. 6905–6923, 2018.
- [7] A. Triki-Lahiani, A. Bennani-Ben Abdelghani, and I. Slama-Belkhodja, "Fault detection and monitoring systems for photovoltaic installations: A review," *Renew. Sustain. Energy Rev.*, vol. 82, no. July 2017, pp. 2680–2692, 2018, doi: 10.1016/j.rser.2017.09.101.
- [8] B. Soumia, M. K. Nallapaneni, and T. Ali, "Data acquisition system: On the solar photovoltaic module and weather parameters monitoring," *Procedia Comput. Sci.*, vol. 132, pp. 873–879, 2018, doi: 10.1016/j.procs.2018.05.099.
- [9] S. Sarswat, I. Yadav, and S. K. Maurya, "Real Time Monitoring of Solar PV Parameter Using IoT," *Int. J. Innov. Technol. Explor. Eng.*, vol. 9, no. 1S, pp. 267–271, 2019, doi: 10.35940/ijitee.a1054.1191s19.
- [10] R. Satpathy and V. Pamuru, "Off-grid solar photovoltaic systems," in *Solar PV Power*, Elsevier, 2021, pp. 267–315.
- [11] B. Bhandari and S.-H. Ahn, "Off-grid hybrid renewable energy systems and their contribution to sustainable development goals," in *Hybrid Energy System Models*, Elsevier, 2021, pp. 75–89.
- [12] R. Satpathy and V. Pamuru, "Rooftop and BIPV solar PV systems," in *Solar PV Power*, Elsevier, 2021, pp. 317–364.
- [13] R. Satpathy and V. Pamuru, "Solar PV systems and applications," in *Solar PV Power*, Elsevier, 2021, pp. 243–266.
- [14] L. Ashok Kumar, S. Albert Alexander, and M. Rajendran, "Inverter topologies for solar PV," in *Power Electronic Converters for Solar Photovoltaic Systems*, Elsevier, 2021, pp. 1–39.
- [15] I. 61724-1, "Photovoltaic System Performance Monitoring—Guidelines for Measurement, Data Exchange, and Analysis (Part 1)," 2017.