

## Numerical Structural Analysis on a Composite Main Wing of WIG Craft

A. Priyanto<sup>a\*</sup>, M. F. Abdullah<sup>a</sup>, N. Mehdi<sup>a</sup>, Rahimuddin<sup>b</sup>

<sup>a</sup>Marine Technology Centre (MTC), Universiti Teknologi Malaysia, 81310, UTM Johor Bahru, Johor, Malaysia

<sup>b</sup>Universitas Hasanudin, Makassar, Indonesia

\*Corresponding author: agoes@utm.my

### Article history

Received :21 February 2014

Received in revised form :

3 March 2014

Accepted :25 May 2014

### Graphical abstract

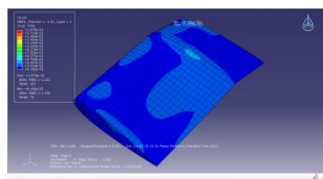

### Abstract

This paper presents a finite element model for structural analysis of composite main wing for an one-seater Wing in Ground Effect (WIG) craft. FEA models have been developed using sandwich construction having composite skin – spar laminates and foam core. The analysis for main wing structure through numerical structural analysis are developed using commercial FEM code ABAQUS. Displacement boundary conditions are employed for the global model. A critical area with high displacement and stress is developed with global mesh. Materials failure criteria for composites are applied on the model and failure index is checked

**Keywords:** FEA; main wing structure; skin – spar composite; failure criteria; buckling

© 2014 Penerbit UTM Press. All rights reserved.

### 1.0 INTRODUCTION

When a wing is closely flying on the ground or on the water surface within a couple of meters height, the lift force is greatly increased due to the ground effect. Therefore, it is called as a WIG (Wing in Ground Effect) craft. The WIG vehicle has a special feature of marine application which has much wider wing than the conventional airplane wing and the hull type fuselage that borrows some merits from both airplane and ship which can transport quickly many passengers or heavy payload such that can transport quickly heavy payload. Since 1960's many types of WIG crafts have been developed by Russia for military or civil uses<sup>1,2</sup>.

Composite materials are considered to have great potential in marine applications for their superior performance in saving weight and improving corrosion resistance and impact strength. Sandwich construction combining FRP skin sheets with a light core material offers an alternative to skin–spar type construction for the main wing, fuselage and tail wing of WIG crafts. Driven by need to enhance the operational performance, composite sandwich material has been used on high-performance either ship or WIG craft construction<sup>3</sup>. Two typical examples are Skyjood Class vessel and WIG AirFish8-001 registered in the Singapore Registry of ships, which are both made of sandwich constructions<sup>4,5</sup>.

Composite WIG craft/ship structures are also gaining attention over conventional ones due to their high performance subject to slamming load/pressure when taking off and landing. Ojeda *et al.*<sup>6</sup> presented a structural response of a composite craft subject to slamming pressure, and no flow fluid was considered in

the study. The slamming events greatly affect on the vertical bending moment (VBM) resulted in the ringing of structure. This effect is stronger in composite structure than in common material<sup>7</sup>.

If accuracy in cruise design and analysis of composite structure and no water flow fluid was considered in the study is required, interaction between structural deformation and the corresponding slamming pressure be considered. This paper presents simulation of main wing structure using finite element analysis (FEA). The procedures have been implemented through commercially available ABACUS Workbench platform when structure models have been extensively used.

### 2.0 MAIN WING STRUCTURE

The one-seater WIG craft's hull form<sup>8</sup> has 7.4 m length, 0.8 m breadth, and a deep-V configuration<sup>8</sup> to facilitate the craft in high speed as Figure 1. The dead-rise angle is 15° and suitable for moderate waves but any lower would be suitable for flat water. The hull is to incorporate with a stepped hull in order to reduce water drag resistance.

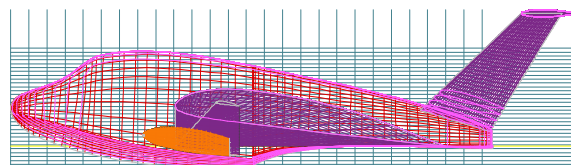

Figure 1 A hull form design of one-seater WIG craft

The WIG craft design’s requirements are payload of 400 kgf, maximum cruising speed of 100 km/h in ground effect zone, a cruising altitude (*h*) of *h/c*=0.15. NACA 6409 main wing airfoil section was adopted to fulfill the aerodynamic performance of the wing. The maximum lift coefficient is 0.4 at 4° (in ground effect)<sup>9</sup>. Chord lengths (*c*) at wing root and tip are 4.0 m and half span is 5.0 m.

The structural design load of the main wing was defined from relationship the main wing’s lift the horizontal tail’s lift and inertia load at maximum cruising speed. The main wing structure as Figure 2 load distribution was applied using chordwise (*F<sub>x</sub>*) and spanwise (*F<sub>y</sub>*) distribution load equations<sup>10</sup> in considering the load factor of 2 that was given by the principal load thickness directional. According to the netting rule, the principal load directional thickness of the main skin–spar girder can be sized by the crippling buckling strength (*σ<sub>b</sub>*) determined using Equations (1) and (2).

$$\frac{F_x}{A} + \frac{M_z(y)}{I_z} \leq \frac{\sigma_b}{S.F} \tag{1}$$

$$\frac{F_y}{A} \leq \frac{\sigma_b}{S.F} \tag{2}$$

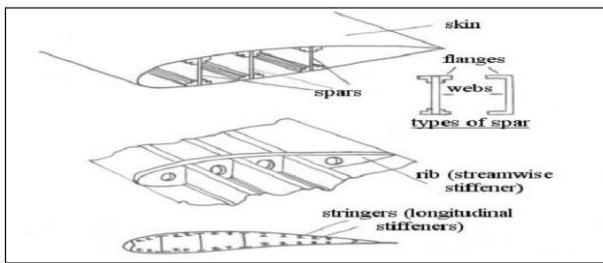

Figure 2 Main wing structure

3.0 COMPOSITE STRUCTURE DESIGN

In this study, composite sandwich skin is for main wing construction. Determination of properties of sandwich structure, such as skin/core type, thickness and laminate configuration are based on factors including material performance, and weight. Considering that the skin material must be strong enough to withstand slamming blast load, carbon/epoxy FRP laminate was chosen as the sandwich of skin sheet due to its high stiffness and strength. For the choice of core material, the density should be low so that the overall weight of sandwich can be largely reduced. The compressive modulus should also be high enough to prevent large deformation.

Properties of carbon/epoxy lamina are listed in Tables 1 and 2. The layer orientation of the skin sheet was selected based on

the buckling uni-axial load (*P*) as shown in Figure 3 for calculations ranging from skin laminates of [0/90]<sup>4</sup> to [0/90]<sup>12</sup>. Composite skin thickness considers the compressive and/or shear loads which are sensitive to buckling failures. The critical buckling load (*P*) as Figure 5 is a function of the number of half-wave *m* in the *x* direction and *n* in the *y* direction and will change based on the buckling modes<sup>12</sup>. The buckling of local rectangular composite sandwich skin under uni-axial loads assuming pin-pin supports is expressed.

$$P = \pi^2 \left[ \frac{D_{11}m^4 + 2(D_{12} + 2D_{66})m^2n^2(a/b) + D_{22}n^4(a/b)^4}{a^2m^2} \right] \tag{3}$$

Where, *D<sub>11</sub>*, *D<sub>12</sub>*, *D<sub>22</sub>* and *D<sub>66</sub>* are the bending stiffness, *a* and *b* are the sandwich plate length and breadth, respectively.

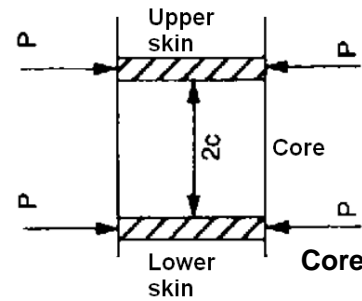

Figure 3 Laminates buckling model

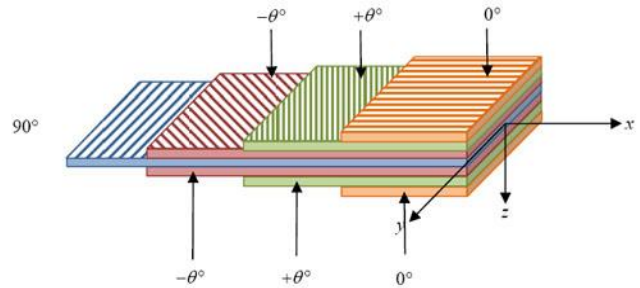

Figure 4 Laminates [0/90]<sup>7</sup>

From Equations (1)–(3), the composite buckling strengths (*σ<sub>b</sub>*) were obtained for various numbers of 4–16 laminates as defined in Figure 4, for design requirement it was chosen:

- 12 laminates or [0/90]<sub>12</sub> for skin, *σ<sub>b</sub>* is 52 kPa;
- 4 laminates or [0/90]<sub>4</sub> for spar, *σ<sub>b</sub>* is 195 kPa; and
- 4 laminates or [0/90]<sub>4</sub> for ribs, *σ<sub>b</sub>* is 195 kPa

Table 1 Properties of carbon/epoxy composite (uni directional)<sup>11</sup>

Properties (GPa)	<i>E<sub>1</sub></i>	<i>E<sub>2</sub></i>	<i>G<sub>12</sub></i>	<i>G<sub>13</sub></i>	<i>G<sub>23</sub></i>	<i>ν<sub>12</sub></i>
Carbon/epoxy	192	10.6	6.1	6.2	3.7	0.3

**Table 2** Strength parameter for carbon/epoxy<sup>11</sup>

Properties (MPa)	$\sigma_{1t}$	$\sigma_{2t}$	$\sigma_{1c}$	$\sigma_{2c}$	$\tau_s$
Carbon/epoxy	2715	56	1400	250	101

Spar girders and rib stiffened skin are the main components of a typical main wing structure. The sandwich carbon/epoxy composite forms a much stiff and strong system. In the initial design, the total weight for sandwich composite main wing structure as shown in Figure 5 is calculated about 93.9 kgf which consists of 35.64 kg of for each upper and lower skin, 20.48 kg for front and rear “I” spar girder and 2.16 kg for three ribs as shown in Figure 6.

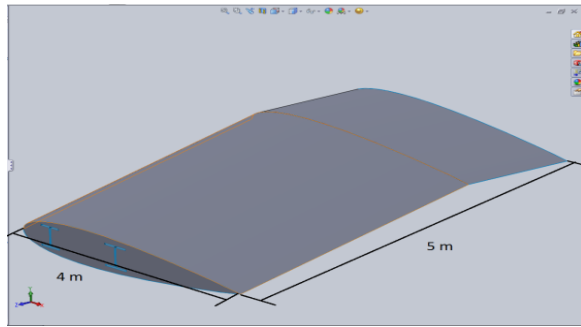
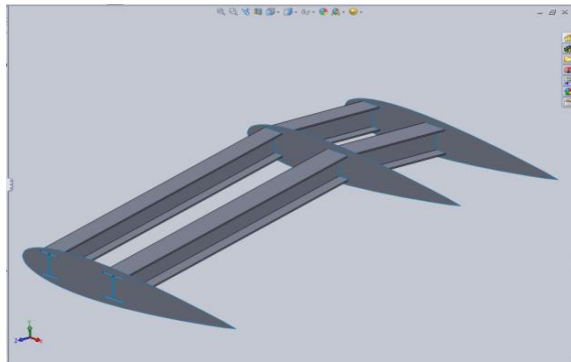
**Figure 5** Skin structure**Figure 6** “I” spar and ribs structure

#### 4.0 FINITE ELEMENT MODEL SET UP

The numerical model for the initial design of main wing structure is using the finite element (FE) structural model. The FE model includes a global main wing structure used for global response.

The finite element model of the main wing structure is built in ABACUS platform. It consists of upper and lower skin, fore and rear spar, and three ribs structure. The structure is modeled as a 3D surface body using SHELL elements as Figure 7. This particular element is suitable for analyzing thin to moderately-thick shell structures. It is a 4-noded element with six degrees of freedom at each node; translation in the  $x$ ,  $y$ , and  $z$  directions, and rotations about the  $x$ ,  $y$  and  $z$ -axes.

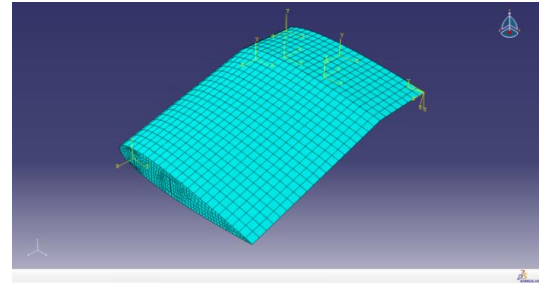
**Figure 7** SHELL elements meshing

The coordinate system was kept consistent through out the entire analysis. The origin was located at the connection main wing with hull on the central symmetry plane; positive  $x$  direction was toward trailing edge; positive  $y$  direction to free surface pointing upward; and positive  $z$  was perpendicular to the central symmetry plane toward port side (left side). The displacement boundary conditions (BC) as Figure 8 applied in the FE model were as follows: (1) one single node close to the hull fuselage was constrained in the  $x$ -direction (longitudinal). No restriction was imposed in the  $z$ -direction movement. This boundary condition was not sufficient since the hull fuselage would tend to move in the  $x$ -direction. Therefore a 2<sup>nd</sup> boundary condition was employed, i.e. (2) an initial displacement along axes that had been assigned so that whole wing could displace along  $x$  axes and depends on the value of the initial displacement.

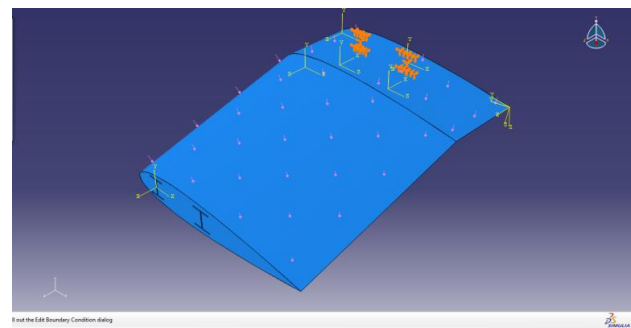
**Figure 8** Boundary condition on the FE model

Thickness and properties are assumed as the initial design through the entire structure. The sandwich composite material properties listed in Tables 1 and 2 are imported into ABACUS using setup of shell element. In the global model laminates are built as upper laminate, core, lower laminate for all component structures with individual thickness and material properties. Average element size used in ABACUS was 0.2 m. It was seen that the variation in Von Mises stress values at the centre of the upper skin of 27 kPa, 30 kPa, and 31 kPa was insignificant for checking the convergence with variation element sizes 0.4 m, 0.3

m and 0.2 m respectively, thus simulation was carried out with 0.2 m.

## 5.0 RESULTS AND DISCUSSION

Our primary intention in the global model was to find the region where maximum displacement occurs. As the WIG craft is experiencing slamming/pitching event on the hull when taking off or landing, large slamming pressure blast under main wing will also induce high displacements at the end portion of the main wing structure. That is why we see higher displacement of  $U_z = 2.02$  mm concentrated near the end portion as shown in Figure 9, when the assumed pressure blast 45 kPa was applied. The displacement is mainly due to the pressure distribution along chordwise and spanwise in addition to vertical and horizontal bending moments. The sandwich skin will undergo Von Mises stress at the centre of 27 kPa. Unfortunately, the sandwich skin was not further analyzed in term of FE sub-model to obtain the inter-laminar shear stresses distribution. These inter-laminar shear stresses could indicate the interface between skin laminates which leads whether the two laminates are de-bonded if the crack is present at the interface.

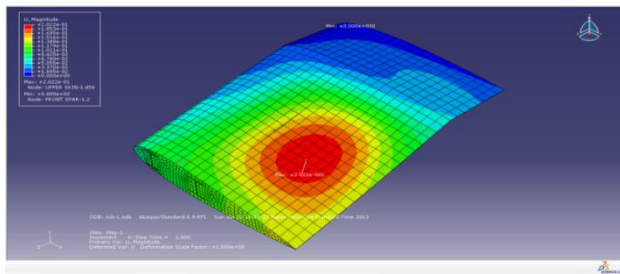

Figure 9 Displacement of the main wing structure

Failure criterion was applied on the FE model to verify the integrity of the sandwich under the given load. Failure mode of composite sandwich structure mainly includes laminate or core yielding, laminate/core de-bonding, buckling, etc. In this FE model, laminate sheet and core are assumed perfectly bonded. Therefore, the Tsai-Hill failure criterion on the laminate sheet is considered of the Von Mises failure. A parameter called failure index " $I_F$ " is introduced in buckling case to evaluate the strength, and  $I_F > 1$  is set to signal failure of particular element<sup>13</sup>.

$$F(\sigma_2 - \sigma_3)^2 + G(\sigma_3 - \sigma_1)^2 + H(\sigma_1 - \sigma_2)^2 + 2(L\tau_{23}^2 + M\tau_{13}^2 + N\tau_{12}^2) = I_F \quad (4)$$

where  $F, G, H, L, M$  and  $N$  are anisotropic material strength parameters. Equation (4) can be simplified to the plane stress form of failure strength in uniaxial tension and compression in the three directions of anisotropic as follows;

$$\frac{\sigma_1^2}{X^2} - \frac{\sigma_1\sigma_2}{X^2} + \frac{\sigma_2^2}{Y^2} + \frac{\tau_{12}^2}{S^2} = I_F \quad (5)$$

Where

$$X^2 = \sigma_{1t}\sigma_{1c}; Y^2 = \sigma_{2t}\sigma_{2c}; S^2 = \tau_s^2 \quad (6)$$

Equation (6) is the strength parameters of carbon/epoxy and listed in Table 2.

The results for the analysis as Figure 10 show that all failure index  $I_F$  values in this FE model were less than 1, meaning that the failure criterion were satisfied in the entire main wing structure. Also for each element, the maximum value  $I_F$  appeared at the sandwich ribs element node 357, which mean failure would first occur at the sandwich ribs due to buckling.

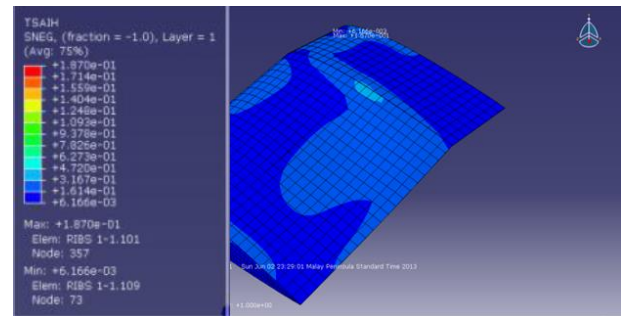

Figure 10 Failure index results

## 6.0 CONCLUSION

The FE model has been developed for a design composite main wing structure for one-seater WIG craft made from sandwich composites of the laminates. Unfortunately, the sandwich composite was not further analyzed in term of FE sub-model to obtain the inter-laminar shear stresses distribution. These inter-laminar shear stresses could indicate the interface between laminates which leads whether the two laminates are de-bonded if the crack is present at the interface. Failure criterion has also been employed and it has been observed that they are satisfied under the given pressure blast conditions.

## Acknowledgement

We are grateful for the UTM and Ministry of Science, Technology and Innovation of Malaysia MOSTI that funded the research of WIG craft in 2009 – 2011.

## References

- [1] N. Kornev, and K. Matneev, 2003. *Complex Numerical Modeling of Dynamics and Crashes of Wing-In-Ground Vehicles*, AIAA, 2003–600.
- [2] K. Benedict, N. Kornev, M. Meyer and J. Ebert, 2002. Complex Mathematical Model of the WIG Motion Including the Take-off Mode. *Ocean Engineering*. 29: 315–357.
- [3] S. E. Hellbert. 2003. *Experiences from the Design and Production of the VIBY*. In: 6<sup>th</sup> International Conference on Sandwich Structures.
- [4] <http://www.wigetworks.com>, AirFish 8–001.
- [5] A. P. Mouritz, E. Gellert, P. Burchill, K. Challis. 2001. *Review of Advanced Composite Structures for Naval Ships and Submarines*. Composite Structures.
- [6] Ojeda, Roberto, GangadharaPrusty, B. Salas, Marcos. 2006. Finite Element Investigation on the Static Responses of a Composite Catamaran Under Slamming Loads. *Ocean Engineering*. 31(7): 901–929.
- [7] Y. W. Kwon, P. K. Kendall. 2009. *Fluid-structure Interaction of Composite Structures Subjected to Dynamic Loading*. In 24<sup>th</sup> Annual Technical Conference of the American Society for Composites (ASC), September 15–17.
- [8] A. Priyanto, A. Maimun, Noverdo, S. Jamei, A. Faizal, and Waqiyuddin, 2012. A Study on Estimation of Propulsive Power for Wing in Ground Effect (WIG) Craft to Take Off. *Jurnal Teknologi (Science and Engineering)*. 59: 43–51.

- [9] S. Jamei, A. Maimun, S. Mansor, N. Azwadi and A. Priyanto. 2013. Design Parametric Study on Aerodynamic Performance of a Compound Wing in Ground Effect. *Journal of Aerospace Engineering*. in press.
- [10] F. Wojewodka. 1950. *Design of Simple Light Aircraft*. McGraw-Hill Book Company, New York, NY.
- [11] I.M. Daniel, and O. Ishai. 2006. *Engineering Mechanics of Composite Materials*. Second edition. Oxford University Press, New York.
- [12] C. Kassapoglou. 2010. *Design and Analysis of Composite Structure*. Delft of University, Netherland.
- [13] S. W. Tsai and T. H. Hahn, 1980. *Introduction to Composite Materials*. Westport, CT: Technomic.