

Characteristic and Performance of Polyvinylidene Fluoride Membranes Blended with Lithium Chloride in Direct Contact Membrane Distillation

S. O. Lai^{a*}, K. C. Chong^a, K. M. Lee^a, W. J. Lau^b, B. S. Ooi^c

^aUniversiti Tunku Abdul Rahman, Kuala Lumpur Campus, Jalan Genting Kelang, 53300 Kuala Lumpur, Malaysia

^bAdvanced Membrane Technology Research Centre (AMTEC), Universiti Teknologi Malaysia, 81310 UTM Johor Bahru, Johor, Malaysia

^cSchool of Chemical Engineering, Engineering Campus, Universiti Sains Malaysia, Seri Ampangan, 14300 Nibong Tebal, S.P.S. Pulau Pinang, Malaysia

*Corresponding author: laiso@utar.edu.my

Article history

Received :15 September 2013

Received in revised form :
17 November 2013

Accepted :15 January 2014

Graphical abstract

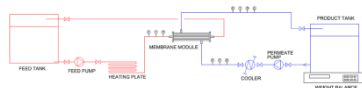

Abstract

Membrane distillation (MD) is one of the recent rising membrane separation techniques adopted in the desalination and wastewater treatment. Unlike other pressure-driven separation processes such as reverse osmosis and nanofiltration, MD is a thermal-driven process which involves vapor pressure difference across the feed and permeate solutions. As such, MD requires low energy consumption. Hydrophobic polymeric materials such as polyvinylidene fluoride (PVDF) are frequently used in direct contact membrane distillation (DCMD) due to low surface energy and promising thermal resistance. In this study, the DCMD hollow fiber membranes were separately prepared with PVDF and PVDF blended with lithium chloride (LiCl) through dry/wet phase inversion method. Subsequently, the membranes were used in a DCMD process to remove sodium chloride (NaCl) under different feed inlet temperatures to examine the effect of LiCl additives on the neat membrane. The result showed that by adding LiCl into the neat membrane solution, the finger-like structure was changed to a sponge-like structure with microvoids. Furthermore, the performance of the LiCl additive membrane in terms of permeate flux was found to be 20% higher compared to that of the neat membrane. Other results of the membrane characteristics were also discussed.

Keywords: Membrane distillation; lithium chloride; rejection; permeate flux

© 2014 Penerbit UTM Press. All rights reserved.

1.0 INTRODUCTION

Membrane distillation (MD) is a thermal driven membrane separation process which recently attracts the great attention from the academic researchers and industrial sectors in the areas of desalination and wastewater treatment. The principle of transport phenomenon in the MD is thermal driving force of the vapor, where the feed liquid will be rejected by porous hydrophobic membrane due to the vapor pressure difference resulted from different solution temperatures [1]. The MD exhibits low energy consumption compared to the pressure driven process such as reverse osmosis (RO) and nanofiltration (NF). As such, it is believed to have a great potential in the integration of renewable energy such as solar energy and/or low grade heat [2].

There are four available MD configurations which are frequently distinguished by the mechanism of permeate condensation, namely direct contact membrane distillation (DCMD), air gap membrane distillation (AGMD), sweeping gas membrane distillation (SGMD) and vacuum membrane distillation (VMD) [2, 3]. In the DCMD, the condensation takes place on the membrane surface in the cold stream in which the cold liquid is in direct contact with the membrane. When the

condensation happens in the cold membrane surface with a separation of stagnant air gap, the process is known as AGMD [2, 3]. In the meantime, SGMD and VMD are the MD process where the condensation takes place out of the membrane module, where permeate are removed by sweeping gas and vacuum driving force, respectively inside the membrane module [2, 3]. Of the four MD configurations, many laboratory and pilot plant scale researches have been conducted by DCMD due to its simplest setup and largest heat and mass transfer efficient [2].

The membrane in the DCMD process plays an essential role and it is a pivotal component in separating the cold permeate and hot feed solution. The membrane should exhibit a hydrophobic nature on the feed side as it restricts the flow of liquid over the membrane to the permeate side [4]. As a result, the DCMD membranes are typically fabricated by hydrophobic materials such as polyvinylidene fluoride (PVDF), polypropylene (PP) and polytetrafluoroethylene (PTFE). In general, a good performance DCMD membrane should fulfill several criteria [2–4]. First, the membrane should have a low membrane pore size which usually ranges between 10 nm and 1 µm and a narrow pore size distribution to prevent the transfer of large particulates across the membrane as well as to avoid membrane pore from wetting. Second, the membrane should

have a high porosity ranging between 35% and 85% to allow high degree of heat and mass transfer which contributes to the higher permeate flux. Third, the membrane should be as thin as possible to increase the heat and mass transfer efficiency, while maintaining sufficient mechanical strength in withstanding the impact of driving forces. Finally, the membrane shall exhibit long-term performance stability, as well as excellent chemical and thermal resistance.

Over the years, there were several studies on the effect of lithium chloride (LiCl) as a non-additive on membrane morphology and permeate flux. LiCl is often referred as a pore forming agent in the PVDF membrane preparation [5]. This is due to the characteristic of LiCl being able to dissolve rapidly in the water and increase the diffusion rate of the polymer from dope solution which leads to the formation of large cavities and porous structure [6]. Several studies found that low concentration of LiCl could result in the enhancement of permeate flux due to the increase of liquid-liquid demixing and thermodynamic effect, whereas higher concentration of LiCl would delay demixing process as a result of the suppression of microvoids formation due to kinetic effect [5–7].

The aim of this work was to fabricate and characterize PVDF neat membrane and PVDF membrane blended with non-solvent additives, i.e., LiCl, and eventually compare their performance in the NaCl removal. The membranes were characterized in terms of its pore size, porosity, hydrophobicity, surface and cross sectional morphology in order to determine the effect of LiCl on the membrane characteristics. Subsequently, the fabricated membrane was evaluated in a DCMD experiment to remove NaCl under various operating parameters.

2.0 EXPERIMENTAL

2.1 Materials

Commercial PVDF pellet (Kynar 740, Mn = 156,000) as the main membrane fabrication material was supplied from Arkema Inc., Philadelphia, USA. The solvent used in this study was N,N-dimethylacetamide (DMAC, > 99.5%) purchased from Sigma Aldrich. LiCl (purity ≥ 99%) obtained from Sigma Aldrich was applied as non-solvent additive in the dope solution. NaCl (purity > 99.5%) supplied by Prochem was used to synthesis 3.5 wt% NaCl feed aqueous solution by dissolving NaCl powder in distilled water.

2.2 Fabrication of Hollow Fiber Membrane

The PVDF pellets were heated for 24 hours at 70°C in vacuum oven to eliminate the moisture content. The membrane dope solutions were stirred until they became homogenous and were later degassed at room temperature for 24 hours. The dope solutions of 17 wt% PVDF/83 wt% DMAC and 12 wt% PVDF/83 wt% DMAC/ 5 wt% LiCl were labeled as PVDF-neat and PVDF-LiCl, respectively (Table 1). The membranes were fabricated using dry/wet phase inversion method which was described in detail elsewhere [8]. The spinning parameters can be found in Table 2. The fabricated membranes were drenched in the water to remove the solvent and non-solvent additives residuals. Lastly, the membranes were eventually dried at room temperature before being utilized in the experimental study.

Table 1 Composition of the casting solution

Membrane	PVDF (wt%)	DMAC (wt%)	LiCl (wt%)
PVDF-neat	17	83	–
PVDF-LiCl	12	83	5

Table 2 Hollow fiber spinning condition

Parameter	Value
Dope extrusion rate (ml/min)	4.50
Spinneret OD / ID (mm/mm)	1.3 / 0.6
Bore liquid	Distilled water
Bore liquid temperature (°C)	25
Bore liquid flow rate (ml/min)	2
External coagulant	Tap water
External coagulant temperature (°C)	25
Air gap distance (cm)	10
Room relative humidity (%)	55 ± 5

2.3 Membrane Characterization

Scanning electron microscope (SEM) (HITACHI S3400N) was used to examine the spun membrane morphology. The membranes were carefully fractured in liquid nitrogen to conserve its completeness for the SEM imaging. Subsequently, the membrane samples were attached on a holder and coated with a conductive layer by sputter coater machine (SC7620, Emitech, United Kingdom). The membrane pore size was determined based on the SEM image, and the mean pore size was reported. The membrane contact angle was measured by contact angle goniometer (Ramé-Hart 250, USA) using sessile drop technique. Gravitational method which has widely been adopted [9] was applied in the membrane porosity calculation based on the fraction of the volume of membrane pore to the volume of membrane as expressed in Equation. (1):

$$\varepsilon = \frac{(W_1 - W_2) / \rho_w}{(W_1 - W_2) / \rho_w + W_2 / \rho_b} \times 100\% \quad (1)$$

where W_1 is the weight of the wetted membrane, W_2 is the weight of dry membrane, ρ_w is the specific gravity of isopropanol (0.786 g cm⁻³) and ρ_b is the specific gravity of the PVDF (1.78 g cm⁻³).

2.4 DCMD Experimental Setup

Figure 1 illustrates the schematic diagram of DCMD experimental setup in this study. Sixteen hollow fiber membranes were inserted into the membrane module and two ends were sealed with epoxy adhesive. The cross flow method allowed the hot feed solution to flow through lumen side, whereas cold permeate solution to flow at the shell side. The feed solution of 3.5 wt% NaCl was heated to the temperature ranging between 40 and 55°C using electrical heater (HTS-1003, LMS, Japan) and permeate solution consisting of distilled water was cooled down to 18°C by a water cooled chiller (CA-1112CE, Eyela, Japan). The feed and permeate liquids were circulated within the system by closed loop concept with the assistance of booster pump. The permeate flux was continuously measured and recorded by a electronic weight balance (GF6100,

A&D, Japan) integrated with a data logger (AD1688, A&D, Japan). The NaCl concentrations of feed and permeate were

consistently monitored in terms of conductivity using a conductivity meter (4520, Jenway, United Kingdom).

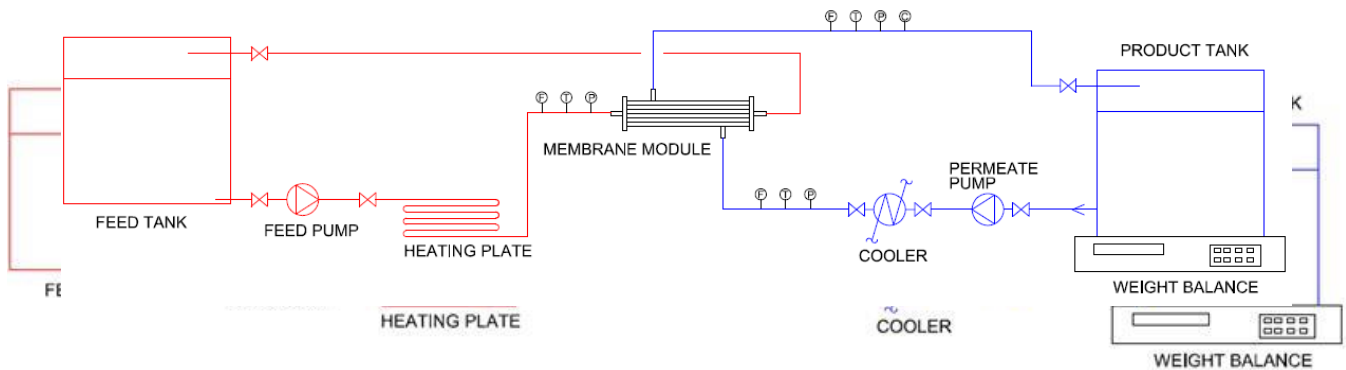

Figure 1 Schematic diagram of DCMD experimental setup

The permeate flux and rejection rate of the membrane was calculated using Equations (2) and (3) [10], respectively:

$$J = \frac{\Delta W}{A \Delta t} \quad (2)$$

where J is the permeate flux ($\text{kg}/\text{m}^2 \text{ hr}$), ΔW is the difference between the initial and final permeate weight (kg), A is the effective surface area of the membrane (m^2) and Δt is the sampling time (h).

$$R = \frac{C_f - C_p}{C_f} \quad (3)$$

where R is the rejection rate (%), C_f is the feed concentration and C_p is the permeate concentration.

3.0 RESULTS AND DISCUSSION

3.1 Membrane Characteristics

The membrane morphology results of cross sectional and inner surfaces are presented in Figure 2. The structure of PVDF-neat (Figures 2(a) and 2(b)) demonstrated a finger-like layer developed from inner to outer membrane surface. This structure might be attributed to the nature of DMAC as a strong solvent which allowed an earlier occurrence of liquid-liquid phase separation during the induced phase inversion. This eventually led to the formation of finger-like layer due to rapid diffusion of DMAC into the pore layer [11]. Cross section of PVDF-LiCl membrane illustrated in Figures 2(d) and 2(e) clearly exhibited the membrane morphology altering from finger-like layer to sponge-like layer separated with microvoids. The alteration of the membrane structure with the addition of LiCl could be explained by the increasing rate of PVDF precipitation during the immersion, and thus leading to the formation of microvoid membrane structure [7, 11–12]. Figures 2(c) and 2(f), on the other hand, demonstrated the inner membrane surface morphology of PVDF-neat and PVDF-LiCl membranes, respectively. As clearly shown in Figure 2(f), the porosity of the membrane inner surface was drastically increased via the addition of LiCl into the dope solution, if compared to that of PVDF-neat (Figure 2(c)). This finding was possibly attributed to

the viscosity of the dope solution. The viscosity of the dope solution increased with the addition of LiCl due to the strong lithium cation interaction with the electron donor group of PVDF, resulting in the elevation of precipitation rate during phase inversion process which therefore formed a more open structure [6]. However, it is noteworthy to mention that the adverse effect of the LiCl addition in the PVDF membrane fabrication was the reduction in membrane mechanical strength due to the presence of large macrovoid morphology [6, 12].

Table 3 summarizes the membrane characteristics for both PVDF-neat and PVDF-LiCl membranes. It was surprising noted that the mean pore size and contact angle for both membrane were analogous which were $400 \mu\text{m}$ and 76° , respectively. However, the porosity of PVDF-LiCl membrane (85%) was increased significantly in relative to that of PVDF-neat membrane (70%). Besides, the membrane thickness increased by 12.5% with the addition of LiCl into the membrane solution [12].

3.2 Membrane Performance

Figure 3(a) depicts the permeate flux of PVDF-neat and PVDF-LiCl membranes with respect to different feed inlet temperatures. Both membranes showed a similar trend, where the permeate flux was positively proportional to the feed inlet temperature. The permeate fluxes increased by 2.5 folds for both PVDF-neat (from 1.5 to $4.9 \text{ kg}/\text{m}^2 \cdot \text{hr}$) and PVDF-LiCl (1.9 to $5.9 \text{ kg}/\text{m}^2 \cdot \text{hr}$) membranes with the increment of the feed inlet temperature from 40 to 55°C . This could probably be explained by the increase of the transmembrane vapor pressure (i.e., driving force in the DCMD) in the feed solution which subsequently amplified the evaporation of feed solution [1–3, 13]. As illustrated in Figure 3(a), PVDF-LiCl membrane exhibited a better permeate flux performance in relative to PVDF-neat membrane, possibly due to the higher porosity which led to the greater surface area for evaporation and lower conductive heat loss [1–3, 13]. Figure 3(b) demonstrates the NaCl rejection rate of PVDF-neat and PVDF-LiCl membranes with respect to different feed inlet temperatures. Both membranes presented a relatively consistent rejection rate under different feed inlet temperatures, which was close to the MD theoretical rejection rate of 99% [1]

Table 3 Characteristics of the spun membrane

Membrane	PVDF-neat	PVDF-LiCl
Internal diameter (μm)	600	400
Thickness (μm)	160	180
Mean pore size (μm)	400	400
Porosity (%)	70 ± 0.75	85 ± 1.25
Contact angle ($^\circ$)	76 ± 0.50	76 ± 0.20

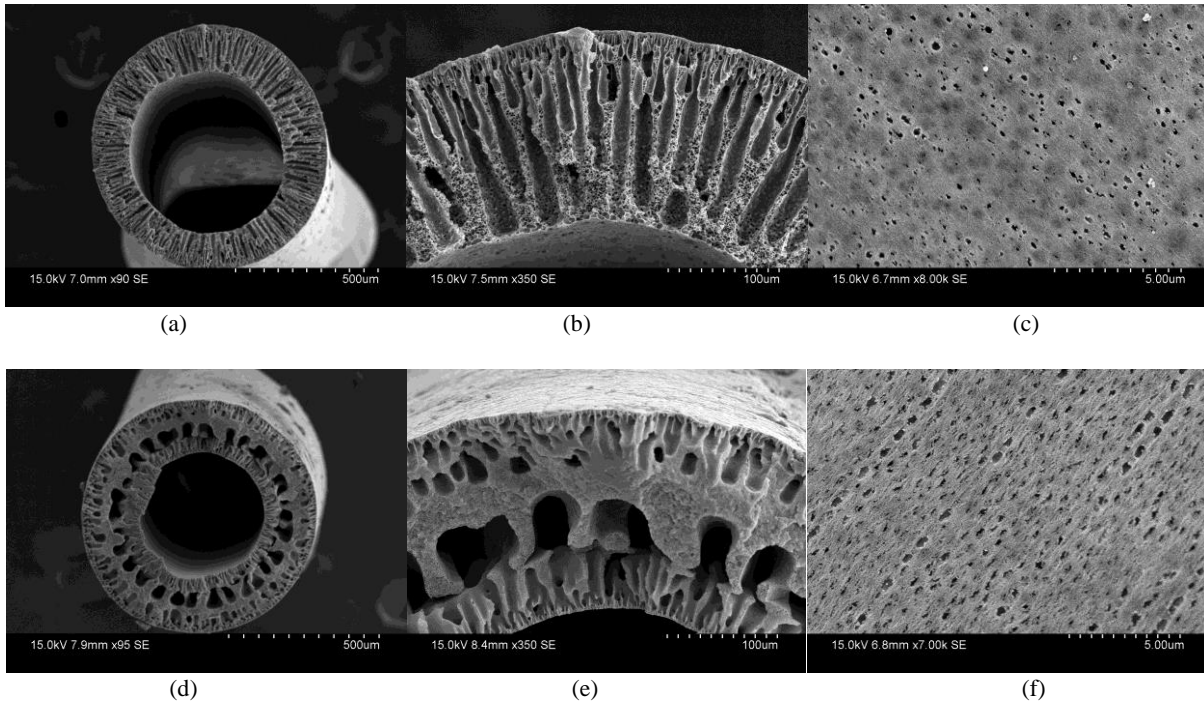

Figure 2 SEM morphology of spun membrane (a) cross section of PVDF-neat membrane; (b) thickness enlargement view of PVDF-neat membrane; (c) inner surface of PVDF-neat; (d) cross section of PVDF-LiCl membrane; (e) thickness enlargement view of PVDF-LiCl membrane; (f) inner surface of PVDF-LiCl

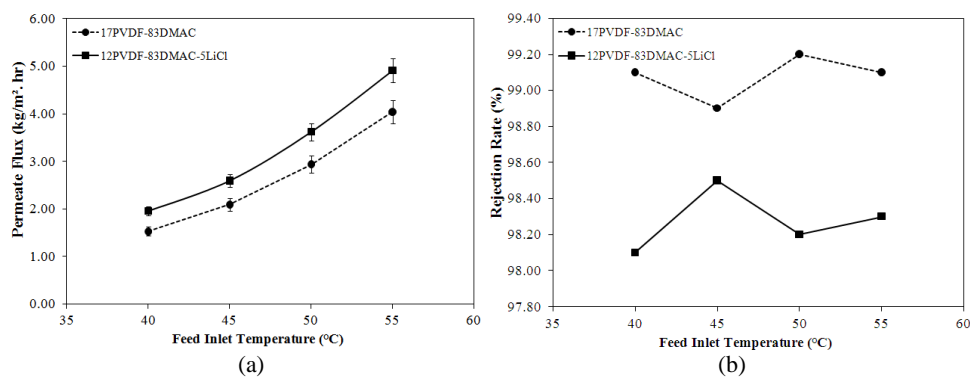

Figure 3 (a) Permeate flux of PVDF membranes as a function of feed inlet temperature (b) Rejection rate of PVDF membranes as a function of feed inlet temperature

4.0 CONCLUSION

In the present work, PVDF neat membrane and PVDF membrane blended with LiCl were fabricated through dry/wet phase inversion method. The fabricated membranes were physically examined in terms of its morphology and characteristics. The membrane morphology was altered from a finger-like layer extended from the inner towards outer

membrane surface to a macrovoid structure by adding LiCl. In addition, the porosity of PVDF-LiCl membrane increased from 70% to 85%, while still maintaining a good hydrophobicity. In addition, PVDF-LiCl demonstrated a better DCMD performance in terms of permeate flux under varied feed inlet temperature (40 to 55 °C) compared to PVDF-neat membrane, while a good NaCl rejection rate (> 98%) was still observed. It was hence concluded that PVDF-LiCl was suitable to be adopted in the

DCMD process in the fields of desalination and wastewater treatment.

Acknowledgement

The authors would like to thank Universiti Tunku Abdul Rahman for providing financial support under Universiti Tunku Abdul Rahman Research Grant (Vote no: 6200/C30).

References

- [1] Kevin, W. Lawson, Douglas, R. Lloyd. 1997. Membrane Distillation. *Journal of Membrane Science*. 124: 1–25.
- [2] M. S. El-Bourawi, Z. Ding, R. Ma, M. Khayet. 2006. A Framework for Better Understanding Membrane Distillation Separation Process. *Journal of Membrane Science*. 285: 4–29.
- [3] M. Tomaszwska. 2007. *Polish Journal of Environmental Studies*. 9: 27.
- [4] Abdullah Alkudhiri, Naif Darwish, Nidal Hilal. 2012. Membrane Distillation: A Comprehensive Review. *Desalination*. 287: 2–18.
- [5] A. Mansourizadeh, A. F. Ismail. 2010. Effect of LiCl Concentration in the Polymer Dope on the Structure and Performance of Hydrophobic PVDF Hollow Fiber Membranes for CO₂ Absorption. *Chemical Engineering Journal*. 165: 980–988.
- [6] A. Bottino, G. Capannelli, S. Munari, A. Turturro. 1988. High Performance Ultrafiltration Membranes Cast from LiCl Doped Solutions. *Desalination*. 68: 167–177.
- [7] M. Tomaszwska. 1996. Preparation and Properties of Flat-sheet Membranes from Poly(vinylidene fluoride) for Membrane Distillation. *Desalination*. 104: 1–11.
- [8] A. F. Ismail, I. R. Dunkin, S. L. Gallivan, S. J. Shilton. 1999. Production of Super Selective Polysulfone Hollow Fiber Membranes for Gas Separation. *Polymer*. 40: 6499–6506.
- [9] A. L. Ahmad, N. Ideris, B. S. Ooi, S. C. Low, A. Ismail. 2013. Synthesis of Polyvinylidene Fluoride (PVDF) Membranes for Protein Binding: Effect of Casting Thickness. *Journal of Applied Polymer Science*. 128: 3438–3445.
- [10] Deyin Hou, JunWang, Dan Qu, Zhaokun Luan, Xiaojing Ren. 2009. Fabrication and Characterization of Hydrophobic PVDF Hollow Fiber Membranes for Desalination Through Direct Contact Membrane Distillation. *Separation and Purification Technology*. 69: 78–86.
- [11] Fu Liu, N. Awanis Hashim, Yutie Liu, M. R. Moghareh Abed, K. Li, 2011. Progress in the Production and Modification of PVDF Membrane. *Journal of Membrane Science*. 375: 1–27.
- [12] Mohamed Khayet, Takeshi Matsuura. 2011. *Membrane Distillation Principles and Applications*. Amsterdam: Elsevier.
- [13] Amir Bahmanyar, Morteza Asghari, Nafiseh Khoobi. 2012. Numerical Simulation and Theoretical Study on Simultaneously Effects of Operating Parameters in Direct Contact Membrane Distillation, *Chemical Engineering and Processing*. 61: 42–50.