

Effect of Hydrophobicity Degree on PVDF Hollow Fiber Membranes for Textile Wastewater Treatment Using Direct Contact Membrane Distillation

N. M. Mokhtar^{a,b}, W. J. Lau^{a,b*}, P. S. Goh^{a,b}

^aAdvanced Membrane Technology Research Centre (AMTEC), Universiti Teknologi Malaysia, 81310 UTM Johor Bahru, Johor, Malaysia

^bFaculty of Petroleum and Renewable Energy Engineering, Universiti Teknologi Malaysia, 81310 UTM Johor Bahru, Johor, Malaysia

*Corresponding author: lwoeijje@utm.my

Article history

Received :21 August 2013

Received in revised form :

30 October 2013

Accepted :15 November 2013

Graphical abstract

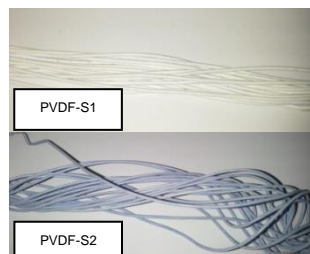

Images of PVDF hollow fiber membranes blended with different types of additives after MD tested with RB5 solution

Abstract

The objectives of this study are to study the effect of hydrophobicity degree of polyvinylidene fluoride (PVDF) hollow fiber membranes blended with different types of additives i.e. ethylene glycol (EG) and polyvinylpyrrolidone (PVP) on textile wastewater application. The degree of hydrophobicity of each membrane was analyzed using contact angle goniometer. The membrane morphology and gas permeability were characterized prior to filtration experiment. Both membranes were tested using direct contact membrane distillation (DCMD) system and their performances were evaluated with respect to water flux and dye removal. This study revealed that the membrane with higher contact angle has greater stability in terms of flux and dye rejection compared to the membrane with low hydrophobic property. This is mainly due to the low surface energy obtained by the highly hydrophobic membrane that prevented the liquids from both sides to penetrate through membrane pores.

Keywords: Direct contact membrane distillation; textile wastewater; polyvinylidene fluoride; reactive black 5

© 2013 Penerbit UTM Press. All rights reserved.

1.0 INTRODUCTION

Colored textile effluents represent severe environmental problems as they contain mixture of chemicals, auxiliaries and dyestuffs of different classes and chemical constitutions with elevated organic parameters (e.g. biological oxygen demand (BOD), chemical oxygen demand (COD), total organic carbon (TOC), adsorbable organic halogens (AOX), suspended solids (SS), pH and color) and inorganic parameters (e.g. metals, chloride, sulphate, sulphide and nitrogen).^{1,2} Textile industries are very dependent on water usage which in general consume between 0.06 and 0.40 m³ of fresh water for each 1 kg of finished product.³⁻⁵ In addition to this, textile industry is also the largest generators of toxic chemical wastewater in the world. The pollution sources in the textile effluents come from the wet processes (i.e. scouring, desizing, mercerizing, bleaching, dyeing and finishing), desizing, scoring and bleaching processes; these three processes of the textile line processing have produced large quantities of wastewater compared to other processes.³ However, the severe water pollution from textile effluents is basically coming from the dyeing process.⁶ This step requires high concentrations of organic dyes, additives and salts

to produce high quality of fabrics. In view of this, textile wastewater must be treated properly before releasing it to the river. It must be pointed out that the treatment of dyeing wastewater has potential to recover some of the valuable chemical components for reuse purpose.² However, most of the existing treatment methods are reportedly inefficient to handle textile wastewater with a wide range of pollutant concentrations.²

To tackle this problem, the use of membrane distillation (MD) in textile wastewater treatment could be the most ideal candidate owing to its low fouling tendency which resulted from relatively low operating pressure (average 1 bar). Furthermore, the hot effluent discharged from textile industry has also made the MD process very suitable for this treatment process which requires a hot feed solution to operate. Criscuolli *et al.*¹ reported that the effluent from dyeing baths in the textile - line process could consistently reach between 80 and 90 °C. MD technology is one of the novel strategies to treat the textile wastewater since the textile processing industry is a prime candidate for the development of advanced water treatment strategies.⁷ In this paper, the main objective is to study the effect of degree of hydrophobicity of different PVDF hollow fiber membranes

towards the membrane separation performances in DCMD process. The spun membranes were evaluated in terms of morphology, hydrophobicity and gas permeability. DCMD process was employed for the treatment of waters colored with reactive black 5 (RB5) dye to study the membrane performances in terms of permeate flux and separation efficiency.

2.0 EXPERIMENTAL

2.1 Materials

PVDF polymer (Kynar 760) was purchased from Arkema Inc., Philadelphia, USA in the form of pellets. N-methyl-2-pyrrolidone (NMP, 99.5%) was used as solvent without further purification. Ethylene glycol (EG, MW = 62 g/mol) (Merck) and polyvinylpyrrolidone (PVP, MW = 30,000 g/mol) (Fluka Analytical) were used as a different types of additives in the polymer solution. Reactive Black 5 (RB5, MW = 991g/mol) from Sigma-Aldrich was used as to synthesize dyeing solution by dissolving it in deionized water produced by ELGA Micromeg Deionizer.

2.2 Fabrication of PVDF Hollow Fiber Membranes with Different Additives

Prior to dope solution preparation, PVDF pellets were first dried in vacuum oven at $60 \pm 2^\circ\text{C}$ overnight to remove all the moisture. Afterwards, 18 wt% of PVDF was dissolved in NMP solvent under stirring rate around 350 rpm and at 40°C for 30 min. Then, the temperature of the solution was controlled at 60°C and stirred at 550 rpm. After the polymer was completely dissolved in NMP, 6 wt% of the additive (EG or PVP) per total weight of the solution was started to add slowly in the dope solution. The solution was left to cool down to the room temperature after a permanent homogeneous dope solution was obtained. Using the solutions prepared, PVDF membranes with two different properties were fabricated using dry-jet wet spinning method as described elsewhere.⁸ After completing the spinning process, the fabricated hollow fiber membranes were soaked in a water bath for at least 24 h to remove residual solvent and additive from the membrane matrix. The membranes were post-treated via non-solvent exchange method before drying at room temperature.

2.3 Contact Angle Measurement

To evaluate the degree of membrane hydrophobicity, a contact angle goniometer (OCA15plus, DataPhysics) equipped with image-processing software was used. A piece of membrane was placed on a platform and DI water was used as liquid at room temperature. A micro-syringe was used to generate the droplets (1–2 mL) on the membrane surface. The contact angle of membrane was then measured based on the digital image captured. Three measurements were taken from the membrane to yield the average result.

2.4 Gas Permeation Measurement

The membrane was first potted into a fitter and the effective membrane length was measured before putting the membrane sample into the module. Nitrogen gas was used in the gas permeation test to measure the porosity. The gas pressure was varied starting from small magnitude until certain pressure. Usually, the upstream pressure is in the range of 0.5 - 4 bar for a

porous membrane. The measurement which is based on the volume displacement method started with the collection of bubble volume in certain high in predetermined time. Based on the common gas permeation method by Wang *et al.*,⁹ gas permeance, J_G for porous membrane can be expressed as:

$$J_G = \frac{2r_p \varepsilon}{3RTL_p} \left(\frac{8RT}{\pi m} \right)^{0.5} + \frac{r_p^2 \varepsilon}{8\mu RT L_p} \bar{P} \quad (1)$$

$$J_G = K_0 + P_0 \bar{P} \quad (2)$$

where J_G is the gas permeance ($\text{mol/m}^2 \cdot \text{s} \cdot \text{Pa}$), r_p and L_p are pore radius and effective pore length, respectively (m), ε is surface porosity, R is gas constant ($8.314 \text{ J/mol} \cdot \text{K}$), μ is gas viscosity ($\text{kg/m} \cdot \text{s}$), M is gas molecular weight (0.028 kg/mol N_2), T is gas temperature (K), and \bar{P} is mean pressure (Pa). By plotting J_G with mean pressures according to Equation (1) and (2), mean pore size and effective porosity over pore length, ε/L_p can be calculated from the intercept (K_0) and slope (P_0) as follows:

$$r_p = 5.333 \left(\frac{P_0}{K_0} \right) \left(\frac{8RT}{\pi M} \right)^{0.5} \mu \quad (3)$$

$$\frac{\varepsilon}{L_p} = \frac{8\mu RT P_0}{r_p^2} \quad (4)$$

2.5 Field Emission Scanning Electron Microscopy (FESEM) Analysis

The dry hollow fiber samples were immersed in liquid nitrogen and fractured, and then sputtered with platinum using a sputtering device (JFC-1100E, JEOL). The membrane cross-section of PVDF-EG (designated as PVDF-S1 membrane) and PVDF-PVP (designated as PVDF-S2 membrane) samples were examined using FESEM (JSM-6700, JEOL) at fixed magnification.

2.6 Direct Contact Membrane Distillation (DCMD) Experiments

Twenty hollow fiber membranes with an effective length of 19 cm were assembled in a stainless steel tube with inner diameter of 3/8 in to form a membrane module. The basic properties of each PVDF hollow fiber membranes and modules are summarized in Table 1. The membrane modules were coated with fiber glass to minimize heat loss to surrounding. DCMD experiments were conducted on a laboratory-scale circulating unit, as illustrated in Figure 1. The hot solution was fed through the lumen-side of membrane while the cooling water was passed through the membrane shell-side in a counter-current flow. The experiments were carried out using feed solution containing 500 ppm RB5 at 60°C while the cold water temperature was kept at 20°C . The feed and permeate flow rates were fixed at 4 L/min and 3 L/min, respectively with operating hydraulic pressure set below 0.5 bar. The solution temperatures were measured with penetration stem dial thermometers with an accuracy of $\pm 0.1^\circ\text{C}$. The temperatures of the feed and distillate tanks were precisely controlled by using a coiled heater (830, PROTECH) and chiller (F26-ED, JULABO). The concentration of the RB5 in the feed and permeate tanks were measured using UV-vis spectrophotometer (DR5000, Hach) with absorbance measured at 597nm which the maximum absorption occurs. The vapor

permeation flux, J ($\text{kg}/\text{m}^2\cdot\text{h}$) and separation factor (%) were determined using the following equations.

$$J = \frac{\Delta W}{A \Delta t} \quad (5)$$

$$\beta = 1 - \frac{C_p}{C_f} \quad (6)$$

where ΔW (kg) is the permeation weight collected over a predetermined time Δt (h) of DCMD process duration, A (m^2) is the effective permeation area (based on the external diameter of hollow fibers), C_p and C_f are the RB5 concentration in the bulk permeate and feed solution, respectively.

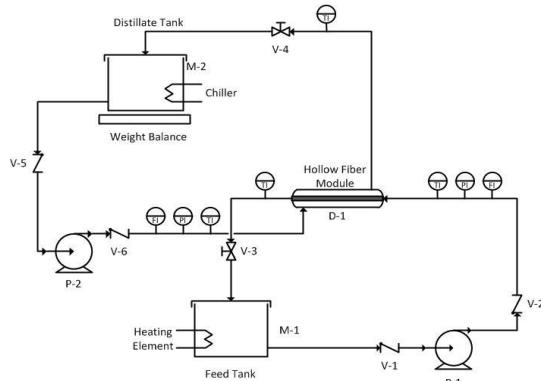

Figure 1 Schematic DCMD experimental setup

3.0 RESULTS AND DISCUSSION

3.1 Characteristics of PVDF Hollow Fiber Membranes

As shown in Table 1, PVDF-S2 membrane possessed low contact angle value than the PVDF-S1 membrane, indicating PVP has played a role in transforming the membrane properties from hydrophobic to relatively hydrophilic. In contrast with PVDF-S1 membrane, this membrane maintained hydrophobic behavior despite of its EG addition. Although PVDF-S2 was relatively hydrophilic, it has a drawback in gas permeation

measurement which showed its effective surface property much lower than the PVDF-S1 membrane. Generally, membrane made of pure PVDF polymer would show higher N_2 permeance and effective surface porosity. But, opposite results were obtained in this study for PVDF-S2 membrane. The membrane possessed similar results with previous studies using polyetherimide (PEI) membranes.^{10,11} This occurrence may be developed by the hydrophilic properties of the PVDF-S2 membrane.

Figure 2 shows the FESEM micrographs of the cross sectional morphology of the prepared PVDF-S1 and PVDF-S2 membranes. It can be seen that both membranes possessed different morphology structures from outer to inner layer. As observed from the morphological analysis, finger-like structure was developed at the outer skin layer and inner layer for both membranes. For PVDF-S1 membrane, the finger-like structure is much thinner and longer than PVDF-S2 membrane at the cross sectional of outer layer. Although these two membranes have a combination of sponge-like substructure and finger-like macrovoids at the middle of the membranes, the PVDF-S2 membrane is found to possess less spongy structure and have larger macrovoids than that of the PVDF-S1 membrane. This behavior must be related with the types of additives added to the PVDF dope solution. Despite of same polymer concentration, both membranes demonstrated different morphology structures in which PVDF-EG membrane possessed more dense structure than the PVDF-S2 membrane. This significant difference may be explained by the diffusion of water (as the coagulant and bore fluid composition) into the dope solution during the spinning process. The dense structure of the PVDF-S1 membrane is mainly due to delay solvent-non-solvent during phase inversion, making the polymer solidifies in a longer time. However, the diffusion rate for both membranes is considered faster than neat PVDF dope solution due to the addition of additives. It is well-known that the additive's role in membrane formation is generally as a pore forming agent and a phase separation enhancer for the PVDF membrane. It has been proved by the FESEM images that both membranes possessed large macrovoids at the middle of the cross-section which is caused by the easier diffusion between non-solvent in the coagulation medium and solvent in the dope solution due to the hydrophilicity of EG and PVP.

Table 1 Characteristics of PVDF hollow fiber membranes

Membrane	PVDF-S1	PVDF-S2
Contact angle ($^\circ$)	87	68
Pore size (μm)	0.15	0.17
Effective surface porosity, ε/L_p (m^{-1})	567.18	1.22
N_2 permeance at 1 bar ($10^{-3} \text{ cm}^3/\text{cm}^2\cdot\text{s}\cdot\text{cm.Hg}$)	44.28	0.12

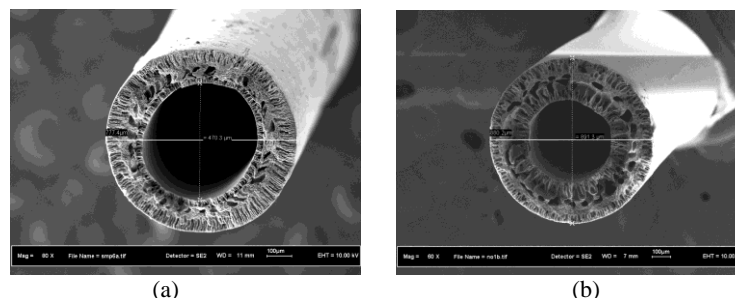

Figure 2 FESEM images of (a) PVDF-S1 and (b) PVDF-S2 hollow fiber membrane

3.2 DCMD Test with Reactive Black 5 Solutions

The performances of the PVDF hollow fiber membranes were further evaluated in the DCMD system to produce water free of dye component. Figures 3 shows the permeate flux of PVDF-S1 and PVDF-S2 membranes versus time for a feed solution containing 500 ppm RB5. As can be seen, the permeate fluxes of PVDF-S2 membrane were much higher than PVDF-S1 membrane for the first 60 min of MD operation. The PVDF-S1 membrane is reported to produce 8.39 kg/m².h at first 30 min followed by a very stable permeate flux production till the end of experiment with slight variation (9.81 ± 0.22 kg/m².h). On the contrary, the PVDF-S2 membrane performances were declined after 1 h, its vapor permeation fluxes were lower than PVDF-S1 membrane for the same operation time. These dissimilarity trends between PVDF-S2 membrane and PVDF-S1 membrane were mainly attributed by the structural properties and the degree of hydrophobicity of each membrane. From the figure, it is found that PVDF-S1 membrane possessed better performance than PVDF-S2 membrane with consistent and uniform permeates fluxes throughout the tested. These steady fluxes may be attributed by the higher hydrophobicity of the PVDF-S1 membrane. This fabricated PVDF-S1 membrane only allows vapor molecules to pass through the pores of the membrane and has strong ability to prevent pore wetting problem due to the high contact angle value. Comparing with PVDF-S2 membrane, the maximum permeate flux obtained by PVDF-S1 membrane is 10.57 kg/m².h at first 30 min and then decline to 8.61 kg/m².h at operation time of 150 min. It can be seen from the figure that PVDF-S2 membrane permeate flux decreased with time which indicated that the membrane cannot withstand prolonged test and has low durability.

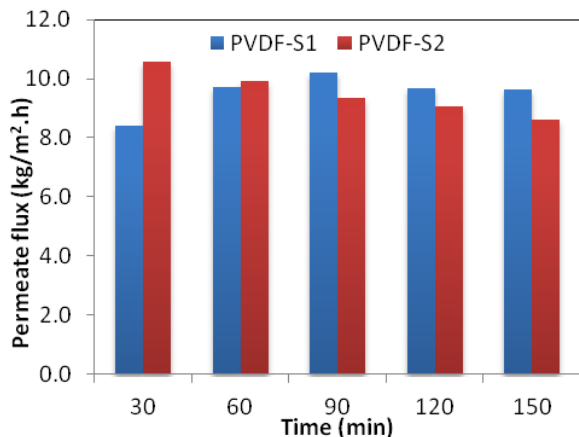

Figure 3 Permeate flux of PVDF hollow fiber membranes as a function of operation time

The fouling potential is much anticipated in this experiment as higher dye concentration was used as the feed solution. As shown in Figure 4, PVDF-S1 membrane demonstrated consistent separation efficiency until 150 min of MD tested with performance of 99.89 ± 0.01%. On the other hand, the PVDF-S2 membrane declined uniformly from t=30 min until t=150 min. This separation performance for both membranes is tallied with the permeate flux obtained in previous discussion. As discussed earlier, vapor flux for PVDF-S2 membrane has decreased with time due to fouling potential in the MD process. However, the minimum separation factor achieved by PVDF-S2 membrane is still maintained at a high level which is 99.59%. Since PVDF-S2 membrane has a larger

mean pore size than the PVDF-S1 membrane, it is highly anticipated that more dye particles were retained and filled the membrane pores after a certain period of time. As higher solute concentration was used, the higher tendency of concentration polarization was occurring during this MD tested. Therefore, it is expected that PVDF-S2 membrane has a severe concentration polarization than the PVDF-S1 membrane. This is due to the higher flux achieved by PVDF-S2 membrane at first 60 min of operation. As more water vapor is transported to the cold side, the solute concentration in the membrane module is increased, causing an increment of concentration polarization in the membrane module. Moreover, the hydrophilic behavior of PVDF-S2 membrane was contributed to the pore wetting problem at the membrane surface. However, this membrane was not fully wetted because the operating hydraulic pressure was operated at pressure < 0.5 bar, i.e. much lower than the wetting pressure of PVDF-S2 membrane itself. Larger macrovoids in the PVDF-S2 membrane is one of the possible reasons causing the membrane to have higher flux and lower resistance against fouling. However, the fouling layer that builds up on the membrane surface after a certain period was decreased the flux and separation efficiency as well. It is interesting to note that MD membrane usually obtained higher solute rejection almost to 100%. It is supported by this study in which both membranes showed at least 99% dye rejection even under prolonged operating time. This experimental data proved that MD has a minimum fouling problem if compared with other pressure-driven membrane processes like nanofiltration and reverse osmosis.

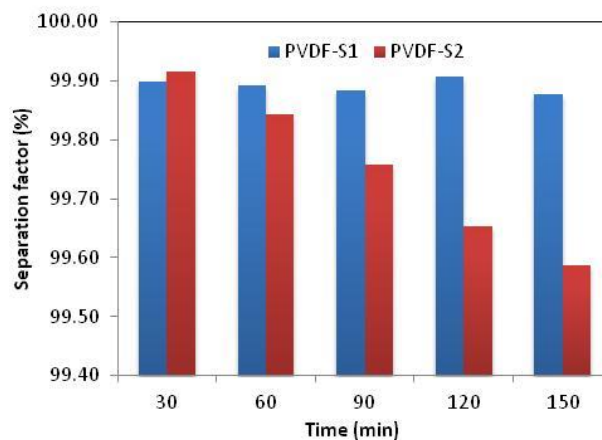

Figure 4 Separation efficiency of PVDF hollow fiber membranes as a function of operation time

4.0 CONCLUSION

The effect of degree of hydrophobicity on the PVDF morphological structure, permeation property and MD performances was systematically studied. This work demonstrated the ability of PVDF-S1 and PVDF-S2 hollow fiber membranes in treating RB5 dyeing solution via DCMD process. It can be concluded that the degree of hydrophobicity is an important criteria in the MD process as the hydrophobic character of PVDF-S1 membrane could have greater pore wetting resistance and reduced fouling compared to the PVDF-S2 membrane. In comparison to other pressure-driven membrane processes, it is found that MD process using PVDF membranes prepared in this work is very potential in treating dyeing solution due to its low operating pressure without compromising dye rejection rate.

Acknowledgement

The authors gratefully acknowledge Universiti Teknologi Malaysia (UTM) for funding this project with Research University Grant (Tier 1) (Grant no. Q.J.130000.2542.04H86).

References

- [1] A. Criscuoli, J. Zhong, A. Figoli, M. C. Carnevale, R. Huang, E. Drioli. 2008. *Water Research*. 42: 5031.
- [2] W. J. Lau, A. F. Ismail. 2009. *Desalination*. 245: 321.
- [3] R.O. Yusuff, J.A. Sonibare. 2005. *Global Nest: the International Journal*. 6: 212.
- [4] N. B. Amar, N. Kechaou, J. Palmeri, A. Deratani, A. Sghaier. 2009. *Journal of Hazardous Materials*. 170: 111.
- [5] G. Ciardelli, N. Ranieri. 2001. *Water Research*. 35: 567.
- [6] B. Van der Bruggen, E. Curcio, E. Drioli. 2004. *Journal of Environmental Management*. 73: 267.
- [7] U. Rott, R. Minke. 1999. *Water Science and Technology*. 40: 1999.
- [8] W. J. Lau, A. F. Ismail. 2009. *Journal of Membrane Science*. 334: 30.
- [9] D. Wang, K. Li, W. K. Teo. 1995. *Journal of Membrane Science*. 105: 89.
- [10] R. Naim, A. F. Ismail, A. Mansourizadeh. 2012. *Procedia Engineering*. 44: 328.
- [11] R. Naim, A. F. Ismail. 2013. *Journal of Hazardous Materials*. 250-251:354.