

# Northumbria Research Link

Citation: Kouhini, Sepideh Mohammadi, Alizadeh Jarchlo, Elnaz, Khademi, Sasan, Ghassemlooy, Zabih and Alves, Luis Nero (2020) A Polynomial Analog Baseband Predistorter for Compensation of Wireless Amplifier's Distortion. In: 2020 12th International Symposium on Communication Systems, Networks and Digital Signal Processing (CSNDSP). Institute of Electrical and Electronics Engineers Inc., Piscataway, NJ, pp. 841-846. ISBN 9781728160511; 9781728167435

Published by: Institute of Electrical and Electronics Engineers Inc.

URL: <https://doi.org/10.1109/CSNDSP49049.2020.9249571>  
<<https://doi.org/10.1109/CSNDSP49049.2020.9249571>>

This version was downloaded from Northumbria Research Link:  
<http://nrl.northumbria.ac.uk/id/eprint/46261/>

Northumbria University has developed Northumbria Research Link (NRL) to enable users to access the University's research output. Copyright © and moral rights for items on NRL are retained by the individual author(s) and/or other copyright owners. Single copies of full items can be reproduced, displayed or performed, and given to third parties in any format or medium for personal research or study, educational, or not-for-profit purposes without prior permission or charge, provided the authors, title and full bibliographic details are given, as well as a hyperlink and/or URL to the original metadata page. The content must not be changed in any way. Full items must not be sold commercially in any format or medium without formal permission of the copyright holder. The full policy is available online: <http://nrl.northumbria.ac.uk/policies.html>

This document may differ from the final, published version of the research and has been made available online in accordance with publisher policies. To read and/or cite from the published version of the research, please visit the publisher's website (a subscription may be required.)



**Northumbria  
University**  
NEWCASTLE



**UniversityLibrary**

# A Polynomial Analog Baseband Predistorter for Compensation of Wireless Amplifier's Distortion

Sepideh Mohammadi Kouhini  
Technische Universität Berlin,  
Germany  
Sepideh.M.Kouhini@campus.tu-berlin.de

Elnaz Alizadeh Jarchlo  
OSRAM GmbH, Germany  
E.Alizadeh@osram.com

Sasan Khademi  
ACECR University, Iran  
sasan.khademi67@gmail.com

Zabih Ghassemlooy  
OCRG, Faculty of EE, Northumbria  
University, UK  
z.ghassemlooy@northumbria.ac.uk

Luís Nero Alves  
Instituto de Telecomunicações  
Universidade de Aveiro  
Aveiro, Portugal  
nero@ua.pt

**Abstract**—This paper presents a new analog polynomial pre-distortion circuit using 350nm CMOS technology to reduce the distortion of power amplifier in wireless communication systems. The proposed pre-distortion circuit uses the polynomial approach. The coefficients of the polynomial are controlled by multiplying them with sufficient digit defined through indirect learning process to provide best practice linearization. Circuit level simulation of the proposed circuit is using Cadence DFW II is used as proof of concept. The simulation set-up comprises a power amplifier, excited with a four carrier GSM signal, pre-distorted by the proposed circuit. Simulation results show that using the pre-distortion circuit the inter-modulation distortion is reduced on average by 16 dB.

**Keywords**— Analog pre-distortion, power amplifier, polynomial model, linearization.

## I. INTRODUCTION

In the last decades, the number of wireless users has significantly, increased. The needs of having high data rate and large capacity in dense networks requires highly efficient systems. In addition, the modern wireless communication uses advance modulation schemes in the wide band system. These features apply strict linearity requirement to the power amplifiers (PA). PA performance plays a crucial role in wireless communication quality and its efficiency determines the overall communication link performance. However, the PAs have unavoidable static and dynamic distortion that requires sophisticated linearization process to establish a high-performance wireless communication link. Amplifier linearization is a very concerning and challenging issue, especially for base-station (BS) transmitters (Tx) [1]. In order to compensate the exhibited distortion, one common approach relies on pre-distorting the input signal by mimicking the inverse nonlinear behavior of PAs, called pre-distortion (PD). A number of different linearization methods including the feed-forward [3], [4], feedback [5], digital PD [6] and analog PD [7], [8] have been widely employed to improve the linear characteristic of the PA. As for implementation, the digital PD will no longer be the optimum candidates. This is because of their bandwidth

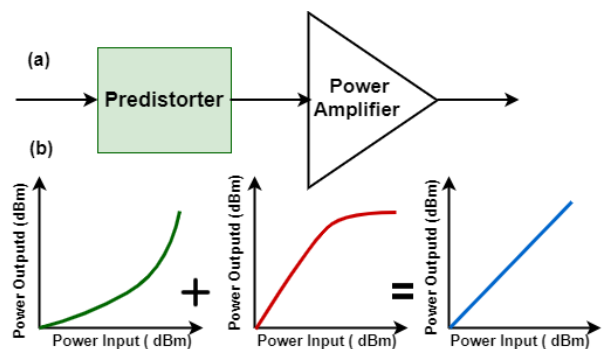

Fig. 1. Combination of predistorter and power amplifier (a): Predistorter (PD) and power amplifier (PA) block diagram. (b): AM-AM characteristic of the predistorter, power amplifier, and linearized AM-AM power amplifier. The AM/AM response implies the nonlinear relationship between the output and input power or amplitude.

limitations and the need for high power supply [1], [2]. The challenge in analog PD methods is in designing a circuit that will accurately produce an inverse characteristic of the original PA's distortion [9], see Fig. 1. The objective of this work is to implement distortion compensation using recurring analog integrated circuit design (ICs). Analog pre-distortion circuit can be relaxed with respect to the limiting bandwidth. Moreover, analog pre-distortion circuits offer low power consumption compared to the digital-based PDs [18]. In this paper, we present an adaptive CMOS analog polynomial PD to improve the wireless communications link quality and performance. The proposed circuit is based current mode design approach. Current mode offers several advantages over conventional voltage mode design, namely: i) low voltage capability, as it explores the voltage compression characteristics of MOSFET transistors; ii) adequate for mathematical function synthesis, especially, addition, multiplication, squaring and power functions; and iii) reduced power consumption. The proposed pre-distortion circuit is able to support, fixed order polynomial function synthesizer with accurate coefficient programming. The proposed circuit is validated through simulation with Spectre, under the Cadence DFW II design environment. For that matter, the circuit is used to linearize a real class-AB PA. The polynomial coefficients are computed in Matlab based on the PA model.

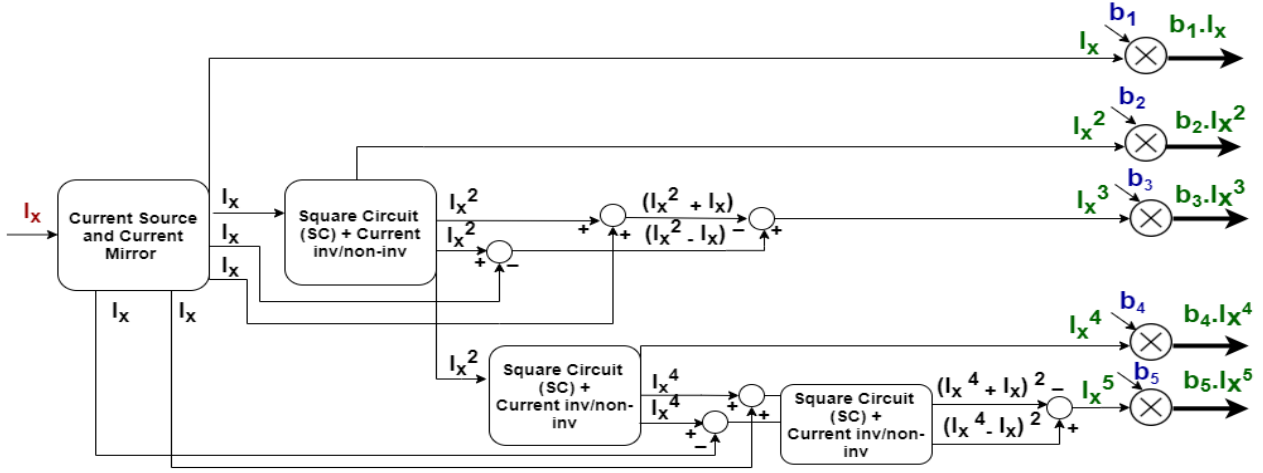

Fig. 3 Proposed 5<sup>th</sup> order polynomial block diagram. This polynomial is built by combination of squarer cell and current inverting non-inverting modules. The coefficients of polynomial adjusts through current multiplier with sufficient digit extracted from indirect learning.

The rest of the paper is organized as follows; section II describes the polynomial PD concept. Section III presents the proposed circuit, and in Section IV presents and discusses the simulation results. Sections V and VI draw the conclusions and outlook.

## II. POLYNOMIAL PREDISTORTER CONCEPT

PAs exhibit static and dynamic distortions. Static distortion indicates a memoryless nonlinearity and dynamic distortion refer to memory effects [17]. Distortion compensation circuits can be classified according to the type of nonlinearity they can compensate. The present work focus only on static distortion compensation. Figs. 1. (a) and (b) illustrates the gain profiles of the desired PD, PA and cascaded PD (PD-PA). The cascaded PD-PA attempts to combine two nonlinear systems into a single linear system, thus allowing the PA to operate closer to the saturation region (i.e., being more efficient in terms of the energy usage). The proposed PD is compensating the magnitude and phase nonlinearity of the signal, therefore as it shown in Fig. 2. we have used the following equations to represent the PA induced distortions:

$$I + jQ = R_n \cos(\theta_n) + jR_n \sin(\theta_n) \quad (1)$$

$$R_n = \sqrt{I_n^2 + Q_n^2} \text{ and } \theta_n = -\arctan(Q_n/I_n) \quad (2)$$

$I$  and  $Q$  are input signal, thus  $R_n$  is the amplitude and  $\theta_n$  is the phase of the input signal. The input of PA without PD is:

$$I_{in\_PA} = R_n \cos(\omega t + \theta_n) \quad (3)$$

The output of PA, which contains both the amplitude

(AM/AM)  $R_n'$  and phase (AM/PM)  $\theta_n'$  distortions, is given by:

$$I_{out\_PA} = A_n(R_n') \cos(\omega t + \theta_n' + \phi_n(R_n')) \quad (4)$$

Where  $A$  is the gain of PA and  $\phi_n(R_n')$  is additive phase distortion. In complex format. The output of PA is given as:

$$\begin{aligned} I_n' &= A_n(R_n') \cos(\theta_n' + \phi_n(R_n')) \\ Q_n' &= A_n(R_n') \sin(\theta_n' + \phi_n(R_n')) \end{aligned} \quad (5)$$

It is important to note that, the amplitude and phase distortions only depend on the amplitude and independent of the phase distortion [19]. Therefore, we can first compensate for the amplitude distortion followed by the phase correction. In order to that  $I_n'$  and  $Q_n'$  are equal to  $I_n$  and  $Q_n$ , respectively we have:

$$A_n(R_n') = R_n \quad (6)$$

$$\theta_n' + \phi_n(R_n') = \theta_n \quad (7)$$

In [13], [20] and [21], polynomial functions were used to represent the nonlinear models. One options was to use the inverse of PA transfer function as means to compensate for the non-linearity using polynomial functions [13]. Polynomial PDs are used to cancel out the static nonlinearities of PAs by minimizing the out-of-band even order intermodulation distortion (IMD). The output of PD is given by equation (8). Where  $I_x$  is the input signal and  $b_1, \dots, b_5$  are the PD coefficients for the amplitude and phase correction, respectively, which are configurable.

In the following section, we propose a new method to implement an adaptive fifth order polynomial PD, see Fig. 3.

$$I_{o\_PD\_mag} = b_{5\_mag}(I_x^5) + b_{4\_mag}(I_x^4) + b_{3\_mag}(I_x^3) + b_{2\_mag}(I_x^2) + b_{1\_mag}(I_x^1)$$

$$\begin{aligned} I_{o\_PD\_Phase} &= b_{5\_Phase}(I_x^5) + b_{4\_Phase}(I_x^4) + b_{3\_Phase}(I_x^3) + b_{2\_Phase}(I_x^2) \\ &+ b_{1\_Phase}(I_x^1) \end{aligned} \quad (8)$$

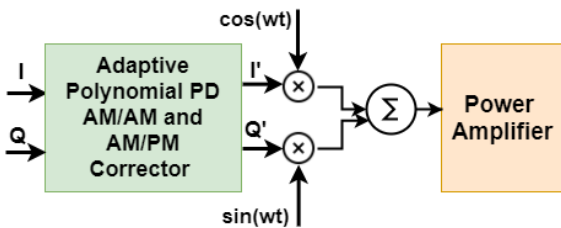

Fig. 2 The block diagram of PD signal generation

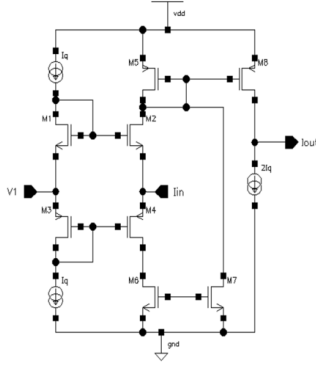

Fig. 4 Squarer Circuit [14].

### III. PROPOSED POLYNOMIAL CIRCUIT

Fig. 3 demonstrates the proposed polynomial system level circuit. The overall polynomial function includes sub-circuits using well-established current-mode (CM) techniques. The need for the CM building blocks, instead of the voltage mode, is because of the overall dynamic range. Commonly, the nodes within CM circuits are low impedance nodes, presenting small voltage swings, and low impedance leads to low time constant circuits, thus a good possibility of achieving a high bandwidth. Moreover, CM circuits have simple architectures and operate with a significant level of independence from the supply voltages [15]. Another advantage of using the CM approach for all sub-circuits is that, the operation of addition/subtraction is simply achieved through a connection node, following Kirchhoff current law, which is far much simpler and have wider bandwidth, than the addition/subtraction of voltages.

In the proposed circuit of Fig. 3, the input current  $I_x$  is replicated through a multiple-output current mirror. These replicated currents are then processed by the squarer circuits and adder/subtraction blocks, which isolate the basic terms of the polynomial, i.e., the monomials. In the final stage, current multipliers set the values of the monomial coefficients by multiplying the result monomial signals by the reference currents, which are set for this purpose. In the following, the sub-circuits used to implement the blocks of the polynomial architecture of Fig.3 are described in detail.

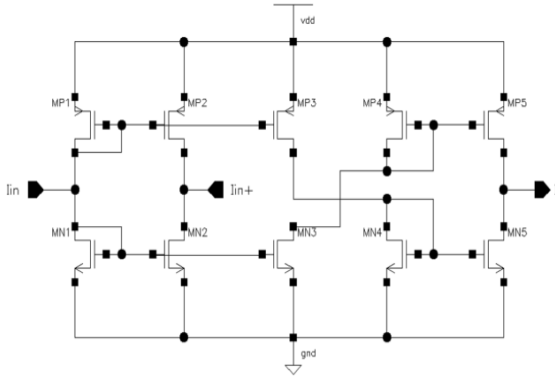

Fig.5 Inverting-non inverting circuit. [13]

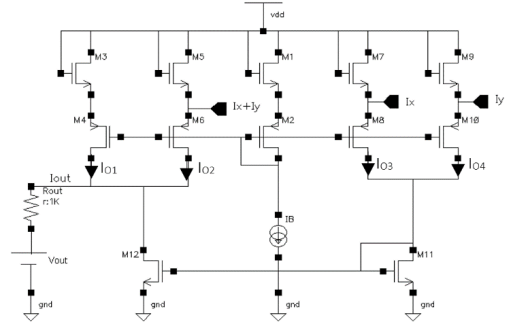

Fig. 6 Four quadrant current multiplier [4].

#### A. Squarer Circuit

The squarer circuit follows the work presented in [14], which is derived from a class-AB current mirror, see Fig. 4  $I_{in}$  is the input current signal,  $I_q$  is the bias current and  $I_{out}$  is the output current. Transistors  $M_1$  to  $M_4$  constitute a trans-linear loop, with all transistors operating in the saturation region. Adopting the proposed design in [14], the following relations are reached based on trans-linear principle:

$$V_{gs2} + V_{gs4} = V_{gs1} + V_{gs3} \quad (9)$$

$$\sqrt{I_{D2}} + \sqrt{I_{D4}} = \sqrt{I_{D1}} + \sqrt{I_{D3}} \quad (10)$$

$$2\sqrt{I_q} = \sqrt{I_{D2}} + \sqrt{I_{D3}} \quad (11)$$

$$I_{D4} = I_{D2} + I_{in} \quad (12)$$

Where  $V_{gs1}$  to  $V_{gs4}$  are the gate-source voltage of  $M_1$  to  $M_4$ , respectively. Moreover,  $I_{D1}$  to  $I_{D4}$  are the drain current of  $M_1$  to  $M_4$ , respectively, which are given by [14]:

$$\frac{I_{D2}}{I_q} = 1 - \frac{1}{2} \frac{I_{in}}{I_q} + \left(\frac{I_{in}}{4I_q}\right)^2 \quad (13)$$

$$\frac{I_{D4}}{I_q} = 1 - \frac{1}{2} \frac{I_{in}}{I_q} + \left(\frac{I_{in}}{4I_q}\right)^2 \quad (14)$$

The output current is given [14]:

$$\frac{I_{out}}{I_q} = \frac{1}{8} \left(\frac{I_{in}}{I_q}\right)^2 \quad (15)$$

#### B. Inverting-Non Inverting Circuit

This is based on the current mirrors, which provide a replica of the input current in two of its output terminals - one in the same direction of the input current and the other in the reverse direction. Fig. 5 illustrates the inverting noninverting circuit, where  $I_{in}$  is the input current, and  $I_{in+}$  and  $I_{in-}$  are the direct and reverse direction output currents, respectively. All transistors are operating in the saturation region [13]. Currents generated by this circuit can be replicated and applied to the distinct sections of the circuit, see Fig. 5, through the use of additional current mirrors with a sufficient current ratio.

#### C. Current Multiplier

The nonlinear characteristics of the PD needs to be adjusted such that it is opposite to the PA, which is changing with the temperature and component aging. Therefore, the circuit allow controlling the polynomial

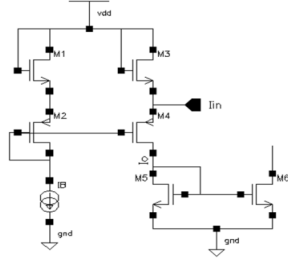

Fig. 7. Translinear loop circuit of multiplier [4].

coefficients through current multiplier sub-circuits at each of the respective output currents of each polynomial order. In this approach, each coefficient terms of the polynomial, will multiply the current produced by the sub-circuits of each polynomial order by the constant coefficients of  $b_1$  to  $b_5$ . Fig. 6 shows the circuit of the current multiplier, which is based on the four-quadrant analog multiplier structure using three trans-linear loops. The operation steps of this current multiplier can be described with reference to Fig. 7. Note, considering M1-M4 form a trans-linear loop, assuming equal threshold voltage for all (in absolute value), which leads to [16]:

$$\sqrt{I_{D1}} + \sqrt{I_{D2}} = \sqrt{I_{D3}} + \sqrt{I_{D4}} \quad (16)$$

From Fig. 7, we have:

$$I_{D1} = I_{D2} = I_B, I_{D3} = I_{Do} - I_{in}, I_{D4} = I_{Do} \quad (17)$$

Thus, substituting (9) in (8) yields to:

$$2\sqrt{I_B} = \sqrt{I_o - I_{in}} + \sqrt{I_o} \quad (18)$$

The output current is extracted by double squaring equation (19) as [16], which leads to have  $I_o$  based on input current and bias current:

$$I_o = \frac{I_{in}^2}{16I_B} + I_B + \frac{I_{in}}{2} \quad (19)$$

Extending this result to the circuit shown in Fig. 6, which is composed of basic block of the form of that in Fig. 7, we have:

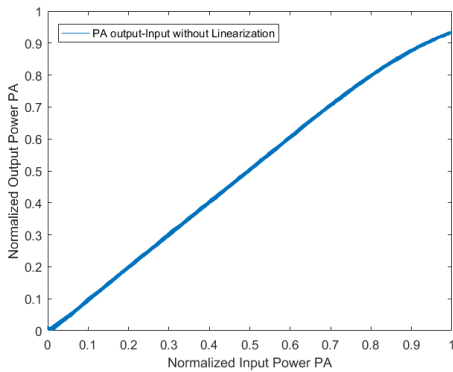

Fig. 8. Nonlinear behaviour of PA

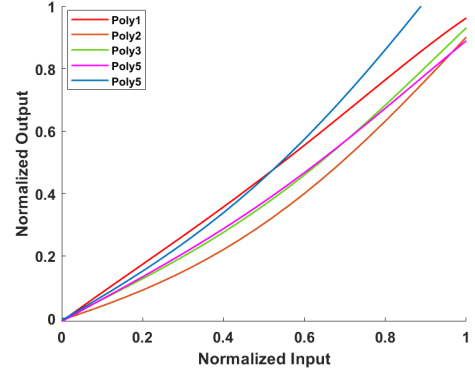

Fig. 9. Illustrative set of 5<sup>th</sup> order polynomial input-output characteristics obtained through randomizing (within the admissible region) the currents that control the polynomial coefficients.

$$I_{out} = I_{o1} + I_{o2} - (I_{o3} + I_{o4}) = \frac{I_x I_y}{8I_B} \quad (20)$$

By applying a constant current to  $I_x$  and the current produced by a monomial sub-circuit to  $I_y$ , the polynomial coefficients can be configured properly. The coefficients are digits number, which are normalized to proper current value in the range of CMOS transistors. Thus, using the presented sub-circuits to implement each of the blocks of the architecture of Fig. 3, and considering a four quadrant current multiplier applied to each of the currents generated by each monomial term, the following 5<sup>th</sup> order polynomial function can be implemented using the proposed analog PD circuit. In table (1) the simplified ratio of designed parameters for weight and length of transistor in each blocks are shown.

#### IV. VALIDATION OF PROPOSED MODEL

To test the polynomial performance, a four-carrier GSM baseband signal is used and pre-distorted. This signal has complex-valued, and therefore the following procedure is considered. Knowing that PAs react mostly to the amplitude of the input signal, the dominant behavior can be characterized by its gain and phase characteristics. The non-linear behavior of our PA model is shown in Fig. 8. Therefore, instead of receiving the in-phase and quadrature components of input signal, the analog PD will deal with the baseband amplitude signal. In order to compensate both the

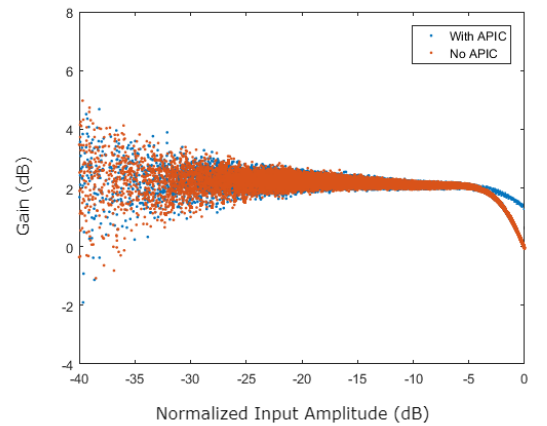

Fig. 10. AM/AM charecteric by implementing PD



amplitude and phase characteristics of the PA two replicas of the polynomial circuit are implemented operating in parallel and processing the same input signal, i.e., a current that is proportional to the amplitude of input signal and another PD is in charge of phase correction. Next, the coefficients of the two 5<sup>th</sup> order polynomial circuits are varied, i.e., by modifying the constant current inputs of the four quadrant current multipliers. Then the real and imaginary part of distorted amplitude and gain are extracted

Fig. 9 shows the normalized output of polynomial vs. the input for a range of coefficients as given in Table (2). This figure illustrates the ability of the proposed 5<sup>th</sup> order polynomial circuit in adapting to the behavior of distinct PAs by simply configuring the currents ( $b_1$  to  $b_5$ ), which controls the polynomial coefficients.

To validate the performance of the proposed polynomial circuit, we have tuned its current controlled coefficients so that it will pre-distort the nonlinear behavior of the PA model, which was retrieved from laboratory measurements of a real PA circuit (i.e., a class AB-based GaN transistor). With the analog PD running in a circuit simulator, we used the PA model to perform this validation test. For this purpose, the input signal is applied to the PA model and its output is retrieved. Then, the coefficients of the two static 5<sup>th</sup> order polynomials are tuned in MATLAB and using the iterative indirect learning method using the input and output signals of the PA under test [18]. Next, the two circuits implemented in Cadence Spectre are tuned to fit the coefficient. This is performed by varying the values of the current sources, which controls  $b_1$  to  $b_5$  coefficients of each analog polynomial. The baseband amplitude and phase of input signal is separated and normalized to the accepted

Table1: Ratio of weight and length (W/L) transistor dimension of sub circuits.

| Square Cell                    | Dimension |             |       |             |
|--------------------------------|-----------|-------------|-------|-------------|
|                                | W/L       | Transistors | W/L   | Transistors |
| Transistors                    |           |             |       |             |
| M1                             | 10/1      | M5          | 26/1  |             |
| M2                             | 10/1      | M6          | 5.6/1 |             |
| M3                             | 65/1      | M7          | 5.6/1 |             |
| M4                             | 65/1      | M8          | 26/1  |             |
| Current Inverting-Noninverting | Dimension |             |       |             |
| MN1                            | 4/1       | MP1         | 13/1  |             |
| MN2                            | 4/1       | MP2         | 13/1  |             |
| MN3                            | 4/1       | MP3         | 13/1  |             |
| MN4                            | 4/1       | MP4         | 13/1  |             |
| Current Multiplier             | Dimension |             |       |             |
| M1                             | 14/1      | M2          | 25/1  |             |
| M3                             | 14/1      | M4          | 25/1  |             |
| M5                             | 14/1      | M6          | 25/1  |             |
| M7                             | 14/1      | M8          | 25/1  |             |
| M9                             | 14/1      | M10         | 25/1  |             |

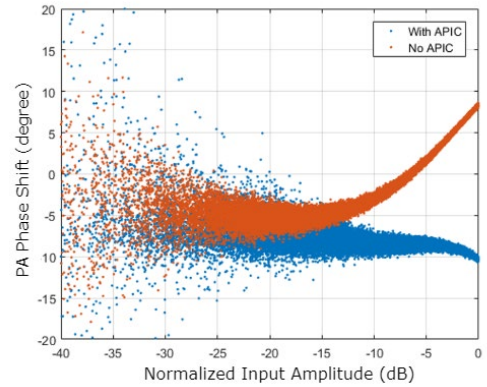

Fig.11. AM/PM charecteric of power amplifier with and without PD. (AM/PM: amplitude to phasedistortion).

level of input current and processed. The resulting output currents are converted back (by scaling only) to the pre-distorted baseband input signal, which is then applied (in MATLAB) to the referred PA model, and the improvement on output distortion is assessed. Fig. 10 presents the gain characteristic of the PA with and without PD, which demonstrate successful compensation.

Fig. 11 presents the phase characteristics of the PA without and with PD. It demonstrates that, the proposed scheme clearly reduces the PA's phase shift deviation at higher input amplitudes. In Fig. 12, the spectrum of the PA output signal with and without APIC is depicted. As shown, the analog PD is able to reduce the dominant inter-modulation distortion by about 12 and 16 dB on the left and right regions of the spectrum, respectively. Moreover, the PA

Table 2. Set of current to generated poly1, ..poly 5, which each of the polys are 5<sup>th</sup> order polynomial for magnitude correction.

| Output Polynomial | Current coefficient |              |              |              |              |
|-------------------|---------------------|--------------|--------------|--------------|--------------|
|                   | $b_{5\_mag}$        | $b_{4\_mag}$ | $b_{3\_mag}$ | $b_{2\_mag}$ | $b_{1\_mag}$ |
| Poly1             | 5uA                 | 7ua          | 13uA         | 27uA         | 29uA         |
| Poly2             | 25uA                | 20uA         | 15uA         | 10uA         | 5uA          |
| Poly3             | 20uA                | 15uA         | 20ua         | 5ua          | 10uA         |
| Poly4             | 7uA                 | 4uA          | 7uA          | 20uA         | 20uA         |
| Poly5             | 7uA                 | 7uA          | 7uA          | 4uA          | 4uA          |

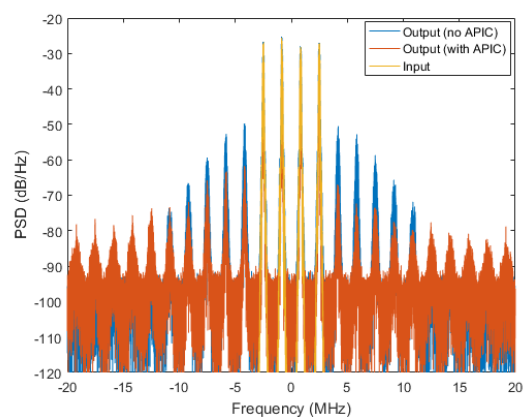

Fig.12 Power spectral density before and after implementing PD

model was initially set in a highly compressed operation, by presenting a high distortion level - with an intermodulation ratio of about 25 dB (see Fig. 12).

## V. CONCLUSION

In this paper a new analog polynomial PD circuit was presented for use in wireless communication. The polynomial PD circuit was proposed to meet the linearity requirement for advanced wireless system by using the current-mode sub-circuits to allow a wide dynamic range with configuration of the transfer function based on the characteristics of PAs. The proposed circuit was successfully validated through a mixture of circuit-level simulations (i.e., using Cadence) and system-level simulation using MATLAB to mimic the PA input-output behavior. The IMD level was reduced by 16dB using the proposed analog PD.

## VI. OUTLOOK

The presented analog circuit can be used to make predistortion linearizing effect for other type of wireless communication link such as optical communication. One of the limiting factors in optical communications is nonlinear behavior in the transmitter and receiver due to nonlinear behavior of amplifier and driver of LED and photodiode. This claim will be validated only by placing the proposed PD before the nonlinear part of communication link and configured it. In addition, RF-based wireless communications is being combined with visible light communication in certain applications in order to improve the link's availability, increase transmission capacity and improve the performance. Therefore, the proposed linearization scheme can also be adopted.

## ACKNOWLEDGMENT

This work was supported by a project called APIC (Analog Predistorter in Integrated Circuit), funded by the Institute Telecommunication of Aveiro and finalized during the EU H2020 VisIon 764461 project.

## REFERENCES

- [1] N. Ceylan, J. -. Mueller and R. Weigel, "Optimization of EDGE terminal power amplifiers using memoryless digital predistortion," in *IEEE Transactions on Microwave Theory and Techniques*, vol. 53, no. 2, pp. 515-522, Feb. 2005.
- [2] H. H. Boo, S. W. Chung and J. L. Dawson, "Adaptive Predistortion Using a  $\Delta\Sigma$  Modulator for Automatic Inversion of Power Amplifier Nonlinearity," in *IEEE Transactions on Circuits and Systems II: Express Briefs*, vol. 56, no. 12, pp. 901-905, Dec. 2009.
- [3] H. Choi, Y. Jeong, C. D. Kim and J. S. Kenney, "Efficiency Enhancement of Feedforward Amplifiers by Employing a Negative Group-Delay Circuit," in *IEEE Transactions on Microwave Theory and Techniques*, vol. 58, no. 5, pp. 1116-1125, May 2010.
- [4] D. Kim, B. Kim, and S. Nam, "A Transconductor and Tunable  $G_{\{m\}}-C$  High-Pass Filter Linearization Technique Using Feedforward  $G_{\{m\}}-C$  Canceling ", *IEEE Transactions on Circuits and Systems II: Express Briefs* vol. 62, no. 11, p. 1058-1062, 2015.
- [5] H. H. Boo, S. Chung and J. L. Dawson, "Digitally Assisted Feedforward Compensation of Cartesian-Feedback Power-Amplifier Systems," in *IEEE Transactions on Circuits and Systems II: Express Briefs*, vol. 58, no. 8, pp. 457-461, Aug. 2011.
- [6] N. Naskas and Y. Papananos, "Neural-network-based adaptive baseband predistortion method for RF power amplifiers," in *IEEE Transactions on Circuits and Systems II: Express Briefs*, vol. 51, no. 11, pp. 619-623, Nov. 2004.
- [7] M. Seo *et al.*, "Ultrabroadband Linear Power Amplifier Using a Frequency-Selective Analog Predistorter," in *IEEE Transactions on Circuits and Systems II: Express Briefs*, vol. 58, no. 5, pp. 264-268, May 2011.
- [8] K. Lim *et al.*, "A 60-W Multicarrier WCDMA Power Amplifier Using an RF Predistorter," in *IEEE Transactions on Circuits and Systems II: Express Briefs*, vol. 56, no. 4, pp. 265-269, April 2009.
- [9] M. Cho, "Analog predistortion for improvement of rf power amplifier efficiency and linearity ", *Ph.D. dissertation, Georgia Institute of Technology*, 2016
- [10] Mikyung Cho and J. S. Kenney, "Variable phase shifter design for analog predistortion power amplifier linearization system," *WAMICON 2013*, Orlando, FL, 2013, pp. 1-5.
- [11] E. Westesson and L. Sundstrom, "A complex polynomial predistorter chip in CMOS for baseband or IF linearization of RF power amplifiers," *1999 IEEE International Symposium on Circuits and Systems (ISCAS)*, Orlando, FL, 1999, pp. 206-209 vol.1.
- [12] R. N. Braithwaite, "Analog Linearization Techniques Suitable for RF Power Amplifiers Used in Integrated Transmitters," *2013 IEEE Compound Semiconductor Integrated Circuit Symposium (CSICS)*, Monterey, CA, 2013, pp. 1-4.
- [13] B. A. Minch, "An inverted CMOS class-AB transconductor featuring rail-to-rail common-mode input range and constant transconductance gain," *2014 IEEE Biomedical Circuits and Systems Conference (BioCAS) Proceedings*, Lausanne, 2014, pp. 428-431, doi: 10.1109/BioCAS.2014.6981754.
- [14] M. Hamiane, "A cmos-based analog function generator: Hspice model- ing and simulation ", *International Journal of Electrical and Computer Engineering*, vol. 4, no. 4, p. 532, 2014.
- [15] P. Singth, "A review and evolution of current mode circuits and realiza- tion of cda using cmos". *RADIOENGINEERING*, VOL. 28, NO. 1, November 2019 7
- [16] A. Baharmast, S. J. Azhari and S. Mowlavi, "A new current mode high speed four quadrant CMOS analog multiplier," *2016 24th Iranian Conference on Electrical Engineering (ICEE)*, Shiraz, 2016, pp.1371-137
- [17] O. Hammi, "Quantification of power amplifiers' static and dynamic distortions using frequency domain metrics," *2013 IEEE International RF and Microwave Conference (RFM)*, Penang, 2013, pp. 287-290.
- [18] E. Westesson and L. Sundstrom, "Low-power complex polynomial predistorter circuit in CMOS for RF power amplifier linearization," *Proceedings of the 27th European Solid-State Circuits Conference*, Villach, Austria, 2001, pp. 486-489.
- [19] Stonick, John T., et al. "Memoryless polynomial adaptive predistortion [TV transmitters]." *1995 International Conference on Acoustics, Speech, and Signal Processing*. Vol. 2. IEEE, 1995.
- [20] W. Gao, "Linearization of Wideband Wi-Fi Power Amplifiers Using RF Analog Memory Predistortion," *2018 IEEE International Conference on Communications (ICC)*, Kansas City, MO, 2018, pp. 1-6, doi: 10.1109/ICC.2018.8422874.
- [21] Lee, Kwang-Pyo, Soon-II Hong, and Eui-Rim Jeong. "The Polynomial Digital Pre-Distortion Technique Based on Iterative Architecture." *International Journal of Electrical and Computer Engineering* 6.1 (2016): 106.