



Development of an Internet of Things solution to monitor and analyse indoor air quality



Dylan Wall, Paul McCullagh*, Ian Cleland, Raymond Bond

School of Computing, Faculty of Computing, Engineering and The Built Environment, Ulster University, Jordanstown BT370QB, United Kingdom

ARTICLE INFO

Article history:

Received 18 December 2020

Revised 16 March 2021

Accepted 18 March 2021

Available online 21 April 2021

Keywords:

IoT

Indoor

Air

Quality

Analytics

Tutorial

ABSTRACT

Monitoring air quality is set to become more important at home, in the workplace and at social venues, particularly regarding promoting wellness and safeguarding social interaction. We present a didactic approach to implementing indoor air quality monitoring using an Internet of Things (IoT) solution, based upon low cost air quality sensors and edge computing nodes. We provide a tutorial that allows this solution to be replicated; similar solutions could have widespread use. Our test implementation monitored kitchen and study, each equipped with a Bosch BME680 sensor connected to a microcontroller for data transmission to a local server for storage on a database. A web based dashboard allowed for the feedback of sensor data. Two, 2-week data collection periods were undertaken to demonstrate the proof of concept. The first period was in the summer 2020 and the second in the autumn 2020 (during coronavirus 'lockdown' conditions). Analysis of the data showed a strong relationship between humidity and air quality (correlation coefficients of -0.624 in summer and -0.692 in autumn), with air quality degrading in the autumn. As humidity increases, air quality decreases; temperature has a weaker relationship with air quality. Further analysis showed that cleaning products can adversely impact on the air quality. Poor air quality can be mitigated by opening a window to speed up the dissipation rate of pollutants. The quantification of indoor air quality can inform activities such as cooking, heating, usage of disinfectants and monitoring of ventilation, which can potentially benefit of people with respiratory illness.

© 2021 The Authors. Published by Elsevier B.V.
This is an open access article under the CC BY-NC-ND license
(<http://creativecommons.org/licenses/by-nc-nd/4.0/>)

1. Introduction

Air pollution has detrimental effects to population health. According to The World Health Organisation (WHO), 4.2 million deaths can be attributed to ambient air pollution; furthermore, 91% of the global population live in areas where the pollution level exceeds WHO air quality guidelines [1]. In their 2020 report [2], the European Environment Agency (EEA) stated that exposure to air pollution in Europe was responsible for 417,000 premature deaths (based on data from 2018). The report postulated that prior exposure to air pollution may increase vulnerability to viruses such as coronavirus and there is a possibility that air pollution could exacerbate the spread of viruses in the population. Poor air quality can not only make

* Corresponding author.

E-mail address: pj.mccullagh@ulster.ac.uk (P. McCullagh).

symptoms of lung conditions worse but is a factor in asthma development in young children [3]. In the tragic case of Ella Adoo-Kissi-Debrah, an inquest at Southwark Coroner's Court (London, December 2020) found that air pollution was a factor in the girl's death [4]. This was a legal precedent and Ella's mother was keen to disseminate this information to serve her memory.

Exposure to indoor air pollution adversely affects occupants' health [5]. It is especially important for individuals living with asthma, chronic obstructive pulmonary disease (COPD) and lung cancer to be in an environment of good air quality. Adverse health complications include headaches, nausea, skin irritation, kidney failure; as well as exacerbation of the previously mentioned respiratory illnesses. Each year, close to 4 million people die prematurely from illness attributable to household air pollution from pollution associated with cooking and heating [6]. Carbon Dioxide levels can be used as a good proxy for the quality of ventilation and the build-up of compounds which are harmful to health. Colclough et al. [7] reported elevated night-time levels in houses. However, indoor air contains many different compounds, many of which have a negative impact on health [8]. These include formaldehyde, organic chemicals and inorganic chemicals, house dust and combustion products, radon gas, biological contaminants such as mould, pollen and dust mites and water vapour, manifest as increased humidity. One of the main contributors to poor ambient indoor air quality are volatile organic compounds (VOCs). These are gases emitted from building materials, furnishings, and cleaning products, which contain carbon organic chemicals [9]. Recent evidence also shows a link between indoor VOCs and biomass use [10]. Other pollutants originating from cookers, heaters, stoves, and open fires include carbon monoxide, nitrogen oxide and sulphur dioxide. Shrubsole et al. [11] have provided indoor air quality guidelines for selected volatile organic compounds (VOCs) in the UK.

The Coronavirus pandemic of 2020 has raised new concerns regarding the quality of our indoor air and the potential for spreading infection [12]. People in the UK spend on average 90% of their time indoors [13], and at the time of writing, this figure is likely to be much greater, as individuals in many countries are encouraged to stay at home, in what is commonly known as 'lockdown' [14]. Ironically, the measures introduced by most developed countries to reduce transmission of COVID-19 in the spring of 2020 led to significant reductions in emissions of outdoor transportation related air pollutants. Staying at home, e.g. for remote working, might protect us from spreading or contracting the virus, but poor indoor ventilation might lead to other health problems [15]. Stagnant air can also be a medium for transmission as infectious particles do not escape the environment. Simulations have been developed to show the extent of transmission of infectious particles, e.g. through a sneeze or cough [16]. Many recent studies provide evidence for indoor airborne transmission of viruses, particularly in crowded, poorly ventilated environments. Morawska et al. [17] state: "While uncertainties remain regarding the relative contributions of the different transmission pathways, we argue that existing evidence is sufficiently strong to warrant engineering controls targeting airborne transmission as part of an overall strategy to limit infection risk indoors". High efficiency particulate air (HEPA) purifier products are emerging which address the issue of indoor air pollution; with an example being that of the Dyson Pure Cool, which is capable of automatically sensing indoor gases and particles, and then, purify the air accordingly. However a simpler solution is to ensure adequate ventilation through the opening of windows [18].

Several IoT systems that monitor air quality have been reported [19–23]. These papers have documented that IoT technology can enable the monitoring of indoor air quality with inexpensive sensors and appropriate communication. However it is often difficult to replicate such a study as sufficient hardware and software information is not normally supplied in research study methodology. The aim of this article is to demonstrate the development, testing and evaluation of a low-cost air quality monitoring system and transfer this knowledge to others. IoT is relevant as it employs sensing and potentially actuation with (often) low cost devices, connected by networks (usually the Internet). The devices can work pervasively on behalf of people, in this case the occupants of a dwelling. By specifying the hardware and making the software available, the work we have undertaken can facilitate knowledge transfer.

The backdrop of the development was of course the 2020 pandemic. As knowledge of transmission has emerged, poorly ventilated indoor spaces has become an area of significant interest. Of course an infection vector is a pre-requisite for onward transmission. However, at present with significant community prevalence, with many asymptomatic individuals, maintaining good air quality is a first line of defence, permitting some degree of normal social interaction. In a meta-analysis by Yanes-Lane et al. [24], 18 of 96 (18.8%) close contacts exposed to asymptomatic index patients were COVID-19 positive (from five transmission studies). However, beyond the current pandemic, quantification of air quality and maintenance of superior quality air will have lasting significance for people with respiratory conditions and to reduce transmission of the common cold and seasonal flu.

2. Background to technology development

IoT is a new concept where smart objects are seamlessly integrated as part of a network; indeed, the smart objects can interact with the world without any human input. IoT allows these smart objects or 'things' to sense, process and execute tasks based on decisions pre-defined in their software; this is where IoT could prove beneficial in controlling indoor air pollution. IoT provides the capabilities of a low cost, unobtrusive solution by monitoring and controlling the indoor air quality in real time; allowing preventative actions to be taken, such as, actuating the opening of a window directly or providing notifications to the occupants to open a window. Furthermore, an IoT indoor air monitoring system can provide

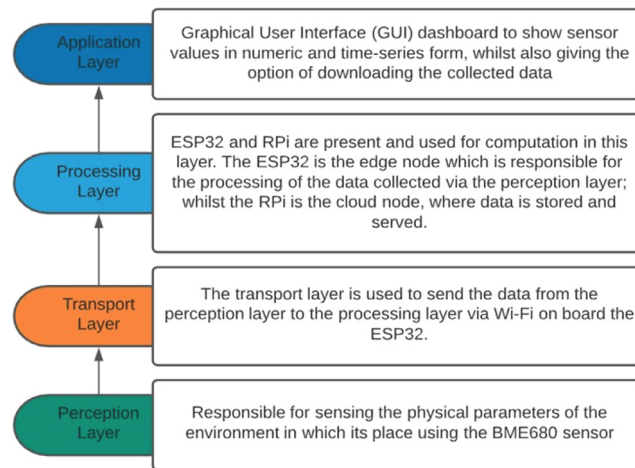

Fig. 1. Four-layer architecture with implementation detail for each layer.

a significant amount of quantitative data, which will prove beneficial in understanding patterns and identifying factors that impact on the air quality, and for the development of innovative solutions to improving air quality.

Ambient temperature, relative humidity and pollutants contribute to the overall indoor air quality (IAQ). Several IoT IAQ applications have been reported which influence the design of our system. Abraham and Li [25] reported a wireless sensor network for the monitoring of indoor air quality. Their system consisted of sensor nodes which measured temperature, humidity, light and IAQ. The sensor nodes communicate readings to a base station using the IEEE (Institute of Electrical and Electronics Engineers) 802.15.4 protocol, with persistent storage on a database via a webserver. Postolache et al. used a similar acquisition architecture (based on IEEE 802.11), but in addition their solution utilized neural networks to process the sensor data to detect air pollution events and sensor abnormalities [26]. Ljubojevic et al. employed IAQ as a factor which contributed to overall human Quality of Life (QoL) [27]. Their monitoring solution consisted of temperature, humidity, and total volatile organic compound sensors. The sensor data were processed by an Arduino Uno, and stored locally on a SD card for further analysis. The implementation provided in the 'tutorial' section utilizes elements from these studies to provide a low-cost, end to end solution.

3. Tutorial: step by step guide to implementation

This section provides a guide to the implementation of the proposed monitoring solution. The end-to-end solution is comprised of hardware and software design, implementation, normalisation, data collection and data analytics.

Step 1: IoT architecture and system design

According to Sethi and Sarangi [28], the most used IoT architectures are comprised of three or five layers. The three-layer architecture consists of a perception layer, a network layer and an application layer; however, as IoT capabilities and applications continued to grow the three-layer architecture was not sufficient for the finer details of IoT. The five-layer architecture refined the network layer to a transport layer and a processing layer. Furthermore, the five-layer architecture added a business layer which deals with profit models; however, as this is exclusively a research study the business layer is out of scope and has been excluded. Fig. 1 illustrates the structure of the four-layer architecture with the exclusion of the business layer subsequently adopted.

Built upon this architecture, Fig. 2 gives a diagrammatic view of IAQ system components. These comprise: BME680 air quality sensor, ESP32 microcontroller unit (edge device), Raspberry Pi (RPi) server and Web server. The headless RPi is running a LAMP (Linux, Apache, MySQL, PHP) server paired with the NO-IP dynamic DNS service to allow for a low cost, low power server; two characteristics which are imperative in this IoT system. A headless RPi is where there are no I/O peripherals, only a power supply. The total cost of the hardware is approximately £100 pounds (sterling).

The perception layer is responsible for sensing the physical parameters of the environment in which its placed. As the aim of this study is to monitor and analyse indoor air quality, the perception layer is comprised of a Bosch BME680 breakout board. The BME680 is classed as a 4-in-1 sensor, which has the capabilities of sensing temperature, humidity, pressure, and gas [29]; it can detect VOCs, the main culprit in indoor air pollution. The transport layer is responsible for the data transportation from the perception layer to the processing layer. This is accomplished by a Wi-Fi-enabled ESP32 microcontroller, which sends the data to a RPi. The ESP32 component is present in both the transport layer and the processing layer. The processing layer is responsible for the storage, analytics and processing of the data sent over the transport layer. The ESP32 processes the data collected via the perception layer. The data are stored locally and the Indoor Air Quality calculation is performed. Further data processing is performed on the server side with software implemented by a RPi. It processes the sensor data and sends it to a MySQL database; whilst also serving a dynamic and responsive web application in the ap-

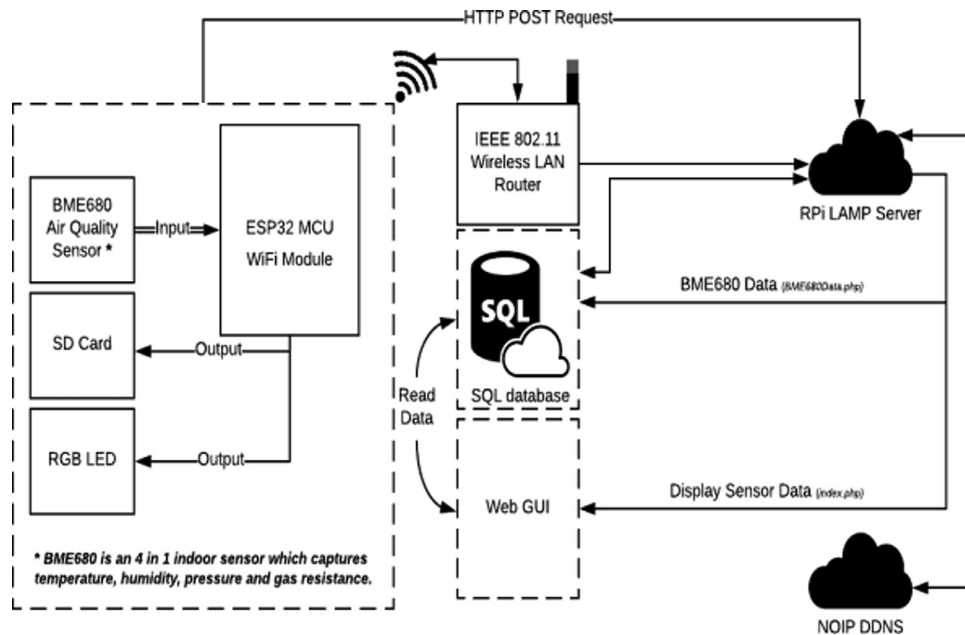

Fig. 2. IAQ system components and their interaction.

plication layer. The application layer is responsible for delivery of application specific services to the user. It provides the graphical user interface (GUI) dashboard, responsible for the displaying sensor values and IAQ calculations.

Live monitoring of one or more sensor nodes is achieved using a custom built web application, where users (e.g. household participants, researchers, service companies) can observe sensor readings, and the computed IAQ score. The system is designed to work with a standard home installation wireless router. The LAN Router provides wireless connectivity between the ESP32 microcontroller and the edge and server nodes. The ESP32 polls the BME680 sensor for the sensor readings; the gas and humidity readings become inputs to a function to calculate the IAQ index developed by Bird for static weather stations [30].

The IAQ index is a function of humidity that contributes up to 25% and gas concentrations that contributes up to 75%. The algorithm works as follows, when the humidity reaches 40% it is classed as optimal, resulting in a 0% contribution to IAQ index. However, when humidity level drops towards 0% or increases towards 100%, there is a gradual contribution to the overall IAQ index. Similarly, for gas concentration a linear relationship is assumed with the IAQ index, and the output scaled accordingly between 0% and 75% for the minima and maxima of the BME680 sensor. Combined humidity and gas measurements are converted into quantitative IAQ index with values scaled from 0 to 500, where a 500 value is 'hazardous' and descriptive values are applied for interim stages from 'good' to 'hazardous' air quality.

However, the computed IAQ index is not a metric measured by the BME680 sensor, instead it is a computation which takes place in the ESP32 microcontroller from Bird's software function; its returned index has been implemented exclusively as a proof of concept which has not been used in deriving the result set of this study. In its place, gas resistance (Ω) has been used to determine the cleanliness of the air (see Step 6). Once calculated, the IAQ index and sensor readings are stored locally on an SD card; the data are also sent via a HTTP POST request to the server, hosted on a RPi. The RGB LED (see Fig. 2) serves as a hardware debugging feature, it works by turning green if the sensor data have been successfully transmitted to the server, or red otherwise. Server side Hypertext Preprocessor (PHP) code is then used to process the data, and store the results to the MySQL database.

The stored data are displayed on a Graphical User Interface by a web application. The information provided is comprised of the individual sensor readings, IAQ index, and a two-hour time series of both the individual sensor readings and the IAQ index. In addition, the RPi server is linked to the No-IP Free Dynamic Domain Name System (DDNS) service. This is achieved by a script written on the RPi, which is run at 30 min intervals, and informs the No-IP service of the newly updated IP. This gives the local sever the capability of being accessed from outside the local network.

Step 2: Study DESIGN

The study was implemented in three phases, taking an agile software engineering approach. Phase 1 comprised of hardware and software implementation, phase 2 comprised of data collection and phase 3 data cleaning and analysis. The first period was 28th July–11th August 2020, with a second data collection period 5th–19th November 2020. Each experimental data collection period lasted two weeks. The second period coincided with a local lockdown, meaning that people spent more time in the house, further exacerbating the seasonal trend. Over each two weeks, data were collected from the kitchen

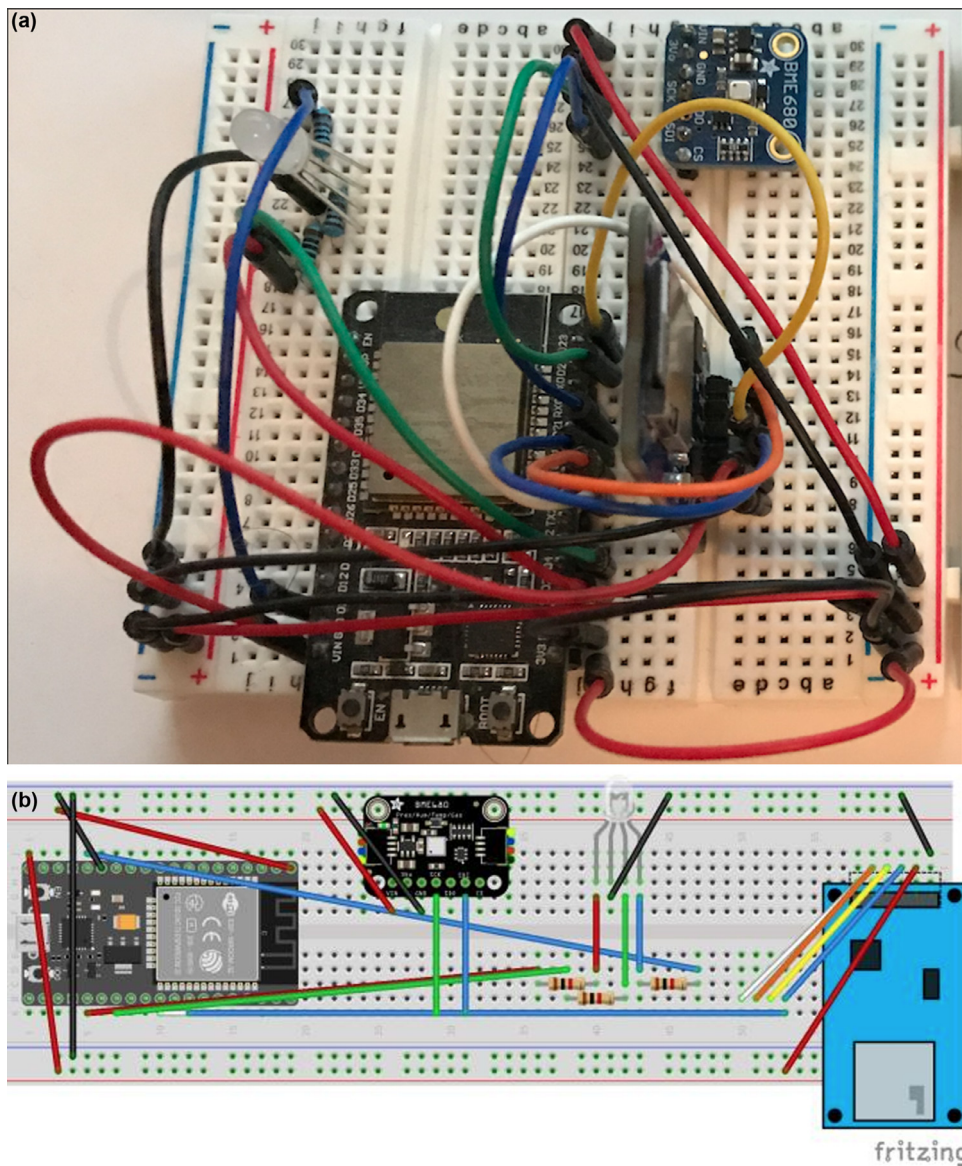

Fig. 3. Hardware setup illustrating BME680 sensor and ESP32 micro controller unit (physical components left and wiring right).

and study, these data were stored on the ESP32 MCU and on the server for persistence and further analysis. At the end of the data collection period, the data were cleansed and a statistical analysis was performed.

Step 3: Hardware implementation

The acquisition hardware collected the air quality data and stored these data locally via an SD card and in a database. Fig. 3 illustrates the acquisition hardware system combining BME680 and ESP32. The completed hardware acquisition components are described in Table 1.

Step 4: Software components

The software design has been implemented in three sections (data acquisition, back-end analysis, front-end display) with appropriate software tools, Table 2. The software components are available on GitHub at [31].

Fig. 4 provides a view of the code structure. Once the microcontroller is powered up, the software enters the *setup()* stage; this is where the internet connection is established. When the setup is complete, the software enters the *loop()* stage (an infinite loop), where the code runs until the device powers down. However, when the internet connectivity drops out, execution remains stuck in the loop, necessitating a manual reset.

The data acquisition software polled the BME680 sensor (approximately) every 10 s, calculated the IAQ index, stored the sensor data and IAQ index into both the SD (secure digital) card, and the MySQL database located on the RPi server. In addition, all of the data collected from the sensors were inserted into the MySQL database via prepared statements. This

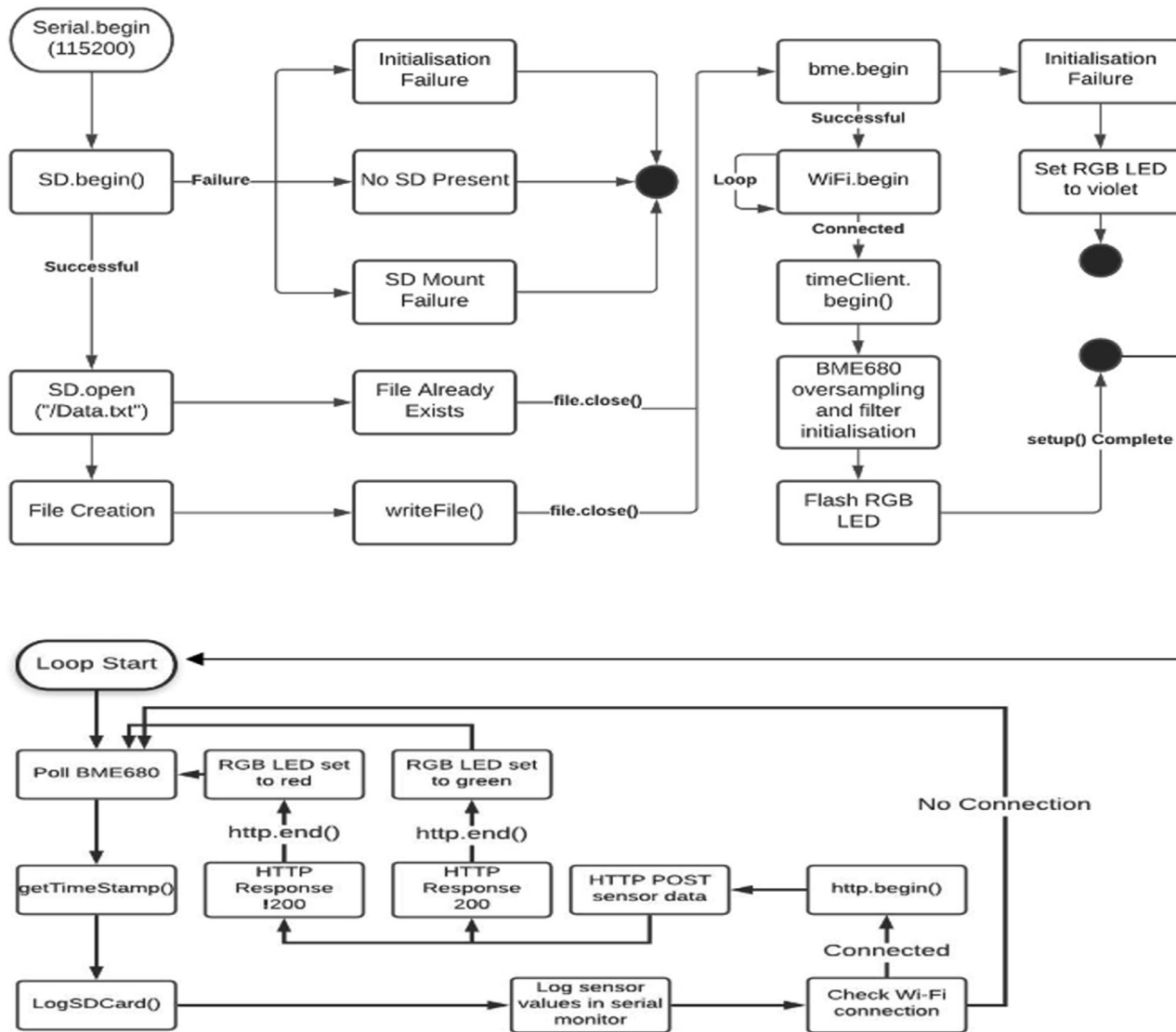

Fig. 4. ESP32 code structure – state flow diagram.

Table 1
Hardware acquisition components.

Component	Description
ESP32 Microcontroller	Inexpensive microcontroller which has integrated Wi-Fi to allow for transmission of the collected and processed data. This is classed as the "brain" of the system, where all the computation occurs.
Bosch BME680	Gas sensor measuring relative humidity, barometric pressure, ambient temperature, and gas (VOC) [21]. It also contains a small MOX sensor; the heated metal oxide changes resistance based on the volatile organic compounds (VOC) in the air, so it can be used to detect gasses and alcohols such as Ethanol, Alcohol and Carbon Monoxide. This sensor allows for the monitoring of IAQ using the mentioned variables. Furthermore, there is an onboard IIR filter in the this sensor; the IIR filter protects sensor readings against transient changes in conditions, e.g. a door slamming will cause the pressure to change momentarily, and the IIR filter will filter out these transient spiky values.
SD Card Reader	Micro SD card where the sensor data are locally stored.
RGB LED	Used as hardware debugging feature, to visualise the events specified in the requirements lists.
3 × 2K Ohm Resistors	Used to limit the current on the <i>red</i> , <i>green</i> , and <i>blue</i> legs of the LED to reduce brightness.

Table 2
Software components: code components are available at [31].

Type	Integrated development environment	Language(s)
Data acquisition	Arduino	C/C++
Back-end analysis	Eclipse, RStudio	PHP, MySQL, R
Front-end display	Eclipse	HTML5,CSS, JS, Ajax

approach adds a layer of security to the web application by splitting the query from the data, so that the data submitted cannot be used to alter how the query is run; thus preventing injection attacks.

Following the successful insertion of data into the database, the data were then displayed on a GUI, using a responsive and dynamic dashboard web application, as seen in Fig. 5.

The dashboard makes use of Hypertext Markup Language (HTML5), Cascading Style Sheets (CSS), and JavaScript. The dashboard gives a graphical insight into the data collected from the sensor systems in both the kitchen and study. ChartJS was used to display time series graphs of the sensor reading stored in the MySQL database. The values seen on the left side of Fig. 5, are dynamically updated every 10 s, whereas the time series values are updated every 1 min to show two hour epochs of data. AJAX was used to auto-update the data, meaning the web application can send and retrieve data from the server asynchronously without interfering with the display and behaviour of the existing page.

When the data collection period elapsed, the data were cleansed and a statistical analysis was performed using the R programming language. R is open-source software that allows for rapid prototyping for statistical analysis and visualisations; moreover, R provides several useful libraries and tools for machine learning.

Step 5: Controlled actuation experiment

Cleaning products and indoor chemical reactions release VOCs which reduces air quality. To further understand this, a controlled experiment was conducted using two commonly used household products. The experiment was conducted over a 75 min timeframe.

Fig. 6 shows the time series of the controlled experiment, with the y axis representing gas resistance. To ensure a fair test, the BME680 sensor was ran for the "burn-in" period of 60 min, as recommended in the sensor specification. The sensor is stabilized at 300 K Ω . The first contaminant introduced was that of a disinfectant aerosol spray. The aerosol was sprayed approximately eight feet from the sensor; resulting in a significant almost instantaneous drop in gas resistance, which indicates a strong presence of VOCs. The aerosol was sprayed at 14:40, and at 14:44 the gas resistance arrived its lowest resistance, indicating 'hazardous' air quality. From 14:44 the VOCs start to slowly dissipate for a 10 min period; until the window is opened at 14:55, where the air quality improves at a faster rate. At 15:03 the sensor has reached a state of semi-stabilization, where the gas resistance is at approximately 290 K Ω . At 15:07, the window was closed and a second product was introduced, in the form of a generic incense stick. The incense burnt for a period of 23 min, which resulted in a slow decrease of the air quality level. The incense was then removed from the room and the air quality increases over a 4 min period, until the window was reopened at 15:34, resulting in the rapid increasing of air quality and the re-stabilization of the sensor readings. The event timings allowed the sensor to resistance to return to near baseline and were guided by feedback from the dashboard.

The results from this controlled experiment gives insight into the impact of these two commonly used household products. Both products lower the air quality of the room; however, it is clear to see that the aerosol disinfectant spray lowers the air quality much quicker and takes a longer period to dissipate.

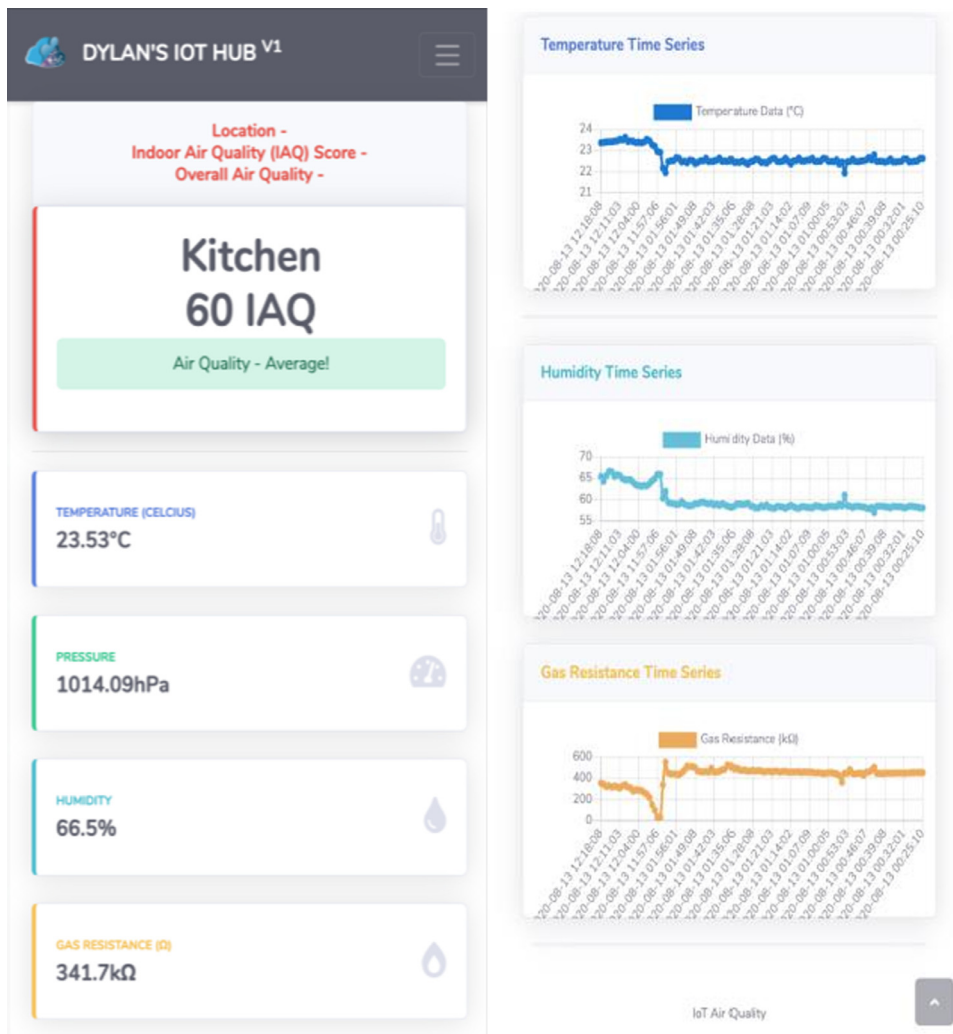

Fig. 5. Dashboard visualization using the web application.

Table 3
Normalisation of BME680 – summer and autumn.

Location	Epoch	Minima (KΩ)	Maxima (KΩ)	Mean, μ (KΩ)	Std dev, σ (KΩ)
Kitchen	Summer	10.41	816.03	454.63	98.12
	Autumn	15.56	783.65	438.77	120.18
Study	Summer	6.88	436.85	250.83	47.61
	Autumn	6.15	612.92	328.09	77.22

Step 6: Normalisation for trend comparison across sensors

Gas resistance is the metric measured by the BME680 sensor, the higher the gas resistance, the cleaner the air. However, over both two-week data collecting periods, it was observed that the sensor placed in the kitchen had a higher maxima gas resistance value than the sensor placed in the study, as seen below in Table 3.

To identify trends in the collected gas resistance data, gas values were normalised for both the kitchen and study. The Z-score normalization technique was used:

$$Z = (x - \mu) / \sigma$$

where Z is the standard score, x is the raw score or gas resistance values, μ is the population mean, and σ is the population standard deviation.

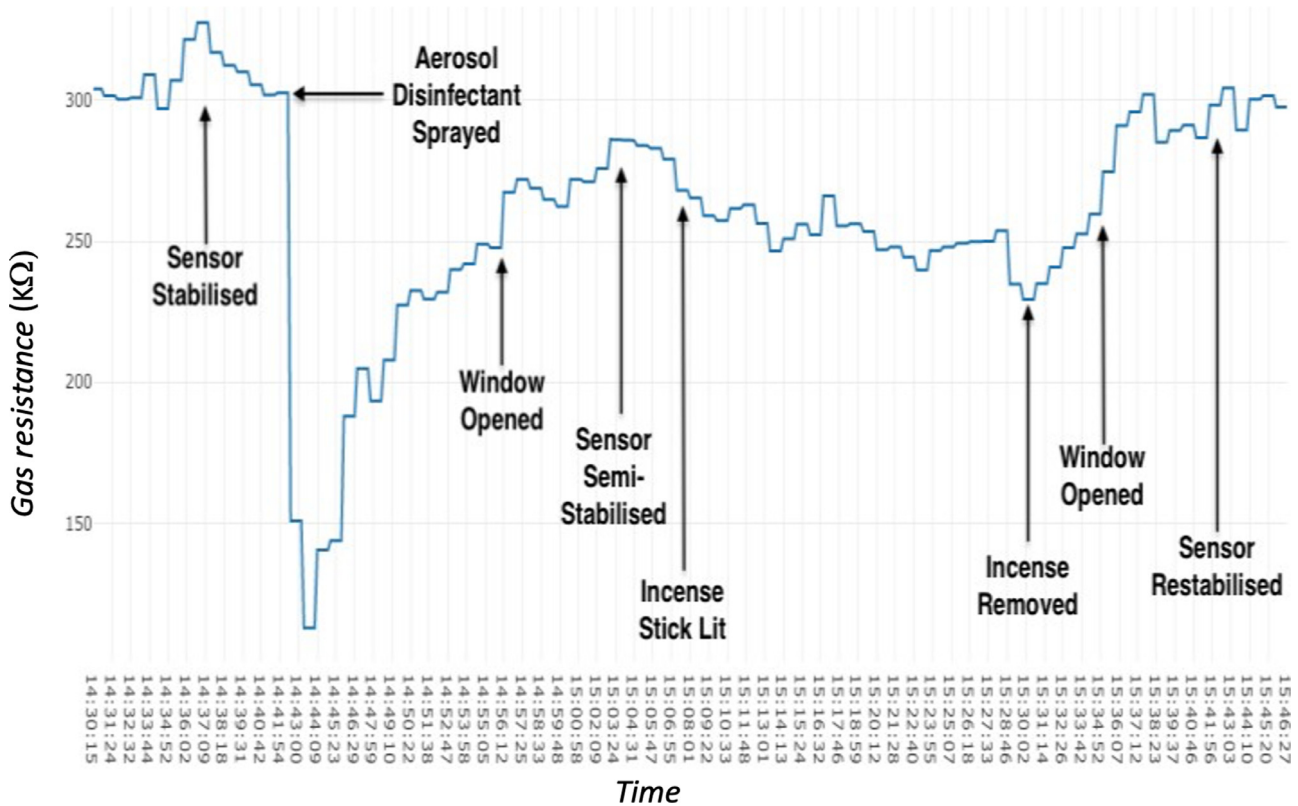

Fig. 6. Controlled experiment: effect of disinfectant and incense (gas resistance against time).

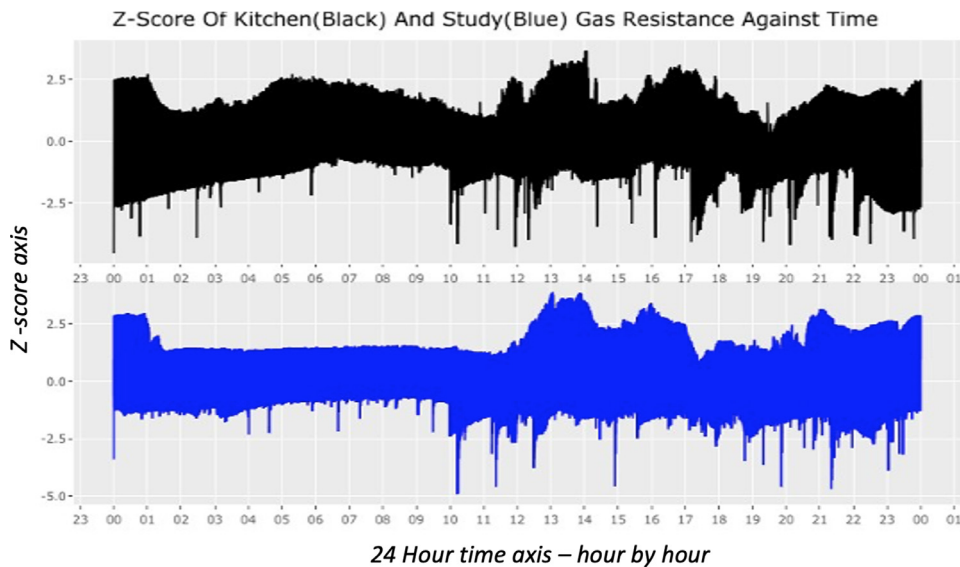

Fig. 7. Z-Score time series: normalized gas resistance (y-axis) against time (one day is the x axis time frame). Top figure (black) is the kitchen and bottom figure (blue) is the study (Summer).

4. Results – longer term monitoring

Fig. 7 shows the Z-score values of the normalized gas resistance from the kitchen and study. The x axis consists of a full 24 h day, with 14 days of data superimposed. This indicates the overall trends of the full data collection period. The data indicate that from 01:00 to 09:00 the air quality in the study stays low and consistent. This is due to minimal ventilation throughout the night, with the window and door being closed. In comparison, the kitchen air quality through 01:00–09:00 indicates that the air quality gradually increases until 06:00, then it starts to decrease until 09:00; however, the air quality remains cleaner in the kitchen, due to the door being open throughout the night, which promotes air flow.

Furthermore, a shared trend across both locations, is that gas resistance peaks around 13:00, and then both locations share the same pattern to approximately 17:00; when the kitchen air quality starts to diminish, due to cooking (while heating oils and fats when cooking, harmful VOC's can be released). This kitchen trend continues approximately 19:30, which represents a pattern of further meal preparation from one member of the household. There are downward 'spikes' in both datasets, this is due to the sensor having to be reset, an error condition due to inconsistent Wi-Fi.

To further understand the datasets, correlation tests were performed on gas resistance against both humidity and temperature. Figs. 8 and 9 are produced from the *GGally* package in R. In this case we are only interested in the correlations between gas (relating to air quality) and temperature and humidity. The matrix illustrates scatterplots of each variable pair (lower left), Pearson correlation (upper right) and variable distribution (diagonal). Fig. 8 shows gas, temperature, and humidity correlation in the kitchen. The temperature to gas correlation is weak at $R = -0.157$ and there is no evidence of linearity; represented on the bottom left scatter plot. Fig. 9 is the matrix containing the data collected from the study, which shows that the correlation between gas resistance and temperature is weak with a negative $R = -0.111$. The values indicate that temperature has minimal impact on the IAQ. However, in both the kitchen and study, the correlation between gas and humidity is much stronger, (kitchen $R = -0.624$, study $R = -0.692$). This indicates that there is a strong negative linear relationship between both humidity and gas resistance; meaning that as humidity rises, gas resistances lowers, resulting in poorer IAQ. In addition, this is visually represented on the middle left scatter plot on both Figs. 8 and 9; where a negative linear trend can be observed. The temperature to humidity correlation is weak (kitchen $R = -0.193$, study $R = -0.298$) and there is no evidence of linearity; represented on the bottom middle scatter plots.

The recordings were repeated in the month of November (Autumn) to investigate whether the air quality would suffer due to people spending extra time at home. This was exacerbated by a COVID-19 'lockdown' which meant that external social meeting activities were inhibited by the authorities [32]. This of course meant that people would be at home more often.

Fig. 10 shows the Z-score values of the normalized gas resistance from the kitchen and study, again with 14 days of data superimposed for the autumn period. Fig. 11 overlays the autumn series upon the summer period, for kitchen and study. While the trends are maintained, the air quality gets worse in the evenings. This may be due to the heating being on for longer and the necessity of less ventilation to keep draughts out of the rooms. Table 4 provides a comparison of the correlation coefficients for kitchen and study for each measure, across the recording epochs. These are derived from summer

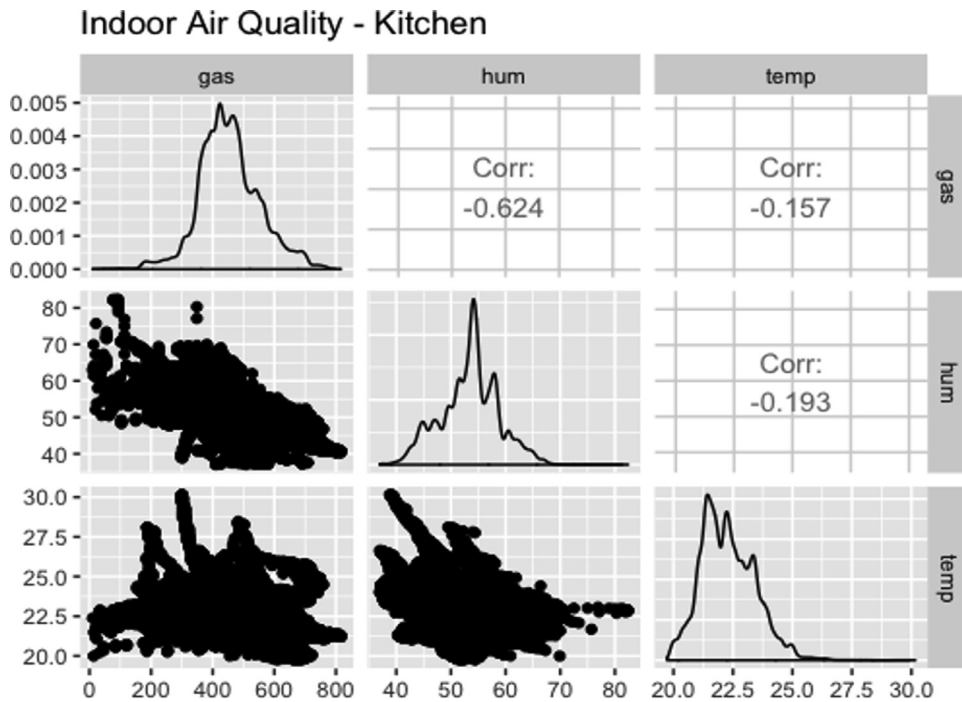

Fig. 8. Gas, temperature and humidity correlation – kitchen (summer).

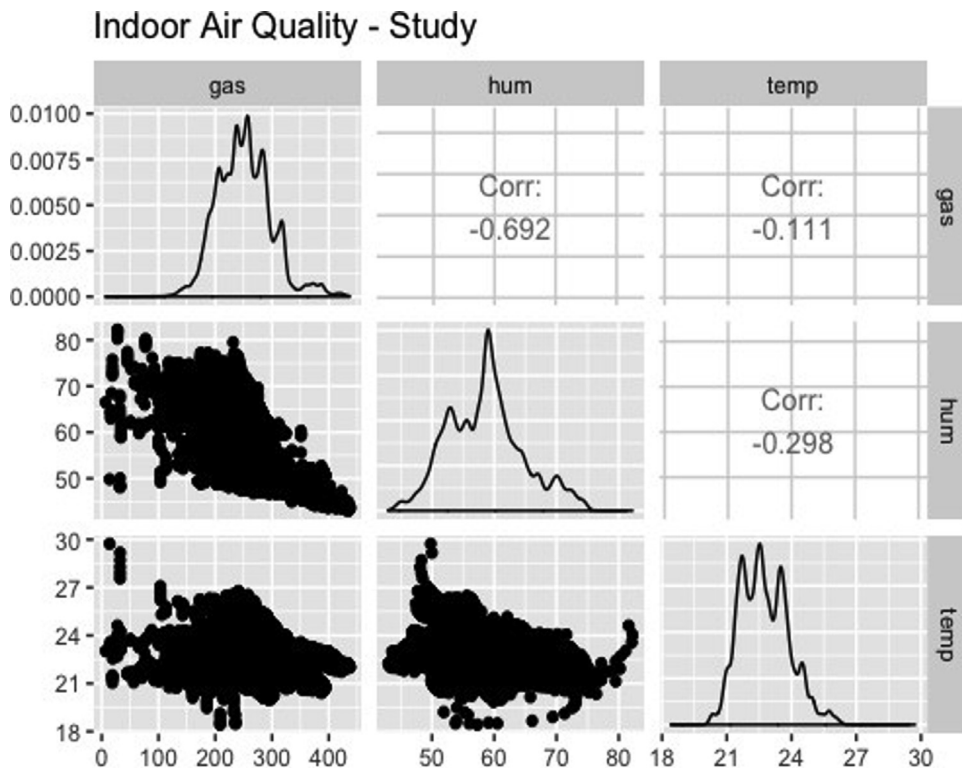

Fig. 9. Gas, temperature and humidity correlations – study (summer).

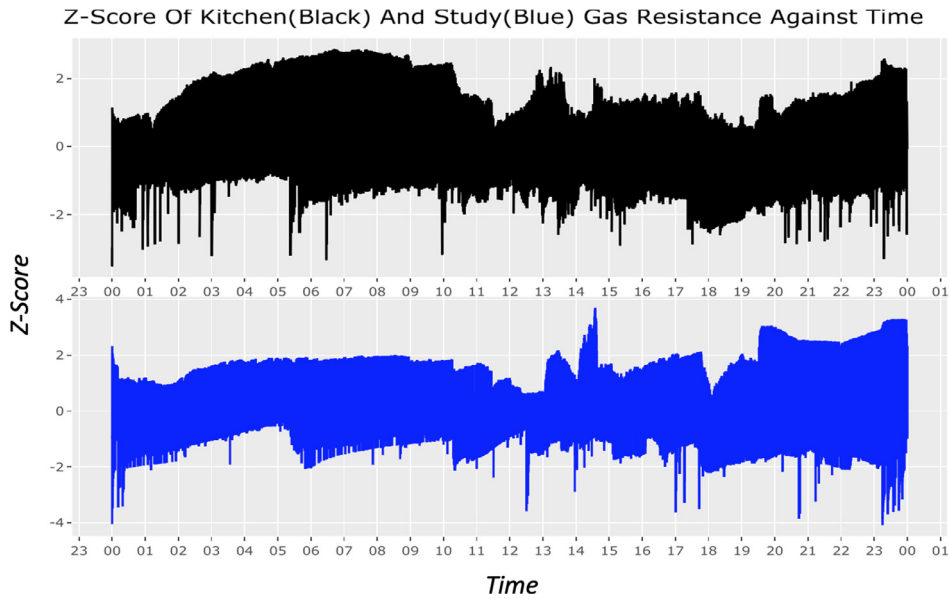

Fig. 10. Z-Score time series: normalized gas resistance (y-axis) against time (one day is the x axis period). Top figure (black) is the kitchen and bottom figure (blue) is the study (autumn).

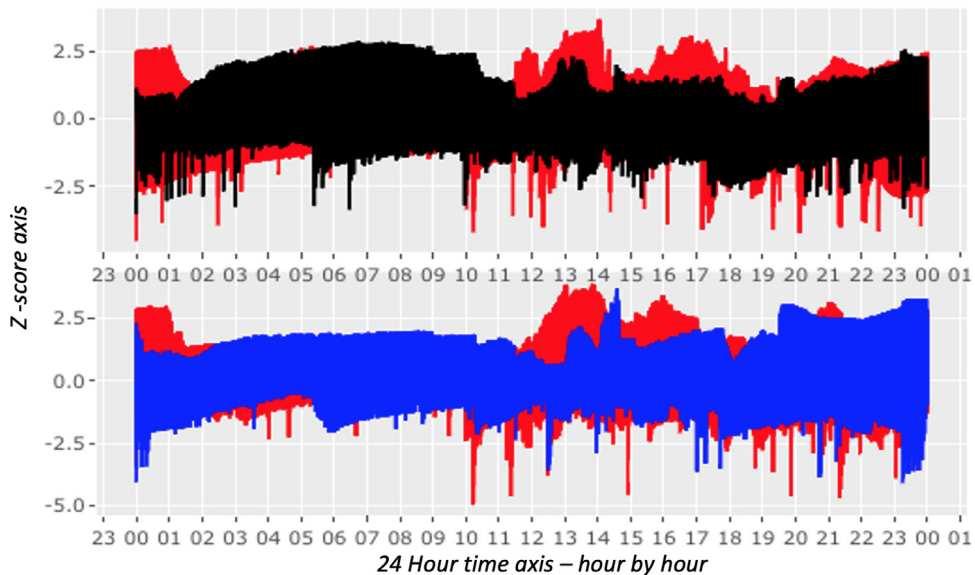

Fig. 11. Summer data (red) is overlaid by the autumn data; kitchen (black) and study (blue).

data (Figs. 8 and 9) and autumn data (Figs. 12 and 13). The high negative correlation between humidity and gas resistance is confirmed. Temperature has a higher correlation to gas resistance and hence IAQ in the autumn epoch.

5. Discussion

This work presented a tutorial and demonstration for the implementation of an IoT approach to monitoring of indoor air quality. The solution shows that low cost (less than £100) IoT components can indeed monitor air quality. A low cost IoT solution could be significant in the task of monitoring, quantifying and then improving IAQ. As this study shows, the indoor BME680 sensor can sense the environment and provide useful information about IAQ. Furthermore, these data could then be used in a smart home environment, where an action, like opening a window or turning on an air purifier, could be triggered once the air quality drops below a set threshold; which could mitigate against risk of any illness attributed to poor IAQ. However we have not implemented any intervention over the two 2-week trials, so further work is required. The data collection was limited to summer and autumn. Hence we provide two snapshots to show variation and hence provide

Indoor Air Quality - Kitchen - Winter

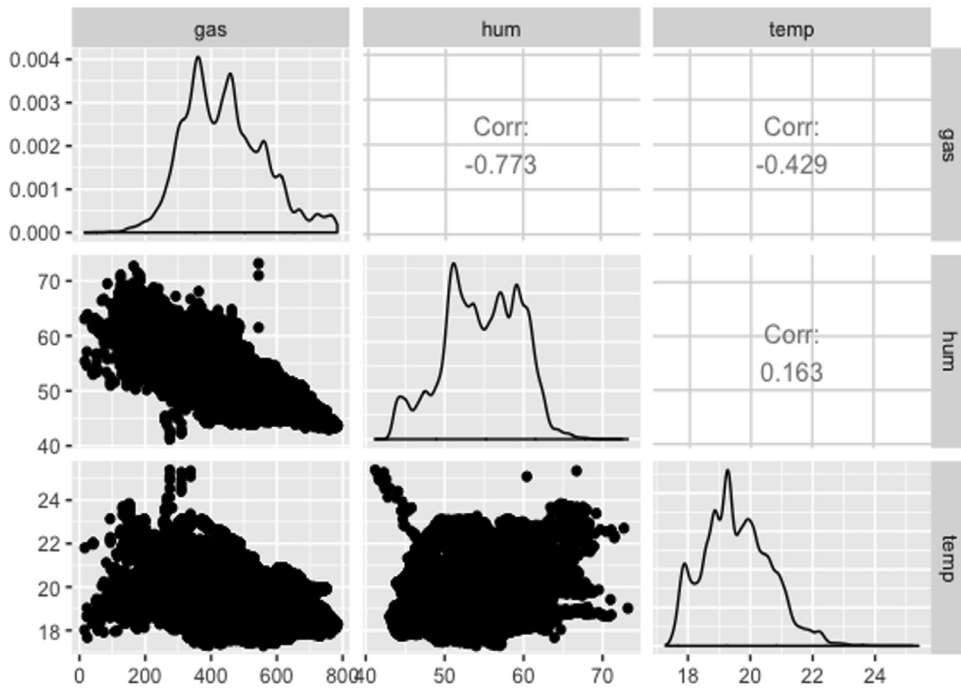

Fig. 12. Indoor air quality kitchen (autumn).

Indoor Air Quality - Study - Winter

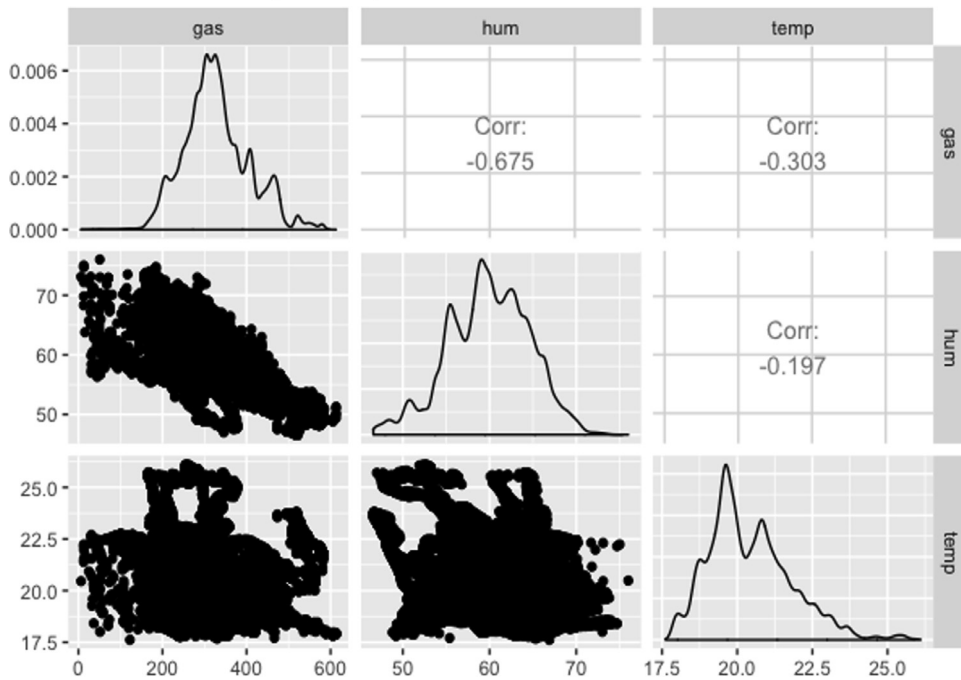

Fig. 13. Indoor air quality study (autumn).

Table 4
Correlations between humidity, temperature, and air quality – summer and autumn.

Location	Epoch	Humidity – gas, R	Temperature – gas, R	Humidity – temperature, R
Kitchen	Summer	-0.624	-0.157	-0.193
	Autumn	-0.773	-0.429	-0.163
Study	Summer	-0.692	-0.111	-0.298
	Autumn	-0.675	-0.303	-0.197

verification of the approach. Of course, it would be beneficial to collect a full 12 months of data, to observe the change in IAQ with season and weather events.

The dashboard provides users with more of an awareness of IAQ, allowing the user to view the IAQ as numerical values or as a time series. Furthermore, a proof of concept IAQ calculation gives descriptive information from the sensor data, which would allow users to view their IAQ index. However, additional work on user interface may be required to address interpretation and improve user experience. The dashboard includes a function which allows users to download the accumulated IAQ sensor data from both the kitchen, and study; amounting to 270,000 rows, of data from each two week period. This could be exported and analysed by researchers, resulting in an increase of awareness surrounding IoT and IAQ monitoring.

However, two factors such are worthy of further consideration: precision and reliability. The first refers to the consistency of the gas resistance values of the BME680 sensor, and involves sensitivity and dynamic range. Overall the sensor worked as it should in detecting resistance variation (VOCs and pollutants), however the sensor placed in the kitchen consistently read higher resistance values, than the one in the study (refer to Table 3). This was confirmed when the sensors were tested side by side in the same room as part of a calibration procedure. Due to this sensor calibration limitation, the air quality labels could be inaccurate. Indeed, we found that the IoT sensors varied in their sensitivity and dynamic range and hence normalisation was needed for comparison across sensors. This is indeed a major issue with trust in IoT networks.

A second limiting factor was that of a 'drop-out' of internet connectivity in the ESP32. This relates to the reliability of the end to end system. Loss of connectivity resulted in the ESP32 having to be manually reset via the onboard reset button. This poses a problem if the sensor were to drop connection during the night and shows that an IoT solution may be compromised by any vulnerable component, in this case internet connectivity. Once the ESP32 had been reset, the BME680 had to run through its "burn-in" period, where the gas resistance values would read at its lowest resistance, giving large downward artefacts as seen in Fig. 7. This is due to the structure of the code that is written on an Arduino platform microcontroller, like the ESP32. It could be mitigated by having less reliance on synchronous edge node communication.

The aerosol disinfectant sprayed used in the controlled experiment has demonstrated a >99.9% effectiveness against coronavirus strains from the same family as the COVID-19 in third party laboratory testing. The manufacturers are confident that it will work as effectively against the new strain [33]. This suggests that disinfectant aerosols, which have been used frequently throughout the COVID-19 pandemic, may result in elevated IAQ in homes and offices buildings throughout the country. Whilst people are protecting themselves from COVID-19 using aerosol disinfectants, they may be putting themselves at higher risk of the long-term illnesses attributed with poor air quality. The speed of transmission and detection, see Fig. 6, may replicate the indoor mode of infection (e.g. by a cough or sneeze) and indeed underlines the need for ventilation to assist expedited dispersion.

A controlled study conducted by Markowicz and Larsson [34], proved the strong linear relationship between gas resistance and humidity. There was 3-fold increase of the air concentrations of VOC concentration, (emanating from plastics, apparel, furniture and wallpaper) shortly after increasing the humidity. Thus we have not reported new knowledge, but this does provide some independent verification of our technology implementation and validation of our findings. The monitoring system could be extended as follows.

It would be appropriate to scale up the sensor nodes and place them in every room of the home to get a greater understanding of the IAQ of the whole home. This would be in addition to extending the recording period. Furthermore, implementing the Bosch Sensortec Environmental Cluster (BSEC) [35] library in place of the IAQ index calculation developed by Bird [31], would prove more efficient and reliable in providing an IAQ index. In addition, the BSEC library calculates multiple IAQ indices, with one of them being sIAQ. This acronym stands for *static Indoor Air Quality*, the calculation for this index has been optimised to perform best with static applications, such like the one developed in this study. Whereas, the BSEC IAQ index is best optimised for mobile applications such like a smart watch, for example. However, this library requires large computational requirements, which could negatively impact the performance of the data transmission to the server.

Attention should be given to power consumption, as the current software implemented on each system utilizes an infinite loop which is inefficient. A restructuring of the code would allow for sleep cycles to take place, and only would wake up and take a reading from the sensor, resulting in a greener computing solution. Machine learning could be implemented on the back end to predict IAQ events based on meta data (e.g. weather forecast, occupancy derived from smart home sensors); the prediction could provide preventive intervention to maintain good air quality. Such an approach would find significant support given the recurrent lockdowns due to COVID-19 but this would be of particular benefit to those suffering long term respiratory conditions. Open-source technologies and low cost hardware were used where possible in the development. Moreover, simply detecting anomalies or using time series analysis to detect changes in the trend would be helpful in

altering occupants' behaviour. The solution consisted of one BME680 4-in-1 IAQ monitoring sensor; however, the design is such that scalability can be accommodated, e.g. if an extra sensor were added to monitor a specific such as, particulate matter (PM).

6. Conclusions

A recent article in BBC futures stated that: "There's a murky relationship between air pollution and coronavirus, which may mean that tackling air pollution will be a crucial part of easing lockdown" [36]. There is increasing evidence that links the transmission of virus to indoor air quality. Airborne transmission of bioaerosols produced by asymptomatic individuals during breathing and speaking is responsible for a substantial portion of the spread of coronavirus disease [37, 38]. Fluid mechanics simulations indicate the potential for indoor virus spread in contained spaces [39]. Nwanaji-Enwerem et al. [15] propose practical measures: (i) remove shoes at the door to avoid tracking harmful particles inside. (ii) consider using a high efficiency particulate air (HEPA) purifier in the home. This can help remove larger viral/microbiome agglomerates from the air; (iii) open windows to improve indoor air circulation and dilute indoor contaminants; (iv) ventilate the kitchen to avoid harmful exposures to fumes and particulate matter; (v) when cleaning, avoid the overuse of chemicals and air fresheners that may simply be contributing additional hazardous substances to the air. In addition, we would add our contribution that indoor air quality monitoring based on IoT can alert to deterioration, allowing for some actuation.

The paper presents a tutorial to implementing an end-to-end IoT solution to monitoring indoor air quality; based on a four layer IoT architecture. It is important to emphasise that we are not claiming to measure any correlations with the COVID-19 virus, but we postulate that enhancing IAQ has some potential to mitigate against the indoor spread of common air-borne viruses and pollutants which affect respiratory disease. The developed system aims to be an IAQ monitoring solution that provides data for the user, in near real time, assuming itself as a potential solution to mitigate against poor air quality based on the paradigm of IoT.

The results from the two 2-week data collection periods show that the IAQ often contrasts with what is classed as normal for healthy everyday living. The collected dataset may provide a contribution to environmental IAQ studies, as it provides two, 2-week sets of IAQ data, for two contrasting locations in the same house.

An advantage of this end-to-end IoT system is the use of wireless technology for communication between the sensor nodes and the low power RPi server. The responsive web application uses remote real-time monitoring, due to the use of the free NO-IP service. This may help the user to maintain good IAQ in the home, which could result in preserving wellbeing. According to United Nations Economic Commission for Europe (UNECE), air pollution is now considered to be the world's largest environmental health threat [40], and we believe that further monitoring is need to inform and become a factor for change.

Declaration of Competing Interest

The authors declare that they have no known competing financial interests or personal relationships that could have appeared to influence the work reported in this paper.

Acknowledgements

The authors wish to acknowledge support of tutors in MSc Internet of Things, in particular Dr Shuai Zhang, the Course Director, and Professor Chris Nugent the Head of School of Computing.

References

- [1] World Health Organization, 2020. [Online]. Ambient air pollution, Available: <https://www.who.int/airpollution/ambient/en/>. [Accessed: Feb- 2021].
- [2] Air quality in Europe – 2020 Report (No 09/2020), European Environment Agency, <https://www.eea.europa.eu/publications/air-quality-in-europe-2020-report> [Accessed: Feb- 2021].
- [3] British Lung Foundation, 2020. [Online]. What is indoor air pollution? - British Lung Foundation Available: <https://www.blf.org.uk/support-for-you/indoor-air-pollution/about-indoor-air-pollution>. [Accessed: Feb -2021].
- [4] BBC News. [Online]. Ella Adoo-Kissi-Debrah: air pollution a factor in girl's death, inquest finds, <https://www.bbc.co.uk/news/uk-england-london-55330945> [Accessed: Feb -2021]
- [5] K.W. Tham, Indoor air quality and its effects on humans—a review of challenges and developments in the last 30 years, *Energy Build.* 130 (2016) 637–650.
- [6] World Health Organization 2020. [Online]. Household air pollution and health, Available: <https://www.who.int/news-room/fact-sheets/detail/household-air-pollution-and-health>. [Accessed: Feb -2021].
- [7] S. Colclough, O. Kinnane, N. Hewitt, P. Griffiths P, Investigation of nZEB social housing built to the passive house standard, *Energy Build.* 179 (2018) 344–359 2018.
- [8] P. Bluyssen, *The Indoor Environment Handbook, How to Make Buildings Healthy and Comfortable*, Earthscan, London, 2009.
- [9] Indoor Air Quality Scientific Findings Resource Bank [Online]. Volatile Organic Compounds, [iaqscience.lbl.gov](https://iaqscience.lbl.gov/voc-summary), 2020. Available: <https://iaqscience.lbl.gov/voc-summary>. [Accessed: Feb -2021].
- [10] D. Mulenga, S. Siziya, Indoor air pollution related respiratory ill health, a sequel of biomass use, *SciMedicine J.* (2019), doi:10.28991/SciMedJ-2019-0101-5.
- [11] C. Shrubsole, S. Dimitroulopoulou, K. Foxall, B. Gadeberg, A. Doutsis, IAQ guidelines for selected volatile organic compounds (VOCs) in the UK, *Build. Environ.* 165 (2019) 106382 ISSN 0360-1323, doi:10.1016/j.buildenv.2019.106382.
- [12] M.Y. Zakaria Abouleish, Indoor air quality and coronavirus disease (COVID-19), *Public Health* (2020) [Accessed: Feb 2021], doi:10.1016/j.puhe.2020.04.047.

- [13] N. Klepeis, A. Tsang, J. Behar, Analysis of the National Human Activity Pattern Survey (NHAPS) Respondents from a Standpoint of Exposure Assessment, National Exposure Research Laboratory, Office of Research and Development, U.S. Environmental Protection Agency, Las Vegas, Nev., 1996.
- [14] World Health Organization, 2020. [Online]. Minimizing the COVID-19 risk: advice to individuals, communities and governments for the winter holidays, <https://www.euro.who.int/en/health-topics/health-emergencies/coronavirus-covid-19/news/news/2020/12/minimizing-the-covid-19-risk-advice-to-individuals,-communities-and-governments-for-the-winter-holidays> [Accessed: Feb- 2021].
- [15] J.C. Nwanaji-Enwerem, J.G. Allen, P.I. Beamer, Another invisible enemy indoors: COVID-19, human health, the home, and United States indoor air policy, *J. Expo. Sci. Environ. Epidemiol.* 30 (2020) 773–775, doi:10.1038/s41370-020-0247-x.
- [16] Hexagon.com [Online]. Stay Safe with Coronavirus Simulations <https://hexagon.com/about/covid-19/simulations>. [Accessed: Feb- 2021].
- [17] L. Morawska, J.W. Tang, W. Bahnfleth, et al., How can airborne transmission of COVID-19 indoors be minimised? *Environ. Int.* 142 (2020) 105832 ISSN 0160-4120, doi:10.1016/j.envint.2020.105832.
- [18] Health and Safety Executive. Ventilation and air conditioning during the coronavirus (COVID-19) pandemic, <https://www.hse.gov.uk/coronavirus/equipment-and-machinery/air-conditioning-and-ventilation.htm> [Accessed: Dec- 2020].
- [19] G. Parmar, S. Lakhani, M.K. Chattopadhyay, An IoT based low cost air pollution monitoring system, in: Proceedings of the 2017 International Conference on Recent Innovations in Signal processing and Embedded Systems (RISE), Bhopal, 2017, pp. 524–528, doi:10.1109/RISE.2017.8378212.
- [20] M.F.M. Firdhous, B.H. Sudantha, P.M. Karunaratne, IoT enabled proactive indoor air quality monitoring system for sustainable health management, in: Proceedings of the 2nd International Conference on Computing and Communications Technologies (ICCCCT), Chennai, 2017, pp. 216–221, doi:10.1109/ICCCCT.2017.7972281.
- [21] J.H. Jo, B.W. Jo, J.H. Kim, S.J. Kim, W.Y. Han, Development of an IoT-based indoor air quality monitoring platform, *J. Sens.* 2020 (2020) 8749764 Article ID14 pages, doi:10.1155/2020/8749764.
- [22] A. Alshamsi, Y. Anwar, M. Almulla, M. Aldhoori, N. Hamad, M. Awad, Monitoring pollution: applying IoT to create a smart environment, in: Proceedings of the 2017 International Conference on Electrical and Computing Technologies and Applications (ICECTA), Ras Al Khaimah, 2017, pp. 1–4, doi:10.1109/ICECTA.2017.8251998.
- [23] L. Zhao, W. Wu, S. Li, Design and implementation of an IoT-based indoor air quality detector with multiple communication interfaces, *IEEE Internet Things J.* 6 (6) (2019) 9621–9632, doi:10.1109/JIOT.2019.2930191.
- [24] M. Yanes-Lane, N. Winters, F. Fregones, M. Bastos, S. Perlman-Arrow, J.R. Campbell, et al., Proportion of asymptomatic infection among COVID-19 positive persons and their transmission potential: a systematic review and meta-analysis, *PLoS One* 15 (11) (2020) e0241536, doi:10.1371/journal.pone.0241536.
- [25] S. Abraham, X. Li, A cost-effective wireless sensor network system for indoor air quality monitoring applications, *Proc. Comput. Sci.* 34 (2014) 165–171.
- [26] O. Postolache, J. Pereira, P. Girao, Smart sensors network for air quality monitoring applications, *IEEE Trans. Instrum. Meas.* 58 (9) (2009) 3253–3262.
- [27] M. Ljubojevic, M. Simic, Z. Babic, M. Zoric, Quality of life context influence factors improvement using houseplants and Internet of Things, in: Proceedings of the 2016 IEEE International Black Sea Conference on Communications and Networking (BlackSeaCom), Varna, 2016, pp. 1–5, doi:10.1109/BlackSeaCom.2016.7901574.
- [28] P. Sethi, S. Sarangi, Internet of Things: architectures, protocols, and applications, *J. Electr. Comput. Eng.* 2017 (2017) 1–25.
- [29] BME680, Bosch Sensortec, 2020. [Online]. Available: <https://www.bosch-sensortec.com/products/environmental-sensors/gas-sensors-bme680/> [Accessed: Feb -2021].
- [30] D. Bird. G6EJD/BME680-Example, GitHub, 2020. [Online]. Available: <https://github.com/G6EJD/BME680-Example>.
- [31] D. Wall. Software components, <https://github.com/DylanWall96?tab=repositories&q=&type=public&language=>, [Accessed: Feb- 2021].
- [32] BBC News [Online]. Coronavirus: NI to face new lockdown measures from next Friday (19th NOV 2020), <https://www.bbc.co.uk/news/uk-northern-ireland-55004210>.
- [33] Dettol.co.uk, 2020. [Online]. Understanding the novel coronavirus (COVID-19)", Available: <https://www.dettol.co.uk/about-us/understanding-coronavirus/> [Accessed: Feb 2021].
- [34] P. Markowicz, L. Larsson, Influence of relative humidity on VOC concentrations in indoor air, *Environ. Sci. Pollut. Res.* 22 (8) (2014) 5772–5779.
- [35] Sensortec, B.Bosch Sensortec Environmental Cluster (BSEC), Bosch Sensortec, 2020 [online][Accessed: Feb -2021].
- [36] I. Gerretsen, How air pollution exacerbates Covid-19, <https://www.bbc.com/future/article/20200427-how-air-pollution-exacerbates-covid-19> [Accessed: Dec- 2020].
- [37] K.A. Prather, C.C. Wang, R.T. Schooley, Reducing transmission of SARS-CoV-2, *Science* 368 (6498) (2020) 1422–1424 (2020)[Crossref], [PubMed], [Google Scholar], doi:10.1126/science.abc6197.
- [38] L. Morawska, D.K. Milton, It is time to address airborne transmission of COVID-19, *Clin. Infect. Dis.* (2020) ciaa939, doi:10.1093/cid/ciaa939.
- [39] R. Bhagat, M. Davies Wykes, S. Dalziel, P. Linden, Effects of ventilation on the indoor spread of COVID-19, *J. Fluid Mech.* 903 (2020) F1, doi:10.1017/jfm.2020.720.
- [40] United Nations Economic Commission for Europe. [Online]. Air pollution and health <https://unece.org/air-pollution-and-health> [Accessed: Feb -2021].