

**EXAMINING THE ANTECEDENTS AND STRUCTURE OF
CUSTOMER LOYALTY IN A TOURISM CONTEXT**

A Dissertation

by

XIANG LI

Submitted to the Office of Graduate Studies of
Texas A&M University
in partial fulfillment of the requirements for the degree of

DOCTOR OF PHILOSOPHY

August 2006

Major Subject: Recreation, Park and Tourism Sciences

**EXAMINING THE ANTECEDENTS AND STRUCTURE OF
CUSTOMER LOYALTY IN A TOURISM CONTEXT**

A Dissertation

by

XIANG LI

Submitted to the Office of Graduate Studies of
Texas A&M University
in partial fulfillment of the requirements for the degree of

DOCTOR OF PHILOSOPHY

Approved by:

Chair of Committee,	James F. Petrick
Committee Members,	Joseph T. O'Leary
	Gerard T. Kyle
	William M. Pride
Head of Department,	Joseph T. O'Leary

August 2006

Major Subject: Recreation, Park and Tourism Sciences

ABSTRACT

Examining the Antecedents and Structure of Customer Loyalty

in a Tourism Context. (August 2006)

Xiang Li, M.S., Nanjing Normal University;

M.S., East Carolina University

Chair of Advisory Committee: Dr. James F. Petrick

The purpose of this study was to gain an understanding of the structure and antecedents of cruise passengers' loyalty. Specifically, the study examined the dimensionality of the loyalty construct. Moreover, the study investigated the utility of applying the Investment Model (Rusbult 1980, 1983) to reveal the psychological processes underlying loyalty formation. The study also attempted to, guided by the Investment Model, integrate the seemingly segregated findings of loyalty antecedents from marketing and leisure/tourism literature.

Based on the Investment Model and other marketing and leisure/tourism studies on loyalty, a conceptual framework was established for this study. An online panel survey was conducted to examine this model. Subjects (N = 554) were online panelists who were repeat cruisers and who have cruised at least once in the past 12 months.

In this study, loyalty was conceptualized as a four-dimensional construct: cognitive loyalty, affective loyalty, conative loyalty, and behavioral loyalty. Further, the first three components were postulated as three subdimensions of a higher order construct, attitudinal loyalty. However, this conceptualization was not supported by the

data. Alternatively, post-hoc analyses revealed that attitudinal loyalty was a first-order one-dimensional construct, containing cognitive, affective, and conative components. Moreover, behavioral loyalty was positively and significantly influenced by attitudinal loyalty. In sum, this study supported the traditional two-dimensional conceptualization of loyalty, which argues that loyalty has an attitudinal and a behavioral component.

Following the Investment Model, this dissertation suggested that satisfaction, quality of alternatives, and investment size were three critical antecedents of consumers' attitudinal loyalty. These theoretical relationships were supported by the present study, and collectively, the three predictors accounted for over 74 percent of the variance in attitudinal loyalty. Finally, this dissertation hypothesized that quality and value, two constructs related to loyalty, served as antecedents of satisfaction, with quality also leading to value. Results of the study supported all these hypotheses, and satisfaction was found to partially mediate the quality-attitudinal loyalty, and value-attitudinal loyalty relationships. Results of the present study provide important direction for the development of a holistic theoretical framework to explain the formation and structure of customers' brand loyalty.

DEDICATION

This dissertation is dedicated to
my parents, Prof. Zhi Li and Lvmeng Lu
and
to my lovely wife, Yuan Zhou

谨以此文献给我亲爱的父母和妻子

ACKNOWLEDGEMENTS

There are numerous people who have provided guidance and support to this study. I would like to thank each of them.

First, I extend immense gratitude to Dr. James Petrick, my advisor, mentor, and friend. The opportunity to work with you is one of the best things that ever happened to me. Thank you for making students your priority, and for being a great role model for me with your passion, wisdom, and professionalism. I am also deeply grateful to the members of my advisory committee. I would like to thank Dr. Joseph O’Leary for his vision, encouragement, and advice to my study and career development. I also wish to thank Dr. Gerard Kyle for his rigor and attention to detail, which helped to ensure this dissertation be the very best work I was capable of producing. Thanks also to Dr. William Pride for his support and patience, which greatly eased my tension throughout the process of dissertation writing.

Special thanks to Jeremy Taylor and his team for their technical support to the online survey. Thanks for your excellent work and professionalism, and for demonstrating great patience to my endless editing and questions. Mr. Drew Cavin and Carter Hunt also deserve to be recognized for their assistance in the pilot survey.

In addition, a number of RPTS faculty members have provided additional support in mentoring my education. Dr. John Crompton, one of our profession’s most valuable resources, has consistently provided guidance and advice to my doctoral study over the years. This dissertation also benefited tremendously from my multiple

conversations with Drs. Ulrike Gretzel, Clare Gunn, Sanjay Nepal, David Scott, Amanda Stronza, and Clifton Watts.

Several A&M professors in other departments also made great contributions to this dissertation. Special thanks to Drs. Ramona Paetzold (Management), Steve Rholes (Psychology), and Oi-Man Kwok (Educational Psychology) for their inputs to the research design and statistical analysis of this study. Moreover, I would not have been able to complete this dissertation without the support from a great number of prestigious scholars in different disciplines and countries. Among them, I would like to thank Drs. Christopher Agnew (Purdue), Sheila Backman (Clemson), Mark Havitz (University of Waterloo, Canada), Timothy Jones (Nipissing University, Canada), Duarte Morais (Penn State), Mark Pritchard (Arizona State University), Stowe Shoemaker (University of Houston), and Sharyn Rundle-Thiele (Griffith University, Australia) for their constructive comments in the evolution of this dissertation. I would also thank marketing scholars who responded to my two requests posted on the American Marketing Association Listserv, and participants to my presentations at Michigan State University and the University of South Carolina for sharing their views and ideas. In addition, I also owe a great deal to Drs. Thomas Skalko and Hans Vogelsong at East Carolina University, who have provided enduring support, direction, and “kicks” over the course of my studies. Thanks to all of you!

I was also fortunate to be surrounded by a number of knowledgeable and helpful individuals during my three years at Texas A&M. Among them, I am particularly indebted to Chia-Kuen Cheng, for his tremendous support. I will miss our “Friday

afternoon conversations” after graduation. Many thanks to Megan Cronan, Hyounggon Kim, Yu-Chin Huang, Kam Hung, Michael Hunt, Andrew Kerins, Po-Hsin Lai, Kristi Montandon, Kindal Shore, Yung-Ping Tseng, Stacy Tomas, and Catherine Tonner. Sincere thanks to all the RPTS staff for their assistances over the years. Thanks, Marguerite, for being there for us!

Finally and most importantly, a heartfelt thanks to my parents and my sister for their faith in me and for giving a meaning for all I have gone through. Thank you, Mom and Dad! To my lovely wife, Yuan, thank you for your numerous sacrifices, unyielding devotion and unwavering love. You are the sunshine in my life!

TABLE OF CONTENTS

	Page
ABSTRACT	iii
DEDICATION	v
ACKNOWLEDGEMENTS	vi
TABLE OF CONTENTS	ix
LIST OF FIGURES	xiii
LIST OF TABLES	xv
 CHAPTER	
I INTRODUCTION.....	1
Justification for the Study	1
What Is Loyalty?	2
What Determines Loyalty?.....	3
Context of the Study.....	4
Purpose of the Study	5
Objectives and Hypotheses	6
Delimitations	9
Limitations	9
Conceptual Definitions.....	9
Organization of the Dissertation.....	11
II LITERATURE REVIEW.....	13
Conceptualization of the Loyalty Construct.....	13
Traditional View	14
Behavioral Loyalty	14
Attitudinal Loyalty	18
Composite Loyalty	23
Section Summary	26
Dimensionality Issues Related to Loyalty.....	26
Loyalty as a Multidimensional Construct	27
Loyalty-Formation Deconstructs.....	29
Loyalty-Related Outcomes.....	31
Section Summary	34

CHAPTER	Page
Antecedents of Loyalty	35
General Framework of Loyalty Determinants	35
Satisfaction and Loyalty.....	39
Perceived Quality and Loyalty	44
Perceived Value and Loyalty	49
Switching Costs/Sunk Costs and Loyalty	53
Other Determinants Suggested.....	61
Section Summary	61
Synopsis of the Chapter.....	62
 III CONCEPTUAL DEVELOPMENT	 63
Commitment and Its Relationship with Loyalty	65
The Investment Model and Its Competing Theories	71
Theoretical Roots of the Investment Model.....	71
The Investment Model	74
Satisfaction Level.....	75
Quality of Alternatives	76
Investment Size	77
Commitment.....	78
Consequences of Commitment.....	79
Empirical Support of the Model.....	80
Alternative Commitment Conceptualization.....	81
Johnson's Commitment Framework	82
Pritchard et al.'s Conceptualization of Commitment Formation	85
Three-Component Model of Organizational Commitment	87
Proposed Conceptual Model	89
Justification	89
The Conceptual Model	95
Synopsis of the Chapter.....	96
 IV METHODOLOGY	 97
Research Design.....	97
Instrument Development	100
Pilot Test	102
Variables Measured for This Study.....	105
Loyalty	106
Satisfaction	107
Investment Size	107
Quality of Alternatives	108

CHAPTER	Page
Perceived Value.....	108
Perceived Quality	109
Demographic Variables.....	110
Selection of the Subjects and Data Collection	111
Data Analysis Procedures.....	114
Descriptive Analysis	114
Preliminary Data Analysis	116
Model and Hypotheses Testing.....	116
Synopsis of the Chapter.....	120
 V DESCRIPTIVE FINDINGS.....	 121
Sample Characteristics	121
Nonresponse Bias Check.....	126
Sampling Bias Check	132
Preliminary Data Analysis	135
Practical Issues	135
Sample Size and Missing Value.....	135
Univariate and Multivariate Outliers.....	136
Continuous Scales	136
Linearity	137
Univariate and Multivariate Normality.....	137
Measurement Properties	138
 VI HYPOTHESES TESTING.....	 144
Testing the Dimensional Structure of Loyalty	144
Testing the Investment Model.....	157
Preparing the Measurement Model	158
Assessing Convergent Validity	162
Assessing Discriminant Validity.....	164
Assessing Reliability	164
Hypothesized Model Analysis	168
Extra Multiple Regression and Correlation Analysis.....	172
Section Summary	174
Testing the Full Conceptual Model.....	174
Preparing the Measurement Model	175
Assessing Convergent Validity	177
Assessing Discriminant Validity.....	178
Assessing Reliability	178
Hypothesized Model Analysis	180
Section Summary	187

CHAPTER	Page
Synopsis of the Chapter.....	187
V CONCLUSIONS AND IMPLICATIONS	189
Review of the Findings	189
The Dimensional Structure of Loyalty	189
The Investment Model	191
The Full Conceptual Model.....	193
Theoretical and Managerial Implications.....	197
Theoretical Implications.....	197
The Structure of Loyalty	198
The Antecedents of Loyalty	200
Managerial Implications.....	204
Recommendations for Future Research	210
Limitations of Present Study	210
Future Research.....	212
REFERENCES.....	218
APPENDIX A SUMMARY OF SELECTED STUDIES ON LOYALTY CONCEPTUALIZATION (1969-2005)	253
APPENDIX B SUMMARY OF SELECTED RECENT STUDIES ON DETERMINANTS OF CUSTOMER LOYALTY (1997-2005)	259
APPENDIX C PILOT TEST QUESTIONNAIRE	268
APPENDIX D FINAL INSTRUMENT.....	274
APPENDIX E INFORMATION SHEET	284
APPENDIX F COVARIANCE MATRICES	286
VITA	292

LIST OF FIGURES

FIGURE	Page
1.1 A Conceptual Model of the Structure and Antecedents of Customer Loyalty.....	8
2.1 A Four-Category Typology of Loyalty	25
2.2 The Traditional View on the Loyalty Construct	26
2.3 Dick and Basu's (1994) Loyalty Framework	27
2.4 Two Trends of Recent Loyalty Conceptualization	28
2.5 Previously Researched Antecedents of Service Loyalty.....	38
3.1 The Investment Model	75
3.2 Consistency Between Empirical Evidence and the Investment Model	91
3.3 The Conceptual Model	95
4.1. Major Steps in Data Analysis.....	115
6.1 Hypothesized Second-Order Model of Attitudinal Loyalty	146
6.2 Alternative First-Order Model of Attitudinal Loyalty	149
6.3 Modified First-Order Model of Attitudinal Loyalty	154
6.4 Model A: Exploring the Relationship Between Attitudinal Loyalty and Behavioral Loyalty	156
6.5 Model B: Theoretical Model on the Investment Model Hypotheses	158
6.6 Measurement Model Based on Model B.....	159
6.7 Modified Measurement Model Based on Model B.....	168
6.8 Hypothesized Model Based on Model B.....	169
6.9 Model C: Full Theoretical Model.....	174
6.10 Measurement Model Based on Model C.....	175

FIGURE	Page
6.11 Modified Measurement Model Based on Model C	180
6.12 Hypothesized Model Based on Model C.....	181
6.13 Competing Models in Analyzing the Quality-Satisfaction-Attitudinal Loyalty Link	184
6.14 Competing Models in Analyzing the Value-Satisfaction-Attitudinal Loyalty Link	186
7.1 The Revised Conceptual Framework of the Structure and Antecedents of Loyalty.....	197
7.2 A Speculated Nomological Network.....	217

LIST OF TABLES

TABLE	Page
2.1 Sample Behavioral Loyalty Measures.....	17
2.2 Sample Attitudinal Loyalty Measures.....	21
2.3 A Summary of Rival Conceptualizations on Satisfaction - Loyalty Relationship.....	42
2.4 A Summary of Rival Conceptualizations on Quality - Loyalty Relationship.....	45
2.5 A Summary of Rival Conceptualizations on Value - Loyalty Relationship	50
2.6 A Summary of Rival Conceptualizations on Switching Cost/Investment - Loyalty Relationship	55
2.7 Sample Switching Costs/Investment Measures.....	59
3.1 A Summary of Alternative Conceptualizations on Commitment and Loyalty Relationship	68
4.1 Summary of Major Fit Indices	118
5.1 Brand-Based Response Breakdown	123
5.2 Demographic Characteristics of the Sample	125
5.3 Chi-Square Comparisons of Early and Late Respondents	129
5.4 Chi-Square and Gamma Comparisons of Early and Late Respondents.....	129
5.5 T-Test Comparisons of Early and Late Respondents.....	131
5.6 Chi-Square (and Gamma) Comparisons of Respondents and the Entire Panel.....	132
5.7 Comparison of Demographic Characteristics of Respondents, General Cruisers, and American Online Travelers	134

TABLE	Page
5.8 Scale Reliability, Mean, and Standard Deviation.....	140
5.9 Implied Correlations Between Major Constructs.....	142
6.1 Goodness-of-Fit Statistics of the Second-Order Model	147
6.2 Portion of the MI Output for the Second-Order CFA Model (Sorted Descending).....	147
6.3 Goodness-of-Fit Statistics of the First-Order Model.....	148
6.3 Portion of the MI Output for the First-Order CFA Model (Sorted Descending).....	149
6.5 Exploratory Factor Analysis of Loyalty Items	150
6.6 Reliability and Alpha-if-Item-Deleted Analysis	151
6.7 The Improvement in Fit of the Measurement Model	153
6.8 Modified First-Order CFA Model Estimates	155
6.9 Goodness-of-Fit Statistics of Model A.....	156
6.10 Attitudinal Loyalty-Behavioral Loyalty Model Estimates.....	157
6.11 Portion of the MI Output for the Measurement Model Based on Model B (Sorted Descending).....	160
6.12 Factor Loading, Reliability, and Related Information for Model B.....	163
6.13 Correlations Between Major Constructs in Model B	164
6.14 Summary of Regression Analyses.....	167
6.15 Goodness-of-Fit Statistics of the SEM Models Based on Model B.....	170
6.16 Summary of SEM Analysis on Model B.....	170
6.17 Comparison of Results of the Present Study with a Meta-Analysis of the Investment Model	173

TABLE	Page
6.18 Portion of the MI Output for the Measurement Model Based on Model C (Sorted Descending).....	177
6.19 Factor Loading, Reliability, and Related Information of Perceived Value and Quality.....	179
6.20 Correlations Between Major Constructs in Model C.....	179
6.21 Goodness-of-Fit Statistics of the SEM Models Based on Model C.....	181
6.22 Summary of SEM Analysis on Model C.....	182
6.23 Analysis of Structural Models I, II, & III.....	185
6.24 Analysis of Structural Models I', II', & III'.....	187
6.25 Summary of Findings.....	188

CHAPTER I

INTRODUCTION

Justification for the Study

Brand loyalty has been a popular research topic among marketing scholars since it was first identified (Brown 1952), though the idea can be traced back to when the discipline of marketing first took shape (Copeland 1923). The concept has received renewed interest in recent years, presumably due to the emergence of the relationship marketing paradigm (Gronroos 1994; Sheth and Parvatiyar 1995a), which emphasizes the importance of establishing relationships between customers and businesses. Facing fierce competition and limited resources, many marketers have shifted their focus from acquiring new customers to retaining existing customers, and from completing a “one-shot” deal to securing customers’ lifetime value (Berger 1998; Bolton 1998). As a result, brand loyalty, which was “originally intended to provide customers with quality assurance and little else,” has evolved into a market segmentation tool (Sheth and Sisodia 1999, p. 78), and may become the core of brand-customer relationships in the future (Fournier 1998). Leisure, recreation and tourism researchers have also prioritized “loyalty” as a subject of special practical importance for research and operations (Backman and Crompton 1991a, 1991b; Iwasaki and Havitz 1998).

Despite extensive research devoted to “loyalty,” brand loyalty research has been consistently criticized for lacking theoretical grounding and conceptual depth (Iwasaki and Havitz 2004; Jacoby and Chestnut 1978; Oliver 1999; Pritchard, Havitz, and

Howard 1999). It is particularly disquieting that consensus has not been reached on what loyalty is, and what constitutes the major driving forces of brand loyalty. Moreover, the vast majority of previous loyalty studies have focused on consumer goods, while the advent of the “service economy” (Gummerrsson 2002) or the “experience economy” (Pine and Gilmore 1999) stresses the need for more research on service products. Therefore, the present study seeks to systematically examine consumer loyalty in a tourism context. Of particular interest are two questions: What is loyalty?; and what determines loyalty?

What Is Loyalty?

Traditionally, the conceptualization of loyalty has adopted three major approaches (Jacoby and Chestnut 1978; Morais 2000; Rundle-Thiele 2005). It has been suggested that loyalty may refer to customers’ behavioral consistency, attitudinal predisposition toward purchase a brand, or a combination of the two approaches. However, recent studies have challenged the dominant two-dimensional conceptualization of loyalty (Jones and Taylor In press; Pritchard, Howard, and Havitz 1992; Rundle-Thiele 2005). It has been suggested that the two-dimensional conceptualization provides inadequate guidance for practitioners designing loyalty programs (Rundle-Thiele 2005). Thus, most researchers seem to agree that loyalty is a multi-dimensional construct, yet it remains controversial what the key dimensions of loyalty are.

Following recent development in loyalty conceptualization (Back 2001; Jones and Taylor In press; Oliver 1997; Oliver 1999), this dissertation conceptualizes loyalty

as a four-dimensional construct including: cognitive, affective, conative, and behavioral loyalty. Specifically, the cognitive, affective, and conative components of loyalty may be collectively considered as attitudinal loyalty. Further, all three dimensions of attitudinal loyalty may lead to behavioral loyalty.

What Determines Loyalty?

Existing literature is also divided in identifying the major driving forces of loyalty. Numerous factors have been suggested as antecedents of loyalty. Among them, satisfaction (Anderson and Srinivasan 2003; Bloemer and Lemmink 1992; Yoon and Uysal 2005), switching costs and investments (Backman and Crompton 1991a; Beerli, Martin, and Quintana 2004; Morais, Dorsch, and Backman 2004), perceived quality (Baker and Crompton 2000; Caruana 2002; Olsen 2002; Yu, Wu, Chiao, and Tai 2005), and perceived value (Agustin and Singh 2005; Chiou 2004; Lam, Shankar, Erramilli, and Murthy 2004; Yang and Peterson 2004) have been found to be conceptually and practically relevant. However, consensus has not been reached on the critical factors that actually determine loyalty (Agustin and Singh 2005). Most of all, a theoretical framework is still lacking in the selection and justification of what constitute loyalty determinants.

This study proposes that the Investment Model (Rusbult 1980a, 1980b, 1983) from the social psychology literature may integrate extant research findings, and lend a concrete theoretical foundation to the discussion on loyalty formation. The Investment Model, built on interdependence theory (Kelley and Thibaut 1978; Thibaut and Kelley 1959), suggests that one's commitment to an interpersonal relationship is strengthened

by the amount of satisfaction that one derives from the relationship, fueled by the size of the investment in the relationship, and weakened by the quality of alternatives to the relationship (Rusbult, 1980a, 1980b, 1983). In the past two decades, the Investment Model has been empirically supported by numerous studies (Le and Agnew 2003). Further, a recent meta-analysis of 52 previous studies examining the Investment Model concluded that “the Investment Model is not strictly an interpersonal theory and can be extended to such areas as commitment to jobs, persistence with hobbies or activities, loyalty to institutions, decision-making, and purchase behaviors” (Le and Agnew 2003, p. 54). Thus, it is concluded that the Investment Model might provide a useful framework in guiding this dissertation.

Context of the Study

One industry in need of retaining loyal customers is the cruise industry. This is mainly due to the fact that the cruise industry is characterized by a high level of repurchase (i.e., behaviorally loyal customers) (Petrick 2004a). Yet, it has been observed that the industry is facing some major market challenges, and is hence in need of a better understanding of its customers. Despite a record number of cruise ship passengers in recent years (Lois, Wang, Wall, and Ruxton 2004; Wood 2000), the current atmosphere of the cruise industry suggests that the market is changing, and that getting and retaining customers will become more difficult. The cruise industry is highly consolidated, where the majority of cruise capacity development has come from the four major cruise lines (Wie 2005). To continue the current market balance and to block potential competitors from entry, the four cruise lines have been investing heavily on cruise capacity

expansion (Lois et al. 2004; Petrick 2004a). This growth in berths has thus made it imperative for the industry, among other things, to retain its current clientele, and improve repurchase rate, in order to maintain present occupancy rates.

Amplifying the severe competition of the cruise industry is a recent change in the demographic profile of passengers. The Cruise Line International Association (CLIA) (2003) reported that the industry is facing younger (average age is 52 years old), and less wealthy (median income of \$57,000) clientele today. The changing demographics of cruisers and fierce competition make it crucial for cruise line management and tour operators to examine variables that influence cruise ship passengers to repurchase a cruise vacation. Thus, it seems that research focusing on customer loyalty, a construct traditionally considered relevant to customers' purchase decisions (Hellier, Geursen, Carr, and Rickard 2003; Petrick 1999), may provide operational significance to the cruise industry.

Purpose of the Study

This dissertation seeks to gain an understanding of the structure and determinants of cruise passengers' loyalty. Specifically, the study will examine the dimensionality issue of the loyalty construct, and identify measures of loyalty from a multidimensional perspective. Further, this study attempts to investigate the utility of using the Investment Model (Rusbult 1980a, 1980b, 1983) to examine the determinants of loyalty in a tourism service context.

Objectives and Hypotheses

The objectives of this study are four-fold:

Objective One of this dissertation is to identify the dimensions of loyalty, with specific focus on the breakdown of the attitude aspect of loyalty, in order to present a clear picture of the structure of the loyalty construct. Based on recent conceptual development on the structure of loyalty (Back 2001; Jones and Taylor In press; Lee 2003), it is proposed that:

Proposition 1: Loyalty is explained by behavioral loyalty and attitudinal loyalty, which can be further broken down to three factors: cognitive, affective, and conative loyalty.

Specifically,

Hypothesis 1a: Cognitive, affective, and conative loyalty will be explained by attitudinal loyalty as a higher order factor.

Hypothesis 1b: Behavioral loyalty will be significantly and positively influenced by attitudinal loyalty.

Objective Two, also the primary objective of this dissertation, is to reveal the psychological processes underlying loyalty formation in the context of a tourism service, by introducing the Investment Model from social psychology.

Proposition 2: The Investment Model is useful in explaining customers' commitment/attitudinal loyalty.

Specifically, based on the Investment model (Rusbult 1980a, 1980b, 1983), it is hypothesized that:

Hypothesis 2a: A customer's attitudinal loyalty to a service brand will be significantly and negatively influenced by the quality of alternative options.

Hypothesis 2b: A customer's attitudinal loyalty to a service brand will be significantly and positively influenced by his/her satisfaction level.

Hypothesis 2c: A customer's attitudinal loyalty to a service brand will be significantly and positively influenced by his/her investment size.

Objective 3 of this dissertation is to quantitatively examine the interrelationship between satisfaction, and its two related concepts, perceived quality and perceived value, and their relationship with loyalty. Perceived quality (Baker and Crompton 2000; Caruana 2002; Olsen 2002; Yu et al. 2005), and perceived value (Agustin and Singh 2005; Chiou 2004; Lam et al. 2004; Yang and Peterson 2004) have been frequently suggested to directly or indirectly lead to loyalty by marketing researchers. Following extant research findings on the relationship between satisfaction and perceived quality and perceived value (Petrick, 1999; 2004c), it is hypothesized that:

Hypothesis 3a: Satisfaction will be significantly and positively influenced by perceived quality.

Hypothesis 3b: Satisfaction will be significantly and positively influenced by perceived value.

Hypothesis 3c: Perceived value will be significantly and positively influenced by perceived quality.

Hypothesis 3d: The effect of perceived quality on attitudinal loyalty is mediated by satisfaction.

Hypothesis 3e: The effect of perceived value on attitudinal loyalty is mediated by satisfaction.

As the fourth and final objective, it is anticipated that the theoretical discussion of this dissertation may provide some preliminary insight on customer relationship management in a tourism context. All the hypothesized relationships are visually presented in Figure 1.1.

FIGURE 1.1
A CONCEPTUAL MODEL OF THE STRUCTURE AND ANTECEDENTS OF CUSTOMER LOYALTY

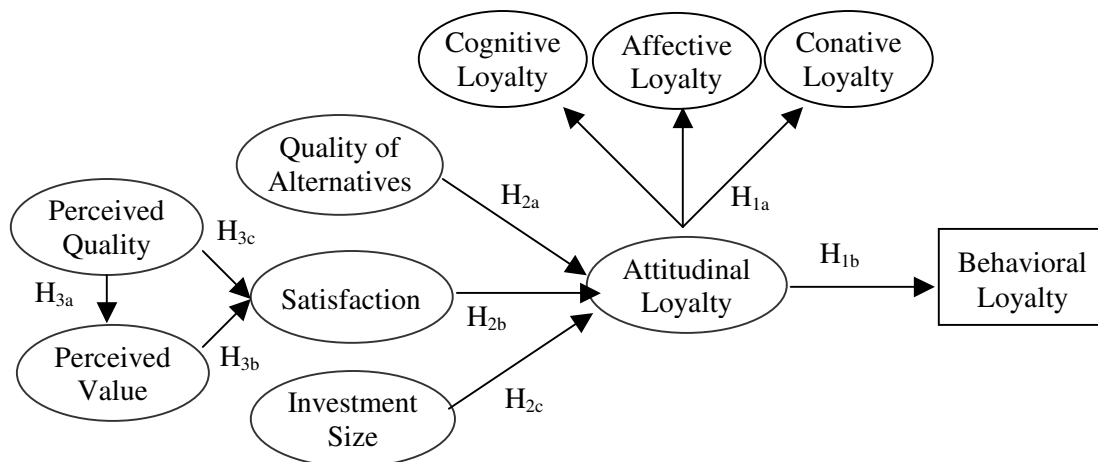

Delimitations

The study is subject to the following delimitations:

- (1) The study will be delimited to American customers of the cruise lines utilized in the current research;
- (2) Specific situational factors (such as seasons or destinations of the cruise trips) will not be considered;
- (3) The study will focus on customers' loyalty to service brands, and will not identify or describe customers' decision-making processes;
- (4) Other than the number of cruises they have taken before, cruise passengers' previous travel experiences and behavior related issues are not investigated in this survey.

Limitations

This study is limited to cruise passengers of the cruise lines utilized in the current research. The online panel survey approach utilized in this study precludes cruise passengers who do not have Internet access or Internet skills from being researched. Another limitation of this study is it did not consider the differences in cruise lines. Finally, as most cross-sectional designs, the concurrent measurement of variables in this study makes it unfeasible to examine and interpret the postulated temporal sequence and directional influences among variables (MacCallum and Austin 2000).

Conceptual Definitions

AFFECTIVE LOYALTY — The customer's favorable attitude or liking toward the service brand / provider based on satisfied usage (Harris and Goode 2004).

BEHAVIORAL LOYALTY — The frequency of repeat or relative volume of same-brand purchase (Tellis 1988).

COGNITIVE LOYALTY — The existence of beliefs that (typically) a brand is preferable to others (Harris and Goode 2004).

CONATIVE LOYALTY — Behavioral intention to repurchase the service brand characterized by a deep brand-specific commitment (Harris and Goode 2004).

CRUISE PASSENGERS — A customer aged 25 and older who has taken a cruise vacation for leisure purposes within the past 12 months.

INVESTMENT — A transaction that “consists of an exchange of assets whose property rights are retained by the investor and the retainer’s promise to remunerate the investor at a future point in time” (Dorsch and Carlson 1996, p. 257).

INVESTMENT SIZE — “The magnitude and importance of the resources that are attached to a relationship—resources that would decline in value or be lost if the relationship were to end” (Rusbult, Martz, and Agnew 1998, 359).

LOYALTY — “A deeply held psychological commitment to rebuy or repatronize a preferred product/service consistently in the future, thereby causing repetitive same-brand or same brand-set purchasing, despite situational influences and marketing efforts having the potential to cause switching behavior” (Oliver 1999, p. 34).

PERCEIVED QUALITY — “A consumer’s judgment about a product’s overall excellence or superiority” (Zeithaml 1988, p. 3)

PERCEIVED VALUE — “The consumer’s overall assessment of the utility of a product based on perceptions of what is received and what is given” (Zeithaml 1988, p. 14).

QUALITY OF ALTERNATIVES — “The perceived desirability of the best available alternative to a relationship” (Rusbult et al. 1998, p. 359).

SATISFACTION — “An affective state that is the emotional reaction to a service experience” (Spreng, MacKenzie, and Olshavsky 1996, p. 17).

SWITCHING COSTS — “The technical, financial or psychological factors which make it difficult or expensive for a customer to change brand” (Beerli et al. 2004, p. 258).

Organization of the Dissertation

Overall, this dissertation is guided and organized accordingly by two research questions: What is loyalty? and what determines loyalty? Chapter I has presented an introduction to this study, and has discussed the state of the cruise industry. Also briefly described are the conceptualization of loyalty and the Investment Model, which will be used as the guiding theoretical framework of this study. In addition, the purpose, objectives, hypotheses, definitions of key terms, delimitation and limitations have been presented.

Chapter II is a review of related literature. The traditional view and recent developments related to the construct loyalty will be explored. Antecedents of loyalty, suggested by marketing and leisure/tourism literature will also be synthesized.

Chapter III discusses the theoretical underpinnings of the structure and determinants of loyalty. Further, the linkages between these variables will be discussed.

Chapter IV will discuss the methodology employed for the current study and will present the methods utilized to investigate the problem. Chapter V reports the descriptive results of the research, while Chapter VI focuses on model and hypothesis testing.

Finally, Chapter VII concludes the study by summarizing the findings, discussing their implications, and suggesting areas for further research.

CHAPTER II

LITERATURE REVIEW

This chapter attempts to provide an in-depth review of the customer loyalty literature, mainly from the fields of marketing and leisure/tourism. This literature review centers the two guiding questions of this dissertation, i.e., “what is loyalty” and “what determines loyalty.” Accordingly, the first part commences by discussing the traditional understanding of the loyalty construct. It follows a review on recent developments in the conceptualization of loyalty. Meanwhile, measurement issues are discussed throughout the section. The second part focuses on antecedents of loyalty suggested by marketing, leisure and tourism studies. Previously used measures of these antecedents are also reviewed. The purpose of this literature review is threefold: 1) to review the different perspectives that have been proposed in the conceptualization of loyalty; 2) to understand determinants of loyalty that have been suggested by extant literature; and 3) to identify potential theoretical gaps.

Conceptualization of the Loyalty Construct

The loyalty construct has been a central research concern among marketing scholars in the past 80 years (Rundle-Thiele 2005). Most researchers credit Copeland for originating the concept (Rundle-Thiele 2005), although the term “brand loyalty” was coined much later (Brown 1952; Guest 1944). In his seminal work on consumers’ buying habits, Copeland (1923) categorized consumers’ brand attitudes into three types (recognition, preference, and insistence), and maintained that brand preference and insistence were benefits of branding convenience goods.

Traditional View

Until recently, the conceptualization of loyalty adopted three major approaches (Jacoby and Chestnut 1978; Morais 2000; Rundle-Thiele 2005). It has been suggested that loyalty may refer to customers' behavioral consistency, attitudinal predisposition toward purchase a brand, or a combination of the two approaches. The present section provides a brief overview of these approaches. Each approach will be discussed in terms of its conceptual development, measurement, strengths and limitations. A summary of marketing and leisure studies on loyalty conceptualization is provided in Appendix A.

Behavioral Loyalty

The majority of early loyalty studies took a behavioral approach, and interpreted loyalty as synonymous with repeat purchase. The concept of behavioral loyalty was first defined in the 1950s (Cunningham 1956), and was grounded on a stochastic view of consumer behavior (Rundle-Thiele 2005). Essentially, the stochastic view proposes that consumer behavior, as well as market structure, are characterized by randomness rather than rationality (Bass 1974; Hoyer 1984). Tucker (1964, p. 32) went so far as to assert that "no consideration should be given what the subject thinks or what goes on in his central nervous system; his behavior is the full statement of what brand loyalty is." More recently, Ehrenberg (1988) contends that we need to understand how people make brand purchases, before understanding why people buy. Finally, from a measurement perspective, O'Mally (1998, p. 49) suggests that behavioral measures of loyalty provide "a more realistic picture of how well the brand is doing vis-à-vis competitors, and the

data generated facilitate calculation of customer life-time value, enhance prediction of probabilities, and assist in developing cost-effective promotions.”

Research into behavioral loyalty typically relies on data from either the actual purchasing behaviors of the consumer (such as scanner panel data) or the customer’s self-reported purchasing behavior (Jacoby and Chestnut 1978). Back’s (2001) review of loyalty measurement in the marketing and hospitality literature reports at least seven behavior-related approaches: (1) market share; (2) choice probability; (3) exponential smoothing; (4) Dirichlet model; (5) logistic regression; (6) event history analysis; and (7) time series. The most frequently used measures of behavioral loyalty include:

- (1) Proportion of purchase of one brand in relation to the total purchase of the same product category (Brown 1952; Copeland 1923; Cunningham 1956; Iwasaki and Havitz 1998). To measure this, a researcher may ask customers to report how many times they purchased their favorite brand, and how many total purchases they have made in that product category. The brand purchases divided by total purchases in that product category thus makes a behavioral representation of customer loyalty. For the purpose of the current study, this is how behavioral loyalty will be operationalized.
- (2) Purchase probability (Frank 1962; Lipstein 1959; Ostrowski, O'Brien, and Gordon 1993), which measures relative frequency of purchase or Markov probability of future purchases.
- (3) Average purchase sequence (Brown 1952; Iwasaki and Havitz 1998; Kahn, Kalwani, and Morrison 1986; Pritchard et al. 1992; Tucker 1964) as a measure of

whether the brand purchaser shows undivided loyalty, unstable loyalty, or no loyalty at all. This is done by examining the sequence of one's brand purchases in one product category. It has been suggested that four to six consecutive purchases of the same brand could be considered to represent loyalty (Morais 2000).

- (4) Price premium (Aaker 1996; Jacoby and Kyner 1973; Pessemier 1959) describes brand switching behavior and intentions of switching brands. That is, authors measure the amount a customer will pay for a brand in comparison to another brand offering similar benefits, or the increase in costs (e.g., price, time) necessary to solicit individuals to switch brands.

Other widely-used measures in leisure or tourism studies include duration (i.e., the long-term length of total participation) (Iwasaki and Havitz 1998; Park 1996), intensity (i.e., time devoted to purchase, use, or participation in certain activity per day/week/month/year) (Iwasaki and Havitz 1998; Park 1996), and frequency (i.e., number of purchases, uses, or participation over a specified time-period) (Iwasaki and Havitz 1998; Petrick 2004a). It has been argued that in service or durable goods markets, collecting repeat-purchase data can be difficult (Rundle-Thiele 2005). Thus, most loyalty studies in service marketing and leisure/tourism fields rely on customers' self-reported data. Table 2.1 presents a list of sample questions used in behavioral loyalty measurement.

A major criticism of the behavioral loyalty approach is that it neglects the importance of understanding customers' decision making process underlying their

purchase behaviors (Back 2001). It does this by failing to distinguish customers making purchase decisions because of genuine brand preference or attachment, from those who purchase solely for convenience or cost reasons. In other words, underlying customers' repeat purchase choice may be inertia [i.e., customers repeat purchasing of the same brand for the sake of saving time and energy (Assael 2004)], rather than the bond of a

TABLE 2.1
SAMPLE BEHAVIORAL LOYALTY MEASURES

Behavioral loyalty items	Origin in the literature
Over the last 3 years how much of your total expenditure on car insurance to all companies have you spent with [company name].	(Hellier et al. 2003)
How many car insurance companies can you name that compete against [company name] for car insurance companies.	(Hellier et al. 2003)
Please estimate how many times during the last 12 months you have flown with XYZ.	(Pritchard et al. 1999)
Please estimate how many times in the last 12 months you have used airlines in general.	
The proportion of budget allocated to a set of suppliers.	(Anderson and Sullivan 1993; Jones and Sasser 1995; Soderlund 1998)
In a typical year, how many days do you spend recreating at [destination name]	(Lee 2003)
In a typical year, how many days do you spend recreating at other destination beside [destination name]	
Including this one, how many cruises have you taken with [company name] in your lifetime?	(Petrick 2004a)
Approximately when was your first [company name] cruise?	
How likely are you to spend more than 50% of your clothing budget at this store?	(Nijssen, Singh, Sirdeshmukh, and Holzmueller 2003)
If I had to do it all over again I'd buy heavy lease equipment from a different company	(Taylor, Celuch, and Goodwin 2004)

Part of this table is adapted from (Rundle-Thiele 2005, p. 55)

customer to a brand or service provider (Fournier 1998). Furthermore, due to the inconsistency between behavioral loyalty measures, one individual classified as loyalty based on Method A, may be classified as disloyal by Method B (Morais 2000). Thus, several researchers have argued that the loyalty phenomenon cannot be adequately understood without measuring individuals' attitude toward a brand (Backman and Crompton 1991b; Day 1969; Dick and Basu 1994).

Attitudinal Loyalty

The stochastic philosophy essentially maintains that marketers are unable to influence buyer behavior in a systematic manner. In comparison, the deterministic philosophy suggests that behaviors do not just happen, they can be “a direct consequence of marketers' programs and their resulting impact on the attitudes and perceptions held by the customer” (Rundle-Thiele 2005, p. 38). Researchers holding a deterministic view hence advocate the need to understand the loyalty phenomenon from an attitudinal perspective.

Guest (1944) was arguably the first researcher to propose the idea of measuring loyalty as an attitude. He used a single preference question asking participants to select the brand they like the best, among a group of brand names. A number of later researchers followed his approach, and conceptualized loyalty as attitudes, preferences, or purchase intentions (although some researchers have argued that behavioral intentions may fall into the domain of behavioral loyalty (Jones 2003)), all of which can be considered as a function of psychological processes (Jacoby and Chestnut 1978). Terms such as cognitive loyalty (Jarvis and Wilcox 1976) and intentional loyalty (Jain, Pinson,

and Malhotra 1987) subsequently emerged to capture different components of the psychological processes. More recently, Reichheld (2003) argued that loyalty may be conveniently and effectively assessed using only one variable – “willingness to recommend” (i.e., word of mouth, which is traditionally considered as an attitudinal loyalty outcome). The author found that the tendency of loyal customers to bring in new customers is of vital importance for a company’s growth. Therefore, customers’ willingness to recommend is a particularly effective measure of customers’ loyalty, in comparison to traditional measures such as satisfaction or customer retention rate.

The attitudinal measure of loyalty suffers even more conceptual controversy than the behavioral approach. Different researchers have linked or equated attitudinal loyalty with different concepts, such as (relative) attitude toward the brand or brand providers (Dick and Basu 1994; Morais et al. 2004), attachment (Backman 1991), commitment (Kyle, Graefe, Manning, and Bacon 2004; Park 1996; Pritchard 1991), involvement (McIntyre 1989) and so on. Back (2001) suggests that no less than eight different attitudinal loyalty measurements exist in the literature, which are: (1) latitude of acceptance and rejection; (2) modified latitude of acceptant and rejection; (3) latitude of acceptance, rejection, and noncommitment; (4) time path analysis model; (5) standard vs. halo models; (6) modified organizational commitment scales with involvement; (7) model of service relationships; and (8) satisfaction and loyalty models. More recently, Rundle-Thiele (2005) identified six useful measures of attitudinal loyalty, including (1) repurchase intention or ATA (Attitude toward the Act) measures; (2) preference; (3) commitment; (4) word-of-mouth; (5) purchase probability or the Juster scale (An 11-

point scale examining respondents' likelihood to undertake a particular action in the future), and (6) affect.

In the leisure and tourism literature, there have also emerged a variety of attitudinal loyalty measures. One frequently used measure is to examine respondents' attitude toward a brand or service provider via a series of semantic differential items (e.g., good-bad, interesting-not interesting). This method has been adopted by a number of researchers (Backman and Crompton 1991a,1991b; Backman and Shinew 1994; Morais et al. 2004; Petrick 1999). Another widely applied measure is Pritchard's (1991) Psychological Commitment Index (PCI), which was originally developed to examine commitment / attitudinal loyalty. Several recent studies have adopted PCI in their loyalty measurement (Iwasaki and Havitz 2004; Kyle et al. 2004; Pritchard et al. 1999). Table 2.2 presents a list of sample questions and statements used in affective loyalty measurement.

A major criticism of the attitudinal loyalty approach is that it lacks power in predicting actual purchase behavior, even though a recent meta-analysis on attitude-behavior studies (Kraus 1995) reported that attitudes significantly predict future behavior (Rundle-Thiele 2005). It has been found that using attitudinal loyalty alone may not capture the whole picture of the loyalty phenomenon (Morais 2000). Moreover, some authors have suggested that the limited explanatory power of attitudinal loyalty could be the result of intervening influences from other constraining factors to purchase behaviors (Backman and Crompton 1991b).

TABLE 2.2
SAMPLE ATTITUDINAL LOYALTY MEASURES

Type Implied	Attitudinal Loyalty Items	Origin in the Literature
Intention/ Probability of Repurchase	In the near future I intend to use more of the services offered by my bank.	(Ganesh, Arnold, and Reynolds 2000)
	How likely are you to do most shopping for clothing items at this store?	(Nijssen et al. 2003)
	How likely are you to shop at this store the very next time to buy clothing items?	(Nijssen et al. 2003)
	I will definitely go back to my current (Davis, Banks, Birtles, Valentine, and Cuthill) next time I use the same services.	(Lee and Cunningham 2001)
	If this café is busy I just go elsewhere.	(Butcher, Sparks, and O'Callaghan 2001)
	It wouldn't bother me if I changed cafes tomorrow. How likely or unlikely is it that you would choose Bank X the next time you are in need of bank services? I would return to this hotel.	(Butcher et al. 2001) (Olsen and Johnson 2003) (Bowen and Chen 2001)
Word of Mouth	I would highly recommend my bank/dealer/brand to family and friends.	(Beerli et al. 2004; Delgado-Ballester and Munuera- Aleman 2001)
	How likely are you to recommend this company/clothing store to friends, neighbors and relatives?	(Mittal, Kumar, and Tsiros 1999; Nijssen et al. 2003)
	How likely is it that you will speak favorably of the bank to others? I say positive things about this restaurant to other people.	(Olsen and Johnson 2003) (Bloemer, de Ruyter, and Wetzels 1999)
Commitment	I feel a sense of personal commitment to this car mechanic.	(Mittal and Lassar 1998)
	I would find it extremely difficult to discontinue patronage of my current [bank].	(Lee and Cunningham 2001)
	I have a long-term view of future co-operation with this business.	(Eriksson and Vaghult 2000)
	I consider myself to be loyal to this brand.	(Beatty and Kahle 1988; Beerli et al. 2004; Taylor et al. 2004)

TABLE 2.2 Continued

Type Implied	Attitudinal Loyalty Items	Origin in the Literature
	How committed are you to buying your favorite brands, rather than an alternative brand? Pritchard's (1991) Psychological commitment scale (PCI)	(Knox and Walker 2001)
	Allen and Meyer's (1990) organizational commitment scale	(Hong 2001; Iwasaki and Havitz 2004; Kyle et al. 2004) (Park 1996)
Preference	I think of this café as "my" café. This is my favorite café by a long way. This brand is clearly the best on the market. If you were to fly between the same two cities and all airlines had the same departure and arrival times, which airline would you select as your first choice? I consider...my first choice among fast food restaurants. I would rank COMPANY X as #1 amongst the other service providers I listed. Compared to COMPANY X, there are few alternatives with whom I would be satisfied I try to fly with XYZ airline because it is the best choice for me. To me, XYZ is the same as other airlines.	(Butcher et al. 2001) (Butcher et al. 2001) (Delgado-Ballester and Munuera- Aleman 2001) (Ostrowski et al. 1993) (Bloemer et al. 1999; Taylor et al. 2004) (Jones and Taylor In press) (Jones and Taylor In press) (Muncy and Fisk 1987; Pritchard et al. 1999) (Muncy and Fisk 1987; Pritchard et al. 1999)
Brand Attitude/ General Feeling	Please indicate how you feel about COMPANY X (e.g., not interesting—interesting, attractive—repelling, etc.) Destination cognitive and affective image	(Backman and Crompton 1991a; Backman and Crompton 1991b; Backman and Shinenew 1994; Morais et al. 2004; Petrick 1999) (Baloglu 2001)

Part of this table is adapted from (Rundle-Thiele 2005, p. 49)

Composite Loyalty

The above review seems to imply that neither the behavioral nor attitudinal loyalty approach alone provides a satisfactory answer to the question “what is loyalty?” Day (1969) argued that genuine loyalty is consistent purchase behavior rooted in positive attitudes toward the brand. His two-dimensional (i.e., attitudinal and behavioral) conceptualization of loyalty suggested a simultaneous consideration of attitudinal loyalty and behavioral loyalty. Specifically, Day proposed a composite index of loyalty, which has been widely used by loyalty researchers.

$$L = P[B] / A$$

L: Loyalty
 P[B]: Proportion of brand purchase
 A: Loyal attitude

Lutz and Winn (1974), who proposed a similar approach, also advocated that adding attitudinal components to the behavioral measure of loyalty can bring more explanatory power and make more conceptual sense. Building on Day’s conceptualization, Jacoby and Chestnut (1978) provided a broad definition of loyalty, which profoundly influenced the direction of later loyalty research (Knox and Walker 2001). By incorporating six necessary and collectively sufficient conditions, loyalty was defined by Jacoby and Chestnut (1978, p. 80) as “ (1) the biased (i.e. non random), (2) behavioral response (i.e. purchase), (3) expressed over time, (4) by some decision-making unit (5) with respect to one or more alternative brands out of a set of such brands, and (6) is a function of psychological (decision making, evaluative) processes.”

A number of researchers operationalized loyalty using this composite approach (Backman and Crompton 1991b; Dick and Basu 1994; Morais et al. 2004; Petrick 2004a; Pritchard et al. 1999; Selin, Howard, Udd, and Cable 1988; Shoemaker 1999). In the field of leisure and tourism, Backman and Crompton (1991b) conceptualized psychological attachment and behavioral consistency as two dimensions of loyalty. They examined tennis players' activity loyalty via three measures (attitudinal, behavioral, and composite). Results revealed that "attitudinal, behavioral, and composite loyalty capture the loyalty phenomenon differently" (p. 217).

In another paper, Backman and Crompton further proposed a 4-category typology of loyalty based on respondents' score on the attitude and behavior dimensions (Backman and Crompton 1991a) (See Figure 2.1). These segments include low loyalty (customers in this group demonstrate low intensity of brand patronage and little attachment, i.e., they do not feel strongly toward the service, and do not participate or purchase very often), latent loyalty (customers in this group demonstrate low intensity of brand patronage despite favorable attitude, i.e., they prefer the service, but purchase very little due to situational factors or other reasons), spurious loyalty (customers in this group demonstrate frequent brand purchases but weak attitudinal bonds, i.e., they lack strong feelings about a service, yet still participate or purchase it frequently), and high loyalty (customers in this group demonstrate high level of behavioral consistency and psychological attachment, i.e., their continuous patronage is based on favorable attitude toward the service). Subsequent tourism and leisure studies have supported this operationalization (Backman and Veldkamp 1995; Heiens and Pleshko 1996; Selin et al.

1988). A recent stream of research on tourist destination loyalty (Baloglu 2001; Kozak, Huan, and Beaman 2002; Niininen and Riley 2003; Oppermann 1999; Oppermann 2000; Pritchard and Howard 1997) has since adopted this typology.

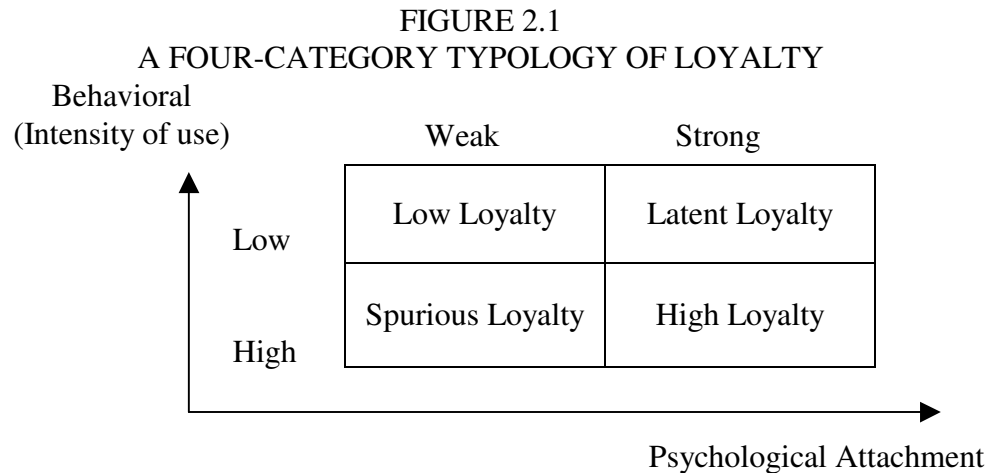

Adapted from (Backman 1988, p. 38)

A parallel conceptualization has also emerged in mainstream marketing studies. Dick and Basu (1994) conceptualized loyalty as the relationship between relative attitude (attitudinal dimension) and repeat patronage (behavioral dimension). The cross classification of these two dimensions results in a similar four quadrant loyalty matrix to Backman and Crompton's (1991a). Their typology also includes spurious and latent loyalty, although what Backman and Crompton (1991a) termed as “high” and “low” loyalty were termed as “loyalty” and “no loyalty” by Dick and Basu. The authors further suggested that the relationship between relative attitude and repeat patronage is influenced by social norms and situational factors. The same loyalty classification has been reported by other marketing researchers (Griffin 1995; Heiens and Pleshko 1996).

Section Summary

Overall, it is concluded that at least in the field of marketing, loyalty studies can roughly be grouped into behavioral loyalty, attitudinal loyalty, and composite loyalty approaches (Morais 2000; Rundle-Thiele 2005). It seems that most marketing and leisure researchers, until recently, have adopted the composite loyalty approach, which suggests considering loyalty in terms of both attitudes and behavior (see Figure 2.2).

FIGURE 2.2
THE TRADITIONAL VIEW ON THE LOYALTY CONSTRUCT

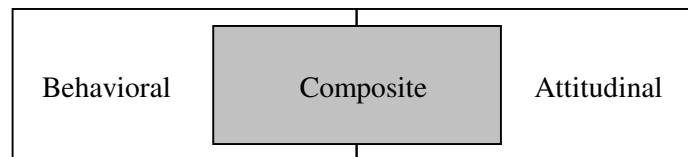

Adapted from (Rundle-Thiele 2005, p. 20)

Dimensionality Issues Related to Loyalty

As loyalty research has evolved, the dominant two-dimension conceptualization of loyalty has been challenged, with different views on loyalty dimensionality being proposed. It has been suggested that the two-dimensional conceptualization provides inadequate guidance for practitioners designing loyalty programs (Rundle-Thiele 2005). Further, the dimensionality issue of loyalty has warranted increasing concern as marketers who misunderstood this may be: “1) measuring the wrong things in their attempts to identify loyal customers; 2) unable to link customer loyalty to firm performance measures; and 3) rewarding the wrong customer behaviors or attitudes when designing loyalty programs” (Jones and Taylor In press). The following section

briefly overviews this issue [see Jones and Taylor (In press) and Rundle-Thiele (2005) for comprehensive reviews].

Loyalty as a Multidimensional Construct

As indicated, while some researchers have conceptualized loyalty as a uni-dimensional construct (i.e., loyalty as repeat purchase, or loyalty as brand preference), the current dominant view is that loyalty contains more than one dimension. Rundle-Thiele (2005) suggested that the multi-dimensional views of loyalty might be traced back to Dick and Basu's (1994) attitude-based conceptual framework (see Figure 2.3).

FIGURE 2.3
DICK AND BASU'S (1994) LOYALTY FRAMEWORK

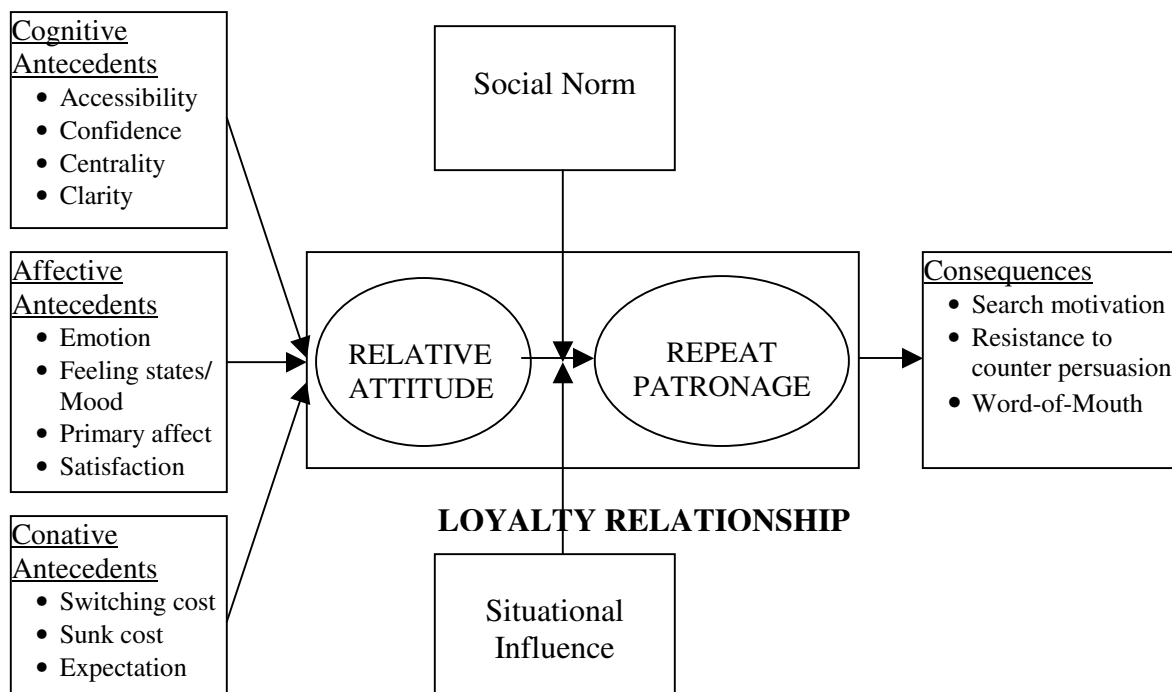

*Reprinted with permission from "Customer Loyalty: Toward an Integrated Framework." by A. S. Dick and K. Basu, 1994. *Journal of the Academy of Marketing Science*, 22 (2), 99-113. COPYRIGHT 1994 by Sage Publications, Inc.

Dick and Basu (1994), who themselves held a traditional composite view of loyalty, identified a series of cognitive (e.g., clarity of attitudes), affective (e.g., emotion) and connotative (e.g., switching costs) antecedents of relative attitude based on psychology theory on attitude (Eagly and Chaiken 1993). According to them, true brand loyalty only exists when consumer beliefs, affect, and intention all point to a focal preference toward the brand or service provider. Further, the framework suggests that relative attitude determines repeat patronage, whereas the effect of relative attitude on repeat patronage is moderated by social norms and situational influence. Finally, consequences of loyalty (in terms of both relative attitude and repeat patronage) include search motivation, resistance to counter persuasion, and word of mouth.

It seems most of the recent studies examining multi-dimensional loyalty have approached the issue in two ways: one focusing on the building of loyalty, and the other focusing on loyalty-related outcomes (see Figure 2.4). Referring to Dick and Basu's (1994) model, it seems the first group of researchers is interested in the "upstream" of loyalty, and expands the construct to incorporate what Dick and Basu identified as loyalty's antecedents. The second group, on the other hand, shows more interests in the "downstream," and looks into the consequences of loyalty suggested by Dick and Basu.

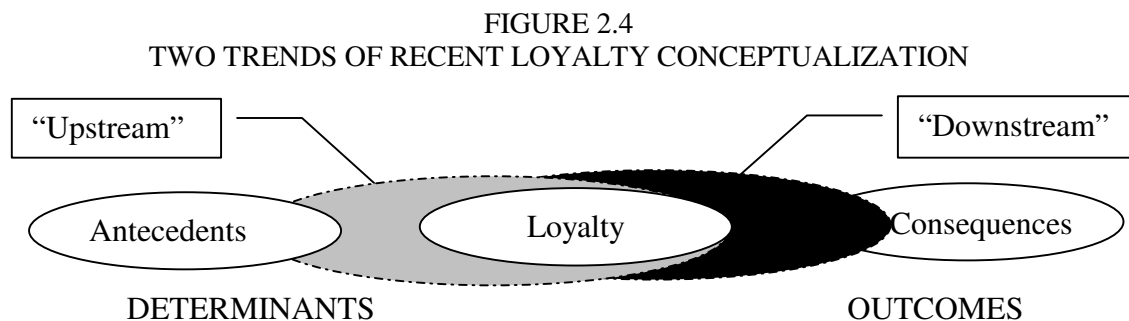

Loyalty-Formation Deconstructs

Many "upstream" studies are somewhat influenced by Oliver's work (1997, 1999). Oliver followed the same cognition-affect-conation structure as Dick and Basu (1994), but suggested that loyalty formation is more likely to be an attitudinal development process, and that customers may demonstrate different levels of loyalty in different stages of this process. Thus, Oliver seemed to imply that loyalty is neither a dichotomy (loyalty vs. no loyalty), nor multi-category typology (e.g., low, spurious, latent, and high loyalty), but a continuum. Specifically, Oliver (1997, 1999) posited that the loyalty-building process starts from some cognitive beliefs (cognitive loyalty), followed by affective loyalty (i.e., "I buy it because I like it"), to conative loyalty (i.e., "I'm committed to buying it"), and finally actual purchase behaviors (action loyalty, or "action inertia"). Although the temporal sequence of loyalty formation remains controversial (Rundle-Thiele 2005), a number of researchers have adopted Oliver's four-dimensional loyalty conceptualization (Back 2001; Harris and Goode 2004; Jones and Taylor In press; Lee 2003; McMullan and Gilmore 2003).

Following Oliver's conceptualization, McMullan and Gilmore (2003) developed a scale to measure the four phases of loyalty. An initial pool of items was generated from existing scales measuring satisfaction, service quality, commitment, and so on. A 28-item scale based on an expert panel's recommendation was then tested in a restaurant-dining context (i.e., measuring customers' loyalty to a specific restaurant). Results from the validity and reliability test supported the four-dimensional conceptualization.

In a similar vein, Harris and Goode (2004) operationalized and tested Oliver's 4-facet measure in two online service scenarios (online book purchasing and online flight tickets purchasing). Their survey of online customers resulted in a 16-item, 7-point loyalty scale. The authors concluded that the hypothesized cognitive-affective-conative-action loyalty sequence provided a better fit of the data than other possible variations.

More recently, Jones and Taylor (In press) explored the dimensionality issue of customer loyalty. The authors' review showed that with the cognitive component being increasingly emphasized, recent marketing literature seems to support a three-dimensional conceptualization of loyalty (cognitive, attitudinal, and behavioral). The interpersonal psychology literature, on the other hand, has traditionally adopted a 2-dimensional conceptualization (behavioral and cognitive). Their results support a two-dimensional loyalty construct, in which behavioral loyalty remains as one dimension, while attitudinal and cognitive loyalty are combined into one dimension. It is noteworthy that the behavioral measures used by Jones and Taylor primarily targeted behavioral intentions. Thus, using Oliver's terminology, Jones and Taylor (In press) revealed a conative versus cognitive/attitudinal loyalty structure.

In the leisure and tourism field, Back (2001) suggested that Oliver's (1997, 1999) conceptualization extended the traditional two-dimensional view. Based on the tripartite model of attitude structure (Bagozzi 1978; Breckler 1984), Back argued that cognitive loyalty, affective loyalty, and conative loyalty are essentially three components of the traditionally-termed attitudinal loyalty construct, and all three should lead to action/behavioral loyalty. Furthermore, Back argued that the cognitive, affective, and

conative phases of loyalty may not necessarily be a sequential formation process, as suggested by Oliver (1997, 1999). To Back, the three aspects are more likely to be independent factors of attitudinal loyalty attributable to unique variance. Empirical testing in a hotel setting revealed that both affective and conative loyalty were positively associated with behavioral loyalty, while cognitive loyalty was not (Back 2001; Back and Parks 2003).

Lee (2003) also adopted Oliver's conceptualization. However, Lee argued that "the cognitive stage is more likely to be an antecedent to loyalty rather than loyalty itself" (p. 22). Thus, Lee's loyalty measure contained three dimensions, which were attitudinal, conative, and behavioral loyalty. Her study lent partial support for the three-dimensional conceptualization. Although conative loyalty was significantly and positively influenced by attitudinal loyalty, the direct effect of conative loyalty on behavioral loyalty was found to be negative, which was opposite to the hypothesized direction. The author postulated that this negative relation might be the result of perceived constraints.

Overall, it seems the four-dimension loyalty construct broadens, rather than invalidates the traditional two-dimension view. Nevertheless, consensus has not been reached on the specific process, or dimensions included, in loyalty formation.

Loyalty-Related Outcomes

The "downstream" line of research, as indicated, expanded the loyalty construct to what Dick and Basu (1994) would define as consequences of loyalty. Scholars following this line of research contend that the traditional or Oliver's view of loyalty

dimensions may be readily measured through a series of manifest factors. Morais (2000) argued that including loyalty-related outcomes into loyalty constructs does not necessarily conflict with the traditional two-dimensional loyalty conceptualization. He suggested that the incorporation of future purchase intentions, word-of-mouth communication, or resistance to counter-persuasion (all traditionally considered as loyalty consequences) in the loyalty construct could be considered as the broadening of the scope of behavioral and attitudinal loyalty. .

Zeithaml, Berry, and Parasuraman's research (1996) on customers' behavioral responses to service quality, though not explicitly focusing on customer loyalty, inspired a series of subsequent studies. Their 13-item, 5-dimension scale on behavioral consequences of service quality (dimensions included: loyalty to company, propensity to switch, willingness to pay more, external response to problem, and internal response to problem) is believed to tackle various aspects of loyalty-related outcomes, and has hence been widely used in loyalty measurement.

For instance, de Ruyter et al. (1998) proposed a three-dimensional service loyalty structure: preference loyalty, price indifference loyalty and dissatisfaction response. To them, preference loyalty corresponds to attitudinal loyalty, while price indifference loyalty represents the cognitive component of loyalty. Dissatisfaction loyalty, on the other hand, refers to customers' willingness to voice their negative service experiences. Zeithaml, et al.'s (1996) 13-item scale was reorganized to reflect the three-dimensional conceptualization. Their empirical study of customers from five different service industries provides support for the three-dimensional service loyalty measure.

Bloemer et al. (1999, p. 1086) maintained that “operationalization of service loyalty would have to consider behavioral, attitudinal and cognitive aspects,” and all these elements are present in Zeithaml et al.’s (1996) scale. They argued that Zeithaml et al.’s (1996) original 4-dimensional conceptualization (i.e., word-of-mouth communications; purchase intention; price sensitivity; and complaining behavior), in comparison to the 5-dimension scale resulted from factor analysis, made more conceptual sense. Their empirical study on four service industries supported the 4-dimensional measure.

Rundle-Thiele (2005) synthesized extant literature on loyalty dimensions, and argued that attitudinal and behavioral dimensions alone “provide little guidance for marketers seeking to create marketing programs” (p. 56). Her literature review identified seven dimensions of loyalty, namely allegiance, attitudinal loyalty, complaining behavior, preferential purchase, propensity to be loyal, resistance to competing offers, and situational loyalty. However, data collected from two service contexts (wine and insurance purchase) did not support this conceptualization. Instead, an empirical exploration uncovered a four-dimension structure of loyalty, with three behavioral dimensions (namely citizenship behavior, resistance to competing offers, and preferential purchase) and attitudinal loyalty.

In the leisure and tourism field, Morais (2000) suggested that loyalty has been traditionally associated with reduced information search for alternative brands/providers, increased word of mouth communications, increased resistance to counter-persuasion, increased repurchase intentions, consistent purchase behavior, and positive

attitudes toward the provider(s). In their study, Morais and his colleagues (2004, p. 238) further argued that “historically, loyalty has been operationalized based on its predicted outcomes.” As a result, they measured loyalty in terms of attitudes toward the provider, word-of-mouth communications, and resistance to counter-persuasion.

Finally, some researchers have tried to integrate loyalty outcome measures (“downstream”) with the loyalty formation process (“upstream”). For instance, Jones and Taylor (In press) suggested the existence of eight types of loyalty-related outcomes: repurchase intentions, switching intentions, strength of preference, advocacy, altruism, willingness to pay more, exclusive consideration, and identification with the service provider. To examine the overall dimensions of loyalty, the authors conducted higher-order models. Results supported a two-dimensional (behavioral, and a combined cognitive/attitudinal loyalty) loyalty construct.

Section Summary

In summary, this section reviewed some recent developments related to the conceptualization of loyalty. Consensus seems to have been reached that loyalty is a multi-dimensional construct. However, it remains controversial what the key dimensions of loyalty, and the major loyalty-related outcomes are. It is noteworthy that to some researchers, the distinction between what constitutes loyalty per se, and what constitutes the outcome of loyalty is getting blurred. Preliminary efforts have been made to integrate the increasingly fragmented literature, whereas the generalizability of such results is still questionable. Next, we turn to a review of loyalty antecedents.

Antecedents of Loyalty

Identifying the determinants of loyalty has been another important research topic among loyalty researchers (Agustin and Singh 2005; Chiou 2004; Dick and Basu 1994; Lee 2003; Morais, Dorsch, and Backman 2005; Srinivasan, Anderson, and Ponnavaolu 2002; Thatcher and George 2004). Appendix B summarizes some of the recent studies on the antecedents of loyalty. This section will start from a brief overview of recent studies on loyalty antecedents, and follow with a more detailed discussion on several of the frequently examined loyalty determinants. It is noteworthy that researchers may hold totally different conceptualizations of loyalty when they discuss what the determinants of loyalty are. In other words, authors may refer to different things when they use the term “loyalty.” To be true to what has been used, this author employ the term “loyalty” in the original sense that authors of papers being reviewed use it.

General Framework of Loyalty Determinants

Dick and Basu (1994, p. 102), in a broad sense, postulated a series of cognitive (i.e., “those associated with informational determinants”), affective (i.e., “those associated with feeling states involving the brand”), and conative (i.e., “those related to behavioral dispositions toward the brand”) antecedents of relative attitude, which further lead to repeat patronage. Specifically, cognitive antecedents they identified include accessibility, confidence, centrality, and clarity of attitudes; affective antecedents include emotion, feeling states/mood, primary affect, and satisfaction; and conative antecedents include switching costs, sunk costs, and expectations (See Figure 2.3 for

their conceptual framework of loyalty formation). To date, empirical support to many of these proposed relationships is still lacking.

Backman and Crompton (1991b) identified five sets of factors that may be useful in predicting activity loyalty, which are motivation, level of involvement, price sensitivity, side bets, and number of different activities. Their study on tennis and golf participants revealed that three kinds of loyalty conceptualization approaches (i.e., attitudinal, behavioral, and composite) capture the loyalty phenomenon differently. For instance, level of involvement did not contribute to the prediction of behavioral loyalty, but was a significant predictor of attitudinal loyalty and composite loyalty. Side bets or investments added little to the explanation of behavioral loyalty or attitudinal loyalty, but were significantly associated with the composite measure of loyalty.

Srinivasan and colleagues (2002) examined the antecedents of customer loyalty in an online business-to-consumer context. Eight e-business factors (8Cs) were conceptually proposed to impact e-loyalty: (1) customization (the ability of an e-retailer to satisfy individual customers' needs), (2) contact interactivity (the availability and effectiveness of customer support, and the efforts to assist communication with customers), (3) cultivation (the extent to which an e-retailer provides desired information and incentives to its customers), (4) care (the attention and effort that an e-retailer puts to customers), (5) community (an online social entity comprised of existing and potential customers), (6) choice (the range of product categories and the variety of products within any given category), (7) convenience (the user-friendliness of the web site), and (8) character (an overall image or personality that the e-retailer projects to consumers).

Empirical tests revealed that all of these factors, except convenience, impacted online customers' loyalty.

Hennig-Thurau, Gwinner, and Gremler (2002) reviewed a number of approaches adopted by extant literature in explaining long-term relational outcomes (loyalty and word-of-mouth communication). Loyalty antecedents identified in these approaches included satisfaction, service quality, trust, commitment, and so on. The authors proposed a model integrating relational benefits (i.e., confidence benefits, social benefits, and special treatment benefits) and relationship quality (i.e., satisfaction and commitment). Their tests across several service categories demonstrated that customer satisfaction, commitment, confidence benefits, and social benefits all contributed to relationship marketing outcomes.

Lee (2003) examined the role of service quality, satisfaction, activity involvement, and place attachment in predicting destination loyalty in a forest setting. Her research on forest recreationists revealed that both satisfaction and place attachment appeared to have a mediating role between service quality and loyalties. Lee additionally found that satisfaction has a direct effect on conative loyalty, but not attitudinal or behavioral loyalty.

Most recently, Agustin and Singh (2005), drawing from need, motivation, and social exchange theories, conceptualized and investigated the differential curvilinear effects of multiple determinants of loyalty intentions. Using consumer data on relational exchanges in two different service contexts (retail clothing and non-business airline

travel), the authors reported support for the enhancing role of trust, and the maintaining role of transactional satisfaction and value, on loyalty intentions in both contexts.

Finally, Jones (2003) synthesized extant literature on drivers of service loyalty, and categorized them as non-relationship drivers (i.e., loyalty determinants that are specific to the service itself) and relationship drivers (i.e., loyalty determinants that are specific to the relationship with the service provider). Non-relationship drivers, which have been more widely studied and are more in line with the purpose of this study, are graphically presented in Figure 2.5.

FIGURE 2.5
PREVIOUSLY RESEARCHED ANTECEDENTS OF SERVICE LOYALTY

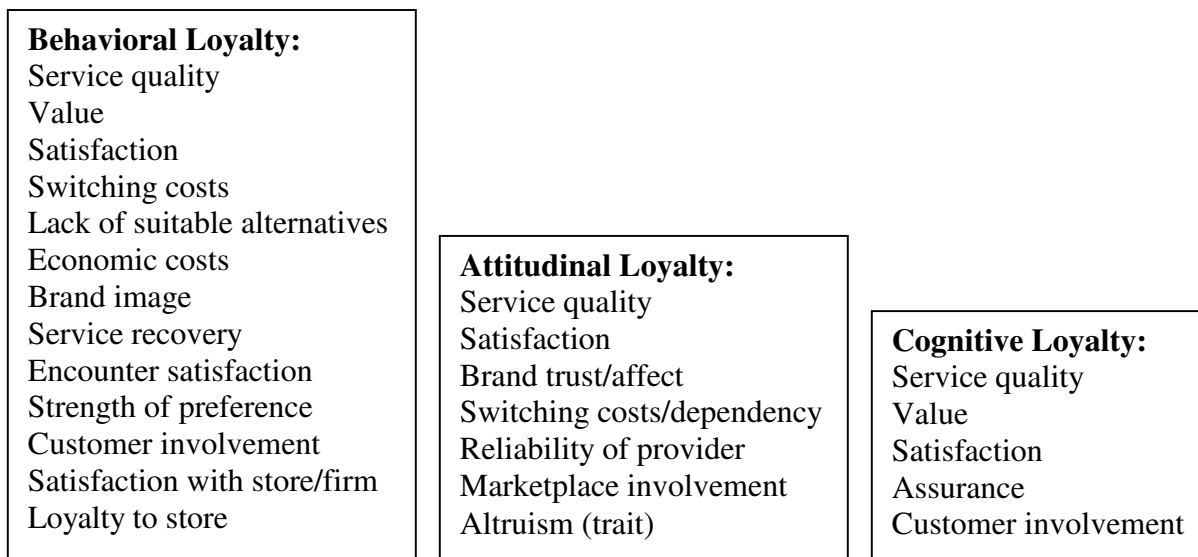

*Reprinted with permission from *Personal, Professional, and Service Company Commitments in Service Relationships*. by T. Jones (2003), Unpublished Dissertation, Queen's university. COPYRIGHT 2003 by Tim Jones.

Satisfaction and Loyalty

Among all factors potentially related to loyalty, satisfaction may be the most straightforward one. Satisfaction is traditionally considered as an overall affective response resulting from the use of a product or service (Oliver 1981). Many marketing (Anderson and Srinivasan 2003; Beerli et al. 2004; Bloemer and Kasper 1995; Bloemer and Lemmink 1992; Chiou 2004; Homburg and Giering 2001; Lam et al. 2004; Olsen 2002; Ping 1993; Yu et al. 2005) and leisure/tourism (Back 2001; Bowen and Chen 2001; Yoon and Uysal 2005) studies have shown that customer satisfaction may affect indicators of customer loyalty. As a matter of fact, the positive effect of satisfaction on loyalty has been somewhat taken for granted, and recent research has focused more on identifying moderators and/or mediators of the effect of satisfaction on loyalty (Abdullah, Al-Nasser, and Husain 2000; Bloemer and de Ruyter 1998, 1999; Homburg and Giering 2001; Lee 2003; Lee, Lee, and Feick 2001; Mittal and Lassar 1998; Yang and Peterson 2004), or the nature of the satisfaction-loyalty relationship (Agustin and Singh 2005; Bowen and Chen 2001; Gómez, McLaughlin, and Wittink 2004; Mittal and Kamakura 2001).

For instance, Bloemer and his colleagues (Bloemer and Kasper 1995; Bloemer and Lemmink 1992; Bloemer and de Ruyter 1998, 1999) conducted a series of studies on satisfaction and loyalty. Bloemer and Lemmink (1992) examined the assumed positive influence of customer satisfaction on loyalty in a car sales context. Specifically, three different types of customer satisfaction (satisfaction with the car, satisfaction with the sales service, and satisfaction with the after-sales service), and two kinds of loyalty

(brand loyalty and dealer loyalty) were differentiated and measured. Results supported the hypothesis that customer satisfaction with the car is a major determinant of brand loyalty, while sales service satisfaction and after-sales service are major determinants of dealer loyalty. However, dealer loyalty was found to be an intervening variable in the relation between satisfaction and brand loyalty. It was additionally found that the strength of the relationship between different types of satisfaction and loyalty indicators differs between various market segments.

Two later studies by Bloemer and his colleagues (Bloemer and Kasper 1995; Bloemer and de Ruyter 1998) focused more on the nature of satisfaction (manifest satisfaction and latent satisfaction) and loyalty (true loyalty and spurious loyalty). Both studies revealed that satisfaction is a major antecedent of loyalty. It was further found that the amount of elaboration (i.e., involvement and deliberation on brand or store choice) moderates the relationship between satisfaction and loyalty.

In a destination visiting context, Yoon and Uysal (2005) also reported a positive relationship between tourist satisfaction and destination loyalty. Specifically, their study investigated the relationship between motivation, satisfaction, and loyalty. In addition to the positive direct effect of satisfaction on loyalty, travel push motivations were also found to have a positive and direct relationship with destination loyalty.

It seems most existing studies anticipate direct, linear, and positive effect of satisfaction on loyalty. Yet some empirical findings have presented a more complex picture (Agustin and Singh 2005; Mittal, Ross Jr., and Baldasare 1998; Mittal and Kamakura 2001; Oliver 1999). Some researchers have argued that the strength of the



relationship between satisfaction and loyalty may vary significantly under different conditions (Anderson and Srinivasan 2003). For example, Jones and Sasser (1995) suggested that the strength of the satisfaction-loyalty link depends upon the competitive structure of the industry. Although Oliver (1997) considered loyalty as a type of “long-term effect” related to satisfaction, he also warned that, even with the presence of satisfaction, true loyalty may only be achieved in special situations (Oliver 1999).

Another line of research has focused on the nature of the satisfaction-loyalty link. For instance, Oliva, Oliver, and MacMillan (1992) argued that satisfaction may not directly lead to loyalty until a certain threshold is attained, just as dissatisfaction does not necessarily lead to switching until the threshold is breached. They concluded that satisfaction and loyalty are related in a linear and nonlinear fashion, depending on transaction costs. In a similar vein, Heskett and colleagues (1997) suggested that customer loyalty should increase rapidly after customer satisfaction passes a certain threshold. Consistent with this “threshold” argument, it has been found that “delighted” (i.e., “tremendously satisfied”) customers have a much higher probability of retention than those who are merely “satisfied” (Lam et al. 2004; Oliver 1997). A series of recent studies have also found evidence of nonlinearities for the relationship between satisfaction and behavioral loyalty (Agustin and Singh 2005; Bowen and Chen 2001; Gómez et al. 2004; Mittal and Kamakura 2001).

Despite the intuitive appeal, the view that customer satisfaction positively determines loyalty is not without disagreement (Fornell 1992; Hellier et al. 2003; Lee 2003; Skogland and Siguaw 2004) (see Table 2.3). For instance, Lee (2003) suggested

that satisfaction has a direct significant effect on conative loyalty, but not on attitudinal or behavioral loyalty. Petrick (1999), on the other hand, identified an inverted relationship between the two constructs, in which loyalty served as an antecedent of repeat visitors' satisfaction. This also makes conceptual sense in that participants of his study were all repeat golfers, who have previous experiences with the service provider (i.e., loyalty occurred before the most recent satisfaction). Lam et al. (2004) also suggested a reciprocal effect of customer loyalty on customer satisfaction, but their empirical test did not support this relationship.

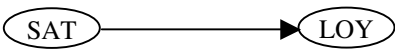
TABLE 2.3
A SUMMARY OF RIVAL CONCEPTUALIZATIONS ON
SATISFACTION - LOYALTY RELATIONSHIP

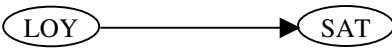
	Relationship	Selected Studies
View 1: 	Satisfaction exerts a direct, linear influence on loyalty	(Anderson and Srinivasan 2003; Back 2001; Bowen and Chen 2001; Beerli et al. 2004; Bloemer and Lemmink 1992; Chiou 2004; Homburg and Giering 2001; Lam et al. 2004; Olsen 2002; Ping 1993; Yoon and Uysal 2005)
View 2: 	Satisfaction and loyalty are related in a linear and nonlinear fashion	(Agustin and Singh 2005; Bowen and Chen 2001; Gómez et al. 2004; Mittal and Kamakura 2001; Oliva et al. 1992).
View 3: 	Customer loyalty influences satisfaction level	(Dwyer, Schurr, and Oh 1987; Lam et al. 2004; Petrick 1999; Shankar, Smith, and Rangaswamy 2003)

Researchers have also argued that customers may be influenced by numerous internal and external factors. In some cases, “negative bonds (e.g. consumer inertia,

brand promotion, customer information processing limitations, supplier monopoly) tie the customer to the service supplier, even though customer satisfaction with the company may not be particularly high” (Hellier et al. 2003, p. 1770).

In terms of measurement, it has been suggested that the majority of marketing and tourism research on satisfaction has built upon the disconfirmation of expectations paradigm (Baker and Crompton 2000). The disconfirmation paradigm assumes that each individual customer has a certain level of expectations about what the performance of a service or product would or should be. Consumer satisfaction/dissatisfaction is the result of the comparison of a consumer’s prior expectations and their postpurchase evaluation (Oliver 1980). If expectations exceed performance, negative disconfirmation or dissatisfaction results. Conversely, if the performance is perceived to meet or exceed expectations, customers are satisfied. One problem with the disconfirmation paradigm is it implies that lowering one’s expectations will always result in a higher level of satisfaction. Following this logic, those who expect and receive poor performance might be termed “satisfied” (LaTour and Peat 1979). Further, it has been proposed that the effects of expectations on satisfaction are weaker in a recreation context as the intangible nature of services can make reliable expectations harder to be established (Barsky and Labagh 1992; Johnson 1998). In some contexts, measuring satisfaction via an expectation-performance comparison could even be misleading, while a performance-only measure may hence be preferred (Petrick 2004c; Petrick and Backman 2002c; Tam 2000).

To date, a variety of measures of satisfaction have been suggested. Among these, two widely employed approaches are transaction-specific and overall satisfaction (Lam et al. 2004; Li and Vogelsong 2003; Tian 1998; Yang 2004). The transaction-specific approach views satisfaction as customers' psychological benefits obtained from a particular product consumption experience (e.g., service encounter). Thus, measuring transaction-specific satisfaction may provide specific diagnostic information about product offerings (Lam et al. 2004). Compared to transactional-specific satisfaction, cumulative or overall satisfaction reflects customers' cumulative impression of and attitude toward certain brand or service performance (Tian 1998; Yang and Peterson 2004). Overall satisfaction is considered as a more fundamental indicator of goods or service providers' performance (Bitner and Hubbert. 1994; Gustafsson, Johnson, and Roos 2005; Lam et al. 2004). It has thus been suggested that overall satisfaction, in comparison to transactional-specific satisfaction, is a more relevant and meaningful predictor of customer loyalty (Gustafsson et al. 2005; Lam et al. 2004; Olsen and Johnson 2003; Yang and Peterson 2004). Further, the strong positive effect of overall satisfaction on customer loyalty intentions has been examined across a wide range of product and service categories (Gustafsson et al. 2005).



Perceived Quality and Loyalty

Quality is another construct frequently associated with loyalty. Most studies on the quality-loyalty link have also involved a measure of satisfaction. Whereas satisfaction is either an end state or appraisal process resulting from exposure to a service experience (Rust and Oliver 1994), quality refers to an evaluation of "the

attributes of a service which are primarily controlled by a supplier” (Baker and Crompton 2000, p. 787).

At least three types of relationships between quality and loyalty have been identified in the literature (see Table 2.4). One school of thought suggests that quality

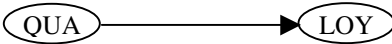
TABLE 2.4
A SUMMARY OF RIVAL CONCEPTUALIZATIONS ON
QUALITY - LOYALTY RELATIONSHIP

	Relationship	Selected Studies
View 1: 	Quality exerts a direct influence on loyalty	(Bitner 1990; Bloemer et al. 1999; Lee and Cunningham 2001; Zeithaml et al. 1996)
View 2: 	Quality indirectly influences loyalty through satisfaction	(Caruana 2002; Olsen 2002; Yu et al. 2005)
View 3: 	Satisfaction partially mediates the positive effect of quality on loyalty	(Baker and Crompton 2000; Lee et al. 2004)

can exert a direct influence on loyalty (Bitner 1990; Bloemer et al. 1999; Lee and Cunningham 2001; Zeithaml et al. 1996), while another views that satisfaction mediates the positive effect of quality on loyalty (Caruana 2002; Olsen 2002; Yu et al. 2005). Finally, still another argument holds that quality influences loyalty both directly and indirectly (Baker and Crompton 2000; Lee, Graefe, and Burns 2004).

For instance, Lee and Cunningham (2001) examined the determinants of service loyalty, assuming that consumers perform a cost/benefit analysis when deciding whether they want to be “regular customers” or not. The determinants of loyalty they identified

include service quality, transaction costs, and switching costs. Their results, based on data from bank and travel agency customers, indicate that service loyalty is determined by perceived service quality, as well as “cost considerations that arise from present transactions and future switching possibilities” (p. 122).

Olsen (2002) examined the relationship between perceived quality performance, customer satisfaction, and repurchase loyalty, using four different “generic” product categories of seafood. It was suggested that satisfaction plays a mediating role between quality and repurchase loyalty. Results also implied that for better predictability, quality, satisfaction, and loyalty should be defined and measured using a relative attitude approach (i.e., respondents are asked to make comparative evaluation of the focal brand against alternative options).

Baker and Crompton (2000) examined the interrelationship between quality, satisfaction, and behavioral intention (in terms of behavioral loyalty and willingness to pay more) in a festival participation context. Their analysis supported the hypothesized model, in which perceived quality had a stronger effect on loyalty (and willingness to pay more) than satisfaction.

Lee et al. (2004) explored the relationships between service quality and satisfaction, and their effects on behavioral loyalty among forest visitors. They found that service quality was an antecedent of satisfaction and that satisfaction played a mediating role between service quality and behavioral intentions. Further, quality was also found to have a direct effect on behavioral loyalty. The authors thus concluded that the effect of service quality on behavioral intention is as important as that of satisfaction.

For many researchers, their different views on the quality-loyalty relationship may result from fundamentally different understandings of the relationship between quality and satisfaction. To date, no less than six relationships between service quality and satisfaction have been suggested in the literature (Tian-Cole and Crompton 2003). Although some tend to consider satisfaction and quality as synonymous (Howart, Absher, Crilley, and Milne 1996; LeBlanc 1992), most researchers conceptualize the two as distinct, but related constructs. One group of service marketing and leisure/tourism researchers consider service satisfaction as transaction-specific, while quality is more likely to be a general attitude toward the service provider. Thus, satisfaction is an antecedent of service quality (Bitner 1990; Bolton and Drew 1991a; Bolton and Drew 1992; Bolton and Drew 1991b; Parasuraman, Zeithaml, and Berry 1988; Patterson and Johnson 1993). Another group of researchers consider both service quality and satisfaction at the transaction (rather than global) level, suggesting that service quality is more likely to lead to satisfaction (Bloemer and de Ruyter 1995; Cronin Jr. and Taylor 1992; Oliver 1993; Oliver 1997; Petrick 2004c). Some researchers have also suggested that the same relationship exists when both constructs are considered on a global level (Bigne, Sanchez, and Sanchez 2001; Kotler, Bowen, and Makens 1996).

In the leisure and tourism literature, Brown (1988) suggested that recreation satisfaction is the realization of participants' desired outcomes from engaging in recreation activities, while the availability of recreation opportunities will influence the amount of benefits recreationists receive. Following this conceptualization, Crompton and his colleagues (Crompton and Love 1995; Crompton and MacKay 1989) defined

service quality as the quality of service attributes (i.e., the constituent elements of the recreation/tourism opportunities provided by recreation/tourism suppliers), while satisfaction is a psychological outcome resulting from visitors' participation in recreation or tourism activities. They hence coined the term "quality of opportunity" (or "quality of performance") to refer to service quality, and "quality of experience" to refer to satisfaction in the recreation and tourism field (Crompton and Love 1995). Studies following this conceptualization generally suggest that quality of performance /opportunity leads to quality of experience (Baker and Crompton 2000; Crompton and Love 1995; Crompton and MacKay 1989; Crompton, MacKay, and Fesenmaier 1991; MacKay and Crompton 1988; Otto and Ritchie 1996). In general, leisure and tourism scholars tend to agree that there exists a quality → satisfaction → behavioral intention/loyalty sequence.

In terms of the measurement of service quality, one of the most frequently employed service quality measures is SERVQUAL (Petrick 2004c), developed by Parasuraman, Zeithaml, and Berry (Parasuraman, Berry, and Zeithaml 1991; Parasuraman et al. 1988). Similar to the disconfirmation paradigm used in the conceptualization of satisfaction, service quality is conceptualized as the difference between consumers' expectations and their assessments of service performance (Parasuraman, Zeithaml, and Berry 1985). Parasuraman, Zeithaml, and Berry's findings across several service industries (1988) revealed that customers' assessment of service quality could be further broken down into five distinct dimensions, namely, tangibles, reliability, responsiveness, assurance, and empathy. Even though the scale has been

extensively used, many researchers have criticized its empirical applicability (Petrick 2004c). It has been suggested that the SERVQUAL conceptualization confounds satisfaction and attitude (Cronin Jr. and Taylor 1992; Cronin Jr. and Taylor 1994). Moreover, empirical examination has consistently reported that performance-only measures generate superior results to contrast measures using expectations (Crompton and Love 1995; Cronin Jr. and Taylor 1992; Cronin Jr. and Taylor 1994; Petrick and Backman 2002a). As a result, several alternative measures of service quality have been proposed to measure service quality (Baker and Crompton 2000; Hartline and Ferrell 1996; Oh 1999; Petrick 2004c).

Perceived Value and Loyalty



Recent literature has increasingly linked perceived value with loyalty either directly or indirectly (Agustin and Singh 2005; Anderson and Srinivasan 2003; Chiou 2004; Hellier et al. 2003; Lam et al. 2004; Parasuraman and Grewal 2000; Yang and Peterson 2004). A widely used definition of perceived value is that it is “the consumer’s overall assessment of the utility of a product based on perceptions of what is received and what is given” (Zeithaml 1988, p. 14). Parasuraman and Grewal (2000, p. 169) maintained that, perceived value “is composed of a ‘get’ component—that is, the benefits a buyer derives from a seller’s offering—and a ‘give’ component—that is, the buyer’s monetary and nonmonetary costs in acquiring the offering.”

Similar to quality, perceived value is also frequently associated with satisfaction, when considered as a determinant of loyalty. Woodruff (1997) recommended that measuring perceived value may contribute to our understanding of customer satisfaction.

Oliver (1999, p. 34) speculated that the relationship between satisfaction and loyalty might be “mediated by other exchange-relevant constructs,” while Neal (2000, p. 19) went so far as to suggest that it is “value (Thatcher and George) drives loyalty, not satisfaction... Satisfaction is a necessary but not sufficient component of loyalty.”

Extant literature is divided in the relationship between perceived value and loyalty (see Table 2.5). A group of researchers have suggested that perceived value directly determines loyalty (Agustin and Singh 2005; Bolton and Drew 1991a; Bolton and Drew 1991b; Parasuraman and Grewal 2000; Sirdeshmukh, Singh, and Sabol 2002), while other studies have revealed that perceived value either moderates the satisfaction-loyalty relationship (Anderson and Srinivasan 2003; de Ruyter and Bloemer 1999), or indirectly influences loyalty through a mediator (i.e., satisfaction) (Chiou 2004; Lam et al. 2004; Yang and Peterson 2004).

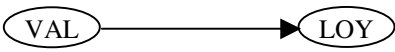
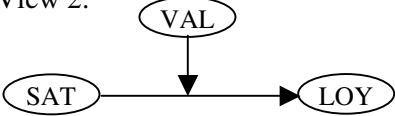
TABLE 2.5
A SUMMARY OF RIVAL CONCEPTUALIZATIONS ON
VALUE - LOYALTY RELATIONSHIP

	Relationship	Selected Studies
View 1: 	Perceived value directly determines loyalty	(Agustin and Singh 2005; Bolton and Drew 1991a; Bolton and Drew 1991b; Parasuraman and Grewal 2000; Sirdeshmukh et al. 2002)
View 2: 	Perceived value moderates the satisfaction-loyalty relationship	(Anderson and Srinivasan 2003; de Ruyter and Bloemer 1999)
View3: 	Perceived value indirectly influences loyalty through a mediator (e.g., satisfaction).	(Chiou 2004; Lam et al. 2004; Yang and Peterson 2004)

Sirdeshmukh, Singh, and Sabol (2002) posited that customer value is a superordinate goal for consumers in relational exchanges. According to goal and action identity theories (Carver and Scheier 1990; Vallacher and Wegner 1987), a superordinate goal is likely to regulate consumer actions at the lower level, such as consumer loyalty to service providers. “Consumers are expected to regulate their actions—that is, engage, maintain, or disengage behavioral motivation—to the extent that these actions lead to attainment of superordinate goals” (p. 21). Put differently, to achieve the superordinate goal, customers will indicate loyalty intentions as long as the transaction provides superior value. Their empirical tests in both airline travel and retailing services supported this view. Similarly, Bolton and Drew (1991a, 1991b) reported that value is an important determinant of consumers’ loyalty intention toward telephone services. Chang and Wildt (1994) also revealed that customer-perceived value is a major contributor to purchase intention.

Anderson and Srinivasan (2003) surveyed customers’ online purchase experiences, to examine the effect of e-satisfaction on e-loyalty. Perceived value (conceptualized as one of the business-level variables) was hypothesized as a moderator of this relationship. The authors proposed that “the relationship between e-satisfaction and e-loyalty appears strongest when the customers feel that their current e-business vendor provides higher overall value than that offered by competitors” (p. 128). Their tests supported the moderator role of perceived value in the satisfaction-loyalty link. Similar findings were also reported by de Ruyter and Bloemer (1999).

In contrast, Chiou (2004) proposed and empirically showed an attribute satisfaction → perceived value → overall satisfaction → loyalty intention chain. Thus, overall satisfaction mediates the positive effect of perceived value on loyalty. In other words, perceived value has a positive effect on overall satisfaction, which in turn leads to loyalty. Lam and colleagues (2004) found that satisfaction mediates the relationship between perceived value and loyalty, in a Business-to-Business context. It is noteworthy that their study showed that satisfaction totally mediated the relationship between perceived value and loyalty when loyalty was measured as word-of-mouth (i.e., recommending to other customers), but only partially mediated the relationship when loyalty was measured as repeat patronage. Thus, they concluded that perceived value have both a direct and an indirect positive effect (through satisfaction) on behavioral loyalty. Similar results were reported by Yang and Peterson (2004).

Despite the central role of perceived value in marketing research (Holbrook 1994), sophisticated value measures with psychometric validity have traditionally been lacking in the literature (Petrick and Backman 2004; Semon 1998). The commonly used self-reported unidimensional measure is criticized for being both misleading and uninformative (Petrick 2004c). Measurement problems related to perceived value have been cited as a main cause for the rather elusive interrelationships between satisfaction, perceived value, service quality, and repurchase intentions (Jayanti and Ghosh 1996; Petrick 2004c; Petrick and Backman 2002b).

Recent research has produced several multidimensional scales for measuring perceived value (Lin, Sher, and Shih 2005), which include Mathwick, Malhotra, and

Rigdon's (2001) EVS, Petrick's (2002) SERV-PERVAL, and Sweeney and Soutar's (2001) PERVAL. Among these, the SERV-PERVAL scale has been found to be useful in a tourism context (Chang 2005; Petrick 2004b; Petrick 2004c). Following Zeithaml's (1988) conceptualization of perceived value, the scale operationalizes perceived value as a five-dimensional construct consisting of quality, monetary price, non-monetary price, reputation, and emotional response.

Switching Costs/Sunk Costs and Loyalty

In their comprehensive framework of customer loyalty, Dick and Basu (1994) suggested switching costs and sunk costs as two types of conative antecedents of loyalty. The effect of switching costs on customer loyalty has since been examined by many researchers (Beerli et al. 2004; Gremler 1995; Hellier et al. 2003; Lam et al. 2004; Lee et al. 2001; Lee and Cunningham 2001; Ping 1993; de Ruyter et al. 1998; Yang and Peterson 2004). Switching costs refers to "the technical, financial or psychological factors which make it difficult or expensive for a customer to change brand" (Beerli et al. 2004, p. 258), while sunk costs are investments that "have been irrevocably committed and cannot be recovered" (Wang and Yang 2001, p. 180). Switching costs are the costs customers anticipate to occur in the future, whereas sunk (economic, transaction, or other) costs are those which have been incurred in present transactions (Lee and Cunningham 2001). It has been argued that switching costs are not only economic in nature, but also can be psychological and emotional (Yang and Peterson 2004). For consumers, "switching costs include those that are monetary, behavioral, search, and learning related" (Yang and Peterson 2004, p. 805).

When customers have made an initial investment in certain services or goods, or when the costs of switching brands are expected to be high, it is reasoned that the customer tends to remain (behaviorally) loyal (Beerli et al. 2004; Dick and Basu 1994). Such “lock-in” (Zauberger 2003) is the result of both the perceived risk/expense involved in switching, and the accompanying decrease in the appeal of alternative offerings (Beerli et al. 2004; Klemperer 1995; Selnes 1993; Wernerfelt 1991). “The net effect of switching efforts will depend upon the strength of the switching costs relative to the corresponding benefits made available” (Yang and Peterson 2004, p. 806). Nevertheless, if loyalty is defined in terms of both repeat behavior and positive attitude, the relationship between loyalty and switching costs could be complex (Beerli et al. 2004). For instance, the effect of switching costs on loyalty has been suggested to vary with the type of industry, the category of the product and the characteristics of the customer (Beerli et al. 2004; Fornell 1992).

Similar to perceived quality and value, consensus regarding the role of switching (and sunk) costs in determining loyalty has not been reached in the fields of either marketing or economics (Viard 2002) (see Table 2.6). One group of researchers believes that switching costs have a direct and positive effect on loyalty (Beerli et al. 2004; Klemperer 1995; Lam et al. 2004; Selnes 1993; Wernerfelt 1991), particularly when switching costs and customer satisfaction converge. It has been suggested that, all else being equal, a customer will be motivated to stay in existing relationships to economize switching costs (Dwyer et al. 1987; Heide and Weiss. 1995). However, the weight of switching costs as an antecedent of loyalty could be comparatively small, as opposed to

satisfaction (Fornell 1992). For instance, Beerli and colleagues' (2004) study on bank customers reported that both satisfaction and switching costs directly determine loyalty, while satisfaction plays a much more important role.

TABLE 2.6
A SUMMARY OF RIVAL CONCEPTUALIZATIONS ON
SWITCHING COST/INVESTMENT - LOYALTY RELATIONSHIP

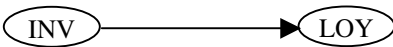
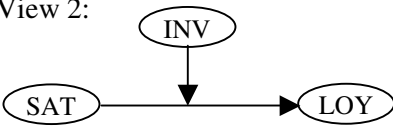
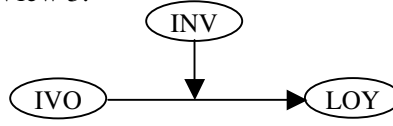
	Relationship	Selected Studies
View 1: 	Switching costs/Investments have a direct and positive effect on loyalty	(Backman and Crompton 1991b; Beerli et al. 2004; Klemperer 1995; Lam et al. 2004; Morais et al. 2005; Morais et al. 2004; Selnes 1993; Wernerfelt 1991)
View 2: 	Switching costs/Investments moderates the effect of satisfaction on loyalty.	(Anderson and Sullivan 1993; Hauser, Simester, and Wernerfelt 1994; Lee et al. 2001; Sharma and Patterson 2000; Yang and Peterson 2004).
View 3: 	Side bets/Investments, moderated the effects of involvement on attitudinal loyalty (commitment)	(Iwasaki and Havitz 2004; Iwasaki and Havitz 1998; Kyle et al. 2004)

In contrast, another line of research argues that switching costs, as a moderator, can significantly influence customer loyalty through such determinants as customer satisfaction and perceived value (Yang and Peterson 2004). Further, the moderating effect of switching costs on customer loyalty is contingent upon situational variables such as the types of businesses, customers, market structure, and products, and may not

always be significant (Lee et al. 2001; Nielson 1996; Yang and Peterson 2004). Research has revealed that switching costs can assume a significant moderating effect on customer loyalty through satisfaction (Anderson and Sullivan 1993; Hauser et al. 1994; Lee et al. 2001; Sharma and Patterson 2000). For instance, Lee, Lee, and Feick (2001) examined the effect of switching costs on the satisfaction-loyalty link in mobile phone service in France. Their findings supported that there is a moderating effect of switching costs on customer loyalty. Nonetheless, Yang and Peterson's (2004) hypotheses on the moderating role of switching costs were not supported by their data. They found that "the moderating effects of switching costs on the association of customer loyalty and customer satisfaction and perceived value are significant only when the level of customer satisfaction or perceived value is above average" (p. 799).

Similar concepts have also emerged in the field of leisure and tourism. Notably, leisure and tourism scholars' view on this issue has traditionally been influenced by Becker's (1960) conceptualization of "side bets" (Backman and Crompton 1991a, 1991b; Iwasaki and Havitz 2004; Kim, Scott, and Crompton 1997; Kyle et al. 2004; Lee 2003; Park 1996). To the extreme, Park (1996), followed Allen and Meyer's (1990) organizational commitment conceptualization, and suggested side bets or investment loyalty as one dimension of the loyalty construct. Side bets or investments in recreation behaviors may be indicated by equipment owned, organizational membership, emotional attachment, experience, money spent, efforts, and so on (Buchanan 1985; Park 1996). Thus, most of the related discussion involves products, rather than brands. It has been suggested that it is the lack of alternative options and accumulation of investments in a

particular program/activity/brand, that make recreationists or tourists reluctant to switch to other alternatives (Park 1996). To date, the role of side bets or investments in loyalty formation remains controversial among leisure and tourism scholars.

Backman and Crompton (1991b) examined the role of side bets in predicting attitudinal, behavioral, and composite loyalty. They reported that side bets or investments added little to the explanation of behavioral loyalty or attitudinal loyalty, but were significantly associated with the composite measure of loyalty. In another study, Backman and Crompton (1991a) found that side bets are useful in differentiating high, spurious, latent, and low loyalty participants.

Iwasaki and Havitz conceptualized (1998) and examined (2004) the enduring involvement → psychological commitment → behavioral loyalty linkage. They reported that side bets, along with other personal moderators, moderated the effects of involvement on commitment's formative factor. Kyle et al. (2004) examined the same model in a trail hiking setting. Building on previous sociology and leisure work on behavioral or structural commitment (Becker 1960; Buchanan 1985; Johnson 1973; Kim et al. 1997), they operationalized side bets as social and financial investments. These investments, along with psychological commitment, were hypothesized as the determinants of behavioral loyalty (mediated by activity and setting resistance). Their results showed that social investment is useful in predicting activity resistance, while both investments help predict setting resistance, and both types of resistance positively influence behavioral loyalty.

From a different theoretical perspective, Morais and his colleagues (Morais, Backman, and Dorsch 2003; Morais et al. 2005; Morais et al. 2004) proposed a resource investment view on loyalty formation, which was conceptually grounded on Foa and Foa's (1974; 1980) resource theory. They suggested that customers may invest six types of resources (i.e., love, status, information, services, goods, and money) in their relational exchanges with a service provider. Specifically, the authors suggested that if customers consider that a provider is making an investment in them, they will in turn make a similar investment in the provider, and those investments will lead to loyalty. Two 14-item scales were developed, one for Providers' Perceived Resource Investments (PPRI), and one for Customers' Reported Resource Investments (CRRI). Both scales contain four dimensions: love, status, information, and money. An empirical examination on white water rafting customers suggested investments of love, status, and information were more closely associated with loyalty than investments of money.

In terms of measurement, no widely accepted measures for switching costs or investment have emerged. In general, researchers tend to emphasize either customers' anticipated cost or established investment, or both. Table 2.7 summarizes several related measures.

TABLE 2.7
SAMPLE SWITCHING COSTS/INVESTMENT MEASURES

Type	Measures	Origin in the Literature
Switching Cost	It takes me a great deal of time and effort to get used to a new company. It costs me too much to switch to another company. In general it would be a hassle switching to another company.	(Jones, Mothersbaugh, and Beatty 2000; Yang and Peterson 2004)
	It would cost my company a lot of money to switch from DPS to another courier firm. It would take my company a lot of effort to switch from DPS to another courier firm. It would take my company a lot of time to switch from DPS to another courier firm. If my company changed from DPS to another company, some new technological problems would arise. My company would feel uncertain if we have to choose a new courier firm.	(Lam et al. 2004)
	On the whole, I would spend a lot of time and money to change primary wholesalers All things considered, the company would lose a lot in changing primary wholesalers Generally speaking, the costs in time, money, efforts, and grief to switch primary wholesalers would be high. Overall, I would spend a lot and lose a lot if I changed primary wholesalers Considering everything, the costs to stop doing business with the current wholesaler and start up with the alternative wholesaler would be high.	(Ping 1993; Sharma and Patterson 2000)
	What level of \$ costs do you feel would be incurred in switching to another car insurance company? What amount of inconvenience do you feel would be incurred in arranging to switch to another car insurance company? What amount of time do you feel would be involved in arranging to switch to another car insurance company? What is the likelihood that you will lose money if you switch to another car insurance company?	(Hellier et al. 2003)

TABLE 2.7 Continued

Type	Measures	Origin in the Literature
Switching Cost	<ul style="list-style-type: none"> • I have invested a lot of money in _____ (e.g., costs, equipment, membership, lessons). • I have emotionally invested in _____ • I have invested a lot of time in _____ • It is costly to switch _____ to other activities • Costs associated with switching _____ to other activities are expensive • I don't mind giving up _____ 	(Iwasaki and Havitz 2004)
Side Bets /Sunk Costs	<ul style="list-style-type: none"> • I usually subscribe to magazines related to golf/tennis. • I frequently visit scores to view new equipment related to my interest in golf/tennis. • I often talk to my friends about gold/tennis. • I spend a great deal of money on golf/tennis. • I usually watch golf/tennis on television. • Golf/tennis is an important part of my business life. • Many of my close friends are golfers/tennis players. • Being a golfer/tennis player gives me status. 	(Backman and Crompton 1991b)
Resource Investments	<p>Providers' Perceived Resource Investments (PPRI), 14-item, 4-dimension scale, e.g. "The outfitter treated me as an important customer" and "The outfitter educated me about all aspects of running the trip."</p> <p>Customers' Reported Resource Investments (CRRI), 14-item, 4-dimension scale, e.g., "I consider the outfitter's staff to be my close friends" and "I spent a lot of time and money to make this trip happen."</p>	(Morais et al. 2003; Morais et al. 2004)
Behavioral Commitment	<p>Social Investment</p> <ul style="list-style-type: none"> • I enjoy discussing hiking with my friends • Most of my friends are in some way connected with hiking <p>Financial Investment</p> <ul style="list-style-type: none"> • Please specify your estimated investment in hiking equipment to date. • About how much did you spend on all expenses relating to hiking in the last 12 months? 	(Kim et al. 1997; Kyle et al. 2004)

Other Determinants Suggested

As indicated, marketing and leisure/tourism researchers have suggested a variety of determinants of loyalty. Other than the above-mentioned factors, factors such as trust (Agustin and Singh 2005; Anderson and Srinivasan 2003; Ball, Coelho, and Machás 2004; Chaudhuri and Holbrook 2001; Chen 2001; Chu 2003; Delgado-Ballester and Munuera- Aleman 2001; Garbarino and Johnson 1999; Harris and Goode 2004; Morgan and Hunt 1994; Sirdeshmukh et al. 2002; Thatcher and George 2004), image (Abdullah et al. 2000; Back 2001; Bloemer and de Ruyter 1998; Cai, Wu, and Bai 2004; Lessig 1973), and involvement (Backman and Crompton 1991b; Backman and Shinenw 1994; Bloemer and de Ruyter 1999; Hong 2001; Kim et al. 1997; Park 1996; Pritchard and Howard 1997; Thatcher and George 2004) have also been frequently mentioned. For instance, Garbarino and Johnson (1999) showed that the role of satisfaction in affecting loyalty intentions becomes less central, whereas trust assumes greater importance, when satisfaction is defined at a transactional level. Pritchard and Howard (1997) proposed three antecedents of travelers' loyalty to travel services, namely, involvement/importance of the purchase decision, perceived differences in travel service performances, and satisfaction. They found that true loyalty is best indicated by empathetic service delivery, sign involvement, and satisfaction.

Section Summary

Existing literature seems to have presented a rather mixed picture of the antecedents of loyalty. Numerous factors have been suggested as antecedents of loyalty. Among them, satisfaction, switching costs, perceived quality, and perceived value have

been found to be conceptually and practically relevant. However, consensus has not been reached on the critical factors that actually determine loyalty (Agustin and Singh 2005).

Synopsis of the Chapter

This chapter reviewed extant loyalty literature from two perspectives: “what is loyalty” and “what determines loyal.” It seems that until recently, mainstream loyalty studies followed attitudinal, behavioral, or composite approaches. A recent conceptual development argues that more dimensions should be included in loyalty conceptualization. As a result, the construct of customer loyalty remains elusive and unpredictable (Agustin and Singh 2005). The lack of a clear conceptual structure for loyalty has also contributed to a rather complex situation for studies examining the precursors of loyalty. It is particularly disquieting that theoretical justification is still lacking in the selection of dimensions or antecedents of loyalty. Thus, it seems necessary to find a theory to integrate the seemingly segregated literature.

CHAPTER III

CONCEPTUAL DEVELOPMENT

As was presented in the previous chapter, there is a large body of loyalty literature in the fields of both marketing and leisure/tourism. As indicated, numerous studies have linked a variety of factors to loyalty. Most of these studies are exploratory in nature, where authors connect closely or distantly related variables with loyalty. Typical reasons offered for such connections include suggestions from previous literature, plausible relevance, and authors' own postulation, while reliable theoretical foundations for these connections are lacking (Jones and Taylor In press). As a result, it could be argued that conflicting results have been revealed and inconclusive conclusions reached. It could further be argued that a whole picture of the loyalty building process is yet to emerge. This seems to be partly due to a lack of methodological and operationalization consensus. More fundamentally, this seems to result from a lack of theoretical support for the inherent social psychological mechanism of loyalty formation. As noted by multiple researchers, there is a need for an alternative theoretical explanation of the construct of customer loyalty (Dick and Basu 1994; Fournier 1998; Morais et al. 2005).

Among theories that may assist in our understanding of loyalty is the multidisciplinary research on interpersonal commitment (Johnson 1973, 1991a; Levinger 1979a, 1979b; Rusbult 1980a, 1980b, 1983). In the field of marketing, theorists have argued that relational exchanges between customers and suppliers, characterized by "very close information, social, and process linkages, and mutual commitments made in

expectation of long-run benefits” (Day 2000, p. 24), could be the future paradigm of marketing practices and research (Berry 1983; Fyall, Callod, and Edwards 2003; Gronroos 1994; Palmer and Mayer 1996; Sheth and Parvatiyar 1995b). As a result, a number of relational variables such as commitment, closeness, trust, and relationship quality (all traditionally used to describe interpersonal relationships) have been linked to loyalty-related outcomes (Jones and Taylor In press). Fournier’s (1998) work on brand relationships revealed the utility of interpersonal relationship theories in examining brand-person type of relationships. Further, Jones and Taylor (In press) articulated that

...service loyalty, as compared to loyalty to tangibles, is dependent on the development of interpersonal relationships (Iacobucci and Ostrom 1996; Macintosh and Lockshin 1998), then examination of the loyalty-related outcomes that ensue from interpersonal relationships (i.e., romantic partnerships and friendships) could prove useful in the conceptualization of the service loyalty construct.

Thus, it can be argued that interpersonal relationship theory might be useful in the explanation and examination of the brand loyalty phenomenon.

This dissertation proposes that the Investment Model (Rusbult 1980a, 1980b, 1983) from the social psychology literature may integrate extant research findings, and lend a concrete theoretical foundation to the discussion. As the Investment Model was originally developed to explain interpersonal commitment, this chapter starts from a brief review on commitment and its conceptual relationship with loyalty. After that, an overview of the Investment Model, as well as alternative commitment conceptualizations, are provided and compared. The chapter ends with a developed conceptual model.

Commitment and Its Relationship with Loyalty

Over the past 40 years, a substantial number of research efforts have been conducted in the study of commitment. Mainline conceptualization of commitment started in the sociology and psychology disciplines (Kyle et al. 2004; Pritchard et al. 1999; Yair 1990). Sociological studies on commitment, following Becker's (1960) idea of "side bets," focus on the social factors and structural conditions that tie individuals to a consistent line of activity (Buchanan 1985; Kanter 1968; Scott and Godbey 1994). Psychological studies, on the other hand, stress personal choices or cognitions that bind one to a behavioral disposition (Festinger 1957; Shamir 1988; Thibaut and Kelley 1959). Recent work in the fields of organizational behavior, leisure, and marketing (Crosby and Taylor 1983; Kim et al. 1997; Kyle et al. 2004; Mowday, Porter, and Steers 1982) has attempted to approach the issue from both perspectives and integrate the notion in a socio-psychological framework.

The definition of commitment is rather controversial. Gustafsson et al. (2005) mentioned that, "marketing scholars have variously defined commitment as a desire to maintain a relationship..., a pledge of continuity between parties..., the sacrifice or potential for sacrifice if a relationship ends..., and the absence of competitive offerings..." (p. 211). Overall, it seems at least three types of definitions of commitment have emerged, reflecting fundamentally different views on this construct:

- (1) Commitment as consistent behavior. For instance, Bryan (1977, p. 184) described commitment as "the extent of the individual's time and effort invested" in an activity. Yair (1990, p. 214-215), similarly, defined commitment

as “a behavior that continues over a long period of time and involves the giving up of other alternatives, whether willingly or otherwise.”

(2) Commitment as psychological bonding. For example, Crosby and Taylor (1983, p. 414) suggested that “psychological commitment refers to a tendency to resist change in preference in response to conflicting information or experience.” In a same vein, Chen (2001, p. 12) defined commitment as “a psychological attachment or an affective attachment which produces an enduring desire to maintain long-term relationships. Resistance to change to competitors is the evidence of commitment.”

(3) Commitment as a socio-psychological binding mechanism. Buchanan (1985, p. 402) viewed commitment as “the pledging or binding of an individual to behavioral acts which result in some degree of affective attachment to the behavior or to the role associated with the behavior and which produce side bets as a result of that behavior.” Morais (2000, p. 43) considered commitment as “...the binding of individuals to a consistent behavioral pattern due to various forms of investments and personal motivations, attitudes, and values.” Kim et al. (1997, p. 323) suggested that commitment is “those personal and behavioral mechanisms that bind individuals to consistent patterns of leisure behavior.”

The third view seems to be consistent with the way many theorists conceptualize the structure and formation of commitment (Allen and Meyer 1990; Johnson 1973, 1991a; Meyer and Allen 1997; Rusbult 1980a, 1983). Therefore, this dissertation follows

this line of thought, and refers to commitment as a combined effect of psychological attachment and sociological constraints.

Due to its conceptual importance, commitment has been associated with several discipline-specific concepts, such as involvement (Crosby and Taylor 1983; Havitz and Dimanche 1997; Kim et al. 1997; Pritchard 1991; Shamir 1988), recreation specialization (Bryan 1977; Buchanan 1985; Scott and Godbey 1994; Scott and Shafer 2001), and place attachment (Kaltenborn 1997; Kyle et al. 2004; Lee 2003). However, it could be argued that none of these concepts are as conceptually close to commitment as loyalty is (Chen 2001). Day (1969) was arguably the first to introduce the concept of commitment to marketing loyalty studies. He asserted that exhibiting commitment to the brand is necessary in determining the existence of loyalty. Jacoby and Kyner (1973) maintained that “the notion of commitment provides an essential basis for distinguishing between brand loyalty and other forms of repeat purchasing behavior and holds promise for assessing the relative degrees of brand loyalty” (p. 3).

For marketing and leisure/tourism scholars, it appears that there is a certain form of attitudinal bias underlying both psychological commitment and loyalty (Pritchard et al. 1999). This seems to have caused some conceptual confusion between the two terms. Historically, there are at least three schools of thoughts on the relationship between psychological commitment and loyalty (Chen 2001; Lee 2003; Pritchard et al. 1999) (Table 3.1). View 1 states that commitment and loyalty are synonymous (Assael 1987; Buchanan 1985; Jacoby and Kyner 1973), and may be used interchangeably.

View 2 posits that commitment is synonymous to attitudinal loyalty (Backman 1991; Backman and Crompton 1991b; Day 1969; Jacoby and Chestnut 1978; Kyle et al. 2004; Park 1996; Pritchard 1991), or psychological commitment is affective plus conative loyalty (Chen 2001).

View 3 states that commitment is an antecedent of loyalty (Dick and Basu 1994; Oliva et al. 1992), with psychological commitment leading to loyalty (Lee 2003; Pritchard et al. 1999), or behavioral loyalty (Beatty, Homer, and Kahle 1988; Gustafsson et al. 2005; Iwasaki and Havitz 2004; Iwasaki and Havitz 1998).

TABLE 3.1
A SUMMARY OF ALTERNATIVE CONCEPTUALIZATIONS ON
COMMITMENT AND LOYALTY RELATIONSHIP

	Relationship	Studies
View 1: Commitment = Loyalty	Commitment and loyalty are synonymous	Assael(1987); Buchanan(1985); Jacoby and Kyner (1973)
View 2: Commitment <Loyalty	Commitment and attitudinal loyalty are synonymous	(Backman 1991; Backman and Crompton 1991b; Day 1969; Jacoby and Chestnut 1978; Kyle et al. 2004; Park 1996; Pritchard 1991)
	Commitment is synonymous with affective plus conative loyalty	Chen (2001)
View3: Commitment→Loyalty	Commitment leads to loyalty	(Dick and Basu 1994; Lee 2003; Oliva et al. 1992; Pritchard et al. 1999)
	Commitment leads to behavioral loyalty	(Beatty et al. 1988; Gustafsson et al. 2005; Iwasaki and Havitz 1998, 2004)

Even the same author may hold different views of the commitment-loyalty relationship over time. For example, it seems Pritchard's understanding towards the relationship evolved from "psychological commitment as attitudinal loyalty" (Pritchard

1991, p. 23), to “commitment as a component of attitudinal loyalty”(Pritchard et al. 1992, p. 160), to commitment leads to loyalty (Pritchard et al. 1999).

Most researchers would probably agree that commitment and loyalty are at least somewhat related (Chen 2001; Lam et al. 2004; Lee 2003; Pritchard et al. 1999). This could make it tempting to equate the two constructs as the same, due to their conceptual proximity (Pritchard et al. 1992). However, most researchers (other than those who view commitment in a behavioral sense) would probably argue that commitment and loyalty are distinct constructs, with commitment as the psychological attachment, attitude, or mechanism behind habitual repurchase, while loyalty is repeat behavior resultant from favorable attitudes (Chen 2001; Lee 2003). Thus, there is an increasing consensus that loyalty is broader than commitment, in that it includes a behavioral connotation. For the purpose of clarification, some authors propose to use the term “psychological commitment” to avoid any behavioral connotation (Crosby and Taylor 1983; Morais 2000; Pritchard 1991). For these reasons, the current study did not believe View 1 was a viable option.

What remains controversial is whether commitment is a subsection of (View 2), or a separate construct from loyalty (View 3). Most researchers (Backman 1991; Backman and Crompton 1991b; Day 1969; Jacoby and Chestnut 1978; Kyle et al. 2004; Park 1996; Pritchard 1991) seem to agree with the former (View 2). Conceptually, as consensus has been reached that loyalty encompasses attitudinal components, while psychological commitment may be treated as a socio-psychological binding mechanism, it is logical to equate the attitudinal dimension of loyalty with commitment (Lee 2003).

However, Dick and Basu (1994) indicated that relative attitude is predicted by the strength of psychological antecedents. Thus, commitment influences, rather than equates to attitudinal loyalty. Pritchard et al. (1999) also distinguished commitment and loyalty. Their study showed that the tendency to resist changing preference (as evidence of commitment) is a key precursor to loyalty, and mediates the three formative processes of commitment and loyalty. Chen (2001) argued that "regarding commitment as a part of loyalty rather than as a distinct construct, however, contributes to the definitional problems between commitment and loyalty" (p. 3). Some authors have therefore been very cautious when describing the relationship between attitudinal loyalty and psychological commitment. For example, Iwasaki and Havitz (2004) stated that "attitudinal loyalty is *reflected in the components of* [emphasis added] psychological commitment" (p. 50).

So, the key issue regarding the commitment-loyalty relationship seems to be whether we can equate commitment with the attitudinal dimension of loyalty. This author suggests that first of all, our answer depends on how we define and measure commitment and loyalty. For authors using the term loyalty in a behavioral sense, the distinction between psychological commitment and (behavioral) loyalty could be fairly straightforward. For authors incorporating an attitudinal dimension in their loyalty conceptualization, the conceptualization and operationalization of attitudinal loyalty is critical in differentiating these two constructs. That is, it is important to clarify what attitudinal loyalty is, if it is not commitment. For instance, Pritchard et al. (1999) used a 4-item brand preference scale developed by Muncy (1983) and Selin et al. (1988), to

measure customers' attitudinal loyalty. However, it may be argued that such preference measures might not be able to capture the conceptual richness of attitudinal loyalty. In other words, brand preference seems to lack the "emotional attachment" or "psychological bonding" connotation of attitudinal loyalty (Day 1969; Jacoby and Chestnut 1978). On the contrary, psychological commitment, defined as a socio-psychological binding mechanism, might do a better job in capturing such connotation.

Moreover, another fair question to ask is: why do we need to differentiate psychological commitment from attitudinal loyalty? It has been argued that attitudinal loyalty and commitment are generally highly correlated in empirical tests, and they both are indicators of customers' attitude toward the brand, thus differentiating the two might not add much value to our understanding of the phenomenon (Rundle-Thiele, personal communication). On the contrary, from a researcher's perspective, an obvious advantage of equating the two constructs is we can thus benefit from the rich history of commitment studies from different disciplines.

Based on the above discussion, it seems the predominant view that psychological commitment can be considered as the attitudinal subsection of loyalty still holds conceptual and practical value. This dissertation hence adopts this view in conceptualizing loyalty.

The Investment Model and Its Competing Theories

Theoretical Roots of the Investment Model

The Investment Model is "a theory of the process by which individuals become committed to their relationships as well as the circumstances under which feelings of

commitment erode and relationships end” (Rusbult, Drigotas, and Verette 1994, p. 116). The model is theoretically grounded within interdependence theory (Kelley and Thibaut 1978; Thibaut and Kelley 1959). It is also influenced by Lewin’s (1951) field theory, social exchange theory (Blau 1964), and other related sociological conceptualizations (Becker 1960; Johnson 1973).

Interdependence theory (Kelley 1979, 1983; Kelley and Thibaut 1978; Thibaut and Kelley 1959), also called comparison-level theory (Ganesh et al. 2000) or theory of interpersonal relations (Anderson and Narus 1984, 1990), is considered by many as a branch of social exchange theory (Anderson and Narus 1984; Young and Perrew 2000). According to interdependence theory, the behaviors one participant enacts in a dyadic relationship and the resultant outcomes of each behavior, depend on the behavior of the other participant, which results in a condition of mutual dependence. Specifically, this theory proposes that one participant’s dependence on a relationship is a function of (a) satisfaction with the relationship, and (b) a comparison of the best available alternatives to the relationship. To facilitate the following discussion, the participant in discussion is hereafter referred to as John, and his partner is referred to as Mary.

Thibaut and Kelley (1959) stressed the conceptual differences between satisfaction and dependence. To them, satisfaction level refers to the positive versus negative emotions John experiences in a relationship, while dependence refers to John’s reliance on the relationship for need fulfillment (Le and Agnew 2003; Rusbult et al. 1994). Interdependence theory suggests that three things influence John’s satisfaction: rewards (i.e., pleasure, gratification the person enjoys), costs (i.e., factors that operate to

inhibit or deter the performance of a sequence of behavior), and comparison level (CL). Comparison level is “the standard against which a member evaluates the ‘attractiveness’ of the relationship or how satisfactory it is” (Thibaut and Kelley 1959, p. 21). The outcomes obtained from the relationship, compared against this standard, determine the degree of satisfaction John experiences from the relationship. John’s satisfaction with the relationship should be greater to the degree that the rewards relative to costs obtained in that relationship exceed his comparison level. Notably, this is conceptually similar to the disconfirmation of expectations paradigm in marketing studies (Oliver 1980).

However, satisfaction by itself may not explain more complex scenarios, in which individuals choose to stay in an obviously unsatisfying relationship (Rusbult et al. 1994). Interdependence theory further posits another comparison criterion, the comparison level for alternatives (CL_{alt}). Comparison level for alternatives is a standard that represents the average quality of outcomes available to the participant from the best alternative relationship. It represents the lowest level of outcomes John will accept and still remain in the relationship (Thibaut and Kelley 1959). Thus, John compares the current relationship with anticipated outcomes in the best alternative option, and decides whether to remain with or to leave Mary. Simply put, John’s dependence on a relationship is stronger when the outcomes obtained in the current relationship are perceived to be better than those anticipated from alternative relationships.

Although interdependence theory originally focused on close interpersonal relationships, marketing researchers have found it useful in consumer research (LaTour and Peat 1979, 1980), interorganizational exchange research (Anderson and Narus 1984,

1990), and relationship marketing studies (Blois and Wilson 2000; Caruana 2004; Ganesh et al. 2000). For example, Anderson (1984, 1990) tried to understand the working relationships between distributor and manufacturer, from an interdependence theory perspective. Their empirical tests found that two constructs developed based on interdependence theory (outcome given CL and outcome given CL_{alt}) gave significant explanation for the behavioral constructs such as satisfaction/cooperation and manufacturer control.

The Investment Model

The Investment Model was initially developed as a means of describing satisfaction and commitment related to romantic involvement (Rusbult 1980b). Following major principles of interdependence theory, the Investment Model has attempted to clarify and extend interdependence theory (Rusbult et al. 1994). It extends interdependence theory in two aspects (Rusbult et al. 1998): First, while interdependence theory focuses on dependence (i.e., the degree to which one's needs are satisfied in a relationship), the Investment Model focuses on commitment, a consequence of increasing dependence. Basically, commitment is a subjective, psychological experience of the state of dependence (Le and Agnew 2003; Rusbult et al. 1994).

Secondly and more importantly, the Investment Model asserts that a third factor, investment size, is necessary when examining interpersonal relationship persistence (Rusbult 1978). Similar to interdependence theory, the Investment Model also distinguishes satisfaction and commitment, with the former referring to John's feelings toward Mary and their relationship, and the latter referring to John's tendency to

maintain the relationship and feel attached to it (Rusbult 1991). It argues that the explanation presented by interdependence theory does not capture the whole story. That is, there may exist another factor accounting for the survival of relationships in the face of tempting alternatives and fluctuating satisfaction. Rusbult suggested that this additional factor is the investment, or any tangible or intangible resources attached to a relationship that may be lost or diminished once the relationship is dissolved. Thus, the Investment Model maintains that John's commitment to the relationship is strengthened by the level of satisfaction that John derives from the relationship, is fueled by his investments to the relationship, and is weakened by the quality of alternatives to the relationship (Figure 3.1).

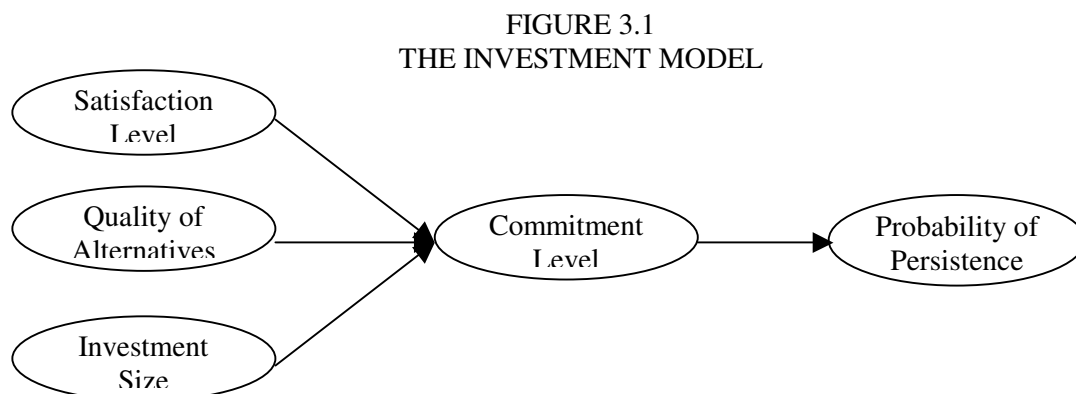

*Reprinted with permission from "The Investment Model Scale: Measuring Commitment Level, Satisfaction Level, Quality of Alternatives, and Investment Size." by C. Rusbult, J. Martz, and C. Agnew 1998. *Personal Relationships*, 5 (4), 357-91. COPYRIGHT 1998 by Blackwell Publishing.

Satisfaction Level

The Investment Model assumes that people are generally motivated to maximize rewards and minimize costs (Rusbult 1980a). Following interdependence theory, the

model proposes that John's satisfaction (SAT) with the relationship is a function of the subjective estimate of rewards (REW) John derives from Mary and the relationship, the amount of costs he suffers (CST) in the relationship, and John's expectations concerning the quality of relationships in general (CL). Thus, John will feel more satisfied to the degree that he derives rewards from the relationship, suffers few costs, or has a lower standard for evaluating relationships. Further, John's satisfaction with the relationship positively influences his commitment to Mary.

Moreover, the outcome value is a function of the subjective estimate of the value of the attributes associated with the relationship, each weighted by its subjective importance (Rusbult 1991). Thus, John's satisfaction level can be defined as:

$$SAT = REW_i (\sum [r_i i_i]) - CST_i (\sum [c_i i_i]) - CL$$

where r_i represents John's subjective estimate of the reward of attribute i available in the relationship with Mary, c_i represents John's subjective estimate of the cost of attribute i available in the relationship, and i_i represents its subjective importance (Rusbult 1991).

Finally, as suggested by interdependence theory, John's generalized expectation (CL) results from two sources: John's past experiences, and John's social comparison with friends and family.

Quality of Alternatives

At the same time John evaluates his own relationship, he may also contemplate what might be experienced outside the current relationship. That is, what the relationship experience would be if John were not with Mary, but in the best alternative situation (Rusbult et al. 1994). This "alternative" option could be an actual person or relationship,

or it may be having no relationship at all (i.e., being independent is considered preferable to any relationship for some people). The quality of alternatives (ALT) is defined as:

$$ALT = REW_j (\sum [r_j i_j]) - CST_j (\sum [c_j i_j]) - CL$$

where r_j represents John's subjective estimate of the reward of attribute j available in the alternative situation, c_j represents John's subjective estimate of the cost of attribute j available in that situation, and i_j represents its subjective importance (Rusbult 1991).

The quality of alternatives is "individual-level forces" pulling one from sustaining the relationship. John's commitment to Mary is reduced to the degree that the quality of alternatives is high. Conversely, John may feel more committed to the relationship when the "pulling forces" are weak.

Investment Size

Finally, investment size is proposed to contribute to the stability of a partnership. A variety of things may be tied to John's current relationship, for which John becomes bound to Mary and their relationship. Investments (INV) refer to any tangible or intangible resources attached to a relationship that may be lost or diminished once the relationship is dissolved. This includes intrinsic/direct investments (DIR INV), such as time or self-disclosure. Also included are extrinsic/indirect investments (IND INV), such as mutual friends and social status that the relationship brings. In certain circumstances, "social norms and moral prescriptions may serve as compelling sources of investment" (Rusbult 1991, p. 159). Therefore, John's subjective investment may be mathematically represented as:

$$INV = DIR\ INV (\sum [DI_k i_k]) + IND\ INV (\sum [II_k i_k])$$

where DI_k represents John's subjective direct investment in attribute k , II_k represents John's subjective indirect investment in attribute k , and i_k represents its subjective importance (Rusbult 1991).

Commitment

In the Investment Model, commitment is conceptualized as a function of three basic forces: satisfaction, quality of alternatives, and investment size. The three forces may sometimes work in concert. For instance, poor satisfaction, attractive alternative option, and low investment size, may work together and push John to leave Mary. Elsewhere, the three forces may strain against each other, for instance, substantial investment and poor alternatives may trap John in a less satisfactory relationship. It has been suggested that "not all of these factors must be present for commitment to be experienced", and "there can be a lack of commitment when only one component is promoting commitment" (Le and Agnew 2003, p. 39). Represented mathematically, commitment (COM) is defined as:

$$COM = (SAT - ALT) + INV$$

Conceptually, Rusbult's view of commitment "is related to the probability that he/she will leave the relationship, and involves feelings of psychological attachment" (Rusbult 1980a, p. 174). Rusbult (1991, p. 156) also pointed out that commitment is one's "tendency to maintain a relationship and feel attached to it... Commitment is a psychological state — including both cognitive and emotional components — that directly influences [John's] decisions to continue or end a relationship." Other Investment Model theorists (Le and Agnew 2003) have suggested that commitment is

“characterized by an intention to remain in a relationship, a psychological attachment to a partner, and a long-term orientation toward the partnership” (p. 38). Thus, the Investment Model’s view of commitment is behavior oriented. Some researchers have hence criticized the model for confounding commitment with its outcome (Johnson 1991a, 1991b). Nevertheless, this further validates the view adopted in this dissertation that commitment and attitudinal loyalty are basically the same thing. Specifically, the bonding force that Investment Model theorists refer to as “commitment” is conceptually akin to what marketing and leisure/tourism researchers call “attitudinal loyalty,” in that it contains a behavioral intention (conative) component, but does not directly contain a behavioral component.

Consequences of Commitment

The Investment Model suggests commitment directly mediates the effects of three determining forces on John’s pro-relationship behaviors. Commitment is suggested as a “central macromotive in relationships” (Rusbult et al. 1994, p. 123). For John, feelings of commitment may serve to: (1) subjectively summarize the nature of John’s dependence on a relationship; (2) direct John’s reactions to both familiar and novel relational situations; and (3) shape tendencies to engage in relationship maintenance processes. Rusbult, Drigotas, and Verette (1994) summarized relationship maintenance behaviors as:

- (1) John’s decision to remain in or end relationships;
- (2) John’s tendencies to accommodate, including exit (“behaviors that are actively destructive to the future of relationship” p. 125), voice (“active

attempts to improve conditions in a relationship” p. 125), loyalty (“optimistically waiting for positive change” p. 125), or neglect (“passively allow conditions in a relationship to deteriorate” p. 125);

- (3) Derogation of alternatives, to convince John that the alternative to Mary or their relationship is not that attractive;
- (4) Willingness to sacrifice self-interest for the good of a relationship; and
- (5) Perceived relationship superiority or relationship-enhancing illusion, to evaluate the current relationship through comparisons to similar ones.

Empirical Support of the Model

Since its introduction to the literature, the utility of the Investment Model has been extensively examined. Le and Agnew (2003) conducted a meta-analysis on 52 previous Investment Model studies, including 60 independent samples, and 11,582 participants, and reported robust significant correlations between the three antecedents with commitment. Satisfaction was found to be the strongest predictor of commitment, whereas quality of alternatives and investments were of similar absolute magnitude. Collectively, these three factors accounted for an average of 61 percent of the variance in commitment.

Although the Investment Model was originally proposed to examine interpersonal relationships (e.g., romantic involvement and friendship), it has been tested across various non-personal settings, such as organizational and job commitments (Farrell and Rusbult 1981; Oliver 1990), business interactions (Ping 1993; Ping 1997; Tuten and Urban 1999), brand commitment (Tuten 2005), and so on. Support for the

model has also been obtained in nonrelational domains, although the model has been shown to better predict interpersonal relations (Le and Agnew 2003). Le and Agnew (2003, p. 54) concluded that “the Investment Model is not strictly an interpersonal theory and can be extended to such areas as commitment to jobs, persistence with hobbies or activities, loyalty to institutions, decision-making, and purchase behaviors.”

Alternative Commitment Conceptualization

As indicated, commitment has attracted research attention from multiple disciplines over several decades. A number of commitment theories and classifications have been proposed. These include interpersonal commitment conceptualizations such as Rusbult’s Investment Model (Rusbult 1980a, 1980b, 1983), Johnson’s commitment framework (Johnson 1973, 1982, 1991a, 1991b; Johnson, Caughlin, and Huston 1999), and Levinger’s social exchange model of cohesiveness (Levinger 1979a, 1979b). In addition, other theorists have focused on commitment as a tie between an individual and lines of activity (Becker 1960), organizations (Allen and Meyer 1990; Kanter 1968), particular role partners (Stryker 1968, 1980), identity (Burke and Reitzes 1991), internal and external customers (Morgan and Hunt 1994), and brands (Pritchard et al. 1999). The following section briefly reviews three competing conceptualizations of commitment, which have all cast significant influences in the fields of marketing and leisure/tourism. It is believed that highlighting both their commonality with and differences from the Investment Model will shed light on the understanding of the commitment and loyalty phenomenon.

Johnson's Commitment Framework

Johnson's commitment framework evolved over time. Initially, following Becker's (1960) step, he (Johnson 1973) classified commitment into personal commitment — defined as “the extent to which an actor is dedicated to the completion of a line of action” (p. 396), and behavioral commitment — “those consequences of the initial pursuit of a line of action which constrain the actor to continue that line of action” (p. 397), which can be further categorized into social commitment and cost commitment. Later, Johnson (1982) expanded the conceptual domain of behavioral commitment into structural commitment, which is defined as “external constraints which come into play as a consequence of the initiation of the line of action and which make it difficult to discontinue should one's sense of personal commitment decline” (p. 53).

In 1991, Johnson systematically amplified his original conceptualization, and added a third factor (moral commitment) to his “commitment framework” (Johnson 1991a). His fundamental premise is “people continue in relationships because they feel that they want to, ought to, or have to do so” (p. 118). Specifically, he proposed that “the decision to continue a relationship is a function of three different experiences of commitment: (1) personal commitment, the feeling that one wants to continue the relationship; (2) moral commitment, the feeling that one ought to continue it; and (3) structural commitment, the feeling that one has to continue it. ” (p. 118-119). The motivation and action of maintaining or dissolving a relationship is the joint effect of social structure, individual psychology, and dyadic negotiation (Johnson 1991b).

Johnson (1991a) delineated the three forms of commitment based on two dimensions: 1) the extent to which a factor is experienced as internal or external to the individual, with personal commitment (stemming from one's attitude and self-concept), and moral commitment (stemming from one's own value system and sense of right and wrong) being internally experienced, while structural commitment (stemming from one's assessment of the costs of termination) is externally experienced; and 2) the extent to which the experience is voluntary or constrained in nature. Specifically, personal commitment is one's own choice, while moral and structural commitments both involve a sense of constraint.

Johnson (1991a) further specified the sources of these three commitments. According to the model, one's personal commitment flows from (1) his/her attitude toward the relationship, (2) attitude toward the partner, and (3) his/her relational identity (i.e., "the extent to which one's involvement in a relationship is incorporated into one's self-concept" p. 120). One's moral commitment also comes from three sources, which are (1) a belief in the value of consistency, (2) values regarding the stability of particular types of relationships; and (3) a sense of obligation to the particular person with whom one is involved in the relationship. Finally, there are at least four kinds of constraining factors resulting in structural commitment: (1) irretrievable investments, (2) social reaction, (3) difficulty of termination procedures, and (4) availability of acceptable alternatives.

Johnson's commitment framework is sociological in nature. His conceptualization is also influenced by interdependence theory (Kelley and Thibaut

1978; Thibaut and Kelley 1959). This can be seen from his answer to the question of “commitment to what.” To this question, he maintained that “the basic definitional element in a social relationship is interdependence...commitment to the maintenance of a relationship is defined as commitment to lines of action that will prevent the elimination of interdependence” (Johnson 1991a, p. 120). For Johnson, commitment is not a unitary concept (hence he does not articulate a definition of commitment), for which he “refused to label the outcome of [his] model as 'commitment', preferring to focus on the implications of three different commitment experiences for the development of plans of action” (Johnson 1991b, p. 172).

Johnson’s early conceptualization of commitment (as personal and behavioral commitment) is highly influential, particularly in leisure and recreation studies (Kim et al. 1997; Kyle et al. 2004; Kyle and Mowen 2005; Scott and Shafer 2001; Yair 1990, 1992). His 1991 framework has not yet been widely tested, although data from one of his recent studies (Johnson et al. 1999) supported the major propositions of the framework. Further, Adams and Jones’ (1997) review of the marriage commitment literature seem to support Johnson’s framework. Their analysis suggested that most conceptualizations of interpersonal commitment implicitly or explicitly contained three types: an attraction type, a moral type, and a constraint type.

Despite its merit, Rusbult (1991) argued that Johnson’s personal commitments construct is conceptually similar to satisfaction level in the Investment Model, while structural commitment is similar to the investment size and quality of alternative categories. What is unique about his commitment framework is the proposal that moral

commitment, a construct that is captured in the investment size construct in the Investment Model, should be considered as an independent force. However, the necessity of adding this dimension has been questioned (Levinger 1991; Rusbult 1991). Further, although moral commitment makes conceptual sense in an interpersonal context, its applicability in a nonpersonal setting (e.g., a customer is committed to a service provider because s/he feels that switching to other brand will be morally wrong) warrants further examination

Pritchard et al.'s Conceptualization of Commitment Formation

Pritchard et al.'s (Pritchard et al. 1999) conceptualization of commitment has recently gained popularity among commitment researchers in leisure studies (Kyle et al. 2004). Their main premise is that “the strength of a consumer’s commitment is determined by a complex causal structure in which their resistance to change is maximized by the extent to which they: (1) identify with important values and self-images associated with the preference, (2) are motivated to seek informational complexity and consistency in the cognitive schema behind their preference, and (3) are able to freely initiate choices that are meaningful” (p. 344).

In their theorizing process, Pritchard and his associates (Pritchard 1991; Pritchard et al. 1999; Pritchard et al. 1992) drew on consumer behavior and organizational behavior literature. Their conceptualization is mainly based on the work of Crosby and Taylor (1983), who suggested that the “tendency to resist changing preference” provided the principle evidence of commitment, and commitment was best explained by two antecedent processes: informational processes and identification processes. In addition,

they were inspired by Salancik's (1977) work, which suggested that commitment is strengthened when people sensed their decision was (1) not easily reversed (revocability, which is conceptually similar to Crosby and Taylor's "informational processes"), (2) known to significant others (publicness, which is conceptually similar to Crosby and Taylor's "identification processes"), and (3) undertaken as an exercise of free choice (volition).

Combining the two conceptualizations (Crosby and Taylor 1983; Salancik 1977), Pritchard et al. (1999) proposed that "psychological commitment is best defined by a tendency to resist change and that three formative processes activate this tendency" (p. 337). Resistance to change refers to individuals' unwillingness to change their preferences toward, important associations with, and/or beliefs about the commitment object. Consistent with Crosby and Taylor, Pritchard et al. argued "resistance to change, as the principal evidence of commitment, will act as a mediator between the construct's antecedent processes and loyalty" (p. 337).

The three formative processes activating the tendency to resist change are informational, identification, and volitional processes. After empirical testing and validation, Pritchard et al. (1999) found that (1) informational processes are represented by informational complexity, which refers to the degree of complexity of a person's cognitive structure; (2) volitional processes are represented by volitional choice, which is defined by the perception that a decision to perform an action has been taken out of one's free choice; and (3) identification processes are represented by position involvement, which is the degree to which self-image is linked to brand preference.

Some leisure scholars have started to accept Prichard et al.'s work in their conceptualization of commitment (Iwasaki and Havitz 1998, 2004; Kyle et al. 2004). However, it remains debatable whether the model Prichard et al. suggested should be considered as the formation process of commitment, or just an internal structure of commitment. For instance, Prichard et al. themselves maintained that, "psychological commitment is best defined by a tendency to resist change and that three formative processes activate this tendency" (p. 337). Thus, it may be argued that the model does not necessarily depict a whole picture of what determines commitment, as it does not include a description of the external driving forces of commitment.

Three-Component Model of Organizational Commitment

The organizational behavior literature also has a rich history of commitment studies, which have been traditionally associated with employee turnover intention and efficiency (Bansal, Irving, and Taylor 2004; Jones and Taylor 2004). Allen and Meyer (1990) integrated various organizational commitment conceptualizations, and proposed a three-component commitment model (affective commitment, continuance commitment, and normative commitment), which is fairly similar to Johnson's commitment framework.

In their conceptualization (Allen and Meyer 1990; Meyer and Allen 1997), the affective component of organizational commitment refers to employees' emotional attachment to, identification with, and involvement in the organization. Affective commitment may be considered as a desire-based attachment to the organization (i.e., employees remain with the organization because they *want to*) (Bansal et al. 2004).

The continuance component refers to commitment based on the sacrifice and costs that employees associate with leaving the organization. Continuance commitment may be considered as a cost-based attachment that binds employees in the organization (i.e., employees remain with the organization because they *need to*). Some marketing researchers call this type of commitment “calculative commitment” (Gilliland and Bello. 2002; Gustafsson et al. 2005; Sargeant and Woodliffe 2005), which reflects a disposition to stay based on a rational, economic evaluation of the costs and benefits involved in maintaining a relationship.

Finally, the normative component refers to employees' feelings of obligation to stay with the organization. Normative commitment may be considered as an obligation-based attachment to the organization (i.e., employees remain with the organization because they *ought to*—it is the “right thing to do”).

Measures of these three forms of commitment have been developed and refined (Allen and Meyer 1990; Meyer, Allen, and Smith 1993). The three-dimension conceptualization and their measures have been extensively employed and accepted by organizational behavior and management researchers (Allen and Meyer 1996; Jones and Taylor 2004; Meyer, Stanley, Herscovitch, and Topolnytsky 2002; Payne and Huffman 2005). Marketing researchers have also started to adopt the three-component classification in their examination of business-to-business commitment (Gruen, Summers, and Acito. 2000) or business-to-customer commitment (Bansal et al. 2004; Jones and Taylor 2004). In the leisure literature, Park (1996) borrowed Allen and Mayer's (1990) three-component conceptualization, and proposed a multidimensional

model of attitudinal loyalty. Park suggests that attitudinal loyalty consists of: investment loyalty (accumulation of side-bets); normative loyalty (awareness of expectations from social groups); and affective loyalty (identification with the activity). Notably, Park used commitment and attitudinal loyalty interchangeably throughout his discussion.

Its wide acceptance aside, the three-component classification of commitment is by nature not an explanatory model of the commitment formation process. Put differently, the classification provides a useful framework to catch the multiple dimensions of commitment, while not explicitly explaining why commitment occurs. Further, the three-component classification does not necessarily conflict with the Investment Model. One may argue that affective commitment can be captured by the satisfaction construct of the Investment Model, normative commitment is included within investment size, and continuance commitment is similar to investment size and quality of alternatives.

Proposed Conceptual Model

Justification

As discussed, Rusbult's Investment Model (Rusbult 1980a, 1980b, 1983), rooted in interdependence theory, proposes that one's commitment to a relationship is determined by his/her satisfaction level, the quality of alternative relational options, and his/her investments. Although somewhat ignored in the leisure/tourism field, this model has had substantial support from social psychology and other disciplines (Le and Agnew 2003). A comparison of the model with extant commitment conceptualizations in different disciplines suggests that the Investment Model not only shares conceptual

commonality with other theories, but also presents a clear and parsimonious explanation of the commitment formation process. Following the mainstream conceptualization in the marketing and leisure/tourism literature (Backman 1991; Backman and Crompton 1991b; Day 1969; Jacoby and Chestnut 1978; Kyle et al. 2004; Park 1996; Pritchard 1991), this dissertation posits that the Investment Model may help explain the formation process of the attitude dimension of the loyalty construct.

Interestingly, commitment determinants identified by the Investment Model are consistent with extant empirical evidence from the marketing and leisure/tourism loyalty literature, which may not be a coincidence (see Figure 3.2). Specifically, the Investment Model suggests satisfaction as a major determinant of commitment. The review of marketing and leisure/tourism literature in Chapter II shows that, satisfaction (Anderson and Srinivasan 2003; Bloemer and Lemmink 1992; Yoon and Uysal 2005) has been frequently identified as loyalty's major antecedent by marketing and leisure/tourism literature as well. The Investment Model also suggests investment size as a key determinant of commitment. This is also consistent with the conceptualization of marketing and leisure/tourism scholars, who suggest that switching costs or investments may serve as another antecedent of loyalty (Backman and Crompton 1991b; Beerli et al. 2004; Morais et al. 2004).

Finally, although the concept of "quality of alternatives" is somewhat new to the fields of marketing and leisure/tourism, some authors have tackled the idea. For instance, Ping (1993) incorporated theoretical elements of the investment model in his investigation on retailer-supplier relationships. He suggested that "the relationship

FIGURE 3.2
CONSISTENCY BETWEEN EMPIRICAL EVIDENCE AND
THE INVESTMENT MODEL

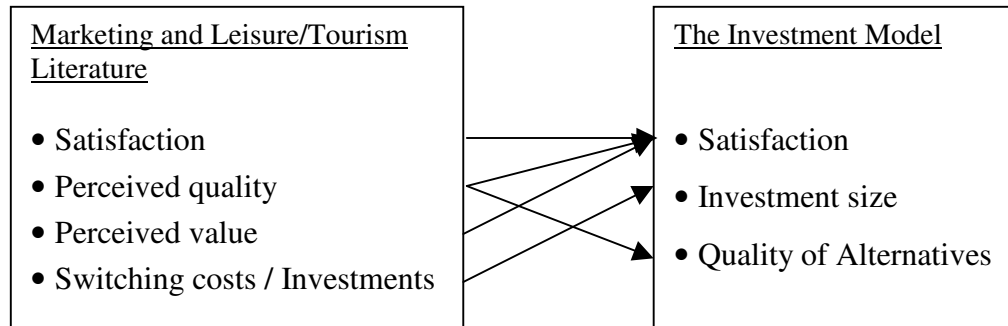

‘structural constraints’ of alternative attractiveness,” among others, is one of the key antecedents of loyalty, and other response intentions of hardware retailers. Ganesh et al. (2000) suggested that the application of interdependence theory to customer loyalty processes may exhibit “a certain degree of theoretical discrimination in regard to the different types of customer loyalty” (p. 69). Their findings suggest that, partly due to the different levels of shifts in their comparison level and comparison level of alternatives, dissatisfied switchers (i.e., customers who have switched service providers because of dissatisfaction) seem to differ significantly from other customer groups in their satisfaction and loyalty behaviors. Pritchard and Howard (1997) also suggested that perceived differences in travel service performance is an antecedent of tourist loyalty. Specifically, they suggested that “large interbrand differences in quality increase the tendency for consumers to be brand loyal” (p. 4).

Moreover, perceived quality and perceived value, two of satisfaction’s related constructs, have also been suggested to either directly or indirectly influence customer

loyalty. Although no consensus has been reached regarding their relationships with loyalty (see Figure 2.3 and Figure 2.4 for alternative views), a number of researchers have found that the effects of perceived quality (Baker and Crompton 2000; Caruana 2002; Olsen 2002; Yu et al. 2005) and perceived value (Agustin and Singh 2005; Chiou 2004; Lam et al. 2004; Yang and Peterson 2004) on loyalty are (partially or completely) mediated by satisfaction. Thus, this dissertation speculates that quality and value are two major antecedents of satisfaction, which then leads to attitudinal loyalty. Plus, perceived quality may also cast a positive effect on value as suggested by some researchers (Parasuraman and Grewal 2000; Petrick 2004c).

In regards to loyalty conceptualization, most recent loyalty studies have approached the multi-dimensionality issue of loyalty from two perspectives: one focusing on loyalty's building process (Back 2001; Jones and Taylor In press; Lee 2003), and the other focusing on loyalty-related outcomes (Morais et al. 2004; Rundle-Thiele 2005; de Ruyter et al. 1998; Zeithaml et al. 1996). The first group is exemplified by Oliver's work (1997, 1999), which suggests loyalty is a continuum, starting from some cognitive beliefs (cognitive loyalty), followed by affective loyalty (i.e., "I buy it because I like it"), conative loyalty (i.e., "I'm committed to buying it"), and finally actual purchase behaviors (action loyalty, or "action inertia"). A number of researchers have since adopted Oliver's four-category loyalty conceptualization (Back 2001; Harris and Goode 2004; Lee 2003; McMullan and Gilmore 2003). The second line of research expanded the loyalty construct to what Dick and Basu (1994) would define as consequences of loyalty. Researchers following this line of research have contended that

loyalty may be readily measured through a series of manifest indicators (Bloemer and de Ruyter 1998; Morais et al. 2004; Rundle-Thiele 2005; de Ruyter et al. 1998). Finally, some researchers have tried to integrate the loyalty outcome measures by examining the loyalty formation process (Jones and Taylor In press).

This dissertation follows the first line of thought, and conceptualizes loyalty as a four-dimensional construct. The first three phases of the four-dimension structure of loyalty is theoretically rooted in the tripartite model of attitude structure (Breckler 1984), which has been widely accepted (Breckler 1984; Breckler and Wiggins 1989; Eagly and Chaiken 1993; Jackson et al. 1996; Reid and Crompton 1993; Zanna and Rempel 1988). The tripartite model suggests that there are three components of people's attitudes: cognition, affect, and behavior. For example, Breckler's (1984) study on attitude toward snakes identified affect, cognition, and behavior as three distinct components of an attitude. It has also been suggested that, the cognitive, affective, and behavioral processes are independent of each other, and each component of attitude exhibits unique variance that is not shared by the other two (Bagozzi 1978). Further, it has also been argued that attitudes do not have to embrace all three components at the same time (Tian 1998). Thus, the three components may not be sequential as suggested by Oliver (1997, 1999). Finally, the attitude-behavior linkage has been both theoretically and empirically established in the past (Ajzen 1991, 2000; Ajzen and Driver 1991, 1992; Ajzen and Fishbein 1980; Albarracin, Johnson, Fishbein, and Muellerleile 2001; Fishbein and Ajzen 1975).

Thus, consistent with Back (2001), this dissertation proposes that cognitive loyalty, affective loyalty, and conative loyalty are essentially three components of the traditionally termed attitudinal loyalty. Moreover, it is posited that the cognitive, affective, and conative phases of loyalty do not necessarily follow a sequential formation process, as suggested by Oliver (1997, 1999). Collectively, the three components form a higher order factor called attitudinal loyalty, which leads to action/behavioral loyalty.

From a measurement perspective, the two lines of thoughts on loyalty structure might not necessarily conflict with each other. For instance, willingness to recommend/positive word-of-mouth may be considered as one form of conative loyalty by the first group of researchers (Lee 2003), but labeled as one form of loyalty outcome by the second group (Morais et al. 2004). It seems that the four types of loyalty per se (Oliver, 1997, 1999) may be measured by various loyalty-related outcomes. Thus, this dissertation follows Jones and Taylor (In press), and tries to integrate the two streams of loyalty conceptualization together.

Furthermore, to this author, four-dimensional loyalty is also consistent with the traditional two-dimension view, which has been widely accepted across disciplines, and has generated meaningful results. By incorporating, rather than invalidating the traditional view, the four-dimensional structure of loyalty has been argued to be conceptually acceptable by marketing and leisure/tourism researchers (Back 2001; Harris and Goode 2004; Lee 2003; McMullan and Gilmore 2003).

The Conceptual Model

Based on the above discussion, a conceptual model is developed (Figure 3.3). Following the Investment Model (Rusbult 1980a, 1980b, 1983), it is suggested that satisfaction, quality of alternatives, and investment size are three critical antecedents of consumers' commitment/attitudinal loyalty. In a tourism context, this means tourists' attitudinal loyalty to service provider is strengthened by their level of satisfaction with the touristic services, and the investments they have made and potential switching costs they anticipated, and weakened by their perceived quality of alternative options. Following previous conceptualization of the interrelationships between satisfaction, quality, value, and loyalty, this dissertation posits that both quality (Caruana 2002; Olsen 2002; Yu et al. 2005) and value's (Chiou 2004; Lam et al. 2004; Yang and Peterson 2004) effects on loyalty are mediated by satisfaction, with quality also leading to value (Parasuraman and Grewal 2000; Petrick 2004c).

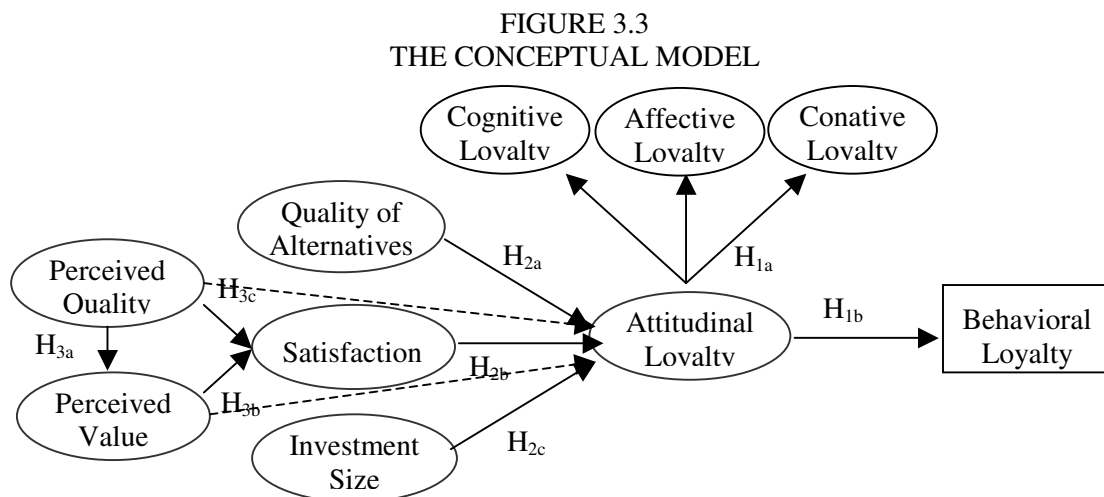

Note: The dotted line represents partial mediation

Following the recent developments in loyalty conceptualization (Back 2001; Jones and Taylor In press; Oliver 1997, 1999), loyalty in this model is conceptualized as a four-dimensional construct: cognitive, affective, conative, and behavioral loyalty. Specifically, the cognitive, affective, and conative components of loyalty may be collectively considered as attitudinal loyalty, which further lead to behavioral loyalty.

Synopsis of the Chapter

Despite the merit of existing findings, a theoretical understanding of the conceptual domain and antecedents of loyalty seems to be lacking. This chapter suggested that the Investment Model of interpersonal commitment (Rusbult 1980a, 1980b, 1983) might provide a useful theoretical framework in delineating the major determinants of customer loyalty. Specifically, it was suggested that satisfaction, quality of alternatives, and investment size are three critical antecedents of consumers' commitment/attitudinal loyalty. Alternative commitment conceptualizations in sociology, marketing and leisure/tourism, and organizational behavior literature were compared to the Investment Model. It was concluded that the Investment Model might provide a conceptually sound and parsimonious explanation to the question "what determines loyalty." Further, Oliver's (1997, 1999) four-dimensional loyalty conceptualization is adopted in this dissertation. A conceptual model based on the Investment Model and the four-dimensional loyalty conceptualization is hence structured, as to describe the formation process of loyalty.

CHAPTER IV

METHODOLOGY

This chapter describes the methods used to conduct an online panel survey to examine the structure and antecedents of cruisers' brand loyalty. The first section overviews the research design of this study. This is followed by a discussion of the development of the questionnaire used in the survey, as well as the data collection procedures. The chapter ends with an explanation of the statistical techniques used for data analysis.

Research Design

The present study adopts a quantitative methodology, guided by the positivist / scientific realism paradigm (Hunt 2002). Although this study deals primarily with unobserved (latent) variables, such as loyalty, satisfaction, and so on, the indicators for these constructs were assumed to be measurable in a self-reporting manner. A self-administered questionnaire survey, which has been deemed to be appropriate for measuring self-reported beliefs and behaviors (Neuman 1997; Rundle-Thiele 2005), was employed for data collection. Although all three major survey methods (i.e., face-to-face, self-administered, and telephone interviews (Bernard 2000) have been used in loyalty studies, self-administered (mail) surveys have been the most frequently employed approach (Rundle-Thiele 2005). It has been suggested that self-administered questionnaire surveys are preferable to the other two survey methods when the researcher is dealing with literate respondents, when the response rate is estimated to be high, and when the questions being asked do not require a face-to-face interview or

visual aids (Bernard 2000). The present study meets these three conditions, which will be discussed in the next section. Other advantages of self-administered surveys include comparatively lower cost and a low level of intrusiveness (Rundle-Thiele 2005).

Specifically, this study utilized an online panel survey. By interviewing the same (randomly sampled or not) individuals over and over again, panel studies are often used for longitudinal research purposes (Bernard 2000). Online survey panels, however, “are made up of individuals who are pre-recruited to participate on a more or less predictable basis in surveys over a period of time” (Dennis 2001, p. 34). Most such panels are professionally managed by survey companies, and pre-grouped into different panels based on consumption attributes. To conduct online panel surveys, researchers need to specify characteristics of the people they want to study to the survey company. The survey company will then select people from one or more of their panels, and invite them to participate. Online survey panelists are compensated for their participation, which hence generally result in prompt and complete responses.

To date, online panel surveys have been fairly commonplace in marketing research (Dennis 2001; Deutskens, de Jong, de Ruyter, and Wetzels 2006; Duffy, Smith, Terhanian, and Bremer 2005; Hansen 2005; Van Ryzin 2004; Sparrow and Curtice 2004). In general, online panel research has been found to: have greater speed and relatively lower cost; make research more visual, flexible and interactive; reduce interviewer effects; allow for target sampling for low-incidence groups; and to have low intrusiveness (Dennis 2001; Deutskens et al. 2006; Duffy et al. 2005). Also worth mentioning is that due to technological development, online surveys can effectively

reduce or avoid incomplete responses, which can be a serious issue in statistical analysis (Byrne 2001).

Vriens et al. (2001) listed cost-efficiency, speed, and getting the right information as three goals of research design. Online panel surveys may be preferable to other research methods due to its advantage in meeting the first two objectives. However, researchers have expressed concern regarding the validity of information collected from online panel studies. A major issue related to online (panel) surveys is sampling bias (Duffy et al. 2005; Hwang and Fesenmaier 2004; McWilliams and Nadkarni 2005). Specifically, online panel studies may suffer from three types of sampling biases: only people with Internet access are reached; only those who agree to participate in the panel are reached; and not all panelists who are invited respond (Duffy et al. 2005). McWilliams (2005) reported that online panel samples tend to be younger, richer, and better educated, in comparison to general American travelers. Online panel members are also more active travelers, though they report less business travel and far more leisure trips. Some researchers have even argued that repeat and paid participation in surveys might bias online survey panelists' attitude and behavior, and make them closer to "professional respondents" (Dennis 2001).

However, Dennis' (2001) six case studies comparing, among other things, panelists' brand and product attitude, responses to sensitive questions, and political opinions did not detect evidence of negative panel effects. A more recent study by Duffy et al. (2005) compared data collected from online and face-to-face surveys, and suggested that differences are more obvious in responses to some survey questions than

others. For instance, online and face-to-face methodologies generated similar responses for questions regarding attitudes towards immigration, but generated different results for questions like political activism and knowledge-based cholesterol questions. The authors speculated that such outcomes may be due to: a) online panel approach tending to attract a more knowledgeable and more viewpoint-oriented sample; and b) face-to-face respondents being more susceptible to social desirability bias. Deutskens and colleagues (Deutskens et al., 2006) were also interested in whether online and mail surveys produce convergent results. Their study on a large business-to-business service quality assessment showed that despite minor differences, online and mail surveys generated equivalent results. Overall, it is concluded that although online panel surveys may generate some sampling bias, it is a valid and efficient research method, particularly when the representativeness of public opinion is not the primary concern of a study.

Instrument Development

A self-administered online survey was used to collect the data. The survey questionnaire was developed with the use of a comprehensive review of related literature, as well as extensive personal communications with leading loyalty researchers in the fields of tourism and hospitality, marketing, and leisure.

To strengthen the depth of this review, the current author also posted a request on the Listserv of the American Marketing Association (<http://www.marketingpower.com>) for updated literature on loyalty (or commitment) measurement and conceptualization. Over twenty responses were received from marketing scholars all over the world through this process. A number of recent journal and conference papers, technical reports, books,

and dissertations were collected, which provided useful guidance for the development of the questionnaire.

Two types of scales were used in the survey: semantic differential and Likert-type scales. Both have been extensively used in previous loyalty research (Rundle-Thiele 2005). Likert-type scale is arguably the most common form of scaling (Bernard 2000; DeVellis 2003) in terms of measuring people's internal states such as attitudes and emotions (Bernard 2000; Gay and Airasian 2000). A typical Likert-type scale asks respondents to indicate their degrees of agreement with or endorsement of a declarative statement (DeVellis 2003; Gay and Airasian 2000). In general, the response options contain three to seven points, anchored by *Strongly Agree* and *Strongly Disagree* (Bernard 2000; DeVellis 2003; Gay and Airasian 2000). Semantic differential items use adjective pairs that are bipolar in nature (e.g., good-bad, hot-cold) or unipolar in nature (e.g., good-not good, hot-not hot)(Netemeyer, Bearden, and Sharma 2003). The respondents give a quantitative rating to a target concept (stimulus) presented by researchers along the continuum (usually 7 points) that characterizes the stimulus (Gay and Airasian 2000; Netemeyer et al. 2003).

One common concern related to using Likert-type or semantic differential scales is whether we should treat such categorical scales as continuous in statistical analysis (Byrne 2001; Rundle-Thiele 2005), as most multivariate statistical techniques are applicable only to continuous scales. It has been suggested that this problem may be negligible when the number of categories is large (Byrne 2001). Specifically, Bentler and Chou (1987, p. 88) suggested that as long as the categorical variables are normally

distributed, “continuous methods can be used with little worry when a variable has four or more categories.” Considering this, and following Green and Rao’s (1970) recommendation, it was decided that this study would adopt 7-point scale categories whenever appropriate.

Moreover, despite some critiques regarding using multiple items to measure one construct (Gardner, Cummings, Dunham, and Pierce 1998; Peter 1979), this study followed the more common practice and adopted multi-item measurement (Rundle-Thiele 2005), rather than single-indicator measurement. It has been suggested that the use of multi-items can increase reliability, decrease measurement errors, and effectively categorize people into groups (Churchill 1979; Peter 1979; Rundle-Thiele 2005). Further, for statistical approaches such as SEM, the use of a minimum of three items per construct is generally recommended (Kline 2005).

Pilot Test

After the initial version of the questionnaire was developed, fourteen experts were invited to review and pretest the instrument. These experts were mainly faculty members or Ph.D. students specializing in leisure or tourism marketing, all with extensive experience in quantitative research. Additionally, more than half of them had cruised before. A variety of comments and suggestions were collected regarding choice of scales, length and organization of the questionnaire, wording of specific statements, and design and format issues. Many of the comments were pertaining to the wording of scale statements. For instance, several experts mentioned that the wording of two items (“Costs associated with switching <name> to another cruise line are expensive” and “I

don't mind giving up <name>”, both adapted from (Iwasaki and Havitz 2004) measuring investment size were not entirely clear to them. When such problems occurred, the current author checked back to the original literature first (i.e., where the scale was adapted from), and consulted the experts for their recommendation at the same time. In most cases, only slight rewording was made in order to be true to the original scale. It was decided that major changes would be made based on experts' suggestions in collaboration with the pilot test results.

A shortened questionnaire was pilot tested among three undergraduate classes (leisure and tourism classes at the sophomore, junior, and senior level). Having consulted with these students in advance, it was decided that the questionnaire would be adjusted to a dining context, with a local restaurant that the students as a whole were most loyal to as the subject. Some cruising-related questions were hence not included in the pilot questionnaire. One hundred and fourteen students who had eaten at the restaurant in the past 12 months participated in the pilot test and provided valid responses.

When using measuring instruments like survey questionnaires, researchers are always concerned with the problems of validity and reliability, among others (Bernard 2000; Gay and Airasian 2000; Netemeyer et al. 2003). Validity may be partially established through adapting existing scales for the context (i.e., cruising in the study) under investigation (Rundle-Thiele 2005). In order to estimate the internal consistency reliability of each of the scales, Cronbach's coefficient alpha was employed, which is the most widely used practice for this purpose in cross-sectional studies (Cohen, Cohen,

West, and Aiken 2003; Netemeyer et al. 2003). Nunnally and Bernstein (1994) suggested that coefficients of 0.70 or higher were acceptable, while coefficients of 0.90 or above indicated good reliability. On the other hand, other researchers have argued that when the research is in the exploratory stage (Hatcher 1994) or when the number of items in a scale is less than six (Cortina 1993), Cronbach's alphas greater than 0.5 may be considered acceptable (Morais 2000). With two exceptions, all constructs measured in the pilot survey had alphas greater than 0.7. Thus, it seems that most scales used in the survey demonstrated reasonable level of internal consistency.

One of the two scales in question was the scale measuring investment size. As indicated, the investment size in this study was conceptualized as switching costs and sunk costs. In the pilot survey, this was measured by Iwasaki and Havitz's 6-item side bets scale (2004), with minor a modification to fit the scale to the brand level. A closer examination of the scale and survey results, together with comments from the expert panel and students' comments on the pilot study, led this researcher to conclude that the three items of the scale related to switching behavior (e.g., "I don't mind giving up_____") could be confusing to the respondents. It was therefore decided to use Jones et al.'s (2000) 3-item switching cost scale to replace this part of the scale.

Another scale which had drawn this researcher's attention even before the pilot study was the quality of alternatives scale. Two versions of the scale used by Investment Model researchers were obtained, and modified to a dining context. They were both presented (though separately) in the pilot survey questionnaire, as to determine the effectiveness of the scales. One 4-item scale used semantic differential scales (e.g., "If

you were not eating at _____, would it be easy to find another restaurant with the same level of quality?” from 1 “*Hard to Find*” to 7 “*Easy to Find*”), while the other was a 5-item Likert-type scale (e.g., “My dining needs could easily be fulfilled in an alternative restaurant”, from 1 “*Strongly Disagree*” to 7 “*Strongly Agree*”). Somewhat to this researcher’s surprise, respondents expressed confusion and miscomprehension to the 4-item scale. On the contrary, the version using Likert-type scales seemed to have delivered the message more effectively and the result of the reliability test was more robust. Thus, it was decided that the 5-item Likert-type scale should be used in the formal survey.

Variables Measured for This Study

The final survey instrument, starting with a screening question on whether the respondent took a cruise vacation in the past 12 months or not, contained three groups of questions. The first part of the questionnaire was related to respondents’ perception of and experiences with the brand (i.e., cruise line they had cruised within the past 12 months). All major constructs being explored in this study were tested in this section, including loyalty, satisfaction, quality of alternatives, investment size, perceived value, and perceived quality. The second part of the questionnaire was about respondents’ general cruising and traveling profile. The last part measured selected demographic characteristics of the respondents. The following is a review of factors being measured in this study, with particular focus on the justification of choices of scales.

Loyalty

In this study, loyalty was operationalized as a four-dimensional construct, as suggested by Oliver (1997, 1999). Specifically, these include cognitive loyalty, affective loyalty, conative loyalty, and action loyalty. Although at least two scales have been developed to measure the four-dimensional conceptualization (Harris and Goode 2004; McMullan and Gilmore 2003), neither was deemed to be appropriate measurements for the purpose and context of this study. Harris and Goode's (2004) scale was developed for two online service scenarios (online book purchasing and online flight tickets purchasing), and the scale is hence fairly context-specific. McMullan and Gilmore's (2003) scale was developed for a service context (restaurant-dining). However, as the authors did not go through such scale development procedures as using multiple samples, or examining with confirmatory analysis (Netemeyer et al. 2003), the scale might still need further examination. Thus, this dissertation measured the first three dimensions of loyalty (collectively represent attitudinal loyalty), with a 9-item, 7-point Likert-type scale (e.g., "<Name> cruise provides me superior service quality as compared to other cruise brands") proposed by Back (2001; Back and Parks 2003). The scale, with each dimension of loyalty being measured by 3 items, was developed based on marketing literature (Beatty et al. 1988; Loken and John 1993; Oliver 1997).

Action or behavioral loyalty, following the most frequently-used approach, was measured by proportion of brand purchase (Brown 1952; Copeland 1923; Cunningham 1956; Iwasaki and Havitz 1998). Specifically, this was operationalized as the total

number of cruises the respondent has taken with the focal cruise line in the past 3 years, divided by the total number of cruises that the respondents had taken in these 3 years.

Satisfaction

As indicated, two widely employed satisfaction measures are transaction-specific and overall satisfaction (Lam et al. 2004; Li and Vogelsong 2003; Tian 1998; Yang 2004). Overall satisfaction, which is a summary evaluation of subjects' entire product use experience (Spreng et al. 1996), has been considered as a more relevant and meaningful predictor of customer loyalty (Gustafsson et al. 2005; Lam et al. 2004; Olsen and Johnson 2003; Yang and Peterson 2004). Therefore, this study measured overall satisfaction via Spreng et al.'s (1996) measure. Specifically, respondents were asked to rate their overall experiences with the cruise line on four 7-point semantic differential scales anchored by *very dissatisfied/very satisfied*, *very displeased/very pleased*, *frustrated/contented*, and *terrible/delighted*. This measure was proposed to be able to capture both valence and intensity aspects of satisfaction, as suggested by Oliver (1989). Similar items have also been used by other marketing and leisure scholars (Childress and Crompton 1997; Crosby and Stephen 1987; Petrick and Backman 2002c; Tian 1998).

Investment Size

Consistent with marketing literature, this study conceptualized investment size in terms of switching costs and sunk costs. Jones et al.'s 3-item switching cost scale (2000) and three items of Iwasaki and Havitz's (2004) side bets/sunk costs scale were used/adjusted to a brand level, to measure people's switching and sunk costs. This resulted in a 6-item, 7-point Likert type scale, anchored by 1 *Strongly Disagree* and 7

Strongly Agree. Costs related to time, monetary, and emotional efforts were all tackled in the measurement. A sample item was “It costs me too much to switch to another cruise line.”

Quality of Alternatives

Very few measures of quality of alternatives can be found in the field of marketing and tourism. A closer look at existing scales (Anderson and Narus 1984; Ping 1993) suggests that they may not be appropriate in the current context. It was therefore decided that modifying Rusbult’s (Rusbult et al. 1998) 5-item (global items) scale on quality of alternatives may serve the purpose of this study better. However, Rusbult’s scale was initially developed for measuring interpersonal relationships, while the present study focuses on customer-brand relationships. To ensure that the reworded scale did not lose the original conceptual connotations, three senior Texas A&M University faculty members from the fields of psychology, management, and tourism, all familiar with the Investment Model, were consulted in the process of modification. The modified scale questions were further validated by the pilot test on 114 undergraduate students. The 5-item, 7-point Likert-type scale asked the respondents their feelings about alternative cruise brands and leisure options. A sample item is “The cruise lines other than <name> Line which I might be cruising with are very appealing.”

Perceived Value

A variety of value measures can be found in the literature (Agustin and Singh 2005; Duman and Mattila 2005; Hellier et al. 2003; Yang and Peterson 2004). While several multidimensional scales for perceived value (Mathwick et al. 2001; Petrick 2002;

Sweeney and Soutar 2001) have been developed in recent years, most of them are rather lengthy and serve better for diagnostic purposes. For the purpose of this study, it was overall value, rather than the dimensional structure or antecedents of value, that need to be measured. Thus, in this study, cruisers' perceived value was measured via a 4-item, 7-point Likert type scale, recommended by Sirdeshmukh et al. (2002), which was adapted from existing value measures (Dodds, Monroe, and Grewal 1991; Grisaffe and Kumar 1998). Specifically, the four items included the benefits obtained given the price paid, the time spent, and the efforts involved in cruising with <name>. For instance, respondents were asked "For the effort involved in cruising with <name>, I would say cruising with <name> is," from *Not at all worthwhile* (1) to *Very worthwhile* (7).

Perceived Quality

One of the most frequently employed quality measures is SERVQUAL (Petrick 2004c), developed by Parasuraman, Zeithaml, and Berry (Parasuraman et al. 1991; Parasuraman et al. 1988), who conceptualized service quality as the difference between consumers' expectations and their assessments of service performance (Parasuraman et al. 1985). However, some researchers have criticized its conceptual validity and empirical applicability (Cronin Jr. and Taylor 1992, 1994; Petrick 2004c). Moreover, empirical examination has consistently reported that performance-only measures generate superior results to contrast measures using expectations (Crompton and Love 1995; Cronin Jr. and Taylor 1992, 1994; Petrick and Backman 2002a). As a result, several alternative approaches have been proposed to measure service quality (Baker and Crompton 2000; Hartline and Ferrell 1996; Oh 1999; Petrick 2004c).

In this study, service quality at the global level was measured using the quality subscale of Petrick's SERV-PERVAL scale (Petrick 2002). This quality scale focuses on the reliability dimension of service quality, as the majority of leisure-based studies have found it to be the best predictor within the SERV-QUAL scale (Asubonteng, McCleary, and Swan 1996; Backman and Veldkamp 1995; Howat, Crilley, and Milne 1995; Knutson, Stevens, and Patton 1995; Ostrowski et al. 1993; Petrick 2002). Specifically, subjects were asked whether the service of a cruise "is of outstanding quality," "is very reliable," "is very dependable," and "is very consistent," on 7-point scales anchored by *definitely false* and *definitely true*.

Demographic Variables

Respondents' demographic information that was collected in this study included: gender, age, education level, ethnicity, marital status, and household income. Gender was operationalized by asking respondents to check one of the two categories: male or female. Age was operationalized by asking respondents what year they were born. Education was operationalized by asking respondents to describe their level of education from "Less than high school" to "Post graduate work started or completed," following TIA (Travel Industry Association of America) (2005). Ethnicity was operationalized by asking respondents to check their ethnic background from six categories. Following Petrick(1999), the first five categories included: Black or African-American; White; Hispanic; Asian; Native American/American Indian. Respondents were also given the option of selecting "other" and were then asked to specify their ethnic background. Household income was operationalized by asking respondents to check one of 12

categories, ranging from “Less than \$20,000” to “\$250,000 or more,” following Travel Industry Association’s online traveler survey (TIA 2005). Finally, marital status was operationalized by presenting respondents five options: married; single, never married; divorced; separated; and widowed.

As this study is part of a larger project on cruise passengers’ brand perception, a few other variables were also measured in section two of the questionnaire, such as respondents’ involvement (Kyle, Absher, Norman, Hammitt, and Jodice In press), brand parity (Muncy 1996), willingness to recommend (McGregor 2006; Reichheld 2003), repurchase intention (Grewal, Monroe, and Krishnan 1998; Petrick 2004a), complaining behavior (Rundle-Thiele 2005), and so on. As these variables are not directly related with the theoretical model of interest in this study, measures and results associated with these variables were not discussed in details.

Selection of the Subjects and Data Collection

The sample size for this study was determined with the use of multiple statistical guidelines. Morais (2000) suggested that a sufficiently large sample is needed to both capture the desired effect sizes, and to be representative of a population. He recommended using Cohen’s (1988) power analysis in estimating sample size. According to the power analysis, if we set a priori a significance level (α) to 0.05, statistical power (β) to 0.8, and effect size (γ) to 0.2, the minimum sample size necessary for such studies should be 194 (Morais 2000). Krejcie and Morgan (1970) and McNamara (1992) suggested that, no matter how large the population to be represented is, a sample size of 384 could be sufficient. Petrick (1999) followed the rule of thumb

suggested by Dillman(1978) and Nunnally and Bernstein(1994), which requires a minimum cell size of 30 for the segmentation variable with the largest number of categories. This rule thus suggests a sample size of 360, as the largest number of categories for any one variable in this study is 12. Finally, for SEM studies, a sample size of about 200 is typically considered as adequate for small to medium structural equation models (Boomsma 1983; Loehlin 1992; Ullman 2001). Other accepted rules of thumb include 5 cases per estimated parameter (Bentler and Chou 1987), or 15 cases (Research Consulting 2001; Stevens 1996) per measured variable. Considering that there are 81 parameters to be estimated and 33 measured variables for the present model, a sample size between 405 (i.e., 81×5) to 495 (i.e., 33×15) was deemed to be appropriate for this study.

To allow cross validation with general cruise passengers' profile reported by CLIA (CLIA 2005), this researcher specified four demographic and behavioral characteristics of the sample when acquiring the online panel from Zoomerang, an online survey company. Participants of this study were cruise travelers who cruised at least once in the past 12 months, who are over 25 years old and have a household income of \$25,000 or more, and volunteer to complete the survey. Moreover, a 50-50 gender distribution would be desired. For survey design purposes, only responses from those who cruised with the nineteen member cruise lines of the Cruise Lines International Association (CLIA 2006b) were collected. These 19 cruise lines make up 95 percent of the overall North America cruise market (CLIA 2006a).

The survey was conducted from March 15 to March 22. Once the survey was deployed, the survey company sent out 2,283 email invitations to a select group of individuals. These individuals were predetermined, based on panelist profile, as meeting the four criteria outlined above. For taking the survey, respondents would be entered in a drawing to win one of three \$500 prizes or one of fifteen \$100 prizes. Using incentives is a common practice in online panel survey (Zoomerang 2005). Although in general three types of incentives (points incentives, sweepstakes, and occasionally monetary incentives) are used by the survey company (Zoomerang 2005), the present project employed only sweepstakes, which was believed to generate the least bias, comparing to the other two options.

The online survey was setup with the help of professional programmers. ASP.Net was used in creating the front-end, while Microsoft SQL Server was used as the backend to store the data (Taylor, Personal Communication). The survey started from an Information Sheet and then a screening question, asking whether the respondent took a cruise vacation in the past 12 months or not. For respondents who said “Yes”, they were asked which cruise line they cruised with in their most recent cruise vacation, and the list of nineteen cruise lines adapted from CLIA’s website (CLIA 2006b) were presented to them. Clicking any of the nineteen cruise company names would lead the respondent to the actual survey, which was customized to the cruise line being chosen. That is, if the respondent indicated that s/he cruised with Carnival Cruise Line in their most recent cruise vacation, all the brand-related questions s/he was asked would be about Carnival

Cruise Line. For those who had not cruised with any of the listed cruise lines in the past 12 months, they were thanked and asked to disregard this survey.

The survey took approximately 12 minutes to complete. A technical mechanism was used to ensure that all questions had to be answered before submission. Once a survey was completed, the respondent would be directed to the sweepstakes entry, where they need to key in their email address for a drawing to win the prizes. The majority of responses were expected to be collected in the first 48 hours after the survey was deployed.

Data Analysis Procedures

The data analysis procedures included seven major steps, from descriptive analysis, preliminary data analysis, to model and hypothesis testing (see Figure 4.1). To do so, the Statistical Package for the Social Sciences 11.0 (SPSS) and Analysis of MOment Structures 5.0 (AMOS) were utilized.

Descriptive Analysis

Descriptive statistics were first examined, with the aim of developing sample profiles and to identify distributions of the variables. Nonresponse bias was also checked. In order to address the general concern regarding sampling bias related to online survey panels, the sample demographic characteristics were cross validated with profiles of general American online travelers (TIA 2005), and cruise passengers (CLIA 2005).

FIGURE 4.1.
MAJOR STEPS IN DATA ANALYSIS

Analysis	Purpose
<i>Step 1</i>	
Descriptive Statistics	Investigate sample characteristics; Evaluating overall data quality
↓	
<i>Step 2</i>	
Preliminary Data Analysis	Addressing practical issues prior to the analysis; Examine the measurement properties of scales used
↓	
<i>Step 3</i>	
Examining Model A: Second-order CFA on the structure of Loyalty	Testing H1a and H1b
↓	
<i>Step 4</i>	
Examining SEM Model B: The Investment Model	Testing H2a-c
↓	
<i>Step 5</i>	
Multiple Regression and Correlation Analysis	An extra test of H2a, H2b, and H2c; Comparing the results to meta-analysis results, and examining whether the replication of the Investment Model is successful
↓	
<i>Step 6</i>	
Examining SEM Model C: The Full Conceptual Model	Testing H3a-c
↓	
<i>Step 7</i>	
Testing the Mediation Effect: Baron and Kenny's (1986) Principle	Testing H3d and H3e

Preliminary Data Analysis

Ullman (2001) and Hatcher (1994) suggested that a number of practical issues should be examined before conducting SEM analysis, such as checking sample size and missing data, absence of outliers and so on. Among these, Byrne (2001, p. 267) stressed that “the requirements that the data be of a continuous scale and have a multivariate normal distribution” are two particularly important assumptions associated with SEM. Moreover, preliminary information regarding measurement properties, such as scale reliability, mean, and standard deviation, was also reported.

Model and Hypotheses Testing

The main part of data analysis focused on hypothesis testing. A structural equation modeling (SEM) procedure was employed to test these hypotheses. SEM is a popular approach that has been extensively used in the social sciences. SEM is a statistical methodology that takes a confirmatory approach to the data analysis for inferential purposes (Byrne 2001). Essentially, SEM may be viewed as a combination of exploratory factor analysis and multiple regression analyses (Ullman 2001). In contrast to exploratory factor analysis, SEM demands that the (presumably causal) structure of intervariable relations, grounded in theory and/or empirical findings, be specified a priori. One advantage of SEM is it is capable of controlling measurement error. Moreover, in addition to dealing with observed variables as most statistical tools can, SEM procedures allows the incorporation of latent constructs, which are constructs that cannot be directly measured (Byrne 2001). Ullman (2001, p. 656) claimed that “when the phenomena of interest are complex and multidimensional, SEM is the only analysis

that allows complete and simultaneous tests of all the relationships.” All these implied that SEM was the proper statistical tool to be used for this study.

The analyses were conducted using AMOS 5.0, and followed guidelines suggested by Byrne (2001) and Ullman (2001). AMOS was chosen over other model-fitting programs such as LISREL and EQS, for its unique strength in preventing errors in model specification (Kline 2005), and its extensive bootstrapping capabilities, which is an effective tool for dealing with non-normal data (Rundle-Thiele 2005).

Specifically, the data analysis started with second-order confirmatory factor analysis on the structure of attitudinal loyalty (H1a). As a special type of SEM (Ullman 2001), CFA “seeks to determine the extent to which items designed to measure a particular factor (i.e., latent construct) actually do so” (Byrne 2001, p. 99). A second-order factor CFA posits that the first-order factors estimated can be explained by some higher-order structure. In this case, it was postulated that cognitive loyalty, affective loyalty, and conative loyalty are subdimensions of a second-order factor, namely attitudinal loyalty. Following MacCallum and Austin’s recommendation (2000), an alternative model, based on the traditional conceptualization that attitudinal loyalty is a one-dimensional factor, was also tested. The structure of the loyalty construct, and H1a and H1b were thus tested.

Once the structure of the loyalty construct was determined, the focus of data analysis became the examination of the Investment Model portion of the conceptual model (see Figure 3.3), and then the full hypothesized model. Results of this modeling process were then used in testing the hypotheses (H2a-c, and H3a-c). By default, AMOS

estimates parameters based on the maximum likelihood (ML) method (Byrne 2001), which is considered favorable to other estimation methods when sample size is medium to large (Ullman 2001). This also seems to apply to the current case.

The major task of this step is assessing the fitness of the model. A variety of fit indices have been presented in the literature, including comparative fit indices (e.g., NFI, NNFI, CFI, RMSEA, etc.), absolute fit index (e.g., MFI; Chi-square), indices of proportion of variance accounted (e.g., GFI, AGFI, etc.), degree of parsimony fit indices (e.g., PGFI, AIC, CAIC, etc.), residual-based fit indices (RMR), and so on (Ullman 2001). Although overall Chi-square value is probably the most widely-employed criterion for model fitness, most researchers argued that Chi-square is highly sensitive to sample size, and is hence not too helpful in determining the extent to which a model does not fit (Byrne 2001). Following Byrne's (2001) recommendation, GFI, CFI, and RMSEA would be used in assessing the fitness of the model (see Table 4.1).

TABLE 4.1
SUMMARY OF MAJOR FIT INDICES

Statistic	Abbrev.	Acceptable Level
Chi-square	χ^2	$p > 0.05$
Normed Chi-square	NC (χ^2/DF)	<5 (Bollen 1989; Marsh and Hocevar 1985)
Comparative Fit Index	CFI	>0.9 (Bentler 1990)
Root Mean Square Error of Approximation	RMSEA	<0.1 (Browne and Cudeck 1993; MacCallum, Browne, and Sugawara 1996)
Goodness-of-fit Index	GFI	>0.9 (Hu and Bentler 1995)

Adapted from (Byrne 2001; Kline 2005; Rundle-Thiele 2005, p. 148)

As an additional step to examine whether the present replication of the Investment Model was successful or not, standard multiple regression and correlation analysis was used to determine factors that significantly predict attitudinal loyalty. Standard regression analysis provides a measure of the amount of variance of the dependent variable that can be explained by the set of independent variables (Adjusted R^2) and standardized measures of the partial correlation of each IV with the DV (β) (Morais 2000). Being a less rigorous method as compared to SEM, multiple regression was not used as the primary tool for hypothesis testing in this study. However, as the majority of previous investment model studies used multiple regression and correlation analysis (Le and Agnew 2003), it was believed that same approaches should be used to make the results more comparable.

Finally, the principle of Baron and Kenny's (1986) procedure on testing mediating effects was used to formally examine H3d and H3e. Baron and Kenny's (1986) procedure, which was originally designed for regression analysis, focused on the change of effect of the independent variable on the dependent variable, at the presence of the mediator. To date, this procedure has been widely applied in different disciplines (Lam et al. 2004; O'Connor, Arnold, and Burris 2005; Shaw, Gupta, and Delery 2005; Smith, Collins, and Clark 2005; Wanberg, Glomb, Song, and Sorenson 2005), including leisure and tourism (Duman 2002; Pritchard et al. 1999). Its principle has also been applied in SEM (Lam et al. 2004; Pritchard et al. 1999).

Synopsis of the Chapter

This chapter discussed the methodology employed in this study. The research design was reviewed, with particular focus on the justification of using online panel survey for the study. Next, the development of the questionnaire was discussed, emphasizing the choice of scales. Steps such as literature review, expert panel editing, pilot test, and formal study, were also described. What followed was a brief review of the data collection process, addressing specific issues related to sample size and subject selection. Finally, the statistical approaches to the data analysis were outlined.

CHAPTER V

DESCRIPTIVE FINDINGS

This chapter is comprised of two major sections. First, a profile of the respondents is presented, and efforts are made in identifying the sampling and non-response bias. Second, several practical issues, such as outliers, linearity, and normality assumptions are addressed before formal analysis. Plus, reliability of the scales used, intercorrelations among major factors, as well as other related descriptive information about variables of interest are summarized.

Sample Characteristics

The sampling procedure described in Chapter IV yielded a total of 727 responses, or, a response rate of 31.8 percent out of the 2,283 email invitations that were sent. Due to the nature of an online panel survey, it is hard to compare response rates across different studies, of which the length, topic, and incentive used may vary substantially. In general, a response rate of 8-12% might be considered as commonplace (Gretzle, Personal Communication). Further, to evaluate level of panelist engagement, many online survey companies use click-through rate (CTR) (Zoomerang 2005), which is calculated by dividing the number of people who click (i.e., open the survey, not necessarily complete it) the survey by the number of people who are invited (Gretzle, Personal Communication). The average click-through rate of Zoomerang, the survey company used in this study, is approximately 15 percent, while the industry standard is about 20 percent (Zoomerang 2005). It can be reasoned that the response rate (calculated by the amount of completed, valid responses divided by effective sample size) should be

even lower than the CTR. Overall, it may be concluded that the response rate of the present study compares favorably to other online panel studies.

However, a closer look at the data showed that there were a number of responses that did not meet one or more of the preset criteria for taking the survey. Specifically, participants of this study were expected to be cruise travelers who had cruised at least once in the past 12 months, who were over 25 years or older and had a household income of \$25,000 or more. Although supposedly only people who met these criteria were invited to participate the survey, it turned out that a number of respondents did not belong to the intended group (based on their responses to the above questions). Despite the fact that respondents answered “Yes” to the screening question (*Have you taken a cruise vacation in the past 12 months?*, and *IF YES, which cruise line did you cruise with in your most recent cruise vacation?*), there were still 8 respondents who reported “0 times” to Question 3 (*During the last 3 years, how many times did you cruise with <Name>?*), and 36 respondents answered “0 times” to Question 4 (*During the last 3 years, how many times did you cruise with any cruise line (including <Name>?)*).

Moreover, behavioral loyalty is operationalized in this study, as a proportion of brand purchases (between 0 and 1). Using Carnival Cruise Line as an example, if a respondent cruised with Carnival recently, we assume his or her answer to Question 3 (*During the last 3 years, how many times did you cruise with Carnival Cruise Line?*) should be less or equal to his or her answer to Question 4 (*During the last 3 years, how many times did you cruise with any cruise line (including Carnival Cruise Line?)*). However, 15 respondents’ answer to Q3 was greater than their answer to Q4. In addition,

5 respondents reported a household income lower than \$25,000, and 1 respondent reported that she was born in 2006. Although such responses might have resulted from typing errors, they were considered as invalid and not useful responses in this study, and were hence deleted from further analysis. Table 5.1 presents a breakdown of completed responses and usable surveys, based on which cruise line respondents had chosen. Results from a Chi-square test of independence showed that the deletion of responses was not systematically associated with the cruise line being chosen ($\chi^2_{16}=0.654$, $p>0.999$). The foregoing process resulted in a total of 666 valid responses.

TABLE 5.1
BRAND-BASED RESPONSE BREAKDOWN

	Completed Surveys	Percentage (%)	Usable Surveys	Percentage (%)
Carnival Cruise Line	208	28.6	192	28.8
Celebrity Cruises	78	10.7	70	10.5
Costa Cruises	5	0.7	5	0.8
Crystal Cruises	5	0.7	5	0.8
Cunard Line	4	0.6	4	0.6
Disney Cruise Line	28	3.9	27	4.1
Holland America Line	57	7.8	54	8.1
MSC Cruises	2	0.3	2	0.3
Norwegian Cruise Line	77	10.6	73	11.0
Norwegian Coastal Voyage Inc.	2	0.3	2	0.3
Oceania Cruises	7	1.0	7	1.1
Orient Lines	2	0.3	2	0.3
Princess Cruises	86	11.8	76	11.4
Radisson Seven Seas Cruises	5	0.7	5	0.8
Royal Caribbean International	157	21.6	139	20.9
Seabourn Cruise Line	0	0.0	0	0.0
Silversea Cruises	2	0.3	1	0.2
Swan Hellenic	0	0.0	0	0.0
Windstar Cruises	2	0.3	2	0.3

Finally, as suggested by previous literature (Petrick 2004a; Rundle-Thiele 2005), it was deemed that only repeat cruisers should be included in the examination of the loyalty phenomenon. Thus, 112 first-time cruisers were excluded from the rest of the analysis. The effective sample size of the present study was hence 554.

Description of the Sample

Table 5.2 shows the demographic characteristics of the effective sample. This sample was slightly dominated by male respondents (55.8%). The average age of the respondents was 53.9. In terms of racial diversity within the sample, the vast majority were white (91.7%). Minority groups represented in this sample included Black or African American (4.9%), Hispanic (1.4%), Asian (1.3%), and Native American or American Indian (0.2%).

Respondents were also asked about their education level, with options ranging from “Less than high school” to “Post graduate work started or completed.” Approximately one tenth (9.4%) of the respondents completed high school or less, and 26.7 percent of the respondents had some college education. The remaining 63.9 percent of people had a college degree or more.

Respondents were further asked about their household income for the previous year. The median income range of the respondents was \$75,000 to less than \$100,000. Nearly half of the respondents fell into the categories of “\$50,000 to Less than \$75,000” (23.8%) and “\$75,000 to Less Than \$100,000” (21.1%). While 6.0 percent of the respondents’ family earned less than \$40,000 annually, 8.9 percent of them made more than \$200,000 last year.

TABLE 5.2
DEMOGRAPHIC CHARACTERISTICS OF THE SAMPLE

Variable	Category	Frequency	Percent (%)
Gender	Female	245	44.2
	Male	309	55.8
	Total	554	100
Education	Less than high school	1	0.2
	Completed high school	51	9.2
	Some college, not completed	148	26.7
	Completed college	180	32.5
	Post graduate work started or completed	174	31.4
	Total	554	100
Ethnicity	Black or African American	27	4.9
	White	508	91.7
	Hispanic	8	1.4
	Asian	7	1.3
	Native American/American Indian	1	0.2
	Other	3	0.5
	Total	554	100
Income	\$25,000 to less than \$30,000	10	1.8
	\$30,000 to less than \$40,000	23	4.2
	\$40,000 to less than \$50,000	53	9.6
	\$50,000 to less than \$75,000	132	23.8
	\$75,000 to less than \$100,000	117	21.1
	\$100,000 to less than \$125,000	74	13.4
	\$125,000 to less than \$150,000	52	9.4
	\$150,000 to less than \$200,000	44	7.9
	\$200,000 to less than \$250,000	21	3.8
	\$250,000 or more	28	5.1
Total	554	100	
Marital Status	Married	446	80.5
	Single, never married	46	8.3
	Divorced	43	7.8
	Separated	2	0.4
	Widowed	17	3.1
	Total	554	100
Age	-	554	53.9

Finally, information regarding respondents' marital status was collected. Most of the respondents were married (80.5%), while 8.3 percent were single and never married, and 7.8 percent were divorced.

In addition to demographic questions, respondents were also asked about their cruising history (*How many cruises have you taken in your lifetime?*; and *With how many different cruise lines have you cruised in your lifetime?*) and brand purchase history (*Approximately when (which year) was your first <Name> cruise?*; and *How many cruises have you taken with <Name> in your lifetime?*). On average, respondents had taken 8.3 cruises with 3.4 different cruise lines in their lifetime. For their brand purchase history (i.e., number of years they have cruised with the specific cruise line they chose), respondents had taken an average of 3.1 cruises with the cruise line, and had a history of 6.2 years cruising with that line.

Nonresponse Bias Check

It has been suggested that when the response rate of a study is less than 60 percent, researchers should examine the possibility of non-response bias (Salant and Dillman 1994). Moreover, an Internet-based survey is subject to "a substantial potential for nonresponse error, although the nature and extent of bias appears to be case specific" (Hwang and Fesenmaier 2004). Therefore, it is deemed necessary to investigate potential differences between respondents and non-respondents with respect to key variables in this study.

The most straightforward way of nonresponse bias assessment is to randomly select a number of non-respondents and contact them (e.g., via telephone interview)

(Morais 2000; Petrick 1999). Information regarding key variables under investigation can then be collected, and compared to that of respondents. However, this approach requires direct access to the panelists' contact information, which was confidential property of the survey company. Therefore, this method was not used in this study.

Instead, the author decided to investigate nonresponse bias indirectly. Two tests were used for this purpose. Considering the purpose of the nonresponse bias check was to compare the current sample to the complete panel, it seemed to make more sense to include all 666 valid responses for this part of examination, although the actual statistical analysis focused only on the repeater portion of the sample. First, late respondents were compared to early respondents along key variables. This approach, also called "time trend extrapolation test" (Armstrong and Overton 1977), or the "continuum-of-resistance" model (Filian 1976), was first suggested by Oppenheim(1966), and has since become a common practice for assessing nonresponse bias in social science (Court and Lupton 1997; Datta, Guthrie, and Wright 2005; Jain and Ratchford 1982). The underlying assumption is that those providing responses late are more like nonrespondents than early respondents, given that they would have become nonrespondents had not multiple contacts been made (Crompton and Tian-Cole 2001; Datta et al. 2005). Note that the present study did not use multiple rounds of mails or emails to elicit responses, which essentially invalidated the rationale of the time trend extrapolation test. Nevertheless, the underlying justification of using this approach was quite straightforward: Based on the survey company's suggestion, the majority of responses would be collected 48 hours after the survey was deployed. Therefore, the

researcher originally scheduled to turn off the survey after 48 hours, when 643 responses (589 useful ones) had been collected. In other words, the 84 responses (77 useful ones) submitted after 48 hours would have fallen into the category of nonresponses, if the survey were actually discontinued.

Following Petrick (1999), the 589 early useful responses and 77 late useful responses were compared on six demographic characteristics, and their satisfaction and loyalty (i.e., cognitive loyalty, affective loyalty, conative loyalty, behavioral loyalty). The six demographic characteristics included gender, age, household income, education level, ethnicity background, and marital status.

In order to examine differences between the two groups, three basic statistical tools were used: Chi-square, Gamma, and independent *t*-tests. The Chi-square test of independence is considered as an appropriate tool for examining the association of two groups along nominal variables (Ott and Longnecker 2001). Thus, it was utilized to assess the group differences in gender, ethnicity background, and marital status. Gamma, with straightforward limit (+1 to -1) and PRE (proportional reduction in error) interpretation, has been argued to be particularly useful in testing the level of association between ordinal variables (Blalock 1979). Therefore, this study employed Gamma in addition to Chi-Square, to investigate the differences between the two groups in household income and education level. Finally, for continuous variables (i.e., age, satisfaction, and the four types of loyalty), independent *t*-tests were used to test the differences between the two groups (Ott and Longnecker 2001).

Table 5.3 presents the Chi-square analysis comparing early and late respondents' gender, ethnic background, and marital status. The tests revealed no significant difference between the two groups in terms of gender ($\chi^2_1=0.112, p=0.737$), ethnic background ($\chi^2_5=3.417, p=0.636$), and marital status ($\chi^2_4=1.145, p=0.887$). Results of analysis showed that in terms of gender, ethnicity, and marital status, early respondents closely resemble late respondents.

TABLE 5.3
CHI-SQUARE COMPARISONS OF EARLY AND LATE RESPONDENTS

Variable	Chi-Square	DF	<i>p</i>
Gender	0.112	1	0.737
Ethnic Background	3.417	5	0.636
Marital Status	1.145	4	0.887

Table 5.4 presents the Chi-square and Gamma analysis comparing early and late respondents' education and household income. The tests revealed no significant difference between the two groups in education ($\chi^2_4=1.565, p=0.815; \gamma=0.046, p=0.605$), and household income ($\chi^2_9=5.848, p=0.755; \gamma=-0.023, p=0.782$). Put differently, early and late respondents share similar level of education and household income.

TABLE 5.4
CHI-SQUARE AND GAMMA COMPARISONS OF
EARLY AND LATE RESPONDENTS

Variable	Chi-Square	DF	<i>p</i>	Gamma	<i>p</i>
Education Level	1.565	4	0.815	0.046	0.605
Household Income	5.848	9	0.755	-0.023	0.782

Results of the *t*-tests comparing early and late respondents on the variables of age, cognitive loyalty, affective loyalty, conative loyalty, behavioral loyalty, and satisfaction are displayed in Table 5.5. Age was calculated as 2006 minus the year the respondent was born. Behavioral loyalty was operationalized as the total number of cruises the respondent has taken with <name> in the past 3 years, divided by the total number of cruises that the respondents had taken in these 3 years. Satisfaction was measured by Spreng et al.'s (1996) 4-item overall satisfaction scale. An index was created by summing up the ratings on the four satisfaction items (Petrick and Backman 2002c), which is a common practice of scale application (Maxim 1999). Same approach was also used to create indices for cognitive, affective, and conative loyalty.

The *t*-test analysis comparing the age of early respondents (mean=53.2) and late respondents (mean=50.2) showed marginal difference ($t_{664}=1.897$, $p=0.058$). In other words, late respondents might be younger than early respondents. Results of the *t*-test analysis examining behavioral loyalty showed no significant differences between early (mean=0.74) and late (mean=0.72) respondents ($t_{664}=0.729$, $p=0.466$). The results revealed no difference ($t_{664}= -1.258$, $p=0.209$) between the two groups (mean_{early}=14.3; mean_{late}=15.1) in terms of cognitive loyalty. Neither was difference ($t_{664}= -1.258$, $p=0.217$) detected between early (mean=14.6) and late (mean=15.4) respondents' affective loyalty. Further, *t*-test analysis examining conative loyalty ($t_{664}=-0.996$, $p=0.319$) showed no significant differences between the two groups (mean_{early}=14.4; mean_{late}=15.0). Finally, no difference ($t_{664}= -1.564$, $p=0.118$) was found between early (mean= 23.2) and late (mean=24.2) respondents in satisfaction. Overall, the *t*-test results

suggest that early respondents are not different from late respondents in terms of loyalty and satisfaction, although they might have a slight chance of being younger than late respondents.

TABLE 5.5
T-TEST COMPARISONS OF EARLY AND LATE RESPONDENTS

Variable	<i>t</i> -test	DF	<i>p</i>
Age	1.897	664	0.058
Cognitive Loyalty	-1.258	664	0.209
Affective Loyalty	-1.236	664	0.217
Conative Loyalty	-0.996	664	0.319
Behavioral Loyalty	0.729	664	0.466
Satisfaction	-1.564	664	0.118

A second way of checking nonresponse bias in this study became possible after the researcher obtained secondary data about the panelists from the survey company's database (Morais 2000). Three demographic characteristics (age, gender, and household income) of the 666 valid responses were compared to those of the 2,283 people who received an email invitation of this study. The results thus demonstrated whether respondents demographically represent the whole panel or not.

Table 5.6 presents the Chi-square and Gamma analysis comparing respondents and the entire panel with respect to their household income and age, and Chi-square analysis comparing the two groups on gender. The Chi-square and Gamma tests revealed no significant difference between the two groups in terms of household income ($\chi^2_4=2.949$, $p=0.566$; $\gamma=0.029$, $p=0.362$), and age ($\chi^2_3=4.484$, $p=0.214$; $\gamma=0.061$, $p=0.075$). The Chi-square analysis also did not find any difference in gender between the

two groups ($\chi^2_1=0.159, p=0.69$). Overall, it may be concluded that respondents reasonably represent the entire panel for the variables of gender, income and age.

TABLE 5.6
CHI-SQUARE (AND GAMMA) COMPARISONS OF RESPONDENTS
AND THE ENTIRE PANEL

Variable	Chi-Square	DF	<i>p</i>	Gamma	<i>p</i>
Household Income	2.949	4	0.566	0.029	0.362
Age	4.484	3	0.214	0.061	0.075
Gender	0.159	1	0.69	-	-

Sampling Bias Check

As indicated, research findings obtained via Internet-based surveys have been criticized for containing sampling bias (Hwang and Fesenmaier 2004; McWilliams and Nadkarni 2005). In the case of online panel studies, they may suffer from three types of sampling biases: only people with Internet access are reached; only those who agree to participate in the panel are reached; and not all panelists who are invited respond (Duffy et al. 2005). Some researchers have even suspected that online survey panelists might have become “professional respondents” (Dennis 2001). Thus, it seems necessary to investigate the existence of such sampling bias.

To identify the potential sampling bias of the online panel survey, it would be helpful to know whether respondents of the present study (N=666) are typical cruise passengers on an industry scale. More broadly, it would also be interesting to know whether these online panelists can represent online travelers (i.e., American travelers who currently use the Internet). Thus, respondents’ demographic statistics were

compared to that of Cruise Line International Association's *2004 Cruise Market Profile* (CLIA 2005) and Travel Industry Association of America's *Travelers' Use of the Internet (2005 Edition)* (TIA 2005) (see Table 5.7). Due to differences in samples chosen and questions asked, statistical analysis was not always possible. Thus, the following discussion is basically descriptive.

CLIA's report is based on data collected from 2,034 national online interviews, using three pre-determined criteria: adults 25 years or older; household incomes \$40,000 or higher; and half male, half female (CLIA 2005). Their results showed that average cruisers are 50 years old, have a household annual income of \$99,000. They are generally married (83%), have college educations (65%), and have taken multiple cruises (2.6 times).

Similarly, respondents to this survey are 52.9 years old on average, have a median income range of \$75,000 to \$100,000 and an average income of over \$102,000. They are also typically married (79.3%), have some or completed college education (58.8%). However, the respondents have taken an average of 7.1 cruises in their lifetime, which is more than that of the CLIA's sample. The author speculated that this may be partially due to the pre-set criteria that participants of the present study should have cruised at least once in the past 12 months. That is, respondents of this study are currently active cruisers. On the whole, it might be inferred that online panelists surveyed in this study are demographically similar to typical cruisers, but behaviorally they have been more active.

TABLE 5.7
COMPARISON OF DEMOGRAPHIC CHARACTERISTICS OF RESPONDENTS,
GENERAL CRUISERS, AND AMERICAN ONLINE TRAVELERS

Variable Name		2005 Online Travelers (N=611 ¹)	Present Sample (N=666)	2004 Cruisers (N=2,034)
Gender	Male	47%	54.1%	50%
	Female	53%	45.9%	50%
Age	18-34	33%	9.6% ²	-
	35-54	47%	41.0%	-
	55+	20%	49.4%	-
	Average Age	-	52.9	50
Income	<25K	9%	-	-
	25-50K	34%	17.6% ³	-
	50-75K	19%	23.7% ³	-
	75-100K	18%	21.0% ³	-
	100K+	20%	37.8% ³	-
	Average Household Income	\$73K	102K ⁴	\$99K ⁵
Education	College Graduate or More	42%	58.8%	66%
	Post Graduate Work	16%	30.8%	24%
Marital Status	Married	64%	79.3%	83%
	Single (Never Married)	24%	8.9%	8% ⁶
	Divorced/Separated/Widowed	12%	11.9%	9% ⁶
Cruises Taken in Lifetime		-	7.1	2.6

¹ The survey interviewed 1,300 randomly selected American adults, with 47 percent, or 611 of them fell into the category of “online travelers.”

² The sample included only people of 25 years old or above.

³ The sample included only people with household income of \$25k or above.

⁴ Calculated using the midpoint of each category, and “250K or more” was assumed as 300K

⁵ The sample included only people with household income of \$40k or above.

⁶ Answer choices included only “married”, “single”, and “divorced or separated.”

Further, in comparison to general American online travelers (TIA 2005), it seems that the present sample (as well as cruisers overall) are older, wealthier, and better educated (not necessarily statistically). A higher percentage of cruisers are married. Thus, online cruise travelers surveyed in this study do not seem to represent general online travelers demographically. Overall, based on descriptive statistics, it may be concluded that the present sample is demographically similar to typical cruise passengers, but behaviorally more active, and they might not represent general online travelers.

Preliminary Data Analysis

Practical Issues

Ullman (2001) and Hatcher (1994) suggested that a number of practical issues should be examined before conducting SEM analysis, such as checking sample size and missing data, looking for outliers and so on. Byrne (2001, p. 267) further stressed the importance of checking requirements of the data being of a continuous scale and having a multivariate normal distribution before running SEM. These issues were addressed in the following discussion, which was based on the full model.

Sample Size and Missing Value

For this sample there are 554 participants, 33 observed variables, and 81 parameters to be estimated (in the full model). The ratio of cases to observed variables is 16.8:1. The ratio of cases to estimated parameters is 6.8:1. The ratios were deemed to be adequate for further analysis (Bentler and Chou 1987; Stevens 1996; Ullman 2001). Additionally, a special mechanism was used to prevent incomplete submission (i.e.,

respondents couldn't submit incomplete response), thus there were no missing data. We also conducted power analysis following the guideline of MacCallum, Browne, and Sugawara (1996). The test examines the probability of rejecting the null hypothesis of close fit where ϵ (RMSEA) ≤ 0.05 . With $df=480$ and $n=554$, the power of this test was shown to be strong ($\pi > 0.99$) (Cohen et al. 2003).

Univariate and Multivariate Outliers

Univariate outliers are characterized as cases with abnormally large standardized scores for continuous variables (Tabachnick and Fidell 2001). Tabachnick and Fidell (2001) provided a rule of thumb that cases with standardized scores in excess of 3.29 ($p < 0.001$) might potentially be outliers. Results of SPSS DESCRIPTIVE revealed no cases with extremely standardized scores. Multivariate outliers are cases with strange combinations of scores on two or more variables, which might distort statistics (Tabachnick and Fidell 2001). In AMOS, Mahalanobis distance was used to detect multivariate outliers (Byrne 2001). Although there were several cases having fairly large Mahalanobis d-squared values, no isolated cases with unreasonably large values relative to other cases were detected. Overall, no univariate or multivariate outliers were identified.

Continuous Scales

As indicated, whether we should treat such categorical scales as Likert-type or semantic differential scales as continuous in statistical analysis has been a common concern (Byrne 2001; Rundle-Thiele 2005). It has been suggested that this problem may not be an issue when the number of categories is large (Byrne 2001). All variables in this

study were measured with 7-point scale categories. It was thus concluded that the requirement that the data be of a continuous scale was met.

Linearity

One most common way to assess linearity is to examine all pairwise scatterplots in SPSS. With more than thirty observed variables under investigation, it is not feasible to do so. Thus, following Ullman (2001), randomly selected pairs of scatterplots were examined using SPSS GRAPHS. All observed variables appeared to be linearly related, if at all.

Univariate and Multivariate Normality

Univariate normality of the observed variables was first assessed through the Kolmogorov-Smirnov test (as $N > 50$ in this study) in SPSS. All of the observed variables were significantly skewed, with their results of Kolmogorov-Smirnov tests being significant ($p < 0.001$). Further, the “test for normality” function was performed on the full model using AMOS. The univariate skewness and univariate kurtosis values indicated mild univariate non-normality on most variables. From a multivariate perspective, Mardia’s (1970) normalized estimate of multivariate kurtosis was found to be fairly large, which indicated significant positive kurtosis (Byrne 2001; Hoyle and Panter 1995). Therefore, the data seemed to have a multivariate nonnormal distribution.

Micerri (1989) reported that very few psychometric data sets actually meet the normality assumption. The typical consequences of violations of this assumption include the inflation of Chi-square values, fit indices (e.g., CFI and TLI), and the standard errors associated with the parameter estimates (Byrne 1998; West, Finch, and Curran 1995).

One approach to dealing with multivariate non-normal data is to use a normal theory method (in the present case, the maximum likelihood estimation) with nonparametric bootstrapping (Byrne 2001; Kline 2005), which is available in AMOS. Bootstrapping “assumes only that the population and sample distribution have the same basic shape” (Kline 2005, p. 197). As long as the sample size is reasonably large, bootstrapping allows researchers to assess the stability of parameter estimates from randomly selected sub-samples of the original sample, and thereby report their values with a greater degree of accuracy (Byrne, 2001). In the following sections, bootstrap results based on 500 bootstrap samples were reported where applicable. This included the Bollen-Stine bootstrap χ^2 (BS_{boot}), which is the Chi-square test statistic for model fit based on Bollen and Stine’s (1992) bootstrap procedure. Moreover, bootstrapped estimates for major model parameters (e.g., path coefficients, critical ratio, R_{SMC}^2 , and so on) were reported to assess the stability of parameter estimates.

Measurement Properties

Cronbach’s coefficient alpha, which is the most widely used measure for examining scale reliability in cross-sectional studies (Cohen et al. 2003; Netemeyer et al. 2003), was examined in the current study. Nunnally and Bernstein (1994) suggested that coefficients of 0.70 or higher were acceptable. The reliability coefficients for the scales utilized in the present study are reported in Table 5.8.

The three 3-item scales measuring cognitive, affective, and conative loyalty were adopted from Back (2001; 2003), which was developed based on the marketing literature (Beatty et al. 1988; Loken and John 1993; Oliver 1997). In their original study, Back and

Parks (2003) reported that the α of these three scales ranged from 0.85 to 0.87. In the present study, they had reliability coefficients of 0.92, 0.94, and 0.90 respectively.

Satisfaction was measured using Spreng et al.'s (1996) four-item measure. The reliability coefficient of satisfaction was 0.96. Perceived quality was measured via the quality subscale of Petrick's SERV-PERVAL (Petrick 2002), and the four items used yielded a coefficient of 0.98.

As indicated, quality of alternatives was measured using the modified quality of alternative scale by Rusbult and associates (1998). The reliability coefficient of the five items was 0.90 in this study, while Rusbult et al.'s own multiple scale development tests reported α ranging from 0.82 to 0.88.

In this study, cruisers' perceived value was measured via a 4-item, 7-point Likert-type scale, recommended by Sirdeshmukh et al. (2002). The four items measuring perceived value produced a reliability coefficient of 0.96. Finally, Jones et al.'s 3-item switching cost scale (2000) and three items of Iwasaki and Havitz's (2004) side bets/sunk costs scale were used/adjusted to a brand level, to measure people's switching and sunk costs. The resultant 6-item scale measuring investment size had a reliability coefficient of 0.85. Since all scales yielded reliability coefficients above 0.8, they were deemed reliable.

TABLE 5.8
SCALE RELIABILITY, MEAN, AND STANDARD DEVIATION

Scale Items ¹	Source of Measure	Coeff. α (Previous)	Coeff. α (Current)	Mean	S.D.
Cognitive Loyalty (COG)	(Back 2001; Back and Parks 2003)	0.85	0.92		
cog1 <name> provides me superior service quality as compared to other cruise lines				5.18	1.60
cog2 I believe <name> provides more benefits than other cruise lines in its category				4.90	1.64
cog3 No other cruise line performs better services than <name>				4.27	1.88
Affective Loyalty (AFF)	(Back 2001; Back and Parks 2003)	0.87	0.94		
aff1 I love cruising with <name>				5.49	1.61
aff2 I feel better when I cruise with <name>				4.64	1.77
aff3 I like <name> more than other cruise lines				4.60	1.90
Conative Loyalty (CON)	(Back 2001; Back and Parks 2003)	0.86	0.90		
con1 I intend to continue cruising with <name>				5.56	1.67
con2 I consider <name> my first cruising choice				4.91	1.95
con3 Even if another cruise line is offering a lower rate, I still cruise with <name>				4.00	1.98
Satisfaction (SAT)	(Spreng et al. 1996)	0.91 ²	0.95		
sat1 Your overall experience with <name> is: from "very dissatisfied" to "very satisfied"				5.91	1.39
sat2 Your overall experience with <name> is: from "very displeased" to "very pleased"				5.86	1.47
sat3 Your overall experience with <name> is: from "very frustrated" to "very contented"				5.75	1.61
sat4 Your overall experience with <name> is: from "terrible" to "delighted"				5.78	1.47
Quality (QUA)	(Petrick 2002)	0.92	0.98		
qua1 The service of <name> is of outstanding quality				5.66	1.49
qua2 The service of <name> is very dependable				5.74	1.44
qua3 The service of <name> is very consistent				5.68	1.46
qua4 The service of <name> is very reliable				5.69	1.47

TABLE 5.8 Continued

Scale Items ¹		Source of Measure	Coeff. α (Previous)	Coeff. α (Current)	Mean	S.D.
Quality of Alternatives (QALT)		(Rusbult et al. 1998)	0.82-0.88	0.90		
qalt1	The cruise lines other than <name> which I might be cruising with are very appealing				5.35	1.42
qalt2	My alternatives to <name> (e.g., cruising with another cruise line, spending my vacation on other leisure activities instead of cruising, etc.) are close to ideal				4.75	1.39
qalt3	If I weren't cruising with <name>, I would do fine-I would find another good cruise line				5.48	1.47
qalt4	My alternatives to <name> (e.g., cruising with another cruise line, spending my vacation on other leisure activities instead of cruising, etc.) are appealing to me				5.03	1.47
qalt5	My cruising needs could easily be fulfilled by an alternative cruise line.			5.27	1.61	
Value (VAL)		(Sirdeshmukh et al. 2002)	0.92	0.96		
val1	For the price I paid for cruising with <name>, I would say cruising with <name> is a: from "very poor deal" to "very good deal"				5.34	1.38
val2	For the time I spent in order to cruise with <name>, I would say cruising with <name> is: from "highly unreasonable" to "highly reasonable"				5.38	1.34
val3	For the effort involved in cruising with <name>, I would say cruising with <name> is: from "not at all worthwhile" to "very worthwhile"				5.51	1.40
val4	I would rate my overall experience with <name> as an: from "extremely poor value" to "extremely good value"				5.50	1.47
Investment (Switching & Sunk Costs) (INV)		(Iwasaki and Havitz 2004; Jones et al. 2000)	-	0.85		
inv1	It takes me a great deal of time and effort to get used to a new cruise line.				3.20	1.67
inv2	It costs me too much to switch to another cruise line.				2.90	1.70
inv3	I am emotionally invested in cruising with <name>				3.75	1.93
inv4	I have cruised multiple times with <name>				4.75	2.48
inv5	I have spent a lot of money in cruising with <name>				5.04	1.76
inv6	In general it would be a hassle switching to another cruise line.	2.78	1.81			

¹All items were measured on 7-point scales²According to (Duman and Mattila 2005)

Further, inter-correlations between major constructs were obtained from AMOS, as recommended by Hatcher (1994). The correlations indicate the strength of the association between the constructs in discussion. Table 5.9 reports the results of the correlation analysis.

TABLE 5.9
IMPLIED CORRELATIONS BETWEEN MAJOR CONSTRUCTS

	INV	QALT	QUA	VAL	SAT	CON	AFF	COG	BEHLOY
Investment Size (INV)	1.000								
Quality of Alternatives (QALT)	-0.437	1.000							
Quality (QUA)	0.477	-0.315	1.000						
Value (VAL)	0.38	-0.25	0.795	1.000					
Satisfaction (SAT)	0.394	-0.26	0.826	0.797	1.000				
Conative Loyalty (CON)	0.703	-0.495	0.718	0.651	0.775	1.000			
Affective Loyalty (AFF)	0.699	-0.493	0.715	0.648	0.771	0.989	1.000		
Cognitive Loyalty (COG)	0.696	-0.49	0.711	0.645	0.767	0.983	0.978	1.000	
Behavioral Loyalty (BEHLOY)	0.232	-0.164	0.237	0.215	0.256	0.328	0.326	0.325	1.000

Kline (2005) warned that extremely high intercorrelations among variables (e.g., > 0.85) could cause SEM results to be statistically unstable. Essentially, variables that are highly correlated might be actually measuring the same thing. As can be seen, quality, satisfaction, and value were highly correlated, but did not exceed the recommended threshold (i.e. 0.85). Quality of alternatives, as expected, was inversely

correlated with all other variables (i.e., an increase in quality of one brand might be somewhat associated with a decrease of the quality of alternatives). Investment size was moderately correlated with other factors. Behavioral loyalty was only mildly correlated with the other factors. Finally, the postulated three subdimensions of attitudinal loyalty had exceedingly high correlations between each other, which could be problematic in the following SEM analysis (Kline 2005). This will be further explored in the next chapter.

CHAPTER VI

HYPOTHESES TESTING

This chapter reports the procedures and results related to the formal hypotheses testing process. First, Hypotheses 1a and 1b regarding the dimensional structure of attitudinal loyalty and loyalty as a whole are explored via a second-order CFA and its alternative model. Second, hypotheses related to the Investment Model portion of the complete conceptual model (i.e., H2a-c) are examined, after the measurement model is prepared and the validity and reliability of measures utilized are examined. In addition, a standard multiple regression procedure is also utilized to generate results comparable to existing studies on the Investment Model. Finally, hypotheses regarding the interrelationship between quality, satisfaction, value, and loyalty (i.e., H3a-c) are tested, using the same approach. Further, the principle of Baron and Kenny's (1986) procedure for evaluating mediating effects is applied to examine H3d and H3e.

Testing the Dimensional Structure of Loyalty

The first step of formal analysis started with testing Hypothesis 1a, which states that three components of loyalty (cognitive, affective, and conative loyalty) will be explained by attitudinal loyalty as a higher order factor. To empirically examine this, a second-order confirmatory factor analysis model was deemed to be the appropriate statistical tool.

A second-order factor model posits that the first-order factors estimated (in this case, cognitive, affective, and conative loyalty) are actually caused by a broader and more encompassing construct (in this case, attitudinal loyalty). In other words, a second-

order CFA analysis may be used when a researcher attempts to examine the ability of a higher order factor to account for the correlation between the first order factors (Russell 2002). Using second-order CFA models allows a stronger statement about the dimensionality of the construct (Hair 1998). To ensure a second-order CFA model to be identified, there must be at least three first-order factors (Kline 2005).

The second-order CFA model was tested following a procedure recommended by Byrne (2001). First, the identification of the higher order portion of the model was addressed. Specifically, the model was initially just-identified with three first-order factors, as there were six data points, while the number of estimable parameters was also six (i.e., three factor loadings, three residuals, and the variance of the higher order factor had been constrained to 1.0) (Byrne 2001). The just-identified model is not usually useful to researchers as hypotheses about adequacy of the model cannot be tested (Ullman 2001). As suggested by Byrne (2001), this problem can be solved by placing equality constraints on certain parameters known to yield estimates that are approximately equal, through the application of the critical ratio difference (CRDIFF) method. It was found that the estimated values of higher order residuals related to affective loyalty (-0.006¹) and conative loyalty (-0.017¹) were almost identical. More importantly, the computed critical ratios for differences between the two residuals were -0.421. To test whether the two parameters are equal in the population, the value (-0.421) was compared to a table of the standard normal distribution. Given that the absolute value of -0.421 is less than 1.96, the hypothesis that the two residual variances

¹ The negative residuals here, considering their magnitude, may be treated as 0 (Kline, 2005).

are equal in the population could not be rejected. Thus, it was decided to constrain the variance of the residuals related to affective loyalty and conative loyalty to be equal. The hypothesized model, with the equality constraints specified, is presented in Figure 6.1.

FIGURE 6.1
HYPOTHESIZED SECOND-ORDER MODEL OF ATTITUDINAL LOYALTY

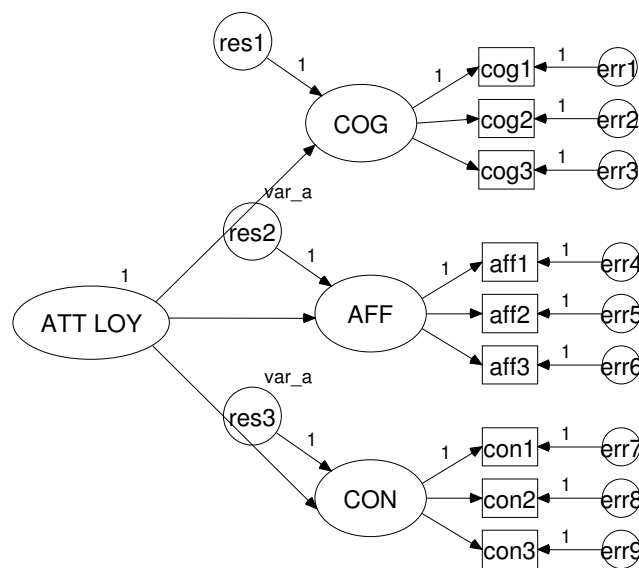

The next step involved obtaining the goodness-of-fit statistics and modification indices (MI) (Sörbom, 1986) related to the hypothesized model. The goodness-of-fit statistics (see Table 6.1) indicated a poor fit, considering the model was neither too large nor complex. The MIs can be conceptualized as a χ^2 statistic with one degree of freedom (Byrne, 2001). The multiple large MI values (see Table 6.2 for a portion) further evidenced that there could be substantial misfit in the hypothesized second-order model structure. By definition, a MI value of 3.84 or above indicates that a statistically

TABLE 6.1
GOODNESS-OF-FIT STATISTICS OF THE SECOND-ORDER MODEL²

Statistics	Results
χ^2 (DF)	432.289 (25), $p < 0.001$
NC	17.292
BS _{boot}	$p = 0.002$
CFI	0.939
RMSEA	0.172
GFI	0.829

TABLE 6.2
PORTION OF THE MI OUTPUT FOR THE SECOND-ORDER CFA MODEL (SORTED
DESCENDING)

Covariances:

	M.I.	Par Change
err7 <--> err4	154.66	0.373
err7 <--> err3	51.419	-0.252
err9 <--> err4	39.961	-0.237
err9 <--> err5	39.543	0.19
err4 <--> res2	30.664	-0.078
err4 <--> err6	29.557	-0.133
err7 <--> err9	29.083	-0.218
err5 <--> err6	29.004	0.106
err7 <--> err6	28.561	-0.141
err4 <--> res3	25.001	0.081
err7 <--> err1	24.543	0.138
err4 <--> err3	22.703	-0.155
err7 <--> err5	21.502	-0.112

Regression Weights:

	M.I.	Par Change
Aff1 <--- con1	35.836	0.123
con1 <--- aff1	34.083	0.135
Aff1 <--- con3	12.142	-0.061
Aff2 <--- con3	11.638	0.048
cog3 <--- con1	11.215	-0.081
con1 <--- cog3	9.554	-0.061
con3 <--- aff1	9.244	-0.088
con1 <--- con3	7.98	-0.053
con3 <--- con1	7.079	-0.074
Aff3 <--- con1	6.935	-0.048
Aff3 <--- aff1	6.511	-0.048
cog1 <--- con1	5.465	0.045
Aff2 <--- con1	4.932	-0.037

significant reduction in the Chi-square would occur had a fixed parameter were freely estimated (Byrne 2001; Hair et al. 1998). Thus, the most straightforward way of improving the model is to add some paths based on the MI information. However, theoretical support needs to be found before doing so (Byrne 2001; Hair et al. 1998;

² Mardia's (1970) coefficient of multivariate kurtosis = 37.381; critical ratio= 31.264.

Kline 2005). Further, adding paths is generally undesirable as it could complicate a model, and make it hard to interpret (Hatcher, 1994). It seems that the present MI results were fairly complex, and did not present a meaningful solution to improve the model fit.

For years, statisticians have called for the use of alternative models (i.e., comparing the performances of rival a priori models) in model specification and evaluation (Bagozzi, 1988; Joreskog and Sörbom 1996; MacCallum and Austin 2000). The above-mentioned second-order CFA model was based on the recently-emerged three-dimension attitudinal loyalty conceptualization (Back 2001; Jones and Taylor In press; Oliver 1997, 1999). Alternatively, the traditional loyalty literature has consistently reported that the attitudinal aspect of loyalty was one single dimension (Backman and Crompton 1991b; Day 1969; Dick and Basu 1994; Jacoby and Chestnut 1978; Petrick 1999; Pritchard et al. 1999; Selin et al. 1988). Following this line research, it was decided that a first-order CFA model, with attitudinal loyalty being measured by all nine loyalty items, should be evaluated as an alternative model (see Figure 6.2). The model fit and portion of the MI information are presented in Table 6.3 and Table 6.4.

TABLE 6.3
GOODNESS-OF-FIT STATISTICS OF THE FIRST-ORDER MODEL³

Statistics	Results
χ^2 (DF)	447.031(27), $p < 0.001$
NC	16.557
BS _{boot}	$p = 0.002$
CFI	0.938
RMSEA	0.168
GFI	0.828

³ Mardia's (1970) coefficient of multivariate kurtosis = 37.381; critical ratio = 31.264.

FIGURE 6.2
ALTERNATIVE FIRST-ORDER MODEL OF ATTITUDINAL LOYALTY

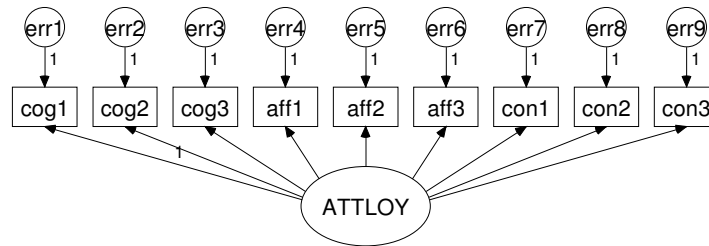

TABLE 6.4
PORTION OF THE MI OUTPUT FOR THE FIRST-ORDER CFA MODEL
(SORTED DESCENDING)

Covariances:

	M.I.	Par Change
err4 <--> err7	159.862	0.382
err3 <--> err7	50.153	-0.248
err5 <--> err9	45.897	0.205
err4 <--> err9	39.204	-0.237
err7 <--> err9	30.106	-0.223
err4 <--> err6	27.148	-0.129
err5 <--> err6	27.016	0.102
err3 <--> err4	23.122	-0.157
err6 <--> err7	23.072	-0.127
err1 <--> err2	21.31	0.107
err1 <--> err7	19.123	0.124
err5 <--> err7	16.715	-0.099
err5 <--> err8	14.224	-0.078

Regression Weights:

	M.I.	Par Change
aff1 <--- con1	38.484	0.129
con1 <--- aff1	35.28	0.137
aff2 <--- con3	12.724	0.05
cog3 <--- con1	12.075	-0.083
con1 <--- cog3	10.859	-0.065
aff1 <--- con3	10.779	-0.058
con3 <--- aff1	8.644	-0.085
con1 <--- con3	8.273	-0.054
con3 <--- con1	7.237	-0.075
aff3 <--- aff1	6.055	-0.047
aff3 <--- con1	5.604	-0.043
cog3 <--- aff1	5.107	-0.056
aff1 <--- cog3	5.01	-0.041

At first glance, the fitness level of this first-order model was no different from the second-order one. In other words, neither model provided a good fit of the data initially. Although the model fit might be improved by reparameterizing the model on the basis of the MI information, researchers have continuously been reminded that such decisions must be made for substantive conceptual reasons (Byrne 2001; Hatcher 1994; Kline 2005; Ullman 2001). In light of these results, it was decided that reliability analysis and exploratory factor analysis should be used to purify measures, as recommended by Churchill (1979).

This examination started with exploratory factor analysis (EFA), as to investigate the potential pattern of variables of interest. Note that the EFA results should and would only serve as a reference for the present discussion on loyalty dimensionality. An EFA was conducted using SPSS Factor. Interestingly, as can be seen in Table 6.5, the nine loyalty items all loaded nicely on one single dimension, instead of the three dimensions hypothesized.

TABLE 6.5
EXPLORATORY FACTOR ANALYSIS OF LOYALTY ITEMS

	Factor 1	Communality
COG1	0.907	0.823
COG2	0.924	0.853
COG3	0.887	0.787
AFF1	0.894	0.799
AFF2	0.945	0.893
AFF3	0.938	0.88
CON1	0.884	0.782
CON2	0.939	0.882
CON3	0.857	0.735
Variance extracted	82.60%	
Eigenvalue	7.434	

Next, Cronbach's alpha, and alpha-if-item-deleted analysis was also performed on the 9-item scale using SPSS RELIABILITY. Not surprisingly, Cronbach's alpha for the nine items was quite high, and deleting any one of the items would have little effect on alpha (see Table 6.6).

TABLE 6.6
RELIABILITY AND ALPHA-IF-ITEM-DELETED ANALYSIS

Overall	Cronbach's alpha = 0.973
Item	alpha if item deleted
COG1	0.970
COG2	0.969
COG3	0.970
AFF1	0.970
AFF2	0.967
AFF3	0.967
CON1	0.971
CON2	0.968
CON3	0.972

The EFA results seemed to support the one-dimension conceptualization of attitudinal loyalty. Further, recall that the intercorrelations among cognitive loyalty, affective loyalty, and conative loyalty were exceptionally high (all exceeding 0.97) (see Table 5.10). Kline (2005) suggested that when two factors have a correlation over 0.85, they may not be accommodated in one structural equation model, as the two factors demonstrate poor discriminant validity (Rundle-Thiele 2005). In other words, they may be measuring the same construct. It seemed the present instrument might not successfully measure three different aspects of attitudinal loyalty as intended. These

results indicated that the first-order model (Figure 6.2), based on the one-dimensional conceptualization of attitudinal loyalty, was theoretically and statistically more grounded than the second-order model.

Moreover, the alpha-if-item-deleted analysis showed that when all nine items were used to measure one single first-order factor (i.e., attitudinal loyalty), they might be redundant with each other. Byrne (2001, p. 134), in her discussion on model modification based on MI information, also suggested that “error correlations between item pairs are often an indication of perceived redundancy in item content.” To solve such problems, some researchers have suggested that deleting questionable items could be an effective way to improve a measurement model without sacrificing its theoretical meaningfulness (Bentler and Chou 1987; Byrne 2001; Morais et al. 2003). Further, Hatcher (1994) recommended that to avoid excessive complexity in measurement models, researchers may limit the number of indicators used to measure one latent variable to around four. Netemeyer and associates (2003) also mentioned that researchers should take scale length into consideration, and shorter scales are typically preferred.

In light of these recommendations, it was determined that several items may be deleted to generate a better measure of one-dimensional attitudinal loyalty. This modification process, though post hoc in nature, strictly followed recommended procedures (Bentler and Chou 1987; Byrne 2001). Items associated with questionable MIs, insignificant paths (if at all), large standardized error, and most importantly, conceptual or semantic fuzziness were considered as candidates for deletion.

Specifically, four items including CON3 (“Even if another cruise line is offering a lower rate, I still cruise with <name>”), AFF1 (“I love cruising with <name>”), CON1 (“I intend to continue cruising with <name>”), and COG1 (“<name> provides me superior service quality as compared to other cruise lines”), were deleted sequentially. This deletion process started with CON3, which had the largest standard error, and a comparatively weaker path. Two other items, AFF1 and CON1 were subsequently deleted, as both items were associated with multiple significant MIs. As a matter of fact, several expert panelists mentioned in the pilot test phase that AFF1 sounded rather confusing to them. Finally, COG1 was deleted based on its comparatively large residuals, and weak loadings, as well as its semantic redundancy with the other two cognitive items. Table 6.7 presents the improvement in model fit, which resulted from this deletion process.

TABLE 6.7
THE IMPROVEMENT IN FIT OF THE MEASUREMENT MODEL

	χ^2 (DF)	NC	BS _{boot}	CFI	RMSEA	GFI
Model 1 (all 9 items)	447.031(27), $p < 0.001$	16.557	0.002	0.938	0.168	0.828
Model 2 (deleting CON3)	364.314 (20), $p < 0.001$	18.216	0.002	0.943	0.176	0.845
Model 3 (deleting CON3, AFF1)	189.494 (14), $p < 0.001$	13.535	0.002	0.965	0.151	0.910
Model 4 (deleting CON3, AFF1, CON1)	74.033 (9), $p < 0.001$	8.226	0.002	0.985	0.114	0.957
Model 5 (deleting CON3, AFF1, CON1, COG1)	26.131 (5), $p < 0.001$	5.226	0.012	0.994	0.087	0.982

The above process resulted in a one-dimensional loyalty measure containing five items: COG2 (“I believe <name> provides more benefits than other cruise lines in its category”), COG3 (“No other cruise line performs better services than <name>”), AFF2 (“I feel better when I cruise with <name>”), AFF3 (“I like <name> more than other cruise lines”), and CON2 (“I consider <name> my first cruising choice”). Although the Chi-square was significant, the test is well known for its sensitivity to sample size (Byrne 1998), and it has been suggested that the use of multiple indices may collectively present a more realistic picture (Byrne 2001; Hoyle and Panter 1995; McDonald and Ringo Ho 2002). Thus, it was deemed that the five-item model (see Figure 6.3, and Table 6.8), with $\chi^2(5, N=554)=26.131, p<0.001, CFI=0.994, GFI=0.982, RMSEA=0.087$, demonstrated good fit.

FIGURE 6.3
MODIFIED FIRST-ORDER MODEL OF ATTITUDINAL LOYALTY

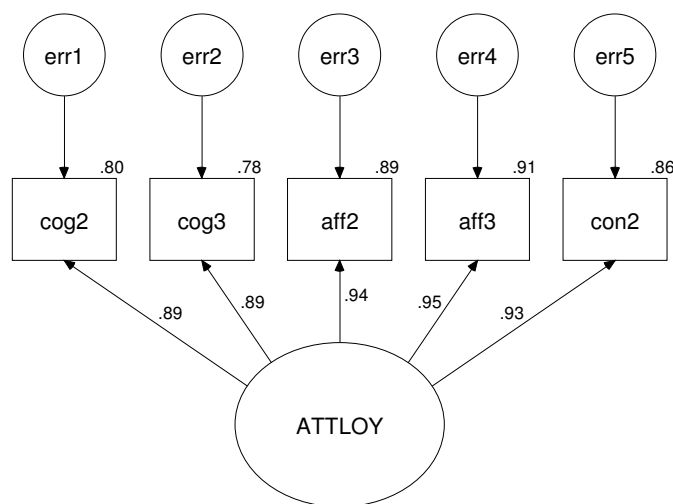

TABLE 6.8
MODIFIED FIRST-ORDER CFA MODEL ESTIMATES

	Std. Factor Loading	Standard Error	Critical Ratio (<i>t</i> value)	<i>p</i>	RSMC2
cog2	0.894 (0.894)	-	-	-	0.800 (0.800)
cog3	0.885 (0.885)	0.036 (0.03)	31.782	***	0.784 (0.783)
aff2	0.943 (0.943)	0.030 (0.029)	37.577	***	0.890 (0.889)
aff3	0.954 (0.954)	0.032 (0.032)	38.834	***	0.910 (0.910)
con2	0.930 (0.929)	0.034 (0.029)	36.060	***	0.864 (0.863)

*** $p < 0.001$

Note: Bootstrapped estimates are listed in parenthesis

Up to this point, it was concluded that the modified first-order model of attitudinal loyalty demonstrates better fit of data than the second-order CFA model. Therefore, Hypothesis 1a, which states, “Cognitive, affective, and conative loyalty will be explained by attitudinal loyalty as a higher order factor,” is not supported.

Hypothesis 1b suggests behavioral loyalty is significantly and positively influenced by attitudinal loyalty. This may be examined by testing a structural equation model with attitudinal loyalty as an exogenous variable, and behavioral loyalty as an endogenous variable (see Figure 6.4).

The model, with χ^2 (9, N=554)=52.399, $p < 0.001$, CFI=0.988, GFI=0.969, RMSEA=0.093, demonstrated reasonable level of fitness (see Table 6.9). Standardized path coefficients and other related information of this model are displayed in Table 6.10. Analysis of the critical ratio (i.e., *t* value) regarding the path of attitudinal loyalty predicting behavioral loyalty revealed that the path was significant ($p < 0.001$). Statistically, the null hypothesis that the coefficient for that path is equal to zero may thus be rejected. It was concluded that H1b was supported. However, it was noted that

the R_{SMC}^2 (0.115) of BEHLOY was fairly low. For an endogenous variable, squared multiple correlations (R_{SMC}^2) represents the proportion of its variance that is explained by its predictor(s) (Byrne 2001; Kline 2005). Thus, the low R_{SMC}^2 value indicated that attitudinal loyalty accounted for only a small portion of the variance associated with behavioral loyalty.

FIGURE 6.4
MODEL A: EXPLORING THE RELATIONSHIP BETWEEN
ATTITUDINAL LOYALTY AND BEHAVIORAL LOYALTY

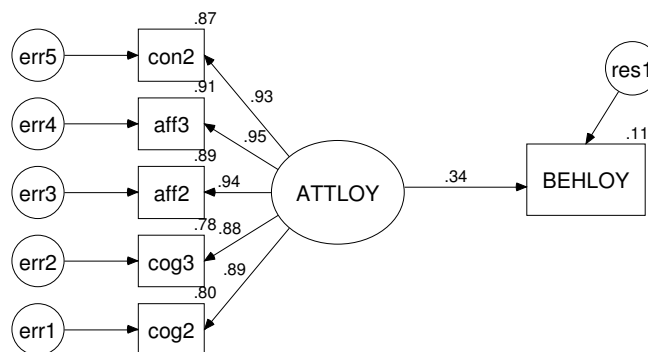

TABLE 6.9
GOODNESS-OF-FIT STATISTICS OF MODEL A⁴

Statistics	Results
χ^2 (DF)	52.399(9), $p < 0.001$
NC	5.822
BS _{boot}	0.002
CFI	0.988
RMSEA	0.093
GFI	0.969

⁴ Mardia's (1970) coefficient of multivariate kurtosis = 15.179; critical ratio = 18.232.

TABLE 6.10
ATTITUDINAL LOYALTY-BEHAVIORAL LOYALTY MODEL ESTIMATES

		Std Path Coefficient	Standard Error	Critical Ratio (<i>t</i> -value)	<i>p</i>	R _{SMC} ²
cog2	<--- ATTLOY	0.894 (0.894)	-	-	-	0.800 (0.800)
cog3	<--- ATTLOY	0.885 (0.885)	0.036 (0.03)	31.733	***	0.783 (0.783)
aff2	<--- ATTLOY	0.942 (0.942)	0.03 (0.029)	37.449	***	0.888 (0.887)
aff3	<--- ATTLOY	0.954 (0.954)	0.032 (0.032)	38.857	***	0.91 (0.911)
con2	<--- ATTLOY	0.931 (0.93)	0.034 (0.029)	36.190	***	0.867 (0.866)
BEHLOY	<--- ATTLOY	0.339 (0.338)	0.008 (0.008)	8.209	***	0.115 (0.116)

*** $p < 0.001$

Note: Bootstrapped estimates are listed in parenthesis

Overall, the preceding discussion provide partial support to Proposition 1, which states that loyalty is comprised of behavioral loyalty and attitudinal loyalty, while the latter can be further broken down to three factors: cognitive, affective, and conative loyalty. On one hand, the three-dimensional attitudinal loyalty conceptualization did not find empirical support. On the other hand, the significant and positive relations between attitudinal loyalty and behavioral loyalty, which had been consistently suggested by the literature (Backman and Crompton 1991b; Dick and Basu 1994; Kyle et al. 2004; Iwasaki and Havitz 2004), was empirically validated.

Testing the Investment Model

Next, hypotheses regarding the Investment Model, i.e. H2a, H2b, and H2c, were tested. The theoretical model is displayed in Figure 6.5. Based on the Investment Model in social psychology (Rusbult, 1980a, 1980b, 1983), this dissertation hypothesized that satisfaction and investment would significantly and positively influence one's attitudinal loyalty, while quality of alternative options would significantly and negatively influences one's attitudinal loyalty. To examine this theoretical model, the author began

with the assessment of the measurement model, followed by hypothesis testing on the basis of a simultaneous examination of the measurement and structural model.

Conceptually, the measurement model depicts the relations between the latent variables and their observed measures (i.e., the scale items), while the structural model focuses on the links among the latent variables of interest (Byrne 2001).

FIGURE 6.5
MODEL B: THEORETICAL MODEL ON THE
INVESTMENT MODEL HYPOTHESES

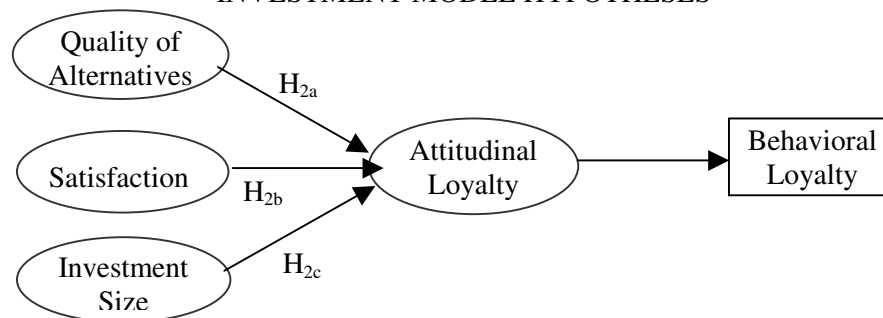

Preparing the Measurement Model

The measurement model was assessed using confirmatory factor analysis, where all factors involved are assumed to covary with each other (Kline 2005)(see Figure 6.6). Note that behavioral loyalty was considered as an observed variable and measured by one item in this model. The use of one item for measurement precluded it from being analyzed in the measurement model (Rundle-Thiele 2005).

The purpose of this step is to evaluate whether the measuring instrument is appropriately measuring the underlying constructs they are designed to measure (Byrne 2001). Researchers have been recommended to test their measurement model first so any inadequate fits can be assessed, prior to consideration of the full model (Byrne 2001). In

addition, it was deemed necessary to use the measurement model to assess the construct validity (i.e., convergent and discriminant validity) of attitudinal loyalty (the modified 5-item measure), investment size, quality of alternatives, and satisfaction, and the reliability (i.e., indicator reliability, composite reliability, and average variance extracted) of items measuring these constructs.

FIGURE 6.6
MEASUREMENT MODEL BASED ON MODEL B⁵

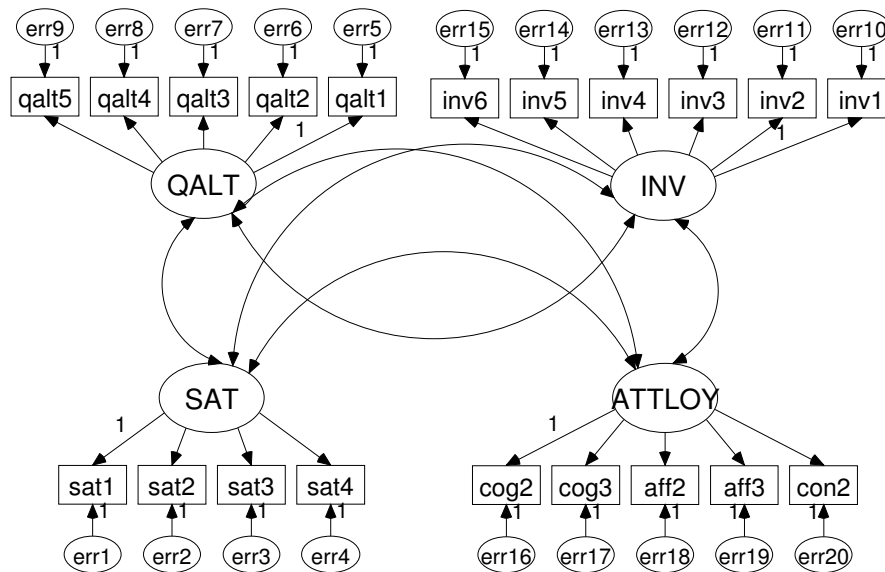

The measurement model based on Model B demonstrated some misfit, as its goodness-of-fit statistics, χ^2 (164, N=554)=979.01, $p < 0.001$, CFI=0.923, GFI=0.842, RMSEA=0.095, fell out of the acceptable range (see Table 4.1). The MI information

⁵ Mardia's (1970) coefficient of multivariate kurtosis = 180.303; critical ratio= 71.53.

TABLE 6.11
 PORTION OF THE MI OUTPUT FOR THE MEASUREMENT MODEL BASED ON
 MODEL B (SORTED DESCENDING)

Covariances:			Regression Weights:		
	M.I.	Par Change		M.I.	Par Change
err13 <--> err14	168.924	1.878	inv4 <--- inv5	123.76	0.587
err12 <--> INV	81.273	-0.442	inv5 <--- inv4	123.189	0.296
err8 <--> err6	67.483	0.349	inv3 <--- aff2	72.273	0.248
err12 <--> ATTLOY	59.571	0.309	inv3 <--- ATTLOY	60.711	0.277
err11 <--> err10	50.174	0.397	inv3 <--- aff3	58.391	0.207
err4 <--> err3	44.151	0.133	inv3 <--- sat4	57.868	0.266
err11 <--> err15	38.08	0.338	inv3 <--- SAT	57.531	0.325
err4 <--> err1	34.071	-0.11	inv3 <--- con2	53.252	0.193
err6 <--> err9	28.029	-0.21	inv3 <--- cog3	52.459	0.199
err11 <--> INV	26.685	0.248	inv3 <--- sat2	48.82	0.245
err2 <--> err1	25.674	0.081	inv3 <--- sat3	42.724	0.209
err12 <--> err11	24.906	-0.295	inv3 <--- sat1	41.179	0.239
err13 <--> err20	20.473	0.33	inv3 <--- cog2	40.5	0.2
err12 <--> err18	18.61	0.147	qalt4 <--- qalt2	34.242	0.171
err6 <--> INV	15.588	0.174	inv3 <--- qalt5	28.86	-0.172
err11 <--> ATTLOY	15.418	-0.153	inv3 <--- QALT	24.115	-0.23
err14 <--> QALT	13.958	0.258	qalt2 <--- inv1	21.6	0.125
err18 <--> err20	13.581	-0.079	inv2 <--- qalt4	21.553	0.158
err13 <--> err17	13.117	-0.311	qalt2 <--- inv2	21.46	0.122
err14 <--> err15	12.501	-0.262	qalt5 <--- inv3	21.194	-0.091
err10 <--> err14	12.273	-0.263	inv2 <--- aff2	21.125	-0.13
err15 <--> ATTLOY	12.186	-0.129	qalt2 <--- qalt4	20.893	0.14
err1 <--> ATTLOY	12.135	0.08	qalt2 <--- INV	20.684	0.166
err11 <--> err14	12.129	-0.269	inv3 <--- qalt4	20.126	-0.158
err12 <--> err10	12.014	-0.199	inv2 <--- aff3	18.736	-0.114
err10 <--> err15	11.905	0.183	inv1 <--- inv2	18.257	0.122
err6 <--> err17	11.597	0.141	inv2 <--- ATTLOY	18.145	-0.147
err10 <--> INV	11.38	0.157	inv2 <--- qalt2	17.988	0.153
err19 <--> SAT	11.273	-0.083	inv2 <--- inv1	17.618	0.126
err16 <--> SAT	11.173	0.094	inv2 <--- sat4	17.606	-0.142
err3 <--> err2	10.902	-0.055	inv2 <--- QALT	16.955	0.186
err7 <--> SAT	10.819	0.105	inv1 <--- sat4	16.332	-0.133

given by AMOS (see Table 6.11 for a portion) suggested that multiple significant MIs were associated with one single item: INV3. The item (“I am emotionally invested in

cruising with <name>”) was originally adapted from Iwasaki and Havitz’s (2004) side-bets scale. It was postulated that the wording of this item might have caused it to confound with indicators of satisfaction, attitudinal loyalty, and quality of alternatives. These three constructs measure respondents’ affective evaluation of the focal brand, similar to INV3. Thus, it was determined that deleting this item would improve the model without compromising the theoretical meaningfulness of the measure (Bentler and Chou 1987; Byrne 2001; Morais et al. 2003).

Further, it was noted that the model fit could be significantly improved by permitting the errors to correlate between items INV4 (“I have cruised multiple times with <name>”) and INV5 (“I have spent a lot of money in cruising with <name>”) ($\Delta\chi^2=213.408$, $\Delta df=1$). Jöreskog (1993) argued that “Every correlation between error terms must be justified and interpreted substantively” (p. 297). In the present case, it was believed that the specification of an error correlation between INV4 and INV5 could be substantiated, as it makes intuitive sense that the two items are associated (i.e., the more one cruises with a cruise line, the more money s/he will spend).

In a similar vein, it was considered appropriate to reestimate the model with the error covariance between QUALT2 and QUALT4 specified as a free parameter ($\Delta\chi^2=74.126$, $\Delta df=1$). The two items (QUALT2, “My alternatives to <name> are close to ideal”; and QUALT4, “My alternatives to <name> are appealing to me) appear to elicit similar responses reflecting the same mind set.

The deletion of one item and specification of two error correlations resulted in a good fit of the measurement model, χ^2 (144, N=554)=467.021, $p<0.001$, CFI=0.968,

GFI=0.917, RMSEA=0.064. As indicated, the validity and reliability of scales used in the model was investigated next. Table 6.12 presents the standardized factor loading, reliability, and other related information.

Assessing Convergent Validity

Convergent validity refers to “the degree to which two measures designed to measure the same construct are related” (Netemeyer et al. 2003, p. 142). Convergent validity of indicators is evidenced by the ability of a scale’s items to load on its underlying construct (Bagozzi 1994). Hatcher (1994) recommended that convergent validity may be assessed by reviewing the *t*-tests for factor loadings. Anderson and Gerbing (1988, p. 416) also suggested that “Convergent validity can be assessed... by determining whether each indicator’s estimated pattern coefficient on its posited underlying construct factor is significant.” As shown in Table 6.12, all item loadings were statistically significant ($p < 0.001$), which rejected the null hypothesis suggesting that the factor loadings are equal to zero. The fact that all *t*-tests were significant indicated that all items were measuring the construct they were associated with. In addition, convergent validity may be further evidenced if each indicator’s standardized loading on its posited latent construct is greater than twice its standard error (Anderson and Gerbing 1988). All items under investigation met this requirement.

TABLE 6.12
FACTOR LOADING, RELIABILITY, AND RELATED INFORMATION FOR MODEL B

	Cronbach α	Composite Reliability ^b	AVE ^c	Std. Factor Loading	Standard Error	Critical Ratio (<i>t</i> value) ^a	R _{SMC} ²
Satisfaction	0.953	0.955	0.841				
sat1				0.886 (0.887)	-	-	0.784 (0.787)
sat2				0.953 (0.955)	0.031 (0.047)	36.891	0.908 (0.912)
sat3				0.911 (0.909)	0.036 (0.061)	32.919	0.829 (0.827)
sat4				0.919 (0.919)	0.033 (0.065)	33.637	0.844 (0.844)
Quality of Alternatives	0.904	0.897	0.637				
qalt1				0.806 (0.805)	-	-	0.65 (0.649)
qalt2				0.633 (0.630)	0.049 (0.043)	15.534	0.4 (0.398)
qalt3				0.855 (0.855)	0.048 (0.059)	22.943	0.731 (0.732)
qalt4				0.772 (0.774)	0.05 (0.048)	20.03	0.597 (0.6)
qalt5				0.899 (0.899)	0.052 (0.06)	24.369	0.808 (0.808)
Investment Size	0.806	0.815	0.491				
inv1				0.814 (0.814)	-	-	0.663 (0.664)
inv2				0.826 (0.827)	0.049 (0.044)	21.288	0.683 (0.684)
inv4				0.432 (0.432)	0.079 (0.073)	9.976	0.187 (0.188)
inv5				0.411 (0.410)	0.056 (0.054)	9.453	0.169 (0.169)
inv6				0.867 (0.866)	0.052 (0.056)	22.329	0.752 (0.751)
Attitudinal Loyalty	0.965	0.966	0.873				
cog2				0.897 (0.897)	-	-	0.805 (0.805)
cog3				0.884 (0.884)	0.035(0.03)	32.005	0.782 (0.782)
aff2				0.944 (0.944)	0.03 (0.028)	38.109	0.891 (0.89)
aff3				0.951 (0.951)	0.032 (0.031)	39.019	0.905 (0.905)
con2				0.931 (0.931)	0.034 (0.029)	36.652	0.867 (0.866)

^a: All *t*-tests were significant at $p < 0.001$

Note: Bootstrapped estimates are listed in parenthesis

^b: Composite reliability assesses the internal consistency of items in a scale (Hatcher 1994; Netemeyer et al. 2003).

^c: AVE (Average Variance Extracted) assesses the amount of variance captured by an underlying construct in relations to the amount of variance resulting from measurement error (Hatcher 1994).

Assessing Discriminant Validity

Discriminant validity “assesses the degree to which two measures designed to measure similar, but conceptually different, constructs are related”(Netemeyer et al. 2003, p. 142). Hatcher (1994) recommended that discriminant validity might be assessed by comparing the average variance extracted (AVE) for the pairs of factors of interest and the square of the correlation between the two factors. AVE (Fornell and Larcker 1981) assesses the amount of variance captured by an underlying construct in relation to the amount of variance resulting from measurement error. Discriminant validity is demonstrated if both AVEs are greater than the squared correlation. This requirement was satisfied after checking the AVEs and the squared correlation value for each of the six pairs of factors (see Table 6.13). Thus, discriminant validity is established.

TABLE 6.13
CORRELATIONS BETWEEN MAJOR CONSTRUCTS IN MODEL B

	INV	QALT	SAT	ATTLOY
Investment Size (INV)	<i>0.491</i> ^a	0.145 ^c	0.121	0.382
Quality of Alternatives (QALT)	-0.381 ^b	<i>0.637</i>	0.097	0.276
Satisfaction (SAT)	0.348	-0.312	<i>0.841</i>	0.554
Attitudinal Loyalty (ATTLOY)	0.618	-0.525	0.744	<i>0.873</i>

^a. The diagonal entries (in italics) represent the average variance extracted by the construct.

^b. The correlations between constructs are shown in the lower triangle.

^c. The upper triangle entries represent the variance shared (squared correlation) between constructs

Assessing Reliability

“Scale reliability is the proportion of variance attributable to the true score of the latent variable” (DeVellis 2003, p. 27). As indicated, Cronbach’s coefficient alpha is one

of the most common approaches to examine internal consistency (i.e., item interrelatedness) of measurement (Netemeyer et al. 2003; DeVellis 2003). As shown in Table 6.12, all four factors demonstrated satisfactory α values (i.e., $\alpha > 0.7$). In addition, some researchers have suggested utilizing a combination of several other criteria, such as indicator reliability, composite reliability, and AVE (Hatcher 1994; Netemeyer et al. 2003).

Indicator reliability refers to the square of the correlation between a latent factor and that indicator. It depicts the percent of variation in the item of interest that is captured by the latent factor that this item is supposed to measure (Hatcher 1994) (see R_{SMC}^2 in Table 6.12). It is generally desirable for latent factors to capture more than 50 percent of the variation in the indicator, in other words, $R_{SMC}^2 > 0.5$ (Fornell and Larcker 1981; Kyle et al. In press). Three items fell below this threshold (QALT2, INV4, and INV5) indicating that the reliability of these items may be questionable.

Composite reliability, analogous to coefficient alpha, also reflects the internal consistency of items in a scale (Hatcher 1994; Netemeyer et al. 2003). Hair and colleagues (1998) suggested that 0.7 or above as acceptable, while Bagozzi and Yi (1988) recommended 0.6 as the cutoff. In the present case, composite reliability of all constructs was deemed acceptable, as they ranged from 0.815 (INV) to 0.966 (ATTLOY).

Finally, AVE (Fornell and Larcker 1981) is considered as the most stringent test of internal structure/stability (Netemeyer et al. 2003). Fornell and Larcker suggested that AVE over 0.5 is desirable, as that means the variance due to measurement error is less

than the variance captured by the construct. In the present case, only the AVE of Investment Size (0.491) was below Fornell and Larcker's cutoff. Considering that composite reliability for the 5-item Investment Size scale was satisfactory (0.815), its AVE value was not substantially below the suggested threshold, but two of its five items did not demonstrate reasonable indicator reliability, it was determined that this scale was only moderately reliable.

Combined, the above-mentioned tests provided empirical support that scales used to examine Model B were valid and reliable measures. Some additional examination on the 5-item attitudinal loyalty scale was deemed to be necessary, as the scale was a product of post hoc analysis. It was decided that the additional examination would focus on the nomological validity of the measure.

Nomological validity, as one type of construct validity, refers to the extent to which a measure operates within a set of theoretical constructs and their respective measures (Netemeyer et al. 2003). Nomological validity is considered to be established when the proposed measure successfully predicts other constructs that past theoretical and empirical work suggests it should predict. To test the nomological validity, the author ran three regression models using SPSS REGRESSION, where attitudinal loyalty (operationalized as the mean of the five items) were modeled as predictors of three behavioral outcomes. The three variables, all of which have been suggested by literature as loyalty outcomes, included repurchase intention (Morais et al. 2004; Petrick 1999, 2004a), willingness to recommend (Dick and Basu 1994; Morais et al. 2004), and complaining behavior (Davidow 2003; Dick and Basu 1994; Rundle-Thiele 2005).

Table 6.14 presents the results of the regression analyses. As can be seen, these findings provide support for the nomological validity of the 5-item attitudinal loyalty measure. As attitudinal loyalty increased, so did respondents' repurchase intention and willingness to recommend, while their willingness to make complaints decreased. In all three models, attitudinal loyalty's effect on the dependent variables was statistically significant, and its effects on these loyalty outcomes were consistent with what has been previously observed (Davidow 2003; Dick and Basu 1994; Morais et al. 2004; Petrick 1999, 2004a; Rundle-Thiele 2005). In the cases of repurchase intention and willingness to recommend, it seemed that attitudinal loyalty explained a substantial portion of the variance (68.3% and 61.5% respectively). It was hence determined that the 5-item attitudinal loyalty measure could be used in the rest of the analysis.

TABLE 6.14
SUMMARY OF REGRESSION ANALYSES

Dependent Variable	B	SE	β	F	df	R ²	R _{adj} ²
Repurchase Intention ^a	0.552	0.016	.827***	1195.218	553	0.684	0.683
Willingness to Recommend ^b	1.288	0.043	0.785***	883.765	553	0.616	0.615
Complaining Behavior ^c	-0.0766	0.029	-0.112**	6.962	553	0.012	0.011

Note. ** $p < .01$, *** $p < .001$

^a Measured by Grewal et al's (1998) two-item, five-point scale

^b Measured by Reichheld's (2003) one-item, 11-point scale

^c Measured by Rundle-Thiele's (2005) seven-item, 7-point scale

On the basis of the previous discussion, it was concluded that the validity and reliability of measures used for Model B had been established. Moreover, the modified measurement model (Figure 6.7) demonstrated good fit. It was hence determined that the

hypothesized model, which would further investigate the predictive validity of these constructs, was ready to be examined.

FIGURE 6.7
MODIFIED MEASUREMENT MODEL BASED ON MODEL B⁶

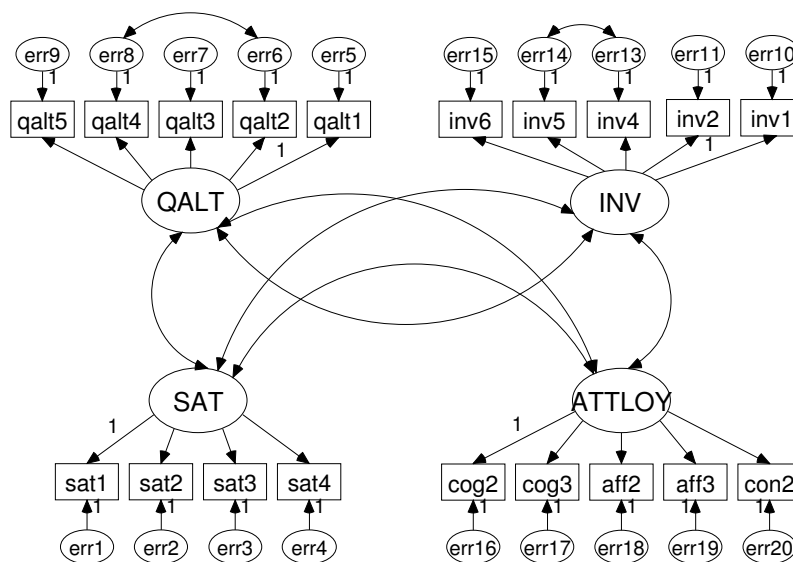

Hypothesized Model Analysis

The final phase of the analysis on Model B included the simultaneous estimation of the measurement and structural models (see Figure 6.8). This step allows the researcher to test specific hypotheses and to determine how well the hypothesized model fit the data (Sylvia 2004).

⁶ Mardia's (1970) coefficient of multivariate kurtosis = 177.311; critical ratio = 73.869.

FIGURE 6.8
HYPOTHESIZED MODEL BASED ON MODEL B⁷

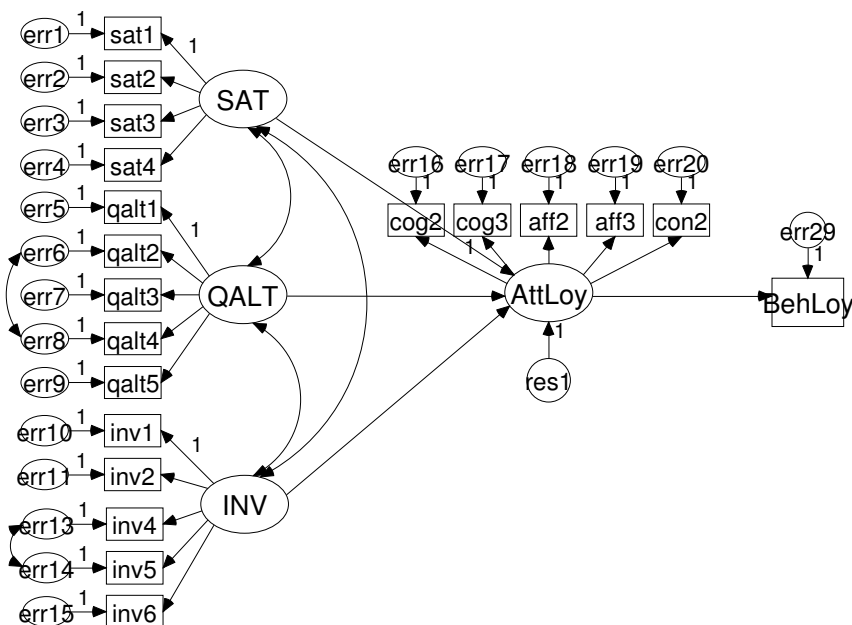

It turned out that the hypothesized model, $\chi^2 (162, N=554)=588.128, p<0.001$, CFI=0.958, GFI=0.905, RMSEA=0.069, also demonstrated acceptable fit (see Table 6.15). All paths were significant ($p<0.001$), and no further model specification was considered to be appropriate. Thus, it was believed that the hypotheses regarding relations between latent constructs could be tested based on this model (see Table 6.16).

⁷ Mardia's (1970) coefficient of multivariate kurtosis = 183.009; critical ratio= 79.605.

TABLE 6.15
GOODNESS-OF-FIT STATISTICS OF THE SEM MODELS BASED ON MODEL B

	χ^2 (DF)	NC	BS _{boot}	CFI	RMSEA	GFI
Measurement Model Based on Model B	979.01 (164), $p < 0.001$	5.98	0.002	0.923	0.095	0.842
Modified Measurement Model Based on Model B	467.021(144), $p < 0.001$	3.243	0.002	0.968	0.064	0.917
Hypothesized Model Based on Model B	588.128(162), $p < 0.001$	3.63	0.002	0.958	0.069	0.905

TABLE 6.16
SUMMARY OF SEM ANALYSIS ON MODEL B

Direct Effect	Std Path Coefficient	Standard Error	Critical Ratio (t-value)	<i>p</i>
AttLoy <--- QALT	-0.222 (-0.222)	0.038 (0.039)	-7.508	***
AttLoy <--- SAT	0.554 (0.553)	0.038 (0.046)	17.512	***
AttLoy <--- INV	0.343 (0.343)	0.035 (0.035)	10.72	***
BehLoy <--- AttLoy	0.343 (0.342)	0.008 (0.008)	8.318	***

*** $p < 0.001$

Note: Bootstrapped estimates are listed in parenthesis

Hypothesis 2a states that quality of alternative options significantly and negatively influences one's attitudinal loyalty. The results suggested that, as predicted, respondents' attitudinal loyalty was negatively influenced by quality of alternative ($\beta = -0.222$, $p < 0.001$). In other words, respondents' level of attitudinal loyalty decreases when s/he perceives that the quality of alternative options improves. These alternative options may be other cruise lines. They may also be other leisure and vacation choices available for cruise passengers. Quantitatively, according to the standardized coefficient, for each unit of increase in quality of alternative brands, customers' attitudinal loyalty drops 0.222 units. Thus, H2a is supported.

Hypothesis 2b suggests that satisfaction will be a positive antecedent of one's attitudinal loyalty. Results revealed that satisfaction was a positive predictor of attitudinal loyalty ($\beta = 0.554, p < 0.001$). Put differently, respondents' level of attitudinal loyalty increases when his/her level of satisfaction with the brand increases. The standardized coefficient information implies that, for each unit of increase in satisfaction, customers' attitudinal loyalty increases 0.554 units. Thus, H2b is supported.

Hypothesis 2c suggests that customers' amount of investment in a brand positively influences one's attitudinal loyalty. Consistent with this prediction, attitudinal loyalty was found to be positively influenced by investment size ($\beta = 0.343, p < 0.001$). That is, respondents' level of attitudinal loyalty increases when their investment in the brand accumulates. Quantitatively, for each unit of increase in investment size, customers' attitudinal loyalty increases 0.343 units. Thus, H2c is supported.

Combined, the above findings suggest that cruise passengers' brand loyalty is positively influenced by his or her satisfaction level and investment size, but negatively influenced by the quality of alternative options. Additionally, the squared multiple correlation coefficients (R_{SMC}^2) for attitudinal loyalty (as an endogenous variable) was calculated, which indicates the strength of the model (Kyle et al. 2004). The result ($R_{SMC}^2 = 0.741$) showed that satisfaction, investment size, and quality of alternatives accounted for 74.1 percent of the variation in attitudinal loyalty. With the vast majority of attitudinal loyalty being explained by its three antecedents, the current result was considered to be strong in social science (Cohen 1988; Kenny, 1979).

Although all hypotheses regarding the Investment Model were supported, and the proposition that the Investment Model is useful in explaining customers' commitment/attitudinal loyalty might hence be validated, another question remained unanswered. That is, while the Investment Model was originally a social psychology theory developed to explain interpersonal relationships (i.e., person-person), and this dissertation attempted to replicate it in a customer-brand type of relationship, was this replication successful? To answer this question, the results of the present analysis needed to be compared with that of the Investment Model literature.

Extra Multiple Regression and Correlation Analysis

Le and Agnew (2003) recently conducted a meta-analysis of 52 studies on the Investment Model. The meta-analysis included 60 independent samples, and 11,582 participants, and most of these studies focused on explaining interpersonal commitment. They found that satisfaction ($\beta = 0.510$) was the strongest predictor of commitment, whereas quality of alternatives ($\beta = -0.217$) and investments ($\beta = 0.240$) were of similar absolute magnitude. Collectively, these three factors accounted for an average of 61 percent of the variance in commitment. Moreover, the correlations between the three antecedents and commitment were 0.68 (satisfaction-commitment), -0.48 (quality of alternatives-commitment), and 0.46 (investment size-commitment) respectively.

Note that all the Investment Model studies involved in the meta-analysis utilized multiple regression as the primary analytical tool, while the present study employed SEM in data analysis. Although SEM is essentially a combination of exploratory factor analysis and multiple regression analyses (Ullman 2001), it was decided that the same analytical method should be used to make results more comparable.

Thus, following other Investment Model studies' approaches (Rusbult 1980b; Rusbult et al. 1998), the author averaged the items of each latent variable (i.e., satisfaction, quality of alternatives, investment size, and attitudinal loyalty) to create an index for each construct, and then regressed satisfaction, quality of alternatives, and investment size simultaneously to attitudinal loyalty. The correlations of the three antecedents and attitudinal loyalty were also calculated. Table 6.17 compares the results of the present study to Le and Agnew's (2003) meta-analysis.

TABLE 6.17
COMPARISON OF RESULTS OF THE PRESENT STUDY WITH
A META-ANALYSIS OF THE INVESTMENT MODEL

Independent Variables	Meta-Analysis	Present Study
Quality of Alternatives	$\beta = -0.217$; $r = -0.480$	$\beta = -0.22$; $r = -0.461$
Satisfaction	$\beta = 0.510$; $r = 0.680$	$\beta = 0.529$; $r = 0.720$
Investment Size	$\beta = 0.240$; $r = 0.460$	$\beta = 0.343$; $r = 0.601$
R^2	0.610	0.688

As can be seen, when applying multiple regression and correlation, results of the present study were almost identical (yet slightly better) to those of the meta-analysis. The same as the meta-analysis results, satisfaction ($\beta = 0.529$; $r = 0.72$) was found to be the strongest predictor of attitudinal loyalty, whereas quality of alternatives ($\beta = -0.22$; $r = -0.461$) and investments ($\beta = 0.343$; $r = 0.601$) were of similar absolute magnitude. Collectively, these three factors accounted for approximately 69 percent of the variance in attitudinal loyalty. This comparison showed the replication of the Investment Model in a customer-brand context was successful.

Section Summary

This section examined hypotheses regarding the Investment Model with the use of structural equation modeling. Data analysis provided empirical support for all three hypotheses, with both satisfaction and investment size having positive effects on attitudinal loyalty, while quality of alternatives was found to negatively influence attitudinal loyalty. Moreover, results compared to a meta-analysis showed that the replication of the social psychology theory in a consumption context was successful.

Testing the Full Conceptual Model

As an extension of the Investment Model, this dissertation further posits that both quality (Caruana 2002; Olsen 2002; Yu et al. 2005) and value's (Chiou 2004; Lam et al. 2004; Yang and Peterson 2004) effects on loyalty are (totally or partially) mediated by satisfaction, with quality also leading to value (Parasuraman and Grewal 2000; Petrick 2004c). The theoretical model is displayed in Figure 6.9.

FIGURE 6.9
MODEL C: FULL THEORETICAL MODEL

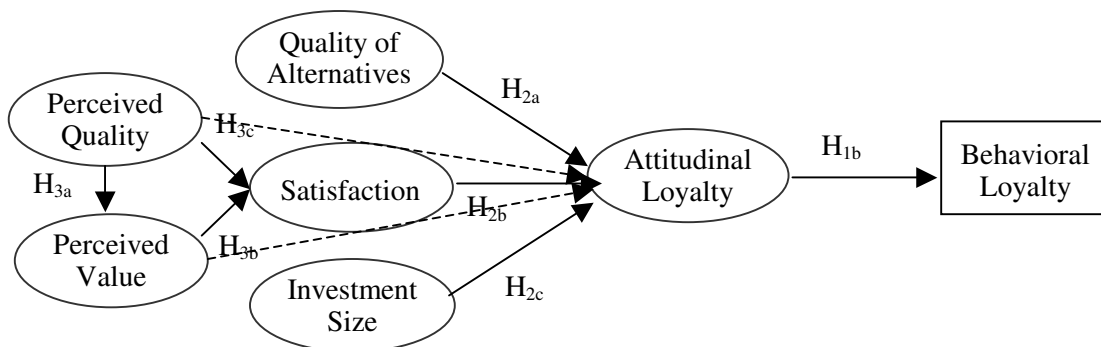

Note: The dotted line represents partial mediation

Procedures, similar to the previous section were applied in testing Model C. That is, the analysis began with the assessment of the measurement model, which also assessed the convergent and discriminant validity of perceived quality and value (the two constructs not included in the examination of Model B), and the reliability (i.e., indicator reliability, composite reliability, and average variance extracted) of items measuring these constructs. This was then followed by hypothesis testing, on the basis of a simultaneous examination of the measurement and structural model.

Preparing the Measurement Model

Again, the measurement model was assessed using confirmatory factor analysis (Kline 2005)(see Figure 6.10). The measurement model based on Model C

FIGURE 6.10
MEASUREMENT MODEL BASED ON MODEL C⁸

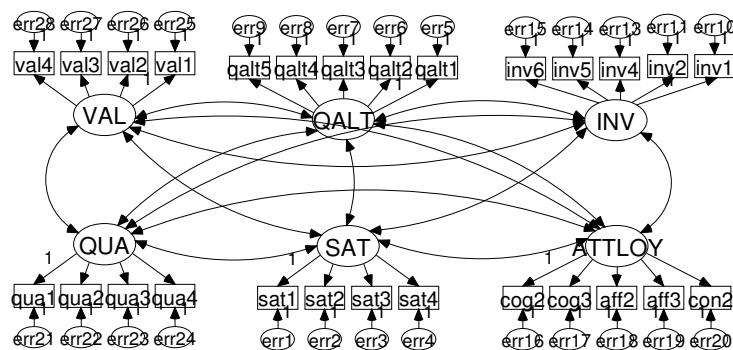

⁸ Mardia's (1970) coefficient of multivariate kurtosis = 335.171; critical ratio= 99.677.

demonstrated some misfit, χ^2 (309, N=554)=1336.044, $p<0.001$, CFI=0.942, GFI=0.848, RMSEA=0.078. With prior knowledge about Model B, this was not unexpected.

Based on the MI information (see Table 6.18), the author decided to make the same modifications as for Model B. The error covariance between INV4 and INV5 ($\Delta\chi^2=212.364$, $\Delta df=1$), and QUALT2 and QUALT4 ($\Delta\chi^2=74.566$, $\Delta df=1$), was again specified as free parameters in order to improve the model fit without sacrificing the conceptual meaningfulness of the model.

The specification of the two error correlations resulted in good fit of the measurement model, χ^2 (307, N=554)=1049.114, $p<0.001$, CFI=0.958, GFI=0.876, RMSEA=0.066. Although the GFI value was slightly lower than the suggested cutoff of 0.9 (Hu and Bentler 1995), the other indices all suggested good fit.

This modified measurement model was then used to assess the validity and reliability of the constructs in Model C. As the measurement properties of satisfaction, quality of alternatives, investment size, and attitudinal loyalty were examined in the previous section, it was determined that only perceived quality and perceived value needed to be examined for validity and reliability. Table 6.19 presents the related information for these two constructs.

TABLE 6.18
 PORTION OF THE MI OUTPUT FOR THE MEASUREMENT MODEL
 BASED ON MODEL C (SORTED DESCENDING)

Covariances:			Regression Weights:		
	M.I.	Par Change		M.I.	Par Change
err13 <--> err14	180.752	2.022	inv4 <--- inv5	139.818	0.634
err8 <--> err6	67.653	0.349	inv5 <--- inv4	136.06	0.319
err28 <--> VAL	60.075	-0.149	qalt4 <--- qalt2	34.341	0.171
err28 <--> err26	49.876	-0.106	val4 <--- qua3	30.129	0.103
err26 <--> err25	48.42	0.111	val4 <--- qua4	29.049	0.101
err24 <--> err23	47.918	0.047	val4 <--- QUA	27.651	0.104
err4 <--> err3	46.376	0.136	val4 <--- qua1	24.957	0.093
err4 <--> err1	37.729	-0.115	val4 <--- qua2	24.859	0.095
err28 <--> QUA	33.675	0.118	inv5 <--- con2	23.848	0.17
err6 <--> err9	27.569	-0.209	val4 <--- sat1	23.63	0.097
err23 <--> err21	26.544	-0.053	qalt2 <--- INV	22.535	0.167
err22 <--> err21	25.652	0.042	inv5 <--- sat4	22.269	0.217
err27 <--> err25	24.79	-0.076	inv5 <--- SAT	22.14	0.263
err14 <--> ATTLOY	22.434	0.243	inv5 <--- sat2	21.797	0.215
err21 <--> QUA	22.157	-0.079	qalt2 <--- inv1	21.385	0.124
err13 <--> err20	21.17	0.341	inv5 <--- cog2	21.207	0.19
err26 <--> VAL	21.094	0.077	qalt2 <--- inv2	21.179	0.122
err2 <--> err1	19.044	0.068	qalt2 <--- qalt4	20.981	0.14
err1 <--> SAT	18.021	-0.084	inv5 <--- ATTLOY	19.433	0.206
err27 <--> err26	16.349	0.05	inv4 <--- val2	18.771	0.306
err13 <--> VAL	14.731	0.257	inv5 <--- aff3	18.564	0.154
err18 <--> err20	14.671	-0.082	inv4 <--- VAL	18.013	0.332
err6 <--> INV	14.411	0.195	val4 <--- sat2	17.985	0.08
err14 <--> QALT	12.869	0.254	val4 <--- SAT	17.821	0.096
err14 <--> INV	12.844	-0.277	inv4 <--- val3	17.349	0.28
err23 <--> QUA	12.636	0.051	inv2 <--- qalt4	17.22	0.133
err11 <--> err14	12.627	-0.265	inv4 <--- val1	17.153	0.283

Assessing Convergent Validity

As outlined in the previous section, convergent validity is evidenced when *t*-tests for factor loadings are significant and when each indicator's standardized loading on its posited latent construct is greater than twice its standard error (Anderson and Gerbing

1988). In the present case, all t -tests were significant ($p < 0.001$), and each indicator's standardized loading on its posited latent construct was more than twice its standard error. As both requirements were met, it was concluded that convergent validity of the measures of interest (i.e., perceived value and perceived quality) was established.

Assessing Discriminant Validity

Discriminant validity is evidenced when both AVEs of a pair of factors are greater than their squared correlation (Hatcher 1994). This requirement was believed to have been satisfied after checking the AVEs and the squared correlation value for each of the fifteen pairs of factors (see Table 6.20). Thus, discriminant validity of the two constructs was established.

Assessing Reliability

Tests used for reliability examination included Cronbach's coefficient alpha, indicator reliability, composite reliability, and AVE (Hatcher 1994; Netemeyer et al. 2003). Ideally, researchers have suggested that a reliable scale should have a Cronbach's alpha over 0.7 (Nunnally and Bernstein 1994), composite reliability above 0.6 (Bagozzi and Yi 1988), and AVE more than 0.5 (Fornell and Larcker 1981). Besides, each item's R_{SMC}^2 should be over 0.5. All these requirements were satisfied in the case of both the value and quality scales. It was hence determined that both scales demonstrated acceptable reliability.

On the basis of the previous discussion, it was concluded that the validity and reliability of measures used for Model C had been established. Moreover, the modified measurement model (Figure 6.11) demonstrated reasonable fit. It was hence determined

TABLE 6.19
FACTOR LOADING, RELIABILITY, AND RELATED INFORMATION OF PERCEIVED VALUE AND QUALITY

	Cronbach α	Composite Reliability	AVE	Std. Factor Loading	Standard Error	Critical Ratio (<i>t</i> value) ^a	R _{SMC} ²
Perceived Value	0.957	0.957	0.849				
val1				0.889 (0.889)	-	-	0.791 (0.791)
val2				0.928 (0.928)	0.029 (0.03)	35.015	0.861 (0.861)
val3				0.947 (0.947)	0.029 (0.039)	36.987	0.897 (0.897)
val4				0.919 (0.919)	0.032 (0.036)	34.168	0.845 (0.844)
Perceived Quality	0.981	0.981	0.929				
qual				0.941 (0.939)	-	-	0.885 (0.882)
qua2				0.976 (0.975)	0.018 (0.017)	54.679	0.952 (0.951)
qua3				0.958 (0.957)	0.02 (0.028)	49.601	0.918 (0.917)
qua4				0.980 (0.979)	0.018 (0.02)	55.95	0.96 (0.959)

^a: All *t*-tests were significant at $p < 0.001$

Note: Bootstrapped estimates are listed in parenthesis

TABLE 6.20
CORRELATIONS BETWEEN MAJOR CONSTRUCTS IN MODEL C

	INV	VAL	QUA	ATTLOY	QALT	SAT
Investment size (INV)	<i>0.491^a</i>	0.182 ^c	0.125	0.382	0.145	0.121
Value (VAL)	0.427 ^b	<i>0.849</i>	0.630	0.551	0.102	0.623
Quality (QUA)	0.353	0.794	<i>0.929</i>	0.567	0.094	0.663
Attitudinal Loyalty (ATTLOY)	0.618	0.742	0.753	<i>0.873</i>	0.276	0.555
Quality of Alternatives (QALT)	-0.381	-0.319	-0.307	-0.525	<i>0.653</i>	0.097
Satisfaction (SAT)	0.348	0.789	0.814	0.745	-0.312	<i>0.841</i>

^a. The diagonal entries (in italics) represent the average variance extracted by the construct.

^b. The correlations between constructs are shown in the lower triangle.

^c. The upper triangle entries represent the variance shared (squared correlation) between constructs.

that the hypothesized model, which would further investigate the predictive validity of these constructs, was ready to be examined.

FIGURE 6.11
MODIFIED MEASUREMENT MODEL BASED ON MODEL C⁹

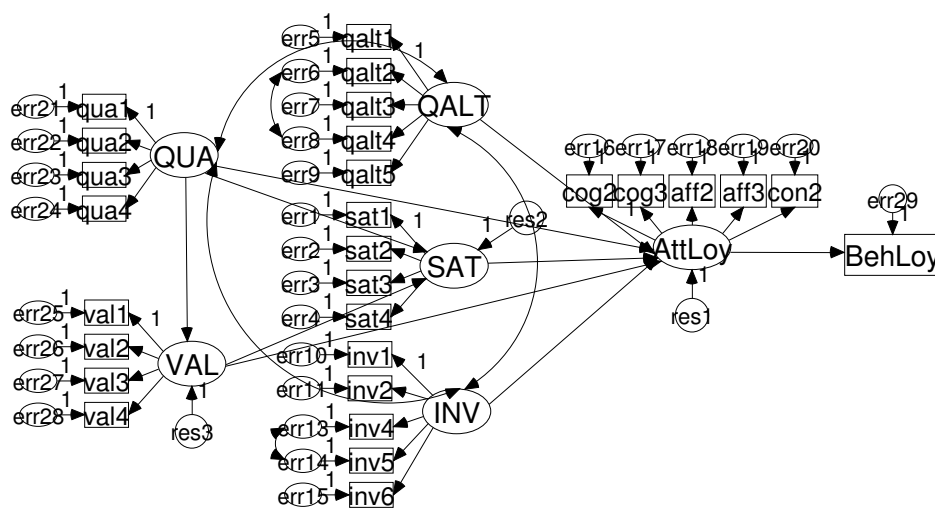

Hypothesized Model Analysis

The final phase of the analysis on Model C included the simultaneous estimation of the measurement and structural models (see Figure 6.12). Overall, the hypothesized model (assuming partial mediation), $\chi^2(337, N=554)=1208.674, p<0.001, CFI=0.952, GFI=0.866, RMSEA=0.068$, demonstrated marginal fit, as the GFI is somewhat lower than the suggested cutoff. With all other indices demonstrating good fit, any additional

⁹ Mardia's (1970) coefficient of multivariate kurtosis = 334.804; critical ratio= 96.131.

modification might make the model overcomplicated. Thus, the author decided to use this model to test Hypotheses 3a-e (see Table 6-22).

FIGURE 6.12
HYPOTHESIZED MODEL BASED ON MODEL C¹⁰

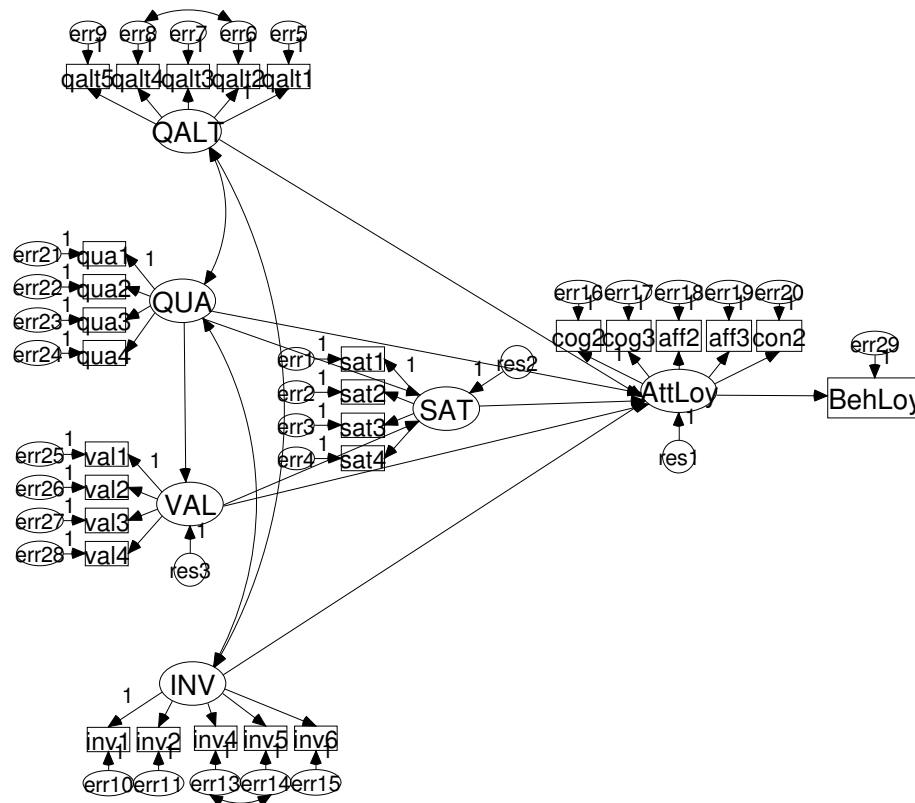

TABLE 6.21
GOODNESS-OF-FIT STATISTICS OF THE SEM MODELS BASED ON MODEL C

	χ^2 (DF)	NC	BS _{boot}	CFI	RMSEA	GFI
Measurement Model Based on Model C	1336.044 (309), <i>p</i> <0.001	4.324	0.002	0.942	0.078	0.848
Modified Measurement Model Based on Model C	1049.114 (307), <i>p</i> <0.001	3.417	0.002	0.958	0.066	0.876
Hypothesized Model Based on Model C	1208.674 (337), <i>p</i> <0.001	3.587	0.002	0.952	0.068	0.866

¹⁰ Mardia's (1970) coefficient of multivariate kurtosis = 338.804; critical ratio= 96.131.

TABLE 6.22
SUMMARY OF SEM ANALYSIS ON MODEL C

Direct Effect	Std Path Coefficient	Standard Error	Critical Ratio (t-value)	<i>p</i>
VAL <--- QUA	0.795 (0.794)	0.03 (0.037)	23.161	***
SAT <--- QUA	0.511(0.518)	0.039(0.058)	11.425	***
SAT <--- VAL	0.383(0.374)	0.045(0.068)	8.556	***
AttLoy <--- INV	0.304(0.304)	0.031(0.03)	10.34	***
AttLoy <--- QALT	-0.21(-0.211)	0.0359(0.034)	-7.707	***
AttLoy <--- SAT	0.244(0.243)	0.054(0.073)	5.294	***
AttLoy <--- VAL	0.154(0.15)	0.051(0.053)	3.549	***
AttLoy <--- QUA	0.269 (0.273)	0.048 (0.063)	5.767	***
BehLoy <--- AttLoy	0.336(0.338)	0.008(0.008)	8.15	***

*** $p < 0.001$

Note: Bootstrapped estimates are listed in parenthesis

Hypothesis 3a, 3b, and 3c examined the relationships between quality, value, and satisfaction. Specifically, Hypothesis 3a states that perceived quality has a positive effect on satisfaction. The results suggested that, as predicted, respondents' satisfaction level was positively influenced by quality ($\beta = 0.511$, $p < 0.001$). In other words, respondents are more satisfied when they perceive the quality of the cruise line service to be better. Quantitatively, for each unit of increase in quality, customers' satisfaction increases 0.511 units. Thus, H3a is supported.

Hypothesis 3b suggests that perceived value positively determines one's satisfaction level. The results revealed that, as postulated, value was a positive predictor of satisfaction ($\beta = 0.383$, $p < 0.001$). That is, respondents' level of satisfaction increases when his/her perceived value of the service increases. Quantitatively, the standardized coefficient information implied that for each unit of increase in value, customers' satisfaction increases 0.383 units. Thus, H3b is supported.

Hypothesis 3c suggests that perceived quality has a significant and positive effect on perceived value. Consistent with this prediction, value was found to be positively influenced by quality ($\beta= 0.795, p< 0.001$). That is, respondents' perception of value increases when they perceive that the quality of the service improves. Quantitatively, for each unit of increase in quality, customers' perceived value increases 0.795 units. Thus, H3c is supported.

Hypothesis 3d and 3e are related to the mediating role of satisfaction in the relationships between quality and attitudinal loyalty, and value and attitudinal loyalty. Although the significant paths had evidenced the existence of partial mediation, it was decided that Baron and Kenny's (1986) procedure on mediating effects should be used to formally examine the relations.

The Baron and Kenny's (1986) procedure suggests researchers should test: (1) $Y=f(X)$; (2) $M=f(X)$; and then (3) $Y=f(M, X)$, to examine if X's effect on Y is mediated by M. The role of M as a mediator is not established until: (a) X's effect on Y in Model (1) and X's effect on M in Model (2) are both significant, (b) M significantly affects Y in Model (3) and, (c) the effect of X on Y in Model (3) is substantially less than its effect in Model (1). If the effect of X becomes insignificant in Model (3) then the effect is called a complete mediation, while if this effect is notably reduced but X's effect on Y is still significant in Model (3), then the mediation effect is a partial one (Baron and Kenny 1986; Kenny, Kashy, and Bolger 1998). This procedure has been widely applied in different social science disciplines (Lam et al. 2004; O'Connor et al. 2005; Shaw et al. 2005; Smith et al. 2005; Wanberg et al. 2005), including leisure and tourism (Duman,

2002; Pritchard et al. 1999). Although Baron and Kenny's procedure was originally designed for regression analysis, its principle can also be used in SEM (Lam et al. 2004; Pritchard et al. 1999). In essence, the testing procedure may be considered as comparing rival models (Pritchard et al. 1999).

In order to test H3d, which states that the effect of perceived quality on attitudinal loyalty is mediated by satisfaction, three structural models were analyzed, and the results are shown in Figure 6.13 and Table 6.23.

FIGURE 6.13
COMPETING MODELS IN ANALYZING THE QUALITY-SATISFACTION-
ATTITUDINAL LOYALTY LINK

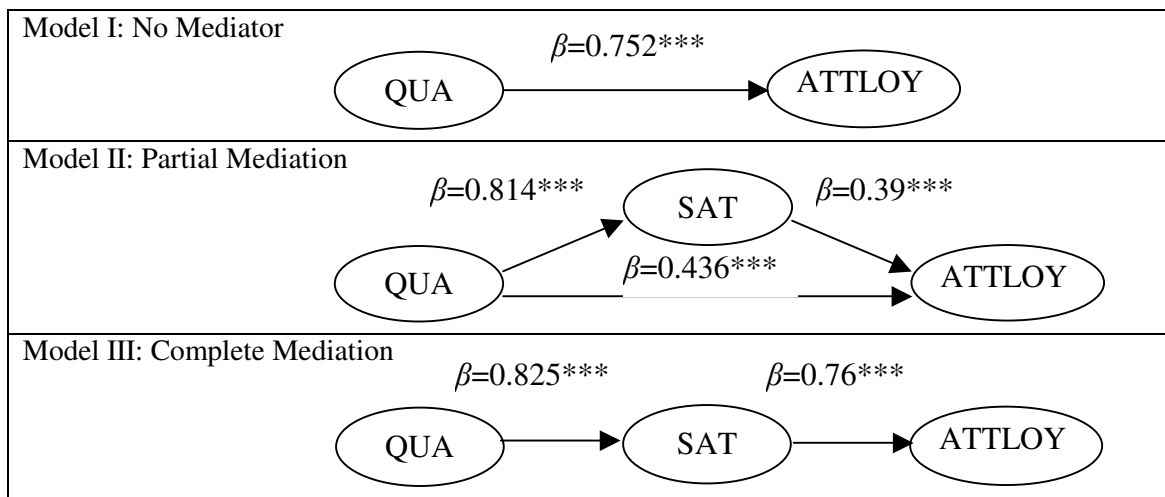

***: $p < 0.001$

Referring to Figure 6.13 and Table 6.17 for the standardized path coefficient estimates of Models I, II, and III, it can be found that all of the mediating conditions set by Baron and Kenny (1986) were satisfied. Specifically, (a) quality had a positive effect on attitudinal loyalty in the absence of satisfaction (Model I), (b) quality had a positive

effect on satisfaction (Model II), and (c) the effect of quality on attitudinal loyalty was substantially reduced in the presence of customer satisfaction (from 0.752 to 0.436), while the estimate for the path from quality to attitudinal loyalty was still significant. Further, the partial mediation model (Model II) demonstrated better fit than Model III, which assumed complete mediation ($\Delta\chi^2=68.469$, $\Delta df=1$), and also explained a larger portion of attitudinal loyalty. Therefore, it was concluded that the relationship between quality and attitudinal loyalty was partially mediated by satisfaction. Hypothesis 3d is hence supported.

TABLE 6.23
ANALYSIS OF STRUCTURAL MODELS I, II, & III

	Model I	Model II	Model III
<i>Direct Effect</i>			
AttLoy<---QUA	0.752 (0.752)***	0.436 (0.44)***	-
SAT<---QUA	-	0.814 (0.813)***	0.825 (0.825)***
AttLoy<---SAT	-	0.39 (0.385)***	0.76 (0.758)***
<i>R_{SMC}²</i>			
AttLoy	0.566 (0.567)	0.619 (0.62)	0.577 (0.575)
SAT	-	0.662 (0.663)	0.68 (0.681)
<i>Goodness-of-Fit</i>			
χ^2 (DF)	153.34 (26)	326.91 (62)	395.379 (63)
NC	5.898	5.273	6.276
BS _{boot}	0.002	0.002	0.002
CFI	0.984	0.976	0.969
RMSEA	0.094	0.088	0.098
GFI	0.939	0.916	0.900

*** $p < 0.001$

Note: Bootstrapped estimates are listed in parenthesis

Hypothesis 3e states that satisfaction is a mediator between perceived value and attitudinal loyalty. A similar approach to above was used (see Figure 6.14 and Table 6-24). Based on the standardized path coefficient estimates of Models I', II', and III', it

was found that the mediating effect of satisfaction between value and attitudinal loyalty was indeed present (Baron and Kenny 1986). Specifically, (a) value had a positive effect on attitudinal loyalty in the absence of satisfaction (Model I'), (b) value had a positive effect on satisfaction (Model II'), and (c) when the path between the mediator (i.e., satisfaction) and attitudinal loyalty was opened, the effect of value on attitudinal loyalty was substantially reduced (from 0.739 to 0.407), while the estimate for the value-attitudinal loyalty path was still significant. Moreover, the partial mediation model (Model II') provided better fit than Model III' (assuming complete mediation) ($\Delta\chi^2=64.308$, $\Delta df=1$). It also explained attitudinal loyalty better than the other two models. Therefore, considering that the estimate for the path from value to attitudinal loyalty was still significant, it was concluded that the relationship between value and attitudinal loyalty was partially mediated by satisfaction. Hypothesis 3e is hence supported.

FIGURE 6.14
COMPETING MODELS IN ANALYZING THE
VALUE-SATISFACTION-ATTITUDINAL LOYALTY LINK

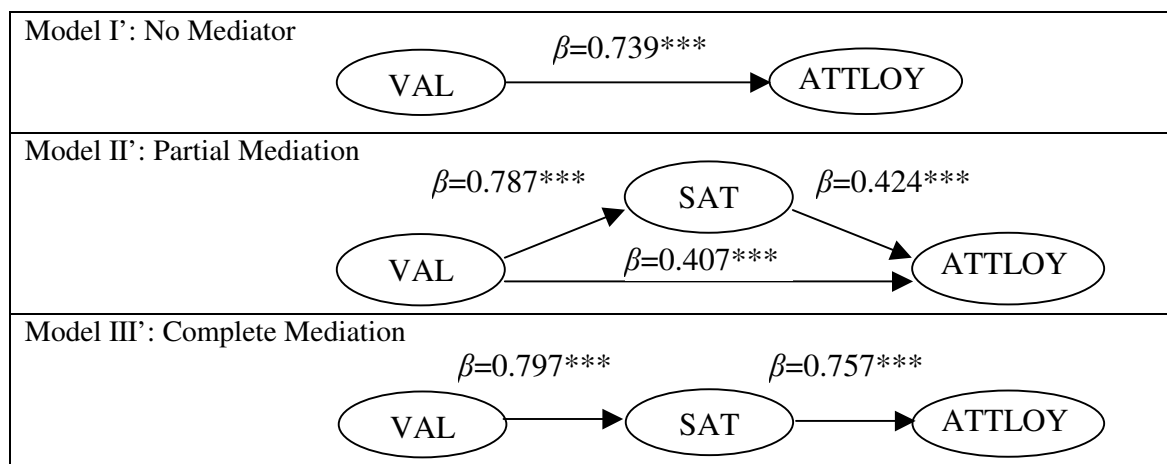

***: $p < 0.001$

TABLE 6.24
ANALYSIS OF STRUCTURAL MODELS I', II', & III'

	Model I'	Model II'	Model III'
<i>Direct Effect</i>			
AttLoy<---VAL	0.739 (0.736)***	0.407 (0.403)***	-
SAT<---VAL	-	0.787 (0.783)***	0.797 (0.793)***
AttLoy<---SAT	-	0.424 (0.427)***	0.757 (0.755)***
<i>R_{SMC}²</i>			
AttLoy	0.546 (0.542)	0.617(0.617)	0.573 (0.571)
SAT	-	0.619 (0.614)	0.635 (0.63)
<i>Goodness-of-Fit</i>			
χ^2 (DF)	215.976 (26)	393.592 (62)	457.9 (63)
NC	8.307	6.348	7.268
BS _{boot}	0.002	0.002	0.002
CFI	0.971	0.965	0.959
RMSEA	0.115	0.098	0.106
GFI	0.926	0.904	0.893

*** $p < 0.001$

Note: Bootstrapped estimates are listed in parenthesis

Section Summary

This section examined the full conceptual model, with specific focuses on the role of perceived quality and perceived value. Both constructs were found to be antecedents of satisfaction, while quality also led to value. The partial mediation effects of satisfaction between quality and attitudinal loyalty, and value and attitudinal loyalty, were also found to exist. Collectively, these antecedents explained 77.9 percent (i.e., $R_{SMC}^2=0.779$) of the variance associated with attitudinal loyalty.

Synopsis of the Chapter

The present chapter investigated the hypotheses outlined in Chapter I. Structural equation modeling analysis found acceptable fit for the proposed model of the relationships between suggested loyalty antecedents and loyalty. With the exception of Hypothesis 1a, which posits that attitudinal loyalty is a three-dimensional, second-order

factor, all other hypotheses were supported. In an attempt to organize the results, a condensed summary of the study's major findings is displayed in Table 6.25.

TABLE 6.25
SUMMARY OF FINDINGS

Relationship	Results
<i>H1a</i> : Cognitive, affective, and conative loyalty will be explained by attitudinal loyalty as a higher order factor	<i>Not supported</i> Attitudinal loyalty was found to be a one-dimensional, first-order factor.
<i>H1b</i> : Behavioral loyalty will be significantly and positively influenced by attitudinal loyalty.	<i>Supported</i> Behavioral loyalty was found to be positively influenced by attitudinal loyalty, although the latter only explains a tiny portion of the former.
<i>H2a</i> : A customer's attitudinal loyalty to a service brand will be significantly and negatively influenced by the quality of alternative options.	<i>All supported</i> Consistent with literature, satisfaction was found to be the major determinant of attitudinal loyalty. Collectively, these three factors account for over 70 percent of the variances of attitudinal loyalty.
<i>H2b</i> : A customer's attitudinal loyalty to a service brand will be significantly and positively influenced by his/her satisfaction level.	
<i>H2c</i> : A customer's attitudinal loyalty to a service brand will be significantly and positively influenced by his/her investment size.	
<i>H3a</i> : Satisfaction will be significantly and positively influenced by perceived quality.	<i>All Supported</i> The magnitude of the effect of quality on satisfaction was about the same as that of the value. Moreover, quality is a strong predictor of value.
<i>H3b</i> : Satisfaction will be significantly and positively influenced by perceived value	
<i>H3c</i> : Perceived value will be significantly and positively influenced by perceived quality	
<i>H3d</i> : The effect of perceived quality on attitudinal loyalty is mediated by satisfaction	<i>Supported</i> The mediation effect was a partial one, in that perceived quality still has direct effect on attitudinal loyalty.
<i>H3e</i> : The effect of perceived value on attitudinal loyalty is mediated by satisfaction	<i>Supported</i> The mediation effect was a partial one, in that perceived value still has direct effect on attitudinal loyalty.

CHAPTER VII

CONCLUSIONS AND IMPLICATIONS

This final chapter is divided into three sections. The first section reviews findings reported in Chapter VI. The next section discusses the theoretical and practical implications of the findings. Finally, based on the results of the current study, recommendations for future research are provided.

Review of the Findings

The purpose of this study was to gain an understanding of the structure and antecedents of cruise passengers' loyalty. Specifically, the study examined the dimensionality of the loyalty construct. Moreover, the study investigated the utility of using the Investment Model (Rusbult 1980a, 1980b, 1983) to reveal the psychological processes underlying loyalty formation in a tourism service context. This Investment Model guided study also attempted to integrate the seemingly segregated findings related to the antecedents of loyalty from the marketing and leisure/tourism literature.

The Dimensional Structure of Loyalty

This dissertation postulated that three components of loyalty (cognitive, affective, and conative loyalty) collectively formed a higher order factor, namely attitudinal loyalty (Hypothesis 1a). To empirically examine this, a second-order CFA model was employed with attitudinal loyalty as a second-order factor, and cognitive, affective, and conative loyalty (each explained by three indicators) being first-order factors explained by the second-order factor. However, the model demonstrated substantial misfit, and no meaningful modifications could be made to the model.

Moreover, the extremely high correlations between the three factors (i.e., cognitive, affective, and conative loyalty) seemed to suggest that these three factors might not be accommodated in the same SEM model (Kline 2005).

Alternatively, a competing model based on the traditional conceptualization that attitudinal loyalty is a one-dimensional, first-order factor was also examined. Initially, the first-order CFA model, using all nine items included in the second-order model, also demonstrated some misfit. However, some exploratory tests showed that this misfit might be due to redundant items. Thus, it was decided that several items should be deleted, to assist in obtaining a theoretically grounded and parsimonious measure of attitudinal loyalty (as a one-dimensional first-order construct). Following item deletion procedures recommended by the literature and guided by theory (Bentler and Chou 1987; Byrne 2001; Hatcher 1994), four items were deleted due to substantial MIs, relatively large residuals, weak path coefficients, and conceptual ambiguity. The resultant five-item measure of attitudinal loyalty, containing two cognitive loyalty items, two affective loyalty items, and one conative loyalty item, demonstrated a good fit. In light of these results, the author concluded that Hypothesis 1a was not supported, while the traditional conceptualization, held by multiple authors (Backman and Crompton 1991b; Day 1969; Dick and Basu 1994; Jacoby and Chestnut 1978; Petrick 1999; Pritchard et al. 1999; Selin et al. 1988), that attitudinal loyalty is a one-dimensional first-order factor held valid.

Further, this dissertation hypothesized that attitudinal loyalty had a positive effect on behavioral loyalty (H1b). This was examined by testing a model with the five-item

attitudinal loyalty measure as an exogenous variable, and behavioral loyalty as an endogenous variable. The model was a good fit of the data, and the path of attitudinal loyalty predicting behavioral loyalty was found to be significant. Nevertheless, the R_{SMC}^2 of behavioral loyalty was fairly low, which indicated that attitudinal loyalty accounted for only a small portion of the variance associated with behavioral loyalty. Overall, Hypothesis 1b was supported by the data, though the low variance explained suggests that behavioral loyalty is caused by more than just attitudinal loyalty.

The Investment Model

Based on the Investment Model in social psychology (Rusbult 1980a, 1980b, 1983), this dissertation hypothesized that a customer's attitudinal loyalty was weakened by the quality of alternative options (H2a), while strengthened by his/her satisfaction with (H2b) and investment in (H2c) a brand. Again, the author examined these relationships with the use of structural equation modeling analysis.

The analysis started with an assessment of the measurement model, in order to evaluate whether the instrument measured the latent variables as it was supposed to. The measurement model was also used to assess the construct validity of latent variables examined in this model (i.e., attitudinal loyalty, satisfaction, investment size, and quality of alternatives), and reliability of items measuring these constructs.

The initial model exhibited some misfit, and the Modification Indices information implied that one item measuring investment size ("I am emotionally invested in cruising with <name>") might confound with multiple satisfaction and quality of alternatives indicators. After deleting this item, and specifying two error

correlations (both made conceptual and intuitive sense), the measurement model provided a good fit of the data. Meanwhile, after significant post-hoc modification, all scales used to examine the model demonstrated reasonable validity (i.e., convergent and discriminant validity) and reliability (i.e., indicator reliability, composite reliability, and average variance extracted), although the investment size scale was found to be only moderately reliable. Additional tests on the nomological validity of the 5-item attitudinal loyalty measure were also performed. The nomological validity of this scale was evidenced as it successfully predicted three types of loyalty outcomes (i.e., repurchase intention, willingness to recommend, and complaining behavior).

The hypotheses were then tested based on a simultaneous estimation of the measurement and structural models. All hypothesized paths were found to be significant. That is, respondents' attitudinal loyalty was negatively influenced by quality of alternatives, but positively influenced by satisfaction and investment size. Among these three antecedents, satisfaction was found to be the strongest predictor of loyalty, while investment size was the second best predictor. Collectively, the three predictors accounted for over 74 percent of the variance in attitudinal loyalty. In comparison to other social science models, the explanatory power of this model could be considered strong (Cohen 1988; Kenny 1979).

Specifically, Hypothesis 2a stated that quality of alternative options could significantly and negatively influence one's attitudinal loyalty. Alternative options may include other cruise lines, or other leisure and vacation choices available for cruise passengers. Results from this study revealed that, as predicted, respondents' attitudinal

loyalty was negatively influenced by quality of alternatives. In other words, cruise passengers' level of attitudinal loyalty was found to decrease when s/he perceived that the quality of alternatives improves.

Hypothesis 2b suggested that customers' satisfaction is a positive antecedent of one's attitudinal loyalty. Results revealed that satisfaction had a positive influence on attitudinal loyalty. That is, cruise passengers' level of attitudinal loyalty was found to increase when their level of satisfaction with the brand increased.

Hypothesis 2c suggested that customers' amount of investment in a brand positively influences their attitudinal loyalty. Consistent with this prediction, attitudinal loyalty was found to be positively influenced by investment size. Put differently, cruise passengers' level of attitudinal loyalty was found to increase when their investment in the brand accumulated.

Additionally, the present results were compared with those of previous Investment Model studies, using multiple regression and correlation analysis. Results of the present study were found to dovetail with those of a recent meta-analysis of 52 previous studies on the Investment Model (Le and Agnew 2003). This further evidenced that the present replication of the Investment Model in a customer-brand context was successful.

The Full Conceptual Model

As an extension of the Investment Model, this dissertation posited that both quality and value's effects on loyalty would be (totally or partially) mediated by satisfaction, with quality also leading to value (H3a-e). The marketing and

leisure/tourism literature has consistently suggested that quality and value are conceptually related to satisfaction (Baker and Crompton 2000; Cronin Jr., Brady, and Hult 2000; Petrick 2004c; Yu et al. 2005). Moreover, a number of researchers have found that the effects of perceived quality (Baker and Crompton 2000; Caruana 2002; Olsen 2002; Yu et al. 2005) and perceived value (Agustin and Singh 2005; Chiou 2004; Lam et al. 2004; Yang and Peterson 2004) on loyalty are partially or completely mediated by satisfaction. The set of hypotheses (H3a-e) hence suggested that quality and value were two antecedents of satisfaction, and their effects on loyalty were (partially or completely) mediated by satisfaction.

Similarly, SEM was applied in testing the full model. The same two error correlations were specified in the measurement model, as in the examination of the Investment Model. The resultant measurement model demonstrated an acceptable fit of the data. The author also checked the psychometric properties of perceived quality and value (two constructs not included in the examination of the Investment Model). Both scales exhibited good validity (i.e., convergent and discriminant validity) and reliability (i.e., indicator reliability, composite reliability, and average variance extracted).

The hypotheses were then tested based on a simultaneous estimation of the measurement and structural models. All hypothesized paths were found to be significant. Collectively, the five predictors (i.e., satisfaction, investment size, quality of alternatives, perceived quality and perceived value) accounted for approximately 78 percent of the variance associated with attitudinal loyalty.

Specifically, Hypothesis 3a which stated that perceived quality would have a positive effect on satisfaction, was supported. It was further found that cruise passengers' satisfaction level was positively influenced by quality. In other words, cruise passengers' were more satisfied when they perceived the service quality of the cruise line to be better.

Hypothesis 3b suggested that perceived value positively determines one's satisfaction level. The results supported this hypothesis, and revealed that value was a positive predictor of attitudinal loyalty. That is, cruise passengers' level of satisfaction increased when, in their perception, the value of the service increased.

Hypothesis 3c suggested that perceived quality would have a significant and positive effect on perceptions of value. Consistent with this hypothesis, value was found to be positively influenced by quality. That is, cruise passengers' perception of value increased when they perceived that the quality of the service improved.

Hypothesis 3d and 3e were both related to the mediating role of satisfaction in the quality-satisfaction-attitudinal loyalty link, and the value-satisfaction-attitudinal loyalty link. The principle of Baron and Kenny's (1986) procedure for examining mediating effects was applied in the examination of these relations.

Hypothesis 3d stated that the effect of perceived quality on attitudinal loyalty would be mediated by satisfaction. To examine this hypothesis, three competing structural models were analyzed. Respectively, the three models suggested that quality had a direct effect on attitudinal loyalty, quality's effect on attitudinal loyalty was partially mediated by satisfaction, and quality's effect on attitudinal loyalty was

completely mediated by satisfaction. The analysis of these three models revealed that all the mediating conditions set by Baron and Kenny (1986) were satisfied. Specifically, (a) quality had a positive effect on attitudinal loyalty in the absence of satisfaction, (b) quality had a positive effect on satisfaction, and (c) the effect of quality on attitudinal loyalty was substantially reduced in the presence of customer satisfaction, although the estimate for the path from quality to attitudinal loyalty was still significant. Moreover, the partial mediation model demonstrated better fit and explained a larger portion of attitudinal loyalty. Therefore, it was concluded that H3d was supported, and the relationship between cruise passengers' perceptions of quality and attitudinal loyalty was partially mediated by satisfaction.

Hypothesis 3e stated that satisfaction would be a mediator between perceived value and attitudinal loyalty. To examine this hypothesis, the same procedure used in testing H3d was applied and three competing structural models were analyzed. Respectively, the three models suggested that value had a direct effect on attitudinal loyalty, value's effect on attitudinal loyalty was partially mediated by satisfaction, and value's effect on attitudinal loyalty was completely mediated by satisfaction. Again, all the mediating conditions set by Baron and Kenny (1986) were satisfied regarding the value-satisfaction-loyalty link. That is, (a) value had a positive effect on attitudinal loyalty in the absence of satisfaction, (b) value had a positive effect on satisfaction, and (c) the effect of value on attitudinal loyalty was substantially reduced in the presence of customer satisfaction, although the estimate for the value-attitudinal loyalty path was still significant. Moreover, the partial mediation model demonstrated better fit and also

explained a larger portion of the variance in attitudinal loyalty. Therefore, it was concluded that H3e was supported.

Theoretical and Managerial Implications

Theoretical Implications

The current study was based on the conceptual framework displayed in Chapter III (Figure 3.2). The framework was revised (Figure 7.1) based upon empirical findings of this study, and was largely validated, with the exception of the three-dimensional conceptualization of attitudinal loyalty.

FIGURE 7.1
THE REVISED CONCEPTUAL FRAMEWORK OF THE STRUCTURE
AND ANTECEDENTS OF LOYALTY

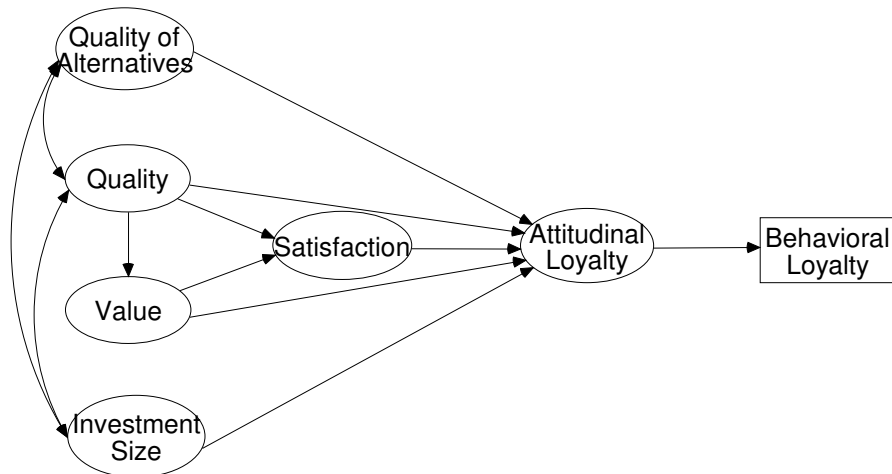

The Structure of Loyalty

This study attempted to explore the dimensional structure of the loyalty construct. Following recent developments in loyalty studies (Back 2001; Jones and Taylor In press; Oliver 1997; Oliver 1999), loyalty in this dissertation was conceptualized as a four-dimensional construct, comprised of cognitive, affective, conative, and behavioral loyalty. As consensus has been reached that loyalty contains a behavioral component (Backman and Crompton 1991b; Cunningham 1956; Iwasaki and Havitz 2004; Morais et al. 2004; Pritchard et al. 1999), the present study focused particularly on the first three dimensions of loyalty (i.e., cognitive, affective, and conative loyalty), and hypothesized that they may collectively form a higher order factor, namely attitudinal loyalty. However, this conceptualization was not supported by the data. Alternatively, a modified model, based on the traditional conceptualization that attitudinal loyalty is a first-order, one-dimensional construct (Backman and Crompton 1991b; Day 1969; Dick and Basu 1994; Jacoby and Chestnut 1978; Petrick 1999; Pritchard et al. 1999; Selin et al. 1988), was found to fit the data substantially better.

Further, the dissertation also postulated that attitudinal loyalty would lead to behavioral loyalty. This attitude-behavior link was empirically supported by the data, which is consistent with the literature (Ajzen 2000; Ajzen 1991; Ajzen and Driver 1992; Ajzen and Driver 1991; Ajzen and Fishbein 1980; Albarracin et al. 2001; Fishbein and Ajzen 1975).

In sum, this study supported the traditional two-dimensional conceptualization of loyalty, which argues that loyalty has an attitudinal and a behavioral component

(Backman and Crompton 1991b; Day 1969; Dick and Basu 1994; Jacoby and Chestnut 1978; Petrick 1999; Pritchard et al. 1999; Selin et al. 1988). Moreover, this finding seems to be congruent with psychology literature on interpersonal commitment, which has consistently suggested that pro-relationship acts (i.e., commitment) have two components, behavioral and cognitive (Jones and Taylor In press). Findings of this dissertation are also in congruous with that of a recent marketing study by Jones and Taylor (In press). Jones and Taylor's study on service company customers also supported a two-dimensional loyalty construct: behavioral loyalty remaining as one dimension, while attitudinal and cognitive loyalty, originally conceptualized as two independent dimensions of loyalty, were found to be combined into one dimension. Jones and Taylor (In press) hence concluded that "...regardless of the target (friend, spouse, service provider), loyalty captures, in essence, what Oliver (1999) referred to as 'what the person does' (behavioral loyalty) and the psychological meaning of the relationship (attitudinal/cognitive loyalty)." Nevertheless, both psychology literature and Jones and Taylor's study operationalized behavioral loyalty/commitment as intentions, which are considered conative in this dissertation's view.

While the two-dimensional conceptualization of brand loyalty is not new to marketing or psychology researchers, what the present results reveal is that the two dimensions might be more complex than previously suggested. Remaining in the final 5-item attitudinal loyalty measure are cognitive, affective, and conative components, which is consistent with the tripartite model of attitude structure in the psychology literature (Breckler 1984; Breckler and Wiggins 1989; Eagly and Chaiken 1993; Jackson

et al. 1996; Reid and Crompton 1993; Zanna and Rempel 1988). One might speculate that although these three aspects of loyalty loaded in the same dimension, they could account for unique aspects of the construct.

The Antecedents of Loyalty

The primary purpose of this dissertation was to investigate the utility of using the Investment Model (Rusbult 1980a, 1980b, 1983) to examine the psychological processes underlying loyalty formation in a tourism service context. The review in Chapter II suggested that a variety of factors (e.g., satisfaction, quality, value, switching costs/investment, etc.) have been found to associate with loyalty. Moreover, for each of these factors, the literature may report conflicting findings on its effect on loyalty (for example, quality has been suggested to have direct effect on loyalty, indirect effect on loyalty partially mediated by satisfaction, or indirect effect on loyalty completely mediated by satisfaction). It was believed that the Investment Model might provide useful guidance in integrating the seemingly segregated literature.

The Investment Model (Rusbult 1980a, 1980b, 1983) suggests that one's commitment to an interpersonal relationship is weakened by the quality of alternative options, while strengthened by his/her satisfaction with and investment in the relationship. The present study found these three determinants also work in a consumer-brand scenario, and that all three variables uniquely predict attitudinal loyalty. Collectively, the three variables explained the vast majority of the variance in cruise passengers' attitudinal loyalty to a cruise brand, with satisfaction being the strongest predictor.

Specifically, satisfaction was found to have a significant and positive effect on attitudinal loyalty. In addition to supporting the basic premise of the Investment Model, this finding is also consistent with research on the relationship between satisfaction and loyalty in both the marketing (Anderson and Srinivasan 2003; Beerli et al. 2004; Bloemer and Kasper 1995; Bloemer and Lemmink 1992; Chiou 2004; Homburg and Giering 2001; Lam et al. 2004; Olsen 2002; Ping 1993; Yu et al. 2005) and leisure/tourism (Back 2001; Bowen and Chen 2001; Yoon and Uysal 2005) literatures.

Investment size was also found to positively predict attitudinal loyalty. In addition to supporting the Investment Model, this finding also validated arguments in both the marketing and leisure/tourism literature that switching or sunk costs have a positive and direct effect on loyalty (Backman and Crompton 1991b; Beerli et al. 2004; Klemperer 1995; Lam et al. 2004; Selnes 1993; Wernerfelt 1991). This finding also provided partial support to Morais and associates' (Morais et al. 2004, 2005) application of Foa and Foa's (1974; 1980) resource theory in explaining the development of service loyalty. Their work revealed that customer loyalty was positively influenced by the resource investments that customers and service providers made in each other.

Additionally, recent marketing studies on e-commerce and knowledge economy have suggested that customers may be locked into the system, procedure, or protocol they are familiar with, due to the complexity of information-intensive products, which make the market a "winner-take-all" (Frank and Cook 1995) or "tippy" (Varadarajan and Yadav 2002) one. Customers' familiarity with a brand resultant from initial product trial

is essentially their investment. From this perspective, the concept of investment size might be applicable to contexts beyond service products.

Finally, this study found that quality of alternative options significantly and negatively influences one's attitudinal loyalty. This is consistent with Ping's (1993) study on the retailer-supplier relationship and Ganesh et al.'s (2000) study on customer loyalty. Moreover, the concept of quality of alternatives stresses that not only other brands in the same product category could make valid alternative options in a customer's mind, there may exist a variety of other products and options providing similar benefits. This may be related to the line of marketing research on noncomparable alternatives (Bettman and Sujan 1987; Bolton, Kannan, and Bramlett 2000; Chakravarti, Janiszewski, Mick, and Hoyer 2003; Johnson 1984, 1988) or "generic competition" (Kotler 1984), which argues that consumers occasionally face noncomparable choices (e.g., choosing between a television and a vacation). Furthermore, this might also be conceptually associated with the stream of research in leisure studies on substitutability of leisure behavior (Ditton and Sutton 2004; Iso-Ahola 1986; Manning 1999; Shelby and Vaske 1991), which argues that recreationists may seek alternative options offering similar benefits or enjoyment to satisfy their recreation needs.

In addition, the concept of quality of alternatives echoes the resource-based theory in marketing and management strategy studies (Barney 1991; Conner 1991; Dierickx and Cool 1989; Makadok 2001; Reed and DeFillippi 1990). The resource-based theory suggests that to hold the potential of sustainable competitive advantage (SCA), a company's resources must be valuable, rare, imperfectly imitable and not

strategically substitutable (Barney 1991). This suggests that when the core benefits that a cruise line offers can be easily emulated by other cruise lines, it is unlikely that its customers will remain loyal. Nor will the cruise line keep its SCA over its competitors.

Combined, this study provided evidence that cruise passengers' brand loyalty is positively affected by their satisfaction level and investment size, and negatively influenced by the quality of alternative options. These findings confirm the usefulness of the Investment Model as a holistic theoretical framework to explain the development of customers' brand loyalty.

As an extension of the Investment Model, this dissertation further posited that perceived value and quality were not direct determinants of customer loyalty. Based on extant marketing and leisure/tourism literature, it was conceptualized that quality and value were two major antecedents of satisfaction. Both constructs' effects on loyalty were mediated by satisfaction, with quality also leading to value.

In regards to quality, at least three types of quality-loyalty relationships have been proposed in the literature (see Table 2.4). The revealed partial mediation effect of satisfaction on the quality-loyalty link was consistent with Baker and Crompton (2000) and Lee et al. (2004). These results may help solve the controversy pertaining to the role of quality in the loyalty formation process.

Perceived value is another construct that has been frequently suggested to be related to loyalty formation. To date, no less than three value-loyalty relationships have been proposed in the literature (see Table 2.5). This study revealed that the effect of value on attitudinal loyalty was partially mediated by satisfaction, which is consistent

with several recent marketing studies (Chiou 2004; Lam et al. 2004; Yang and Peterson 2004). The value-satisfaction-loyalty link is thus deemed theoretically grounded and empirically supported. It is hoped that the current analysis will help better understand the interrelationships of these constructs.

Overall, the theoretical framework proposed in this dissertation (see Figure 7.1) attempted to integrate extant findings related to the structure and antecedents of the loyalty construct. It was revealed that loyalty could be predicted by three major determinants: satisfaction, investment size, and quality of alternatives. Two antecedents of satisfaction, i.e., perceived quality and perceived value, may influence the formation of loyalty mainly through satisfaction, with quality also positively influencing value.

Managerial Implications

As indicated, one of the objectives of the current investigation was to provide some preliminary insights for cruise management. Many previous studies have focused on the outcomes of loyalty (Morais 2000), which have helped managers to understand their customers and their product performances. What might be more intriguing to managers is to understand why customers are loyal or disloyal to a brand. Facing more sophisticated cruisers and challenged by more aggressive competitors, cruise line management who understand the underlying reasons for customer loyalty building might have an advantage in retaining their share of the market. In addition to reexamining the measures of loyalty that other researchers have suggested, this dissertation also provides an explanation of the loyalty building process, which makes intuitive sense. Although this study is primarily theoretical, it is believed that the revealed conceptual relationships

among loyalty and its antecedents may provide a useful framework for managerial decision-making and problem diagnosis.

First of all, this dissertation provides a feasible framework for managers to evaluate their customer retaining strategies. For cruise lines attempting to keep their current clientele, this dissertation identifies three areas that they need to focus on, namely satisfaction, quality of alternatives, and customers' investment size.

For instance, this study found that investment size, operationalized as both switching and sunk costs, was an important predictor of cruise passengers' loyalty. Based on this finding, it is recommended that cruise lines should tangibilize customers' investments. One way to do so is by providing immediate reward for patronage, which many cruise lines have already offered in their customer loyalty programs. Other strategies include building personal relationships with customers, organizing customer clubs, building customer profiles, free service upgrades for repeat customers, and providing customized services: These tactics should help enhance customers' sense of community and personal involvement with a brand. For example, to substantialize the idea of switching costs, a cruise line may design commercials stressing the fact that for repeat purchases, customers will no longer need to worry about making complicated travel decisions or getting unpredictable services. Instead, the cruise line truly understands its customers' needs and can provide more customized services, as it has recorded customers' preferences and other information in its database. The challenge for managers is to make such benefits more appealing and obvious, and to deliver these benefits to customers efficiently and effectively.

The quality of alternatives issue stresses the importance of being innovative and offering unique experiences. As indicated, customers will be less loyal to a cruise line when they perceive other cruise lines' quality or other leisure activities' quality as superior. Equally, customers are more likely to stay loyal when they believe the benefits provided by a cruise line are not substitutable by others. Since technical aspects of a cruising service are unlikely to be major differentiators between one cruise line and its competitors (Zeithaml, Parasuraman, and Berry 1990), cruise lines may focus on improving performances on specific service attributes (e.g., food, entertainment, ship condition) (Tian 1998). In addition to providing better quality, a cruise line may also try to make the comparison of service quality difficult. That is, if a cruise line can provide unique services (such as exotic destinations, different routes, special travel packages, unusual entertainment programs), which are not readily available from other cruise lines, then the comparability of alternatives is decreased. The resource-based theory suggests that a company should establish barriers to inhibit competitors from trading, replicating, or substituting its privileged asset position (Dierickx and Cool 1989; Reed and DeFillippi 1990). For cruise lines, creating a unique experience for cruisers might be the key to keeping a competitive advantage.

The concept of quality of alternatives also reminds managers to look beyond their own products and their current competitors, and to avoid "marketing myopia" (Levitt 1960). Essentially, a cruise line is not just competing with another line for customers. The landscape of competition could be much broader than one might think. For instance, when customers' limited budgets force them to choose between a cruise

vacation, a tour to Las Vegas, or a high-definition television, the cruise line has to compete with the destination (i.e., Las Vegas), and television marketers. Previous studies suggest that when facing such choices, consumers tend to abstract “product representations to a level where comparisons are possible” (Johnson 1984, p. 751). Thus, in the foregoing example, customers may attempt to compare the ultimate enjoyment they can get from the three options. This again stresses the importance of providing excellent service and unique benefits.

Although improving customer satisfaction is not a new idea, what this dissertation suggests is that satisfaction is strongly predicted by quality and value. Researchers have acknowledged that customer satisfaction is subjective in nature, and that it may be influenced by factors beyond managers’ power (Baker and Crompton 2000). Thus, from a managerial perspective, cruise lines can improve customer satisfaction by enhancing the quality and value of their services, both of which are under management’s control (Baker and Crompton 2000; Petrick 2004c). To improve service quality, cruise management needs to better understand benefits sought by their passengers, and move their resources accordingly to improve service attributes that can satisfy such benefits (Petrick 2004c; Tian 1998). This further suggests that cruise management should invest resources in customer research. To optimize customers’ perceived value, cruise management may focus on improving brand reputation (by both advertising and public relation efforts) and reducing customers’ monetary (e.g., using innovative packaging or providing loyalty discounts) and non-monetary costs (e.g.,

providing access for online purchases, or facilitating passengers' embarkation and disembarkation) (Petrick 2004b).

Secondly, the theoretical framework outlined in this dissertation also provides clues for managers who plan to win over customers from their competitors. As indicated, a recent trend in the cruise industry is that the four major cruise lines have been investing heavily on cruise capacity expansion, in order to continue the current market balance and to block potential competitors from entry (Lois et al. 2004; Petrick 2004a). One may argue that increasing capacity is just one option to win the competition. For managers of Cruise Line A who are interested in getting Cruise Line B's customers, what can they do? The most straightforward way is to persuade customers that they will be more satisfied with A's service. However, this could be hard as customers haven't tried A's product, and their current loyalty to B might make them reluctant to do so. This dissertation found that in addition to satisfaction, direct determinants of cruisers' loyalty also included quality of alternatives and investment size. Thus, to decrease cruisers' loyalty to B, it is recommended that Cruise Line A should keep customers informed that A is providing superior service to B (better quality of alternatives), should facilitate customers switching from B to A, and provide immediate rewards to customer who switch (lower investment size).

Thirdly, the theoretical framework provides a useful tool for cruise managers to evaluate their own performances, and monitor their customers' loyalty. Results of this dissertation suggest that both the behavioral and attitudinal aspects of loyalty should be measured, to generate a full understanding of customers' brand loyalty. When customer

loyalty fluctuates over time, investigating customers' perceived service quality, value, satisfaction, quality of alternatives, and investment size should help identify where the problem is. Moreover, quality, value, and satisfaction can be measured for product benchmarking purposes. That is, if a cruise line wants to compare its own performance with that of its competitors or the industry leader, evaluating customers' perception of service quality, value, and satisfaction may provide a set of useful benchmarking metrics.

Finally, this dissertation suggests that cruise managers might need to change the way they view brand loyalty. As indicated, brand loyalty was "originally intended to provide customers with quality assurance and little else" (Sheth and Sisodia 1999, p. 78). That is, managers used to associate their customers' loyalty with service quality and satisfaction only. This mentality might lead managers to believe that a satisfied customer will inevitably become a loyal customer, which is not necessarily true.

Lately, brand loyalty has been recognized as a market segmentation tool (Sheth and Sisodia 1999). Customers with different types of loyalty have been found to constitute market segments of different profitability (Backman and Crompton 1991a; Petrick 2004a; Petrick 1999). Another determinant of loyalty, namely quality of alternatives, might be used to effectively segment markets. Results of the current study suggest that managers should better understand the position of their products (services or goods) in their customers' mind, by comparing their products to alternative options available on the market. By understanding these alternatives, cruise management should be better equipped to improve the allocation of their resources.

More recently, it has been advocated that brand loyalty may become the core of brand-customer relationships (Fournier 1998). If building loyalty is viewed as a way to improve brand-customer relationships, the last determinant of loyalty, customers' investment size, could contribute to understanding such relationships. As indicated, customers' investments to a brand are not simply money, but they also involve relational costs based on their trust and belief in the cruise line. It is thus suggested that managers should design and deliver rewards for such investments. One way to do this would be to build customer clubs where loyal customers will be provided special offers, "insider information" about new products, special pricing for friends and relatives, members-only souvenirs and so on (Miller and Grazer 2003). By understanding the major drivers of loyalty, management should be able to better engineer customers' decision making processes, and alter customers' experience to enhance their probability of repurchase.

Recommendations for Future Research

Limitations of Present Study

This study was an initial attempt to understand the structure and antecedents of the loyalty construct. As stated in Chapter I, the results may be limited to respondents who participated in this study, and who cruised at least once with one of CLIA's nineteen cruise lines in the past 12 months. Replication of the present study in markets outside North America may enhance the representativeness of the present results. This study is further limited by analyzing only cruise travelers. Thus, further research is necessary in order to determine whether the theoretical relationships identified in this

study are generalizable to cruise passengers in other cultures and geographic regions, other types of travelers, and ultimately consumers of different services or goods.

Since nonresponse checks identified no major differences between the valid sample drawn and the population (i.e., the whole online panel), it was postulated that results of this survey might be generalizable to repeat cruisers in the whole panel who met the pre-set participating criteria and who received the survey invitation. Further, the sampling bias checking implied that participants in this study are demographically similar to general cruise passengers, but behaviorally more active cruisers. Thus, the present findings have the potential to be generalizable to the group of currently active repeat cruise passengers among general North American cruisers.

This study is further limited by its data collection approach. The online panel survey approach utilized in this study precluded cruise passengers who do not have Internet access or Internet skills from being researched. Future research should use multiple survey methods for cross-validation purposes.

Another limitation of this study is that it did not consider differences in cruise lines. Employing different marketing strategies and loyalty programs and targeting different market segments, the nineteen cruise lines used in this study might exhibit considerable differences affecting customer loyalty building. It is uncertain whether and how these “noises” will influence the theoretical relationships suggested. It is quite possible that the current results are very different at the individual cruise line level, and that by combining cruise lines, the present results cannot be applied at the individual cruise line level.

Additionally, the 5-item attitudinal loyalty scale used in this study, though demonstrating good validity and reliability, was generated from post hoc analyses. Another scale, the 5-item investment size measure, was found to contain some psychometric problems. Future studies are needed to better operationalize these two constructs by going through a complete scale development process (DeVellis 2003; Netemeyer et al. 2003).

Finally, the theoretical framework proposed in this study postulates temporal sequence and directional influences among variables. However, the cross-sectional design of this study made it unfeasible to accurately examine such relations (MacCallum and Austin 2000). To better examine the conceptualized relationships, longitudinal studies with better experimental controls are warranted.

Future Research

The present study provides empirical evidence of the dimensional structure of the loyalty construct and the utility of the Investment Model in explaining loyalty formation. The theoretical framework proposed in this study further provides fertile ground for future research examining these relationships.

This dissertation, based on the Investment Model (Rusbult 1980a, 1980b, 1983) in social psychology, suggested that customers will be more loyal as their own investments in a brand increase. Morais and associates (Morais et al. 2004; 2005), based on Foa and Foa's (1974; 1980) resource theory, revealed that customer loyalty was positively influenced by the resource investments that customers and service providers made in each other. Thus, consistent with the Investment Model, Morais and associates'

(Morais et al. 2004; 2005) suggested that customer loyalty is influenced by customers' investment in a brand/service. Different from the Investment Model, they found that service providers' relational investment (i.e., in customers' mind, the amount of investments the service provider made to customers) is also a useful predictor of loyalty. It would be interesting to see if adding the latter factor (i.e., service providers' relational investment) would improve the prediction of loyalty and enhance the explanatory power of the present model.

The nature of the relationships between satisfaction, quality of alternatives, and investment size and loyalty also needs further examination. Oliva, Oliver, and MacMillan (1992) argued that satisfaction may not directly lead to loyalty until a certain threshold is attained, just as dissatisfaction does not necessarily lead to switching until a threshold is breached. They found that satisfaction and loyalty were related in a linear and nonlinear fashion. In a similar vein, Heskett and colleagues (1997) suggested that customer loyalty should increase rapidly after customer satisfaction passes a certain threshold. The nonlinear relationship argument may also hold true in the cases of investment size and quality of alternatives. More sophisticated research design and analytical tools are needed in future studies to detect the nature of these relationships.

Further, it would be intriguing to further explore the interrelationships between satisfaction, quality of alternatives, and investment size. Theoretically, satisfied customers may be more likely to repurchase the same product. Their repeat patronage should provide them rewards such as discounts, less information search costs, less decision-making efforts, lower perceived risk in product usage, and so on. These benefits

could essentially become customers' investments in their relationship with the brand, which could make them less likely to switch to other brands. Thus, one might postulate that satisfaction influences one's investment size. It also makes conceptual sense that the more satisfied a customer is, and the more investments one makes in a brand, the more reluctant the customer will be to seek alternative product offerings, or view alternative options favorable, as this might result in cognitive dissonance (Festinger 1957).

Researchers have found that high investment size accompanies a decrease in the appeal of alternative offerings to customers (Beerli et al. 2004; Klemperer 1995; Selnes 1993; Wernerfelt 1991). Thus, satisfaction and investment size might also influence quality of alternatives. Conversely, it makes intuitive sense that one might feel more satisfied with a brand, and be more willing to purchase the brand, if other brands are perceived inferior in quality. Thus, quality of alternatives might influence satisfaction and investment size. In the current study, the three factors were assumed to covary with each other, while in-depth analysis of the nature of their interrelationships may provide new insights in the loyalty formation process.

The current study also suggests that perceived quality and value are two major antecedents of satisfaction. Parasuraman and Grewal (2000, p. 169) suggested that perceived value "is composed of a 'get' component—that is, the benefits a buyer derives from a seller's offering—and a 'give' component—that is, the buyer's monetary and nonmonetary costs in acquiring the offering." One might argue that perceived value is by definition related to investment size, and the investments customers make in a brand will influence their perception of the value of that brand.

In a similar vein, one might also be able to associate customers' perceived quality with quality of alternatives. If quality is defined as customers' assessment of the overall excellence of a brand (Zeithaml 1988), this assessment would not be completely independent of the customers' judgment of other brands. Underlying this assessment might be comparative evaluation (Olsen 2002), where one compares the performance of a brand with other brands available in the market. Additional research is needed to further examine the relationships between value and investment size, and quality and quality of alternatives.

Further, several variables (e.g., gender, ethnicity, and sexual orientation of respondents, duration of the relationship) have been found to moderate the relationship between commitment and its theorized determinants, in previous Investment Model studies (Le and Agnew 2003). It is postulated that a similar group of moderators may exist in the present theoretical relationships as well. Such variables as socio-economic characteristics, customers' propensity to be loyal (Rundle-Thiele 2005), and perceived brand parity (Iyer and Muncy 2005; Muncy 1996), may all potentially influence the loyalty formation processes. More research is necessary in order to explore the role of these potential moderators.

Finally, although brand loyalty is a discipline-specific concept, bonding forces between individuals and different objects have been studied in a variety of disciplines. While marketing scholars have traditionally been interested in customers' attachment to products (i.e., involvement) or brands (i.e., loyalty), other disciplines have identified people's bonding with other individuals, teams, organizations, places, and so on. For

years, psychologists and sociologists have studied the bonding between human beings in terms of attachment (Bowlby 1969; Bowlby 1980; Bowlby 1973), interpersonal commitment (Johnson 1973; Levinger 1965; Rusbult 1980a) or side bets (Becker 1960). In the fields of organizational behavior and management, employees' commitment to organizations has been an active research topic (Allen and Meyer 1990; Mowday, Steers, and Porter 1979; Payne and Huffman 2005). Human geographers and environmental psychologists (Low and Altman 1992; Tuan 1977; Tuan 1974) are also interested in people's bonding with places (i.e., place attachment). Sports marketing researchers (Funk 1998; Gladden and Funk 2002) have focused on the concept of fan loyalty, while leisure and tourism researchers have studied a variety of issues from destination loyalty (Kozak et al. 2002; Niininen and Riley 2003; Oppermann 2000) to recreationists' commitment to public agencies (Kyle and Mowen 2005).

To date, different disciplines have investigated the abovementioned phenomena using different approaches. No consensus has been reached on how to term the underlying forces that glue individuals to different objects (be it attachment, commitment, or loyalty), not to mention how and why these phenomena occur. However, beyond differences in terminology and research methods, there might be some principles which hold valid across different contexts and objects. This author speculates a nomological network (see Figure 7.2), and postulates that researchers, once breaking disciplinary barriers, may benefit from a common theoretical ground and perspectives from other disciplines. The present study, applying a social psychology theory in explaining a marketing phenomenon, may represent one baby step in this journey.

FIGURE 7.2
A SPECULATED NOMOLOGICAL NETWORK

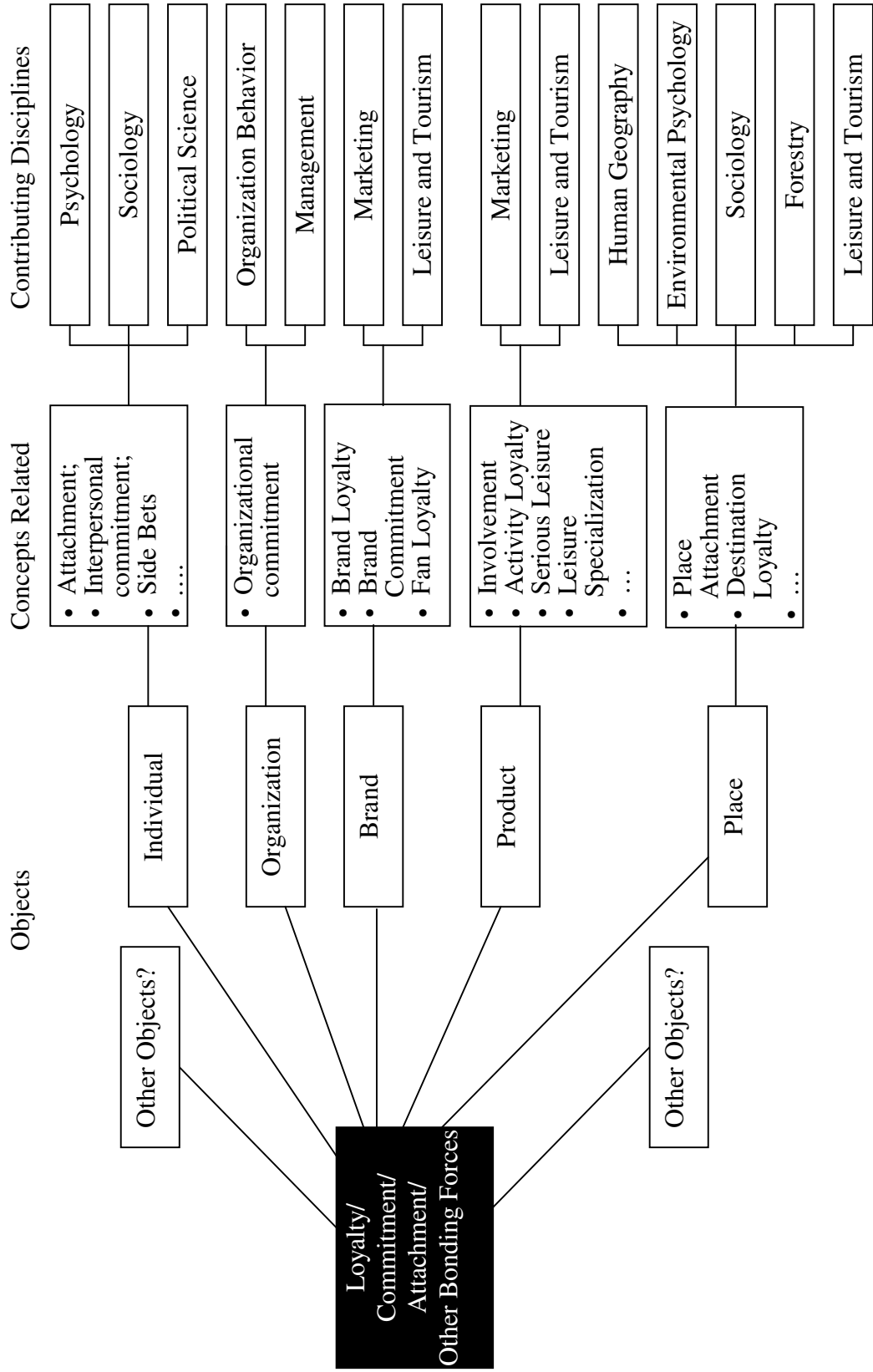

REFERENCES

- Aaker, D. A. (1996). "Measuring Brand Equity across Products and Markets." *California Management Review*, 38 (3): 102-20.
- Abdullah, M., A. Al-Nasser, and N. Husain (2000). "Evaluating Functional Relationship between Image, Customer Satisfaction and Customer Loyalty Using General Maximum Entropy." *Total Quality Management*, 11 (4/5&6).
- Adams, J. M., and W. H. Jones. (1997). "The Conceptualization of Marital Commitment: An Integrative Analysis." *Journal of Personality and Social Psychology*, 72 (5): 1177-96.
- Agustin, C., and J. Singh (2005). "Curvilinear Effects of Consumer Loyalty Determinants in Relational Exchanges." *Journal of Marketing Research*, 42 (1): 96-108.
- Ajzen, I. (1991). "The Theory of Planned Behavior." *Organizational Behavior and Human Decision Processes*, 50: 179-211.
- (2000). "Nature and Operation of Attitudes." *Annual Review of Psychology*, 52: 27-58.
- Ajzen, I., and B. L. Driver (1991). "Prediction of Leisure Participation from Behavioral, Normative, and Control Beliefs: An Application of the Theory of Planned Behavior." *Leisure Sciences*, 13: 185-204.
- (1992). "Application of the Theory of Planned Behavior to Leisure Choice." *Journal of Leisure Research*, 24: 207-24.
- Ajzen, I., and M. Fishbein (1980). *Understanding Attitudes and Predicting Social Behavior*. Englewood Cliffs, NJ: Prentice Hall.
- Albarracin, D., B. T. Johnson, M. Fishbein, and P. A. Muellerleile (2001). "Theories of Reasoned Action and Planned Behavior as Models of Condom Use: A Meta-Analysis." *Psychological Bulletin*, 127: 142-61.
- Allen, N. J., and J. P. Meyer (1990). "The Measurement and Antecedents of Affective, Continuance, and Normative Commitment to the Organization." *Journal of Occupational Psychology*, 63: 1-8.
- (1996). "Affective, Continuance, and Normative Commitment to the Organization: An Examination of Construct Validity." *Journal of Vocational Behavior*, 49 (3): 252-76.

- Anderson, E., and M. W. Sullivan (1993). "The Antecedents and Consequences of Customer Satisfaction for Firms." *Marketing Science*, 12 (2): 125-43.
- Anderson, J. C., and D. W. Gerbing(1988). "Structural Equation Modeling in Practice: A Review and Recommended Two-step Approach." *Psychological Bulletin*, 103: 411-423.
- Anderson, J. C., and J. Narus (1984). "A Model of the Distributor's Perspective of Distributor-Manufacturer Working Relationships." *Journal of Marketing*, 48 (4): 62-74.
- (1990). "A Model of Distributor Firm and Manufacturer Firm Working Partnerships." *Journal of Marketing*, 54 (1): 42-58.
- Anderson, R. E., and S. S. Srinivasan (2003). "E-Satisfaction and E-Loyalty: A Contingency Framework." *Psychology & Marketing*, 20 (2): 123-38.
- Armstrong, S. J., and T. S. Overton (1977). "Estimating Nonresponse Bias in Mail Surveys." *Journal of Marketing Research*, 14: 396-402.
- Assael, H. (1987). *Consumer Behavior and Marketing Action*. (3rd ed.). Boston: Kent.
- (2004). *Consumer Behavior: A Strategic Approach*. Boston: Houghton Mifflin.
- Asubonteng, P., K. J. McCleary, and J. E. Swan (1996). "Servqual Revisited: A Critical Review of Service Quality " *Journal of Services Marketing*, 10 (6): 62-81.
- Back, K. (2001). *The Effects of Image Congruence on Customer Satisfaction and Brand Loyalty in the Lodging Industry*. Unpublished Ph.D. Dissertation, The Pennsylvania State University.
- Back, K., and S. C. Parks (2003). "A Brand Loyalty Model Involving Cognitive, Affective, and Conative Brand Loyalty and Customer Satisfaction." *Journal of Hospitality & Tourism Research*, 27 (4): 419-35.
- Backman, S. J. (1988). *The Utility of Selected Personal and Marketing Characteristics in Explaining Consumer Loyalty to Selected Recreation Services*. Unpublished Ph.D. Dissertation, Texas A&M University.
- (1991). "An Investigation of the Relationship between Activity Loyalty and Perceived Constraints." *Journal of Leisure Research*, 23 (4): 332-44.
- Backman, S. J., and J. L. Crompton (1991a). "Differentiating between High, Spurious, Latent, and Low Loyalty Participants in Two Leisure Activities." *Journal of Park and Recreation Administration*, 9 (2): 1-17.

—— (1991b). "The Usefulness of Selected Variables for Predicting Activity Loyalty." *Leisure Sciences*, 13: 205-20.

Backman, S. J., and K. J. Shinew (1994). "The Composition of Source and Activity Loyalty within a Public Agency's Golf Operation." *Journal of Park and Recreation Administration*, 12 (3): 1-18.

Backman, S. J., and C. Veldkamp (1995). "Examination of the Relationship between Service Quality and User Loyalty." *Journal of Park and Recreation Administration*, 13 (2): 29-41.

Bagozzi, R. P. (1978). "The Construct Validity of the Affective, Behavioral, and Cognitive Components of Attitude by Analysis of Covariance Structures." *Multivariate Behavioral Research*, 13 (1): 9-31.

—— (1994). *Principles of Marketing Research*. Oxford, UK: Basil Blackwell.

Bagozzi, R. P., and Y. Yi (1988). "On the Evaluation of Structural Equation Models." *Journal of the Academy of Marketing Science*, 16(Spring), 74-94.

Baker, D. A., and J. L. Crompton (2000). "Quality, Satisfaction and Behavioral Intentions." *Annals of Tourism Research*, 27 (3): 785-804.

Ball, D., Coelho, P. S., and Machás, A (2004). "The Role of Communication and Trust in Explaining Customer Loyalty." *European Journal of Marketing*, 38 (9/10): 1272-93.

Baloglu, S. (2001). "An Investigation of a Loyalty Typology and the Multidestination Loyalty of International Travelers." *Tourism Analysis*, 6 (1): 41-52.

Bansal, H. S., P. G. Irving, and S. F. Taylor (2004). "A Three-Component Model of Customer Commitment to Service Providers." *Journal of the Academy of Marketing Science*, 32 (3): 234-50.

Barney, J. (1991). "Firm Resources and Sustained Competitive Advantage." *Journal of Management*, 17 (1): 99-120.

Baron, R. M., and D. A. Kenny (1986). "The Moderator-Mediator Variable Distinction in Social Psychological Research: Conceptual, Strategic, and Statistical Considerations." *Journal of Personality and Social Psychology*, 51 (6): 1173-82.

Barsky, J. D., and R. Labagh (1992). "A Strategy for Customer Satisfaction." *Cornell Hotel and Restaurant Administration Quarterly*, 33 (5): 32-40.

- Bass, F. M. (1974). "The Theory of Stochastic Preference and Brand Switching." *Journal of Marketing Research*, 11 (February): 1-20.
- Beatty, S. E., P. Homer, and L. R. Kahle (1988). "The Involvement-Commitment Model: Theory and Implications." *Journal of Business Research*, 16 (2): 149-67.
- Beatty, S. E., and L. R. Kahle (1988). "Alternative Hierarchies of the Attitude-Behavior Relationship: The Impact of Brand Commitment and Habit." *Journal of the Academy of Marketing Science*, 19 (Summer): 1-10.
- Becker, H. S. (1960). "Notes on the Concept of Commitment." *American Journal of Sociology*, 66 (1): 32-40.
- Beerli, A., J. D. Martin, and A. Quintana (2004). "A Model of Customer Loyalty in the Retail Banking Market." *European Journal of Marketing*, 38 (1/2): 253-75.
- Bentler, P. M. (1990). "Comparative Fit Indexes in Structural Models." *Psychological Bulletin*, 107: 238-46.
- Bentler, P. M., and C.-P. Chou (1987). "Practical Issues in Structural Modeling." *Sociological Methods & Research*, 16: 78-117.
- Berger, P. D. a. N. I. N. (1998). "Customer Lifetime Value: Marketing Models and Application." *Journal of Interactive Marketing*, 12 (1): 17-30.
- Bernard, H. R. (2000). *Social Research Methods: Qualitative and Quantitative Approaches*. Thousand Oaks, CA: Sage Publications.
- Berry, L. L. (1983). "Relationship Marketing." In *Emerging Perspectives on Service Marketing*. edited by L. G. Shostack L. L. Berry, and G. D. Uph. Chicago, IL: American Marketing Association. pp. 25-28.
- Bettman, J. R., and M. Sujan (1987). "Effects of Framing on Evaluation of Comparable and Noncomparable Alternatives by Expert and Novice Consumers." *Journal of Consumer Research*, 14 (2): 141-54.
- Bigne, J. E., M. I. Sanchez, and J. Sanchez (2001). "Tourism Image, Evaluation Variables and after Purchase Behaviour: Inter-Relationship." *Tourism Management*, 22 (6): 607-16.
- Bitner, M. J. (1990). "Evaluating Service Encounters: The Effects of Physical Surroundings and Employee Responses." *Journal of Marketing*, 54 (2): 69-82.

Bitner, M. J., and A. R. Hubbert. (1994). "Encounter Satisfaction versus Overall Satisfaction Versus Quality." In *Service Quality: New Direction in Theory and Practice*, edited by Roland T. Rust and Richard L. Oliver. Thousand Oaks, CA: Sage. pp. 72-94.

Blalock, H. M. J. (1979). *Social Statistics* (2nd ed.). New York: McGraw-Hill.

Blau, P. M. (1964). *Exchange and Power in Social Life*. New York: Wiley.

Bloemer, J. M. M., and H. D. P. Kasper (1995). "The Complex Relationship between Consumer Satisfaction and Brand Loyalty " *Journal of Economic Psychology*, 16 (2): 311-29.

Bloemer, J. M. M., and J. G. A. M. Lemmink (1992). "The Importance of Customer Satisfaction in Explaining Brand and Dealer Loyalty." *Journal of Marketing Management*, 8 (4): 351-63.

Bloemer, J. M. M., and K. de Ruyter (1995). "Integrating Service Quality and Satisfaction: Pain in the Neck or Marketing Opportunity?" *Journal of Consumer Satisfaction Dissatisfaction and Complaining Behavior*, 8: 44-52.

—— (1998). "On the Relationship between Store Image, Store Satisfaction and Store Loyalty." *European Journal of Marketing*, 32 (5/6): 499-513.

—— (1999). "Customer Loyalty in High and Low Involvement Settings: The Moderating Impact of Positive Emotions." *Journal of Marketing Management*, 15: 315-30.

Bloemer, J. M. M., K. de Ruyter, and M. Wetzels (1999). "Linking Perceived Service Quality and Service Loyalty: A Multi-Dimensional Perspective." *European Journal of Marketing*, 33 (11/12): 1082-106.

Blois, K., and D. Wilson (2000). "*Relationship Marketing in Organizational Markets: From Competition to Cooperation*." In *Oxford Textbook of Marketing*, edited by K. Blois. Oxford, England: Oxford University Press. pp. 534-548.

Bollen, K. A. (1989). *Structural Equations with Latent Variables*. New York: Wiley.

Bollen, K. A., and R. A. Stine. (1992). "Bootstrapping Goodness-of-Fit Measures in Structural Equation Models." *Sociological Methods and Research*, 21: 205-29.

Bolton, R. (1998). "A Dynamic Model of the Duration of the Customer's Relationship with a Continuous Service Provider: The Role of Satisfaction." *Marketing Science*, 17 (1): 45-66.

- Bolton, R. N., and J. H. Drew (1991a). "A Longitudinal Analysis of the Impact of Service Changes on Customer Attitudes." *Journal of Marketing*, 55 (January): 1-9.
- (1991b). "A Multistage Model of Customers' Assessments of Service Quality and Value." *Journal of Consumer Research*, 17 (March): 375-84.
- (1992). "Mitigating the Effect of Service Encounters." *Marketing Letters*, 3: 57-70.
- Bolton, R. N., R. K. Kannan, and M. D. Bramlett (2000). "Implications of Loyalty Program Membership and Service Experiences for Customer Retention and Value." *Journal of the Academy of Marketing Science*, 28 (1): 95-98.
- Boomsma, A. (1983). *On the Robustness of Lisrel (Maximum Likelihood Estimation) against Small Sample Size and Nonnormality*. Unpublished Ph.D. Dissertation, University of Groningen.
- Bowen, J. (1990). "Development of a Taxonomy of Services to Gain Strategic Marketing Insights." *Journal of the Academy of Marketing Science*, 18 (Winter): 43-49.
- Bowen, J., and S. Shoemaker (1998). "Loyalty: A Strategic Commitment." *Cornell Hotel & Restaurant Administration Quarterly*, 39 (1): 12-25.
- Bowen, J. T., and S. Chen (2001). "The Relationship between Customer Loyalty and Customer Satisfaction." *International Journal of Contemporary Hospitality Management*, 13 (5): 213-17.
- Bowlby, J. (1969). *Attachment and Loss: Attachment*. New York: Basic Books.
- (1973). *Attachment and Loss: Separation, Anxiety, and Anger*. New York: Basic Books
- (1980). *Attachment and Loss: Sadness and Depression*. New York: Basic Books.
- Breckler, S. J. (1984). "Empirical Validation of Affect, Behavior, and Cognition as Distinct Components of Attitude." *Journal of Personality and Social Psychology*, 47 (6): 1191-205.
- Breckler, S. J., and E. C. Wiggins (1989). "Affect Versus Evaluation in the Structure of Attitudes." *Journal of Experimental Social Psychology*, 25: 253-71.
- Brown, G. (1952). "Brand Loyalty: Fact or Fiction?" *Advertising Age*, 23: 53-55.

- Brown, P. J. (1988). "Quality in Recreation Experience." In *Proceedings of the National Recreation Forum*, General Technical Report SE-52. US Forest Service, Asheville, NC pp. 412-421.
- Browne, M. W., and R. Cudeck (1993). "Alternative Ways of Assessing Fit." In *Testing Structural Equations Models*. edited by K.A. Bollen and J. S. Long. Newbury Park, CA: Sage. pp. 445-455.
- Bryan, H. (1977). "Leisure Value Systems and Recreational Specialization: The Case of Trout Fishermen." *Journal of Leisure Research*, 9: 174-87.
- Buchanan, T. (1985). "Commitment and Leisure Behavior: A Theoretical Perspective." *Leisure Sciences*, 7 (4): 401-20.
- Burke, P. J., and D. C. Reitzes (1991). "An Identity Theory Approach to Commitment." *Social Psychology Quarterly*, 54 (3): 239-51.
- Butcher, K., B. Sparks, and F. O'Callaghan (2001). "Evaluative and Relational Influences on Service Loyalty " *International Journal of Service Industry Management*, 12 (4): 310-17.
- Byrne, B. M. (1998). *Structural Equation Modeling with Lisrel, Prelis, and Simplis: Basic Concepts, Applications, and Programming*. Mahwah, NJ: Lawrence Erlbaum Publishers.
- (2001). *Structural Equation Modeling with Amos: Basic Concepts, Applications, and Programming*. Mahwah, NJ: Lawrence Erlbaum Publishers.
- Cai, L., B. Wu, and X. Bai (2004). "Destination Image and Loyalty." *Tourism Review International*, 7 (3/4): 153-62.
- Carman, J. M. (1970). "Correlates of Brand Loyalty." *Journal of Marketing Research*, 7: 67-76.
- Caruana, A. (2002). "Service Loyalty: The Effects of Service Quality and the Mediating Role of Customer Satisfaction." *European Journal of Marketing*, 36 (7/8): 811-28.
- (2004). "The Impact of Switching Costs on Customer Loyalty: A Study among Corporate Customers of Mobile Telephony." *Journal of Targeting, Measurement & Analysis for Marketing*, 12 (3): 256-68.
- Carver, C. S., and M. F. Scheier (1990). "Origins and Functions of Positive and Negative Affect: A Control-Process View." *Psychological Review*, 97 (1): 19-35.

Chakravarti, A., C. Janiszewski, D. G. Mick, and W. D. Hoyer (2003). "The Influence of Macro-Level Motives on Consideration Set Composition in Novel Purchase Situations." *Journal of Consumer Research*, 30 (2): 244-58.

Chang, S.-C. (2005). "The Dimensions and Measurement Items of Perceived Value on Tourism Services." *Service Industry Management Review*, 1 (1): 105-28.

Chang, T. Z., and A. R. Wildt (1994). "Price, Product Information, and Purchase Intention: An Empirical Study." *Journal of the Academy of Marketing Science*, 22: 16-27.

Chaudhuri, A., and M. B. Holbrook (2001). "The Chain of Effects from Brand Trust and Brand Affect to Brand Performance: The Role of Brand Loyalty." *Journal of Marketing* 15 (2): 81-94.

Chen, S. (2001). *An Investigation into the Relationship between Commitment as Loyalty: Commitment as a Key Mediating Variable for Loyalty*. Unpublished M.S. thesis, University of Nevada, Las Vegas.

Childress, R. D., and J. L. Crompton (1997). "A Comparison of Alternative Direct and Discrepancy Approaches to Measuring Quality of Performance at a Festival." *Journal of Travel Research*, 36 (2): 43-7.

Chiou, J. (2004). "The Antecedents of Consumers' Loyalty toward Internet Service Providers." *Information & Management*, 41: 685-95.

Chu, Y. (2003). *The Drivers and Antecedents of Satisfaction, Trust, Commitment, and Loyalty among Chinese Customers*. Unpublished Ph.D. Dissertation, The University of Texas - Pan American.

Churchill, G. Jr. (1979). "A Paradigm for Developing Better Measures of Marketing Constructs." *Journal of Marketing Research*, 16 (1): 64-73.

Churchill, G. Jr. and C. Surprenant (1982). "An Investigation into the Determinants of Customer Satisfaction." *Journal of Marketing Research*, 19 (4): 491-504.

Cohen, J. (1988). *Statistical Power Analysis for the Behavioral Sciences* (2nd ed.). Hilldale, NJ: Lawrence Erlbaum Publishers.

Cohen, J., P. Cohen, S. G. West, and L. S. Aiken (2003). *Applied Multiple Regression/Correlation Analysis for the Behavioral Sciences* (3rd ed.). Mahwah, NJ: Lawrence Erlbaum Publishers.

Conner, K. R. (1991). "A Historical Comparison of Resource-Based Theory and Five Schools of Thought within Industrial Organization Economics: Do We Have a New Theory of the Firm?" *Journal of Management*, 17 (1): 121-54.

Copeland, M. T. (1923). "Relations of Consumers' Buying Habits to Marketing Methods." *Harvard Business Review*, 1 (3): 282-289.

Cortina, J. M. (1993). "What Is Coefficient Alpha? An Examination of Theory and Application." *Journal of Applied Psychology*, 78 (1): 98-104.

Court, B., and R. A. Lupton (1997). "Portfolio Development: Modeling Destination Adopters, Inactives and Rejecters." *Journal of Travel Research*, 36 (1): 35-43.

Crompton, J. L., and L. L. Love (1995). "The Predictive Validity of Alternative Approaches to Evaluating Quality of a Festival." *Journal of Travel Research*, 34: 11-24.

Crompton, J. L., and K. J. MacKay (1989). "Users' Perceptions of the Relative Importance of Service Quality Dimensions in Selected Public Recreation Programs." *Leisure Sciences*, 11: 367-75.

Crompton, J. L., K. J. MacKay, and D. R. Fesenmaier (1991). "Identifying Dimensions of Service Quality in Public Recreation." *Journal of Park and Recreation Administration*, 9 (3): 1-13.

Crompton, J. L., and S. Tian-Cole (2001). "An Analysis of 13 Tourism Surveys: Are Three Waves of Data Collection Necessary?" *Journal of Travel Research*, 39: 356-68.

Cronin J. J. Jr., M. K. Brady, and G. T. M. Hult (2000). "Assessing the Effects of Quality, Value, and Customer Satisfaction on Consumer Behavioral Intentions in Service Environments." *Journal of Retailing*, 76 (2): 193-216.

Cronin J. J. Jr. and S. A. Taylor (1992). "Measuring Service Quality: A Reexamination and Extension." *Journal of Marketing*, 56 (3): 55-68.

—— (1994). "SERVPERF Versus SERVQUAL: Reconciling Performance-Based and Perceptions-Minus-Expectations Measurement of Service Quality." *Journal of Marketing*, 58 (1): 125-31.

Crosby, L. A., and N. Stephen (1987). "Effects of Relationship Marketing on Satisfaction, Retention, and Prices in the Life Insurance Industry." *Journal of Marketing Research*, 24 (November): 404-11.

Crosby, L. A., and J. R. Taylor (1983). "Psychological Commitment and Its Effects on Post-Decision Evaluation and Preference Stability among Voters." *Journal of Consumer Research*, 9 (March): 413-31.

Cruise Line International Association (CLIA) (2003). "Cruise Industry Overview-Marketing Edition 2003." Retrieved July 1, 2004 from http://www.cruising.org/press/overview/ind_overview.cfm#execsum.

——— (2005). "CLIA's 2004 Cruise Market Profile: Report of Findings." Retrieved April 8, 2006 from http://www.cruising.org/press/research/2004%20market%20Profile%20Presentation_files/frame.htm.

——— (2006a). "About CLIA." Retrieved April 8, 2006 from <http://www.cruising.org/about.cfm>.

——— (2006b). "Cruise Lines & Ship Profiles." Retrieved March 11, 2006 from <http://www.cruising.org/CruiseLines/index.cfm>.

Cunningham, R. M. (1956). "Brand Loyalty - What Where How Much?" *Harvard Business Review*, 34: 116-28.

Datta, D. K., J. P. Guthrie, and P. M. Wright (2005). "Human Resource Management and Labor Productivity: Does Industry Matter?" *Academy of Management Journal*, 48 (1): 135-45.

Davidow, M. (2003). "Organizational Responses to Customer Complaints: What Works and What Doesn't." *Journal of Service Research*, 5(3): 225-250.

Davis, D., S. Banks, A. Birtles, P. Valentine, and M. Cuthill (1997). "Whale Sharks in Ningaloo Marine Park: Managing Tourism in an Australian Marine Protected Area." *Tourism Management*, 18 (5): 259-71.

Day, G. S. (1969). "A Two Dimensional Concept of Brand Loyalty." *Journal of Advertising Research*, 9: 29-35.

——— (2000). "Managing Market Relationships." *Journal of the Academy of Marketing Science*, 28 (Winter): 24-30.

Dekimpe, M. G., J.-B. E. M. Steenkamp, M. Mellens, and P. V. Abeele (1997). "Decline and Variability in Brand Loyalty." *International Journal of Research in Marketing*, 14 (5): 405-20.

Delgado-Ballester, E., and J. L. Munuera- Aleman (2001). "Brand Trust in the Context of Consumer Loyalty." *European Journal of Marketing*, 35 (11/12): 1238-58.

- Dennis, J. M. (2001). "Are Internet Panels Creating Professional Respondents?" *Marketing Research*, 13 (2): 34-38.
- Deutskens, E. C., A. de Jong, K. de Ruyter, and M. G. M. Wetzels (2006a). "Comparing the Generalizability of Online and Mail Surveys in Cross-National Service Quality Research." *Marketing Letters*, forthcoming.
- Deutskens, E. C., K. de Ruyter, and M. G. M. Wetzels (2006b). "An Assessment of Equivalence between Online and Mail Surveys in Service Research." *Journal of Service Research*, 8 (4): 1-11.
- DeVellis, R. F. (2003). *Scale Development: Theory and Applications*. (2nd ed.). Thousand Oaks, CA: Sage Publications.
- Dick, A. S., and K. Basu (1994). "Customer Loyalty: Toward an Integrated Framework." *Journal of the Academy of Marketing Science*, 22 (2): 99-113.
- Dierickx, I., and K. Cool (1989). "Asset Stock Accumulation and Sustainability of Competitive Advantage." *Management Science*, 35 (Dec.): 1504-11.
- Dillman, D. A. (1978). *Mail and Telephone Surveys: The Total Design Method*. New York: John Wiley.
- Ditton, R. B., and S. G. Sutton (2004). "Substitutability in Recreational Fishing." *Human Dimensions of Wildlife*, 9: 87-102.
- Dodds, W. B., K. B. Monroe, and D. Grewal (1991). "The Effects of Price, Brand and Store Information on Buyers' Product Evaluations." *Journal of Marketing Research*, 28: 307-19.
- Dorsch, M. J., and L. Carlson (1996). "A Transaction Approach to Understanding and Managing Customer Equity." *Journal of Business Research*, 35 (3): 253-64.
- Duffy, B., K. Smith, G. Terhanian, and J. Bremer (2005). "Comparing Data from Online and Face-to-Face Surveys." *International Journal of Market Research*, 47 (6): 615-39.
- Duman, T. (2002). *A Model of Perceived Value for Leisure Travel Products*. Unpublished Ph.D. Dissertation, The Pennsylvania State University.
- Duman, T., and A. S. Mattila (2005). "The Role of Affective Factors on Perceived Cruise Vacation Value." *Tourism Management*, 26 (3): 311-23.
- Dwyer, F. R., P. H. Schurr, and S. Oh (1987). "Developing Buyer-Seller Relationships." *Journal of Marketing*, 51 (April): 11-27.

- Eagly, A. H., and S. Chaiken (1993). *The Psychology of Attitudes*. Orlando, FL: Harcourt Brace Jovanovich.
- Ehrenberg, A. S. C. (1988). *Repeat Buying: Theory and Application* London: Charles Griffin and Co.
- Engel, J. F., M. R. Warshaw, and T. C. Kinnear (1994). *Promotional Strategy: Managing the Marketing Communications Process* (8th ed.). Burr Ridge, IL: Irwin.
- Eriksson, K., and A. L. Vaghult (2000). "Customer Retention, Purchasing Behavior and Relationship Substance in Professional Services." *Industrial Marketing Management*, 29: 363-72.
- Farrell, D., and C. E. Rusbult (1981). "Exchange Variables as Predictors of Job Satisfaction, Job Commitment, and Turnover: The Impact of Rewards, Costs, Alternatives, and Investments." *Organizational Behavior and Human Performance*, 28: 78-95.
- Festinger, L. (1957). *A Theory of Cognitive Dissonance*. Evanston, IL: Row-Peterson.
- Filian, F. L. (1976). "Exploring and Correcting for Non-Response Bias Using Follow-Ups of Non-Respondents." *Pacific Sociological Review*, 19 (3): 401-08.
- Fishbein, M., and I. Ajzen (1975). *Belief, Attitude, Intention and Behavior: An Introduction to Theory and Research*. Reading, MA: Addison-Wesley.
- Foa, E. B., and U. G. Foa (1980). "Resource Theory: Interpersonal Behavior as Exchange." In *Social Exchange: Advances in Theory and Research*. edited by K. J. Gergen and M. S. Greenberg and R. H. Willis. New York: Plenum. pp. 77-101.
- Foa, U. G., and E. B. Foa (1974). *Societal Structures of the Mind*. Springfield, IL: Charles C Thomas.
- Fornell, C. (1992). "A National Customer Satisfaction Barometer: The Swedish Experience." *Journal of Marketing*, 56 (1): 6-21.
- Fornell, C., and D. Larcker (1981). "Evaluating Structural Equation Models with Unobservable Variables and Measurement Error." *Journal of Marketing Research*, 18, 39-50.
- Fournier, S. (1998). "Consumers and Their Brands: Developing Relationship Theory in Consumer Research." *Journal of Consumer Research*, 24 (March): 343-73.

- Fournier, S., and J. L. Yao (1997). "Reviving Brand Loyalty: A Reconceptualization within the Framework of Consumer-Brand Relationships " *International Journal of Research in Marketing*, 14 (5): 451-72.
- Frank, R. E. (1962). "Brand Choice as Probability Process." *Journal of Business*, 35: 43-56).
- Frank, R. H. and P. J. Cook (1995). *The Winner-Take-All Society*. New York: Free Press.
- Funk, D. C. (1998). *Fan Loyalty: The Structure and Stability of an Individual's Loyalty toward an Athletic Team*. Unpublished Ph.D. Dissertation, The Ohio State University.
- Fyall, A., C. Callod, and B. Edwards (2003). "Relationship Marketing - the Challenge for Destinations." *Annals of Tourism Research*, 30 (3): 644-59.
- Ganesh, J., M. J. Arnold, and K. E. Reynolds (2000). "Understanding the Customer Base of Service Providers: An Examination of the Differences between Switchers and Stayers." *Journal of Marketing*, 64 (3): 65-87.
- Garbarino, E., and M. S. Johnson (1999). "The Different Roles of Satisfaction, Trust, and Commitment in Customer Relationships." *Journal of Marketing*, 63 (April): 70-87.
- Gardner, D. G., L. L. Cummings, R. B. Dunham, and J. L. Pierce (1998). "Single-Item Versus Multiple Item Measurement Scales: An Empirical Comparison." *Educational and Psychological Measurement*, 58 (6): 898-915.
- Gay, L. R., and P. Airasian (2000). *Educational Research: Competencies for Analysis and Application*. (6th ed.). Upper Saddle River, NJ: Prentice Hall.
- Gilliland, D. I., and D. C. Bello (2002). "Two Sides to Attitudinal Commitment: The Effect of Calculative and Loyalty Commitment on Enforcement Mechanisms in Distribution Channels." *Journal of the Academy of Marketing Science*, 30 (1): 24-43.
- Gladden, J. M., and D. C. Funk (2002). "Developing and Understanding of Brand Association in Team Sport: Empirical Evidence from Professional Sport Consumers." *Journal of Sport Management Science*, 16: 54-81.
- Gómez, M. I., E. W. McLaughlin, and D. R. Wittink (2004). "Customer Satisfaction and Retail Sales Performance: An Empirical Investigation." *Journal of Retailing*, 80 (4): 265-78.
- Green, P. E., and V. R. Rao (1970). "Rating Scales and Information Recovery - How Many Scales and Response Categories to Use?" *Journal of Marketing*, 34 (July): 33-39.

- Gremler, D. D. (1995). *The Effect of Satisfaction, Switching Costs, and Interpersonal Bonds on Service Loyalty*. Unpublished Ph.D. Dissertation, Arizona State University.
- Grewal, D., K. B. Monroe, and R. Krishnan (1998). "The Effects of Price-Comparison Advertising on Buyers' Perceptions of Acquisition Value, Transaction Value and Behavioral Intentions." *Journal of Marketing*, 62: 46-59.
- Griffin, J. (1995). *Customer Loyalty: How to Earn It, How to Keep It*. San Francisco: Jossey-Bass.
- Grisaffe, D. P., and A. Kumar (1998). "Antecedents and Consequences of Customer Value: Testing an Expanded Framework." in MSI Working Paper # 98-107. Cambridge, MA: Marketing Science Institute.
- Gronroos, C. (1994). "From Marketing Mix to Relationship Marketing: Towards a Paradigm Shift in Marketing." *Asia-Australia Marketing Journal*, 2 (1): 9-29.
- Gruen, T., J. O. Summers, and F. Acito. (2000). "Relationship Marketing Activities, Commitment, and Membership Behaviors in Professional Associations." *Journal of Marketing*, 64 (July): 34-49.
- Guest, L. (1944). "A Study of Brand Loyalty." *Journal of Applied Psychology*, 28: 16-27.
- Gummesson, E. (2002). "Relationship Marketing and a New Economy: It's Time for Deprogramming." *Journal of Services Marketing*, 16 (7): 585-89.
- Gustafsson, A., M. Johnson, and I. Roos (2005). "The Effects of Customer Satisfaction, Relationship Commitment Dimensions, and Triggers on Customer Retention." *Journal of Marketing*, 69 (4): 210-18.
- Hair, J. F., Jr., R. E. Anderson, R. L. Tatham, and W. C. Black(1998). *Multivariate Data Analysis* (5th ed.). Upper Saddle River, NJ: Prentice Hall.
- Hansen, T. (2005). "Understanding Consumer Online Grocery Behavior: Results from a Swedish Study." *Journal of Euromarketing*, 14 (3): 31-58.
- Harris, L. C., and M. M. H. Goode (2004). "The Four Levels of Loyalty and the Pivotal Role of Trust: A Study of Online Service Dynamics." *Journal of Retailing*, 80: 139-58.
- Hartline, M. D., and O. C. Ferrell (1996). "The Management of Customer-Contact Service Employees." *Journal of Marketing*, 60 (October): 52-70.

- Hatcher, L. (1994). *A Step-by-Step Approach to Using the SAS System for Factor Analysis and Structural Equation Modeling*. Cary, NC: SAS Institute Inc.
- Hauser, J. R., D. I. Simester, and B. Wernerfelt (1994). "Customer Satisfaction Incentives." *Marketing Science*, 13: 327-50.
- Havitz, M., and F. Dimanche (1997). "Leisure Involvement Revisited: Conceptual Conundrums and Measurement Advances." *Journal of Leisure Research*, 29 (3): 245-78.
- Heide, J. B., and A. M. Weiss. (1995). "Vendor Consideration and Switching Behavior for Buyers in High-Technology Markets." *Journal of Marketing*, 59 (July): 30-43.
- Heiens, R. A., and L. P. Pleshko (1996). "Categories of Customer Loyalty: An Application of the Customer Loyalty Classification Framework in the Fast Food Hamburger Market." *Journal of Food Products Marketing*, 3 (1): 1-12.
- Hellier, P. K., G. M. Geursen, R. A. Carr, and J. A. Rickard (2003). "Customer Repurchase Intention: A General Structural Equation Model." *European Journal of Marketing*, 37 (11/12): 1762-800.
- Hennig-Thurau, T., K. P. Gwinner, and D. D. Gremler (2002). "Understanding Relationship Marketing Outcomes: An Integration of Relational Benefits and Relationship Quality " *Journal of Service Research*, 4 (3): 230-47.
- Heskett, J. L., E. W. Sasser, and L. A. Schlesinger (1997). *The Service Profit Chain*. New York: Free Press.
- Holbrook, M. B. (1994). "The Nature of Customer Value: An Axiology of Services in the Consumption Experience." In *Service Quality: New Directions in Theory and Practice*,. edited by Roland Rust and R. Oliver. Thousand Oaks, CA: Sage Publications, pp. 21-71.
- Homburg, C., and A. Giering (2001). "Personal Characteristics as Moderators of the Relationship between Customer Satisfaction and Loyalty—An Empirical Analysis." *Psychology & Marketing*, 18 (1): 43-66.
- Hong, S. (2001). *A Study of the Developmental Process of Participant Loyalty in Leisure*. Unpublished Ph.D. Dissertation, University of Connecticut.
- Howart, G., J. Absher, G. Crilley, and I. Milne (1996). "Measuring Customer Service Quality in Sports and Leisure Centers." *Managing Leisure*, 1: 77-89.
- Howat, G., G. Crilley, and L. Milne (1995). "Measuring Customer Service Quality in Recreation and Parks." *Australian Parks & Recreation* (Summer): 37-43.

Hoyer, W. D. (1984). "An Examination of Consumer Decision Making for a Common Repeat Purchase Product." *Journal of Consumer Research*, 11: 822-29.

Hoyle, R. H., and A. T. Panter (1995). "Writing About Structural Equation Models." In *Structural Equation Modeling*. edited by R. H. Hoyle. Thousand Oaks, CA: Sage, pp. 158-176.

Hu, L. T., and P. M. Bentler (1995). "Evaluating Model Fit." In *Structural Equation Modeling: Concepts, Issues, and Applications*. edited by R. H. Hoyle. Thousand Oaks, CA: Sage, pp. 76-99.

Hunt, S. D. (2002). *Foundations of Marketing Theory: Toward a General Theory of Marketing*. Armonk, NY: Sharpe.

Hwang, Y. H., and D. R. Fesenmaier (2004). "Coverage Error Embedded in Self-Selected Internet-Based Samples: A Case Study of Northern Indiana." *Journal of Travel Research*, 42 (3): 297-304.

Iacobucci, D., and A. Ostrom (1996). "Commercial and Interpersonal Relationships: Using the Structure of Interpersonal Relationships to Understand Individual-to-Individual, Individual-to-Firm, and Firm-to-Firm Relationships in Commerce." *International Journal of Research in Marketing*, 13: 53-72.

Iso-Ahola, S. E. (1986). "A Theory of Substitutability of Leisure Behavior." *Leisure Sciences*, 8 (4): 367-89.

Iwasaki, Y., and M. Havitz (1998). "A Path Analytic Model of the Relationships between Involvement, Psychological Commitment, and Loyalty." *Journal of Leisure Research*, 30 (2): 256-80.

——— (2004). "Examining Relationships between Leisure Involvement, Psychological Commitment and Loyalty to a Recreation Agency." *Journal of Leisure Research*, 36 (1): 45-72.

Iyer, R., and J. A. Muncy (2005). "The Role of Brand Parity in Developing Loyal Customers." *Journal of Advertising Research*, 45: 222-28

Jackson, L. A., C. N. Hodge, D. A. Gerard, J. M. Ingram, K. S. Ervin, and L. A. Sheppard (1996). "Cognition, Affect, and Behavior in the Prediction of Group Attitudes." *Personality and Social Psychology Bulletin*, 22 (3): 306-16.

Jacoby, J. (1971). "A Model of Multi-Brand Loyalty." *Journal of Advertising Research*, 11 (June): 25-31.

Jacoby, J., and R. Chestnut (1978). *Brand Loyalty Measurement and Management*. New York: Wiley.

Jacoby, J., and D. B. Kyner (1973). "Brand Loyalty vs Repeat Purchasing Behavior." *Journal of Marketing Research*, 10 (February): 1-9.

Jain, A., C. Pinson, and B. Ratchford (1982). *Marketing Research: Applications and Problems*. New York: John Wiley.

Jain, A. K., C. Pinson, and N. K. Malhotra (1987). "Customer Loyalty as a Construct in the Marketing of Banking Services." *International Journal of Bank Marketing*, 5: 49-72.

Jarvis, L. P., and J. B. Wilcox (1976). "Repeat Purchasing Behavior and Attitudinal Brand Loyalty: Additional Evidence." In *Marketing: 1776-1976 and Beyond*. edited by K. L. Bernardt. Chicago, IL: American Marketing Association, pp. 151-152.

Javalgi, R. G. C. R., M. (1997). "Service Loyalty: Implications for Service Providers." *The Journal of Services Marketing*, 11 (3): 165-79.

Jayanti, R. K., and A. Ghosh (1996). "Service Value Determination: An Integrative Perspective." *Journal of Hospitality and Leisure Marketing*, 34 (4): 5-25.

Johnson, M. D. (1984). "Consumer Choice Strategies for Comparing Noncomparable Alternatives " *Journal of Consumer Research*, 11 (3): 741-53.

——— (1988). "Comparability and Hierarchical Processing in Multialternative Choice " *Journal of Consumer Research*, 15 (3): 303-14.

——— (1998). *Customer Orientation and Market Action*. Upper Saddle River, NJ: Prentice Hall.

Johnson, M. P. (1973). "Commitment: A Conceptual Structure and Empirical Application." *The Sociological Quarterly*, 14 (Summer): 395-406.

——— (1982). "Social and Cognitive Features of the Dissolution of Commitment to Relationships." In *Personal Relationships 4: Discussing Personal Relations*. edited by S. Duck. London: Academic Press, pp. 51-73.

——— (1991a). "Commitment to Personal Relationships." *Advances in Personal Relationships*, 3: 117-43.

——— (1991b). "Reply to Levinger and Rusbult." *Advances in Personal Relationships*, 3: 171-76.

- Johnson, M. P., J. P. Caughlin, and T. L. Huston (1999). "The Tripartite Nature of Marital Commitment: Personal, Model, and Structural Reasons to Stay Married." *Journal of Marriage and the Family*, 61 (Feb): 160-77.
- Jones, M. A., D. L. Mothersbaugh, and S. E. Beatty (2000). "Switching Barriers and Repurchasing Intentions in Services." *Journal of Retailing*, 76 (2): 259-74.
- Jones, T. (2003). *Personal, Professional, and Service Company Commitments in Service Relationships*. Unpublished Ph.D. Dissertation, Queen's University.
- Jones, T., and E. W. Sasser (1995). "Why Satisfied Customers Defect?" *Harvard Business Review*, 73 (6): 88-99.
- Jones, T., and S. F. Taylor (2004). "The Nature and Dimensionality of the Commitment Construct: Does to Whom or What We Are Committed Matter?" *In Proceedings of 2004 Academy of Marketing Science Conference*. Vancouver, British Columbia, Canada: Academy of Marketing Science. Retrieved Sept. 14, 2005 from <http://www.nipissingu.ca/faculty/timj/research.htm>
- (In press). "The Conceptual Domain of Service Loyalty: How Many Dimensions?" *Journal of Services Marketing*. Retrieved Sept. 14, 2005 from <http://www.nipissingu.ca/faculty/timj/research.htm>
- Jöreskog, K. G. (1993). "Testing Structural Equation Models." In *Testing structural equation models*, edited by K. A. Bollen and J. S. Long. Newsbury Park, CA: Sage, pp. 294-316
- Jöreskog, K. G., and D. Sörbom (1996). *LISREL 8 User's Reference Guide*. Chicago: Scientific Software International.
- Kahn, B. E., M. U. Kalwani, and D. G. Morrison (1986). "Measuring Variety Seeking and Reinforcement Behaviors Using Panel Data." *Journal of Marketing Research*, 23: 89-100.
- Kaltenborn, B. P. (1997). "Nature of Place Attachment: A Study among Recreation Homeowners in Southern Norway." *Leisure Sciences*, 19: 175-89.
- Kanter, R. M. (1968). "Commitment and Social Organization: A Study of Commitment Mechanisms in Utopian Communities." *American Sociological Review*, 33 (4): 499-517.
- Kelley, H. H. (1979). *Personal Relationships: Their Structures and Processes*. Hillsdale, NJ: Lawrence Erlbaum Publishers.

—— (1983). "The Situational Origins of Human Tendencies: A Further Reason for the Formal Analysis of Structures." *Personality and Social Psychology Bulletin*, 9: 8-30.

Kelley, H. H., and J. W. Thibaut (1978). *Interpersonal Relations: A Theory of Interdependence*. New York.

Kenny, D. A. (1979). *Correlation and Causality*. New York: John Wiley & Sons.

Kenny, D. A., D. A. Kashy, and N. Bolger (1998). Data Analysis in Social Psychology. In *Handbook of Social Psychology* (4th ed., Vol. 1), edited by D. Gilbert, S. T. Fiske and G. Lindzey. New York: McGraw-Hill, pp. 233-265.

Kim, S. S., D. Scott, and J. L. Crompton (1997). "An Exploration of the Relationships among Social Psychological Involvement, Behavioral Involvement, Commitment, and Future Intentions in the Context of Birdwatching." *Journal of Leisure Research*, 29 (3): 320-41.

Klemperer, P. (1995). "Competition When Consumers Have Switching Costs: An Overview with Applications to Industrial Organization Macroeconomics and International Trade." *Review of Economics Studies*, 62 (October): 515-39.

Kline, R. B. (2005). *Principles and Practice of Structural Equation Modeling* (2nd ed.). New York: Guilford.

Knox, S., and D. Walker (2001). "Measuring and Managing Brand Loyalty." *Journal of Strategic Marketing*, 9 (2): 111-29.

Knutson, B., P. Stevens, and M. Patton (1995). "DINESERV: Measuring Service Quality in Quick Service, Casual/Theme and Fine Dining Restaurants." *Journal of Hospitality and Leisure Marketing*, 3 (2): 35-44.

Kotler, P. (1984). *Marketing Management: Analysis, Planning, and Control*. (5th ed.). Englewood Cliffs, NJ: Prentice Hall.

Kotler, P., J. Bowen, and J. Makens (1996). *Marketing for Hospitality and Tourism*. Upper Saddle River, NJ: Prentice Hall.

Kozak, M., T. Huan, and J. Beaman (2002). "A Systematic Approach to Non-Repeat and Repeat Travel: With Measurement and Destination Loyalty Concept Implications." *Journal of Travel & Tourism Marketing*, 12 (4): 19-38.

Kraus, S. J. (1995). "Attitudes and the Prediction of Behavior: A Meta-Analysis of the Empirical Literature." *Personality and Social Psychology Bulletin*, 21 (1): 58-75.

- Krejcie, R. V., and D. W. Morgan (1970). "Determining Sample Size for Research Activities." *Educational and Psychological Measurement*, 30 (3).
- Kyle, G., J. Absher, W. Norman, W. Hammitt, and L. Jodice (2006, In press). "A Modified Involvement Scale." *Leisure Studies*
- Kyle, G., A. R. Graefe, R. Manning, and J. Bacon (2004). "Predictors of Behavioral Loyalty among Hikers along the Appalachian Trail." *Leisure Sciences*, 26: 99-118.
- Kyle, G., and A. J. Mowen (2005). "An Examination of the Leisure Involvement—Agency Commitment Relationship." *Journal of Leisure Research*, 37 (3): 342-263.
- Lam, S. Y., V. Shankar, M. K. Erramilli, and B. Murthy (2004). "Customer Value, Satisfaction, Loyalty, and Switching Costs: An Illustration from a Business-to-Business Service Context." *Journal of the Academy of Marketing Science*, 32 (3): 293-311.
- LaTour, S. A., and N. C. Peat (1979). "Conceptual and Methodological Issues in Consumer Satisfaction Research." In *Advances in Consumer Research*. edited by William F. Wilkie, Vol. 6. Ann Arbor, MI: Association for Consumer Research. pp. 431-437.
- (1980). "The Role of Situationally-Produced Expectations, Others' Experiences, and Prior Experience in Determining Consumer Satisfaction." In *Advances in Consumer Research*. edited by Jerry C. Olson, Vol. 7. Ann Arbor, MI: Association for Consumer Research, pp. 588-592.
- Le, B., and C. R. Agnew (2003). "Commitment and Its Theorized Determinants: A Meta-Analysis of the Investment Model." *Personal Relationships*, 10: 37-57.
- LeBlanc, G. (1992). "Factors Affecting Customer Evaluation of Service Quality in Travel Agencies: An Investigation of Customer Perceptions." *Journal of Travel Research*, 30 (4): 10-16.
- Lee, J. (2003). *Examining the Antecedents of Loyalty in a Forest Setting: Relationships among Service Quality, Satisfaction, Activity Involvement, Place Attachment, and Destination Loyalty*. Unpublished Ph.D. Dissertation, The Pennsylvania State University.
- Lee, J., J. Lee, and L. Feick (2001). "The Impact of Switching Costs on the Customer Satisfaction-Loyalty Link: Mobile Phone Service in France." *Journal of Services Marketing*, 15 (1): 35-48.

Lee, J. H., A. R. Graefe, and R. C. Burns (2004). "Service Quality, Satisfaction, and Behavioral Intention among Forest Visitors." *Journal of Travel & Tourism Marketing*, 17 (Special issue: Consumer Psychology of Travel/Tourism Behavior): 73-82.

Lee, M., and L. F. Cunningham (2001). "A Cost/Benefit Approach to Understanding Service Loyalty " *Journal of Services Marketing*, 15 (2): 113-30.

Lessig, V. P. (1973). "Consumer Store Image and Store Loyalty." *Journal of Marketing Research*, 38 (October): 72-74.

Levinger, G. (1965). "Marital Cohesiveness and Dissolution: An Integrative Review." *Journal of Marriage and the Family*, 27: 19-29.

—— (1979a). "A Social Exchange View on the Dissolution of Pair Relationships." In *Social Exchanges in Developing Relationships*. edited by R. L. Burgess and T. L. Huston. New York: Academic Press, pp. 169-193.

—— (1979b). "A Social Psychological Perspective on Marital Dissolution." In *Divorce and Separation: Context, Causes, and Consequences*. edited by G. Levinger and O. C. Moles. New York: Basic Books, pp. 37-60.

—— (1991). "Commitment vs. Cohesiveness: Two Complementary Perspectives." *Advances in Personal Relationships*, 3: 145-50.

Levitt, T. (1960). "Marketing Myopia." *Harvard Business Review*, 38 (July-August): 138-49.

Lewin, K. (1951). *Field Theory in Social Science*. New York: Harper.

Li, X., and H. Vogelsong (2003). "An Examination of Satisfaction Variables and Indicators at a First-Time Festival." in *Proceedings of 2003 Northeastern Recreation Research Symposium*. Lake George, NY: USDA Forest Service. pp. 440-446.

Lin, C. H., P. J. Sher, and H. Y. Shih (2005). "Past Progress and Future Directions in Conceptualizing Customer Perceived Value." *International Journal of Service Industry Management*, 16 (3-4): 318-38.

Lipstein, B. (1959). "The Dynamics of Brand Loyalty and Brand Switching." in *Proceedings of the Fifth Annual Conference of the Advertising Research Foundation*. New York: Advertising Research Foundation, pp. 101-108.

Loehlin, J. C. (1992). *Latent Variable Models*. Hillsdale, NJ: Lawrence Erlbaum Publishers.

Lois, P., J. Wang, A. Wall, and T. Ruxton (2004). "Formal Safety Assessment of Cruise Ships." *Tourism Management*, 25 (1): 93-109.

Loken, B., and D. R. John (1993). "Diluting Brand Beliefs: When Do Brand Extensions Have Negative Impact?" *Journal of Marketing*, 57: 71-84.

Low, S. M., and I. Altman (1992). "Place Attachment: A Conceptual Inquiry." In *Place Attachment*. edited by I. Altman and S. M. Low. New York: Plenum Press. pp. 1-12.

Lutz, R. J., and P. R. Winn (1974). "Developing a Bayesian Measure of Brand Loyalty: A Preliminary Report." In *Proceedings of the American Marketing Association*. Chicago, IL: American Marketing Association, pp. 104-108.

MacCallum, R. C., and J. T. Austin (2000). "Applications of Structural Equation Modeling in Psychological Research." *Annual Review of Psychology*, 51: 201-26.

MacCallum, R. C., M. W. Browne, and H. M. Sugawara (1996). "Power Analysis and Determination of Sample Size for Covariance Structure Modeling." *Psychological Methods*, 1 (2): 130-49.

Macintosh, G., and L. S. Lockshin (1997). "Retail Relationships and Store Loyalty: A Multi-Level Perspective." *International Journal of Research in Marketing*, 14 (5): 487-97.

—— (1998). "Retail Relationships and Store Loyalty; a Multi-Level Perspective." *International Journal of Research in Marketing*, 14: 487-98.

MacKay, K. J., and J. L. Crompton (1988). "A Conceptual Model of Consumer Evaluation of Recreation Service Quality." *Leisure Studies*, 7 (1): 41-49.

Makadok, R. (2001). "Toward a Synthesis of the Resource-Based and Dynamic-Capability Views of Rent Creation." *Strategic Management Journal*, 22 (5): 387-401.

Manning, R. E. (1999). *Studies in Outdoor Recreation*. Corvallis, OR: Oregon State University Press.

Mardia, K. V. (1970). "Measures of Multivariate Skewness and Kurtosis with Applications." *Biometrika*, 57: 519-30.

Marsh, H. W., and D. Hocevar (1985). "Application of Confirmatory Factor Analysis to the Study of Self-Concept: First- and Higher Order Factor Models and Their Invariance across Groups " *Psychological Bulletin*, 97 (3): 562-82.

- Mathwick, C., N. Malhotra, and E. Rigdon (2001). "Experiential Value: Conceptualization, Measurement and Application in the Catalog and Internet Shopping Environment." *Journal of Retailing*, 77 (1): 39-56.
- Maxim, P. S. (1999). *Quantitative Research Methods in the Social Sciences*. New York: Oxford University Press.
- McDonald, R. P., & Ringo Ho, M.-H. (2002). "Principles and Practice in Reporting Structural Equation Analyses." *Psychological Methods*, 7(1): 64-82.
- McGregor, J. (2006). "Would You Recommend Us?" *Business Week*, 3969: 94-95.
- McIntyre, N. (1989). "The Personal Meaning of Participation: Enduring Involvement." *Journal of Leisure Research*, 21 (2): 167-79.
- Mcmullan, R., and A. Gilmore (2003). "The Conceptual Development of Customer Loyalty Measurement: A Proposed Scale." *Journal of Targeting, Measurement and Analysis of Marketing*, 11 (3): 230-43.
- McNamara, J. F. (1992). "Sample Sizes for School Preference Survey." *International Journal of Education Reform*, 1 (1): 83-90.
- McWilliams, E. G., and N. Nadkarni. (2005). "Differences in Reported Travel Behavior for an Online Panel Versus Mail Panel. " *e-Review of Tourism Research (eRTR)*, 5(3). Retrieved March 11, 2006 from <http://ertr.tamu.edu>.
- Meyer, J. P., and N. J. Allen (1997). *Commitment in the Workplace: Theory, Research, and Application*. Thousand Oaks, CA: Sage Publications, Inc.
- Meyer, J. P., N. J. Allen, and C. A. Smith (1993). "Commitment to Organizations and Occupations: Extension and Test of a Three-Component Model." *Journal of Applied Psychology*, 78 (4): 538-51.
- Meyer, J. P., D. J. Stanley, L. Herscovitch, and L. Topolnytsky (2002). "Affective, Continuance, and Normative Commitment to the Organization: A Meta-Analysis of Antecedents, Correlates, and Consequences." *Journal of Vocational Behavior*, 61 (1): 20-52.
- Micerri, T. (1989). "The Unicorn, the Normal Curve, and Other Improbable Creatures." *Psychological Bulletin*, 105: 156-66.
- Miller, A. R., and W. F. Grazer (2003). " Complaint Behavior as a Factor in Cruise Line Losses: An Analysis of Brand Loyalty." *Journal of Travel & Tourism Marketing*, 15 (1): 77-91.

- Mittal, B., and W. M. Lassar (1998). "Why Do Customers Switch? The Dynamics of Satisfaction Versus Loyalty." *The Journal of Services Marketing*, 12 (3): 177-94.
- Mittal, V., and W. A. Kamakura (2001). "Satisfaction, Repurchase Intent, and Repurchase Behavior: Investigating the Moderating Effect of Customer Characteristics " *Journal of Marketing Research*, 38 (1): 131-42.
- Mittal, V., P. Kumar, and M. Tsiros (1999). "Attribute-Level Performance Satisfaction, and Behavioral Intentions over Time: A Consumption System Approach." *Journal of Marketing*, 63 (April): 86-101.
- Mittal, V., W. T. Ross Jr., and P. M. Baldasare (1998). "The Asymmetric Impact of Negative and Positive Attribute Level Performance on Overall Satisfaction and Repurchase Intentions." *Journal of Marketing*, 62 (January): 33-47.
- Morais, D. B. (2000). *Reconceptualization of Loyalty under a Resource Investment Perspective: A Study of Group Leaders in the Leisure Service Industry*. Unpublished Ph.D. Dissertation, Clemson University.
- Morais, D. B., S. J. Backman, and M. J. Dorsch (2003). "Toward the Operationalization of Resource Investments Made between Customers and Providers of a Tourism Service." *Journal of Travel Research*, 41 (4): 362-74.
- Morais, D. B., M. J. Dorsch, and S. J. Backman (2004). "Can Tourism Providers Buy Their Customers' Loyalty? Examining the Influence of Customer-Provider Investments on Loyalty." *Journal of Travel Research*, 42 (3): 235-43.
- (2005). "Building Loyal Relationships between Customers and Providers: A Focus on Resource Investments." *Journal of Travel & Tourism Marketing*, 18 (1): 49-57.
- Morgan, R. M., and S. D. Hunt (1994). "The Commitment-Trust Theory of Relationship Marketing." *Journal of Marketing*, 58 (3): 20-38.
- Mowday, R. T., L. W. Porter, and R. M. Steers (1982). *Employee-Organization Linkages: The Psychology of Commitment, Absenteeism, and Turnover*. New York: Academic Press.
- Mowday, R. T., R. M. Steers, and L. W. Porter (1979). "The Measurement of Organizational Commitment." *Journal of Vocational Behavior*, 14: 224-47.
- Muncy, J. A. (1996). "Measuring Perceived Brand Parity." *Advances in Consumer Research*, 23 (1): 411-17.

- Muncy, J. A. and R. P. Fisk. (1987). "Cognitive Relativism and the Practice of Marketing Science." *Journal of Marketing*, 51(1): 20-33.
- Muncy, J. D. (1983). *An Investigation of the Two-Dimensional Conceptualization of Brand Loyalty*. Unpublished Ph.D. Dissertation, Texas Tech University.
- Neal, W. (2000). "When Measuring Loyalty Satisfactorily, Don't Measure Cs." *Marketing News*, 34 (13): 19.
- Netemeyer, R. G., W. O. Bearden, and S. Sharma (2003). *Scaling Procedures: Issues and Applications*. Thousand Oaks, CA: Sage Publications.
- Neuman, W. L. (1997). *Social Research Methods - Qualitative and Quantitative Approaches*. Boston: Allyn & Bacon.
- Nielson, C. C. (1996). "An Empirical Examination of Switching Cost Investments in Business-to-Business Marketing Relationships." *The Journal of Business and Industrial Marketing Management*, 11: 38-60.
- Niininen, O., and M. Riley (2003). "Towards the Conceptualization of Tourism Destination Loyalty." *Tourism Analysis*, 8 (2): 243-46.
- Nijssen, E., J. Singh, D. Sirdeshmukh, and H. Holzmüller (2003). "Investigating Industry Context Effects in Consumer-Firm Relationships: Preliminary Results from a Dispositional Approach." *Journal of the Academy of Marketing Science*, 31 (1): 46-60.
- Nunnally, J., and I. Bernstein (1994). *Psychometric Theory*. (3rd ed.). New York: McGraw-Hill.
- O'Connor, K. M., J. A. Arnold, and E. R. Burris (2005). "Negotiators' Bargaining Histories and Their Effects on Future Negotiation Performance." *Journal of Applied Psychology*, 90: 350-62.
- O'Mally, L. (1998). "Can Loyalty Schemes Really Build Loyalty?" *Marketing Intelligence and Planning*, 16 (1): 47-65.
- Oh, H. (1999). "Service Quality, Customer Satisfaction, and Customer Value: A Holistic Perspective." *Hospitality Management*, 18: 67-82.
- Oliva, T. A., R. L. Oliver, and I. C. MacMillan (1992). "A Catastrophe Model for Developing Service Satisfaction Strategies." *Journal of Marketing*, 56 (July): 83-95.

- Oliver, N. (1990). "Rewards, Investments, Alternatives and Organizational Commitment: Empirical and Evidence and Theoretical Development." *Journal of Occupational Psychology*, 63: 19-31.
- Oliver, R. (1981). "Measurement and Evaluation of Satisfaction Process in Retail Setting." *Journal of Retailing*, 57 (Fall): 25-48.
- (1993). "A Conceptual Model of Service Quality and Service Satisfaction: Compatible Goals, Different Concepts." *Advances in Services Marketing and Management*, 2: 65-85.
- (1997). *Satisfaction: A Behavioral Perspective on the Consumer*. New York: Irwin/Mcgraw-Hill.
- Oliver, R. L. (1980). "A Cognitive Model of the Antecedents and Consequences of Satisfaction Decisions." *Journal of Marketing Research*, 17 (4): 460-69.
- (1989). "Processing of the Satisfaction Response in Consumption: A Suggested Framework and Research Propositions." *Journal of Consumer Satisfaction Dissatisfaction and Complaining Behavior*, 2: 1-16.
- (1999). "Whence Consumer Loyalty." *Journal of Marketing Research*, 63(Special Issue): 33-44.
- Olsen, L. L., and M. D. Johnson (2003). "Service Equity, Satisfaction, and Loyalty: From Transaction-Specific to Cumulative Evaluations." *Journal of Service Research*, 5 (3): 184-95.
- Olsen, S. O. (2002). "Comparative Evaluation and the Relationship between Quality, Satisfaction, and Repurchase Loyalty." *Journal of the Academy of Marketing Science*, 30 (3): 240-49.
- Onkvisit, S., and J. J. Shaw (1994). *Consumer Behavior: Strategy and Analysis*. New York: Macmillan College Pub. Co.
- Oppenheim, A. N. (1966). *Questionnaire Design and Attitude Measurement*. New York: Basic Books.
- Oppermann, M. (1999). "Predicting Destination Choice – a Discussion of Destination Loyalty." *Journal of Vacation Marketing*, 5 (1): 51-65.
- (2000). "Tourism Destination Loyalty." *Journal of Travel Research*, 39 (1): 78-84.

- Ostrowski, P. L., T. V. O'Brien, and G. L. Gordon (1993). "Service Quality and Customer Loyalty in the Commercial Airline Industry." *Journal of Travel Research*, 32 (2): 16-24.
- Ott, R. L., and M. Longnecker (2001). *An Introduction to Statistical Methods and Data Analysis*. (5th ed.). Pacific Grove, CA: Duxbury.
- Otto, J. E., and J. R. B. Ritchie (1996). "The Service Experience in Tourism." *Tourism Management*, 17 (3): 165-74.
- Palmer, A. J. and R. Mayer (1996). "Relationship Marketing: A New Paradigm for the Travel and Tourism Sector?" *Journal of Vacation Marketing*, 2 (4): 326-33.
- Parasuraman, A., L. L. Berry, and V. A. Zeithaml (1991). "Refinement and Reassessment of the SERVQUAL Scale." *Journal of Retailing*, 67 (4): 420-50.
- Parasuraman, A., and D. Grewal (2000). "The Impact of Technology on the Quality-Value-Loyalty Chain: A Research Agenda." *Journal of the Academy of Marketing Science*, 28: 168-74.
- Parasuraman, A., V. A. Zeithaml, and L. L. Berry (1985). "A Conceptual Model of Service Quality and Its Implications for Future Research." *Journal of Marketing*, 49 (Fall): 41-50.
- (1988). "SERVQUAL: A Multiple-Item Scale for Measuring Consumer Perceptions of Service Quality." *Journal of Retailing*, 64 (1): 12-40.
- Park, S. H. (1996). "Relationships between Involvement and Attitudinal Loyalty Constructs in Adult Fitness Programs." *Journal of Leisure Research*, 28: 233-50.
- Patterson, P. G., and L. W. Johnson (1993). "Disconfirmation of Expectation and the Gap Model of Service Quality: An Integrated Paradigm." *Journal of Consumer Satisfaction, Dissatisfaction and Complaining Behavior*, 6: 90-99.
- Payne, S. C., and A. H. Huffman (2005). "A Longitudinal Examination of the Influence of Mentoring on Organizational Commitment and Turnover." *Academy of Management Journal*, 48: 158-68.
- Pessemier, E. (1959). "A New Way to Determine Buying Decision." *Journal of Marketing*, 24 (2): 41-46.
- Peter, J. P. (1979). "Reliability: A Review of Psychometric Basics and Recent Marketing Practices." *Journal of Marketing Research*, 16 (February): 6-17.

- Petrick, J. F. (1999). *An Examination of the Relationship between Golf Travelers' Satisfaction, Perceived Value, Loyalty and Intentions to Revisit*. Unpublished Ph.D. Dissertation, Clemson University.
- (2002). "Development of a Multi-Dimensional Scale for Measuring the Perceived Value of a Service." *Journal of Leisure Research*, 34 (2): 119-34.
- (2004a). "Are Loyal Visitors Desired Visitors?" *Tourism Management*, 25 (4): 463-70.
- (2004b). "First Timers' and Repeaters' Perceived Value." *Journal of Travel Research*, 43 (1): 29-38.
- (2004c). "The Roles of Quality, Value, and Satisfaction in Predicting Cruise Passengers' Behavioral Intentions." *Journal of Travel Research*, 42 (4): 397-407.
- Petrick, J. F., and S. J. Backman (2002a). "An Examination of Golf Travelers' Satisfaction, Perceived Value, Loyalty, and Intentions to Revisit." *Tourism Analysis*, 6 (3/4): 223-37.
- (2002b). "An Examination of the Construct of Perceived Value for the Prediction of Golf Travelers' Intentions to Revisit." *Journal of Travel Research*, 41 (1): 38-45.
- (2002c). "An Examination of the Determinants of Golf Travelers' Satisfaction." *Journal of Travel Research*, 40 (3): 252-58.
- (2004). "Using Square Measures of Perceived Value to Fill Round Holes in the Service Literature – Why Product-Based Measures Are Inadequate for Tourism Research. A Response to Al-Sabbahy, Ekinci, and Riley." *Journal of Travel Research*, 42 (4): 429-31.
- Pine, B. J., and J. H. Gilmore (1999). *The Experience Economy*. Boston: Harvard Business School Press.
- Ping, R. (1993). "The Effects of Satisfaction and Structural Constraints on Retailer Exiting, Voice, Loyalty, Opportunism, and Neglect." *Journal of Retailing*, 69: 320-52.
- Ping, R. A., Jr. (1997). "Voice in Business-to-Business Relationships: Cost-of-Exit and Demographic Antecedents." *Journal of Retailing*, 73: 261-81.
- Pritchard, M. P. (1991). *Development of the Psychological Commitment Instrument (PCI) for Measuring Travel Service Loyalty*. Unpublished Ph.D. Dissertation, University of Oregon.

- Pritchard, M. P., M. E. Havitz, and D. Howard (1999). "Analyzing the Commitment-Loyalty Link in Service Contexts." *Journal of the Academy of Marketing Science*, 27 (3): 333-48.
- Pritchard, M. P., and D. Howard (1997). "The Loyal Traveler: Examining a Typology of Service Patronage." *Journal of Travel Research*, 35 (4): 2-10.
- Pritchard, M. P., D. Howard, and M. E. Havitz (1992). "Loyal Measurement: A Critical Examination and Theoretical Extension." *Leisure Sciences*, 14: 155-64.
- Raj, S. P. (1982). "The Effects of Advertising on High and Low Loyalty Consumer Segments." *Journal of Consumer Research*, 9 (1): 77-89.
- (1985). "Striking a Balance between Brand 'Popularity' and Brand Loyalty." *Journal of Marketing*, 49 (1).
- Reed, R., and R. J. DeFillippi (1990). "Causal Ambiguity, Barriers to Imitation, and Sustainable Competitive Advantage." *Academy of Management Review*, 15: 88-102.
- Reichheld, F. F. (2003). "The One Number You Need to Grow." *Harvard Business Review*, 81 (12): 2-10.
- Reid, L. J., and J. L. Crompton (1993). "A Taxonomy of Leisure Purchase Decision Paradigms Based on Level of Involvement." *Journal of Leisure Research*, 25: 182-202.
- Research Consulting (2001). "Structural Equation Modeling Using AMOS: An Introduction." Vol. 2006: UT-Austin. Retrieved March 15, 2006 from <http://www.utexas.edu/its/rc/tutorials/stat/amos/>
- Rundle-Thiele, S. (2005). *Loyalty: An Empirical Exploration of Theoretical Structure in Two Service Markets*. Unpublished Ph.D. Dissertation, University of South Australia.
- Rusbult, C. E. (1978). *The Development of Commitment in Interpersonal Relationships: An Investment Model*. Unpublished Ph.D. Dissertation, University of North Carolina at Chapel Hill.
- (1980a). "Commitment and Satisfaction in Romantic Associations: A Test of the Investment Model." *Journal of Experimental Social Psychology*, 16: 172-86.
- (1980b). "Satisfaction and Commitment in Friendships." *Representative Research in Social Psychology*, 11: 96-105.

—— (1983). "A Longitudinal Test of the Investment Model: The Development (and Deterioration) of Satisfaction and Commitment in Heterosexual Involvements." *Journal of Personality and Social Psychology*, 45: 101-17.

—— (1991). "Commentary on Johnson's 'Commitment to Personal Relationships': What's Interesting, and What's New?" *Advances in Personal Relationships*, 3: 151-69.

Rusbult, C. E., S. M. Drigotas, and J. Verette (1994). "The Investment Model: An Interdependence Analysis of Commitment Processes and Relationship Maintenance Phenomena." In *Communication and Relational Maintenance*. edited by D. J. Canary and L. Stafford. San Diego: Academic Press, pp. 115-139.

Rusbult, C. E., J. M. Martz, and C. R. Agnew (1998). "The Investment Model Scale: Measuring Commitment Level, Satisfaction Level, Quality of Alternatives, and Investment Size." *Personal Relationships*, 5: 357-91.

Russell, D. W. (2002). "In Search of Underlying Dimensions: The Use (and Abuse) of Factor Analysis in Personality and Social Psychology Bulletin." *Personality and Social Psychology Bulletin*, 28(12):1629-1646.

Rust, R. T., and R. L. Oliver (1994). "Service Quality: Insights and Managerial Implication from the Frontier." In *Service Quality: New Directions in Theory and Practice*. edited by Roland T. Rust and Richard L. Oliver. Thousand Oaks, CA: Sage, pp. 1-19.

de Ruyter, K., and J. Bloemer (1999). "Customer Loyalty in Extended Service Settings." *International Journal of Service Industry Management*, 10 (3): 320-36.

de Ruyter, K., M. Wetzels, and J. Bloemer (1998). "On the Relationship between Perceived Service Quality, Service Loyalty and Switching Costs." *International Journal of Service Industry Management*, 9 (5): 436-53.

van Ryzin, G. G. (2004). "The Measurement of Overall Citizen Satisfaction." *Public Performance & Management Review*, 27 (3): 9-28.

Salancik, G. R. (1977). "Commitment and the Control of Organizational Behavior and Belief." In *New Directions in Organizational Behavior*. edited by B. M. Staw and G. R. Salancik. Chicago: St. Clair, pp. 1-54.

Salant, P., and D. A. Dillman (1994). *How to Conduct Your Own Survey*. New York: John Wiley.

Sargeant, A., and L. Woodliffe (2005). "The Antecedents of Donor Commitment to Voluntary Organizations." *Nonprofit Management and Leadership*, 16 (1): 61-78.

- Scott, D., and G. Godbey (1994). "Recreation Specialization in the Social World of Contract Bridge." *Journal of Leisure Research*, 26: 275-95.
- Scott, D., and C. S. Shafer (2001). "Recreational Specialization: A Critical Look at the Construct." *Journal of Leisure Research*, 33 (3): 319-43.
- Selin, S. W., D. R. Howard, E. Udd, and T. T. Cable (1988). "An Analysis of Consumer Loyalty to Municipal Recreation Programs." *Leisure Sciences*, 10: 217-23.
- Selnes, F. (1993). "An Examination of the Effect of Product Performance on Brand Reputation, Satisfaction and Loyalty." *Journal of Marketing*, 27 (9): 19-35.
- Semon, T. T. (1998). "Existing Measures Make Value Hard to Quantify." *Marketing News*, 32 (11): 18.
- Shamir, B. (1988). "Commitment and Leisure." *Sociological Perspectives*, 31: 238-58.
- Shankar, V., A. K. Smith, and A. Rangaswamy (2003). "Customer Satisfaction and Loyalty in Online and Offline Environments." *International Journal of Research in Marketing*, 20: 153-75.
- Sharma, N., and P. G. Patterson (2000). "Switching Costs, Alternative Attractiveness and Experience as Moderators of Relationship Commitment in Professional, Consumer Services." *International Journal of Service Industry Management*, 11 (5): 470-90.
- Shaw, J. D., N. Gupta, and J. E. Delery (2005). "Alternative Conceptualizations of the Relationship between Voluntary Turnover and Organizational Performance." *Academy of Management Journal*, 48 (1): 50-68.
- Shelby, B., and J. J. Vaske (1991). "Resource and Activity Substitutes for Recreational Salmon Fishing in New Zealand." *Leisure Sciences*, 13: 21-32.
- Sheth, J., and A. Parvatiyar (1995a). "Relationship Marketing in Consumer Markets: Antecedents and Consequences." *Journal of the Academy of Marketing Science*, 23 (Fall): 255-71.
- (1995b). "The Evolution of Relationship Marketing." *International Business Review*, 4 (4): 397-418.
- Sheth, J., and R. Sisodia (1999). "Revisiting Marketing's Lawlike Generalizations." *Journal of the Academy of Marketing Science* 27(1): 71-87.
- Shoemaker, S. L., R (1999). "Customer Loyalty: The Future of Hospitality Marketing." *Hospitality Management*, 18: 345-70.

Sirdeshmukh, D., J. Singh, and B. Sabol (2002). "Consumer Trust, Value, and Loyalty in Relational Exchanges." *Journal of Marketing*, 66 (1): 15-37.

Skogland, I., and J. A. Siguaw (2004). "Are Your Satisfied Customers Loyal?" *Cornell Hotel & Restaurant Administration Quarterly*, 45 (3): 221-34.

Smith, K. G., C. J. Collins, and K. D. Clark (2005). "Existing Knowledge, Knowledge Creation Capability, and the Rate of New Product Introduction in High Technology Firms." *Academy of Management Journal*, 48 (2): 346-57.

Soderlund, M. (1998). "Customer Satisfaction and Its Consequences on Customer Behavior Revisited." *International Journal of Services Industry Management*, 9: 169-88.

Sörbom, D. (1986). *Model Modification. (Research Report, 86-3)*. Uppsala, Sweden: University of Uppsala, Department of Statistics.

Sparrow, N., and J. Curtice (2004). "Measuring the Attitudes of the General Public via Internet Polls: An Evaluation." *International Journal of Market Research*, 46 (1): 23-44.

Spreng, R. A., S. B. MacKenzie, and R. W. Olshavsky (1996). "A Reexamination of the Determinants of Consumer Satisfaction." *Journal of Marketing*, 60 (3): 15-32.

Srinivasan, S. S., R. Anderson, and K. Ponnaveolu (2002). "Customer Loyalty in E-Commerce: An Exploration of Its Antecedents and Consequences " *Journal of Retailing*, 78: 41-50.

Stevens, J. (1996). *Applied Multivariate Statistics for the Social Sciences*. Mahwah, NJ: Lawrence Erlbaum Publishers.

Stryker, S. (1968). "Identity Saliency and Role Performance." *Journal of Marriage and the Family*, 4: 558-564.

—— (1980). *Symbolic Interactionism: A Social Structural Version*. Menlo Park, CA: Cummings.

Sweeney, J. C., and G. N. Soutar (2001). "Consumer Perceived Value: The Development of a Multiple Item Scale." *Journal of Retailing*, 77 (2): 203-20.

Sylvia, S. N. (2004). *An Ecological Understanding of Recreational Physical Activity Among Young Adults*. Unpublished Ph.D. Dissertation, The Pennsylvania State University.

Tabachnick, B. G., and L. S. Fidell (2001). *Using Multivariate Statistics*. (4th ed.). Needham Heights, MA: Allyn & Bacon.

Tam, J. L. M. (2000). "The Effects of Service Quality, Perceived Value and Customer Satisfaction on Behavioral Intentions." *Journal of Hospitality and Leisure Marketing*, 6 (4): 31-43.

Taylor, S. A., K. Celuch, and S. Goodwin (2004). "The Importance of Brand Equity to Customer Loyalty." *Journal of Product & Brand Management*, 13 (4): 217-27.

Tellis, G. J. (1988). "Advertising Exposure, Loyalty, and Brand Purchase: A Two-Stage Model of Choice " *Journal of Marketing Research*, 25 (2): 134-44.

Thatcher, J. B., and J. F. George (2004). "Commitment, Trust, and Social Involvement: An Exploratory Study of Antecedents to Web Shopper Loyalty." *Journal of Organizational Computing & Electronic Commerce*, 14 (4): 243-68.

Thibaut, J. W., and H. H. Kelley (1959). *The Social Psychology of Groups*. New York: Johnson Wiley

Tian, S. (1998). *Testing the Efficacy of an Attitudinal Process Model of the Relationship between Service Quality and Visitor Satisfaction in a Tourism Context*. Unpublished Ph.D. Dissertation, Texas A&M University.

Tian-Cole, S., and J. L. Crompton (2003). "A Conceptualization of the Relationships between Service Quality and Visitor Satisfaction, and Their Links to Destination Selection." *Leisure Studies*, 22 (1): 65-80.

Travel Industry Association of America (TIA) (2005). "Travelers' Use of the Internet (2005 Edition)." Washington DC: Travel Industry Association of America.

Tuan, Y.-F. (1974). *Topophilia: A Study of Environmental Perception, Attitudes, and Values*. Englewood Cliffs, NJ: Prentice Hall.

——— (1977). *Space and Place: The Perspective O Experience* Minneapolis: University of Minnesota Press.

Tucker, W. T. (1964). "The Development of Brand Loyalty." *Journal of Marketing Research*, 1: 32-35.

Tuten, T. L. (2005). "The Effect of Gay-Friendly and Non-Gay-Friendly Cues on Brand Attitudes: A Comparison of Heterosexual and Gay/Lesbian Reactions." *Journal of Marketing Management*, 21 (3/4): 441-61.

Tuten, T. L., and D. J. Urban (1999). "Specific Responses to Unmet Expectations: The Value of Linking Fishbein's Theory of Reasoned Action and Rusbult's Investment Model." *International Journal of Management*, 16 (4): 484-89.

- Ullman, J. B. (2001). "Structural Equation Modeling." In *Using Multivariate Statistics*. edited by Barbara G. Tabachnick and Linda S. Fidell. (4th ed.) Needham Heights, MA: Allyn & Bacon, pp. 653-771.
- Vallacher, R. R., and D. M. Wegner (1987). "What Do People Think They Are Doing? Action Identification and Human Behavior." *Psychological Review*, 94 (1): 3-15.
- Varadarajan, P. R., and M. S. Yadav (2002). "Marketing Strategy and the Internet: An Organizing Framework." *Journal of the Academy of Marketing Science*, 30: 296-312.
- Viard, V. B. (2002). *Do Switching Costs Make Markets More or Less Competitive? The Case of 800-Number Portability*. Stanford, CA: Stanford University.
- Vriens, M., M. Wedel, and Z. Sándor (2001). "Split-Questionnaire Designs: A New Tool in Survey Design and Panel Management." *Marketing Research*, 13 (2): 14-19.
- Wanberg, C. R., T. M. Glomb, Z. Song, and S. Sorenson (2005). "Job-Search Persistence During Unemployment: A 10-Wave Longitudinal Study." *Journal of Applied Psychology*, 90: 411-30.
- Wang, X. H., and B. Z. Yang (2001). "Fixed and Sunk Costs Revisited." *Journal of Economic Education*, 32 (2): 178-85.
- Wernerfelt, B. (1991). "Brand Loyalty and Market Equilibrium." *Marketing Science*, 10 (3): 229-45.
- West, S. G., J. F. Finch, and P. J. Curran (1995). "Structural Equation Models with Nonnormal Variables: Problems and Remedies." In *Structural Equation Modeling: Concepts, Issues, and Applications*. edited by R. H. Hoyle. Thousand Oaks: CA: Sage, pp. 56-75.
- Wie, B. W. (2005). "A Dynamic Game Model of Strategic Capacity Investment in the Cruise Line Industry." *Tourism Management*, 26 (2): 203-17.
- Wilkie, W. L. (1990). *Consumer Behavior* (2nd ed.). New York: Wiley & Sons Inc.
- Wood, R. E. (2000). "Caribbean Cruise Tourism - Globalization at Sea." *Annals of Tourism Research*, 27 (2): 345-70.
- Woodruff, R. B. (1997). "Customer Value: The Next Source of Competitive Advantage." *Journal of the Academy of Marketing Science*, 25 (2): 139-64.
- Yair, G. (1990). "The Commitments to Long Distance Running and Levels of Activity: Personal or Structural?" *Journal of Leisure Research*, 22 (3): 213-27.

- (1992). "What Keeps Them Running? The "Circle of Commitment" of Long Distance Runners." *Leisure Studies*, 11: 250-70.
- Yang, J. T. (2004). "Qualitative Knowledge Capturing and Organizational Learning: Two Case Studies in Taiwan Hotels." *Tourism Management*, 25 (4): 421-28.
- Yang, Z., and R. T. Peterson (2004). "Customer Perceived Value, Satisfaction, and Loyalty: The Role of Switching Costs." *Psychology & Marketing*, 21 (10): 799-822.
- Yoon, Y., and M. Uysal (2005). "An Examination of the Effects of Motivation and Satisfaction on Destination Loyalty: A Structural Model." *Tourism Management*, 26 (1): 45-56.
- Young, A. M., and P. L. Perrewe (2000). "What Did You Expect? An Examination of Career-Related Support and Social Support among Mentors and Proteges." *Journal of Management*, 26 (4): 611-32.
- Yu, C.-M. J., L.-Y. Wu, Y.-C. Chiao, and H.-S. Tai (2005). "Perceived Quality, Customer Satisfaction, and Customer Loyalty: The Case of Lexus in Taiwan." *Total Quality Management & Business Excellence*, 16 (6): 707-19.
- Zanna, M. P., and J. K. Rempel (1988). "Attitudes: A New Look at an Old Concept." In *The Social Psychology of Knowledge*. edited by D. Bar-Tal and A.W. Kruglanski. Cambridge, U.K.: Cambridge University Press, pp. 315-334.
- Zauberman, G. (2003). "The Intertemporal Dynamics of Consumer Lock-In." *Journal of Consumer Research*, 30 (3): 405-19.
- Zeithaml, V. A. (1988). "Consumer Perceptions of Price, Quality and Value: A Means-End Model and Synthesis of Evidence." *Journal of Marketing*, 52 (July): 2-22.
- Zeithaml, V. A., L. L. Berry, and A. Parasuraman (1996). "The Behavioral Consequences of Service Quality." *Journal of Marketing*, 60 (2): 31-46.
- Zeithaml, V. A., A. Parasuraman, and L. L. Berry (1990). *Delivering Quality Service: Balancing Customer Perceptions and Expectations*. New York: The Free Press.
- Zoomerang (2005). "Zoompanel and Sample Sales Training." San Francisco, CA.

APPENDIX A

SUMMARY OF SELECTED STUDIES ON

LOYALTY CONCEPTUALIZATION (1969-2005)

Authors	Significant Findings
Day (1969)	<ul style="list-style-type: none"> • Two types of brand loyalty are defined: spurious and true brand loyalty. • Spurious brand loyalty is the consistent purchasing of one brand because there are no others readily available or because a brand offers a long series of deals or had a better shelf or display location. • True brand loyalty is a favorable brand attitude and consistent purchase of one brand. The most important determinant factor of true brand loyalty is commitment. • Brand loyalty should be assessed using both attitudinal and behavioral data.
Carman (1970) Jacoby (1971)	<ul style="list-style-type: none"> • Brand loyalty is systematically related to store loyalty. • Consumers who are store loyal and thereby stop at relatively few stores are more likely to exhibit greater brand loyalty. • Brand loyalty is the tendency to prefer and purchase more of one brand than of others. Brand loyalty is often defined as the proportion or percentage of purchases devoted to any one brand in a product class or as the number of different brands purchased during a given period of time or the sequences and frequency of such purchases. • Customers may be loyal to several brands.
Jacoby and Chestnut (1978)	<ul style="list-style-type: none"> • Brand loyalty is defined as 1) the biased, 2) behavioral response, 3) expressed over time, 4) by some decision-making unit, 5) with respect to one or more alternative brands out of a set of such brands, and 6) is a function of psychological processes • A true brand loyalty is based on commitment. • True brand loyal customers offer their suppliers a triple payoff: 1) lower costs for marketing, 2) lower costs on transaction and communications, and 3) a very loyal customers by more than others.
Churchill and Surprenant (1982)	<ul style="list-style-type: none"> • Consumers who are highly loyal to a brand of one product may have very little loyalty to a brand of another product. • A significant number of consumers who are brand loyal to one brand display “secondary loyalties” to another competitive brand in the category.
Raj(1982)	<ul style="list-style-type: none"> • Brand loyal customers were defined as consumers who devoted more than 50 percent of their product class purchases to one specific brand. • Increased advertising caused brand loyals rather than non-loyals to increase their purchasing.

Authors	Significant Findings
Raj (1985)	<ul style="list-style-type: none"> • “Sole loyalty” refers to those respondents who exclusively buy a single brand. • “Primary loyalty” indicates that a specific brand was selected most often, with some other brands being the buyer’s “secondary choice”.
Selin, Howard, Udd, and Cable(1988)	<ul style="list-style-type: none"> • For low-involved participants, their participation of recreation programs may represent habitual behavior rather than active decision making. • Loyal patrons were more likely to be older and have more agency experience than less loyal participants.
Wilkie (1990)	<ul style="list-style-type: none"> • Brand loyalty is backed up by considerable relevant learning. • The need for variety and adventure underpin consumers’ willingness to try the new and work against long-term brand loyalty.
Backman and Crompton(1991b)	<ul style="list-style-type: none"> • Conceptualized psychological attachment and behavioral consistency as two dimensions of loyalty. • "Attitudinal, behavioral, and composite loyalty capture the loyalty phenomenon differently"
Backman and Crompton(1991a)	<ul style="list-style-type: none"> • Proposed a 4-category typology of loyalty based on respondents’ score on the attitude and behavior dimensions: low, latent, spurious, and high loyalty
Onkvisit and Shaw (1994)	<ul style="list-style-type: none"> • One dimension of post-purchase feelings that is described as a consistent preference (in terms of attitude and behavior) for a particular brand over time. • Spuriously loyalty buyers lack attachment to the differential attributes offered by any brand and can be immediately captured by another brand that offers a better deal, a coupon, or enhanced point-of-purchase visibility through displays and other devices.
Dick and Basu (1994)	<ul style="list-style-type: none"> • Brand loyalty is conceptualized through the relationship between relative attitude toward an entity and patronage behavior. • The view of customer loyalty is broadened to encompass relative attitude, underlying processes, various contingencies and characteristics of different loyalty targets. • Situational influence and social norm interact with relative attitude to produce repeat patronage.

Authors	Significant Findings
Engel, Warshaw, Kinnear (1994)	<ul style="list-style-type: none"> • “ True brand loyalty” usually emerges when the initial purchase is motivated by a high degree and of involvement accompanied by perceived differences between alternatives. • Brand loyalty is confined to a set of brands regarded as essentially equivalent.
Bloemer and Kasper (1995)	<ul style="list-style-type: none"> • “The positive impact of manifest satisfaction on true brand loyalty is greater than the positive impact of latent satisfaction on true brand loyalty.” • “Manifestly satisfied consumers are really brand loyal; latently satisfied consumers are potential brand switchers.”
Dekimpe, Steenkamp, Mellens and Abeele (1997)	<ul style="list-style-type: none"> • “Little support is found for the often-heard contention that brand loyalty is gradually declining over time.” • “while the short-run variability around a brand’s mean loyalty level is not negligible, no evidence is found that this variability has systematically increased over time, and it can be reduced considerably through a simple smoothing procedure.” • “the brand-loyalty pattern for market share leaders is found to be more stable than for other brands.”
Fournier and Yao(1997)	<ul style="list-style-type: none"> • “Not all loyal brand relationships are alike, in strength or in character;” • “Many brand relationships not identified as loyal. According to dominant theoretical conceptions are especially meaningful from the consumer’s point of view;” • “Current approaches to classification accept some brand relationships that, upon close scrutiny, do not possess assumed characteristics of loyalty or strength at all.”
Javalgi and Moberg(1997)	<ul style="list-style-type: none"> • “The importance of the conceptual framework that is delineated in this article lies in its intended use by marketers to: (1) identify the type of loyalty condition that is normally prevalent in their industry; and then (2) recognize the various strategies available to them to build and retain loyalty”
Macintosh and Lockshin(1997)	<ul style="list-style-type: none"> • Results supported the attitude to behavior linkage suggested by the Dick and Basu (1994) loyalty framework.
Knox and Walker (2001)	<ul style="list-style-type: none"> • “Proposed four styles, namely loyals, habituals, variety seekers, and switchers. It is useful to examine two dimensions of loyalty – attitudinal loyalty and behavioral loyalty to enable marketing management to target marketing activity according to the behavioral style of customers.”

Authors	Significant Findings
Bowen and Shoemaker (1998)	<ul style="list-style-type: none"> • Study of relationship marketing focuses on brand loyalty in the lodging industry. • The model of the study is based on the Morgan and Hunt's (1994) commitment and trust model. • Identified factors that build loyalty (i.e., availability of upgrade, ease of check-out, employees' willingness of communication). • Gap analysis – performance versus importance of loyalty factors.
de Ruyter, Wetzels and Bloemer (1998)	<ul style="list-style-type: none"> • “The results of our study suggest that there are three dimensions of service loyalty that can be identified: preference loyalty, price indifference loyalty and dissatisfaction response”
Bloemer and de Ruyter (1999)	<ul style="list-style-type: none"> • “The relationship between satisfaction and loyalty with respect to extended services is moderated by positive emotions in the case of high involvement service settings. In contrast, this type of interaction does not play a role of significance in determining customer loyalty with services that can be classified as low involvement services”
Bloemer, de Ruyter and Wetzels (1999)	<ul style="list-style-type: none"> • “Four dimensions of service loyalty can be identified: purchase intentions; word-of-mouth communication; price sensitivity; and complaining behavior”
Pritchard, Havitz and Howard (1999)	<ul style="list-style-type: none"> • “Results found a tendency to resist changing preference to be a key precursor to loyalty, largely explained by a patron's willingness to identify with a brand.” • “Model assessments to this point lead us to conclude that the M-E-M [mediating-effects-model] provides the best description of commitment and its link with loyalty.”
Ganesh, Arnold and Reynolds (2000)	<ul style="list-style-type: none"> • “As theory suggests and as is empirically validated here, customers who have switched service providers because of dissatisfaction seem to differ significantly from other customer groups in their satisfaction and loyalty behaviors.”
Homburg and Giering (2001)	<ul style="list-style-type: none"> • “Specifically, variety seeking, age, and income are found to be important moderators of the satisfaction loyalty relationship.”

Authors	Significant Findings
Lee and Cunningham (2001)	<ul style="list-style-type: none"> • “The results indicate that, in addition to service quality perceptions, transaction/switching cost factors have a significant impact on service loyalty.” • “To develop customer loyalty and maintain a long-term relationship with customers, service firms should continually improve and differentiate service quality, thus positively influencing customers. perceptions and ensuring positive outcomes to their cost/benefit analysis.”
Odin, Odin and Valette-Florence (2001)	<ul style="list-style-type: none"> • “The results obtained and reported in Fig. 3 show that the two dimensions of risk [risk importance and risk probability] influence brand loyalty significantly and positively.” • “This research has managed to clarify the loyalty concept, and notably to point out the importance of the distinction between loyalty and purchase inertia.”
Yu and Dean (2001)	<ul style="list-style-type: none"> • “Key findings are that both positive and negative emotions, and the cognitive component of satisfaction correlate with loyalty. Regression analysis indicates that the affective component serves as a better predictor of customer loyalty than the cognitive component. Further, the best predictor of both overall loyalty and the most reliable dimension of loyalty, positive word of mouth, is positive emotions.” • “Positive emotions are positively associated with positive word of mouth and willingness to pay more, and negatively associated with switching behavior.”
Zins (2001)	<ul style="list-style-type: none"> • “This study investigates the antecedents of future customer loyalty in the commercial airline industry by applying structural models under four prototypical past loyalty conditions.”
Rundle-Thiele(2005)	<ul style="list-style-type: none"> • Empirical testing supports a four-dimensional structure of loyalty, with three behavioral dimensions (namely citizenship behavior, resistance to competing offers, and preferential purchase) and attitudinal loyalty
Jones and Taylor (In press)	<ul style="list-style-type: none"> • Their results supported a two-dimensional loyalty construct, with behavioral loyalty as one dimension, while attitudinal and cognitive loyalty were combined into one dimension.

Part of this table is adapted from Back (2001, p. 28-30) and Rundle-Thiele (2005, p. 271-278)

APPENDIX B

SUMMARY OF SELECTED RECENT STUDIES ON

DETERMINANTS OF CUSTOMER LOYALTY(1997-2005)

Authors	Variables Investigated	Context	Related Findings
(Pritchard and Howard 1997)	Loyalty Satisfaction Involvement Perceived differences in service quality	Three travel services	<ul style="list-style-type: none"> • Empathetic service delivery is a key feature in differentiating loyal customer relationships • A second characteristic of true loyalty is sign involvement. • The third attitude that differentiated true loyalty from other types of patronage was satisfaction.
(Bloemer and de Ruyter 1998)	Store image Store satisfaction Store loyalty Store deliberation	Department store	<ul style="list-style-type: none"> • The positive relationship between manifest satisfaction and store loyalty is stronger than the positive relationship between latent satisfaction and store loyalty • Satisfaction mediates the relationship between store image and store loyalty • Both involvement and deliberation have a negative effect on store loyalty
(de Ruyter et al. 1998)	Service loyalty • Preference loyalty • Price indifference loyalty • Dissatisfaction response Service quality Switching cost	Health centers and city theatres	<ul style="list-style-type: none"> • Found a positive relationship between perceived service quality and preference loyalty and price indifference loyalty, but no significant relationship between perceived service quality and dissatisfaction response • “The influence of service quality on service loyalty varies significantly per industry and that, hence, findings from one industry cannot be generalized to other industries.” • “In industries characterized by relatively low switching costs, customers will be less loyal as compared to service industries with relatively high switching costs.”
(Bloemer et al. 1999)	Loyalty Quality	Entertainment, fast food, supermarkets, and health care services	<ul style="list-style-type: none"> • The relationship between service quality and service loyalty at the level of the individual dimensions is notably different across industries. • Four dimensions of service loyalty can be identified: purchase intentions, word-of-mouth communication; price sensitivity; and complaining behavior

Authors	Variables Investigated	Context	Related Findings
(Petrick 1999)	Satisfaction Perceived value Loyalty Intentions to revisit	Golfing	<ul style="list-style-type: none"> • Loyalty is an antecedent to satisfaction, and satisfaction is an antecedent to perceived value • Personal variables have little affect on golf travelers' overall satisfaction, perceived value, loyalty and intentions to revisit • Overall satisfaction, perceived value and loyalty explain unique portions of the variance in intentions to revisit.
(Baker and Crompton 2000)	Quality Satisfaction Behavioral Intention <ul style="list-style-type: none"> • Willingness to pay more • Festival loyalty 	Festival	<ul style="list-style-type: none"> • “Both quality and satisfaction had significant indirect effects on both domains of behavioral intentions with the stronger linkage being with loyalty to the festival.” • Satisfaction did not fully mediate the effect of quality on behavioral intentions. • Perceived quality has a stronger total effect on behavioral intentions than satisfaction.
(Back 2001)	Satisfaction Image congruence Loyalty	Hotel	<ul style="list-style-type: none"> • Found a positive association between customer satisfaction and attitudinal brand loyalty • Found that customer satisfaction was positively associated with behavioral brand loyalty when mediated by attitudinal brand loyalty • Customer satisfaction is positively related to social and ideal social image congruence.
(Bowen and Chen 2001)	Satisfaction Loyalty	Hotel	The relationship between satisfaction and loyalty is non-linear
(Homburg and Giering 2001)	Satisfaction Loyalty Customer characteristics <ul style="list-style-type: none"> • Gender • Age • Income • Involvement • Variety seeking 	Car purchase	“Variety seeking, age, and income are found to be important moderators of the satisfaction–loyalty relationship.”

Authors	Variables Investigated	Context	Related Findings
(Lee et al. 2001)	Satisfaction Loyalty Switching cost	Mobile phone service	Switching cost plays a moderating role in satisfaction-loyalty link
(Lee and Cunningham 2001)	Service loyalty Service quality Transaction cost Switching cost	Banks Travel agencies	"...in addition to service quality perceptions, transaction/switching cost factors have a significant impact on service loyalty."
(Caruana 2002)	Satisfaction Quality Loyalty	Retail banking	<ul style="list-style-type: none"> • Customer satisfaction plays a mediating role in the effect of service quality on service loyalty. • Education and age are the major variables explaining the presence of service loyalty
(Hennig-Thurau et al. 2002)	Communication Customer satisfaction Commitment Confidence benefits Social benefits Special treatment benefits Relationship Marketing Outcomes <ul style="list-style-type: none"> • Customer loyalty • Word-of-Mouth 	Bowen's (1990) three service categories	<ul style="list-style-type: none"> • Satisfaction and commitment as mediators between relational benefits and relationship marketing outcomes • Customer satisfaction, commitment, and trust are dimensions of relationship quality (with trust being also a type of relational benefit) influence customer loyalty, either directly or indirectly • Social benefits have important influences on relationship marketing outcomes. • The offer of special treatment benefits to customers does not appear to significantly influence customer satisfaction or customer loyalty.
(Olsen 2002)	Quality Satisfaction Repurchase (behavioral) loyalty	4 categories of seafood products	<ul style="list-style-type: none"> • Satisfaction is a mediator between quality and repurchase loyalty • Quality, satisfaction, and loyalty should be defined and measured within a relative attitudinal framework

Authors	Variables Investigated	Context	Related Findings
(Srinivasan et al. 2002)	e-Loyalty Customization, Contact interactivity Cultivation Care Community Choice Convenience Character	Online B2C	All the 8Cs—customization, contact interactivity, care, community, convenience, cultivation, choice, and character, except convenience, impact e-loyalty
(Sirdeshmukh et al. 2002)	Trust Value Loyalty	Retail clothing Nonbusiness airline travel	Value completely mediates the effect of frontline employee trust on loyalty in the retailing context and partially mediates the effect of management policies and practices trust on loyalty in the airlines context.
(Anderson and Srinivasan 2003)	E-Loyalty E-Satisfaction Individual level factors: <ul style="list-style-type: none"> • Inertia • Convenience motivation • Purchase size Firms' business level factors <ul style="list-style-type: none"> • Trust • Perceived value 	Electronic commerce	<ul style="list-style-type: none"> • Although e-satisfaction has an impact on e-loyalty, this relationship is moderated by (a) consumers' individual level factors (inertia, convenience motivation, and purchase size), and (b) firms' business level factors (trust and perceived value). • Convenience motivation and purchase size were found to accentuate the impact of e-satisfaction on e-loyalty, whereas inertia suppresses the impact of e-satisfaction on e-loyalty. • Both trust and perceived value significantly accentuate the impact of e-satisfaction on e-loyalty.

Authors	Variables Investigated	Context	Related Findings
(Hellier et al. 2003)	Repurchase intention Service quality, Equity Value Customer satisfaction Past loyalty Expected switching cost Brand preference	Comprehensive car insurance and personal superannuation services	<ul style="list-style-type: none"> • Past purchase loyalty is not directly related to customer satisfaction or current brand preference and that brand preference is an intervening factor between customer satisfaction and repurchase intention. • Although perceived quality does not directly affect customer satisfaction, it does so indirectly via customer equity and value perceptions.
(Lee 2003)	Service Quality Satisfaction Activity Involvement Place Attachment Destination Loyalty	Forest	<ul style="list-style-type: none"> • Satisfaction mediates the relationship between service quality and conative loyalty • Satisfaction does not have a direct significant effect on attitudinal or behavioral loyalty • Place attachment mediates the relationships between service quality and attitudinal and behavioral loyalties
(Olsen and Johnson 2003)	Service equity Satisfaction Loyalty	Bank	<ul style="list-style-type: none"> • Satisfaction mediates the effect of equity on loyalty when (a) Equity and satisfaction are transaction specific, and customers are relatively satisfied with no reason to complain; (b) Equity and satisfaction are transaction specific, and customers are relatively dissatisfied with a reason to complain; or (c) Equity and satisfaction are cumulative, and customers are relatively dissatisfied with a reason to complain. • Equity mediates the effect of satisfaction on loyalty when equity and satisfaction are cumulative and customers are relatively satisfied with no reason to complain. • Cumulative evaluations are better predictors of customers' loyalty intentions.

Authors	Variables Investigated	Context	Related Findings
(Beerli et al. 2004)	Quality Satisfaction Switching cost Loyalty <ul style="list-style-type: none"> • Loyalty based on inertia • True loyalty 	Bank	<ul style="list-style-type: none"> • Satisfaction and personal switching costs are antecedents of customer loyalty, with the former exerting far greater influence than the later. • Satisfaction is an antecedent of perceived quality in the retail banking market, and not vice versa • The degree of elaboration does not have a moderating influence on the relationships between satisfaction/switching costs and customer loyalty
(Chiou 2004)	Attributive satisfaction Overall satisfaction Perceived value Perceived trust Expected technology change Loyalty intentions	ISP industry	<ul style="list-style-type: none"> • Perceived value is very important in generating overall customer satisfaction and loyalty intention toward an ISP • Perceived trust of an ISP enhances perceived value, overall satisfaction, and loyalty intention. • Future ISP technology expectancy exerted a negative influence on a consumer's overall satisfaction and loyalty intention toward their ISP.
(Iwasaki and Havitz 2004)	Leisure involvement Psychological commitment Behavioral loyalty Personal and social moderators	Recreation service	<ul style="list-style-type: none"> • Commitment mediates the influence of enduring involvement on behavioral loyalty. • Significant evidence was found for the direct effects of skill, motivation, social support, and social norms on enduring involvement • Skill, motivation, social support, and side bets significantly moderated the effects of enduring involvement on commitment's formative factors
(Lam et al. 2004)	Customer Value Satisfaction Loyalty Switching Costs	B-2-B service setting	<ul style="list-style-type: none"> • Two behavioral indicators of customer loyalty (recommendation and patronage) are positively related to customer satisfaction and switching costs. • Satisfaction as the mediator between customer value and loyalty • Hypothesis regarding the reciprocal effect of customer loyalty on customer satisfaction not supported

Authors	Variables Investigated	Context	Related Findings
(Morais et al. 2004)	Resource investment <ul style="list-style-type: none"> Providers' Perceived Resource Investments Customers' Reported Resource Investments 3 loyalty outcomes	White water rafting	<ul style="list-style-type: none"> If customers perceived that a provider was making an investment in them, they in turn made a similar investment in the provider, and those investments led to loyalty. The findings revealed that investments of love, status, and information were more closely associated with loyalty than investments of money.
(Kyle et al. 2004)	Leisure Involvement Psychological Commitment Behavioral Commitment Resistance to Change Behavioral Loyalty	Appalachian Trail (AT) hiking	<ul style="list-style-type: none"> Setting Resistance and Activity Resistance positively influenced behavioral loyalty. Setting Resistance and Activity Resistance mediate the effect of Psychological and Behavioral Commitment on behavioral loyalty
(Yang and Peterson 2004)	Perceived value Satisfaction Loyalty Switching costs	Online service usage	<ul style="list-style-type: none"> The moderating effects of switching costs on the association of customer loyalty and customer satisfaction and perceived value are significant only when the level of customer satisfaction or perceived value is above average Customer loyalty is positively influenced by customer satisfaction and perceived value. Satisfaction is positively influenced by perceived value
(Agustin and Singh 2005)	Loyalty intentions Transactional satisfaction Trust Value	Retail clothing and non-business airline travel	<ul style="list-style-type: none"> Found support for the enhancing {"motivator"} role of trust, and the maintaining {"hygiene"} role of transactional satisfaction on loyalty intentions in both contexts. The role of value is aligned with a maintaining {"hygiene"} mechanism, not a hypothesized bivalent mechanism. The effects of loyalty determinants depict systematic curvilinearities that are captured by both significant linear and quadratic effects.

Authors	Variables Investigated	Context	Related Findings
(Yoon and Uysal 2005)	Motivation Satisfaction Destination Loyalty	Tourism	<ul style="list-style-type: none"> • Tourist destination loyalty is positively affected by tourist satisfaction with their experiences • Satisfaction was found to be negatively influenced by the pull travel motivation, but not influenced by push motivation • Travel push motivation has a positively direct relationship with destination loyalty.

APPENDIX C
PILOT TEST QUESTIONNAIRE

STUDENT SURVEY

Have you eaten at Freebirds in the past 12 months?

Yes

No **IF No, please ignore the rest of this survey and return it to the instructor, thanks!**

1-1). On average, how many times **per month** do you eat at Freebirds? _____ Times

1-2). On average, how many times **per month** do you eat at any restaurants (including Freebirds)? _____ Times

2. How would you rate your past experience with Freebirds on the following scales? Please circle a number from 1 *negatively* to 7 *positively* for each of the four scales.

Very Dissatisfied	1	2	3	4	5	6	7	Very Satisfied
Very Displeased	1	2	3	4	5	6	7	Very Pleased
Frustrated	1	2	3	4	5	6	7	Contented
Terrible	1	2	3	4	5	6	7	Delighted

3. How would you rate your attitude toward Freebirds as a customer? Please circle the number that best represents how much you agree with the following statements from 1 “*strongly disagree*,” to 7 “*strongly agree*.”

	Strongly Disagree			Neutral			Strongly Agree
Freebirds provides me superior service quality as compared to other restaurants	1	2	3	4	5	6	7
I intend to continue eating at Freebirds	1	2	3	4	5	6	7
I believe Freebirds provides more benefits than other restaurants in its category	1	2	3	4	5	6	7
I love eating at Freebirds	1	2	3	4	5	6	7
I consider Freebirds my first dining choice	1	2	3	4	5	6	7
No other restaurant brand performs better services than Freebirds	1	2	3	4	5	6	7
Even if another restaurant brand is offering a lower rate, I still eat at Freebirds	1	2	3	4	5	6	7
I feel better when I eat at Freebirds	1	2	3	4	5	6	7
I like Freebirds more than other restaurant brands	1	2	3	4	5	6	7

4. The following statements are related to the quality of Freebirds. Please rate each item on a scale of 1, “*definitely false*”, to 7 “*definitely true*”.

	Definitely False				Definitely True		
The service of Freebirds is of outstanding quality	1	2	3	4	5	6	7
The service of Freebirds is very dependable	1	2	3	4	5	6	7
The service of Freebirds is very consistent	1	2	3	4	5	6	7
The service of Freebirds is very reliable	1	2	3	4	5	6	7

5. On a scale of 0 to 10 (from 0 “*Not at all likely*”, 5 “*Neutral*”, to 10 “*Extremely likely*”), how likely is it that you would recommend Freebirds to a friend or colleague?

Not at all likely	0	1	2	3	4	5	6	7	8	9	10	Extremely likely
--------------------------	---	---	---	---	---	---	---	---	---	---	----	-------------------------

6. The likelihood that you would consider eating at Freebirds again is:

Very Low	1	2	3	4	5	Very High
-----------------	---	---	---	---	---	------------------

7. Please indicate the degree to which you agree or disagree with each of the following statements regarding eating at another restaurant, from 1 “*strongly disagree*,” to 7 “*strongly agree*.”

	Strongly Disagree			Neutral		Strongly Agree	
It is costly to switch from Freebirds to another restaurant.	1	2	3	4	5	6	7
Costs associated with switching from Freebirds to another restaurant are expensive.	1	2	3	4	5	6	7
Freebirds really cares about keeping regular customers.	1	2	3	4	5	6	7
I am emotionally invested in eating at Freebirds.	1	2	3	4	5	6	7
Freebirds makes efforts to increase regular customers' loyalty.	1	2	3	4	5	6	7
I have eaten multiple times at Freebirds.	1	2	3	4	5	6	7
I have spent a lot of money in dining at Freebirds.	1	2	3	4	5	6	7
Freebirds makes various efforts to improve its tie with regular customers.	1	2	3	4	5	6	7
I don't mind giving up Freebirds.	1	2	3	4	5	6	7

8. Below are several statements that describe attitudes toward other restaurant brands. Please circle the number that best represent **your opinion** from 1 *negatively* to 7 *positively* for each of the four scales.

- How appealing are restaurants other than Freebirds to you?

Others Not At All Appealing	1	2	3	4	5	6	7	Others Are Extremely Appealing
-----------------------------	---	---	---	---	---	---	---	--------------------------------

1.If you were not eating at Freebirds, would it be easy to find another restaurant with the same level of quality?

Hard to Find	1	2	3	4	5	6	7	Easy to Find
--------------	---	---	---	---	---	---	---	--------------

2.How would you feel about eating at home instead of eating out?

I'd Feel Terrible	1	2	3	4	5	6	7	I'd Feel Good
-------------------	---	---	---	---	---	---	---	---------------

3.How do other restaurants compare to Freebirds?

Others Are Much Worse	1	2	3	4	5	6	7	Others Are Much Better
-----------------------	---	---	---	---	---	---	---	------------------------

9. Please reflect back on all your experience with Freebirds, and indicate how strongly you agree with the following statements, from 1 “*strongly disagree*,” to 7 “*strongly agree*.”

	Strongly Disagree		Neutral		Strongly Agree		
I am willing "to go the extra mile" to remain a customer of Freebirds	1	2	3	4	5	6	7
I feel loyal towards Freebirds	1	2	3	4	5	6	7
Even if Freebirds would be more difficult to reach, I would still keep going there	1	2	3	4	5	6	7

10. Below are several statements that describe different behaviors that you might consider as a customer of Freebirds. Please indicate the likelihood of your behaviors by circling the number that applies (from 1 “*very unlikely*” to 7 “*very likely*”).

<i>How likely are you to...</i>	Very Unlikely				Very Likely		
Make negative comments about Freebirds to friends and family	1	2	3	4	5	6	7
Discourage friends or family from choosing Freebirds for their dining needs	1	2	3	4	5	6	7
Tell Freebirds if I am unhappy with their services.	1	2	3	4	5	6	7
Follow up problems I encounter by writing to management, if needed.	1	2	3	4	5	6	7
Post my complaint on the internet if I am dissatisfied.	1	2	3	4	5	6	7
Not hesitate to hurt Freebirds' reputation, if it was unresponsive.	1	2	3	4	5	6	7
Seek to get even with Freebirds if it failed to address my complaints.	1	2	3	4	5	6	7

11. Listed below are several statements regarding your relationship with Freebirds. Please circle the number that best reflects your feeling, from 1 “*strongly disagree*,” to 7 “*strongly agree*.”

	Strongly Disagree		Neutral			<u>Strongly Agree</u>	
I consider myself to be a loyal patron of Freebirds.	1	2	3	4	5	6	7
If I were to eat out again, I would eat at another restaurant	1	2	3	4	5	6	7
I try to eat at Freebirds because it is the best choice for me.	1	2	3	4	5	6	7
To me, Freebirds is the same as other restaurants.	1	2	3	4	5	6	7

12. Please evaluate Freebirds on the following factors by circling the number that best reflects your perceptions.

For the price I paid for eating at Freebirds, I would say eating at Freebirds is a:	Very Poor Deal	1	2	3	4	5	6	7	Very Good Deal
For the time I spent in order to eat at Freebirds, I would say eating at Freebirds is:	Highly Unreasonable	1	2	3	4	5	6	7	Highly Reasonable
For the effort involved in eating at Freebirds, I would say eating at Freebirds is:	Not At All Worthwhile	1	2	3	4	5	6	7	Very Worthwhile
I would rate my overall experience with Freebirds as:	Extremely Poor Value	1	2	3	4	5	6	7	Extremely Good Value

13. This question relates to your view on purchasing in general. Please circle the number that best represents how much you agree with the following statements from 1 “*strongly disagree*,” to 7 “*strongly agree*.”

	Strongly Disagree		Neutral			Strongly Agree	
I would prefer to have others try a new brand rather than myself.	1	2	3	4	5	6	7
I would rather stick to well known brands when purchasing.	1	2	3	4	5	6	7
I rarely introduce new brands and products to my friend and family.	1	2	3	4	5	6	7
I rarely take chances by buying unfamiliar brands even if it means sacrificing variety.	1	2	3	4	5	6	7

14. If you were to eat out again, **the probability** that the restaurant would be with Freebirds is: (*please circle one*)

Very Low	1	2	3	4	5	Very High
-----------------	---	---	---	---	---	------------------

15. Please indicate the degree to which you agree or disagree with each of the following statements from 1 “*strongly disagree*,” to 7 “*strongly agree*.”

	Strongly Disagree		Neutral			Strongly Agree	
The restaurants other than Freebirds which I might be dining at are very appealing	1	2	3	4	5	6	7
My alternatives to Freebirds are close to ideal (e.g., eating at another restaurant, eating at home, etc.)	1	2	3	4	5	6	7
If I weren't eating at Freebirds, I would do fine-I would find another good restaurant	1	2	3	4	5	6	7
My alternatives are appealing to me (e.g., eating at another restaurant, eating at home, etc.)	1	2	3	4	5	6	7
My dining needs could easily be fulfilled in an alternative restaurant.	1	2	3	4	5	6	7

THANK YOU SO MUCH FOR YOUR PARTICIPATION!!

APPENDIX D
FINAL INSTRUMENT

Have you taken a cruise vacation in the past 12 months?

IF YES, which cruise line did you cruise with in your most recent cruise vacation:

- Carnival Cruise Lines
- Celebrity Cruises
- Costa Cruises
- Crystal Cruises
- Cunard Line
- Disney Cruise Line
- Holland America Line
- MSC Cruises
- Norwegian Coastal Voyage Inc.
- Norwegian Cruise Line
- Oceania Cruises
- Orient Lines
- Princess Cruises
- Radisson Seven Seas Cruises
- Royal Caribbean International
- Seabourn Cruise Line
- Silversea Cruises
- Swan Hellenic
- Windstar Cruises

IF YOU HAVE NOT CRUISED WITH ANY OF THE CRUISE LINES LISTED ABOVE IN THE PAST 12 MONTHS, PLEASE DISREGARD THIS SURVEY. THANK YOU FOR YOUR WILLINGNESS TO HELP!

This study is being conducted by the Department of Recreation, Park, and Tourism Sciences at Texas A&M University in College Station, Texas. Your input in the following questionnaire will help us in understanding cruise passengers' experiences. Careful responses to questions about your cruising will be greatly appreciated by us, the researchers, as well as the thousands of people who take cruises each year. You will have up to 60 minutes to complete this survey.

Question 1. Approximately when (which year) was your first <name> cruise? (Please fill in 4-digit year)

_____ Year

Question 2. How many cruises have you taken with <name> in your lifetime?

_____ Cruises

Question 3. During the last 3 years, how many times did you cruise with <name>?

_____ Times

Question 4. During the last 3 years, how many times did you cruise with any cruise line (including <name>)?

_____ Times

Question 5. How many cruises have you taken in your lifetime?

_____ Cruises

Question 6: With how many different cruise lines have you cruised in your lifetime?

_____ Cruise Lines

Question 7: How would you rate your overall experience with <name> on the following scales? Please choose a number from 1 *negatively* to 7 *positively* for each of the four scales.

Very Dissatisfied	1	2	3	4	5	6	7	Very Satisfied
Very Displeased	1	2	3	4	5	6	7	Very Pleased
Frustrated	1	2	3	4	5	6	7	Contented
Terrible	1	2	3	4	5	6	7	Delighted

Question 8. As a customer, how would you rate your attitude toward <name> as opposed to other cruise lines (no matter if you have cruised with them or not)? Please choose the number that best represents how much you agree with the following statements from 1 “*strongly disagree*,” to 7 “*strongly agree*.”

	Strongly Disagree		Neutral			Strongly Agree	
<name> provides me superior service quality as compared to other cruise lines	1	2	3	4	5	6	7
I intend to continue cruising with <name>	1	2	3	4	5	6	7
I believe <name> provides more benefits than other cruise lines in its category	1	2	3	4	5	6	7
I love cruising with <name>	1	2	3	4	5	6	7
I consider <name> my first cruising choice	1	2	3	4	5	6	7
No other cruise line performs better services than <name>	1	2	3	4	5	6	7
Even if another cruise line is offering a lower rate, I still cruise with <name>	1	2	3	4	5	6	7
I feel better when I cruise with <name>	1	2	3	4	5	6	7
I like <name> more than other cruise lines	1	2	3	4	5	6	7

Question 9. The following statements are related to the quality of a typical <name> cruise. Please rate each item on a scale of 1, “*definitely false*”, to 7 “*definitely true*.”

	Definitely False			<u>Definitely True</u>			
The service of <name> is of outstanding quality	1	2	3	4	5	6	7
The service of <name> is very dependable	1	2	3	4	5	6	7
The service of <name> is very consistent	1	2	3	4	5	6	7
The service of <name> is very reliable	1	2	3	4	5	6	7

Question 10. The likelihood that you would consider purchasing a <name> cruise again is (*please choose one*):

Very Low	1	2	3	4	5	Very High
-----------------	---	---	---	---	---	------------------

Question 11. Please indicate the degree to which you agree or disagree with each of the following statements regarding cruising with another cruise line, from 1 “*strongly disagree*,” to 7 “*strongly agree*.”

	Strongly Disagree			Neutral		Strongly Agree	
It takes me a great deal of time and effort to get used to a new cruise line.	1	2	3	4	5	6	7
It costs me too much to switch to another cruise line.	1	2	3	4	5	6	7
<name> really cares about keeping regular customers	1	2	3	4	5	6	7
I am emotionally invested in cruising with <name>	1	2	3	4	5	6	7
<name> makes efforts to increase regular customers' loyalty	1	2	3	4	5	6	7
I have cruised multiple times with <name>	1	2	3	4	5	6	7
I have spent a lot of money in cruising with <name>	1	2	3	4	5	6	7
<name> makes various efforts to improve its tie with regular customers	1	2	3	4	5	6	7
In general it would be a hassle switching to another cruise line.	1	2	3	4	5	6	7

Question 12. The following question relates to your attitude toward alternative options to cruising with <name>, such as cruising with another cruise line, spending your vacation on other leisure activities instead of cruising, etc. Please indicate the degree to which you agree or disagree with each of the following statements from 1 “*strongly disagree*,” to 7 “*strongly agree*.”

	Strongly Disagree			Neutral		Strongly Agree	
The cruise lines other than <name> which I might be cruising with are very appealing	1	2	3	4	5	6	7
My alternatives to <name> (e.g., cruising with another cruise line, spending my vacation on other leisure activities instead of cruising, etc.) are close to ideal	1	2	3	4	5	6	7
If I weren't cruising with <name>, I would do fine—I would find another good cruise line	1	2	3	4	5	6	7
My alternatives to <name> (e.g., cruising with another cruise line, spending my vacation on other leisure activities instead of cruising, etc.) are appealing to me	1	2	3	4	5	6	7
My cruising needs could easily be fulfilled by an alternative cruise line.	1	2	3	4	5	6	7

Question 13. Please reflect back on all your experiences with <name>, and indicate how strongly you agree with the following statements, from 1 “*strongly disagree*,” to 7 “*strongly agree*.”

	Strongly Disagree		Neutral			Strongly Agree	
I am willing "to go the extra mile" to remain a customer of <name>	1	2	3	4	5	6	7
I feel loyal towards <name>	1	2	3	4	5	6	7
Even if a <name> cruise would be more difficult to book, I would still keep cruising with them	1	2	3	4	5	6	7

Question 14. On a scale of 0 to 10 (from 0 “*Not at all likely*”, 5 “*Neutral*”, to 10 “*Extremely likely*”), how likely is it that you would recommend <name> to a friend or colleague?

Not at all likely	0	1	2	3	4	5	6	7	8	9	10	Extremely likely
--------------------------	---	---	---	---	---	---	---	---	---	---	----	-------------------------

Question 15. Below are several statements that describe different behaviors that you might consider as a customer of <name>. Please indicate the likelihood of your behaviors by circling the number that applies (from 1 “*very unlikely*” to 7 “*very likely*”).

<i>How likely are you to...</i>	Very Unlikely		Neutral			Very Likely	
Make negative comments about <name> to friends and family	1	2	3	4	5	6	7
Discourage friends or family from using <name> for their cruising needs	1	2	3	4	5	6	7
Call <name> if I am unhappy with their services.	1	2	3	4	5	6	7
Follow up problems I encounter by writing to management, if needed.	1	2	3	4	5	6	7
Post my complaint on the internet if I am dissatisfied.	1	2	3	4	5	6	7
Not hesitate to hurt <name>'s reputation, if it was unresponsive.	1	2	3	4	5	6	7
Seek to get even with <name> if it failed to address my complaints.	1	2	3	4	5	6	7

Question 16. Listed below are several statements regarding your relationship with <name>. Please choose the number that best reflects your feeling, from 1 “*strongly disagree*,” to 7 “*strongly agree*.”

	Strongly Disagree		Neutral			Strongly Agree	
I consider myself to be a loyal patron of <name>.	1	2	3	4	5	6	7
If I were to cruise again, I would cruise with another cruise line	1	2	3	4	5	6	7
I try to cruise with <name> because it is the best choice for me.	1	2	3	4	5	6	7

Question 17. If you were to purchase another cruise, the probability that the vacation would be with <name> is: (*please choose one*)

Very Low	1	2	3	4	5	Very High
-----------------	---	---	---	---	---	------------------

Question 18. Please evaluate a typical <name> cruise on the following factors by clicking the number that best reflects your perceptions.

For the price I paid for cruising with <name>, I would say cruising with <name> is a:	Very Poor Deal	1	2	3	4	5	6	7	Very Good Deal
For the time I spent in order to cruise with <name>, I would say cruising with <name> is:	Highly Unreasonable	1	2	3	4	5	6	7	Highly Reasonable
For the effort involved in cruising with <name>, I would say cruising with <name> is:	Not At All Worthwhile	1	2	3	4	5	6	7	Very Worthwhile
I would rate my overall experience with <name> as an:	Extremely Poor Value	1	2	3	4	5	6	7	Extremely Good Value

Question 19. Please indicate how well the following statements describe you as a consumer, from 1 “*strongly disagree*,” to 7 “*strongly agree*.”

	Strongly Disagree		Neutral			Strongly Agree	
I am always seeking new ideas and experiences	1	2	3	4	5	6	7
When things get boring I like to find some new and unfamiliar experience	1	2	3	4	5	6	7
I prefer a routine way of life to an unpredictable one full of change	1	2	3	4	5	6	7
I like to continually change activities	1	2	3	4	5	6	7
I do not like meeting consumers who have new ideas	1	2	3	4	5	6	7
I like to experience novelty and change in my daily routine	1	2	3	4	5	6	7

Question 20. The following question relates to your view on the differences between cruise lines (no matter if you have cruised with them or not). Please choose the number that best represents how much you agree with the following statements from 1 “*strongly disagree*,” to 7 “*strongly agree*.”

	Strongly Disagree		Neutral			Strongly Agree	
I can't think of any differences between the major cruise lines	1	2	3	4	5	6	7
To me, there are big differences between the various cruise lines	1	2	3	4	5	6	7
The only difference between the major cruise lines is price	1	2	3	4	5	6	7
A cruise is a cruise; most cruise lines are basically the same.	1	2	3	4	5	6	7
All major cruise lines are the same.	1	2	3	4	5	6	7

Question 21. This question relates to your view on purchasing in general. Please choose the number that best represents how much you agree with the following statements from 1 “*strongly disagree*,” to 7 “*strongly agree*.”

	Strongly Disagree		Neutral			Strongly Agree	
I would wait for others to try a new brand before trying it myself	1	2	3	4	5	6	7
I would rather stick to well known brands when purchasing.	1	2	3	4	5	6	7
I rarely introduce new brands and products to my friends and family.	1	2	3	4	5	6	7
I rarely take chances by buying unfamiliar brands even if it means sacrificing variety	1	2	3	4	5	6	7

Question 22. We are interested in your attitude toward cruising as a leisure activity. Please choose the number that best represents how much you agree or disagree with the following statements from 1 “*strongly disagree*,” to 5 “*strongly agree*.”

	Strongly Disagree					Strongly Agree				
You can tell a lot about a person by seeing them cruising	1	2	3	4	5					
I find a lot of my life is organized around cruising	1	2	3	4	5					
When I participate in cruising, others see me the way I want them to see me	1	2	3	4	5					
Cruising is one of the most enjoyable things I do	1	2	3	4	5					
When I participate in cruising, I can really be myself	1	2	3	4	5					
To change my preference from cruising to another leisure activity would require major rethinking	1	2	3	4	5					
Cruising is one of the most satisfying things I do	1	2	3	4	5					
Participating in cruising says a lot about who I am	1	2	3	4	5					
Cruising is very important to me	1	2	3	4	5					
Most of my friends are in some way connected with cruising	1	2	3	4	5					
I identify with the people and image associated with cruising	1	2	3	4	5					
Participating in cruising provides me with an opportunity to be with friends	1	2	3	4	5					
I enjoy discussing cruising with my friends	1	2	3	4	5					
Cruising occupies a central role in my life	1	2	3	4	5					
When I'm on a cruise, I don't have to be concerned with the way I look	1	2	3	4	5					

Question 23. Are you? Male Female

Question 24. What year were you born? (Please fill in 4-digit year) _____ Year

Question 25. Which of the following best describes your education level?

- Less than High School Completed High School
 Some College, not completed Completed College
 Post graduate work started or completed

Question 26. What is your ethnic background?

- Black or African-American White Hispanic
 Asian Native American/American Indian
 Other

If you selected “Other”, please specify: _____

Question 27. What was your approximate total household income last year?

- | | |
|---|---|
| <input type="checkbox"/> Less Than \$20,000 | <input type="checkbox"/> \$20,000 to Less Than \$25,000 |
| <input type="checkbox"/> \$25,000 to Less Than \$30,000 | <input type="checkbox"/> \$30,000 to Less Than \$40,000 |
| <input type="checkbox"/> \$40,000 to Less Than \$50,000 | <input type="checkbox"/> \$50,000 to Less Than \$75,000 |
| <input type="checkbox"/> \$75,000 to Less Than \$100,000 | <input type="checkbox"/> \$100,000 to Less Than \$125,000 |
| <input type="checkbox"/> \$125,000 to Less Than \$150,000 | <input type="checkbox"/> \$150,000 to Less Than \$200,000 |
| <input type="checkbox"/> \$200,000 to Less Than \$250,000 | <input type="checkbox"/> \$250,000 or More |

Question 28. What is your marital status?

- | | | |
|------------------------------------|--|-----------------------------------|
| <input type="checkbox"/> Married | <input type="checkbox"/> Single, Never Married | <input type="checkbox"/> Divorced |
| <input type="checkbox"/> Separated | <input type="checkbox"/> Widowed | |

APPENDIX E
INFORMATION SHEET

INFORMATION SHEET

Examining the Antecedents and Structure of Customer Loyalty in a Tourism Context

Thank you for participating in the study of “Examining the Antecedents and Structure of Customer Loyalty in a Tourism Context.” The purpose of this study is to examine what you think or feel about a cruise vacation. This study will involve cruise travelers who cruised at least once in the past 12 months, who are over 18 years old and volunteer to complete this survey. This study is confidential in that no identifiers linking you to the study will be included in any sort of report that might be published. If you agree to be in this study, you will be asked to fill out the questionnaire, which will take approximately 12 minutes. All your responses will be used only for the purpose of the study. You understand that your participation in this study is very important.

Your decision whether or not to participate will not affect your current or future relations with Texas A&M University. If you decide to participate, you are free to refuse to answer any of the questions that may make you uncomfortable. You can withdraw at any time without your relations with the university, job, benefits, etc., being affected.

This research study has been reviewed by the Institutional Review Board- Human Subjects in Research, Texas A&M University. For research-related problems or questions regarding subjects' rights, you can contact the Institutional Review Board through Ms. Angelia M. Raines, Director of Research Compliance, Office of the Vice President for research at (979) 458-4067, araines@vprmail.tamu.edu.

Responding to this survey, you acknowledge that you understand the following: your participation is voluntary; you can elect to withdraw at any time; there are no positive or negative benefits from responding to this survey; the researcher has your consent to publish materials obtained from this research.

If you have further questions, you can contact Dr. James Petrick, Department of Recreation, Park, and Tourism Sciences at (979) 845-8806, jpetrick@tamu.edu, or Robert Li at (979) 260-6865, roblix@neo.tamu.edu. By clicking on the button below you confirm that you have read and understood the information provided above and that you agree to participate in this survey.

I have read and understood the information provided above
and I agree to participate in this survey

APPENDIX F
COVARIANCE MATRICES

Covariance Matrix of Manifest Variables of Model A:

	BEHLOY	con2	aff3	aff2	cog3	cog2
BEHLOY	0.09					
con2	0.218	3.791				
aff3	0.189	3.299	3.616			
aff2	0.148	2.974	3.047	3.129		
cog3	0.154	2.998	2.99	2.808	3.532	
cog2	0.143	2.713	2.623	2.434	2.452	2.684

Covariance Matrix of Manifest Variables of Model B:

	cog2	con2	aff3	aff2	cog3	BehLoy	inv6	inv5	qalt5	inv1	inv2	inv4
cog2	2.684											
con2	2.713	3.791										
aff3	2.623	3.299	3.616									
aff2	2.434	2.974	3.047	3.129								
cog3	2.452	2.998	2.99	2.808	3.532							
BehLoy	0.143	0.218	0.189	0.148	0.154	0.09						
inv6	1.455	1.772	1.856	1.687	1.766	0.192	3.275					
inv5	1.233	1.522	1.448	1.313	1.296	0.182	1.123	3.101				
qalt5	-1.152	-1.538	-1.526	-1.381	-1.349	-0.133	-1.109	-0.416	2.588			
inv1	1.209	1.403	1.451	1.406	1.431	0.133	2.086	0.905	-0.801	2.779		
inv2	1.146	1.385	1.383	1.267	1.346	0.142	2.211	0.908	-0.659	1.983	2.882	
inv4	1.474	1.984	1.704	1.549	1.366	0.241	1.685	2.837	-0.765	1.348	1.438	6.146
qalt1	-0.753	-1	-1.045	-0.919	-0.984	-0.111	-0.693	-0.192	1.615	-0.506	-0.395	-0.353
qalt2	-0.51	-0.713	-0.721	-0.673	-0.508	-0.077	-0.327	-0.045	1.193	-0.143	-0.028	-0.326
qalt3	-0.812	-1.084	-1.172	-1.061	-1.067	-0.122	-0.975	-0.264	1.822	-0.759	-0.574	-0.496
qalt4	-0.78	-1.055	-1.042	-0.973	-0.843	-0.079	-0.675	-0.205	1.651	-0.5	-0.266	-0.39
sat1	1.542	1.793	1.694	1.641	1.556	0.066	0.744	0.749	-0.628	0.578	0.609	0.912
sat2	1.634	1.924	1.798	1.727	1.639	0.075	0.782	0.845	-0.741	0.579	0.591	0.938
sat3	1.656	2.047	1.874	1.807	1.704	0.086	0.872	0.834	-0.811	0.604	0.602	1.144
sat4	1.531	1.85	1.724	1.658	1.603	0.053	0.809	0.839	-0.702	0.543	0.531	0.939

	qalt1	qalt2	qalt3	qalt4	sat1	sat2	sat3	sat4
cog2								
con2								
aff3								
aff2								
cog3								
BehLoy								
inv6								
inv5								
qalt5								
inv1								
inv2								
inv4								
qalt1	2.001							
qalt2	1.165	1.918						
qalt3	1.436	1.109	2.145					
qalt4	1.342	1.384	1.381	2.152				
sat1	-0.437	-0.381	-0.37	-0.468	1.92			
sat2	-0.487	-0.43	-0.422	-0.528	1.766	2.158		
sat3	-0.476	-0.403	-0.431	-0.491	1.765	2.026	2.603	
sat4	-0.423	-0.367	-0.375	-0.485	1.582	1.889	2.079	2.171

Covariance Matrix of Manifest Variables of Model C:

	val1	val2	val3	val4	qua1	qua2	qua3	qua4	cog2	con2	aff3	aff2	cog3	BehLoy
val1	1.907													
val2	1.601	1.787												
val3	1.584	1.679	1.968											
val4	1.679	1.609	1.801	2.171										
qua1	1.326	1.351	1.537	1.724	2.211									
qua2	1.313	1.33	1.496	1.687	1.991	2.07								
qua3	1.241	1.268	1.423	1.644	1.92	1.958	2.141							
qua4	1.285	1.34	1.499	1.711	2.003	2.019	2.051	2.169						
cog2	1.376	1.338	1.537	1.691	1.667	1.621	1.597	1.651	2.684					
con2	1.603	1.616	1.872	1.997	2.082	1.945	1.879	1.965	2.713	3.791				
aff3	1.494	1.524	1.742	1.887	1.977	1.868	1.816	1.9	2.623	3.299	3.616			
aff2	1.477	1.507	1.703	1.839	1.894	1.784	1.747	1.813	2.434	2.974	3.047	3.129		
cog3	1.319	1.341	1.54	1.657	1.828	1.693	1.67	1.746	2.452	2.998	2.99	2.808	3.532	
BehLoy	0.076	0.069	0.075	0.078	0.071	0.065	0.065	0.063	0.143	0.218	0.189	0.148	0.154	0.09
inv6	0.876	0.815	0.884	0.93	0.914	0.83	0.848	0.861	1.455	1.772	1.856	1.687	1.766	0.192
inv5	0.668	0.69	0.773	0.795	0.747	0.736	0.733	0.735	1.233	1.522	1.448	1.313	1.296	0.182
qalt5	-0.667	-0.628	-0.73	-0.793	-0.775	-0.714	-0.709	-0.739	-1.152	-1.538	-1.526	-1.381	-1.349	-0.133
inv1	0.764	0.644	0.649	0.763	0.625	0.591	0.572	0.591	1.209	1.403	1.451	1.406	1.431	0.133
inv2	0.822	0.703	0.683	0.769	0.694	0.61	0.603	0.62	1.146	1.385	1.383	1.267	1.346	0.142
inv4	1.208	1.156	1.194	1.221	0.821	0.912	0.846	0.893	1.474	1.984	1.704	1.549	1.366	0.241
qalt1	-0.378	-0.337	-0.385	-0.493	-0.485	-0.433	-0.413	-0.451	-0.753	-1	-1.045	-0.919	-0.984	-0.111
qalt2	-0.346	-0.302	-0.386	-0.455	-0.404	-0.396	-0.411	-0.442	-0.51	-0.713	-0.721	-0.673	-0.508	-0.077
qalt3	-0.44	-0.361	-0.405	-0.494	-0.481	-0.403	-0.406	-0.444	-0.812	-1.084	-1.172	-1.061	-1.067	-0.122
qalt4	-0.497	-0.394	-0.494	-0.593	-0.564	-0.525	-0.507	-0.518	-0.78	-1.055	-1.042	-0.973	-0.843	-0.079
sat1	1.186	1.168	1.354	1.522	1.555	1.517	1.447	1.544	1.542	1.793	1.694	1.641	1.556	0.066
sat2	1.305	1.274	1.457	1.622	1.646	1.6	1.538	1.597	1.634	1.924	1.798	1.727	1.639	0.075
sat3	1.367	1.371	1.56	1.714	1.71	1.689	1.595	1.697	1.656	2.047	1.874	1.807	1.704	0.086
sat4	1.217	1.25	1.365	1.512	1.588	1.533	1.465	1.55	1.531	1.85	1.724	1.658	1.603	0.053

	inv6	inv5	qalt5	inv1	inv2	inv4	qalt1	qalt2	qalt3	qalt4	sat1	sat2	sat3	sat4
val1														
val2														
val3														
val4														
qua1														
qua2														
qua3														
qua4														
cog2														
con2														
aff3														
aff2														
cog3														
BehLoy														
inv6	3.275													
inv5	1.123	3.101												
qalt5	-1.109	-0.416	2.588											
inv1	2.086	0.905	-0.801	2.779										
inv2	2.211	0.908	-0.659	1.983	2.882									
inv4	1.685	2.837	-0.765	1.348	1.438	6.146								
qalt1	-0.693	-0.192	1.615	-0.506	-0.395	-0.353	2.001							
qalt2	-0.327	-0.045	1.193	-0.143	-0.028	-0.326	1.165	1.918						
qalt3	-0.975	-0.264	1.822	-0.759	-0.574	-0.496	1.436	1.109	2.145					
qalt4	-0.675	-0.205	1.651	-0.5	-0.266	-0.39	1.342	1.384	1.381	2.152				
sat1	0.744	0.749	-0.628	0.578	0.609	0.912	-0.437	-0.381	-0.37	-0.468	1.92			
sat2	0.782	0.845	-0.741	0.579	0.591	0.938	-0.487	-0.43	-0.422	-0.528	1.766	2.158		
sat3	0.872	0.834	-0.811	0.604	0.602	1.144	-0.476	-0.403	-0.431	-0.491	1.765	2.026	2.603	
sat4	0.809	0.839	-0.702	0.543	0.531	0.939	-0.423	-0.367	-0.375	-0.485	1.582	1.889	2.079	2.171

VITA

Name: Xiang (Robert) Li

Address: Department of Recreation, Park and Tourism Sciences, c/o Dr. Jim Petrick, 2261 TAMU, Texas A&M University

Email Address: roblix@hotmail.com

Education: M.S., Physical Geography, Nanjing Normal University, Nanjing, P.R. China, 2001.
M.S., Recreation and Leisure Facilities and Services Administration, East Carolina University, Greenville, NC, 2003.

Professional Experience:

Specialist of Destination Marketing, Events Organizing, & Tourism Planning, Market Development Dept., Nanjing Municipal Tourism Bureau, Nanjing, P.R. China, 1996 to 2001.