

UKRAINIAN MEDICAL STOMATOLOGICAL ACADEMY

Yeroshenko G.A., Klepets O.V., Perederii N.O., Vatsenko A.V.,
Ulanovska-Tsyba N.A., Riabushko O.B., Shevchenko K.V.

Biological features of the human vital activity

**Training text-book
on Medical biology (module I)
for students of medical and stomatological faculties**

Poltava – 2021

Composite authors:

Yeroshenko G.A., Klepets O.V., Perederii N.O., Vatsenko A.V.,
Ulanovska-Tsyba N.A., Riabushko O.B., Shevchenko K.V.

Reviewers:

L.Ya. Fedoniuk – the head of the Medical Biology department of the Ternopil National Medical University, doctor of biological sciences, professor.

L.Ye. Kovalchuk – the head of the Medical Biology and Medical Genetics department of Ivano Frankivsk National Medical University, doctor of medical sciences, professor.

S.M. Bilash – the head of the Clinical Anatomy and Operative Surgery Department of Ukrainian Medical Stomatological Academy, doctor of biological sciences, professor

O.M. Bieliaieva – the head of the Foreign Languages with Latin and Medical Terminology Department of Ukrainian Medical Stomatological Academy, candidate of pedagogical sciences, associate professor.

Recommended by the Academic Board of the Ukrainian Medical Stomatological Academy as a training text-book for English-speaking students in speciality 221 Dentistry and 222 Medicine in a higher educational institutions of the Ministry of Health of Ukraine (dated 10.03.2021, minutes of the meeting № 7).

B 60 Biological features of the human vital activity. Training text-book on Medical biology (module I) for students of medical and stomatological faculties / G.A. Yeroshenko, O.V. Klepets, N.O. Perederii et al. – Poltava, 2021. – 82 p.

ISBN 978-617-7464-73-9

Textbook for students of the international faculty of training foreign students in the specialty 222 – Medicine, 221 – Dentistry

Training text-book includes the tests of the 1st level (with one right answer), tests of the 2nd level – with the numerous choice of answers, typical tasks, in accordance with the Program of Medical biology for the students of medical and stomatological faculties of Higher Medical Educational Establishments of III–IV levels of accreditation, and also materials for self-preparation work.

Text-book will help students to master theoretical knowledge during audience classes and self-dependent preparation to the module control.

Methodical edition includes tests from the base of previous years tests of licensed examination «Krok-1» and tests which worked out by teachers of Medical biology departments that will help students to prepare effectively and pass module control as well as licensed examination.

UDC 577:61 (075.8)

The test tasks highlighted by the frame are taken from the «Krok-1» database.

TOPIC: Introduction to the course of medical biology.

Levels of living matter organization. Optical systems in biological research

Medical biology as a science about human vital activity. The essence of life. Forms of life, its fundamental properties and traits. Structural levels of life organization as a result of evolution. Importance of ideas about the levels of living for medicine. Optical systems in biological research. Structure of the light microscope. Making of temporary micropreparations, studying and description.

Medical biology as a science about human vital activity

Biology (from greek *bios* – life, *logos* – science) – the science about life and the general regularities of existence and development of living organisms: life processes, interaction with the environment, origin, historical and individual development of all living organisms. The theoretical foundation of biology based on Darwin's theory of evolution, cell theory of Teodor Schwann (1838) and Matias Schleiden (1839), Rudolf Virchow who has introduced the cell theory in medicine and other discoveries.

Modern biology is a complex of fundamental researches of wildlife in different levels. At the present moment of development biology could solve many biomedical problems, to penetrate into cells structure, its molecular organization and to get new understanding of the processes inside the cell.

Medical biology is the science about processes and mechanisms that occur in the human body, regularity of human cellular and tissue structure, individual human development, evolutionary and adaptive processes in human populations, adaptation to environmental conditions and influence of teratogenic and mutagenic factors, parasitic diseases, that exist in different human populations, and methods of their prevention and diagnosis, also many other theoretical and practical problems of a man. One of the major tasks of medical biology – the study of human heredity, genotype of inherited diseases, genetic heterogeneity and individual genotypes and morphological differences of people, their environmental adaptability, development of boundary conditions, physiological characteristics and behavior.

Levels of living matter organization

Levels of life (levels of living matter) are structural organization of biosystems, reflecting their hierarchy depending on the degree of difficulty. There are basic structural levels:

Microsystems:

1. *Molecular-genetic* (fundamental) (size ≤ 1 nm):
elementary unit – gene;
elementary processes – replication and other processes of matrix synthesis, gene mutation.
2. *Subcellular* (size: 1–100 nm).
3. *Cell* (fundamental) (size: 0.2–20 microns).

Mesosystems:

4. *Tissue* (sizes: 10–100 microns).
5. *Organ* (sizes: ≥ 0.1 mm).
6. *Organismic (or ontogenetic)* (fundamental) (size: few mm – few dozens m).

Macrosystems:

7. *Population-species* (fundamental).
8. *Biogeocenotic* (or ecosystem).
9. *Biosphere* (global).

Basic properties of organisms

Questions about the human nature have been interested humanity throughout its development, but the final answer is not ready yet. Most scientists believe that life is a special form of existence of matter that differs from non-alive nature by features of the structure and functioning which in biology is called **vital activity**.

Living organisms – complete biological system capable of self-regulation, self-renewal and self-reproduction (the fundamental properties of living). In their chemical composition is dominated by organic compounds: proteins, lipids, carbohydrates, nucleic acids, etc. They are forming by four chemical elements: carbon, hydrogen, oxygen and nitrogen. Time of existence of organic compounds is limited. That is why biological systems are constantly changing and forming new ones.

Each biological system is capable to *self-regulation* – it means regulation of their vital functions and maintaining their internal medium. That is why all living organisms are able to adapt for changes in the environment and respond for changes by intensity of their vital processes.

The necessary condition for existence of living beings is *metabolism*. As an open system living organism receives all necessary product from environment giving back the waste products of their metabolism. Metabolism is closely associated with the transformation of energy: during the formation of complex compounds the energy expended but their cleavage is released. Functioning of any living organisms is impossible without wasting of energy so one of the most important process is a constant flow of energy from the environment. Only green plants and some prokaryotes and protozoans are capable of photosynthesis, absorbing light energy. Most organisms obtain the energy by means of food.

An important property of living organisms is *ability for reproduction*. Life of an individual organism as biological system is limited by particular term so existence of each species is provided by total reproduction of individuals.

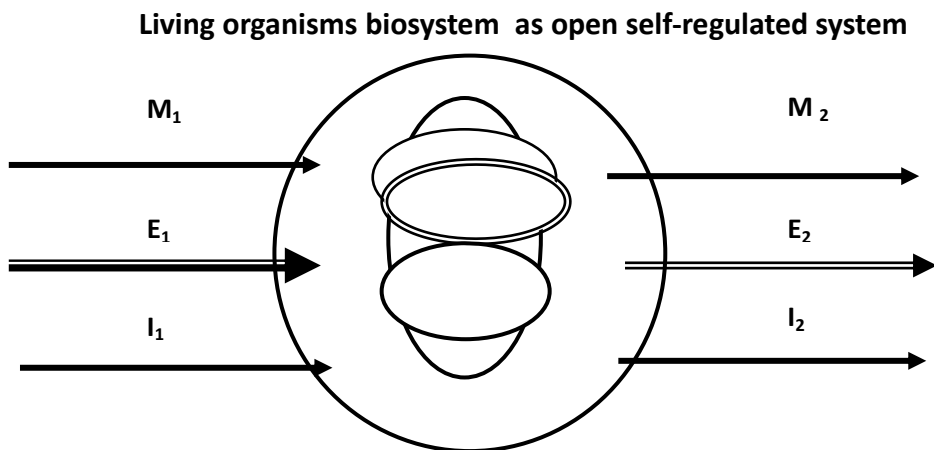
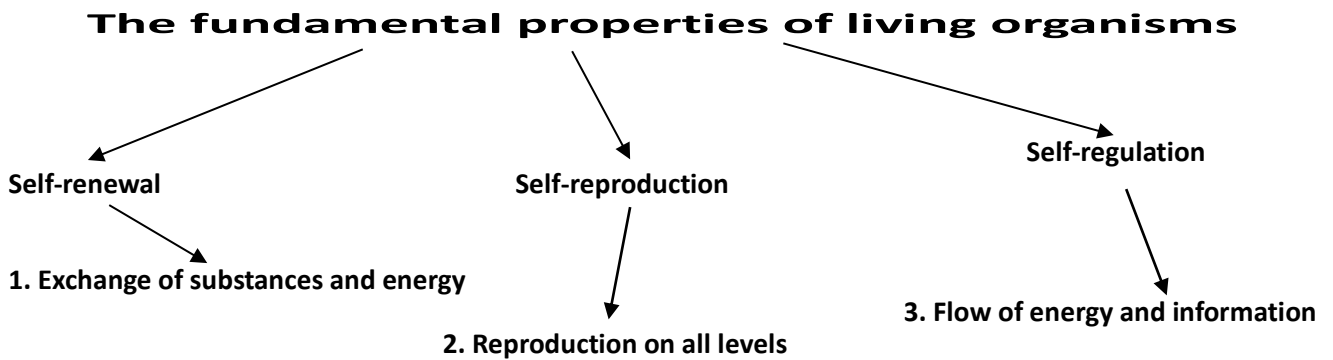

M_1 – M_2 – metabolism; E_1 – E_2 – exchange of energy; I_1 – I_2 – exchange of information.

Optical systems in biological research. Structure of the light microscope

During performing of biological research are using well-known as well as specific methods:

- the method of observation;
- method of biological experiment;
- historical method;
- descriptive method;
- microscopic method;
- X-ray analysis;
- stepped centrifugation;
- electron microscopy;
- scanning electron microscopy;
- electron microscope of histochemistry;
- microspectral analysis;
- statistical methods.

The **optical microscope**, often referred to as **light microscope**, is an optical device for obtaining magnifications of very small objects, with using of visible light and a system of lenses.

Optical microscopes are the oldest design of microscope and were possibly invented in their present compound form in the 17th century. Basic optical microscopes can be very simple, although there are many complex designs which aim to improve resolution and sample contrast.

Every optical microscope consists of mechanical, optical and lighting systems.

The *mechanical part* of microscope includes:

- base (for supporting the microscope);
- arm (for retention of tube);
- tube (for retention of ocular);
- stage, or subject table (for placing the specimen);
- revolver (for shifting and retention of the objectives)
- screw of stage moving;
- macroscrew (for moving a tube);
- microscrew (for adjustment of image clarity);
- screw of condenser.

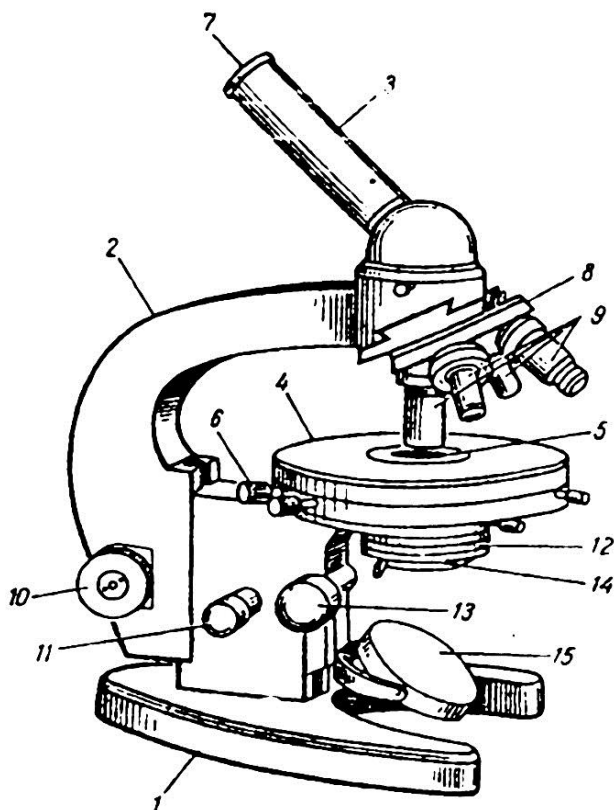

The structure of light microscope: 1 – base; 2 – arm; 3 – tube; 4 – stage; 5 – aperture of stage; 6 – screw of stage moving; 7 – ocular; 8 – revolver; 9 – objectives; 10 – macroscrew; 11 – microscrew; 12 – condenser; 13 – screw of condenser; 14 – diaphragm, 15 – mirror.

The *optical part* of microscope consists of:

- ocular, or eyepiece (placed in the upper tube part; the increasing degree can be x7, x10, x15);
- objectives (provide a different magnification, containing the lens of small increasing (x8), the lens of large increasing (x40) and the immerse (x90) lens);
- aperture of stage (for passing light to the specimen).

To the *light part* of microscope are included:

- condenser (a system of lenses (mirrors) that collects and directs rays from a light source to the studied object);
- diaphragm (limiting beams of light rays);
- mirror (directs the flow of light; it has two surfaces – the plate and the concave one: to have the intensive lighting at the condenser lacking they use the concave glass surface; while working with immerse lens one can use the condenser and the flat glass).

Consideration of any specimen begins at a small increase, which examines the general plan of its structure. In-depth study of structural components is provided on a large increase of the microscope.

Remember! *The total increasing of microscope is equal to the ocular increasing multiplied by the lens increasing (e.g. the eyepiece 7 x the lens 8 = 40 times). The microscope gives an increased and reversed imaging of the object!*

The rules for work with microscope:

1. Set the microscope with the stand towards you and the subject table opposite you.
2. Put in the working state the lens of a small increasing. For this purpose rotate the revolving nosepiece till the required lens occupies the middle place in comparison with the tube and the subject table. When the lens occupies the middle place the light click is heard and the lens is fixed. Remember that the learning of any object begins with a small increasing!
3. By means of a coarse adjustment pick up the lens above the subject table up to altitude of about 0.5 cm.

4. Looking through the eyepiece with your left eye rotate the glass in various directions until the vision field will be lit up brightly and evenly.
5. Put the preparation on the subject table so that the object would be in the center of the subject table opening.
6. Further, under the eyesight control slowly lower the draw tube by the coarse of adjustment so the lens to be found at the distance of 2 mm from the preparation.
7. Look through the eyepiece and simultaneously slowly pick the tube up until the object picture appears in the field of vision.
8. To come to the object vision at the large microscope increasing first of all it's necessary to place the object in the center of the vision field. If the object isn't centered so at a large increasing it may stay out of the vision field.
9. Moving the revolving nosepiece put the lenses of large increasing in working state.
10. Lower the tube under the eye control (see how the tube is lowering not into the eyepiece but from one side) nearly to the contact with the preparation.
11. Then looking through the eyepiece slowly (!) to pick the tube up till the object picture is in the vision field.
12. To have the careful focusing use the fine adjustment.
13. When studying the smallest objects in light microscope they use **immerse** (from Latin *immersion* – to plunge into) lens. While working with this lens it's necessary to drop the special substance on the cover glass. This substance has the similar refraction index with the glass. Normally to gain this goal they use the cedar oil. There is no air layer between the lens and the covering glass. That's why the light ray passes through the homogeneous with regard to the refraction index without any refraction.
14. Lower the tube (looking at it from one side) so that the lower lens would plunge into the immerse oil drop.
15. Then looking through the lens by means only of the fine adjustment you should lower and then raise the lens carefully to receive the exact vision.

Remember! The work with the optical microscope requires more careful attention!

1st level tests (one correct answer)

- | | |
|--|--|
| <p>1. One of the basic properties of living organisms is ability for reproduction. What of the following level of organization of living organisms is carried out of this process on the basis of matrix synthesis?</p> <ol style="list-style-type: none"> A. Organismic B. Subcellular C. Cellular D. Tissue E. Molecular. <p>2. Existence of life on all levels is determined the structure of lower level. What level of organization existence of life is preceded and provides on cellular level:</p> <ol style="list-style-type: none"> A. Molecular B. Tissue C. Organismic D. Population-species E. Biocenotic. <p>3. To the light part of microscope belong:</p> <ol style="list-style-type: none"> A. Mirror B. Revolver C. Base <p>7. Which process takes place during lowering of condenser of light microscope:</p> <ol style="list-style-type: none"> A. Illumination of the specimen diminishes B. Illumination of the specimen increases C. Focus is changed D. The image of object becomes more clear E. The contrasty of image of object diminishes. <p>8. What function of micrometer screw:</p> <ol style="list-style-type: none"> A. Exact focus of object's image | <ol style="list-style-type: none"> D. Arm E. Ocular. <p>4. To the optical part of microscope belong:</p> <ol style="list-style-type: none"> A. Objective B. Micrometer screw C. Mirror D. Base E. Macrometer screw. <p>5. To the mechanical part of microscope belong:</p> <ol style="list-style-type: none"> A. Tube B. Condensor C. Ocular D. Mirror E. Objective. <p>6. Immersion is used for increasing:</p> <ol style="list-style-type: none"> A. x 7 B. x 10 C. x 40 D. x 20 E. x 90. <ol style="list-style-type: none"> B. Diminishing of the object C. Improvement of light of the object D. Focusing of image E. Increasing of image. <p>9. Part of the field of vision is lighted up well and part is black if:</p> <ol style="list-style-type: none"> A. Dirty lenses of objective B. Dirty lenses of ocular C. Dirty glass |
|--|--|

- D. Objective did not occupy the fixed position in the revolver disk
- E. Dirty covering glass.
10. Image of object on a microslide is visible on small increasing but does not on large increasing of microscope because:
- A. Dirty covering glass
- B. Covering glass lies under the microslide
- C. Dirty lenses of ocular
- D. Objective is out of plane of image focus
- E. Insufficient light of object.
11. Define property of life which provides heredity between parents and descendants:
- A. Self-regeneration
- B. Self-regulation
- C. Self-reproduction
- D. Development
- E. Growth.
12. What factors conditioned appearance of independent systematic unit of *Homo sapiens* in the process of evolution?
- A. Social
- B. Biological
- C. Anthropogenic
- D. Physical
- E. Chemical.
13. Choose the wrong answer:
- A. Organism is the opened biological system
- B. Multicellular organism is not simply sum of cells in the «cellular state»
- C. Organism is a self-regulated system
- D. Organism is not self-regulated system
- E. Organism is opened self-regenerative and self-reproductive system.
14. Choose the correct answer:
- A. Cell is an elementary unit of structure and development of organisms
- B. Cell is able to development
- C. Cell is an elementary opened biological system which is able to the self-regeneration and development
- D. Cell is an elementary opened biological system which is able to the self-regeneration and self-regulation
- E. Cell is an elementary opened biological system which is able to the self-regeneration.
15. What level of organization is fundamental and determines the typical metabolism?
- A. Organismic
- B. Subcellular
- C. Cellular
- D. Tissue
- E. Molecular-genetic.
16. Chromosome of prokaryotes is a circular DNA molecule. Name the level of organization of hereditary material:
- A. Chromosomal
- B. Microfibre
- C. Molecular-genetic
- D. Nucleosome
- E. Tissue.
17. One of fundamental level is organismic. On this level genotype is determined by ontogenesis of organism,

- its phenotype, adaptation and behavior in the environment. What ecological problems do arise up for a man on this level?
- A. Increase of amount of population
- B. Development of border states
- C. Increase of agriculture cenosis
- D. Pollution of environment
- E. Destruction of ozone layer.
18. Organisms which do not have membranous organelles and their genetic material does not have nucleosome organization belong to the group:
- A. Fungi
- B. Viruses
- C. Eukaryotes
- D. Prokaryotes
- E. Protozoa.
19. Living matter is characterized by evolutionally conditioned structural levels of organization. On which of these levels the genotype determines the typical for an organism metabolism and energy:
- A. Molecular-genetics
- B. Organs
- C. Organismic
- D. Cellular
- E. Tissue.
20. Metabolism, changing of an energy and information are necessary for the existence of living biological systems. Which ensuring universal substance provides needs of metabolic energy?
- A. Adenosine triphosphate
- B. Dioxadenyltriphosphate
- C. Glucose
- D. Creatine phosphate
- E. Acetyl-CoA.
21. Wildlife is characterized by the evolutionally conditioned structural levels of the organization. What level is the genoplast as a control system?
- A. Molecular-genetic
- B. Organism
- C. Biogeocenotic
- D. Tissue
- E. Overmolecular.
22. What forms of life exhibit their properties only at the stage of intracellular parasitism?
- A. Bacteria
- B. Bacteriophages
- C. Cyanea
- D. Parasitic fungi
- E. Salmonella.
23. Cell as an open biological system is characterized by metabolism, energy and information. What mitochondrial formation process provides the maximum amount of energy during respiration?
- A. Krebs cycle
- B. Glycolysis
- C. Transport H^+ channel by ATP synthase
- D. Moving of electrons in electron transport chain
- E. Photorespiration.
24. Each biological system is capable of self-regulation: the regulation of their vital functions, maintaining of

homeostasis. What is important property defines self-regulation?

- A. Energy conversion
- B. Update of molecular composition
- C. Adapting to environmental changes
- D. Reproductions of biosystems
- E. Synthesis of nucleic acids.

25. Attribute of life is the preservation and transmission of information flow. What process provides information safety on the molecular genetic level?

- A. Mitosis
- B. Sexual reproduction
- C. Transcription
- D. Gene expression
- E. Replication.

26. Each biological system adapts to the environmental changes and defines changes in their life functions and homeostasis maintaining. What is the fundamental property of living systems which determines the ability to adapt to the different environmental conditions?

- A. Self-renewal
- B. Self-regulation
- C. Metabolism
- D. Self-renewal
- E. Reproduction.

27. What is the name of the genotypes and phenotypes adapted to each other in their environmental populations?

- A. Biogeocenosis
- B. Genoplast
- C. Anthropocenosis
- D. Population
- E. Isolation.

28. On which levels do environmental problems appear such as growth of mutagenic effects and mutational increase in their genofund?

- A. Organism
- B. Subcellular
- C. Cellular
- D. Tissue
- E. Molecular-genetic.

2nd level tests

(few correct answers)

1. Name the level of organization of the living systems on which a genotype is determined by the typical cellular metabolism:

- A. Molecular-genetics:
- B. Organismic
- C. Cellular
- D. Population-species
- E. Subcellular
- F. Biosphere.

2. Name the fundamental level of life organization:

- A. Ontogenetics
- B. Subcellular
- C. Cellular
- D. Molecular-genetics
- E. Population-species.

3. Name the level of life organization where genotype determines ontogenesis:

- A. Population-species
- B. Molecular-genetics
- C. Cellular
- D. Organismic
- E. Subcellular
- F. Biosphere.

4. Fundamental properties of a cell as a open biosystem are:

- A. Self-correction
- B. Self-regulation
- C. Self-reproduction
- D. Self-providing.

5. Cell or an organism have such properties as an open alive system:

- A. Metabolism
- B. Variation
- C. Ontogenesis
- D. Discrete unit.

TOPIC: Cell morphophysiology. Structural components of cytoplasm

Structural-functional organization of eukaryotic cells. Chemical composition of cells: macro- and microelements. Water, importance of hydrogen bonds in the processes of cellular activity. Organic compounds – carbon-containing substances of living organisms. Cytoplasm and cytoskeleton. Cyclosis. Cytoplasmic organelles – membranous and non-membranous, importance and principles of functioning. Inclusion of cells, their function. Methods of studying of structure and functioning of cells.

Cell theory. The study of cellular activity is one of the necessary steps in understanding of pathological processes that students continue to study on the pathological anatomy and physiology departments, inner and surgical diseases and also on other departments where the diseases studied on organisms, systems and tissue-organ levels.

Cell theory was established in 1838–1839 (T. Schwann, M. Schleiden). The main statements of the cell theory have retained their value to the present time, but nowadays were obtained new data about structure and vital functions of cells.

The modern cell theory includes such statements:

- Cell is an elementary structural-functional and genetic unit of life.
- Cells of different organisms homologous by their structure.
- Cell division occurs by dividing of an initial mother cell.
- Multicellular organisms are complexes of various cells and their derivatives which are incorporated in the whole integrated system of tissues, organs and united among themselves by intercellular, humoral and nervous forms of regulation.

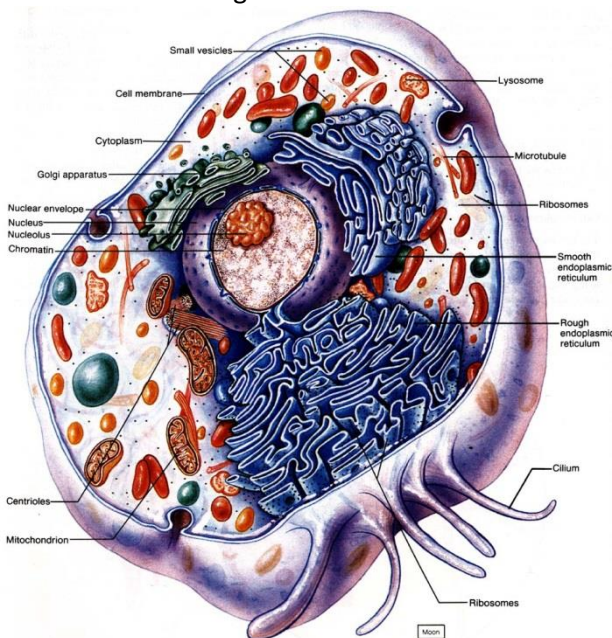

The cell.

Cell is the smallest structure of life, which has all characteristics and properties of life.

The concept of cell as the smallest unit of life proved by T. Schwann and R. Virchow who believed that every cell is characterized by all attributes of living things.

According to the modern data, all living organisms are opened self-regulated systems where important components are nucleic acids and proteins. DNA codes information about the structure of proteins, but proteins are complexes of molecules which have functional specificity and determine realization of genetic information and properties of life: ability to self-reproduction and self-regulation, ensure the flow of matter and energy during metabolism, heredity and variability, sensitivity, movement, adaptation. Such properties firstly defined on the cellular level that is why cells are elementary structural and functional units of life.

Non-cellular and cellular forms of life

Throughout the organic world can be divided into two life forms: cellular and non-cellular.

Non-cellular forms of life – viruses – are forming the kingdom of Vira which is divided by the type of nucleic acids on riboviruses and deoxyviruses. Viruses of human and vertebrates include 17 families where 6 of them are DNA-containing (DNA genomic) and 11 ones are RNA-containing (RNA genomic).

Viruses are form of life that exhibit the properties of living cells and only parasitizing in pro- and eukaryotes. Viruses are microscopic in size but vary in wide limits: from 15–18 nm to 300–400 nm and have different shapes: bacilli-shaped, spherical, spermatozoid-shaped et al.

Viruses differ from pro- and eukaryotes by structural organization and functional features. They contain only one of the nucleic acids – DNA or RNA and have non-cellular structure. Viruses are not capable of growth and binary fission. Viruses are formed acquiring certain shape and exact size that do not change. Reproduction of virus is cell replicating by means of nucleic acids. In the virus there are no an autonomous process of metabolism

and own systems of energy storage and protein synthesis, they use enzyme systems, energy sources of living cells, turn the work of cells to produce new viral particles.

Viruses exist in two forms: extracellular – *virion* and intracellular – a *virus*. According to the structure virions are divided into simple and complex. Simple virions consist of NA and protein. NA is covered with outer protein envelope – *capsid*, which protect viral genome from external environment. NA and protein form together *nucleocapsid*.

Complex virions have NA, protein, lipids, carbohydrates and enzymes. Lipids, carbohydrates and proteins make up the outer membrane called *supercapsid*.

The molecular weight of viral DNA is 10–100 times less than the molecular weight of bacterial DNA. The genome contains up to several hundred genes. DNA can be single and double-stranded, they are capable of being locked in the ring and replicated in this form, transcribed, acquired resistance to endonuclease enzymes, and incorporate into the cell genome.

Viral RNA are similar to the RNA of cells but can be one-stranded and double-stranded. One-stranded RNA depending on the functions are divided into 2 groups. Some of them are able to perform the function of iRNA (positive genom), others may be a matrix for the formation of iRNA during reverse transcription (negative genom).

Viruses, which parasite in bacterial cells, are called *bacteriophages*. They have a more complex structure than most viruses. The bacteriophage consists of the head and the appendage. The head contains nucleic acid. The capsid of the head has a cubic structure, and the appendage is spiral. Penetrating to the bacterial cell, the phages inject the nucleic acid through the canal of appendage. In a bacterial cell, phage's nucleic acid is intensively multiplied, causing its lysis. Sometimes the penetration of phages into a bacterial cell is not accompanied by its lysis, and the phage's DNA is embedded in the bacterial genome and transmitted to its descendants.

Viruses have a great importance, the most of them cause diseases of plants, animals and humans. In human viral diseases are: smallpox, taiga encephalitis, measles, influenza, AIDS and others. In addition, viruses can provide transfer of genetic material (transduction).

Cellular life forms, depending on presence of formed nucleus, divided into prokaryotes and eukaryotes.

Prokaryotes – organisms whose cells have no nucleus. **Eukaryotes** – organisms whose cells have one or more nuclei. Prokaryotes include representatives of bacteria and blue-green algae.

The cells of prokaryotes are small in size (0.1–0.25 mcm – mycoplasma; 1.10 mcm – bacteria, blue-green algae). Prokaryotes cells have a cell membrane, cytoplasm. The membrane is represented by the complex structure of the cell wall and cytoplasmic membrane. On the surface the mucous capsule can be formed. In the cytoplasm are organelles: ribosomes and membrane formation – mesosome, photosynthetic membranes, etc.

In the middle zone of prokaryotic cell it can be founded *nucleoid* (localization of hereditary material) where the bacterial chromosome – circular molecule of DNA which is not connected with protein histones – localized.

Prokaryotic cell hasn't typical membranous organelles. There are no centrioles, the system of microtubules and microfilaments is poorly developed. Prokaryotes cells have an intensive metabolism, often occurring mutations and faster processes of adaptation to the environment. Cell reproduction is binary fission with doubling of DNA molecule.

Comparison of prokaryotes and eukaryotes

Cell structure	Prokaryotes	Eukaryotes
Cell membrane	+	+
Nucleus	–	+
Hereditary material	Circular DNA	Linear chromosome, DNA-histone, proteins
ER	–	+
Ribosome	Smaller in size	Larger in size
Golgi complex	–	+
Lysosome	–	+
Mitochondrion	–	+
Mesosome	+	–

Eukaryotes include representatives of three kingdoms: Plants, Fungi, Animals. Their cells have a nucleus, membrane organelles (ER, Golgi complex, lysosomes) and developed non-membranous organelles (ribosomes, microtubules and microfilaments system, centrioles). Hereditary material presented by linear chromosomes that include DNA, histones, acidic proteins. The main way of division is mitosis – complex of evolutionary process which provides transmission and distribution of hereditary material.

Structural and functional organization of eukaryotic cells

Eukaryotic cells are constructed of three main components: membrane, cytoplasm and nucleus. There are two subtypes of cell: cells of unicellular organisms which are also individual organisms and cells of multicellular organisms (plants, animals, fungi).

Particular importance in cellular organization belongs to biological membranes (biomembranes) which form: cell membrane (plasmalemma), membrane of nucleus and membrane of mitochondria and plastids, membranous organelles (endoplasmic reticulum, Golgi apparatus, lysosomes, peroxisomes, vacuoles).

Membranes are complex molecular systems, liquid-crystalline solutions of globular proteins in lipid biostructures which define the basic life processes at the cellular level.

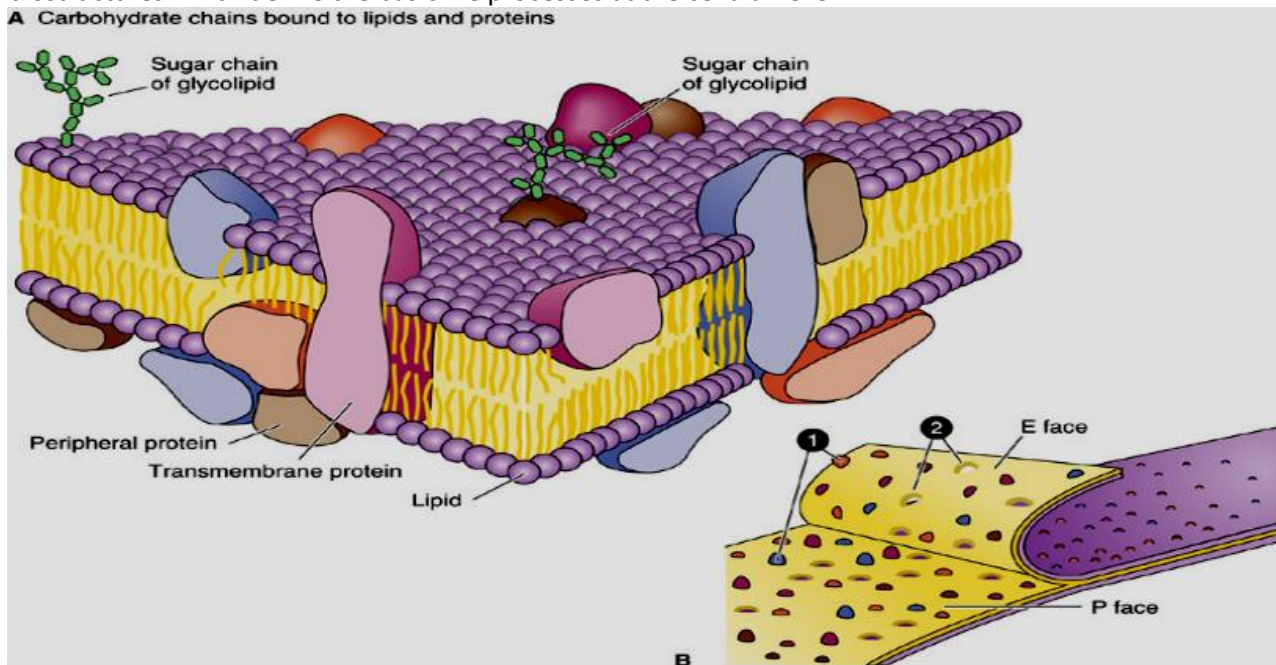

Cell membrane.

Organelles of cytoplasm. Cells of multicellular organisms separated by cell membrane, which formed a membrane covered by the layer outside (thickness 10–20 nm). Inside the membrane the cortical layer of cytoplasm has attached where the large number of microfilaments and microtubules are formed by the contractile proteins. Cells filled by cytoplasm where the nucleus localized.

Cytoplasm (cytosol + cytoskeleton + organelles + inclusion). Chemical content:

- Water ($\geq 75\%$);
- Salt (1–2%);
- Gases (CO_2 , O_2 , N_2 , NH_4^+);
- Organic matter (20–25%) – about 10,000 different proteins, fats, carbohydrates, NA.

Functions of cytoplasm:

- environment for biochemical reactions;
- support structure of organelles;
- the growth and differentiation of cells;
- restoration of molecules structures;
- reservoir for different substrates;
- ensure constancy of the concentration of substances which are necessary for the existence of cells (homeostasis);
- transformation of damaged materials.

The cytoplasm is the main mass of a cell, its internal content, except the nucleus. It contains 75–85% water, 15–25% protein and many other substances. Cytoplasm is homogeneous, colorless, transparent with viscous liquid. Cytoplasm is a multicomponent, multifunctional complex. The cytoplasm contains the cytosol (cytoplasmic matrix), organelles and inclusions.

Cytosol (or hyaloplasm) is 55% of total cells mass. This colloid formed by mix complex of macromolecules: fats, carbohydrates and non-organic substances (more than 10,000 different proteins).

In the cytosol there are non-organic (water, salts, gases) and organic substances. Water is the main part of cytosol (75%). Salts are 1–2% cytosol, they form ions. Mostly they are carbonates, bicarbonates, phosphates, sulfates and chlorides of sodium, potassium, calcium, magnesium and iron. They determine the osmotic properties of cytosol. Many of them are involved in biological processes. Cells has oxygen, carbon, nitrogen and ammonia. CO₂ is a result of metabolism, the final product of oxidation reactions and permanently removed from cells.

Organic substances constitute 20–25% of living cells mass. The main groups of these substances are: proteins, fats, carbohydrates and nucleic acids. They define the structure and function of cells (energy substrates oxidation and so on).

Functions of cell organelles provides by continuous, necessary for them surroundings of cytosol. From the cytosol organelles receive the necessary materials and involved to the maintenance of cell homeostasis. Chemical reactions occurring in the cytosol provide constancy of a cell and its structural organization. In the cytosol constantly maintained concentration of water, gas, substances for chemical reactions, pH. These conditions are necessary for the flow of biochemical and physiological processes. Due to continuous synthesis of molecules all damaged molecules are exchanged by new synthesized molecules.

Cytoskeleton is a network of protein filaments and microtubules which covered inside by cytoplasmic membrane and goes through the internal space of a cell. Cytoskeleton consists of three types of structures: 1) *microtubules* (formed by several proteins fibrils containing globular protein – tubulin; 2) *microfilaments* (the thinnest) which formed by globular proteins – actin; 3) *intermediate filaments* (several microfilaments combination).

Functions of cytoskeleton:

1. Determination of volume and shape of cells and their changes. The main role has fibrillar net – *cortex* that covers membrane inside. Microfilaments and microtubules are connected to the net which greatly stabilizes the shape of cells. The system of protein filaments is able for contraction and tension which leads to the change of shape.
2. Movement of organelles and their transport. Cytoskeleton filaments attached to the cell organelles. This is stabilizing of their position in cytoplasm. Changing the length of fibrils leads to movement of cellular structures.
3. Forming of compartments of cytoplasm. Binding of several cytoskeleton filaments created favorable conditions for the placement of complex enzymatic proteins. It provides structural union of enzymes for specific metabolic processes.
4. Integration of all cytoplasm to the organic whole.
5. Formation of spindle during mitosis and specific organelles (villi and flagella). Providing contractile function of muscle fibers.
6. Formation of contacts between cells (*desmosomes*).

Cytoplasm is heterogeneous in its structure. Membrane components of cytoplasm are closed zones (*compartments*) which specialized to perform certain functions. Content of separated or interconnected compartments is isolated by membranes from hyaloplasm and plasmallema.

Membrane structures of cytoplasm can be divided into several groups:

- 1) *One-membranous organelles* are vacuole, endoplasmic reticulum (ER), Golgi complex, lysosomes, peroxisome.
- 2) *Two-membranous organelles* – mitochondria and plastids. They have an outer and inner membranes, which do not pass each other, opposite to nuclear membrane where the outer membrane can be connected with ER membranes.
- 3) *Non-membranous organelles* – ribosomes, centrioles, microtubules, microfilaments, myofibrils, etc.

Tubular and vacuole system presented by tubular or flattened cavity (tank) and separated from the membrane of hyaloplasm and placed throughout the cytoplasm.

Endoplasmic reticulum.

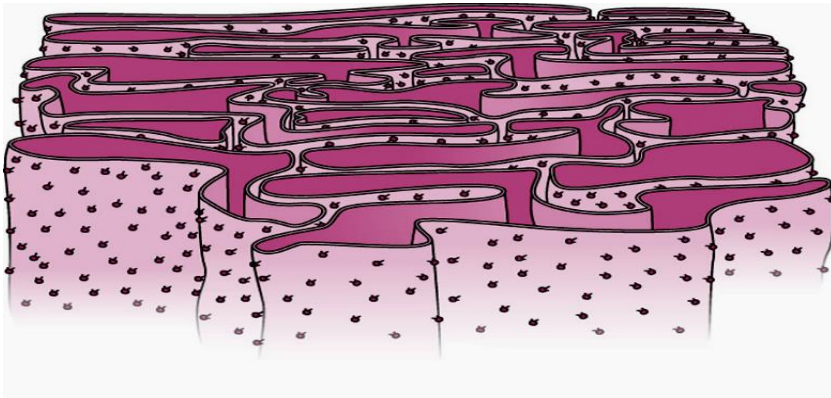

There are many ribosomes on *rough (or granular) ER* because it synthesizes proteins, most of these proteins secreted from cells, for example, proteins that are secreted by cells of glands. Here also formed proteins and lipids of plasmalemma.

Tanks can form tightly packed layer structure – the most active sites of protein synthesis, called ergoplasm.

Agranular (or smooth) ER does not have ribosomes. It takes part in an exchange of fats, carbohydrates, steroid hormones and other substances. In the tubules there are accumulation and transport of substances from sites of synthesis to zone of formation of granules. In the cells of various organs ER can perform specific functions. For example, in liver cells with developed smooth ER toxic substances and some drugs are destroyed. In tubes of smooth ER in muscle cells ions Ca^{2+} , required for the constriction process, are deposited.

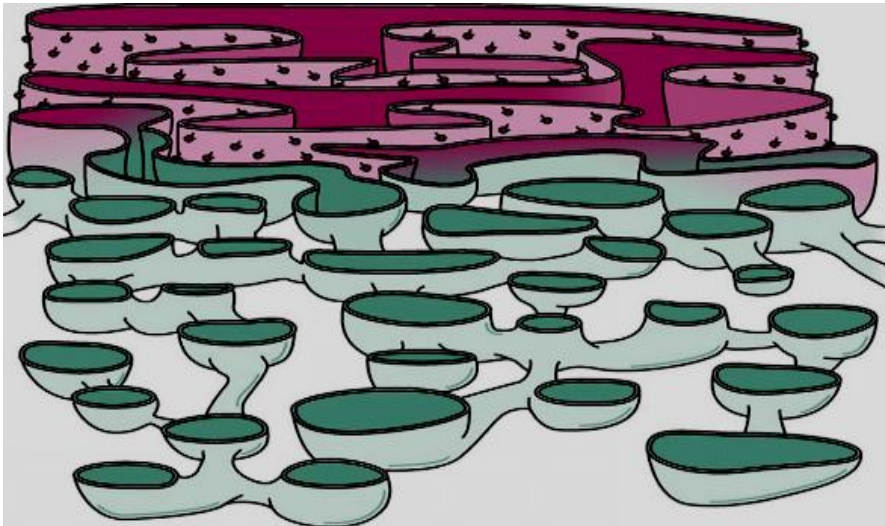

Golgi complex formed by dictyosome (from several to thousands per cell). Dictyosome formed from 3–12 flat discoid cisterns, the edges are separated by blisters (vesicles).

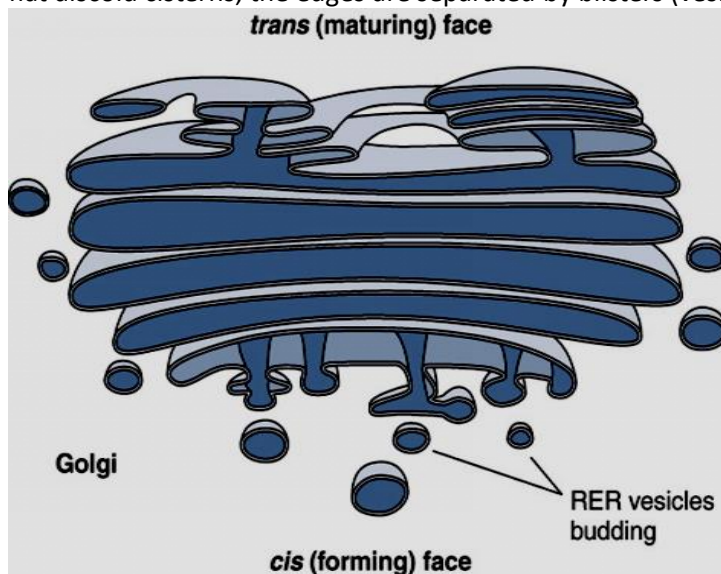

Some areas – expansion of tank form larger vesicles (vacuoles). Golgi complex forms secretory vesicles and vacuoles containing proteins and other compounds secreted by cells.

Preceded secretion (prosecret) comes to the dictyosome from synthesis zone, there some chemical modification occurs, and then the secret is separated into portions membrane (segregation). Golgi complex forms lysosomes and also synthesizes polysaccharides, glycoproteins, glycolipids.

System of cytoplasmic structures is a single entity and some individual elements can pass through each other. Thus the outer membrane of nuclear envelope membrane becomes granular ER, etc.

Mitochondria – two-membranous semi-autonomous organelles of all eukaryotic cells, round or oval-shaped; dimensions: thickness 0.5 mm, length 5–10 microns for the most cells.

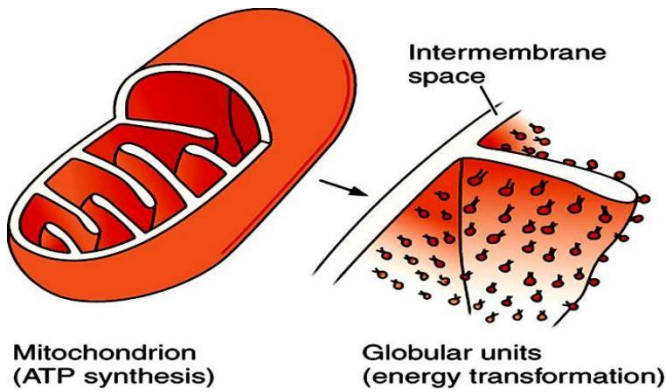

Matrix. In the matrix there are grains (diameter 20–40 nm), which accumulate Ca^{2+} and Mg^{2+} , and polysaccharides (glycogen), 2–6 copies of circular DNA molecules (proteins without histones), ribosomes, tRNA, enzymes of DNA replication, transcription and translation.

According to the size and structure of ribosomes, DNA organization of this organelle is similar to prokaryotes mitochondrion. Mitochondrial DNA genes of synthesis include the mitochondrial rRNA, tRNA and inner proteins. Most mitochondrial proteins encoded in nuclear DNA and are formed in the cytoplasm.

Lysosomes – one-membranous organelles, which sometimes are covered outside with a layer of fibrous protein.

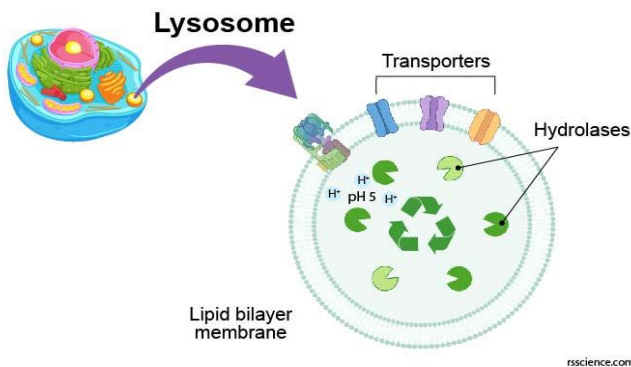

Lysosomes divided into four types: primary lysosomes, secondary lysosomes, residual cells and autophagous.

Primary lysosomes are small membranous structures, 100 nm in diameter, filled with enzymes in an inactive state.

Secondary lysosomes formed from the merger of primary endocytosis of vacuoles. Processes of digestion of substances that come during endocytosis take place by means of hydrolytic enzymes.

Secondary lysosomes are divided into heterolysosomes and autolysosomes.

Microbodies are group of membranous organelles, vesicles, diameter is about 0.1–1.5 μm with grained matrix and protein inclusions. These organelles include, for instance, **peroxisome**. They contain enzymes oxidase, which catalyze the deamination of amino acids and the formation of hydrogen peroxide (H_2O_2). Hydrogen peroxide is a toxic product, it can be destroyed by enzyme peroxidase (catalase).

Peroxisomes are bounded by ER membrane and formed on extended sections of tanks. In animals and some plants peroxisomes take part in the splitting of fats and carbohydrates.

Vacuoles are membrane organelles of plant cells that perform important functions. In the young cells they are small, then grow and merge forming one or more large vacuoles, occupying up to 80% of the cytoplasm. Functions:

- maintaining turgor pressure;
- osmoregulation;
- accumulation of substances excreted by cells;
- accumulation of reserve substances (proteins, monosaccharides, inulin);
- accumulation of enzymes which digest nutrients during germination of seeds.

Ribosomes are small round bodies with diameter of 20–30 nm, located on hyaloplasm membranes and granular ER.

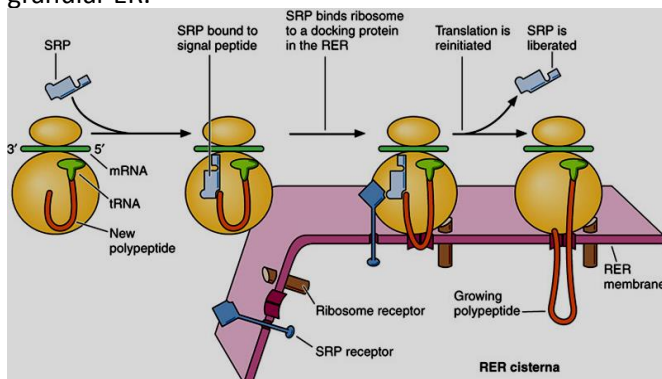

Ribosomes consist of small and large subunits, the association occurs in the presence of informational RNA. Each subunit is located on the molecule of rRNA and proteins.

Ribosomes which are combined with iRNA resemble a series of necklaces and this structure called *polysomes*. Free polysomes are located in cytoplasm or attached to membranes of granular ER. The proteins that are used for own needs of cell are synthesized in polysomes of hyaloplasm, but proteins which cells secret (digestive enzymes, saliva mucin and others) are synthesized on polysomes of granular ER.

Centrioles are non-membranous organelles, according to the electron microscope have the appearance of hollow cylinder (width 0.15 μm , length 0.3–0.5 μm). The walls of cylinder is formed by 27 microtubules, grouped in 9 triplets. Near the centrioles there are satellites of microtubules, fibrous roots, additional microtubules, which form a special zone – *centrosphere*. Centrioles (2–3) and centrosphere form the **cell center**. Cell center changes its structure during the cell cycle. For example, from prophase to telophase centrioles have similar structure, but during mitosis two cell center are formed with two centrioles.

At the end of telophase when despiralization of chromosomes occurs and interphase nuclei formed new one, maternal spindle division is destroyed and daughter centrioles move to the small distance and lose their previous perpendicular placement. In G_1 (G_0) during interphase cell center is formed by 3 centrioles. The functions of centrioles – formation of division apparatus during mitosis, providing movement of chromatids (chromosomes) in anaphase (mitosis), organization of cytoplasmic microtubules (cytoskeleton) during interphase. Centrioles are characteristic of animal cells, they are absent in higher plants, fungi and some Protozoa. Threads of mitotic spindle consists of microtubules. When cell division centrioles diverge in opposite directions and form the poles of the cell they provide moving apart of sisters' chromatids (chromosomes) in anaphase (mitosis).

Cytoplasm of eukaryotic cells contains two types of structural elements of non-membranous nature – microtubules and microfilaments.

Microtubules are tubular formation of different lengths (24 nm diameter, wall thickness is 5 nm). Located in the free state in cytoplasm of cells they are structural elements of cilia, flagella, mitotic spindle threads, centrioles. Microtubules are formed from subunits of proteins by their polymerization (in the presence of Mg^{2+}). In cytoplasm free tubes perform controversial feature, determine the shape of cells and directed movement of cytoplasmic components.

Microfilaments – long and thin structure of the cytoplasm (thickness is 7 nm) which can form bundles. Especially many of them located in the cortical layer of cytoplasm. There are actin microfilaments (contain contractile proteins – actin), which provide cellular forms of movement, for example, ameboid type. They serve as the frame function and determine the movement of intracellular organelles and hyaloplasm.

Under plasmalemma and in space around the nucleolus there are thick bundles of microfilaments (about 10 nm) – intermediate microfilaments. In different types of cells they are constructed from different proteins. The system of intermediate microfilaments is also dynamically moving as well as systems of microtubules and actin filaments. In dividing cells, they break up into two horseshoe-shaped structures after formation of daughter cells surrounding by nucleus again. Therefore, their main function is mechanical. This proves the fact, that in many epithelial cells, especially integumentary epithelium, intermediate microfilaments form thick bundles of monofibrills that help for cells to be more elastic.

1st level tests (one correct answer)

1. A 36-year-old patient underwent tooth extraction at a dental clinic. After two weeks the stratified squamous epithelium regenerated at the site of extraction. What organelles were involved in the restoration of the mucous membrane?

- A. Centrosomes
- B. Mitochondria
- C. Smooth endoplasmic reticulum
- D. Ribosomes
- E. Lysosomes.

2. During histologic examination of the skeletal muscle specimen, the investigator discovers an organelle that has 2 membranes: smooth outer membrane and internal, that forms multiple ridges of visible folds (crysts). Which of the following is the most likely function of this structure?

- A. Formation of mitotic spindle
- B. Synthesis of carbohydrates
- C. Synthesis and energy accumulation in the form of ATP
- D. There is no correct answer
- E. Intracellular digestion of macromolecules.

3. A patient with chronic hepatitis undergoes blood test for serum protein fractions. Total protein levels are low, which indicates that in the hepatic cells the following organelles are functionally disturbed:

- A. Granular endoplasmic reticulum
- B. Mitochondria
- C. Cytoskeleton
- D. Golgi apparatus
- E. Lysosomes.

4. Long-term taking of medicines can affect cells of the liver. Particularly, it can cause marked hypertrophy of agranular endoplasmic reticulum due to the following function of this organelle:

- A. Nucleic acid synthesis

- B. Protein synthesis
- C. Formation of maturation spindle
- D. Detoxication of harmful substances
- E. Intracellular digestion.

5. Cells of a healthy liver actively synthesize glycogen and proteins. What organelles are the most developed in them?

- A. Cell center
- B. Lysosomes
- C. Mitochondria
- D. Peroxisomes
- E. Granular and agranular endoplasmic reticulum.

6. The organisms to be identified have a nucleus surrounded by a nuclear membrane. Genetic material is concentrated predominantly in the chromosomes that consist of DNA strands and protein molecules. These cells divide mitotically. Identify these organisms:

- A. Bacteriophages
- B. Prokaryotes
- C. Eukaryotes
- D. Viruses
- E. Bacteria.

7. Cytochemical investigation revealed high content of hydrolytic enzymes in the cytoplasm. This phenomenon indicates the activity of the following organelles:

- A. Lysosomes
- B. Endoplasmic reticulum
- C. Mitochondria
- D. Polysomes
- E. Cell center.

8. Human red blood cells contain no mitochondria. What is the main pathway for ATP production in these cells?

- A. Oxidative phosphorylation

- B. Creatine kinase reaction
 C. Cyclase reaction
 D. Anaerobic glycolysis
 E. Aerobic glycolysis.
9. The cell of the laboratory animal was overdosed with Roentgen rays. As a result albuminous fragments formed in the cytoplasm. What cell organoid will take part at their utilization?
 A. Golgi complex
 B. Ribosome
 C. Endoplasmic reticulum
 D. Lysosomes
 E. Cell centre.
10. In course of practical training students studied a stained blood smear of a mouse with bacteria phagocytosed by leukocytes. What cell organella completes digestion of these bacteria?
 A. Mitochondrions
 B. Granular endoplasmic reticulum
 C. Golgi apparatus
 D. Ribosomes
 E. Lisosomes.
11. There is an organelle in cell. The function is: lysosome formation, polysaccharide synthesis, lipid synthesis and other. Name this organelle.
 A. Lysosome
 B. ER
 C. Complex Golgi
 D. Peroxisome
 E. Ribosome.
12. Child has a dyspepsia caused by dehydration of organism. What solution is needed to renew osmotic pressure of circulatory blood?
 A. Isotonic solution NaCl
 B. Hypotonic solution
 C. Hypertensive solution
 D. Salt solution
 E. 1% solution of glucose.
13. Glass-shaped cells inside the epithelium of mucous membrane of intestine and respiratory tracts excrete the glycoprotein mucin which forms mucus in solution. What organoid secretes the mucus?
 A. ER
 B. Lysosome
 C. Golgi complex
 D. Ribosome
 E. Cell centre.
14. In the cells of frog experimentally destroyed the system of microtubules, located in a cytoplasm. Cells became sphere-shaped. What function of microtubules?
 A. Modify products which are coming to the cell
 B. Forming of secondary protein structure
 C. Forming of cytoskeleton
 D. Secretion of steroid hormones
 E. Detoxication of products.
15. The main function of hepatocyte is detoxication. The organelle, which performs this function, is:
 A. Mitochondria
 B. Centrosome
 C. Nucleus
 D. ER
 E. Ribosome.
16. Oval-shaped structure and two membranes with cristae has:
 A. Lysosome
 B. Rybosome
 C. Mitochondria
 D. Centrosome
 E. ER.
17. In the cells of muscles tissue there is an intensive aerobic process of forming and accumulation of ATP energy. In what cell organoid do these processes take place?
 A. Peroxisome
 B. ER
 C. Lysosome
 D. Mitochondria
 E. Cell centre.
18. The virus of flu got into the cell. The mechanism of biosynthesis of protein reorganized abnormally and afterwards the synthesis of viral protein began to carried out:
 A. On polyribosomes
 B. In nucleus
 C. In lysosome
 D. In peroxisome
 E. In cell centre.
19. One-membranous organelle contains enzymes and provides intracellular digestion. Name this organelle.
 A. ER
 B. Centrosome
 C. Lysosome
 D. Ribosome
 E. Mitochondria.
20. The 40-years man has a wound after pulling out of tooth where the active process of regeneration takes place. Define the organelle performs this process immediately:
 A. Ribosome
 B. Lysosome
 C. ER
 D. Centrosome
 E. Mitochondria.
21. One-membranous circle-shaped organelle has a size 0.2–1 mcm and contains enzymes. The forming of this organelle connected with Golgi complex. Name this organelle:
 A. Centrosome
 B. Ribosome
 C. Plastids
 D. Mitochondria
 E. Lysosome.
22. Circle-shaped organelle (one-membranous) with hydrolytic enzymes has a name:
 A. Centrosome
 B. Lysosome
 C. ER
 D. Complex Golgi
 E. Ribosome.
23. In one of organoids there are processes of protein construction and complexing of protein with carbohydrates, fats take place. Name this organoid:
 A. Golgi complex
 B. ER
 C. Lysosome
 D. Ribosome
 E. Mitochondria.
24. What organic matters are synthesized on the membranes of granular ER?
 A. Nucleic acids
 B. Protein
 C. Carbohydrate
 D. Lipids
 E. ATP.
25. Which organelle completes digestion of bacteria:
 A. Lysosome
 B. Mitochondria
 C. Granular ER
 D. Golgi complex

- E. Ribosome.
26. In all kind of cells there are non-membranous organoids which consist of two different particles. They have microscopic sizes and take part in the process of protein synthesis. Name this organelle:
- Ribosome
 - Lysosome
 - Complex Golgi
 - Cell centre
 - Mitochondria.
27. During the study of pancreas cells by an electronic microscope some organelle was found out which consists of plenty ductings, cisterns and connected with plasmalemma:
- Centrosome
 - Mitochondria
 - ER
 - Lysosome
 - Peroxisome.
28. Near the nucleus some organelle was found out which consists of two cylinders and formed microtubules and located perpendicularly. It determines that this organelle is a constituent of mitotical spindle of division in animal cells. The name of this organelle is:
- Mitochondria
 - Ribosome
 - ER
 - Centrosome
 - Lysosome.
29. There are inconstant structures in nucleus which disappear at the beginning of cell division and afterwards again appear. They contain protein, RNA and take part in forming of subunits of ribosomes. How are such structures called?
- Nucleolus
 - Nucleosome
 - Polysome
 - Microfilaments
 - Microtubules.
30. Sick person has a pancreatitis. This disease can be reason of autolysis of pancreas caused by function of:
- Lysosome
 - Mitochondria
 - Ribosome
 - ER
 - Microvilli.
31. In animal cell two-membranous organelle which has molecules of DNA and ribosome was found. What is the basic function of this organelle:
- Synthesis of protein
 - Synthesis of ATP
 - Transport and modification of protein
 - Synthesis of cytoplasm protein
 - Formation of ribosome.
32. Forming of subunits of ribosomes is broken experimentally (by the action of mutagenic factors). What metabolic process will be destroyed?
- Synthesis of ATP
 - Biosynthesis of carbohydrates
 - Photosynthesis
 - Cell division
 - Synthesis of protein.
33. There are membranous organelles in eukaryotes cell, which appear in complex Golgi and have enzymes for destruction of H_2O_2 . What function of this organelle?
- Formation of ATP
 - Synthesis of polypeptide
 - Breaking up of protein
 - Synthesis of carbohydrates
 - Oxidation of lipids.
34. Mitochondria is semiautonomous organelle, matrix has 2–6 own rings of DNA, ribosomes, RNA, enzymes of replication, transcription and translation. Where the information about the primary structure of most mitochondria protein is coded?
- DNA of cytoplasm
 - DNA of sexual chromosomes
 - RNA of matrix
 - DNA of mitochondria
 - DNA of chromosomes.
35. Two types of cells appeared in the process of evolution: prokaryotes and eukaryotes. Which kinds of organelles are peculiar to the both types?
- Lysosome
 - ER
 - Mitochondria
 - Ribosome
 - Golgi complex.
36. ER is represented by smooth and rough systems which are functionally different. Protein and lipid synthesis are taking place:
- In Golgi complex
 - In smooth ER
 - In rough ER
 - In smooth and rough ER
 - In ribosomes.
37. Animal cells are able to the active movement. What structures provide such peculiarity:
- Actin microfilaments
 - Microtubules
 - Intermediate microfilaments
 - Cell centre and microtubules of spindle
 - Myofibrils.
38. Cell come under ionizing radiation influence by means of deficit of vitamin E. As a result of this is increased output of enzyme hydrolases to the cytoplasm and complete destruction of intracellular structures. What organelles are richer of hydrolases and can be reason of autolysis?
- Lysosome
 - ER
 - Golgi complex
 - Microtubules
 - Mitochondria.
39. Ribosomes have 4 active centre, 3 in each subunits: M-centre (connection with mRNA), A-centre (aminoacids centre), P-centre (peptide centre), PTF-centre (peptidyltransferase centre). Define centre of formation of peptide bonds?
- A-centre
 - M-centre
 - P-centre
 - PTF-centre
 - P- + A-centre.
40. Detoxification of harmful matters takes place in hepatocytes which come with the blood to the liver. What organelle provides detoxication of matters in hepatocytes:
- Rough ER
 - Peroxisome
 - Mitochondria
 - Lysosome
 - Golgi complex.

2nd level tests
(several correct answers)

1. Choose structures and substances of ribosomes:

- A. DNA+protein
- B. rRNA+protein
- C. small subunit + big subunit
- D. small subunit + big subunit+mRNA
- E. Phosphoric acid.

2. DNA is located:

- A. In nucleus
- B. In mitochondria and plastids
- C. In vacuoles
- D. In ribosome
- E. In cytoplasm
- F. In cell centre
- G. In chromosomes.

3. Name membranous organelles:

- A. Cell membrane
- B. Centriole
- C. Complex Golgi
- D. Ribosomes
- E. Lysosome
- F. Vacuole.

4. Lysosome provides:

- A. Protein processing
- B. Secretion
- C. Intracellular digestion
- D. Cyclosis
- E. Accumulation of waste products.

5. Non-membranous organelles are:

- A. Vacuoles
- B. Cell centre
- C. ER
- D. Ribosome
- E. Microtubules and microvilli
- F. Chromosomes
- G. Flagella, cilia.

6. Two-membranous organelles are:

- A. Mitochondria

- B. Cell centre
- C. ER
- D. Ribosome
- E. Microvilli and microtubules
- F. Chloroplasts
- G. Nucleus.

7. The man has a wound with pus. Which organelles provide process of healing?

- A. Lysosome
- B. Golgi complex
- C. Ribosome
- D. Nucleus
- E. ER.

8. Preparation has taken on cell which caused destruction of mitochondria. What processes will be broken:

- A. Lipid synthesis
- B. Glycolysis
- C. Spindle formation
- D. Providing of energy
- E. Protein synthesis.

9. Preparation has taken on cell which caused destruction of cell centre. What processes will be broken? Which organelles will be formed?

- A. Centrioles
- B. Protein synthesis
- C. Mitosis and spindle formation
- D. Chromosomes will not move apart
- E. Microfilaments and microtubule.

10. What organelles of cytoplasm contain DNA?

- A. Ribosomes
- B. Mitochondria
- C. Chromosomes
- D. Chromatin
- E. Peroxisome
- F. Chloroplasts.

TOPIC: Cell membrane. Transport through the plasmalemma

Cell as an open system. Assimilation and dissimilation. Cell membranes, their structure and function. Principle of compartmentation. Receptors of cells. Transport of substances through the plasmalemma. Flows of substances and energy. Stages of energy exchange. The energy of a cell, ATP. Distribution of energy.

Cell as an open system

A cell consists of many different arranged molecules. Molecular complexes formed organelles, which also have structure of cell systems. The interior part of cell biomembranes is divided into compartments where only specific reactions take place. Thus, the cell is a complex system of macromolecules at several levels of organization. It is indivisible whole system in which you can identify a number of subsystems that are responsible for specific functions: membrane, cytosol, nucleus, mitochondria and others. Cellular organelles are structurally and functionally linked. Vital functions of cells may only be exercised in a coordinated connection between them. A cell is an open system because it does not completely isolated from the environment. For life and functioning cells must constantly interact with the environment. In particular, between environment and cells the matter, energy and information are constantly exchange. These processes provided orderly in time and space, coordinated flow of metabolic and physiological processes.

The flow of substances associated primarily with cell metabolism, which is the unity of catabolism and anabolism.

Anabolism is the process of substances flow into the cell and convert them to specific molecular complexes which characterized by cells. This process goes with the flow of energy. Synthesis of substances in animal cells is due to metabolism process in cytoplasm consists of:

1) products of digestion, which came from circulatory system. In the digestive tract the digested food turns to low-molecular organic substances: amino acids, nucleotides, carbohydrates – non-specific and identical for all nature. After they enter into cell and form the metabolic foundation.

2) catabolism products which are formed in cells. **Catabolism** is a set of biochemical processes of dissociation of macromolecules which cells release as energy of chemical bonds. Metabolism in cells supporting its stable molecular structure of both inorganic and organic compounds. Due to metabolism there are two very important functions have performed: (1) supported the structure of cells and (2) getting an energy that comes from organic matter.

Energy flow

There are many breakdown products turn into cell – monosaccharides, glycerol, lipids, amino acids and others. Together with product the energy «comes» into the cell that is «accumulated» in chemical bonds between molecules and atoms then converted into ATP by means of macroergic links between phosphoric acids. The energy required to maintain stability of cellular systems: support structure, homeostasis and all anabolic functions.

For all animals the main process is tissue respiration. This is amount of biochemical reactions cleavage (dehydrogenation) of some organic compounds (glucose, lipids, amino acids, etc.), compounds of hydrogen with oxygen in the mitochondria and the formation of H₂O and also ATP. Cellular high-energy «fuel» in form of molecules of adenosine triphosphate (ATP), freely diffusing in the cell and certain «portions» gives energy for anabolic processes. Molecule of ATP is a nucleotide consisting of adenine, ribose and three residues of orthophosphoric acid. The processes of destruction of organic matter occurs in the mitochondrial matrix where the enzymes of oxidation and inner membrane containing ATP-synthetase forming ATP are present.

ATP and other energy-rich compounds called *macroergic*. Enzyme cleavage of phosphate of ATP is accompanied by forming a considerable amount of energy – 8 kcal (instead of 3 kcal of chemical bonds that are allocated during disconnection). This connection is called macroergic. The energy of ATP is converted in cells into various types of work: chemical, osmotic, mechanical and others.

Anaerobic glycolysis which occurs in cytoplasm of cells is less effective due to the incomplete breakdown of glucose molecules. This process gives only 10% of the required energy. Products of glycolysis come in mitochondria, where fully oxidized and releases energy which is also converted into macroergic links of ATP.

Information streams

There are three flows of information in cells.

1. **Cells perceive changes in the environment** (mainly chemical signals) and **can react with them**. Adaptation provided with the change of activity or formation of new required enzymes and other macromolecules. Intracellular processes leading to the necessary changes of shape, size and functioning of cells. As a result, an adequate response to signals allows cells to adapt and survive in the environmental conditions that change.

2. Hereditary information is stored in molecules of DNA as the genetic code – a sequence of triplets of nucleotides. This information used to support structural and functional organization of cells and their long existence as a stable system. Information rewritten from DNA to RNA molecules that provide the necessary

synthesis of structural proteins and enzymes. Formed proteins provide a manifestation of certain characteristics and properties of cells. In other words, the flow of information in cells pointing to signs of DNA: **DNA ↔ RNA → protein → trait**. Convert and transfer of information provided by the processes of transcription, translation and expression.

3. Besides, life is connected with the storage and transmission of information flow in cell generations and generations of organisms. Therefore, one information flow is directed DNA from one cell to DNA of daughter cells. This flow of information associated with the process of reproduction. It provided the DNA replication of the parent cells, the formation of chromosomes, the process of uniform distribution of ancestral material between daughter cells during mitosis. This flow of information ensures the reproduction and continued existence of populations of cells: **DNA → 2 daughter DNA → two daughter cells**. So, living cells supported by a constant «stream» through the matter, energy and information.

Cell membranes

Membranes are complex molecular systems, liquid-crystalline solutions of globular proteins in lipid biostructures that define the basic life processes at the cellular level.

Structure of the cell membrane is described by the **fluid mosaic model**, which was proposed by Seymour Johnatan Singer and Garth L. Nicolson in 1972. According to this model, membrane consists of two layers of phospholipids stabilized by specific oriented proteins.

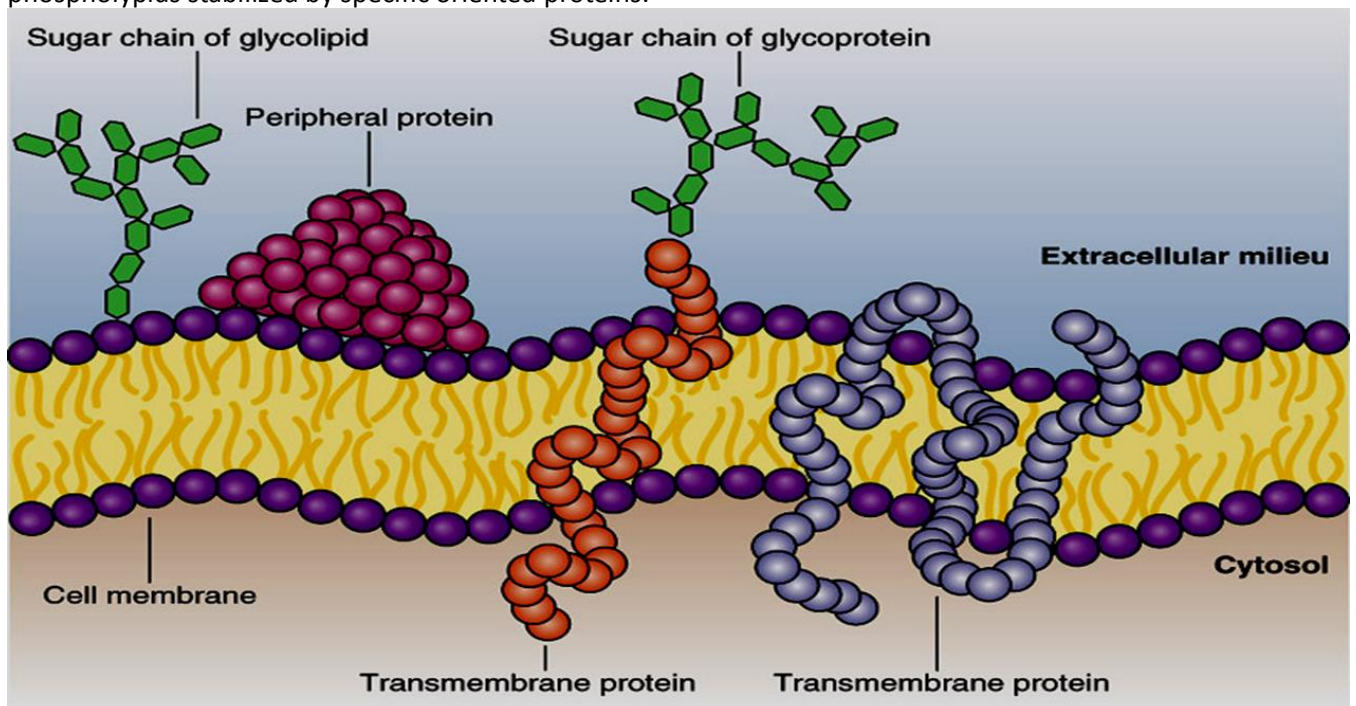

Biomembranes perform the following functions:

1. Separates cell from the external environment (barrier function).
2. Create separate compartments inside cells.
3. Control the transport of substances in the cell and out of it.
4. Provide specific intercellular contacts and immunological reactions.
5. Percept biologically active substances, ions .
6. Have ability to perceive, increase and transmit external signals inside cells.
7. Provide formation and transport of substances across the membrane.
8. Create conditions for the biochemical reactions that are catalyzed by hydrophobic membrane proteins.
9. Defines the interaction between individual proteins which are immersed in the membrane.
10. Receptor function (by means of special structures that define the chemical and physical factors of receptors). Receptors are glycoproteins and glycolipids. There are receptors which sensitive to hormone-specific antigens proteins and others. Specific receptors responsible for recognition of cells, recognition of chemical and physical signals.

Structural-chemical organization of membranes

Common feature of all membranes – they are thick (about 10.5 nm) layers of lipoproteins. The composition of membranes are lipids (40%), about 50% of proteins, 5–10% carbohydrates.

Lipids of membranes are numerous groups of hydrophobic substances which are poorly soluble in water and well – in organic solvents. The peculiarity of their molecules: division into two functional parts: *nonpolar hydrophobic* «tails» and *hydrophilic charged polar* «heads». This determines the ability to independently create

two-lipid membrane structure of thickness 5.7 nm. Outer cytoplasmic membrane (*plasmalemma*) is peripheral surface structure that separates the cell from the environment, provides the link from the extracellular environment to the substances and percept all signals.

Plasmalemma is a lipoprotein complex thickness (about 10 nm). Outside there is overmembrane layer – *glycocalyx* (3–4nm). Glycocalyx is a glycoprotein complex, which is associated with plasmalemma. Carbohydrates form the chains of polysaccharides which are associated with membrane proteins and lipids. In glycocalyx can be found some proteins which are not associated with bilipid layer, they provide extracellular cleavage agents.

Ordering of the internal content of eukaryotic cells is achieved by *compartmentation* – separation membranes to «compartments» which differ in composition of enzymes. Separate compartments are represented by organoids. Separation of content on the cell compartments provides simultaneous flow of various enzymatic processes, sometimes even antagonistic, implements the regulation of metabolic flows, maintaining the difference of concentrations of substances and generate electric potential difference.

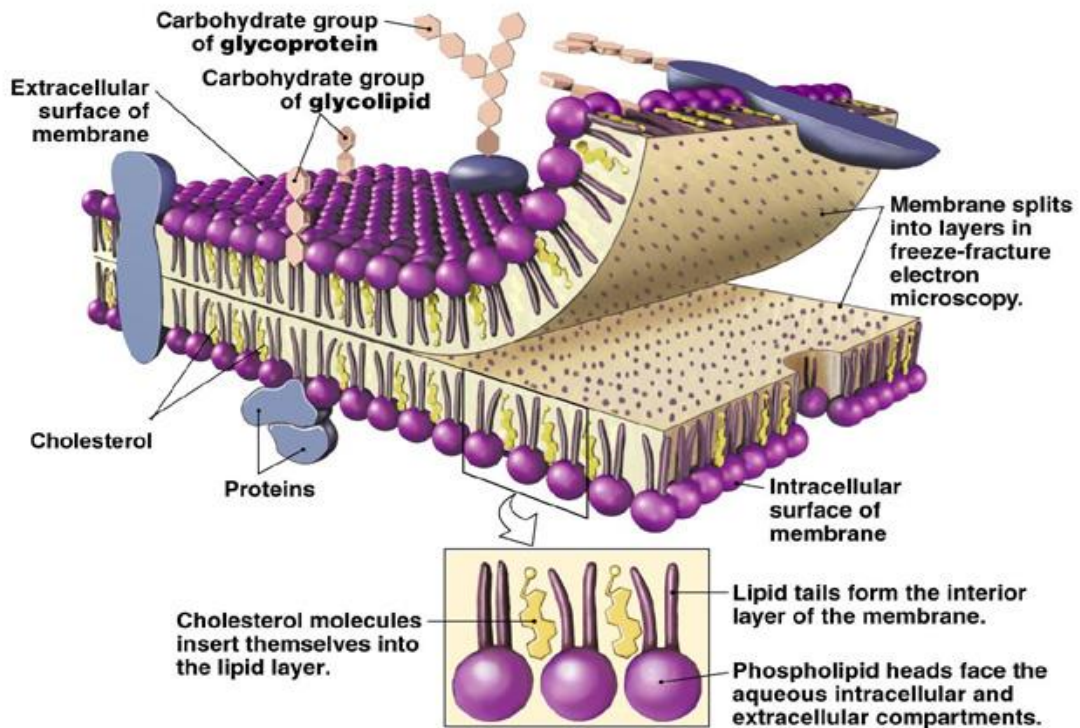

Transport of substances through the plasmalemma

One of the most important functions of biological membranes is the providing of selection which controlled permeability for substances transported to cells in the process of life.

Molecules of substances and ions which are transported may be carried through the membrane independently of other compounds – *uniport*; transport may occur simultaneously in one direction – *symport*, and may occur simultaneously in opposite directions – *antiport*. Symport and antiport are kinds of *co-transport* while speed of process is controlled by the presence of two substances in the transport process.

The role of biomembranes in transport lies in the regulation of energy flows. If transport is accompanied by decrease in free energy, it gets free and is called *passive*. Transfer of substances through the membrane, which is associated with an increase in free energy is called *active*.

All kinds of ion transport and transport of substances through cell membranes are divided into 4 groups:

- passive diffusion
- easy diffusion
- primary active transport
- secondary active transport.

In addition to these kinds membrane produce specific cellular mechanisms of movement of substances, associated with disruption of membrane integrity – *cytosis* (endo- and exocytosis).

Passive diffusion occurs without special mechanisms substances penetrate through the membrane due to membrane defects or kinks. Passive diffusion ensures the transfer of low molecular substances such as water, some ions (Na^+) and organic substances. Passive diffusion occurs through channel structures when they are

open. The integral protein forms a channel structure where ions move. There are channels that provide penetration for Na^+ , K^+ , Ca^{2+} . Ca-dependent channels open with an increase of intracellular Ca^{2+} and sensitive to certain substances used in medicine.

Easy diffusion takes place with the participation of specific proteins – carriers of concentration gradient of substances.

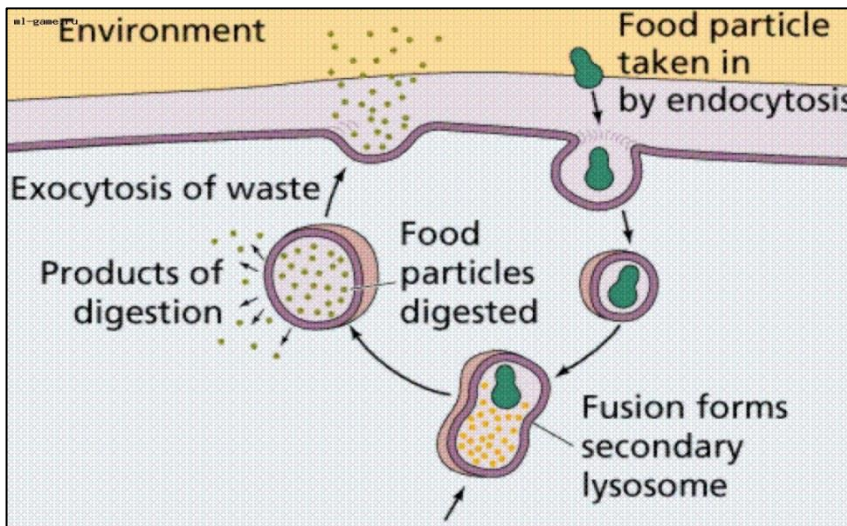

Primary active transport takes place by means of specific carriers, but in contrast to the easy diffusion, – against the concentration gradient of substances transported and expenditure of energy of ATP hydrolysis. Transport performs by ATP- phases ion pumps. The most common in animal cells Na, K-ATP-phase integral protein of plasmalemma and Ca-ATP-phase, which occurs in the cytoplasmic and intracellular membranes. The processes of primary active transport in the regulation of cellular functions take a leading role.

Passive and active transport is provided by special structures. These include channels, carriers, enzymes that provide the movement of ions, substances against their concentration gradient due to the energy of ATP.

Ion transport, which occurs due to transport ATP-phase (ion pumps) provided the energy of ATP hydrolysis, called *primary active transport*. In cases where the energy required for transport, created independently, for example, in the primary active transport, a process called *secondary active transport*.

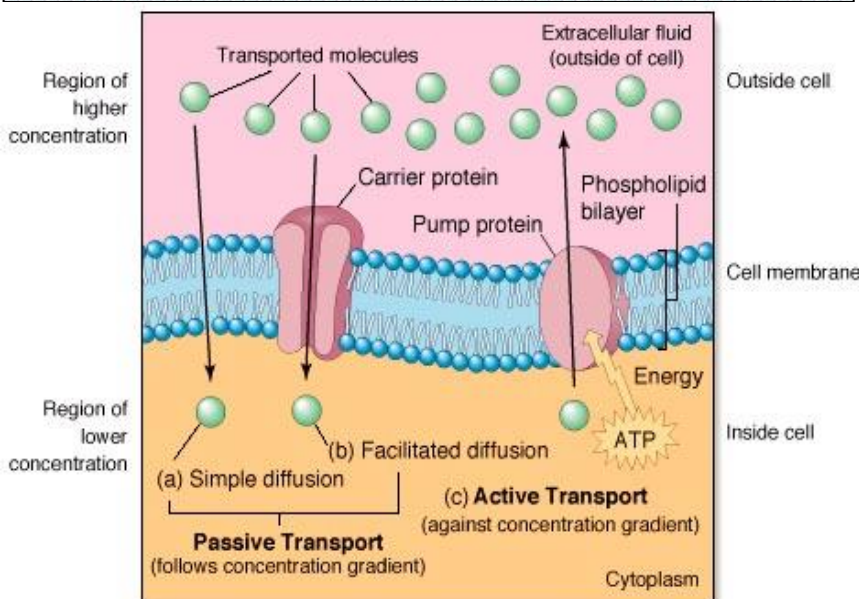

Secondary-active transport provides transport into the cell aminoacids and monosaccharide. Transfer performs by means of protein-carriers. Secondary active transport also include transport processes, which combined with enzymatic modification of substances. Mitochondria is an example of system where the secondary active transport of Ca^{2+} performs by means of respiration energy or ATP.

Receptors are specific molecules which are found on the cell surface of membranes. They receive specific chemical signals from neighbouring cells or from environment within an organism. These signals provoke cell to do something or to allow certain molecules to enter or exit the cell. Receptors are protein molecules, covered by plasma membrane (*surface receptor*) or the cytoplasm (*nuclear receptor*) of cell where one or more specific kinds of signal-molecules may join. Molecule which binds to a receptor is called by *ligand* and may be present as protein molecule (short protein) or other small molecule, for example drug, toxin etc. Each type of receptor can bind only certain ligand shapes.

Cell typically has many kinds of receptors. Receptor functions are to open biochemical ways when the proper ligands are inserted. Ligand binding stabilizes a certain receptor form. This is often associated with receiving or loosing of protein activity, ordinarily leading to some sort of cellular response. But some lygands block receptors without inducing any response. Ligand-induced changes in receptors result in cellular changes, which form the biological activity of the ligands.

Osmosis (from greek «osmos» – pressure) – diffusion of the solvent (H₂O) through the semipermeable membrane. Because cytoplasm has a higher concentration of ions than surrounding cell environment, the water moves to the cytoplasm where its concentration is lower, which creates the osmotic pressure. Since the cell is in a state of complete equilibrium with the environment, continuous diffusion of water changes the concentration of substances and osmotic pressure. Water goes to the cell and can lead to destruction of cells, especially in hypotonic environment. Cell constantly opposes to the flow of water, spends its energy on pumping and secretion for the formation of solid membrane. Resistance of cell osmosis and osmotic pressure is determined by the environment. So, for example, human erythrocytes in blood are isotonic, because they have low resistance to osmotic shock and injected of hypotonic solutions are destroyed them (hemolysis).

Filtration is the movement of fluid through the holes of the membrane. In osmosis, water transport may be performed by filtration. Filtering plays an important role in many physiological processes. Thus, the formation of primary urine is the result of filtration of blood plasma from the difference of pressure in the capillaries. Freshwater unicellular Protozoa, such as amoeba, have significant resistance and only small amount of water penetrates through its membrane.

Endo- and exocytosis

Endocytosis – is an absorption of substances by the cell. It begins with sorption on the surface of membrane material. Binding with plasmalemma determined by the presence of surface membrane receptors. Then on the surface of the plasma membrane formed small protruding inside cells. Then these protruding cutting off from membranes and form vesicles which are freely located in cytoplasmic membrane. Next step – the vesicles are interconnected with lysosomes. Enzymes of lysosomes break down biopolymers to monomers which through the membrane vesicle run to the cytosol (intracellular digestion).

Phagocytosis is the absorption of solid particles. It occurs in many free-living organisms and in some cells of multicellular organisms. The process of phagocytosis plays an important role in the reaction of organism to infection.

Pinocytosis – is absorption of liquid substances. It is widespread process among different cell types. It is especially expressed in intestinal epithelial cells, which provide the absorption of nutrients in epithelial cells of blood capillaries. Phagocytosis occurs in many free-living organisms and in some cells of multicellular organisms. The process of phagocytosis plays an important role in the reaction of organism to infection. Pinocytosis is widespread among different cell types. It is especially pronounced in intestinal epithelial cells, which provide the absorption of nutrients in epithelial cells of blood capillaries.

Exocytosis – the process of removing substances from cells. Intracellular products, which closed in vacuoles or vesicles, suitable for cytoplasmic membrane. Within the contact the plasma membrane and vacuole membrane merge, vesicle content comes out.

The processes of endo- and exocytosis occur with the participation of fibrillar cytoplasm components – microtubules and contractile microfilaments.

1st level tests (one correct answer)

1. A molecular-level process of spontaneous passive transport of water-soluble molecules across a cell membrane is modeled. The molecules move across cell membranes from an area of higher concentration toward an area of lower concentration via specific transmembrane integral proteins. This transport does not directly require chemical energy from ATP hydrolysis. Which of the following transport mechanisms is most likely mentioned?

- A. Facilitated diffusion
- B. Pinocytosis
- C. There is no correct answer
- D. Osmosis
- E. Active transport.

2. Golgi complex exports substances from a cell due to the fusion of the membrane saccule with the cell membrane. The saccule contents flows out. What process is it?

- A. Active transport
- B. Facilitated diffusion
- C. Exocytosis
- D. Endocytosis
- E. All answers are false.

3. Cytoplasmic membrane contains glycolipids and glycoproteins. On the membrane surface they are forming:

- A. Receptors
- B. Glycocalix
- C. Protective layer
- D. Ion channels
- E. Antigens.

2. On the membranes of cells are located alarm molecules – protein-receptors. They connect molecules and initiate response. Receptors, which perceive hormones or neuromediators:

- A. Slow the transport of substances
- B. Activate the pinocytosis
- C. Enhance of active diffusion

- D. Promote formation of the open channels in membranes
- E. Enhance passive diffusion.
3. Doctor wrote a prescription with the expressed lipophilic properties for some patient. What is the main mechanism of its suction:
- Active transport
 - Connection with transport proteins
 - Filtration
 - Passive diffusion
 - Pinocytosis.
4. During microscopy of blood smear some kinds of macrophages surround by the foreign substances have found out. Name this stage of phagocytosis:
- Incomplete phagocytosis
 - Approach process
 - Intracellular digestion
 - Adhesion
 - Immersion.
5. Which kind of organelle provide destruction of substances which have taken up by the neutrophil?
- Golgi complex
 - Peroxisome
 - Lysosome
 - ER
 - Mitochondria.
6. Acetylcholin stimulates contraction of skeleton muscles but decreases power of heart muscles. Why this substance caused different effects in cells:
- Because of different organization of cytoplasm
 - Different effects caused by differences of cell receptors
 - Peculiarities of cell movement
 - Different organization of cell membrane
 - This peculiarity defines numbers of cell receptors.
7. Transport of glucose takes place without energy consumption but with the carriers of integral protein. Such mechanism has a name:
- Simple diffusion
 - Active transport
 - Osmosis
 - Phagocytosis
 - Endocytosis.
8. Cell as opened biosystem is characterized by:
- Self-regulation
 - Metabolism
 - Presence of holes
 - Presence of cell receptors
 - Exocytosis.
9. Substances absorb by means of channels which spread from the external membrane into the cytoplasm. This process has a name:
- Osmosis.
 - Endocytosis
 - Phagocytosis
 - Exocytosis
 - Pinocytosis.
10. Human starvation causes process when mitochondria in liver cells swell and become bubble-shaped. Degeneration and swelling of mitochondria lead to disorder in:
- Formation of high-energy compounds
 - Synthesis of monosaccharides
 - Formation of secretory vesicles
 - Formation of yolk in the egg
 - Regulation of osmotic pressure cells.
11. Some organelle has its own protein synthesis system. This organelle is:
- Lysosome
 - Golgi apparatus
 - Mitochondria
 - Vacuole
 - Endoplasmic reticulum.
12. Laboratory animals have got an excessive X-ray exposure. As a result protein fragments have formed in the cytoplasm. What cell organelles participate in protein recycling process?
- Lysosomes
 - Golgi complex
 - Ribosome
 - Endoplasmic reticulum
 - Cellular center.
13. Biochemical analysis has revealed some cell organelles with digestive enzymes. These organelles are:
- Golgi complex
 - Lysosomes
 - Endoplasmic reticulum
 - Mitochondria
 - Ribosomes.
14. Some organelles in the healthy liver cells actively synthesized glycogen and protein. How do we call this organelle?
- Lysosomes.
 - Cellular center
 - Agranular and granular ER
 - Mitochondria
 - Peroxisomes.
15. 18-year old student has revealed an increase of thyroid gland. Medical examination has revealed an increased metabolism. These symptoms occur as a result of hypersecretion of the hormone thyroxine. What are the cell organelles of the thyroid gland responsible for the secretion and release of hormones:
- Golgi complex
 - Mitochondria
 - Ribosome
 - Centrosome
 - Lysosomes.
16. Substances derived from the cell as a result of the connection of membranous structure to the Golgi apparatus. The content of such a structure is thrown out of the cell. This process is called:
- Active transport
 - Osmosis
 - Endocytosis
 - Exocytosis
 - Facilitated diffusion.
17. Ribosomes are organelles that perform binding of amino acids to the polypeptide chain. Number of cellular ribosomes in different organs varies and depends on their function. What body organ contains the biggest number of ribosomes:
- Secretory cells of the pancreas
 - Bladder epithelium
 - Epithelium of the tubules of the kidneys
 - The top layer of epidermal cells of the skin
 - Epithelium of the small intestine.
18. The patient with rheumatism has a destruction and disruption of his cartilage cells. In this process is involved one of the cell organelles:

- A. Ribosomes
 - B. Cellular center
 - C. Microtubules
 - D. Golgi complex
 - E. Lysosome.
19. In the breeding ground where animal cells are grown an amino acid leucine with radiation label has added. By means of radiography method a high concentration of the labeled amino acids near by specific organelles were found. These organelles are:
- A. Lysosomes
 - B. Ribosomes
 - C. Smooth endoplasmic reticulum
 - D. Cellular center
 - E. Golgi complex.
20. The patient's blood has the low levels of albumin and fibrinogen. Reduced activity of the liver hepatocytes organelles was detected too. What organelle is the cause of this condition?
- A. Agranular endoplasmic reticulum
 - B. Mitochondria
 - C. Granular endoplasmic reticulum
 - D. Golgi apparatus
 - E. Lysosomes.
21. Mucopolysaccharidoses refers to diseases of accumulation due to some enzymes absence. Enzymes accumulated in cellular organelles and excreted with urine. Which organelles accumulate mucopolysaccharides?
- A. Cellular centre
 - B. Golgi complex
 - C. Mitochondria
 - D. Endoplasmic reticulum
 - E. Lysosomes.
22. Some diseases cause changes in the cells, accompanied by disorder of membranes of lysosomes. What changes have developed in the cells?
- A. Disorder of transcription
 - B. Pathological mitosis
 - C. Disorder of translation
 - D. Autolysis
 - E. Accumulation of substances.
23. There are two cellular forms of life: prokaryotes and eukaryotes. Prokaryotes have no nucleus. What feature is more typical for the prokaryotic cells?
- A. Lack of ribosomes
 - B. Lack of membranous organelles
 - C. Special structure of the membrane
 - D. Special form of cells
 - E. Presence of membrane.
24. Proteins of ion channel are firmly embedded into the lipid bilayer. Their hydrophilic amino acids interact with the hydrophilic phosphate group of phospholipids, hydrophobic amino acids – with hydrophobic chains of fatty acids and permeates through the membrane. What is the name of such membrane proteins?
- A. Peripheral
 - B. Integral
 - C. Surface
 - D. Glycolipids
 - E. Glycoproteins.
25. Some lypoprotein complex has a thickness about 10 nm and outside – overmembranous layer – glycocalyx. Name it:
- A. Receptors
 - B. Glycocalyx
 - C. The protective layer
 - D. Ion channels
 - E. Plasmalemma.
26. Membranes are complex molecular systems that determine the basic processes of life at the cellular level. Name one of the functions of biomembranes:
- A. Formations of compartments inside individual cells
 - B. Takes part in DNA replication
 - C. Do not accept biologically active substances
 - D. Prevents formation of the intercellular contacts
 - E. Destroys glycocalyx.
27. Lipid bilayer of biomembranes consists of phospholipids, cholesterol and glycolipids. Which of these lipids determine the degree of fluidity of membranes' bilayer?
- A. Phospholipids
 - B. Glycocalyx
 - C. Cholesterol
 - D. Glycolipids
 - E. Hydrophilic tails.
28. Name the type of cellular contact where the areas of thickness between the cells that forms mechanical connections appears:
- A. Simple contact
 - B. Desmosome
 - C. Thick locking contact
 - D. Synaptic
 - E. Tight contact.
29. What is the name of a space inside cell, surrounded by a membrane and associated with the performance of a special function?
- A. Receptors
 - B. Glycocalyx
 - C. Compartment
 - D. Protective layer
 - E. Ion channels.
30. The process of mutual penetration of molecules or atoms of one substance among other molecules or atoms that usually leads to equalization of their concentration throughout of occupied volume has a name:
- A. Diffusion
 - B. Phagocytosis
 - C. Compartment
 - D. Ion channel
 - E. Exocytosis.

TOPIC: Nucleus. Human karyotype. Genome and chromosomal mutations

Nucleus is the central informational unit of cells. The structure of the interphase nucleus. Chromosomal and genomic level of hereditary material. Nucleolus as a derivative chromosomes, role in the formation of ribosomes. Chromatin: euhromatin, heterochromatin. Karyotype: morphofunctional characteristics and classification of human chromosomes. Ideogram. Rules of chromosomes. Chromosome analysis.

Cell nucleus (Brown, 1833) is a component of eukaryotic cells. The nucleus has a membrane, karyoplasm (nuclear sap), nucleolus, chromatin.

Nuclear membrane has double-membrane structure and pores with a diameter of 80–90 nm. Outer and inner membranes separated by nuclear space (width of 20–60 nm). Area of pores or *pore complex* has a certain structure (diameter about 120 nm.). The number of pores depends on the functional state of cells. For example, in erythroblasts, where hemoglobin intensively accumulated, on 1 μm of nuclear membrane is about 30 pores and in mature erythrocytes of animals – about 5 pores.

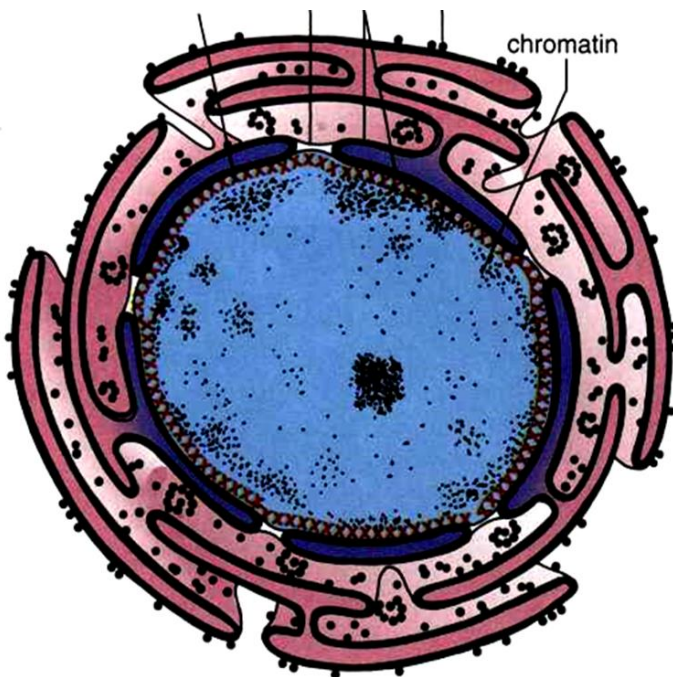

In the area of pore complex begins the protein layer, which covers inner nuclear membrane – thick plate, that performs the function of support and promotes ordered placement of chromosomes in the interphase nucleus.

Karyoplasm (nuclear sap) – nucleus matrix, it is the internal environment of the nucleus, it plays an important role in providing of normal functioning of the genetic material. The composition of the nuclear sap are fibrillar proteins which perform the function of support.

Nucleolus is a structure where the formation and maturation of ribosomal RNA (rRNA) take place. rRNA genes occupy specific locus on one or more chromosomes, for example, in humans 13–15, 21–22 pairs contain nucleolus organizers loci forming of nucleolus. Such sites of metaphase chromosomes are narrowed, they are called *secondary constrictions*.

Chromatin is a form of interphase chromosomes, nucleoprotein (DNA, histones, acidic proteins) with nucleosome organization which can have as a spiral or non-spiral structure during cell cycle.

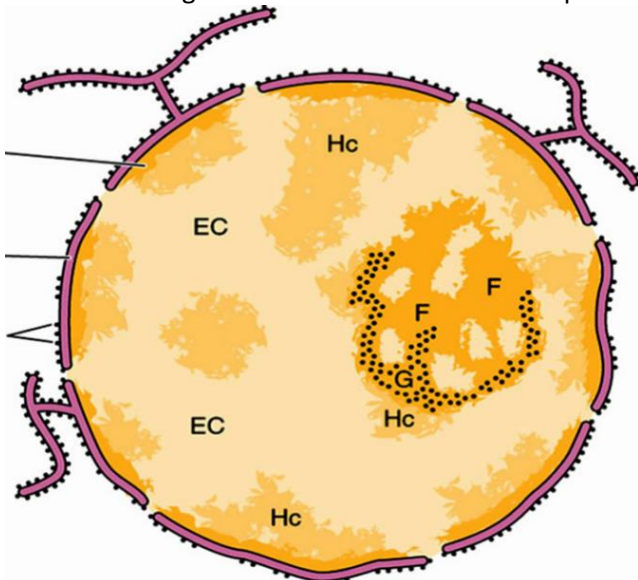

There are following **levels of packaging of chromatin**:

1. *Molecular* – DNA double helix.
2. *Nucleosome* – filament diameter of 10–12 nm.
3. *Fibrilla* – elementary chromatin helix diameter of 25–30 nm.
4. *Chromonema* – interphase structure with diameter of 200 nm.
5. *Chromatide-chromosome* – metaphase chromosome (1 or 2 chromatids). Chromatid has a diameter of 600 nm.

Chromatin can be also defined as interphase nuclear material, which is painted by alkaline dyes. Depending on the state there can be distinguished euchromatin and heterochromatin. **Euchromatin** differs by lesser degree of packing (more light on colouring) and there are areas that are transcribed («opened» for transcription).

Heterochromatin includes a section packed (dark on colouring); genetically inert («closed» for transcription). It can be distinguished constitutional (structural) and facultative heterochromatin.

Constitutional heterochromatin is located around centromere and telomere of chromosomes and also presented in some internal areas of individual chromosomes. It supports the general structure of the nucleus and attached to the nuclear membrane determining interaction between homologous chromosomes during meiosis, involved in regulation of gene activity.

Facultative heterochromatin formed by whole chromosomes and contain genes in transcriptionally inactive state. An example of facultative heterochromatin is a **Barr body** – one of the sexual chromosome of mammalian female (X-chromosome), which is highly spiralsed and inactivated. Genes of such non-active chromosomes are not transcribed and excluded. Formation of facultative heterochromatin accompanies the cellular differentiation and it represent a mechanism of exclusion of genes which are not required by specialized cells.

The functions of nucleus:

1. saving of genetic information in DNA molecules;
2. realization of genetic information through the regulation of protein synthesis. This is supported by the structural ordering of cells regulated their metabolism, functions and processes of division;
3. transfer of genetic information to the next generations as a result of DNA replication through the formation of chromosomes and their separation.

Karyotype. Autosomes and heterosomes

Karyotype is a relatively stable system of chromosomes in the nuclei of somatic cells, characterized by a specific diploid number of chromosomes, certain size, shape and groups of linked genes. Karyotype is a species characteristic. Karyotype of most organisms is characterized by diploid number of chromosomes ($2n$). Chromosomes of one pair have the same shape, size, and they are called *homologous* (except only sexual heterochromosomes X and Y which are non-homologous and morphologically different). Each species has a stable diploid set of chromosomes in somatic cells ($2n$): man – 46, ascaris – 2, rabbit – 44, chimpanzees – 48. Human karyotype was established in 1956 by Swedish scientists T. Tjio and A. Levan on the culture of human cells.

Among the chromosomes are isolated autosomes and heterosomes.

Autosomes are the same chromosome in the male and female organisms, there have genes which determine the different characters of the body, except sex.

Heterosomes (gonosomes, allosomes) are the sexual chromosomes, which differ in male and female organisms, they determine the sex of an organism and properties, related to sexual reproduction.

Sexual cells contained single or haploid set of chromosomes, it denoted (n). Then fertilization restores diploid set of chromosomes. Each chromosome has a homologous one. Homologous pairs are represented by one «mother's» chromosome and the second – «father's».

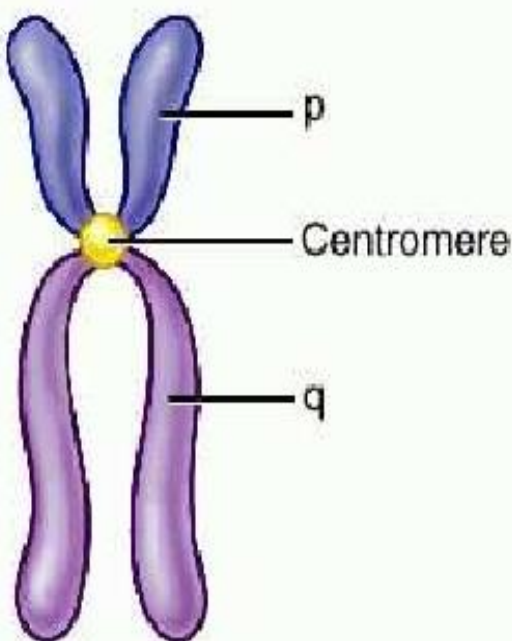

Metaphase chromosomes have primary constriction – *centromere*, which divides the chromosome into 2 arms: short – p and long – q :

Location of chromosomes centromeres determines the **morphological type of chromosomes**:

- 1) *metacentric chromosomes* – chromosome centromere is in the middle and divides it into two equal arms;
- 2) *submetacentric chromosomes* – centromere divides chromosome into two non-equal arms, which slightly differ by length;
- 3) *acrocentric chromosomes* have centromere, located closely to the edge of chromosome and divides it into short and long arms, which differ by length noticeably; short arms often have satellite;
- 4) *telocentric chromosomes* have centromere, which located strictly at the edge of chromosome and thus have only one arm; such chromosomes are absent in human karyotype.

The structure of chromosomes: 1 – centromere; 2 – satellite; 3 – telomere; 4 – arm; 5 – chromonema.

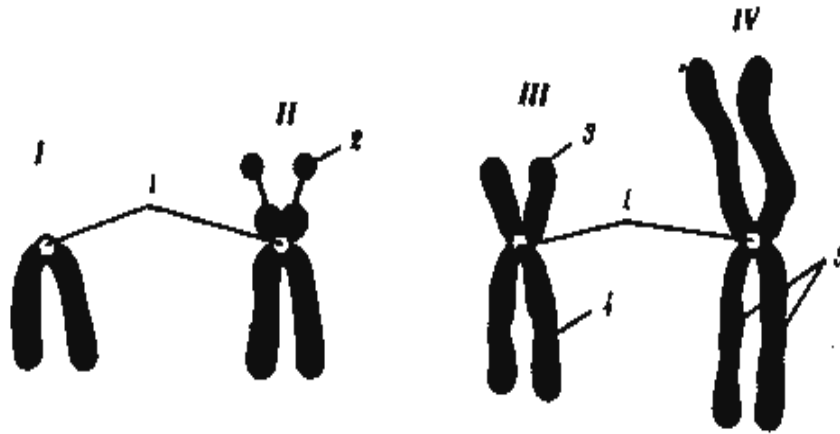

Types of chromosomes: I – telocentric; II – acrocentric; III – submetacentric; IV – metacentric.

Some chromosomes have *secondary constrictions*. It is near the end of chromosomes and separates in small area, called the *satellite*. Secondary constrictions are usually present in acrocentric chromosomes. Arms of chromosomes have the end – *telomere*. Telomeric ends of chromosomes do not give chromosomes to connect with each other.

Specification of karyotype

Determining of the karyotype can be used in any population of cells but for studying of human karyotype the mononuclear leukocytes are used which extracted from blood or using cell culture which are intensely divided (fibroblasts of the skin, bone marrow cells).

The study of human karyotypes is performing in cell culture. Chromosomes studying performs during mitotic division when chromosomes are most spiralized (by means of colchicine – alkaloids which blocking the formation of microtubules and «stretching» of chromosomes to the poles of the cell).

These cells in metaphase stage are fixed, painted and photographed under the microscope; then pictures form the systematic karyotype – numbered set of pairs of homologous chromosomes (autosomes), images of chromosomes with short arms oriented vertically upwards, their numbers held in order of decreasing of size, pair of sexual chromosomes are putting separately and placed at the end of the set.

Historically first, non-detailed karyotypes (which allowed to make classification the morphology of chromosomes), performed with painting by Romanovsky–Gimze then further details of structure of chromosomes in the karyotype became possible to determine with using of techniques with differential staining of chromosomes.

For studying and chromosome identification using morphometric analysis: measure the length of the chromosomes (in microns) and determine *centromere index* (ratio of length short arm of chromosome to the length of all chromosomes $p + q$, where p – length of the short arm of chromosome, q – length of the long arm of chromosome):

$$j = \frac{p}{p + q}$$

Further intensive study of human chromosomes in laboratories around the cytologist accompanied the creation of systems of classification and nomenclature of chromosomes. It was necessary to unify the nomenclature of human chromosomes.

Chromosome analysis. Denver system of classification of chromosomes

In 1960 in Denver (USA) has developed the first international classification of human chromosomes. It was created «Standard system of nomenclature of mitotic chromosomes of a man». Its foundation was laid by morphometric features of metaphase chromosomes: the size and location of centromeres (Patau, 1960).

According to the shape and size of metaphase chromosomes they are divided into 7 groups, denoted by Latin letters: A, B, C, D, E, F, G; separately distinguished sex chromosomes.

Each pair of chromosomes has its own serial number from 1 to 23. But only the sexual chromosomes are not numbered. They are designated as X-and Y-chromosome.

Group	Number	Size (mcm)	Centromere index, %	Characteristics
A	1, 2, 3	11.0; 10.8; 8.3	Chr. 1: 48–49 Chr. 2: 38–40 Chr. 3: 45–46	Often long arm Chr. 1 has «secondary constriction». Chr. 2 is the biggest submetacentric. Chr. 3 is almost on 20% shorter than Chr. 1.
B	4, 5	7.7	Chr. 4, 5: 24–30	Big submetacentric chromosomes.
C	6, 7, 8, 9, 10, 11, 12	7.2; 6.8; 5.7; 5.8; 5.8; 5.8; 5.8	Chr. 6–12: 27–35	Middle size, submetacentric. Chr. 9 often has secondary constriction in arm <i>q</i> . X-chromosome is similar to the longest from group C with higher centromere index.
D	13, 14, 15	4.2	Chr. 13–15: 16	Acrocentric, have satellite.
E	16, 17, 18	3.6; 3.5; 3.2	Chr. 16: 40 Chr. 17: 31 Chr. 18: 26	Short metacentric and submetacentric.
F	19, 20	2.9	Chr. 19, 20: 36–46	Very different during staining.
G	21, 22	2.8; 2.3	Chr. 21, 22: 13–33	Small acrocentric chromosomes. Y-chr. is bigger than chromosomes from group G. Satellite is absent. During staining distal part of long arm has fluorescence.

Preparation are fixing, painting and studying but for convenience of study and analysis of karyotypes the ideogram is used (S. Navashyn). *Ideogram* is a schematic representation of the karyotype that shows all of the pairs of homologous chromosomes in the nucleus, which are lined up in order of size, so that the centromeres are aligned and the short arm is uppermost. An ideogram is a useful point of reference for analyzing mutations.

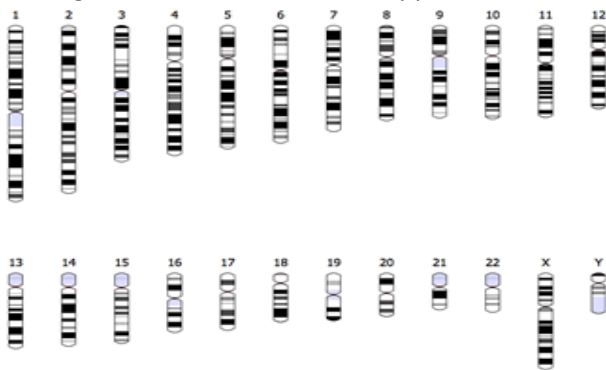

Ideogram of human karyotype

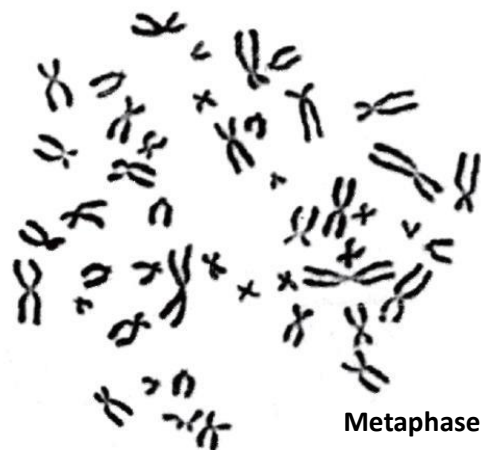

Metaphase plate

Differential staining

Many scientists have noted in chromosomes which are stained by conventional methods, some heterogeneity of staining density. Kasperson and collaborators (1968) found that after processing of the chromosomes by special staining the fluorescence is not uniform and distributed as segment.

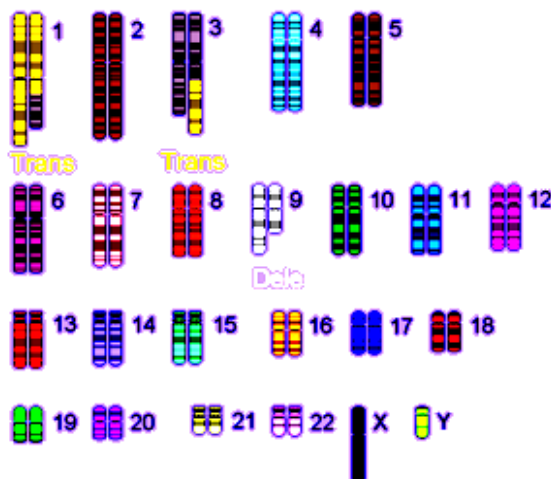

Di Differential staining of chromosomes

The same pictured segment can be obtained by using dye of Giemsa. At the Paris Conference on Standardization and nomenclature of human chromosomes in 1971 the following signs for colored segments were adopted:

- a) *Q-segment* (quinacrine).
- b) *G-segment* (Giemsa dye) – segments that are colored by Giemsa dye under certain additional methods of treatment of chromosomes.

Q and G segments are identical. Q-method can detect in the interphase nucleus Y-chromosome by a bright fluorescence.

c) *R-segments* (reverse) painted after heat treatment. Placed between the Q (or G) segments.

d) *C-segments* (constitutive heterochromatin) is areas around centromeres of both arms of chromosomes.

Differential staining associated with the chemical features of chromosomes (DNA nucleotides and proteins). Differential color allows us to set a pair of homologous chromosomes and identify chromosomal aberrations. For the more detailed analysis of the chromosome set are using differential staining of chromosomes. With conventional methods it is difficult to distinguish one color from another chromosome in the middle group. Differential staining allows clear to pick homologous pair. Each pair of chromosomes has a transverse zones, ordered placement and its number of transverse bands. This analysis, combined with genetic observations, allowed to begin drawing up maps of human chromosome, i.e., find the location of genes on specific chromosome regions.

1st level tests
(one correct answer)

1. Chromosomal complement of a woman contains a chromosome with arms p and q of equal length. What morphological type does this chromosome belong to?

- A. Metacentric
- B. Acrocentric
- C. Submetacentric
- D. Telocentric
- E. Subacrocentric.

2. An action of electromagnetic radiation on epithelial cells of intestine and kidney has studied in laboratory. Which state of the cell is more sensible to destructive factor:

- A. Mitosis
- B. Phagocytosis
- C. Excretion
- D. Pinocytosis
- E. Endocytosis.

3. Which substance can destroy the spindle in the process of mitosis (metaphase stage):

- A. Colchicine
- B. Iodine
- C. Methanol
- D. KCl
- E. Ethanol.

4. After karyotyping of a healthy man some small acrocentric chromosome has found. What is this chromosome:

- A. Y-chromosome
- B. X-chromosome
- C. Chromosome of group A
- D. Chromosome of group B
- E. Chromosome of group C.

5. How many homologous chromosomes pairs are there in normal $2n$ somatic cell:

- A. 22 pairs
- B. 23 pairs
- C. 24 pairs
- D. 46 pairs
- E. 44 pairs.

6. 14-years girl has a Turner syndrome (absence of one sexual chromosome). Her karyotype is:

- A. 45, XO
- B. 46, XX
- C. 47, XXY
- D. 46, XY
- E. 47, trisomy of 13th pair.

7. Name the chromosome which has centromere with almost two equal arms:

- A. Telocentric
- B. Subcentric
- C. Metacentric
- D. Acrocentric

E. Satellite.

8. Man sexual chromosome is taking:

- A. From group A
- B. From group C
- C. From group D
- D. From group F
- E. From group G.

9. Number of chromosome in human karyotype is 46.

This amount was detected due to work of:

- A. Barr
- B. Navashyn
- C. Levitsky
- D. Patau
- E. Tiyo and Levan.

10. X-chromosome is placed:

- A. In group C
- B. In group A
- C. In group D
- D. In group G
- E. In group F.

11. Which mechanism provides human karyotype saving in generation of somatic cells:

- A. Endomitosis
- B. Meiosis
- C. Mitosis
- D. Fertilization
- E. Meiosis+fertilization.

12. Which mechanism provides human karyotype saving in generation of sexual reproduction:

- A. Endomitosis
- B. Meiosis
- C. Mitosis
- D. Fertilization
- E. Meiosis+fertilization.

13. Number of chromosomes in human somatic cells is:

- A. 48
- B. 46
- C. 24
- D. 36
- E. 44.

14. Y-chromosome belongs to:

- A. Metacentric
- B. Submetacentric
- C. Acrocentric
- D. Telocentric
- E. Satellite.

15. How many groups are taking from the human karyotype:

- A. 4
B. 6
C. 7
D. 5
E. 10.
16. Karyotyping in practical medicine is using for the:
A. Definition of human sex
B. Diagnostics of chromosomal diseases
C. Definition of blood groups
D. Diagnostics of molecular diseases
E. Definition of type of inheritance.
17. There are two bodies of sexual chromatin in epithelium of buccal smear of some women. What is set of her sexual chromosomes:
A. Two
B. Three
C. One
D. Four
E. Five.
18. Karyotype of healthy man contains 46 chromosomes. How many autosomes do somatic cells have:
A. 23
B. 22
C. 44
D. 46
E. 92.
19. On the basis of some classification by a convention of experts held at Denver, Colorado in 1960. What is the principle of Denver system:
A. presence of satellite in chromosomes
B. size and shape of chromosomes
C. painting of chromosomes
D. telomere localization
E. number of chromosomes.
20. Metaphase plate has a chromosome with centromere index 0.21–0.23 (21–23%). This chromosome belongs to the:
A. group A, submetacentric
B. group G, acrocentric
C. group B, acrocentric
D. group C, metacentric
E. group G, telocentric.
21. After staining of amniotic liquid with fluorescent dyes some small colon-shaped body was found. Possible karyotype of fetus is:
A. 46, XY
B. 47, XXX
C. 46, YY
D. 47, XXX
E. 46.
22. A labeled thymidine is added to a cell culture then a cell has examined using radioautography method. In which cell organelles the labeled nucleotide was detected?
A. Lysosome
B. Nucleus
C. Microbody
D. Centrosome
E. Golgi complex.
23. During the cell's life cycle where actively synthesizing proteins some parts of chromosomes – nucleoli – became more visible. At the same time an increasing number of ribosomes in granular ER has increased. It happens due to the fact that nucleolus forms:
A. Lysosomes
B. Chromosomes
C. Mitochondria
D. Subunits of ribosomes
E. Cell center.
24. A scientist has discovered some structure formed by eight histone molecules, proteins and DNA molecules, which makes about 1.75 turns around them. What is this structure?
A. Half of chromatids structure
B. Nucleosome
C. Chromatids
D. The elementary fibrils
E. Chromosomes.
25. Fragment of chromosomes that forms a nucleolus within the cell and contains multiple tandem of rRNA genes is called:
A. Lysosome
B. Nucleus
C. Nucleolus organizers
D. Centrosome
E. Golgi complex.
26. What is the name of chromosomal end, characterized by the lack of ability to connect to other chromosomes or their fragments and performs a protective function?
A. Centromere
B. Kinetohor
C. Short shoulder
D. Telomere
E. Long shoulder.
27. What is the name of condensed state of chromatin, which forms a nucleus chromocenter at interphase stages and contains areas of intense staining in metaphase chromosomes?
A. Euchromatin
B. X-chromatin
C. Y-chromatin
D. Heterochromatin
E. Chromosome.
28. During a research of female blood cells in some polymorphonuclear leukocytes a special addition connected to the nucleus has found. What is the name of this structure?
A. Body of sex chromatin
B. Euchromatin
C. X-chromatin
D. Y-chromatin
E. «Drumsticks».
29. A cell nucleus contains chromatin (DNA in the nucleus) which is characterized by «openness» and transcriptional activity. What type of chromatin is it?
A. Heterochromatin
B. X-chromatin
C. Y-chromatin
D. Chromosome
E. Euchromatin.

30. What protein structure on the chromosome is formed on the centromeres of chromosomes in eukaryotes where connected the spindle fibers during a cell division?

- A. Short shoulder
- B. Centromere
- C. Telomere
- D. Kinetohor

E. Long shoulder.

31. How do we call a research and analysis of the morphology, number and structure of chromosomes?

- A. Karyotyping
- B. Differential staining
- C. Chromosomal analysis
- D. Ideogram
- E. Preservation of genetic material.

2nd level tests

(several correct answers)

1. Interphase nucleus has:

- A. Two membranes
- B. Chromosomes
- C. Karyoplasm
- D. Nucleolus

E. Hetero- and euchromatin

F. Ribosomes

G. Interphase chromatin.

2. Which processes and structures will break after distraction of protein tubulin:

- A. Structure and movement of cytoplasm
- B. Golgi complex and ER
- C. Cell centre and spindle formation.

D. Chromosome and division process

E. Ribosome and protein synthesis.

3. Some physical agents can disturb the cell centre. What processes and structure are involved in this process:

- A. Centrioles
- B. Protein synthesis
- C. Mitosis and spindle formation.

D. Diversion of chromosomes

E. Flagella and microfilaments.

4. Homologous chromosomes are characterized by:

- A. The same form and size
- B. Moving to the one pole
- C. Conjugate during meiosis
- D. Contain the same groups of linked genes

E. Moving to the different poles

F. Can have different poles and different linked group.

5. Chromosome of bacteria has organized as:

- A. Nucleosome
- B. Double strands of DNA
- C. Double strands of DNA+RNA

D. DNA+histone

E. One myofibril.

6. On this stage are studying of human karyotype:

- A. Prophase
- B. Anaphase
- C. Metaphase

D. Telophase

E. Prometaphase.

7. Call the levels of organization of eukaryotic cell:

- A. Polynucleotide DNA chain
- B. Double DNA chain
- C. Nucleosome thread

D. Chromatin fibre

E. Prophase chromatin

F. Interphase chromonema.

8. Interphase chromosome contains:

- A. Sugar, phosphategroup, nitrogenousbase
- B. Histone proteins

C. DNA

D. Nucleosome.

9. Sexual chromosomes belong to the group:

- A. A
- B. C
- C. D

D. G

E. F

F. E.

10. Chromosome of eukaryotic cells has such levels of organization:

- A. PolynucleotideDNAchain
- B. Double DNA chain
- C. Nucleosome

D. Chromatin fibre

E. Prophase chromatid

F. Interphase chromonema.

11. Human karyotype contains:

- A. Telocentric chromosome
- B. Acrocentric chromosome
- C. Metacentric chromosome

D. Satellite

E. Submetacentric chromosome.

12. Human karyotype is characterized by:

- A. Diploid number of chromosomes
- B. 44 A + 2 G
- C. Forms of chromosomes only submetacentric

D. 46 chromosomes + 2 sexual chromosomes

E. Chromosomes meta- and submetacentric

F. Specific by the forms and size.

13. Ideogram of human karyotype is proposed by:

- A. Denver
 B. Navashyn
 C. Levitsky
- 14. Eukaryotic cell chromosome during interphase has special levels of organization of tightly coiled DNA (packing):**
 A. Polynucleotide DNA chain
 B. Double DNA
 C. Nucleosome thread
- 15. At what mitosis stage is karyotype usually defined:**
 A. Prophase
 B. Anaphase
 C. Metaphase
- 16. Metacentric chromosomes are present in group:**
 A. A
 B. C
 C. D
- 17. Normally human sexual chromosomes are:**
 A. Telocentric
 B. Acrocentric
 C. Metacentric
- 18. Euchromatin has such levels of packing as:**
 A. DNA chain
 B. Double DNA chain
 C. Nucleosome thread
- 19. Secondary and tertiary structures of chromosomes define:**
 A. Polynucleotide DNA chain
 B. Double DNA chain
 C. Nucleosome thread
- 20. Human karyotype contains:**
 A. Diploid number of chromosomes
 B. Individual by shape and size
 C. Constant chromosomes number
- D. Patau
 E. Caspersen
 F. Tijo and Levan.
- D. Chromatin fibre
 E. Interphase chromatide.
- D. Telophase
 E. Interphase.
- D. G
 E. F
 F. E.
- D. Satellite
 E. Submetacentric.
- D. Chromatin fibre
 E. Interphase chromatide.
- D. Chromatin fibre
 E. Interphase chromatide.
- D. Haploid number of chromosomes
 E. All chromosomes have homologous pair.

TOPIC: Molecular basis of heredity. Characteristics of nucleic acids

The molecular basis of heredity. Characterization of nucleic acids: DNA and RNA, spatial organization, species specificity, the role in storing and transferring genetic information. DNA replication. Maintaining genetic stability of cells: self-correction and DNA repairation.

Transformation and transduction

It is considered that molecular biology exists since 1953, the year when Watson and Crick had discovered the double-strand DNA structure thus proving that DNA can be the storage place for hereditary information. But the history of this period is much older. The nucleic acids at first were determined by F. Miescher in 1868 in the cells rich in nucleus material (leukocytes, salmon spermatozoas). The term «nucleic acids» was proposed in 1889.

F. Griffith performed his experiments with mice in 1928. He infected the animals with virulent and non-virulent pneumococcus strains. The animals, that had been infected with virulent bacteria, perished the ones that had non-virulent bacteria survived. Then he killed the virulent bacteria with high temperature and mixed them with living non-virulent bacteria. He used the obtained mixture to infect the mice, which died after that. Scientists came to the conclusion that some compounds of virulent bacteria influenced the non-virulent ones to become like them. He called this phenomenon **transformation**. The substance, causing transformation, hadn't been determined, and Griffith's discovery wasn't appreciated properly.

O. Avery and his colleagues repeated Griffith's experiments in 1944. They extracted the basic organic compounds of bacteria – DNA, proteins, carbohydrates and lipids. Positive results were obtained only when DNA of virulent bacteria had been added to non-virulent ones. That means that DNA transfers virulent property information. Most of scientists were disagreed with Avery; they thought proteins to contain hereditary information of bacteria and higher creatures.

A. Hershey and M. Chase performed their experiments in 1952. They cultivated bacteria on a nutritive medium, containing radioactive S and P. Having used bacteriophages they proved that bacteria contained radioactive phosphorus only when being transferred to the nutritive medium without any radioactive elements. It is known that phosphorus is included into nucleic acids, while sulfur is contained in proteins.

Other phenomenon discovered that time was **transduction** – the transmission of genetic material from one bacterium (donor) to another one (recipient) with moderate bacteriophages. Viruses releasing bacteria cells where they are parasites could catch the part of their DNA and while transferring in new cells transductions these bacteria features to their new hosts. For instance, in the historical experiments of G. Lederberg and N. Zinder (1952) there were *Salmonella typhimurium* and lac⁺-gene (of lactose splitting). Transduction phenomenon was also founded in lots of bacteria: salmonelles, shigelles, bacilles, actinomyces, etc. The phage carrying the genetic material to the bacteria is called the transducing phage. According to the bacteriophage type the exactly restricted bacteria chromosome fragment (specific or restricted transduction) or any bacteria chromosome fragment (common or non-specific transduction) is transmitted from the donor to the recipient. The phages transmit some of the genes at the specific transduction and 1–2% of the genes at the common transduction. The transduction phenomenon is widely used by genetics all over the world at the genetic mapping: the frequency of two neighboring genes to transduction indicates the distances between these genes on the chromosome. Transduction is used at the intragenic mutation mapping. The transduction process is a real proving of the DNA genetical role.

The scientists opened also the **conjugation process** at that time – new way of the genetic material exchange in bacteria. The enterobacteria *Pseudomonas* has this process. The one-dimensioned genetic material transmission from the donor («male» cell) to the recipient («female» cell) occurs during the conjugation as during the transformation and the transduction. The conjugation process is controlled by special plasmides – fertility factors (F-plasmides). The cells containing even one of such plasmides (F⁺-cell) receive the donor features. At the same time the cell lacking such a plasmide (F⁻-cell) receive the recipient features. The transmission of the donor chromosome genes occurs in linear sequence and is accompanied by their recombination to the chromosome recipient genes. The size of the fragment received is usually determined by the cells contact time. Such conjugation special features are used for the bacteria genetic mapping where the distance between the genes are expressed not in the recombination per cents but in the minutes. The conjugation is a specific process providing the hereditary variability increasing in prokaryotes. It should be mentioned that there exists the term «chromosome conjugation». It is a pair temporary becoming closer of the homological chromosomes while the exchange of their homological regions is quite possible – the so-called **crossing-over**. In some seaweeds and microscopical fungi the conjugation is a sex process form at which the content of two similar cells without any flagelli are merged.

DNA amount in different cells was known by that time. It was determined that its amount in somatic cells is twice larger than in sexual ones. There are 2 kinds of nucleic acids (DNA, RNA) in the cell organisms. But as for the viruses – they contain either DNA, either RNA. The viruses are classified into 2 main groups – DNA – containing and RNA-containing ones. Protein contents were various enough in different organisms. DNA is organized in one chromosome – nucleoid – in all prokaryotes cells. It is one macromolecule with molecular weight of about 10^9 and about 1 mm long, packed in the spiralized loops. Small cyclic DNA molecules are present in plasmides. In eukaryotic cells DNA is mainly located in nucleus as the deoxyribonucleic (DNP) complex, the major part of chromatin or chromosomes. It is considered that the eukaryotic chromosome like the bacteria one consists of one DNA molecule with very high molecular weight (e.g., the molecular weight of the largest drosophila chromosome is about $7,9 \times 10^{10}$).

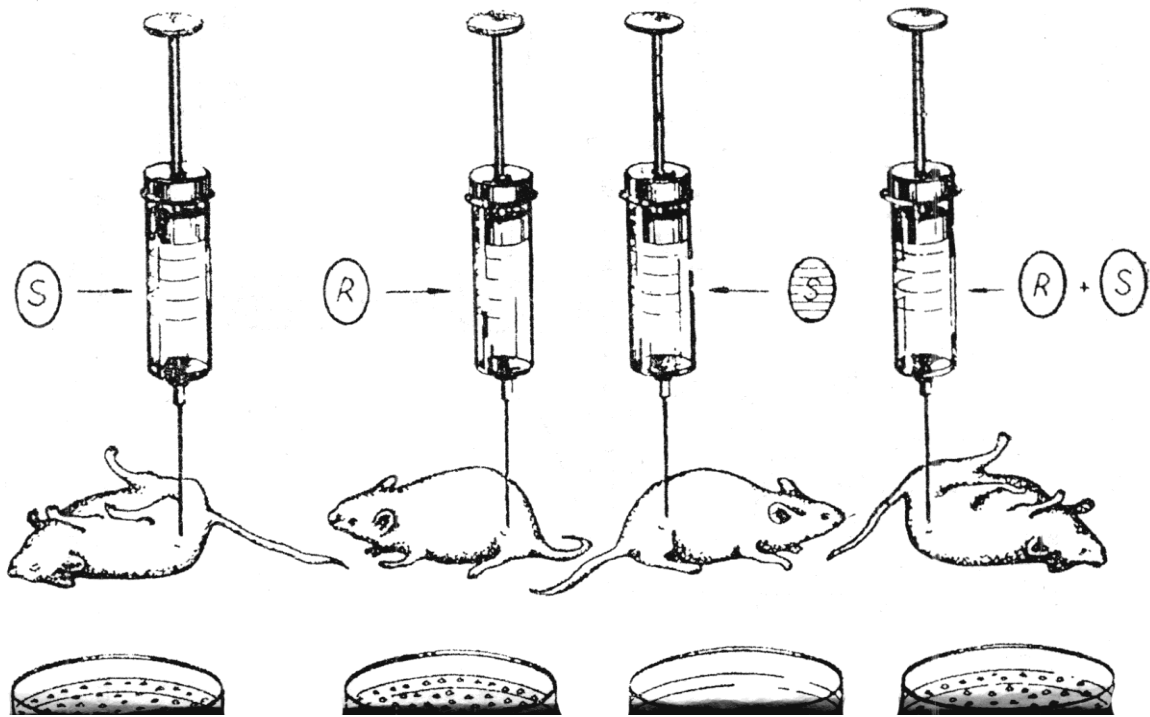

Griffith's experiment on transformation

By 1952 it was determined that DNA consists of nucleotides, nucleotides composition and the way they join each other were known. R. Franklin proved that DNA molecule is coiled into a spiral with nitrogenous compounds located inside the spiral. L. Pauling suggested the three-chained structure of DNA. The same did Morris Wilkins who had a laboratory with R. Franklin, F. Crick and D. Watson working there. But F. Crick and D. Watson only suggested the well-known double helical model of DNA molecule structure and considered that nucleotides sequence cipher genetic information.

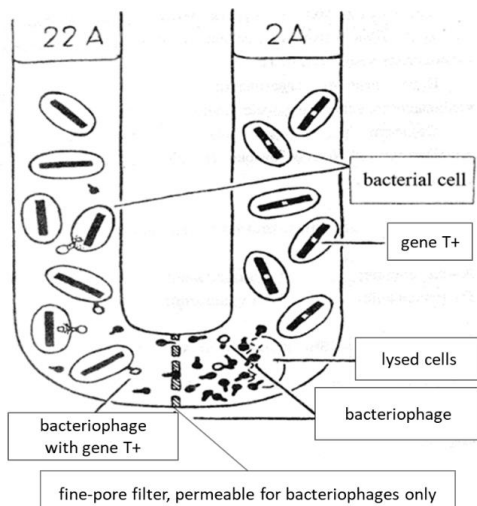

The phenomenon of transduction: 22A – non-synthesis tryptophan bacterial strain, 2A – synthesis tryptophan bacterial strain (T+)

Watson and Crick thought in the following way. DNA is a polymer molecule consisting of nucleotides. It's interesting to know that the human DNA contains about 3 billions of nucleotides. At any cell division the number of mistakes in nucleotide sequence achieves of about 50 thousand. In human organism cells loses in average 20 thousand of nitrogenous bases simultaneously at the 37 °C for 1 day. External influences increase the number of these losses. Each nucleotide consists of nitrogenous base, deoxyribose sugar and phosphate.

Nucleotides from a chain with the help of DNA-polymerase that joins deoxyribose of one nucleotide to the phosphate of the other. Thus the polynucleotide chain is formed with a 5'-position phosphate on one side and the hydroxile of a 3'-position on the other. That's why there are so called 5'- and 3'- ends of polynucleotide chain.

Nucleic acids. DNA and RNA

Nucleic acids are the polymers, which monomers are nucleotides.

Nucleotides are constructed of three chemical components:

- 1) nitrogenous bases,
- 2) sugar pentoses
- 3) phosphoric acid residue.

The structure includes four DNA nucleotide bases: adenine, guanine (purine bases), thymine and cytosine (pyrimidine bases) of the RNA also includes four nitrogenous bases, but instead of thymine is uracil. Nucleotides DNA containing pentoses – deoxyribose, RNA nucleotides – ribose.

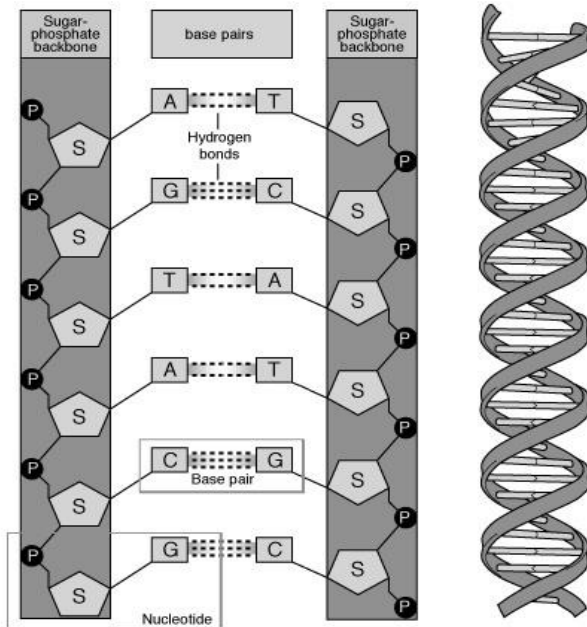

E. Chargaff and his colleagues proved that DNA contents of one species are similar still being different in various species by 1950. They had determined an important peculiarity called **Chargaff's rule** later: **A=T, G=C**. By 1952 it was determined that DNA consists of nucleotides, nucleotides composition and the way they join each other were known. R. Franklin proved that DNA molecule is coiled into a spiral with nitrogenous compounds located inside the spiral. L. Pauling suggested the three-chained structure of DNA. The same did Morris Wilkins who had a laboratory with R. Franklin, F. Crick and D. Watson working there.

But James Watson and Francis Crick only suggested the well-known double helical model of DNA molecule structure and considered that nucleotides sequence cipher genetic information. Watson and Crick thought in the following way. DNA is a polymer molecule consisting of nucleotides.

It's interesting to know that the human DNA contains about 3 billions of nucleotides. At any cell division the number of mistakes in nucleotide sequence achieves of about 50 thousand. In human organism cells loses in average 20 thousand of nitrogenous bases simultaneously at the 37°C for 1 day. External influences increase the number of these losses. Each nucleotide consists of nitrogenous base, deoxyribose sugar and phosphate.

Structure of DNA molecule

Nucleotides from a chain with the help of DNA-polymerase that joins deoxyribose of one nucleotide to the phosphate of the other. Thus the polynucleotide chain is formed with a 5'-position phosphate on one side and the hydroxile of a 3'-position on the other. That's why there are so called 5'- and 3'- ends of polynucleotide chain. There are four kinds of nucleotides depending on the nitrogenous base:

- 1) purines:
 - adenine;
 - guanine;
- 2) pyrimidines:
 - thymine;
 - cytosine.

Basing their conclusions on X-ray structural analysis and Chargaff's rule Watson and Crick suggested that two chains of DNA join to form a single helix according to the principle of complementary by hydrogen bonds between their nitrogenous bases. Certain position of nucleotides with different nitrogenous bases determines hereditary information. This model was created according to the principles of complementary and antiparallel direction.

Principle of complementary means that certain nitrogenous bases of both chains from hydrogen bonds:

- adenine is paired with thymine by two hydrogen bonds;
- guanine is paired with cytosine by three hydrogen bonds.

Complementary is also the spatial and chemical connections between molecules, which leads to the formation of compact structure with the maximum number of chemical bonds. Complementary bases lie in one plane, almost perpendicular to the main axis of the helix. Neighboring base pairs in B-form DNA facing to second on 36 degree.

Carbohydrate-phosphate skeleton of the molecule is located outside. On the surface of the spiral grooves may be divided into two groups: large – 2.2 nm in length and small – width of 1.2 nm.

Antiparallel principle is the case that 5'-end of one chain is joined to 3'-end of another one.

This principle means that two polynucleotide chain connected from 5'-end to the 3'-end of the second named circuit and vice versa. One chain is directed from top to bottom of the second 5'-to 3'-th hydrocarbon atom, and the second - from the bottom up.

Two polynucleotide strands coiled into a spiral one around another. The helix diameter is 2 nm. One turn of the helix makes 3.4 nm including 10 pairs of nucleotides. Thus the distance between nucleotide pairs is 0.34 nm.

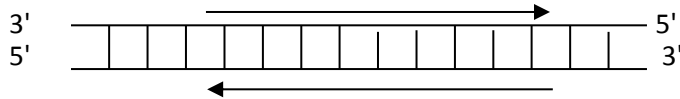

DNA is located in the chromosomes of the nucleus, in mitochondria and plastids, RNA – in the nucleus (or nuclear RNA precursors of RNA) in the cytoplasm, mitochondria and plastids of eukaryotic cells. Dimensions of double-stranded DNA are characterized by the number of pairs (p.n.) per molecule of DNA and significant change in scope. Dimensions of polynucleotide RNA chains can be various from few tens-hundreds - for tRNA, small rRNA, small nuclear RNA to several thousand nucleotides (ribosomal, information, viral RNA).

DNA right-coiled polynucleotides chains are antiparalleled that determined the direction of connections: one chain formed in 3' → 5' end, and the second – in the direction 5' → 3' end. Therefore, at each of the ends of linear DNA is 5'- the end of one chain and the 3'- end of the second. The structure of DNA has been named as B-shaped. Sometimes occurs left-coiled DNA – Z-form and A- and C-forms, which differ from B-form by helix parameters, such as A-form DNA is wider (2 nm) and spiral coil includes 11 pairs of nucleotides.

Properties of DNA:

1. In DNA encoded genetic information about the structure of proteins (genetic code).
2. DNA is capable of doubling (replication) that provides transmission of genetic information to new cell generation.
4. Molecule DNA damage structures capable of self-correction and repair.
5. DNA may change and undergoes mutations.
6. DNA provides a process of genetic information, defines the transcription and translation (provides synthesis of RNA and polypeptides).

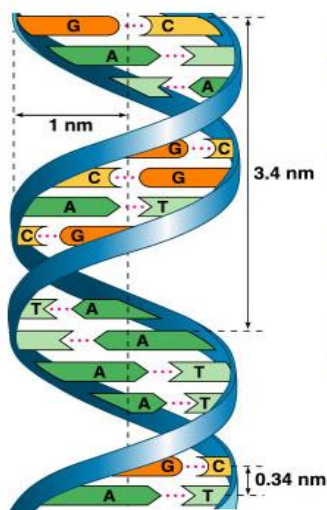

(a) Key features of DNA structure

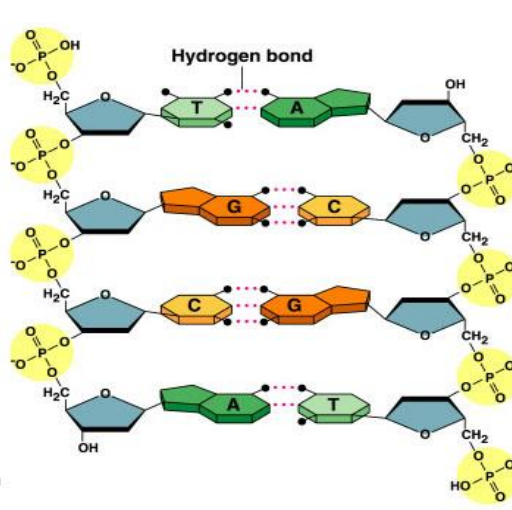

(b) Partial chemical structure

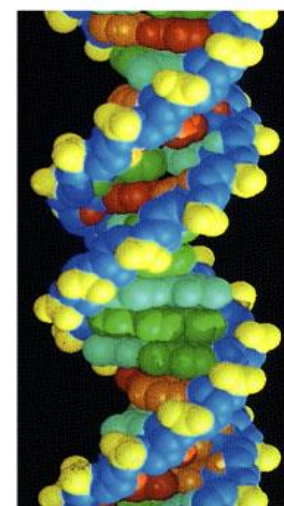

(c) Space-filling model

Ribonucleic acids (RNA)

Ribonucleic acids are presented by polynucleotide chain that consists of 4 types of nucleotides. Every nucleotide contains: ribose sugar, with carbons numbered 1' through 5', phosphate group and one of 4 nitrogenous bases – adenine, guanine, cytosine and uracil. Phosphate group is attached to the 3' position of one ribose and the 5' position of the next. One RNA chain can form a double structure when different parts of chain have antiparallel fragments that associate by hydrogen bonds. The bases may form hydrogen bonds

between cytosine and guanine, between adenine and uracil and between guanine and uracil. Some viruses have RNA which performs function as a transmitter of the inherited information instead of DNA. In cell there are three basic RNA types which have various functions: *informative iRNA* or *messenger* which also named *matrix mRNA*, *transport tRNA*, *ribosomal rRNA*. All three types of RNA are synthesized on the matrices-molecules of DNA by means of enzymes of RNA-polymerase, this process known as transcription. Initiation of transcription begins with the binding of the enzyme to promoter sequence in the DNA. The DNA double helix is unwound by the helicase enzyme activity of the enzyme. The enzyme then progresses along the template strand in the 3' to 5' direction, synthesizing a complementary RNA molecule with elongation occurring in the 5' to 3' direction. DNA sequence also notes where termination of RNA synthesis will occur.

mRNA. This molecule consists of 300–3000 nucleotides, one chain of linear molecules appears during transcription as complementary copy of genes of DNA. They have encoding areas which are presented by the sets of codons (triplets) what is determined sequence of amino acid. mRNA as in DNA, genetic information is encoded in the sequence of nucleotides arranged into codons consisting of three bases. Each codon encodes for amino acid except the stop codons which finishing biosynthesis of protein. Bacterial matrix RNA as a result of feature of «reading» can be polycistrons which include information about some structural genes. Eukaryotic mRNA molecules often require extensive processing and transport, while prokaryotic molecule does not.

Maturation of mRNA (before this molecule is termed pre-mRNA) includes **splicing**. This is the process by which pre-mRNA is modified to remove certain fragments of non-coding sequences called as *introns*. The fragments that remain include protein-coding sequences are called as *exons*. Sometimes pre-mRNA messages may be spliced in several different ways, allowing a single gene to encode multiple proteins. This process is called as alternative splicing. Processing of mRNA differs from eukaryotes, bacteria, archea. Non-eukaryotic mRNA mature upon transcription and requires no processing, except in rare cases. Eukaryotic pre-mRNA requires more extensive processing.

tRNA. An important role in the process of realization of the inherited information belongs to tRNA which transport amino acid to the ribosomes. Molecules of tRNA – are polynucleotide chains, which are synthesized on the certain areas of DNA and also contain the small amount of nucleotides – 75–95. As a result of complementary cooperations between bases of different areas, tRNA acquire structure which reminds the leaf of clover.

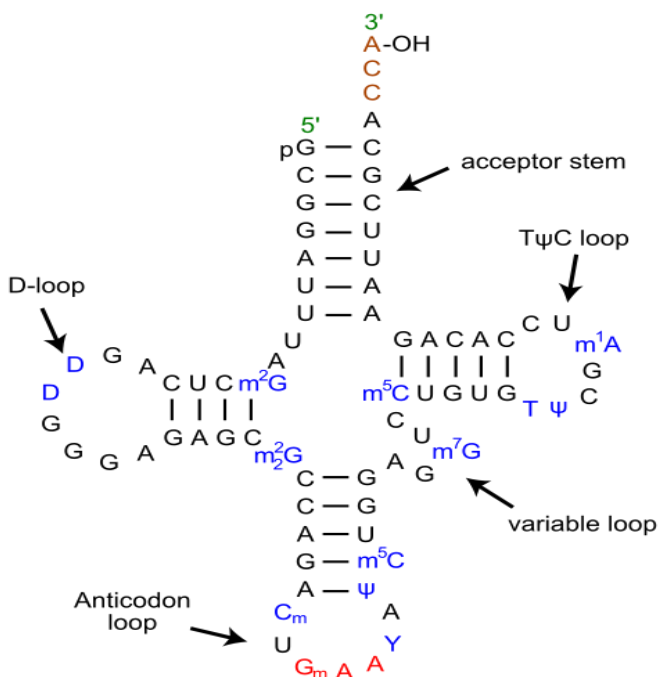

One end of the tRNA carries the genetic code in a three-nucleotide sequence called anticodon. The anticodon forms three base pairs with codon in mRNA during translation stage. Molecule of mRNA encodes a protein as a series of codons each of which is recognized by a particular tRNA. On the other end each tRNA is attached to the amino acid that corresponds to the anticodon sequence. This attachment to the tRNA 3' end is catalyzed by enzymes called aminoacyl-tRNA synthetase. Each type of tRNA molecule can be attached to only one type of amino acid. Because the genetic code contains multiple codons that specify the same amino acid, tRNA molecules bearing different anticodons may also carry the same amino acid.

During protein synthesis, tRNAs are delivered to the ribosome by specific proteins called elongation factors which help in decoding the mRNA codon sequence.

tRNA already connected to the ribosome transfers the growing polypeptide chain from its 3' end to the amino acid attached to the 3' end of the new tRNA, this reaction catalyzed by the ribosome. The different types of tRNA have the same tertiary structure. The feature of tRNA is a presence in the molecule of the modified nucleotides. Modifications of bases of anticodon have an important value. For example, in the first position of anticodon of tRNA there can be basis inosine which is able to connect with three bases of mRNA (U, C, A). As a result such tRNA is able to determine 3 codons-synonyms which encode one amino acid.

rRNA is a part of the ribosom. rRNA provides a mechanism for decoding mRNA into AA and interacts with tRNA during translation by providing peptidyltransferase activity. The tRNAs bring the necessary amino acids corresponding to the mRNA codon. rRNAs form two subunits of ribosomes, there are large subunit and small

subunit. mRNA goes between the small and large subunits and the ribosome catalyzes the formation of a peptide bond between the 2 amino acids that are contained in the rRNA.

DNA replication

Replication – is a difficult biological process of reaction of matrix synthesis which provides doubling of molecule of DNA. It takes place as a semiconservative mechanism on principle of complementary. Replication determines reproduction on molecular level, this is a basis of reproduction of organisms, providing of existence of separate organisms, populations and kinds development. Model of DNA offered by Watson and Krick allowed to understand principle of doubling of DNA (replication of DNA). Each of chains of DNA has sequences of nucleotides complementary to the second chain so doubling of DNA chains must go separately and then each of them becomes a matrix for the construction of new chain (semi-complementary mechanism). Regarding to the simplicity of mechanism of replication this process is difficult, clearly organized and it takes place with participation of many proteins and with the charges of energy. These proteins determine the corresponding genes of DNA, i.e. DNA determines replication.

Replication includes such stages: initiation, elongation and termination. This process is initiated at particular points in the DNA which are targeted by proteins that separate the two chains and initiate DNA synthesis. Origins contain DNA sequences recognized by replication initiator proteins which makes to separate the two strands and initiate replication forks: leading strand is the template strand of the DNA double helix so that the replication fork moves along it in the 3' to 5' direction.

As a result of this new synthesized strand complementary to the original strand to be synthesized 5' to 3' in the same direction. When strands are separated, RNA primers are created on the template strands. Also leading strand receives one RNA primer per active origin of replication while the lagging strand receives several. Such several fragments of RNA primers found on the lagging strand of DNA are called *Okazaki fragment (short molecules of one-stranded DNA that are formed on the lagging strand during replication of DNA)*. For example, there are between 100 to 200 nucleotides long in eukaryotes.

DNA-polymerase extends the leading strand in one continuous motion and the lagging strand in a discontinuous motion (due to the Okazaki fragments). RNAase cuts the RNA fragments used to initiate replication by DNA-polymerase, and another DNA-polymerase enters too. When this process is finished the single mark on the leading strand and several marks on the lagging strand can be found.

Self-correction of DNA. Repair

On DNA mutagenic factors (spontaneous, induced) influence constantly. Most changes of mutations can block of DNA replication and cause death of cell. Therefore all cells have the special systems of correction of damages in the DNA. Ability of cells to correct a damage in the molecules of DNA is named repair. The mechanism of reparation is based on a presence in the DNA molecule two complementary chains. Cell has repair enzymes which can find a damage in the molecule of DNA and restore its structure. Many of lesions cause structural damage to the DNA molecule and can be eliminated by means of cell's ability to transcribe the gene that the affected DNA encodes.

Other lesions induce harmful mutation in the cell's genome, which affect the survival of its cells after mitosis. DNA repair process is constantly active as it responds to damage in the DNA structure. When normal repair processes fail and when cellular apoptosis (programmed death) does not occur, irreparable DNA damage may occur. Failure to correct molecular lesions in cells that form gametes can introduce mutations into the genomes of the daughter cells. The number of DNA repair is dependent on many factors, including the cell type, the age of the cell, and the extracellular environment. Being hereditary information carrier, DNA is capable of unique abilities of replication.

Replication includes the following stages:

- uncoiling of the helix by topoisomerase;
- breaking down of hydrogen bonds between complementary nitrogenous bases of two chains by helicase;
- joining of three nucleotides to nitrogenous bases according to complementary principle;
- joining of these nucleotides into a chain by DNA-dependent DNA-polymerase.
- sewing of the DNA fragments by DNA-ligase.

Thus, daughter DNA molecules have one old and one newly synthesized strand. Such a way of replication is called *semi-conservative*. It provides exact imprinting of information in ascendant molecule (template synthesis).

Replicon – the genomic region replication process unit that is under the control of one initiation point (beginning replication point).

The term was proposed by F. Jakob and S. Brenner. The prokaryotic genome is only one replicon as it is. From the initiation point the replication goes in two dimensions sometimes even with different speed. The eukaryotic genome consists of a great number (often till some scores) of replicons.

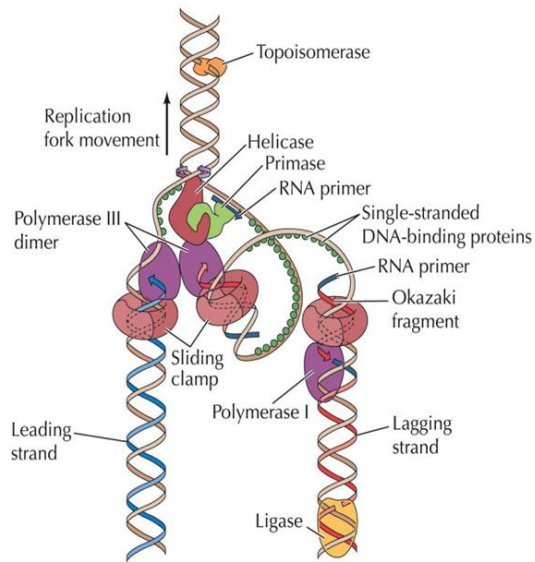

Reparation (Latin: *reparation* – restoration) – the characteristic of all organism cells; the native (natural) DNA structure restoration process which is affected during the normal DNA biosynthesis in cell as well as the physical and chemical agents. It is performed by the specific enzyme cell systems. The best studied is the replication process of bacteria DNA that is affected by the ultraviolet rays or the ionizing radiation.

3 major reparation mechanisms:

- *Photoreparation* – the cleavage by the deoxypyrimidinphotoliasse enzyme, activated by visible light, of cyclobutane dimers under the ultraviolet irradiation action.
- *Excision (removing reparation)* – the DNA damage recognizing, the damaged region cutting off (removing, excision), the DNA resynthesis on the intact chain matrix; the DNA chain continuity restoration.

- *Postreplicative* – occurs in the cases when the previous reparation kind doesn't manage with the liquidating of all DNA damages taking place in cell before its replication. In this case the damaged molecules restoration leads to the existence of molecules with one-fibrous gaps and the native structure is restored with the using of recombination stage.

The reparative enzymes participate in the reduplication and recombination as well as in the mutational process. In the latest case we separate a special reparation kind – the so-called inducible reparation that is susceptible to the mistakes. As a result the native DNA structure restoration occurs but with the distortion of genetic information in it.

The future doctor is to remember that some hereditary pathological conditions are caused by the reparative system disturbances:

- Pigment xerodermia.
- Ataxy-teleangiectasy.
- Progeria (early aging).

Cancer therapy procedures such as chemotherapy and radiotherapy work by overwhelming the capacity of the cell to repair DNA damage, resulting in cell death. Cells that are most rapidly dividing the most typically cancer cells are affected. Modern cancer treatments attempt to localize the DNA damage to cells and tissues only associated with cancer by means of physical means (concentrating the therapeutic agent in the region of the tumor) or biochemical means (exploiting a feature unique to cancer cells in the body).

The bacteria and yeast strains defected on the replication process and possessed the increasing sensitivity to the damaged agents are used by genetics as the indicators in genetic toxicology. In multicellular organisms the reparation is expressed as the regeneration of irradiated organs and tissues. In modern science one differentiates 2 terms: *reparation* – the restoring after the damage under the pathological condition; *regeneration* – the restoration of cells, tissues under the normal (physiologic) conditions. In phylogenesis this processes begin to function in Hydras, Nematodes and Reptiles.

Gene mutations

Gene mutations – change of structures of genes, which are recreated in the cycles of replication and show up in posterities by the new variants of characters. Mutation are changes in genomic sequence – DNA sequence of genome or the DNA or RNA sequence of virus. They can be defined as sudden or spontaneous changes in the cell. Mutations are caused by radiation, viruses, transposons, mutagenic chemicals as well as errors that occur during meiosis or DNA replication.

Changes of structure of genes can be such:

1. Mutations of replacement of one nitrogenous bases other (20% spontaneous mutations).
2. Mutations with a frameshifting during changes of amount of nucleotides pairs in genes (70% mutations).
3. Mutations of inversion of sequences of gene nucleotides.

Mutations of *replacement of nitrogenous bases* arise under the action of chemical factors (chemical mutagenes) and able to change bases of nucleotides of DNA. When such mutations do not noticed by the enzymes of reparation in the next cycle to the variable nucleotide can join complementary nucleotide, but it already other nucleotide. Replacements of bases can be during erroneous including of the modified bases. Mutations sometimes resulted of formation of nonsense codons which are more frequent (in 75% cases) and formation of codons which determine other amino acid, as a result, there are gene mutations.

Chromosomal inversion: reversing the orientation of a chromosomal segment.

Insertion: add one or more extra nucleotides into the DNA. Insertions in the coding region of a gene may alter splicing of the mRNA or cause a shift in the reading frame. Such mutations change a genetic code, disturb amino acid composition within the limits of the inverted area.

Gene mutations which may cause a genetic disorder are repaired by the DNA repair system of the cell. Each cell has a number of processes through which enzymes recognize and repair mistakes in DNA molecule. This is the reason of hereditary diseases. But mutation may occur in a somatic cells too. Such mutations will be present in all daughter cells, and certain mutations can cause the cell to become malignant, and thus cause cancer. Because DNA can be damaged or mutated in many ways, the process of DNA repair is an important way in which the body protects itself from disease. If a mutation is present in gametes it can give rise to offspring that carries the mutation in all of its cells.

Biological role of nucleic acids:

- Genetical information saving.
- Genetical information realizing.
- Genetical information transmission.
- Participation in all stages of protein synthesis.
- Immunological memory providing.
- Neurological memory providing.
- All biosynthetic processes regulation (subcellular and cellular regulation levels).
- Involving practically in all live processes in alive matter.

Average values of nucleic and amino acids:

✓ One nucleotide molecular weight	345 conditional units (c.u.)
✓ One amino acid molecular weight	100 conditional units (c.u.)
✓ One nucleotide occupies in DNA molecule	0.34 nm

1st level tests

(one correct answer)

1. During cell division DNA replication occurs after a signal is received from the cytoplasm, then a certain portion of the DNA helix unwinds and splits into two individual strains. What enzyme facilitates this process?

- A. Helicase
- B. RNA polymerase
- C. Ligase
- D. Restrictase
- E. DNA polymerase.

2. Among organic substances of a cell there is a polymer composed of dozens, hundreds and thousands of monomers. This molecule is capable of self-reproduction and can be an information carrier. X-ray structure analysis shows this molecule to consist of two complementary spiral threads. Name this compound:

- A. DNA
- B. RNA
- C. Cellulose
- D. Carbohydrate
- E. Hormone.

3. In the course of evolution there developed molecular mechanisms for correction of damaged DNA molecules. This process is called:

- A. Reparation
- B. Transcription
- C. Translation
- D. Replication
- E. Processing.

4. Under the influence of physical factors there can develop defects in a DNA molecule. Ultraviolet irradiation, for instance, can cause development of dimers. Dimers are two adjacent pyrimidine bases joined together. Name these bases:

- A. Thymine and cytosine
- B. Adenine and thymine
- C. Guanine and cytosine
- D. Adenine and guanine
- E. Guanine and thymine.

5. Patients suffering from xeroderma pigmentosum have extremely photosensitive skin due to disrupted excision repair. Specify the process that is affected in such patients:

- A. Repair of DNA molecule
- B. Synthesis of iRNA
- C. Maturation of iRNA
- D. Synthesis of protein primary structure
- E. Intron extraction and exon connection.

6. Nucleolar organizers of the 13–15, 21, 22 human chromosomes contain about 200 cluster genes that synthesize RNA. These regions of chromosomes bear the information on the following type of RNA:

- A. rRNA
- B. tRNA
- C. mRNA
- D. snRNA
- E. tRNA + rRNA.

7. During cell division DNA replication occurs after a signal is received from the cytoplasm, then a certain portion of the DNA helix unwinds and splits into two individual strands. What enzyme facilitates this process?

- A. Helicase
- B. RNA polymerase
- C. Ligase
- D. Restrictase
- E. DNA polymerase.

8. Cells of a person working in the Chernobyl Exclusion Zone have undergone a mutation in DNA molecule. However, with time the damaged interval of DNA molecule has been restored to its initial structure with a specific enzyme. In this case the following occurred:

- A. Repair
- B. Replication
- C. Transcription
- D. Reverse transcription
- E. Translation.

9. According to the model of double DNA helix that was suggested by Watson and Creek, it was established that one of chains would not be lost during replication and the second chain would be synthesized complementary to the first one. What way of replication is it?

- A. Semiconservative
- B. Analogous
- C. Identical
- D. Dispersed
- E. Conservative.

10. An experiment proved that UV irradiated skin cells of patients with xeroderma pigmentosum restore the native structure of DNA slower than the cells of healthy people due to the defect in repair enzyme. What enzyme takes part in this process?

- A. Endonuclease
- B. RNA ligase
- C. Primase
- D. DNA polymerase
- E. DNA gyrase.

11. Among the organic matters of cells some polymer found out which consists of 10 thousand monomers. This molecule is able to be a carrier of genetic information. By X-ray analysis is discovered that molecule consists of two spiral threads. Name this organic compound:

- A. rRNA
- B. DNA
- C. Hemoglobin
- D. Insulin
- E. Cellulose.

12. The DNA daughter's spirals are formed as a result of replication and consist of one maternal chain and one daughter. Such method of replication is named:

- A. Conservative
- B. Analogous
- C. Identical
- D. Disperse
- E. Semiconservative.

13. During DNA replication there can be substituting of one basis by other that can result in appearance of one nonsense triplets. As a result of such replacement will be:

- A. Doubling of basis in synthesized DNA chain
- B. Stop of polypeptide chain synthesis
- C. Loosing of nitrogenous base

- D. Enhance of polypeptide synthesis
- E. Inversion of nucleotide.

14. Damage of structural gene – area of DNA molecule took place. But replacement of amino acid did not happens because afterwards damage was liquidated. What is a process:

- A. Translation
- B. Transcription
- C. Reparation
- D. Opposite transcription
- E. Replocation.

15. In the cell of man the damage of DNA molecule took place caused by the action of ultraviolet. What system will provide proceeding in the damaged area by specific enzyme on unharmed chain:

- A. Termination
- B. Regeneration
- C. Replication
- D. Initiation
- E. Reparation.

16. It is known that the sequence of replacement of nucleotides in DNA and m-RNA determines the proper sequence of including of amino acid in a polypeptide chain. This accordance of sequence of nucleotides with the sequence of amino acid has a name:

- A. Gene
- B. Triplet nature
- C. Universality
- D. Replication
- E. Genetic code.

17. In the cells of man constantly there are processes of maintainance, self-reproduction and genetic information transfer. Leading role belongs in these processes:

- A. Nucleic acids
- B. Polypeptide
- C. Lipids
- D. Carbohydrates
- E. Proteins.

18. In an experiment artificially stopped conjugation of bacteria *Escherichia coli* through certain spans of time. Knowing what kind of genes passed to the recipient cell it is possible to define:

- A. Order of genes in bacterial chromosome
- B. Speed of replication
- C. Nucleotides of DNA
- D. Frequency of mutant genes
- E. Presence of gene-regulator.

19. What organic compounds carry out the role of mediators between the molecules of DNA as the carriers of genetic information and polypeptide chains as elementary features:

- A. RNA
- B. Carbohydrates
- C. Lipids
- D. Protein
- E. ATP.

20. Through the human organism the flow of matters, energy and information passes constantly. «Reading» and realization of genetic information at development of the dental system on molecular level is connected with properties of:

- A. Nucleic acids
- B. Carbohydrates
- C. Lipids

- D.** Aminoacids
E. Mineral matters.
21. During replication with certain frequency there are spontaneous errors can happen. For example, changed cytosin joins to adenin. As a result there is replacement of nucleotides pair. The mechanism of self-correction is working in such cases. What enzyme provides the self-correction of DNA:
- A.** DNA-polymerase
B. Ligase
C. Reparation enzymes
D. RNA-polymerase
E. DNA-glycoliase.
22. Under the action of ultraviolet in the DNA molecule appears double thymine (T=T). All the same changes of DNA will bring to the deletion in next replication or to replacement of nucleotides pair in DNA molecule. What reparation provides proceeding of DNA molecule:
- A.** Before-replication reparation
B. Dark reparation
C. Postreplication reparation
D. Light reparation
E. SOS-reparation.
23. Prokaryotes and eukaryotes cells characterized by reproduction. Molecular mechanism of reproduction base on:
- A.** Reparation
B. Transcription
C. Replication
D. Karyokinesis
E. Genes amplification.
24. Molecula of mRNA is connected with protein and forms informosomes. This structure has a function:
- A.** Provides connection with ribosomes
B. Makes stability of mRNA linear structure
C. Provides forming of mRNA tertiary structure
D. Destroy of mRNA
E. mRNA saving.
25. DNA molecule has different space forms depended on environment. Bacteria takes on special form during the spore formation in dehydrate cell surrounding:
- A.** Z-form
B. D-form
C. A-form
D. B-form
E. C-from.
26. Stress arises as a result of DNA replication in aspiral. Name enzymes which remove DNA stress:
- A.** DNA-topoisomerase
B. DNA-polymerase
C. RNA-primase
D. DNA-helicase
E. DNA-ligase.
27. For the treatment of bacteriosis are using medicines which break replication of bacteria cells. Replication enzyme, which repressed by medicine, is called:
- A.** DNA-gyrase
B. DNA-ligase
C. RNA-primase
D. DNA-polymerase
E. DNA-helicase.
28. mRNA contains information and non-information parts. 5'-end has a CAP, 3'-polyadenil fragment (poly-A). The function of this parts in mRNA is:
- A.** Attach to the ribosome
B. Transport through the nuclear pores
C. Connection with rRNA ribosomes
D. Protect mRNA against fission
E. Define mRNA space structure.
29. DNA has different forms. In replication process DNA takes on:
- A.** B form
B. A form
C. C form
D. D form
E. Z form.
30. Bacteria in conjugation process forms cytoplasm bridge where from the cell-donor to recipient cell is moving DNA fragment (plasmids). The meaning of this process is:
- A.** Deletes mutation
B. Provides metabolism
C. Activation of mutation process
D. Provides exchange and recombination of genetic materials
E. Increase heterozygous genes.
31. Ultraviolet rays break integrity of molecules DNA that cause formation of pyrimidine dymers (reason of mutations). Why radiation-exposed cells survive in light better than in darkness:
- A.** Photoreparation takes place
B. Activation of mitosis
C. Recombinative reparation takes place
D. Activation of DNA-polymerase
E. Another kinds of reparations take place.
32. DNA molecule has different space forms depended on environment. On replication process DNA takes a form:
- A.** A
B. B
C. C
D. D
E. Z.
33. Genome of eukaryotes cell has a large amount of replication points therefore replication goes in both directions. The meaning of this process is:
- A.** S-period shortening
B. Lesswasteof energy
C. More strict replication
D. Reparation improves
E. Less mutation arising.
34. Which group of organisms have circle-shaped form but have no histones:
- A.** Viruses
B. Bacteria
C. Protozoa
D. Fungi
E. Bacteriophage.
35. The second complementary chain of DNA replication is delayed. Originally formed primers and complementary fragments Okazaki (Okadzaki) connected by ligase. What determines a complex mechanism of the synthesis on the second chain?
- A.** The large size of DNA polymerase

- B. Complementarity chains
 - C. Triphosphonucleotides absence
 - D. Antiparallele of DNA chains
 - E. The repair process.
36. What is the mechanism of horizontal transfer of genetic information between organisms?
- A. Transduction
 - B. Transformation
 - C. Transcription
 - D. Gene drift
 - E. Transgenesis.
37. In the human genome there are 220 genes of proteins similar to proteins of bacteria. What process contributed of the emergence of these genes in the human genome?
- A. Transduction
 - B. Genes mutations
 - C. Transformation
 - D. Genetic recombination
 - E. These genes in the genome have been since the beginning of human evolution.
38. What kind of reparations played an important role in the early stages of organic evolution?
- A. SOS-repair
 - B. Recombinant repair
 - C. Photorepair
 - D. Postreplicative repair
 - E. Excessive repair.
39. Pigment xeroderma is a disease caused by repair disorder under influence of UV radiation. The patient has a keratinization of skin, eye disease, expanding capillaries. What exogenous factors will significantly worsen the patient's condition?

- A. High humidity
 - B. High temperatures (above 20°C)
 - C. Low temperatures (below 0°C)
 - D. Radiation
 - E. Light.
40. Under the influence of various physical and chemical agents in the DNA biosynthesis a damage of a cell can occur. The ability of cells to fix damage to DNA molecules is called:
- A. Reparation
 - B. Transcription
 - C. Replication
 - D. Transduction
 - E. Transformation.
41. According to the model of DNA double helix, proposed by Watson and Crick, there were found that one of DNA chain is kept during replication process but other chain has synthesized complementary. How does this method of replication call?
- A. Analogical
 - B. Semiconservative
 - C. Identical
 - D. Disperse
 - E. Conservative.
42. For the treatment of urogenital infections are using hinolones-inhibitors of the enzyme DNA helicase. What process is broken under the action of hinolones?
- A. Recombination of genes
 - B. Amplification of genes
 - C. Replication
 - D. Reparation
 - E. Reverse transcription.

2nd levels tests (several correct answers)

1. One nucleotide consists of:

- A. Pentose, phosphate group, nitrogenous base
- B. Hexose, phosphate group, nitrogenous base
- C. Aminoacids, phosphate group, thymine
- D. Nitrogenous base and uracil
- E. Tetrose, phosphate group, adenine.

2. DNA consists of:

- A. Nucleoside+phosphategroup
- B. Purine bases
- C. Pyrimidine bases
- D. Adenine, thymine, guanine, uracil
- E. Thymine, guanine, adenine, cytosine
- F. Thymine, uracil, pseudouracil, guanine, cytosine
- G. Nitrogenous bases + deoxyribose.

3. Which enzymes take part in replication process:

- A. RNA-primase
- B. DNA-polymerase
- C. RNA-polymerase
- D. DNA-ligase
- E. Helicase
- F. Aminoacil-tRNA-synthetase
- G. Topoisomerase
- H. Enzymes of reparation.

4. RNA molecule has:

- A. Nucleoside+phosphate acid
- B. Purine base

- C. Pyrimidine base
- D. Adenine, thymine, guanine, uracil
- E. Thymine, uracil, pseudourasil, guanine, cytosine
- F. Nitrogenous bases+deoxyribose.

5. Primary and secondary structures of DNA are:

- A. Polynucleotide DNA chain
- B. Double DNA chain
- C. Nucleosome thread
- D. Chromatine fibre
- E. Prophase chromatide
- F. Interphase chromatide.

6. Self-correction of DNA provide:

- A. RNA-primase
- B. DNA-polymerase
- C. RNA-polymerase
- D. DNA-ligase
- E. Helicase
- F. Aminoacil-tRNA-synthetase
- G. Topoisomerase
- H. Enzyme of reparation.

7. Name the processes had discovered genetic role of nucleic acids:

- A. Transformation
- B. Self-correction
- C. Conjugation of bacteria
- D. Replication

- E. Transduction
 - F. Reparation
 - G. Recombination in bacteria.
- 8. Replication is characterized by:**
- A. Semiconservative mechanisms
 - B. DNA-polymerasetakesplace
 - C. Presence of RNA-primase
 - D. Splicing by means of DNA-ligase
 - E. Presence of helicase
 - F. tRNA provides transport of nucleotides
 - G. Topoisomerase provides DNA integrity
 - H. Action of reparation enzymes.

9. Reparation process includes enzymes:

- A. DNA-primase
- B. RNA-polymerase
- C. DNA-polymerase
- D. DNA-ligase
- E. Helicase
- F. Aminoacyl-tRNA synthetase
- G. Topoisomerase
- H. Reparation enzymes.

10. Which cytoplasm organelles of eukaryotes cell contains DNA:

- A. Ribosome
- B. Mitochondria
- C. Chromosomes
- D. Chromatin
- E. Peroxisome
- F. Chloroplasts.

11. RNA functions are:

- A. Ability of replication
- B. Transfer of genetics information
- C. Provides hereditary information realization.

12. Biopolymers are:

- A. Myoglobin

- B. DNA
- C. tRNA
- D. ATP
- E. Insulin.

13. Some physical factors provoke destruction in the DNA-topoisomerase structure. Which processes will be disturbed:

- A. Structure and movement of cytoplasm
- B. DNA synthesis
- C. Cell centre and spindle formation
- D. Mitosis
- E. Ribosome and protein synthesis
- F. Replication.

14. iRNA functions are:

- A. Ability for replication
- B. Self-correction
- C. Provides realization of hereditary information
- D. Provides translation
- E. Ability for gene mutations forming
- F. Regulation intracellular processes.

15. Nucleotide of rRNA consists of:

- A. Ribose, phosphate group, nitrogenous bases
- B. Ribose, phosphate group
- C. Ribose, phosphate group, pseudouracil
- D. Adenine, guanine, cytosine, pseudouracil
- E. Adenine, guanine, cytosine, thymine.

16. tRNA consists of:

- A. Nucleoside + phosphate group
- B. Purine bases
- C. Pyrimidine bases
- D. Adenine, guanine, cytosine, thymine
- E. Adenine, guanine, cytosine, uracile
- F. Guanine, cytosine, thymine
- G. Nitrogenous bases + ribose + phosphate group.

TASKS

1. One DNA chain has a nucleotide sequence: ATG-ACC-GAC-ACG-CAC-GTA-CCT-GCA-TAC-GGG-TCA-GTT-TGC. Determine a second DNA chain.
2. DNA fragment contains 1120 adenylnucleotide that consists of 28% of common quantity. How many guanil, cytidyl and thymidyl nucleotides are there in this fragment? What is the length of this fragment?
3. The chemical analysis shows that 26% of the common iRNA is the adenine, 6% – guanine, 40% – uracil. What nucleotide content does the corresponding region of double chain DNA has?
4. RNA has a nucleotide sequence: AAU-UUC-CCA-GGC-CCU-AGC. Determine the sequence of «right» non-coding DNA chain.
5. Part of right DNA chain has a structure: GGG-CAT-AAC-GCT-CCA-GTC-CCC. Determine:
 - a) sequence of left chain;
 - b) length of this DNA region;
 - c) content of each nucleotide in this DNA fragment.
6. In DNA molecule there is 30% deoxyadenosinmonophosphate. How many deoxyguaninmonophosphate are there in this fragment?

TOPIC. Structure of pro- and eukaryotes gene

Gene as a unit of genetic function. Structure of pro- and eukaryotes gene. Structural, regulator genes, tRNA, rRNA. Genetic code, its peculiarities.

The ideas about gene in science have passed their historical path of formation and development

In 1865 Gregor Mendel opened the laws of heredity for explanation of regulation of inheritance and concept about the inherited factors (genes).

In 1909 Wilhelm Johansen firstly used the word «gene».

In 1911 Thomas Morgan and employees worked out on «chromosomal theory». They considered that a gene is an area of chromosome, accountable for the display of certain sign.

In 1926 T. Morgan wrote a book «Theory of gene», where he marked also, that a gene is a unit of mutation, recombination and function.

In 1934 in the Nobel lecture T. Morgan said: «Among geneticists there is no a consent in looks to nature of genes... If gene is a material unit, it is a piece of chromosome».

In 1940 George Biddle and Edward Tatum (USA) studied genetic control of metabolic reactions at mould of *Neurospora crassa* and suggested a hypothesis «**one gene is one enzyme**». However a gene still remained abstract unit.

In 1960s the work of French geneticists François Jacob and Jacques Monod described the genetic regulation of the *lac* operon.

Barbara McClintock had demonstrated the concept of transposition in 1951 and was widely credited for following discovery of the process in bacteria and yeast in the late 1960s and early 1970. McClintock understood the role of *transposons* (transposable elements are sequences of DNA that can move or transpose themselves to new positions within the genome of a single cell) in evolution and genome change well before other researchers grasped the concept.

According to modern knowleges, **gene** is a molecular unit of heredity of a living organism. Gene is an area of molecule of DNA that includes promoter, structural sequence and terminator. Each of elements of gene has a difficult structure and functional areas are certain.

Regulatory gene is a gene involved in controlling the expression of one or more other genes. Regulator gene may encode a protein, or it may work at the level of RNA.

Promoter is a region of DNA to which RNA polymerase binds to initiate the transcription of DNA into mRNA.

Operator is a sequence of DNA that interacts with a repressor of operon to control the expression of adjacent structural genes.

Structural gene is a gene that codes for any RNA or protein product other than a regulatory element.

Terminator is a DNA sequence at the end of a transcription unit that causes RNA polymerase to stop transcription.

Protein-repressor is a protein that binds DNA at an operator site and thereby prevents transcription of one or more adjacent genes.

Corepressor is a protein that decreases gene expression by binding to a transcription factor which contains a DNA binding domain. The corepressor is unable to bind DNA by itself.

Encoding part contains information about the sequence of nucleotides in RNA.

Exon is a region of a gene that contains the code for producing protein. Exons are separated by introns, long regions of DNA that have no apparent function.

Intron is a portion of DNA that lies between two exons, is transcribed into RNA, but does not appear in mRNA after maturation because introns removed and the exons spliced together, and so is not expressed in protein synthesis.

Enhancer is a DNA control element frequently found to the start site of a gene, which when bound by a specific transcription factor, enhances the levels of expression of the gene, but is not sufficient alone to cause expression.

Silencer sequences that reduce transcription may also be present. These sequences bind to repressor proteins and turn transcription off by interfering with RNA polymerase binding.

lac Operon Model

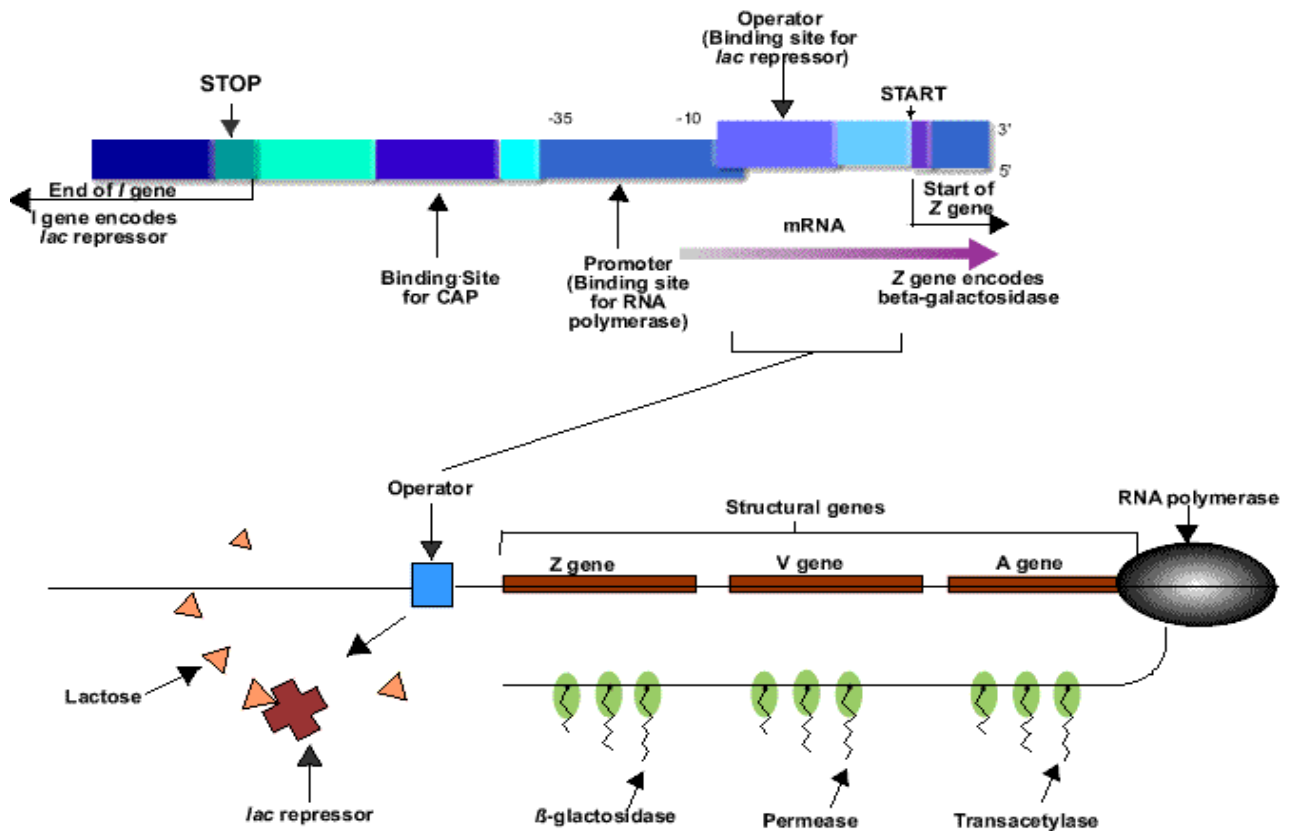

Genome organization

Human genome (total complement of genes in an organism) is the genome which is stored on 23 chromosome pairs plus the small DNA of mitochondria. 22 of the 23 chromosomes are autosomal chromosome pairs while the remaining pair is sex-determining. There are between 20,000 and 25,000 human protein-coding genes. The estimate of the human gene number has been repeatedly revised down as genome sequence quality and gene finding methods have improved. In the last century, predictions estimated that human cells had as many as 2,000,000 genes. Number of human genes seems to be less than a factor of two greater than that of many much simpler organisms. But larger proportion of human genes are related to central nervous system and brain development. Each chromosome contains various rich and poor regions of genes, which can be correlated with chromosome band. The significance of these nonrandom patterns of gene density does not understood properly. Coding genes of human genome contains thousands of RNA genes, including tRNA, rRNA and other non-coding RNA genes. Protein-coding sequences (coding exons) comprise less than 1.5% of the human genome. But there are known regulatory sequences, the human genome contains vast regions of DNA the function of which still remains unknown.

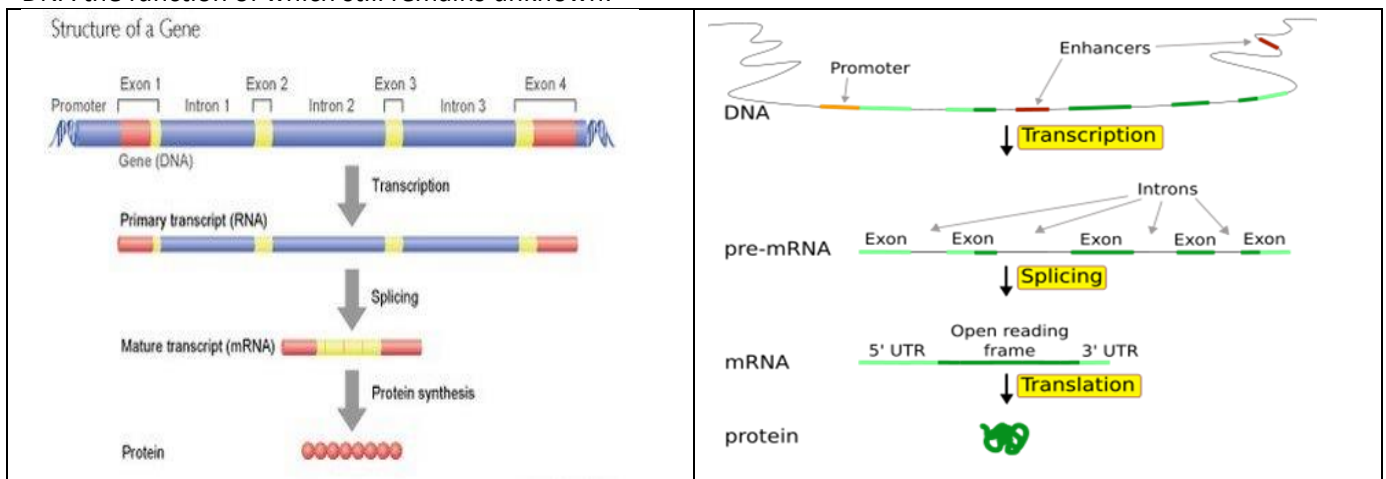

Gene classification:

Gene characteristics:

- specific;
- discreteness;
- stability;
- pleiotropy, penetrance.

Regulator:

- activators;
- repressors;
- promoters;
- terminators;
- operator;
- delimiters etc.

Structural:

- unique;
- repeating;
- transposons;
- silent (mutant without expression).

Operon regulation of eukaryotes gene activity

The new expression of preexisting genetic information in response to changing environmental signals (for example in human oocytes).

1. Eukaryotic cells contain more genetic information that they use at any one time (*Escherichia coli* at al.).
2. Although transcriptional controls undoubtedly exist in eukaryotes there is a little evidence for the presence of repressors and operators. Genes that affect the expression of other genes have been found in such diverse eukaryotes as fungi, corn and mice. But the mechanisms by which they achieve their regulatory effect is not yet known.
3. Eukaryotic cells, as the name tells us, have a nucleus and it is here that gene transcription takes place. Protein synthesis, on the other hand, i.e. translation, occurs out in the cytoplasm.
4. In prokaryotes, transcription and translation occur simultaneously. In eukaryotes, the production of mRNA by transcription is followed by the export of that messenger into the cytoplasm before translation can begin.
5. The prokaryotes messengers tend to be very unstable. After serving as the templates for a number of rounds of translation, they are degraded. Unless they are replaced by new transcripts, synthesis of that protein will soon halt. On the other hand, the messengers in eukaryotes may be quite stable. In the rapidly developing oocyte, for instance, maternal messengers are formed that will not be translated for several days after their formation and then only in fertilization has occurred.
6. Both in animals and in plants hormones serve as powerful gene expression modulators. Though at least some of their effects are brought about via their influence on gene transcription (mainly steroid ones, i.e., corticosteroids, sex hormones).
7. The non-histone proteins establish which genes will be transcribed.
8. According to G.P. Georgiev scheme (1972), in eukaryotes each operon consists of *acceptor* (or non-informative) *zone* and *informative zone*. The acceptor zone determines the structural proteins functioning via protein receptors.
9. It is considered that in eukaryotes each operon has a lot of regulative genes.
10. Structural genes that are responsible for the different ways of one biochemical reactions chain may be concentrated not only in one operon but may be disseminated through the genome.
11. In common, the eukaryotic genetic apparatus is the following: **acceptor zone (regulative) and informative (structural) zone – exon – intron – exon.**

Regulation of gene expression occurs at the following stages – processing, translation and posttranslational modifications. It is less beneficial energetically but acts much quicker. Finally all gene activity regulation processes exist to provide the cell and the whole organism with proteins needed at certain times. Although the organization of DNA molecule makes it remarkably resistant to changes in its sequence of bases, such changes do occur. These changes are called **gene**, or **«point» mutations**.

Genetic code

Genetic code is a system of rules by which information encoded in genetic material (sequences of DNA or mRNA) is translated into **amino acids** sequences.

The peculiarities of biological code are as follows:

- *Triplet nature* (one amino acid is specified by three adjacent nucleotides).
- *Code is specific* (unambiguous) (each triplet codes a certain amino acid).
- *Code is universal* (it is similar for all living organisms).
- *Code is degenerated* (most amino acids are specified by several triplets).
- *Code is non-overlapping* (each nucleotide is a member of one triplet only).
- *Collinearity*: a linear arrangement of codons in mRNA determines a linear arrangement of amino acids in protein.

Symbols of nucleotides:

A – adenyl
G – guanyl
T – thymidyl

C – cytidyl
U – uridyl

Three-letter abbreviations of amino acids:

Phe – phenylalanine
Leu – leucine
Ile – isoleucine
Met – methionine
Val – valine
Ser – serine
Pro – proline
Tyr – tyrosine
Cys – cysteine
His – histidine

Arg – arginine
Thr – threonine
Asn – asparagine
Asp – asparaginic (aspartic) acid
Gly – glycine
Trp – tryptophan
Ala – alanine
Lys – lysine (lysin)
Glu – glutamic acid
Gln – glutamine

THE TABLE OF GENETIC CODE

First base	Second base				Third base
	U (A)	C (G)	A (T)	G (C)	
U (A)	Phe	Ser	Tyr	Cys	U (A)
	Phe	Ser	Tyr	Cys	C (G)
	Leu	Ser	–	–	A (T)
	Leu	Ser	–	Trp	G (C)
C (G)	Leu	Pro	His	Arg	U (A)
	Leu	Pro	His	Arg	C (G)
	Leu	Pro	Gln	Arg	A (T)
	Leu	Pro	Gln	Arg	G (C)
A (T)	Ile	Thr	Asn	Ser	U (A)
	Ile	Thr	Asn	Ser	C (G)
	Ile	Thr	Lys	Arg	A (T)
	Met	Thr	Lys	Arg	G (C)
G (C)	Val	Ala	Asp	Gly	U (A)
	Val	Ala	Asp	Gly	C (G)
	Val	Ala	Glu	Gly	A (T)
	Val	Ala	Glu	Gly	G (C)

*Nucleotides in brackets – for DNA, outside brackets – for RNA.

1st level tests
 (one correct answer)

1. Biochemical analysis of amino acid contents of freshly synthesized polypeptides shows that in the process of their translation the first amino acid in each of these proteins will be the same. Name this amino acid:

- A. Methionine
- B. Phenylalanine
- C. Histidine
- D. Isoleucine
- E. Serine.

2. During a class in molecular biology, the mutations resulting in production of abnormal hemoglobin are being studied. What amino acid substitution occurs when S-hemoglobin is being produced, resulting in the development of sickle-cell anemia?

- A. Histidine is substituted with arginine
- B. Glycine is substituted with asparagine
- C. Threonine is substituted with lysine
- D. Lysine is substituted with glutamine

3. A patient with pulmonary tuberculosis is prescribed rifampicin that inhibits RNA- polymerase enzyme at the stage of initiation of the following process:

- A. Termination
- B. Transcription
- C. Translation
- D. Replication
- E. Elongation.

4. You are studying functioning of a bacteria operon. The operator gene has been released from the repressor gene. Immediately after this the following process will start in the cell:

- A. Transcription
- B. Translation
- C. Replication
- D. Processing
- E. Repression.

5. Genetic structure of eukaryote is «exon-intron-exon». This structural-functional organization of gene caused by transcription peculiarities. What will be pro-mRNA according to the schema?

- A. Exon-intron-exon
- B. Exon-exon-intron
- C. Exon-exon
- D. Intron-exon
- E. Exon-intron.

6. It is known that information about the sequence of amino acids in protein molecule it is written as a sequence of four types of nucleotides in the molecule of DNA, thus different amino acids are encoded by the different amount of triplets – from one to six. Such feature of genetic code is named:

- A. Degeneracy
- B. Non-overlapping
- C. Triplet nature
- D. Universality
- E. No punctuation.

2. Eukaryotes have the sequences of nucleotide in the DNA molecule of DNA which increase speed of transcription. These activators of transcription are named:

- A. Exons
- B. Transposons
- C. Enhancer
- D. Introns
- E. Codons.

3. At the study of features of genetic code students found out, that some amino acids correspond by 6 codons, 4 codons, 3 codons, 2 codons. What property of genetic code it is related to:

- A. Degeneracy
- B. Non-overlapping
- C. Triplet nature
- D. Universality
- E. No punctuation.

4. It is known that information about the sequence of amino acids in protein molecule is written as a sequence of nucleotides in the molecule of DNA. There are many amino acids that are encoded by a few different triplets. Such property of genetic code is named:

- A. Degeneracy
- B. Non-overlapping
- C. Triplet nature
- D. Universality
- E. No punctuation.

5. It is known that genetic code has triplet nature and degenerate characteristics. Replacement of what nucleotide in an encoding triplet can not disturb it content:

- A. Second
- B. First
- C. Third
- D. Second and third
- E. First and second.

6. Polypeptide synthesized on a ribosome consists of 54 amino acids. What amount of codon had mRNA which was a matrix during a synthesis:

- A. 44
- B. 27

C. 108

D. 162

E. 54.

7. Sequence of triplets of mRNA exactly answers to the sequence of amino acid in polypeptide chain. Such property of genetic code is named:

- A. Degeneracy
- B. Non-overlapping
- C. Triplet nature
- D. Universality
- E. Colinearity.

8. During questioning of students from a theme «Molecular biology» the teachers asked: «Why a genetic code is universal?» Correct must be an answer: «Because genetic code is...»:

- A. Universal for all organisms
- B. Has information about protein structure
- C. Triplet nature
- D. Codes amino acids
- E. Colinearity.

9. It is discovered that not all point mutations like replacements of pair of nitrogenous bases cause replacement of amino acid in polypeptide. What property of genetic code is it:

- A. Degeneracy
- B. Non-overlapping
- C. Triplet nature
- D. Universality
- E. No punctuation.

10. The various forms of life appeared in the process of evolution. What characteristic does explain unity of all living organisms:

- A. Genetic material of all living forms is DNA
- B. Identical enzyme complex
- C. Universal genetic code
- D. Identical organization of the inherited material
- E. Cellular organization of living organisms.

11. In molecular biology scientists use the method of determination of order of nucleotides location inside gene by means of amino acid content. What property of genetic code it is based on:

- A. Degeneracy
- B. Non-overlapping
- C. Triplet nature
- D. Universality
- E. Colinearity.

12. One of main conditions of life there are permanent chemical transformations of substances – metabolism that is regulated by quantitative composition and activity of enzymes. What molecular structures control the synthesis of these proteins-enzymes:

- A. Structural gene
- B. Gene-regulator
- C. Gene clusters
- D. Tandem genes
- E. Satellite DNA genes.

13. In the nucleolar organizers of human chromosomes 13–15, 21, 22 there are about 200 cluster genes that synthesize RNA. What RNA are synthesized by these areas of chromosomes:

- A. tRNA
 B. rRNA
 C. mRNA
 D. mnRNA
 E. tRNA+rRNA.
14. It is observed that the amino acid selenocystein goes in the proteins content, that associates with tRNA. Which codons of genetic code is used for insert of selenocystein in polypeptide:
- A. Any codon
 B. Codon which codes cystein
 C. Four-nucleotides codon
 D. Stop-codon
 E. Two codons together.
15. Information from unit of transcription is read one-way from 5'-end to 3'-end. What is this determined:
- A. Promoter organization
 B. Terminator
 C. Enhancer
 D. Silensor
 E. Structural genes.
16. Genes form clusters (5 genes of different histons which is divided by spacer areas, introns are absent) repeated many times, for example, in the genome of man – 35 times. Why such organization of histone genes is needed:
- A. For forming of nucleoli
 B. For rapid formation of nucleosome
 C. For the formation of nucleus membranes
 D. For formation of subunits of ribosomes
 E. For formation of apparatus of division.
17. In a nucleolar organizer the genes of rRNA presented in great numbers. They form clusters and have many copies (for a man are approximately 100 copies). Why such organization of rRNA genes is needed for genome:
- A. For providing of replication
 B. For rapid formation of subunits of ribosomes
 C. For activating of genes in DNA
 D. For the rapid synthesis of tubulin-proteins
 E. For the rapid synthesis of proteins-histons.
18. One of main conditions of life there are permanent chemical transformations of substances – metabolism that is regulated by quantitative composition and activity of enzymes. What molecular structures control the synthesis of these proteins-enzymes:
- A. Structural gene
 B. Gene-regulator
 C. Gene clusters
 D. Tandem genes
 E. Satellite DNA genes.
19. During the regeneration of epithelium of mucous membrane of oral cavity the replication (autoreproduction) of DNA took place according to semiconservative mechanism. Nucleotides of new DNA strand are complementary to:
- A. Informational codons
 B. Maternal strand
 C. Introns
 D. DNA-polymerase enzyme
 E. RNA-polymerase enzyme.
20. Mitochondria are organelles of the cell with their own DNA (mitochondrial genome). Unlike nuclear all mitochondrial genes don't have:
- A. Terminal areas
 B. Promoters
 C. Structural parts
 D. Exon-intron organization
 E. Enhancers.
21. Experimentally has established the number and sequence of amino acids in the hormone insulin molecule. This sequence is encoded by:
- A. Sequence of structural genes
 B. The number and sequence of nucleotides in exon parts
 C. The number and sequence of nitrogenous bases of DNA
 D. Certain alternating exon and intron areas
 E. The number and sequence of nucleotides in intron areas.
22. Patients treatment with a hereditary form of immunodeficiency the following method of gene therapy was used: enzyme gene was introduced into the cells of a patient by means of retrovirus. What feature of the genetic code allows the use of retroviruses as vectors of functional genes?
- A. Specificity
 B. Degeneracy
 C. Colinearity
 D. Universality
 E. No punctuation.
23. Some triplets of mRNA (UAA, UAG, CAA) don't encode any amino acid but they are terminator in the reading of information (can stop translation). What are these triplets?
- A. Anticodon
 B. Operators
 C. Stop codon
 D. Exon
 E. Introns.
24. It is established that some protein in human organism includes amino acid selenocysteine. How does this amino acid come to the ribosome?
- A. Through the transport protein
 B. Through the specific tRNA
 C. Through the mRNA
 D. Because of the chaotic movement
 E. Through the ER membranes.
25. In the cytoplasm for the protein synthesis is used at least 31 species of tRNA and in mitochondria – about 22 different tRNA. Why do mitochondria have reduced number of tRNA species?
- A. The features of mitochondrial genetic code
 B. Anticodon mtRNA determines all synonymous codons
 C. Mitochondrial genetic code is different
 D. The number of amino acids in the matrix of mitochondria is reduced
 E. Mitochondrial tRNA have a different structure.
26. In the human genome there are many genes which homologous to genome of flies on 61%, to genome of worms – 43%, to genome of yeast – 46%. What do these genes define?

- A. Define replication, repair, transcription, translation
 - B. Determine membrane proteins
 - C. Determine metabolism
 - D. Determine mitochondrial proteins
 - E. Determine receptor proteins.
27. Under the influence of a mutagen the gene composition has changed, but despite this the cells continued to synthesize the same protein. What is characteristic of the genetic code may be observed?
- A. Specificity
 - B. Degeneracy

- C. Colinearity
 - D. Universality
 - E. No punctuation.
28. DNA has an exon part. What is it?
- A. Nonsense areas
 - B. Substantial area that encode the primary structure of protein molecules
 - C. Enhancer
 - D. Tandem genes
 - E. Regulatory part of gene.

2nd level tests (several correct answers)

1. Genetic code has characteristics:

- A. Universality
- B. Colinearity
- C. Specify
- D. Self-regulation

2. Gene is:

- A. Fragment of DNA
- B. Material unit of life organization

3. Gene of prokaryotes – operon has:

- A. Nucleoside+phosphoricacids
- B. Promoter
- C. Acceptor locus
- D. Structural part

4. Determine the characteristics of genetic code which provide saving of genetic information:

- A. Universality
- B. Colinearity
- C. Specify
- D. Complementary

5. Gen of eukaryote has:

- A. Exons + introns
- B. Promoter
- C. Acceptor locus
- D. Structural part

6. What is the basic structural-functional differences in organization of eukaryotes genes and prokaryotes one:

- A. Exon-intron organization
- B. Polycistrons
- C. Monocistrons
- D. Regulation provide only protein-repressors

- E. Degeneracy
 - F. One amino acid is coded by one anticodon
 - G. Can be non-triplet
 - H. «Reading» from two DNA chain.
- C. DNA fragment which determine phenotype
 - D. DNA fragment provides polypeptide synthesis.

- E. Operator
- F. Regulator
- G. Terminator.

- E. Degeneracy
- F. One amino acid is coded by one anticodon
- G. Triplet nature
- H. «Reading» from two DNA chain

- E. Operator
- F. Regulator
- G. Terminator.

- E. Regulation is combinative
- F. Can change activity during their life
- G. Alterative splicing is possible.

TASKS

1. There are 800 amino acids in protein content. What is the length of gene that codes the protein synthesis?
2. Structural gene includes 990 nucleotides (one DNA chain) but 30% of this amount are introns. Determine the number of aminoacids which code this gene.
3. Eukatyote gene (two DNA chains) contains 30000 nucleotides. Functional part is 25%, structural part – 40% (exons). How many amino acids includes a protein coded by this gene?
4. Vasopressin (protein) consists of 9 amino acids, coded by: TGT-TAT-TTT-GAA-GAT-TGT-CCT-CGT-GGT. Determine:
 - a) how many DNA nucleotides and triplets;
 - b) length of gene;
 - c) aminoacids content of vasopressin.
5. Fragment of corticotropin hormone has a such structure: ser-tir-ser-met-pro-ala-ile. Determine tRNA anticodons.
6. What kind of DNA molecule replacement has more influences: one nucleotide deficiency or whole nucleotide falling?
7. What is the length of genes determining the normal hemoglobin molecule that consists of 287 aminoacids?
8. Protein chain has a nucleotide content: *valine-leucine-histidine-serine-isoleucine-alanine-arginine-proline-tyrosine*. Determine sequence of gene.
9. DNA codons which are coding valin: CAA, CAG, CAT, CAC. Determine the mRNA codons.

TOPIC. Organization of information flow in the cell.

Regulation of gene expression. Molecular mechanisms of the human variation

Organization of information flow in a cell. Molecular mechanisms of human variation. Transcription. Processing, splicing. Translation (initiation, elongation, termination). Posttranslational modification of proteins. Prokaryotes expression of genes. Exon-intron organization of eukaryotes genome. Molecular mechanisms of human variation.

Gene expression – is a difficult molecular mechanism of realization of the inherited information in a concrete phenotype.

The process of expression of gene includes such stages:

1. **Transcription** is a difficult biological process of reactions of matrix synthesis that provides an information transfer from the sequence of DNA nucleotides to the sequence of RNA nucleotides.
2. **Processing** is a process of maturation of mRNA (or tRNA). Pro-mRNA undergo modification and splicing that provides stability of mRNA and connection to ribosomes.
3. **Translation** is a difficult biological process of reactions of matrix synthesis that provides an information transfer from the sequence of RNA nucleotides to the aminoacids sequence.
4. **Folding and polypeptide modification** in cell (in a cytoplasm and vacuolar system) that results structural organization of proteins and forming of functional activity.
5. **Expression** in a trait. Protein performs special function that at morphological level determines a concrete attribute of phenotype (at co-operating with other genes). All stages of gene expression take place by means of dozens enzymes and energy. Basis of gene expression are molecular processes of transcription, processing, translation and modification.

Not only informing part of gene participates in the process of transcription but also other the regulator and structural areas. Pro-mRNA contains many elements as characteristic of DNA. Processing modifies pro-mRNA and forms mRNA which contains less structural-functional elements. As a result of translation on the basis of mRNA molecules appear fully other nature – proteins which have no similar elements with nucleic acids and have other peculiarities and organization. Protein folding is the process by which a protein structure assumes its functional shape or conformation. Folding is the physical process by which a polypeptide folds into its characteristic and functional structure. Each protein exists as an unfolded polypeptide when translated from a sequence of mRNA to a linear chain of AA. Failure to fold into native structure produces inactive proteins that are usually toxic.

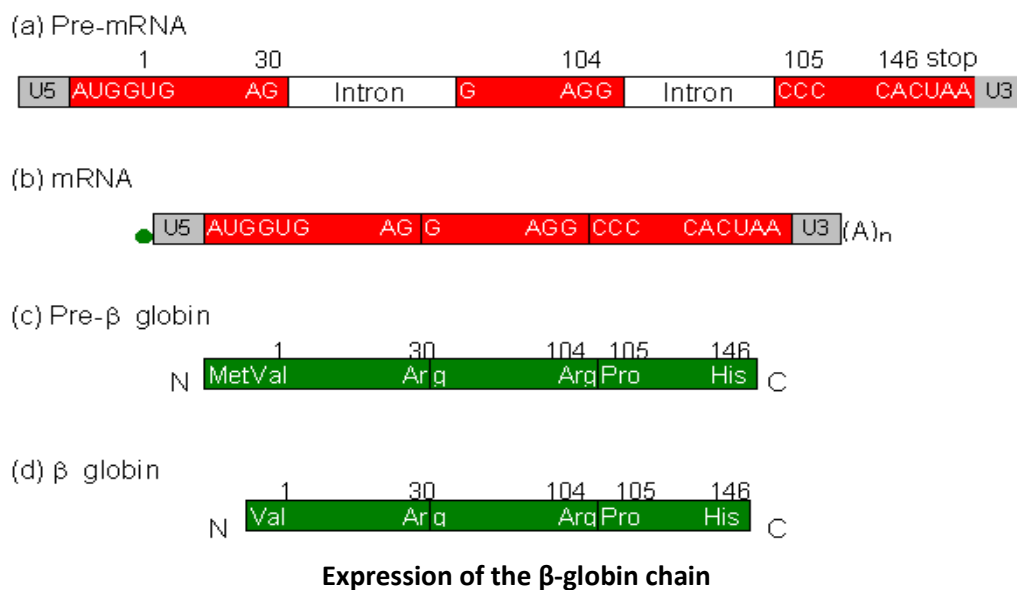

Gene expression. Genetic apparatus is the thinly managed system. It is known that genes do not show permanent activity. Gene has unactive state but when is necessary gene is activated and determines synthesis of protein. So cells have certain mechanism which controls amount of any enzyme in the interval of time. The synthesis of proteins is regulated by a genetic apparatus and factors of internal and external environment.

In 1961 Jacob and Monod explored the idea that the control of enzyme expression levels in cells is a result of feedback on the DNA transcription sequences. Jacob and Mono made key experimental and theoretical discoveries that demonstrated that in the case of the lactose system outlined above (in the bacterium *Escherichia coli*), there are specific proteins that are devoted to repressing the transcription of the DNA to its product (RNA which in turn is decoded into protein). This repressor (*lac* repressor) is made in all cells, binding directly to DNA at the genes it controls, and physically preventing the transcription apparatus from gaining access to the DNA. In the presence of lactose, this repressor binds lactose, making it no longer able to bind to DNA, and the transcriptional repression is lifted. In this way the feedback loop is constructed that allows the set of lactose-digesting proteins products to be made only when they are needed.

Informative RNA transcribes from a few genes is named *polycistronic*. The function of these cistrons (cistron is a gene) is controlled by the area of molecule of DNA, that is named an operator. It is the certain area of sequence of nucleotides long 27 pairs of bases. This segment of DNA is located between promoter (before transcription RNA-polymerase attaches to this place) and beginning of the first structural gene. Cistron synthesizes mRNA if an operator is switched on and stops a synthesis when it is turned off. An operator is switched on or turned off by protein named repressor which synthesized by a regulator gene. Repressor contacts with an operator and represses, decreases its activity, or not contacts with operator that allows to find out activity of structural genes. So *repressor is a negative regulator*. All elements of gene functioning of genes includes operon.

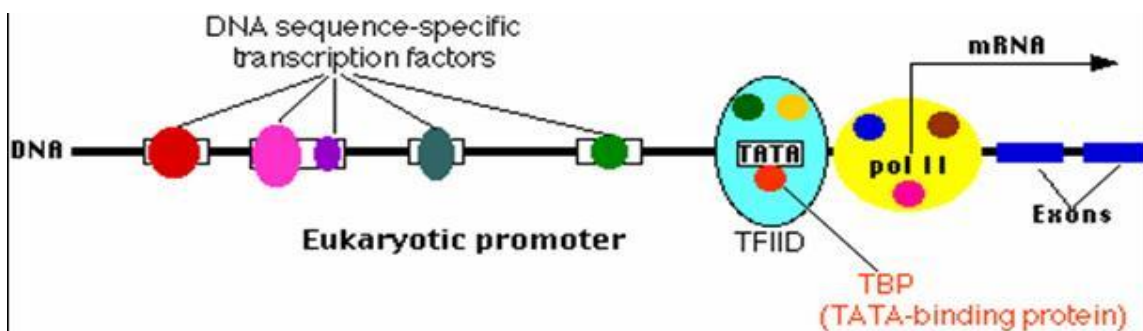

Protein-repressor is a necessary element of operon functioning. **Operon** – sequence of DNA nucleotides, structural genes which are coding synthesis of certain proteins group. It is a functioning unit of genomic DNA containing a cluster of genes under the control of a single regulatory signal or promoter. Operon contains one or more structural genes which are generally transcribed into one polycistronic mRNA (single mRNA molecule that codes for more than one protein).

Unit of transcription consists of:

- 1) gene-regulator (coding of formation of protein repressor)
- 2) promoter – DNA fragment where RNA-polymerase attaches and transcription starts
- 3) operator – part of promoter which can bound repressor
- 4) structural genes – DNA fragment which coding mRNA
- 5) terminator part is stopping the transcription.

Organisms have two major stages separating a protein-coding gene from its protein: DNA on which the gene resides must be transcribed from DNA to mRNA and after it must be translated from mRNA to protein. RNA-coding genes must still go through the first stage but are not translated into protein. The process of producing functional molecule of either RNA or protein is called gene expression, and the resulting molecule itself is called product of gene.

The main peculiarity of eukaryotes gene regulation

The genome of eukaryotes is considerably more difficult (for example, the haploid human genome has approximately 30,000–35,000 genes located in 23 chromosomes, but prokaryotes genome has only one chromosome and about thousand genes. The haploid human genome occupies totally over 3 billion DNA base pairs. Also human genome contains 23,000 protein-coding genes, fewer had been expected before its sequencing. But only about 1.5% of the genome codes for protein, while the rest consists of non-coding RNA genes, regulatory sequence, introns, noncoding DNA. In addition to protein coding genes, the human genome contains thousands of RNA genes, including tRNA, rRNA, and other non-coding RNA genes.

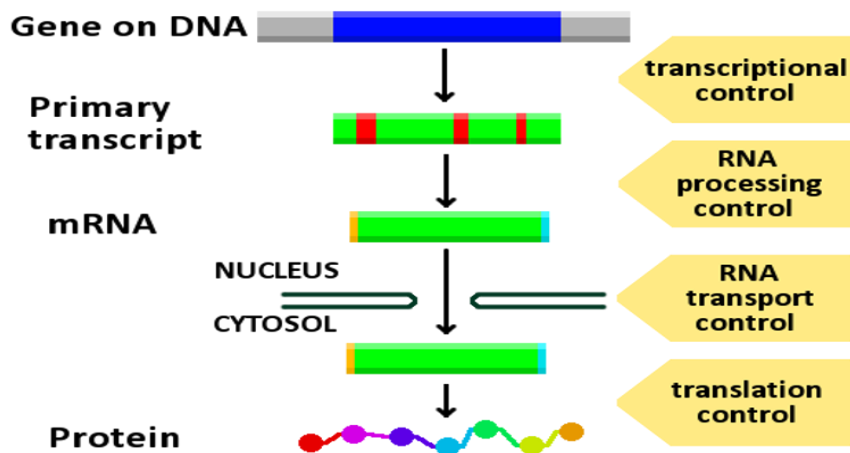

1. In eukaryotes the nuclear membrane divides on processes of transcription and translation, chromosome localized in nucleus, but ribosomes are in a cytoplasm. Expression of genes in eukaryotes includes more stages.
2. Amplification of genes influences on expression of eukaryotes genes – frequent increasing of number of identical genes copies which are the aim of intensification of synthesis of molecules necessary on the certain moment of time.
3. For the representatives of eukaryotes it is not found complete set of operon organization of genetic material. The genes of enzymes of certain metabolism cycle can be located in different chromosomes. They usually do not have the proper system as a gene-regulator, operator and promoter, that is why synthesized mRNA are monocistrons. Eukaryotes gene regulation is combinative (several genes-regulators take part in this process).
4. Feature of genome of eukaryotes is a presence of the special «amplifying» segments of DNA – *enhancers*. They can be situated on the long distance from promoter. Their function is participating in regulation of activity of structural genes. Some protein-regulators perform coordinating influence on activity of many genes, they have pleiotropy effect.
5. The genome of eukaryotes undergo regulator influence from the endocrine system of organism. Many hormones are the inducers of transcription. For example, it touches steroid hormones, which reverse associated with protein-receptors that carry them to the nucleus.
6. Control of expression of genes in eukaryotes takes place also on the stage of translation (for example, by means of influence on factor of initiation of translation. Therefore, even presence of mRNA in the cytoplasm do not start synthesis).
7. Some genes of eukaryotes are repeating several times and the certain areas of DNA do not perform their genetic role, for example, satellite DNA. The genome of eukaryotes is degenerate. Unique properties of different kinds – 15–98 %. Human unique sequences of nucleotides is 56%. Among this there are ten, hundreds and even millions sequences in the genomes of eukaryotes which are repeating. They are among unique DNA. Transposable elements are sequences of DNA that can move themselves to new positions within the genome of a single cell. Transposition can create phenotypically significant mutations and alter the cell's genome size (transposozoons). Genes which are repeating carry out a various biological role: regulation of DNA, participating in a crossing-over, designate of limit between exons and introns and others. Unique DNA is complement of structural genes, but more than half of them are not active.
8. Regulation of gene expression can be on the stage of posttranslational changes.

Transcription is making of complementary RNA copy from the sequence of DNA. During transcription DNA sequence is read by RNA polymerase which produces a complementary, antiparallel RNA chain. Transcription results in an RNA complement that includes uracile (U) instead of thymine (T).

There are three stages of transcription:

- 1) **Initiation** (proteins called transcription factor mediate the binding of RNA polymerase and the initiation of transcription. After certain transcription factors are attached to the promoter does the RNA polymerase bind to it. The completed assembly of transcription factors are forming a transcription initiation complex).
- 2) **Elongation** (process of increase of RNA chain). RNA polymerase with certain speed (about 1 second – 30 nucleotides) moves along encode chain of DNA and synthesizes RNA.
- 3) **Termination** (completion of transcription. RNA-polymerase goes to the certain area of gene – terminal area with terminal codon. Transcription complex disconnected. DNA is forming again double-strand spiral structure).

Translation – synthesis of polypeptide chain, includes three stages: initiation, elongation, termination.

During translation, mRNA produced by transcription is decoded by the ribosome to produce a specific amino acid chain, that will later fold into an active protein. The mRNA carries genetic information encoded as mRNA sequence from the chromosomes in nucleus to the ribosomes. mRNA is read by translational machinery in a sequence of nucleotide triplets called codons. Each of those triplets codes for a specific AA.

Then ribosome molecules in cytoplasm translate this code to a specific sequence of amino acids. Aminoacyl tRNA ribosome synthetase catalyzes the bonding between specific tRNA. This aminoacyl-tRNA goes inside the ribosome, where mRNA codons are matched through complementary base pairing to specific tRNA anticodons. The ribosome has three sites for tRNA to bind: aminoacyl site, peptidyl site and the exit site. In activation the certain correct amino acid is covalently bonded to the tRNA. The amino acid is joined by its carboxyl group to the 3' OH of the tRNA by ester bond. tRNA has an amino acid connected to it and called «charged». *Initiation* involves the small subunit of the ribosome binding to the 5' end of mRNA. *Elongation* is a growth of the amino acid chain (future polypeptide chain). Termination of the polypeptide occurs when A-site of the ribosome faces to stop codon (UAA, UAG, UGA). But no tRNA can recognize or bind to this stop codon. Instead, the stop codon induces the binding of a release factor protein that prompts the disassembly of the entire big and small subunits ribosome-mRNA complex. The rate of translation varies; it is higher in prokaryotic cells (up to 17–21 amino acid per one second) than in eukaryotic cells (up to 6–9 amino acids per one second).

Posttranslational modification of proteins

In a ribosome in the process of translation the polypeptide chains of protein molecules which correspond to primary protein structure are synthesized. Secondary and tertiary structures are further formed. Depending on functions of protein (an enzyme, antibody, building proteins, etc.) it participates in process of providing morphofunctional features, i.e. in forming of special attribute. It is the eventual stage of process of realization of genetic information – expression in certain attribute.

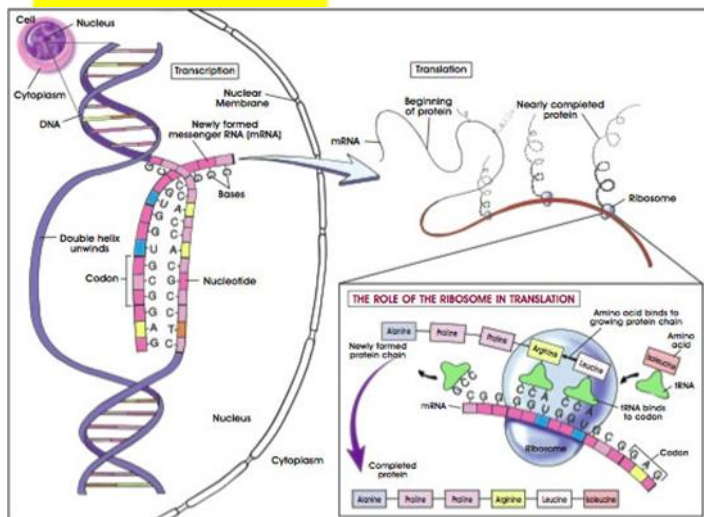
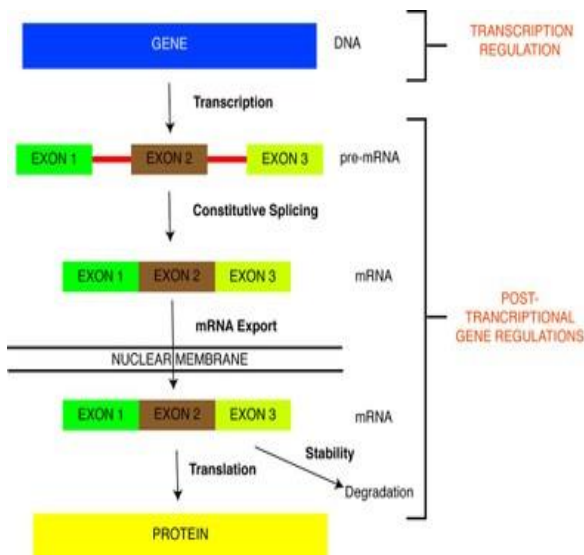

Posttranslational transformations of proteins begin after their synthesis. For the first, folding takes place, due to this the polypeptides acquire specific spatial organization. Farther on the membranes of the vacuolar system there are modification processes: protein molecules unite in complexes, aggregates. For example, protein haemoglobin appears from four proteins: two alfa-globins and two of beta-globins. In addition they are united by non-protein molecule which includes iron.

Molecular mechanisms of variation

Variation is property of organisms to acquire new variants of attributes. Variation can be *inherited (genotypic)* and *uninherited (phenotypic)*. The inherited variation is related to the changes of genotype.

Substantially values have molecular mechanisms that result in disturbance on molecular-genetic level of mutations. Reasons of such mutations are:

- errors of replications,
- errors of recombinations,
- gene mutations which arise up

spontaneously or it is induced under act of chemical, physical and biological mutagenes. The mechanisms of gene mutations are various: replacement of nucleotides, fall of nucleotides (microdeletion), insertion, inversion, duplication, ect.

Changes on molecular-genetic level result of mutations which on organism level can be neutral, somatic or generative. According to the *phenotypic variation* mutation can be expressed as monogenic diseases, depending on the type of inheritance. So, autosomal-recessive diseases expressed only on the homozygous state, autosomal-dominant – in homo- and heterozygous state. The certain group of diseases is related to molecular-genetic disturbance of the inherited material in mitochondria. Such disturbances are inherited on maternal line and cause of mitochondrial metabolic diseases (about 50 such diseases are known). So, disturbance on molecular level of the inherited material considerably can influence on development of organism and phenotype.

1st level tests
(one correct answer)

1. A man is a carrier of HIV that is an RNA virus. The cells of this patient synthesize viral DNA. This process is based on:

- A. Reverse transcription
- B. Replication
- C. Transcription
- D. Repair
- E. Translation.

2. T-lymphocytes are determined to be affected with HIV. In this case viral enzyme reverse transcriptase (RNA-dependent DNA-polymerase) catalyzes the synthesis of:

- A. DNA based on the viral RNA matrix
- B. Viral RNA based on the DNA matrix
- C. Viral protein based on the viral RNA matrix
- D. Viral DNA based on the DNA matrix
- E. Informational RNA based on the viral protein matrix.

3. Amino acids join to each other in ribosomes of granular endoplasmic reticulum. Knowing the sequence of amino acids and applying genetic code, it is possible to determine the sequence of nucleotids in:

- A. mRNA
- B. Introns
- C. Proteins
- D. Carbohydrates
- E. rRNA.

3. Experimental studies revealed steroid hormones to have an effect on proteosynthesis. They influence synthesis of the following substances:

- A. Specific messenger RNA
- B. Adenosine triphosphate
- C. Specific transfer RNA
- D. Guanosine triphosphate
- E. Specific ribosomal RNA.

4. Labeled amino acids alanine and tryptophane were introduced to a mouse in order to study localization of protein biosynthesis in its cells. Around what organelles will the accumulation of labeled amino acids be observed?

- A. Ribosomes
- B. Agranular endoplasmic reticulum
- C. Cell centre
- D. Lysosomes
- E. Golgi apparatus.

5. RNA that contains AIDS virus penetrated into a leukocyte and by means of reverse transcriptase forced a cell to synthesize a viral DNA. This process is based upon:

- A. Reverse transcription
- B. Operon repression
- C. Reverse translation
- D. Operon depression
- E. Convariant replication.

6. A patient with pulmonary tuberculosis is prescribed rifampicin that inhibits RNA- polymerase enzyme at the stage of initiation of the following process:

- A. Termination
- B. Transcription
- C. Translation
- D. Replication
- E. Elongation.

7. Genetic information is stored in DNA but does not participate directly in protein synthesis within DNA cells. What process ensures transfer of genetic information into polypeptide chain?

- F. Translation
- A. Formation of rRNA
- B. Formation of tRNA
- C. Formation of iRNA
- D. Replication.

8. At the stage of translation in the rough endoplasmic reticulum, the ribosome moves along the mRNA. Amino acids are joined together by peptide bonds in a specific sequence, and thus polypeptide synthesis takes place. The sequence of amino acids in a polypeptide corresponds to the sequence of:

- A. mRNA codons
- B. tRNA nucleotides
- C. tRNA anticodons
- D. rRNA nucleotides
- E. rRNA anticodons.

9. At the stage of translation in the rough endoplasmic reticulum, the ribosome moves along the mRNA. Amino acids are joined together by peptide bonds in a specific sequence, and thus polypeptide synthesis takes place. The sequence of amino acids in a polypeptide corresponds to the sequence of:

- A. mRNA codons
- B. tRNA nucleotides
- C. tRNA anticodons
- D. rRNA nucleotides
- E. rRNA anticodons.

10. It was proved that a molecule of immature mRNA (precursor mRNA) contained more triplets than amino acids found in the synthesized protein. The reason for that is that translation is normally preceded by:

- A. Processing
- B. Initiation
- C. Reparation
- D. Mutation
- E. Replication.

11. Examination of a patient revealed reduced contents of magnesium ions that are necessary for attachment of ribosomes to the granular endoplasmic reticulum. It is known that it causes

disturbance of protein biosynthesis. What stage of protein biosynthesis will be disturbed?

- A. Translation
 - B. Transcription
 - C. Replication
 - D. Aminoacid activation
 - E. Termination.
12. Streptomycin and other aminoglycosides prevent the joining of formylmethionyl-tRNA by bonding with the 30S ribosomal subunit. This effect leads to disruption of the following process:
- A. Translation initiation in procaryotes
 - B. Translation initiation in eucaryotes
 - C. Transcription initiation in procaryotes
 - D. Transcription initiation in eucaryotes
 - E. Replication initiation in procaryotes.
13. What are functions of gene-regulator?
- A. Control of protein-repressor
 - B. Coding of mRNA
 - C. Coding of tRNA
 - D. Termination of transcription
 - E. Termination of translation.
14. Processing is «maturation» of mRNA. This process includes splicing. What process will be disturbed as a result of splicing disorders?
- A. Formation of mutant mRNA
 - B. Degradation of mRNA
 - C. Genetic code does not change
 - D. Codon replacement
 - E. Nucleotides replacement.
15. During biosynthesis of enzymes the main flow of information in cell will be:
- A. tRNA-mRNA-DNA-polypeptide
 - B. mRNA-polypeptide-DNA
 - C. DNA-mRNA-polypeptide
 - D. DNA-polypeptide-mRNA
 - E. Polypeptide-mRNA-DNA.
16. At the end of mRNA chain there is a «stop» fragment called:
- A. Terminator
 - B. Promoter
 - C. Repressor
 - D. Operator
 - E. Regulator.
17. According to the hypothesis of lactose operon (Jacob, Monod, 1961), in *Escherichia coli* inductor is lactose. This substance joins to the:
- A. Protein-repressor
 - B. Gene-operator
 - C. Gene-regulator
 - D. Promotor
 - E. Structural gene.
18. Gene which codes the amino acids chain of protein-repressor is called:
- A. Promoter
 - B. Terminator
 - C. Regulator
 - D. Modifier
 - E. Operator.
19. Gene-operator releases from protein-repressor. After this is the beginning of:
- A. Aminoacids activation
 - B. Translation
 - C. Replication
 - D. Processing
 - E. Transcription.

20. Promoter marks the site at which transcription of mRNA starts but here deletion of two nucleotides pairs takes place. It leads to the:

- A. Absence of protein synthesis
 - B. Anomaly of protein formation
 - C. Unlimited protein synthesis
 - D. Normal protein formation
 - E. Termination of protein synthesis.
21. Different human cells can simultaneously synthesize different proteins because:
- A. At the same time in cells transcribe different DNA fragments
 - B. One organism has different DNA
 - C. In the same organism different cells have different processes of protein biosynthesis
 - D. Mutations take place
 - E. Proteins have different structure.
22. Sick person has disorder of magnesium ions decreasing which are necessary for attachment of ribosome to ER. Disturbance of protein synthesis takes place on stage of:
- A. Translation
 - B. Transcription
 - C. Replication
 - D. Polysome formation
 - E. Transduction.
23. During studying of protein synthesis the mouse is used. It got injection of marked alanine and thryptophan. These aminoacids are localized near by:
- A. Ribosome
 - B. Smooth ER
 - C. Cell centre
 - D. Lysosome
 - E. Golgi complex.
24. Lymphocyte is affected by AIDS virus. In this situation information flow goes from:
- A. RNA-DNA-mRNA-polypeptide
 - B. DNA-mRNA-polypeptide-DNA
 - C. DNA-polypeptide-mRNA
 - D. mRNA-polypeptide-DNA
 - E. Polypeptide-RNA-DNA-mRNA.
25. Eukaryotes genetic apparatus has a structure: exon-intron-exon. Determine the structure of pro-mRNA in accordance of this scheme?
- A. Exon-intron-exon
 - B. Exon-exon-intron
 - C. Exon-exon
 - D. Intron-exon
 - E. Exon-intron.
26. Fragment of DNA molecule has exon parts. What is it?
- A. Intervening sequence
 - B. Expressed sequence
 - C. Enhancers
 - D. Tandem genes
 - E. Regulation part.
27. Some of chemical elements are able to provoke mutations (deletion type). Determine disturbance in structural part of gene.
- A. Genetic code does not change
 - B. Exchange of several nucleotides
 - C. Inversion in DNA fragment
 - D. Disorder in DNA reading frame
 - E. Exchange in DNA fragment.

28. Processing includes splicing (cutting off introns and sewing together exons by means of enzymes). Disorder of splicing leads to:
- mRNA degradation
 - Mutant mRNA forming
 - Genetic code does not change
 - Exchange of codons
 - Exchange of mRNA codons.
29. Most of the mutations (inversion type) caused by insertion of mobile elements into structural genes. There are 90 nucleotides pairs inserted into genes. It can be reason of:
- Insertion of 30 aminoacids in polypeptide chain
 - Mutant gene does not provide transcription
 - Inclusion of extra amino acids will not happen
 - Mutation without displacement of DNA reading frame
 - Inclusion of 90 aminoacids in polypeptide chain.
30. Some triplets mRNA (UAA, UAG, UGA) do not code any amino acids but they are terminators in translation process. How does it call?
- Stop-codons
 - Operators
 - Anticodons
 - Exons
 - Introns.
31. Under the action of mutagene factors the content of several triplet is changed. But cell continues synthesis of the same protein. It happens because of such characteristics of genetic code:
- Triplet nature
 - Universality
 - Degeneracy
 - No punctuation
 - Colinearity.
32. Ribosome subunits formation was blocked in the cell with the help of chemical drugs. It will lead to disturbances the synthesis of:
- Carbohydrates
 - Proteins
 - Lipids
 - DNA
 - RNA.
33. mRNA has information about amino acids sequence in polypeptide chain. Determine the quantity of tRNA which transports amino acids to the place of protein synthesis.
- Number of proteins
 - Number of nucleotides
 - Number of amino acids
 - Number of triplets
 - Number of different types of tRNA.
33. Which molecules of nucleic acids determine synthesis of polypeptides on ribosomes:
- pro-mRNA
 - tRNA
 - mRNA
 - rRNA
 - snRNA.
34. Which enzyme provides transcription process:
- Topoisomerase
 - RNA-polymerase
 - DNA-polymerase
 - Endonuclease
 - Helicase.
35. Amino acids activation provides by specific enzymes. Such enzymes are called:
- Nuclease
 - Aminoacyl-tRNA-synthetase
 - DNA-polymerase
 - Polynucleotidyligase
 - Ligase.
36. Translation process takes place with the help of several dozens of ribosomes on the one mRNA chain. Complex of ribosomes has a name:
- Golgi complex
 - Big subunit
 - Small subunit
 - Rough ER
 - Polysome.
37. Which process provides realization of hereditary information in polypeptide chain:
- Translation
 - rRNA formation
 - tRNA formation
 - mRNA formation
 - Replication.
38. Translation takes place in bacteria cell. Matrix for synthesis one mRNA molecule is:
- Fragment of one DNA chain
 - DNA molecule
 - One DNA chain
 - DNA chain without introns
 - DNA chain without exons.
39. In some human cell there is mRNA with exons and introns fragments. It happens because of absence of:
- Processing
 - Replication
 - Transcription
 - Translation
 - Prolongation.
40. Linear protein molecule corresponds to its primary structure. Which chemical bond appears between amino acids molecules:
- Peptide
 - Hydrogen
 - Disulphide
 - Hydrophobic
 - Ion.
41. Some gene codes polypeptide chain and contains 4 exons and 3 introns. After processing matured mRNA contains nucleotides which are complementary to:
- All introns
 - Two exons and one intron
 - One exon and one intron
 - Four exons
 - Four exons and three introns.
43. Most of structural genes are not functionally the same. They have exons and introns. Name «unmatured» molecule being synthesized on the DNA fragment:
- pro-mRNA
 - mRNA
 - tRNA
 - rRNA
 - snRNA.
44. Process of synthesis «unmatured» mRNA is called:
- Termination
 - Replication
 - Elongation
 - Translation
 - Transcription.

45. mRNA is shorter than pro-mRNA. Totality of transformation stages from pro-mRNA to mRNA is called:

- A. Replication
- B. Processing
- C. Recognition
- D. Translation
- E. Termination.

46. Some chemical factors provoke disturbance of subunits formation. As a result of this process will be disturbed synthesis of:

- A. Carbohydrates
- B. Proteins
- C. Lipids
- D. DNA
- E. RNA.

47. Sick child recovers from flu. Formation of large amount of immunoglobulin was found as a result of increasing synthesis of proper mRNA. What do we call process of protective proteins synthesis:

- A. Translation
- B. DNA mutation
- C. DNA reparation
- D. DNA replication
- E. Transcription.

48. Sick woman needs increased quantity of protein.

Which medicine is necessary to take:

- A. Medicine which increases translation
- B. Medicine which decreases translation
- C. Medicine which decreases transcription
- D. Medicine which increases replication
- E. Medicine which decreases replication.

49. Name the non coding parts of genes:

- A. Intron
- B. Exon
- C. Muton
- D. Recon
- E. Site.

50. Speed of translation in bacteria cells is 12–17 amino acids per second, but for eukaryotes – only 2. This speed is bound up with:

- A. Spatial disconnection between transcription and translation
- B. Peculiarity of prokaryotes ribosomes
- C. Size of eukaryotes ribosomes is bigger than prokaryotes
- D. Absence of processing at prokaryotes
- E. Transcription mistakes.

51. After translation process there are processes of protein «maturation» take place (formation of secondary and tertiary structures, making complex with lipids and

carbohydrates molecules, etc.). Name the process of formation of active proteins which have metabolic functions:

- A. Polypeptide elongation
- B. Posttranslational modification
- C. Inductive translation
- D. Peptide termination
- E. Dipeptide translocation.

52. According to researches there are 35% of human genes is «reading» from different frames, but 40% undergo alternative splicing. What is the meaning of this process:

- A. 1 gene codes 1 protein
- B. 1 gene codes several mRNA kinds
- C. 1 gene codes 1 mRNA
- D. 1 gene codes 1 polypeptide
- E. Does not any meaning.

53. Prion protein (PrP) is coding by gene PRNP, which localized on 20 chromosome and has two forms – normal cellular and infective. Which conditions provide arising of prion disease:

- A. Deletion gene PRNP
- B. Mutation gene PRNP
- C. Increasing expression of gene PRNP
- D. Decreasing expression of gene PRNP
- E. Degradation PrP.

54. One of forms of phenylketonuria arises up as a result of mutation which takes place in 12th intron. As a result of mutation last exon does not join. What process will be disturbed:

- A. Termination of transcription
- B. Attachment poly-A
- C. Transcription
- D. Translation
- E. Splicing.

55. Speed of biosynthesis of prokaryotes protein is higher, than in eukaryotes. It is determined by:

- A. High level of metabolism
- B. Transcription and translation are not divided by space and time
- C. Presence of enhancers
- D. Structure of prokaryotes RNA-polymerase
- E. High activity of enzymes of transcription and translation.

56. Information from unit of transcription is read one-way from 5'-end to 3'-end. What is it determined:

- A. Silensor
- B. Enhancer
- C. Terminator
- D. Promotor organization
- E. Structural genes.

2nd level tests

(several correct answers)

1. What enzymes and processes characterize translation:

- A. Recognition
- B. RNA-polymerase
- C. Peptide bond formation
- D. Initiation
- E. Elongation

- F. Aminoacyl-tRNA-synthetase
- G. Topoisomerase
- H. Terminal proteins.

2. What from the following substances are biopolymers:

- A. Myoglobin
- B. DNA

- C. tRNA
- D. ATP
- E. Insuline.

3. What enzymes and organoids of cell take part in the process of translation:

- A. Ribosome subunits
- B. mRNA
- C. RNA-polymerase
- D. A-center of ribosome
- E. P-center of ribosome
- F. Aminoacyl-tRNA-synthetase
- G. Granular ER
- H. Aminoacyl-tRNA.

4. Gene activity of prokaryotes provide:

- A. Protein-regulator
- B. Gene-regulator
- C. Repressor
- D. Effectors
- E. Enhancer.

5. Organization of biological information flow in a cell goes in directions:

- A. DNA → RNA → tRNA → protein
- B. RNA ↔ DNA
- C. RNA → protein
- D. DNA → RNA → polypeptide
- E. DNA → DNA.

6. Name stages of transcription:

- A. Elongation
- B. Determination
- C. Recognition
- D. Initiation
- E. Termination.

7. Name enzymes which take part in transcription:

- A. RNA-primase
- B. DNA-polymerase
- C. RNA-polymerase
- D. RNA-ligase
- E. Helicase

- F. Restrictase
- G. Nuclease
- H. Reparation enzymes.

8. Name stages of translation:

- A. Elongation
- B. Determination
- C. Recognition
- D. Initiation
- E. Termination.

9. What enzymes take part in mRNA maturation, where this process is taking place:

- A. Nucleus
- B. Granular ER
- C. RNA-polymerase
- D. RNA-ligase
- E. Helicase
- F. Aminoacyl-tRNA-synthetase
- G. Nuclease
- H. Mitochondria.

10. Where the synthesis (translation) of proteins which are not secreted, but remain in the cytoplasm takes place:

- A. Granular ER
- B. Cytoplasm ribosomes
- C. Mitochondria
- D. Nucleus
- E. Golgi complex.

11. What enzymes are used in the genic engineering:

- A. Reverse transcriptase
- B. Helicase
- C. RNA-polymerase.

12. What are the basic structural-functional differences between eukaryote gene organization and prokaryote one:

- A. They have exon-intron organization
- B. Polycistrons structure
- C. Monocistrons structure
- D. Regulation provide only protein-repressors.

TASKS

1. What change in the DNA molecule has stronger influence on a protein structure: fall of one nucleotide from triplet or whole triplet? Why?
2. Protein consists of 150 amino acids. How many nucleotides includes gene that codes the protein, if introns fragment are 50%.
3. What changes will take place in the structure of protein molecule, if in the encoding area of DNA: TAACAAAGAACAAAA between 7 and 8 nucleotides to insert cytosine and between the thirteenth and fourteenth – thymine, at the end of chain to add 3 G and 2 C?
4. The polypeptide area of virus of tobacco mosaic consists of next amino acids: ser-gly-ser-ileu-tre-pro-ser. As a result of mutagene factor influence on mRNA the cytosine transforms on guanine. Define changes in polypeptide structure after influence of mutagene. But mean that place of serine can be determine by six triplets in genetic code table.

TOPIC. Cell cycle. Cell division

Organization of cell in course time. Cell cycle. Methods of cell division: amitosis, mitosis. Endomitosis, polyteny. Changes of cells and their structures during a mitotical (cellular) cycle (interphases and mitosis). Cellgrowth. Factors of growth. Mitotical activity of tissue. Disorders of mitosis, somatic mutations. Life of cells out of an organism. Cloning of cells.

Cell cycle

All eukaryotes cells appear as a result of doubling and then division of genetic material of nucleus (mitosis, meiosis), division of cell body (cytokinesis). Once formed, cells live and function until they again divided or will perish. Some cells e.g. erythrocytes, neurons and muscle cells of heart are not able for division. However for majority it is possible to talk about a *cellular life cycle*.

Cell cycle is a period of cell life from its appearance to the next division or death. Its characterized by numerical processes which take place in cell: growth, differentiation, functioning, etc. Lifetime of every cell is limited but in an order to exist long period multicellular organism must to form new cells constantly. Therefore fission is the key phenomenon in life of all organisms.

Cell division

One of the statement of cell theory asserts that new cell are forming from the previous one. This process is named fission. Single-cells organisms division results in the increase of amount of individuals. In multicellular organisms the life is begun with formation of zygote as a result of gametes fusion.

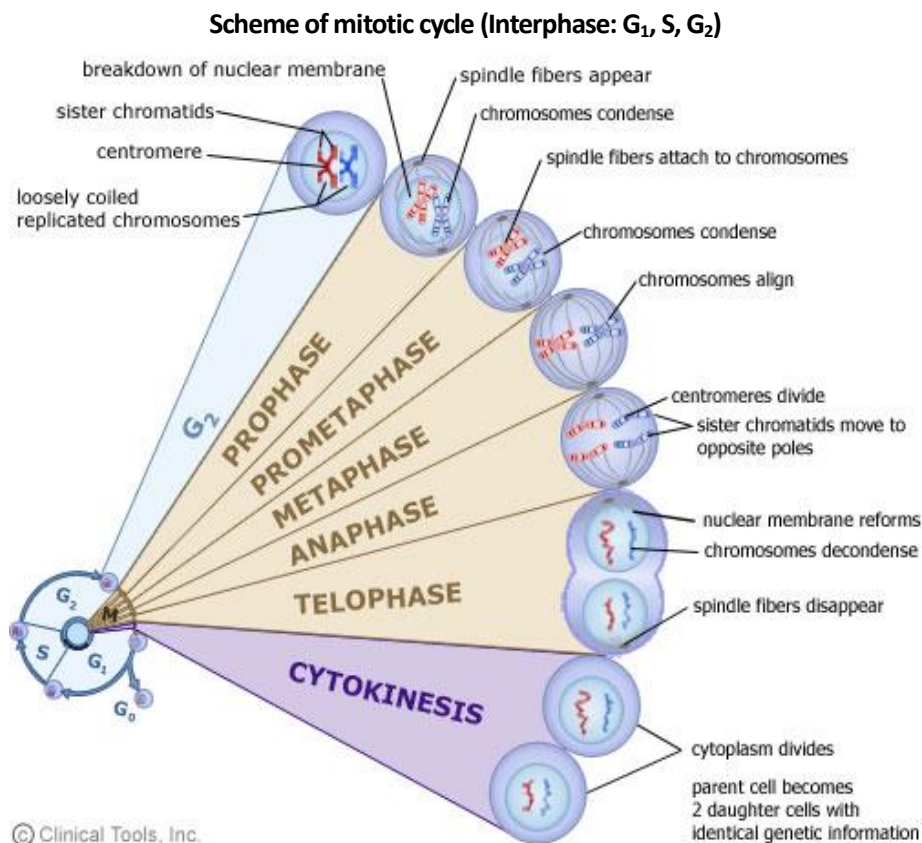

The milliards of cells which are differentiated grow and form tissue and organs, appear in the process of intensive division of zygote. Reproduction of cells and proliferation are reason of growth and renewal of many structures in multicellular organism. The basis of fission lies in molecular-genetic mechanism of DNA replication.

Cell cycle structure. Number of events that takes place in a cell leading to its division and duplication (DNA replication). In cells without a nucleus – prokaryotic, the cell cycle occurs by means of process named binary fission. In cells with a nucleus – eukaryotic, the cell cycle can be divided in three stages: 1) *interphase*: during which the cell grows, accumulating nutrients needed for mitosis and duplication its DNA; 2) *mitosis* phase, during which the cell splits itself into two daughter cells, and 3) *cytokinesis* – the final phase, where the new cell is completely divided.

Cell-division cycle is a vital process by which one-celled fertilized egg develops into a mature organism, as well as the process by which some internal organs are renewed. Cell cycle consists of long interphase and short period of mitosis and cytokinesis. For example, for the leucocytes of mitosis and cytokinesis take 10 minutes and the stages of interphase – almost 24 hours. An interphase is a basic period of life of cells. In this period cells are not divided, but supporting the homeostasis and performing certain functions. The study of different groups of cells of separate organism testifies that majority from them is in an interphase. Only small part of cells can be involved in mitosis (approximately 1 %).

Cell cycle is characteristic for the most varieties of cells. All cells have different duration of both all cycle and separate periods, even in different tissue of the same organism. For example, for a man duration of cell cycle for the skin epithelium takes 10–20 days, for leucocytes – 4–5 days, for the cells of marrow 8–12 hours. Time of cells life is programmed genetically and inherited from generation to generation. On the certain stage of vital functions the special proteins molecules in special concentration «signal» about the necessity of its division or death.

Resting (G_0) phase. Nonproliferative cells in multicellular eukaryotes generally enter the quiescent G_0 state from G_1 and may remain rest for long periods of time, possibly indefinitely (especially for neurons). This is very common for cells that are fully differentiated. Cellular senescence is a state that occurs in response to DNA damage or degradation that would make a cell's progeny nonviable; it is often a biochemical alternative to the self-destruction of such a damaged cell by apoptosis (programmed death). As well, growth and division of such a cell could become cancerous.

Interphase – is the period of cell life cycle where cell lives, functions and then prepares to the division. First period of interphase – **presynthesis, or G_1** (gap is an interval). During this period genetic information is reading and realized – actively forms RNA and proteins. In this period, which is the longest, cells grow, differentiated and perform their functions. The nucleus has diploid chromosomes number and each cell has only one molecule of DNA. Genetic formula of cells in this period – **$2n2c$** , where «n» is haploid set of chromosomes, «c» is amount of DNA copies.

During the next **synthetic period (S)** doubling and synthesis of DNA begin. As a result, each chromosome is composed of two daughter DNA molecules connected to each other in the centromere. Number of genes increased in 2 times. Doubling the number of chromatin proteins is observed too. Genetic formula of cells in this period – **$2n4c$** . DNA replication is a critical time of cells to divide. This replication is the basis of both asexual and sexual reproduction and ensures the continuity of life. The beginning of DNA synthesis is considered the beginning of the S-period. After doubling of DNA cell can no longer return to the G period and must necessarily divide. Moment of S-phase beginning is called the *restriction point*. DNA synthesis starts with the appearance of specific signaling molecules, activators of S-phase protein. At the end of S-phase, after the complete DNA replication, protein-activator are destroyed and cell can enter to the next period. Cells which do not have «permission» to divide unable to pass the restriction point. These cells are temporarily staying in a state of «resting» in the G_0 -phase, supporting the metabolism and carry out their functions. In multicellular organisms the most cells in the final result of differentiation generally lose the ability to divide. For example, neurons or muscle cells which can function throughout the life of the organism. But epithelial tissues regenerate by dividing stem cells and semistem cells too.

In **postsynthesis period G_2** cells «prepared» to mitosis. Thus there is a gradual destruction of the cytoskeleton, and spiralization (condensation) of chromatin begins. There is an increasing the synthesis of ATP, proteins, RNA, lipids and carbohydrates. New cell organelles are formed. Cells were significantly increased in size. Synthesizing specific proteins-regulators facilitating the transition from G_2 to cell division. Period G_2 becomes prophase of mitosis. This is the time of the cell cycle when formed from chromatin chromosomes firstly become visible in the microscope.

Summary of interphase:

- G_1 – chromosome represented as single chromatin thread (genetic formula – $2n2c$);
- S – after doubling of DNA of homologous chromosomes, each consisting of 2 chromatin threads ($2n4c$);
- G_2 – doubled centrioles.

The importance of the cell cycle:

- a) during the cell cycle division, growth and differentiation of cells take place. As a result of this forming of the various tissues and organs;
- b) cell cycle ensures continued support for the integrity of tissues and organs. Tissues and organs can exist for a long time and perform their functions only if the cells (do not have a limited lifespan) is constantly renew;
- c) during period of G_0 the cells maintain their metabolism and function. The number of cell functions provides integrated functioning of an organism;
- d) during S-period in cells DNA is doubled. This is a key stage of preparation for division and multiplication;
- e) at the beginning from the chromatin are formed chromosomes – the main structural units of uniform distribution of hereditary material between daughter cells;
- f) the basic mechanism of mitosis is the division of hereditary material in cells;
- g) cytokinesis ensures separation of one daughter cell from another;
- h) generative cells of the cell cycle ensures reproduction of multicellular organisms.

Mitosis

Mitosis is a complex biological process of division of the cell nucleus (karyokinesis) and cytoplasm (cytokinesis), which ensures transmission and distribution of the hereditary material of new cell generation.

Adult body is composed of trillions of cells. Fertilized egg of human (single cell) is the basis of all cells of an adult organism, it is the source of creation of trillions of nuclei, each of them contain the same genetic information as the fertilized egg.

Scheme of the basic stages during mitosis

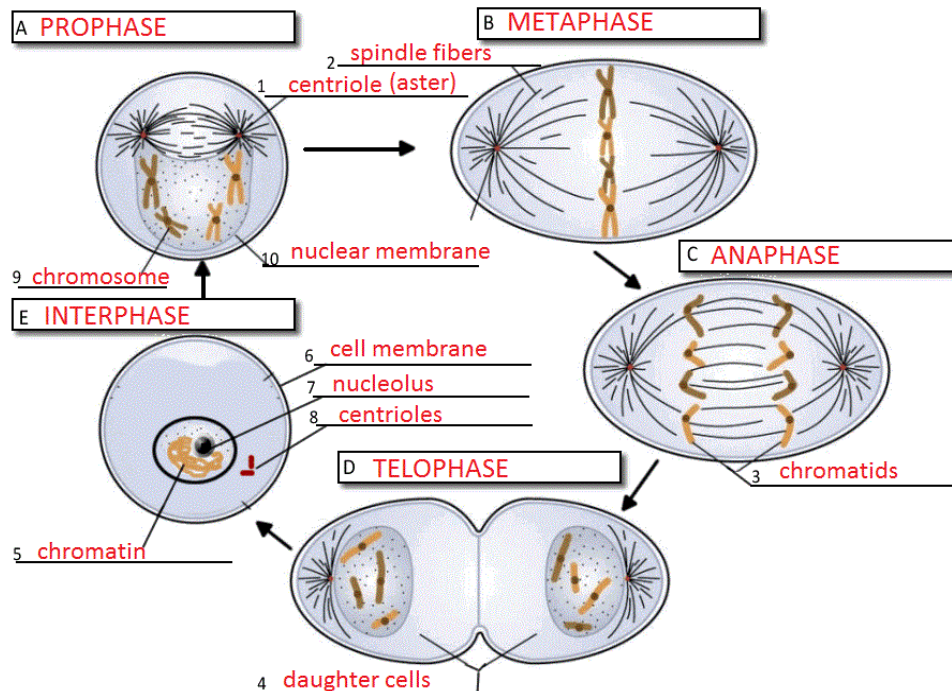

The stages of Mitosis:

- **prophase** -- chromatin condensation (become visible under the light microscope);
- **prometaphase**—disappearance of the nucleus membrane, formation of spindle division,
- **metaphase** – the movement and localization of chromosomes in the center of the cell;
- **anaphase** – chromatids moving to the different poles of the cell;
- **telophase** – despiralization of chromosomes(chromatin), formation of chromatin threads and membrane forming around them, the formation of grooves dividing of the parent cell;
- **cytokinesis** – the division of the parent cell into two daughter (2n2c).

The process of mitosis is the part of life cycle of cells. It is conventionally divided into five successive phases: prophase, prometaphase, metaphase, anaphase and telophase. The duration of each phase of mitosis can be different – from a few minutes to hundreds of hours, depending on the type of cells, tissues, organs activity, physiological state of the body. Also depends on external factors (temperature, light, chemicals) and internal factors (hormones).

Prophase. When a cell goes the prophase stage, nucleus material undergoes significant changes. Long chromatin fibers are compressed, forming loops and spirals. They are clearly visible under the light microscope as separate chromosomes. At this stage each chromosome has two chromatids. Genetic formula in this period – **2n4c**, each chromatid is a single molecule of DNA associated with histones. In the dense contact chromatids there is a special general sequence DNA – centromeres, which later becomes associated with spindle division. Gradually disappearing nucleoli.

Prometaphase. This phase begins suddenly (20–30 sec) by disintegration of nuclear membrane into small vesicles similar to ER vesicles. Now spindle microtubules can penetrate into the region of nucleus, cytoplasm and karyoplasm mixed, forming mixoplasm. Chromosomes are more condensed, then the centromeres of chromosomes are formed *kinetochores* – special protein structure which connect duplicated chromatids to spindle fibers. Groups of spindle microtubules division interact with kinetochores microtubules providing movement of chromosomes. Polar microtubules, lying outside the spindle division, called astral. Kinetochores microtubules are directed in different ways from the two sister chromatids and pull them in different directions, leading to the orderly movement of chromosomes.

Metaphase. The focus of chromosomes in the equatorial plane means that the cell has reached metaphase. Grouped chromosomes called metaphase plate where they held tension microtubules. Next, microtubules attached to kinetochores begin to stretch the chromosome in different directions and chromatid separated from each other. During the metaphase chromosomes are in an orderly condition, have a clear structure and well visible under a microscope. Therefore, the study karyotype (count the number, the study of forms and structures of chromosomes) is performed at this stage. During this period, each chromosome has two chromatids, which are slightly separated on the ends, so the chromosomes are X-shaped.

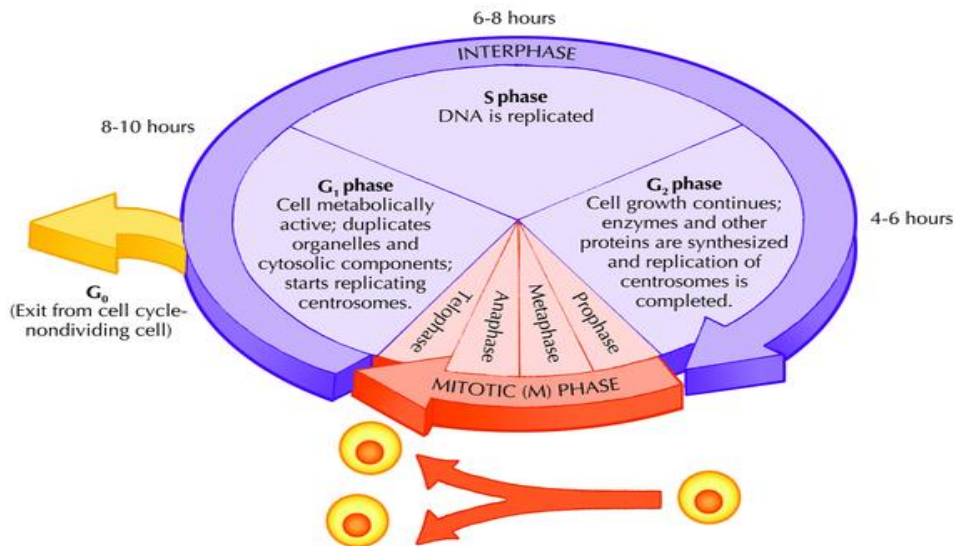

By the end of phase has completed DNA replication in area of centromere and chromatid completely separated. Metaphase usually takes a short time and ends with separation of chromosomes.

Anaphase. During anaphase each chromatid of chromosomes separated by spindle microtubules from each other and move to opposite ends of the cell. All chromatid move with equal velocity about 1 mm/min. Daughter chromosomes (former chromatid metaphase chromosomes) contain a single molecule of DNA. They have stick-shaped form, joined at the centromere region. Their separation goes simultaneously and quickly. After anaphase in different parts of cells has collected two equal sets of chromosomes. The genetic formula – $2n2c + 2n2c$.

Telophase. The next stage of mitosis is called telophase (from the Greek *telos* – end). Two identical sets of chromosomes ($2n2c$) are in opposite ends of the spindle, which starts to disintegrate. Around each of two groups of chromosomes form new nuclear membranes, which are collected by merging vesicles are formed typical nucleus. Inherited chromosome material begins to unfold to the state of chromatin. Nucleolus reappear. When these changes are completed, mitosis ends, and each daughter nuclei again included in the next cycle.

Cytokinesis. The next stage of the cell cycle – division of body cells. It is called cytokinesis. Thus on the equator cell division constriction is formed. This structure is formed in the late telophase. Constriction forms from the cytoskeleton microfilaments, creating ring. Rings gradually undergo constriction and increasingly deepening around the perimeter. After this parent cell is divided into two daughter cells. After cytokinesis, both daughter cells contain all the necessary components.

The result of mitosis – the formation of two genetically identical nuclei that have a complete set of DNA molecules ($2n2c$), necessary for realization of all genetic information.

Biological sense of mitosis – equal distribution of hereditary material between the daughter cells.

Molecular basis of mitosis is the process of DNA replication – doubling the previous genetic material that allows equally distribute it between daughter cells.

The importance of mitosis:

1. The distribution of genetic material through mitosis is the basis of asexual reproduction.
2. All cells of a multicellular organism resulting from mitotic division of primary parent cell – a zygote.
3. Mitosis activates the growth, differentiation and development of a multicellular organism.
4. After formation of the body, the mechanism of mitosis maintains its integrity for a long time by renew of damaged or «worn out» cells.
5. This process provides the physiological regeneration of tissues and organs, provides their long functioning.

Pathology of mitosis. Various external and internal factors can lead to disruption of the mitosis flow, leading to various pathologies of cells. For example, disturbances of cytokinesis leads to multinuclei cells. On the basis of mitosis some mechanisms exist where tissues can increase the number of hereditary material without changing the number of cells.

Amitosis is also called *karyostenosis* or *direct division* – an unusual form of cell division in which the nucleus and cytoplasm divide by constriction without the formation of chromosomes. This process mostly occurs in the lower organisms like yeast, fungi, bacteria, amoeba. This type of cellular division is a primitive type of division in which the nucleus of the cell divides (karyokinesis) on two unequal parts and then the cytoplasm divides (cytokinesis). In amitosis the chromatin fibers do not condense into chromosomes. The chromosomes do not appear as chromatids and centromeres are not distinctly seen. During the division of cells in amitosis the chromatin fibers do not replicate as in mitosis. The genetic material does not get equally distributed when the nucleus divides into

two nuclei. Thus the two daughter cells do not look identical. Then the cytoplasm which is viscous gets divided that is the cytokinesis.

Endomitosis is the division of chromosomes not followed by nuclear division that results in an increased number of chromosomes in the cell. This process of duplication of the DNA content of the nuclei without accompanying spindle formation or cytokinesis, resulting in a polyploid nucleus. In other words, it is a process by which chromosomes replicate without the division of the cell nucleus. This leads to increasing of number of chromosomes in a few times, compared to the diploid set and occurrence of polyploid cells. Endomitosis is found in the intensively functioning cells of various tissues such as liver cells.

Polyteny (endocycling) is the presence within a cell of polytene chromosomes (large chromosomes with multiple synapsed). In polyteny large chromosomes formed by repeated DNA replication and consisting of many chromatids side by side. Thus, polyteny produces hundreds of copies of the same chromosome. Polytene chromosomes are visible in the interphase nucleus. Polytene cells cannot multiply. They are destined to die.

1st level tests

(one correct answer)

1. Ability to divide is characteristic of prokaryotic and eukaryotic cells. Prokaryotic cell division is different from that of eukaryotic, but there is one molecular process that is the basis of both types of division. Name this process.

- A. DNA replication
- B. Transcription
- C. Reparation
- D. Translation
- E. Gene amplification.

2. In the life cycle of a cell during mitosis a natural change in the amount of genetic material occurs. The DNA doubles at the following stage:

- A. Interphase
- B. Prophase
- C. Metaphase
- D. Anaphase
- E. Telophase.

3. At a certain stage of cell cycle chromosomes reach cellular poles, undergo despiralization; nuclear membranes are being formed around them; nucleolus is restored. What stage of mitosis is it?

- A. Telophase
- B. Prophase
- C. Prometaphase
- D. Metaphase
- E. Anaphase.

4. Histologic specimen of endometrium demonstrates isolated epithelial cells with chromosomes that form a «plate» located in the equatorial plane of the cell. What stage of the cell cycle is it?

- A. Metaphase
- B. Interphase
- C. Prophase
- D. Anaphase
- E. Telophase.

5. A specimen of an onion rootlet includes a cell in which the fully condensed chromosomes are located in the equatorial plane making the monaster. What phase of the mitotic cycle is the cell in?

- A. Metaphase
- B. Early telophase
- C. Prophase
- D. Interphase
- E. Late telophase.

6. Moving of the daughter chromatids to the poles of the cell is observed in the mitotically dividing cell. On what stage of the mitotic cycle is this cell?

- A. Anaphase

- B. Metaphase
- C. Telophase
- D. Prophase
- E. Interfase.

7. While studying maximally spiralized chromosomes of human karyotype the process of cell division was stopped in the following phase:

- A. Anaphase
- B. Metaphase
- C. Prophase
- D. Interphase
- E. Telophase.

8. Normal, actively dividing cells of human red bone marrow are analyzed. What number of cells' chromosomes is typical for G1 period?

- F. 46
- G. 48
- H. 47
- I. 45
- J. 23.

9. Life cycle of a cell includes the process of DNA autoreduplication. As a result of it monochromatid chromosomes turn into bichromatid ones. What period of cell cycle does this phenomenon fall into?

- A. S
- B. Go
- C. G1
- D. G2
- E. M.

10. In the life cycle of a cell during mitosis a natural change in the amount of genetic material occurs. The DNA doubles at the following stage:

- A. Interphase
- B. Prophase
- C. Metaphase
- D. Anaphase
- E. Telophase.

11. How many DNA molecules does somatic cell have in postsynthetic period (mitotic cycle)?

- A. 92
- B. 46
- C. 23
- D. 48
- E. 24.

12. Name the period of cell cycle where synthesis of DNA takes place.

- A. Presynthesis (interphase)

- B. Synthesis (interphase)
 C. Mitosis
 D. Premitotic period of interphase
 E. Postsynthesis period of interphase.
13. How many DNA molecules does human somatic cell have in presynthesis period?
 A. 23
 B. 92
 C. 46
 D. 69
 E. 48.
14. During mitosis studying in onion cell spiral-shaped chromosomes found out. There are located in the cell equator midway. Name this phase of mitosis.
 A. Interphase
 B. Prophase
 C. Anaphase
 D. Telophase
 E. Metaphase.
15. Synthesis of protein-tubulines was blocked in the cell. Such proteins take place in spindle forming. It will lead to disturbance in the process of:
 A. Separation of chromosomes
 B. Spiralization of chromosomes
 C. Cytokinesis
 D. Despiralization of chromosomes
 E. Mitosis.
16. Maximum condensed chromosomes are present in the cell during:
 A. Metaphase
 B. Prophase
 C. Interphase
 D. Anaphase
 E. Telophase.
17. Daughter chromatids are moving to the opposite poles at:
 A. Anaphase
 B. Metaphase
 C. Telophase
 D. Prophase
 E. Interphase.
18. Cell cycle includes many processes such as growth, organelle formation, protein synthesis, RNAs, lipids and carbohydrates synthesis. On this stage DNA does not synthesize:
 A. Presynthesis
 B. Synthesis
 C. Premitotic
 D. Telophase
 E. Anaphase.
19. Mitotic cycle is a mechanism provides organism development, regeneration and reproduction. It is possible because of:
 A. Equal chromosomes separation
 B. Chromosomes duplication
 C. Diploid cells formation
 D. Non-equal chromosomes formation
 E. Changes in genetics information.
20. Changeable structures in nucleus (contain protein and RNA) which disappear at the beginning and appear at the end of division called:
 A. Nucleolus
 B. Nucleosomes
 C. Histone
 D. Microfibrils
 E. Heterochromatine.
21. What mitotic phase of human cell has 92 single-chromatid chromosomes:
 A. Anaphase
 B. Telophase
 C. Metaphase
 D. Prophase
 E. Interphase.
22. Human somatic cells are diploid (2n). But polyploid cells of marrow can have 64n chromosomes number. What is mechanism of their forming:
 A. Endomitosis
 B. Polytenia
 C. Mitosis
 D. Amitosis
 E. Meiosis.
23. Some human cells along the whole life do not undergo mitosis and their content is invariable. There are:
 A. Neurons
 B. Endothelium
 C. Muscle cells
 D. Epidermis
 E. Blood cells.
24. After radiation influence disturbance of DNA takes place during S period of interphase. What will happen in such cells:
 A. Blocking of replication and mitosis
 B. Prereplication reparation
 C. Postreplication reparation
 D. Replication continues and mitosis takes place
 E. SOS-reparation takes place.
25. In the culture of peripheral blood of liquidators of Chernobyl disaster leucocytes with chromosomes from 44 to 48 were found that can testify disorder of mitotic cycle. Where do such abnormal process takes place:
 A. Anaphase
 B. S-period (interphase)
 C. Prophase
 D. Presynthesis period
 E. Postsynthesis period.
26. During experiment on the cell culture, which are divided by mitosis, some substance destroying the spindle is used. What do we call this substance:
 A. Penicillin
 B. Colchicine
 C. Histamine
 D. Methionine
 E. Iodine.
27. Define the mitosis phase where nuclear membrane restores their structure:
 A. Interphase
 B. Prophase
 C. Prometaphase
 D. Anaphase
 E. Telophase.
28. Period between two division is called:
 A. Interphase
 B. Prometaphase
 C. Telophase
 D. Cytokinesis

- E. Replication.
29. Replication takes place in:
- Telophase
 - S-period
 - Presynthesis period
 - Prometaphase
 - Postsynthesis period.
30. Nucleolus disappears during cell division and after division appears again. Phase of disappearance is:
- Interphase
 - Postsynthesis period
 - Prophase
 - Telophase
 - Metaphase.
31. Call the processes of presynthesis period:
- DNA replication
 - Protein synthesis and division of centrioles
 - DNA, RNA, protein synthesis, cell growths, accumulation of energy
 - DNA replication, accumulation of energy
 - Transcription.
32. Call the processes of synthesis period:
- DNA replication
 - Protein synthesis and division of centrioles
 - DNA, RNA, protein synthesis, cell growths, accumulation of energy
 - DNA replication, accumulation of energy
 - Transcription.
33. Call the processes of postsynthesis period:
- DNA replication
 - DNA reparation
 - Processing
 - Centrioles doubling
 - Synthesis of spindle protein.
34. Determine genetic information after synthetic period:
- $1n\ 1c$
 - $2n\ 2c$
 - $2n\ 4c$
 - $4n\ 4c$
 - $4n\ 2c$.
35. Determine genetic information after presynthetic period:
- $1n\ 1c$
 - $2n\ 2c$
 - $2n\ 4c$
 - $4n\ 4c$
 - $4n\ 2c$.
36. The chromosomes become aligned at the equator midway between the spindle poles in the stage of:
- Interphase
 - Prophase
 - Metaphase
 - Anaphase
 - Telophase.
37. Chromosomes have single-chromatids structure in the stage of:
- Prophase
 - Prometaphase
 - Metaphase
 - Anaphase
 - Telophase.
38. Each cell divides into two daughter cells and an equal distribution of chromosomes results:
- Replication and chromosomes moving
 - Independent separation of chromosomes (anaphase)
 - Crossing-over and separation of chromatids
 - Amplification of genes and independent separation of chromosomes
 - Replication and chromatids separation.
39. Duration of human cell cycle is different: skin epithelium – 10–20 days, leukocytes – 4–5 days, marrow – 8–12 hours. On the cellular level duration is regulated by:
- Protein synthesis (S-phase activators)
 - Synthesis of histone protein
 - Intensification of S-period
 - Intensification of protein tubuline
 - Does not regulate.
40. The base of cell division of eukaryotes and prokaryotes is molecular process called:
- Reparation
 - Transcription
 - Replication
 - Karyokinesis
 - Amplification of genes.
41. The genetic material in the interphase nucleus has a form of chromatin filaments (chromatin net). What will be the number of chromosomal and DNA strands in the G_1 period of interphase?
- $2n2c$
 - $1n1c$
 - $1n2c$
 - $2n4c$
 - $2n3c$.
42. There are five phases in mitosis. What phase contains 46 singular chromosomes in the human cell?
- Anaphase
 - Telophase
 - Metaphase
 - Prophase
 - Prometaphase.
43. A mitotic division of a somatic cell has interrupted by means of colchicine. As a result some mononuclear polyploid cells has formed. Mitosis was interrupted on the following phase:
- Telophase
 - Prophase
 - Metaphase
 - Anaphase
 - Cytokinesis.
44. During mitotic division the process of spindle formation has interrupted by means of colchicine. What stage of the mitotic cycle is broken?
- Cytokinesis
 - Prophase
 - Anaphase
 - G_1
 - G_2 .
45. During cell division a researcher was able to observe some phase where membrane of the nucleus and the nucleolus were absent, centrioles were at the poles of the cell. The chromosomes looked like filaments, which are free in the cytoplasm. For which phase it is typical of?
- Interphase
 - Metaphase
 - Anaphase
 - Prophase
 - Telophase.
46. Experimental studying of new medicines revealed a blocking effect at the process of protein tubulin constriction (base of a spindle structure). Which of the following phase of the cell cycle has disturbed?

- A. G₂
- B. S period
- C. Telophase
- D. Anaphase
- E. G₁

47. Using a spatula a scraping has taken from the mouth of man. In intact stained epithelial cells some clearly visible oval nuclei, different by size, were found. What kind of cell division has observed:

- A. Shizogony
- B. Amitosis
- C. Mitosis
- D. Meiosis
- E. Binary fission.

48. Prokaryotic and eukaryotic cells are characterized by the ability to divide. The division of prokaryotic cells is different from the eukaryotic division. A division of prokaryotic cells is called:

- A. Mitosis
- B. Meiosis
- C. Binary fission
- D. Karyokinesis
- E. Amitosis.

49. The genetic material in interphase nucleus has a form of chromatin net. What will be the number of chromosomal threads and DNA strands in the G₁-period of interphase?

- A. 2n2c
- B. 1n1c
- C. 1n2c
- D. 2n4c
- E. 2n3c.

50. Mitotic cycle is characterized by alternating periods of cycle changes and in particular phases of mitosis. What substances play a key role in the successive changes during the cell cycle?

- A. Cyclindependent kinase
- B. Cycline A
- C. Mitosis-stimulating factor
- D. Integrin and cadherin
- E. Growth factors.

51. Cell division is controlled by different mechanisms. Normal cells are dividing and forming a continuous layer but when there is not free space – division stops. Tumor cells do not stop dividing and form a multilayer stratum. What proliferation regulatory mechanism does not work in the formation of tumors?

- A. Regulation by protein p15 i p21
- B. Regulation by growth factor
- C. Regulation by cyclindependent kinase
- D. Contact inhibition
- E. Effect of tumor necrosis factor.

2nd level tests (several correct answers)

1. On this stage of mitotic cycle chromosomes become visible:

- A. Prophase
- B. Anaphase
- C. Metaphase
- D. Telophase
- E. Interphase.

2. Cell cycle is:

- A. Complex of events involves cell preparation and division
- B. Existence starts from the cell formation to division or death
- C. Period where cell performs complex of specific functions
- D. Natural changes of structural-functional characteristics of cell
- E. Cell life cycle results to reproduction and transmission of hereditary information.

3. Mitotic cycle is:

- A. Complex of events, which involves cell preparation and division
- B. Existence starts from the cell formation to division or death
- C. Several processes start from first division to the next and provide formation of new generation
- D. Natural changes of structural-functional characteristics of a cell
- E. Cell life cycle results to reproduction and transmission of hereditary information.

4. Biological significance of mitosis:

- A. Provides transmission of hereditary material from generation to generation
- B. Provides formation of new generations which are equal by hereditary information
- C. Universal mechanisms of eukaryotes reproduction during their ontogenesis

D. Mechanisms determines saving, transmission and «reading» of hereditary information.

5. Phases of mitotic cycle are:

- A. Reproductive
- B. Interphase
- C. Mitosis
- D. Karyokinesis.

6. Name the periods where such processes take place: 1) protein synthesis; 2) DNA replication?

- A. Mitosis
- B. Postsynthesis period
- C. Synthesis period
- D. Presynthesis period.

7. Some physical agents can disturb synthetic processes (G₁ period). What stages of cell cycle in somatic cell will be disturbed as a result of this event:

- A. G₂ period
- B. Mitosis
- C. S period.

8. Different chemical factors can provoke disturbance of enzymes which take place of DNA uncoiling. It will lead to block DNA despiralization in this cell on the phase of:

- A. Mitosis
- B. S period
- C. Replication
- D. Telophase.

9. Spindle formation was blocked in the cell with the help of colchicine. Which mitosis stage will be disturbed?

- A. Interphase
- B. Mitosis
- C. Metaphase
- D. Anaphase.

10. DNA replication takes place on:

- A. Interphase
- B. G₁
- C. G₂

- D. S.
11. Which type of mitosis do not lead to the chromosomes decreasing:
- Amitosis
 - Mitosis
 - Meiosis.
12. What type of cell division is typical for somatic cells:
- Amitosis
 - Mitosis
 - Meiosis.
13. Mitosis has an important biological significance because:
- It is base of gametes formation
 - Provides saving of chromosomes number
 - Provides receiving of genetically homogenous daughter cells
 - Provides reduction of chromosomal set.
14. Constancy of chromosomes number maintains from generation to generation with the help of:
- Mitosis
 - Meiosis
 - Endomitosis
 - Fertilization.
15. How many chromosomes does metaphase plate have:
- 46;
 - 23+23;
 - 23;
 - 92.
16. Indicate correlation of chromosomes and DNA number at:
- Telophase (mitosis)
 - Metaphase (mitosis)
 - S period (interphase)
 - Telophase (meiosis)
 - Meiosis (anaphase).
17. Chromatids are moving to the opposite poles during anaphase. In this period genetic information contains the following amount of DNA and chromosomes:
- 92 chromosomes, 92 DNA
 - 46 chromosomes, 46 DNA
 - 23 chromosomes, 23 DNA.
18. During the following period chromosomes become aligned at the cell equator midway between the poles at the stage of:
- Prophase
 - Metaphase
 - Anaphase
 - Telophase.
19. In order to study a karyotype it is necessary to stop work of enzymes which take place of DNA replication. What process will be disturbed as a result of this event in the first place:
- DNA replication
 - DNA reparation
 - G₂ period
 - Synthesis of spindle protein
 - S period
 - Mitosis.
20. Somatic 2n cell at mitosis division was broken by a colchicine. How many chromosomes does the nucleus have:
- Anaphase – 4n
 - Metaphase – 2n
 - Metaphase – 4n
 - Anaphase – 2n.
21. Which difference between mitosis and amitosis:
- Chromosome doubling on the base of DNA reduplication
 - Chromosomes spiralization on the period of nucleus division
 - Formation of two nuclei from the one mother's nucleus
 - DNA duplication before cell division.
22. Place the following processes one after another:
- Chromosomes doubling
 - Spindle formation
 - Chromosomes condensation, nucleus membrane disappears
 - Chromosomes are moving to the opposite poles
 - Chromosomes arrange on equator
 - Cytokinesis
 - Division of chromosomes.
23. Mitosis was broken by a chemical substance. As a result of this process one single-nucleus cell has formed. In which phase was this process disturbed first? Determine the chromosomes number.
- Prophase
 - Metaphase
 - Anaphase
 - Telophase
 - Diploid
 - Haploid
 - Polyploid.
24. On anaphase and metaphase plate there are:
- n
 - 4n
 - 2n
 - n+n
 - 2n+2n.
25. Process, which causes forming of polyploid cell called:
- Amitosis
 - Mitosis
 - Meiosis
 - Endomitosis
 - Polyteny.

TASKS

- In different groups of cells all initial cells have 2n chromosomes number and 2c DNA number. After division in next interphase different cells have following number of chromosomes: first group of cells is 2c, in other group – 1c, third group – 4c and the last group is vary from diploid to increasing or decreasing but number of DNA were not divisible by haploid number of DNA. Name types of cell division for each group of cell.
- Some chemical factors provoke disturbances in synthetic period of mitotic cycle. Is it possible for this cell to undergo mitosis?
- Nerve cells of embryo after several mitotic cycles lose ability for reproduction and differentiation. Name the period of mitotic cycle where matured specialized cells perform their function?
- DNA content analyze in embryonic fibroblast nuclei culture multiplying by mitosis showed the cells with DNA content 2c – 46%, 4c – 12%, the rest of the cells were with intermediate DNA content. How can we explain such phenomenon?

TOPIC. Biological peculiarities of human reproduction. Gametogenesis. Meiosis. Fertilization

Peculiarities of human reproduction. Reproduction as a mechanism of genetic continuity providing from generation to generation. Gametogenesis. Meiosis. Fertilization as a process of restoration of diploid chromosomes number and increasing of genes recombination.

Reproduction is a most important qualitative characteristics of all alive organisms. **Reproduction** is the ability to produce new individuals that provides functional and material heredity.

Types of reproduction

	Asexual	Sexual
1. Sources of hereditary information for the offspring development	One or several somatic cells of parental organisms	Specialized sexual cells (gametes) which form parental organisms
2. Parents	One individual	One (hermaphrodite), two parental individuals
3. Offspring	Without somatic mutation is a copy of parental organism	Genetically different because of combinative variation
4. The main cellular mechanism	Mitosis	Meiosis
5. Evolution meaning	Provides saving of species, adaptation to the environment, improve stabilized selection.	Provides combinative variation by means of genetic variety, forms evolutionary and ecological perspectives.

Types of asexual reproduction

<i>Monocytogenic (by means of one cell)</i>	<i>Polycytogenic (by means of few cells)</i>
1. Cell fission	1. Vegetative
2. Endogony	2. Strobilation, fragmentation
3. Budding	3. Polyembryony
4. Schizogony	4. Budding
5. Sporulation	5. Sporulation

Gametogenesis is a process of development of sexual cells. There are two types of gametogenesis. *Spermatogenesis* is a development of male sexual cells and *ovogenesis* – development of female sexual cells (ovum).

Early periods of ontogenesis includes differentiation on somatic and primary sexual cells – generative cells (*gonocytes*).

They have some morphological peculiarities and ability for migration. Man's differentiation of gonocytes takes place on 5th week of embryogenesis, farther cells migrate to the buds of bowel mesentery and then to the buds of sexual glands.

Their localization in sexual glands is determined genetically and it stimulates formation of male or female sexual glands (primary morphological differentiation of sex). In ♀ embryos all gonocytes migrate in peripheral layers that stimulates formation of ovaries, in ♂ embryos – in the middle of bud which results in development of testis.

Gonocytes in sexual glands lose mobility and undergo gametogonia (*oogonium and spermatogonium*).

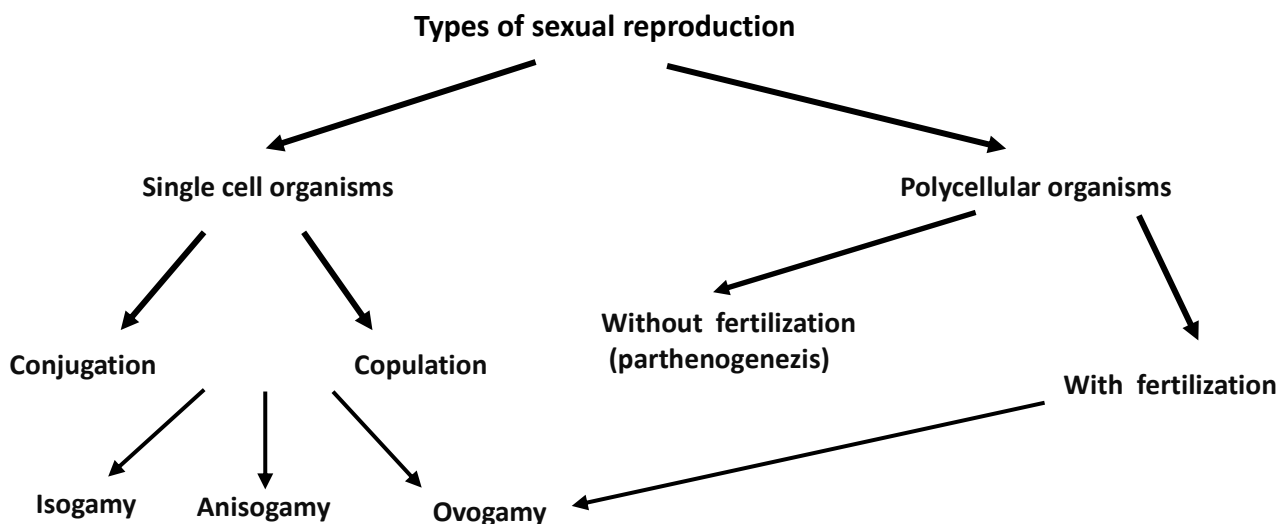

Ovogenesis – development of female sexual cell.

Ovogenesis consists of 3 periods:

1. Multiplication.
2. Growth.
3. Maturation.

The period of *multiplication* takes place before birth of girl (prenatal period) in embryo ovaries. *Oogonium* (diploid cell) is mitotically divided and formed plenty of oocytes (approximately 7 million cells). At this time DNA is synthesized in oocytes. After the seventh month of development gradual elimination of these cells (apoptosis) begins and during birth period there are about 1 million oogonia in ovaries. The programmed death takes place before 10–12 years. At this time there are only 300–400 oocytes which run to the period of growth. *Growth* of oocytes is characterized of cytoplasm increasing and accumulation of different substances which are necessary for blastogenesis. Nucleus and ovoplasm also increased in volume due to the synthesis of substances or their moving from the tissue components of follicle. Synthesis and accumulation of substances for the next processes of development take place during prophase I meiosis.

In the maturation period there is special division of gametocytes – meiosis. **Meiosis** is a division of diploid cells with formation of haploid cells and includes 2 divisions:

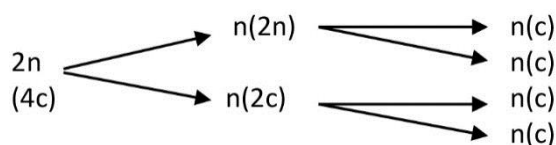

Meiosis uses many of the same mechanisms as mitosis a type of cell division used by somatic cells to split one cell into two identical daughter cells. Meiosis and fertilization events produces a series of transitions back and forth between alternating haploid and diploid states. The organism phase of the life cycle can occur either during the diploid state (*gametic* or $2n$ cycle), during the haploid state (*zygotic* or $1n$ cycle), or both (*sporic* or *haplodiploid* cycle, in which there are two distinct organism phases, one during the haploid state and the other during the diploid state). In this sense there are three types of life cycles that utilize sexual reproduction, differentiated by the location of the organisms phases.

So meiosis I is referred to as a reductional division. In this division the longest phase is *prophase I* which are divided into 5 phases such as:

- **leptotene**
- **zigotene**
- **pachytene**
- **diplotene**
- **diakinesis.**

Leptotene (phase of thin threads) is characterized by processes where individual chromosomes (each consisting of two sister chromatids) change from the diffuse state they exist in during the cell's period of growth condense into visible strands within the nucleus. Chromosomes assume a long thread like shape, they contract and become thick. *Number of chromosomes – 2n, DNA – 4c* because of replication in S-period of Interphase. Each chromosome is made up of only one chromatid and half of the total chromosomes are paternal and half maternal. In this phase process of conjugation begins too.

Zygotene occurs as the chromosomes approximately line up with each other into homologous chromosome pairs. During this phase the synapsis (pairing) of homologous chromosomes takes place and forms of *synaptonemal complex*. Pairing is brought about by a «zipper» and may start at the centromere, at the chromosome ends or at any other parts. Individuals of a pair are equal in length and in place of centromere. Such pairing is highly specific and exact.

Pachytene is the stage when *crossing over* occurs. By means of conjugation chromosomes become thick. Paired chromosomes are called *bivalent or tetrad chromosome (chromatids – 4n, DNA – 4c)*. Nonsister chromatids of homologous chromosomes randomly exchange fragments over regions of their homology (in such places chiasmata forms). The exchange of information between the nonsister chromatids results in a recombination of information. This event has an important biological significance.

In diplotene (phase of double threads) the *synaptonemal complex degrades*. On this phase of prophase I meiosis homologous chromosomes push off, beginning from the area of centromere, but the sisterly chromosomes of every homologous remain united on all length. Homologous chromosomes remain united and visible *chiasmata* – places of joining and crossing of chromosomes, where reparation is completed. Depending of chiasmata amount chromosomes divided into different kind: one chiasmata – as a cross, two – as a loop.

Diakinesis (the phase of passing to the division). The amount of chiasmata diminishes on this phase, bivalents shorten and become compact, nucleoli disappear. Nuclear membrane disintegrates into vesicles, and the meiotic spindle begins to form. The rest of the phase closely resembles prometaphase of mitosis. On this phase there is blocking takes place. Such blocking of meiosis I take off hormones of hypophysis and also hormones of ovary which begin to work in puberty period. Each woman during the reproductive period produces about 400–450 eggs, approximately 1 ovum per month. Therefore every oocyte more than 10–40 years is undergo different factors (physical, chemical, biological) which can be reason of gametes pathology.

Metaphase I characterized by following events: homologous pairs move together along the metaphase plate: kinetochore microtubules from both centrioles attach to their kinetochores, the homologous chromosomes align along an equatorial plane. The biological basis of the independent assortment of chromosomes is the random orientation of each bivalent along the metaphase plate, with respect to the orientation of the other bivalents along the same equatorial line.

Anaphase I. There is casual divergence of homologous chromosomes which consist of two sisterly chromosomes to the different poles and second recombination of genetic material takes place which is related to casual and independent divergence of chromosomes (groups of linked genes) to the different cells and formation of two haploid sets but with diploid amount of DNA. Formation of secondary gametocytes (scheme):

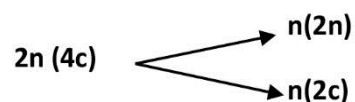

During oogenesis *telophase I* has special features such as: all mass of ovoplasm passes only to the one cell (*secondary oocyte*), second cell grows into *reduction body – primary polocyte*. After finishing of the first division (maturation stage) in the ovaries of woman there is ovulation where the second division takes place. After this the short interphase (interkinesis) starts but without replication because all chromosomes are doubled.

Meiosis II (second division of meiosis) places in uterine tubes and reminds mitosis. But prophase is determined by destruction of nuclear membranes and forming of spindles. At this time there is ovulation – a mature follicle bursts and the oocyte II goes to the uterine tubes.

Egg (maternal gamete) has haploid set of chromosomes (n). For human there are 22 autosomes and 1 heterochromosome X (gonosome). So eggs constantly are in development status and characterizing the eggs of mammals mean oocytes from follicle of the ovary. For the woman diameter of such cells (secondary oocyte) of 130–150 micrometers. They have nucleus, cytoplasm (ovoplasm) and system of eggs membranes.

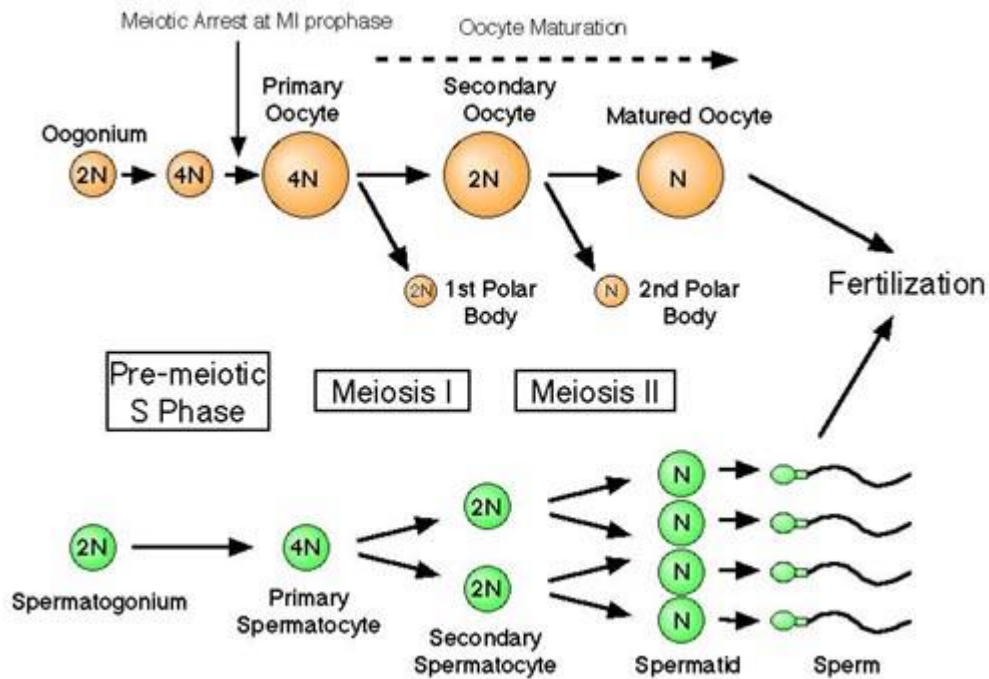

Egg is surrounded by system of membranes which performs protective functions and determine transport and exchange of matters. Distinguish such membranes:

1. *Corona radiata*. External follicle membrane which is formed from follicle cells and intercellular matter. On the surface there are accumulations of follicle cells and forming of «hump» (cumulus oophorus) which disappears after fertilisation.
2. *Zona pellucida*. Transparent membrane formed the products of follicle cells and oocyte.
3. *Yolk membrane* – thin transparent membrane formed from glycoproteins. Provides specificity and attachment of spermatozoon.
4. *Cytoplasm membrane*. Typical cellular membrane which has fibres. Basic function is regulation of transport.

Egg is a specially differentiated female gamete which after fertilization provides beginning of development of organism (blastogenesis).

Spermatogenesis – formation of male gametes (spermatozoa) in testis (reproductive organs). All cycle of sperms development takes approximately 2,5 months. In seminal tubes there are few cells layers each of them is presented by different cells on the certain stage of spermatogenesis. Development of spermatozoa is provided by large cells that occupy space from a basale membrane to the lumen.

An external layer is formed by spermatogonium. Before reproductive period these cages are mitotically divided – it is a period of multiplication. Activated to development all spermatogonium are divided forming the clones of cells which are located near the basale membrane, other spermatogonium continue to be mitotically divided.

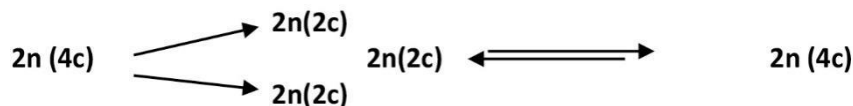

The clone of cells move nearer to the lumen and goes to the growth period. Spermatogonium grow, amount of DNA is doubled $2n(4c)$ – they are named spermatocytes I. They undergo first division of meiosis (reduction) in prophase stage which are divided into leptotene, zigotene, pachytene, diplotene (the stage of diakinesis is absent). On pachytene there are conjugation of homological chromosomes (formation of bivalens) and crossing-over occur.

In diplotene homological chromosomes go away partly but remain joined in some areas (chiasmata).

During maturation periods are forming secondary spermatocytes – haploid cells with diploid DNA number ($2c$).

During short interphase without DNA replication (chromosomes already doubled) the second division of meiosis starts (reminds mitosis). 4 spermatids appears which have haploid number of chromosomes and DNA ($1n1c$), DNA with nuclear proteins forms a dense chromatin complex which is not active.

Ovogenesis is the development of female sexual cells

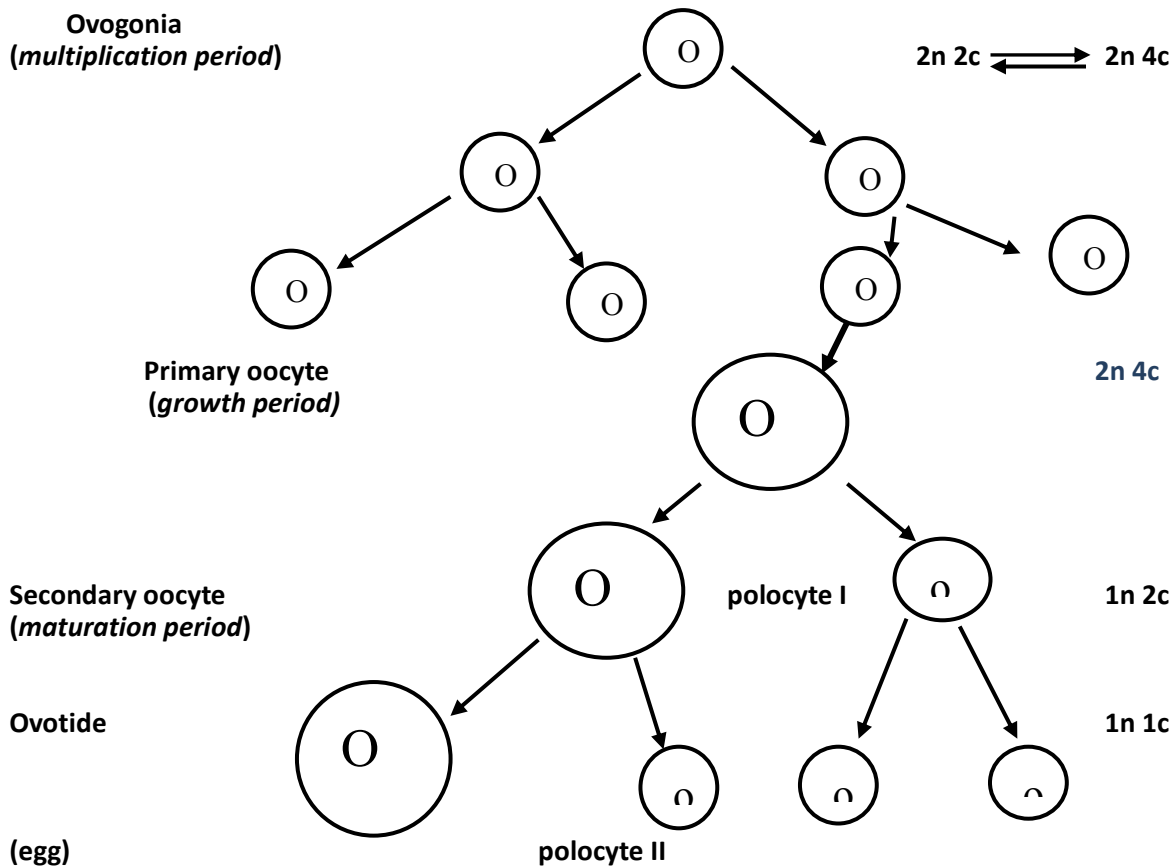

Spermatozoa (sperms) – differentiated male gametes which provide fertilization of an ovum.

Spermatozoa – high-differentiated cells which have head, neck and tail perform specialized functions:

- fertilization and formation of zygote;
- transmission ♀ genome to descendants;
- stimulations of development (division) of fertilized ovum.

Sizes of head is $4 \times 3 \times 2$ micrometers, general length is 20–30. In a head there is an acrosome, placed in front of heads. Here there are enzymes which destroy eggs membranes. The nucleus has oval form, DNA and proteins are formed condensed chromatine. Head is covered by thin layer of cytoplasm with membrane outside. Neck – the shortest part formed from two centrioles. One is near by nucleus and second approaches to the tail of spermatozoa. Tail – is a longest part of spermatozoa, divided into: middle, head (central) and ending parts. Central part of the tail is mobile. Keeping the general plan of structure the spermatozoa is characterized by polymorphism. There are cells with the defect of head, pear-shaped, with doubled gametes, tailless and with two tails. The amount of such spermatozoa does not exceed 10–30%.

Fertilisation is the fusion of gametes to produce a new organism, In human the process involves the fusion of an ovum with a sperm which eventually leads to the development of an embryo. The process occurs within the body of the female in internal fertilisation.

An ovume (oocyte II metaphase cell) after ovulation gets in female sexual ways. It secretes in an environment chemical matters (hormones) which activate motion of male gametes. Spermatozoa move by active motion of tail and also reduction of uterus, pestle pipes and vibrations of hairs. Hormones cause aggregating also (agglutination of spermatozoa).

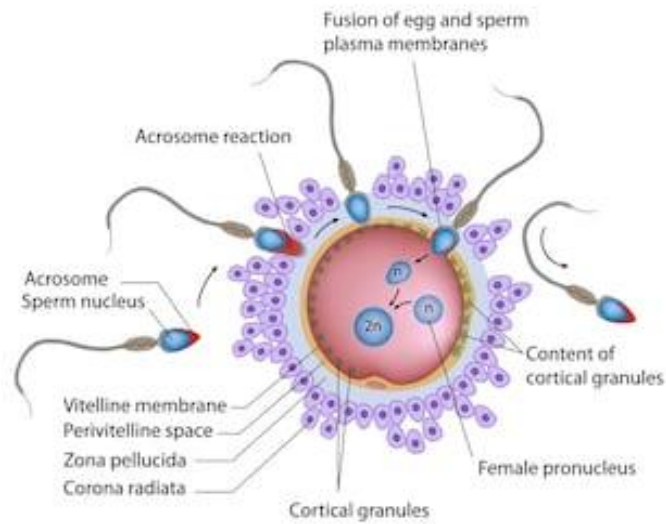

Sperm-egg association during fertilization

During the contact of spermatozoa with the ovum membrane an **acrosomal reaction** is starting – an acrosome destroys and proteolytic enzymes are dissolved eggs membranes. The cytoplasm membranes of ovum and spermatozoa are joining together and through the cytoplasm bridge male nucleus and centriole move into ovum cytoplasm. Fusion of gametes is regulated by specific proteins – factors of fusion which are located on the head of spermatozoa.

Metabolism and membranous potential of cells are changed as a result of fusion, there are morphological and physiological reactions begin. Eggs membrane disconnected. These processes name a **cortical reaction**. After penetration of nucleus of spermatozoa the biosynthesis of protein is activated in ovum. Female cell which is on the stage of metaphase II meiosis activates, meiosis is completed.

The nucleus of spermatozoa (male pronucleus) changes and become interphase nucleus and then prophase one. At this time replication starts and amount of genetics material becomes **1n2c**.

The nucleus of an ovum after completion of meiosis also acquires diploid DNA number (1n2c) and become female pronucleus (one polar body appears also – secondary polocyte). Both pronuclei approached and form general metaphase plate and **synkaryon** (the nucleus of a fertilized egg immediately after the male and female nuclei have fused). It is the final moment of two gametes fusion – **syngamy**.

Journey of an Egg

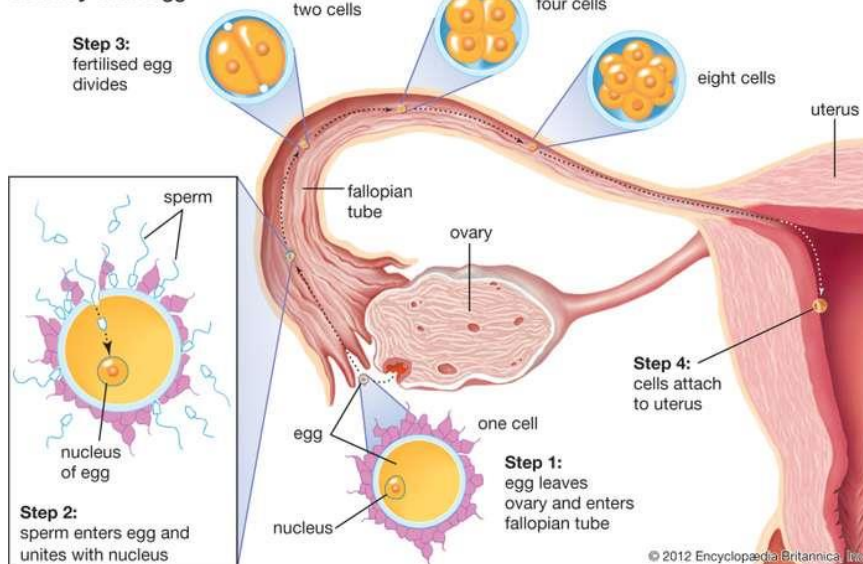

Fertilization and further development of fertilized egg

Further the first division results in formation of two blastomeres with diploid number of genetics material (**2n2c**) – **blastogenesis proceeds**. It is development of an embryo during cleavage and germ layer formation. Generally, the phases of early development occur in next following sequence: **diploid zygote – cleavage – morula – blastula**.

1st level tests
(one correct answer)

1. According to the rule of constant chromosomes number each species of animals has a definite amount of chromosomes. Which of the following mechanisms controls of chromosomes constancy:

- A. Meiosis
- B. Schizogony
- C. Amitosis
- D. Regeneration
- E. Budding.

2. The elementary unite of heredity (asexual and sexual reproduction) is:

- A. One pair of nucleotide
- B. One DNA strand
- C. Two DNA strands
- D. One nucleotide
- E. One gene.

3. Using the non-damaged epithelium cells smear of oral cavity the oval nuclei with different size there were detected. What do we call this type of cell division?

- A. Amitosis
- B. Schizogony
- C. Binary fission
- D. Mitosis
- E. Meiosis.

4. After meiosis in some women the non-divergence of one pair of chromosomes was found. How many chromosomes will be present in mature ovum?

- A. 22 or 24
- B. 23
- C. 45 or 47
- D. 23 or 25
- E. 46.

5. Acrosome is forming from:

- A. Nucleus
- B. ER
- C. Golgi complex
- D. Centrioles
- E. Cytoplasm.

6. During gametogenesis first and second meiotic division are taking place in stage of:

- A. Growth
- B. Forming
- C. Maturation
- D. Multiplication
- E. Synthetic period.

7. How many chromosomes do the sexual cells have after first meiotic division:

- A. 23
- B. 46
- C. 44
- D. 92
- E. 22.

8. How many chromosomes do the sexual cells have at the end of second meiotic division:

- A. 23
- B. 46
- C. 44
- D. 92
- E. 22.

9. First division of meiosis are taking place in:

- A. Ovogonia
- B. Spermatogonium
- C. Spermatid

D. Primary spermatocytes

E. Polocyte.

10. Which kind of cells have diploid number of chromosomes:

- A. Secondary oocytes
- B. Oocytes
- C. Ovum
- D. Polocyte
- E. Spermatozoa.

11. During ovogenesis haploid cells are forming (1n1c):

- A. Ovogonia
- B. Primary ovocytes
- C. Primary polocytes
- D. Zygotes
- E. Ovum.

12. During spermatogenesis haploid cells are forming (1n1c):

- A. Spermatogonium
- B. Primary spermatocytes
- C. Secondary spermatocytes
- D. Zygotes
- E. Spermatozoa.

13. At what meiosis phase does conjugation of chromosomes take place:

- A. Anaphase 1st meiotic division
- B. Anaphase 2st meiotic division
- C. Metaphase 1st meiotic division
- D. Prophase 1st meiotic division
- E. Prophase 2st meiotic division.

14. Define phase of 1st meiotic division where crossing-over takes place:

- A. Leptotene
- B. Zygotene
- C. Pachytene
- D. Diplotene
- E. Diakinesis.

15. Name unmaturing man's sexual cell where crossing-over takes place:

- A. Spermatogonium
- B. Primary spermatocytes
- C. Secondary spermatocytes
- D. Zygotes
- E. Spermatozoa.

16. Name unmaturing female sexual cell where crossing-over takes place:

- A. Ovogonia
- B. Primary ovocytes
- C. Secondary ovocytes
- D. Zygotes
- E. Ovum.

17. Name stage of gametogenesis where all cells are identical:

- A. Growth
- B. Forming
- C. Maturation
- D. Multiplication
- E. Zygote.

18. The genetic information in sexual cells are stored in:

- A. Ribosomes
- B. ER
- C. Golgi complex
- D. Nucleus

- E. Centriole.
19. During two meiotic divisions are forming:
- Somatic cells
 - Diploid cells
 - Haploid cells
 - Genetic identical cells
 - Mutational cells.
20. Name the process of genetic material reshuffling on gene level which provides variety of organic world?
- Crossing-over
 - Conjugation
 - Binary fission
 - Diakinesis
 - Cytokinesis.
21. The Mammal's ovum contains thousand molecules of mRNA, tRNA, rRNA. Such molecules are forming during prophase I meiosis. Which process provides synthesis large amount of RNA in ovum:
- DNA replication
 - Transcription
 - Translation
 - Amplification of genes
 - Reparation.
22. Fertilization is the union of an ovum and one sperm but there are many sperms are going towards the ovum. Name the process of polyspermy blocking:
- Increasing of ovum's metabolism
 - Destroying of membranous receptors
 - Forming of membranous receptors of eggs
 - Destroying of membranous receptors of eggs
 - Decreasing of membrane's penetration.
23. Human ovum contains thousand molecules of mRNA, tRNA, rRNA. Such molecules are forming during stage of diplotene. Which process provides synthesis large amount of RNA in ovum?
- Amplification of genes
 - DNA replication
 - Transcription
 - Reparation
 - Translation.
24. What is the name of the final phase of prophase I meiosis?
- Diplotene
 - Diakinesis
 - Zygotene
 - Pachytene
 - Leptotene.
25. What phase of prophase I meiosis has the visible chromosomes in form of thin threads?
- Diplotene
 - Leptotene
 - Zygotene
 - Diakinesis
 - Pachytene.
26. The form of sexual reproduction where a filial organism formed an unfertilized ovum has a name:
- Meiosis
 - Schizogony
 - Parthenogenesis
 - Conjugation
 - Copulation.
27. Name the type of sexual reproduction in some kind of animals and plants when the big female sexual cell fuses with a small male cell:
- Anizogamy
 - Isogamy
 - Copulation
 - Conjugation
 - Oogamy.
28. Polvembrony is:
- Process of development of several embryo from one fertilized ovum
 - Process of development of embryo from unfertilized ovum
 - Development of embryo from one ovum and several spermatozoa
 - Development of embryo from several eggs
 - Development by means of schizogony.
29. Eggs of different organisms have a different amount of yolk. This difference depends from the kind of reproduction. All Mammals form placenta and their eggs have less amount of yolk. What is the name of that egg?
- Oligolecital
 - Polvlecital
 - Telolecital
 - Mesolecital
 - Centrolecital.
30. All Mammals have a yolk distribution in regular intervals, but insects have a middle distribution, fishes and birds have a special part of the cell without yolk. What type of cell is typical for the humans?
- Polvlecital
 - Telolecital
 - Mesolecital
 - Isolecital
 - Centrolecital.

2nd level tests

(several correct answers)

1. At what gametogenesis stage does meiosis take place:

- Multiplication
- Growth
- Maturation
- Formation.

2. At what meiosis stage do synapsis and crossing-over take place:

- Prophase I
- Prophase II
- Metaphase I
- Pachytene.

3. During gametes forming (meiosis) homologous chromosomes are:

- Going to the one pole to one gamete
- Undergo conjugation and moving towards the different poles to different gametes
- Exchange of homologous parts and by means of chiasmata are forming different figures.

4. Results of 1st meiotic division are:

- Formation of new cells with the same chromosomes number
- Formation of new cells with haploid chromosomes number and DNA

- C. Formation of new cells with haploid chromosomes number and diploid number of DNA;
- D. Formation of cells with reshuffling genetic information by means of crossing-over.
- 5. Transmission of inherited characters of species in each generation conditioned by:**
- A. Behavior of chromosomes in mitosis
- B. Behavior of chromosomes in meiosis
- C. Features of cytoplasm division between daughters cells in mitosis
- D. Features of cytoplasm division between daughters cells in meiosis.
- 6. How many chromosomes and which number of DNA have:**
- A. Spermatogonium
- B. Primary spermatocytes
- C. Secondary spermatocytes
- D. Spermatozoon
- E. Primary sexual cells (gonocytes).
- 7. Which mechanisms provide saving of constant karyotype in each generation:**
- A. Meiosis
- B. Mitosis
- C. Fertilization.
- 8. At what gametogenesis zone stage does meiosis take place?**
- D. Multiplication
- E. Growth
- F. Maturation
- G. Forming.
- 9. Cells of organism have 22 pairs of chromosomes. How many chromosomes will be:**
- A. Spermatozoa
- B. Ovum
- C. Zygote
- D. Somatic cells.
- 10. What mechanisms provide genetic variety of gametes in the process of meiosis?**
- A. Non-equal arrangement during meiosis (ovogenesis)
- B. Independent separation of homologous chromosomes during meiosis I
- C. Crossing-over
- D. Conjugation
- E. Random combination of non-homologous chromosomes during separation.
- 11. What are the mechanisms provide saving of constant karyotype in each generation in the process of sexual reproduction:**
- A. Mitosis;
- B. Endomitosis;
- C. Meiosis;
- D. Meiosis + fertilization.
- 12. What number of chromosomes have:**
- A. Ovogonia
- B. Primary ovocytes
- C. Secondary ovocytes
- D. Ootid
- E. Polocytes.
- 13. Describe the behavior of non-homologous chromosomes during meiosis:**
- A. All non-homologous chromosomes derived from each parent (including joined chromosomes) transmit to the gametes
- B. Non-homologous chromosomes at metaphase I meiosis are arranged their chromatids between poles
- C. Non-homologous chromosomes are forming different bivalent which are separating independly from each other
- D. Non-homologous chromosomes derived from each parent are separating randomly during 1st division and define forming of different reshuffling gametes.
- 14. Name the forms of asexual reproduction:**
- A. Polyembryony
- B. Schizogony
- C. Conjugation
- D. Parthenogenesis.
- 15. The latest type of reproduction arose from the evolution process is:**
- A. Vegetative
- B. Asexual
- C. Sexual
- D. Parthenogenesis.
- 16. Characteristics of asexual reproduction:**
- A. Paternal organisms are forming specialized cells – gametes
- B. Offsprings are forming from one or several parental lines
- C. Parent – one or two individuals
- D. Reproduction provides one individual
- E. The main mechanism of reproduction is mitosis
- F. The main mechanism of reproduction is meiosis
- G. Offsprings – genetical copy of parent
- H. Offsprings are genetically different from the parent as a result of combinative variation.

TASKS

- There are two spermatozoa into the ovum. What are the ways of them?
- During spermatogenesis 4 sperms from one spermatogonia are forming, but during ovogenesis – only one ovum and 3 polar bodies (shortly eliminated). What is the biological importance of non-equal separation of cytoplasm during ovogenesis? How many chromosomes do the ovum and polar bodies have?
- The man's testis in growth period has 22,000 primary spermatocytes. How many secondary spermatocytes and sperms can be formed?
- The women's ovary in growth period has about 400 primary ovocytes. How many secondary ovocytes and polocytes can be formed?
- Some ovogonia has one mutant gene which has formed in presynthetical period. How many secondary ovocytes can get such gene?
- Primary ovocyte has mutant gene (before DNA duplication). How many zygotes will get such gene?

Contents

Introduction to the course of medical biology. Levels of living matter organization.	
Optical systems in biological research	3
1 st level tests	6
2 nd level tests	8
Cell morphophysiology. Structural components of cytoplasm	9
1 st level tests	15
2 nd level tests	17
Cell membrane. Transport through the plasmalemma	19
1 st level tests	23
Nucleus. Human karyotype. Genome and chromosomal mutations	26
1 st level tests	30
2 nd level tests	32
Molecular basis of heredity. Characteristics of nucleic acids	34
1 st level tests	41
2 nd level tests	44
Tasks	45
Structure of pro- and eukaryotes gene	46
1 st level tests	49
2 nd level tests	52
Tasks	52
Organization of information flow in the cell. Regulation of gene expression.	
Molecular mechanisms of the human variation	53
1 st level tests	57
2 nd level tests	60
Tasks	61
Cell cycle. Cell division	62
1 st level tests	66
2 nd level tests	69
Tasks	70
Biological peculiarities of human reproduction. Gametogenesis. Meiosis. Fertilization	71
1 st level tests	77
2 nd level tests	78
Tasks	79